

THE WORLD'S FIRST TELEVISION JOURNAL

The Official Organ
of the Television Society

6!

Television

A MONTHLY MAGAZINE

MARCH

Vol. 1

1928

No. 1

All about Television,
the Invisible Ray, etc. etc.

Also an exclusive Constructor article

How to make a Simple
"TELEVISOR"

fully described in this issue

How to Make a
Selenium Cell,

and other interesting
features



WEEKS

**Marconi
Type D.E.5.
Dull Emitter
Power Valve**

For L.F. Amplification

As last valve of an amplifier it requires a steady negative grid bias of 6-3 volts with an anode voltage of 120. Used as a detector or high frequency amplifier, the anode voltage should be 40.

Filament Volts 5-6. Filament Current amps 0.25
Anode Volts 20-120. Impedance (ohms) 8,000.
Amplification factor 7.

Price 12/6

D.E.5A.

A Super-
Power
Valve for
the
last stage.

Price 20/-.

**Marconi
Type L.S.5.
Super Power Valve**

The L.S.5 is the best valve for power amplification work with high voltage. As transmitter it can be allowed to dissipate a maximum of 10 watts at an anode voltage not exceeding 400 volts.

Filament Vols. 4.25-5.25. Filament current amps 0.8.
Anode Battery Volts 60-400.
Impedance (ohms) 6,000. Amplification factor 5.

Price 30/-

L.S.5A.

A modification of the L.S.5, particularly suitable for large amplifiers, etc.

Price 30/-



*Marconi Valves
HELP the
experimenter*

The two valves illustrated here are of special interest to every experimenter in wireless and television. Both the D.E.5 and the L.S.5 are eminently suitable for low frequency amplification.

The L.S.5 in particular is recognised as the best valve yet designed for power amplification work.

The other Marconi power valves are the 4-volt D.E.P.410 (12/6), and D.E.P.610 (12/6) which is for 6-volt accumulators. Both give great amplification without distortion.

MARCONI VALVES ARE USED IN THE PRINCIPAL BROADCASTING STATIONS AND BY LEADING EXPERIMENTERS.

FREE.

The Marconiphone Company have just published the results of numerous laboratory tests in the form of a book entitled "500 Marconi Valve Combinations." This time and money saver will gladly be sent free and post free to every reader of "TELEVISION" who fills in the coupon below.

MARCONI VALVES
-do everything that a valve should do

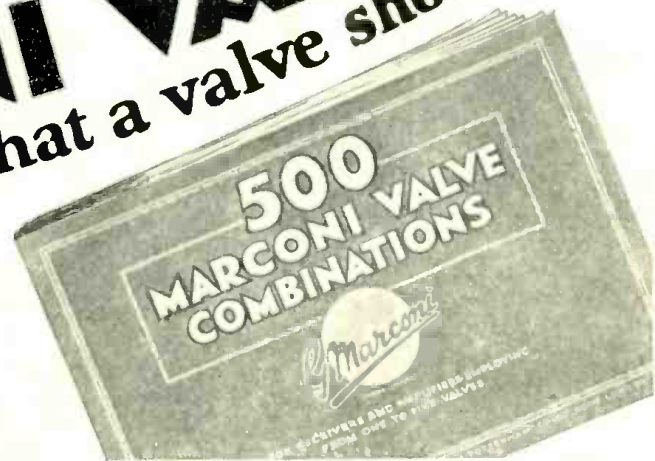

Coupon

THE MARCONIPHONE CO., LTD.,
210/212, Tottenham Court Road, London, W.1.

Please send me a copy of "500 Marconi Valve Combinations."

Name

Address T.1

Mention of "Television" when replying to advertisements will ensure prompt attention.

Explore and Discover

The wider
circle...the
greater
possibilities
by using



The Ever Ready Co. supplied the dry batteries which were used by Mr. Baird at the Leeds demonstration of Noctovision.

Wireless reception - Audible or Visible

EVER READY^{REGD.}

BRITAIN'S BEST BATTERIES

are the Key to efficiency

We shall be pleased to advise on the installation of all types of batteries on receipt of particulars. Service Dept. I.H. The Ever Ready Co. (Gt. Britain), Ltd., Hercules Place, Holloway, London, N.7

Mention of "Television" when replying to advertisements will ensure prompt attention.

*Six-Sixty "every time!"
says the Constructor*



**SIX SIXTY
GLOWLESS VALVES**

"TELEVISION is here," says the constructor, "and every Radio fan will soon be busy making the necessary additions and alterations to his apparatus to enjoy this wonderful phenomenon. My own set is in fine fettle and I am looking forward with eager anticipation to the time when I can sit back in my chair and enjoy the pleasures of Television. Thank goodness my set incorporates the best possible components, and above all things Six-Sixty valves. The greatest care should be exercised in choosing your valves and you will find that by the process of elimination you are bound to come to Six-Sixty. Never once in the whole of my experience as a Wireless Constructor have I been let down by a Six-Sixty valve. I have nothing but the highest praise for Six-Sixty from every point of view, and practically all the constructors of my acquaintance hold the same views. All I say to you is: 'Try Six-Sixty valves yourself and find out what perfection is.' Ask your dealer to-day."

THE ELECTRON CO., Ltd., 122-124, Charing Cross Road, London, W.C.2.

Mention of "Television" when replying to advertisements will ensure prompt attention.

The Loudspeaker of to-day —and of the future

TO-MORROW,
Television ;
to-day and
to - m o r r o w ,
“CELESTION,” the
loudspeaker which,
like the best of
violins, improves
with age.

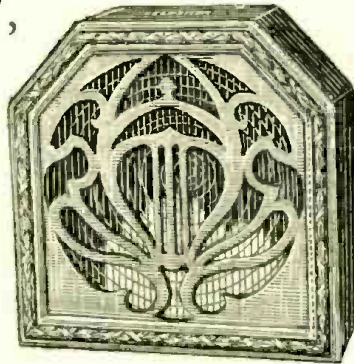

MODEL C12

“Television” will reflect mirror-like and life-like what is happening afar off.

“Celestion,” mirror-like, reflects *sound* true to life. It produces the notes of the piano and the organ precisely, whilst the “s” sound in

speech, so often distorted even on earphones, comes through exactly as it is spoken.

“Celestion” is extremely handsome in appearance and adds distinction to

any drawing-room. It breathes “craftsmanship” and great care in production. Insist on “Celestion”—the all-British loudspeaker!

Write for illustrated folder!
Models in oak or mahogany
from £5. 10s. to £25.

CELESTION

THE VERY SOUL OF MUSIC

THE CELESTION RADIO CO.,
Hampton Wick, Kingston-on-Thames.

Showrooms:
33/35, VILLIERS ST., STRAND, W.C. 2.
Telephone; Gerrard 0397.

French Agents:
Constable & Co., Paris.

ON DEMONSTRATION—FIRST ON MERIT

Mention of “Television” when replying to advertisements will ensure prompt attention.

“ TELEVISION ”

The World's First Television Journal

A Monthly Magazine devoted to the interests and progress of the science of seeing by wire and wireless



WIRELESS

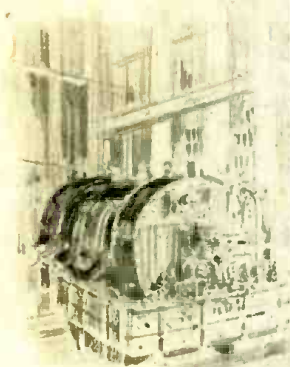

ELECTRICITY



MECHANICS



CHEMISTRY



OPTICS



CINEMATOGRAPHY

MARCH 1928

	PAGE
EDITORIAL	7
GREETINGS TO THE WORLD'S FIRST TELEVISION JOURNAL	8
TELEVISION 1873—1927	10
<i>A brief outline.</i>	
SOME NEW USES FOR TELEVISION	12
<i>Drawn by W. Heath Robinson.</i>	
OPTICAL PROJECTION	13
<i>By Professor Cheshire, C.B.E., A.R.C.S., F.I.P.</i>	
THE BIRTH OF THE TELEVISION SOCIETY	16
TECHNICAL NOTES	17
<i>By the Technical Editor.</i>	
GLIMPSES INTO THE FUTURE	18
<i>No. 1, "Television in Warfare," by R. Heath Bradley.</i>	
COMMERCIAL TELEVISION	21
<i>When may we expect it?</i>	
JOIN THE TELEVISION SOCIETY	24
FOR THE CONSTRUCTOR	26
HOW TO MAKE A SIMPLE TELEVISOR	29
TELEVISION ON THE CONTINENT	36
<i>By M. Dumont.</i>	
LIGHT-SENSITIVE CELLS	38
<i>By K. M. Dowberg.</i>	
NOCTOVISION	40
<i>By R. F. Tiltman, F.R.S.A., A.M.I.R.E., A.Rad.A.</i>	



Seeing Across the Atlantic!

AT the beginning of this year the record distance over which television had been publicly demonstrated was between London and Glasgow, by Mr. J. L. Baird. To transmit vision over such a distance—435 miles—seemed at the time to be a most phenomenal achievement; yet, just after we had gone to press with this issue there burst upon the world the startling news that the Atlantic had been spanned by television! again by Mr. Baird!

Just what does this mean? It means that recognisable images of human beings seated in the heart of London were seen in New York, over 3,500 miles away!

This public demonstration, carried out in the early hours of the morning of February 9th, turns out to be the culmination of months of secret experimenting.

On the night of the demonstration there assembled at the offices of the Baird Company, in Long Acre, a small party made up of Press representatives and privileged guests. The transmissions commenced at midnight, London time, or 7 p.m., New York time.

In order to give the watchers at the New York end an opportunity to adjust the receiving apparatus, the image of a ventriloquist's doll was first transmitted. The image sound produced by this doll, which sounded for all the world like the drone of a huge bee, was then sent over a telephone line to the company's private experimental wireless station at Coulsdon. From this station the image sound was then flashed across the Atlantic on a wave-length of 45 metres.

On the American side, the signal was picked up by an amateur receiving station at Hartsdale, a suburb of New York. After amplification the signal was then applied to the receiving televisor, upon the ground glass screen of which the image appeared. This screen measured about two inches by three inches.

Four watchers were anxiously gathered round the apparatus. These were Capt. O. G. Hutchinson, the Joint Managing Director of the Baird Company, who had gone to New York specially to conduct the experiments; Mr. Clapp, one of the company's engineers; Mr. Hart, the owner of the amateur wireless station at Hartsdale, and Reuter's press representative.

When the image of the doll's head had been satisfactorily tuned in, Mr. Hart started up his transmitter, called a receiving station operator at Purley, near London, and asked that Mr. Baird should take his place before the transmitter instead of the doll. This message was telephoned from the receiving station to the laboratories at Long Acre.

For half an hour Mr. Baird sat before the transmitter, moving his head this way and that, until the message came through from New York that his image had come through clearly. Mr. Fox, a Press representative, then took Mr. Baird's place, and continued to sit before the televisor until word came through that his image was coming through excellently. It appeared that Mr. Fox's features were particularly striking, from a television point of view, and transmitted better than those of other sitters.

Mrs. Howe, the wife of another journalist present, was then transmitted, and, although her features were not recognisable at the American end there was no mistaking the fact that a woman was seated before the transmitter.

Those assembled at the London end were able to see, on a check receiver, a pilot image of what was being transmitted. This image, which was full size, showed the head of the sitter, the complete details of the features showing in black relief on an orange-coloured background. By means of this pilot image the transmitting operator was enabled to check the outgoing transmission and correct any irregularities.

Atmospherics and other interference, and also fading of signals marred the image as received at the New York end at times, but in spite of these disabilities, reception was, on the whole, very good. The demonstration proved quite conclusively that if a much higher powered wireless transmitter had been employed, the image would have been received in New York entirely free from atmospheric and other disturbances. An important feature is that only two operators were required to attend to the television transmission, one at each end of the circuit.

By special arrangement with the Baird Company, we are being afforded special facilities and information which will enable us, in our next issue, to give our readers a more technical and illustrated account of how this latest wonderful dream of science has been achieved.

Mullard



THE VALVE WITH THE WONDERFUL

MULLARD P.M. FILAMENT

For the very best radio and television reception you need Mullard P.M. Valves.

Mullard
THE · MASTER · VALVE

Mention of "Television" when replying to advertisements will ensure prompt attention.



Varley
LTD.

AND TELEVISION

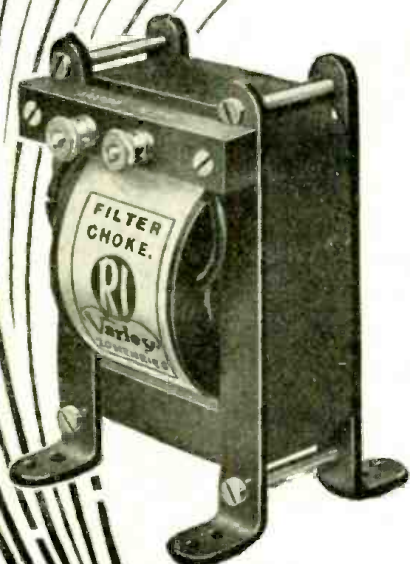

Filter Choke.
21/-
This Output Filter Choke has the largest iron core of any proprietary Filter Choke on the market.

AT the NATIONAL RADIO EXHIBITION, Olympia, held in September, 1927, we had on show eighteen new products. The previous six months was a record of ruthless scrapping of any existing products that were not up-to-date, and the designing of new and better components incorporating the most modern developments of radio science.

What is the result to-day? We are in the unique position of being ahead of existing design, and our contribution to Television will play no less a part than it has done in the case of Radio.

Already several R.I. and Varley components—among them our new Filter Choke, and our Bi-duplex wire-wound Anode Resistances—have been used on the Output side of Television apparatus, and the near future will see many of our products become standard lines in one of the biggest scientific developments of the day.



Bi-duplex Wire-wound Anode Resistances.
Made in a complete range of sizes up to 500,000 ohms. Prices complete with universal holder, 5/8 to 17/8.



THE MARK OF PROGRESS

Kingsway House, 103, Kingsway, London, W.C.2.

Telephone: Holborn 5303

Mention of "Television" when replying to advertisements will ensure prompt attention.

Take up Television

Television is a new science with gigantic possibilities. Every experimenter who enters this new field may become the discoverer of vital improvements or devices which will make his name known throughout the scientific world. In any new industry there is unlimited scope for experimental developments directly resulting from the efforts and brains of keen amateurs. Come into this new science at once. Be one of the first television experimenters in your district.

Television Supplies Limited specialise in all television requirements and are directly in touch with the most reliable information, designs and apparatus for television experimenters. Their Engineers and Laboratories are equipped to meet the needs of all who take up this new science. All the essential components referred to in the Televisor article in this magazine are available—Selenium Cells, Slot Discs, Spiral Discs, and all Television apparatus of the highest technical standards. Distribution will be made through all radio dealers. Price lists and detailed particulars on application.

The very heart of Television

There is no doubt that the whole success of the experimental Televisor described in this magazine lies in the use of a high efficiency ultra-sensitive Selenium Cell. Television Supplies Limited have concentrated on the design of the most efficient Selenium Cell yet invented.

Its chief characteristics are:—

- (1) Unequalled Sensitivity. (2) Lowest Resistance. (3) Highest Ratio. (4) Negligible Lag.
- (5) Reliability, Constancy and Robustness. (6) Every Cell gives practically instantaneous response to rapid variations in light intensity and is subjected to searching tests for sensitivity before despatch.

TELEVISION SUPPLIES LIMITED SELENIUM CELL Type K.4, condenser pattern, has a sensitised area of approximately 400 square mm. This Cell is of the highest sensitivity, lowest resistance, and greatest robustness of any Selenium Cell yet designed. - - - **Price 20/-**

TELEVISION SUPPLIES LIMITED SELENIUM CELL Type G.1, grid pattern, is a cheaper but quite satisfactory type of cell capable of excellent performance. - - - **Price 10/-**

Both these Cells are eminently suitable for the experimental Televisor described in this magazine.

— To ensure prompt delivery orders should be placed immediately. —

Television
SUPPLIES LTD.

Tel. No.
 Putney
 2771

Quill Lane, Putney, London, S.W.15

Mention of "Television" when replying to advertisements will ensure prompt attention.

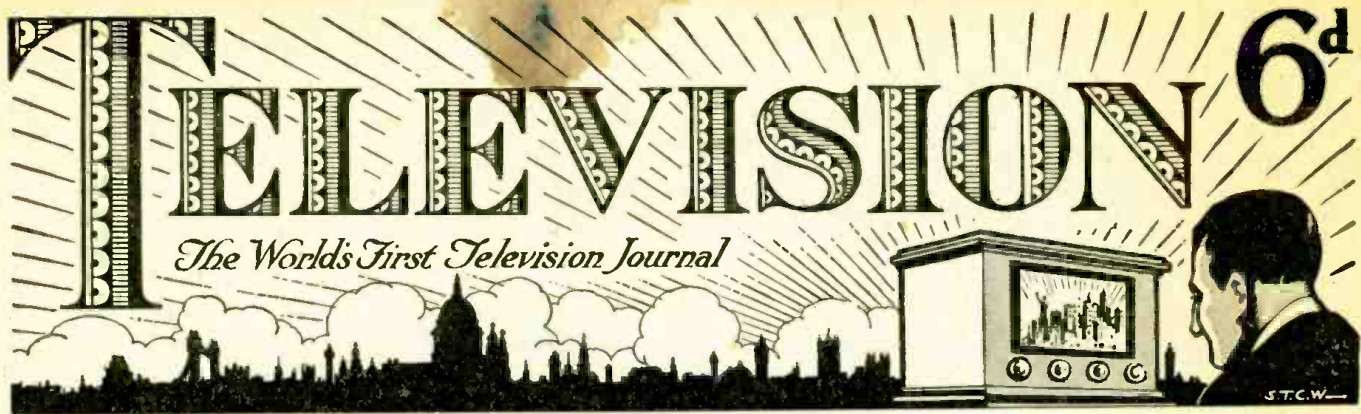

The Official Organ of The Television Society

Edited by A. DINSDALE, A.M.I.R.E.

Consultants: Dr. C. TIERNEY, D.Sc., F.R.M.S.; W. J. JARRARD, B.Sc. (1st Hons. Lond.), A.R.C.S., A.I.C.

Technical Editor: J. C. RENNIE, B.Sc., A.M.I.E.E.

Vol. I]

MARCH 1928

[No. 1

EDITORIAL

OF all scientific subjects, perhaps the one which is creating the most interest in the public mind at the present time is television. It is, however, a subject upon which almost no literature or authentic information has been available, either to the interested amateur or to the scientist.

* * *

It is the object of this, the first journal of its kind in the world, to fill this want, and to supply an organ the sole object of which will be to keep interested members of the public supplied with up-to-date and authentic information upon this new branch of science, which bids fair in time to rival wireless broadcasting in importance and popularity.

* * *

WE might, perhaps, be criticised as being premature in introducing a journal devoted solely to a subject which has as yet hardly emerged from the laboratory. But television, while it is not yet available to the general public, has long since emerged from the realm of theory; it was demonstrated in this country over two years ago, and has since been accomplished over long distances both here and in the U.S.A.

It is part of our policy to give our readers detailed technical descriptions of the apparatus and methods used by experimenters the whole world over. For example, as we write these lines a newspaper dispatch informs us that the General Electric Company, of Schenectady, N.Y., has just succeeded in broadcasting television, through the world-famous broadcasting station, WGY, to four private homes. This means that the home television set is already in sight. In our next number we expect to be in a position to give our readers a full description of the General Electric Company's apparatus.

WE also intend to publish in this journal articles by leading authorities at home and abroad, both on television and upon the allied subjects which it embraces, such as optics, mechanics, chemistry, electricity, and telephony, both wire and wireless.

* * *

ANOTHER feature of exceptional interest to the experimenter will be our constructional articles which, commencing with the description published in this issue of an extremely simple form of televisior, will take the reader by simple steps over the ground which has had to be covered by all investigators in the subject, until finally he will be in a position to conduct television experiments of his own, by wire or by wireless, over a distance.

* * *

IN another part of this magazine we give details of the arrangement which has been come to with the Baird Television Development Company, whereby our readers may obtain from us free licences to use the Baird patents for experimental purposes. These licences may also be obtained direct from the Television Society, of which this journal is the official organ.

Editorial & Publishing Offices:

The Television Press,
Limited,

26, Charing Cross Road,
London, W.C.2.

Telephone: Regent 6437.

SUBSCRIPTION RATES. 7/6 PER ANNUM,
POST FREE.

MSS. and other material for Editorial
consideration should be accompanied
by a stamped addressed envelope, and
should be typewritten.

Greetings to the World's



SIR OLIVER LODGE, F.R.S., D.Sc.

There are too many magazines already, and now you are starting one called TELEVISION. But the subject is exciting a good deal of interest, and doubtless a journal which will set forth the latest developments may be a help towards the accomplishment of television as a factor in everyday life. So I send greeting to the world's first television journal, and wish it success.

Oliver Lodge



SIR JOHN C. W. REITH.

Those whose responsibility it is to keep in touch with this comparatively recent scientific development are keenly interested in well-conceived efforts to make electrical vision a practical reality, and I wish your enterprise every success.

Reith



MR. JOHN L. BAIRD.

TELEVISION comes at an opportune moment, and will, I feel sure, be the means of introducing many to a fascinating field of research, and a most interesting hobby.

Television offers unparalleled opportunities to the young engineer.

John Baird



ADMIRAL MARK KERR, R.N., C.B., M.V.O.

As a naval man I am intensely interested in the development of television known as noctovision, and the demonstration which I witnessed of the fog-penetrating powers of this apparatus lead me to believe that its development will have most far-reaching consequences in the direction of minimising the risks of navigation.

I extend a most hearty welcome to TELEVISION, and feel sure that it will contribute most usefully to the development of this new science.



SIR PHILIP GIBBS, K.B.E.

In sending a blessing to the first birthday of TELEVISION, I feel that I am greeting the arrival of a new power in life which may change the habits and thoughts of mankind. It is one more advance in the rapidity of communication between distant minds, and we may see, one day, across the world. May this miracle of television help us to see beauty and truth more clearly, and pierce through the brick walls of human misunderstanding. The genius of Mr. John Baird gives mankind a far-reaching vision.

Philip Gibbs

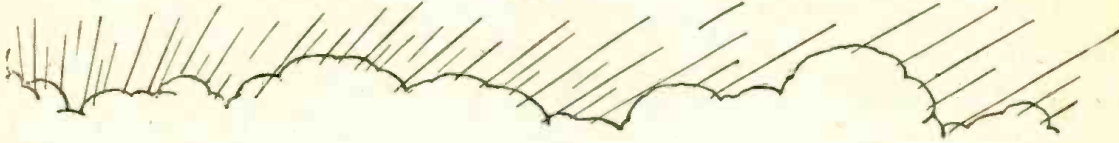

First Television Journal



THE DUKE OF MONTROSE, C.B., C.V.O.

I feel sure that the TELEVISION magazine will contribute to the development of a most interesting scientific invention, and I wish it all success.



SIR EDW. MANVILLE, M.I.E.E., M.P., J.P

I am delighted to see a magazine devoted exclusively to the new science of television. I know there is much useful work which a journal of this order can undertake. Therefore I wish you every success.

Edw. Manville



SIR JOHN S. SAMUEL, K.B.E., D.L., F.R.S.E.

I am delighted to learn of the publication of TELEVISION, and wish for it a long career of usefulness. Mr. Baird's marvellous invention is one of the most marked advances in science of modern times, and is destined to operate to the lasting advantage of mankind. We in Glasgow are proud to claim the gifted inventor as a citizen, and I personally shall never forget the experience I had on the evening of Thursday, May 26th, 1927, in the Central Station Hotel, Glasgow, when I was present at the first practical demonstration of television, and when I personally spoke from Glasgow to Mr. Baird in London through his televisor, while seeing him at the same time. This was, I understand, the pioneer experiment of his completed invention, but great strides have taken place since then, and when attending the meeting of the British Association at Leeds last September I had an opportunity of seeing the marvellous development and extension of his discoveries which had taken place.

I send my most hearty greetings to the world's first television journal.

John Samuel



CAPTAIN S. R. MULLARD.

Hearty congratulations on the first real effort to give the world a reliable source of information about the new wonderland of television.

I know that tens of thousands will read your Journal with great interest. Good luck in your pioneer adventure.

S. R. Mullard



CAPTAIN O. G. HUTCHINSON.

It was prophesied by Professor Ayrton, I think, nearly 40 years ago that a day would come when with an electric voice we would encompass the world, so that the friend to whom we called would hear us even if we were at the opposite ends of the earth. That day is here, and now we have reached the beginning of another era. The electric eye has come to supplement the electric ear, and with it we shall be able in time to come to sweep the earth with electrical vision and see our friends wherever they may be.

O. G. Hutchinson

TELEVISION 1873 — 1927



A brief outline of what has been accomplished in little over half-a-century

TELEVISION is the newest child of science, although even at this early stage it is an infant that shows great promise for the future, and therefore it is quite understandable that some people who have not closely observed the coming of this promising youngster might, on seeing the first copy of the first television journal in the world, exclaim "What is Television?"

Television is usually rather loosely defined as "seeing by wireless," for that is the popular term under which it so frequently masquerades. This is, however, hardly correct, for television is seeing by *telegraphy*, either with or without wires. The Patent Office, which defines such terms, makes this quite clear by correctly laying down that television apparatus is that used for "transmitting instantaneously to a distance images of views, scenes, or objects by telegraphy, either wire or wireless."

It may be regarded as reproduction of sight, for television enables us to actually, visually, witness living scenes, people, and objects at a distance just as if we were actual eye-witnesses on the spot. It means the transmission of the living image of living, moving things, with all gradation of light, shade, and detail, to a receiving screen where they are faithfully reproduced with all movements. Television, therefore, is instantaneous vision over any distance by wireless or wire. Natural colouring is not seen.

Television not Photo-Telegraphy.

Television is very frequently confused with photo-telegraphy, which is

quite a different thing. Perhaps the most simple way to define the difference is to state that the former is *living* and the latter *still*.

Photo-telegraphy is the transmission of separate still pictures or photographs. Even "Webster's Dictionary" confuses television and photo-telegraphy, but it should be clearly understood that the one refers to vision of living scenes at the moment of them taking place and the other to the mere sending of a "still" picture.

The history of television, or rather the history of television *attempts*, may be said to date from the discovery of the light-sensitive properties of selenium 54 years ago. Selenium, of

in 1873 at the Atlantic cable terminal station at Valentia.

Three years after this discovery various experimenters had constructed selenium "cells," and it was immediately suggested that they would make it possible to see by telegraphy. Within the next few years many scientists described systems to accomplish this remarkable feat, and it was confidently asserted that vision over the telephone line would be an accomplished fact very shortly.

The problem of television was to break up each living image into many thousands of fragments, convey these "pieces" to the receiver and re-assemble them on the receiving screen in a fraction of a second. It is necessary to make a complete traversal of the screen in about one-tenth of a second so that the images are seen instantaneously owing to the "time lag" of the eye.

The Photo-Electric Cell.

In 1888 another method of turning light into electricity was discovered, and what are called "photo-electric cells" were constructed and used as an alternative to the sluggish selenium cell. These photo-electric cells also proved insufficiently sensitive to the very small amount of light that is reflected from the scene or object being transmitted.

The invention of the thermionic valve by Fleming, and the development of the three-electrode valve so familiar in the present-day radio set, appeared to give a means of amplifying the weakest currents to any degree, but even the magnification



The first photograph ever taken by Television.

course, is a metal, the electrical resistance of which varies when light falls upon it. The discovery of these properties was made quite accidentally

possible in this way was insufficient. Right through the history of television it was clearly evident that the main stumbling-block was the light-sensitive device.

Shadows.

Early experimenters in the field of television who may be mentioned are Rignoux and Fournier, Szczepanik, Rosing, Belin; but there were a host of others. All these workers attacked the problem in their own particular manner, and although success eluded them in early days they laid foundations which were, no doubt, of value in later experiments.

By 1923 several scientists had advanced towards television to the extent of sending *shadows*, and this was taken as a hopeful sign. This feat was achieved by Jenkins and Moore, U.S.A.; Holweck and Belin, France; and Baird, England.

The difference between sending mere shadows and sending the living

image with all gradations of light and shade is, however, very great, and in view of the long years of fruitless experiments it was said that many years would pass before a living image of the human face would be transmitted and recognised at the receiving end.

First Demonstration.

However, in January, 1926, Mr. J. L. Baird, a Scottish engineer, gave before members of the Royal Institution the first demonstration of true television in the world, sending the images of faces from one room to another. The results were, naturally, quite crude, and there was much room for refinement and improvement, but, still, it *was* television, and was recognized as a most remarkable achievement.

Longest Distance Transmitted.

Since the date of this first demonstration steady progress has been made, and at the beginning of last

year Mr. Baird demonstrated television between London and Glasgow with the aid of only two assistants, this being the longest distance so far covered.

American Demonstrations.

In America the American Telephone and Telegraph Company have also demonstrated television, in April of last year, transmitting images between Washington and New York, a distance of 200 miles. It may be noted, however, that nearly 1,000 men were required to operate their apparatus.

At the present time many experimenters are working on television in different countries, and we hear occasionally somewhat startling claims from continental sources. Until, however, these claims are backed up by demonstration they may well be ignored. On the other hand, in view of demonstrated results, there is no

(Continued on page 23, third column.)

Mr. Baird's original Televisor, now in South Kensington Science Museum.

This is the transmitting portion of the original apparatus used by Mr. J. L. Baird in experiments which led him from the wireless transmission of outlines in 1925 to the achievement of true television nine months later, when, on January 27th, 1926, the transmission of living human faces with light, shade and detail was demonstrated before members of the Royal Institution, this being the first demonstration of true television ever given.

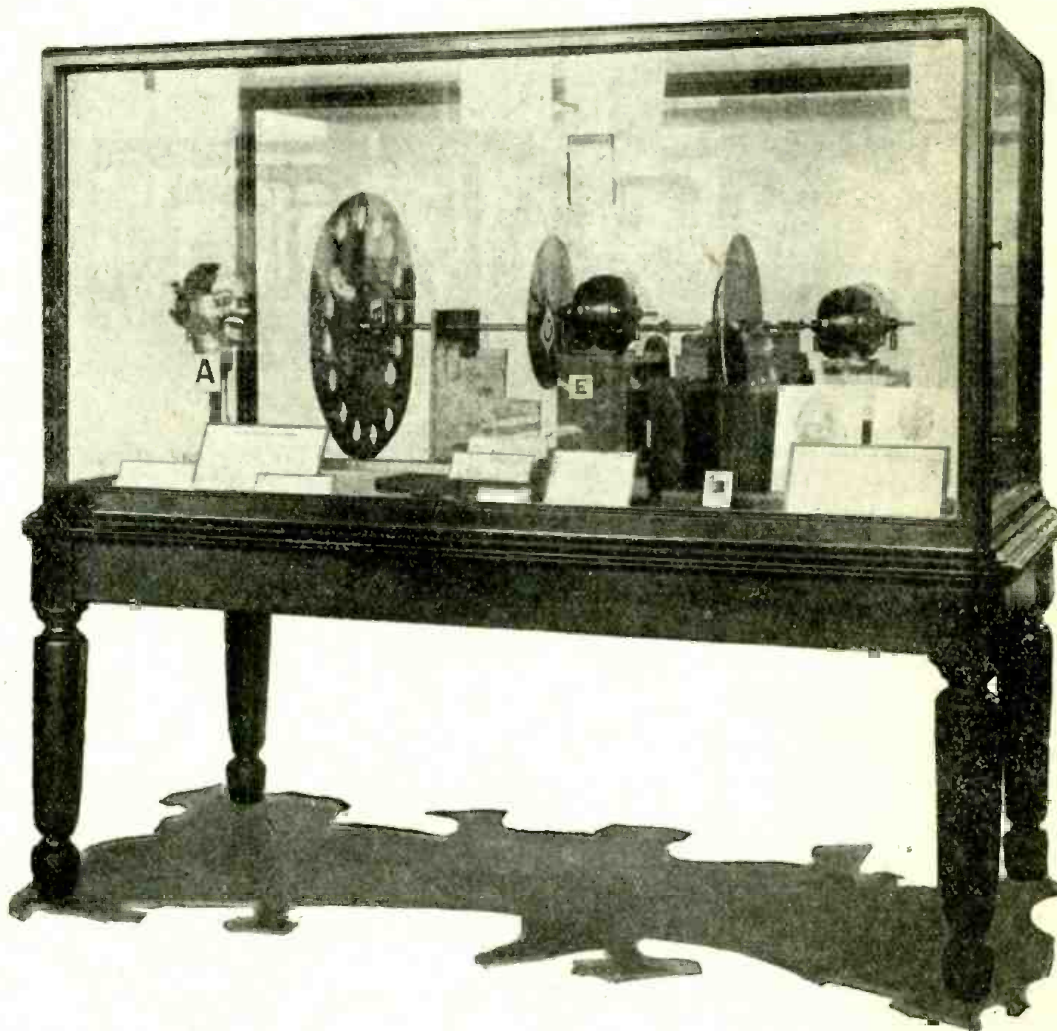

SOME NEW USES FOR TELEVISION

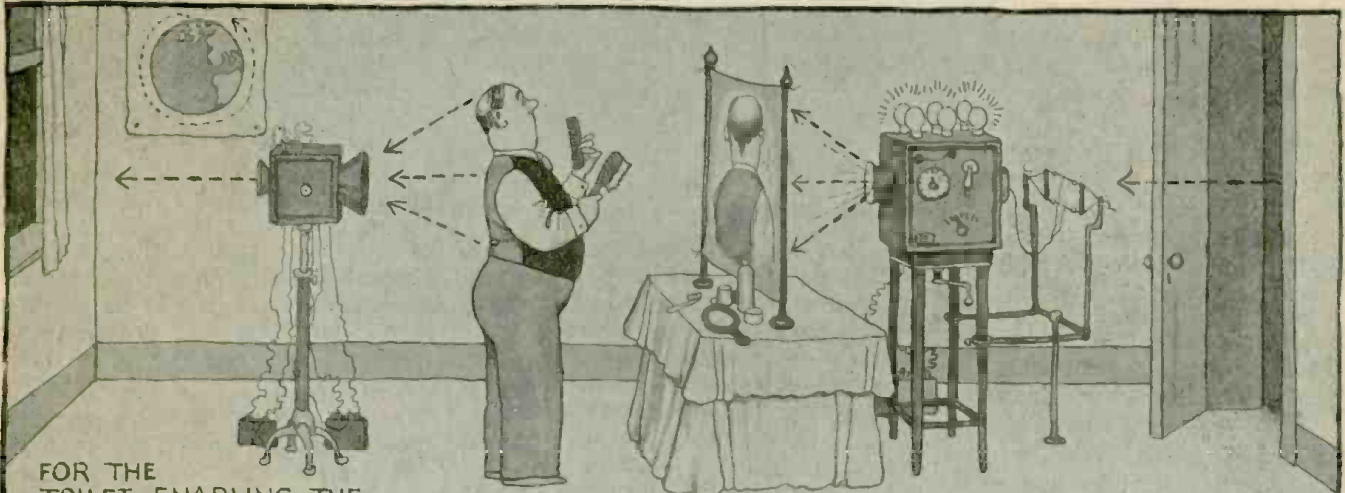

FOR THE TOILET-ENABLING THE TELEVISIONER TO SEE THE BACK OF HIS HEAD WHEN BRUSHING HIS HAIR

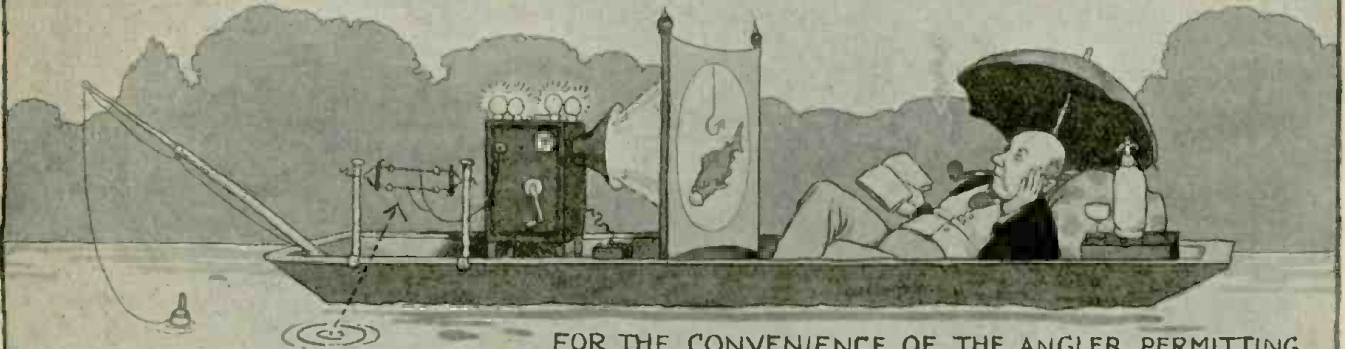

FOR THE CONVENIENCE OF THE ANGLER, PERMITTING HIM TO KEEP HIS EYE ON THE BAIT WITHOUT UNDUE EXERTION

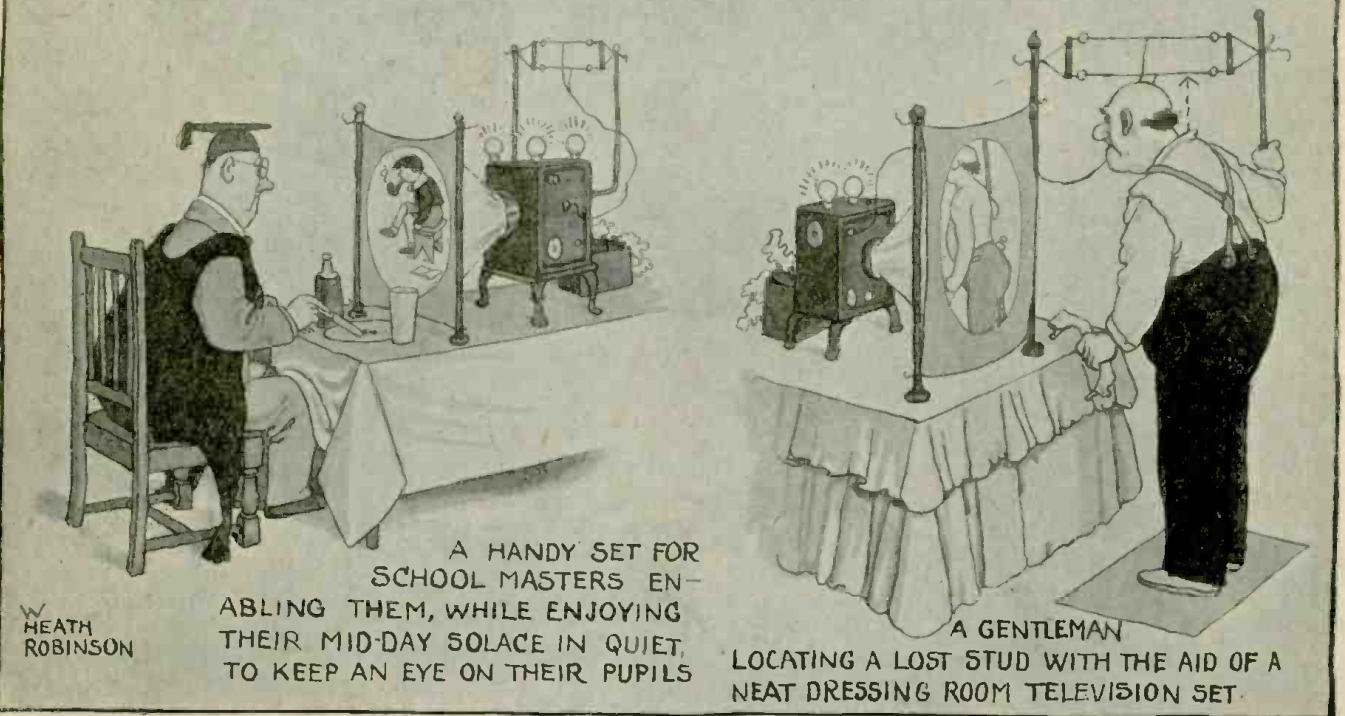

A HANDY SET FOR SCHOOL MASTERS EN-ABLING THEM, WHILE ENJOYING THEIR MID-DAY SOLACE IN QUIET, TO KEEP AN EYE ON THEIR PUPILS

A GENTLEMAN LOCATING A LOST STUD WITH THE AID OF A NEAT DRESSING ROOM TELEVISION SET

W
HEATH
ROBINSON

Drawn by W. HEATH ROBINSON



OPTICAL PROJECTION

By Professor CHESHIRE, C.B.E., A.R.C.S., F.I.P.

(Late Director of the Optical Engineering Department of the Imperial College of Science and Technology, South Kensington)

NOTE.—This is the first of a short series of simple introductory articles on optics, which have been specially written for this paper by one of the greatest optical authorities of the day. Professor F. J. Cheshire has recently retired from the Imperial College of Science and Technology, South Kensington, London, where he was the Director of the Optical Engineering Department. For 25 years he was a lecturer on Physics at Birkbeck College, and during the war he held the position of Technical Director of the Optical Munitions Department and a Deputy-Director General of the Ministry of Munitions. He was President of the Optical Society from 1916 to 1920, and President of the Royal Microscopical Society, 1922-24. Optics is, of course, one of the branches of science with which television is connected.

“WHY is it that during an eclipse of the sun the patches of light, which are found on the ground beneath a plane tree, and which are formed by rays which have passed through the spaces between the leaves, take the shape of the eclipsed sun?” In these words did Aristotle, about 350 B.C. propound his famous problem concerning the optical projection of pictures. Nearly 2,000 years, however, elapsed before a satisfactory solution of this problem was given by Maurolycus. This solution we shall refer to later when considering the action of a lens.

Fig. 1. illustrates Aristotle’s problem. It is a photograph taken some years ago of the pictures of the eclipsed sun projected through the leaves of a (plane) tree on to the pavement of a street in Bombay.

Now the telescope for astronomical



Fig. 1.—Images of Eclipsed Sun on Pavement at Bombay.

purposes was not invented until the year 1608, but for many years before this date eclipses of the sun had been observed and studied by the method described—a method now generally referred to as the “pinhole camera” method.

Fig. 2 is a facsimile of a quaint diagram which occurs in a book written by Gemma-Frisius in the year 1545. It shows an astronomical observatory fitted up as a large pin-hole camera for the observation of an eclipse of the sun which was visible at Louvain in the year 1544. An image of the eclipsed sun was projected, through an aperture in a shutter on one side of the room, on to a wall which acted as a screen on the other side, and upon which the various phases were drawn in by the observer. To facilitate this operation fiducial lines were drawn upon the screen, thus anticipating in some way the reticules and micrometers which were later fitted to the eye-pieces of telescopes.

Paradoxical as it may seem, the astronomer had in the arrangement shown by Fig. 2, although without lenses, the optical equivalent of a telescopic magnifying system. To

an observer stationed at the pin-hole the sun seen directly would have subtended an angle of half a degree, as would also have done the image on the screen as seen from the same

GEMMAE FRISII MEDICI ET MATHEMATICI, De Radio Astronomico & Geometrico liber.

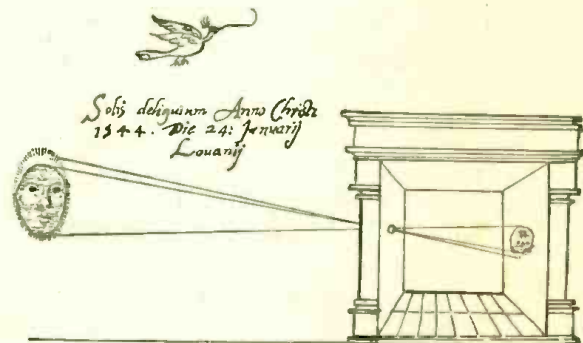

Sic nos exactè Anno .1544. Louanii eclipsim Solis obseruauimus, inuenimusq; defecere paulò plus q̄ dextantem, hoc est. 10. vncias siue digitos vt nostri loquuntur. Fuitq; medium deliquii nono Kalen. Februaris hora .8. minutis .53. plus minus ante medium diem. Apparuit autè inferior Solis pars denigrata, quanquam communes tabulae superiorem delineant.

Fig. 2.—Ancient Method of Observing Eclipses.

place. From a position, however, midway between the pinhole and the picture on the screen, the latter would have been seen as subtending an angle of one degree, i.e. under a linear magnification of two! Nearer still the magnification would have

Optical Projection—continued.

been correspondingly greater. This interesting method, however, was in practice very limited in its application. The pinhole could not be enlarged for obtaining more light,



Fig. 3.—Pinhole Photograph of Landscape.

because of the falling off in definition of the pictures which resulted. Later it was discovered that the pinhole could be enlarged to any size if then filled up with a lens of such a power as to give a focussed image on the screen. This image could then be examined with a second lens, used as a hand-magnifier. The astronomical telescope in use to-day is essentially such an optical arrangement. The value of the pinhole camera for obtaining distortionless pictures of architectural subjects is well known, but the possibilities of the method for landscape work is perhaps less known. In the hands of an expert like the late Sir William Abney, beautiful work has been done.

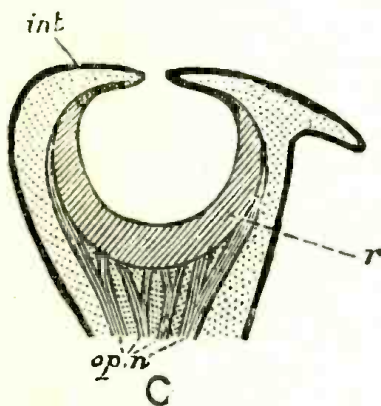

Fig. 4.—Section of the Eye of Nautilus.

In Fig. 3 we have an example of his work taken through an aperture of 0.1 mm. diameter, and with an exposure of one minute.

It is a remarkable fact that we have in the pearly nautilus an animal with a pinhole camera type of eye. Fig. 4 is a section.

Of this eye, for a description of

which we cannot do better than quote from Sir Ray Lankester's article on "Mollusca," in the ninth edition of the Encyclopædia Britannica. He says there: "The eye of Nautilus is among the most interesting structures of that remarkable animal. No other animal which has the same bulk and general elaboration of organisation has so simple an eye as that of Nautilus. When looked at from the surface no metallic lustre, no transparent coverings, are presented by it. It is simply a slightly projecting hemispherical box like a kettle-drum, half an inch in diameter, its surface looking like that of the surrounding integument, whilst in the middle of the drum membrane is a minute hole. Owen very naturally thought that some membrane had covered this hole in life, and had been ruptured in the specimen studied by him. It, however, appears from the researches of Hensen that the hole is a normal aperture leading into the globe of the eye, which is accordingly filled by seawater during life. There is no dioptric apparatus in Nautilus, and in place of refracting lens and cornea we have actually here an arrangement for forming an image on the principle of the 'pinhole camera.' There is no other eye known in the whole animal kingdom which is so constructed."

A fundamental property of wave-motion, first enunciated by Huygens, is that every little bit or element of a wave surface is propagated in the direction of a normal to that surface. A spherical wave propagated in a homogeneous medium, for example, remains spherical throughout its travel, each little element of its surface being continuously propagated along a radius of the sphere. Fig. 5 is taken from Huygens' treatise on light, published in 1690.

We are now in a position to pass on to the consideration of optical projection by means of lenses and lens systems, but first we must understand the relationship between a "wave" diagram, and a "ray" diagram as used for explaining the action of a lens. Suppose that in Fig. 6 A represents a source of light so small that for our present purpose it can be treated as a point. The spherical light-waves given out by this source can be represented diagrammatically by a number of equidistant concentric circles spreading out from the point A.

In one direction, suppose that these waves fall upon a lens which cuts out of each successive spherical wave, as it reaches and passes through it, a circular watch-glass-shaped disc, or "calotte," as it is sometimes called, and since the centre of this calotte has to pass through a greater thickness of glass (in which light waves travel more slowly) than its circular edge, this centre will be relatively retarded and thus fall behind, with the result that if the lens is sufficiently thick at the middle all the calottes passing into the lens, with convex front surfaces, will emerge as concave-fronted ones. Thus

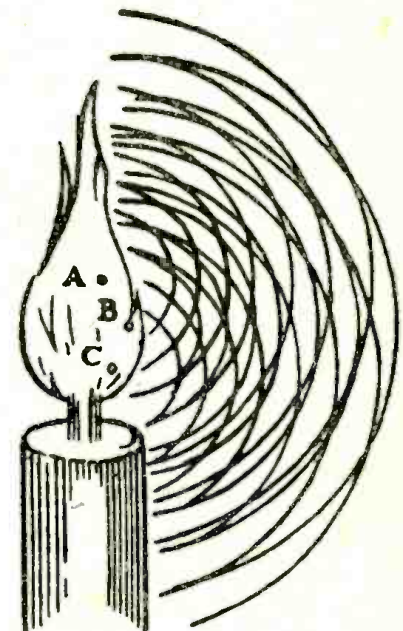

Fig. 5.—Radiation of Light from a Candle, according to Huygens.

whilst the normals of the incident waves, in the direction of travel, diverge outwards from a point (the source A), those of the emergent waves converge to a point (focus C). As a consequence the waves emerging from the lens B, whilst passing onwards, contract continuously into smaller and smaller calottes, with greater and greater curvature, until they come finally to a point or focus at C, through which they pass and proceed once more as convex-fronted, diverging waves, similar to those proceeding from A.

In the second, or ray diagram, Fig. 6, the waves have been left out and replaced by a number of normals, drawn to the wave-surface on the one side starting from A, and on the other side to the wave-surfaces converging

to c. The waves therefore are real things; rays are simply straight lines which show the directions along which waves travel. Thinking and

Having done this remove the lens and fill up its place with a stretched sheet of tinfoil. Now take a stout pin and prick a hole in the foil. An inverted image of the candle

will appear on the screen. Prick a second hole, but on a different part of the screen, will make its appearance. Prick away until a dozen or more perforated tinfoil, slide the lens back carefully in its own plane to its original position. As this is done and the rays passing through the various apertures picked up by the lens, one by one, the corresponding images on the screen will fall together in the most striking way, until, finally, when the lens comes to its final position covering all the apertures, only one central image will be found on the screen. Now prick more holes until the whole of the tinfoil in front of the lens has been removed. Nothing further happens except that the single image becomes brighter and brighter. This experiment shows us then, that one of the primary functions of a lens is to allow of the use of a large aperture with its great light-collect-

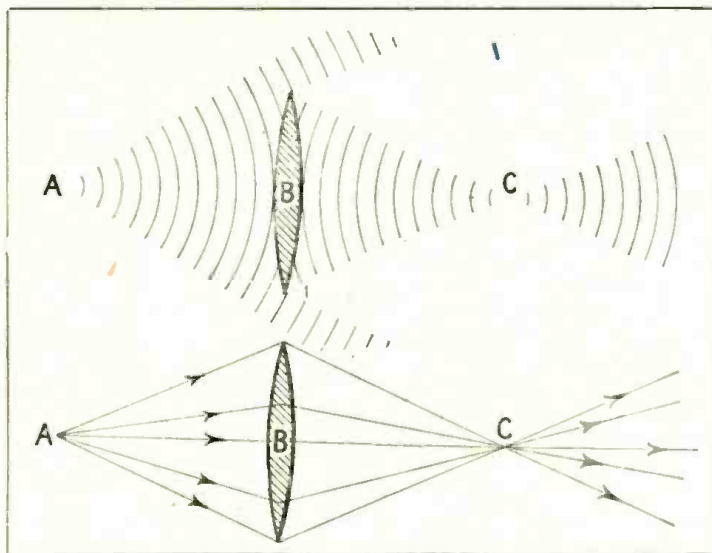

Fig. 6.—Wave and Ray Diagrams for a Lens.

visualising should be done in terms of waves—mathematical calculations are generally better done in terms of rays.

A charming experiment for demonstrating the action of a lens in picture projection can be carried out as follows (see Fig. 7): Take a converging lens of as great a diameter as possible and arrange it in a well-darkened room to project an image of a candle or other light source (better an arc) on to a screen. Conveniently the size of the image should be approximately equal to that of the object.

images are seen, each, of course, in the continuation of the straight line joining the object and the aperture producing it.

Note that if two apertures are made fairly close together the corresponding images on the screen more or less overlap one another. Now, without disturbing the per-

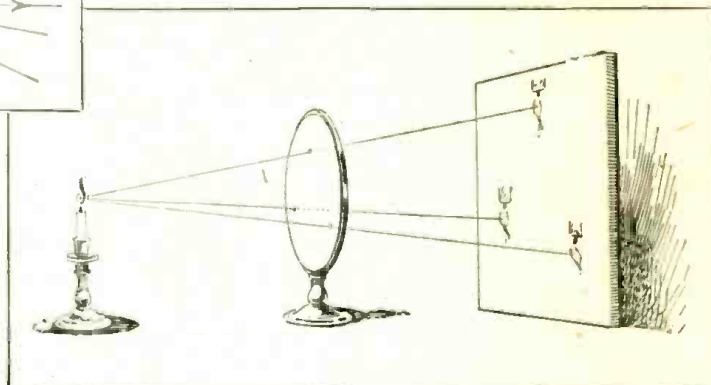

Fig. 7.—Showing Perforated Tinfoil in Action.

ing power for imaging purposes. Later we shall find that this larger aperture is also necessary for the definition of detail structure in the image.

ORDER FORM.

To TELEVISION PRESS, LTD.,
26, CHARING CROSS ROAD,
LONDON, W.C.2.

I enclose herewith { *Postal Order*
Money Order
Cheque } for 7/6 in respect of one year's subscription
to "Television," commencing with the..... issue.

NAME.....

ADDRESS.....

(Postal and Money Orders should be crossed & Co. and Cheques should be made payable to Television Press, Ltd.)

The Birth of the Television Society

By A Correspondent



Dr. CLARENCE TIERNEY, D.Sc., F.R.M.S.,
the Chairman of the Executive Committee.

At the conclusion of Mr. Baird's lecture on television, on the occasion of the conversation of the British Association at Leeds University, a vote of thanks to the lecturer was proposed by Mr. W. G. W. Mitchell, B.Sc., F.R.M.S., a member of the British Association, in the course of which he suggested, "in view of the wide public interest in television," that a society be



Mr. W. G. W. MITCHELL, B.Sc., F.R.M.S.

formed forthwith to further the development of problems associated with television, noctovision, phonovision and allied subjects, and give a stimulus to this new branch of science.

The proposal was seconded by Lieut.-Colonel J. Robert Yelf, another member of the British Association, supported by the chairman, Dr. Tierney, and carried unanimously by the large gathering.

At a subsequent meeting, which had been specially convened for the purpose, 45 signatories, mostly members of the British Association, formed themselves founder members of the Television Society of Great Britain. The resolution to form an executive committee was passed, and the title of the Society approved.

An executive committee was formed under the chairmanship of Dr. Clarence Tierney, D.Sc., F.R.M.S., with Mr. J. Denton, A.M.I.E.E., as honorary secretary.

Dr. Tierney said that it was a great pleasure to him to take the chair of any society which aimed at the advancement of the art of television, particularly so in this instance as the inventor, Mr. Baird, who had made the art a possibility, was an amateur and a Britisher.

It was often the case, the chairman added, that the real application of science was evolved by the amateur, and he was proud to feel that in the art of television an Englishman had carried off the prize. Although the Society now formed was not to exploit Mr. Baird's system of television, for any inventor was at liberty to put forward his ideas for consideration and acceptance by the Society, yet so far he must say that the impetus created in forming the Society was the outcome of the

success directly attendant on the achievements by Mr. Baird in the art of television, and his demonstrations to the British Association at the Leeds meeting.

The Society therefore came into existence "to form a common meeting ground for the assistance of the amateur's needs, for lectures, and for professional research workers and others interested in the progress of



Lt.-Col. J. ROBERT YELF.

television." Immediate arrangements were made to have the Society incorporated, with a distinguished council and a president.

Such a splendid lead having been given, the Television Society of Great Britain cannot fail to become a powerful force in furthering the progress of the fascinating new science. It will, no doubt, be responsible for many new ideas and suggestions, and it is the initial aim of this journal to foster development, no matter from which quarter it may emanate.

Technical Notes

BY THE
TECHNICAL EDITOR



ALTHOUGH television has been talked about for many years, it is only recently that it has been successfully accomplished by Baird. The principles upon which it might be accomplished have been quite well known for thirty or forty years, or even longer, and it may be thought strange that such a state of affairs could exist. If we know how to do something, or how to set about doing it, it would seem that the next stage will be accomplishment. Events have proved, however, that this is not the case, and it is interesting to examine the causes or difficulties which have prevented the successful development of television many years ago.

When the properties of selenium were discovered, that it was affected by light falling on it so that its electrical resistance changed, it seemed as if nothing further need be done, but it is worth while examining this problem from the point of view of quite simple and elementary first principles.

Light is Energy.

If a picture is to be transmitted to a distance it will be necessary to expend some energy at the receiving station to reproduce the picture and obviously this energy must be sent from the transmitting station.

It is equally obvious that the energy must be produced or controlled by the picture which is being transmitted, and here we come up against the first serious limitation. A picture is merely an affair of light and shade or of different colours, and it is visible because of the different amounts or kinds of light that pass from it to the eye. It is quite well appreciated that light is a form of energy, and the classical definition of energy is that it is "the capacity for doing work." We have, therefore, arrived at the stage that the picture emits energy and that energy is required at the receiving station to reproduce the picture.

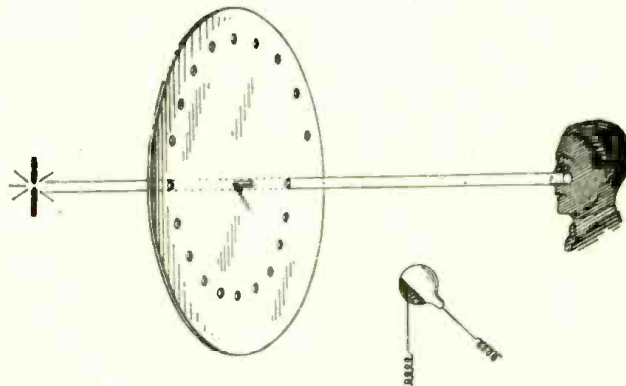

The energy which is available in the form of light is very small, for the human eye is a most remarkably sensitive organ. To put it into figures, a candle emits energy; the

amount of energy from a candle falling on a square centimetre at a distance of one metre from the candle is about a one-hundred-thousandth part of a millionth of one horse-power, or if we take as the unit a millionth of a millionth part of a horse-power, the energy is ten units on each square centimetre.

Light and Shade.

But this is not sufficient, because we do not usually want to transmit a picture of a candle flame, but a picture which merely reflects light in different degrees of light and shade. The light reflected from a picture (which is the light by which we see it) is only a very small fraction of the light which falls on it, and the problem is rendered still more difficult because we have not merely to use these infinitely small amounts of energy to do the job, but we have got to distinguish between two infinitely small amounts so as to reproduce the differences of light and shade.

It is clear, therefore, that if television is to be obtained in fact, amplification will be of great help to us, provided the amplifier can be relied upon to amplify accurately and reproduce the differences, but a more direct way of attacking the problem is to increase the amount of light energy which is available for use, and this has been tried by most experimenters in the field.

As soon, however, as we try increasing the light we meet another difficulty, for there is no known way

Continued on page 23.

Glimpses into the Future — N°1

Television

The first of an interesting series outlining the possibilities of Television in warfare, commerce, entertainment and every-day life.

THE BATTLE OF THE RIDGE

By R. HEATH BRADLEY

THE mist rolled slowly back from the valley, and the trampled earth steamed under the warmth of the early morning sunshine. The vast army stretched itself in preparation for the activities of the day after the tense vigilance of the night. The guns continued to thunder as they had done, day and night, for over a week.

A new war was in progress. Two nations, forgetting the awful lesson of the last Great War which was to end wars, deliberately ignoring the futility of fighting, had thrown diplomacy to the winds and had sprung at each other, bristling with terrible death-dealing inventions, eager to match their strength.

Years before this catastrophe, it had been prophesied that the next war would be fought in the air, and yet here were two vast armies, crouching in trenches, and attempting to reduce each other to pulp with long-range guns, much as they did in the years following 1914. Certainly the two huge air fleets had been active from the very hour that war was declared, but they were so well matched in their aggressive and defensive methods that little had come of their attempts beyond the destruction of many machines and the death of their gallant pilots and observers. The ultimate objectives of the opposing forces were, as in all times, the cities and other strategic

points, and though these might be attacked from the air it was on the earth that the final battles must be fought to decide which force should occupy them.

From the hour at which war was declared, the Red Army had rushed forward, destroying everything in its path, whilst the opposing Blue Army had hurried out with equal speed to meet its enemies. The time had come when they were both at equal distances from, but on opposite sides of, a ridge of hills many miles in length. Neither force had been lacking volunteers amongst its airmen, who had attempted to gain information concerning the disposition of the other army; and although several had been successful in breaking through the air defences of the enemy, not one had been able to return with the information he had gained. Thus both forces were in a condition of "stalemate," and all they could do was to put up barrages which were so ferocious in their intensity that neither army could advance to the coveted ridge.

In the first few days each force had indulged in long-distance bombardment, but it was soon realised that, whilst spectacular, it was probably ineffectual, and now the firing had settled down into a steady barrage from both sides of the hill.

On the day this story opens there was great activity on the huge

aerodrome behind the trenches of the Blue Army. A new aeroplane was being put through its final overhaul, and it was a machine very different from the others lined up at the end of the long stretch of ground. It was small, and obviously designed for great speed. It carried no guns or bombs, but below the fuselage was some apparatus, the most significant feature of which was a camera-like affair, with a telephoto lens, pointing downwards. A young flying officer stood near by, buckling on his parachute, waiting to make an attempt which could hardly fail to end in his destruction, and yet might, if all went well, give his country the information necessary to enable a decisive move to be made.

A New Weapon.

Some distance away, at G.H.O., the staff officers were gathered in front of what appeared to be a large wireless receiving set, in the front of which was a ground-glass screen. Directly in front was a large table on which was pinned a map of the countryside. One-half of the map was marked with lines, crosses and numbers, indicating the positions of the Blue Army's trenches, gun positions, and aeroplane hangars. Straggling across the centre of the map was the brown shading marking the position of the all-important ridge and beyond, nothing but the country-

in Warfare

side as it was known before its occupation. Sitting before the map were two officers wearing head-phones.

One of these officers suddenly turned to General X. "He's just given the stand-by signal, sir," he said.

All eyes were turned towards the screen, on which there suddenly appeared a circular shape, a quickly-moving shadow. Around the edge were small teeth at regular intervals and across it—a hair-line. It was the view as seen by the Televisor fitted beneath the aeroplane. The swift-moving shadow was the earth over which the plane was skimming as it gathered speed; the small teeth were points of the compass, and the hair-line was the compass needle, jerking slightly as the machine encountered uneven ground.

Presently the needle became steady and the shadow gradually took form as the aeroplane rose. The officers gazing so intently at the screen saw a line of trees flash by; the silver glint of a pond; the white ribbon of a road. As the machine rose still further the picture became more comprehensive. It was possible to recognise the country over which it was passing.

After a few minutes, during the rare and minute intervals in the roar of the guns, the drone of the engine could be heard and, for a moment,



a roof became visible near the edge of the picture. "Why, that's this very house," exclaimed one of the officers. "We ought to be able to see him." Several hurried towards the window, and, sure enough, there was the plane steadily climbing and heading towards the ridge.

The objects on the screen became smaller as the plane rose. Every few seconds one of the officers wrote down a number so that the other might see it, and he, in his turn, made a mark on the map. The airman was signalling, with a pre-arranged code, his speed and, by a rapid calculation and a glance at his watch, the officer at the map was able to trace the exact route of the plane, varying its course according to the movement of the compass needle and making allowances for the angle at which the airman was climbing.

Over the Ridge.

The aeroplane was now travelling at tremendous speed, and so high

as to make the picture on the screen almost unrecognisable. But still the speed and the position of the compass needle gave the two vigilant officers all the information they needed.

"He's over the ridge," suddenly exclaimed the officer who was tracing the airman's route, and a moment later several of the others exclaimed, with quick intakes of the breath, "Spotted," as the image of an aeroplane in flight flashed across the screen.

During the next minute or two several puffs of smoke obscured the view, showing that the plane was being subjected to fire, but it was obvious that it was too high to be touched. Yet all the onlookers knew that, for the flyer to be successful in his task, he would presently have to descend. It seemed inevitable that he must then be brought down—the Red defence was too good to hope that he might escape. Would he be able to show G.H.Q. anything of importance before that fate befell him?

The next few seconds showed that

The Battle of the Ridge—continued.
 he was to be even more successful than had been hoped. The picture suddenly became distorted, as though it had been tilted, and those of the officers who had not yet got their "air-legs" felt suddenly dizzy as the aeroplane went into a breath-catching dive.

Suddenly it swung to the right, flattened out, and there on the screen was a view of the enemy trenches. Rapidly another officer bent over the map, making quick sketches whilst the other officer still continued tracing the aeroplane's route. Presently the machine was flying directly over the front line of trenches and, as the pilot tilted upwards for a brief moment, the picture showed that they were made in practically straight lines, stretching away in the distance.

But, whilst the position of the trenches was interesting, it was the guns that the airman was seeking. The picture again tilted as the aeroplane swung round, heading behind the line of trenches. Time and time again the view was obscured by smoke as the enemy sought to bring the machine down, but luck favoured the airman for, as he swung round again, the eager watchers saw, at regular intervals, dark patches of trees from which flashes appeared at regular intervals.

Gun positions! Batteries arranged, thanks to the precise methods which were a characteristic of the Red Army, at exactly regular intervals in a dead straight line. Rapidly, as the plane tilted for a moment, the officers counted the number of batteries, whilst those at work on the map marked the exact positions.

"Winged!"

And then the end came quickly. The picture swayed dizzily from side to side; then for a moment it righted itself, only to swing over again. For a brief fraction of time the officers saw an expanse of sky as it gave an extra large lurch.

"Winged, poor chap," exclaimed General X., and even as he spoke the picture swayed again and, as if by a miracle, showed a glimpse of a parachute with a tiny figure hanging from it.

"He's jumped, by gad," cried the General. "God grant he lands safely. The Reds may be our enemies, but I have still sufficient faith to believe they will treat him with the respect

due to a prisoner of war and a very gallant gentleman."

A moment later the screen became blank, as though wiped clean by an invisible hand. The plane had crashed, but the first Televisor to be used in actual warfare had done its work.

* * * * *

There followed some rapid calculations and many telephone messages. Soon after, the gun-fire from the Blue Army took on such an intensity that it would seem nothing could live against it. And, had it been possible to look over the ridge of the hill, it would have been evident that it was no longer a barrage. The shells were falling further back, until it seemed that a broad strip of the countryside behind the enemy's lines was nothing but a heaving mass of volcanic spouts of earth.

So it kept on throughout the day, and all the while the firing from the Red Army became steadily less and less. So much so, that in the late afternoon the Blue troops received orders which caused them to shout hilariously with joy at the prospect of moving, after the week's nerve-breaking inactivity.

At last they were on the move, streaming up the hill-side, and passing through the enemy's barrage with comparatively few casualties. And, before nightfall, advance observation posts were established on the ridge of the hill, looking down across the country held by the Red Army. Still the firing continued with unabated ferocity, now directed on new positions visible to the observation posts. Already the Red Army was in retreat, and although this was not the last battle by many, it inflicted such terrible punishment on the Reds that they never recovered sufficiently to offer any very effective resistance to the victorious progress of the Blues.

So, in the fullness of time, came the Armistice and the Red Army released a very gallant officer whose name would go down in history as the man who won the Battle of the Ridge, thanks to his courage and his clever piloting of the first Televisor equipped aeroplane.

"I am also sure that before long television will be brought to practical success, and this will enable us to transmit the vision of actual events over the greatest distances."—SENATORE MARCONI in a speech (January, 1927).

Yours!
 for the asking



FREE GIFT!

A BEAUTIFUL
 TWO-COLOUR

Harlie

**POCKET
 LOG
 CHART**

Get one from your dealer. Just ask him for it, there is no obligation or if he is out of stock, we shall be pleased to send one post free!

HARLIE BROS.

Dept. T.
 Balham Rd., Lower Edmonton, N.9

Telephone: Tottenham 3446.

COMMERCIAL TELEVISION

When may we expect it?

By The Editor.

DURING the last two years or so we have read in the general press a great deal about television, what it is, and how it is accomplished. Many descriptions have been published of various successful demonstrations given in this country and in the United States of America, and the *Man in the Street* is no doubt very anxious to know just when television will become a commercial possibility.

At the end of last year Mr. J. L. Baird, the leading inventor in the field, made a prophecy that he considered it possible that televisions of a crude form might be available to the general public before the end of 1927. This prophecy was, however, made in the most guarded language, and was, of course, merely a prophecy. Time has shown that it was somewhat premature.

As and when the inventions reach the marketing stage the Baird Company will no doubt proceed to license manufacturers to construct and market this apparatus, and furthermore will arrange to receive royalties, probably on a basis similar to that on which the B.B.C. commenced its operations. We do not find, however, that any definite statement or implication appeared in the prospectus of the Baird Company that these televisions were to be marketed within any specified time.

On inquiring into the facts we find that although the Baird Television Development Company has, in accordance with legal precedent, taken to itself the widest possible powers under its Memorandum of Association, including the broadcasting of programmes and the manufacture of televisions, it is obvious from the very name of the Company that it exists primarily for the purpose of developing Mr. Baird's inventions and acquiring Patent and other protection for them.

Let us examine the position carefully in the light of past experience

in the matter of great scientific achievements.

Take flying, for example. When the brothers Wright made their first historic experiments, optimistic prophecies were made to the effect that in a few years' time there would be no more railways or steamships; we should travel by air instead. Experience has shown that many years elapsed before even the first air service was established on a commercial basis, and railways and steamships are still with us to this day.

Again, let us consider wireless. Marconi first spanned the Atlantic from Poldhu to Newfoundland on the 12th of December, 1901, and it was confidently predicted by him and by others that a transatlantic wireless telegraph service, to rival the cables, would soon be a reality. But year after year passed, and the long-promised commercial service did not materialise, with the result that the Marconi Company came in for a considerable amount of criticism. Actually it was October, 1907, before the first transatlantic wireless service was opened on a commercial basis.

Consider the development of radio-telephony. From the date of Fessenden's original crude experiments, nearly twenty years elapsed before wireless telephony could be said to be a practical commercial possibility; yet modern broadcasting owes its existence to those original experiments.

Wireless, or radio, as we know it to-day, really means wireless reception. Millions of us listen-in daily; yet scarcely one in a million knows anything at all about the transmitting side of the question, and the transmitting side, if not more important, is at least as important as the receiving side. Wireless receivers were in existence long before the advent of broadcasting and there were many amateur enthusiasts to operate them. But all they had to listen to was Morse code from

ships and other commercial transmitting stations. Until the prototype of the modern broadcast transmitter was developed to a reasonable degree of perfection there was no speech or music to be heard.

In the light of such experience we may reasonably expect a similar process of development to take place in television. There is no doubt about it that television is an accomplished fact, in spite of the verbose statements to the contrary which have been made in certain quarters, and in spite of the pseudo-scientific arguments, designed to prove the impossibility of its achievement, which have been loudly voiced by carping critics. Mr. Baird has publicly demonstrated it in this country innumerable times, and according to a recent newspaper announcement has lately transmitted between London and New York.

But, as we have already seen, a period of time must always elapse between experimental achievement and commercial exploitation. In these days of enormously accelerated scientific progress, however, we may perhaps be forgiven for expecting the advent of commercial television within a shorter space of time than it has taken other inventions to appear upon the market.

In the meantime we, from our own knowledge of this new science, would strongly advise the public to take no heed of the irresponsible remarks of ignorant critics; for it must not be overlooked that the actual knowledge of these same carping critics is but little greater than that of the *Man in the Street*, and their practical achievements in the field of television, nil.

The Baird Company, secure in the knowledge of the results which it has already obtained, will, we feel sure, treat such worthless criticisms with the supreme contempt which they deserve, and continue to work steadily towards the realisation of the plans which it has made.

MODERN RADIO



*The Langham
5-Valve Portable.*

The Langham Portable represents the latest advance in modern radio design. It requires no aerial or earth, has a full continental range, and there is only one tuning control. There is no other set of this type so efficient, so perfect in detail and yet so very convenient in use. You can use it where you like—there are no outside connections or accessories—and when you have finished with it you simply shut it up and put it out of the way. You can have it for a week's trial in your own home—money refunded if you are not satisfied. Write or call for full particulars now.

Only £6 Down

Absolutely complete and ready for use. Balance by small instalments.

The **LANGHAM** Portable Radio

LANGHAM RADIO
Albion House, 59, New Oxford St.
W.C.1.

This is the Langham Radio Speaker. Reproduction of the whole range of speech and music is perfect at any volume. The Cabinet is in Solid Oak—also Mahogany or Walnut. You do not really know what your Set can do until you've tried the Langham Radio Speaker.

**Only £1 down,
or £5 5s.
cash.**

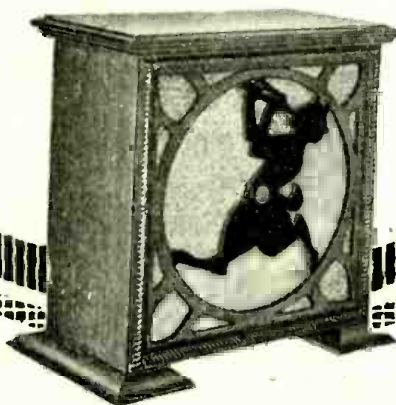

Mention of "Television" when replying to advertisements will ensure prompt attention.

Technical Notes—*continued from page 17.*

of producing a very high degree of illumination without at the same time producing an excessive amount of heat, as well as other forms of radiant energy which are objectionable. This, of course, is well known in cinematograph work, where the powerful arc lamps which are used are dangerous to the actors, often blinding them and producing serious eye troubles.

Reflected Light.

There is another point which should be emphasised here. Direct lighting gives a very much bigger supply of energy than reflected light, but we cannot produce a picture by direct lighting. One could *imagine* a picture made up of a screen with hundreds of thousands of little electric lamps packed closely together and each lamp lighted to a greater or less degree so as to produce light and shade, and perhaps colour as well. The idea is fantastic, and since we cannot use it we must be content with the very much smaller amount of energy that is available as reflected light from an ordinary picture. Direct lighting in a practical form merely enables us to produce silhouettes or shadowgraphs, and most of the so-called television systems that have been developed in other countries do in fact nothing more than transmit a shadow or silhouette, because they have not been able to utilise the very much smaller amounts of energy that are available in a picture.

In common with other inventors, Baird met this problem, and he devised an ingenious way out of the difficulty, known as the travelling light spot. It is not used in his later forms of apparatus, for, as is now well known, he has succeeded in transmitting pictures in darkness instead of using excessive lighting, but his method of the travelling light spot was used in the recent transmission by the American Telephone and Telegraph Company with quite successful results.

The "Exploring" Light Spot.

The essence of television transmission is that each spot or point on the picture is examined in turn and a signal-current corresponding to the light value at that point is sent to the receiving station, all the signals following one another in rapid

succession. Since each spot on the picture is looked at successively, it is sufficient for the purposes of television if a spot is brightly illuminated only when it is being "looked at" by the transmitter, and so Baird arranged that a spot of light of very intense brilliance should be traversed over the object or picture which is being transmitted, at the same rate as the transmitting apparatus examines it, so that the spot of light is always at the point for which a signal is being transmitted. The illumination on the rest of the picture does not matter.

The principle of examining a picture spot-by-spot in succession is technically known as exploring the picture, and in television the complete picture is explored in one-sixteenth of a second, so that sixteen separate pictures per second are transmitted so as to reproduce movement is exactly the same way as a cinematograph film does. The very intense spot of light also travels over the picture or object at the same rate, so that, although it may be so intense as to reproduce burning if left stationary, it merely flashes across the picture rapidly and no burning or even dazzling effect is produced to an onlooker, or a person whose image is being transmitted.

The average intensity of illumination is determined by the size of the light-spot relatively to the size of the whole picture. If a face is being transmitted, the full size of the picture might be about eight inches square, or sixty-four square inches, and the light-spot might be one-quarter of an inch square (i.e. one-sixteenth of a square inch, or less). The ratio of the light-spot to the area of the picture is about 1 : 1000, so that the average illumination is one-thousandth of the intensity of the light-spot. It will be seen, therefore, that this travelling light-spot gives us a means of increasing a thousand-fold or more the amount of light energy which is available.

A further development of the light-spot, which is also due to Baird will be described in the next number.

To ensure
receiving your copy of
"Television" place a regular
order with your
newsagent

Television 1873-1927—*continued from page 11.*

doubt that television sets will be available for the enthusiastic amateur in the near future.

Early apparatus will be crude, for there is much refinement and improvement needed as yet, but television is definitely established as a new branch of science and its development will be just as sure as the advancement seen in other scientific fields.

In spite of convincing demonstrations of television recently there are still, we believe, many people who view any suggestion of seeing at a distance as a mere flight of imagination. But it is something far more solid than that.

The curious part of it is that these same people will tune their seven-valve radio set and calmly listen to voices and music from a distance of 500 miles, or more, but they cannot grasp the idea of *seeing* the speakers and singers at that distance.

This is doubtlessly because the telephone has been reduced to a commonplace by custom and usage, whereas television is quite a novelty to the majority. Really the one is no more or less strange than the other, if viewed logically.

The two processes are really rather similar. In telephony sound is turned into electricity, sent out as electrical vibrations, and turned back into sound. In television, light is turned into electricity, sent out as electrical vibrations, and turned back into light. In each case all that is sent through the wires or ether is a fluctuating current of electricity.

For many years the range of man's vision was governed by the limitations of human eyesight; then came the telescope to increase the range considerably, although still within very definite limits. The coming of television means that sight will be possible over distances as great as those now spanned by telephony.

By electricity it is possible to-day to see the living images of objects and people at a distance, and so the dream of 50 years has been crystallised out as a definite scientific fact.

There is no question that, in view of the fact that it needed over half a century of patient research before the problem of television was solved, its conquest was one of the most difficult tasks ever undertaken by scientists. At the same time it must be realised that there is still much ground to be covered and work to be done before perfection is attained.

JOIN THE TELEVISION SOCIETY



VISCOUNT HALDANE OF CLOAN,
F.R.S., K.T., O.M., P.C.

*The wonderful might
of Thought gives rise to
great changes in the world
in which we live.*

Haldane

"The wonderful might of Thought gives rise to great changes in the world in which we live."

THERE is no shadow of doubt that the Television Society, which was formed on September 7th, 1927, will have very wide and far-reaching results upon the development of the new science.

At the inauguration gathering, specially convened by members of the British Association during their meeting at Leeds, over fifty were present, and forty-five signatures were secured affirming the foundation of the Society. Particulars of the general opening meeting to take place in London will be announced in this journal at an early date.

PRESIDENT.

LORD HALDANE OF CLOAN.

VICE-PRESIDENTS.

PROFESSOR MAGNUS MACLEAN, M.A., D.Sc., LL.D.
ALD. W. T. PATRICK, J.P.
SIR JAMES PERCY, D.L., J.P.
SIR JOHN SAMUEL, LL.D.

COUNCIL.

PROFESSOR CHESHIRE, C.B.E., A.R.C.S., F.I.P.
J. J. DENTON, A.M.I.E.E.
A. DINSDALE, A.M.I.R.E.
WM. C. KEAY, Esq.
ADMIRAL MARK KERR.
PROFESSOR LEES, D.Sc., F.R.S.
DR. WM. MARTIN, M.A., LL.D.
W. G. MITCHELL, Esq., B.Sc., F.R.MET.S.
PROFESSOR MAGNUS MACLEAN, M.A., D.Sc., LL.D.
SIR JAMES PERCY, D.L., J.P.
MISS MARY PROCTOR, F.R.A.S., F.R.MET.S.
J. CAMERON RENNIE, Esq., B.Sc., A.M.I.E.E.
SIR JOHN SAMUEL, D.L.
DR. CLARENCE TIERNEY, D.Sc., F.R.M.S.
LIEUT.-COLONEL YELF.

TREASURER.

WM. C. KEAY, Esq.

HON. SEC. (pro tem.).

J. J. DENTON, A.M.I.E.E., c/o Engineers' Club,
Coventry Street, London, W.



MISS MARY PROCTOR, F.R.A.S.,
F.R.Met.S

With good wishes to the Television Society

Mary Proctor.

The Society exists, in the words of the chairman of the executive committee (Dr. Clarence Tierney, D.Sc., F.R.M.S.), "to form a common meeting ground for the assistance of amateurs, and for lectures, also for



SIR JAMES PERCY, D.L., J.P.

Two of the most significant events of 1928 are the birth of the Television Society and the launching of the Television Magazine. They are signs of the times. Milestones on the road of scientific progress.

I feel sure the new Society will secure the co-operation of all those who are interested in the development of Television in all its varying phases.

As for the new magazine, it has just come along at the right moment when thousands of enquiring minds are eager for fresh knowledge of the new science.

I feel certain that the Television Magazine will prove to be a helpful handmaiden to what I believe is going to be in the near future a great and ever-growing industry. Anyhow, I wish the new journal all success and a long career of usefulness in the public service.—
Sir James Percy, D.L., J.P.

professional research workers and others interested in the progress of television," and every possible encouragement will be given to the ever growing number of experimenters by the publication of original papers.

Above we publish the names of the distinguished officers of the executive.

The following correspondence has passed between the Chairman of the Executive Committee of the Society and the Baird Television Development Co., and is of particular interest and importance to members.

(Continued on page 44.)

H.T. for Television

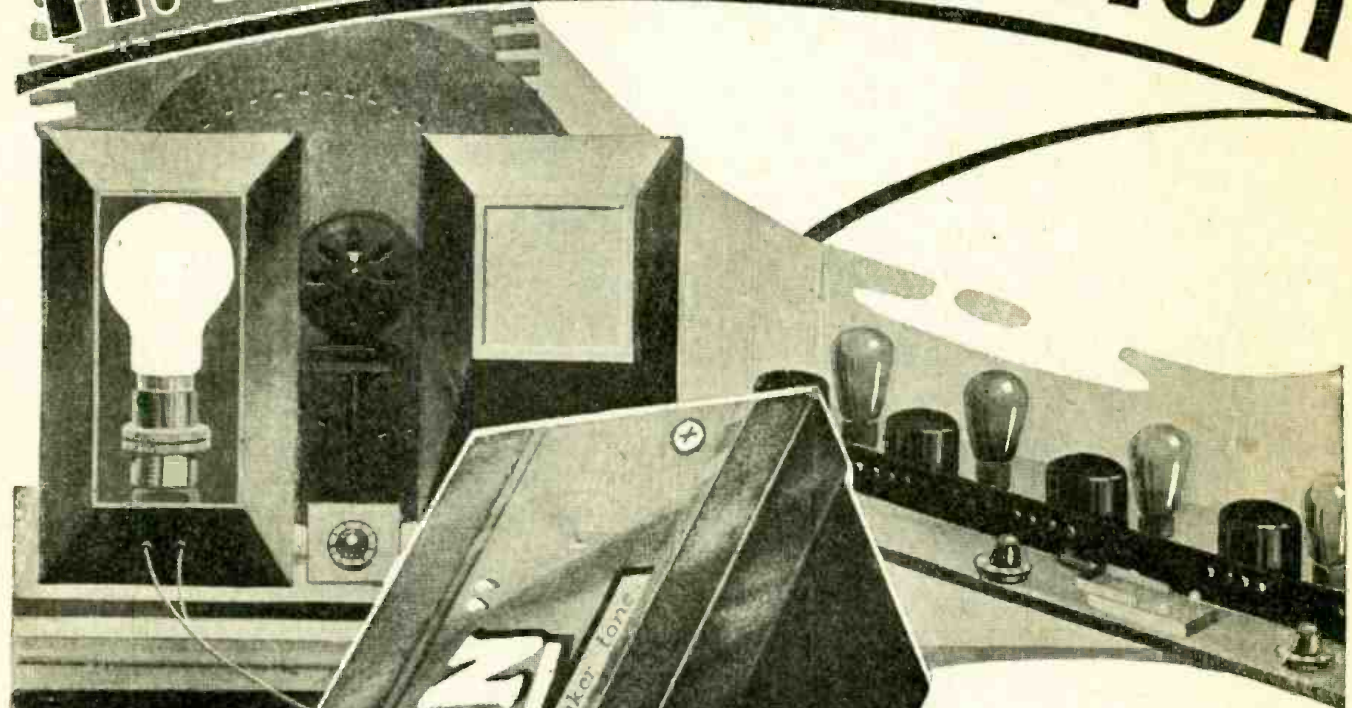

100 Volts
(Reading
108 v.)
12/11

YOU must use Lissen H.T. Batteries for Television because you need pure D.C. current—600 volts of such noiseless current as the new chemical combination used in the Lissen battery will give you.

Remember, any noise in a battery will result in a distressing flicker of the image; you cannot get perfect television results except by using the best H.T. current you can get—and you want therefore the Lissen New Process Battery. For there is such a large generation of oxygen from each cell of the Lissen battery that however great the demand of your television amplifier, the voltage will not falter, nor the smooth flow of the current be interrupted.

For television as for radio—ask for Lissen batteries in a way that shows you want the Lissen Battery and no other—never take a substitute, for 10,000 radio dealers are waiting to serve you.

SHOULD BE LISSEN

LISSEN, LTD., FRIARS LANE, RICHMOND, SURREY. Managing Director, THOMAS N. COLE

Mention of "Television" when replying to advertisements will ensure prompt attention.

FOR THE CONSTRUCTOR

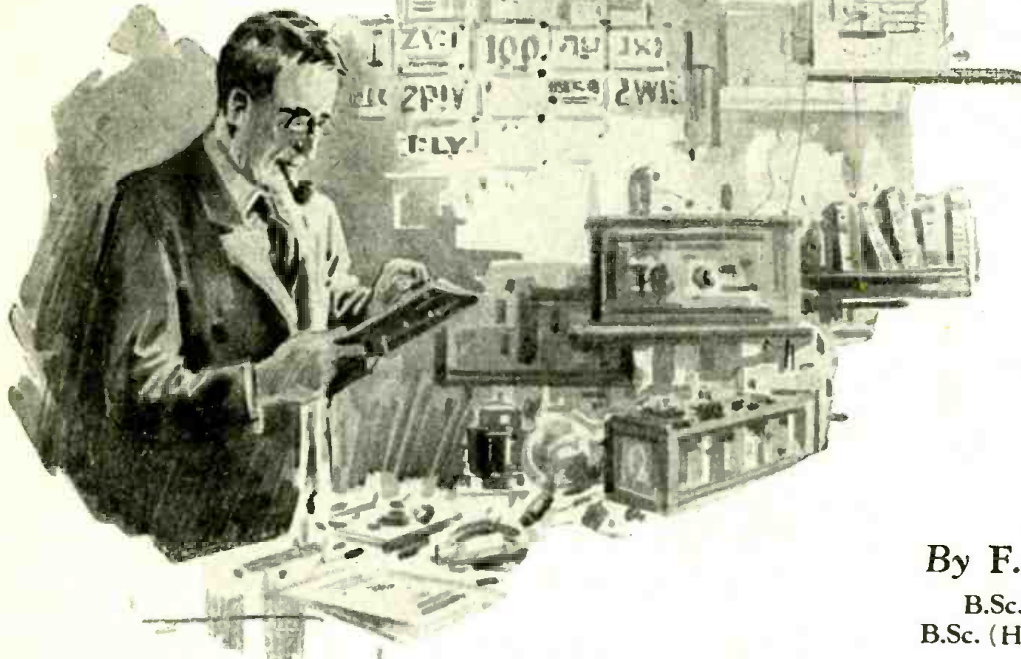

How to Make a Selenium Cell of the Condenser Type

By F. J. BINGLEY

B.Sc. (Hons. Maths.),
B.Sc. (Hons. Physics), Lond.

THIS type of cell is extremely sensitive and rapid in action, and is eminently suitable for use with the televisior described on page 27. It consists in essence of a copper and mica condenser, one edge of which has been filed down so as to expose the edges of the copper, the filed face being coated with selenium.

Those readers who have taken apart a commercially made cell of this type may be excused for declaring that an amateur would find it impossible even to assemble one, for at first sight it appears to be a very intricate and delicate piece of apparatus. The writer would, therefore, ask them at the outset not to be discouraged, as it is quite possible with a little practice to make very sensitive cells at small cost, and can assure them that he has made several, all of which worked very successfully in the televisior mentioned above.

Commencing with the materials required, the first and most obvious is the selenium. This can be obtained in 100 gm. bottles containing sticks of the element at a cost of about eight shillings from Messrs. Griffin, in Kingsway, the makers being Kahlbaum, of Germany. For the leaves of the condenser some copper foil, about .001 inch thick, is required.

The writer used silvered copper foil, obtained in sheets about 12 by 4 inches, from Calipe Dettmer, Poland Street, London, W., though silvered copper is by no means essential. For the insulating material mica about .008 inch thick, obtainable from any wireless dealer, is used, while the

which will cost about sixpence, and will make four cells. The above, together with a few 8 B.A. steel screws and nuts and brass washers, completes our list of materials.

With regard to tools, very few will be required, and these will generally be already in use in the experi-

Fig. 1. Working Drawings

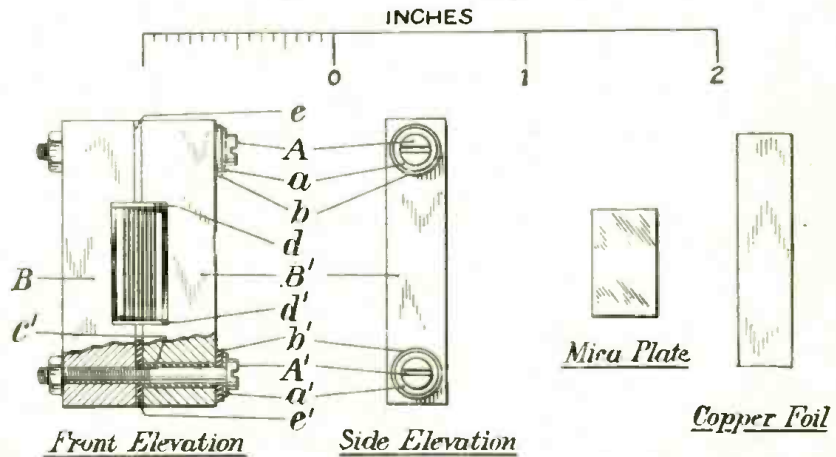

condenser is clamped together by two brass bars cut from a piece of $\frac{3}{8}$ by $\frac{1}{8}$ inch drawn rod, a foot-length of

menter's workshop. A hacksaw and drill, together with a few twist drills and files, and a small vice are

essential, while an 8 B.A. taper tap would be useful, but can be dispensed with as the writer gives a design



(see Fig. 1) which entails no tapping. The various operations will now be described under the appropriate headings.

The Clamping Bars.

B B' (Fig. 1) elevation. Cut off two 1½ inch lengths of the drawn brass rod already mentioned, clamp together in the vice with the ¾ inch faces in contact, and file out the pocket ¾ by ¼ inch (see Fig. 1, elevation). Now mark off and centre punch in one bar the centres of the holes for the clamping screws; clamp the two bars together in the vice with the pockets facing as they will be in the completed cell, and drill 8 B.A. clearing holes through both bars simultaneously. If the reader has a lathe its use in this operation will be obvious. It should be mentioned in passing that all dimensions may be obtained from the scale drawings (Fig. 1). Remove the bars from the vice and open out the holes in one with an ¼ inch drill: cut out a strip of mica ¾ inch wide and roll it round the shank of an 8 B.A. clearing drill until its outside diameter is ¼ inch, then push it into one of these ¼ inch holes, and make a similar bush for the other hole. Also cut out a few

a brass washer, are to be fitted under the head of each of the screws A A'. In Fig. 1 B B' are the mica washers,

while a a' are brass washers; in this manner the screws A A' are completely insulated from the bar B'.

The Condenser.

See Fig. 1, front elevation; also Figs. 2 and 3. Cut out about 40

Fig. 3.

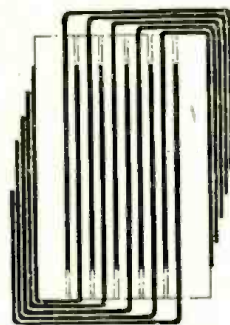

clamped tightly together in contact by brass sides

Enlarged view (not to scale) of condenser showing method of folding back the projecting tabs

or more plates, 7/16 by 1½ inch, and also a long strip of copper foil 3/32 inch wide, from which cut off 16 1¼ inch lengths. Now proceed as if building up a very miniature condenser,

sheet as shown in Fig. 2A. Lay down a piece of mica on the table, then a piece of copper as shown in Fig. 2A, then another piece of mica, followed by a piece of copper projecting the opposite direction (Fig. 2B), then mica again, and so on, the copper projecting alternately in different directions just as in building up a condenser. When the 16 pieces of copper have been used, fasten the brass clamps together, not forgetting the brass and mica washers under the screwheads, so that the pockets form a rectangular opening ¾ by ¼ inch. Add more pieces of mica in equal numbers on each side of the condenser, until it measures ¼ inch thick, this being tested by trying one end in the gap between the two brass clamps. Then add three or four more pieces on each side, bend the two sets of copper leaves in opposite directions as shown in Fig. 3, which is diagrammatic, showing only ten condenser leaves instead of 16, these being shown edge-on as thick black lines. Now loosen the clamping bolts holding the clamps together and push the condenser into the gap between the clamps, putting a few packing pieces of mica at each end to keep the top parts of the copper foil (see Fig. 3) away from the brass parts. The parts at the sides (Fig. 3) serve to make contact one with each clamping piece. Hold cornerwise in the vice, so as to leave both screwheads accessible, and find a suitable number of pieces of mica to form the packing strips e'

Fig. 4.

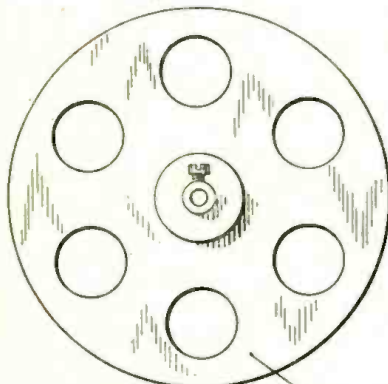

Interruptor Disc

¼ inch diameter mica washers with 8 B.A. clearing hole in the centre: two or three of these, together with

except that one longer edge of each piece of copper foil is placed level with one longer edge of the mica

Fig. 5.

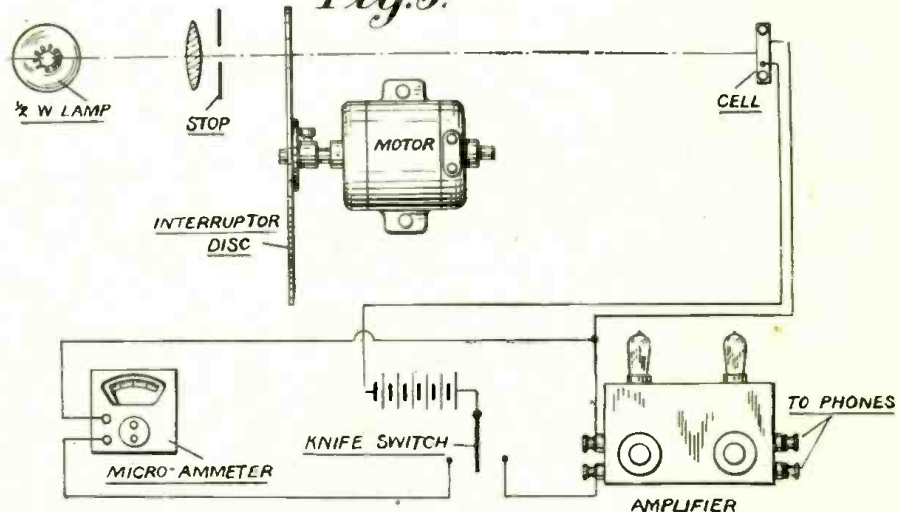

(Fig. 1), mark out and drill with holes to clear the screws. The latter are then removed one at a time,

the packing inserted, and are finally screwed up tightly. Leave the width of the packing full; it can be filed down flush afterwards.

bands of copper about .001 inch wide (the edges of the copper foil) separated by the thickness of the mica, say .008 inch, alternate pieces being

It consists of a domestic electric iron turned upside down, on the sole of which is placed the cell to be coated, the whole being surrounded by asbes-

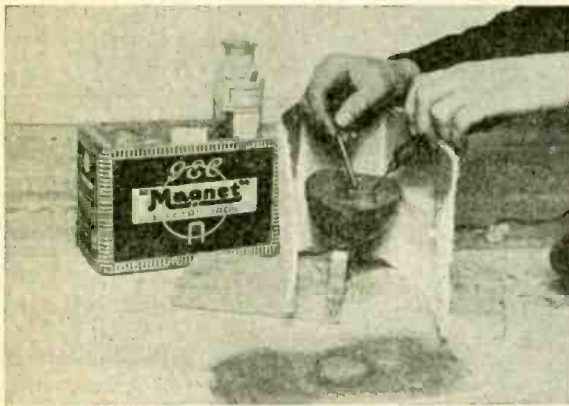

Fig. 6.—Coating the Cell,

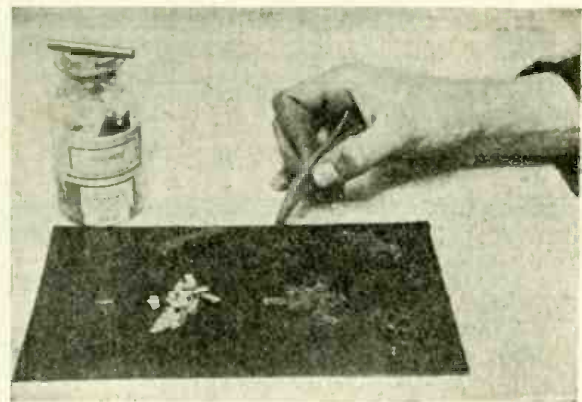

Fig. 7.—Parts of Cell.

It will be noticed that the mica pieces used in the condenser are $\frac{1}{2}$ inch wider ($\frac{1}{4}$ inch) than the thickness of the clamping bars ($\frac{1}{8}$ inch), so that on one side the condenser projects $\frac{1}{2}$ inch above the level of the brass clamps. This projecting side should be the one where the copper foil was placed level with the mica, the object being now to take a fine file and file this down flush, leaving a surface consisting of narrow

connected together and the two groups being connected, one to each brass clamp. Test the insulation with a 60 volt H.T. battery and a voltmeter, and if this is satisfactory the coating may be commenced.

Coating the Cell.

Now follows what is really the most difficult operation, and several attempts may be necessary (though these may be performed on the same cell by scraping off the unsuccessful coating) before the technique is acquired. In the photograph (Fig. 6) a successful heating apparatus is shown.

tos millboard. Failing this, a sand bath carrying a plate of $\frac{1}{8}$ inch steel and heated by a bunsen burner would serve equally well.

When the cell has reached the correct temperature the selenium

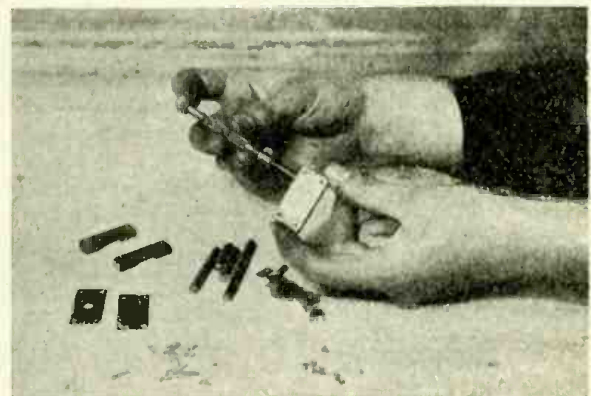

Fig. 8.—Assembling Cell.



Fig. 9.—Showing the Interrupter in use

should run fairly easily when tried by holding the end of a stick of it against the face of the condenser. Obtain a good even coating on the cell, rubbing with a circular motion, and erring rather on the generous side than otherwise (see photograph, Fig. 6), the cell being held firmly by pressing down with a screwdriver. Now obtain a piece of glass from, say, a photographic negative, and scrape the surface of the cell at frequent intervals, removing the surplus from the glass each time. Presently the temperature will drop until the selenium abandons its tendency to collect into globules and assumes a

(Continued on page 37.)

How to make a Simple Televisor

Specially described and tested for "Television" by our Technical Staff.

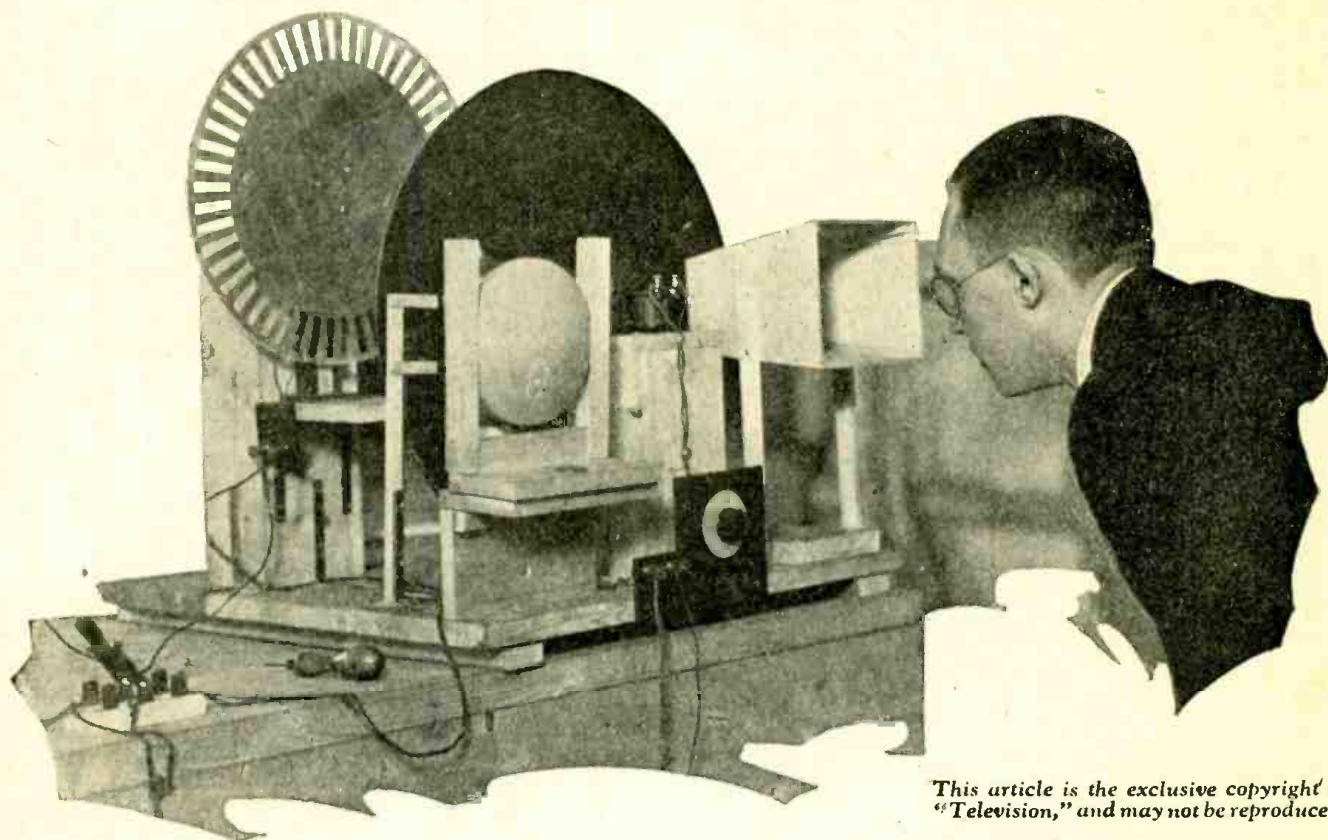

This article is the exclusive copyright of "Television," and may not be reproduced.

AMATEURS must have read the numerous accounts of the demonstrations given of television during the past two years, but although much has been published on this work nothing whatsoever appears to have been done to give practical assistance to the amateur in carrying out research work in his own home. This at first seems surprising, as the very large part played by the amateur in the development of wireless is well known and appreciated.

Television, however, is a much more complex subject than wireless, and requires a knowledge of science which is not usually within the grasp of the man in the street. The subject, however, has been greatly developed within the past two years, and in the South Kensington Museum, open to the view of the public, is a quite simple apparatus with which "television" of shadows was first achieved.

There would seem to be no outstanding reason why the ordinary

amateur should not build for himself a similar device and enjoy the unparalleled pleasure of exploring for himself this new branch of science. There is always something infinitely fascinating in exploring a completely novel field, and we propose to give in this article constructional details which will enable the amateur to build for himself a simple machine which will show the transmission of outlines in a crude form.

In subsequent issues we shall publish further devices and improvements, and also assist in any way we can amateur constructors in solving and elucidating the problems which they are bound to meet.

The mechanical part of the apparatus consists essentially of a simple disc perforated by two spiral sets of holes. We have purposely reduced the device to its simplest possible form, and in this first machine the same disc will be used both for transmitting and receiving, so that

there will be no synchronising problems to deal with. Synchronising devices will be dealt with in a subsequent issue.

We will begin by giving the details of this disc. Cardboard may be used and forms a fairly satisfactory medium, and one very easy to handle. It may be obtained from any stationer's, and should, preferably, have one side covered in black. There is considerable latitude in the thickness of card, but it must be sufficiently substantial to give rigidity. The first step is to cut from this card a circle 20 inches in diameter, then mark off eleven circles, the first with a radius of 9 inches, the second with a radius of $8\frac{1}{2}$ inches, and so on until the final one with a radius of $7\frac{1}{2}$ inches. The circumference must then be divided up into twenty equal segments and radii drawn. Where the radii intersect these circles the squares are cut, as shown in diagram, Fig. 1.

In place of cardboard thin sheet metal, such as tin-plate, may be

used. A very suitable tin-plate is the material known as Taggart. This is almost as thin as paper, being, in

venient to drill the holes in place of cutting them with a chisel or knife. Round holes must then, of course, be used. A round hole does not give such good results as a square hole, but if it is desired to get the best results the circular hole can be filed square with a rat-tailed file.

If you are using cardboard there is a tendency to warp which makes the use of tin or other metal preferable. In place of tin an aluminium plate gives a more satisfactory disc, and can be recommended in preference, although, of course, in cutting it entails a greater amount of mechanical skill and labour.

with a 10-inch radius, then with the same centre mark off a second circle with a radius of 9 inches, then a third circle as shown in the drawing, and so on until you come to the tenth circle with a radius of 7 1/4 inches. Now divide the circumference of your disc into twenty parts. To do this you will require a large pair of dividers. First of all draw two diameters at right angles to each other, thus dividing the disc into four equal parts, then divide each of these four equal parts into five equal sections, using your dividers to do this, or, of course, you may divide the disc by using a protractor and drawing radii at angles of 360 degrees divided by 20, that is 18 degrees.

You will now have your disc divided into twenty segments, and at the point where the radii cut the concentric circles square holes should be cut, as shown in the sketch, Fig. 1; or, of course, as previously stated, round holes may be used. The centre of the disc must be bored with a hole to fix on the spindle of the driving motor.

Any simple little 4-volt motor may be used. In the actual model which we are describing the motor used was obtained from Messrs. Bond, of Euston Road, London, its spindle being 3/16 inch in diameter. A Meccano pulley was used for fixing. Three bolts (3/16 inch diameter) were used to fix the disc to the pulley, as shown in the sketch, Fig. 9.

The motor carrying its disc is then fixed to a pedestal, the dimensions of which are given in Fig. 2. This pedestal is simply a wooden box, 1/2 inch wood being used, and is

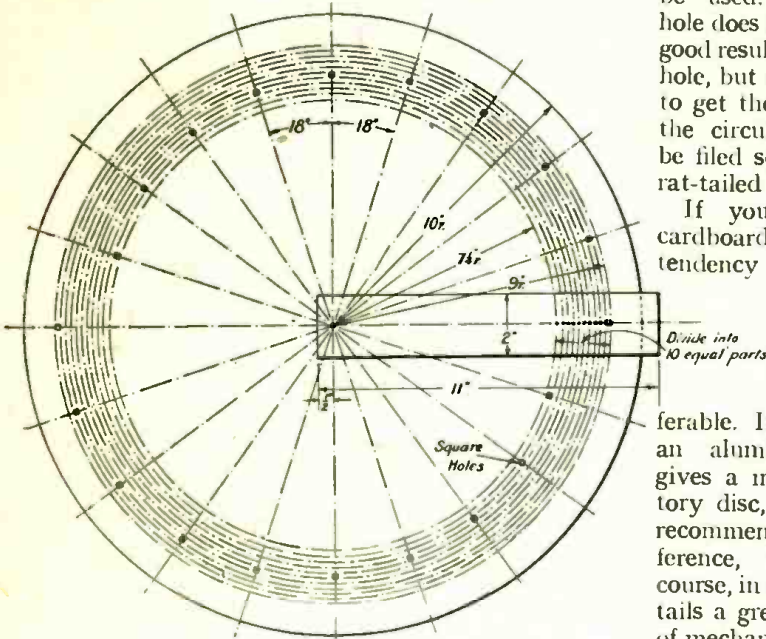

Fig. 1.

fact, the same material out of which biscuit tins and similar light tinware is made. It is very easily handled, and can readily be cut with an ordinary pair of scissors. It is sold in sheets of 22 inches by 30 inches. Any ironmonger will supply these.

A heavier grade of tin may, of course, be used, but it is not so easily handled.

In marking off the circles the proper instrument to use is a large protractor, but this may not be available, in which case a strip of cardboard 11 inches long by 2 inches wide may be employed. This is used in a similar way to a draftsman's trammels. With the point of a pair of dividers pierce the cardboard at one end and place on the tin as shown in the sketch, Fig. 1.

Using the point of the dividers as a pivot, mark off the radii along the card, and at the end of each radius pierce a hole with another pair of dividers. Then using the cardboard as a link swing a circle round on the tin-plate, this being repeated for each radius.

Where thick tin is used it may be more con-

The marking off of the disc is done as follows: First of all, using either a sufficiently large protractor, a pair of trammels or, if you have not any of these, a piece of cardboard as previously described, mark off a circle

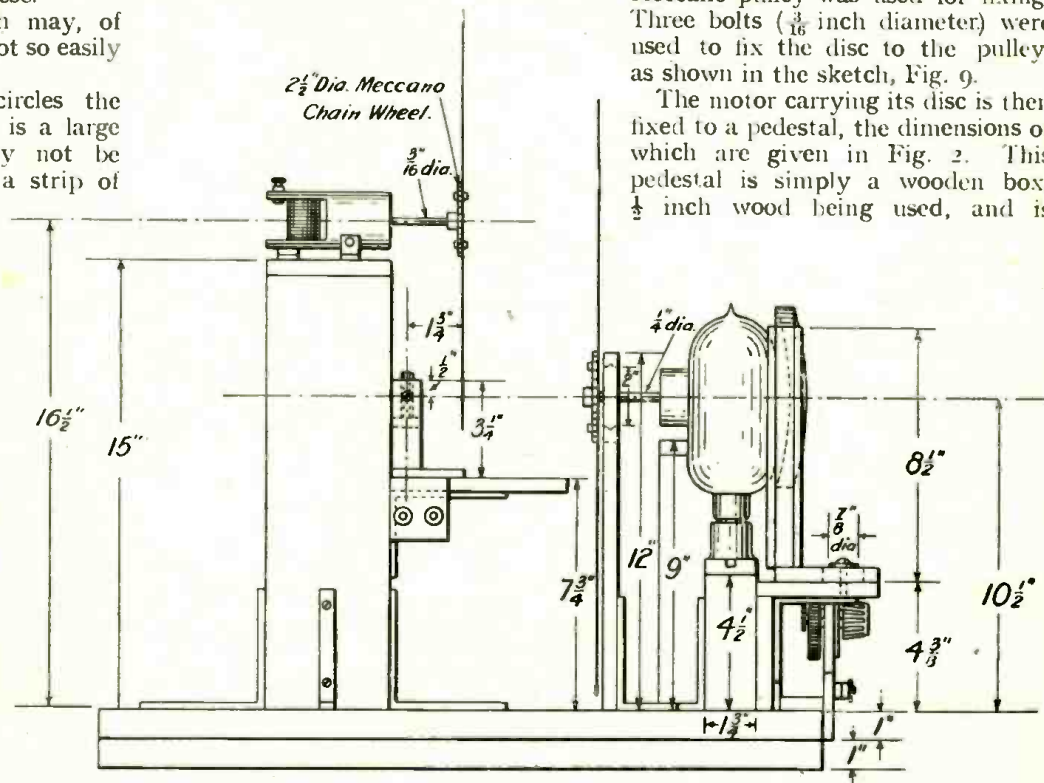

Fig. 2.

First in Wireless in 1919

PETO-SCOTT

CO., LTD.

First in Television in 1928

BACK in 1919 (before Broadcasting began) Peto-Scott Co., L'd., were the first to supply the needs of the early Wireless experimenting public. Now in 1928 (after nine successful years) Peto-Scott Co., Ltd., are the first to supply all the needs of the early experimenter in Television. To the latter, as well as to the former, Peto-Scott offer the same standard of quality and the same unrivalled service. At the time of going to press we have in stock all the components required to construct the Televisor described in this issue. Here is what you require:—

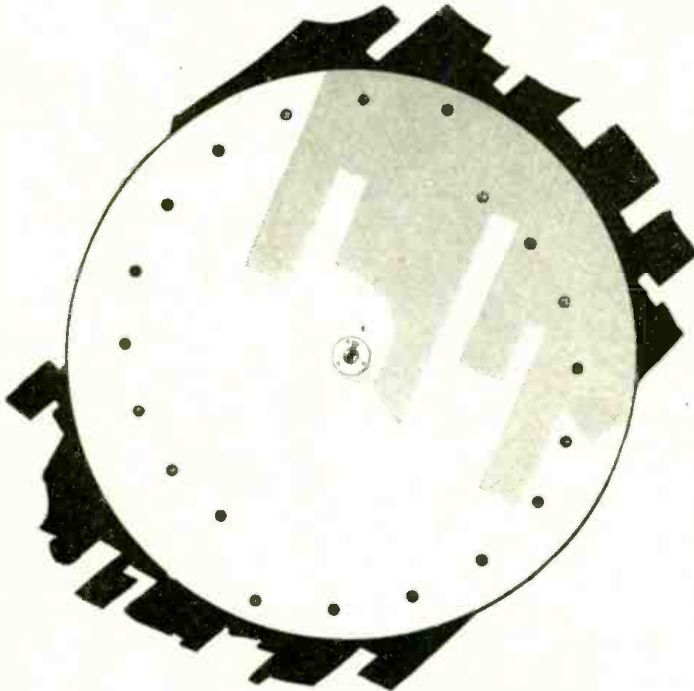

- 4-volt Electric Motors, from 15/-.
- 6-inch Mangin Mirrors, 12/- Mounted in adjustable metal stands, 19/6.
- Imitation Mangin Mirrors, 8/6.
- Osgilim Lamps, 3/3.
- Aluminium Discs, sold in pairs, 20" and 14" diameter, accurately punched to specification and fitted with brass flanges for attaching to motor spindle, 12/6 per pair.
- Selenium Cells, from £1.
- Parts for Amplifier.

We can supply 1/60th horse-power Electric Motors for working from mains 200/250 D.C. or A.C. Speed, 2,000 r.p.m. Price £2 14s. (These will take little current from the mains and will save cost of heavy accumulators).

DEALERS should write for generous terms.

WATCH OUR FUTURE ADVERTISEMENTS AND SEND NOW FOR DETAILED LIST OF PARTS.

PETO-SCOTT Co., LTD.

77, City Road, London, E.C. 1.

Branches: 62, HIGH HOLBORN, LONDON, W.C. 1.
4, MANCHESTER STREET, LIVERPOOL.

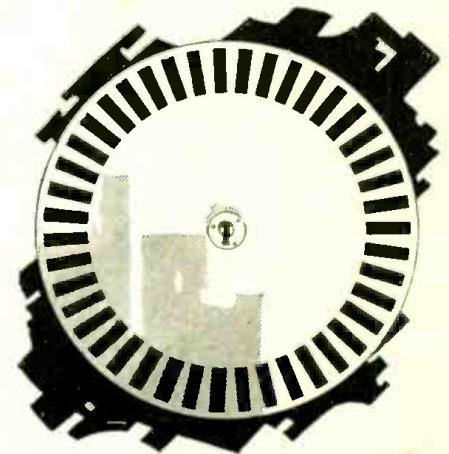

Mention of "Television" when replying to advertisements will ensure prompt attention.

 1867

EVERYTHING



ELECTRICAL



**The
Valves that
were used in
the original
Television
experiments**

**OSRAM
L.S.5.**

**MR. BAIRD USES
OSRAM VALVES**

The L.S.5. Osram
Valve is used in
Baird Televisor
Receivers

YOU will require Osram Valves for
your own home-constructed Televisor
as they provide faithful reproduction
of the current variations produced by
the "Electric Eye."

Write for full particulars
and characteristics

**Osram
Valves**

MADE IN ENGLAND

Advt. of The General Electric Co., Ltd., Magnet House, Kingsway, London, W. C. 2.

Mention of "Television" when replying to advertisements will ensure prompt attention.

attached to a baseboard made of the same material.

We have now a revolving disc suitably mounted, and this constitutes the first and most essential part of our "televisor."

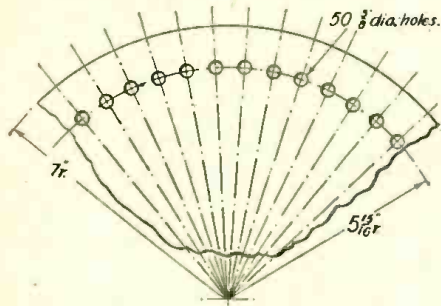

Fig. 3.

The next step is to construct our light interrupter disc. The light interrupter disc is 10 inches in diameter, and has fifty holes arranged round its circumference, the holes and spaces between being equal. Two alternative constructions of this disc are shown in Figs. 3 and 4. To make the disc the most suitable material is thin tin, but aluminium may be used, and makes a more rigid job, although it is not perhaps so easy to handle. This second disc is fitted to the shaft of a little electric motor of the same type as that used for the exploring disc, and the whole

is mounted upon another pedestal, as shown in sketches, Figs. 2 and 3. We come now to what may be

considered the heart of the whole apparatus, that is the selenium cell, and this is a snag which has destroyed the hopes of many amateurs who started along the road towards television.

In another part of this journal an account appears upon "How to make a Selenium Cell." But some readers may not wish to go to this trouble, and while it is highly advisable for those who are taking up the study of television to construct their own cells, it may be preferable to buy at least one commercial cell to enable results to be achieved without delay. Experimenters may then commence to construct their own cells, having by them the standard article with which to compare results.

Suitable selenium cells may be purchased from Messrs. Watson, Hilger, Sullivan, Baird and

Tatlock, and a number of other firms. The amateur should not grudge the price of a good cell, as apart from

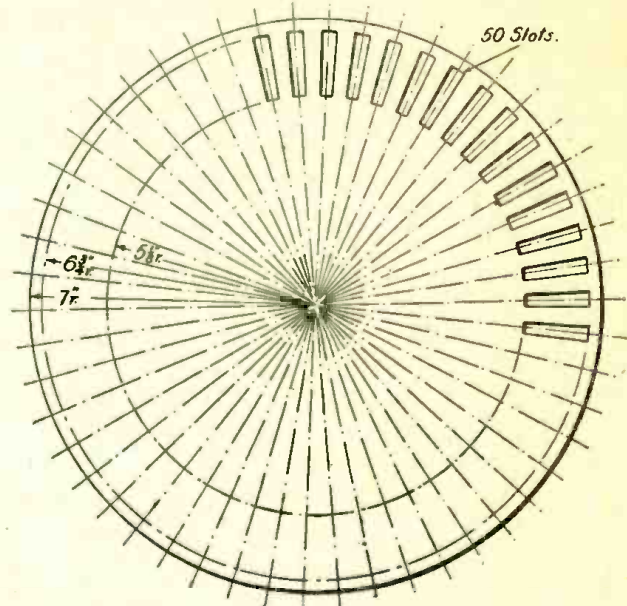

Fig. 4.

the apparatus being described at present, these cells will be of the greatest use in future experiments, the same applying to the little motors, reflectors and lamps which he will also be called upon to purchase.

The selenium cell, of whatever type he decides upon, is fixed behind the disc and in line with the perforations and slots, as shown in sketches, Figs. 2 and 5. The next item then is the lamp. A projection type lamp, such as an Osram 400 watt, is suitable, or an ordinary 100-watt lamp may be used. Behind the lamp is the reflector. This is a Mangin mirror 6 inches in diameter, and can be purchased from any cinematograph or optical suppliers. The object of this mirror is to concentrate the light of the lamp upon the cell. In operation the light from the lamp is focussed upon the holes in the disc, so that an image of the lamp filament falls upon the cell.

Now for the first test of the apparatus. The first thing to do is to find if the cell is functioning properly, and this requires a three-valve low frequency amplifier. Any good three-valve amplifier will serve the purpose.

There are on the market a number of ex-army mark 4 three-valve amplifiers which can be purchased very cheaply,

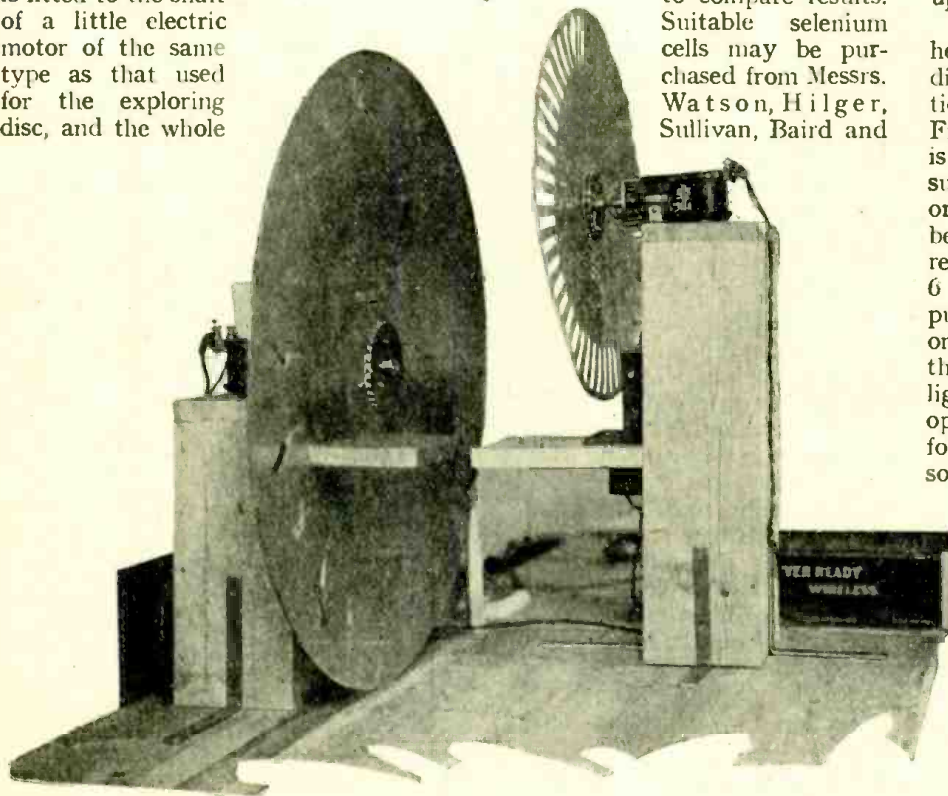

Side Elevation of Apparatus, showing Arrangement of Spirally Perforated Disc.

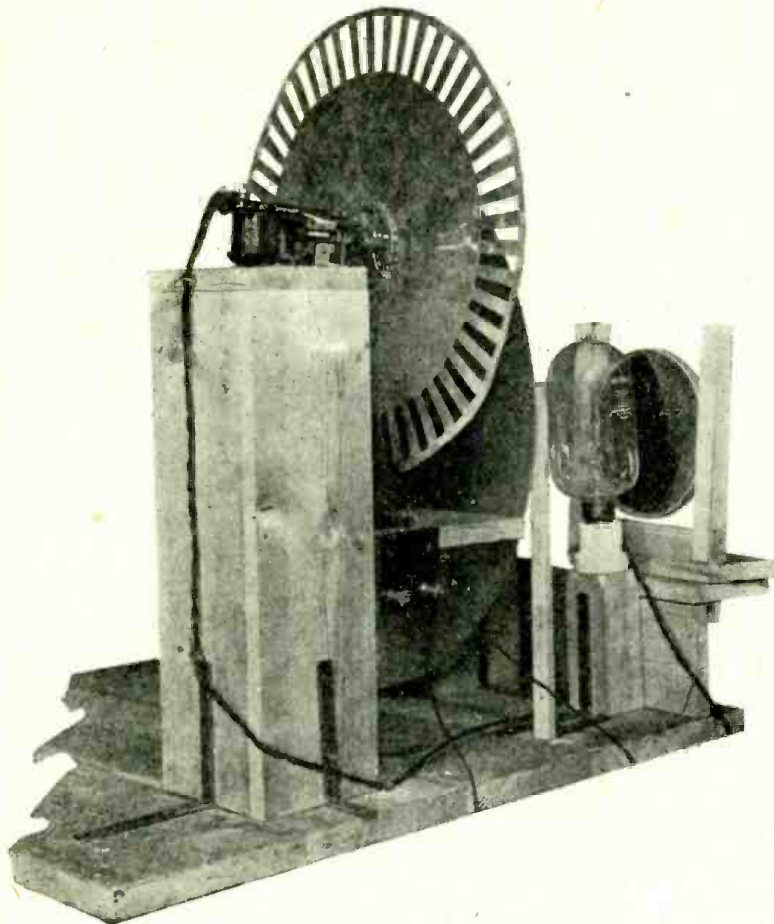

Side Elevation of Apparatus, showing Light Interrupter Disc with Motor, Projection Lamp and Mirror.

Having got the Neon tube to obey the light impulses we have finished the first part of our "televisor," and the most difficult part. The remaining constructional details to enable us to show an image will be given in the next issue. The present

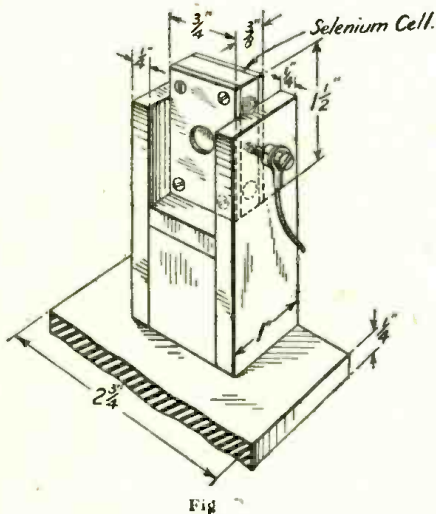

Fig.

article is the first of the series describing television in its very simplest form. Articles in subsequent issues will be published, using this first elementary "televisor" as a basis for further improvements and devices, always having the object in view to make each step progressive and as cheap as possible. With this in view an endeavour will be made to incorporate, in the next televisor to be described, all parts purchased for the first set, so that the expense incurred may be looked upon as an investment of permanent value.

If any questions arise in the construction of this apparatus we shall be very pleased to answer any queries, which should be sent to the "Queries Department," enclosing a coupon cut from the current issue.

Announcement

Readers are reminded that the construction of any television apparatus, as described in the issues of this Magazine constitutes an infringement of the Baird patents and renders the infringer liable to legal proceedings unless he is the possessor of the constructors' sub-licence that may be obtained in accordance with the offer herein contained on page 42.



APPLICATION FORM.

In accordance with the offer contained on page 42 of the issue of "Television" for March, 1928,

I _____

of _____

(description) hereby apply to Television Press, Limited, for the issue to me of a CONSTRUCTOR'S SUB-LICENCE and agree to be bound by the provisions of such sub-licence.

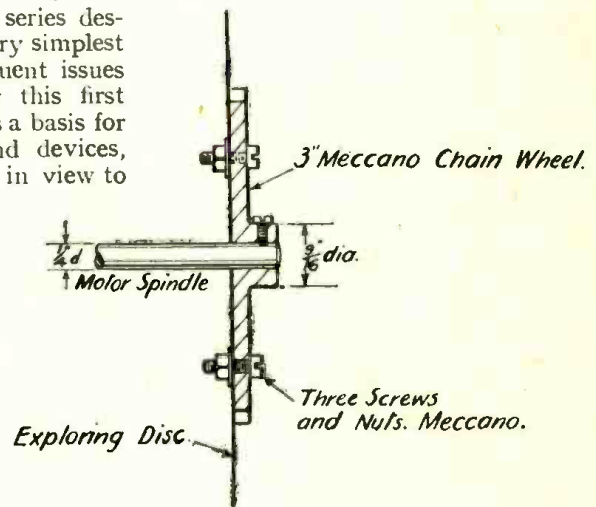

Fig. 9.

Full size Blue prints of the Discs may be obtained on application to the Editor, price 2/-.

TELEVISION ON THE CONTINENT

By M. DUMONT (*Our Paris Correspondent*)

A VAST amount of television research work has been carried out in France and Germany. The general line of research followed by Continental workers appears to have been along the avenue of the cathode ray, but this approach, while it appeared a promising line of attack, has been singularly barren of results, and it must be assumed that the practical difficulties connected with the application of cathode rays to television are very formidable.

In France the most prominent workers are MM. Belin and Holweck, and Dauvillier. In Germany, while much work has been done on photo-telegraphy and facsimile telegraphy, very little, apart from purely theoretical work, has been accomplished in television, although it must be remembered that much early research work was carried out in Germany by Ernst Rhumer.

The greatest authorities upon television in Germany to-day are, probably, Dr. Korn and Dr. Nesper; the former is best known for his work on photo-telegraphy, and the latter as the inventor of the Dr. Nesper headphones extensively used in radio.

They have recently published in collaboration a work on television and photo-telegraphy ("Bildrundfunk"), but this, while it contains accounts of the work of Baird and Jenkins, describes no German television apparatus or results, although a rather full account is given of the high speed photo-telegraphy of Dr. Karolus.

Among the French workers the most prominent is probably M. Belin, whose name is already famous in connection with his system of photo-telegraphy which has been in operation for several years. M. Belin has

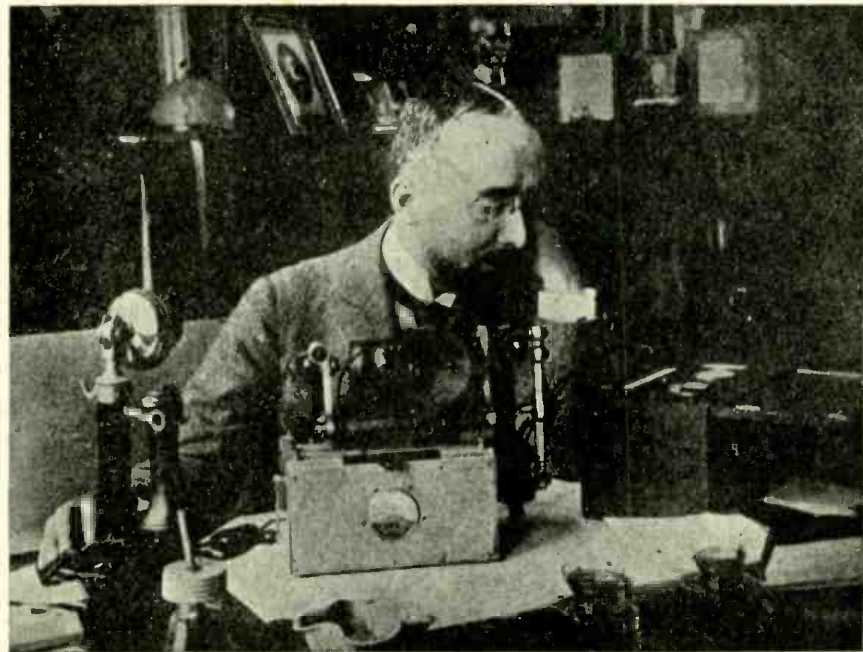

M. BELIN in his Laboratory.

carried out extensive research work on television, and recently, in conjunction with Mr. Holweck (whose name is best known as the inventor of the Holweck vacuum tube), has succeeded in sending shadows.

The apparatus of MM. Belin and Holweck consists of the transmitter of two mirrors vibrating at right angles to each other, these mirrors being driven by cranks attached to an electric motor and geared so that they vibrate at widely different speeds. By their combined action an image of the object to be transmitted is explored by a potassium photo-electric cell.

The receiving station consists of a fluorescent screen traversed by a cathode ray, the path of this ray being controlled by two magnets energised by A.C. currents from the windings of the motor driving the mirrors at the transmitter. The combined action of the magnetic fields causes the light spot to traverse the screen in a zig-zag path corresponding to the path of the image over the cell. The intensity of this spot

of light is controlled by a grid actuated by the current from the cell at the transmitter. The general arrangement is shown in the accompanying illustration.

With this apparatus crude shadows of simple objects, such as geometrical figures, a pencil, and a key, have been sent across M. Belin's laboratory at Malmaison at demonstrations given early this year.

M. Dauvillier has also carried out extensive research work on television. Like M. Belin, he uses vibrating mirrors for his transmitter and a cathode ray tube for his receiver, and he also has been successful in sending shadows. He has found, however, that his photo-electric cell is not sufficiently sensitive to respond to the small light available in the transmission of the living images of real scenes and objects, and he estimates that the sensitivity of his apparatus would have to be increased by one thousand times in order to achieve true television.

In Germany the A.E.G. use for their high-speed photo-telegraphy a

light valve developed by Dr. Karolus. This valve is a modification of a device invented many years ago by Dr. Kerr, an English physicist. Kerr discovered that if certain substances, such as nitro-benzine, were placed between two polarizing Nicol prisms the angle of polarization could be altered by applying electrostatic stress to the substance, so that if the Nicol prisms were turned into such a position that no light passed, and a potential was then applied to two plates immersed in the nitro-benzine, light immediately passed. This device has no time lag, and would therefore seem eminently suitable for television purposes, and, in fact, its use for television has been repeatedly suggested. It is reported that the A. E. G. have been actively engaged on developing a system of television on these lines, but no demonstrations have so far been given, and nothing definite has been made public.

The Apparatus of MM. Belin and Holweck.

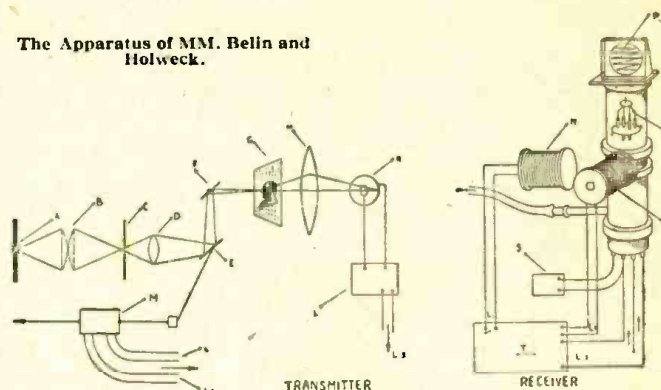

A beam of light from the light source, A, is focussed through the lenses B and D, and the diaphragm C, on to the vibrating mirror, E, which reflects the beam on to another mirror, F, which vibrates in a plane at right-angles to E. The combined action of these two mirrors causes the light beam to travel to and fro across the transparency, G, containing the representation of the object to be transmitted. After passing through the transparency, the beam is focussed by the lens, H, on to the photo-electric cell, K, the output of which is amplified and sent to the receiver, where it controls the degree of intensity of the kathode ray. This-ray is bent to and fro across the receiving fluorescent screen, P, by the action of the magnets, N and O, which are controlled by the same source of current which actuates the vibrating mirrors at the transmitter, thus ensuring synchronism between the transmitter and the receiver.

For the Constructor—

continued from page 28.

thin uniform and adhering layer: when this happens leave it alone, and watch it as it cools slowly. A change will gradually take place, and instead of the surface appearing shiny like stoved enamel, it will cloud over and turn grey, while a close examination will reveal the formation of small grey crystals in the surface. The selenium is, in fact, changing from the non-conducting amorphous to the conducting crystalline or metallic form: leave it to cool off slowly. If desired, when it reaches such a temperature that the hand can be placed on it in comfort, it can be coated with the varnish used for photographic negatives, but this is not essential. Also two little ebonite cover plates, the front one with a suitable hole and mica window, may be fitted and held in place by four 8 B.A. countersunk screws each if desired (see left-hand side of photographs, Figs. 7 and 8).

Testing.

Fit up a simple light interrupter as sketched in the diagram (Figs. 4 and 5). Focus the image of the filament on the cell and start the motor. A simple test to show if the cell is of

any use at all is to place it in series with a 60-volt battery and a pair of 2,000 ohm 'phones, which should give a clear and distinct note, the pitch of which varies with the speed of the motor, and which stops altogether when the light is shut off.

A more drastic test is to cut down the light to a minimum by stopping down the lens and by taking the cell about 9 feet away, and then amplifying the current sent by an H.T. battery in series with the cell with a two- or three-valve amplifier, the output of which goes to a pair of headphones. Even under those conditions the note should be pure and clear, ceasing entirely when the light is switched off. If parasitic noises (sounding very much like bad atmospherics on a wireless receiver) are heard the cell is useless. A good cell will stand at least 300 volts, in series with it, without breaking down or becoming parasitic.

Another test which can be applied if the reader has access to a mirror galvanometer or a micro-ammeter is a sensitivity test: the diagram (Fig. 5) shows a double-throw, single-pole knife-switch, used to change over from amplifier to micro-ammeter. The test will be comparative only, but is interesting as showing the

progress made in cell construction. Sensitivity may be defined as the ratio of resistance in the dark to resistance in the light, but as the light value is not stipulated it is only a relative definition, nevertheless it will afford interesting comparisons, using always the same source of light, say a 100 watt lamp, between different cells made by the reader, or between his cells and a commercial cell.

APRIL CONTENTS

includes:

**How to Make a Simple
Televisor—(concluded)**

* * *

**Hints on the Operation
of the Simple Televisor**

* * *

**Infra-Red Rays:
Properties
and Measurements**

LIGHT-SENSITIVE CELLS

By K. M. DOWBERG

TWO forms of light-sensitive devices are known: those which depend upon photo-emissivity, to which class belong photo-electric cells, and those which depend upon photo-conductivity, the outstanding example of which is the selenium cell. For television purposes the photo-electric cell holds the field as it is instantaneous, unlike the selenium cell which suffers from inertia. The photo-electric cell consists of a vacuum tube partially coated with a light-sensitive substance such as potassium. Light falling upon potassium causes it to emit electrons so that a current flows from the cell. This action is fundamentally different from the action of selenium, which does not emit electrons, but has its resistance reduced by the action of light.

The photo-electric effect was first discovered by Hertz, who noticed that sparks passed across the spark gap more easily when ultra-violet light fell upon the gap.

A German scientist named Hallwachs investigated this phenomenon and found that the effect was located at the negative pole, and was most pronounced with the metals rubidium, potassium, and sodium.

The modern photo-electric cell (Fig. 1) consists essentially of one or other of these metals enclosed in a vacuum, the metal coating forming one pole and a loop of wire the other.

The cell acts as a generator of electric current, but the current produced is infinitesimally minute and requires enormous amplification. The problem of amplifying these extremely small currents has been one of the greatest difficulties met with in television.

The type of cell which seems to be most favoured is the potassium cell, and this has been used very extensively both on the Continent and in the U.S.A.

Zworykin and Nakkin in America have developed a type of cell in which the potassium coating is incorporated to form part of three electroed valves.

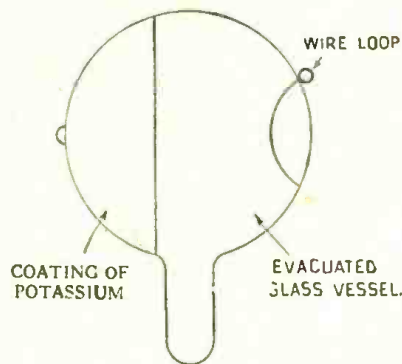

By these means they obtained a form of amplifying device combined with a cell and considerable advantages are claimed by them for this arrangement. Although it is not obvious that great benefit is gained by combining the cell and amplifying valve in one unit. Occasionally photo-electric cells are provided with an atmosphere of some inert gas, such as helium, rubidium in an atmosphere of helium being a favourite combination. Such gas-filled cells, however, although they are more sensitive than the vacuum type, tend to become unsuitable in operation, and are not so reliable as the high vacuum photo-electric cell.

All types of photo-electric cells are practically instantaneous in their response to light, and it is this property which renders them essentially suitable for television purposes.

The Selenium Cell.

Selenium is an element and belongs to the same chemical group as sulphur. Its outstanding position is among light-sensitive substances. It was discovered quite accidentally by a telegraph operator, Mr. May.

The Chief Engineer of the Post Office Telegraph Department desired to find a suitable material for high resistances to be used in connection with the transatlantic cable. Knowing that selenium had an immensely high resistance, he constructed a number of resistances from this element and sent them to the terminus of the transatlantic cable

—a little village in the west of Ireland called Valentia. Here they were put in use. Trouble, however, ensued. One day the operator was much worried by his instrument behaving in a very erratic fashion. He found that the needles seemed to move every time he passed between the light which was shining through the window and the selenium resistance. He investigated this, and found that every time the sunlight fell upon the selenium the needle of his instrument moved. The operator (a Mr. May, whose name should certainly be put on record) communicated this result to Mr. Willoughby Smith, who investigated it further, and later read a paper on the subject to the Society of Telegraphic Engineers. His disclosure created a wide stir amongst scientific circles, and the discovery was taken up and investigated both in England and throughout the world.

Graham Bell, the inventor of the telephone, Shelford Bidwell, Siemens, and a number of others used selenium to construct what they termed cells. That is to say, they endeavoured to increase the reaction obtainable by exposing the maximum amount of selenium to the light and making the coating of selenium as thin as possible. I append below descriptions of selenium cells made by Siemens and by Bell.

Bidwell used a construction which is still followed at this date by many experimenters. He wound two parallel wires on to an oblong-shaped piece of unglazed porcelain and rubbed over this molten selenium. Now, selenium is only sensitive to light in its metallic form.

To obtain this the crystallised selenium must be heated to almost melting point and kept at this temperature for a period of half an hour or longer.

To construct a cell such as that used by Siemens, a piece of unglazed porcelain or soap-stone should be obtained (this may be got from any scientific supply stores), the wire,

which may be of No. 30 S.W.G. copper, is wound round this in a double spiral, and the whole construction (Fig. 2) heated to a little above melting point of the selenium. The selenium, which is in the form of sticks, may also be obtained from the larger scientific suppliers. This is rubbed on much as sealing wax might be rubbed over a heated surface, and it also behaves in a very similar fashion to sealing wax. The coating should be extremely thin. The thinner the coatings, the more rapid and more efficient will be the selenium cells.

The object in constructing most selenium cells has been to provide as large a path as possible for the current, and to achieve this another popular type of cell is the so-called condenser construction. This con-

sists of a number of thin copper plates insulated from each by mica, and bolted together to form a solid block. Alternative plates are connected to different poles, and the surface of this block is machined to form a flat plane. This plane surface is then coated with selenium, so that the selenium forms a bridge between

the two sets of plates. This construction forms a very efficient and simple method of constructing a selenium cell, but it requires machine tools which are not always available to amateurs.

Another type of selenium cell is that developed by Mr. Brown in America, and the method used consists in covering a conducting plate with a thin layer of selenium, and over the top of this selenium placing a sheet of gold leaf; the gold leaf acting as one pole and the plate as the other. Gold leaf being transparent, the light passes through this and reaches the cells. The construction allows of a large surface of selenium coming into operation, but a certain amount of light is lost coming through the gold leaf.

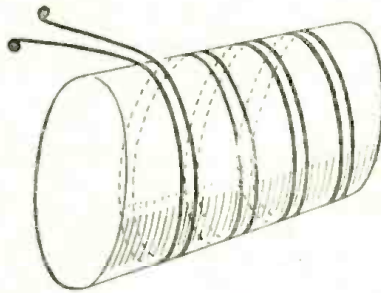

THE PERFECT TERMINAL

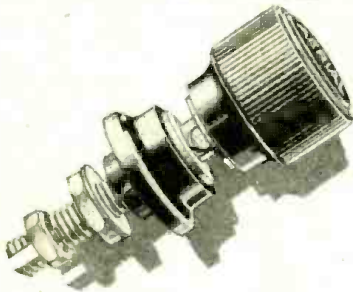

Patent

FOR perfect design, finish and workmanship Belling-Lee Terminals are unequalled. Recommended and used by all the leading Radio experts, and by manufacturers of the best battery eliminators, Belling-Lee Terminals have long since proved themselves to be the best designed terminals for Radio.

PRICES: Type 'B.' Standard large insulated mod l, polished black bakelite, 9d. each. Type 'M.' As Type 'B' but smaller and with only the engraved top insulated. Best nickel-plat'd brass, 6d. each. Both types guaranteed, and made with 30 different engravings.

BELLING-LEE TERMINALS

BELLING & LEE, Ltd., Queensway Works Ponders End, Middlesex

SURE-A-LITE

the better battery

FOR TELEVISION

Sure-a-lite cells are larger than those in other H.T. batteries. Therefore Sure-a-lite give greater efficiency, unequalled recuperating powers, long life and silent working.

We make no attempt to cut our prices; you get full value for money from Sure-a-lite batteries, and you will continue to do so. The new Sure-a-lite batteries will be on sale immediately. They incorporate a grid bias battery and are supplied sealed and with a deep dust-proof cover.

Rely on the battery experts—and ask your radio dealer—he knows!

SURE-A-LITE

BRINGS MOST IN — GIVES MOST OUT!
REGISTERED TRADE MARK

"Supra" 66 volt 7/11
100 volt 14/3
"Giant" 50 volt 10/6
100 volt 17/6
These incorporate
Grid Bias, Lappel
every 1 1/2 v. up to 6 v.



THE BATTERY COMPANY,
92 HURST STREET, BIRMINGHAM.

All Communications respecting Advertisements should be addressed to—

"Television" Advertisement Department,

63, Lincolns Inn Fields, London, W.C.2.

Telephone: HOLBORN 7070
Temporary Line: HOLBORN 6234

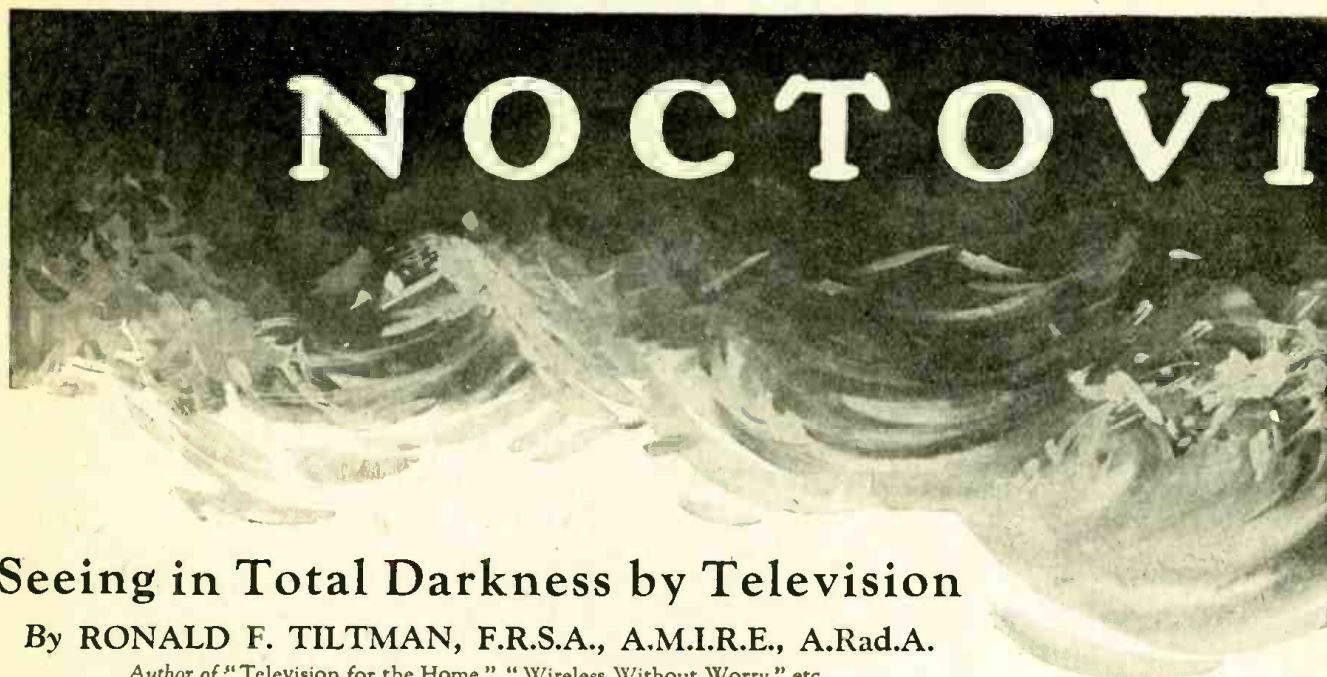

Seeing in Total Darkness by Television

By RONALD F. TILTMAN, F.R.S.A., A.M.I.R.E., A.Rad.A.

Author of "Television for the Home," "Wireless Without Worry," etc.

IN the course of experiments connected with the development of his television apparatus, Mr. J. L. Baird, the inventor of the "televisor," has produced one of the most remarkable developments of modern times. With the aid of what he aptly calls "the noctovisor," he has overcome the powers of darkness and has demonstrated the possibility of *seeing in total darkness*, or fog, by means of television.

The sensational demonstrations of this "noctovision," which the inventor gave in Leeds on the occasion of the British Association meeting early in September, will be well remembered, for they were very freely reported in the press. He gave short distance tests from one room to another in Leeds, and these certainly excited the greatest interest. In spite of admission being restricted to ticket-holders only, there were continuous queues formed both in the hope of obtaining tickets and also to view the demonstrations.

A Long-Distance Test.

In order to prove his assertion that distance was no drawback, he also gave several 170-mile tests, people seated in the dark at Leeds being seen as if under normal lighting conditions on a receiving screen in London.

On September 7th last Mr. Baird arranged one of these amazing 170-mile demonstrations. Two telephone lines were used; over one came the

image of Lieut.-Colonel J. R. Yelf, a member of the British Association, and over the other I conversed with the inventor, asking for various movements of the head and hand to be made while I watched the results on the screen.

For this demonstration I entered a darkened room on the top floor of a building near Leicester Square. Before me was a large cabinet, near the top left-hand corner of which was inset a panel of frosted glass, roughly a foot square.

There was a humming sound as the apparatus was awakened to life, and then a smear of orange light appeared behind this glass panel, whirling from top to bottom. In this light, as synchronising adjustments of the apparatus were made, the flickering image of a face appeared. The image was about 2 inches square and outlined in black lines. At times it was remarkably clear, although, of course, by no means perfect, but occasionally it became obscured by black lines which oscillated across the image.

It was positively uncanny—like a page from the Arabian Nights tales—to sit in London and watch this swaying reproduction of the living face of a person who sat *in complete darkness* nearly two hundred miles away. A face which, in obedience to telephoned requests, turned, opened its mouth, and made other movements.

The Infra-red Ray.

This mastery over darkness is made possible by the use of what are known as infra-red rays; these, being outside the visible spectrum, cannot be seen with the human eye.

The spectrum is, of course, divided up into sections. Working downwards we come firstly to gamma rays as given off by radium, then X-rays, ultra-violet rays, the visible part of the spectrum we know as light, infra-red rays, and, lowest of all, wireless waves. To the human eye the only visible part of the spectrum is that which lies between the colours of violet and red.

After his first demonstrations of television, when the subject who is being "televised" had to face a powerful battery of blinding lamps which nearly scorched the skin, the inventor decided that it was essential to reduce the amount of illumination required before his apparatus would be commercially successful.

After some months of research he was able to demonstrate television, using no more than normal lighting power from a few ordinary electric lamps.

In view of this success, he next decided to continue his experiments, having in mind what appeared to be the fantastical idea of dispensing with light altogether, for he remembered that he was not dealing with the human eye in his tests but the

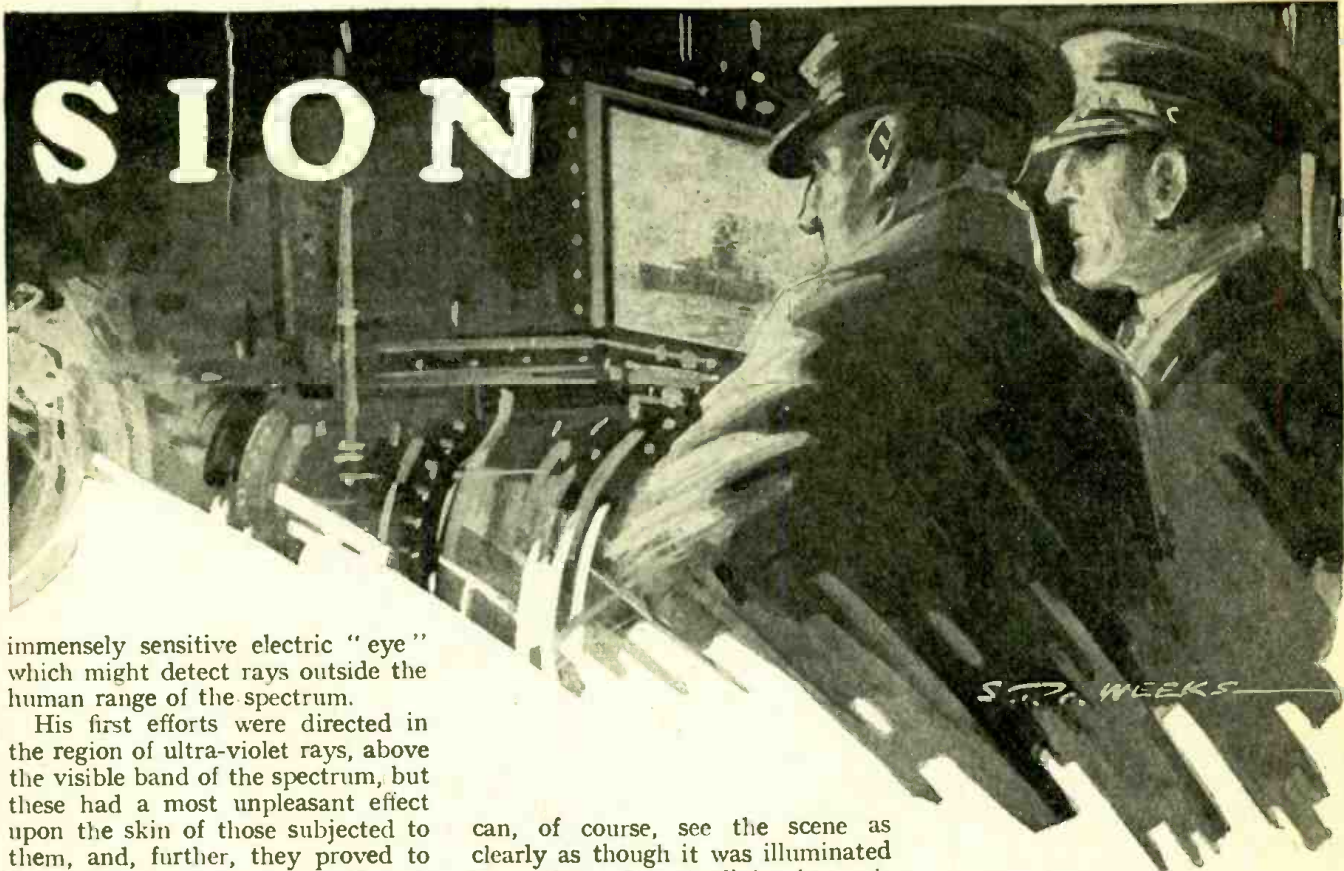

immensely sensitive electric "eye" which might detect rays outside the human range of the spectrum.

His first efforts were directed in the region of ultra-violet rays, above the visible band of the spectrum, but these had a most unpleasant effect upon the skin of those subjected to them, and, further, they proved to have little penetrative power through air.

Next he turned his attention to another region of the spectrum, the infra-red beneath the range visible to human eyesight. By evolving a fresh light-sensitive cell these rays proved to be satisfactory, and he was able to dispense altogether with visible light. The ordinary photoelectric cell is almost unaffected by the infra-red rays, being chiefly acted upon by the violet end of the spectrum. The bolometer or the thermopile are too slow for television purposes. Mr. Baird, therefore, had to evolve a light-sensitive device sensitive to infra-red rays and without inertia.

Bathed in Invisible Light.

In demonstrations the person being "televised" sits before the apparatus apparently in total darkness; at the same time the normal lights of the room are switched on but shielded by a secret light filter, which extracts all visible rays from the light and only allows the invisible infra-red rays to pass. Thus the person is really bathed in light, but as it cannot be detected by human eyesight he is quite unconscious of the fact.

The "eye" of the "televisor"

can, of course, see the scene as clearly as though it was illuminated normally, and so the living image is transmitted as usual, and when received on the television screen appears to be brightly lighted.

One of the first public demonstrations of "noctovision" was given before about forty members of the Royal Institution in December, 1926.

Writing in *Nature* shortly afterwards, Dr. Russell, F.R.S., who had also witnessed an early demonstration, said: "Mr. Baird has now developed a method by which the image of a person is transmitted, although he is in complete darkness. . . . These images were not outlines or shadowgraphs, but real images by diffused reflected rays. The application of these rays to television enables us to see what is going on in a room which is apparently in complete darkness. So far as I know, this achievement has never been done before."

As soon as "noctovision" was achieved it was demonstrated before Military, Air Force, and Naval experts. Representatives of four governments came to inspect the apparatus, and immense interest was aroused in all quarters—even greater interest than was aroused by the original demonstrations of television.

Noctovision Tests in London.

These infra-red rays can be flashed through the lenses of a searchlight just as any visible light, and they have greater penetrating powers than normal light. The inventor had a searchlight fitted on the roof of his London laboratory some months ago. This was equipped with the filtering device which retarded the passage of the visible light, but the beam of invisible rays was there, and on test Nelson's Monument and other London landmarks were picked out in darkness and seen on the television screen.

In all these "noctovision" tests it is, of course, necessary to employ a television receiving screen, upon which is revealed the lighted image of whatever is in the path of the "black light," as it has been called.

It happens that infra-red rays, by their very nature, are ideal for fog penetration, and therefore "noctovision" will be an important development in these respects. Fog penetration tests have been given before illumination experts and lighthouse authorities.

The discovery of the fog-penetrating powers of the infra-red rays was

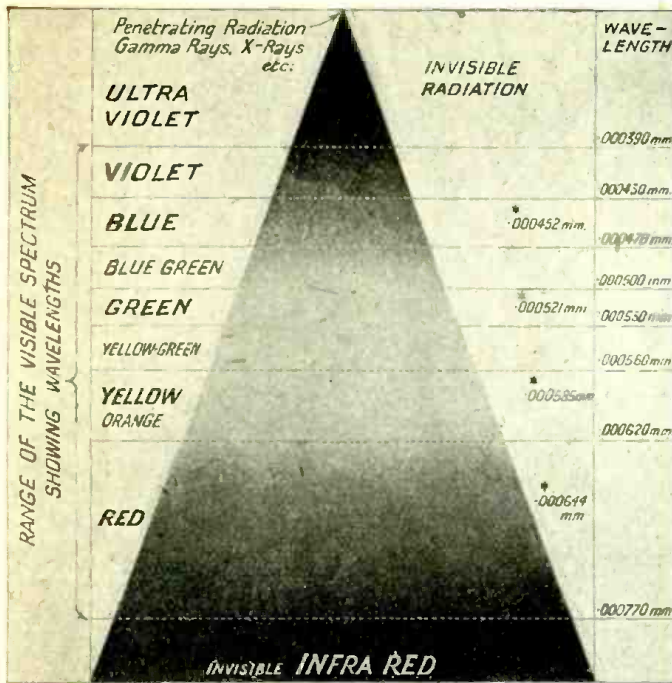

Part of the Frequency Spectrum, showing the relative position of Infra-Red Rays.

Electrician—and during the test it was particularly noticed that the curling smoke from a cigarette could be clearly seen rising in front of the person's face.

When a test of "noctovision" was given to the same representative of this paper he was shown the face of a person who was in total darkness, and asked for the cigarette to be smoked again, as in the television test. This time it was, however, quite impossible to see any trace of the smoke. Thus the smoke and fog-penetrating powers of the infra-red rays were first brought into prominence.

There has been much speculation, from time to time, as to exactly what uses this "noctovision" can be put, for there is no doubt that the development has very great potentialities.

Its fog-penetrating power appears to be one of its most valuable assets, and it is bound to have vast commercial possibilities in the safer navigation of ships and aeroplanes; in fact, all transport on which fog has a paralysing effect.

As darkness has throughout the ages been the cloak for warlike activity it seems that "noctovision" must be a factor in all future methods of attack and defence. To have control over a searchlight, which will illuminate objects at a distance without betraying its presence to the human eye, cannot fail to be of significance in this respect.

"Noctovision" gives mankind another faculty, that of vision in darkness and fog, and it must therefore rank as an outstanding wonder—even among the multitude of scientific achievements for which the past decade has been so noteworthy!

Noctovision—continued.

made accidentally. Mr. Baird had demonstrated his original television before a representative of a technical paper—if my memory serves me rightly it was the

Announcement

THE proprietors of this periodical, Messrs. Television Press, Ltd., have the pleasure to announce that they have made arrangements with the owners of the World Patent Rights in the well-known Baird System of Television whereby they are able to empower their readers to become sub-licensees under such patents as affect their country of residence, for the limited purpose of the construction of one set of apparatus for television, if erected and operated by the sub-licensee purely as an amateur.

In order to avail themselves of this offer our readers need only fill in and cut out the application form, which will be found on page 35 of this issue, and address it to the Editor, "Television," 26, Charing Cross Road, W.C. 2.

The conditions relating to the grant of these sub-licences are as follows:—

1. The sub-licence will be granted for a period of two years from the date of grant to each applicant and will be strictly personal and incapable of assignment.
2. The sub-licence covers the manufacture of one set only to be constructed in accordance with the directions and illustrations contained in this and the following numbers of this journal.
3. No apparatus may be constructed after the expiration of the said period of two years.
4. Apparatus constructed under this sub-licence may be used at any time.
5. Apparatus constructed under this sub-licence is to be used by the sub-licensee only and may not be sold at all, and may not be given to any other person except in the event of the death of the sub-licensee.
6. Any breach of any of the above provisions renders the sub-licence immediately void and the sub-licensee liable to the legal consequences of infringement.

7. The proprietors of this journal reserve to themselves the right at any time to withdraw this offer without prejudice to the rights conferred by any sub-licences already granted.
8. The proprietors further reserve the right to refuse the grant of this sub-licence to any applicant at their sole discretion.

"Coming Events Cast their Shadows..."

"I tremble to think of the responsibility of a future Postmaster-General when visual sights are transmitted as well as sounds."—Lieut.-Col. MOORE-BRABAZON, M.P., February, 1927.

* * *

"Without a doubt in the course of a year or two television will be perfected, and the amateur who listens will also be able to see by wireless."—WILLIAM LE QUEUX, M.Inst.R.E. (1926). * * *



Where there is
development
there is Mullard!

THE amazing rapidity with which radio has become universally popular is as wonderful as radio itself.

Mullard realised that there was a vast public ready to listen long before broadcasting became a reality . . . to-day, Mullard is known and appreciated all over the world.

Television is but one step further, a step which is and will be associated with Mullard to the highest degree.

Mullard
MASTER · RADIO

Mention of "Television" when replying to advertisements will ensure prompt attention.

Join the Television Society (continued from page 24)

We should like to take this opportunity of expressing our genuine appreciation of the public-spirited action of the Baird Company in granting the Society's request.

"Netherton,"

Coulsdon,

Surrey.

Dec. 29th, 1927.

The Baird Television Development Co., Ltd., Motograph House, Upper St. Martin's Lane, W.C. 2.

DEAR SIRs,

As Chairman of the Executive Committee of the Television Society, I am asked to put before you for your kind consideration a request that you might grant to Amateur Constructors free use of your Television Patents, for experimental purposes only, as this would unquestionably greatly facilitate the development of the art.

I would point out that this course was adopted by the Marconi Company when wireless was in its infancy, and has resulted in every way beneficially.

I am, yours faithfully,

CLARENCE TIERNEY.

Jan. 23rd, 1928.

DEAR SIR,

With reference to your letter of the 29th ult., the Directors of this Company have considered the question of granting to the Television Society a licence authorising the society to grant to their members Amateur Constructors' Licences, and the Solicitors have been instructed to prepare, and I will forward you in due course, a draft of the proposed licence for your approval.

Yours faithfully,

T. W. BARTLETT,

Secretary.

Dr. Clarence Tierney, "Netherton," Coulsdon.

Particulars of the licensing conditions are given elsewhere in this issue.

To QUERIES DEPT., TELEVISION PRESS, Ltd., 26, Charing Cross Road, London, W.C.2

Please supply me with additional information on the points raised in the attached letter.

Name

Address

March, 1928.

ELECTRADIX

Bargains

Special Apparatus suitable for Television.

- 500 CYCLE ALTERNATORS
H.T. GENERATORS
MULTI STAGE AMPLIFIERS
SELENIUM CELLS
PROJECTORS AND LENSES

A really fine selection of Precision Instruments including the famous "Dix-Onemeter."

GENERAL CATALOGUE of Radio Apparatus—Electrical and Precision Instruments. 72 Pages, well Illustrated. Copy Post Free for 4d. stamps.

Visit our Showrooms, there is much that will interest you.

Telephone: City 0191.

ELECTRADIX RADIOS

218, Upper Thames St., London, E.C.4

5 Catalogues FREE
A.F. BULGIN & CO
9, 10, 11, CURSITOR ST. CHANCERY LANE, E.C.4
TRADE DECKO MARK

SELENIUM

amorphous or crystalline for photo electric cells. Sufficient for one cell, 2s. post free

N. HEYWOOD

16, Baronsfield Rd., Twickenham

MEMBER'S APPLICATION FORM.

Please send me particulars of the opening meeting in London, and consider my candidature for Fellowship or Associateship.

Name

Address

Academic Qualifications

or

Scientific Pursuits

The Secretary (pro tem.), The Television Society, The Engineers' Club, Coventry Street, London, W.

TELEVISION

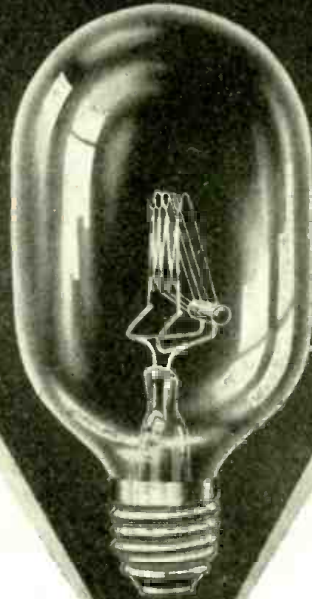

Philips Projector Lamps are suitable for use in the simple Televisor described in this issue. Philips Neon Lamps can also be supplied for this apparatus.

Use Philips Lamps—and See
Makers of all types of Electric Lamps

PHILIPS PROJECTOR LAMPS

PHILIPS LAMPS LTD., PHILIPS HOUSE, 145, CHARING CROSS ROAD, LONDON, W.C.2
Mention of "Television" when replying to advertisements will ensure prompt attention.

BANISH BATTERY TROUBLES FOR EVER!

WONDERFUL NEW SOURCE OF H.T. SUPPLY—THE GREATEST BOON IN RADIO!

The Standard Wet H.T. Battery has brought to listeners everywhere the boon of perfect, and positively permanent H.T. Supply at an amazingly low cost.

WONDERFUL IMPROVEMENT IN QUALITY OF RECEPTION.

Hundreds of users are unanimous in declaring it to be the perfect and most economical source of H.T. Supply, that makes reception from any set clearer, more beautiful in tone, and with a complete absence of background noises.

IT RE-CHARGES ITSELF OVERNIGHT!

Just think what this means! No matter how long you use it, in the morning it is full-powered—fresh as the dawn! Permanent H.T. Power is now yours. You can do away with the ever-present worry of run-down batteries and spoiled programmes. Use this amazing battery how you will, night after night, it will supply your set with steady, abundant H.T. current, ensuring pure, distortionless reception that will amaze you.

TAKE THE FIRST STEP NOW!

FREE BOOK

Seize this opportunity with both hands, and send at once for FREE booklet describing every detail for installing and maintaining this super-efficient and money-saving battery. Send postcard now to:—

(Dept. T), THE WET H.T. BATTERY CO., 12, Brownlow Street, London, W.C.1.

PRICES

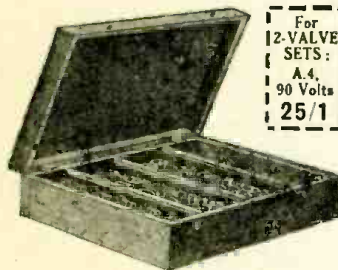

For 2-VALVE SETS:	For 3-5 VALVE SETS:	For SUPER SETS:
A.4.	D.6.	F.6.
90 Volts	108 Volts	126 Volts
25/1	37/3	69/6

NO DEPOSIT!

DEFERRED TERMS. CARRIAGE PAID ON ALL GOODS FOR 10/- OR OVER. Single units of 1½ volts from 4½d. each. State number and type of valves when ordering.

IMPORTANT. Experimenters contemplating building a Televisor must employ an *unvarying* H.T. current to get good results. The Standard Battery is specially suitable for this reason and can be built up to any required voltage.



Use

HART BATTERIES

for the

LOW TENSION and HIGH TENSION CIRCUITS

of TELEVISION APPARATUS

as used exclusively in the pioneer experimental work

by

Mr J.L. BAIRD

HART ACCUMULATOR CO., LTD. STRATFORD, LONDON, E.15

BIRMINGHAM: 165, Edmund St. BRISTOL: 37, Victoria St. CARDIFF: 50, Charles St. GLASGOW: 107, Wellington St. MANCHESTER: 88, Chapel St. YORK: 6, Bridge St. WESTMINSTER: 35, Victoria St., S.W.1.

FOR PERFECT L.F. AMPLIFICATION

use the Watmel Low-frequency Auto-Choke

THE amplification curve of the WATMEL Auto-Choke—literally "as straight as a die"—speaks for itself. It tells of long endeavour and successful achievement—of unsurpassed purity of tone—of whippers built up into voluminous sound. It reveals, in a manner bordering on the remarkable, the way to natural-toned reproduction, without sacrificing one iota of volume. The WATMEL Auto-Choke, by virtue of its patent core and specially balanced auto-windings, gives a **step-up** increase in volume in any wireless receiver equal to a transformer-coupled stage of low frequency amplification, but with the purity of a crystal.

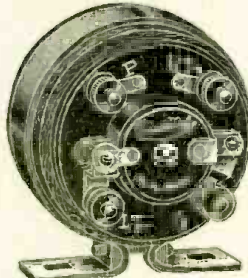

1st Stage
2nd Stage

18/6

No EXTRA Condenser or Grid Leak required

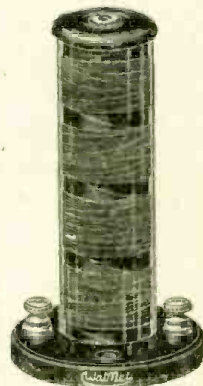

Watmel H.F. Choke

THE WATMEL H.F. Choke is an instrument which, like our other products, has been very carefully designed. Everyone realizes that for a H.F. Choke to be efficient, the self-capacity must be very low, and this together with the many other requirements are obtained in the WATMEL H.F. Choke. The windings of the WATMEL H.F. Choke are protected by a transparent cover the whole being mounted on a bakelite base with nickel-plated terminals. Price 5/-

Full details from your local dealer or from:—

THE WATMEL WIRELESS CO., LTD. Imperial Works, High Street, Edgware, Middlesex

Telephone: Edgware 0323

Mention of "Television" when replying to advertisements will ensure prompt attention.



THE BEST CONDENSERS IN THE WORLD

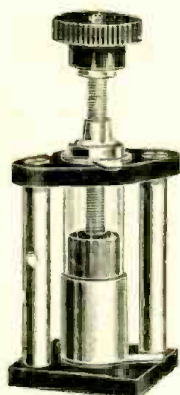

*J.B. Neutralising
Condenser.*

LOOK at the workmanship, the accuracy in every detail, the perfect finish, and you'll be convinced of the efficiency of J.B. Condensers. Go a step further, and substitute J.B. in any Receiver and the resulting improvement will immeasurably strengthen that conviction.

Every modern improvement, every detail that makes for sharper and more efficient tuning is incorporated in J.B. Condensers. TELEVISION—the "BIG THING" of the future—is relying on that essential accuracy and sharpness in tuning which J.B. Condensers ensure.

Look ahead and be in a position to take advantage of coming developments by making sure that your radio receiver is up to date.

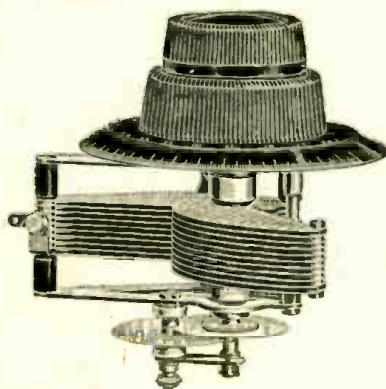

*J.B. Log Slow
Motion.*

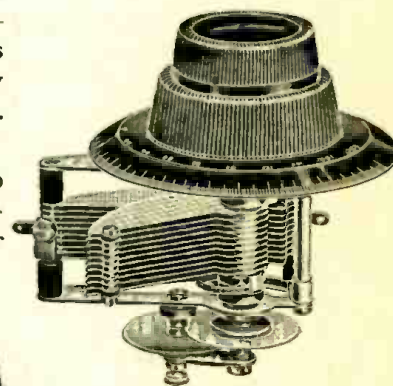

*J.B., S.L.F. Slow Motion
(J.B. True Tuning S.L.F.)*

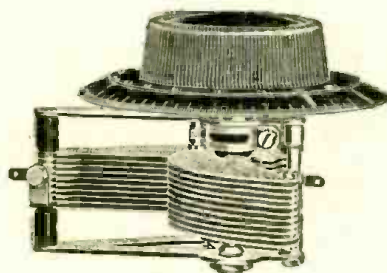

J.B. Log Plain.

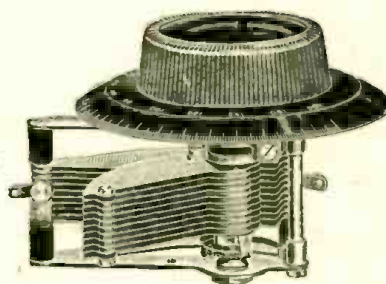

J.B., S.L.F. Plain.

JACKSON BROS.
B. POLAND ST- OXFORD ST
LONDON - W.1. Telephone -
GERRARD 7414

Mention of "Television" when replying to advertisements will ensure prompt attention.

FOR WIRELESS try RAYMOND'S

"MULLARD MASTER THREE" IMPORTANT

NO SOLDER—ONLY 20 WIRES TO CONNECT SET OF COMPONENTS.

The Components specified:

- | | |
|--|--|
| 2 Terminal strips, 2½ in. by 2 in. by ½ in. | 1 Broadcast-wave Master Three coil. |
| 1 Coil base. | 1 On and off switch (Bulgin). |
| 1 S.L.F. variable condenser, .0005 mfd. (J.B.) | 1 R.C.C. unit, type A (R.I.-Varley). |
| 1 S.L.F. variable condenser, .0000 mfd. (J.B.) | 1 L.F. transformer, (G.P. (R-I-Varley)) |
| 1 H.F. choke (Climax). | 1 Combined grid leak, 2 megohms, and condenser, .0003 mfd. |
| 3 Anti-vibratory valve-holders with terminals. | 8 Wander plugs—4 red, 4 black. |
| 1 Pair panel brackets. | Suitable length of red and black flex. |
| 4 Terminals—A, E, L.S.—, L.S.F. | 1 Ebonite bush, ¾ in diam., ¾ in hole, ½ in. thick. |
| 1 Set of A B C connecting links (unit). | |
| 2 Spade terminals—1 red, 1 black. | |

And 3 Mullard P.M. Valves.

ABOVE KIT **£6 17 6**

FREE Grid Bias, 9 volts 100 Volt H.T. (British) with above. Aluminium Panel, 18 in. by 7 in.

ABOVE KIT **£4 12 6**

FREE with £4/12/6 Kit—Aluminium Panel, 18 in. by 7 in., 2 Slow Motion Dials, and 9 volt Grid Bias.

SET OF THE SEASON COSSOR MELODY MAKER

COMPONENTS FOR SAME

Post **£4 10 0** Kit. **Extra**

2 Ormond .0005; 2 Do S.M. Dials; 6 T.C.C. Condensers .001, .002, two .0003, .0001, 2 mfd. 2 Grid Lk. Clips, B.B.; 1 var. B.B. Rheostat; 3 Dubilier Leaks, .25 3, 4 meg.; 3 Lotus V.H.; 1 Ferranti A.F.3; 2 Panel Switches; 1 Cossor Melody Wound Coil; Terminals, Name Tabs; Glazite, 9 volt Grid Bias (all as specified).

NOTE Drilled High-grade 21 by 7 Polished Panel, with Radion Strip, **FREE** with above kit.

NOTE Handsome American Cabinets, hinged lid, baseboard. List: Oak, 25/-, for 18/11; Mahogany, polished, list 32/-, for 22/6, if purchased with above kit. **ALL CARRIAGE AND PACKING EXTRA.**

ALL VALVES STOCKED.

EDISWAN NEW THREESOME LIST OF COMPONENTS.

Three Coupling Units. Tubular Fixed Condenser. Multi-flex Cable and Plug .0003 Variable with S.M. Dial. 2-way Geared Coil Holder, Connecting Wire, Red and Black Flex.

The lot post free **42/- nett.**

EBONITE PANEL 2/6 The two with 5-Ply Baseboard above kit only.

Ediswan Valves, 10/6 each; Power 12/6.

2 60-volt Batteries (if purchased same time), the 2 for 12/6 nett. Very good make. 2-volt Accumulators (with parts), 7/11 nett. All other accessories stocked. Please add sufficient for carriage.

K. RAYMOND

27 & 28a, LISLE STREET, LONDON, W.C.2
COME TO LEICESTER SQUARE TUBE.

Important. This address is at the back of Daly's Theatre.
BE SURE IT IS RAYMOND'S. Phone: Gerrard 4637.

Mention of "Television" when replying to advertisements will ensure prompt attention.

We stock Igranic, Climax, Ever-Ready, Hellesen, Siemens', Formo, Ferranti, Wearite, Ormond, J.B., Benjamin, Lotus, Mullard, Dubilier, Lissen, Lewcos, Utility, Magnum, Peto-Scott, Peerless, Burndept, Pye, Marconi, McMichael, Cosmos Carborundum, R.I.-Varley, Gambrell, Brown's, Sterling, Amplions—in fact everything it is possible to stock for Wireless.

OUR NEW 100-PAGE CATALOGUE 1/-

(Allowed off first 10s. order.)
Profusely Illustrated, valve data etc. Very handy for reference

IT IS IMPOSSIBLE TO ADVERTISE ALL THE WIRELESS PARTS NOW ON SALE, BUT IF YOU WANT THEM TRY **RAYMOND'S FIRST!**

Be sure you visit the Bargain Window.

- CABINETS.
 - HEADPHONES.
 - VALVES.
 - BATTERIES.
 - LOUD SPEAKERS.
 - H.T. UNITS.
 - FRAME AERIALS.
 - VOLTMETERS.
- At Lowest Prices.

ALL WIRELESS FANS WILL BE TELEVISION ENTHUSIASTS.

COSSOR, MULLARD, B.T.H., EDISWAN and SIXTY-SIX valves stocked.

ORMOND, LISSEN R.I.-VARLEY and all Proprietary Lines in Wireless.

WE ARE OPEN
ALL DAY SATURDAY
ALL DAY THURSDAY
ALL DAY EVERY DAY
Hours 9 a.m. to 8 p.m.
Sat. 9 a.m. to 9 p.m.

Bring this Advertisement, it means a free gift with your Order.



FORMO
ARTHUR PREEN & CO LTD

"1928" LOG Condenser 5/-

Behind Panel - 2"
Span fully open 3½"

4½ ounces

Perfect to Logarithmic Law

Absolutely the SMALLEST LIGHTEST AND MOST EFFICIENT

See it for the FIRST TIME at the **BRITISH INDUSTRIES FAIR**
Stand No. 8 (Wireless Section)
Literature containing full details from **THE FORMO CO. CROWN WORKS, 22, CRICKLEWOOD LANE, LONDON, N.W.2**
Telephone: Hampstead 1787



LOOK YOUR VISION WILL TELL YOU

Where to get New Valves, or dud ones repaired

For Price List send to—
NORTH LONDON VALVE CO., LTD.,
22½, Cazenove Road, Stoke Newington, London, N.16
Telephone No.: CLISSOLD 0082.

We specialise in giving the experimenter his requirements.



CDM COMPONENTS

are suitable for use in all circuits, best material and workmanship being employed in our manufactures. **QUALITY TELLS!**

H.F. CHOKES.

Vertical	5/- each.
Clip-in Type	4/- "

FIXED CONDENSERS.

.0005 to .002 with clips now	1/8 each.
.0025 to .006	2/- "
.01	3/6 "
Grid Condenser and Leak	2/- "

If your dealer does not stock, write direct to the Sole Manufacturer:—

C. D. MELHUISE,
8, Great Sutton St., Goswell Rd., E.C.1.
Phone: Clerkenwell 7494.
Send for catalogue of our guaranteed products.

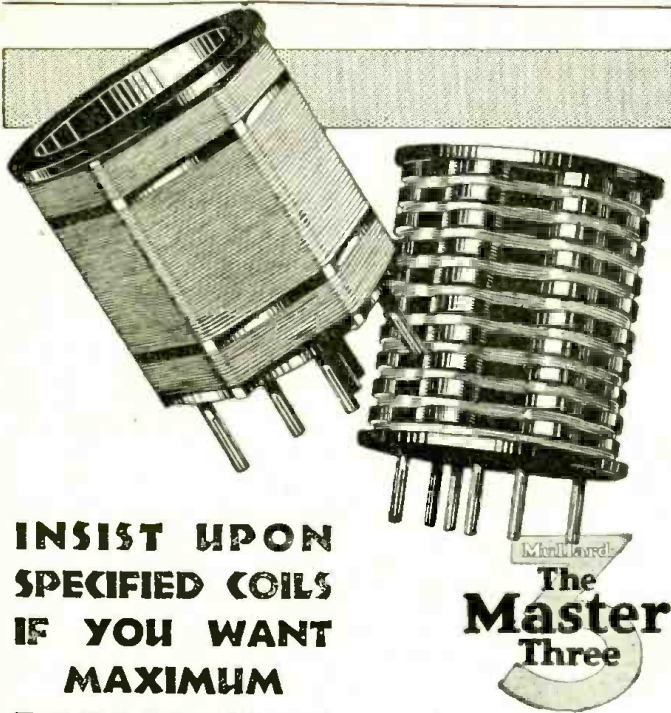

INSIST UPON SPECIFIED COILS IF YOU WANT MAXIMUM EFFICIENCY

Mullard
The Master Three

IF you are about to construct the Mullard Master Three Receiver you should remember that there is every reason why you should adhere to the author's specification.

SELECTIVITY to the desired degree is easily obtained with Colvern Coils. A few turns to requirement should be removed from the aerial winding and the end of the wire reconnected to Pin No.4.

RANGE depends to an extremely high degree upon efficient coils and it is very important that these should have a very low high-frequency resistance. To obtain this Colvern Coils are accurate space-wound. Experience proves that the use of Colvern Coils increases the range of a radio receiver. In the case of the Master Three Colvern Coils give maximum range.

VOLUME is similarly dependant upon the efficiency of coils. Logically, the signal strength of distant stations is greatly increased by Colvern Accurate Space-Wound Coils.

Therefore be advised—adhere strictly to the author's specification, you will be most satisfied.

Prices:—

Broadcast Wavc.

Accurate Space-wound to give maximum efficiency.

7/6

Long Wavc.

Sectional wound to give lowest high-frequency resistance.

8/6

Colvern Aluminium Panel.

is also specified for the Mullard Master Three Receiver 18" x 7" : 14 gauge; sprayed instrument black; drilled for variable condensers switch and panel brackets.

7/6

COLVERN ACCURATE SPACE WOUND COILS

Colvern Ltd., Mawney's Road, Romford.

CYLDON SUPREMACY

COMING EVENTS CAST THEIR SHADOWS BEFORE THEM

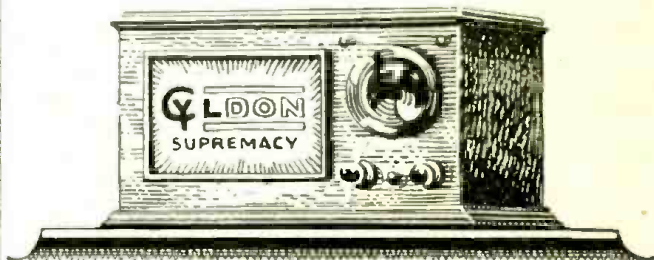

The "Cyldon" Laboratories are experimenting daily to meet the needs of Television Apparatus. All intending constructors should fill in the attached coupon, when progressive particulars of new components will be posted from time to time.

SYDNEY S. BIRD & SONS, LTD.

Cyldon Works, Sarnesfield Road, Enfield Town, Middlesex.

Telephone: Enfield 2071-2.

Telegrams: "Capacity, Enfield."

Post this Coupon.

Please send particulars of your components for Television.

Name

Address

Mention of "Television" when replying to advertisements will ensure prompt attention.

SOME MAGNUM PRODUCTS

- A.C. MAINS UNIT.
- VALVE HOLDERS.
- H.F. CHOKES.
- L.F. TRANSFORMERS.
- H.F. TRANSFORMERS.
- WAVE METERS.
- CALIBRATED RESISTORS.
- COUPLING UNITS.
- D.C. ELIMINATORS.
- COILS.
- H.T. AUTO FUSES.
- GRID LEAKS.
- CONDENSERS.
- SCREENING BOXES.
- ANGLE BRACKETS.
- EBONITE PANELS.
- SCREENED COILS.

Constructional Kits for all the Well-known Sets.

RECEIVERS
 THE MAGNUM SCREENED 3, 4 and 5, unrivalled for selectivity.
 PURITY THREE.
 THE "CUBE" THREE. No earth or aerial, completely self-contained
 PORTABLE THREE.



AN ANNOUNCEMENT

SINCE the inception of broadcasting the house of Burne-Jones has become recognised, far and wide, as pioneers. Specialisation has always been made in high grade radio apparatus described in the leading technical journals for the home constructor. The remarkable efficiency of Magnum products coupled with specialised service has created a reputation second to none. With the advent of television opening up new fields of intense interest and possibilities, the same policy of concentration for the home constructor's requirements will be adopted. Readers of "Television" are assured of complete satisfaction in their dealings with us.

C Catalogues and Lists dealing with the apparatus described in this issue will be sent on receipt of 1½d. stamp.

BURNE-JONES & CO. LTD.,
MAGNUM HOUSE
 TELEPHONE: HOP 6257
288, BOROUGH HIGH ST.
LONDON. S. E. 1

LISENIN

POSITIVE GRIP TERMINALS ARE ABSOLUTELY IDEAL.

(Patent No. 245586.)

The ends of the leads are so gripped that they cannot possibly come adrift. Pressure is so distributed that a break is practically impossible. (See illustration.) Further, the ragged ends of the flex covering are covered up, and one's leads look and behave as they ought to behave when fitted with Lisenin Positive Grip Terminals, as used in

"RADIO FOR THE MILLION"

"AMATEUR WIRELESS" "WIRELESS WORLD" SETS

AND BY LEADING SET MANUFACTURERS.

Follow the Lead of Experts. Insulated sleeves are made in standard colours, Red, Green, and Black. Plugs and sockets are interchangeable, and all metal parts N.-plated.

Liberal discounts to Manufacturers; samples gladly submitted to Trade enquiries.

THE LISENIN WIRELESS Co., 17, Edgware Rd., London, W.2. Phone: Paddington 2734.



Wander Plug. Note taper. 2d.



Spade End. 4d.



Plug and Socket. 4½d.



Socket and Plug. 4½d.

GOOD H.T. BATTERIES ARE ESSENTIAL.



Columbia "Layerbilt"

For Television apparatus, really good H.T. Supply is absolutely essential. There is a far greater drain on H.T. Batteries in Television apparatus than in an ordinary Wireless Receiver. The immense capacity of the Columbia "Layerbilt" makes this battery ideal for Television Receivers. Always ask for Columbia "Layerbilt" — the 100% Battery.

Price 25s.

If you have any difficulty write us direct, giving name and address of your Dealer.

The Columbia "Layerbilt" is manufactured and guaranteed by the National Carbon Co., the largest battery manufacturers in the world.

J. R. MORRIS, 15, Kingsway, London, W.C.2.

Scotland: J. T. Cartwright, 3, Cadogan Street, Glasgow.



Does YOUR H.T. BATTERY Last 9 Months?

The Modern Trend of receiver design invariably calls for Larger Capacity Batteries. Ripaults Self-Regenerative H.T. Dry Batteries, through the elimination of internal resistance, have a greatly increased capacity output, and tests have proved that they possess at least 50% longer life than the normal type.

Is it not better to have a 15/8 battery which lasts, say 9 months, than a battery at 7/9 which only lasts 3?

RIPAULTS SELF-REGENERATIVE H.T. DRY BATTERIES

are super in construction and of exceptional capacity. OBTAINABLE FROM ALL DEALERS. Supplied in Standard, Double, Treble and Quadruple capacities.



They give **50%** Longer Service.

FREE. "Life Chart" and "Right Choice" table. Write for Folder, TV/10.

RIPAULTS LTD. King's Road, LONDON, N.W.1

Mention of "Television" when replying to advertisements will ensure prompt attention.

PRODUCTS of QUALITY **MB** AND DISTINCTION

THE **MB** 5-VALVE PORTABLE RECEIVER



IN HANDSOME LEATHER CASE COMPLETE
READY FOR OPERATING, GIVING THE
CHOICE OF A NUMBER OF STATIONS.

PRICE, INCLUDING ALL ROYALTIES

30 GUINEAS.

Read the following copy of a letter sent to us.

Four Gables, Boston Spa.

October, 1927.

DEAR SIRS,

It may interest you to know that the last few weeks I have been touring Scotland and had with me one of your McMichael Portable Sets. For the whole of the trip I was able to hear Daventry quite distinctly and at John O'Groats, which is the farthest north I could get, it came in quite loudly and distinctly.

I think this is rather a wonderful performance considering the great distance from Daventry.

I am enclosing a photo or two which may interest you.

Yours faithfully,

(Signed) ARTHUR PROCTER.

The **MB** SUPERSONIC BLOCK UNIT

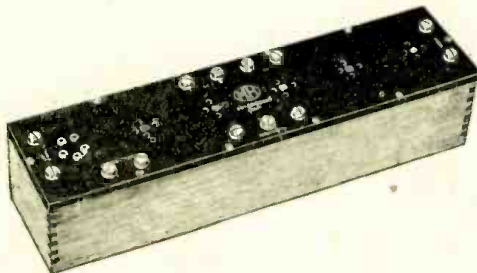

The **MB** 5-Valve Supersonic Block Unit is the "Heart of a Super-Het," and was designed especially to facilitate the assembly of a Super-Het Receiver—and more particularly for those enthusiasts not having the confidence in their ability to make up a receiver of a somewhat delicate nature. Purchasers of this Block Unit can listen in within an hour of reaching home with their purchase.

Price (including 5-Point Oscillator), 300-600 metres, £6 6s.

This unit forms the nucleus of the 6-Valve Receiver used by Mr. Allen, A.M.I.R.E., for the direct reception of the three Empire Broadcast Programmes transmitted by 2FC, Sydney, Australia, a distance of 13,000 miles.

THE **MB**
6-VALVE SUPERSONIC RECEIVER

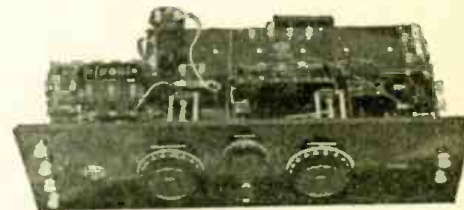

A simple arrangement of **MB** components for a 6-Valve Supersonic Receiver giving loudspeaker results capable of reception over a waveband of 10 metres to 2,000 metres.

The total cost of parts to build this Receiver as illustrated amounts to approximately £13. Full detailed list, prices and diagrams on application. If desired, the complete receiver, constructed in our works, as illustrated, may be purchased with short-wave coils and auto-oscillator (for B.B.C. stations) for £17 17s. Royalties extra £5. Cabinet extra £2 2s.

The outstanding problem in short-wave reception is to combine amplification and ease of control. The **MB** Supersonic system gives the maximum of amplification and an ease of control which is a revelation.

Telephone :
SLOUGH
441-442

L.M. MICHAEL LTD
Manufacturers of Wireless and Scientific Apparatus
WEXHAM ROAD, SLOUGH, BUCKS.

Telegrams :
'RADIETHER,
SLOUGH.'

London Office and Wholesale Showrooms : 179, STRAND, W.C.2. (Telephone Central 6988)

Mention of "Television" when replying to advertisements will ensure prompt attention.

The Music Charmer

A three-valver which every radio enthusiast will soon be talking about. Cost £3 10s. 0d.—only 27 connections and no soldering required—Loudspeaker reception from many British and Continental stations. One tuning control. Fully described in March "Wireless Magazine."

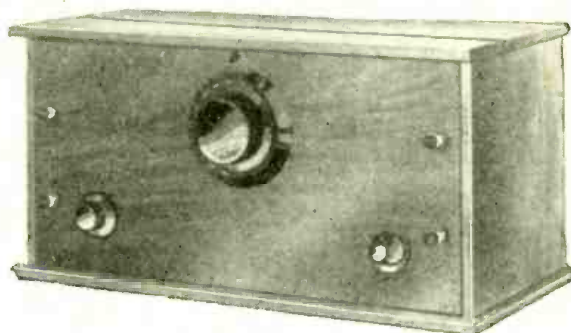

Other contents include:

Special exclusive article by G. K. Chesterton on "Give us Controversial Broadcasts"—Build your own Moving Coil Loudspeaker, etc., etc.

Full-size Blueprints of all sets described in this issue offered at half-price until March 31st.

WIRELESS MAGAZINE

for March, on Sale on February 24th, 1/-

The success of a
**Televisor or a
 Wireless Receiver**
 depends on the Component Parts used

By specifying and making sure you get "EELEX" you are sure of good results. Write for Catalogue 231, which describes and prices all "EELEX" parts, sent free on request. Drop a postcard NOW to

J. J. EASTICK & SONS Television and Wireless Dept.,
 Eelex House, 118, Bunhill Row, London, E.C.4

Save Valves by using
CORTABS

Their advantages are self-evident. They are non-conducting and non-corrosive. A carton of 12 popular wordings only costs

9d.

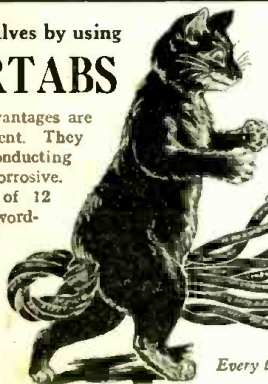

LIST OF WORDINGS.

Aerial. H.T. —
 Earth. L.T. +
 H.T. + 1. L.T. —
 H.T. + 1. Bias +
 H.T. + 2. Bias —1.
 H.T. + 3. Bias — 2.

Every tail should wear a tab.

MONEY HICKS & MILLS, 54-60, BRITANNIA ROAD, WALHAM GREEN S.W.6.

INDEX TO ADVERTISERS.

	PAGE
Marconi Co., Ltd.	ii
Ever Ready	1
The Electron Co., Ltd.	2
The Celestion Radio Co.	3
R. I. and Varley, Ltd.	5
Television Supplies, Ltd.	6
Harlie Bros.	20
Langham Radio	22
Lissen Ltd.	25
Peto-Scott, Ltd.	31
General Electric Co., Ltd.	32
Belling & Lee, Ltd.	39
The Battery Co.	39
Mullard	43
Electradix Radios	44
A. F. Bulgin & Co.	44
N. Heywood	44
Philips Lamps Ltd.	45
The Wet H.T. Battery Co.	46
Hart Accumulator Co., Ltd.	46
The Walmel Wireless Co., Ltd.	46
Jackson Bros.	47
K. Raymond	48
The Formo Co.	48
North London Valve Co., Ltd.	48
C. D. Melhuish.	48
Colvern Ltd.	49
Sydney S. Bird & Sons, Ltd.	49
Burne-Jones Co.	50
The Lisenin Wireless Co.	50
J. R. Morris	50
Ripaults Ltd.	50
L. McMichael, Ltd.	51
Wireless Magazine	52
J. J. Eastick & Sons	52
Money Hicks & Mills	52
Igranic Electric Co., Ltd.	iii
Dubilier Condenser Co. (1925) Ltd.	iv

Mention of "Television" when replying to advertisements will ensure prompt attention.

You cannot fool the eye



L.F. Transformer, Type "G."

Gives the most even amplification of all frequencies under working conditions. A massive instrument in which neither materials nor workmanship has been stinted. Two ratios—3.6:1, for 20,000-30,000 ohm valves, and 7.2:1, for 6,000 ohm valves.

Price 30/-.



Igranic Wire-Wound Shielded Resistor.

The perfect wire-wound resistor for R.C. coupling. Being shielded, stray capacities are eliminated and a straighter characteristic is obtained at the high frequencies.

80,000 ohms	..	Price 4/6
150,000 "	..	" 5/6
50,000 "	..	" 7/6



Igranic Filament Rheostats

This is one of the range of rheostats which meet every possible requirement for perfect voltage control.

Prices from 2/- to 4/-.

Distortion in telephony often passes unnoticed, but in television it does not. You can fool the ear but you cannot fool the eye. Therefore absolutely distortionless amplification is essential and only the best components can give this.

Igranic components have been developed by a highly-trained research staff with unrivalled experience, and represent the highest standard that low frequency amplifier components have attained. In using Igranic components you have a guarantee of satisfaction. You take no risks. *The complete illustrated Igranic catalogue, List No. J.462, gives full particulars of these and the many other Igranic Devices.*



149, QUEEN VICTORIA STREET,
LONDON, E.C. 4.

Works. BEDFORD.

Branches:

BIRMINGHAM, BRISTOL, CARDIFF, GLASGOW
LEEDS, MANCHESTER, NEWCASTLE.

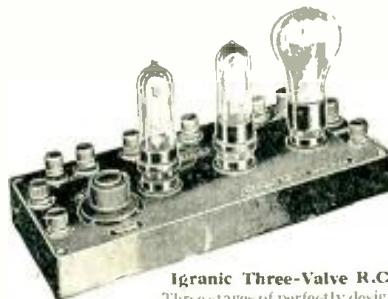

Igranic Three-Valve R.C. Amplifier.

Three stages of perfectly designed resistance capacity amplification. Volume control is provided. The most even amplification possible is obtainable with this amplifier.

Price 50/- With out valves and roya ty.



Igranic Universal High Resistance.

The only satisfactory type of volume control for transformer or R.C. amplifiers. Potentiometer type.

Model A	..	0-1 megohms.
" B	..	0-5 "

Price 5/6. As illustrated.



Igranic Grid Leak.

Retains its value indefinitely. The spring clips allow very convenient mounting.

Price 2/3.

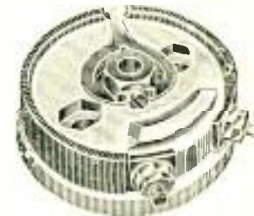

Igranic-Pacnet Pre-Set Resistor.

For the base-board control of valve filaments. Ideal where a panel rheostat is not required.

Price 1/8.

Mention of "Television" when replying to advertisements will ensure prompt attention.

MAKE A JOB OF IT

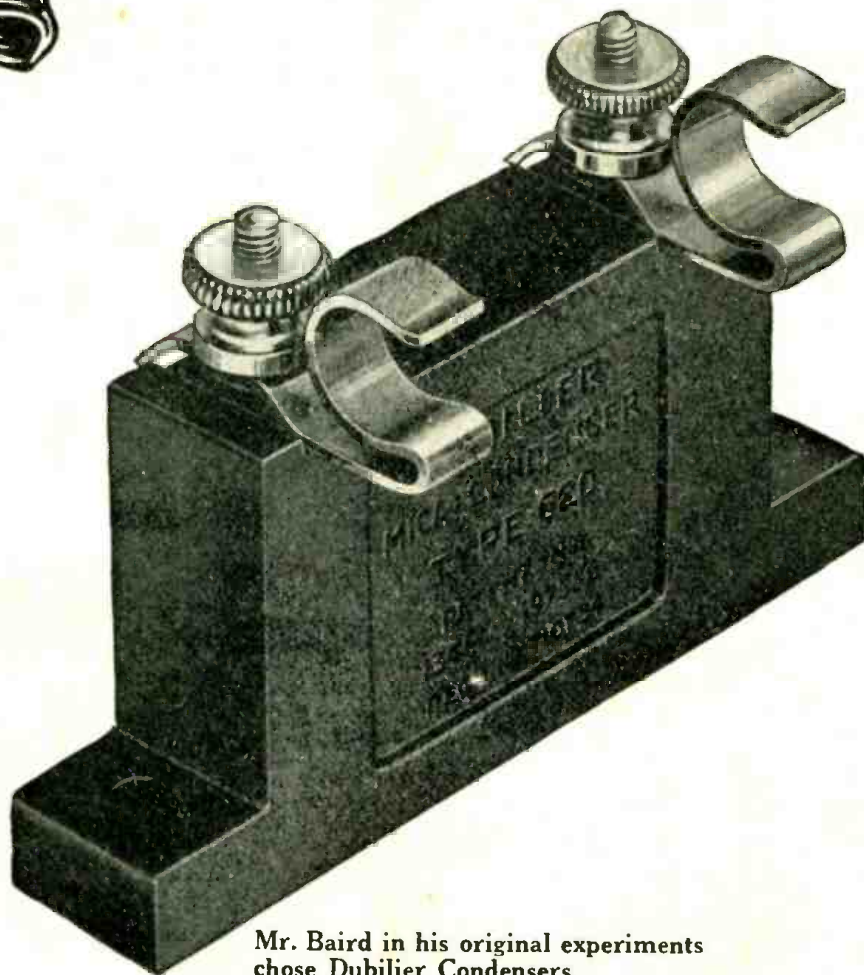

Mr. Baird in his original experiments chose Dubilier Condensers.

You cannot do better than follow his example.

Sheer superiority in design and materials has put and kept Dubilier Condensers at the top of the tree ever since Radio Sets were first constructed.

That explains why there are more Dubilier Condensers sold than there are all other makes put together.

Put your trust in Dubilier Condensers.

DUMETOHM CLIPS.

Both 610 and 620 condensers between the capacities of 0.00005 and 0.0005 mfd. are supplied with a pair of detachable Dumetohm grid leak clips (as shown) as well as with an insulated terminal clip for series mounting.

TYPES 610 & 620.

Capacities.	Prices
0.00005 to 0.0009 mfd.	2 6
0.001 to 0.006 "	3 -
0.007 to 0.009 "	3 6
0.01 mfd. ..	4 -
0.015	4 6



Advr. of the Dubilier Condenser Co. (1925) Ltd.

Ducon Works, Victoria Rd., North Acton, W.3

T.C. 101

Printed by HAZELL, WATSON & VINEY, LTD., 52, Long Acre, London, W.C. 2. and published for the Proprietors, TELEVISION PRESS, LTD., 26, Charing Cross Road, London, W.C. 2, by THE ALDINE PUBLISHING CO., LTD., Crown Court, Chancery Lane, London, W.C. Address for advertisements, "TELEVISION" ADVERTISEMENT DEPT., 63, Lincoln's Inn Fields, London, W.C. 2. Sole Agent for U.S.A., INTERNATIONAL NEWS. Registered for transmission by Canadian Magazine Post.