

Lawrence H. Davis

PF
PHOTOFACT[®]

INDEX

APRIL • 1954

the monthly
REPORTER
for the **ELECTRONIC**
SERVICE INDUSTRY

25 CENTS



PORTABLES

No. 1

CHOICE

of service technicians for

TV CONTROLS*



*Not Claims! Not Predictions!
But Plain Facts! More Service
Technicians prefer IRC TV Controls
than the next 2 brands combined.
Proved by unbiased, authoritative,
independent surveys.*



**ASK FOR *IRC* TV CONTROLS...
MOST SERVICE TECHNICIANS DO!**



INTERNATIONAL RESISTANCE COMPANY

423 N. Broad Street, Philadelphia 8, Pa.

Wherever the Circuit Says 

In Canada: International Resistance Co., Ltd., Toronto, Licensee

TELL YOUR CUSTOMERS THIS TV TRUTH

"Why pay more? You don't have to buy a new set. You don't have to pay a high premium for UHF reception on a new set. On your present set you can get ^{all} UHF Channels for ONLY \$19.95 with a genuine Regency CONVERTER - no costly installation - perfect reception with a Regency \$19.95 CONVERTER."

Learn this TV truth yourself - there's more profit in low cost, volume conversion.

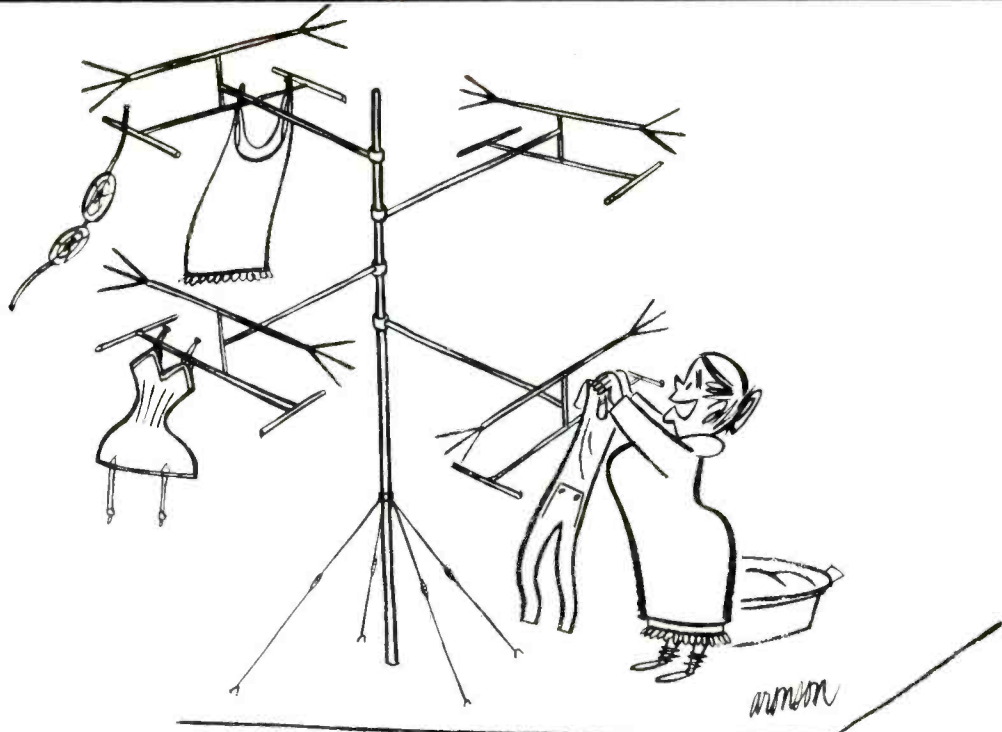

DAD THOUGHT THIS ANTENNA
WOULD HELP, BUT ALL WE NEEDED
WERE SPRAGUE CAPACITORS!

Don't Be Vague... Insist on SPRAGUE

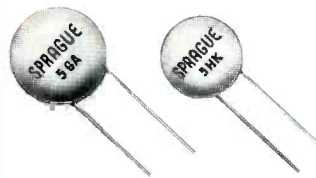

Insist on Sprague CERAMICS

Tiny, tough, dependable... in every application... whether discs, plates, buttons, or door knobs. And there's a Sprague ceramic capacitor to meet every service need. You give your customers dependable service, guard yourself against costly call-backs, when you use only Sprague Ceramic capacitors.



Insist on Sprague TWIST-LOK* 'LYTICS

Sprague TVL's fill the top performance bill in the toughest TV circuits. High temperatures, surge voltages, ripple currents won't faze them. Like all Sprague capacitors, Twist-Lok 'Lytics are your first line of defense against expensive call-backs.



Insist on Sprague BLACK BEAUTY® TELECAPS®

The most imitated capacitor Sprague ever introduced. But you get Sprague performance only when you insist on Sprague Telecaps. Hundreds of millions are in use today as first choice of quality conscientious manufacturers and servicemen. It's the premium molded tubular at no extra cost.

Accept no substitutes. There is a Sprague Distributor in every sales area in the United States. Write for the name of your nearest source of supply today.

☆ Trademark

SPRAGUE

Get your copy of Sprague's latest radio and TV service catalog C-609. Write Sprague Products Company*, 105 Marshall St., North Adams, Mass.

*Distributors' Division of Sprague Electric Company

**WORLD'S LARGEST
CAPACITOR MANUFACTURER**

JAMES R. RONK
Editor
LESTER H. NELSON
Managing Editor
W. WILLIAM HENSLER
Technical Editor

Editorial Staff

PHYLLIS J. AUKERMAN
WILLIAM E. BURKE
HENRY A. CARTER
ROBERT B. DUNHAM
JAMES M. FOY
DON R. HOWE
FRED McKINNEY
GLENN M. McROAN
EVELYN S. MOUSER
MARGARET NEFF
C. P. OLIPHANT
GLEN E. SLUTZ
PAUL C. SMITH
ANTHONY M. ANDREONE
Art Director
GLENN R. SMITH
Staff Artist
ROBERT W. REED
Photography

ARCHIE E. CUTSHALL
DOUGLAS G. BOLT
HARRY A. MARTIN
Production

★
HOWARD W. SAMS
Publisher

Business Department:
Donald B. Shaw, V. P.
Treasurer
F. T. Dobbs, Secretary
Joe H. Morin, Sales Mgr.
Ann W. Jones, Advertising
Shirley A. Owens, Literature
Service Mgr.
J. C. Keith, V. P.
Charge of Circulation

Printed by
THE WALDEMAR PRESS
Joseph C. Collins, Mgr.

Eastern Representatives
Paul S. Weil and
Donald C. Weil
39-01 Main Street,
Flushing 54, New York
Independence 3-9098



the monthly
REPORTER
for the ELECTRONIC
SERVICE INDUSTRY

VOL. 4 • NO. 4

APRIL • 1954

CONTENTS

Shop Talk	Milton S. Kiver	5
Antenna Principles	Don R. Howe	7
Understanding Receiving-Tube Operation	William E. Burke	10
How Much Is Your Labor Worth?	James M. Foy	13
UHF (Circuits and Equipment for UHF Reception)	Glen E. Slutz	15
Audio Facts	Robert B. Dunham	17
It's Time for Portables	Henry A. Carter	18
Examining Design Features	Don R. Howe	23
In the Interest of Quicker Servicing	Henry A. Carter	25
A Universal Substitute Speaker		29
Notes on Test Equipment	Paul C. Smith	31
Auto Radio Servicing Can Be Profitable	Henry A. Carter	37
Dollar and Sense Servicing	John Markus	39
A Stock Guide for TV Tubes		63
+ More or Less —		88

SUBJECT REFERENCE

ANTENNAS AND ACCESSORIES		
Belden 8275 UHF-VHF Lead-In	87	
Broadband Dipoles	53	
Folded Dipole	53	
Half-Wave Dipole	7	
Parasitic Antennas (Yagis)	53	
Wave Propagation	7	
AUDIO		
McIntosh Model C-108 Audio Compensator	17	
Motorola Speaker	85	
RADIO		
Aircastle Model 610.FE-153 Auto Radio	23	
Auto Radio Servicing	37	
Browning Model RJ-42 (Tertiary IF Winding)	83	
Heterodyne Filters	23	
SERVICING		
Condensation on Picture Tubes	41	
Germanium Diodes	43	
Labor Charges	13	
Parts Cabinets	41	
Signal Polarity	5	
Substitute Speaker	29	
Vertical Linearity Troubles	25	
Vertical Retroce Blanking	68	
TELEVISION		
Admiral Chassis 23A1 (Dual Power Supply)	83	
Granco UHF Converter Model LCU	15	
Granco UHF "Hide-Away" Converter	86	
Sylvania Chassis 1-513-1, -2, -3, -4	84	
Techmaster UHF Converter Model TV101-U	86	
TEST EQUIPMENT		
Hickok Model 650 (Conversion for Color TV Servicing)	31	
Hickok Model 695 Television-FM Sweep Generator	75	
Jackson Model CRO-2 Oscilloscope (Sync Polarity Reversal)	33	
Triplet Model 3423 Tube Tester (Testing Selenium Rectifiers)	74	
TUBES		
Amplification Factor	72	
Plate Resistance	11	
Relationships Between Tube Constants	73	
Special Construction in Tubes	74	
Transconductance	73	
Tube Operation	10	

Copyright by Howard W. Sams & Co., Inc.
No part of the PF INDEX may be reproduced without written permission. No patent liability is assumed with respect to the use of information contained herein.

The PF INDEX is published monthly by Howard W. Sams & Co., Inc., 2201 East 46th Street, Indianapolis 5, Indiana. The PF INDEX is on sale at 25¢ a copy at 1093 jobbers of Electronic Parts throughout the United States and Canada. (In Canada 30 cents.) When available, back numbers may be obtained by sending 35¢ for each copy desired. Acceptance under Section 34.64 P. L. & R. authorized at Indianapolis, Indiana
SUBSCRIPTION DATA: For those desiring the convenience of delivery to their homes or shops, each issue of the INDEX will be mailed direct, promptly upon publication. The subscription charge is \$4.00 annually in the United States and U. S. possessions.

Bill Clemens says—

Midget Radio Service (a 3-Man Shop)
129 S. Elizabeth St., Lima, Ohio

**"TRIPLLETT 660 saves us
50 to 100 man hours
per month."**

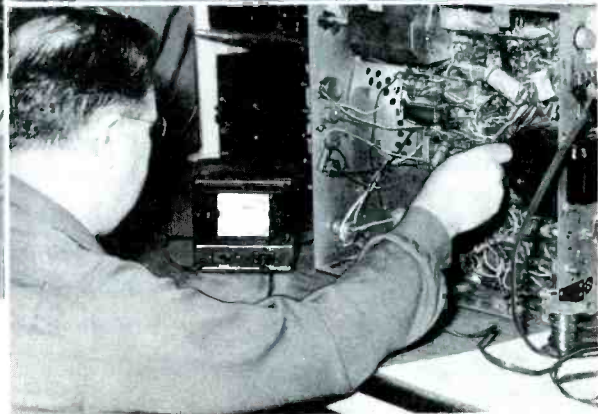
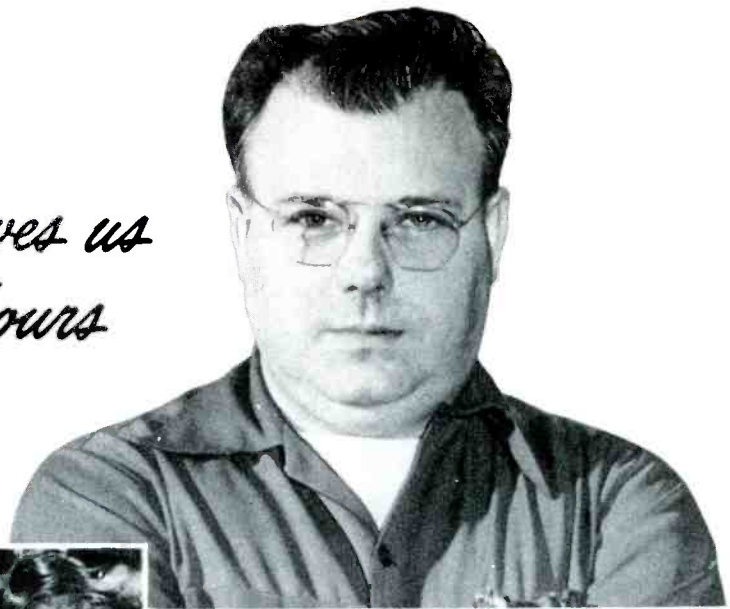

1. ISOLATING THE TROUBLE—Plug the power cord of the chassis into LOADCHEK and note the reading. With your eye on the large meter remove the rectifier tube and you can tell immediately which side of the tube the trouble is on. You have already eliminated 50% of your probing time.

2. LOCATING THE SHORT—With Loadchek you can quickly check the shorted side, part by part, without laying down tools or picking up test leads. Here, the trouble was a short in the transformer, spotted without having to warm up set. Overloads are found the same way.

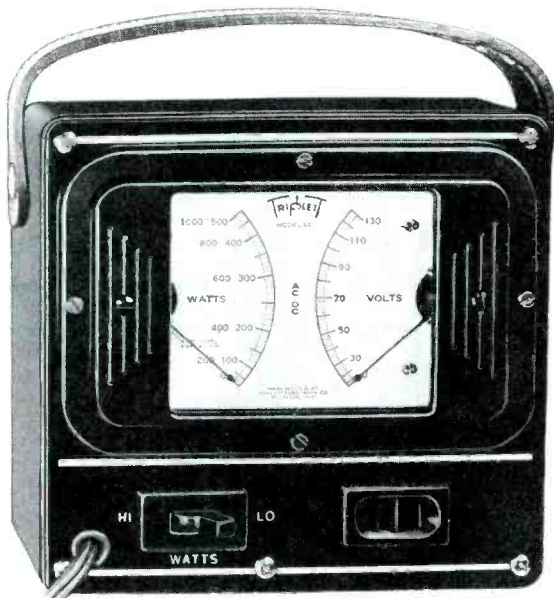

Locates trouble in a hurry

The above pictures illustrate but one of the many time-saving uses of Triplet 660 Loadchek. This versatile instrument accurately measures power consumption, enables you to see instantly any deviation from normal load, without disconnecting a single part... finds trouble in a hurry.

For Radio and TV servicing—for almost any kind of electrical trouble-shooting—LOADCHEK saves hours of painstaking work every day. At its moderate cost no service technician can afford to be without it. Try one today—and see! Write for free booklet.

TRIPLLETT ELECTRICAL INSTRUMENT CO., BLUFFTON, OHIO, U.S.A.



Triplet

Suggested U. S. A. DEALER NET \$29⁵⁰
Price subject to change without notice.

ShopTalk

MILTON S. KIVER

President, Television Communications Institute

Signal Polarity

Do you have trouble determining what the correct signal polarity should be at points beyond the second detector in a television receiver? Knowing this polarity is useful information for receiver servicing or circuit tracing, and the polarity is not very difficult to determine if you go about it in the right way.

Signal polarity can be expressed in several ways. The most common and the simplest method to use is the notation of sync pulse positive (Fig. 1A) and sync pulse negative (Fig. 1B). This indicates the direction in which the sync pulses are pointing, up for positive and down for negative. Another notation which has also been used refers to the signal polarity in terms of positive and negative picture phases. This is based on the polarity a signal must have to be properly applied to the control grid of the picture tube. If the signal is in the form shown in Fig. 1A, then it would not be suitable for such application and it would be said to possess a negative picture phase. Conversely, if the values are reversed, as shown in Fig. 1B, then this signal could be applied to the grid for proper picture presentation and we say that the signal is in the positive picture-phase form. In other words, the control grid of the picture tube is our

reference. When a signal possesses the proper polarity for application to this element, it is said to possess a positive picture phase; otherwise it is in the negative picture phase.

In the circuit tracing of a receiver, we can determine what the correct signal polarity is at any point beyond the video second detector by using any one of a number of so-called reference points. First and foremost is the picture tube itself. Which element, control grid or cathode, is receiving the video signal? If the signal is applied to the grid, then the sync pulses must represent the most negative portion of the signal. In other words, we have a sync pulse negative signal or one which possesses a positive picture phase.

If the video signal goes to the cathode, the sync pulses must represent the most positive portion of the signal. This follows from the fact that a positive voltage at the cathode is equivalent to a negative voltage at the grid, and the sync pulse portion of the signal must be negative at the grid in order to drive the tube into cutoff.

If you do not happen to be near the picture tube when you wish to determine signal polarity in a certain circuit, there are other reference points in the receiver. For example,

most vertical-deflection systems employ a blocking oscillator; and to trigger this circuit effectively, positive vertical sync pulses are required. Therefore, you can start at the grid of the blocking oscillator with the assumption that the sync pulses at that point are positive and work back through the circuit to whatever point you wish.

Another suitable reference point is at the grid of a keyed AGC tube. In order for this stage to provide AGC voltage, a positive sync pulse must be provided at the grid at the same time that a positive triggering pulse reaches the plate from the horizontal-output transformer. Knowing the sync pulse is positive at the grid then enables you to work back from the grid.

The foregoing might be termed primary reference points because they are the easiest to deal with. However, there are other points which we could call secondary reference points. For example, there is the video second detector where signal polarity first becomes important. As a general rule, if the signal from the video IF system is applied to the cathode of the detector tube, the signal polarity at the detector output is sync pulse negative. On the other hand, if

* * Please turn to page 67 * *

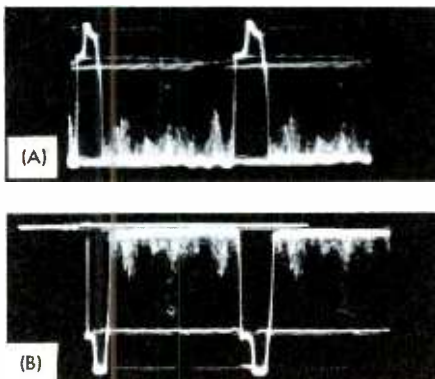

(left)
Fig. 1. A Video Signal with the Sync Pulses (A) Most Positive and (B) Most Negative.

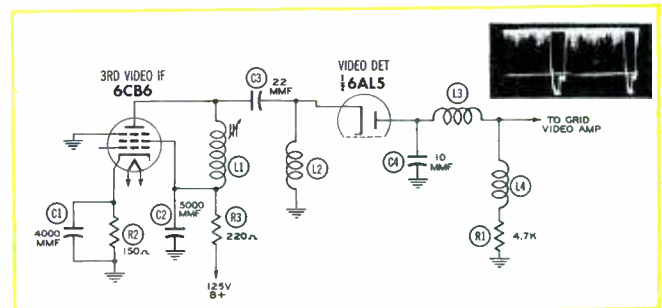

Fig. 2. In This Video Detector Circuit, the Output Video Signal Will Be Sync Pulse Negative.

\$50,000 "TELL & SELL" CONTEST

400 FABULOUS PRIZES

For Dealers and Servicemen* who use RCA Tubes

1954 Dodge, Deluxe 1/2-Ton Panel Truck
—complete with "Truck-o-matic" transmission, radio, heater and accessories . . . plus a full set of RCA Test Equipment, aluminum ladder, and winner's business name and address on truck panel.

1st prize
(your choice)



1954 DeSoto Automatic "Hard-Top"—170-H.P. Fire Dome V8 engine, Power-Flite Transmission, Power Steering . . . completely equipped, including radio and heater.

HURRY, HURRY, HURRY . . . contest closes April 30, 1954. See your RCA Distributor Salesman right away, and get your copy of the "clue book" that includes complete contest rules, official entry blank, and clues that will help you win.

* Your RCA Distributor Salesman will be glad to help you . . . because if you win, he wins a duplicate prize!

PLUS Powerful promotion campaign to help you sell more in '54

The RCA "Tell and Sell" campaign was designed to help you sell your service on a local level. Everything you need, from giant illuminated signs and window displays, to a consumer booklet that will give your customers the facts of TV servicing—is available from your RCA Distributor. See him today!

Consumer Booklet
Tells the customer what is needed to bring him expert service. Points you out as "the man who keeps the show going."

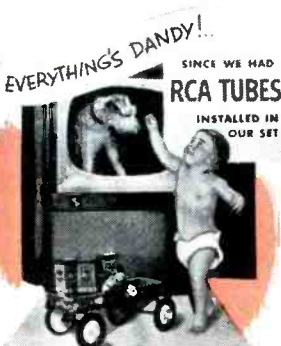

1954 RCA BABY DISPLAY



NEW GIANT OUTDOOR SIGN



NEW RCA SERVICE DECAL



RCA DOOR-BELL FLIPPER



DRAMATIC "EDGE LIT" SIGN

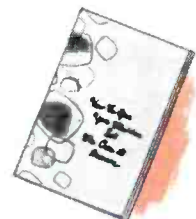

RCA TUBE RACK



RADIO CORPORATION of AMERICA
ELECTRON TUBES
HARRISON, N. J.

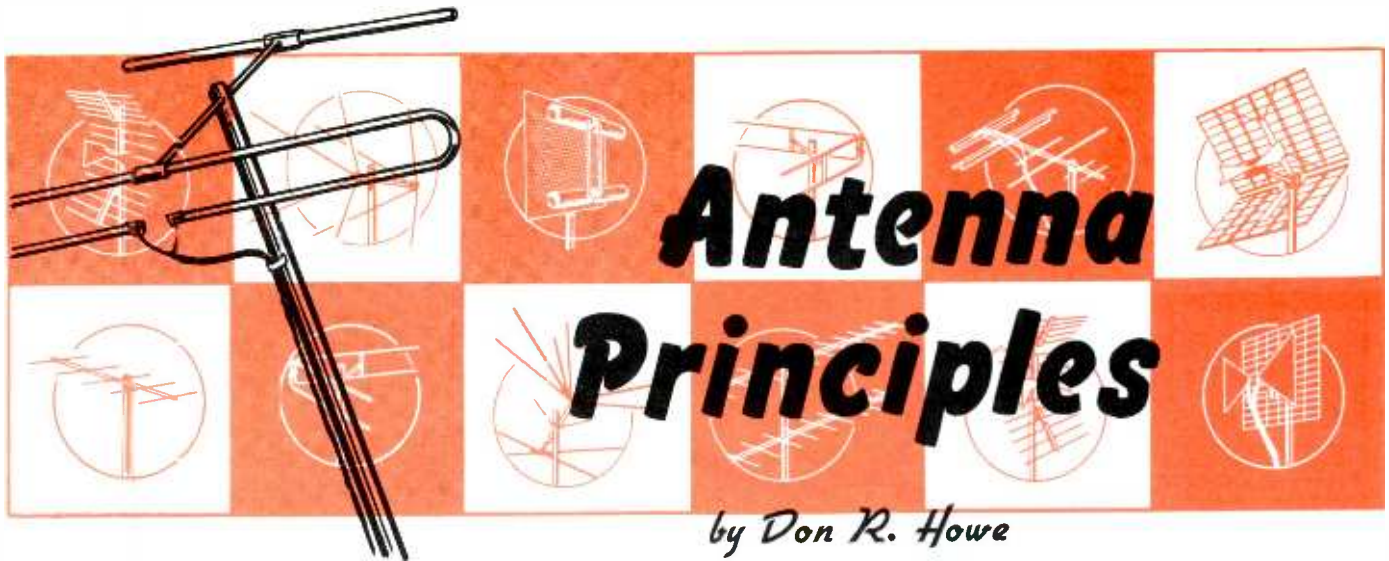

Antenna Principles

by Don R. Howe

Basic Facts About Radio Waves and Elementary Antenna Types Used in Their Reception

THE RADIO WAVE AND PROPAGATION

The purpose of a receiving antenna is to collect electromagnetic energy from space. This electromagnetic energy is in the form of a radio wave from a transmitting station. It is therefore important that we understand some of the characteristics of this radio wave before considering the antenna.

The energy in a radio wave is contained in two fields, a magnetic and an electrostatic field. These two fields are at right angles to one another, as shown in Fig. 1. The direction of these fields, as indicated by the arrows, is reversed at the end of each half cycle. Every propagated radio wave contains both fields, because one field in a traveling wave cannot exist without the other.

The polarization of a radio wave is determined by the relative position of the electrostatic lines of force. When these lines of force are horizontal with respect to the earth, the wave is said to be horizontally polarized. Vertical polarization exists when these lines are perpendicular to the earth's surface. For an antenna to give maximum performance, its polarization must correspond to the polarization of the received signal. It is therefore necessary for the polarization of the received signal to be known. This problem is simplified by the acceptance of a standard which specifies that all television signals should be transmitted with horizontal polarization.

Consideration must be given to some of the salient points with regard to the propagation of television signals. UHF and VHF signals rely primarily on a line-of-sight path. Other paths of propagation are provided by ground reflection, by refraction, and by sporadic E-layer reflection. When a radio wave is reflected from the ground, a phase shift is introduced at the point of reflection. An additional phase shift results because the reflected signal travels a greater distance than the direct signal. A reflected signal and a direct signal may arrive at an antenna in such a way that they will either cancel or reinforce each other. An example of this effect is the presence of nulls and peaks as an antenna is tried at several heights.

Refraction of the radio wave is a bending which may result in reception beyond the horizon. This refraction is caused by a change in the dielectric constant of the atmosphere. A variation of water-vapor content in the air and changes in the atmospheric temperature and density are factors responsible for deviation in the dielectric constant. Conditions of refraction are continually varying and therefore cannot be relied upon for reception.

The sporadic E-layer consists of scattered areas of high ionization in the atmosphere. When the ionization becomes sufficient, radio waves may be reflected back to earth. A higher-frequency signal will be reflected as the ionization increases; however, reflections from the sporadic E-layer are not believed to occur much above 100 megacycles. This limits effects of these reflections to the low VHF channels. Reflections of this type are extremely erratic and are even less reliable than the conditions of refraction.

A television signal may also be refracted by another phenomenon. This refraction occurs because of temperature inversion, which occurs when a layer of warm air is above a layer of cool air.

A well-defined boundary may then exist between the two layers. The amount of refraction that takes place at this boundary will be dependent upon the frequency of the signal as well as upon the degree of difference between the refractive indexes of the two layers. The refractive index is defined as the square root of the dielectric constant of a particular volume of air.

THE ANTENNA

Half-Wave Dipole.

A half-wave antenna is one of the very basic types. Perhaps the most frequently encountered half-wave antenna is the center-fed antenna or dipole. A great majority of the more complicated television antennas are basically dipoles with refinements to improve their directional characteristics and gain. It is therefore necessary for any analysis of television antennas to be based

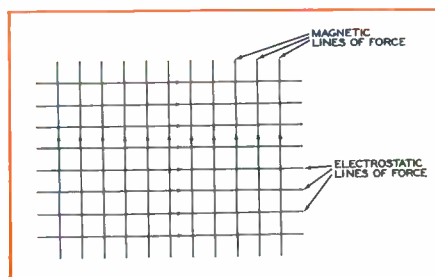
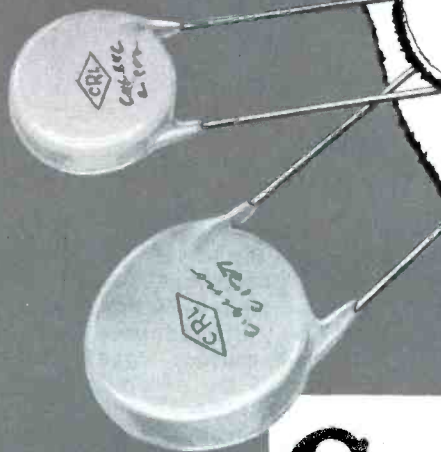
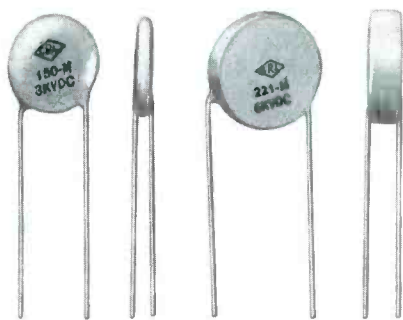

Fig. 1. Relationship of Magnetic and Electric Fields in a Radio Wave.



Centralab announces

new **HI-VO-DISC*** capacitors



DD30

DD60

3000-VDCW and 6000-VDCW discs that are highly efficient as bypass and coupling capacitors in high-frequency circuits under conditions of extreme humidity or temperature

Centralab does it again — gives you and your customers more for your money in two new series of high-voltage disc capacitors. You'll agree that they're tip-top additions to the world's greatest line of ceramic capacitors.

Every unit in both the DD30 and DD60 series is tested at twice rated working voltage. So you know you can count on them for high capacity and performance up to 85° C.

There are other reasons why these CRL Hi-Vo-Discs help end profit-robbing call-backs: The heavy, special phenolic insulation has triple-high-temperature wax impregnation. Tolerances are held to $\pm 20\%$.

CRL Hi-Vo-Discs are conveniently packaged five to an envelope, 25 to a carton. Keep a supply of them on hand. Get them from your Centralab distributor.

Centralab

A DIVISION OF GLOBE-UNION INC.
Milwaukee 1, Wisconsin
In Canada
804 Mt. Pleasant Rd., Toronto 12, Ontario

Write for Catalog Sheet 28-2

Complete information on Centralab's 3000- and 6000-volt Hi-Vo-Discs.

Write for your copy to CENTRALAB, A Division of Globe-Union Inc., 942D E. Keefe Avenue, Milwaukee 1, Wisconsin.

*Trademark

D-2154

upon a thorough understanding of the dipole.

The voltage and current distribution in a dipole can be more easily understood by first referring to a quarter-wavelength transmission line which has a generator connected to it. See Fig. 2A. This quarter-wavelength line appears the same to the generator as the series resonant circuit in Fig. 2B. The currents in each leg of the line are flowing in opposite directions; consequently, the fields set up around the conductors tend to cancel one another. The line would therefore be a very inefficient antenna. By moving the two legs individually 90 degrees so that they fall in a straight line, as shown in Fig. 2C, the currents can be caused to flow in the same direction and the fields will no longer cancel each other. The conductors then form a dipole antenna.

The voltage present on the dipole is maximum at the ends of the antenna and minimum at the center. Since the voltage and the current are 90 degrees out of phase in a dipole antenna, the current will be maximum at the center and minimum at the ends of the antenna.

A maximum transfer of energy from the antenna to the lead-in cannot be accomplished unless the impedances are properly matched. Some thought should therefore be given to the impedance characteristics of the dipole. The minimum impedance of the antenna will be at the center where the current is maximum. The impedance at the center is approximately 73 ohms. As the feed point is moved toward the ends of the antenna, the impedance increases. This intrinsic property is utilized in some systems of matching lead-ins to dipole antennas.

Field patterns are of valuable assistance in determining antenna characteristics. Two patterns are usually required to gain an accurate

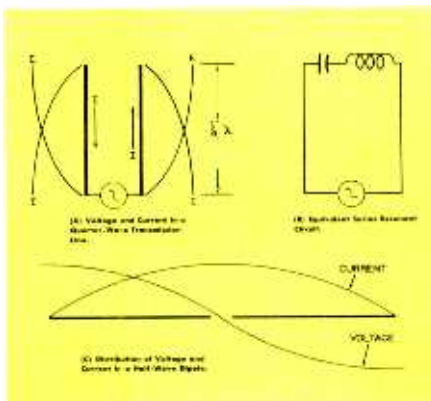

Fig. 2. Development of a Half-Wave Antenna.

picture of an antenna. One pattern reveals the horizontal directivity, and the other pattern is required for vertical directivity. The development of such a pattern is more easily understood by first considering the antenna as radiating a signal. If measurements were made and an infinite number of points having the same signal strength were located, a three-dimensional figure would be obtained, such as that shown in Fig. 3A. The cross section obtained by passing the plane A-A' through the three-dimensional figure would reveal the horizontal directivity of the antenna. This cross section is normally illustrated as shown in Fig. 3B. The vertical directivity is developed in a like manner by passing plate B-B' through the figure. The resultant pattern is shown in Fig. 3C.

Fig. 3B shows that maximum pickup is obtained from a direction at right angles to the antenna. The relative lengths of the arrows C and D indicate how much greater the signal would have to be from an angle of 60 degrees when compared to an angle of 90 degrees. This pattern also shows that the antenna is bi-directional. This means that the antenna will perform equally well in two directions. The antenna is non-directional in the vertical plane, as indicated in Fig. 3C. In this case, the arrows E and F are of the same magnitude.

These patterns were developed by considering the antenna as radiating a signal. The same patterns are valid for receiving, because the antenna has the same characteristics. This situation is known as antenna reciprocity and is true for all types of antennas.

It is important to know how an antenna of this type will perform at frequencies where it no longer constitutes a half wavelength. As the frequency increases over the design frequency, the reactance of the antenna increases. The input resistance also increases; and the input impedance of the antenna, since it is the vector sum of these two quantities, increases in a like manner. The change in input impedance causes a mismatch between the antenna and the lead-in and results in a very inefficient system.

The frequency response of the dipole may be broadened somewhat by increasing the diameter of the conductors. Making the diameter of the elements larger causes the capacitance per unit length to increase and causes the inductance per unit length to decrease. This results in a lowered L/C ratio and a corres-

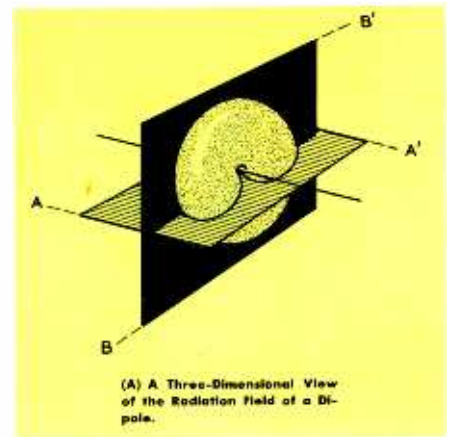

(A) A Three-Dimensional View of the Radiation Field of a Dipole.

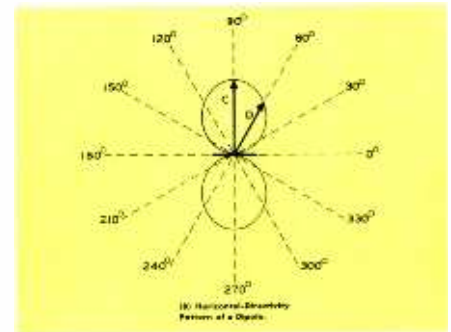

(B) Horizontal-Directivity Pattern of a Dipole.

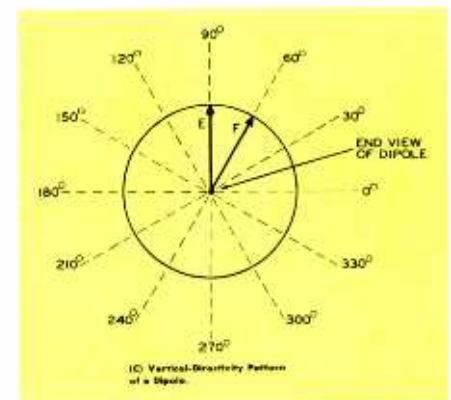

(C) Vertical-Directivity Pattern of a Dipole.

Fig. 3. The Derivation of Directivity Patterns.

ponding decrease in the Q of the antenna. The response curve of the antenna will become broader, and an increase in bandwidth will be obtained. The graphs of Fig. 4 show how the input impedance will vary as the frequency is changed and also how an increase in conductor diameter will result in a smaller change of impedance with a change in frequency. It may be noted from the graphs that the impedance changes according to a repetitive cycle. At odd multiples of a half wavelength, the impedance returns to approximately the value of a single half-wave dipole.

The input impedance does not constitute the only variable when the

* * Please turn to page 52 * *

UNDERSTANDING RECEIVING TUBE

OPERATION

by

WILLIAM E. BURKE

Relationships Between Physical and Electrical Properties of Tubes Used in Radio and Television Reception

The flow of current in any vacuum tube is not a random process. It follows a pattern governed by the geometry of the tube and by the materials used in its construction. The term geometry refers to the separation and placement of the electrodes and to the size and shape of all of the various parts. These are details which determine the maximum voltages that can be applied to the electrodes, the maximum plate current that the tube will carry, the voltage gain that the tube will provide, and other related electrical factors. For any one tube, these factors are expressed as a group of numbers and are labeled as tube constants.

The study of the derivation of tube constants is only a small portion of the entire science of vacuum tubes, but it should be capable of imparting some knowledge to the service technician to aid in increasing his rate of servicing. This knowledge should help the service technician in determining the intended function of a faulty circuit and the reasons for tube failures, and it will also help in solving other troubles which concern the tubes in a receiver.

The average worker in the electronics field should consider more than the outward appearance of vacuum tubes. Why will one type of tube work in a certain circuit whereas another type will not work? Why does one have to be replaced more often than another which looks similar? The service technician should know the answers to these questions and to others like them.

The multitude of tube types required in electronics has resulted in superficial resemblances among the various ones. These may be identical in outward appearances, yet the internal physical construction and electrical characteristics can vary over wide limits. An example of this outward resemblance and internal difference can be seen in Fig. 1. The

bulb types, bulb sizes, the base types, and even the base connections of the two tubes are identical even though the 6AG5 is an RF pentode having a very small power output and the 6AN5 is a beam-power amplifier having a power-output rating of 1.3 watts. Thus, it seems that not all the information concerning a tube can be derived from outward appearances.

There are two possible sets of conditions under which any vacuum tube can operate. These are labeled as static and dynamic. The term "static" implies that only DC potentials are applied to the tube electrodes, while the term "dynamic" describes the changing conditions encountered by the tube when a signal is applied. The latter term is the one which is of most interest to the service technician, for in a receiver the tube will be operating in the dynamic condition. The plate resistance of a tube, for example, may have two values; but the dynamic or AC value is the one that is stressed in this article.

There are many possible constants which can be used to describe the characteristics of any one tube, but three of these are of maximum interest to the service technician. These are: (1) the AC plate resistance, (2) the transconductance, and (3) the amplification factor. The AC plate resistance is a characteristic which is applicable to all tubes including diodes, while the other two constants apply only to tubes having three or more electrodes.

The operation of a vacuum tube depends upon a source of electrons and upon the establishment of a potential difference between a cathode and a plate. The function of the potential difference can be demonstrated by reference to Fig. 2. Two metal plates, C for cathode and P for plate, are shown; and it is assumed that no free electrons are present and that a potential difference exists be-

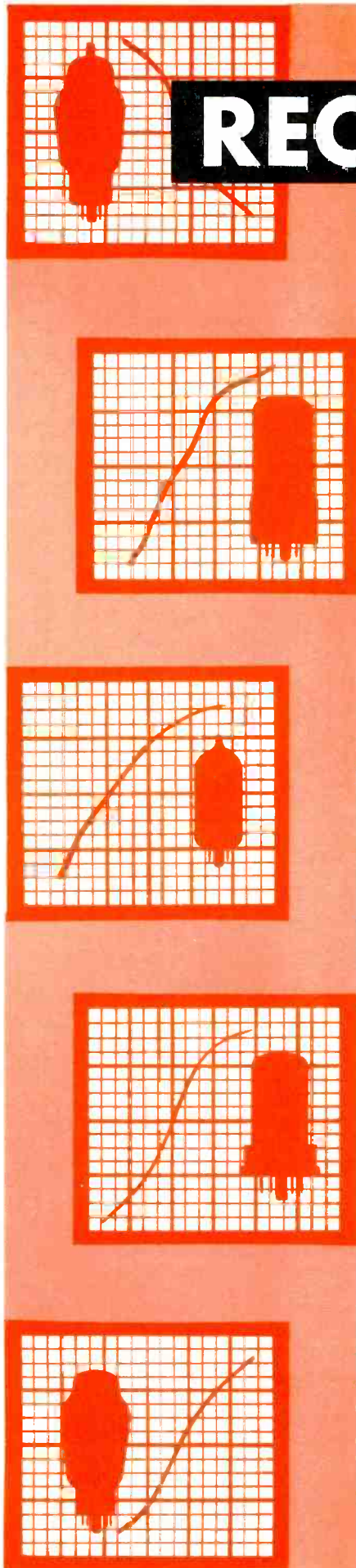

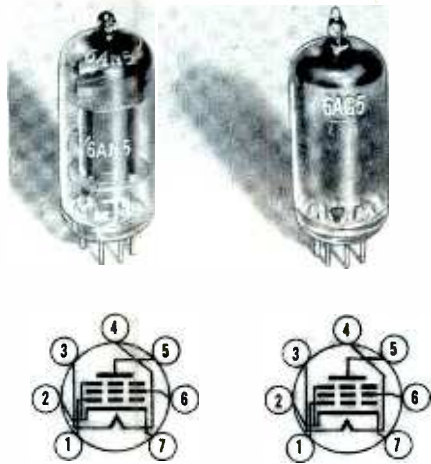

Fig. 1. Similarity in Outward Appearances of Two Electrically Dissimilar Tubes.

tween the plates so that P is positive with respect to C. When the two plates are of equal area, the potential level varies uniformly with distance. The dotted line (x) in the lower portion of the figure illustrates this uniform variation of potential. Actually in a vacuum tube, C has a comparatively small surface with respect to P, and therefore the potential changes much more rapidly near the cathode than near the plate.

Suppose for the moment that the plate potential is removed. The heating of the cathode by a filament will produce an emission of electrons from the cathode, and a space charge of these electrons will form near the cathode. This space charge will reach and maintain a state of equilibrium in which the number of electrons emerging from the cathode is exactly balanced by the number of electrons returning to the cathode. This is fundamental to all vacuum tubes, and the equilibrium will be maintained until some force is impressed on the electrons in the space charge. This will occur when a positive potential applied to the plate attracts electrons from the space charge. As a result the potential gradient is altered, as shown by curve (y); the potential gradient is much lower near C because most of the attractive field of P ends at the electrons in the space charge and never reaches the cathode. The cathode emission in an ordinary tube is always much greater than the plate current, and the potential of the space charge is negative; electrons traversing from cathode to plate must first overcome this negative field before being attracted to the plate. In this case, the potential gradient is represented by curve (z).

The potential gradient which exists in the tube when a grid is in-

serted is illustrated by Fig. 3. Curve (x) in Fig. 3 represents the potential gradient when there is zero potential on the grid. In this case the grid has no effect on the space charge, and the potential gradient is similar to curve (y) of Fig. 2. The potential of the grid can be made either positive or negative. If it were made positive, its potential with respect to the cathode would attract electrons from the space charge and would increase the electron flow to the plate. The combined potentials of grid and plate would produce the gradient curve of (y).

When the grid is made negative, its potential with respect to the cathode would augment the effect of the space charge and electrons leaving the cathode would be required to over-

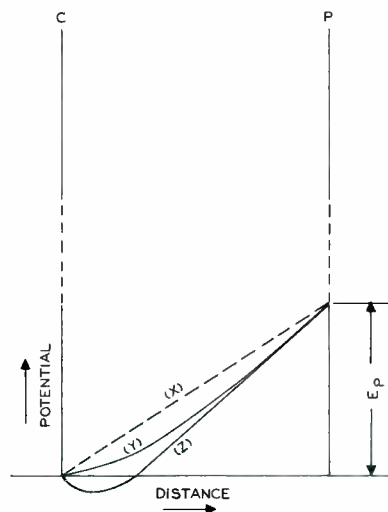

Fig. 2. Variation of Potential Distribution in a Diode Due to Space Charge.

come the combined potentials. Curve (z) represents an extreme case of this nature in which the potential gradient from C to G is so large that only a few electrons are capable of reaching the plate; the plate current will be practically zero in this case.

Plate Resistance, r_p

When a constant plate voltage is applied to a tube and plate current flows, a constant amount of power from the plate-voltage source is expended. This power is needed to move the electrons across the space between the cathode and the plate and is lost when converted into heat by the impact of the electrons as they reach the plate. Since the voltage applied to the tube does not produce an infinite current, as it would across a perfect conductor, the tube must have an internal resistance. By using Ohm's

law, we can calculate the internal resistance in this manner:

$$R_p = \frac{E}{I} \quad (1)$$

where

R_p = DC plate resistance,

E = known DC plate voltage,

I = measured plate current.

The result of this equation is a DC resistance which is a characteristic of all tubes. It is not a useful constant for it applies only to an instantaneous value of plate voltage and current and varies with different values of each. There is a second form of plate resistance which is more descriptive of the characteristics of a tube.

The AC plate resistance of a tube is defined as the ratio of a small change in plate voltage to the corresponding change in plate current when the grid voltage is constant. It is expressed by an equation:

$$r_p = \frac{\Delta E_p}{\Delta I_p} \quad (\text{when } E_g \text{ is constant}) \quad (2)$$

where

r_p = plate resistance,

ΔE_p = a small change in plate voltage,

ΔI_p = a small change in plate current,

E_g = grid voltage.

* * Please turn to page 71 * *

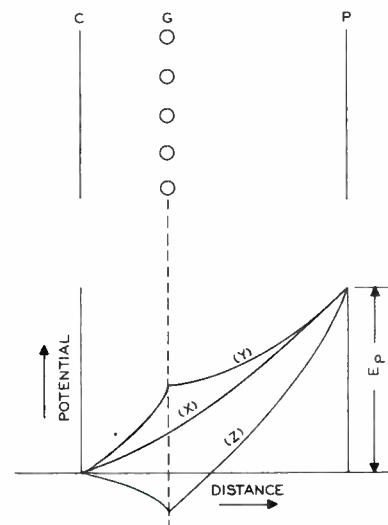

Fig. 3. Variation of Potential Distribution in a Triode Due to Grid Potential.



*Only One...
of its kind!*

NEW!

UNIQUE!

DIFFERENT!

WARD'S
Exclusive **TOWER-JACK**

• Now, WARD'S TOWER-JACK makes erecting Telescopic Masts a one man job. Just mount the antenna on the top section — and then raise it away. Each section is held firmly until secured with pin and guy-wires. WARD'S TOWER-JACK is then attached to the next succeeding sections until the mast is fully extended. Completely pre-assembled, the TOWER-JACK is easy to use... easy to carry from job to job. Handles any two-to-five section mast from 1 1/4" to 2 1/4" in diameter. Greatest time and money saver for telescopic mast erecting ever devised... Order your WARD TOWER-JACK today. Model TJ-1.

**Model
TJ-1**

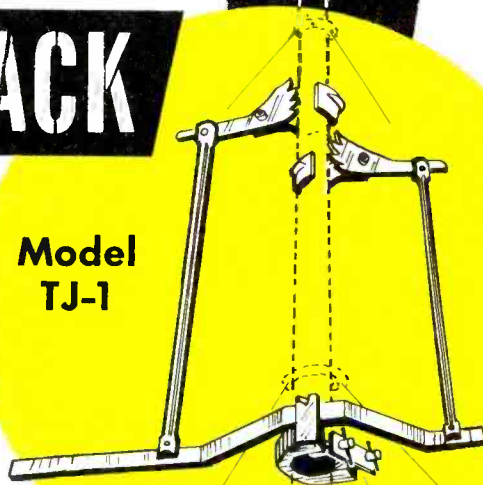

Shipping
Wt. 11 lbs.

WARD PRODUCTS CORP.

DIVISION OF THE GABRIEL COMPANY

1148 EUCLID AVE. CLEVELAND 15, OHIO

In Canada: Atlas Radio Co., Ltd., Toronto, Ont.





How Much

IS YOUR LABOR WORTH



by

JAMES M. FOY



A large number of radio and television service technicians have asked for guidance in the determination of their repair charges. What the specific charges should be cannot be answered in so many words, but some ideas that will aid in the computing of charges on a fair and equitable basis can be presented.

A service technician is primarily interested in making a reasonable charge for his time. A reasonable charge is one that will cover his cost and leave a margin of profit. If he charges too little, he will eventually be out of business; if he charges too much, he will lose customers' trade to competition. In either case the final result is the same.

The basic computation is the value of the technician's own time. It is suggested that this amount should be the amount per hour that he would be worth if he were working as a radio-television service technician for someone else. This amount will vary according to the wage scale in his own community. One other factor to be considered is his technical proficiency. One technician is able to do a skillful repair job in a short period of time. Another technician does the same job in a longer time. It is logical that the fast, accurate technician will be able to charge a higher hourly rate than the technician who works much slower. For the purpose of this illustration, let us assume that the basic value of time is set at \$1.50 per hour.

The next step is to estimate the overhead cost of doing business. This might be calculated on a monthly basis. The overhead costs are those that are not directly chargeable to any particular job. For an example of what these overhead burdens might be, see Chart I.

CHART I

Examples of Overhead Costs

Item 1.	Rent	\$50.00
Item 2.	Utilities	20.00
Item 3.	Heat	10.00
Item 4.	Office supplies and postage	10.00
Item 5.	Advertising expenses	20.00

Item 6.	Shop supplies	5.00
Item 7.	Depreciation of equipment	10.00
Item 8.	Operating cost of transportation	20.00
Item 9.	Miscellaneous expenses	15.00
	Total overhead for one month	\$160.00

Explanation of overhead costs listed in Chart I:

Item 1. Rent is a large variable; it depends upon the location of the shop in the community and upon many other factors. In selecting a figure to be used for illustration, it was intended for that purpose only and is not indicative of what the rent should be.

Item 2. Utilities cost. This refers to the average monthly amount paid for light, telephone, water, and other utilities.



Item 3. Heat. This is the average monthly amount spent. If \$120 worth of coal were purchased during the winter, this would average over the year at \$10 per month.

Items 4 and 5. Office supplies, postage, and advertising expenses. These are self-explanatory.

Item 6. Shop supplies. Solder, soldering paste, friction and rubber tape, assortment of nuts, bolts, and

* * Please turn to page 64 * *

Now... SOLDERING MADE TWICE AS EASY!

**FIRST, the Soldering Aid.
Now, the NEW CBS-HYTRON
SOLDER DISPENSER
makes soldering twice as easy.**

No more tangling with haywire coils of solder. Your thumb on knurled control wheel of unique Solder Dispenser feeds solder . . . retracts it neatly when job is done . . . without waste. A one-hand tool, Dispenser eliminates time out to unroll and straighten solder. Holds 72 inches of solder . . . a month's supply. It's compact . . . light . . . convenient . . . pencil-like . . . with handy pocket clip. Soldering becomes a pleasure with this time-and-money saver. Servicemen say, "Wouldn't be without it."

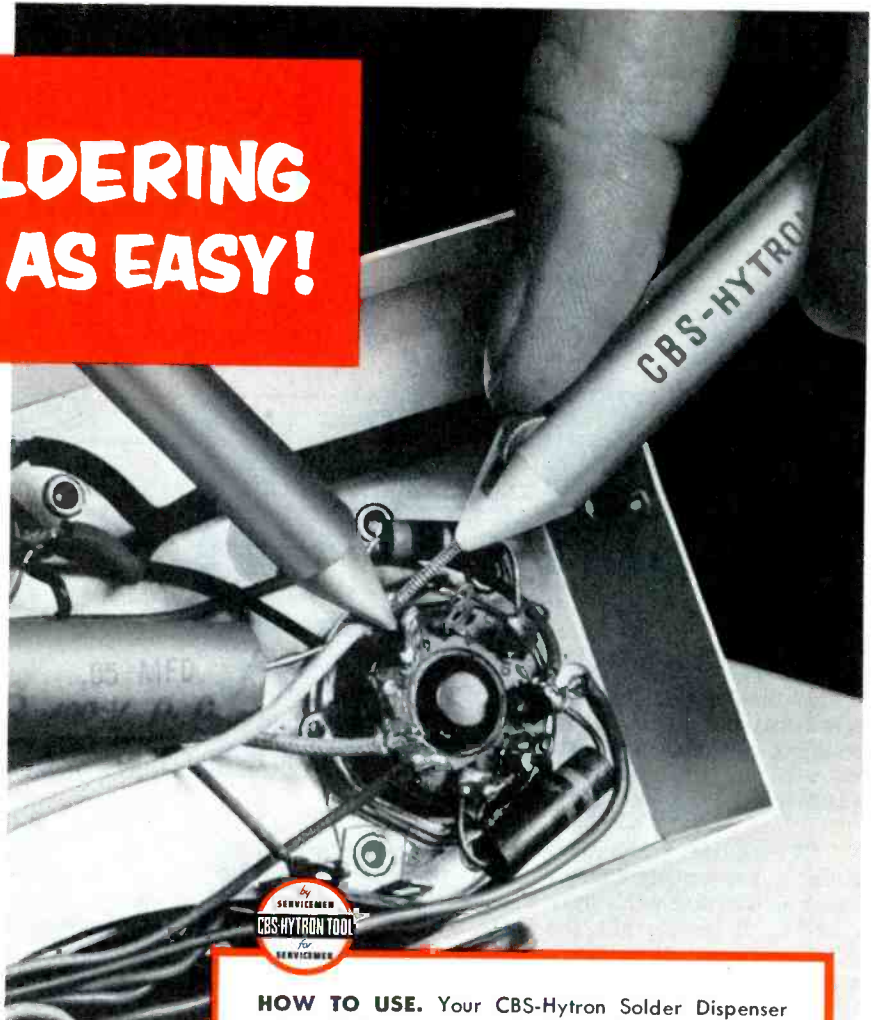

FREE . . . APRIL 15
THROUGH MAY 31

You can get this complete package free from April 15 through May 31. Your CBS-Hytron distributor will give you a free Solder Dispenser (loaded with 20 Refills) . . . and a plastic tube of 80 additional Refills. Enough to last 5 months.



HOW TO USE. Your CBS-Hytron Solder Dispenser comes ready to use . . . with 20 lengths of 0.050-inch, 40/60 activated rosin-core solder.

To start: Point Dispenser vertically downward. Shake a length of solder into position . . . at the same time rotating the knurled wheel toward you to begin the feed. Roll out an inch of solder and go ahead with the job. Need more solder? Just rotate the wheel with your thumb. When through, turn wheel away from you to draw unused solder back into Dispenser.

Knurled cap of Dispenser unscrews for refilling. Your package of 80 specially cut and sealed Refills gives you four months' supply. Plus the month's supply already loaded in the Dispenser.

Your new Solder Dispenser is fun to use . . . a natural companion to your Soldering Aid. And your Dispenser saves you time and money, too. Get yours today!

WITH YOUR ORDER FOR CBS-HYTRON TUBES . . . ONLY 75 RECEIVING OR 3 PICTURE TUBES

Just order 75 CBS-Hytron receiving tubes . . . or 3 CBS-Hytron picture tubes. Your CBS-Hytron distributor will give you this valuable, time-and-money saver . . . free. Remember, offer is limited to April 15 through May 31. And the unique Solder Dispenser and Refills are available *only* on this special offer.

ACT NOW!

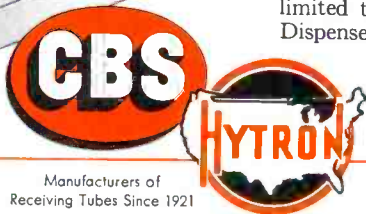

Manufacturers of
Receiving Tubes Since 1921

CBS-HYTRON Main Office: Danvers, Mass.

A Division of Columbia Broadcasting System, Inc.

A member of the CBS family: CBS Radio • CBS Television
Columbia Records, Inc. • CBS Laboratories • CBS-Columbia • and CBS-Hytron

RECEIVING • TRANSMITTING • SPECIAL-PURPOSE • TV PICTURE TUBES • CRYSTAL DIODES AND TRANSISTORS

**A description of circuits and equipment
 for Ultra High Frequency reception.**

by GLEN E. SLUTZ

UHF Converter Granco Model LCU

The UHF all-channel converter, Granco Model LCU shown in Fig. 1, is manufactured by Granco Products, Inc., of Long Island City, New York. This unit converts the UHF signal to a frequency which can be received on either a channel-5 or channel-6 setting of the television receiver with which it is used. The choice of channels 5 or 6 depends upon which of these channels happens to be unoccupied in the particular operating location.

Two front-panel controls are employed in the Granco Model LCU: (1) a function selector switch with OFF, VHF, and UHF positions; and (2) a tuning control. The unit features a slide-rule type of tuning dial. On the rear of its chassis, it has an



Fig. 1. Granco UHF Converter Model LCU.

AC socket for the TV set so that the television receiver may be turned on and off by the switch on the converter. With this setup, the ON-OFF switch on the receiver is left in the ON position at all times. In the VHF

position of the function switch on the converter, the unit is kept in a standby condition; and the signal from the VHF antenna is coupled to the antenna input terminals of the television receiver. In UHF position, the function switch sets the converter into operation and the output of the converter is fed to the TV receiver. At the same time the VHF antenna is disconnected, shorted, and grounded to prevent interference.

A schematic of the Granco Model LCU is presented in Fig. 2. The unit employs two capacitively tuned coaxial cavities — one for the preselector and the other for the 6AF4 oscillator. Both the preselector and the oscillator feed a 1N82 crystal-diode mixer, the output of which is amplified by a 6CB6 pentode. The power supply in the converter

* * Please turn to page 86 * *

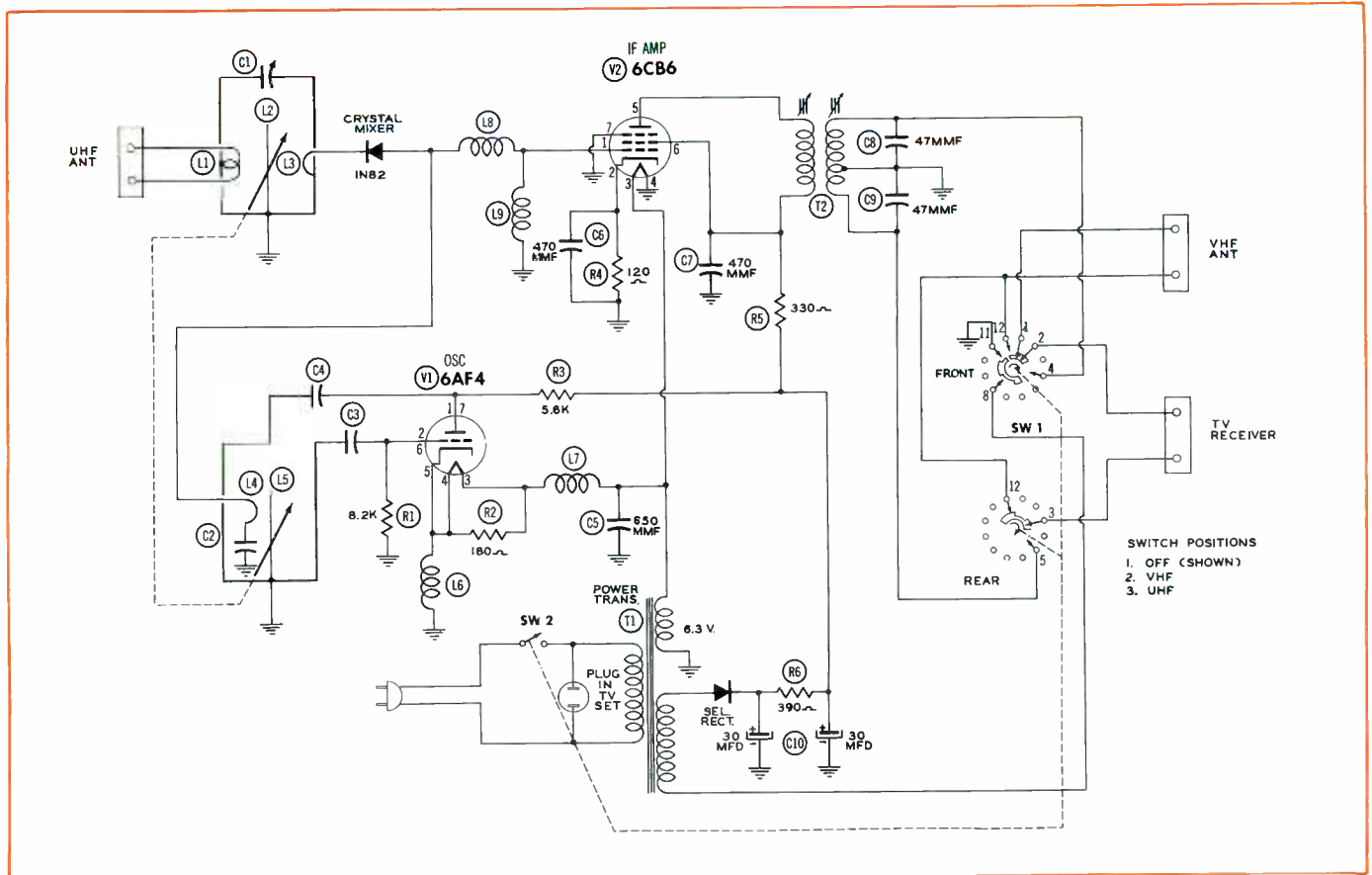
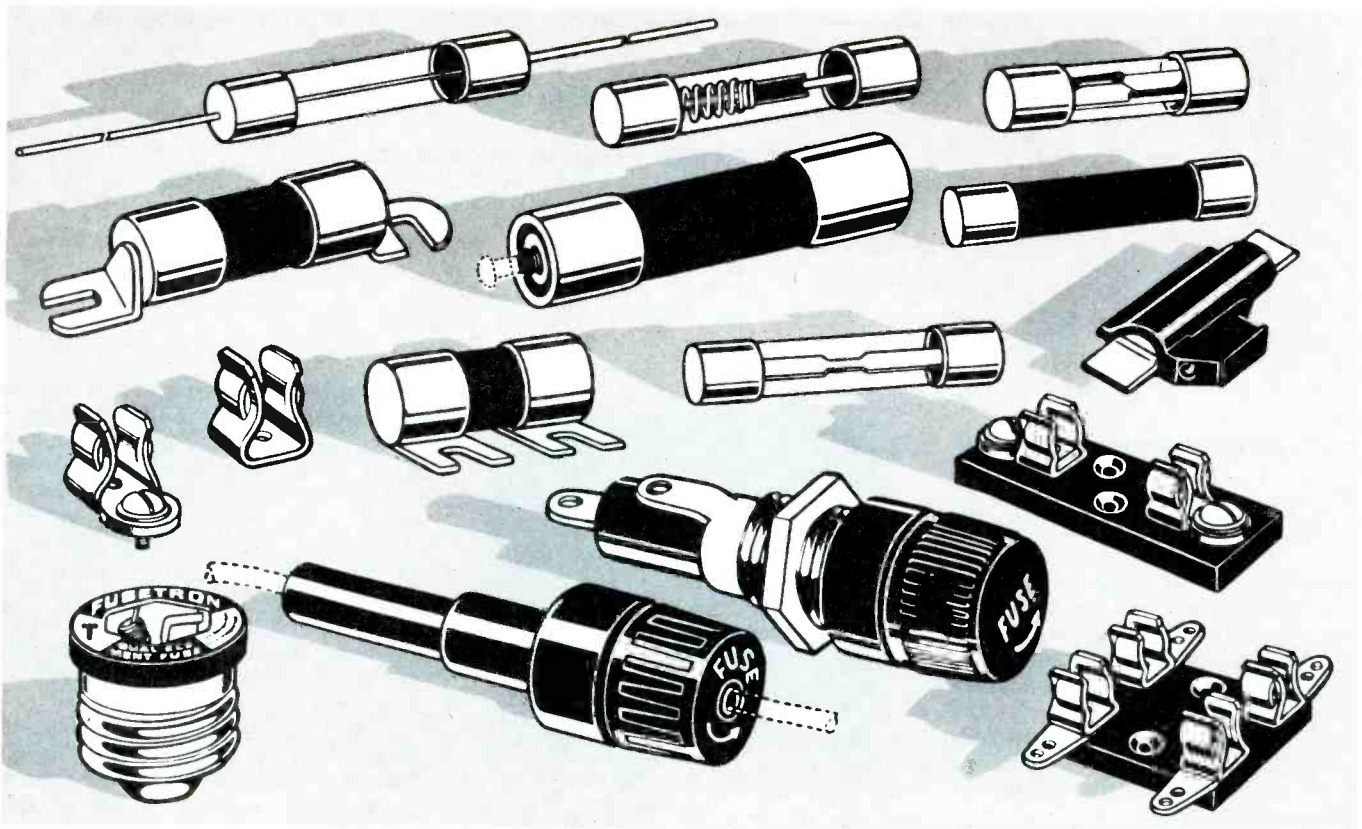
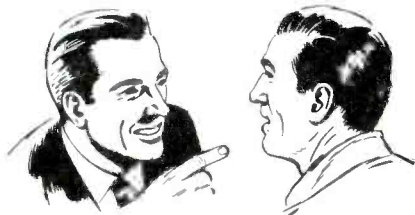

Fig. 2. Schematic of Granco Model LCU.



WHY YOU WILL FIND IT PROFITABLE to STANDARDIZE on **BUSS FUSES**



BUSS OFFERS A COMPLETE LINE OF FUSES

It is easy and economical for you to choose the exact fuse for your requirements. Select from dual-element (slow blowing) renewable and one-time types . . . in sizes from 1/500 ampere up, plus a companion line of fuse clips, blocks and holders.

A fuse is a small but significant component part — for a faulty fuse that fails to protect — or a fuse that blows needlessly may reflect, in your customer's mind, on your product or service.

Dependable electrical protection is not an accident with BUSS fuses.

The makers of BUSS fuses maintain rigid quality control by testing every fuse in a sensitive electronic device that rejects any fuse not properly calibrated, properly constructed and right in all physical dimensions.

That is why you can be sure that a BUSS fuse will always operate as intended under all service conditions.

"Trouble-free" BUSS fuses can help protect your goodwill, reputation and profits.

Then be profit wise, change your buying and stock records today — to standardize on genuine BUSS fuses.

In sales and service capitalize on the **BUSS** trademark.

Millions and millions of BUSS fuse installations in homes, on farms and in industry have firmly established BUSS as the known brand. When you furnish a BUSS fuse your customer accepts it as the best possible fuse. So let the BUSS trademark help, in its own little way, to build your reputation for quality and service.

NEW Complete

TELEVISION FUSE LIST

- Shows proper fuse to use
- How fuse is mounted
- What fuse protects

SEND TODAY FOR YOUR FREE COPY!



Makers of a complete line of fuses for home, farm, commercial, electronic and industrial use



Audio-Facts

McIntosh Model C-108 Audio Compensator

by
**Robert B.
Dunham**

The majority of high-fidelity systems make use of preamplifier, equalization, compensation, and control circuits incorporated either in a separate unit or in the amplifier or tuner if a tuner is employed. The separate preamplifier and control unit, which can be installed in a suitable location, is used in most of the larger installations in order to obtain the desired flexible control of the system.

The McIntosh Model C-108 Audio Compensator is an excellent example of high quality preamplifier and control unit of the separate-unit type. Its electrical and mechanical features are very interesting and reflect the trend in design of units of this type.

The manufacturer describes the Model C-108 as being a complete control unit for professional and home entertainment systems. That is a good description, for this piece of high quality audio equipment is capable of providing excellent results when it is operated in the correct manner with most any high-fidelity sound system.

Simplicity of operation is very desirable because the uninitiated user may find that a panel full of controls is quite confusing. Nevertheless, certain controls must be provided if the best sound reproduction is to be obtained. It is interesting to see how this problem is handled in the McIntosh Model C-108.

Looking at the front of the C-108, shown in Fig. 1, the following controls are visible:

- Selector switch,
- Rumble filter,

- Crossover switches,
- Bass tone control,
- Roll-off switches,
- Treble tone control,
- Aural compensation switch,
- Volume control and On-Off switch.

This array of controls gives a good idea of the flexibility which can be obtained with this unit. At first glance, they may present an awesome and forbidding sight; but their names explain their purpose and use. The operating instructions accompanying the C-108 are very complete and easily understood. Careful study of these instructions makes it evident that operation of the unit is not so complicated as it seemed at first.

The manufacturer has been foresighted in that he has furnished special stickers to be attached to records. After the correct equalization control settings have been found for a record, the settings can be indicated on the sticker for convenient reference.

The following items are visible from the rear, as shown in Fig. 1:

- Five input jacks,
- Two input-level controls,
- Output jacks,
- Auxiliary output jack,
- Power and output cables,
- AC receptacle,
- Three 12AX7 tubes.

A schematic diagram of the equipment to be discussed appears in Fig. 2. Many features of construction and design may be noted in the illustration of Fig. 3, and their discussion will progress through the units, starting at the inputs.

Inputs

Five inputs are provided as follows:

Input No. 1 for an AM-FM tuner, tape recorder, crystal phonograph pickup, or crystal microphone.

Input No. 2 for the same as input No. 1.

Input No. 3 for a low-impedance microphone.

* * Please turn to page 78 * *

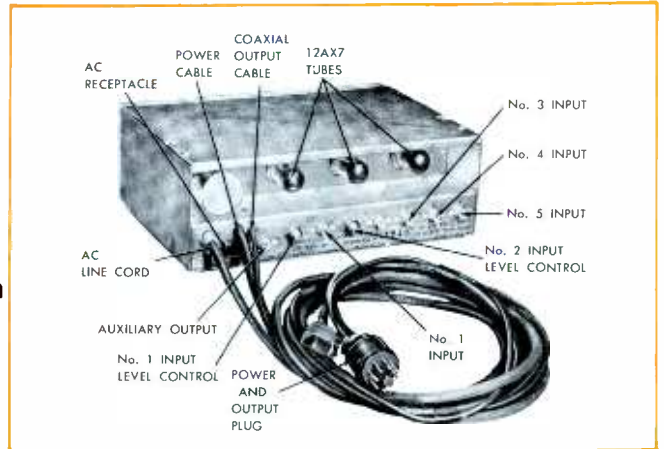
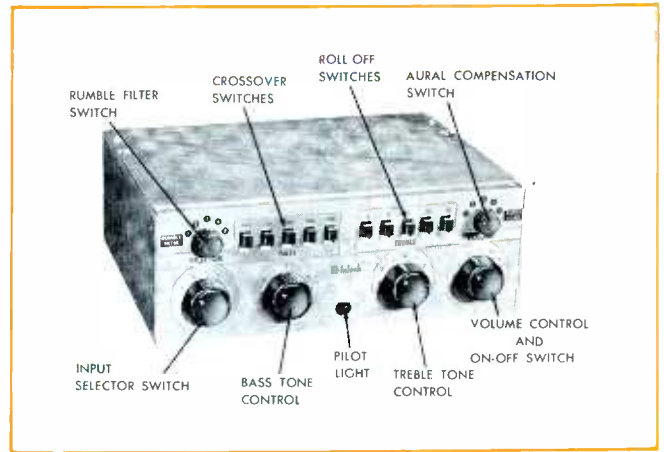

Fig. 1. Front and Rear Views of McIntosh Model C-108 Audio Compensator.



Service Procedures to Speed Repair on Portable Radios

It's Time for PORTABLES

by HENRY A. CARTER

Starting shortly, the sunshine, the temperatures, and the length of the day will effect their proper combination and the portable radio season will be with us again. For entertainment on the beach, or at picnics, for keeping abreast of sporting events, or for the simple purpose of staying close to news developments in the world, the portable set is affectionately held in high regard. It is small, cute, but eminently practical.

In most parts of the country, climatic conditions are such that a boom during the summer months is the usual pattern of service requirements for the portable design. These service requirements, however, do furnish a good opportunity for income, particularly valuable since it may offset the slide in revenue from service operations on other types of electronic equipment for entertainment.

So, when portables start showing up in your shop in the near future, have your stock of replacement batteries, tubes, and other accessories in order to accurately and speedily effect repairs.

Some of these jobs can be pretty tough. Portables are small, and compact design has to be employed to make them that way. Where spacing is critical, it doesn't take too much misuse to provide trouble.

A group of some typical present-day portables is presented in the photograph in the heading. Actually the job of repairing these personal portables can be eased by setting up a regular routine or system for checking them. The following attempts to aid the reader in locating and recognizing the troubles in these sets. Also discussed are ways of reducing future failures and representative case histories of actual service experiences.

Isolation Transformer

A point that can never be overstressed is the importance of using a variable isolation transformer when working on AC-DC sets, whether they are portables or not. The first and foremost reason for this is the safety factor. Working on these sets when they are plugged into the line can be extremely dangerous. Even if your workbench is wood and has no metal in it, a few pieces of test equipment which do not use isolating power

transformers may be around; and so the danger exists between the ground lead of such an instrument and the chassis of the radio.

Another good reason for using a variable isolation transformer is that it provides a means of varying the line voltage to give a set a more thorough test. This can be a great advantage when testing to see at what line voltage a local oscillator will quit operating. Sometimes, a converter tube becomes weak or a resistor changes value and causes oscillator cutout at moderately low line voltages. If you have no way of varying the line voltage, you are hampered in trouble shooting this difficulty. A type of variable isolation transformer can be seen in Fig. 1.

Batteries

Battery replacement information is almost a must. All too often a customer will bring in a set to get batteries without knowing what type of batteries it uses. Service literature listing the proper battery for a given set is needed in a situation like this.

Batteries should always be tested under load. Measuring the voltage of a battery when it is out of the circuit is useless from a practical standpoint. For instance, a battery which measures near normal voltage without a load may drop to a very low value when current is drawn; yet if the load is removed again, it will jump back up to normal voltage. This is due to the fact that as a battery ages the internal resistance increases to such a point that all the voltage may be dropped across this internal resistance. For this reason, a battery that shows virtually the proper voltage when measured without a load may be seriously deficient when measured under load. When a battery under load drops below 60 per cent of its new-battery rated voltage, it should ordinarily be replaced.

One further word about batteries — a selection of the various types and sizes should be stocked. It is not a good policy to overstock, however, because batteries age on the shelf and their efficiency is reduced.

Trouble-Shooting Tips

Listed below are a number of troubles commonly encountered in portable radios. A receiver may have any one or a number of these.

1. Weak batteries.
2. Dead tubes.
3. Microphonic tubes.
4. Defective selenium rectifiers.
5. Corroded battery contacts and tube sockets. (Corrosion is especially prevalent in areas near salt water.)
6. Corroded or loose switch contacts. (Check to make sure that the door switch shuts the set off when the door is closed.)



Fig. 1. A Variable Isolation Transformer.

7. Broken antenna connections. (Connections to antennas in doors are susceptible to breakage.)

8. Frayed battery leads or line cords. (Replace these to prevent future shorts.)

9. Broken cabinets. (Replace these to eliminate the possibility of shock to customers.)

10. Faulty alignment. (For good sensitivity, alignment is very important in portables.)

One other thing that should always be done as a precaution against future failures is to check the current drain of the A and B batteries. A receiver employing four tubes with the filaments connected in parallel should draw between 225 and 250 milliamperes from the A battery, assuming that the set uses 1S5, 1R5, 1T4, and 3S4 tubes. With filaments in series, the current should be about 50 milliamperes. A receiver which uses a 67 1/2-volt B battery will normally draw approximately 7 to 10 milliamperes from this battery, while one employing a 90-volt battery will draw about 15 milliamperes. If a receiver draws current far in excess of these figures, two things should be done. First, look up service data available on the particular set to see if that much current should be drawn. If the set draws more than normal current, look for a leaky capacitor or some other defective component.

Tools

Some of the tools that can be very useful in servicing portable radios can be seen in Fig. 2. These tools must naturally be small and slender. Most personal portable radios are very small and necessarily cramped for space. For this reason, a pencil soldering iron is sometimes required to reach a particular connection. An iron of this type is shown in Fig. 2. This soldering iron is not too good for general shop use because of the very small tip which does not produce much heat; however, it is ideal for service work on portables. In most cases, a soldering gun will be small enough to get at the components in portables, whereas regular soldering irons are too large and radiate excessive heat which can very easily overheat components. It is a well-known fact that very little heat is required to alter the resistance of a half-watt resistor or to melt the plastic insulation off the wiring. The need for extra long or needle-nosed pliers for this work is quite obvious, since the space is so limited and the parts so close together that larger pliers are cumbersome.

The soldering pick and the wire-dressing tools are ideal for tracing circuits and for locating shorts in these small sets. These tools can also be seen in Fig. 2.

Case Histories

In order to present an over-all picture of the many different troubles that can happen to portable radios, we have chosen a few case histories which have proved to be quite interesting. They are not being presented to evaluate the various sets in any way. Instead, we hope that by citing these experiences, you will be able to save considerable time when you are confronted with similar problems.

A. NO RECEPTION

Case No. 1.

A customer brought a Crosley Model 11-301U into the shop for repairs. He said that the set had been getting a little weak and that it suddenly quit playing altogether except for some static and noise. When asked if he wanted new batteries put into the set while it was in the shop, he replied that he did since he had thrown the old ones away the fall before and had been using the radio on AC.

After a check of the tubes, the next step taken was to check the rectifier, which in this case was a 65-milliamperere selenium unit. It proved to be very weak and was replaced. This did not, however, completely finish the job. Although the voltages came back up to normal and the static and noise were louder at the same volume setting as before, it was still impossible to tune in a station.

The converter tube had already been checked, so it was known to be good; therefore, the next step was to check the components in the converter stage. While checking the oscillator coil with an ohmmeter, it was found that the primary was open. After the coil was replaced, the set was completely realigned.

* * Please turn to page 58 * *



Fig. 2. Typical Tools for Servicing Portable Radios.

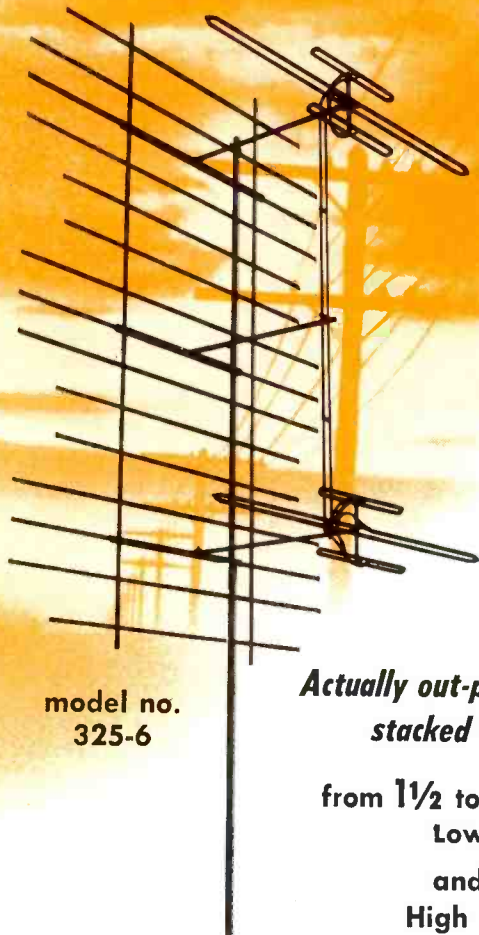

model no.
325-6

**Actually out-performs the
stacked CHAMPION**

from **1½ to 3 DB more**
Low Band gain
and **1 DB more**
High Band gain!

Channel Master proudly introduces the SUPER CHAMP — the newest addition to the Champion antenna family. The Super Champ is a super-powerful antenna that provides extraordinary VHF-UHF reception at greater distances than has ever before been possible.

How it Works:

The Tri-Pole assemblies of the stacked Champion have been wider-spaced by the addition of a third reflecting screen between the antennas. These antennas are joined with a newly-designed half-wave stacking harness. The result: Tri-Pole assemblies are spaced a full half-wave on the Low Band, increasing both Low and High Band gain.

Champion Performance on UHF

In addition to its sensational VHF performance, Channel Master's entire Champion series — including the Super Champ — has been carefully designed to provide excellent reception on the UHF band. Write for complete technical details.

AVAILABLE TWO WAYS:

1. **As a complete antenna, model no. 325-6**
Consists of two Tri-Pole assemblies, three reflecting screen assemblies and a special stacking harness for wide-spaced Tri-Pole. **\$54¹⁷**
list
2. **As a Conversion Kit, model no. 325-7**
For converting standard 2-bay Champions into Super Champs. Consists of reflecting screen and specially-designed stacking harness. **\$14⁵⁸**
list

CHANNEL MASTER'S *new* **SUPER CHAMP**

featuring wide-spaced stacking of Tri-Pole assemblies

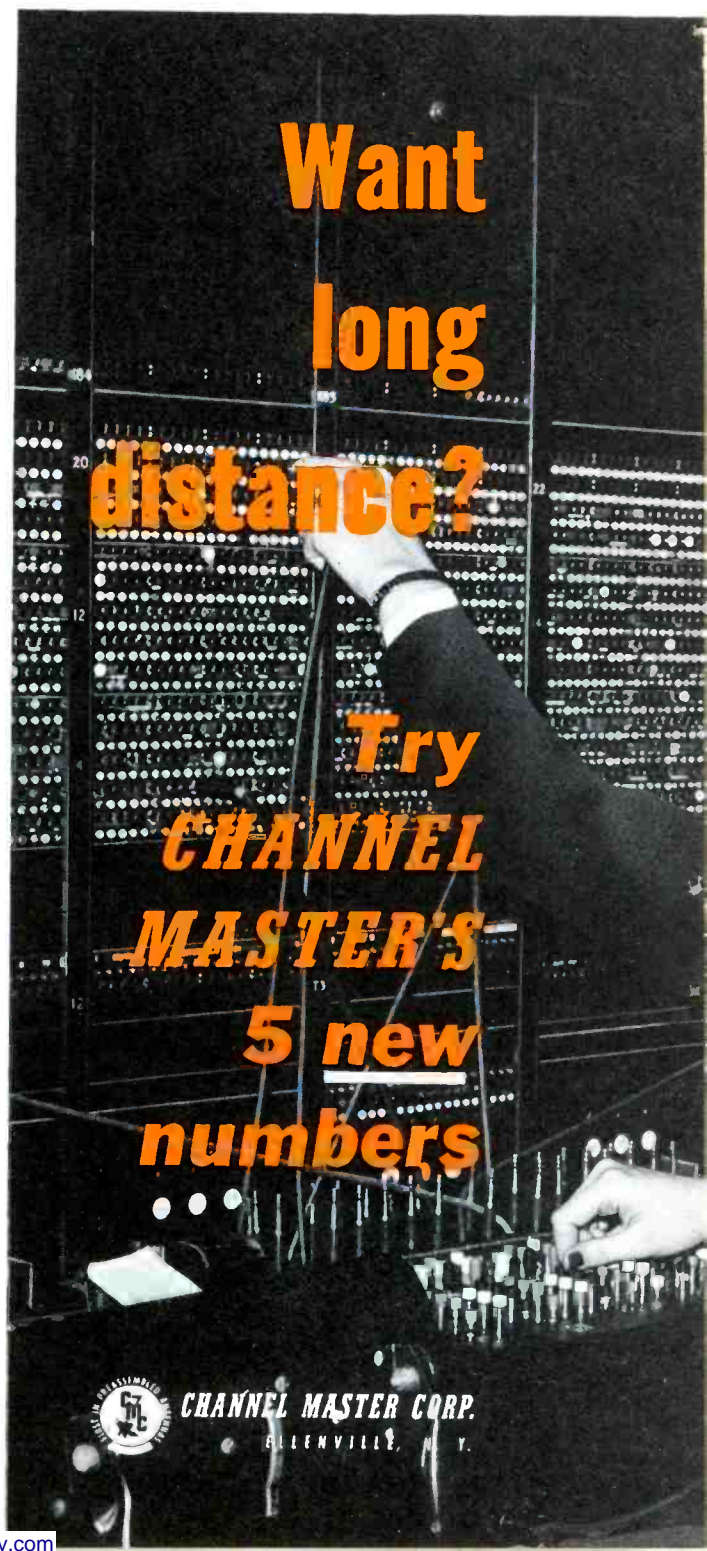

**Want
long
distance?**

**Try
CHANNEL
MASTER'S
5 new
numbers**



CHANNEL MASTER CORP.
ALLENVILLE, N. Y.

Designed for **POWER!** Low Priced for **ACTION!**

These new antennas are the most sensitive of their type — feature Channel Master's famous built-in quality at remarkable low prices, to help you meet competition on any level.

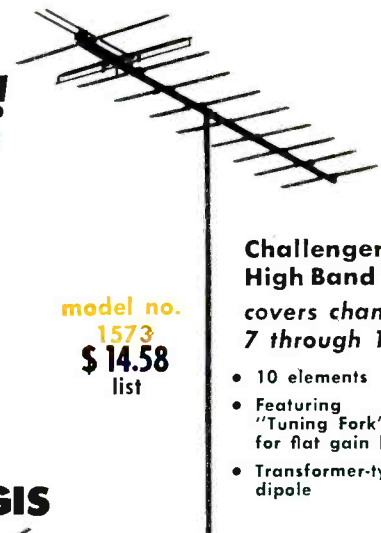

model no.
1573
\$ 14.58
list

Challenger High Band Yagi
covers channels 7 through 13

- 10 elements
- Featuring "Tuning Fork" for flat gain level
- Transformer-type dipole

CHALLENGER BROAD BAND YAGIS

Here's Broad Band coverage with the high gain and directivity of the Yagi. Ideal for areas served at present by two or more VHF stations on the same band and areas where new VHF stations are being added to present ones, on the same band. Feature 100% aluminum construction; are completely preassembled. They give high gain across the band; high front-to-back ratio. Can be stacked for extra sensitivity.

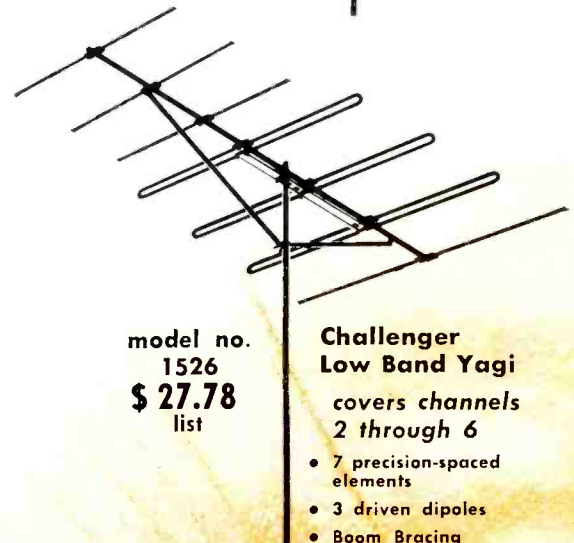

model no.
1526
\$ 27.78
list

Challenger Low Band Yagi
covers channels 2 through 6

- 7 precision-spaced elements
- 3 driven dipoles
- Boom Bracing

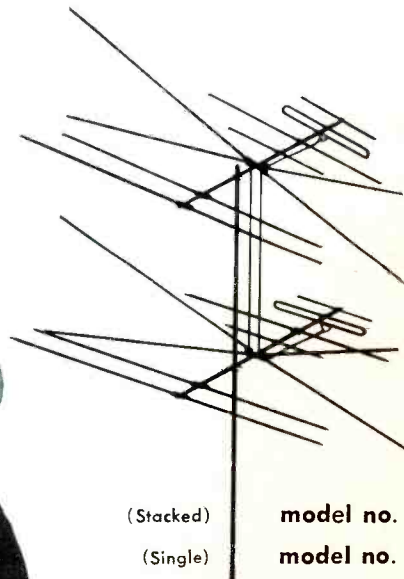

(Stacked)

model no. 321-2 **\$ 25.97** list

(Single)

model no. 321 **\$ 12.64** list

GLOBE TROTTER

- All-channel VHF fringe area coverage.
- All-channel UHF primary area coverage.
- 100% aluminum construction.
- Completely preassembled — no loose hardware.

MULTI-BOW

covers channels 14 through 83

- Outstanding fringe area reception.
- All-aluminum, solid sheet elements.
- "Free-Space" terminals.
- Heavy-duty welded wire screen, bright zinc electroplated.
- 4-bay antenna.

model no.
410
\$ 11.11
list

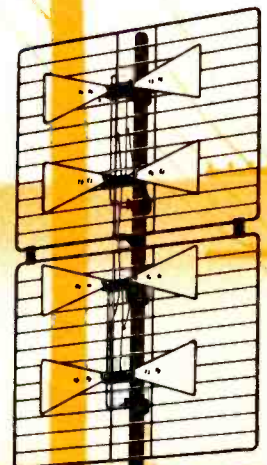

The World's Largest Manufacturer
of Television Antennas

Copyright 1954 Channel Master Corp.

Don't improvise...



RTV-ize!

FOR FAST, SURE, ECONOMICAL CONTROL REPLACEMENTS

As easy as using the 'phone book. As sure as if you looked up the original specs of that chassis. All because Clarostat engineers, responsible for the majority of TV controls in use, have compiled the replacement data available to you in the **Clarostat TV Control Replacement Manual** and the **Supplementary Sheets**.

Listings are by set-manufacturer's model and chassis, part number, Clarostat catalog number, function and description. Cross references, too.



← **New 265-page Second Edition.**

→ **Supplementary sheets available from your distributor.**



→ **RTV replacements available when Standard types won't do.**

→ **Standard types, especially field-assembled "Pick-A-Shaft"* and "Ad-A-Switch"* controls.**

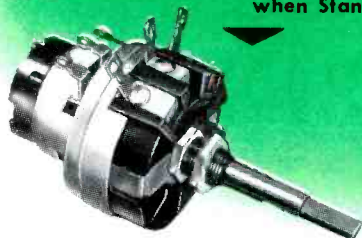

The 265-page *Clarostat TV Control Replacement Manual* (2nd Edition) and *Supplementary Sheets* to this Manual provide you with our latest TV control-replacement data. Ask your distributor for the *Manual* and *Supplementary Sheets*.



* Trade Mark

CONTROLS AND RESISTORS

CLAROSTAT MFG. CO., INC., DOVER, NEW HAMPSHIRE
In Canada: Canadian Marconi Co., Ltd., Toronto, Ontario

Examining

DESIGN FEATURES

by DON R. HOWE

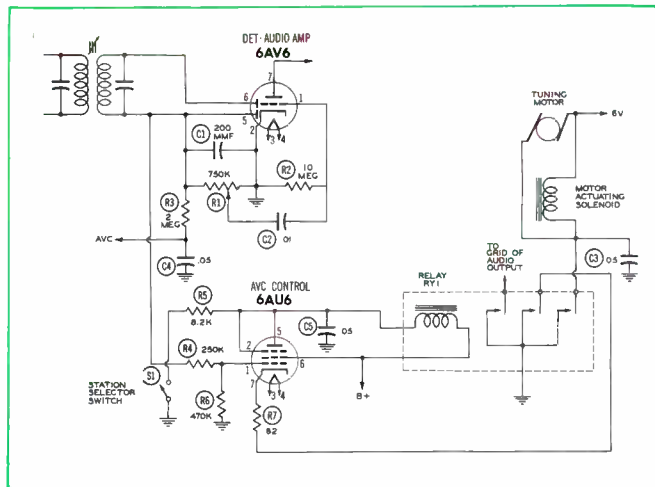

Fig. 1. A Schematic Diagram of the Automatic Tuning System Used in the Aircastle Model 610.FE-153.

Aircastle Model 610.FE-153 Automatic-Tuning System

The Aircastle Model 610.FE-153 automobile radio utilizes a new system of automatic station selection in addition to the manual tuning. The automatic system is placed in operation by pushing the station-selector bar. The receiver then begins sweeping the broadcast band. When a station is received, the mechanism is automatically stopped. If another station is desired, the selector bar is pushed, and the procedure is repeated.

In order to understand this system, it is convenient to follow step by step the operation of the circuit in Fig. 1. The components associated with this circuit are shown in Fig. 2.

The first step in placing the automatic station selector into operation is to push the selector bar. This closes switch S1 and causes current to flow through relay RY1 and resistor R5. Three circuits are controlled by the action of this relay. When the relay closes, the grid of the audio-output tube is grounded thus disabling the audio section during the tuning.

The cathode circuit of the 6AU6 control tube is grounded by a set of contacts in the relay, and the tube conducts. The conduction of this tube causes current to flow through the relay and hold it closed after the selector bar is released.

The third function of the relay is to activate the tuning motor and

the motor-actuating solenoid. The motor is hinged in such a manner that the activating solenoid causes the motor shaft to be pulled against a rubber drive wheel. Rotation of this drive wheel by the motor causes the tuning mechanism to tune across the band.

Upon reception of a signal, a voltage will appear across resistor R6 in the grid circuit of the 6AU6 control tube. The voltage on the grid is sufficiently negative to cut off the tube. Current will cease to flow through the relay RY1, and it will open.

The grid of the audio-output stage is no longer grounded; consequently, the stage will function normally and amplify the audio signals.

Power is removed from the tuning motor and from the motor-actuating solenoid. The cathode circuit of the control tube is not returned to ground, because the relay contacts are open. The automatic tuning system will remain inoperative until the selector bar is again pushed.

Heterodyne Filters

The pleasure in listening to AM broadcast stations is often interrupted by an annoying heterodyne from an adjacent station. In order to alleviate this situation, several manufacturers of high-fidelity tuners have incorporated a 10-kilocycle filter in their models. Two examples of this filter are shown in Figs. 3 and 4.

Fig. 3 is a schematic diagram of the filter as used in the Capehart chassis CR-129. The 10-kc filter formed by inductance L1 and capacitance C3 represents a parallel resonant circuit. By inserting this filter in series with the lead to the first audio amplifier, a very high impedance is offered to any 10-kc signal. The resonant circuit is very sharply tuned so that a minimum of adjacent signals are affected. The annoying heterodyne is therefore discriminated against without introducing distortion to the remaining signal.

The filter employed in the Hallicrafters Model 1622 is a series

* * Please turn to page 83 * *

Fig. 2. A Bottom View of the Aircastle Model 610.FE-153 Showing the Components of the Automatic-Tuning System.

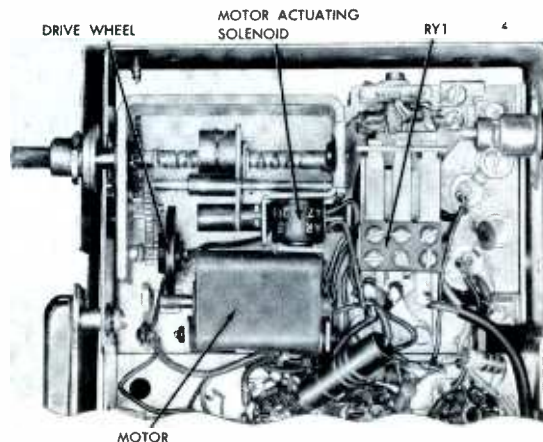



RADIART
Seal-Vent
VIBRATORS

are **TOPS**

The complete rugged service line of vibrators that has dominated the field for years. Exclusive design plus controlled manufacture guarantees long-life performance! Built to "take it", they work under the most adverse conditions. You too will agree RADIART VIBRATORS are the STANDARD of COMPARISON!

the Complete
Replacement Line

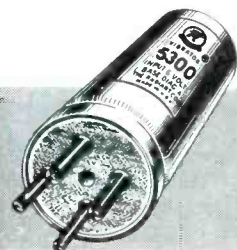

THE **RADIART** CORPORATION
CLEVELAND 13, OHIO

TV ANTENNAS • AUTO AERIALS • VIBRATORS • ROTORS • POWER SUPPLIES

In the Interest of . . .

Quicker Servicing

by HENRY A. CARTER

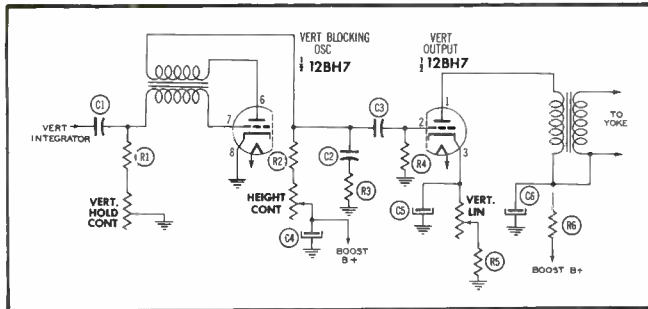
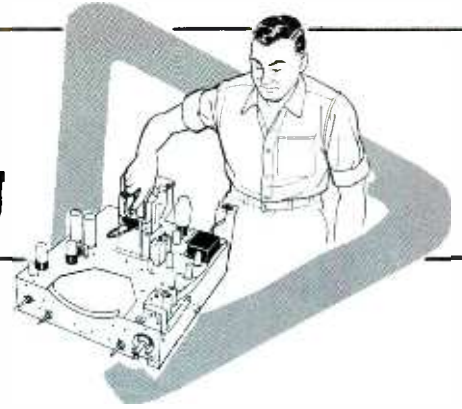

Fig. 1. Schematic Diagram of Vertical Circuit of Typical TV Chassis.

Vertical Linearity Troubles

The task of locating troubles, which cause poor vertical linearity, can frequently be very difficult because of their varied origins. Occasionally, customers, through their inability to properly describe the symptoms, will unintentionally make the situation even more difficult by giving misinformation. As a matter of fact, where a certain distortion of picture has existed long enough, a person tends to think of it as being normal, because he does not remember what the picture looked like when the set was operating properly.

Such was the case with a 12 1/2 inch television set which was brought into a repair shop. The complaint was that the set had no picture. When asked how the set had worked before this failure, the technician was told that it had always been a good set, with a good picture.

Upon replacement of the horizontal-output transformer which had caused the loss of picture, an attempt was made to adjust the raster to the test pattern. The technician found it impossible to obtain a good linear picture. The top and bottom were cramped very badly, and the center of the pattern was stretched excessively. In fact, the raster was so distorted that the large circle of the test pattern more nearly resembled a square. When this was brought to the attention of the customer, it was stated that the picture had not been that way before. Therefore, the service technician believed that the trouble must be in the circuit on which he had just worked.

He began by checking the boost voltage, since the vertical-output tube obtains its voltage from that source. He found the boost voltage to be of normal amplitude. Next, the components of the plate and cathode circuits

of the vertical-output tube were checked and found to be normal. The grid circuit was then checked, and a discrepancy appeared there. In measuring the resistance from grid to ground, it was found that the value of the resistor in the circuit did not comply with the schematic diagram. The schematic called for a value of 3.3 megohms (R4 in Fig. 1), but the circuit contained a 1.5-megohm resistor. It was obvious in this case that an error was made at the factory. The conclusion was reached by looking up the schematic of the 16- and 17-inch sets made by this manufacturer. Their larger sets employed a 1.5-megohm resistor in the grid circuit of the vertical-output tube. This was the only difference that could be found in the circuit.

Since this wiring error was made at the factory, the customer was apparently mistaken in thinking that the set had operated properly before and had evidently watched the set with this condition existing for sufficient time to become accustomed to it and consider it perfectly normal. You can imagine how much trouble the technician had in convincing the customer that the trouble had been in the set all along and was not something caused by the repair.

Fig. 2 shows a picture taken from a television screen. The picture

* * Please turn to page 41 * *



Fig. 2. Picture Resulting From Open Wave-Shaping Network.

Fig. 3. Partial Schematic of Vertical Section Showing Wave-Shaping Network.

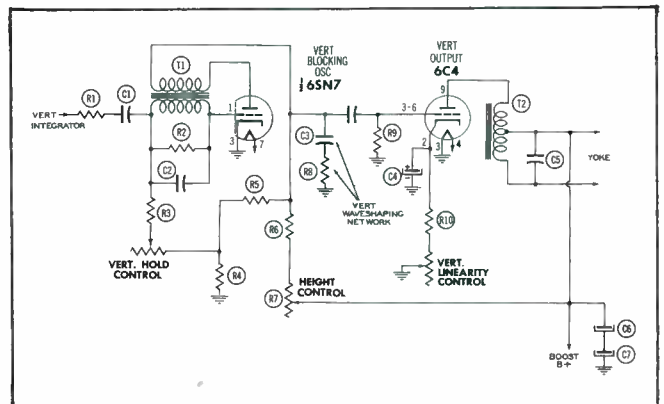

HICKOK

Price
\$129.50

New Television

5" CATHODE RAY RAY Oscilloscope



**MODEL
665**

FEATURES...

- Unitized construction of circuitry . . . HICKOK offers the only commercial scopes that are unitized for the serviceman. This unitized construction makes possible the minimum interaction between amplifiers and sweeps.
- Truss construction . . . new light weight, however, provides greater strength than conventional chassis construction. Designed to withstand shock, vibration and humidity.
- New 16" case depth . . . allows more freedom of placement on your service bench.
- Improved ventilation design . . . adequately improved venting around the amplifiers permits these circuits to operate "COOL," and thus deliver longer, more trouble-free performance.

This new HICKOK 5" Scope has all the needed characteristics for accurate TV alignment and service work. Designed, built and guaranteed by HICKOK, the Model 665 will perform every function required of it and give long, trouble-free service within the range of its technical characteristics.

Technical SPECIFICATIONS

- Frequency Range: 0.5 cycles to 700KC, down 3 db.
- Accelerating Potential: 1775 Volts (high intensity), provides very sharp focus.
- Square Wave Response: Flat, 60 cps. to 100KC, with less than 1% tilt, less than 2% overshoot.
- Dual Fuse: B+ is fused and the line is fused.
Fused B+ provides protection against transformer damage. This is another HICKOK exclusive feature.
- Amplifier: Push-pull, vertical sensitivity 20 MV RMS per inch.
Horizontal, 30 MV RMS per inch.
Vertical Input Impedance: 15 MMF, 2.2 Megohms.
Horizontal Input Impedance: 52 MMF, 0.1 Megohms.
- Sweep Oscillator Range: 18 cps. to 50KC.
- Blue hammertex steel case.
- 13" H., 16"D., 9 $\frac{1}{8}$ " W. 23 lbs. net.

THE HICKOK ELECTRICAL INSTRUMENT CO.
10566 Dupont Avenue • Cleveland 8, Ohio



Free!!

New Hickok Oscilloscope book. 24 pages describing and illustrating a scope's best use in servicing work. Priced at \$1 . . . offered free to professional service technicians and engineers in this special limited offer. Write for your free copy today!

Your Best Buy in a Cathode Ray Scope

HICKOK

HERE IS WHAT IT WILL...

...HELP YOU DO...

**MODEL
665**

- Trouble-shoot a TV receiver and quickly go from stage-to-stage to locate TV trouble.
- Accurately view actual peak-to-peak wave shapes.
- See excellent Square-Wave response. Better than scopes costing up to \$20 more.

High
Frequency



Low
Frequency

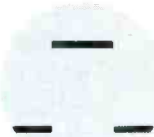

- High Input Resistance. Important to have to above 2 megohms—higher than this is of no value.
- Low Input Capacitance. All HICKOK Scopes have this important feature.
- Ask your Parts Jobber for a demonstration of the HICKOK 665 soon. See for yourself how the 665 will profitably speed your present TV service work.

Outstanding ... has all the essential features for profitable TV receiver servicing.

Value ... better than any other scope in its price range.

Proved ... by thousands of TV Technicians who are already profitably using the 665.

Price ... is low ... \$129.50.

Quality ... and value is exceptionally high. This scope is not a kit—not a box of parts—not an off-brand scope made for a Known Company by an Unknown Manufacturer—not a cut price deal to unload an inferior scope.

Guaranteed ... the 665 is completely engineered, tested, manufactured and guaranteed by HICKOK, and backed by 44 years of engineering accomplishment as the world's leading manufacturer of electrical-electronic test equipment.

LOW CAPACITANCE

Probe...

The HICKOK TVP-1 low capacitance probe extends the usefulness of any scope. Available from your Parts Jobber.

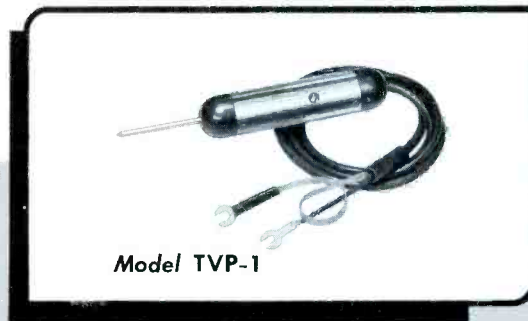

Model TVP-1

THE HICKOK ELECTRICAL INSTRUMENT COMPANY
10566 DUPONT AVENUE • CLEVELAND 8, OHIO

8 vertical outputs
 1 deflection yoke
 1 filter choke
 5 width and linearity controls
 17 exact replacement flybacks
 23 TV power transformers

55 NEW TV REPLACEMENT COMPONENTS HAVE BEEN ADDED TO THE STANCOR LINE

STANCOR
 YOUR MOST COMPLETE SOURCE
 OF TV REPLACEMENT
 TRANSFORMERS

28 flybacks (27 exact duplicates)
 55 TV power transformers
 8 deflection yokes
 9 width and linearity controls
 15 vertical outputs
 8 blocking-oscillators
 3 focus coils
 5 filament transformers
 22 filter chokes
 19 audio outputs

NOW 172 TV REPLACEMENT COMPONENTS ARE IN THE STANCOR LINE

Ask for Stancor's new TV Replacement Guide listing replacement applications for these transformers in 6800 TV models and chassis. FREE from your local Stancor distributor, or from Chicago Standard Transformer Corporation.

Stancor transformers are listed in Sams Photofact Folders and in Counterfacts.



CHICAGO STANDARD
 TRANSFORMER CORPORATION

3594 ELSTON AVE. • CHICAGO 18, ILL.

EXPORT SALES: Roburn Agencies, Inc., 39 Warren Street, New York 7, N.Y.

A UNIVERSAL SUBSTITUTE SPEAKER

Parts and Design of a Unit for Checking Audio on Speakerless Chassis

The average owner of a television receiver is inclined to notice a defect in the picture on his set before he pays particular attention to a deterioration in the sound. To the service technician, however, both symptoms are important for correctly diagnosing the trouble. It is therefore essential that a sound check be made on every television receiver brought into the shop for repair, even though the complaint may be with the picture alone.

A sound check requires that a speaker be employed when a set is serviced. Some technicians remove the speaker every time a chassis must be taken out of its cabinet for bench work. Others take the speaker into the shop only when special sockets or plugs are required to connect it to the receiver chassis; special sockets or plugs are needed usually when field coils, chokes, or output transformers are a part of the speaker assembly. Still other service technicians feel that, regardless of type, the speaker assembly should be left in the cabinet unless a defective unit is suspected. They believe that a good speaker may be damaged by handling.

Each procedure has its advantages and disadvantages. The first two involve the risk of possible damage to the speaker, but they assure that the correct speaker will be available at the bench position. The third method insures against speaker damage, but it is likely to involve lost bench time while a substitute unit is made up. If the shop services only receivers made by certain manufacturers, test speakers are probably part of the shop equipment. Any change in chassis design, however, could bring about a change in

**Fig. 1. Internal Parts
Layout of Substitution
Speaker Assembly.**

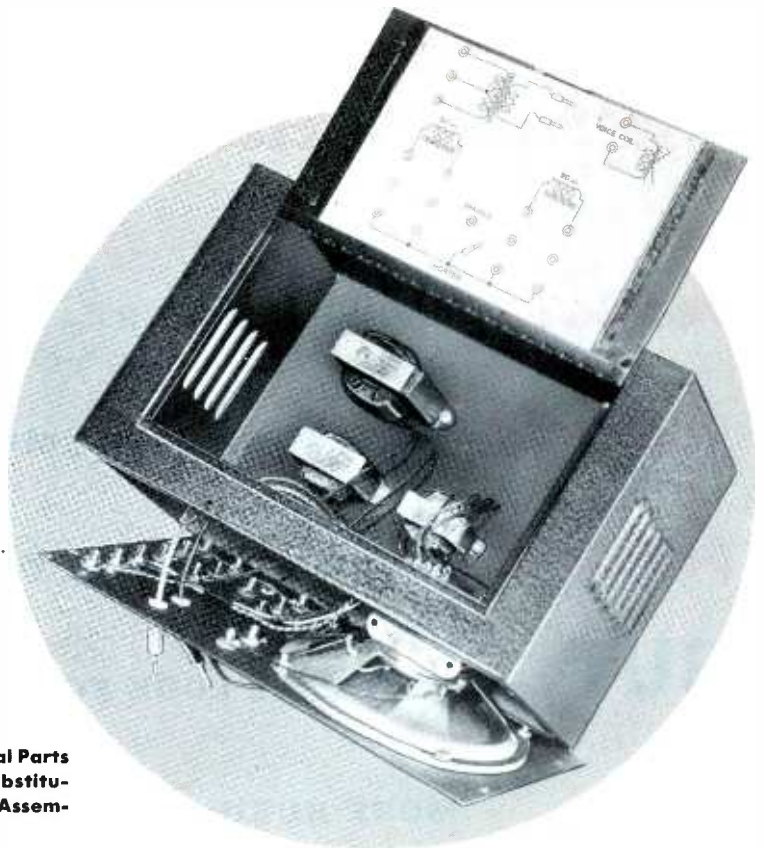

the speaker assembly or connecting cable; and this would require another test speaker. A great number of individual test speakers would be necessary if the shop serviced all makes and models.

A very common method of assembling a substitute speaker in the shop is to take a speaker, an output transformer, and a choke (if required) and to connect these components to the receiver by means of test or clip leads. Obviously, this is a time-consuming process, and sometimes errors are made which cause further loss of time. An example of such an occurrence might be the inadvertent omission of a power-supply component mounted on the speaker in the set. The voltage distribution to other parts of the chassis can change because of this omission, and the result may be the appearance of trouble where trouble does not really exist.

The problem of having a test speaker in the shop for every job and of making it possible to leave the customer's speaker in the cabinet has been solved by one shop with the unit described here. This device uses only a few parts all of which can be easily obtained. The complete unit was built in less than one hour. It has enough flexibility to permit almost any newly encountered speaker assembly to be duplicated by the simple addition of a new set of leads and a new plug or socket.



Basically, this unit is not new since many service shops have used test speakers from the time they started in business. Its flexibility, resulting from the use of plugs and jacks instead of switches, makes it practically impossible to find any existing speaker assembly which cannot be duplicated in a matter of a few minutes. It has been used for several months by a shop servicing all makes and models without finding one speaker that could not be duplicated.

This particular unit was built into a portable box of lightweight metal, but it is conceivable that some shops would prefer to make it a permanent part of mounted bench equipment. A PM speaker, two heavy-duty chokes, an output transformer, and the necessary jacks are mounted in the box, as shown in Fig. 1. The box and all the components are standard items available from parts distributors. A list is included with this article to show the parts used in this particular assembly. Choice of each item can be dependent upon availability or personal preference, since the only critical items are the plugs and sockets used on the receiver end of the cables. These must duplicate the plugs and sockets used by the receiver manufacturers.

The values of the two chokes were chosen after checking several

* * Please turn to page 76 * *

**PEOPLE WON'T LOOK FOR YOU TO GIVE YOU
RADIO AND TELEVISION SERVICE BUSINESS...**

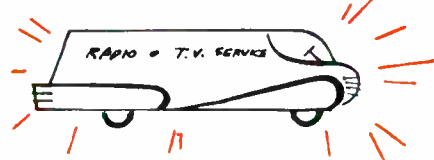
because YOU'RE PRETTIER  THAN YOUR COMPETITOR OR
because YOU EMPLOY MORE MEN  OR
because YOU HAVE FLASHIER TRUCKS 
BUT... THEY WILL LOOK FOR YOU AND GIVE YOU

MORE BUSINESS* IF YOU ARE A



BONDED ELECTRONIC TECHNICIAN



and YOU'LL KEEP THE BUSINESS IF YOU USE



QUALITY RADIO AND TELEVISION TUBES



because THEY ARE **RIGHT... FOR SOUND AND SIGHT!**

**BETTER ASK YOUR RAYTHEON TUBE DISTRIBUTOR IF YOU CAN
QUALIFY FOR THIS EXCLUSIVE SALES STIMULATOR**

*In a recent survey Raytheon Bonded Electronic Technicians indicated that the Raytheon Bonded Program boosts their volume and profit at least 10 per cent.



Excellence in Electronics

RAYTHEON MANUFACTURING COMPANY

Receiving Tube Division
Newton, Mass., Chicago, Ill., Atlanta, Ga., Los Angeles, Cal.

RAYTHEON MAKES ALL THESE

RECEIVING AND PICTURE TUBES • RELIABLE SUBMINIATURE AND MINIATURE TUBES • SEMICONDUCTOR DIODES AND TRANSISTORS • NUCLEONIC TUBES • MICROWAVE TUBES

notes
on

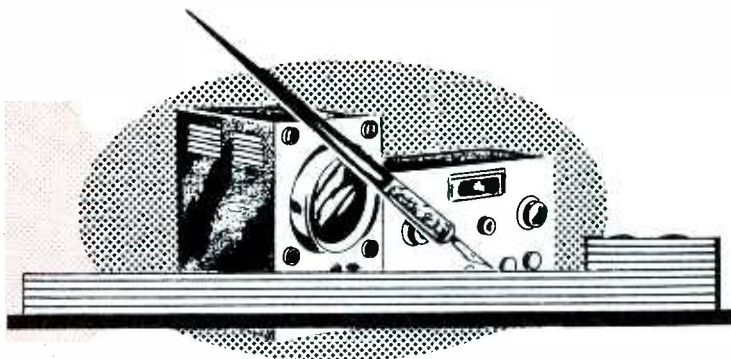

TEST EQUIPMENT

Presenting Information on Application, Maintenance, and Adaptability of Service Instruments

by PAUL C. SMITH

Converting the Hickok Videometer for Color-Television Servicing

Previous mention was made in this column concerning a conversion kit supplied by the Hickok Electrical Instrument Company for use with their Model 650 videometer. With this kit, No. 60C, the owner of a Model 650 may convert it to the Model 650C which provides a black or white dot pattern. The availability of the white dots extends the usefulness of the instrument to include adjustment of focus, DC convergence, centering of individual beams, purity coil, and dynamic convergence of color TV receivers. The dot pattern also permits the checking of linearity and aspect ratio in the same manner as is done in monochrome receivers.

Such a conversion was recently made in our laboratories and proved to be rather simply and easily done. A photograph of the kit appears in Fig. 1. The kit consists of a 6AB4 tube with all of its necessary circuit components mounted on a bracket, self-tapping mounting screws, a single-contact terminal strip, and a plug for a half-inch hole. Complete step-by-step instructions and diagrams are furnished with the kit. To make this conversion, it is necessary to drill only three extra holes — two in the chassis to mount the bracket assembly and a half-inch hole in the top of the case to allow for screw-driver adjustment of the switch shaft.

The first step is to remove the Model 650 from its case by removing

ten screws from the front panel and two screws from the rear of the case. Figs. 2A and B show the chassis and front panel removed from the case, and the areas involved in the conversion are indicated.

The second step is to unsolder the connection of C30 at the ground lug under one of the nuts holding the socket of the 12AY7 (V8) to the chassis. The unsoldered end of C30 is then transferred to a ground lug on terminal strip U as indicated on the instruction leaflet in the kit. C30 is designated as .1 mfd in the instruction leaflet but is specified with a value of .05 mfd in the Hickok manual for the 650. Actually in the 650 that we converted, C30 was comprised of three capacitors in parallel between pin 2 of V8 to the chassis. Whatever the arrangement may be in any particular case, the object in moving C30

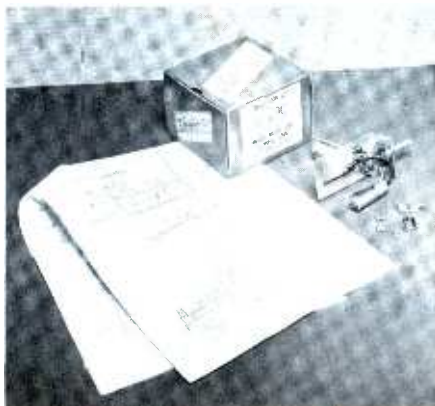

Fig. 1. Hickok Kit No. 60C for Converting the Hickok Model 650 Videometer to Model 650C.

is to clear a space for mounting the converter assembly and to provide room for making the necessary connections.

A template is furnished with the instruction leaflet for the purpose of locating the mounting holes for the converter bracket. This template can be cut out and placed at the proper position on the chassis, and the positions for the two mounting holes can be marked with a center punch. The mounting holes are drilled with a No. 35 drill, and the bracket can then be fastened in place with the two self-tapping screws.

The single-contact terminal strip is then mounted under one of the nuts holding the socket of the 12AY7 (V8) to the chassis. In our case this was the nut nearest pins 4 and 5 of V8.

Since complete step-by-step instructions are furnished with the kit, it is an easy matter to complete the wiring into the circuit of the converter assembly.

Only three electrical connections are made from the assembly, not counting the ground connection which is made automatically as the bracket is mounted to the chassis.

Another cutout template is furnished for locating the half-inch hole necessary for operation of the switch. The switch shaft is slotted for screw-driver operation. When the switch is not being operated, this hole is covered by the hole plug supplied with the kit.

Fig. 3 shows the chassis after the assembly has been mounted and wired. After a careful check of the installation, the chassis may be re-

draw a bead on quality...

IF YOU'RE IN TV SERVICE FOR KEEPS

Television service is big business—one of the fastest growing in the nation. If you're shooting for all the marbles and aiming for the secure future TV service provides, remember today's service builds tomorrow's reputation.

As in any big business, the strongest foundation for the future is a reputation built upon sound technical and business methods. In TV service, it's good business to back up your highly specialized workmanship with the highest quality replacement parts.

You can depend on Du Mont quality picture tubes to do more for your service.



Photo by Robert R. Long - From PHOTOGRAPHY ANNUAL

Replacement Sales, Cathode Ray Tube Division
Allen B. Du Mont Laboratories, Inc., Clifton, N. J.

PIONEER IN BIG PICTURE TUBES • ORIGINATOR OF THE FAMOUS BENT-GUN AND SELFOCUS •
LEADER IN HIGH-RESOLUTION • MAJOR SUPPLIER TO MOST FINE TELEVISION RECEIVER MANUFACTURERS

*Trade-Mark

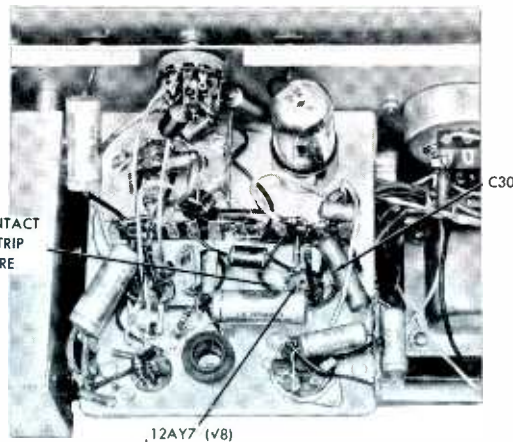

Fig. 2. Two views of the Hickok Model 650 Chassis Showing the Area of Conversion.

placed in the case and the unit is ready for testing. For normal operation the newly installed switch should be turned clockwise, and for white dots or bars the switch should be turned counterclockwise. The manufacturer's notes state that if the greater intensity of the white bars or dots should be desired, a 100K-ohm, half-watt resistor can be soldered from pin 2 of the 12AX7 (V9) to chassis ground. The location of this tube can be seen in drawing No. 762W in the instruction book for the Model 650.

Sync Polarity Reversal With the Jackson CRO-2 Oscilloscope

Owners of the Jackson CRO-2 oscilloscope may not know that a reversal of the polarity of the internal synchronizing signal can be obtained by adjustment of one of the front-panel controls, namely, the polarity control. This is a two-position control with one position marked +UP and the other marked -UP to indicate that in the first case a signal of positive polarity applied to the vertical input will cause the beam to be deflected toward the top of the screen and in the second case a signal of negative polarity will cause a deflection in the same direction. Thus, the use of the polarity control will cause a waveform to be inverted on the screen when the control is switched from one position to another. This is the purpose of the control as described in the instruction manual for the Model CRO-2.

A partial schematic showing the 5UP1 cathode-ray tube and a portion of the deflection circuits appears in Fig. 4. S3 is the aforementioned polarity control or switch; and it can be seen that its action is to apply the output from C11 or C12 to first one

then the other vertical-deflection plate, depending upon the position of S3.

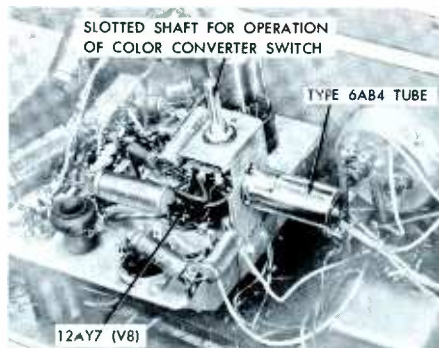

Fig. 3. Chassis of Hickok Model 650 After Conversion.

Internal synchronization of the scope sweep is obtained by applying a portion of the vertical-amplifier signal to the grid of the sweep multi-

vibrator. This signal is taken from the junction of R29 and R30, and therefore its polarity depends upon the position of S3.

In applications where polarity of sync signal is important or critical, S3 can be used to select the desired polarity, provided that the accompanying inversion of waveform is not objectionable.

Read the Instruction Manual

Add to the "Famous Last Words" column — "Shucks! I don't need any instruction manual."

Or, we might begin with "Breathes there a man with soul so dead who never to himself has said . . ." — "Hey! A brand new Super-sonics 8! I wonder what this knob

* * Please turn to page 74 * *

Fig. 4. Partial Schematic of Jackson CRO-2 Oscilloscope Showing Polarity Reversal Switch and Take-off Point of the Internal Sync Signal.

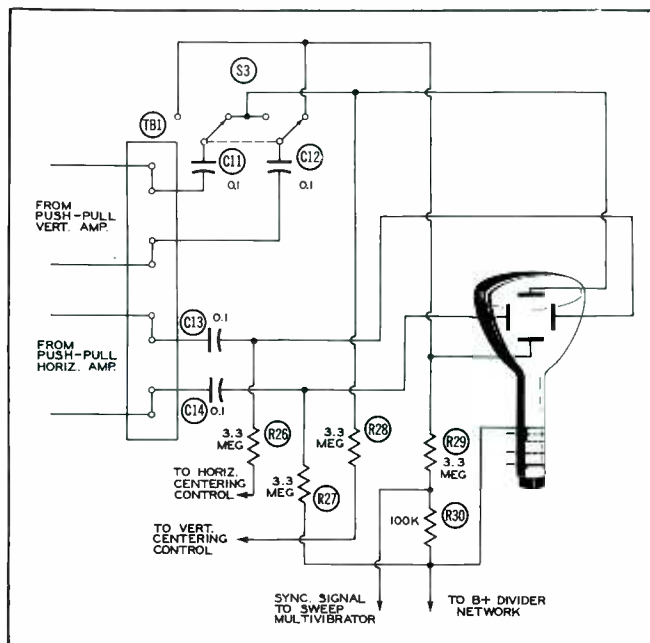



*For auto radio repairs
that are right the first time...*

...use Mallory Precision Parts

You need have no worries about customer call-backs . . . if you use Mallory components in your repair work. Mallory vibrators, capacitors and controls are precision-designed . . . precision-built . . . to give you and your customers precision performance.

That's why it is to your advantage to depend on Mallory components for all your service jobs—automobile radios . . . TV sets . . . home radios.

For UHF television conversions, Mallory converters lead the field.

All these Mallory components are designed for high temperatures . . . an essential for auto radio service

Mallory Vibrators

were the first vibrators on the market and Mallory produces more for set manufacturers than all other makes combined. The Mallory Vibrator's patented, tuned mechanism assures long, dependable performance. Use them always . . . and be sure you have a copy of the latest MALLORY VIBRATOR GUIDE. It's a complete cross reference listing and service guide.

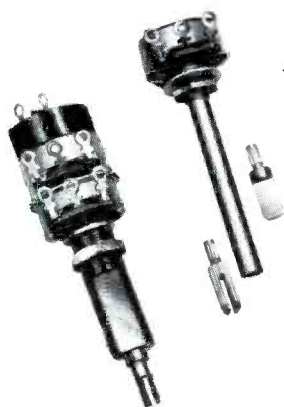
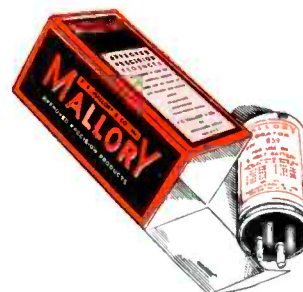

Mallory Midgetrols®

will meet all your control needs in both single and dual types. They are easy to install because of simplified design and construction. Accurate resistance values and extremely smooth taper curves mean long, trouble-free performance. Ask your Mallory Distributor for a copy of the MALLORY AUTO RADIO CONTROL GUIDE.

Mallory Capacitors

are widely used and preferred as original equipment by radio and TV set manufacturers. *The design and precision construction of Mallory Capacitors assure longer life up to 85°C—in all standard ratings.* Mallory FPs are the only fabricated plate capacitors for the replacement market. Mallory Plascaps® with superior moisture-proofing and permanently secured leads are right for your plastic tubular capacitor needs.

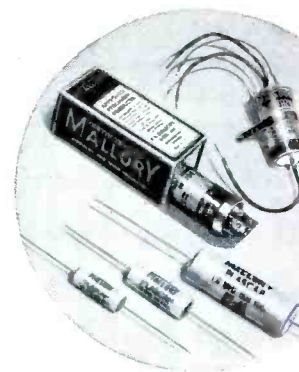

P. R. MALLORY & CO. Inc.

MALLORY

CAPACITORS • CONTROLS • VIBRATORS • SWITCHES • RESISTORS
RECTIFIERS • POWER SUPPLIES • CONVERTERS • MERCURY BATTERIES

APPROVED PRECISION PRODUCTS

P. R. MALLORY & CO. Inc., INDIANAPOLIS 6, INDIANA

ADVANCED FLYBACKER CUTS DOWN SERVICE TIME

RCP Model 123 Provides Fast, Reliable Test of Flyback Transformers and Yokes.

Designed for speedy servicing of the horizontal output circuit in all TV receivers, the Flybacker is the latest design to come from the laboratories of the Radio City Products Co., 152 W. 25th Street, New York 1, N. Y.

Extremely sensitive, the Model 123 Flybacker immediately shows up a single shorted turn in a flyback transformer or yoke. Its light, portable design serves to advantage in the shop and in the home.

All tests can be carried out with the components in place in the TV receiver. Call-backs can be prevented by checking all flyback transformers and yokes in stock for opens, shorts, etc. Flybacker tests are also applicable to inductive windings on any transformer, choke speaker, solenoid, relays, etc., where the impedance is not relatively low. In fact, the instrument may be used as a proportional AC Ohmmeter.

Easy to Operate

Minimum of connections necessary. All you do is remove flyback plate caps—set switches—apply leads and then read meter. The slightest change in inductance due to a shorted turn or the effect of intermittents shows up on the meter immediately as "BAD."

First introduced in December of last year, the instrument was an immediate success. Service users everywhere have heaped praise upon its efficiency and advanced design.

Here's what they say—

Punxsutawney, Pa.

"Remarkable instrument—Congratulations!"

Cincinnati, Ohio.

"Very good!"

Brooklyn, N. Y.

"Excellent unit—very versatile



The RCP Flybacker is reasonably priced at only \$39.75

—needed by every serviceman
—has already paid for itself!"

Donora, Pa.

"Wonderful instrument. . . ."

PERFECTED PEAK-TO-PEAK MEASUREMENT ACHIEVED WITH VTVM "DO-ALL"



RCP Model 655 provides for the accurate measurement of complex waveshapes.

New circuit developments inherent in the RCP Model 655 provide for the efficient and accurate measurement of complex waveshapes. It gives a true reading measurement of complex and sinusoidal voltages with necessary peak-to-peak or RMS value read directly for the analysis of waveforms in video, sync and deflection circuits.

Service users indicate a greater efficiency is attained since sets can be serviced as the manufacturers say—the peak-to-peak way. The combination of this P. to P. meter and service notes to match, take the guesswork out of service and speed up the overall service operation.

Versatility of measurement, built into each Model 655, serves a variety of industrial applications in the service of vibrator power supplies, AC generators and all equipment utilizing any type of waveform or DC.

The range and the coverage available with the RCP Model 655 provides a multitude of advantages. For example, peak-to-peak AC measurements of from .2V to 4200V on 7 ranges; AC RMS measurements of .1V to 1500V on 7 ranges; DC measurements of from .02V to 1500V on 7 ranges; RESISTANCE measurements of from .2 ohms to 1,000 Megohms on 7 ranges.

Match the Model 655 with any peak-to-peak VTVM—You will find that comparable performance can only be found in much higher priced instruments. Of high impedance design, the Model 655 makes use of an electronic balanced push-pull circuit and peak-to-peak rectification. The result is an absence of circuit loading, waveform error or frequency distortion.

Considering the many advantages available, the price—only \$59.50—beats any competitive product on the market.

For further information write Dept. PF-4, Radio City Products Co., 152 West 25th Street, New York 1, N. Y.

Auto RADIO SERVICING



CAN BE PROFITABLE

by Henry A. Carter

The popularity of the car radio has increased in leaps and bounds since World War II. Very few new cars are now sold without a radio. Customers are constantly seeking shops with facilities for servicing auto radios. Few general shops have the space and special equipment required for this work; and even if they do, labor time may not be available. Hence, a need exists in many communities for repair shops that can service automobile radios.

The object of this writing is to acquaint the reader with some of the things which must be considered in order to equip and operate a repair shop for automobile radios on a profitable basis.

In order to get factual data, we contacted the owner of a local auto-radio service shop. He was very cooperative in supplying us with this information we needed.

Location

The first thing to consider in entering this field is the importance of the location of the shop. There are two types of locations which are most suitable. Probably the best is in or near what is usually referred to as "automobile row" where most of the

new- and used-car agencies are concentrated. Almost every American town or city has such a section. By locating in automobile row, your place of business would be convenient to those dealers who are a potential source of business. Most used-car dealers prefer to have the radios in their cars in operating condition, for they know that the over-all impression of the prospective buyer depends to a certain extent upon the condition of the car radio. The dealers can be solicited for this work.

The second best location is in a downtown section which is convenient to both downtown shoppers and workers. If the location is within walking distance of the downtown shopping area, the car can be left at the service shop and the shopper can conduct his business without need of transportation. In many cases, the repair work can be completed by the time the owner returns. This convenience relieves the car owner of parking problems.

In the case of the office worker, it would be advantageous if space

were available so that this car could be stored for the day. Thus the owner could leave the car in the morning and pick it up after work. This point should be considered in selecting a location. The most ideal condition would be where the lot on which the building is located is of sufficient size to provide the required parking space. If this space is not available, owners of nearby vacant or parking lots should be contacted to see whether arrangements can be made to provide this space.

If the rent downtown or near automobile row is prohibitive, then heavily traveled streets leading in and out of town may be considered. If this is the case, it is advantageous to locate near a shopping center on one of these streets.

Requirements for the Building

When considering a building for housing an auto-radio repair shop, one requirement should be uppermost in mind — it should have drive-in facilities.

This arrangement is advantageous to any location and is imperative in those sections of the country where extremely bad weather is experienced. Moreover, the drive-in feature is a convenience for both the customer and the service technician. The customer can drive right in and does not have to park his car on the street. Furthermore, his impression of the place of business is enhanced by the facilities provided to do this specialized work.

* * Please turn to page 47 * *



Fig. 1. Operator of Auto-Radio Service Shop at Work.

ONLY
\$15⁹⁵
LIST

For *low cost* concealed
conversion...

GRANCO

**UHF
HIDEAWAY
ALL-CHANNEL TUNER***

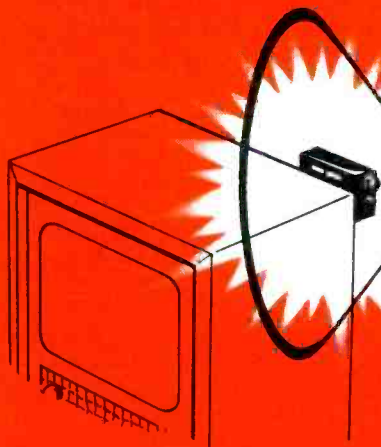

ASK YOUR DISTRIBUTOR to show you the Granco Hideaway models. Better still, try one with any VHF set in any UHF locality with an indoor or outdoor UHF antenna. You'll be amazed! Literature on request.

*Patent Pending

Greatest advance yet in UHF conversion! So small—attaches to rear of TV cabinet with only dial showing, and knob and switch at side. So simple—works on indoor UHF antenna in most localities. So inexpensive—even brand new set calls for a Hideaway when UHF stations come along.

ACTUALLY COSTS LESS THAN STRIPS

No need to pull out heavy chassis. No need to fuss with turrets. No need for realignment. Excellent performance, due to coaxial tuning, preselection, and far greater amplification than with strips.

FEATURES...

- Smallest UHF converter made—only 5½ x 3½ x 2½.
- Yet a giant in performance—has everything for superlative performance—coaxial tuning, preselection, fine tuning, etc.
- Simplest concealed job known. Mounts on rear of TV cabinet. Or placed on top like any other converter, if preferred.
- On-the-button high-ratio tuning. Easy to operate.
- Preselection for clean, interference-free pictures. A "must" in areas with two or more UHF or VHF channels.
- High amplification means satisfactory operation with indoor UHF antenna in most locations.
- Actually costs less and is more efficient than usual UHF strips. What's more, it provides continuous tuning over entire UHF band, eliminating need for additional strips.
- In three models: HT-1, requires very little power from set, \$15.95 list.
- HT-2, self-powered, \$18.95 list.
- Model HT-3, self powered, plus low-noise amplifier, \$21.95 list.

Granco

GRANCO PRODUCTS INC.

36-17 20th Avenue
LONG ISLAND CITY 5, N. Y.



Dollar and Sense Servicing

by *John Markus*

Editor-in-Chief, McGraw-Hill Radio Servicing Library

PRICE CUTTING. One definition for the word discount is "allow for exaggeration in," and that must pretty much coincide with the thinking of customers all over the World instead of just in your own home town. In India, discounts are a particular headache to radio dealers because the Indian customer loves to bargain so much that he'll generally ask for the discount even before the list price.

The leading editorial in a recent issue of Radio Times of India is devoted to this problem of discounts. Credit is given where due: "We, in the radio trade in India, are fully aware of this exaggeration. We got it, like an infection, from the system of the radio trade followed in the USA way back right since 1927."

They go on to say that in this game of bargaining, nobody emerges fully satisfied. Even after the deal is closed, dealer and customer both mutter unhappily to themselves, "I might have secured a still better price if I had persevered" — a philosophy that destroys confidence.

The real loser, says the editorial, is the radio dealer. In a typical deal for a set having a list price of 300 rupees and carrying a dealer discount of 90 rupees, the customer will end up with a discount of 80 rupees. This leaves the dealer with a gross profit of 10 rupees, for which he is accused of profiteering because the customer is fully convinced that the sale price of 220 rupees is the full list price! Sounds familiar, doesn't it?

A radio-dealer conference in Delhi passed a recommendation that the present trade discount be reduced by 15 per cent, in a move to remove at least a part of the exaggeration from the discount. One manufacturer has already acted, and the others in India are expected to follow. It means tough going for a while until the deal-

ers in India learn to squelch their own bargaining instincts and develop salesmanship techniques instead. We wish them success.



CANAL 7. William C. Batista came up to the office of Electronics Magazine the other day with snapshots of his fine new TV station in Sao Paulo, Brazil. Mostly it's the latest GE equipment with studio in a beautiful structure that was once a wide-open night club. Just outside is a circus arena set up for a regular Sunday morning circus performance for the kiddies. On the roof of the building in one photograph, a huge neon sign spelling out CANAL 7 caught our eye. A query revealed that this was Spanish for Channel 7. Canal and channel are both waterways, so why shouldn't they be airways too?

Actually, a great many technical words are almost the same in the two languages. Pick up a Spanish radio magazine, and you'll be surprised at how many words you can recognize.

Around the World outside the United States, Cuba leads in television stations with 10 on the air. Runners-up are Great Britain 8, Canada 7, West Germany 7, and Mexico 6. Brazil now has 4, with 3 of them in Sao Paulo, according to Batista.



HANSOM RADIO. Enough people prefer the slowness and charm of the 19th-century hansom cab to support a horse-drawn cab service in St. Louis, Mo. Just as in modern taxicabs, Motorola two-way radio in the hansom cab cuts down idle time between fares. Thus service technicians get new business in a stable, of all places.

THE WINNER. It looks as if glass has come out ahead in the race with metal for walls of picture tubes. RCA, pioneering the metal tubes for black-and-white TV, gave them up quietly about six months ago, according to TV Digest. Except for replacements, RCA is now making only glass picture tubes for color as well as for monochrome.



KILL DEVIL HILL. To find the exact spot where the Wright brothers built this country's first airplane hangar 50 years ago, National Park Service men used a modern military mine detector after getting nowhere with visual searching over the shifting sands near Kill Devil Hill in North Carolina. When the detector registered the presence of metallic objects, they dug into the sand and found rusted nails, spikes, tin cans, and traces of household utensils of 1903 vintage.



LINE-UP. If initial tests prove successful, televising of the daily line-up of arrested persons at New York City police headquarters may become a regular program feature at each of the 85 precincts in the city, but nowhere else. A microwave station is contemplated, with microwave converters added to standard 21-inch TV sets. Almost all detectives would then be able to view the morning line-up without leaving their own commands. The private TV system could also be used for broadcasting pictures of missing persons and of suspects who are sought.

* * Please turn to page 81 * *

FACTS

NOT JUST CLAIMS

**FACT- 53 CLAIMS GRANTED
IN 5 UNITED STATES PATENTS—**

#2,585,670; 2,609,503; 2,625,655; 2,644,091; 2,661,423, others pending.

FACT- These antennas positively receive **ALL** channels 2-83 from **ALL** directions without a rotor motor.

FACT- These antennas have consistently **OUT-GAINED** and **OUT-PERFORMED** all others in actual public demonstrations.

FACT- These antennas will unquestionably **OUT-PERFORM** all others, on **YOUR** roof, with **YOUR** set, or **YOUR** money back.

FACT- **SAVES YOU MONEY.** Eliminates rotor motor, uses only **ONE** transmission line, uses only **ONE** antenna for both UHF & VHF—and only **ONE** simple, quick installation.

FACT- Perfect pictures have consistently been received as far as 3 times the guaranteed distances.

FACT- **ONLY** one antenna, **ONLY** one transmission line, **ONLY** one installation. You solve once and for all your **PRESENT** and **FUTURE** antenna problems.

MONEY BACK GUARANTEED TO RECEIVE *All* CHANNELS 2-83 FROM *All* DIRECTIONS AND POSITIVELY OUTPERFORM *All* OTHER ANTENNAS WITH OR WITHOUT A ROTORMOTOR

Guaranteed
60 mi UHF
60 mi VHF



SUPER 60

LIST PRICE
\$36.75
SEE YOUR
JOBBER

Guaranteed
100 mi VHF
30 mi UHF



ULTRA 150

LIST PRICE
\$43.50
SEE YOUR
JOBBER

**9 POSITION
ELECTRONIC
ORIENTATION
SWITCH**



PRICE INCLUDES

Antenna arrays - necessary stacking bars - 9 position switch - switch-to-set coupler - necessary hook-up harness - 7 1/2" stand-offs Individually boxed in mailable carton.

**NEW POLYMICALENE
4 CONDUCTOR TRANSMISSION LINE**

- Low Loss External Air Dielectric
- Matched Impedance
- Eliminates End Sealing
- Eliminates Condensation
- Up to 50% Less Loss Than Tubular When Wet
- Easily Spiraled
- No Breaking or Shorting
- Patents Pending - T. M. Reg.

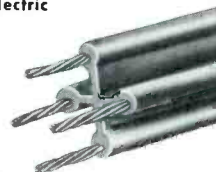

ALL CHANNEL ANTENNA CORP.,

70-07 Queens Blvd., Woodside 77, N. Y.

Hickory 6-2304

In the Interest of Quicker Service

(Continued from page 25)

would readily lead one to think that the set contained two separate and distinct troubles. It appears to have vertical-linearity trouble as well as an arcing in the high-voltage section. Any television technician who has never encountered a trouble resembling this may come to the conclusion that it is in the yoke or perhaps even in the damper circuit, since the vertical circuit obtains its plate voltage from that circuit.

However, such is not the case, although the trouble is caused by a very limited portion of the circuit. There are at most two components involved, namely those which made up the vertical wave-shaping network shown in Fig. 3. If either of these components becomes open for any reason, it will cause this effect in this particular set. If the capacitor C3 shorts, there will be 155 volts applied to the resistor R8, thereby burning it in half, opening the circuit and causing the effect shown in Fig. 2. This effect may also be caused by a cold solder joint in this circuit.

Fig. 4 illustrates the many varied results obtained from different receivers employing similar circuits. All resulted from an open circuit in the wave-shaping network.

Condensation on the Picture Tube

Is there anything more exasperating than to bring a chassis out

of a cold truck into the home of a customer and have the picture tube fog up so badly that it is impossible to install the set until it warms up? The process is always the same — wipe and wait and then wipe some more. About the time you think it is warm enough to put back into the cabinet, you feel the screen with your hand and find it wet again.

Condensation sometimes has another effect in addition to that of fogging the screen. It frequently causes a high-voltage leak between the bare anode connector found on some sets and the picture-tube coating. A leak of this kind can usually be detected by the odor of ozone that is produced. Condensation usually has very little effect on the picture unless it is bad enough to cause an actual spark to jump from the anode. Such a spark causes a ticking sound and a little black streak in the picture.

A very simple method for dealing with the condensation problem is shown in Fig. 5. This method consists of an ordinary home type of hair dryer blowing warm air on the screen of the picture tube. In a very short time, the tube will be warm enough to install without worrying about any more condensation. Although this requires a little time, it is still far short of that time required for the tube to reach room temperature on its own.

Hair dryers are owned by many housewives; however, they are so inexpensive that it would be advisable

to purchase one and carry it in the truck during the winter season. It will more than pay for itself in time saved.

Parts Cabinets

How can a shop be operated efficiently if the technician must search the length and breadth of the building each time he needs a particular component? It is a tiresome job to look through a drawer full of every kind of hardware imaginable for a lock washer to put on a volume control. Some people have photographic memories, but not many of us are blessed with this wonderful asset. It would be much easier to keep track of parts and accessories if we could just file them in the same manner in which we file correspondence. With this thought, of course, comes the automatic realization that it is quite impractical because of the odd component shapes; therefore, we have to do the next best thing that is practical. That would seem to be the use of cabinets having drawers which can be divided into smaller compartments.

There are a number of manufacturers producing small-parts cabinets which will easily meet these requirements. They can be found to meet almost everyone's taste and needs. We have knowledge of one technician who has employed the use of old cabinets that were made for dental instruments. He said they work out very well because they contain so many small, slender compartments which make them ideal for holding resistors and coupling capacitors.

Another service shop bought up a great many old wooden filing cabinets made for 3 by 5 cards. He then installed partitions in the drawers to form smaller compartments. This also worked out very well.

Fig. 6 illustrates just one of the many types of small-parts cabinets available to the technician. This cabinet was chosen for illustration because we thought it a good example of the type needed in a radio and television repair shop. It is small enough that it does not take up too much room for the number of drawers it contains, and yet it is very sturdily constructed. The over-all dimensions for the 20-drawer unit is 10 inches high, 12 1/2 inches long, and 6 inches from front to back. It has nonskid rubber feet on the bottom so that it can be placed on almost any surface. It is available with 12, 16, 20, 32, 64, and 128 drawers. Manufactured by Akro-Mils, Inc., it is sold under the trade name of Haz-Bin, Jr. It can be purchased at most radio parts distributors.

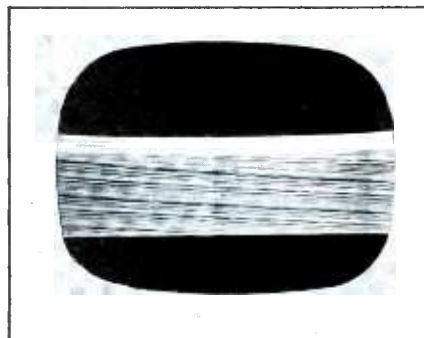
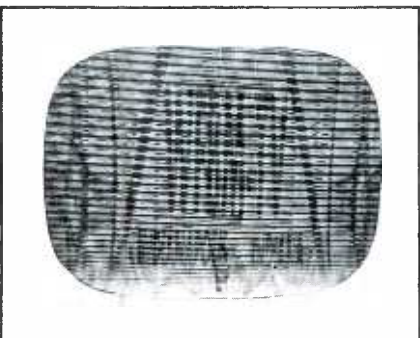

Fig. 4. Various Symptoms Resulting From Open Wave-Shaping Networks.

\$5000 IN PRIZES

... easy to win

503 PRIZES!

\$2000 - 1st prize

\$500 - 2nd prize,

\$100 - 3rd prize

100 - \$10 prizes,

400 - \$5 prizes

HOW TO WIN

To win one of these 503 prizes all you have to do is complete in 25 words or less "I like Pyramid capacitors because_____." You fill in this statement on a Pyramid contest entry blank which can be obtained from any electronic parts jobber selling Pyramid capacitors. You have this entry blank countersigned by your jobber or one of his salesmen and forward it to us attached to a Pyramid Dry Electrolytic Capacitor box top—the top being the part which carries the description of the item. There is no limit to the number of entries which you may make in this contest but each entry must be accompanied by a box top. Full rules for the contest appear on the entry blank.

It's so easy. Here is the kind of statement that might win:

"I like Pyramid capacitors because the line is so complete that I can always get what I need and don't have to worry about an off-brand capacitor."

"I like Pyramid capacitors because they always check out perfectly and don't deteriorate and so I know I won't have to call back at my expense."

PYRAMID



PYRAMID FEATURES:

- 1 Only one quality—the best at no premium. All Pyramid capacitors are made of materials commanded by rigid military specifications.
- 2 All Pyramid capacitors are non-hygroscopic.
- 3 Highest quality insulator material used in all production results in low leakage factor.
- 4 Exclusive non-contamination technique guarantees close tolerances and no deterioration. Peak performances for life.
- 5 Pyramid capacitors operate unchanged at ambient temperature of 85° centigrade.
- 6 Designed by service technicians across the country for their requirements.
- 7 Individually packaged for protection.
- 8 Permanently legible, high visibility ratings on each item.
- 9 100% absolute electronic inspection before shipment.

Pyramid is in its 10th year as a leading manufacturer of high-quality capacitors.

PYRAMID ELECTRIC COMPANY

1445 HUDSON BOULEVARD
NORTH BERGEN, N. J.

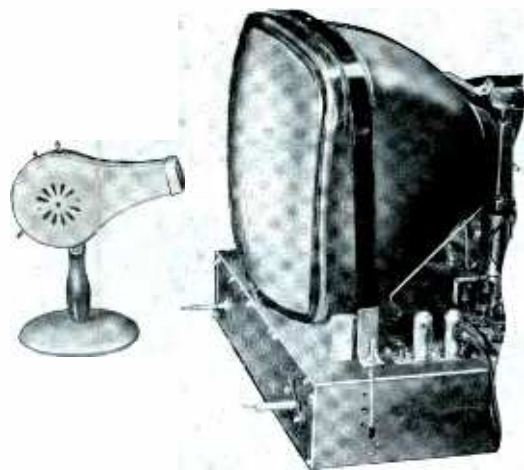

Fig. 5. Method of Warming Cold Picture Tube to Prevent Condensation.

The plastic drawers in this cabinet measure 1 3/8 by 2 3/4 by 5 3/4 inches inside. Fig. 7 shows the varied ways that the drawers may be divided into small compartments as desired. There is a lip on the back of each drawer to prevent the accidental spilling of the contents when the drawer is pulled all the way out. A place is provided on the front of each drawer for the index labels which are also provided with the cabinet.

Servicing Germanium Diode Circuits

Germanium diodes fail so infrequently that many service technicians are misled and do not suspect trouble in this particular component. It would be pure folly to believe these diodes incapable of ever failing. Germanium diodes can develop troubles very similar to those that develop in vacuum tubes. They may go

completely dead, become weak, or even become intermittent in operation. In some instances, it can be determined whether or not a diode is defective by tapping it and noticing whether the picture is affected.

Many technicians feel that a resistance measurement is effective in determining the condition of a germanium diode. Although it is true that a very high inverse resistance (several thousand ohms) would indicate that the unit is probably defective, such a test is not always dependable. If a substitute unit is available, a more positive indication can be obtained by connecting the new unit into the circuit. In most sets, this is a simple operation since only two leads need to be unsoldered. In some cases, the diode is mounted in clips which permit easy removal.

In those receivers having the germanium diode mounted in an en-

closed assembly, a signal-tracing procedure is most effective in determining the condition of a germanium diode. This is especially true in the case of a video-detector assembly. The voltages and currents present in this circuit are low, and the likelihood of a component failure other than the diode itself is remote. If the signal is traced to the input of the detector assembly and is absent in the output circuit, it is very probable that the germanium diode is defective.

The observance of polarity is necessary when replacing a germanium diode. If the unit is improperly wired into the circuit, a complete loss of signal or erratic operation will result; and under some conditions, damage to the new diode will result. When substituting a new diode for the purpose of checking the operation of a circuit, the failure to observe the proper polarity will give a false indication.

Excessive heat can permanently damage a germanium diode. Extreme care should be exercised when soldering germanium-diode connections. An effective way of dissipating some of the heat is accomplished by gripping the lead with long-nosed pliers between the diode and the solder connection. By doing this, the pliers absorb some of the heat from the wire.

The length to which the leads are cut is quite important in some circuits. If the leads are made too long, feedback might result. If the leads are made too short, undue strain might cause the diode terminals to be damaged. Lead dress is also an important consideration. The new unit should be mounted in as nearly the same position as the old unit.

Henry A. Carter



Fig. 6. Small-Parts Cabinet.

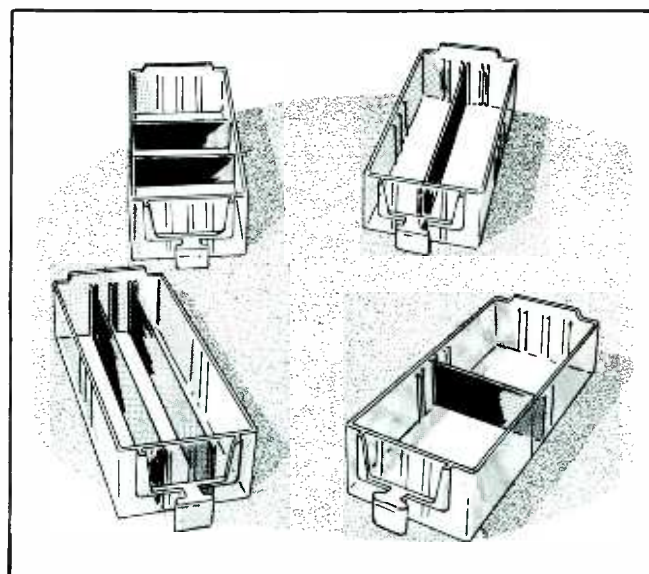

Fig. 7. Different Ways of Dividing Drawers into Compartments.

WIN \$8,000⁰⁰



STAN MUSIAL

1ST PRIZE \$
\$1,000⁰⁰ \$
CASH \$

MICKEY MANTLE



Westinghouse LEAGUE LEADERS AND DEALERS AID CONTEST

You never saw such an easy contest! Just fill in the names of the teams which were leading each major league on August 1, 1953. Then you have the first leg on the \$1,000 CASH First Prize in the exciting League Leaders and Dealer Aid Contest.

Fill in the Entry Blank illustrated on the opposite page. Have your distributor salesman certify that you have purchased 25 Westinghouse Receiving Tubes OR 1 Westinghouse Picture Tube. And mail your

ET-95049

Entry Blank NOW! An early entry can win one of the big prizes for you.

After naming League Leaders on August 1, 1953, write your answer to the cartoon situation pictured on the Entry Blank. Winners will be judged on the basis of correctness of team selection, and aptness, originality and effectiveness of cartoon solution.

Enter as often as you wish. The more entries you submit, the better chance you have at the 209 Big Cash and Merchandise Prizes. Ask your distributor salesman for additional entry blanks. He will be glad to sign them when he takes your tube order.

**YOU CAN BE SURE...IF IT'S
Westinghouse**

RELIATRON[®] TUBES

WESTINGHOUSE ELECTRIC CORPORATION, ELECTRONIC TUBE DIVISION, ELMIRA, N. Y.

IN PRIZES...

209 PRIZES FOR SMART SERVICE MEN

2ND PRIZE— \$700 in YOUR Choice of Merchandise

3RD PRIZE— \$400 in Merchandise YOU Select

4TH PRIZE— \$300 YOU Choose the Merchandise

FIRST, SECOND, THIRD AND FOURTH PRIZE WINNERS WILL MEET MICKEY MANTLE OR STAN MUSIAL IN THE BIG PRIZE AWARD DINNER WESTINGHOUSE HAS PLANNED FOR YOU IN NEW YORK

- 5 Fifth Prizes of \$140 Each in Merchandise
- 30 Seventh Prizes of \$35 Each in Merchandise
- 20 Sixth Prizes of \$70 Each in Merchandise
- 50 Eighth Prizes of \$20 Each in Merchandise
- 100 Ninth Prizes of \$15 Each in Merchandise

GET ENTRY BLANK ILLUSTRATED BELOW FROM YOUR **RELIATRON** TUBE DISTRIBUTOR

1. League Leaders on August 1st, 1953, were:

AMERICAN LEAGUE

NATIONAL LEAGUE

2. Here is what I would say to the lady in the Cartoon:

(ATTACH AN ADDITIONAL SHEET OF PAPER IF NECESSARY—100 WORDS MAXIMUM)

MY NAME

SHOP NAME

STREET

CITY.....STATE.....



THIS SPACE FOR DISTRIBUTOR SALESMAN'S CERTIFICATION

I certify this Entry Blank has been qualified by the purchase of (25 Westinghouse Receiving Tubes) (1 Westinghouse Picture Tube)

SALESMAN'S SIGNATURE

COMPANY NAME

CITY.....STATE.....

SEND ALL ENTRIES TO:

WESTINGHOUSE TUBE CONTEST

Box 610, Grand Central Station, New York 17, New York

To build a healthy, growing service business...

YOU NEED THESE 6 NEW

WALSCO

SERVICE ITEMS



NEW WALSCO CLEAN-O-MATIC...
Covers contacts on "Standard Coil" tuners and keeps them clean, silent, oxidation-free. Very easy to install. Tube of "Tunerlub" and crocus cloth included.
Cat. No. 1200 \$1.50 net



NEW WALSCO REEL-EASY
Portable wire reel holder. Light, durable, compact—weighs only 1 1/2 lbs. Handy to carry, easy to dispense lead-in wires. Eliminates tangled cables.
Cat. No. 503 \$3.60 net



NEW WALSCO VIEW BINS
Keeps small parts handy, sorted, visible and dust-free. Sturdy, tilt-type, spill-proof drawers reveal contents. No hidden corners. Silver hammetone finish. Welded steel.
Cat. No. 1010-6 bin \$4.95 net
Cat. No. 1010-12 bin 9.50 net
Cat. No. 1010-24 bin 16.95 net



NEW WALSCO TOOLS
New I.F. alignment tool for all UHF RCA, Zenith and other sets.
Cat. No. 2527 \$0.42 net
"Slug Saver" front end alignment tool for all "Standard Coil" tuners. Impossible to lose slugs with this patented tool.
Cat. No. 2528 \$0.63 net
Solder-ease tool. Bristles of brush and prongs of stainless steel. Solder will not stick.
Cat. No. 2529 \$0.99 net



NEW WALSCO FEED-THRU BUSHING
Bring antenna cables into the house the professional way. This bushing fits all lead-in and rotor cables. Terminate "open line" outside... bring flat line through bushing to set. Fits walls up to 1 1/2". Requires 3/4" hole.
Cat. No. 1551 \$1.17 net



NEW WALSCO GUY-TITE
Tighten guy wires faster and better with this new WalSCO tool. Does the job of a turnbuckle at a fraction of its cost.
Cat. No. 1568 Box of 100 \$3.60 net
Cat. No. 1566 Tool and 18 tites 4.95 net



WALSCO ELECTRONICS CORPORATION

3602 Crenshaw Blvd. • Los Angeles 18, Calif.

Canadian Factory Distributor: Atlas Radio Corp., Ltd., 560 King St. West Toronto 2-B.
Overseas Distributor: Ad Auriema, Inc., 89 Broad St., New York 4, N.Y.

Auto Radio Servicing Can Be Profitable

(Continued from page 37)

The service technician is not required to work outdoors, and the car is near the tools and test equipment.

Another requirement for the building is adequate space to accommodate at least two cars and the necessary shelves, benches, and equipment. Fig. 1 shows a work bench and typical storage shelf for sets already repaired. The width of the space where the cars are parked while removing or installing radios should be sufficient to allow the car doors on both sides to be opened simultaneously. A minimum width of 14 feet is recommended.

Besides the working area, a showroom for displaying new auto radios and accessories should be provided. This room can also serve as a waiting room for those customers who might prefer to wait while the work is being done on their cars.

Stock

Stocking an auto-radio shop is much the same as stocking any other, except that emphasis is placed on items such as the following:

Vibrators

Buffer capacitors

High-current fuses

Suppressors

Vibrator transformers

Auto antennas

Auto antenna lead-in cables

Replacement speakers

Back-seat speaker assemblies

These items should comprise the largest portion of the stock, for they will cover about 75 per cent of the servicing needs. In addition to these a regular stock of such items as tubes, capacitors, and resistors is required. It is also suggested that new auto radios be stocked for sale. These should be two or three types which are more or less universal; that is, they should be the types which are manufactured with several varieties of control heads for different makes of cars.

Arrangements should be made with dealers of new cars or with distributors of new equipment so that sets like those of the original can be obtained if the owner prefers this type unit. Assemblies of back-seat radio speakers are included in the foregoing list of stock, because there is quite a large market for them if car owners are made aware of their availability.

Tools

In addition to the usual hand tools used by every radio and TV technician, a different line of tools is needed. These tools are essential for making installations as well as for removing and reinstalling receivers. The following is a list of the tools that are required. (Parts marked with an asterisk are particularly required for installing auto antennas.)

Combination open-end and box wrenches, sizes 3/8 to 7/8"

Socket wrenches, sizes 3/8 to 1"

Ratchet wrenches, sizes 3/8 to 3/4"

*Electric drill

*Bits up to and including 1/2"

*One-inch reamer and brace

*Knockout punches

Extension light with shade

It is not necessary to have all three types of wrenches in the list; however, they are convenient and speed the work. Since these tools are most often used in the automobile to remove and install radios, it is suggested that they be mounted on a board or tool rack as shown in Fig. 2. In this way the tools are always where they can be found without having to hunt for them every time they are needed.

Job Tickets

A very valuable aid to the service technician is the use of three-section job tickets. They simplify such jobs as customer identification, chassis identification, and records. Fig. 3 shows a typical example of one of these tickets.

Each section of the job ticket has the same number printed on it. The first section has a string for attaching it to the receiver and contains the name and phone number of the repair shop. The second section is used for a servicing record and has spaces for the following information:

Customer's name

Customer's address

Customer's phone number

Date on which set came into shop

Date on which set is promised the customer

Complaint

Material used

Prices of materials used

Labor charges

Total charges

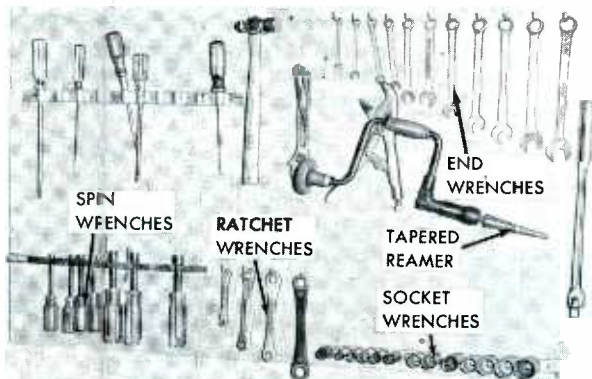

Fig. 2. Rack for Tools Used in Auto When Installing and Removing Receivers.



Fig. 3. Typical Job Ticket Showing Three Sections.

Speaking Of EXTRA HIGH OUTPUT

THESE ASTATIC CRYSTAL
PICKUP CARTRIDGES ARE
YOUR MOST BRILLIANT PERFORMERS

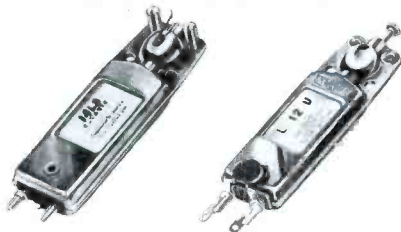
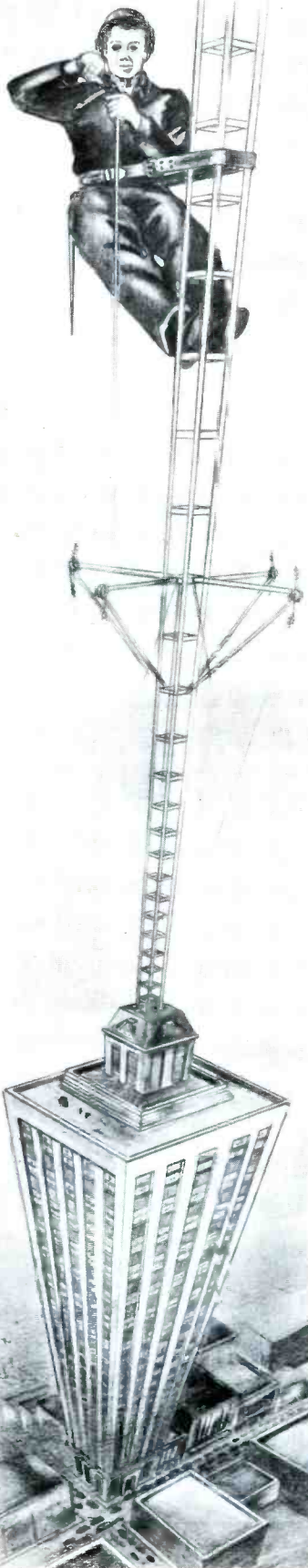

Astatic 14, 15
and 16L-3 Types,
Extra High
Output Series

Astatic L-12-U Model,
Dual-Output, Remov-
able Condenser
Harness, Universal
Type

The most effective answers to a host of high output requirements are found among these examples of advanced Astatic engineering and precision mass production. The performance data for each appears below. But these cold statistics cannot cover the warm richness of tone, the smoothness of response and other familiar Astatic qualities designed and built into these units. If you have not already done so, start adopting them now to the fullest possible extent in your cartridge replacement stocks. Higher established quality of results is assured with Astatic Crystal Cartridges. Write today for full details of crystal cartridges replaced by those shown, other pertinent information.

KNOWN THE WORLD OVER FOR HIGHEST
QUALITY AT LOWEST POSSIBLE COST

Model	List Price	Minimum Needle Pressure	Output Voltage 1000 c.p.s. 1.0 Meg. Load	Frequency Range c.p.s.
14L3-AG*	\$ 7.00	10 gr.	2.8†† 2.4†	50-4,000
14L3-D	8.50	10 gr.	2.8†† 2.4†	50-4,000
15L3-AG*	7.00	10 gr.	4.0†† 3.5†	50-5,000
15L3-D	8.50	10 gr.	4.0†† 3.5†	50-4,000
16L3	6.00	16 gr.	6.2†† 4.0†	50-5,000
L-12-U	5.50	1 oz.	1.25†† or 4.0	50-5,000

* "AG" in model designation stands for ALL-GROOVE needle tip of special design and size to play 33-1/3, 45 and 78 RPM Records.
† RCA 12-5-31-V Test Record or Equivalent.
†† Audio-tone 78-1 Test Record.



EXPORT REPRESENTATIVE, 401 Broadway, New
York, N. Y. Cable Address: ASTATIC, New York



Fig. 4. View of Air Hose Used for Injecting
Antistatic Powder Into Tires.

It is suggested that the first section of the ticket might be attached to the chassis for identification when it first comes into the shop. It should then be left on so that the next time that particular set comes in for repair, it will be easily identified and the records can be checked to see what was done the last time it was in for service. The third section is the customer's claim check showing the name, address, and phone number of the auto-radio repair shop.

Suggestions

Spending too much time on an automobile receiver before removing it can be wasted time. It may be true that a certain percentage of car radios can be fixed without removing them; but particularly with some of the new sets, time can actually be saved by pulling them even though they may only require a new tube. Many of the newer radios have tube-compartment covers which are very difficult to get off and on while the radio is still in the car.

Another reason for removing a radio is to check the buffer capacitors, if the vibrator is replaced. Many auto-radio shops replace the buffers as a precautionary measure without bothering to check them. It may be that a defective buffer capacitor caused the original vibrator to fail and the replacement of the capacitors will prevent possible damage to the replacement vibrator.

It is also good practice when possible to check the current drain of the radio when replacing the vibrator. This will aid in determining whether the vibrator was abused or just went bad from age. The measured current drain can be compared to that specified in the service literature on that particular receiver. If the current reading is more than one ampere too high, check the components of the set for a leaky capacitor or a short.

Hardware items such as knobs and mounting nuts are not so apt to get lost if they are placed back on the set immediately after removing it from the car. At the same time, tag the set with a job ticket. If there are any long brackets used in mounting the receiver, these should be attached together with a piece of masking tape on which the job-ticket number can be marked for identification. Then they should be placed in a box where they can be found with no difficulty.

The auto-radio shop owner whom we contacted for information had an air compressor and hose which was used to inject antistatic powder into automobile inner tubes. This powder minimizes much of the radio interference caused by static build-up in the tires. Fig. 4 shows the air hose connected to a pipe coming up from the compressor in the basement.

There are many types of DC power supplies available on the market and suitable for use in an auto-radio repair shop. However, since some of the new cars are starting to use 12-volt systems, the power supply will have to be capable of delivering this amount of voltage. The output voltage of the supply should be variable to enable the service technician to test the set under typical operating conditions, since the voltage in the car changes with varying load and engine speed. A vibrator may work perfectly under normal voltage but not when the voltage drops to 5 or 5.5 volts, which it may very well do when the car is sitting still with the lights on. The vibrator should operate until the voltage drops to approximately 5 volts. If it does not operate at this low voltage, the chances are that it will give trouble and should be re-

Fig. 5. View of Test Bench Showing Instruments, Tools, and DC Power Supply.



placed. Fig. 5 shows a bench and test panel in an auto-radio service shop. Notice the meters and the voltage control for the DC power supply.

Advertising by shops of this type should emphasize the fact that they specialize in servicing automobile radios. People seem to have more confidence in a person or company that specializes in a particular field.

A large amount of work can be obtained from automobile dealers and garages. The best way to secure this business is to contact the managers of dealerships and garages and acquaint them with your servicing facilities and location. Very few dealers or garages have service departments that are equipped to do radio servicing. In many cases, arrangements can be made to do their installation jobs as well as their radio repair work. They may prefer to remove the sets themselves and bring them to your shop for service; in this way, they will also make a

small profit for themselves. Figs. 6 and 7 show a new radio being installed in a 1954 Chevrolet for a new-car dealer. The particular radio for this car has the speaker separate from the chassis. Fig. 6 shows the speaker being put into place, and Fig. 7 shows the chassis being positioned. The installation was completed by mounting the antenna and by running power and antenna connections to the receiver.

Should the reader decide to enter the specialized field of auto-radio servicing, the foregoing material may be helpful, since it has been drawn chiefly from the actual experience of a successful operator in this business. We wish to thank Francis L. Eddy, owner and operator of Eddy Radio Service, Indianapolis, Indiana, for his splendid cooperation during the preparation of this article.

Henry A. Carter



Fig. 6. View of Service Technician Installing Speaker Preparatory to Installing Radio in New Car.



Fig. 7. View of New Radio Being Placed Into Position.

Before you install another antenna

take this

Irving Rose, prominent Chicago designer and president of Voice and Vision, noted television and high fidelity center, takes the “look test” of fringe reception from Milwaukee.



using JFD Super JeT antenna

using antenna A



1. Four TV receivers of one brand, same model, same production run were set up. Technicians went over these sets to make sure they were identically aligned.
2. Three other leading high gain TV antennas were installed—each oriented for maximum performance. Each antenna was connected to a set by identical type lead-in.
3. Each receiver was tuned with infinite care to the same channel to make certain the reception was as good as possible. The picture is the proof—the result can be immediately seen—the JFD Super JeT outperformed all others.
4. The chart shows why the “Look-test” is your proof positive of sharper, clearer, more brilliant pictures . . . in Black and White or Color on all channels present and future.

JeT 213 (single Bay) \$20.75

JeT 213S* (2-Bay) \$42.50

*complete with stacking transformer

"look-test"

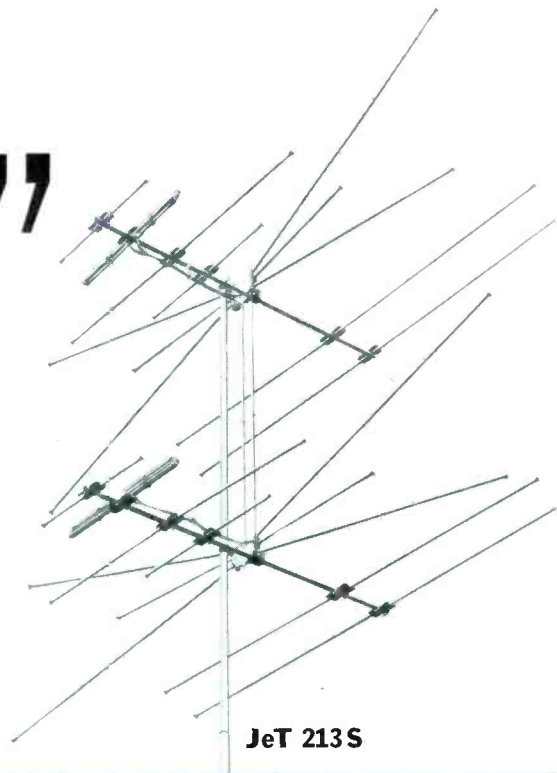

Here is your clinical proof that only the **JFD Super JeT TV antenna Out-Performs** all others on all channels

using antenna B



using antenna C



Burton browne advertising

ANTENNA LIST	CHANNELS												
	2	3	4	5	6	7	8	9	10	11	12	13	
Competitor A Radar Screen with 3 dipoles (2-bay) Partly Pre-Assembled	\$42.36	4.5	4.3	7.3	7.0	7.0	10.00	10.75	11.5	11.7	11.0	11.5	11.6
Competitor B Radar Screen with 2 dipoles (2-bay) Not Assembled	\$34.95	0.75	3.25	4.5	3.5	3.5	6.0	7.0	6.5	7.75	8.0	7.5	6.0
Competitor C Bedspring (4-bay) Pre-Assembled	\$55.00	4.0	5.0	7.0	6.25	5.0	5.25	6.0	5.25	7.25	9.25	6.5	7.0
JFD Superjet Model JeT 213 S (2-bay) Pre-Assembled	\$42.50	6.5	7.5	9.5	8.5	8.5	11.0	11.0	12.0	12.0	11.25	11.75	12.0

DB GAIN



**JFD Manufacturing Company,
Brooklyn 4, N. Y.**

World's largest manufacturers of TV antennas and accessories

Write for Bulletin #230

Crystal or Ceramic?

An analysis of factors to be considered in the replacement of phonograph pickup cartridges

- 1 How Do Crystal and Ceramic Pickup Cartridges Generally Compare?**
 The chief differences are two: The ceramic cartridge is relatively immune to damage from excessive heat and/or humidity, while the crystal pickup cartridge is subject to damage and deterioration when exposed to excessive climatic conditions. The second difference is output. The ceramic cartridge has only $\frac{1}{2}$ to $\frac{1}{3}$ the voltage output of a comparable crystal unit. In all other respects the two types are very much alike and one can be made to equal the other in frequency response and ability to track in the record grooves.
- 2 Can Ceramic Pickup Cartridges be Substituted for Crystal Pickup Cartridges?**
 Yes, providing the output voltage and response of the ceramic is comparable to the crystal. If not comparable, the associated circuit must be modified to provide the necessary frequency characteristics and additional gain.
- 3 What are the Usual Results When Ceramic Pickup Cartridges are Substituted for Crystal Pickup Cartridges Without Making any Circuit Changes?**
 To make up for the generally lower voltage of the ceramic cartridge it is necessary to operate the phonograph at a higher volume control setting. Sometimes the phonograph does not have the additional gain available without excessive hum pickup.
- 4 Are any Manufacturers Currently Using Ceramic Phono Cartridges in Their Original Equipment Production?**
 Yes. However, they do not use ceramic pickup cartridges interchangeably with crystal pickup cartridges in the same model phonograph. Individual circuits are patterned to either ceramic or crystal phono cartridges.
- 5 What is the Actual Output of Crystal vs. Ceramic Cartridges?**
 Generally speaking, crystal cartridges have three to five times the output level of comparable ceramic cartridges for 78 rpm—two to three times for fine groove and 3-speed designs.
- 6 Are Ceramic Cartridges Considered Superior to Crystal Cartridges?**
 They are superior only insofar as their natural resistance to excessive heat and/or humidity is concerned. The crystal cartridge generally is higher in output level than the ceramic cartridge.
- 7 Is it True that Hot and Humid Climates Dictate the Use of Ceramic Pickup Cartridge over Crystal?**
 Either a ceramic or a specially-protected crystal such as the Shure "HS" (Humi-Seal) series should be used where extreme humidity conditions exist. Ceramics (but not the crystals) can withstand temperatures above 125°F without permanent damage.
- 8 What is the Risk in Recommending the Substitution of a Ceramic for a Crystal Unit When Making a Phono Cartridge Replacement?**
 The phonograph manufacturer generally modifies his circuits when changing from crystal to ceramic cartridges; so it can be assumed as unwise to use ceramic cartridges as replacements for crystal cartridges. On the same basis, it would be unwise to use crystal cartridges as replacements for ceramic cartridges.
- 9 In the Final Analysis What Factor Should be Carefully Considered?**
 Equipment manufacturers utilize highly skilled engineering staffs. They devote a great deal of research and testing to the specification and selection of phono cartridges giving the most desirable performance with their particular equip-



This analysis has been prepared as a service to the industry by Shure Brothers, Inc., Manufacturers of both Crystal and Ceramic Phonograph Pickup Cartridges. If you are interested in obtaining extra copies (including a specific output level comparison chart) write SALES DIVISION

SHURE BROTHERS, Inc.

Manufacturers of Microphones and Acoustic Devices • 225 W. Huron St., Chicago 10, Illinois

Antenna Principles

(Continued from page 9)

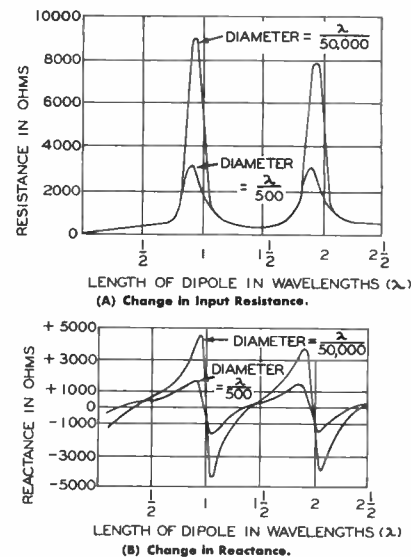

Fig. 4. Effects Produced by Changes in Dipole Length.

dipole is not a half wavelength. Under these conditions, the field pattern will undergo considerable change. When the antenna becomes one wavelength, the field pattern consists of four major lobes at an angle of approximately 54 degrees with the antenna. This is shown in Fig. 5. Additional patterns are shown for various multiples of a half wavelength. It may be noted that as the number of wavelengths increases, more lobes are formed. This means increased susceptibility to interference from unwanted stations.

The actual physical length of a dipole is somewhat shorter than a half wavelength in space. This may be partially attributed to the resistance of the antenna conductors which reduce the speed of the wave traveling in the antenna. An additional effect is introduced by a relationship between conductor thickness and conductor length.

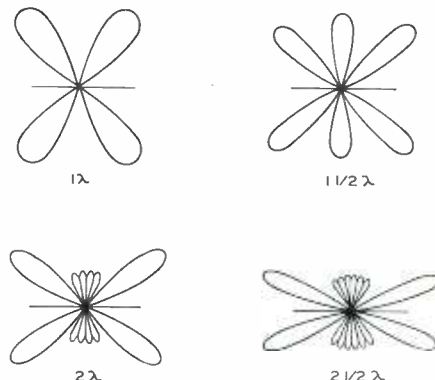

Fig. 5. Field Patterns of a Dipole at Various Multiples of a Half Wavelength.

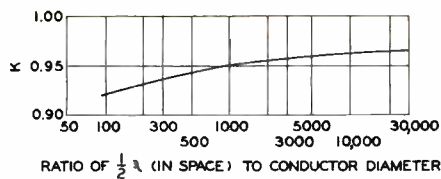

Fig. 6. Effect of the Diameter of the Conductor on the Value of K.

The length of a half wave in space is given by the formula

$$L = \frac{492}{f}$$

where

L = the length of a half wave, in feet,

f = the frequency, in megacycles.

The length of a half-wave dipole requires a modification of this formula so that

$$L = \frac{492 K}{f}$$

where

K = a constant dependent upon the conductor diameter and upon the length of a half wave.

The constant K will vary as shown in Fig. 6.

If the antenna is supported by insulators at the ends, the capacitive effect of these insulators will also require a slight reduction in antenna length.

Folded Dipole.

The folded dipole is a variation of the dipole antenna. The folded dipole consists of a half-wave section in parallel with a conventional dipole and shorted together at the ends. An example of this antenna appears in Fig. 7. The spacing between the sections is small when compared to the length. For the low VHF channels, this spacing may be 2 to 3 inches; on the high VHF band, the spacing is usually 1 to 2 inches.

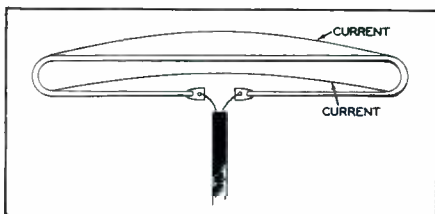

Fig. 7. A Folded Dipole Antenna.

The total length around the loop may be found by applying the formula

$$L = \frac{955}{f}$$

where

L = the total length, in feet,

f = the frequency, in megacycles.

The addition of another element causes the current to divide equally between the two sections, as shown in Fig. 7. This causes the characteristic impedance of the antenna to be four times the impedance of a single dipole. The increased value would then be approximately 300 ohms. The antenna may then be properly matched to 300-ohm ribbon.

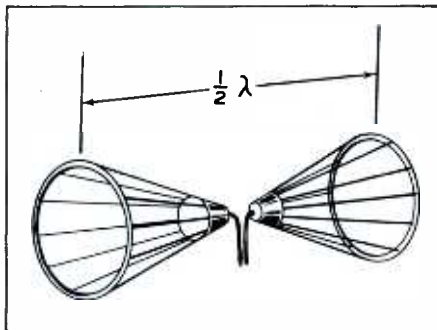

Fig. 8. A Conical Antenna.

The directivity and gain of a folded dipole are approximately the same as for a single dipole.

The presence of an added section in parallel with the single dipole effectively increases the size of the conductor. As a result, the antenna will exhibit slightly increased bandwidth.

Broadband Dipoles

As mentioned previously, an increase in the diameter of the dipole elements results in a broader frequency response because the Q of the system is lower. Large diameters become increasingly effective at the higher frequencies; consequently, excellent results are possible in the

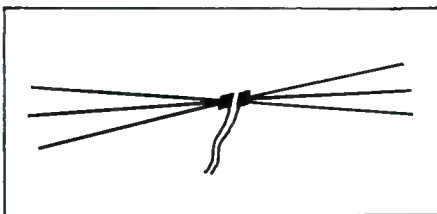

Fig. 9. A Version of the Conical Antenna Used for VHF Television Reception.

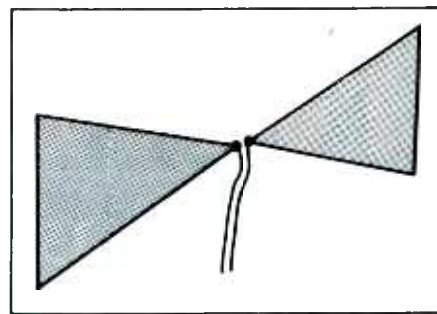

Fig. 10. The Fan Dipole Used for UHF Television Reception.

UHF spectrum. Mechanical limitations reduce the possibilities of achieving broader frequency response by this method on the VHF channels.

Another type of broadband dipole is the conical antenna illustrated in Fig. 8. The performance of this type of antenna is such that the reactive component of the input impedance is maintained at a fairly constant level over a wider bandwidth than is possible with a conventional dipole. This means that a better impedance match between the antenna and the lead-in is possible over a broad range of frequencies. The antenna in Fig. 8, however, is not too practical because of its large physical dimensions. As a compromise solution to this problem, a more practical design was developed. The more familiar modified form of the conical is shown in Fig. 9. This type of construction has permitted a practical design for television applications.

With the expansion of UHF television, another form of the conical gained wide acceptance. This design is the well-known fan dipole or bow tie shown in Fig. 10. This version of the conical presents a solid surface area to the signal.

Although these basic types of antennas are used in many different combinations, their principles of operation remain the same.

Parasitic Antennas

The elementary half-wave dipole in its various forms does not

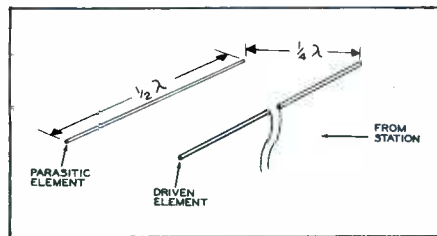

Fig. 11. A Two-Element Array With One Driven Element and One Parasitic Element.

NEW

Model RM-15 ROOF MOUNT

AGAIN South River has the serviceman in mind! With the new South River Roof Mount Model RM-15 his job is a quick, easy, efficient operation. A unique "walk-up drop-lock" feature permits ONE MAN roof-mounting for single mast installations. This mount allows fast, simple installation from a horizontal position. After the antenna and mast are "walked-up" to the vertical position, the mast holder DROPS into a special notch and LOCKS securely. The serviceman is then free to guy the mast.

Made of heavy-gauge metal, heavily plated for rust resistance and embossed at all critical points for extra strength and rigidity, the 5" long mast socket accommodates masts measuring up to 1 1/2" O. D.

The mast is secured in the mounting socket with 2 rugged hex screws, eliminating the danger of the installation vibrating loose. Two "in line" holes in mounting base permit bolting directly into heavy roof cross member.

FROM

South River

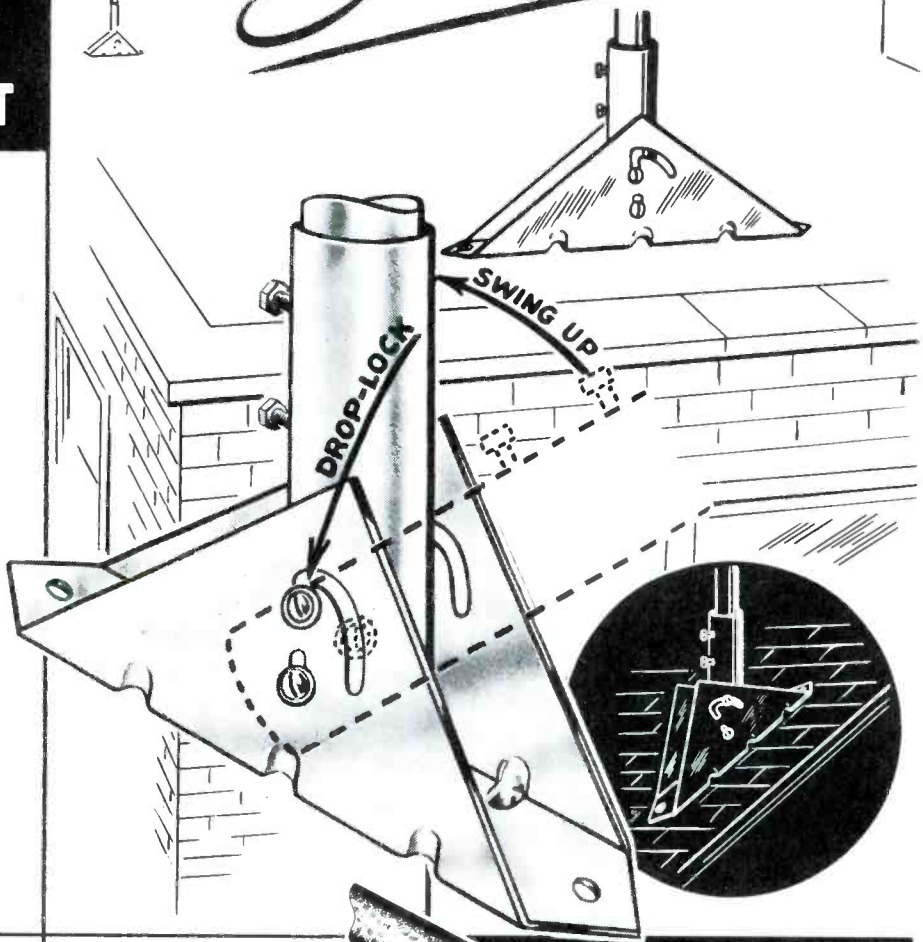

Rust-Proof

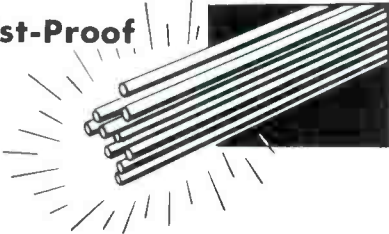

ALUMINUM TUBING

Only South River is able to offer the industry this super-strength product extruded especially for us. The new aluminum tubing is fabricated of 63S-T6, a special structural alloy designed for maximum strength. Aluminum itself is bright and non-rusting, affording a lasting finish. Made with a .054 wall by 1-1/4" dia., in 10' lengths, the tubing is supplied 25 to a bundle.

Stronger, Tight-Twist GUY WIRE

Do the best installation job... use South River's new hot-dip galvanized guy wire, carefully drawn with a tighter, stronger twist for extra durability under stress—providing tensile strength up to 70,000 lbs. per square inch. Produced in either 18 gauge or GENUINE 20 gauge, both available in either 4 or 6 strands, this vital product comes to you in 1,000' lengths on metal spool, or in continuous loops of 50' and 100' lengths.



Exclusive STEEL TUBING

Hot-Dip Galvanized Inside and Outside!

South River presents another FIRST in the industry... 18 gauge steel tubing, hot-dip galvanized INSIDE AND OUTSIDE... affording maximum utility and long life because of complete, all-over protection. It greatly increases the resistance of steel to the extreme atmospheric corrosion of shore and industrial areas. Hot-dip galvanizing is the only experience-proven rust resistant finish known. The tubing is available in 5' and 10' lengths, 10 to a bundle, is 1-1/4" dia., and is supplied with either plain or swaged end for mast extension.

South River's INSIDE AND OUTSIDE hot-dip galvanized steel tubing is another step forward in combating rust and corrosion. Your use of this product will prove that you keep abreast of important, new developments, for increased customer satisfaction.

South River

METAL PRODUCTS CO., INC., South River, New Jersey

Write for Complete Catalog

PIONEER MANUFACTURER AND OUTSTANDING PRODUCER OF THE FINEST LINE OF ANTENNA MOUNTINGS

In Canada — A. T. R. Armstrong Ltd., Toronto

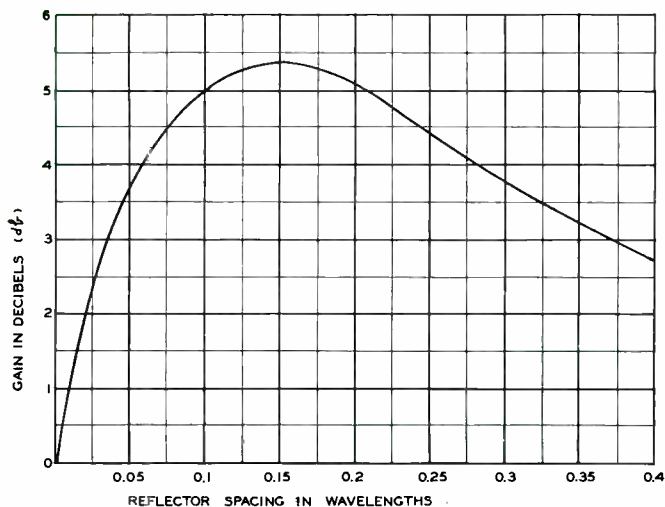

Fig. 12. Variations of Gain With Respect to Element Spacing.

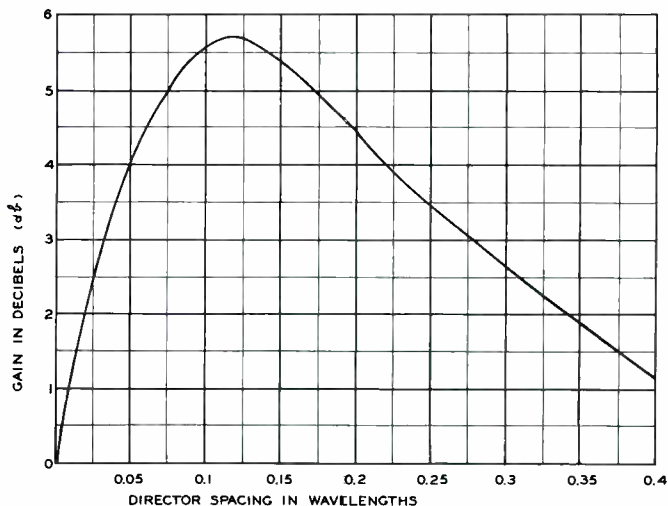

Fig. 14. The Effect of Director Spacing on Antenna Gain.

always provide adequate reception, particularly in areas of low signal strength or where ghosts constitute a problem. Conditions such as these compel the use of antennas with higher gain or sharper directivity, if satisfactory results are to be obtained. Many of the complicated antenna arrays which exhibit the characteristics discussed have evolved from the basic dipole. It should therefore prove beneficial to follow the step-by-step sequence in the development of one of the more complicated types of antennas. Perhaps one of the most logical types to select for this analysis is the Yagi antenna, since it is widely employed for television installations.

If a half-wave resonant conductor is brought into close proximity with a half-wave dipole, several interesting things occur. For our first assumption, consider this resonant conductor to be one-quarter

wavelength from the dipole and in a plane parallel to it. The dipole is connected to a feedline and is called the "driven element"; the other element is not connected to a feedline and is called a "parasitic element." This arrangement is shown in Fig. 11.

In order to analyze this antenna, assume that the antenna intercepts a signal from the direction indicated by the arrow in the figure. The signal from this direction strikes the driven element and induces a voltage in it. When the signal strikes the parasitic element, a similar condition exists and a voltage is also induced in it. Since the parasitic element is not connected to a load, it reradiates virtually all of the induced signal. The reradiated signal returns to the driven element and induces a signal in it. The voltage induced by this reradiated signal has a phase relationship which will reinforce the original signal in the driven element.

A gain has therefore been introduced into the antenna system. When a parasitic element acts in this manner, it is called a "reflector."

The input impedance of a dipole-reflector combination is less than the impedance of a dipole and constitutes a problem in matching this type of antenna with a transmission line.

The gain of a two-element array is a function of the spacing between the director and the reflector. The manner in which the gain varies with spacing is shown in the graph of Fig. 12. This graph indicates that maximum gain is obtained by placing the reflector .15 wavelength from the driven element. This spacing would modify the phase shift necessary for proper reinforcement of the signal in the dipole. Some method must be employed to make the phase shift the same as obtained with a quarter-wavelength spacing.

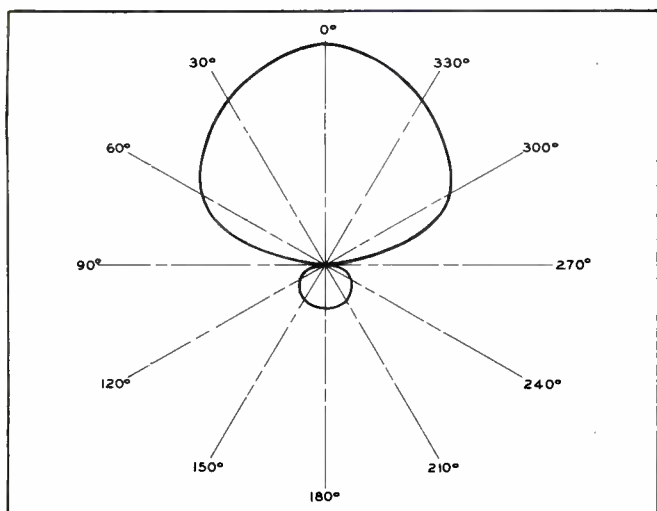

Fig. 13. The Horizontal Directivity Pattern of a Two-Element Antenna.

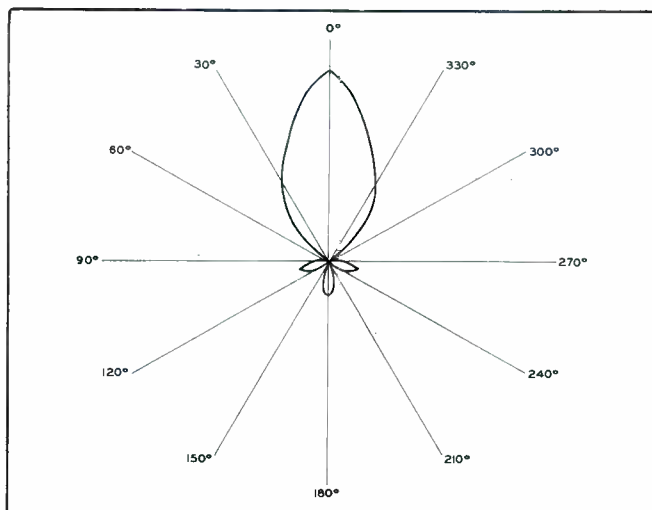

Fig. 15. The Horizontal Directivity Pattern of a Three-Element Antenna.

If a resonant circuit is tuned to a frequency lower than the applied signal, the circuit will act inductively and the current will lag the voltage. Since the reflector acts as a resonant circuit, it may be physically lengthened and tuned to a frequency lower than the dipole. The reflector will then act inductively and introduce the phase shift necessary for proper reinforcement of the signal in the driven element. The degree of phase shift required when the spacing between parasitic and driven elements is .15 wavelength is accomplished by making the reflector 5 per cent longer than a half wavelength. The two-element antenna will then exhibit maximum gain.

The directivity pattern is altered somewhat from the figure-eight pattern of the dipole antenna. This is readily seen by referring to Fig. 13 which shows the horizontal pattern for the two-element array.

Maximum gain is obtained in only one direction with very small gain in the opposite direction. The ratio of response in the forward direction to the response from the rear is referred to as "front-to-back ratio." A high front-to-back ratio is a very desirable characteristic when a source of interference is located to the rear of an antenna.

A further improvement in gain and front-to-back ratio may be ob-

tained by the addition of a third element. This element is placed in front of the antenna, parallel to it, and in a plane containing the driven element and the reflector. This second parasitic element is referred to as the "director." The effect produced by the director is a function of its spacing with reference to the driven element and its length. A gain curve similar to the one for the reflector is shown in the graph of Fig. 14. This graph indicates that the spacing for maximum gain is approximately .1 wavelength between the driven element and a single direction. The action of a director is similar to that of a reflector in that it reradiates the intercepted signal; however, because of its position with respect to the signal source and the driven element, it is necessary to introduce a phase shift opposite in nature to that of the reflector. The phase shift is accomplished by making the director shorter than the driven element. It will then be resonant to a higher frequency. The director will act capacitively, since it is tuned above the operating frequency; and this condition will cause the voltage to lag the current. The proper amount of phase shift occurs when the director is approximately 4 per cent shorter than the driven element.

The addition of this third element reduces the input impedance of the antenna. Furthermore, the main lobe of the directivity pattern is narrowed, as shown in Fig. 15. An idea of the front-to-back ratio may be obtained by noting the difference in the size of the forward and rear lobes.

More elements may be added to the antenna to modify its characteristics further. These added elements are usually directors because they provide the most improvement. A second reflector does not ordinarily

when it's a
QUAM
Adjust-a-Cone[®]
SPEAKER

you can
SELL IT
and
FORGET IT!

Quam Speakers just don't come back. Ask any serviceman or distributor who handles them. The patented Adjust-a-Cone suspension and the patented U-shaped coil pot, combined with Quam's advanced production and inspection procedures, are your assurance that every Quam Speaker is a trouble-free speaker.

A FREE copy of the latest Quam Catalog, listing over 100 replacement speakers, is available from your distributor, or from the Quam-Nichols Company.

ask for **QUAM** the quality line for all your speaker needs

QUAM-NICHOLS COMPANY
234 EAST MARQUETTE RD. • CHICAGO 37, ILLINOIS

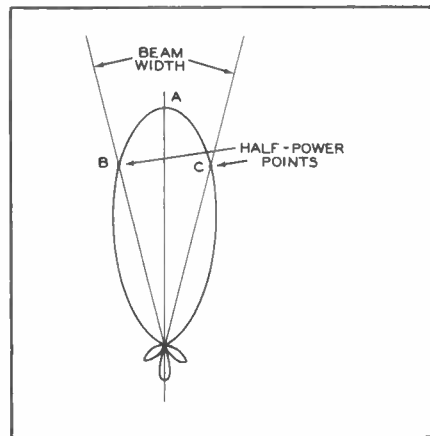

Fig. 16. Determining Beam Width From a Horizontal Response Pattern.

improve the antenna sufficiently to warrant its use. Such is not the case for directors; several more directors may be added. Most Yagi antennas for television do not have more than 12 elements. The use of more than this usually results in the antenna being too directive for ordinary applications.

Every element that is added to the array will decrease the input impedance. If several elements are used, the input impedance may fall to a value of 10 or 15 ohms. It is therefore necessary that some method be employed to raise this impedance to a value that will more nearly match the impedance of the transmission line. One satisfactory solution is the use of a folded dipole for the driven element. Other methods consist of various types of matching to raise the input impedance.

Frequency response is another characteristic which must be considered. An increase in the number of elements causes a corresponding decrease in the bandwidth of the antenna. The Yagi antenna is highly sensitive to frequency changes. Manufacturers of television antennas employ many methods for overcoming this limitation in the multielement antenna. Manipulation of element size, spacing, and length are just a few of such methods. The extent to which these methods are employed depends upon the performance required for the particular antenna array. For example, front-to-back ratio may be compromised in favor of gain.

The directivity of an antenna is frequently given in terms of beam width which is the included angle between half-power points on the main lobe. A half-power point is one where the response to a received signal is .707 times the response in a direction through the center of the main lobe. This is illustrated in Fig. 16. The response from point B or point C is equal to .707 times the response from point A. As the antenna is made more directive, this angle becomes smaller and the antenna is said to have a narrow beam width.

TOTAL NUMBER OF ELEMENTS	2	3	4
GAIN IN DECIBELS	5	7	9
FRONT-TO-BACK RATIO IN DECIBELS	13	20	25

Fig. 17. Typical Characteristics of Various Parasitic Antenna Arrays.

The Yagi antenna is relatively simple in construction. Much of this simplicity lies in the fact that the center of the parasitic elements may be grounded to the same metal support rod. This is possible because the centers of these half-wave elements are at practically zero voltage. When the center point is grounded, the operation of a parasitic element remains undisturbed.

The characteristics of several types of parasitic arrays are shown in the table of Fig. 17. This table indicates that as the number of elements is increased, the gain and

front-to-back ratio will also increase. As elements are added, each one will have less effect than the last. This is true because the elements are farther from the driven element.

The Yagi is essentially a narrow-band antenna, although compromise designs are often incorporated to extend the bandwidth. Another intrinsic characteristic of this antenna is its sharp directivity which necessitates careful orientation at the time of installation.

Don R. Howe

A New Champion!
tops in the field of molded tubular capacitors
C-D's Cub
CORNELL CUB

- * Outperforms all other molded tubulars in humidity tests!
- * Stands up under temperatures up to 100°C.
- * You get more for your dollar with this premium tubular designed and built especially for replacement needs, with "better-than-the-original" performance!
- * Ask your C-D jobber about the special "Cub-Kit"!

For the name of your C-D distributor, see the yellow pages of your classified phone book. Write for Catalog to: Dept. PF-44 Cornell-Dubilier Electric Corp., South Plainfield, N. J.

CONSISTENTLY DEPENDABLE
CORNELL-DUBILIER

There are more C-D capacitors in use today than any other make.

PLANTS IN SOUTH PLAINFIELD, NEW JERSEY; NEW BEDFORD, WORCESTER AND CAMBRIDGE MASSACHUSETTS; PROVIDENCE AND HOPE VALLEY, RHODE ISLAND; INDIANAPOLIS, INDIANA; SANFORD AND FUGUAY SPRINGS, NORTH CAROLINA. SUBSIDIARY RADIART CORPORATION, CLEVELAND, OHIO



It's Time for Portables

(Continued from page 19)

It is rather difficult to say just what caused the coil to open, but it had a spot which looked as if it had been touched by a hot soldering iron. This may very well be what had happened.

The servicing experience with this radio illustrates the need for using care when soldering in portable radios so that components will not be

damaged. It also shows that the presence of static and noise is an indication that the trouble probably lies in the RF or IF portions of the receiver.

Case No. 2.

The customer who brought in a General Electric Model 140 complained that he could not get any stations on it. The trouble was detected soon after the front cover was opened. Fig. 3 shows a close-up photo of the broken antenna strap which connects the antenna loop in the front cover to the chassis within the case.

There is nothing unusual about this trouble. We only mention it to point out the fact that it can be rectified without having to stock these straps or without making a visit to the distributor. It is only necessary to obtain a piece of brass or bronze shim stock from your nearest hardware store or auto parts dealer. Make sure that it is very thin and yet has spring to it. Cutoff a strip 3/16 inch wide and 2 inches long. Take the cover off the front door of the set by removing the very small screws, two of which are visible in Fig. 3. Cut off the piece of broken strap on the door even with the edge of the loop antenna. Pull the other end of the broken strap out of the chassis until it can be unsoldered from the wire to which it is attached. Fig. 4 is a view of the loop antenna after the door cover is removed.

Slip the new strap under the antenna loop, between the loop and the broken strap, so that it is projecting out from under the other side of the loop and so that the end is lying on the end of the broken strap where the loop is soldered. (See Fig. 4.) Then solder the new strap directly on the broken one. Solder the other end of the new strap to the wire which leads into the radio, and work the wire and strap back into the cabinet slot so that the strap assumes the shape of the original design. It may be necessary to shape the new strap so that it will not touch the cabinet or chassis. This can best be done by using long-nosed pliers.

This service experience points out the importance of a preliminary visual inspection. Much needless labor may be avoided if this rule is followed.

Case No. 3.

The customer who brought in a General Electric Model 600 thought that it only needed a new battery pack. However, when the new battery was

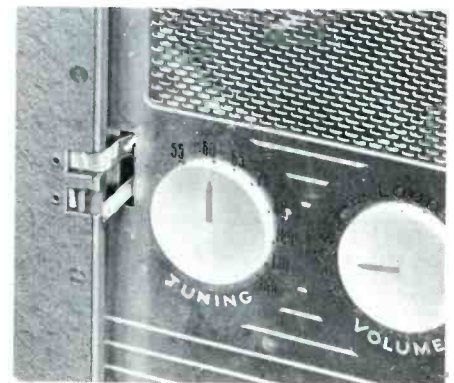

Fig. 3. Close-up of General Electric Portable Showing Broken Antenna Strap.

**I JUST WANT THE FACTS—HOWARD,
NOTHING PAYS OFF LIKE THE FACTS**



**PERMO'S CATALOGS,
REPLACEMENT GUIDES AND SALES AIDS
HAVE ALWAYS BEEN LOADED WITH FACTS**

NOW!
in addition

**PERMO
PHONO NEEDLES**

WILL BE LISTED IN
SAMS' PHOTOFACTS

PERMO, INC.
CHICAGO 26



installed, the set failed to operate. The next step was to check all the tubes, and these seemed to be satisfactory. The current drain was then measured and was found to be a little higher than the set normally required according to the service information.

As a result of the slightly high current, it was determined that the trouble was most likely to be in the audio stage and of such a nature as to cause the plate current to be higher than normal. The output transformer was checked while still in the circuit. It showed zero ohms across the primary. When it was unsoldered from the circuit, however, it proved to be in good condition. Next the resistance was measured from the plate to the screen of the audio-output tube, and a short was indicated. This led to the belief that the plate bypass capacitor was shorted; however, when disconnected, the bypass capacitor did not show a short. When it was put back into the circuit in the exact place where it had been before, a short again showed between plate and screen. A very close examination of the capacitor leads showed that a single strand of wire projecting from the screen-grid lug had punctured the insulation on the plate lead of the bypass capacitor thereby shorting it to the screen grid.

This experience illustrates the manner in which a current-drain measurement is helpful in tracing a trouble. It also points out the need for careful inspection of lead dress and component placement in portable receivers.

Case No. 4.

A Motorola Model 5A1 was brought into the shop with the belief that it only needed batteries. However, the customer was in for a disappointment because, after the batteries were installed, the radio still failed to function.

After checking the tubes and finding them all to be good, the next

step was to measure the voltages of all the tubes starting with the 3S4 and working toward the front end of the set. In doing this, it was found that the plate of the 1S5 AF amplifier had zero voltage instead of the 14 volts that it should have had. By next employing an ohmmeter, it was found that the plate was shorted to ground. Upon close examination, it was disclosed that the tube sockets for the 1S5 and the 3S4 were very close and that the soldering lugs were bent outwards in such a manner that the No. 5 pins were touching. Thus, the audio

was being shorted directly to ground through the grounded center tap of the filament on the 3S4 socket. The remedy was simply and rapidly executed by straightening the tube-socket lugs of both sockets. After an alignment touch-up, the set was again as good as new.

Again in the case of this service problem, the nearness of components to each other was a factor. Compact design is a characteristic of personal portables, and short circuits are inclined to appear occasionally.

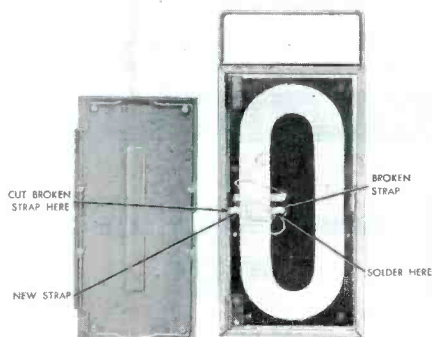

Fig. 4. View of General Electric Antenna Showing Placement of Straps.

there is
a correct
CORNELL-DUBILIER

REPLACEMENT*
VIBRATOR

for every
original equipment
vibrator made

all you need is C-D

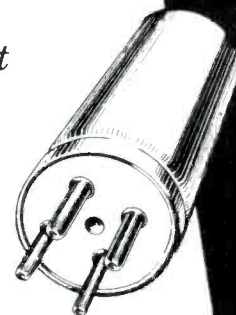

*ask your distributor for your "C-D VIBRATOR GUIDE"



CONSISTENTLY DEPENDABLE
CORNELL-DUBILIER
SOUTH PLAINFIELD, NEW JERSEY



ROTORS • CAPACITORS • VIBRATORS • ANTENNAS • CONVERTERS

The *FIRST STEP* in

HIGH FIDELITY

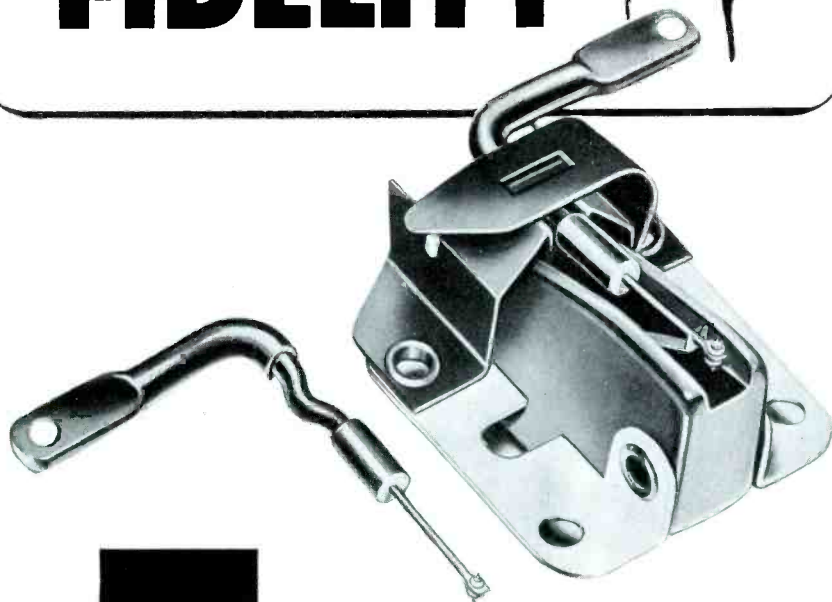

TITONE

CERAMIC CARTRIDGE

There is no wiser investment a phonograph owner can make than a TITONE ceramic cartridge.

Costing no more than ordinary "replacement" cartridges, TITONE gives a world of difference in results — an entirely new experience in true high-fidelity sound, no matter what the make of phonograph.

And only *two models* will replace most present-day installations!

No other cartridge gives all these features!

No preamplifier or equalizer needed • Unaffected by moisture or temperature • Wide frequency range • Outstanding response • High sensitivity • Low distortion • High compliance • No hum pickup • Superior tracking ability • Wide adaptability • Proper groove fit • Only needle rotates • Simple to replace

(Used by America's foremost manufacturers of high-fidelity phonographs, TITONE is an original discovery and development of the Sonotone laboratories. Literature available.)

ELECTRONIC APPLICATIONS DIVISION

SONOTONE CORPORATION

Elmsford, New York



be an expert on RECORD CHANGER SERVICING

with the HOWARD W. SAMS
"AUTOMATIC RECORD CHANGER
SERVICE MANUALS"

Get the only authoritative compilation of its kind—complete coverage of virtually all Automatic Record Changers produced since 1948—in 4 great PHOTOFAC T Manuals. All data complete, accurate, uniform—based on first-hand lab analysis of the actual changers. Helps you service any model quicker, easier—for greater profits. Own and use the complete Library!

NEW VOLUME 5. Complete electrical and mechanical data on 22 record changers and tape recorders produced in 1952 and 1953. Features exclusive "exploded view" diagrams, "all-view" photos, full change cycle data, adjustments, service hints, complete replacement parts lists. Shows methods used for record support, record selection, pickup arm handling, needle setdown point determination, tripping, etc. Tape recorder coverage includes full head-adjustment, cleaning and operation details. All data is authoritative and accurate, obtained directly from lab analysis of the actual equipment. Makes you an expert on changer and recorder repairs. 288 pages, 8½ x 11".

ORDER CM-5. Only.....\$3.00

VOLUME 4. Covers 38 changers and recorders produced during 1951.

ORDER CM-4. Only.....\$3.00

VOLUME 3. Covers 44 changers and recorders produced during 1949 and 1950.

ORDER CM-3. Only.....\$3.00

VOLUME 2. Covers 45 changers and recorders produced in 1948 and early 1949.

ORDER CM-2. Only.....\$4.95

Get into profitable Changer Repair work—
ORDER THE COMPLETE "CHANGER LIBRARY"

HOWARD W. SAMS & CO. INC.

ORDER THIS OUTSTANDING BOOK

FROM YOUR PHOTOFAC T DISTRIBUTOR

Case No. 5.

An RCA Victor Model 3-BX-51 was brought in with the report that it was dead on both battery and line operation. First, it was found that the batteries were dead by simply connecting the set to new batteries. The set operated, but it had a whistle at the high end of the tuning band. The whistle was disregarded until the rest of the troubles were solved. Then the set was tried on AC and found inoperative; therefore, the output of the selenium rectifier was measured and proved to be very low. The selenium rectifier was then checked and found to be practically dead. (Selenium rectifiers can best be checked with a selenium-rectifier tester or with some of the new type of tube testers which have facilities for checking them.)

Replacing the selenium rectifier corrected the major trouble, but the set still had the whistle and howl on the high end of the band. Two different procedures were required to eliminate this. First, all leads and components in or near the RF and oscillator circuits had to be carefully dressed away from each other and as near to the chassis as possible. This was done to minimize the possibility of feedback and regeneration. The second and final step which stopped the whistle was to realign the set. Realignment requires very little time on these small sets and does a great deal to make them perform at their peak.

Case No. 6.

The customer who brought in an RCA Victor Model B-411 complained of frequent battery failures. This is a common complaint among portable-radio users. These failures are usually brought about by the fact that people tend to lose track of time when outdoors on a picnic or camping trip and actually use the radio more than they realize.

There are times, however, when the complaint is justified; but in this case, the customer's wife had used the radio while in the hospital and had probably gone to sleep once or twice without turning it off.

The set could have contained an intermittent short or leaky capacitor which did not show up while the set was in the shop. At any rate, new batteries were installed and the current drain monitored with a DC milliammeter for over an hour; and during this testing time, the current never once changed from normal. The A current was 225 milliamperes, and the B current remained at a constant 7.5 milliamperes.

It was explained to the customer that the A battery would need replacing quite frequently because the radio only employed one 1 1/2-volt flash-light cell.

B. INTERMITTENT OPERATION

Case No. 7.

A service problem with a Westinghouse Model H-185 was quite interesting and slightly misleading in that the set would only operate at specific hours of the day or night. The part that made the problem misleading was the fact that the set did not die out gradually, but instead it would quit all at once as though a resistor or coil were opening up. It was determined that the line voltage must have something to do with the trouble because of the definite hours that the set operated, but it was thought at first that the voltage was perhaps increasing at that time and causing a component to break down. However, such was not the case because, when placed on a variable isolating transformer, the radio could be made to stop playing simply by turning down the secondary voltage to 105 or 110 volts. Therefore, a decrease rather than an increase in line voltage was causing the trouble.

It was known from previous experience that this type of trouble was caused by the oscillator failing at low voltages. The next step was to measure the B+ voltage while reducing the line voltage. This measurement proved that the B+ voltage was dropping much more quickly than the line voltage. Hence, the selenium rectifier was tested and replaced. After replacement, the line voltage could be reduced to 92 volts before the local oscillator would cease to operate.

The only other trouble with the set was a microphonic tube. This was corrected by placing a rubber band around the tube and then twisting the rubber band about two turns and placing it around an adjoining IF can. While this procedure took care of this particular set, it is sometimes necessary to take more drastic steps to eliminate microphonics. Sometimes, a piece of paper folded and placed between the tube and an adjoining component will suffice; and at other times, wrapping a length of solder around the tube may fix it.

Microphonics have been found to originate at other points than in tubes. Such points might be in the stator plates of the tuning capacitor. Loose stator plates near the speaker may cause microphonics. The vibration of the speaker causes the plates to vibrate producing a variation in the capacitance of the

tuning unit and resulting in frequency modulation of the local oscillator. The resultant detuning effect occurs at the vibration rate and produces a squeal or whistle. The suggested remedy is the replacement of the tuning capacitor, although in some instances the stator plates can be resoldered.

The case histories which have been cited are typical of those problems confronted by service technicians working with portable radios. Mechanical problems and power-supply defects constitute a high percentage of the failures in portable radios.

Procedure for Servicing Portable Radios

The servicing of certain types of radios requires that a special procedure be used for each particular set. When an automobile radio is being serviced, the first thing that should be noted when the set is turned on is whether or not the vibrator is operating. When an AC-DC set is turned on, it should be noted whether or not the filaments are lighted.

The portable radio, in turn, has some operating characteristics which are peculiar to its type. These characteristics dictate to some extent the servicing procedure which should be used, and the list of preliminary steps which follow should be performed when servicing portable radios. They are (1) a visual inspection, (2) a temporary application of power, and (3) a current measurement. These tests should be done in the order given. Such preliminary tests may eliminate some of the more difficult trouble shooting in a great many instances.

STEP 1. VISUAL INSPECTION.

Visual inspection can disclose more defects in portable radios than in any other type of set, since the manner in which the portable radio is used makes it susceptible to certain types of visually apparent damage. Some of these defects were cited in the preceding case histories. Others might include such defects as corroded changeover switches, corroded battery wires, damaged speakers, and damage to components by battery acids. Look over the set carefully. Even though the things noted during this inspection might not be responsible for the complete breakdown, many of them should be corrected to prevent future trouble.

STEP 2. APPLY POWER.

If the set is being operated on batteries, some sound (even if it's

You get no "knocks"



with
AEROVOX

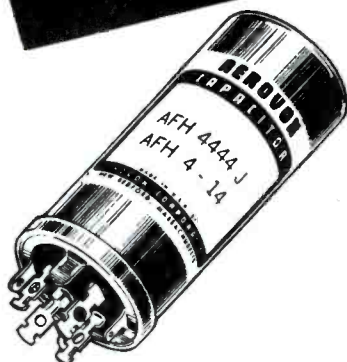

Take twist-prong electrolytics, for instance. Aerovox Type AFH (85° C) listings are outstandingly complete.

It's easy to pick the right number—capacity, voltage, combination-wise—for any job. And of course it is bound to "fit like a glove." Install it—forget it. Aerovox dependability never lets you down.

You get no "knocks" with Aerovox. The profit is all yours.

GET THE FACTS!

Latest Aerovox catalog contains outstanding selection of capacitors and resistors for profitable servicing. Ask your distributor for your copy.



AEROVOX CORPORATION

NEW BEDFORD, MASS.

See your Aerovox distributor!

In Canada: AEROVOX CANADA LTD., Hamilton, Ont.

only noise) should be heard in the speaker two or three seconds after the switch is turned on. If no sound is heard, turn off the set and proceed with step 3. If the set is being operated on AC and employs a rectifier tube, note whether the rectifier tube is lighted. If it is not, test the rectifier tube and the wiring associated with the rectifier filament circuit. Assuming that the filament has lighted, sound should be heard from the speaker about ten or fifteen seconds after the set is turned on. If none is heard, turn off the set and proceed with the current tests as outlined in step 3. If the set being repaired employs a selenium rectifier, sound should be heard two or three seconds after the set is turned on. If no sound is heard, turn off the set and proceed with current measurements outlined in step 3.

If noise is heard in any of the above cases, it is safe to assume that the set can be left on without danger of further damage. Several plans of attack can be followed. Some service technicians use signal-tracing methods to great advantage. They prefer to use their signal tracer to locate the defective stage, and then they test the tube and associated components until the trouble is located.

Other service technicians prefer to test all of the tubes first; one or more might be defective. Even if such is not the case, the test serves to analyze all of the tubes, the condition of which is very important as far as the operation of the portable radio is concerned. If the tube check does not disclose the defect, a voltage check can be performed.

An important thing to remember when servicing portable radios is that the filaments are quite fragile and a momentary surge of voltage can very easily burn out the filament. Because of this, many service technicians prefer to work on the set while using battery power whenever possible. Obviously this cannot be done when the set operates satisfactorily on battery but not on AC. Whether battery or AC power is used, remember that a completely dead set might have a direct short and power should be removed immediately to prevent further damage.

STEP 3. CURRENT MEASUREMENT.

The purpose of this test is to determine whether the currents being drawn in the filament and B+ lines are normal. Knowledge of improper current drain in either of these lines can oftentimes lead the service technician directly to the trouble. When battery power is being used, the milliammeter can be placed in series with the bat-

**INTERNATIONAL
RECTIFIER
CORPORATION**

EL SEGUNDO
CALIFORNIA

**RADIO TV
TYPE
SELENIUM
RECTIFIERS**



**NOW
AVAILABLE
AT
YOUR
FAVORITE
JOBBER**

**Widest Range
in the Industry**

Ask for Bulletin JRP-2

**INTERNATIONAL RECTIFIER
CORPORATION**

1521 E. Grand Ave., El Segundo, Calif. • Phone: ORegon 8-6281
CHICAGO: 205 W. Wacker Drive • Phone: Franklin 2-3889
NEW YORK: 501 Madison Avenue • Phone: Plaza 5-8665

A STOCK GUIDE FOR TV TUBES

The following chart has been compiled to serve as a guide in establishing proper tube stocks for servicing TV receivers. The figures have been derived by combining (1) a production factor (the number of models and an estimate of the total number of receivers produced by all manufacturers) and (2) a depreciation factor (based on an average life of six years for each receiver, and the figures are reduced accordingly each two months).

The main points to remember in using this chart are:

1. The figures shown are based on a total of 1,000 units. This was done in order to eliminate percentage figures and decimals. The figure shown for any tube type then represents a percentage of all tubes now in use. For example, a figure of 100 would imply that that particular tube type constitutes 10 per cent of all tube applications.

2. Some consideration should be given to the frequency of failure of a particular type of tube. A tube used in the horizontal-output stage will fail much more frequently

than a tube used as a video detector. Thus, even though the same figure may be given for both tubes, more of the horizontal-output type should be stocked.

3. The column headed '46 to '53 is intended for use in those areas where television broadcasting was initiated prior to the freeze. Entries in this column include all tubes used since 1946 except those having a value of less than one, which is the value of the minimum entry in this chart. The '52 to '53 column applies to the TV areas which have been opened since the freeze. Since the majority of receivers in these areas will be of the later models, only the tubes used in these newer sets are considered in this column. The minimum value of one also applies to this column.

4. The listing of a large figure for a particular tube type is not necessarily a recommendation for stocking that number of tubes. The large figure does indicate that this tube is used in many circuits and emphasizes the necessity for maintaining a stock sufficient to fill requirements between regular tube orders.

	46-53 Models	52 & 53 Models		46-53 Models	52 & 53 Models		46-53 Models	52 & 53 Models		46-53 Models	52 & 53 Models
1AX2 **	--	--	6AU5GT	4	4	6BZ7	3	4	6V3A*	--	--
1B3GT	40	44	6AU6	134	124	6C4	10	10	6V6GT	22	20
1V2	1	--	6AV5GT	2	4	6CB6	95	138	6W4GT	32	34
1X2	2	2	6AV6	15	17	6CD6G	8	9	6W6GT	7	12
1X2A	4	6	6AX4GT	4	3	6CF6*	--	--	6X5GT	1	1
5U4G	45	48	6AX5GT	2	3	6CL6	1	1	6X8	3	5
5V4G	7	--	6BA6	15	11	6J5	3	3	6Y6G	3	1
5Y3GT	3	2	6BC5	11	8	6J5GT	2	1	7C5	1	--
6AB4	3	3	6BE6	5	6	6J6	34	31	7N7	2	1
6AC7	9	9	6BG6G	14	7	6K6GT	17	10	12AT7	15	14
#6AF4	1	1	6BH6	8	--	6S4	8	10	12AU6	1	--
6AG5	36	11	6BJ6	1	--	6SH7GT	2	--	12AU7	44	28
6AG7	3	3	6BK5	1	2	6SL7GT	4	3	12AV7	4	4
6AH4GT	2	3	6BK7	4	7	6SN7GT	77	86	12AX4	2	4
6AH6	8	10	6BK7A	--	1	6SN7GTA	1	1	12AX7	4	5
6AK5	4	4	6BL7GT	6	9	6SQ7	3	3	12AZ7	--	1
6AL5	77	78	6BN6	3	3	6SQ7GT	3	3	12BH7	9	13
#6AN4	--	--	6BQ6G	--	--	#6T4	--	--	12BX7 **	--	--
6AQ5	13	13	6BQ6GT	16	25	6T8	14	14	12BY7	1	3
6AQ7GT	2	2	6BQ7	7	14	6U4GT **	--	--	12BZ7 **	--	--
6AS5	2	2	6BQ7A	2	2	6U8	4	8	12SN7GT	7	5
6AT6	4	3	6BX7**	--	--	6V3	2	4	25BQ6GT	3	5
									25L6GT	5	5
									25W4GT	2	2
									25Z6	1	--
									5642	2	2

A stock of these tubes should be maintained in UHF areas.
 **Minimum stock recommended.
 * New tubes recently introduced.

tery leads. If AC power is used, the total current being drawn from the rectifier (tube or selenium) can be measured; but more information can usually be obtained if the currents in the filament and B+ lines are measured separately. Usually this can be made possible by unsoldering only two wires.

If the current in the filament string is low, suspect a bad tube or defective components in series with the filament string. If the current is high, suspect a bad tube, or shorted or leaky components in the filament string. Improper bias on one or more of the stages can also cause abnormal current in the filament string; so keep this in mind.

Improper B+ current drain results from the same defects that are encountered in other types of radios. After it has been determined that improper current is being drawn, the same trouble-shooting procedure that is used in any radio can be followed.

Another point to remember is that low current drain can be caused by a weak supply. If the batteries are weak, or if the rectifier is defective, low voltage will result. This in turn causes low current. If the voltage at the output of the rectifier is low, be sure to test the rectifier whether it is a tube or a selenium type. Also be sure to check the current-limiting resistor, if one is employed.

If proper A and B voltages are being applied and the current drain is near normal in both lines, the service technician can continue with his preferred method of trouble shooting and can be reasonably sure that no further damage will result.

Try the steps that have been listed — they should cut down on your repair time. The set owner can help in many instances. The technician should get all the information regarding the complaint so that he may then concentrate his efforts in making tests for the trouble while operating the set under the same conditions during which the trouble occurred.

HENRY A. CARTER

V-M HIGH FIDELITY 936HF RECORD CHANGER ATTACHMENT

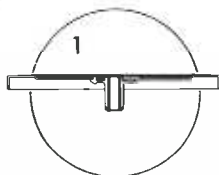

Model 936HF, list **\$69.95***
 Model 935HF, list **\$59.95***
 (less metal pan)

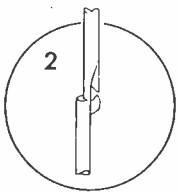

**Leads in Features
That help you profit!**

The custom-engineered 936HF is the first changer specifically designed for high fidelity performance. It helps you win more profitable hi-fi sales and satisfied customers. Comes complete with two plug-in heads and V-M 45 Spindle.

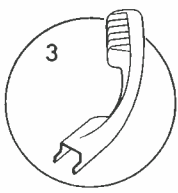

CHECK THESE QUALITY V-M FEATURES

- 1 Exclusive laminated, balanced, precision-formed turntable!
- 2 Patented tri-o-maticTM spindle!
- 3 Exclusive die cast tone arm!
- 4 Exclusive 4-pole, 4-COIL motor!

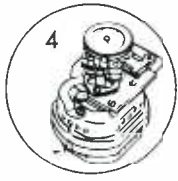

MANY MORE DELUXE FEATURES.

V-M Portable high-fidelity P-A Package.
 Model 960 changer, list . . . **\$64.50***

Model 160 amplifier and 10" Jensen speaker, list **\$66.50***

* Slightly higher in the west.



WRITE FOR SPECIFICATIONS
 For complete, illustrated specifications on V-M Model 936HF and the V-M high fidelity P-A Package write to

V-M CORPORATION
 BENTON HARBOR 7, MICHIGAN

WORLD'S LARGEST MANUFACTURER OF PHONOGRAPHS AND RECORD CHANGERS

How Much Is Your Labor Worth

(Continued from page 13)

screws, clip leads, and any other type of supply used in the shop and not chargeable to a particular job can be included under this item.

Item 7. Depreciation of equipment. Suppose that \$1200 worth of workbenches, tools, testing and other equipment had been purchased and had an average expected life of 10 years; then the cost of depreciation would be \$1200 x 10% or \$120 per year, which is at the rate of \$10 per month. (Do not accept this 10% rate as the proper average for all shop equipment. Check with the Internal Revenue Bureau; the rates are higher on much of the equipment.)

Item 8. Transportation. The advent and development of television has made transportation essential for even the small service shop. A large part of television servicing is done in the home. The service technician alone can determine whether or not his business warrants a separate vehicle for pickup, delivery, and installation. Since it is possible to use a private automobile for this purpose, the figure of \$20 in Chart I was based on the assumption that such was the case. This figure covers only the operating costs of transportation; depreciation on the car has not been charged, although this can be done



if the car is used an appreciable amount for service calls. If a delivery truck is used, both operating costs and depreciation should be included in overhead costs.

Item 9. Miscellaneous expenses. This is the expense of various small items which might include dues, subscriptions, and taxes.

Overhead can now be computed in terms of an hour spent in repairing a radio or television set. How many hours in the month will the technician be doing repair work? Let us say on the average he will spend 8 hours per day for 25 working days in the month; 8 x 25 = 200 hours per month.

Then:

\$160 per month overhead ÷ 200 hours = \$.80 per hour overhead cost. The total estimated costs now are:

Basic labor	\$1.50 per hour
Overhead costs	<u>.80 per hour</u>
Total costs	\$2.30 per hour

On the basis of the foregoing estimates, it is apparent that the service technician must charge \$2.30 per hour in order to recover his expenses and clear \$1.50 per

hour for himself. The service technician would not, however, be willing to operate his own business for \$2.30 per hour. He can make as much by working for a competitor for \$1.50 per hour. He is justified in adding a profit to compensate for the risks involved and also to cover unforeseen expenses.

Each service technician must decide for himself whether that profit should be 10%, 20%, 30%, or some other percentage of total cost. For the purpose of this illustration, the profit percentage used is 20%.

The charge is computed as follows:

Basic labor	\$1.50 per hour
Overhead costs	<u>.80 per hour</u>
Total costs	\$2.30 per hour
Profit (20% of total cost)	<u>.46</u>
Total hourly charge for labor	\$2.76 per hour

In the preceding illustrations, only the simplest way to estimate the hourly charge for labor has been presented. There are several other pertinent factors which must be considered. One of these is the competition. Charges cannot be far in excess of the prices charged by a competitor. All service organizations will be confronted with price cutting to a certain extent. When this happens, each service technician must determine the best policy to be followed. He may have to reduce his overhead cost in some manner. He may even have to be satisfied with a smaller profit. As a general rule we believe that if he watches his overhead closely and keeps it to a minimum, cultivates good salesmanship, and establishes a reputation for fair and honest customer treatment, he will be able to meet competition as it develops.

Another factor of the utmost importance is the variation in service activity each shop will encounter. The value of maintaining a high percentage of productive hours will be seen from the succeeding examples.

As has been demonstrated, the total hourly labor charge of \$2.76 per hour was based on 200 hours of productive labor per month.

When the total monthly income is figured on this basis, the computation is as follows:

Labor charge per hour	\$2.76
Productive labor	x <u>200 hours</u>
Total income for the month	\$552.00
Overhead expenses for the month	<u>-160.00</u>
Net profit and owner's wages for the month	\$392.00

Now suppose that, although the technician did work for 200 hours during the month, only 120 hours was productive labor or actual repair work chargeable to the customer. The remainder (of 80 hours) was spent in getting new business, in idle time, in taking care of records, and sometimes in doing work for which the technician felt he could not charge. What does this do to his net income? Remember that overhead costs are chiefly

independent of the amount of productive labor. The net income is computed as follows:

Labor charge per hour	\$2.76
Productive labor	x <u>120 hours</u>
Total income for the month	\$331.20
Overhead expenses for the month	<u>-160.00</u>
Net profit and owner's wages for the month	\$171.20

How can the service technician receive compensation for the 80 hours of uncharged labor? He can add it to the overhead costs. For example:

Overhead costs	\$160.00 per month
Unproductive time (80 hours at \$1.50 per hour)	+ <u>120.00</u>
Total overhead to be recovered	\$280.00

$\$280 \div 120 \text{ hours productive labor} = \$2.33 \text{ per hour overhead cost}$. Then the total charge per hour should be:

Overhead cost	\$2.33 per hour
Basic wage	<u>1.50 per hour</u>
Total cost	\$3.83 per hour
Profit (20% of total cost)	<u>.77</u>
Total hourly charge for labor	\$4.60

If the hourly charge of \$4.60 per hour were used for 120 hours of productive labor, then the net income for the month would be the same as when the charge was \$2.76 per hour for 200 hours of productive work.

This can be proved in the following manner:

Hourly charge for labor	\$4.60
Productive hours	<u>120</u>
Total income for the month	\$552.00
Overhead expenses for the month	<u>-280.00</u>
Nonproductive labor charge recovered through overhead	+ <u>120.00</u>
Net profit and owner's wages for the month	\$392.00

These figures clearly illustrate that when the productive hours are decreased, the shop owner must either increase his hourly charge or be satisfied with less profit. If he does not figure that the business will stand the increased hourly charge, then he must reduce the overhead or increase the productive labor during the month.

Productive time must be kept at maximum to absorb the overhead, to make possible a reasonable charge to

XCELITE Hand Tools
PREFERRED BY THE EXPERTS



**FOCALIZER
ADJUSTMENT
GOT YOU OVER A BARREL?**



**This XCELITE Tool
Makes It Easy!**

- Beryllium-copper blade does not affect image as does steel.
- No frequent re-grinding, as with plastic or fibre blades.
- 10" shank to reach into chassis easily!
- Broad blade to grip screw snugly!
- Big hand-fitting quality XCELITE handle!

One of a complete line of XCELITE screwdrivers, screwholders, nut drivers and pliers for radio and TV men—ask your supplier!



XCELITE, INCORPORATED
(Formerly Park Metalware Co., Inc.)
DEPT. Q
ORCHARD PARK, N. Y.

For Originality
LOOK TO XCELITE

*How to solve
your storage
problems*

IT'S FREE!

new
**EQUIPTO
BOOKLET**

**Helps lick toughest
storage problems!**

Here's "must" reading for anyone who plans, buys, or uses storage equipment. Shows how you can have custom-arranged facilities, yet pay only the price of standardized units. Learn how to survey, make floor plans and elevations of your own particular requirements. Change arrangement of components anytime. Buy only what you need; expand as you go.

These and many more valuable facts are yours in this fully illustrated new Equipto booklet. Send for your free copy today.

Equipto

Division of Aurora Equipment Company
830 Prairie Avenue, Aurora, Illinois

the customer, and to leave a satisfactory income for the business.

Thus far only the owner-operated or one-man shop has been considered. Computing the labor charges for a larger shop will not be difficult if the same general outline is followed. The overhead costs, as shown in Chart I, will probably increase. The amount of this increase will depend upon the number of men employed. A larger business may take more space; therefore the rent will be higher. More supplies will be used to repair more radios and television sets, advertising expenses may be greater, more test equipment will probably be needed and will increase the depreciation expense, and the transportation requirements will be expanded.

In addition, the shop owner will have wages to be paid. This will require more tax forms and records. In general, it would seem that the prime consideration when employing additional personnel is the amount of work that is available. Once again, as in the one-man shop, the hours spent on productive labor will to a large extent determine the net profit. All of these are factors which the shop owner must decide for himself when contemplating business expansion.

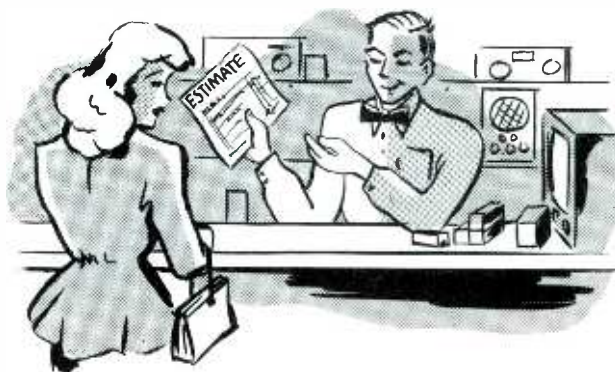

The material appearing in this article has been excerpted from the booklet "How Much Is Your Labor Worth," by Donald B. Shaw, Vice President and Treasurer of this company. This brochure is available through your PHOTOFAC distributor.

Another booklet prepared as an aid in figuring profits is "Accounting Procedures for Radio and TV Service Technicians," by the same author. It explains the balance sheet, which is a financial statement showing business conditions on a given date. From the balance sheet the following can be determined: what the business owns (assets), what it owes (liabilities), and what the owner is worth (net worth or capital). Such a balance sheet is a valuable statement for the owner's use in comparing one period with another to determine his progress, and it is an important source of information when he files his income tax returns. From the information in the balance sheet, it is easier for the owner to decide whether to add new employees or to change the manner of business operation in some other way. It will help him to determine costs of merchandise and labor. If the time is taken to keep such records accurately, better business management can result.

"Accounting Procedures for Radio and TV Service Technicians" is also available through your regular PHOTOFAC source.

JAMES M. FOY

Shop Talk

(Continued from page 5)

the plate of the tube receives the incoming signal and the output is taken from the cathode, then the signal polarity is sync pulse positive. These particular facts do not necessarily have to be remembered; they can be quite easily reached by reasoning.

Consider, for example, the video detector circuit shown in Fig. 2. The cathode receives the video signal from the third video IF amplifier, while the plate circuit contains the detector load resistor and peaking coil. The signal at the cathode possesses the form shown in Fig. 3. For current to flow through the tube, the cathode must be driven negative with respect to the plate. This, in effect, eliminates the positive portion of the incoming signal. However, this is of little interest, since both halves of the modulated video signal are mirror images of each other and either one may be used.

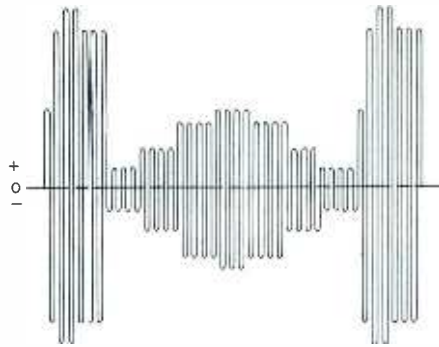

Fig. 3. How the Video Signal Looks When It Enters the Video Second Detector From the IF System.

with it (as in the previous diagrams), then conditions change. This is perhaps best illustrated by an example. In Fig. 5, a video detector is shown placed across the circuit. The cathode terminal of the germanium diode is grounded, and the signal is applied to the other element which might be considered as being equivalent to the

If we compare the polarity of this output signal with that obtained when the video signal is applied to the plate of a series-connected diode, we see that the two differ by 180 degrees. Therefore, with shunt diodes, the sync pulses in the output signal will be most negative when the incoming signal is applied to the plate of the diode and most positive when applied to the cathode of the shunt diode.

Another good secondary point from which to figure signal phase exists at the horizontal-phase detector. If this is of the synchroguide or pulse-width variety, then a positive horizontal sync pulse must be fed to the control grid of the AFC tube. If a horizontal-phase detector of the type shown in Fig. 6 is employed, it must receive both positive and negative sync pulses from the preceding sync separator if it is to function properly. The question is: "Which of the applied pulses is positive and which is negative?" The answer is to be found in the fact that the pulse

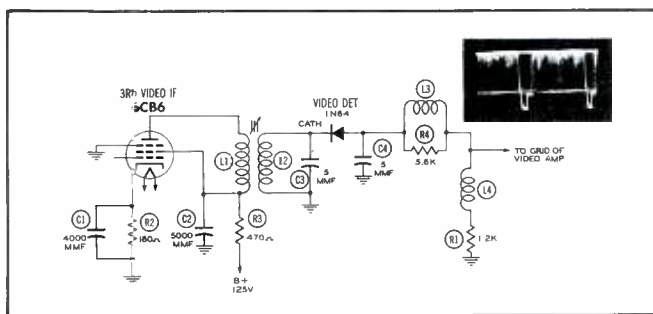

Fig. 4. A Germanium Diode Used As the Video Second Detector.

For the negative portion of the signal, maximum current will flow through the detector diode when the cathode is most negative; and this occurs at the sync pulse tips. The tube current, flowing down through R1, will develop the maximum negative voltage at these instants, thereby providing us with an output signal in which the sync pulses possess the maximum negative polarity. If the tube is turned around, then the polarity of the output signal will reverse.

The same action occurs when a germanium diode is employed. See Fig. 4. It is only necessary for the service technician to know which element of the crystal corresponds to the tube cathode and which to the tube plate. This is indicated in Fig. 4 and, if understood and remembered, will offer no more problem than a tube.

There is one pitfall to avoid, however. If the detector element (tube or crystal) is placed across the circuit (Fig. 5) rather than in series

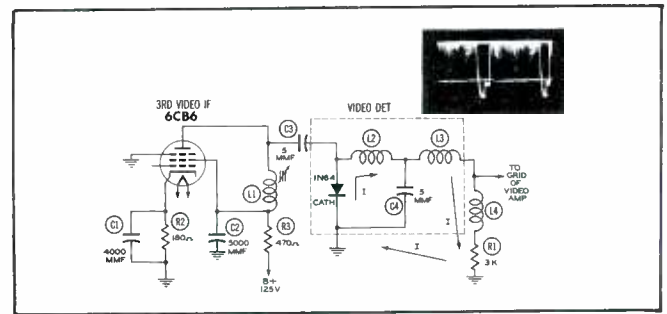

Fig. 5. The Diode Detector in This Circuit is Across the Signal Path and This Will Affect the Polarity of the Output Signal.

plate. Current will flow from cathode to plate when the signal is positive, and the maximum current will flow at the sync pulse tips. The electrons will flow around the circuit in the manner indicated, developing at this moment the maximum negative voltage across the diode load resistor R1. Consequently, the output signal obtained from this circuit will have the sync pulses most negative.

fed to the diode plate must be positive in order to cause this section of the phase detector to conduct. By the same reasoning, the cathode of the other diode section must receive the negative pulse.

Once you have identified the signal polarity at a certain point (using one of the reference points discussed above), the next task is to

Fig. 6. A Horizontal-Phase Detector Employed in AFC Systems.

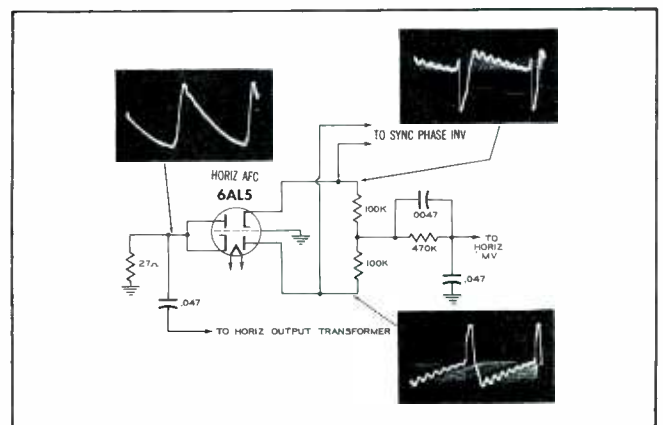

STOP HACKING that chassis



No "redesign" headaches when you use genuine RCA VICTOR Service Parts

Remember: When servicing RCA TV receivers use genuine RCA Victor Service Parts. These parts are tailored to the chassis, both mechanically and electrically. They are the only exact replacements.

You save 5 ways when you use genuine RCA Victor Service Parts. Here's How:

- Direct mechanical fit
- Exact circuit replacement
- Less installation time
- Eliminates need for extra parts
- Original performance assured

Be sure—use genuine RCA Service Parts—and enjoy a more profitable service business.

Get a copy of the new RCA TV Service Parts Guide, Form No. SP-1017, from your local RCA Distributor. Lists key parts from 249 RCA Victor TV receivers.



RADIO CORPORATION of AMERICA
SERVICE PARTS HARRISON, N.J.

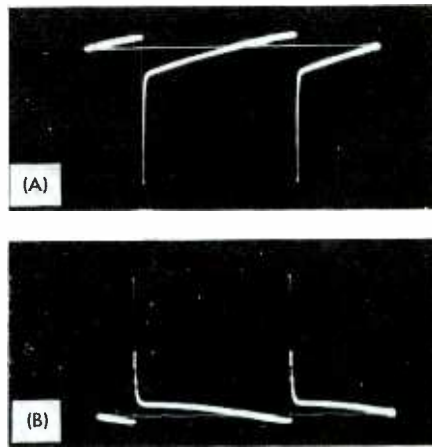

Fig. 7. The Waveforms of a Vertical Output Stage (A) at the Grid and (B) at the Plate.

trace the signal back stage by stage until you reach whatever point you desire. To carry out this latter procedure successfully, here are some pointers to keep in mind.

1. Each straight amplifier inverts the signal 180 degrees. That is, the polarity goes from positive to negative or negative to positive. By a straight amplifier, we mean one in which the signal is applied to the grid and obtained from the plate.

2. If the signal is received by the cathode and obtained from the plate, no polarity reversal occurs. By the same token, if the signal is applied to the grid and taken from the cathode, the same condition holds — there is no polarity change.

3. Signal passage through a diode such as a noise gate, for example, again results in no change of polarity. This is of particular importance when tracing a signal through the sync-separator section.

If you should use an oscilloscope to check the polarity of the signal, remember that what you see on the screen of the scope depends on the number of vertical amplifiers in the instrument and whether or not any cathode followers are employed. Hence, you cannot automatically assume that the pattern you see on a scope screen represents the signal polarity at the point where the signal is being picked up and being fed to the instrument. However, you can definitely establish whether or not the scope inverts the signal it receives by going to one of the reference points discussed previously and by checking the signal there.

Vertical-Retrace Blanking

While on the subject of signal polarity, it may not be amiss to consider the vertical-deflection system.



you're on easy street
with **PHOTOFACT**

**TUBE PLACEMENT and
TUBE FAILURE CHECK CHARTS**

TUBE PLACEMENT CHARTS: included in each and every PHOTOFACT TV Folder. Shows top and bottom views; top view is positioned as chassis would be viewed in customer's home. Shows tube locating key or blank pin; gives tube function, type and placement; includes fuse type, location and circuit protected.

TUBE FAILURE CHECK CHART: in each and every PHOTOFACT TV Folder. Shows common trouble symptoms and lists tubes whose failure may be responsible for each type of trouble. Includes schematics of series filament strings for quicker reference.

TUBE FAILURE CHECK CHART

22 other exclusive features consistently in every PHOTOFACT Folder—the world's best data for faster, more profitable servicing.

No. 111, 112, 113, 114, 115, 116, 117, 118, 119, 120, 121, 122, 123, 124, 125, 126, 127, 128, 129, 130, 131, 132, 133, 134, 135, 136, 137, 138, 139, 140, 141, 142, 143, 144, 145, 146, 147, 148, 149, 150, 151, 152, 153, 154, 155, 156, 157, 158, 159, 160, 161, 162, 163, 164, 165, 166, 167, 168, 169, 170, 171, 172, 173, 174, 175, 176, 177, 178, 179, 180, 181, 182, 183, 184, 185, 186, 187, 188, 189, 190, 191, 192, 193, 194, 195, 196, 197, 198, 199, 200, 201, 202, 203, 204, 205, 206, 207, 208, 209, 210, 211, 212, 213, 214, 215, 216, 217, 218, 219, 220, 221, 222, 223, 224, 225, 226, 227, 228, 229, 230, 231, 232, 233, 234, 235, 236, 237, 238, 239, 240, 241, 242, 243, 244, 245, 246, 247, 248, 249, 250, 251, 252, 253, 254, 255, 256, 257, 258, 259, 260, 261, 262, 263, 264, 265, 266, 267, 268, 269, 270, 271, 272, 273, 274, 275, 276, 277, 278, 279, 280, 281, 282, 283, 284, 285, 286, 287, 288, 289, 290, 291, 292, 293, 294, 295, 296, 297, 298, 299, 300, 301, 302, 303, 304, 305, 306, 307, 308, 309, 310, 311, 312, 313, 314, 315, 316, 317, 318, 319, 320, 321, 322, 323, 324, 325, 326, 327, 328, 329, 330, 331, 332, 333, 334, 335, 336, 337, 338, 339, 340, 341, 342, 343, 344, 345, 346, 347, 348, 349, 350, 351, 352, 353, 354, 355, 356, 357, 358, 359, 360, 361, 362, 363, 364, 365, 366, 367, 368, 369, 370, 371, 372, 373, 374, 375, 376, 377, 378, 379, 380, 381, 382, 383, 384, 385, 386, 387, 388, 389, 390, 391, 392, 393, 394, 395, 396, 397, 398, 399, 400, 401, 402, 403, 404, 405, 406, 407, 408, 409, 410, 411, 412, 413, 414, 415, 416, 417, 418, 419, 420, 421, 422, 423, 424, 425, 426, 427, 428, 429, 430, 431, 432, 433, 434, 435, 436, 437, 438, 439, 440, 441, 442, 443, 444, 445, 446, 447, 448, 449, 450, 451, 452, 453, 454, 455, 456, 457, 458, 459, 460, 461, 462, 463, 464, 465, 466, 467, 468, 469, 470, 471, 472, 473, 474, 475, 476, 477, 478, 479, 480, 481, 482, 483, 484, 485, 486, 487, 488, 489, 490, 491, 492, 493, 494, 495, 496, 497, 498, 499, 500, 501, 502, 503, 504, 505, 506, 507, 508, 509, 510, 511, 512, 513, 514, 515, 516, 517, 518, 519, 520, 521, 522, 523, 524, 525, 526, 527, 528, 529, 530, 531, 532, 533, 534, 535, 536, 537, 538, 539, 540, 541, 542, 543, 544, 545, 546, 547, 548, 549, 550, 551, 552, 553, 554, 555, 556, 557, 558, 559, 560, 561, 562, 563, 564, 565, 566, 567, 568, 569, 570, 571, 572, 573, 574, 575, 576, 577, 578, 579, 580, 581, 582, 583, 584, 585, 586, 587, 588, 589, 590, 591, 592, 593, 594, 595, 596, 597, 598, 599, 600, 601, 602, 603, 604, 605, 606, 607, 608, 609, 610, 611, 612, 613, 614, 615, 616, 617, 618, 619, 620, 621, 622, 623, 624, 625, 626, 627, 628, 629, 630, 631, 632, 633, 634, 635, 636, 637, 638, 639, 640, 641, 642, 643, 644, 645, 646, 647, 648, 649, 650, 651, 652, 653, 654, 655, 656, 657, 658, 659, 660, 661, 662, 663, 664, 665, 666, 667, 668, 669, 670, 671, 672, 673, 674, 675, 676, 677, 678, 679, 680, 681, 682, 683, 684, 685, 686, 687, 688, 689, 690, 691, 692, 693, 694, 695, 696, 697, 698, 699, 700, 701, 702, 703, 704, 705, 706, 707, 708, 709, 710, 711, 712, 713, 714, 715, 716, 717, 718, 719, 720, 721, 722, 723, 724, 725, 726, 727, 728, 729, 730, 731, 732, 733, 734, 735, 736, 737, 738, 739, 740, 741, 742, 743, 744, 745, 746, 747, 748, 749, 750, 751, 752, 753, 754, 755, 756, 757, 758, 759, 760, 761, 762, 763, 764, 765, 766, 767, 768, 769, 770, 771, 772, 773, 774, 775, 776, 777, 778, 779, 780, 781, 782, 783, 784, 785, 786, 787, 788, 789, 790, 791, 792, 793, 794, 795, 796, 797, 798, 799, 800, 801, 802, 803, 804, 805, 806, 807, 808, 809, 810, 811, 812, 813, 814, 815, 816, 817, 818, 819, 820, 821, 822, 823, 824, 825, 826, 827, 828, 829, 830, 831, 832, 833, 834, 835, 836, 837, 838, 839, 840, 841, 842, 843, 844, 845, 846, 847, 848, 849, 850, 851, 852, 853, 854, 855, 856, 857, 858, 859, 860, 861, 862, 863, 864, 865, 866, 867, 868, 869, 870, 871, 872, 873, 874, 875, 876, 877, 878, 879, 880, 881, 882, 883, 884, 885, 886, 887, 888, 889, 890, 891, 892, 893, 894, 895, 896, 897, 898, 899, 900, 901, 902, 903, 904, 905, 906, 907, 908, 909, 910, 911, 912, 913, 914, 915, 916, 917, 918, 919, 920, 921, 922, 923, 924, 925, 926, 927, 928, 929, 930, 931, 932, 933, 934, 935, 936, 937, 938, 939, 940, 941, 942, 943, 944, 945, 946, 947, 948, 949, 950, 951, 952, 953, 954, 955, 956, 957, 958, 959, 960, 961, 962, 963, 964, 965, 966, 967, 968, 969, 970, 971, 972, 973, 974, 975, 976, 977, 978, 979, 980, 981, 982, 983, 984, 985, 986, 987, 988, 989, 990, 991, 992, 993, 994, 995, 996, 997, 998, 999, 1000.

NOW! GET THE PROOF FOR YOURSELF!

FREE We'll send you a Free Photofact TV Folder—just ask us for it!

Learn for yourself how PHOTOFACT pays for itself by earning bigger profits for you! We'll send you the proof—a FREE specimen PHOTOFACT TV Folder that shows all the features found consistently and exclusively ONLY in PHOTOFACT. Send for your FREE specimen TV Folder now. Examine it. Compare it. You'll see why PHOTOFACT belongs in your shop! And you'll want to ask your parts distributor about the pay-as-you-earn-plan. Only \$25 down brings you the entire PHOTOFACT Library. Write for FREE specimen TV Folder—learn now how to earn more!

HOWARD W. SAMS & CO., INC.
2201 E. 46th St., Indianapolis 5, Ind.

HOWARD W. SAMS & CO., INC.

Waveform polarity is important when you wish to install a retrace-blanking circuit. A negative-going pulse is desired when the blanking voltage is fed to the grid of the picture tube, and a positive-going pulse is desired when the blanking voltage is to be applied to the picture-tube cathode. The problem then is to determine the polarity of the pulses at various points in the vertical system.

A good place to start is the grid of the vertical-output tube. The waveform at this point is always of the form shown in Fig. 7A. Note that the retrace portion of this waveform is negative and hence suitable for application to the picture-tube grid.

In the plate circuit of the output amplifier, the waveform is reversed (Fig. 7B); and as a result, positive pulses can be obtained for use at the picture-tube cathode.

If the vertical-output transformer possesses separate primary and secondary windings, then what you obtain across the secondary winding depends upon the manner in which the unit is wired. The best test is to check the pulse polarity with a scope so that you know whether or not it inverts the signal.

This question of voltage polarity across the vertical-output transformer can become quite confusing unless certain facts concerning transformer operation are known. These are:

1. A signal passing through a transformer will suffer a 180-degree reversal only if the primary and secondary windings possess the proper relationship to each other. To illustrate, let us suppose that the primary winding of the transformer in Fig. 8 is connected as shown to the plate circuit of the vertical-output amplifier. The polarity of the signal at point A on the secondary (with respect to ground) may either be the same as that shown on the plate or 180 degrees out of phase with it, depending on how the unit is wired. Suppose you find that the polarity is unchanged. Then, you can achieve the desired reversal by reversing the connections of the primary winding. To keep the picture from being reversed vertically at the same time, simply reverse the lead connections to the vertical windings of the deflection yoke.

2. If the secondary winding has a tap on it and this tap is at AC ground potential, then the pulse polarity at one end of the secondary winding will be opposite to its polarity at the other end. Having a tap on the secondary

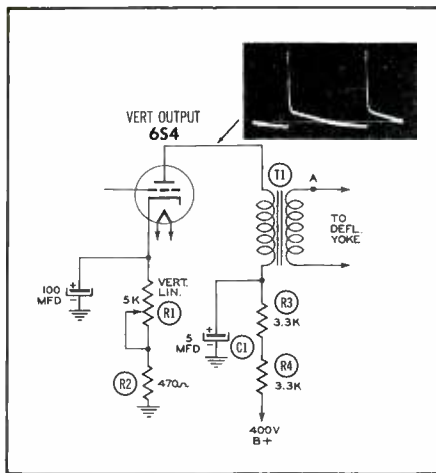

Fig. 8. The Polarity of the Signal Appearing at Point A Depends Upon the Manner in Which the Transformer T₁ is Wired.

winding is rather uncommon; usually there is no tap, and one end is placed at ground potential by means of bypass filter capacitors.

3. When the vertical-output transformer is an autotransformer, then the polarity conditions that prevail are shown in Fig. 9. Note again the significance of the position of the ground.

For those who wish additional information on the installation of vertical-retrace circuits, reference should be made to page 9 of the September-October 1951 issue of the PF INDEX.

REVIEW.

An interesting article appeared in the January 1954 issue of Radio & Television News relating the "blow-by-blow case histories" of the first 16 sets actually encountered by a new service technician, Jay Stanley. The title of the article is "My Start in TV Servicing," and it will do us all some good and some of us a lot of good to read part of this interesting account.

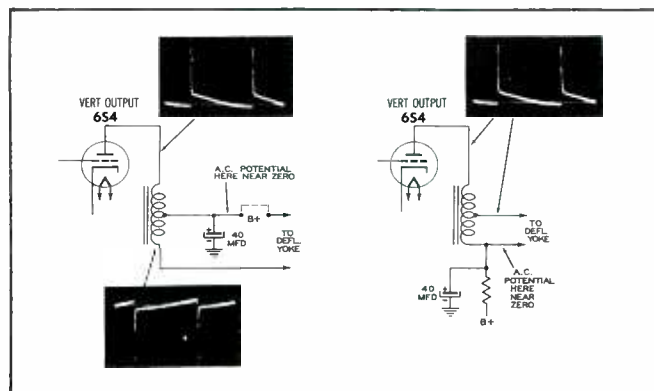

Fig. 9. The Signal Polarity Along an Autotransformer Depends Upon the Position of the AC Ground Point.

Radio & Television News magazine is published by the Ziff-Davis Publishing Company, 366 Madison Avenue, New York 17, New York. Subscription rates are \$5.00 for one year in the United States, its possessions, and Canada. Single copy price is 35 cents.

Do you remember the first five or ten television sets you serviced? If the occasion does not evoke pleasant memories, pull up a chair with the rest of us because we all pulled some pretty silly boners at about that time. Fortunately, however, we learned something from those miscues; and as time went on, we made fewer and fewer of them.

To the man who is just getting started in television, it is reassuring to know that his trials and tribulations are not unique but follow a pattern similar to the one which most of us have experienced. Success and failure are different points along the same scale, and where you stand is really determined by where other men stand. If the mistakes you make are common ones, well, there's hope for you yet.

Mr. Stanley knew that someday television would come to his part of the country, but he did not feel it was imminent enough to aggressively prepare himself for it. Hence, when the freeze lifting came and a local station with it, he had advanced no farther than unit 2 (about antennas) of a 10-unit course on TV. As usually happens when television arrives for the first time in any locality, the demand for technicians exceeds the supply; and whether Mr. Stanley wanted to or not, there he was servicing TV receivers.

Before we examine some of his case histories, it should be noted that Mr. Stanley was not a newcomer to the electronics field. He had possessed an amateur license since 1932, had had formal college training in communications engineering, and had



You make More Profit in less time with Webcor Hi-Fidelity changers

When your customer wants a hi-fi installation, better put in a Webcor changer. For two reasons. First, because a Webcor takes just a few minutes to install. So you make more profit on each job. And second . . . you don't have to "sell" your customer on a Webcor changer. Through national ads, publicity and word of mouth, millions of Americans think of Webcor as the TRUE high-fidelity changer. So your reputation is well made when you suggest a Webcor 3-speed automatic changer. If you are not presently handling profitable Webcor products, call your distributor today!



Webcor template FREE



Webcor Mounting Board \$2.50

Webcor Hi-Fi 3-speed changers are world famous for quality. With Webcor you have:

- A choice of TWO different sizes
- A choice of THREE different colors
- A choice of TWO pickups (magnetic or ceramic)

PLUS . . . exclusive Velocity Trip, Step Drive, powerful motor super-thick Flocking, Balanced Tone Arm. From \$49.50.

All music sounds better on a Webcor

Webcor®

Chicago 39, Illinois

©WC1954

spent nearly a year in Signal Corps radar and airborne-radio schools. Hence, he did possess an excellent background for television servicing; and if a man like that could make some of the errors he did, then those less fortunately endowed should take heart. As any experienced service technician will fervently attest, television is unique unto itself with its own peculiarities found nowhere else in electronics.

Among the first service jobs with which Mr. Stanley was confronted was a new set to be checked before delivery to the customer. Unluckily, there was something wrong. No picture could be obtained on the screen, and the sound was very weak.

The job appeared to require signal tracing, so the chassis was removed from the cabinet. Then the signal was checked first at the video second detector and then at each of the video IF stages with the same result, no signal.

Apparently the trouble was in the tuner or in the first IF, and it was decided to make voltage checks first in the IF stage since this was the easiest to reach. In checking he found that the No. 1 lug on this tube socket was floating free in the air, completely broken off from the socket. Apparently the heavy tuner had moved in shipment and had pulled off the wire leading to pin No. 1 of the IF socket.

From this experience, Mr. Stanley learned that visual inspection of a set was frequently as important as electrical checking. This is especially important with sets which have been transported over long distances, say from the factory to the retailer.

In another service job, an early 7-inch transformerless receiver had a dark picture. The voltage seemed to be somewhat low, and several hours were spent checking low-voltage filter capacitors in the selenium-rectifier doubler circuit and in substituting rectifiers. Nothing seemed to help much, and the voltage remained low throughout the entire receiver.

Not knowing what to do next, Mr. Stanley decided to dig out the service notes on the set. The very first note under "Sound — No Picture or Raster" suggested checking a high-voltage, oil-filled capacitor in the RF power supply. Accordingly, replacing the capacitor cleared up the trouble.

Reliable—

AIDS FOR SERVICEMEN

These books will help you do the BEST service job in the quickest time



Elements of Mathematics for Radio, TV, and Electronics

By *Bernhard Fischer & Herbert Jacobs*. Begins with arithmetic and makes every step in the math needed by servicemen crystal clear. No one using this book can fail to understand the reasoning and applications of the calculations he must make to do a good job on today's radio, TV and electronic equipment. Hundreds of training exercises and problems are included. Ready April 9

Mandl's TV Servicing

By *Matthew Mandl*. The first choice of thousands of servicemen, this outstanding guide shows, in the most usable terms, how to locate and correct flaws in TV receivers and how to improve reception in difficult areas. Includes time-saving trouble index. \$5.50

TV Service Course Lab Manual

By *M. Mandl*. What-to-do and what-to-observe directions give training in the recognition and adjustment of trouble in each part of the TV receiver. \$3.90

Radio and TV Mathematics

By *Bernhard Fischer*. This handbook of problems and solutions gives worked-out examples of over 400 common problems requiring math. Arranged under radio topics for quick reference. \$6.75

TV and FM Antenna Guide

By *E. M. Noll & M. Mandl*. Clear, brief review of antenna theory and specific directions for determining the best type of antenna for the particular site and installing it for best performance. \$5.25

Hearing Aids

By *M. Mandl*. Explains the construction of the major types of modern hearing aids, comparing their advantages and disadvantages, and gives directions for servicing. \$3.50

Order from your parts dealer or from

The Macmillan Company
60 FIFTH AVENUE, NEW YORK 11, N.Y.

Service literature is an excellent source of information on the solution of troubles that most frequently affect a receiver. Therefore, one of the things that every service technician can do to assist himself is to maintain an up-to-date file on such literature.

Another interesting case that Mr. Stanley encountered those first few weeks was a set in which the buzzing sound in the audio changed in strength with changes in scene content. As the author indicated, this was one of those cases in which the doctor "cures" the patient by burying him and hopes that nobody ever digs him up. Unfortunately, somebody always does, and a recall becomes necessary.

From the symptoms just mentioned, the trouble appeared to be intercarrier buzz; and so the chassis was removed and the transformers in the ratio detector adjusted with a VTVM. The set sounded a lot better and Mr. Stanley felt that perhaps he had corrected the trouble, although he wondered how the alignment of the ratio-detector transformer could effect picture pulling which the set exhibited at times. Since the set was working satisfactorily at the moment, he decided to take a chance that it would continue to operate. He collected his money for the call and left.

The customer phoned again the next night and announced that the buzzing was back. Evidently the transformer alignment (or misalignment) was not the problem, and the best thing to do was to take the set into the shop.

At the shop, Mr. Stanley decided to check into the literature on hum and buzz, and there he found the suggestion that leakage in the tube elements in the video IF or the tuner can cause the symptoms noted, including picture pulling. The IF checked all right, so the RF was investigated next. The final tube tested was the 6BZ7 RF amplifier; and when this tube was replaced, all the symptoms disappeared and the set returned to normal operation.

The lesson to learn from this case history is perhaps one of the hardest for any one to learn, whether he is a beginner or an "old-timer" in servicing. One should carefully observe the set for all its symptoms, not just for those which are most obvious. In the foregoing case history, the buzz was the symptom that struck most forcefully; the picture pulling, unless quite severe, could be easily overlooked. Try at all times to keep your mind open when inspecting a set. Don't just note the most obvious

and then disregard everything else, feeling secure in your belief that there is no other trouble. Unfortunately, you cannot cure troubles by ignoring them.

The need for the proper test equipment is something the beginning service technician discovers very quickly. A call came in for service on a set that would work satisfactorily for a couple of hours, then it would lose horizontal sync. Mr. Stanley's first guess was that synchronization could be restored by carefully adjusting the various horizontal AFC circuit controls while keeping an eye on the picture.

The first half hour was spent turning the screw on the horizontal-frequency coil and the horizontal lock-range trimmer. He did not find the difficulty so he took the set into the shop. (Frequent removal of sets to the shop is a characteristic of most beginners. As experience is gained, the number drops sharply.) Since the writer's service oscilloscope was still in kit form, he resorted to voltage and resistance measurements and finally even to a change in the horizontal-oscillator transformer. He still had no luck.

At this point the need for a scope became quite evident, and Mr. Stanley was forced to borrow a unit from a friend. As suspected, the double-hump waveform supposed to be on the horizontal lock-range coil was completely off form. By running through the alignment procedure again, this time watching the scope screen, the proper waveform was obtained and the set returned to a state of synchronization.

The moral of this case history is apparent. If you ever expect to become a "top-notch" service technician, you will need good equipment. No one the author knows has ever been able to get around this axiom.

It is recommended that the original article should be read by those who wish to learn more of Mr. Stanley's adventures. He found out that sometimes the service technician creates his own grief by using unreliable parts, that he must have a good eye for physical symptoms as well as electrical, and that his chances of quick success are enhanced considerably if he does a little thinking before he acts.

Milton S. Kiver

Understanding Receiving Tube Operation

(Continued from page 11)

The symbol Δ is used here to indicate a small change; and with vacuum tube theory, the change must be as small as possible. The value of r_p for any tube is useful in that it is a factor in determining the proper load impedance for the tube and in determining the voltage gain that a circuit using that tube will produce.

Most triode tubes will usually have a value of r_p within the range from 500 to 10,000 ohms. The plate resistance of most pentodes, however, will generally range from 40,000 ohms to 2 megohms. A pentode has a high plate resistance because a plate-voltage change has very little effect on the plate current. This fact is due to the shielding effect of the screen and suppressor grids. In equation (2), it can be seen that a very small value of ΔI_p will produce a very large value of r_p .

The numerical value of the plate resistance for any one type of tube is listed in tube data handbooks or tube manuals. Observation will disclose that a certain value of DC plate voltage is also listed. Only at that voltage will the specified value of r_p be realized. At any other voltage the plate resistance will have a different value, and a circuit designer can take advantage of this fact to vary the plate resistance of the tube over a narrow but definite range. Pentodes possess the greatest range of variation in that, by paralleling of electrodes, the normal r_p of a pentode can be reduced to that of a triode. For example, a 6SJ7

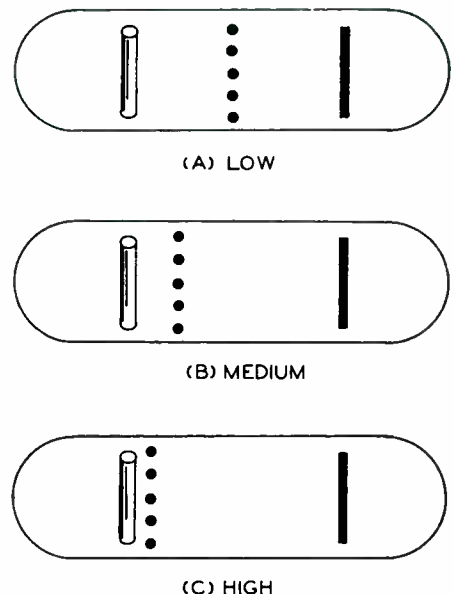

Fig. 4. Variation of Cathode-Grid-Plate Spacing in Tubes Having Different Amplification Factors.

make easy
extra Profits
with these
**NEW BUD
PRODUCTS**



REAR SEAT SPEAKER GRILLE

Beautiful, sturdy metal grille to protect speakers installed on deck behind rear seat of automobiles. Designed to cover standard sizes of speakers used in this location. Complete with sufficient installation wire, selector switch and switch bracket. Finished in beautiful silver grey hammertone to reduce possibility of glare.

CS-2260 — Plate only 3/16" x 9" x 5 1/2" Dealer Cost \$1.80
CS-2261 — Plate, switch, switch bracket and wire Dealer Cost \$3.00

WIRELESS PHONOGRAPH OSCILLATOR



Designed to enable any standard record player to be converted to wireless operation. Records can be played through radio without interconnecting wires. 2-tube design assures faithful reproduction. Completely wired and tested including 2 tubes. Finished in grey hammertone. Operates on 115 V-AC or DC. Frequency range is 1100-2150 K.C. Weight 1 lb.

WO-6A — Dealer Cost \$9.00

Write for copy of new 1954 Catalog



BUD Radio, Inc.

2118 EAST 55TH STREET DEPT. X CLEVELAND 3, OHIO

**RADELCO HI-CHANNEL
BROAD BAND YAGI**

*Gives Clearer,
Brighter*

**TV PICTURES
ON ALL 7
HIGH BAND
VHF CHANNELS**



Ideal for areas having two or more high channel stations. Completely preassembled.

LIST
\$995

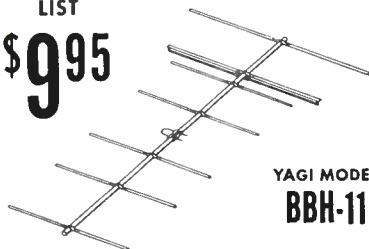

YAGI MODEL
BBH-11

ORDER FROM YOUR
NEAREST PARTS JOBBER

FOR OVER

**30
YEARS**

EBY



- SOCKETS (JAN APP)
- SHIELDS (JAN APP)
- BINDING POSTS
- BATTERY PLUGS
- PLUGS AND CONNECTORS
- RACK & PANEL CONNECTORS
- FUSE HOLDERS
- FUSE BLOCKS
- SUBMINIATURE SOCKETS
- TRANSITOR SOCKETS
- UHF SOCKETS
- PRINTED CIRCUIT SOCKETS
- TURRET SOCKETS
- CRT SOCKETS
- HIGH VOLTAGE SOCKETS
- TELO CONTACT CLEANER
- TV HARNESSSES
- TV ANTENNA ACCESSORIES

**CRT TEST
SOCKET
ADAPTER
No. 1000**

Permits operating tests on any CRT while set is in operation.

Inserted between CRT base and socket, eliminating the need of removing chassis. Available at your local jobber.

EBY

SALES CO.
130 LAFAYETTE STREET
NEW YORK 13, N. Y.

in the pentode connection is listed with 0.7 megohms for the plate resistance; in the triode connection, the r_p of the 6SJ7 is only 8,250 ohms.

Amplification Factor, μ

The addition of the control grid to form the triode tube provides amplification of a signal. To express the amount of amplification that a tube is capable of producing, a second tube constant is commonly used. This is the amplification factor μ . It is defined as the ratio of a small change in plate voltage to the small change in grid voltage which would be needed to return the plate current to its original value. Expressed as an equation, it is

$$\mu = \frac{\Delta E_p}{\Delta E_g} \quad (3)$$

where

μ = amplification factor,

ΔE_p = a small change in plate voltage,

ΔE_g = a small change in grid voltage,

I_p = plate current.

The μ of a triode tube can also be derived from a formula which takes into account the physical geometry of the tube. The formula includes the distance between grid and plate, the number of grid wires per centimeter of grid length, and the radius of the individual grid wires. Fig. 4 illustrates the internal spacing of tubes having various values of μ . The low- μ triode, shown in Fig. 4A, has the grid spaced relatively close to the plate; in Fig. 4B, the grid is farther from the plate and the tube is said to have a medium μ ; and in Fig. 4C, the high- μ triode has the grid very far from the plate. The grid exerts its influence upon the electrons in the space-charge area by electrostatic forces; and since electrostatic forces vary inversely as the square of the distance, the nearer the grid is to the space charge, the more control it will exert on the electron flow. The number of grid wires per centimeter of grid length and the radius of the grid wires have a direct effect on the μ of a tube. If either factor increases, the μ will increase proportionally.

Some tubes are made with a variable- μ feature; in these the separation between individual grid wires is greater in the center than at the ends of the grid. As the grid bias is increased in the negative direction, the ends of the grid will cut off some of the plate current first. The grid bias must be increased still further

before complete plate-current cutoff is reached.

Reference to a tube data handbook, or tube manual as it is commonly named, will disclose the fact that the value of μ for a triode is usually listed but that for a pentode it is not. In triodes, the value of μ is dependent mainly upon the physical geometry of the tube electrodes, though it will vary just slightly at extremely low values of plate current. For most multielectrode tubes, however, the amplification factor μ varies appreciably with changes in operating conditions. Its value is therefore not listed for pentodes in most tube manuals.

Transconductance, g_m

The usefulness of any vacuum tube depends upon the ability of the grid to control the plate current. The effectiveness of the control exerted by the grid when the plate voltage is held constant is called the transconductance or mutual conductance. This is probably the most important of the tube constants, for it provides a means of evaluating tubes of the same type. A tube having a transconductance of 2,000 is better than a tube of the same type having a transconductance of only 1,000. This fact is the basis of the tests used in one type of tube-testing equipment, namely, the mutual-conductance type of tube tester.

Transconductance is the ratio between a small change in plate current and the small change in grid voltage producing it when the plate voltage is held constant. It can be expressed by

$$g_m = \frac{\Delta I_p}{\Delta E_g} \quad (\text{when } E_p \text{ is constant}) \quad (4)$$

where g_m = transconductance,

ΔI_p = a small change in plate current,

ΔE_g = a small change in grid voltage,

E_p = plate voltage.

The unit of transconductance is the mho; but since its value is generally too large for common usage, the micromho is the usual reference. It has become customary to drop the word micromho and to say simply that a tube has a transconductance of, for example, 1,000.

The transconductance of a tube, like the plate resistance and amplification factor, is dependent upon the physical size of the tube elements and their spacing; it is chiefly de-

pendent upon the grid-cathode structure and the amount of cathode emission. The transconductance of a tube will decrease with usage of the tube mainly because of the decrease in emission.

Relationship Between r_p , μ , and g_m

The three tube constants (μ , r_p and g_m) are interrelated quantities in that they vary in value relative to each other in a definite manner. This relationship can be derived mathematically.

Since,

$$\mu = \frac{\Delta E_p}{\Delta E_g}$$

$$g_m = \frac{\Delta I_p}{\Delta E_g}$$

and

$$r_p = \frac{\Delta E_p}{\Delta I_p}$$

and since ΔI_p appears in the last two formulas, they can be made equal to each other as follows:

$$\Delta I_p = g_m \times \Delta E_g = \frac{\Delta E_p}{r_p}$$

Transposing yields

$$r_p \times g_m = \frac{\Delta E_p}{\Delta E_g}$$

$$\text{Since } \frac{\Delta E_p}{\Delta E_g} = \mu,$$

then by substitution

$$\mu = r_p \times g_m \quad (5)$$

By transposition

$$g_m = \frac{\mu}{r_p} \quad (6)$$

and

$$r_p = \frac{\mu}{g_m} \quad (7)$$

Through the use of these three formulas, any one constant can be calculated if the other two are known. An example of this can be given. It was stated previously that the μ of a pentode is not usually listed in tube manuals. If it is necessary to find

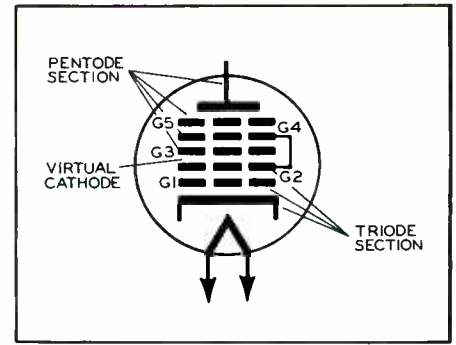

Fig. 5. Multiple-Electrode Tube Used for Frequency Conversion.

this constant, it can be calculated for a particular set of conditions. For example, the 6SJ7 with a plate voltage of 250 volts, a screen voltage of 100 volts, and a negative grid voltage of 3.0 volts has a plate resistance of 0.8 megohms and a transconductance of 2,000.

Thus

$$\mu = g_m \times r_p = .002 \text{ mhos} \times 800,000\Omega$$

$$\mu = 1600.$$

This value of μ is obtained for this pentode only under the voltage conditions given. It will be different under different values of plate, screen, and grid voltages.

This interrelation between the three constants is the basis for evaluating the worth of a tube. The amplification factor μ does not usually vary during the life of a tube, provided it is measured under identical conditions every time. The plate resistance increases with tube age because of lowering of cathode emission. By referring to equation (6), it can be seen the g_m will decrease when r_p increases and μ stays constant. Some tube testers actually measure the plate resistance of a tube and rate the tube in terms of the equivalent transconductance. Other testers measure the amount of cathode emission with respect to the normal emission. A third type of tester, which is fairly new, measures the plate conductance which is the

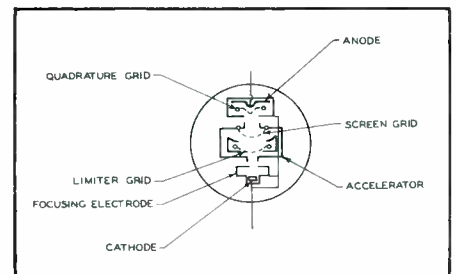

Fig. 6. Gated-Beam Tube Utilizing Principles of Electron Optics.

reciprocal of plate resistance and rates a tube in percentage of total plate conductance.

Special Constructions

The variation in the geometry of vacuum tubes is almost infinite; tubes are being constructed to fulfill innumerable special purposes. The beam-power tube was developed when a pentode with a low plate resistance was needed. In this type, the wires of the screen grid are aligned directly behind the individual wires of the control grid. This alignment allows the potential field of the plate to have more effect on the potential gradient between cathode and grid. The plate voltage as a result has more control of the plate current than in a pentode, and the tube has a lower plate resistance and a higher transconductance.

The development of the superheterodyne receiver produced a demand for a tube which could combine the functions of oscillator and mixer in one envelope. The 6SA7 is a tube of this type, and Fig. 5 shows the layout of the electrodes. The cathode and grids Nos. 1 and 2 form a triode oscillator section where grid No. 2 acts as the plate. The positive potential on grid No. 2 forms a virtual cathode between grid No. 2 and grid No. 3 for the pentode section comprising grids Nos. 3, 4, and 5, and the plate.

A beam of electrons can be made to behave similar to a light ray, and this principle is used in many tube types including the 6BN6. This tube was developed for FM receivers to combine the functions of a limiter, discriminator, and audio amplifier; and the construction features are shown in Fig. 6. The cathode supplies the electrons which are then formed into a beam by the action of the focusing electrode and by the positive potential on the accelerator. Because of the sharply focused electron beam, the first control grid (or limiter grid) has a step-shaped control characteristic; the plate current rises abruptly from zero to a definite maximum as the limiter-grid voltage changes from negative to positive. The action might be likened to an off-on switch. The limiting action of the tube occurs at this limiter grid, because a variation in signal strength on this grid has no effect on the current through the tube provided that the signal voltage does not cross through zero.

The electron beam leaving the limiter grid undergoes further acceleration from the accelerator and screen grid, and then it goes through the quadrature grid to the plate. The

electron beam induces an alternating voltage on the quadrature grid and causes the tuned circuit which is attached to the grid to oscillate at the center frequency of the FM signal. This grid voltage lags 90 degrees behind the center frequency when the signal is unmodulated. Under these conditions, the limiter grid allows current to flow only on the positive half cycles. The quadrature grid cuts out one-half of this half cycle.

When the input signal is frequency modulated, the phase difference between the two grids varies and the quadrature grid permits more or less of the positive half cycle of the current to pass. When the input frequency decreases, the two grids allow current flow for a longer time. If the input frequency is increased, the two grids allow current flow for a shorter time. The composite variations in the plate current constitute an audio signal which is equivalent to the frequency modulation of the IF signal.

There are other special-purpose tubes. The few which have been mentioned are those that deviate most from standard vacuum-tube operation.

William E. Burke



*"Joe dropped the
JENSEN NEEDLE . . .
we've got to find it."*

Adv.

Notes on Test Equipment

(Continued from page 33)

is for? I'll just turn it a little and see what happens."

Now, we trust that neither illustration applies in your case; but human nature being as it is, sometimes the instruction manual does not receive all the consideration it deserves. The majority of the manufacturers of test instruments supply operating manuals which explainfully the operation of the instruments. In addition, these manuals may contain many examples showing how the instruments can be used in actual applications. Some of these applications might never suggest themselves to the operator were it not for the manual.

So, let's not permit those instruction manuals to gather dust on the shelf or in a drawer somewhere. Refer to them frequently, and they will increase your efficiency on the everyday jobs and may help you solve those "toughies" that baffle you occasionally.

Testing Selenium Rectifiers With the Triplet 3423 Tube Tester

Recently we obtained a new roll chart for the Triplet Model 3423 tube tester and noted the addition of a section containing instructions for testing selenium rectifiers commonly encountered in radio and TV servicing.

The instructions read as follows: "Use X and Y top cap leads and connect the X-lead to negative side of the rectifier and Y-lead to positive side. Use value switch for test as with tubes. No short test is necessary. Ratings 130 volts."

Examples of dial and toggle settings for a few rectifiers are listed in Table I as they appear on the roll chart.

The dial and toggle settings for all the selenium rectifiers listed are identical, with the exception of that of dial B which is varied in accordance with the milliamperage rating of the rectifier.

Cross checking of a number of good and bad rectifiers of various ratings indicated that it seems possible to obtain a reliable check on the Triplet Model 3423 of most of the 130- to 160-volt rectifiers ranging from 15 to 400 ma in current rating.

Setting of dial B did not appear to be critical. A setting from 40 to 51 gave a reading consistent with the actual rectifier condition in all examples tested.

TABLE I

ROLL CHART LISTING OF SELENIUM-RECTIFIER TEST SETTINGS						
TUBE	A	B	CDEFG	UP	DOWN	READS
65 ma	OFF	50	2Y0X6	--	Y	Good
100 ma	OFF	51	2Y0X6	--	Y	Good
150 ma	OFF	40	2Y0X6	--	Y	Good

Accordingly, we have expanded the chart and have listed in Table II the commonly used rectifiers together with the manufacturers' code numbers for easy reference. This table should aid in determining the current ratings of a rectifier, if the code number is known, as well as aid in providing replacement data after the current requirements are determined.

CURRENT RELEASES

Hickok Model 695 Television-FM Alignment Signal Generator

The Hickok Model 695 is a new electronic sweep generator designed to meet the top requirements of professional TV service technicians or laboratories. Since the sweep is completely electronic, vibration or wearing of moving parts is eliminated. The sweep is said to be absolutely linear and free from amplitude modulations. A front-panel switch allows for internal retrace blanking, and a

phasing control provides adjustment for superimposing trace and retrace waveforms when retrace blanking is not used. Adjustment of sweep width does not necessitate readjustment of the phasing control.

VHF coverage is obtained with three RF oscillators covering channels 2 through 13 on fundamentals. Output signal level is .3 volt. Intermediate frequencies from zero to 50 mc are provided. Tuning is continuous, and the dial is marked in sectors for each VHF channel.

Both step and continuous attenuation are provided, and the unit is triple shielded to insure that RF leakage is held to the very minimum. This allows receiver IF's to be checked for oscillations which sometimes occur with very weak signals. One position of the RANGE SELECTOR switch allows for STANDBY operation of the filaments of all tubes.

A source of bias voltage variable from 0 to 12 volts is provided,

and this voltage is metered directly by a voltmeter on the front panel.

Dimensions of the Model 695 are 16 1/4 inches high, 13 1/4 inches wide, and 8 inches deep. Weight is 24 pounds.

Competition for the Service Technician

Since the advent of television, the public has been showered with many advertisements which offer (for a modest sum) a booklet or device that supposedly would enable the TV set owner to make his own repairs and thus save himself the amount he would normally pay the service technician for those repairs. Apparently the end is not yet in sight, for there recently came to our attention such an advertisement offering a tube checker for the home repairman.

The ad was conservative; it stated that this device would check radio and TV tubes from the picture tube on down, and the price was only \$3.95. (This, incidentally, you would save on your first repair job, according to the ad.) You could also check electrical circuits, the ad stated.

Considerable speculation arose as to what scientific principles were involved in the operation of this little wonder, and eventually curiosity overcame our better judgment. The money was forwarded, and in due course of time the instrument was in our hands. A birds'-eye view of the instrument appears in Fig. 5.

After exhaustive tests in our laboratories, our advice to you is to refrain from throwing away your present tube checker in its favor because there are still some conditions this instrument cannot check.

As we had surmised, when used as a tube checker the instrument operates solely as a filament-continuity checker. The instrument is wired in such a manner that when it is plugged into the standard 115-volt AC or DC source the tube-socket pins, commonly used as filament connec-

TABLE II

RATING (IN MA)	MANUFACTURERS			
	FEDERAL	MALLORY	SARKES-TARZIAN	SELETRON (RADIO RECEPTOR)
20 (15)	1159			8Y1
35		6S35		
50	1214			
65	1002	6S65	65	8J1
75	1003	6S75	75	5M4
	1007A*		78D*	6QS1
100	1004A	6S100	100	5M1
	1101A	6S100A	100A	
	1014A		108	
	1008A*		108D*	
150	1005A	6S150	150	5P1
				6P1
				6P2
200	106A	6S200	200	5R1
	1029A		208D*	
	1009A*			
250	1010	6S250	250	5Q1, 6Q1
				6Q2
300	1090A	6S300	300	6Q4
350	1023A	6S350	350	5QS1, 6QS1
				6QS2, 6QS4
400	1130			

*Dual section; check each section separately.



tions in most tubes, are connected to the voltage source. A 200K-ohm resistor (for current limiting) is in series with one side of the line cord, and an NE-2 neon glow lamp is in series with the other side. Thus, when a tube having filament continuity is placed in the proper socket, the circuit is completed and the neon lamp will glow, indicating a good tube.

An instruction leaflet is included with the checker and gives directions for making continuity checks of such items as TV cords, fuses, lamps, motors, motor armatures, push buttons, resistors, and door buzzers and chimes. Two test leads are provided for making the continuity checks. The four test sockets are for 7-pin miniatures, 9-pin miniatures, and tubes with loctal or octal bases. Picture tubes must be checked using the test leads.

Now, every service technician knows that the judgment of a good or bad radio or TV tube is not based solely on filament continuity, therefore it is hardly necessary to point out the limitations of this type of instrument. The point to be made is that here is another possible source of misunderstanding between the service technician and the set owner. The set owner is led to believe that the use of this instrument will enable him to do his own tube checking as easily and conclusively as would the service technician. What conclusions will be drawn if by chance he checks some tubes rejected by a service technician because of shorted elements, low emission, or low transconductance? The customer may lose confidence in the service technician, for he probably still remembers earlier articles in various publications which inferred that all service technicians were unscrupulous. Obviously, all service technicians are not unscrupulous. Cleanup campaigns conducted by the service technicians themselves and their organizations have been so successful in correcting isolated cases which caused the charges to be made that such charges are seldom made now. It would be unfortunate if this device were to cause further misunderstanding.

We would not have the reader think that we are taking an alarmist's point of view about this item; probably neither the service technician's economic security nor reputation is in danger. It does serve, however, as an example of the type of "do it yourself" advertising which encourages the layman to attempt a task best left to the qualified service technician.

PAUL C. SMITH

A Universal Substitute Speaker

(Continued from page 29)

receivers. It was found that most speaker fields or speaker-mounted chokes are covered by the values of this pair of chokes. It can be seen in the schematic of Fig. 2 that the output transformer used in the substitution box is a universal type. The secondary taps were chosen to obtain an approximate impedance match between the more widely used output tubes and the speaker voice coil. Note in the schematic of Fig. 2 and in the photograph of Fig. 3 that the secondary leads of the transformer have been extended with flexible wire, brought through the front panel, and terminated with individual plugs. This allows the voice coil to be used alone or to be connected to the transformer secondary.

An alternative construction design may be used if greater flexibility in matching is desired. There are six taps on the secondary of the universal output transformer. For more critical matching, each of the secondary taps may be brought out to individual jacks on the front panel. Instruction sheets packed with most universal output transformers list the taps to be used with any particular combination of output tube and speaker. This data is helpful in determining what connections need be made for a given condition.

Spare jacks have been placed on the front panel of the substitution box for terminating unused cable leads and for incorporating any additional components to meet future requirements. Four interconnected jacks and a flexible lead from them have been included for use in those cases where shorting connections must be made between two or more of the terminals on the speaker plug or socket. Two short leads termi-

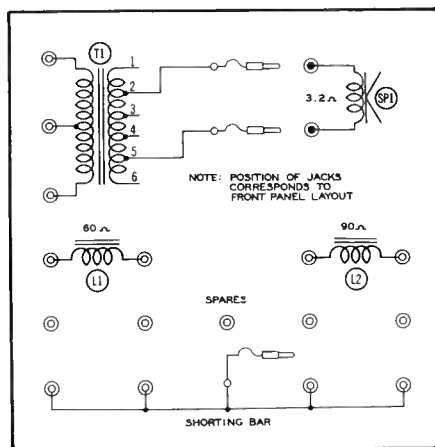

Fig. 2. Schematic of Substitution Speaker Assembly.



Fig. 3. Front-Panel Layout of Speaker Box and Some of the Cables.

nated with banana plugs on each end were made to provide a means of shorting between any of the jacks. These leads can be conveniently stored by plugging them into the spare jacks.

The physical layout of the jacks on the front panel can be seen in the photograph of Fig. 3. The arrangement of these jacks can be varied to suit personal preference. In any case, it is recommended that a sketch be made of the internal connections in the substitution box and fastened on the underside of the lid for quick reference. If all the secondary taps are terminated in front-panel jacks, the data pertaining to their proper connection can also be included on this sketch.

Because of its flexibility, this unit can be used as any of the following assemblies:

1. Voice coil only.
2. Voice coil and any one of two chokes.
3. Voice coil and shorting bar (commonly used for B+ protection).
4. Single-ended output only.
5. Single-ended output and any one of two chokes.
6. Single-ended output and shorting bar.
7. Push-pull output only.
8. Push-pull output and any one of two chokes.
9. Push-pull output and shorting bar.
10. Any one of two chokes.

The cable assemblies can be seen in the photograph of Fig. 2. Each cable assembly uses wires three feet long, but obviously this length would depend upon individual preference or requirements. The termination

PARTS LIST FOR UNIVERSAL TEST SPEAKER

BOX ASSEMBLY		CABLES	
ITEM	QUANTITY	ITEM	QUANTITY
Bud No. C994 cabinet	1	Alligator clips	2
Quam No. 6A1 speaker (SP1)	1	Cinch No. 13E (phono plug)	1
Merit No. A2900 transformer (T1)	1	Cinch No. 5A1	1
Merit No. C2994 choke (L2)	1	Cinch No. 5A2	1
Merit No. C2996 choke (L1)	1	Cinch No. 5A3	1
Three-lug tie strip	1	Eby No. 119-2M	1
Five-lug tie strip	1	Cinch No. 5B1	1
Grommets	3	Amphenol No. 71-35	1
Banana jacks	18	Eby No. 60-4M	1
Banana plugs	7	Eby No. 60-5F	1
Flexible wire	4 feet	Banana plugs	32
Mounting screws, nuts, and washers	As needed	Flexible hook-up wire in 5 colors	As needed

at the receiver end of these cables is usually in the form of a plug or sometimes a socket. These plugs or sockets were selected to duplicate those used by receiver manufacturers and were found to be standard stock items, as indicated by the second portion of the parts list and Fig. 2. Five types of two-prong plugs were used and have been found satisfactory. For the many chassis which use single terminal jacks for each wire to the speaker, a set of two leads with small alligator clips was made. This assembly also serves for those sets using two wires soldered directly to the voice-coil terminals. These are all of the two-lead assemblies which were found necessary. One three-terminal plug, one four-terminal plug, one five-terminal plug, and one five-terminal socket complete the assemblies required at the present time by the shop using this particular unit.

The simpler applications of this unit should be easily understood.

The following example should clarify one of the more complex uses of the test speaker.

The RCA Victor chassis KCS47E uses a four-terminal plug on the speaker assembly. A schematic of the circuits associated with the speaker is presented in Fig. 4. Terminals Nos. 1 and 2 on the plug are shorted and are also connected to one side of the output transformer. Plate voltage to the output stage is supplied through this jumper. Terminal No. 4 is the plate lead of the output transformer, and No. 5 is not used. On this plug, terminal No. 3 is completely absent. When the universal speaker assembly is connected by means of the cable using a four-terminal plug, the shorting strap is duplicated by plugging the wires from terminals Nos. 1 and 2 on the plug into the shorted jacks. This is illustrated in Fig. 5. A connection is made to the output transformer by inserting the flexible lead from the shorted jacks into one of the primary jacks. The

other primary jack receives the plug from terminal No. 4; the line from terminal No. 5 is plugged into one of the spare positions, or left dangling loose; the two flexible leads from the secondary of the output transformer are inserted into the voice-coil jacks; then the unit is ready for use. The four lower right-hand jacks hold two spare flexible leads. They can be inserted in these jacks for storing since the jacks are not connected in the circuit in most applications.

The application of this unit is not necessarily limited to television receivers, for the unit is equally useful in simulating the complex speaker assemblies sometimes found in the larger console radios.

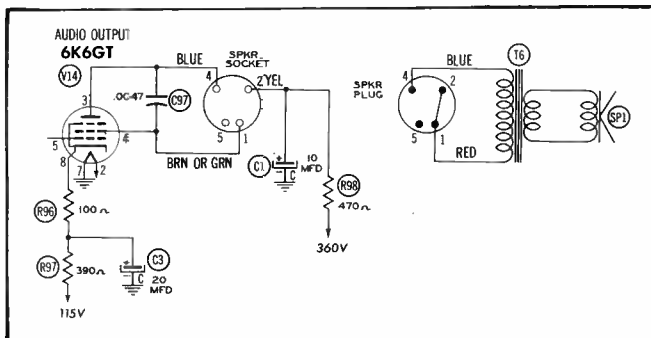

Fig. 4. Schematic of Speaker Circuits in RCA Victor Chassis KCS47E.



Fig. 5. Test Speaker Connections to RCA Victor Chassis KCS47E.

Audio Facts

(Continued from page 17)

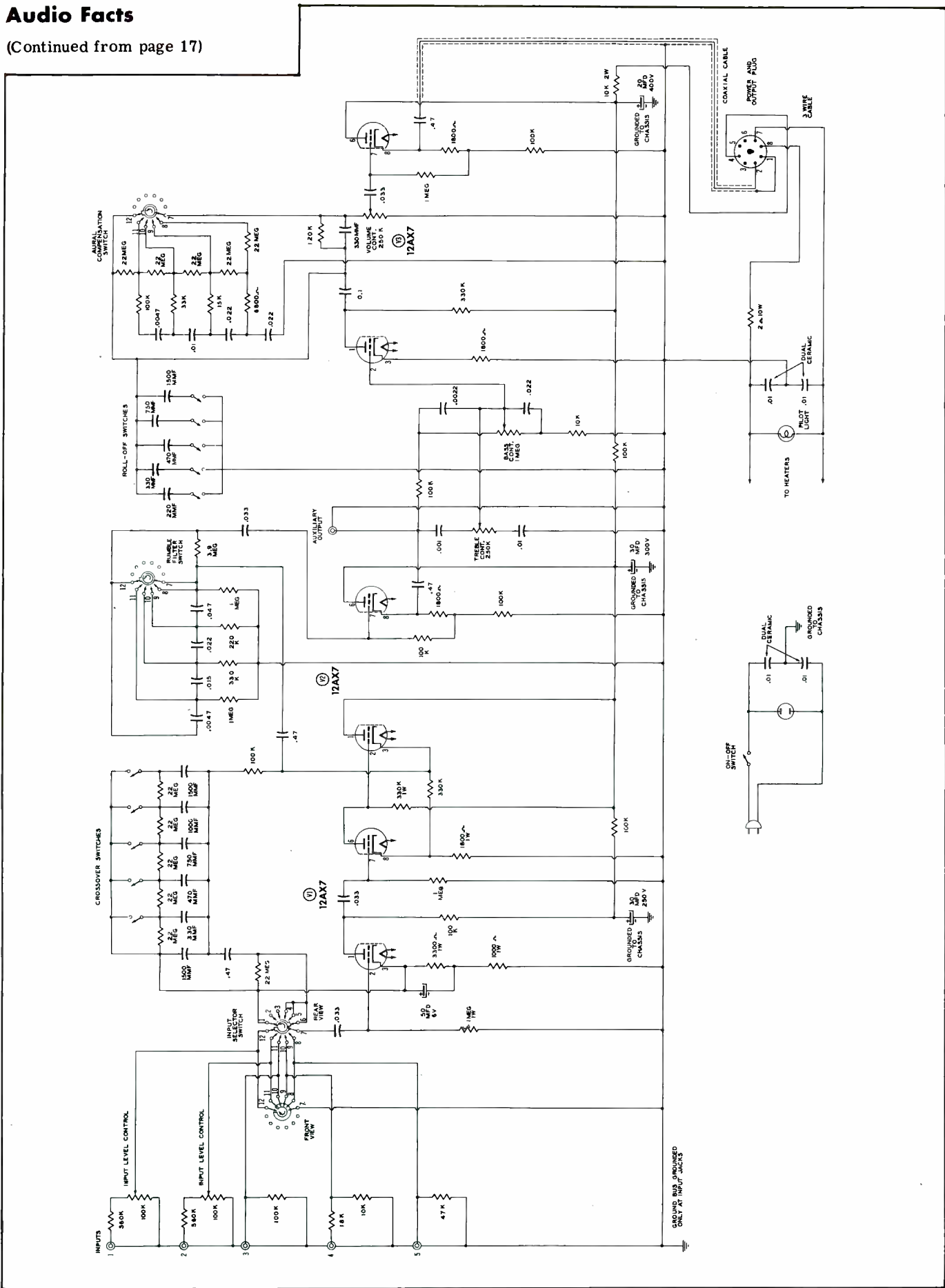

Fig. 2. Schematic Diagram of McIntosh Model C-108 Audio Compensator.

Input No. 4 for high-level magnetic cartridges (Pickering).

Input No. 5 for low-level magnetic cartridges (Audax Polyphase or Weathers FM).

Inputs Nos. 1 and 2 are equipped with level controls so that the input signal can be set to a level which will not overload the input circuit.

Inputs Nos. 4 and 5 can be terminated for any make of magnetic cartridge by installing the resistors recommended by the manufacturer of the cartridge.

All inputs connect into the circuit through the input selector switch which has three main functions. First, it selects the desired input channel. Second, it grounds the unused channels to eliminate crosstalk and possible hum. Third, it switches the crossover compensation into the feedback circuit when the switch is turned to channels 4 and 5. This is accomplished by removing the short across the 22-megohm isolation resistor which connects switch terminal No. 1 to terminal No. 6.

It can be noted that three 12AX7 tubes are used. This is typical of present-day trends, for these high-gain dual triodes seem to be used in the majority of low-level audio stages.

The two stages formed by the two sections of the first 12AX7 (V1) are conventionally coupled. The second stage (one-half of V1) is direct coupled to the third stage which is a cathode follower. The 1,800-ohm resistor, common to both cathodes, provides negative feedback and adds to the stability of the circuit.

Feedback from the cathode of the third stage (pin 3 of V2) to the cathode of the first stage (pin 3 of V1) provides the necessary low-frequency compensation on the channels intended for use with magnetic phonograph cartridges. On channels 1, 2, and 3, negative feedback without the low-frequency discrimination is accomplished through the 100K-ohm resistor and the .47-mfd capacitor.

Crossover Switches

Crossover is accomplished by an interesting and neat assembly of five single-pole single-throw slide switches clearly visible in the illustrations. Each switch, when in the down position, adds capacity in series with the 100K-ohm feedback resistor thereby lowering the crossover frequency because of the increase in negative feedback at the lower frequencies. (Negative feedback reduces output.) As mentioned before, these switches are only effective on channels 4 and 5.

The cathode of the third stage (first section of V2) couples to the grid of the fourth stage (other section of V2) which is also a cathode follower. Incidentally, the cathode-follower characteristics of high input impedance and low output impedance have been used to advantage in this unit.

Rumble-Filter Switch

When the Rumble-Filter switch is in positions 2, 3, 4, and 5, a high-pass filter is inserted in the circuit between the third and fourth stages. This filter gives a sharp attenuation of the lower frequencies and becomes effective at progressively higher frequencies as the switch is advanced to position 5. This attenuation of the low frequencies reduces the effects of turntable rumble and other unwanted low-frequency sounds. The rumble filter is effective on all input channels.

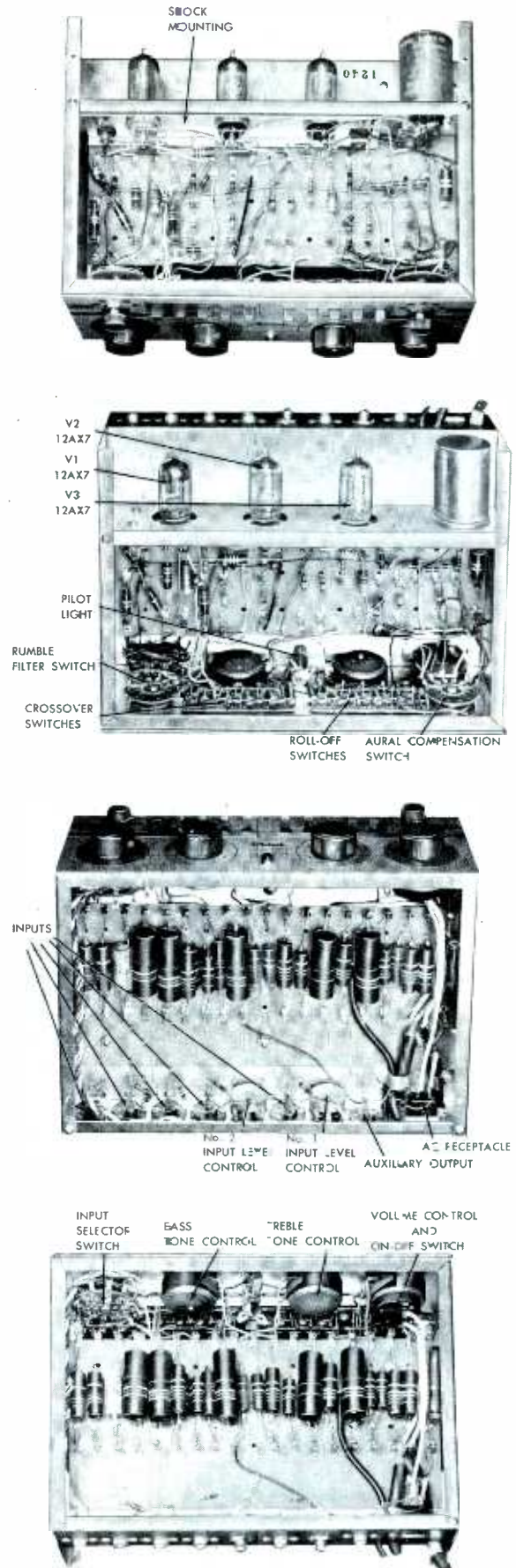
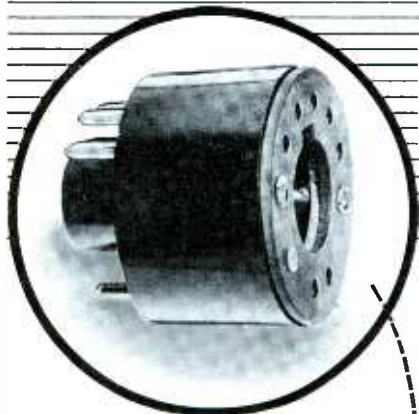

Fig. 3. Top and Bottom Views of McIntosh Model C-108 Audio Compensator With Top and Bottom Covers Removed.

HBG*

is here!



for **Quick TV Set
Adjustment and
Alignment!**

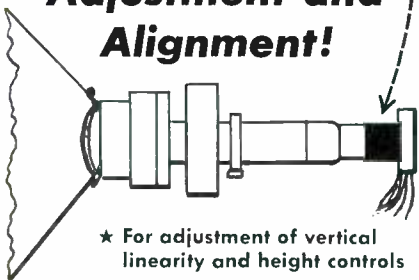

- ★ For adjustment of vertical linearity and height controls
- ★ Accurate positioning of focus coil or magnet
- ★ Precise setting of yoke
- ★ Complete with instructions



See Your Jobber Today!



EXPORT: Scheel International
4237 N. Lincoln Ave., Chicago 13, Illinois

The low output impedance characteristics of the cathode follower in the fourth stage are effective in reducing the loading effects of the tone-control circuits and also provide for satisfactory coupling of a tape recorder to the auxiliary output jack. When a tape-recorder input is connected into this jack, the signal can be monitored by the sound system connected to the output of the Model C-108.

Tone Controls

The two tone controls located in the circuit between the fourth and fifth stages are of the conventional divider type. These controls allow separate control of the bass and treble frequencies and provide a wide range of boost or droop on all channels.

Roll-Off Switches

The roll-off switches are another group of five single-pole single-throw switches. These serve the purpose of shunting certain sizes of capacitors across the output circuit of the fifth stage in order to attenuate or roll off the high frequencies. Both the amount of roll-off and the frequency at which it starts depend upon the amount of capacity switched into the circuit. With none of the switches in the down position there is no high-frequency roll-off; but with them all down, there is rapid roll-off from the vicinity of 600 cps to an attenuation of about 25 db at 10,000 cps. Thus, a different switch setting or combination of switch settings can provide most any degree of roll-off in any of the five channels.

Aural-Compensation Switch

Reference to the schematic shows that when this switch is in its first position the compensating network is bypassed. In any of the other four positions, a portion of this filter network is switched into the circuit to balance the sound output (for the volume control setting used) in order to compensate for the characteristics of the listener's ear with regard to loudness. A full discussion of the characteristics of the human ear and the need for loudness control appeared in "Audio Facts" in the September-October 1953 issue of the PF INDEX. This compensation has the effect of boosting the bass and the higher treble frequencies and increases as the switch is advanced to position 5. The most satisfactory setting is found by selecting the most pleasing position after all other controls have been adjusted. The Aural Compensation switch, which is in the circuit on all channels, permits use of the ordinary uncompensated volume control located in the grid circuit of the output stage.

The output stage is a cathode follower which permits a long output cable to be used. The manufacturer recommends that a cable over 30 feet in length should not be used unless provisions are made to reduce the capacitance of the cable.

All circuit grounds connect to the ground bus which is grounded to the chassis at the input jacks. The can of the electrolytic decoupling capacitor and the dual .01-mfd AC-line bypass capacitor ground to the chassis and not to the ground bus.

The 2-ohm 10-watt resistor in the heater line drops the heater voltage to reduce hum and tube noises.

Since the Model C-108 was designed for use with McIntosh power amplifiers, appropriate cables are furnished to connect it to one of these amplifiers. The unit can be used with other amplifiers, however, by using the proper type of cables. Since it is not self-powered, a separate power supply Model D-101 is supplied for furnishing the required power if the C-108 is not used with one of the McIntosh amplifiers.

A hum-balancing potentiometer connected across the heater lines is located in the power amplifier and D-101 power supply. If the Model C-108 is used with some other make of amplifier or power supply, provisions should be made to center tap the heater lines and to ground this center tap.

The shielded output cable connects to pin No. 2 of the power connector plug attached to the end of the cable. See Fig. 1.

The AC receptacle is controlled by the On-Off switch mounted on the volume controls.

The tubes are shock mounted and are accessible for checking or replacing without dismantling the unit, although dismantling would be no problem since the top and bottom covers can be lifted off after only two screws holding each one have been removed.

Although shown without cabinet, this unit is also available designated as Model C-108A with wooden cabinet, or as C-108H with cabinet mounting panel.

Both circuitry and mechanical features may initially seem complex; but, actually, design is straightforward and only a moderate number of parts are used. Flexibility of control is noteworthy in this unit, and the design certainly contributes toward this end.

ROBERT B. DUNHAM

PF INDEX - April, 1954

Dollar and Sense Servicing

(Continued from page 39)

ETCHINGS. The industry is still groping for the magic solution to the problem of paying receiver production-line workers more money for fewer hours of work a day, as demanded by unions, while at the same time lowering production costs so prices can be cut, as demanded by the public. Most of the larger companies have one or more guinea-pig production lines going on printed, etched, or otherwise mechanized wiring techniques for receivers; but not a single manufacturer is using any one technique exclusively. The increased initial costs of equipment for mechanization so nearly balance the saving in labor that little or nothing has been gained as yet.

The most mechanized firm today appears to be GE, with its dip-soldering techniques built around special terminals that place practically all soldered joints on top of the chassis. GE has an etched-wiring line going, too, as does Philco and a few others, for cost comparison. The old-fashioned method of twisting and soldering, joint by joint, is still holding its own with manufacturers just as it is with service technicians.

Newly announced techniques like Project Tinkertoy are principally for high quality military electronic gear. The silvered wiring is fired onto small steatite plaques after which titanate capacitors and strip resistors are applied, the plaques are assembled into cubes for stages, and the stages are hooked together with still more etched-wiring panels — all on intricate machines such as only our government can afford.

For essentially the same purpose, that of getting a needed new electronic design produced in a hurry, GE is working in a different direction. They translate a required circuit design into codes that can be punched out on a negative, then they feed the negative into an electronic computer which controls the machines that do the work. One machine, an automatic punch press, punches out the holes in a chassis or an etched-wiring panel one by one in their required locations as commanded by the computer.

Another machine takes this etched-wiring panel and drops into the correct holes one by one the correct parts having leads that have been preformed. Changing the negative changes the design. The system is economical for small runs, but the cost is too high for competition with hand assembly of large orders on modern receiver production lines.

Still needed is a machine or technique that can outperform the women on the line.



SHOW BUSINESS. Nine TV sets, each tuned to a different station, are stopping sidewalk traffic and bringing it into the shop of a Modesto, California, television dealer. Each set is connected to a different antenna, for optimum reception. A card in front of each set identifies the channel number and the city from which the program is coming. The channels are 4, 5, 7, 8, 10, 12, 24, 36, and 47 — all in San Francisco and vicinity.

Try this sometime, if you can pull in enough stations in your area to put on a good show. Keep the sets close together, so people can watch all the programs at once. Could be a good way of moving trade-ins or of attracting new service business.



NEW TUBES. Out they pour — new tube types designed especially for color TV receivers. There's a 6BJ7 triple-diode for use as DC restorer in the three signal channels, a 6AU4GT half-wave rectifier for use as damper diode, a 3A3 half-wave rectifier for high-voltage pulses, a 6AN8 triode-pentode, a 6BD4 beam tetrode, and a 6BY6 pentagrid amplifier — to mention a few. Make room on the shelves; or rather, build some new shelves. We have yet to see a shop in full operation that had spare space on its tube shelves.



COLOR CALLS. Six to ten service calls a year are predicted by Du Mont's service manager, Harold Schulman, for color TV sets. This upsurge of service business will be required because of the greater complexity of the sets, new types of components, the need for repeating operating instructions to customers, the inexperience of service technicians with color circuits initially, and the anticipated color-transmission difficulties that will be blamed on receivers.

look for the Howard W. Sams "BOOK TREE"



at your PARTS DISTRIBUTOR

Make it a habit to "browse" at the Howard W. Sams "Book Tree". You'll find it at your Parts Distributor. It's loaded with the time-saving, profit-building books you want and need. Keep ahead with these timely, practical publications that help you learn more and earn more daily.

LOOK FOR THESE TITLES: Television Books

"Telecasting Operations"	\$7.95
"Photofact Television Course"	3.00
"TV Servicing Short-Cuts"	1.50
"TV Test Instruments"	3.00
"UHF Converters"	1.00
"UHF Antennas"	1.50
"Television Antennas"	2.00
"Servicing TV in the Customer's Home"	1.50
"Making Money in TV Servicing"	1.25
"TV Tube Location Guide" Vols. 4, 3, 2, each	2.00
"TV Tube Location Guide" Vol. 1	1.50

Audio Publications

"Recording & Reproduction of Sound"	\$7.95
"Audio Amplifiers" Vols. 4, 3, 2, each	3.95

Record Changer Manuals

"Automatic Changer Manual" Vols. 5, 4, 3, each	\$3.00
"Automatic Changer Manual" Vol. 2	4.95

Handy Service Guides

"Radio Receiver Tube Replacement Guide"	\$1.25
"AM-FM Servicing Short-Cuts"	1.50
"Dial Cord Stringing Guide" Vols. 4, 3, 2, 1, each	1.00

Auto Radio Service Manuals

"Auto Radio Manual" Vols. 3, 2, each	\$3.00
"Auto Radio Manual" Vol. 1	4.95

Communications Receivers

"Communications Receivers" Vols. 2, 1, each	\$3.00
---	--------

Coyne and Boyce Books

"Coyne TV Servicing Cyclopedea"	\$5.95
"Coyne Transistors"	1.50
"Coyne Practical TV Servicing"	4.25
"Coyne Latest Test Instruments"	3.25
"Coyne TV & Radio Handbook"	2.75
"Coyne Industrial Electronics"	3.75
"Boyce Video Handbook"	5.95
"Boyce Radio Handbook"	4.95

See these and dozens of other invaluable books on the Howard W. Sams "Book Tree"!

HOWARD W. SAMS & CO., INC.
Indianapolis 5, Indiana

Look for these books —
order them at your Parts Distributor

NEW LIFE FOR OLD RADIOS

SUPEREX

Vari-Tenna

modern replacement for old-fashioned hank of wire and antenna coll. **\$125** List



- Boosts sensitivity and gain up to 25 times.
- Pulls in hard-to-get stations.

50,000,000 old and inexpensive radio sets now in use NEED a VARI-TENNA . . . including many of your own customers'. Superex Vari-Tenna gives all the power and reception of modern sets . . . lets you hear stations never before available.

and EXTRA power for all radios

NEW

SUPEREX ENERGIZED

Ferri-Loopstick

List \$150

Even brand new radios, still equipped with old-fashioned loop antennas, can benefit from this "hot" loopstick. Adds 20% gain to even the powerful Ferri-Loopstick. Q up to 350, will outperform any coil with a core 3 times its length. 1-hole snap in mount; self-locking vinyl adjustment collar.



Popular enough to be imitated

Recommend these compact, highly sensitive money makers.

Grayburne
FERRI-LOOPSTICK

List 75c

Pulls in stations strong and clear. Customers rave over performance.

Grayburne
VARI-LOOPSTICK

List \$1.00

Same as Ferri-Loopstick with variable micrometer adjustment.

BE SMART! Boost your reputation as a technician . . . make handsome profits. Recommend Superex products to your customers on every call.

Superex ELECTRONICS CORP. successor to Grayburne
23 Atherton St., Yonkers, N. Y.

OLD TUBES. Some say an older tube in a receiver has just as much chance of lasting another year as a brand-new tube in that socket. This theory applies primarily to outright burnout of the filament or heater; some tubes may not die, but they certainly "wither away." The cathode takes the hardest wear, so that emission goes down and down.

In radio sets having AVC and located in cities near powerful stations so that there is ample reserve of gain, the withering-away of a cathode wouldn't even be noticed for many, many years. In rural locations for radio and in practically all TV receiver sockets, low emission does make a difference, though. The conclusion is that except for local-reception radios, new tubes can be recommended and installed with a clear conscience to replace those which are a few years old.

The Navy ran into the opposite situation during the last war, wherein the men were throwing out tubes that had just got nicely settled and stabilized in their sockets. Tests of discarded tubes showed that the majority were all right or were merely slightly low in transconductance. Putting in all new tubes just to catch one bad one caused a lot of new troubles until the orders came down the line to use common sense in replacing tubes.



UNIVERSAL TV. A television receiver having a 12-channel tuner and a 4-standard switch has been announced by Philips of Eindhoven, Holland as a universal set for use throughout Europe. With a 17-inch tube, it is to sell for \$355, as compared to \$288 for a 17-inch 10-channel single-standard European set. The four broadcasting standards to which the set responds are: Belgian 625-line with AM sound; French 819-line with AM sound; standard European 625-line with FM sound; British 405-line with AM sound.



IMPLOSIONS. Mortality due to breakage of picture tubes is only 0.0004 per cent, says RETMA after surveying its members. Only 100 of the 27,000,000 tubes made for sets now in use were reported to have imploded. Most of these were 21-inch rectangulars with cylindrical faces; so be careful with these big babies.

NIGHT OWLS. Question: How many TV-radio appliance dealers stay open nights? To find the answer, chairman Mort Farr of NARDA surveyed some 400 dealers. Over half stayed open one night a week; 18 per cent were two-nighters, 2 per cent were four-nighters, 12 per cent were five-nighters, and 6 per cent made it every weekday night. His advice, based on personal experience, is to stay open more evenings even if it means closing mornings, because total sales can thereby be boosted as much as 20 per cent with little or no increase in overhead.



CAUGHT. To stop thefts from cars parked in a lot near a bowling alley, police in La Mesa, Calif., put an officer up on the roof with a Motorola "Handi-Talkie." Soon after, he spotted the car prowlers at work and radioed their description to the dispatcher at police headquarters. Then, as police converged on the area, he directed them by radio to all possible exits from the lot so as to block escape routes. The entire gang was rounded up.



"SAVES ME 45 MINUTES
on every tuning slug retrieving job"

RETRIEVE TUNING SLUGS
without removing the chassis

Magic-Tip TV Special's extra long, slender blade permits technician to reach all the way into tuning unit from the front of the cabinet. Once contact is made with slot in tuning slug a gentle forward pressure causes Magic-Tip internal pin to lock the slug securely to blade tip. When slug is returned to desired position in tuning unit a gentle backward pressure unlocks the tip, permitting blade to be withdrawn and leaving tuning slug in place.

TWO SIZES:
TV-16" \$2.98 postpaid
TV-12" \$2.24 postpaid
Satisfaction or refund

HUNT UP HUNTER
make hard jobs easy!

at your Jobber or **HUNTER TOOLS**

Send for free Catalog

HUNTER TOOLS
Box 564-PF • Whittier, Calif

PRINTED TV. A complete receiver printed in nine major sections has been announced as ready for mass production by Kaye-Halbert TV Corp., of Culver City, California. The sections snap into a vertical frame behind the picture tube and are easily removed for repair or replacement. The firm estimates that their scheme will permit doing 95 per cent of the servicing right in the home.

Whether the idea will click remains to be seen; if it does, it'll be another first. Servicing problems and high cost are just a few of the bugaboos that have held up extensive commercial use of printed circuits created by etching techniques.



LOOKING IT UP. On an electronics research project, up to 25 per cent of total working time is spent in finding, correlating, and assimilating printed material on the subject. Finding the right books and articles is difficult even in a large library, because there may be no convenient and consistent master system for indexing articles in scores of different magazines.

Contrast this with servicing, where a single listing in the PF Cumulative Index locates all the information needed for the servicing project of the moment, and only a minute more is needed to pull that information out of the specific "Photofact Folder."



STRIPS. Organization and maintenance of tube stock on shelves is made easy by new RCA pressure-sensitive labels. These come in booklets, each containing 408 different stickers on thin backing sheets. Just peel off the label and "plunk" it on the edge of the shelf. Alongside the type number on the label is a space in which your selected minimum inventory can be written in pencil. To the RCA tube department go congratulations for this really useful servicing aid.



ROBOT SPEAKER. If you're ever asked to provide equipment that'll give a sales talk automatically

when someone opens a refrigerator door, breaks a light beam, steps on a switch type of mat, or pushes a button, get in touch with the Powell Announcer Corp., 30 East Oak Street, Chicago. They make an announcer exactly for the purpose. It will store up to 125 words on its endless quarter-inch steel tape. The unit is about the size of a small toolbox, and hence it can be concealed when customer mystification is desired. Messages are easily erased and changed.



NONSENSE. An English-Russian electronics dictionary prepared in Russia, and extracted therefrom by devious means, contains the following gems: walkie-no-back-talkie, all-around-looking antenna, woggle joint, wow-wows, and walnut capacitor. Each is followed by the equivalent Russian term, presumably to guide Russian engineers in translating PF INDEX and other American electronics publications. Could there be sabotage behind the curtain?

John Markus

Examining Design Features

(Continued from page 23)

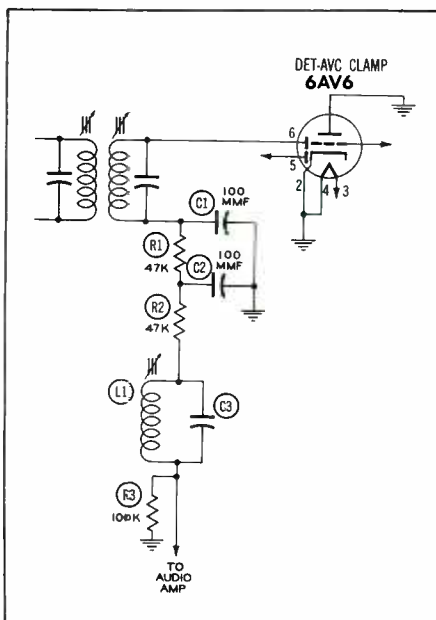

Fig. 3. Partial Schematic of the Capehart Chassis CR-129 Showing the 10-Kilocycle Filter.

resonant circuit, as shown in Fig. 4. This circuit, which is comprised of the inductance L1 and the capacitance

C5, shunts the 10-kc signal while offering a high impedance to other frequencies.

Such circuits should seldom require alignment, but adjustments are provided to compensate for any drift which might occur.

Admiral Chassis 23A1 Dual Power Supply

In a television receiver, two values of B+ voltages are usually required because of the operating requirements of the different tubes. These voltages are ordinarily obtained by the use of voltage-divider networks. This method is relatively inefficient from the standpoint of power consumption. Another disadvantage of this system is that one value of B+ voltage may depend to a certain extent upon the current drawn from the other section.

A different approach to the problem of obtaining the desired voltages is employed in the Admiral Chassis 23A1. The power supply is shown schematically in Fig. 5.

Taps are provided on the secondary winding of the power transformer. By using this type of winding, two separate rectifiers may be employed.

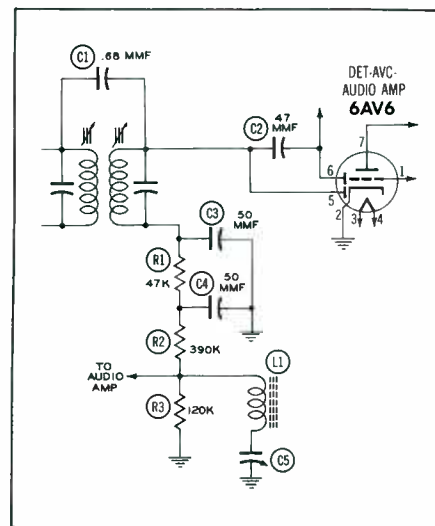

Fig. 4. The 10-Kilocycle Heterodyne Filter As Used in the Hallicrafters Model 1622.

As a result, two B+ voltages which are relatively independent of one another are provided. This system is also more efficient than the use of voltage-divider networks.

Browning Model RJ-42 Tertiary IF Winding

In AM tuners where fidelity of reproduction constitutes a prime consideration, it is desirable that the IF

stages amplify a band of frequencies with as little distortion as possible. It is therefore necessary that the response curve of the IF stages have a nearly flat top over the desired range of frequencies.

The Browning Model RJ-42 tuner employs a tertiary winding in the IF transformers to broaden the IF response of the receiver. The effect of this third winding is to flatten the top portion of the response curve. The tertiary winding is paralleled with a variable capacitor to form a parallel resonant circuit at the intermediate frequency. See Fig. 6. The resonant circuit is coupled to a winding of the transformer and absorbs energy from it. The loading effect produced by the coupling acts as an additional load and broadens the response of the transformer. Thus the sidebands which represent the higher modulation frequencies are properly coupled through the transformer.

Sylvania Chassis 1-513-1, -2, -3, -4

The mechanical construction and layout of television receivers have undergone many changes over the years since the industry began. To illustrate the manner in which these changes are still continuing to appear,

Fig. 5. The Power Supply of an Admiral Chassis 23A1.

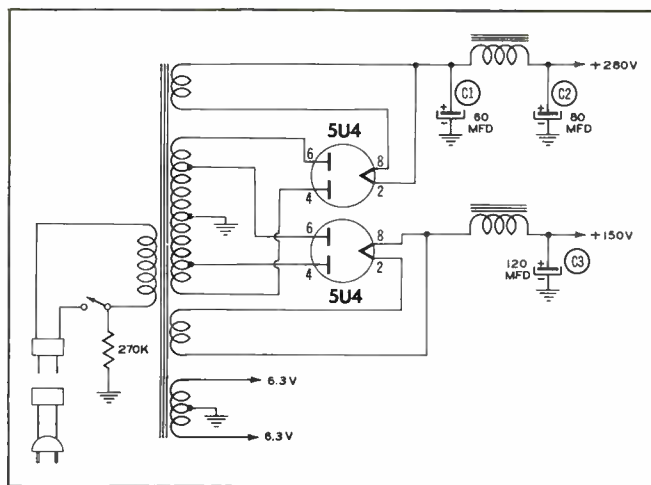

we have selected a new Sylvania receiver (Chassis 1-513-3) and have noted a few of its design features, which are also incorporated in Chassis 1-513-1, -2 and -4.

The receiver employs a 27-inch picture tube which is cabinet mounted. The use of such large tubes has increased the requirements of sturdiness and rigidity in cabinet designs. It has also made the task of picture-tube replacement more difficult. For picture-tube removal in the Sylvania receiver, the manufacturer recommends that the chassis be removed

first. Then the cabinet should be laid over on its front side. After the mounting fasteners and rods are loosened and the neck components are taken off the tube, two persons should reach down along opposite sides of the tube, slip their fingers under the face of the tube, and lift it from the cabinet. The job is not a one-man operation.

Because of the size of the picture tube and the space limitations within the cabinet, the chassis of the receiver does not extend to the front of the cabinet. The tuner with the

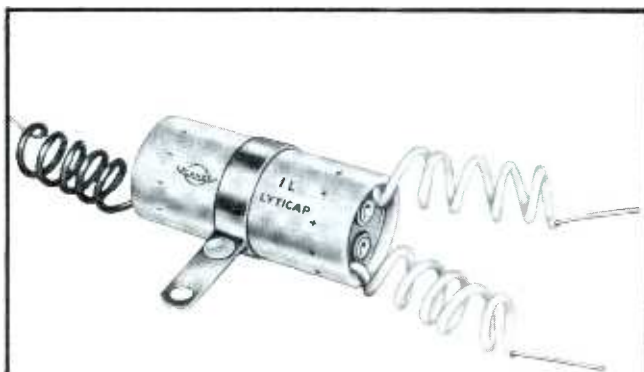

NEW DUAL SECTION ELECTROLYTIC CAPACITORS HERMETICALLY SEALED IN ALUMINUM TUBES WITH COMPLETELY FLEXIBLE INSULATED LEADS. By riveting the leads directly to the condenser end disc, Planet has eliminated the use of rigid terminal risers ordinarily used on this type construction. This allows Planet Type 1L capacitors to fit into a smaller space and eliminates the possibility of lead breakage.



"ENGINEERED FOR QUALITY"
GUARANTEED FOR ONE YEAR

PLANET MANUFACTURING CORPORATION
225 BELLEVILLE AVENUE
BLOOMFIELD, N. J.

Write for Catalog 200—Lists Specifications on Stock Items

Build Your Own Cabinets WITH SNAP-ON DRAWERS



Finished in GUN-METAL GRAY



SNAP-ON DRAWERS snap together on sides, top and bottom. No tools needed.

- **MODERN** —Light weight, functional in design.
- **EFFICIENT** —Parts are quickly, easily located.
- **PRACTICAL** —You build to suit your needs.
- **SELECTIVE** —You have a choice of three sizes.
- **ECONOMICAL**—You buy only what you actually need.
- **CONVENIENT**—When you need more room
- **SO SIMPLE** —Just snap on another SNAP-ON DRAWER.

• YOUR FAVORITE JOBBER CAN GIVE YOU PROMPT SERVICE

SNAP-ON DRAWER CO.
MORROW, OHIO

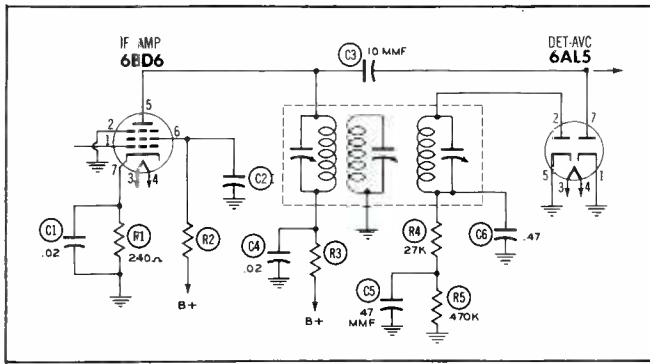

Fig. 6. A Schematic Representation of an IF Transformer As Used in the Browning Model RJ-42.

associated front-panel controls is mounted separately from the chassis. Also apart from the chassis are the volume and brightness controls which are cabinet mounted and are connected to the main chassis by means of a cable. The front-panel controls are mounted below the picture tube and emerge from the cabinet at a slightly upward angle for the convenience of the user.

The separate tuner assembly obtains its operating voltage through a cable with a plug connector. The output of the tuner is fed to the main chassis through a shielded phono cable terminated with a conventional phono plug. This method of coupling is permissible because the distributed capacity in the cable contributes to the proper tuning of the mixer plate circuit to the intermediate frequency. A special grounding strap with a clip is used to ground the tuner to the main chassis. Space is provided on the tuner assembly for both VHF and UHF tuners.

A slanted mounting of the two low-voltage rectifier tubes used in the receiver is unusual. The reason for this slanted arrangement is to allow maximum clearance between the large bulb of the picture tube and the components on the chassis.

This Sylvania receiver employs another design feature which has been gaining increased popularity in present-day sets. The crystal used for video detection is mounted in a pair of clips on the top of the final video IF transformer. A metal cap snaps over the top of the transformer can for protection and shielding. The clips which hold the detector crystal are marked to indicate the correct polarity, in case replacement of the crystal is necessary.

Three interesting provisions are found in the high-voltage assembly of the Sylvania receiver. A spring-loaded sliding rod is connected to the high-voltage cage in such a way that whenever the protective back cover on the set is removed, the rod releases and places a short circuit between the socket of the second high-voltage rectifier and ground. Most of the residual high voltage in the doubler circuit is thereby eliminated.

CAUTION: This interlock device must be inactivated by the service technician when the set is operated on the bench or in the cabinet with the back cover removed.

To facilitate servicing of the high-voltage circuit, most of the components are mounted on an insulated

plate which can be removed by loosening one screw, pulling one plug, unsoldering two yoke leads, and disconnecting the high-voltage lead and the cap leads to the horizontal-output tubes and damper tubes. The components mounted on this removable plate are the two high-voltage rectifiers, the horizontal-output transformer, the high-voltage filter capacitors, the linearity coil, and various resistors and capacitors associated with the high-voltage circuit. The plugs and sockets furnish the required connections to the horizontal-deflection yoke and to the supply voltage.

One of the high-voltage filter capacitors is mounted up near the top of the high-voltage cage. A small molded cap, such as those used to connect twisted wires in electrical fixtures, is placed over the capacitor terminal. This cap covers the sharp edges of the terminal and thereby reduces the possibility of corona discharge between the capacitor and the grounded cage.

Unusual PM Speaker

A rather unique speaker is used in the Motorola Model 63X21 radio receiver. The permanent magnet and voice coil are mounted on the front of the speaker as opposed to the conventional rear mounting. A metal bracket extends across the front of the speaker cone to support the magnet. This type of construction may be seen in Fig. 7. The main advantage of this arrangement lies in the space that is conserved. Although the oval speaker is 6 inches by 9 inches, the total depth of the unit is only 1 3/4 inches. A greater proportion of the available space in the receiver cabinet may therefore be devoted to the chassis and its components. Mounting the voice coil and magnet within the speaker cone does not seriously affect the sound reproduction.

Don R. Howe

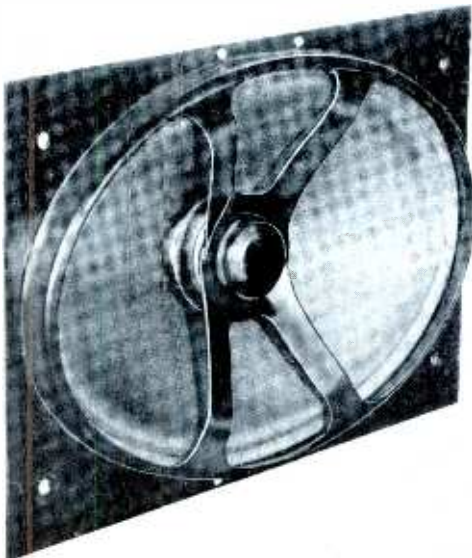

Fig. 7. Speaker With Inverted Voice Coil and Magnet.

CORRECTION

In the schematic in Fig. 3 of the article entitled "Intermittent Recorder" on page 37 of the February 1954 issue of the PF INDEX, there should be a connection between the center tap of the high-voltage winding of the power transformer and the junction of resistors R6, R17, and R27. Capacitors C4 and C8 should be .1 mfd, capacitors C7 and C11 should be .02 mfd, and resistor R28 should be 50K ohms.

UHF

(Continued from page 15)

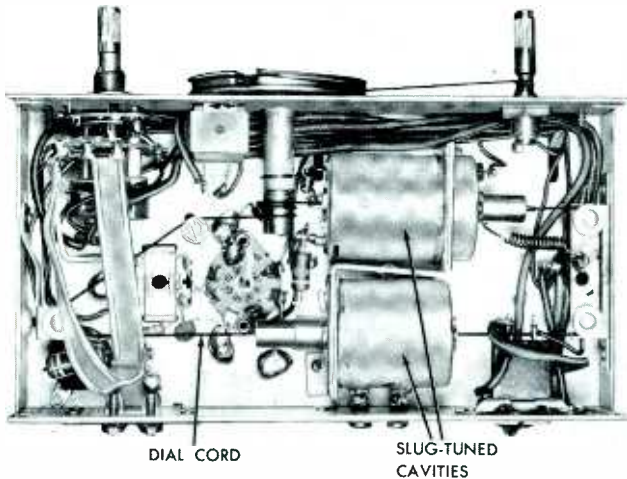

Fig. 3. Bottom Chassis View of Granco Model LCU.

consists of a transformer, a selenium rectifier, and an RC filter.

The Granco Model LCU differs from previous Granco converters in that it employs only one cavity for preselection. This cavity and the oscillator cavity are mounted beneath the chassis in a horizontal position and are tuned by means of an arrangement of dial cords connected to the brass slugs in the cavities. This feature is visible in the photograph of Fig. 3 which shows a bottom chassis view of the converter. The manufacturer recommends that if trouble is suspected in either of the tuner cavities, the entire cavity unit should be replaced. Another servicing recommendation states that in areas of strong local reception on channels 5 or 6, shielded 300-ohm twin lead should be used to connect the antenna terminals on the TV set to the output terminals of the converter. Using shielded twin lead will minimize interference during UHF reception.

Granco UHF "Hide-Away" Converter

As a departure from both the built-in type of UHF converter and the external or accessory tuner, Granco will soon release a UHF converter which may be attached out of sight in the rear of a TV receiver. The unit mounts on the back protective cover and is of flat construction so that less than 1 3/4 inches of clearance between the set and the wall is sufficient. The converter has a metal case to provide interference shielding between the converter and the TV receiver.

The manufacturer states that the design of this "Hide-Away" converter is based on a new version of

the coaxial-cavity tuner which Granco has used in several other models of UHF converters. The unit is adjusted by an inconspicuous tuning knob extending beyond the edge of the TV cabinet. A miniature slide-rule tuning dial is positioned so that it can be seen by looking toward the rear edge of the TV cabinet. For selecting the type of reception desired, a VHF-UHF switch is incorporated in the converter. The output of the unit is in the frequency range of VHF channels 5 and 6.

Three types of the new "Hide-Away" converter will be marketed. The first type gets its power from the TV set by means of an adapter disc inserted between a tube and its socket. The second type is self-powered, and so is the third model which has a high-gain amplifier. The latter is recommended by the manufacturer for use in low-signal areas.

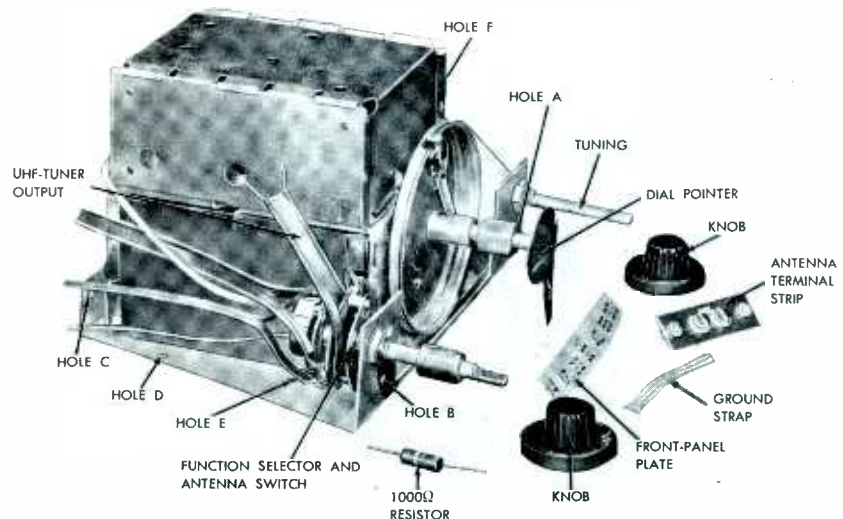

Fig. 4. Techmaster UHF Converter Model TV101-U.

Techmaster UHF Converter Model TV101-U

Shown in Fig. 4 is the Techmaster Model TV101-U which is a UHF tuner designed to provide reception of channels 14 to 83 on any 630 type of receiver. This tuner in combination with the VHF tuner in the receiver provides a double conversion of the UHF signal to the receiver IF.

The schematic diagram of the Model TV101-U is presented in Fig. 5. Two coaxial cavities in the antenna input circuit form a broadly tuned preselector. The UHF signal which leaves the preselector enters a 1N82 crystal mixer and is mixed with a local oscillator signal. The resultant difference signal is applied to a self-biased 6BZ7 cascade IF amplifier. This stage is connected in cascade to provide low noise amplification of the difference signal which is in the frequency range of VHF channels 5 and 6. The output signal is connected by means of a switch to the receiver VHF tuner. The latter is tuned to either one of the aforementioned channels, depending on which is unoccupied by a VHF station.

The antenna switch SW2 is ganged with the VHF-UHF switch SW1 so that, when VHF operation is desired, the B+ supply line to the UHF tuner is opened and the input to the VHF tuner is connected to the VHF antenna. For UHF operation, B+ is provided to the UHF tuner and the output of the UHF tuner is fed to the VHF-tuner input. No switching is performed in the filament circuit to the UHF tuner; this maintains the section in a stand-by condition during VHF operation.

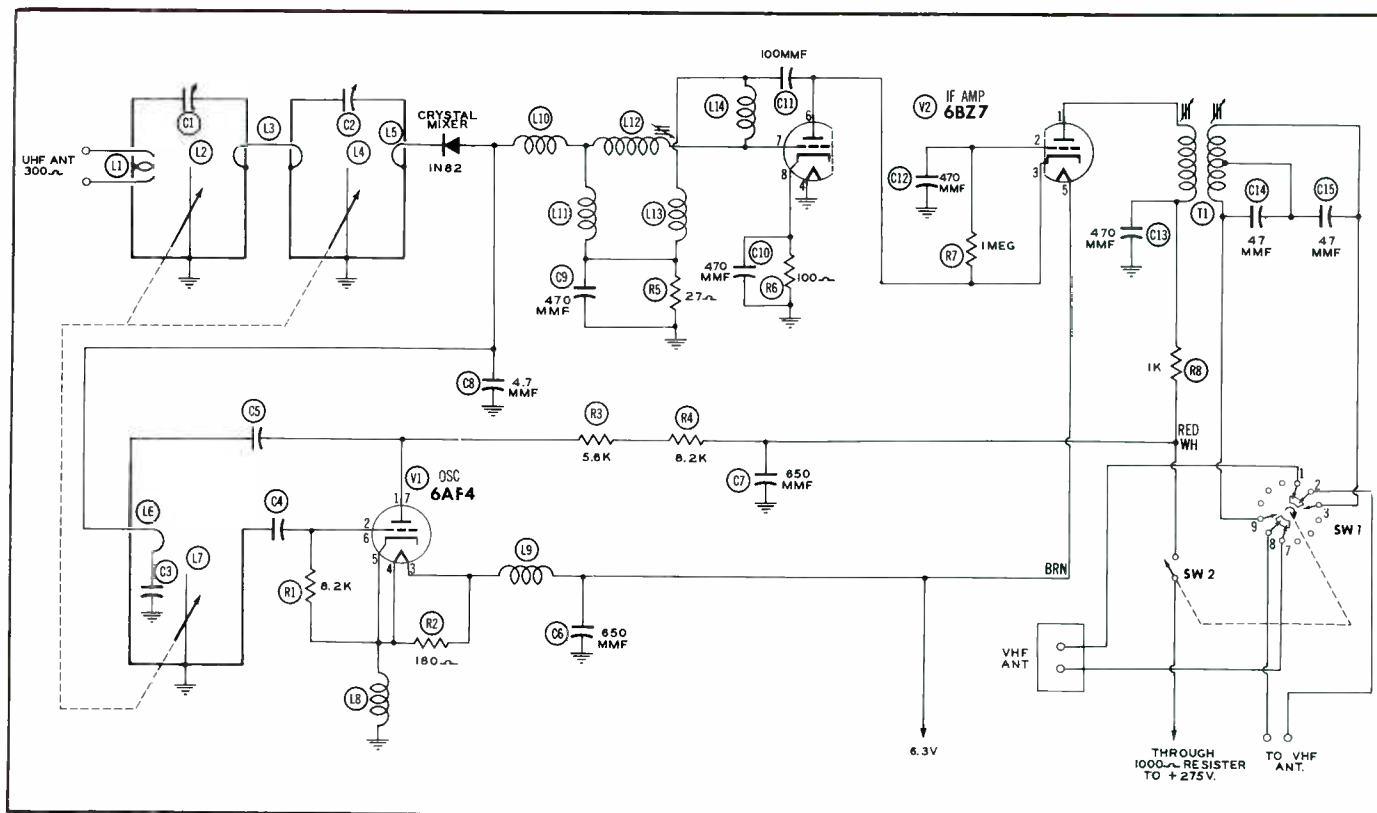

Fig. 5. Schematic of Techmaster Model TV101-U.

The Techmaster UHF tuner is physically designed for mounting on the 630 chassis in the open space which exists in the front center of the chassis. Some chassis have a mounting bracket which extends across the front of this space and encloses it. On these chassis, the TV101-U tuner is fastened to the front bracket by means of machine screws through holes A and B. See Fig. 4. The back of the tuner is secured to the chassis through hole C. On those 630 chassis which do not have the front mounting bracket, the tuner is mounted to the floor of the cabinet by wood screws through holes D, E, and F.

The front-panel escutcheon plate is fastened to the front of the cabinet with two small brass nails supplied with the tuner. Other materials included with the tuner are two knobs, a decal, a dial pointer, a 1,000-ohm resistor, a grounding strap, an antenna terminal strip, and miscellaneous hardware.

Wiring the tuner to the receiver is a fairly direct procedure. The filament power is available at the heater pins on the socket of the audio-amplifier tube. The B+ supply voltage for the tuner is obtained by using the 1,000-ohm resistor as a series-dropping resistor and by connecting the other end of the resistor to the 275-volt line in the receiver.

The output of the UHF tuner is on the short 300-ohm line designated in Fig. 4. This line is spliced and soldered to the 300-ohm line feeding the VHF tuner on the receiver. Each of the longer lengths of twin lead on the UHF tuner go to antenna terminal strips, the lead marked with white paint goes to the VHF antenna terminals and the lead bearing a red mark goes to the UHF antenna terminals. These markings are not visible in the photograph but are readily found on the actual unit.

UHF Transmission Line With a Cellular Core

The Belden Manufacturing Company of Chicago, Illinois, is producing a UHF-VHF lead-in which is tubular in shape and has a core of cellular plastic. The Belden 8275 Celluline* lead-in is shown in Fig. 6.

One of the principal advantages in the use of this line is that no end seal is required to keep out moisture. The tiny cells in the core material are filled with an inert gas that maintains the electrical properties of the line constant under various climatic conditions. The wire in the lead-in is made of copper-covered steel strands purported to have greater resistance to break-

*Registered trademark of Belden Manufacturing Company.



Fig. 6. Belden 8275 UHF-VHF Lead-In.

age from flexing or stretching than all-copper conductors.

The specifications of Belden 8275 lead-in are as follows:

Wire — 7 x 28 stranded, "Weld-ohm" annealed copper-coated steel, two in parallel.

Jacket — brown polyethylene plastic.

Core — cellular polyethylene.

Round diameter — .300 inch.

Glen E. Slutz

INDEX TO ADVERTISERS

April, 1954

Advertiser	Page No.
Aerovox Corp.	62
All Channel Antenna Corp.	40
Astatic Corp., The	48
Bud Radio, Inc.	72
Bussmann Mfg. Co.	16
CBS-Hytron	14
Centralab (Div. Globe-Union, Inc.)	8
Channel-Master Corp	20 & 21
Chicago Standard Trans. Corp.	28
Clarostat Mfg. Co., Inc.	22
Cornell-Dubilier Electric Corp.	57, 59
Allen B. DuMont Labs., Inc.	32
Eby Sales Co.	72
Equipto Div. Aurora Equip. Co.	66
Granco Products, Inc.	38
Hickok Electrical Instrument Co.	26 & 27
Hunter Tool Co.	82
International Rectifier Corp.	62
International Resistance Co.	2nd Cover
Jensen Industries, Inc.	74
JFD Manufacturing Co.	50 & 51
Littelfuse, Inc.	4th Cover
Macmillan Co., The	70
Mallory & Co., Inc., P. R.	34 & 35
Perma-Power Co.	80
Permo, Inc.	58
Planet Mfg. Corp.	84
Pyramid Electric Co.	42
Quam-Nichols Co.	56
Radelco Mfg. Co.	72
Radiart Corp.	24
Radio City Products Co., Inc.	36
Radio Corp. of America	6, 68
Raytheon Mfg. Co.	30
Regency Div., I. D. E. A., Inc.	1
Sams & Co., Inc., Howard W.	60, 68, 81
Shure Bros., Inc.	52
Snap-on Drawer Co.	84
Sonotone Corp. (Titone)	60
South River Metal Products Co.	54
Sprague Products Co.	2
Superex Electrical Instrument Co.	82
Sylvania Electric Products Inc.	3rd Cover
Triplett Electrical Instrument Co.	4
V-M Corp.	64
Walsco Electronics Corp.	46
Ward Products Corp.	12
Webster-Chicago Corp.	70
Westinghouse Electric Corp.	44 & 45
Xcelite, Inc.	66

While every precaution is taken to insure accuracy, we cannot guarantee against the possibility of an occasional change or omission in the preparation of this Index.



HOW NEW IS TELEVISION?

Man has an egotistical habit of wanting to be first among his fellow men in any endeavor. With the introduction of anything new and worth while, there are individuals, groups, or even nations who lay claims to the various developments which might have contributed to such an invention.

Television is no exception. During the last three or four years, scientists from countries other than the United States have claimed that they were the true inventors of television. However, the record speaks for itself — at least those records to which we have access. During recent months a group of scientists have made a startling discovery which may be destined to change our whole concept about the origin of television.

If what these scientists claim is true, television or some form of it is far from new. The story they have unfolded is so strange that it would be an understatement to say that it is fantastic. They say that they have proof of their claim, so we felt that a report of their findings would be of interest to our readers.

While exploring in Egypt in 1923, a party of archeologists uncovered the tomb of an Egyptian Pharaoh who ruled about 1350 B. C. Much publicity was given this find, because it was one of the first tombs that was intact at the time it was discovered. The tomb was that of Tutankhamen, more commonly referred to as King Tut. For some unknown reason, this tomb had not been pilfered and robbed as so many of the tombs discovered earlier had been. As a result, the inscriptions and articles found in the tomb gave a great deal of information which prior to that time had been unknown about the life of the early Egyptians.

For many years, scientists had realized that the ancient Egyptians had developed a high form of civilization several thousand years before Christ. The ancient Egyptians knew much about the use of metals, used irrigation techniques for making their land productive, made pottery, and wove material of linen. These facts are substantiated by records which the Egyptians left in the form of hieroglyphics. The discovery of the Rosetta Stone near the mouth of the Nile by Napoleon's soldiers in 1799 proved to be the medium through which translation of hieroglyphics was accomplished. This stone contained some accounts which had been written in two languages — one Greek and the other the long-forgotten hieroglyphics. After much study the meaning of the hieroglyphics was determined, and this knowledge enabled the scientists to read about the way of life of the ancient Egyptians. Although this discovery was of extreme importance, there were still many missing links. Many of the terms used in the ancient language could not be deciphered. Only recently was some additional light shed upon the subject.

On the walls of King Tut's tomb, many picture stories were found. The one shown below is typical and is a replica of a drawing which is now in the British Museum. The figures at the left depict a portion of the burial ceremony wherein the deceased is being prepared for his long sleep. The experts have established a meaning for most of the figures shown in this drawing, but we are now concerned with those that heretofore have been a mystery.

The lavish jewelry which was placed with the mummy has always seemed a little puzzling, since there seemed to be no other provision for the aesthetic pursuits or entertainment of the deceased throughout his long wait. A search for indications of some means of entertainment led to a most startling discovery.

Referring to the drawing, note the animals on the extreme right. They may have been pets, but their stature has led scientists to believe that they are symbolic of power. Furthermore, they appear to be supporting an object which bears a striking resemblance to a television chassis with an oval type of picture tube. Surely, this ancient people could not have had television as we know it today; on that the scientists agree. Some archeologists feel that the presence of the TV chassis in the drawing merely illustrates the uncanny ability of the ancient Egyptians to foresee the future; others claim that the drawing indicates that some form of sight transmission actually existed during those early times.

Such bold statements as these always are greeted with cries of "Hoax!" For scoffers and believers alike, remember this is the April issue!



Push the tube that PROTECTS YOU TWO WAYS!

**SYLVANIA
PICTURE TUBES
GUARD YOUR
REPUTATION
AND PROFITS!**

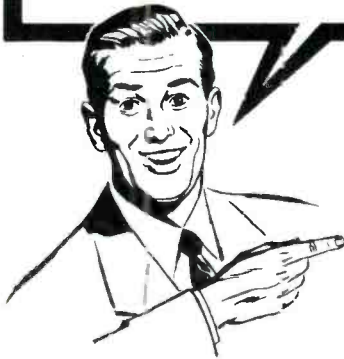

Be sure to show your customers the name SYLVANIA now etched on the lower left face of every Sylvania Picture Tube.

These tubes are small in size (imperceptible when the tube is lighted), but they're mighty big in importance! For, they identify a genuine Sylvania Picture Tube... the tube found best in exhaustive tests conducted by an independent laboratory on tubes of 9 different makes.

Naturally, this high performance record helps maintain your reputation. It

also helps protect your profits . . . eliminates customer complaints and costly call-backs.

Remember, most customers regard a picture tube as an important investment. So, you're doing them a valuable service when you sell them the best their money can buy . . . a SYLVANIA! For new characteristics booklet covering all the latest Sylvania Picture Tubes, call your regular Sylvania Distributor or write direct to Dept. 4R-2904 Sylvania today!

Sylvania Television Program telling millions!
Most of your customers have seen and heard about Sylvania's high quality during the big popular show "Beat the Clock" on CBS-TV. Week after week, from coast to coast, the facts about Sylvania quality are being demonstrated to millions.



**Get this new booklet
for your files!**

SYLVANIA

Sylvania Electric Products Inc.  1740 Broadway, New York 19, N. Y.

In Canada: Sylvania Electric (Canada) Ltd.
University Tower Bldg., St. Catherine Street, Montreal, P. Q.

LIGHTING • RADIO • ELECTRONICS • TELEVISION

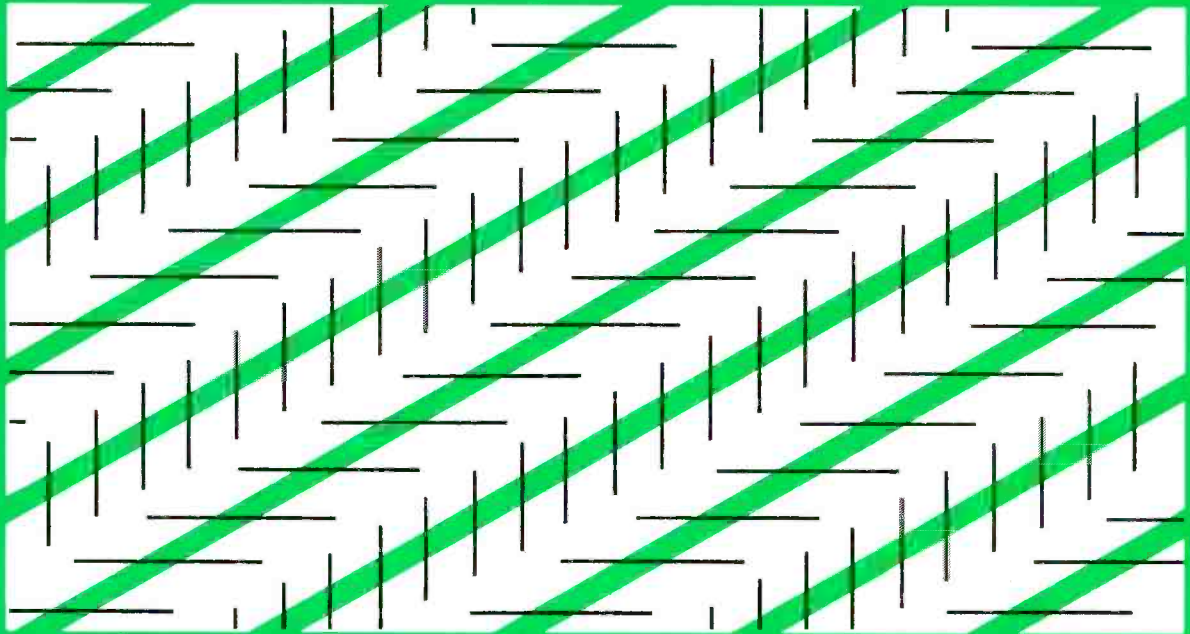

THINGS ARE **NOT** AS THEY SEEM...

The long lines are strictly parallel—that they appear otherwise is an optical illusion.

This fuse merely has the metal caps cemented to the glass.

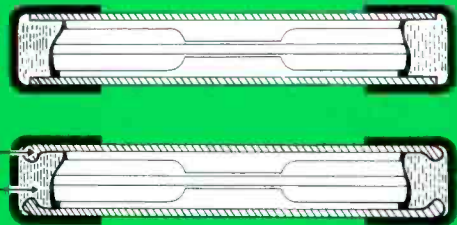

The difference between these two fuses is no illusion...

This Littelfuse has the caps locked to glass like this.

The ends of the glass are formed^A. The solder which is bonded in a separate operation to the cap reflows through the small aperture and spreads out to form a permanent collar-button lock^B between cap and glass—impervious to moisture and vibration. The exclusive Littelfuse feature eliminates fuse failure due to loose caps.

Littelfuse leads all other fuse manufacturers in design patents on fuses. Lock-cap assembly patent no. 1922642

LITTELFUSE

DES PLAINES, ILLINOIS