

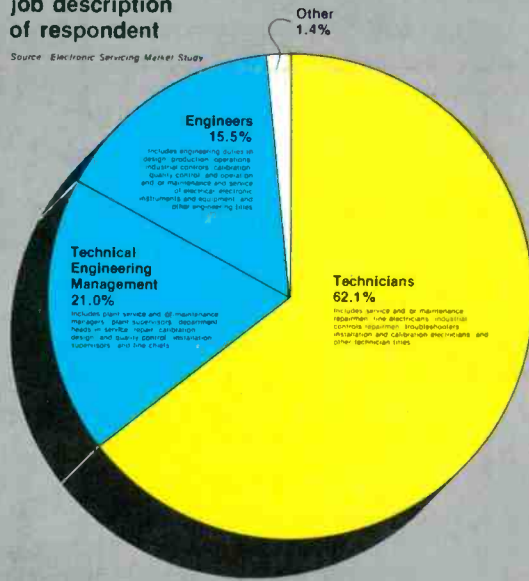
# Electronic Servicing

## Maintenance electronics:

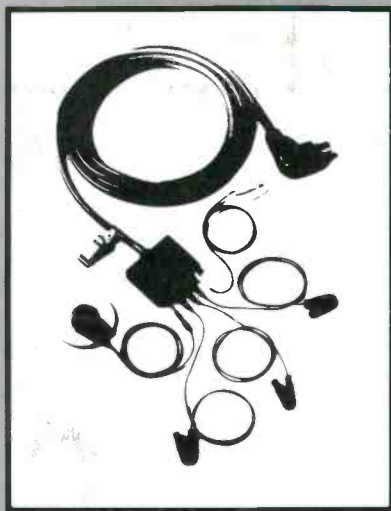
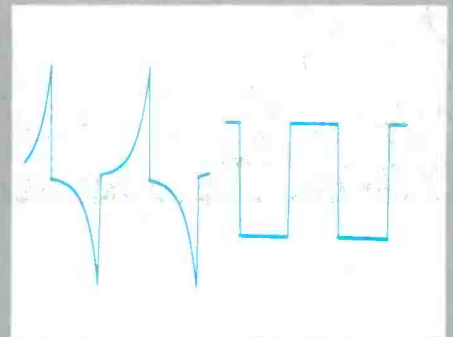
a new  
editorial  
section

Occupation, title,  
job description  
of respondent

Source: Electronic Servicing Market Study



## Varistor and diode waveforms



## Repairing medical equipment



# SYLVANIA ECG<sup>®</sup> SEMICONDUCTOR GUIDE HELPS SOLVE GE AND RCA'S PROBLEMS.



No one knows better than Sylvania that the show must go on. So when a faulty semiconductor in any brand of home entertainment product turns into a showstopper, it's Sylvania to the rescue. Our ECG<sup>®</sup> semiconductor guide is the most used, and useful, guide in the industry. It makes it easy to replace any ailing performer with an ECG semiconductor that will get the show back on the road.

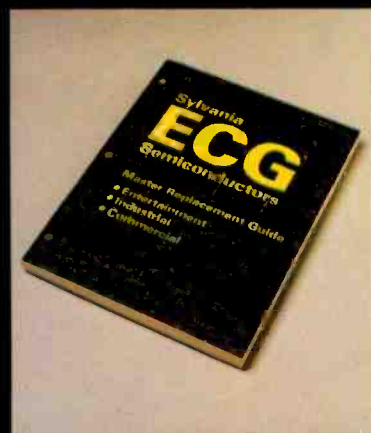
ECG is a registered trademark of GTE Sylvania

When it comes to replacement parts the right place to come is Sylvania. Your Sylvania distributor carries a complete line of ECG<sup>®</sup> semiconductors, picture tubes, receiving tubes, and test equipment designed to make any brand work like it's brand new.

Sylvania. The easy way to get even the hardest part.

**SYLVANIA**

**GTE**



Circle (1) on Reply Card



## Electronic Servicing

Editorial, advertising and circulation correspondence should be addressed to P.O. Box 12901, Overland Park, KS 66212 (a suburb of Kansas City, MO); (913) 888-4664.

### EDITORIAL

Bill Rhodes, *Editorial Director*  
Carl Babcoke, *Editor*  
Cindy Nelson, *Managing Editor*  
Joan Jackson, *Editorial Assistant*  
JoAnn Vella, *Editorial Assistant*

### ART

Dudley Rose, *Art Director*  
Linda Franzblau, *Graphic Designer*

### CIRCULATION

John C. Arnst, *Director*  
Evelyn Rogers, *Manager*

### ADMINISTRATION

George H. Seferovich, *President*  
George Laughead, *Publisher*

### ADVERTISING

Cameron Bishop, *Marketing Director*  
Jim Reilly, *National Sales Manager*  
Lauri Gash, *Production*

Regional advertising sales offices listed near Advertiser's Index.



Member,  
American Business Press



Member,  
Audit Bureau  
of Circulation

ELECTRONIC SERVICING (USPS 462-050) (with which is combined PF Reporter) is published monthly by Intertec Publishing Corp., 9221 Quivira Road, Overland Park, KS 66212. Controlled Circulation Postage paid at Shawnee Mission, KS 66201. Send Form 3579 to P.O. Box 12901, Overland Park, KS 66212.

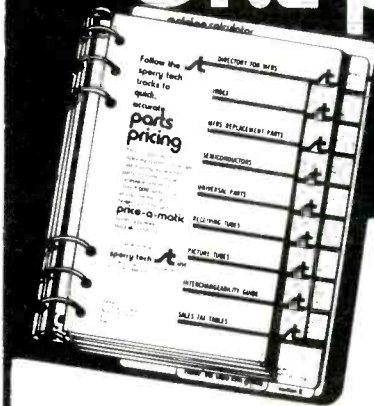
ELECTRONIC SERVICING is edited for technicians who repair home-entertainment electronic equipment (such as TV, radio, tape, stereo and record players) and for industrial technicians who repair defective production-line merchandise, test equipment, or industrial controls in factories.

Subscription prices to qualified subscribers: 1 year—\$10, 2 years—\$16, 3 years—\$20, in the USA and its possessions. All other foreign countries: 1 year—\$13, 2 years—\$22. Subscription prices to all others: 1 year—\$25, 2 years—\$50, in the USA and its possessions. All other foreign countries: 1 year—\$34, 2 years—\$68. Single copy price \$2.25; back copies \$3.00. Adjustment necessitated by subscription termination to single copy rate. Allow 6 to 8 weeks delivery for change of address. Allow 6 to 8 weeks for new subscriptions.



INTERTEC PUBLISHING CORP.

# ONE parts book for all brands



NOW...The Sperry Tech Pricing Book places over 8,000 fast-moving parts right at your finger tips!...

- Over 3,000 direct factory replacement parts, including 17 major MFR's both domestic and off shore
- Over 1,100 popular receiving tube prices
- Complete universal parts listings... capacitors, circuit breakers, circuit boards, crystals, interlocks, rectifiers, resistors, sockets, tuners (rebuilt), batteries, fuses, pilot bulbs, tube brighteners, etc.
- 750 picture tube prices (including a complete interchangeability guide)
- Manufacturers directory with names, addresses, and telephone numbers

When you appear on the job with a professional parts pricing book you make the best impression on customers... cultivates repeat business. At the same time you can adjust prices in a manner that will compensate for obsolete parts in inventory you can't resell or return, so you can start realizing a profit from your parts sales.


When price changes occur you automatically receive an up-dated section reflecting new prices... this way you know your parts prices are always current.

**But that's not all...** as part of our subscription service, parts usage is ranked by popularity and is up-dated each year... a vital factor in controlling obsolescence.

**CALL TOLL FREE/800-228-4338.**

(Between 8:00 AM and 5:00 PM CST Monday thru Friday)

—and we'll send you a complete parts book, postage prepaid with the mark-up percentage you feel is correct for your shop for only \$24.50. You'll have the opportunity to examine the contents before deciding on our automatic up-dating service.

sperry tech  inc. P.O. Box 5234 Lincoln, Nebraska 68505

Circle (4) on Reply Card

In September

## Electronic Servicing

**Forest Belt opens up the new industrial servicing department; Wayne Lemons reports on testing industrial semiconductors; a special test lab by Gill Grieshaber; movie projector repairs; and more on microprocessors.**

---

## 13 Reports from the Test Lab

### 14 Eliminating RF interference

*Wayne Lemons*

RF carriers can be demodulated by audio circuits, thus causing noise or undesired sounds to be heard. Here is a new and effective method of removing such interferences.

---

### 22 MRO Industrial electronic servicing

*George Laughead*

Maintenance electronics, whether industrial, biomedical or in other areas, is the growth area for electronic servicing. Starting this month, each issue of **Electronic Servicing** will feature articles aimed at the maintenance technician.

---

### 24 Typical repairs of medical equipment

*Joseph J. Carr*

Electronic medical equipment fails in predictable and recurrent ways. Several common problems are explained.

---

### 29 A second look at waveforms, Part 3

*Gill Grieshaber*

Scope waveforms illustrate many facts about fast-recovery diodes, varistor rectification, horizontal drive and a passive circuit with gain.

---

### 35 Instructing a microprocessor

*Jack Webster*

The binary code of microprocessors should be changed to a faster condensed code.

---

### 38 Sam Wilson's Technical Notebook

*J. A. "Sam" Wilson*

A charged capacitor can be constructed without the moving of any electrons. Described also is an experiment with innovative results.

<b>Departments</b>	5 Electronic Scanner	42 New Products
	6 Symcure	43 Catalogs & Literature
	7 Readers' exchange	44 The Marketplace
	10 People in the News	44 Advertisers' index
	40 Test Equipment	

**About the cover** Graphic design by Linda Franzblau

© Copyright, 1979, by Intertec Publishing Corporation. All rights reserved. Material may not be reproduced or photocopied in any form without written permission of publisher.

# electronicscanner

news of the industry

---

---

**RCA is reported to be planning large-scale production of SelectaVision videodisc players beginning this fall in Indianapolis. Also being prepared is a catalog of about 250 videodiscs which will include feature films, TV replays, music by popular artists, opera and ballet. Initially, the videodiscs are to be sold by the same channels as the Selectavision players. However, it is expected the discs later will be distributed through normal phonograph-record channels.**

**Color TV sales to dealers totalled 4,789,500 for the first six months of 1979, an increase of 1.6% over the same period of 1978.**

**Magnavox expects to have high-volume production of Magnavision videodisc players by the third quarter of 1980. Test sales in two cities have been very successful. However, most of the videodisc player components now are manufactured in Europe by Philips. By next year, 90% of the components should be supplied by American manufacturers.**

**Zenith Radio Corporation has offered to buy the Heath division from Schlumberger Limited. Heath is famous for sales of Heathkit products, and recently has begun to sell small computers, printers and video terminals.**

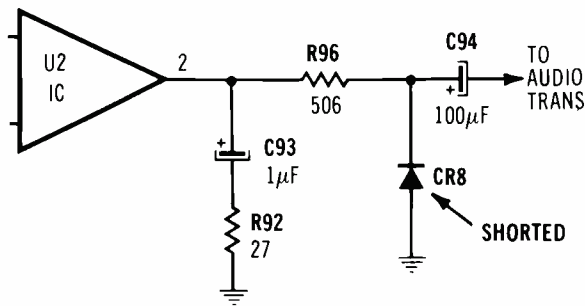
**Electrohome of Toronto, Canada has agreed to produce four 19-inch color TV models for the Victor Company of Japan. Electrohome is a licensee of Victor, and the TVs will be sold in the United States.**

**The National Electronic Service Dealers Association [NESDA] has changed their address to 2708 Berry St., Fort Worth, TX 76109. The new phone number is (817) 921-9061. Additionally there is a new phone number at the same address for The International Society of Certified Electronic Technicians (ISCET). That number is (817) 921-9101.**

---

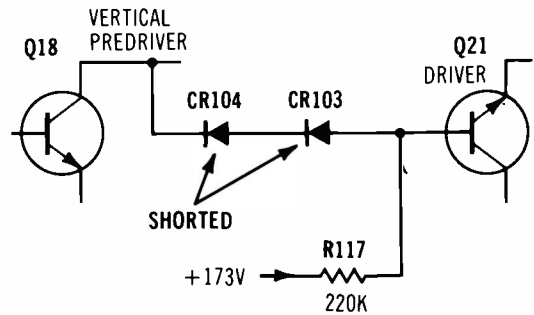


Chassis—RCA CTC87  
PHOTOFACT—1778-2



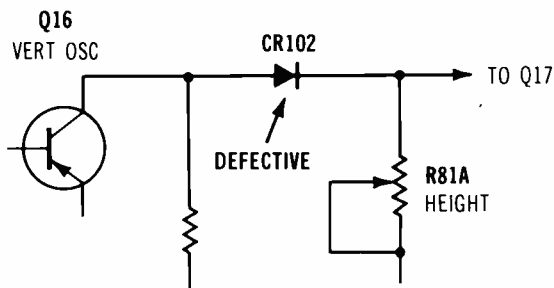
**Symptom**—No sound or weak sound  
**Cure**—Check diode CR8, and replace it if shorted

Chassis—RCA CTC87  
PHOTOFACT—1778-2



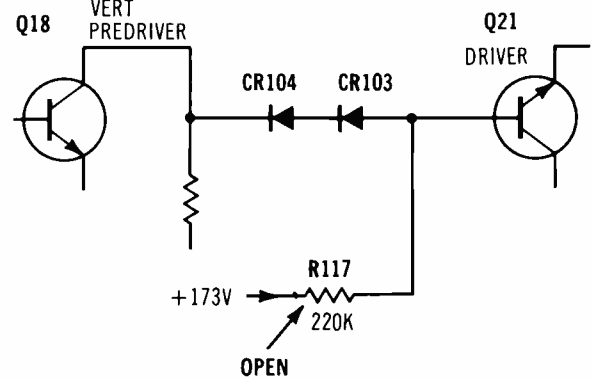
**Symptom**—Compression at the top, perhaps retrace lines  
**Cure**—Check diodes CR103 and CR104, and replace if shorted or leaky

Chassis—RCA CTC87  
PHOTOFACT—1778-2



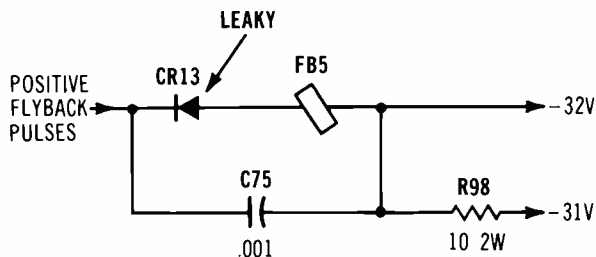
**Symptom**—Vertical rolls intermittently  
**Cure**—Replace diode CR102 as a test for erratic operation

Chassis—RCA CTC88  
PHOTOFACT—1787-1



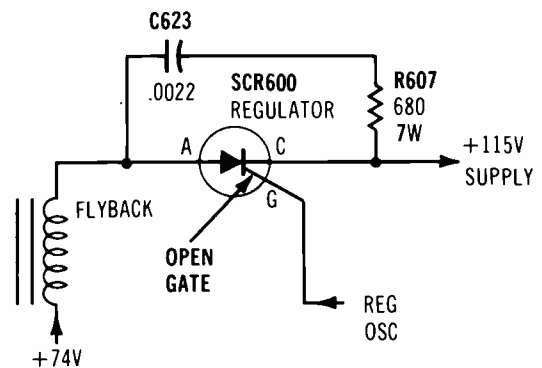
**Symptom**—Height shrinks severely during first half minute, and Q20 overheats  
**Cure**—Check resistor R117, and replace it if open

Chassis—RCA CTC88  
PHOTOFACT—1787-1



**Symptom**—Intermittent loss of height followed by shutdown  
**Cure**—Check diode CR13, and replace it if leaky

Chassis—RCA CTC93  
PHOTOFACT—1810-2



**Symptom**—Shuts down occasionally  
**Cure**—Replace regulator SCR600 as a test for an open gate

# reader's exchange

There is no charge for a listing in *Reader's Exchange*, but we reserve the right to edit all copy. If you can help with

a request, write directly to the reader, not to **Electronic Servicing**.

**Editor's note:** Beginning with the September '79 issue, all ads will be edited to show no more than five items. Requests already submitted will be broken down into as many ads as necessary. Since space is limited, this will accommodate more readers.

**Needed:** E. H. Scott radio parts and a Scott Philharmonic radio. Robert Teska, 334 Willard, Toledo, OH 43605.

**For Sale:** More than 200 new Clarostat radio/TV controls, with shafts and switches, \$75 plus shipping. Hughes Electronics, Route 2 Box 280, Kings Mountain, NC 28086.

**For Sale:** B&K-Precision equipment: model 415 sweep/marker with probes and manual, \$350; model 1243 color/bar generator, \$50; model 801 capacitor Analyst, \$75. Shipping paid when money order received. **Needed:** stereo power monitor meters and dummy loads. Bob Mitchell, Apt. 208, Turek Building, Tavernier, FL 33070.

**Needed:** Horizontal-output transformer (VZ12017) for a model 6911C Broadmoor color TV. Don Gossage, 4721 Ipswitch Street, Boulder, CO 80301.

**For Sale:** Bell & Howell home-entertainment electronics course, \$70; Bell & Howell school model-24 5-inch scope with manual, like new, \$95. Prices include freight. Also, have some out-of-print Photofacts to trade for ones I need. Gordon Handy, 300 Vienna Drive #214, Palm Springs, FL 33461.

**Needed:** Schematic for a Devry Technical Institute scope. Bailey's Radio & TV, 709 Madison Road, Williamsburg, VA 23185.

**For Sale:** B&K-Precision model 466 CRT tester and rejuvenator. Like new. Send \$95 cashier's check for post-paid delivery. John S. Messier, 2945 Novus St., Sarasota, FL 33577.

**Needed:** Old RCA signs, displays or figures of "His Master's Voice" featuring the dog Nipper. C. E. Garrison, Box 604 VHFS, Warrenton, VA 22186.

**For Sale:** Heath IM-5228 VTVM, new, with HV probe, under warranty, \$75; Heath IM-28 VTVM, \$50; Heath IT-3120 FET/transistor tester, \$60; Heath IT-27 transistor tester, \$10; Heath IT-5230 CRT tester/rejuvenator with 6 sockets, \$90; Heath 0-11 scope, -5 dB at 5 MHz, \$60; EICO 625 tube tester, \$20. All in good shape and operation, with manuals, cables and probes. Shipped prepaid for the first check. Richard

Muller, Rich's TV, 3731 West 55th Place, Chicago, IL 60629.

**Needed:** Original or copy schematic of model RCB-15 Roberts mobile CB radio. R. T. Blinkhorn, Wilcox Brothers, 5157 Liberty Avenue, Pittsburgh, PA 15224.

**For Sale:** Telematic color test rig with adapters; Heathkit mini color-alignment generator with manual; Bell & Howell scope with manual and accessories. Like new for half price. Clarence Gillow, 608 Black Drive, Prescott, AZ 86301.

**For Sale:** Sylvania CK3000 test jig with 57 adapters and manual; Sencore YF-33 Ringer, new with training tape; Heath IT-5230 CRT tester; Heath IG-57A sweep/marker generator; Heath IG-28 color/dot generator; Heath IG-102 scope with special probes; Heath IG-37 stereo generator; Heath IG-102 RF generator; Polaris HV probe; model 213 EMC tube tester; and Telematic substitute tuner, battery model. Make offers. Mike Murphy, 40512 Regency Drive, Sterling Heights, MI 48078.

**Needed:** Zenith radios with big round dials; cathedral-type radios; type 53 and 3KP4 tubes; and manual or copy of instruction manual for a model E200C Precision signal generator. Don Patterson, 636 Cambridge Road, Augusta, GA 30909.

**Needed:** Any technical information about Microswitch keyboard, 82SW??-3, customer part number A59731000-017P. Will buy or copy and return. Pascal Larmet, 1429 Elva Drive SW, Atlanta, GA 30331.

**For Sale:** The following Heath equipment: IM-48 audio analyzer, \$45; IG-37 FM generator, \$50; IG-28 color/bar generator, \$50; IG-72 audio generator, \$15; IT-3120 transistor tester, new, \$45; IG-102 RF generator, new, \$25; educational kits EF-1, EF-2 and EF-3, \$30; PKW-101 probe, \$12. Also 3 years of **Electronic Servicing**, \$30. D. J. Mace, RD4 Box 84, Bellefonte, PA 16823.

**Needed:** Model 680 Conar color generator, need not work. J. A. Quarato, 802 Holland, Vandergrift, PA 15690.

**For Sale:** Model 970 B&K-Precision transistor Analyst, \$250; VIZ WR-50C RF generator, never used, \$100. Gary Castellini, 3567 Lincoln Avenue, Vineland, NJ 08360.

**Needed:** TLY306 (S) deflection yoke, for 114° 22mm neck size, and it has 5 leads; or a suitable substitute. Michael Helgerson, Box 103, Electric City, WA 99123.

**For Sale:** Lectotech V7 combination color/bar genera-

## Readers' exchange

tor and vector scope; model TR-15A Sencore transistor checker. Both in excellent condition in original cartons and with manuals. Max Goodstein, 25-11 Union Street, Flushing, NY 11354.

**Needed:** Schematic and parts list for model 500C Fisher receiver. Bill Agard, 19255 S.E. 269th, Kent, WA 98031.

**For Sale or trade:** Large quantities of 6AU6, 6AG5, 6AL5 and 6CB6 tubes, and 100 TV tuners. Make offers. Troch's, 290 Main Street, Spotswood, NJ 08884.

**Needed:** These parts for a model 770 Concertone stereo-tape recorder: flywheel idler wheel, tape transport motor, flywheel-idler tension spring, and a pressure roller. Or a source of Concertone parts. J. Baud, 1008 5th Avenue N.W., Austin, MN 55912.

**For Sale:** Radiation-sensor head containing 6 1B85 geiger tubes, salvaged from Warwick. Tubes sell for \$36 each, but condition is not known. Send \$35 check for shipment by UPS. Radio Control Central, P.O. Box 56122, Chicago, IL 60656.

**Needed:** Service or operating manual for model 535 Tektronix scope. Will buy, or copy and return. John Maxin, 217 West Larkspur, Munhall, PA 15120.

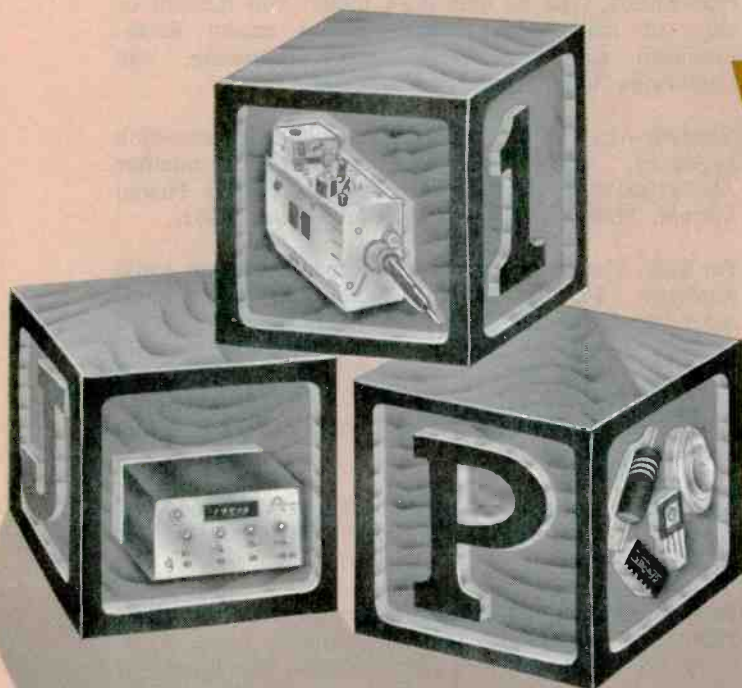
**For Sale:** Heathkit model IO-12 5-inch scope with 2 probes, manual and schematic, \$85; B&K-Precision model 415 sweep/marker generator with cables, manual and schematic, \$300; Castle VHF tuner substituter with cables and manual, \$25; model A-460 Approved Electronic VHF field-strength meter, \$40; 180 Photofacts below folder 400, \$90; Sencore YF-33 HV probes, new, \$25; Bendix AN5851-1 sextant with manual, \$75. Long's TV Service, 720 Goshen, Salt Lake City, UT 84104.

**Needed:** Original or replacement interstage audio transformer for model 55C Atwater Kent antique radio. Has been replaced with a Thordarson T-33A91, although originally the interstage and output transformers were in the same can. Frogde TV & Radio, 41 East Main, Mt. Sterling, KY 40353.

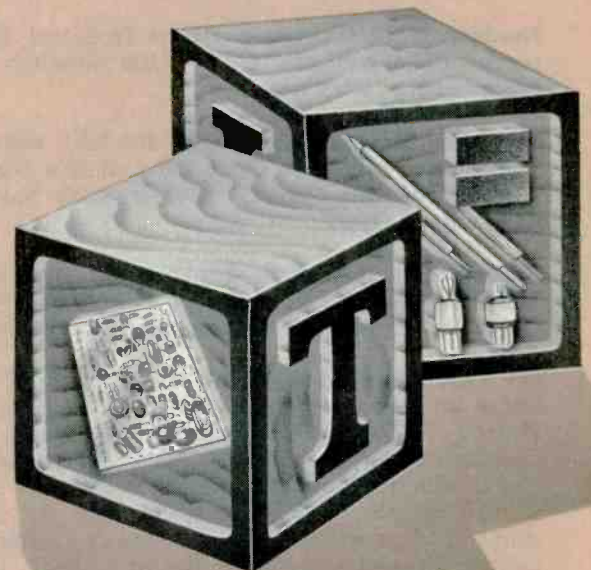
**Needed:** 12FR8 Tube. The Lectronic Shoppe, 102 W. Main St., Everson, WA 98247.

**For Sale:** Heathkit IG-57A sweep and marker generator, assembled and calibrated with probes, manuals, attenuator, cables, \$150. L. Hynar, 6408 E. Ellis, Mesa, AZ 85205.

**For Sale:** Zenith color TV test rig model 800-880; 1½-years old, in like-new condition, with 21-inch



# We're not a





diagonal color picture-tube and all cables for connection to tube or solid-state TVs, \$280. Fred Blair, 2114 Cowlin Ave., Commerce, CA 90040.

**For Sale or Trade:** Portable record players with automatic changers; 500 paperback books for radio and TV test equipment. Troch's, 290 Main Street, Spotswood, NJ 08884.

**For Sale:** Rem cathode recovery unit and CRT checker with adapters, \$190; B&K-Precision DVM model 280 with direct 100k probe, \$65, needs resistor; Sencore Hybrider, \$200. Raymond Duffy, 1821 NE 65 St., Ft. Lauderdale, FL 33308.

**Needed:** Scopes, Heath IT-12 signal tracers, wow and flutter meters, distortion analyzers, frequency counters and other test equipment. J. C. Clark, 1702 Converse, Cheyenne, WY 82001.

**Needed:** Hitachi digital MOS IC, Hitachi type HD3107. Robert W. Miller, Rt. 1, Anadarko, OK 73005.

**For Sale:** Sencore Super Mack color pix tube tester-rejuvenator, like new, \$250 or best offer. Don Steadman, 8822 Juniper Court, Orland Park, IL 60462. 60462.

**For Sale:** EICO 10MHz scope with probes, solid-state,

triggered sweep, \$300; RCA RF generator, 170kHz-50MHz, \$60. Heath electronic switch, ID-101, factory calibrated, \$40; Heath VC-2 voltage calibrator, \$15; Heath IP-27 low-voltage power supply, ½-50V at 1.5a, factory calibrated, \$150; Heath IP-17 high-voltage power supply 0v to 400Vdc factory calibrated, \$150. All units are complete and have manuals. John A. Alvarez, P.O. Box 522, Jackson Heights, NY 11372.

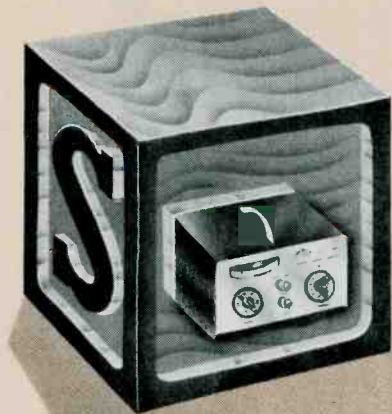
**Needed:** Craig FM stereo, 8-track floor-mount tape player, model 3142. Charles Wilson, 1406 Stephens Ave., Anniston, AL 36201.

**For Sale or Trade:** 75 trunk and gutter mounts and cable for 3/8 whip, four 8-ft high-output fluorescent fixtures with tubes. Need CRT tester and dual-trace scope. A. D. Electronics, 108 Carey St., Deerfield, MI 49238.

**Needed:** Operating manual for Superior TV50 Genometer. For sale: RCA 113599 flyback. Pauls Radio and CB, 1108 Normdave Dr., Dayton, OH 45418.

**Needed:** Schematic or manual for model CB Solar capacitance/resistance checker. Will purchase, or copy and return. For sale or trade: 100 loctal tubes, all types, some in cartons, all checked for quality and shorts, \$50 postpaid. Howard Adams, 209 W. Shadywood Dr., Midwest City, OK 73110.

# new kid on the block.



We're PTS and our reputation as a full service company has grown like blockbusters. In fact, more and more servicing dealer/technicians are using PTS services as building blocks for a profitable foundation for tuner and module repair. You see, we do it all . . . tuner repair, module rebuilding and exchange, and we carry a full line of equipment, tuner test analysts and instruments, original or superior tuner parts, replacement baluns, replacement semiconductors and alignment tools and accessories. We're PTS. The Only Name You Need To Know.

PTS products are available from any PTS stocking distributor and PTS tuner/module servicenters located nationwide.



**PTS ELECTRONICS, INC.**  
The Only Name You Need To Know

Circle (5) on Reply Card

P.O. BOX 272, BLOOMINGTON, IN 47402

# people in the news

**Hank Hermes**, US JVC Corporation's vice president of service and engineering has been presented the first annual Distinguished Video Industry Service Award. Hermes was cited for his work in expanding and coordinating the work of service personnel with that of dealers and distributors.

Wahl Clipper has announced the promotion of **Ruth Heflebower** to assistant to the sales manager for Wahl's line of ISO-TIP soldering irons, guns and accessories.

**David C. Carlson** has been appointed manager, advertising communications for Quasar. Carlson most recently held the position of public relations manager for Walgreen.

**Donald M. Cook** has been appointed division vice-president and general manager, RCA Distributor and Special Products Division. Cook was previously division vice president, government services marketing for the RCA Service Company.

Hitachi has announced the appointment of **Clyde W. Smith** as vice-president of research and development. Smith was previously director of a/v engineering at Thomson-CSF and was responsible for the microcam program.

**William P. Feely, III**, formerly director of transportation, Quasar, was named one of 15 winners of **Fleet Owner** magazine's 1979 award for outstanding vehicle color and design. The award was presented May 24 at the culmination of the 17th annual National Fleet Owner Conference at the Drake Hotel in Chicago.

Shure Brothers has announced the promotion of **Joseph J. Kaleba** to the position of vice-president of manufacturing. Kaleba was previously assistant vice president of manufacturing.

**William F. Quinn** has been appointed personnel director of Channel Master. Prior to coming to the company he was personnel manager of Transkit.

**Burton Bard** has been appointed regional sales manager for Alpha Wire. Before joining Alpha, Bard was with C.C. Electronics serving as sales manager.

**Dr. Charles M. Herzfeld** has been appointed director of research for ITT. Herzfeld had been technical director of ITT's Telecommunications and Electronics Group, North America. **William W. Crossman** has been elected a vice president of ITT. Crossman is group general manager of ITT's Illumination and Electrical Products group worldwide.

**James L. von Harz** has been elected a vice president of ITT, von Harz is group general manager of the company's North American Components group and ITT Cannon worldwide.

**Joseph V. Cherry**, director-quality assurance for ITT Cannon Electric has been elected a vice president of the North American division of ITT. Previously, Cherry served as quality assurance director for Trivex. **Alexander R. Brishka**, manager of RF connector operations for ITT Cannon Electric, has been promoted to

manager engineering for ITT Cannon's plant at Phoenix.

**George J. Mitchell** has been promoted to director of MAXAR Product Operations, Communications, Products Division, Motorola. Previously, he was product manager of the MAXAR product line.

Continental Specialties has added **Sid Cottin** to its executive staff. Cottin will serve as consulting advisor to CSC's sales and marketing departments.

**Charles Levine** has been named merchandise manager for Radio Shack consumer electronics store chain. Levine will be responsible for working with the company's staff of buyers in the areas of product selection and advertising.

**Becca Bowen** and **Bernie Hochman** have been appointed district managers for Gusdorf Corporation. Bowen is responsible for sales and merchandising in southern Texas. Hochman is responsible for sales and merchandising Gusdorf Electronics Furniture in Missouri, Iowa, and southern Illinois.



PTS President Roland Nobis (right) presents the "Man of the Month" award to **Bill Terrell**, PTS regional manager. Terrell is responsible for the company's branches in Detroit, Grand Rapids and Columbus, OH.

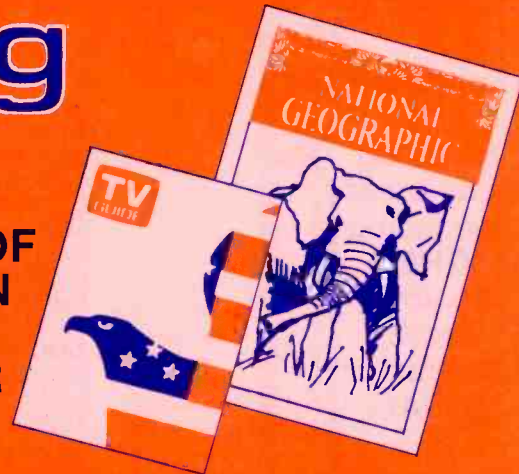


# Subscribe to Zenith Receiving Tubes



**NOW! EARN A FULL YEAR OF  
READING ENJOYMENT ON  
ZENITH RECEIVING TUBE  
PURCHASES FROM YOUR  
ZENITH DISTRIBUTOR**

**Offer valid thru 9/30/79**



You will receive as a gift from your Zenith Distributor a one year subscription to either Playboy Magazine, National Geographic or TV Guide each time you purchase 50 Receiving Tubes (excluding 6GH8A) from your participating Zenith Distributor.

Simply fill out your order on the reverse side and enter the name and address of where you want to receive your gift subscription. Your Zenith Distributor will validate your subscription and forward it to Zenith for processing.

902-1985



*The quality goes in before the name goes on®*

## GIFT SUBSCRIPTION AWARD

**SEND MY GIFT SUBSCRIPTION TO:**

PLAYBOY     NATIONAL GEOGRAPHIC     TV GUIDE

Dist. Invoice No. \_\_\_\_\_

Issued by \_\_\_\_\_

\_\_\_\_\_

Distributor Name

City \_\_\_\_\_ State \_\_\_\_\_

I WANT THE SUBSCRIPTION MAILED TO

NAME \_\_\_\_\_

ADDRESS \_\_\_\_\_

CITY \_\_\_\_\_ STATE \_\_\_\_\_ ZIP CODE \_\_\_\_\_



Printed in U.S.A.



Subscribe to Zenith Gift Awards



# Subscribe to Zenith **RECEIVING TUBES**

Send your 50 receiving tube order (excluding 6GH8A) to your Zenith Distributor TODAY!

QUANTITY	TYPE	QUANTITY	TYPE	QUANTITY	TYPE
_____	6LB6	_____	6HS5	_____	6DT3/6DQ3
_____	6HM5/6HA5	_____	38HE7	_____	6EH7/EF183
_____	6CJ3/6DW4B	_____	6EJ7/EF184	_____	33GY7A
_____	6JE6C/6LQ6	_____	3HM5/3HA5	_____	2AV2
_____	6GJ7/ECF801	_____	8FQ7/8CG7	_____	5GH8A
_____	3DJ3	_____	12HG7/12GN7	_____	26LX6
_____	6KT8	_____	6GF7A	_____	6JH5
_____	6FQ7/6CG7	_____	6JU8A	_____	6BL8/ECF80
_____	6HV5A	_____	6JA5	_____	6AQ5A/6HG5
_____	6U10	_____	6JS6C	_____	6KE8
_____	3A3C/3AW3/3B2	_____	17JZ8	_____	6CG8A
_____	6JB5/6HE5/6JC5	_____	6BK4C/6EL4A	_____	6DU3/6DQ3A
_____	6Z10/6J10	_____	6KD6	_____	2HA5
_____	3DB3/3CY3	_____	6EA8	_____	
_____	12HL7	_____	6JC6A	_____	
_____	6BA11	_____	3AT2B	_____	
_____	6LF6/6MH6	_____	21HB5A	_____	
_____	6JS6B	_____	6LX6	_____	

## Reward yourself with Zenith's Great Subscription Summer Giveaway



**NOW! ENJOY GREAT ENTERTAINMENT.  
YOUR CHOICE OF SUMMER READING!  
PLAYBOY • NATIONAL GEOGRAPHIC  
• TV GUIDE**

Offer void after 9/30/79

SEND IN YOUR RECEIVING TUBE ORDER TODAY FOR 50 ZENITH RECEIVING TUBES (excluding 6GH8A) TO YOUR ZENITH DISTRIBUTOR AND START YOUR GIFT SUBSCRIPTION TODAY.

**ZENITH**



Subscribe to Zenith Gift Awards

# Reports from the test lab

Each report about an item of electronic test equipment is based on examination and operation of the device in the **ELECTRONIC SERVICING** laboratory. Personal observations about the performance, and details of new and useful features are spotlighted along with tips about using the equipment for best results.

By Carl Babcoke

Hickok model LX-303 digital multimeter is pocket sized, but it has many performance and automatic features of larger instruments. These features include a 3½-digit liquid-crystal display (LCD) that is easier to read in bright lighting, automatic polarity indication, automatic zeroing, automatic overrange indication and stable, accurate readings.

## DC volts

Accuracy of the five dc voltage ranges (that provide readings from 0.1mV to 1000V) is  $\pm 0.5\%$  reading  $\pm 0.5\%$  of full scale (FS). Input impedance is  $10M\Omega$  for all ranges. An X10 slip-over probe extends the maximum readings (and the protection) to 10kV.

## AC volts

Two ac-voltage ranges (0-100V and 0-1000V) provide readings from 0.1V to 600V with  $\pm 1\%$  of reading  $\pm 0.5\%$  FS accuracy. Frequency response of the 100V range checked flat to 400Hz, -6dB at 3.5kHz, and -12dB at about 6kHz. Input impedance is rated at  $4.3M\Omega$ .

## Resistance readings

Six ranges measure resistances between  $0.1\Omega$  and  $19.99M\Omega$ . Accuracy is  $\pm 0.5\%$  of reading  $\pm 0.5\%$  FS for all except the  $20M\Omega$  range which has  $\pm 1.5\%$  accuracy.

Voltage across the test leads at a full 1999 readout is about 300mV (0.3V). Therefore, silicon transistors and diodes do not conduct, and accurate resistance readings can be



Figure 1 Advanced features of the Hickok model LX-303 small digital multimeter include a range-switch knob that moves sideways, and an unblinking number 1 and decimal overrange indicator.

obtained in-circuit. If a diode or transistor resistance must be tested, the  $X1M\Omega$  or  $X10M\Omega$  ranges should be used because of the small current.

## DC current

Current between 0.01nA and 199.9mA is measured in six dc-current ranges with  $\pm 0.5\%$  of reading  $\pm 0.5\%$  FS accuracy, except the 100mA range which has  $\pm 2.5\%$ . Voltage drop across the meter does not exceed 200mV.

## Selecting functions

Ohms or volts/milliamperes functions are selected by the on/off switch (Figure 1). Desired ranges are obtained by sliding the range switch sideways. Multipliers for ac-voltage and dc-voltage ranges are above the range-switch knob, and those for resistance and current are below. Four banana jacks (recessed to prevent electrical shocks) marked common, ohms/milliamperes, dc volts and ac volts are provided for the test leads.

Maximum count of the LCD display is 1999. For example, the 100Vdc range can show a readout up to 199.9V before overrange occurs. Overrange for any function is indicated by a steady display of the left-hand number 1 and the decimal point without other numbers (Figure 2).

Minimum life of the 9V battery is said to be 200 hours, but typically about 300 hours can be expected from an alkaline battery. A sliding door above the LCD display covers the battery.

Voltage ranges are protected to 1000Vdc or peak ac, and resistance ranges are protected to 120V.

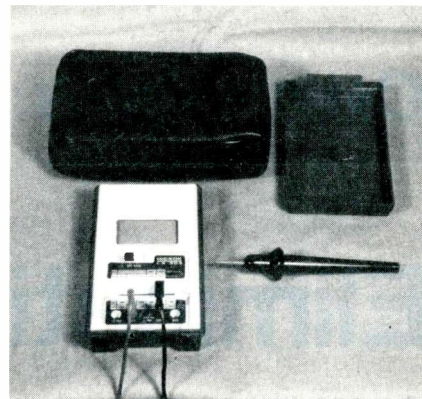


Figure 2 At the meter's right is the X10 dc probe, while the padded case and protective lid are above. The case is optional, but the test leads and lid are provided with the meter.

## General features

Hickok model LX-303 is small enough to fit in a hip or coat pocket. Dimensions are 1-3/8"x3-3/8"x5-7/8" and the weight is 12 ounces including the battery. A snap-on cover serves as storage for the two test leads and protects the meter when it is transported in tool box or tube caddy. Readings on the sharp black-on-white display are updated three times per second so tests can be finished rapidly.

Optional accessories for LX-303 include a padded carrying case, an adapter for 120Vdc operation, a 10Adc current shunt, an X10 slip-over probe for dc voltage, and a 40kVdc probe for checking TV high voltages.

## Comments

Comparison with several digital meters of 0.1% ratings showed the Hickok LX-303 had good accuracy. Also, it successfully passed the difficult test of providing accurate readings with half-wave unfiltered dc voltage. (Some digital meters give low or erratic readings during this test.)

The slip-on X10 probe allowed safe readings of dc voltage at the horizontal-output tube plate and the CRT focus voltage. Also, it gave far less detuning or loading than other probes when measurements were made in IF and oscillator stages.

The sample meter performed very well on all functions, and no problems were experienced. Especially appreciated was the assurance that no meter damage will occur if the meter (with test leads and cover) is inserted into the carrying case and then tossed into a tool box. □

Circle (100) on Reply Card



## Case studies:

# Eliminating RF interference

Here is an effective new method of identifying and removing interference coming from modulated RF carriers in audio amplifiers.

By Wayne Lemons, CET

Side effects of radio frequency pollution often take many different forms. Symptoms range from intermittent interference lines on certain TV channels to the audio of CB transmitters that is heard over public-address systems.

One reason for the variety of symptoms is that the interferences can enter the equipment either through the RF/IF section or through the audio stages. The techniques for eliminating these two basic kinds of interference are very different.

Therefore, the unusual testing system described here applies only to accidentally detected audio that travels through audio amplifiers.

### Demodulated audio

When modulated RF of sufficient amplitude enters an audio amplifier, the high level can drive a tube or transistor into a nonlinear part of the operating curve. This nonlinearity demodulates the carrier and produces audio from the original modulation. After this audio is formed and added to the desired audio in the amplifier, it cannot be eliminated. The only solution is to *prevent* the demodulation.

The cure, therefore, is to reduce the level of the modulated carrier until it is too weak to cause accidental detection. RF signals cannot be heard, so there is no problem so long as the RF carrier is not detected.

### Bypassing the RF

Eliminating RF from an audio stage *appears* to be very simple. Just bypass the RF with a capacitor of small value that will not affect the normal audio. Although the idea seems plausible, the added capacitor seldom helps enough, and often makes the interference worse.

High-frequency signals are not likely to enter at the audio-input terminals. Most inputs have shielded cables and wiring which should act as a bypass capacitor. Additionally, many amplifiers have 100pF to 330pF fixed capacitors connected directly across the inputs.

These interfering carriers use the power cables, speaker wires, any other unshielded wires or even the metal braid of the shielded wires to enter the amplifier wiring. Such wires act as antennas to bring the RF signals near the amplifier stages.

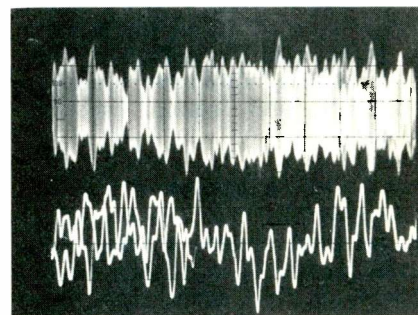
Next, the unwanted RF signals use the chassis or a ground loop of the board wiring to flood the amplifier with a strong RF level. Although the RF can reach a susceptible transistor input by stray capacitances of the wiring, it may travel through other hidden paths. Amplifier wiring has many unsuspected impedances and resonances to RF frequencies which couple and even amplify the RF. When such strong carriers reach a transistor base, demodulation can occur.

### Wrong bypassing

An incorrectly connected bypass capacitor can increase interference, as shown in Figure 1. The internal capacitor forms a loop to couple

the RF on the wire inside the chassis, and the loop acts as an antenna to radiate the RF energy.

The better way of bypassing any wire that enters the shielded chassis is to use a feedthrough capacitor or connect a conventional capacitor *outside* the chassis (see Figure 2).



The top scope trace is typical of modulated RF carriers that are demodulated to audio (bottom trace) by nonlinearity in amplifiers.

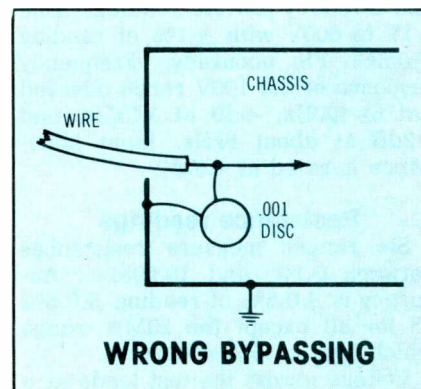


Figure 1 Bypassing RF *inside* the shielded chassis can form a loop to couple the RF from the wire to the circuit wiring.



## Shielding and ground wires

One misconception is that a metal shield around an amplifier will prevent RF signals from entering. But shields are not absolutely necessary. In fact, the interfering signals might use the metal chassis as an injection loop.

Providing a true ground at these high frequencies is almost impossible. A chassis grounded to earth might be *hot* at some points and *cold* at others. Also, a ground wire probably won't help because every wire with RF has hot and cold points at each quarter wave length. A random-length

ground wire might even increase the interference.

## RF impedances

As stated previously, the principal cause of demodulated interference in an audio amplifier is high impedance in an audio amplifier is high impedances to RF (circuit resonances). These unintentionally tuned circuits can multiply the RF level by many times, and they are formed by the wiring versus the stray capacitances.

For example, a bypass capacitor from input plug to ground might act as a coupling capacitor from an RF-hot spot on the ground direct to the base. In other circuits, the

shunt capacitors complete a resonant Pi network that takes a weak signal at low impedance and transforms it to a stronger signal at high impedance.

The surprising discovery about resonances in audio amplifiers is that there are so many of them. A single input circuit might have several resonances between 10MHz and 220MHz or higher. Within this range, the resonance peaks can be either broad or sharp. Breaking up these resonances is the secret of eliminating audio-rectified interferences.

## FM audio interference

Frequency-modulated (FM) signals often are demodulated in audio amplifiers by hidden tuned circuits and nonlinearity. This seems impossible. Normal FM receivers must have elaborate demodulation circuits that operate by phase shift to produce audio. None of that is found in an audio amplifier.

However, there is a more simple kind of FM demodulation (called slope detection) where the signal moves up and down the skirt of a resonant circuit. Thus FM audio is recovered by conventional AM detection.

In audio amplifiers, the frequency slope is formed by the accidental tuned circuits, and the nonlinearity of an overloaded audio stage supplies the AM detection. Both conditions are necessary for FM audio to be produced in an audio stage. The interference can be prevented by either swamping the resonances or reducing the nonlinearity (or both).

These *fixes* are based on practical experience. When I first announced a series of FM broadcasts, I was surprised and dismayed to find many record players, tape recorders and sound systems in the vicinity would reproduce the audio. Therefore, one of my extra jobs was to eliminate the interference.

## Silent interference

Even more puzzling are the cases where FM carriers cause trouble without being heard. One such problem involved the background music and paging system in a supermarket. Intermittently the music would stop and no micro-

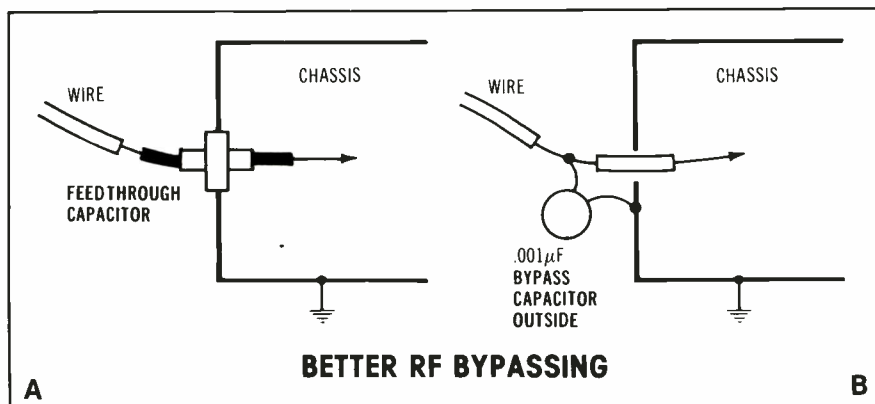


Figure 2 Here are two good methods of preventing RF from entering the chassis on a wire.

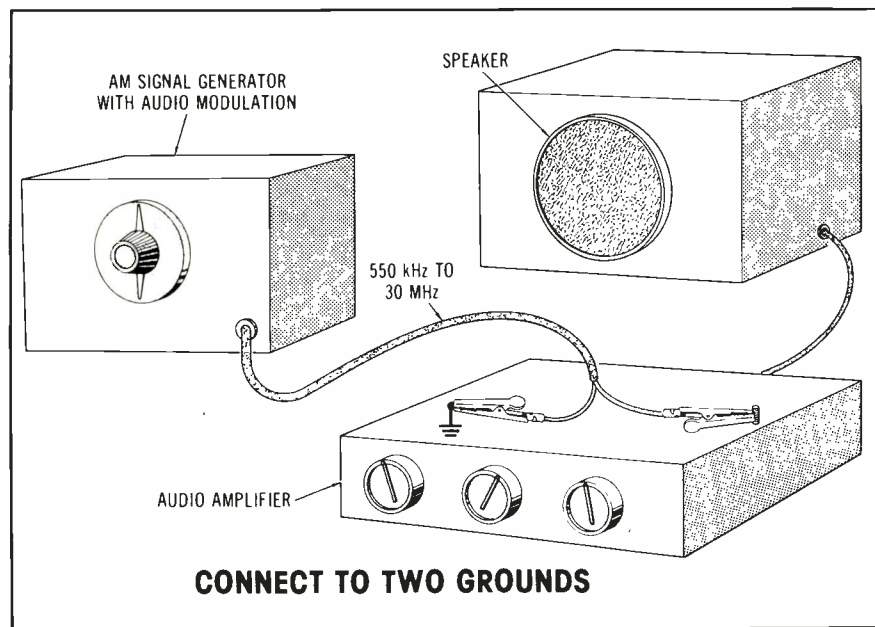


Figure 3 A modulated generator signal is connected to two widely separated grounds of the amplifier. As the frequency is varied, the generator signal activates the unplanned RF-resonant circuits so they can be swamped, detuned or the RF removed from transistors by filtering.

## RFI interference

phone paging could be done during that time. The 15s to 30s of paging silence was accompanied by a loud buzzing noise in the speakers. The store owner found that turning down the microphone gain would bring back the background music. Evidently the problem originated in the microphone preamplifiers. However, the symptoms would not occur while I was there.

Finally, an observant grocery helper noticed that the problem always happened when a taxi came to a nearby taxi stand. The driver was asked to transmit with his 2-way FM radio as I listened to the store sound system. His broadcasts were the cause of the mysterious silences, but he was using the radio legally and had no responsibility. So, this required elimination of the problem by modification of the microphone preamplifiers. The method described next provided the cure.

### Tracking down interference

Debugging radio-frequency interference (RFI) raises many questions and calls for many decisions. Can the circuit modifications be made in an electronic shop, or must the offending transmitter be used as a source while the audio system is in the usual position? How can a technician be certain the RFI is eliminated?

In order to answer those questions for myself, I discovered (almost by accident) a system of debugging that is almost infallible.

The only item of equipment is an AM signal generator of any quality. Those with rough and distorted signals are excellent, so long as the RF output and modulation are very high. The generator applies many frequencies to the amplifier as the testing proceeds.

### Create an RF loop

As shown in Figure 3, the generator is attached so *the signal travels from ground to ground* across the chassis or circuit board. Do not connect the generator signal to the amplifier input or inputs. Allow the input terminals to float.

If the amplifier has provisions for a speaker, connect a test speaker. If not, connect the preamplifier (or tape deck) to a signal tracer or power amplifier that in turn drives a speaker. The object is to listen to the audio coming from the problem amplifier or preamp.

Turn the generator RF output and modulation to maximum. Turn one channel to maximum gain on the amplifier being tested. Rotate the generator dial from one end to the other of all bands and listen for the audio tone. Any amplifier that is susceptible to radio interference will produce a generator tone at several different frequencies. Probably some frequencies will have a louder tone.

### CB interference

If the complaint involves CB radios, tune carefully through the 27MHz to 28MHz band. Any tone

that's heard indicates the amplifier probably will reproduce CB audio.

Next step is to stop the audio rectification. From this point, some trial and error experimentation is in order, for there are no absolute answers.

Generally, the first or second audio transistors are prime suspects. These usually operate at full gain without any control between them and the input terminals. Test by listening to the tone as the amplifier gain control (downstream from the suspected stage) is turned to zero. If turning down the control eliminates the tone, the source of the audio rectification is ahead of the control.

### Try bypasses first

After the principal frequency of the rectification is located, try connecting a 470pF ceramic capacitor with very short leads between base and emitter of the input transistor, as shown in Figure 4. Tacksolder the leads in place. *Do not touch the capacitor*; a hand can act as an antenna.

A capacitor can be mounted to a wooden or plastic tongue depressor (Figure 5) to speed up these tests.

If the 470pF ceramic did not make the tone louder, leave it in place and try a 270pF ceramic from base to ground (or from emitter to ground if the input is at the emitter). Try grounding the capacitor to various ground points within reach. If a spot can be found that radically reduces the interference

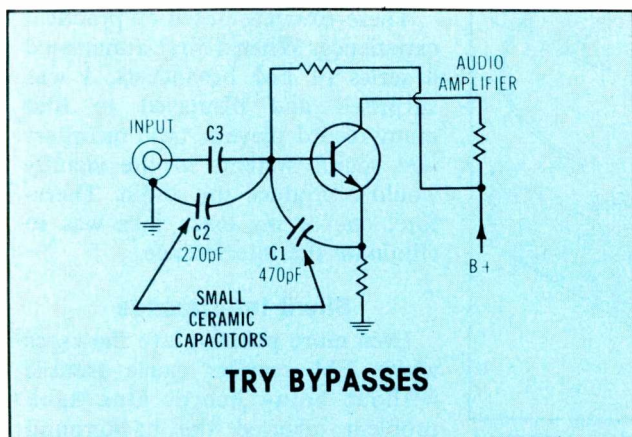


Figure 4 First tack solder ceramic capacitors (having very short leads) to these points of the first preamplifier transistor. Unless the RFI interference is worse with them connected, leave them there.

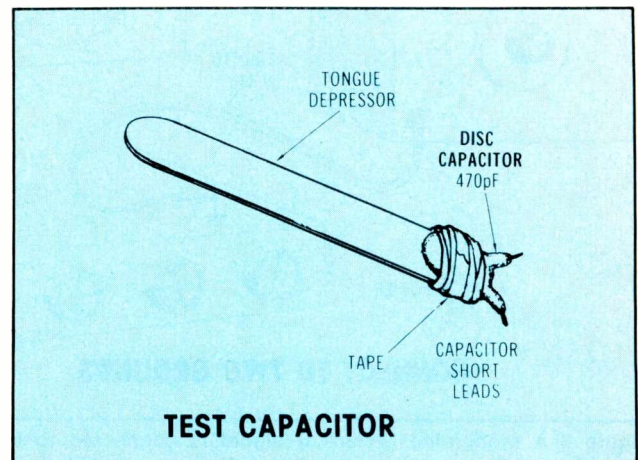
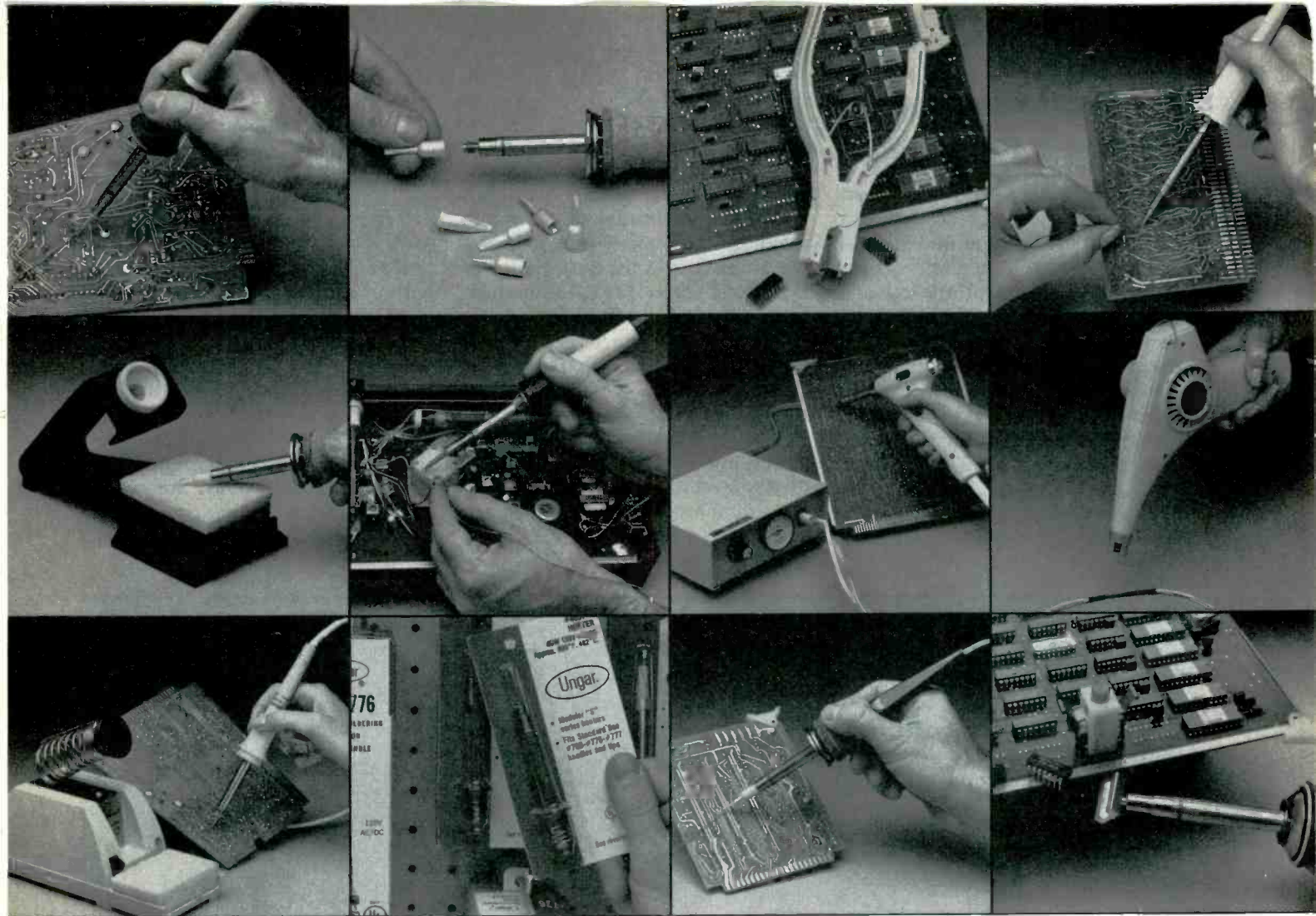


Figure 5 Don't hold a capacitor while temporarily connecting it. Instead, tape the capacitor to an insulator (such as a tongue depressor).





Surprised? Don't be. Because today, Ungar has one of the broadest, most complete lines of soldering and desoldering equipment and accessories in the business. Product by product, you'll find application-oriented designs that let you neatly handle any job that may come along.

Take, for example, the Ungar soldering irons. Modularly designed to give you a complete choice of handles, heaters and tips. You get the versatility you need. And fast, easy, economical on-line replacements. Plus, the

right tool for every job — micro-electronics, bench or field service, repairs of energized circuits, compatibility with sensitive components.

Or consider Hot Vac® 2000. A revolutionary new design in desoldering tools. Lightweight. Pistol-grip. Easy to clean. Extra long life tips. And try our versatile, lightweight Heat Gun on your assemblies and repairs.

There's an Ungar tool for



special jobs too. Like our highly sophisticated Ungarmatic® Soldering Station. And special kits for desoldering DIPs and ICs.

The point is, where there's solder, there's Ungar. Tools and accessories that let you handle every job. Drop us a line and we'll send you our new catalog. It's free. And it includes everything you need for successful soldering. Except the solder. For our complete catalog, write to Ungar, Division of Eldon Industries, Inc., P.O. Box 6005, Compton, CA 90220 (213) 774-5950.

# The Only Thing We Don't Make Is The Solder.

Circle (6) on Reply Card



## RFI interference

tone, solder the capacitor there.

Next, leave those capacitors in place and cut the transistor input wire (base or emitter according to the input). As shown in Figure 6, bridge the cut with a  $390\Omega$  resistor for the grid circuit (or a  $39\Omega$  value if in the emitter circuit). To check for more RF reduction, disconnect the previously installed capacitors, one by one. Unless the interference is reduced by removing one or both capacitors, leave them in place. Also, try moving the  $270\text{pF}$  capacitor to the side of the added  $39\Omega$  or  $390\Omega$  resistor that is toward the input terminals while leaving the

other capacitors in place (Figure 7).

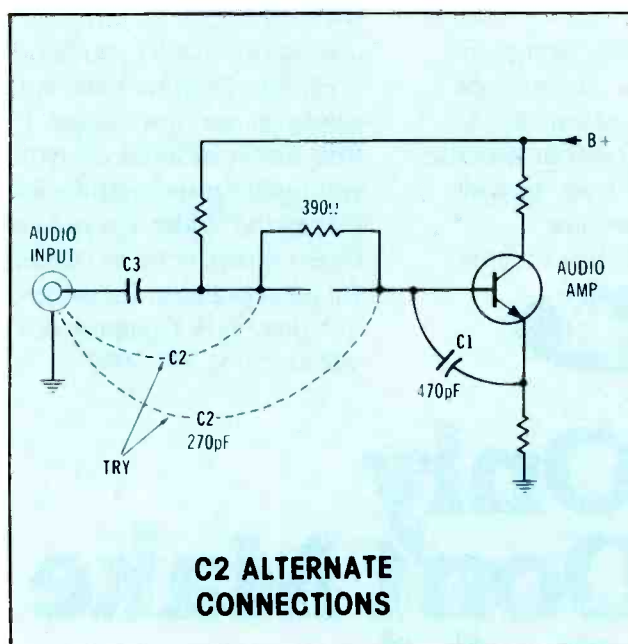
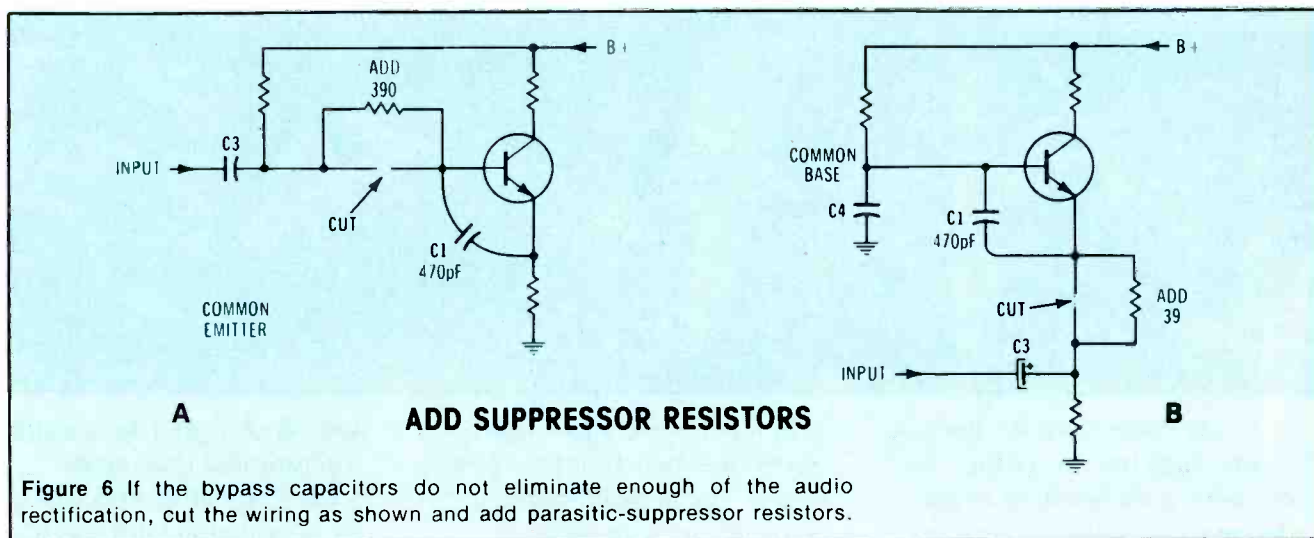
If the RF interference remains excessive, try a  $470\text{pF}$  capacitor from the first transistor collector to ground. Any improvement indicates the problem is at the base circuit of the second stage. Try the same tests as detailed for the first stage.

A small-value unbypassed resistor added to the emitter circuit (Figure 8) might reduce the RF interference. Try a  $.01\mu\text{F}$  ceramic from the B+ (or B-) supply to ground. If the power line enters the chassis, try bypasses as shown in Figure 9. (In one stubborn case it helped to operate a preamp from batteries.)

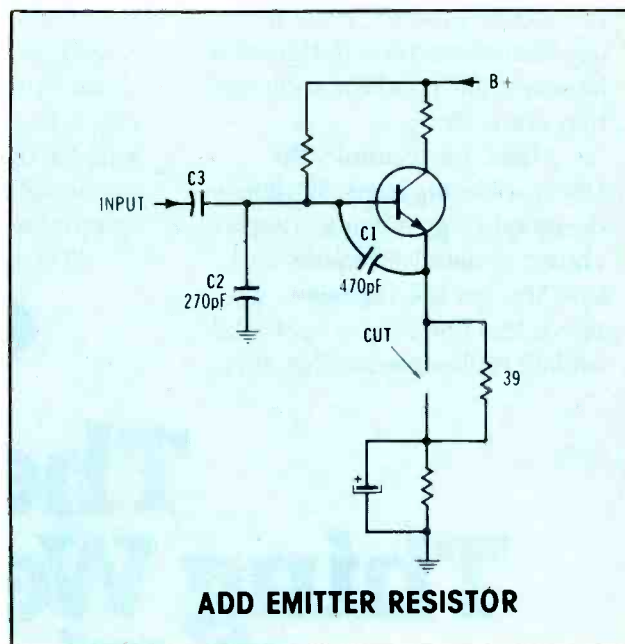
## Persevere

If the RF interference has not been eliminated by now, the amplifier has a stubborn problem. But there are more things to try.

Modify the input wiring by cutting and removing the input wire right at the transistor base. Run a separate short wire direct to the input capacitor. If the wire is more than an inch long, shield it. If a shielded wire is used, ground it at only one end, trying each end for the best result. Or ground both ends at separate points. Sometimes a different or smaller input coupling capacitor will reduce the



**Figure 7** Test alternate connections of C2 and choose the one giving the least audio demodulation.



**Figure 8** An unbypassed small-value resistor added to the emitter circuit might reduce the RF interference.

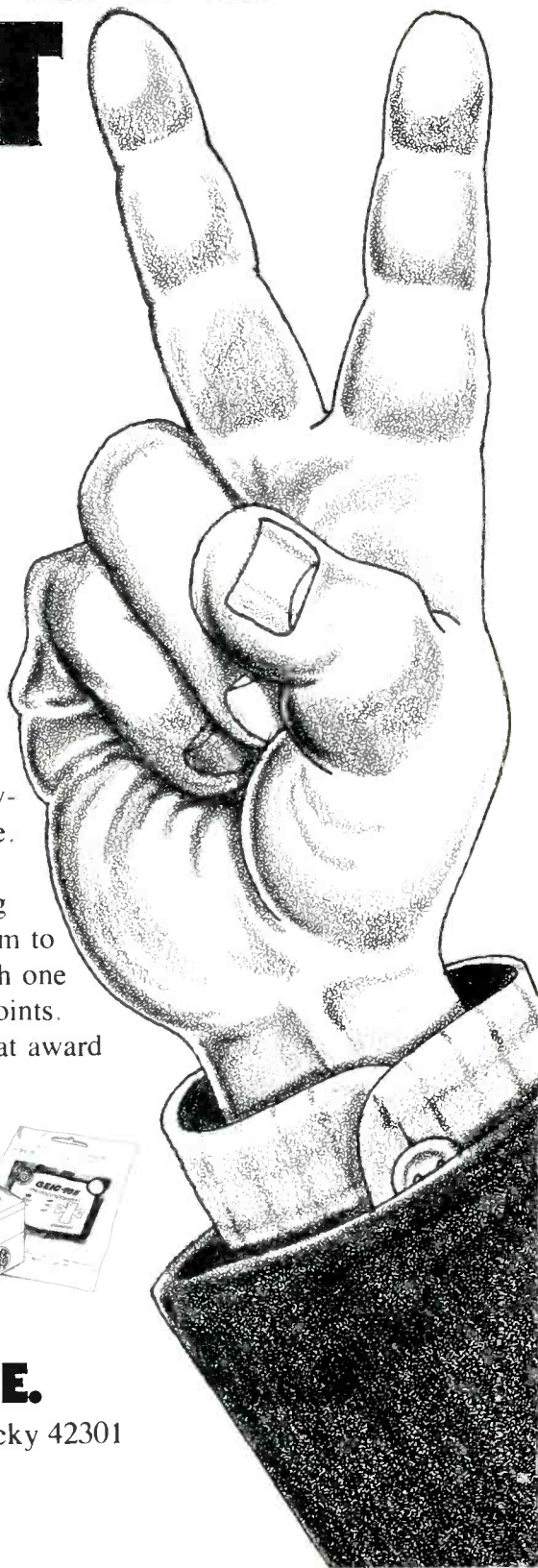
# YOU CAN GET TWICE AS BIG A DEAL AT GENERAL ELECTRIC.

## BUT ONLY DURING SEPTEMBER & OCTOBER.

Earning "pro plus" points by stocking up on GE receiving tubes, triplers and semiconductors was a big deal before. But now we've gone one better by doubling the deal!

That means you have twice as many reasons for saving those valuable tags, bags and flaps—and for submitting them to GE "pro plus" Award Headquarters before October 31. Each one will be worth twice its normal value in "pro plus" award points. Which means you can double the rate at which you earn that award or weekend-for-two trip you have in mind.

We cannot extend the time limit for this kind of double-dealing; but no one will ask questions if you decide to boost the size of your order. Just remember to save the tags & bags & flaps and turn 'em in during September and October. We want to be sure you get the big deal you deserve.



## WE'RE AT YOUR SERVICE.

Tube Products Department—Owensboro, Kentucky 42301

GENERAL  ELECTRIC



## RFI interference

interference. If it is an electrolytic type, make certain it is not leaky. Ground the input terminal; if the collector dc voltage changes and holds the different reading, the capacitor is leaky.

### What about RF chokes?

RF chokes should be used only as a last resort. The inductance can resonate with stray capacitance and create a *new* resonance. For example, I once completely removed CB interference from an amplifier by using chokes, only to find the amplifier now received the local FM station!

The Figure 10 circuit suppressed RF rectification in a Bogen pre-amplifier that handled low-impedance microphones. The chokes were VHF types wound on ferrite cores. Addition of a  $330\ \Omega$   $\frac{1}{4}W$  carbon resistor across each choke might be necessary to break up other resonant points.

### Final tests

After the amplifier seems to have an acceptable level of RF interference, again use full generator output and sweep through all available frequencies. If no frequencies can be heard very loudly, the amplifier is ready for the ultimate test. Hold a 2W or 3W CB walkie-talkie with the antenna near the amplifier wiring and press the transmit button. There should be no acoustic feedback and the CB audio should not be heard in the amplifier speaker.

After the amplifier is reinstalled in its regular location, repeat the test with the CB walkie-talkie. If the amplifier can withstand this severe test, it should keep out all unwanted RF signals.

### Summary

The secret of eliminating the demodulation of RF in any audio amplifier is in breaking up all RF resonances and *hot spots* by bypass detuning, with parasitic-suppressing resistors or by rerouting and re-dressing the wiring of sensitive input stages.

Use of an RF generator to monitor the effectiveness of each fix gives assurance that the interference will still be missing after the amplifier is delivered. □

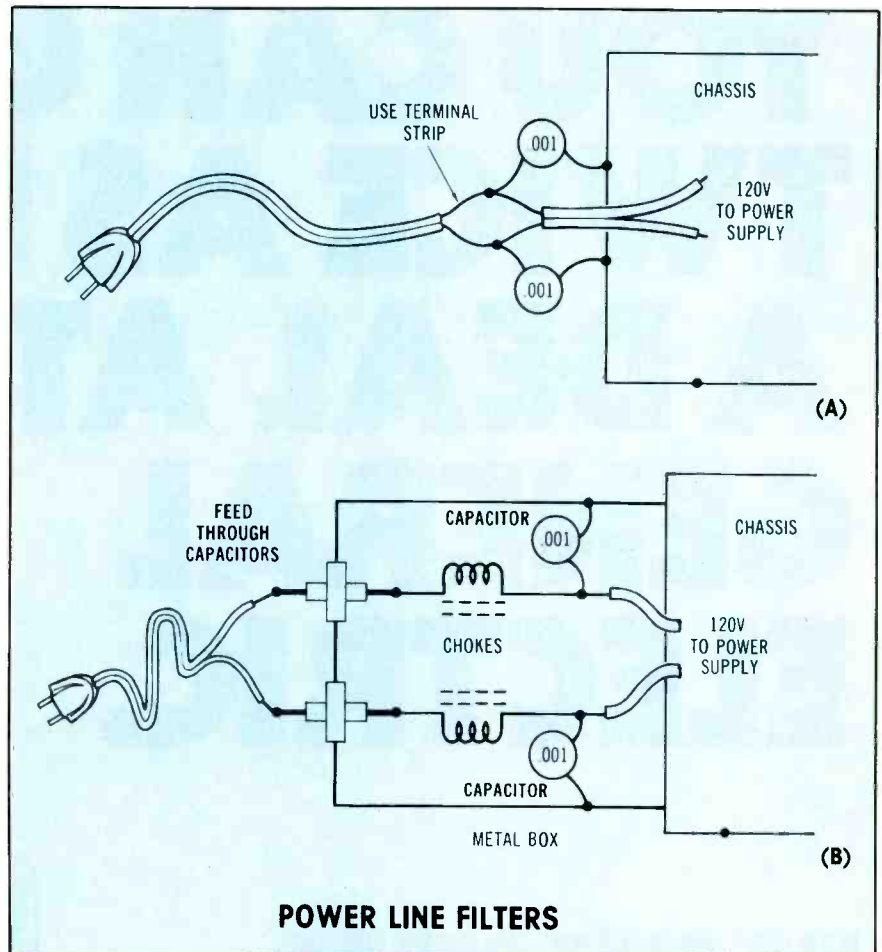


Figure 9 These two methods are recommended for preventing RF on the line-voltage cable from entering the chassis.

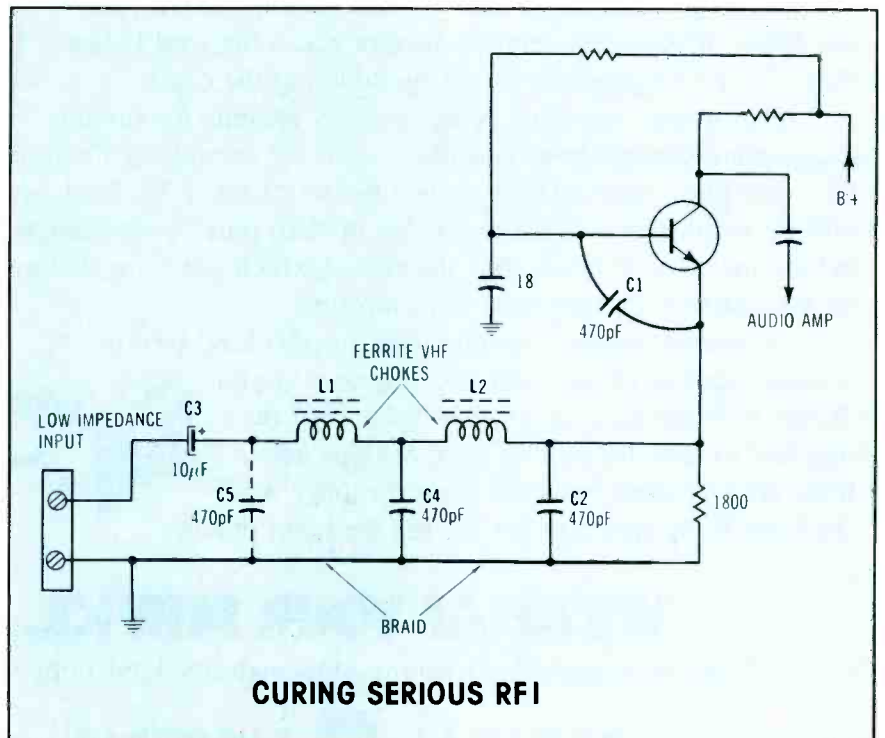
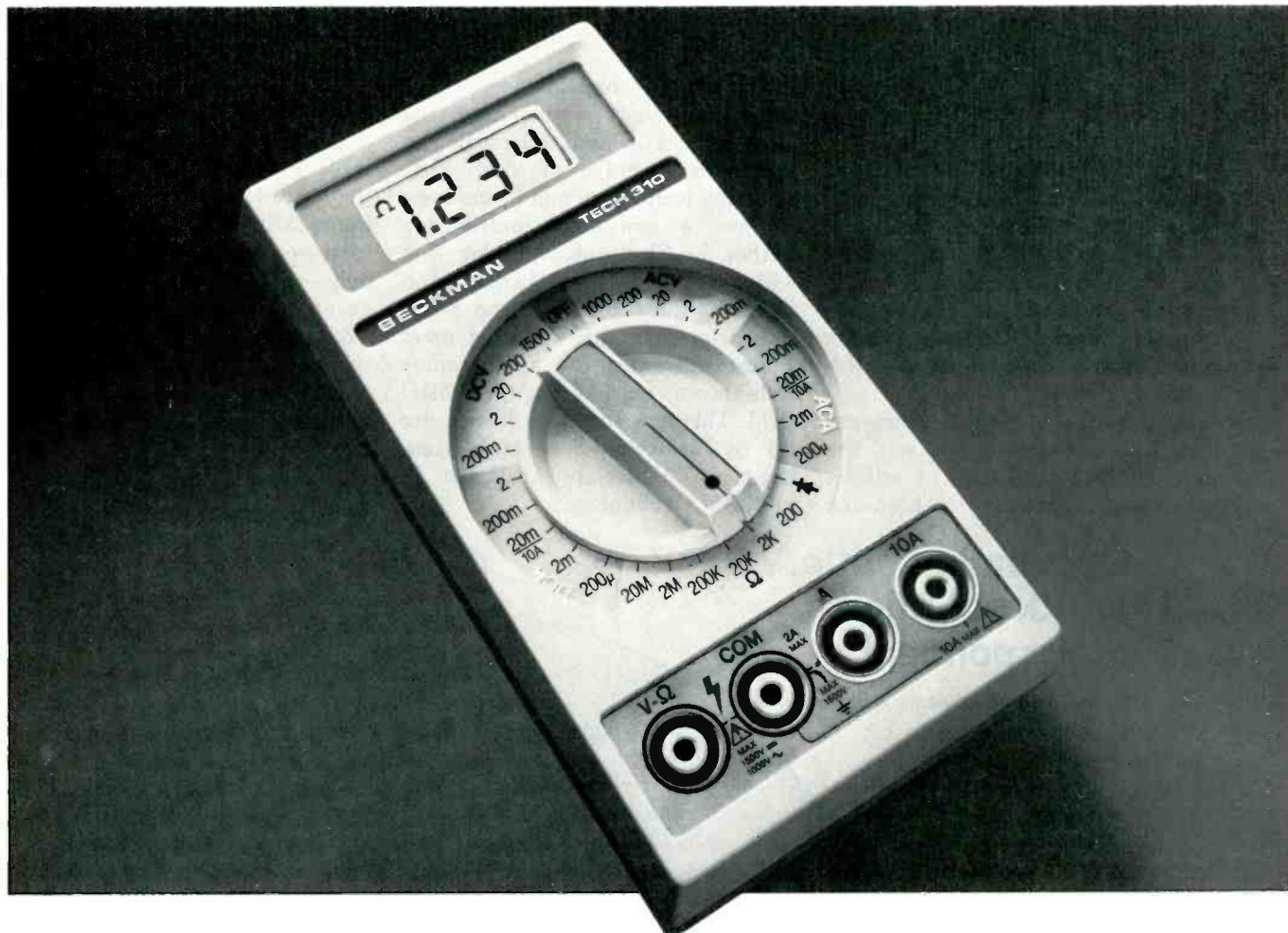


Figure 10 A stubborn case of RF interference required this elaborate filtering of the low-impedance input to the transistor emitter. If the chokes cause serious resonances at other frequencies, parallel them with  $330\ \Omega$  carbon resistors.

# WHEN THE GOING GETS TOUGH, BECKMAN'S NEW DIGITAL MULTIMETERS KEEP GOING.



## Featuring new continuity function.

If you've ever been troubled by a faulty multimeter—or had to use one that wasn't quite up to the tougher jobs—your troubles are over. Now there's the Beckman line of digital multimeters. A new generation of 3½-digit models that combine superior reliability with highly versatile features.

Features like a unique continuity test function. With Beckman's new Insta-Ohms™ quick continuity indicator, you no longer need an analog VOM for fast, convenient continuity checks.

There's also 10-amp current ranges, in-circuit resistance measurement capability in all six-ohm ranges, a dedicated diode test function, and up to two years normal operation from a common 9V battery.

The Model TECH 310 with all these features,

7 functions, 29 ranges, and 0.25% Vdc accuracy is only \$130.

The Model TECH 300 with 0.5% Vdc accuracy, but without the continuity function or the 10-amp current ranges, is just \$100.

Whichever model you choose, you get a multimeter that won't let you down. There's exceptional overload and 6kV transient protection, plus ruggedness to take a 6-foot fall and to come up working.

So get the Beckman digital multimeter that performs and keeps on performing. No matter how tough the going gets. For information on the complete line and accessories, write or call your local distributor or the Advanced Electro-Products Division, Beckman Instruments, Inc., 2500 Harbor Boulevard, Fullerton, CA 92634, (714) 871-4848, ext. 3651.

# BECKMAN

Circle (7) on Reply Card

August 1979 *Electronic Servicing* 21



# MRO industrial

By George Laughead, publisher

Over the past year the staff of this magazine has researched, studied and planned our response to a growing area of jobs and applications for electronic servicing. The one area that stands out is that which we label MRO (maintenance repair operations) industrial electronic servicing.

It is with pride and excitement that I can announce to you the start of a regular group of articles each month that apply to both the

independent technician and service shop, and also to the industrial electronic serviceman. Forest Belt, a leader in coverage of electronics, servicing technology and techniques, is now a consulting/contributing author for **Electronic Servicing** who will work exclusively on writing and directing the editorial in the MRO industrial electronic servicing area. Forest will enlist the aid of many well-known experts in the MRO field. This new section will measure up to **Electronic Servicing's** standards of editorial excellence in electronic technology.

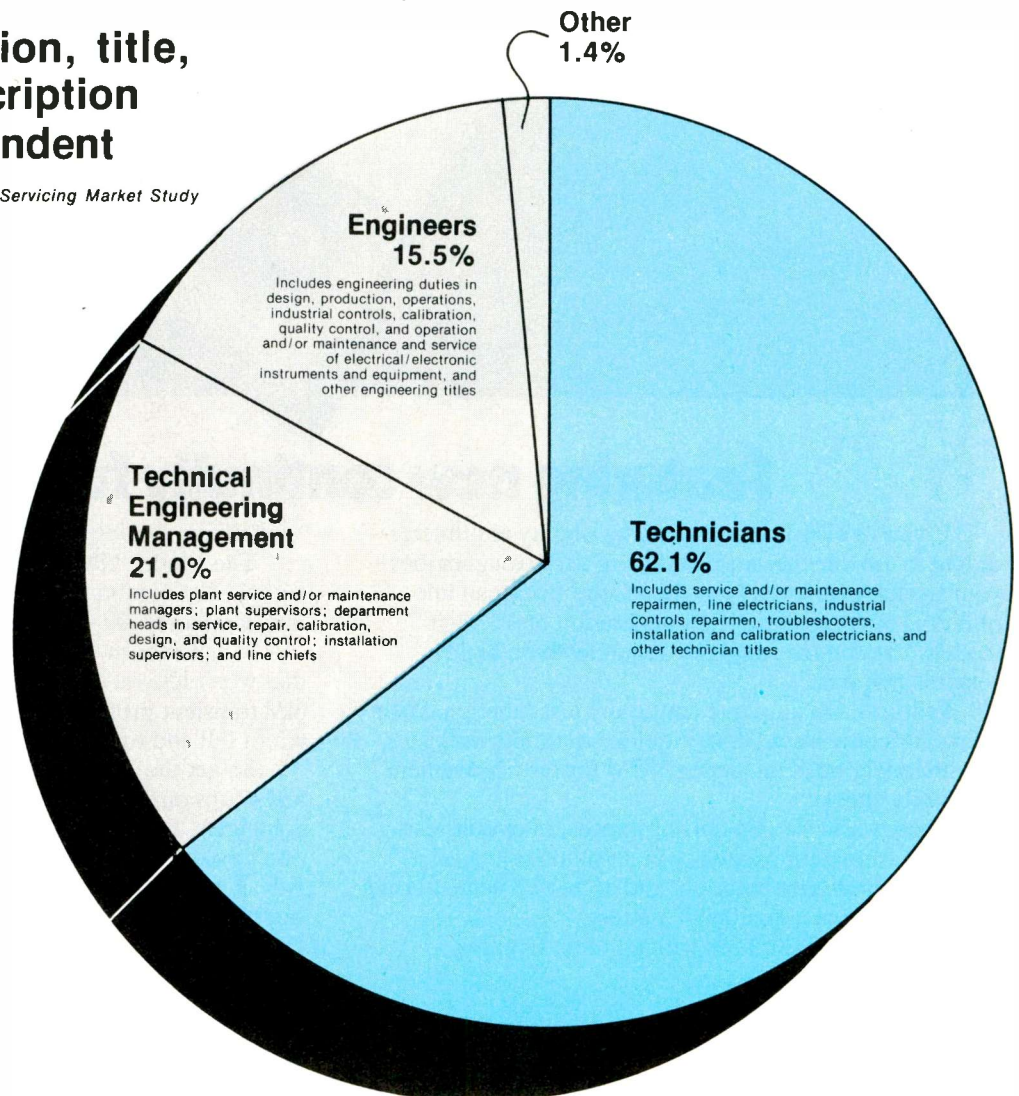
## Why MRO?

Because it is the responsibility of trade magazines like **ES** to guide their readers into new areas for their skills and techniques to be used—perhaps even more profitably—and because we have a large group of readers who are already working in the industrial sector of the electronic servicing field.

Last year **ES** completed a survey of our subscribers who classify themselves as MRO. The survey was closed after receiving a 31% return. This article features the first

## Occupation, title, job description of respondent

Source: *Electronic Servicing Market Study*



# electronic servicing

information on the survey to be released in the magazine.

The report revealed the type of equipment and knowledge required in the MRO industrial servicing field. For one, more than 92% of the respondents indicated that a working knowledge of solid-state circuitry is required for their jobs, and more than 84% report a working knowledge of digital circuitry is required. Additionally, approximately 40% indicate that knowledge of microprocessors and minicomputers is required. This illustrates that the level of technol-

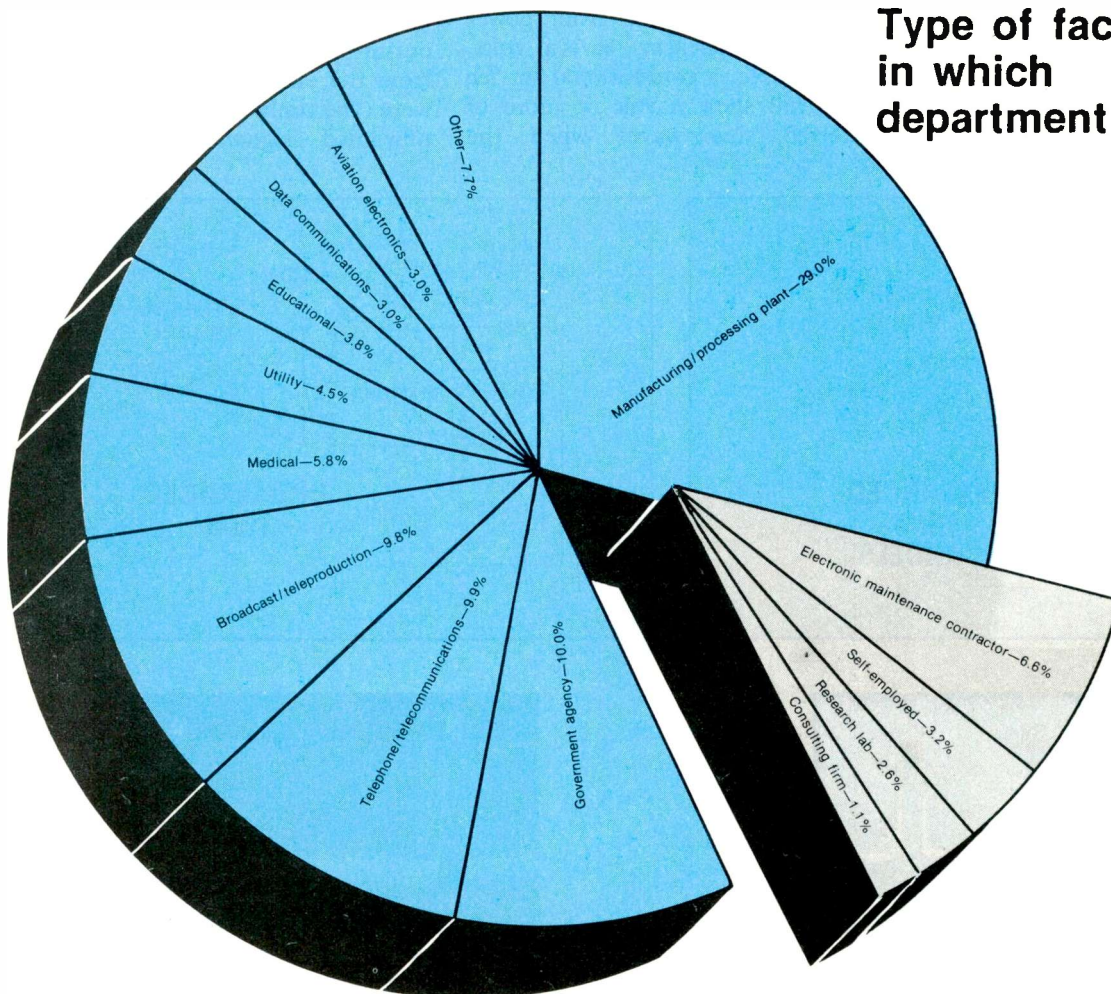
ogy implementation has risen to a new high.

Test equipment plays a major role in the MRO field. Indicative of the increasing sophistication of the field is that 47% of the respondents report that they use logic analyzers and probes as part of their working equipment. Other sophisticated devices, including distortion analyzers, curve tracers, and spectrum analyzers, were listed by a substantial percentage.

The growth of the MRO field has only begun. Starting in this issue we touch only one area with an

article on bio-medical electronic repair and techniques. In September, Forest's first article as part of this new thrust will appear. For those of you not involved in the industrial area, ES will continue to carry all the regular departments and articles that deal directly with the problems and concerns of the independent electronic technician. Our expert in this area, Carl Babcoke, editor of ES, will continue to personally monitor, write and review. Between Forest and Carl, **Electronic Servicing** will now offer you the best of both areas. □

**Type of facility  
in which  
department is located**



■ In-house facility 86.5%  
 Independent outside facility 13.5%

Source: *Electronic Servicing Market Study*



# Typical medical equipment

Diagnosing and repairing medical electronics equipment is no more difficult than servicing home-entertainment machines.

By Joseph J. Carr, CET

Electronic medical equipment is more durable and usually less complex than comparable consumer electronic merchandise. Therefore, typical repairs of medical equipment are not complicated, but more importance must be placed on competent work because of the human lives involved.

Some common and recurrent problems with medical equipment include component failures as well as defects caused by nurses and doctors.

## 60 Hz interference

Various muscular activities of human hearts produce corresponding electrical signals that can be monitored on the skin's surface. These waveforms are recorded on electrocardiograms (ECGs). One possible problem is an unwanted mixture of ECG signals with 60Hz power-line waveforms.

Amplitude of the chest signals monitored by ECGs is very small, typically about 1mV, while the 60Hz signals radiated from power wiring might measure several volts. For example, a conventional service scope will show a volt or more of distorted sine waves when the

operator's finger is touched to the scope probe.

Fortunately, the 1mV heart signals can be acquired in a differential fashion, while the offending 60Hz signal is common to both ECG inputs.

Figure 1A shows the three ECG leads during normal operation. The desired signal is obtained between the right arm (RA) and left arm (LA), with the right-leg connection serving as a common ground. The IC differential amplifier accepts out-of-phase RA and LA signals from the electrodes as though they were the only inputs. The 60Hz unwanted signal is picked up

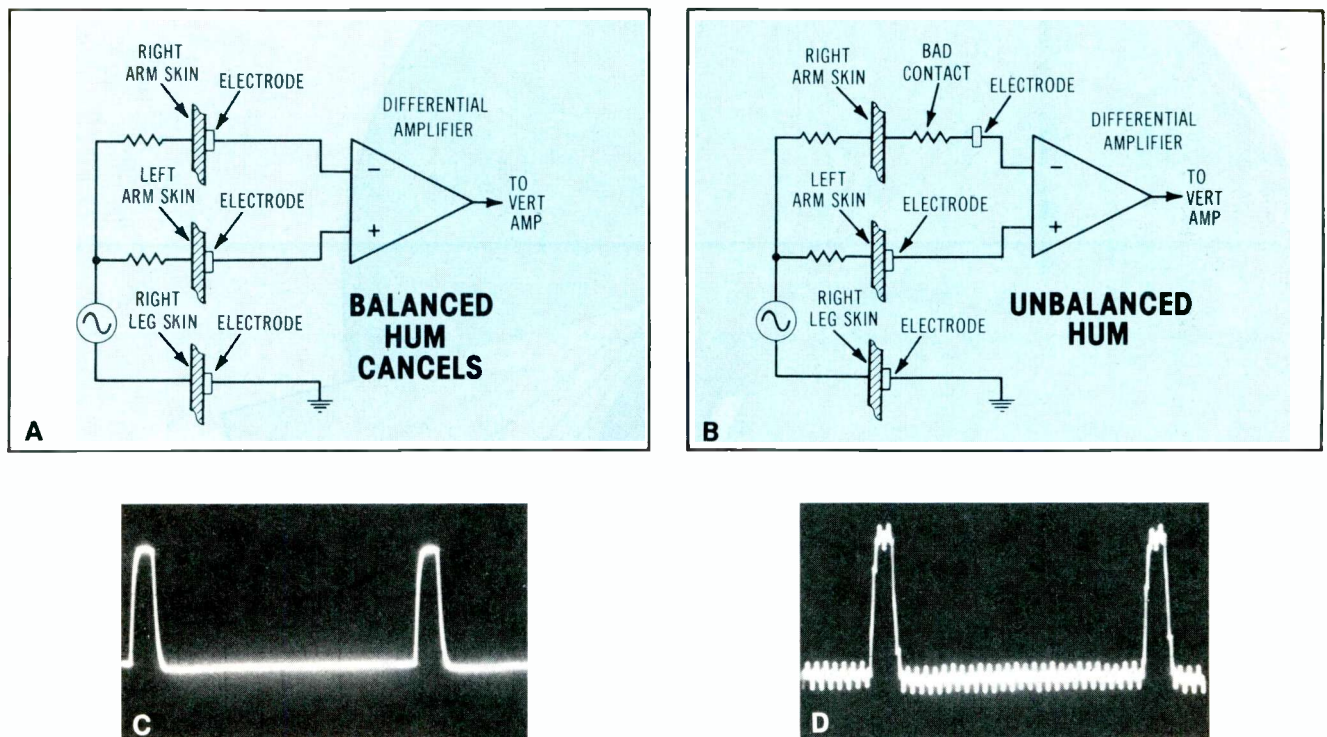


Figure 1 Differential amplifiers accept signals *between* the inputs while cancelling any in-phase signals applied to both inputs. (A) Correct connections cancel the 60Hz hum and allow the heart signals to be viewed. (B) A bad electrode contact upsets the balance, thus reducing the cancellation of hum and permitting hum to be mixed with the signal. (C) With an ECG pulse simulator signal, normal balance of attached electrodes minimizes the hum signal. (D) Hum on the pulse waveform results from bad electrode connections.

# repairs

in-phase by both RA and LA electrodes. This commonmode signal is cancelled inside the IC. (See Figure 1C.)

A poor connection at one electrode (RA or LA) adds resistance in series with that input signal (Figure 1B). This reduces the RA/LA signal slightly, but it completely unbalances the 60Hz at those electrodes; therefore, the 60Hz interference is not cancelled (Figure 1D).

During five years of servicing medical equipment, I have seen no circuit problems that caused 60Hz interference. However, the 60Hz pattern is found almost daily in any large hospital. It invariably originates in wiring connections between the ECG and the patient.

A typical ECG patient cable is pictured in Figure 2. The instrument end of the cable has a 5-pin military-type connector, and a tip-jack terminal block is at the other end. The various electrode wires are short (16 to 24 inches) and they plug into the terminal block. Most of the breaks occur in these leader wires. They can occur at either end, but most often give trouble at the pin-tip end.

First step for troubleshooting the 60Hz problem is to short the ECG amplifier input and notice if the interference disappears. If it does, the problem is external to the ECG. Some technicians prepare a five-pin male connector with all leads shorted together so it can serve as a "deadhead" plug. With this test connector substituted for the cable, the technician operates the lead selector on the ECG. If the base line remains stable and without any 60Hz disturbance at all positions, then the trouble is in the cable.

Next, the cable is tested by connecting it to the ECG, shorting

together all leader wires, and then observing the screen while trying all positions of the lead selector. No combination of leads should show 60Hz interference.

If the 60Hz pattern persists after the ECG and its leads have been checked, there are still two possibilities: a bad connection is between an electrode and the patient's skin; or a bad power-line ground exists at the ECG machine, an electric bed, or any other instruments attached to the patient.

Adhesive on the disc electrodes tends to dry up, causing a poor connection to the skin as the electrode pulls loose. This is a simple matter to correct, but it is *not* the technician's duty to replace an electrode on a patient.

In fact, **never touch a patient in any way**, even when asked to do so

by a hospital staff member. There is a *principle of privacy* here, and a patient might sue the hospital if a non-medical person touched him or her.

If the interference is gone after an electrode is changed, but reappears about the time the technician's tools are packed, then the nurse must be informed that either a better electrode or a more-effective skin preparation is needed. Some electrodes (especially the low-cost paper disc types) don't hold properly on moist skin. The heavier type with foam-rubber backing is recommended.

The third wire of a power cable should ground the ECG instrument. But a poor connection in the ac outlet is a common cause of 60Hz interference. Hospital-grade outlets are marked with a color dot, and

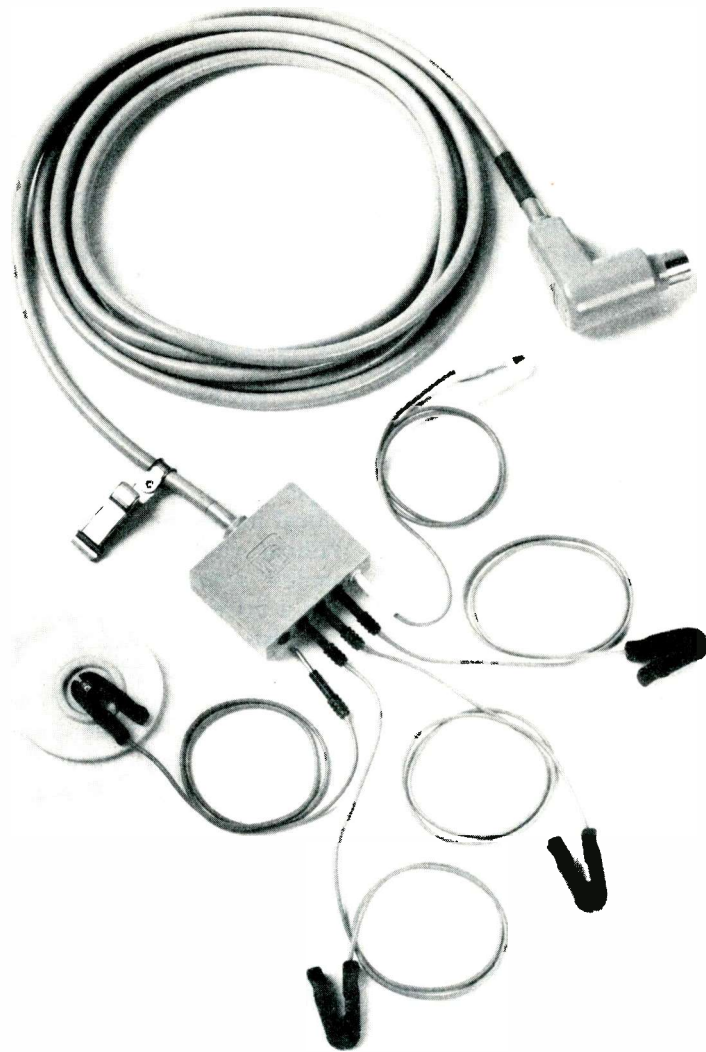


Figure 2 A typical patient ECG cable can operate with as many as five electrode leads. Opens usually occur near the ends. (Courtesy of Electronics For Medicine)



## Medical repairs

are more rugged than mass-merchandised types. If a separate ground wire is connected temporarily to the ECG and it reduces the 60Hz pattern, the house electrician should be instructed to change the outlet.

### Scope trace is too high

In the intensive-care unit (ICU) areas of a hospital, the ECG of each patient is monitored *continuously* on a medical oscilloscope (a strip-chart recorder is used occasionally to provide permanent records).

When such a scope malfunctions, the complaint might be that the trace can't be moved into the upper (or lower) area of the screen, or that the upper (or lower) peaks of the waveform are clipped.

If either Q1 or Q2 of Figure 3A becomes open, then the trace can be moved only in the top or bottom of the screen, depending on which transistor is open. Both transistors are mounted on the main chassis near the filter capacitors in this Hewlett-Packard scope (Figure 3B).

Another problem involving the same vertical-output transistors is evidenced by amplitude that varies as the *position* control is adjusted. In dual-trace mode, one position control often moves both traces. The solution is to test and replace Q1 or Q2. In fact, 2N5294 transistors are not expensive, and the shotgunning replacement of both is a practical compromise.

### Fuzzy ECG charts

A fuzzy or smeared tracing is the most common complaint against strip-chart recorders. Often the medical person who reports the problem will assume the trouble is a worn or "bad" stylus. Of course, this is possible, but a frequent problem is that the tracing paper has been loaded incorrectly.

Paper in an ECG machine is paraffin-treated so it turns black when heated, and the writing stylus is an electrically heated shaft (a hollow tube with a resistance heating element). The paper is pulled over a straight writing edge (Figure 4A) where the stylus contacts it. The paper should be pulled taut at the edge, but if someone loads the

paper incorrectly, the reverse tension is defeated and the trace is smeared. Incidentally, it is a simple matter to load the paper correctly, but a longer, harder job to do it incorrectly. It is advisable to be very tactful when telling a doctor or nurse that the paper was not loaded according to factory specifications.

### No beam on scope

Monitor scopes are used where patients are seriously ill, and a scope that's out of order is a critical matter to the medical staff. Without vital information from a monitor scope, they cannot anticipate a crisis or effectively respond to a crisis after it occurs. Therefore, any severe malfunction in a CCU or ICU monitor scope usually justifies an emergency service call. Few hospitals have back-up units.

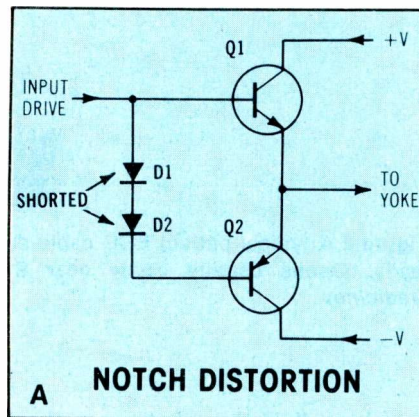
Complete loss of the scope trace

(assuming that strip-chart recorders in the system continue to operate) usually is caused by problems in the power supply. In fact, the power supplies of any medical equipment should be tested first with voltmeter and scope. After several breakdowns of each model, a technician begins to anticipate which supply is most likely to fail.

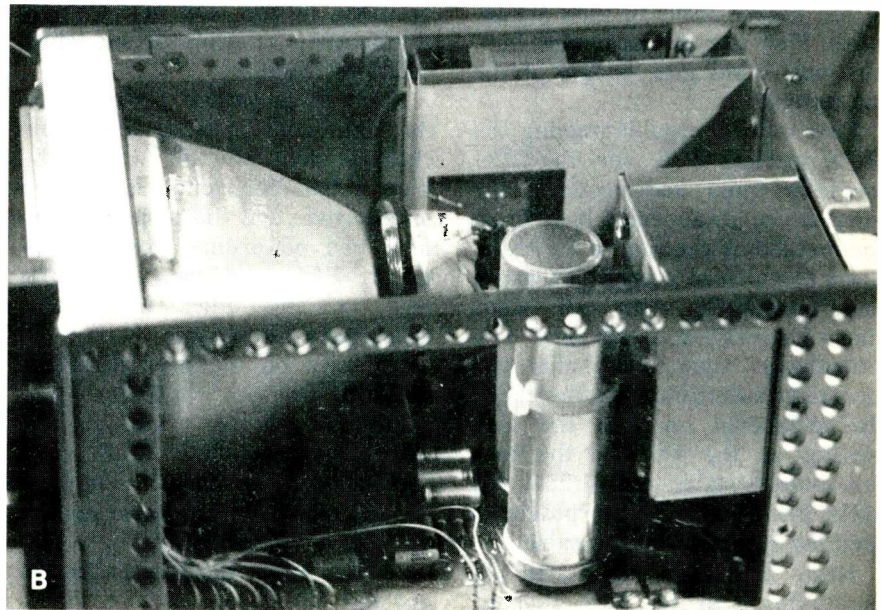
### Partial sweep

Standard sweep rate for ECG and arterial blood-pressure monitor scopes is 25mm/S, although other speeds sometimes are included. A sawtooth waveform of a 4-second repetition rate (0.25Hz) is required to sweep a standard 10cm scope screen. This deflection usually is provided by push-pull tubes or transistors.

Older tube-equipped models have sweep problems usually caused by



**Figure 3** Vertical deflection and centering depend on push-pull transistors. (A) The vertical-output stage resembles those of many audio amplifiers, complete with base diodes to minimize crossover (notch) distortion. (B) In model 7803B Hewlett-Packard ECG, the output transistors are mounted near two filters on the main chassis.





weak or dead tubes. Some models have zener diodes that limit the maximum amplitude (Figure 5). If the zeners short, the sweep starts near the center of the screen.

Certain solid-state models using the totem-pole type of horizontal amplifier (Figure 3A) have similar symptoms when the crossover (or notch) distortion diodes are shorted. The beam is shifted toward the middle. An examination of the sawtooth waveform by the bench scope will reveal the type of defect (Figure 6).

### Wide trace

Model 769 multichannel scope by Sanborn (later Hewlett-Packard)

has sweeps that are reversed from usual TV practice. The beam is swept *horizontally* by a 0.33Hz sawtooth, while the *vertical* height is deflected at 15.75kHz. This would produce a raster, except for blanking that eliminates the electron beam until it is needed to form one of the traces. A gating amplifier generates a pulse that unblanks the CRT once for each channel during each vertical sweep. Therefore, a dot of light appears to move from left to right across the screen for each horizontal sweep that requires 3 seconds. Actually, the dot of light is made up of many separate dots lighted in sequence. Timing of the unblanking pulses is

determined by the input signal waveform.

A band of light across the screen instead of the expected traces can be caused by any of several defects that disrupt the beam blanking.

Loss of filtering in one of the power supplies is the usual source of these blanking problems. Look for excessive ripple and wrong dc voltages of the +6V, -6V, -200V and +250V supplies. Failure of a series-pass transistor in one of the 6V supplies can cause a band of light across the CRT screen.

Another (and more perplexing) cause of the light bands is shown in the vertical-sweep and high-voltage section (Figure 7). Notice that the

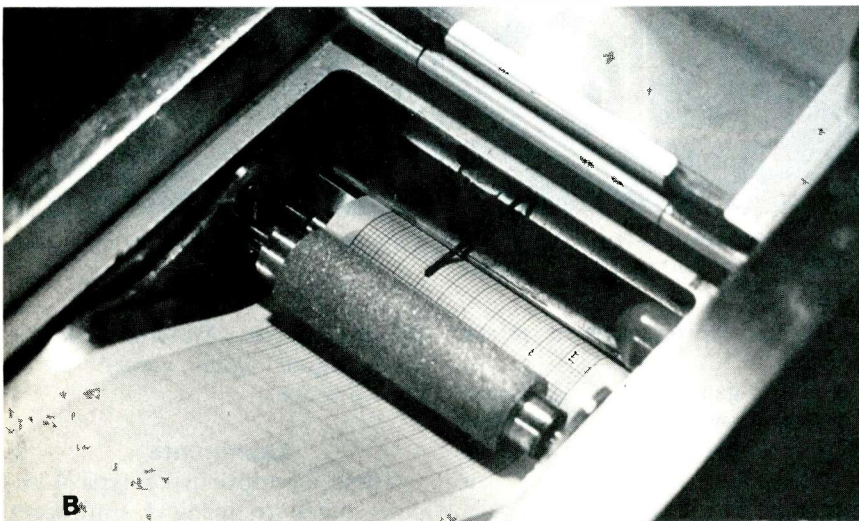
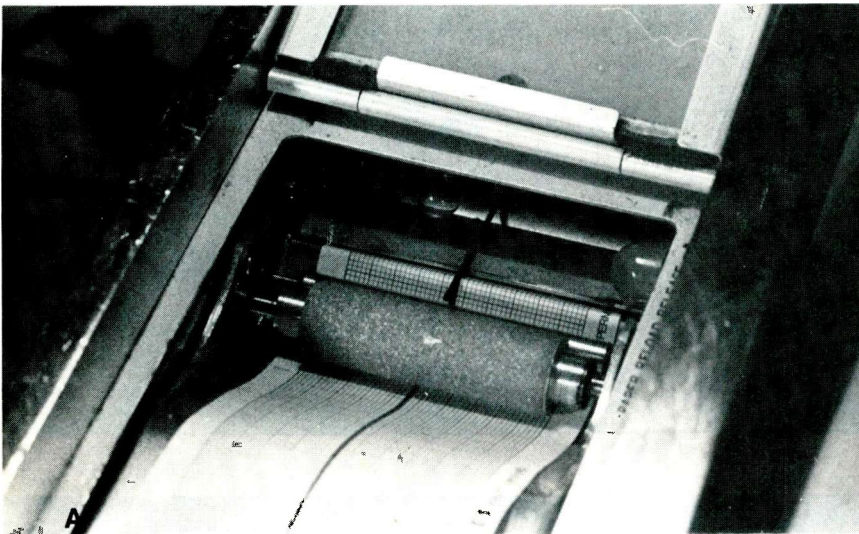


Figure 4 (A) When strip-chart ECG paper makes a sharp angle near the heated stylus, clear traces are produced. (B) But when the paper is threaded incorrectly (making a broad curve over the roller), all traces are blurred.

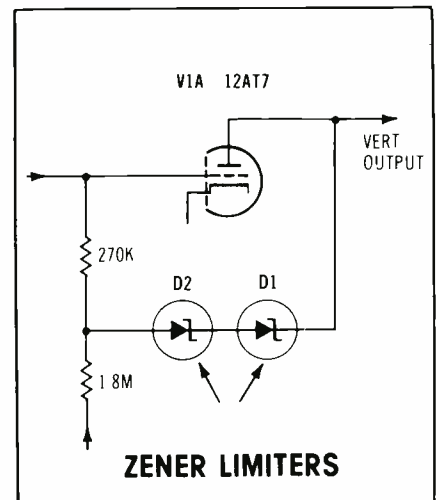


Figure 5 Driver stage of the Sanborn/H-P model 769 has zener diodes to limit the maximum amplitude. Shorted diodes move the trace to the right.

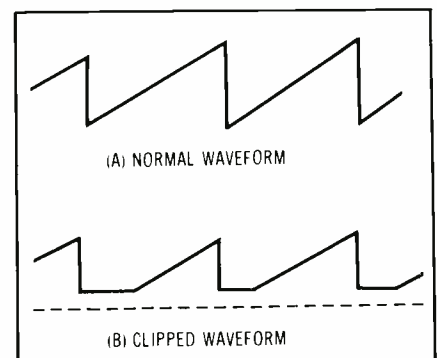


Figure 6 (A) A 0.33Hz sawtooth is the correct horizontal sweep waveform in the Hewlett-Packard model 769 ECG. (B) Clipped sawteeth are produced by a defect in the horizontal sweep.



## Medical repairs

circuit is similar to the horizontal sweep in monochrome TV receivers. (In fact, if a flyback is ordered from Hewlett-Packard, the replacement will be a Triad D-604, which is familiar to many TV technicians.) C1 is the first suspect, although C3 also should be tested.

### Missing section of trace

Non-fade medical scopes are special-purpose digital storage scopes. That is, they have a special semiconductor memory (that is similar to the memory in computers) rather than a storage mesh in the CRT.

As shown in Figure 8, the incoming analog waveform is digitized by an analog-to-digital (A/D) converter. Each amplitude level of the analog input waveform is converted to a binary digital number that represents the instantaneous amplitude. Typically, between 100 and 300 samples are taken every second.

The A/D converter can sample only one point at a time, so each waveform can be represented accurately by a table of binary values (which are stored in successive locations of the memory). This memory bank (a shift register circuit) is scanned as many as 100 times per second for display on the CRT screen (the CRT display is refreshed at every sweep). Then a digital-to-analog (D/A) converter changes the binary words back to the original analog levels for the scope's vertical amplifiers.

The memory is updated from the A/D once every few horizontal scans by overwriting the most recent data in place of the older data. On the CRT screen, the display gives the illusion of a real-time trace that does not fade.

Figure 8B shows one kind of symptom seen on the CRT when one of the shift registers goes bad. The waveform has a void or gap in the part of the trace that's served by the defective shift register. Loss of data produces a black space in the trace.

If one cell (that is, a single flip flop) is defective, only a single dot of trace seems to be missing. Probably it is not worthwhile re-

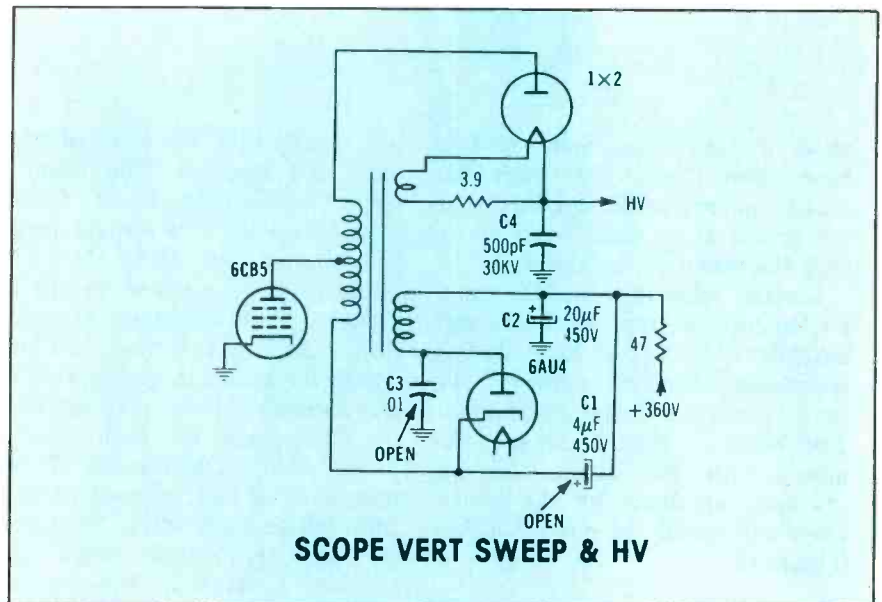


Figure 7 Circuit of the Hewlett-Packard model 769 vertical sweep is similar to the horizontal-output stage of TVs.

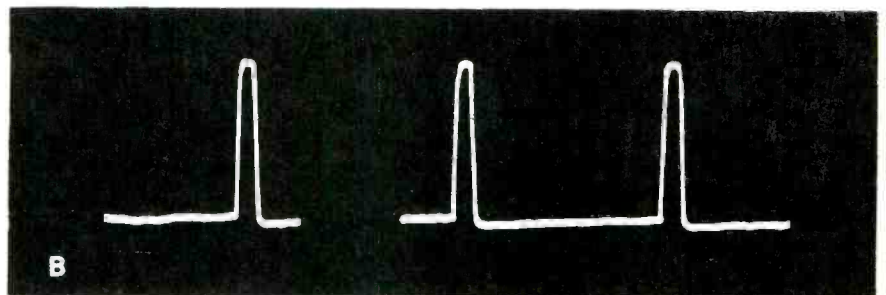
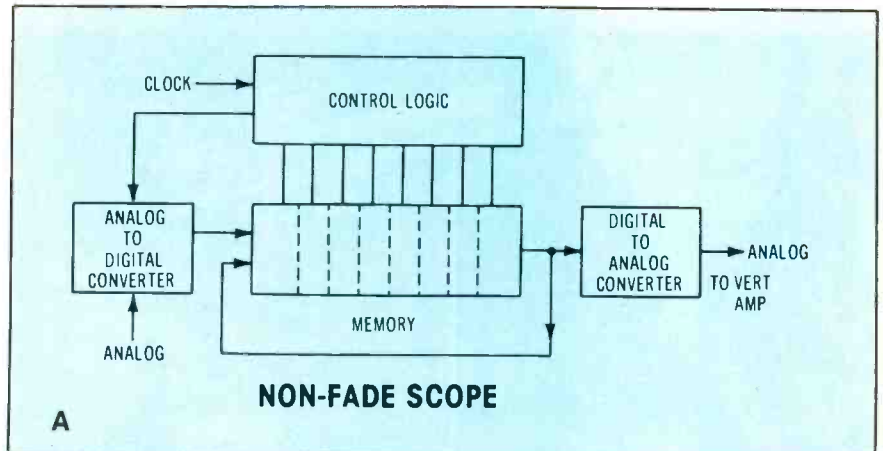


Figure 8 Medical non-fade scopes have a digital memory. A defect in a shift register can remove part of the trace.

placing an IC for such a minor symptom.

A longer gap on the CRT screen is produced when all shift register cells are either set to 00000000 or 11111111, and a wrong mark on the screen results from a few cells that are set permanently at either high or low logic states. To determine the type of defect, compare

the incomplete waveform with the same input signal viewed on a service scope.

### Comments

These descriptions of typical repairs made to medical equipment indicate that competent electronic technicians can perform equally well in this new field. □

# A second look at waveforms, part 3

Scope waveforms are used to explain problems with slow-recovery diodes, details of varistor rectification, some facts about horizontal drive, plus a passive resistance/capacitance circuit that seems to give a gain.

By Gill Grieshaber, CET

Electronic facts, theories and specific applications are much easier to remember when illustrated visually. Scope waveforms can perform these illustrations in many cases. Two subject areas that need additional clarification are the necessity of fast-recovery diodes and the proper choice of varistors that are used for voltage regulation.

## Fast-recovery diodes

Any technician who has installed a 60-Hz supply diode as replacement for a TV video-detector diode knows now that those two types are not interchangeable. Difficulties with other diode replacements are not so easy to solve. These problems have arisen from the universal adoption of horizontal-sweep rectification. Known variously as pulse or scan rectification, the dc is obtained by rectifying a sample of the horizontal-sweep signal.

A 60-Hz diode will become hot and soon short if used for such rectification. *Fast-recovery diodes are absolutely essential for use in sweep-rectified supplies.* An explanation based on square-wave input signal has been given in Sam Wilson's Technical Notebook of July 1978.

However, the same shortcoming of 60-Hz diodes can be demonstrated also with sine waves where the two peaks are more definite.

## Diode switching

The Figure 1 circuit was set up to test the switching of various diodes at different frequencies. Preliminary tests showed most 60-Hz power-supply diodes worked properly up to at least 400Hz. Two frequencies were chosen for the comparison waveforms. They were 15kHz (near the horizontal-sweep frequency) and 150Hz, which was easy to obtain without dial changes on the decaded ranges of the VIZ model WA-504B sine/square generator.

Results are given in Figure 1. Two LEDs also were tested. The waveforms resembled those of an old damper diode in photo C, but the voltage yields were much lower.

Clearly, diodes intended for 60-Hz power are not recommended for supplies operating from higher frequencies. But there are more lessons to be learned from the waveforms.

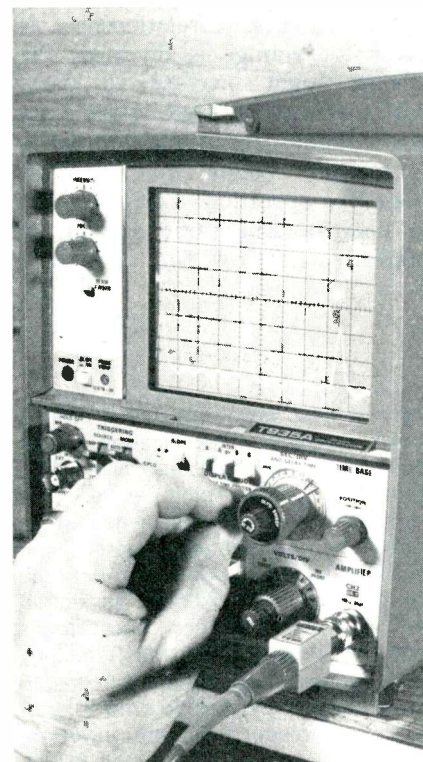
## Other diode applications

Don't use a 60-Hz diode to replace a defective one in the signal-rectifying section of any VOM or ac voltmeter that is used to measure audio signals. A slow-recovery diode can cause an error as large as 50% (-6dB) at 20kHz.

Even more important is the selection of diodes used for vertical or horizontal blanking in TV receivers. A slow-recovery diode in those video applications might cause a black or white line to be

seen at top, bottom or either side of a raster.

The top trace of Figure 2 repeats the 15-kHz sine wave after it is rectified by the slowest-recovery diode, while the lower trace is the same after the generator is changed to square-wave output. Notice that about 40% of the negative peak remains there—it was not clipped by the diode. If this diode is used to replace a horizontal blanking diode, the blanking would be missing over about 19% of the horizontal cycle. A portion of the



All waveforms were taken from a model T935A Tektronix scope.



## Waveforms

left edge of the picture might be too bright or too dark (depending on the exact circuit).

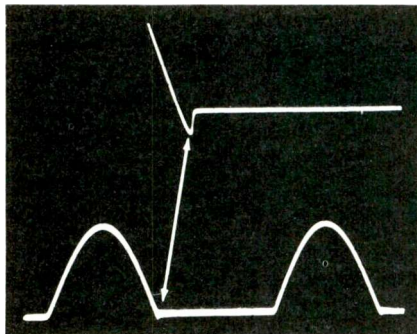
Another critical application involves the so-called bias-blanking diodes at the picture-tube grids in RCA CTC36, CTC38 and others. Those diodes *appear* to pass blanking pulses to the CRT grids, thus eliminating any horizontal retrace lines. Instead, the negative-going pulses reduce the grid-to-ground positive voltages slightly during each horizontal-retrace time. If one of these diodes is slow in turning off, the positive trailing edge of each pulse will force its picture-tube grid to become more positive, and a vertical stripe of color will be seen at the left edge of the raster. The tint of the color stripe will indicate which grid is affected.

Incidentally, any defect in one of these diodes brightens that one color in the raster. In other words, a leaky, shorted or open diode will increase the brightness of the associated color. A defective diode at the blue CRT grid will increase the blue in the raster (and the color picture too, of course).

### DC voltage from varistors

Varistors have a nonlinear voltage-versus-current relationship. If a varistor voltage is doubled, the current might increase 10 times (varies with type). That seems a bit like a diode, but a varistor has a symmetrical action that prevents diode-like operation. *Varistors have no polarity.* The same amount of current will flow for a certain

**Figure 1** Top waveform of all photos shows half-wave rectification of a 150Hz sine wave. Bottom trace is the same for 15kHz sine wave. The percentages refer to the measured dc voltage actually obtained versus the possible voltage. (A) A top-hat-type conventional 60Hz diode performed very well at 150Hz (top trace) for a 100% dc output. When the frequency was changed to 15kHz (bottom trace), the dc voltage dropped to only 60% of the former reading and the waveform showed substantial conduction during the negative peak. This diode is *not* suitable for sweep, scan or pulse



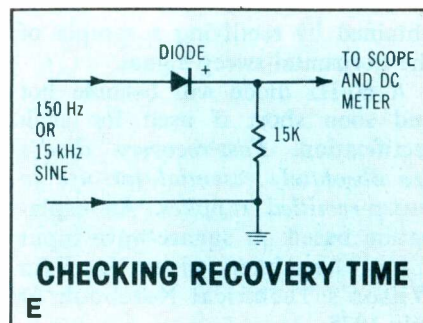
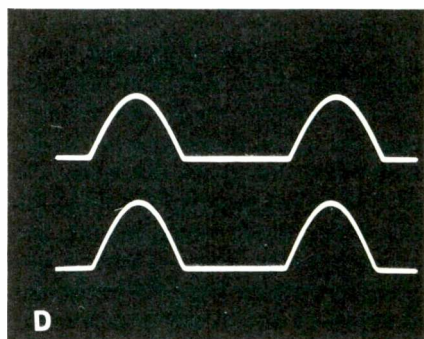
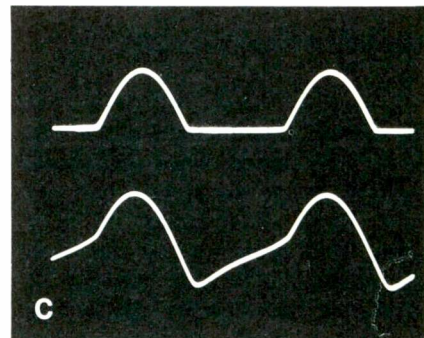
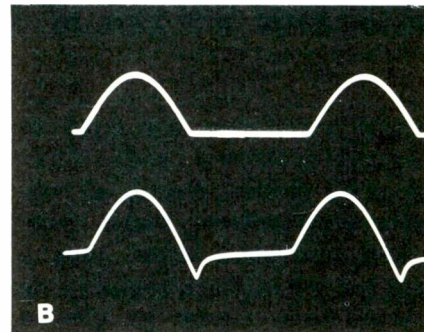
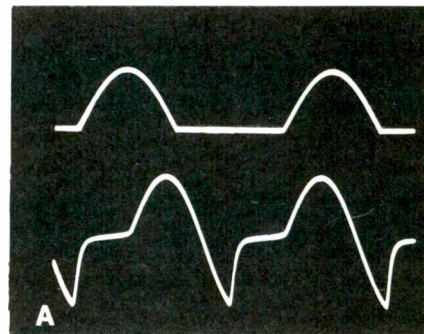
When used in the Figure 1 circuit at 150Hz, a slow-recovery diode waveform shows a tiny overshoot where the descending sine wave becomes a base line in the lower scope trace. After the overshoot area is magnified 10 times horizontally and 10 times vertically by the scope, the top waveform shows that the overshoot is a small area of conduction into the negative peak before the diode recovers and becomes open. Therefore, the problem of slow recovery exists even at low frequencies, but it is not noticeable until the repetition rate approaches the duration of this undesired diode conduction.

positive voltage as for the same negative voltage.

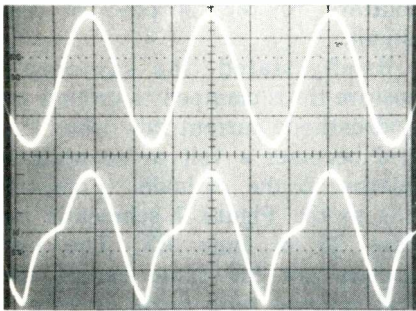
According to these facts, dc voltage *never* should be produced when a varistor is placed in a rectifier-type circuit. Nevertheless, a circuit that produces a negative dc voltage by varistor "rectification" is included in each chassis of many different TV models.

The answer to these opposing facts is found in the input-signal waveform. If sine waves, triangular waves, ramps or symmetrical square

rectification because any conduction during the opposite peak produces heat. (B) A fast-recovery diode had only a slight pulse at the 15kHz negative-voltage line (bottom trace) and a 96% dc voltage. (C) An old damper diode gave only 96% at 150Hz (top trace) and 76% at 15kHz (bottom trace). (D) The base/emitter junction of a silicon diode gave the best results, with identical waveforms and 100% dc readings. This is comparable to a video-detector diode. (E) These tests were made using only a sine-wave generator, a load resistor and the diode being evaluated.







When the slow-recovery diode of Figure 1A was operated from a 50kHz sine wave (top scope trace), the output showed conduction of almost the entire sine wave (bottom trace).

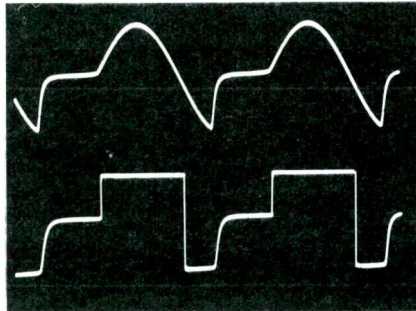
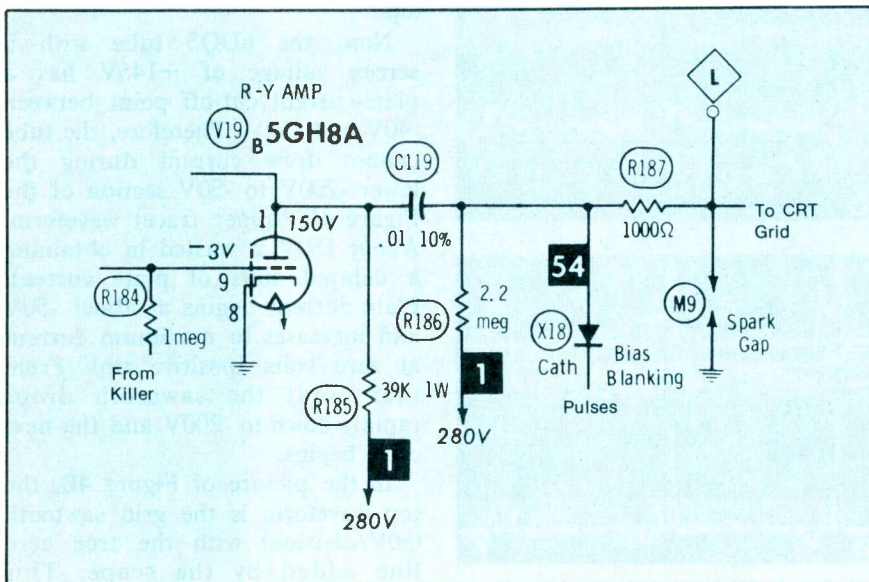


Figure 2 The slow-recovery diode response to a 15kHz sine wave (top scope trace) is compared to a 15kHz square wave (bottom trace). Obviously, such diodes are not suitable for use in horizontal-blanking circuits.



In this dc-restoration circuit from an RCA CTC36 color TV, diode X18 must be a fast-recovery type or color stripes will appear at the left edge of the picture.

waves are supplied to the varistor circuit, no dc voltage will be produced. *Only short-duty-cycle pulses can force a varistor to rectify.*

Figure 3A is the circuit used to test several parameters of varistor rectification, and Figure 3B shows acceptable results that were obtained when the varistor was matched to the pulse voltage. The zero-voltage line is the horizontal line nearest the top, while the lower line is the average-voltage line. At 50V per scope division, there is about 40VPP between the two lines. Therefore, the dc voltage from this rectification is about -40V (average voltage is less positive than zero

volts); a dc meter measured -38.2 V. This dc voltage proves that some kind of rectification has taken place.

As explained in Part 1 (June), all waveforms have the positive peak above the average-voltage line and the negative peak below it. This average-voltage line is the reference point for any voltage reaching the varistor.

According to the Figure 3B waveform, the positive peak measures 200VPP and the negative peak has 65VPP. Because the positive peak has about three times the negative peak amplitude, 10 to 15 times as much current will flow during the positive peak as during

the negative peak.

Compare those figures with diode rectification of a 1000-to-1 current ratio. The varistor operation is about the same as very inefficient diode rectification. (A diode used instead of the varistor in Figure 3A could produce about -200Vdc if the positive peak was rectified.)

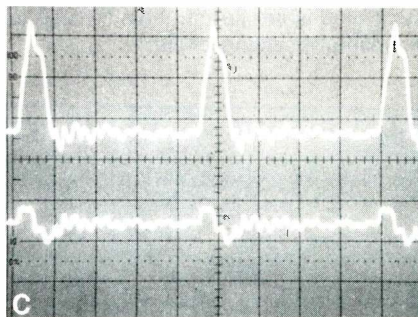
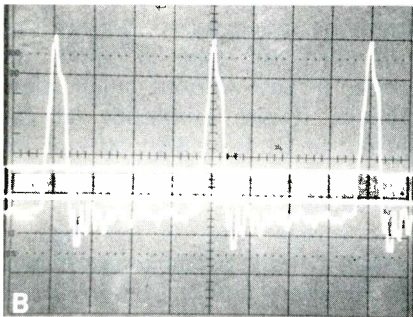
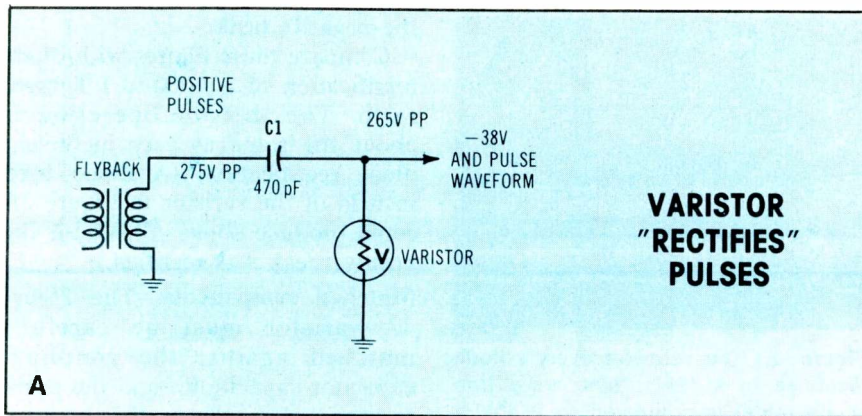
**Matched components**—The Figure 3A varistor must be carefully matched against the coupling-capacitor capacitance and the peak-to-peak voltage from the horizontal-sweep circuit. A large C1 capacitance is necessary to prevent any unwanted tilt and to allow the pulses to pass without much attenuation. If the amplitude at the output of C1 is at least 90% of the input, the capacitance value is satisfactory.

A varistor that is too high in resistance will produce insufficient dc voltage. Another varistor of too low resistance also might reduce the dc voltage or produce none; however, the reason for this low voltage is different from that of the excessive resistance. The top scope trace of Figure 3C is the flyback waveform at the input of C1, and the lower trace shows the reduced amplitude from C1 when a low-resistance varistor was substituted. Notice that the base-line ringing is not changed much, but the positive peak has been reduced substantially. This condition produced less than 1V of negative voltage.

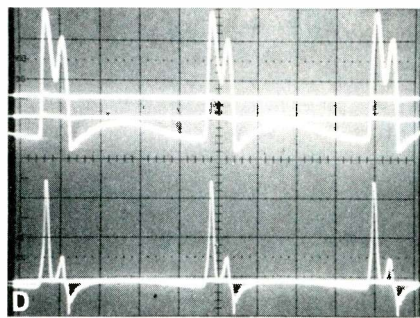
**Varistor current**—The Figure 3D waveforms prove that more current flows during the larger positive peak than during the negative peak. Positive horizontal-sweep pulses of 540VPP were connected to the Figure 1E circuit, producing -74Vdc. The two-tipped pulses with zero and average lines are shown by the top scope trace. A 1K resistor was connected between the varistor and ground to provide a waveform of varistor current (bottom trace). Both average and zero lines are the same, and no dc voltage was measured across the 1K resistor. Notice that the left tip has maximum current and other positive and negative parts have much less. Therefore, proper conditions were established for varistor rectification.



## Waveforms



**Figure 3** Definite conditions are required before a varistor can produce dc voltage. The input signal must have pulse waveform. (A) The schematic is typical of shunt rectification, but the signal is horizontal-sweep pulses and a varistor is substituted for a diode. (B) The lower horizontal line is the average voltage of the waveform, and the upper one is the zero line. When the zero line is above the average line, the waveform will measure as a negative voltage. Signal of 275VPP produced -38V. (C) The same 275VPP pulse signal (top trace) was reduced to only 85VPP at the varistor when a varistor of insufficient resistance was used. Less than -1V was measured. (D) Another source of 540VPP pulses



produced -74V. Lines on the top trace are the same as for the previous waveform. The bottom trace is the current through the varistor, which proves more current flowed during the highest tip.

Of course, the varistors are non-polarized and can be wired with either lead toward the signal. Polarity of the rectified dc depends *only* on the pulse polarity. *Positive-going pulses produce negative dc, and negative-going pulses produce positive dc voltage.*

### Horizontal output tube

It is stated frequently that damper-tube current contributes the left half and output-tube current furnishes the right half of horizontal deflection as seen on the picture-tube screen. Although actual circuits do *not* have equal damper and

output-tube conduction times, the saying does clarify the sources of horizontal-yoke current. Therefore, this explanation of the grid-drive waveform will begin with the assumption that output-tube plate current flows for about the second half of each cycle.

In Figure 4A schematic, the 200VPP of oscillator rounded-sawtooth waveform does not seem to match the -50V of bias (-53V without both scope probes). These conditions are not possible with class "A" amplification. However, class "A" operation would have current flow at all times and that is

contrary to the purpose of the circuit.

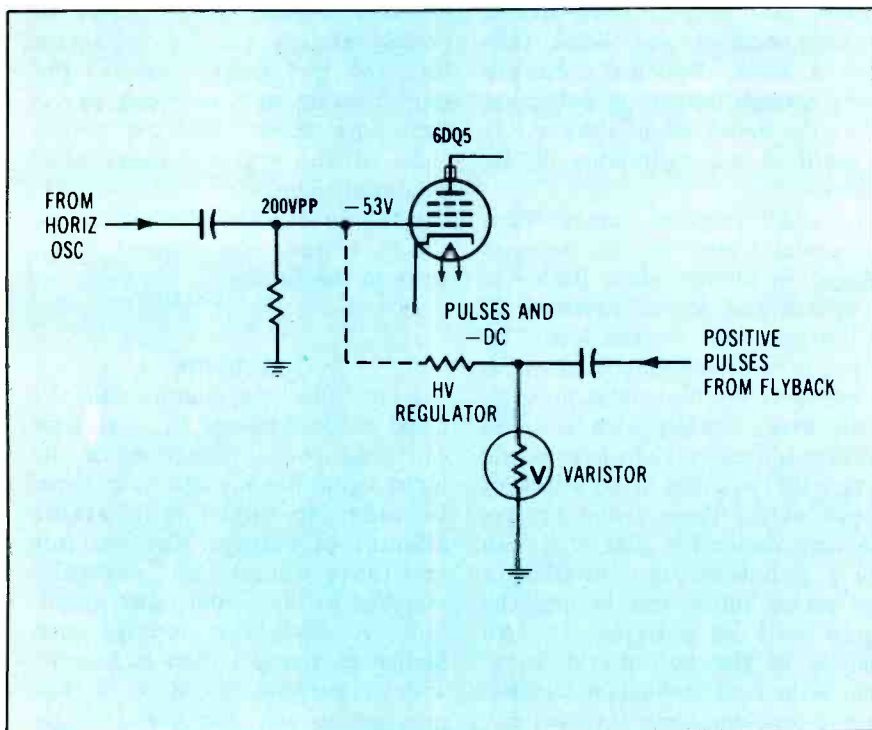
Briefly stated, the sawtooth's positive tip is clamped to ground by grid/cathode current flow when the grid becomes a volt or so positive relative to the cathode. (Compare this to the Figure 2 schematic on page 26 in June ES. The two circuits are the same except the grid/cathode tube diode is substituted for the solid-state diode.) Therefore, all of the sawtooth (except the positive volt at the tip) is negative. The sawtooth traces an instantaneous dc voltage that during each cycle varies between -200V at the bottom and about 0V at the top.

Now, the 6DQ5 tube with a screen voltage of +145V has a plate-current cut-off point between -40V and -50V. Therefore, the tube cannot draw current during the lower -200V to -50V section of the Figure 4B (upper trace) waveform. About 150V is wasted in obtaining a delayed start of plate current. Plate current begins at about -50V and increases to maximum current at zero volts (positive tip). From that point the sawtooth drops rapidly down to -200V and the next cycle begins.

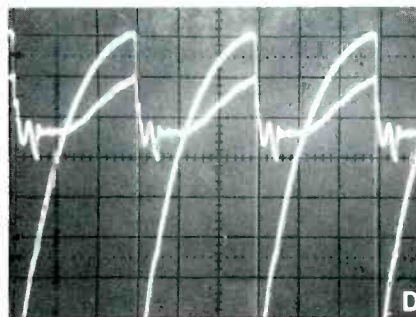
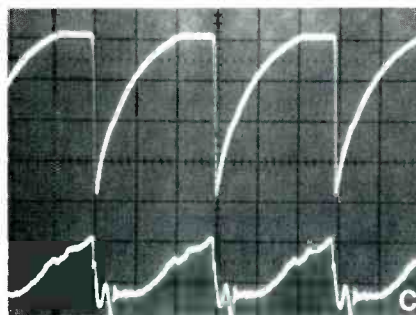
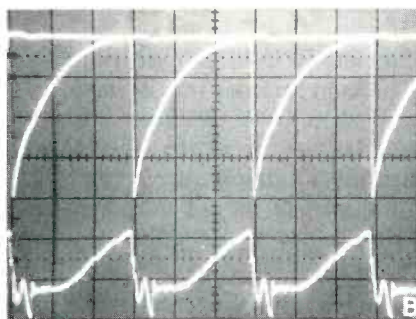
In the picture of Figure 4B, the top waveform is the grid sawtooth (50V/division) with the true zero line added by the scope. This waveform does not show where the output tube conducts, but plate current is shown by the lower dual trace. If a line is drawn between the point of the lower trace where the positive sawtooth first begins and the sawtooth grid waveform above, the intersection of line and sawtooth shows the cut-off grid voltage when measured from the zero line at the top.

Figure 4C is placed just below 4B so an accurate visual comparison can be made between the two. Figure 4C shows the effects of HV regulation by variation of the output-tube grid bias, which is explained later.

An easier way of proving the cut-off voltage by using a dual-trace scope is shown in Figure 4D. The grid sawtooth is forced off the screen by a 20V/division scope gain setting and the smaller current



**Figure 4 (A)** This schematic is typical of horizontal-output tube grid circuits. Dotted lines show how a varistor HV regulator is connected. **(B)** Top trace is the 200VPP oscillator signal at the output grid, with zero line added by the scope. The plate current waveform is shown by the lower dual trace. **(C)** These waveforms are the same as those in B, but external negative voltage from a varistor has increased the dc grid voltage from -50V to -70V. The instantaneous grid voltage never reaches zero; therefore, the plate current is lower (bottom trace). Both B and C were made with the same scope adjustments, so comparisons may be made. **(D)** To find the grid bias where plate current begins, the sawtooth was made taller and then the current lower trace was moved up until the sawtooth slope crossed the current line at the corner where plate current began. The vertical position of the current baseline shows the cutoff point was -48V. Careful scope measurements showed retrace occupied 17%, damper current flowed for 28% and output tube current flowed for 55% of the whole cycle. But, for the trace section of the cycle alone, damper current flowed for 34% and tube current flowed for 66%. This is not the 50/50 ratio usually stated.



waveform is moved up and down by the vertical-centering control until the corner where plate current begins is crossed by the sawtooth line. The voltage can be read from the scope calibrations. In this case the cut-off voltage was -48V.

### Varistors control HV

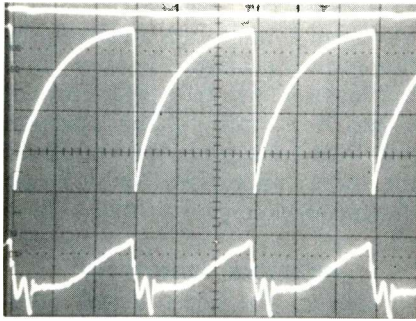
Many of the latest model tube-equipped color TVs included varistors in circuits that controlled the high voltages. As shown by the alternate section of the Figure 4A schematic, positive-going pulses from the flyback were rectified by a varistor. Then the negative voltage from the rectification was applied through isolation resistors to the control grid of the horizontal-output tube where it raised the negative voltage that was produced by grid/cathode clamping of the oscillator sawtooth. Increased negative grid bias limited the maximum plate current, thus reducing the high voltage and slightly narrowing the picture width. HV regulation by this method was adequate, but it allowed more HV variations than did the old 6BK4 circuit.

Figure 4C shows the zero-voltage line in relation to the grid sawtooth. Amplitude and waveshape were not changed by the added dc voltage. The lower-trace current waveform shows less current than the normal amount in Figure 4B. This was expected from the bias increase from -50V up to -70V. However, it was predicted that the higher bias would move the point (where current began) to the right on the sawtooth. That point remained at exactly the same location regardless of bias; only the plate current changed. This seemed to be wrong until the screen voltage was measured. With normal -50V at the grid, the screen measured +145V and the HV was 24.5kV. But with -70V, the screen measurement increased to +205V and the HV went down to 21.5kV.

The increase of screen voltage cancelled the increased negative grid voltage so the point on the grid sawtooth where plate current began remained the same in both cases. This explains why the screen-grid voltage is not regulated (but is supplied through a dropping resis-



## Waveforms



**Figure 5** Positive voltage from a leaking coupling capacitor or a gassy output tube cancels part of the negative grid voltage and produces clipping of the sawtooth tip (top scope trace). Plate current (lower trace) flows for a longer time, thus causing the output tube to overheat. The measured grid voltage was  $-40V$ , or  $10V$  lower.

tor); with poor screen regulation, moderate variations of ac and dc grid voltage have no detrimental effect on sweep performance. But with good regulation, an increase of ac or dc grid voltages would cause a white drive line down through the picture near the center.

**Positive grid**—A common problem with output circuits of this kind is leakage in the grid-coupling capacitor or a gassy horizontal-output tube. Both cases result in a dc grid voltage that is less negative than it should be. Figure 5 shows the clipping of the sawtooth tip when a positive voltage was leaked to the grid, and reducing the grid voltage to about  $-40V$ . The flat-topped waveform is typical of an insuffi-

cient negative grid voltage. Of course, the output tube draws excessive current and often fails after a time. Receivers having barely enough horizontal deflection before the defect might show a loss of width at the right edge of the picture.

An allied problem occurs when the oscillator plate resistor becomes reduced in ohmic value. Both the dc voltage and the ac waveform at the output grid are too low. The output tube draws slightly excessive current and the horizontal linearity is distorted, usually with a small compression at the right edge of the picture that appears to be a lack of proper width. These symptoms are not very noticeable and they can fool a technician into installing a new set of tubes and hoping the repair will be satisfactory. An analysis of the output-grid waveform is the best method of identifying the problem, since the sawtooth is distorted and the amplitude is below tolerance.

### Can an R/C filter give gain?

The conventional way of measuring peak-to-peak voltages with a scope is to measure the total graticule divisions between the highest part of the waveform (tip of positive peak) and the lowest part (negative peak). Usually the two points that comprise the reading are not one above the other (identical time of occurrence) but one happens before the other.

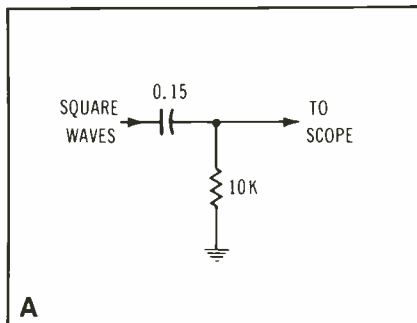
There is one example of a passive filter (without tubes, transistors or any amplifying device) that pro-

duces a voltage gain of almost two. When a square wave (Figure 6) passes through an R/C high-pass filter of the proper values, the output pulses from one peak to the next have about twice the amplitude of the square waves that produced them.

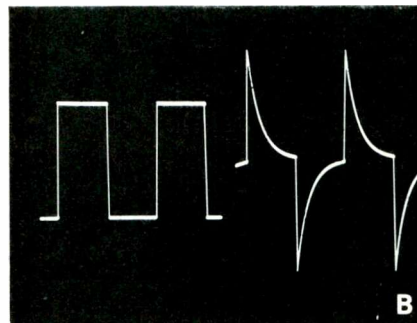
Can you explain whether or not this is a true voltage gain? If so, write to the Editor.

### Comments

A rectifier-type circuit with the usual diode replaced by a varistor can produce dc voltage when the input signal has a pulse waveshape. In order to obtain any usable amount of voltage, the varistor resistance must be carefully matched to the actual pulse amplitude. A diode can supply much higher dc voltages than is possible with a varistor, so it is a fair question to ask why varistors are used in HV regulator circuits. The reason is dependability. A varistor can dissipate a strong single pulse transient (such as a high-voltage arc) without damage. Under the same conditions, a diode would become shorted. □

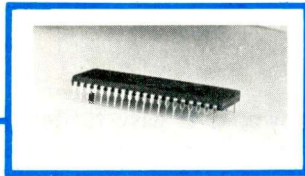


**Figure 6** A square wave that is differentiated by the high-pass filter of A produces pulses that have almost double the total height of the original square waves (B). Can a filter amplify?



The waveforms were photographed with half of the scope screen covered. No scope adjustments were made between the photographs. Vertical lines have been added for clarity.

**Editor's Note:** The profitable repairs of modern solid-state circuits demand a higher level of awareness about the behavior of sophisticated electronic circuits in addition to help from better test equipment. These two can be combined in the analysis of scope waveforms. Scopes are universal for any type of electronic circuits. No longer is it sufficient to know the approximate waveshape and peak-to-peak amplitude of the correct signal. The true instantaneous voltage (both ac and dc) must be known. This is particularly valuable when part of a waveform occurs in the cut-off region. A few examples have been given in this 3-part series. Send comments to Editor, **Electronic Servicing**, P.O. Box 12901, Overland Park, KS 66212.



# Instructing a microprocessor

By Jack Webster

*For speed and accuracy, the binary code needed to instruct a microprocessor is converted into one of the condensed codes.*

A number of different codes are used for converting decimal numbers into a more simple system for controlling a microprocessor. Two important ones are the *octal* code and the *hexadecimal* code.

## Machine language

It is important to remember that a microprocessor can operate only with binary numbers. Most present-day microprocessors require combinations of eight Binary DigITS (bits); each 8-bit combination is called a *byte*.

The following is an example of a byte that commands a 6800 microprocessor to add the contents of accumulator B to the contents of accumulator A:

0 0 0 1 1 0 1 1

An accumulator is a form of short-term memory; each accumulator holds a byte of data. In the previous example, accumulator A has been loaded with one byte of data and accumulator B holds another byte. The 00011011 instruction commands the microprocessor to add together the two bytes that are stored in the two accumulators.

It is not difficult to write a single instruction in binary form. This type of instruction is called *machine language*. However, a single program (group of instructions) might consist of 300 instructions. Such a large number probably would produce too many errors when copying the program into a microprocessor.

## Octal code

Figure 1 shows how the 8-digit byte is converted into the more convenient octal code. First, the binary number is divided into three sections, beginning at the right. Notice that a zero must be added to the section at the left to complete the third 3-digit number.

Table 1 reviews the various number systems, and it can be used for reference during the conversion examples that follow.

Notice that binary 000 corresponds to decimal 0, and 011 corresponds to decimal 3. From Figure 1, therefore, the digital 00011011 can be expressed as octal number 033.

In this same way, all instructions in 8-bit bytes can be represented by three octal numbers per byte. It is easier and less error-prone for an operator to punch 033 on a

keyboard rather than a byte of 00011011.

When 033 is punched on a keyboard, it is necessary for an electronic system to convert that number to the binary machine code the microprocessor understands and can obey. This is illustrated in Figure 2.

After the octal code for a microprocessor instruction is

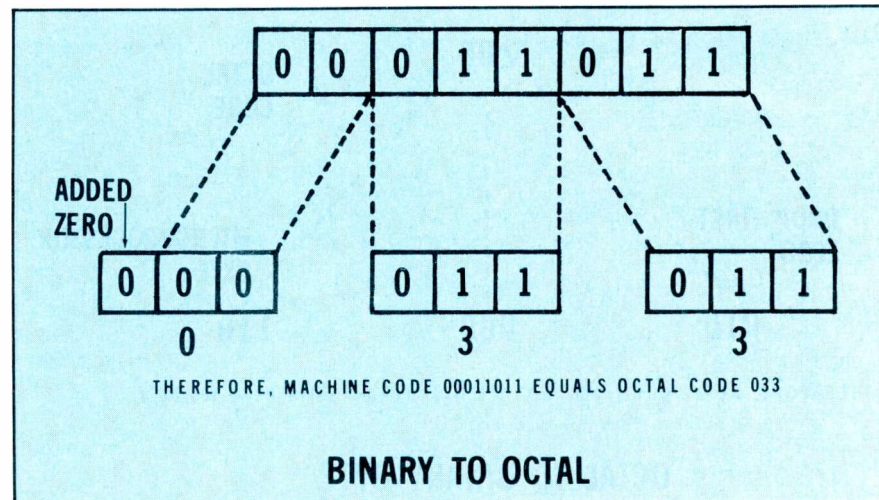


Figure 1 An 8-digit binary machine code byte is converted to octal code by adding a zero at the left and arranging in groups of three.

Decimal Number	Hexadecimal Number	Octal Number	3-Digit Binary	4-Digit Binary
0	0	0	000	0000
1	1	1	001	0001
3	3	3	011	0011
4	4	4	100	0100
5	5	5	101	0101
6	6	6	110	0110
7	7	7	111	0111
8	8	10	....	1000
9	9	11	....	1001
10	A	12	....	1010
11	B	13	....	1011
12	C	14	....	1100
13	D	15	....	1101
14	E	16	....	1110
15	F	17	....	1111

Table 1 Conversions between decimal, hexadecimal, octal and binary are made easy by this table.



# Microprocessors

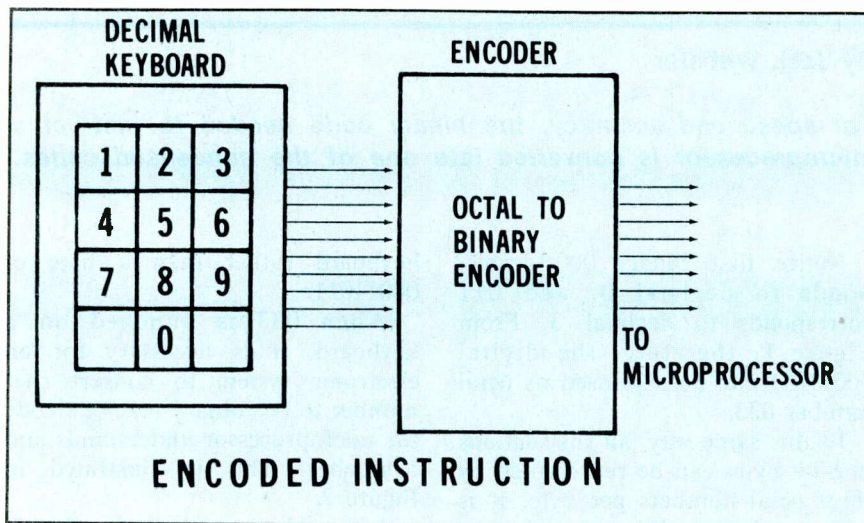


Figure 2 When decimal 033 is punched on the keyboard, the instruction 00011011 is delivered to the microprocessor.

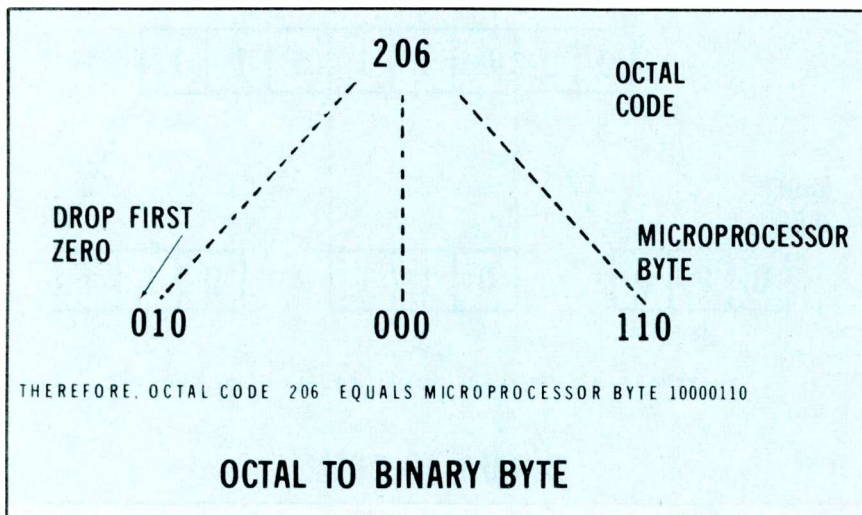


Figure 3 Conversion from octal instruction 206 to machine code 1000110 is illustrated here.

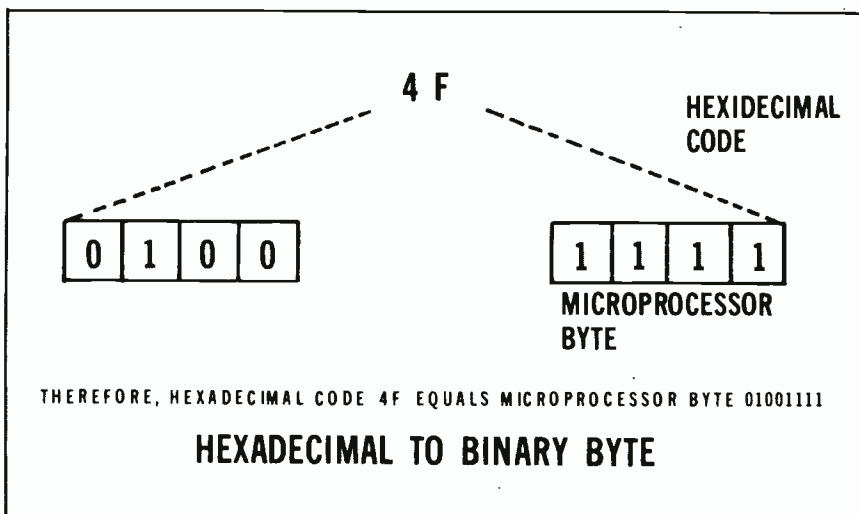


Figure 4 This is the method of converting hexadecimal 4F to machine code 01001111.

known, it is easy to determine the required binary byte for the microprocessor. For example, the 6800 octal code for loading the contents of the memory into accumulator A is 206 (this code is provided by the manufacturer). Figure 3 shows the procedure for converting this octal code to the binary byte.

Each number of the octal code is divided into a 3-bit binary number and the left-hand zero is dropped. The maximum allowable value of the first digit in the octal code is 3 (binary 011) so a left-side zero is always present.

## Hexadecimal code

A hexadecimal code may be used instead of the octal. Use Table 1 for a review of the hexadecimal count. Sixteen symbols are needed for the 16 numbers of the count. The 10 Arabic numbers of the decimal count are used in addition to the first six letters of the English alphabet (traditionally, only capital letters are used here).

According to the manufacturer, the hexadecimal code 4F clears the contents of accumulator A. In other words, the number in accumulator A is replaced by digital lows when the hexadecimal code 4F is delivered to the microprocessor.

Figure 4 shows how the hexadecimal code 4F is converted to an 8-bit byte for instructing the microprocessor.

A flow chart is used to show the step-by-step procedure needed to place a program into effect. A diamond-shaped block in a flow chart indicates that a decision is to be made by the microprocessor, and Figure 5 shows an example of this kind of step. In this case, value B is subtracted from A and then a decision is made about the answer.

If the answer is equal to or less than zero, an alternate path is taken to the right (in this example). Otherwise, the regular program is to be followed.

The alternate path (to the right) is called a branch or a jump. Branching is done with the 6800 microprocessor by order of the machine code 00101111. Conversion of this machine code to the more convenient hexadecimal code is illustrated in Figure 6.

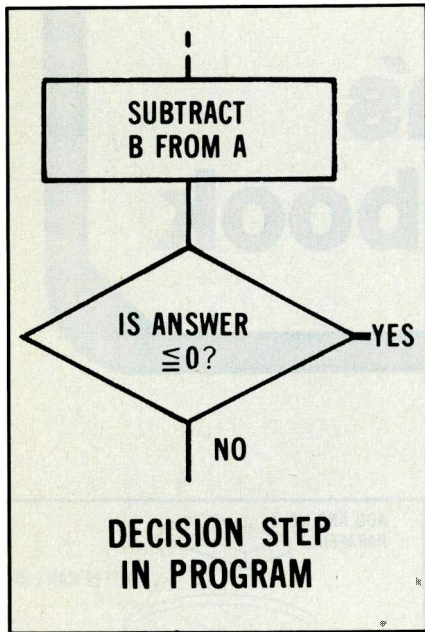


Figure 5 A diamond-shaped block in a programming flow chart indicates that the microprocessor must make a decision based on the previous step.

#### Baudot code

The previous coverage has concentrated on codes used for instructing the microprocessor. But the output of the microprocessor is also in binary machine language. Normally, this output is converted into an alphanumeric readout. That is, the readout has letters of the alphabet and Arabic numbers.

One method of obtaining an alphanumeric readout is to deliver the microprocessor output coded signal to a teletype machine. The Baudot code (Figure 7) is used for this purpose.

A 5-digit binary number has 32 possible Baudot symbols. If code 11011 precedes the printout, the bit numbers that follow represent the figures column. For example:

11011 (FIGURES)  
10101 (6)  
10011 (2)

From those three codes, the machine prints the number 62. Also, the following bit numbers would print the word PIN:

11111 (LETTERS)  
10110 (P)  
00110 (I)  
01100 (N)

Additional printout codes will be discussed in a future article.

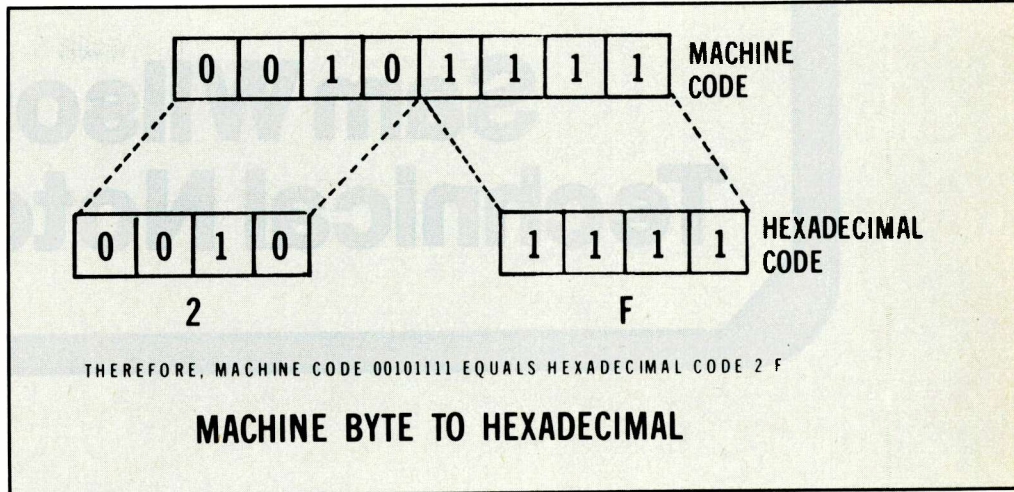


Figure 6 According to the example, binary byte machine code 00101111 equals 2F hexadecimal code.

BIT 5 4 3 2 1	LETTERS CASE	FIGURES CASE
0 0 0 0 0	BLANK	BLANK
0 0 0 0 1	E	3
0 0 0 1 0	LINE FEED	LINE FEED
0 0 0 1 1	A	.....
0 0 1 0 0	SPACE	SPACE
0 0 1 0 1	S	BELL
0 0 1 1 0	I	8
0 0 1 1 1	U	7
0 1 0 0 0	CAR. RET.	CAR. RET.
0 1 0 0 1	D	\$
0 1 0 1 0	R	4
0 1 0 1 1	J	(APOS)'
0 1 1 0 0	N	(COMMA),
0 1 1 0 1	F	!
0 1 1 1 0	C	:
0 1 1 1 1	K	(
1 0 0 0 0	T	5
1 0 0 0 1	Z	"
1 0 0 1 0	L	)
1 0 0 1 1	W	2
1 0 1 0 0	H	STOP
1 0 1 0 1	Y	6
1 0 1 1 0	P	0
1 0 1 1 1	Q	1
1 1 0 0 0	O	9
1 1 0 0 1	B	?
1 1 0 1 0	G	&
1 1 0 1 1	FIGURES	FIGURES
1 1 1 0 0	M	.
1 1 1 0 1	X	/
1 1 1 1 0	V	;
1 1 1 1 1	LETTERS	LETTERS

#### BAUDOT CODE

Figure 7 A 5-digit binary number at the output of a microprocessor can have 32 possible Baudot code symbols.



# Sam Wilson's Technical Notebook

By J. A. "Sam" Wilson, CET

This Technical Notebook describes an experiment that any technician can perform. The results will prove an important point about the dielectric in a capacitor.

## Making an electret

A permanent source of electric flux can be produced easily. It is called an electret, and it is constructed by these steps:

- Attach an insulated wire to a metal coffee can lid, as shown in Figure 1.
- Spray the inside with a non-stick coating such as used in frying pans. The reason is given later.
- Melt some paraffin in the lid, filling it to the brim. A large candle can furnish the heat.
- Prepare a flat piece of metal of smaller diameter than the lid (to avoid arcs) and attach a length of insulated wire.
- After the paraffin is melted, remove the heat source.
- Connect a source of about 30kVdc (perhaps from a TV set) to the can lid and the other piece of metal. Taking care to avoid arcs and

shocks, hold the metal so it barely touches the top of the paraffin as it hardens. Remember: the 30kV must be in contact with the paraffin until it is solid. (See Figure 1B.)

- Disconnect the high voltage.
- Remove the top plate (again using precautions against shock). Then remove the paraffin from the can lid; the non-stick coating makes removal easier.

That piece of paraffin now is an *electret*, which is a permanent source of electric flux in the same way a permanent magnet is a source of magnetic flux.

Electrets have several important uses, and some will be explained in a later issue.

## Charged capacitor

For the next step, place the electret (charged paraffin) between two metal plates (Figure 2). *The assembly is a charged capacitor!*

That is a very important statement because a charged capacitor has been created without any charge having been placed on the plates. After the experiment with the pails (a capacitor was formed from two metal and one insulator pails), several readers disagreed with the explanation. Their contention was that the voltage (which remains in a capacitor after the charging voltage is removed) is produced by an excess of electrons on one plate and a deficiency of electrons at the other plate.

In this experiment, a *charged dielectric* was installed between two metal plates. Thus a *charged capacitor* was formed. Obviously, no electrons were moved when the

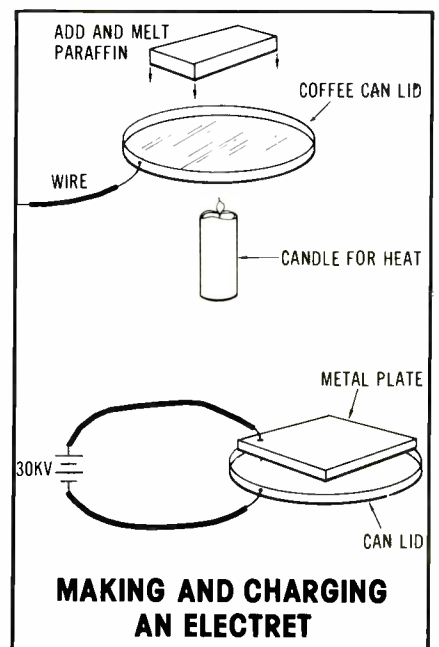


Figure 1 An electret can be made in just a few steps. Paraffin is melted (A), and while it cools (B), a voltage is connected. After the finished electret is removed, it retains an electric flux.

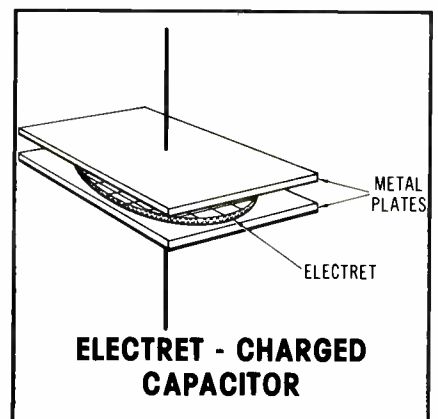


Figure 2 When an electret is placed between metal plates, it becomes a charged capacitor.

Your comments or questions are welcome. Please give us permission to quote from your letters. Write to Sam at:

J.A. "Sam" Wilson  
c/o Electronic Servicing  
P.O. Box 12901  
Overland Park, Kansas 66212

electret was changed to a charged capacitor.

It is not necessary for electric charges (such as electrons) to be moved into and out of capacitor to charge or discharge it.

Instead, a capacitor is charged when the electric field between the plates causes the dipoles in the dielectric to become oriented. The previous electret experiment would not work properly if the charging was accomplished by charge carriers on the plate surfaces.

### Wire capacitor

Earlier in the series, a capacitor made of a solid piece of wire was proposed. It was based on the capacitance formula:

$$C = \frac{k \times N \times A}{d}$$

When the numerator was made to equal the value 1 ( $k \times N \times A = 1$ ), and the denominator equal to 1/1,000,000,000,000,000 centimeter, the mathematical result is a capacitor of 1,000,000,000,000,000 farads!

A few readers stated the denominator should be  $d^2$ . Not so. The equation is correct as written.

Several humorous letters suggested applications such as integrated circuit capacitors and energy storage for solar cells.

Some perceptive readers recognized the major weakness of the wire capacitor. Such very close spacing would cause excessive leakage, and the voltage rating would be so low that the capacitor would be useless.

Solve these problems and you can start a profitable capacitor business.

### More questions

Readers continue to ask questions about operation of the dielectric in a capacitor. They ask, "If the dielectric determines a capacitor's charge, how can a capacitor with a vacuum dielectric ever become charged?"

Also, some readers insist that I stated there is no excess of electrons on one plate and a deficiency on the other.

These are the important statements:

- A capacitor made with a vacuum dielectric can be charged, but it will not store energy.

- Energy is stored in the dielectric of a capacitor, while the charges stay on the capacitor plates.

- *When a capacitor is charged*, there is an excess of electrons on one plate and a deficiency on the other.

Nothing contrary has been stated in this series.

### Ring counter

One reader asks for the schematic of a free-running ring counter made with neon lamps. If another reader can help, please send the schematic in care of the editor.

### Innovative experiments

Students of electronics laboratory courses need to have the work made interesting for them at times. When I taught university-level electronics, I gave the students several opportunities to design their own circuits. They were urged to be innovative, so they were told *what* was to be accomplished but not *how* to do it. Although I as teacher had a clear idea about how the problem could be solved, I often was surprised by the unique (and often more simple) solutions.

**Energy control**—In an advanced class about control circuitry, the assignment was to design a circuit that automatically would reduce house temperature at night and restore the usual temperature by day.

It was expected that the students would use their knowledge of control principles and digital circuitry to solve the problem by devising an elaborate electronic circuit. Most groups did take that approach, but one lazy group chose a non-digital solution.

A shelf that could be adjusted for height was placed below the wall-mounted thermostat. On the shelf was a socket and conventional 15-W light bulb with a shade to direct the warm air upward toward the thermostat while mini-

mizing the visible light. A 24-hour timer was plugged into a duplex power outlet and adjusted to turn on the bulb during the night hours.

Heat from the bulb raised the temperature at the thermostat and fooled it into acting as though the whole room was warmer. Therefore, the thermostat allowed the furnace to operate less often, reducing the home temperature all night. During the daylight hours, the timer turned off the bulb, and the home temperature was restored to normal.

The system worked very well after a few preliminary adjustments of the bulb height to obtain the desired temperature differential.

Other innovative experiments will be given next month.

### Water in light bulb?

After the story in the January issue about students who amazed the teacher with the light bulb that operated normally although water was inside, a letter was received from reader John T. Bailey. He doubted the technical accuracy of the story. Excerpts are given from that letter.

John's first job was to conduct visitors through the Westinghouse plant so they could watch lamp bulbs being manufactured. "For a general-purpose lamp, the lead wires were sealed by fusing the glass stem around the Dumet wires. Then the stem was fused by gas flames to the bulb and leaving a tip for exhausting the air by blowing in an inert gas after which the tip was sealed off by fusion. Next, the base (brass in those days) was cemented to the bulb with a bakelite cement, and the wires were soldered to the base. Now, for the part I don't understand. It is beyond me how a needle worked in between the glass and the metal base could let any water into the bulb....the stem press where the wires are sealed is well within the bulb and thus out of reach of a needle. I'm beginning to believe the water *did* come in through the wires!"

While all readers are concentrating on this mystery, I will try to get water into at least one of the gross of light bulbs I purchased. □

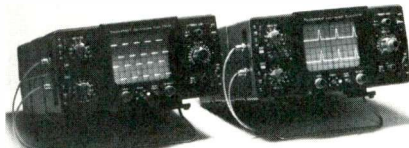


# test equipment report

## Semi-conductor testers

The LTC-905 curve tracer for testing solid-state device quality, in or out of circuit, in precise voltage or current steps is being made available by **Leader**. The unit has a sweep frequency of 120Hz with sweep voltage selectable in eight steps from 10 to 100V. It is also equipped with a variable horizontal gain control enabling use with any scope. It is priced at around \$200.

Circle (20) on Reply Card



sweep speed to 40ns/division. Suggested list prices are \$795 for the D1015 and \$895 for the D1016.

Circle (21) on Reply Card

## Scopes

Two 15MHz dual-trace models are included in **Tektronix'** Tequipment line. Tequipment D1015 and D1016 are dual-trace instruments with automatic, normal and TV triggering; V/division ranges from 5 mV to 20V; time base sweep speeds from 0.2  $\mu$ s to 200ms/division (times five magnifier increases the maximum

## Regulated power supply

**PTS Electronics** has developed a regulated digital power supply/test instrument for substituting and measuring critical control voltages. DG-5 regulated voltage control center/digital voltmeter is a high current power supply with a full 5A regulated output over the entire 0 to



30Vdc range, and has three low current voltage supplies, 0-15Vdc/50mA, 0-20Vdc/100mA, and 0-30Vdc/200mA. An additional feature is a digital  $\pm$ 200Vdc voltmeter that when selected, can monitor any of the four output voltages or an external voltage, either positive or negative, 0-200Vdc and has an accuracy to .05%. The unit has a user net of \$269.95.

Circle (22) on Reply Card

## ORIGINAL JAPANESE SEMICONDUCTORS & IC

CALL TOLL FREE  
NATIONWIDE 800/543-1607  
OHIO 800/582-1630

TYPE	25UP10-24	1-9	TYPE	25UP10-24	1-9	TYPE	25UP10-24	1-9	TYPE	25UP10-24	1-9
2SA 234	45	53	2SC 756	150	180	2SC 1975	130	170	STK 435	450	500
2SA 473	45	55	2SC 756	150	180	2SC 2028	50	64	TA 7045M	200	220
2SA 484	190	210	2SC 775	140	160	2SC 2029	150	180	TA 7055P	200	220
2SA 485	190	210	2SC 776	200	220	2SC 2036	50	64	TA 7060P	95	110
2SA 489	110	125	2SC 777	300	325	2SC 2091	90	110	TA 7061P	90	110
2SA 490	30	45	2SC 828	200	220	2SC 2092	150	180	TA 7062P	95	110
2SA 497	100	120	2SC 781	200	220	2SC 2098	320	340	TA 7063P	200	220
2SA 500	30	45	2SC 782	35	40	2SC 2102	50	64	TA 7064P	200	220
2SA 537A	150	170	2SC 789	80	90	2SD 90	130	145	TA 7203P	250	270
2SA 562	30	35	2SC 793	200	220	2SD 91	130	145	TA 7204P	200	220
2SA 563	30	35	2SC 798	200	220	2SD 92	145	160	TA 7205P	160	180
2SA 634	40	45	2SC 828	20	27	2SD 93	160	180	TA 7310P	130	145
2SA 643	30	40	2SC 828	20	27	2SD 180	160	180	TBA 8105H	190	210
2SA 673	30	40	2SC 838	35	40	2SD 187	30	40	TC 5080P	340	355
2SA 683	40	50	2SC 839	30	40	2SD 188	160	210	TC 5081P	340	355
2SA 684	40	50	2SC 867	320	340	2SD 201	230	240	TC 5082P	340	355
2SA 695	40	50	2SC 897	200	220	2SD 202	340	355	UHC002	500	520
2SA 699A	50	64	2SC 900	20	27	2SD 256A	130	145	UHC004	500	520
2SA 706	85	100	2SC 930	20	27	2SD 234	60	70	UHC005	500	520
2SA 719	25	35	2SC 945	20	27	2SD 235	60	70	UPC 20C	210	220
2SA 720	25	35	2SC 959	100	120	2SD 236	130	145	UPC 563	190	210
2SA 723	20	27	2SC 1000	35	40	2SD 255	30	40	UPC 575C	130	145
2SA 744	420	440	2SC 1013	50	64	2SD 287	250	270	UPC 578	190	210
2SA 745H	360	400	2SC 1014	50	64	2SD 291	210	250	UPC 993H2	80	90
2SA 747	420	440	2SC 1018	70	80	2SD 313	80	70	UPC 1001H	190	210
2SA 847	40	50	2SC 1080	180	210	2SD 357D	100	100	UPC 1002H	190	210
2SB 54	30	40	2SC 1060	70	80	2SD 325	60	70	UPC 1020H	190	210
2SB 55	40	50	2SC 1061	70	80	2SD 358	70	80	UPC 1025	190	210
2SB 75	30	40	2SC 1078	340	355	2SD 359D	70	80	UPC 1156	190	210
2SB 77	30	40	2SC 1080	340	355	2SD 356	70	80	UPD 657C	800	840
2SB 186	20	27	2SC 1096	65	70	2SD 359	80	90	MPS 11A	600	620
2SB 187	20	27	2SC 1098	50	64	2SD 381	85	100	PLL D2A	500	530
2SB 324	25	35	2SC 1111	210	250	2SD 422	160	200	PLL D2A	740	800
2SB 367	110	125	2SC 1114	420	440	2SD 525	90	110	IS 84	45	55
2SB 405	25	35	2SC 1118	250	270	2SD 526	60	70	IS 188	35	40
2SB 434	80	90	2SC 1168A	340	355	2SK 23	85	100	IS 1953	16	18
2SB 473	70	80	2SC 1169	70	80	2SK 30	190	210	IS 1007	35	40
2SB 474	70	80	2SC 1169	70	80	2SK 33	60	70	IS 1211	35	40
2SB 507	70	80	2SC 1169	70	80	2SK 34	190	210	IS 1555	20	22
2SB 511	70	80	2SC 1169	70	80	2SK 41	50	64	IS 1556	20	22
2SB 536	110	125	2SC 1173	30	40	2SK 45	40	45	IS 1557	20	22
2SB 557	210	250	2SC 1173	50	64	2SK 49	40	45	IS 1885	16	18
2SB 586	110	125	2SC 1178	320	340	2SK 55	60	70	IS 2066	20	22
2SB 596	110	125	2SC 1209	1100	1250	2SK 61	110	125	IS 2093	35	40
2SB 600	500	600	2SC 1226	50	64	2SK 68	40	45	IS 2473	16	18
2SC 183	40	50	2SC 1264	50	64	2SK 68	40	45	IN 54	12	13
2SC 184	40	50	2SC 1237	180	200	2SK 22Y	140	160	IN 60	12	13
2SC 281	25	35	2SC 1238	220	240	2SK 95	130	145	10D10	45	55
2SC 372	20	27	2SC 1306	130	170	2SK 97	180	210	VO 68	25	35
2SC 373	20	27	2SC 1307	220	240	2SK 99	90	110	VO 6C	25	35
2SC 380	20	27	2SC 1318	30	40	2SK 40	130	145	VO 6C	25	35
2SC 381	20	27	2SC 1319	30	40	2SK 41	130	145	WZ 061	20	22
2SC 382	30	40	2SC 1383	30	40	2SK 45	130	145	WZ 062	20	22
2SC 387A	30	40	2SC 1384	30	40	2SK 48	340	355	WZ 063	20	22
2SC 394	30	40	2SC 1400	30	40	2SK 48	340	355	WZ 064	20	22
2SC 458	20	27	2SC 1403	320	340	2SK 49	130	170	WZ 075	20	22
2SC 481	130	145	2SC 1418	80	70	2SK 214D	130	145	WZ 081	20	22
2SC 482	110	125	2SC 1475	70	80	2SK 214E	250	270	WZ 090	20	22
2SC 489	130	145	2SC 1567A	25	30	2SK 214F	180	200	WZ 095	20	22
2SC 495	45	55	2SC 1667	300	320	2SK 315	180	200	WZ 192	20	22
2SC 509	110	125	2SC 1678	130	145	2SK 410	180	200	WZ 200	20	22
2SC 517	300	320	2SC 1687	40	45	2SK 411	130	145	WZ 280	20	22
2SC 525	30	40	2SC 1728	100	120	2SK 412	130	145	SG 613	520	540
2SC 627	130	145	2SC 1730	45	53	2SK 413	150	175	HA 1151	180	200
2SC 696	110	125	2SC 1760	90	110	2SK 414	180	200	HA 1156	180	200
2SC 710	20	27	2SC 1775	30	40	2SK 415	200	220	HA 1306W	200	220
2SC 712	20	27	2SC 1806	150	175	2SK 416	180	200	HA 1322	250	270
2SC 712	20	27	2SC 1908	25	35	2SK 417	130	145	HA 1339	250	270
2SC 730	300	320	2SC 1945	450	500	2SK 418	180	200	LA 403	180	200
2SC 732	20	27	2SC 1957	60	70	2SK 419	190	210	LA 403P	180	200
2SC 733	20	27	2SC 1968	360	400	2SK 420	220	240	LA 4400	190	210
2SC 734	20	27	2SC 1973	70	80	2SK 421	180	200	LA 4400L	190	210
2SC 735	20	27	2SC 1974	130	170	2SK 422	180	200	STK 011	360	400
						2SK 423	420	440	STK 015	420	440

Minimum Order \$5.00  
Ask for our 48 page catalog containing 800 Japanese transistors, IC, FET, diodes and test equipment and parts for sale.

**FUJI-SVEA ENTERPRISE**  
a Division of Fuji-Svea Incorporated  
P.O. Box 40325 Cincinnati, Ohio 45240  
Hours: Mon-Fri 10-7 Sat 11-5 (EST)

Circle (8) on Reply Card

"If it's any comfort to you, Mrs. Peabody, it looks like the little fellow died of old age!"



Martin Townsend

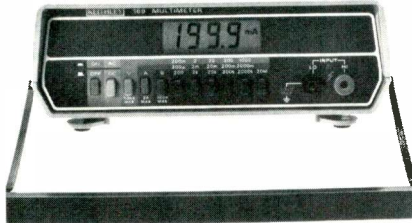
### Bench/portable DMM

**Data Tech** has introduced the Model 30L 3½-digit digital multimeter. The unit has a basic dc accuracy of 0.1% and uses 0.43-inch LED displays. When the battery option is included, the meter displays an indication while charging and an indication when battery voltage is low. When batteries are discharged to a specified low level, the unit is shut off to prevent erroneous readings.

The unit sells for \$169.



Circle (23) on Reply Card



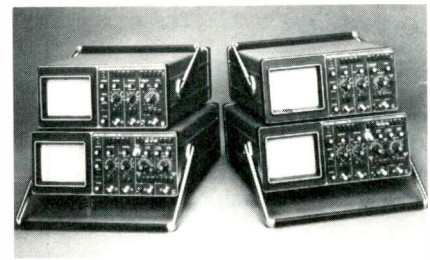
### LCD-display DMM

**Keithley Instruments** has introduced the Model 169, a 5-function, 3½-digit LCD-display DMM. It has a large 0.6-inch display, function and range annunciators, 1-year battery life and is packaged in a bench-sized case. The unit operates on C sized carbon-zinc batteries. Model 169 is available for \$149.

Circle (24) on Reply Card

### General purpose scopes

**Philips** has announced the introduction of two general purpose 35 MHz oscilloscopes with digital and computer applications. The scopes, PM 3216 and PM 3218 have a maximum sweep speed of 10 ns/div and a trigger hold-off facility that eliminates double triggering on digital signals, making it unnecessary to use the timebase in the uncalibrated mode, according to the manufacturer.



Circle (25) on Reply Card

## APPLIANCE REPAIR BOOKS



**Thirteen Handbooks** written in easy-to-understand language by experts in the service field with illustrations and diagrams! Acclaimed by instructors and professionals alike! How to diagnose and repair air conditioners, refrigerators, washers, dryers, ranges, microwave ovens, dishwashers, vacuum cleaners, electrostatic air cleaners, RV gas appliances, hair dryers, motors, water heaters, coffeemakers, can openers, floor polishers, steam irons, food mixers, lawn care appliances, electric knives, electric and digital clocks and many others. Also fundamentals of solid state, setting up a shop, using test instruments and more. Only \$2.65 to \$4.90 ea.

SEND FOR FREE PRICE LIST

Gamit, Dept. ES  
110 W. St. Charles Road,  
Lombard, Illinois 60148

Circle (13) on Reply Card

The 27W iron that lasts and lasts and lasts.

**ISO TIP**

## Industrial 30 Soldering Iron

Get longer element life from the Industrial 30 . . . with a special power-reducing diode that also prolongs tip life. And the element can be replaced in minutes if it ever does wear out.

Iron-coated tip design (1/8" standard) lengthens tip life and reduces the need for filing.

Light, well balanced. Features clip-on hook and "on" indicator lamp. Other tip shapes and safety stand available.

**WAHL CLIPPER CORPORATION**  
Sterling, Illinois • (815) 825-6525  
"Manufacturing Excellence Since 1919"



**Production 50 iron, too.** 50W iron maintains its temperature at any setting between 200°-400°C with ±2% accuracy.

Ask your local supply house.

Circle (9) on Reply Card



NATESA  
5908 S.  
Troy  
Chicago  
IL 60629



### ARE YOU A PRO?

...the not for profit association championing independents' right to compete, and delivering valuable benefits continuously since 1950.

- LEADING SPOKESMAN
- TRADE INFORMATION DISPENSER
- WATCHDOG
- LOBBYIST
- YARDSTICK OF STANDARDS
- CONSUMER RELATIONS
- COUNSELOR
- PROBLEM SOLVER

We are not freeloaders. So our check for \$60.00 dues is attached. As our special premium, please ship the indicated \$15.00 Manual.

- Practical Business Manual  
- OR -  
 Service Contract Manual

IT'S NO PUZZLE  
TO ORDER



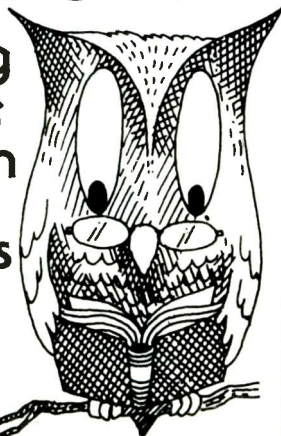
### OELRICH SERVICE FORMS

FOR TV-RADIO & 2-WAY RADIO SERVICE LEGAL FORMS FOR CALIF. FLA. UTAH NOW AT YOUR PARTS JOBBER OR WRITE FOR CATALOG B64  
OELRICH PUBLICATIONS  
4040 N. NASHVILLE AVE. CHICAGO, ILLINOIS 60634

Circle (10) on Reply Card

# WISDOM is...

giving  
to the  
March  
of  
Dimes



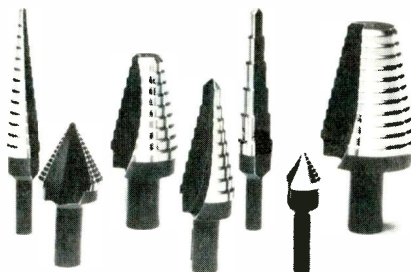
Birth defects  
are forever.  
Unless you help.

THIS SPACE CONTRIBUTED BY THE PUBLISHER

# productreport

### Drill bits

Klein Tools has announced a new line of drill bits. The Klein-Unibits are used for drilling multiple size holes in thin material with a single



bit. The bits are available in seven sizes and will drill holes from 1/8-inch diameter to 1-3/8-inch diameter. Center punching is not required on most sizes.

Circle (26) on Reply Card

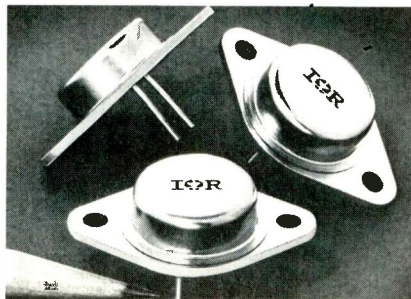
### Music tapes

Music tapes for The TMM-150 in standard broadcast cartridges exceed 10 hours of non-repetitive programs and can be purchased or leased through Telex distributors. Several features make the unit versatile. For remote controlled stop-start, an external switch can be connected. A front panel jack accepts any standard paging microphone with on-off switch. During paging the music is automatically muted. Separate volume controls for music and paging are provided. The TMM-150 fits any size installation, according to the manufacturer.

Circle (27) on Reply Card

### Power transistors

A series of very fast switching NPN power transistors with a peak current rating of 50A and designed for use in power supplies and



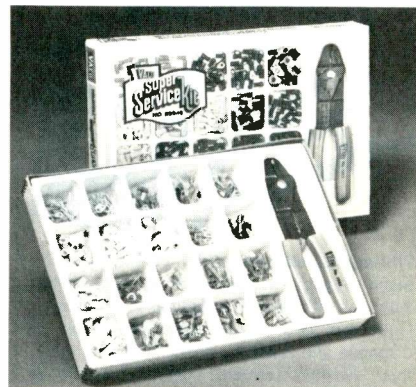
amplifiers has been introduced by International Rectifier. Designated 2N6338 through 2N6341, the devices feature a rise time of 0.3μs, a storage time of 1.0μs and a fall time of 0.26μs at 40A. They have sustaining voltages of 100 to 150V and current ratings of 25A (continuous) and 50A (peak). In quantities of 100 to 999, they are priced at \$3.75 to \$9.75.

Circle (28) on Reply Card

### Milliammeter

Sperry Instruments has developed an improved version of the model SP-250 volt-ohm-milliammeter with temperature ranges. The meter housing has been redesigned using ABS plastics for additional mechanical ruggedness. The housing also has a tapered effect that allows easy use of the meter when it is standing in the upright position. The unit has capabilities up to 1200Vac, 1200Vdc, 600mAdc, four resistance ranges, as well as a temperature indicator that reads from -40F to 1200F. The meter comes ready to use with voltage test leads, battery, fuse, operating instructions and 6-month warranty.

Circle (29) on Reply Card



### Terminal kit

Vaco has announced the introduction of their solderless terminal kit No. 89949. The kit features 18 each of 20 of the most popular insulated terminal styles. In addition, the kit contains the combination crimping tool, which slices six sizes of bolts, strips wire, crimps both insulated and non-insulated terminals and cuts wire.

Circle (30) on Reply Card

# catalogs literature

**ETCO's Electronic Ideas Book** is a 64-page publication with items for hobby, industry and education. Items are in stock and ready for immediate delivery, according to the company.

Circle (31) on Reply Card

**B&K Precision** has a 48-page general line test instrument catalog designated "BK-80." The catalog features a broad range of test instruments.

Circle (32) on Reply Card

**General Electric** offers a free, pocket-size reference booklet for replacing the original manufacturer's part with a GE Color TV HV tripler. The booklet features 21 different types of GE triplers and also includes circuit diagrams and specifications.

Circle (33) on Reply Card

**Antenna Specialists** has a 100-page catalog detailing more than 250 professional land-mobile antennas and accessories. Copies are available to qualified 2-way radio specialists.

Circle (34) on Reply Card

**C. M. Levit Electronics** offers a 6-page tube and price list. More than 2000 types of regular and hard-to-find tubes and transistors are in inventory.

Circle (35) on Reply Card

**A. W. Sperry Instruments** has issued a revised comprehensive full line, short form catalog and price sheet. The catalog, MES-100 Issue D, contains detailed specifications for Snap-Around ammeters, multi-testers, insulation testers, voltage indicators and accessories.

Circle (36) on Reply Card

## Directional RF wattmeters from Dielectric

The new 1000-A Wattmeter from Dielectric accepts plug-in elements that permit RF measurements from

100 mW to 5000 watts full-scale and from 2 MHz to 1 GHz. The large 4½" meter face is easy to read and has ± 5% full scale accuracy and great resolution.

The 1000-A is available in a convenient all-purpose kit that includes a SNIFFER adjustable RF signal sampler, spare UHF connector and patch cable. All contained in a durable carrying case.

### RF Instruments for Professionals

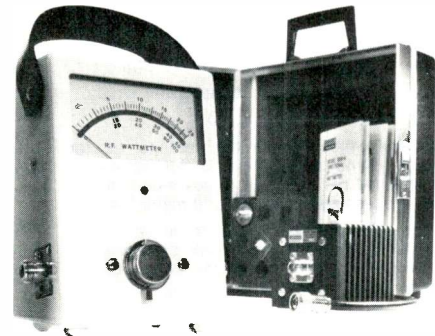
For the name of your local distributor, call Toll Free 800-341-9678.

A limited number of distributor locations are currently available; inquiries welcomed.



**DIELECTRIC COMMUNICATIONS**

A UNIT OF GENERAL SIGNAL  
RAYMOND, MAINE 04071 • TEL. 207-655-4555 • 800-341-9678



Circle (11) on Reply Card

## You Are Not ALONE!



If you think that being in business makes you INDEPENDENT, think again! Consumerists and government agencies are your silent — but greedy — partners; AND THEIR SHARE COMES FIRST, even if you don't make a profit.

**WELL, YOU DON'T HAVE TO  
FACE THEM BY YOURSELF**

**JOIN NESDA  
AND YOUR LOCAL &  
STATE ASSOCIATIONS**

Send for more information to:  
NESDA, 2708 W. Berry St.  
Fort Worth, Texas 76109



## endeco soldering & desoldering equipment

### SOLDERING IRONS

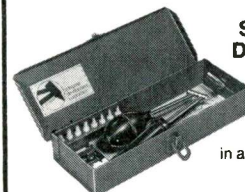
Pencil style. Safety light. Two heats — 20w and 40w. 6 tips. Unbreakable handle. 2 and 3 wire neoprene cords.

### DESOLDERING IRONS

Pencil style. Safety light. Some operate at 40w, idle at 20w. 8 tip sizes. 2 and 3 wire neoprene cords.

### SOLDERING & DESOLDERING KITS

Everything needed to solder or desolder or both. All in a handy lifetime metal box with hasp.



See your distributor or write ...

### Enterprise Development Corp.

5127 E. 65th St. • Indianapolis IN 46220  
PHONE (317) 251-1231

Circle (12) on Reply Card



Advertising rates in the Classified Section are 35 cents per word, each insertion, and must be accompanied by cash to insure publication.

Each initial or abbreviation counts a full word. Minimum classified charge \$3.00.

For ads on which replies are sent to us for forwarding (blind ads), there is an additional charge of \$3.00 per insertion to cover department number, processing of replies, and mailing costs.

Classified columns are not open to advertising of any products regularly produced by manufacturers unless used and no longer owned by the manufacturer or a distributor.

## For Sale

**T.V. SALES & SERVICE SHOP** in central New Jersey. Located on main hwy. 19 years grossed \$110,000.00 1978. Zenith franchised dealer. Unlimited potential. Owner moving. Write in confidence to: Electronic Servicing, P.O. Box 12901, Dept. 521, Overland Park, KS 66219. 6-79-3t

**AM RADIO** reception for interiors of buildings, ships, etc. Catalog. EXTRONIX, 64 Gough, Lyland, PA 18974. 5-79-6t

**REPLACEMENT COLOR YOKES—DEALER ONLY.** Zenith 95-2501-2532-2638-2667-S-89633 etc. \$19.94. Magnavox 361380-1 \$21.95, Sylvania, GE etc. \$17.95 to \$22.95. Request for price list on your letterhead. David Sims Enterprises, Inc., 665 Jericho Turnpike, Huntington Station, N.Y. 11746, (516) 549-3925. 5-79-tf

**TECH BENCH** kit or plans. Designed for the TV/Radio Tech. Test instrument shelf on two power columns with 10 fused outlets. Bench has four fused outlets with C-MOS grounding, four large tool drawers and neon bench lighting. E-Z build construction. Plans and kit information \$1.98 plus 50 cents handling. Technical Workshop, Box 368, Placentia, CA 92670. 5-79-3t

**AUTOMOBILE RADIO** and tape replacement parts: Delco, Chrysler, Philco-Ford, Motorola, Panasonic and many others. Large inventory. Laran Electronics, Inc., 3768 Boston Road, Bronx, NY 10469, (212) 881-9600, out of New York State, (800) 223-8314. 5-79-tf

**TV & RADIO TUBES**, 36 cents EA!! Free color catalog. Cornell, 4221 University, San Diego, California 92104. 8-76-tf

**ELECTRONIC SURPLUS: CLOSEOUTS, LIQUIDATIONS!** Parts, equipment stereo, industrial, educational. Amazing values! Fascinating items unavailable in stores or catalogs anywhere. Unusual FREE catalog. ETCO-011, Box 762, Plattsburgh, N.Y. 12901. 6-78-tf

**COLOR PICTURE TUBE REBUILDING EQUIPMENT.** Semi automatic electronically controlled process. Complete training. Call or write Atoll Television, 6425 W. Irving Park, Chicago, IL 60634. Phone 312-545-6667. 7-79-3t

**HEATH SCHLUMBERGER SG57A** TV Post Marker/Sweep Generator, like new \$150.00, also approx. 300 vintage Sams Photo Fact folders \$50.00. J. Criley, 633 Herman Rd., Butler, PA 16001. 9-79-1t

**TV SALES & SERVICE BUSINESS.** Also, storage rental income in Central N.D. Nice, clean, small town atmosphere. Fossum, Inc., Cooperstown, N.D. Phone 701-797-3221. 8-79-1t

**ELECTRICAL BUSINESS** in small central Nebraska town. TV and radio sales and service and electrical wiring. Will sell inventory and lease or sell brick building. Reason for selling—retiring. Golden Rule Electric, Palmer, NE 68864. 8-79-1t

**TV REPAIR SHOP INVENTORY.** Stock of tubes, panels, parts and service literature. Full line of test equipment, all in excellent condition. Write to P.O. Box 538, Big Timber, MT 59011, 406-932-3344. 8-79-1t

**LIKE NEW** Sound Technology 1700B distortion analyzer with Intermodulation Distortion and Auto Level Set options. Late model with connections for Stereo Test Panel; in factory carton \$2100. Like new Radiometer SMG 1c Stereo RF Generator. More than 55 dB separation at 1khz. \$800. Like new Measurements Corp. Model 940 Intermodulation Analyzer, \$250. Call day or evening, Ray Valdes, 305-557-2317. 8-79-1t

**FLORIDA**—growing TV Business—2,400 sq. ft. bldg., on busy road. W/Living quarters—\$55,000—nego. terms. Owner retiring illness. W/2 vans & large TV stock—optional—\$10,000. Robert Butler Real Estate, P.O. Box 308, Crystal River, Florida 32629. 8-79-1t

**ESTES PARK, COLORADO** Translator TV stations plus TV Sales and Service business. Established with room for growth. Prescott Agency, Box 1935, Estes Park, Colorado. (303) 586-3331. 8-79-1t

**ESTABLISHED** Zenith, Sony, Sanyo Sales and Service. 19 years in business. Good reputation. Full shop with modern equipment. Selling component stereo and auto decks and radios. 3300 sq. feet. Double garage doors in rear. Center of town shopping area. Only Sony TV service in 75 miles. **Good Reputation.** Jones TV, 140 W. Division, Ephrata, WA 98823, 509-754-4082. 8-79-1t

**PICTURE TUBE** rebuilding equipment. Operational 6-position ovens and all associated equipment and supplies. P.O. Box 1913, Springfield, Mass. 01101. 8-79-1t

## Business Opportunity

**MEN/WOMEN FOR FUN!** Shaklee Independent Wholesale Distributors earn \$200-\$5,000 monthly. Bonus, New Car, Etc. Details, Golden, RT2, Box 392ES, Fair Grove, MO 65648 Phone (1-417) 759-2738. 3-79-12t

**WANTED FOR CASH!** We buy scrap electronic parts containing gold, silver, platinum! Immediate top dollar cash offer by return mail. Ship to: American Metals Co., P.O. Box 30009, Dept. ES, St. Andrews Branch, Charleston, SC 29407. 11-78-tf

## Advertising Services

**TERRIFIC SWAP OFFERS NATIONWIDE!** 7 issues \$3.50. "Electronics Trader," Box 73-ES, Folly Beach, SC 29439. 8-79-tf

## Wanted

**NEEDED:** Troubleshooting position in Massachusetts area. Over 2,000 hours training/experience in AM/FM radio, B&W and color TV, audio amps, tape recorders, and VCR's. Will soon be CET level. For more info please write: Kevin Tribute 77B 1613, Box R, Napanoch, N.Y. 12458. 8-79-1t

**TV TECHNICIAN AND DEALERS, "INCREASE YOUR INCOME THOUSANDS OF DOLLARS YEARLY,"** "Rent-Lease-Sell TV's with a guaranteed system." Send stamp for free details, basic plan \$15.00, deluxe version \$25.00, master plan \$40.00...Perry's Rental System, Box 881, Morro Bay, CA 93442. 8-79-3t

## Help Wanted

**CLOSED CIRCUIT TELEVISION TECHNICIAN:** University of Illinois seeking maintenance technician for small format television equipment. Starting \$13,270, raises to \$17,035 over two years, plus annual increases. Two years electronics study, two years electronic maintenance required. Contact: Don Swift, Personnel Services, University of Ill., Champaign, IL 61820, (217) 333-3109. Affirmative Action, Equal Opportunity Employer. 8-79-3t

**TECHNICIANS WANTED:** Television-audio-communications. Excellent fringe benefits, salary depends on experience. Miller's Electronics, Highway 24, Goodland, Kansas 67735, 913-899-2386. 8-79-2t

# advertisers' index

Beckman Industries .....	21
The Cooper Group .....	IBC
Dielectric Communications .....	43
Enterprise Development Corp. ....	43
Fuji Svea .....	40
Gamit Enterprises Inc. ....	41
General Electric Tube Div. ....	19
NATESA .....	42
NESDA .....	43
Oelrich Publications .....	42
PTS Electronics .....	8-9
Sperry Tech .....	3
GTE Sylvania .....	IFC
Ungar .....	17
Wahl Clipper Corp. ....	41
Zenith Radio Corp. ....	9-10, BC

## Electronic Servicing

### Advertising Sales Offices

**NATIONAL SALES MANAGER/CHICAGO**  
Jim Reilly, 1011 E. Touhy Ave., Suite 245  
Des Plaines, IL 60018  
Phone: (312) 299-2601

**KANSAS CITY, MISSOURI**  
Helen Hull, P.O. Box 12901  
Overland Park, KS 66212  
Phone: (913) 888-4664

**NEW YORK, NEW YORK**  
Joe Concert, 4 W. 58th St.  
New York, NY 10019  
Phone: (212) 888-1977

**FT. LAUDERDALE, FLORIDA**  
Brinker and Brinker  
2240 N.E. 53 Street  
Ft. Lauderdale, FL 33308  
Phone: (305) 771-0064

**SAN FRANCISCO, CALIFORNIA**  
John MacKay, 703 Market St., Room 1109  
San Francisco, CA 94103  
Phone: (415) 546-1040

**LONDON, ENGLAND**  
John Ashcraft & Co., 12 Bear St.  
Leicester Square, London, WC2H 7AS  
England, Phone: 930-0525

**AMSTERDAM, HOLLAND**  
John Ashcraft & Co., John J. Lucassen  
Sloterweg 303  
1171 VC-Badhoevedorp, Holland  
Phone: 2968-6226

**TOKYO, JAPAN**  
International Media Representatives, Ltd.  
2-29 Toranomon 1-chome, Minato-ku  
Tokyo 105, Japan  
Phone: 502-0656

# now 3-strong

## Xcelite<sup>®</sup> family of attaché tool cases



TC-150/ST

**And here's the newest addition ... Model TC-150/ST...** containing an intermediate assortment of tools for the technician, serviceman, or field engineer. It contains 53 items in all, including 24 famous Xcelite "Series 99" interchangeable-blade tools, a broad variety of other Xcelite Professional screwdrivers, nutdrivers, pliers, cutters, strippers, measuring tape, and specialized electronic tools, plus a Weller<sup>®</sup> pencil-type, changeable tip Soldering Iron and rosin core solder. Tools are mounted in rugged pockets on removable pallets in a durable, attractive case with Whiskey-tan Marvlon exterior and sun-tan vinyl lining. Plenty of extra space for additional tools, prints and manuals! Solid brass hardware and padded handle are additional quality touches.

**It joins the other members of the family ...** Model TC-100/ST, the "big daddy" of Xcelite's cased tool sets, with the greatest variety—a total of 86 types and sizes of drivers, wrenches, pliers, cutters, strippers...and Model TC-200/ST, the 37-piece set that's unequalled in economy and value.

See the new TC-150/ST at your distributor now. And ask for Xcelite literature, which will give you a detailed listing of the contents of all three Xcelite Attaché Tool Cases.



TC-100/ST



TC-200/ST



**The Cooper Group**  
**Electronics Division**

BOKER<sup>®</sup> • CRESCENT<sup>®</sup> • LUFKIN<sup>®</sup> • NICHOLSON<sup>®</sup> • WELLER<sup>®</sup> • WISS<sup>®</sup> • XCELITE<sup>®</sup>  
P. O. BOX 728, APEX, NORTH CAROLINA 27502, 919/362-7511

Circle (2) on Reply Card



**FOR YOUR OWN  
REPUTATION  
AND IN  
YOUR CUSTOMERS'  
BEST  
INTEREST  
ALWAYS INSIST ON**



**EXACT REPLACEMENT  
PARTS AND ACCESSORIES**

Zenith's Instant Parts Program (ZIP) is the simplest, least expensive Zenith inventory control system ever devised for TV service technicians. Organizes the most needed, most used Zenith TV replacement parts and accessories so they are where you want them, when you want them.

And ZIP keeps these parts organized thru periodic checks by your Zenith distributor

salesman who replaces slow moving stock numbers with new, more popular parts. As a result, your original investment is protected and your supply of Zenith parts remains current.

And you need never again risk your reputation with "will fits."

Call your Zenith distributor now for all the details on the ZIP program that best suits your individual needs.

ZENITH RADIO CORPORATION/SERVICE, PARTS & ACCESSORIES DIVISION  
11000 Seymour Avenue/Franklin Park, Illinois 60131

Circle (3) on Reply Card