

Keep Tabs On Power Use with an In-Line Wattmeter

48784

OCTOBER 1989

Popular Electronics

THE MAGAZINE FOR THE ELECTRONICS ACTIVIST!

COMBINED WITH **Hands-on Electronics**

High-Voltage DC Power Supply

Use it to drive laser tubes, plasma globes, flash tubes, and more

A New Age for Radio

New technology will soon change how you respond to radio, and how radio responds to you!

Shortwave Converter

It's easy to add shortwave reception to any AM radio



A GERNSBACK PUBLICATION

Antenna Measurements for Hams and SWL's

Tune up your antenna for peak performance



Tapped-Coil Crystal Radio

A fun project that really performs, and our step-by-step instructions make building it easy!



\$2.50 U.S.
\$2.95 CANADA

3 NEW
FactCards
IN THIS ISSUE

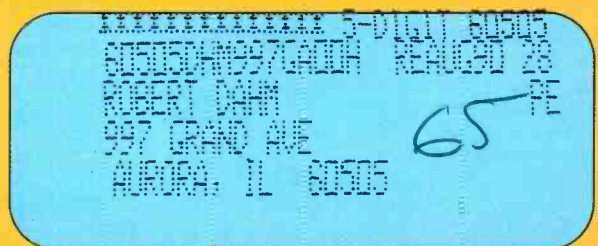

Heath[®] Summer Electronic Celebration.

Make life easier...

Full-featured remote control center for your TV, VCR and CATV. Designed to control units operated via infrared signals. Three AAA batteries included. GDZ-143 (1 lb.).....\$29.95



Recharge your NiCd batteries BP-1234 (4 lbs.).....\$17.95

Amber screen fish finder

MI-2020 (6 lbs.).....\$244.95
Accessories: Transom Mount Transducer MIA-2020-1 (4 lbs.).....\$44.95
Through-Hull Transducer MIA-2020-2 (6 lbs.).....\$99.95



Full color fish finder MI-2040 (10 lbs.).....\$399.00



Save \$20 on portable electronic speller/game player. Words checked against 80,000-word dictionary. SA-103 (1 lb.) Now \$59.95

Save 28% on portable dictionary/thesaurus/speller. LM-2000 (1 lb.) Now \$179.95

Dial up these savings...

Save 28% on Southwestern Bell wall phone. Switchable for tone and pulse (rotary) phone systems. Easy hookup. FC-2505 (3 lbs.) Now 24.99



Full-featured Southwestern Bell memory phone. One-touch dialing of up to 24 numbers and three emergency numbers. Last number redial and hold. Switchable pulse/tone dialing. Styled for desk or wall. BT-1550 (3 lbs.) Now \$49.95

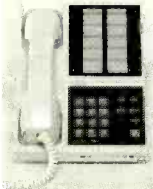

For the electronic hobbyist...

Connector adapter kit. Make 108 different coaxial connector adapters with gold-plated pins and Teflon insulation. Kit contains male and female, N, BNC, UHF, SMA TNC and mini UHF connectors. Special in-between fittings allow you to assemble your own adapters in seconds. HCA-3000 (2 lbs.).....\$69.95



Coax adapter cables. Solves frustrating coax connection problems. Twenty cables let you make almost any connection. 50 ohm impedance. TPI-5000 (5 lbs.)..... Now \$49.95



Smallest auto-ranging DMM made. Fits in shirt pocket. This practically goof-proof, 3 1/2 digit display shows readings up to 999. A handy extra meter that's affordable and accurate. SM-2300-A (1 lb.) \$24.95



Two modular 10X 350 MHz scope probes. Perfect for 50 or 100 MHz Oscilloscope. P-350-2 (1 lb.) \$99.95

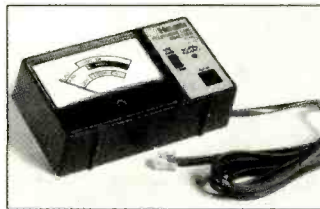

Do-it-yourself telephone line analyzer. Save yourself the cost of expensive service calls by checking your own lines, phones and phone cords. Check out do-it-yourself wiring, too. Phone-line powered; doesn't require batteries or external power. ST-2204 (1 lb.) Now \$19.95



Kit projects...

Heathkit Flood Alarm. detects leaking water pipes or basement wall seepage. Three hours to build. Needs 9V battery. Kit GD-1701 (2 lbs.).....\$12.95



Program your doorbell with a favorite tune. Includes songbook with 50+ college, seasonal, Christmas and special occasion songs. Back door button activates a part-tune. Takes standard 16 VAC, 50/60 Hz bell transformer. Two-evening kit. Kit TD-1089 (3 lbs.).....\$32.95



Noise generator kit. To properly check out any stereo or sound system with a spectrum analyzer, you need a noise source with a nearly constant energy output. One-evening kit. Kit AD-1309 (2lbs.).....\$24.95



Save time and money with breakout box. Access all 25 lines of RS-232C cable linking computer system devices. One-evening kit. Kit PMK-130 (2 lbs.)\$79.95



Power line monitor. Warns you of problem-causing AC line conditions by displaying line voltage at any AC electrical outlet. Accuracy of 1.5%. Kit IM-2203 (3 lbs.)\$39.00



Measure RF voltages. Easy-to-build probe measures RF voltage for DC voltmeters with 10 and 11 megohm input impedances. Kit PK-3-A (1 lb.) Now \$9.95



Save on Scanners...

1. Save \$31 on Uniden 10-channel/10-band handheld scanner. Super portable, programmable, direct channel access, channel lockout, keyboard lock switch prevents accidental reprogramming. Requires 5, AA (not included) or rechargeable NiCd batteries. BC-55X-LT (1lb.)..... Now \$108.88

2. Save \$51 on 100-channel/11-band Uniden handheld scanner. Automatic and manual search, weather search, 10 priority channels, squelch, lockout and delay. Snap on battery pack included. BC-100X-LT (3 lbs.).....\$178.88

3. Save \$30+ on Uniden tabletop scanner. 11 bands of coverage, 5 or 15 channels-per-second scanning speed. Features automatic memory search, backup, priority, programmable lockout, scan speed control and automatic squelch setting. Takes 117 VAC, 60 Hz from an external wall outlet. BC-175X-L (3 lbs.)..... Now \$138.88

4. Save \$61+ on 100 channel/11-band Uniden mobile scanner. Auto search aircraft, police, marine and emergency bands. Programmable. Audio output is 1.5 watts at 10% THD; requires 13.8 VDC (vehicle battery or AC adapter). BC-580X-LT (5lbs.).....\$198.88

5. Save \$81+ on deluxe Uniden 10-channel/12-band mobile scanner. Covers 800 MHz band for full 12-channel coverage. Weather search, priority, squelch, lockout, delay, auto + manual band search. Takes 13.8 VDC. BC-760X-LT (5 lbs.).....\$248.88

Heathkit[®]
to order CALL TOLL FREE
1-800-253-0570
Use order code 217-107



for credit card orders, 24 hours a day. Some items are close outs. All items are available in limited quantities. Prices for some items were previously reduced.

For your free Heathkit catalog call 1-800-44-HEATH.

Popular Electronics®

THE MAGAZINE FOR THE ELECTRONICS ACTIVIST!

CONSTRUCTION ARTICLES

TAPPED-COIL CRYSTAL RADIO	Stanley Czarnik	33
<i>Tune in radio broadcasts the way grandpa did half a century ago</i>		
HIGH-VOLTAGE DC GENERATOR	Vincent Vollono	37
<i>Learn the principals of high-voltage generation</i>		
HIGH-PERFORMANCE SHORTWAVE CONVERTER	Michael A. Covington, N4TMI	42
<i>A car radio and our shortwave converter puts SWL'ing on the road</i>		
IN-LINE AC WATTMETER	Gregory R. McIntire	67
<i>Keep an eye on the power consumption of your major appliances</i>		
BLINKING LICENSE-PLATE HOLDER	Jim Stephens	74
<i>This decorative holder gives your license plate an air of distinction</i>		

FEATURE ARTICLES

A NEW AGE FOR RADIO	Gerry L. Dexter	40
<i>On-the-road information systems are the wave of the future</i>		
SILENCE YOUR COMPUTER'S FAN	Leo Simpson	45
<i>We show you several ways to quiet that noisy computer fan</i>		
ELECTRONIC QUACKERY	Stanley Czarnik	61
<i>The shocking history of electronics and medicine</i>		
ANTENNA MEASUREMENTS FOR HAMS AND SWL'S	Joseph J. Carr	70
<i>Test and tune your antennas like a pro, without using a transmitter</i>		
HOME-FINANCE SOFTWARE	Jeff Holtzman	77
<i>Get your family's finances under control with a little electronic help</i>		
THE DIGITAL ELECTRONICS COURSE	Robert A. Young	80
<i>Logic levels, probes, pulsers, and more</i>		

SPECIAL FEATURE

GIZMO		49
<i>Including: Panasonic EIS Camcorder; Gazelle Systems OPTune Disk Optimizer; Cambridge Soundworks Ensemble Speaker System; and more</i>		

HANDS-ON REPORTS

ELECTRONIC ARTS GRAND-SLAM BRIDGE		64
--	--	----

COLUMNS

THINK TANK	Byron G. Wels	22
ANTIQUÉ RADIO	Marc Ellis	82
<i>Digging deeper into the "Wasp"</i>		
CIRCUIT CIRCUS	Charles D. Rakes	84
<i>Simple test gear and more</i>		
COMPUTER BITS	Jeff Holtzman	86
<i>Backing up is not hard to do</i>		
DX LISTENING	Don Jensen	88
<i>From Timbuktu to Katmandu!</i>		
SCANNER SCENE	Marc Saxon	90
<i>A back-to-basics scanner</i>		
HAM RADIO	Joseph J. Carr	94
<i>Getting on 17 meters</i>		

DEPARTMENTS

EDITORIAL	Julian S. Martin	2
LETTER BOX		4
ELECTRONICS LIBRARY		6
NEW PRODUCTS		14
FACTCARDS		47
FREE INFORMATION CARD		65
ADVERTISER'S INDEX		108

Popular Electronics (ISSN 1042-170X) Published monthly by Gernsback Publications, Inc., 500-B Bi-County Boulevard, Farmingdale, NY 11735. Second-Class postage paid at Farmingdale, NY and at additional mailing offices. One-year, twelve issues, subscription rate U.S. and possessions \$21.95, Canada \$26.95, all other countries \$29.45. Subscription orders payable in U.S. funds only, International Postal Money Order or check drawn on a U.S. bank. U.S. single copy price \$2.50. © 1989 by Gernsback Publications, Inc. All rights reserved. Hands-on Electronics and Gizmo trademarks are registered in U.S. and Canada by Gernsback Publications, Inc. Popular Electronics trademark is registered in U.S. and Canada by Electronics Technology Today, Inc. and is licensed to Gernsback Publications. Printed in U.S.A.

Postmaster: Please send address changes to Popular Electronics, Subscription Dept., P.O. Box 338, Mount Morris, IL 61054-9932.

A stamped self-addressed envelope must accompany all submitted manuscripts and/or artwork or photographs if their return is desired should they be rejected. We disclaim any responsibility for the loss or damage of manuscripts and/or artwork or photographs while in our possession or otherwise.

As a service to readers, Popular Electronics publishes available plans or information relating to newsworthy products, techniques and scientific and technological developments. Because of possible variances in the quality and condition of materials and workmanship used by readers, Popular Electronics disclaims any responsibility for the safe and proper functioning of reader-built projects based upon or from plans or information published in this magazine.



Larry Steckler

*EHF, CET
Editor-In-Chief & Publisher*

Art Kleiman

Editorial Director

Julian S. Martin, KA2GUN

Editor

Carl Laron

Managing Editor

Robert A. Young

Associate Editor

John J. Yacono

Associate Editor

Byron G. Wels, K2AVB

Associate Editor

Teri Scaduto

Assistant Editor

Kathryn Campbell

Editorial Assistant

Joseph J. Carr, K4IPV

Marc Ellis

Jeffrey K. Holtzman

Don Jensen

Charles D. Rakes

Marc Saxon

Contributing Editors

Ruby M. Yee

Production Director

Karen S. Tucker

Production Manager

Robert A. W. Lowndes

Editorial Associate

Marc Spiwak

Editorial Associate

Marcella Amoroso

Production Assistant

Andre Duzant

Art Director

Russell C. Truelson

Technical Illustrator

Injae Lee

Assistant Illustrator

Jacqueline P. Cheeseboro

Circulation Director

Michele Torrillo

P.E. Bookstore

BUSINESS AND EDITORIAL OFFICES

Gernsback Publications, Inc.
500-B Bi-County Blvd.
Farmingdale, NY 11735
1-516-293-3000
Fax: 1-516-293-3115
President: **Larry Steckler**
Vice President: **Cathy Steckler**

Advertising Sales Offices listed on page 108.

Cover photography by
Diversified Photo Services

Composition by
Mates Graphics
and
Magtype

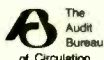

The publisher has no knowledge of any proprietary rights which will be violated by the making or using of any items disclosed in this issue.

THAT'S HOW YOU CAN HELP US

Every working day the mailman delivers buckets of mail to our offices and a good part of that mail is addressed to the Editor. Reader mail is a main stream of information from the subscribers and newsstand buyers of **Popular Electronics**.

Your letters give the editorial staff an insight to the thinking of our readership. You tell us what you like and dislike. You make suggestions and ask questions. You point out discrepancies in articles and add interesting tidbits. What some of you really do best is write the articles that appear in every issue.

Without the reader mail, **Popular Electronics** would lose touch with its readership. That would be the last thing we would want to happen. So we ask you, when you have reason to write to us, please do. If your letter is nothing more than a small praise or criticism, write it down and mail it.

Now, do yourselves and the editors a favor. In each letter make a comment about the best article you read in the current issue. Tell us why you like it. Please keep it short and type it, if possible. Unfortunately, time does not permit us to answer every letter, but by surveying the letters received, the editors will discover what you like best, uncover trends, and enable us to prepare future articles to your liking.

While you are at it, look about your shop area and see if any of your original projects are suitable for publication in **Popular Electronics**. You may be a budding author.

In the publishing business, we want our readers to write. That's how you can help us!

Julian S. Martin, KA2GUN
Editor



Letters

ANOTHER SUPER-WASP SURFACES

The July issue of **Popular Electronics** caught my eye on a newsstand, and as I thumbed through it, Marc Ellis' column on the A.C. Super-Wasp immediately grabbed my attention. I'm now very thankful that my trip that day took me past the newsstand, as I have owned an A.C. Super-Wasp since it was given to me by my uncle. I've always wanted to know more about the radio, but I've never seen anything published on it before.

I was 16 or 17 when I got the radio. Like most kits, it had a home-made walnut cabinet and an external factory power supply. I was a young ham, and if it did not copy good CW I wasn't interested in it. However, I did have the presence of mind to keep it intact, with all of its coils—although the power supply did find its way to driving a 6V6 novice transmitter, which I felt was a much more worthwhile use for it than powering the old Super-Wasp.

Some time later, I started to refinish the old cabinet—but, like most projects, it never really did get completed. I still have the radio and the power supply with all of the plug-in coils. Now, with the inspiration of that "Antique Radio" column, I will attempt to complete the refinishing project and put the radio and power supply back together.

I look forward to the remainder of the articles on the radios and would like to get copies of some of the original documentation if it is available. I plan to build the receiver mentioned in the article and compare it to the original in performance. That should prove to be an interesting project, and now that I'm a bit older, I think there is a better chance that it will be completed.

H.P.
Longwood, FL

MIS-MEASURING INDUCTANCE

I subscribe to **Popular Electronics** and enjoy it immensely. My hobby is electronics and I work in the Q.A. department of a major loudspeaker manufacturer.

I was very pleased at first sight of your article "Measuring Inductance on a Capacitance Meter" in the July issue. However, after a couple of brief tests and some thought, I believe the article and calculations are flawed for some practical applications. I tested two inductors: a small ballast used for a fluo-

rescent-light fixture with a known value (1.6 H), and a factory-marked 45-mH coil for use in a cross-over network. (My meter also operates at approximately 400 Hz on the capacitance scale.) After testing I ended up with calculated values at only about 50–75% of the true ones.

Here's what I believe is happening: In our Q.A. lab, we do extensive testing of iron-core inductors (coils) for use in cross-over networks. (At the relatively high values mentioned in your tests, chances are most readers will be testing iron-core, rather than air core, inductors.) Unfortunately, in the case of iron cores the *value* changes, sometimes substantially, with changes in *current* in the windings. That is why we test all such inductors at exactly 1 ampere for our applications. It is also why our GenRad model 1658 Digi-bridge—a wonderfully accurate digital LCR bridge—is useless for testing iron-core inductors at our current levels. The bridge only passes about 10 mA through the coil during an inductance check, which is totally inadequate for a true reading. I believe that is what is happening during a typical capacitance/multimeter test. (I checked with an ammeter, and only 0.5 mA is being used in my meter when used in the capacitance mode.)

So, are the article and calculations accurate? Yes and no. If you are testing air-core inductors only, there's no problem. With iron cores, it is probably accurate at very low current levels, similar to those used by your meter. But realistically, for a power-supply choke or a crossover network (especially coming out of a high-power amplifier), the calculated values would be a fraction of their true ones.

Please continue with your excellent magazine. I hope I have been of some assistance.

J.M.R.
Canyon County, CA

FREEDOM WITH EXPRESSIONS

While reading the article "Measuring Inductance on a Capacitance Meter" (**Popular Electronics**, July 1989), I discovered an error in the expression for "K." The expression is:

$$K = 10^6 / (2\pi f)^2,$$

which can be reduced to $K = 25330 / f^2$ —not $K = 25530 / f^2$, as written in the article.

Aside from that typo, the article was very informative.

T.H.
Madison, WI

PARTS, TOO

A recent article entitled "The Parts Connection," by Jack Cunkelman provided not only worthwhile, interesting reading, but also a two-page listing of parts distributors. However, there was a significant omission from that listing—the Catalog Division of Arrow Electronics, Inc., the world's second largest electronics-components distributor.

Arrow Catalog is a separate sales division of Arrow that has been specifically created

and designed to provide the extra service required by customers who order components in smaller quantities. The division is an ideal source for those with electronic projects or experiments.

We've taken the liberty to enclose a company profile in the format used by the author of the article. We hope that information can be of assistance to your readers.

Arrow Electronics, Inc.
Catalog Division
1860 Smithtown Ave.
Ronkonkoma, NY 11779

Catalog: 520 pages, free

Telephone Orders/Inquiries: 1/800-93-ARROW

Hours: 8:00 a.m. to 6:30 p.m., Eastern time

Payment: Open account, Visa, Master Card

Minimum Order: \$25

Shipping Methods: UPS, customer can specify priority or overnight delivery

Shipping Charges: Carrier rate

Notes: A complete source, from batteries, wire, cable, and power supplies to capacitors, connectors, switches, relays, and IC's

Robert A. Schiesel
Vice President and General Manager
Arrow Electronics, Catalog Division

INNOVATIVE TINKERING

Using the clear information provided in two recent **Popular Electronics** articles—"Fqx Hole Radio" (March, 1989) and "The Cliff Dweller's SWL Antenna" (May, 1989)—I went whole hog and built a razor-blade radio with a super antenna. I just received a shortwave broadcast from Tokyo, Japan! Through a small amplifier, I taped a little of a conversation between two Japanese people. I am still amazed.

L.P.
Pittsburgh, PA

WITHOUT A TRACE

We have learned that a trace is missing from the PC board for the "Tele Monitor" (**Popular Electronics**, June 1989). To correct for that, add a jumper between the pad for the anode of diode D3 and the adjacent pad for resistor R4.—Editor

IDENTITY CRISIS

Regarding the letter titled "Mistaken Identity" in the July issue of **Popular Electronics**, further checking revealed that the reason the photo of the *Uniden Bearcat 760XLT* that appeared in my column in the March issue was described in the text as a *950XLT* is that those two models are, in fact, one and the same. If you ask Uniden for a photo of the *950XLT*, they send one of the *760XLT*, because the sets are identical in every respect except for the model number. Most likely the different model numbers are used because dealers selling the *950XLT* offer it at \$250, while those selling the *760XLT* sell it for \$329,

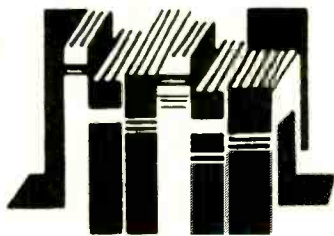

Electronics Library

To obtain additional information on the books and publications covered in this section from the publisher, please circle the item's code number on the Free Information Card

USING QUICKC: Second Edition

by Werner Feibel

This book teaches readers to program in two environments: version 2 of Microsoft QuickC and the compatible Microsoft C compiler. Beginners can follow the book's step-by-step instructions and build upon programming fundamentals to reach an intermediate level of programming skill. Those who are already experienced in C programming will appreciate the information presented on the new features of version 2, and can use the book as a long-term reference.

The book covers topics including simple data types and operators; complex data types such as arrays, strings, structures, and unions; file handling and memory management; the pre-processor; C's control structures; and graphics. Sample programs are included to help readers develop a better understanding of important concepts; readers are also encouraged to solve application problems by writing their own programs.

Using QuickC: Second Edition is available for \$21.95 from Osborne McGraw-Hill, 2600 Tenth Street, Berkeley, CA 94710.

CIRCLE 93 ON FREE INFORMATION CARD

MANAGING TECHNOLOGY: The Strategic View

by Lowell W. Steele

To be successful in today's competitive business environment, managers need a comprehensive strategy for nurturing and controlling technology. This book explains how to encourage technological innovation for overall growth, while using existing technology more productively. Solid advice and helpful insights are interspersed with vivid case histories drawn from the author's 29-year career at General Electric.

Managers and technical personnel who want to gain—and keep—the competitive

edge will appreciate the discussions on how technology can be used to achieve a company's strategic objectives. The book explains how to integrate business functions such as marketing or manufacturing with the major components of technology. It also examines methods for reducing the time and effort needed in developmental programs, for realistic risk appraisal, and for making a company's operational conventions and strategic goals mesh. Guidelines are included for selling technology to managers who lack technical know-how, and for evaluating a technical operation's performance.

Managing Technology: A Strategic View is available in hardcover for \$39.95 from McGraw-Hill Book Company, 11 West 19th Street, New York, NY 10011; Tel. 1-800-2-MCGRAW.

CIRCLE 96 ON FREE INFORMATION CARD

THE PACKET RADIO HANDBOOK: 2nd Edition

by Jonathan L. Mayo, KR2T

Since the first edition of this book appeared a couple of years ago, packet radio has changed in two significant ways: It has grown from a new and relatively unknown communication mode to one operated by over 35,000 packet-radio stations in North America alone. And packet-radio technology has kept pace, with multimode digital controllers, high-speed modems, and advanced networking systems. This second edition has been updated to include all those

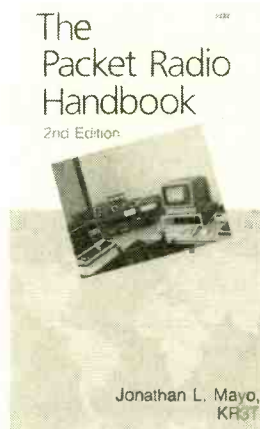

advances—which seasoned operators should appreciate—and presents a thorough understanding of packet-radio basics for beginners.

The book offers a complete course on packet radio, covering everything from the history of its development to SAREX (Shuttle Amateur Radio EXperiment)—placing a packet-radio station on the Space Shuttle.

It explains how to set up an amateur station, describes the hardware needed, details networking and protocols, examines packet-radio equipment and accessories, and presents a look at what the future holds in store. Several indexes and a glossary are included for reference.

The Packet Radio Handbook: 2nd Edition is available for \$15.95 from Tab Books Inc., Blue Ridge Summit, PA 17294-0850; Tel. 1-800-233-1128.

CIRCLE 98 ON FREE INFORMATION CARD

DATA COMMUNICATIONS: A Comprehensive Approach, Edition II

by Gilbert Held and Ray Sarch

The fully revised and extensively updated second edition of this book features authoritative information on the principles, functions, and scope of data communications in today's world. Aimed at readers with a data-processing or computer background who are new to the field of data communications, the second edition presents materials to provide an in-depth understanding



of the underlying principles of this rapidly expanding discipline, which the book describes as "the means of tying together coherently all local and far-flung computerized devices."

The book provides in-depth coverage of both the conceptual foundation and the essential technology involved, including components, network design and configurations, transmission media, protocols, topologies, architectures, and future technology. Technical, regulatory, and historical aspects and public- and private-network strategies are also discussed. The second edition features new material on T1 multiplexing, local-area networks, fiber optics, intelligent modems, and ISDN. Many technical illustrations and review questions are provided as learning aids.

Data Communications: A Comprehensive Approach, Edition II is available in hardcover for \$44.95 from McGraw-Hill Book Company, 11 West 19th Street, New York, NY 10011; Tel. 1-800-2-MCGRAW.

CIRCLE 96 ON FREE INFORMATION CARD

UPGRADING AND REPAIRING PCs

by Scott Mueller

Much more than a repair manual, this book contains a wealth of information about IBM PC's, Personal System/2's, and compatibles. It provides an extensive overview of each system, and outlines the differences between models and the many configuration options available. The peripheral and add-on market is also examined, as is the software market. The guide to personal-computer repair, maintenance, troubleshooting, and upgrading contains all the information PC users need to get the most from their systems.

This book is aimed at PC users who want a thorough understanding of how personal computers work, and who aren't afraid to take the cover off and poke around the "guts" of their systems. The book teaches the skills needed to do so safely and constructively.

After a discussion of the development of IBM PC's and the different types of systems available, there are detailed descriptions of the IBM PC, PS/2, and compatible models, including technical specifications—particularly helpful when making purchasing decisions. Proper teardown, disassembly, and inspection procedures are explained, and disk drives and peripherals are examined in depth.

The book shows how to identify and fix common system problems, how to execute hardware and software diagnostics, and how to perform essential preventative maintenance. But the main focus is on upgrading—including how to add floppy drives to a system, how to upgrade storage capacity with a new hard-disk drive, how to increase a system's speed and memory, how to handle the high-powered new software, and how to convert from one system to another.

Upgrading and Repairing PCs is available for \$24.95 from Que Corporation, 11711 N. College Ave., Carmel, IN 46032.

CIRCLE 94 ON FREE INFORMATION CARD

USING PFS: FIRST PUBLISHER

by Katherine Murray

This book is an easy-to-follow guide to PFS: First Publisher, the affordable desktop-publishing program from Software Publishing Corporation. It shows readers how to design and produce a wide variety of high-quality documents, including newsletters, brochures, fliers, and reports. Using a step-by-step approach, the book starts at square one, explaining how to get up and running with First Publisher, and how to enter and edit text. It goes on to present the essential design techniques needed to create effective documents, then offers details on how

to create and manipulate graphics, how to combine text and graphics, and how to construct templates. Finally, it teaches readers how to master the program's advanced features.

Convenient appendixes offer additional design tips, as well as advice on turning your publication into a finished product—including dealing with printers, and selecting paper and inks. For readers who are currently using DeskMate, there is a section on First Publisher's DeskMate version.

Using PFS: First Publisher is available for \$22.95 from Que Corporation, 11711 N. College Ave., Carmel, IN 46032; Tel. 1-800-428-5331, ext. 899.

CIRCLE 94 ON FREE INFORMATION CARD

CB Thoroughbreds with winning credentials.

the  **Black Stallions™**



Model M-900
Trunk Mount

Sleek and spirited, the new A/S Black Stallion™ CB antennas have an unfair advantage over all other brands—the long, proud heritage of the most respected name in professional communication antennas. With the finest 17-7PH stainless steel whips, high-tech protective black DURA-COAT™ finish, and contemporary styling, these exceptional antennas have no peers for strength and beauty.

Now's the time to catch a Black Stallion for yourself. Send for your free 16-page "CB/Monitor Antennas" booklet today.



Model M-902
Trunk Mount



Model M-904
Magnet Mount



Model M-906
On-Glass®

the antenna specialists co.

A member of The Allen Group Inc.

30500 Bruce Industrial Parkway • Cleveland, OH 44139-3996 • 216/349-8400

© 1988 by The Antenna Specialists Co.



CIRCLE 19 ON FREE INFORMATION CARD

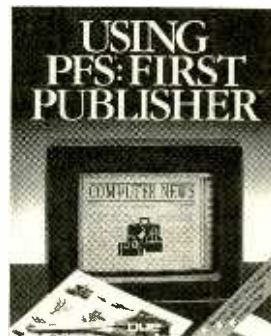

THE CET EXAM BOOK, 2nd Edition

by Ron Crow and Dick Glass

THE CET STUDY GUIDE, 2nd Edition

by Sam Wilson

Written by the people who make up the certification exams for the International Society of Certified Electronics Technicians (ISCET) and the Electronics Technicians Association (ETA), the newly revised and updated books are excellent study tools for the Associate and Journeyman-Consumer Electronics exams. They include all the latest information on satellite communications and troubleshooting and repairing microcomputers, VCR's, stereo equipment, and other consumer-electronic products. Tab Books is offering a special discount to those who purchase the two books at the same time.

The CET Exam Book is a detailed study guide for the Associate-level exam, which is for students and technicians with less than four years of electronics experience and is a prerequisite for taking the Journeyman exam. The book provides extensive information on the test itself, and presents sample questions and answers with full explanations of all the principles involved. It shows you how to examine your test

(Continued on page 12)

Take any 3 books for \$3⁹⁵ (values up to \$165.85)

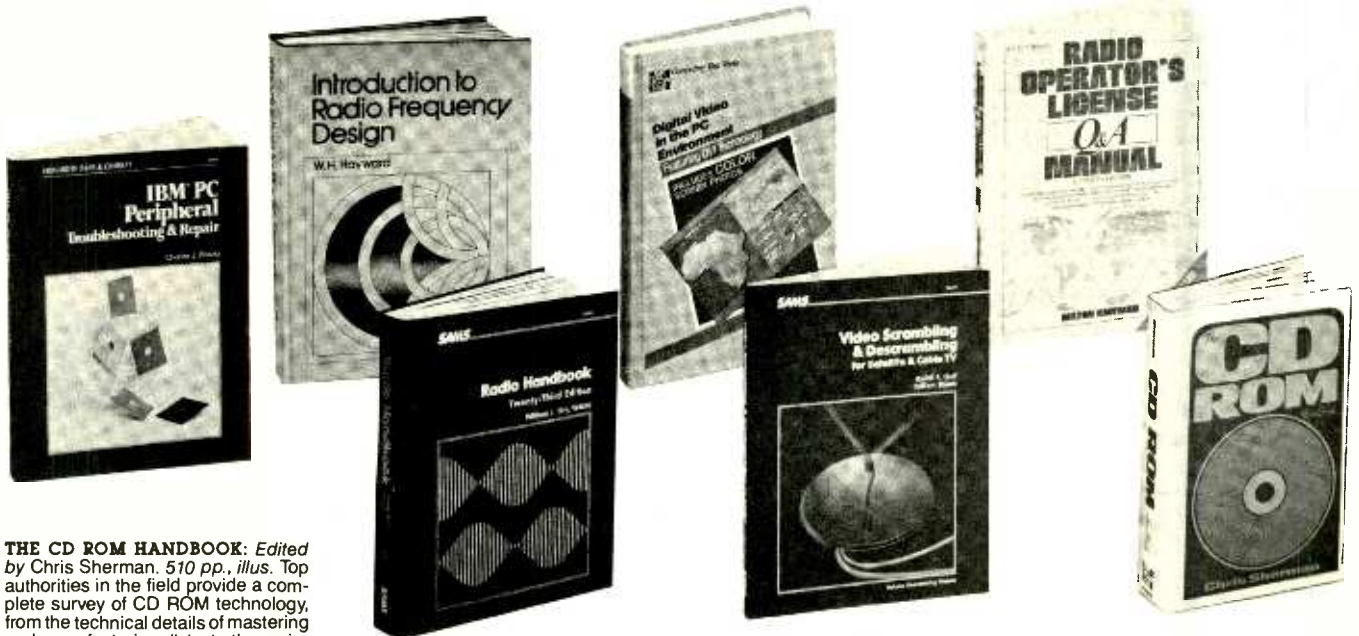

THE CD ROM HANDBOOK: Edited by Chris Sherman. 510 pp., illus. Top authorities in the field provide a complete survey of CD ROM technology, from the technical details of mastering and manufacturing disks to the major applications, error detection and correction, and data conversion.
565/783 Pub. Pr., \$59.95

DIGITAL VIDEO IN THE PC ENVIRONMENT: Featuring DVI Technology. By Arch C. Luther. 330 pp., illus. Discover full explanations of video, audio, and optical storage media and how to combine them to create versatile, user friendly information systems with vast storage capacity in this useful guide.
391/769 Pub. Pr., \$39.95

RADIO HANDBOOK, 23/e. Edited by William I. Orr. 667 pp., 1,073 illus. and tables 7½ x 10 format. Expert contributors show you how to select, design, build, test, and operate all kinds of equipment, including mobile, marine, receiving, and electronics test equipment in this update of the classic Handbook.
584638-1 Pub. Pr., \$29.95

EMERGENCY/STANDBY POWER SYSTEMS. By Alexander Kusko. 288 pp., 116 illus. From specifications to performance data, here's everything you need to know to evaluate the need for emergency power, and prepare to meet it. Comprehensive help from equipment choices to codes and standards.
356/890 Pub. Pr., \$34.50

AMATEUR RADIO: Theory and Practice. By R. L. Shrader. 340 pp., illus. Here's a complete beginner's guide—requiring no previous background in radio or electronics—that will give you the basic theory necessary to pass any and all of the FCC Amateur Radio License exams.
571/465 Pub. Pr., \$28.95

REGULATED POWER SUPPLIES, 3/e. By I. M. Gottlieb. 423 pp., illus. This practical book provides you with everything you need to know to design and use modern regulated supplies, including regulation techniques and detailed discussions of actual circuitry.
585136-9 Pub. Pr., \$19.95

when you join the PRACTICAL ELECTRONICS BOOK CLUB

- Your one source for electronics books from dozens of different publishers
- the latest and most useful information
- discounts of up to 40% off publishers' list prices

UNDERSTANDING SECURITY ELECTRONICS. By J. E. Cunningham. Revised by J. J. Carter. 292 pp., illus. The basic principles of electronic security systems, their application, and the pros and cons of every type of system are all covered in this easy-to-understand guide.
585119-9 Pub. Pr., \$15.95

IBM PC PERIPHERAL TROUBLESHOOTING AND REPAIR. By C. J. Brooks. 272 pp., illus. Here's a complete guide to diagnosing and isolating hardware failures for disk drives, video-display monitors, keyboards, modems, printers. Provides step by step, device specific troubleshooting routines, diagrams, and flowcharts.
585098-2 Pub. Pr., \$19.95

RADIO OPERATOR'S LICENSE Q & A MANUAL, 11/e. By M. Kaufman. 553 pp., illus. This classic study guide has everything you need to pass the new FCC General Radiotelephone Operator License exams—including the most recent FCC-type sample tests and all 1986 changes to the FCC exam.
585100-8 Pub. Pr., \$19.95

OPTOELECTRONICS: A Text-Lab Manual. By M. Tischler. 213 pp., illus. These 32 clearly defined experiments teach you how to use optical electronic devices and circuits in electric power generation, data transmission, and telecommunications. Each experiment requires only standard components.
647/860 Pub. Pr., \$19.95

EXPERIMENTS IN AMPLIFIERS, FILTERS, OSCILLATORS, AND GENERATORS. By M. Tischler. 170 pp., illus. The use and application of linear integrated circuits are clearly demonstrated by these 35 experiments requiring only standard commercial and industrial grade parts.
647/801 Pub. Pr., \$22.95

CABLE TELEVISION TECHNOLOGY. By K. T. Deschler. 262 pp., illus. This timely book covers all aspects of cable television operation, from the traditional "lineman" topics to satellite antennas and fiber optic links. Also includes guides to coaxial cable testing, CATV terms, and graphic symbols.
273/782 Pub. Pr., \$18.95

VIDEO SCRAMBLING AND DE-SCRAMBLING FOR SATELLITE AND CABLE TV. By R. F. Graf and W. Sheets. 246 pp., illus. From the theory and techniques of video encryption and decryption, to an overview of government rules and regulations, all the information you need is here in one convenient place.
585107-0 Pub. Pr., \$19.95

RF CIRCUIT DESIGN. By C. Bowick. 176 pp., illus. Experienced rf circuit designers looking for a practical approach to the design of rf amplifiers, impedance matching networks, and filters will find that this lavishly illustrated guide fits the bill.
585118-0 Pub. Pr., \$22.95

SEMICONDUCTOR DEVICES. By M. Zambuto. 402 pp., illus. Here's a well-organized and up-to-date explanation of the physical mechanisms of modern semiconductor devices. The coverage is intuitive, minimizing the use of quantum physics.
727/007 Pub. Pr., \$47.95

BASIC TELEVISION AND VIDEO SYSTEMS, 5/e. By B. Grob. 464 pp., illus. Emphasizing the principles of operation and servicing, this fully illustrated, thorough book covers all the basics, from cameras, picture tubes, and video signals to FM sound signals, cable television, and fiber optics.
249/334 Pub. Pr., \$35.95

PROGRAMMABLE LOGIC CONTROLLERS. By F. D. Petruzella. 205 pp., illus. This first look at Programmable Logic Controllers focuses on their principles and offers practical information on installation, programming, and maintenance. Features wiring diagrams, data manipulation and math instructions, and troubleshooting techniques.
496/870 Pub. Pr., \$28.50



PRINCIPLES OF ACOUSTIC DEVICES. By V. M. Ristic.
583248-8 Pub. Pr., \$46.95

750 PRACTICAL ELECTRONIC CIRCUITS. Edited by R. S. Phelps.
582842-1 Pub. Pr., \$24.95

ATE: AUTOMATIC TEST EQUIPMENT. By A. C. Stover.
617/929 Pub. Pr., \$44.95

Bob Middleton's HANDBOOK OF ELECTRONIC TIME-SAVERS AND SHORTCUTS. By R. G. Middleton
583865-6 Pub. Pr., \$29.95

MICROELECTRONICS, 2/e. By J. Millman and A. Grabel.
423/30X Pub. Pr., \$51.95

A HANDBOOK FOR INVENTORS: How to Protect, Patent, Finance, Develop, Manufacture, and Market Your Ideas. By C. D. MacCracken.
582811-1 Pub. Pr., \$18.95

MICROPHONE MANUAL: Design and Application. By D. M. Huber.
584660-8 Pub. Pr., \$29.95

ELECTRONIC SPEECH RECOGNITION: Techniques, Technology, and Applications. Edited by G. Bristow.
079/137 Pub. Pr., \$53.95

TROUBLESHOOTING AND REPAIRING SATELLITE TV SYSTEMS. by R. Maddox.
583703-X Pub. Pr., \$26.95

John D. Lenk's TROUBLESHOOTING AND REPAIR OF AUDIO EQUIPMENT. By J. D. Lenk.
583895-8 Pub. Pr., \$21.95

THE SATELLITE TV HANDBOOK. By A. T. Easton.
585121-0 Pub. Pr., \$16.95

COMPLETE GUIDE TO VHS CAMCORDER TROUBLESHOOTING AND REPAIR. By J. D. Lenk.
585166-0 Pub. Pr., \$41.00

COMPLETE HANDBOOK OF ELECTRIC MOTOR CONTROLS. By J. E. Traister.
584542-3 Pub. Pr., \$33.00

THE ILLUSTRATED DICTIONARY OF ELECTRONICS. By R. P. Turner and S. Giblisco.
584808-2 Pub. Pr., \$23.95

ADVANCED DIGITAL TROUBLESHOOTING. By A. J. Evans.
584763-9 Pub. Pr., \$19.95

ELECTRICAL SYSTEMS FOR COMPUTER INSTALLATIONS. Edited by R. J. Lawrie.
367/299 Pub. Pr., \$34.50

UNDERSTANDING FIBER OPTICS. By J. Hecht.
583896-6 Pub. Pr., \$17.95

INTRODUCTION TO RADIO FREQUENCY DESIGN. By W. H. Hayward.
582748-4 Pub. Pr., \$39.00

BATTERIES AND ENERGY SYSTEMS, 2/e. By C. L. Mantell.
400/318 Pub. Pr., \$48.50

DIGITAL FILTERS: Theory and Application. By N. K. Bose.
584509-1 Pub. Pr., \$44.95

HOW TO MEASURE ANYTHING WITH ELECTRONIC INSTRUMENTS. By J. A. Kuecken.
584537-7 Pub. Pr., \$19.95

MASTERING ELECTRONICS, 2/e. By J. Watson.
684/804 Pub. Pr., \$24.95

ADAPTIVE ANTENNAS: Concepts and Performance. By R. T. Compton, Jr.
584767-1 Pub. Pr., \$50.00

Any 3 books for \$3.95 if you join now and agree to purchase two more books—at handsome discounts—during your first year of membership.

CIARCIA'S CIRCUIT CELLAR, VOL. V By S. Ciarcia.
109/627 Pub. Pr., \$21.95

ELECTRONIC CIRCUITS COOKBOOK. By H. L. Helms.
584640-3 Pub. Pr., \$28.00

COMPLETE GUIDE TO TELEPHONE EQUIPMENT TROUBLESHOOTING AND REPAIR. By J. D. Lenk.
583851-6 Pub. Pr., \$35.00

CALCULUS FOR ELECTRONICS, 4/e. By A. E. Richmond and G. W. Hecht.
532/55X Pub. Pr., \$34.95

OPERATIONAL AMPLIFIERS AND LINEAR INTEGRATED CIRCUITS: Theory and Applications. By D. J. Dailey.
399/31X Pub. Pr., \$34.95

IBM PC TROUBLESHOOTING AND REPAIR GUIDE. By R. C. Brenner.
585123-7 Pub. Pr., \$19.95

CMOS COOKBOOK, 2/e. By D. Lancaster as rev. by H. M. Berlin.
584591-1 Pub. Pr., \$18.95

FEEDBACK AMPLIFIER PRINCIPLES. By S. Rosenstark.
539/146 Pub. Pr., \$35.95

More Books to Choose from

ELECTRICAL AND ELECTRONIC DRAWING, 5/e. By C. J. Baer and J. R. Ottaway.
030/286 Pub. Pr., \$39.50

INTEGRATED CIRCUITS FOR COMPUTERS: Principles and Applications. By W. L. Schweber.
536/244 Pub. Pr., \$28.95

PASCAL FOR ELECTRONICS. By E. J. Pasahow.
487/243 Pub. Pr., \$17.95

TURBO PASCAL FOR ELECTRONICS. By E. J. Pasahow.
487/324 Pub. Pr., \$14.95

UNDERSTANDING IC OPERATIONAL AMPLIFIERS, 3/e. By R. Melen and H. Garland.
585120-2 Pub. Pr., \$12.95

MICROCOMPUTER TROUBLESHOOTING AND REPAIR. By J. G. Stephenson and B. Cahill.
585106-7 Pub. Pr., \$24.95

LENK'S TROUBLESHOOTING AND REPAIR OF MICROPROCESSOR-BASED EQUIPMENT. By J. D. Lenk.
585122-9 Pub. Pr., \$21.95

EASY-UP ANTENNAS FOR RADIO LISTENERS AND HAMS. By E. M. Noll.
585108-3 Pub. Pr., \$16.95

COMPACT DISC TROUBLESHOOTING AND REPAIR. By N. Heller and T. Bentz.
585099-0 Pub. Pr., \$19.95

INTRODUCTION TO TELEVISION SERVICING. By W. C. Brandenburg.
071/766 Pub. Pr., \$26.96

UNDERSTANDING AUTOMOTIVE ELECTRONICS, 3/e. By W. B. Ribbens.
584761-2 Pub. Pr., \$17.95

Here's how the Practical Electronics Book Club works to serve you:

- **Practical information . . . we make it easy to get!** For reliable hands-on information, turn to the Practical Electronics Book Club. Every 3 or 4 weeks (12-15 times a year) members receive the Club Bulletin offering more than 30 books—the best, newest, most important books from all publishers.
- **Dependable service . . . we're here to help!** Whether you want information about a book or have a question about your membership, just call us toll-free or drop us a line. To get only the books you want, make your choice on the Reply Card, and return it by the date specified. If you want the Main Selection, do nothing—it will be sent to you automatically. (A small shipping and handling charge is added to each shipment.)
- **Club convenience . . . we do the work!** You get a wide choice of books that

- simply cannot be matched by any bookstore. And all your books are conveniently delivered right to your door. You also get 10 full days to decide whether you want the Main Selection. (If the Club Bulletin ever comes late and you receive a Main Selection you don't want, return it for credit at our expense.)
- **Substantial savings . . . and a bonus program too!** You enjoy substantial discounts—up to 40%!—on every book you buy. Plus, you're automatically eligible for our Bonus Book Plan which allows you extra savings on a wide selection of books.
- **Easy membership terms . . . it's worthwhile to belong!** Your only obligation is to purchase 2 more books—at handsome discounts—during the next 12 months, after which you enjoy the benefits of membership with no further obligation. You or the Club may cancel membership anytime thereafter.

Fill out the card and mail today! If the card is missing, write to:
PRACTICAL ELECTRONICS BOOK CLUB
 11 West 19th Street—Dept. PRD, 4th Floor, New York, NY 10011.

D10000

Electronics Library

(Continued from page 7)

scores to determine in which areas you need more work. The book contains information on practical mathematics, capacitance and inductance, oscillators and demodulators, meters, dependency logic notation, microprocessors, electronics troubleshooting, and more.

The *CET Study Guide* also covers the Associate-level test, before presenting the information needed to help you pass the Journeyman exam. It includes basic theory

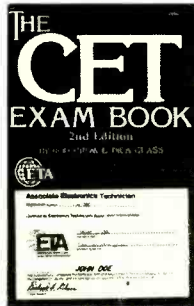

and practical workbench techniques that deal with television, radio, VCR, stereo, microcomputer, and other consumer-electronics equipment, along with up-to-date information on digital electronics. The study guide includes a comprehensive review of all the topics covered on the exams, including two-terminal components, three-terminal amplifying components and basic circuits, antennas, transmission lines, linear circuits in consumer products, and more. Two 75-question exams, containing questions similar to those on the actual tests, are provided, including answers and test-taking tips.

The CET Exam Book, 2nd Edition and The CET Study Guide, 2nd Edition are available in hardcover for \$33.90 (plus postage and handling) for both books, or \$21.95 each if ordered separately. Paperback versions are also available for \$13.95 and \$14.95, respectively. For more information, contact Tab Books Inc., Blue Ridge Summit, PA 17294-0850; Tel. 1-800-233-1128.

CIRCLE 98 ON FREE INFORMATION CARD

TANTALUM CAPACITORS CATALOG

from Sprague Electric Company

For applications where high reliability and long service life are especially important, tantalum electrolytics have become the preferred choice. Sprague manufactures three types—foil, wet-electrolyte, and solid-electrolyte—and those are described in the *Tantalum Capacitors Catalog #TA-100*. Within those three categories, the 220-

page book presents 27 different capacitor types and 27 MIL styles covered by MIL-C-39003 and MIL-C-39006.

The catalog is designed to be informative and easy to use. Text and illustrations provide an introduction to tantalum capacitors—how they're made, and what they're used for. Each category includes a photograph, a detailed description, and package-outline drawings along with the listings of specific part numbers and ratings. The devices are cross-referenced in tables by type number, and the book contains parameter-comparison charts and comprehensive indexes.

Tantalum Capacitors (#TA-100) is available at no charge from Sprague distributors or directly from Sprague Electric Company, P.O. Box 9102, Mansfield, MA 02048.

CIRCLE 91 ON FREE INFORMATION CARD

THE 8088 PROJECT BOOK

by Robert Grossblatt

The availability of reasonably priced microprocessors opened new horizons for the hobbyist designer, who was no longer relegated to the simplest basic projects. With microprocessors, the hobbyist could design projects using the same techniques as professional design teams—once he learned how to make those devices work. Designing with microprocessors involves writing software, programming a CPU, and requires learning new ways of thinking and a new numbering system.

Now, From the author of the popular "Drawing Board" column in *Radio-Electronics* comes a hands-on course in microprocessor-

THE 8088 Project Book

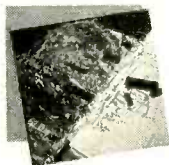

Robert Grossblatt

based design. The book is designed to show hobbyists who have some basic knowledge of digital-circuit design, programming, and electronics how to get started in microprocessor design. In his easy-going style, Bob Grossblatt blends expertise with humor as he de-mystifies this complex subject. He leads his readers step-by-step through the design and construction of an 8088 controller and 17 hardware and software enhancements. While the book is written around

an 8088, the information it presents is applicable to just about any microprocessor on the market. And by the end of the book, readers should be able to apply what they've learned to design and build their own microprocessor-based projects.

The book includes information on 8088 architecture, pinouts, and instructions; hardware designing; adding input/output (I/O); using dynamic memory; turning the system into a "smart" terminal; using buffers for protection; and powering the system with batteries. The book also describes how to troubleshoot each component. A section is devoted to applications for the controller, including a home-security system, an appliance controller, a remote control, a timer, and an ASCII keyboard-character display.

The 8088 Project Book is available for \$18.95 from Tab Books Inc., Blue Ridge Summit, PA 17294-0850; Tel. 1-800-233-1128.

CIRCLE 98 ON FREE INFORMATION CARD

QuickBASIC MADE EASY: Version 4.5

by Wendon Wiegand and Dean Brown

Written for novice programmers (and those who just want to learn QuickBASIC quickly), this book provides a step-by-step introduction to reading and writing programs with that full-featured BASIC compiler. QuickBASIC combines full editing and debugging capabilities with an on-line hypertext-based help system. The book explains how to get the program up and running, how to work with QuickBASIC menus, and how to start programming. Useful and fun programming examples are given, and new concepts are introduced in the framework of programs that even beginners can execute.

Once the fundamentals have been mastered, readers are shown the full magnitude of QuickBASIC's sophisticated programming structures, and its editing and debugging features. The book explains how to use QuickBASIC's control structures to make programs that are more efficient and easily understood. Preprogrammed functions and arrays are also examined. The book concludes with a discussion of modular programming, in which modules that can be used in several different programs are created. A disk containing all the programs and data files discussed in the book, and some variations as well, is available separately.

QuickBASIC Made Easy is available for \$19.95 (the disk costs \$6.00 for 5 1/4-inch or \$7.00 for the 3 1/2-inch size) from Osborne McGraw-Hill, 2600 Tenth Street, Berkeley, CA 94710.

CIRCLE 93 ON FREE INFORMATION CARD

ILLUSTRATED OS/2

by J. Emmett Beam

Like any new software designed to make the computer operator's life easier, until a thorough understanding of OS/2's ins and outs is reached, everything might seem even more complicated. This guide makes an easy task of learning the new OS/2 operating system by presenting information in individual learning modules, and including a "Recommended Learning Sequence" that leads the reader from simple to complex concepts. It provides hundreds of examples, practice exercises, and hands-on training activities, as well as alphabetized commands for easy reference.



The book shows readers how to take advantage of OS/2's multitasking capabilities, interprocess communications, and increased speed and memory. It includes in-depth information on Assembler, Linker, and Codeview debugger utilities for programmers; practical tips on using Presentation and Session Manager interfaces; and techniques for running MS/PC-DOS within the OS/2 environment.

Illustrated OS/2 is available for \$19.95 from Wordware Publishing Inc., 1506 Capital Avenue, Plano, TX 75074.

CIRCLE 90 ON FREE INFORMATION CARD

MARINE RADIOTELEGRAPH OPERATOR LICENSE HANDBOOK: (Limited Reprint Edition)

by Edward M. Noll

To operate or maintain a marine radiotelegraph station, you must hold a valid radiotelegraph license of the proper class for that station. To obtain that license, you must pass an FCC examination that includes several written problems as well as the code test itself. The book (a limited reprint of Ed Noll's original book, now out-of-print)

is intended as a guide to help you prepare to take the written exam.

Its opening chapters provide the general background needed to answer the test's technical questions. The following chapters, which are based on the FCC *Study Guide and Reference Material for Commercial Radio Operator Examinations*, comprise the main part of the study guide. They contain hundreds of sample questions, similar to those that appear on the actual test. The correct answers are included, along with explanations when needed. Grouped according to specific subject areas, the questions cover all the information necessary for the radiotelegraph-license written test. A separate chapter is included for those who intend to take the additional exam for a radar endorsement.

Six appendixes are also included. They contain extracts from radio laws and treaties, and from the FCC Rules and Regulations as well.

The Marine Radiotelegraph Operator License Handbook is available for \$50.00 (postage and handling will be added on C.O.D. orders) from WPT Publishing, 979 Young Street, Woodburn, OR 97071; Tel. 503-981-5159.

CIRCLE 89 ON FREE INFORMATION CARD



EMINENCE



MOTOROLA

Polydax



PIONEER

1-800-338-0531

18" EMINENCE WOOFER

MADE IN USA

100 oz magnet, 3" voice coil. 250 watts RMS, 350 watts max. 8 ohm, 30 Hz resonant frequency. 22-2700 Hz response. Efficiency: 95 dB 1W/1M. Paper cone, treated accordian surround. Net weight: 29 lbs.



#290-200 \$98.90 (1-3) \$89.50 (4-up)

3-WAY 100W CROSSOVER

12 dB/octave rolloff. 800Hz, 5000Hz crossover points. 8 ohm. 100 watts RMS.



#260-210 \$12.50 (1-9) \$9.95 (10-up)

SPEAKER CONTROL PANEL

Panel with 50 watt L-pads for tweeter and midrange and built-in LED power meter. 5" x 2 1/2" 100 watt version available.



#260-235 \$14.50 (1-5) \$12.90 (6-up)

WALNUT SPEAKER CABINET KIT

Super quality, genuine walnut veneer cabinet. Kit includes: routed and mitred top, sides, and bottom in unfinished 3/4" walnut veneer. Cut your own custom holes in the front and rear to match your drivers. 15" x 24" x 11". Volume: 1.9 cubic feet.



#260-350 \$22.50 (1-3) \$19.95 (4-up)

12" SUB WOOFER

Dual voice coil sub woofer. 30 oz magnet, 2" voice coils. 100 watts RMS, 145 watts max. fs = 25 Hz. 6 ohm (4 and 8 ohm compatible). SPL = 89 dB 1W/1M. Response: 25-700 Hz. QTS = 31, VAS = 10.3 cu. ft.. Pioneer #A30GU30-55D. Net weight: 6 lbs.



#290-145 \$39.80 (1-3) \$36.80 (4-up)

15" THRUSTER WOOFER

Thruster by Eminence. Made in USA. Poly foam surround, 56 oz magnet. 2-1/2", 2 layer voice coil. 150 watts RMS, 210 watts max. 4 ohm. fs = 23.5 Hz, QTS = 33, VAS = 17.9 cu ft. SPL = 94.8 dB 1W/1M. Net weight: 15 lbs.



#290-180 \$43.50 (1-3) \$39.80 (4-up)

12" POLY WOOFER

Super duty, 40 oz magnet. 100 watts RMS, 145 watts max. 4 and 8 ohm compatible (6 ohm). 2" voice coil. fs = 25 Hz. QTS = .166, VAS = 10.8 cu ft. Response: 25-1500 Hz. Net weight: 9 lbs. Pioneer #A30GU40-51D



#290-125 \$36.80 (1-3) \$34.50 (4-up)

PIONEER HORN TWEETER

Mylar dome. 2.93 oz. barium ferrite magnet. 8 ohm. Response: 1800-20000 Hz. 35W RMS, 50W max. fs = 2000 Hz, SPL = 106 dB. Pioneer #AHE60-51F



#270-050 \$6.50 (1-9) \$5.90 (10-up)

GRILL FRAME KIT

With this kit you can make speaker grill frames up to 30" x 40". Kit includes 4 corner pieces, 2 "T" brackets, and 7 frame bars. Grill mounting kit included.



#260-333 \$8.50 (1-9) \$7.80 (10-up)

TITANIUM COMPOSITE TWEETER

Titanium is deposited on a polymer dome to combine the advantages of both hard and soft dome technologies. 8 ohm. Ferro fluid cooled voice coil. fs = 1200 Hz, SPL = 90 dB 1W/1M. 50 watts RMS, 70 watts max. 4" round. Polydax part #DTW100T125.



#270-047 \$27.50 (1-9) \$24.80 (10-up)



340 E. First St., Dayton, Ohio 45402
Local: 1-513-222-0173
FAX: 513-222-4644

* 15 day money back guarantee *\$15.00 minimum order *We accept Mastercard, Visa, Discover, and C.O.D. orders *24 hour shipping *Shipping charge = UPS chart rate *\$1.00 (\$3.00 minimum charge) *Hours: 8:30 am- 6:00 pm EST, Monday - Friday *Mail order customers, please call for shipping estimate on orders exceeding 5 lbs.



CIRCLE 14 ON FREE INFORMATION CARD



New Products

To obtain additional information on new products covered in this section from the manufacturer, please circle the item's code number on the Free Information Card

BIT-HOLDING SCREWDRIVER

Designed for ease of use, the *Paladin PA 1955* screwdriver has six interchangeable bits that are conveniently stored in its handle when not in use. To change bits, the user unscrews the handle's cap, chooses the proper bit (from the 2 Phillips, 2 slotted, and 2 hex that are included) and inserts it into the magnetized tip.

One PA 1955 can replace a full set of ordinary screwdrivers. The patented handle design allows the user to generate more torque with little effort, and the ergonomic handle is formed to "fit" the user's



hand comfortably. The handle—which is extremely resistant to hot and cold temperatures, oil, gas, and acid—is injection-molded onto the shaft for durability, and the screwdriver shaft is guaranteed against breakage.

The PA 1955 bit-holding screwdriver has a suggested list price of \$24.95. For further information, contact Paladin Corporation, 3543 Old Conejo Road, Suite 102, Newbury Park, CA 91320.

CIRCLE 101 ON FREE INFORMATION CARD

VCR EDIT CONTROLLER

The *EC-42* edit controller is a hardware-and software-interface package used to connect consumer or professional VCR's to an Amiga or IBM-compatible computer for dubbing and editing purposes. The package includes the hardware-interface unit, all cables, a source-VCR modification kit, a set-up program, edit-control software,

a VHS tape, and a user's manual. It will synchronize the source VCR to the recorder VCR for very accurate edits, and even works with VCR's that don't normally have any edit-control options, functions, or jacks. (Frame accuracy— ± 4 frames on some machines—depends on the transport mechanism of the source VCR. For best editing results the recording VCR should have flying erase heads to eliminate chroma artifacts and timing glitches.)

The edit controller does require a computer with a parallel port and BASIC and two VCR's (VHS, S-VHS, 3/4, and some Beta models) with camera-remote jacks. (To test your machine for compatibility, place the source VCR in the play/pause mode and press the rewind/search button for one second. If, after the search function

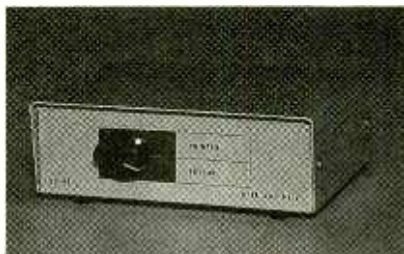

stops, the machine begins to play, the controller will work with that VCR.) A simple modification must be done to the source VCR: Two jacks must be installed with leads going to the rewind and fast-forward search switches. That allows the pre-roll and search functions to operate. Detailed modification instructions are included with the edit controller.

The *EC-42* provides full keyboard control of play/pause, record/pause, and forward/reverse search in both manual and computer-control modes. For fades, wipes, or special effects, an S.E.G. trigger control is included. An A/B switch allows the operation of the controller and a printer from the same parallel port.

The *EC-42* edit controller costs \$149.00 plus \$4.00 shipping and handling. (Minnesota residents add 6% sales tax.) Modification of the source VCR will be done for \$35.00. For further information, contact Hill and Hill Post Production Research and Development, 34 East Superior Street, Suite 251, Duluth, MN 55802.

CIRCLE 102 ON FREE INFORMATION CARD

STEREO RACK SYSTEM

Sharp's SYS-7000 stereo rack system allows listeners to tailor the sound to suit their personal tastes. With an "Acoustic Image Processor," "X-Bass" circuitry, and surround sound, the system can create the ambience of a small jazz club or a large concert hall, depending on the user's listening preferences. The Acoustic Image Processor provides 16 choices in the way

that sound can be reproduced by the system, and a 5-band graphic equalizer offers yet another means to personalize sound.

The system's 120-watts-per-channel amplifier produces a full, rich sound through the four speakers that are provided: a pair of 12-inch, 3-way front speakers with passive radiators and two sur-



round speakers. The digital tuner offers 14 station presets and autotune for convenient tuning. The dual-cassette deck provides high-speed dubbing from tape to tape, continuous-play capability, and Dolby-B noise reduction. A belt-drive semi-automatic turntable rounds out the system. All of the components, as well as the surround-sound and X-Bass features, can be operated via the system's remote-control unit.

The *SYS-7000* stereo rack system has a suggested retail price of \$999.95. For more information, contact Sharp Electronics Corporation, Consumer Audio Division, Sharp Plaza, Mahwah, NJ 07430.

CIRCLE 103 ON FREE INFORMATION CARD

MAGNETIC TEST PROBE

The *Lil Devil* magnetic test probe from *Jensen Tools* can cut the time spent troubleshooting solenoid devices by as much as 99%. The probe operates by sensing the magnetic field in electrical relays, coils, valves, stepper switches, and other devices. If an electrical problem is



encountered, an LED at the end of the probe immediately lights, indicating exactly where the trouble lies.

When the Lil Devil is used properly, it can eliminate the need for time-consuming hookups and reference to schematics. It works on both AC and DC devices and is very easy to use. The tip of the probe is simply placed on or near a coil or shaft projecting through the device to be tested. If the LED lights up, the device is energized; if not, the device is de-energized. The pen-shaped probe, which measures just $3/4 \times 35/8$ inches, also recognizes North and South poles.

The Lil Devil magnetic test probe is available in two models—the Standard, for testing larger solenoids, and the High Sensitivity, for subminiatures and reed relays. Their suggested list prices are \$28.00 and \$33.00, respectively, including instructions and recommendations for proper use. For additional information, contact Jensen Tools, 7815 South 46th Street, Phoenix, AZ 85044.

CIRCLE 104 ON FREE INFORMATION CARD

DIGITAL TEMPERATURE METERS

B&K-Precision's series of three hand-held digital temperature meters feature $3\frac{1}{2}$ -digit LCD displays and standard 9-volt battery power sources. The 920 dual-input and the 970 single-input models span from $\pm 58^\circ$ to $+1999^\circ\text{F}$. The compact model 900 probe meter spans $\pm 58^\circ$ to $+302^\circ\text{F}$.

The model 920 dual-input digital temperature meter has two K-type thermocou-

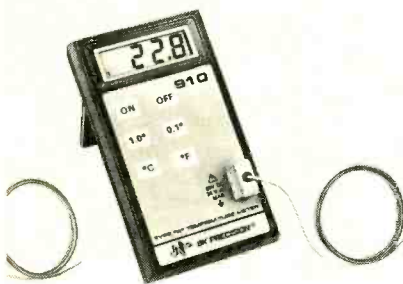

ple sensor probes, with selectable probe-1 or probe-2 temperature readings and Centigrade or Fahrenheit measurement. It meets the needs of many industrial and laboratory applications for monitoring two temperatures, such as ambient and internal. The model 910 (pictured) offers the same high precision and versatility, plus selectable 1° or 0.1° resolution. It features a single K-type thermocouple sensor probe.

The model 900 is intended for HVAC, building maintenance, and general purpose applications. It measures just $5.6 \times 1.8 \times 1.1$ inches, and features selectable

internal or external operation. In the external mode, a socket in the model 900 accepts an external K-type thermocouple probe for 0°F to 1500°F measurements. The internal mode uses a probe with a semiconductor-type sensor. The unit automatically turns on when the self-contained probe is extended and turns off when it is retracted.

The models 900, 910, and 920 digital temperature meters have suggested list prices of \$55.00, \$80.00, and \$110.00, respectively. For further information, contact

B&K-Precision, Maxtec International Corporation, 6470 West Cortland Street, Chicago, IL 60635.

CIRCLE 105 ON FREE INFORMATION CARD

DISK EMULATOR

In recent years, disk emulators have been replacing mechanical drives in some applications, particularly for operations involving frequent disk transfers, such as large program loads, database manipula-

HITACHI SCOPES AT DISCOUNT PRICES

<p>V-212 \$419 List \$560 Save \$141</p> <p>20MHz Dual Trace Oscilloscope All Hitachi scopes include probes, schematics and Hitachi's 3 year warranty on parts and labor. Many accessories available for all scopes.</p>	<p>V-425 List \$995</p> <p>\$835</p> <ul style="list-style-type: none"> • DC to 40MHz • Dual Channel • CRT Readout • Cursor Meas • DC Offset • Alt Magnifier • Compact Size 	<p>V-1060 List \$1595</p> <p>\$1,325</p> <ul style="list-style-type: none"> • DC to 100MHz • Dual Channel • Delayed Sweep • CRT Readout • Sweep Time • Autoranging • Trigger Lock • 2mV Sensitivity 																								
<p>V-223 20MHz D.T. 1mV sens. Delayed Sweep, DC Offset, Vert Mode Trigger</p> <p>V-422 40MHz D.T. 1mV sens. DC Offset Vert Mode Trigger, Alt Mag</p> <p>V-423 40MHz D.T. 1mV sens. Delayed Sweep, DC Offset, Alt Mag</p> <p>V-660 60MHz D.T. 2mV sens. Delayed Sweep, CRT Readout</p> <p>V-1065 100MHz D.T. 2mV sens. Delayed Sweep, CRT Readout, Cursor Meas</p> <p>V-1100A 100MHz Q.T. 1mV sens. Delayed Sweep, CRT Readout, DVM, Counter</p> <p>V-1150 150MHz Q.T. 1mV sens. Delayed Sweep, Cursor Meas, DVM, Counter</p>	<table border="1"> <thead> <tr> <th>LIST</th> <th>PRICE</th> <th>SAVE</th> </tr> </thead> <tbody> <tr> <td>\$770</td> <td>\$695</td> <td>\$75</td> </tr> <tr> <td>\$975</td> <td>\$725</td> <td>\$150</td> </tr> <tr> <td>\$955</td> <td>\$825</td> <td>\$130</td> </tr> <tr> <td>\$1,195</td> <td>\$1,025</td> <td>\$170</td> </tr> <tr> <td>\$1,895</td> <td>\$1,670</td> <td>\$225</td> </tr> <tr> <td>\$2,295</td> <td>\$2,045</td> <td>\$250</td> </tr> <tr> <td>\$3,100</td> <td>\$2,525</td> <td>\$575</td> </tr> </tbody> </table>	LIST	PRICE	SAVE	\$770	\$695	\$75	\$975	\$725	\$150	\$955	\$825	\$130	\$1,195	\$1,025	\$170	\$1,895	\$1,670	\$225	\$2,295	\$2,045	\$250	\$3,100	\$2,525	\$575	
LIST	PRICE	SAVE																								
\$770	\$695	\$75																								
\$975	\$725	\$150																								
\$955	\$825	\$130																								
\$1,195	\$1,025	\$170																								
\$1,895	\$1,670	\$225																								
\$2,295	\$2,045	\$250																								
\$3,100	\$2,525	\$575																								

ELENCO PRODUCTS AT DISCOUNT PRICES

<p>20MHz Dual Trace Oscilloscope \$359 MO-1251</p> <ul style="list-style-type: none"> • 6" CRT • Built in component tester • TV Sync X-Y Operation 	<p>SCOPE PROBES</p> <p>P-1 65MHz, 1x, 10x \$19.95</p> <p>P-2 100MHz, 1x, 10x \$23.95</p> <p>Fits all scopes with BNC connector</p>	<p>35MHz Dual Trace Good to 50MHz \$495 MO-1252</p> <ul style="list-style-type: none"> • High luminance 6" CRT • 1mV Sensitivity • 6KV Acceleration Voltage • 10ns Rise Time • X-Y Operation + Z Axis • Delayed Triggering Sweep
<p>Top quality scopes at a very reasonable price. Contains all desired features. Two 1x, 10x probes, diagrams and manual. Two year guarantee.</p>		
<p>Autorangeing DMM M-5000 \$45</p> <ul style="list-style-type: none"> 9 Functions Memory and Data hold 1/2% basic acc 3 1/2 digit LCD 	<p>True RMS 4 1/2 Digit Multimeter M-7000 \$135</p> <ul style="list-style-type: none"> .05% DC Accuracy 1% Resistance with Freq. Counter and deluxe case 	<p>Multimeter with Capacitance and Transistor Tester \$55 CM-1500</p> <p>Reads Volts, Ohms, Current, Capacitors, Transistors and Diodes with case</p>
<p>Digital Capacitance Meter CM-1550 \$58.95</p> <p>9 Ranges .1pf-20,000ufd .5% basic acc Zero control with case</p>	<p>Digital LCR Meter LC-1801 \$125</p> <p>Measures Coils 1uH-200H Caps 1pf-200uf Res. 0.1-20M</p>	
<p>AC Clamp-On Current Adapter ST-265 \$22</p> <p>0-1000A AC Works with most DMM</p>	<p>Bench DMMs</p> <p>M-3500 3 1/2 digit \$125 M-4500 4 1/2 digit \$175 1% acy 0.5% acy</p>	<p>SOLDERING STATION TEMPERATURE CONTROLLED SL-30 \$135</p> <p>Digital display Temp range: 300F-900F Grounded tip Overheat prot</p>
<p>Wide Band Signal Generators</p> <p>SG-9000 \$129 RF Freq 100K-450MHz AM Modulation of 1KHz Variable RF output</p> <p>SG-9500 with Digital Display and 150MHz built-in Freq Ctr \$249</p>	<p>3 1/2 Digit Probe Type DMM M-1900 \$39</p> <p>Convenient one hand operation Measures DCV, ACV, Ohms Audible continuity check, Data hold</p>	<p>Function Generator Blox #9600 \$28.95</p> <p>Provides sine, tri, sq wave From 1Hz to 1MHz AM or FM capability</p>
<p>Digital Triple Power Supply XP-765 \$249</p> <p>0-20V at 1A 0-20V at 1A 5V at 5A</p> <p>Fully Regulated, Short circuit protected with 2 Limit Cont., 3 Separate supplies</p> <p>XP-660 with Analog Meters \$175</p>	<p>Quad Power Supply XP-580 \$59.95</p> <p>2-20V at 2A 12V at 1A 5V at 3A -5V at 5A</p> <p>Fully regulated and short circuit protected</p> <p>XP-575 without meters \$39.95</p>	<p>10MHz XT 100% IBM Compatible 5 Year Warranty \$595 MODEL PC-1000</p>
<p>Four-Function Frequency Counters</p> <p>F-1000 1.2GH \$259 F-100 120MHz \$179</p> <p>Frequency, Period, Totalize, Self Check with High Stabilized Crystal Oven Oscillator, 8 digit LED display</p>	<p>GF-8016 Function Generator with Freq. Counter \$239</p> <p>Sine, Square, Triangle Pulse, Ramp, 2 to 2MHz Freq Counter .1-10MHz</p> <p>GF-8015 without Freq. Meter \$179</p>	<p>15 Day Money Back Guarantee 2 Year Warranty WRITE FOR FREE CATALOG</p>
<p>WE WILL NOT BE UNDERSOLD! UPS Shipping: US 5% (\$10 Max) IL Res., 7% Tax</p>		

CIRCLE 13 ON FREE INFORMATION CARD

AMAZING NEW Pocket Reference

480 pages of tables, maps, formulas, and conversions and it fits in your shirt pocket (3.2" x 5.4" x 0.6")!

\$9.95*



* Plus \$2.00 shipping & handling.
Colorado residents add 5% tax.

Small sample of contents

Air Tool CFM vs PSI	Radio Alphabet
Battery Charging	TEN Radio Codes
Tire Manufacturer Codes	Telephone Area Codes
Lumber Sizes & Grades	Lost Credit Card Phones
Concrete & Mortar	Sound Intensities
Element Tables	Wind Chill Factors
Computer ASCII Codes	Frequency Spectrum
IBM® PC Error Codes	Geology Mineral Tables
IBM® Interrupts-IO Map	Glues and Solvents
80286 Hard Disk Types	Bolt Torque Tables
Printer Control Codes	Wood Screw/Nail Sizes
Electric Wire Size vs Load	Math Formulas & Tables
NEMA Motor Frames	Plane/Solid Geometry
Wire & Sheet Gauges	Copper/Steel/PVC Pipe
Resistor/Capacitor Colors	Rope, Cable and Chain
Pilot Lamp Specs	Tap-Die-Drill Sizes
Fuse & Battery Specs	Sand Paper & Abrasives
RF Coil Winding Data	Weid Electrode & Solder
Wire Size vs Turns/Inch	3200 Conversion Factors

Money Back Guarantee - If not completely satisfied, return book postage prepaid, in mint condition for a 100% refund!

Sequoia Publishing Inc.
Dept 901, P.O. Box 620820
Littleton, CO 80162

CIRCLE 15 ON FREE INFORMATION CARD

New Products

tions, assemblies and compilations, and programs that use overlays or templates. Offering instant access and high transfer rates, they can significantly increase system speed.

KAPAK's *NOVO DRIVE 8000* disk emulator for IBM PC, XT, AT, PS 2/30, and compatibles is implemented with semiconductor memory on a single printed circuit card. Plug-in SIMM memory modules supply 1-8MB of storage, upgradable by the user. Immediate access to data, inherent with RAM's, makes the *NOVO DRIVE*

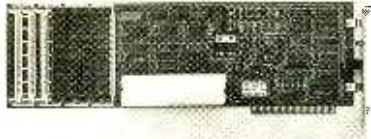

8000 many times faster than mechanical drives. The system interface logic uses *Direct Memory Access (DMA)* to move data every memory cycle. Its solid-state design enhances reliability.

Installation is easy with "Auto Format" firmware; no special drivers or programs are required. It configures itself in less than a minute with little effort by the user. Boot

firmware, including several configuration options, is part of the product. One option allows booting to proceed directly for the *NOVO DRIVE 8000* instead of trying the floppy drive first.

Data is effectively non-volatile—unlike in virtual drives, which lose their data each time the system is turned off. An AC power adapter, separate from the computer, maintains data when the computer is off. In case of AC power failure, on-board batteries will supply power for at least four hours. The disk emulator can even be transferred from one system to another with no loss of data.

The *NOVO DRIVE 8000* disk emulator costs \$375.00 without memory modules. For additional information and price quotes on memory modules, contact KAPAK Design, 12280 Saratoga-Sunnyvale Road, Saratoga, CA 95070.

CIRCLE 106 ON FREE INFORMATION CARD

DUAL-BAND TRANSCEIVER

Kenwood's TH-75A 2m/70cm transceiver compresses many dual-band mobile-transceiver features into one compact, hand-held package. It offers four ways to scan, including dual-memory scan with time-operated or carrier-operated scan-stop modes. The unit has selectable full-duplex operation, and its dual-watch function lets users monitor both bands at the same time. Ten memory channels for each band store frequency, CTCSS, repeater offset, frequency-step information, and reverse. The two memories allow "odd-split" operation, and are backed up by a lithium battery. The battery-saving hand-held transceiver uses 1.5 watts on 2m and 70cm bands (5 watts when it is operated on 12-volts DC).

The TH-75A features an extended re-

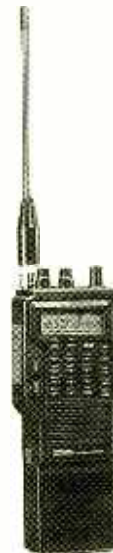

You got it to work? Good!

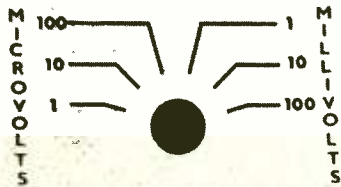

COARSE ADJUST

NOW MAKE IT LOOK GOOD

Let DATAK be your designing partner. Use our dry transfer title sets to put that finishing touch to your custom project. Over 2200 titles plus alphabets and numbers insure that you'll have the words you need. Switch markings and dial plate arcs are in a companion set. Use DATAKOAT spray for complete protection. Sprays are not mailable.

948 Blk (949 Wht) 10 pt. .105" Electronic Titles (24 sheets) \$12.50
9581 Blk (9591 Wht) 12 pt. .125" Electronic Titles (24 sheets) 12.95
968 Blk, Wht, Red asst. Meter dial & Switch Markings (12 sheets) 12.95
04177 DATAKOAT Gloss Spray (12 oz) 5.75
04178 DATAKOAT Matte Spray (12 oz) 5.75

Minimum order: \$20.00 (add 7% shipping. NJ and CA also add sales tax)

WRITE FOR A FULL CATALOG AND SAMPLES TODAY

16 DATAK Corp. • 3117 Paterson Plank Rd. • N. Bergen, NJ 07047

CIRCLE 8 ON FREE INFORMATION CARD



One tree can make
3,000,000 matches.



One match can burn
3,000,000 trees.



A Public Service of The Advertising Council

the Elementary Spelling Ace's memory were taken directly from the dictionary. A special feature also allows the child to enter a personalized list of vocabulary words. That list is then incorporated into a variety of fun and educational games including Spelling Flashcards, Wordblaster, Jumble, and Hangman. The Ace helps the child to master spelling words by repeating the misspelled words until they are spelled cor-



rectly. It keeps score for the child and has adjustable skill levels.

Other features include a large 16-character, dot-matrix display, separate function keys, automatic one-touch scrolling, and automatic power shut-off. The keyboard of

the Elementary Spelling Ace is set up like that of a regular typewriter.

The Elementary Spelling Ace, with the illustrated *Merriam-Webster's Elementary School Dictionary*, has a suggested retail price of \$99.00. For additional information, contact Franklin Computer Corporation, 122 Burrs Road, Mt. Holly, NJ 08060.

CIRCLE 109 ON FREE INFORMATION CARD

VACUUM TUBE/VOLTMETER

KAPPA/VIZ is now offering the *WV-98C Senior VoltOhmyst Vacuum Tube/VoltMeter*, formerly known as the RCA WV-98C. (KAPPA/VIZ's VTVM is identical to that

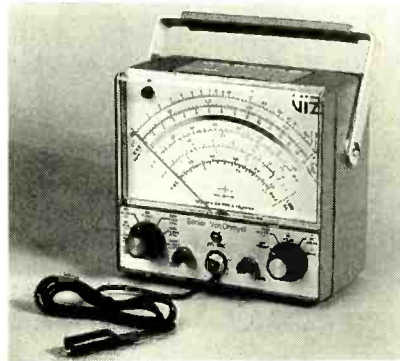

industry-recognized standard measuring device.) It offers a large, 3-color, mirror-scale meter for accurate reading and 11-megohm input resistance in all ranges. The instrument is enclosed in a heavy-duty, die-cast shielded case.

The WV-98C Senior VoltOhmyst has a suggested retail price of \$297.00. For further information and specifications, contact KAPPA/VIZ Test Equipment, 175 Commerce Drive, Fort Washington, PA 19034; Tel. 800-643-5237.

CIRCLE 110 ON FREE INFORMATION CARD

TIME CALCULATOR

Calculated Industries' Time Master was designed for audio and video production, recording, aviation, scheduling, sports, and anyone who works with time-value conversions. The pocket-sized calculator eliminates the need to convert time values, since it calculates directly in all time formats—hours, minutes, seconds, hour—minutes—seconds, hours—minutes, and minutes—seconds. The Time Master also converts between any time format with the touch of a button, and works with points-in-time values in either 12- or 24-hour clockings. The device's **HOURLY RATE** key allows users to multiply time values by specific unit costs.

The device also works as a regular math



calculator, with percent, memory, and automatic shut-off. It has a built-in stopwatch-timer function, and includes an easy-to-read user's guide, batteries, and a 1-year warranty.

The Time Master calculator has a suggested retail price of \$59.95. For more information, contact Calculated Industries, 22720 Savi Ranch Parkway, Yorba Linda, CA 92686; Tel. 1-800-854-8075.

CIRCLE 112 ON FREE INFORMATION CARD

MICROCOMPUTER

HiTech's SAM3001/386 microcomputer offers the PC market 16-MHz speed and 1MB of RAM at a reasonable price. Cen-



tered around the Intel 80386 microprocessor, the Compaq-compatible system also includes a 1.2MB floppy-disk drive, an HDD/FDD controller, a 200-watt power supply, and an enhanced 101-key keyboard. The 80287 or 80387 mathematics coprocessor is available as an option.

The SAM3001/386 microcomputer, which comes with a 90-day warranty, is priced at \$999.00. For further information, contact HiTech International, 712 Charcot Avenue, San Jose, CA 95131.

CIRCLE 113 ON FREE INFORMATION CARD

New from AOR

2000 Channels 5MHz to 1500MHz

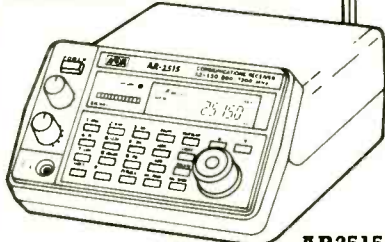

AR2515

- Covers 5MHz to 1500MHz in AM/FM/Wide FM modes. Continuous coverage.
- 2000 Channel Memory
- 1984 Scan Frequencies & 16 Search Groups.
- Scan/Search speeds up to 36 channels or increments per second.
- Built in RS 232 computer interface
- 25 Day Satisfaction Guarantee. Full Refund if not Satisfied.
- Size 3 1/4" H x 5 3/4" W x 7 1/4" D. Wt. 2.1lb. 10 oz.
- Supplied with AC & DC power cords. Telescopic antenna.

Total Price, Freight Prepaid (Express Shipping Optional)
*Upgrades of AR2002's to AR2515 specs Available

\$695.00



COMMUNICATIONS
10707 E. 106th St. Indpls., IN 46256

Toll Free 800-445-7717

Visa and MasterCard
(COD slightly higher)

In Indiana 317-849-2570 Collect FAX (317) 849-8794

CIRCLE 25 ON FREE INFORMATION CARD

NOW! Training includes XT-compatible computer plus NRI's remarkable Robotic Discovery Kits!

Get training for industry's hottest new jobs as you build and program complete robotic control systems

Now you can get the skills in demand for the new jobs in industry today. With NRI's new at-home training in Robotics Technology, you actually build a fully IBM XT-compatible computer, then use it to program and control working robotic systems . . . each one engineered to recreate the exact operations performed by the robotic equipment found in today's industrial workplace.

It's no secret. Industry is being transformed by technology—with everything from precision electronic instruments to giant locomotives now being produced with the help of advanced robotic systems. And with automation have come jobs . . . thousands of jobs building, programming, and servicing the robotic systems in use today.

Now, unlike any other school, NRI offers you training that prepares you to take advantage of these new opportunities . . . training that gives you the practical know-how and the hands-on skills to advance on

Robotics comes to life as you see real-world industrial control principles in action

Your NRI Robotic Discovery Kits come complete with everything you need to create working, moving robotic systems. You get structural members, motors, gear drives, sensors, scanners, potentiometers, plus a special Robotics Interface that links the robots you build to your computer.

Together, your computer and the robotic devices you construct become fully integrated

knowledge of electronic circuits and components as you experiment with your NRI Discovery Lab® and professional digital multimeter.

Rapidly, theory becomes understanding as you move on to digital logic, computer fundamentals, right up to writing practical programs to control specific robotic operations using NRI's Robotic Programming Language software included in your course.

Your success is assured by your personal NRI instructor, whose expertise and personal guidance are always available to you whenever you need a helping hand along the way.

Get training you can build a career on—send for your FREE catalog today!

See for yourself how NRI's breakthrough training can put you at the heart of the robotics revolution. Send today for NRI's big, 100-page, full-color catalog that gives you all the details about NRI's exciting new training in Robotics Technology, plus training in computer electronics, TV/video/audio servicing, electronic music technology, security electronics, and other growing high-tech career fields.

If the coupon is missing, write to: NRI School of Electronics, McGraw-Hill Continuing Education Center, 4401 Connecticut Avenue Washington, D.C. 20008

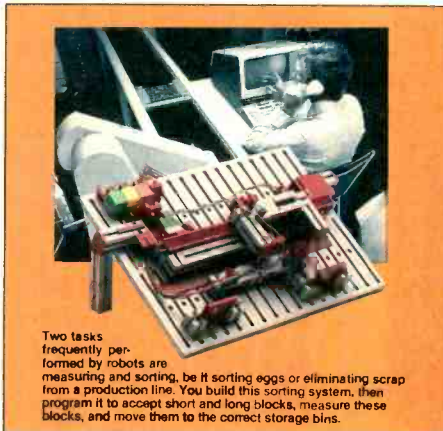

Two tasks frequently performed by robots are measuring and sorting, be it sorting eggs or eliminating scrap from a production line. You build this sorting system, then program it to accept short and long blocks, measure these blocks, and move them to the correct storage bins.



This "teachable" robotic arm is the most complex robot model you construct. Once you manually put the robot through a sequence of operations, it will "remember" these steps and perform them whenever asked.

the job or start a new career as a robotics and industrial control technician.

The powerful XT-compatible computer you build becomes central control for the robotic systems you construct

As an integral part of your NRI hands-on training, you build a fully IBM XT-compatible computer from the keyboard up. You assemble the power supply, install the 5¼" floppy disk drive, and attach the high-resolution monitor. Most important of all, by performing meaningful tests and demonstrations at each stage of assembly, you come to a full understanding and appreciation of the microprocessor technology that makes today's robotics applications possible. But that's just the beginning.

You go on to use your computer to program and control a diverse array of robotic systems you create with NRI's remarkable Robotic Discovery Kits.

automation systems, programmed by you to do the types of operations and tasks performed in today's industrial environments. Tasks such as plotting polar coordinates to create graphic displays of numeric data . . . sorting different size objects and routing these objects to separate containers . . . even performing a preprogrammed sequence of operations again and again just as robots now do on manufacturing lines.

Nothing is left out, nothing is left to chance. You get everything you need—the skills, the confidence, and the equipment—to feel completely at home with today's robotics technology.

Step by step, you get the training you need to move into robotics fast

You need no previous experience to succeed with NRI training, because NRI takes you from electronics basics all the way up to the state of the art in robotics technology. You train from the ground up . . . first gaining a working



McGraw-Hill Continuing Education Center
4401 Connecticut Avenue
Washington, D.C. 20008



For career courses approved under GI Bill
 check for details

Check one catalog only

- Robotics Technology
- Computers and Microprocessors
- Security Electronics
- Electronic Music
- Digital Electronics Servicing
- TV/Video/Audio Servicing
- Radio Communications
- Cellular Telephone
- Data Communications
- Basic Electronics

Name _____

Address _____

City _____ State _____ Zip _____

Accredited by the National Home Study Council 18-109

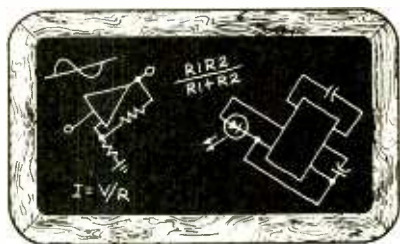

Think Tank

By Byron G. Wels

IF I HAD IT TO DO ALL OVER AGAIN

I was 12-years old when it all began. I had a date with a pretty girl and went to her house to pick her up. Her older brother was a ham, and I wound up spending the evening (and half the night) with him. She was furious, but I didn't care. Some six months later, I had my own ham license, and the call K2AVB. So naturally, when World War II ended, I got a job on an electronics assembly line.

I went into electronics full tilt, and worked my way into research and development work for a major electronics manufacturer. That was followed by a stint as chief electronics tech for another manufacturer, and then I learned (it took me long enough) that I could earn more money with a typewriter than with a soldering iron.

I worked as an editor for some of the country's top magazines, so that having achieved as I have, I can sit here and reminisce with you guys. The problem is that it's a one-way street. You just don't talk back, and I wish you would. The mail does come in, though, and I enjoy reading every letter.

Recently, I've been getting a spate of letters from everybody from raw beginners to college physics professors. Remember about the tolerance of series resistors? I figured that when a bunch of electronics-type editors started getting into that, their answer would be final. Not by a long shot. You readers started to express your opinions too, and the mail has poured in. I started making two piles on the desk...Those with ideas for *Think Tank*, and those that talked about the series resistors.

So since you enjoy problems, here's one for you to work on. You have a five-gallon bucket and a three-gallon bucket and a limitless supply of water. The problem is, you've got to bring back precisely seven gallons of water. It can be done. Now you tell me how! We'll publish the answer in the next issue. Send your answers in with a schematic and write-up for this column.

B.C. "Hearing Aid". By, sometimes I do something so clever that I actually amaze myself! Last year, during the baseball season, our entire production line would almost shut down during the games. There was a blaring transistor radio at each station along the line, and employees would shout and cheer whenever something important happened. That's when management realized that the games were holding up production, and they notified every-

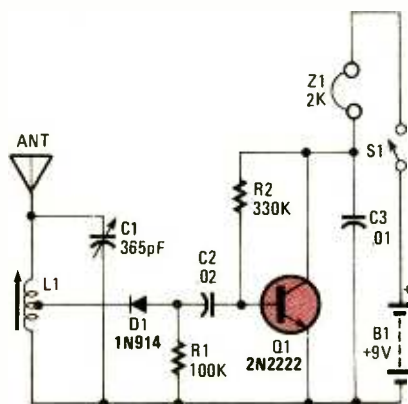

Fig. 1. The BC Hearing Aid is really a miniature radio that is built to resemble a hearing aid. The antenna is nothing more than a length of wire connected to coil L1 (an adjustable, ferrite loopstick).

body that no radios were going to be allowed during the next season.

I started to pretend to be losing my hearing, saying "scuse me" and "pardon?" whenever anyone spoke to me, and collected a lot of hearing aid literature, which I left on my bench. Then I built the circuit in Fig. 1 into a small hearing aid housing.

Came the baseball season, I started wearing it at work, and while everybody else had to wait to get home, I was getting the play-by-play all day. The only problem is that you can't jump up and holler when something happens. After the season I'll allow my hearing to gradually improve.

Coil L1 is an adjustable, ferrite loopstick, sold under the brand name "Vari-Loopstick." Almost any NPN transistor will work here as well. The external antenna is just a random length of wire, and you don't really need the ground. I did find that under certain circumstances, simply touching the antenna or ground might improve reception. — Fred Rubin, Chicago, IL.

Actually Fred, I'm not much into spectator sports. I don't even know how they make a touchdown in baseball! But this sounds like a good one that many of our readers can use. Look for your *Fips* book. It's on the way!

Light Minder. By, the wife and I have been trying to fix up our "greatest investment," and the last thing we bought was one of those outside pole lights. Well, I installed it physically, and it looked great. Then I sank a length of conduit underground from the lamp to the cellar window, and ran a length of Romex cable through that.

I added a switch to turn the lamp on and off, but that got to be a nuisance, so I came up with this circuit (see Fig. 2) to automatically turn the lamp on at dusk and off at dawn. That's where catch-22 began. At dusk, the lamp comes on, the light from the lamp hits the photocell, the light goes out.

To correct that problem, I mounted the photocell in a black cardboard tube that I'd sealed with polyurethane, and attached it, pointing upward, to the top of the lamp housing.

The only other problem I came up

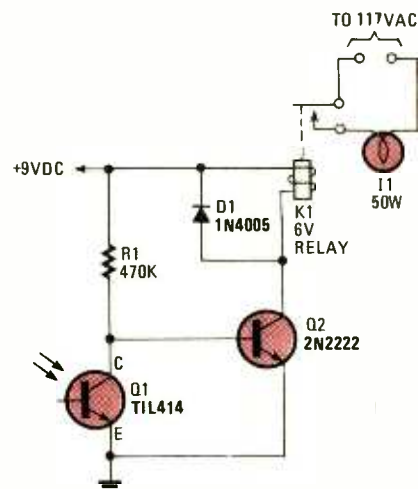

Fig. 2. The Light Minder is an extremely simple circuit that uses a phototransistor to determine when sunlight has diminished enough to warrant turning on outside lights.

with, was that dusk takes on many forms. If it gets particularly cloudy during the middle of the day, the lamp comes on. When that happens, I simply use the primary switch as an override. I hope that other readers will enjoy this circuit. It has numerous additional applications, such as controlling garage lights, etc. —George Mead, New York, NY

Good idea, George. I'd recommend that readers look into the possibility of a 117-volt derived, 9-volt power supply, or at the very least, make sure you use alkaline batteries for longer life. Look for your Fips Book in the mail, okay?

Injecto-Trace. I had been looking for something like this for a long, long time. It's a combination tool, and as such saves me a lot of space on the workbench. (See Fig. 3) It's small enough to be mounted on a piece of perfboard, and can be slipped into any convenient plastic housing, just to doll it up a bit. I was going to call it a "one-evening project," but if you do any amount of construction and/or servicing, it becomes, as you'll find out, an "every-evening project!"

In the injection mode, it makes a fine signal injector for inputting anything from audio frequencies on up. And as a signal tracer, it works from audio up to 400 MHz and more.

Now how do you convert it from a signal injector to a signal tracer? Simple. Just plug in a pair of high-imped-

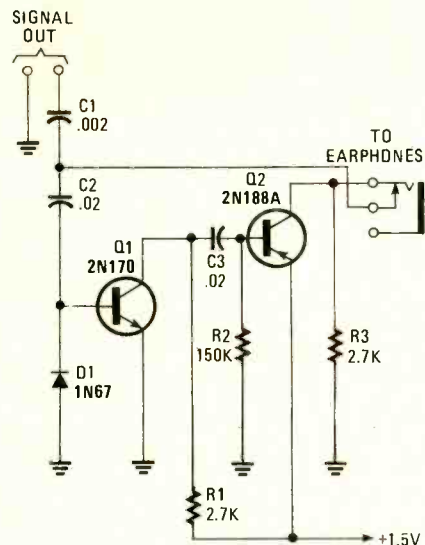

Fig. 3. Injecto-Trace combines two of the most simple, but useful, test instruments (signal injector and signal tracer) into a single circuit. Introducing an earphone to, or removing it from, jack J1 determines the circuit's mode of operation.

ance magnetic phones. The closed-circuit jack takes care of whatever switching has to be done. Inserting the plug breaks the feedback circuit, and it's done!

Power for the unit is drawn from any 1.5-volt cell, and the larger the cell you use, the longer it will last before you have to change it. Now I know that this has to be worth a Fip's Book. Right? —Frank D'Andrea, Cleveland, OH.

Frank, it was a nice change, seeing a handy piece of test equipment after all the third brake lights, metronomes, and code-practice oscillators. Your Fips Book is on the way!

Modulation Monitor. The FCC says we mustn't exceed 100% modulation, and it's a good idea. Excessive modulation creates distortion and band splatter that wrecks havoc with other stations. But exactly how do you go about monitoring your percentage of modulation? Frankly, most of us depend on signal reports from other stations.

If you're constantly getting "5 x 5" reports, the chances are that you're

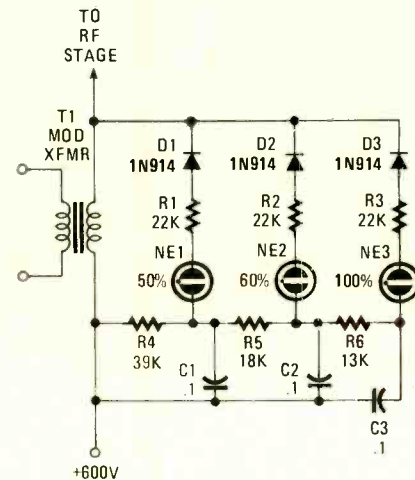

Fig. 4. The Modulation Monitor is designed to indicate the percentage of modulation in a given signal. The circuit uses switching diodes to fire the neon lamps when negative-peak modulation hits 50, 80, and 100 percent.

okay and have nothing to worry about. While modulation monitors are available, they also happen to be expensive.

The unit shown here (see Fig. 4) is inexpensive, easy to build, and sufficiently accurate to do the job, and do it well. I built mine into a "little black box," using rubber grommets on the face in
(Continued on page 25)

AMAZING KITS

Our fascinating electronic kits are designed to challenge your imagination and allow you to construct projects as described below.

Helium Neon Laser

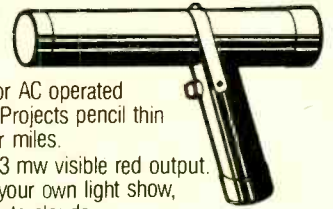

Battery or AC operated system. Projects pencil thin beam for miles.

- Up to 3 mw visible red output.
- Make your own light show, illuminate clouds
- Laser gun for creative and fun games.
- Optical experiments in the lab or classroom.

LGUM1K Kit & Plans (without laser tube) \$59.50
LT01R Full Spec Class II Laser Tube \$99.50

Simulated Laser for Beginners



Construct a low cost 3 color simulated-laser device, variable pulsed or continuous light.

- Visible high intensity 2000 mCD
- Small spot is excellent for pointer or shooting gallery.
- Optical experiments and alignment.

LHPM1K Kit, Lens, & Plans (3 Emitters) \$54.50

Plasma Fire Saber



Construct a fascinating plasma saber that produces a piercing red beam of neon. Length and intensity controlled by hand grip.

- Excellent special effects and display demonstration.
- High-visibility safety baton for jogging or cycling.
- Semaphore signaling and pointing.

PFS1 Plans \$6.00 PFS1K Kit & Plans \$49.50

Plasma Lightning Globe

Construct a plasma globe that creates the spectacular extraordinary effect of a lightning storm. Experiment with other lightbulbs and receptacles to achieve unique and astonishing effects.

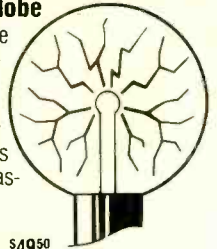

PG5 Plans \$6.00

PG5K Kit, Globe & Plans \$49.50

Human Energy Forcefield

Become an electric man! Construct a novel device that transforms your body into a walking power source.



- Energize lights, objects and "other people."
- Demonstrate feats of magic and mystery.
- Enhances "apparent" telekinetic motion.

HEF1 Plans \$6.00 HEF1K Kit & Plans \$89.50

CALL 1-800-221-1705 to order.

VISA, M/C Accepted. Or send Check or M.O. in U.S. funds (include \$3.00 S&H per kit; \$1.00 per plan). Assembled kits are available. Send \$1.00 for catalog.

INFORMATION UNLIMITED

Box 716, Dept. PE Amherst, NH 03031 (603)673-4730

Your Source for time- and money-saving ideas, practical projects and expert guidance.

An absolutely no-risk guarantee.



1122P \$14.95



3081 \$25.95



1381P \$15.95



1784 \$17.95



1530P \$16.95



2605 \$25.95



1675P \$9.95

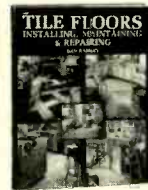

1998P \$12.95



1763P \$11.95



3148P \$14.95



1790P \$15.95



3149 \$29.95
Counts as 2

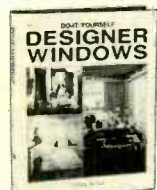

1922P \$15.95



3087 \$23.95

Select 5 Books for only \$395 (values to \$137.70) and get a FREE Gift!

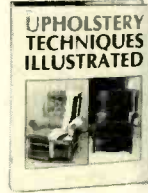

2602P \$17.95



3051 \$24.95
Counts as 2

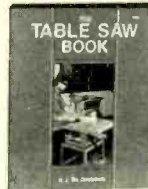

2789P \$15.95



3014 \$2.95



1967P \$11.95



3074 \$21.95



1984P \$10.95

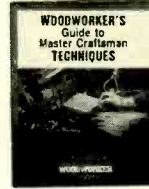

3061 \$25.95
Counts as 2



2629 \$24.95



3001 \$23.95
Counts as 2



2806P \$15.95



2994P \$12.95



2829 \$29.95



2987P \$16.95

Membership Benefits • Big Savings. In addition to this introductory offer, you keep saving substantially with members' prices of up to 50% off the publishers' prices. • **Bonus Books.** Starting immediately, you will be eligible for our Bonus Book Plan, with savings of up to 80% off publishers' prices. • **Club News Bulletins.** 14 times per year you will receive the Book Club News, describing all the current selections—mains, alternates, extras—plus bonus offers and special sales, with scores of titles to choose from. • **Automatic Order.** If you want the Main Selection, do nothing and it will be sent to you automatically. If you prefer another selection, or no book at all, simply indicate your choice on the reply form provided. As a member, you agree to purchase at least 3 books within the next 2 years and may resign at any time thereafter. • **Ironclad No-Risk Guarantee.** If not satisfied with your books, return them within 10 days without obligation! • **Exceptional Quality.** All books are quality publishers' editions especially selected by our Editorial Board.

FREE when you join!

Six Easy Home-Improvement Projects

A treasury of do-it-yourself projects to add value and comfort to your home.



HOW-TO BOOK CLUB

Blue Ridge Summit, PA 17294-0800

Please accept my membership in the How-To Book Club and send the 5 volumes listed below, plus my FREE copy of 6 Easy Home-Improvement Projects (343P), billing me \$3.95 plus shipping and handling charges. If not satisfied, I may return the books within ten days without obligation and have my membership cancelled. I agree to purchase at least 3 books at regular Club prices (plus shipping/handling) during the next 2 years and may resign any time thereafter.

Name _____
 Address _____
 City _____
 State _____ Zip _____ Phone _____
 Signature _____

Valid for new members only. Foreign applicants will receive special ordering instructions. Canada must remit in U.S. currency. This order subject to acceptance by the How-To Book Club. PPH1089



3053 \$19.95



2984P \$12.95

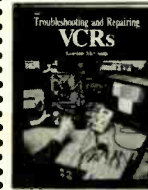

2960 \$26.95
Counts as 2



2971P \$10.95

THINK TANK

(Continued from page 23)

which the neon indicator lamps are mounted.

Switching diodes are used to fire the neon lamps when negative-peak modulation hits 50, 80, and 100 percent. To use the circuit, keep an eye on the lamps. You should attempt to keep the 50% lamp firing all the time, and the 80% lamp should be on as much as possible. But you should try to prevent the 100% lamp from lighting at all.

I know that you haven't done a great deal with amateur radio, and I thought I'd give it a shot with this circuit. —Martin Leandro, Austin, TX

Marty, I agree that it's time. In fact, it's past time. But we draw our circuits from guys just like you. If you want to see more amateur-related circuits, why just send 'em in!

Field-Strength Meter. While this is a project, the most-important thing was

an experiment I did with it! The project itself is a quick, throw-together circuit built essentially from junkbox parts. It's basically a FSM bridge circuit, using a 0-1-mA meter as a readout. But let's take a quick gander at the experiment. See Fig. 5.

I located an empty parking lot on a Sunday when the stores were closed, and brought a 50-foot length of clothesline with me. I marked a center spot in the middle of the lot, and had my wife hold the end of the line at the center. Using chalk, I drew a 50-foot circle by holding the line taut. Now I established a "north" position and intersected the circle with chalk at that point. I proceeded to mark (using a magnetic compass) the additional compass points at NNE, NE, ENE, etc. Now I pulled my car over the center mark so the car was facing north, the antenna directly over the center mark.

My wife keyed up the transmitter, and I moved from point-to-point around the circle, holding the field-strength meter

MORE AMAZING KITS: ... to challenge your imagination and allow you to construct projects as described below.

High Potential Force Field Generator

Construct a multi-functional HV module intended for the laboratory researcher, hobbyist, educator and science fair enthusiast.

- Build a directional ion ray gun, etc.
- Build a high speed ion motor
- Blast or drill sub-micron holes
- Build a lightning ball
- Create an anti-gravity effect
- Experiment with static electricity

HVM7 Plans \$8⁰⁰ HVM7K Basic Kit & Plans \$99⁵⁰



100,000 Volt Stun Gun



Construct your own high energy personal protection unit.

- Intimidating effect up to 20 feet away
- Research into muscle building

STG2 Plans ... \$7⁰⁰ STG2K Kit & Plans ... \$49⁵⁰

Solid State Tesla Coil

Construct a multi-functional electronic HF Energizer Module.

- Create swirling plasma tornado, and a plasma globe
- Build a "Jacob's Ladder"
- Experiment with high frequency energy

TCL4 Plans ... \$6⁰⁰ TCL4K Kit & Plans ... \$49⁵⁰



Miniature FM Wireless Mike

Construct a device that transmits sound to your FM radio, over considerable distances (up to 3 miles).

- Become your neighborhood disc jockey
- Monitor children/invalids
- Build a security system

FMV1 Plans \$6⁰⁰

FMV1K Kit & Plans \$34⁵⁰



Sound Activated Neon Beacon

Highly visible ignited plasma length varies with volume of sounds and music.

- Visual enhancement of music
- Excellent amusement for bars, recreational areas
- Attention getting for point of sales

SAN1 Plans ... \$6⁰⁰ SAN1K Kit & Plans ... \$49⁵⁰

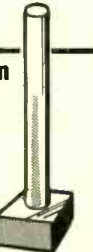

Ultrasonic Acoustical Generator

Build a pocket-size device capable of warding off aggressive dogs, other animals and intruders.

- Uses complex sonic shock waves as an intrusion deterrent
- Experiment in acoustical ultrasonics

• Deter rodents and other garden pests

UAG1 Plans ... \$6⁰⁰ UAG1K Kit & Plans ... \$49⁵⁰



CALL 1-800-221-1705 to order.

VISA, M/C Accepted. Or send Check or M.O. in U.S. funds (include \$3⁰⁰ per kit; \$1⁰⁰ per plan). Assembled kits are available. Send \$1⁰⁰ for catalog.

INFORMATION UNLIMITED

Box 716, Dept. PE Amherst, NH 03031 (603)673-4730

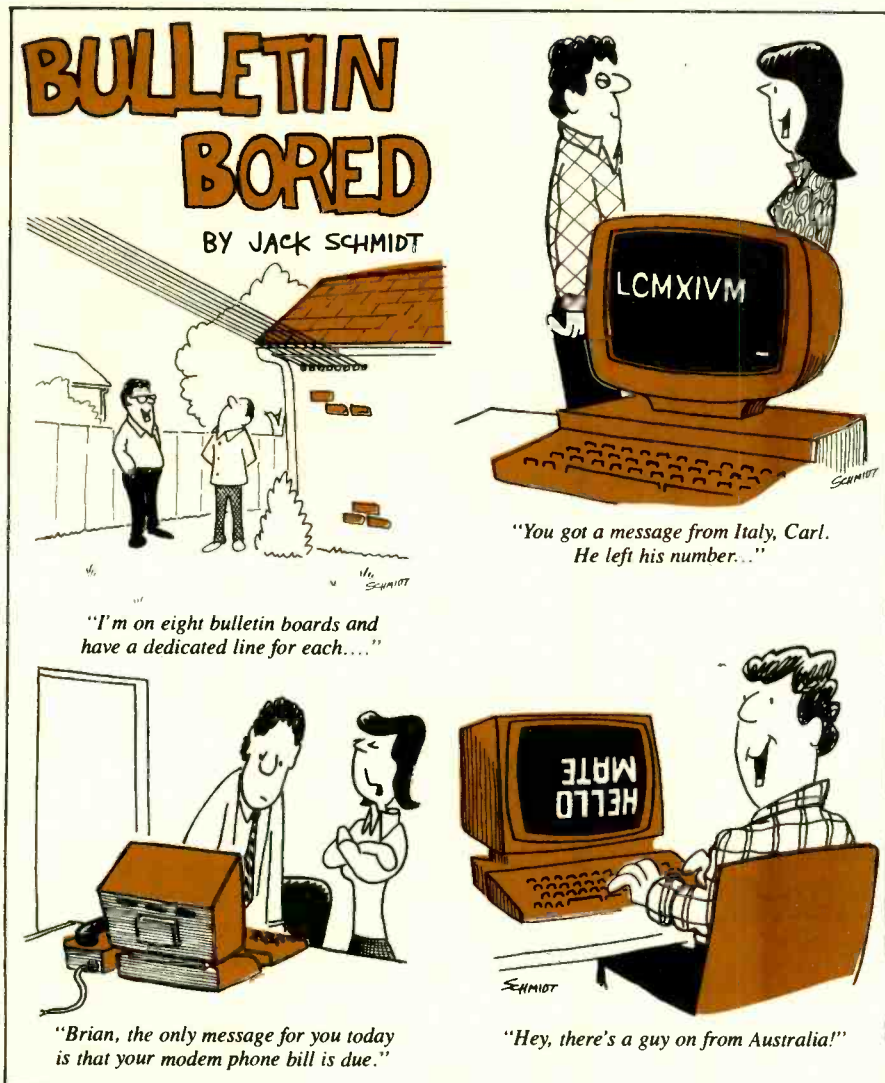

Handy 8 inch arm allows easy access to infrared emitters in

- TVs
- VCRs
- Computers
- Any IR beam

90 DAY MONEY BACK GUARANTEE!!

ORDER TODAY!

DuPerron Electronics
1724 Kippy Dr.
Colton, CA 92324

Only \$17.95 postage paid.
CA residents include 1.08 sales tax.
Please allow 2-4 weeks for delivery.

CIRCLE 7 ON FREE INFORMATION CARD

THINK TANK

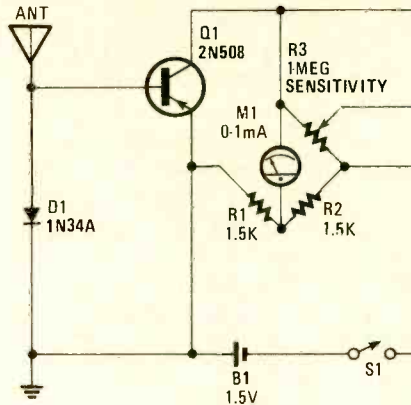

Fig. 5. The Field-Strength Meter is basically a bridge circuit, equipped with a 0-1-mA meter as a readout.

and recording the readings on a clip board marked on a sheet of polar-coordinate graph paper, as the parking lot was. When I'd finished, I had something really valuable. It was a pattern of radiation from my car antenna. Now I know where any dips are, which direction offers maximum field strength, and am able to orient the car for maximum transmission efficiency.

I know the experiment was more important than the apparatus, but I'd dearly love a copy of the Fips Book! — Michael Hernandez, Omaha, NE

Say no more, Mike! The book is on the way. Readers should be advised that to make this a more-permanent unit, carefully take the meter apart, reverse the meter face and paint the back of the scale white, then use rub-on type lettering to mark the meter face in "S" units. However, since this is a relative-reading meter, it really doesn't matter how the scale is calibrated.

Power Inverter. This circuit (see Fig. 6) can deliver high voltage AC or DC. It's a simple inverter set-up and can be used to power a Tesla Coil, a Jacob's Ladder, or a spark gap. While my circuit uses a pair of 2N3055's, by reversing the polarity, you could change those NPN's for PNP's. I should also point out that the resistor values are not critical, and anything from 1000 ohms to 2000 ohms should suffice. Talking about non-critical, the transformer can be any 6.3 or 12.6 volt type.

Apply the input voltage (12-volts DC) so the positive goes to the transformer's

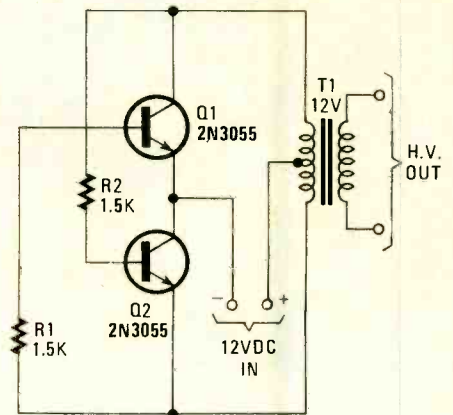

Fig. 6. The Power Inverter is built around a pair of 2N3055's fed from a 12-volt source. The transistors alternately turn on, creating a rising and collapsing magnetic field in the primary of T1, causing a voltage to be induced into the secondary winding of T1.

center-tap, and the negative goes to the two transistor emitters. Any bridge-type rectifier and filter can be used at the output if you need direct current. Is that good enough for a Fips Book, Byron? — Doug Hoff, Vacaville, CA.

You got it, Doug! But next time, send in some additional text with your diagram, huh?

One tree can make 3,000,000 matches.

One match can burn 3,000,000 trees.



HSC Halted SINCE 1963! Electronics Components & Test Equip.
specialties co. Prototyping & Hobby Supplies
Computers, Lasers & Optics

SPECIAL!

HSC #4715 ONLY \$7.50
5K OHM BOURN KNOB POT
SNAPS INTO PANEL
LESS THAN 1 SQUARE

ONLY \$7.50
IPF-122
N-CHANNEL POWER FET
TO-3 PACKAGE
8 AMP/100 VOLT
HSC #9837
MARKED WITH HEWLETT PACKARD PART NUMBER
INCLUDES DATA SHEET

Send \$1.00 for Giant Flyer
40 Pages of great deals

ATS-803A **\$198.00**
SANGEAN
A World of Listening

SALE!

56 Page BioMetal Guidebook
Extensive information on BioMetal, Micro and shape memory alloys in general. Discusses SMA history, benefits, uses, activation methods. With circuits, micrographs and more. 56 pgs, illustrated.
Order No. 3-002
BioMetal Guidebook \$9.95

Switches, Relays and Oscillators
A relay that switches 110 VAC with a 1-1/2 Volt battery? Test Also seal-welding contacts, and oscillating switch. Includes 5 cm BioMetal wire, spring, switch, latch, battery holder, guidebook. Uses one AA cell. Exciting & practical device.
Order No. 3-015
Switches, Relays and Oscillators \$6.95

Simple Android Parts
Explore the robotics of the future. Build models that mimic living systems like ears, elbows, tails, fluttering wings. Includes 7.5 cm BioMetal wire, rubber tubing, wires, workbase, spring, battery holder and guidebook. Needs two AA batteries.
Order No. 3-014
Simple Android Parts \$14.95

BioMetal from Mondo-tronics...
... Electric Movement Without Motors Or Solenoids!

BioMetal™ - The Electronic Motion Breakthrough

Mondo-tronics presents BioMetal, a highly improved nickel titanium Shape Memory Alloy (SMA) that shortens in length when electrically activated. Putting with over 3 Newtons (10 ounces) of force, the thin BioMetal wire offers an entirely new way of making things move.

Compared to NiTi, a popular SMA developed in the 1960's, BioMetal has a much longer lifetime and greater repeatability. BioMetal samples have been operated over 20 million cycles with virtually no change in performance. With BioMetal's SMAs can compete with the lifetime demands of motors and solenoids.

In many instances BioMetal outperforms motors and solenoids thanks to its longer lifetime, smaller size and very low mass. BioMetal's direct linear action can simplify designs, reduce costs, and increase overall performance. BioMetal has vast potential for use in everything from toys to robotics, almost any place requiring electrically driven action.

Shape Memory Alloys have crystal structures that can assume radically different forms at distinct temperatures. When passing an electric current, the wire shortens in length, and pulls with a usable amount of force. When cooled, BioMetal returns to its original shape. If not overheated or overextended, BioMetal will perform for millions of repeated cycles.

As performance depends on the heating and cooling rate, BioMetal's small diameter provides optimum results. BioMetal can be heated by electric current, with higher currents providing faster activation. Caution must be used to prevent overheating the wire. Cooling speed can be increased by coating the BioMetal wire with silicone rubber (which acts as a heat sink to draw the heat away), or even by immersing the wire in a fluid such as water with a small amount of glycerine.

In applications requiring greater strength, several BioMetal wires can be used in parallel. This gives much faster response than would a single larger wire having an equal cross-sectional area. Many unique and clever devices are possible using groups of wires - one only needs look at nature for examples of linear muscle contractions and their applications.

3 CONVENIENT LOCATIONS:

HSC of Santa Rosa 6819 S. Santa Rosa Ave. Cotati, CA (707) 782-2277	HSC of Sacramento 5549 Hamlock St. Sacramento, CA (916) 338-2545
--	---

**3500 RYDER ST.
SANTA CLARA, CA 95051**

**Call CA Residents & Info Toll Free Order Line
NOW! 408-732-1573 800-4-HALTED**

ORDERS ONLY, PLEASE...

CIRCLE 9 ON FREE INFORMATION CARD

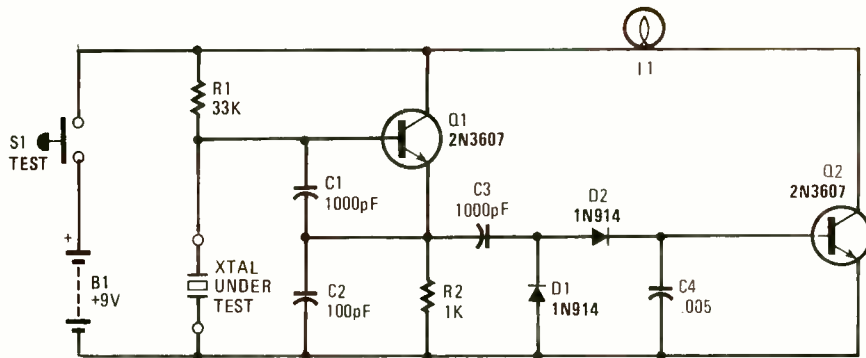

Fig. 7. The Crystal Checker—essentially an oscillator/amplifier with a broad frequency range—is built around two transistors, a couple of general-purpose silicon diodes, and a few support components.

Crystal Checker. I was going through my junkbox, and found myself faced with a huge assortment of crystals. Were they good or bad? The normal way of doing things is to build a circuit to operate at a particular frequency, then select a crystal that's rated for operation at a frequency that's as close to that desired as possible, and try it out. But I wanted something a bit more positive, so I built a crystal tester that works well enough to suit the purpose.

The Crystal Checker (see Fig. 7) is a simple circuit built around two transistors, a couple of general-purpose silicon diodes, and a few support components. When assembling your own version of the circuit, it is recommended that you place a crystal socket at the top of your housing, and make S1 (push-to-test) a momentary-contact switch.

To use the circuit, insert a questionable crystal in the socket, press S1, and if the lamp lights, the crystal is sound and working. If not, deep-six it.

The resistors can all be quarter-watt types, and you've probably got all the parts that you'll require in your junkbox. What you'll have to buy, if anything, can most likely be purchased locally.

The circuit is essentially an oscillator/amplifier with broad frequency ranges. Are those Fips Books still holding out Byron? —Sam Nasmith, Oklahoma City, OK.

Actually no, Sam. I'm sending your copy, but guys, we're running low. We'll still offer a reward for submitting circuits to Think Tank, but if you want a Fips book, shake a leg!

LED Light Chaser. This is an unusual light chaser that uses two strings of LED's. You can intermingle them with one string appearing as a mirror image of the other, or with both strings flashing at

random. They can be set for a single red lighting sequentially, and a single green going out sequentially. By flipping a switch, the red and green strings can be reversed.

Arrange the LED's in a circle with LED 1 at 12:00 o'clock, and the rest equally spaced to fill the circle. My own unit is built around a 2½-inch circle, but it can be any size and as many additional flip-flops and LED's as desired can be added. We placed the red ones at odd numbers and the greens at even numbers, however, any desired format can be used.

See Fig. 8. The flip-flops are wired as ring counters with the red ones connected to the Q outputs, and the greens to the \bar{Q} outputs. The switches in the clock circuit provide four clock speeds from very slow to very fast.

When S5 is flipped to the on position, the LED's flash at random and the lighting sequences might change each time the circuit is turned on. With the clock set at its slowest speed, the pattern becomes obvious.

When switch S1 is operated momentarily, a single red LED will light, and a green (the one ahead of the red) will go out. Flipping switch S4 very quickly changes the sequence to a green lighting and a red going out. You must have the clock going slowly to make S4 effective. In either case, a rotary motion will appear to take place.

Switches S2 and S3 allow you to change the operating frequency of the control oscillator, which consists of half a 7404 hex inverter (U5-a—U5-c). The addition of switches S2 and S3 allows the control oscillator to operate at four different frequencies.

—Thomas L. Conroy, Walpole, MA.

Interesting circuit, Tom. It's one I'm certain a lot of our readers are going to want to try. The use of red and green

AMAZING PLANS:

Step-by-step plans allow you to construct useful and amazing devices. Sources for all parts are included.



EML1 Electronic Coil Gun Launcher. Propels a projectile using a pulse of magnetic energy. EML1 Plans (parts indiv. available)\$8⁰⁰

GRA1 Gravity Generator. Electrical phenomena produces effect of anti-gravity. Great for science fair. GRA1 Plans (parts indiv. available)\$10⁰⁰

RUB4 Ruby/Glass Laser. Portable unit generates up to a 3000 watt pulse capable of piercing the hardest steel. RUB4 Plans (parts indiv. available)\$20⁰⁰

LC7 CO₂ Laser. 35 watts continuous burning or etching wood, cut plastics, drill, heat treat. LC7 Plans (parts indiv. available)\$20⁰⁰

BTC3 Easy to Build Table Top Tesla Coil. Produces 10-14" streamers. BTC3 Plans (parts indiv. available)\$10⁰⁰

TCC7 Tesla Coil. Engineering designs on 3 systems presently being operated in museums. TCC7 Plans\$25⁰⁰

Hard to Find Specialized Components

FLBKB - Three separate flyback transformers available for the price of one. Intended for hundreds of projects.

Order #FLBKB with free plans\$24⁵⁰

VG20 - 20KV rectifier diode used in many projects\$3⁵⁰

HVC1 - 1000 pfd at 15KV ceramic capacitor used in many projects\$3⁵⁰

CD25B - 25 to 50,000 volt miniature transformers used in stun guns, pulsers, etc.\$16⁵⁰

LE1HP - 2000 MCD high intensity narrow beam light emitter. Intended for use with simulated lasers, remote control communications and other optical applications\$5⁵⁰

LT4R - 4 to 5 MW helium neon laser tube. Includes plans for power source.\$149⁵⁰

PB12 - 12" dia. brilliant museum quality plasma balls with plans for power supply.\$195⁰⁰

CALL 1-800-221-1705 to order.

VISA, M/C Accepted. Or send Check or M.O. in U.S. funds (include \$1⁰⁰ S&H per plan). Send \$1⁰⁰ for complete catalog.

INFORMATION UNLIMITED
Box 716, Dept. PE Amherst, NH 03031 (603)673-4730

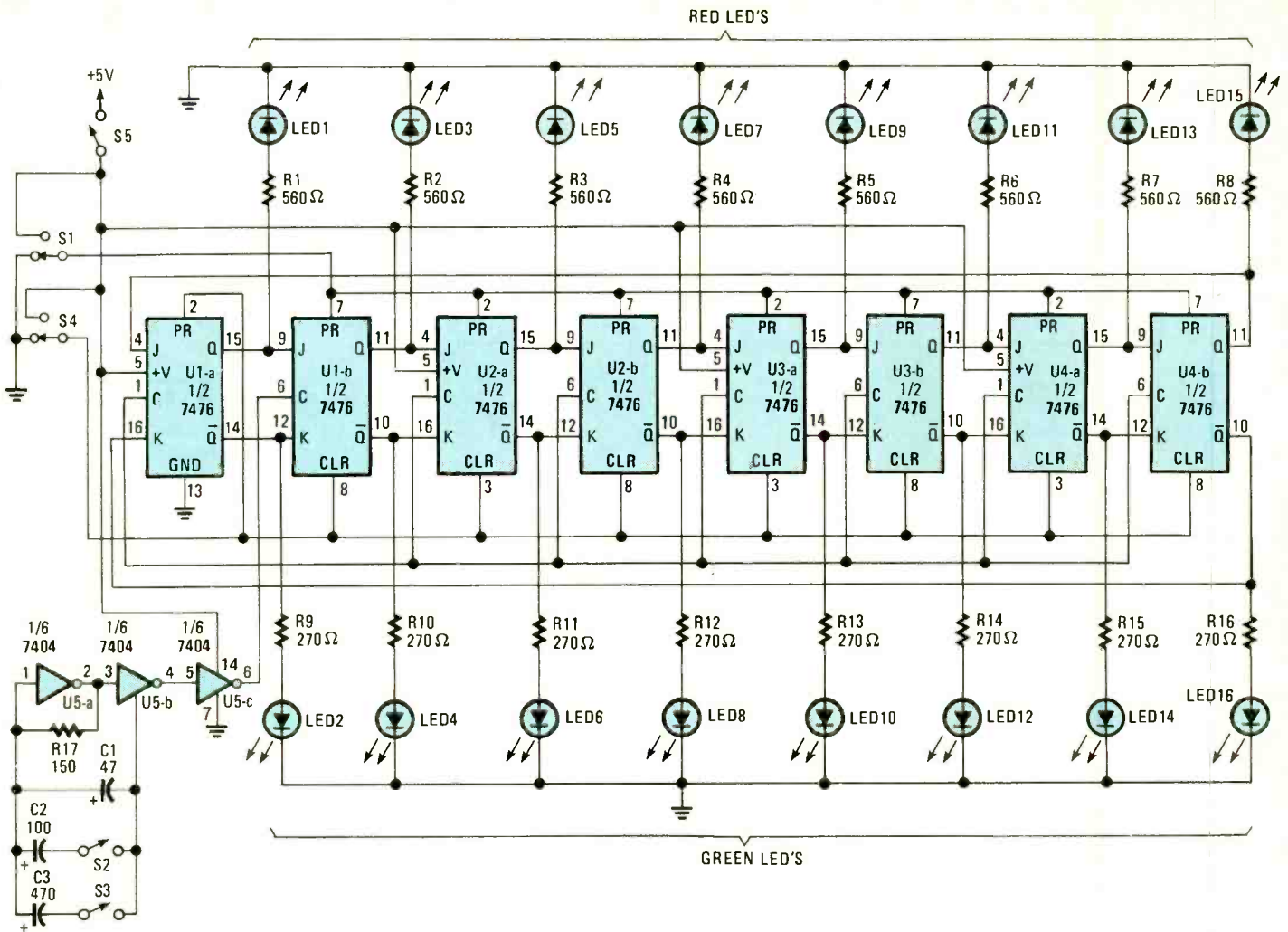

Fig. 8. This LED light chaser uses two strings of LED's connected to several flip-flops that are configured as a ring counter.

LED's makes me think that this could make a nice Christmas novelty, and if you start working on it now, you could

be ready for the holidays! Check off one more Fips book! That's all for this month. To see your

ideas in print, send them to *Think Tank*, Popular Electronics, 500-B Bi-County Blvd., Farmingdale, NY 11735. ■



\$3.50

THINK TANK

53 PAGES, OVER 130 PROJECTS!
SIMPLE, EASY-TO-BUILD AND USEFUL IDEAS FOR YOUR HOME, HOBBY, CAR.

■ HERE'S THE ANSWER to that eternal question among electronics hobbyists—"What will I do?" In WELLS' THINK TANK you'll find over 53 pages jam-packed with over 130 one-evening projects that will keep you absorbed. These are tantalizing devices that you can quickly put together and then use immediately. There are projects for your car, your home, your work bench, other hobbies, such as photography, music, and stereo. Telephone projects, light controls, and a vast assortment of miscellaneous do-it-yourself items. Flipping through the pages of this book, the question becomes "Which one will I start with!"

■ THE THINK TANK originally appeared in Hands-On

Electronics Magazine, and immediately won a good deal of reader acceptance. The mail poured in as readers offered their own circuits or asked for assistance with electronics projects they worked on.

■ WHAT KIND OF PROJECTS will you find in the WELLS' THINK TANK BOOK? The index, which occupies the entire back page, lists them. Choose from nearly a dozen amplifiers, an assortment of automotive projects from automatic parking lights to electronic air horns, battery chargers to battery monitors. You'll find fuzz boxes for your guitar to a tremolo unit. A darkroom timer for your photo buffs. And at a price of only \$3.50, you can't go wrong!

THINK TANK—Circuits for Experimenters and Project Builders!

169—Please send one copy of THINK TANK at \$3.50. Shipping \$1.25 (U.S. and Canada only).

169—Please send _____ copies of THINK TANK. Total cost is sum of copy price and shipping cost multiplied by number of copies ordered.

Please print

Allow 6-8 weeks for the material to arrive.

(Name)

(Street Address)

(City)

(State)

(Zip)

Detach and mail today:
POPULAR ELECTRONICS
BOOKSTORE
P.O. Box 4079
Farmingdale, NY 11735

All Payment must be in U.S. Funds!

PE1089

EXPAND YOUR CAREER HORIZONS...



The CIE Microprocessor Trainer helps you to learn how circuits with microprocessors function in computers.

START WITH CIE.

Microprocessor Technology. Satellite Communications. Robotics. Wherever you want to go in electronics... start first with CIE.

Why CIE? Because we're the leader in teaching electronics through independent study. Consider this. We teach over 25,000 students from all over the United States and in over 70 foreign countries. And we've been doing it for over 50 years, helping thousands of men and women get started in electronics careers.

We offer flexible training to meet your needs. You can start at the beginner level or, if you already know something about electronics, you may want to start at a higher level. But wherever you start, you can go as far as you like. You can even earn your Associate in Applied Science Degree in Electronics.

Let us get you started today. Just call toll-free **1-800-321-2155** (in Ohio, 1-800-362-2105) or mail in

CIRCLE 11 ON FREE INFORMATION CARD

the handy reply coupon or card below to:
Cleveland Institute of Electronics,
1776 East 17th Street, Cleveland, Ohio 44114.

CIE World Headquarters

Cleveland Institute of Electronics, Inc.
1776 East 17th Street • Cleveland, Ohio 44114

AHO-131

Please send your independent study catalog.
For your convenience, CIE will try to have a representative contact you — there is no obligation.

Print Name _____

Address _____ Apt. _____

City _____ State _____ Zip _____

Age _____ Area Code/Phone No. _____

Check box for G.I. Bill bulletin on Educational Benefits

Veteran Active Duty **MAIL TODAY!**

Just call toll-free **1-800-321-2155** (in Ohio, 1-800-362-2105)

“All I want is
fair prices.
Is that too
much to ask?”



There is a way to get better prices on programming. The American Home Satellite Association. An organization created exclusively to protect and enhance your enjoyment of your satellite TV system.

With AHSA's group buying power you'll save on premium services, superstations and basic programming services. Enjoy savings on accessories, equipment, and programming guides, too.

A place to turn for help.

From locating satellite signals to locating a reputable dealer, the toll free AHSA "Helpline" has the answer. AHSA provides educational videotapes and informative books, too. At very special member prices.

Plus, 10 times a year, AHSA's official newsletter, *Sky Report*, will bring you the latest word on products, legislation, programming, and more. Not to mention reviews of new products and services.

You're not alone anymore.

With your voice behind us, AHSA is promoting legislation to guarantee fair access at reasonable prices. Addressing zoning and piracy issues. Even sending expert witnesses to Congressional hearings. Join other dish owners around the nation, and become a force to be reckoned with.

Rush my free information kit.

Name _____

Address _____

City _____ State _____ Zip _____

Sign me up right away and send my complete membership kit.

Check enclosed for \$36 (made out to AHSA)

Bill my VISA MasterCard

Card # _____

Exp. Date _____

Authorized Signature _____

X _____

30-day Money Back Guarantee



**American Home
Satellite Association**

Return completed coupon to:
American Home
Satellite Association, Inc.,
Suite 800, 500 108th Ave. NE,
Bellevue, WA 98004-5560
Or call Toll Free
1-800-321-AHSA (2472).

QRB

Tapped Coil Crystal Radio

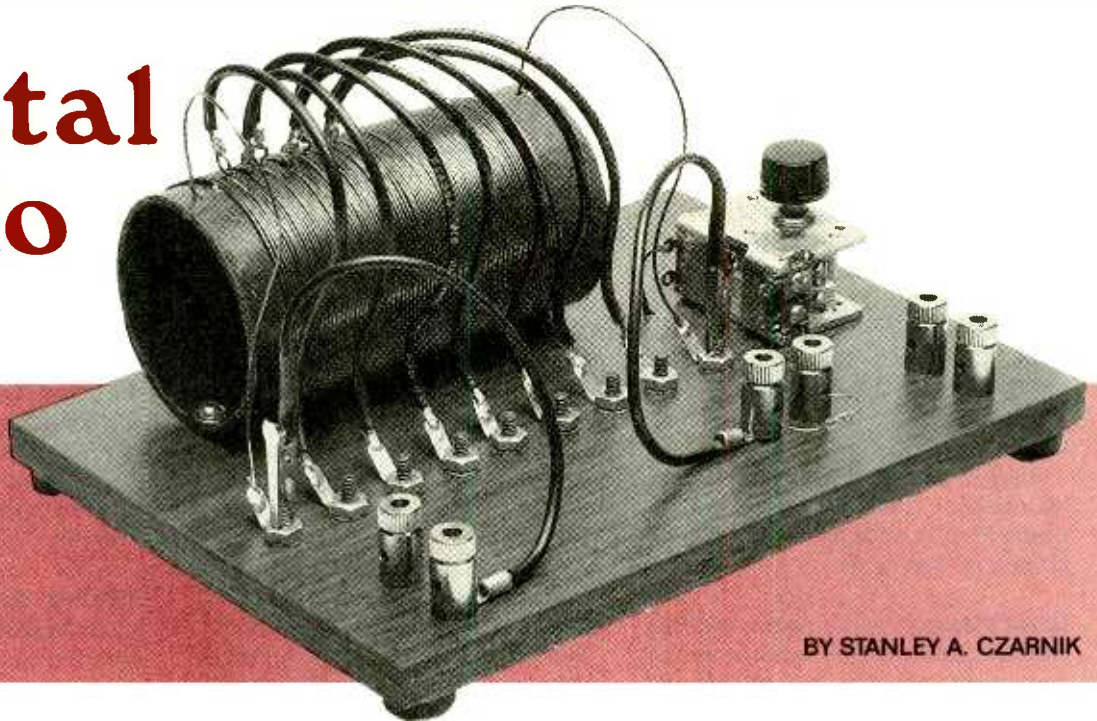

BY STANLEY A. CZARNIK

*There's many a way
to tune a crystal receiver.
This golden oldie does it
with a tapped coil
and variable capacitor.*

Tracing the origin of crystal radio-wave detectors (that's what they called 'em in Grandpa's day) can be a little tricky. One reason is that it took some time for experimenters to appreciate the nature of crystal detection and crystal rectification.

The first relevant discovery was made in 1874 by the German physicist, Karl Ferdinand Braun. Braun noticed that certain metal sulfides conducted electricity in an unsymmetric fashion. The current, in other words, would pass very easily in one direction, but with great difficulty, or resistance, in the other di-

rection. The effect, of course, is rectification, but Braun did not realize that until 1883. Finally, in 1901, Braun harnessed his crystal rectifier to the purpose of radio-wave detection.

Crystal Detectors. In the United States, it was H. H. Dunwoody who discovered the crystal radio-wave detector in the year 1906. The crystal was a piece of carborundum, otherwise known as silicon carbide. Silicon carbide is also the first solid substance known to be electroluminescent. Just imagine: strange illuminations from a crystal set! The phenomenon came to be called *Detektorleuchten*, literally, *detector lights*.

Crystal detection and rectification got a lot of attention. It was very quickly noticed that several natural substances could detect radio waves when in contact with a tiny metal point or small piece of fine wire. Among the substances tried were: galena (lead sulfide), iron pyrites (iron sulfide), molyb-

denite (molybdenum sulfide), zincite (zinc oxide), cerusite (lead carbonate), and silicon. The wire contact was most often made of gold, silver, copper, or bronze. There were many types of crystal-detectors, but each of them provided a means of holding the mineral specimen and a way of controlling the position and pressure of the wire contact, often called the *cat's whisker*.

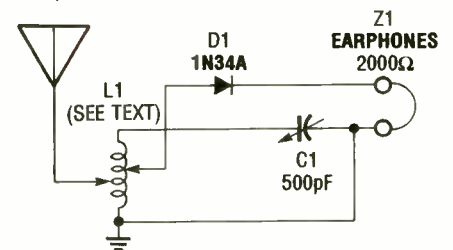

Fig. 1. What makes this crystal radio special is the tapped RF coil. Apart from that, the circuit is similar to many other simple crystal receivers. Exactly where and how the various parts and components are mounted is up to you, but follow the layout shown in the photos if this is your first radio project.

In some detectors, the cat's whisker was replaced with a second mineral different from the first. The two-crystal system was marketed under trade names like Periken Detector, the Pyron, and the Bronc Cell. The two-crystal detector, never very common, was actually more reliable than the conventional single crystal and cat's whisker arrangement.

Alternatives. The crystal detector was a very simple and, perhaps for that reason, a very popular radio-wave detection device. But it was certainly not the only one, nor was it always the best or the most sensitive. Prior to the final success of the vacuum tube in the 1920's, there were a wide variety of other detectors based on every conceivable physical principle. There were electrolytic detectors, electrostatic detectors, magnetic detectors, thermal detectors, primitive spark-gap detectors, and of course the famous *coherer*, which was often little more than a glass tube supplied with two electrodes and some iron filings.

There is also at least one recorded instance of a radio-wave detector made from, believe it or not, a disembodied human brain.

Brain Waves. In September of 1901, A. Fredrick Collins performed a series of experiments designed to "verify, if possible, the casual observation long since made that approaching electrical storms manifested their presence in persons afflicted with certain forms of nervousness and other pathological conditions, though the storm influencing them might be many miles beyond." Collins reasoned that, somehow, the brain picks up the electrical disturbances in the air just as a radio-wave detector reveals the presence of sparks from a spark coil.

Collins began by setting up a simple spark transmitter and an equally simple receiver connected to a couple of needles for insertion into his experimental brains. He started with an unidentified mammalian brain from the local butcher. According to Collins, it worked. He was encouraged, and went on to repeat the experiment with the living brain of an anesthetized cat. According to Collins, that worked too.

*If anybody knows or is able to discover more about A. F. Collins and his brain radio, I would very much like to hear from you. You can write to me in care of **Popular Electronics**—Stanley A. Czarnik

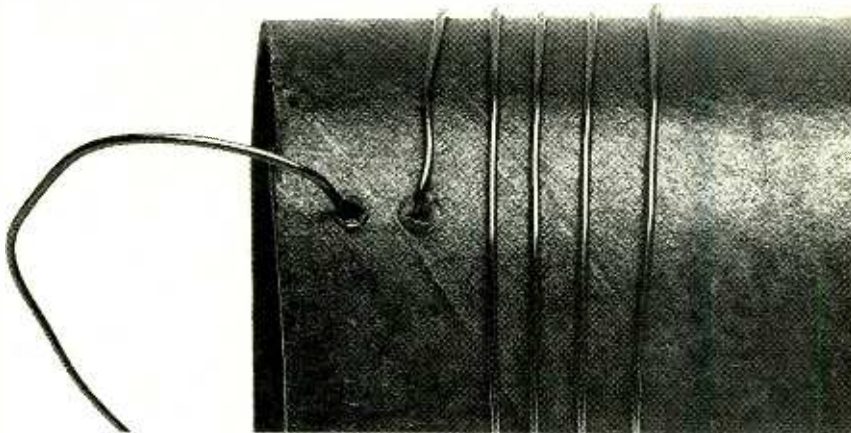

1 Begin coil L1 by pushing a length of 20- or 22-gauge magnet wire down and then up through two small holes punched near the end of the cardboard coil form. Follow that with 4 turns of wire around the tube.

Finally, and inevitably, Collins decided to try a human brain. "It is a most difficult object to obtain," he says. But he did find one, nice and fresh, a "magnificent specimen." He placed the brain on a slab of glass, inserted the needles, and completed the wiring using his battery-operated telephone receiver. Collins claims that the brain radio enabled him to listen to a bolt of lightning striking a house a quarter mile away.

Without a doubt, Collins' circuit ranks as one of the most ghastly and bizarre electrical devices ever constructed.*

(Incidentally, Collins was not unique in his interest in both human physiology and electronics. Indeed, many "re-searchers" of his day explored the ways that electricity could be used to ease human suffering. Many were well meaning and sincere; others had less altruistic motives. For more on that topic, see the article entitled "Electronic Quackery" elsewhere in this issue.)

The Project. You do, in fact, require a human brain to build a radio, but the

one you already have will do just fine! You also need a germanium diode, a 500-picofarad variable capacitor, a high-impedance earphone or headset, some magnet wire, and a few other odds and ends. The *Tapped-Coil Crystal Radio* described in this article features a tapped, radio-frequency coil and a fairly sensitive tuning system. Your radio will certainly operate without an internal power supply of any kind (see Photo 1).

Winding the Coil. What makes this radio special is the tapped coil (L1). It is also the most difficult part to make. However, building one is not nearly as difficult as it looks. There is an easy way to wind the coil. What's necessary is a medium-size nail, some adhesive tape, and a wooden dowel rod between 1/2 and 5/8 inch in diameter, six or more inches long.

Step 1. Obtain a spool of 20- or 22-gauge, copper magnet wire and a cardboard or thin plastic tube about 2 inches in diameter and about 6-inches long. Punch or drill a small hole about 1/4

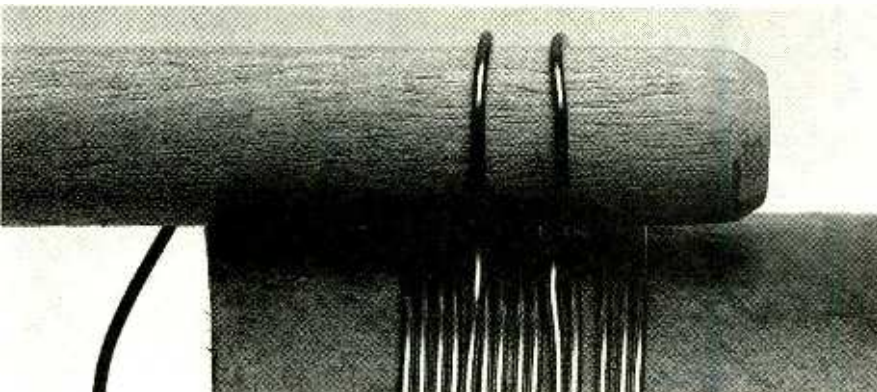

2 Wind every 5th turn of wire around a wooden dowel rod about 1/2 or 5/8 of an inch in diameter. Do that for the first 35 turns of wire. Pinch the wire in towards the bottom of the dowel rod with your fingers as you go along.

inch from one end of the tube. Punch another small hole right next to the first one and about 1/4-inch closer to the middle of the tube. Make the holes just large enough to accommodate the magnet wire.

Unroll 8 or 10 inches of magnet wire and push the entire length down through the second hole towards the inside of the tube. Now, push the wire up through the first hole towards the outside of the tube. Pull the wire gently until only a 1/4-inch length of wire lies between the two holes on the inside of the tube. The purpose here is to secure the wire at the end of the tube. That prevents the coil from unraveling. Wind exactly 4 turns of wire around the tube.

Step 2. Place the dowel rod directly over the holes and the 4 turns of wire (see Photo 2). Loop the wire around the dowel as shown in Photo 2. Gently pinch the loop in toward the bottom of the rod with your fingers. That loop of wire is destined to become a coil tap. Repeat the operation 6 more times, concentrating the windings together and counting the turns as you go.

Step 3. When you're finished you should have a total of 7 loops of wire over the dowel rod. Every loop over the rod will be separated by 4 turns of wire under the rod. In other words, every 5th turn for the first 35 turns will have a coil tap (see Photo 3). After placing the 7th and final loop over the rod, complete the RF coil by winding another 45 turns of wire around the tube. That makes a grand total of 80 turns of wire.

Now, before doing anything else, secure the wire next to both sides of the dowel rod with 2 long strips of adhesive tape. You will want to have the tape handy before you finish winding the coil. Taping the wire down is very important.

Complete *Step 3* exactly like you began *Step 1*, but at the opposite end of the tube. That means making 2 more holes, the first 1/4-inch away from the end of the tube, the second 1/4-inch away from the first. Run the wire down through the second hole and up through the first. Measure off an 8- or 10-inch lead and cut the wire at that point. There, you are now a true master coil winder!

Step 4. You're ready to twist your taps. Gently remove the dowel rod from under the wire loops. The loops should remain in their place; that is the purpose of the tape. Obtain a nail 2 or 3 inches long and about 1/8 inch in diameter. Place the nail in the first loop and

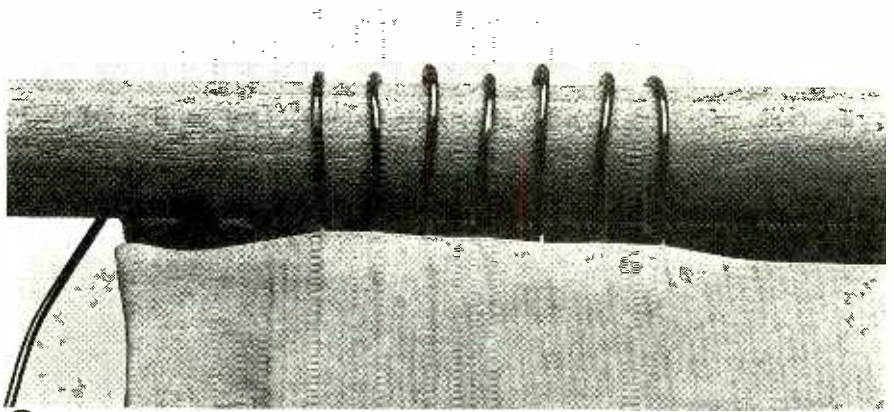

3 After winding the 35th turn of wire around the dowel rod, finish the coil with another 45 turns of wire. That makes a grand total of 80 turns. Tape the wire in place with two long pieces of adhesive tape. Each of the 7 loops of wire around the dowel rod is destined to become a twisted coil tap.

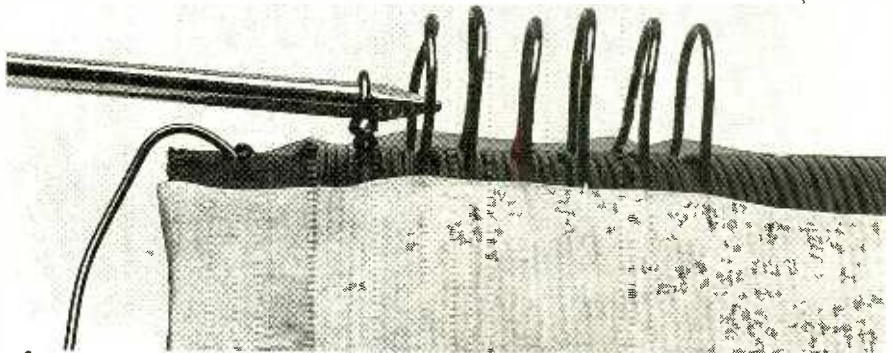

4 Now remove the dowel rod and, one by one, twist the loops of wire around once or twice with a nail about 1/8 of an inch in diameter. Do not put too much strain on the magnet wire. A little manual dexterity at this point really helps

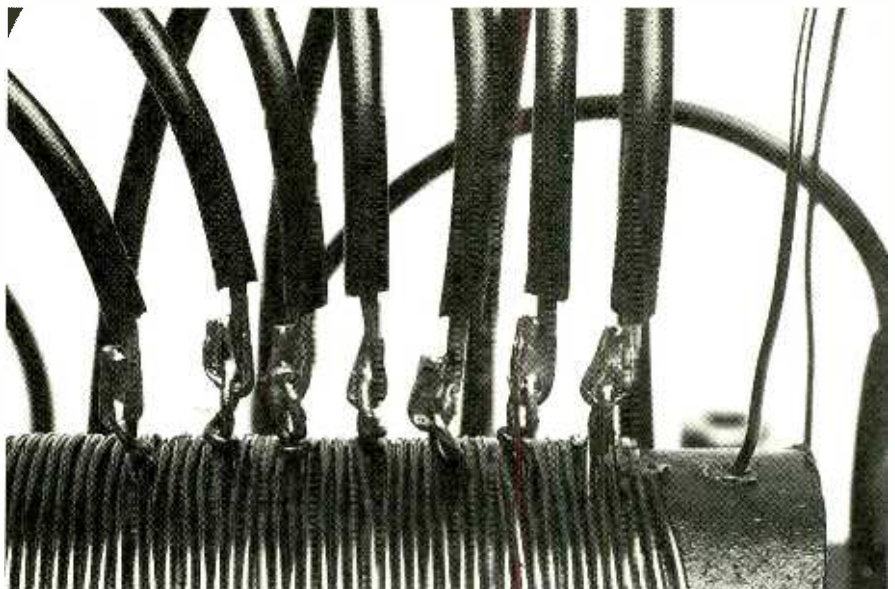

5 The twisted taps on top of your radio-frequency coil will look something like this when you're all done assembling your coil.

twist the wire around once or twice, or just enough to hold it (see Photo 4). Do not put too much strain on the magnet wire. Remove the nail and repeat the procedure with the other 6 loops.

When you're done, remove the adhesive tape. If you have twisted the taps

properly, the magnet wire will not move and the coil will not unravel.

Step 5. Your RF coil is complete, but you still need to wire it up. First get rid of the insulation on each of the twisted taps. One way of doing that is with the sharp edge of an X-acto blade.

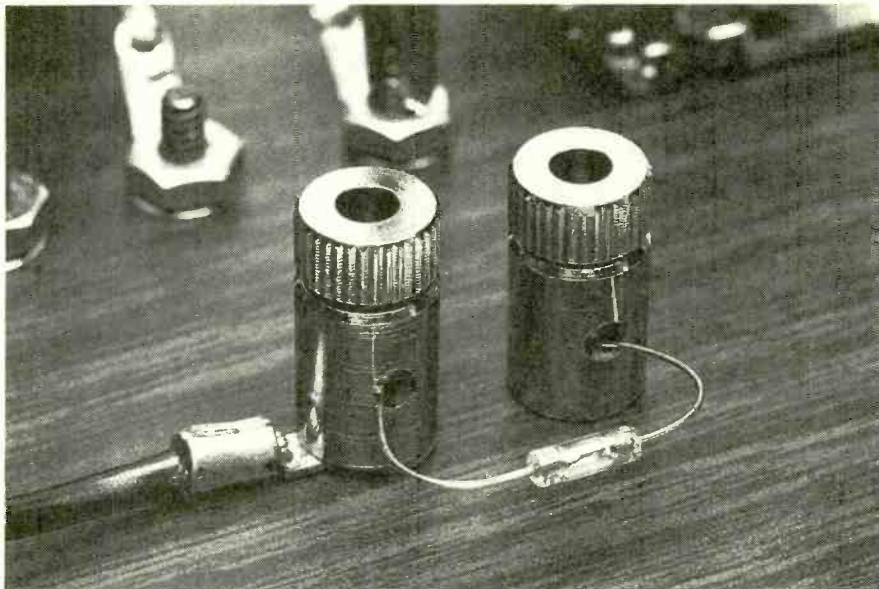

6 Do not solder the germanium diode (DI) permanently in place. Terminal connectors make it possible to experiment with various other diodes and even other detection devices should you ever wish to do so.

lugs and 9 machine screws, one for each coil wire, inserted from the bottom of the baseboard.

You also need a spot for the variable capacitor and places to attach the antenna, the ground, the earphone, and the germanium diode. It is a good idea not to solder the diode permanently to the rest of the circuit (see Photo 6). That makes it possible to experiment with various other diodes and even other detection devices should you ever wish to do so. I chose to use temporary connectors for the antenna, ground, and earphone as well.

Wiring. The radio circuit is not complicated and is similar to other simple crystal receivers (see Fig. 1). I recommend putting as many of the connections as possible on the underside of the baseboard. That contributes much to the finished appearance of the project.

PARTS LIST FOR THE TAPPED COIL CRYSTAL RADIO

- CI—500-pF, variable-tuning capacitor
- DI—1N34A germanium diode, or equivalent
- L1—Hand-wound coil (see text)
- Z1—High-impedance headphones, 2000 ohms or more
- 20 or 22 gauge magnet wire, cardboard or thin plastic tube (about six inches long and two inches in diameter), alligator clips (2), binding posts or Fahnestock clips (6), wooden baseboard (about 6" wide × 8" long × 3/8" thick), wire for antenna and ground connections (about 50 feet), soldering lugs, rubber feet, assorted hardware screws and washers, hook-up wire, solder, etc.

The Tapped Coil Crystal Radio is available as a kit from Yeary Communications, 12922 Harbor Boulevard, Suite 800, Garden Grove, CA 92640. The catalog number is DCTR-1-K and the price is \$10.00. Add 12% for shipping (minimum \$2.00) and \$1.75 for insurance. California residents add 6% sales tax. Also available from Yeary are *All About Crystal Sets* by Charles Green (\$7.95) and *Radios That Work For Free* by K. E. Edwards (\$7.95).

Finally, cut 7 lengths of hook-up wire each about 7- or 8-inches long. Strip 1/4 or 3/8 inch of insulation off one end of each piece of wire, and then, one by one, solder the wires to the coil taps (see Photo 5). You now have finished preparing the most difficult part of the Tapped Coil Crystal-Diode Radio.

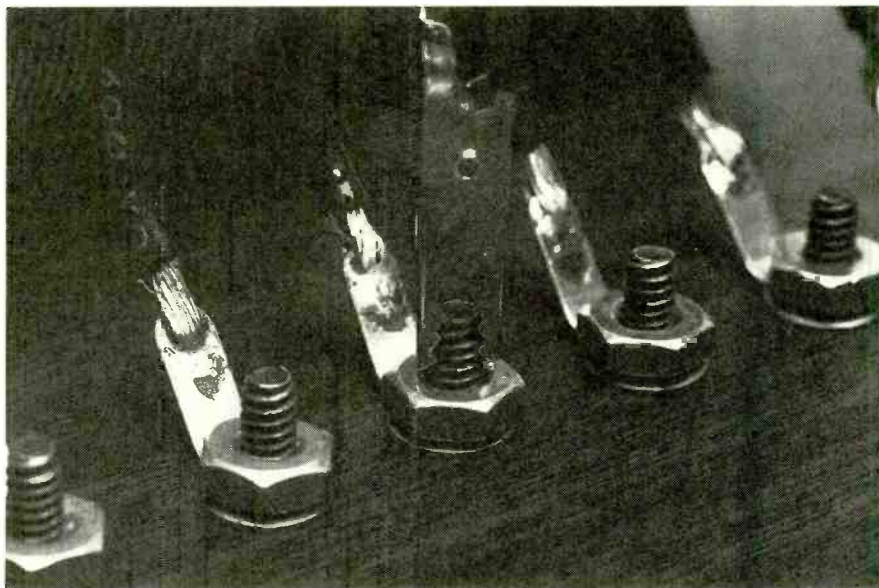

7 Each coil-tap lead wire is attached to a small soldering lug and a screw inserted from the bottom of the baseboard. Alligator clips provide a means of connection to the coil-tap terminals, and the screws provide a convenient, gripable surface.

Layout. The rest of the construction is actually very easy, but it does call for some attention to functional design. You need to think about how the radio will look when you're done with it. Exactly where and how the various parts and components are to be mounted is up to you.

The purpose of the taps on the radio-frequency coil is to provide access to a number of different inductor values. That means each tap lead, as well as the beginning and end of the coil itself, must terminate in some sort of connector. You can use Fahnestock clips or a terminal strip. I used some soldering

Drill all holes first, and that includes 4 holes for the rubber feet necessary to prevent the hardware at the bottom of the board from scratching up the furniture. Now mount the variable capacitor, coil-tap terminals, and binding posts. The radio-frequency coil, which is fairly delicate, should be mounted and wired last after all other connections on the bottom of the baseboard have been completed.

Attach two wires to the rotor (moving plates) of the variable capacitor, C1. Connect one of those wires to one of the earphone terminals and the other (Continued on page 105)

Voltage, by definition, is the electrical pressure that causes current to flow through a conductor. When that pressure is sufficiently high, a high voltage is produced. But how do we define high voltage? Is 100, 1000, or 10,000 volts considered high voltage? When compared to 10 volts, they all can be considered high voltage.

As far as safety goes, high voltage can be considered any voltage that endangers human life. It's obvious that 1000 volts poses a greater hazard than does 100 volts, but that does not mean that 100 volts is safe to handle. As far as safety goes, 100 volts is still considered high voltage—and that fact must be understood.

The *Miniature High-Voltage DC Generator*, presented in this article, is capable of generating around 10,000-volts DC. So high a voltage can ionize air and gases, charge high-voltage capacitors, and can also be used to power a small laser or image tube, and has many other applications that are useful to both the experimenter and the researcher.

Circuit Description. Figure 1 is a schematic diagram of our Miniature High-Voltage DC Generator. The circuit is fed from a 12-volt DC power supply. The

input to the circuit is then amplified to provide a 10,000-volt DC output. That's made possible by feeding the 12-volt output of the power supply to a DC-to-DC up converter. The output of the up-converter is then fed into a 10-stage, high-voltage multiplier to produce an output of 10,000-volts DC.

Let's see how the circuit works. First, let's start with U1 (a 14584 hex Schmitt trigger). Gate U1-a is set up as a square-wave pulse generator, which provides a very clean square-wave (pulsating DC) output. The output of U1-a is fed to the inputs of U1-b to U1-f, which are connected in parallel to increase the available drive current.

The pulsating output of the paralleled gates is fed to the base of Q1, causing it to toggle on and off in time with the oscillations of U1-a. The collector of Q1 is connected in series with the primary winding of T1. The other end of T1 is connected through C2 (a 220- μ F unit) to ground. Capacitor C1 retards the rise and fall times (sloping leading and trailing edges) of the square-wave DC signal, producing an AC-like, DC waveform.

The on/off action of the transistor, caused by the pulsating-signal applied to Q1, creates a rising and collapsing field in the primary winding of T1 (a small ferrite-core, step-up transformer).

Learn how very-high voltages are generated from relatively low power sources and apply the same techniques to your own experimental circuits

BY VINCENT VOLLONG

High-Voltage DC Generator

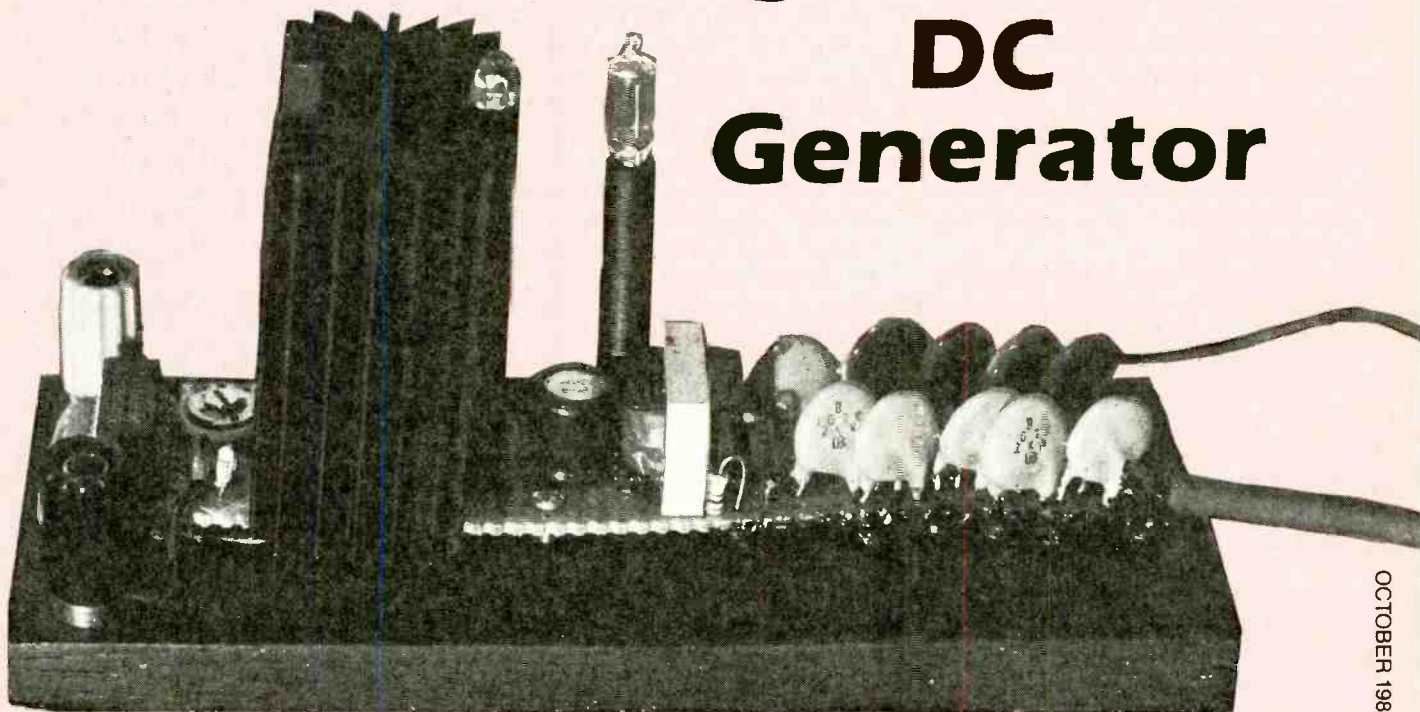

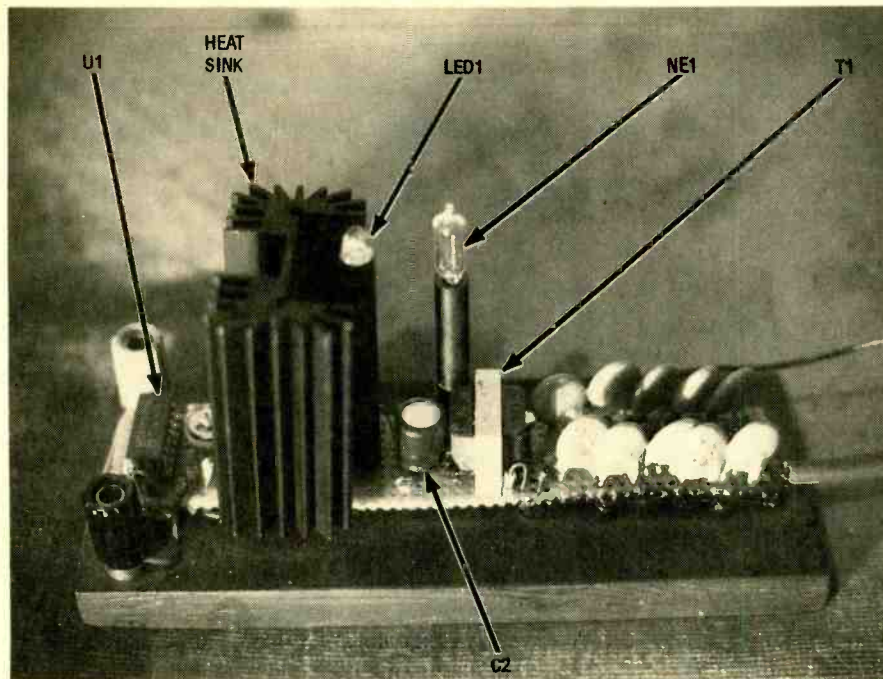

In the author's prototype, LED1 and NE1 were mounted to 1/2-inch stand-offs, and the entire circuit (minus the power supply) was mounted to a block of wood. The wood block helps to isolate and insulate the circuit board from any metallic objects.

tors must be rated for at least 2000 volts each. Because diodes with that voltage rating can be hard to find and expensive, D1 through D10 are each really two series-connected 1-amp, 1000-volt rectifier diodes.

Construction. The unit can be assembled on perfboard, as is the case with author's prototype shown in the photo. Transistor Q1 must be properly heat sunk or it will overheat quickly and self destruct.

The multiplier must be assembled in such a way so as to prevent any ion leakage. When a high-voltage source is terminated at a sharp point, the density of charge is concentrated at that point. The ions both on the point and near the point are like charges, so they repel each other and quickly leak off. So it is very important when soldering the multiplier to keep all connections rounded by using enough solder to make a smooth, ball-like joint.

The solder side of the multiplier should be insulated to prevent contact with any metallic object. On the author's prototype, a high-voltage insulating compound was used on the solder side of the board. High-voltage putty can also be used. Also in the prototype, the output of the circuit is simply a heavily shielded wire, like that used to feed high voltage to the anode of a TV picture tube. That type of wire can safely handle voltages in the 15,000-

20,000-volt range, and will also help to prevent leakage.

Positive and Negative Ions. The polarity of the diodes in the multiplier will determine the polarity of the ions. In the author's prototype, the multiplier is set up to generate positive ions. If the diodes were reversed, negative ions would be produced.

In a positive-ion generating multiplier, like that used in the author's prototype, which generates approximately 10,000 volts DC, the output is a shock hazard. A negative-ion generating multiplier with a -10,000-volt DC output, offers the same shock hazard as the positive +10,000-volt output.

Experiments. If you place the high-voltage output wire about 1/2 to 3/4 inch from a ground wire, you will draw a spark of 10,000 volts. But remember, the oscillator is built around a CMOS device, which is static sensitive, and any high-voltage kickback will toast the unit. So when experimenting with the spark, do not use the circuit ground. A more reliable method would be to draw a spark to an earth ground.

Flash Lamp Electric Storm. When the output of the Miniature High-Voltage DC Generator is connected to a small flash tube, the high voltage ionizes the Xenon gas in the tube, creating a small electrical storm within the tube's glass envelope.

Getting Different Voltages. By tapping the multiplier circuit at various stages you'll get output voltages ranging from 1,000 volts to 10,000 volts DC. For instance, by placing a tap at the cathodes of D2, D6, voltages of 2000, and 6000 volts are made available.

Troubleshooting. If you get no output or a low output from the circuit, check that the input to logic gates is below 15 volts. The application of an input voltage exceeding that limit will blow out the IC. Also check (with an oscilloscope) that you get a square-wave output of approximately 12 kHz at pin 6 of U1.

The switching transistor must be mounted on a heat sink or it will overheat. Make sure the heat sink is of a suitable size to keep the transistor cool.

If a 2-kilovolt (kV) diode is placed at the output of transformer T1, you should get an unloaded output of approximately 800 to 1000 volts DC.

If you have a problem with the output of the unit, it is best to disconnect the multiplier from the oscillator and check the output of the transformer. In that way you will know if the problem lies in the oscillator or the multiplier.

The multiplier components must be rated for at least twice the input voltage. The diodes and capacitors used in the multiplier circuit should be rated at 2000 volts. However, you may choose to do as the author did; use two series-connected 1-kV units for each diode in the multiplier to give an effective rating per pair of 2 kV.

Safety. The output of the circuit is high-voltage DC, which will cause an electric shock if touched. So use caution. Also with the circuit turned off, the capacitors in the multiplier are still charged, and will discharge through the path of least resistance—your body—if you comes in contact with the circuit. So discharge the circuit by connecting the output lead to ground with the power off.

The Miniature High-Voltage DC Generator emits a fair amount of ozone. If the circuit is to be operated for a long period of time, make sure that you do so in a well ventilated room. Ozone is harmful in moderate to large quantities.

When drawing a spark discharge, the circuit emits radio and television interference. That can be seen as static lines on your television set or heard as noise on your AM radio.

A new age for radio is on the horizon. An age where your car radio will scan the skys for traffic information, page you, or play only what you wish to hear.

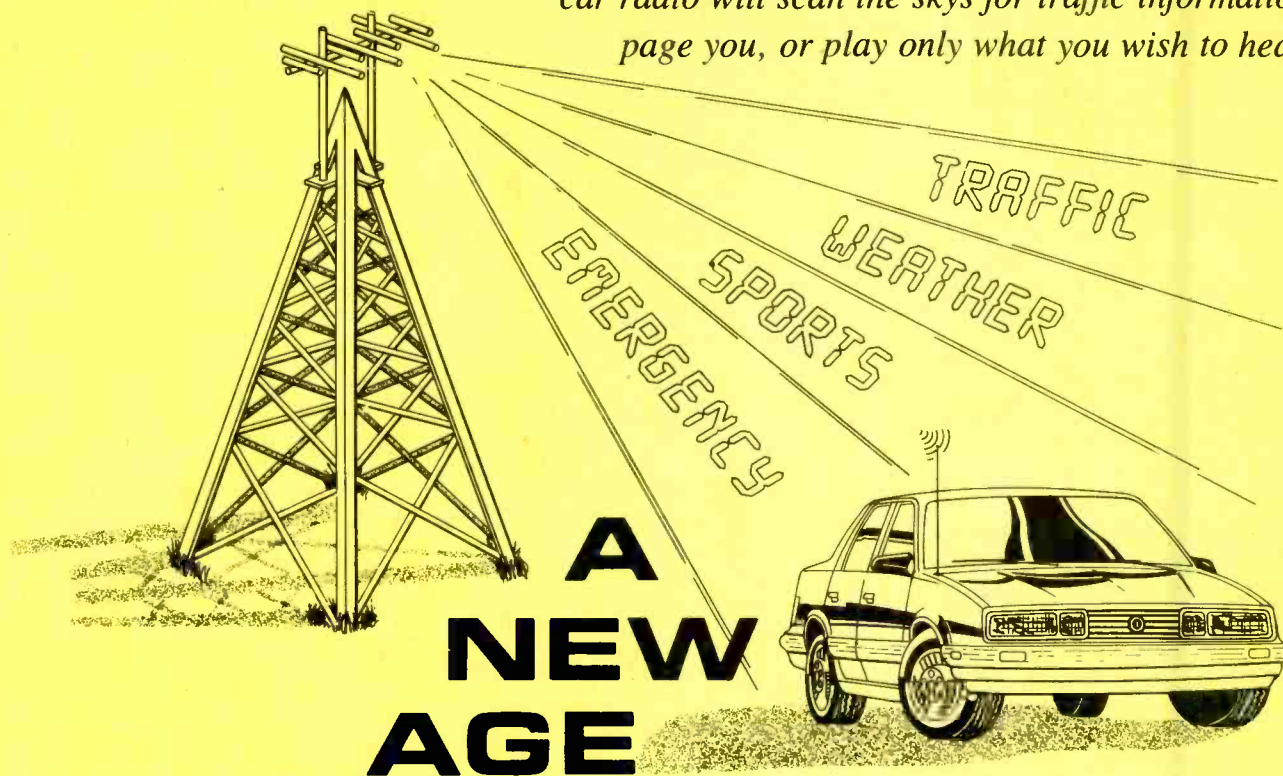

A NEW AGE FOR RADIO

BY GERRY L. DEXTER

Imagine this: you are tooling along on the freeway, just tickling the speed limit. The cassette player in your dash is pumping out rock at wattage that could power a small city. Suddenly, in mid-song, the music is interrupted and a synthesized voice informs you that a serious accident has occurred a few miles ahead on the route you're traveling, creating a traffic snarl. You compensate by slowing down and exercising greater caution.

That scenario is no pipe dream; in Europe it's already a reality. In fact, informing you of traffic conditions is just one of many new tricks that special radio receivers will be able to perform when they take advantage of the Radio Data System (or RDS)—a method of encoding special information onto FM subcarriers. The technology already exists, but the U.S. can't use it until the FCC lays down the ground rules.

Once it's implemented, RDS will make home, portable, and especially car radios far more responsive to an individual listener's particular needs. RDS will not only improve upon existing radio services, it will also offer a number of exciting new benefits.

For example, at home an RDS radio could flash news bulletins and other information as text on a small display

screen built right into the radio. On the road, should a motorist move out of a radio station's range, an RDS radio will be able to automatically tune itself to another frequency carrying the same program content. The motorist who wants to hear news, classical music, current affairs, or any of a number of different program types can instruct his car radio to find it for him, even if he travels from state to state!

The RDS Signal. The Radio Data System consists of intelligence placed on a subcarrier and inserted by a radio station at the input to its transmitter. It has some similarities to Sub-Carrier Authorization (or SCA)—transmissions used by FM broadcasters to supply reading services for the blind, background music, medical news, etc.—in that it is an additional component to the FM signal and requires a special receiver to pick it up. However, with RDS

the intelligence is placed on a 57-kHz AM subcarrier within a broadcaster's channel space (see Fig. 1). RDS can only be implemented on the FM-broadcast band because of the bandwidth required.

RDS data is sent in digital form at 1,187.5 bits per second, and is transmitted in "blocks" of 26 bits each (see Fig. 2). Each block contains a 16-bit "information word" representing the intelligence, and a 10-bit "check word" for error checking. Four such blocks make up a "group."

The RDS system allows for a total of 32 different kinds of groups each containing a specific type of information (one for paging, one for noise-reduction data, etc.) At present, less than half of the 32 group types have been designated for specific applications.

The order of the groups and their content determine which job they can perform. The groups can be inserted into a transmission in various sequences to tailor a system to the needs of any given country.

Generally speaking, RDS signals contain two types of information: information for the receiver—enabling it to respond intelligently to signals from a radio station (for example, noise reduction and bandwidth data)—and

RDS Data Groups

Here is a list of the various groups of information currently used by the RDS. Each has a special abbreviation listed in parenthesis.

Program Identification (PI)—A data code which enables the receiver to tell the difference between countries or areas where the same program is being transmitted. It also provides an identification of the program and would enable a radio to automatically locate another station airing the same program.

Program Service Name (PS)—Data in this group would be used to display an eight-character name or abbreviation for the network tuned.

Program Type (PTY)—Used to identify a particular type of program. The listener could instruct the radio to tune for jazz, classical, rock, news, etc. Up to 30 different program classifications could be selected from.

Traffic Program Identification (TP)—An ON/OFF signal that would turn an indicator on the receiver on to indicate the radio was tuned to a station or service that frequently aired road and traffic information.

List of Alternative Frequencies (AF)—Up to 25 frequencies of stations airing the same program or service could be listed so receivers with memories could find alternate channels more quickly.

Traffic Announcement Identification (TA)—An ON/OFF signal to alert the motorist to a traffic announcement. The data signal could switch the radio over from cassette mode, switch it on from the "standby" mode, or change stations in time to catch the announcement.

Decoder Identification (DI)—A signal to switch the decoder between stereo and monaural.

Music-Speech (MS)—This signal would tell the receiver whether music or speech was being transmitted and allow future radios with dual volume controls to be better adjusted to individual taste.

Program Item Number (PIN)—This data would allow the user to set the radio to respond to a particular program; *i.e.* the radio could turn itself on and locate the program desired, doing so at the proper date and time.

Radio Text (RT)—Text (news and so on) for display on the radio receiver.

Information Concerning Other Networks (ON)—As many as 25 alternative frequencies or as many as 8 other networks can be stored. That would allow the radio to know where to look for a particular network as the motorist moves from one service range to another.

Transparent Data Channel (TDC)—A radio-text service sent in a format applicable to display on a TV screen. Such data could also be used for computer-program transmission.

In-House Application (IH)—For use within the broadcaster's own facility (For example, source of transmission information, in-house paging, etc.)

Clock-Time and Date (CT)—Data would cause the correct time and date to be shown on the receiver display. One would never have to reset the clock, even if one moved through different time zones. ■

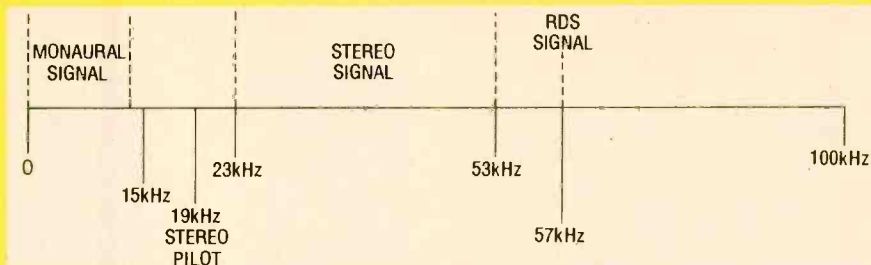

Fig. 1. Here we show the Radio Data System subcarrier as part of the FM broadcast signal. The subcarrier is AM, so it occupies a single frequency and not a range of them.



An RDS receiver can find the exact information you wish to listen to and indicate the program content in alphanumeric form on its display.

those that enable the broadcaster to communicate directly with the listener through a display built into the receiver itself or a voice synthesizer. As it is currently designed, the RDS system has provisions to perform over a dozen specific tasks (see the boxed text entitled *RDS Data Groups*.)

The History of RDS. Before RDS got rolling in Europe, England's British Broadcasting Corporation (BBC) tried to get radio manufacturers to make RDS radios, but the firms weren't interested in building something that could receive signals that weren't even there to be picked-up. So the BBC began equipping its VHF FM-broadcast stations with some basic RDS services; which is like creating the chicken and hoping the egg will follow.

Of course, now manufacturers are involved. Phillips has developed an RDS radio, and Sony and other Far-East firms have gotten into the act as well. Even

the BBC itself decided to market an RDS set under its own brand name.

RDS designers envision several possible RDS receiver designs. For instance, a scanning receiver with two front ends: one to receive a program in progress and a second to silently search for other frequencies carrying the same program, network, or program type. Such a receiver could store information about alternative frequencies and choose the strongest if the current one drops-out.

Other features include displays that could present station or network names, country of origin, program information, time, date, or other text.

Although the BBC has been a major player in promoting RDS, it hasn't been alone. The effort in creating RDS has largely been a Europe-wide affair. Austria, Finland, West Germany, Italy, Holland, and Sweden have all brought RDS into being, and most of the continent will have at least a partial system in operation by 1990.

In fact, a continent-wide standard was adopted by the European Broadcasting Union after ten years of design work and on-the-air tests dating back to 1974. The single standard will allow a motorist to drive from one country to another and still be able to enjoy his RDS receiver, even though specific RDS services may vary from country to country.

RDS will, however, be particularly welcome in the United Kingdom where a reworking of their overall broadcasting scheme is creating more and more
(Continued on page 102)

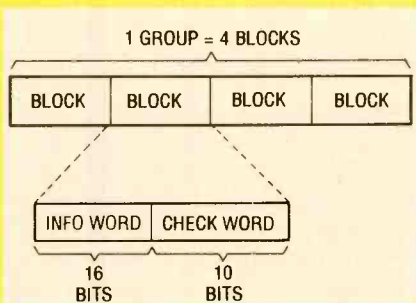

Fig. 2. This is the breakdown of one group in an RDS signal: one group is composed of four blocks; each block contains a check word of 10 bits and an info word of 16 bits.

How would you like to tune in the BBC, Radio Moscow, South America, and trouble spots around the world while driving to work, or even while vacationing? The *HPS Converter* connected to your car's radio can make it possible!

The HPS (*High-Performance Shortwave*) Converter is a simple project that can be assembled in just a few hours. You can make your car a traveling shortwave-listening post.

Several one-transistor shortwave-converter circuits have been published recently and they will all work, but the HPS Converter outperforms all of them. The converter circuit uses the Signetics NE602 frequency-converter integrated-circuit chip. One evening, with just a 3-foot antenna, I logged over 30 stations between 9.5 and 10 MHz, and about ten of them—including the BBC from England, as well as stations from France, and Austria—were loud and clear like listening to local broadcast stations. Signal selectivity is much better than with most shortwave radios priced under \$150, and tuning is easy because a single, popular shortwave band stretches across the whole dial.

Why a Car Radio? Car radios are among the best AM receivers made. They have to endure vibration and give decent reception with a puny antenna. Think about it: a 33-inch whip is only $\frac{1}{360}$ th of a wave at 1000 kHz, so the length for a $\frac{1}{4}$ -wave antenna at that frequency would be 90 times longer.

Not only that, but car radios are well shielded to keep out electrical noise coming from the engine. Their metallic cases make them ideal to use with converters. You can be sure the car radio won't hear anything but the tuned station entering through the antenna jack; local AM stations won't intrude on your shortwave listening.

In fact, you must use a car radio. Other kinds of receivers with antenna jacks don't work well with the converter, because they usually use the external antenna to supplement, rather than replace, the built-in loop. As a result, there's no way to keep AM broadcast signals from blanketing the dial.

Best of all, AM car radios are cheap, because people get rid of them when they upgrade to FM stereo. I bought one at a swap meet for one dollar. If you can't find a deal like that, go to a



High-Performance Shortwave Converter

junkyard or a car-stereo dealer and offer up to \$5 for a working AM radio. Any AM/FM set will work equally well, of course, on the AM band.

Frequency Conversion. Figure 1 shows the schematic diagram of the HPS Converter circuit. The NE602 chip, U1, contains oscillator and mixer stages. The mixer combines the oscillator signal with the input RF (*Radio-Frequency*) signal to produce signals whose frequencies are the sum and difference of the input frequencies. For example, an 8.5-MHz oscillator and a 10-MHz incoming signal will give output signals at 18.5 MHz ($10 + 8.5$) and 1.5 MHz ($10 - 8.5$). Re-

call that 1.5 MHz is 1500 kHz and an ordinary AM radio will tune to it. The other output, 18.5 MHz, is so far out of the broadcast band that it won't have any effect on the AM radio. Both the original signal at 10 MHz and the oscillator signal at 8.5 MHz are seen at the output, but the radio will tune them out.

The choice of crystal depends on what shortwave band you want to hear. The most active band at night is 5.9–6.5 MHz. To hear that band on an AM radio, you can use a typical 5-MHz micro-processor crystal in the oscillator. The 9.5–10-MHz band is less crowded and includes the time-signal station WWV. For that band, you'll need a crystal of

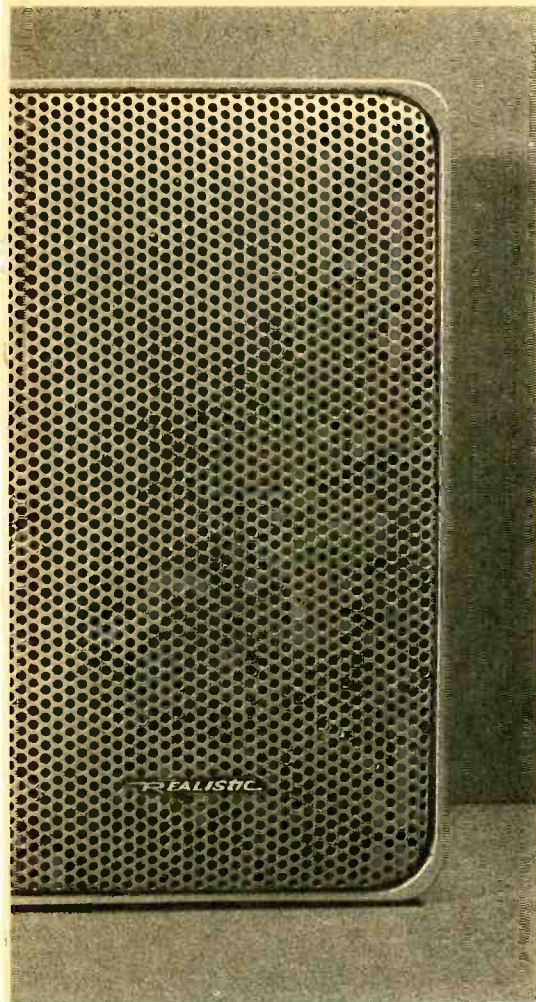

A car radio and our high-performance shortwave converter can put your shortwave-listening hobby on the road.

around 8.5 to 8.9 MHz. There is no standard microprocessor crystal in that range, but you can use an amateur-radio crystal, have a crystal custom-made, or use a CB crystal.

Why a CB crystal? CB crystals oscillate at around 27 MHz in their third-overtone mode. In this circuit, however, they'll oscillate on their fundamental frequency, which is only a third as high. For example, a channel-5 receiving crystal is rated at 26.560 MHz and oscillates at 8.853 MHz in this circuit—ideal for the 9.5–10-MHz band. Any CB crystal, receiving or transmitting, will get you at least part of that band, though with some high-channel CB crystals you'll lose stations below about 9.6 MHz.

The Filter Circuit. Transformer T1 rejects signals that are outside the band you are interested in. If T1 weren't there, you'd hear signals below the crystal frequency as well as above it. That is called imaging. Here's an example: A 7.5-MHz signal is picked up by the antenna and mixes with the 8.5-MHz oscillator frequency. The difference between those two signals is 1 MHz—right in the center of your AM dial. Thus, transformer T1 should pass signals from 9 to 11 MHz and attenuate all others.

The transformer, T1, used in the circuit is a 10.7-MHz IF transformer salvaged from an FM radio. They are fairly easy to obtain new from parts stores and mail-order houses. Most 10.7-MHz IF transformers will tune across the 9.5- to 10-MHz band without modification; all you need to do is turn its tuning slug. To get the 6.0- to 6.5-MHz shortwave band, you'll have to add a 150-pF capacitor (C1 in the diagram).

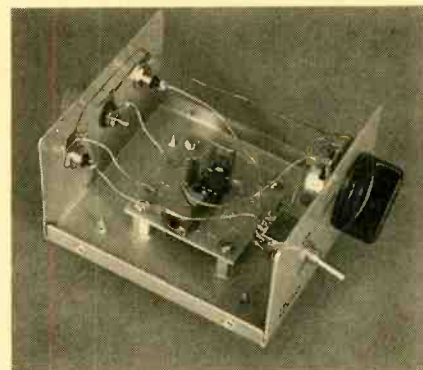

As you can see the converter can be placed in a very small cabinet if you wish to conserve space. As long as the enclosure is metal that will not cause any reception problems.

The GAIN control, potentiometer R1, prevents overloading from extremely strong signals. It's wired backward, compared to the usual configuration for a GAIN control, so that T1 will always see the same resistive load. If your antenna will always be short—under 6 feet—you can omit R1 and connect the antenna directly to T1, terminal 1.

Construction. The HPS converter was



The rear panel of the converter housing reveals the two jacks for connecting the antenna and receiver. The center jack goes to the 12-volt DC supply. The power-supply ground is the cable shield.

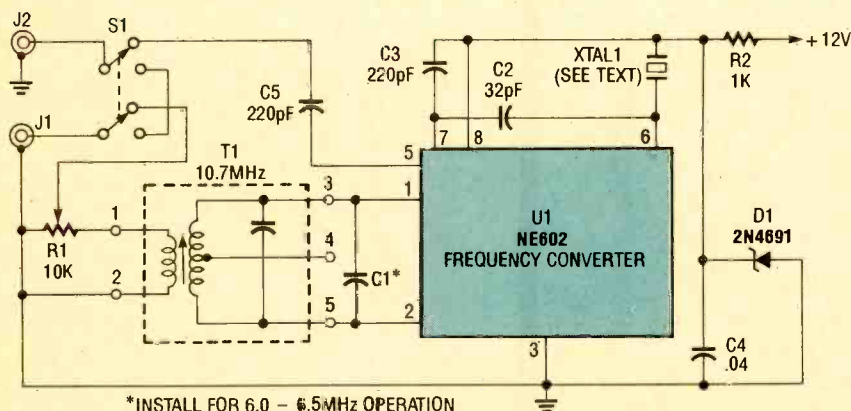

Fig. 1. The NE602 integrated-circuit chip amplifies the output signal by ten times. Interconnecting leads should be kept short and layout should appear neat for satisfactory operation.

built on perfboard and placed in a small metal enclosure. If you wish to construct yours on a printed-circuit board, a foil pattern is presented for you in Fig. 2. A parts-placement diagram for the foil pattern is given in Fig. 3 to help you stuff the board properly.

The metal enclosure blocks out signals from nearby AM stations and shielded cable between the converter and the radio is recommended for further isolation. Keep in mind that the shielded cable should be kept as short as possible.

As an important option, a DPDT antenna ON/OFF switch, S1, was included to take the converter out of the circuit for

PARTS LIST FOR THE HPS CONVERTER

CAPACITORS

- C1—150-pF, ceramic-disc (see text)
 C2—32-pF, ceramic-disc
 C3, C5—220-pF, ceramic-disc
 C4—0.04- or 0.05- μ F, ceramic-disc

ADDITIONAL PARTS AND MATERIALS

- U1—NE602N frequency-converter, integrated circuit
 D1—6.2-volt, 0.4- or 1-watt Zener diode
 R1—10,000-ohm panel-mount potentiometer
 R2—1,000-ohm, 1/4-watt, 5% resistor
 J1, J2—RCA phono jack
 S1—DPDT, toggle switch, panel mount
 T1—10.7-MHz IF transformer (green color coded)
 XTAL1—8.5-MHz crystal or CB channel-5 receiving crystal (see text)
 XTAL2—5.0-MHz microprocessor crystal for 6-MHz band

AM car radio, 8-ohm speaker, 12-volt, 200-mA (or better) wall-plug power supply (see text), metal enclosure, shielded cable, wire, perfboard, knob, solder, hardware, etc.

The following are available from Small Parts Center, 6818 Meese Drive, Lansing, MI 48911: T1, \$0.80; U1 \$2; XTAL1, \$1.60; XTAL2, \$5.50; an etched and drilled circuit board, \$4.00 postpaid; a complete kit of parts less crystal and enclosure, \$10.50 postpaid. Send a check or money order only. Add \$2.50 per order to cover shipping and handling if ordering only the non-postpaid items. Michigan residents add appropriate sales tax.

XTAL2, costing \$1.62 as part number X051, is available from Digi-Key Corporation, P.O. Box 677, Thief River Falls, MN 56701-0677; Tel. 800-344-4539. They accept Visa and MasterCard. Add \$3 per order for shipping and handling. Minnesota residents add appropriate sales tax.

JAN Crystals, 2341 Crystal Drive, Fort Myers, FL 33906; Tel. 800-237-3063, will custom-make a crystal for any frequency for less than \$10. Specify a load capacitance of 32 pF, a tolerance of .005%, in an HC-18/U package.

regular AM listening. The wiring for the optional switch must be totally contained within the metal case.

Figure 4 shows the complete inter-unit hookup. The converter needs only a +12-volt power supply such as a car battery if you wish to install it in a vehicle. You can use dry cells or a suitable DC power supply if the unit will not be

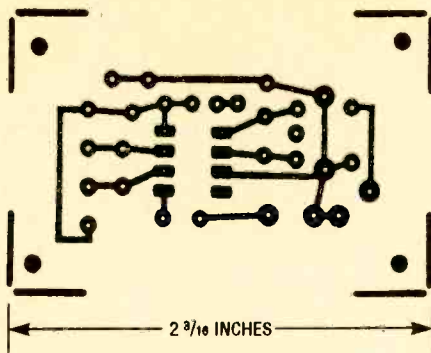

Fig. 2. This foil trace pattern is presented for you to use for your printed-circuit board if you choose to make your own from scratch.

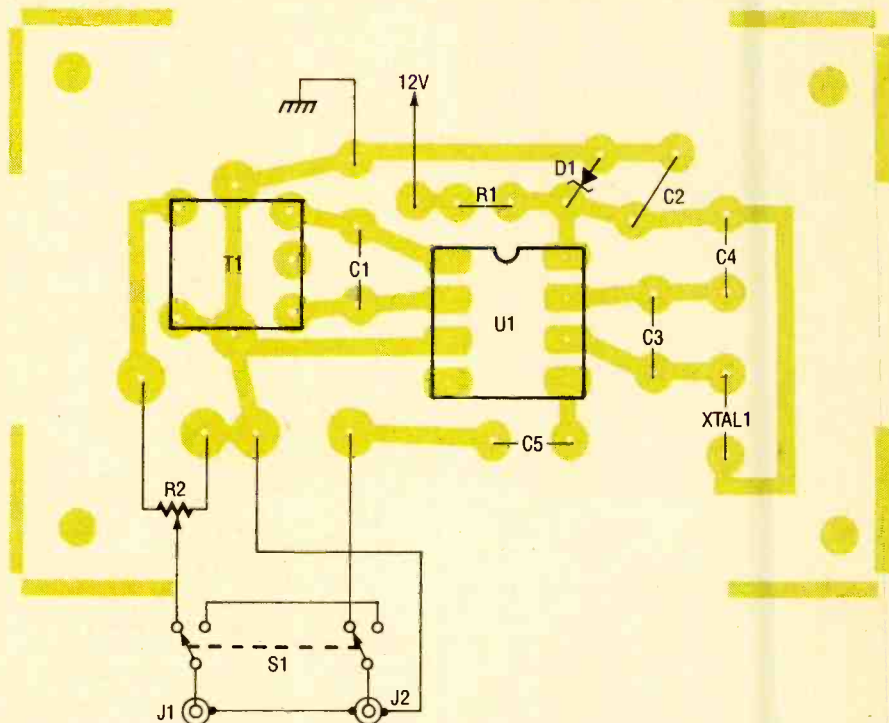

Fig. 3. Use this parts-placement diagram to stuff your own circuit board. You need only orient the diode, transformer, and integrated circuit properly to get the converter to work.

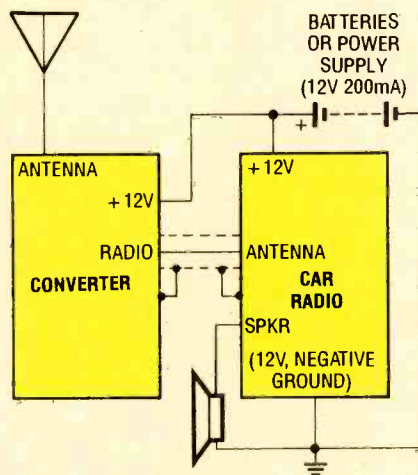

Fig. 4. The complete setup is illustrated in this diagram. The converter is grounded through the cable shield. You could add a ground wire if you wish.

installed your car.

The unit requires less than 200 mA of current at 12 volts, but for home installation, you must of course take the radio's power requirements into account. You'll of course need an 8-ohm speaker if your radio doesn't have a built-in one. A small bookshelf loudspeaker will sound really good, however common 4- or 5-inch replacement speakers will work equally well in a homemade cabinet.

Regardless of the type of installation, a wise move would be to connect the power lead from the converter to the 12-volt supply bus inside the AM radio so that the radio's ON/OFF switch will control

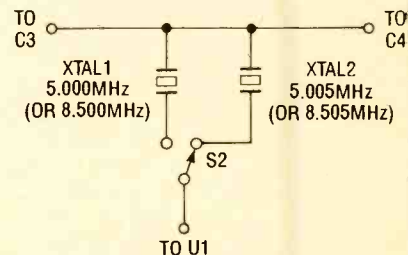

Fig. 5. A SPST crystal-selector switch can choose between crystals to enable a digital receiver to tune in 5-kHz steps. Lead length is critical, so keep it short.

the converter also. The ground for the power supply (or battery) travels through the grounded shield on the cable that connects the converter and the AM radio, so it requires no wire of its own.

(Continued on page 99)

Silence your Computer's Fan



Are you plagued by a noisy fan in your computer? We show you a number of ways to go about making it a lot quieter.

BY LEO SIMPSON

Face it, users of personal computers can really have it tough. Not only do they have to put up with inscrutable instruction manuals and impenetrable software, they also have to listen to the noisy fans in their machines.

There are two main reasons why computer fans are so noisy: First, nearly all fans are rigidly mounted within the power-supply case. That means that all the noise they generate is amplified by the resonant metalwork of the computer. Second, many of the fans are just plain noisy in themselves right from the day they were installed by the manufacturers. Some have slack and noisy bearings, some produce a lot of hum, and some have poor blade design and so make a lot of wind noise.

But whatever the cause of the noise problem, it is not helped by mounting the fan rigidly. In fact, many fans are riveted to the power-supply case.

What Can You Do? The first hurdle is to gain access to the fan. In many computers, that is not easy. The fan is mounted inside the power supply. It provides cooling for the power supply as well as the rest of the computer.

To gain access to the inside of the computer you will need the correct screwdriver or nutdriver. Using the wrong screwdriver can butcher the soft screws used in a computer. At the very least, that'll create a mess, at worst, it may prevent you from getting inside the metalwork. So use the correct screwdriver.

There is one trap to be aware of when selecting the correct screwdriver. Some computers made in Asia use screws that look like Phillip's head screws. However, Phillip's screwdrivers don't fit too well. You may find Torx screwdrivers are a better fit even though the screws are not the Torx type.

Having extracted the power supply from the computer chassis, you now have to gain access to the interior. On IBM PC's, you may find that one of the screws holding the power-supply case together has no screwdriver slot. That fiendish device is a "drive screw" and is designed to stop you from opening up the case.

If you have a good pair of pliers you may be able to get a grip on the head of the screw and remove it. Failing that, you may have to cut a slot in the head,

using a hacksaw or a small abrasive cutting wheel in a Dremel Moto-tool. When you get the screw out, throw it away. You should replace it with a self-tapper having a proper slot or Phillip's head.

The next job is to inspect the fan, which will normally be attached to the lid of the case. It pulls air through holes in the case and blows it out through a hole or louvers in the rear of the computer.

The first question to be answered is whether it is a DC or an AC fan. On almost all computers the fan will be a 12-volt DC model and it will usually be a brushless type.

Reducing the Voltage. Assuming that yours is a 12-volt fan, you can gain a worthwhile reduction in noise merely by reducing the voltage fed to it. We suggest you try reducing the voltage to around 9 volts. That gives quite a marked reduction in noise while not making a big difference in air-flow. Do

*This story first appeared in *Silicon Chip, Australia* (February, 1988); reprinted with permission.

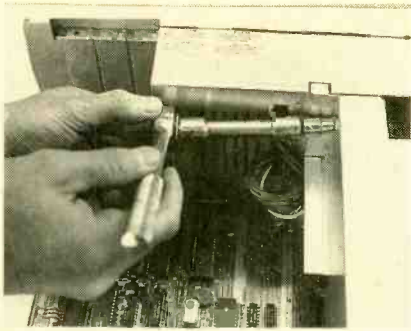

Removing the power supply from your IBM-compatible is a matter of using the correct nutdriver or 1/4-inch drive socket wrench. Don't forget to disconnect the main power cord before starting.

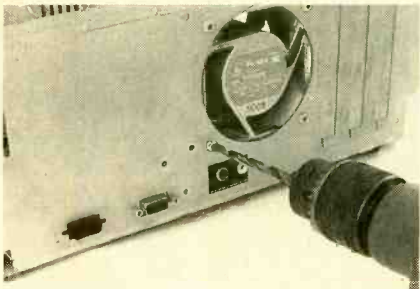

On many computers, such as this Tandy 1000, the fan will be riveted to the case. Turn the chassis upside down while drilling out the rivets so the metal particles do not fall into the computer.

not reduce the voltage to below 8 volts. Many fan motors will not work reliably below 8 volts.

There are two ways to reduce the voltage to the fan. One is to connect a 2.7-volt or 3.3-volt, 1-watt Zener diode in series with one of the supply leads. The second method is to connect a 5-watt resistor in series with the fan. The value of the resistor will have to be calculated.

With better quality fans, the current drain or the wattage will be stamped on the fan housing. For example, a Commodore PC5 that we modified used a Papst model 8312 DC fan rated at 1.8 watts. To find the current drain, we divide the wattage by 12-volts to get a current drain of 150 milliamps.

To calculate the resistor value, we then divide the desired voltage drop (3-volts) by the current:

$$R = 3 / 0.15 = 20 \text{ ohms}$$

Therefore, we could have used a 22-ohm or an 18-ohm resistor, rated at 5 watts.

Zener Diode. If you don't know the fan's current drain, it is easier to use a Zener diode to drop the voltage, because no calculations are required.

To fit the Zener diode (or resistor) in place, cut the positive supply wire to the fan and strip about 1/2-inch of insulation from the two wire ends. Tin the wires with solder and then slip a short length of heatshrink tubing (say 1-1/4-inches) over one wire. Now clip the leads to the Zener so that they are about 3/8-inch long.

Solder in the Zener diode so that the cathode lead (end with the stripe) is connected to the incoming supply. The other lead connects to the fan. That done, slide the sleeving over the Zener to cover both connections and shrink it in place.

Compliant Mounting. While reducing the voltage to a DC fan can reduce noise, you can obtain a much bigger reduction by mounting the fan compliantly. That involves the use of screws and nuts supported by small grommets to isolate the computer frame from the fan's vibrations.

Figure 1 shows the method of mounting the fan. The four screw holes in the lid of the power-supply case are drilled

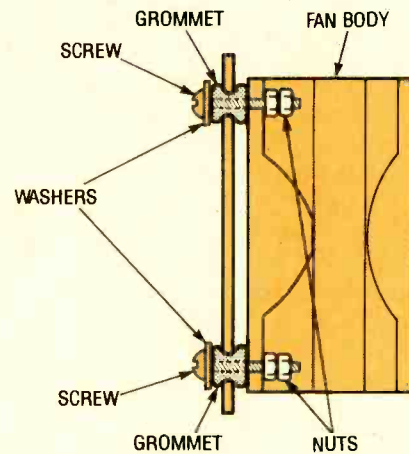
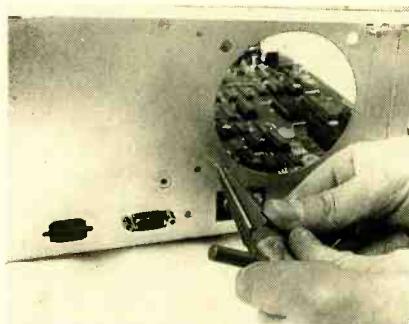

Fig. 1. This is how most fans are mounted. Note the use of locknuts to secure the screws.



To mount the fan compliantly, you need to ream out the mounting holes to accept small grommets. Again, turn the chassis upside down so that the metal shavings don't fall into the computer.

out to allow for small grommets. We used grommets that needed a chassis hole 1/4-inch in diameter. The grommets you use may be different, so size the holes accordingly. Then the fan is secured using appropriate screws, nuts, and washers.

As we mentioned, often the fan will be riveted in place. That means you will have to drill the rivets out. Use a drill that is no larger than necessary. We suggest a 3/16-inch or 7/32-inch drill bit. Then use a tapered reamer to open the holes in the power-supply cover to 1/4-inch.

Having proceeded this far, you may like to try oiling the fan's bearings. You will need to strip off the cover on the motor shaft and then use a pair of fine circlip pliers to remove the circlip and then disassemble the fan. You can also use a screwdriver to remove the clip if need be.

Take care with the disassembly. If the fan has roller bearings they are likely to be spring-loaded and will flick out and be lost forever if you're not careful.

Frankly, we don't think it is worth trying to oil the fan motor's bearings. It is just too much trouble. If the bearings are noisy, we suggest replacement of the fan.

Cautions and Provisos. Before you decide to dive into your machine, there are some points to consider. First, don't on any account meddle with a machine which is still under warranty. Any modification, no matter how trivial, may void the warranty.

Second, if your computer is filled with peripheral boards and a hard-disk drive, it may not be wise to reduce the voltage to the fan. It is possible that reduced voltage to the fan may cause the ventilation to be inadequate.

Third, if your computer has a hard-disk drive, it is highly likely that most of the noise comes from the hard drive rather than from the fan. You can tell if that is the case by blocking off the fan vent with your hand. If that causes a big reduction in noise, then it will be worthwhile to proceed with the fan modifications. If not, leave it alone.

A final point to consider is the machine's ultimate resale value. If any modifications you make are visible and look amateurish, you will surely reduce the machine's resale value, so neat work is a must. Perhaps a reduction in noise is more important than resale value, but it is still a point you should consider before proceeding with modifications.

Steady as She Goes

PANASONIC MODEL PV-460 EIS CAMCORDER. Manufactured by: Panasonic Company, One Panasonic Way, Secaucus, NJ 07096. Price: \$2150.

After all that zipping and zooming in and out that comes from the over-enthusiastic use of variable-focal-length lenses, probably the next most likely cause of ruined home videos is the picture jitter and bounce resulting from hand-holding the camcorder. All the experts, all the books, and all the manuals tell you to use a tripod to hold things steady, but that advice is always for others. *You* are in too much of a hurry to grab that once-in-a-lifetime shot, or know that *you* can hold the camera steady as a rock—it's everyone else who has the problem.

The focal-length ratios of the current generation of camcorder optics are usually around 8:1, with some lenses providing a ratio of 10:1 (usually about 80mm to 8mm) or maybe even 12:1. Converting to the equivalent in 35mm still-camera lenses, with which you may be more familiar, 8mm works out to be equivalent to about 32mm (moderately wide-angle), and 80mm to 320mm (long telephoto). If you're a 35mm photographer, you know that you'd never think of using a lens with a focal length of much more than 135mm without mounting the camera and lens on a tripod to prevent blurring. For some reason, though, the equivalent lens—not to mention a longer one—on a video camera does not inspire the same kind of respect, and most of us have no qualms at all about hand-holding that camcorder. The image shakes and shudders in the viewfinder as the result of normally imperceptible muscle tremors, which are magnified along with the image by the lens's long focal length—but which you never notice until you play back the tape on your TV.

Panasonic has made an attempt to improve the quality of home video production with its Model PV-460 camcorder. This full-size VHS-HQ unit, with a 10:1 zoom lens, features a system known as



CIRCLE 50 ON FREE INFORMATION CARD

EIS, for *Electronic Image Stabilization*. In general terms, the EIS system senses camera movement and then corrects for it, more or less instantaneously, by using very small electric motors to move lens elements and keep the image steady on the image sensor. (At least, that might be the way it works. We can't tell you exactly since we couldn't get anyone at Panasonic to tell us, despite weeks of trying.) According to the camera manual, the EIS system corrects not only for camera shake and jitter caused by hand-holding, but also for larger-scale unwanted image displacement that can take place when using the camera in motion—while walking or in a car, for example. Well, EIS works, but with a limited degree of success.

In Hollywood, Academy awards are given not only for outstanding performances, but also for outstanding technical achievements. One year the Oscar in that area was won by a device called the Steadicam. The Steadicam is a heavy and cumbersome contraption into which a cameraman literally straps himself and his camera to take moving shots where dollies and cranes are impossible to use, and only

a hand-held camera will do the job. Gyroscopic stabilizers in the Steadicam compensate for unwanted movement, and allow the camera to achieve an extremely smooth—almost floating—motion. George Lucas used a Steadicam in filming backgrounds for the "Green Moon of Endor" chase scene in *Return of the Jedi*, the last *Star Wars* film. Other notable Steadicam scenes have appeared in films such as *Brain Wave* and *Bound for Glory*. One scene in the latter starts in a moving railway boxcar and follows the actors as they jump from the car and stroll into a camp of migrant workers located alongside the track. This is done in one continuous take, and would not have been possible without the Steadicam.

Panasonic's EIS system might be called the "poor man's Steadicam." Prior to using it, we had the impression that we would be able to achieve Steadicam-like results with a home video system. Well, that's not quite the case. What Panasonic doesn't tell you is that even a professional cameraman has to attend a one-week Steadicam school before he's qualified to
(Continued on page 7)

TURN PAGE FOR CONTENTS

This month in GIZMO®

Panasonic EIS Camcorder	pg. 1
Gazelle Systems OPTune Disk Optimizer	pg. 2
Cambridge Soundworks Ensemble Speaker System	pg. 4
Technics Portable CD Player	pg. 5
Azden Wireless Microphone	pg. 6
Cobra Trapshooter Talking Radar Detector	pg. 8
Hayes Modem	pg. 9
Phone-Answering System	pg. 9
High-Performance Microphones	pg. 10
Mid-Size Stereophone	pg. 10
Surround-Sound Processor	pg. 10
Telephone Guardian	pg. 10
Epique Speakers	pg. 11
Personal Stereo	pg. 11
Upgraded Audio Cassettes	pg. 11
VCR with LCD Remote	pg. 11
Automotive Hot-Air Extractor	pg. 12
Multi-Speed Turntable	pg. 12
Satellite-TV Remote Control	pg. 12
Video Doorphone	pg. 12

Gizmo is published by Gernsback Publications, Inc., 500-B Bi-County Blvd., Farmingdale, NY 11735. Senior Writer: Josef Bernard. Contributors to this issue: George Arthur, Daryl Black, and Elvira Segura-Langton. © Copyright 1989 by Gernsback Publications. Gizmo is a registered trademark. All rights reserved.

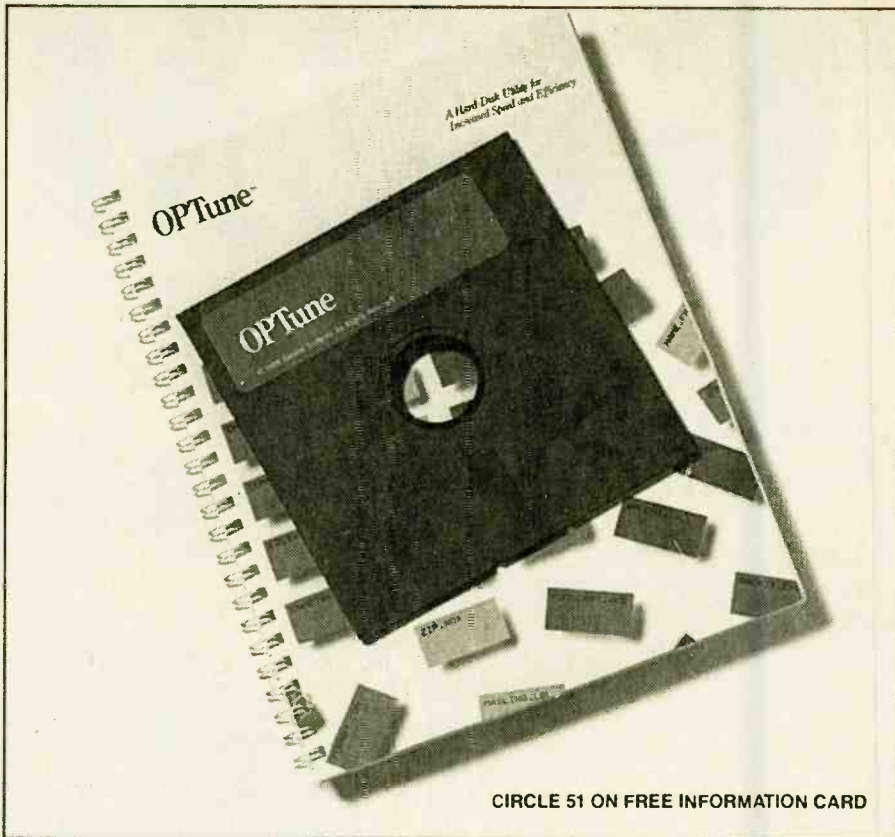

CIRCLE 51 ON FREE INFORMATION CARD

FLOPLESS DISKS

OPTUNE DISK OPTIMIZER (FOR MS-DOS SYSTEMS). Published by: Gazelle Systems, 42 North University Avenue, Suite 10, Provo, UT 84601. Price: \$99.95.

Not only do computers simplify many tasks and free up your time for other things, they also free up your time to worry about such computer-related questions as "What happens if I push this key here?" "How can I make this thing go faster?" and "How do I know my hard disk isn't going to go *kablooie* and take all my work with it?" While the answer to the first question is up to you to determine, concern over the other two can be minimized through the use of a disk-optimizer program such as *OPTune*, from *Gazelle Systems*.

Storing computer data reliably has been a problem ever since the old days when paper tape and audio cassettes were the primary media for personal computers. Floppy and hard disks certainly are immensely more reliable, but there still exists a certain potential for disaster, particularly for hard disks. And when such a disaster occurs, it is frequently catastrophic. In addition, the more you use your hard disk, the longer it takes to load and store files on it. While this increase in access time usually happens impercepti-

bly, it is noticeable over the long run, and you start wondering why it is that your hard disk seems to access things more slowly than the same model drive in your neighbor's computer.

While it is not a panacea, *OPTune* can improve your situation in all those areas by making your hard disk perform more efficiently. The key to *OPTune's* operation is its ability to lift files from the disk and then replace them either in the same spot, or in a more favorable location on the disk. Bear this in mind as you read about what the program can do; it will make it easier to understand.

First, let's examine how *OPTune* can speed up the general read/write operations of a hard-disk drive by adjusting what is known as the *interleave* of the sectors on the disk. The surface of a hard (or floppy) disk is divided into invisible tracks, like a series of concentric circles, and into pie-shaped wedges called sectors. Under MS-DOS, each sector of each track can hold 512 bytes of data. As the disk spins beneath the read/write head of the drive, data stored in a sector is picked up and transferred to the computer. It takes time for that to happen—so much time (in computer terms) that by the time the data in one sector has been read and transferred, the next sector (which usually contains the next 512 bytes of data in the file) has come and gone. To allow the computer to access sectors that are logically contiguous, the physical sectors are spread out. That is, the first sector may be followed by two sectors containing data from other files,

followed in turn by the next sector of the file you want. The way those sectors are arranged is called the interleave.

In many systems the interleave is 3:1—each logically contiguous sector is separated from the next by two sectors that will be ignored (of course, those sectors also contain data, but when it gets read depends on where you start). Read one, skip two, read the next, skip two ... and so on. The interleave figure tells you how many sectors have to pass beneath the read/write head for just one to be read (or written), in this case three.

In many computer systems, the interleave—for one reason or another—is set improperly and more “padding” sectors are used than are necessary. That wastes the computer’s (and your) time by forcing the computer to dawdle while waiting for the next logical sector to come around. In fact, if the interleave is wrong, it may be necessary to wait an entire revolution or so before the appropriate sector comes around again—it may get missed by just one sector the first time.

OPTune can look at a hard-disk drive and determine what its optimum interleave is. Then, upon your giving it the go-ahead, it can reformat the disk (lifting your data safely out of the way as it does so and then writing it back) with that optimum interleave. Gazelle claims improvements in speed of from 50 to 300 percent in some cases through adjusting hard-disk interleave. (When we used OPTune on our drive to check the interleave, it told us that everything was “just right,” and that no improvement was possible. Ah, well ...)

That explains why your system may be slower or faster than that of someone else who has the same equipment. But what about the gradual slowdown in access times? The reason for that lies in changes in file size that take place as files are modified and remodified. When your hard disk was brand new and had plenty of free space, it was pretty fast because (subject to the interleave) all the sectors of a particular file followed one after the other. And, file “A” followed file “B,” and so forth.

Eventually, though, you added to the size of file “A,” perhaps by only a thousand bytes or so. It could then no longer fit in its entirety where it used to fit, because it would have overrun the territory occupied by file “B.” So part of file “A” got put in the original file “A” space, and the rest went somewhere else on the disk. As the file grew over time, more and more space had to be found for it, but since the size of other files had probably changed as well, it became more and more fragmented, with bits and pieces being stored here and there, wherever there was room on the disk.

The computer’s operating system keeps track of the whereabouts of all these fragments in a private directory called the file allocation table, or *FAT*, that tells it where

all the pieces of a particular file are. Whenever you call up a file, the operating system looks at the *FAT* and then sends the disk drive’s read/write head here and there about the surface of the disk collecting all the pieces. That takes a lot of time—much more than if all the pieces were logically contiguous, as they were when the disk was new and pristine.

OPTune “defragments” files. It reads and collects all the scattered bits and pieces, and then writes them all out together in one contiguous group. (Of course, it adjusts the *FAT* accordingly.) That makes to retrieving data much faster. OPTune can also organize frequently used files in the same physical area of the disk, so that the read/write head wastes even less time in moving around. (Gazelle claims that this not only reduces access time, but also wear and tear on the head-positioning mechanism.)

Over long periods of time, the magnetic fields on a disk weaken. In the case of data this is not usually an important consideration since those fields are created anew each time the data file is updated. (Those program files that, once installed, may not be rewritten, might be affected by such weakening. Sometimes you might note DOS trying several times to read a file before it can do so successfully; this can be a sign of impending trouble.) However, the fields that constitute the low-level formatting of the disk—which tell the disk controller where to find the various tracks and sectors—are normally not touched once that formatting is performed at the very beginning of the disk’s existence. If those magnetic fields should weaken, serious trouble can ensue.

Gazelle suggests that you use OPTune’s “Tune Disk” mode once a year or so (they also suggest intervals for running the other portions of the OPTune program) to renew that formatting information, and, incidentally, to rewrite program and data files. Our initial reaction to that recommendation was, “Uh-uh, not us—it’s too risky. If it ain’t broke, don’t fix it!” However, upon giving the matter some thought, and realizing all the writing and rewriting that was going on anyway in other OPTune modes, we realized that the procedure is probably not as risky as it first appears. In the long run it’s probably safer to do the tuneup than not.

OPTune also has a number of safety features built into it, many of which you can elect to use or not depending on your hurry and degree of imprudence. For example, in Tune Disk’s “safe” mode, the program writes both the hard disk’s *FAT* and the contents of the track currently being operated on to a floppy disk. In the event of a power failure or other catastrophe, there’s enough information on the floppy to save the day.

OPTune is extremely easy to use—some might even call it “intuitive.” (Al-

though, as far as we’re concerned, you have to have a fair amount of computer experience before intuition comes into the picture.) The program can be run from a series of menus, which also provide information about what each operation does; from the DOS command line; or from an *AUTOEXEC* file (for defragmenting and packing files on a daily basis). It never gave us any problems. There’s also a well-produced manual that even includes some explanation of how and why the program does what it does. (It doesn’t explain interleave, but that’s OK—you read about it here!)

What else does OPTune do? One of its fringe benefits is that every time one of the optimization (defragmenting) procedures is used (there are three levels of optimization available) the program sorts your files. You can request that they be sorted by filename, extension, size, or date, and in ascending or descending order. That makes it easy for human eyes to find things when the disk directory is displayed. OPTune also includes a *CHKDSK* (Check Disk) program that runs automatically whenever the main program is invoked, and can also be run manually. It reports on and can repair potential disk defects arising from bad sectors.

Finally, OPTune offers you the opportunity to “park” your hard disk’s read/write heads whenever you exit the program. Parking the heads moves them over a reserved, unused, portion of the disk so that if they should come into contact with it, as they might if the computer were moved or otherwise subjected to jolting, they will not do so in an area where data is stored.

While we do not find OPTune to be an absolute necessity—not yet, anyway—it is an extremely useful utility, and one that we are glad to have in our collection of frequently used software. ■

Coming Next Month In **GIZMO**

- Olympus S-VHS Camcorder
- DataDesk Turbo-101 Computer Keyboard
- XPRES Automotive Moving-LED Sign
- Seiko Kitchen Computer
- Sony Infrared Cordless Headphones
- And Much More!

CIRCLE 52 ON FREE INFORMATION CARD

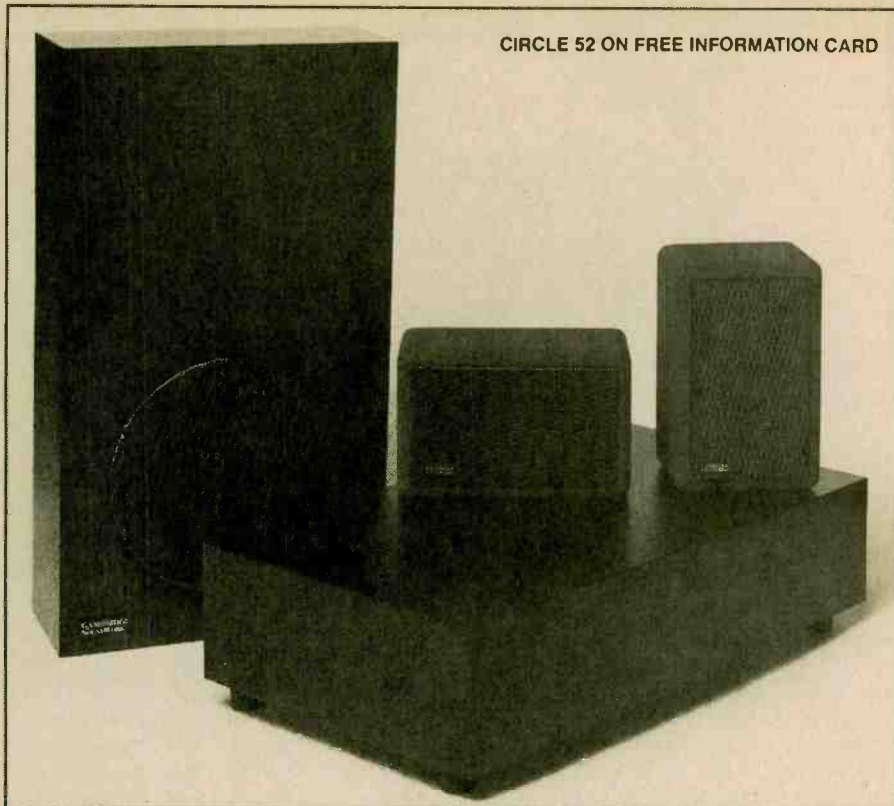

All Together Now . . .

CAMBRIDGE SOUNDWORKS ENSEMBLE SPEAKER SYSTEM. Manufactured by: Cambridge Soundworks, 154 California St., Newton, MA 02158. Price: \$499.

Whenever Henry Kloss designs a new speaker system, it is incumbent upon a reviewer of that system to begin his report with a recapitulation of Mr. Kloss's previous achievements. So here goes: Henry Kloss has been responsible for the following original speaker designs, as well for the founding of the companies manufacturing and marketing them: AR (Acoustic Research), KLH (he was the "K"), and Advent. Actually, it is said that the Advent company manufactured speakers just to finance its real purpose, which was the development of a large-screen projection TV. Following the marketing of the Advent Videobeam, Mr. Kloss founded the company that produced the Kloss Novabeam projector, a successor to the Advent design. All of those products did reasonably well for themselves, if not better. So much for history.

Now, as befits a pioneer in the area of "bookshelf" speakers, Mr. Kloss has devised another "bookshelf" design. And what is novel about this one, from a company called *Cambridge SoundWorks*, is perhaps not so much its design as the way in which it is marketed. We'll talk about both.

First, the speakers themselves: Mr. Kloss's previous "bookshelf" speakers were such only in comparison to other equivalent speaker systems of their time—you needed a pretty hefty bookshelf to hold them, and maybe a helper to hoist them up there. Most of the speaker's volume, of course, was required for the efficient functioning of its low-frequency components. In the new *Ensemble* system, the low-frequency drivers are housed in an enclosure entirely separate from that containing the mid- and high-frequency ones. That has several advantages. First, it means that the high-frequency part of the system really *can* fit on a bookshelf—it measures only 5¼ × 8½ × 4 inches, and weighs just 5 pounds. Second, and related to the first, is the fact that since the low-frequency drivers are in their own enclosures, and since it is pretty difficult for the ear to pinpoint the origin of low-frequency sounds, the low-frequency units can be placed almost anywhere it is convenient to do so. Performance rather than aesthetics is the deciding factor on where they should go. The low-frequency units measure 12 × 21 × 4½ inches and their orientation is not critical; they can be positioned so that any one of their three axes is parallel to the floor.

Setting up the speakers is not a big deal. Cambridge supplies everything, including pre-stripped 20- and 30-foot lengths of speaker cable (if that's not enough, they'll send you more without charge), several kinds of little rubber feet to put under the speakers, and logos to attach to the front of the speakers if you feel like it. (The high-

frequency satellite units are finished in an unobtrusive, but very sexy, soft gray-plastic material called Nextel.) The well-illustrated manual that comes with the system offers several suggestions for speaker placement, as well as indicating which placements provide the best results under which circumstances, and how you can correct for an overabundance or deficiency of low- or high-frequencies in your situation. Since the speakers have no switches for adjusting their frequency response (to cut or boost the high frequencies, for example) this type of adjustment is about your only option short of putting an equalizer in the line somewhere ahead of them.

How does the Ensemble sound? Not bad. Our initial impression was of a mid-range peakiness similar to that artificial brightness you find in some movie and TV-show soundtracks, but with the help of our "personal audio consultant" (who we'll mention shortly) and some repositioning of the high-frequency units, that soon became much less obvious to the ear. We found the bass to be excellent—nice and tight, without a trace of boominess. While the output of the Ensemble is not going to fill a large hall, it is certainly more than you would expect to come out of such little boxes, and is adequate with most amplifiers for a typical room.

Now, here comes the strange part. You can't just walk into a store and buy a pair of Ensembles. They're not even sold in stores! The *only* way you can get a set of these speakers is by phone!

Then what's all this "listen before you buy" nonsense you always hear about? Doesn't that rule hold for the great Henry Kloss? Well . . . yes and no.

This is how it works. When you call Cambridge Soundworks' toll-free line you are connected not with a salesman, but with your own "personal audio consultant," someone who presumably has years of audio experience under his belt and knows everything there is to know about everything audio. He discusses with you your needs, your expectations, your audio equipment, your listening environment, and all the other factors that may influence your choice of a speaker system. The conversation(s) can get quite technical (and lengthy) if you're so inclined, or can be entirely superficial. The process is a lot like booking a package tour. You tell the travel agent where you want to go and what you like to do, and he sets everything up for you. It's the same with Cambridge.

The Cambridge method works on faith, whereby you place your trust in the hands of a complete stranger who would really like to sell you something, and allow him to tell you whether or not the Ensemble system is for you. Well, you can always get your money back within 30 days if you're not happy, which is more than you can say for the package tour.

(Continued on page 9)

Maybe We Got a Lemon

TECHNICS SL-XP6 PORTABLE CD PLAYER. From: Technics, One Panasonic Way, Secaucus, NJ 07096. Price: \$259.95.

Some things in life seem to be there just to disappoint or frustrate us. Stereo TV, for instance, or blackened redfish. We get our hopes up so high ... and then they're dashed to the rocks by the stark truth of reality. That's what happened with the Technics SL-XP6 portable CD player.

What a great idea! A battery-operated CD player that you can fasten to your belt and take along with you when you go out walking or jogging. At least, that's what we thought. What *else* would you do with a battery-operated CD player that came equipped with a carrying case with a belt loop? Well, there must be something else, because it sure doesn't like being moved around very much. This player has other shortcomings as well, and we'll get to them shortly.

Actually, this little marvel of engineering probably has a lot more going for it than you'll get out of reading our opinion of it. After all, it really *is* something to cram an entire digital music-reproduction system into a package not much larger than the CD's it plays (it plays both 3- and 5-inch discs), and weighing just under 14 ounces with its self-contained rechargeable batteries. The player has a lot of smarts, too. It can be programmed to play a CD's tracks in any order you desire, or to decide for itself and play them in random order. In its RESUME mode it can even remember what track it was playing when you shut it off, and start up from the beginning of that track when you turn it back on.

The problem was that, once we discovered that the player wasn't going to do what we thought we had every right to assume that it would—namely, play CD's while we were out getting some exercise—we found ourselves in one of those frames of mind where everything about it seemed to be wrong. If your application for a portable CD player includes a lot of sitting in one place, you may have a much higher opinion of the SL-XP6 than we did.

Naturally, when we received the player from Technics we couldn't wait to try it out. We charged up the two "AA" nickel-cadmium cells—one of the nice things about this model is that the rechargeable cells reside in a compartment in the player; you don't have to lug around an accessory battery pack. The recharger/AC supply plugs into a jack at the back of the unit. As soon as sufficient time had elapsed (about three hours for a full charge, which will last for about two hours of play) we put the player into its carrying case, slipped our



CIRCLE 53 ON FREE INFORMATION CARD

belt through the case's belt loop, and set off for a brisk musical walk.

At least, that's the way it was supposed to have happened. But it seems that things were out to confound us from the very beginning. The snug-fitting case has an interior seam that interferes with the alignment of the player's headphone jack and volume control and the cutouts for them. If you just slip the player into the case that misalignment will prevent you from inserting the headphone plug into its jack. You can make the case go on so that things do align properly, but it takes a bit of care and some twisting and pushing. In any event, the case fits so tightly that it easily moves the NORMAL-RESUME-RANDOM switch out of position as you "slip" the player into it. Of course, you can't see this happening, so at first you have no idea why your CD is not playing its selections in the order you expected.

OK, the player is finally in its case, the phones plugged in, and you're ready to insert a CD. Oops, you can't do that with the player in the case. You have to take it out for the lid to open, and even to get at the switch that opens the lid. That means unplugging the earphones, etc., inserting the disc, then putting the player back in the case so everything lines up but so no switch settings are changed, plugging the phones back in, and then you're ready to go again. Fortunately, the POWER, PLAY, PAUSE, and other controls are at the top of the unit, where they're accessible by lifting the flap of the carrying case. Unfortunately, to plug in the recharger/AC supply, or to use the player from an external DC supply (as you might if using it in a car), or to plug its output into an external amplifier, you have to have it out in the open. All of those connections are inaccessible when the player is in its case.

As you stand outside, thinking about where you're going to walk today, the sound coming through the earphones is quite good—possibly the best you've ever heard from a portable sound system. That's a bit of encouragement. Then you

start off on your walk. *Chfff. Chfff. Chfff.* What's that? It's keeping time with your footsteps. Every (*Chfff*) time you put down your (*Chfff*) right foot, the (*Chfff*) player goes, "*Chfff.*" It turns out to be the error-correction circuitry complaining. Taking a step apparently jolts the playback mechanism so badly that the error-correction circuits cannot compensate completely, and what you get is a burst of noise. Walk a little faster (we haven't even gotten warmed up yet!) and the player begins to lose it altogether—no more "*Chfff. chfff. chfff.*" just big, silent dropouts. And what makes things worse is that after recovering from a dropout the player does not always pick up exactly where it left off and sometimes jumps to another track entirely. This player ought to have a warning printed on it: "**DO NOT USE ABOVE 1½ MPH.**"

The SL-XP6 comes with a wired-remote control, which goes in line with the earphones. That is, you plug the remote-control cord into the player's earphone jack, and plug the phones into the little control unit at the end of that cord. Technics brags that the extra length of the remote control cord gives you extra freedom to move. Well, it should! The earphone cord is so short that if you used it alone with the player fastened to your belt, you'd have to take posture lessons from Quasimodo!

There's very little to the remote control—just a click switch and a volume control that works in series with the player's own control. Click the switch once and you start playing; click it again and you stop. If you click it twice rapidly, you skip to the next selection on the CD. While the control allows you to skip forward, if you want to return to a place you have passed (or bounced over) you can't just back up a little bit. You have to skip forward all the way until you have come full circle. True, you can go backward using the buttons on the player itself, but then what's the sense in having a remote control?

A quick read of the instruction manual
(Continued on page 9)

Look, Mike, No Wires!

AZDEN WMS-PRO WIRELESS MICROPHONE. Manufactured by: Azden Corporation, 147 New Hyde Park Rd., Franklin Square, NY 11010. Price: \$250.

The weakest part of a video camcorder system is its audio section. It is possible to record video on affordable S-VHS equipment that comes close to rivaling that shot by the professionals. The cameras are equipped with high-quality optics that sometimes include motorized zoom lenses with a 12:1 range of focal lengths. Some camcorders even include digital-effects "laboratories" that permit the inclusion of professional-looking fades, wipes, and dissolves to take you from one scene to the next. What today's camcorders *don't* have is a decent sound section.

With the possible exception of a few high-end 8mm camcorders, for example, there is no provision for stereo sound. We're not asking for digital recording, or even VHS Hi-Fi; just two simple longitudinal audio tracks (with Dolby, of course), a decent frequency response, and a decent microphone. *Anything* to raise the standard of home-video audio out of the hole in the ground in which it started—and still wallows!

Well, a small measure of help is here in the form of the *WMS-PRO* wireless microphone from *Azden*. It is not going to turn mono into stereo, or lo-fi into hi- or even medium-fi, but it will make it a lot easier to get acceptable sound in what would otherwise be difficult or impossible situations.

The microphones that are built into camcorders suffer from a number of limitations. First, of course, is their frequency response. Since, however, the quality of the audio is already hampered by the system used to record it, there is little that can be done to improve things in that area.

The second impediment to good quality audio is the microphone's location—permanently mounted on the camcorder pointing in the same direction as the lens. That approach does have its merits, since your usual intent is to record sound from the same object at which you're pointing the camcorder. Those camcorder-mounted microphones are usually highly directional to keep their attention "focused" on the scene being recorded and to reject extraneous noise originating outside the field of view. There have been one or two "zoom microphone" designs, where the pickup pattern of the mike widened or narrowed to more or less match what the lens saw at a particular focal length, but we don't think that those were ever very successful.



CIRCLE 54 ON FREE INFORMATION CARD

However, those on-camera mikes are not suitable for all occasions. For instance, if you are simultaneously both cameraman and narrator, your voice will originate from a point outside of the mike's pickup pattern. You won't be ignored entirely by the microphone, but you will sound muffled and be subject to being overridden by sounds originating within that pickup pattern. (You can, by the way, remedy that situation with a simple clip-on mike plugged into the camcorder's *AUX MIKE* jack. If that is your only problem, a wireless mike is not necessary.)

Also, your subject may be some distance away from the camera (and mike); that often happens when you're using the lens in its telephoto mode. And, while a little ambient noise creates "atmosphere," you don't want the sounds of the passing traffic to drown out the voice of your narrator or the *prima donna* across the street. You could, of course, use a microphone with a long cable, but aside from the loss of signal strength and the potential for noise pickup that go along with long mike cables, it's just plain in-

convenient (not to mention being ugly and a hazard to passing traffic.) The solution is a wireless microphone.

You have to be careful about wireless mikes. There are the cheap, \$10 or \$20 ones, and there are the professional ones that cost hundreds and hundreds of dollars. The cheap ones are fun for experimenters, but they have about as much frequency stability as a piece of cooked spaghetti in a hurricane. Also, they operate in the FM broadcast band where, to get the kind of power output you'd want, you'd have to operate them illegally. As for the professional ones, who can afford them?

The Azden *WMS-PRO* occupies a sort of middle ground. With a list price of \$250 it certainly gets taken immediately out of the \$10-\$20 class. Yet it offers a number of desirable features without the price tag that would take it completely out of reach of most home recordists. For example, it comes with two microphones—a clip-on for hands-free operation, and a more conventional, hand-held one. It also offers a choice of two operating frequencies:

169.445 and 170.245 MHz, both safely out of the FM broadcast band and in a region where legal operation at the transmitter's approximately 200-mw output is permissible. If one of those frequencies is in use (an indicator on the receiver unit will show this; you can also monitor what the receiver is hearing through an earphone supplied with the unit), you simply switch to the other. That also opens up the possibility of recording in stereo, using two wireless mikes with one frequency for each channel. That assumes, of course, that you have equipment that will record in stereo.

The Azden receiver and transmitter are both the same size—in fact, they use identical cases and each requires a 9-volt alkaline battery. Azden says the battery will last for about eight hours in the transmitter; longer in the receiver. The receiver, which sprouts a telescoping whip antenna, is intended to be mounted in the camcorder's accessory shoe (or, lacking that, anywhere else there's room) by means of Velcro fasteners. It has an output cable that plugs into the camcorder's AUX MIKE jack. (Note that this is a low-level input; the unit will not work satisfactorily if its output is fed to a line-level "AUX" jack.) As noted, there is also an earphone jack that lets you monitor what the unit is receiving.

The transmitter comes with a detachable clip that allows you to fasten it to your belt or elsewhere; you could also stick it in a pocket or pocketbook, or tape it to your body if you don't mind a small bulge. The cables of both the clip-on and hand-held mikes double as antennas for the transmitter, and ideally should be allowed to dangle freely for maximum range. In the case of the clip-on one, at least, you'll probably find yourself concealing it by running it up a sleeve or something. This will reduce the transmitting range somewhat, but may improve the aesthetics of things.

(A word about using clip-on mikes: try not to clip them so they will be mounted directly under your chin. In that position they will miss a lot of high frequencies, and their output may sound muffled. It's better to fasten them to a lapel or shirt pocket.)

After we verified that both the transmitter and receiver worked (and stayed on frequency, which they seemed to do very nicely) our main concern was with range—how far away from the camera could we get before our signal dropped out, and how close to it before overload set in? Of course, with only 200 milliwatts of output power, overload is not a serious consideration, but you never know until you try. Azden claims a maximum range for the WMS-PRO transmitter/receiver pair of about 250 feet (depending on terrain, of course). We found it to be less, but then we were using the clip-on mike with the cable/antenna routed under our clothing. Even so, we were able to get an

appreciable distance from the camcorder before our signal began to drop out and noise to creep in—certainly much farther than any manageable length of cable would have permitted. And, happily, we were able to snuggle right up next to the camcorder with the receiver mounted atop it without the slightest trace of overload.

In our experiments, we found a less-than-obvious (to us, anyway) use for a wireless mike that may have application elsewhere. One of our shots required the camcorder to be on one side of a closed window and the subject to be on the other. With the WMS-PRO, we got excellent audio with no need for special cables or other awkward and circuitous arrangements. The radio signal, like light, traveled right through the glass.

All in all, we were quite pleased with the WMS-PRO. We still feel it is a bit overpriced (you should at least get *metal* cases, not plastic, for that kind of money) but if you can find it discounted or on sale somewhere, this wireless microphone could make a worthwhile addition to your kit of video tools. ■

CAMCORDER

(Continued from page 1)

use the device. One of the things taught there is a special way of walking (also used by non-Steadicam cameramen doing hand-held shots), which involves a cross between a crouch and a waddle, to absorb and smooth out the jolts generated in normal striding. And if you expect to achieve Steadicam-like results from the EIS system, then you'd better learn to walk that way too.

The EIS system offers several modes of operation. It can be used to compensate for only vertical motion (as in walking), which places no restrictions on horizontal panning, or it can compensate for motion in both the horizontal and vertical axes, which is useful for keeping the image steady at long telephoto lengths. In that mode, a pushbutton located on the side of the camcorder will free the EIS mechanism to permit rapid horizontal panning while still compensating for horizontal movements. Releasing the button re-engages the EIS mechanism. And, of course, the camcorder can be operated entirely without EIS.

The first thing we tried was taking the camcorder for a walk with it perched on our shoulder. We found the Panasonic unit somewhat awkward to hold (which may have contributed to our somewhat less-than-spectacular results), possibly as a result of its weight of about 10 pounds with battery and full-size VHS cassette. Walking on an uneven surface produced uneven results. There was none of that floating sensation we had hoped for in our video; the shot clearly reflected the difficulty we had in our progress along an uneven road.

(Note also that professionals allow themselves to be guided by an assistant when doing hand-held shots; that way they can concentrate on the viewfinder and not worry about watching where they're going. Trying to do it all yourself, as we did, is going to sacrifice some quality no matter what equipment you're using.) Later, when we realized how much jolting a "standard" walk generated, we took more care and achieved better—although not spectacular—results.

In our area we have some badly wash-boarded dirt roads and, as a sort of "ultimate test" of the EIS system, we lashed the camcorder to the passenger seat of our sporty little car and put it to the torture test. To our surprise, the results were not bad. The corrugations in the road were reflected in our video, but not to the extent that we felt them ourselves as we were driving. We suspect that if the camera were to have been hand-held by the passenger in a car with a nicely cushioned American-type suspension, the results would have been quite good.

The Panasonic EIS system takes a good bit of getting used to. When the camera is moved (as in a normal-speed pan), the EIS system works very hard to resist that movement. Finally, when it can hold on no longer, it lets go with a slight visual "jolt" and tries to catch up with your pan. In doing so, it overshoots when you stop the pan, and then sort of drifts back to about where you expected it to land. The final result is less objectionable than it appears in the viewfinder of the camcorder, possibly because as you are shooting the scene you remain aware of both what you are doing, and of what the camera is doing. Those two are not necessarily the same thing. The end result does impart a little of that "floating" quality to your videotaped pictures.

As you become familiar with the way the system works you learn to think the way it does. In a "real" Steadicam system there is a lot of weight, not to mention the action of the gyroscopes, to keep you from moving the camera too quickly. With the EIS camcorder you have to learn to keep your movements slow and deliberate. Once you do that, you will be moving in tune with the EIS mechanism, which copes much better with slow movements than with sudden ones, and you should be able to achieve some very smooth results with the camcorder.

How successful is the Panasonic EIS system? If you just sort of charge into it and expect it to compensate for all your movements, EIS is going to be a big disappointment. If, however, you learn to work with it, it can probably make a big improvement in your videos, especially in adding a large measure of steadiness to hand-held telephoto shots. The PV-460 did quite well at that. EIS is still no substitute for a tripod, though. ■

CIRCLE 55 ON FREE INFORMATION CARD

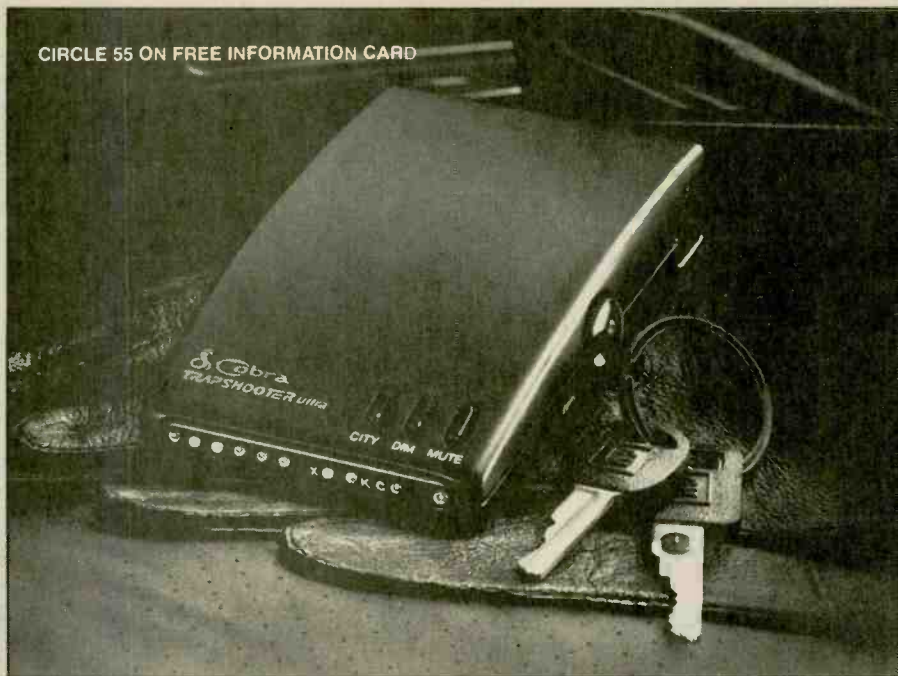

Be Careful. Slow Down!

COBRA TRAPSHOOTER ULTRA TALKING RADAR DETECTOR, MODEL RD-3170. Manufactured by: Cobra Consumer Electronics Group, Dynascan Corporation, 6500 West Cortland Street, Chicago, IL 60635. Price: \$249.95.

We don't usually get involved with radar detectors. However, when we heard about one that *talked*, we had to see it. (Or hear it, rather.)

Cobra's Model RD-3170 Trapshooter Ultra radar detector actually offers you three modes of operation: Upon detecting a "whiff" of radar it can simply sound an alarm, or it will play a tune, or (if you so desire) it will go into its act and talk to you.

The Trapshooter Ultra is supplied with a variety of mounting options, most of them intended to facilitate quick removal (an unfortunate necessity in most areas because of the temptation these gadgets offer to thieves). The detector even comes with a soft carrying case so that you can take it with you when you leave the car.

The manual provided with the Trapshooter Ultra recommends several ways of mounting it: It can mount on a removable sun-visor clip, on the windshield with a suction-cup mount, or on the dashboard using Velcro fasteners to secure either a mounting bracket (the same one used for visor-mounting) or the unit itself (because of the Velcro, it can still be easily removed). The main consideration is that the unit be able to "see" out the windshield to detect radar signals. Mounting it where it will be shielded by the metal of

the vehicle's body will defeat its purpose—metal deflects the microwave radar signals and will prevent the detector from, er, detecting. The manual also suggests that the detector be placed on the passenger side of the vehicle, where its LED's (more about them later) will not be a distraction to the driver.

The Trapshooter Ultra derives its power from the battery of the vehicle in which it is mounted. Two power cords are provided, one that plugs into the vehicle's cigarette lighter receptacle, and another (with a fuse) intended to be connected directly to the battery, or at any rate to some point in the electrical system. At the other end of each power cord is a small coaxial plug that plugs into a jack in the side of the detector. Several small clips are provided to help you to position the power cord neatly out of the way.

At the driver/passenger end of the detector is a string of small amber and green LED's, which indicate various modes of operation and also the type and strength of the radar signal detected. The unit also contains two tiny transducers (you can't really call them speakers at their size), a volume control, and a VOICE/MELODY/ALARM switch. Rounding out the array of controls are three small pushbutton switches at the top of the device: One is for dimming the LED's for night driving, another is for adjusting the device to city or country driving (it supposedly will sniff out radar signals up to four miles away in the COUNTRY mode), and a final one is for a SELF-TEST/MUTE feature. The SELF-TEST feature can be used to set the volume control to a level that is clearly audible yet not overbearing. You can use the MUTE feature when you're stuck in a radar field and the alarm message becomes annoying.

We had no difficulty in installing or

using the Trapshooter Ultra. Things fit together nicely, and everything performed as promised. We did find, however, that the LED's became practically invisible against the backlighting of the sky when the detector was mounted on the sun visor. Perhaps that is just as well, since the indicators can be a distraction when they become active. Not only are there indicators to show in which band the radar signal is operating—X or K (10.525 or 24.150 GHz)—but also a flashing LED to show that a signal is being received and a string of five LED's to indicate signal strength and thereby the relative proximity of the radar device.

We spend a lot of time in a part of the country where traffic is light and the spaces are wide open. (In many areas traffic is so sparse that it is patrolled by airplane.) Still, near towns and the occasional small city there are those spots where the police like to lurk and trap speeders. For your sake, kind GIZMO reader, we sought out some of them and drove repeatedly through them.

Of the Trapshooter Ultra's three operating modes, the alarm mode is the most ordinary. When in this mode the detector goes "beep" when it detects X-band signals, and "braap" when it hears K-band ones. That's it. Things get more interesting in the melody mode. At lower signal levels, when the radar device is some distance away, the detector plays several bars of Bach's *Minuet in G Major* from the *Anna Magdalena Notebook* (perhaps more familiar to you as the Toys' only hit, "A Lovers' Concerto"). As the signal strengthens, it plays a few more bars, and as it gets stronger still the tempo picks up and even more of the melody is heard. There is probably only so much of that you can take.

What's most interesting, of course, is the VOICE mode. In the VOICE mode the first indication of a radar signal is a "bing-bong" chime from the detector. At the next level, the warning becomes, "Bing-bong. Be careful," in a man's voice. As Mr. Trapshooter becomes more excited he announces, "Bing-bong. Be careful, slow down." Finally, approaching a state of panic, he announces, over and over, and faster and faster, "Slow down, slow down, slow down ..."

We have mixed feelings about this. Where, we wonder, does Mr. Trapshooter come off telling us to slow down? How does he know how fast we're going? He is, in fact, not too bright—we've gotten the "slow down" message even when creeping along in traffic.

On the other hand, on the long, lonely stretches of highway between towns it's sometimes nice to hear a human voice and to have someone to talk to, even if he's only synthesized.

"Be careful, slow down." Nice to have you along, Mr. T. ■

SPEAKER SYSTEM

(Continued from page 4)

The Ensemble is not an audiophile's system. You have to suspend your technical curiosity and just believe that Henry Kloss has done it again and produced another high quality and somewhat revolutionary speaker, and that he knows what's best for you. Not much emphasis is placed on specifications in the speaker literature—you have to hunt even to find the nominal impedance of the system, which is 6 ohms, and frequency response is *never* mentioned. (For the curious, the system uses 4-inch midrange drivers with half-round, long-throw surrounds; 1 3/4-inch direct radiator tweeters with 3/8-inch integral center domes; and, in the low-frequency units, 8-inch long-throw acoustic-suspension woofers with butyl surrounds. The voice-coil gaps of all drivers are ferrofluid-filled.)

After the speakers arrive, you are encouraged to experiment with their placement until you achieve a quality of sound with which you're satisfied. If you have difficulty in getting there, your "personal audio consultant" is available at the other end of the phone to provide assistance. If, in the end, you still can get no satisfaction, you can return the speakers for a full refund.

While the approach taken by Cambridge and Mr. Kloss is a novel one, we can see a number of good points in it, and perhaps it is not as strange as it seems. After all, you do get expert advice (presumably under low pressure), and you do get to listen to the speakers in your own home (which is precisely what you would want to do if you were to buy a set of speakers from a local dealer), and you do get to return them no-questions-asked if you don't care for the way they sound. You probably couldn't ask for much more ... except maybe the specs. ■

CD PLAYER

(Continued from page 5)

would lead you to believe that the remote control works on the "pause-play principle." Not so. When you click it once it doesn't cause things to pause—it makes them *stop!* The next click starts the player ... from the very beginning of the disc. Not only is this frustrating if you don't know about it, but as far as we're concerned it's plain stupid. We complained about the matter to Technics and were told that if we put the player into the RESUME mode, it would restart from the beginning of the track rather than from the beginning of the disc. That's still not PAUSE (although there is a PAUSE control on the player it-

self); besides, that mode of operation is not even mentioned in the manual. You have to know someone at Technics, or have read it here.

The SL-XP6 comes with fit-in-the-ear-type headphones. We generally prefer that kind, and those provided by Technics are of very good quality. However, with the remote control in the earphone line, guess which part of your body winds up carrying its weight? At first you can dismiss it as a very minor annoyance, but after half an hour and a couple of miles it begins to feel as though you're carrying a lead plumb bob suspended from your ears. Surely, this is one case where headphones with a band to spread the weight of the unit across the top of your head would have been a much better idea.

We are somewhat at a loss to understand the place of the SL-XP6 portable CD player in the world. As a portable we have to rate it a failure, unless perhaps you use it only for the sit-down portion of a daily commute. And as a home unit it is easily surpassed in convenience by CD players that have real full-featured wireless remote controls and are available at a considerably lower price. Where the SL-XP6 CD player seems to excel is as a marvelous piece of electronic miniaturization ... and an outstanding example of poor ergonomic engineering. ■

For more information on any product in this section, circle the appropriate number on the Free Information Card.

ELECTRONICS WISH LIST

Easy-to-Use Modem

Most computer-communications equipment has been directed toward business users. The *Hayes Personal Modem 1200*, and *Smartcom EZ* software from *Hayes Microcomputer Products, Inc.* (705 Westech Drive, Norcross, GA 30092) offer a complete data-communications solution for personal-computer users in the home. The hardware/software package includes everything needed to equip a personal computer for communications. The 1200-baud modem, which weighs less than a pound, plugs into an ordinary wall outlet, from which it receives its power. Permanently attached cables connect the device to the computer's serial port (adapters are supplied for various types of fittings) and to modular phone connectors. The *Smartcom EZ* software allows the user to place and receive calls automatically, and provides commands for dialing remote computers, sending and receiving files, printing text, and saving information on diskettes. Users have the ability to create "phone book" entries for storing often-called numbers. Price: \$179.

CIRCLE 56 ON FREE INFORMATION CARD

Answering System with Time Stamp

Now you can know exactly *when* that unidentified person who hung up on your answering machine didn't leave you a message. The *Timekeeper Answering System (AN-8531)*, from *Cobra* (Cobra Electronics Group, Dynascan Corporation, 6500 West Cortland Street, Chicago, IL 60635) features digital time/day voice "stamping" for each message (or non-message, as the case may be). The single-cassette unit also offers one-touch operation, personal memo recording, remote turn-on, auto-answer resetting, and power-failure message protection. It comes with a multi-function beeperless remote control with security coding. Price: \$119.95.

CIRCLE 57 ON FREE INFORMATION CARD

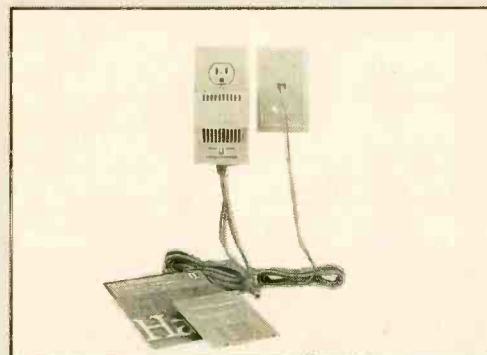

Hayes Personal Modem



Cobra Phone-Answering System

ELECTRONICS WISH LIST

For more information on any product in this section, circle the appropriate number on the Free Information Card.

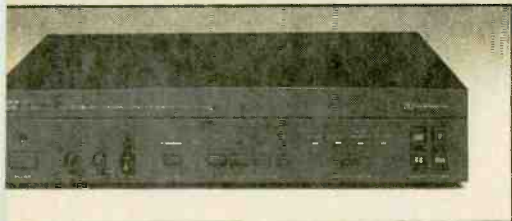

SSI Surround-Sound Processor

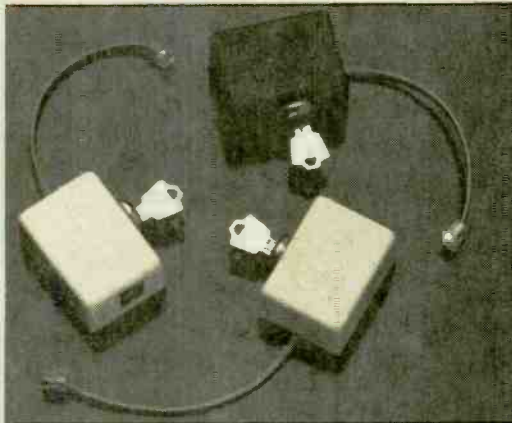

GSA Phone-Security System



Audio Technica Mini-Stereophone



Shure Microphone

Surround-Sound Processor

"The Essential Link" between audio and video components is how its manufacturer, *SSI Products, Inc.* (400 South Date Avenue, Alhambra, CA 91803) describes the *System 4000* surround-sound processor, claimed to reproduce sound the way the film makers intended it to be heard. At the heart of the *System 4000* is SSI's proprietary "Dynamic Logic" technology, which expands the sound image in all directions to create a wider, deeper, quieter soundfield—without the crosstalk present in other decoders—by monitoring incoming audio for steering information as well as original dynamic levels. The unit features wireless-remote operation and audio switching, making it easy to control an entire audio/video system. The *System 4000*'s 45-watts-RMS amplifier can be switched to drive rear- or center-channel speakers and includes sub-bass outputs. Three modes of surround-sound operation are possible: Dolby Surround, Music Surround, and Mono Enhance. Price: \$699.

CIRCLE 58 ON FREE INFORMATION CARD

Telephone Guardian

The *Call Guard* is claimed to be the only electronic-security device that can prevent outgoing telephone calls while still permitting incoming calls to be received. According to its manufacturer, *GSA Systems, Inc.* (2233 Theodore St., Crest Hill, IL 60435), *Call Guard* was developed in response to customer requests for a device that would "reduce the excessive telephone bills caused by unauthorized employee telephone use, and by kids calling 'gabb' lines when their parents were busy or away." *Call Guard* is installed by peeling away the backing strip and affixing it to any phone surface. Its non-removable modular jack is then plugged into the phone, and the phone line is plugged directly into the *Call Guard*. The device is available in both pulse and tone models. Price: \$49.95.

CIRCLE 59 ON FREE INFORMATION CARD

Mid-Size Stereophone

Combining the lightweight advantages of a mini-stereophone with the wider dynamic range more commonly found in heavier around-the-ear units is the model *SG600CD* stereophone from *Audio-Technica U.S., Inc.* (1221 Commerce Drive, Stow, OH 44224). Weighing less than 3 ounces, this model is ideally suited for use with portable CD players. Central to the design of the unit is a lightweight diaphragm assembly that responds quickly to high-frequency transients, and a high-efficiency magnet assembly. Each earpiece has a seal that reduces the intrusion of outside sound while maintaining a closed cavity for optimum low-frequency performance. The *SG600CD* has a frequency range of 20–20,000 Hz, and operates with its impedance between 4 and 16 ohms. Its 72-inch cord is terminated in a 1/8-inch mini-plug, and a 1/4-inch adapter is included. Price: \$39.95.

CIRCLE 60 ON FREE INFORMATION CARD

New Microphones

The culmination of one of the most extensive research-and-development efforts ever undertaken in the 64-year history of *Shure Brothers Inc.* (222 Hartrey Avenue, Evanston, IL 60202-3696), the *Beta Series* of microphones, offers on-stage performers advances in several significant areas. The *Shure Beta 58* is intended for use in demanding vocal applications, while the *Beta 57* is designed for the miking of musical instruments, particularly drums, cymbals, horns, and instrument amplifiers. The microphones exhibit a very high gain-before-feedback capability, which maximizes monitor output when onstage sound levels are extremely high. That performance level is achieved largely through a "true supercardioid" pickup pattern that stays uniform at all frequencies. Both microphones also feature pneumatic shock-mount systems that minimize the transmission of handling and stand noise, and include "hum-bucking" coils that permit their use even in strong magnetic fields. Price: \$258.

CIRCLE 61 ON FREE INFORMATION CARD

For more information on any product in this section, circle the appropriate number on the Free Information Card.

ELECTRONICS WISH LIST

VCR with LCD Remote

If you have trouble reading the tiny little letters of your VCR's on-screen programming menu (or the VCR display itself) from across the room, *Goldstar* (Goldstar Electronics International, Inc., 1050 Wall Street West, Lyndhurst, NJ 07071) offers a VCR, the *GHV-1290M*, that will make life easier for you. The 2-head, 3-speed VHS-HQ unit includes a remote control with an LCD window in it. You can watch the information that you enter displayed up close—right in the palm your hand, on the remote control. Other features of the VCR include an 8-event, 1-year timer; quick-time recording up to 8 hours; 24-hour standby, and digital display of time, channel, function, and counter. Price: \$599.95.

CIRCLE 62 ON FREE INFORMATION CARD



Goldstar VCR With LCD Remote

Audio Cassette Upgrade

"Responding to the need for audio cassettes capable of handling today's most demanding digital sources," *TDK Electronics Corp.* (12 Harbor Park Drive, Port Washington, NY 11050) has announced "the most complete upgrading of its audio cassette line in more than ten years." Improvements to the line include the addition of two high-performance normal-bias (Type I) cassettes, *AR* and *AR-X*, and significant improvements in performance of seven tape grades: *D* and *AD* (Type I); *SD*, *SA*, and *SA-X* (Type II, high-bias); and *MA* and *MA-X* (Type IV, metal). The tape formulations incorporate advances in magnetic-particle technology, along with advances in binder and coating technologies. Three new anti-resonance cassette mechanisms, said to improve musical transparency, have also been introduced: *HP-AR*, *SP-AR*, and *SP-AR II*. Several new "CD-length" cassettes have been introduced, including *AR-100*, *SA-76*, *SA-100* and *MA-110*, as well as 46-minute lengths in several formulations. Price: Not Available.

CIRCLE 63 ON FREE INFORMATION CARD

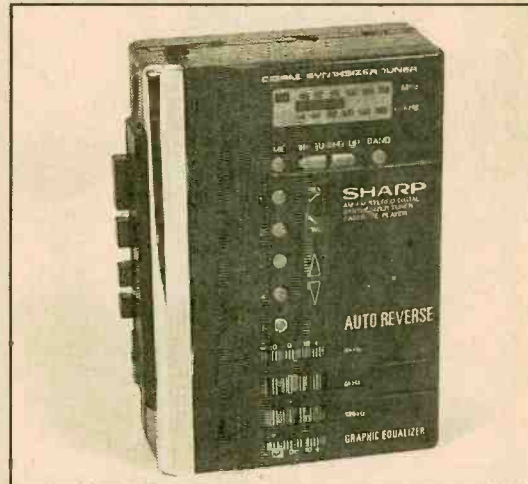

Sharp Personal Stereo

Personal Stereo

The *JC-568* is *Sharp Electronics Corporation's* (Sharp Plaza, Mahwah, NJ 07430-2135) top-of-the-line personal stereo. (Nothing but the best for **GIZMO** readers!) This cassette player with built-in AM/FM stereo tuner features auto reverse, Dolby-B noise reduction, and a 3-band graphic equalizer. The synthesized pushbutton tuner offers five AM and five FM individual memory presets. The *JC-568* comes with collapsible headphones and a detachable belt clip. Price: \$139.95.

CIRCLE 64 ON FREE INFORMATION CARD

Designer Speakers

In keeping with its philosophy that "loudspeakers should not sound like loudspeakers but rather like the instruments and voices they reproduce," *Epicure Products Inc.* (25 Hale St., Newburyport, MA 01950) has introduced a new line of five speaker systems. These products continue that philosophical tradition and add the proviso that the aesthetics of the design be given as much emphasis as sonic accuracy. Each of the *Epicure* systems incorporates a cabinet geometry that reduces diffraction and reflection effects. The models share the common design attributes of narrow front baffles, non-parallel cabinet side walls, and uniquely flared and louvered bass-reflex vents. New drive components that take advantage of the latest developments in materials research are also incorporated in the designs. That blend of form and function, says *Epicure*, produces an accuracy, openness, freedom from distortion and coloration, and stable stereo imaging not associated with products in this price class. At the top of the line is the *Model 1*, which uses a 1-inch polycarbonate dome tweeter and dual 4-inch mineral-filled polypropylene (MFP) cone midrange drivers housed in a separate narrow sub-cabinet fastened to the top of a main cabinet that contains two 8-inch MFP-cone woofers. Carpet spikes are used to attach the speaker system to the floor and *Epicure's* *SPEQ* (Speaker Placement *E*qualizer) is used to match the system's output to the room. At the other end of the line is the *Model 5*, a 2-way 6-inch bookshelf design using the same tweeter as the other models. Price: \$350-\$1400 per pair.

CIRCLE 65 ON FREE INFORMATION CARD

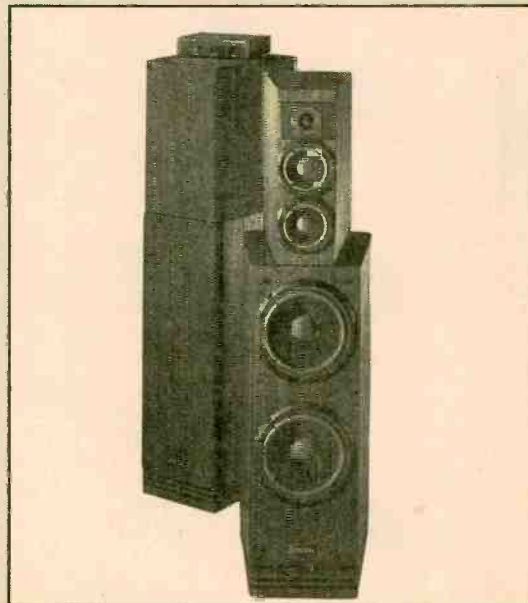

Epicure Speakers

ELECTRONICS WISH LIST

For more information on any product in this section, circle the appropriate number on the Free Information Card.



Esoteric Sound Multi-speed Turntable

Non-Obsolete Turntable

Since modern turntables usually provide only two speeds—33 $\frac{1}{3}$ and 45 RPM—most collectors of phonograph records find themselves forced into owning at least two (if not more) turntables to play their collections of recordings made at various speeds. The 6-speed *Vintage* turntable from *Esoteric Sound* (4813 Wallbank Avenue, Downers Grove, IL 60515) allows collectors to replace several pieces of old (and possibly inoperative, not to mention potentially damaging) equipment with a single turntable/arm combination of modern design. The *Vintage* turntable offers the usual 33 $\frac{1}{3}$ -, 45-, and 78- (actually 78.28) RPM speeds, as well as the 71.29-, 78.59- and 80-RPM speeds required by a number of older recordings made with different systems. In addition to offering six fixed speeds, the *Vintage* has a $\pm 8\%$ variable pitch control for fine adjustments. The semi-automatic turntable features automatic arm return, and auto shutoff. The low-mass arm accepts P-mount cartridges. For those who want to play vertically cut discs, a built-in switch is available as an extra-cost option. Price: \$229.

CIRCLE 66 ON FREE INFORMATION CARD

Remote Controls

Whether you want a remote control that's simple or sophisticated, the *R.L. Drake Company* (P.O. Box 112, Miamisburg, OH 45342) has a model for you. Although designed specifically for use with Drake's new line of TVRO IRD's (*Integrated Receiver/Downconverters*), the five new remote controls address the needs of most satellite-dish owners. For people who don't care for a lot of "bells and whistles," the *EZ View* features an operating range of 30 feet and contains 24 function keys. It comes with a pad of 72 pre-printed labels that viewers can use to help find their favorite satellite services more quickly and simply. The more sophisticated *PRC1024* and *PRC2400* are full-featured units that can also learn the infrared codes of two additional devices, such as a TV, VCR, or other product that uses an infrared remote control. They can even accommodate another manufacturer's satellite system. With 41 function keys, those remotes are said to be able to operate even the most sophisticated consumer electronics products. Finally, the models *RCU2400* and *RCU1024* are available as second remote controls for two of Drake's new IRD's. For people with more than one TV hooked up to their satellite systems, those infrared remotes are intended for line-of-sight use, while the UHF devices—which are not limited to line-of-sight operation—that came with the IRD's can be used elsewhere in the house. Prices: \$54.95–\$119.95.

CIRCLE 67 ON FREE INFORMATION CARD



R.L. Drake Remote Controls

Video Doorphone

"Knock, knock." "Who's there?" Find out in safety with the *VDP-1000* video doorphone intercom system from *Components Specialties, Inc.* (P.O. Box 624, Lindenhurst, NY 11757). The system includes an outdoor camera unit enclosed in a steel box for surface mounting; a flush-mount plate for in-the-wall installation is also included. The outdoor camera unit features automatic lights that go on with the camera when the buzzer is pressed, or when the monitor switch on the indoor unit is activated. The indoor monitor unit has an integral intercom handset, a 5-inch screen with a resolution of more than 500 lines, a pushbutton telephone, a built-in condenser mike, and a door-release button (with optional electric door release). The *VDP-1000* system includes a power supply, all connecting cables, and a 100-foot extension cable. Price: \$995.

CIRCLE 68 ON FREE INFORMATION CARD

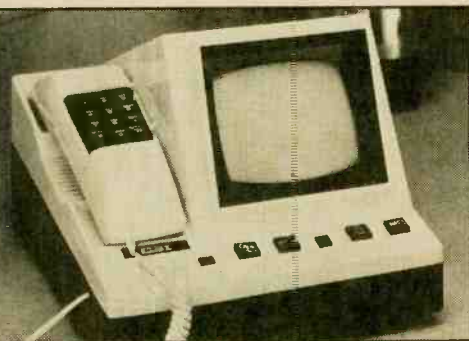

Video Doorphone

Automotive Hot Air Extractor

Let the sun cool down your car on steamy summer days, with *Hammacher Schlenner's* (147 E. 57th St., New York, NY 10022), the *Automotive Hot Air Extractor*. The device "pulls the stagnant air out of your car to reduce its interior temperature by as much as 40°F on hot sunny days." Solar powered, the unit's fan draws hot air through its exterior exhaust vent, with cooler air entering "through the car's permanently opened circulation vents." The fan's 270-milliamp motor is powered by a built-in photovoltaic panel. Fabricated of polycarbonate, the Extractor fits windows up to 26 inches wide and allows the car to be locked securely. It cannot be used with tinted windows. Price: \$32.95

CIRCLE 69 ON FREE INFORMATION CARD



Automotive Hot Air Extractor

ELECTRONIC

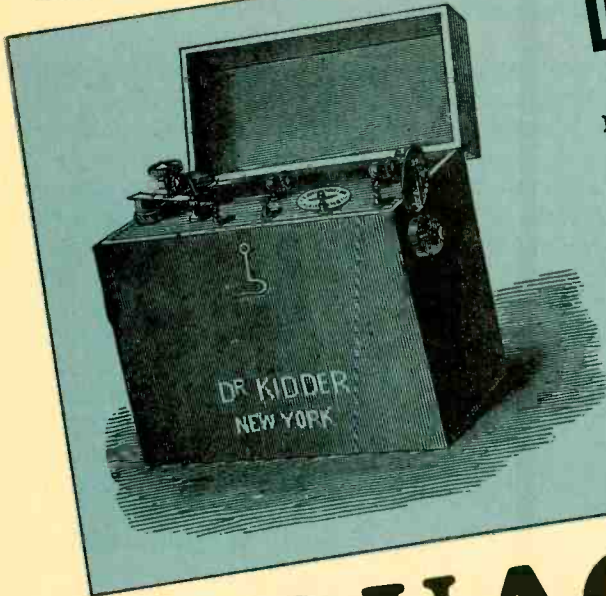

Diseases Conquered.
HIGHEST AWARDS

From American Institute for Eighteen consecutive years—1872 to 1890—and wherever exhibited in competition.

Gold Medal in 1875.

LARGEST VARIETY OF

**ELECTRO-MEDICAL APPARATUS
AND APPLIANCES.**

To distinguish the genuine from the spurious, send stamp for twenty-four page pamphlet. Address

Jerome Kidder Manufacturing Co.,
820 BROADWAY,
NEW YORK, N. Y.

QUACKERY

*The shocking history
of electrotherapy is a long and interesting one
full of successful experiments, and failures in understanding.*

BY STANLEY A. CZARNIK

Through the ages, man has looked for ways to cure bodily ills. One path that captivated early medical "researchers" was electrotherapy—the use of electric shocks to cure or mask chronic ailments. In fact, the history of electrotherapy dates back to the beginnings of Western civilization, with reports of "electric fish" being used for medical purposes. So, to begin our story about electrotherapy, let's travel to the Nile River and the Mediterranean Sea.

Cold Fish. Long before man understood the nature of electricity, he knew that certain creatures, particularly certain species of fish, could deliver a frightful jolt to the unwary. Examples of such fish include *Torpedo Marmorata* (electric ray), *Malopterurus Electricus* (electric catfish), and *Gymnotus Electricus* (electric eel). In fact, we now know that some of those creatures can gen-

erate electrical impulses of close to 600 volts.

The earliest recorded use of electric fish for electrotherapeutic purposes dates back to the first century A.D. It was a Roman physician, Scribonius Largus, who first used the high voltage discharge of a torpedo fish for the relief of intense headaches and a disturbance of uric-acid metabolism known as gout.

The treatments were very simple. For the relief of severe headaches, Scribonius advised placing a live torpedo fish on the spot that is in pain. The fish should then be allowed to shock the patient until the affected area is thoroughly numb. Scribonius further recommends having two or three torpedos on hand just in case one is not enough. It is likely that Scribonius intended not to cure his patients, but merely to ease their suffering.

But what, exactly, does the torpedo fish do? The first rational explanation of

such bioelectric therapy comes from the Greek anatomist, physiologist, and physician, Claudius Galen.

Galen approached the problem by noting the effect of the shock. That being a certain "difficulty of motion and sensation," a stiffening, not unlike the effect of extreme cold. Similar effects must follow from similar causes, and so Galen reasoned that the physical influence of the animal's shock depends on a "frigorific" principle—a kind of quick freeze. Galen, of course, knew nothing of modern physics or biology.

Predictably, there were those who thought the pain-relieving agent, frigorific or otherwise, could be extracted from the electric animals and stored for emergency use.

One magical recipe from the 6th century instructs the ancient pharmacist to place a living torpedo fish in a metal receptacle along with a quantity of oil and some water. To that must be

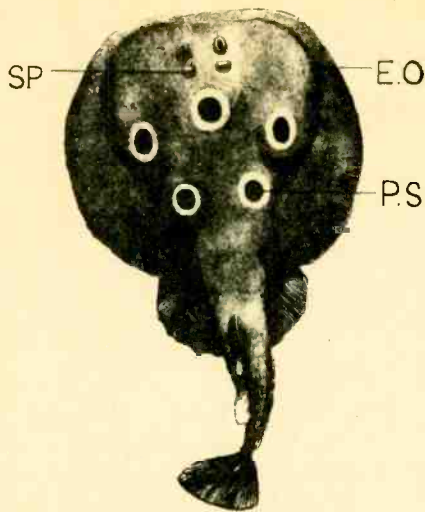

Electric fish, like this small species of the Genus Torpedo, were the first sources of electricity for medical purposes. This view of the dorsal surface of the animal shows the gill slits or spiracles (SP), several eye-like pigment spots (PS), and the electric organ (EO) between the brain and the front of the large pectoral fin. The picture originally appeared in The Outline of Science (1922).

added a narcissus plant picked during the last quarter of the moon. The mix is then to be cooked until nothing is left of the fish and, with that, the preparation is complete. The oil should be applied to the patient three times a day.

The Leyden Jar. The science of electrotherapy made very little progress until the middle of the 18th century with the exception of using static generators in the place of fish. Then, in 1745, occurred one event central to the development of electrical medicine: the invention of the first primitive capacitor, the Leyden Jar. Today, the function and action of capacitors is taken pretty much for granted. But, 250 years ago, the Leyden jar was among the wonders of the scientific world.

The Leyden capacitor permitted the use of far stronger medical shocks than had been possible with the older static generators. The new technology drew a great deal of attention to the dramatic effect of electricity on the human body. And, it did not take long for natural philosophers to figure out that the shock delivered by a Leyden jar and the bioelectric discharge of electrical organisms were identical.

Experimenters reported miracles. The brilliant French scientist, Jean Antione Nollet, claimed that electrification caused the pulse and respiration of people to increase. With high-voltage impulses from a Leyden jar, Nollet also

treated paralytics. He thought the electricity might penetrate deeply enough to unclog or disentangle malfunctioning nerves. In 1747, Gianfrancesco Pivati, an Italian attorney, claimed that with electricity he could make medicine pass from the inside to the outside of a sealed container. And in Wittenberg, Georg Mathias Bose saw a beatification, or halo, around the head of a person electrified in the dark.

Bose later admitted that the halo was an exaggeration, but it is no exaggeration to say that natural philosophers and medical men everywhere were fascinated with electricity. In the *Journal de Medicine* alone, between 1750 and 1780, there appeared no less than 26 papers on the subject of electrical medicine, and 12 of them were on the electrical treatment of paralysis.

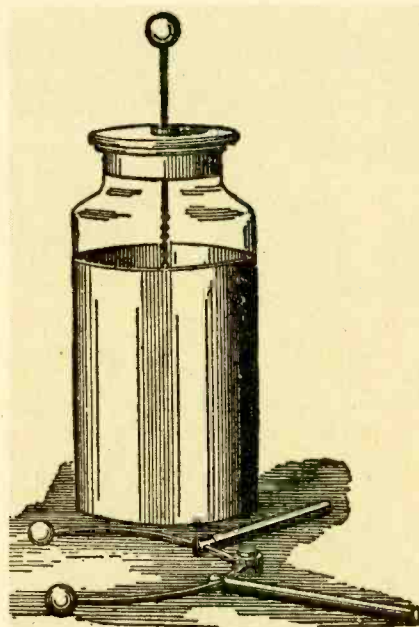

The Leyden jar, invented in 1745, allowed physicians to administer far stronger medical shocks than had been possible with static generators. This picture appeared originally in Hawkins Electric Guide (1917).

Franklinism. The news reached North America quickly. Benjamin Franklin, already known for his electrical experiments, tells us that paralytics from all over Pennsylvania were brought to him for high-voltage injections. Franklin treated his patients with the discharge from a pair of 6 gallon Leyden capacitors. The shock from jars of that size must have been quite painful.

But, it somehow seemed to work. In a letter to Sir John Pringle written late in 1757, Franklin said that, following electrical treatment, his patients got better

rapidly. No benefits, however, were noted after the fifth day. Franklin guessed that the suggestive effect of electrotherapy, rather than the electricity itself, might really be responsible for the improvement.

In any case, electrotherapeutic shock treatment was identified with its famous American practitioner and became known as "franklinism."

Galvanism. The already intense interest in electrophysiology was stimulated still further when Luigi Galvani, in 1791, reported the artificial excitation of a dead animal. The original experiment is well-known. Galvani found that when an arc made of two dissimilar metals is brought into contact with the legs of a dismembered frog, the legs would twitch. What Galvani did, of course, is build a primitive wet cell, but, that's not how he interpreted his discovery. He thought that he had stumbled upon an electric force natural to animal life. He called it "animal electricity."

The experiment's fame was almost inevitable. Wherever there were frogs and some scraps of metal, people could see for themselves the wonderful "reanimation" of dead limbs. Physicians and physiologists thought that, finally, the vital force of life itself could be manipulated. Even corpses were subjected to "galvanic" treatment, just to make certain they were really dead, and so prevent premature burial.

Galvani's discoveries were extended and developed by Alessandro Volta who replaced the frog's moist tissue with a conductive aqueous solution and so constructed the first true battery. But Galvani and his frog legs were not quickly forgotten. To many scientists of the 19th century, a direct current of electricity was still a galvanic current,



This antiquated medical generator was manufactured by the H.G. Fisher Company of Chicago, Illinois. The rotary switch on the left allows selection of alternating current, "galvanic" current, or a "combination" of the two. The device is made of cast iron.

Mesmerism. At about the same time, towards the end of the 18th century, another novel type of medical treatment was becoming popular, especially in France. That was "mesmerism," an early form of hypnotic therapy named after its originator, an Austrian physician by the name of Franz Anton Mesmer. Anton Mesmer claimed to be able to control and direct a universal life-enhancing force (or fluid) known as "animal magnetism."

Mesmer's magnetic fluid was affected by environmental and astrological conditions of all sorts. It could also be manipulated with laboratory instruments and used to clear out certain "blockages" in the body.

One of Mesmer's treatments involved a large tub filled with powdered iron. The purpose of the tub was to hold the animal magnetic fluid. Mesmer put metal bars in his tub of iron filings and had patients stand around and touch the bars. Contact with the mystical animal force through the conductive bars would correct any latent magnetic deficiency.

Animal magnetism and animal electricity were a lot alike. Indeed, one contemporary writer published a demonstration according to which the animal magnetic and electric forces were virtually the same thing.

Clearly, the theory and techniques of electrical medicine were everywhere, even where there was no electricity!

Interruptions. In the second and third quarters of the 19th century, the history of electrical medicine begins to get

Books and Articles.

Becker, R.O. and A.A. Marino, *Electromagnetism and Life*. Albany, State University of New York Press, 1982.

Hoff, H.H., "Galvani and the Pre-Galvanian Electrophysiologists." *Annals of Science* 1 (1936), pp. 157-172

Kellaway, P., "The Part Played by Electric Fish in the Early History of Bioelectricity and Electrotherapy." *Bulletin of the History of Medicine* 20 (1946), pp. 112-137.

Stainbrook, E., "The Use of Electricity in Psychiatric Treatment During the Nineteenth Century." *Bulletin of the History of Medicine* 22 (1948), pp. 156-177.

Strong, F.F., *High-Frequency Currents*. New York, Rebman Company, 1908.

Sutton, G., "Electric Medicine and Mesmerism." *Isis* 72 (September 1981), pp. 375-392.

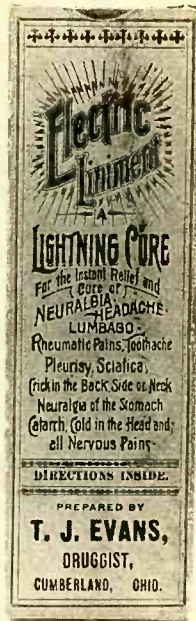

It is difficult to say just how "electric" this Electric Liniment really was. But the references to electricity and lightning on the box probably helped sell the product, or at least somebody thought they would.

quite complicated. One reason was the increasing sophistication of biology, physiology, and medical science in general. Another reason involves the development of new electrotherapeutic generators following Michael Faraday's discovery in 1831 of electromagnetic induction and, very soon after that, the invention of the induction coil.



Following the discoveries of Jacques d'Arsonval and Nikola Tesla, high-frequency alternating currents became available for medical purposes. It was often applied through glass "vacuum electrodes" such as this one. The vacuum electrode was devised by Fredrick Finch Strong, an American physician, in 1897.

The Leyden jar provided physicians with a single high-voltage pulse. Galvanic batteries provided a continuous source of direct current. By contrast, the induction coil, equipped with a vibrator mechanism, provided a stream of high-voltage interruptions.

So closely was the induction coil associated with Faraday's original electromagnetic experiments that interrupted currents were frequently called "faradic currents." The application of such currents was sometimes termed "faradization." The famous French doctor, Guillaume Duchenne, was probably the first to use faradic electricity for medical purposes. Here was a new kind of electrical medicine.

Duchenne and others immediately noted that galvanic and faradic electricity had distinct physical consequences. Faradic currents had an obvious tonic effect. Certain German researchers came to think of faradic electricity as an ideal stimulant, something like an ice-cold bath.

Low-voltage galvanic currents, on the other hand, were often noted for inducing a sense of peace, calm, and even sleep. However, when galvanic applications became too strong, the reactions became very different: giddiness, dizziness, staggering, vomiting, and sometimes convulsions. Electrotherapists were all of the opinion that such reactions had to be avoided.

Body And Mind. Disorders of all sorts were treated with electrical medicine during the 19th century, and that includes disorders of the mind.

For example, in the 1880's, a Norwegian physician by the name of Engelskjøn reported the electrotherapeutic treatment of deep melancholia. The man, 50 years of age, had been suffering for about 3 months. Engelskjøn attached electrodes to the patient's head and applied faradic current. After a single treatment, a pleasant smile appeared on the man's face and he said, "Now it is gone." The depression returned again the next day; but, following additional electrotherapy, the man got better and went back to work.

Engelskjøn, an observant researcher, noticed that electrical medicine produced psychopathological reactions of its own. In other words, there were side effects. They included sleeplessness, restlessness, malaise, and abnormal limb sensations. The collection of symptoms developed as the original
(Continued on page 108)



ELECTRONIC ARTS GRAND SLAM BRIDGE



CIRCLE 125 ON FREE INFORMATION CARD

Improve and refine your Bridge skills with a solid partner who knows the game.

This reviewer cannot play enough bridge, so when a copy of *Grand Slam Bridge* crossed my desk, I hoped my dream partner had finally appeared. To my surprise, when I found I could program the software to make me the South bidding a slam every deal, it opened the doorway to bridge heaven.

Grand Slam Bridge plays bridge pretty much the way you want it to, and you don't have to search for a fourth. In fact, the computer can play three of the four hands well enough to challenge an accomplished player. If you are a neophyte to bridge, you can call on different hint techniques and you can bid and play with all four hands showing on the table (known as *double dummy*). As an expert player, you can set up your own hand and practice the type of hands that come up once in a blue moon. There's more to Grand Slam Bridge than that, so read on!

Getting Started. Grand Slam Bridge comes on two 5¼-in. diskettes. The game can be played on a one-disk, a two-disk, or a hard-disk system. The reviewer used a hard disk to run Grand Slam Bridge.

Like all other programs, first make backup copies of the two disks by using the DISKCOPY command and following the computer's simple prompts. You don't have to worry about accidentally writing on the original disks; they are copy protected.



The opening screen for Grand Slam Bridge offers 4 options. First-time users should run the Demo option (3) first.

If you want to install the software on your hard disk, start by placing the installation disk (labeled "Disk B") into drive A:. Go to the C: drive, which is the hard disk for most IBM and IBM-compatible computers, and type A:INSTALL. Hit the <ENTER> key and follow the simple instructions. Grand Slam Bridge will be loaded on the hard disk in a newly created sub-directory called BRIDGE. To play the game, enter the BRIDGE sub-directory and type BRIDGE. Hit the <ENTER> key and you're on your way to becoming a Bridge Master.

If Grand Slam Bridge doesn't look quite *right* on your monitor, you can reset the program's system options from one of the menus. You can select a different monitor type, the display colors, or choose monochrome operation. The menu takes you by the hand so that detailed reading and instructions are not necessary.

Grand Slam Bridge always starts in the practice mode unless you have in-

structed it otherwise. In that mode you can take back bids and replay tricks.

You can quit the game by either following the simple menu or return immediately to DOS by depressing the "boss" key, which you can define for your computer.



The Options Menu pops up when "2" is entered at the main screen. All the options are self explanatory so that the player need only follow instructions.

Bidding and Playing. Under normal conditions you are South and the dealer at the beginning of play. For either contract or auction play, the deal rotates thereafter and you remain South. If your team wins the bidding, you get to play both hands (North and South). During the bidding process, you can view the bidding set aside in a panel. Once the bidding is over, the play begins and that's when the illusion of an active, competitive bridge really takes hold. At the completion of each hand, the screen shows all four hands so that you can hold your own postmortem. (The

(Continued on page 108)

Build an In-Line

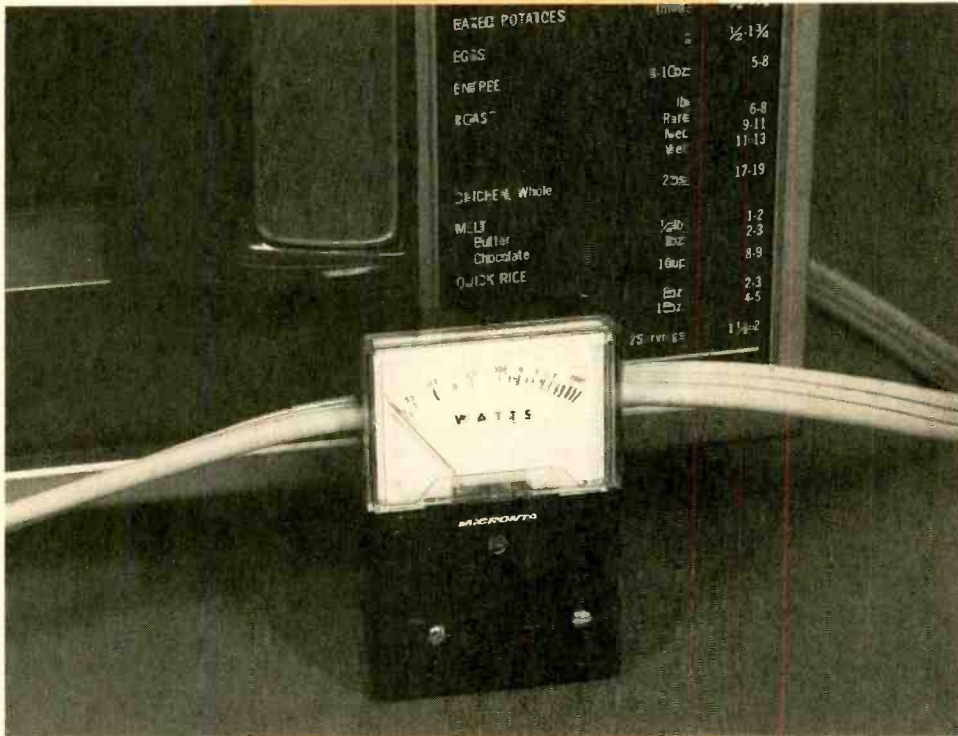

AC Wattmeter

BY GREGORY R. McINTIRE

If you are like me, you have reason from time to time to know how much power an AC-line powered device is using. Manufacturers stamp the rated power consumption (in watts) somewhere on almost all electrical appliances. However, many of those appliances use different amounts of power at different times, depending on what part of their cycle, etc., they are in.

Almost everyone has, at some time or another, plugged more devices into household AC circuits than the outlets would normally allow by using multi-outlet accessory strips and wall plugs. Also, household wiring schemes and personal convenience sometimes results in an array of power-hungry devices being on a single circuit. For instance, my air conditioner, TV, ham radio, shortwave receiver, stereo system,

Keep an eye on the power consumption of your major appliances with your in-line AC wattmeter and use the information it provides to cut utility costs!

oscilloscopes, etc., are all on the same circuit.

Usually and perhaps surprisingly that causes few problems. However, a fuse will occasionally blow. That happens because too many devices are in the "on" part of their cycle at the same time. But which device(s) is using how much power, and when?

I needed a simple, calibrated, wattmeter that I could plug into each device's line cord to measure the power being consumed during each part of its cycle (where applicable). After first attempting to design a clamp-on type of meter, I determined that its associated circuitry would have to be more complex than I was willing to build.

I also wanted to keep cost at a minimum. After much trial and error, a simple, passive (no batteries!) device—the AC-Line Wattmeter—was born!

The Main Ingredients. The parts needed are minimal: a small transformer (from an old radio, TV etc.), several feet of #34 or smaller enameled wire, one foot of #16 wire, a Germanium diode (Radio Shack 276-1123 or similar), a 50,000-ohm trimmer po-

tentiometer, a short extension cord (two- or three-wire type), and a sensitive milliammeter.

I used a Radio Shack 28-4012 multi-meter kit (\$7.95). That gave me a suitable meter movement and a case for my project at a low cost. You could use any other suitable meter and a case of your own design if you wish.

You could use the Radio Shack 273-1385 miniature transformer, but many electronic hobbyists have junkboxes full of small transformers. Any old, small (1 x 1 inch), laminated type transformer should work. It doesn't matter what windings or turns ratio the transformer has because we are going to re-wind it. Now don't get cold feet! It's really simple.

Rewinding the Transformer. First remove the thin metal jacket or frame

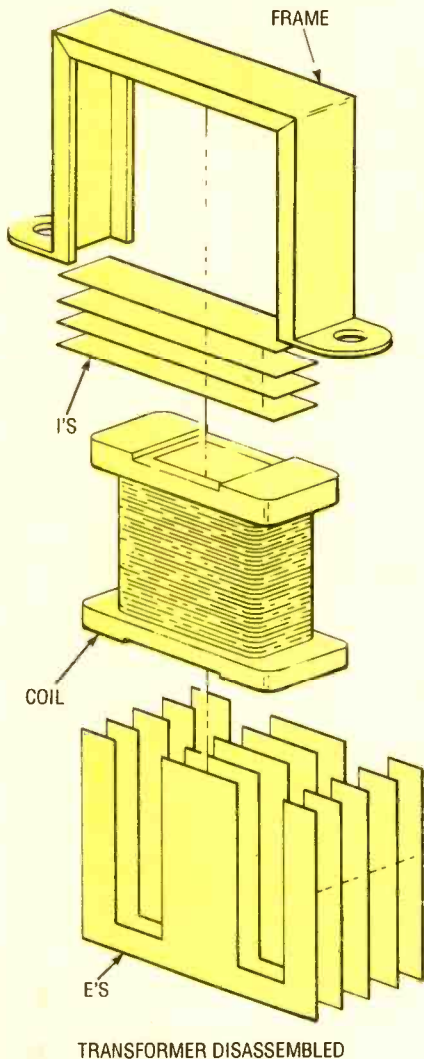
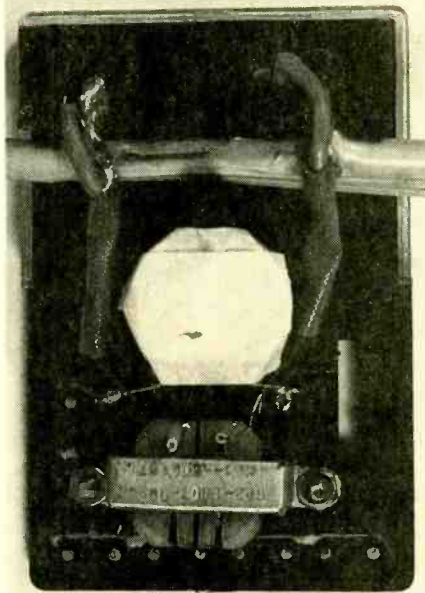

Fig. 1. Here are the component parts of the standard transformer. When assembled, the metallic E's and I's go around and through the center of the coil form.

PARTS LIST FOR THE AC LINE WATTMETER

- DI—IN34A general-purpose germanium diode
- R1—50,000-ohm potentiometer
- TI—See text
- PL1/SO1—117-volt AC extension cord
- M1—Ammeter, see text
- Enclosure, #16 enamelled wire, #34 enamelled wire, solder, hardware, etc.



Here's what the inside of the finished project looks like. The modified transformer, mounted inside of a Radio Shack multimeter kit case, is located just below the meter movement, and connected to the meter via its secondary leads.

that encloses the transformer core. (Most small transformers are dipped or sprayed with wax. That creates a small nuisance and messy fingers but that's okay). Now closely examine the thin laminated iron sections.

The entire core looks like several layers of square sections of thin iron. Those sections are not complete squares, however. There are two shapes, commonly known as E's and I's (see Fig. 1). A plastic spool containing many turns of wire goes around the center of the E, and the rest of the E and the straight piece goes around the windings.

Now carefully take a knife and/or small screwdriver and gently pry one thin section of the core out of the spool. You will soon discover that alternate E sections are inserted into the plastic spool from opposite ends. Each E section should have a straight piece butted up against its open end so as to

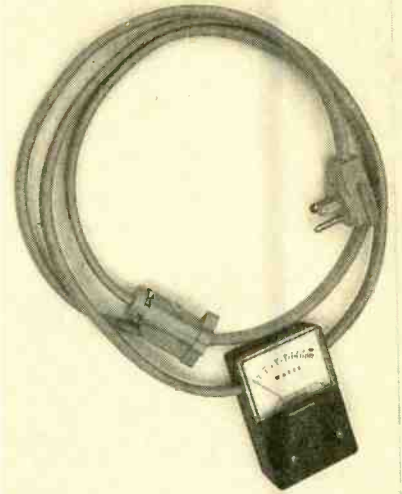

Shown here is the author's prototype unit. Note that the dial markings tend to get closer together as they progress toward full scale.

form a square core section with a bar going across the center (through the spool).

Your particular transformer may have several sections going in the same direction and then alternate, as opposed to alternating every other section. Don't worry about keeping the sections in any particular order.

After pulling out all the metal laminations, you should have a plastic spool of wire covered with some kind of tape. Peel off the tape and unwind or cut out the wire. (You may be able to salvage the wire if the removal part is done carefully.)

Now rewind the spool with approximately 400 turns of #34 or smaller enamel coated wire. The winding will serve as the secondary of the transformer. The reason for using #34 or smaller wire is that there may not be enough room for larger wire. Be sure to leave plenty of wire on each end for connections later. (Use the wire that you salvaged from the transformer only if it's of a small enough gauge.)

After completing the 400-turn winding, cover it with a layer or two of electrical tape. Now wind five turns of #16 enameled wire (which serves as the primary of the transformer) around the tape covering the secondary winding, leaving plenty of length at the ends. Wrap the second coil with electrical tape also. The primary coil will be connected in series with one of the conductors of the short extension cord, so be certain that it's outer surfaces will not come into electrical contact with the core laminations when the transformer

is re-assembled.

Insert the thin metal laminations back into the coil form. If you don't remember exactly how they came out, simply insert one E in one end of the coil form, then insert another E in from the other end. Be sure to put an I section on the end of each E. (Actually, that messy wax is kind of nice to help hold the sections together during re-assembly!) Once all of the E's and I's are in place, put the metal frame around the transformer as it was originally.

Putting it Together. Because of the simplicity of the rest of the circuit, I will leave it up to you as to how/where to mount the transformer and meter. Component layout is not critical. You may use any small project box. I mounted the transformer inside the Radio Shack multimeter kit's case (though doing so was somewhat difficult due to the stiffness of the three-conductor extension cord that I used).

After physically mounting the modified transformer and meter, hook one end of the transformer's secondary winding (400-turn coil) directly to the meter (see Fig. 2). Hook the other end of the secondary winding in series with diode D1 and trimmer potentiometer R1, and finally to the free terminal of the meter (as shown in Fig. 2). The direction (polarity) of the diode will have to be determined by experimentation if your meter is unmarked like mine was. If the needle goes the wrong way, simply reverse the diode.

Adjust R1 for maximum resistance. Cut one conductor of a short AC extension cord somewhere between the plug end and the socket end. Connect the primary winding of T1 in series with the cut conductor of the extension cord. That also places it in series with any device plugged into the cord.

Calibration. The amount of current going through the secondary winding to the meter will be directly proportional to the amount of current being drawn by the appliance connected to the AC Line Wattmeter. However, the numbers on the face of the meter will not likely be of any value. An easy way to make a new face for a meter is to put a piece of white "contact paper" on the existing meter face.

Contact paper is an adhesive-backed, vinyl-plastic material used for lining cupboards, and is available from most do-it-yourself home-improvement stores. After applying the blank face,

you need some means of determining the power level at various deflections of the meter needle.

The easiest way to do that is to connect several lamps to the AC Line Wattmeter, using a multi-outlet strip to put them in parallel. Connect a 100-watt lamp to the outlet strip, plug the AC Line Wattmeter's line cord into a wall outlet. If there is no needle deflection, carefully adjust R1 until there is a slight deflection. If the needle goes the wrong way, reverse D1.

Plug some high-wattage device into the meter, such as a popcorn popper or whatever you have that consumes around 1500 watts, and readjust R1 for full-scale deflection of the needle. At this point, you may replace R1 with a fixed resistor of equal value to R1's setting. Now with a single 100-watt lamp connected, make a pencil mark right under the needle at the point of deflection.

Add another 100-watt lamp and make a mark for the 200-watt setting. Continue in the same manner until you are either up to 1500 watts or you run

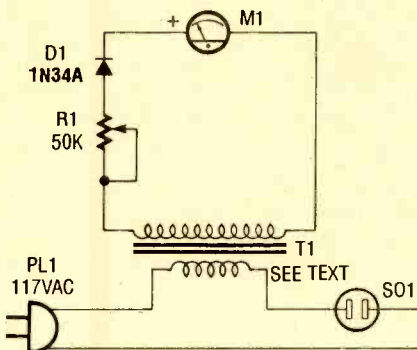

Fig. 2. The AC Line Wattmeter is an extremely simple circuit, consisting of nothing more than a germanium diode, a trimmer potentiometer, a modified transformer, and a 2- or 3-conductor extension cord.

out of light bulbs! I only had four 100-watt bulbs so after calibrating up to the 400-watt point, I found that my toaster would bring the needle right on the 400-watt mark. So, I just plugged in the toaster and one lamp to get the 500-watt setting. Another lamp gives the 600-watt setting, etc.

You can use combinations of toasters, blenders, lamps, or whatever it takes to get specific power-consumption levels.

I used several power resistors and Ohms law ($E = IR$) to make up my first 100-watt "load" then found a light bulb that matched it perfectly in needle de-

flection when each was plugged into the meter individually. The reason for the power resistors is that you can't measure and use the "cold" resistance of a light bulb because it will be in the area of ten times greater when hot (on).

You may, of course, put 50-watt increments on your dial by using 50-watt lamps. However, there is a minimum wattage that can be measured due to the fact that there is a voltage drop across the diode in the meter. With my meter, 30 watts is the minimum value. That value could be raised by using more than 5 turns of the heavy wire on the transformer. I was restricted to five turns due to the small physical size of the transformer I used.

You will notice that the spacing between the 100-watt increments gets closer and closer towards the upper end of the dial. That is because we are calibrating the meter in units of "watts" instead of "amps." The meter is actually measuring current (amperes), but since the AC-line voltage is fairly constant, the value in watts is proportional to the value of the current.

If you want to know how many amps any of your appliances is using, simply divide the number of watts that the meter measures by the voltage of your AC line ($I = P/E$). In fact, you could calibrate the meter in amps using that approach.

Have you ever installed a diode "bulb saver" on any of your light bulbs? It is interesting to see how many watts a 100-watt bulb uses with a bulb saver on it! Would you guess that your TV set uses more or less power at two in the morning after the station goes off the air? You might be surprised to see the difference! How about when you flip the "energy saver" switch in your refrigerator? How much power does it save? How efficient is that power supply that you built? How many watts go in to get 24 watts (12 volts times 2 amps) out? There's a lot of interesting things to be learned by measuring power consumption, and this simple little project will allow you to do just that. It's accuracy is only limited to the care you put into its calibration.

If the basic meter is incapable of monitoring the kind of power you wish to test, you might consider modifying the circuit to read higher powers. For instance, a resistor whose resistance is equal to that of the meter placed in parallel with the meter should allow you to measure twice the power. You must recalibrate the meter, however. ■

ANTENNA MEASUREMENTS

Making an antenna perform at its best almost always requires that you measure certain antenna characteristics. Two especially helpful attributes to gauge are the antenna feedpoint impedance and the resonant frequency. Such measurements tell you if the antenna length is optimal, and if the antenna impedance matches the receiver (or transmitter) for maximum signal transfer.

There are many instruments on the market that allow us to measure those quantities, but hams and SWLs have a significant problem in using some of the more common ones. Those instruments rely on a lot of transmitter RF power to operate. So a ham is forced to radiate more power than should be necessary, while an SWL is left out altogether because he or she is not legally allowed to operate a transmitter. But there are several instruments available that will allow both hams and SWLs to measure and adjust their antennas. Three that we will deal with here are the impedance bridge, the noise bridge, and the dip oscillator. But first let's discuss a little antenna theory so we understand what we're measuring and why.

Resonant Antennas. Although there are many fine nonresonant antennas that work well, they are often not very simple. If you want a good working antenna that is simple and easy to build, a resonant antenna is for you. There are two main types of resonant antennas: the horizontal dipole and the vertical. We will use those two as examples for the sake of discussion.

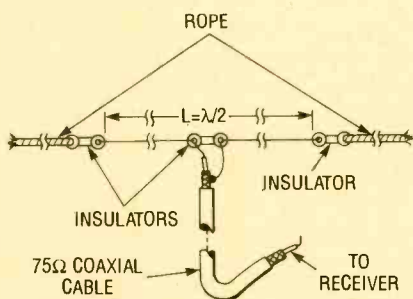

Fig. 1. In a dipole antenna current moves through two separate wires in a complimentary fashion to radiate waves. The current is supplied to the antenna by the transmitter through coaxial cable.

A dipole antenna (see Fig. 1) is a half-wavelength long, and is mounted horizontally. Its length in feet should be $468/f$, where f is the frequency in megahertz. A dipole is fed in the center by the transmission-line coaxial cable. The center conductor of the line is connected to one quarter-wavelength section, while the outer conductor (shield) of the line is connected to the other quarter-wavelength section.

Figure 2 shows the voltage (V) and current (I) distributions along the dipole. The current peaks at the feedpoint, where the voltage is at a null. Because the dipole is resonant, ideally the feedpoint impedance is purely resistive with no reactive portion. Although the actual situation is a little more complex, the feedpoint impedance (also plotted in Fig. 2 as Z) is approximately the quotient of the voltage and current.

Note that the impedance is quite high at the ends (on the order of 2500 ohms), while at the feedpoint it drops to 73 ohms. The minimum value is true only in so-called "free-space" (a vacuum), although it can be approximated if the antenna is correctly installed. The actual impedance may be very low, and range to more than 100 ohms depending upon the height of the antenna above ground and its distance from surrounding objects. For most dipoles, 75-ohm coaxial cable is a good impedance match.

A vertical antenna is shown in Fig. 3,

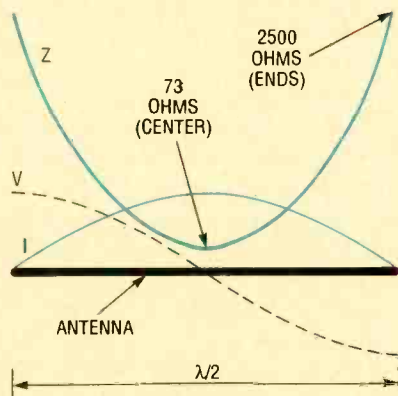
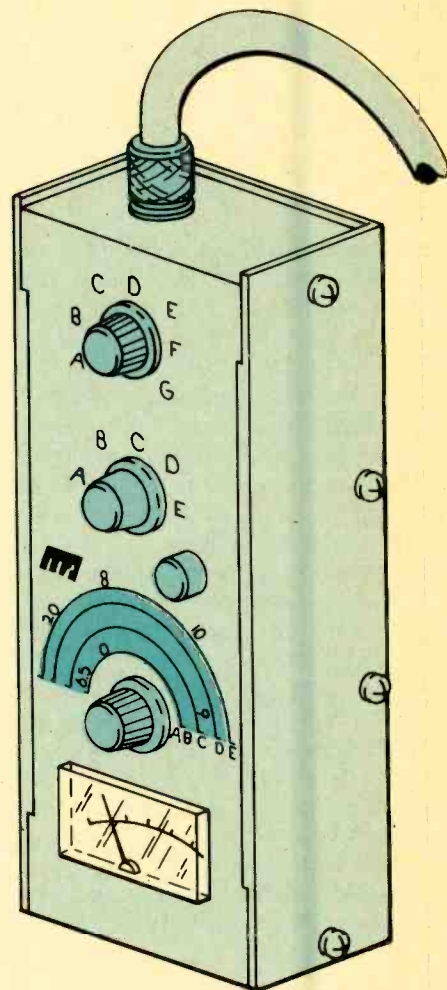

Fig. 2. If you look at the curves for voltage and current through a dipole and apply ohms law, you should be able to see why the curve for impedance looks like it does.



and its voltage and current distributions are shown in Fig. 4. Such an antenna can be modeled as half a dipole mounted vertically. The simplest vertical antenna is a quarter-wavelength high, and is fed at the base with 52-ohm coaxial cable. The actual feedpoint impedance in an ideal vertical is about 37 ohms, so directly feeding it with 52-ohm cable results in only a small impedance mismatch.

There are two factors of import to the builder of either type of antenna: resonant frequency and feedpoint impedance. At the resonant frequency the antenna feedpoint impedance is purely resistive because capacitive and inductive reactance cancel each other out. At frequencies above resonance the impedance becomes inductive, while at frequencies below resonance the impedance becomes capacitive. That's why series inductors are used to

for Hams and SWL's

BY JOSEPH J. CARR

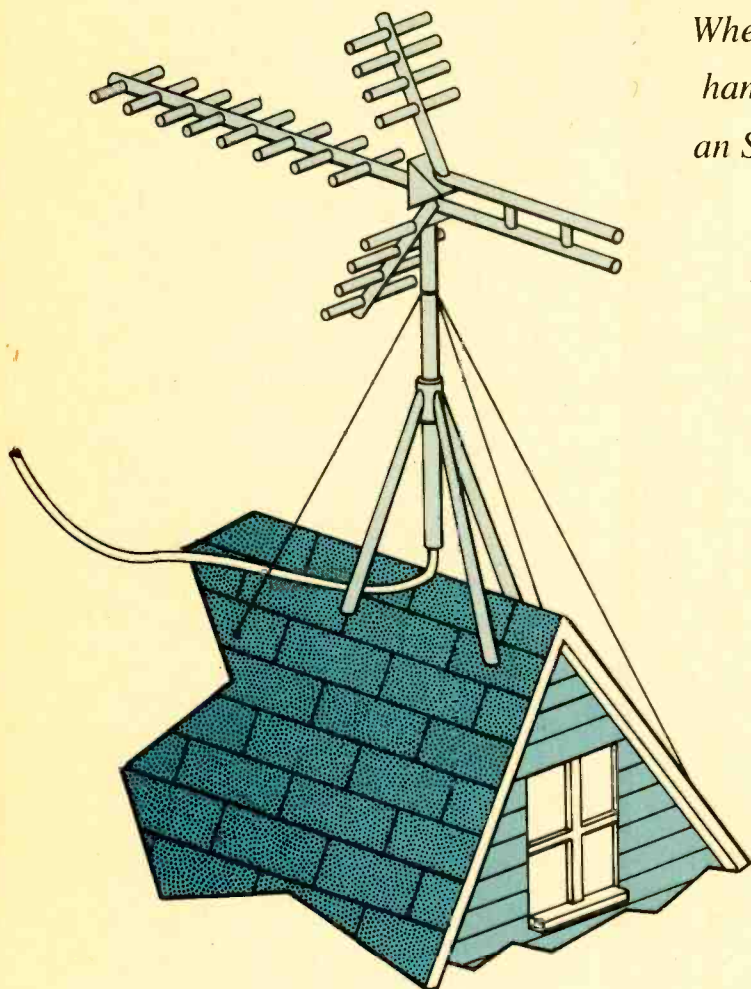

Whether you're a ham operator or an SWL, you can test and tune your antenna like a pro without using a transmitter.

impedance-match short antennas, and series capacitors are used to impedance-match long antennas. The only thing that will affect natural resonance is the antenna-element length. It is not possible to affect a change by adjusting the transmission-line length, only the element length.

The impedance at the feedpoint is ideally 37 ohms on a vertical and 73 ohms on a dipole. However, certain factors can alter the impedance. It is thus necessary to know what the actual impedance is so that it can be managed.

The RF Impedance Bridge. The idea for the RF impedance bridge (also called an RF Z bridge) is derived from the Wheatstone-bridge circuit, but has at least one reactive device in at least one arm. The most usual circuit uses a differential capacitor in two of the arms,

a fixed resistor in another arm, and the antenna impedance in the remaining arm. Such an instrument can be used by both hams and SWL's if it has an internal amplifier that allows the use of a low power signal generator in place of a transmitter.

All RF bridges display their reading in ohms, but some have various features of interest. For example the Model

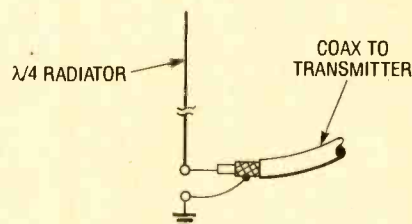

Fig. 3. A vertical antenna is the simplest antenna possible. It is nothing more than a wire carrying current from the transmitter sticking up into the air.

MFJ-204B from MFJ Enterprises, Inc. (Box 494, Mississippi State, MS 39762) contains an internal signal generator that covers the entire HF range. The MFJ unit has a calibrated frequency dial on the front panel, but for those who want to accurately measure the output frequency there is a FREQ OUT jack.

The MFJ-204B can be operated either with an external power pack or from internal 9-VDC batteries. The power supply can be either one of your own construction or one of the universal ones available from sources such as Radio Shack. That feature is more important than many people believe. I have almost ruined some instruments in my workshop because they are not used often enough to keep their battery from leaking. The MFJ-204B, however, allows me the option to use an internal battery or an external power supply or battery.

The RF Noise Bridge. Noise bridges are the most useful, low cost, and often overlooked test instruments available. Several companies have produced low-cost noise bridges and each bridge has its idiosyncrasies. For example, the Omega-T Extended-Range Antenna Noise Bridge is a small cube with only one dial, a pair of BNC coax connectors (for antenna and receiver). The dial is calibrated in ohms, and measures only the resistive component of antenna impedance. The Omega-T is no longer available new, but can be seen at hamfests quite often.

There is a device produced by Palomar Engineers (1924 West Mission Road, P.O. Box 455, Escondido, CA 92025) that is a little less eye-appealing, but does everything the Omega-T does, plus, it allows you to make a rough measurement of the reactive compo-

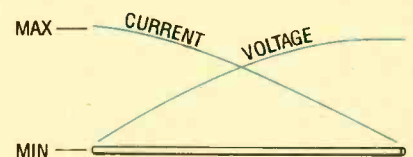
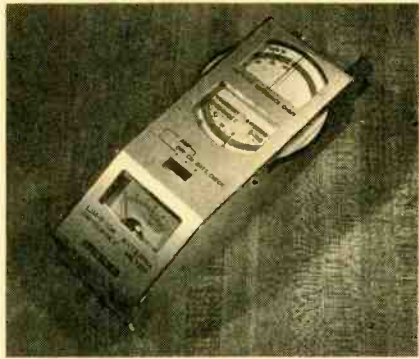

Fig. 4. Notice how the voltage curves of a vertical antenna are identical to that of half a dipole; In loose terms a vertical antenna is just that.

OCTOBER 1989



This is an older model impedance bridge. It can be used by SWL's as well as ham operators because it contains an amplifier to boost the signal from any low power oscillator for test purposes.

ment of impedance. Recently, The Heath Company (Benton Harbor, MI 49022) added their Model HD-1422 (available in kit form) to the line-up, and it too allows you to measure reactance. The harmonic content of the Heath unit is enhanced by chopping the noise with a squarewave.

The MFJ Enterprises MFJ-202B is another low-cost noise bridge that includes both resistance and reactance controls. Both the MFJ-202B and the MFJ-204B use letters to label marked positions on the resistance control dial. For each device, the resistance is measured at each point to create a customized calibration chart that is shipped with each unit.

Over the years some people have found noise bridges very useful for a variety of test and measurement applications, especially in the HF and low VHF regions, and for more than just testing of antennas. Almost any resonant

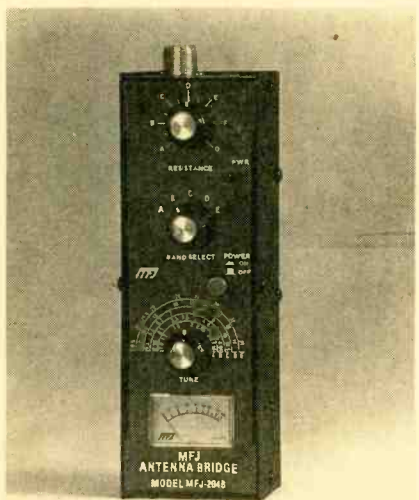

This antenna bridge requires no external signal generator to operate since it has one built in. In fact, its oscillator can cover the entire HF range.

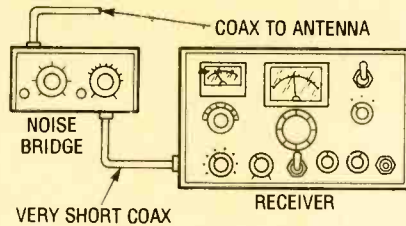

Fig. 5. Connecting a noise bridge is simple, but be sure to use a very short piece of coax between the receiver and the bridge. If you don't, your readings will be inaccurate because of the coax's characteristic impedance.

device or circuit within the frequency range of the device can be tested with the noise bridge.

Testing Antennas With Bridges. To measure impedance with a noise bridge you must connect the bridge as shown in Fig. 5. Set the noise-bridge RESISTANCE control to the antenna feedline impedance (usually 50 or 75 ohms for most antennas). Set the REACTANCE control to mid-range (zero). Next, tune the receiver to about the expected resonant frequency of the antenna. Turn the bridge on, and fine-tune the receiver for a maximum noise.

Adjust the resistance control on the bridge for a null (i.e., minimum noise) as indicated by your S-meter, or your ear if you haven't got a meter. Next, adjust the REACTANCE control for a null. Since there is some interaction between the two controls, repeat the adjustments of the controls for the deepest possible null, as indicated by the lowest noise output on the S-meter. You can now read the impedance and resistance of the antenna system right off the control dials.

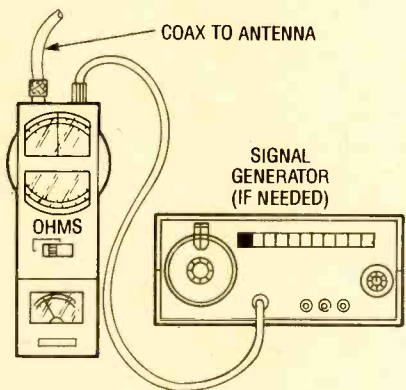

Fig. 6. Impedance bridges are very easy to connect, especially if they have a built-in signal generator. That also makes them particularly useful to SWL's who can't use transmitters as a signal source.



Looking down at the MFJ-204B you will see a FREQUENCY output jack as well as an ANTENNA output jack. It allows you to read the operating frequency on an accurate meter for fine tuning the antenna.



The dial on this Omega-T Extended-Range Antenna Noise Bridge is calibrated in ohms, and measures only the resistive component of antenna impedance. If that is all you require you cannot buy one new but you can probably find one at a hamfest.

A perfectly resonant antenna will have a reactance reading of zero ohms, and a resistance of nearly 50 to 75 ohms. Real antennas may have some reactance (the less the better), and a resistance that is somewhat different from the expected 50 or 75 ohms. Impedance-matching methods can be used to transform the actual resistive component to the 50- or 75-ohm impedance characteristic of the transmission line in use.

If the resistance is close to zero, then suspect that there is a short circuit in the transmission line, and an open circuit if the resistance is close to 200 ohms. A reactance reading on the X_L (inductive) side of zero indicates that the antenna is too long, while a reading on the X_C (capacitive) side of zero indicates an antenna that is too short.

Let's discuss the procedure for using an impedance bridge. Start by connecting the impedance bridge to the antenna as shown in Fig. 6. It is best to use a transmission line that is an electrical half-wavelength long between the bridge and antenna. That would be:

$$L(\text{feet}) = 492V/f$$

where V is the velocity factor of the transmission line (which you can look up in the *ARRL Handbook*) and f is the frequency in MHz. The resonant point is found by setting the RESISTANCE control to the expected feedpoint impedance and then varying the frequency to find the null on the meter. Finding the feedpoint impedance is done by setting the frequency to the expected resonant frequency, and varying the RESISTANCE control to find the null.

DIP Oscillators. One of the most common instruments for determining the resonant frequency of an antenna is the so-called "dip oscillator," or "dip meter." They are basically oscillators with their inductors exposed to allow them to interact with their environment. Originally called the "grid-dip meter," the basis for the instrument is the fact that its inductor's output energy will be completely absorbed by a nearby resonant circuit or antenna (which, electrically speaking, is a resonant LC tank circuit).

When the inductor of the dip oscillator is brought close to a tank circuit, if the oscillator is operating at the resonant frequency of the external tank, then a small amount of energy is transferred from the oscillator to the tank. The energy loss shows up on the meter as a slight "dipping" action.

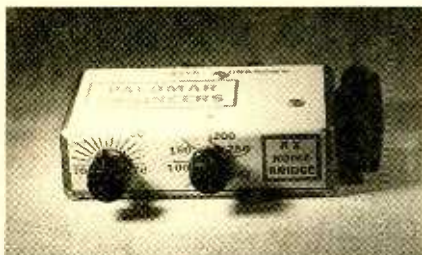

Although this noise bridge is not very eye catching, it allows its user to measure both the resistive and reactive components of an antenna's impedance.

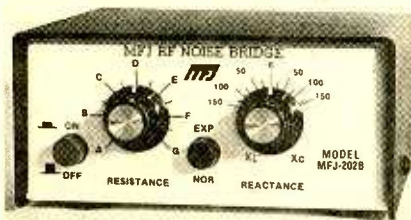

This MFJ RF noise bridge comes with its own individual calibration chart for the most accurate measurement of antenna resistance possible.



This Heath dip meter comes with a variety of coils so that it can cover a wide frequency range. Although you have to build it yourself, if done properly it is a quality instrument.

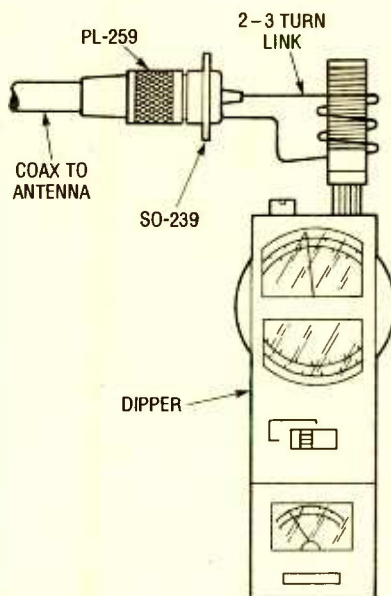
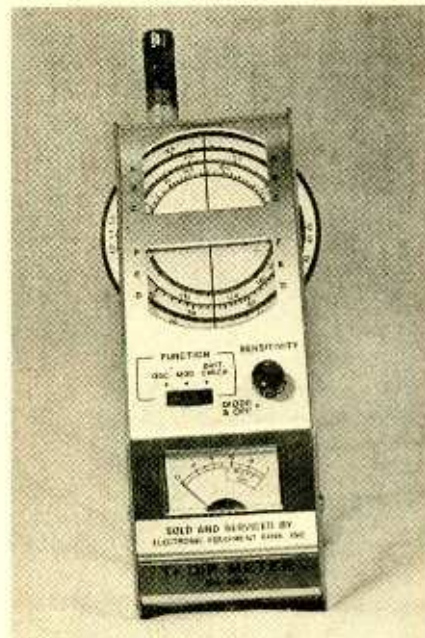

Fig. 7. A dip meter can be inductively coupled to an antenna system. That is useful when the radiator cannot be easily accessed, such as if it is roof mounted.

Antennas are resonant circuits, and can be treated in a manner similar to LC tank circuits. One way to couple a dip oscillator to a vertical antenna radiator is to bring its inductor into close proximity to the base of the radiator. If that is not feasible because the radiator is not accessible (say if the antenna is erect), you can inductively couple the oscillator as in Fig. 7. Just connect a small two- or three-turn loop to the transmitter end of the transmission line, and then bring the inductor of the dipper close to it. A better way is to connect the loop directly to the antenna feedpoint.

There are two problems with dip meters that must be recognized in order to best use them. First, the dip is extremely sharp, and is easily missed if the meter's FREQUENCY dial is turned too rapidly. To make matters worse, it is nor-



A recent newcomer to the arena of dip meters is this Electronic Equipment Bank unit. Among its features are battery checking and a modulating mode.

mal for the meter reading to drop gradually as you tune from one end of its range to the other. But if you tune very slowly, then you will notice a very sharp dip when the resonant point is reached.

The second problem is the dial calibration. The dial gradations of inexpensive dip meters are too close together, and are often erroneous. It is better to monitor the output of the dip oscillator on a receiver, and depend upon the calibration of the receiver for the frequency reading.

Of course, there are several good models on the market, each with its own features. The Heath Solid-State Dip Meter, for example, is a popular kit-built instrument that has been around for many years. If you're not too keen on building your own equipment, a relatively new product on the market is the Electronic Equipment Bank (516 Mill Street, Vienna, VA 22180) Dip Meter. It's a quality instrument with a reasonable price tag.

Conclusion. Both hams and SWLs can use the instruments discussed in this article to measure, match, and adjust HF antennas. Hams can use other methods because they can use their transmitters as a signal source, but SWLs have traditionally been shafted by instrument makers. Not anymore, for the instruments described can be used without any transmitter power. ■

BLINKING

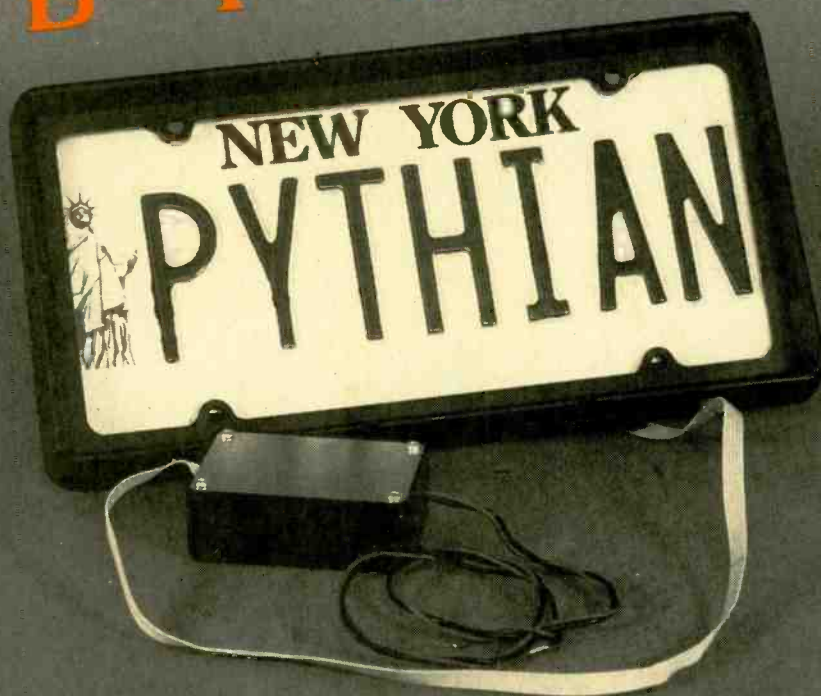

License-Plate Holder

Frame your license plate in lights with this decorative, flashing license-plate holder!

BY JIM STEPHENS

Those little, blinking, license-plate holders you've seen on autos in front of you at the stop lights is one way that digital electronics has been put to use for something other than calculators and computers. I saw right away that the blinking lights were nothing more than the outputs of a digital ring counter in disguise. And I felt it would be a simple matter to assemble one from scratch at far less than the cost of those sold at local, retail, auto-accessory stores.

The *Blinking License-Plate Holder* described in this article can be put together in one evening, and the result is truly fascinating and educational. Component selection presented the greatest challenge. After all, a digital light sequencer could be built in several ways: around transistors, individual

flip-flops, or even from a digital shift register circuit.

I chose the flip-flop method, but elected to use a CMOS IC (the 4017 decade counter) that had flip-flops wired internally to give the sequence I needed. The 4017 has ten outputs (0 to 9) that are sequenced in perfect steps, thereby enabling me to use only two chips and a few support components.

My first intent was to have one little light traveling around the outside of the plate each time the brake lights were activated. However, I noticed there were other sequences. I chose an opposite-rotation light pattern, in which the lighting sequence begins at the top center of the license-plate holder. From there, two sequential light strings travel outward (in opposite directions) and meet at bottom center, pause momen-

tarily, and return to the top center in an oscillating manner.

It is the latter configuration that (in my opinion) provides the most eye-catching display, and so it is the one used here. However, other patterns are possible by simply rearranging the lamps on the plate holder.

About the Circuit. At the heart of the light-sequencing circuit is a 4017 decade, counter/divider. A functional block diagram of the 4017 is shown in Fig. 1. The outputs of the counter are numbered from zero to nine, and are shown in quotations.

The 4017 is a 5-stage Johnson counter, consisting of a string of flip-flop circuits that are internally chained together so that they shift a binary "one" along the chain for each

positive-going pulse presented to its clock input at pin 14. Each flip-flop has a pin to the outside world.

After output 9 returns to a low state, output zero goes high and the pattern is repeated. Only one output is high at a time; all others are in the low state. The outputs from the five flip-flops (taken from their associated output pins) are used to trigger 5-pairs of lamps through driver transistors.

Figure 2 is the complete schematic diagram of the blinking sequencer. Two chips, U1 (the 4017 decade counter/divider) and U2 (a 7555 oscillator/timer), perform the timing and trigger functions. Ten lamps (I1 through I10), which are controlled through driver transistors Q1-Q5, flash in relation to the pulses that are output by the decade counter, U1. Because I wanted two lamps lit at any one time, each transistor drives a pair of parallel-connected lamps. Configuring the circuit in that manner saves considerably in parts (and cost).

In this application, the 7555 is configured for astable (free-running) operation. When power is applied to the circuit, U2 begins to oscillate at a fre-

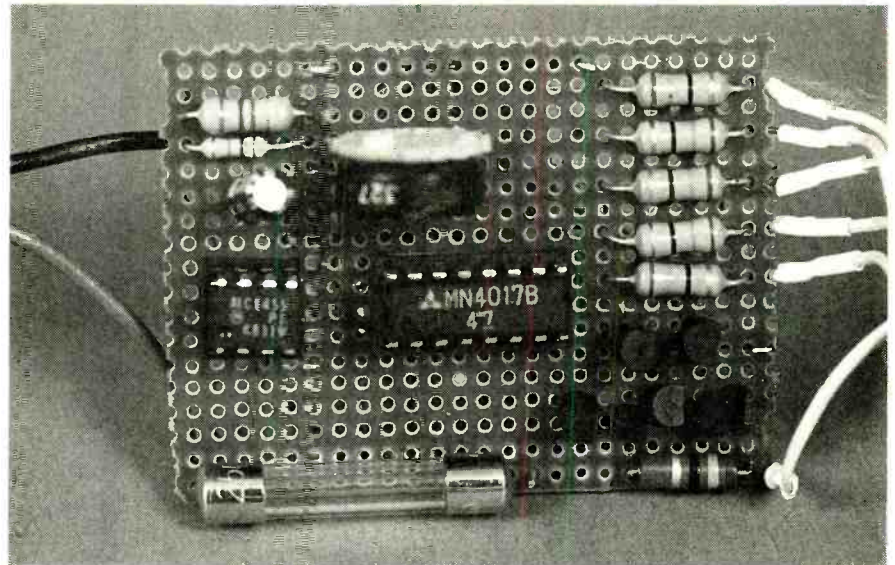

There is nothing critical about the component layout, but it would be in your best interests to follow the general layout shown here. The points to be wired to the off-board components are conveniently located near the edge of the board.

quency determined by the value of R8 and setting of R2, which are connected between pins 6 and 7 of U2, by controlling the IC's discharge rate. The potentiometer (R2) allows you to adjust the blink rate to your individual liking. Potenti-

ometer R2 can be set as low as one cycle per second or as high as 20 cycles per second.

The square-wave output of U2 at pin 3 is fed to the clock input of U1 at pin 14. The clock enable (pin 13) and reset (pin 15) of U1 are permanently grounded so that the pattern is continuous and the 4017 does not constantly clear the states as it would if those pins were left unconnected. That causes U2 to advance one count for each positive transition of the clock signal. As previously noted, the 10 outputs of U1 are tied together in pairs, with each output pair feeding a driver transistor. Because of that arrangement, each driver transistor is triggered on twice during the 0-9 output sequence.

Let's take a closer look at that process. Refer to Figs. 2 and 3. When power is initially applied to the circuit, output 0 is high, so Q4 turns on, immediately lighting lamps 17 and 18 (which in the author's prototype are located at the top of the license-plate holder).

On the first clock pulse received from U2, output "1" of U1 at pin 2 goes high, causing Q4, and thus lamps 17 and 18 to remain on for a second clock pulse. The next positive transition of the clock causes output "2" to go high, biasing Q1 on, which causes lamps 11 and 12 to light. The third clock pulse causes output "3" to go high, turning on Q3 which, in turn, causes 15 and 16 to light.

That sequence continues until count 5 is reached, lighting the bottom-center lamps (19 and 110). Count 6 keeps 19 and 110 lit for an additional count, so that the sequence appears to pause.

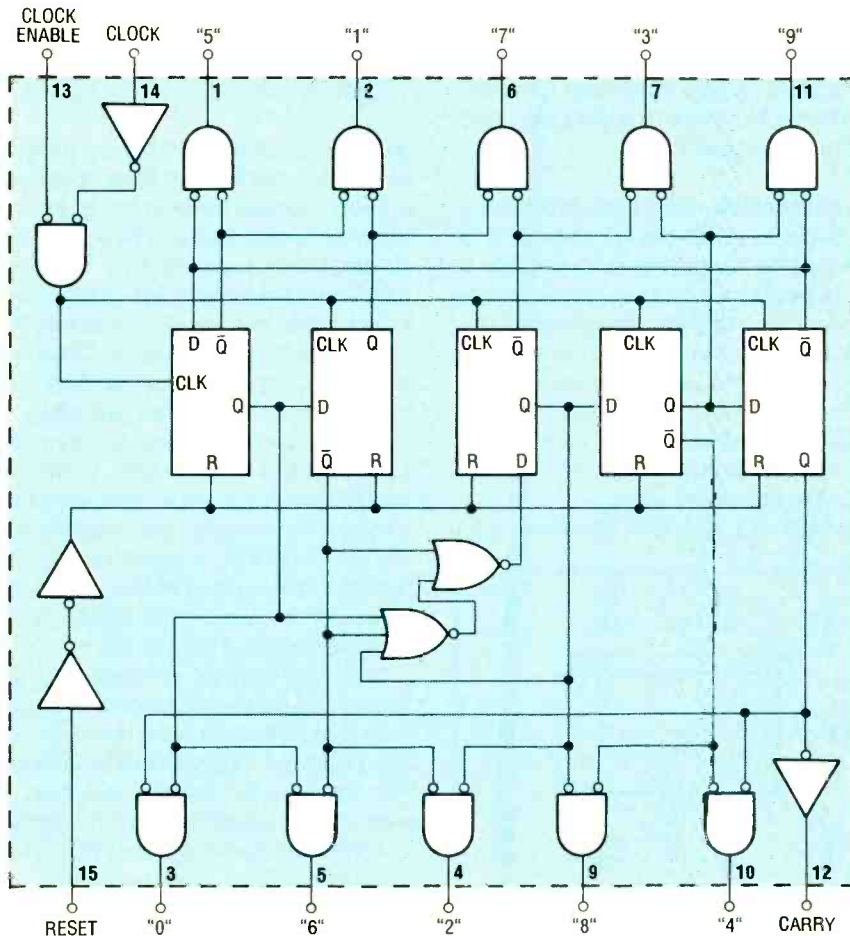

Fig. 1. The 4017 is a 5-stage Johnson counter, consisting of a string of flip-flop circuits that are internally chained together. Its outputs (0 through 9) are shown in quotations.

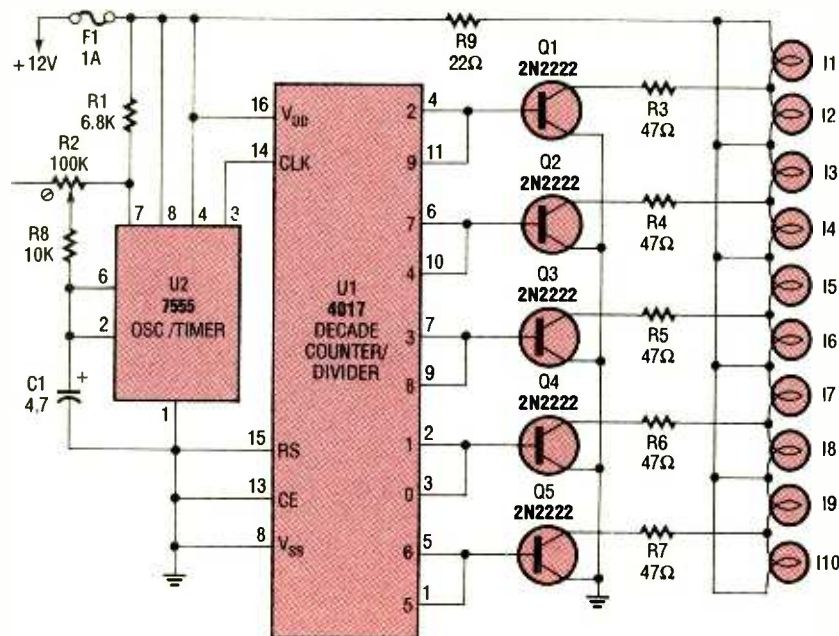

Fig. 2. The complete schematic diagram of the blinking sequencer. The circuit is built around a 4017 CMOS decade, counter/divider and a 7555 CMOS oscillator/timer.

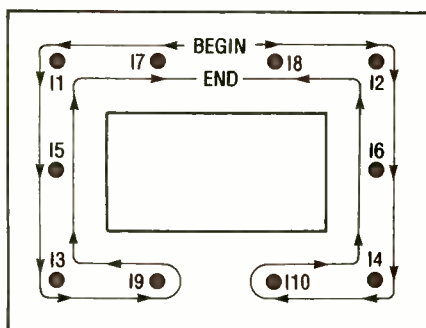

Fig. 3. The lighting sequence begins at the top center of the license-plate holder; two light paths branch out, traveling in opposite directions and down both sides, meet bottom center, and retrace the original path, returning to the top-center position.

On the seventh count, the retrace sequence begins, lighting lamps I3 and I4; count 8 lights I5 and I6; count 9 lights I1 and I2, and count 0 lights I7 and I8 (top center of the license-plate holder). At that point the sequence begins anew.

In short, the way the circuit is set up, the lighting sequence appears to pause twice during the cycle—once at the top center of the frame and again at the bottom center. After pausing at the bottom center lamps, the sequence continues, retracing the same path to the top of the license-plate holder, where the sequence starts all over again.

Miniature incandescent lamps (pea lamps) were used instead of LED's be-

cause the luminance given off by LED's is somewhat less than desirable for this application. The units used give off a large amount of light and can be seen from a distance with no trouble. To ensure that the lamps glow sufficiently bright, five 2N2222 transistors were used as drivers that switch the lamps on and off at the proper time.

Construction. Because the circuit contains so few parts, all components (except the lamps) were mounted on a small perfboard chassis. In the author's prototype, the inter-component connections were made with lengths of wire-wrap wire, using the point-to-point wiring technique. The use of IC sockets is recommended to avoid soldering directly to the pins of the IC's, which could possibly cause damage.

CMOS IC's are very sensitive, and

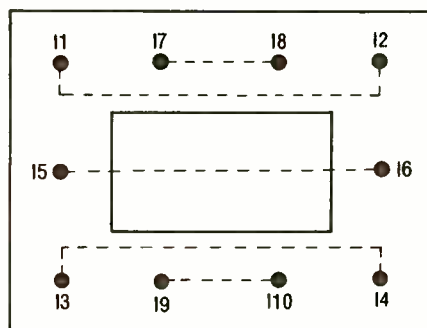

Fig. 4. The actual lighting sequence depends heavily upon the positioning of the ten lamps. The dashed lines show how the lamps are paired off.

PARTS LIST FOR THE BLINKING LICENSE-PLATE HOLDER

SEMICONDUCTORS

U1—CMOS 4017 decade counter/divider, integrated circuit
 U2—7555 CMOS oscillator/timer, integrated circuit
 Q1-Q5—2N2222 general-purpose NPN silicon transistor

RESISTORS

(All resistors are 1/2-watt, 5% units, unless otherwise noted.)
 R1—6800-ohm
 R2—100,000-ohm, miniature, PC-mount potentiometer
 R3-R7—47-ohm
 R8—10,000-ohm
 R9—22-ohm

ADDITIONAL PARTS AND MATERIALS

C1—4.7-µF, 35-WVDC, miniature electrolytic
 I1-I10—Miniature 60-mA, 6-volt, colored lamps, (RS 272-1098)
 F1—1-amp, slow-blow fuse
 Perfboard material, plastic license-plate holder (see text), enclosure, IC sockets, ribbon cable (6 strand) (see text), 18 gauge automotive hook-up wire, silicon-rubber sealant compound, wire tap-in connector (RS 64-3052), wire, solder, hardware, etc.

special care should always be used to avoid too much heat. Static build-up can be avoided by touching a ground before handling the IC's. Note that the 12-volt bus is protected by a 1-amp fuse. That fuse protects the wiring of the brake lights in case of a short in the wiring or a shorted transistor. Once the board is completed, the next step is to prepare the plate-holder assembly.

Most auto-supply stores stock plastic license-plate frames with a hollow around the back edge. The wires that connect the lamps to the circuit board will run inside that hollow channel. The lamps are mounted through 3/32-inch holes drilled through the plastic bezel at the locations shown in Fig. 4.

Note that each set of lamps (as mentioned previously) are placed opposite from its parallel twin in the author's configuration. The lamps should be pushed into the hole so that no more than 1/8 inch shows through the front. The lamps are then secured in place with a small amount of silicon-rubber cement.

The connections from the lamps to the board-mounted components in the author's prototype were made
 (Continued on page 97)

ur-
aft
ore
m-
ork
y to
get my finances organized with the help of my computer—and keep them that way!

But how do I select the right software? The market is flooded with commercial, shareware, and public-domain software for IBM's and compatibles; which of them can do the job? Are they all more-or-less capable, or are there real differences between them? Is price an indicator of quality?

BY JEFF HOLTZMAN

Because of the sheer number of programs on the market, I found it impossible to compare them all. So what I did was evaluate three of the most popular programs for compatibles, ranging in price from \$47.75 to \$219.98. One called FastBucks is a shareware program; the other two, Managing Your Money (denoted MYM) and Quicken, are sold through regular commercial channels and are available for other machines.

Managing Your Money. This program is the "Swiss Army Knife" of home-finance managers. Not only will it help you balance your checkbook, it can help you keep track of several accounts of various types. In addition, you can create budget forecasts, and carry amounts over from year to year.

Further, MYM allows you to create "portfolios" that track your investments, including stocks and bonds, certificates of deposit, etc. With add-on modules you can do electronic banking from home, and you can hook into the wire services to track stocks and bonds in real time.

The basic program includes modules

HOME-FINANCE SOFTWARE

Getting home finances in a order can be difficult; keeping them that way can be close to impossible; unless you've get some help from an electronic friend.

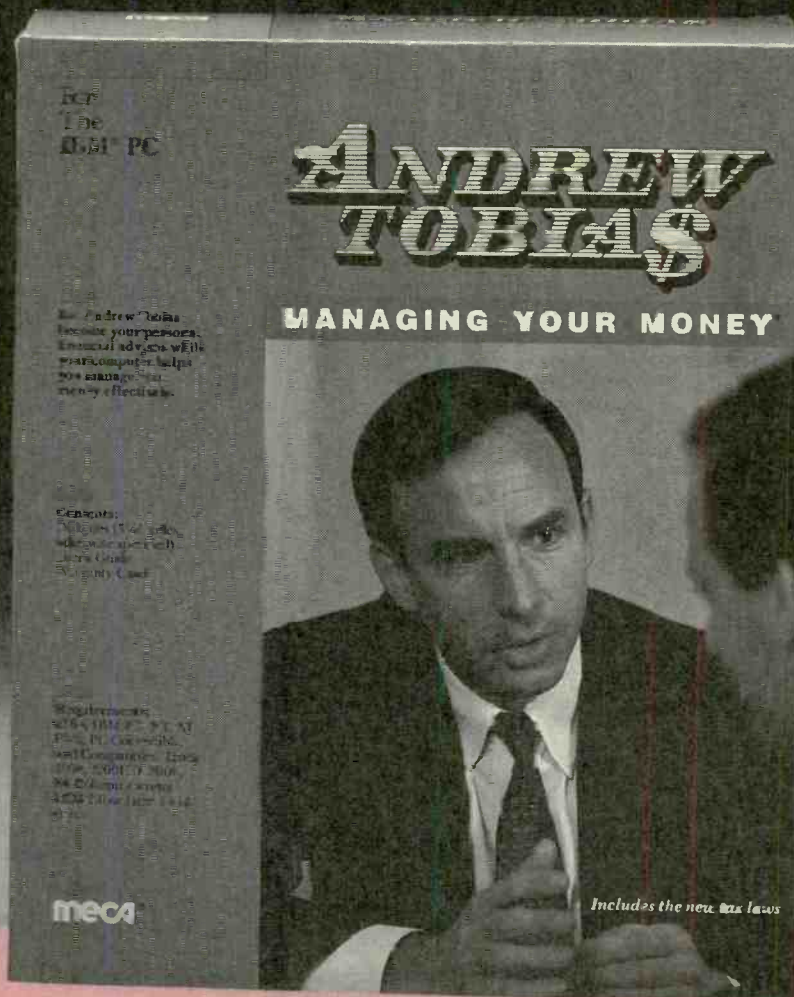

MYM * UNRECONCILED TRANSACTIONS in: * 19:23:39a
City Bank 254-5262-6

Chk#	Date	Payee/Payor	In	Out	Budget
	1/6/86	Jeff Thomas	\$500.00		Renta
	1/7/86	Sara's Customer	\$1,050.75		Freel
	1/8/86	IBM	\$157.50		Divid
	1/10/86	City Bank	\$15.73		Inter
	1/15/86	Sid's Employer	\$1,750.00		Salar
1100	1/21/86	Mobil Oil		\$100.00	Auto:
1101	1/21/86	National Bank		\$1,222.30	Split
1102	1/21/86	Shell Oil		\$15.00	Auto:
1103	1/21/86	Safeway Foods		\$50.00	Groce
1104	1/21/86	Ma Bell		\$125.00	Telep

Account balance: \$1,938.90

Speed scroll -

F1 - Spend money	Alt-F4 - Print check register
F2 - View/Edit transaction	F5 - Automatic transactions All
Alt-F2 - View/Edit allocations	Alt-F5 - Add as automatic transaction
F3 - Delete transaction	F6 - Reconcile this account
F4 - Print checks	F7 - Sort transactions by Check #
F9 - Back up to Money Accounts	F10 - Return to MINI MENU

Press ESCape for Help

From the Managing Your Money's check register you can spend or receive money, edit an old transaction, allocate or re-allocate money to your budget categories, create automatic transactions, print the register, and more.

that allow you to estimate your life-insurance needs and the income tax you're likely to owe. A financial calculator allows you to try various scenarios. For example: "I want to borrow \$50,000 to buy a house; if I pay 11% annually for 30 years, what would my monthly payment be?"

MYM also includes a word processor (whose command keys are configurable), a card file (for keeping track of names and addresses), and an appointment calendar.

Everything is tied together through a user interface that is admirably consistent from module to module. Also, an extensive on-line help system is accessible at any time by pressing the <ESC> key; the information displayed is context-sensitive (i.e., it's keyed to the current menu.)

For most people, the most used module will be the accounts manager. Here you can set up several accounts of various types (checking and savings accounts, of course, but also separate accounts for charge cards and petty cash, if desired).

To choose an account to work with, you must move a highlight bar and press <F1>. Then you come up in a simulated check register that shows check number, date, payee, and amount. Here you can either edit an old transaction (a deposit or a withdrawal) or enter a new one. The data-entry screen looks like a check, so it's easy to fill out. MYM automatically takes care of increment-

ing the check number for you, and the program can print your checks. Deluxe Computer Forms sells compatible checks for about \$50 per 500. When you get your statement from the bank, MYM makes child's play of reconciling it with your checkbook.

Each transaction, whether deposit or withdrawal, can be allocated to a single category or to multiple categories. For example, a check to your local grocery store would probably be allo-

cated just to Groceries (or whatever you choose to call that category), but a check to VISA or MasterCard might get split over several categories. The ability to split transactions in that way gives you a powerful tool to find out where it's all going. Of course, you can call up the "Money Account" screen at any time to find out the current balances of all your accounts.

All accounts are linked by the budgeting system. So even if you maintain separate his and her (or personal and business) accounts, all transactions from all accounts are summed in the same budget categories. But if you like, you can set up separate data subdirectories to maintain completely separate accounting systems. Optionally, you can enable an accounts-payable/accounts-receivable system that makes MYM act pretty much like a real accounting program.

Other modules allow you to enter and track your investments. A special module called "Your Net Worth" brings together all information from the other modules (your accounts, investments, insurance, etc.) to provide a comprehensive summary of your financial shape. That type of report is invaluable when applying for a loan; having the information so neatly organized is bound to impress your banker.

A strong point is the program's handling of loans. You can set up an automatic transaction to pay your monthly mortgage, for example; MYM will auto-

MYM * BUDGET CATEGORIES: ANNUAL TOTALS * 10:35:01a

Budget Category	Type	Year-to-date Actual	Remaining Budget	Annual Total
Insurance: Business	Expense	\$0.00	\$0.00	\$0.00
Insurance: Personal	Expense	\$0.00	\$1,500.00	\$1,500.00
IRA Contribution	Expense	\$0.00	\$4,000.00	\$4,000.00
Medical	Expense	\$100.00	\$1,000.00	\$1,100.00
Miscellaneous	Expense	\$0.00	\$1,750.00	\$1,750.00
Mortgage: Interest	Expense	\$1,166.23	\$64.55	\$1,230.78
Mortgage: Principal	Expense	\$55.11	(\$58.34)	(\$3.23)
Office Expenses	Expense	\$0.00	\$700.00	\$700.00
Prof'l Journals	Expense	\$0.00	\$75.00	\$75.00
Rental Expense	Expense	\$0.00	\$4,200.00	\$4,200.00
Sports	Expense	\$0.00	\$1,450.00	\$1,450.00
Taxes: Federal	Expense	\$4,874.99	\$14,750.01	\$19,625.00

Speed scroll -

F1 - Add a new category	F5 - Empty all categories
F2 - View/Edit a category or summary	F6 - View summary graphs
F3 - Delete a category	F7 - Change screen display to show: Annual Totals
F4 - Print Budget Summary reports	

F10 - Return to MINI MENU

Press ESCape for Help

Managing Your Money's budget screen allows you to view each income and expense category in several formats (current month, year to date, or by tax category). Various graphs and reports are available.

* COMPOUND CALCULATIONS *

10:48:30a

COMPOUND INTEREST	LOANS AND ANNUITIES
PRESENT VALUE: \$1,000.00 YEARLY ADDITION: \$100.00 ANNUAL YIELD: 10.000 % NUMBER OF YEARS: 20.0000 FUTURE VALUE: \$12,455.00 Fill in any FOUR of the lines above. Press F1 to calculate.	AMOUNT OF LOAN: \$50,000.00 INTEREST RATE: 11.000 % TOTAL NUMBER OF PAYMENTS: 360 MONTHLY PAYMENT: \$476.16 Fill in any THREE of the lines above. Press F1 to calculate.
CURRENT YIELD & YIELD TO MATURITY	INTEREST RATE vs. YIELD
CURRENT PRICE: COUPON RATE: % PURCHASE DATE: MATURITY DATE: Fill in ALL of the blanks above. Press F1 to calculate.	Daily Compounding ANNUAL INTEREST RATE: 5.250 % EFFECTIVE ANNUAL YIELD: 5.390 % Press F1 to calculate.

F1 - Calculate the cursor quadrant
 F2 - Clear all quadrants
F10 - Return to MINI MENU
Press ESCape for Help

Managing Your Money provides several "calculators" that let you try out various financial scenarios.

F1-Help	Account	Edit/Find	Quick Entry	Print	Activities			
DATE	NUM	PAYEE/MEMO	PAYMENT	C	DEPOSIT	BALANCE		
@Category List								
@Category Description								
<table style="width: 100%; border: none;"> <tr> <td style="width: 50%; border: none;"> Services Supplies Tax Tax--Federal Tax--Local Tax--Other Tax--State Utilities _Other-Exp Esc-Cancel </td> <td style="width: 50%; border: none;"> Outside Services Supplies Travel & Entertainment Federal Taxes Local Taxes Other Taxes State Taxes Utilities and Phone Other Expenses ↑, ↓ Select ← Use </td> </tr> </table>							Services Supplies Tax Tax--Federal Tax--Local Tax--Other Tax--State Utilities _Other-Exp Esc-Cancel	Outside Services Supplies Travel & Entertainment Federal Taxes Local Taxes Other Taxes State Taxes Utilities and Phone Other Expenses ↑, ↓ Select ← Use
Services Supplies Tax Tax--Federal Tax--Local Tax--Other Tax--State Utilities _Other-Exp Esc-Cancel	Outside Services Supplies Travel & Entertainment Federal Taxes Local Taxes Other Taxes State Taxes Utilities and Phone Other Expenses ↑, ↓ Select ← Use							
8/16 1987	NOTE:	BEGINNING THIS BANK ACCOUNT C SAMPLE SET OF @ CAT						
8/16 1987		GENERAL BUSINESS US						
8/16 1987		***** INSTRUCTIO * To see them, pres						
8/16 1987		* Then, to delete u press Ctrl-L.						
8/16 1987		* To use them, foll instructions in t						
QSMPL_B Esc-Cancel						Ending Balance: \$0 00		

Quicken's check register allows you to categorize each transaction using one or more categories; you bring up the list by pressing <CTRL-C>.

matically split the transaction between interest and principle categories (the interest is deductible, one of the advantages of owning rather than renting).

All that power comes at a price: complexity. Because there's so much here, it takes time and a fair amount of study to absorb everything. If you get stuck, the company maintains a technical-support line. However, it's almost always busy; I found it nearly impossible to break through. Who wants to spend all day doing finances?

Quicken. Where MYM tries to be all things to all people, Quicken focuses on doing one thing, and doing it well: namely, maintaining a check register. Like MYM, you can set up several accounts; in Quicken they do not sum to a single-budget system. Like MYM, Quicken allows you to split transactions, to create automatic transactions (for monthly bills), and to categorize each transaction. However, if you wanted to split a loan payment, you'd have to look up the principal and interest values

Software and sources.

Managing Your Money (\$219.98), **MECA Ventures, Inc.**, 355 Riverside Avenue, Westport, CT 06880; Tel. 203/222-9150. Versions available for IBM and compatibles, Macintosh, and Apple II.
CIRCLE 120 ON FREE INFORMATION CARD

Quicken (\$49.95), **Intuit**, 540 University Avenue, Palo Alto, CA 94301; Tel. 415/322-0573. Versions available for IBM and compatibles, and Apple II.
CIRCLE 121 ON FREE INFORMATION CARD

FastBucks (\$47.75 for program and printed manual; \$17.25 additional for one year of updates), **Software Expressions**, P.O. Box 301002, Houston, TX 77320-1002; Tel. 713/541-3063. Versions available for IBM and compatibles.
CIRCLE 122 ON FREE INFORMATION CARD

FastBucks (\$5 plus \$5 S&H), **Public Brand Software**, P.O. Box 51315, Indianapolis, IN 46251; Tel. 800/425-DISK. Order disk number IN18.1.
CIRCLE 123 ON FREE INFORMATION CARD

FastBucks (\$5 plus \$4 S/H), **The Public (Software) Library**, P.O. Box 35705, Houston, TX 77235-5705; Tel. 713/665-7017. Order disk number 2-AC-753+.
CIRCLE 124 ON FREE INFORMATION CARD

from the amortization schedule provided by your bank.

You use the program by entering several checks at a check-writing screen; as with MYM, the screen is quite intuitive. Then you print those checks; the manual contains a number of hints for getting your checks lined up properly. The company sells special checks designed for use with the program.

You can enter checks that you wrote manually in a simulated check register; you can also edit and delete transactions there. Quicken provides a number of shortcut keys for moving through the register—you can search on the payee and memo fields, you can go to a specific date, you can "jump" by a month, and more. Quicken also provides several reports: transaction list (i.e., the register), by budget category, automatic transactions, and more.

One interesting feature is Quicken's automatic bill minder. With it, you designate desired transactions as repetitive; on the appropriate date, Quicken will automatically remind you to pay the bill(s).

Quicken also has several features that can help you keep the books in a small business (or a department in a large corporation). A separate utility is available for about \$20 that allows you to transfer Quicken data to Lotus 1-2-3
(Continued on page 102)

THE DIGITAL ELECTRONICS COURSE

TAKING A CIRCUIT'S PULSE

What is a logic 1 or 0? How are they represented, detected, and used in digital-logic circuits? Read on and find out.

BY ROBERT A. YOUNG

As you may know, digital circuits operate on a binary numbering scheme that has two numbers: 1 and 0. Those numbers are represented in a circuit by the presence of a voltage. If the voltage falls in one range, the number is a 1; if it falls into another range, it is a 0. The two voltage ranges are commonly referred to as voltage levels; high or low, which are also referred to as on/off, in/out, and positive/negative.

The two logic families that are commonly used today—TTL (Transistor-Transistor Logic) and CMOS (Complementary Metal-Oxide Semiconductor)—have different power-supply requirements, which means the voltage levels they use to represent 1's and 0's can be different. TTL circuits require a pretty strict +5-volt supply (denoted V_{CC}), while CMOS circuits can operate from supply voltages ranging from 3 to 15 volts (denoted V_{DD}).

Because TTL circuits are restricted to using one power-supply voltage, their output logic states are indicated by strictly defined voltage levels. In TTL inte-

grated circuits, a logic 1 is represented by a voltage of between 2 and 5 volts. A logic 0 is represented by anything less than 0.8 volts.

On the other hand, because CMOS circuits can operate from a wide range of supply voltages, their voltage levels are defined in percentages of the supply voltage. For CMOS's, any voltage above 70% of the supply represents a logic 1, and anything below 30% represents a logic 0.

Note that both families have voltage ranges that are undefined (see Fig. 1). If a logic signal falls into an undefined range, its value is considered indeter-

minate and the device may fail. Since we will be using 5 volts to power our experiment board, the logic levels for CMOS devices with a 5-volt supply are also shown in Fig. 1.

Basic Logic Gates. The operation of the basic logic gates—AND, OR, and NOT (inverter) gates—can easily be simulated by simple switch circuits (see Fig. 2 for an example), where the high and low logic states can be referred to as on and off, respectively. When the switch is open (the output across the load is said to be in the low state), no current flows through the lamp, so the lamp does not

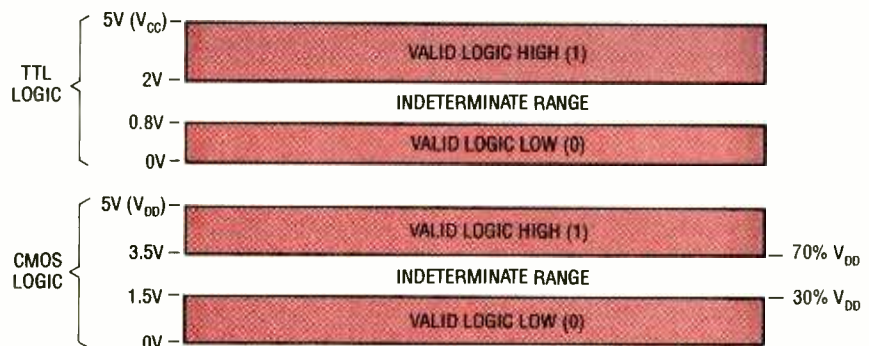

Fig. 1. In TTL integrated circuits, output logic states are indicated by strictly defined voltage levels; between 2 and 5 volts for a logic 1, and anything less than 0.8 volts for a logic 0. CMOS circuits, on the other hand, can operate from a wide range of supply voltages, so their logic levels are defined in percentages of the supply voltage; any voltage above 70% of the supply voltage represents a logic 1, and anything below 30% of the supply voltage represents a logic 0.

Our gratitude is extended to the EIA/CEG for the creation of the course upon which this series is based, especially to the consultants who brought it to fruition: Dr. William Mast, Appalachian State University; Mr. Joseph Sloop, Surry Community College; Dr. Elmer Poe, Eastern Kentucky University.

light. But when the switch is closed (said to be in the high state), current flows through the lamp, causing it to light.

In keeping with the switch analogy, we can put together a circuit—using a power source, a lamp, and two switches, as shown in Fig. 3A—to mimic the operation of a simple 2-input AND gate. When both S1 and S2 are open, no current flows in the lamp, so it does not light. The output of the circuit is said to be in the logic-low (off) state. When either S1 or S2 is left open, the lamp will be off. But, if both S1 and S2 are closed, current flows through the circuit, lighting the lamp.

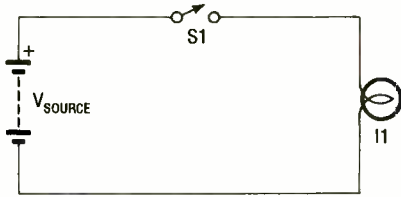

Fig. 2. The operation of a basic logic gate can easily be represented by a simple switch circuit where high and low logic states can be referred to as on and off, respectively.

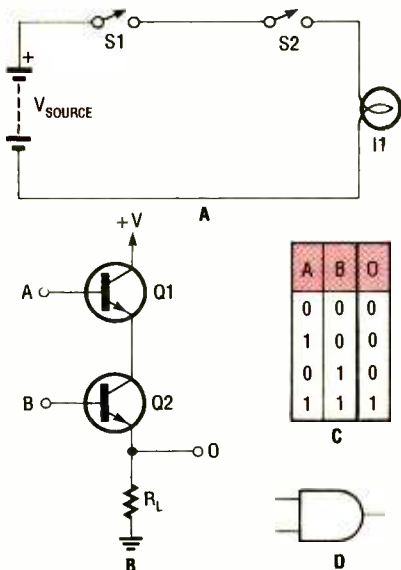

Fig. 3. The switch circuit in A can be used to demonstrate the operation of an AND gate. The switches can be effectively replaced by transistors as in B, to get the functional transistor equivalent. The AND-gate truth table is shown in C and its schematic symbol is shown in D.

Figure 3B is the functional transistor equivalent of the AND gate; its truth table is shown in Fig. 3C; and its schematic symbol is shown in Fig. 3D.

Let's take a close look at the transistor equivalent of the AND gate (see Fig. 3B). When both the A and B inputs are low,

neither Q1 nor Q2 conduct, so the output of the circuit (V_{out}) is low. If a high is applied to input A (causing Q1 to conduct) and a low is applied to input B (keeping it off), the output of the circuit is still low, because the path through the two transistors is incomplete.

If a low were applied to input A and a high applied to input B, the output of the circuit is low. However, when both inputs to the circuit are high, both transistors conduct, allowing a voltage to be developed across the load resistor, R_L , so V_{out} is high. Note: In order for the output of an AND to go high, both inputs must be high. Note that the truth table states that the only time that an AND-gates' output goes high is when its inputs are high.

Now let's turn our attention to Fig. 4 for a look at OR-gate operation. Figure 4A shows the transistor equivalent of an OR gate, its truth table is shown in Fig. 4B, and its schematic symbol is shown in Fig. 4C. Note that in Fig. 4A there are two possible paths for current flow—one through Q1, and the other through Q2.

When both the A and B inputs to the circuit in Fig. 4A are low, the two transistors remain off, so the output is low. When either input is high, its respective transistor turns on, forcing the output high; the output is obviously high when a high is applied to both inputs at once. Note that the foregoing observation agrees with the truth table.

The NOT gate or inverter is a simple switch arrangement that inverts—provides the complement of—the input signal. In other words, if the input signal is a logic 1, the output is a logic 0; for a logic-0 input, the output is a logic 1. The transistor functional equivalent for the inverter is shown in Fig. 5A; its truth table is in B; and its schematic symbol is shown in C.

Logic Probes and Pulsers. Logic probes and pulsers are simple test instruments that may be used to check the operation of logic circuits. One of the main uses for a logic probe is to tell

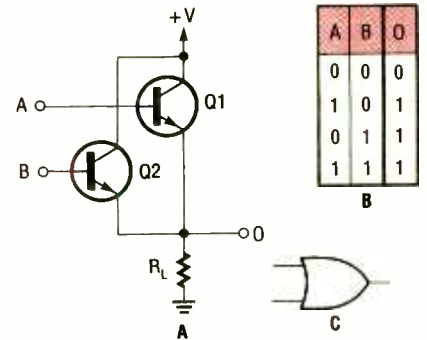

Fig. 4. The transistor functional equivalent of an OR-gate is shown in A; its truth table is in B; and its schematic symbol is in C. Notice that if either transistor is active, the output will go high as indicated by the table.

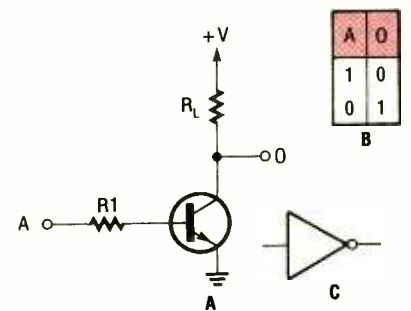

Fig. 5. The transistor equivalent of an inverter is shown in A. Notice that the transistor takes the place of one of the switches in the DIP switch set up. Its truth table and its schematic symbol are shown in B and C, respectively.

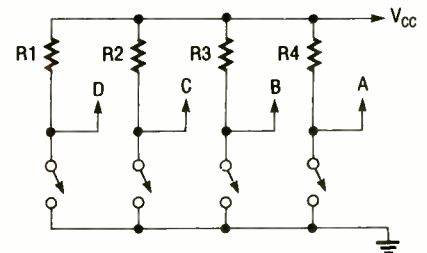

Fig. 6. The DIP switch you use may contain more than four individual switches. If so, you might want to connect the extra ones.

the user the status (either high or low) of a pin to which it is connected.

Most probes derive their operating power from the device under test (commonly referred to as the DUT) through alligator clips that are clipped to the board's power-supply buses. If a probe is self powered, it will still have an alligator clip to connect it to the device's ground. That ground is used as a reference for the voltages that the

(Continued on page 100)

PARTS LIST FOR THE PROBE EXERCISE

- S1—DIP switch, 4 positions or greater
- R1-R4—4700-ohm resistor
- R5—100,000-ohm multi-turn trimmer potentiometer
- Logic probe, breadboard, voltmeter, and No. 22 wire



Antique Radio

tions were on a paper or card fastened to the underside of the cover. I once saw an advertisement for a reproduction of this card—but I can't remember where. Perhaps another reader knows who is offering it and would be willing to contact Ray. Write to Raymond F. Shetrone, 2313 Harvard Ave., Ft. Meyers, FL 33907.

Back to the Wasp! Now back to the Pilot A.C. Super-Wasp. For readers who haven't read the earlier installments of the restoration, this is a 5-tube re-

By Marc Ellis

DIGGING DEEPER INTO THE "WASP"

Since the July issue, *Antique Radio* has been devoted to the study and restoration of a *Pilot A.C. Super-Wasp* receiver. But while I've been writing about the receiver, mail from readers has been piling up—including a lot of very interesting photographs. So this month I'm going to compromise. I'm going to tell you more about the Pilot project, but I'm also going to leave my own camera on the shelf and give all the picture space to two readers: Ray Shetrone and Bob Smith.

A Crosley Carnival. I picked those particular readers to feature this month, because they sent in virtually matching views of two different Crosley receivers. Bob's set is a 3-tube *Ace 3B*, while Ray's is a 2-tube *Model VI*.

As you can see by comparing the photographs, the construction of the sets is quite similar. However, the *Ace* is equipped with the adjustable dual-spiderweb coil (just to the right of the rightmost tube in the interior shot) typical of Crosley regenerative-detector circuits, while the *Model VI* is equipped with a fixed RF coil and is probably not regenerative.

The *Ace*'s two audio transformers tell us that its regenerative detector is followed by two stages of audio amplification. The *Model VI* has no audio transformer, so I'm guessing that it has a stage of RF amplification preceding the detector tube. The *Ace* probably provided comfortable speaker volume on reasonably strong signals; the *VI* was undoubtedly strictly an earphone set.

Both sets use the familiar Crosley "book type" tuning capacitor. In fact, the *VI* has a pair of them (though only one shows in the photograph).

Bob writes that he'd like to find a *Crosley 50* for his collection. He owned one as a teenager and really enjoyed it. After returning from World War II, he decided to put it back into service and



The front panel of Ray Shetrone's *Crosley VI*. Note the tube-viewing "portholes" just above the two-filament rheostats at right.

left it with a radio repairman who was going to help him find a replacement tube. The repairman then "lost" the radio, and Bob never saw it again. If you can help, write Robert G. Smith, Box 130 Rt. 1, White Pine, TN 37890.

Ray (who, incidentally, was one of the people who helped me identify the Philco "mystery control" discussed in a previous issue) writes that the *Model VI*—still in his possession after nearly 65 years—was the first radio ever owned by his family. When last powered up (about 15 years ago), the set still worked just fine!

Ray's "Brand X" Radio. With his letter, Ray also included photographs of another set, a 1-tube regenerative job that he picked up at a yard sale. Though he's had it operating, Ray couldn't find any identifying markings on the receiver, and wasn't sure of the brand or model.

Thanks to the very clear photograph, however, I can recognize this set as an *Aeriola Senior*, made by *Westinghouse* in about 1922. The identifying markings and operating instruc-

generative receiver covering the frequency range of 500–14.2 meters (600 kHz to about 18.5 MHz) with the help of five sets of plug-in coils. Essentially an update of an earlier battery-operated model (the *Pilot Wasp*), the set operated from a separate power supply that could be purchased as an accessory from the set manufacturer, acquired as a generic item from another source, or simply home-brewed.

In July, we took a detailed look at Pilot's late 1920's to early 1930's product line—discussing the relationship of the A.C. to the models that preceded and followed it. In August we focused on the radio's circuitry, with special emphasis on the more unusual and interesting components. Last month was devoted to correcting the worst problem discovered to date: a tuning capacitor that had been partially dismantled—apparently as part of a do-it-yourself band-spread modification.

Checking Known Troublemakers. With the tuning capacitor once again equipped with a full set of plates and ready for reinstallation in the radio, I



Interior shot of Model VI gives us a good look at the famous Crosley "book-style" tuning capacitor. Fixed RF coil (right) suggests set isn't regenerative.

began to check out the parts known to be frequent sources of trouble in vintage sets: the audio transformers, carbon resistors, and tubes.

Though they look quite substantial in their heavy metal cases, audio transformers are actually relatively fragile. The very fine wire used in audio-transformer windings is vulnerable to burnout by even small overloads, such as might be caused by the application of too high a plate voltage. And at some time during its long history, this set could easily have been connected to a power supply having incorrect specifications.

I always look at the audio transformers fairly early in the game when assessing the condition of a 1920's-era set. But, in this case, my concerns proved to be groundless. One by one I disconnected the primaries and secondaries of the two transformers, gave each an ohmmeter check, and found that the set had electrical continuity.

The set's three glass-enclosed, "fuse style" carbon-composition resistors were also ohmmeter-checked. It's been my experience that such units tend to change greatly in value as they age.

The two half-megohm resistors used in the resistance-coupling circuit between the detector and first audio amplifier measured out at 450k and 550k, which is quite acceptable. The 3-megohm grid-leak resistor, however, turned out to be closer to 2 megohms. The latter value is not an unusual one for that application, but after the radio is operational, I plan to try a 3-megohm resistor (using a modern one if necessary) to see if I note a difference in performance.

Maybe I've just been lucky, but I find that tubes are somewhat overrated as sources of trouble in vintage radios. Most of the ones I've checked have been fine. If a tube *does* show a problem, it's more likely to be a little weak rather than completely inoperable. In

my experience, open filaments, inter-element shorts, and similar traumatic failures have been comparatively rare.

However, I have a good tube tester (a very picky, retired military model) and I use it. I'd hate to fire up a newly-acquired set only to burn out some difficult-to-replace component because of a shorted tube. And if a radio is performing poorly, it only makes sense to first rule out weak tubes before looking for deeper problems.

In any case, my tester gave the



Panel of Bob Smith's Ace 3B shows family resemblance to Model VI. Note portholes and rheostats for 3 tubes. Knob above tap switch (no equivalent on the "VI") controls regeneration.

Super-Wasp's tube complement a clean bill of health. So if I do encounter problems with the radio, they probably won't stem from that source.

Some Interesting Tube Brands. Incidentally, though the tube *types* used in the A.C. Super-Wasp are very common ones, the *brands* that came supplied with the set are interesting and unusual. For example, the type 24-A screen-grid RF amplifier is a National Carbon Company *Eveready Raytheon* brand (labeled ER224A). Mergers that make strange bedfellows of well-known brand names are usually considered a sign of future shock—but we came upon this one by traveling into the past!

The two '27 tubes that were installed in the audio-amplifier sockets are beautiful blue-glass Arcturus types. They're each marked "Arcturus No. 127 Detector," and (though they weren't used as such in this radio) obviously represent a special design for detector service. I notice that the plate electrodes of these tubes are solid-metal structures—as opposed to the wire-screening style seen in the more common versions of the '27. As a matter of fact, I have another "Arcturus No. 127," without the "Detector" marking, in my tube collection. And though its plate is made of sheet metal rather than wire screen-

ing, the metal is not solid but perforated with a grouping of holes. Perhaps one of you tube historians can throw some light on this for us.

The '27 that came installed in the detector socket is even more exotic. It bears a logo consisting of the letters "JRC" within a red-bordered blue diamond, and the type number is shown as JY-227. The fellow who sold me the Wasp tells me that this is the logo of a Japanese outfit (Japan Radio Corp.?) that is still in business today. The tube appears to be of conventional construction, with the usual screen-wire plate.

Speaking of the detector tube, many of the original ads for the A.C. Super-Wasp insisted that the '27 used for that purpose *must* be of Pilot manufacture ("Pilotron" brand). They claimed that other brands were unfit for use as regenerative detectors because something about their conventional filament design caused an unpleasant rushing noise at the point of regeneration. Pilotron filaments were especially designed to avoid that problem.

Since I don't have a Pilotron type 27

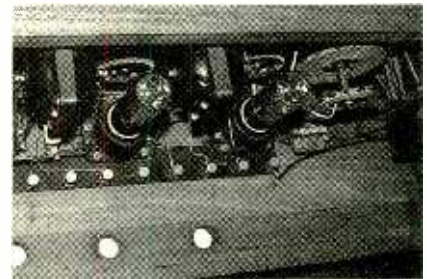

Interior of the "3B." Rear segment of dual spiderweb coil (at right) is the "tickler." Attached to front-panel knob, it is moved in and out to control regeneration. Note internal binding posts for power, etc. These are panel-mounted on the "VI."

in my collection, I'm going to have to hope that this "problem" is mostly a product of advertising hype. I do have plenty of standard RCA and Cunningham versions of the tube, however, and it will be very interesting to compare their performance as detectors with that of the JRC tube and the "detector" and "non-detector" versions of the Arcturus.

I have no idea, of course, if the tubes now in the set are the ones that were originally installed in it. Pilot apparently did not supply tubes with the A.C. Super-Wasp kit, even though they strongly recommended their Pilotron

(Continued on page 96)

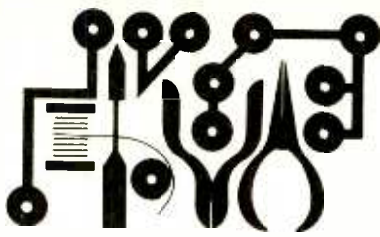

Circuit Circus

By Charles D. Rakes

ing the value of R12 or decreased by increasing that resistor's value. The minimum value for R12 should not be less than 680 ohms.

Even though the circuit layout isn't critical, neatness and short interconnecting leads are a definite plus in the finished product. The circuit can be assembled on perboard or (if you are well versed in printed-circuit fabrica-

SIMPLE BUT USEFUL TEST GEAR, AND MORE!

This month's Circus offers a variety of circuits, some of which are suitable for full-fledged construction projects that should keep the soldering iron hot for many hours. We start off by featuring a circuit that's designed to make relative sound-level measurements. Intensity levels from less than 70 dB to over 115 dB are spread over four ranges and are easily read on a 10-segment, LED level indicator.

Sound-Level Meter. Figure 1 shows the schematic diagram of the Sound-Level Meter. Sound is picked up by MIC1 (an electret microphone element) and fed to the input of the first op-amp, U1-a (half of an LM1458N dual op-amp). The values of R3 and R4 set the op-amp's gain—which is equal to $R4/R3$ —at 100; that's done using the values shown for those resistors. The signal is then fed to the input of the second op-amp (U1-b), where it is boosted again by a factor of between 1 and 33, depending upon the setting of the range switch, S1.

With the range switch set in the "A" position, R6 is 1K and R7 is 33K, so that stage has a gain of 33. In the "B" position, the gain is 10; in the "C" position, the gain is 2.2; and in the "D" position, the gain is 1.

Op-amp U1-b's output is converted to a varying DC signal by a voltage-doubler, rectifier circuit that's made up of components D1, D2, C3, and C4. Transistor Q1 is connected in an emitter-follower circuit to isolate the DC signal from the input circuitry of U2 (an LM3914 dot/bar display driver).

Transistor Q2, Zener diode D3, and resistor R13 make up a voltage-regulator circuit that reduces the 9-volt power source to a regulated 5-volt level and is used to power U2 (which is connected in the dot-display configuration).

As the signal voltage fed to the input of U2 at pin 5 varies, one of ten LED's will light to correspond with the input-voltage level. At the input's lowest operating level, U2 produces an output at pin 1, causing LED1 to light. The highest in-

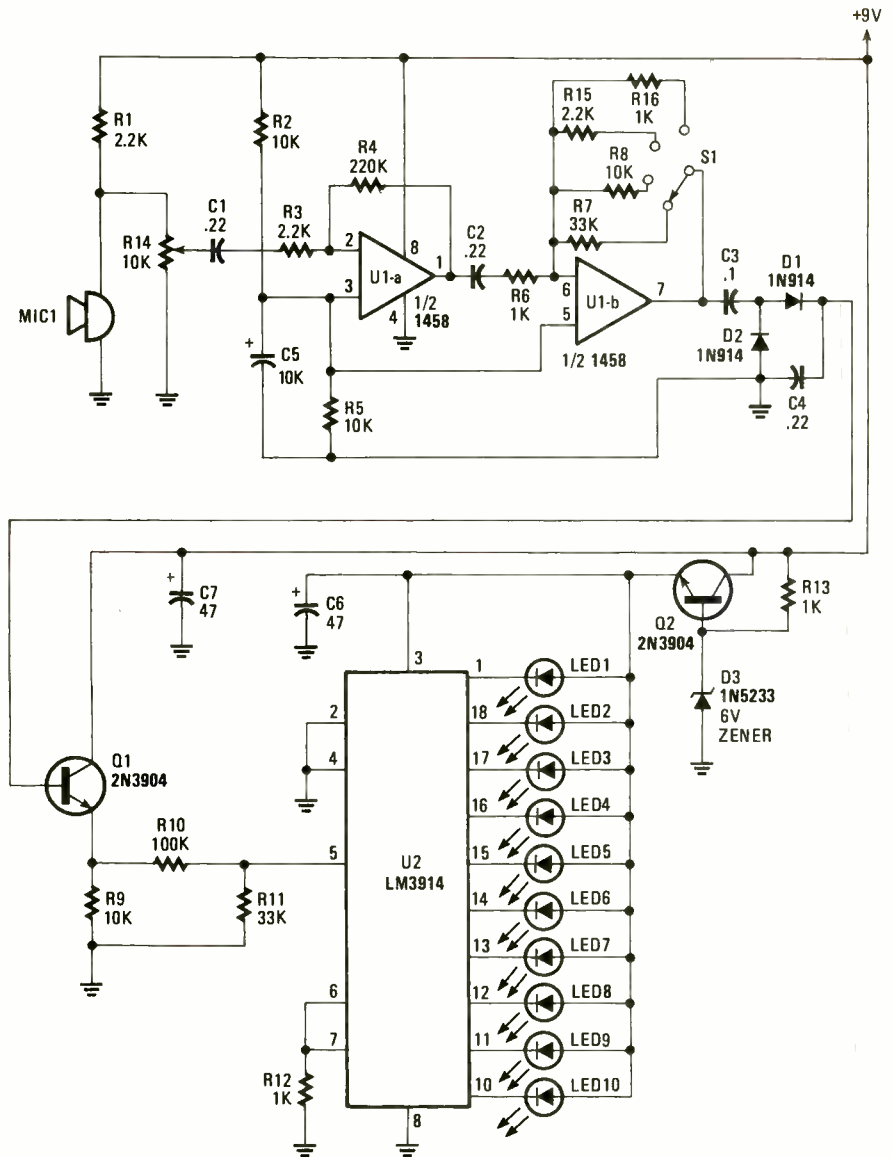

Fig. 1. The Sound-Level Meter is built around two integrated circuits—the LM1458N dual op-amp and the LM3914 dot/bar display driver—which are supported by two transistors and a handful of additional components.

put level presented to the input of U2 (about 1.2 volts) causes LED10 to turn on.

Resistors R10 and R11 make up a simple voltage-divider network, which reduces Q1's output-signal voltage to an operating range that matches the input requirements of U2. Resistor R12 sets the LED's drive current. The light output of the LED's can be increased by reduc-

tion) a printed-circuit board can be made. However, if the perboard approach is taken, use sockets for the IC's. If you anticipate using the sound meter often, it would be worth your time to house the circuit in a small plastic cabinet with MIC1 mounted in one end and the LED's, and the range switch located on the top.

PARTS LIST FOR THE SOUND-LEVEL METER

SEMICONDUCTORS

U1—LM1458N dual op-amp, integrated circuit
 U2—LM3914 dot/bar-display driver, integrated circuit
 Q1, Q2—2N3904, general-purpose, NPN silicon transistor
 D1, D2—1N914, general-purpose silicon diode
 D3—1N5233, 6-volt 1/2-watt Zener diode
 LED1-LED10—Jumbo light-emitting diode

RESISTORS

(All resistors are 1/4-watt, 5% units, unless otherwise noted.)
 R1, R3, R15—2200-ohm
 R2, R5, R8, R9—10,000-ohm
 R4—220,000-ohm
 R6, R12, R13, R16—1000-ohm
 R7, R11—33,000-ohm
 R10—100,000-ohm
 R14—10,000-ohm potentiometer

CAPACITORS

C1, C2, C4—0.22- μ F, mylar or ceramic disc
 C3—0.1- μ F, ceramic disc
 C5—47- μ F, 16-WVDC, electrolytic

ADDITIONAL PARTS AND MATERIALS

MIC1—Electret microphone element
 S1—Single-pole, 4-position rotary switch
 Printed-circuit or perfboard materials, enclosure, IC sockets, 9-volt transistor-radio battery and battery holder, wire, solder, hardware, etc.

The easiest way to calibrate the Sound-Level Meter is with a commercial sound-level meter. However, if one is not available, the following method will do fine, especially if the circuit is to be used in making relative sound-level comparisons.

A number of low-cost piezo sounders—for which the manufacturers have specified a dB output-sound level at a fixed distance—are available from several suppliers. To calibrate the circuit using sounders, take a sounder for which the output dB level is specified. Let's say that the unit chosen is rated for 100 dB at a distance of one inch.

Place MIC1 about one inch from the sounder, then set range-switch S1 to the "C" position and adjust R14 so that the fifth LED turns on to indicate 100 dB.

Now with the simple calibration procedure completed the approximate range of each switch position is as follows: Position "A" = 65 dB to 85 dB; position "B" = 80 dB to 96 dB; position "C" = 94 dB to 105 dB; and position "D" = 100 dB to over 115 dB.

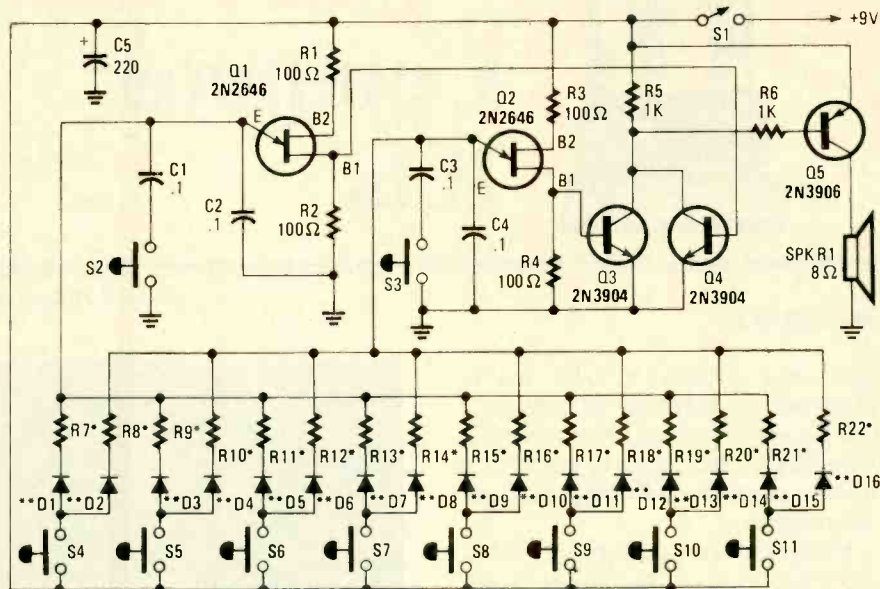

* SEE TEXT
 **D1-D16 ARE 1N914

Fig. 2. The Electronic Bagpipe is made up of two oscillator circuits that are built around unijunction transistors (UJT's), Q1 and Q2. The outputs of the oscillators are fed to an audio mixer (consisting of Q3 and Q4), the output of which is fed to the base of Q5, which is used to drive speaker SPKR1.

A jet airplane flying directly overhead, and at close range, can produce sound levels greater than 120 dB, which is near the threshold level that can actually cause pain. The ambient noise level found in many manufacturing facilities can vary from a low of 65 dB to levels over 80 dB. A normal conversation between two people in a quiet room will average between 75 and 80 dB at a measured distance of 1 foot from the speakers. For a quick circuit check, you can position the microphone about one foot away from, and directed toward you, and speak in a normal manner and adjust R14 so that LED5 lights on the "A" range.

Of course, our simple Sound-Level Meter won't match the performance of the professional high-cost units, but for the time and money spent, it can be a handy test instrument to have around the shop.

Electronic Bagpipe. Our next circuit, see Fig. 2, is my version of a simple Electronic Bagpipe that's not only fun to build, but can be a neat gift for that special child. The circuit mimics the dual-tone drone sound that's produced by the unusual wind instrument.

Here's how the sounds are made. Unijunction transistors Q1 and Q2 are connected in similar audio-oscillator circuits. Each of the oscillator frequencies is determined by one of the two resistors

PARTS LIST FOR THE ELECTRONIC BAGPIPE

SEMICONDUCTORS

Q1, Q2—2N2646 N-channel unijunction transistor
 Q3, Q4—2N3904 general-purpose silicon NPN transistor
 Q5—2N3906 general-purpose silicon PNP transistor
 D1-D16—1N914 general-purpose diode

RESISTORS

(All resistors are 1/4-watt, 5% units.)
 R1-R4—100-ohm
 R5, R6—1000-ohm
 R7-R22—3300-ohm

CAPACITORS

C1-C4—0.1- μ F, ceramic-disc
 C5—220- μ F, 16-WVDC, electrolytic

ADDITIONAL PARTS AND MATERIALS

SPKR1—8-ohm, 4-inch speaker
 S1—SPST toggle switch
 S2-S11—Normally open pushbutton switch
 Printed-circuit or perfboard materials, enclosure, IC sockets, 9-volt, transistor-radio battery and battery holder, speaker grille, wire, solder, hardware, etc.

selected by one of the pushbutton switches, S4 through S11. Odd-numbered resistors, R7-R21, determine the frequency for the Q1 oscillator circuit and the even-numbered resistors, R8-R22, determine the frequency for Q2's circuit.

(Continued on page 104)



Computer Bits

By Jeff Holtzman

the files in it, all subdirectories of it, all the files in those subdirectories, etc.)

For example, you might create directories called \DATA and \PROG, from which most other subdirectories would branch, depending on the type of data. The \DATA directory might lead, for example, to DATABASE, SPREAD, and TEXT subdirectories; TEXT might lead to STORIES, LETTERS, and PAPERS. The complete path to PAPERS would be specified:

BACKING UP

It's never a popular topic. But it's something you've got to consider if you value the work you do on your PC. There are several ways for your hard-earned program and data files to get scrambled:

- The disk itself could go bad. Common hard disks are rated for only a year of full-time use.
- AC power could dip and you could lose anything from a single bit in a text file to your entire hard disk, if garbage happened to get written to the system areas of the disk.
- An errant software program could corrupt your disk unintentionally.
- A co-worker, friend, or family member could inadvertently wipe out one or more files.
- A malicious program or person could intentionally wipe out one or more files.

Undoubtedly, there are more modes of failure. The point is to be prepared. Being prepared doesn't necessarily mean that you must somehow copy the entire contents of your 40MB hard disk to floppies every day. It does mean making copies of changing information (your text and other data files). It also means striking a balance between the amount of time it takes to back up reproducible files (programs, etc.) vs. the amount of time it would take to reinstall those files should disaster strike.

Finding that balance may be easy, or it may not. In my case, it's easy: Everything on my main PC gets backed up regularly, as follows: weekly backups on alternating tapes to an Irwin Magnetics 785 tape drive, and daily backups to alternating sets of 1.2 MB floppy disks. All backups are stored in a fireproof box in the basement. If I install a significant new piece of hardware or software, I perform an interim tape backup before doing so. That way, if anything happens, I just turn the Irwin loose for about 20 minutes, and all 40 megabytes are restored just as they were.

My needs are probably more stringent than yours, because I make my

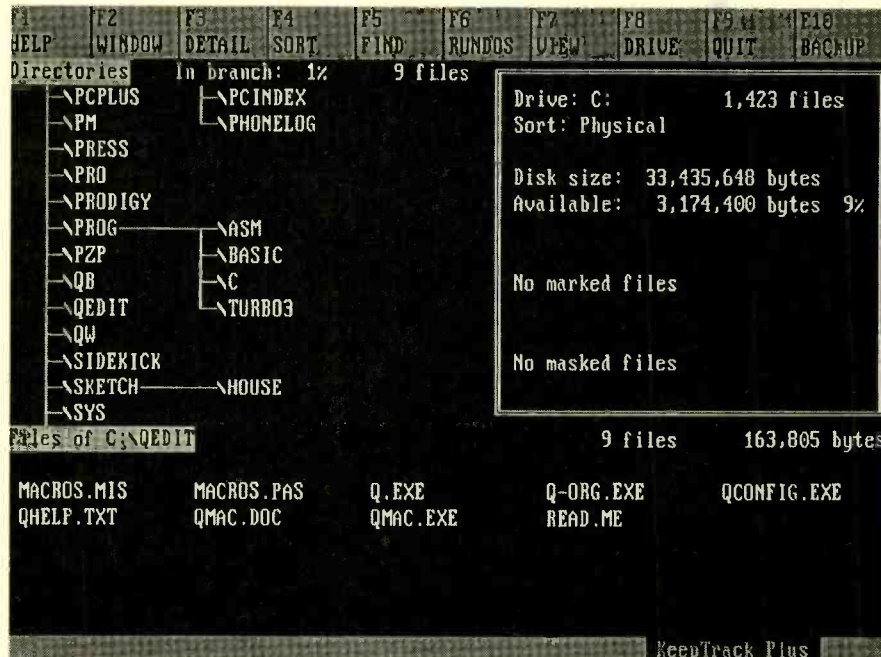

KeepTrack Plus is a backup/restore program for the PC family. It works with any DOS-compatible media (all disk densities, Bernoulli boxes, network drives, etc.), and as a bonus has powerful file- and disk-management features.

living spending anywhere from 40 to 80 hours a week in front of (and inside and behind) various personal computers. If you use your PC just a few times a week, you won't have the incentive I have to perform religious backups. But imagine that your hard disk crashed. Are you sure there's nothing irreplaceable on it? Are you sure you want to go through the hassle of reinstalling all your program disks?

If you're not sure, but haven't the means or the patience for daily backups, there are other ways of protecting yourself. Here's one plan.

Getting Organized. The first thing to do is get your hard disk organized. The goal, as far as backup efficiency is concerned, is to locate all the changeable files (your data files) in one branch of the subdirectory structure, and all the fixed files (programs) in another. Then you'll only have to focus your efforts in either branch as necessary. (By branch, I mean any directory or subdirectory, all

\DATA\TEXT\PAPERS. The point is that, whenever you changed something in any file in any of those subdirectories, you would just backup the \DATA branch, and everything would be captured on disk. Assuming, of course, that you have and use proper backup software.

How to Do It. How would you perform the backup? You can use DOS's BACKUP program, but it's pretty unreliable. You could also use DOS's XCOPY program, but doing so can be tricky, and not very reliable either. The third option is to use a separate backup program. I've been using a program called *KeepTrack* (KT) to do floppy-based backups for several years without problems. The latest version is called *KeepTrack Plus*.

Whereas, some backup programs use incompatible disk formats to speed the backup process, KT sticks with standard DOS formats. That means you can simply COPY a file from a backup diskette any time you want without going

through a specific restore procedure. And that doesn't mean KT is slow; it's actually much speedier than DOS COPY and XCOPY commands because it buffers data from the hard disk in RAM while waiting for floppy operations to be completed.

The program maintains an ongoing list of which files are stored on which disks (they're numbered sequentially), so it's easy to find what you need. KeepTrack Plus is also an excellent disk manager. If you've got various files spread all over your disk and despair of ever getting them organized, KT can make it child's play. You can even move entire branches from one part of the directory tree to another without copying and then deleting the originals.

KeepTrack Plus lets you choose between full and partial backups, and it can backup to various disk sizes in various drives (360K diskettes in a 1.2MB drive, for example). In addition, the program can backup to another hard disk, special devices like Bernoulli Boxes, and it can backup drives on a network.

In Use. When you start the program, you're presented with an on-screen graphic representation of the directory structure of your hard disk. As you move the highlight from directory to directory, a list of files in each directory is presented below. In addition, a window along the right side of the screen contains statistical information about disk size, files selected for various operations, etc. Last, the meanings of the function keys are listed along the top of the screen.

To organize a disorganized hard disk, you could go through the directory structure, marking files (by pressing the space bar) that you'd like to group together in a single directory. Then issue the copy command <SHIFT-F4>.

Things work pretty much the same way for copying, moving, and deleting files. KeepTrack presents you with a menu of options allowing you to choose how you want to select the desired files. You can work with previously marked files, you can pick a single file, specify a group of files by name (*.TXT, for example), by date, or by branch. Just highlight the desired option, press the <ENTER> key, and let KeepTrack do its thing.

VENDOR INFORMATION: KeepTrack Plus Version 2.0 (\$99), The Finot Group, 2390 El Camino Real, Suite 3, Palo Alto, CA 94306; Tel. 415/856-2020.

KeepTrack has several extra features that are quite useful. Many file and disk managers allow you to view the files in each directory sorted by name, extension, time/date, backup status, or unsorted. KeepTrack of course allows those options. In addition, the program will sort files by those same criteria, but ignoring the directory structure. That allows you to see *all* the files that begin with A in one group, the B files in another, etc. A variation of that command allows you to locate files with duplicate names, another useful operation that comes in handy when you are trying to clean up a messy hard disk.

Doing The Backup. To set up a backup system for an occasional PC user, I'd buy a truckload of 1.2MB diskettes (I'd prefer the 1.44MB 3.5-inch type, but they're still too expensive.) Then I'd create four sets of disks: A, B, C, and D. I'd use the A and B sets to backup the programs branch and the C and D sets to backup the data branch of the hard disk. The A and B backup disks wouldn't get used very often—once when I first set up the system, and then on an alternating basis each time I installed a major piece of software.

For example, first I'd backup the \PROGRAMS branch to both sets A and B. Then, a few months later, after buying, installing, and customizing a new word processor, I'd backup the entire branch to set A, overwriting the original backup. A few months later, after collecting a number of public-domain utilities, I'd overwrite the B set. And so on.

Meanwhile, I'd perform weekly backups to the C and D sets. For example, suppose each set contains 12 disks. Because I wouldn't be creating much data per week, one disk would usually suffice for backing up all changed files. So, once a week for twelve weeks I'd backup to the C set. After I reached disk 12, I'd switch to the D set. If I ran out of disks before 12 weeks passed, it wouldn't matter. The point is to back the files up, and to avoid hassles doing so.

The only potential hassle in that scheme is the long subdirectory names mentioned in the scheme above: Typing those names would quickly become tiring. However, those names were used for illustrative purposes only; when you set up your own system, you should substitute two- or three-letter names (\PRO and \DAT, for example) that give just enough information for you to figure out just what is contained in that particular subdirectory. ■

NEW

MT-2 BLISTERED 2000 OHM/VOLT MULTIMETER 12 RANGES, AC & DC VOLTS, DC CURRENT, RESISTANCE MIRROR SCALE, FUSE AND DIODE PROTECTED. **\$9.95**

DMR-26 3½ DIGIT ½ INCH LCD 0.7% ACCURACY, DROP PROOF CASE, D.C. VOLTS TO 200 V., A.C. VOLTS TO 500 V., D.C. CURRENT TO 10 AMP., RESISTANCE TO 2 MEG, DIODE TEST, HEAVY DUTY TEST LEADS, OFF POSITION **UNDER \$27.00**

DMR 2012 3½ DIGIT 34 RANGE 0.5% DROP PROOF CABINET, CARRYING CASE, CAP, A.C. & D.C. VOLTS, D.C. CURRENT, RESISTANCE, DIODE TEST, BUZZER, HFE TEST * ALL RANGES FUSE & DIODE PROTECTED **UNDER \$65.00**

DMR-2208 3½ DIGIT 35 RANGE 0.3% CAP, A.C. & D.C. VOLTS, A.C. & D.C. CURRENT, FREQ., LOGIC ½ INCH LCD, DIODE AND FUSE PROTECTED, DIODE TEST, DROP PROOF CABINET AND CARRYING CASE **UNDER \$63.00**

V-20 NEW AND IMPROVED 20,000 OHM/VOLT VOLTOHMETER A.C. & D.C. VOLTS, D.C. CURRENT, RESISTANCE, OUTPUT JACK, 4½ INCH METER (D'ARSONVAL) * EQUIVALENT UNITS TWICE THE PRICE **UNDER \$74.00**

FREE CATALOG AVAILABLE WITH COMPLETE LINE OF ELECTRONIC TEST UNITS.

EMCO ELECTRONICS
P.O. BOX 327, PLAINVIEW, N.Y. 11803

WE WELCOME ALL BIDS, AND WE HAVE DISTRIBUTORS AND CATALOG HOUSES NATIONWIDE

CIRCLE 18 ON FREE INFORMATION CARD

Be an FCC LICENSED ELECTRONIC TECHNICIAN!



Earn up to \$30 an hour and more!

Learn at home in spare time. No previous experience needed!

No costly School. No commuting to class. The Original Home-Study course prepares you for the "FCC Commercial Radiotelephone License". This valuable license is your "ticket" to thousands of exciting jobs in Communications, Radio-TV, Microwave, Computers, Radar, Avionics and more! You don't need a college degree to qualify, but you do need an FCC License.

No Need to Quit Your Job or Go To School
This proven course is easy, fast and low cost! **GUARANTEED PASS** — You get your FCC License or money refunded. **Send for FREE facts now. MAIL COUPON TODAY!**

COMMAND PRODUCTIONS
FCC LICENSE TRAINING, Dept. 203 - P.O. Box 2824, San Francisco, CA 94126

Please rush **FREE** details immediately!

NAME _____
ADDRESS _____
CITY _____ STATE _____ ZIP _____

OCTOBER 1989

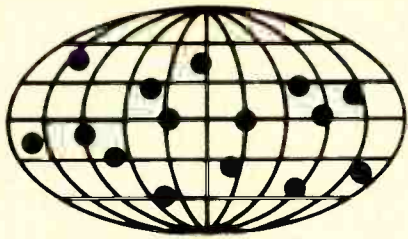

DX Listening

FROM TIMBUKTU TO KATMANDU!

By Don Jensen

Ever since I was a kid, I've had this urge to travel to the mid-Sahara and the Himalayas to visit those exotic ends-of-the-earth cities, like Timbuktu and Katmandu. The odds are, of course, that I'll never really make it to those semi-legendary locales. But, thanks to shortwave, at least I can vicariously visit one of those fantasy destinations, Nepal's capital, the city of Katmandu.

Nepal is a remote mountainous land of some 19-million people, wedged in tightly between India and China. Its only real access to the outside world is by air and overland, through the Indian port of Calcutta, some 700 miles to the south. It is truly, one of the world's least-accessible countries.

This spring, it became even more inaccessible as a result of a trade dispute that resulted in India closing down most of that tiny Himalayan country's outside links.

Nepal's hereditary ruler, King Birendra, has looked with some concern at the fate of neighboring Sikkim, another tiny kingdom absorbed by India in 1974, and Bhutan, which increasingly has fallen under the sway of its sub-continental "big brother." At the time of this writing, Nepal's efforts to demonstrate a greater degree of independence were continuing, but with increasing difficulty.

All of that makes the role of *Radio Nepal's* shortwave voice more important to that small Asian nation. Radio Nepal can be heard here in North America with some regularity, and periodically with quite good signals during the fall and winter months.

The best chance for shortwave listeners to log Radio Nepal is on its 5,005-kHz frequency between about 1115 and 1400 UTC. Nepal's local time is a rather



John Bryant was an active DX listener as a teenager in the 1950's. Today he is a professor and former head of the School of Architecture at Oklahoma State University. His interest in SW has not diminished over the years. His favorite shortwave targets are the Chinese and Indonesian regional and local stations.

strange five hours and 45 minutes ahead of Coordinated-Universal Time (UTC), which means that you're apt to hear the station's time "pips" marking its local hour and half hour at 15 minutes before and after the UTC hour.

You may hear the station identified in the Nepali language as *Yo Radio Nepal ho*, but there are also frequent English ID's as well.

If you're successful in logging Radio Nepal, reception reports may be sent to the station's Radio Broadcasting Service, PO Box 634, Singha Durbar, Katmandu, Nepal.

Feedback. The mail continues to arrive at my DX listening post! Keep your comments, questions, and logging tips coming. I'll try to cover the most interesting and universal questions in this section of the column. Send your letters

to *DX Listening*, **Popular Electronics**, 500-B, Bi-County Blvd., Farmingdale, NY 11735.

An Ann Arbor, MI reader, Radley MacNeille Smith, raises an interesting subject this month.

"In a recent column," writes Rad, "you discussed the limits of the shortwave-frequency range. On a recent business trip, I discovered another frequency range—long wave. I was amazed that my host was able to travel throughout Germany and Belgium and still receive the BBC direct from London on 250 kHz.

"Is there any chance of receiving the BBC on this frequency in the mid-western US? I've tried using a World War II Signal Corps receiver that tunes in the band from 200 to 500 kHz using a 30-foot, long-wire antenna. All I can get is heavy interference, similar to that heard when an AM set is used near a fluorescent light.

"If not European LW (long-wave) broadcasts, what should I be able to hear on these frequencies?"

Indeed, Rad, long-wave-broadcast listening on the frequencies below the regular, domestic, AM-radio band has a long history in Great Britain and Continental Europe, though it is almost unknown in North America.

To have any success, you need a receiver that's particularly sensitive to those low frequencies (many short-wave sets are not) and probably a pre-amplifier as well. A long antenna, with antenna tuner, is a definite plus; 30 feet is really much too short a "long wire" to catch much of a long-wave signal.

Long-haul, long-wave reception is, like long-distance reception on the medium-wave AM band, it requires a path of darkness between transmitter and receiver. Furthermore, trans-Atlantic reception of the very powerful transmitters (1500 kilowatts and more, which is 300 times more powerful than the strongest outlet) is possible under optimum conditions.

If you want to try for any of them, European- and African LW stations operate between 148 and 283 kHz. However, success isn't likely in the Midwest, where you are located, during the current "active" stage of the approximate 11-year sunspot cycle.

In North America, between 190 and 525 kHz, your most likely long-wave loggings will be non-directional aeronautic- and maritime-navigation beacons. While a few still voice weather announcements, most such signals are Morse-code identifiers, consisting of

two or three letters or a letter-number combination.

I recently had the opportunity to hear a Chicago long-wave monitor, Joe Woodlock, discuss his experiences in DX'ing those beacons. He explained that they typically run very low power and hence, one tends to hunt for stations in new states, not foreign countries, the way that SWL's do.

Still, he said, he had managed to hear such beacon signals from South America and even remote Easter Island!

If you can learn to "read" Morse code ("CW"), at least well enough to identify those continuously repeated identifiers, tuning the long-wave beacons can be challenging. And you may wish to join the Longwave Club of America, 45 Wildflower Road, Levittown, PA 19057, which publishes a regular monthly bulletin devoted to DX'ing those low frequencies below 540 kHz.

Another reader, Joseph Anderson, writing from Omaha, NE, reminds me that I promised, several months ago, to include a bit of information on some keys that can help to identify non-English-speaking programs.

Indeed I did, Joe. And here are some words and phrases that are often heard during identification announcements:

In "Spanish," you may hear identifications like *Esta es Radio Exterior de Espana*, with *esta es* translating as "this is." In its English transmissions, the station calls itself the *Spanish Foreign Radio*.

"Lisbon's" shortwave service, when broadcasting in Portuguese, may announce as *Aqui Radiodifusao Portuguesa*, meaning "Here is *Radio Portugal*."

Ici Radio France Internationale or *Ici Paris* (pronounced, of course, as *Par-ee*'), *Radio France Internationale* is easy enough to understand, if you know that *ici* in French has a similar meaning to the Portuguese *aqui* or "Here is..."

In Russian, the originating studio is usually identified by the word, *Govorit* and the city; e.g., *Govorit Moskva*. The equivalent in the Arabic language is *Huna*. For example, *Radio Jordan's* station at Amman identifies itself in the Arabic language as *Huna Amman*.

Down the Dial. What are you hearing? Why not add your loggings to the list of reader contributions to this segment of our column. Here are some of the loggings others are noting on the short-wave bands. All times mentioned in this

column are given in Universal Coordinated Time (UTC).

China—3,290 kHz. Home-service programming is normally in the Chinese language, but a language lesson show, "English for Communes," can be heard at 1430 UTC on this frequency and parallel outlets, 6,890, 6,920 and 7770 kHz.

Colombia—4,755 kHz. One of the major broadcasting networks in this South American nation is called CARACOL. The key shortwave outlet of this chain, *CARACOL en Bogota* can be heard in Spanish around 0400 UTC.

Denmark—25,850 kHz. *Radio Denmark's* programming in Danish is noted signing on here at 1400 UTC.

Dubai—9,640 kHz. *United Arab Emirates Radio* from the Persian Gulf region has been noted beginning its English language transmission at 0330 UTC with ID, frequency announcement, and news. It operates in parallel on 11,940 kHz.

Hong Kong—7,180 kHz. The BBC's East Asia relay station at Hong Kong can be heard on this frequency with a relay of World Service programming, including, from 1600 UTC, World News, and News from Britain.

Kenya—4,934 kHz. The *Voice of Kenya's* shortwave outlet has been heard in English with identification, time checks, music, and news beginning at around 0245 UTC.

South Africa—3,215 kHz. The Dutch-based, Afrikaans-language home service is called *Radio Oranje* and it has been noted by US listeners at around 0330 UTC with easy-listening music and an identification jingle.

Turkey—6,340 kHz. A rather challenging shortwave catch is the *Turkish Police Radio's* signal, heard in the eastern US from just before 0500 UTC, when its broadcasting day begins. ■

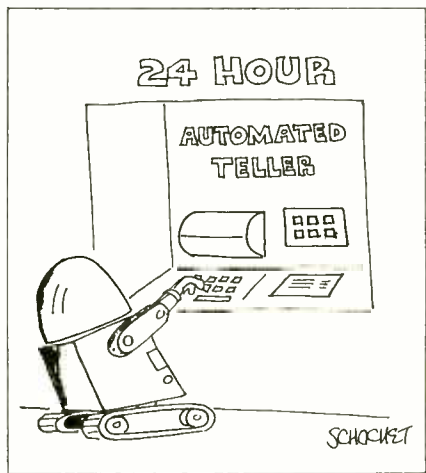

Official 1934 SHORT WAVE RADIO MANUAL

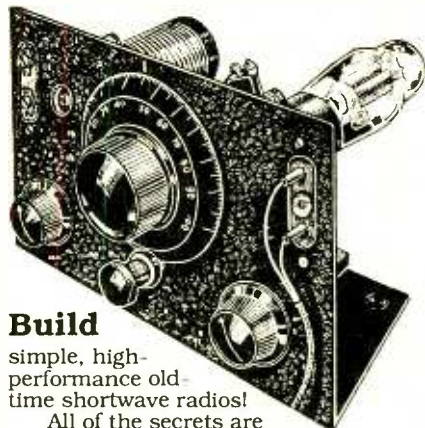

Build

simple, high-performance old-time shortwave radios!

All of the secrets are here: the circuit diagrams, parts layout, coil specifications, construction details, operation hints, and much more!

This is a compilation of shortwave construction articles from "Short Wave Craft" magazines published in the 20's & 30's. It's wall-to-wall "how-to."

Included are circuit diagrams, photographs, and design secrets of all shortwave receivers being manufactured in 1934 including some of the most famous: SW-3, the SW-5 "Thrill Box", the deForest KR-1, the Hammurland "Comet Pro", and many more.

Also included is a new chapter showing how you can use transistors to replace hard-to-find vacuum tubes. You'll even see the circuit that was lashed together on a table top one night using junk box parts, a hair curler and alligator clips. Attached to an antenna strung across the basement ceiling and a 9 volt battery, signals started popping in like crazy. In a couple of minutes an urgent message from a ship's captain off Seattle over 1500 miles away was heard asking for a navigator to help him through shallow water!

These small regenerative receivers are extremely simple, but do they ever perform! This is a must book for the experimenter, the survivalist who is concerned about basic communication, shortwave listeners, ham radio operators who collect old receivers, and just about anyone interested in old-time radio.

Great book! Fun to read! One of the best old-time radio books to turn up in years. Heavily illustrated! Order a copy today! 8 1/2 x 11 paperback 260 pages only \$15.70 postpaid!

Lindsay Publications
Box 12- WF6, Bradley IL 60915

Send a copy of *Short Wave Radio Manual*. Enclosed is \$15.70. Chk, MC, Visa. Send a free catalog of other books.

Name _____
Address _____
City _____ St _____ Zip _____



Scanner Scene

By Marc Saxon

These have proven suitable for surreptitious mounting in cases of grumpy landlords. Write for their brochure, or call (716) 773-1445.

R. G. Blaskow, Route #1, Box 67A, Georgetown, GA 31754 asks for your assistance. He needs the circuit for a *Tennelec Memoryscan*, a programmable scanner that was manufactured in the late 1970's.

A letter from Paul Filiczowski, Burch

A BACK-TO-BASICS SCANNER

Somewhere, lost in the cloud of dust kicked up by keyboard-programmable-scanner technology, sits the basic, plug-in crystal, no frills, dependable, and inexpensive-type scanner. Maybe you don't remember scanners that need plug-in crystals—one per frequency—but they were what everybody was using until programmables became popular about ten years ago.

You can still buy those scanners, however. If you have a few specific frequencies you know of that you always monitor, aren't interested in fancy stuff like scan/search, and are looking for something that is simplicity itself to operate, then these are excellent workhorses. They are rugged and untemperamental, and much cheaper than programmables, to boot.

One good example is the *Realistic PRO-56* from Radio Shack. It scans eight channels and offers squelch, lockouts, manual selection, and LED channel indicators. You can use it to receive channels in the following frequency ranges: 144 to 174 MHz, and 450 to 512 MHz, as long as you plug in a crystal representing each of the frequencies. Crystals cost about \$5 each.

The PRO-56 is battery operated (a 9-volt battery does it all), and it can also be run from an optional AC or DC adapter. The Radio Shack catalog lists the *Realistic PRO-56* for \$99.95, but sometimes they carry it in sales flyers at a substantially reduced price (like \$69.95). The price, of course, doesn't include the crystals.

These little scanners are fine for any number of uses, and you may find that they fill several of your own needs for monitoring weather and local public-safety operations without any fear of equipment breakdown, malfunction, memory loss, or severe drain on your finances. Even Grandpa can operate one of these without bothering to read the owner's manual. Check it out.

We Get Letters. Mike Wampler wrote to ask about using a scanner while liv-



For dependable, no-frills scanning, check out the Realistic PRO-56. The plug-in crystal unit scans 8 channels and is ultra-easy to operate.

ing in an apartment where they don't allow external antennas. Someone had told him that he might get good results on UHF by running the scanner from the cable-TV feedline.

While I have never personally attempted to operate a scanner from a CATV line, somehow it didn't strike me as being a great idea at first flash. On the other hand, if you're desperate, it may be better than using a damp noodle for an antenna.

If the apartment building is a steel-frame structure, no type of indoor antenna is going to produce much in the way of results. Some have reported reasonable results using a magnetic-mount mobile antenna stuck to the metal case of an air conditioner (the part that's outside the window). Not only can it be removed when not in use, it can also be painted to match the color of the building or air conditioner so it can't be easily seen from the street.

A company called Com-Rad Industries (P.O. Box 554, Grand Island, NY 14072-1445) makes low-profile "disguised" antennas in several models covering the 27- to 500-MHz range.

Run, MI expresses confusion on a matter that has brought mail in here regularly for a long time. He notes that his scanner won't properly accept certain frequencies such as 162.6125, 173.7875, and 173.9875 MHz and others in the 152- to 174- MHz band with four digits after the decimal point. The answer is not to worry. Many scanners will accept only frequencies with three digits after the decimal point, and the final digit must always be a zero or a five. Those who attempt to program in a frequency such as 173.9875 will find that the scanner wants to acknowledge programming only for 173.985 or 173.990 MHz.

Regardless of whether your scanner reads out 2.5 kHz above or below the specific frequency you attempted to enter, it will nevertheless pick up all of the signals there to be monitored on your originally desired frequency; neither you nor your scanner will notice the 2.5-kHz difference. Trust me.

So many of the more interesting federal frequencies between 162 and 174 MHz are designated as having
(Continued on page 101)

SELECT 5 BOOKS for only \$4⁹⁵

(values to \$161.25)
and get a **FREE Gift!**

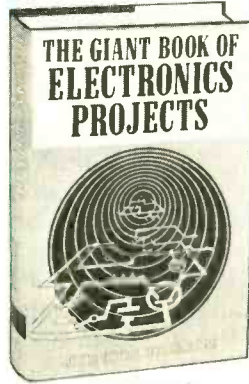
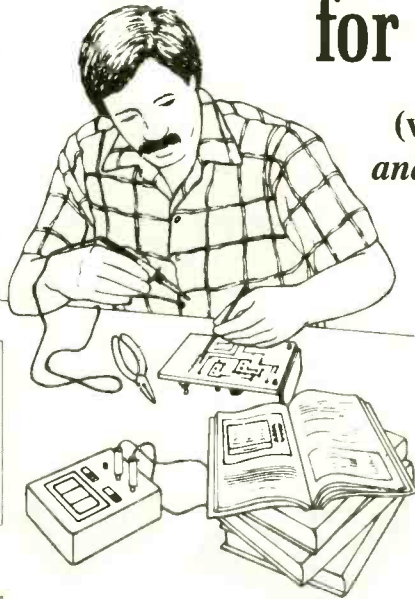

1367P \$18.95

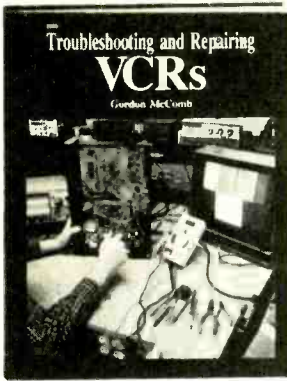

2960P \$16.95



2883P \$16.95



3107 \$26.95
Counts as 2



2922P \$15.95



2809P \$14.95



2826P \$15.95



2613 \$24.95
Counts as 2



1667P \$15.95



3195 \$28.95
Counts as 2

Electronics projects . . . ideas . . . the latest technology
all at up to 50% off publishers' prices!

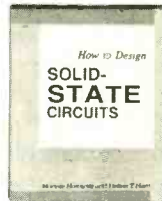

2975 \$24.95



3002 \$49.50

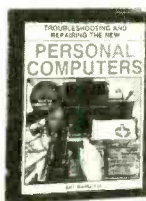

2809 \$27.95
Counts as 2



3054 \$19.95

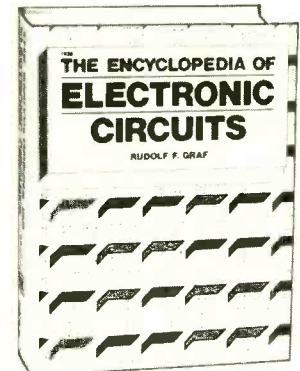

1938 \$60.00
Counts as 3



3212 \$34.95
Counts as 2



2992 \$24.95



2831P \$14.95



3115 \$21.95

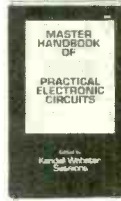

2980 \$28.95



1599P \$17.95



2912P \$14.95

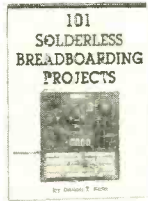

2985 \$24.95

FREE when you join the ELECTRONICS BOOK CLUB!

15 Easy Electronic Projects
from Delton T. Horn

Projects you can build—some unique, some old favorites—from the author's vast treasury of electronics know-how.



Membership Benefits • Big Savings. In addition to this introductory offer, you keep saving substantially with members' prices of up to 50% off the publishers' prices. • **Bonus Books.** Starting immediately, you will be eligible for our Bonus Book Plan, with savings of up to 80% off publishers' prices. • **Club News Bulletins.** 14 times per year you will receive the Book Club News, describing all the current selections—mains, alternates, extras—plus bonus offers and special sales, with scores of titles to choose from. • **Automatic Order.** If you want the Main Selection, do nothing and it will be sent to you automatically. If you prefer another selection, or no book at all, simply indicate your choice on the reply form provided. As a member, you agree to purchase at least 3 books within the next 12 months and may resign at any time thereafter. • **Ironclad No-Risk Guarantee.** If not satisfied with your books, return them within 10 days without obligation! • **Exceptional Quality.** All books are quality publishers' editions especially selected by our Editorial Board.

PE1089

All books are hardcover unless numbers are followed by a "P" for paperback. (Publishers' Prices Shown)
© 1989 ELECTRONICS BOOK CLUB®, Blue Ridge Summit, PA 17294-0810



2707 \$26.95
Counts as 2



2735P \$14.95

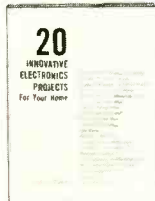

2947 \$21.95



2887 \$16.95



3072 \$24.95



2733 \$14.95

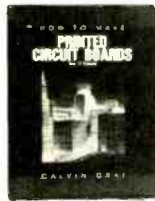

2898 \$23.95



1532P \$14.95



2925P \$8.95

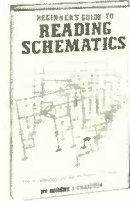

1536P \$9.95

OCTOBER 1989



Ham Radio

GETTING ON 17 METERS (DX! DX! DX!)

By Joseph J. Carr, K4IPV

For nearly a decade, hams in the USA have itched to use the 17-meter band (18.068 MHz to 18.168 MHz). Although the World Administrative Radio Conference (WARC '79) authorized the band for ham use in 1979, the FCC only this year released the band for use by ham-radio operators in the USA. While the delay is not really the fault of the FCC, as some would have us believe (they had to remove other users), it has been annoying to have 17-meter capability on our HF transceivers and not be able to use it.

Even today, ten years after WARC-79, amateur use is considered "secondary." That is, use by hams is contingent on noninterference to US Government stations still on the band. There are still a few foreign shortwave broadcasters on 17 meters. In addition, we must tolerate interference from those stations. Fortunately, not a large number of non-ham stations still use the band (Heaven forbid another 40-meter band!).

The frequency limits on 17 meters are 18.068 MHz to 18.168 MHz. Radiotelegraph (A1) CW emissions are allowed anywhere in the band. Digital and certain other emissions (F1B) are allowed in the sub-band 18.068 MHz to 18.110 MHz, while SSB radiotelephone is permitted over the sub-band, 18.110 MHz to 18.168 MHz. The output power limit is 1,500 watts.

What to Expect. What can we expect on the new 17-meter band? In three words: DX, DX, and DX. The new band should prove exciting! Take a look at where it's situated in the electromagnetic spectrum: between 20 meters (14 MHz) and 15 meters (21 MHz). Thus, it should share some of the good and bad features of both older bands. It will be open worldwide during most of the day, and should fade to oblivion at night (sometime after 15 meters dies, but before 20 meters dies).

Some of the best DX for any given propagation path occurs on frequen-

cies just below what radio science calls the *Maximum Usable Frequency* (MUF). There are many times throughout the year when the MUF is between 15 and 20 meters. How many times have you noted that 15 meters (and up) is dead, but 20 meters is wide open? At those times, it may prove true that 17 meters is the band of choice. In short, 17 meters should be a darn-good DX band.

Getting on 17 Meters. Assuming that your transceiver already operates on 17 meters, the only real issue remaining is the antenna. Like its adjacent bands, 17 meters will easily accommodate every common form of HF antenna: verticals, dipoles, and beams (yagis and quads). The beam antennas are less difficult to build than 20-meter models, and a little more difficult to make than 15-meter models (the issue is size).

Table 1 shows the dimensions for the more popular forms of antennas: quarter wavelength, half wavelength, and 5/8-wavelength; Figs. 1 through 3 show some of the basic forms of those antennas. The dimensions given in Table 1 are in feet and tenths of feet. To convert to inches multiply by 12. For example, a mid-band half-wavelength antenna is 25.83-feet long. To convert

the ".83" portion of that figure to inches: $0.83 \times 12 = 9.96$. Rounded off, the antenna is 25-feet, 10-inches long. Keep in mind when adjusting such antennas that the resonant frequency changes at a rate of about 50-kHz per inch (kHz/inch) for half-wave antennas in that band.

Figure 1 shows the classic half-wavelength dipole antenna. That type of antenna is simple to build and well behaved. You don't need a degree in engineering and a lab full of test equipment to make it work... and work well. While it is not a full performance beam, it doesn't cost much to build—less than \$30 (and a lot less if you use the simplest materials or can scrounge well).

For best operation, the half-wavelength antenna should be at least 25 feet off the ground, although anything over 13 feet will work pretty well. That advice, incidentally, is rule of thumb only, because the actual performance (which means radiation pattern) also depends on nearby objects. The antenna should be mounted horizontally between two supports. The center insulator should be of the high-Q variety. An alternative is to use a 1:1 balun; a suitable unit is available from The Radio Works (Box 6159 Portsmouth, VA 23703; Tel. 804/484-0140). Their catalog is available for \$2.00.

Figure 2 shows the quarter-wavelength vertical antenna. The radiator is shown here to be a length of aluminum tubing. However, it will also work by using a 2- x 2-inch piece of wood (or thick-wall PVC pipe) with a quarter wavelength of #14 or heavier wire attached to (but insulated from) it. The radials are made of #14 wire. Use at least two radials, but keep in mind that the general rule is *the more the better*

TABLE 1—17-METER BAND ANTENNA DIMENSIONS
(Units in Feet)

TYPE OF ANTENNA	LOW END 18068	MID CW 18089	MIDBAND 18118	MID SSB 18139	HIGH 18168
1/2 wave	25.9	25.87	25.83	25.8	25.76
1/4 wave	12.94	12.95	12.92	12.9	12.88
5/8 wave	32.38	32.34	32.29	32.25	32.2

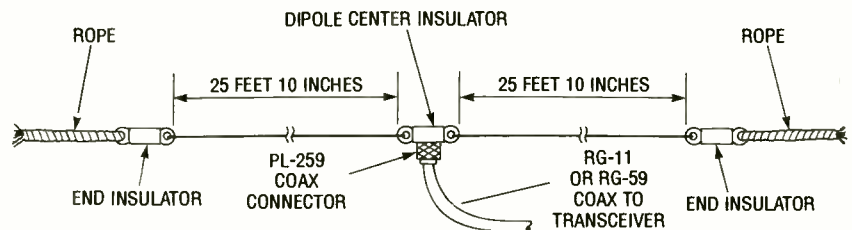

Fig. 1. Half-wavelength dipole for 17 meters. For best operation, it should be at least 25 feet off the ground, although anything over 13 feet will work pretty well.

(although the "return per radial" drops above 16).

Perhaps a good compromise is to use four quarter-wave radials spaced equally about the vertical radiator (that's the method used on CB antennas and other ground-plane units).

Finally, Fig. 3 shows the $\frac{5}{8}$ -wavelength vertical antenna. That form of vertical typically has the lowest angle of radiation (it is a real horizon kisser) of all common verticals, and is thus a big hit for the DX'er who lacks space. (Note: A half-wavelength vertical also meets that criteria. I recently bought a

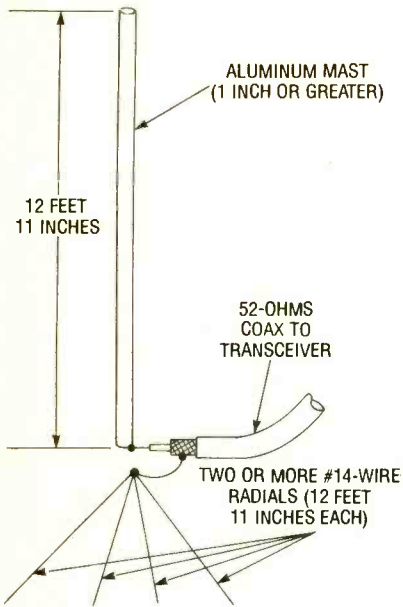

Fig. 2. The radials, for this quarter-wavelength vertical for 17 meters can be made from #14 wire.

Cushcraft R-4 and expect to review it in this column shortly—if the rain stops long enough for me to erect it, that is).

Notice the dimensions of the $\frac{5}{8}$ -wavelength vertical shown in Fig. 3 (which are also given in Table 1). Does anything seem familiar? Those lengths are also used on 40-meter and 20-meter antennas! For example, the mid-band $\frac{5}{8}$ -wavelength antenna is 32.29-foot long. That length is also a $\frac{1}{2}$ -wavelength on 14.49 MHz (just outside the 20-meter band), so it could be used on 20 meters if a series capacitor is used to electrically shorten the antenna.

Similarly, 32.29 feet is also $\frac{1}{4}$ wavelength on 7.247 MHz (40-meter band). It should be possible to build a coaxially switched system that would allow us to use the same 32-foot radiator on three different bands. One proposed solution is shown in Fig. 4. I haven't tested it yet, but it is one possible approach for the activist to try.

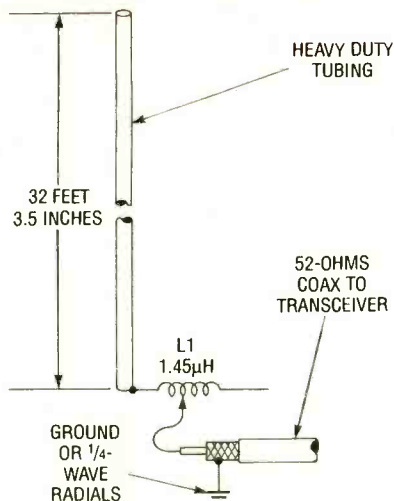

Fig. 3. The $\frac{5}{8}$ -wavelength vertical antenna typically has the lowest angle of radiation of all common verticals, and is a big hit among DX'ers who lack space.

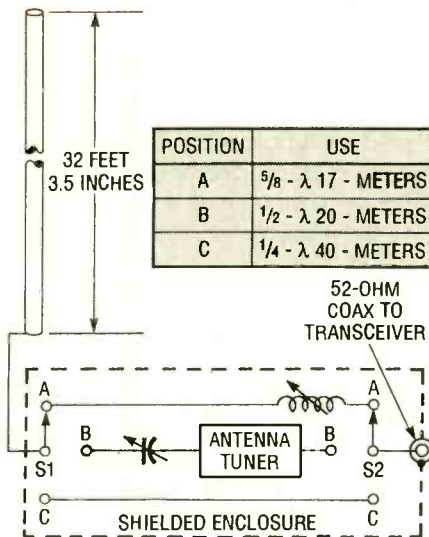

Fig. 4. Although untested (by the author), this switching arrangement will let you to use a $\frac{5}{8}$ -wavelength, 17-meter antenna on the 17-, 20-, and 40-meter bands.

In building the $\frac{5}{8}$ -wavelength vertical, keep safety utmost in mind. First, don't even think of mounting the antenna anywhere near a power line. If it falls onto the line while you are erecting it, then you will be killed (despite alleged insulation on the line). Second, make sure that you know where it will land if it should fall—the damage caused could be substantial. Finally, use heavy-gauge tubing. Lightweight tubing won't stand up to wind pressures.

Alas, we have come to the end of the space allotted to us for this month. Until next time, send your tips, comments, or questions, for this column to *Ham Radio*, Popular Electronics, 500-B Bi-County Blvd., Farmingdale, NY 11735.

FREE! New Catalog of Hard-To-Find Precision Tools



Jensen's new catalog is jam-packed with more than 2,000 quality items. Your single source for hard-to-find precision tools used by electronic technicians, scientists, engineers, schools, instrument mechanics, laboratories and government agencies. This popular catalog also contains Jensen's world-famous line of more than 40 tool kits. Call or write for your free copy today!

JENSEN TOOLS INC. 7815 S. 46th Street
Phoenix, AZ 85044
(602) 968-6231

CIRCLE 10 ON FREE INFORMATION CARD

ATTENTION! ELECTRONICS TECHNICIANS

EARN YOUR
**B.S.E.E.
DEGREE**

THROUGH HOME STUDY

Our New and Highly Effective Advanced-Placement Program for experienced Electronic Technicians grants credit for previous Schooling and Professional Experience, and can greatly reduce the time required to complete Program and reach graduation. No residence schooling required for qualified Electronic Technicians. Through this Special Program you can pull all of the loose ends of your electronics background together and earn your B.S.E.E. Degree. Upgrade your status and pay to the Engineering Level. Advance Rapidly! Many finish in 12 months or less. Students and graduates in all 50 States and throughout the World. Established Over 40 Years! Write for free Descriptive Literature.

COOK'S INSTITUTE
OF ELECTRONICS ENGINEERING

CTE 4251 CYPRESS DRIVE
JACKSON, MISSISSIPPI 39212

CIRCLE 17 ON FREE INFORMATION CARD

ANTIQUE RADIO

(Continued from page 83)

brand as a detector. So it was up to the kit constructor to purchase the brand of his choice. About all I can do is surmise that at least some of the tubes are probably original. For one thing, tubes don't wear out that easily; for another, all of the tubes in the set have the pear-shaped bulbs typical of the era when the set was released.

More Owner Modifications. The tuning-capacitor modification wasn't the only change made in the radio by its old-time owner. Neatly mounted inside the roomy cabinet, on the back and side walls, are a variety of components put there to accomplish various purposes.

For example, there's a porcelain knife switch wired across the antenna and ground terminals—making it possible to bypass the radio and short the antenna to ground during electrical storms. Another assembly, consisting of a turnbutton-type switch and two phone jacks, was connected to the set's audio output. According to a hand-lettered instruction card mounted inside the cabinet's hinged lid, the jacks were intended for headphones and a speaker, and the switch was there to choose between them.

It's easy to understand the necessity for that arrangement. The phones were needed to hear weak signals. But once meticulously tuned in, a signal might well increase several times in strength. (Automatic volume-control circuits were still a few years in the future.) Then it would be capable of operating the speaker at comfortable volume and, in fact, might be uncomfortably loud in the headphones. It was important to be able to switch back and forth between the two kinds of reproducers with a minimum of hassle.

Like the battery radios that were its close relatives, the A.C. Super-Wasp had no means for adjusting volume. And the owner's final modification sought to rectify that problem. A rheostat-and-knife-switch arrangement mounted on the back wall of the cabinet was identified on the instruction card as a volume control.

Even though I elected to get rid of the crude band-spread arrangement, I intend to keep all of these owner modifications. The components are authentic and were installed neatly. The work was done in response to needs that



Ray's "mystery" yard-sale find is actually the fairly rare 1922-vintage Aeriola Senior. It was made by Westinghouse, and marketed by RCA.

were typical of the era, and certainly enhance operating convenience. I'll have to recreate the method of wiring the volume control into the circuit, since it had been disconnected some time in the past. But I think that would be a worth-while project.

Where Do We Go From Here? Before reinstalling the front panel and the repaired tuning capacitor, I plan to give the set a deep cleaning. And since there are a lot of hard-to reach nooks and crannies on the chassis, it's lucky that the grime is in the form of easily-removable dust. Even so, I expect to

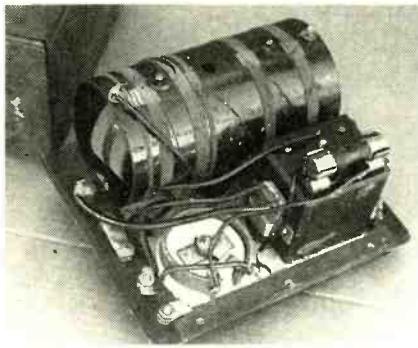

Here's a look behind the Aeriola's panel. Note the rotating "tickler" (regeneration control) coil tucked inside the left end of the large RF tuning coil.

wear out a lot of Q-tips before I'm through.

Another item I have to take care of before putting the set back together is the repair and/or replacement of defective wiring. The rubber insulation of the hook-up wire originally used in the radio has become very brittle with age, and a lot of it flaked off where I had to disturb it during my earlier repairs. The trick will be to find some replacement wire that looks authentic (vinyl-covered wire in bright primary colors just won't do the job) and to install it without de-

stroying the insulation on still more of the original wire.

Both of those jobs are tedious, and are likely to demand a lot of care and patience. But attention to detail is what radio restoration is all about, and you certainly can't reverse 60-years' worth of aging in five minutes!

Readers in Need. A.L. Jones (241 Cleveland Ave., Lynchburg, VA 24503) is looking for service information and a replacement belt for his Zenith receiver. He's a middle-school Technology Education teacher and is restoring the radio as a class project. Unfortunately, A.L. hasn't been able to locate the model number of the set, only the serial number.

Isn't it ironic that many manufacturers engraved set serial numbers, which have very little importance to us now, on permanent metal tags—while entrusting the all-important model number to a flimsy paper label, or some other equally fragile medium? Here's a hint, A.L., look for a fading stenciled code number on the rear apron of the chassis just above the antenna-ground terminal strip.

From the tube lineup that A.L. sent along (6J5, 6H6, 6F5, 6K7 (2), 6L7, 6F6, and 5Y4) and the fact that the set has an electric dial-drive motor, I'd say that the radio is a *Model 9S262*, or something that is very similar to that set. I'd like to tell you that I know this from my encyclopedic knowledge of set layouts and model numbers, but, as it happens, reader Frank De Stasi wrote me about his 9S262 (see January, 1989 issue) and enclosed a schematic diagram.

Since I have that schematic in my possession, I'm going to send it to A.L. along with Frank's address. Maybe they can compare notes. Once the correct model number is established, Antique Electronic Supply (688 W. First St., Tempe, AZ 85281) should be able to supply the correct belt.

Time for just one more item before we finish up for this time. Theodore J. Krainski (29 Raritan Ave., South River, NJ 08882) would like to purchase a nice *Echophone EC-1* in good running order. Contact him directly if you think you can help him out.

Bye for this Month. In the meantime, I'd like to hear from you! Address your correspondence to *Antique Radio, Popular Electronics*, 500-B Bi-County Blvd., Farmingdale, NY 11735. ■

BLINKING LICENSE-PLATE

(Continued from page 76)

through a flat, 6-conductor, ribbon cable, like that used for the interconnections between computers and their peripherals. However, telephone hook-up wire or any small-gauge wire can be used since the circuit draws very little current.

The author chose ribbon cable because it lays flat and allows the trunk to close without pinching. The color coded wires help with the final wiring of the cable to the circuit board. The end of the ribbon cable is held securely to the bezel with a liberal amount of silicon compound.

Ribbon cable is available locally through various outlets (such as Radio Shack). The cable, which comes in 25- and 34-conductor configurations, can be split to provide the 6-conductor cable required.

Five of the cable's conductors go to the lamps, which are mounted on the license-plate holder, and the remaining wire connects to the +12-volt source through F1. Each lamp wire connects to one set of lamps. The lamps are not mounted to the license-plate holder in side-by-side pairs, but instead are separated as shown in Fig. 4. The dashed line between lamps indicate pairs, and shows their location on the license-plate holder in relation to one another.

Heavy 18-gauge automotive wire was used in the author's prototype to feed power to the circuit. That type of wire was chosen for the power leads (ground and the fused +V wires) because the author decided to make the connections to the brake-light power leads through small crimp-type "tap-in" connectors, which eliminated the need to actually splice into the brake-light wires. That type of connector is available from Radio Shack (in packages of 10) and other electronic supply stores.

The fused +V lead from the circuit board is connected to the positive brake-light lead inside the trunk through a tap-in connector. Simply position the fused wire from the circuit next to the brake-light wire and squeeze the tap-in connector around both; then fold the hold-down clip of the connector around the tap-in.

Once the tap has been made, use a voltmeter to determine whether +12 volts is being fed to the circuit when the brake pedal is depressed. As for the ground wire, it can be connected to

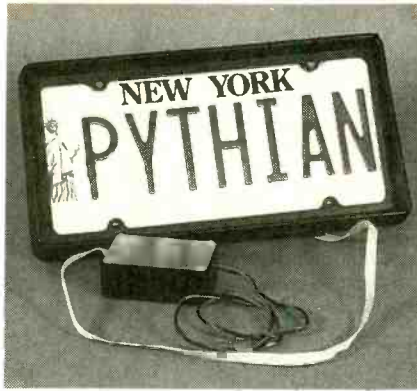

The finished project is shown here. All components, except for the lamps, are housed in a small plastic project box. Heavy, 18-gauge wires connect the circuit to the power source, and flat ribbon cable connects the lamps to the circuit board.

the auto's chassis, or to the black ground lead at the brake light (if there is one) using a second tap-in connector.

Troubleshooting. Once the circuit is under power, the lights on the bezel should start blinking immediately. If they do not, several things should be checked. Of course, a voltmeter must be connected to the power-supply pins of the IC's to verify that they are getting the correct power. For the 4017, pin 16 is +V and pin 8 is ground; for the 555, +V is pin 8 and ground is pin 1.

A logic probe can be placed on pin 3 of the timer to verify that clock pulses are being sent to the 4017. The rate should be fairly fast and the high and low transitions should be clear. If not, either R2 must be adjusted, or the value of R1 (connected to pin 7 of U2) may need to be reduced.

The Blinking License-Plate Holder is a great little project to show off your true genius, since it will be seen by everyone. Both my kids want one for their cars, and I expect orders to be pouring in from the neighbors anytime now. ■

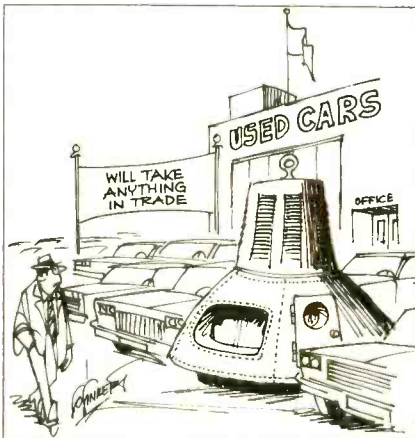

LEARN VCR

CLEANING/MAINTENANCE/REPAIR

EARN UP TO \$1000 A WEEK, WORKING PART TIME FROM YOUR OWN HOME!

Secrets Revealed!

NO Special Tools or Equipment Needed

EARN UP TO \$80 AN HOUR AND MORE!

THE MONEY MAKING OPPORTUNITY OF THE 1990'S

IF you are able to work with common small hand tools, and are familiar with basic electronics (i.e. able to use voltmeter, understand DC electronics). . . . IF you possess average mechanical ability, and have a VCR on which to practice and learn. . . . then we can teach YOU VCR maintenance and repair!

FACT: up to 90% of ALL VCR malfunctions are due to simple MECHANICAL or ELECTRO-MECHANICAL breakdowns!

FACT: over 77 million VCRs in use today nationwide! Average VCR needs service or repair every 12 to 18 months!

Viejo's 400 PAGE TRAINING MANUAL (over 500 photos and illustrations) and AWARD-WINNING VIDEO TRAINING TAPE reveals the SECRETS of VCR maintenance and repair—"real world" information that is NOT available elsewhere!

Also includes all the info you'll need regarding the BUSINESS-SIDE of running a successful service operation!

FREE INFORMATION

CALL TOLL-FREE 1-800-537-0589
Or write to: Viejo Publications
3540 Wilshire BL. STE 310
Los Angeles, CA 90010 Dept HO

CIRCLE 16 ON FREE INFORMATION CARD

NEW SUPER LONG PLAY TAPE RECORDERS

12 Hour Model — \$119.00*
USES D-120 TAPE

Modified Panasonic Slimline, high quality, AC-DC Recorders provide 6 continuous hours of quality recording & playback on each side of cassette for a total of 12 hours.
Built-in features include:
• Voice level control. • Digital counter, etc. TDK DC 120 Cassette Furnished.



PHONE RECORDING ADAPTER

Records calls automatically. All Solid state connects to your telephone jack and tape recorder. Starts recording when phone is lifted. Stops when you hang up. \$28.50*
FCC APPROVED

VOX VOICE ACTIVATED CONTROL SWITCH

Solid state. Self contained. Adjustable sensitivity. Voices or other sounds automatically activate and control recorder. Uses either recorder or remote mike. \$28.50*
*Add for ship & hdg. Phone Adapter & Vox \$1.50 ea. Records \$4.00 ea. Cal. Res. add tax. Mail order, VISA, MIC, COD's OK. Money Back Guarantee. Qty. disc. avail. Dealer Inquiries invited, Free data.
AMC SALES INC. Dept B 9335 Lubec St., Box 928, Downey, CA 90241 Phone (213) 869-8519

CIRCLE 6 ON FREE INFORMATION CARD

OCTOBER 1989

97

Enter A World Of Excitement with a Subscription to Popular Electronics®

Get the latest electronic technology and information monthly!

Now you can subscribe to the magazine that plugs you into the exciting world of electronics. With every issue of Popular Electronics you'll find a wide variety of electronics projects you can build and enjoy.

Popular Electronics brings you informative new product and literature listings, feature articles on test equipment and tools—all designed to keep you tuned in to the latest developments in electronics. So if you love to build fascinating electronics, just fill out the subscription form below to subscribe to Popular Electronics... It's a power-house of fun for the electronics enthusiast.

EXCITING MONTHLY FEATURES LIKE:

- CONSTRUCTION**—Building projects from crystal sets to electronic roulette
- FEATURES**—Educational training on digital electronics, Ohm's Law, Antennas, Communications, Antique Radio, Simplified Theory
- HANDS-ON-REPORTS**—User test comments on new and unusual consumer products
- SPECIAL COLUMNS**—Think Tank, Circuit Circus, Computer Bits, DX Listening, Antique Radio, Amateur, Scanner Scene

PLUS: ALL OUR GREAT DEPARTMENTS!

You'll get 12 exciting and informative issues of Popular Electronics for only \$18.95. That's a savings of \$11.05 off the regular single copy price. Subscribe to Popular Electronics today! Just fill out the subscription order form below.

48784
FEBRUARY 1989
COMBINED WITH **Hands-on Electronics**
THE MAGAZINE FOR THE ELECTRONICS ACTIVIST!

Expand your hearing range and explore the exciting world of ultrasonic sound!

Update your camp or work telephone system!

Read those low-value resistors on any DMM!

A classic design updated for today's technology!

Put those useful IC's to work for you!

Build The Lightning Bulb
Spectacular effect, easy construction, and a budget near zero take a winner's project!

Antique Radio
An in-depth look at an old-time circuit!

Save 37% Off The Regular Subscription Rate

30 U.S. 35 CANADA
3 New FactCards This Issue

FOR FASTER SERVICE CALL TODAY
1-800-435-0715

IN ILLINOIS 1-800-892-0753 (7:30AM-8:30PM)
EASTERN STANDARD TIME

Popular Electronics® SUBSCRIPTION ORDER FORM

P.O. Box 338, Mt. Morris IL. 61054

YES! I want to subscribe to Popular Electronics for 1 Full year (12 Issues) for only \$18.95. That's a savings of \$11.05 off the newstand price.

Payment Enclosed Bill me later
Please charge my: Visa Mastercard

Acct. #

Signature _____

Exp. Date _____

PLEASE PRINT BELOW:

NAME _____

ADDRESS _____

CITY _____

STATE _____

ZIP _____

Allow 6 to 8 weeks for delivery of first issue. U.S. Funds only.
In Canada add \$5.00 Postage. All Other Foreign add \$7.50 Postage.

APE-K9

SHORTWAVE CONVERTER

(Continued from page 44)

Adjustment. After assembling the HPS Converter, set it up as diagrammed in Fig. 4, power up the system, turn the gain control to maximum, and tune-in a shortwave station near the middle of the band. Then adjust the tuning slug in T1 for the strongest (loudest) signal. Once adjusted, T1 is broad enough to cover the whole band.

Next, calibrate the dial. There are several ways to do that. I used a calibrated



The HPS Converter is shown here with its cover on. The ON/OFF switch bypasses the converter for normal AM operation of the receiver, and the GAIN knob controls the amount of antenna signal delivered to the converter.

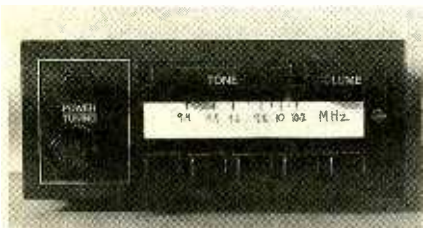

A custom-made dial scale is the finishing touch: manually tune the receiver to pull in signals on the 10-MHz band and mark them off on the scale.

signal generator to make my own dial markings. Alternatively, you can just tune in shortwave stations and wait for them to announce their frequencies. Also, you can tune in AM broadcasters without the converter, then add the crystal frequency to the frequency of the AM station.

Other Considerations. If your radio is digitally tuned, you face a challenge. Digital radios can only tune to multiples of 10 kHz (1000, 1010, 1020, etc.), while many shortwave broadcasters are on multiples of 5 kHz (9.575, 9.915, etc.). Figure 5 shows a possible solution: use two crystals in the converter, 5-kHz apart, and choose between them with an SPST switch (S2). That will allow you to tune in 5-kHz increments. ■

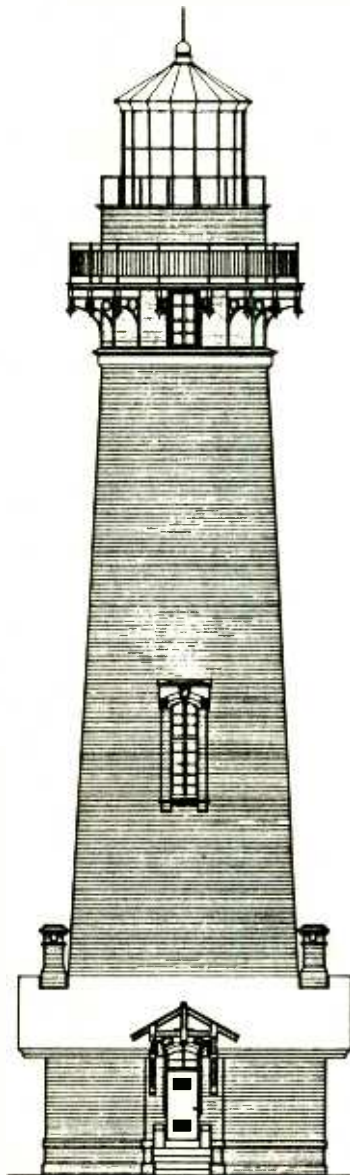

PIGEON POINT LIGHTHOUSE, SAN MATEO COUNTY, CA

PRESERVATION PLAN ON IT

Planning on restoring a house, saving a landmark, reviving your neighborhood?

Gain a wealth of experience and help preserve our historic and architectural heritage. Join the National Trust for Historic Preservation.

Make preservation a blueprint for the future.

Write:

National Trust
for Historic Preservation
Department PA
1785 Massachusetts Ave., N.W.
Washington, D.C. 20036

Put Professional Knowledge and a COLLEGE DEGREE in your Technical Career through HOME STUDY

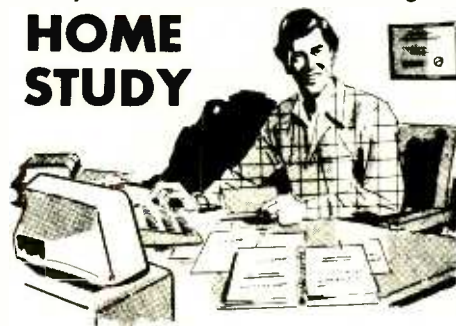

Add prestige and earning power to your technical career by earning your Associate or Bachelor degree through directed home study.

Grantham College of Engineering awards accredited degrees in **electronics and computers.**

An important part of being prepared to *move up* is holding the right college degree, and the absolutely necessary part is knowing your field. Grantham can help you both ways—to learn more and to earn your degree in the process.

Grantham offers two degree programs—one with major emphasis in **electronics**, the other with major emphasis in **computers**. Associate and bachelor degrees are awarded in each program, and both programs are available completely by correspondence.

No commuting to class. Study at your own pace, while continuing on your present job. Learn from easy-to-understand lessons, with help from your Grantham instructors when you need it.

Write for our free catalog (see address below) or telephone us at (213) 493-4421 (no collect calls) and ask for our "degree catalog."

Accredited by
the Accrediting Commission of the
National Home Study Council

GRANTHAM
College of Engineering
10570 Humbolt Street
Los Alamitos, CA 90720

DIGITAL COURSE

(Continued from page 81)

probe will test. Most probes can test both TTL and CMOS circuits, and so can work with a range of power-supply voltages.

When the tip of a probe is placed in contact with a point of interest, light-emitting diodes on the probe indicate whether the point being monitored is at a logic high, a logic low, or pulsing. Some probes use sound to signal the condition of a point.

Many logic probes have a pulse-stretcher or memory mode, which allows the probe to stretch pulses that occur too quickly for an LED or the human eye to respond to. For example, a single low-going 1-microsecond pulse is too short in duration to cause a visible flash of the LED indicator. Some probes can respond to pulses of 0.25 microsecond or less in the pulse or memory mode.

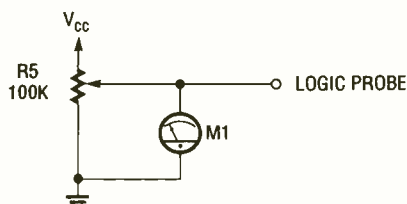
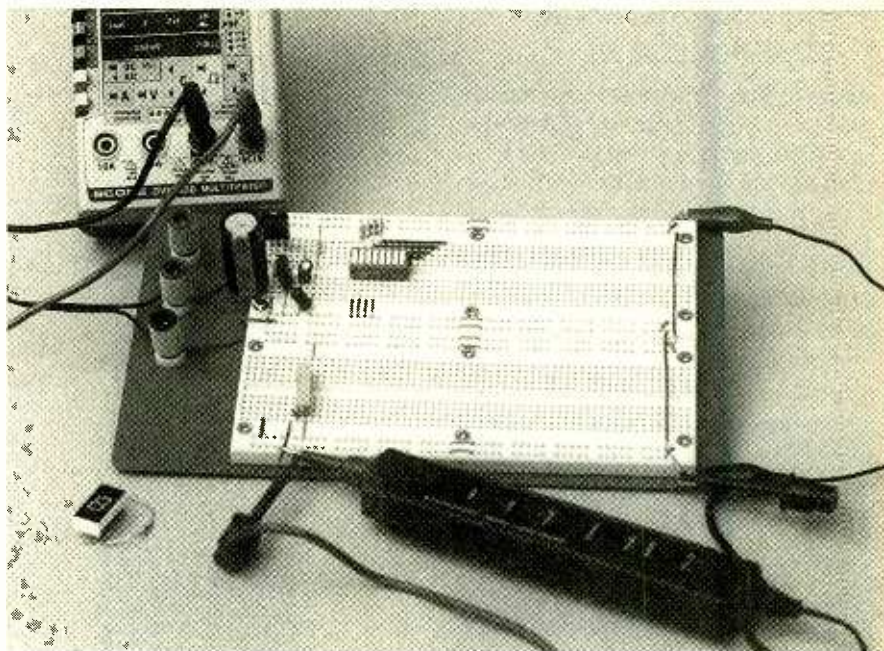

Fig. 7. Connect a 100,000-ohm potentiometer, a voltmeter, and a logic probe as shown here to observe the voltage level at which the probe changes to a high or a low.

A logic pulser, on the other hand is essentially a pulse generator. In its manual mode, it generates a logic low followed by a logic high each time its trigger switch is depressed. Logic probes often have a continuous mode in which they generate a train (series) of pulses at a rate that depends on the pulser you are using. The device is capable of sourcing or sinking sufficient current to override IC outputs in either the logic-high or logic-low state.

Getting to Work. In this exercise we'll use a DIP switch to function as the gating (logic) circuit, and the regulated 5-volt power supply that you built in the first exercise (**Popular Electronics**, June 1989) to serve as the voltage source.

You will also need a logic probe. Most logic probes have a TTL/CMOS switch; it should be set to the TTL position for this exercise. (The TTL operational mode has been chosen because our power-supply output is regulated to +5 volts,



In this experiment, a multi-position DIP switch is used to demonstrate the operation of logic circuits. A multi-turn potentiometer can be used to show the operational characteristics of a logic probe. When monitoring the voltage across the wiper of the potentiometer, note the voltage levels at which the probe indicates a high or low.

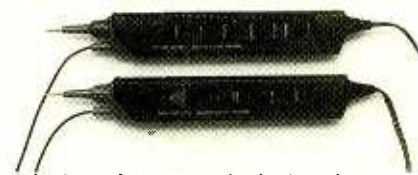

A logic probe (top) and a logic pulser (bottom) are the most useful pieces of equipment to have around when troubleshooting low-speed logic circuits. The probe shown here can test both main families of logic and comes with switch-selectable pulse stretching. The pulser shown here can send out single or multiple pulses.

which is the operating voltage for TTL circuits.) If your probe has a normal/memory (normal/pulse) switch, set it to the normal position.

Connect the red lead of the logic probe to V_{CC} (the supply's positive bus) and connect the black lead to ground on the 5-volt power supply. You can verify that the probe is properly connected to the circuit by first touching the probe tip to the +V bus, and then to the ground bus, while observing the LED indicators.

Now that the probe is set to deal with the signal level that we'll be using, place the DIP switch on the breadboard. Run a resistor between the positive supply and one side of each switch (see Fig. 6). Use small jumper wires to connect the unused sides of the switches to ground and apply power.

The Digital Microprocessor Course is reprinted here with the permission of the Electronic Industries Association/Consumer Electronic Group (EIA/CEG). The complete parts kit is available from EIA/CEG. For further information, contact EIA/CEG Product Services Department, 1722 Eye Street, NW, Suite 200, Washington, DC 20006; or call 202/457-4986.

Close every other switch and you'll be ready to test for highs and lows. Use the probe to check the logic level present at each junction between a switch and its resistor (points A, B, C, and D in Fig. 6). The probe should show a high for each open switch and a low for each closed switch.

Next turn off the power, discharge the capacitors and breadboard a 100,000-ohm potentiometer, a voltmeter, and a logic probe to form a circuit like that shown in Fig. 7. Apply power to the circuit. Assuming that the potentiometer is initially adjusted to its minimum resistance setting, slowly increase the resistance of (thereby increasing the voltage drop across) the potentiometer. Record the voltages at which the logic probe indicates a logic low and a logic high.

Do some experimenting and see what observations you can make. Try making the switch equivalents of the AND, OR, and inverting gates. ■

SCANNER SCENE

(Continued from page 90)

these split frequencies that it's good to understand this simple, yet universally confusing, quirk of many scanners.

For those who have written to ask if we can supply information on restoring the missing cellular frequencies in the *Uniden Bearcat BC-200/205XLT* scanner, it is now available. There's no charge for the data sheet, but we ask that those who want a copy please enclose a self-addressed, stamped (U.S. 25-cent) return envelope with the request. Be sure to specify that you want the BC-200/205XLT information. Use the address at the end of the column.

Odd Things on the Bands Department. If your scanner picks up computer-like transmissions in the UHF band, it just might be one of the new wireless modems now on the market. These sort of cordless telephones for computers can be used, for instance, between a computer in an office and hand-held, vehicular, or fixed-location computers in factories, warehouses, and other large areas. Almost 1,300 wireless-remote units can be in contact with the "home" computer through those wireless modems via simplex, half duplex, or full duplex.

The transmitter puts out up to 2 watts, ASCII mode, and operates in the 450- to 470-MHz band. Mobiles and portables can operate in the 406- to 512-MHz band with two data channels. Data is sent (factory selectable) at 1200 to 960 baud. This could offer some interesting high-tech monitoring possibilities.

People in the San Francisco area with radio-controlled garage doors found their control circuits had gone dead recently. That's because those devices operate in the 308- to 312-MHz band and they were being jammed by area U.S. Navy operations on 311.6 MHz. It wasn't intentional, but the powerful U.S.N. transmitter atop Mount Diablo was accused of "burning out" a number of openers—to the chagrin of suburbanites in the Bay Area. Life gets more complex each day.

We are always pleased to hear from our readers with questions, suggestions, helpful hints, and what-have-you about VHF/UHF communications. Our address is: *Scanner Scene*, **Popular Electronics**, 500-B Bi-County Blvd., Farmingdale, NY 11735. And be sure to tune in next month, "same time same station," for some more scanner-related news. ■

WATCH FOR THIS ISSUE ON SALE SEPTEMBER 5

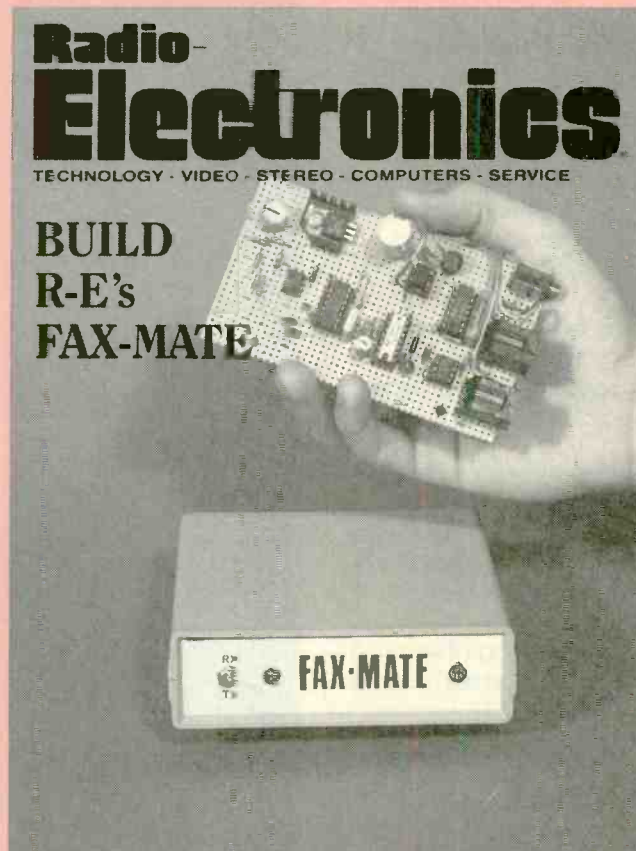

OUR OCTOBER ISSUE FEATURES:

BUILD R-E'S FAX-MATE

Save yourself the expense of a second phone line.

BUILD A REMOTE-CONTROLLED A/B SWITCH

For the ultimate couch potato: Never leave your easy chair again!

FMX: IS IT GOOD FOR FM?

Not everyone agrees. Get the details of this hot technical argument.

CIRCUIT COOKBOOK

More than two dozen practical CMOS bilateral switch circuits.

COMPUTER DIGEST

Putting the 68705 microcontroller to work.

**PLUS: Hardware Hacker
Audio Update
Hardware Reviews
Software Reviews
And lots more!**

NEW AGE FOR RADIO

(Continued from page 41)



Radio Data System equipment can page you and even tell you who you must call. Of course, that feature could be either good or bad!

broadcast stations and even some new networks. RDS should make it much easier to locate and keep tuned to a particular program, station, or network service during the transition period.

By the end of 1987 the BBC already had five basic RDS features in place on all of its network and local FM stations throughout England, and expected to convert its stations in Northern Ireland, Wales, and Scotland before the end of 1989.

If RDS comes to this country, it is expected to be of benefit to motorists if for no other reason than it will free them from a lot of radio-fiddling while driving, and that may even reduce the number of accidents somewhat. The Radio Data System looks as though it will bring a bright new age to good old radio. ■

FINANCE SOFTWARE

(Continued from page 79)

spreadsheet format. (That format is also used by other software packages.)

FastBucks. This program provides a capable, although somewhat awkward, system for maintaining a check register for one or more accounts. Like MYM and Quicken, FB lets you create checking, savings, credit-card, and cash accounts. Further, it has several financial calculators that, like those in MYM, allow you to postulate "what if" in various financial scenarios.

A unique feature is the program's "recursive budget model" that lets you allocate various amounts to various categories; FB then allocates excessive amounts on a pro-rated basis, so that larger categories will get a larger chunk of the excess. The automatic prorating is simpler than, say, creating a budget in a spreadsheet and manually adjusting amounts until all funds are allocated in a satisfactory manner.

However, the data entry screen for check-writing is awkward to use, although it has improved over the pre-

Account Manager

1. --- Checking Account
2. --- Charge Account
3. --- Savings Account
4. --- Cash Account

Global Reports--Graphs

5. --- Account Balances
6. --- Cash Flow Report
7. --- Category Graphs
8. --- Cash Flow Graphs

Utilities

9. --- Start New Account
- A. --- Delete An Account
- B. --- Fix Data Files
- C. --- Edit Account Name

FastBucks Home Finance Program

Version 4.02

Serial Number 0000000000

Home Budget Model

- D --- Create New Budget
- E --- Update Old Budget
- F --- Print Old Budget

Financial Calculations

- G --- Investments
- H --- Depreciation
- I --- Loans

Select item with Cursor Keys or Alphanumeric Key, then hit RETURN

FastBucks' main menu links you to the Account Manager, Reports, Utilities, the Home Budget Model, and the Financial Calculators.

Your budget for the first round totaled \$ 1150.00. This compares to a discretionary "worthy" income of \$ 1270.00. The difference \$ 120.00 has been prorated over all variable expense accounts.

Monthly Variable Expense Refinement

Food/Beverages	228.87	Clothing	55.22	Dry Cleaning	11.01
Hair/Beauty	22.09	Home Maintenance	110.13	Heating Fuel	55.22
Water	33.13	Electricity	55.22	Telephone	110.43
Gasoline/Oil	22.09	Auto Maintenance	55.22	Parking/Tolls	
Dentist	110.43	Physician	22.09	Drugs-Sundries	33.13
School Supplies	110.43	Family Allowance	55.22	Lunch Allowance	44.17
Sports		Theater		Restaurants	
Entertainment		Magazines/Books	55.22	Sitters	
Child Care		Vac'n Savings	110.43	Other Savings	110.43
Contributions		Hobbies		Other Expenses	

Change Freeze Next Last Up Down Back

Hit F10 When Done Esc = Abort Cursor Keys : | | | |

FastBucks' Budget Model: You can allocate and re-allocate expenses in several rounds, each time varying the amounts in each category. The program will then distribute the excess (or shortfall) to all categories on a prorated basis.

vious version. In addition, the program can't print checks. Also, whereas both MYM and Quicken allow you to create budget categories on the fly, FB only allows you to create and delete them from the main menu.

On the plus side, FB has a versatile system for graphically displaying the information you enter. One screen shows a bar graph of expense categories; you use the left and right arrow keys to move a pointer along the horizontal axis and a legend appears at the bot-

tom of the screen indicating the meaning and the exact amount of the current bar.

Conclusions. In general, Quicken is the easiest to use, and Managing Your Money (MYM) is the most powerful. FastBucks provides quite a few more functions than Quicken, but not as many as MYM, and FastBucks' user interface is the weakest of the three. However, you might want to try FastBucks before laying out any serious cash. ■

19 Reasons Why TAB Is Your Source for Electronics Books

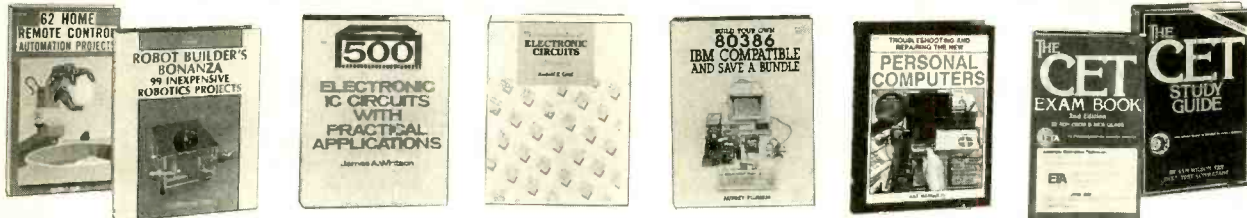

■ **Buy Both and Save (#5350C) — Yours for only \$24.45!**
62 Home Remote Control and Automation Projects

by D. Horn. 280 pp., 222 illus.

■ **The Robot Builder's Bonanza: 99 Inexpensive Robotics Projects**
 by G. McComb. 352 pp., 283 illus.

■ **500 Electronic IC Circuits with Practical Applications**

by J. Whitson. Scores of practical uses for IC circuits.

352 pp., 600+ illus., #2920H, \$29.95

■ **Encyclopedia of Electronic Circuits—Vol. 2**

by R. Graf. 700+ circuits. 744 pp., 728 illus. #3138P, \$29.95

■ **Build Your Own 80386 and Save a Bundle**

by A. Pilgrim. Get power and efficiency at a down-to-earth price!
 232 pp., 84 illus. #3131H, \$24.95

■ **Troubleshooting and Repairing the New Computers**

by A. Margolis. Save hundreds of dollars in repair costs!
 416 pp., 350 illus. #2809H, \$27.95

■ **Save \$10 on the Set (#5300C)— Yours for \$33.90!**

Pass the Associate and Journeyman Exams with Flying Colors!

The CET Exam Book—2nd Ed. by D. Glass and R. Crow.

The CET Study Guide—2nd Ed. by S. Wilson.

The TAB Electronics Hobby Series — Save Over \$25 on the set (#5282C)— yours for just \$75!

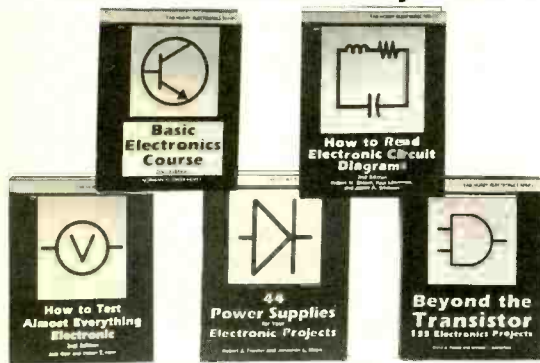

■ **Basic Electronics Course—2nd Ed.** by N. Crowhurst. Master the fundamentals and prepare for the future! 400 pp., 347 illus., #2613H, \$24.95

■ **How to Read Electronic Circuit Diagrams—2nd Ed.**

by R. Brown, P. Lawrence, and J. Whitson. Become proficient in the "language" of modern circuitry! 224 pp., 213 illus., #2880H, \$20.95

■ **How to Test Almost Everything Electronic—2nd Ed.**

by J. Darr and D. Horn. An outstanding bestseller, over 35,000 copies sold!
 180 pp., 138 illus., #2925H, \$16.95

■ **44 Power Supplies for Your Electronics Projects**

by R. Traister and J. Mayo. Find the simple or advanced circuits you need for all your project designs! 220 pp., 208 illus., #2922H, \$24.95

■ **Beyond the Transistor: 133 Electronics Projects**

by R. Turner and B. Rutherford. Make the most of semiconductors—no experience necessary! 240 pp., 173 illus., #2887H, \$16.95

■ **Troubleshooting and Repairing VCRs**

by G. McComb. Save money making your own VCR repairs! 336 pp., 200 illus.
 #2960H, \$26.95

■ **Build Your Own Universal Interface**

by B. Chubb. Use your computer to control almost anything! 285 pp., 224 illus.
 #3122H, \$27.95

■ **The Master Handbook of IC Circuits—2nd Ed.**

by D. Horn. Build 979 different circuits using 200+ popular ICs! 544 pp., 960 illus.
 #3185H, \$34.95

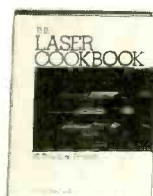
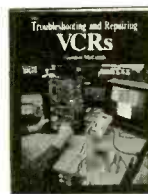

■ **Customize Your Home Entertainment System**

by S. Sokolowski. Build audio and video enhancements with 22 inexpensive projects! 288 pp., 100 illus. #3234H, \$24.95

■ **The 8088 Project Book** by R. Grossblatt.

Design and construct an 8088 computer and 17 hardware and software enhancements! 256 pp., 125 illus. #3171H, \$27.95

■ **The Laser Cookbook**

by G. McComb. 88 inexpensive, fun-filled and useful projects!
 401 pp., 361 illus. #3090H, \$25.95

TO ORDER, Call Toll Free: 1-800-822-8158

(in PA and AK call direct 1-717-794-2191) or mail coupon to:
 TAB BOOKS Inc., Blue Ridge Summit, PA 17294-0840

Please send me the book(s) below.

No. _____ Price _____ No. _____ Price _____

No. _____ Price _____ No. _____ Price _____

PA, NY, and ME residents add applicable sales tax (in Canada add \$5.00 shipping & handling.)

Check or money order enclosed (made payable to TAB BOOKS Inc.)
 Charge my VISA MasterCard American Express

Acct. No. _____ Exp. _____

Signature _____

Name _____

Address _____

City _____

State/Zip _____

SATISFACTION GUARANTEED—If you are not completely satisfied, return the books for a complete refund.

PE89

CIRCUIT CIRCUS

(Continued from page 85)

When S4 is pressed, the positive supply is connected to both R7 and R8 through isolation diodes D1 and D2, causing both oscillators to operate. A narrow, fast-rising positive pulse is developed at B1 of both Q1 and Q2 for each cycle of operation. Transistors Q3 and Q4 serve as a simple audio mixer, which is used to combine the pulses from each oscillator. The mixed signal at the collectors of Q3 and Q4 is coupled through R6 to the base of Q5, which amplifies and drives an 8-ohm speaker, SPKR1.

The resistor values (R7–R22) for determining the oscillator's operating frequency should be selected in pairs to generate the dual-tone drone of the bagpipe, and should be values ranging between 3.3k and 33k. A good musical ear or frequency counter will be helpful in selecting the resistors and tuning the instrument. The sixteen resistors, R7–R22, can be replaced with the same number of miniature trimmer potentiometers to simplify the tuning.

Switches, S2 and S3 are used to reduce the oscillator's frequency by about one-half, when closed, to produce a new group of tones. The circuit is not critical and can be assembled on perfboard or a printed-circuit board of your own design and housed in a suitable plastic or wood enclosure. The selection or building of a special enclosure can turn this simple circuit into a very special project of which you can be proud.

3-in-1 Test Set. Our third circuit is actually a three-in-one Test Set designed around a 4049 hex inverter/buffer. See Fig. 3. Two inverters (from that six-inverter unit) are used in a dual-frequency signal-injector circuit, another inverter is used as a logic probe, and the remaining three inverters are used as a sensitive dual-input, audio-signal tracer.

The signal-injector portion of the Three-in-One Test Set consists of gates U1-a and U1-b, which are configured as a two-frequency, pulse-generator circuit. Under normal conditions, the generator's output frequency is around 10 kHz, but when S2 is closed, the output frequency drops to about 100 Hz. For higher frequencies decrease the values of C1 and C2 and for lower frequencies increase the capacitor values. Both AC and DC outputs are offered.

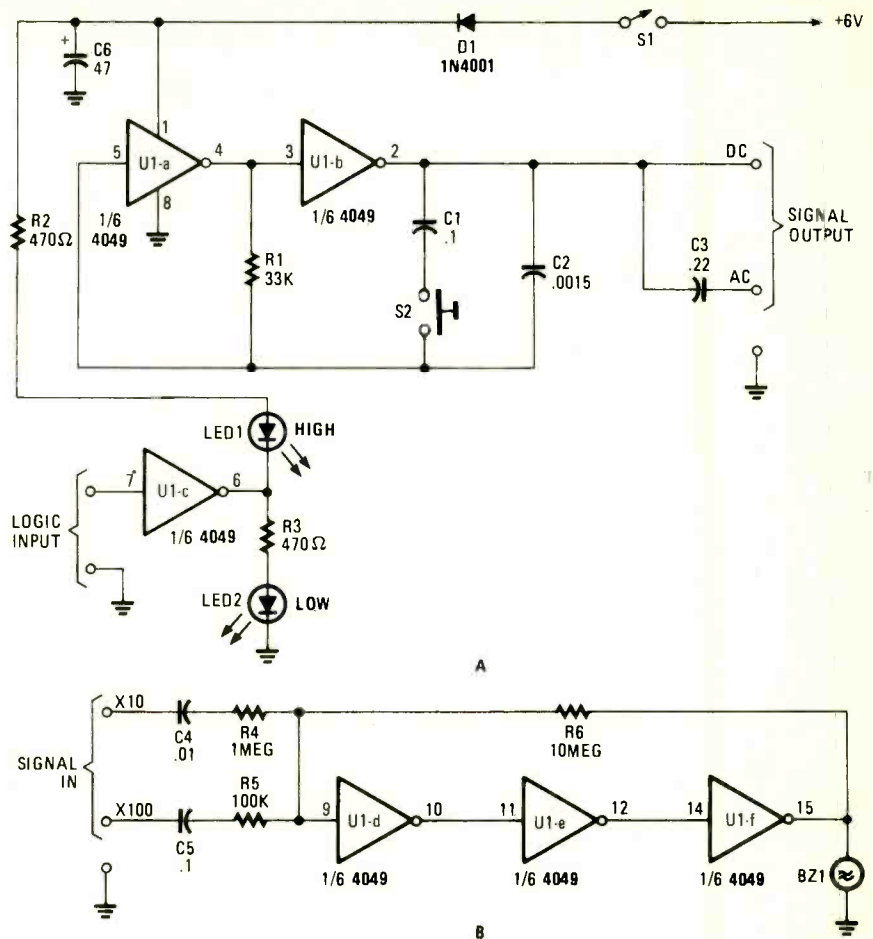

Fig. 4. The 3-in-1 Test Set combines three of the most useful test instruments—a signal injector, a logic probe, and an audio signal tracer. The signal tracer has two inputs that allow it to accept two signal levels; the one you use depends upon the magnitude of the signal injected into the circuit.

PARTS LIST FOR THE 3-IN-1 TEST SET

SEMICONDUCTORS

U1—4049 hex inverting buffer, integrated circuit
D1—1N4001 silicon diode
LED1, LED2—any color LED

RESISTORS

(All resistors are ¼-watt, 5% units.)
R1—33-ohm
R2, R3—470-ohm
R4—1-megohm
R5—100,000-ohm
R6—10-megohm

CAPACITORS

C1, C5—0.1-µF, ceramic-disc

C2—.0015-µF, ceramic-disc
C3—0.22-µF, mylar or similar
C4—.01-µF, ceramic-disc
C6—47-µF, 16-WVDC, electrolytic

ADDITIONAL PARTS AND MATERIALS

S1—toggle or slide power switch
S2—normally open push-button switch
BZ1—Piezo sounder element without internal driver.
Printed-circuit or perfboard materials, enclosure, IC sockets, 4 "AAA" batteries and battery holder, wire, solder, hardware, etc.

The logic-probe portion of the circuit is made up of U1-c, and a couple of LEDs, which are used to indicate the "high" or "low" logic state by turning on an LED. When a logic high is applied to the input of U1-c, the output of the inverter goes low. The low output of U1-c reverse biases LED2, so it remains off. That low output also forward biases

LED1, causing it to light. But when a logic low is presented U1-c's input, the situation is reversed, so that LED2 lights and LED1 goes dark. Resistors R2 and R3 limit the current flow through the LEDs to about 10 mA.

The audio-signal tracer portion of the circuit is made up of U1's three remaining inverters (U1-d through U1-f), which

are configured as a linear audio-amplifier that is used to increase the input signal level by a factor of 10 or 100. The amplified output signal feeds a miniature piezo element for audible detection.

The cost of parts for this multi-purpose tester should be less than five dollars without drawing from your junkbox, and far less if you do. The method of construction is your choice (perfboard or a printed-circuit board), but whichever method is used, keep the leads short and the layout neat.

Simple VCO. Our last circuit, see Fig. 4, places a 555 into service as an ultra-simple, voltage-controlled oscillator (VCO). The output frequency of the VCO (U1) varies inversely with the input voltage. With a 1-volt input, the oscillator's output frequency is about 1500 Hz, and with a 5-volt input, the output frequency of the oscillator drops to around 300 Hz.

The output frequency range of U1 can be altered by varying the values of C1, R2, and R3. Increasing the value of any of those three components will lower the oscillator frequency, and de-

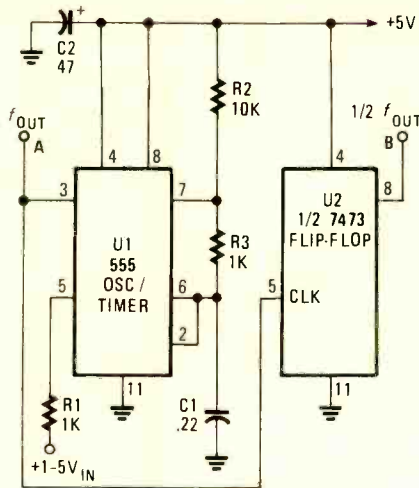

Fig. 3. In this circuit, a 555 oscillator/timer is used as a simple VCO. The signal produced by the VCO is fed to U2 (half of a 7473 dual TTL flip-flop), which provides a square-wave output that varies at half the input frequency.

creasing any of those values will cause the frequency to rise.

The output-waveform symmetry suffers as the frequency varies from one extreme to the other. At the highest frequency, the waveform is almost equally

PARTS LIST FOR THE SIMPLE VCO

U1—555 oscillator/timer, integrated circuit
 U2—7473 dual TTL J-K flip-flop, integrated circuit
 R1, R3—1000-ohm, ¼-watt, 5% resistor
 R2—10,000-ohm, ¼-watt, 5% resistor
 C1—0.22- μ F mylar capacitor
 C2—47- μ F, 16-WVDC, electrolytic capacitor

ADDITIONAL PARTS AND MATERIALS
 Printed-circuit or perfboard materials, enclosure, IC sockets, 5-volt power source, wire, solder, hardware, etc.

divided. But as the frequency drops, the output of the circuit turns into a narrow pulse.

If a symmetrical waveform is required, add the second IC, U2 (half of a 7473P dual TTL J-K flip-flop) to the oscillator circuit.

However, there's one catch: The signal frequency output by U2 is only one-half of what's going in. To overcome that deficiency just double the frequency of the VCO and the problem will be solved. ■

TAPPED COIL RADIO

(Continued from page 36)

to the first coil-tap terminal. If you have designed a radio similar to the one in the photograph, that will be the terminal on the far left. Attach another wire to the stator (stationary plates) of C1 and connect it to the last (the ninth) coil-tap terminal; that should be the terminal on the far right.

Now run a wire from the other earphone terminal to the cathode of the germanium diode, D1. Run another short piece of wire from the first coil-tap terminal to the ground terminal.

Locate your RF coil and attach it to the baseboard with 2 screws pushed through 2 small holes made on the underside of the cardboard tube. Be very careful not to damage the windings on the coil when you make those holes. The twisted taps should be situated on the top side of the tube.

Now, one by one, solder each coil-tap lead wire to the appropriate coil-tap terminal on the baseboard. Make certain that the sequence of coil-tap terminal connections corresponds to the sequence of twisted taps on top of the coil. The length of the lead wires should be trimmed as you go along.

Complete the radio by attaching one end of a 6-inch piece of hook-up wire to the antenna terminal and the other end to a small alligator clip. Now attach one end of another 6-inch piece of hook-up wire to the anode of D1 and another small alligator clip to the other end. The clips provide a secure means of connection to the coil-tap terminals, and the screws provide a nice place to put the clips (see Photo 7).

Operation. There is no space left here for a detailed discussion of antenna systems and ground sources. And anyway, you're probably anxious to try out your new crystal radio. So, go to it!

Attach a wire to the ground terminal of the radio and connect it to a water pipe or a metal water faucet—the one over the kitchen sink, for example. Obtain a long piece of wire and attach it to the antenna terminal. Hang the antenna wire over a nearby door. If you live in or near a big city, such an indoor antenna will work quite well, although a simple outdoor antenna will work even better.

Now, hook up the earphone, and place the alligator clip connected to D1 on coil-tap terminal number 9. Place the other clip (the one connected to

the antenna wire) on coil-tap terminal number 1 or 2. Adjust C1 a bit and you should hear a good, clear signal. Move the antenna clip over to the other coil-tap terminals. Then try moving the other clip. Every time you move the alligator clips, you are changing the inductance of the coil. Now go back and adjust C1. The number of inductor-capacitor combinations is very large, and the clarity and variety of the signals you receive may surprise you.

Discovering More. For more information on projects and experiments with crystal radios, see *All About Crystal Sets*, by Charles Green (Allabout Books, Fremont, CA) and *Radios That Work For Free*, by K. E. Edwards (Hope and Allen, Grants Pass, OR), both available from Yeary Communications (see Parts List). For more on the history of crystal sets and other early radio receivers, see *The Cat's Whisker*, by Jonathan Hill (Oresko Books, London) and *Early Radio Wave Detectors*, by V. J. Phillips (Peter Peregrinus, London). For more on the Collins experiment, see "The Effect Of Electric Waves On The Human Brain," by A. F. Collins, published in *Electrical World And Engineer*, Volume 39, Number 8, February 22, 1902, pp. 335-338. ■

ELECTRONICS MARKET PLACE

FOR SALE

DESCRAMBLERS. All brands. Special: Jerrold combo 400 and SB3 \$165. Complete cable descrambler kit \$39.00. Complete satellite descrambler kit \$45.00. Free catalog. **MJH INDUSTRY**, Box 531, Bronx, NY 10461-0531.

CABLE descrambler liquidation. Major makes and models available. Industry pricing! (Example: Hamlin Combo's, \$44 each... minimum 10 orders). **Dealers only!** Call **WEST COAST ELECTRONICS**, (818) 709-1758.

LISTEN to the world! Huge catalog of shortwave receivers, antennas, accessories, plus radioteletype and facsimile decoding equipment. Send \$1 to: **UNIVERSAL RADIO**, 1280 Aida Drive, Dept. PE, Reynoldsburg, OH 43068.

CB RADIO OWNERS!

We specialize in a wide variety of technical information, parts and services for CB radios. 10-Meter and FM conversion kits, repair books, plans, high-performance accessories. Thousands of satisfied customer since 1976! Catalog \$2.

CBC INTERNATIONAL
P.O. BOX 31500PE, PHOENIX, AZ 85046

SURPLUS ELECTRONICS. New giant wholesale catalog. Hundreds of incredible bargains. \$2. **Box 840**, Champlain, NY 12919.

LASER Listener II, other projects. Surveillance, descrambling, false identification, information. Plans, kits, other strange stuff. Informational package \$3.00 refundable. **DIRIJO/BOND ELECTRONICS**, Box 212, Lowell, NC 28098.

ENGINEERING software, PC/MSDOS. Hobbyists — students — engineers. Circuit design, FFT analysis, mathematics, logic simulation, circuit analysis. Free catalog, (614) 491-0832, **BSOFT SOFTWARE**, 444 Colton Rd., Columbus, OH 43207.

CONTROLLERS Z80 based systems. Write **CUSTOM COMPUTER APPLICATIONS**, 22639 Rosedale Street, St. Clair Shores, MI 48080.

NEW HE NE LASER TUBES \$35



Dealer Inquiries Invited.
Free Catalog!

MEREDITH INSTRUMENTS: 6403 N. 59th Ave.
Glendale, AZ 85301 • (602) 934-9387
"The Source for Laser Surplus"

CABLE TV Boxes. Jerrold, Scientific Atlanta combo's \$150. Call (314) 474-5656 or write 3309 Lance, Columbia, MO 65202.

LASER components! New surplus tubes, power supplies, optics. Build a working laser for under \$75.00. Free plans with order. \$1.00 (refundable) brings list. **FUNDSEV**, 1546A Peaceful Lane, Clearwater, FL 34616.

LONG play cassette recorders, accessories, lowest prices. Free brochure. **PRODUCTIVE PRODUCTS**, Box 930024, Norcross, GA 30093.

CABLE TV converters and descramblers bargain headquarter's: Zenith, Scientific Atlanta, Tocom, Hamlin combo w/remote \$130. Oak M35B \$60. Jerrold 400-DRX3DIC w/remote \$134. Visa-M/C-COD. Call now (415) 584-1627.

ROOM surveillance telephone, \$175.00. Monitor room or telephone conversations. **Range unlimited.** 1 (800) 633-8277. Catalog \$3.00. **LISTEN ELECTRONICS**, 603 Elgin, Muskogee, OK 74401.

FLOOD your mailbox! You get 100's of radio & electronic & computer specialty catalogs. Send \$10 with your name & address to: **ELECTRONIC LIST SERVICE**, PO Box 1683, Brookline, MA 02146.

CLASSIFIED AD ORDER FORM

To run your own classified ad, put one word on each of the lines below and send this form along with your check to:

Popular Electronics Classified Ads, 500-B Bi-County Boulevard, Farmingdale, N.Y. 11735

PLEASE INDICATE in which category of classified advertising you wish your ad to appear. For special headings, there is a surcharge of \$11.00.

() Plans/Kits () Business Opportunities () For Sale
() Education/Instruction () Wanted () Satellite Television

Special Category: \$11.00

PLEASE PRINT EACH WORD SEPARATELY, IN BLOCK LETTERS.

(No refunds or credits for typesetting errors can be made unless you clearly print or type your copy.) Rates indicated are for standard style classified ads only. See below for additional charges for special ads. **Minimum: 15 words.**

1	2	3	4	5
6	7	8	9	10
11	12	13	14	15 (\$23.25)
16 (\$24.80)	17 (\$26.35)	18 (\$27.90)	19 (\$29.45)	20 (\$31.00)
21 (\$32.55)	22 (\$34.10)	23 (\$35.65)	24 (\$37.20)	25 (\$38.75)
26 (\$40.30)	27 (\$41.85)	28 (\$43.40)	29 (\$44.95)	30 (\$46.50)
31 (\$48.05)	32 (\$49.60)	33 (\$51.15)	34 (\$52.70)	35 (\$54.25)

We accept MasterCard and Visa for payment of orders. If you wish to use your credit card to pay for your ad fill in the following additional information (Sorry, no telephone orders can be accepted.):

Card Number

Expiration Date

PRINT NAME

SIGNATURE

IF YOU USE A BOX NUMBER YOU MUST INCLUDE YOUR PERMANENT ADDRESS AND PHONE NUMBER FOR OUR FILES. ADS SUBMITTED WITHOUT THIS INFORMATION WILL NOT BE ACCEPTED.

CLASSIFIED COMMERCIAL RATE: (for firms or individuals offering commercial products or service) \$1.55 per word prepaid (no charge for ZIP code)...**MINIMUM 15 WORDS.** 5% discount for same ad in 6 issues within one year; 10% discount for 12 issues within one year if prepaid. **NON-COMMERCIAL RATE:** (for individuals who want to buy or sell a personal item) \$1.25 per word, prepaid...no minimum. **ONLY FIRST WORD AND NAME** set in bold caps at no extra charge. Additional bold face (not available as all caps) **30¢ per word additional.** Entire ad in boldface, \$1.85 per word. **TINT SCREEN BEHIND ENTIRE AD:** \$1.90 per word. **TINT SCREEN BEHIND ENTIRE AD PLUS ALL BOLD FACE AD:** \$2.25 per word. **EXPANDED TYPE AD:** \$2.05 per word prepaid. Entire ad in boldface, \$2.45 per word. **TINT SCREEN BEHIND ENTIRE EXPANDED TYPE AD:** \$2.55 per word. **TINT SCREEN BEHIND ENTIRE EXPANDED TYPE AD PLUS ALL BOLD FACE AD:** \$2.95 per word. **DISPLAY ADS:** 1" x 2 1/4"—\$175.00; 2" x 2 1/4"—\$350.00; 3" x 2 1/4"—\$525.00. **General Information:** Frequency rates and prepayment discounts are available. **ALL COPY SUBJECT TO PUBLISHERS APPROVAL. ADVERTISEMENTS USING P.O. BOX ADDRESS WILL NOT BE ACCEPTED UNTIL ADVERTISER SUPPLIES PUBLISHER WITH PERMANENT ADDRESS AND PHONE NUMBER.** Copy to be in our hands on the 15th of the fourth month preceding the date of issue (i.e., Sept. issue copy must be received by May 15th). When normal closing date falls on Saturday, Sunday or Holiday, issue closes on preceding work day. Send for the classified brochure. Circle Number 49 on the Free Information Card.

PLANS & KITS

BUILD this five-digit panel meter and square wave generator including an ohms, capacitance and frequency meter. Detailed instructions \$2.50. **BAGNALL ELECTRONICS**, 179 May, Fairfield, CT 06430.

ELECTRONIC kits! Transmitters! Recorders! Phone devices! Bug detectors! Surveillance items! More! Catalog \$1.00: **XANDI ELECTRONICS**, Box 25647, 32GG, Tempe AZ 85285-5647.

SPEAKERS — subwoofers, woofers, midranges, tweeters for auto, home, MI, commercial applications. 88 page color catalog — \$2.00. Amplifiers, microphones, DJ equipment. **McGEE RADIO**, 1901 McGee, Kansas City, MO 64108.

PRINTED circuit boards etched & drilled. Free delivery. **K & F ELECTRONICS, INC.**, 33041 Groesbeck, Fraser, MI 48026. (313) 294-8720.

DETECTION — surveillance, debugging, plans, kits, assembled devices. Latest high-tech catalog \$5. **DETECTION SYSTEMS**, 2515 E. Thomas, #16-864J, Phoenix, AZ 85016.

CATALOG: hobby/broadcasting/HAM/CB: Cable TV, transmitters, amplifiers, surveillance devices, computers, more! **PANAXIS**, Box 130-H10, Paradise, CA 95967.

VIDEOPHILIP II manuals. Volume 1 — hardware, Volume 2 — software. Either \$32.45. Both \$54.95. Volume 3 — projects/software — \$42.45. **NEW!!!** Volume 4 — repair/software — \$97.45. CODs — (602) 782-2316. Catalog — \$3.00. **TELECODE**, Box 6426-H, Yuma, AZ 85366-6426.

SURVEILLANCE, debugging, protection. Worlds largest new catalog — \$5.00 kits — assembled — all price ranges. **TECHNOLOGY SERVICES**, 829 Ginette, Gretna, LA 70056.

PROJECTION TV Convert your TV to project 7 foot picture... Easy!... Results comparable to \$2,500 projectors... **Plans and 8" Lens \$24.95...** Professional systems available... Illustrated catalog free. **MACROCOMA**, 15HB Main Street, Washington Crossing, PA 18977. Creditcard orders 24 hrs. (215) 736-3979.

49 best low cost Ham radio projects. Free list. Send SASE. **3037 AUDREY DRIVE**, Gastonia, NC 28054.

FIBER optics, kits, also robotics. Call for free catalog. **TECHNOLOGY SALES**, (201) 996-0943, Box 29, RR-3, Pittstown, NJ 08867.

DIGITAL CAR DASHBOARDS

BUILD yourself a complete electronic dashboard. Free details, \$1.00 P&H. **MODERN LABS**, 2900 Ruisseau, St.-Elizabeth, QC, J0K 2J0, Canada.

ATTENTION CABLE BROKERS

SURPLUS CATV converters and descramblers at wholesale prices. Unmodified units only. Oak M35B \$30.00. Hamlin MLD 1200 \$38. (415) 337-8301.

EDUCATION/INSTRUCTION

MAGIC! Four illustrated lessons plus inside information shows you how. We provide almost 50 tricks including equipment for four professional effects. You get a binder to keep the materials in, and a one-year membership in the International Performing Magicians with a plastic membership card that has your name gold-embossed. You get a one-year subscription to our quarterly newsletter, "IT'S MAGIC!" Order now! \$29.95 for each course + \$3.50 postage and handling. (New York residents add applicable state and local sales tax). **The Magic Course**, 500-B BiCounty Blvd., Farmingdale, NY 11735.

LEARN IBM PC assembly language. 80 programs. Games, quizzes, animation, utilities. Includes license. 360K \$5.00, 720K \$6.00, Book \$18.00. **ZIPFAST**, Box 12238, Lexington, KY 40581-2238.

F.C.C. Commercial General Radiotelephone License. Electronics home study. Fast, inexpensive! "Free" details. **COMMAND**, D-178, Box 2824, San Francisco, CA 94126.



TUBES - 2000 TYPES DISCOUNT PRICES!

Early, hard-to-find, and modern tubes. Also transformers, capacitors and parts for tube equipment. Send \$2.00 for 24 page wholesale catalog.

ANTIQUE ELECTRONIC SUPPLY

688 W. First St. • Tempe, AZ 85281 • 602/894-9503

ANTIQUE radio collectors/historians, join Antique Wireless Association — meets, flea markets, historical conference, quarterly bulletin. \$10.00 yearly. **ANTIQUE WIRELESS ASSOCIATION**, PO Box E-A, Breesport, NY 14816.

LEARN how to clean and service VCRs. Low cost video tapes show how the professionals do it. Write for free catalog. **ELECTRONIX INC.**, 313 W. Main St., Fairborn, OH 45324.

CCD Video camera. Learn how imaging ICs work and how to use them to build a low cost video camera. Send \$19.95. **VITRONICS**, PO Box 7, Station G, Calgary, Alberta T3A 2G1.

CLEAN your own VCR. Save \$30 - \$100 in repair costs! It's easy! Written by certified electronics technician. \$10.00. **VIDEOTEK**, Box 3684, Joplin, MO 64803.

CABLE-TV BOXES Descramblers • Converters

FREE CATALOG

TRANS-WORLD CABLE CO.

12062 Southwest 117th Ct., Suite 126

Miami, Florida 33186

800-442-9333

SATELLITE TV

FREE Catalog. Systems, Upgrades, Houston, Union, Chapparral, etc. Save \$\$\$\$\$. **SKYVISION**, 2008 Collegeway, Fergus Falls, MN 56537. (218) 739-5231.

FREE 36 page catalog. America's largest! All major brands. Save 40 — 60%. Since 1977 nobody under-sells **WEST INC.**, 1741 Cedardale Road, Mt. Vernon, WA 98273. Visa/MC/Disc/Amex/COD. 1 (800) 222-9064.

CABLE EQUIPMENT

CABLE TV Secrets — the outlaw publication the cable companies tried to ban. HBO, Movie Channel, Showtime, descramblers, converters, etc. Suppliers list included. \$8.95. **CABLE FACTS**, Box 711-H, Pataskala, OH 43062.

TV FILTERS

T.V. tunable notch filters. Free brochure. **D. K. VIDEO**, Box 63/6025, Margate, FL 33063. (305) 752-9202.

BUSINESS OPPORTUNITIES

EASY work! Excellent pay! Assemble products at home. Call for information. (504) 641-8003 Ext. 5730.

YOUR own radio station! AM, FM, TV, cable. Licensed/unlicensed. **BROADCASTING**, Box 130-H10, Paradise, Ca 95967.

INVENTIONS, ideas, technology wanted for presentation to industry/exhibition at national innovation exposition. Call 1 (800) 288-IDEA.

MASTERCARD AND VISA are now accepted for payment of your advertising. Simply complete the form on the first page of the Market Center and we will bill.

CABLE TV. CONVERTERS WHY PAY A HIGH MONTHLY FEE?

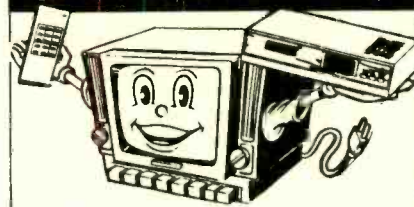

All Jerrold, Oak, Hamlin, Zenith, Scientific Atlanta, Magnavox and all specialized cable equipment available for shipment within 24 hours. For fast service MC / VISA or C.O.D. telephone orders accepted (800) 648-3030 60 Day Guarantee (Quantity Discounts) 8 A.M. to 5 P.M. C.S.T. **CLOSED WEEK-ENDS.** Send self-addressed Stamped envelope (60¢ postage) for Catalog.

MIDWEST ELECTRONICS INC.

P.O. Box 5000
Suite 311 (PE)
Carpentersville, IL 60110

No Illinois Orders Accepted.

CABLE TV CONVERTERS IN STOCK

Stocking all types of converters — Panasonic, Jerrold, Tocom, Pioneer, Scientific Atlanta, Zenith, Oak, Hamlin, Eagle, and others brands available.

Call or write for **FREE CATALOG** 10 am - 6 pm Eastern, Mon. - Fri.

VIDEO-LINK Enterprises, Inc.

165 WEST PUTNAM AVE.
GREENWICH, CT 06830
Phone (203) 622-4386

GET OUT OF THE DARK.

Open your eyes and see just how many subjects are covered in the new edition of the Consumer Information Catalog. It's free just for the asking and so are nearly half of the 200 federal publications described inside. Booklets on subjects like financial and career planning; eating right, exercising, and staying healthy; housing and child care; federal benefit programs. Just about everything you would need to know. Write today. We'll send you the latest edition of the Consumer Information Catalog, which is updated and published quarterly. It'll be a great help, you'll see. Just write:

Consumer Information Center
Dept. TD, Pueblo, Colorado 81009

U.S. General Services Administration

BUY BONDS

ADVERTISING INDEX

POPULAR ELECTRONICS magazine does not assume any responsibility for errors that may appear in the index below.

Free Information No.	Page
6	AMC Sales 97
5	All Electronics 17
—	Amazing Concepts 23, 25, 27
—	American Home. Sat. Assoc. 32
—	Antique Electronic Supply 107
13	C & S Sales 15
—	CB City 106
11	CIE 31
—	Command Productions 87
22	Communications Electronics . CV4
17	Cook's Institute 95
7	DuPerron Electronics 26
12	Digi Key 3
21	Electronics Book Club 24, 93
—	Electronic Tech. Today CV3
18	Emco 87
—	Grantham College 99
9	Halted Specialties 26
20	Heathkit CV2
10	Jensen Tools 95
—	Lindsay Publications 89
—	McGraw Hill Book Club 8
—	Meredith Instruments 106
—	Midwest Electronics 107
—	NRI Schools 21
—	Pacific Cable 5
14	Parts Express 13
15	Sequoia Publishing 16
—	Tab Books 103
19	The Antenna Specialists 7
8	The Datak Corporation 16
—	Trans World 107
—	Video-Link 107
16	Viejo Publications 97

ADVERTISING SALES OFFICE

Gernsback Publications, Inc.
500-B Bi-County Blvd.
Farmingdale, NY 11735
1-(516) 293-3000
President: Larry Steckler
Vice President: Cathy Steckler

For Advertising ONLY
516-293-3000
Fax 1-516-293-3115
Larry Steckler
publisher

Arline Fishman
advertising director
Christina Estrada
advertising assistant
Shelli Weinman
advertising associate
Lisa Strassman
credit manager

SALES OFFICES
EAST/SOUTHEAST
Becky Akers
Pattis/3M

310 Madison Ave., Suite 1804
New York, NY 10017
1-212-953-2121
Fax 1-212-953-2128

MIDWEST/Texas/Arkansas/Okla.

Ralph Bergen
540 Frontage Road—Suite 339
Northfield, IL 60093
1-312-446-1444
Fax 1-312-446-8451

PACIFIC COAST/Mountain States
Marvin Green
5430 Van Nuys Blvd., Suite 316
Van Nuys, CA 91401
1-818-986-2001
Fax 1-818-986-2009

GRAND SLAM BRIDGE

(Continued from page 64)

feeling of play is so realistic, this reviewer found himself scolding the computer.) The screen display shows the score sheet with the proper entries. If you wish to save the dealt hand, you can do so. In fact, you can save as many hands as your floppy diskette or fixed disk can hold, however the game's directory can only list 50 games at a time.

Options. Grand Slam Bridge offers the same options you experience at the bridge table. You can play in the practice mode or match mode. In the match mode all deals are random. You can toggle on any of the four bidding options for each partnership—cue bid, two bid, major suit—and set the level of aggression. You even have the option to preselect game hands to North-South, slam hands, and notrump hands. You can play bridge with one to four players.

The real bonus you experience with Grand Slam Bridge is that you don't

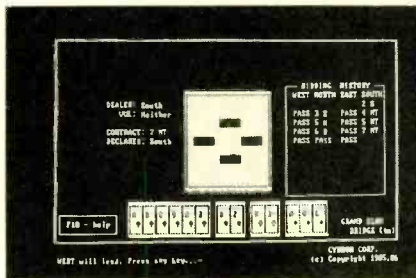

How exciting? Just look at the screen of a random hand that South has to play at 7 Spades. That's Grand Slam Bridge.

have to be a computer maven to run the program. The manual is written for bridge players and almost all of it is devoted to playing the game. Beginners will enjoy game information, bidding systems, defensive systems, and playing suggestions that you can take to the real-life game table.

Grand Slam Bridge plays defensive bridge using these systems: *fourth best*—will lead fourth best card; *top of suit*—lead top of bad three of a four card suit; *signals*—will give and try to interpret encouraging, discouraging, and suit-preference bids; and count in trump plus dummy's long suit in a notrump contract.

Grand Slam Bridge plays offensive bridge equally well beginning with the initial bid. The manual covers that topic very well.

The Grand Slam Bridge package comes with two 5-1/4-inch diskettes or one 3-1/2-inch diskette; none of the disks are copy protected. The diskettes run on IBM PC/XT/AT, and Compaq units requiring 256K of RAM, and on the Tandy 1000 Series with 384K of RAM; IBM monochrome, CGA, and Hercules Graphics are supported.

You can purchase Grand Slam Bridge at most software and computer outlets in North America, or direct from Electronic Arts by telephone (800/245-4525) or mail (Direct Sales, P.O. Box 7530, San Mateo, CA 94403) for \$59.95 US, plus \$3 S&H (California residents should add 7% tax). For more information on Grand Slam Bridge and other popular game programs from Electronic Arts, circle No. 125 on the Free Information Card. ■

ELECTRONIC MEDICINE

(Continued from page 63)

condition improved. He called it "electrical neurosis."

The electrical treatment of psychiatric problems was often successful. In the case of hysteria, electrotherapy of any kind seemed to help. But the question "Why does it work?" kept coming up. As Engelskjön confessed in 1884, "The effect of electricity is still wholly unclear."

High-Frequency. In 1888, the French scientist, Jacques d'Arsonval, made an important discovery while experimenting with the effects of alternating currents on muscular contraction. He noticed that as the frequency of the alternations increased, the more vigorous the contractions became. The correlation held until very high frequencies were reached.

Historians usually credit d'Arsonval with being the first to note the physical effects of high-frequency alternating current. However, it was Nikola Tesla who, in 1891, was probably the first to suggest the possible therapeutic use of such high-frequency oscillations. He knew immediately that the physiological consequences of high-frequency would be different from traditional electrotherapeutic methods. But whether those consequences would be beneficial, he cautioned, "remains to be proved." In many ways that is still true today. For more on the history of electrical medicine, see the boxed text entitled "Books and Articles" appearing with this article. ■

Electronics Paperback Books

GREAT PAPERBACKS AT SPECIAL PRICES



BP173—COMPUTER MUSIC PROJECTS \$6.95. Shows how to use your home computer to produce electronic music. Many circuits. Mostly jargon free.



BP233—ELECTRONIC HOBBYISTS HANDBOOK \$9.95. Single source of easily located info that the electronics hobbyist needs in his day-to-day pursuit of this fascinating hobby.



PCP103—PRACTICAL MIDI HANDBOOK \$9.95. Explains what MIDI (the Musical Digital Interface) can do and how you can put it to work. Covers Keyboards, drum machines, sequencers, mixers, guitars and computer music.



RFTD—RADIO'S FIRST TWO DECADES \$3.50. This story of radio's early days makes for fascinating reading. Spark-gap transmitters, KDKA's beginnings, and much more.



PCP102—INTRODUCING DIGITAL AUDIO \$9.95. CD, DAT, and sampling. What is involved in the digital part of audio signals. Principles and practices of digital audio techniques.



BP195—INTRODUCTION TO SATELLITE TV \$9.95. A definitive introduction to the subject written for the professional engineer, electronics enthusiast, or others who want to know more before they buy 8 x 10 in.

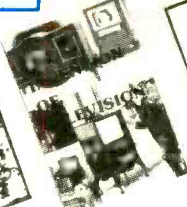

BP238—GETTING THE MOST FROM YOUR MULTIMETER \$5.95. Covers basics of analog and digital meters. Methods of component testing (includes transistors, thyristors, resistors, capacitors and other active and passive devices).

TELE—THE INVENTION OF TELEVISION \$9.95. Everything you never learned about television from its start as a dream in the 1800's to the promise of tomorrow.

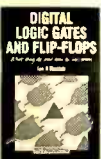

PCP107—DIGITAL LOGIC GATES & FLIP-FLOPS \$10.00. What they do and how to use them. You'll probably never need another book on this subject.



BP143—INTRO TO PROGRAMMING THE ATARI 800/800 XL \$5.95. Perfect complement to the Atari user's manual. Even shows how to use animated graphics.



BP130—MICRO INTERFACING CIRCUITS—BOOK 1 \$5.75. Practical add-ons transform your computer into control or measurement equipment.



BP144—MICRO INTERFACING CIRCUITS—BOOK 2 \$5.75. Interfacing sound and speech generators, temperature and optical sensors, motor controllers, and more.



BP144—FURTHER PRACTICAL ELECTRONICS CALCULATIONS AND FORMULAE \$9.00. Companion volume to BP53. Book carries on with new data not found in earlier edition. 450 pages.



BP125—25 SIMPLE AMATEUR BAND ANTENNAS \$5.50. All kinds of antennas for all kinds of amateur radio reception.



BP125—25 SIMPLE AMATEUR BAND ANTENNAS \$5.50. All kinds of antennas for all kinds of amateur radio reception.



BP125—25 SIMPLE AMATEUR BAND ANTENNAS \$5.50. All kinds of antennas for all kinds of amateur radio reception.



BP125—25 SIMPLE AMATEUR BAND ANTENNAS \$5.50. All kinds of antennas for all kinds of amateur radio reception.

Quality Paperbacks



PCP106—SYNTHESIZERS FOR MUSICIANS \$10.00. Covers principles of modern synthesis—linear arithmetic, phase distortion, frequency modulation, sampling.



BP127—HOW TO DESIGN ELECTRONIC PROJECTS \$5.75. How to use standard circuit elements to make custom electronic projects.



BP110—HOW TO GET YOUR ELECTRONIC PROJECTS WORKING \$5.75. How to find the faults in your projects, repair them and get them working.



BP121—DESIGN & MAKE YOUR OWN PC BOARDS \$5.75. Everything you need to know before you make printed-circuit boards for your projects.



BP256—INTRO TO LOUDSPEAKERS AND ENCLOSURE DESIGN \$5.95. Explore all the aspects of speaker design including speakers, enclosures, and crossovers. Wind up with a description of a state-of-the-art speaker system.



BP85—INTERNATIONAL TRANSISTOR EQUIVALENTS \$7.50. Locates possible substitutes for a popular user-oriented selection of modern transistors. Japanese, European and American types.



BP117—PRACTICAL ELECTRONIC BUILDING BLOCKS, Book 1 \$5.75. Build the blocks and then combine them to form almost any custom project of your choice.



BP77—MICRO-PROCESSING SYSTEMS AND CIRCUITS \$5.95. Guide to the elements of micro-processing systems. Teaches all the fundamentals.



BP118—PRACTICAL ELECTRONIC BUILDING BLOCKS, Book 2 \$5.75. Amplifiers for all kinds to add to the circuits from Book 1 of this series.



BP109—HOW TO GET YOUR COMPUTER PROGRAMS RUNNING \$5.95. Have you ever written your own programs only to find that they do not work? This book shows you how to find errors.

Affordable Prices



BP248—TEST EQUIPMENT CONSTRUCTION \$5.95. Details the construction of simple, inexpensive, yet extremely useful test equipment. 10 different instruments are included.



BP108—MODERN OP-AMP PROJECTS \$5.00. Includes a Slide Timer, AF Signal Gen, Mike Pre-amp, Scratch Filter, and much more.



BP59—SECOND BOOK FOR CMOS IC PROJECTS \$5.50. Multivibrators; amplifiers; triggers & gates; special devices including reaction timer, simple electronic organ, and more.

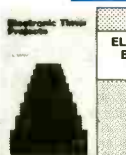

BP182—MIDI PROJECTS \$6.95. Details of how to interface many popular home computers with MIDI music systems.

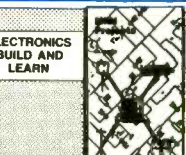

BP65—SINGLE IC PROJECTS \$5.75. All projects in this book are based on one IC and are simple to construct. Great way to get started with IC's.

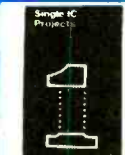

BP49—POPULAR ELECTRONIC PROJECTS \$5.95. A collection of a wide range of electronic projects and circuits for the experimenter.



BP97—IC PROJECTS FOR BEGINNERS \$5.50. Written especially for the less experienced experimenter. Complete parts layouts and wiring diagrams.



BP260—CONCISE INTRO TO OS/2 \$5.95. Learn how the OS/2 operating system is structured and how to use it effectively. Written with the non-expert busy person in mind.



BP98—POPULAR ELECTRONIC CIRCUITS, Book 2 \$5.95. More useful circuits. None of these projects duplicate those in Book 1 of this series.

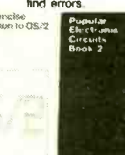

CHECK OFF

THE BOOKS YOU WANT

ELECTRONIC TECHNOLOGY TODAY INC.
P.O. Box 240, Massapequa Park, NY 11762-0240

SHIPPING CHARGES IN USA AND CANADA

\$0.01 to \$5.00 \$1.25
\$5.01 to 10.00 \$2.00
\$10.01 to \$20.00 \$3.00
\$20.01 to \$30.00 \$4.00
\$30.01 to \$40.00 \$5.00
\$40.01 to \$50.00 \$6.00
\$50.01 and above \$7.50

SORRY, No orders accepted outside of USA and Canada

Number of books ordered

Name _____
Address _____
City _____ State _____ Zip _____

Total price of merchandise \$ _____
Sales Tax (New York State Residents only) \$ _____
Shipping (see chart) \$ _____

All payments must be in U.S. funds Total Enclosed .. \$ _____

uniden®

\$12,000,000 Scanner Sale

Uniden Corporation of America has purchased the consumer products line of Regency Electronics Inc. for \$12,000,000. To celebrate this purchase, we're having our largest scanner sale in history! Use the coupon in this ad for big savings. Hurry...offer ends February 28, 1990.

★★★ MONEY SAVING COUPON ★★★

Get special savings on the scanners listed in this coupon. This coupon must be included with your prepaid order. Credit cards, personal checks and quantity discounts are excluded from this offer. Offer valid only on prepaid orders mailed directly to Communications Electronics Inc., P.O. Box 1045 - Dept. UN13, Ann Arbor, Michigan 48106-1045 U.S.A. Coupon expires February 28, 1990. Coupon may not be used in conjunction with any other offer from CEI. Coupon may be photocopied. Add \$12.00 for shipping in the continental U.S.A.

Regency TS2-T \$259.95
 Regency R1800-T \$239.95
 Regency R1099-T \$99.95
 Regency RH806B-T \$419.95
 Regency RH256B-T \$294.95
 Bearcat 200XLT-T2 \$229.95
 Bearcat 100XLT-T \$184.95
 Bearcat 800XLT-T2 \$229.95
 Uniden HR2510-T \$229.95
 Uniden HR2600-T \$274.95
 Uniden PRO500D-T2 \$29.95

COUPON COUPON

COUPON COUPON

★★★ VALUABLE COUPON ★★★

Bearcat® 760XLT-T

List price \$499.95/CE price \$244.95/SPECIAL 12-Band, 100 Channel • Crystalless • AC/DC Frequency range: 29-54, 118-174, 406-512, 806-956 MHz. Excludes 823.9875-849.0125 and 868.9875-894.0125 MHz. The Bearcat 760XLT has 100 programmable channels organized as five channel banks for easy use, and 12 bands of coverage including the 800 MHz band. The Bearcat 760XLT mounts neatly under the dash and connects directly to fuse block or battery. The unit also has an AC adaptor, flip down stand and telescopic antenna for desk top use. 6-5/16" W x 1 1/2" H x 7 3/4" D. Model BC 590XLT-T is a similar version without the 800 MHz. band for only \$194.95. Order your scanner from CEI today.

NEW! Regency® Products

R4030-T Regency 200 ch. handheld scanner \$254.95
 R4020-T Regency 100 ch. handheld scanner \$189.95
 R4010-T Regency 10 channel handheld scanner \$114.95
 R1800-T Regency 100 channel mobile scanner \$244.95
 P200-T Regency 40 channel CB Mobile \$38.95
 P210-T Regency 40 channel CB Mobile \$56.95
 P220-T Regency 40 channel CB Mobile \$79.95
 P300-T Regency 40 channel SSB CB Mobile \$137.95
 P400-T Regency 40 channel SSB CB Base \$174.95
 PR100-T Regency visor mount radar detector \$54.95
 PR110-T Regency "Passport" size radar detector \$114.95
 PR120-T Regency "micro" size radar detector \$144.95
 MP5100XL-T Regency 40 Ch. marine transceiver \$139.95
 MP5101XL-T Regency 60 Ch. marine transceiver \$159.95
 MP6000XL-T Regency 60 Ch. marine transceiver \$209.95
 MP2000XL-T Regency handheld marine trans. \$189.95

Regency® RH256B-T

List price \$799.95/CE price \$299.95/SPECIAL 16 Channel • 25 Watt Transceiver • Priority The Regency RH256B is a sixteen-channel VHF land mobile transceiver designed to cover any frequency between 150 to 162 MHz. Since this radio is synthesized, no expensive crystals are needed to store up to 16 frequencies without battery backup. All radios come with CTCSS tone and scanning capabilities. A monitor and night/day switch is also standard. This transceiver even has a priority function. The RH256 makes an ideal radio for any police or fire department volunteer because of its low cost and high performance. A 60 Watt VHF 150-162 MHz. version called the RH806B-T is available for \$429.95. A UHF 15 watt, 16 channel version of this radio called the RU156B-T is also available, and covers 450-482 MHz. but the cost is \$454.95.

★★★ Uniden CB Radios ★★★

The Uniden line of Citizens Band Radio transceivers is styled to compliment other mobile audio equipment. Uniden CB radios are so reliable that they have a two year limited warranty. From the feature packed PRO 810E to the 310E handheld, there is no better Citizens Band radio on the market today.

PRO310E-T Uniden 40 Ch. Portable/Mobile CB \$83.95
 PRO330E-T Uniden 40 Ch. Remote mount CB \$104.95
 PRO500D-T Uniden 40 Channel CB Mobile \$38.95
 KARATE-T Uniden 40 channel rescue radio \$53.95
 GRANT-T Uniden 40 channel SSB CB mobile \$166.95
 MADISON-T Uniden 40 channel SSB CB base \$244.95
 PC122-T Uniden 40 channel SSB CB mobile \$119.95
 PRO510XL-T Uniden 40 channel CB Mobile \$38.95
 PRO520XL-T Uniden 40 channel CB Mobile \$56.95
 PRO530XL-T Uniden 40 channel CB Mobile \$79.95
 PRO540E-T Uniden 40 channel CB Mobile \$97.95
 PRO640E-T Uniden 40 channel SSB CB Mobile \$137.95
 PRO710E-T Uniden 40 channel CB Base \$119.95
 PRO810E-T Uniden 40 channel SSB CB Base \$174.95

★★★ Uniden Radar Detectors ★★★

Buy the finest Uniden radar detectors from CEI today.
 TALKER-T2 Uniden talking radar detector \$144.95
 RD7-T Uniden visor mount radar detector \$99.95
 RD9-T Uniden "Passport" size radar detector \$114.95
 RD9XL-T Uniden "micro" size radar detector \$144.95
 RD25-T Uniden visor mount radar detector \$54.95
 RD500-T Uniden visor mount radar detector \$74.95

Bearcat® 200XLT-T

List price \$509.95/CE price \$239.95/SPECIAL 12-Band, 200 Channel • 800 MHz. Handheld Search • Limit • Hold • Priority • Lockout Frequency range: 29-54, 118-174, 406-512, 806-956 MHz. Excludes 823.9875-849.0125 and 868.9875-894.0125 MHz. The Bearcat 200XLT sets a new standard for handheld scanners in performance and dependability. This full featured unit has 200 programmable channels with 10 scanning banks and 12 band coverage. If you want a very similar model without the 800 MHz. band and 100 channels, order the BC 100XLT-T for only \$189.95. Includes antenna, carrying case with belt loop, ni-cad battery pack, AC adaptor and earphone. Order your scanner now.

Bearcat® 800XLT-T

List price \$549.95/CE price \$239.95/SPECIAL 12-Band, 40 Channel • No-crystal scanner Priority control • Search/Scan • AC/DC Bands: 29-54, 118-174, 406-512, 806-912 MHz. Excludes 823.9875-849.0125 and 868.9875-894.0125 MHz. The Uniden 800XLT receives 40 channels in two banks. Scans 15 channels per second. Size 9 1/4" x 4 1/2" x 1 1/2". If you do not need the 800 MHz. band, a similar model called the BC 210XLT-T is available for \$178.95.

Bearcat® 145XL-T

List price \$189.95/CE price \$94.95/SPECIAL 10-Band, 16 Channel • No-crystal scanner Priority control • Weather search • AC/DC Bands: 29-54, 136-174, 406-512 MHz. The Bearcat 145XL is a 16 channel, programmable scanner covering ten frequency bands. The unit features a built-in delay function that adds a three second delay on all channels to prevent missed transmissions. A mobile version called the BC560XL-T featuring priority, weather search, channel lockout and more is available for \$94.95. CEI's package price includes mobile mounting bracket and mobile power cord.

President® HR2510-T

List price \$499.95/CE price \$239.95/SPECIAL 10 Meter Mobile Transceiver • Digital VFO Full Band Coverage • All-Mode Operation Built-in liquid crystal display • Auto Squelch RIT • Preprogrammed 10 Khz. Channels Frequency Coverage: 28,0000 MHz. to 29,6999 MHz. The President HR2510 Mobile 10 Meter Transceiver made by Uniden, has everything you need for amateur radio communications. Up to 25 Watt PEP USB/LSB and 25 Watt CW mode. Noise Blanker. PA mode. Digital VFO. Built-in S/RF/MOD/SWR meter. Channel switch on the microphone, and much more! The HR2510 lets you operate AM, FM, USB, LSB or CW. The digitally synthesized frequency control gives you maximum stability and you may choose either pre-programmed 10 Khz. channel steps, or use the built-in VFO for steps down to 100 Hz. There's also RIT (Receiver Incremental Tuning) to give you perfectly tuned signals. With receive scanning, you can scan 50 channels in any one of four band segments to find out where the action is. Order your HR2510 from CEI today.

NEW! President® HR2600-T

List price \$599.95/CE price \$299.95/SPECIAL 10 Meter Mobile Transceiver • New Features The new President HR2600 Mobile 10 Meter Transceiver is similar to the Uniden HR2510 but now has repeater offsets (100 Khz.) and CTCSS encode.



BC760XLT 800 MHz. mobile scanner SPECIAL!

★★★ Uniden Cordless Telephones ★★★

XE750-T Uniden Cordless Phone with speaker \$99.95
 XE550-T Uniden Cordless Phone \$79.95
 XE300-T Uniden Cordless Phone \$69.95

★★★ Extended Service Contract ★★★

If you purchase a scanner, CB, radar detector or cordless phone from any store in the U.S. or Canada within the last 30 days, you can get up to three years of extended service contract from Warrantech. This service extension plan begins after the manufacturer's warranty expires. Warrantech will perform all necessary labor and will not charge for return shipping. Extended service contracts are not refundable and apply only to the original purchaser. A two year extended contract on a mobile or base scanner is \$29.99 and three years is \$39.99. For handheld scanners, 2 years is \$59.99 and 3 years is \$79.99. For radar detectors, two years is \$29.99. For CB radios, 2 years is \$39.99. For cordless phones, 3 years is \$34.99. Order your extended service contract today.

OTHER RADIOS AND ACCESSORIES

BC55XL-T Bearcat 10 channel scanner \$114.95
 BC70XL-T Bearcat 20 channel scanner \$159.95
 BC175XL-T Bearcat 16 channel scanner \$156.95
 R2066-T Regency 60 channel scanner \$149.95
 R1099-T Regency 45 channel scanner \$109.95
 TS2-T Regency 75 channel scanner \$269.95
 UC102-T Regency VHF 2 ch. 1 Watt transceiver \$114.95
 BP55-T Regency 16 amp reg. power supply \$179.95
 BP205-T Ni-Cad batt. pack for BC200/BC100XLT \$39.95
 B8-T 1.2 V AA Ni-Cad batteries (set of eight) \$17.95
 FBE-T Frequency Directory for Eastern U.S.A. \$14.95
 FBW-T Frequency Directory for Western U.S.A. \$14.95
 RFD1-T Great Lakes Frequency Directory \$14.95
 RFD2-T New England Frequency Directory \$14.95
 RFD3-T Mid Atlantic Frequency Directory \$14.95
 RFD4-T Southeast Frequency Directory \$14.95
 RFD5-T N.W. & Northern Plains Frequency Dir. \$14.95
 ASD-T Airplane Scanner Directory \$14.95
 SRF-T Survival Radio Frequency Directory \$14.95
 TSG-T "Top Secret" Registry of U.S. Govt. Freq. \$14.95
 TTC-T Tune in on telephone calls \$14.95
 CBH-T Big CB Handbook/AM/FM/Freeband \$14.95
 TIC-T Techniques for Intercepting Communications \$14.95
 RRF-T Railroad frequency directory \$14.95
 EEC-T Embassy & Espionage Communications \$14.95
 CIE-T Covert Intelligence, Elect. Eavesdropping \$14.95
 MFF-T Midwest Federal Frequency directory \$14.95
 A60-T Magnet mount mobile scanner antenna \$35.95
 A70-T Base station scanner antenna \$35.95
 A1300-T 25 MHz-1.3 GHz Discone antenna \$109.95
 USAMM-T Mag mount VHF ant. w/ 12' cable \$39.95
 USAK-T 3/4" hole mount VHF ant. w/ 17' cable \$35.95
 Add \$4.00 shipping for all accessories ordered at the same time. Add \$12.00 shipping per radio and \$4.00 per antenna.

BUY WITH CONFIDENCE

To get the fastest delivery from CEI of any scanner, send or phone your order directly to our Scanner Distribution Center. Michigan residents please add 4% sales tax or supply your tax I.D. number. Written purchase orders are accepted from approved government agencies and most well rated firms at a 10% surcharge for net 10 billing. All sales are subject to availability, acceptance and verification. All sales on accessories are final. Prices, terms and specifications are subject to change without notice. All prices are in U.S. dollars. Out of stock items will be placed on backorder automatically unless CEI is instructed differently. A \$5.00 additional handling fee will be charged for all orders with a merchandise total under \$50.00. Shipments are F.O.B. CEI warehouse in Ann Arbor, Michigan. No COD's. Most items listed have a manufacturer's warranty. Free copies of warranties on these products are available by writing to CEI. Non-certified checks require bank clearance. Not responsible for typographical errors.

Mail orders to: Communications Electronics, Box 1045, Ann Arbor, Michigan 48106 U.S.A. Add \$12.00 per scanner for U.P.S. ground shipping and handling in the continental U.S.A. For Canada, Puerto Rico, Hawaii, Alaska, or APO/FPO delivery, shipping charges are two times continental U.S. rates. If you have a Discover, Visa, American Express or Master Card, you may call and place a credit card order. 5% surcharge for billing to American Express. Order toll-free in the U.S. Dial 800-USA-SCAN. In Canada, dial 800-221-3475. FAX anytime, dial 313-971-6000. If you are outside the U.S. or in Michigan dial 313-973-8888. Order today. Scanner Distribution Center and CEI logos are trademarks of Communications Electronics Inc. Sale dates 9/1/89 - 2/28/90 AD #090189 Copyright © 1989 Communications Electronics Inc.

For credit card orders call 1-800-USA-SCAN

COMMUNICATIONS ELECTRONICS INC.

Consumer Products Division P.O. Box 1045 □ Ann Arbor, Michigan 48106-1045 U.S.A. For orders call 313-973-8888 or FAX 313-971-6000