

Consumer Electronics' Hottest New Products

48784

Popular Electronics

JUNE 1990

Exhaust Gas Monitor for your Car

Is your car poisoning you? Build this monitor and find out!

Programmable Garage/Yard Light Controller

Get outdoor lighting when and where you need it most

All About Solar Power

Learn about this important energy source, and reduce your electric bills in the bargain!

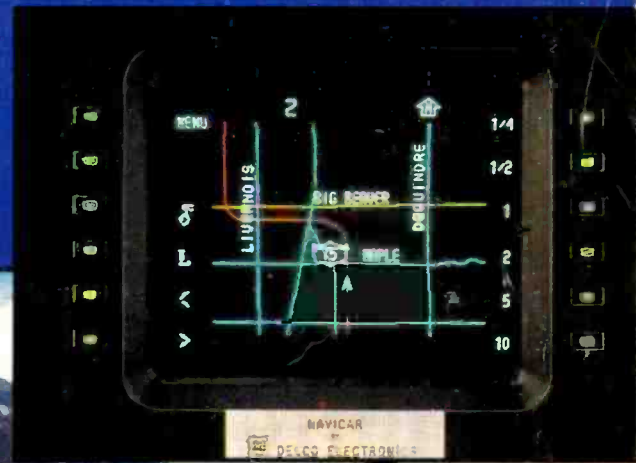

Automotive Electronics in the 1990's

Heads-up displays, car-navigation systems, obstacle detection, and more will make man's favorite toy safer and more reliable in the years ahead.



\$2.50 U.S.
\$2.95 CANADA

3 NEW
FactCards
IN THIS ISSUE

***** CAR-RT SURT ** DR27
95014DRK645MROID AUG90 39
LLOYD DARKNELL JR RESP
6450 MYRTLEWOOD DR D55 X
CUPERTINO, CA 95014

Popular Electronics®

THE MAGAZINE FOR THE ELECTRONICS ACTIVIST!

CONSTRUCTION ARTICLES

BUILD AN EXHAUST MONITOR FOR YOUR CAR	<i>Bob Flynn and Leo Simpson</i>	31
<i>Are auto exhaust fumes draining the life out of you? This gas-detection circuit can alert you to a potentially dangerous situation!</i>		
BUILD A PROGRAMMABLE GARAGE/YARD LIGHT CONTROLLER	<i>Mike Giamportone</i>	38
<i>It does the job of motion-sensing night lights at less than half the cost.</i>		
LOONEY TONES MUSIC SYNTHESIZER	<i>Walter W. Schopp</i>	59
<i>This simple tone generator provides 4096 variations to its 256 notes.</i>		

FEATURE ARTICLES

AUTOMOTIVE ELECTRONICS IN THE 1990'S	<i>Robert Angus</i>	35
<i>Advances in technology make man's favorite toy more fun to use...and safer, too!</i>		
1990 WINTER CONSUMER ELECTRONICS SHOW	<i>Josef Bernard</i>	42
<i>There's nothing new under the sun...or is there!</i>		
THE DIGITAL ELECTRONICS COURSE	<i>Robert A. Young</i>	62
<i>Learn about time-dependent logic circuits.</i>		
EXPERIMENTING WITH SOLAR POWER	<i>Geeta Dardick</i>	65
<i>Experimenting with solar power can be fun, educational, and perhaps profitable.</i>		
ADDING AN EXTERNAL DRIVE TO YOUR LAPTOP COMPUTER	<i>Fred Blechman</i>	69
<i>If price has kept you from adding an external drive to your laptop, perhaps this \$150 alternative is for you.</i>		
CHOOSING AND USING CAPACITORS	<i>Joseph J. Carr</i>	71
<i>Learn about the many types of fixed and variable capacitors, and how to use them.</i>		

PRODUCT REVIEWS

GIZMO		47
<i>Including: Sony Cordless Phone; Radio Shack Sound-Level Meter; Citizen Pocket Color TV; BBE Sonic Maximizer, and much more!</i>		
HANDS-ON REPORT		76
<i>Hamtime: The digital clock simulator designed for hams and SWLs.</i>		
PRODUCT TEST REPORT	<i>Len Feldman</i>	78
<i>Mission Cyrus Two Integrated Amplifier.</i>		

COLUMNS

THINK TANK	<i>Byron G. Wels</i>	23
<i>The answer to last month's puzzle.</i>		
ANTIQUE RADIO	<i>Marc Ellis</i>	80
<i>Some words from the readers.</i>		
COMPUTER BITS	<i>Jeff Holtzman</i>	82
<i>The sizzling 386.</i>		
DX LISTENING	<i>Don Jensen</i>	84
<i>Soccer broadcasts for SWLs.</i>		
CIRCUIT CIRCUS	<i>Charles D. Rakes</i>	86
<i>Determining meter movement specifications.</i>		
HAM RADIO	<i>Joseph J. Carr</i>	92
<i>Operating your station.</i>		
SCANNER SCENE	<i>Marc Saxon</i>	94
<i>Fast-food frequencies.</i>		

DEPARTMENTS

EDITORIAL	<i>Carl Laron</i>	2
LETTER BOX		4
ELECTRONICS LIBRARY		6
NEW PRODUCTS		15
FACTCARDS		45
FREE INFORMATION CARD		63
ADVERTISERS INDEX		105

Popular Electronics (ISSN 1042-170X) Published monthly by Gernsback Publications, Inc., 500-B Bi-County Boulevard, Farmingdale, NY 11735. Second-Class postage paid at Farmingdale, NY and at additional mailing offices. One-year, twelve issues, subscription rate U.S. and possessions \$21.95, Canada \$26.95, all other countries \$29.45. Subscription orders payable in U.S. funds only, International Postal Money Order or check drawn on a U.S. bank. U.S. single copy price \$2.50. © 1990 by Gernsback Publications, Inc. All rights reserved. Hands-on Electronics and Gizmo trademarks are registered in U.S. and Canada by Gernsback Publications, Inc. Popular Electronics trademark is registered in U.S. and Canada by Electronics Technology Today, Inc. and is licensed to Gernsback Publications. Printed in U.S.A.

Postmaster: Please send address changes to Popular Electronics, Subscription Dept., P.O. Box 338, Mount Morris, IL 61054-9932.

A stamped self-addressed envelope must accompany all submitted manuscripts and/or artwork or photographs if their return is desired should they be rejected. We disclaim any responsibility for the loss or damage of manuscripts and/or artwork or photographs while in our possession or otherwise.

As a service to readers, Popular Electronics publishes available plans or information relating to newsworthy products, techniques and scientific and technological developments. Because of possible variances in the quality and condition of materials and workmanship used by readers, Popular Electronics disclaims any responsibility for the safe and proper functioning of reader-built projects based upon or from plans or information published in this magazine.



Editorial

Larry Steckler
EHF, CET

Editor-In-Chief and Publisher

EDITORIAL DEPARTMENT

Carl Laron
Managing Editor

Robert A. Young
Associate Editor

John J. Yacono
Associate Editor

Byron G. Wels, K2AVB
Associate Editor

Teri Scaduto
Assistant Editor

Kathy Terenzi
Editorial Assistant

Marc Spiwak
Editorial Associate

Joseph J. Carr, K4IPV
Marc Ellis

Jeffrey K. Holtzman

Don Jensen

Charles D. Rakes

Marc Saxon

Contributing Editors

PRODUCTION DEPARTMENT

Ruby M. Yee
Production Director

Karen S. Tucker
Production Manager

Marcella Amoroso
Production Assistant

ART DEPARTMENT

Andre Duzant
Art Director

Russell C. Truelson
Technical Illustrator

Injae Lee
Assistant Illustrator

Jacqueline P. Cheeseboro
Circulation Director

Michele Torrllo
P-E Bookstore

BUSINESS AND EDITORIAL OFFICES

Gernsback Publications, Inc.

500-B Bi-County Blvd.

Farmingdale, NY 11735

1-516-293-3000

Fax: 1-516-293-3115

President: Larry Steckler

Vice President: Cathy Steckler

Advertising Sales offices listed on page 105.

Cover photography courtesy of
General Motors

Composition by
Mates Graphics
and
Magtype



The
Audit
Bureau
of Circulation



The publisher has no knowledge of any proprietary rights which will be violated by the making or using of any items disclosed in this issue.

AN ALL-AMERICAN LOVE AFFAIR

If we were to list the most important things in our lives, the vast majority of us would put our families first. But what would come next? Our friends? Our religion? Our community?

How about our car? While it probably won't occupy the first few spots (though I know a few people who would put it right at the top), for many it will appear fairly high. After all, except for our home, it's the most expensive and important item we'll ever buy—and we have to buy one every few years.

In this country, our love affair with the automobile has reached epic proportions. And as summer rolls around, the roads become even more clogged with vacationers and day trippers; to get to the beach here on Long Island, it's not unusual to hit the road by 7 a.m. to "beat the traffic."

With all those cars out there, there's bound to be trouble sooner or later. But as described in "Automotive Electronics in the 1990's," electronics enhancements on the drawing board or on the way shortly will help make man's favorite toy safer and more convenient to use.

In the meantime, have you ever wondered what sitting in all of that bumper-to-bumper traffic is doing to your lungs? In this issue we tell you how to build an "Exhaust Gas Monitor for your Car" that can warn you of potential danger on the road or in your garage.

But all the electronics in the world can't replace due care and common sense—and we hate to replace readers. So, please, let's all be extra careful when we get behind the wheel this summer, and all year round.

Carl Laron
Managing Editor

Radio ShackSM Parts PlaceSM

YOUR ONE-STOP STORE FOR BIG ELECTRONIC VALUES

Build with the Best—Over 1000 Components in Stock!

Parts "Hotline" Service! Thousands of Items Available

Your Radio Shack store manager can special-order a huge variety of parts and accessories direct from our electronics warehouse—Realistic[®] Long-Life tubes, linear and digital ICs, microprocessors, support chips, phono cartridges and styli, crystals, special-purpose batteries, diodes, selected modules for TVs and audio equipment, autosound wiring harnesses, accessories, even SAMS Photofacts[®]. No handling charge, no shipping charge—just speedy delivery to the Radio Shack near you!

Amateur Radio License Guides

495 to 1995

Home Study Courses For FCC License Tests

Novice Voice Class License
Prep Course. With cassettes.
#62-2402 19.95
Technician Class Manual.
#62-2403 4.95
General Class FCC License
Course. #62-2404 19.95



Brushless Fan

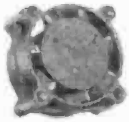

16⁹⁵

Operates
On 12VDC

Tiny, tough and efficient! Rated 150 mA. 1 9/16" x 1 9/16" x 1 3/16". #273-244

IR Detector

349

Module operates on 5VDC, board mountable. 5/8" x 1/2" x 1 9/32". With data. #276-137

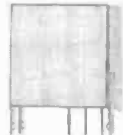

Simplifies
IR Design

IC Tool Set

6⁹⁵ Set



Install and remove 6-pin to 40-pin DIPs without damage. Works with LSI, MSI, and DIP devices. Both tools are groundable. #276-1581

Motor and Chime



(1) 1.5-3V DC Motor. For robotics, projects. 1 1/2" x 1 5/16" dia. #273-223
(2) Doorbell Chime. IC/mini-speaker combo. 6-18VDC. 5" leads. #273-071

Diode Rectifiers



3-Amp "Barrel" Type Diodes
200-Amp Surge

Type	Peak Inverse Voltage	Cat. No.	Pkg. of 2
1N5400	50	276-1141	99
1N5402	200	276-1143	1 19
1N5404	400	276-1144	1 29

Speaker Stuff



(1) MEGACABLE[™]. Hi-wattage, 12-gauge. #278-1268 ... Per Foot 99¢
(2) Gold Terminals for MEGACABLE. #64-401 ... Set of 8/4.99
(3) Terminal Knobs. Screw-down large cable. #274-619 ... Set 5.95

Dress It Up



(1) Classy Two-Piece Enclosure. Accepts PC board and 9V battery. 5 9/16" x 2 1/4" x 1 1/16". #270-257 ... 4.99
(2) Project Labels. Four 7 7/8" x 3" sheets of rub-on letters and symbols. #270-201 Set 2.99

Halogen Lamps

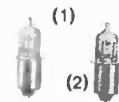

3⁹⁵ Each

(1) HPR50. For 4-cell flashlights and 6-volt lanterns. #272-1189
(2) HPR52. For 2-cell flashlights and 3-volt lanterns. #272-1190

Gold-Plated Plugs and Jacks



(1) Phono Plug. #274-850 ... 2.49
(2) Chassis-Mount Phono Jack. #274-852 ... 2-pk./2.49
(3) Straight In-Line Phono Jack. #274-854 ... 2.99
(4) 2-Conductor 1/4" Phono Plug. Monaural. #274-855 ... 3.49
(5) Three-Conductor (Stereo) 1/4" Phono Plug. #274-856 ... 3.99
(6) 1/8" Plug. #274-857 ... 2.79
(7) 3-Conductor 1/8" Phono Plug. Stereo. #274-858 ... 3.49
(8) 3-Conductor 1/4" In-Line Phone Jack. #274-859 ... 3.99

Wire Connectors & Accessories

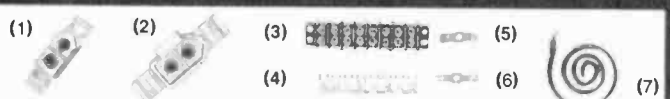

Fig.	Pos.	Type	Amps	Cat. No.	Each
1	2	Male	20	274-151	99
-	6	Male	15	274-152	1 69
-	12	Male	12	274-153	1 99
-	2	Female	20	274-154	99
2	6	Female	15	274-155	1 69
-	12	Female	12	274-156	1 99

(3) 2-Row Strip. #274-670 ... 1.99
(4) Jumper. 8-pos. #274-650, 1.59
(5) 45° T-Lugs. #274-645 ... 4/79¢
(6) Dual Solder-Lug Adapters. #274-644 Pkg. of 4/79¢
(7) Heavy-Duty Bonded Wire. 25 ft., 2 x 18-gauge. #278-1250 ... 3.99

Engineering Calculator



3⁹⁵

Uses Standard
Electronic Symbols

EC-4035 makes design math a snap! Has 110 functions, memory. With case and batteries. #65-983

30-Range Multimeter



7⁹⁵

Tests Capacitors
and Transistors

A great value! Measures to 1000VDC and 750VAC. With 0.5" digital display. Battery extra. #22-194

Panel-Mount Counter

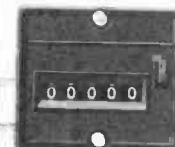

14⁹⁵

Electromechanical — Counts to 99,999

One count per 12VDC pulse, pushbutton reset. Mounts in 1 1/16" x 1" hole. Depth: 1 1/16". With leads and data. #277-222

Over 1000 items in stock! Binding Posts, Books, Breadboards, Buzzers, Capacitors, Chokes, Clips, Coax, Connectors, Fuses, Hardware, ICs, Jacks, Knobs, Lamps, Multitesters, PC Boards, Plugs, Rectifiers, Resistors, Switches, Tools, Transformers, Transistors, Wire, Zeners, More!

Prices apply at participating Radio Shack stores and dealers

Radio Shack
AMERICA'S
TECHNOLOGY
STORESM

A DIVISION OF TANDY CORPORATION

CIRCLE 8 ON FREE INFORMATION CARD



Letters

TOP(-TO-BOTTOM) SECRET

I have been an interested reader of Marc Ellis' "Antique Radio" column for some years. Being no longer young, I can relate to much of what he writes from personal experience.

Still, it was with considerable surprise that I noted the circuit diagram in the lower left-hand corner of page 82 in the April issue of **Popular Electronics**. It appeared to me that Mr. Ellis had happened across a very secret experiment—one that I had thought was well-buried in the sands of time.

In the late 1920's, a number of us were working for a government agency, known only as "H-2," on a project designed to provide long-range communications that could not be intercepted by unfriendly ears. After a number of approaches were discarded as unfeasible, one of our team came up with what seemed to be a most elegant solution. "Since any eavesdropper would be listening for signals in the atmosphere," he reasoned, "why not transmit through the earth itself? No one would expect to hear anything from rocks."

The result was similar to the diagram in your April issue, which is actually a simplified receiver circuit that was just one step along the way in our experiment. The basics are there, however—an antenna positioned for burial in the earth, the ground floating in the atmosphere, an inductor tuned to very low frequencies, etc.

We never knew the ultimate conclusion to our experiments. The project was so confidential that testing was assigned to another team, and we were discharged with thanks. I do believe, however, that the Navy is fooling around with something like that in Wisconsin.

J.N.J.
Skokie, IL

No, that wasn't an "April Fool's" joke—you caught a classic goof. Perhaps the "perpetrator" should be remanded to the care of "H-2" or some similar secret government agency.—Editor

POWER-SUPPLY WARNING

There is a serious problem related to the "Transformerless Power Supply" that appeared in the April issue of **Popular Electronics**. Even though the article cautions about enclosing the device in a non-conductive container, it never states that any de-

vice powered by this supply can become extremely hazardous. The schematic shows one side of the line connected directly to the device's output. Since there is no mention of using a polarized plug, the "hot" side of the 117-VAC house wiring can be inadvertently connected directly to the chassis of the device to be powered.

Though I would strongly suggest that you avoid building this or any other transformerless design, if you insist on doing so use a polarized plug and be sure to wire the neutral side to the ground leg of the circuit.

R.A.C.
Stoneham, MA

VERSATILE CODE ALARM REVERSALS

We've found several problems in our article, "The Very Versatile Code Alarm," as it appeared in the April issue of **Popular Electronics**. The schematic diagram (Fig. 1) improperly shows Q2's base connected to the positive rail (that connection should be deleted), and Q4's emitter and collector connections reversed. R14 and R15 have also been swapped. In the parts-placement diagram (Fig. 4), Q2 is positioned improperly; its base should be connected to pin 13 of U1, its emitter should be connected to R2, and its collector should be connected to the base of Q3.

Mike and Karen Giamportone

NEW VIOLET-RAY GENERATORS

In the article "Violet-Ray Generators" (**Popular Electronics**, February 1990), the author's suggestion to insert a wire into the electrode socket in the handle of the high-voltage generator creates a potential shock hazard, since one end of the secondary winding is grounded by being connected through the vibrator circuit to the 117-volt AC power source. Touching the wire terminal and a grounded conductor simultaneously would result in a potentially dangerous electrical shock.

Violet-ray generators were deliberately made with a recessed electrode socket in the handle so that only the glass electrode itself would be exposed. That design would allow only the harmless high-frequency current to pass out through the glass wall of the electrode, insulating the user from contact with the 117-volt power source.

Violet-ray-type high-frequency generators are still being manufactured by Electro-Technic Products, Inc., in Chicago. However, they are no longer intended for medical or therapeutic purposes. New uses include vacuum-leak detection, locating small holes in tank linings and coatings, and microdroplet liquid mixing (as in blood testing and analytical chemistry). Even a solid-state high-frequency unit that doesn't have vibrator contacts to wear out is offered. The new versions of the violet-ray generator have three-prong grounded line cords and are provided with a line-voltage isolating feature.

In addition to the usual high-voltage/high-frequency experiments that can be performed with these units, they are an excellent power source for corona-discharge photography (Kirlian electrophotography), as featured in the March issue of **Popular Electronics**. An added advantage is the absence of nasty electrical shocks that can occur when using ignition coils for the high-voltage power source.

A self-contained high-frequency unit—about 2 inches in diameter and 14 inches long and producing 50,000 volts at about 500,000 Hz—is available as their model S43504 Tesla coil for \$79.95 plus shipping from Electro-Technics' Fisher Scientific Education Materials Division, 4901 West LeMoyné Street, Chicago, IL 60651.

T.J.B.
Waukegan, IL

STILL A WINNER

I just finished reading "Experiments in Electrophotography" by Stanley A. Czarnik in the March issue of **Popular Electronics**. I experimented with that procedure back in 1979 for my high-school Senior Science Fair project. (I won first place in the physical sciences division and went on to place in the regionals.)

My apparatus for producing the corona discharge was very similar to Mr. Czarnik's, with a few exceptions. I was using an auto-ignition coil connected to a 6-volt lantern battery. The vibrating switch was an electric exhaust-fan motor driving a small cam that opened and closed a set of ignition points. I experimented with several types of electrodes, but for the actual photographs, I used Kodak Land film (used in the old Land-type cameras that developed film by turning a crank on the side of the camera). The film packs were made of metal, so I made a connection from the coil directly to the metal film pack (the subject was placed directly on the film, since the film itself acted as the dielectric). This method was clumsy in that the film pack had to be removed in the dark, photographed, and returned to the Land camera for developing (also in the dark). For all of that work, I got some very beautiful pictures of fingertips, assorted metal objects, and a "phantom leaf" effect.

I think the next time I visit my parents I'll rummage through the attic and see if I can find the equipment I used. I'd like to give the petri-dish method a try. It really is a very interesting and "energizing" project.

R.R.
Columbus Air Force Base, MS

MOBILE CHARGER PRICE CHANGE

In my article, "Mobile Battery Charger" (**Popular Electronics**, March 1990), the wrong price was printed for the kit. The correct price for the kit is \$13.00, not \$23.00.

Luther Stroud
P.O. Box 1951
Ft. Worth, TX 76101

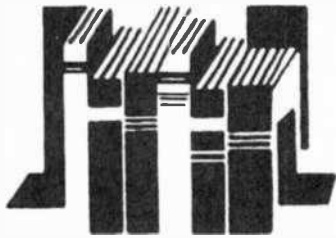

Electronics Library

To obtain additional information on the books and publications covered in this section from the publisher, please circle the item's code number on the Free Information Card

ENCYCLOPEDIA MACINTOSH

by Craig Danuloff
and Deke McClelland

Thousands of tips, little-known techniques, quick reference charts, resources, and product reviews—all intended to help readers get the most from their Macs—fill this comprehensive volume. For easy accessibility, entries are alphabetized under five major headings. "Systems Software & Utilities" provides detailed information on 40 topics, including customization, disks and drives, error codes, macros, security. Background and technical data are accompanied by practical tips and shortcuts targeted to novices, intermediate, and expert users. Hundreds of public-domain "shareware" utilities are reviewed. The "Applications" section explores all major Macintosh

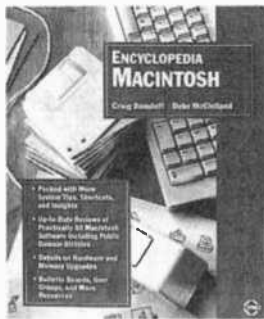

tosh application software with reviews that contrast the major applications, hints for effective software use, and complete quick-reference keyboard charts for every major Macintosh application.

Individual components—the CPU, desk drives, mice, monitors, and more—fall under the "Hardware" heading, where explanations are provided of what each part does, how it works, and when it is needed. Along with technical charts and diagrams, a detailed comparison of different Macintosh models and do-it-yourself instructions for installing additional memory and perform-

ing other upgrades are included. The "Resource" section contains lists of additional information sources, such as books, magazines, user groups, and bulletin boards, as well as vendor information. A comprehensive "Glossary" rounds out the book.

Encyclopedia Macintosh is available for \$24.95 from Sybex Inc., 2021 Challenger Drive, Number 100, Alameda, CA 94501.

CIRCLE 90 ON FREE INFORMATION CARD

VENTURA PUBLISHER: A Creative Approach

by Elizabeth McClure

By providing a natural sequence of exercises and building upon each task as it is learned, this book lets readers progress at their own pace to the level of desktop-publishing proficiency that they require for their own purposes. With an emphasis on long-range document planning throughout the book, Ventura Publisher concepts and commands are presented in order of their actual use in the desktop-publishing process, allowing readers to gradually take control over every aspect of their publications—typographic styles, page layout, graphics, and printing.

Following an overview of system configuration and operation, the book demonstrates each step, including how to load text and picture files, create and change style sheets, format paragraphs, set font and type sizes, create and position graphics, use special effects, add tables, and print out finished documents. A tutorial reinforces each procedure. The book also includes information on using Ventura with popular CAD programs.

Ventura Publisher: A Creative Approach is available for \$17.95 from Tab Books Inc., Blue Ridge Summit, PA 17294-0850; Tel. 1-800-233-1128.

CIRCLE 98 ON FREE INFORMATION CARD

A CONCISE INTRODUCTION TO dBASE

by J. W. Penfold

The dBASE family of database programs dates all the way back to CP/M computers, with dBASE II, dBASE III, and III Plus, for today's IBM PC's and compatibles, as well as the recently released dBASE IV, are probably the best-known database programs for microcomputers. This book provides the reader with an overview of those programs, with quick startup the main goal.

Written for database users rather than programmers, it presents the fundamental information required to create and use a database. The basics are provided without a lot of details, to help the reader avoid getting bogged down when first starting out. The book explains in a straightforward mar-



ner what a database is and does, how to use dBASE to create and use a database. The differences between the various versions of dBASE are explained; all versions from the original dBASE II to the sophisticated dBASE IV are covered.

A Concise Introduction to dBASE (order No. BP263) is available for \$7.95 (including shipping and handling) from Electronic Technology Today, Inc., P.O. Box 240, Massapequa Park, NY 11762-0240.

CIRCLE 97 ON FREE INFORMATION CARD

TOOLS AND ACCESSORIES CATALOG

from Paladin Corporation

Paladin's complete line of West German-made tools and accessories is depicted in a 152-page, full-color catalog. The brochure contains product shots, application photos, and diagrams that explain the features and advantages of each product.

The catalog includes sections devoted to each of the following applications: electronic, production, screwdrivers, electrical-industrial, cable preparation, telecommunications, and connectors. A special section is devoted to new products, including insulated safety tools and power transmission tools. To help the user find the tools needed for each application, the catalog includes extensive cross-references.

The Tools and Accessories Catalog is free upon request from Paladin Corporation, 3543 Old Conejo Road, Suite 102, Newbury Park, CA 91320; Tel. 805-499-0318.

CIRCLE 92 ON FREE INFORMATION CARD

UNDERSTANDING AUDIO AND VIDEO

by Michael Riggs

A joint venture of Pioneer Electronics and Stereo Review magazine, this reference book examines the basic electronics and operating principles behind audio and video systems and components. The guide is intended for the enthusiast as well as the novice consumer, and covers units such as

compact-disc and laser-disc players, and surround-sound processors, as well as today's televisions, VCR's, and audio receivers.

Each chapter discusses product specifications and offers hints and tips for obtaining optimum performance from audio and video components. Easy-to-follow illustrations and diagrams supplement the text. The last chapter examines future technologies, including HDTV. Comparisons to current technologies are presented, along with a look at the impact the new technologies might have on the consumer-electronics market. A convenient appendix answers many commonly asked questions concerning audio/video equipment.

Understanding Audio and Video is available for \$5.95 through Pioneer retailers. For a source near you, contact Pioneer Electronics (USA) Inc., 2265 East 220th Street, P.O. Box 1720, Long Beach, CA 90801-1720.

CIRCLE 91 ON FREE INFORMATION CARD

APPLE IIc USER'S GUIDE

by Lon Poole

This adaptation of the author's popular *Apple II User's Guide* follows the same easy-to-use format to introduce readers to the computer and its common accessories, including external disk drives and printers. Readers can use the book to progress to whatever level of proficiency they require. For those who just want to get up and running as quickly as possible, the first three chapters provide all the basics—descriptions of the various components with explanations of what they do and how they work,

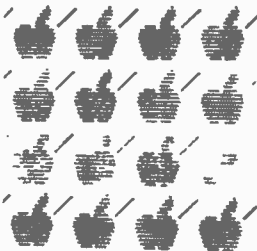

how to get a program started, how to use a printer, and how to use store-bought software for word processing, financial analysis, bookkeeping, education, and entertainment. For those who are interested in programming, the next eight chapters explore how to write programs using Applesoft, the version of BASIC that is used on the Apple IIc. One of the appendices contains a complete description of every com-

MORE THAN TIME



Most Accurate Clock by Heathkit

Discover the world's most accurate time piece plus a large assortment of other electronic products in your **FREE Heathkit Catalog**. It's filled with both kit and ready-to-use home theater components, weather stations and amateur radio products, along with kit

laptop computers and a wide variety of self-study courses for the novice or seasoned electronics enthusiast. Order your **FREE Heathkit Catalog** today. Time's a wasting!

1-800-44-HEATH
(1-800-444-3284)

Send to: Heath Company, Dept. 107-904
Benton Harbor, Michigan 49022

Name _____

Address _____

City _____

State _____

Zip _____

CIRCLE 19 ON FREE INFORMATION CARD

mand, statement, and function available in Applesoft BASIC, including disk commands. The book also covers how to use the Apple IIc's color graphics, sound features, the Apple IIc mouse, and ProDOS, Apple's newest operating system.

Apple IIc User's Guide costs \$18.95. It is available from Osborne/McGraw-Hill, 2600 Tenth Street, Berkeley, CA 94710.

CIRCLE 93 ON FREE INFORMATION CARD

INVENTING FOR FUN AND PROFIT

by Jacob Rabinow

Jacob Rabinow is a prolific inventor who holds patents on several mechanical and electrical devices, including the automatic regulation of watches and clocks formerly used in all American automobiles, the automatic letter-sorting machines used by the U.S. Postal Service, the magnetic-particle clutch, the "best-match" principle for reading machines, and many safety mechanisms for ordnance devices. Firmly believing in invention as a form of art, he brings the process to life in this light-hearted, non-technical book.

In his "biographies" of each of these inventions, Rabinow explains how they were conceived, how they were born, how they

"matured" and graduated from the Patent office, how they entered the technical world, and what ultimately became of them. In his book's opening chapter, the author poses intriguing questions about inventing: Are you an inventor? What triggers a new idea? How does it get developed? Should it be patented? Should it be sold or produced? He then proceeds to answer those questions, through anecdotes and witty real-life stories, in the remaining chapters. In the course, he touches on topics such as the merits of the patent system, the economics of invention, the nature of creativity, and the need for improvements in secondary and higher education.

Inventing for Fun and Profit is available for \$18.75 from San Francisco Press, Inc., Box 6800, San Francisco, CA 94101-6800.

CIRCLE 89 ON FREE INFORMATION CARD

COMPUTER INTERFACING: Connection to the Real World

by Martin Cripps

Although it was originally prepared to support advanced-undergraduate and post-graduate classes in computer interfacing, the informal, easily understood style of this
(Continued on page 12)

Join
the

Electronics and Control Engineers' Book Club®

TROUBLESHOOTING ELECTRONIC EQUIPMENT WITHOUT SERVICE DATA, Second Edition. By R.G. Middleton. 320 pp., illus. This indispensable new edition features all the information that made the first edition so successful, plus the latest developments in digital testing, phase checks, IC troubleshooting, and repair of VCRs, stereos, TVs, tape recorders, and much, much more.
585092-3 Pub. Pr., \$30.00 Club Pr., \$22.50

PRINTED CIRCUITS HANDBOOK, Third Edition. By C.F. Coombs, Jr. 960 pp., 556 illus. Here in one handy volume is all the information you need to design, manufacture, test, and repair printed wiring boards and assemblies. This new edition features ten all-new chapters, including three on SMT.
126/097 Pub. Pr., \$64.95 Club Pr., \$45.50

SOUND SYSTEM ENGINEERING, Second Edition. By D. Davis and C. Davis. 665 pp., illus. The definitive source for all professionals responsible for audio system design, covering everything from concert halls to virtually every oscillator in use today. Packed with proven strategies for solving design and engineering problems and cutting your clients' costs.
584657-8 Pub. Pr., \$39.95 Club Pr., \$31.50

MCGRAW-HILL ENCYCLOPEDIA OF ELECTRONICS AND COMPUTERS, Second Edition. S. Parker, Editor-in-Chief. 1,047 pp., 1,250 illus. Featuring 160 new and revised articles, this new edition treats the entire spectrum of applications, devices, systems, and theory in areas ranging from the flow of electricity to hardware, software, robotics, and IC fabrication.
454/99X Pub. Pr., \$79.50 Club Pr., \$54.95

COMMUNICATIONS RECEIVERS: Principles and Design. By Ulrich L. Rohde and T.T.N. Bucher. 608 pp., 402 illus. Everything you need to know if you design or work with communications receivers, from theory to practical design approaches. Coverage includes all types of receivers: shortwave, broadcast, radar, military, marine, aeronautical, and more.
535/701 Pub. Pr., \$64.95 Club Pr., \$44.50

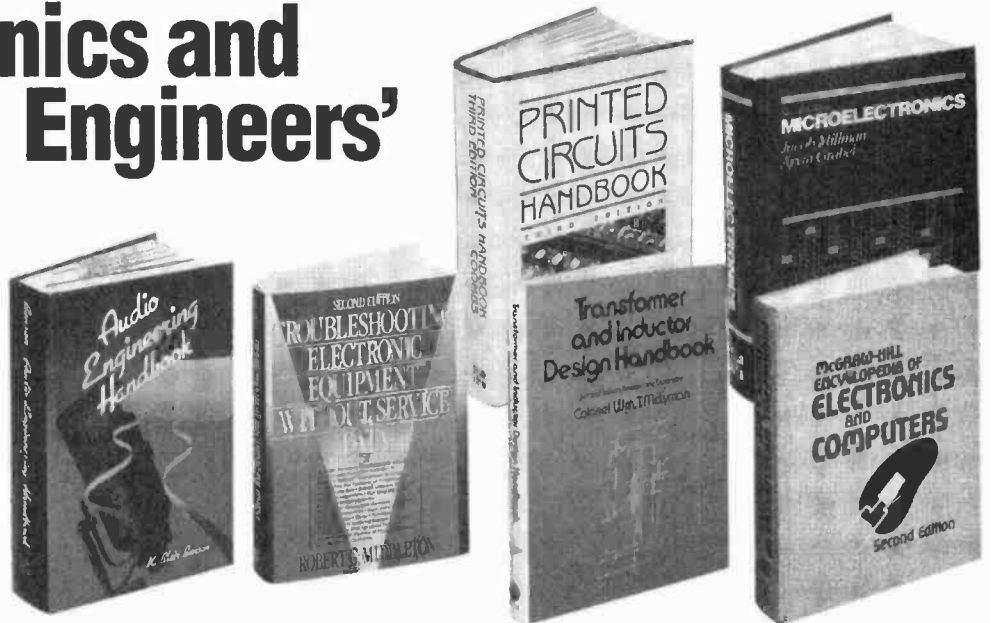

- your one source for engineering books from over 100 different publishers
- the latest and best information in your field
- discounts of up to 40% off publishers' list prices

New Members!
Take any one of these great professional books **\$289** for only as a premium with your first selection!

Spectacular values up to **\$199.50**

MOBILE CELLULAR TELECOMMUNICATIONS SYSTEMS. By W.C.Y. Lee. 442 pp., 215 illus. A to Z coverage of state-of-the-art cellular systems, from design to implementation and troubleshooting. Clearly explains spectrum efficiency, propagation models and prediction, interference treatment, and more.
370/303 Pub. Pr., \$62.95 Club Pr., \$44.50

TRANSFORMER AND INDUCTOR DESIGN HANDBOOK, Second Edition. By Col. W.T. McLyman. 440 pp., illus. All the information you need to design today's lighter, smaller transformers and inductors, without relying on out-moded approximation methods. In ready-reference tabular format, this new edition covers the latest equations in transformer and gapped design applications.
584646-2 Pub. Pr., \$55.00 Club Pr., \$38.50

MICROCOMPUTER TROUBLESHOOTING AND REPAIR. By J. G. Stephenson and B. Cahill. 354 pp., illus., softcover. This nuts-and-bolts guide provides expert tips, troubleshooting tools and shortcuts, and practical help on deciding if you really do have to bring it in to the shop. It also explains techniques for anticipating and defending against most common computer problems.
585106-7 Pub. Pr., \$24.95 Club Pr., \$18.95

MICROELECTRONICS, Second Ed. By J. Millman and A. Grabel. 1,001 pp., 646 illus. Takes you from the basics of semiconductor properties to an understanding of the operation of solid-state devices, and then to more advanced topics. Its up-to-date coverage, real-life examples, and practical data make this an ideal reference for the working engineer.
423/30X Pub. Pr., \$56.95 Club Pr., \$41.50

ENGINEERING MATHEMATICS HANDBOOK, Third Ed. By J. J. Tuma. 572 pp., illus. This best-selling handbook gives you the essential mathematical tools—formulas, definitions, theorems, tables, and models for computer programming — that you need for your day-to-day engineering calculations.
654/433 Pub. Pr., \$52.50 Club Pr., \$34.50

ENGINEERING FUNDAMENTALS FOR THE PROFESSIONAL ENGINEERS' EXAM, Third Ed. By L. M. Polentz. 432 pp., 170 illus. Features worked-out solutions and full explanations for all sample problems so you can learn how to solve them. It's a dependable way to prepare for the exam or a perfect on-the-job reference.
503/931 Pub. Pr., \$39.50 Club Pr., \$27.95

AUTOMATIC CONTROL SYSTEMS, Fifth Ed. By B. C. Kuo. 736 pp., illus. Provides an overview of automatic control systems, including in-depth coverage of classical control techniques, optimal control theory, and analog and digital control system design. This up-dated edition discusses the latest ideas on the use of computers to design control systems and as components of such systems.
583706-4 Pub. Pr., \$57.40 Club Pr., \$43.50

CIARCIA'S CIRCUIT CELLAR, Volume VII. By S. Ciarcia. 256 pp., 100 illus., softcover. More do-it-yourself circuits from the master—Steve Ciarcia. Step-by-step guidance on projects ranging from a gray-scale video digitizer and the Circuit Cellar AT Computer to parallel interfacing and the Neighborhood Strategic Defense Initiative.
109/699 Pub. Pr., \$19.95 Club Pr., \$15.95

THE COMPACT DISC: A Handbook of Theory and Use. By K. C. Pohlmann. 288 pp., illus. softcover. The most readable and comprehensive guide to CD technology offers clear descriptions of disc design and manufacturing . . . player circuitry . . . and comparisons of different types of players—all without complicated theoretical or mathematical discussions.
585096-6 Pub. Pr., \$29.95 Club Pr., \$22.50

PORTABLE ELECTRONICS DATA BOOK

360 pp., 6 x 9, illus., softcover 585390-6

A-to-Z coverage of all the essential facts, figures, and formulas you need, in a format that's easy to use and easy to carry. John Douglas-Young has filled this handy on-the-job companion with equations, algorithms, calculus formulas, and BASIC programs in areas ranging from alternating current and amplifiers to transducers and waveguides . . . and they're all yours **ABSOLUTELY FREE!**

A \$19.95 Value — Yours ABSOLUTELY FREE when you join!

BASIC TELEVISION AND VIDEO SYSTEMS, Fifth Ed. By B. Grob. 592 pp., illus. Provides the clearest picture of how television and video systems work, and what to do when they don't. Covers television receivers, VCR's, video cameras, and cable systems — all in readable, practical detail.
249/334 Pub. Pr., \$39.95 Club Pr., \$24.95

BUILD YOUR OWN UNIVERSAL COMPUTER INTERFACE. By B. Chubb. 309 pp., illus., softcover. Guiding you from theory to step-by-step assembly instructions, this lively manual shows you how to construct a computer interface and hook it up to virtually any IBM or IBM compatible personal computer, including the XT, XT-286, AT, and System/2 Model 30. 585080-X Pub. Pr., \$19.95 Club Pr., \$15.95

HANDBOOK OF ELECTRICAL NOISE MEASUREMENT AND TECHNOLOGY, Second Ed. By C.A. Vergers. 440 pp. 213 illus. Provides answers to all your questions about noise origins, causes, effects. Also shows you how to predict and measure noise, and how to design low-noise circuits.
583947-4 Pub. Pr., \$39.95 Club Pr., \$29.95

SWITCHGEAR AND CONTROL HANDBOOK, Second Ed. Edited by R. W. Smeaton. 1,056 pp., 789 illus. The only handbook that treats all aspects of switchgear control, including design, applications, safety, and maintenance. Updated to reflect the changes brought about by the use of computers, solid-state devices, and programmable controls.
584/494 Pub. Pr., \$83.00 Club Pr., \$56.95

ANTENNA APPLICATIONS REFERENCE GUIDE. Edited by R. C. Johnson and H. Jasik. 496 pp., 368 illus. and tables. Covers the major applications of antenna technology in all areas of communications and their design methods. Emphasizes important new applications such as earth station, satellite, seeker, aircraft, and microwave-relay antennas.
322/848 Pub. Pr., \$59.95 Club Pr., \$42.50

RADIO HANDBOOK, Twenty-Third Ed. Edited by W. I. Orr. 667 pp., 1,073 illus. and tables. The latest edition of the most complete, current resource on radio technology and its applications. Expert contributors show you how to select, design, build, test and operate all kinds of equipment.
584638-1 Pub. Pr., \$29.95 Club Pr., \$23.95

AUDIO ENGINEERING HANDBOOK. Edited by K. B. Benson. 1056 pp., 722 illus. The ideal on-the-job reference for professionals who design, operate, and service audio equipment. It's a one-volume source of fundamental audio acoustics engineering information and practical how-to source book covering generation, transmission, storage, and reproduction of the audio signal.
047/774 Pub. Pr., \$83.50 Club Pr., \$59.95

Be sure to consider these important titles as well!

BUCHSBAUM'S COMPLETE HANDBOOK OF PRACTICAL ELECTRONIC REFERENCE DATA, Third Ed. By W.H. Buchsbaum. 583888-X Pub. Pr., \$34.95 Club Pr., \$26.50

ON-LINE ELECTRICAL TROUBLE-SHOOTING. By L. Lundquist. 391/106 Pub. Pr., \$34.50 Club Pr., \$26.50

ESSENTIAL CIRCUITS REFERENCE GUIDE. By J. Markus & C. Weston. 404/823 Pub. Pr., \$59.95 Club Pr., \$47.50

INTRODUCING PC-DOS AND MS-DOS, Second Ed. By T. Sheldon. 585/651 Pub. Pr., \$28.95 Club Pr., \$19.95

HANDBOOK OF ELECTRONICS CALCULATIONS FOR ENGINEERS AND TECHNICIANS, Second Ed. Edited by M. Kaufman & A. H. Seldman. 335/281 Pub. Pr., \$49.95 Club Pr., \$37.50

INTRODUCTION TO DIGITAL SIGNAL PROCESSING. By J. G. Proakis and D. G. Manolakis. 584954-2 Pub. Pr., \$50.00 Club Pr., \$37.50

CIRCUIT DESIGN FOR ELECTRONIC INSTRUMENTATION: Analog and Digital Devices from Sensor to Display, Second Ed. By D. Wobshall. 712/31X Pub. Pr., \$52.95 Club Pr., \$36.95

BOB MIDDLETON'S HANDBOOK OF ELECTRONIC TIME-SAVERS AND SHORTCUTS. By R.G. Middleton. 583865-6 Pub. Pr., \$29.95 Club Pr., \$22.50

DIGITAL AND MICROPROCESSOR TECHNOLOGY, Second Ed. By P. J. O'Connor. 585184-9 Pub. Pr., \$42.00 Club Pr., \$33.50

OP-AMP HANDBOOK, Second Ed. By F.W. Hughes. 583851-3 Pub. Pr., \$39.00 Club Pr., \$27.50



FOR FASTER SERVICE IN ENROLLING CALL TOLL-FREE 1-800-2-MCGRAW

MAIL THIS COUPON TODAY

**McGraw-Hill Book Clubs
Electronics and Control Engineers'
Book Club®**
P.O. Box 582, Hightstown, NJ 08520-9959

Please enroll me as a member and send me the two books indicated, plus the PORTABLE ELECTRONICS DATA BOOK. I am to receive one book for just \$2.89, the other at the discounted member's price, plus local tax, shipping and handling charges. I agree to purchase a minimum of one additional book during my first year of membership as outlined under the Club plan described in this ad. I understand that a shipping and handling charge is added to all shipments.

Your FREE Data Book

585390-6

Write Code No. of the \$2.89 selection here

Write Code No. for the First selection here

Signature _____

Name _____

Address/Apt. # _____

City _____

State _____ Zip _____

This order subject to acceptance by McGraw-Hill. All prices subject to change without notice. Offer good only to new members. Foreign member acceptance subject to special conditions.

ECGB-035

Here's how the Club works to serve YOU:

■ IMPORTANT INFORMATION... WE MAKE IT EASY TO GET!

In our rapidly changing world, those who perform best are those who are best informed. Designed exclusively for the practicing engineer, the Electronics and Control Engineers' Book Club provides you with information that is relevant, reliable, and specific enough to meet your needs. Each Club bulletin comes your way 14-16 times a year and offers you more than 30 books to choose from — the best and newest books from all publishers!

■ DEPENDABLE SERVICE... WE'RE HERE TO HELP!

Whether you want information about a book or have a question about your membership, our qualified staff is here to help. Just call us toll-free or write to our Customer Service. We also make sure you get only the books you want. All you do is simply tell us your choice on the Reply Card and return it to us by the specified date. If you want the Main Selection, do nothing — it will be sent to you automatically. (A small shipping and handling charge is added to each shipment.)

■ CLUB CONVENIENCE... WE DO THE WORK!

Beyond the benefit of timely information, Club membership offers many other benefits. For example, you get a wide choice of books that cannot be matched by any bookstore — anywhere. And all your books are conveniently delivered right to your door. You also get the luxury of 10 full days to decide whether you want the Main Selection. If you should ever receive a Main Selection you don't want because the Club bulletin came late, just return it for credit at our expense.

■ SUBSTANTIAL SAVINGS... AND A BONUS PROGRAM TOO!

In keeping with our goal to provide you with the best information at the greatest possible savings, you will enjoy substantial discounts — up to 40%! — on every book you buy. Plus, you're automatically eligible for our Bonus Book Plan which allows you savings up to 70% on a wide selection of books.

■ EASY MEMBERSHIP TERMS... IT'S WORTHWHILE TO BELONG!

Your only obligation is to purchase one more book — at a handsome discount — during the next 12 months, after which you enjoy the benefits of membership with no further obligation. Either you or the Club may cancel membership anytime thereafter.

Electronics Library

(Continued from page 7)

book should make it useful to industrial- and home-computer users who want to progress beyond programming. It is primarily concerned with the structure and design of computer interfaces. Particular emphasis is placed on connecting to the real world, rather than to peripherals, since real-time

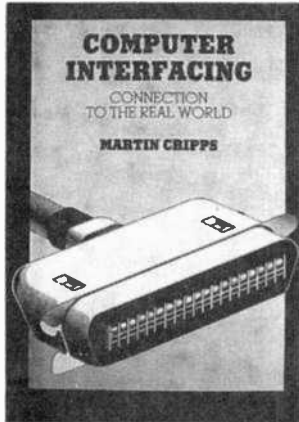

and on-line control and logging systems are among the most difficult systems to implement. The use and techniques of programmable logic are covered extensively, as are the difficulties of integrating hardware and software, the problems encountered in testing, and the environmental restrictions that are likely to stop designs from operating correctly. The book presents practical solutions for overcoming all of those commonly encountered difficulties.

Computer Interfacing: Connecting to the Real World costs \$24.95 and is available from Routledge, Chapman & Hall, 29 West 35th Street, New York, NY 10001; Tel. 212-244-3336.

CIRCLE 88 ON FREE INFORMATION CARD

SOLID STATE ELECTRONIC DEVICES: Third Edition

by Ben G. Streetman

This book is written to provide an introduction to solid-state electronic devices for undergraduate electrical engineers and other students, as well as for practicing engineers and scientists who want to update their understanding of modern electronics. It provides a thorough understanding of existing devices, and helps the reader develop the skills needed to apply that knowledge and evaluate new devices and applications by reading the current literature. With the latter goal in mind, the text introduces most of the commonly used semiconductor terms and concepts, and relates them to a broad range of devices.

To help the reader understand junctions and transistors, the book explores the basics of semiconductor materials and conduction in solids. It also offers detailed coverage of quantum concepts; drift, diffusion, and recombination of charge carriers; the p-n junction and its applications in junction diodes, tunnel diodes, photodiodes, and LED's; and principles of transistor operation, including bipolar-junction and field-effect varieties. The book explains how transistors are employed in integrated circuits, and discusses applications of the theory of junctions and conduction processes to lasers, switching devices, and microwave devices. Numerous examples and problems help the reader understand the material presented.

Solid State Electronic Devices: Third Edition is available in hardcover for \$54.00 from Prentice-Hall, Englewood Cliffs, NJ 07632.

CIRCLE 99 ON FREE INFORMATION CARD

COIL CATALOG

from Automatic Coil Corp.

Including 655 military and commercial coils plus RF chokes, catalog AC-36 is a detailed, 15-page coil-specification guide for five popular military radios—models AN/PRC 104, AN/PRC 77, AN/VRC-12, AN/GRC-106, and WRC-1. The catalog identifies the Signal Corps module numbers used in each radio, and also identifies all coils, toroids, and filters used by Signal Corps part number and by Automatic Coil's cross-reference number. Photographs of each radio and of all coil types are shown.

The catalog's commercial section is devoted to standardized toroidal inductors



and encapsulated toroidal RF chokes. Toroidal inductors are used in EMI and RFI filters, power supplies, switching regulators, Triac and SCR controls, transformers, and loading coils. They make excellent inductors because their magnetic field is almost

wholly confined within the core and the flux density is essentially uniform over the entire magnetic path.

The Coil Catalog #AC-36 is free upon request from Automatic Coil Corp., 3545 N.W. 71st Street, Miami, FL 33147.

CIRCLE 78 ON FREE INFORMATION CARD

ELECTRICITY AND ELECTRONICS: A Survey, Second Edition

by Dale R. Patrick and Stephen W. Fardo

This introductory textbook takes the "big-picture" or "systems" approach to key concepts of electricity and electronics. In a basic, easy-to-understand way, the book covers many applications, testing procedures, and operational aspects of equipment and devices. The book is divided into two sections: The first provides extensive coverage of the basics of electricity and the second is an overview of electronics.

To help the reader understand the material, definitions of important terms are presented at the beginning of each chapter and a review section appears at the end of each chapter. Suggested student activities, which are low-cost projects, emphasize practical applications and problem-solving techniques. The use of mathematics is kept to an absolute minimum; when used, it is accompanied by clear discussions, applications, and illustrations.

Electricity and Electronics: A Survey (Second Edition) is available in hardcover for \$42.00 from Prentice-Hall, Englewood Cliffs, NJ 07632.

CIRCLE 99 ON FREE INFORMATION CARD

A FLOPPY DISK PRIMER

from Maxell Corporation

With personal computers playing increasingly important roles in our lives at work and at home, floppy disks continue to play a vital role in data storage. Disk reliability is a major consideration, as is knowing how to use and store them properly. Maxell's booklet fully explains magnetic-recording techniques and floppy-disk applications. The handbook provides an overview of the computer, its principles, operation, capabilities, and terminology; the process of magnetic recording; an in-depth look at the structure of floppy disks; the processes of choosing, formatting, and using floppies; and a look at the future of magnetic-recording technology. In addition, it provides valuable tips on the proper use of floppy disks, advising users always to make a back-up copy of the data recorded on a disk, keep disks in their protective jackets, and store disks upright in their boxes.

A Floppy Disk Primer is free upon request. Write to Maxell Floppy Disk Handbook, Maxell Corporation of America, P.O. Box CN4649, Trenton, NJ 08650.

CIRCLE 87 ON FREE INFORMATION CARD

PVC TUBING

from Panduit Corp.

Bulletin IG-PVCT describes Panduit's line of extruded PVC tubing for 300- and 600-volt applications. Made of insulation-grade PVC, the all-purpose, flexible, non-shrinkable tubing is designed to insulate and protect lead wires, wire-harness assemblies, solder joints, and components in electrical/electronic assemblies. The bulletin de-

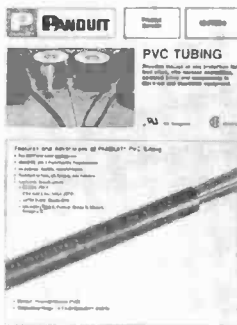

scribes all 39 stock sizes of the tubing, ranging from 0.020 to 2.5 inches with wall thicknesses from 0.012 to 0.077 inches depending on size.

PVC Tubing Bulletin IG-PVCT is free. Contact Product Manager, Insulation/Abrasion Protection Products, Panduit Corporation, 17301 Ridgeland Avenue, Tinley Park, IL 60477-0981; Tel. 1-800-777-3300.

CIRCLE 86 ON FREE INFORMATION CARD

DVORAK'S GUIDE TO PC TELECOMMUNICATIONS

by John C. Dvorak and Nick Anis

Designed to simplify the world of telecommunications, this information package consists of a more-than-1000 page book with two diskettes. Together, they provide reliable, easy-to-use utilities; interactive tutorials; communications software; and special discounts from major on-line services—more than \$1500 worth of software and services. The package covers all IBM PC's and compatibles and has special sections on the Apple Macintosh and public-domain shareware.

The book explains all about modems, how they work, and how to get the most out of them. It explains how to set up an office at home, and provides helpful tips for linking two remote computers. It explores each of

the major electronic-mail systems and bulletin board services, focusing on how they can work for you. The most popular telecommunications packages are reviewed, along with on-line services and even obscure databases. The book also includes an assortment of mail-in "coupons" for discounts on telecommunications-related products and services.

The two 5¼-inch disks work with the book to provide a total learning experience. The first disk is a "Modem Tutor," that provides a make-believe experience of using on-line

services and bulletin boards in a slide-show-like presentation. The second disk, "Telix SE," is a comprehensive and intuitive terminal program with an instant one-step set-up. It offers many built-in protocols and features, and includes important utilities.

Dvorak's Guide to PC Telecommunications is available for \$49.00 from Osborne/McGraw-Hill, 2600 Tenth Street, Berkeley, CA 94710-9938.

CIRCLE 93 ON FREE INFORMATION CARD

(Continued on page 14)

HITACHI SCOPES AT DISCOUNT PRICES

Digital Storage Scopes V-6025 20MS/S 50MHz Bandwidth 2K Word Memory Capacity \$2349.00 Advanced storage functions create new dimensions in scope such as one shot observation, flicker free display, bright display for even high speed event, trace observation for low speed event, hard copy by plotter and data output to computer.		V-212 \$425 List \$595 Save \$170 DC to 20MHz Dual Channel	V-1060 \$1,359 List \$1595	<ul style="list-style-type: none"> • DC to 100MHz • Dual Channel • Delayed Sweep • CRT Readout • Sweep Time • Autoranging • Trigger Lock • 2mV Sensitivity
V-422 40MHz V-423 40MHz V-425 40MHz V-660 60MHz V-1065 100MHz V-1100A 100MHz V-1150 150MHz	D.T., 1mV sens. D.T., 1mV sens. Delayed Sweep, DC Offset, Alt Mag D.T., 1mV sens. DC Offset, CRT Readout, Cursor Meas D.T., 2mV sens. Delayed Sweep, CRT Readout D.T., 2mV sens. Delayed Sweep, CRT Readout, Cursor Meas. 1mV sens. Delayed Sweep, CRT Readout, DVM, Counter 1mV sens. Delayed Sweep, Cursor Meas, DVM, Counter	LIST PRICE SAVE \$940 \$740 \$200 \$1,025 \$825 \$200 \$1,070 \$849 \$221 \$1,295 \$1,145 \$150 \$1,895 \$1,670 \$225 \$2,450 \$2,095 \$355 \$3,100 \$2,675 \$425		

ELENCO PRODUCTS AT DISCOUNT PRICES

20MHz Dual Trace Oscilloscope MO-1251 \$375 • 6" CRT • Built in component tester • TV Sync	FREE DMM with purchase of ANY SCOPE SCOPE PROBES P-1 65MHz, 1x, 10x \$19.95 P-2 100MHz, 1x, 10x \$23.95	35MHz Dual Trace Oscilloscope MO-1252 \$495 • High luminance 6" CRT • 1mV Sensitivity • 6KV Acceleration Voltage • 10ns Rise Time • X-Y Operation + Z Axis • Delayed Triggering Sweep
--	---	--

Top quality scopes at a very reasonable price. Contains all desired features. Two 3x, 10x probes, diagrams and manual. Two year guarantee.

PRICE BREAKTHRU on Auto Ranging DMMs MDM-1180 \$24.95 MDM-1181 \$27.95 MDM-1182 \$29.95 • 3 1/2 LCD Display • 27 Functions • Auto Manual Ranges • Audio Continuity • Data Hold (MDM-1182) • .1% Accuracy (MDM-1181)	True RMS 4 1/2 Digit Multimeter M-7000 \$135 .05% DC Accuracy 1% Resistance with Freq. Counter and deluxe case	Multimeter with Capacitance and Transistor Tester CM-1550 \$58.95 Reads Volts, Ohms, Current, Capacitors, Transistors and Diodes with case	Digital Capacitance Meter CM-1550 \$58.95 9 Ranges 1pf-20,000ufd .5% basic acy Zero control with case	Digital LCR Meter LC-1801 \$125 Measures Caps. 1uH-200H Caps. 10f-200uf Res. 0.1-20M
Bench DMMs M-3500 \$125 3 1/2 digit 4 1/2 digit .1% acy .05% acy	AC Current Meter ST-101C \$69.95 1000 Amps Data Hold 8 Functions Deluxe Case	Solderless Breadboards 9436 SHOWN 9430 1,100 pins \$15 9434 2,170 pins \$25 9436 2,860 pins \$35 All have color coded posts	AC Clamp-On Current Adapter ST-265 \$25.00 0-1000A AC Works with most DMM	

Soldering Station SL-30 \$99 Temperature Controlled Digital display Temp range 300F-900F Grounded tip Overheat protect	Color Convergence Generator SG-200 \$69.95 Finest in the industry 10 rock steady patterns	10MHz Oscilloscope S-3000 \$275 10MHz Color AC Triggered Sweep Calibrated Vert & Hor Reads Volts & Freq	Temperature Probe M-110CF \$29.95 Semiconductor type Range 58F-302F Fits most digital multimeters	Autoranging DMM M-5000 \$45 9 Functions Memory and Data hold 1/2 % basic acc 3 1/2 digit LCD
--	--	---	---	---

Wide Band Signal Generators SQ-9000 \$129 RF Freq 100K-450MHz AM Modulation of 1KHz Variable RF output SQ-9500 with Digital Display and 150MHz built-in Freq Ctr \$249	TRIPLE POWER SUPPLY XP-620 Assembled \$65 Kit \$45 2 to 15V at 1A, 2 to 15V at 1A (for 4 to 30V at 1A) and 5V at 3A Contains all the desired features for doing experiments. Features short circuit protection all supplies	Function Generator Blox \$28.95 #9600 Provides sine, 1/2 sine, wave from 1Hz to 1MHz, AM or FM capability	Decade Blox #9610 or #9620 \$18.95 #9610 Resistor Blox #7 ohms to 1M & 100K pot #9620 Capacitor Blox #7pf to 10Mfd
--	--	--	---

Digital Triple Power Supply XP-765 \$249 0-20V at 1A 0-20V at 1A 5V at 5A Fully Regulated, Short circuit protected with 2 Limit Cont., 3 Separate supplies XP-660 with Analog Meters \$175	Quad Power Supply XP-580 \$59.95 2-20V at 2A 12V at 1A 5V at 3A 5V at 5A Fully regulated and short circuit protected XP-575 without meters \$39.95	LEARN TO BUILD AND PROGRAM COMPUTERS WITH THIS KIT! INCLUDES: All Parts, Assembly and Lesson Manual MODEL MM-8000 \$129.00 Starting from scratch you build a complete system. Our Micro-Master trainer teaches you to write into RAM, ROMS and run a 6805 microprocessor, which uses similar machine language as IBM PC. You write the initial instructions to tell the 6805 processor to get started and store these instructions in permanent memory in the 2816 EPROM. Teaches you all about input and output ports, computer buses. Build your own keyboard and learn how to scan keyboard and display. No previous computer knowledge required. Simple easy to understand instruction teaches you to write in machine language.
---	--	---

Four-Function Frequency Counters F-100 120MH \$179 F-1000 1.20H \$259 Frequency, Period, Totalize, Self Check with High Stabilized Crystal Oven Oscillator, 8 digit LED display	GF-8016 Function Generator with Freq. Counter \$249 sine, Square, Triangle Pulse, Ramp, 2 to 2MHz Freq Counter, 1-10MHz GF-8015 without Freq. Meter \$179
---	---

WE WILL NOT BE UNDERSOLD!
 UPS Shipping: 48 States 5% (\$10 Max) IL Res., 7% Tax

C & S SALES INC.
 1245 Rosewood, Deerfield, IL 60015
 (800) 292-7711 (708) 541-0710

15 Day Money Back Guarantee
2 Year Warranty
WRITE FOR FREE CATALOG

CIRCLE 9 ON FREE INFORMATION CARD

Electronics Library

(Continued from page 13)

NIGHT SIGNALS

by Cynthia Wall, KA7ITT

The American Radio Relay League (ARRL) has published a short novel about amateur-radio operators. The story features Marc and Kim, two teenagers whose "on the air" romance is the starting point for adventure. When Marc is injured in a hiking accident and stranded in the Oregon mountains, it is his ingenuity with radio gear and Kim's determination—plus the help of local search



and rescue agencies and the Oregon National Guard—that lead to his rescue.

Night Signals costs \$5.00 plus \$2.50 shipping and handling (\$3.50 for UPS) from ARRL, 225 Main Street, Newington, CT, 06111.

CIRCLE 76 ON FREE INFORMATION CARD

THE TECHNOLOGY STORE: 1990 CATALOG

from Radio Shack

Offering 18 pages filled with everything the electronics hobbyist, amateur-radio enthusiast, and general electronics consumer could need, Radio Shack's 1990 catalog includes several new items. Three new Realistic camcorders offer features such as hi-fi sound and "pro" editing, and new VCR's include a four-head, MTS-stereo model with on-screen programming. There are new items, as well as old favorites, in most product categories. The catalog includes selections of radios, antennas, scanners, audio and video equipment, computers and peripherals, breadboards, electrical components, home-office supplies, metal detectors, marine radios, CB's, batteries, weather-radio receivers, wire and cables, radio-controlled toys, kits, security systems, radar detectors, and much more.

Radio Shack: *The Technology Store 1990*

Catalog #446 is available at local Radio Shack Stores.

CIRCLE 85 ON FREE INFORMATION CARD

PRECISION WEATHER INSTRUMENTS

from Digitar

Until recently, professional-quality weather stations were bulky, difficult to operate, and expensive. By applying microprocessor technology, Digitar has created personal weather stations that are accurate, easy to use, and affordable for use in homes, offices, schools, or farms. The Weather Pro offers outside temperature, wind speed, wind direction, time, and more. The Weather Data adds to those features inside temperature and five alarms. The Weather Master also adds barometric pressure, altitude with alarm, and elapsed time. The PCW Computer Weather Station includes all of those features and functions (except altitude) and, with the optional PCW Expanded Software, can store and graph months of weather history. The catalog also includes accessories, such as mounting options, extension cables, power options, an anemometer, and a rain collector.

The Precision Weather Instruments catalog is free upon request from Digitar, 3465 Diablo Avenue, Hayward, CA 94545; Tel. 415-732-7814.

CIRCLE 84 ON FREE INFORMATION CARD

THE XT-AT HANDBOOK for Engineers, Programmers, and Other Serious PC/XT and PC/AT Users

by Choisser & Foster

The handbook provides hard-to-find information in a convenient, well-organized form in a compact booklet. This updated version has been expanded to include additional diagnostic error codes, more cable-conector descriptions, an expanded description of beep codes, and a CPU summary table. Other new sections include descriptions of the disk-drive and power-supply cables, line-drawing screen codes, and library commands, and explain how the AT Keyboard Controller is used for I/O. The original material includes memory and I/O maps, Bios data-area descriptions and entry points, hard-disk-drive types, and handy summaries for DOS and programming commands. Two sections explore the bus connector, covering both the mechanical layout and the electronic definition of each bus signal.

The XT-AT Handbook for Engineers, Programmers, and Other Serious PC/XT and PC/AT Users costs \$9.95 for single copies, and \$5.00 each for quantities of five or more. It is available from Annabooks, 12145 Alta Carmel Court, Suite 250, San Diego, CA 92128; Tel. 800-462-1042 (619-271-0061 in CA).

CIRCLE 83 ON FREE INFORMATION CARD

Protel Easytrax®

Outstanding value in
Printed Circuit Board/CAD

Protel Easytrax is a new, low-cost design package for PC and Macintosh users that includes everything required to produce professional quality Printed Circuit Board artwork.

Our easy-to-learn menu-driven design system breaks the 'expert barrier' - you'll be designing in minutes, not hours. Our comprehensive tutorials guide you through the program's extensive features that take the tedium out of board layout.

When we say professional - we mean through-hole component boards of up to 32 x 32 inches with 6 signal layers plus ground and power planes. A fully independent print/plot program is included which supports standard plotters, dot matrix and laser printers, Gerber® photoplotting and NIC drill tapes.

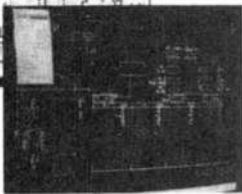

ONLY \$395

Easytrax can be run on
your PC or Mac!

CALL TOLL FREE (800) 544-4186

for complete specs and FREE evaluation disks.

50 AIRPORT PARKWAY, SAN JOSE, CA 95110, USA (408) 437-7771, FAX (408) 437-4913



Employers

Willing workers available now at as little as 1/2 your usual cost.

This is your chance to get help you've needed, but thought you couldn't afford.

No business too large or too small. Call your private industry council or write National Alliance of Business, P.O. Box 7207, Washington, D.C. 20044



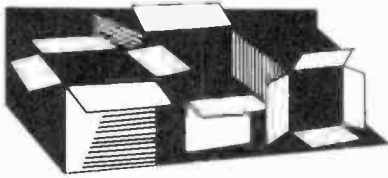

New Products

To obtain additional information on new products covered in this section from the manufacturer, please circle the item's code number on the Free Information Card

LINEAR AMPLIFIER

Using two 3-500Z transmitting tubes, the Ameritron AL-82 delivers full legal power on all modes. The linear amplifier features dual illuminated meters. The grid-current meter gives a constant reading of grid current, which is the most reliable indicator of overall amplifier performance. The multimeter displays plate voltage, plate current, peak RF-power output, and drive power/ALC. An 1800-watt hypersil transformer, rated for continuous commercial service, is stan-

dard, along with heavy-duty rectifiers in a full-wave bridge supply with computer-grade capacitors. Two bias settings allow either RTTY or CW operation at 1500 watts of continuous output at nearly 70% plate efficiency, or low-distortion, 1500-watt PEP SSB, SSTV, or AM output. The AL-82 covers 160, 80, 40 20, and 15 meters and gives 80% rated output on 12 and 17 meters. Upon presentation of a proper amateur license, the unit can be modified to also cover 10 meters.

Several features ensure safety and efficiency, including silver-plated tank components and a Pi-L tank circuit, which permits full impedance matching over the entire 160-meter band. The cooling system keeps the components and 3-500Z tubes safely below the manufacturer's ratings, and the



filament supply has inrush-current limiting. Complete shielding and by-passing helps prevent TVI and RFI at the high-power levels developed in the AL-82.

The AL-82 full-legal-power linear amplifier has a suggested retail price of \$1995.00. For further information, contact Ameritron, 921 Louisville Road, Starkville, MS 39759; Tel. 601-323-9715.

CIRCLE 101 ON FREE INFORMATION CARD

DIGITAL MULTIMETERS

Three digital multimeters from A. W. Sperry, the models DM-4100A, DM-4200A, and DM-4300A have the capacity to read up to nine functions on as many as 35 ranges. The 3½-digit, hand-held multimeters are designed for professionals at work in the field or the lab, yet their simplicity will appeal to hobbyists as well.

Several safety features are offered in each. Housed in shock-resistant ABS plastic, they can stand up to the stress of everyday work and are electrically insulated to protect the user from potential shock hazards. Electronic overload protection against accidental application of voltage to resistance and continuity circuits, combined with



EMINENCE



1-800-338-0531



18" EMINENCE WOOFER

MADE IN USA

100 oz. magnet, 3" voice coil. 250 watts RMS, 350 watts max. 8 ohm, 30 Hz resonant frequency, 22-2700 Hz response. Efficiency: 95 dB 1W/1M. Paper cone, treated accordion surround. Net weight: 29 lbs.



#290-200 \$98.90 (1-3) \$89.50 (4-up)

TITANIUM COMPOSITE TWEETER

Titanium is deposited on a polymer dome to combine the advantages of both hard and soft dome technologies. 8 ohm. Ferro fluid cooled voice coil. fs=1200 Hz. SPL = 90 dB 1W/1M. 50 watts RMS, 70 watts max. 4" round. Polydax part #DTW100T125



#270-047 \$27.50 (1-9) \$24.80 (10-up)

3-WAY 100W CROSSOVER

12 dB/octave rolloff. 800Hz, 5000Hz crossover points. 8 ohm. 100 watts RMS.



#260-210 \$12.50 (1-9) \$9.95 (10-up)

SPEAKER CONTROL PANEL

Panel with 50 watt L-pads for tweeter and midrange and built-in LED power meter. 5" x 2 1/2" 100 watt version available



#260-235 \$14.50 (1-5) \$12.90 (6-up)

12" POLY WOOFER

Super duty, 40 oz. magnet. 100 watts RMS, 145 watts max. 4 and 8 ohm compatible (6 ohm). 2" voice coil. fs = 25 Hz. QTS = .166. VAS = 10.8 cu ft. Response: 25-1500 Hz. Net weight: 9 lbs. Pioneer #A30GU40-51D



#290-125 \$36.80 (1-3) \$34.50 (4-up)

15" WOOFER

Original Sanyo woofer. Paper cone with vented dust cap and treated cloth surround. 12 oz. magnet. 60 watts RMS, 85 watts max. 8 ohm. Resonance: 26 Hz. Response: 25-2,500 Hz.



#291-155 \$23.80 (1-5) \$21.90 (6-up)

PIONEER HORN TWEETER

Mylar dome. 2.93 oz. barium ferrite magnet. 8 ohm. Response: 1800-20000 Hz. 35W RMS, 50W max. fs = 2000 Hz, SPL = 106 dB. Pioneer #AHE60-51F



#270-050 \$6.50 (1-9) \$5.90 (10-up)

12" SUB WOOFER

Dual voice coil sub woofer. 30 oz. magnet, 2" voice coils. 100 watts RMS, 145 watts max. fs = 25 Hz. 6 ohm (4 and 8 ohm compatible). SPL = 89 dB 1W/1M. Response: 25-700 Hz. QTS = .31, VAS = 10.3 cu. ft. Pioneer #A30GU30-SSD. Net weight: 6 lbs.



#290-145 \$39.80 (1-3) \$36.80 (4-up)

15" THRUSTER WOOFER

Thruster by Eminence. Made in USA. Poly foam surround, 56 oz. magnet. 2-1/2", 2 layer voice coil. 150 watts RMS, 210 watts max. 4 ohm. fs = 23.5 Hz, QTS = .33, VAS = 17.9 cu ft. SPL = 94.8 dB 1W/1M. Net weight: 15 lbs.



#290-180 \$43.50 (1-3) \$39.80 (4-up)

GRILL FRAME KIT

With this kit you can make speaker grill frames: up to 30" x 40". Kit includes 4 corner pieces, 2 "T" brackets, and 7 frame bars. Grill mounting kit included.

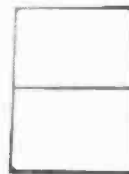

#260-333 \$8.50 (1-9) \$7.30 (10-up)



340 E. First St., Dayton, Ohio 45402
Local: 1-513-222-0173
FAX: 513-222-4644

* 15 day money back guarantee *\$15.00 minimum order *We accept Mastercard, Visa, Discover, and C.O.D. orders *24 hour shipping *Shipping charge = UPS chart rate *\$1.00 (\$3.00 minimum charge) *Hours: 8:30 am - 6:00 pm EST, Monday - Friday *Mail order customers, please call for shipping estimate on orders exceeding 5 lbs.

CIRCLE 6 ON FREE INFORMATION CARD



New Products



rugged construction, increase the DMMs' durability and reliability.

All three models are pocket-sized for one-handed operation and feature an instant continuity buzzer, 150-hour battery life, recessed input terminals for maximum safety, built-in tilt stands for bench-top use, and overload protection on all ranges. The 10-amps DC model DM-4100A is and the 10 amps AC/DC model DM-4200A provide battery testing; the DM-4200A and the 10 amps AC/DC DM-4300A provide H_{fe} transistor testing, and the DM-4300A provide capacitance testing as well.

The DM-4100A, DM-4200A, and DM-4300A digital multimeters have suggested retail prices of \$34.95, \$64.95, and \$79.95, respectively. For further information, contact A.W. Sperry Instruments Inc., 245 Marcus Boulevard, Hauppauge, NY 11788; Tel. 516-231-7050.

CIRCLE 102 ON FREE INFORMATION CARD

LAPTOP COMPUTER

Radio Shack has introduced the first Tandy-labeled, 80286-based laptop computer, the *Tandy 2800 HD*. Designed to provide power and portability for users who travel frequently and need the performance of an 80C286 microprocessor, the 2800 HD operates at selectable clock speeds of 12 or 6 MHz. It has one megabyte of internal memory, expandable to 2 MB; an internal 20-MB hard-disk drive; and one 3½-inch floppy-disk drive. The laptop can also serve as a desk-top system that can be stored conveniently out of the way when not in use.

The 2800 HD features a full-size (9½- × 8½-inch), back-lit, EGA-compatible LCD with 640 × 400 resolution; an enhanced 84-key keyboard with true 101-key emulation mode, and a standard keyboard 3.5-mm key stroke; and an "executive black" case with built-in handle. Additional features include a bidirectional parallel port, a serial communications port, connections for an

external EGA monitor and a 101-key keyboard, an internal modem slot, and an 80C287 coprocessor slot. The 2800 HD has a replaceable, rechargeable lead-acid battery that provides up to two hours of computing power. The battery can be charged inside or outside the system; an external



battery charger is included. Batteries can be exchanged easily without turning the system off.

The Tandy 2800 HD laptop computer has a suggested retail price of \$3,499.00. Options include an internal 2400-bps modem (\$199.95), a 1-MB memory upgrade (\$399.95), a replacement battery (\$49.95), and a choice of carrying cases. All items are available at Radio Shack Computer Centers, stores, and dealers nationwide. For additional information, contact Radio Shack, 700 One Tandy Center, Fort Worth, TX 76102.

CIRCLE 103 ON FREE INFORMATION CARD

CAMCORDER MICROPHONES

To expand the audio capabilities of and, ultimately, the uses for, camcorders, *Ambico* has added the V-0624, V-0626, and V-0630 (pictured) to its line of auxiliary microphones. The V-0624 "Shotgun" microphone plugs into the external mic input of the camcorder and can be easily switched between "wide" to capture a room full of sound and "tele" to focus in on a single voice. A wind screen eliminates unwanted noises, including the hum of the camcorder's autofocus and zoom motors. A mounting shoe is also included.

The V-0626 captures true stereo sound. It

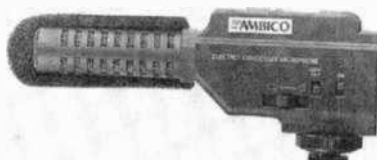

allows the user to record two channels at the same time for excellent voice and music reproduction on original recordings, as well as for adding a post-production soundtrack. The stereo microphone comes with a one-foot-long connecting cable for camcorder hookup, a 10-foot-long cable for tape deck hookup, and a mounting shoe.

The V-0630 "Zoom-Zoom" microphone offers complete flexibility with a unique variable zoom control that can slide from a "wide" pick-up range to a focused "tele" pickup range, stopping anywhere in between. The user can pin-point sound from every subject, no matter how close or far away they are. The six-inch microphone also has a "low cut" switch to help eliminate low-frequency noise, a built-in mounting shoe, a wind screen, and a battery-check LED indicator.

The V-0624 Shotgun and the V-0626 stereo microphone each cost \$79.95; the V-0630 Zoom-Zoom microphone costs \$99.95. For further information, contact Ambico, 50 Maple Street, P.O. Box 427, Norwood, NJ 07648-0427.

CIRCLE 104 ON FREE INFORMATION CARD

FREQUENCY COUNTER

Designed to provide an array of convenience features over an exceptionally broad frequency range, *Beckman Industrial's FC130A* microprocessor-controlled frequency counter measures frequency, period, and RPM from 0.01 Hz to 1.3 GHz. Standard features include very high resolution (as low as 10 nHz for a 1-Hz output); a bright, 8-digit LED readout with floating point and overflow; 10-mV input sensitivity, continuously variable gate-time selection; switchable AC or DC coupling; a built-in self-diagnosis routine; and a switchable



× 20 input attenuator and low pass filter. Suggested applications range from general audio to amateur and business radio, cordless-phone repairs, rotational measurement, and tuning transmitters in the keyed state. Suitable for both bench and field use, the FC130A is useful for research and development, troubleshooting and repair, and equipment calibration.

The instrument measures periods from 8 nanoseconds to 100 seconds, with at least seven digits displayed per second of gate time. The RPM feature allows the user to accurately measure from 0.6 to 7200-million RPM. Two separate channels are used; channel A covers frequency measurements from 0.01 Hz to 120 MHz and channel B covers 50 MHz to 1.3 GHz.

The FC130A frequency counter—complete with a power cord, operator's manual, two BNC-to-alligator-clip test cables, and a spare fuse—has a list price of \$595.00. For further information, contact Beckman Industrial Corporation, 3883 Ruffin Road, San Diego, CA 92123-1898; Tel. 619-495-3217.

CIRCLE 105 ON FREE INFORMATION CARD

POWER SUPPLIES

Beckman's MPS Series of DC power supplies consists of two models designed for bench-top applications, the education market, and research-and-development work. The models MPS60 and the MPS100 have dual output readings of ± 15 VDC at 2.0 amps and 30 VDC at 3.5 amps, respectively. Each unit offers full output power, providing full power handling indefinitely for higher reliability and longer life. Digital



metered displays provide simultaneous viewing of output voltage and current. That feature eliminates the need to measure the output to obtain an accurate output voltage or to limit the output current. In addition, the MPS100 features remote sensing, which regulates the output voltage at the load to compensate for test-lead voltage loss. Both models offer several protection features, including current limiting, reverse-polarity protection, and isolated outputs.

The MPS60 and MPS100 DC power supplies, each backed with a three-year warranty, cost \$395.00 and \$425.00, respectively.

tively. For additional information, contact Beckman Industrial Corporation, 3883 Ruffin Road, San Diego, CA 92123.

CIRCLE 106 ON FREE INFORMATION CARD

HALL-EFFECT ADAPTER AND PROBE

The SOAR model CTA-600 from CG Instruments is a Hall-effect clamp-on adapter and probe that measures up to 600 amps AC or DC and provides a linearized output of 1 mV per amp input to any analog or digital multimeter. The compact unit measures approximately 5½ x 1¾ x 1½ inches and weighs less than a pound.

The instrument exhibits an accuracy of $\pm 2\%$ of measured value (+2A) from 1–600 amps DC, and $\pm 3\%$ measured value (+0.2A) from 1–600 amps AC. It will accept a one-inch-diameter cable and has insulation capabilities to 2 kV DC. Output



meter readings require either a 100-mV DC voltage range or a 1-volt DC voltage range. The clamp-on adapter requires a 9-volt battery source; an LED low-battery indicator is built-in. The CTA-600 is equipped with standard banana-jack outputs. It has a minimum load impedance of 40 Kohm/V and an operating temperature range from 0–40°C.

The SOAR CTA-600, complete with cable and carrying case, costs \$109.95. For further information, contact CG Instruments Corp., 434 Windsor Park Drive, Dayton, OH 45459; Tel. 513-434-6952.

CIRCLE 107 ON FREE INFORMATION CARD

SPEAKER SWITCHERS/CONTROLS

Building on its popular SDS4 switcher, Sonance has created a family of five controls, each capable of operating four sets of stereo speakers with four specific applications. The streamlined units can be installed as part of a component audio or audio/video system or placed separately.

The basic SDS4 switcher is designed for connecting four pairs of speakers to a single amplifier, and operating any combination of speakers. A parallel source output makes it

PREMIER 386-20MHz AT COMPUTER WITH VGA COLOR MONITOR



- 80386 AT computer at 20 MHz.
- 40 MB—28 millisecond hard drive with 1:1 interleave controller.
- One MB RAM expandable to eight MB on motherboard.
- One 5-1/4" floppy disk drive.
- One 3-1/2" floppy disk drive.
- Eight expansion slots; six 16-bit, two 8-bit.
- One serial port and one parallel port.
- 80387 Intel™ or Weitek™ math coprocessor socket.
- 3 half-height exposed and two half-height internal drives.
- Real time clock calendar with battery backup.
- Included software: Dr. DOS installed.
- 101 AT style keyboard. • Full size AT case.
- VGA/8-bit video adapter displays up to 800 x 600 resolution. • Made in USA.
- One Year On-Site Warranty!
- Factory New! Factory Perfect!

VGA Color Monitor:

- 14" high resolution monitor.
- .31 dot pitch. • IBM compatible
- Resolution: 640 x 480.
- Analog input signal.

Due to a special arrangement, we were able to obtain a large inventory of these laptop computers. As a result, we can now offer them to you at HUGE SAVINGS!

Mfr. Sugg. Retail:
\$3,999.99

DAMARK PRICE:

\$1999.99

Item No. B-1982-139121
Insured Ship/Hand.: \$40.00

**FOR FASTEST
SERVICE CALL
TOLL FREE**

1-800-729-9000



DAMARK INTERNATIONAL, INC.
6707 Shingle Creek Parkway, Minneapolis, MN 55430
Customer Service • 612-566-4940

Please rush me: _____ Zenith Laptop Computer(s)
@ \$1999.99 each, plus \$40.00 s/h each.
Item No. B-1982-139121
MN res. add 6% sales tax.

Name _____
Address _____
City, State, Zip _____
 Check/MO VISA Master Card Discover
Card No _____
Exp. Date _____ Ph. # (____) _____
Signature _____

DELIVERY TO 48 U.S. STATES ONLY

New Products

easy to link two or more switchers if more speakers are used in the system. When using 8-ohm speakers, the SDS4 will present a load of not less than 4 ohms to the amplifier regardless of the number of speakers selected for play. It features automatic impedance protection when more than two pairs are activated.

Using the same basic circuitry, the SDS4-MP has a manually operated, user-defined protection circuit instead of automatic impedance protection. The SDS4-AB is designed for use when both multiple-source switching and multiple-speaker switching are desired. It adds two-source input control so that a TV, stereo system, or other source can be selected and routed to the speakers.

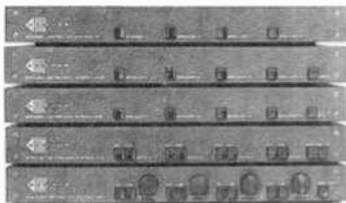

The SDS4X2 increases the SDS4's capabilities still further, allowing each of the four pairs of speakers to access either one of the sources independently, without regard to any of the other pairs of speakers connected. The most advanced control in the series is the SDS4-VC, offering source and volume selection to provide total output control of a distribution system with as many as four pairs of speakers. It adds to the SDS4's features volume controls, source selectors, and on-off switches for each pair of speakers. It also provides a user-defined, manual impedance-protection circuit.

The SDS4, SDS4-MP, SDS4-AB, SDS4X2, and SDS4-VC have suggested retail prices of \$210, \$180, \$240, \$300, and \$440, respectively. For further information, contact Sonance, 32992 Calle Perfecto, San Juan Capistrano, CA 92675; 800-582-7777.

CIRCLE 108 ON FREE INFORMATION CARD

POCKET THESAURUS/SPELL-CHECKER

Designed for home, school, or office use, Texas Instruments' model RR-2 hand-held thesaurus/spell-checker is the first of its kind to let users move from one meaning or synonym to other lists of completely different meanings and synonyms. Its "chaining" function lets the user start out with one word, choose the nearest synonym or meaning, and then request synonyms for that word. In the thesaurus mode, over

40,000 entry words will return more than 590,000 synonyms, along with their parts of speech and the correct breaks for hyphenation.

The spell-checker provides the correct spelling of more than 97,000 words by entering them phonetically. An endings key provides the user with a list showing the word with its most common endings, elimin-



inating confusion about how to pluralize, add suffixes, and change tenses. For crossword fans, missing letter and missing series keys are particularly handy.

Part of Texas Instruments' "Pocket Solutions" line, the RR-2 measures approximately 7 x 3½ x ½ inches and weighs about seven ounces. It runs on four AAA batteries (not included). It has a typewriter-style keyboard; control keys are grouped for convenience, and up and down arrow keys scroll through word lists quickly. The 15-character dot-matrix display has adjustable contrast, and includes messages and status indicators to show what function is being performed.

The RR-2 thesaurus/spell-checker has a suggested retail price of \$120.00. For further information, contact Texas Instruments, Consumer Relations, P.O. Box 53, Lubbock, TX 79408; Tel. 806-747-1882.

CIRCLE 109 ON FREE INFORMATION CARD

HOME SATELLITE RECEIVER

The Monterey 30, Chaparral Communications' most affordable home satellite receiver, offers a wide range of features. Those include digital or analog stereo, providing clear, sharp audio signals on every channel, and "AutoTrack" for automatic location of satellites during installation. Designed for ease of use, the

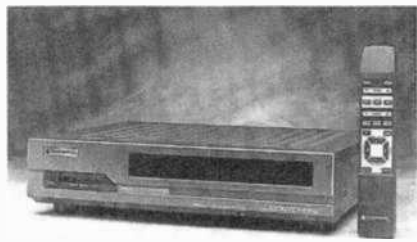

Monterey 30 features on-screen menus and a UHF remote control that let the user choose programs from anywhere in the house. One hundred channels can be custom programmed for fast and easy selection.

The Monterey 30 home satellite receiver has a suggested retail price of \$1,400. For further information, contact Chaparral Communications, 2450 North First Street, San Jose, CA 95131; Tel. 408-435-1530.

CIRCLE 110 ON FREE INFORMATION CARD

MULTIPLE DC OUTLET

The innovative MFJ-1112 multiple DC-power outlet saves both money and space by providing six pairs of heavy-duty binding posts for connecting accessories in one compact unit. It connects directly to any 12-volt DC power supply; RF bypassing prevents RF from the DC line from getting in the



power supply. The black aluminum cabinet measures just 13½ x 2¼ x 2½ inches and comes with a one-year guarantee.

The MFJ-1112 multiple DC outlet has a suggested list price of \$24.95. For additional information, contact MFJ Enterprises Inc., P.O. Box 494, Mississippi State, MS 39762; Tel. 601-323-5869 (800-647-1800 for orders).

CIRCLE 111 ON FREE INFORMATION CARD

PORTABLE DOT-MATRIX PRINTER

Its battery power, compact size (9½ x 6½ inches), and light weight (just over 2 pounds) make Acculex's DPP-500 a truly portable printer. Its 8-Kbyte buffer, push-button controls, and LED status indicators invite comparisons to larger, desk-top printers. The DPP-500 can be operated from either 110 VAC with a supplied 6-VDC wall adapter, or from the internal battery pack (which automatically recharges when operating with the wall adapter).

The DPP-500 is a benchtop 40-column printer with switch-selectable serial (RS-232) or Centronics (IBM) interface modes of communication. The serial port is completely user-configurable for baud rates up to 9600 and allows automatic line feed as well as regular or condensed text and a choice of eight different international character sets.

The printer supports the full 256 ASCII

(Continued on page 22)



Make good money in a challenging career as a security electronics technician— even start a profitable new business of your own

**All-new
from NRI!**

Now NRI trains you to be today's expert security electronics technician as you install and troubleshoot state-of-the-art security systems in your own home and auto.

Violent crime, theft, fire... they're facts of life in the U.S. today. But now there's good news, too. All across the nation people are fighting back with high-tech electronic security systems. In fact, Americans will spend over 17 billion dollars on security services and equipment by the year 1991.

For you, this new consumer demand for electronic security systems means even more good news. It means a breakthrough opportunity to get in on the ground floor of a booming new industry. Now, no matter where you live, you can start a high-paying career—even a business of your own—installing, servicing, and maintaining residential and commercial security systems.

Best of all, NRI's ready now to give you the hands-on security electronics training you need to get started fast.



You train with and keep a closed-circuit television camera, mount, and 9" monitor; state-of-the-art fire/intrusion alarm control panel with digital dialer; remote entry keypad; passive infrared motion detector; smoke detector; remote control auto alarm with motion detector; ignition disable relay, and siren; NRI Discovery Lab® for circuit demonstrations; and hand-held multimeter with 3 1/2 digit readout.

Right away, you get the skills you need to install and service all security systems NRI's at-home Security Electronics training gives you solid electronics know-how, plus a complete working knowledge of popular security devices in use today.

You learn how to install and service magnetic contacts and pressure mats... microwave, ultrasonic, and passive infrared detectors... personal identification systems and electronic listening devices... even central station alarm systems and today's most sophisticated fire warning equipment. But that's not all.

Your hands-on training includes state-of-the-art CCTV equipment plus home and auto electronic alarm systems you keep NRI gives you hands-on experience with today's newest, most popular security systems as you train with the professional closed-circuit television surveillance equipment and high-quality electronic home and auto alarm systems included in your course.

Step by step, you learn by doing... evaluating your own security needs, installing

complete electronic alarm systems in your own home and auto, testing and troubleshooting working alarm circuits. You actually safeguard your own property while gaining



Installing home security systems like this closed-circuit camera and monitor is just one way you can make money as a security electronics technician.

the expertise you need to move fast into an exciting career—even a business of your own—as today's expert security electronics technician.

Send for your FREE catalog today

For all the details about NRI's at-home Security Electronics training, send the coupon today. If the coupon is missing, write to NRI School of Electronics, McGraw-Hill Continuing Education Center, 4401 Connecticut Avenue, Washington, DC 20008.

NRI SCHOOL OF ELECTRONICS

McGraw-Hill Continuing Education Center
4401 Connecticut Avenue, Washington, DC 20008.

Check one catalog only

- | | | | |
|--|---|---|---|
| <input type="checkbox"/> Security Electronics | <input type="checkbox"/> Robotics | <input type="checkbox"/> Air Conditioning, Heating, and Refrigeration | <input type="checkbox"/> Small Engine Repair |
| <input type="checkbox"/> Computers and Microprocessors | <input type="checkbox"/> TV/Video/Audio Servicing | <input type="checkbox"/> Electrician | <input type="checkbox"/> Automotive Servicing |
| | <input type="checkbox"/> Basic Electronics | | <input type="checkbox"/> Locksmithing |

Name _____ Age _____

Address _____

City _____ State _____ Zip _____

Accredited Member National Home Study Council

For career courses approved under GI Bill check for details.

18-060



New Products

(Continued from page 18)

enhanced character/graphics set (both upper and lower case) and is completely dot-addressable for custom graphics applications. Its switch-selectable communication mode and built-in buffer allow it to be used for receiving data from computers, datalog-

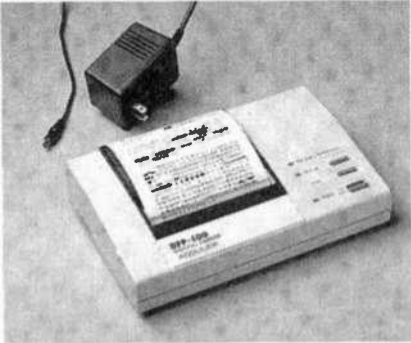

gers, digital panel meters, and other controllers/displays that support data transmission. A built-in paper-feed switch makes it easy to replace paper.

The DPP-500 portable serial/Centronics printer has a list price of \$442.00. For more information, contact Acculex, A MetraByte Co., 440 Myles Standish Blvd., Taunton, MA 02780; Tel. 508-880-3660.

CIRCLE 112 ON FREE INFORMATION CARD

FASCIMILE SWITCH

Eliminating the need for a separate phone line for a fax machine or modem, the *FAXSWITCH II* from *VSI* allows a telephone to share the same line with a fax machine or a modem as well as an answering machine. That saves the customer the cost of installation and monthly rental of an unnecessary dedicated telephone line.

FAXSWITCH II operates on any touch-tone or rotary phone line in a single- or multi-line system, in an attended or unattended mode. Unattended fax or modem calls are answered automatically after a preset number of rings; attended calls can be transferred by either the caller from a remote location or by the receiving party by pressing a certain button on the telephone



keypad (or by dialing a number on a rotary phone). It switches to the fax mode only upon receipt of an incoming facsimile call. At all other times, the line is fully available for normal voice use, including the use of an answering machine. An exclusion feature provides privacy and line isolation from interruptions from voice or data calls.

The *FAXSWITCH II*, with a two-year warranty, has a suggested retail price of \$225.00. For additional information, contact VSI Telecommunications, Inc., 9329 Douglas Drive, Riverside, CA 92503-5618; Tel. 800-999-8232.

CIRCLE 113 ON FREE INFORMATION CARD

DUAL STEPPER-MOTOR CONTROL

Designed for stand-alone operation, the *Sintec MD-2* stepper-motor driver package features a basic language and development microcontroller with pre-written software subroutines, and requires no dedicated PC. Matched dual stepper motors and cables are included, along with extensive documentation. Front-panel lights display the status of each motor and the limit switches. Suggested applications include controlling



robotic arms, X-Y tables, telescopes, conveyors, and automatic-production equipment. The stepper-motor driver package is also available without the microcontroller, for programming directly from a PC.

The complete MD-2 package costs \$745.00; the price for the two stepper motors and cables without the microcontroller is \$459.95. For additional information, contact Sintec Company, 28 Eighth Street, P.O. Box 410, Frenchtown, NJ 08825; Tel. 800-526-5960.

CIRCLE 114 ON FREE INFORMATION CARD

COMMUNICATIONS-MAINTENANCE KIT

Jensen Tools' JTK-46C communications-maintenance kit contains every tool needed to access, test, and repair telephones, modems, facsimile machines, teletype equipment, switches, and distribution systems. The kit includes cabinet/chassis-access tools—hollow-shafted nutdrivers, Phillips and slotted screwdrivers, an adjustable



wrench, and hex keys. A selection of strippers for work with stranded or solid wire are included, as well as a wire-wrapping tool, pin- and IC-insertion/extraction tools, a modular line tester, pliers, and other tools for telecom/datacom applications.

The *JTK-46C* communications-maintenance kit costs \$319.00. For more information, contact Jensen Tools, Inc., 7815 South 46th Street, Phoenix, AZ 85044; Tel. 602-968-6231.

CIRCLE 115 ON FREE INFORMATION CARD

STATIC-SAFE SERVICE KIT

Everything needed to set up a static-safe electronic-repair station while making a service call is included in the *Statfree CP636* field-service kit from *Charleswater Products*. The fully portable kit comes in a canvas pouch that fits easily inside a standard briefcase. Capable of draining electrostatic discharges from personnel, equipment, and spare parts, the kit includes a static-



dissipative vinyl work surface, an elastic wristband, and two grounding cords. The 0.030-inch-thick work surface measures 18 x 22 inches and provides a surface resistivity of 10⁹ ohms/sq.

The *Statfree CP636* static-safe field-service kit costs \$40.00. For further information, contact Charleswater Products, Inc., 93 Border Street, West Newton, MA 02165; Tel. 617-964-8370. ■

CIRCLE 116 ON FREE INFORMATION CARD

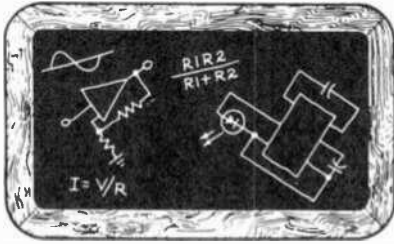

Think Tank

By Byron G. Wels, K2AVB

THE ANSWER TO LAST MONTH'S PUZZLE IS...

Last month we left you with the question, "where in a circuit containing a battery, a switch, and a load does current flow from negative to positive?" The simplest way to solve that puzzle is to draw out the circuit, look at it carefully, and tell me in which component the current flows from positive to negative. If you said inside the battery, you are absolutely correct!

The credit (read that as "blame") for this one goes to Julian Martin, who works right down the hall from me. But it's awfully good, and will really bend your mind.

It seems there was an island, populated by a village of op-amps who always told the truth, and another village of inverters, who always told lies. And this little germanium chip came to a fork in the road, where he saw another component, and realized that he wanted to go to the op-amp village, where he'd be greeted with warmth and civility. He did *not* want to go to the inverter village where he'd get chopped up and shorted out. To complicate matters, he couldn't tell whether this unit he came upon was an op-amp or an inverter. So he asked one question, and arrived happily and safely among the op-amps. Now my question to you is what was the question he asked?

If you figure this one out, write to me with your solution. Frankly, I'm expecting the mail to be very light on this one, because it is a little tough. So for the reader who might not appreciate that mind bender, here's another one, a little easier. This one was suggested by Tim Adkins, of Oneida, TN. I'll give you the answer in this issue.

It seems a technician wanted the perfect hamburger, so he mixed salt and pepper together. He placed it on a sheet of white paper, and realized he had the wrong mix; wanting to start over, he separated the salt from the pepper. The question is, how did he separate the salt from the pepper?

How old are you? Some of the mail

coming in indicates that we have very wide age range among our readers. One chap signed his letter with "73" and explained that that is ham lingo for "best regards" not his age, which is actually 74! And some are so young that they must have gotten a subscription to the magazine immediately on having learned to read. If you think you qualify as "youngest" or "oldest" let me know. We'll keep everybody posted on this.

I received a complaining letter in this month's mail, from Donna Nall. She objects to my referring to my readers as "you guys." She claims that lots of our readers are women. Donna, I hope so. Let's face it, women can be as handy with a soldering iron (if not more so) as men are. We would really like to hear from the ladies of the electronics age who read this column. So come on ladies, send in your circuits, your ideas, your telephone numbers...only kidding about the telephone numbers!

Okay, that's enough of the chatter...let's get to the meat 'n' potatoes. You guys (sorry, Donna!) seem to have been going at it hammer and tongs. So let's see what you've come up with for this month.

Motor Controller. Back in the early days of electronics, a motor-controlling rheostat consisted of a huge brute-force variable resistor placed in series with the motor. So huge were those things that a large wheel the size of an automobile steering wheel had to be used to operate them, and the operator was a burly type with tattoos on his muscled arms!

Today we use electronics to do the dirty work. However, finding a circuit for a foolproof controller has always been a problem. Many are erratic and unstable or else are very costly. I discovered a circuit (see Fig. 1) that avoided those problems by combining two simple circuits to make a smooth-as-butter controller. The first circuit is a relaxation oscillator, built around a unijunction

Put Professional Knowledge and a COLLEGE DEGREE in your Technical Career through HOME STUDY

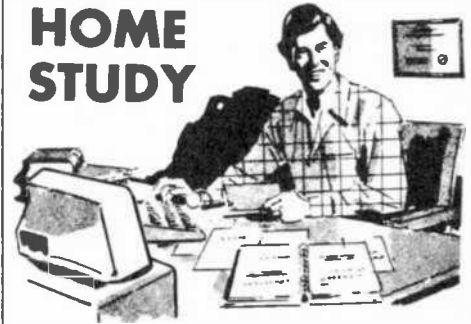

Add prestige and earning power to your technical career by earning your Associate or Bachelor degree through directed home study.

Grantham College of Engineering awards accredited degrees in

electronics and computers.

An important part of being prepared to *move up* is holding the right college degree, and the absolutely necessary part is knowing your field. Grantham can help you both ways—to learn more and to earn your degree in the process.

Grantham offers two degree programs—one with major emphasis in **electronics**, the other with major emphasis in **computers**. Associate and bachelor degrees are awarded in each program, and both programs are available completely by correspondence.

No commuting to class. Study at your own pace, while continuing on your present job. Learn from easy-to-understand lessons, with help from your Grantham instructors when you need it.

Write for our free catalog (see address below), or phone us at toll-free 1-800-955-2527 (for catalog requests only) and ask for our "degree catalog."

Accredited by
the Accrediting Commission of the
National Home Study Council

GRANTHAM
College of Engineering
10570 Humbolt Street
Los Alamitos, CA 90720

JUNE 1990

SPECIAL FROM ETT SAVE \$\$ TODAY

□ 2617T—BUILD A REMOTE-CONTROLLED ROBOT regular \$9.95 SPECIAL \$6.95. Fool-proof instructions for putting together your own full-size working robot at a fraction of the commercial cost.



□ 2645T—117 PRACTICAL IC PROJECTS YOU CAN BUILD regular \$10.95 SPECIAL \$9.95. Dozens of fully tested ready-to-build circuits you can put together from readily available, low-cost IC's.

□ BP53—PRACTICAL ELECTRONICS CALCULATIONS AND FORMULAE regular \$6.95 SPECIAL \$5.95. Six basic sections: Units and Constants, Direct Current Circuits, Passive Components, Alternating Current Circuits, Networks and Theorems, Measurements.



□ 2706T—BUILDING METAL LOCATORS regular \$9.95 SPECIAL \$8.95. A treasure hunter's project book. Build your own high-quality metal detector for a fraction of the factory-built cost.

□ BP234—TRANSISTOR SELECTOR GUIDE regular \$10.00 SPECIAL \$9.00. Offers a range of selection tables compiled so as to be of maximum use to all electronics engineers, designers and hobbyists.



□ ETT CAT—ELECTRONIC TECHNOLOGY TODAY INC. CATALOG \$2.00. 36-pages list a wide variety of electronics books. Included with catalog is a coupon good for \$3.00 off your first purchase.

MAIL TO: Electronic Technology Today, Inc.
P.O. Box 240
Massapequa Park, NY 11762-0240

SHIPPING CHARGES IN USA AND CANADA

\$0.01 to \$5.00	... \$1.25	\$30.01 to \$40.00	\$5.00
\$5.01 to 10.00	... \$2.00	\$40.01 to \$50.00	\$6.00
\$10.01 to \$20.00	\$3.00	\$50.01 and above	\$7.50
\$20.01 to \$30.00	\$4.00		

SORRY, No orders accepted outside of USA and Canada

Total price of merchandise \$	_____
Shipping (see chart) \$	_____
Subtotal \$	_____
Sales Tax (NYS only) \$	_____
Total Enclosed \$	_____

Name _____
Address _____
City _____ State _____ Zip _____

THINK TANK

transistor (Q1), that fires at a rate determined by the RC time constant of R1/C1. The second circuit is a Triac (TR1) with a snubber circuit in its gate so that it can control inductive loads. Add an optoisolator to that pair of circuits, and presto...a stable motor controller.

A simple layout on perfboard assures easy assembly. Be sure to use a Triac that is rated for the motor you wish to control. Always remember to arrange the circuit components so that those parts operating at dangerous voltages won't be exposed. Safety should always be first. Fips Book Byron?

—Danny Goodman, Linden, TN

Good circuit Danny, but unfortunately, we're out of Fips Books again. However, watch the mails anyway. I'm sending you a copy of our "Think Tank" book instead.

Universal Timer. Byron, I'm 13 years old and an avid experimenter. I've learned that many circuits require a

timer, and instead of having to build a timer for each and every circuit, I built this unit separately, and can hook it up as it's needed. I guess you could call it a "bench" timer!

It will shut off any circuit (yes, any circuit) after a certain delay. The heart of the circuit (see Fig. 2A) is a 555 timer. The delay is controlled by the setting of R1 and the value of C1. When switch S2 is depressed, relay K1 locks in and the load gets power. When connecting an AC load, for safety's sake, make sure you observe line polarity. Switch S1 is the original switch on the controlled device which provides override control. While you can use the circuit to control almost anything, be sure that the relay's contacts are heavy enough to handle the load. While any nine-volt battery can provide the supply voltage, I've included a suitable power-supply schematic (see Fig. 2B) as well.

Now does this rate me a book? Or must I try again?

—Michael Michrowski, Tarzana, CA
Mike, I hope the book gets to you. The

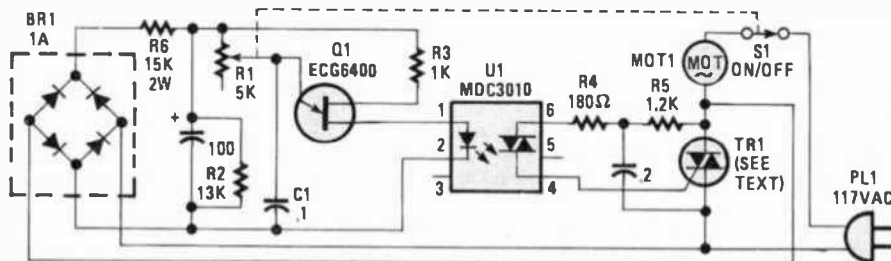

Fig. 1. This Motor-Controller circuit can be broken down into two sub-circuits: a relaxation oscillator, built around Q1, a unijunction transistor, and an optocoupler-controlled Triac circuit.

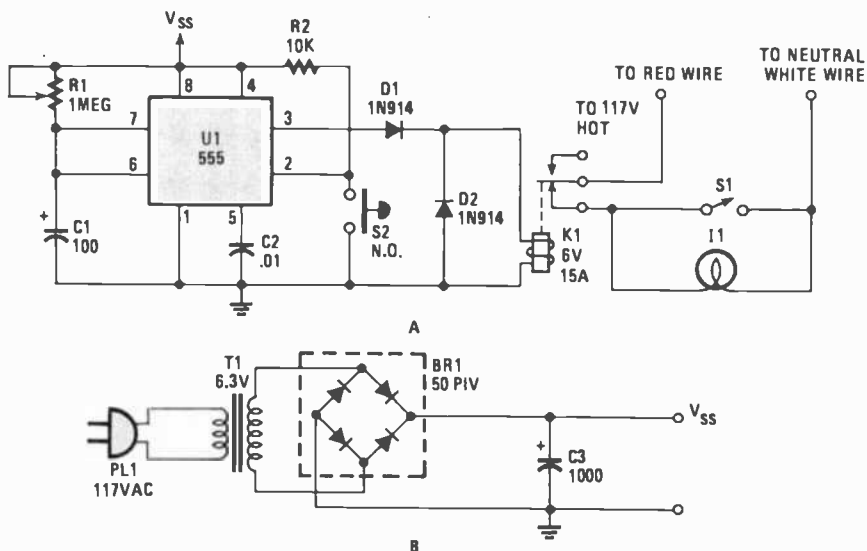

Fig. 2. The Universal Timer can be configured for make/break operation by connecting a second circuit to be controlled between the center and upper contacts of K1.

only address we could find was on the back of your envelope, and the post office did a number on that with their rubber stamps! Anyway, if you don't get the book, send me a letter with a clearly written address and we'll forward another copy.

Automobile Lamp Monitor. A friend of mine is really responsible for this project. While driving his car, the lights would occasionally malfunction, but while testing them in the driveway they'd work just fine! After having spent many hours trying to correct the problem, he asked me how he could monitor his lights while driving.

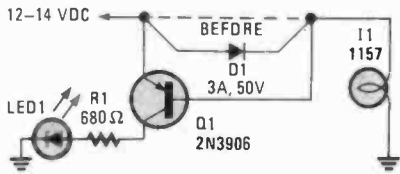

Fig. 3. The Automobile Lamp Monitor is placed in series with the lamp to be monitored so that when the lamp blows, Q1 is biased on causing LED1 to glow.

The answer to his problem is shown in Fig. 3. We now have an LED that lights everytime the car bulb lights, and will not light when the bulb doesn't light, because of bulb, wire, or ground failure. Lamp I1 represents the light being monitored.

When power is applied to the circuit, current flows through diode D1 to I1, pulling the bias voltage presented to the base of Q1 low. That low causes Q1 to turn on, effectively connecting LED1's anode to the +12-14 volt supply.

Building and installing the circuit is simple, and can take many routes. One easy way is to mount the assembly (after testing) in a clear-plastic film can that has been cut in half. After the components are in place, fill the can with clear silicone caulk. Choose the color and size LED you prefer. The cans can be mounted in the corners of the front and rear windows, on the dash, in the console beside you, or you could draw an outline of the car on plexiglas and mount the LED's to the plexiglas.

The most common turn signal/brake light is an 1157, which contains two filaments in the same bulb. The shorter filament is the brighter one and is used for turns and brake lights. The 1157 draws .9 ampere. That is important to know when selecting D1. The monitor can be used to check on the operation of any DC lamp as long as D1 can handle the

current draw. As a variation, you might want to add another transistor and resistor to light the LED only when a car lamp fails. And as a final note, just one monitor per filament, please! You'll find that all parts are inexpensive and readily available.

—Mike Giamportone, Yale, MI

Mike, you scored again! When I first read through your submission, I said "Oh no! Not another third brake light!" But I should have known better. You always seem to come up with the new, different, and novel.

Twinkle, Twinkle. This simple circuit (see Fig. 4) can be used to simulate the flickering flame of a candle, a twinkling star, or a miniature fireplace. A 4011 CMOS NAND gate is used to form two astable multivibrators (oscillators). The upper multivibrator (consisting of U1-a, U1-b, R1, R2, and C1) produces the flicker. The lower multivibrator (consisting of U1-c, U1-d, R3, R4, and C2) causes the intensity of the flickering to rise and fall every four or five seconds.

The outputs of both multivibrators are applied to the base of transistor Q1,

★QUALITY PARTS ★DISCOUNT PRICES ★FAST SHIPPING

ALL ELECTRONICS CORP.

<p>THUMBWHEEL SWITCH</p> <p>1 pole 10 position decimal encoded switches which interlock to make up desired number or digits. Terminates to 11 pc pins (1 common and 10 poles). Each section measures .31" wide X .20" high X .78" deep. End plates can be added to form a .94" high base. CAT# SWTH-9 \$1.25 each 10 lot \$10.00 END PLATES - CAT# SW-9EC \$1.00 per set</p>	<p>0 - 6 HOUR AUTO SHUT-OFF TIMER</p> <p>M.H. Rhodes, Inc. Mark-Time# 90007 Wall-box timer fits standard 3" deep wall box. Rated 20 amp @ 125 Vac. Turn knob to desired time. Includes hardware, large wall plate, and knob. UL and CSA listed. CAT# TMC-6 \$5.75 each</p>	<p>INSTRUMENT ENCLOSURES</p> <p>High quality molded ABS instrument enclosures. Integrated PC board + controls and top sets of vertical mounting slots for front and rear panels. All enclosures are 6" wide X 6 1/4" deep. Choice of three heights. Includes non-stick rubber feet and hardware. Available in beige, heavy, black, and blue. Panel kit: CAT# 1-8 10 for \$65.00 2 1/4" CAT# MB-A \$7.50 each 10 for \$65.00 2 5/8" CAT# MB-B \$7.75 each 10 for \$65.00 2 7/8" CAT# MB-C \$8.00 each 10 for \$75.00 Please specify color.</p>	<p>RECHARGEABLE BATTERY PACK (USED)</p> <p>Four AA nickel cadmium batteries connected in series to make a 4.8 volt pack. Batteries are in a 2 X 2 configuration with a 2 pin connector attached. The four batteries can be separated into single AA size solder tab nickel cadmium batteries or reworked into other configurations. SPECIAL SALE PRICE NOW \$3.00 per pack + 10 packs for \$25.00 CAT# NCB-41AAU</p>
<p>TIL-98 PHOTO TRANSISTOR</p> <p>10-18 cans with window. For wide-angle viewing applications. Spectrally and mechanically compatible with TL-318. CAT# TL-98 \$1.60 each + 10 for \$8.00</p> <p>TIL-818 PHOTO DIODE</p> <p>10-14 cans with window. Infrared emitting photo diode. CAT# TL-818 \$1.20 each + 10 for \$8.00</p>	<p>NICKEL-CAD BATTERIES (RECHARGEABLE)</p> <p>AAA SIZE \$1.80 each 1.2 volt 180 mAh CAT# NCB-AAA AA SIZE \$2.00 each 1.25 volt 180 mAh CAT# NCB-AA A SIZE \$2.30 each WITH 90.0% R.T.A.B. CAT# NCB-A A SIZE \$4.20 each 1.2 volt 1800 mAh CAT# NCB-D D SIZE \$4.50 each 1.2 volt 1300 mAh CAT# NCB-D</p>	<p>LED CHASER KIT</p> <p>Fast. No variable speed led chaser. 10 led flash sequentially at whatever speed you set them to. Easy to build kit includes pc board, parts and instructions. Ideal for spotlighting effects. Comes turn, etc. Operates on 3 to 9 volts. PC board is 5" X 2 1/2". A great one hour project. CAT# AEC \$6.50 each</p> <p>SPECIAL PURCHASE PHOTOFLASH CAPACITOR</p> <p>Rubicon CE photo flash capacitor. 0.78" dia. X 1 1/4" high. These are new capacitors that have been prepped with 1.4" black and red wire leads soldered to the terminals. CAT# PPC-210 \$2.50 each 10 for \$22.50 + 10C for \$200.00</p>	<p>LED'S</p> <p>1 TRANSISTOR JUMBO DIFFUSE D T-1-36 ultra REP. CAT# LED-1 10 for \$1.20 + 100 for \$13.00 GREEN CAT# LED-3 10 for \$8.00 + 100 for \$17.00 YELLOW CAT# LED-4 10 for \$2.00 + 100 for \$17.00 FLASHING LED with built in flashing control operates on 8 volts. REP. CAT# LED-4 10 for \$8.00 GREEN CAT# LED-4 10 for \$8.00 91-POLAR LED Light RED and direction. GREEN the other. Two leads. CAT# LED-4 2 for \$1.70 CAT# LED-4 10 for \$15.00</p> <p>LED HOLDER</p> <p>Three types. CAT# LED-10 10 for \$15.00</p>
<p>SWITCHES</p> <p>ITT PUSH BUTTON ITT MDR series 3/4" X 1/2" prep. rectangular. Key cap. S.P.S.T. NO. Push to close. RATED 0.1 amp switching. 0.25 amp carry current. P.C. mount. CAT# PB-4 \$54 each + 10 for \$8.00 100 for \$50.00</p> <p>SPDT PUSHBUTTON Marquardt #1541. Rated 8 amps @ 125/250 Vac. Black plastic pushbutton. Switch body .82" X .94" X .65". CAT# PB-1 \$1.85 each + 10 for \$15.00</p>	<p>XENON TUBE</p> <p>1" long. Resistor with 3 1/2" red end. Each leads. Ideal for electronic flash or camera program. CAT# PLT-4 2 for \$1.00</p>	<p>22/44 PIN CONNECTOR</p> <p>.156" pin spacing. 0.250" between double rows, gold contacts. P.C. mounting. SPECIAL. Same as AMP# 2-33055-6. CAT# EBC-10 \$1.00 each + 10 for \$8.00</p> <p>ELECTRONIC GAME BOARD</p> <p>The inner workings of an electronic Scrabble game. Operates on 8 Vol. 8 digit alpha-numeric result. 40 button keypad, 14 transistors, 2 I.C.'s, 1 alarm circuit and other goodies. Top and bottom row of keypad buttons are function keys. Resistor keys are numeric. No instructions available. 8" X 6 1/2". CAT# ST-4 \$1.75 each + 10 for \$15.00</p>	<p>LOOK WHAT \$1.00 WILL BUY</p> <p>200 ASSORTED 1/4 WATT RESISTORS Burnt leads, carbon comp. and carbon film. CAT# ORS \$1.00 per assortment</p> <p>200 ASSORTED 1/2 WATT RESISTORS Burnt leads, carbon comp. and film. CAT# GRABR \$1.00 per assortment</p> <p>50 ASSORTED DISC CAPACITORS Most are cut (0.5 cents). Some to 500 volts. CAT# GRABDC \$1.00 per assortment</p> <p>18 VALUES OF ELECTROLYTICS Contains both sizes and radial types from 1 mfd. CAT# GRABE \$1.00 per assortment</p>
<p>WALL TRANSFORMERS</p> <p>ALL PLUG DIRECTLY INTO 120 VAC OUTLET</p> <p>12 VDC @ 500 mA CAT# DC7E-125 \$4.99 8 VDC @ 200 mA CAT# DC7E-200 \$2.25 9 VDC @ 1 amp CAT# DC7E-9V \$6.00 14 VDC @ 500 mA CAT# DC7E-14 \$4.25</p>	<p>RELAYS</p> <p>8-8 VDC SIP REED RELAY 1.5" X 1.5" X 1.5" .50" high. 800 ohm coil. S.P.S.T. normally open relay. 0.5 amp contacts. SP configuration. CAT# RR7-8V \$1.00 each + 10 for \$10.00</p> <p>8-8 VDC LATCHING RELAY Analogous REL-20V. Minimum 800V. Dead coil latching relay. 8 VDC. 170 ohm coil. 1 amp. I.T.L. compatible. UL and CSA recognized. 0.78" X 1.28" X 1.28". CAT# LRL-4C \$2.80 each</p>	<p>TELEPHONE COUPLING TRANSFORMER</p> <p>Mini Products International. 6194-10-1011. Primary: 800 ohm. Secondary: 60000 ohm. 8.77 X 0.81 X 0.68" high. 5.0 dc. rms @ 0.17" diameter. Primary inductance 300 mH min. at 100 Hz. CAT# TCT-1 \$1.25 each + 10 for \$11.00</p>	<p>LOOK WHAT \$2.00 WILL BUY</p> <p>18 AMP SNAP-ACTION SWITCH 8 pieces of a 18 amp 125/250 Vac normally open switch. Body is 1 3/4" X 1 1/2" X 1 1/2". Burnt contacts. 200V. CAT# GRABR \$2.00 per package</p> <p>TO-22 TRANSISTORS 32 assorted TO-22 general purpose bipolar transistors. Various types. NPN and PNP. Some have metal case, some standard marking. CAT# GRABTR \$2.00 per assortment</p> <p>SWITCHES 10 resistor value. 1/4 watt. 1/2 watt. 1 watt. 5 watt. 10 watt. CAT# GRABSW \$2.00 per assortment</p>
<p>SERVO MOTOR</p> <p>5 VDC servo with potentiometer. Metal top. rotation or remote control motor. 140 degrees. Plus connected to motor wires. Run either 800 to 3000 rpm. 1.25" X 1.25" X 1.25". 3/16" diameter holes which attached to motor shaft can be used as a connector or can be easily removed. Prepped with resistors, chassis and wire leads. CAT# SV-2 2 for \$1.00</p>	<p>12 VOLT DC COIL S.P.S.T. Omron GSE 1-14P. 4 amp contacts. 250 volt ac. Super duty steel. CAT# RLY-797 \$1.80 each</p>	<p>OPTO SENSOR</p> <p>10 shipped package with mounting ears. LED opening. 3/4" mounting holes. CAT# ORS \$2.00 each 100 for \$4.00</p>	<p>AC LINE CORDS</p> <p>Black 16, 18, 20, 25, 30, 35, 40, 45, 50, 55, 60, 65, 70, 75, 80, 85, 90, 95, 100, 105, 110, 115, 120, 125, 130, 135, 140, 145, 150, 155, 160, 165, 170, 175, 180, 185, 190, 195, 200, 205, 210, 215, 220, 225, 230, 235, 240, 245, 250, 255, 260, 265, 270, 275, 280, 285, 290, 295, 300, 305, 310, 315, 320, 325, 330, 335, 340, 345, 350, 355, 360, 365, 370, 375, 380, 385, 390, 395, 400, 405, 410, 415, 420, 425, 430, 435, 440, 445, 450, 455, 460, 465, 470, 475, 480, 485, 490, 495, 500, 505, 510, 515, 520, 525, 530, 535, 540, 545, 550, 555, 560, 565, 570, 575, 580, 585, 590, 595, 600, 605, 610, 615, 620, 625, 630, 635, 640, 645, 650, 655, 660, 665, 670, 675, 680, 685, 690, 695, 700, 705, 710, 715, 720, 725, 730, 735, 740, 745, 750, 755, 760, 765, 770, 775, 780, 785, 790, 795, 800, 805, 810, 815, 820, 825, 830, 835, 840, 845, 850, 855, 860, 865, 870, 875, 880, 885, 890, 895, 900, 905, 910, 915, 920, 925, 930, 935, 940, 945, 950, 955, 960, 965, 970, 975, 980, 985, 990, 995, 1000, 1005, 1010, 1015, 1020, 1025, 1030, 1035, 1040, 1045, 1050, 1055, 1060, 1065, 1070, 1075, 1080, 1085, 1090, 1095, 1100, 1105, 1110, 1115, 1120, 1125, 1130, 1135, 1140, 1145, 1150, 1155, 1160, 1165, 1170, 1175, 1180, 1185, 1190, 1195, 1200, 1205, 1210, 1215, 1220, 1225, 1230, 1235, 1240, 1245, 1250, 1255, 1260, 1265, 1270, 1275, 1280, 1285, 1290, 1295, 1300, 1305, 1310, 1315, 1320, 1325, 1330, 1335, 1340, 1345, 1350, 1355, 1360, 1365, 1370, 1375, 1380, 1385, 1390, 1395, 1400, 1405, 1410, 1415, 1420, 1425, 1430, 1435, 1440, 1445, 1450, 1455, 1460, 1465, 1470, 1475, 1480, 1485, 1490, 1495, 1500, 1505, 1510, 1515, 1520, 1525, 1530, 1535, 1540, 1545, 1550, 1555, 1560, 1565, 1570, 1575, 1580, 1585, 1590, 1595, 1600, 1605, 1610, 1615, 1620, 1625, 1630, 1635, 1640, 1645, 1650, 1655, 1660, 1665, 1670, 1675, 1680, 1685, 1690, 1695, 1700, 1705, 1710, 1715, 1720, 1725, 1730, 1735, 1740, 1745, 1750, 1755, 1760, 1765, 1770, 1775, 1780, 1785, 1790, 1795, 1800, 1805, 1810, 1815, 1820, 1825, 1830, 1835, 1840, 1845, 1850, 1855, 1860, 1865, 1870, 1875, 1880, 1885, 1890, 1895, 1900, 1905, 1910, 1915, 1920, 1925, 1930, 1935, 1940, 1945, 1950, 1955, 1960, 1965, 1970, 1975, 1980, 1985, 1990, 1995, 2000, 2005, 2010, 2015, 2020, 2025, 2030, 2035, 2040, 2045, 2050, 2055, 2060, 2065, 2070, 2075, 2080, 2085, 2090, 2095, 2100, 2105, 2110, 2115, 2120, 2125, 2130, 2135, 2140, 2145, 2150, 2155, 2160, 2165, 2170, 2175, 2180, 2185, 2190, 2195, 2200, 2205, 2210, 2215, 2220, 2225, 2230, 2235, 2240, 2245, 2250, 2255, 2260, 2265, 2270, 2275, 2280, 2285, 2290, 2295, 2300, 2305, 2310, 2315, 2320, 2325, 2330, 2335, 2340, 2345, 2350, 2355, 2360, 2365, 2370, 2375, 2380, 2385, 2390, 2395, 2400, 2405, 2410, 2415, 2420, 2425, 2430, 2435, 2440, 2445, 2450, 2455, 2460, 2465, 2470, 2475, 2480, 2485, 2490, 2495, 2500, 2505, 2510, 2515, 2520, 2525, 2530, 2535, 2540, 2545, 2550, 2555, 2560, 2565, 2570, 2575, 2580, 2585, 2590, 2595, 2600, 2605, 2610, 2615, 2620, 2625, 2630, 2635, 2640, 2645, 2650, 2655, 2660, 2665, 2670, 2675, 2680, 2685, 2690, 2695, 2700, 2705, 2710, 2715, 2720, 2725, 2730, 2735, 2740, 2745, 2750, 2755, 2760, 2765, 2770, 2775, 2780, 2785, 2790, 2795, 2800, 2805, 2810, 2815, 2820, 2825, 2830, 2835, 2840, 2845, 2850, 2855, 2860, 2865, 2870, 2875, 2880, 2885, 2890, 2895, 2900, 2905, 2910, 2915, 2920, 2925, 2930, 2935, 2940, 2945, 2950, 2955, 2960, 2965, 2970, 2975, 2980, 2985, 2990, 2995, 3000, 3005, 3010, 3015, 3020, 3025, 3030, 3035, 3040, 3045, 3050, 3055, 3060, 3065, 3070, 3075, 3080, 3085, 3090, 3095, 3100, 3105, 3110, 3115, 3120, 3125, 3130, 3135, 3140, 3145, 3150, 3155, 3160, 3165, 3170, 3175, 3180, 3185, 3190, 3195, 3200, 3205, 3210, 3215, 3220, 3225, 3230, 3235, 3240, 3245, 3250, 3255, 3260, 3265, 3270, 3275, 3280, 3285, 3290, 3295, 3300, 3305, 3310, 3315, 3320, 3325, 3330, 3335, 3340, 3345, 3350, 3355, 3360, 3365, 3370, 3375, 3380, 3385, 3390, 3395, 3400, 3405, 3410, 3415, 3420, 3425, 3430, 3435, 3440, 3445, 3450, 3455, 3460, 3465, 3470, 3475, 3480, 3485, 3490, 3495, 3500, 3505, 3510, 3515, 3520, 3525, 3530, 3535, 3540, 3545, 3550, 3555, 3560, 3565, 3570, 3575, 3580, 3585, 3590, 3595, 3600, 3605, 3610, 3615, 3620, 3625, 3630, 3635, 3640, 3645, 3650, 3655, 3660, 3665, 3670, 3675, 3680, 3685, 3690, 3695, 3700, 3705, 3710, 3715, 3720, 3725, 3730, 3735, 3740, 3745, 3750, 3755, 3760, 3765, 3770, 3775, 3780, 3785, 3790, 3795, 3800, 3805, 3810, 3815, 3820, 3825, 3830, 3835, 3840, 3845, 3850, 3855, 3860, 3865, 3870, 3875, 3880, 3885, 3890, 3895, 3900, 3905, 3910, 3915, 3920, 3925, 3930, 3935, 3940, 3945, 3950, 3955, 3960, 3965, 3970, 3975, 3980, 3985, 3990, 3995, 4000, 4005, 4010, 4015, 4020, 4025, 4030, 4035, 4040, 4045, 4050, 4055, 4060, 4065, 4070, 4075, 4080, 4085, 4090, 4095, 4100, 4105, 4110, 4115, 4120, 4125, 4130, 4135, 4140, 4145, 4150, 4155, 4160, 4165, 4170, 4175, 4180, 4185, 4190, 4195, 4200, 4205, 4210, 4215, 4220, 4225, 4230, 4235, 4240, 4245, 4250, 4255, 4260, 4265, 4270, 4275, 4280, 4285, 4290, 4295, 4300, 4305, 4310, 4315, 4320, 4325, 4330, 4335, 4340, 4345, 4350, 4355, 4360, 4365, 4370, 4375, 4380, 4385, 4390, 4395, 4400, 4405, 4410, 4415, 4420, 4425, 4430, 4435, 4440, 4445, 4450, 4455, 4460, 4465, 4470, 4475, 4480, 4485, 4490, 4495, 4500, 4505, 4510, 4515, 4520, 4525, 4530, 4535, 4540, 4545, 4550, 4555, 4560, 4565, 4570, 4575, 4580, 4585, 4590, 4595, 4600, 4605, 4610, 4615, 4620, 4625, 4630, 4635, 4640, 4645, 4650, 4655, 4660, 4665, 4670, 4675, 4680, 4685, 4690, 4695, 4700, 4705, 4710, 4715, 4720, 4725, 4730, 4735, 4740, 4745, 4750, 4755, 4760, 4765, 4770, 4775, 4780, 4785, 4790, 4795, 4800, 4805, 4810, 4815, 4820, 4825, 4830, 4835, 4840, 4845, 4850, 4855, 4860, 4865, 4870, 4875, 4880, 4885, 4890, 4895, 4900, 4905, 4910, 4915, 4920, 4925, 4930, 4935, 4940, 4945, 4950, 4955, 4960, 4965, 4970, 4975, 4980, 4985, 4990, 4995, 5000, 5005, 5010, 5015, 5020, 5025, 5030, 5035, 5040, 5045, 5050, 5055, 5060, 5065, 5070, 5075, 5080, 5085, 5090, 5095, 5100, 5105, 5110, 5115, 5120, 5125, 5130, 5135, 5140, 5145, 5150, 5155, 5160, 5165, 5170, 5175, 5180, 5185, 5190, 5195, 5200, 5205, 5210, 5215, 5220, 5225, 5230, 5235, 5240, 5245, 5250, 5255, 5260, 5265, 5270, 5275, 5280, 5285, 5290, 5295, 5300, 5305, 5310, 5315, 5320, 5325, 5330, 5335, 5340, 5345, 5350, 5355, 5360, 5365, 5370, 5375, 5380, 5385, 5390, 5395, 5400, 5405, 5410, 5415, 5420, 5425, 5430, 5435, 5440, 5445, 5450, 5455, 5460, 5465, 5470, 5475, 5480, 5485, 5490, 5495, 5500, 5505, 5510, 5515, 5520, 5525, 5530, 5535, 5540, 5545, 5550, 5555, 5560, 5565, 5570, 5575, 5580, 5585, 5590, 5595, 5600, 5605, 5610, 5615, 5620, 5625, 5630, 5635, 5640, 5645, 5650, 5655, 5660, 5665, 5670, 5675, 5680, 5685, 5690, 5695, 5700, 5705, 5710, 5715, 5720, 5725, 5730, 5735, 5740, 5745, 5750, 5755, 5760, 5765, 5770, 5775, 5780, 5785, 5790, 5795, 5800, 5805, 5810, 5815, 5820, 5825, 5830, 5835, 5840, 5845, 5850, 5855, 5860, 5865, 5870, 5875, 5880, 5885, 5890, 5895, 5900, 5905, 5910, 5915, 5920, 5925, 5930, 5935, 5940, 5945, 5950, 5955, 5960, 5965, 5970, 5975, 5980, 5985, 5990, 5995, 6000, 6005, 6010, 6015, 6020, 6025, 6030, 6035, 6040, 6045, 6050, 6055, 6060, 6065, 6070, 6075, 6080, 6085, 6090, 6095, 6100, 6105, 6110, 6115, 6120, 6125, 6130, 6135, 6140, 6145, 6150, 6155, 6160, 6165, 6170, 6175, 6180, 6185, 6190, 6195, 6200, 6205, 6210, 6215, 6220, 6225, 6230, 6235, 6240, 6245, 6250, 6255, 6260, 6265, 6270, 6275, 6280, 6285, 6290, 6295, 6300, 6305, 6310, 6315, 6320, 6325, 6330, 6335, 6340, 6345, 6350, 6355, 6360, 6365, 6370, 6375, 6380, 6385, 6390, 6395, 6400, 6405, 6410, 6415, 6420, 6425, 6430, 6435, 6440, 6445, 6450, 6455, 6460, 6465, 6470, 6475, 6480, 6485, 6490, 6495, 6500, 6505, 6510, 6515, 6520, 6525, 6530, 6535, 6540, 6545, 6550, 6555, 6560, 6565, 6570, 6575, 6580, 6585, 6590, 6595, 660</p>

AMAZING SCIENTIFIC & ELECTRONIC PRODUCTS

PLANS PARTS ARE IN STOCK

GRA1 — ANTI GRAVITY GENERATOR	\$10.00
L7 — 40 WATT BURNING CUTTING LASER	\$20.00
RUB4 — HI POWER PULSED DRILLING LASER	\$20.00
BTC5 — 1 MILLION VOLT TESLA COIL	\$20.00
MCP1 — HI VELOCITY COIL GUN	\$15.00
LLS1 — LASER LIGHT SHOW 3 METHODS	\$20.00
EH1 — ELECTRONIC HYPNOTISM TECHNIQUES	\$8.00
EML1 — LOWER POWERED COIL GUN LAUNCHER	\$8.00
JL3 — JACOB LADDER 3 MODELS	\$10.00
SD5 — SEE IN THE DARK	\$10.00
LEV1 — LEVITATION DEVICE	\$10.00

KITS ASSISTANCE PROGRAM AVAILABLE

FMV1K — 3 MILE FM VOICE TRANSMITTER	\$34.50
PFS1K — HAND CONTROLLED PLASMA FIRE SABER	\$49.50
NIG7K — HI FLUX NEGATIVE ION GENERATOR	\$34.50
PG5K — PLASMA LIGHTNING GLOBE	\$49.50
LHC2K — VISIBLE SIMULATED 3 COLOR LASER	\$44.50
HDD1K — HOMING/TRACKING BEEPER TRANSMITTER	\$44.50
LGU6K — 2.5 MW HAND-HELD VISIBLE LASER GUN	\$249.50
BTC3K — 250,000 VOLT TABLE TOP TESLA COIL	\$249.50
RG2K — ION RAY GUN, project energy without wires	\$129.95
TKE1K — TELEKINETIC ENHANCER/ELECTRIC MAN	\$79.50
VWPM7K — 3 MILE AUTO TELEPHONE TRANSMITTER	\$49.50

ASSEMBLED

ASSEMBLED IN OUR LABS

LJST10 — INFINITY XMTR Listen in via phone lines	\$199.50
IPG70 — INVISIBLE PAIN FIELD BLAST WAVE GENERATOR	\$74.50
ITM10 — 100,000 VOLT INTIMIDATOR UP TO 20'	\$99.50
JAT30 — AUTOMATIC TELEPHONE RECORDING DEVICE	\$24.50
PSP40 — PHASOR SONIC BLAST WAVE PISTOL	\$89.50
ONE10 — ALL NEW 26" VIVID COLORED NEON STICK	\$74.50
LBU20 — 5 TO 1MW VISIBLE RED HeNe LASER GUN	\$199.50
BLS10 — 100,000 WATT BLASTER DEFENSE WAND	\$89.50

EASY ORDERING PROCEDURE - TOLL FREE 1-800-221-1705 or 24 HRS ON 1-603-673-4730 or FAX IT TO 1-603-672-5406

VISA, MC, CHECK, MO IN US FUNDS. INCLUDE 10% SHIPPING. ORDERS \$100.00 & UP ONLY ADD \$10.00. CATALOG \$1.00 OR FREE WITH ORDER.

INFORMATION UNLIMITED

P.O. BOX 716, DEPT. P.N., AMHERST, NH 03031

THINK TANK

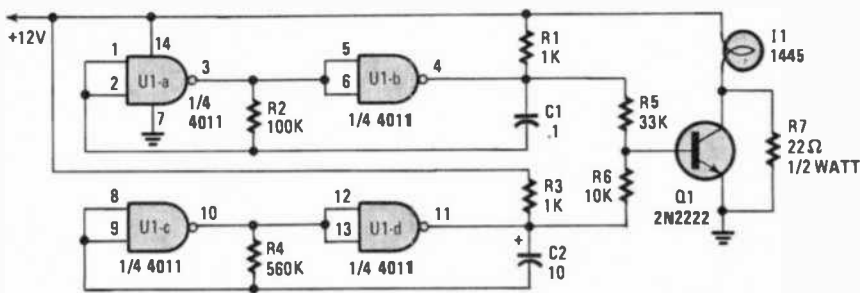

Fig. 4. In this circuit, a 4011 is used as the basis of a dual astable multivibrator (oscillator) circuits whose outputs are fed to transistor Q1, which provides sufficient drive to the lamp. It is the outputs of the oscillators (operating at different frequencies) that produce the flickering effect.

which is used to control the current through I1. Resistor R1 allows enough current to flow through I1 to keep it lit at a reduced level when Q1 isn't conducting.

The outputs of the two multivibrators cause the level of conduction through Q1 to vary intermittently in intensity and frequency. The resulting intermittent signal randomly increases and decreases the brightness of the flickering produced, providing a fairly realistic effect that's similar to a candle flame in a light breeze. By making C2 equal to C1 and R4 equal to R2, a sort of wavering, can be achieved. I've used the circuit for the past few years to light up our jack-o-lantern on Halloween. It looks realistic and it sure beats messing around with candles.

—Jim Keenan, Toronto, OH

Jim, I wanted to save this one until Halloween, but it was just too good to hold onto all of that time! Hope you've got some additional circuits to share with us. We've got a lot of books to send your way!

Floppy/Hard Drive Tester. This circuit (see Fig. 5) was developed so that non-technically oriented assemblers could be sure that power-supply connectors were properly wired before being plugged into subsystems. Some costly assemblies had been damaged by the incorrect application of power.

The component values provided are neither critical nor optimum. They were simply the values available, and they work satisfactorily to clearly discriminate between the 5-volt and 12-volt supply lines. Other values may be substituted to permit the circuit to work with other voltages. Plug PL1 of the tester was wired to agree with the power requirements of the device to be connected. When the tester is plugged into a properly wired power-supply connector, LED2 and LED3 light to indicate the correct voltage and polarity has been applied to the circuit.

If either LED1 or LED4 lights, an incorrect voltage is being applied. If neither the LED2 nor LED4 (for the 12-volt line) or

23477

ELECTRONIC COMPONENTS

Whether you order 1 part or all 23,477... MOUSER stocks to meet your needs and... can ship today!!

MOUSER also makes it easy to do business.

Try us! Call today for your FREE CATALOG (800) 992-9943

2401 Hwy 287 North Mansfield, TX 76063

MOUSER ELECTRONICS
Sales & Stocking Locations Nationwide

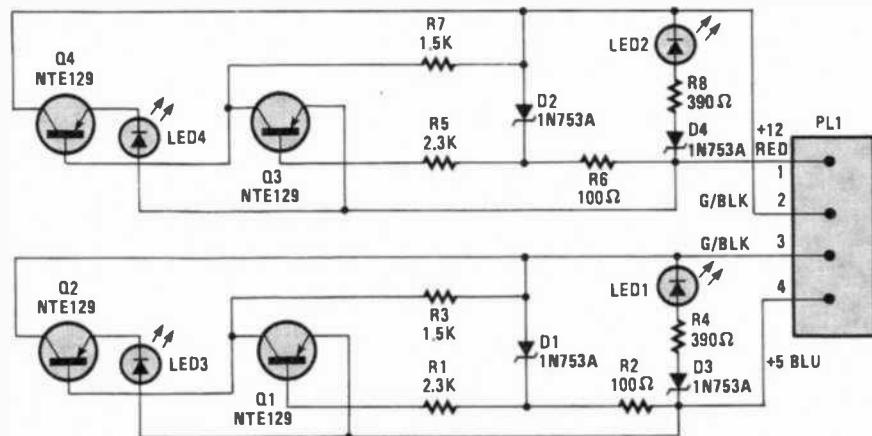

Fig. 5. When the Floppy/Hard Drive Tester tester is plugged into a properly wired power-supply connector, LED2 and LED3 light to indicate the correct voltage and polarity has been applied to the circuit.

neither LED1 nor LED3 lights, voltage is not present, or is of the wrong polarity. When +5 volts is applied to pin 4 of PL1, which is referenced to pin 3, no current will flow through either the base or collector of Q1. That allows current to flow through the base and collector of Q2 causing LED3 to light. If +12 volts is applied to pin 4 of PL1 (referenced to pin 3), current will flow through the base and collector of Q1, turning off Q2 and LED3. Current will also flow through the red LED, causing it to light.

Pins 1 and 2 of PL1 operate in a similar fashion, lighting the red LED if only +5 volts is supplied, and lighting LED2 if +12 volts are present. I hope that qualifies me for a Fips book.

—Vic Schmidtman, Fremont, CA

Great idea, Vic but we're out of the Fips book. I'm sending you a Think Tank book. Hope you enjoy it!

Versatile Supply. By, I'm studying electronics at British Columbia Institute of Technology, hoping to get a better job than sales clerk at a convenience store, where I worked previously. Unfortunately, working out problems at school is difficult, especially when your next-door classmate is the class clown. I decided to take some of the simpler problems home, but I needed a bench power supply for some of the experiments. They say "necessity is the mother of invention." Here's what "mom" came up with:

This circuit (see Fig. 6) is a variable power supply with a twist. By connecting the 250k potentiometer across the output, I can get a split DC voltage source. Simply use the black binding post as ground, and the white as negative. Red becomes the positive. Adding the two .01 capacitors will reduce the output ripple by half.

I don't really expect a Nobel Peace Prize for this development but is it worth one of your Think Tank books?

—Fernando Afafe, Vancouver, BC Canada

Keep your fingers crossed, Fernando!

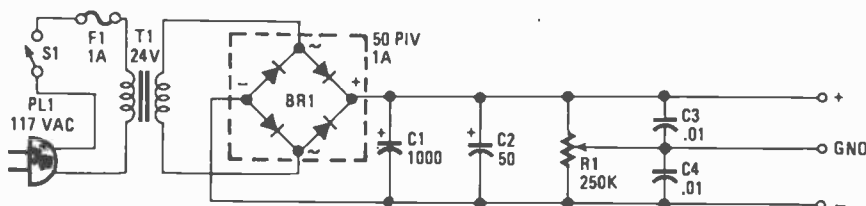

Fig. 6. The Versatile Supply is a simple unregulated dual-polarity DC power supply that has a potentiometer (R1) added between the positive and negative output terminals that allows you to vary the output voltage level. The wiper of R1 serves as the ground terminal.

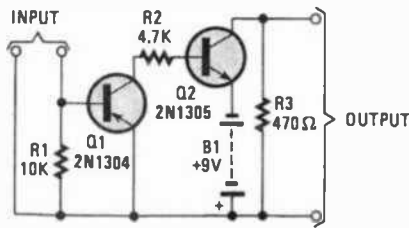

Fig. 7. This general-purpose amplifier is a rather simple circuit that can be placed in a signal path to provide any necessary signal boost; at the output of a crystal radio, for example.

You never can tell. Until that Nobel Prize comes through however, I'm sending you a Think Tank book, and thanks!

Cheapie Amp. This general-purpose amplifier (see Fig. 7) will work with almost any components, and does a masterful job when hooked up to just about anything. While there isn't much in the way of power output, it does a great job on a signal tracer and with a cheap (I keep using that word) small transformer with a high-impedance primary and low-impedance secondary, it can even drive a loudspeaker, though not to earth-shaking levels. Believe me, you can substitute freely as far as transistors are concerned, using an NPN first and a PNP at the output, or vice-versa.

It works great as an output for a crystal radio, and you might even find the resulting volume a bit much. Here's how it works:

The 10k resistor (R1) supplies base bias to Q1. Base bias for Q2 is provided through R2 (a 4.7k unit), which couples the output of Q1 to the base of Q2. Nothing here is critical, and it's a fun project to experiment with. I connected the input of the amplifier to the output of my crystal set, and plugged a small speaker into the output of the amplifier.

My only problem Byron, is that this is not my first submission, and I already have a Fips book. Got anything else I can use?

—Douglas P. Hoff, Vacaville, CA

HAM RADIO IS FUN!

It's even more fun for beginners now that they can operate voice and link computers just as soon as they obtain their Novice class license. You can talk to hams all over the world when conditions permit, then switch to a repeater for local coverage, perhaps using a transceiver in your car or handheld unit.



Your passport to ham radio adventure is TUNE-IN THE WORLD WITH HAM RADIO. The book tells what you need to know in order to pass your Novice exam. Two cassettes teach the code quickly and easily.

Enclosed is my check or money order for \$19.00 plus \$3.50 for shipping and handling or charge my

() VISA () MasterCard () Am. Express

Signature _____

Acct. No. _____

Good from _____ Expires _____

Name _____

Address _____

City _____ State _____ Zip _____ PE

THE AMERICAN RADIO RELAY LEAGUE
225 MAIN ST.
NEWINGTON, CT 06111

THINK TANK

Sure do Doug! A Think Tank book is now on the way.

"I Shot an Arrow in the Air... It fell to Earth, I knew not where." I lose more darned arrows that way! So I built a lightweight strobe to launch in my model rockets at night (see Fig. 8). After assembly, this unit weighs a scant 1.5 ounces without the batteries, and it flashes every 2.5 seconds.

The 555 timer (U1), L1 and Q1 form a boost-type switching power supply that gradually charges capacitors C4 and C5. When the voltage on C5 reaches 300 volts, diodes D3 and D4 conduct, turning on SCR1. Capacitor C2 dumps its charge into T1 causing the lamp to flash.

With a little scrounging, you ought to be able to find most of the parts. Lightweight batteries are the tough part. I used five 1.2 volt 1/3AA NiCd units in series. You might even try four N cells in series. But watch out; L1 can get warm, so don't touch. I learned about that the hard way. And for some final notes, SCR1 is an EC103D 400-PIV, sensitive-gate SCR. Transformer T1 is a 300-volt to 6000-volt trigger transformer. Lamp I1 is a 300-volt flashtube that requires a 6000-volt trigger, and Q1 is a IRF710 N-channel hexFET.

Now when I shoot a rocket in the air at night, the flashtube tells me where to look.

—Paul C. Florian, San Marcos, TX

Good shot Paul, your book is on the way, and I hope you enjoy it.

Launcher. I'm not into model rocketry myself (by the way, I'm 12 years old) but I designed a fantastic rocket launcher that has an "armed" LED plus ten other LED's, which represent count "9" to "ignition." See Fig. 9.

The circuit is built around a 555 timer (U1) configured for astable operation and a 4017 counter/divider. The output of U1 at pin 3 is fed to the clock input of U2, which sequentially activates one of its ten outputs, turning on its associated LED. On the count of ten, a green LED comes on to indicate IGNITION. The signal at the anode of LED2 is also fed to the base of transistor Q1, causing it to turn on. When Q1 is turned on, relay K1 is energized, feeding +6 volts to the igniter connected across the contacts of K1. It's a hard-wired system.

The wire leading to the igniter should be about 20 feet long. To operate the

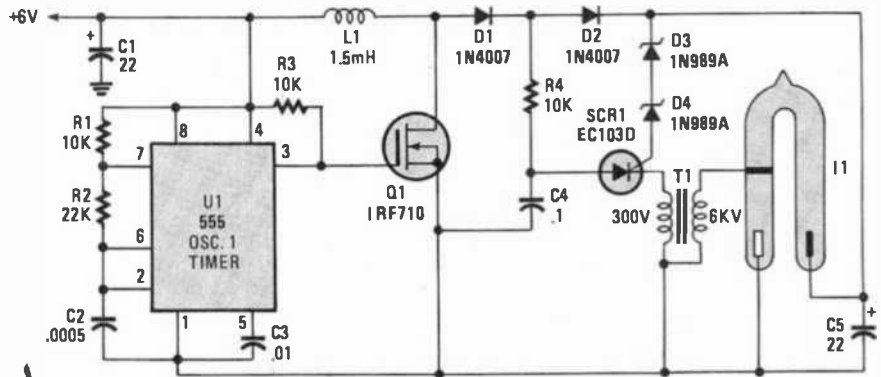

Fig. 8. At the heart of this strobe-light circuit is a 555 oscillator/timer whose output controls the flash rate of the strobe lamp.

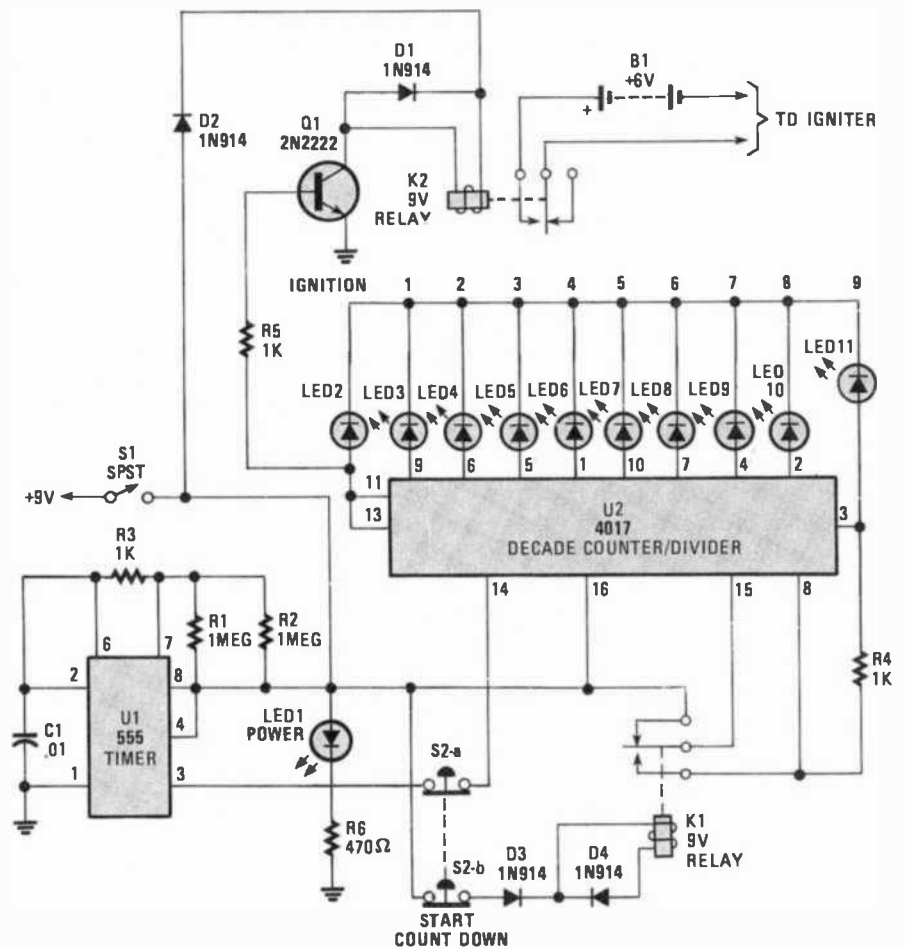

Fig. 9. This Launcher circuit is basically a countdown timer, which is designed to automatically ignite a rocket's engines when the ignition LED comes on.

launcher, simply connect the two wires to the igniter, open switch S2, close S1 and the "armed" LED will light. Then close switch S2, and up, up, and away!

—Jeff Wilson, Deltona, FL

Great circuit, Jeff and one that's certainly earned you a Think Tank book.

Well we've once again come to the end of the space allotted to us for this month, but before we leave here is the answer to the question "how do you

separate salt from pepper: Run a plastic comb through your hair to generate some static electricity, and then pass the comb through the salt and pepper mix. The pepper adheres to the comb, the salt doesn't.

And don't forget to keep those circuits coming in. Send your contributions to *Think Tank*, **Popular Electronics**, 500-B Bi-County Boulevard, Farmingdale, NY 11735. ■

Enter A World Of Excitement with a Subscription to Popular Electronics®

Get the latest electronic technology and information monthly!

Now you can subscribe to the magazine that plugs you into the exciting world of electronics. With every issue of Popular Electronics you'll find a wide variety of electronics projects you can build and enjoy.

Popular Electronics brings you informative new product and literature listings, feature articles on test equipment and tools—all designed to keep you tuned in to the latest developments in electronics. So if you love to build fascinating electronics, just fill out the subscription form below to subscribe to Popular Electronics... It's a power-house of fun for the electronics enthusiast.

EXCITING MONTHLY FEATURES LIKE:

- CONSTRUCTION**—Building projects from crystal sets to electronic roulette
- FEATURES**—Educational training on digital electronics, Ohm's Law, Antennas, Communications, Antique Radio, Simplified Theory
- HANDS-ON-REPORTS**—User test comments on new and unusual consumer products
- SPECIAL COLUMNS**—Think Tank, Circuit Circus, Computer Bits, DX Listening, Antique Radio, Amateur, Scanner Scene

PLUS: ALL OUR GREAT DEPARTMENTS!

You'll get 12 exciting and informative issues of Popular Electronics for only \$18.95. That's a savings of \$11.05 off the regular single copy price. Subscribe to Popular Electronics today! Just fill out the subscription order form below.

Build a Booster Amp for your Car Stereo

NOVEMBER 1989 48784

Popular Electronics®

THE MAGAZINE FOR THE ELECTRONICS-ACTIVIST! COMBINED WITH **Hands-on Electronics**

Build an **Electronic Darkroom Timer**
Simple to make, it delivers picture-perfect results every time!

Innovations '89
The best-of-the-best in consumer electronics

Supplying the Electronics Workshop
Where to turn when that special something is nowhere to be found

Preventive Computer Maintenance
Take these simple steps now to prevent big repair bills later

Quantum Mechanics, the Universe, and Electronics
Learn the true story about what makes electronics work

Save 37% Off The Regular NEWSSTAND Rate

meter
ency signals
ntional meters

3 NEW FunCards IN THIS ISSUE

Circuit Circus
Some simple circuits that make troubleshooting easier

FOR FASTER SERVICE CALL TODAY
1-800-435-0715

IN ILLINOIS 1-800-892-0753 (7:30AM-8:30PM)

EASTERN STANDARD TIME

Popular Electronics® SUBSCRIPTION ORDER FORM

P.O. Box 338, Mt. Morris IL. 61054

YES! I want to subscribe to Popular Electronics for 1 Full year (12 Issues) for only \$18.95. That's a savings of \$11.05 off the newsstand price.

Payment Enclosed Bill me later

Please charge my: Visa Mastercard

Acct. #

Signature _____

Exp. Date _____

PLEASE PRINT BELOW:

NAME _____

ADDRESS _____

CITY _____

STATE _____

ZIP _____

Allow 6 to 8 weeks for delivery of first issue. U.S. Funds only.
In Canada add \$5.00 Postage. All Other Foreign add \$7.50 Postage.

APE-FØ

“All I want is
fair prices.
Is that too
much to ask?”



There is a way to get better prices on programming. The American Home Satellite Association. An organization created exclusively to protect and enhance your enjoyment of your satellite TV system.

With AHSA's group buying power you'll save on premium services, superstations and basic programming services. Enjoy savings on accessories, equipment, and programming guides, too.

A place to turn for help.

From locating satellite signals to locating a reputable dealer, the toll free AHSA "Helpline" has the answer. AHSA provides educational videotapes and informative books, too. At very special member prices.

Plus, 10 times a year, AHSA's official newsletter, *Sky Report*, will bring you the latest word on products, legislation, programming, and more. Not to mention reviews of new products and services.

You're not alone anymore.

With your voice behind us, AHSA is promoting legislation to guarantee fair access at reasonable prices. Addressing zoning and piracy issues. Even sending expert witnesses to Congressional hearings. Join other dish owners around the nation, and become a force to be reckoned with.

Rush my free information kit.

Name _____

Address _____

City _____ State _____ Zip _____

Sign me up right away and send my complete membership kit.

Check enclosed for \$36 (made out to AHSA)

Bill my VISA MasterCard

Card # _____

Exp. Date _____

Authorized Signature _____

X _____

30-day Money Back Guarantee



**American Home
Satellite Association**

Return completed coupon to:
American Home
Satellite Association, Inc.,
Suite 800, 500 108th Ave. NE,
Bellevue, WA 98004-5560
Or call Toll Free
1-800-321-AHSA (2472).

QRB



BUILD AN EXHAUST MONITOR FOR YOUR CAR

BY BOB FLYNN AND LEO SIMPSON

Are you worried about exhaust gases seeping into your car with possibly tragic consequences? If so, here's an exhaust-gas monitor that can be fitted to any van or car.

Do you get a headache during or after a trip in your car or van? Is it a slight frontal headache or a real head-splitter? Either way, you could be suffering from the effects of exposure to carbon monoxide.

There are two easy ways that you can be exposed to that utterly colorless, odorless, but very deadly gas. First, you may be driving in slow "bumper-to-bumper" traffic. Because so many cars are close together with their engines running at idle, it is inevitable that you will be breathing exhaust gases from the cars in front, at the sides, and even from your own car. And if you have your air conditioner on the "fresh air" setting, the effects may be worse than if you were driving with the window open.

Second, if the rear door of your van or the trunk of your car does not seal properly, exhaust fumes will be sucked in at the rear of your vehicle as you drive along. And contrary to what you might

*This story first appeared in *Silicon Chip, Australia* (July, 1989); reprinted with permission.

WARNING

Neither the publisher nor the author make any representations as to the accuracy of the information contained herein and disclaim any liability for damages or injuries, whether caused by or arising from inaccuracies of the information, misinterpretation of the directions, misapplication of the information or otherwise.

think, opening the windows might not make very much of an improvement. So while you are driving along seemingly unaffected, your rear-seat passengers could be getting a very bad dose with possibly fatal consequences.

Don't think that just because your exhaust system is not faulty that you are safe. Normally operating vehicles can produce lots of carbon monoxide, sufficient to put you and your family in great danger. Table 1 shows the effect of various concentrations of carbon monoxide in air on humans. Note that these are mostly short-term effects (apart

from death, which is a long-term effect).

An interesting point to consider here is that people often associate dizziness and nausea with "car sickness" or "motion sickness." However, if you look at the modest concentrations of carbon monoxide (CO) in Table 1, it is quite possible that what is often blamed on "car sickness" could be a good dose of carbon monoxide.

Why is carbon monoxide so dangerous? The reason is that it combines with hemoglobin in the blood and prevents it from carrying oxygen to the brain. If enough hemoglobin in your blood is affected, your brain will suffer from oxygen starvation. As Table 1 shows, quite modest concentrations of carbon monoxide can spell real danger. That's because carbon monoxide has over 200 times more affinity with hemoglobin than oxygen.

In severe cases of carbon monoxide poisoning, a blood transfusion is the only way to save the victim from death. And what of the long term effects of

TABLE 1—THE EFFECTS OF CARBON MONOXIDE ON HUMANS

Concentration of CO in Air	Toxic Symptoms Developed
0.02% (200 ppm)	Slight headache within 2 to 3 hours
0.04% (400 ppm)	Frontal headache within 1 to 2 hours, becoming severe within 2.5 to 3.5 hours.
0.08% (800 ppm)	Dizziness, nausea and convulsions within 45 minutes, insensible within 2 hours.
0.16% (1600 ppm)	Headache, dizziness and nausea within 20 minutes, death within 2 hours.
0.32% (3200 ppm)	Headache, dizziness and nausea within 5 to 10 minutes; death within 30 minutes.
0.64% (6400 ppm)	Headache, dizziness in 1 to 2 minutes; death in 10 to 15 minutes.
1.28% (12,800 ppm)	Death in 1 to 3 minutes.

frequent exposure to modest levels of carbon monoxide? At the time of this writing, we had no information on that aspect, but we would not be surprised if there were adverse effects.

The Risks of Exposure. On a number of quite new vans and cars that have been examined, the rear door or trunk lid did not seal properly because the rubber gasket was defective or non-existent (quite common on courier vehicles) or the catch was out of adjustment. In addition, many Japanese vans have a battery compartment in the floor at the rear, which is often inadequately sealed, allowing exhaust fumes to enter.

As the vehicles are driven along the road, they quite naturally suck in their own exhaust fumes and, as our tests showed, you can't guard against that occurrence simply by opening the windows at the front. The only remedy in that case is to stop the vehicle and fix the leak. But what if your trunk lid or rear door is perfectly sealed? Are you safe from exposure to the carbon monoxide in exhaust gases? No you are not. If you are driving in traffic or stopped at traffic lights with other vehicles, you are bound to be exposed.

That applies particularly if you drive with a window open or with your air-conditioning set to "fresh air." Under such circumstances, you should set the air-conditioner to "recirculate." So whether or not your vehicle has defective seals, you still need an exhaust-gas monitor to tell you if you are being exposed.

Exhaust Monitor. With those problems in mind, we set out to produce a simple, effective, yet easy-to-build exhaust gas monitor. The end result was a

circuit built around a TGS 812 solid-state gas sensor (made by Figaro of Japan), which is housed in a small plastic case.

Note: The TGS 812 has been discontinued in favor of an advanced version of the unit, the TGS 822, which the manufacturer assures us will function equally well in the Exhaust Gas Monitor. In addition, the TGS 822 has the same dimensions and pinouts as the earlier model, and is available from the supplier given in the Parts List.

The TGS 822 gas sensor is a semiconductor device based on sintered tin oxide (SnO₂). When combustible or reducing gases are absorbed on the semiconductor surface, its resistance is markedly reduced. When the gas dissipates, the resistance returns to normal.

Examples of combustible gases are hydrocarbon vapors (from gasoline, methylated spirits, etc.), natural gas, methane, hydrogen and so on. And the prime example of a reducing gas is carbon monoxide. It is also combustible and burns with a clear blue flame.

The TGS sensor is housed in a case that's about 3/4 inch in diameter with 6 pins protruding through the base. At the top, it has a 1/2-inch opening that is covered by two layers of very fine mesh. There is also a small hole on the underside, again covered with mesh, so that gases can pass through the unit. Inside is a heater and a semiconductor element. The heater consumes about 600 milliwatts and is there to purge the semiconductor element of gases that are deposited onto its surface.

The double layer of wire mesh is there to prevent the risk of explosion when the sensor is exposed to dangerous concentrations of gas.

The Circuit. Now let's look at the circuit. Figure 1 is a schematic diagram of

the Exhaust Gas Monitor. The circuit consists of the TGS 822 gas sensor (R19), an LM324 quad op-amp (U1), a 3-terminal regulator (U2), two BC548 general-purpose transistors, a piezoelectric buzzer (BZ1), and a few additional support components.

The 7805 3-terminal regulator provides a constant +5 volts to the circuit from a nominal 12-volt supply such as a car battery. The +5-volt output of the regulator (U2) feeds the heater circuit (pins 2 and 5) of the TGS 822 as well as the rest of the circuit, except for the piezo siren which is powered from the +12-volt power supply.

Basically what happens is that the circuit monitors the resistance across pins 4/6 and pins 3/1 of R19 (the gas detector). When the resistance between those two points drops, the circuit sounds an alarm.

Op-amp U1-a is the core of the circuit; it monitors the resistance of R19. The sensor is connected in series with a 10k resistor to form a voltage divider across the +5-volt supply. The voltage at the center point of that divider is monitored via a 4.7k resistor at pin 5 of U1-a. That voltage is compared with a reference voltage set by R10 at pin 6.

Normally, the resistance of R19 is high, and so the voltage at pin 5 of U1-a will be low. That means that the output of U1-a will be low. When carbon monoxide or other relevant gases come in contact with R19, its resistance goes low and the voltage at pin 5 of U1-a goes high. That causes the output of U1-a to go high, allowing the oscillator stage (U1-d) to run. The oscillator operates at about 1 Hz and turns Q2 on and off once every second to drive the piezo alarm. The alarm is loud enough to be effective, but is not so loud as to be painful.

Since the base current for Q2 flows through LED1, there is also a visual indication of the alarm. Op-amps U1-b and U1-c provide a 2-minute muting period for the alarm when it is first turned on. That is necessary because when first turned on the TGS sensor will be "poisoned" by gases that have been absorbed on its surface while it has been in the unpowered state. Its resistance is therefore initially quite low, but within two minutes the heater will purge the device and its resistance will go high.

Op-amp U1-b can be regarded as an RC timer with a very large capacitance connected to pin 2 (ignore U1-c for the moment). When power is first

battery line. On the output side of the regulator, a green LED in series with a 390-ohm resistor gives an indication that the unit is turned on.

Construction. The Exhaust Gas Monitor is housed in a standard plastic utility box that measures about $5\frac{1}{8} \times 2\frac{5}{8} \times 1\frac{1}{8}$ inches with a plastic lid. All the circuit components are fitted onto a printed-circuit board. A template for the Monitor's printed-circuit board is shown in Fig. 2. The board is mounted onto the lid of the case so that R19 (the gas sensor) and piezo alarm BZ1 protrude slightly from the front panel.

The first step in construction is to carefully examine the printed-circuit board for any faults in etching; e.g., shorts be-

tween traces or pads, and open circuits (breaks) in traces. Once done, and you are satisfied that there are no faults, insert two printed-circuit pins for the +12-volt and ground supply connections using Fig. 3 as a guide.

Next insert and solder the resistors and the three 0.1 μ F monolithic capacitors (C2, C4, and C4). The three electrolytic capacitors (C1, C3, and C6) are mounted so that they can be laid on their sides. You can then install U1, R10, Q1, and Q2. Make sure that those components are correctly polarized before you solder them in place.

The 7805 3-terminal regulator (U2) is mounted on the copper side of the board so that air can circulate around it. Poke its leads through the board

holes so that they protrude about a $\frac{1}{4}$ inch on the component side. Solder the leads so that the 7805 is vertical. Afterward, mount the piezo alarm (BZ1) on the board, using a pair of screws and matching nut, and then solder its leads to the board. Note that the leads are polarized: red for positive, black for negative.

With that done, R19 can be soldered into the circuit. Its leads are arranged so that it can go into the circuit either way around but polarity is not important. Its leads should be soldered so that the top of the sensor is level with the top of the piezo alarm.

The two LED's should be mounted so that they stand just slightly higher than the top of the piezo alarm. Watch the polarity of the LED's—their longer lead is positive (i.e., the anode).

Checkout Time. Now check your work thoroughly. Are all components where they should be and cross-checked to agree with the circuit? If not, correct all errors. Now connect a length of polarized twin-lead wire and connect a 12-volt power supply. If R17 (a 5.6 ohm resistor) starts smoking, you've connected the supply the wrong way. The alarm should beep briefly when power is applied and then nothing should happen for about two minutes.

After that, rotate R10 clockwise until the alarm turns on. It should beep on and off continuously at a rate of about 1 Hz (or once per second). If it does, rotate R10 counterclockwise until the alarm turns off. Then use a multimeter to set R10 for a reading of +2 volts between pin 6 of U1 and ground. That is most conveniently measured at the wiper (i.e., the center terminal) of R10 and the printed-circuit connection for ground.

That setting is purely arbitrary by the way, and one that we found gives reasonable sensitivity without nuisance triggering of the alarm. If you want the alarm to be more sensitive, rotate R10 further clockwise.

You can test the Monitor by blowing cigarette smoke into the sensor. It will immediately sound, proving that you are poisoning yourself. Yes, cigarette smoke contains carbon monoxide in addition to other toxins. If you don't smoke, you can test the Monitor by letting it "sniff" the cap from a bottle of methylated spirits. That completes the check out. The circuit is now ready to be installed in a case.

(Continued on page 98)

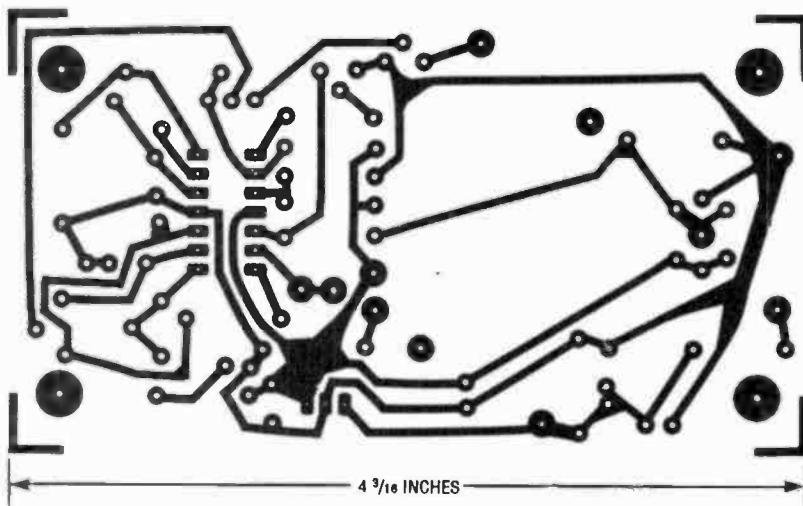

Fig. 2. Here is the full-size artwork for the printed-circuit board. Once the board has been etched, carefully examine it for any faults; e.g., shorts between traces or pads, and open circuits (breaks) in traces.

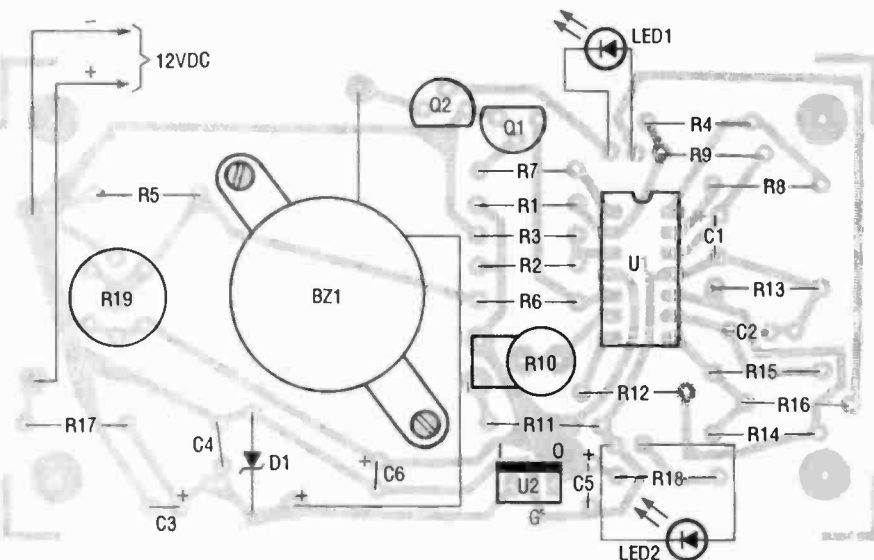

Fig. 3. Here's how to install the parts on the printed-circuit board. The TGS 822 sensor can be installed either way around, but carefully note the orientation of transistors Q1 and Q2. The 7805 3-terminal regulator is mounted on the copper side of the board.

AUTOMOTIVE ELECTRONICS



in the 1990's

New advances on the drawing board, on the way, and here now will make man's favorite toy a lot more fun to use—and safer, too!

BY ROBERT ANGUS

The term "automotive electronics" brings to mind CB radio, trunk-mounted stereo woofers, 200-watt-per-channel power amps, and specially-designed FM circuits to overcome the effects of urban ghosting and rural signal fade. But as we move toward the year 2000, automotive electronics will also mean devices to make driving safer and more enjoyable. It's already technically possible to produce a windshield that lets you see a deer jump across the road in front of you at night; sensors and video cameras which make backing up and parking a snap; an alarm system to prevent dozing at the wheel; satellite-controlled vehicle tracking; automotive navigation systems; and lots more. Some of those innovations are available now;

others will become available in the coming decade.

Heads-Up Display. General Motors and Nissan already have taken one step toward improving driver safety with the introduction of a *Heads-Up Display* (HUD) in some of their vehicles. The HUD projects important information such as speed, directional signals, and fuel levels on the lower part of the windshield.

So far, HUD has been limited to top-of-the-line GM and Nissan models, and estimates are not available as to the amount it adds to the cost of the car. Nissan's system involves a specially treated portion of the windshield; in GM's system, the information is projected optically from a box mounted

atop the dash and the images appear to hover above the car's front bumper. See Fig. 1.

The obvious advantage of the HUD is that with it, drivers need not divert their eyes from the road to view pertinent information. The key word here is "pertinent;" ever since the technique was developed, automotive engineers have been arguing over which information (and how much) should be displayed. Initial tests involved everything from the FM tuning dial to the external temperature. The test drivers reported that they found too much information too confusing; hence the scaleback to bare essentials in characters large enough to be read easily.

GM is also experimenting with "Stored Image Holograms." Like the

HUD, those images are projected to appear at the windshield plane and could be used to provide vehicle-status information (fuel level, high-beams on, etc.) normally displayed by instrument-panel telltales. Another application of the technology would be to provide perimeter marker holograms to assist parking by showing the driver a projection of the vehicle position relative to other objects that can be seen.

NODS. In 1971, GM's Delco Electronics subsidiary started research on using radar to avoid (or at least warn of) potential same-lane collisions. Now, the availability of microprocessors which are not only much better-suited to automotive use, but also much lower in cost, has revived the program and, pending FCC approval, Near-Obstacle Detection Systems (NODS) could be on more expensive models within a few years.

One type of NODS is a rear proximity warning system. When the car is in reverse, a NODS sensor located in the rear of the car detects the presence of objects within a specific distance; see Fig. 2. The driver is then warned through a visual and/or audible signal. Such a NODS system would be particularly valuable for trucks, vans, and cars with high rear decks.

Another NODS under development is a blind-spot detection system. That system is activated when the turn signal is turned on and alerts the driver to the presence of other cars within the vehicle's blind spot. See Fig. 3.

As currently envisioned, NODS will be able to detect solid objects within its range and issue a warning to the driver; it will not act as a control system.

Navigation Systems. Automotive navigation systems have been promised for many years. Now, that promise appears to be becoming a reality through the efforts of Blaupunkt, Philips, GM, and others. One of the first on the market is Blaupunkt's *Travelpilot*, a do-it-yourself kit which includes wheel-rotation sensors, a CD-ROM player, microprocessor/computer, and CRT display, all for a mere \$2400. To complete the package, you need a CD-ROM disc containing routing and travel information.

What the system does is to allow a motorist to tell the computer where he is and where he wants to go. The system plots the route, from his driveway to the parking lot at his destination, and displays it in stick figures on a CRT. There's

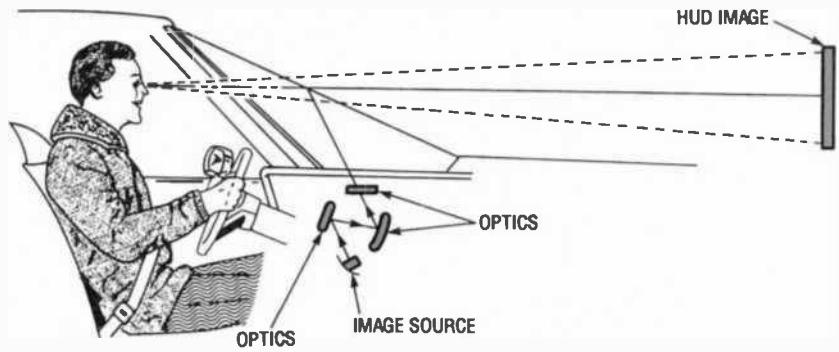

Fig. 1. General Motors' Heads-Up Display (HUD) projects speed and other important information onto the vehicle's windshield. To the driver, the display seems to hover in space above the bumper.

also a synthesized voice to alert the driver to a left turn coming up, or to warn that he hasn't got enough gas to reach the next Interstate interchange. The disc contains, in addition to routing information, details on hotels, restaurants, and tourist attractions to be found along the way.

The only thing holding up North American introduction is the disc. Currently, the only one available is for Germany, which is the only country where the system is already on the market. However, a North-American model was demonstrated at this past winter's Consumer Electronics Show, and discs for the U.S., Canada, France, the Netherlands, Great Britain, and Switzerland are expected to be available soon.

Wayfarer. You come down to breakfast one morning. Mom and Dad announce that they're going to use part of Dad's retirement bonus for a camper to set out and see America. They're both in good health and good drivers, but still you worry. What you need is *Wayfarer*, a

product of Sony, which keeps you posted on their whereabouts automatically at regular intervals. In case of emergency, they can let you know with the push of a single button, whether they're just down the road or on the other side of the continent.

Wayfarer integrates the best of two existing technologies: satellite communications and Loran-C—the federal government's network of navigational beacons. Using information from the

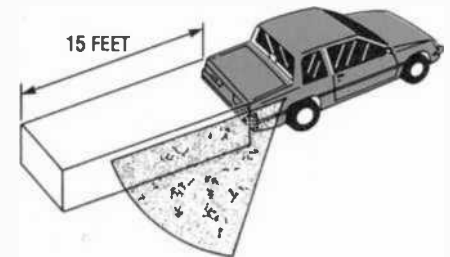

Fig. 2. One application for a Near-Obstacle Detection System (NODS) would be to alert drivers to unseen objects behind and to the sides of the vehicle while backing up. Such a system would be especially useful for cars with large rear decks and for trucks or vans.

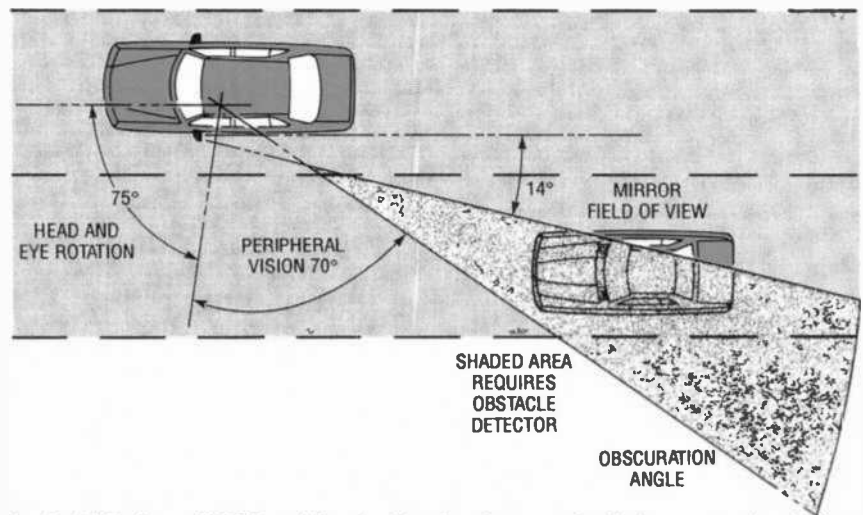

Fig. 3. A blind spot NODS could make changing lanes on the highway a much safer operation by alerting the driver to unseen vehicles.

Loran beacons, the unit automatically determines its location. That data is beamed via an antenna on the roof of the vehicle to the Geostar satellite relays, which transmit them to a Geostar computer in Washington, D.C. From there, the information travels over ordinary telephone lines to its destination.

Originally designed to allow long-haul truckers and operators of vehicle fleets to keep track of their rolling assets, Wayfarer is on the market now, and it costs less than \$3000 plus five cents per message. A consumer version is also in the works.

The system consists of a compact transmitter (5 $\frac{1}{8}$ x 9 $\frac{7}{8}$ x 7 $\frac{1}{8}$ inches) and two antennas, one of which is 16 $\frac{1}{2}$ inches high and looks like a CB antenna. The addition of a simplified keyboard and an LCD display enables the sending of simple messages such as "Arrived OK," "Emergency—Need Help," or even more complicated, more personal messages simply by typing them in. Whatever the message, the system includes date, time, and location automatically.

There is also a two-way version, which costs \$4800 and incorporates a C-band receiver/interface unit that accepts incoming messages as well as wiring for sensors and the remote-control functions of intelligent interfaces. The receiver/interface is the same size as the one-way system's transmitter, and it can be mounted almost anywhere in the vehicle where it's out of the way. If Dad and Mom have one, you can phone a message to the computer in Washington, which then beams it up to the satellite and then to the keyboard/display in your folks' camper. In the event their eyes are on the road rather than on the LCD display, there's an audio alert to notify them of an incoming message.

According to Sony, during the system's first year of operation some 2000 vehicles, mainly trucks, were equipped for the system and more than five million messages were transmitted with 99.5% going through on the first try. Can the system stand up to hundreds of thousands of private users sending millions of messages a year? Geostar has a total of four satellite relays capable of handling Wayfarer messages, with two in use most of the time and the other two serving as backups. The system can handle up to one million messages per hour and transmits via frequencies which are not easily affected by outside interference.

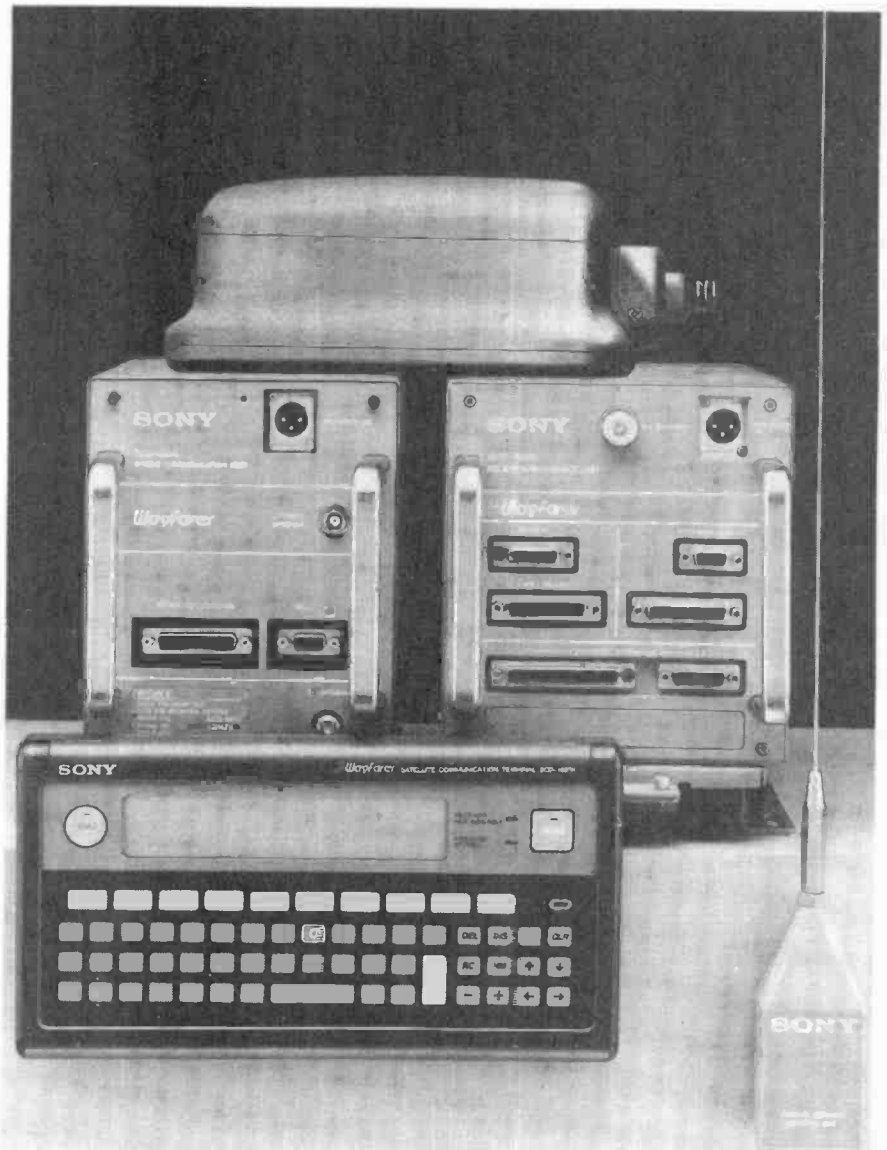

Sony's Wayfarer mobile-communications system uses Loran-C and Geostar satellites to pinpoint vehicle location and provide one- or two-way communications nationwide.

On the Drawing Boards. Falling asleep at the wheel is a problem for senior citizens, long-haul truck drivers, and teenagers travelling across the country who don't know when to quit, and all would benefit from an alarm system designed to stop it. While such a system's cost and bulkiness make it seem an unlikely feature for the foreseeable future, the experts are convinced it's do-able. Sensors that monitor eye movement, grip on the steering wheel, and/or movement on the driver's seat would be used to feed data to a microprocessor, which makes a decision based on the driver's normal patterns. If the microprocessor catches you napping, it sounds a voice alarm. If that doesn't work, it sounds a loud klaxon that's sure to grab the driver's attention.

Closer to reality, and perhaps the most revolutionary of the electronic im-

provements is Night Vision, a technique General Motors has been working on for some time. Based on military research, it uses infrared beams to illuminate objects the eye can't see well at night. The problem is finding a practical way to display the information. The military version involves special infrared goggles, an obvious impracticability in a car. Another involves a specially-treated windshield, similar to the one Nissan uses for its heads-up display. Unfortunately, the coating needed to make the system work also cuts down on visibility in sunshine. A third possibility is a dashboard-mounted CRT which, as we shall see, could have other applications.

The principle on which Night Vision works is *pyroelectrics*—the fact that objects emit or reflect heat at different

(Continued on page 102)

Did you know that by leaving a porch light on when you go out for an evening, you may be telling a thief, "We're out and won't be home until after dark." How do you think visitors or strangers would act if the garage, yard, or porch light came on when they drove up to your home?

Maybe you've been considering one of the commercially available infrared motion-sensing lights. Unfortunately, such devices are prone to false alarms due to rain, wind, or animals. And when you consider the other limitations of such devices—the lights-on time and range, for example—motion-sensing lights may not be all they are cracked up to be. If you are in the market for an inexpensive circuit (\$15–\$20) that can control existing or additional lights from 300 feet away or more, then the *Programmable Automatic Yard and Garage Light Controller* is for you.

The Programmable Automatic Garage and Yard Light Controller is not just another timer circuit that uses large capacitors to provide long delay times...not by a long shot. The controller is instead a precise, digital, timing circuit with 28 different frequencies (delay times) that can easily be programmed by setting a 5-position DIP switch.

Circuit Description. Figure 1 is the schematic diagram of the Programmable Automatic Yard and Garage Light Controller. At the heart of the circuit is the LS7210 programmable digital delay timer—a monolithic, ion-implanted MOS IC that can produce delays from 6 ms (.006 seconds) to infinity. The duration of the generated delay is determined by an RC oscillator and five weighted binary inputs (more on those inputs later).

The timer is coupled with a pair of infrared photo-transistors (Q1 and Q2) and two resistors (R2 and R6), which form the detector (unbalanced bridge) portion of the circuit. During the daylight hours, direct sunlight striking Q1 and Q2 cause them to conduct equally. That causes a voltage that's slightly above ground potential to be applied to the trigger input of U1. At the same time, R2 keeps the bridge unbalanced and prevents excessive current from damaging Q1 or Q2 in bright sunlight.

When it gets dark outside and headlights hit Q1, that unit turns on pulling pin 3 of U1 low. That causes U1's output at pin 13 to go low and start its delay. The low output of U1 is fed to the base of Q3

Would you like to save money on your electric bill and still have a light on when you come home at night? This light controller will provide that convenience, and do it more reliably than commercial motion-sensing night lights.

(forward biasing it), causing it to turn on. With Q3 now conducting, +12 volts (minus the voltage drop across R1 and Q3) is applied to the coil of relay K1, energizing it. With K1 energized, K1's wiper (the center moving contact) is pulled from its upper, normally-closed contact to its normally-open (lower) contact, thereby completing the AC lamp circuit.

The frequency of U1's internal oscillator is determined by the circuit's applied voltage and an external RC network consisting of C1, R5, and R7. The duration of the delay is then determined by the binary weighted inputs (pins 8–12) of U1. The delay duration (in seconds) is given by:

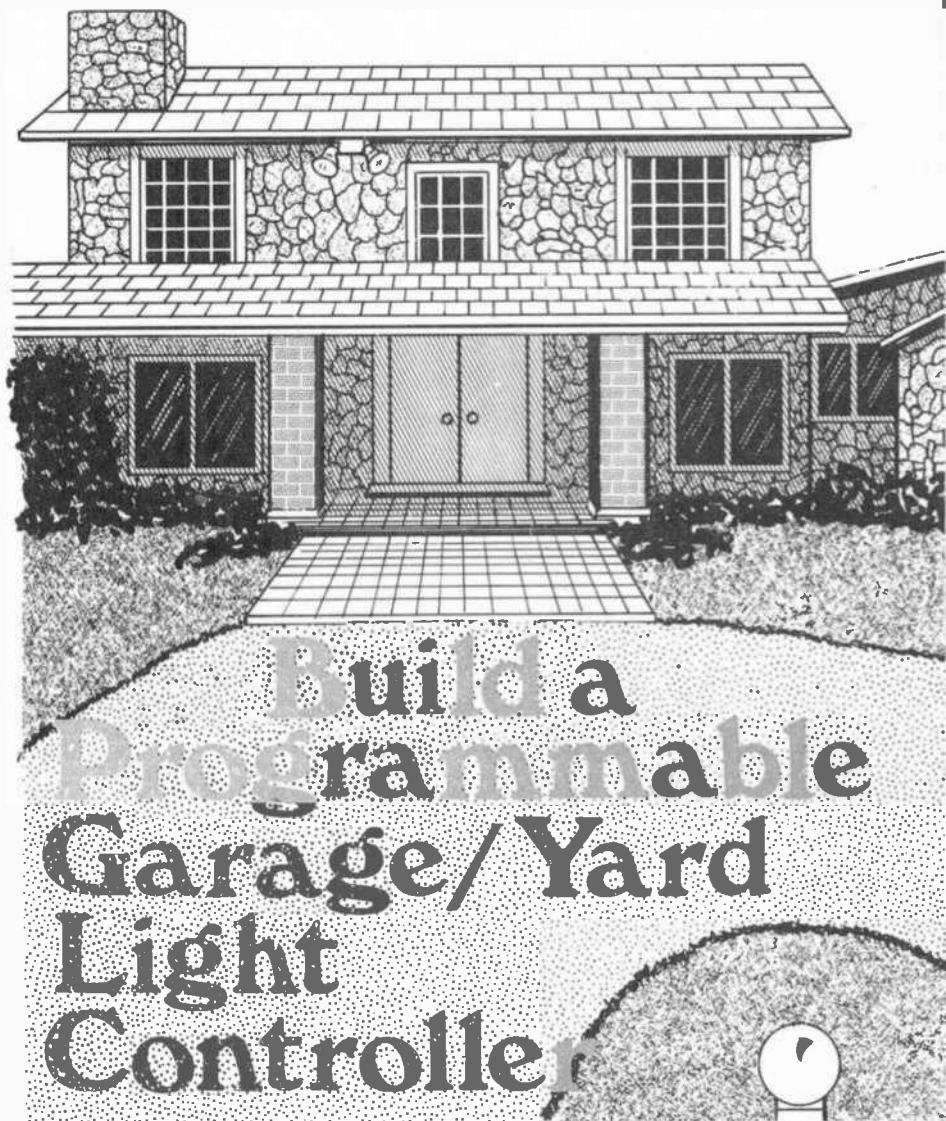

Build a Programmable Garage/Yard Light Controller

$$D = 1 + 1023N/f$$

where f is the oscillator's operating frequency and N is the weighting factor.

Refer to Fig. 2 and Table 1 for this portion of our discussion. Lets say that pin 11 ($\overline{\text{LSB}} + 1$) is tied to V_{cc} , resulting in N being equal to 2. Using a .047- μF capacitor for $C1$ and adjusting the combined total resistance $R5/R7$ to approximately 1.8 megohms yields a frequency of 17 Hz. Plugging that value into the equation we get:

$$D = 1 + 1023 \times 2/17$$

which works out to 120 seconds or a 2 minute delay.

The weighting-factor inputs (pins 8–12) of $U1$ are connected to a 5-posi-

tion DIP switch ($S2$ in Fig. 1), allowing any of those inputs to be grounded by a simple flip of the appropriate switch. Thus, with $U1$'s internal oscillator set at 17 Hz and a flip of the appropriate switch(s), you can set the delay to from 1 minute to 31 minutes.

Adjusting $R7$ (a 1-megohm potentiometer) changes the RC time constant (and the delay) of the circuit. With the circuit built as shown and DIP-switch position-A closed, the delay can run from 20 seconds to 72 seconds. With all DIP switch positions closed and a weighting factor of 31, your delay could be over 37 minutes! If you need a longer delay, just change the values of $C1$ and $R5$ using the information given in Table 2 as a guide.

In the real world, mechanical devices wear out and might fail more often than electronic devices, so a 5-volt DIP relay was chosen for $K1$, allowing it to be easily replaced. If your application requires higher current than that unit can handle, you can control a larger relay with $K1$. If you wish to operate a 12-volt relay, remove $R1$ and install a jumper in its place.

The circuit consumes less than 5 mA in the standby mode and less than 80 mA when triggered. The author powered his circuit with the backup battery from his home-built security system (see "The Very Versatile Code Alarm" in the April, 1990 issue of **Popular Electronics**) Very Versatile Code. The circuit can be powered from a wall-mounted, 12-volt, 200-mA or more, DC power supply, or you can build your own supply if you wish. In any event, be sure to fuse the circuit.

Construction. There is nothing critical about the construction of the circuit, however it is recommended that the

circuit be assembled on a printed-circuit board. The author's printed-circuit pattern is shown in Fig. 3. Once you've etched your board and obtained the necessary components, construction can begin. An iron-on printed-circuit pattern for the Programmable Automatic Yard and Garage Light Controller is available from the supplier listed in the Parts List.

Figure 4 is a parts-placement diagram for the author's printed-circuit board. Begin assembly by first installing IC sockets at the positions where $U1$, $S2$, and $K1$ are indicated. The use of sockets allows for easy replacement of those components should any of them become defective. Using sockets also makes locating the proper positions for the other components a bit easier. The 5-position switch specified for $S2$ can be hard to find; if you encounter difficulty in obtaining a 5-position DIP switch, you can use a 4-position unit, leaving the fifth position empty or permanently placing a jumper wire in that position.

Install all of the on-board parts first, starting with the passive components (resistors, capacitors, etc.) and then the active components—in this case only diode $D1$, keeping in mind the orientation of that polarized component. Allow the sockets to remain empty for now. The next task is to wire the off-board components to the printed-circuit board, but first a little preparation is in order.

Since $Q1$, $Q2$, $R2$, $R8$, and $S1$ are not mounted to the board, they must be housed in their own separate enclosures. The author chose to house those components in a pair of plastic 35-mm photographic-film cans. Drill appropriately sized holes into the film-can lids and mount an LED holder to each lid, and then mount $Q1$ and $R2$ in one lid and $Q2$ in the other. Before mounting $Q1$ or $Q2$ cut the collector leads (the flat side of the unit denotes the collector lead) to about a $1/4$ inch and the emitter leads to $1/2$ inch.

Solder $R2$ to the collector of $Q1$, and solder 2-inch lengths of wire to the leads of $Q2$ and the $Q1/R2$ combination. Afterward seal the backsides of the lids with silicone rubber. If you need a light switch on the circuit, add $S1$, an SPST momentary-contact switch for a single timed delay, and don't forget to wire $R8$ in series with it. Finally install $U1$, $S2$, and $K1$ in their respective sockets to finish up the construction.



BY MIKE GIAMPORTONE

TABLE 1—WEIGHTING BIT ASSIGNMENT

Input	Bit value
$\overline{\text{LSB}}$	1
$\overline{\text{LSB}} + 1$	2
$\overline{\text{LSB}} + 2$	4
$\overline{\text{LSB}} + 3$	8
$\overline{\text{MSB}}$	16

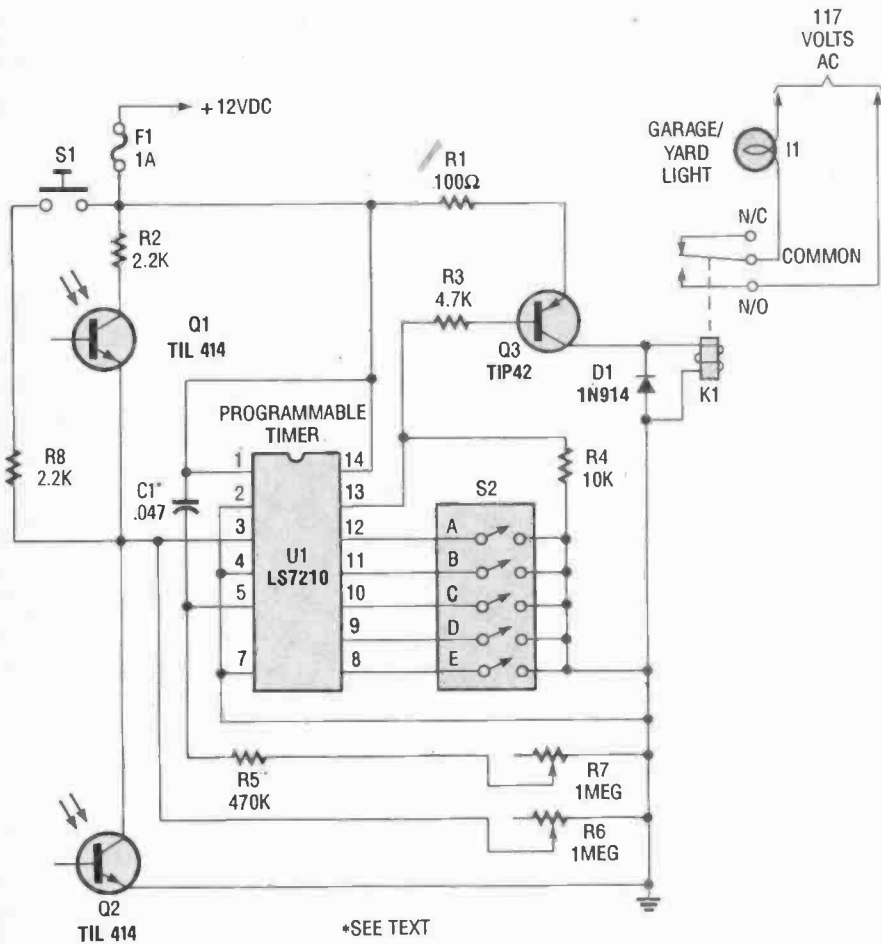

Fig. 1. At the heart of the Programmable Automatic Yard and Garage-Light Controller is the LS7210 programmable digital-delay timer.

TABLE 2—OSCILLATOR COMPONENT SELECTION GUIDE

Resistance (k ohms)	Capacitance (pF)	V _{ss}		
		@ +5	@ +10	@ +15V
47	100	128 kHz	139 kHz	185 kHz
	200	79 kHz	83 kHz	85 kHz
	500	37 kHz	37 kHz	36 kHz
	1000	21 kHz	21 kHz	20 kHz
	5000	500 Hz	500 Hz	475 Hz
470	100	15 kHz	16 kHz	16.5 kHz
	200	9 kHz	9.5 kHz	9.5 kHz
	500	4 kHz	4 kHz	4 kHz
	1000	2.4 kHz	2 kHz	2 kHz
	5000	63 Hz	51 Hz	47 Hz
2000	100	4.2 kHz	4.7 kHz	5 kHz
	200	2.5 kHz	2.7 kHz	2.8 kHz
	500	1.1 kHz	1.1 kHz	1.1 kHz
	1000	670 Hz	617 kHz	610 Hz
	5000	17 Hz	14 Hz	14 Hz
10,000	10 μF	.02 Hz	.015 Hz	.013 Hz

Before powering up the circuit, be sure to set potentiometer R6 to maximum resistance. That sets the circuit for maximum sensitivity. Next set potentiometer R7 to its mid position and close the S2 position-A switch. Once powered up the relay will close and delay begins. If all seems okay, mount the circuit board in its enclosure.

The author's prototype was housed in

a plastic enclosure (with an aluminum front panel) measuring about 3¼ × 2½ × 1½ inches. It will be necessary to drill a pair of holes in the enclosure through which to connect the relay contacts to the AC lamp circuit and the detector section and power supply to the circuit board.

Installation. First you must determine

PARTS LIST FOR THE PROGRAMMABLE AUTOMATIC YARD AND GARAGE LIGHT CONTROLLER

SEMICONDUCTORS

- U1—LS7210 programmable digital timer, integrated circuit
- Q1, Q2—TIL 414 (Radio Shack 276-145) or similar NPN IR phototransistor
- Q3—TIP42/MJE34 PNP power transistor
- D1—1N914B general-purpose, small signal diode

RESISTORS

- (All resistors are ¼-watt, 5% units, unless otherwise noted.)
- R1—100-ohm, 1-watt
 - R2, R8—2200-ohm
 - R3—4700-ohm
 - R4—10,000-ohm
 - R5—470,000-ohm, see text
 - R6, R7—1-megohm, potentiometer

ADDITIONAL PARTS AND MATERIALS

- C1—0.047-μF, 50-WVDC, polyester capacitor, see text
- K1—5-volt, 2-amp, 14-pin DIP relay with 117-volts AC SPDT contacts
- F1—1-amp fuse
- S1—SPST normally-open, momentary-contact pushbutton switch
- S2—5 position DIP switch (see text)
- Printed-circuit board materials, enclosure, 14 pin DIP socket, LED holder, 12-volt, 200-mA or more power source, wire, solder, hardware, etc.

Note: The LS7210 programmable digital-delay timer is available from Belco Electronics, 194 N. Myrtle Ave. Elmhurst, IL 60126; Tel. 312-953-1115. There is no minimum order, but \$3.90 shipping and handling charge will be added to orders of one pound or less. Also, an iron-on printed-circuit board pattern is available by sending \$1.00 and a self-addressed stamped envelope to: Yard Light, 7330 Duce Road, Yale, MI 48097

where the detector portion of the circuit is to be mounted. It is best to mount detector Q1 about 2 to 3 feet from the ground and in a position where your headlights shine on it as you come up your driveway or head toward your garage. Detector Q2 should be mounted at least 6-feet higher than detector Q1 and perhaps located to one side of the structure to which it is to be fastened.

I have a 300-foot driveway and with the IR phototransistors specified and no

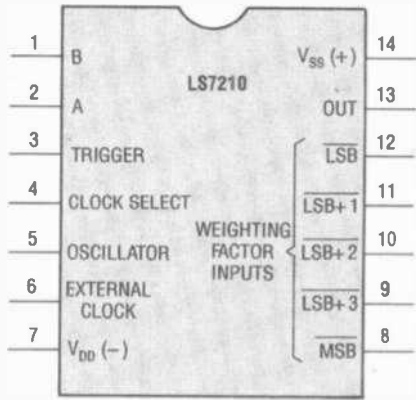

Fig. 2. The LS7210 is a monolithic, ion-implanted MOS IC that can produce delays from 6 ms (.006 seconds) to infinity. The units binary-weighted inputs make it easy to program it for almost any desired delay time.

moon, as soon as I turn into the driveway, my yard light turns on. The detectors (Q1 and Q2) specified may be replaced by other phototransistors or even photoresistors if you wish, but photoresistors have a slower rise time, less sensitivity, are hard to find sealed, and are larger.

Another film can be used—although it may not be needed—to focus Q1 down the driveway and to prevent other light sources from triggering the circuit. The most important parts, and easiest to connect wrong, are Q1 and Q2. Be sure to double check them.

Troubleshooting. If the relay doesn't close as soon as power is applied to the circuit, check the fuse and leads going to the printed-circuit board. Also check for solder bridges, cold solder joints,

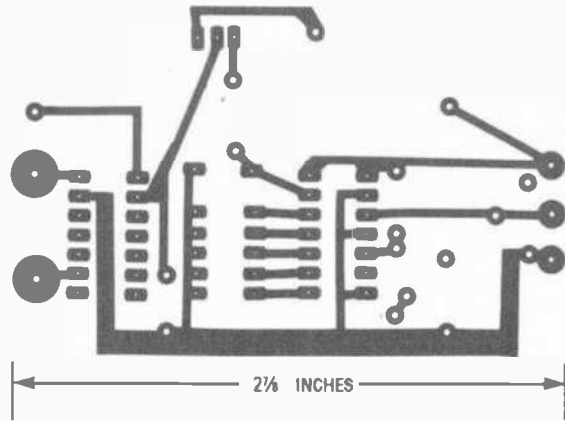

Fig. 3. Use this pattern to make your printed-circuit board.

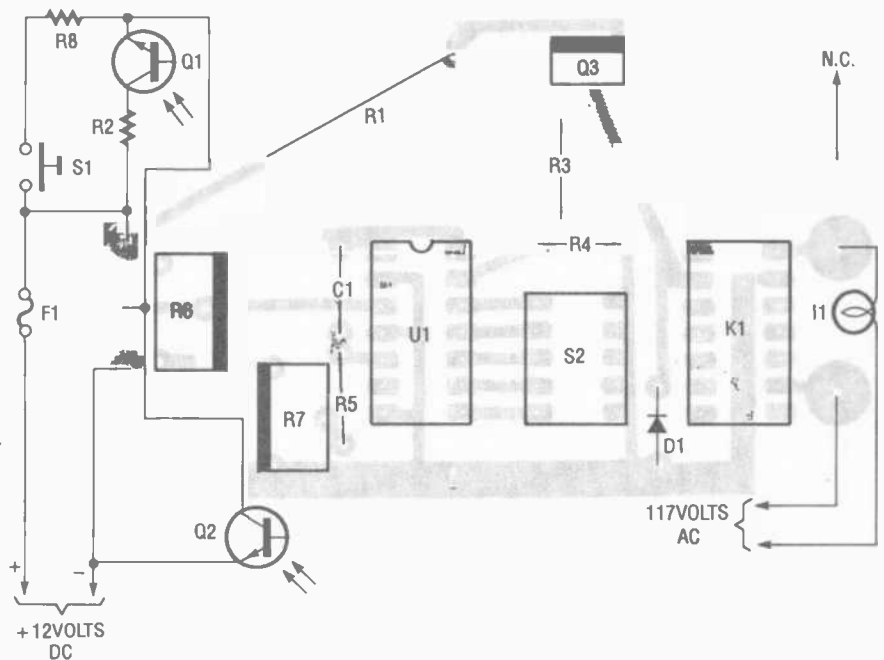
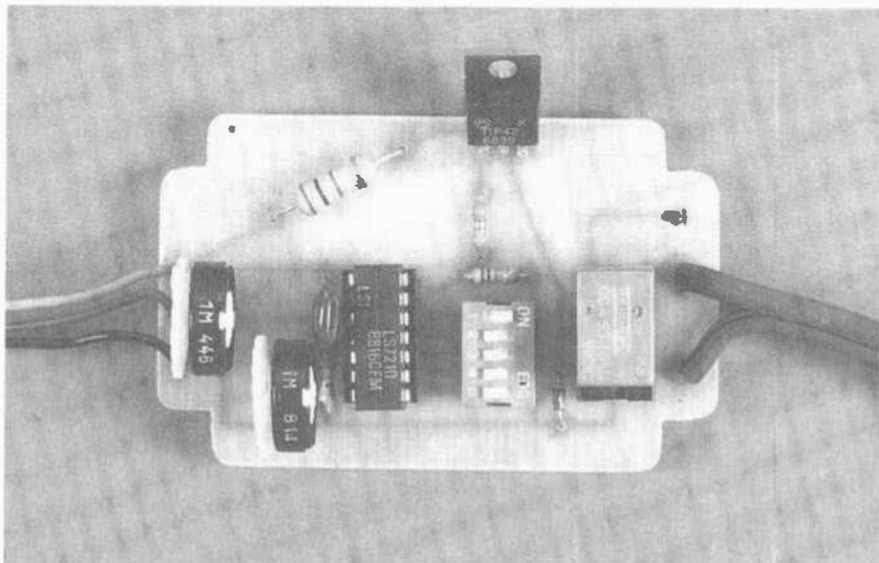

Fig. 4. Guided by this parts-placement diagram, begin assembly by first installing IC sockets at the positions where U1, S2, and K1 are indicated. The use of sockets allows for easy replacement of those components should any of them become defective.



Here is the Programmable Automatic Yard and Garage Light Controller's finished printed-circuit board. Heavy-gauge wire is used for the AC lamp circuit, while color-coded hook-up wire is used to connect the circuit board to the sensors.

and missing traces. If after closure, the relay doesn't open up, check to see if you closed the proper DIP switch position for the delay selected. Also check the voltage at pin 3 of U1; it should be less than 2 volts, unless there is significantly more light on Q1 than on Q2.

During the delay interval, if you check the voltage at pin 5 of U1 with a DMM you should see it oscillate between 6–7 volts. When the circuit is triggered or just powered up, the voltage at pin 13 should be 3 volts, which should rise to about 12 volts after the delay.

There are other applications for the Programmable Automatic Garage/Yard Light Controller; for instance, as mentioned earlier, the circuit might be coupled to your alarm system, so that once the alarm sounds, pin 3 of U1 is pulled high and then the lights come on and shut off after the delay. ■



When a couple of journalists who haven't seen one another for awhile run into each other at a Consumer Electronics Show, the conversation usually runs something like:

"Well, Stan, have you seen anything interesting at the show yet?"

"Not a thing, Les, not a thing. Nothing new at this year's show at all."

That conversation seems to be part of the CES tradition. In all probability the greetings a few years before sounded this way:

"Well, Stan, anything interesting this year?"

"Not especially, Les. Uh, JVC is pushing a new videotape format, something they call VHS. Big deal—just what we need, *another* 'standard!' It'll never touch Beta. Naw, nothing to write home about this time."

The moral—and sad truth—is that our tastes in the field of consumer electronics have become jaded. So much so that unless a product or concept is different enough to knock our eyes out

of their sockets, we tend to write it off as just another gimmick with no potential whatsoever.

While there were a few innovative products shown at this year's Winter CES, mostly it was just "more of the same." Of course, it may be that we were staring the future right in the eye and just haven't realized it yet, but at the time there seemed little to spark either the imagination or the industry. That's why, although we will describe some of the new products that we saw, we will also talk about something less tangible: the trends that seem to be evolving in the consumer-electronics industry.

On the Floor. The first things that hit you when you enter the Winter Consumer Electronics Show are the crowd and the *immensity* of the show. For as far as you can see there are booths, aisles, people, and more of the same. Poking out from above them you can make out familiar names and logos: Pioneer, Emerson, Toshiba. As you begin your wandering up and down and

across the aisles you encounter more old friends, as well as the occasional new and as yet unfamiliar name. And everyone's displaying their latest products and ideas.

Attendance at the 1990 Winter CES was down somewhat—about 70,000 compared to 90,000 or more in recent years—but that's still a lot of people. While the main purpose of the CES is to consummate deals—it's said that 20% of all the year's consumer electronics sales are made during the four days of the show's run—the show is also a showcase for what's new and exciting. That being true, members of the press looking for news make-up a considerable part of the crowd. Of course, what a manufacturer considers new and exciting may not seem to be quite that to someone who's "seen it all." Still, we have to remember that since you weren't there, you might want to know what was.

Video. The most impressive thing we saw in television was a huge (10-foot



1990 WINTER CONSUMER ELECTRONICS SHOW

Looking around during the Winter Consumer Electronics Convention one might think that there's nothing new under the sun—or is there?

BY JOSEF BERNARD

wide) high-definition projection system from Barco. Overall, there was little in the way of HDTV or even Improved-definition TV to be seen; Barco was the exception. It had set up a small "theater" in the brand-new Mirage hotel (where a man-made volcano erupts every quarter-hour). Every time we passed it there was a line waiting to get into the next showing. Inside was the huge (by TV standards) wide-aspect-ratio screen we've mentioned, an enormous liquid-cooled video projector connected to a videodisc player, and an eight-track Fosgate surround-sound system.

The sound was a bit overdone, but the scenes from the demo laserdisc made it bearable. The show began with several minutes of clips from current NTSC-format releases on video. That projector was good; we could have counted each of the 525 scan lines had there been time. Then, the picture dimmed for a moment and, when it returned, we were watching a wide-screen, high-definition travelog. Quite a show! When we tried we could

still tell whether the original material had been shot on tape or on film, but it was very easy to forget that what we were watching on the screen was actually video!

The Barco system is not cheap, but all the components are available today. The catch is the software. There isn't much of it, what there is is only available in Japan, and it's expensive. Of course, if you can afford the hardware, the price of the software is not going to stop you.

NEC had its own small theater and was demonstrating a 120-inch IDTV projection system. Currently available for professional use and expected to be released in a somewhat scaled-down home version this fall, the system processes standard NTSC video using a number of HDTV techniques to improve its quality, notably in the area of scan lines, which become invisible. While not wide-screen, the NEC process does afford a considerable improvement over ordinary NTSC video. If your IDTV needs are less demanding, NEC has a smaller-screen 52-inch rear-projection version;

the price is only \$6500. There was also a prototype computerized control module being demonstrated that could, among other things, dim the house lights when it was time for the show to start.

The brightest projection video system we saw (a front-projection one) was from Vidikron. In a darkened booth, its picture seemed as bright as that on a CRT. The starting price for the Vidikron systems is \$4995.

Video projection systems using LCD light gates have been shown at the last several shows, and a few more were added this year. For the moment we'd recommend you stick with the older tried-and-true methods; we weren't impressed by what we saw. At the other end of the size scale, LCD's were at the heart of a number of pocket-size color TV's. Sanyo had a very smart, and very thin, 2-1/2-inch pocket receiver, and Citizen introduced one to sell at the unbelievable price of just \$129.95. Batteries not included, of course. Finally, Sharp showed (as it has done the past

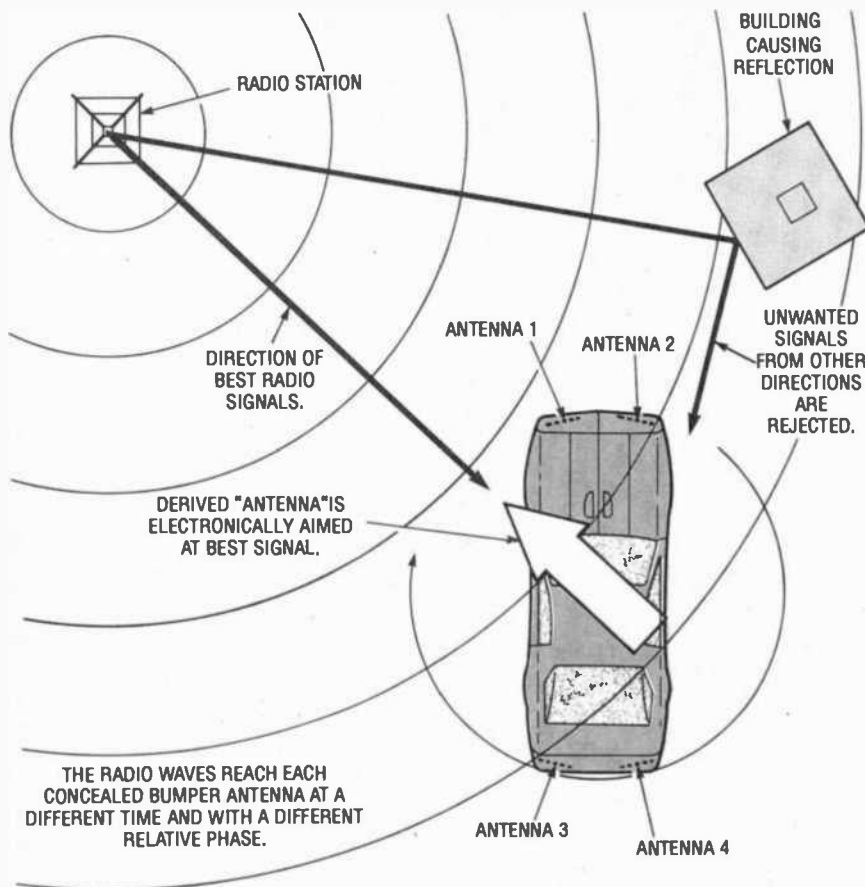

Fig. 1. A phased array of four bumper-mounted antennas is used by Blaupunkt to provide directivity in automobile FM installations. Interference is said to be reduced, and it is claimed that the tuner will lock onto and hold a signal longer than would a conventional installation.

several shows) a 14-inch flat-panel color LCD display. It looked pretty good, but you still can't buy it.

There were several portable VHS VCR's with LCD monitors here and there, the claim being made that it is easier to find material to rent for them than it is for Sony's 8mm Video Walkman. With one or two exceptions, though, those units do not include tuners. If you want to catch up on the news you'll have to bring along one of the LCD TV's mentioned earlier, or get one of Citizen's new plug-in tuner packs.

There were all sorts of camcorders at the show, most of them not much different (if at all) from their predecessors or competitors. In the Sharp booth, though, we did find a couple of innovations. The first was a VHS camcorder with a color-LCD viewfinder. The image was a bit coarse, but having color can simplify composition problems in many situations. The other Sharp camcorder that impressed us was a "cat's eye" model that produced good (albeit somewhat noisy) images in dim light at levels as low as one lux. Since most

other consumer camcorders have a sensitivity down to only about six or eight lux, that is quite an accomplishment.

Digital Audio. The big craze in audio is "DSP" digital signal processing. Once a signal has been digitized—converted from an analog waveform to a string of binary numbers—DSP can be used to manipulate it in any way an analog signal can be, and in many more besides. It's all done with numbers. The contour of a response curve can be changed, equalizing it to match any environment, or perhaps something as simple as a little extra bass or rear-channel delay can be added. You can even synthesize a type of surround sound using digital processing. The possibilities are endless and are just now being explored. DSP is now even appearing in autosound, in a unit announced by Fujitsu.

Digital technology is making itself known in other areas, too, notably in the way the components of an audio/video system are connected to one an-

other. Many mid- and high-end components now sport connectors intended specifically for digital-level signal handling, and that equipment is usually also equipped with optical outputs. The optical outputs use fiber optics to transmit a beam of light modulated by a signal (or signals) from component to component. That does away with distortion and interference caused by the introduction of electrical noise. The technique is especially useful in the electrically noisy autosound environment.

Digital audio tape (DAT) is still waiting in the wings, yet to make a formal entrance (although we did come across a dealer who claimed to be able to supply us with just about any piece of DAT equipment we desired). Sony, for one, showed prototypes of several DAT decks and even handed out pre-recorded DAT's to the press. What we're supposed to play them on is still a mystery, but since Sony also gave out CD's containing the same material we won't worry about it too much for the moment. And, although they did not make a big deal of it, Sony was also showing digitally recorded video up in its by-invitation-only room.

"Vehicular Electronics." After audio and video, perhaps the greatest degree of innovation was in the area of "vehicular electronics". We use that term, rather than "autosound" because there are lots of other electronic things going in cars these days besides music systems.

Perhaps the most exciting thing of all that we saw at the show was an automotive navigation system called TravelPilot, from Blaupunkt. City information is supplied on compact discs costing about \$60 apiece; each disc can hold information on several dozen mid-size cities. The information is displayed in the form of a map to the driver on a small CRT mounted—at least in the prototype installation we were driven around in—on a bracket to his right at dashboard level.

As you drive, a map of the territory you are traversing appears on the screen; several degrees of magnification are available. An arrow-shaped cursor marks your position on the map, and the direction of the arrow indicates your direction of travel. Alternatively, you can program the system's computer with a destination and the arrow will indicate the direction in which you must

(Continued on page 99)

Here are your free FactCards!

Introducing Popular Electronics FactCards.

Each issue, Popular Electronics will present 3 new FactCards, each dealing with one of a variety of electronics topics. Some will deal with electronics basics, some will deal with discrete components, some will deal with IC's, and some will deal with circuits and applications.

All will contain the type of information electronics hobbyists need, but sometimes must search to find. With FactCards, you can find that information in a hurry.

Clip your cards, save them, and start building your FactCards library today!

Popular Electronics

142
Popular Electronics FactCard

MM2112A - 1024-Bit (256 x 4)
MM2112AL - Static RAMS

TRUTH TABLE

CE	WE	D _{IN}	D _{OUT}	MODE
H	X	X	HI-Z	NOT SELECTED
L	L	L	L	WRITE "0"
L	L	H	H	WRITE "1"
L	H	X	D _{OUT}	READ

GENERAL DESCRIPTION

The MM2112A family of high speed 256 x 4-bit static random access read/write memories is manufactured using N-channel depletion-mode silicon-gate technology. Static storage cells eliminate the need for clocks or refresh circuitry and the resultant cost associated with them.

Low threshold silicon gate N-channel technology allows complete DTL/TTL compatibility of all inputs and outputs as well as a single 5V supply. The separate chip enable input (CE) controlling the TRI-STATE® output allows easy memory expansion by OR-tying individual devices to a data bus. Data in and data out have the same polarity. Common input/output pins are provided.

143
Popular Electronics FactCard

MM2112A - 1024-Bit (256 x 4)
MM2112AL - Static RAMS

FEATURES

- Single 5V supply
- All inputs and outputs directly DTL/TTL compatible
- Static operation—no clocks or refresh
- TRI-STATE® output for bus interface
- All inputs protected against static charge
- Access time down to 250 ns

Absolute Maximum Ratings

Voltage at Any Pin	-0.5V to +7V
Storage Temperature	-65°C to +150°C
Power Dissipation	1W
Lead Temperature (Soldering, 10 seconds)	300°C

OPERATING CONDITIONS

	Min	Max	Units
Supply Voltage (V _{CC})	4.75	5.25	V
Ambient Temperature (T _A)	0	+70	°C

144
Popular Electronics FactCard

MM2112A - 1024-Bit (256 x 4)
MM2112AL - Static RAMS

SWITCHING TIME WAVEFORMS

WRITE CYCLE

AC ELECTRICAL CHARACTERISTICS

PARAMETER	MM2112A-2		MM2112A MM2112A-L		MM2112A-4 MM2112A-4L		MM2112A-6 MM2112A-6L		UNITS
	MIN	MAX	MIN	MAX	MIN	MAX	MIN	MAX	
READ CYCLE									
Read Cycle	250		350		450		650		ns
Access Time		250		350		450		650	ns
Chip Enable To Valid Output Time		125		175		200			ns
Previous Read Data Valid	30		40		40		40		ns
Output Enabled to Output ON Delay	5		5		5		5		ns
Chip Enable to Output Disable Time		100		125		150		150	ns
WRITE CYCLE									
Write Cycle	250		350		450		650		ns
Address to Write Set-Up	0		0		0		0		ns
Write Pulse Width	100		150		175		200		ns
Write Recovery Time	0		0		0		0		ns

PARAMETER	MM2112A-2		MM2112A MM2112A-L		MM2112A-4 MM2112A-4L		MM2112A-6 MM2112A-6L		UNITS
	MIN	MAX	MIN	MAX	MIN	MAX	MIN	MAX	
Data Set-Up Time	100		150		175		200		ns
Data Hold Time	0		0		0		0		ns
Chip Enable to Write Set-Up	100		150		175		200		ns
Chip Enable Hold Time	0		0		0		0		ns
Write to Output Disable Time	100		125		150		150		ns

AC ELECTRICAL CHARACTERISTICS

PARAMETER	TYP	MAX	UNITS
-----------	-----	-----	-------

CAPACITANCE

PARAMETER	TYP	MAX	UNITS
Input Capacitance (All Inputs $V_{IN} = 0V$)	4	8	pF
Output Capacitance, $V_O = 0V$	10	15	pF

DC ELECTRICAL CHARACTERISTICS

PARAMETER	CONDITIONS	MM2112A MM2112A-2 MM2112A-4 MM2112A-6		MM2112A-L MM2112A-4L MM2112A-6L		UNITS
		MIN	MAX	MIN	MAX	
Input Load Current	$V_{IN} = 0$ to 5.25V		10		10	μA
Output Leakage Current	$CE = 2V, V_{OUT} = 2.4V$		5		5	μA
Output Leakage Current	$CE = 2V, V_{OUT} = 0.4V$		-10		-10	μA
Power Supply Current	All Inputs = 5.25V, Data Output Open, $T_A = 25^\circ C$		50		39	mA
Power Supply Current	All Inputs = 5.25V, Data Output Open, $T_A = 0^\circ C$					
Input Low Voltage		-0.5	0.65	-0.5	0.65	V
Input High Voltage		2.0	V_{CC}	2.0	V_{CC}	V
Output Low Voltage	$I_{OL} = 3.2 mA$		0.4		0.4	V
Output High Voltage	$I_{OH} = 200 \mu A$		2.2		2.2	V

For new
ideas in
electronics
read
Radio-
Electronics®

During
the next
12
months

Radio-Electronics® will carry up-to-the minute articles on:

- hobby computers
- solid-state technology
- TV games • Video
- color TV • stereo
- test equipment
- radio
- radar detectors
- industrial electronics
- servicing
- TV-radio-stereo
- experimenter circuits
- exceptional construction projects

Don't take a chance on missing even one issue. Subscribe now and save!



NEW IDEAS AND
INNOVATIONS IN
ELECTRONICS

The newest ideas and
innovations in
electronics appear in
Radio-Electronics®,
Keep up-to-date!

Subscribe Today!

GIZMO[®]

JUNE 1990

VOLUME 3,
NUMBER 6

A CHRONICLE OF CONSUMER ELECTRONICS

Batteries Included

SONY SPP-320 CORDLESS TELEPHONE. Produced by: Sony Corporation, One Sony Drive, Park Ridge, NJ 07656. Price: \$369.95.

Grasping at straws, making mountains out of molehills, spinning straw into gold—those are all endeavors in which advertising and public-relations people find themselves engaged at one time or another. Sometimes their claims arise from simple ignorance (“This is the first *veeblefetzer* ever since the time of Philip the Second of Macedonia to use the exclusive ...”), sometimes because there is just nothing else to say (“This year’s fully re-engineered *sorkitonger* has its on-off switch on the *left* side. Relocating it there offers a number of significant advantages over last year’s right-handed ...”). Following that tradition, the main claim being made for Sony’s new SPP-320 cordless phone seems to be that it comes with two batteries. Big deal!

On the whole, the SPP-320 is a very good cordless phone with several very useful features. For that it deserves (and shall receive) words of praise. However like the camel, which is said to be a horse that was designed by a committee, the phone also has several characteristics that seem out of place in what is an otherwise commendable design. First the good news.

The SPP-322 is a very stylish unit. Ours was finished in a high-tech glossy black and, while it would clash a bit with French Provincial decor, the phone should fit in nicely with any modern design. The cordless handset has a six-inch rubber-encased “flex” antenna, which should prevent antenna breakage and damage to furniture and eyes that might be caused by a more conventional telescoping-whip design. The base unit uses an ordinary silver-colored whip. Because of Sony’s somewhat unconventional battery philosophy, the remote handset is designed not to fit into the base unit. Instead, it can stand upright, or be laid down on its back, front, or side. While the handset is quite stable in



CIRCLE 50 ON FREE INFORMATION CARD

its upright position and takes up very little table, desk, or counter space that way, the temptation is still to lie it down to lower its center of gravity. The base unit can be used on a flat surface, or wall-mounted using hardware supplied with it. The cordless handset comes with a belt clip.

This Sony phone is actually three phones in one. There is the cordless handset, of course, but there is also a handset attached by a coiled cord to the base unit (in case, we suppose, you forget the cordless one or it winds up buried under a pile of papers or dirty laundry). And, for hands-free operation, the base unit also

doubles as a speakerphone. About all that’s missing is an operator’s-type headset. (By the way, the unit can also double as an intercom, and a hold button allows you to switch back and forth between functions.) The cordless and base units offer a number of features that are accessible from either one of them. In addition to being able to store ten 16-digit phone numbers for two-button recall, the phone reserves three more memory locations for numbers that can be dialed with the press of a single button. The keypads are easy to use. Curiously, while you can monitor the tones of

(Continued on page 4)

TURN PAGE FOR CONTENTS

This month in GIZMO

Sony Cordless Phone	pg. 1
Radio Shack Sound-Level Meter	pg. 2
Citizen Pocket Color TV	pg. 3
BBE Sonic Maximizer	pg. 5
Franklin Language Master Talking Dictionary	pg. 6
Hitachi VHS Editing VCR	pg. 7
57 Chevy Radio	pg. 8
Portable Cellular Phone	pg. 8
Cellular Phone Mount	pg. 9
Extended Warranty	pg. 9
Tri-Band Radar Detector	pg. 9
Vacuum-Tube CD Player	pg. 9
Audio-Technica CD Cleaner	pg. 10
CD ROM Computer	pg. 10
Front Projection TV	pg. 10
Solar-Powered Kitchen Scale	pg. 10
Auto-Reverse Cassette Deck	pg. 11
Moving Coil Cartridge	pg. 11
One-Bit CD Player	pg. 11
32-inch TV	pg. 11
Casio Keyboard	pg. 12
Fun Products Telephones	pg. 12
Onkyo AM/FM Tuner	pg. 12
Velodyne Subwoofer	pg. 12

GIZMO is published by Gernsback Publications Inc., 500-B Bi-County Blvd., Farmingdale, NY 11735. Senior Writer: Josef Bernard. Contributor to this issue: Brian Fenton. © Copyright 1990 by Gernsback Publications. GIZMO is a registered trademark. All rights reserved.

The Sounds of ... Silence?

RADIO SHACK MODEL 33-2050 SOUND LEVEL METER. From: Radio Shack, One Tandy Center, Fort Worth, TX 76102. Price: \$31.95.

Most of us live in a pretty noisy world. City dwellers are immersed in a sea of sounds, many of which they've come to accept as an unfortunate fact of life. Traffic and other street noises, subways, and even fire and police sirens, are so much a part of our daily city life that they are rarely taken note of. Should, for some reason, that "city heartbeat" falter or cease, then it becomes noticeable by its absence.

Even those of us who enjoy a more bucolic existence at some distance from centers of civilization are targeted for noise pollution by passing planes and helicopters, or by traffic on a highway several miles away. The quieter it gets, the better you can hear the noise.

We create our own local noise environment, too, wherever we are. Appliance motors and plumbing noises are significant contributors to the hum that fills the air of our apartments and houses, usually not noticed till it stops. And, of course, we subject ourselves—or are subjected by our neighbors—to all forms of noise in the form of conversation, radio or recorded music, and TV talk shows.

Much study has been done on the effect of noise on people, both on our bodies and on our minds. It's been found, for example, that too little noise (as might be experienced in an anechoic, or sound-absorbing, chamber) can have a profound psychological effect over a period of time. Too much noise can be responsible for deafness and other disorders. If you're curious about how high the waves in the sea of sound around you are, Radio Shack has a device that can help you find out. Their 33-2050 Sound Level Meter is a small, hand-holdable, battery-operated device that can tell you how loud the sound impinging on your ears really is. Such measurements are difficult to make subjectively, since the ear adjusts itself to ambient levels to prevent overloading (or to increase the intelligibility of low-level sounds). A sound level meter provides an objective means for determining noise intensities.

The meter is simple enough both in principle and in construction. It is essentially a directional microphone coupled through an amplifier to a meter calibrated in decibels. The louder the sound picked up by the microphone, the more the meter deflects. Of course, there's a little more to the device than that. For accuracy, sensitivity can be set on one of seven scales, permitting pretty accurate readings (Radio

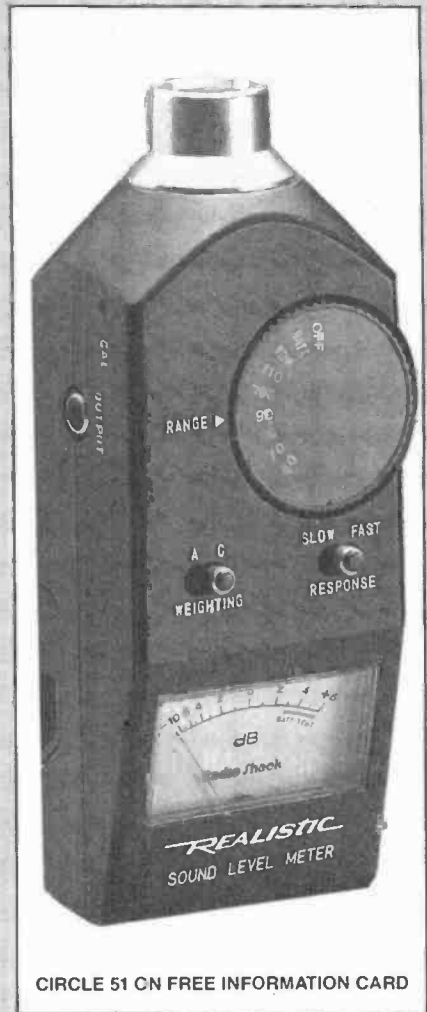

CIRCLE 51 ON FREE INFORMATION CARD

Shack claims an accuracy of ± 2 dB at a sound level of 114 dB) between 50 and 126 dB. Since the background noise in an average residence is about 45 dB, and the scream of a jet engine is a bit above 120 dB, the meter has a pretty wide range, although we wish for our purposes that it had been calibrated for even lower levels. Scales are selected by a large rotary switch that also has battery check and off positions. The meter is calibrated in dB, from -10 dB through 0 to $+6$ dB. If the pointer deflects exactly to the middle 0 point, it indicates that the sound level is exactly that selected by the rotary range switch. For readings lower than 0, you subtract from the range value (80 dB minus 3 dB, for example) and for higher readings you add to it (80 dB plus 4 dB). If the pointer is deflected off scale or doesn't move at all, you switch to a higher or lower range until it reads between the extremes.

Two switches, marked response and weighting, give you flexibility in making your measurements. The former allows you to select either a fast or slow response. Fast is good for taking peak readings, or measuring sounds with a sudden onset and fast decay—cannons going off, and things like that—while the slow position is better
(Continued on page 4)

Harmless TV

CITIZEN P422 POCKET COLOR TV. Manufactured by: Citizen, 2020 Santa Monica Boulevard, Suite 410, Santa Monica, CA 90404. Price: \$129.95.

We'll be honest and tell you right off what attracted us to *Citizen's* small P422 2.2-inch LCD pocket TV. It wasn't the size—there are smaller ones—and it wasn't the quality of the picture—we've seen better—and it wasn't the special features—there are hardly any. It was the *price!* For less than \$130 you get not only a color TV, but a little one that you can carry around in your pocket, to boot. That we had to see.

In view of the price, we weren't expecting a miracle of modern technology (although putting a color TV receiver into a package measuring only about 5 $\frac{1}{16}$ by 3 $\frac{1}{2}$ by 1 $\frac{1}{4}$ inches and weighing just under 11 $\frac{1}{2}$ ounces—four "AA" batteries included—is still quite a feat when you stop to think about it). What we got, though, was perfectly serviceable. Certainly not up to the broadcast-quality standards of today's top-of-the-line monitors, but good enough for following your favorite soap opera at lunchtime or sneaking out to the car to watch the football game while your wife's visiting with her favorite aunt.

The small LCD screen is not an active-matrix design—the high-tech choice—where each pixel has its own transistor built into the screen material behind it to switch it on and off. That less-than-cutting-edge design results in the display responding more sluggishly than it might otherwise do to changes resulting from rapid motion, and sometimes causes a curious after-image effect during rapid pans. Contrast was also somewhat lacking, a frequent problem with LCD's, and the brightness control on the side of the unit, which controls the intensity of a miniature fluorescent backlight behind the screen, caused the picture to wash out when turned too far. Still, we discovered that by viewing the picture slightly off-axis (maybe a peculiarity of our very-early-production model) we got by pretty well. In fact, we found—in our situation, at least—that the built-in stand caused the set to recline at an angle that *forced* us to watch it tilted, very slightly away from us rather than straight-on, and that seemed to improve the contrast a bit. The viewing angle, both horizontally and vertically, was also quite narrow, restricting the set's audience to just one or two close friends. However, that is not the kind of TV set you'd invite 100 people over to watch the Super Bowl on, so you should generally have little or no problem.

Colors were subdued. While there is a tint control (which did not seem to do very much on our unit), there is no means at all

for adjusting the intensity of colors. However, oversaturation will probably not be a problem; colors were, if anything, on the pastel side. The set was best at reds and browns, fair at reproducing greens, and did not seem to fare too well with blues at all. That, too, is the result of "affordable" LCD technology but probably will not matter to a lot of people anyhow. While the resolution of the tiny display is not great, it is adequate to read titles, phone numbers, and at least the larger type of newscast captions.

Tuning is accomplished by pressing a left-pointing or right-pointing arrow on a pair of membrane switches. That sends the tuner up or down the TV band looking for the next receivable station in that direction. The power/band slide switch at the right of the set both turns it on and selects VHF or UHF reception. A red strip that appears on the screen while tuning moves beneath a printed scale indicating the approximate channel location; in UHF the band turns green. A single telescoping antenna serves for both VHF and UHF (there's also a jack for connecting a single external antenna). The sensitivity of the tuner is very good; we had no difficulty in

receiving any of the stations we normally pick up with an external antenna. The tuner showed a tendency to hang up on the noise found in that "no man's land" between channels 6 and 7, but that seems to be a characteristic of most electronic tuners of the sort used in this set. Leaning on one or the other of the tuning buttons moves you right along. Another small problem with the tuner is the fact that it always starts at channel 2 (or 14 on UHF) when you turn the set on. If your favorite is channel 7, you'll have to work a little to get there. Finally, if you forget what channel you're watching, a membrane switch marked call flashes the red or green bar into the appropriate position on the screen when pushed, to jog your memory.

All told, we were quite satisfied with the P422. Keeping in mind the price, we did not get our hopes and expectations up too high, and what we did get from Citizen was about what we had anticipated: a harmless and unspectacular little TV that would function decently enough when called upon to in the field. As your mother might have said, "Watching a little TV never hurt anyone." This could be the little TV she had in mind. ■



CIRCLE 52 ON FREE INFORMATION CARD

CORDLESS PHONE

(Continued from page 1)

the digits you dial from the base-unit keypad (and pulse dialing is also available if you need it), the cordless handset masks (or maybe just doesn't generate) those tones. No matter what digit you press, you hear the same beep. As if in compensation, a string of ten tiny LED's on the unit echoes the digits being pressed. Those same LED's also serve as channel indicators—the SPP-320 searches ten 46–49-MHz frequency pairs for the clearest (a case of overkill as far as we're concerned, at least out where we used the phone) before it finally puts you on the air. In addition, they serve as a battery-strength indicator.

We have mixed feelings about the audio the phone delivered. The range and reliability of the unit were excellent, and operation was noise-free. And reports on our outgoing audio were generally quite favorable. We had trouble with the incoming audio, though, in that it seemed to be overly loud and peaky. There is a high/low volume switch on the cordless handset, but even in its low position the earpiece delivered too much output, at least initially. In fact, there was so much extra audio that the phone spontaneously went into feedback. For some reason that difficulty disappeared after we had used the phone for a while, and the peakiness also seemed to smooth out. We've never had to break in a telephone before.

The operation of the SPP-320 base unit as a speakerphone was generally without the usual stop-start-stop inconvenience, and we're told that, again, our audio was better than might usually have been expected from such a device. On the incoming side, though, it appears that there's some kind of muting circuit built into the speakerphone and that when no audio is being received the speaker goes absolutely dead. We, at least, found that somewhat disconcerting, since it then appeared to us that we had been disconnected.

OK, now for the matter of the battery, or the "bad news. With most cordless phones, a rechargeable battery built into the handset is kept up to charge by the simple expedient of replacing the handset in its base-unit cradle when it is not in use. A charger in the base unit delivers the charging current through a pair of contacts that mate with a matching set on the handset. That, of course, requires you to "store" the handset in the base unit.

Sony's philosophy, though, seems to be that the phone should be operated away from the base unit at all times. Indeed, you can't store the cordless handset in the base unit because there's already a wired handset residing there. The shapes of the two handsets are completely different, making it impossible to fit the cordless handset in the base-unit cradle.

Instead of providing the handset with a built-in battery rechargeable from the outside, Sony gives it a slip-in, slip-out battery that has to be removed from the handset and stuck into a compartment in the base unit for ten hours to be recharged. Because of that, the SPP-320 comes with two battery packs—one to use and one to charge. "DUAL BATTERY SYSTEM" says the box, as if that were a technological breakthrough of some magnitude. Of course the phone has a dual-battery system—if it had only a single battery, you could either charge it or use it, but not both. Some of the time the phone would be unusable!

While we'll admit that the battery packs did seem to exhibit a longer-than-usual life (they're rated at four volts, 500 mA, quite a capacity for a little package such as they are), we must also inform you that they're a pain in the neck to change when the time finally comes to do that. The handset's battery-compartment cover required a goodly amount of pressure to pry it open, and the little charging compartment in the side of the base unit required both hands to access; getting at it necessitated lifting and tilting the whole thing.

Putting aside the power-supply question—and some people, we're told, prefer the dual-battery system and not having to return the handset to a charging cradle all the time—we thought the SPP-320 was pretty good. But, Sony, one of the reasons for using rechargeable batteries is that you're not supposed to have to replace them! If you ever get *that* straight, you'll really have a pretty good phone here. ■

SOUND METER

(Continued from page 2)

sued to determining average noise levels.

The weighting switch gives you a choice of processing the sound through an A- or C-weighting network. The C-weighting position provides a nearly flat response; that is, the response of the meter is uniform at every frequency. That position is useful for determining overall sound levels. The A-weighting curve is logarithmic, matching more closely the response of the human ear. In that position, the meter's sensitivity is greatest between about 500 and 10,000 Hz, approximating the response of your own hearing apparatus. Many published sound measurements are made using A weighting, and having that position on the Radio Shack sound-level meter makes it possible for you to compare readings you make with those from other sources.

Because the microphone is built into the meter case, it is very sensitive to picking up the "hand noise" generated as you hold it. A ¼-inch threaded socket in the bottom of the case allows you to achieve good isolation by mounting the meter on a tripod. The manual also cautions you to hold

the meter not in front of you, but away from your side, to eliminate the possibility of its trying to measure sounds reflected from your body. Finally, there's an RCA-type phono jack in the side of the case that allows you to connect the meter to other amplification or test equipment.

We are fortunate to live in an area where it is fairly—make that *very*—quiet most of the time. Even the few noisy intrusions we get are usually below the 50-dB sensitivity threshold of the Radio Shack meter. So, when our test unit arrived shortly before we were to leave for the Consumer Electronics Show in Las Vegas, we packed it and took it along to see what it could do closer to civilization.

We know from past visits to that show exactly where to find a reliable source of noise that would immediately make an OSHA inspector whip out his citation pad and start scribbling. In the parking lot between the mammoth Las Vegas Convention Center and the Las Vegas Hilton, where additional exhibitors are housed, is an area reserved for manufacturers and vendors of automobile sound equipment—amplifiers, speakers, and the like. To get from one building to the other you have to pass through (or detour widely around) that part of the show. (And if you get lost all you have to do is follow your ears to the thumpings and poundings representing all the energy being pumped out by what must be hundreds and hundreds of vehicular subwoofers.)

We bravely took the meter right into the middle of that, and measured a sound level of about 84 or 86 dB—just below the point where "unsafe levels" begin. That was *outside* the vehicles, however, on the walkway. With your interests in mind, we stuck our metaphorical fingers in our ears and sat down in one of those cars. 98 dB—about the same as a riveter! No wonder they won't let those exhibitors into the building! (Although, somehow, a few manage to get by—we measured a level of about 82 dB from the booth where Popular Electronics was exhibiting, most of it originating from an autosound display on the main floor.)

Radio Shack thoughtfully includes with its meter a table showing some typical sound sources, and the approximate levels of sound or noise (A-weighted) associated with them. There is also a table showing the maximum length of time per day generally regarded as safe exposure to various sound levels. You can (according to that particular table) stand eight hours a day of continuous 90-dB noise without damage to your hearing or thought processes; at 110 dB the time decreases to ½ hour. If you suspect that you are being subjected to a damaging source of noise, the Radio Shack Sound Level Meter may be a worthwhile investment to help you establish your case. Thirty-two dollars is a cheap price to pay to keep your hearing. ■

Crystal Clear Sound

BBE MODEL 1002 SONIC MAXIMIZER.
Manufactured by: BBE Sound, Inc., 5500 Bolsa Ave., Suite 245, Huntington Beach, CA 92649. Price: \$229.

As we've pursued our perennial quest for champagne-quality sound at beer-budget prices, we've come across some interesting gadgets and ideas. Some of them work—putting gum erasers under the speakers to decouple them from a floor or stand is one that seems to—and some don't. Sometimes the results are initially exciting, but soon prove to be too intrusive or their associated gadgetry just too much of a nuisance to use. We recently came across an ad for a processor that claimed to add a "presence, a *being there* sense of excitement" for under \$200. Unable to resist what might prove to be an unbeatable bargain, we got one.

The *BBE 1002 Sonic Maximizer* is produced by a company that in professional audio circles is sometimes known by the name Barcus-Berry Electronics, but is now making itself known to the rest of the audio market simply as *BBE*. There are a number of *BBE* units available for professional use, and they are used by a large number of recording artists' studios. *BBE* circuitry has also been licensed for inclusion in some Aiwa audio equipment. The 1002, which is available by mail direct from *BBE* (or, if you have a branch near you, from Macy's) uses more or less the same circuitry as the more expensive processors, but where most of the studio units allow you separate left- and right-channel control, the 1002 gangs them together. The unit is enclosed in a flat, black box measuring only 16½ × 9 × 1¾ inches. It can be rack mounted or, since it generates negligible heat (it consumes only 10 watts), be placed beneath your receiver, amplifier, or another piece of equipment.

On the front of the box are a power switch, two knobs—one marked "lo contour" and the other "definition," three pushbuttons (processor, tape, and program) and a pair of LED's, one for each channel. That's all. The processor button allows you to take the device in and out of the line for comparison purposes, and the other two are used for taping. At the rear are RCA-type jacks for signal input and output, and for connecting a tape deck. Connection is simple—*BBE* suggests that you connect the 1002 as the first (if you have more than one) processor in one of your amplifier's tape loops. The tape deck jacks at the rear of the unit can replace those, and also allow you to put processed material directly onto tape. Since the *BBE* process is single-ended—there's no encoder-decoder setup required, just the sin-

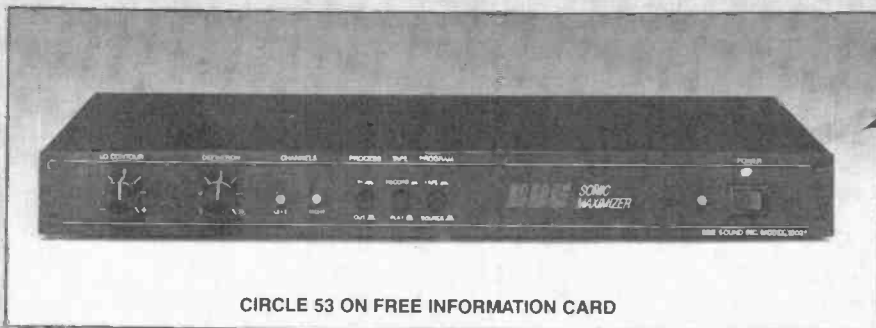

CIRCLE 53 ON FREE INFORMATION CARD

gle unit at either the recording or playback end—you can store "maximized" material on tape for playback on any system, even in your car or in your personal portable stereo.

The premise behind the *BBE* process, which we'll describe in a moment, is that mechanical transducers such as loudspeakers cannot accurately reproduce the waveforms we expect them to. They just can't move quickly, or accurately, enough to do that. The result is distortion both of phase relationships within the signal being reproduced and of the amplitude relationships existing among the high-frequency harmonics that give musical instruments their characteristic timbres. Sound takes on a "muddy," "smeared," or "strangled" quality.

The *BBE* process does two things. First, it attempts to restore the phase relationships within the signal that affect not only sound quality, but imaging as well. It does that by splitting the sonic spectrum into three parts and treating each separately. Frequencies below 150 Hz are separated by a passive low-pass filter and subjected to a group delay of 2.5 milliseconds. The midrange frequencies between 150 Hz and 1200 Hz, where much fundamental musical information lies, after isolation by an active bandpass filter are delayed by about 0.5 ms. Frequencies above that range up to about 20 kHz are not delayed. The end result is the simulation of an "ideal" speaker that introduces no group delays and that preserves phase relationships throughout the audio signal. Of course, your speakers may not be made to sound as close to ideal by that process as some others, but you will, in our experience, hear a difference.

The other portion of the *BBE* process restores harmonic information that gets lost or garbled somewhere along the line. The 1002 does that by using two RMS loudness detectors to monitor the midrange and high-frequency signal bands. The relative harmonic content of the two bands is compared, and a control signal derived from that information is applied to a voltage-controlled amplifier (VCA) to adjust the high-frequency energy content of the composite output signal. The definition control on the front of the unit adjusts the degree of high-frequency processing that takes place. The two bipolar LED's,

which glow either red or green depending on the polarity of the voltage driving them, act as indicators of the amount of processing that is taking place in either channel. We found the LED's, though, to be of little value (except for their entertainment factor) and preferred to rely on our ears.

The FM station to which we listen much of the time suffers from a signal condition that makes it sound as though its audio was being squeezed through tiny little wires that shave off much of the high-frequency information (and dynamics) it should contain. We listen to that station because it is the only one offering its style of programming within earshot, not because we're fond of the "strangled" sound, and thought the *BBE* Sonic Maximizer might help us enjoy it more.

It did. The difference between an unprocessed and a processed signal is immediately apparent. The most perceptible effect is an increase in high frequencies. That does not manifest itself as the sort of edginess or shrillness you might expect if you were to add a piezo tweeter to your system, but rather as a kind of clarity. The sound takes on a sort of transparency, and becomes kinder to the ears. You might compare the sonic quality to the transparency of one of those Caribbean lagoons where boats seem to be floating on air over the sandy bottom ... only without the humidity.

Getting all the parts of the signal to behave more or less coherently by compensating for group delays should also improve the imaging qualities of your speakers. And, while our speakers are already very good in that department, the *BBE* 1002 seems also to add a degree of improvement. Our between-the-speakers soundstage acquired a depth it had previously lacked.

The *BBE* manual is badly in need of additional material on the use of, and further applications for, the device—but we found several. The first, which is hinted at in the instructions, is as a potential replacement for an equalizer. The basic *BBE* process tends to clean up the sound output by a system, and the definition and lo-contour controls (the latter can add or subtract up to 6 dB from signals below 50 Hz) give you a fair degree of control over its quality. We still used our AudioSource

(Continued on page 8)

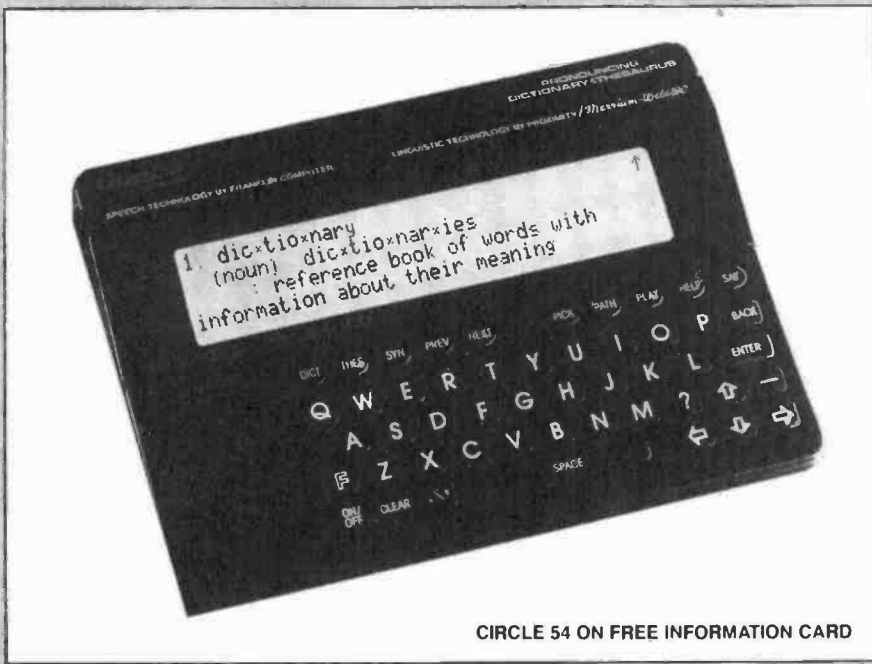

CIRCLE 54 ON FREE INFORMATION CARD

Lex-i-co- GRAPH-ic WON-der

FRANKLIN LANGUAGE MASTER LM4000 TALKING DICTIONARY. Produced by: Franklin Computer, 122 Burrs Road, Mt. Holly, NJ 08060. Price: \$379.95.

Of late we've reported to you on talking translators and talking VCR's. This talking dictionary, we promise, will be the last device capable of speech that we review, at least for a while.

Remember when we mentioned an antediluvian (an-te-di-LU-vi-an: *ancient; before the Flood*) database-management program called WHATSIT, which stood for "Wow! How'd All That Stuff (Get) In There?" Well this talking dictionary, Franklin's Language Master LM4000, ought to be called that. We know, in principle, how it what does what it does, but using it still amazes us.

Continuing the flood of antediluvian material for another paragraph, we can remember when Franklin was getting its start in a little New Jersey town not too far outside Philadelphia. At that time it was marketing a computer that looked and worked remarkably like an Apple II, but that cost somewhat less. Apple didn't much care for the Franklin Ace, as it was called, and after a long battle Franklin decided that its technological know-how could better be applied elsewhere. So it went into the "language machine" business, making little dictionary-type boxes with tiny keyboards and LCD screens. The latest fruit to be born of that evolutionary

tree is the Language Master LM4000, which not only looks up words, but talks as well. It does a lot of other things, too.

Like what, you ask? Well, to start with, the LM4000 has dictionary entries for more than 83,000 words, compiled from Merriam-Webster sources. It can look up any of those, even if you can only guess at the proper spelling. If it can't look up your entry directly, the LM4000 will think about your guess at spelling for a moment or two, and then present you with a list on its four-line-by-40-character display of the words it believes you might have in mind. When you press the key corresponding to the letter beside the word you want, the dictionary entry is looked up and displayed.

The definitions presented are not complex ones, but they are sufficient to allow you to understand and use a word that you might otherwise avoid. And, if you are in doubt as to how to pronounce a word, just press the say key and the Language Master LM4000 will tell you through a small 1/2-inch speaker built in alongside the keyboard. The device's diction sometimes leaves something to be desired, but at least you'll know whether the word is pronounced "IN-surance" or "in-SUR-ance." If you want to look up or hear another word that's displayed on the dictionary's screen—perhaps one that's used in a definition—just press the pick button, move a cursor that appears over to the beginning of the word you want, and press enter. You'll get the definition, and pressing say will get you the pronunciation.

If you need a synonym for a word, there's a SYN button to press. A note at the top of the screen appears if there's more than one "page" of synonyms; if there are none, nothing happens.

The Language Master LM4000 also has

built into it a thesaurus (the-SAU-rus: *book of words, and especially synonyms*). Now, in our experience, as in the definition, a thesaurus is a collection of synonyms; if you want a "fancy" word to use instead of a plain one, you use a thesaurus to locate it. Or, if you want a word with a meaning similar to, but just a little different from, one you know, you can find it in a thesaurus. The thesaurus built into the LM4000, though, seems to be more like an expanded dictionary, providing more information on the meaning of a word than a list of synonyms. (That, we guess, is why there's also a SYN button.) However you argue it though, there are claimed to be 487,000 synonyms for 40,000 words in the LM4000 (Franklin's count, not ours). That's a lot to fit into a little 7 x 5 x 1 1/2-inch, 12-ounce package.

There's more, of course. Built into the LM4000 is a list of 3300 words frequently used on examinations such as the SAT, GRE, and GMAT. You press the key marked play and a list of fifteen games (plus an address you can write to with comments on the Franklin device) appears. Several of those games are based on the SAT word list. In a "flash card" game, the LM4000 can be instructed to speak the word it picks at random from the list in addition to displaying it. It's not such a good idea to try to identify the words just by listening to them, though—the Language Master's pronunciation is not *that* good. At any entry you can enter the dictionary mode, and from there use the thesaurus or synonym finder.

Other games include several versions each of hangman and anagrams. There's also a dice-roller that uses a built-in random number generator.

The best game for us, though, was simply browsing through the dictionary's contents. We found a couple of ways to do that. The first came from the dictionary's ability to display up to 23 words it thinks you mean when it doesn't understand an entry. We were amazed at what the LM4000 knew (and could pronounce), including a number of abbreviations and place names. The other way to get around the dictionary is to use the NEXT and PREV buttons to move through its entries. They're alphabetized, and those buttons permit you to browse back and forth through them.

It's miniature QWERTY-style keyboard aside, we had few problems with the dictionary. The worst was its habit of flashing a "Ready for Word" message on the screen when it wasn't *really* ready. If we were too anxious the device frequently missed the first letter we typed in. "Arid," for instance, became "rid"—not quite what we were looking for. Well, patience is a virtue.

The most astounding thing for us about the Language Master LM4000 was the way

(Continued on page 8)

Jog-and-Shuttle Off to Buffalo

HITACHI VT-F430 VHS EDITING VCR.
From: Hitachi Sales Co., 401 W. Artesia
Blvd., Compton, CA 90220. Price:
\$799.95.

When we first heard about Hitachi's low-priced VHS editing deck, the model VT-F430 (there's also an S-VHS version, the VT-F730, for about \$400 more), we thought it might be interesting to use for a while. After all, as we've mentioned here before, we're sometimes in the habit of sending videocassettes instead of form letters to family members around the country. Having a deck with editing facilities would make that easier, and maybe allow us to get better results, as well. When we started using the deck, we found it had a lot more to offer than just jog-and-shuttle.

In fact, we were so taken with some of the VT-F430's other features that we'll talk about them first, and get to the editing later. Whoever created the control scheme for this unit either knew a lot about what he was doing—and about human nature—or just got very lucky. We prefer to believe the former. The controls function in a way that makes operation almost intuitive.

Here's an example. Let's say you're playing a tape and want to fast-forward to a certain scene not too far away from where you are. You press fast forward (FF) and the action speeds up as the tape runs at several times normal speed toward the scene you're looking for. Aha, here it comes. Now, with most VCR's, you would now have to move your thumb over to the play button on the remote, or already have it hovering there, to drop back into that mode. But on the VT-F430, all you have to do is push FF again and you return to normal playing speed. If you undershoot the mark, press it again to speed up and once more to play. The single button does it all. (To prevent wear and tear, that feature locks itself out after three or four fast-forward/play cycles. Then, if you still haven't found what you're looking for, you have to let the machine stay in play for a few moments before you can start up again.)

Another example of the forethought that went into the 430 concerns the pause-play functions. We're never sure how to get out of pause once we're in it. Do we push play, or do we push pause a second time? We suspect our confusion arises from the fact that on some VCR's things work one way, and on others they work the other. With the Hitachi, it doesn't matter. To get out of pause you push either play or pause—it works either way. We think that is what's called "human factors engineering."

As a final illustration of how "user friendly" this deck is, consider that built

into the infrared remote are ten different command sets for operating TV sets from several different manufacturers. At the upper right of the remote is a slide switch that allows you to move from controlling the VCR to controlling the TV (and to control a second Hitachi VCR, as well). Our problem is that with most controls of this sort, we frequently forget to slide the switch from one position to the other, or are just too lazy to do so. Quite by accident we discovered that we didn't always have to with this remote. Some of the TV functions—ones that were not applicable to the VCR—could be controlled even when the switch was in the VCR position. For example, we could control TV volume, including full muting, at any time. How convenient!

The VT-F430 is not without its eccentricities. When you turn it off it automatically pops into its timer mode (the display flashes "BYE," and then "TIMER") and waits for one of the 8 programmed events in its memory to take place. The only way, it seems, to bypass the programming (maybe you're at home, sick, so you don't need to record *Donahue* that day) or to shut the VCR off entirely for that matter, is to remove the tape. And to do that, we might add, you have to open the flip-down panel that conceals and contains most of the VCR's on-board controls. A very modest machine, the VT-F430.

Now for the editing. While there are undoubtedly some editing decks on the market that can do a lot more than this one, the VT-F430 offers plenty for even the more-than-occasional video editor. Starting with the simple, there's a synchro-edit jack that you can cable to the pause jack of the second deck you use in the process (usually for recording—you use the VT-F430 for playback for a very good reason that we'll come to in a moment). That connection allows the VT-F430 to start and stop the other deck during the editing process.

Next is the jog-and-shuttle knob, actually a concentric ring-and-knob. The ring

allows you to advance the tape, or move it backward, at several different speeds, including one-frame-at-a-time. That's the "shuttle" part. Then, when you are more-or-less where you want to be, the dimpled inner knob can jog you back and forth in single-frame increments until you've reached exactly the frame at which you want to start or end the segment. There are also jog-and-shuttle buttons on the remote control, but they're not nearly as convenient to use as are the ring-and-knob arrangement on the deck.

The deck's memory can store start-and-stop information for automatic assemble-editing of eight segments at a time.

Switches inside the deck's concealed compartment allow you to add a fixed degree of "boost" to the high-frequency end of the luminance signal when you perform a transfer to another deck. A pair of controls allow you to adjust edge sharpness, and to boost the chroma portion of the signal to perk up colors, during playback only, and another one, labeled "Spectrasonic," adds a bass boost at the audio output jacks (of which there are two, one with a variable level control).

Also of use to editors is a built-in titler that can provide up to five lines of 12 characters each. According to the manual, three character sizes, all capitals, are available. Characters are selected by rotating the dimpled jog knob.

There are lots of additional features on the VT-F430 that we liked as well, and a couple of other quirks that deserve mention, too. On the *pro* side, the little remote control has a highly legible LCD (with a clock display) and a memory that can hold eight programs at a time. You enter programming information into the remote and then, when it's all in, transmit it to the deck, which beeps to acknowledge receipt of the material. Also, if you're working with monophonic material, inputting it to just a left-hand audio-in jack will get it on both stereo tracks. It also appears that you can record independently on the stereophonic Hi-Fi tracks and the monophonic



CIRCLE 55 ON FREE INFORMATION CARD

longitudinal one, and then mix them during playback. (Note, however, that the recorded video and Hi-Fi tracks are inextricably tied together; you can't mess with one of them without messing with the other.)

We were going to criticize the fact that the VCR's clock is normally hidden by the "modesty panel," even though there is a window to allow part of the vacuum-fluorescent display to shine through. (That is the display that tells you what's going on, as well as forming the words "BYE" when you turn the machine off, and "HELLO" when you turn it on.) Then we realized that with a clock in the remote, we really didn't need one in the VCR as well ... as if we didn't have enough digital clocks around here already! (You should see this place when the power comes back on after it's been off for a while. It looks like a lightning-bug convention!)

And, as with just about everything else electronic (or otherwise) these days, the documentation could have been clearer. The independence of the TV audio control, for example, is mentioned nowhere. However, we feel that it is features such as that, documented or not, that give the VT-F430 an edge over other similarly priced machines. On the whole, we liked it very much. "BYE." ■

SONIC MAXIMIZER

(Continued from page 5)

equalizer, but could easily tell the improvement, when we took it off line, of a BBE-processed signal over a "straight" one.

A number of years ago we made a music tape (of ourselves, if you must know, on the guitar) on a very early Dolby B cassette deck that never tracked properly no matter how many times we sent it back for servicing. The recording was boomy and muddy but, nevertheless, had material worth salvaging. So, we passed the signal through the BBE unit and, although the recording was still obviously full of defects, it was significantly improved. You can, of course, use the BBE 1002 to add a little zest to your own tape dubs from CD's or black vinyl. As we mentioned earlier, the enhanced signal is recorded on tape and requires no decoding at the playback end.

Having used the BBE 1002 for a while, we've become quite attached to what it does to our music. When we take it out of the circuit (or just turn it off, since then it goes into a pass-through mode and you hear the unprocessed audio) all the sparkle goes out of the sound. It's like coming back from Technicolor Oz to a drab black-and-white Kansas. What a difference! ■

TALKING DICTIONARY

(Continued from page 6)

it pronounced words. Not the quality of its pronunciation, which often lacked somewhat in intelligibility, but the fact that—like Dr. Johnson's dog—it could do it at all. Whatever the algorithms (ALgorithm: *procedure for solving mathematical problems*) devised by Proximity Technology, a branch of Franklin, they're incredible! The scheme used by the Language Master seems not to rely on a lookup table of individual words, but actually to examine each word and—using a complex set of rules kept in some silicon back room inside the LM4000—to derive anew the pronunciation each time. What an accomplishment! Still better, we usually agree with what it says!

While we would never discard our big old *Oxford English Dictionary* in favor of a device such as this, we have to admire it. As a school tool, or as household appliance to be left out where it's within easy reach whenever a question of meaning or pronunciation arises, the Language Master LM4000 serves admirably. Franklin, it looks as though you've made a significant—and maybe even a bit senientious (sen-TEN-tious; *rich; eloquent*) contribution to literacy! ■

ELECTRONICS WISH LIST

For more information on any product in this section, circle the appropriate number on the Free Information Card.



NEC Portable Cellular Phone

Sleek Cellular Phone

Weighing only 14 ounces, NEC America's (383 Omni Drive, Richardson, TX 75080) 2.3 × 1 × 7.2-inch P300 is a streamlined cellular portable phone designed to travel in a pocket, purse or briefcase, or even just in the palm of the hand. A convenient flip-up antenna facilitates carrying and storage (and a six-inch whip is available to increase the range when the phone is used in outlying areas). The P300 offers up to 80 minutes of continuous talk time (or 18 hours of standby operation) and sounds a series of short beeps when battery voltage begins to drop. Recharging takes eight hours with the charger supplied, and an optional rapid charger does the job in 1½ hours. The phone includes such features as a 30-character alphanumeric LCD that can display names and telephone numbers, an electronic phone directory, and speed dialing of up to 99 frequently called numbers; it also offers call restriction, a four-level electronic lock, and can generate DTMF tones for accessing devices such as answering machines and voice-mail systems. The phone's display and built-in clock can be used to remind you of important appointments, and the display indicates whether a call came in while you were away from the phone, as well as the time the call arrived. It does not, however, tell you *who* called. Price: \$1799.

CIRCLE 56 ON FREE INFORMATION CARD

Cruisin' Collectible

If you have a thing for 1957 Chevrolets—and who hasn't?—then Randix Industries (Granite Park, Fortune Boulevard, Milford, MA 01757) has something to warm your nostalgic little heart. Its Model CR 1957 portable stereo radio features authentic '57-Chevy-style grillwork on the front, and a reproduction of the car's rear end on its back. There are also working front parking lights and a built-in horn. The AC/DC portable includes an AM/FM radio and stereo cassette deck, and uses two three-inch dynamic speakers. Price: \$119.99.

CIRCLE 57 ON FREE INFORMATION CARD

For more information on any product in this section, circle the appropriate number on the Free Information Card.

ELECTRONICS WISH LIST

Extended Warranty

Three- and five-year extended warranties on electronic equipment valued between \$100 and \$3000 are offered by *ComponentGuard, Inc.* (100 Summit Lake, Valhalla, NY 10595). Its *ComponentGuard* program provides for unlimited repairs on the equipment covered, with full coverage for all parts and all labor. The purchaser of a policy—policies are frequently available from the same dealer as the equipment they are to cover—fills out a form and sends it to *ComponentGuard*. Returned to him is a "GuardCard" inscribed with his name and membership number. All that's required, should service prove necessary, is for him to present the card at one of over 1200 locations nationwide; there's no need to save old sales receipts or contracts. If a piece of covered equipment is sold, the policy is transferable to the new owner. Price: Approximately 10% of equipment cost.

CIRCLE 58 ON FREE INFORMATION CARD

Vacuum-Tube CD Player

Calm down—it's only the analog-output stage that's involved. *Luxman's* (19145 Gramercy Place, Torrance, CA 90501) *D-105u* compact-disc player uses a twin-triode vacuum-tube amplifier in its output stage (a concept the company calls "BRID," possibly from "hybrid") to provide a highly linear output voltage and the "warm, clean" sound typical of vacuum-tube technology and missed by many since the introduction of transistor amplifiers in the 1960's. The *D-105u* uses dual 18-bit D-to-A converters with eight-times oversampling to remove spurious signals gently. A high-density magnetic clamping mass-loads the disc center in the player, minimizing spindle-motor vibration to improve tracking accuracy and reduce data error, and a three-beam tracking system is used to further ensure accuracy. The player includes a multifunction infrared-remote control and can be daisy-chained with other *Luxman* units for integrated system control. Memory contents for selected functions can be maintained for two weeks or more with no power applied, making it possible to program the player and turn it off, and then switch it on at a later time from an external timer switch to play the program. And, if you don't care for vacuum-tube amplifiers, the *D-105u* is also equipped with both optical and coaxial digital-output jacks for coupling the output signal directly to digital-input equipment. Price: \$1200.

CIRCLE 59 ON FREE INFORMATION CARD

Tri-Band Radar Detector

The first three-band radar detector to carry the *Trapshooter* name is *Cobra's* (6500 West Cortland Street, Chicago, IL 60635) model *RD-3173*. The new model receives "X-," "K-," and "Ka" -band signals, the last being the ones used by the new photographic traffic radar systems. The unit incorporates a dual-horn antenna design for optimum performance on all bands. The *RD-3173's* features include anti-falsing circuitry, high/low/off switch for visual displays, city/highway switch, test/mute function with automatic mute reset, and a five-segment LED signal-strength meter. The unit is supplied with a wide assortment of mounting hardware for versatility, and with a leatherette carrying case. Price: \$299.95.

CIRCLE 60 ON FREE INFORMATION CARD

Aesthetic Car-Phone Mounts

When you spend as much as you will for a cellular phone for your car (and even more on the charges for cellular service!) you'll want the installation to look good. To that end, *MB Quart Electronics* (25 Walpole Park South, Walpole, MA 02081) has introduced its *Tech-Art Series* of cellular-phone mounting kits for European cars. For the owners of Porsche, Audi, Mercedes-Benz, BMW, and Volkswagen automobiles there's a center-dash console model that comes in leather, carpet, or vinyl that matches the manufacturer's original material. Designed to fit to the right of the center console, this model gives the driver easy access to the phone while providing a mount fully integrated with the car interior. A second kit, available for Ferraris, Jaguars, BMW's and Mercedes, is a replacement armrest with a special center cutout designed to accommodate the handsets of most cellular phones. When swung upright, the armrest allows passengers seated in the rear to use the phone without interrupting the driver. Price: \$169-\$1400.

CIRCLE 61 ON FREE INFORMATION CARD



ComponentGuard GuardCard



Luxman Tube-Type CD Player

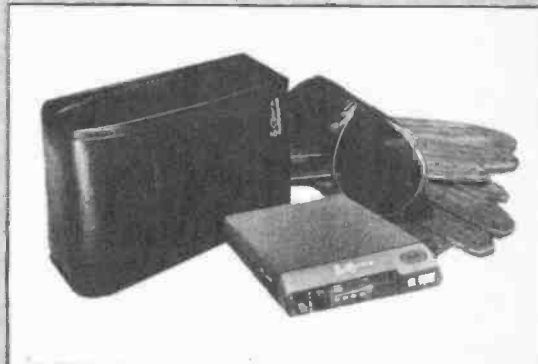

Cobra Tri-Band Radar Detector

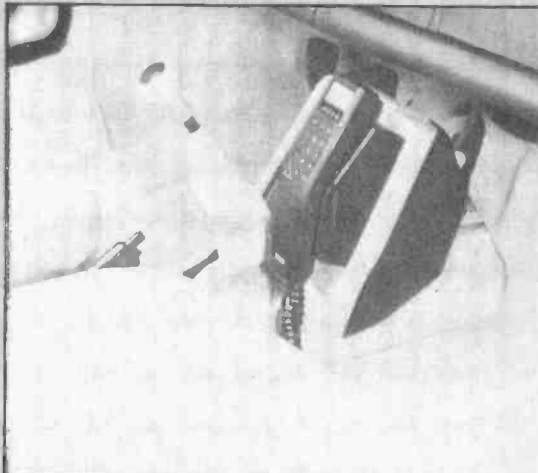

MB Quart Electronics Cellular-Phone Mount

ELECTRONICS WISH LIST

For more information on any product in this section, circle the appropriate number on the Free Information Card.

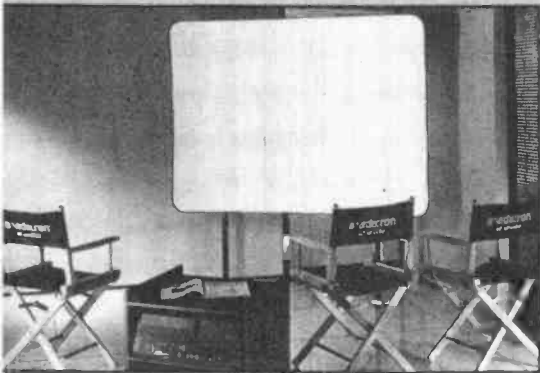

Vidikron Front-Projection TV

The Big (Bright) Picture

The Vidikron (928 Broadway, New York, NY 10010) TGS-1 DP7 front-projection TV system is said to provide an image bright enough to be viewed in daylight or with interior lights on. The three-beam TGS-1 projector, using dual-focus high resolution aspheric lenses, has a light output of 470 lumens and a horizontal resolution of 460 lines, and incorporates a comb filter to improve picture quality. The seven-inch projection tubes, which operate at a color temperature of 6500° Kelvin, have an estimated life of 9000 hours. The projector has tilt-correction circuitry that permits it to be mounted above or below screen height without introducing "keystone" distortion in the projected image. The Vidikron system comes with the company's HGS7 curved seven-foot-diagonal high-gain screen that can be viewed from as much as 70° off-axis. The final component is a black coffee-table-like stand with shelves for the projector and a second piece of video equipment such as a VCR or videodisc player. Price: \$4995.

CIRCLE 62 ON FREE INFORMATION CARD

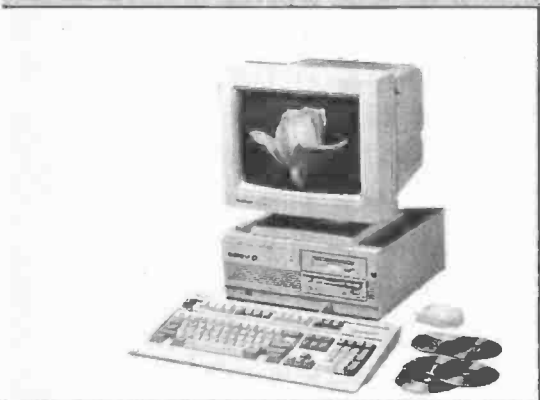

HeadStart CD-ROM Computer

CD-ROM Computer

"Throw away the computer and keep the software!" That might be *HeadStart's* (40 Cutter Mill Road, Suite 438, Great Neck, NY 11021) next advertising campaign. Its under-two-thousand-dollars LX-CD computer system comes with a built-in CD-ROM drive and an estimated \$3000-worth of CD-ROM software totaling more than a gigabyte. Included are the *New Grolier Electronic Encyclopedia*, Microsoft's *Bookshelf* (which includes *The American Heritage Dictionary*, *The World Almanac and Book of Facts*, *U.S. Zip Code Directory*, *Bartlett's Familiar Quotations*, and *The Chicago Manual of Style*), *Hotline Two* (telephone management software with autodialer), the *National Directory of Addresses and Telephone Numbers* (which includes 100,000 business addresses, and phone and fax numbers) and other reference works. The computer itself, which is manufactured for HeadStart by Philips, uses an 8088-1 microprocessor running at a switchable 10 or 4.77 MHz and features an 8087 math coprocessor socket, clock/calendar, 768K of RAM, five expansion slots, and a 101-key PS/2-style keyboard. Also included are a 40-megabyte, 28-*ms* hard-disk drive, 1.44Mb/720K 3½-inch drive, VGA card, serial and parallel ports, mouse—and a set of stereo headphones! When you're not using the CD-ROM drive for reference, you can listen to music on it. Price: \$1999.

CIRCLE 63 ON FREE INFORMATION CARD



Audio-Technica CD Cleaner

Epicyclical CD Cleaner

Audio-Technica U.S. (1221 Commerce Drive, Stow, OH 44224) has a new rotary-action compact-disc cleaner, the AT6090. To use the novel cleaning device, you first open it—it's hinged like a clamshell—and insert the disc to be cleaned on a non-abrasive, nonskid pad, playing surface up (which means label-side down). You squeeze a few drops of the fluid provided with the cleaner onto the surface of the disc and close the lid, which contains a ring with a chamois-like material. Then, putting a finger in an indentation in the lid, you spin it as you would a telephone dial. The rotary action is transferred to the cleaning ring below, and the disc is cleaned and its surface buffed. Price: \$24.95.

CIRCLE 64 ON FREE INFORMATION CARD



Sanyo Fisher Solar-Powered Kitchen Scale

Light-Weight Scale

Japanese culinary technology has made another advance (that's what it says in the press release, folks) through the accuracy and versatility of the AKS100 electronic kitchen scale from *Sanyo Fisher* (21350 Lassen Street, Chatsworth, CA 91311-2329). The solar-powered digital scale, which has a maximum capacity of just over two pounds, or one kilogram, includes several useful features. It has, for example, a net-weight function that zeros out the "tare" of a container (its weight when empty), allowing you to measure the weight of just the contents of, say, a bowl or a measuring cup. You can also preset a weight and then add ingredients to a container on the scale until a beep is heard, signifying that the desired weight has been reached. The photon-powered scale also includes a 99-minute timer, and is said to be able to function by candlelight. Price: \$89.99.

CIRCLE 65 ON FREE INFORMATION CARD

For more information on any product in this section, circle the appropriate number on the Free Information Card.

ELECTRONICS WISH LIST

Auto-Reverse Cassette Deck

The *TA-R200* cassette deck from *Onkyo* (200 Williams Drive, Ramsey, NJ 07446) contains an auto-reverse mechanism with an especially fast response. Rather than relying on mechanical end-of-tape sensors, the deck uses an infrared device to detect the beginning of the leader tape and reverse the direction of tape travel as soon as it is sensed. This virtually eliminates the "dead space" normally encountered when switching sides on auto-reverse systems. The Onkyo deck also incorporates Dolby B and C noise reduction, Dolby HX Pro headroom expansion for improved high-frequency response, and has a record-mute function that can insert five seconds of silence on the tape at the touch of a button. A fully automatic tape selector detects the presence of a normal, high-bias, or metal tape, and adjusts the recording bias and equalization accordingly. The *TA-R200* also allows a user to fine-tune record bias to match a particular tape's magnetic characteristics. Price: \$260.

CIRCLE 66 ON FREE INFORMATION CARD

32-Inch Direct View TV

NEC Technologies (1255 Michael Drive, Wood Dale, IL 60191) has produced its largest direct-view TV console—32 inches—in the *KX-3290S*. Dynamic focusing, electron-beam regulation (EBR), and velocity-scan modulation serve to produce a sharp picture with a resolution of more than 500 lines horizontally. Noise-reduction circuitry is used to further improve picture quality. The CRT itself uses an invar—nickel-iron—slotted shadow mask for resistance to heat-related problems such as doming and discoloration. The console TV includes three direct A/V inputs and two A/V outputs, and has MTS stereo and SAP capability. S-video and standard composite jacks are located at the front, side, and rear for easy hookup of equipment. Audio is provided by a 40-watt stereo amplifier. Other features include on-screen display, auto channel preset, function preset, parental channel lock, and full A/V system remote control. Price: \$2600.

CIRCLE 67 ON FREE INFORMATION CARD

One-Bit CD Player

The *SLP-370* compact-disc player from *Technics* (One Panasonic Way, Secaucus, NJ 07094) represents one of the first of a new generation of players using one-bit technology. At the heart of the unit is a digital-to-analog converter using a single-bit MASH (the term "MASH" is convolutedly derived from "multi-stage noise shaping") pulse-width-modulation converter that does away with conventional A-to-D weighted-voltage conversion techniques to improve linearity and low-level signal reproduction. On the mechanical side, the player is said to be able to provide unusually rapid access to any point on a disc, and includes a feature called "CD Edit Guide" that, when the player is used together with an appropriate Technics cassette deck, automatically calculates track selections to make optimum use of the amount of tape available. The player also comes with a wireless remote control, features 20-selection random-access programming, and has a headphone jack with its own volume control. Price: \$189.95.

CIRCLE 68 ON FREE INFORMATION CARD

Moving-Coil Cartridge

The internationally acclaimed *Audio Technica AT-F5* moving-coil phonograph cartridge is now available in this country from *Signet* (4701 Hudson Drive, Stow, OH 44224). The cartridge uses a high-purity copper wire for its coils, and a specially polished elliptical nude diamond stylus mounted on a beryllium cantilever for rigidity combined with extremely low mass. Of this cartridge British critics have said, "(It has) a transparency of texture and a champagne-like fidelity on transients, strings, bass and percussion," and that, "As a final analogue upgrade very few enthusiasts would regret the purchase of (the AT-F5)." Price: \$250.

CIRCLE 69 ON FREE INFORMATION CARD



Onkyo Auto-Reverse Cassette Deck



NEC Technologies 32-inch TV



Technics One-Bit CD Player



Audio-Technica Moving-Coil Cartridge

ELECTRONICS WISH LIST

For more information on any product in this section, circle the appropriate number on the Free Information Card.

High-Performance Subwoofer

Velodyne Acoustics' (1746 Junction Ave., San Jose, CA 95112) *Servo 1200* subwoofer is a self-contained system incorporating its own 12-inch driver, amplifier, and crossover. At its heart is patented High Gain Servo (HGS) error-correction circuitry featuring a three-stage servo loop whose operating principle is motional feedback. In the first stage an accelerometer—manufactured using a hybrid of piezoelectric and IC technologies—attached to the driver's voice coil monitors the motion of the voice coil and speaker cone and passes the signal generated to the system's main controller. There, in the second stage, a comparator circuit measures that signal against the one input to the system's integral 100-watt-RMS amplifier. The difference between the two represents distortion added by the mechanical speaker elements and, in the third stage of the servo loop, a correction component is generated and applied to the woofer to compensate for the nonlinearity. The twelve-inch speaker cone is made of resin-impregnated fiber, and the voice-coil assembly uses a double-wound, 1.1-inch copper coil, custom spider, and a 56-ounce (3½-pound) magnet. Peak output is 400 watts. Price: \$895.

CIRCLE 70 ON FREE INFORMATION CARD

Helpful Keyboard

Casio (570 Mt. Pleasant Ave., P.O. Box 7000, Dover, NJ 07801) has a new keyboard, the *PT-380*, that can assist you in picking your way through unfamiliar tunes. A compartment at the top accepts four-song ROM packs that activate "Melody Guide" lights above the keys to help a player along. The 32-mini-key keyboard is capable of three-note polyphony (sounding three notes simultaneously) and includes 100 preset sounds and a dozen rhythm patterns. Built in as well are five drum pads that can generate ten different sounds, and four demo songs. The keyboard also comes with a detachable microphone and built-in speaker for sing-along use. Power is supplied by four "AA"-size dry cells or by an optional AC adapter. Price: \$99.95.

CIRCLE 71 ON FREE INFORMATION CARD

High-Performance Tuner

A seven-varactor MOSFET RF section and an IF strip incorporating five ceramic filters are two of the features that make Onkyo's (280 Williams Drive, Ramsey, NH 07446) *Integra T-4700* a near-reference-class AM/FM tuner. Using a system Onkyo calls "APR" (Automatic Precision Reception)—which, by the way, can be overridden by the listener if he so desires—the tuner constantly monitors signal quality to determine the combination of mode (stereo or mono), high-blend, IF bandwidth, and RF sensitivity settings that will yield the best sound. Tuning steps can be either 25 or 50 kHz, enabling good reception on cable systems where broadcast-frequency accuracy may be poor. The unit also has dual antenna inputs and 40 station presets that can be programmed with an alphanumeric identifier (such as a station's call letters) that appears when the preset is selected. The remote control uses a bidirectional digital-data system for interactive operation of this, and other, Onkyo RI (Remote Interactive) components. Price: \$450.

CIRCLE 72 ON FREE INFORMATION CARD

Stoned Phones

RockPhones are for use "in places where people insist on making individual design statements with their desktops," says the company responsible for them, Fun Products (2397 Shattuck Avenue, Suite 201, Berkeley, CA 94704). The unusually finished phones come in two designs, a desktop model and a smaller trimline-style one. The trimline-type has a graphic dial pad, last-number redial, reset, pulse/tone dialing, hearing-aid compatibility, and a two-year warranty. As a bonus, the larger desk model adds the "Fun FX" sound system, a set of pre-programmed sound effects that can be called up from the phone's keypad. At the touch of a button or two you can unleash a variety of laughs, shrieks, screams, crowd noises, and other sound effects on unsuspecting "callees." No wonder they're called Fun Products! Price: \$69 (trimline-style), \$79 (desktop).

CIRCLE 73 ON FREE INFORMATION CARD



Onkyo AM/FM Tuner

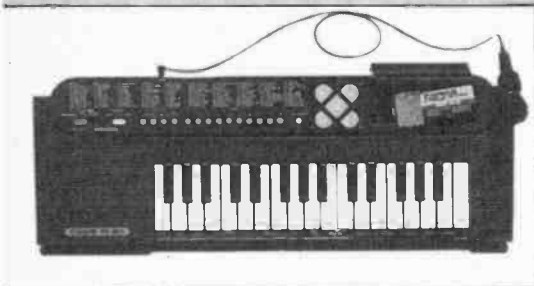

Casio Keyboard



Velodyne Subwoofer



Fun Products Telephones

Loony Tones

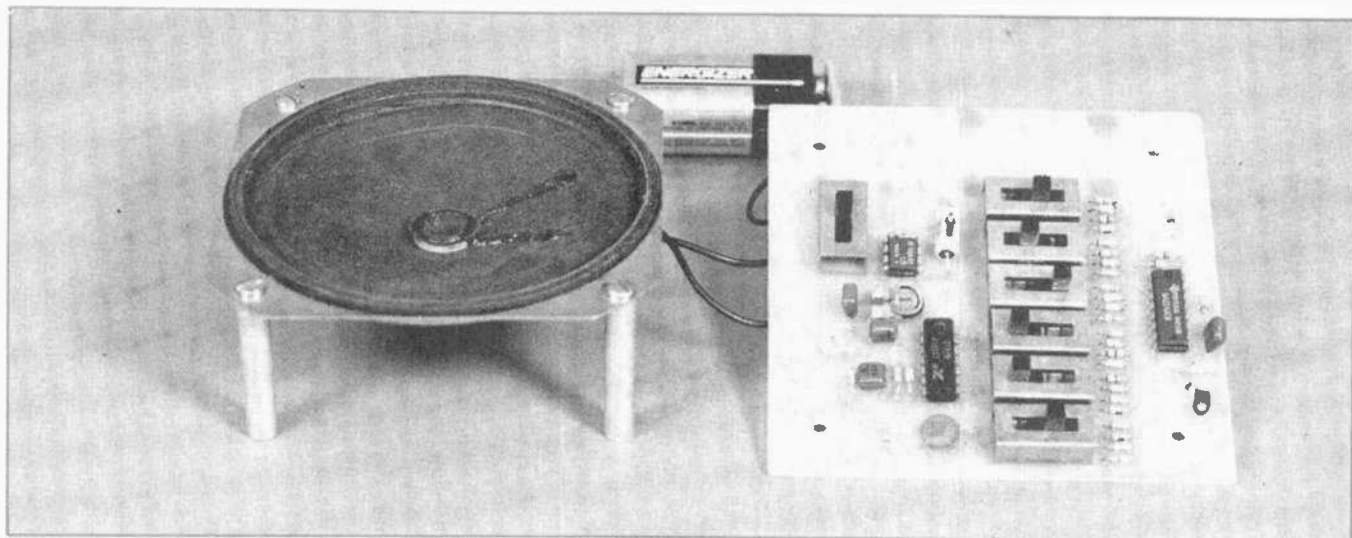

"Music Synthesizer"

This simple synthesizer gives you 4096 variations to its 256 notes

BY WALTER W. SCHOPP

There is a very old axiom that goes something like this: "Given an infinite amount of monkeys, and an infinite number of typewriters, with an infinite amount of time, one of them will eventually write a best seller." Those may not be the exact words of the saying, but the same axiom might hold true that an infinite number of non-musicians, with an infinite number of synthesizers, and an infinite amount of time, could eventually write a great song.

A trained musician can listen to an assortment of notes from a synthesizer and hear music that has yet to be written. They often even hear music when there is none. The layman can not afford an expensive synthesizer to find out if there is music in his soul, so here is your chance to build a small synthesizer and determine if you should become a song writer, or keep the job you have now. You can listen to unrelated musical notes for hours, and who knows, you might be able to pick out that elusive melody that can make you the song writer of the century.

The *Looney Tones Music Synthesizer* will play a 256-note passage that includes 4096 variations. The variations are controlled by the settings of the six

panel-mounted switches. The synthesizer uses two specialized IC's and a small audio amplifier that combine to provide hours of entertainment and prove to the world that you're either tone deaf, or that you're really serious about writing a new song.

How It Works. Figure 1 is a schematic representation of the Looney Tones Music Synthesizer. The circuit is built around an XR2240 programmable timer/counter (U1), an XR2207 voltage-controlled oscillator or VCO (U2), a 386 low-power audio amplifier (U3), and a handful of support components and switches. The programmable timer/counter, U1, contains a built in RC oscillator with eight flip-flops. Those flip-flops can be used to divide the base frequency (f_0) from f_0 to $f_0/128$ in eight stages.

The outputs for all the flip flops are accessible at pins 1 to 8. The base frequency is established by the RC constant of C2 and R3. Those components establish the beat, or speed of the tones. The tempo can be made faster or slower by altering the values of those components. As the flip-flops go through their counting functions, the various output combinations go high and low.

The voltage-controlled oscillator, U2, produces a square wave whose frequency is determined by C4, and the voltage present at the four inputs, pins 4, 5, 6, and 7. By connecting the varying outputs of U1 to those inputs through various resistances, a variety of tones are produced. Switches S1 to S6 are DP4T slide switches. Each slide position switches one of a group of four resistors associated with that particular switch into the circuit. Those six, four-position switches give 4096 variations to the 256-note tune.

The output of U2 is fed to U3 through C5 and R8. Switch S7, a DP4T switch (which is wired as an SPST switch), is used as an on-off switch.

Construction. There is nothing particularly critical about the construction of the circuit. In fact, the circuit (if desired) can be hard wired on a section of perfboard, but (as always) construction is made simple by use of a printed-circuit board. A template of the layout used by the author in the production of his prototype is shown in Fig. 2.

Once you've collected the necessary parts, construction can begin. Figure 3 is the parts-placement diagram for the printed-circuit board layout

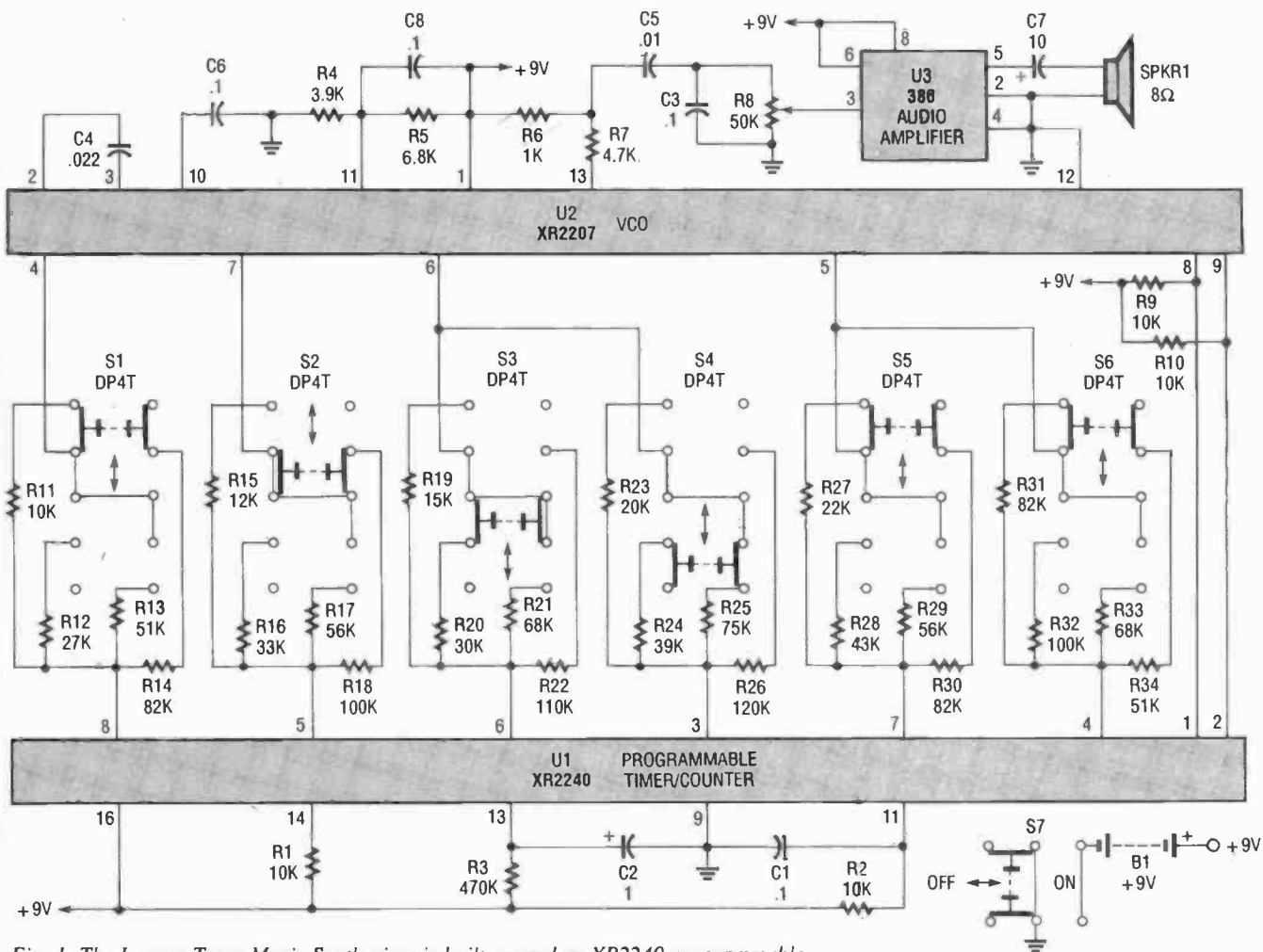

Fig. 1. The Looney Tones Music Synthesizer is built around an XR2240 programmable timer/counter (U1), an XR2207 voltage-controlled oscillator or VCO (U2), a 386 low-power audio amplifier (U3), and a handful of support components and switches.

shown in Fig. 2. As assembled by the author, none of the board-mounted components were allowed to extend higher than the tops of the switches. To aid that requirement, miniature radial-lead electrolytic and ceramic-disc capacitors were mounted to the printed-circuit board and pushed over on their sides. All of the resistors in the circuit are 1/8-watt units to make the project as small as possible.

The holder for the 9-volt transistor-radio battery was made by forming a couple of lengths of solid 14-gauge wire around the battery and the two loops are tack soldered to the foil side of the board. The battery is slid into the loops against the standoff and held in place with a small piece of foam rubber placed at the terminal end of the battery.

The front-panel of the enclosure was made from a piece of unetched printed-circuit board. To make the front panel, lay a sheet of acetate over the layout pattern and trace around the

PARTS LIST

SEMICONDUCTORS

- U1—XR2240 programmable timer/counter, integrated circuit
- U2—XR2207 voltage-controlled oscillator, integrated circuit
- U3—LM386N low-power, audio amplifier, integrated circuit

RESISTORS

- (All fixed resistors are 1/8-watt, 5% units, unless otherwise noted.)
- R1, R2, R9, R10, R11—10,000-ohm
 - R3—470,000-ohm
 - R4—3900-ohm
 - R5—6800-ohm
 - R6—1000-ohm
 - R7—4700-ohm
 - R8—50,000-ohm miniature potentiometer (Digi-Key part K0A54 or similar)
 - R12—27,000-ohm
 - R13, R34—51,000-ohm
 - R14, R30, R31—82,000-ohm
 - R15—12,000-ohm
 - R16—33,000-ohm
 - R17, R29—56,000-ohm

- R18, R32—100,000-ohm
- R19—15,000-ohm
- R20—30,000-ohm
- R21, R33—68,000-ohm
- R22—110,000-ohm
- R23—20,000-ohm
- R24—39,000-ohm
- R25—75,000-ohm
- R26—120,000-ohm
- R27—22,000-ohm
- R28—43,000-ohm

CAPACITORS

- C1, C3, C6, C8—0.1- μ F, ceramic disc
- C2—1- μ F, 25-WVDC, tantalum
- C4—0.022- μ F, ceramic disc
- C5—0.01- μ F, ceramic disc
- C7—10- μ F, 16-WVDC, electrolytic

ADDITIONAL PARTS AND MATERIALS

- S1—S7—DP4T slide switch
- SPKR1—8-ohm speaker (3 1/2 inch)
- B1—9-volt transistor-radio battery
- Printed-circuit board materials, enclosure, battery holder and connector, standoffs, etc.

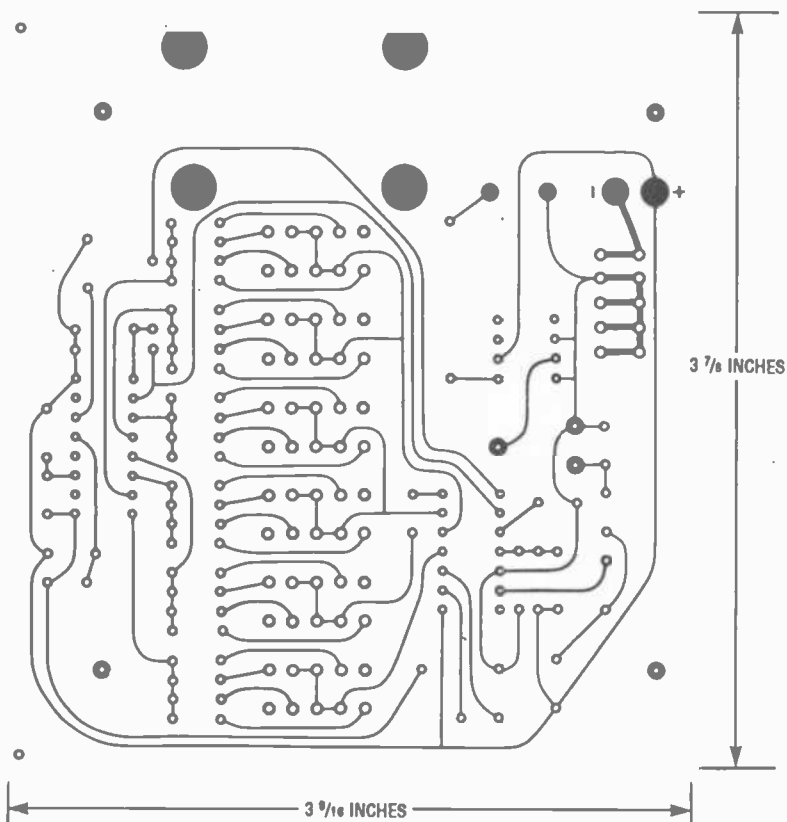

Fig. 2. Here's a template of the layout used by the author in the production of his prototype. There is nothing particularly critical about the construction of the circuit. In fact, the circuit could have been hard wired on a section of perfboard.

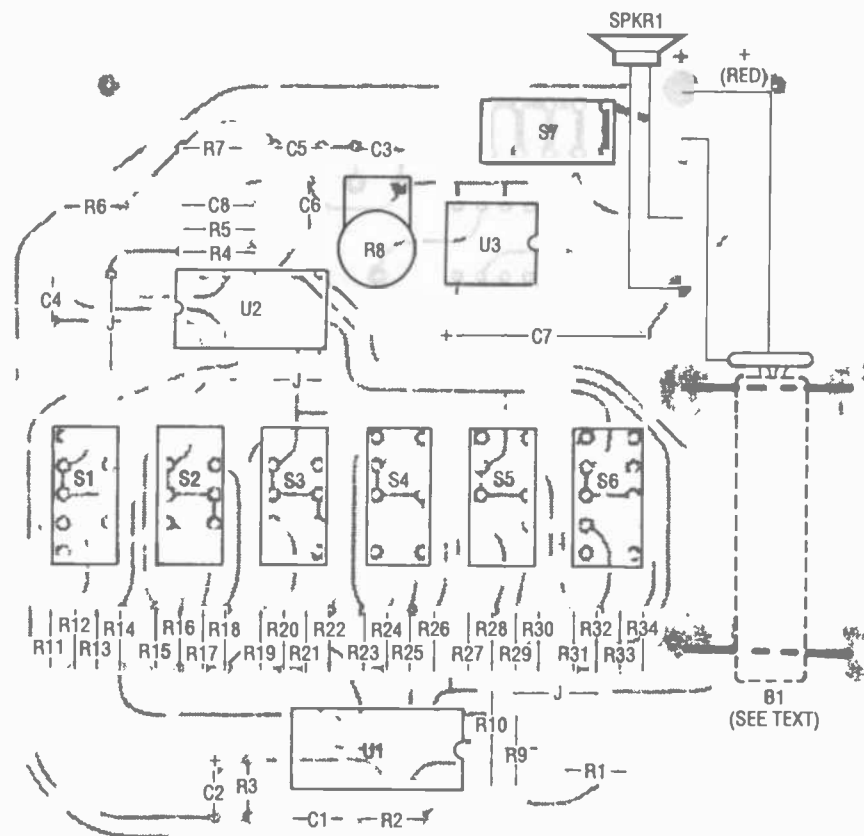
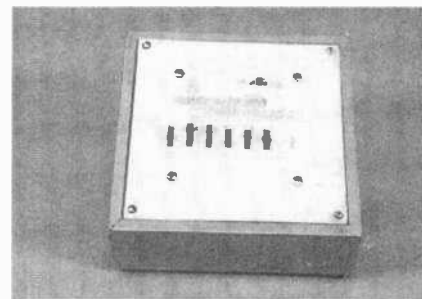

Fig. 3. Once you've collected the necessary parts, assemble the circuit using this parts-placement diagram as a guide. Note: The nine-volt transistor radio battery is not mounted to the components side of the board, but instead is held to the foil side of the board with wire brackets.



The author's prototype was housed in a custom enclosure.

positions of the eight switches and four mounting holes. Labels can then be added to the front-panel template using dry-transfer lettering, and the acetate used to etch the pattern into the board. The pattern for the front panel can be extended out on four sides and made to any size needed for mounting in the chosen enclosure.

Once done, all that remains is to drill out and, where necessary, reshape the holes to conform to the movement of the switch levers. Preparing the front panel in that manner solved the problem of aligning the holes with the switches, and also provides an easy method of lettering the front panel. The switch holes are drilled out in the center and filed square with a small file. File the switch cut outs flush with the inside of the copper rectangle outline.

The complete printed-board assembly is held against the front panel by four 1/2-inch screws. The screws are put through the top of the panel, a flat washer, then through a 1/4-inch unthreaded spacer, through the component board, and into one end of a 1/4 x 1 3/8 inch long threaded standoff.

The 3 1/2-inch speaker is mounted on the other ends of the four threaded standoffs with four screws. The longer standoffs (about 1 3/8 inches) can be made from a 1-inch and a 3/8-inch standoff, or any other combination of lengths that add up to 1 3/8 inches.

The author's prototype was housed in a custom wooden enclosure, whose inside dimensions are 4-inches square and about 2-inches deep. Holes must be drilled in the bottom of the enclosure for the speaker. A small piece of screen can be cut to fit the speaker cutout. The screen can be held in place with four drops of fast-setting epoxy in each corner. The grille will protect the speaker from damage. Four rubber feet can then be attached to the bottom of the enclosure to elevate the bottom surface of the enclosure so that the speaker can be heard.

THE DIGITAL ELECTRONICS COURSE

SEQUENTIAL LOGIC

Create an active logic circuit and learn about time-dependent logic circuits.

BY ROBERT A. YOUNG

Logic circuits are generally divided into two broad groups, known as *combinational logic* and *sequential logic*. Combinational-logic circuits are much simpler than sequential-logic configurations. In combinational logic circuits, decisions are made based on the current input conditions. Combinational logic is essentially the combining of gates in some logical manner in order to achieve a desired output anytime that a certain input combination occurs. Sequential-logic circuits are more complicated in that they involve time-dependent variables and memory units.

Sequential Logic. Sequential-logic circuits, in contrast to combinational-logic circuits, make decisions based not only on existing conditions, but also on past (and perhaps future) conditions. For example, suppose that it's desirable to have a flashing light that automatically turns on at dusk and turns off at daybreak. A further requirement is that it be activated by either of two light sensors.

The circuit in Fig. 1 meets that criteria. That circuit consists of three familiar sub-circuits, with a few additions that

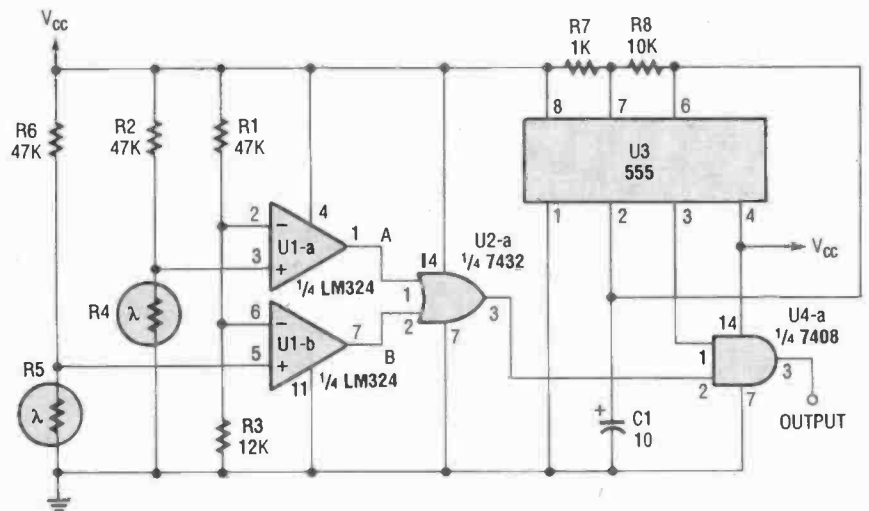

Fig. 1. Our sequential logic circuit consists of three familiar sub-circuits, with a few additions, which you should recognize: U2-a, $\frac{1}{4}$ of a 7432 quad 2-input OR gate; U4-a, $\frac{1}{4}$ of a 7408 quad 2-input AND gate; and a 555 oscillator.

you should recognize; U2-a ($\frac{1}{4}$ of a 7432 quad 2-input OR gate) and U4-a ($\frac{1}{4}$ of a 7408 quad 2-input AND gate). To help refresh your memory take a look at Fig. 2. The truth table for the 2-input OR gate shows that an OR gate's output is high when any one or both of its inputs is high. Note that the AND gate's output is high only when both inputs are high.

With the ratio that exists between R1 and R3, less than half of V_{cc} (about 1.02 volt) is applied to the inverting inputs of U1-a and U1-b. During the daylight hours (when light strikes the LDR's), the resistance of R4 and R5 is very low (about 100 ohms) as compared to R2

and R6 (47k), respectively, so only a small fraction of V_{cc} (about .02 volt) is applied to the non-inverting inputs of U1-a and U1-b.

Because the inverting inputs of U1-a and U1-b are at a higher potential than their non-inverting inputs, the output of those devices are low. Those lows are each applied to one leg of U2-a ($\frac{1}{4}$ of a 7432 quad 2-input OR gate). Note from the truth table for the OR gate (see Fig. 2) that an OR gate's output goes high anytime any one or both of its inputs are high. Thus, with both inputs to U2-a low, its output is low.

(Continued on page 101)

*Our gratitude is extended to the EIA/CEG for the creation of this course, especially to the consultants who brought it to fruition: Dr. William Mast, Appalachian State University; Mr. Joseph Sloop, Surry Community College; Dr. Elmer Poe, Eastern Kentucky University.

EXPERIMENTING WITH SOLAR POWER



Experimenting with solar power can be fun and educational—and who knows, you might solve the energy crises.

BY GEETA DARDICK

Experts are of the opinion that with the price of utility power going up, and the price of solar power coming down, more and more people will harness the sun to satisfy their energy needs. In fact, there are many people doing so with photovoltaic cells already. They include persons living on rural acreage beyond power lines, vacationers who travel in recreation vehicles or boats, urban residents who prefer alternative energy systems to conventional utility power, and the list could easily go on.

A Brief History of Photovoltaics.

Simply put, a photovoltaic cell converts light into electricity, a scientific phenomenon that has been known for 150 years. In 1839, a French physicist named Edmund Becquerel discovered photovoltaics when he placed two identical electrodes in a conducting solution and then illuminated one of the electrodes. Other famous names in the history of photovoltaic power are W.G. Adams and R.E. Day, the twosome who discovered (in 1870) that selenium could convert light to electricity with 1% to 2% efficiency.

In the early 1900's, Albert Einstein's work with quantum mechanics helped scientists understand why electricity could be produced from light. When Einstein won the Nobel Prize in 1921 for discovering the "photoelectric effect" (that light can interact with the atoms of

certain metals to give off free electrons), he helped popularize photovoltaic research.

In the 1940's and 1950's, scientists developed a way to grow crystals of silicon, an element that does a better job of converting light into electricity than selenium. After scientists found a way to add impurities into the silicon (1953), they were able to create silicon solar cells that could convert light into electricity with 6% efficiency. By 1958, an electronics company (Hoffman Electronics) had produced solar cells with an efficiency of nearly 14%.

Nevertheless, during the 1950's and 1960's, silicon solar cells were still not an item in demand by the general public. Primarily they were only used experimentally; by the telephone companies for rural phone transmissions; and in the space program to power radios in space satellites. It was the "energy crisis" of the 1970's that brought photovoltaics out of the closet as a technology whose time had come.

How Solar Cells Work. There are several references (listed in the sidebar entitled "More Information") that offer complex discussions of solar technology, and cover topics such as energy storage systems. For now, here's a brief explanation of solar cells by themselves to whet your appetite for more.

Imagine a sandwich (see Fig. 1). It has a silicon top and bottom to which im-

purities have been added or "doped." As you might know, regular silicon is made up of atoms with four outer electrons. But in this sandwich, the top silicon layer has been doped with phosphorous, which has atoms with five outer electrons. Now it is called an N-type (for negative) semiconductor because it has an excess of negative charges. Also, the bottom layer has been doped with boron, which has atoms with three outer electrons. So now the boron-doped material is called a P-type (for positive) semiconductor because it has fewer electrons than needed.

Thus, there is an imbalance, and the phosphorous electrons want to fill in the gaps left by the lack of boron electrons. Some of those free charges cross the middle (which is called the junction) to do just that. The movement eventually stops because already migrated electrons repel new ones that try to cross the junction. Basically, they still want to move across the barrier, but they don't have enough energy to do so.

Now, imagine a ray of light hitting the silicon sandwich. When the light hits the silicon cell, it excites electrons allowing them to jump across the barrier. That creates an electron flow, which in turn can drive current through any circuits that have been attached to the two halves of the solar cell.

Making Solar Cells. In the solar industry, cells are made from sand (silicon

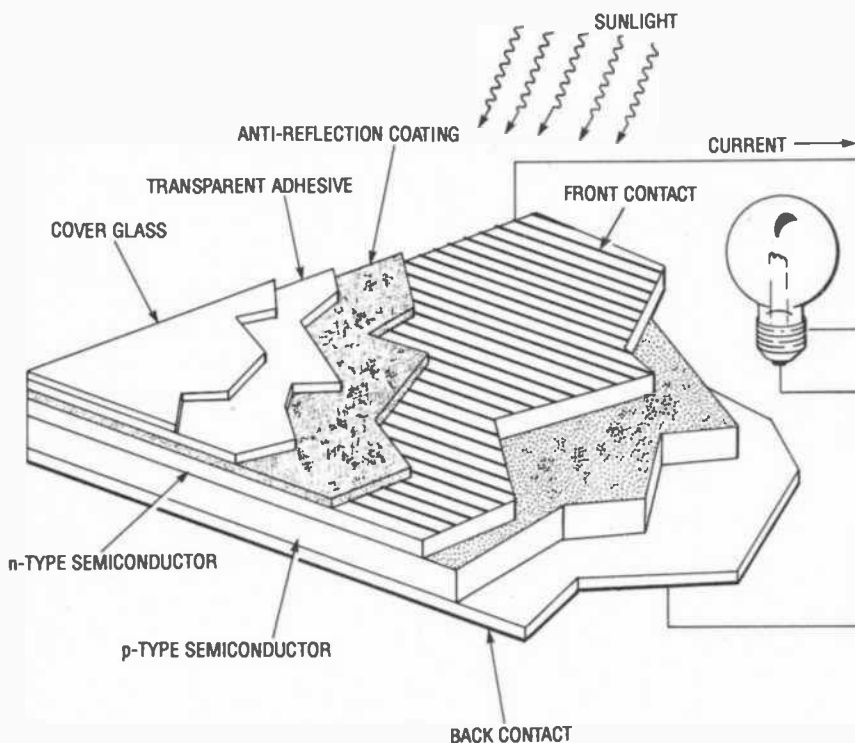

Fig. 1. Solar cells are physically simple devices. They consist of P- and N-type substrates sandwiched between contacts and covered with a layer of glass.

dioxide) that has been highly purified. That semiconductor-grade silicon (which costs almost \$50 per pound) is then grown into silicon crystals via a method called the "Czochralski process" in which a tiny crystal of silicon is dipped and redipped in hot liquid silicon to make a larger crystal.

Then the crystal (which can be as much as 5 inches across) is sliced into many ultra-thin wafers. The surface of

each wafer is etched or textured to enhance its conductivity. Then the p-n junction is formed by placing the wafers in a special furnace with doping gas, or by using machines called automatic ion implanters. Finally, low-resistance contacts are added so that when the solar cells generate electricity it can be sent elsewhere to provide power.

A half volt is the typical output from a

single solar cell. Since, a single cell produces a rather small amount of voltage, the cells are typically grouped together in series to form what is commonly called a "solar module" or "panel." To produce even more power, panels are connected to each other to form solar arrays.

Building Solar Panels. Can you experiment with making your own solar cells? Theoretically yes, but the process is so difficult and costly that it's usually best left to large companies. However, it's relatively easy to build your own solar panel from prefabricated solar cells, an experiment that will enable you to charge batteries and power some appliances by utilizing free energy from the sun.

You can get inexpensive solar cells (\$4 each) from Integral Energy Systems (see the sidebar entitled "More Information" for their address) as well as other suppliers. You might also want to buy an informative page booklet (for \$3.95) that the company publishes called "Build Your Own Solar-Electric Panel." The contents of the booklet will be briefly detailed in the following paragraphs, but it would be good for you to read the entire booklet before making your solar panel.

When you order your solar cells you'll receive 4-inch square cells of polycrystalline silicon that have an output voltage of 0.46 volt and an output current of 2 amps. If you order 35 cells, you should be able to build a 32-watt panel that can run a light bulb or a small black and white TV by using some additional circuitry. The output will be directly related to the number of cells you decide to buy.

After you receive your cells, you'll need to place each one in the sun (or under a lamp) and check it with a multimeter to make sure they all have approximately the same electrical output. Discard any that are a lot lower than the others, because they would effect the output of your entire panel. Since the panel you are making can last many years, it pays to be careful in its production.

Before you start wiring cells together, you'll need to find or make a frame for your cells. You might consider making a panel casing out of plexiglass, or buying used or new cafeteria trays. You'll also need to buy clear silicon rubber with a catalyst.

Using straight pins or finishing nails, you can carefully tack each cell onto a

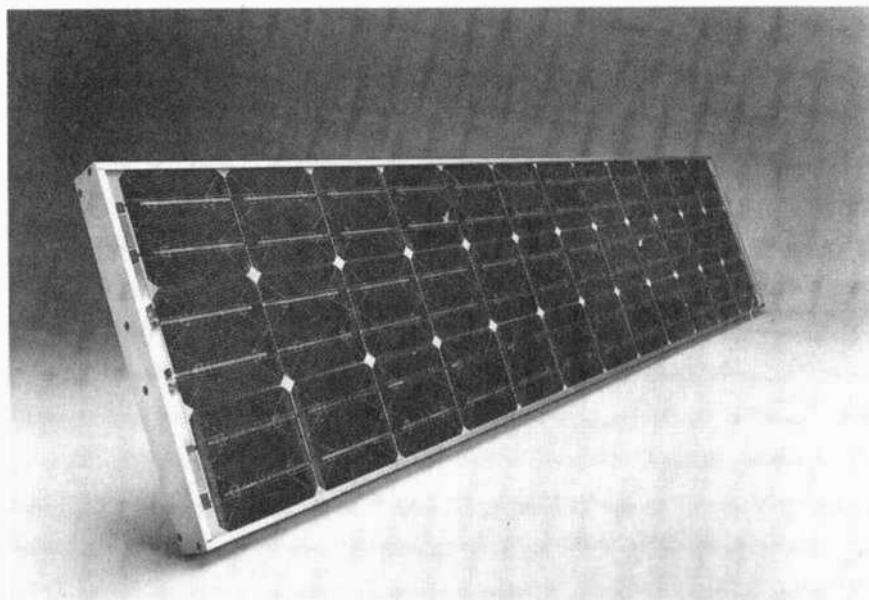

This rather impressive looking solar panel comes from ARCO Solar. Being a bit large for travel, the panel is suitable for household-roof mounting.

board for the soldering process. To wire your cells together, take 16- to 18-gauge wire and cut it long enough to be soldered across the back of one cell and over the top of the next cell's silvered edge. Strip off the insulation on the wire. You'll need to use three or more wires across each cell, that way if some break, the others maintain the connection so that you won't lose power.

Put a little solder on the silvered edge of each cell in three different places. A slight discoloration in the cell might occur near your solder points, but that is okay. However, do avoid prolonged use of your soldering iron.

Now place the end of one of the wires across the solder and carefully place the tip of a hot soldering iron momentarily on it to form a connection. The solder should flow almost instantly. After you have soldered three wires to the first cell, move on to the next and repeat the procedure.

When all of your cells have three wires soldered onto them, put some paper on a wooden board and lay the first cell on it facing down (purple side down). Put straight pins around the cell to keep it steady. Then put a row of solder on the back where the next cell's wires will go. Place the next cell face down with its wires overlapping the row of solder on the first cell's back, and touch it with your hot soldering iron. Repeat the process connecting each cell to the one before it until you have a row of four or five cells, wired together in series.

After you've created several rows of cells, it's time to wire it all up for your panel. Please note that the backs of the cells are positive, and the silver strips along the edge of the front are negative. Lay the rows face-up on whatever frame you've made.

Using thin insulated wire, strip one end long enough to connect it to the three wires from the first cell. Solder it to the three wires as the negative terminal. Run a wire from the back of the last cell; that wire will be your panel's positive terminal.

Now you're ready to test your panel in the sun before using the silicone rubber to seal up the final version. Using a multimeter, check to see if your wiring and connections are good. If you get a reading far below the expected output, check for incorrect polarity or cracked cells before you seal the panel. (Note that you often can use parts of cells, even if an entire cell seems to malfunc-

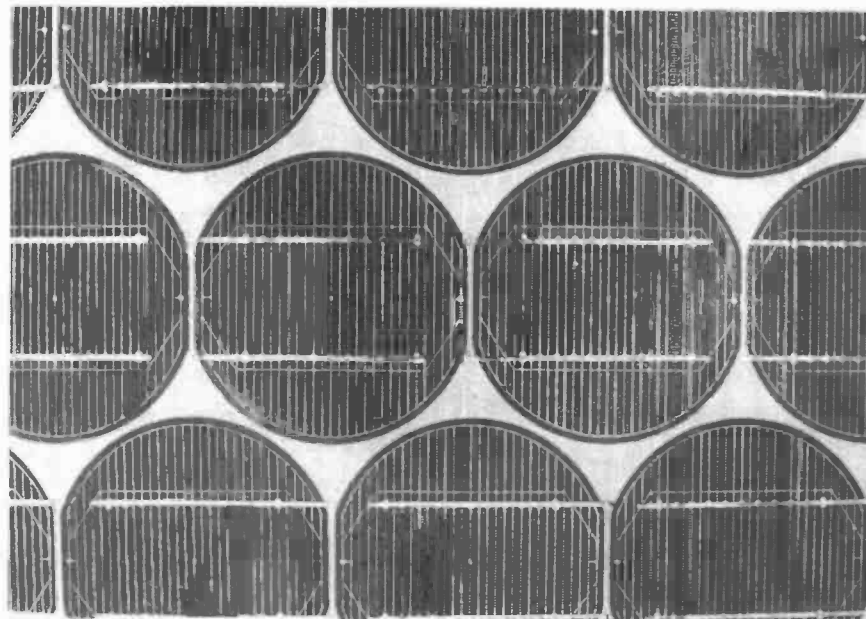

This close-up of the front surface of a solar cell reveals the small traces used as positive contacts. The metal backing is used as the cell's negative terminal.

tion. Just test the separate sections. Use the functional portion, and throw away the rest.)

While sealing the panel with silicone rubber, you'll want to eliminate all the trapped air in order to reduce hot spots that will reduce a panel's output and lifespan considerably. You can use blow dryers (the type used for drying hair) or a vacuum pump. Both processes are described fully in "Build Your Own Solar Electric Panel."

Running Appliances. If making a solar panel is too tedious for your tastes, you can also purchase 1-watt solar auto chargers, which are glass panels with amorphous silicon on the back, but without a frame. They run \$15 each, and all you have to do is add a frame and wire several of them together to create an inexpensive panel. Or, you can always purchase a ready-made panel. They run from about \$30 to \$400 based on output.

You can use the panel's current to run 12-volt appliances directly, recharge 12-volt batteries, or run AC appliances via an inverter. For practical purposes you'll need to hook your panel up to an energy-storage system (such as a bank of batteries). That'll make your solar-power system useful during less-than-optimal times. Check the texts mentioned in the box located on this page for more information.

Presuming you have made a 32-watt, 2-amp panel, how can you know exactly what it can do for you? The answer is mostly determined by the

amount of sunlight in your locale. You can consult a map of average peak hours of sunlight per day within the

More Information.

The following texts are available from Integral Energy Systems, 105B Argall Way, Nevada City, CA 95959; Tel. 916-265-8441.

Practical Photovoltaics, by Richard Komp. Contains a lot of technical information on photovoltaics and new developments in the field, plus detailed instructions for making small solar panels. 181 pages. \$16.95

Solarex Guide to Solar Electricity, by the Solarex staff. All about photovoltaics from the only U.S. manufacturer. 144 pages. \$7.95.

How to Design an Independent Power System, by Terrance Paul. Nine rules to help the reader select inverters, batteries and chargers, 123 pages, \$6.95.

The New Solar Electric Home—The Photovoltaic How-To Handbook, by Joel Davidson. The author is a pioneer in photovoltaic-system design, 404 pages, \$19.95.

The Solar Electric House: A Design Manual For Home Scale Photovoltaic Power Systems, by Steven Strong. A thorough manual for designing and installing solar electric systems. 276 pages, \$19.95.

"The 1989 Electrical Independence Guidebook and Catalogue," by Jon Hill, features solar panels, batteries, and inverters, plus hard-to-find 12 volt appliances from answering machines to water pumps. 83 pages.

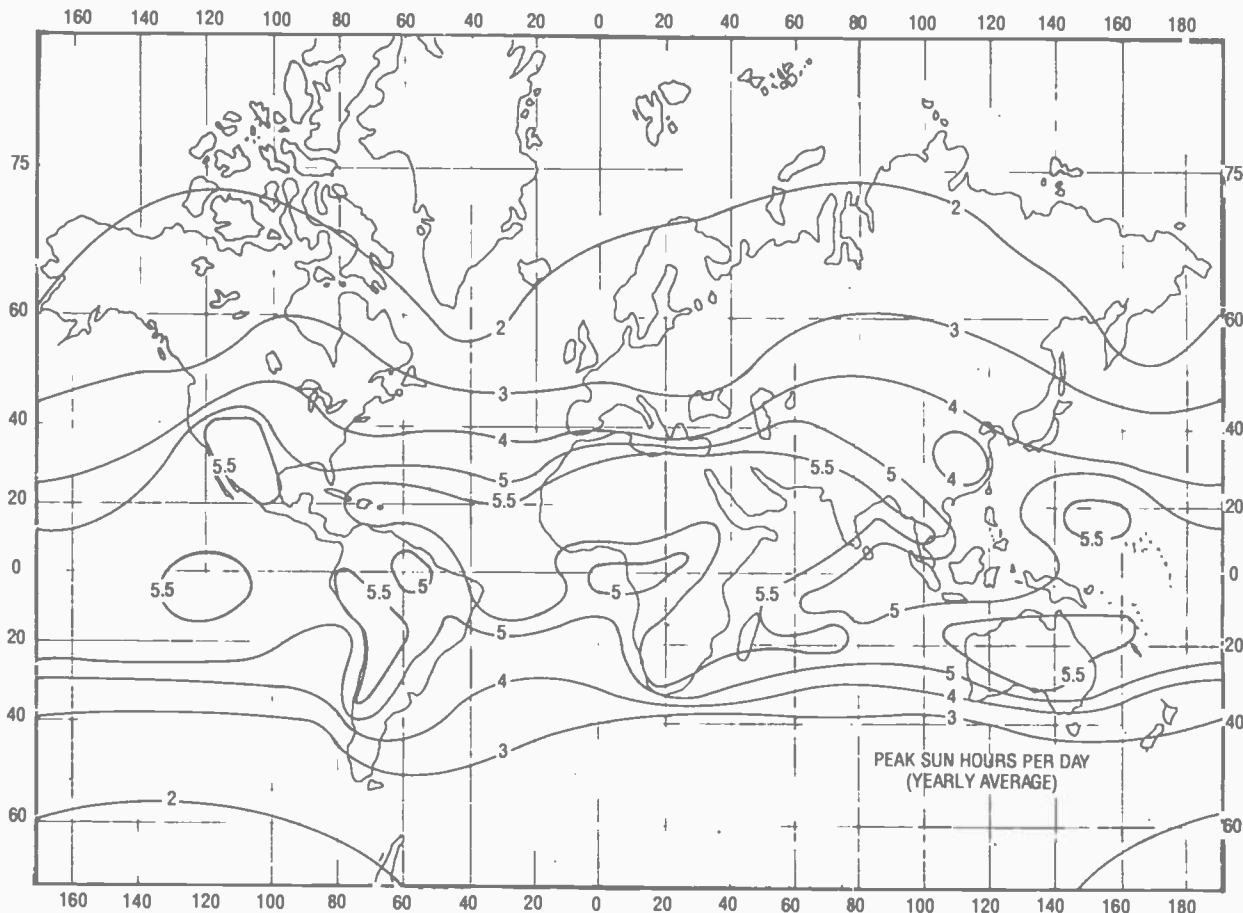

Fig. 2. This is a world solar map. It is used to indicate the average hours of daylight that falls on different regions during a year. The lines connect areas with the same number of useful hours.

United States. A map showing peak sunlight hours per day for the entire world is shown in Fig. 2. Presuming you have six hours of useful sunlight available and some way to store your panel's energy, you can simply multiply 6 hours of sunlight times 2 amps to determine that you will have 12 amp-hours available each day.

Sizing Your System. Will your 30-watt panel be able to run a 15-watt light bulb or a black and white TV? It depends on how long you want to run those appliances, the amount of sun in your area, and the efficiency of your storage cells.

For instance, let's say you want to know if you will be able to watch your TV for two hours in the evening, and then read a book by the light of your 15 watt bulb, for the next three hours. You start by calculating the amp-hours needed for each device. Starting with the light bulb and assuming that it draws 1.3 amps for 3 hours, the calculation would be:

$$1.3 \times 3.0 = 3.9 \text{ amp-hours}$$

If we assume that your TV draws 1.4 amps for 2 hours, the calculation would be as follows:

$$1.4 \times 2.0 = 2.8 \text{ amp-hours}$$

The total usage is then:

$$3.9 + 2.8 = 6.7 \text{ amp-hours}$$

Of course we are assuming your storage cells are very efficient. To figure out the percent usage just divided the total amp-hours you will need by the number of amp-hours produced by your solar panel in you location. Let's say your solar panel produces 12 amp-hours each day; the percent usage is then equal to:

$$6.7/12 = 0.56$$

or 56%. That means you can still run a 12-volt blender (12-volt appliances are also available from Integral Energy Systems).

The Future for Solar Power. In 1980, the price-per-watt of solar power was about \$15.00. Today, it costs about \$6.00 per watt to power most photovoltaic products—a price that still keeps solar

power unable to compete with cheaper utility power. However, industry experts predict that the cost of photovoltaic applications will come down to \$2.00 per watt in the next five to seven years as they continue to make improvements in the manufacture of the solar cell.

Besides photovoltaic power, there's also a new solar-thermal technology called the "luz system" in which rows of parabolic mirrors track the sun across the sky and then focus its rays on vacuum sealed tubes of synthetic oil. Once the oil in the tubes reaches 735°F; it is pumped into a water-filled steam compressor that turns the water to steam and turns an electric turbine to produce power.

Whether it be photovoltaic or luz systems, the problems of pollution are forcing politicians to look again at solar energy as well as other alternative-energy sources. As Senator Tim Wirth of Colorado recently said: "It's time to look once again at renewable, nonpolluting sources of energy. We've got to keep pushing it...to alert the country that real alternatives do exist." ■

Adding an EXTERNAL DRIVE to your LAPTOP COMPUTER

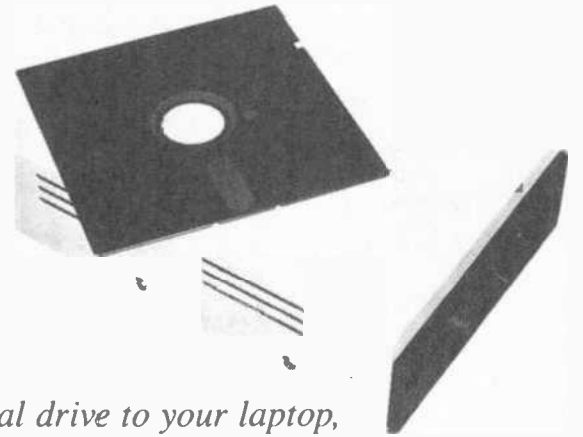

If high prices are keeping you from adding an external drive to your laptop, consider this low-cost, multiple-format alternative.

BY FRED BLECHMAN, K6UGT

According to industry estimates, sales of laptop computers were almost 1.2 million in 1989—nearly double the 1988 figure—and it looks like the 1990 figure will be double that!

The majority of laptops have either one floppy and one hard disk drive, or two floppy drives, with prices ranging from \$1000 to \$6000. Many laptops priced below \$1000 (including the very popular Toshiba T1000) have only one internal floppy-disk drive.

That can be a serious limitation unless you take advantage of the external-drive connector. If you ever had a computer with only one drive, you know how annoying it can be to constantly swap disks when running programs or copying files. Also, more and more programs actually require two floppy drives (or one floppy drive and a hard-disk drive) to operate.

No matter what your drive configuration, perhaps the most important reason to have an external floppy drive is to be able to read the common 360K 5-1/4-inch diskettes on which most programs and data are supplied. Since most laptops come with only 3-1/2-inch floppy drives, they can't read 5-1/4-inch diskettes.

Sure, you can link your laptop to your

desktop machine (provided you have one) via a cable and transfer files using terminal programs. But that is a bother at best, as well as being time consuming, a possible source of errors, and expensive if you don't know the shortcuts.

What Can be Done? External floppy drives are available from the manufacturer, usually at a premium price. For example, the Toshiba external 360K 5-1/4-inch drive with power supply, cabinet, and interface cable, has a list price of \$499! If you don't have a spare drive, and don't want to gather the various parts to add an external drive to your system, you can get that external drive already assembled in a case with

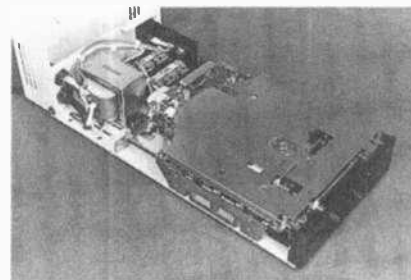

This completely assembled 5-1/4-inch half-height floppy-disk drive is shown with the lid removed from its JMR ISV5 case to reveal its power supply toward the unit's rear.

power supply and cable for just \$375 from Springboard Engineering (7500 Topanga Canyon Blvd., Canoga Park, CA 91303; Tel. 818-346-4647.)

If that is too expensive, Springboard will sell you a generic external drive, in a case with a built-in power supply, and with the correct Toshiba laptop cable, for \$210 plus shipping (call them for details).

Two other sources for ready-to-go external floppy drives for your laptop are CMS Enhancements, Inc. (1372 Valencia Avenue, Tustin, CA 92680; Tel. 714-259-9555) and Practical Computer Technologies, Inc. (3972 Walnut St., Fairfax City, VA 22030; Tel. 703-385-3332.) You must call them for details due to price fluctuations.

If you want to add an external floppy drive to your laptop, there is yet another alternative: I'll describe how you can add your own external floppy drive, including the drive, cabinet, power supply, and cable, for about \$150. If you already have some of those parts, you'll spend even less.

Furthermore, instead of being limited to external 360K 5-1/4-inch drives, you'll be able to use 720K 5-1/4-inch drives, or 720K 3-1/2-inch drives!

While this article will apply specifically to the Toshiba T1000 laptop, the same

cable and drives can be used with all the Toshiba laptops except the T1100, and with computers from many other manufacturers, too.

Choosing a Drive. Figure 1 shows a typical external drive arrangement. A special cable is plugged into the external-drive port on the laptop. That cable connects the laptop to the card-edge on the external floppy drive. External floppy drives for use with a laptop do not need a controller because the laptop contains the controller. The drive is connected to a power supply that uses standard household power. The drive and supply are usually mounted together in a common cabinet.

The most important part of the assembly will obviously be the disk drive itself. For all practical purposes, there are only two sizes of floppy drives in regular use in the microcomputer world: 5-1/4-inch drives—available in 360K, 720K, and 1.2M capacities; and 3-1/2-inch drives that come in 720K and 1.44M capacities. Other formats, such as 160K single-sided 5-1/4-inch, are obsolete, so avoid them. The 3-1/2-inch drives have a few advantages: they are smaller, consume less power, and use more rugged microdiskettes.

You may never have heard of 720K 5-1/4-inch floppy drives, but you're not alone. Sometimes they are called "quad density" or "96tpi" (for 96 tracks-per-inch.) They have never become popular, but they are available, and inexpensive. And since they format exactly like the Toshiba's built-in 720K 3-1/2-inch drive (double sided, 80 tracks, 9 sectors per track, 512 bytes per sector), you can use them to make inexpensive backup diskettes from DOS by using the "DISKCOPY" command.

Most types of drives are advertised

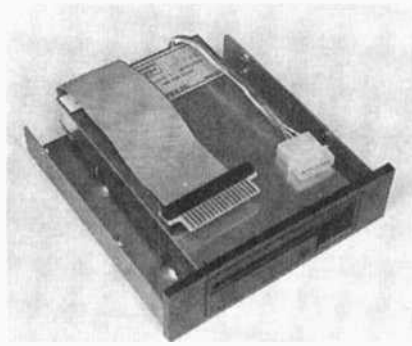

This photo shows a Sony 720K 3-1/2-inch drive. It is setup for mounting in a 5-1/4-inch frame with the proper adapter cables to allow this drive to be plugged in as a physical replacement for a 5-1/4-inch drive.

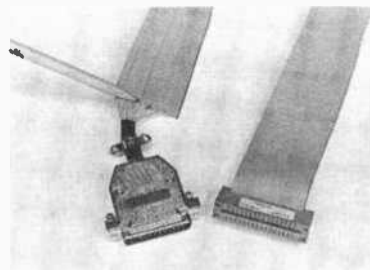

This photo shows the author's home-made cable. Note the label on the card-edge connector. If you label your connector, properly orienting it is a snap.

liberally in computer magazines for \$60-\$80. The 720K 5-1/4-inch drives are harder to find, and you may have to settle for a full-height unit. JB Technologies (21101 Itasca St., Unit #F, Chatsworth, CA 91311; Tel. 818-709-6400) sells several models of them for as little as \$39. The Main Source (9260 Owensmouth Ave., Chatsworth, CA 91311; Tel. 800-882-1238, or 818-882-7500 in California) sells a Fujitsu M2552 version for only \$35.

A last word of advice: although all drive types come in full-height and half-height sizes, I would avoid the full-height drives if possible; they use more power, are based on old technology, and might be refurbished rather than brand new.

The Connectors and Cable. Most laptops that support an external floppy drive have a connector for that purpose. On the Toshiba that port is labelled EXT FDD, for "External floppy-disk drive." It is a female 25-pin DB-25F connector commonly used in microcomputers for serial-interface ports.

On all Toshiba portables, except the T1100 (no longer in production), the

connector is intended to be used with a cable that also mates with a 34-pin female card edge connector at the disk drive end. (Note: The Toshiba 360K 5-1/4-inch external floppy drive has a 25-pin connector instead of a 34-pin card edge.)

The question, of course, is how do you properly mate 34 wires at one end of the cable with 25 wires at the other end? The cable wiring diagram (supplied by Toshiba) is shown in Fig. 2.

You can make one yourself by getting a standard disk-drive 34-conductor cable, which will have a 34-pin card-edge female connector at one end. Cut off the other end, and solder on a DB-25P connector to correspond with the wiring in Fig. 2. The connections at the 25-pin end are pretty scrambled, so be very careful to get them right.

After I made my own cable, I found that Altex Electronics (300 Breesport, San Antonio, TX 78216; Tel. 800-531-5369 or 512-349-8795) sells the 4-foot TEXD-4 Toshiba External Drive Cable (25P-34E) for \$16.95, plus \$3.00 handling, plus shipping.

While that seems high for a cable that can be made for about \$4 worth of parts (Altex charges \$1.33 for a 34-pin edge connector, \$0.73 for a DB-25P solder connector, and \$0.51 a foot for 34-wire ribbon cable), the labor in building it is significant due to the scrambled wiring at the DB-25 end. Take my advice—buy the TEXD-4 instead of hassling with making your own!

The Power Supply The power supply can be built into a cabinet made to hold a half-height 5-1/4-inch drive. For a half-height drive, a small power supply that will provide both 12 and 5 volts DC at about 0.5-amp and a female four-pin disk-drive connector will do. Generally, a full-height drive will need closer to 1 amp at 12 volts and possibly 0.7 amp at 5 volts.

There are lots of surplus power supplies around from old TRS-80, ADAM, Texas Instrument, and other old microcomputers. Just be aware that you'll need to have the power connector wired properly, and a power supply with enough amperage at 5 and 12 volts or you'll get erratic operation.

All Electronics Corp. (P.O. Box 567, Van Nuys, CA 91408; Tel. 800-826-5432 or 818-904-0524) shows a power supply in their catalog that I use in testing. Their catalog number is PS-TX, it sells for \$5 and includes the power transformer

(Continued on page 106)

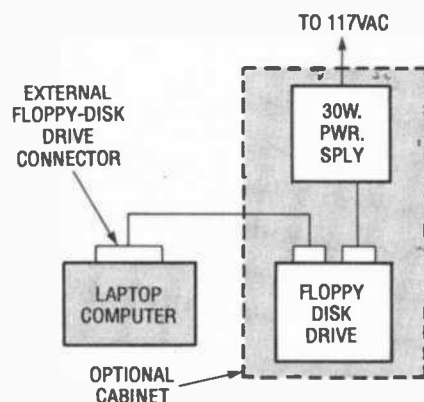

Fig. 1. External disk drives require their own power supply, which is usually built into their case. A multi-conductor cable links the drive with the laptop.

Capacitors (called condensers in early texts) are used in a wide variety of electronic circuits for AC bypassing, decoupling between circuits, DC blocking, tuning, timing, and other functions. Like inductors, capacitors are energy-storage devices. While an inductor stores energy in a magnetic field, a capacitor stores energy in an electric (or electrostatic) field.

Like resistors, capacitors come in two forms: fixed-value and variable. Let's start our overview of capacitors with fixed units, leaving the variable ones until later.

foil were sandwiched together to form high-voltage capacitors.

Units of Capacitance. The capacitance of a capacitor is a measure of its ability to store electrical charge. The principal unit of capacitance is the farad (named after physicist Michael Faraday). One farad (denoted 1 F) is the capacitance that will store one coulomb of electrical charge (6.28×10^{18} electrons) at an electrical potential of one volt. Or, in math form:

$$C = Q/V$$

where: C is the capacitance in farads;

same unit with just a different name.

The capacitance of a capacitor is directly proportional to the area of its plates (for the unit in Fig. 1, that's $L \times W$) and the "dielectric constant" (K) of the dielectric, and is inversely proportional to the thickness (T) of the dielectric (or the spacing between the plates, if you prefer).

The dielectric constant is a property of the insulating material used for the dielectric. It's a measure of a material's ability to support an electric field. A perfect vacuum is said to have a dielectric constant equal to one and it is used as the standard material with



CHOOSING and USING CAPACITORS

Learn about the many types of fixed and variable capacitors—and the right way to use them!

BY JOSEPH J. CARR

Fixed Capacitors. A fixed capacitor consists of a pair of metallic plates facing each other, and separated by an insulating material called a dielectric (see Fig. 1). Although the capacitor depicted is not terribly practical, ones like it were once used quite a bit in transmitters. Spark transmitters of the 1920's often had a glass and tin-foil capacitor fashioned very much like the one shown; back then, layers of glass and

Q is the charge on the capacitor in coulombs; and V is the voltage on the plates in volts.

A farad is far too large a unit for practical electronics work, so smaller units are used. A microfarad (denoted μF) is .000001 farads ($1 \text{ F} = 10^6 \mu\text{F}$). A picofarad (pF) is .000001 μF or 10^{-12} farads. In older radio texts and schematics, picofarads were called micro-microfarads (mmF), but they are the

which everything else is compared. The values of K for some common materials are shown in Table 1.

The value of capacitance for any parallel-plate capacitor—even with multiple plates—can be found from:

$$C = 0.0885KA(N - 1)/T$$

where C is the capacitance in picofarads (pF); K is the dielectric constant; A is the area of one of the plates

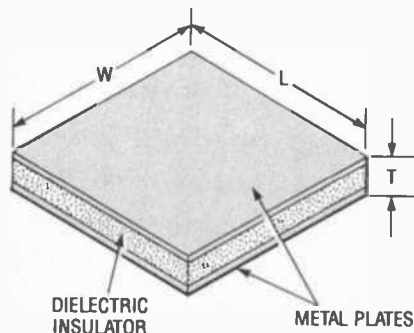

Fig. 1. A capacitor consists of a pair of conductors separated by a dielectric insulating material. Its value depends on its dimensions and the dielectric used.

TABLE 1—DIELECTRIC CONSTANTS

Material	K
Vacuum	1.0000
Dry air	1.0006
Paraffin	
(Wax) Paper	3.5
Glass	5-10
Mica	3-6
Rubber	2.5-35
Dry Wood	2.5-8
Distilled Water	81

(assuming that all the plates are identical); N is the number of plates; and T is the thickness of the dielectric.

Breakdown Voltage. If the electrical potential (i.e. the voltage) between a capacitor's plates gets too large, free electrons in the dielectric material (there are a few in any insulator) will flow. The dielectric is then said to breakdown, allowing current to pass between the plates. The capacitor is thus shorted.

For that reason the maximum breakdown voltage of the capacitor must not be exceeded. For practical purposes there is a rating called the DC working voltage (WVDC for short) that defines the maximum safe voltage that can be applied to the capacitor. Typical values found in common electronic circuits range from 8 to 1,000 WVDC.

Circuit Symbols for Capacitors. The common circuit symbols used to designate fixed-value capacitors are shown in Fig. 2A. In certain types of capacitors, the curved plate shown on the left in Fig. 2A is usually the outer plate (i.e. the one closest to the outside package of the capacitor). That plate's lead is often indicated with a color band next to it on the capacitor body.

The symbols for variable capacitors

are shown in Figs. 2B and 2C. Small trimmer and padder capacitors (which we'll explore in depth later) are often denoted by the symbol in Fig. 2C. For them, the moving set of plates is designated by the arrow.

Paper Capacitors. There are several types of fixed capacitors found in typical electronic circuits and they are all classified by their dielectric material—paper, Mylar, ceramic, mica, polyester, etc.

An old-fashioned paper capacitor consists of a strip of paraffin (wax) paper sandwiched between two strips of metal foil. The sandwich is rolled up to form a tight cylinder and packaged in a hard plastic, bakelite, or paper-and-wax case.

Paper capacitors come in values from about 300 pF to about 4 μ F. Their breakdown voltages are between 100 and 600 WVDC. They were used for a number of different applications in older circuits such as bypassing, coupling, and DC blocking. Unfortunately, no component is perfect. The long rolls of foil used in paper capacitors exhibit a significant amount of stray inductance. As a result, paper capacitors are not used for high frequencies. Although they are found in some shortwave-receiver circuits, they are rarely or never used in VHF equipment.

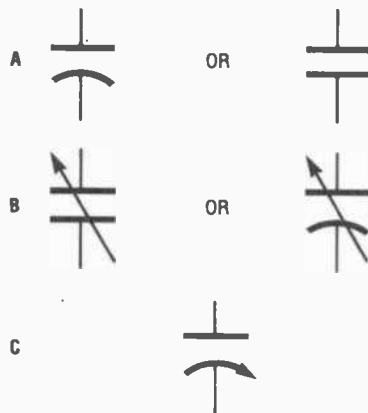

Fig. 2. These are the most common capacitor symbols for fixed capacitors (A); variable capacitors (B); and an archaic symbol for a variable capacitor (C).

In modern applications, or when replacing paper capacitors in older equipment, use Mylar capacitors instead of paper. Select a unit with exactly the same capacitance rating and a WVDC rating that is equal to or greater than the original.

Ceramic and Mica Capacitors.

Several different forms of ceramic capacitors are shown in Fig. 3. Those capacitors come in values from a few picofarads to 0.5 μ F. Their working voltage ranges from 400 to more than 30,000 WVDC.

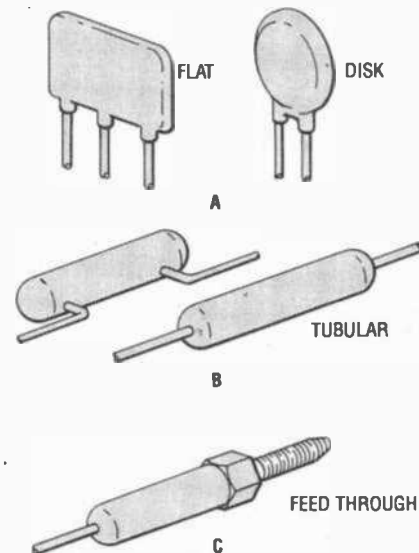

Fig. 3. Among the various forms of ceramic capacitors the disk and flat capacitors (A) are probably the ones you're most familiar with. However you should be aware that they come in tubular cases (B) and as feed-thrus with threads for mounting (C).

Common garden-variety ceramic disc and flat capacitors (see Fig. 3A) are usually rated at either 600 or 1000 WVDC. Tubular ceramic capacitors (see Fig. 3B) are typically much smaller in value than disc or flat capacitors, and are extensively used in VHF and UHF circuits for blocking, decoupling/coupling, bypassing, and tuning.

Feedthrough capacitors (see Fig. 3C) are used for filtering and decoupling. Their bodies are threaded for mounting directly onto metal enclosures. That permits them to pass a signal into a shielding enclosure while decoupling it. They are normally used to pass DC and low-frequency AC lines through shielded panels.

Ceramic capacitors often have a temperature-coefficient rating denoted by a letter printed on their body. That specification indicates how a device's capacitance changes with increasing temperature. A "P" indicates a positive change (increase) in capacitance; or "N" indicates a negative temperature change (decrease), and the letters "NPO" indicate no change (NPO stands for "negative/positive/zero").

Non-zero temperature coefficients are often used in oscillator circuits to

compensate for any frequency drift due to temperature changes. Because of such factors, when replacing a capacitor use one with the same temperature coefficient.

A couple of different types of mica capacitors are shown in Fig. 4. A fixed mica capacitor consists of either metal plates on both sides of a sheet of mica, or a sheet of mica that is silvered (coated) on both sides with metal. The range of values for mica capacitors is around 50 pF to .02 μ F at voltages in the range of 400 to 1000 WVDC. The mica capacitor shown in Fig. 4B is called a silvered mica capacitor. Those capacitors are fairly temperature stable, although for most applications an NPO ceramic-disc will serve better than all but the best mica units. Mica capacitors are typically used for tuning and other high-frequency applications.

Electrolytic Capacitors. It is very difficult to get large values of capacitance from small packages using any of the standard dielectrics discussed thus far. In an electrolytic capacitor, a high-capacity electrolyte is used as the dielectric to remedy that. Electrolytes come in both liquid (wet electrolyte) or paste (dry electrolyte) forms.

Electrolytic capacitors are polarity sensitive. Not only will they fail to work if connected into a circuit backwards, it is likely that the capacitor will explode, so be careful when installing them.

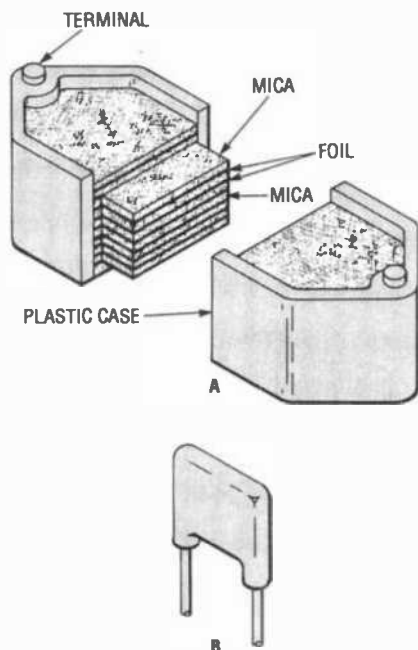

Fig. 4. Mica capacitors come in many different forms. Shown are a transmitting mica capacitor (A); and a silvered mica capacitor (B).

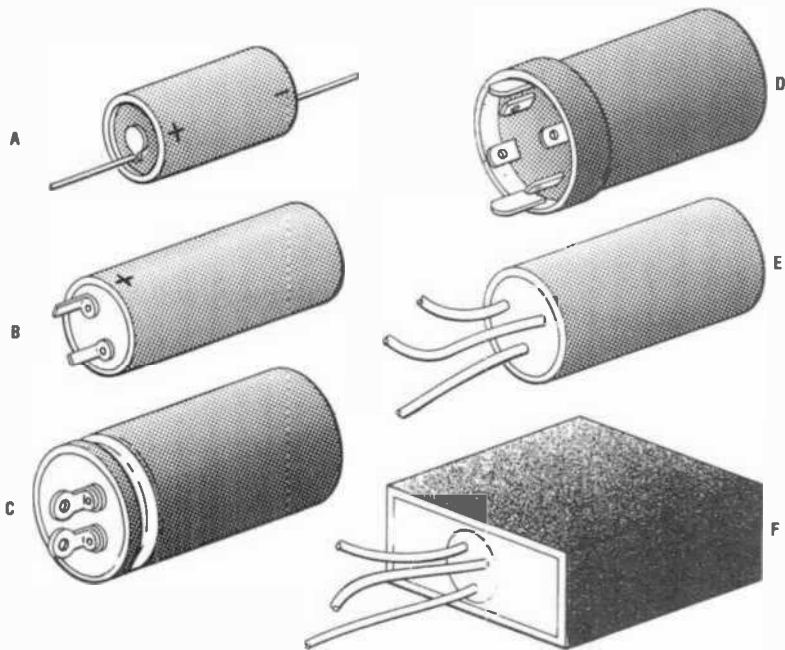

Fig. 5. These are various forms of aluminum-electrolyte capacitors: A) single-section tubular (axial leads); radial lead single-section tubular; C) Large value single-section; D) chassis mounted; E) multi-section tubular; and F) archaic "tubular" or "box" capacitor.

In common aluminum electrolytics, the aluminum-oxide electrolyte is sandwiched between two pieces of aluminum foil. The assembly is then rolled up and inserted into an aluminum cylinder (or "can") that is also used as the negative terminal of the capacitor. Aluminum electrolytics are not very effective at frequencies above 100 kHz, so in radio circuits it is common to find a 0.01- to 0.1- μ F paper or Mylar capacitor shunted across an aluminum electrolytic unit to handle high-frequency signals.

Figure 5 shows several different forms of electrolytic capacitor. The tubular electrolytic capacitor shown in Fig. 5A has a pair of axial leads protruding from its ends. The negative lead (hidden from view) is directly attached to the metal can, but the positive lead will be connected to a terminal on an insulating plug of cardboard or other material. That type of electrolytic is called an axial-lead unit.

Another single-section electrolytic capacitor is shown in Fig. 5B. In that unit (called a radial-lead electrolytic), the electrodes protrude from the same end of the capacitor. Note that one is marked "+" to indicate its polarity.

The heavier single-section capacitor of Fig. 5C will have either heavy-duty terminals or screw terminals. Those capacitors tend to have very high values (e.g. 2,000 μ F and up), but generally have low WVDC ratings (10 to 100 WVDC).

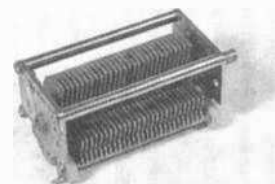

This is a simple single-section air variable capacitor. They can find use in any circuit that requires capacitive tuning at reasonable voltages.

Multi-section electrolytic capacitors are shown in Figs. 5D-F. Such units have two or more electrolytic capacitors in the same package sharing a common negative lead. The version in Fig. 5D is a chassis-mounted capacitor, while those in Figs. 5E and 5F are basically multi-section tubular capacitors. The version shown in Fig. 5E was popular in radios well into the solid-state era. The one in Fig. 5F, however, was archaic by World War II; if you enjoy antique radios, expect to find some of those beasts.

Electrolytics are used for DC power-supply ripple reduction, bypassing, audio coupling, and stage-to-stage decoupling in low-frequency circuits.

The aluminum electrolytic was used almost exclusively for many years, but recently more and more circuits have tantalum-dielectric electrolytics. Those capacitors offer higher frequency operation than aluminum electrolytics, and are physically much smaller. Like the other electrolytics, one lead will be marked to indicate its polarity.

Other Fixed Capacitors. Today, circuit designers have a number of different fixed capacitors that were not commonly available (or available at all) a few years ago. Polycarbonate, polyester, and polyethylene capacitors are used in a wide variety of applications where electrolytic capacitors once ruled supreme.

The new generation of capacitors is also performing tasks that have only recently sprung up. For example, in digital circuits we find tiny 100-WVDC capacitors with ratings of .01 to 0.1 μF . They are used for decoupling the noise on DC power-supply lines. In circuits such as timers and op-amp Miller integrators, where the leakage resistance across the capacitor becomes terribly important, we might want to use a polyethylene capacitor.

Variable Capacitors. Like all capacitors, variable capacitors are made by placing two sets of metal plates parallel to each other. The difference between variable and fixed capacitors is that, in variable capacitors, the plates can be moved to alter the capacitance. There are two principal ways to change the capacitance: vary either the distance between the plates, or the area of the plates that interact.

Figure 6A shows the construction of a typical variable capacitor used as the main tuning control in a radio receiver. The capacitor consists of two sets of parallel plates. The stator plates are fixed in their position, and are attached to the frame of the capacitor. The rotor plates are attached to a shaft that can be rotated to adjust the capacitance.

Another form of variable capacitor found in radio receivers is the compression capacitor shown in Fig. 6B. They consist of metal plates separated by sheets of mica (the dielectric). In order to alter the capacitance, the device might change the area of the plates and mica, or the number of plates facing each other. The entire capacitor is mounted on a frame made of ceramic or some other insulating material. Sometimes mounting screws are provided on the frame.

Still another form of variable capacitor is the piston or compression capacitor shown in Fig. 6C. That type of capacitor consists of an inner cylinder of metal that is coaxial to, and inside of, an outer cylinder of metal. An air, vacuum, or (as shown) ceramic dielectric separates the two cylinders. The capacitance is increased by screwing the

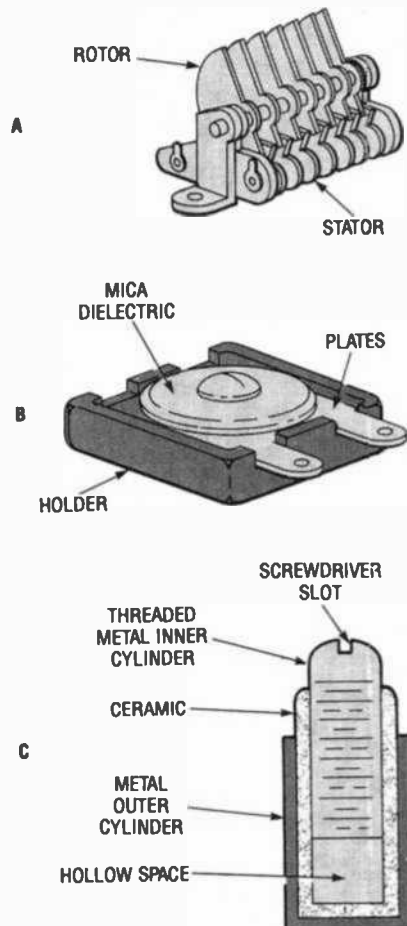
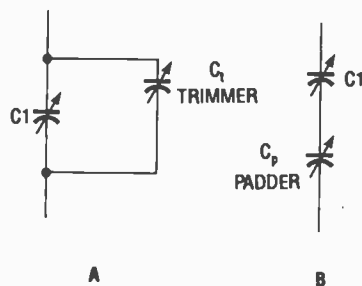

Fig. 6. Variable capacitors are made with parallel metal plates facing each other across a dielectric. In A we show a typical air-dielectric variable capacitor, in B a mica compression variable capacitor, and in C a piston-type variable capacitor.

inner cylinder further into the outer cylinder.

Trimmer and Padder Capacitors. Small variable capacitors are often used in conjunction with the main tuning capacitor of a radio to make its value fine-tunable.



There are two methods of connecting them and their name indicates on how they're connected: First, there is the true trimmer—a small-valued variable capacitor put in parallel with the main capacitor (Fig. 7A). Those capacitors are used to "trim" the value of the main capacitor. When a small variable capacitor is connected in series with some main capacitor (as in Fig. 7B) it's called a padder capacitor. Calling both series and parallel capacitors "trimmers" is a common error—only the parallel capacitors are really trimmers. Such capacitors are often mounted directly on the main capacitor's body or are at least somewhere nearby.

Air Variable Tuning Capacitors. The capacitance of an air variable capacitor is a function of how much the rotor plates interact with the stator plates. In Fig. 8A, the rotor plates are completely outside the stator plate area so they don't interact much, thus capacitance is minimal. In Fig. 8B, the rotor plates have been slightly meshed with the stator plate, the overlapping area is shown shaded. The capacitance in that position is at an intermediate value. Finally, as in Fig. 8C, the rotor is completely meshed with the stator, so capacitance is at a maximum.

Remember the following two rules: When the rotor plates are not at all meshed with the stator plates, the capacitor has minimal capacitance; when the rotor plates are completely meshed with the stator plates then maximum capacitance is available.

Often on such capacitors, the front and rear plates have bearings to ease the rotor's action. The stator plates are typically, attached to the frame of the capacitor, which in most radio circuits is grounded.

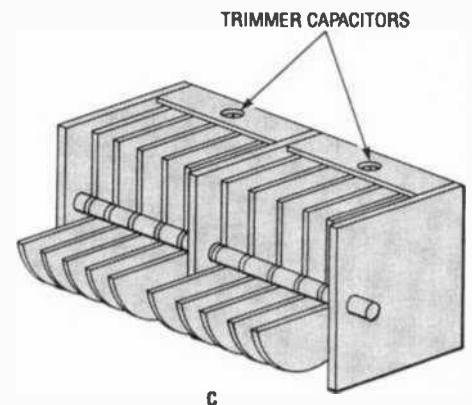

Fig. 7. Trimmer and padder capacitors are often used with main tuning capacitors. Trimmers are connected parallel to their main tuning capacitor (A); padders are connected in series to their main tuning capacitor. Trimmers are often mounted on main capacitor frames (C).

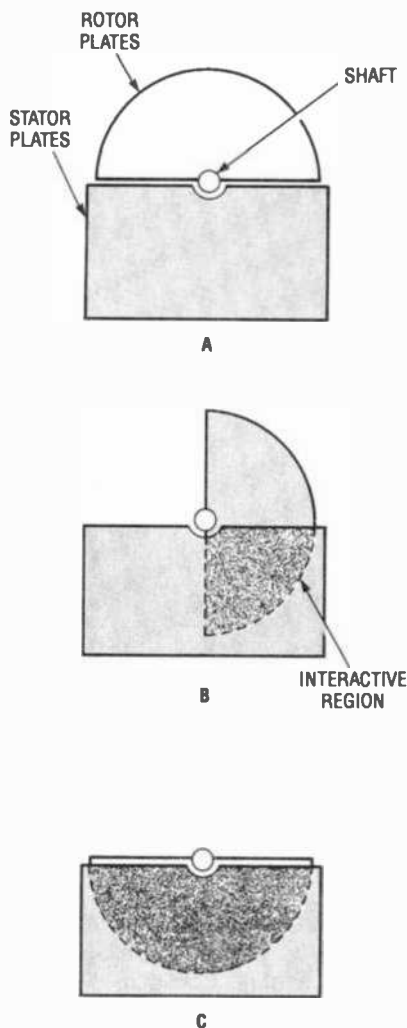

Fig. 8. In variable capacitors the capacitance depends on the amount of the stator plates that interleave with the rotor plates: Shown here are the conditions for minimum capacitance (A), intermediate capacitance (B), and maximum capacitance (C).

Most air variable capacitors have multiple sections—each section is really a variable capacitor by itself, but they are placed on the same frame so that they can be adjusted in unison by a single shaft. Such capacitors are called ganged capacitors. The capacitor sections might all have the same value.

If such a capacitor is used in a superheterodyne radio, the section used for tuning the local oscillator (LO) is padded with a series capacitance to reduce its value. That is done to permit the LO to track the RF amplifiers.

In many superheterodyne radios you will find ganged air variable tuning capacitors in which one section (usually the front section) has fewer plates than the section used for the RF amplifier. Those capacitors are sometimes called cut-plate capacitors because the LO-

section plates are "cut-down" to permit tracking of the LO with the RF.

Single-section capacitors were often used in early multiple tuning-knob radio receivers—the kind where each RF tuned circuit had its own selector knob (like the old TRF sets). But that design was not easy to use, so ganged variable capacitors became popular.

Straight Line Frequency Capacitors.

The variable capacitor shown in Fig. 8 has the rotor shaft in the geometric center of the rotor plate's half-circle. The capacitance of that type of variable capacitor is linearly proportional to the rotor-shaft angle. Because of that, that type of capacitor is called a straight-line capacitor.

Unfortunately, as you will see later on, the frequency of a tuned circuit based on inductors and capacitors is not a linear function of capacitance. If a straight-line unit is used for a tuner, then the frequencies on the dial will be cramped together at one end and spread out at the other (you might have seen such radios). But some capacitors, called straight-line frequency capacitors, are designed to compensate for the nonlinearity of the tuning circuit. The shape of the plates and the location of the rotor shaft are selected to produce a linear relationship between the shaft angle and the resonant frequency of the tuned circuit in which the capacitor is used.



Fig. 9. This is the schematic symbol for split-stator capacitors. They often find application in antenna tuners.

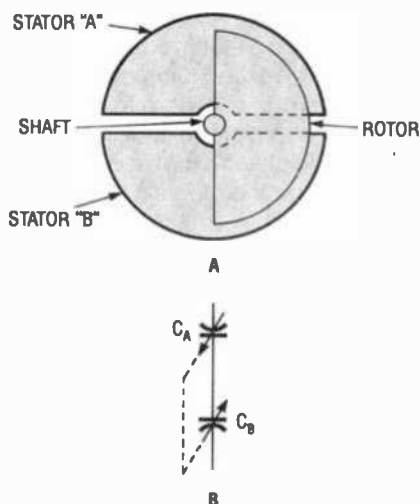

Fig. 10. Differential capacitors are not to be confused with split-stator units. Here we show their mechanical arrangement (A) and circuit symbol (B).

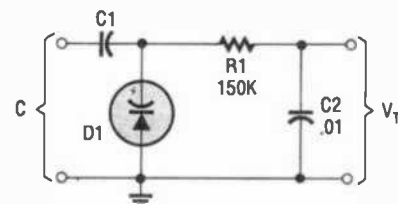

Fig. 11. Solid-state "varactors" are diodes whose junction capacitance can be tuned by varying a reverse-bias voltage applied to it. This is one circuit for doing that.

Special Variables. So far we have discussed only the most standard variable capacitors. They are largely used for tuning radio receivers, oscillators, signal generators, and other variable-frequency oscillators. In this section we will take a look at some special forms of variable capacitors.

Let's start with split-stator capacitors, which are mainly used to tune antennas, especially for balanced-tuner circuits. Figure 9 shows their schematic symbol. They are a form of ganged capacitor, but the internal capacitors do not share the same stator, instead they have the same shaft and rotor. Capacitors in split-stator units normally have the same value so they can be used to tune two separate circuits to the same frequency.

Which brings us to differential capacitors. Although some differential capacitors are often mistaken for split-stator capacitors, they are actually quite different. Split-stator capacitors are tuned in tandem, (i.e. both capacitor sections have the same value at any given shaft setting). The differential capacitor, on the other hand, is arranged so that one capacitor section increases in capacitance, while the other section decreases by exactly the same proportion.

Figure 10A shows the differential capacitor's mechanical construction and Fig. 10B shows its schematic symbol. Note that the rotor plate is shown equally overlapping both stator-A and stator-B. If the shaft is moved clockwise, it will overlap more of stator-B, and less of stator-A, so C_A will decrease and C_B will increase by exactly the same amount. The total capacitance is constant no matter what position the rotor shaft takes, only the proportion between C_A and C_B changes.

Differential capacitors are used in impedance bridges, RF resistance bridges, and other such instruments. If you buy or build a high-quality RF impedance bridge for antenna measure-

(Continued on page 100)



ECODE SYSTEMS HAM-TIME SOFTWARE

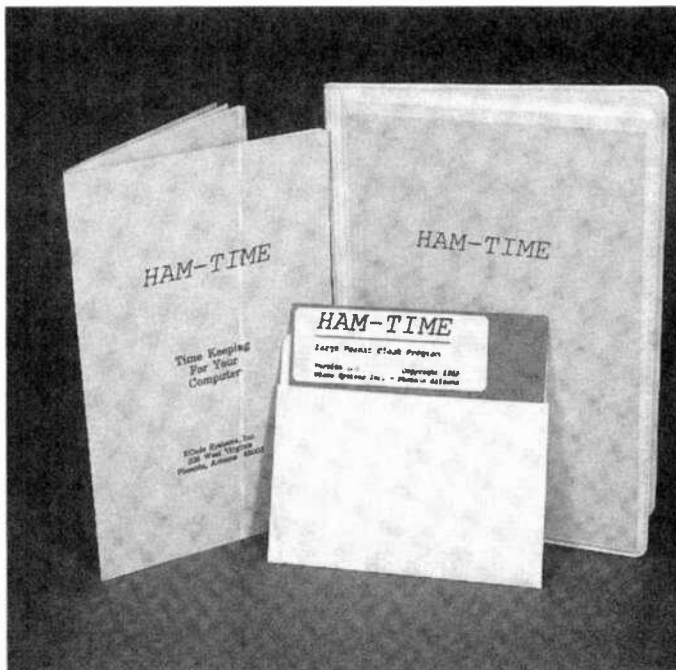

CIRCLE 120 ON FREE INFORMATION CARD

A digital clock simulator designed for hams and SWL's, and anyone else who wants to time events with accuracy

A digital quartz watch is suitable for many timing purposes, however many hobbies require you to know the exact time and sometimes require information that a wristwatch or desk clock cannot provide. For example, amateur radio operators and shortwave listeners have specialized time considerations. For them, Ham-Time—a digital clock simulator—was developed to help keep track of time without having to constantly make conversions between local time and Greenwich Mean Time (GMT).

Outside the ham shack, Ham-Time offers count-down and event-timer functions that are perfect in the laboratory or hobby workshop. Install the Ham-Time software on a laptop portable computer and you'll be the hit at the track, whether it be a 10K run or the "trotters"!

Ham-Time provides the following features in one neat package: a local/GMT dual-time display in 12- or 24-hour formats, fully-functional digital alarm clock, snooze alarm, event count-down timer, audible time indicator, and sports lap timer. If you have trouble determining times in distant cities, Ham-Time has yet another feature just for you (more on that later).

To run Ham-Time you'll need a PC/XT

computer or a compatible with at least 128K of memory, and a floppy-disk drive. The software requires MS-DOS or PC-DOS version 2.1 or later. The computer monitor must be CGA, EGA, or Hercules compatible. The alarm feature and sound functions of the program require a functional speaker. Although not necessary, it is helpful to have a real-time clock in the computer so that you won't have to reset the time whenever the computer is booted.

Setting Up. To get started, here's what you must do. First and foremost, make a backup diskette and store the original diskette in a safe place. That is possible because the diskette supplied for Ham-Time is not copy protected.



The display screen for Ham-Time presents local time and GMT. The main menu is diagrammed across the screen's bottom.

Next, insert the copied diskette into the A drive and run the INSTALL.BAT batch file. That file configures the software based on your graphics format (Hercules, CGA, or EGA). You must specify your format when you invoke the batch procedure as follows: "INSTALL x" where x is a letter corresponding to your monitor setup (i.e. "INSTALL C" for CGA). See the manual for the proper letters to use. The software can be run from the original diskette, another diskette, or your hard disk.

Ham-time relies on your computer's time to obtain the correct local time, but you must tell the program what time zone you live in. Since this report is written in New York, we'll use eastern standard daylight time. A command statement must be added to your AUTOEXEC.BAT file. The manual provides the commands for the seven time zones in the United States and Canada. For our zone we added:

SET TZ = EST5EDT

Of course, the command has to be changed twice a year to compensate for standard and daylight-savings time.

Now you are ready to execute the program. At the DOS prompt type:

HAMTIME

the screen will clear, and a sign-on message will appear for 4 seconds, and then the program will start. If the 4-second wait is too long for you, press any key on the keyboard and the program will begin immediately.

Main Clock Menu. The main clock displays the local time and GMT, along with the correct date for each. GMT is five hours into the next day (and date) before EST reaches midnight. The accuracy of the clock is contingent on the accuracy of the computer's clock. All the function keys are assigned functions indicated in the menu given below the clock display. Here's a brief rundown on those keys:

- <F1>—*Set Alarm.*—Press <F1> and the alarm time is displayed either in the 12-hour or 24-hour format. Be sure to specify AM or PM for the 12-hour style. Once the alarm time is entered, that time will appear on the screen below the current time in the format currently being used by the clock. You can enter the time separating the hours, minutes, and seconds with any punctuation.
- <F2>—*Enable/Cancel Alarm.*—The key toggles between enabling or disabling the alarm clock. This function doesn't affect the alarms's time setting.
- <F3>—*Set Snooze.*—The key should be used to set the snooze delay from 1 to 99 minutes.

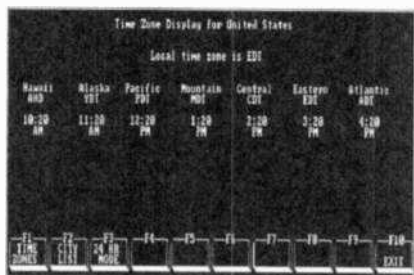

The time zones for the regions in the United States and Canada are listed, and the current times are indicated and constantly updated.



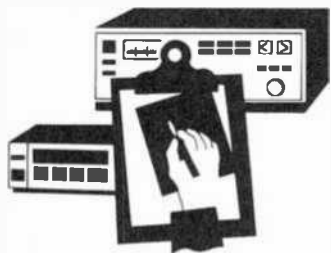

Product Test Reports

Len Feldman

MISSION CYRUS TWO INTEGRATED AMPLIFIER

British-made audio equipment, and especially amplifiers or integrated amplifiers, are generally characterized by a minimal number of controls and straightforward signal paths. Further, British and other European-made amplifiers usually de-emphasize high power-output levels, preferring instead to provide extremely clean power up to their relatively moderate maximum-power-output ratings. Mission's (18303 8th Ave., Seattle, WA 98148) Cyrus series of amplifiers certainly do fit that description.

There are two models in the Mission Cyrus series: the *Cyrus One* and the *Cyrus Two*, which we tested and evaluated in our lab and listening room. The *Cyrus One* is rated at 25 watts per channel into 8-ohm loads (40 watts into 4 ohms), while the *Cyrus Two* is rated at 50 watts per channel into 8-ohm loads (80 watts into 4 ohms).

If a user insists upon more power than that, the *Cyrus Two* can be augmented by what Mission calls their PSX unit. That separate component, when connected to the *Cyrus Two*, provides a separate DC supply to the power-amplifier section of the unit. The internal power supply of the *Cyrus Two* is then totally dedicated to the preamplifier section, while the highly regulated DC supply and the increased current capacity of the PSX unit improves the power amplifier's load-handling ca-

pability and enables the unit to deliver increased output-power levels. To make use of the PSX unit, the *Cyrus Two* must be reconfigured by the dealer or an authorized Mission service center. Once that reconfiguration is done, the amplifier will not function without the auxiliary PSX unit connected and switched on.

The *Cyrus Two* amplifier uses special bipolar output devices with a reported switching frequency of 70 MHz. According to Mission, those components, produced by Thomson of France, have inherently higher current output and lower distortion levels than standard output devices. A toroidal transformer is used in the power-supply section.

The amplifier is built using a die-cast magnesium chassis with an integral heat sink. The amplifier cover is made of die-cast aluminum, which also improves heat dissipation. The unit is just half the width of conventional rack-mounted components, and measures only 8.5 inches in width, by 3.5 inches in height, by 13.5 inches in depth.

The Controls. There are only four rotary control knobs on the front panel of the *Cyrus Two*. The first pair of those are concentrically mounted at the left end of the panel and they handle master volume and balance. The center knob is used to select the "listen" (playback) signal source. The positions labeled in-

clude Phono, CD, Tuner, Video (for connection of the audio output cables of a VCR for playback only), and Tape. There is also a Mute position that is only used when you don't want any program source selected. The third rotary knob controls a switch called "Record" selector; its positions are identical to those of the Listen switch. The big advantage here is that you can listen to one program source while recording from a totally different one. For example, you might want to listen to a radio program, using the Tuner setting of the Listen switch, while the Record selector is set to CD for copying a CD onto tape (assuming, of course, you have a tape deck connected to the amplifier as well). A headphone jack on the left side and a power on/off switch at the lower right of the front panel completes the control layout.

The rear panel of the *Cyrus Two* is somewhat different than that of most other amplifiers in that it is configured as a step, with the input and output terminals located on a horizontal surface that is midway between the top and bottom of the amplifier. Included there are all of the input jacks; the tape-output jacks; a ground terminal; a switch for selecting either moving-magnet or moving-coil phonograph-cartridge pre-amplification; the 4-pin connector for the PSX unit, when used; and four special speaker-output jacks.

European manufacturers have a habit of requiring owners of their equipment to own a soldering iron and being able to use one. We are happy to report that that is not the case with the *Cyrus Series* of amplifiers. While it does take some time to wire the speaker cables to the four color-coded speaker plugs (supplied), the job can be performed using only a small screwdriver (not supplied). Speaker wires are fed into the rear of the little plugs and two small screws are tightened to lock the wire in place and make good contact. The plugs are then inserted into the appropriate jacks on the rear of the amplifier. The plug-in action is much like that of a banana plug, except that somewhat better, tighter contact between plug and socket is maintained.

Since Mission amplifiers are sold throughout the world, a standard three-prong AC power socket is found on the rear surface of the amplifier housing. This system enables the manufacturer to supply the appropriate power cord for the country into which the amplifier is shipped.

CIRCLE 119 ON FREE INFORMATION CARD

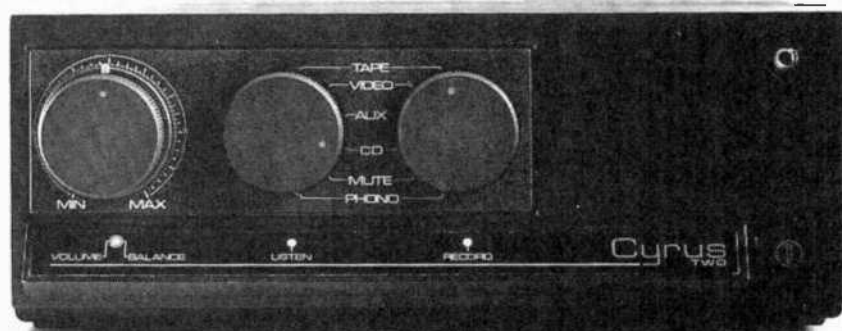

The Mission Cyrus Two Integrated Amplifier.

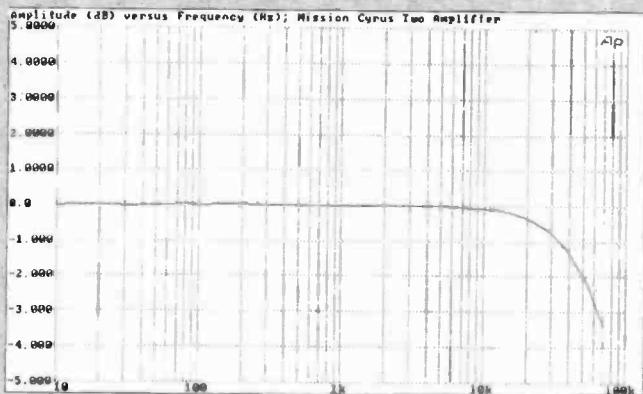

The frequency response was absolutely flat to 10 Hz (the limit of the test equipment); the -3-dB cutoff point occurred at 65 kHz.

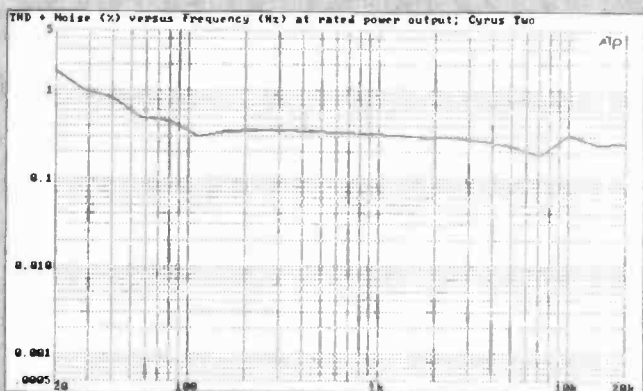

At 1 kHz, the total harmonic distortion (THD) measured 0.3%, an acceptable level but nowhere near as low as claimed by the manufacturer.

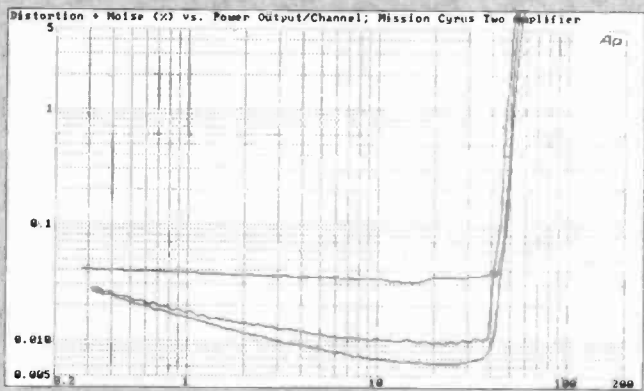

Total harmonic distortion plus noise is plotted here against power output per channel. The upper curve is for a 20-kHz test signal, the middle curve for 20 Hz, and the lower one for 1 kHz.

TEST RESULTS— MISSION CYRUS TWO AMPLIFIER

Specification	Mfr's Claim	PE Measured
Power Per Channel		
8 ohms	50 watts	50 watts
4 ohms	80 watts	70 watts
Damping Factor	100	110
THD, Full Power, 1 kHz		
8 ohms	0.003%	0.31%
4 ohms	0.004%	See text
THD Full Power, 20 kHz		
8 ohms	0.015%	0.25%
4 ohms	0.025%	See text
Frequency Response		
High Level	1 Hz to 50 kHz, -3 dB	to 65 kHz, -3 dB
Phono	20 Hz to 20 kHz, -0.2 dB	See text
Signal-to-Noise (re:1W)		
High Level	86 dB	86 dB
Phono MM	84 dB	84 dB
Phono MC	74 dB	75 dB
Input Sensitivity		
High Level	50 mV	52 mV
Phono MM	0.3 mV	0.32 mV
Phono MC	0.02 mV	0.023 mV
Suggested Price:	\$799.00	

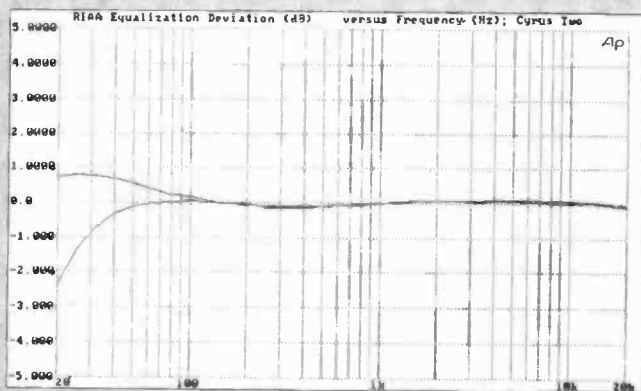

These curves show the phono frequency response. The deviation from standard RIAA equalization is shown in the lower curve; the deviation from IEC equalization is shown in the upper curve.

The Test Results. Although this product was manufactured in Great Britain, its designers chose to specify its performance characteristics using the so-called IHF/EIA Amplifier Measurements Standard. Since that is exactly the standard that our own lab uses to evaluate amplifier products, that made it extremely simple for us (and you) to compare the actual and rated performance of the product. As usual, the manufacturer's claims are listed in a box elsewhere in this report, and next to

each one you will find the result that we obtained for our sample.

The frequency response for the high-level inputs was absolutely flat down to 10 Hz (the limit of our test equipment). The -3-dB cutoff point at the high frequency end of the response curve occurred at 65 kHz as against 50 kHz claimed by Mission.

The amplifier was unable to meet its rated power specifications at its rated distortion. At 1 kHz, the THD was just over 0.3%—certainly not an objectionable

level of distortion, but quite a bit higher than the .003% figure quoted by Mission. At 20 kHz, the THD for this 8-ohm load condition was 0.25%. Again, that is a perfectly acceptable figure, but it exceeds the .015% claimed by Mission. With 4-ohm loads connected to the speaker terminals, the amplifier could not deliver the claimed 80 watts of power per channel at any acceptable levels of distortion, so we arbitrarily backed off our generator to maintain a
(Continued on page 97)



Antique Radio

By Marc Ellis

SOME WORDS FROM THE READERS

It's been several months since I've had the opportunity to turn these pages over to the readers. So now that the Pilot A.C. Super-Wasp project is completed, let's open the mailbags again! As the first order of business, I'd like to acknowledge a Wasp-related correspondence not already discussed in previous columns.

Super-Wasp Roundup. Reader Rodger Henly (Victoria, B.C., Canada) recently sent in a nice shot of a Super-Wasp he's just acquired. It's the battery-operated model rather than the AC version we've been working with, and this is the first photo I've ever seen of such a set. I'd wondered if the front panels of the two versions were similar, and this photo certainly shows that they were. The knobs, dials, and wood-grain finish all appear to be the same.

Rodger was interested in obtaining reprints of all the "Wasp" articles. They are not available as such, but almost every issue of **Popular Electronics** contains information for ordering back issues at a nominal cost. The "Wasp" articles appeared in the July through November 1989 issues, as well as in January and May 1990.

Hipolit Ceckowski (Vernon Hills, IL) sent in a photocopy of an interesting article from a 1930 Ford Motor Company publication. The article discussed the Ford Trade School Amateur Radio Club (of which Hipolit was a member) and included a shot of the club station, W8RC. Occupying a prominent position on the operating desk was a Super-Wasp receiver working into a horn speaker.

Thanks also to the following readers for sharing interesting Wasp-related information from their files: Harold Henry (Jackson, MI); Louis R. Supek (Brunswick, OH); Norman Park (Rigby, ID); J. Clay (Oxford, NC); Harold N. Henry (1630 Donnelly Rd., Jackson, MI 49201). I've included reader Henry's complete address because he'd appreciate suggestions on how to market a schematic copy service based on the extensive collection in his *Gernsback Official Radio Service Manual* (1931).

Finally, a big thank you to two readers: Frank Krantz (Somerdale, NJ) has been very generous with photocopies from his files on the Wasp and other radios discussed in this column. And John G. Webb (Auburn, CA) sent along an invaluable set of operating instructions for

the Super-Wasp (which you'll hear more about in a future issue) as well as pictorial diagrams of the set's construction.

Type 27 Lore. Back when I was studying the tube types found installed in the Super-Wasp, I noted that the two Arcturus-brand 27's were labeled with the designation "detector." Another Arcturus 27 already in my possession did not carry that designation and seemed to have slightly different internal construction. That led me to wonder whether the "detector" versions were specially made for that service.

Readers Joe Cecil (Austin, TX) and Bill Hoy (Charleston, WV) helped me sort that one out. They pointed out that the type 27 was the first tube designed to be heated by alternating current and, as such, was intended for use in the detector stage (which was especially susceptible to hum pickup). When it became common practice to use the 27 in other stages of the radio, Arcturus simply dropped its "detector" designation. The differences in construction I had noted were design changes not related to this issue.

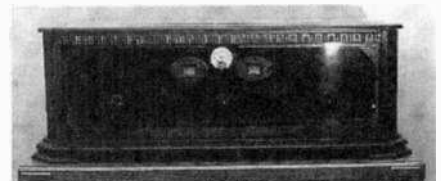

Joe Cecil's vintage-1928 Scott "World's Record Super 10," a powerful and truly magnificent early superheterodyne.

Bill also mentioned that the Arcturus tubes were advertised as reaching operating temperature in about seven seconds. That's in contrast with an average of about a minute for ordinary type 27's. And he tells us that many users of the A.C. Super-Wasp found that the Arcturus 27 performed better in the Wasp's especially hum-sensitive regenerative detector circuit than did the proprietary (*Pilotron*) brand strongly recommended by the set manufacturer.

Joe Cecil enlarged on some information, discussed in a previous column, concerning the perforated metal or wire screening generally used to form the type 27's plate structure. Joe explained that the perforations were for the purpose of letting some of the heat escape from the grid area. An overheated grid would emit electrons as if it were a filament or a cathode, an un-



This is reader Rodger Henly's very nice battery-powered Pilot Super-Wasp. If you think Rodger's workshop is cluttered, you ought to see mine!



Walter Kropf's pretty little "Ware Music Master." He'd like to know its age and value (see text).

wanted effect known as "secondary emission."

The problem was caused by the very hot cathode used in this pioneering AC tube. Later developments in tube design reduced cathode temperatures so that the ventilating holes in the plate were no longer necessary. Adequate heat dissipation could be obtained simply by blackening the plate surface, a practice that is still followed today.

Besides that interesting information, Joe included some nice photos of a truly outstanding set from his collection: the 1928 Scott "World's Record Super 10." Produced by E.H. Scott, the well-known manufacturer of Cadillac-quality radios, the set incorporates two stages of tuned radio-frequency amplification ahead of a powerful super-heterodyne circuit. It looks and works like new, says Joe.

Readers In Need. Can you help with schematics, service data, and/or other information of interest on any of the following radios or pieces of test equipment? If so, please contact the requester directly. *Pilot* model T341 (C.G. Rainville, 2188 Crestview Crescent, Castlegar, B.C., Canada V1N 3B3); *RCA Radiola II* model AR-800 (William H. Robertson, 3552 Clarke Rd., Memphis, TN 38115); *Philco* model 46-480 (Eric Whitney, 730 Barney Ave., Wyoming, OH 45215); *Supreme* "Audiolyzer" model 562, *B&K* tube tester model 606, *Precision Apparatus* signal generator model E-200C, and *Hickock* multitester model 210X (David Lebow, 1102 W. Pine St., Hattiesburg, MS 39401); *Hallicrafters* 6-band stereo receiver model CR-3000 (Herman Kitka, Jr., 7511 Margaret Circle, Anchorage, AK 99518); *RCA* model AR-812 (Frank Elliott, 3900 Sourdough Rd., Bozeman, MT 59715); *Splittidorf* model R500 (Harold E. Shafer, 591 Glendale Dr., Troy, OH 45373).

In the case of the following radios, the inquirers are interested not only in technical data, but also in discovering the approximate age, value, and/or any interesting background information: *Atwater Kent* model 53 (J. Bergamine, 6 S. Delaware St., Stamford, NY 12167); *Grigsby-Grunow Majestic* model 93 (Larry White, P.O. Box 4122, Tulsa, OK 74159); *Crosley* "Super Tridyn Regular" regenerative receiver (Robert R. Nielson, Jr., 685 Wilson Cemetery Rd., Awendaw, SC 29429); *Ware* "Music Master" type 50—see photo (Walter L. Kropf, Rt. 2, Box 127, Mexico, MO 65265); *A.C. Dayton* model XL-20 (Donald White, 2724 Pettigrew, Moses Lake, WA 98837).

Herb Dean (RFD2 Box 84A, Carmel, ME 04419) has a set of *Pilot Super-Wasp* coils, and would like some suggestions on how to incorporate them into a 3-stage battery radio. He has some 1U4 and 5678 tubes available to use in the circuit. Emanuel Ross (85-15 Main St., Apt. 5B, Jamaica, NY 11435) is attempting to duplicate a one-tube super-regenerative portable he built in his youth and needs a 154 tube.

Reader Mark Kruger (17 Cottage St., Stoddard, WI 54648) seeks a set of knobs to complete his *RCA* model 17K. And Samuel Zuckerberg (578 5th Ave., NYC, NY 10036) needs a set (bearing the *Zenith* "Z" logo) for his shutter-dial console. Sam also would like to get an idea of the value of his set but, unfortunately, didn't include a model number.

Nick Lombardo (Gemini Electronics, 2222 Ontario East, Rm. 302, Montreal, QC H2K 1V8, Canada) is just getting started in antique-radio restoration



Sal Mazzer's very nicely restored 1929 *Atwater Kent* model 55C. Write Sal (see "Show and Tell" section) if you can help him with replacement speaker-grill cloth.



Reader George Rutkay's mostly-restored Seeburg "trashcan." I wish you could see the color shot he sent of this jukebox as it looks glowing in the darkness!

and would like to locate people or organizations in the Montreal area who can help him find information and parts.

Two readers are looking for charts for military tube testers: George Huntley (R.R. 4, Rockwood, Ontario, Canada, NOB 2K0) needs one for a model TV7 BU. He's also in the market for audio transformers for an *RCA Radiola III* and a *Westinghouse* model 53; Dr. Curtis Marshall (P.O. Box #267, Brooklandville, MD 21022) would like to locate the "Supplementary Test Data For Older Tubes" for a model TV-10A/U. And by an odd coincidence, Dr. Curtis would also like to find replacement audio transformers (for a *Crosley* model XJ receiver).

Ernest Dedos (365 N. Warren Ave., Brockton, MA 02401) is working on a *Philco* model 40-140 with a defective dynamic speaker. He'd like to get his hands on an exact replacement unit or make contact with someone who can re-cone his old one.

Reader Lowell M. Buckner (249 Hoffman Ave., San Francisco, CA 94141) needs information on building solid-state power supplies to provide B-plus voltages for old battery receivers. And G. Giannotti (408 West 10th St., Antioch, CA 94509) wonders if anyone remembers a circuit for boosting the output of a crystal receiver using two 1N34 diodes in a voltage-doubler hookup.

Finally, Robert Arbanas (1857 Pokogon S.E., Grand Rapids, MI 49506) is looking for a source of small ceramic
(Continued on page 96)



Computer Bits

THE SIZZLING 386

By Jeff Holtzman

The 386 is getting hot. Production volumes of 386 CPU's, supporting chip sets, and complete systems have fallen drastically the past six months. So whether you're in the market for a whole new system or just an upgrade, there's no longer any real choice about what type of CPU you should buy. Yes, you can buy 8088 systems dirt cheap, and 286 systems for not much more.

But it's a false sense of economy that drives a price-only point of view on buying a PC, especially for the technically inclined reader of **Popular Electronics**. Chances are that once you get started with PC's, you're going to get hooked, and you're going to find that you hunger for more memory, more disk storage, more video resolution, and, most important, more CPU speed and versatility. So buy with a view toward something that will last a few years, rather than something that you'll outgrow in a year, or even a few months.

Enough soap box; let's talk about the 386 market—what's available, capabilities, and approximate prices (as of the first of 1990). The discussion will include evaluations of a couple of new 386 boards that I checked out recently.

CPU Types. In case you're new to the 386 world, there are several flavors of the chip, as shown in Table 1. The DX version is what people normally refer to when they say "386." The SX version has just about all the capabilities of the DX, but it has fewer external address lines and a 16-bit data-bus interface, even though internally the SX has 32-bit address and data busses. The 486 is really just a 386DX combined with a numeric

coprocessor and some special RAM called a *cache*.

That type of cache, which differs from a disk cache, allows the CPU to get information from memory quicker than normal, but only for locations that are accessed fairly often. It turns out that 32K to 64K of cache memory is often sufficient to attain a "hit rate" of 90% or more, and the result can be a dramatic performance increase.

The 16-bit data bus of the SX is controversial. On the one hand, it allows a more inexpensive system design; on the other, it involves a definite performance compromise. Some people claim that the price/performance compromise of the SX is a poor one, because for just a few hundred dollars more, you can get a "real" 386 (i.e., the DX). It's not quite that simple, however.

If you look at system-board prices, you'll find that SX boards go for about \$400, and that DX boards start at about \$600, depending on speed and amount of cache memory. It's true that

there's a difference of only \$200 between an SX and a low-end DX board. However, \$200 is a 50% increase, but most likely you won't get a 50% performance increase running real-world applications.

The reason is twofold. First, the vast majority of commercial software is written strictly to 16-bit standards (i.e., for the 8088 and the 80286). Second, virtually all expansion hardware interfaces to the CPU via an 8- or at best a 16-bit bus. So whatever performance increase you'll get will be due mostly to CPU speed, and the inexpensive DX boards typically run at 20 MHz, which is 25% faster than the 16-MHz SX boards currently available. So at best you might get a 25% performance increase, but you'll pay 50% more to get it.

It's also worth pointing out that a \$400 SX board costs twice what typical 12-MHz 286 boards cost, and four times what 8088 boards cost. A 16-MHz SX performs roughly eight times faster than an 8088, so there's no question of value. In terms of raw performance, an SX will edge out a 12-MHz 286, but it will be about equal to a 16-MHz 286, and it will fall behind a 20-MHz 286. However, no 286 will ever have the memory handling flexibility of any 386; nor will any 286 ever have the 386's flexibility in running multitasking software (Windows, OS/2).

If you're not into putting your own system together, you'll find an even greater disparity in complete system prices. Full DX systems tend to cost quite

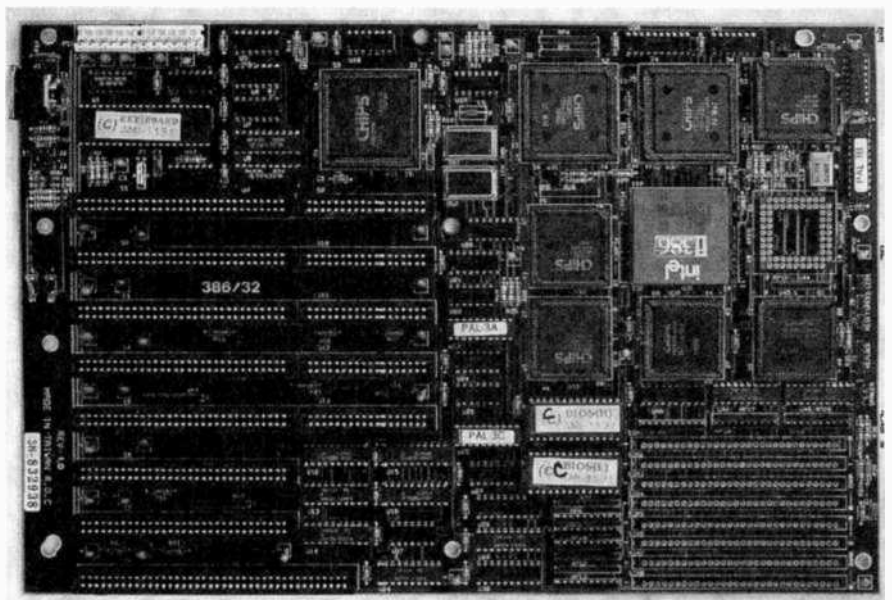

The 80386SX board (JDR part number MCT-386SX) runs at 16-MHz, accepts 2 MB of RAM, and provides full 386 memory-handling capabilities for about \$400, while the 80386DX board (JDR part number MCT-M386-20) runs at 20 MHz, accepts 8 MB of RAM, and costs about \$630; the DX board is shown here.

TABLE 1—386 FAMILY CPU TYPES

Type	Data Bus Width	Maximum Speed (MHz)
80386SX	16 bits	16 (20 coming soon)
80386DX	32 bits	16, 20, 25, 33
80486	32 bits	25

a bit more than SX system prices, because vendors have defined SX boxes as mid-level and DX boxes as high-level, and they populate the different levels with correspondingly different peripherals. Generally speaking, DX systems come with faster and higher-capacity disk, memory, and video subsystems than typical SX boxes, which results in greater cost.

On the other hand, if you're willing to risk dealing with lesser known mail-order vendors, you can find DX systems selling for roughly the same prices as SX systems from more well-known vendors.

Memory Issues. There are other reasons to go 386 (whether SX or DX) rather than 286. One of the biggest is memory. Compared with the previous generation of 80286 boards, most new 386 system boards allow more memory and faster memory to be installed right on the board itself or in a special expansion slot.

Quantity: The new boards often accept either 256K or 1 Mbit chips or SIMM (Single Inline Memory Module) packages. And on a cost-per-bit basis, 1 Mbit chips or SIMM's are a better buy than 256K devices.

Speed: The new boards have expansion buses that for compatibility reasons run at 8 MHz, and you can plug standard AT-style memory cards (Intel's AboveBoard, AST's RAMpage, etc.) directly into that type of bus. However, you can get much better performance by maximizing system-board memory and using the vendor's special memory card. The reason is that the vendor's memory usually runs not at 8 MHz, but at a higher rate. In addition, the memory subsystem is often built around a special architecture (page mode, interleaved, etc.) that also increases performance in a way that cards that are plugged into the standard bus can't.

Flexibility: Regardless of how you get memory into the system, a 386 gives you *much* more flexibility than a 286 in using it. You'll need special software (386MAX is the best package of this type) and time to fine tune it. But when you're done, you'll be able to map RAM into the area between 640K and 1 MB, and load device drivers and TSR's (terminate-and-stay resident software) up there. The effect will be to increase the amount of space available in the lower 640K. If you're running a network, or Windows, or need a lot of space for a large database or spreadsheet, you'll

quickly become addicted to the 386's memory-mapping abilities.

You can perform similar memory tricks with 286's (and even 8088's), but you need a special EMS 4.0 memory card to do it, and those cards typically cost two to four times more than the simple cards needed to expand 386 memory systems.

Hands-on. I looked at SX and DX boards sold by JDR. I tested both boards by removing the video and disk systems from my 386 and plugging them into those cards. I also tested other miscellaneous hardware adapters (I/O cards, Microsoft mouse) and experienced no software or hardware compatibility problems whatsoever.

Both boards come in the XT size, so are good candidates for upgrading older systems. Both boards are well-built multi-layer affairs with no engineering-change jumpers. And both come with clearly written, well illustrated installation/operation guides (a welcome change from the MCT documentation of a few years back!). In addition, each board comes with a socket for a math coprocessor; header connectors for a reset switch, speed-select switch, and LED; standard speaker, keyboard, and front-panel keylock connectors; and AMI BIOS with setup in ROM.

The SX board is built around the flexible NEAT (New Enhanced AT) chip set, and has sockets for as much as 2 MB of memory, which may be added in 512K chunks; a separate RAM card costs about \$130 and allows you to expand system memory to 8 MB. The SX board has five 16- and three 8-bit expansion slots; one of the latter is used in conjunction with a special connector for the RAM card. The SX board also has an on-board battery to back up the system configuration stored in CMOS RAM, and a connector for an optional external battery. A separate utility disk has a setup program and an EMS driver.

The memory system is a page mode/interleave system; it requires 100 ns RAM chips for near-zero wait state operation, or 120 ns chips for one wait state operation. Each 512K chunk requires four 256K x 4 and one 256K x 1 DIP chips. You can set up some of the memory to automatically "shadow" the system BIOS so that it will run from faster RAM rather than slower ROM. You can also automatically designate some portion of the system memory as EMS compatible, although 386MAX would

Vendor Information

MCT-386SX (\$399.95), MCT-M386-20 (\$629)
JDR MicroDevices
 2233 Branham Lane, San Jose, CA 95124
 Tel. 800-538-5000
CIRCLE 117 ON FREE INFORMATION CARD

give you more flexibility than the hardware capabilities of the NEAT set.

The DX board provides a 20-MHz system that, like the SX board, can run at one or near-zero wait states, depending on RAM speed (120 or 100 ns, respectively). The board has two 8-bit, five 16-bit, and one 32-bit expansion slots; it can accept one, two, four, or eight megabytes of memory in SIP panels. The optional memory card (\$100) accepts a maximum of 8 MB of memory (DIP chips).

All in all, I'm impressed with both boards. Both are high quality and provide plenty of expansion capability. I wouldn't hesitate to highly recommend either of them. ■

AMAZING NEW Pocket Reference

480 pages of tables, maps, formulas, and conversions and it fits in your shirt pocket (3.2" x 5.4" x 0.6")!



\$9.95*



* Plus \$2.00 shipping & handling. Colorado residents add 5% tax.

Small sample of contents

Air Tool CFM vs PSI	Radio Alphabet
Battery Charging	TEN Radio Codes
The Manufacturer Codes	Telephone Area Codes
Lumber Sizes & Grades	Lost Credit Card Phones
Concrete & Mortar	Sound Intensities
Element Tables	Wind Chill Factors
Computer ASCII Codes	Frequency Spectrum
IBM® PC Error Codes	Geology Mineral Tables
IBM® Interrupts-I/O Map	Glues and Solvents
80286 Hard Disk Types	Bolt Torque Tables
Printer Control Codes	Wood Screw/Nail Sizes
Electric Wire Size vs Load	Math Formulas & Tables
NEMA Motor Frames	Plane/Solid Geometry
Wire & Sheet Gauges	Copper/Steel/PVC Pipe
Resistor/Capacitor Colors	Rope, Cable and Chain
Pilot Lamp Specs	Tap-Die-Drill Sizes
Fuse & Battery Specs	Sand Paper & Abrasives
RF Coil Winding Data	Weld Electrode & Solder
Wire Size vs Turns/Inch	3200 Conversion Factors

Money Back Guarantee - If not completely satisfied, return book postage prepaid, in mint condition for a 100% refund!

Sequoia Publishing Inc.
 Dept 909, P.O. Box 620820
 Littleton, CO 80162

CIRCLE 15 ON FREE INFORMATION CARD



DX Listening

By Don Jensen

SOCCER ON SHORTWAVE

In the rest of the world they know the game as football. In North America—where we reserve that name for an entirely different sport—we call it soccer. The World Cup matches, pitting 24 of the best national soccer teams against each other in an elimination competition, is the premiere sporting event in the world. It is avidly followed by more fans, in newspapers, on radio, and on television than any other sport. In terms of total fan interest, the World Cup makes the World Series, the Super Bowl, and even the Olympics pale by comparison.

In the United States, during the World Cup finals every four years, the reaction typically is "ho-hum." True, soccer is a growing sport in the U.S., at least among school-age children. Perhaps in a few years those young players will form a hard core of American soccer spectators, anxiously following World Cup play.

That wasn't the case in 1986. This time, though, maybe it will be different. Maybe there will be more attention paid to World Cup soccer since, for the first time in 40 years, a U.S. team is included

among the 24 finalists to have qualified for World Cup play.

When the matches begin this month, shortwave listeners will find live and prerecorded sports coverage of that important sporting event all over the bands. Most of the broadcast will be in other languages, particularly in Spanish and Portuguese for the millions of "futbol" and "futebol" fans in Latin America. But SWL's who are curious enough to tune around a bit further are likely to find match results and even live coverage of the major World Cup contests from Italy.

As of this writing we don't have the specifics on where and when to tune. But undoubtedly one of the first shortwave stations to try for World Cup news should be RAI, *Radiotelevisione Italiana*, or, in English, the Italian Radio and Television Service broadcasting from Rome. For starters, U.S. and Canadian SWL's should look for its normally 20-minute, English-language transmission to North America from 0100 to 0120 UTC on—at the time of this writing—9,575 and 11,800 kHz.

The *British Broadcasting Corpora-*

tion's English language World Service may be—based on past experience—the best choice for coverage of important World Cup matches. The BBC frequencies will probably change from the time of my writing until you read this column. But surely, with at least two-dozen different shortwave frequencies, from just below 6,000 kHz to above 25,700 kHz, you should have little difficulty in finding the BBC. And with a bit of listening, you should quickly find out its World Cup coverage and broadcast times.

Will World Cup play-by-play be heard on the *Voice of America*? Probably not this year. But the odds for such broadcasts in four year's time are much better. For the world soccer organization, known as F.I.F.A., has announced that the United States will host the 1994 World Cup competition. Look for extensive VOA shortwave coverage then.

Feedback. There were many letters in the mailbox this month. How about adding your name to our growing list of "contributing readers?" We are always happy to hear from you with your comments, questions about SWL'ing, and reports on what you're hearing on the shortwave bands. How about a photo of you with your DX'ing gear? This section of our column is your place to be heard, so write to "DX Listening," **Popular Electronics**, 500-B Bi-County Blvd., Farmingdale, NY 11735.

The first letter comes half-way round the world from Shaun Lee, Singapore, who has been listening to shortwave regularly for eight years. "I started reading your volumes early last year," says Shaun, "and I'm proud to say I haven't missed any of them since then!" Shaun notes, correctly, that since most of our readers live in the U.S. and Canada, the schedule data and tips mostly are keyed to North American listeners. For that reason, he says, he has found it particularly useful to write directly to the stations for program schedules so he can choose frequencies and times best suited to his reception in Southeast Asia.

"Most importantly, though, I would like to know if there are any DX clubs in Asia that I could join. I've remained dormant all those years and I think this is the time that I can make more friends in shortwave."

Good idea, Shaun, one that would hold true for any SWL, anywhere in the world. Sharing your hobby interests with others is an excellent way to get more enjoyment yourself! And, yes, there are



Here are some of the people you'll hear broadcasting from Trans World Radio, Bonaire. In the station's studios are (from left) Wally Hollis, Barbara Luck-Baker, Bill Early, McDaniel Phillips, and Chuck Roswell.

several Asian DX'ing clubs that you might consider joining.

Although not always the most prompt in arriving, the Union of Asian DX'ers bulletins, edited by a long-time friend, G. Victor Goonetilleke, are invariably filled with interesting information on Asian stations. You may write Vic for more information at Shangri-la, 298 Kola-muune, Piliyandala, Sri Lanka.

The Radio Listeners Club Indonesia can be reached by writing P.O. Box 15, Batang 51201, Indonesia. In India, there are several clubs, including the Southern Asia Radio Club (63 K.D. Flats, Jamshedpur, 891-005) and Indian DX Club International (GPO Box 646, Calcutta 700-001).

In the column last November, I mentioned evangelical broadcaster, *Trans World Radio*, and the special award certificates available to listeners who have received QSL cards confirming their receptions from each of the TWR stations. Now Chuck Roswell, frequency coordinator for TWR on the island of Bonaire in the Netherlands Antilles, writes to update some of the information.

Chuck notes that under the law in Sri Lanka, one of the station sites, "foreign" organizations cannot own broadcasting facilities, so TWR actually is leasing air time from the owner of the powerful medium-wave transmitter, the *Sri Lanka Broadcasting Corp.* Also, the license for the shortwave transmitter on Sri Lanka is at this time under renegotiation with the government and until an agreement is reached, *Trans World Radio* is not broadcasting SW from that South Asian site.

It is still possible, however, to obtain one of the special certificates for proving reception from TWR stations at Bonaire, Guam, Swaziland, and Monaco, Chuck notes. The religious stations broadcast in a combined total of over 80 languages!

Chuck Roswell forwards the current schedule of TWR English broadcasts to North America on shortwave: Sunday and Monday, UTC, 0300-0530 on 9,535 kHz, and UTC 0255-0530 on 11,930 kHz. Tuesday through Saturday, UTC 0300-0430 on 9,535 kHz, and UTC 0255-0430 on 11,930 kHz. Tune in on either 11,815 or 15,345 kHz at 1055 UTC daily. That program runs until 1257 UTC,

*Credits: John Tuchscherer, WI; Fred Kohlbrenner, PA; Harold Frodge, MI; Jerry Klinck, NY; North American SW Association, 45 Wildflower Road, Levittown, PA 19057)



One tree can make
3,000,000 matches.



One match can burn
3,000,000 trees.



A Public Service of the United States
by The Advertising Council

Make the
most of your
general
coverage
transceiver
with
**Monitoring
Times!**

Every month *Monitoring Times* brings everything you need to make the most of your general coverage transceiver: the latest information on international broadcasting schedules, frequency listings, international DX reports, propagation charts, and tips on how to hear the rare stations. *Monitoring Times* also keeps you up to date on government, military, police and fire networks, as well as tips on monitoring everything from air-to-ground and ship-to-shore signals to radioteletype, facsimile and space communications.

ORDER YOUR SUBSCRIPTION TODAY before another issue goes by. In the U.S., 1 year, \$18; foreign and Canada, 1 year, \$26. For a sample issue, send \$2 (foreign, send 5 IRCs). For MC/VISA orders (\$15 minimum), call 1-704-837-9200.

MONITORING TIMES

Your authoritative source,
every month.

P.O. Box 98
Brasstown, N.C. 28902

Monday-Friday; till 1332 UTC on Sunday and to 1400 UTC, Saturday.

He also notes that North American listeners, particularly those living in the eastern or southeastern U.S. may also want to try to hear TWR's 500-kilowatt superpower, AM medium-wave outlet on 800 kHz.

Information about the award, a schedule of programs, and coverage map are available by writing *Trans World Radio*, Conaire, Netherlands Antilles. Return postage, in the form of International Reply Coupons—available at your post office—or even mint U.S. stamps, are appreciated.

"I've enjoyed **Popular Electronics** magazine since the 1950's," concludes Chuck.

Down The Dial. Listeners are reporting hearing these stations on shortwave:

Canada—6,160 kHz, CKZN is one of two domestic shortwave stations operated by the CBC for listeners in the more remote areas of Canada. This one is located in St. John's, Newfoundland. It may not be an easy catch, but try around sign on at 0825 UTC.

Ecuador—4,680 kHz, *Radio Nacional Espejo*, broadcasting from Quito, the Ecuadorian capital, is typical of the many small broadcasters that operate down in the 60-meter tropical band. Tune in at around 0200 UTC and you are apt to hear programming that sounds like a Spanish soap opera. That's exactly what it is, although throughout Latin America listeners call them *radionovelas* (radio novels).

Philippines—11,715 kHz, *The Voice of America's* relay station in the Philippines has been logged in the U.S. at 1300 UTC with the "Morning Show" for Asian listeners.

Portugal—9,600 kHz, *Radio Portugal* broadcasts in English from 0230 UTC, with news, a commentary, and a mail-bag program reading listeners' letters.

USA—7,520 kHz, WWCR in Nashville, TN, is the newest of the private, religious shortwave broadcasters in the United States. You can find this one around 0230 UTC. ■

PRESERVATION...PLAN ON IT

National Trust for Historic Preservation
Dept. PA, 1785 Massachusetts Ave., N.W.
Washington, D.C. 20036

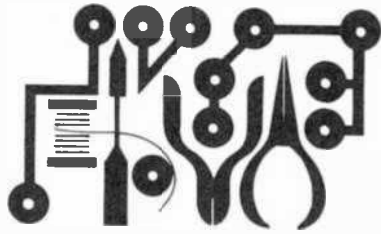

Circuit Circus

By Charles D. Rakes

CALIBRATING SURPLUS METERS

This time around I'd like to share a few simple circuits and techniques that might help solve a problem in one of your on-going or future construction projects. The analog meter has been around for more than a century now and has survived the invasion of high-tech digital equipment to remain a valuable tool in today's electronic circuitry. When it is necessary to monitor a varying voltage, the movement of an analog meter's needle is hard to beat.

The most commonly used analog meter is the D'Arsonval type. In a D'Arsonval meter movement, a needle or pointer is attached to a moving coil that is pivoted between the poles of a permanent magnet. When current is passed through the coil, the electromagnetic force generated by the current opposes the permanent magnetic field, causing the coil to repel and move the pointer to a position on the meter's scale that indicates the amount of current flowing through the coil.

Such meter movements are of the DC variety and come in all shapes, sizes, and current ranges. The generic 50,000 ohms-per-volt multimeter found on just about every experimenter's workbench uses a meter movement with a full-scale sensitivity of about 20 microamps. Each of the meter's voltage ranges use multiplier resistors in series with the meter movement to obtain the desired full-scale voltage reading.

When the multimeter is set to read amperes, all current ranges above the meter's basic range require that a low-value "shunt" resistor be placed in parallel with the meter movement for each current range. The shunt resistor provides an alternate path for current flow, channeling excess current around the meter movement, while allowing a percentage of the applied current to be input to the meter movement.

Meter-Range Tester. Our first test circuit, see Fig. 1, is designed to ease the chore of determining the current range

(DMM) is then used to monitor the voltage developed across the sampling resistor. With S2 in the most sensitive position (A), the digital voltmeter indicates a voltage reading of 1-volt for a 100-microamp current flow, a 0.5-volt reading for a current flow of 50 microamps, and a 5-volt reading for a 500-microamp current.

With S2 set to the B position, a 1-volt reading would indicate a current of 1 mA, a 1-volt reading in the C position would indicate a current of 10 mA, and a 5-volt reading would indicate 50 mA. Figuring out the current flow is simple—just apply Ohm's law:

$$I = E/R$$

To use the circuit, flip S1 to the off position and S2 to position A. Then set R4's wiper to the negative end of the 6-volt source, connect the meter movement to our test jig, and see if the meter can be driven to full scale in the A test position. If not, return R4's wiper to the negative end of rotation and set S2 to position B, and then to position C if necessary. After the meter under test reads full scale, note the voltage reading (as displayed on the DMM) and divide that reading by the sampling resistor value—either R1, R2, or R3 depending on the setting of S2—to determine the meter's full-scale current capacity.

Now that we know the full-scale current capacity of the meter movement, it's time to determine its internal resistance. Once we know that, we can figure the multiplier or shunt resistor needed to use the meter movement as a higher voltage or current indicator.

Determining Meter Resistance. The easiest method for determining the meter movement's internal resistance is shown in Fig. 2. Simply place a digital multimeter (set to the auto-ranging resistance mode) across the meter movement and read the resistance on the digital display. When the majority of today's digital multimeters are set to read resistance, they provide a very low short-circuit current, usually less than 100-microamps. When connected as shown in Fig. 2 that current will not damage the meter. But to be on the safe side, it would be a good idea to use another current meter to check the maximum short-circuit current of your digital multimeter.

That's an easy test to perform. Just place your digital multimeter on its lowest resistance range (if yours isn't an auto-ranging unit) and connect it to a

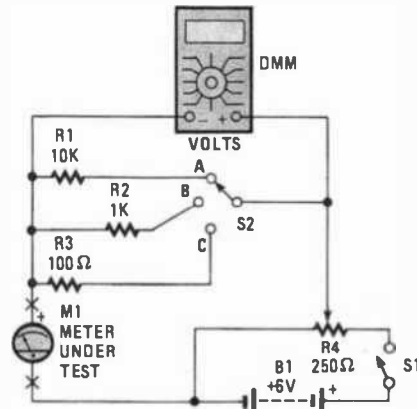

Fig. 1. The Meter-Range Tester is designed to be used in conjunction with a multimeter to determine the full-scale voltage specification of an unmarked meter movement.

PARTS LIST FOR FIG. 1

- R1—10,000-ohm, ½-watt, 5% resistor
- R2—1000-ohm, ½-watt, 5% resistor
- R3—100-ohm, 1-watt, 10% resistor
- R4—250-ohm, 2-watt, potentiometer
- B1—6-volt battery or wall-mounted power supply
- S1—SPST switch, any type
- S2—3-position rotary switch
- Digital multimeter, clip leads, etc.

of almost any meter movement that's tucked away in your junkbox. If the meter movement in question is a surplus unit or one long removed from some discarded equipment don't put too much faith in what's printed on the meter's face. It's very likely that whatever the meter was used in, or was intended to be used in, contained the meter's shunt and/or multiplier resistor.

A simple check with our meter tester can take that meter from its junkbox prison. Here's how the meter range tester operates: A 6-volt DC power source is placed in parallel with a 250-ohm 2-watt potentiometer to supply an adjustable current through one of three sampling resistors—R1, R2, or R3—to the meter under test. A digital multimeter

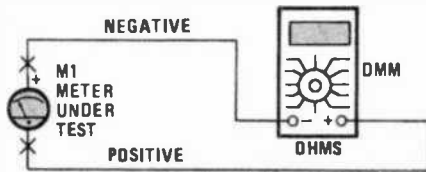

Fig. 2. The easiest method for determining the meter movement's internal resistance is to place a digital multimeter (set to the auto-ranging resistance mode) across the meter movement and read the resistance on the digital display.

DC current meter. Our Micronta auto-ranging multimeter could only muster 25-microamps in the short-circuit test. It's also a good idea to check the polarity of your digital multimeter's test leads in the resistance mode. You can't always count on the red lead to be positive and the black lead to be negative, so check it out.

By the way, don't use an analog meter for this test. All of the analog multimeters that I've checked put out over 100-milliamperes in the short-circuit test when the unit is set to the its lowest resistance range. So if you do happen to connect an analog multimeter to a sensitive meter movement, it's almost certain that the meter-movement's needle will wrap itself around the end peg, and that's not good.

Shunt Resistance. If you're not sure about using the resistance setting of your multimeter, try adding the circuit in Fig. 3 to the Fig. 1 test jig, thereby eliminating the worry. Actually, you're not combining two circuits, but are instead simply connecting a potentiometer in parallel (shunt) with the meter movement. Then all you need do is repeat the procedure outlined for using the test circuit in Fig. 1, and adjust the meter under test for a full-scale reading. Then close S3 and adjust R_x to reduce the meter reading to half scale.

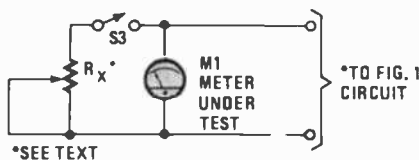

Fig. 3. A shunt resistance can be placed in parallel with any meter movement to increase the maximum allowable input current that the meter can handle.

At that point, the value of R_x equals the value of the internal resistance of the meter. Open S3 and measure the resistance of R_x . For highly sensitive meters (the 20 to 200-microamp types),

a 10K potentiometer will serve; for less sensitive meters, a 1K potentiometer or a resistance decade box will do. On higher current meters, be sure that the power rating of the potentiometer or resistor used for R_x can handle the load.

Once you know the specifications of the meter movement, it can be put to work. For example, if one of our projects needs a meter to monitor a DC voltage and the circuit can supply an additional 1-mA of current, then any meter with a sensitivity of 1 milliamper or better can be used. All that we need to add is the correct multiplier resistor in series with the meter movement and the voltage source.

Range Multiplier. Referring to Fig. 4, if you decide to use a 1-milliamper meter movement to monitor a full-scale voltage of 10-volts, then the multiplier resistor (the unit placed in series with the

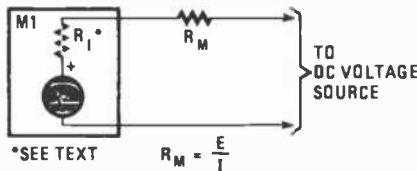

Fig. 4. The Range Multiplier is simply a resistance placed in series with the meter movement to allow the meter to handle higher than specified voltages. In modern multimeters, the multiplier resistance is selected to increase the meter's range in decade steps.

input to the meter, R_M value would be $R = E/I$. Substituting numerical values in the formula (10/.001) gives us a value of 10K for the multiplier resistor.

The meter's internal resistance is a portion of the total multiplier resistor value. The actual external multiplier resistor used would be the calculated value (10K) minus the internal resistance of the meter. Since our 1-milliamper meter movement's internal resistance measured only 68-ohms, which is less than 1 percent of the total multiplier value, a 10K external resistor was used. Any time the meter's resistance is less than 1 or 2 percent of the total multiplier resistor value, it can be ignored and the calculated resistor value ($R = E/I$) is used.

A 1-mA meter has a sensitivity of 1000-ohms-per-volt when used as a voltmeter. The ohms per-volt figure can make determining multiplier-resistor values a breeze, because all you need to do is multiply the desired full-scale voltage range by the ohms-per-volt resistance value and that equals the value of the required multiplier resistor. As

Get A Complete Course In

ELECTRONIC ENGINEERING

8 volumes, over 2000 pages, including all necessary math and physics. 29 examinations to help you gauge your personal progress. A truly great learning experience.

Prepare now to take advantage of the growing demand for people able to work at the engineering level.

Ask for our brochure giving complete details of content. Use your free information card number, or write us directly. \$99.95, Postage Included. Satisfaction guaranteed or money refunded.



**Banner
Technical
Books, Inc.**

1203 Grant Ave.
Rockford, IL 61103

CIRCLE 7 ON FREE INFORMATION CARD

NEW SUPER LONG PLAY TAPE RECORDERS

12 Hour Model — \$119.00*
USES D-120 TAPE

Modified Panasonic Slimline, high quality, AC-DC Recorders provide 6 continuous hours of quality recording & playback on each side of cassette for a total of 12 hours. Built-in features include:
• Voice level control • Digital counter, etc. TDK DC 120 Cassette Furnished.



PHONE RECORDING ADAPTER

Records calls automatically. All Solid state connects to your telephone jack and tape recorder. Starts recording when phone is lifted. Stops when you hang up. FCC APPROVED

VOX VOICE ACTIVATED CONTROL SWITCH

Solid state. Self contained. Adjustable sensitivity. Voices or other sounds automatically activate and control recorder. Uses either recorder or remote mike. \$28.50*

*Add for ship & hdg. Phone Adapter & Vox \$1.50 ea. Recorders \$4.00 ea. Cal. Res. add tax. Mail order. VISA, MIC, COD's OK. Money Back Guarantee. Qty. disc. avail., Dealer Inquiries invited. Free data. ©
AMC SALES INC. Dept B 9335 Lubec St., Box 928, Downey, CA 90241 Phone (213) 869-8519

JUNE 1990

CIRCLE 13 ON FREE INFORMATION CARD 87

SELECT 5 BOOKS

for only \$4.95

(values to \$133.70)
and get a **FREE Gift!**

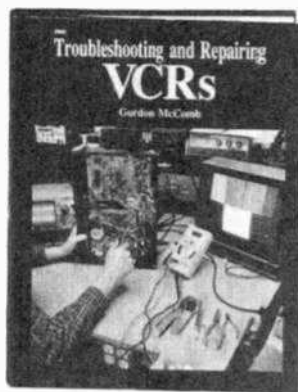
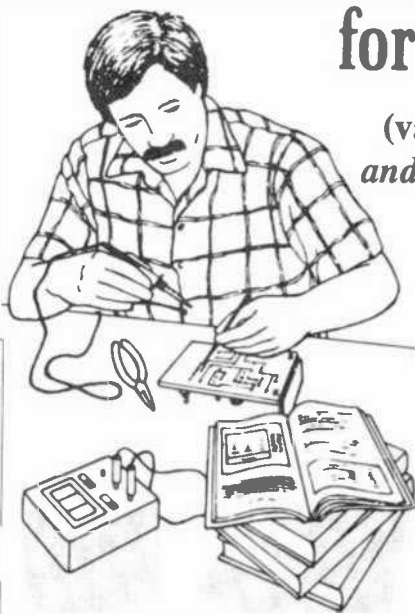

2960 \$27.95
Counts as 2



2728P \$9.95



2600P \$15.95

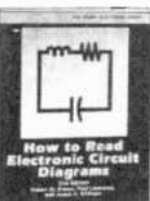

2880P \$14.95



3195 \$28.95
Counts as 2



3090 \$25.95
Counts as 2



2992 \$24.95



2912P \$14.95



2987P \$16.95



2947P \$13.95



2875 \$17.95

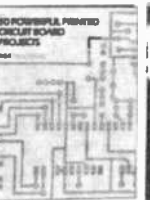

2972 \$23.95



3205 \$24.95



1367P \$24.95



2883P \$17.95



2867P \$18.95



2828P \$15.95



2613P \$15.95



1625P \$22.95



3219 \$27.95
Counts as 2

For 25 years, your most complete source for electronics books.



3165 \$17.95



1897P \$14.95



2809 \$28.95
Counts as 2



3031P \$16.95



3267 \$24.95



3145 \$19.95



3383 \$14.95



1599P \$17.95

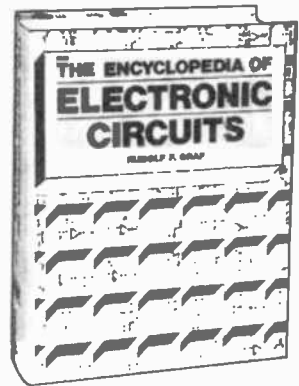

1938P \$29.95
Counts as 2

FREE when you join!

15 Easy Electronic Projects From Delton T. Horn
Projects you can build—some unique, some old favorites—from the author's vast treasury of electronics know-how.

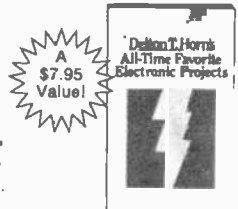

Membership Benefits • Big Savings. In addition to this introductory offer, you keep saving substantially with members' prices of up to 50% off the publishers' prices. • **Bonus Books.** Starting immediately, you will be eligible for our Bonus Book Plan, with savings of up to 80% off publishers' prices. • **Club News Bulletins.** 14 times per year you will receive the Book Club News, describing all the current selections—mains, alternates, extras—plus bonus offers and special sales, with scores of titles to choose from. • **Automatic Order.** If you want the Main Selection, do nothing and it will be sent to you automatically. If you prefer another selection, or no book at all, simply indicate your choice on the reply form provided. You will always have at least 10 days to decide. As a member, you agree to purchase at least 3 books within the next 12 months and may resign at any time thereafter. • **Ironclad No-Risk Guarantee.** If not satisfied with your books, return them within 10 days without obligation! • **Exceptional Quality.** All books are quality publishers' editions especially selected by our Editorial Board.

PE690

If card is missing, use this address to join:

ELECTRONICS BOOK CLUB, Blue Ridge Summit, PA 17294-0810



3155 \$19.95



3258 \$27.95
Counts as 2

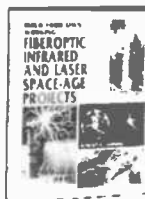

2724P \$16.95



1133P \$14.95



2925P \$9.95

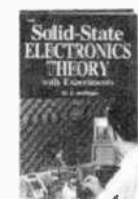

2826 \$25.95

All books are hardcover unless number is followed by a "P" for paperback. (Publishers' Prices Shown)



Ham Radio

By Joseph J. Carr, K4IPV

OPERATING YOUR STATION

Whether you are an old timer or a newly minted novice, operating an amateur-radio station is the principal interest of most hams. There are many other facets of the electronics hobby that allow you to learn technology; indeed, all of **Popular Electronics** is dedicated to the electronics enthusiast. But the one thing that hams can do that others cannot (legally), is go on the air and make contact with other radio amateurs all over the world.

Some "citizen's banders" may object to the claim that it is the amateur operator who gets tremendous benefit from going on the air. But once they compare the freedom of legally using a reasonably high power on bands less crowded than the cacophony on 27 MHz (except maybe 40 meters at night!), they usually start studying the code!

QRP Operating. The Q-signal "QRP" stands for low power. If you've ever tried to out-shout Radio Moscow (heard every evening) on 40 meters, then you know the value of high power. But many amateurs enjoy using low power (or very low power) for making contacts. Using mostly CW, QRP operators must really hone their operating skills to a high level. Some of them merely turn down the carrier control on their transceiver (in CW mode), and operate using 5 to 25 watts. Others buy a special QRP transceiver, such as the very popular Heathkit HW-9. Still others build either a transmitter or transceiver from scratch.

QRP'ing does not require high-gain beam antennas; a good dipole or vertical will do nicely (although the gain doesn't hurt, either!). What it does require, however, is a lot of listening and a lot of skill...but it's an awful lot of fun.

Other Operating Activities. There are any number of amateur-radio activities that revolve around operating. For starters, there is the old fashioned

"rag chew," i.e. getting on the air and simply talking at length with others. You might rap with friends of long standing, or make new friends along the way. Three of my best friends in this life were first met in amateur-radio activities many years ago.

Another popular activity is earning any of several-dozen operating awards that are available. Because of limited space, we will mention only the American Radio Relay League (ARRL, 225 Main Street, Newington, CT 06111) awards.

The *Rag Chewer's Club* award, actually just a certificate, is earned very simply: talk to another amateur on the air for 30 minutes or longer. Report the contact to ARRL (c/o RCC), giving the details of the QSO (including callsign, date, and inclusive times). Include a self-addressed, stamped #10 envelope (SASE) with your request.

The *Worked All States* (WAS) operating award is granted for working at least one amateur station in all 50

states of the USA. The contacts must each be confirmed with a QSL card. Send an SASE to ARRL for a set of WAS rules and an application form (MCS-217). There are special endorsements for all-CW, all-SSB, novice, single band, QRP (low power), or working all 50 states on each of at least five bands.

The *Worked All Continents* (WAC) certificate is awarded for working an amateur station on each of the continents: North America, South America, Europe, Africa, Asia, and Oceania. Again, there are special endorsements for particular accomplishments (e.g., 50-MHz WAC, all-CW, etc.). Like all other awards, original QSL cards are required to confirm each contact.

The *DX Century Club* (DXCC) is a major DX-operating award, and is granted for working, and receiving QSL cards from, amateurs in at least 100 countries (including your own country, which is often overlooked). Each country must be on the ARRL DXCC Countries List. An endorsement sticker is offered for each additional ten countries worked. There is no reason, incidentally, why a novice with a 100-watt rig driving a dipole or simple vertical cannot earn DXCC—many thousands have already done it! An application form is available from ARRL for an SASE, and the DXCC Countries List (which contains much more than just the list) is available from ARRL for \$1.

Contesting is a long-time interest of many amateurs, and at one time I was very active in it. I was never very suc-

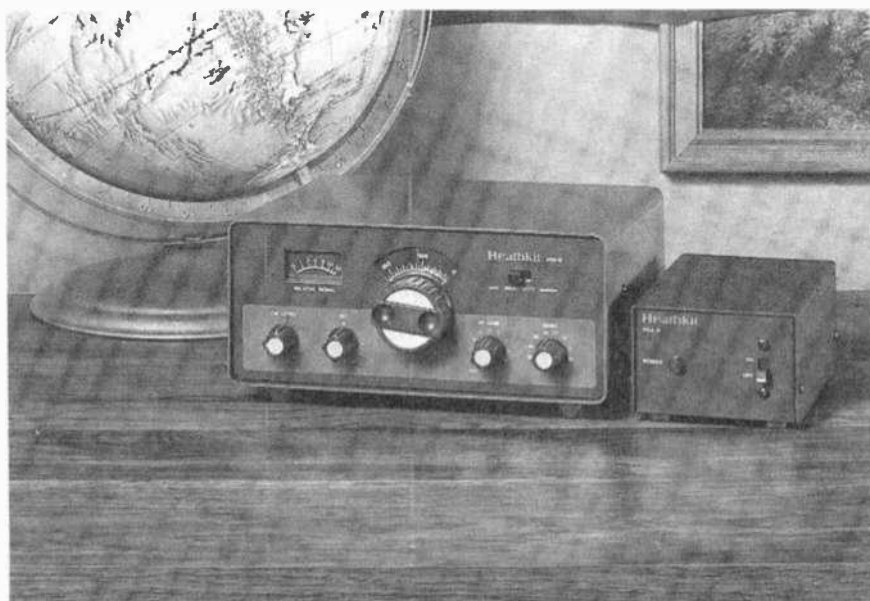

Heathkit HW-9 QRP transceiver is a compact 80- through 10-meter HF unit that's designed to cover the lower 250 kHz of the 80-, 40-, 20-, and 15-meter amateur bands, and can also be used on the 30-, 17-, and 12-meter WARC bands and the lower 250 kHz of the 10-meter band.

cessful on the level, say, of my friend the late Vic Clark (W4KFC), but I did have a lot of fun on the two contests that I preferred the most. Some of the annual contests offered by ARRL include:

Sweepstakes. This event is described as the most prestigious domestic operating contest. It is held annually on two weekends in November (one weekend for phone and one for CW). The "week-end" consists of 24-consecutive hours. Although the total time that the contest is open is longer than 24 hours, each station must operate only over a 24 hour period. Points are earned for each different station worked, with multipliers granted for each ARRL Section.

Note: If you are interested in earning a Worked All States (WAS) award, this is the contest for you. It is literally possible to work all 50 states leisurely during the sweepstakes. But play fair—work the contest so the other operator does not have to lose your contact as a point in his own effort!

International DX Contest (IDX). This contest is similar to the Sweepstakes, except that amateurs in the USA and Canada work amateurs in all other countries. The CW portion is held over a

weekend in February, while the phone portion is held a month later in March.

If the Sweepstakes is a good way to earn a WAS certificate quickly, the International DX Contest is a good way to earn a DXCC—plus a couple of "10 countries" endorsements. I've known a number of amateurs, including a few novices, who earned DXCC in a single weekend. Of course, they didn't sleep much.

IARU HF World Championship. Unlike the IDXC, in which USA/Canadian amateurs work the rest of the world, the International Amateur Radio Union HF World Championship contest has everyone working everyone else. The idea is to roll up the largest tally of ITU zones, DXCC countries, and U.S. states.

Field Day. Always held over the last full weekend in June, Field Day is basically a test of amateur's ability to initiate emergency communications under less than ideal conditions. Amateurs, usually in groups or clubs, take to the field and operate stations for 24 hours disconnected from the power mains and using quickly erected antennas. Although Field Day is a serious test of our public-service ability, it is also

a time of much fellowship and fun...it is, after all, camping. A bit of campfire food, a bunch of friends, and a few (not too many) "807's" (if you are under 35, a modern "807" has a pop top)...that's the life.

Those are only a few of the major contests scheduled every year. Contact ARRL headquarters for details of how to work those contests. Also, if you make inquiries around your own area you might find either a local ham who works contests a lot (and can offer advice), or even a club that is either organized exclusively for contests or have contests as a major interest. Most contests, especially the domestic contests, have club categories in which the aggregate scores of the members are tallied. Those clubs tend to be very competitive, so if that's your "bag," you will find them quite a lot of fun.

Conclusion. Operating is what the amateur-radio hobby is all about, at least for the majority of hams. The activities discussed above are just a few of the many scores of things that you can do to enhance your enjoyment of the hobby. ■

TAKE VINCE AND LARRY'S CRASH COURSE IN SAFETY BELTS.

LESSON
NO. 1

"As you know, Larry, pretty soon all cars will come with automatic safety belts or air bags—and I don't mean your mother-in-law!"

"That's right, Vince, but these new automatic gizmos only do part of the job to keep you from being a windshield warrior. You've still got to make sure your safety belt is buckled up."

YOU COULD LEARN A LOT FROM A DUMMY.
BUCKLE YOUR SAFETY BELT.

A Public Service Station of Ad Council U.S. Department of Transportation

LEARN VCR CLEANING/MAINTENANCE/REPAIR

EARN UP TO \$1000 A WEEK, WORKING PART TIME FROM YOUR OWN HOME!



Secrets
Revealed!

NO Special
Tools or
Equipment
Needed.

EARN UP TO \$60
AN HOUR AND
MORE!

THE MONEY MAKING OPPORTUNITY OF THE 1990'S

IF you are able to work with common small hand tools, and are familiar with basic electronics (i.e. able to use voltmeter, understand DC electronics) . . .

IF you possess average mechanical ability, and have a VCR on which to practice and learn . . . then we can teach YOU VCR maintenance and repair!

FACT: up to 90% of ALL VCR malfunctions are due to simple MECHANICAL or ELECTRO-MECHANICAL breakdowns!

FACT: over 77 million VCRs in use today nationwide! Average VCR needs service or repair every 12 to 18 months!

Viejo's 400 PAGE TRAINING MANUAL (over 500 photos and illustrations) and AWARD-WINNING VIDEO TRAINING TAPE reveals the SECRETS of VCR maintenance and repair—"real world" information that is NOT available elsewhere!

Also includes all the info you'll need regarding the BUSINESS-SIDE of running a successful service operation!

FREE INFORMATION

CALL TOLL-FREE 1-800-537-0589

Or write to: Viejo Publications Inc.

3540 Wilshire BL. STE. 310

Los Angeles, CA 90010 Dept. PE

CIRCLE 14 ON FREE INFORMATION CARD



Scanner Scene

By Marc Saxon

FAST-FOOD FREQUENCIES, WIRELESS MIKES, AND MORE!

Radio Shack has a rather good mid-price scanner available for those who want more scanner than you get with their economy PRO-57 (\$139.95), yet less of the "bells and whistles" offered by the dazzling PRO-2005 (\$419.95). It's dubbed the *Realistic PRO-2024*, and that price tag dangling from it narrowly edges up to the \$200 mark (\$199.95, to be precise).

For that reasonable sum, you get a keyboard-programmable scanner offering 60 channels of memory in the 30- to 54-MHz, 118- to 136-MHz, 138- to 174-MHz, and 380- to 512-MHz bands. Okay, so you don't get the 800- to 900-MHz band—but at this price, if you want to lay an ear on those 800- to 900-MHz sounds, you can go out and buy an add-on 800-MHz converter for far less than \$100 and you've still got a pretty good deal.

The Realistic PRO-2024 has selectable two-speed scanning and frequency searching, priority function, selectable channel lockouts, and scan delay. There's also a six-channel "monitor bank" scratch-pad memory to temporarily store the channels you find while in search mode.

We'd like to see changes in two features—one minor slice of frequency coverage plus a smidgen of hardware. The VHF aeronautics band was recently extended up to 137 MHz from 136 MHz, and the PRO-2024 doesn't reflect that change in its otherwise fairly good coverage. Furthermore, the external antenna connector on the PRO-2024 is one of those "Motorola" types instead of the superior BNC-type that is becoming standard on today's scanners. Still, the PRO-2024 is easy to program and sufficiently versatile to satisfy most of the needs of a general-interest scanner buff who hasn't yet progressed into either the "serious" or "fanatic" scanning stages.

Toss an eyeball in the direction of the Realistic PRO-2024 at any Radio Shack

emporium. If you're in the market for a quality scanner at a reasonable price, it might be just the unit that you're looking for.

Readers Ask. Paul Van Rookhuyzen, Surrey, B.C., Canada, is interested in tuning in on wireless microphones. He observes that the Samson wireless he uses while videotaping weddings at his local church operates on 199.60 MHz, which is outside the tuning range of his Realistic PRO-34 handheld. He wonders if the scanner can be modified to pick up this frequency.

While there are several modifications that can be done to a PRO-34, that isn't one of them. The range of frequencies from 174.60 to 199.60 MHz, which is just above the 174.00 MHz VHF tuning cutoff of most scanners, has ten channels where wireless mikes and "hidden body" (surveillance) transmitters often operate. For those who are able to scan this portion of the spectrum (although the low-powered transmitters have very short ranges), try monitoring:

174.60, 177.60, 181.60, 183.60, 186.60, 190.60, 192.60, 195.60, 196.60, and 199.60 MHz.

Within the frequency coverage of most scanners, those units (and even wireless room "bugs") have been reported on: 165.91, 167.335, 167.345, 167.485, 168.01, 169.20, 169.445, 169.505, 170.245, 170.305, 171.045, 171.105, 171.45, 171.845, 171.905, 172.00, 172.20, and 173.335 MHz. You can also check for wireless microphones in the VHF "low band" on 30.84, 33.14, 33.40, 35.02, and 42.98 MHz.

Cheaper wireless mikes—including those devices sold as toys—usually operate on frequencies between 49.67 and 49.99 MHz.

We are often asked to discuss or recommend scanner clubs or newsletters. To be candid, the only scanner group I ever joined was an excellent national one that had to suspend operations recently when the fellow who ran its operations passed away. We have seen what several other scanner organizations have to offer, as well as what the couple of small newsletters and similar home-brewed "fanzines" are doing. Thus far, there's not much worthy of excitement, deep discussion, or recommendation. We'll keep watching, however, with high hopes for the future.

We received some words of sage advice from John M. Wareham, Fullerton, CA, who has a Realistic PRO-34 handheld. He reports that the scanner is very rugged, and has survived getting knocked off the roof of his car to the garage floor without any ill effects. On

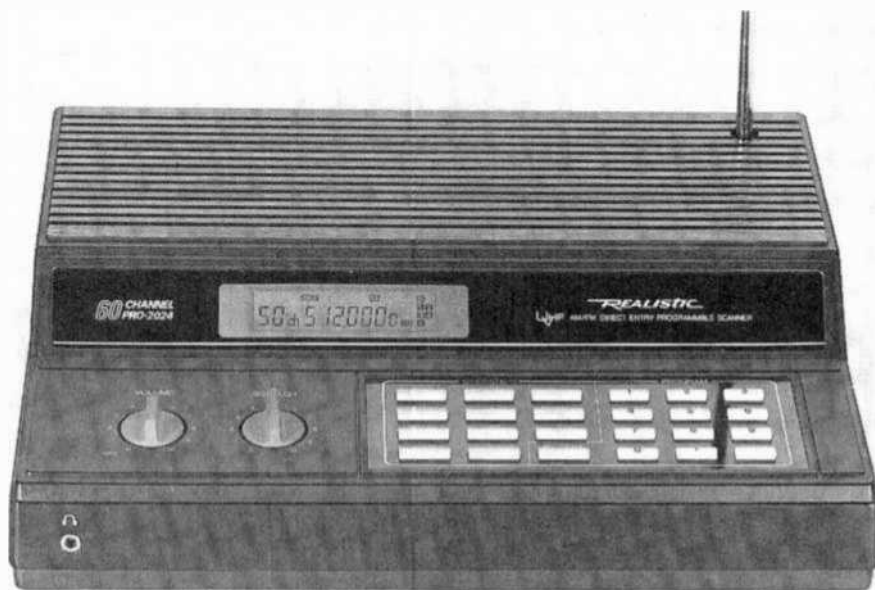

With the Realistic PRO-2024, you get what you pay for—it offers good coverage and several new convenience features at a very fair price.

the flip side of the coin—and here's something to keep in mind for the next few months—the scanner is a bit temperamental in extremely hot weather. Until the scanner cools off somewhat, he says the reception "goes nuts, as well as the LCD." John's words apply to any make or model of handheld scanner. A closed car sitting in the summer sun is definitely *not* the best of all possible storage locations for a handheld scanner.

I don't know what the major fascination is with the frequencies used at the drive-up windows at fast-food places, yet hardly a week goes by without mail that either provides such information or asks when the column will mention those frequencies. Today I received a letter from L.R. of Scranton, PA, advising me that the McDonald's in Scranton (South Side) operates on 154.565 MHz, while the one in Carbondale uses 154.60 MHz. That followed a letter from Ted Janowski, of Hammond, IN, asking if we know the frequencies used by McDonald's and Burger King. Those letters are only two of dozens received recently.

From what we can find out, the majority of the drive-through fast-food communications can be found on 154.565 and 154.60 MHz, with activity also observed on 154.57, 457.525, 457.55, 457.575, 457.60, 467.75, 467.775, 467.80, 467.825, 467.85, 467.875, 467.90, and 467.925 MHz.

Al Rawlins of Ohio asks if we know the frequency used by the Postal Inspection Service. We understand that they operate nationally on 414.75 and 415.05 MHz, and we have monitored postal service transmissions on those frequencies. Other possible frequencies include 169.65 and 169.85 MHz, although we haven't personally picked up any activity on either of those frequencies. It's entirely possible that the 400-MHz-band frequencies replaced the 169-MHz channels. In fact, if you place a scanner into search mode between 406.00 and 420.00 MHz, you're liable to discover all sorts of interesting communications activity from numerous federal agencies.

Keep those cards and letters heading in our direction. We are always interested in receiving your questions, listening tips, suggestions, newly discovered frequencies, and comments on the scanning hobby. Write to: *Scanner Scene*, **Popular Electronics**, 500-B Bi-County Boulevard, Farmingdale, NY 11735. ■

Popular Electronics REPRINT BOOKSTORE

- | | |
|---|---|
| <input type="checkbox"/> 220 Popular Electronics (1990 back issues) \$3.50 | <input type="checkbox"/> 107 Radio-Electronics (1987 back issues) . . \$4.50
Write in issues desired _____ |
| <input type="checkbox"/> 119 Popular Electronics (1989 back issues) \$3.75
Write in issues desired _____ | <input type="checkbox"/> 106 Radio-Electronics (1986 back issues) . . \$5.00
Write in issues desired _____ |
| <input type="checkbox"/> 118 Hands-On Electronics (1988 back issues)\$4.00
Write in issues desired _____ | <input type="checkbox"/> 105 Radio-Electronics (1985 back issues) . . \$5.50
(January, February not available)
Write in issues desired _____ |
| <input type="checkbox"/> 117 Hands-On Electronics (1987 back issues)\$4.50
Write in issues desired _____ | <input type="checkbox"/> 104 Radio-Electronics (1984 back issues) . . \$5.75
(December, February not available)
Write in issues desired _____ |
| <input type="checkbox"/> 116 Hands-On Electronics (1986 back issues)\$5.00
Write in issues desired _____ | |
| <input type="checkbox"/> 115A Hands-On Electronics #6 \$5.50 | |
| <input type="checkbox"/> 115 Hands-On Electronics #5 \$5.50 | |
| <input type="checkbox"/> 114 Hands-On Electronics #4 \$5.50 | |
| <input type="checkbox"/> 113 Hands-On Electronics #3 \$5.50 | |
| <input type="checkbox"/> 112 Hands-On Electronics #2 \$5.50 | |
| <input type="checkbox"/> 111 Hands-On Electronics #1 \$6.00 | |
| <input type="checkbox"/> SP10 Special Projects #10 \$6.00 | |
| <input type="checkbox"/> SP9 Special Projects #9 \$6.00 | |
| <input type="checkbox"/> SP8 Special Projects #8 \$6.00 | |
| <input type="checkbox"/> SP6 Special Projects #6 \$6.00 | |
| <input type="checkbox"/> SP5 Special Projects #5 \$6.00 | |
| <input type="checkbox"/> SP4 Special Projects #4 \$6.00 | |
| <input type="checkbox"/> SP1 Special Projects #1 \$7.00 | |
| <input type="checkbox"/> EH90 Experimenters Handbook (1990) \$4.00 | |
| <input type="checkbox"/> EH88 Experimenters Handbook (1988-89) \$4.50 | |
| <input type="checkbox"/> EH87 Experimenters Handbook (1987) . . . \$5.00 | |
| <input type="checkbox"/> MH89 Popular Electronics Hobbyist
Handbook \$4.50 | |
| <input type="checkbox"/> 126 Radio-Electronics Annual 1986 \$6.00 | |
| <input type="checkbox"/> 125 Radio-Electronics Annual 1985 \$6.00 | |
| <input type="checkbox"/> 210 Radio-Electronics (1990 back issues) . . \$3.50 | |
| <input type="checkbox"/> 109 Radio-Electronics (1989 back issues) . . \$3.75
Write in issues desired _____ | |
| <input type="checkbox"/> 108 Radio-Electronics (1988 back issues) . . \$4.00
Write in issues desired _____ | |

- | | | |
|--|------------------------|--|
| | REPRINTS REPRINTS | |
| <input type="checkbox"/> 169 Think Tank (133 Circuits) \$3.50 | | |
| <input type="checkbox"/> 169A Think Tank Vol. 2 \$3.00 | | |
| <input type="checkbox"/> 168A Fact Cards (#1-33) \$4.00 | | |
| <input type="checkbox"/> 168 Fact Cards (#34-66) \$4.00 | | |
| <input type="checkbox"/> 168C Fact Cards (#67-99) \$3.50 | | |
| <input type="checkbox"/> 168D Fact Cards (#100-132) \$3.50 | | |
| <input type="checkbox"/> 167 Designing With IC's \$4.00 | | |
| <input type="checkbox"/> 166 Collected Works of Mohammed Ullyses Fips
(62 pages, April Fools Collection) \$7.50 | | |
| <input type="checkbox"/> 165 How to Repair CD Disc Players \$5.00 | | |
| <input type="checkbox"/> 164 Modern Electrics (April 1908) \$3.00 | | |
| <input type="checkbox"/> 163 Receiving Satellite TV \$5.00 | | |
| <input type="checkbox"/> 162 Build Your Own Satellite TV Receiver \$5.00 | | |
| <input type="checkbox"/> 161 Descrambling (Feb., 1984) \$3.00 | | |
| <input type="checkbox"/> 160 New Ideas - 42 Circuits \$3.50 | | |
| <input type="checkbox"/> 159 Low Frequency Receiving Techniques
Building and using VLF Antennas \$5.00 | | |
| <input type="checkbox"/> 158 Electro Importing Co. Catalog
(Circa 1918) \$5.95 | | |
| <input type="checkbox"/> 157 All About Kits \$2.00 | | |
| <input type="checkbox"/> 156 How To Make PC Boards \$2.00 | | |
| <input type="checkbox"/> 155 IBM Typewriter To Computer \$2.00 | | |
| <input type="checkbox"/> 154 How To Repair VCR's \$3.50 | | |
| <input type="checkbox"/> 150 Pay TV Decoder (1981) \$3.00 | | |

To order any of the items indicated above, check off the ones you want. Complete the order form below. Include your payment, check or money order (DO NOT SEND CASH), and mail to Popular Electronics, Reprint Department, P.O. Box 4079, Farmingdale, NY 11735. Please allow 4-6 weeks for delivery.

If you need a copy of an article that is in an issue we indicate is unavailable you can order it directly from us. We charge 50¢ per page. Indicate the issue (month & year), pages and article desired. Include payment in full, plus shipping and handling charge. Make checks payable to Gernsback Publications, Inc.

ARTICLE _____		
PAGES _____	MONTH _____	YEAR _____
TOTAL PAGES _____	@50¢ each	TOTAL PRICE _____
MAIL TO: Popular Electronics Reprint Bookstore, P.O. Box 4079, Farmingdale NY 11735		
All payments must be in U.S. funds		
SHIPPING CHARGES IN USA & CANADA		
\$0.01 to \$5.00 \$1.25	\$30.01 to 40.00 . . . \$5.00	SORRY — We only ship to USA & Canada
\$5.01 to \$10.00 \$2.00	\$40.01 to 50.00 . . . \$6.00	
\$10.01 to 20.00 \$3.00	\$50.01 and above . . \$7.50	
\$20.01 to 30.00 \$4.00		
Total price of merchandise \$ _____		
Sales Tax (New York State Residents only) \$ _____		
Shipping Charge (see chart) \$ _____		
Name _____	Total Enclosed \$ _____	
Address _____		
City _____ State _____ Zip _____		

PE690

JUNE 1990

ANTIQUE RADIO

(Continued from page 81)

and molded mica capacitors to be used in rebuilding a *Majestic* AM/FM radio and Richard J. Ludig (1275 Federal Ave., Los Angeles, CA 90025), a collector of old "felt turntable" record changers, would like to meet other Los Angeles-area collectors of similar items.

"Show and Tell" Time. Sal Mazzer (55 Indian Rd., Danville, NJ 07834) shares a photo of his latest restoration, a 1929 *Atwater Kent* model 55C. Sal says that the chassis of this set is the most well-preserved one he's ever seen; even the copper tube-socket contacts gleam like new. Write him if you can supply some grill cloth to replace the torn material in his set. Otherwise, Sal may want to contact *Antique Electronic Supply* (688 W. First St., Tempe, AZ 85281). They market a selection of reproduction antique grill cloths, and will send a sample card for a \$10.00 deposit—which is refundable on return of the card.

I can't even begin to do justice to reader George Rutkay's (Brampton, Ontario, Canada) 11-page letter describing his adventures in restoring a *Seeburg* model 148ML (1947-vintage)

jukebox. Some people call this model the "trashcan" and, if you look at the photo George sent of his restored unit, you can see why. George's "trashcan" had been badly burned in a fire, and the unit was subsequently stored in a damp location causing many of the metal components to rust. Extensive restoration of the electronic, mechanical, and decorative elements was required, and the work is not yet really complete. However, the *Seeburg* is now in good working condition and, as you can see, it also looks quite fine. Thanks for a really fascinating letter, George!

This 'n That. Melvin F. Clapper (5050 Northfield Dr., Fort Wayne, IN 46804) has two interesting radios for sale: (1) A 1938-vintage direction finder made by General Communication Co. of Boston, MA, is a four-tube battery-operated set that comes complete with loop antenna; and (2) a 1927 *RCA Radiola R-17* comes with its accessory dome-type table speaker. Pricing will be fair, says Mel.

Reader Peter Elem (2464 New York Ave., Melville, NY 11747) has a collection of about 400 boxed, unused tubes inherited from a friend who went out of the servicing business. The collection in-

cludes many loctal, octal, and "peanut" types. He'll respond to requests for specific tubes or consider selling the whole bunch as a package.

Want to tap into Billy Pogue's 50-year experience as a radio builder and experimenter? He'll be glad to correspond with you about your problems in restoring tube-type radios. He may not be able to provide you with details about specific radios, but he can definitely give you theoretical advice and suggest ways to substitute for no-longer-available parts. Write him at 4039 Blue Canyon Rd., Lake Havasu City, AZ—and be sure to include a SASE.

Need sources of tubes for restoring British equipment? Here are a couple of good ones suggested to reader Pat Walton (Albuquerque, NM) by *Antique Electronic Supply Co.*: Mr. Philip Taylor, 14 Willow Walk, Canewdon, Rochford, Essex SS4 3QH, Great Britain; The Vintage Wireless Co., Tudor House, Cossham St., Mangotsfield, Bristol BS17 3EN, Great Britain.

Time To Close Up Shop ...but we'll see you next month! In the meantime, write me c/o *Antique Radio, Popular Electronics*, 500-B Bi-County Blvd., Farmingdale, NY 11735. ■

FACTCARDS

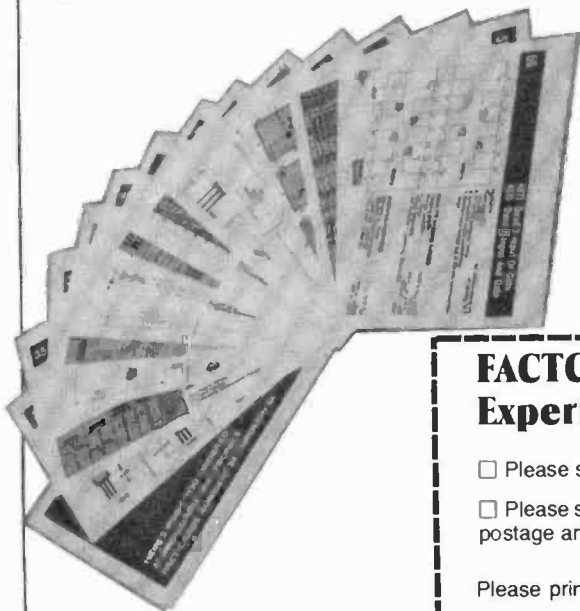

■ ALL YOU NEED to know about electronics from transistor packaging to substitution and replacement guides. FACTCARDS numbers 34 through 66 are now available. These beautifully-printed cards measure a full three-by-five inches and are printed in two colors. They cover a wide range of subjects from Triac circuit/replacement guides to flip-flops, Schmitt triggers, Thyristor circuits, Opto-Isolator/Coupler selection and replacement. All are clearly explained with typical circuit applications.

■ WANT TO EXPAND your knowledge of electronics? Do it the easy way

by studying the Electronics Fact Cards. Do you travel to and from your job each day? Drop a handful of cards in your pocket before you leave, and the bus becomes a schoolroom! At home, you can build some of the projects and not only have fun building and using them, but learn how they work at the same time.

■ YOU'LL BE AMAZED both at how rapidly you learn with these cards, and how easy it is to understand. These new cards are available right now. Don't miss out. Send your check or money order today.

FACTCARDS—Facts at your fingertips for Experimenters and Project Builders!

Please send one copy of FACTCARDS at \$3.50. Shipping \$1.00 (U.S. and Canada only).

Please send _____ copies of FACTCARDS. Total cost is sum of copy price and First Class postage and handling cost multiplied by number of card sets ordered.

Allow 6-8 weeks for the material to arrive.

Please print

(Name)

(Street Address)

(City)

(State)

(Zip)

Detach and mail today:
Popular Electronics Bookstore
P.O. Box 4079
Farmingdale, NY 11735

All Payment must be in U.S. Funds!

PE690

Jampacked with information at your fingertips

CYRUS TWO AMP

(Continued from page 79)

constant 70 watts per channel and plotted distortion versus frequency once again. At 1 kHz, the THD now was over 1%, while at 20 kHz, the THD increased to 3.5%.

Lest you get the impression that this is in any way an inferior amplifier, we would hasten to add that at somewhat lower power levels, things looked a lot better. To confirm that point, we plotted distortion plus noise versus power output levels for three frequencies (1 kHz, 20 Hz, and 20 kHz) for both 8-ohm and 4-ohm load conditions. Just before the onset of clipping at around 40 watts per channel, distortion was less than 0.01% for the 1-kHz test signals, about 0.02% for the 20-Hz signal and less than 0.04% for the 20-kHz test signal. Similarly, with 4-ohm loads, below clipping (at around 60 watts per channel) the THD plus noise at 1 kHz was 0.03%, while at 20 Hz it was 0.4%, and at 20 kHz it measured 0.2%.

The high-level input sensitivity, defined as the voltage input needed to produce 1 watt of output, was measured at 52 millivolts—or close enough to the claimed 50 millivolts. The weighted signal-to-noise ratio for the high-level inputs, with 500 millivolts applied and with the volume control adjusted to produce 1 watt, was exactly 86 dB, as claimed. The damping factor, using 8-ohm loads, was 110.

The input sensitivity for the moving-magnet position of the phono inputs measured 0.35 millivolts while for the moving-coil mode it was .023 mV. The moving-magnet phono signal-to-noise ratio, with a 5-millivolt, 1-kHz signal applied as a reference input and the volume control again adjusted for an output of 1 watt, measured 84.5 dB. For the moving-coil mode, with 0.5 mV of signal applied, the signal-to-noise ratio referred to a 1 watt output was 75 dB, exactly as claimed.

Some words of explanation are needed concerning the phono frequency response. In the United States, record companies insist upon using the original RIAA (Record Industry Association of America) equalization during recording. That would require the complementary RIAA playback curve during the playback of recordings made that way. Much of the rest of the world (European record producers, in particular) have adopted a modified equalization curve for very good rea-

sons. By not continuing to boost bass all the way down to sub-sonic regions, turntable rumble that may be present is greatly attenuated without materially affecting musical bass response.

Having said all that, let's get back to the frequency response measured for the phono section of the Cyrus Two. I measured that response in terms of deviation from both the standard U.S. RIAA curve and in terms of the "new RIAA" curve (as Mission refers to the European IEC standard equalization curve). When referenced to the standard RIAA curve, there was a slight roll-off at the bass end (about -2.5 dB at 20 Hz). When I referenced the new RIAA curve, deviation at 20 Hz was considerably less—no more than 0.7 dB.

Hands-On Tests. While lab measurements tell a lot about an integrated amplifier such as this, its true merits can only be appreciated when it is hooked up to a pair of high quality loudspeakers and given the ultimate test—the test that only a pair of human ears can provide. It was when we conducted extensive listening tests that the superiority of this little amplifier became apparent. For one thing, despite the fact that our sample was a bit short on power even compared to the ratings given by the manufacturer, we never seemed to run out of power—and the reference loudspeakers used in our listening tests are not the most efficient ones around. Normally, they seem to soak up power from most amplifiers, but with the Mission Cyrus Two connected to them, we were able to play some of our reference CD's at good, loud levels without encountering any audible distortion or amplifier "strain." The sound was clean, with enough tight bass to satisfy the needs of rock music fans, but with good overall balance that made for accurate reproduction of more classically oriented musical selections.

There are those, we are sure, who will feel deprived because the amplifier lacks such embellishments as bass and treble tone controls, loudness-control compensation, and the like. But Mission's philosophy seems to be that such enhancements are really not required in a high quality system in which all of the components have been properly selected and matched to each other.

For more information on the Cyrus Two Integrated Amplifier, contact the manufacturer directly, or circle 119 on the Free Information Card. ■

ATTENTION! ELECTRONICS TECHNICIANS

EARN YOUR
**B.S.E.E.
DEGREE**



THROUGH HOME STUDY

Our New and Highly Effective Advanced-Placement Program for experienced Electronic Technicians grants credit for previous Schooling and Professional Experience, and can greatly reduce the time required to complete Program and reach graduation. No residence schooling required for qualified Electronic Technicians. Through this Special Program you can put all of the loose ends of your electronics background together and earn your B.S.E.E. Degree. Upgrade your status and pay to the Engineering Level. Advance Rapidly! Many finish in 12 months or less. Students and graduates in all 50 States and throughout the World. Established Over 40 Years! Write for free Descriptive Literature.

COOK'S INSTITUTE OF ELECTRONICS ENGINEERING



4251 CYPRESS DRIVE
JACKSON, MISSISSIPPI 39212

CIRCLE 20 ON FREE INFORMATION CARD



Join the Crossword Puzzles of the Month Club and put your crossword skills to the test!

Become a member and receive five intriguing, fun and challenging new puzzles — mailed right to your home every month! These are not reprints, but *original, full-size* puzzles edited especially for our members by the noted crossword puzzle expert Henry Hook. Month after month, you'll receive five brand-new puzzles and their solutions . . . five fiendishly clever puzzles with the same degree of difficulty as those in the Sunday New York Times!

Join today! A perfect gift!

An entire year's membership is just \$29.95. (We pay the postage.) Send your check or money order to:

Crossword Puzzles of the Month Club
629 Green Bay Road, Dept. 702
Wilmette, Illinois 60091

Or call toll-free: 1-800-433-4386
and charge it to your MasterCard or Visa.
— 24 hours a day, 7 days a week —

Your satisfaction is guaranteed.

CPHC 0601

JUNE 1990

FUN WITH ELECTRONICS

Coil Design and Construction Manual



◀ □ 160—COIL DESIGN & CONSTRUCTION MANUAL \$5.95. How to make RF, IF, audio and power coils; chokes and transformers. Practically every possible type is discussed.

□ BP87—50 SIMPLE LED CIRCUITS, BK 2 \$5.50. Fifty more uses for the simple LED. Combine this book with BP42 and you'll have a file of 100 useful LED applications.



◀ □ BP45—PROJECTS IN OPTOELECTRONICS \$5.50. Describes a number of projects including infrared transmitters, modulated light transmission and photographic projects.

□ BP33—ELECTRONIC CALCULATOR USERS HANDBOOK \$5.75. Presents formulae, data, methods of calculation, conversion factors, etc., with the calculator user especially in mind, often illustrated with simple examples.



80 (FET) Field Effect Transistor Projects



◀ □ BP39—50 FET TRANSISTOR PROJECTS \$5.50. The projects described in this book include RF amplifiers and converters, test equipment and receiver aids, tuners, receivers, mixers and tone controls and a variety of other circuits.

□ #219—SOLID STATE NOVELTY PROJECTS \$4.95. How to build a number of novelty projects including a musical instrument played by reflecting a light beam with your hand, water warbler for pot plants, musical tone generator, touch switch and more.



MAIL TO: Electronic Technology Today Inc.
P.O. Box 240
Massapequa Park, NY 11762-0240

SHIPPING CHARGES IN USA AND CANADA

\$0.01 to \$5.00	... \$1.25	\$30.01 to \$40.00	... \$5.00
\$5.01 to 10.00	... \$2.00	\$40.01 to \$50.00	... \$6.00
\$10.01 to \$20.00	... \$3.00	\$50.01 and above	... \$7.50
\$20.01 to \$30.00	... \$4.00		

SORRY, No orders accepted outside of USA and Canada

Total price of merchandise	\$ _____
Shipping (see chart)	\$ _____
Subtotal	\$ _____
Sales Tax (NYS only)	\$ _____
Total Enclosed	\$ _____

Name _____
Address _____
City _____ State _____ Zip _____

EXHAUST MONITOR

(Continued from page 34)

Case Assembly. Before the printed-circuit board can be mounted in its enclosure, the lid of the enclosure must be drilled to provide a hole for R19 (the alarm sensor), an adjustment hole for R10, and holes for the board-mounting screws.

We also drilled three 1/4-inch holes in each side of the enclosure to allow ventilation of the sensor and U2 (the 7805 regulator). Additional holes must

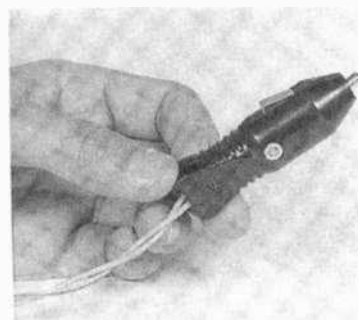

By wiring the power leads to a cigarette lighter plug, you can easily move the unit from vehicle to vehicle.

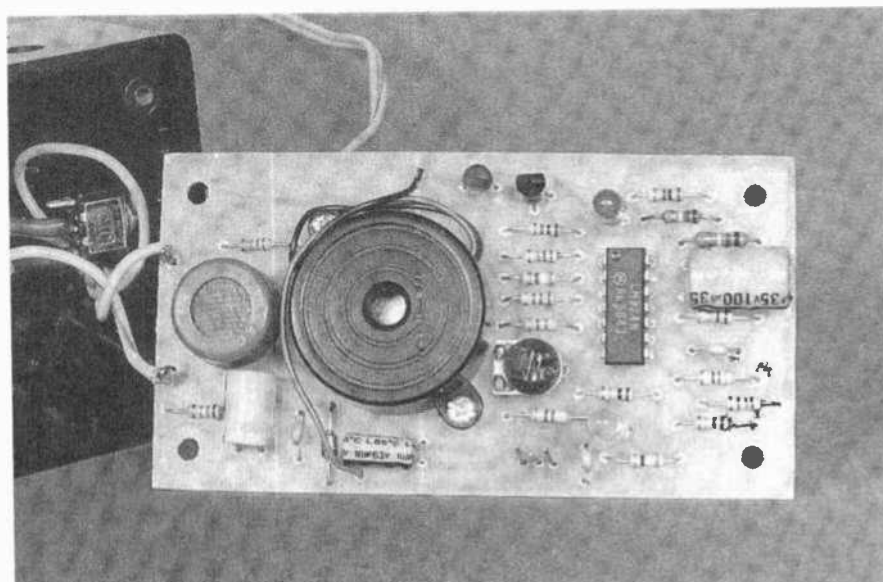

The three electrolytic capacitors are mounted horizontally on the printed-circuit board so that they clear the front panel. Note that the TGS 822 must be installed so that the top of the sensor is level with the piezo alarm.

also be drilled in the enclosure for S1 and for the power-supply leads. Holes should also be drilled in the base of the case to allow it to be mounted permanently, if desired.

With all holes drilled in the lid of the case, the exhaust-gas monitor's printed-circuit board can be mounted in place. Fit a tapped spacer at each corner of the board, with a washer under each spacer. The twin-lead wire should then be removed from the

printed-circuit pins and the switch wired as shown in the parts-placement diagram (Fig. 3).

Put a knot in the twin lead as a strain relief where it enters through the hole in the end of the case. Finally, secure the board assembly to the lid with four machine screws.

Installation. You have two options for connecting the Exhaust Gas Monitor to your vehicle. First, you can use a cigarette-lighter plug. That allows you to move the unit from vehicle to vehicle. Second, you can wire the unit to the +12-volt accessory supply at the vehicle's fuse panel. That way, the Monitor will be powered up only when the ignition is on.

We must make one final point: While the Exhaust Gas Monitor will detect gasoline fumes from all sources, it is not suitable for use on boats in its present form as salt water can damage the sensor.

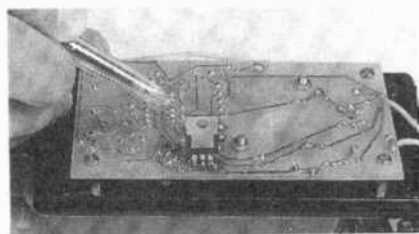

The printed-circuit board is secured to the case lid using machine screws, washers and tapped 1/2-inch spacers. Note that the 3-terminal regulator is soldered to the foil side of the board

ELECTRONICS SHOW

(Continued from page 44)

turn in order to get there from your present location.

The TravelPilot system establishes its whereabouts through the use of an electronic flux compass and sensors mounted in the front wheels. The sensors provide the computer not only with speed information, but by determining the differential between the left- and right-wheel sensors, the TravelPilot can also tell when you are making a turn, whether you're going to the right or the left, and how sharply you're turning. The system is, after it gets settled in (which takes about 100 miles, we're told), self-calibrating. It can automatically match up a turn it senses being made with an intersection shown on the map and, if it's off by a few feet, correct its computed position and update the display to reflect the correction.

While the system is probably far from being a reality in the car you use to commute to work, or even in your cross-country RV, much interest has been shown in it by the trucking industry, and by fire and police departments.

Blaupunkt also showed a car radio that, using four concealed antennas, could lock onto and hold a signal much longer than conventional—even diversity reception—systems (see Fig. 1). Technicians had one programmed with the frequencies, call letters, and programming formats of over 4500 AM and 4900 FM stations in over 5100 U.S. cities. You supply the radio with your approximate location or direction of travel and your listening preference (classical, talk, easy listening, etc.), and it will find the appropriate stations for you as you go.

Several manufacturers showed—believe it or not—surround-sound systems to be used with portable video units for in-car passenger entertainment. And cellular phones got smaller, more portable, and cheaper.

Separating Chaff from Wheat.

Space—and a certain measure of good taste—do not permit us to add much more. We won't go into the whole hall devoted to wristwatches, the telephones shaped like duck-decoys, or the separate exhibit at one of the hotels dedicated to the business of selling and renting videocassettes. There was just too much, and after awhile the mind begins to boggle.

What did stick with us, though, and



This 120-inch rear projection home theater from Mitsubishi carries a price tag of about \$20,000, custom installed. Home theaters are said to be "hot" consumer electronics items these days.

what we see as a favorable portent of things to come, was a continuance of the trend toward things digital—DAT, DSP (which is going to become a very active area), digital interconnects, etc. There were also a number of bit-stream CD players—one bit at 256-times oversampling—that we feel heralds a significant improvement in both the quality of digital sound reproduction and in the price of obtaining it. There are full-featured bit-stream players with prices under \$200!

Home-video theaters were quite prominent, and the word is that this is a very fast-growing segment of the consumer electronics industry. We suspect, though, that the "growth" is a balance-sheet phenomenon—the result of the high ticket price of such installations—we doubt that there are that many of them being sold. There was also little more portable TV at the show, and a further trend to put home electronics



A "cat's eye" camcorder from Sharp can produce usable images down to a level of one lux.



Bit-stream A-to-D conversion is at the heart of Sony's new ES-line CD players. The process is said to reproduce digitally-recorded signals much more faithfully than conventional A-to-D converters, especially at low signal levels.

into the car. And videogames are moving off the CRT and into small portable LCD consoles containing both controls and a color screen.

On the other hand, high- and improved-definition TVs were not very conspicuous at all; our opinion is that it's too soon for the former, and too late for the latter.

And...oh, yes...there were lots and lots of antique-radio reproductions with lots and lots of neon-filled tubing snaking all around them. But if that's a portent of anything at all, we'll just ignore it. ■

Be an FCC LICENSED ELECTRONIC TECHNICIAN!



Earn up to \$30 an hour and more!

Learn at home in spare time. No previous experience needed!

No costly School. No commuting to class. The Original Home-Study course prepares you for the "FCC Commercial Radiotelephone License". This valuable license is your "ticket" to thousands of exciting jobs in Communications, Radio-TV, Microwave, Computers, Radar, Avionics and more! You don't need a college degree to qualify, but you do need an FCC License. **No Need to Quit Your Job or Go To School** This proven course is easy, fast and low cost! **GUARANTEED PASS**— You get your FCC License or money refunded. **Send for FREE facts now. MAIL COUPON TODAY!**

COMMAND PRODUCTIONS
FCC LICENSE TRAINING, Dept. 203
P.O. Box 2824, San Francisco, CA 94126
Please rush FREE details immediately!

NAME _____
ADDRESS _____
CITY _____ STATE _____ ZIP _____

CAPACITORS

(Continued from page 75)

ents, for example, it is likely that it will have a differential capacitor as the main adjustment control. The two capacitor sections would be used in two arms of a Wheatstone-bridge circuit. Be mindful of prices when planning to build such a bridge; I recently bought a differential capacitor for such an instrument and it cost nearly \$50!

Transmitting variable capacitors are yet another family of capacitors. The one requirement of transmitting variable capacitors (and certain antenna-tuner capacitors) is the ability to withstand high voltages. High-power ham-radio or AM-broadcast transmitters will have a DC potential of 1500 to 7500 volts on the RF-amplifier anode, depending upon the type of tube used. If the signal is amplitude modulated, the potential can double. Also, if certain antenna defects arise, then the RF voltages in the circuit can rise quite high. Thus, the variable capacitor used in the final-amplifier plate circuit must be

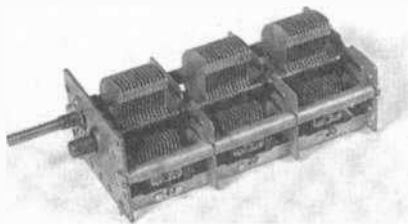

A multi-section variable capacitor is basically several capacitors mechanically ganged to the same shaft. Thus, they move in unison.

able to withstand those potentials.

There are two forms of transmitting capacitors typically found in RF power amplifiers and antenna tuners: air variable capacitors and vacuum variable capacitors. Air variable capacitors often have shafts of nylon so they can be mounted with the frame grounded or floating at high voltage. Vacuum variable capacitors are a variation on piston capacitors, but with a vacuum dielectric ($K = 1.0000$). Some models are adjusted by a DC motor. Other vacuum variables are manually tuned.

Solid-State Capacitors. One of the problems with variable capacitors is that they are large, bulky things that must be mechanically operated. Modern electronic circuits, including most radios today, are electronically tuned

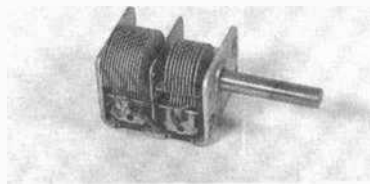

Cut-plate capacitors, sometimes used in superheterodyne receivers, have one section smaller than the other so they can track a local oscillator with the typically lower frequency RF amplifier.

using a varactor diode as the main capacitor. Those "capacitors" operate because the junction capacitance of a PN-junction diode is a function of the reverse-bias voltage applied across the diode. The varactor (also called a "varicap") is therefore a variable capacitor in which the capacitance is a function of an applied voltage. Maximum capacitances can and do run from 15 to 440 pF.

Figure 11 shows the usual circuit for a varicap diode. D1 is the varactor, while capacitor C1 is a DC-blocking capacitor. Normally, the value of C1 is set many times higher than the capacitance of the diode. Where C_d is the diodes capacitance, the total capacitance is:

$$C = C_1 C_d / (C_1 + C_d) \quad (1)$$

Capacitor C1 will affect the total capacitance only negligibly if C1 is much larger than C_d .

The control circuit for the varactor is the current-limiting resistor R1. That resistor is typically 50 to 470k. The shunt capacitor (C2) is used to decouple RF from the circuit to keep it from getting to other circuits and to prevent noise signals from other circuits from affecting the capacitor.

Variable-Capacitor Cleaning.

Antique-radio buffs often find that the main tuning capacitors in their radios are full of crud, grease, and dust. That

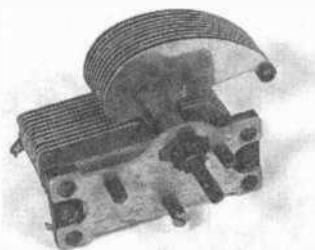

An offset shaft and unusual rotor plates allow this capacitor to track frequency (or wavelength) in LC-tuned resonant circuits.

means ham-radio operators working the hamfest circuit looking for such tuner parts often find just what they need, but they're usually all gooped up with scum, crud, grease, and other stuff. There are several things that can be done about it. First, try using dry compressed air. It will remove dust, but not grease. Aerosol cans of compressed air can be bought from automobile-parts and photography stores.

Another method, if you have the hardware, is to ultrasonically clean the capacitor. Ultrasonic cleaners, however, are expensive.

Still another way is to use a product such as Birchwood Casey Gun Scrubber. The product is used to clean firearms, and is available from most gun shops. Firearms become all gooped up because gun grease, oil, and gun-powder residue combine to create a crusty mess that's every bit as hard to remove as capacitor gunk.

At one time, carbon tetrachloride was used for that purpose and you can see it listed in old radio books. However, carbon "tet," as it's often called, is now well recognized as a health hazard. **Do not use carbon tetrachloride** for cleaning variable capacitors. ■



Support America's colleges. Because college is more than a place where young people are preparing for their future. It's where America — and American business — is preparing for its future.

**Give to
the college of
your choice.**



A Public Service of The Publisher

COUNCIL FOR AD EDUCATION

DIGITAL COURSE

(Continued from page 62)

OR GATE TRUTH TABLE			AND GATE TRUTH TABLE		
A	B	Y	A	B	Y
0	0	0	0	0	0
0	1	1	0	1	0
1	0	1	1	0	0
1	1	1	1	1	1

Fig. 2. Whenever any one or both inputs to an OR gate is high its output will be high. The output of an AND gate is high only when both inputs are high.

The low output of U2-a is applied to one leg of U4-a. Lets assume that power has been applied to the circuit. With power applied to the circuit, U3 oscillates at a rate determined by R7, R8, and C1. The output of U3 at pin 3 is fed to the other leg of U4-a (1/4 of a 7408 quad 2-input AND gate). But because one input to the AND gate is held low, the oscillating output of U3 has no effect on the output of U4-a—it remains low. Note from the AND-gate truth table in Fig. 2 that the output of an AND gate goes high only when all inputs are high.

However, as the sun drops from the sky, light striking R4 and R5 decreases, causing their resistance to increase. As the resistance across R4 and R5 increase, so do the voltage drops across them, and hence the voltage applied to the non-inverting inputs of U1-a and U1-b increases. When the voltage at the non-inverting inputs of the op-amps go slightly more positive than that at their inverting inputs, their outputs toggle high. The high output of the op-amps are or'ed together by U2-a, producing a logic-high output that is fed to U4-a.

With one leg of U4-a constantly high, the output of U4-a goes high with each positive transition of the oscillator (U3). The high output of U4-a can be used to toggle an LED on and off or be used to drive a power control circuit for use with heavier loads.

Sequential Logic Exercise. Bread-

The Digital Microprocessor Course is reprinted here with the permission of the Electronic Industries Association/Consumer Electronic Group (EIA/CEG). The complete parts kit is available from EIA/CEG. For further information, contact EIA/CEG Product Services Department, 1722 Eye Street, NW, Suite 200, Washington, DC 20006; or call 202-457-4986.

PARTS LIST FOR THE SEQUENTIAL-LOGIC EXERCISE

SEMICONDUCTORS

- U1—LM324 quad op-amp, integrated circuit
- U2—7432 quad 2-input OR-gate, integrated circuit
- U3—555 timer/oscillator, integrated circuit
- U4—7408 quad 2-input AND-gate, integrated circuit

RESISTORS

- (All resistors are 1/4-watt, 5% units, unless otherwise noted.)
- R1, R2, R6—47,000-ohm
 - R3—12,000-ohm
 - R4, R5—Light-dependent resistor (0.5-megohm dark, 100-ohms light)
 - R7—1000-ohm
 - R8—10,000-ohm

ADDITIONAL PARTS AND MATERIALS

- C1—10- μ F, 15-WVDC, electrolytic capacitor
- Breadboard, jumper wires, +5-volt power source, etc.

board the circuit shown in Fig. 1. If you left the circuit from last month's installment intact, preparing the circuit in Fig. 1 amounts to nothing more than adding two logic IC's and a few jumpers. Monitor the output of U4-a with either a voltmeter or logic probe.

Apply power to the circuit with full ambient light striking the LDR's (R4 and R5). Is there an output produced at pin 3 of U4-a? There should be none since under full light conditions the non-inverting inputs of U1-a and U1-b are low, so U2-a, and thus U4-a, are also low.

Now cover either LDR and note the change in the output. It should begin toggling high and low. If an oscilloscope is handy, observe the waveform out of the OR gate (U2-a at pin 3), the oscillator (U3 at pin 3), and the AND gate (U4-a at pin 3). Afterward, power down the circuit.

Sketch a circuit using NAND or NOR gates in place of the AND and OR gates. Which is best suited for this application? Remove the AND and OR gates from the circuit, and replace them with the gates you've chosen. Apply power to the circuit and repeat the above exercise. Did the circuit, with the modification, perform as before? Remove power from the circuit, but **do not** disassemble it.

How could the AND gate be eliminated from the circuit? Do some experimenting on your own, and see if you can solve that problem. ■

FRIENDLY VIDEOS

'The Pioneer In AT Clone Videos'

COMPUTER HOW-TO VIDEOS



"Video Tape Is A Great Teacher"



"HOW TO BUILD YOUR OWN IBM 286/386 AT CLONE COMPUTER" Easy to do in a couple of evenings of work with just a screwdriver. A real money-saver!
60 MINUTES VHS \$39.95



"SHAKE HANDS WITH YOUR PC/XT/AT COMPUTER". A complete new-user's hardware and software learning guide. Everything from powering up, to the directory structure. 60 MINUTES VHS \$29.95



"HOW TO UPGRADE YOUR PC OR XT COMPUTER TO AN AT FOR UNDER \$200". All in one evening with only a screwdriver. Complete step-by-step guide, anyone can do it!
30 MINUTES VHS \$24.95



"HP LASERJET SERIES II PRIMER". The most complete video available on laser printing, featuring the LaserJet II printer, desktop publishing, fonts, hardware and software accessories. 60 MINUTES VHS \$49.95

FREE OFFER!

SAVE \$40 NOW by ordering the complete set of all four titles at the ridiculously LOW PRICE of \$100, and receive, absolutely FREE, "After Hours" - a software program to turn your PC into an unattended Message Center!



TOLL FREE: 1-800-PC-BUYER

Customer Service or CA, Call (714) 898-4055

Friendly Videos

PE06

PO Box 5684
Garden Grove, CA 92645 (714) 898-4055

Please rush me the following VHS format titles:
 "Clone Assy" @ \$39.95 "Shake" @ \$29.95
 "PC Upgrade" @ \$24.95 "LaserJet" @ \$49.95
 Complete Set including FREE software @ \$100
 (Add \$1 S&H per video, and sales tax if CA address)

Name _____
 Street Address _____
 City, State, Zip _____
 Telephone _____

WATCH FOR THIS ISSUE ON SALE MAY 1



OUR JUNE ISSUE FEATURES:

BUILD THE LAWN RANGER

The world's first practical robotic lawn mower!

A "UNIVERSAL" POWER SUPPLY

A single PC board can be configured to meet the demands of your next project

ALL ABOUT SURROUND SOUND

We cut through the confusion caused by the plethora of different surround-sound techniques available.

ADD A DISPLAY TO YOUR NEXT PROJECT

How to use LCD multi-character displays.

COMPUTER DIGEST

How fast is your computer?

**PLUS: Hardware Hacker
Audio Update
Hardware Reviews**

**Software Reviews
Video News
And lots more!**

AUTOMOTIVE ELECTRONICS

(Continued from page 37)

rates. A deer jumping in front of your car is obviously warmer than the surrounding environment, and the system can pick up very minor differences in temperature. The problem is that heavy rain tends to cool everything down to the point where the system can't function; even fog makes Night Vision unreliable as it now stands.

Adjustable-rate steering—the 1990's version of power steering—not only is practical, but is relatively easy and inexpensive to accomplish. At low speeds, such as while parking, short turns of the steering wheel would result in large turns of the car's wheels; at interstate speeds, steering-wheel handling would be normal.

In Japan, electronics manufacturers and car makers have flirted with the idea of closed-circuit TV cameras mounted in the front and rear bumpers to provide the best possible view when parking. Commercial vehicles such as buses and trucks now come with black & white TV monitors and cameras almost as standard equipment. American auto safety engineers have been resisting the idea on the grounds that color is virtually essential to differentiate objects; that the cost of color cameras and monitors could easily add \$1000 or more to the price of a car; and that each camera would require its own monitor, making for a very cluttered (and inherently confusing and unsafe) instrument panel. Besides, 18 states now have laws prohibiting the positioning of a TV screen inside a passenger car so that the driver can see it.

That hasn't stopped Philips, the European electronics giant, from showing a detachable 4-inch LCD color TV receiver that mounts on a gooseneck in the front of a car. As it stands, it can receive off-air signals only and uses TV antennas built into the car's bumpers. Eventually, however, it'll serve as the display screen for CARIN—an automotive navigation system Philips hopes to have on the market in a few years. The TV receiver costs \$200 complete with gooseneck, dual antennas, and a diversity-reception unit (to reduce multipath distortion problems) that can accept four antenna inputs.

Put it all together and automotive electronics in the 1990's will be a far cry from the old Motorola Grand Dad had in his dashboard, or even the 8-track tape player Dad had in his. ■

ELECTRONICS MARKET PLACE

FOR SALE

DESCRAMBLERS. All brands. Special: Combo Jerrold 400 and SB3 \$165. Complete cable descrambler kit \$39.00. Complete satellite descrambler kit \$45.00. Free catalog. MJH INDUSTRY, Box 531, Bronx, NY 10461-0531.

LASER Listener II, other projects. Surveillance, descrambling, false identification, information. Plans, kits, other strange stuff. Informational package \$3.00 refundable. DIRIJO/BOND ELECTRONICS, Box 212, Lowell, NC 28098.

CABLE descrambler liquidation. Major makes and models available. Industry pricing! (Example: Hamlin Combo's, \$44 each... Minimum 10 orders). Call WEST COAST ELECTRONICS, 1 (800) 628-9656.

IBM software. Large selection of programs. \$3.00 per disk. For free catalog send SASE to: BYTEHEAD, Dept. E, Box 597, Dundee, IL 60118.

ALARM equipment wholesale prices call or write for free information. ALARM CLUB, 8186 Center, Suite G, LaMesa, CA 92042. (619) 589-2582.

BOOKS, plans, kits; catalog \$2.00 & SASE to NEW WAVE ELECTRONICS, Suite 1524, 164 N. Blackstone, Fresno, CA 93701. Dept. A.

CABLE TV DESCRAMBLERS!



BARGAIN HEADQUARTERS!

• JERROLD • TOCOM • HAMLIN
• SCIENTIFIC ATLANTA • ZENITH
Oak M35B ONLY \$60
6 month warranty! We ship C.O.D.!
Lowest retail/wholesale prices!
FREE CATALOG:
Global Cable Network
1032 Irving St. Suite 109
S.F., CA 94122

ORDER TODAY! 800-327-8544

CAPACITORS, resistors and more, buy any quantity direct from importer. Dealers inquiries welcome. Free details. WORLD TRADE, 2 Sproule Drive, Brampton, Ontario, Canada L6V 4B9.

FREE catalog. Interfaces for IBM compatibles. Digital I/O and Analog input. Control relays, motors, lights, measure temperature, voltage. JOHN BELL ENGINEERING, INC., 400 Oxford Way, Belmont, CA 94002. (415) 592-6411.

CABLE descramblers (Jerrold) from \$40.00. Tocom VIP test chip. Fully activates unit. \$50.00. Call (213) 867-0081.

MICROWAVE TV RECEIVERS 1.9 to 2.7 GHz



2 CH Compact Dish System - \$77.95
5 CH Dish System - \$93.95
12 CH Yagi (Rod) System - \$123.95
30 CH Dish System - \$163.90 Yagi - \$183.90
SUN MICROWAVE INT'L. INC. Send \$1** for
P.O. BOX 34522 catalog on these
PHOENIX, AZ 85067 and other fine
(602) 230-0840 video products.
QUANTITY DISCOUNTS LIFETIME WARRANTY

DIGITIZER for IBM compatible PCs 640 by 480 resolution from VCR video camera \$85.00. Demonstration disk \$3.00. CODEWARE, Box 3091, Nashua, NH 03061.

ABSOLUTELY lowest prices on computers, software and accessories — guaranteed. Write for free information: SEABIRD, 4M Militia Drive, Lexington, MA 02173.

CABLE descramblers. Major makes and models available. Industry pricing! Also a 15 day money back guarantee. For information, catalogs and orders call 1 (800) 777-3862 Ex. 3, BRITANNY ELECTRONICS CO.

FREE CATALOG

FAMOUS "FIRESTIK" BRAND CB ANTENNAS AND ACCESSORIES. QUALITY PRODUCTS FOR THE SERIOUS CB'er. SINCE 1962

**FIRESTIK ANTENNA COMPANY
2614 EAST ADAMS
PHOENIX, ARIZONA 85034**

3-1/2" HD 1.44MB disks \$2.29 each includes formatting! 3M, Sony, Maxell, others. With labels. Our choice of brand. **Guaranteed.** Add 10% shipping. Buy 20 or more and receive our electronics surplus and software lists on 5-1/4" or 3-1/2" disks (state which) **free!** Otherwise \$2.50. Super special, for a limited time, circle and send this ad with your order for 50 or more 1.44MB disks and get a box of 10 5-1/4" 360K disks **free!** Void after 7/31/90. **BEACH RADIO AND APPLIANCES**, 271 Shirley Street, Boston, MA 02152.

ROOM surveillance telephone. \$175.00. Monitor room or telephone conversations. Range unlimited. 1 (800) 633-8277. Catalog \$3.00. LISTEN ELECTRONICS, 603 Elgin, Muskogee, OK 74401.

CB RADIO OWNERS!

We specialize in a wide variety of technical information, parts and services for CB radios. 10-Meter and FM conversion kits, repair books, plans, high-performance accessories. Thousands of satisfied customers since 1976! Catalog \$2.

**CBC INTERNATIONAL
P.O. BOX 31500PE, PHOENIX, AZ 85046**

MECHANICAL electronic parts; gears, motors, sensors, fans and more. Catalog \$2.00, BOX 24361, Vancouver, B.C. V5T 4M5 Canada.

NEON tubes — brand new tubes, different colors, shapes, sizes. All made to the wrong size. Incredible bargains. Great for hobbyists, inventors. Free spec sheet — price list. SASE to SPECTRUM NEON, 18059 Torrence Ave., Lansing, IL 60438.

REMOTE CONTROL KEYCHAIN



Complete w/mini-transmitter and +5 vdc RF receiver
Fully assembled including plans to build your own auto alarm
Quantity discounts available

\$24.95 Check, Visa or M/C
Add \$3 shipping

VISITECT INC./Dept. P (415) 872-0128
PO BOX 5442, SO. SAN FRAN., CA 94080

PLANS & KITS

CATALOG: hobby/broadcasting/HAM/CB: Cable TV, transmitters, amplifiers, surveillance devices, computers, more! PANAXIS, Box 130-H6, Paradise, CA 95967.

MINIATURE FM transmitters! Tracking transmitters! Voice disguisers! Bug detectors! Phone devices! More! Available either as kits or assembled and tested! Catalog \$2.00 (refundable): XANDI ELECTRONICS, Box 25647, 32PP, Tempe, AZ 85285-5647.

DETECTION — Surveillance, debugging, plans, kits, assembled devices. Latest high-tech catalog \$5. **DETECTION SYSTEMS**, 2515 E. Thomas, #16-864J, Phoenix, AZ 85016.

CONNECT your IBM/Apple computer to the outside world. Set of manuals for 10 experiments \$16.00. Specify IBM or Apple. **TECH-LINK, INC.**, 520 Lorena SW, North Canton, OH 44720.

BUILD this five-digit panel meter and square wave generator including an ohms, capacitance and frequency meter. Detailed instructions \$2.50. **BAGNALL ELECTRONICS**, 179 May, Fairfield, CT 06430.

VIDEOCIPHER II manuals. **Volume 1** — hardware, **Volume 2** — software — either \$32.45. **Volume 3** — projects/software — \$42.45. **Volume 4** — repair/software — \$97.45. **Volume 5** — Documentation — \$42.45. **Volume 6** — Experimentation — \$42.45. **Clone Hacker's Bible** — \$32.95. **Cable Hacker's Bible** — \$32.45. CODs: (602) 782-2316. 0100-032 software available. Catalog \$3.00. **TELECODE**, Box 6426-PE, Yuma, AZ 85366-6426.

ANTIQUE RADIO CLASSIFIED

Free Sample!

Antique Radio's
Largest Circulation Monthly.
Articles, Ads & Classifieds.
6-Month Trial: \$11. 1-Yr: \$20 (\$30-1st Class).
A.R.C., P.O. Box 802-L3, Carlisle, MA 01741

70 WATT audio amplifier. Simple and easy to build. Plans \$6.00. T.J.L. ENTERPRISES, Suite 302PE, 1902 Ridge Road, West Seneca, NY 14224.

POWERFUL FM transmitter kits: telephone model, sensitive room model, or homing device. \$19.95 each + \$2.00 shipping. MKL, 2385 Brentwood, TN 37024-2385.

MIDI retrofit kits available for pipe organs, pedalboards, accordions and keyboards. Please write for free details to **TECHNICAL MAGIC**, Dept PE-1, Box 3939 Station C, Ottawa, Ontario, Canada K1Y 4M5. (613) 596-9114. Fax (613) 596-3304.

SURVEILLANCE project book twelve schematics, \$6.00 PP to ALORD, 1880 Mendocino, Ste. C-301, Santa Rosa, CA 95401.

HAM radio kits & assemblies for various QST & 73 construction articles. For catalog send legal size SASE (\$45 postage) to A & A ENGINEERING, 2521 W. LaPalma #K, Anaheim, CA 92801.

ELECTRON TUBES OVER 3000 TYPES IN STOCK!

Also capacitors, transformers
and parts for tube type equipment.
Send \$2.00 for 26 page catalog.

ANTIQUE ELECTRONIC SUPPLY

688 W. FIRST ST., TEMPE, AZ 85281

PHONE: 602/894-9503 FAX: 602/894-0124

T.E.N.S. — electronic pain killer. Electrical nerve simulator blocks out pain. Declared effective by the F.D.A. Construction plans \$14.95. Send M.O. to **KREM ENGINEERING**, #279-20465 Douglas Crescent, Langley B.C., Canada V3A 4B6

SURVEILLANCE transmitter kits are available to law enforcement agencies that operate on frequencies they prefer. Four models of each; telephone, room, combination telephone/room transmitters tune from 65 to 305 MHz. Send \$1.00 (overseas airmail \$2.00) for catalog. Included is **Popular Communications'** book review of "Now Hear This! Electronic Eavesdropping Equipment Design" by Winston Arrington. Book contains 58 transmitter schematics. **SHEFFIELD ELECTRONICS**, 7223 Stony Island Ave., Chicago, IL 60649-2806.

CABLE TV "BOXES"

Converters — Descramblers
Remote Controls — Accessories

- Guaranteed Best Prices •
- 1 Year Warranty — C.O.D.s •
- Immediate Shipping •
- FREE CATALOG •

Call or Write

TRANS-WORLD CABLE CO.

12062 Southwest 117th Court, Suite 126

Miami, Florida 33186

1-800-442-9333



SATELLITE TV

FREE catalog — Do-it-yourself save 40—60%
Lowest prices world wide, systems, upgrades,
parts, all major brands factory fresh and warrantied.
SKYVISION INC., 2008 Collegeway, Fergus Falls,
MN 56537. 1 (800) 334-6455.

CABLE TV CONVERTERS

CABLE TV converters and descramblers dis-
count center. Zenith, Tocom, Hamlin, Oak, Sci-
entific Atlanta, Jerrold. Quantity discount, order
yours today! 1 (800) 962-6836.

FREE CATALOG! 1-800-648-7938

For all information 1-702-362-9026

JERROLD HAMLIN OAK ETC.

CABLE TV DESCRAMBLERS

- Compare our low Low Retail Prices!
- Guaranteed Prices & Warranties!
- Orders Shipped Immediately!

REPUBLIC CABLE PRODUCTS INC.

4080 Paradise Rd. #15 Dept. PE-90

Las Vegas, NV 89109



CABLE TV CONVERTERS WHY PAY A HIGH MONTHLY FEE?

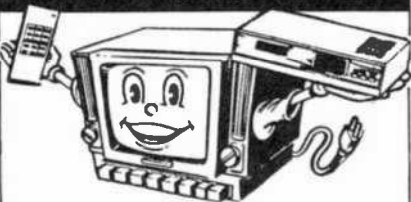

All Jerrold, Oak, Hamlin, Zenith, Scientific
Atlanta, Magnavox and all specialized cable
equipment available for shipment within 24
hours. For fast service MC / VISA or C.O.D.
telephone orders accepted (800) 648-3030
60 Day Guarantee (Quantity Discounts)
8 A.M. to 5 P.M. C.S.T. CLOSED WEEK-
ENDS. Send self-addressed Stamped enve-
lope (60¢ postage) for Catalog.

**MIDWEST
ELECTRONICS INC.**

P.O. Box 5000
Suite 311 (PE)
Carpentersville, IL 60110

No Illinois Orders Accepted.

WANTED

INVENTORS! Call IMPAC — we submit ideas to
manufacturers! For free information package call in
US/Canada 1 (800) 225-5800.

WANTED: Uniden CR2021, Realistic DX400, Mag-
navox D2924. SHORTWAVE, 9747 S. Oswego,
Tulsa, OK 74137. (918) 298-1657.

LM379S dual audio amp 1-1000 call Rick. 1 (800)
873-3729. RESOURCE SYSTEMS, 2475-F Mead-
owbrook Parkway, Duluth, GA 30136.

CABLE TV CONVERTERS IN STOCK

Stocking all types of converters —
Panasonic, Jerrold, Tocom, Pioneer,
Scientific Atlanta, Zenith, Oak, Hamlin,
Eagle, and others brands available.

Call or write for FREE CATALOG

10 am - 5:30 pm Eastern, Mon. - Fri.

VIDEO-LINK Enterprises, Inc.

520 GLENBROOK RD., STE. 202

STAMFORD, CT 06906

Orders 1-800-622-9022

Catalog & info: 203-975-7543

T.V. FILTERS

T.V. notch filters, surveillance equipment, brochure
\$1.00. D.K. Video, Box 63/6025, Margate, FL
33063. (305) 752-9202.

CABLE EQUIPMENT

CABLE TV secrets — the outlaw publication the
cable companies tried to ban. HBO, Movie Channel,
Showtime, descramblers, converters, etc. Sup-
pliers list included. \$8.95. CABLE FACTS, Box 711-
H, Pataskala, OH 43062.

ELECTRONIC DESIGN

HOW to design and build your own comput-
erized product! New manual makes it easy! Simple
step-by-step details from idea to finished product.
Includes introduction to design, choosing the proper
CPU, comparison between many CPUs and micro-
controllers, circuit layout, sample schematics, pro-
gramming, debugging, hints, tips, and more! \$8.00
complete, satisfaction guaranteed, details free,
TRAVCO, 107 E Vallette, Suite 1301F, Elmhurst, IL
60126.

NEW HE NE LASER TUBES \$35

Dealer Inquiries Invited.
Free Catalog!

MEREDITH INSTRUMENTS: 6403 N. 59th Ave.
Glendale, AZ 85301 • (602) 934-9387

"The Source for Laser Surplus"

EDUCATION/INSTRUCTION

MAGIC! Four illustrated lessons plus inside infor-
mation shows you how. We provide almost 50 tricks
including equipment for four professional effects.
You get a binder to keep the materials in, and a one-
year membership in the International Performing
Magicians with a plastic membership card that has
your name gold-embossed. You get a one-year sub-
scription to our quarterly newsletter, "IT'S MAGIC!"
Order now! \$29.95 for each course + \$3.50 postage
and handling. (New York residents add applicable
state and local sales tax). The Magic Course, 500-
B BiCounty Blvd., Farmingdale, NY 11735.

F.C.C. Commercial General Radiotelephone Li-
cense. Electronics home study. Fast, inexpensive!
"Free" details. COMMAND, D-178, Box 2824, San
Francisco, CA 94126.

LEARN IBM PC assembly language. 80 programs.
Disk \$5. Book \$18. ZIPFAST, Box 12238, Lexington,
KY 40581-2238.

SHORTWAVE — ham scanner radio books. Cata-
log \$1.00. TIARE PUBLICATIONS, PO Box 493PE,
Lake Geneva, WI 53147.

VCR repair Save money — make big profits! Learn
how from *How to Keep Your VCR Alive*. "This de-
tailed, step-by-step manual enables anyone with no
previous knowledge or experience to fix most VCR
problems easily, quickly, and inexpensively with a
few simple tools." — *Small Press Review*. Highly
recommended by *Modern Electronics*, *Popular
Electronics*, *Popular Communications* and many
other electronics and video magazines. "Far better
than Viejo at 1/7 the cost." 400+ page book, with
704 illustrations, plus professional head-cleaning
tool, \$24.95. WORTHINGTON PUBLISHING,
6907-202H Halifax River Drive, Tampa, FL 33617.
Call (813) 988-5751 for C.O.D., Visa, or MC. Money-
back satisfaction guarantee!

COMPUTER hobbyist! Learn to repair IBM PCs.
Video and audio tapes available. Prices starting at
\$9.95. Call 1 (800) 462-1183.

Motion Control System **\$159.00**

Includes Computer, Monitor, Keyboard,
Power supply, 4 Motors, and Software.

Call or Send for Free Robotics Catalog

Silicon Valley Surplus 4222 E. 12th St. Serving you since 1983
415 261-4506 Oakland, CA 94601 8 am to 4 pm PST

BUSINESS OPPORTUNITIES

YOUR own radio station! AM, FM, TV, cable. Li-
censed/unlicensed. BROADCASTING, Box 130-
H6, Paradise, CA 95967.

LET the government finance your small business.
Grants/loans to \$500,000. Free recorded message:
(707) 448-0270. (KJ8).

EASY work! Excellent Pay! Assemble products at
home. Call for info. (504) 641-8003 Ext. 5730.

MAKE \$50/hr working evenings or weekends in
your own electronics business. Send for free facts.
MJPI INDUSTRY, Box 531, Bronx, NY 10461.

EARN \$1000's extra as a part-time computer
dealer. Where to buy products at big discounts. Who
to sell to. Financing without cash. Obtaining free
software. Exclusive dealer trade shows. Step-by-
step check list. Industry inside knowledge. Written
by industry pioneer. Order now, only \$19.95 plus
\$4.00 shipping/handling, CA residents add \$1.45
sales tax. CORNERSTONE PUBLICATIONS, Dept
AB, PO Box 5151, San Jose, CA 95150. Allow 2-4
weeks.

DEALER inquiries invited 125watt RMS surface
mount tweeter. Call QUINN AUDIO PRODUCTS,
(407) 585-3534. (407) 964-4161.

MAKE \$2,000/week — reclaiming pure gold from
scrap computers. Free report! (worth \$25.00) 1
(900) 246-2323 (\$2.00 min.).

SECURITY EQUIPMENT

WIRELESS security systems and equipment.
Low cost complete systems, telephone dialers, in-
frared detectors, wireless medical and panic but-
tons etc. Visa/Mastercard. Free literature. HACHEN
SECURITY, 1904 Plymouth, Independence, MO
64058. 1 (800) 869-0483.

FREE MAGAZINES

FREE subscriptions to over 200 major computer
and business magazines — guaranteed. Write for
free information: SEABIRD, 4L Militia Drive, Lex-
ington, MA 02173.

BEST BY MAIL

Rates: Write National, Box 5, Sarasota, FL 34230

OF INTEREST TO ALL

ADVERTISE YOUR IDEAL Inventor's Newsletter. Box 477, Mangum, OK 73554.

STUN GUN! Immobilize any attacker! 65,000 volt! \$49.95 plus \$2.00 shipping. Satisfaction guaranteed. Spectrum, Box 727-AI, Graylake, IL 60030.

MONEYMAKING OPPORTUNITIES

EARN \$50,000 +. OBTAIN 100 bankcards. Send stamp. Universal, 3010 Wilshire, #414, Los Angeles, CA 90010.



Ad Council

United Way

It brings out the best in all of us.

© 1987 UNITED WAY

ADVERTISING SALES OFFICE

Gernsback Publications, Inc.
500-B Bi-County Blvd.
Farmingdale, NY 11735
1-(516) 293-3000

President: Larry Steckler
Vice President: Cathy Steckler

For Advertising ONLY
516-293-3000
Fax 1-516-293-3115

Larry Steckler
publisher

Arline Fishman
advertising director

Denise Haven
advertising assistant

Christina Estrada
advertising associate

Lisa Strassman
credit manager

credit manager

SALES OFFICES

EAST/SOUTHEAST

Becky Akers
Pattis/3M
310 Madison Ave., Suite 1804
New York, NY 10017
1-212-953-2121
Fax 1-212-953-2128

MIDWEST/Texas/Arkansas/ Okla.

Ralph Bergen
540 Frontage Road—Suite 339
Northfield, IL 60093
1-312-446-1444
Fax 1-312-446-8451

PACIFIC COAST/Mountain States

Marvin Green
5430 Van Nuys Blvd., Suite 316
Van Nuys, CA 91401
1-818-986-2001
Fax 1-818-986-2009

ADVERTISING INDEX

POPULAR ELECTRONICS magazine does not assume any responsibility for errors that may appear in the index below.

Free Information No.		Page
13	AMC Sales	87
12	All Electronics	25
—	Amazing Concepts	26
—	American Home Sat. Assoc. ...	30
17	American Radio Relay League .	27
—	Antique Electronic Supply	103
—	Antique Radio Classified	103
7	Banner Technical Books	87
9	C&S Sales	13
—	CB City	103
—	Command Productions	99
10	Communications Electronics .	CV4
20	Cook's Institute	97
—	Crossword Puzzles of the Month Club	93
—	Damark International	17
5	Digi-Key	CV2
—	Electronic Tech. Today	98, 24
—	Electronics Tech. Today .	105, CV3
18	Electronics Book Club	91
—	Firestik II	103
—	Friendly Videos	99
—	Global Cable Network	103
—	Grantham College	23
19	Heathkit	7
—	McGraw Hill Book Club	8
—	Meredith Instruments	104
—	Midwest Electronics	104
—	Monitoring Times	85
11	Mouser	26
—	NESDA	88
—	NRI Schools	21
16	Protol Technology	14
—	Pacific Cable	5
6	Parts Express	15
—	P.E. Reprint Bkst.	95
8	Radio Shack	3
—	Republic Cable	104
15	Sequoia Publishing	83
—	Silicon Valley Surplus	104
—	Sun Microwave	103
—	Trans World	104
—	Video-Link	104
14	Viejo Publications	93
—	Visitect	103

ELECTRONICS PAPERBACKS



□ **BP117—PRACTICAL ELECTRONIC BUILDING BLOCKS, BK-1** \$5.75. Circuits for a number of useful building blocks are presented. Combine these circuits to build the devices you need.

□ **BP192—MORE ADVANCED POWER SUPPLY PROJECTS** \$5.95. Topics covered include switched-mode power supplies, precision regulators, dual tracking regulators and computer-controlled supplies.

More Advanced Power Supply Projects



□ **BP190—MORE ADVANCED ELECTRONIC SECURITY PROJECTS** \$5.95. Projects include a passive infra-red detector, a fibre-optic loop alarm, computer-based alarms and an ultrasonic intruder detector.

□ **BP113—30 SOLDERLESS BREADBOARD PROJECTS, BK-2** \$5.95. All projects are based on CMOS logic IC's. Many components are common to several projects. Each project includes a brief circuit description, component layout and parts list.



Electronic Music Projects



□ **BP74—ELECTRONIC MUSIC PROJECTS** \$5.95. Provides a number of circuits for Fuzz Box, Waa-Waa Pedal, Sustain Unit, Reverberation and Phaser Units, Tremolo Generator and more.

□ **BP255—INTERNATIONAL RADIO STATIONS GUIDE** \$7.95. Provides the casual listener, amateur radio DXer and the professional radio monitor with an essential reference work designed to guide him or her around than ever more complex radio bands.



MAIL TO: Electronic Technology Today, Inc.
P.O. Box 240
Massapequa Park, NY 11762-0240

SHIPPING CHARGES IN USA AND CANADA

\$0.01 to \$5.00	\$1.25	\$30.01 to \$40.00	\$5.00
\$5.01 to 10.00	\$2.00	\$40.01 to \$50.00	\$6.00
\$10.01 to \$20.00	\$3.00	\$50.01 and above	\$7.50
\$20.01 to \$30.00	\$4.00		

SORRY, No orders accepted outside of USA and Canada

Total price of merchandise	\$	_____
Shipping (see chart)	\$	_____
Subtotal	\$	_____
Sales Tax (NYS only)	\$	_____
Total Enclosed	\$	_____

Name _____
Address _____
City _____ State _____ Zip _____

EXTERNAL DRIVE

(Continued from page 70)

and line cord, if they're still available. It was originally used in an old Texas Instruments computer, and it works fine with half-height drives, but I had to add my own disk-drive power connector.

The safest approach is to get a disk-drive cabinet with a built-in power supply. The author's half-height cabinet included a 30-watt power supply and the proper power connector all assembled and ready for the drive. It is called a JMR 15V5, and is available from Hacker Electronics (21016 Devonshire St., Chatsworth, CA 91311. Tel. 818-882-7980) for \$65. Hacker also sells half-height drives (360K 5-1/4-inch or 720K 3-1/2-inch) for \$75, and offers the Toshiba laptop external drive cable for \$10 with either the case or a drive. Call for details and shipping.

Using the External Drive. Whatever external drive you've selected it must have its drive selector (usually a switch or jumper block) set properly. If the selections are 0, 1, 2, and 3, then use 1. If the selections are 1, 2, 3, and 4, use 2. If the selections are A and B, use B.

Okay, now plug your external drive into your laptop. The first thing to remember is that you must turn on the power to your external drive before you boot up your laptop, or the laptop will refuse to recognize that it's there. Apparently, DOS has the BIOS run a check for external drives. Now you're ready to format the drive.

The Toshiba T1000 has MS-DOS 2.10 "built into it." Normally, that would handle only 360K drives. However, the DOS has been patched by Toshiba to read and format the 720K double-sided 80-track 9-sector 512-byte format. It will also read and format 160K, 180K, 360K

and 720K disks in either 5-1/4-inch or 3-1/2-inch drives, if you know some tricks, and if the drive has the capacity. A 360K drive will not read or write 720K.

You should be able to read and write to the external drive as drive B. The Toshiba T1000 has a switch on the side that lets you use the external drive as A or B (although the drive itself is set as drive B.)

If you simply type `FORMAT B:`, the drive will format to its capacity. DOS determines this from a signal returned from the drive. Normally, this is 360K for a 5-1/4-inch drive, and 720K for a 3-1/2-inch drive. If, however, you have a 720K external drive (either 5-1/4-inch or 3-1/2-inch), it will format at 720K unless you instruct it otherwise.

How do you instruct the drive to format at something other than its default? To format 180K (single sided, 40 tracks, 9 sectors per track) enter:

`FORMAT B:/1`

To format 160K (single-sided, 40 tracks, 8 sectors/track) type:

`FORMAT B:/1/8`

To format 360K on a 720K drive (double-sided, 40 tracks, 9 sectors/track) use:

`FORMAT B:/4`

How About That? The really interesting thing here is that, although Toshiba and other laptop makers only seem to talk about a 360K 5-1/4-inch external drive, you can throw on a 3-1/2-inch or 720K 5-1/4-inch and it will work like a charm!

Bear in mind that some incompatibilities can creep into any hardware setup. Track alignment gets critical with 80-track drives, and a disk produced on one drive may have trouble working properly on another drive.

If possible, test some disks produced by your new external drive by trying them in another computer. If all is well, you've now got the convenience of two floppy-disk drives. ■

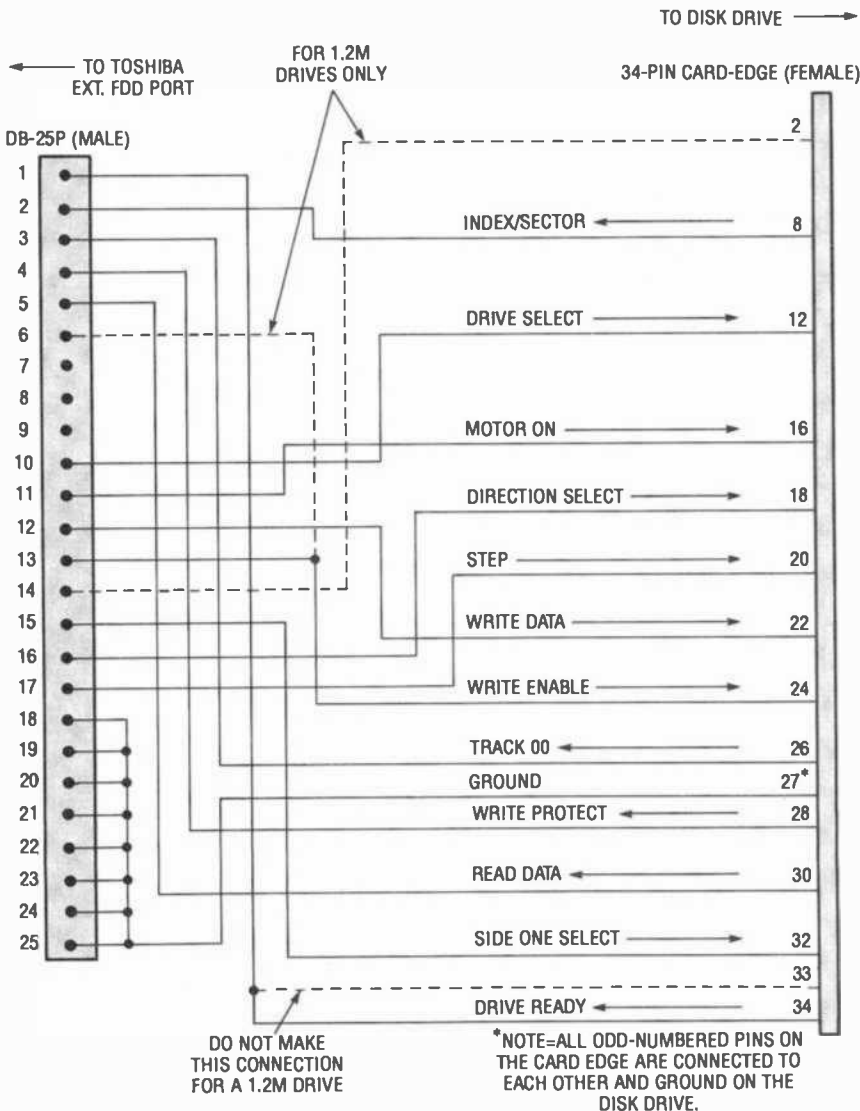
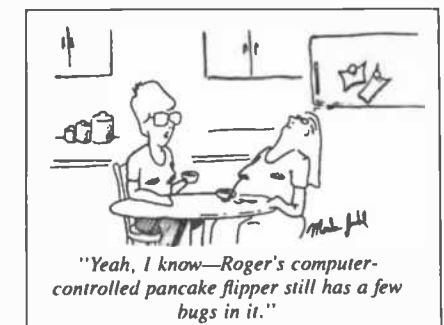

Fig. 2. You'll need to reference this diagram to make your own cable. Note that dashed lines are used to show the modifications necessary to accommodate a 1.2M drive.

Electronics Paperback Books

GREAT PAPERBACKS AT SPECIAL PRICES

BP248—TEST EQUIPMENT CONSTRUCTION \$5.95. Details construction of simple, inexpensive, but extremely useful test equipment. AF Gen, Test Bench Ampl, Audio Millivoltmeter, Transistor Tester and six more.



BP267—HOW TO USE OSCILLOSCOPES AND OTHER TEST EQUIPMENT \$6.95. Mastering the oscilloscope is not really too difficult. This book explains all the standard controls and functions. Other equipment is also described.

BP265—MORE ADVANCED USES OF THE MULTIMETER \$5.95. Use these techniques to test and analyze the performance of a variety of components. Also see how to build add-ons to extend multimeter capabilities.

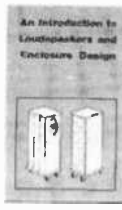

BP256—INTRO TO LOUDSPEAKERS AND ENCLOSURE DESIGN \$5.95. We explore the variety of enclosure and speaker designs in use today so the reader can understand the principles involved.

BP263—A CONCISE INTRO TO dBASE \$6.95. The dBASE series of programs are probably the best known database programs for microcomputers. This book is designed to help you get started working with them.

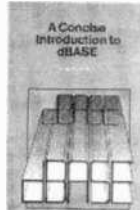

BP260—CONCISE INTRO TO OS/2 \$5.95. If you are a multitasking PC user and want to get the most out of your computer, then you must learn its OS/2 operating system. This book shows you just how to do that, quickly and easily.



BP249—MORE ADVANCED TEST EQUIPMENT CONSTRUCTION \$6.95. Eleven more test equipment construction projects. They include a digital voltmeter, capacitance meter, current tracer and more.



Digital Audio Projects



BP245—DIGITAL AUDIO PROJECTS \$5.95. Practical circuits to build and experiment with. Includes A/D converter, input amplifier, digital delay line, compander, echo effect and more.

BP247—MORE ADVANCED MIDI PROJECTS \$5.95. Circuits included are a MIDI indicator, THRU box, merge unit, code generator, pedal, programmer, channelizer, and analyzer.



BP257—INTRO TO AMATEUR RADIO \$5.95. Amateur is a unique and fascinating hobby. This book gives the newcomer a comprehensive and easy to understand guide to the subject.



PCP102—INTRODUCING DIGITAL AUDIO \$9.95. Covers all kinds of digital recording methods—CD, DAT and Sampling. Bridges the gap between the technician and the enthusiast. Principles and methods are explained.



PCP107—DIGITAL LOGIC GATES AND FLIP-FLOPS \$10.00. Thorough treatment of gates and flip-flops for enthusiasts, student and technicians. Only a basic knowledge of electronics is needed.

BP251—COMPUTER HOBBYISTS HANDBOOK \$8.95. A wrapup of everything the computer hobbyist needs to know in one easy to use volume. Provides a range of useful reference material in a single source.



PCP108—COMPUTERS AND MUSIC \$9.95. Explains the basics of computers and music with no previous knowledge of computers needed. Covers types of music software and explains how to set up your own computer music studio.

- BP195—INTRODUCTION TO SATELLITE TV**..... \$9.95. A definitive introduction to the subject written for the professional engineer, electronics enthusiast, or others who want to know more before they buy. 8 x 10 in.
- BP190—ADVANCED ELECTRONIC SECURITY PROJECTS**.....\$5.95. Includes a passive infra-red detector, a fiber-optic loop alarm, computer-based alarms and an unusual form of ultrasonic intruder detector.
- BP235—POWER SELECTOR GUIDE**.....\$10.00. Complete guide to semiconductor power devices. More than 1000 power handling devices are included. They are tabulated in alpha-numeric sequence, by technical specs. Includes power diodes, Thyristors, Triacs, Power Transistors and FET's.
- BP234—TRANSISTOR SELECTOR GUIDE**.....\$10.00. Companion volume to BP235. Book covers more than 1400 JEDEC, JIS, and brand-specific devices. Also contains listing by case type, and electronic parameters. Includes Darlingtons transistors, high-voltage devices, high-current devices, high power devices.
- BP99—MINI-MATRIX BOARD PROJECTS**.....\$5.50. Here are 20 useful circuits that can be built on a mini-matrix board that is just 24 holes by ten copper-foil strips.
- BP82—ELECTRONIC PROJECTS USING SOLAR CELLS**.....\$5.50. Circuits with applications around the home that are powered by the energy of the sun. Everything from radio receivers, to a bicycle speedometer, to timers, audio projects and more.
- BP117—PRACTICAL ELECTRONIC BUILDING BLOCKS—Book 1**.....\$5.75. Oscillators, Timers, Noise Generators, Rectifiers, Comparators, Triggers and more.
- BP184—INTRO TO 68000 ASSEMBLY LANGUAGE**.....\$6.95. The 68000 is a great new breed of microprocessor. Programming in assembly language increases the running speed of your programs. Here's what you need to know.

BP179—ELECTRONIC CIRCUITS FOR THE COMPUTER CONTROL OF ROBOTS \$7.50. Data and circuits for interfacing the computer to the robot's motors and sensors

- BP239—GETTING THE MOST FROM YOUR MULTIMETER**..... \$5.95. Covers basics of analog and digital meters. Methods of component testing includes transistors, thyristors, resistors, capacitors and other active and passive devices.
- BP97—IC PROJECTS FOR BEGINNERS**.....\$5.50. Power supplies, radio and audio circuits, oscillators, timers, switches, and more. If you can use a soldering iron you can build these devices.
- BP37—50 PROJECTS USING RELAYS, SCR'S & TRIACS**..... \$5.50. Build priority indicators, light modulators, warning devices, light dimmers and more.
- RADIO—100 RADIO HOOKUPS**.....\$3.00. Reprint of 1924 booklet presents radio circuits of the era including regenerative, neutrodyne, reflex & more.
- BP42—SIMPLE LED CIRCUITS**.....\$5.50. A large selection of simple applications for this simple electronic component.
- BP127—HOW TO DESIGN ELECTRONIC PROJECTS**.....\$5.75. Helps the reader to put projects together from standard circuit blocks with a minimum of trial and error.
- BP122—AUDIO AMPLIFIER CONSTRUCTION**.....\$5.75. Construction details for preamps and power amplifiers up through a 100-watt DC-coupled FED amplifier.
- BP92—CRYSTAL SET CONSTRUCTION**.....\$5.50. Everything you need to know about building crystal radio receivers.
- BP45—PROJECTS IN OPTOELECTRONICS**..... \$5.50. Includes infra-red detectors, transmitters, modulated light transmission and photographic applications.

BP185—ELECTRONIC SYNTHESIZER CONSTRUCTION \$5.95. Use this book to learn how to build a reasonably low cost, yet worthwhile monophonic synthesizer and learn a lot about electronic music synthesis in the process

CHECK OFF THE BOOKS YOU WANT

ELECTRONIC TECHNOLOGY TODAY INC.
P.O. Box 240, Massapequa Park, NY 11762-0240

SHIPPING CHARGES IN USA AND CANADA

SORRY No orders accepted outside of USA & Canada

Number of books ordered

Name _____
Address _____
City _____ State _____ Zip _____

\$0.01 to \$5.00	... \$1.25
\$5.01 to 10.00	... \$2.00
\$10.01 to \$20.00	... \$3.00
\$20.01 to \$30.00	... \$4.00
\$30.01 to \$40.00	... \$5.00
\$40.01 to \$50.00	... \$6.00
\$50.01 and above	... \$7.50

Total price of merchandise \$ _____
Sales Tax (New York State Residents only) \$ _____
Shipping (see chart) \$ _____

All payments must be in U.S. funds

Total Enclosed .. \$ _____

P-690

Uniden®

\$12,000,000 Scanner Sale

Uniden Corporation of America has purchased the consumer products line of Regency Electronics Inc. for \$12,000,000. To celebrate this purchase, we're having our largest scanner sale in history! Use the coupon in this ad for big savings. Hurry...offer ends June 30, 1990.

★ ★ ★ MONEY SAVING COUPON ★ ★ ★

Get special savings on the scanners listed in this coupon. This coupon must be included with your prepaid order. Credit cards, personal checks and quantity discounts are excluded from this offer. Offer valid only on prepaid orders mailed directly to Communications Electronics Inc., P.O. Box 1045 - Dept. UN13, Ann Arbor, Michigan 48106-1045 U.S.A. Coupon expires June 30, 1990.

Coupon may not be used in conjunction with any other offer from CEI. Coupon may be photocopied. Add \$12.00 for shipping in the continental U.S.A.

- Regency TS2-T \$259.95
- Regency R1800-T \$239.95
- Regency R1099-T \$99.95
- Regency RH808B-T \$419.95
- Regency RH256B-T \$294.95
- Bearcat 200XLT-T2 \$229.95
- Bearcat 100XLT-T \$184.95
- Bearcat 800XLT-T2 \$229.95
- Uniden HR2510-T \$229.95
- Uniden HR2800-T \$274.95
- Uniden PRO500D-T2 \$29.95

COUPON

COUPON

★ ★ ★ VALUABLE COUPON ★ ★ ★

Bearcat® 760XLT-T

List price \$499.95/CE price \$244.95/SPECIAL 12-Band, 100 Channel • Crystalline • AC/DC Frequency range: 29-54, 118-174, 406-512, 806-956 MHz. Excludes 823.9875-849.0125 and 868.9875-894.0125 MHz. The Bearcat 760XLT has 100 programmable channels organized as five channel banks for easy use, and 12 bands of coverage including the 800 MHz band. The Bearcat 760XLT mounts neatly under the dash and connects directly to fuse block or battery. The unit also has an AC adaptor, flip down stand and telescopic antenna for desk top use. 6-5/16" W x 1 1/2" H x 7 7/8" D. Model BC 590XLT-T is a similar version without the 800 MHz band for only \$194.95. Order your scanner from CEI today.

NEW! Regency® Products

- R4030-T Regency 200 ch. handheld scanner \$254.95
- R4020-T Regency 100 ch. handheld scanner \$189.95
- R4010-T Regency 10 channel handheld scanner \$114.95
- R1800-T Regency 100 channel mobile scanner \$244.95
- P200-T Regency 40 channel CB Mobile \$38.95
- P210-T Regency 40 channel CB Mobile \$56.95
- P220-T Regency 40 channel CB Mobile \$79.95
- P300-T Regency 40 channel SSB CB Mobile \$137.95
- P400-T Regency 40 channel SSB CB Base \$174.95
- PR100-T Regency visor mount radar detector \$54.95
- PR110-T Regency "Passport" size radar detector \$114.95
- PR120-T Regency "micro" size radar detector \$144.95
- MP5100XL-T Regency 40 Ch. marine transceiver \$139.95
- MP5510XL-T Regency 60 Ch. marine transceiver \$159.95
- MP800XL-T Regency 60 Ch. marine transceiver \$209.95
- MP2000XL-T Regency handheld marine trans \$189.95

Regency® RH256B-T

List price \$799.95/CE price \$299.95/SPECIAL 16 Channel • 25 Watt Transceiver • Priority The Regency RH256B is a sixteen-channel VHF hand mobile transceiver designed to cover any frequency between 150 to 162 MHz. Since this radio is synthesized, no expensive crystals are needed to store up to 16 frequencies without battery backup. All radios come with CTCSS tone and scanning capabilities. A monitor and night/day switch is also standard. This transceiver even has a priority function. The RH256 makes an ideal radio for any police or fire department volunteer because of its low cost and high performance. A 60 Watt VHF 150-162 MHz. version called the RH608B-T is available for \$429.95. A UHF 15 watt, 16 channel version of this radio called the RU156B-T is also available and covers 450-482 MHz. but the cost is \$454.95.

★ ★ ★ Uniden CB Radios ★ ★ ★

The Uniden line of Citizens Band Radio transceivers is styled to compliment other mobile audio equipment. Uniden CB radios are so reliable that they have a two year limited warranty. From the feature packed PRO 810E to the 310E handheld, there is no better Citizens Band radio on the market today.

- PRO310E-T Uniden 40 Ch. Portable/Mobile CB \$83.95
- PRO330E-T Uniden 40 Ch. Remote mount CB \$104.95
- PRO500D-T Uniden 40 Channel CB Mobile \$38.95
- KARATE-T Uniden 40 channel rescue radio \$53.95
- GRANT-T Uniden 40 channel SSB CB mobile \$166.95
- MADISON-T Uniden 40 channel SSB CB base \$244.95
- PC122-T Uniden 40 channel SSB CB mobile \$119.95
- PRO510XL-T Uniden 30 channel CB Mobile \$38.95
- PRO520XL-T Uniden 40 channel CB Mobile \$56.95
- PRO530XL-T Uniden 40 channel CB Mobile \$79.95
- PRO540E-T Uniden 40 channel CB Mobile \$97.95
- PRO640E-T Uniden 40 channel SSB CB Mobile \$137.95
- PRO710E-T Uniden 40 channel CB Base \$119.95
- PRO810E-T Uniden 40 channel SSB CB Base \$174.95

★ ★ ★ Uniden Radar Detectors ★ ★ ★

Buy the finest Uniden radar detectors from CEI today. TALKER-T2 Uniden talking radar detector \$144.95

Bearcat® 200XLT-T

List price \$509.95/CE price \$239.95/SPECIAL 12-Band, 200 Channel • 800 MHz. Handheld Search • Limit • Hold • Priority • Lockout Frequency range: 29-54, 118-174, 406-512, 806-956 MHz. Excludes 823.9875-849.0125 and 868.9875-894.0125 MHz. The Bearcat 200XLT sets a new standard for handheld scanners in performance and dependability. This full featured unit has 200 programmable channels with 10 scanning banks and 12 band coverage. If you want a very similar model without the 800 MHz band and 100 channels, order the BC 100XLT-T for only \$189.95. Includes antenna, carrying case with belt loop, ni-cad battery pack, AC adaptor and earphone. Order your scanner now.

Bearcat® 800XLT-T

List price \$549.95/CE price \$239.95/SPECIAL 12-Band, 40 Channel • No-crystal scanner Priority control • Search/Scan • AC/DC Bands: 29-54, 118-174, 406-512, 806-912 MHz. Excludes 823.9875-849.0125 and 868.9875-894.0125 MHz. The Uniden 800XLT receives 40 channels in two banks. Scans 15 channels per second. Size 9 1/4" x 4 1/2" x 1 1/2". If you do not need the 800 MHz band, a similar model called the BC 210XLT-T is available for \$178.95.

Bearcat® 145XL-T

List price \$189.95/CE price \$94.95/SPECIAL 10-Band, 16 Channel • No-crystal scanner Priority control • Weather search • AC/DC Bands: 29-54, 136-174, 406-512 MHz. The Bearcat 145XL is a 16 channel, programmable scanner covering ten frequency bands. The unit features a built-in delay function that adds a three second delay on all channels to prevent missed transmissions. A mobile version called the BC580XL-T featuring priority, weather search, channel lockout and more is available for \$94.95. CEI's package price includes mobile mounting bracket and mobile power cord.

President® HR2510-T

List price \$499.95/CE price \$239.95/SPECIAL 10 Meter Mobile Transceiver • Digital VFO Full Band Coverage • All-Mode Operation Becklit liquid crystal display • Auto Squelch RIT • Preprogrammed 10 KHz. Channels Frequency Coverage: 28.0000 MHz to 29.6999 MHz. The President HR2510 Mobile 10 Meter Transceiver made by Uniden, has everything you need for amateur radio communications. Up to 25 Watt PEP USB/LSB and 25 Watt CW mode. Noise Blanker. PA mode. Digital VFO. Built-in S/R/F/Mod/SWR meter. Channel switch on the microphone, and much more! The HR2510 lets you operate AM, FM, USB, LSB or CW. The digitally synthesized frequency control gives you maximum stability and you may choose either pre-programmed 10 KHz. channel steps, or use the built-in VFO for steps down to 100 Hz. There's also RIT (Receiver Incremental Tuning) to give you perfectly tuned signals. With receive scanning, you can scan 50 channels in any one of four band segments to find out where the action is. Order your HR2510 from CEI today.

NEW! President® HR2600-T

List price \$599.95/CE price \$299.95/SPECIAL 10 Meter Mobile Transceiver • New Features The new President HR2600 Mobile 10 Meter Transceiver is similar to the Uniden HR2510 but now has repeater offsets (100 KHz.) and CTCSS encode.



BC760XLT
800 MHz.
mobile scanner
SPECIAL!

★ ★ ★ Uniden Cordless Telephones ★ ★ ★

- XE750-T Uniden Cordless Phone with speaker \$99.95
- XE550-T Uniden Cordless Phone \$78.95
- XE300-T Uniden Cordless Phone \$69.95

★ ★ ★ Extended Service Contract ★ ★ ★

If you purchase a scanner, CB, radar detector or cordless phone from any store in the U.S. or Canada within the last 30 days, you can get up to three years of extended service contract from Warrantech. This service extension plan begins after the manufacturer's warranty expires. Warrantech will perform all necessary labor and will not charge for return shipping. Extended service contracts are not refundable and apply only to the original purchaser. A two year extended contract on a mobile or base scanner is \$29.99 and three years is \$39.99. For handheld scanners, 2 years is \$59.99 and 3 years is \$79.99. For radar detectors, two years is \$29.99. For CB radios, 2 years is \$39.99. For cordless phones, 3 years is \$34.99. Order your extended service contract today.

OTHER RADIOS AND ACCESSORIES

- BC55XLT-T Bearcat 10 channel scanner \$114.95
 - BC70XLT-T Bearcat 20 channel scanner \$159.95
 - BC175XLT-T Bearcat 16 channel scanner \$156.95
 - R2066-T Regency 60 channel scanner \$149.95
 - R1099-T Regency 45 channel scanner \$109.95
 - TS2-T Regency 75 channel scanner \$269.95
 - UC102-T Regency VHF 2 ch. 1 Watt transceiver \$114.95
 - BP55-T Regency 16 amp reg. power supply \$179.95
 - BP205-T1 Ni-Cad batt. pack for BC200/BC100XLT \$39.95
 - B8-T 1.2 V AA Ni-Cad batteries (set of eight) \$17.95
 - FBE-T Frequency Directory for Eastern U.S.A. \$14.95
 - FBW-T Frequency Directory for Western U.S.A. \$14.95
 - RFD1-T Great Lakes Frequency Directory \$14.95
 - RFD2-T New England Frequency Directory \$14.95
 - RFD3-T Mid Atlantic Frequency Directory \$14.95
 - RFD4-T Southeast Frequency Directory \$14.95
 - RFD5-T N.W. & Northern Plains Frequency Dir. \$14.95
 - ASD-T Airplane Scanner Directory \$14.95
 - SRF-T Survival Radio Frequency Directory \$14.95
 - TSG-T "Top Secret" Registry of U.S. Govt. Freq. \$14.95
 - TTC-T Tune in on telephone calls \$14.95
 - CBH-T Big CB Handbook/AM/FM/Freeband \$14.95
 - TIC-T Techniques for Intercepting Communications \$14.95
 - RRF-T Railroad frequency directory \$14.95
 - EEC-T Embassy & Espionage Communications \$14.95
 - CIE-T Covert Intelligence, Elect. Eavesdropping \$14.95
 - MFF-T Midwest Federal Frequency directory \$14.95
 - A60-T Magnet mount mobile scanner antenna \$35.95
 - A70-T Base station scanner antenna \$35.95
 - A1300-T 25 MHz.-1.3 GHz Discone antenna \$109.95
 - USAMM-T Mag mount VHF ant. w/ 12' cable \$39.95
 - USAK-T 3/4" hole mount VHF ant. w/ 17' cable \$35.95
- Add \$4.00 shipping for all accessories ordered at the same time. Add \$12.00 shipping per radio and \$4.00 per antenna.

BUY WITH CONFIDENCE

To get the fastest delivery from CEI of any scanner, send or phone your order directly to our Scanner Distribution Center. Michigan residents please add 4% sales tax or supply your tax I.D. number. Written purchase orders are accepted from approved government agencies and most well rated firms at a 10% surcharge for net 10 billing. All sales are subject to availability, acceptance and verification. All sales on accessories are final. Prices, terms and specifications are subject to change without notice. All prices are in U.S. dollars. Out of stock items will be placed on backorder automatically unless CEI is instructed differently. A \$5.00 additional handling fee will be charged for all orders with a merchandise total under \$50.00. Shipments are F.O.B. CEI warehouse in Ann Arbor, Michigan. No COD's. Most items listed have a manufacturer's warranty. Free copies of warranties on these products are available by writing to CEI. Non-certified checks require bank clearance. Not responsible for typographical errors.

Mail orders to: Communications Electronics, Box 1045, Ann Arbor, Michigan 48106 U.S.A. Add \$12.00 per scanner for U.P.S. ground shipping and handling in the continental U.S.A. For Canada, Puerto Rico, Hawaii, Alaska, or APO/FPO delivery, shipping charges are two times continental U.S. rates. If you have a Discover, Visa, American Express or Master Card, you may call and place a credit card order. 5% surcharge for billing to American Express. Order toll-free in the U.S. Dial 800-USA-SCAN. In Canada, dial 800-221-3475. FAX anytime, dial 313-971-6000. If you are outside the U.S. or in Michigan dial 313-973-8888. Order today. Scanner Distribution Center and CEI logos are trademarks of Communications Electronics Inc. Sale dates 9/1/89 - 6/30/90 AD #090189-T Copyright © 1989 Communications Electronics Inc.

For credit card orders call
1-800-USA-SCAN

COMMUNICATIONS ELECTRONICS INC.

Consumer Products Division
P.O. Box 1045 □ Ann Arbor, Michigan 48106-1045 U.S.A.
For orders call 313-973-8888 or FAX 313-971-6000