

SPRING EDITION

\$1.25

1973

POPULAR
ELECTRONICS

ELECTRONIC EXPERIMENTER'S HANDBOOK

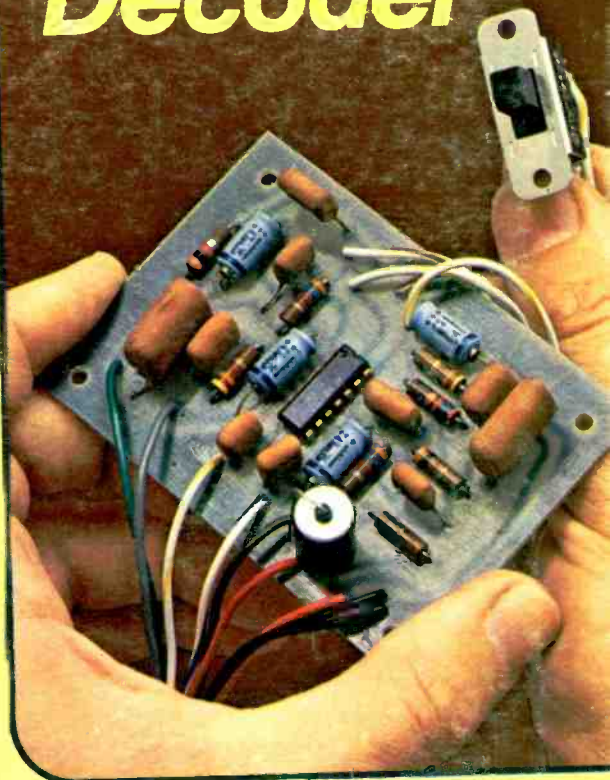
BUILD A...

Six-Digit Digi-Vista
SCR Combination Lock
30-Watt Power Amplifier
Shutter-Speed Meter
Vox Gain Rider
Principes Puzzle
Solid-State Bird
Fil-Oscillator
Laboratory Power Supply
Colossal Woofer
Underwater Fish Finder
Solid-State Laser
Metal Locator
Five-Forty Power Amp

PLUS...

Ten Hi-Fi Fallacies
Know Your Phono Cartridges
Chemicals for Electronics
SSB for Citizens Band
Color Codes Chart
Decibel Table
Reactance Chart

Build the CBS "SQ" 4-Channel Decoder



Don't let the handy size fool you.

The Serviset E/C is a complete, self contained versatile field test instrument. A precision-built, reliable, much-used instrument to compliment your VOM, scope or other equipment, too.

The Serviset E/C is great for servicing all sorts of electronics in the field and on the bench. Whether you're a professional engineer working on communications or EDP devices. An electronics or appliance technician working in radio, television, hi-fi audio or appliance repair. Or an amateur electronics enthusiast, ham radio operator or student.

Checks you'll make with the Serviset E/C include: sync, sweep, video, audio circuits; high or low DC, RF, or pulse voltage supplies; coils, capacitors, resistors, tubes, transistors, diodes, transformers, speakers--whatever you're trouble-shooting from stage to stage, or discrete components. What's more, your Serviset E/C is safe: whatever you check, you won't blow it.

The Serviset E/C. The \$35. Electronic Test Lab (almost) that will follow you anywhere. One of an advanced line of guaranteed electronic test devices from Lee that will save you time and effort. Including our CT-1 Condenser Tester and Leakage Indicator.

*send check or money order. C.O.D., send \$2. deposit.

Serviset E/C, \$34.95 postpaid *from Lee Electronic Labs.

Available also at electronic dealers and all Olson Stores, nationwide.

The \$35. Electronic Test Lab (almost) that will follow you anywhere: Serviset E/C



Lee Electronic Labs, Inc.

BOX 78, WATERTOWN, MASS. 02172 (617) 891-8686

CIRCLE NO. 11 ON READER SERVICE CARD

You get more for your money from NRI



SOLID STATE TRAINING—Learn-by-doing with NRI equipment. TV-Radio Servicing course includes 25" color TV, with handsome woodgrained cabinet at no extra cost; wide-band service type oscilloscope, color bar crosshatch generator, transistorized volt-Ohm meter, and solid-state radio kit. Other courses equally complete.

NRI Programmed Equipment Gives You Priceless Confidence, Makes Learning TV-Radio, Electronics Fast and Fascinating

NRI pioneered the idea of supplying home-study students with custom designed training kits to give practical on-the-job experience as you learn. Today, NRI's "3-Dimensional" training can't be equalled. You get more value— from the exclusive Achievement Kit sent the day you enroll, to "bite-size" texts and custom training equipment. Learning TV-Radio, Electronics or Communications at home is easy, exciting, the NRI simplified, dramatized way.

BE A SKILLED TECHNICIAN IN AMERICA'S FASTEST GROWING INDUSTRY

Regardless of your educational background, you can learn the Electronics field of your choice the practical NRI way. The NRI color catalog, sent to you free and without obligation, tells you how you can qualify quickly to be a part of the fast growing Electronic Age; about engineering jobs in business, industry, broadcasting, government, now offered to men without college degrees. It will open your eyes to the great number of success opportunities available right now in the high-pay world of TV-Radio Servicing, Broadcasting-Communications and Industrial-Military Electronics. With NRI technical training, you can take your choice of a wide variety of career

openings or have a business of your own. And if you choose one of five NRI courses that include FCC License preparation, you must earn your FCC License or NRI refunds your tuition!

MAKE \$5 TO \$7 AN HOUR EXTRA IN SPARE TIME STARTING SOON

Tens of thousands of NRI graduates are proof it is practical to train at home in your spare time. Keep your present job while preparing for a better one, and earn \$5 to \$7 an hour extra in spare time while you train, fixing sets for friends and neighbors. NRI shows you how. Equipment you build and keep becomes useful in your work.

STEP UP TO BETTER PAY, A BRIGHTER FUTURE

NRI can help you, but the decision to act must come from you. Decide now to move ahead . . . mail the postage-free card today for your FREE NRI color catalog. No obligation. No salesman will call. NATIONAL RADIO INSTITUTE, Electronics Division, Washington, D.C. 20016.

APPROVED UNDER GI BILL

If you served since January 31, 1955, or are in service, check GI line on postage-free card or in coupon.

CASH IN ON THE BOOM IN COLOR TELEVISION



The NRI TV-Radio Servicing course includes your choice of black and white or color TV training equipment. Color TV needs thousands of trained men to keep pace with millions of sets being sold every year. NRI prepares you quickly. Cash in on the boom.

Mail insert card for
your **FREE NRI**
color CATALOG

No salesman will call



1973 POPULAR ELECTRONICS ELECTRONIC EXPERIMENTER'S HANDBOOK

SPRING EDITION

DECIBEL TABLE		7
REACTANCE CHART		9
COLOR CODES CHARTS		11
THE PLASTIC TIGER AUDIO POWER AMPLIFIER	Daniel Meyer	13
<i>You can add two more channels of high-quality audio to your hi-fi system with this easy-to-build 30-watt amplifier. It's ideal for powering the rear channels of your quadraphonic setup too!</i>		
SCR COMBINATION LOCK	David E. Fahnstock	22
<i>Five pushbuttons provide 120 combinations with which to foil would-be burglars. You can add more combination capability by increasing the number of switches.</i>		
BUILD AN "SQ" FOUR-CHANNEL DECODER	Murray Esformes	25
<i>You can assemble this basic CBS/Columbia "SQ" unit which will allow you to decode quadraphonic records.</i>		
ASSEMBLE THE SIX-DIGIT DIGI-VISTA	Charles G. Kay & Daniel Meyer	31
<i>A digital clock that provides electronic readout to a tenth of a second can be assembled from readily available modules.</i>		
ASSEMBLING A CAMERA SHUTTER SPEED METER	William Coomes	35
NATIONAL WEATHER BROADCASTS		40
15 THINGS WE DO KNOW ABOUT PHONO CARTRIDGES		41
CHEMICALS FOR ELECTRONICS	Lon Cantor	47
BUILD A VOX GAIN RIDER	David W. Beaty	51
<i>Use your voice-controlled microphone to lower the volume of your sound system. It is battery powered for portability and can be used with any sound system and high-impedance mike.</i>		
TEN HI-FI FALLACIES	J. Gordon Holt	56

ELECTRONIC EXPERIMENTER'S HANDBOOK: Published semi-annually by Ziff-Davis Publishing Company at One Park Avenue, New York, New York 10016. William Ziff, President; Hershel B. Sarbin, Senior Vice President and Secretary; Philip Sine, Financial Vice President and Treasurer.

Copyright © 1973 by ZIFF-DAVIS PUBLISHING COMPANY. All rights reserved.

PRINCEPS PUZZLE.....	James W. Cuccia	60
<i>Even the most rabid puzzle fan may be stopped cold by this electronic "toughie" with its eight lights and eight pushbuttons!</i>		
THE SOLID-STATE BIRD.....	John S. Simonton, Jr.	70
<i>No cages to clean, no water cups to fill, yet this "electronic" bird will whistle and warble like a canary.</i>		
BUILD THE FIVE-FORTY POWER AMPLIFIER.....	Daniel Meyer	73
<i>Eighteen watts per channel from an integrated circuit coupled to a pair of output transistors for clean, low-distortion power at modest cost.</i>		
PROFESSIONAL INTRUDER/FIRE ALARM.....	George Meyerle	79
BUILD THE FIL-OSCILLATOR.....	Roger Melen & Harry Garland	88
<i>A sharp audio filter is combined with a versatile audio waveform generator in this handy laboratory-grade instrument.</i>		
LABORATORY IC POWER SUPPLY.....	Richard J. Valentine	93
<i>A low-cost regulated 0-20 volt, 0.2 ampere supply that incorporates a regulator integrated circuit.</i>		
SINGLE SIDEBAND FOR CB IS NOW!.....	Herbert Friedman	98
AN UNDERGROUND SURVEY METER AND METAL LOCATOR.....	Harold Pallatz	106
BUILD THE PSYCH-TONE.....	Don Lancaster	109
A SUBSTITUTE FOR METERS IN BRIDGE CIRCUITS.....	Ed Friedman	120
THE COLOSSAL WOOFER.....	David B. Weems	122
<i>Do you live in a well-built house miles from the nearest neighbor and enjoy good "bass-y" reproduction? If so, this project is for you. It will handle 100 watts easily, 200 watts peak in the range from 15-300 Hz.</i>		
ASSEMBLE THE POPULAR ELECTRONICS DIGI-VISTA.....	Charles G. Kay & Daniel Meyer	129
THE CASE FOR THE SINGLE WOOFER.....	David B. Weems	139
UNDERWATER FISH FINDER.....	W. L. Green	147
SOLID-STATE LASER FOR THE EXPERIMENTER.....	Forrest M. Mims	150
<i>Here's a Science Fair project "par excellence." A safe semiconductor diode makes it possible to build this secret communicator for about \$20 from standard and readily available components.</i>		

Cover Photo: Dirone-Denner
 For details on how to build an "SQ"
 4-channel decoder, refer to page 25.

EDGAR W. HOPPER, Publisher

WM. A. STOCKLIN, Editorial Director ● **P. B. HOEFER**, Managing Editor
EDWARD I. BUXBAUM, Art Director ● **ANDRE DUZANT**, Technical Illustrator
JOSEPH E. HALLORAN, Adv. Director ● **JOHN J. CORTON**, Adv. Sales
MADELEINE LITTMAN, Adv. Service Mgr. ● **STANLEY NEUFELD**, Assoc. Pub.
FURMAN H. HEBB, Group Vice President, Electronics & Photographic

FREE

LAFAYETTE 1973 CATALOG 730



The World's Largest Consumer Electronics Catalog

Everything In Electronics for Home, Business, Industry

• Stereo/Hi-Fi Components • Musical Instruments and Amplifiers • CB & Ham Equipment • Tools and Test Equipment • Police and Fire Monitor Receivers • Public Address Systems • Photography Equipment • Semiconductors, Books, Parts • Plus Much More!

Your Complete Electronics Buying Guide

**Send
Today!**

Lafayette Radio Electronics
P.O. Box 10, Dept. 09033
Syosset, L.I., N.Y. 11791

Send FREE 1973 Catalog **09033**

NAME _____

ADDRESS _____

CITY _____

STATE _____ ZIP _____

CIRCLE NO. 10 ON READER SERVICE CARD

1973 POPULAR ELECTRONICS EXPERIMENTER'S HANDBOOK

SPRING EDITION

Ziff-Davis Publishing Company
William Ziff
President

W. Bradford Briggs
Executive Vice President

Hershel B. Sarbin
Senior Vice President and Secretary

Philip Sine
Financial Vice President and Treasurer

Phillip T. Heffernan
Vice President, Marketing

Frank Pomerantz
Vice President, Creative Services

Arthur W. Butzow
Vice President, Production

Edward D. Muhfeld
Vice President, Aviation Division

Irwin Robinson
Vice President, Travel Division

George Morrissey
Vice President

Sydney H. Rogers
Vice President

Sidney Holtz
Vice President

Lawrence Sporn
Circulation Director

Jerry Schneider
Administrative Dir., Ziff-Davis Annuals

Ziff-Davis Publishing Company
Editorial, Circulation, and Executive Offices
One Park Avenue, New York, New York 10016
212 679-7200

Midwestern Office
The Pattis Group
4761 W. Touhy Ave., Lincolnwood, Ill. 60644
312 679-1100

Gerald E. Wolfe, Dick Powell,
Dick Govatski, Manley Ludwig
Western Office
9025 Wilshire Blvd., Beverly Hills, Calif. 90211
213 273-8050, BR 2-1161
Western Adv. Manager, Bud Dean

Japan
James Yagi, Oji Palace Aoyama
6-25, Minami Aoyama, 6-Chome, Minato-ku
Tokyo 407-1930/6821



1973 ELECTRONIC EXPERIMENTER'S HANDBOOK is published semi-annually by the Ziff-Davis Publishing Company, One Park Avenue, New York, N.Y. 10016. Also publishers of Stereo Review, Popular Electronics Including Electronics World, Communications Handbook, Tape Recording & Buying Guide and Stereo Directory & Buying Guide

DECIBEL TABLE

Voltage Ratio (Equal Impedance)	Power Ratio	db ← - + →	Voltage Ratio (Equal Impedance)	Power Ratio
1.000	1.000	0	1.000	1.000
0.989	0.977	0.1	1.012	1.023
0.977	0.955	0.2	1.023	1.047
0.966	0.933	0.3	1.035	1.072
0.955	0.912	0.4	1.047	1.096
0.944	0.891	0.5	1.059	1.122
0.933	0.871	0.6	1.072	1.148
0.923	0.851	0.7	1.084	1.175
0.912	0.832	0.8	1.096	1.202
0.902	0.813	0.9	1.109	1.230
0.891	0.794	1.0	1.122	1.259
0.841	0.708	1.5	1.189	1.413
0.794	0.631	2.0	1.259	1.585
0.750	0.562	2.5	1.334	1.778
0.708	0.501	3.0	1.413	1.995
0.668	0.447	3.5	1.496	2.239
0.631	0.398	4.0	1.585	2.512
0.596	0.355	4.5	1.679	2.818
0.562	0.316	5.0	1.778	3.162
0.531	0.282	5.5	1.884	3.548
0.501	0.251	6.0	1.995	3.981
0.473	0.224	6.5	2.113	4.467
0.447	0.200	7.0	2.239	5.012
0.422	0.178	7.5	2.371	5.623
0.398	0.159	8.0	2.512	6.310
0.376	0.141	8.5	2.661	7.079
0.355	0.126	9.0	2.818	7.943
0.335	0.112	9.5	2.985	8.913
0.316	0.100	10	3.162	10.00
0.282	0.0794	11	3.55	12.6
0.251	0.0631	12	3.98	15.9
0.224	0.0501	13	4.47	20.0
0.200	0.0398	14	5.01	25.1
0.178	0.0316	15	5.62	31.6
0.159	0.0251	16	6.31	39.8
0.141	0.0200	17	7.08	50.1
0.126	0.0159	18	7.94	63.1
0.112	0.0126	19	8.91	79.4
0.100	0.0100	20	10.00	100.0
3.16×10^{-2}	10^{-3}	30	3.16×10^3	10^3
10^{-2}	10^{-4}	40	10^2	10^4
3.16×10^{-3}	10^{-5}	50	3.16×10^2	10^5
10^{-3}	10^{-6}	60	10^3	10^6
3.16×10^{-4}	10^{-7}	70	3.16×10^3	10^7
10^{-4}	10^{-8}	80	10^4	10^8
3.16×10^{-5}	10^{-9}	90	3.16×10^4	10^9
10^{-5}	10^{-10}	100	10^5	10^{10}
3.16×10^{-6}	10^{-11}	110	3.16×10^5	10^{11}
10^{-6}	10^{-12}	120	10^6	10^{12}

KITS MITS MEANS CALCULATORS!

ACTUALLY MITS MEANS MICRO INSTRUMENTATION AND TELEMETRY SYSTEMS . . . WHICH IS THE HARD WAY OF SAYING WHAT WE DO.

THE WORLD'S MOST POWERFUL SCIENTIFIC DESK CALCULATOR KIT FOR UNDER \$350.00

- Dynamic Range: 10-99 to 10⁹⁹
- Data Storage: 2 Auxiliary Storage Registers plus up to 7 Push up Stack Registers
- Roll up and Roll down Keys for Complete Control of Operational Stack
- Correct X (Allows Operator to Correct One Digit, Without Re-entering the Entire Problem)
- Polar to Rectangular Conversion and Rectangular to Polar Conversion.

DISPLAY: 14 Large Digits Either Full Floating or Scientific Notation.

3 MODELS: PRICES INCLUDE CARRYING CASE

7400A	3 Registers	KIT	\$299.95
		Assembled	\$379.95
7400B	5 Registers	KIT	\$319.95
		Assembled	\$399.95
7400C	7 Registers	KIT	\$339.95
		Assembled	\$419.95

THE POCKET ACCOUNTANT!

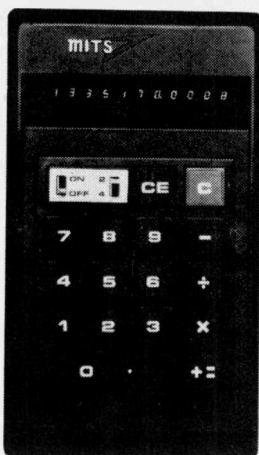
A POCKET CALCULATOR THAT YOU CAN ASSEMBLE FOR \$49.95

3 Models - All With 12-Digit Capacity

1200 SERIES

ADDS · SUBTRACTS
MULTIPLIES · DIVIDES

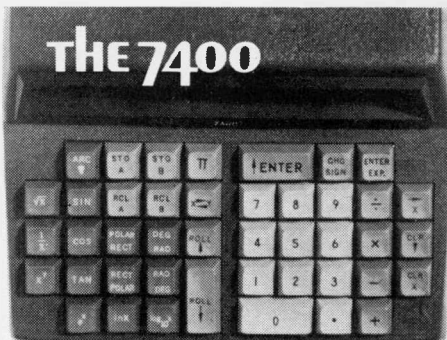
- Bright LED Display
- 100% American Made
- Leading Zero Suppression
- Automatic Display Cut-Off
- Fixed Decimal Output (2 or 4 places)
- Chain & Mixed Operation
- Clear & Clear Entry Keys



MITS® micro Instrumentation & Telemetry Systems, Inc.

5404 Coal Ave., S. E., Albuquerque, New Mexico 87108
505/265-7553

WRITE OR MAIL COUPON FOR ADDITIONAL INFORMATION:



SIZE: 8½" x 12" x 3½" WEIGHT: 4 LBS.

... AND DON'T FORGET the 1230 and 1240 desk calculators: kit form, \$89.95 and \$99.95; or preassembled \$119.95 and \$149.95. . . The 1440 - \$199.95, kit or \$249.95 preassembled, square root, 14 digit LED, MOS LSI circuitry + much, much more. Let us show you how much more . . . clip coupon or mail reader card. We make Digital Clocks (DC4-DC6), 6-Volt Power Supplies (PS 500), and I.C. Testers (ICT 1800), Kits or preassembled. Ask about them -

PRICES:

Model	We Assemble	You Assemble
1212 (12 digits)	\$99.95	\$89.95
1209 (9 digits)	\$79.95	\$69.95
1206 (6 digits)	\$59.95	\$49.95

SIZE: 5¼" x 3¼" x 1½"

AC ADAPTER: Equips any MITS 1200 Series Pocket Calculator for operation from 110 VAC . . . \$6.95

CARRYING CASE: (Leatherette) . . . \$5.95

Use Your BankAmericard or Master Charge

ENCLOSED IS CHECK KIT
FOR MODEL # _____ ASSEMBLED

AMOUNT OF CHECK \$ _____

Include \$5.00 for postage and handling.

Please send information on entire MITS line.

NAME _____

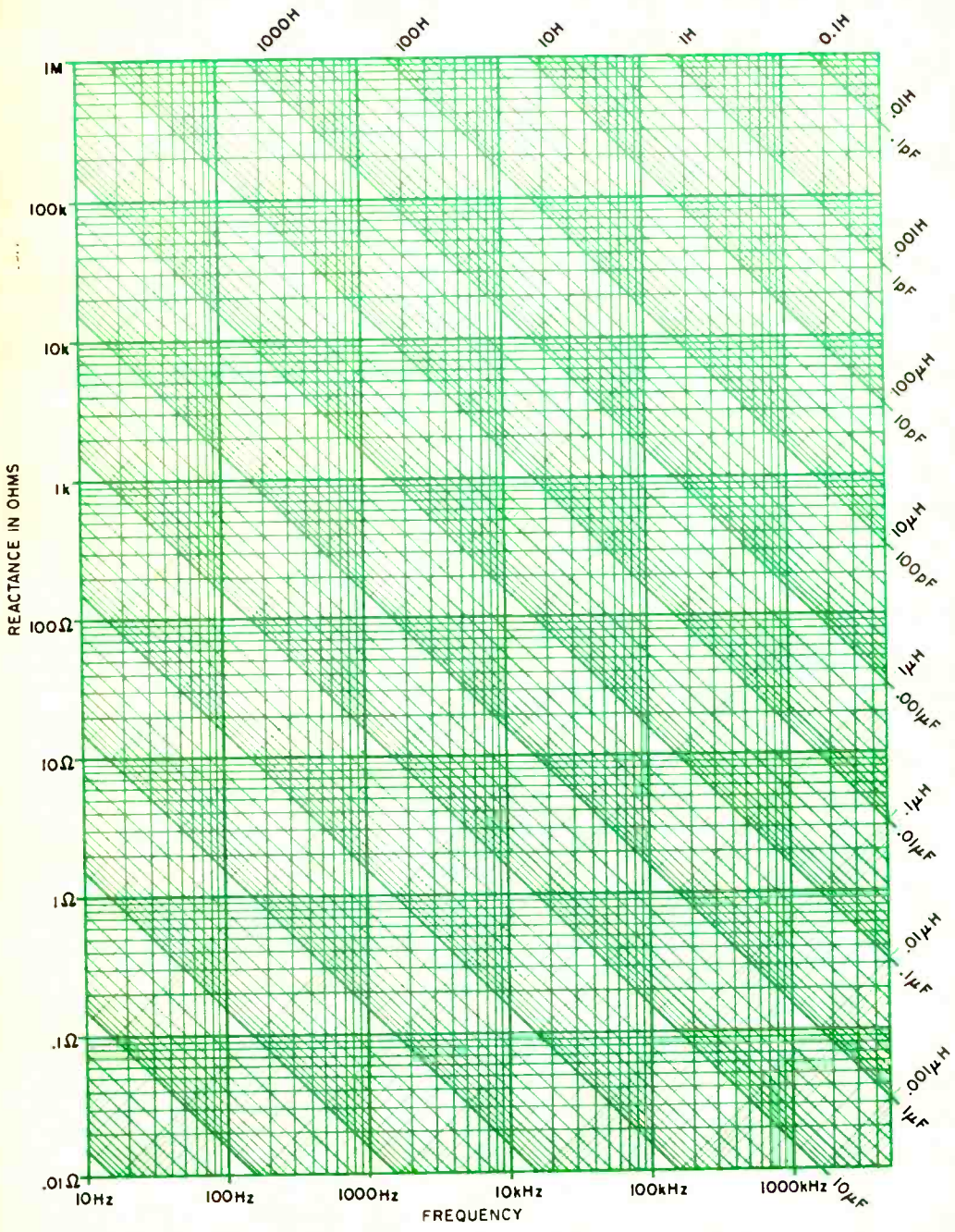
ADDRESS _____

CITY _____

STATE & ZIP _____

CIRCLE NO. 12 ON READER SERVICE CARD

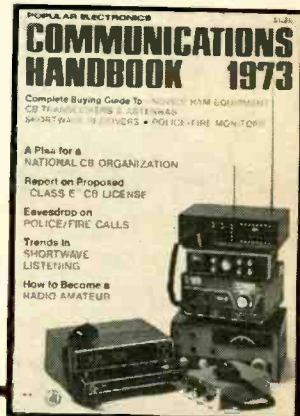
REACTANCE CHART



HAM CB SWL

they come through **LOUD**
AND CLEAR in the all-new
1973 COMMUNICATIONS
HANDBOOK

Here is everything you want
to know — need to know —
about Citizens' Band, Amateur
Radio, Shortwave Listening.



Don't turn a dial

In fact don't even *buy* a dial or anything else until you've checked out the 1973 Communications Handbook. Whatever your radio specialty—whether you're an old hand or just getting started—this vital "how-to" guide will help you get greater value, greater enjoyment out of every minute you spend with your equipment.

CITIZENS' BAND — What it is, how it is used, how to get a license, how to set up your station, loads of great ideas and tips, PLUS three handy buyers' catalogs: 1. a major listing of all known 5-watt input CB transceivers complete with detailed technical specifications, photographs, and pricing. 2. complete line of CB accessories and, 3. selected CB antennas.

AMATEUR RADIO — A true inside view of the excitement, the novelty, the worldwide interest in the fascinating and fast-growing hobby. How to apply for a novice license; how to train and qualify; how to set up your rig; all spiced with interesting photos.

BRING YOUR REFERENCE LIBRARY UP-TO-DATE

If you've missed any of the current and previously published Annuals, a wide selection is still available. To place your order, circle the corresponding numbers on the coupon on this page.

ELECTRONIC EXPERIMENTER'S HANDBOOK—Exciting electronics construction projects—all lab-tested by the editors, complete with parts list, easy "how-to-do-it, how-it-works" instructions, and many with actual PC foil patterns and I.C. diagrams.

1972 Winter . . . #40 1971 Spring . . . #26
 1971 Winter . . . #33 1970 Spring . . . #14

COMMUNICATIONS HANDBOOK—Here in one single package, the combined knowledge and experience of the top men in each field, tunes you in on everything you need to know about CB, SWL and HAM.

1972 . . . #70 1971 . . . #37 1970 . . . #10 1969 . . . #86

TAPE RECORDER GUIDE—Reel-to-reel, cassette, 8-track cartridge—it's all spelled out for you! What's available—how to choose what's best for you and how to get the best use and pleasure from your tape recorder. Includes a complete buyers guide for machines, microphones and accessories, raw tape.

1973 Winter . . . #78 1972 Spring . . . #51
 1971 Winter . . . #56 1971 Spring . . . #19

STEREO DIRECTORY & BUYING GUIDE — Complete, accurate facts on more than 1500 products listing complete specs, model number, descriptions and price. Plus a complete shop-at-home Buyers Guide loaded with expert information on what to look for, what to avoid, how to decide what's best for you at a price you can afford. 1973 . . . #76

SHORTWAVE LISTENING—Starts right out with a look at what's ahead for SWL'rs in 1973 followed by an important article on the how's and why's of reporting and verifications. You'll get all of the shortwave bands around the world plus a list of leading DX clubs and take a look at some interesting SWL QSL cards. There's also a complete BUYER'S GUIDE with complete specs on all known general coverage SW receivers. And that's still not all! . . .

SPECIAL BONUS

Includes "FM DX'ing," "Public Weather Broadcast Frequencies" and a directory of all monitor receivers for picking up police, fire, and public service broadcasts.

So to make sure *you* come through "Loud and Clear" in 1973, get your copy of the 1973 COMMUNICATIONS HANDBOOK today! Only \$1.25 with the convenient coupon below.

ZIFF-DAVIS SERVICE DIVISION, DEPT. CH
 595 Broadway, New York 10012

Please send me _____ copies of the 1973 COMMUNICATIONS HANDBOOK at \$1.25 each plus 35c each for postage and handling. (\$2.50 POSTPAID for orders outside the U.S.A.)

Also, I have circled the numbers below of the additional annuals I wish to receive:

\$1.25 40 70 **\$1.35** 10 86
\$1.50 14 19 26 33 37 51 56 76 78

I am enclosing a total of \$_____ for the annuals ordered above. I have enclosed an additional 35c per copy for postage and handling. (For orders outside the U.S.A., all annuals are \$2.50 per copy, POSTPAID.)

EEH-S73

print name _____

address _____

city _____

state _____

zip _____

PAYMENT MUST BE ENCLOSED WITH ORDER

COLOR CODE CHARTS

COLOR BAND SYSTEM



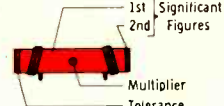
Resistors With Black Body Color Are Composition, Non-Insulated.
Resistors With Colored Bodies Are Composition, Insulated.
Wire-Wound Resistors Have The 1st Digit Color Band Double Width.

RESISTOR CODES (RESISTANCE GIVEN IN OHMS)

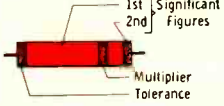
COLOR	DIGIT	MULTIPLIER	TOLERANCE
BLACK	0	1	+20%
BROWN	1	10	+1%
RED	2	100	+2%
ORANGE	3	1000	+3%
YELLOW	4	10000	GMV*
GREEN	5	100000	+5% (EIA Alternate)
BLUE	6	1000000	+12.1 2%
VIOLET	7	10000000	+6%
GRAY	8	.01 (EIA Alternate)	+10% (EIA Alternate)
WHITE	9	.1 (EIA Alternate)	+5% (JAN and EIA Preferred)
GOLD			+10% (JAN and EIA Preferred)
SILVER			+20%
NO COLOR			

*GMV - guaranteed minimum value, or -0 - 100% tolerance.
*3, 6, 12, 1, 2, and 30% are ASA 40, 20, 10, and 5 step tolerances.

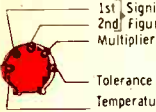
BODY-END-DOT SYSTEM



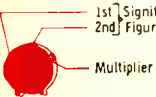
BODY-END BAND SYSTEM



DISC CERAMICS (5-DOT SYSTEM)



DISC CERAMICS (3-DOT SYSTEM)

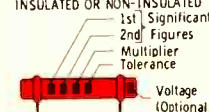


CERAMIC CAPACITOR CODES (CAPACITY GIVEN IN pF)

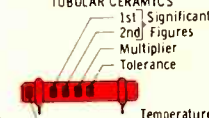
COLOR	DIGIT	MULTIPLIER	TOLERANCE		TEMPERATURE COEFFICIENT PPM/°C	EXTENDED RANGE	
			10 pF or LESS	10 pF or 100MΩ		SIGNIFICANT FIGURE	MULTIPLIER
BLACK	0	1	+2.0 pF	+20%	0(NPO)	0.0	-1
BROWN	1	10	+0.1 pF	+1%	-32(N033)	1.0	-10
RED	2	100		+2%	-75(N075)	1.0	-100
ORANGE	3	1000		+2.5%	-150(N150)	1.5	-1000
YELLOW	4	10000			-220(N220)	2.2	-10000
GREEN	5		+0.5 pF	+5%	-330(N330)	3.3	-1
BLUE	6				-470(N470)	4.7	-10
VIOLET	7				-750(N750)	7.5	-100
GRAY	8	.01	+0.25 pF		-30(P030)		-1000
WHITE	9	.1	+1.0 pF	+10%	General Purpose Bypass & Coupling		-10000
SILVER					+100 (1500, JAN)		
GOLD							

Voltage ratings are standard 500 volts for some manufacturers, but 1000 volts for other companies.

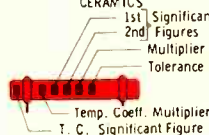
HIGH CAPACITY TUBULAR CERAMIC INSULATED OR NON-INSULATED



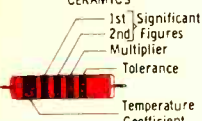
TEMPERATURE COMPENSATING TUBULAR CERAMICS



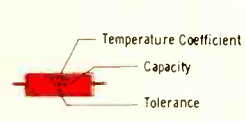
EXTENDED RANGE T.C. TUBULAR CERAMICS



MOLDED-INSULATED AXIAL LEAD CERAMICS

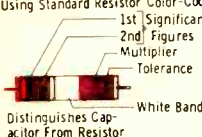


TYPOGRAPHICALLY MARKED CERAMICS

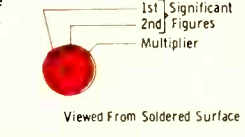


JAN LETTER	TOLERANCE	
	10 pF or LESS	OVER 10 pF
C	+0.2 pF	
D	+0.5 pF	
F	+1.0 pF	±1%
G	+2.0 pF	+2%
J		+5%
K		+10%
M		+20%

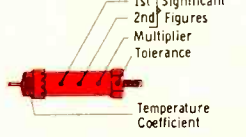
MOLDED CERAMICS Using Standard Resistor Color-Code



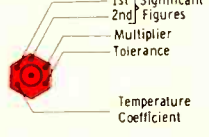
BUTTON CERAMICS



STAND-OFF CERAMICS



FEED-THRU CERAMICS



MOLDED MICA CAPACITOR CODES (Capacity Given In pF)

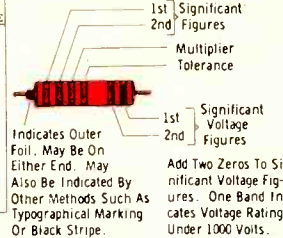
COLOR	DIGIT	MULTIPLIER	TOLERANCE	CLASS OR CHARACTERISTIC
BLACK	0	1	20%	A
BROWN	1	10	1%	B
RED	2	100	2%	C
ORANGE	3	1000	3%	D
YELLOW	4	10000		E
GREEN	5		5% (EIA)	F(JAN)
BLUE	6			G(JAN)
VIOLET	7			I (EIA)
GRAY	8			J (EIA)
WHITE	9			
GOLD		.01	5% (JAN)	
SILVER		.1	10%	

Class or characteristic denotes specifications of design involving Q factors, temperature coefficients, and production test requirements.
All axial lead mica capacitors have a voltage rating of 300, 500, or 1000 volts.
*or $\pm 1.0 \mu\text{F}$ whichever is greater.

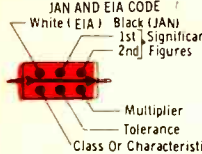
MOLDED PAPER CAPACITOR CODES (Capacity Given In pF)

COLOR	DIGIT	MULTIPLIER	TOLERANCE
BLACK	0	1	20%
BROWN	1	10	
RED	2	100	
ORANGE	3	1000	
YELLOW	4	10000	
GREEN	5	100000	5%
BLUE	6	1000000	
VIOLET	7		
GRAY	8		10%
WHITE	9		5%
GOLD			10%
SILVER			20%
NO COLOR			

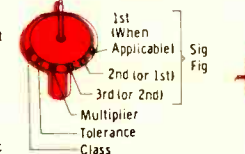
MOLDED PAPER TUBULAR



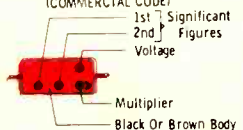
CURRENT STANDARD JAN AND EIA CODE



BUTTON SILVER MICA



MOLDED FLAT PAPER CAPACITORS (COMMERCIAL CODE)



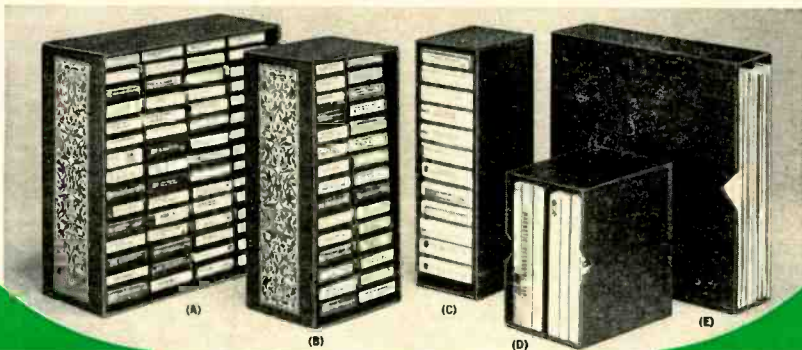
MOLDED FLAT PAPER CAPACITORS (JAN CODE)



Stereo Review Magazine Presents . . .

THE 'STORAGE PROBLEM' SOLVERS

DELUXE MATCHING STORAGE CASES FOR YOUR 12" RECORDS,
7" REELS, CASSETTES AND 8-TRACK CARTRIDGES.



(A) 60-unit cassette case. 13½" h. x 12¾" d. x 5¼" w. Compartments are tilted back to prevent spillage. Includes pressure-sensitive labels for titling. \$14.75 each. 3 for \$42.00.

(B) 30-unit cassette case. 13½" high x 6½" deep x 5½" wide. Tilted compartments, labels included. \$8.40 each. 3 for \$24.00.

(C) 12-unit cartridge case. 13¼" high x 6½" deep x 4½" wide. Tilted compartments, labels included. \$5.25 each. 3 for \$13.75.

(D) 6-unit 7" reel case. 8" high x 7½" deep x 5" wide. Holds reels in original boxes. \$4.75 each. 3 for \$12.65.

(E) 20-unit 12" record case. 13¼" high x 12½" deep x 3½" wide. Holds records in original jackets. \$5.25 each. 3 for \$13.75.

Here's the ideal solution to the problem of keeping all your records and tapes stored neatly, safely, conveniently and attractively. A complete set of matched storage cases, designed by the editors of STEREO REVIEW magazine, for your records and all your tapes: cassette, cartridge and 7" reel. Now you can keep them side-by-side on your bookshelf or cabinet, easy to identify and readily available.

These cases are sturdily constructed and covered in a handsome leatherette. The outer case is elegantly embossed in gold and comes in your

choice of three popular decorator colors—black, brown and green—so that they lend themselves readily to the decor of any room.

STEREO REVIEW large capacity storage cases are just what you've been looking for—they're the ideal solution to keeping your records and tapes neatly stored for easy use.



**AN EXTRA SERVICE FOR YOU—
CHARGE YOUR STORAGE CASE ORDER
TO YOUR AMERICAN EXPRESS
OR BANKAMERICARD ACCOUNT.**

ZIFF-DAVIS PUBLISHING COMPANY, Dept. 23,
EEP 273 One Park Avenue, New York 10016

My remittance in the amount of \$ _____
is enclosed for the cases indicated.

Charge my American Express Card Account # _____

Charge my BankAmericard Account # _____

Signature _____

Print name _____

Address _____

City _____

State _____

Zip _____

- _____ 60-unit Cassette Cases @ \$14.75 each;
3 for \$42.00.
- _____ 30-unit Cassette Cases @ \$8.40 each; 3 for
\$24.00.
- _____ 12-unit 8-Track Cartridge Cases @ \$5.25 each;
3 for \$13.75.
- _____ 6-unit 7" Reel Cases @ \$4.75 each; 3 for \$12.65.
- _____ 20-unit 12" Record Cases @ \$5.25 each; 3 for \$13.75.

Add 50c per unit ordered for postage and handling. Outside U.S.A. add \$1.00 per unit ordered. Payment must be enclosed with order if not charged.

Check color choice for back of case (sides in black only):

Brown Green Black

FOR THE HI-FI BUFF who demanded outstanding performance in a high-power amplifier, there was the Universal Tiger ("Assembling a Universal Tiger," 1973 Handbook). But if your power requirements are more conservative with no lessening in the demand for quality, now there is the "Plastic Tiger," second cousin to the Universal Tiger.

Except for a more conservative output power capability (30 watts as opposed to the Universal Tiger's 80 watts into 8 ohms), the Plastic Tiger has virtually the same outstanding performance of its bigger cousin. By using plastic complementary output transistors capable of more than enough power for the average listening room, the Plastic Tiger is simpler in design and more economical.

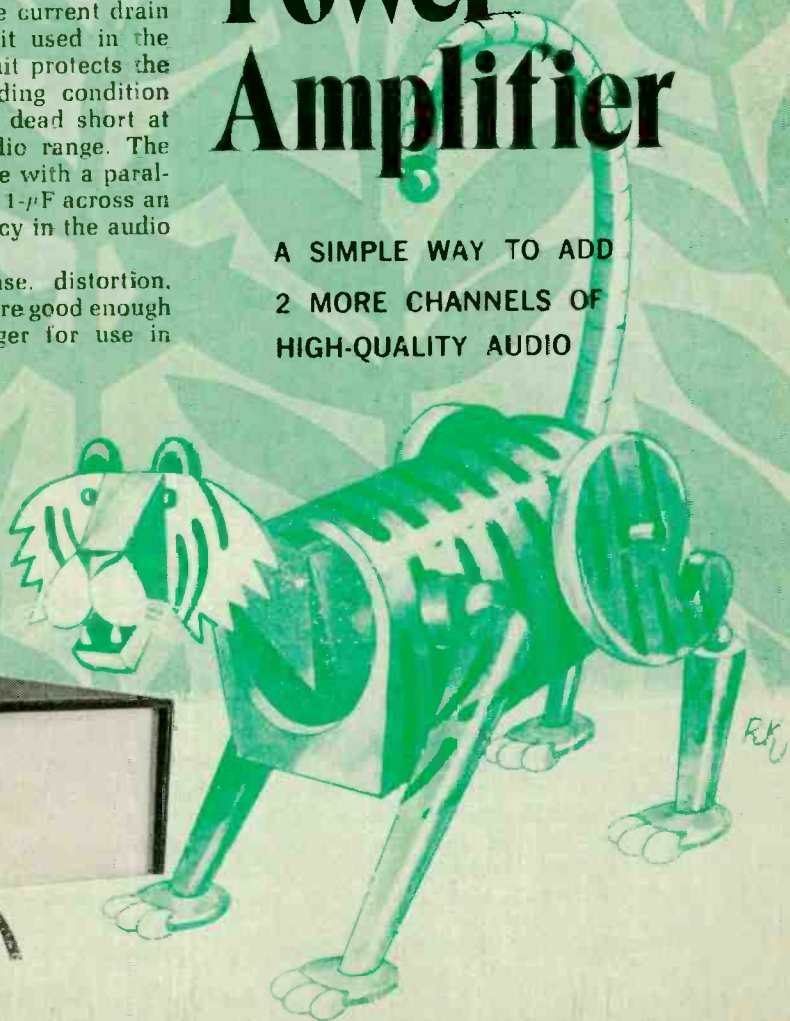
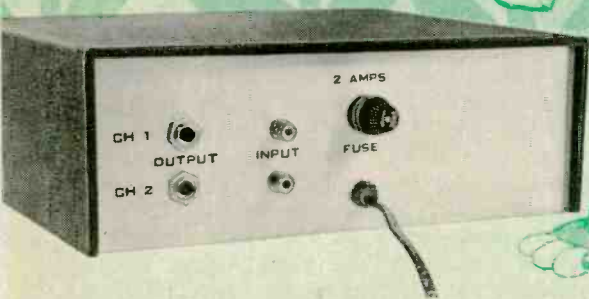
The circuit of the Plastic Tiger is completely stable with any type of input or output termination. The output stage is protected against excessive current drain by the same unique circuit used in the Universal Tiger. This circuit protects the amplifier against any loading condition from an open circuit to a dead short at any frequency in the audio range. The amplifier is also safe to use with a parallel capacitive load of up to 1- μ F across an 8-ohm load at any frequency in the audio range.

The frequency response, distortion, noise, etc., characteristics are good enough to qualify the Plastic Tiger for use in

The Plastic Tiger Audio Power Amplifier

A SIMPLE WAY TO ADD
2 MORE CHANNELS OF
HIGH-QUALITY AUDIO

BY DANIEL MEYER



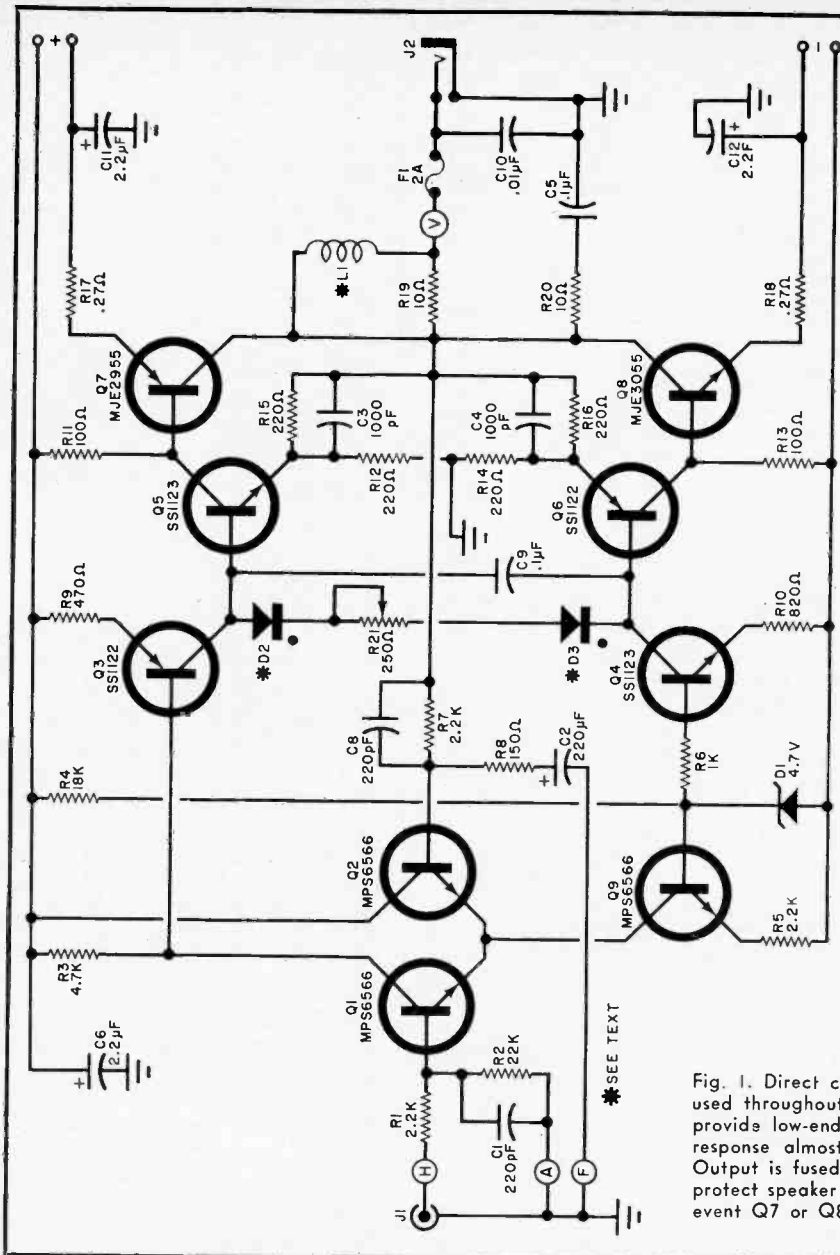


Fig. 1. Direct coupling is used throughout amplifier to provide low-end frequency response almost down to dc. Output is fused by F1 to protect speaker from damage in event Q7 or Q8 should fail.

even a "super" system. It is very unlikely, for example, that it would be possible to detect the difference between this amplifier and an amplifier with better performance with anything but a distortion analyzer. Further, the Plastic Tiger produces no detectable "coloration" to amplified sounds.

Theory of Circuit Design. The circuit of

the Plastic Tiger is shown in Fig. 1. The input stage consists of a differential amplifier with the input signal applied to the base of Q1 and the feedback applied to the base of Q2. Current source transistor Q9 provides controlled emitter current. The high impedance to the signal input point provided by the current source decouples the signal from any hum or noise existing on the -40-volt bus.

PARTS LIST

- C1, C8—220-pF capacitor
 C2—220- μ F, 6-volt electrolytic capacitor
 C3, C4—1000-pF capacitor
 C5, C9—0.1- μ F capacitor
 C6, C11, C12—2.2- μ F, 50-volt electrolytic capacitor
 C7—Not used
 C10—0.01- μ F capacitor
 D1—4.7-volt, 1-watt zener diode (1N4732 or similar)
 D2, D3—Compensating diodes (see text)
 F1—2-ampere standard fuse
 J1—Phono jack
 J2—Single-circuit phone jack
 L1—Single layer of #26 wire close-wound on body of R19
 Q1, Q2, Q9—MPS6566 transistor (Motorola)
 Q3, Q6—SS1122 transistor (Motorola)
 Q4, Q5—SS1123 transistor (Motorola)
 Q7—MJE2955 transistor (Motorola)
 Q8—MJE3055 transistor (Motorola)
 R1, R5, R7—2200-ohm, $\frac{1}{2}$ -watt 10% resistor
 R2—22,000-ohm " " "
 R3—4700-ohm " " "
 R4—18,000-ohm, 1-watt, 10% resistor
 R6—1000-ohm, $\frac{1}{2}$ -watt, 10% resistor
 R8—150-ohm " " "
 R9—470-ohm " " "
 R10—820-ohm " " "
 R11, R13—100-ohm " " "
 R12, R14, R16—220-ohm, $\frac{1}{2}$ -watt, 10% resistor
 R17, R18—0.27-ohm, 5-watt, 10% resistor
 R19, R20—10-ohm, 1-watt, 10% resistor
 R21—250-ohm potentiometer
 Misc.—Fuse holder; printed circuit board; chassis box; $\frac{3}{4}$ " spacers; #18 or #20 hookup wire; mica insulators for Q7 and Q8; heat-transferring silicone paste; 4-40 machine hardware; solder; etc.
 Note—The following items are available from Southwest Technical Products Corp., Box 32040, San Antonio, TX 78216: Circuit board No. 185b for \$2.35; kit of parts for one channel, including circuit board but minus chassis and power supply, for \$18.50 plus postage on 1 lb; complete kit of parts for two channels plus power supply and chassis for \$55.00 plus postage on 10 lb.

The output signal from Q1 drives the base of Q3 which is the positive half of the bidirectional current driver. The negative half of the current driver is the Q4 circuit. Transistors Q3 and Q4 provide the output driver transistors, Q5 and Q6, with a high-impedance current source drive signal.

Diodes D2 and D3, actually base-emitter junctions of silicon transistors, plus

potentiometer R21 provide enough bias voltage to just turn on the driver transistors. A gain of two is provided by Q5 and Q6 operating class AB. This gain is a function of the ratio between R15/R12 and R16/R14.

Current source driver Q9 and a large amount of feedback eliminate any trace of crossover distortion. The load, or speaker system, is driven by the signal present at the collectors of output transistors Q7 and Q8. The lag network made up of R20 and C5 determines the high-frequency roll-off point in the feedback loop as is normally the case with this type of amplifier. Coil L1 decouples the load at high frequencies to insure that the feedback loop cannot be shorted by an external capacitance and cause high-frequency oscillation. Capacitor C10 simply provides r-f bypassing at the load terminals.

In Fig. 2 are shown amplitude and phase plots. The upper plot is for frequencies from 20 Hz on down, while the lower plot is for frequencies 20,000 Hz on up. The frequency and phase plots between 20 and 20,000 Hz form straight lines.

The low-frequency curves show that the amplifier is down 1 dB at 5 Hz with gain approaching unity at dc. The phase shift plot shows that a maximum low-frequency phase shift of about 60° occurs at approximately 0.7 Hz and then gradually approaches 0° again near the dc point.

The high-frequency curves show the amplifier to be down 1 dB at approximately 100,000 Hz, while the unity gain point occurs at 1.3 MHz. The phase plot shows that the amplifier has approximately a 40° phase margin, enough to insure stability under any operating conditions.

A plot of output impedance versus frequency is given in Fig. 3. The wiring resistance is on the order of 0.05 ohm and is included in this plot which was taken at the amplifier's output terminals. The output impedance is quite low over most of the audio range and begins a slow rise beyond 5000 Hz. It reaches a maximum of 0.2 ohm at 20,000 Hz. This is about what would normally be expected from the amount of feedback and the bandwidth of the circuit.

Oscilloscope waveform photos of the square-wave response of the amplifier at

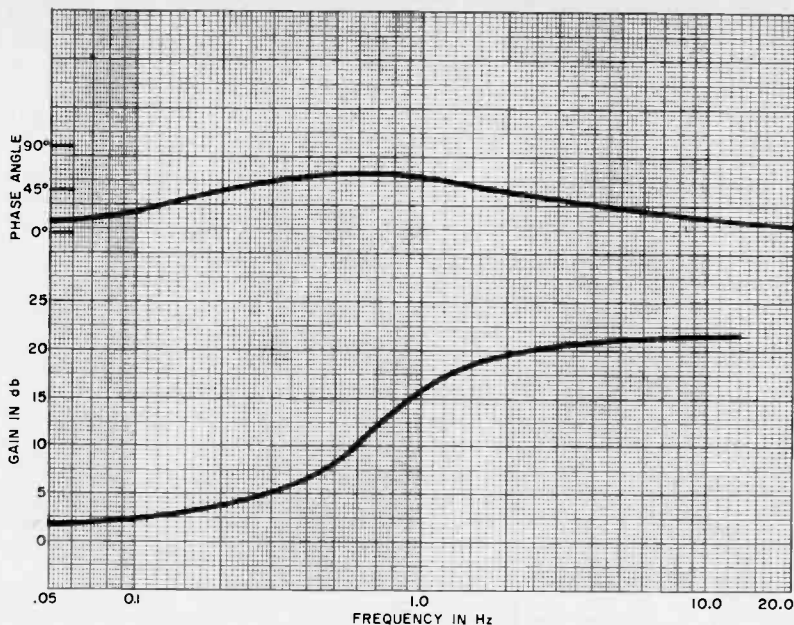
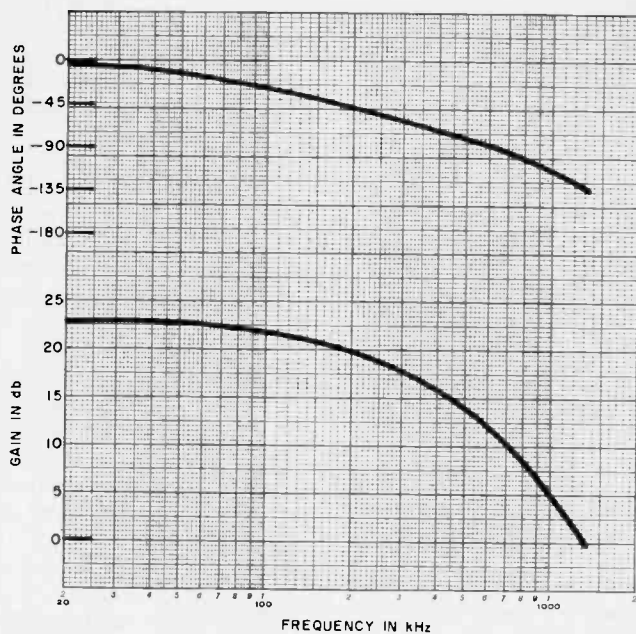


Fig. 2. Shown here are amplitude and phase plots for 20 Hz on down (above) and 20 kHz to 2 MHz (right). Frequency and phase plots for 20-20,000 Hz form straight lines.



10,000 and 100,000 Hz are given in Fig. 4. The 10,000-Hz photo was taken only because this frequency is commonly used in amplifier testing. It is actually too low a frequency for testing an amplifier such as the Plastic Tiger. The 100,000-Hz response photo shows clearly the rise time of approximately $2.5 \mu\text{s}$ and the complete absence of "ringing" when driven with a step input. (Caution: Performing this test

is not recommended for most amplifiers and should not be performed on the Plastic Tiger by the layman.)

Assembly. The majority of the components that make up the Plastic Tiger are to be mounted on a printed circuit board. If you plan to etch and drill your own board, an actual size etching and drilling guide and a components placement dia-

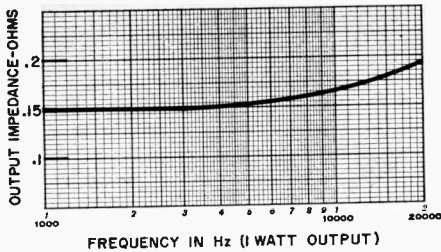


Fig. 3. Output impedance is quite low over audio range, rising to 0.2 ohm at 20 kHz.

gram are provided in Fig. 5. For those who prefer to purchase a ready-made board, refer to the Parts List for source information. Mount the components on the printed-circuit board and solder their leads to the foil pattern.

Power transistors Q7 and Q8 are to be mounted on the bottom of the board with their leads extending up through the holes drilled to accommodate them. To mount the transistors, first bend the outer leads up $\frac{1}{4}$ " from the case and the center leads $\frac{7}{16}$ " from the case. When these leads are correctly bent, the metal side of the transistor cases will be facing down. Insert the transistor leads in the appropriate holes in the circuit board. Squarely position the transistors so that their bottom surfaces are parallel to and $\frac{1}{4}$ " from the foil side of the board. Solder the leads to the foil pattern. If the mounting procedure is not done carefully, Q7 and Q8 will not lie flat on the chassis and heat sinking will not work properly.

Coil L1 is made up of #26 insulated hookup wire close wound in a single layer along the body of R19. The exact value of this coil is not critical, and 8-10 turns

will be the average number you can wind on the resistor. Strip away the insulation from both ends of the coil and solder the exposed wires to the leads of R19. Then mount the L1/R19 assembly in the appropriate location on the circuit board.

Bias diodes D2 and D3 are made from a pair of 2N4918 transistors after first cutting away the collector (center) leads. Use the emitter leads for the cathodes, soldering them to 3" lengths of hookup wire and the free ends of the hookup wire to the holes near the dots on the board. The base leads go to the unidentified anode holes via 3" wires.

Solder color-coded 10" lengths of hookup wire to the foil pattern at holes A, F, and H. Twist these wires together in a neat bundle. Solder one end of a 10" length of #18 or #20 wire to hole G, and 6" lengths of the same wire to both + and both - holes and hole V. Temporarily set the board aside.

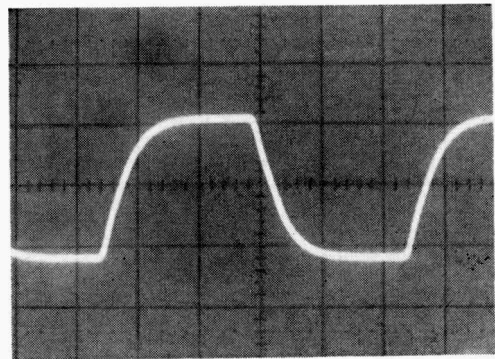
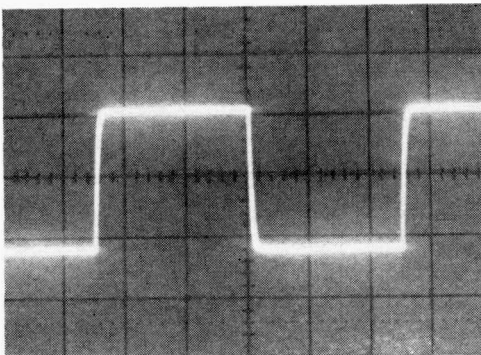
Almost any power supply capable of delivering 2 amperes of current and with +40 and -40 volt sources will adequately power the Plastic Tiger. An example of such a power supply is given in Fig. 6.

The photos in Fig. 7 show an assembled stereo version of the Plastic Tiger. The same assembly procedures apply to both mono and stereo versions. Now, with the exception of the filter capacitors and their mounting clips, mount the power supply components on the chassis as shown. Power switch S1, if used, should be mounted on a 4-lug terminal strip with the center, or common ground, lug not used (the rectifier bridge assembly simply bolts directly to the chassis floor).

After mounting the input and output

Fig. 4. Square wave output waveforms from amplifier show virtually zero distortion

at 10,000 Hz (below left) and absence of ringing at 100,000 Hz (below) and beyond.



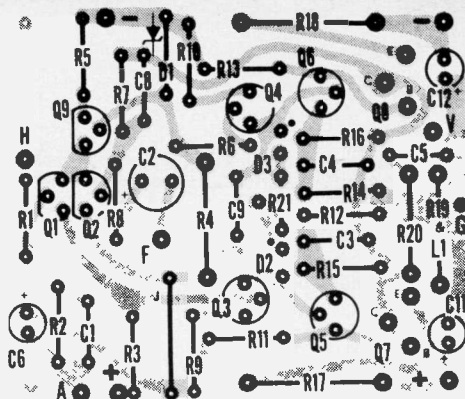


Fig. 5. Actual size etching and drilling guide at left is supplied for those who wish to make their own PC boards. Diagram above shows locations and orientations of components on PC board.

HIRSCH-HOUCK LABORATORIES Project Evaluation

The 30-watt output power rating of the Plastic Tiger amplifier seems to be justified, although its power supply limitations keep it from realizing this power below 300 Hz. At 30 watts/channel, the distortion is only 0.084% at 300 Hz, but is 7% at 100 Hz and far greater with decreasing frequency. Otherwise, the distortion at any power level up to 30 watts/channel is typically well below 0.1% from 20 to 20,000 Hz. At normal listening levels, the distortion is less than 0.07% at any frequency, qualifying the Plastic Tiger as a first-rate high-fidelity amplifier.

The 1000-Hz harmonic distortion remains less than 0.09% from 0.1 watt to 30 watts, clipping rapidly at higher power levels. Intermodulation distortion follows a similar characteristic, but it is slightly greater—typically less than 0.3% up to 30 watts output.

At the point of visual waveform clipping, the output power into 8 ohms was 40.5 watts/channel; into 4 ohms, 33 watts/channel; and into 16 ohms, 25 watts/channel. The 8-ohm clipping level was also checked at low frequencies: at 50 Hz, it was 22 watts; at 20 Hz, it was 18.7 watts.

All of the preceding measurements were made with the Plastic Tiger's bias control set as received. The control was subsequently adjusted for minimum distortion at low power output levels (it is interesting to note that waveform notching could not be observed at any setting of the control). This produced a substantial reduction (two to five times) in both harmonic and IM distortion at power levels below 1 watt but had negligible effect at higher power levels. The optimum setting was with the control at one extreme. No measurements were made on idling currents under this condition, but it is possible that transistor dissipation would be undesirably high. If so, there is no point to the optimization of distortion since it is adequately low at almost any control setting.

The frequency response of the Plastic Tiger was flat across the audio spectrum, down 0.2 dB at 15 Hz and 50,000 Hz, and down 1.7 dB at the lower measurement limit of 5 Hz. The high-frequency output was down 3 dB at 100,000 Hz. Square-wave rise time was 2 μ s, while noise was 83 dB below 10 volts.

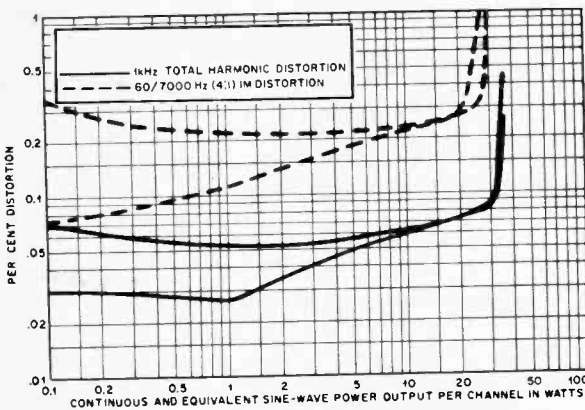
Although the entire amplifier became quite hot during our tests, this was not the case during normal listening usage. In all, the Plastic Tiger is certainly a compact, low-cost powerhouse.

jacks on the front panel, mount the circuit board as follows. Spread a film of heat transferring silicone paste on both sides of four mica insulators; then place the insulators over the appropriate holes in the chassis. Lower the circuit board onto the chassis, aligning the mounting holes of the power transistors with the holes in the insulators and chassis. Press the transistors firmly into the paste. Place the metal sides of the diodes against the respective transistor cases—D2 atop Q7 and D3 atop Q8—and orient them as shown. Fasten the diode/transistor pairs to the chassis with 4-40 machine hardware. Then, at the opposite end of the board, anchor the circuit assembly firmly in place with 4-40 hardware and 1/4" spacers.

Locate the twisted-together wires coming from the circuit board and route them to J1 along the side of the chassis away from the power transformer. Connect and solder the wire coming from hole A to the

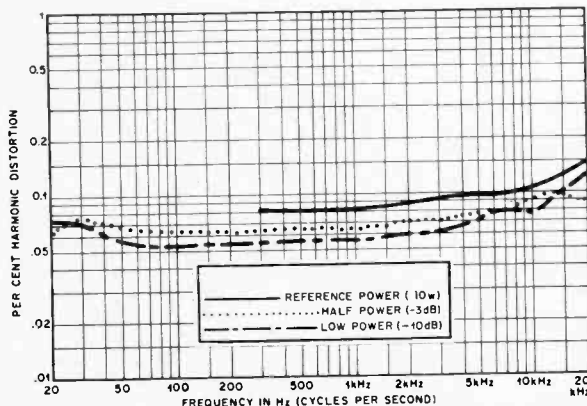
signal, or center, contact of J1. Connect and solder the remaining two wires in the bundle to the ground lug on J1. Use two separate wires coming from holes A and F as directed, grounding them only at the input jack.

Bolt the speaker fuse holder to the floor of the chassis with 4-40 hardware. Also, mount the capacitor clips to the rear apron of the chassis and slip the filter capacitors into them. Wire together the power supply components, referring to Fig. 6. The common (COMM) line from the power supply connects to the circuit ground by running a length of #18 or #20 wire from the junction between C1 and C2 in the power supply to the ground lug on J2. If the stereo version of the amplifier is being built, run a separate wire from the capacitors to the respective jack ground lugs. (Note: Do not solder any connection to J2 or the speaker fuse holder lugs until directed to do so.)



With R21 set as received upper broken and upper solid curves indicate measured distortion. Remaining curves were obtained when R21 was set for minimum distortion.

Curves show extremely low harmonic distortion over entire audio range at various power levels.



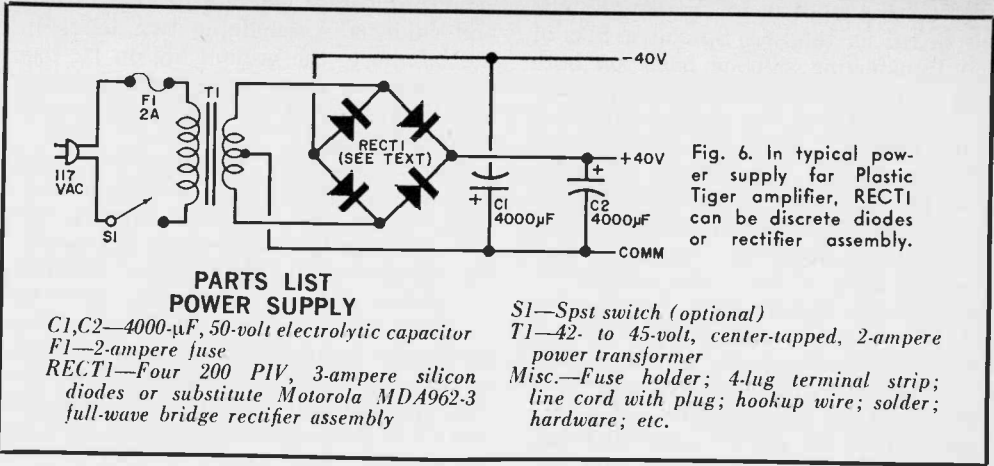


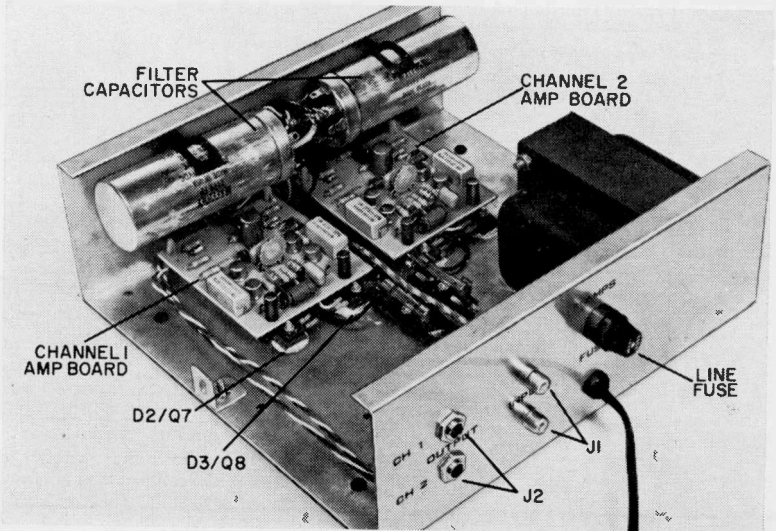
Fig. 6. In typical power supply for Plastic Tiger amplifier, RECT1 can be discrete diodes or rectifier assembly.

Locate the free end of the wire from hole G. Route this wire across the center of the chassis and connect and solder it to the lower hole in the ground lug on the terminal strip. Connect the free end of the wire from hole V to the near lug on the speaker fuse holder; then connect a length of #18 or #20 wire from the other fuse holder lug to the signal contact lug on J2. Lastly, connect C10 to the lugs of J2 and solder all lug connections to the output jack and the speaker fuse holder. All that is left of the wiring is to connect and solder the two wires from the - holes on the board to the negative side of C2 and the two wires from the + holes to the positive side of C1.

Carefully check your wiring, especially in the power supply, against Fig. 1 and Fig. 6 for errors. When you are satisfied that your wiring is correct, use an ohmmeter to check the resistance from each lead of the biasing diodes and output transistors to chassis ground. Reverse the ohmmeter leads and perform the tests again. In all cases, the readings obtained should be several megohms to infinity. If you obtain a short-circuit indication or a very low resistance reading, the component in question is not properly insulated from the chassis and will have to be dismounted and resealed.

Setup and Use. Plug the line cord into

Fig. 7. In photo of completed two-channel version of Plastic Tiger, note the special mounting arrangement given to D2/Q7 and D3/Q8.



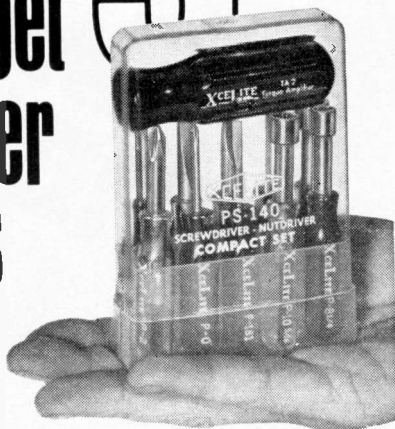
a convenient 117-volt ac outlet and close S1. Check the dc voltages with reference to chassis ground; they should be between 30 and 35 volts in both polarities. Now, check the voltages across R11 and across R13. Typically, there should be little or no measurable voltage across R11. In no case is there to be more than 0.5 volt across R13 if the amplifier is to operate properly. Make a final voltage check from point V to chassis ground; you should read 0.1 volt or less if everything is operating normally. If any of the transistors or other parts become warm or hot when there is no input signal or load on the amplifier, immediately shut down the power and find the source of the trouble before proceeding.

Now, if you have the appropriate instruments available, you can adjust bias control R21 for optimum amplifier performance. First, connect an 8-ohm load to the Plastic Tiger via J2 and drive the amplifier at J1 with a 10,000-Hz sine wave signal of sufficient amplitude to provide a 1-watt output from the amplifier. Observing the waveform of the output signal on an oscilloscope screen, rotate R21 clockwise (viewed from the input end of the circuit board) until the small cross-over notches disappear at the waveform's zero crossing points. If you do not have the appropriate instruments available, just set R21 for a three-quarter clockwise rotation. ♦



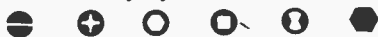
"What ever happened to your idea for an electronic car-theft alarm?"

now 9 midget driver sets



for
double
duty

on dozens of popular screws & nuts



Three new assortments have joined Xcelite's family of "Compact Convertibles." Each an Xcelite "original." Nowhere will you find such a variety of sizes and types in a midget set, for driving slotted, Phillips, Allen, Scrulox®, hex, and clutch head screws. And hex nuts.

All of professional quality, precision made of finest materials. All doing "double duty" with torque amplifier handle that slips over color-coded midget tools for longer reach, greater driving power. Each easily identifiable on the bench or in the service kit thru Xcelite's exclusive, optically clear, plastic "show case" that closes securely with positive snap-lock.

nationwide availability through local distributors

NEW!

PS130 3 slot tip, 2 Phillips screwdrivers,

5 nutdrivers

PS140 4 slot tip, 3 Phillips screwdrivers,

3 nutdrivers

PS6 3 slot tip, 3 Phillips screwdrivers

PLUS PS88, PS120, PS7, PS89, PS44
and PS-TR-1 with varying selections
of screwdrivers and nutdrivers

REQUEST FREE CATALOG.



XCELITE®

XCELITE INC. • 54 BANK ST., ORCHARD PARK, N. Y. 14127
Send General Catalog No. 171 with information on
Midget Driver Sets.

name _____

address _____

city _____

state & zone _____

In Canada contact Charles W. Pointon, Ltd.

CIRCLE NO. 15 ON READER SERVICE CARD

SCR COMBINATION LOCK

SIMPLE CIRCUIT
OPERATES
ON 12 VOLTS

BY DAVID E. FAHNSTOCK

LOCK THE DOOR and throw away the key! With an electronic combination lock, you never have to worry about losing the keys or locking them inside. All you have to do is remember a five-number combination. What's more the combination lock described here needs only a 12-volt supply so it can be used on your car or boat with no attachments or problems. The circuit of the lock is unusually simple and uses silicon controlled rectifiers for trouble-free operation.

The basic system, whose schematic is shown in Fig. 1, uses only five pushbutton switches for 120 combinations. However, you can easily add to the circuit to provide for more combinations (720 for six pushbuttons, 5040 for seven, etc.). The combination can be changed easily and quickly if you think someone has learned what it is.

In addition, the system is timed so that, even if the first number is chosen correctly, the rest of them must be chosen within 3 seconds (which can be adjusted) or the process must be started over again.

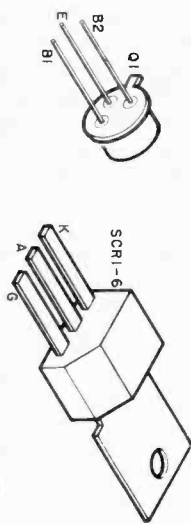
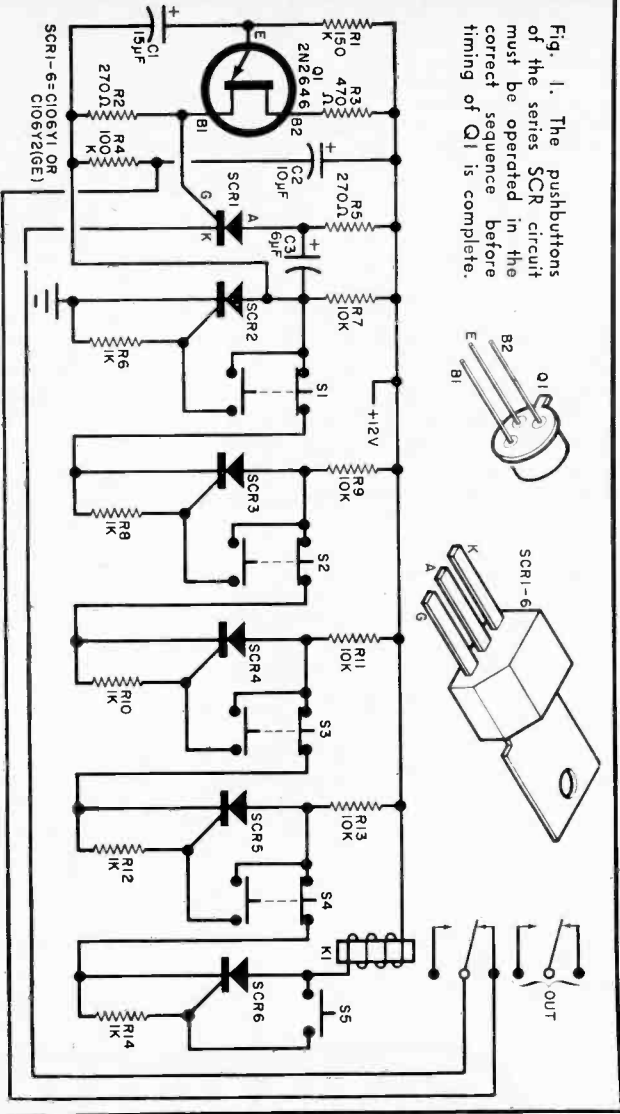
Theory of Circuit Design. The circuit of the combination lock is essentially five SCR's in series, with the last SCR in the chain controlling a relay. The chain is controlled by a UJT timing circuit and "feedback" from the relay.

When switch *S1* is operated, its normally open section turns on *SCR2* and it latches in. With *SCR2* on, there is a potential of about 12 volts across *R7*, with the junction of *R7*, *C3* and *SCR2* negative. This voltage is applied to the timer circuit, charging *C2* through *R4* and *C3* through *R5*. Capacitor *C1* also starts to receive a charge through *R1*, and when this charge is sufficient, *Q1* starts to conduct, producing a positive going spike across *R2*. If the relay is de-energized, its normally closed contacts are in series with *SCR1*. Thus, the positive spike from *Q1* causes *SCR1* to turn on. The resistance of *R4* is too high to permit enough current to flow through *SCR1* to latch it in. However, sufficient current is supplied by the charge on *C2* to maintain the latch until *C2* is discharged.

While *C2* is discharging, a voltage is developed across *R5* which is added to that across *C3*. This causes the anode of *SCR2* to be at the same potential as its cathode, turning it off. Since *SCR2* is the first in the SCR chain, which it turns off, the complete chain is disabled.

When the various switches are operated before the *Q1* circuit runs out of time, the relay is energized. This simultaneously applies power to the external circuit and opens the cathode circuit of *SCR1*. Thus, as long as the relay is energized, *SCR1* cannot turn off the chain

Fig. 1. The pushbuttons of the series SCR circuit must be operated in the correct sequence before timing of Q1 is complete.



PARTS LIST

- C1—15- μ F, 25-volt electrolytic capacitor
- C2—10- μ F, 25-volt electrolytic capacitor
- C3—6- μ F, 25-volt electrolytic capacitor
- K1—12-volt dpdt de relay
- Q1—2N2646 or HEP310 unijunction transis-
tor
- R1—130,000-ohm, $\frac{1}{2}$ -watt resistor
- R2, R5—270-ohm, $\frac{1}{2}$ -watt resistor
- R3—170-ohm, $\frac{1}{2}$ -watt resistor
- R4—100,000-ohm, $\frac{1}{2}$ -watt resistor
- R₇, R₈, R₁₀, R₁₂, R₁₄—1000-ohm, $\frac{1}{2}$ -watt re-
sistor
- R₉, R₁₁, R₁₃—10,000-ohm, $\frac{1}{2}$ -watt resistor
- S1, S5—Spdt pushbutton switch
- SCR1-SCR6—Silicon controlled rectifier (GE
C106Y2 or C106Y1, or Motorola HEP330)
- Misc.—14-conductor cable (may be made
from individual wires), suitable mounting
plate for switches, mounting for PC board,
power relay (optional)

even though Q1 keeps generating pulses.

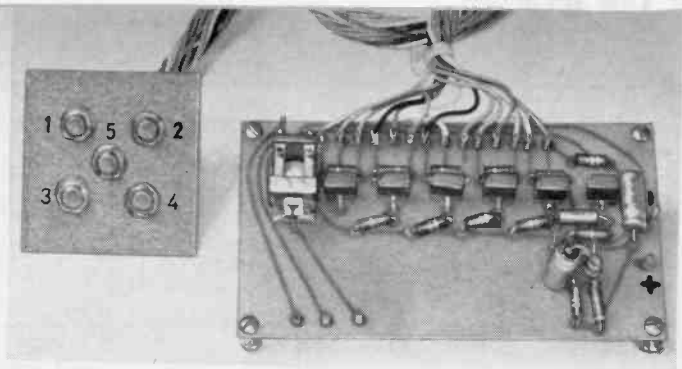
To reset the alarm, any switch other than S5 is operated. For example, if S3 is depressed, the series circuit is broken and SCR5 and SCR6 are turned off, de-energizing K1. This enables SCR1 to operate at the next UJT pulse.

Construction. The circuit is assembled on a printed circuit board whose foil pattern is shown in Fig. 2, which also shows component layout. Install the semiconductors carefully and observe the polarities of the electrolytic capacitors. Use a heat sink (such as long nose pliers) on

the leads of the semiconductors when soldering and use a low-power (35 watt) soldering iron.

In the prototype, the printed circuit board and the switch plate were built as two separate units, interconnected by a length of multi-conductor cable. In this way, the electronics board can be hidden, with only the pushbuttons available for use. The pushbuttons can be arranged in any configuration—as long as you know which is which. The combination can be changed by changing the positions of the switches. The combination shown in the prototype is 1-4-3-2-5.

Although the pushbutton panel is mounted in the open, the actual control board should be hidden from view. If higher control power is needed, the output relay can be used to operate a power relay.



If you want to decrease the 3-second timing for completion of the combination, reduce the value of R1 or C1. To make the time longer, increase the value of either of the two components.

The relay used can be any 12-volt type requiring low coil current. If the existing contacts will not carry sufficient current

for your needs, use an external relay activated through the contacts of the relay on the board.

The lock described here was designed for use with a 12-volt battery. However, if you want to use it on the 117-volt commercial power line, a simple 12-volt dc supply can be added. ♦

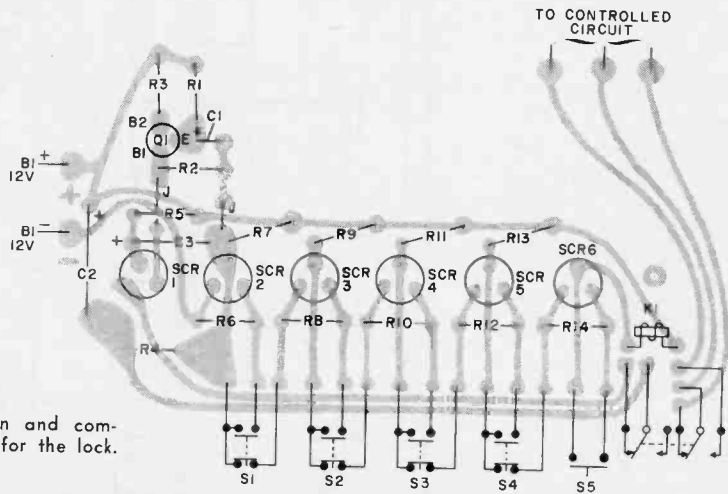
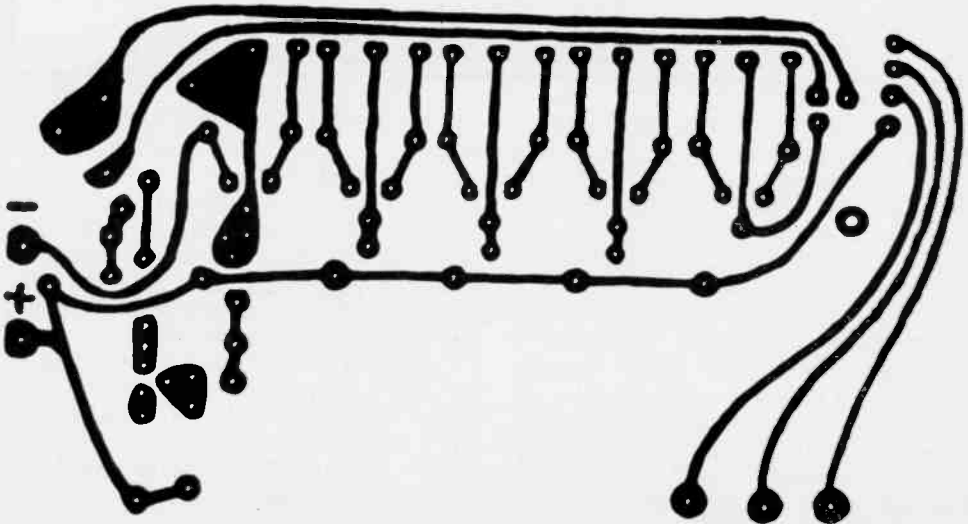
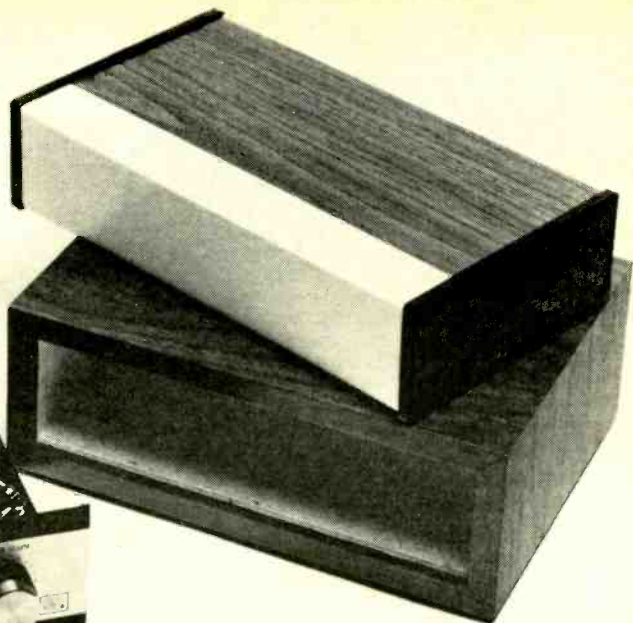
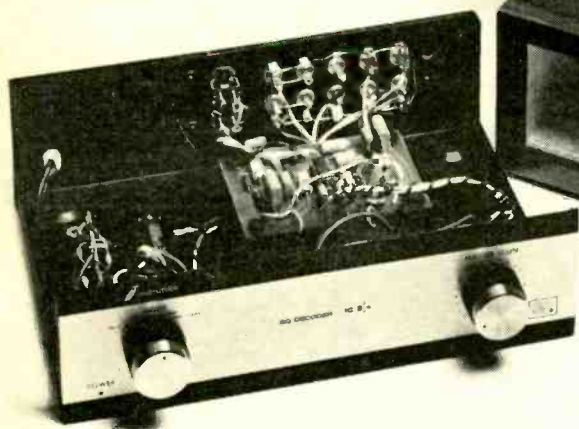


Fig. 2. Foil pattern and component installation for the lock.



The "SQ" decoder with cover removed to show PC board and wiring. The two enclosures at the right are the Ten-Tec (top) and the Instruteck (bottom). See article for details on both of these cabinets.



BUILD AN "SQ" Four-Channel Decoder

This decoder, built around an IC chip, makes an ideal home-construction project. It offers performance equal to or exceeding that of some commercially available units.

BY MURRAY ESFORMES

Vice-President, Engineering, Instruteck Corporation

FOUR-CHANNEL sound offers the promise of a new creative medium for the recording artist and an expanded spatial perspective for the listener. Investigation by CBS of the various possible methods of recording four channels on a two-channel disc has led to the development of the stereophonic-quadrasonic (SQ) matrix system. Through a suitable encoding matrix, it can be used to produce a 2-channel stereo record that can be played on a conventional phonograph and then it can be decoded back to four channels by means of an inverse matrix.

The "SQ" matrix decoder described in this article has been specifically designed, through the joint efforts of CBS Labs, Motorola, and Instruteck, to reproduce "SQ"

Quadrasonic records: CBS Labs setting the standards of performance; Motorola supplying the integrated circuit; and Instruteck fulfilling the equipment requirements for the decoder.

The "SQ" Code. To understand how the decoder operates, a bit of basic knowledge about how the signals are encoded onto the record is required. When the record is cut, the basic "SQ" code calls for the two front quadrasonic channels, L_F and R_F , to be recorded in precisely the same mode as the L and R channels of a conventional stereo disc, thus retaining full front-channel separation.

The back channels, L_B and R_B , are superimposed on the front channels so that the

Editor's Note: There are three companies, CBS/Columbia, Electro-Voice, and Sansui which have independently developed and are marketing decoders for developing four-channel sound from especially produced four-channel matrix discs.

The most publicized system is the CBS/Columbia "SQ" design. There are actually three "SQ" versions being marketed today. The one described in this article is the simplest and, obviously, the least expensive of the three. It does provide maximum separation (limited only by your program source) across the two front speakers and across the rear speakers. It provides approximately 3-dB separation from front to back. The second version, referred to as an "SQ" decoder with front-to-back logic, reduces the front and rear separation to about 14-15 dB but does increase the front-to-back separation to about 6-9 dB. The third system, and obviously the most sophisticated, is referred to as an "SQ" matrix decoder with full logic. This system will provide channel separation of 14-15 dB in all four directions, i.e., across the front and back and from front-to-back. Both the logic designs are produced today using discrete components. The circuits are quite complicated and critical to adjust and we do not think, at the moment that they are quite suitable for home construction.

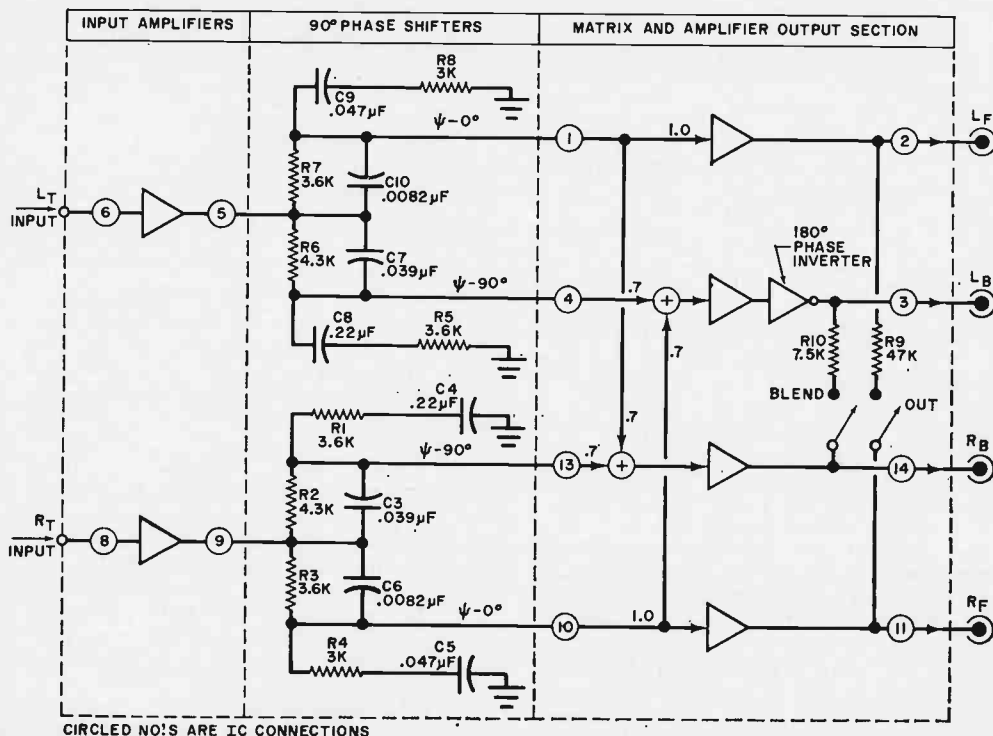
Circuit designs have been developed, based on two new integrated circuits and Motorola, the semiconductor manufacturer, hopes to have samples in the hands of manufacturers some time early this year. It is quite likely that by the time this Handbook reaches you samples will have reached the manufacturers and new designs will be worked up for the Fall market. We hope, that when these chips are available in quantity, to work up an article on the design and home construction of a full-logic "SQ" decoder. In the meantime, this simpler design is an ideal project to tackle and is an excellent way of getting involved with four-channel reproduction. This "SQ" decoder, when completed, does not require any adjustments. All of the individual component circuits are so designed that they provide proper performance.

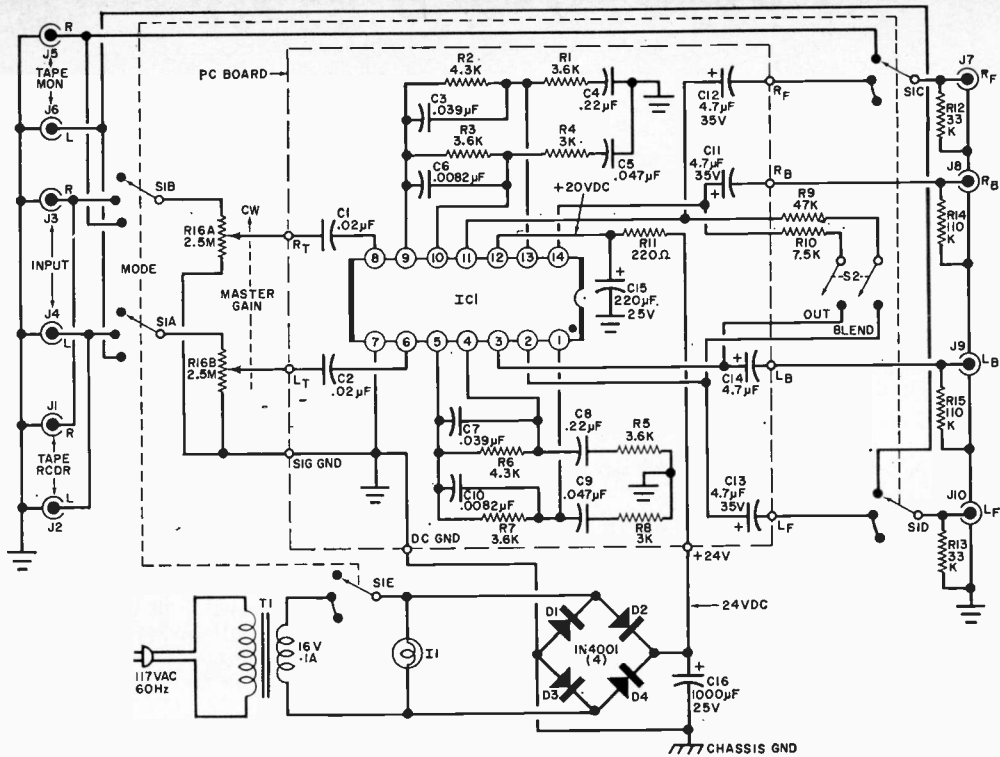
quadrature image is described by the relative phase and amplitude of the signals in the grooves. The left total signal, L_T is a combination of three signals: the left back, L_B , the right back, R_B , and the left front, L_F . The right total signal, R_T is also comprised of three signals, the

right back, R_B , the left back, L_B , and the right front, R_F . It then remains to separate the back and front signals from the total signals.

Theory of Operation. The inputs, L_T and R_T , are derived from the outputs of a

Fig. 1. Block diagram of "SQ" decoder. Circled numbers are IC connections.





C1,C2—0.02 μF , 100 V disc ceramic capacitor

***C3,C7**—0.039 μF , 100 V Mylar capacitor $\pm 10\%$

***C4,C8**—0.22 μF , 100 V Mylar capacitor $\pm 10\%$

***C5,C9**—0.047 μF , 100 V Mylar capacitor $\pm 10\%$

***C6,C10**—0.0082 μF , 100 V Mylar capacitor $\pm 10\%$

C11,C12,C13,C14—4.7 μF , 35 V electrolytic capacitor

C15—220 μF , 25 V electrolytic capacitor

C16—1000 μF , 25 V electrolytic capacitor

***R1,R3,R5,R7**—3600 ohm, $\frac{1}{2}$ W res. $\pm 5\%$

***R2,R6**—4300 ohm, $\frac{1}{2}$ W res. $\pm 5\%$

***R4,R8**—3000 ohm, $\frac{1}{2}$ W res. $\pm 5\%$

R9—47,000 ohm, $\frac{1}{2}$ W res. $\pm 5\%$

R10—7500 ohm, $\frac{1}{2}$ W res. $\pm 5\%$

R11—220 ohm, $\frac{1}{2}$ W res. $\pm 5\%$

R12,R13—33,000 ohm, $\frac{1}{2}$ W res. $\pm 5\%$

R14,R15—110,000 ohm, $\frac{1}{2}$ W res. $\pm 5\%$

R16A,R16B—2.5-megohm tandem audio-taper potentiometer

S1—5-pole, 3-pos. (per pole) selector switch

S2—Dpdt slide switch (mount **R9** & **R10** on unused throw)

T1—Power transformer 117 V; 16 V at 0.1A sec. (Stancor P-8611, use $\frac{1}{2}$ of secondary)

D1,D2,D3,D4—1N4001 diode (1 A, 100 PIV)

I1—18 V, 0.04 A pilot light (#346 or equiv.)

IC1—Integrated circuit (Motorola MC 1312P)

J1-J10—RCA-type phono jack

Misc.—Chassis (Bud #AC406), line cord, grommet, mounting hardware, etc.

*Note: Indicates close-tolerance phase-shift components. Do not substitute.

The following parts are available from Instruteck Corporation, 168 Yantic St., Norwich, Conn. 06360. Etched and drilled PC board; \$2.95. Complete set of phase-shift components (marked *) with IC1; \$13.35. Etched and drilled PC board and all parts located thereon, including **R9** through **R15** (see schematic) and **IC1**; \$19.95. Cabinet \$10.50. Decal for front panel; \$2.00.

Fig. 2. Schematic and parts list for the "SQ" decoder. Refer to the text and parts list for details on obtaining the etched circuit board, a kit containing certain of the close-tolerance components, and the decoder enclosure with a decorative front-panel decal.

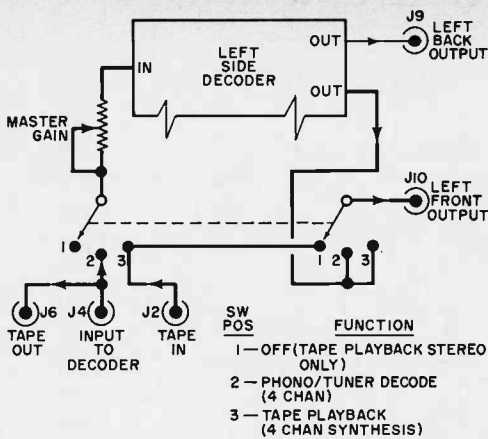


Fig. 3. Left-channel switching and signal flow. Refer to discussion in text.

standard stereo cartridge or the outputs of a preamplifier. Most popular cartridges possess reasonably well-matched amplitude and phase characteristics and can be used with this decoder.

As shown in Fig. 1, the L_T/R_T signals are applied to input amplifiers whose function it is to provide an impedance transformation with high impedance on the input so as not to load the incoming signals and low impedance on the output to drive the phase-shift networks. The signal is then split into two branches containing a reference psi-network ($\psi - 0^\circ$) and a psi-plus quadrature network ($\psi - 90^\circ$), respectively. The psi networks have been computed to provide a constant phase shift of 90° across a band of frequencies from 100 to 10,000 Hz. The merging L_T and R_T signals are fed to the output terminals, unaltered, to form the L_F and R_F outputs, while an appropriate combination of the four phase-shifted signals produces the L_B and R_B outputs. The first pair of outputs, pins 1 and 10, contains dominant L_F and R_F components which are completely isolated from each other and therefore have infinite channel separation. The second pair of outputs, pins 4 and 13, contains dominant L_B and R_B signals which are also completely isolated from each other and thus exhibit infinite channel separation as well.

Portions of signals from the front channels are combined with the back channels of the opposite side (the precise magnitude of the combining signals being indicated by numerical values at the input to the output amplifiers). The previously described circuit characterizes the basic "SQ" decoding function: provides completely discrete front and back channel performance with partial signal transfer between front and back pairs. On the output lines of the decoder, resistors

R_9 and R_{10} are connected across the front and back channels, respectively, through switch S_2 . When the switch is placed in the "Blend" position, cross-channel contamination yields a 10%-40% blend recommended by CBS for matrix operation. It is largely a matter of preference to the listener if the "Blend" mode of operation is desired, since in the unblended mode the Left/Right channel separation, both front and rear, is the greatest.

Construction. The entire decoder has been reduced to an integrated circuit which operates in conjunction with external phase-shift networks. See Fig. 2.

The integrated circuit assures a high standard of performance when used in conjunction with the specified components, not always attainable with its discrete component counterpart.

The "SQ" decoder described may be used as a separate unit, or the decoder circuitry can be incorporated into existing equipment. The integrated circuit with its precision phase-shift components are available from Instruteck as well as a more complete set of specialized parts, including an etched-circuit board.

The custom cabinet, as supplied by Instruteck, is of wood-pulp flakeboard construction with a vinyl walnut-veneer finish. It is supplied as a flat board and will have to be folded and glued at the corners.

Another alternative is a fully assembled, decorator-type cabinet supplied by Ten-Tec as the No. JW-10. For details as to the nearest dealer in your area, write to Ten-Tec, Sevierville, Tenn. 37862. This particular cabinet is just slightly smaller than the Instruteck enclosure. A chassis is also available from them, but is not required as the printed-circuit board can be mounted on the cabinet itself. With this particular enclosure you can dress up the front panel by using press-on type.

In the case of the cabinets supplied by Instruteck, you will have to obtain a Bud #AC406 chassis, or if you are handy with tools, you could bend a piece of aluminum or sheet metal into a "U" shape, $9\frac{1}{8}$ " wide \times $6\frac{3}{4}$ " deep \times $2\frac{5}{8}$ " high. Instruteck will also make available a very impressive metallic decal that can be pressed onto the front panel of the chassis.

One point should be mentioned and that is the "on-off" switch which is shown in the secondary of the power transformer. Obviously, the primary of the transformer will always be connected to the power line with this particular arrangement. The wattage is extremely low and is less than that drawn by an ordinary electric clock. For those who feel that they would prefer an "on-off" switch in the primary, there is no problem

TECHNICAL SPECIFICATIONS

Input Voltage:	0.1 to 1.0 rms
Gain: Front Channels	1.0 (typical)
 Rear Channels	0.7 (typical)
Freq. Response: Normalized	30-20,000 Hz within 2 dB (± 1 dB)
Input Impedance:	2.0 megohms (typical)
Output Impedance:	5000 ohms (max.)
Hum and Noise:	-60 dB
Phase Linearity:	$\pm 5^\circ$ from 100-10,000 Hz
(For any back-channel output referred to the front-channel output.)	
Max. Output Voltage:	2.0 V rms

in adding it to the circuit and on the front panel.

It is recommended that the copper foil side of the printed-circuit card be tinned prior to component insertion. Use a low-wattage soldering iron and small diameter, high-quality rosin-core solder. Make certain not to obstruct the holes in the printed-circuit card, especially the integrated circuit. It is also recommended that the integrated circuit be soldered in last to avoid overexposure to soldering heat.

The printed-circuit board is mounted on four plastic stand-offs in the horizontal plane but could be mounted vertically with no effect on its operation.

The ten phono jacks, providing the various inputs and outputs, should be mounted on the back vertical wall of the chassis. Insulated jacks are recommended so as to minimize ground-loop hum-inducing effects.

Connections. Normally a set of "tape-monitor" connections on the existing stereo amplifier/receiver provide the proper signal

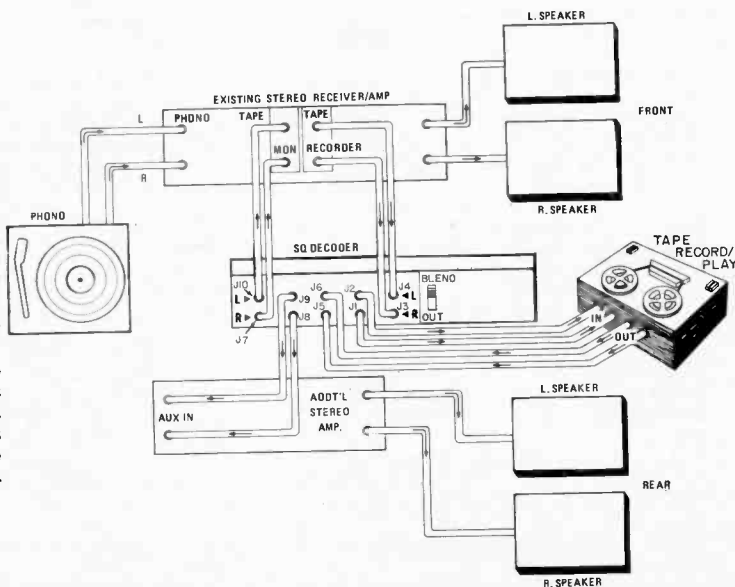
source, plus a way to return the decoded front signals to the existing amplifiers. The rear-channel signals may then be connected to an additional stereo amplifier which, in turn, is connected to a set of rear speakers, as shown in Fig. 4.

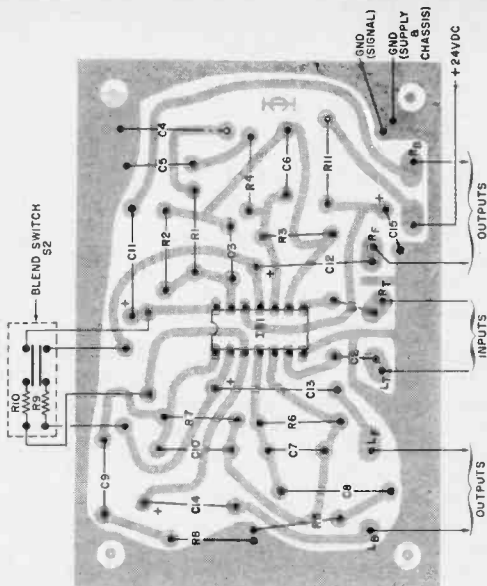
On systems lacking a tape-monitor function, minor modifications are required on the existing equipment to introduce the decoder between the program material and the amplifiers for proper decoding of the signals.

Operation. After the decoder is connected as shown in Fig. 4, power may be applied by placing the mode selector switch, *S1A* and *S1B*, in the "Phono/Tuner" position. In this mode, dc power is applied to the decoder and any program material appearing on the input terminals will be decoded. The "Master Gain" control will set the overall level of the decoded material appearing at jacks *J7*, *J8*, *J9*, and *J10*.

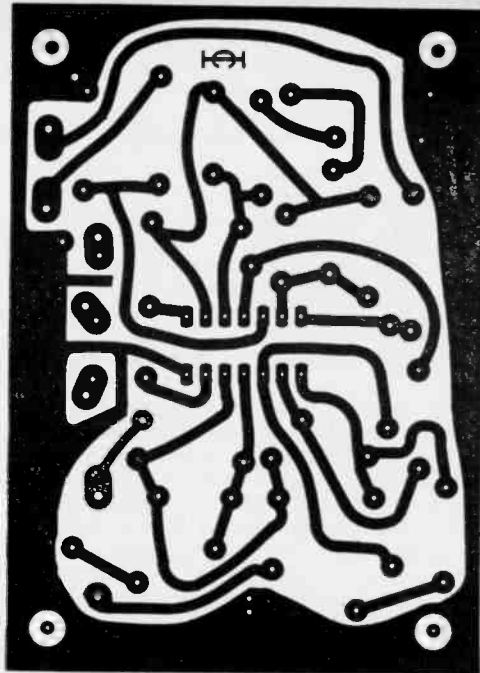
If it is desired to play a pre-recorded tape through the decoder, place the "Mode" switch in the "Tape" position and start up

Fig. 4. Decoder inter-connections. The unit is designed to be connected between the preamp and power amp of any existing hi-fi receiver or any separately housed tuner and power amplifier. It is assumed that you will be using your present hi-fi system for the two front speakers and will add the second stereo amp and its two speakers as separate components. Most of the stereo receivers on the market now have the required tape output.





Parts layout for the component side of the printed-circuit board. Tin the copper-foil side of the board prior to parts insertion. Use a low-wattage iron and a small diameter, high-quality, rosin-core solder.



Actual size PC board shown from foil side.

the player. If direct stereo operation is desired, that is, without going through the matrix circuitry, turn the decoder "Mode" switch to "Off" and normal stereo operation will result. See Fig. 3 for switching and signal flow.

Note: To introduce the decoder into the front channels, the tape-monitor function of the existing stereo must be on.

The decoder can also be used in a variety of other applications, including: (1) decode FM stereo transmissions when quadraphonic matrix program material is being broadcast; (2) play back tapes that have been recorded from quadraphonic broadcasts and/or records; (3) synthesize 4-channel operation from stereo discs, tapes, or FM transmissions. ♦

PERFORMANCE VERIFICATION

For those with access to an audio oscillator and ac voltmeter, the final performance of this decoder should be checked as follows. Note: This test should be done with the decoder disconnected from all other equipment in your audio system.

1. Equipment required: (a) an audio oscillator capable of 1.5 V rms output at 2200 Hz; (b) an ac voltmeter with 1-megohm input impedance; (c) a 620-ohm, 1/2 W resistor.

2. Set the audio oscillator to 2200 Hz, connect the oscillator to the "L" input jack (J4) of the decoder; set the output of the oscillator to 1.0 V rms as measured with the ac voltmeter. Terminate the unused input with the 620-ohm resistor.

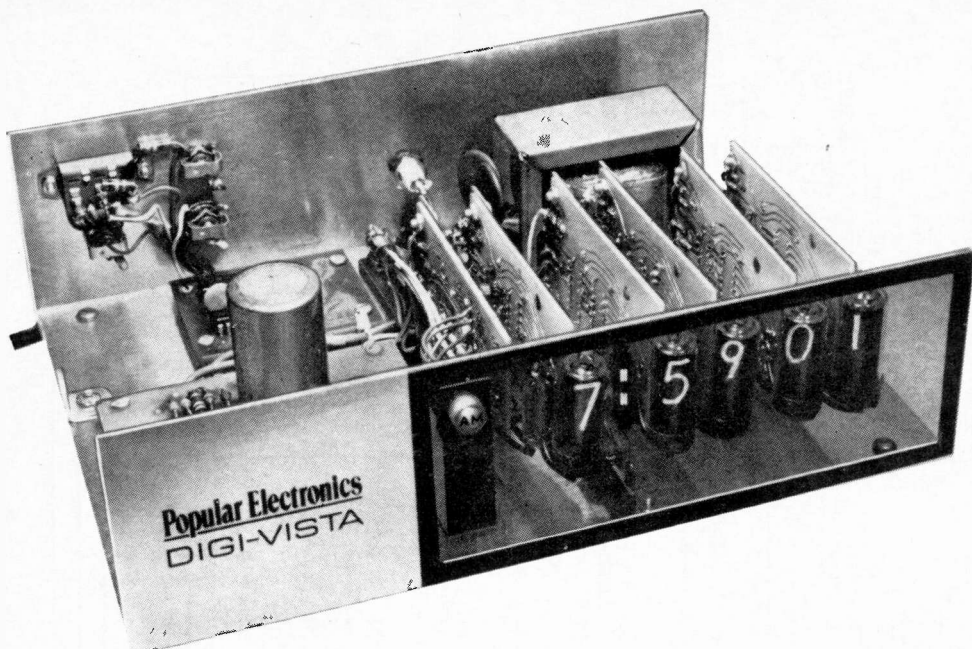
3. Place the decoder "Mode" switch in the "Phono/Tuner" position and set the "Master Gain" control to its maximum clockwise position. Set the "Blend" switch to the "Blend" position (R9 and R10 in the circuit).

4. With the ac voltmeter connected to the left-front output jack (J10), adjust the audio oscillator until the voltmeter reads precisely 1.0 volt rms (the audio oscillator output may have to be increased slightly). This is the reference setting.

5. Measure the outputs with the ac voltmeter: J9 Left-Back, 630 mV \pm 80 mV; J8 Right-Back, 630 mV \pm 80 mV; J7 Right-Front, between 50 and 100 mV.

6. Repeat steps 2, 3, 4, and 5; this time using J3, the right input jack and J7, the right-front for the reference setting and terminate the unused input with the 620-ohm resistor. Look for the following results: J8 Right-Back, 630 mV \pm 80 mV; J9 Left-Back, 630 mV \pm 80 mV; and J10 Left-Front, between 50 and 100 mV.

7. If the results of steps 5 and 6 are not attainable, then it might be wise to examine the phase shifters on the circuit board in case of wrong component insertion.



Assemble the Popular Electronics SIX-DIGIT DIGI-VISTA

ELECTRONIC READOUT TO A TENTH OF A SECOND

TRUE ELECTRONIC digital clocks are hard to find these days—most digital clocks work electrically with some type of mechanical readout. On page 129 of this same issue is a rather detailed article on a “Digi-Vista” clock, a completely electronic unit using transistor-transistor logic and Nixie® readout tubes. Described in detail in that article was a four-digit clock, which indicates hours and minutes and has a blinker to indicate every other second.

In this article we will describe the six-digit Digi-Vista. Since some of the details of theory and construction will not be repeated here, make sure you read the article on page 129 before assembling the six-digit clock.

The six-digit clock indicates hours, minutes, and seconds. The logic-flow diagram of the clock is shown in Fig. 1. The circuit is essentially the same as the four-digit version, except for the addition of a seconds decade counter and a tens-of-seconds modulo-6 counter. These two counters are the same as those previously described for the minutes and tens-of-minutes counters. And since the six-digit version actually counts the seconds rather than indicating them by a flashing lamp, only two IC's (*IC2* and *IC4*) are used on the scaler module. The one-pulse-per-second output of *IC4* drives the seconds decade counter.

The circuits of the pushbutton controls

BY CHARLES G. KAY AND DANIEL MEYER

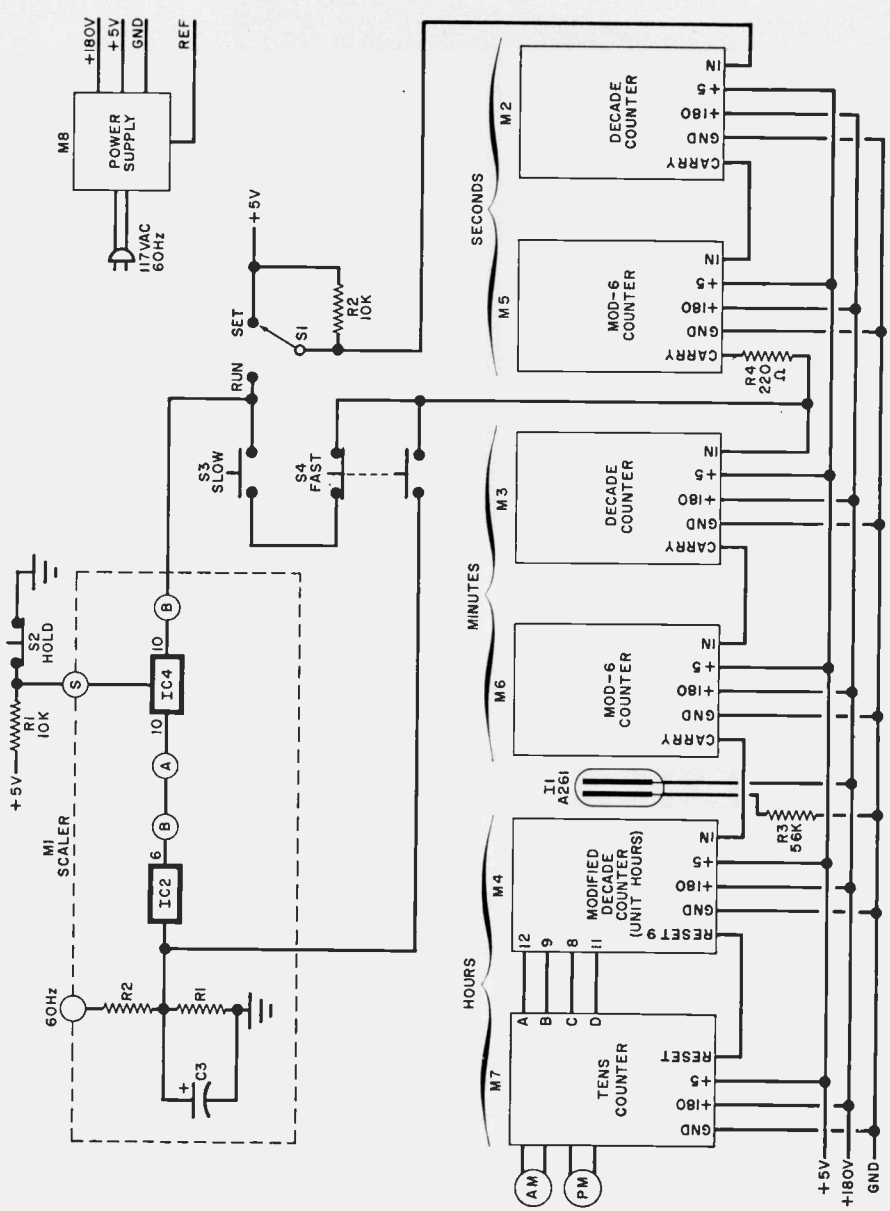
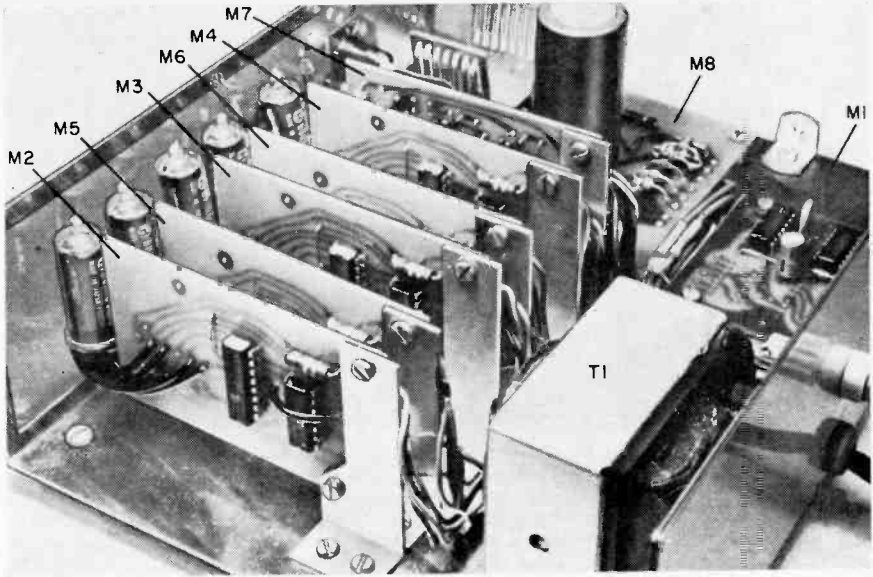


Fig. 1. The logic flow of the six-digit clock is essentially the same as the four-digit clock previously described. Because of the addition of the seconds readouts, only two IC's are used in the scaler module.



Although the prototype was built into a metal cabinet with the arrangement shown here, it could be mounted within any type of cabinet deep enough to accept the modules. The power supply and scaler can be above or below the readouts, and the operating controls hidden away.

PARTS LIST

I1—Neon lamp (optional) Signalite A261 or similar)

M1—Scaler module

M2-M4—Decade counter module

M5,M6—Modulo 6 counter module

M7—Tens counter module

M8—Power supply module

R1,R2—10,000-ohm, $\frac{1}{2}$ -watt resistor

R3—56,000-ohm, $\frac{1}{2}$ -watt resistor

R4—220-ohm, $\frac{1}{2}$ -watt resistor

S1—Spdt slide or toggle switch

S2—Spst normally closed pushbutton switch

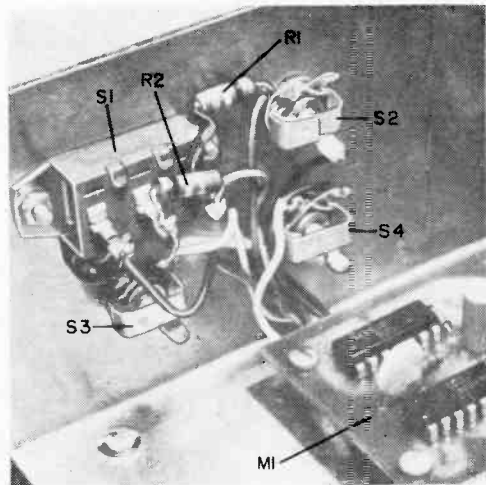
S3—Spst normally open pushbutton switch

S4—Dpdt no/nc pushbutton switch

Misc.—Suitable chassis, polarized plastic glare shield, spacers, mounting brackets, hook-up wire, etc.

Note—The following are available from Southwest Technical Products Corp., Box 32040, San Antonio, TX78216: decade counter module NX-10 at \$15, postpaid; Modulo-6 counter module NX-6 at \$15, postpaid; tens counter module CL-1 at \$8.50, postpaid (specify neon or incandescent lamp); scaler module SC-6 at \$8.75, postpaid; power supply module 169 at \$11.55, plus postage for 4 lb; polaroid plastic at 25¢/sq. in. (specify size required).

The operating controls can be mounted anywhere desired. Once the clock is set, the controls are not used, so they can be hidden from sight on the rear apron, or concealed in chassis.





The colon is made by painting black bands on a neon lamp. If desired, another colon may be used between the seconds (the two readouts on the right) and the adjacent unit minutes indicator. In this time example, the tens hours neon is not lit. To reduce glare and to increase the readout contrast, mount a length of polarized material so as to completely cover the entire readout. Place the polarized material on a shiny metal surface and determine which side reduces the glare most. This will be the side that should be facing the viewer. Use adhesive to fix it in place.

have been changed slightly and a new HOLD pushbutton has been added. When the latter is depressed, counting is stopped and does not start again until the button is released. This permits the user to set the clock to some predetermined time and, when the standard time source (WWV, CHU, or other form of time tick) is correctly indicated, start the clock at the desired point.

Like the four-digit unit, this clock has an a.m./p.m. indicator and can be fitted with an optional alarm circuit. If desired an ad-

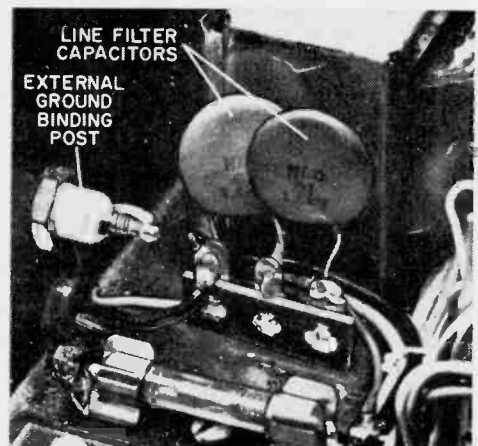
ditional A261 neon lamp, with parts blanked out to make it look like a colon, can be mounted between the minutes and seconds to separate the readings. All modules are the same as those used in the four-digit clock.

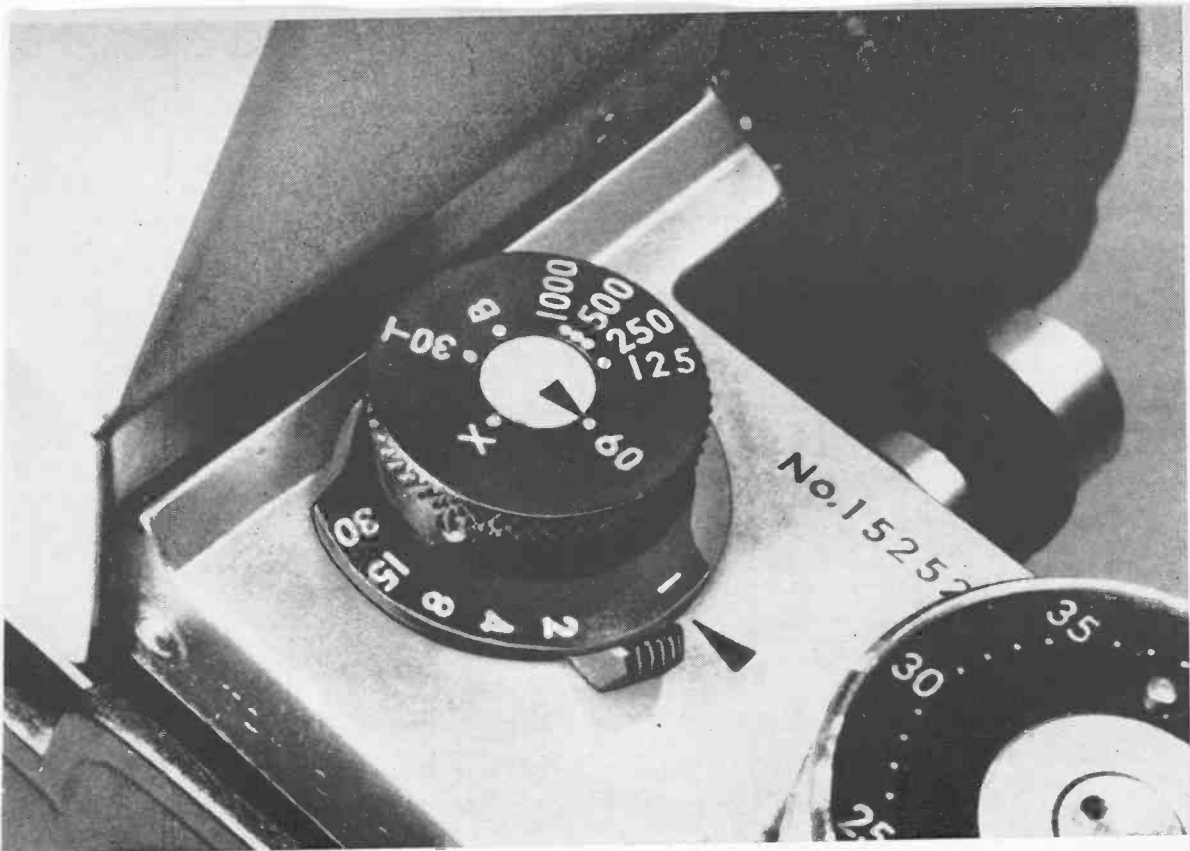
To reduce the possible effects of line transients, each side of the input ac line can be decoupled to an external ground through a pair of 0.1- μ F capacitors with the common capacitor point connected to a five-way binding post. The binding post is connected to a good ground. ◆

Operating controls should be clearly identified wherever they are located. Ordinary press-on type (available at all art stores) can be used for this.



If you experience erratic timekeeping due to a noisy ac line, connect a capacitor from each side of the line to a good ground, via a binding post.





Assembling a **CAMERA SHUTTER SPEED METER**

ONE TO ONE-THOUSANDTH MEASUREMENTS
WITH REASONABLE ACCURACY

A peak-reading voltmeter activated by a phototransistor is calibrated for the range between 1.0- and 0.001-second shutter speeds. The voltmeter circuit uses a high-quality capacitor and a MOSFET. The builder can make his own meter coincide with the scale illustrated through manipulation of the various internal calibration controls.

HOW OFTEN have you wondered whether the shutter speeds marked on your camera are correct? Have you ever missed an important, unrepeatable shot because of over- or under-exposure and considered whether your camera's shutter was at fault?

If you have, you probably took your cam-

era to the repair shop to have it checked. For little more than it cost for that one check-up you can build your own Shutter Speed Meter so that you can check your camera anytime you have a suspicion that it is not performing properly. You can also use this device to check your camera for cold-weather operation.

Shutter speed ranges are 1 to 1/10 sec, 1/10 to 1/100 sec, and 1/100 to 1/1000 sec. In measuring shutter speed, the camera is placed on the pickup unit with a light source over the camera. Then the RESET button is pushed and the shutter is released; shutter speed is read directly from the single-scale meter. Any camera may be checked, whether it has a focal-plane or between-the-lens shutter. The

BY WILLIAM COOMES

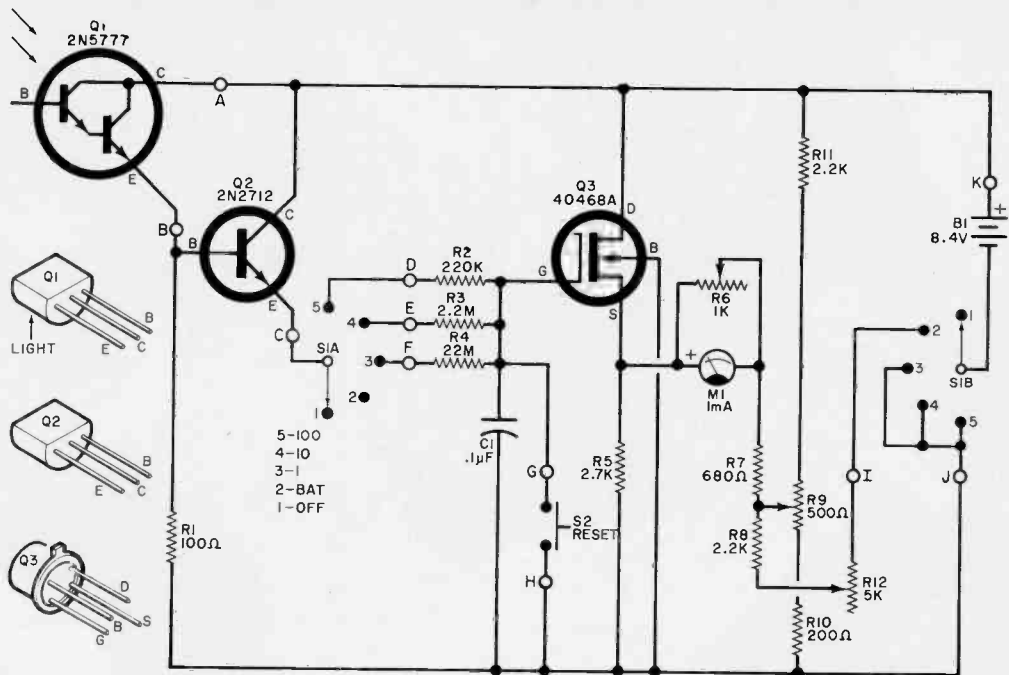


Fig. 1 The circuit is essentially a very high input resistance d.c. voltmeter with a MOSFET. It measures charge on capacitor C_1 , which is a function of how long light is applied to Q_1 .

meter retains a reading for several minutes, depending on the quality of the parts used.

Construction. The Shutter Speed Meter consists of two physically separate sections: a light-sensitive transistor in its own case and an electronics package on which the meter readout is mounted.

The schematic of the circuit is shown in Fig. 1. A foil pattern for a printed circuit board and component mounting layout are shown in Fig. 2. The printed circuit board was designed to mount directly on the meter terminals. If you do not want to use the PC board, assemble the circuit on perforated board following the same layout. Note that 5% resistors are used for R_2 , R_3 , and R_4 to obtain nominal accuracy. For greater accuracy use 1% resistors. It is also important that capacitor C_1 be hermetically sealed (glass or ceramic with metal) and of high quality. If you use the foil pattern, the potentiometers specified in the Parts List cannot be substituted.

A silicon transistor with low leakage must be used for Q_2 . Transistor Q_3 is a MOSFET and must be carefully handled. The MOSFET is shipped with a shorting ring around its four leads to prevent the possibility of elec-

PARTS LIST

- B_1 —8.4-volt mercury battery
- C_1 —0.1- μ F, hermetically sealed capacitor (Sprague 96P-10491 or similar)
- M_1 —0.1-mA, d.c. meter (Calectro D1-9)2 or similar)
- Q_1 —Phototransistor (G.E. 2N5777 or Motorola MRD100 or HEP 312)
- Q_2 —2N2712 transistor
- Q_3 —MOSFET (RCA 40468A)
- R_1 —100-ohm
- R_2 —220,000-ohm, 5%
- R_3 —2.2-megohm, 5%
- R_4 —22-megohm, 5%
- R_5 —2700-ohm
- R_7 —680-ohm
- R_8 , R_{11} —2200-ohm
- R_{10} —200-ohm
- R_6 —1000-ohm potentiometer (Clarostat U39 or similar if PC board is not used)
- R_9 —500-ohm potentiometer (Clarostat U39 or similar if PC board is not used)
- R_{12} —5000-ohm potentiometer (Clarostat U39 or similar if PC board is not used)
- S_1 —2-pole, 5-position rotary switch (Calectro E2-163 or similar)
- S_2 —Momentary pushbutton switch
- Misc.—Plastic cases (Lafayette 99E62721 and 99E80722 or similar), printed circuit board, battery holder, transistor socket, felt, wire, solder, etc.

All resistors
1/2-watt

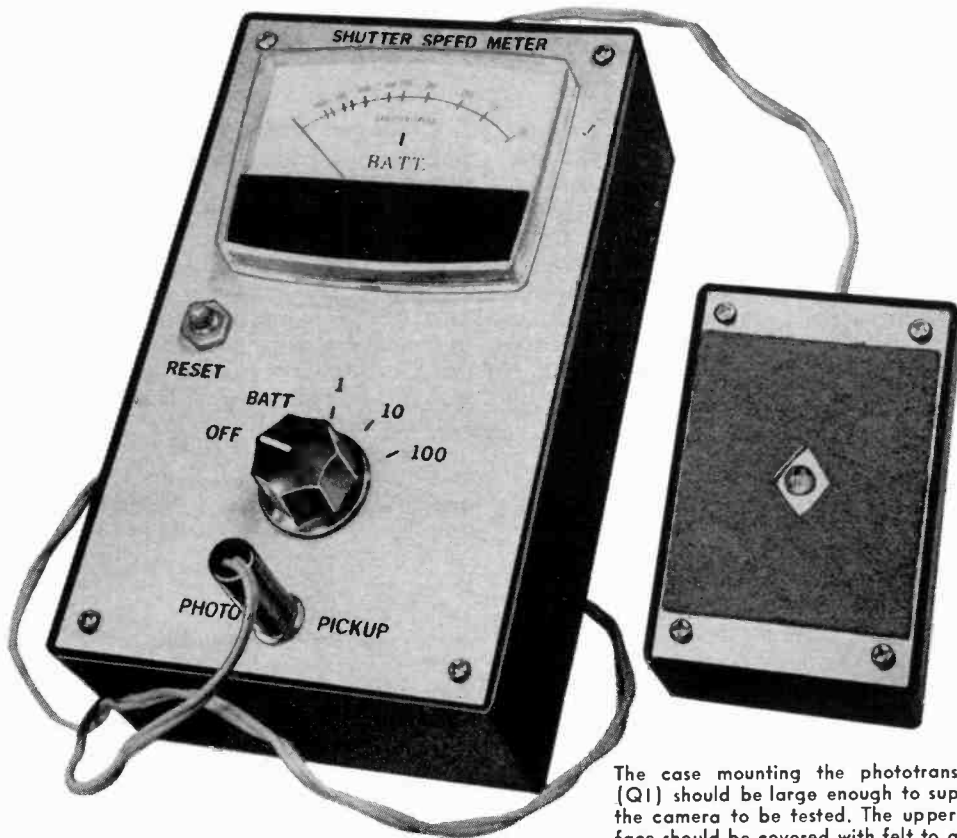
trostatic charges accumulated on the fingers from damaging the transistor's gate. *Do not remove* this shorting ring until after the device has been installed in the circuit. If a shorting rivet is supplied, wind a single turn of copper wire around the four leads, remove the rivet, and leave the wire in place until construction is complete. When soldering Q3 into the circuit, use a heat sink on the leads and a small soldering iron rather than a soldering gun since it is possible for the magnetic field created by a soldering gun to damage the MOSFET. For further safety, ground the metal frame of the soldering iron. If, after construction is complete, you have to make any wiring changes, install a shorting wire around the MOSFET leads.

To remake the meter face, gently remove the front of the meter, taking care not to bend the needle, and carefully remove the meter scale. Cut out or copy the scale shown in Fig. 3 and put it on the meter face. Carefully reassemble the meter, making sure that the mechanical zeroing adjustment is properly aligned.

The printed circuit board and other components, including the meter, are mounted in a 6" x 3 3/4" x 2" plastic box with a metal cover as shown in the photographs. Drill the required mounting holes for the meter so that the top of the meter is about 1/2" from the top of the panel. Drill the mounting hole for rotary switch S1 below the meter, on the panel centerline. RESET switch S2 can be located in any convenient place on the front panel. In the prototype, a miniature earphone jack was used to connect the phototransistor box to the meter box but the wires can be passed through a small hole in the box just as well.

Mount the printed circuit board on the meter terminals and tighten the nuts. This automatically makes the required electrical connections between the meter and the circuit. Mount the battery in a holder secured to the case. Use mercury batteries for stability. Wire up the circuit as shown in Fig. 1, but do not assemble the meter on the box until after calibration.

The box holding phototransistor Q1 must be large enough to support the camera to be



The case mounting the phototransistor (Q1) should be large enough to support the camera to be tested. The upper surface should be covered with felt to avoid scratching the face of the tested camera.

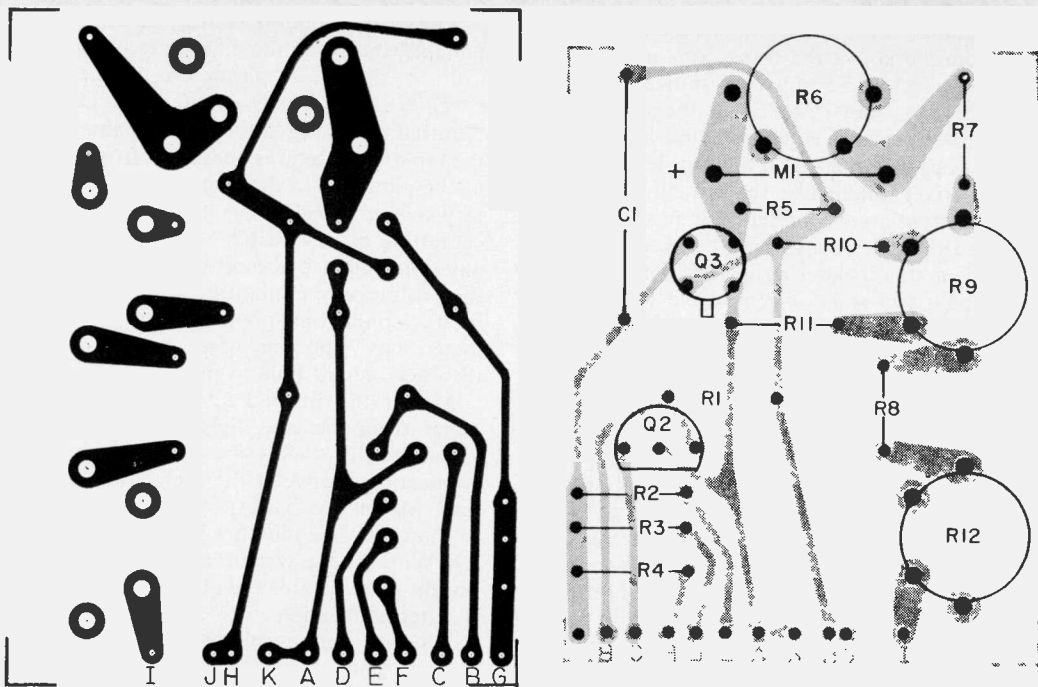
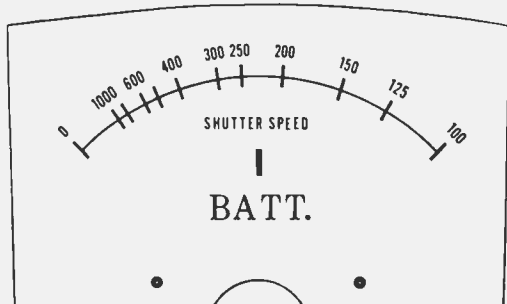


Fig. 2. Make printed circuit board using the actual size foil pattern at left. Install components as shown at right. Board is supported directly on meter terminals and should be drilled accordingly. Alter layout if potentiometers in Parts List are not used.

tested. Drill a hole slightly smaller than the sensitive face (the rounded part) of the phototransistor at the center of the upper panel. Cement the phototransistor to the panel so that the light-sensitive surface is visible through the drilled hole. Attach a piece of felt to the upper surface of the case, cutting out a hole to match the phototransistor hole, to protect the camera finish. In the prototype a transistor socket was used for the *Q1* leads with the cable to the meter box attached to the socket.

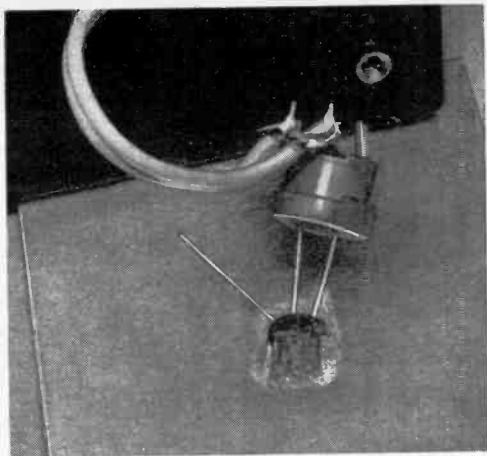
Fig. 3. Cut out or copy this meter scale and substitute it for the original 0-1-mA meter scale.



Checkout and Calibration. If at any time during the following tests, the meter deflects hard below zero, check out the instrument before installing it in the case. Place switch *S1* to OFF and install the battery. Note that the meter needle rests on the left-hand zero mark. If it does not, gently adjust the mechanical zero setting until it does. Place *S1* in the BATT position and note that the meter deflects to the BATT position on the scale. Adjust *R12* if it does not. A new battery may indicate slightly above the mark.

Connect the phototransistor to the circuit and place it near a bright light. Switch *S1* can be in any position (1, 10 or 100). Note that the meter starts to indicate upscale. Remove the light source and note that the meter indication does not change. With the meter indicating upscale, depress *S2*, the RESET switch. The meter should drop to zero immediately. Adjust *R9* to make the zero exact. Repeat this procedure a couple of times, making sure that the meter drops to zero whenever *S2* is depressed.

The next step is calibration. If you have access to a time-interval counter, all you have to do is measure the length of time that charging voltage is present across *C1* when a shut-



Phototransistor is cemented with epoxy to metal lid using a socket to make necessary connections.

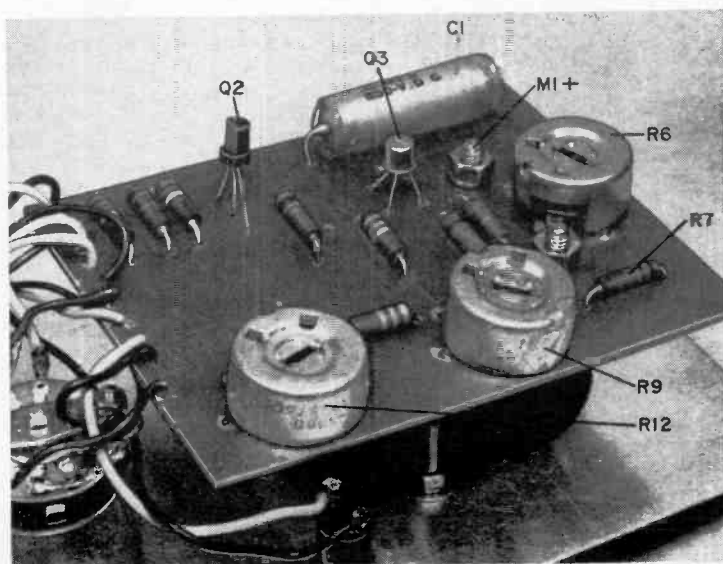
To use meter, camera back is removed and camera is placed on the phototransistor mount. Very bright light source is used to activate the phototransistor when the camera shutter is operated. Be sure the light source is bright to insure the complete saturation of the phototransistor.



ter is tested and adjust $R6$ so that the meter indication matches the counter reading. If you don't have a digital counter, you can use a camera having a 1-sec shutter that is known to be accurate and, using it as a model, adjust $R6$ to get a 1-sec reading on the meter. Depress the RESET button after each test. Another means of calibration is to disconnect $Q1$ temporarily and apply 1.6 volts (a fresh flashlight cell will do) across $C1$. Then adjust $R6$ until the meter indicates exactly full scale.

Operation. Before using the Shutter Speed Tester, always check the battery condition and then depress $S2$ to zero the meter. Make sure the camera lens is wide open. To test the camera shutter speed, remove or open the camera back and place the camera on top of the phototransistor unit. Make sure that

The board mounts directly on the meter terminals and is wired to the front panel components. Be sure to observe the special precautions before handling $Q3$.



Q1 is directly under the center of the space occupied by the film.

Place a strong light source (such as a high-intensity lamp) over the camera not more than a couple of inches away from the lens. A camera with a between-the-lens shutter may be placed with the lens up or down, while types with focal-plane shutters are placed with the back down.

To read the shutter speed, turn on the lamp, select the shutter speed and cock the shutter. Momentarily depress the RESET button and note that the meter indicates zero. Then operate the shutter release. The meter pointer will rise to the correct shutter speed and remain steady. Over a period of several minutes, the meter pointer will slowly drift up-scale.

Besides checking the shutter for accuracy, you can also check its consistency. Take several readings at each shutter speed and note how closely the readings agree. A slight varia-

tion is normal; but if one or more readings differ greatly, the shutter's mechanical operation should be checked.

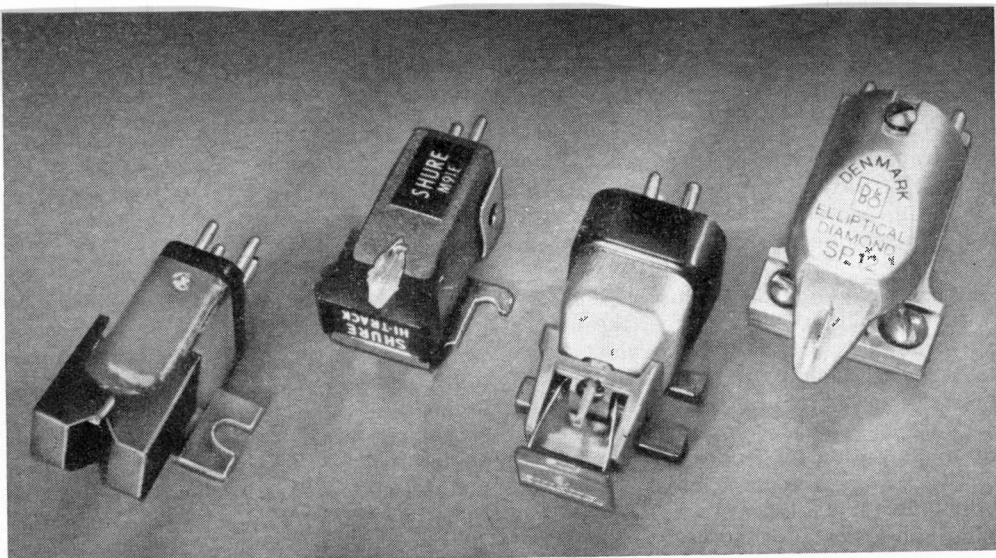
If you make photographs in cold weather, you can get some useful information by running a series of temperature tests. Place the camera in a refrigerator (or outside if it is cold) for a couple of hours to allow all moving parts to get cold. Then make a series of shutter-speed tests before the camera has had time to warm up. You may have to remove the lens so that moisture condensation will not block the light—or you can use a stronger light source. You will probably find that the shutter slows down somewhat at low temperatures; but if it becomes inoperative, special low-temperature lubrication must be used.

If, at any time, you find that your shutter is not operating properly, do not attempt to repair it yourself unless you are expert at the job. Take it to a professional and save time and money. ♦

NATIONAL WEATHER BROADCASTS

The National Weather Service operates a number of weather report stations throughout the United States. Locations of these stations are listed below. These stations have a nominal range of 50 miles. Their transmissions consist of taped weather observations, forecasts, and warnings, repeated every 4 to 6 minutes, updated every two hours, except in cases of emergencies.

Location	Frequency	Galveston, Texas	162.55	Norfolk, Va.	162.55
Akron, Ohio	162.55	Hilo, Hawaii	162.55	Oxnard, Calif.	162.40
Anchorage, Alas.	162.55	Honolulu, Hawaii	162.55	Pensacola, Fla.	162.40
Astoria, Ore.	162.55	Hyannis, Mass.	162.55	Portland, Maine	162.55
Atlanta, Ga.	162.55	Indianapolis, Ind.	162.55	Portland, Ore.	162.55
Atlantic City, N.J.	162.40	Jacksonville, Fla.	162.55	Rockland, Maine	162.40
Baltimore, Md.	162.40	Kansas City, Mo.	162.55	Sacramento, Calif.	162.40
Baton Rouge, La.	162.45	Lake Charles, La.	162.55	Salt Lake City, Utah	162.55
Brownsville, Texas	162.55	Los Angeles, Calif.	162.55	San Diego, Calif.	162.40
Boston, Mass.	162.40	Miami, Fla.	162.55	Sandusky, Ohio	162.40
Buffalo, N.Y.	162.55	Milwaukee, Wis.	162.40	San Francisco, Calif.	162.55
Charleston, S.C.	162.55	Minneapolis, Minn.	162.55	Savannah, Ga.	162.40
Chicago, Ill.	162.55	Mobile, Ala.	162.55	Seattle, Wash.	162.55
Cleveland, Ohio	162.55	Monterey, Calif.	162.40	Seward, Alas.	162.40
Corpus Christi, Texas	162.55	Morehead City, N.C.	162.40	St. Joseph, Mo.	162.40
Dallas, Texas	162.40	Mt. Huleakala, Hawaii	162.40	St. Louis, Mo.	162.55
Denver, Colo.	162.55	New London, Conn.	162.40	Tampa, Fla.	162.55
Des Moines, Iowa	162.55	New Orleans, La.	162.55	Washington, D.C.	162.55
Detroit, Mich.	162.55	New York, N.Y.	162.55	West Palm Beach, Fla.	162.40
Erie, Penna.	162.40			Wichita, Kansas	162.55
Eugene, Ore.	162.40			Wilmington, N.C.	162.55
Eureka, Calif.	162.55				
Ft. Worth, Texas	162.55				



15 Things We Do Know About Phono Cartridges

HOW TO INTERPRET MANUFACTURERS' SPECS

WHO WAS the first person to suspect that it was impossible for a phono cartridge to track perfectly the indentations in a tiny groove on a recording? Possibly it was Edison since he undoubtedly encountered the problem, although the mechanical arrangement and materials he used were quite different from those we know today. At any rate, through the years it has been calmly accepted that perfect tracking is impossible.

For a while, designers of reproduction systems simply made the stylus do what they wanted it to by increasing the tracking force until the stylus had to stay put in the groove. This had its obvious disadvantages; and though today they still recognize the fundamental dilemma, designers have been learning what the problems are and finding better ways of circumventing them than by the use of brute force.

Improvements in cartridge design are by no means the least important in the changes that have been made to get better tracking. While no cartridge is yet

perfect, the past few years have seen an end to the worst imperfections that made disc reproduction an audiophile's headache. However, in picking a cartridge, be aware that they are not all the same—and not all equally good. So check yourself out on these fifteen points (arranged alphabetically for ready reference):

Compliance. As the stylus rides in the groove of a record, there is a great deal of actual contact pressure between the two. This pressure is a result of nothing more than the applied tracking force in an unmodulated groove. When the groove starts pushing the stylus around, contact pressures can rise considerably above 24 tons per square inch and the amount of rise depends on how much the stylus resists the groove's efforts to move it. When the resistance to movement is significant, groove destruction does take place, and the stylus starts to rattle around between the groove walls to produce the familiar shatter of tracking distortion.

For many years, cartridge designers were convinced that both record wear and tracking distortion stemmed from excessive stiffness of the stylus's flexible mounting. Manufacturers tried to "out-compliance" one another until some styli were barely rigid enough to keep the tone arm following the stylus movement. Today, compliance is no longer the limiting factor in trackability of most cartridges—although some designs intended for use in second-rate tone arms are made to have less compliance than the top-flight precision products. High compliance didn't solve the trackability problem anyway; it just helped. Obviously, something else was involved, and the culprit now seems to be stylus inertia or moving mass.

Distortion. One of the difficulties in evaluating cartridge performance is the lack of meaningful measurements for audible distortion. Audio testing organizations customarily publish harmonic and intermodulation distortion figures, but these do not gauge what we hear as tracking distortions. They only measure things which usually (but not always) accompany it. Trackability measurements are more to the point, but these too are useful only for comparisons among different cartridges, since it is possible for one pickup that is tracking better than another to sound as though it were tracking worse—purely as a result of differences in other aspects of the reproduced sound.

Very small amounts of amplifier distortion can make tracking distortion sound much worse than it really is, as can high-frequency peaks in the cartridge and/or loudspeakers; while a response dip in the upper frequency range can make a phono cartridge sound as if it were tracking more cleanly than it actually is.

Durability. Few good cartridges will withstand a clumsy "finger-dusting", but the days when an initially excellent pickup would go to pot in a few months because of hardening of the flexible stylus suspension seem largely behind us. With today's stylus-saving low tracking forces, though, many cartridges will start to sound sour for this reason long before the stylus displays audible signs of wear. This is a

bit of an annoyance but it is better than having a worn stylus chewing up discs before the wear becomes audible. Styli should be checked once a year anyway—just to make sure.

Elliptical Styli. The elliptical stylus was a result of observations that, while high-frequency modulations are best followed by an extremely small-radius stylus, radii below a certain size tend to ride in the bottom of the groove instead of staying propped up between the groove walls.

Combining small side radii with a rather large front and back radii produced the elliptical tip.

Ellipticals do generally sound cleaner in the inner grooves of "difficult" discs (compared to spherical styli), but the gain is not achieved without some losses. Because the stylus/groove contact area of an elliptical is smaller, contact pressure at a given tracking force is considerably higher. Reducing the tracking force can help to offset this, but it cannot cause a concomitant decrease in contact pressure against the walls of a *modulated* groove since the compliance and moving mass figures of an elliptical cannot be made any better than those of a spherical. As a consequence, the 0.7×0.2 -mil elliptical that is tracking cleanly at around 1 gram will do more damage than a 0.7-mil spherical tracking at 3 grams.

Only when the spherical is starting to mistrack on passages where the elliptical is clean will their rate of record wear be about the same. And a good spherical will track the vast majority of discs of serious music as cleanly as a good elliptical. So light tracking force alone is no guarantee of low record wear; the tracking force must be equated with groove/stylus contact area.

Frequency Response. Of the qualitative measurements that can be made on cartridges, a check of frequency response reveals the most information about how a cartridge actually sounds—or how it makes the record sound. The sound should, of course, be as much as possible like that from the master tape from which the disc was cut, but the recent mania for improved trackability has tended to obscure the fact that most current designs do not produce sounds like those

from the tape. And much of the blame for this lies with the elliptical stylus.

Because of the differences in groove-contact characteristics, ellipticals tend to have a broad response dip in the "brilliance" range that sphericals do not. Thus ellipticals sound rather muted and "soft" by comparison. One of the most highly respected top-priced ellipticals, noted for its clean tracking, has a substantial dip in the brilliance range which, apart from making it sound dull, makes it sound cleaner tracking than it is.

A second factor which is somewhat against ellipticals results from the fact that recording studios use spherical cartridges in judging what they're putting on their discs. The improved high-frequency tracing of the elliptical causes a rising high end on discs that were cut to sound flat.

Some ellipticals do sound quite "tapey," though two of the most accurate disc reproducers available (Decca 4RC and Stanton 681A) are spherical.

Magnetic Attraction. This was a problem when some cartridges (Ortofonos, Deccas) were used with iron or steel turntable platters and the cartridge's magnet would draw it toward the platter causing a drastic and inconsistent increase in tracking force. It is seldom a problem today since virtually all transcription turntables and many record changers have aluminum platters. If in doubt, check the platter before using it with a cartridge that has its magnet or pole pieces close to the stylus tip.

Moving Mass. This is another term for inertia—which is the mechanical characteristic that makes any object "want to" retain its present state of motion (or rest). When a disc groove is undulating 20,000 times per second (half cycle of a 10,000-Hz signal), it takes little stylus inertia to make the groove's task an impossible one. The lighter the stylus and its supporting member, the more readily it follows the groove's high frequency undulations, the less record wear there will be, and the cleaner the sound will be. Unfortunately, lightness entails fragility, so a practical stylus assembly must be a compromise. This is one area in which different cartridges have significantly

different attributes and trackabilities.

Noise. Until the vinyl disc was invented, subtleties of noise like amplifier hum and hiss were usually covered by the noise of the shellac record surface. Today's disc is virtually noiseless (when new), so the temptation to play it at high listening levels reveals hum tendencies that might have gone unnoticed as recently as five years ago. In response to this, cartridges and turntables now have better shielding than ever before so that, with a few notable exceptions, it is no longer necessary to "mate" cartridge and turntable for minimum hum.

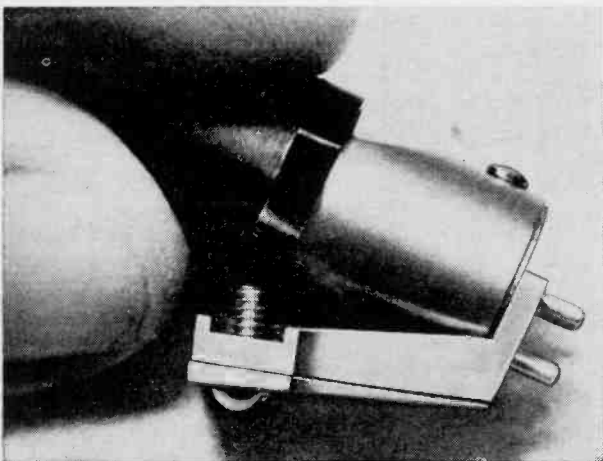
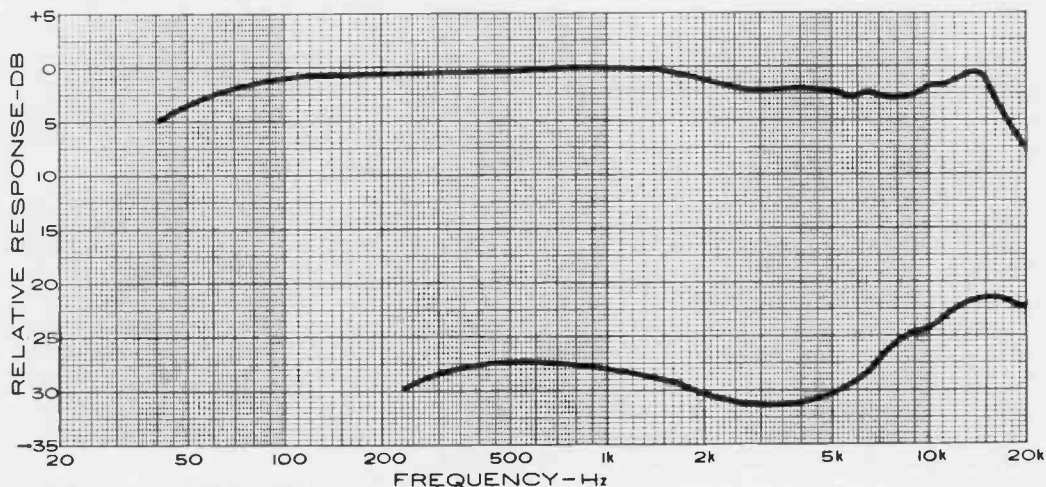
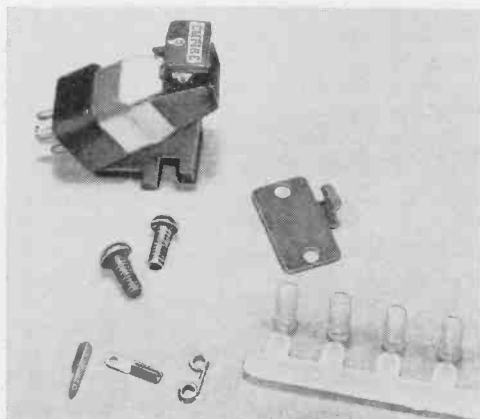
Price. The picture here has changed from what it was a few years ago when you had to pay top price for a cartridge that wouldn't butcher your discs. Prices at the top are still about what they were five years ago, but the money buys you a better cartridge. And of course, now you can buy a high-compliance, low-mass light-tracking cartridge (such as the Goldring G-850) for under \$10.

Record Wear. Low tracking force in itself is not what makes a cartridge easy on record grooves. What is important is the ability to track with a low force without incurring mistracking during loud passages since this is an indication that the stylus compliance is high enough and its moving mass is low enough to offer minimum resistance to the groove's thrusts.

Obviously, stylus-to-groove contact pressure is lowest on each groove when the total applied force is equally divided between the two contact points. When the stylus encounters a modulation it can't follow readily, it tends to press more heavily against that groove wall and less heavily against the other. There still may not be serious groove damage, though, since vinyl is resilient enough to spring back somewhat after such an assault. But when the stylus meets a really impossible modulation, it tends to plow right in and lose momentary contact with the other wall of the groove. Each time it regains contact, it does so with tremendous pressure and an audible click. It is a rapid succession of these clicks that causes the shattering sound of acute mis-

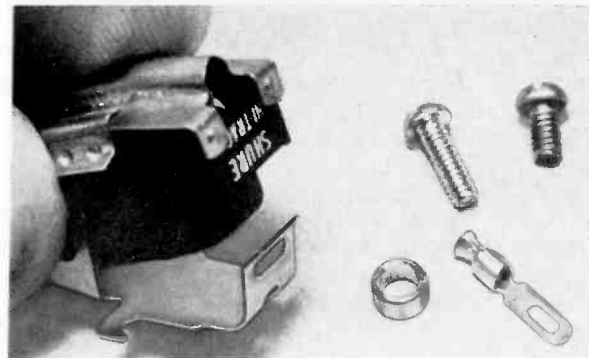
GETTING THE CARTRIDGE MOUNTED

All four of the stereo phono cartridges shown on these two pages use slightly different mounting techniques. Manufacturers have refined the process of cartridge mounting to virtually eliminate tracking error and still insure ease and convenience in performing what was once a nuisance undertaking. At right is the Empire 999VE/X, one of the more highly rated cartridges in \$80 (list) price bracket. Two sizes of molded plastic screws are provided to secure cartridge clip to special mounting bracket (not shown). Cartridge is then easily snapped in place and leads connected. Stylus removal is also quite simple and nameplate guard shown in photo protects stylus in transit. Practically every cartridge you buy includes mounting hardware and some form of stylus protection.

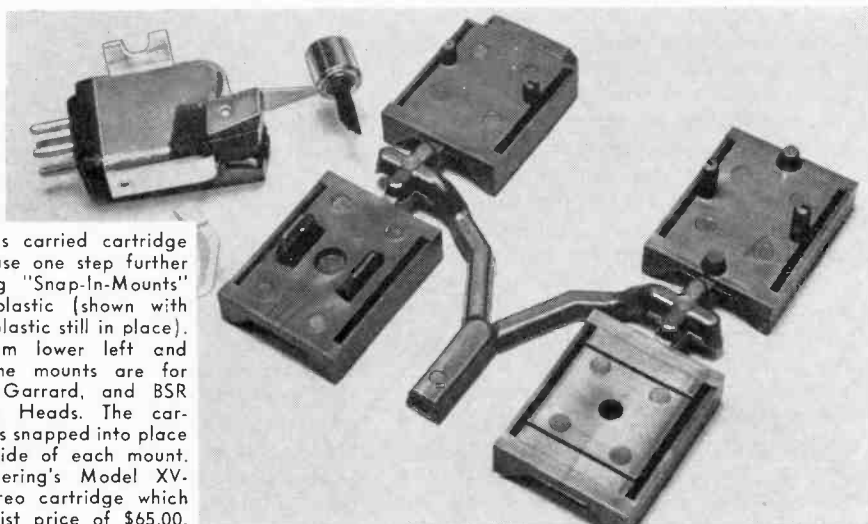


Frequency response graph above was made from test measurements on an Empire 999VE/X. Note the relatively smooth top curve which indicates the overall left channel response. The lower curve shows response in the right channel due to crosstalk from the left channel—indicating stereo separation. A graph of phono cartridge response is usually published in magazine evaluation reports.

Cartridge at left is the Danish import from B&O labelled SP-12 and selling for \$75.00 (list). Like the Empire above it has an elliptical stylus. Note the removable wedge supplied by the manufacturer to correct cartridge mounting in a record changer where the record stacking would drastically alter the preferred 15-degree vertical tracking angle.



The Shure M91E cartridge (left) has an elliptical stylus with a metal guard—shown here under the photographer's index finger. Cartridge is partially disengaged from "Easy-Mount" snap-in bracket which would normally be attached to tone arm head or plug-in shell. As mentioned elsewhere, cartridges are supplied with a variety of mounting hardware and a few examples are shown here—mounting screws (two types with American and British threads), washer/spacers, and lead clips. Most record players and changers are sold with clips soldered to the fine wire leads passing through the tone arm—and color-coded to boot. Mounting has been simplified by standardizing on $\frac{1}{2}$ " (12.7 mm) center-to-center for the two retaining screws that hold the mounting bracket to tone arm shell.



Pickering has carried cartridge mounting ease one step further by supplying "Snap-In-Mounts" cast from plastic (shown with connecting plastic still in place). Starting from lower left and clockwise, the mounts are for Dual, BSR, Garrard, and BSR Single Hole Heads. The cartridge itself is snapped into place on reverse side of each mount. This is Pickering's Model XV-15/750E stereo cartridge which sells for a list price of \$65.00.

tracking. And the groove can't take this kind of abuse. Each click is a sign that the stylus has plowed too deeply into the modulation for the vinyl to recover and the resulting permanent indentations in the groove will continue to sound fuzzy under any condition.

Since the groove is V-shaped, high tracking force helps to overcome the tendency toward momentary losses of contact with either groove wall, thus making the sound cleaner. But if the stylus is still plowing into modulations, fairly clean tracking is no assurance that the record isn't being damaged.

It is the *ability* to track cleanly at a low force that is important, rather than the actual tracking force. A high tracking force accelerates record wear to a degree but the damage is not usually as great as that incurred when a cartridge

is allowed to mistrack on an occasional disc. That is why, even though a cartridge may be able to track most discs cleanly at $\frac{3}{4}$ of a gram, record wear may be less when tracking force is higher—perhaps 1 gram.

Separation. Nearly all modern stereo phono cartridges with pretensions to fidelity have more than the 25 dB of separation through the mid-frequency range that is needed to achieve subjectively total channel isolation. When separation appears to be less, it is usually that way on the disc. Cartridges do still vary rather widely in high-end separation, and those with substantially less than 15 dB separation at 10 kHz can be expected to exhibit some wandering or lack of specificity in directional information.

Stereo separation is a touchy subject among manufacturers, so advertised claims are often more optimistic than factual. This information is best gotten from test reports in magazines.

Signal Output. A source of noise in some early stereo cartridges was their extremely low signal output. Most preamps have a certain amount of hum and/or hiss, which may become audible if the volume control has to be turned up to make the signal loud enough. The answer in most cases was to feed the low-output cartridge through a step-up transformer, which was itself a potent source of hum and frequently gave such a high output level that the preamp was driven to the verge of overload.

Most cartridge designers now recognize the limitations of preamps and provide a nominal cartridge output of about 1 millivolt (per cm/sec of recorded signal velocity). It is still wise, though, to check a cartridge's rated output before buying to anticipate potential noise or overload problems. There is no status value in output ratings so manufacturers' specifications are usually accurate.

Tone Arms. The advantages, shortcomings, or incompatibilities in a tone arm influence the performance of any cartridge. With the exception of Acoustic Research, manufacturers of pivoted tone arms now seem to agree that bias compensation is necessary for optimum cartridge performance—though there is less consensus as to the proper amount of compensation that is needed. (Generally, it is best set experimentally.)

Otherwise, there have been surprisingly few developments in tone arms in recent years. Most manufacturers seem to feel there is no room for improvement—which has been proved wrong by the few really improved designs that have appeared. One eminently successful approach has been the viscous-damped "unipivot" arrangement typified by the Audio & Design and Decca "International" tone arms. Both have many audible advantages and some purely mechanical disadvantages and have not proved to be as popular as they deserve to be. The former has been discontinued; the latter is available through several sources in the U.S. or from dealers in England.

Trackability. This is a term widely used by Shure Bros. in their promotional material after they devised a scheme by which tracking ability could be measured. A trackability test shows, usually in the form of a graph, how much recorded level a cartridge can handle (at a given tracking force) throughout the audio range before it starts to lose intimate groove contact. It is thus an indirect measure of both compliance (affecting trackability at all frequencies) and moving mass (affecting mainly high-frequency trackability), in terms that matter the most to the user: tracking cleanliness and record wear. Obviously the two do go hand in hand.

Tracking Force. It has long been known that tracking force was directly related to record wear; but only in the last few years have researchers been learning just how it is possible for a "featherweight" 2-gram cartridge to wear grooves. The trouble, it seems, is that while we think in terms of force, the groove must contend with pressure.

Since the groove wall is (nominally) a flat surface and the stylus tip is round, they contact one another at a microscopic point (actually two points—one on each side of the groove). Pressure is force per unit area, so if these contact points were true points, with zero area, the contact pressure (force per unit area) from that 2 grams would be infinitely high! Fortunately, the vinyl is flexible enough to let the stylus sink into it at the contact points, making each point about 3/10,000 of an inch in diameter (with 0.7-mil stylus at 2 grams force). This reduces the contact pressure against each groove wall to a mere 48,000 lbs (24 tons) per square inch!

Since vinyl normally collapses when applied pressure exceeds 14,000 lbs/sq in., nobody has yet been able to explain how a disc can survive a single play; but the prevailing attitude of researchers seems to be: "Accept it and be thankful."

What's In Store? There are no breakthroughs in cartridge development in sight. The best we can look forward to is even lighter (and more fragile) stylus assemblies that will give cleaner tracking and more transparent, open sound. Perfect tracking is still not in the cards. ♦

*Getting to know
coolers,
lubricants
and
special agents*

Chemicals for Electronics

IT HAS always been a source of amazement to us that there are so few electronics experimenters who make use of the chemical aids available to them from jobbers and distributors. This is particularly true if the experimenter has encountered the so-called "tough dog." Technically, the TD is an intermittent—a circuit defect that can drive hobbyists wild with frustration.

Intermittents pop up when your equipment works well for 10 or 15 minutes, then loses power, generates distortion, becomes erratic, or quits altogether. The problem is that as you try to track down the trouble, it moves off in another direction. Fortunately, most TD's are related to heat and can be tamed by using a simple chemical tool—an aerosol can of component cooler.

BY LON CANTOR



SPECIAL COOLERS FREEZER SPRAYS

Two recently developed circuit freezer sprays from Injectorall Electronics Corp. are the "Extra Frost" freezer (left) which the company claims is a zero residue freezer spray. Filled to 70 lbs p.s.i. pressure, this extra power is said to provide faster chilling of overheated parts, thus saving time in troubleshooting and protecting transistors from overheating when soldering leads. "Chill-It" (near left) is an aerosol refrigerant which comes with a plastic nozzle so that individual components can be sprayed without turning off the TV receiver. Both of these products are widely available at electronic parts supply houses and come in convenient-size spray cans.

Thermal Intermittents. There are two basic types of thermal intermittents: (1) components that work properly only when they are hot, and (2) components that work properly only when they are cool. Some resistors, for example, start off in fine shape when they are cool, but rapidly change in value when heated up. If you check circuit voltage when the equipment is hot, you may obtain all sorts of "wrong" voltage readings. When the equipment is turned off and the resistors are checked with an ohmmeter, all the readings are good—since in most instances the resistor has cooled down enough to look normal.

In some instances, solid-state devices will have internal metallic contacts that tend to open when the ambient temperature rises. On the other hand, some components have hairline cracks or contacts that do just the opposite: open up when the component is cool. The latter sort of intermittent (enclosing the crack or contact after the equipment has been turned on) is probably one of the most frustrating problems.

No matter what the cause of the failure, all thermal intermittents can be tracked down with a good freezing spray. However, beforehand, take the following steps:

A. Based on the symptoms and your understanding of how the equipment works, use flow logic to isolate the trouble to one or two stages.

B. If the equipment is vacuum-tube operated, replace all the tubes in the suspected

stages. Don't test the tubes because intermittents are seldom detectable on a tube tester.

C. Apply power to the equipment and heat it up as rapidly as possible. Some technicians cover equipment with a cardboard box to speed heating in the absence of ventilation. Let the equipment operate until the trouble either appears or disappears and at this point you have a chance of proceeding with your troubleshooting.

Use a chilling spray with an extension tube to spray each resistor, capacitor, and semiconductor *individually*. Keep the spray away from vacuum tubes—a cold spray can easily crack the glass envelope. When you note a dramatic difference in circuit performance, you'll know you have spotted the culprit. Spraying the faulty component with the cooler should turn the trouble on or off like flipping a switch. Replace the faulty component and "cook" the equipment for at least an hour. Respray the new component to make sure that you have really located the trouble.

Other Component Cooler Uses. Aside from locating thermal intermittents, component coolers are excellent for finding hairline cracks on printed circuit boards. Cracks are a real nuisance, since you can't see them with the naked eye unless you know precisely where to look. A good component cooler will help you spot the trouble fast. Simply spray the cooler (without the extension tube) over the suspected circuit board. The areas covered by printed conductors will frost up,

turning white. The areas without the etched conductors won't change color. Any crack in a conductor will look like a thin, dark line and should stand out prominently.

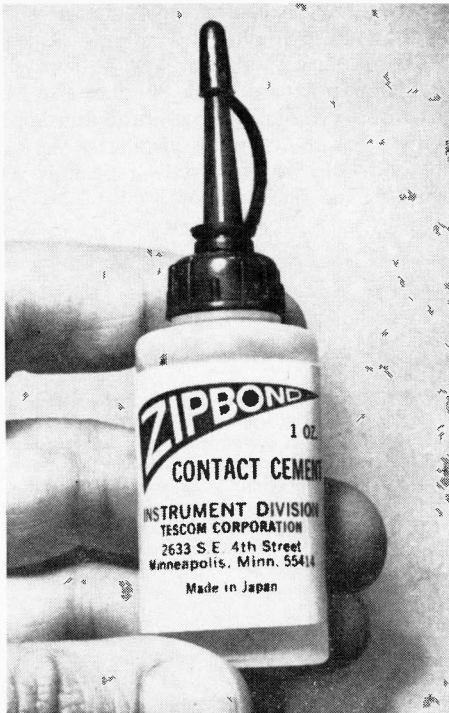
Aerosol freezing sprays make an excellent soldering aid. They can be used to protect delicate components such as transistors, diodes, and integrated circuits which might be damaged by the heat of soldering. Spray the component, chilling it thoroughly and you won't have to worry about using a heat sink. Many experimenters also use component coolers to prevent cold soldered joints. Once the solder is flowing freely and the connection has been made, they give the new joint a quick blast of the chilling cooler. This blast quickly absorbs the heat from the solder and eliminates the possibility that something might move before the solder has set. Also, the cooler washes away excess rosin and residue, leaving a clean, bright, soldered joint. Certainly this method is far preferable to the practice in many laboratories of cooling the solder joint with a little spit at the end of your finger.

A freezing spray can also be used to rescue a power transformer. Experimenters sometimes fire up circuits only to see the power

transformer start to smoke. When this happens, pull the plug fast and reach for your aerosol cooler. If you chill the transformer fast enough, you will keep the wax, varnish and shellac from running and causing internal shorts in the transformer windings.

Choosing a Component Cooler. With all the component coolers on the market, how do you choose the right one? The best coolers are made with blends of Freon. As you are probably aware, Freon is DuPont's trademark for trichlorotrifluoroethane. This product is used both as an aerosol propellant and as a cleaning agent. Special blends of Freon are excellent as coolers working on much the same principle as a refrigerator—a liquid changed to a gas absorbs a tremendous amount of heat. A good component cooler can drop the temperature of a small component to minus 50 degrees Fahrenheit in a matter of seconds.

Some manufacturers of component coolers for the sake of economy will add vinyl chloride to their product. Vinyl chloride is cheaper, but does not cool as well as Freon and, what's worse, tends to run (cooling unwanted components). It also has the undesirable



SPECIAL CHEMICALS

QUICK BONDING LIQUID

Zipbond Contact Cement distributed by Tescom Corp., Instrument Division, 2633 S.E. 4th St., Minneapolis, MN 55414 is one of the most unusual chemicals available to the advanced hobbyist and experimenter. It may be used to bond a wide range of materials—metals, plastics, glass, rubber and hard woods. There is no mixing or heat treating—simply apply a drop of liquid for each square inch of surface to be bonded. Apply light pressure for about a minute and a bond of very high shear strength is made. Zipbond is expensive (\$15.95/oz), requires careful use, and should be refrigerated when being stored.

after-effect of leaving a residue. You can usually detect the presence of vinyl chloride in a circuit cooler with your nose—it smells sharply of chlorine.

Oddly enough, packaging makes a difference in component coolers. Freon products are packed under high pressure and must be in a seamless can. Aerosol cans with seams simply can't hold this amount of pressure and for safety, the law requires the use of seamless cans for all high pressure applications. Coolers packed in seamed cans or using vinyl chloride do cost less, but in most cases, this is considered to be a false economy. For one thing, inadequate cooling can cause you to skip right over a defective component and the better products can chill more components per ounce of cooling fluid.

Lubricants. The experimenter with a home workshop has an incredible variety of lubricants available to him from electronics parts distributors and hardware stores. The most common lubricants are of the type known as all-purpose, penetrating and lubricating oils. Made from petroleum bases, these lubricants are excellent for freeing rusted parts, as well as reducing friction in motor bearings, couplings, etc. Most of these lubricants tend to retard rust. Many are available not only in drop cans, but in aerosol cans.

Some of the more unusual lubricants that should be investigated by the experimenter include white grease, dry graphite and silicones. White grease is excellent for small motors, gears and bearings and is available in small squeeze tubes. Graphite has been used in a powder form for locks and is now

available in aerosol cans. Silicone lubricants are very slippery, wear well, and usually seal out moisture. These lubricants are also available in aerosol cans and function very well over a wide range of operating temperatures.

A Teflon dry lubricant is now available in an aerosol can and is used where very high operating temperatures are encountered. Cryogenically processed Teflon is also used, although it is not commonly available to most experimenters.

Insulating and Protective Coatings.

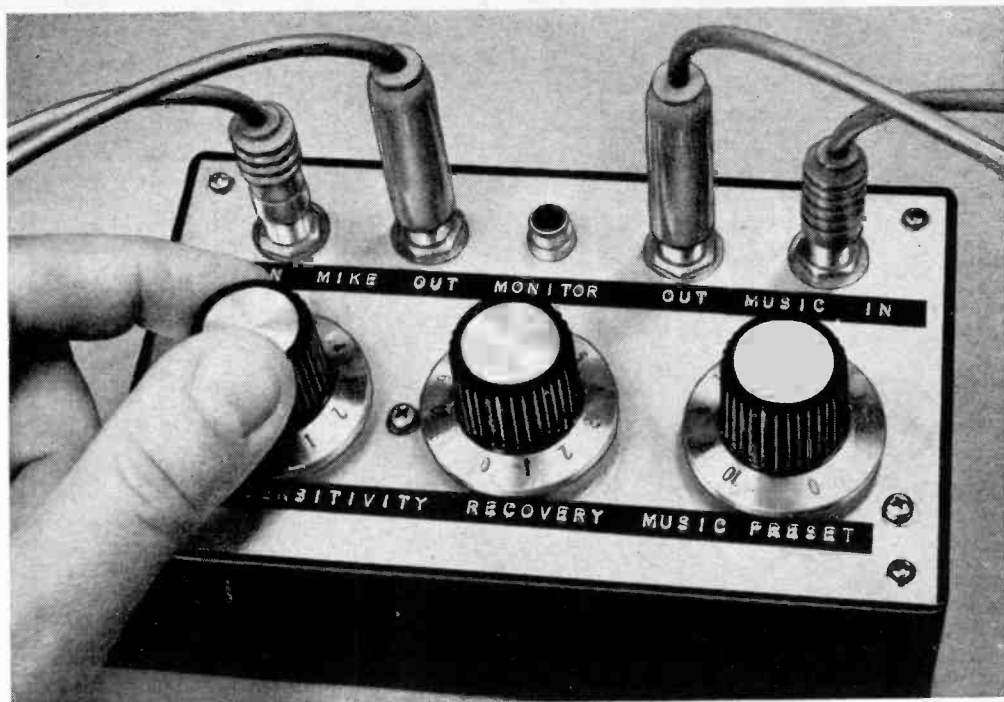
No electronics experimental laboratory workbench is complete without a bottle of brush-on insulating coating (or varnish) and an aerosol can of acrylic protective spray.

Brush-on insulating coatings are particularly useful around high-voltage circuits where they can be used to stop arcing and corona. These coatings can also be used for "potting" components, holding high voltage leads in place, insulating PC boards, and making temporary repairs to exposed wiring.

Acrylic insulating and protective sprays may also be used to coat low voltage exposed wiring, waterproof spark plug cabling in ignition systems, inhibit rust and corrosion on exposed surfaces, act as a protective coating for outdoor antennas (especially in areas where there is salt spray or industrial smog), and/or retard fungus and mildew. Although most of the crystal-clear acrylic sprays are available in aerosol cans, you can also buy a viscous acrylic liquid in a bottle and apply it with a brush. In many instances, the latter method is to be preferred—especially when working in tight corners. ♦



Loss of gain and erratic operation resulted from manufacturing defect in by-pass capacitor. Tipoff was gradual loss of signal after receiver had been in operation for an hour. Cooling down suspect components with freezing spray quickly pin-pointed defective capacitor.



BUILD A VOX GAIN RIDER

VOICE-CONTROLLED MIKE MAKES MUSIC MURMUR

BY DAVID W. BEATY

ONE SURE WAY to spoil a good party is to interrupt the music—live or canned—to make an announcement and have the volume all wrong for speech, with acoustic feedback that shatters everyone's eardrums and entirely too long a delay just to let people know that "soup's on." All of this can be avoided if you equip your sound system with a "VOX Gain Rider." It's a simple circuit that responds to a voice input to a microphone and automatically lowers the volume of the music. This permits you to make your announcement easily and effectively—and the music will continue at its former level as soon as you are finished.

The VOX Gain Rider is battery-powered for portability and can be used in conjunction with any sound system and a high-impedance microphone. In fact, there are a number of ways in which it can be used: to turn down your hi-fi system when the telephone rings; to lower the volume when the baby cries upstairs; to cut down the din in the recreation room when you want to get a message through to the kids; or any suitable situation where one signal can take precedence over another.

Theory of Circuit Design. The schematic of the Gain Rider circuit is shown in Fig. 1. The audio signal from a high-im-

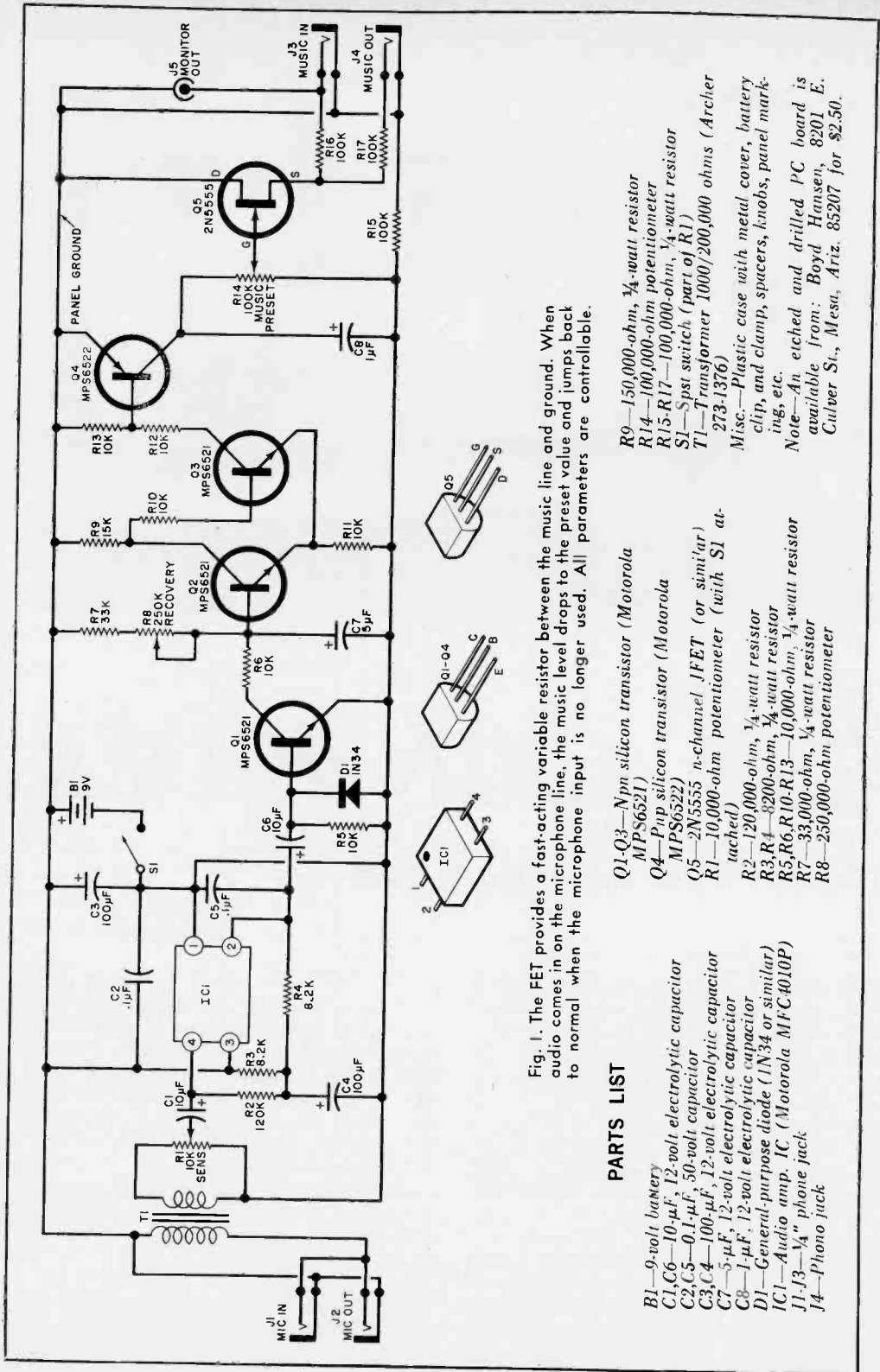


Fig. 1. The FET provides a fast-acting variable resistor between the music line and ground. When audio comes in on the microphone line, the music level drops to the preset value and jumps back to normal when the microphone input is no longer used. All parameters are controllable.

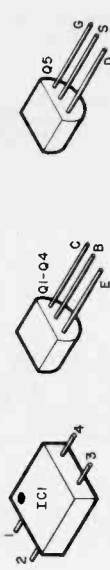
PARTS LIST

- B1—9-volt battery
- C1, C6—10-µF, 12-volt electrolytic capacitor
- C2, C5—0.1-µF, 50-volt capacitor
- C3, C4—100-µF, 12-volt electrolytic capacitor
- C7—5-µF, 12-volt electrolytic capacitor
- C8—1-µF, 12-volt electrolytic capacitor
- D1—General-purpose diode (1N34 or similar)
- IC1—Audio amp. IC (Motorola MFC4010P)
- J1—J3—¼" phone jack
- J4—Phone jack

- Q1-Q3—Npn silicon transistor (Motorola MPS6521)
- Q4—Pnp silicon transistor (Motorola MPS6522)
- Q5—2N5555 n-channel JFET (or similar)
- R1—10,000-ohm potentiometer (with S1 attached)
- R2—120,000-ohm, ¼-watt resistor
- R3, R4—8200-ohm, ¼-watt resistor
- R5, R6, R10-R13—10,000-ohm, ¼-watt resistor
- R7—33,000-ohm, ¼-watt resistor
- R8—250,000-ohm potentiometer

- R9—150,000-ohm, ¼-watt resistor
- R14—100,000-ohm potentiometer
- R15-R17—100,000-ohm, ¼-watt resistor
- S1—Spst switch (part of R1)
- T1—Transformer 1000/200,000 ohms (Archer 273-1376)

Misc.—Plastic case with metal cover, battery clip, and clamp, spacers, knobs, panel markings, etc.
 Note—An etched and drilled PC board is available from: Boyd Hansen, 8201 E. Culver St., Mesa, Ariz. 85207 for \$2.50.



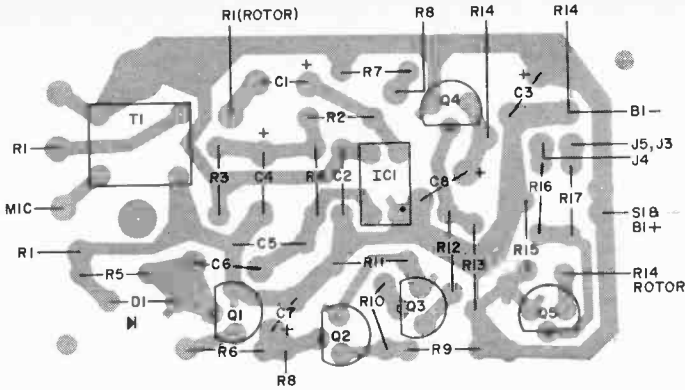
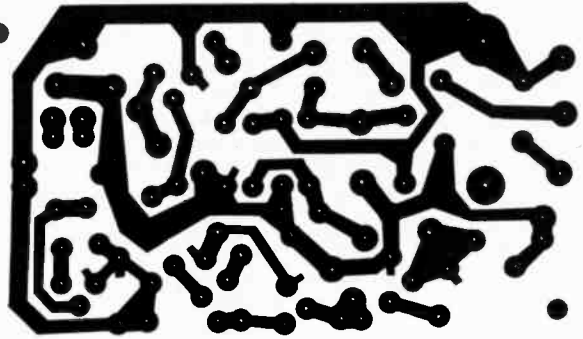


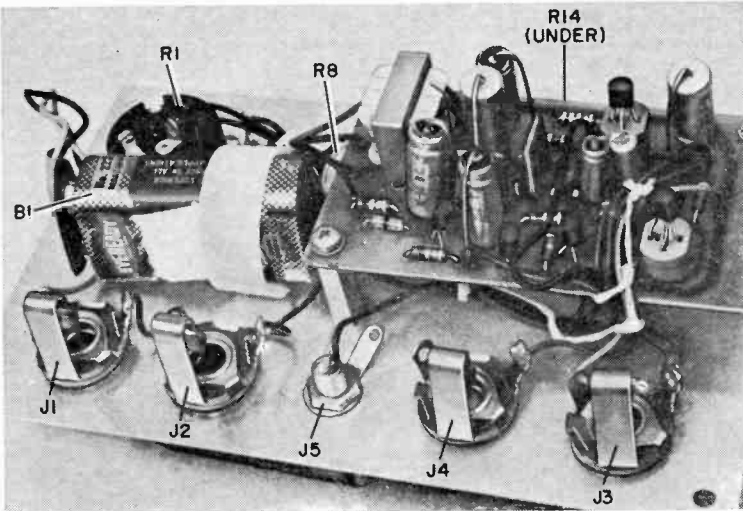
Fig. 2. Actual size PC board etching and drilling guide (right) and component layout (above). Observe the polarity of IC1, transistors, and electrolytic capacitors.



pedance microphone—or similar source—is coupled to the circuit through T1 which provides impedance matching. The proper amount of signal is taken from the arm of potentiometer R1 and applied to

IC1, an audio amplifier module. The IC raises the signal level enough to saturate transistor Q1 on each positive half cycle. This permits C7 to discharge at a rate determined by the time constant of R6

Although the prototype used phone jacks, any other suitable type of connector may be used. A short length of plastic strip supports the 9-volt battery.



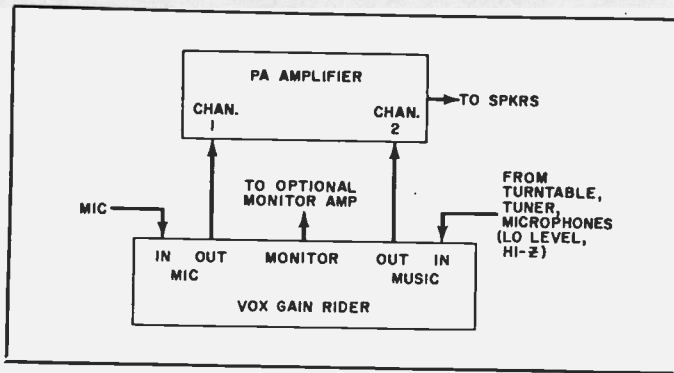


Fig. 3. Connections between the Gain Rider and the audio system using it. Once the music level has been preset, and the recovery period determined, the system is ready to operate anytime the announcement mike is used.

and C7. Capacitor C7 receives its charge through R7 and R8 the RECOVERY potentiometer. When a sufficient number of input cycles have occurred to allow C7 to be discharged below the threshold of Schmitt trigger Q2 and Q3, the latter saturates. This causes Q4 to conduct and places its collector at approximately the level of the supply voltage. Occasional narrow noise pulses on the input are not sufficient to allow C7 to discharge enough to fire the Schmitt trigger.

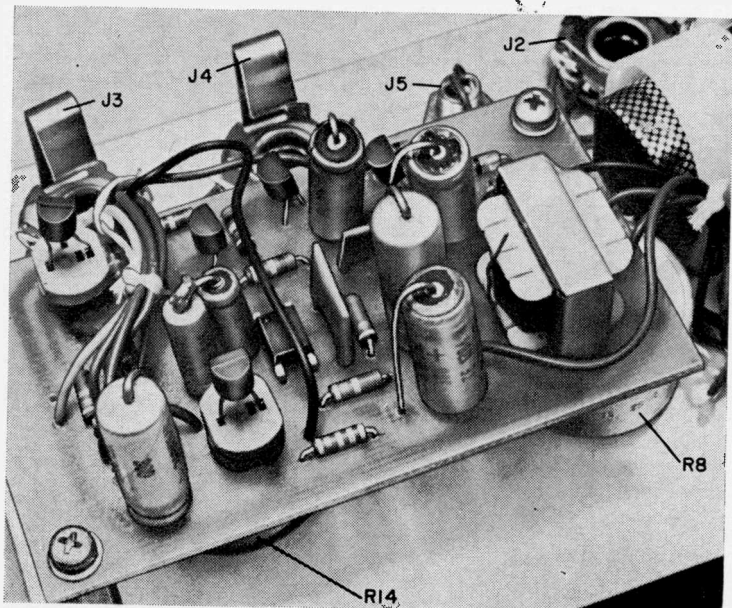
With Q4 conducting, the potential at the wiper of R14 is raised to a maximum of 9 volts, depending on its setting. This provides the gate signal for field effect transistor Q4. The latter acts as a voltage variable resistor to reduce the level of the signal between J3 and J4. The signal from the microphone thus takes precedence over the music signal and is passed

on to the amplifier system via resistor R17 and output jack J4. When the microphone signal is removed, transistor Q1 is not saturated and capacitor C7 is recharged through R7 and R8.

Capacitor C8 controls the "recovery rise time," or the rate at which the music recovers to full volume upon completion of the time period determined by R7, R8, and C7. A "softer" effect may be achieved by substituting values up to 10 μ F for C8.

Construction. The circuit is built up on a printed circuit board using the foil pattern and component layout shown in Fig. 2. Note that the various electrolytic capacitors are mounted "standing up" with one lead soldered directly into its hole and the other lead bent over to reach the other hole. To conserve space,

To conserve board space, note that the capacitors are mounted "on end." The use of transistor sockets is optional, as is the type of phone jacks shown.



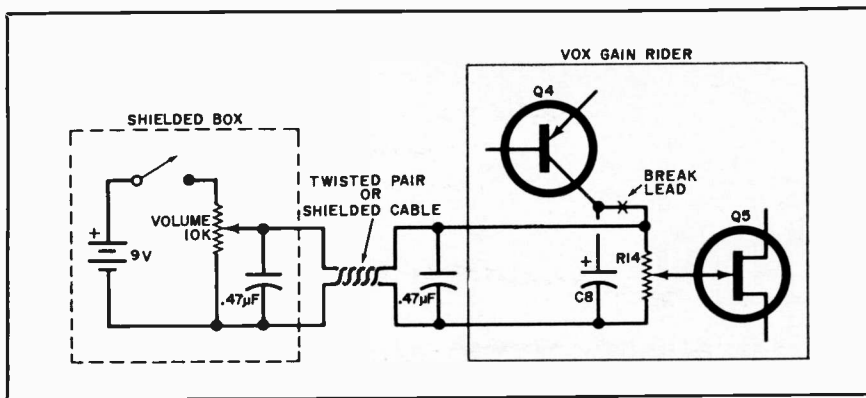


Fig. 4. This modification shows how to control the volume of an amplifier from a distance. In this case, the microphone control feature is removed. The capacitors reduce hum pickup.

¼-watt resistors are suggested; though, if you make your own board layout and have the room use ½ W resistors.

The prototype shown in the photos was built on the metal cover plate of a 6" × 3½" × 2" plastic box. The three potentiometers and five input/output jacks were mounted across the top of the panel and suitably marked. The battery was held in place by a plastic band attached to the chassis. A conventional 9-volt transistor radio battery can be used since the drain is only 6 milliamperes.

Testing and Operation. All connections to and from the Gain Rider circuit should be made with shielded audio cable to reduce 60-Hz hum. Connect a turntable, AM/FM tuner, or any other low-level high impedance audio source to the music input jack J3. Connect an amplifier and speaker to the music output jack J4. Set the amplifier controls for the desired sound level. Set the Gain Rider SENSITIVITY control R1 for minimum and connect a high-impedance microphone to J1. Connect an audio cable from the microphone output jack J2 to the other channel on the amplifier (See Fig. 3).

Set R14 (MUSIC PRESET) and R8 (RECOVERY) to minimum (should be maximum counterclockwise). Then adjust the amplifier gain control for a sound level slightly higher than that normally used.

While speaking slowly into the microphone, advance the SENSITIVITY control until the music level drops suddenly. Continuing to speak slowly into the microphone, advance R1 until the music level drops suddenly with each word. It may

be necessary to pause between words to allow the music level to recover. Record this setting of R1 for future reference.

Speaking into the microphone at normal level, adjust R8 (RECOVERY) until the music level does not recover between normally spaced words, but does recover in a suitable time after you stop speaking. Record the setting of R8.

Obtain the desired level of music while you are talking by adjusting R14 (MUSIC PRESET).

Once the three potentiometers are set as described above, the VOX Gain Rider is ready for use.

Remote Control. The VOX Gain Rider can be used to control the level of a sound system from a remote location by using the modification circuit shown in Fig. 4. The remote control unit is connected to the system through a reasonable length of twisted pair or shielded cable. The capacitance value may have to be increased if the amount of stray pickup is too high.

Helpful Hints. Note that the setting of R1 (SENSITIVITY) depends on the type of input—electric guitars, organs, FM receivers may take different settings. It should also be noted that when used with live performances, the ambient noise level may be sufficient to trigger the circuit unless a good cardioid microphone or a "close-speaking" type is used. If a permanent installation is desired, any well-filtered 9-volt dc power supply may be used to replace the battery. ♦

TEN HI-FI FALLACIES

BY J. GORDON HOLT

How many of these statements do you consider "gospel?" The author's explanations may surprise you!

AUDIOPHILES are avid readers. Unfortunately, some of what they read is incorrect—and they misinterpret some that is correct. The result is that part of the generally accepted information about audio is actually misinformation. Here are ten of the most popular misconceptions about hi-fi.

1. Solid-state equipment is better than vacuum tubes.

The inherent superiority of solid state is such an article of faith with most consumers that the term helps to sell everything from food blenders to clothes driers. Solid-state electronics has three clear-cut advantages: the units can be much more compact, they use less electricity and generate less heat, and they do not have the limited lifespan of components using hot-cathode tubes. Outside of that, one can make just as good a case for tubes as for transistors and their relatives.

In high-fidelity applications, the advantages of solid-state components are: elimination of the power amplifier's output transformer, potentially lower hum (because of the absence of the ac-powered heater), and usually better circuit stability due to the ease of obtaining an extremely wide bandwidth. In terms of sound, which is what most people have in mind when they cite the transistor's supposed superiority, there is no clear-cut difference.

Generally, solid-state equipment produces cleaner, tighter bass than vacuum tubes can provide—mainly because it is possible to make solid-state power amplifiers with higher damping factors than can be achieved with tubes. *But*, it has not yet been possible to produce solid-state equipment, especially in the preamp section, that introduces as little audible distortion at high frequencies as you get in some of the very best tube-type components.

As far as durability is concerned, solid-state equipment has not yet completely lived up to its potential. Transistors do not go downhill gradually—as tubes do—but their rate of sudden failure is still higher than that of tubes. Again, this will doubtlessly be remedied; but as of now, the choice between tubes and solid-state components is more a matter of personal preference than one of clear-cut, objective superiority on the side of either one.

2. If a musical instrument that is being reproduced through one stereo speaker is audible through the other, the reproducer has imperfect stereo separation.

This is true only for test and so-called demonstration records where it is clearly stated that *only* the left or right channel is supposed to be operating. Perfect stereo separation never occurs in nature or in live

music because all sounds radiate in all directions from their source. A left-hand instrument's sound will reach the left-hand microphone first and will be loudest at that mike. But the sound continues to travel, getting weaker all the time, until it reaches the right-hand mike a fraction of a second later. Thus, the right-channel output from that left-hand instrument will be weaker and very slightly delayed in time, but it will be clearly audible. Were it not there at all, the reproduction of that instrument would be *monophonic*, from the left speaker only, and all of the sense of stereo spaciousness would be missing.

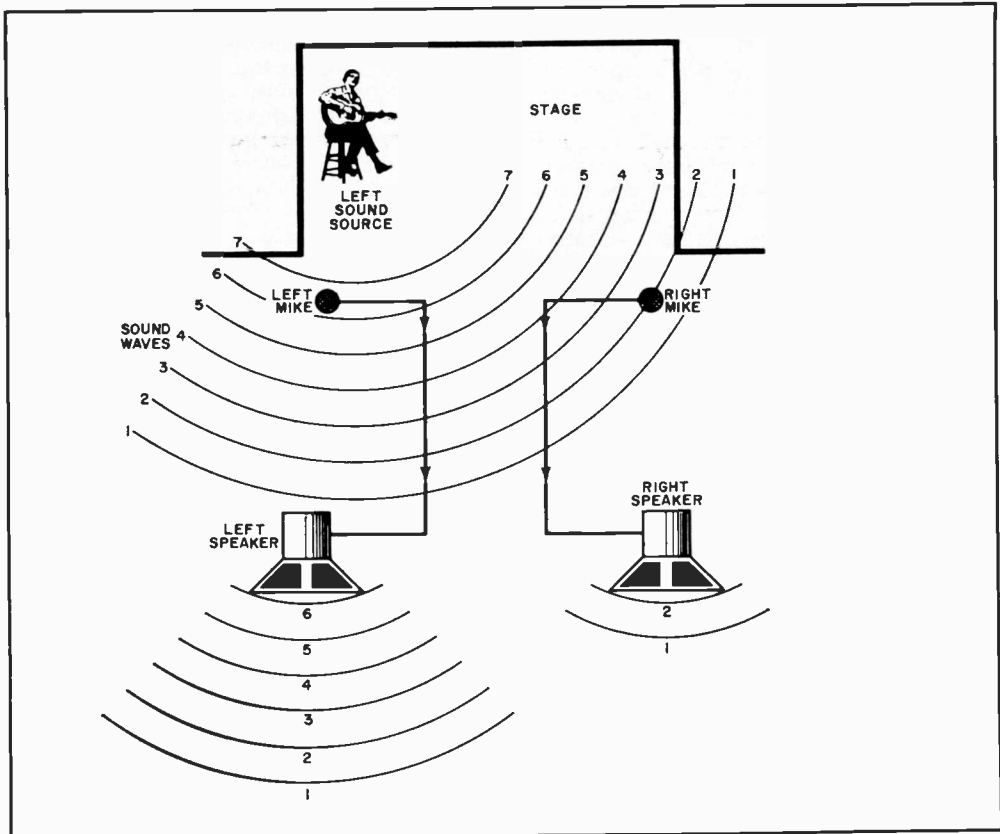
The reason a reproducing system should have the *capability* of total stereo separation is to prevent the left-hand sound (which is slightly ahead of the right-hand sound) from leaking through to the right channel and thus apparently narrowing the dimensional spread between the two channels. In fact, though, some stereo test records themselves have imperfect separation where they are supposed to be presenting exclusively left-

or right-channel signals. Even the best test records do not have enough separation to leave one channel completely dead while the other is working. As long as the "silent" channel is significantly quieter than the functioning one, the system's overall stereo separation is probably adequate.

3. Since different people hear things differently, high fidelity is more a matter of personal taste than objective reality.

This old saw dies hard! Different people react to different aspects of a complex sound —some concentrate on bass clarity, others on brilliance or overall balance, and still others on high-end richness or detail. And each evaluates reproduced sound on the basis of how well it re-creates those aspects of which he is critical. People's hearing acuties differ, also, some having response out to 20,000 Hz or beyond, while others are limited to 6000 Hz or below. But expose any group of people to *exactly* the same set of air vibrations as were present at a live concert, and their sonic perceptions and hearing lim-

As noted in Fallacy No. 2, sound from a source at the left must be reproduced through the right speaker in order to make it faithful to the way it was originally recorded.



itations will react as though they were all hearing the original sounds.

4. A synchronous drive motor has better speed regulation than a non-synchronous one.

This is a half-truth. Since a synchronous motor is "coupled" to the frequency of the ac supply, its average speed over a given period of time is as accurate as that of an electric clock (which uses a synchronous motor). In order to stay exactly locked on to the ac cycles, though, a synchronous motor must be continually speeding up and slowing down ever so slightly and this reduces its instantaneous speed regulation. Either type of motor requires special design provisions to insure that its particular type of speed variation is held to an absolute minimum for the best reproduction.

5. The better the reproducing system, the worse it makes a worn record sound.

Manufacturers of second-rate equipment have used this argument for years to explain why their stuff makes surface noise and record breakup so shatteringly offensive, but 'tain't so! Top-notch equipment will reproduce such distortion with embarrassing clarity—making the distortion quite audible. But the more the electrical distortion in the reproducer and the more peaky or tipped-up its high-end response, the more it exaggerates these problems.

Disc surface noise, reproduced through a low-distortion, resonance-free system, sounds rather like raindrops on pavement. Record breakup sounds like an overlay of fuzz. Both are audible, but neither is intolerable. If they are, it is a sign of a poor system rather than a good one.

6. The more power an amplifier has, the better it is.

There is a grain of truth to this, but there is no necessary relation between power and sound quality. It is generally true that low-power amplifiers are not designed to such high standards with regard to distortion as are high-power units. It is also generally true that low-power amplifiers have lower damping factors. Low distortion and a high damping factor make most loudspeakers sound better. But there have been exceptions, and these low-power amplifiers—as long as they are not driven to their overload point—have sounded as good as, if not better than, some very high-power units.

When considering power, it is also necessary to remember that a 1-dB change in volume is barely perceptible, while doubling the amount of available power from an amplifier will account for only a 3-dB increase in maximum available loudness. Thus, a

change from 60 to 120 watts per channel actually represents a very small increment of volume capacity. The major difference in sound between competing amplifiers is a result of their distortion at output levels of less than 1 watt—a specification that is rarely published, possibly because it provides a valid basis for comparison.

7. The human ear cannot perceive less than such-and-so amount of distortion (or phase shift or frequency response deviation or flutter or what have you).

Statements like this should be interpreted as meaning "My ears cannot perceive less than. . ." An untrained listener can sit happily in a shower of "dreadful-fi" and not perceive anything except perhaps a vague feeling of discontent followed by a headache. Some highly critical listeners have shown their ability to detect, in reproduced music, frequency response variations as small as half a dB and distortion levels that were literally too microscopic to measure on currently available equipment. Thus, any flat statement to the effect that this or that is the smallest amount of anything that the ear can perceive must be viewed as highly suspect—if not altogether irrelevant.

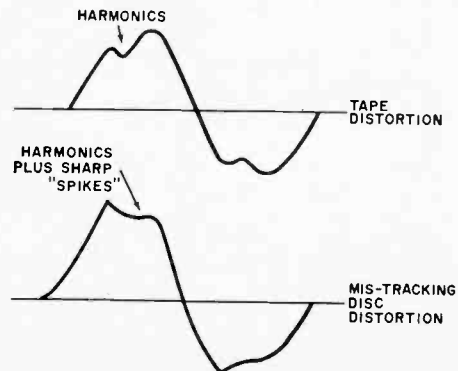
8. Consistently dependable FM reception is possible only within line-of-sight distance from the transmitting tower.

This was proven mathematically several times before commercial FM transmissions disproved it. FM reflects from some atmospheric layer boundaries almost as readily as does AM.

9. Music sounds better on tape.

This subject has been discussed in detail in various publications, but it is still a per-

Tape has more electrical distortion than disc but, mis-tracking distortion due to a poor cartridge can sound more unpleasant.



sistent hi-fi fallacy. In fact, more fidelity is lost through tape duplicating, particularly at high speeds, than is lost when cutting a disc. And there are typically two more tape-copying steps involved in producing a commercial 4-track tape than in producing the discing master tape. But whereas a commercial tape is inherently worse than a disc to start with, the quality of disc playback is directly related to the quality of the cartridge used to play it back. Tracking distortion from a mediocre cartridge sounds worse than the distortion built into a commercial tape. With a top-notch cartridge, however, the disc can be very nearly as clean as the tape, and then the disc's superiority in terms of transient response, noise, and electrical distortion becomes evident. The only time music sounds undeniably best on tape is when it's from the original master tape, which we cannot, unfortunately, buy at the corner hi-fi shop.

10. Professional audio equipment is the standard by which home equipment is judged.

Manufacturers who toss the word "professional" around in describing their home hi-fi equipment would do well to examine the implications they are making, because in terms of performance specifications, professional equipment is often inferior to home-type equipment. Disc and tape reproductions, put much more stringent standards on their operation than is done for the professional recording engineer's equipment.

Some home-type audiophile tape recorders have frequency responses that extend out to 20,000 Hz at 7½ ips; professional machines will rarely make it to 15,000 at that speed (since they are designed primarily for 15 ips). Most audiophile amplifiers produce less than 0.1% distortion at operating levels below overload; professional disc-cutting amplifiers often generate 0.5 to 1.0% distortion at equivalent levels. Many audiophile speaker systems are good to 35 Hz at the bottom and beyond 15,000 at the top (within 3 dB over most of the range); the typical recording studio monitor speaker cuts off at 50 Hz or higher and 12,000 Hz or lower and the response in between may deviate by as much as 6 dB either way. Equalization accuracy for professional equipment is rarely better than ±1 dB, but it is within ±0.5 dB in some audiophile preamps. Professional turntables and tape machines are considered to be excellent if their wow and flutter is below 0.1%; audiophile units aim for, and often achieve, figures below 0.07%. The main points of superiority in professional equipment are ruggedness and ease of servicing and maintenance—which don't usually show when the shopper is comparing prices of professional and audiophile lines. ♦

MESHNA SURPLUS BARGAINS

ELECTRIC EYE ASSEMBLY

Dual electric eye assembly w/transistor for each eye. Brand new. \$1.25.

0-1 MINUTE TIMER

Spring wind, w/electric contacts. 20 amperes. Contacts close on RUN and open at time expiration. Any time set from 0 to 60 seconds. \$1.25.

MERCURY BATTERY CELLS

Each cell 1.4 volts. Can be stacked for various voltages. Worth over 50¢ each. 8 for \$1.00.

WIDE ANGLE COPY LENS

3¼-inch focal length, f 5.6. For hi resolution photo copy, enlarging, opaque projector, etc. Coated optics in 2-inch barrel. \$50 value for \$6.00.

¼ HP ELECTRIC MOTOR

With base mount, late model, small size, brand new. For standard 117 VAC. With thermal cutout. \$10.00.

INTEGRATED CIRCUITS 15¢

Brand new DIP package. Send for listing of IC's at 60% off.

RADIATION SURVEY METER

Like new, government surplus w/instruction book and carrying strap. Reduced to \$6.00, gov. cost over \$60.00.

12-VOLT DC SUPPLY

Kit of parts, operates on regular house current. Operate your auto radio or auto tape player in the house. Also good for battery charging. Provides 12V at 3A. W/directions. \$8.00.

STROBE TUBE

Brand new horseshoe shape. Flash rate 20/sec at 0.2 joules. Photo or psychedelic musical strobe. W/instructions. \$2.25.

GIANT NIXIES \$1.50

Full alphanumeric display, w/spec sheet. Make changing word signs, giant clock, etc. #B7971. \$1.50.

FIBER OPTIC LIGHT PIPE

Fully finished and polished ends. Pipe light underwater, around corners, etc. 75¢ each.

MULTIPLEX ADAPTER

Converts FM radio to multiplex stereo. Solid-state wired chassis, like new. \$5.00.

SOLID-STATE AMPLIFIER

Operates from 6V. Fully wired chassis w/volume control. \$1.25.

WHISTLE SWITCH

Solid-state, w/amplifier mike. Turns light on, radios, etc. by high-pitched sound from whistle. \$1.35.

MEMORY CORE FRAME

Ultra-small memory, wired 1024 cores, measures only 2x2 in. \$6.00 per frame or wired stack with 9 frames and diode matrix \$50.00. Made for RCA.

PANELESCENCE

Flat panel 3½ x ¾ in. wide. Apply 117 VAC and it glows ghostly green, weird and unusual—light of future. 3/\$1.00.

3 LED's for \$1.00

Light emitting diodes w/mercury cell for instant test.

UNDERWATER MIKE

Waterproof underwater mike from gov't contract. Listen to ships, fish, underwater noises, etc., w/amplifier. \$6.50.

CRYSTAL PHONE 25¢

Brand new, hearing aid type. Only 25¢ each in lots of 4/\$1.

PLEASE ADD POSTAGE. ON ALL ABOVE ITEMS.

96-page catalog with hundreds of similar bargains free with each order. Catalog alone 25¢.

MESHNA • P.O. BOX 62A • EAST LYNN, MA. 01904

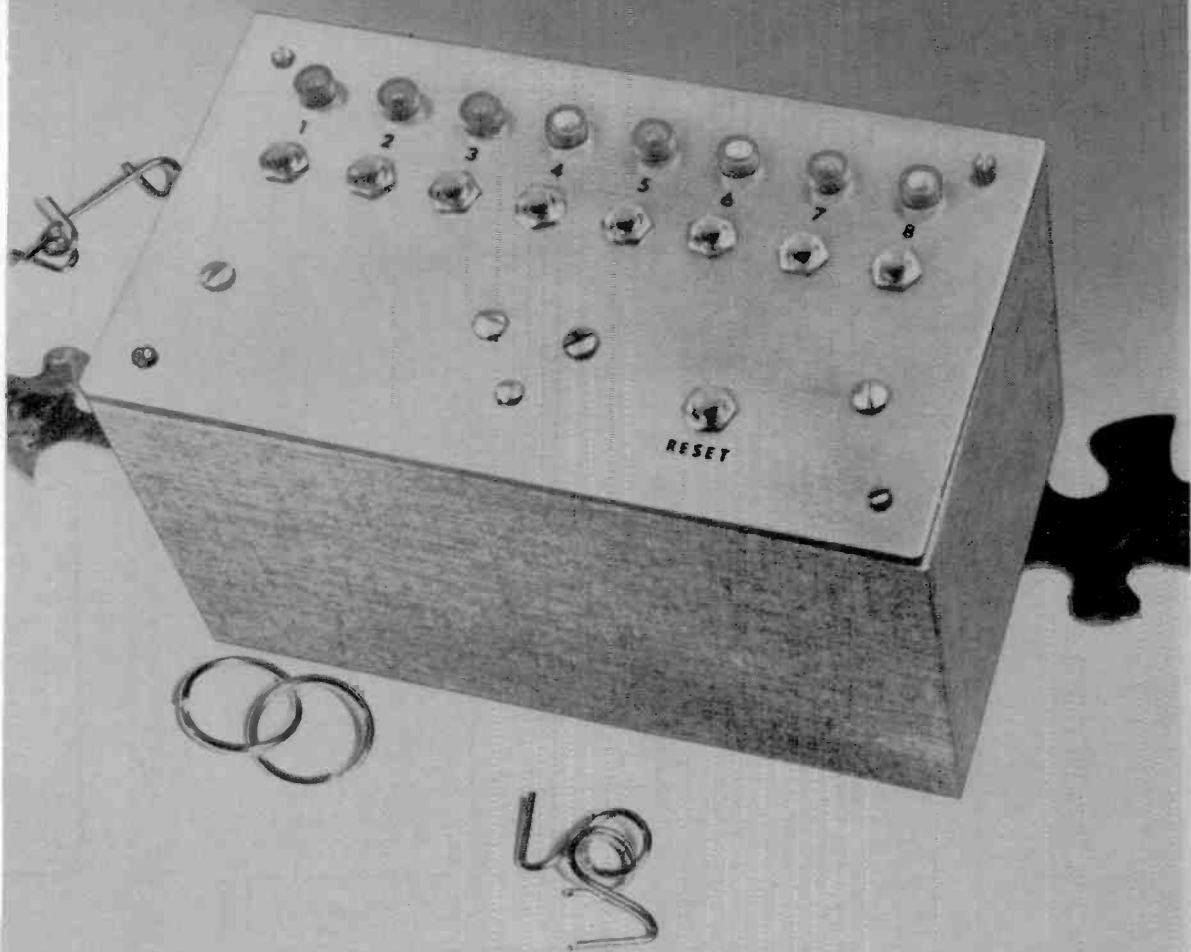
CIRCLE NO. 13 ON READER SERVICE CARD



The
**PRINCEPS
PUZZLE**

*Assemble the first
all-electronic puzzle*

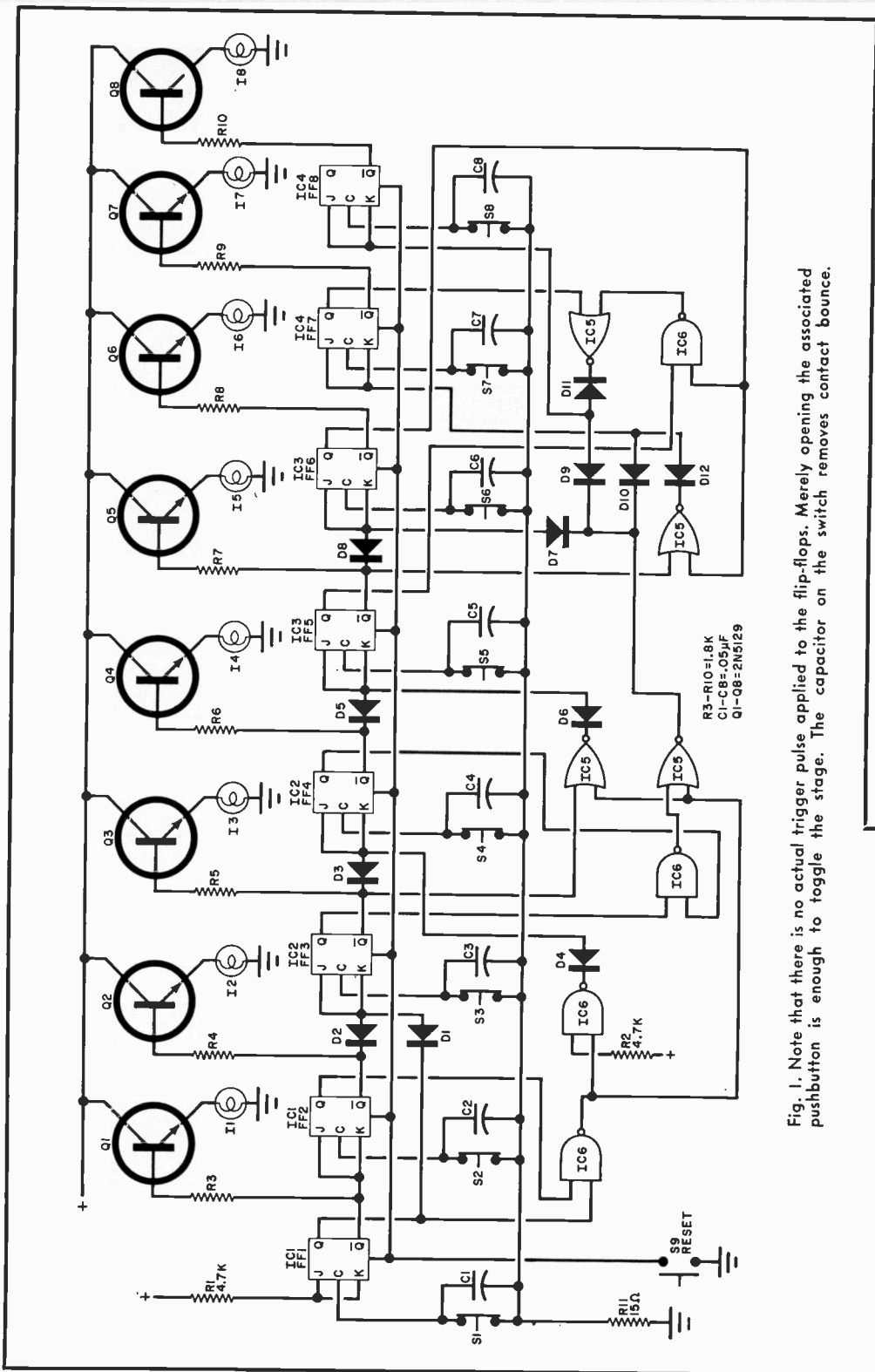
BY JAMES W. CUCCIA



PUZZLES—whether they are word games, jigsaws, entwined nails, or interlocked pieces of wood—are the joy (or bane) of many people's existences. Whatever the overall reaction, however, nearly everyone is fascinated by a real "toughie"—providing he is assured the solution is possible and the whole thing is not a hoax.

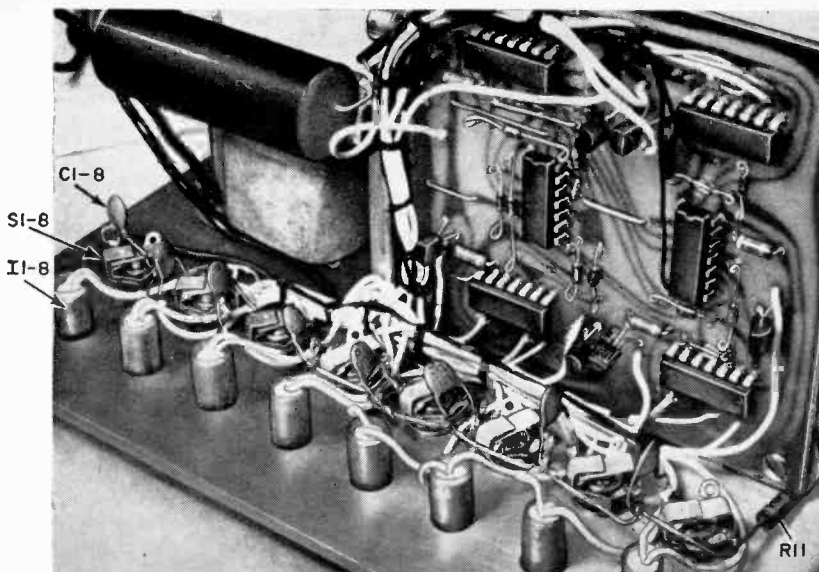
Presented here is an ancient puzzling principle in a new guise—the electronic "Princeps Puzzle." The solution to Princeps Puzzle is based on clear-cut rules of logic (as used in everyday computers) and, assuming you get your unit properly assembled and wired, it is definitely possible—though not quickly obtained through some trick of black magic.

There are eight lights and eight pushbuttons on the puzzle. There



R3-R10=1.8K
 C1-C8=.05μF
 Q1-Q8=2N5169

Fig. 1. Note that there is no actual trigger pulse applied to the flip-flops. Merely opening the associated pushbutton is enough to toggle the stage. The capacitor on the switch removes contact bounce.



Construction is left to the builder. Here, the lamps, switches and capacitors are grouped in lines on the front panel. The PC board is mounted on a pair of brackets.

is also a Reset button which turns on all the lights at any time. The point of the puzzle then is to get them all turned off again by pressing the appropriate numbered buttons. You can figure out the solution to the Princeps Puzzle from the diagram shown in Fig. 1; and we'll give you a hint—it takes 170 pushes of one

button or another in the proper sequence to get all the lights off. Once you get the system down pat, you'll be able to turn off all the lights in a minute or two—after watching your friends push and puzzle and puzzle and push for hours.

The detailed procedure for all 170 steps is too long to print here—besides we don't want to spoil your fun—but we'll send you a copy if you send 25¢ to cover handling and mailing to Editorial Dept., Electronic Experimenter's Handbook, One Park Ave., N.Y., N.Y. 10016.

PARTS LIST

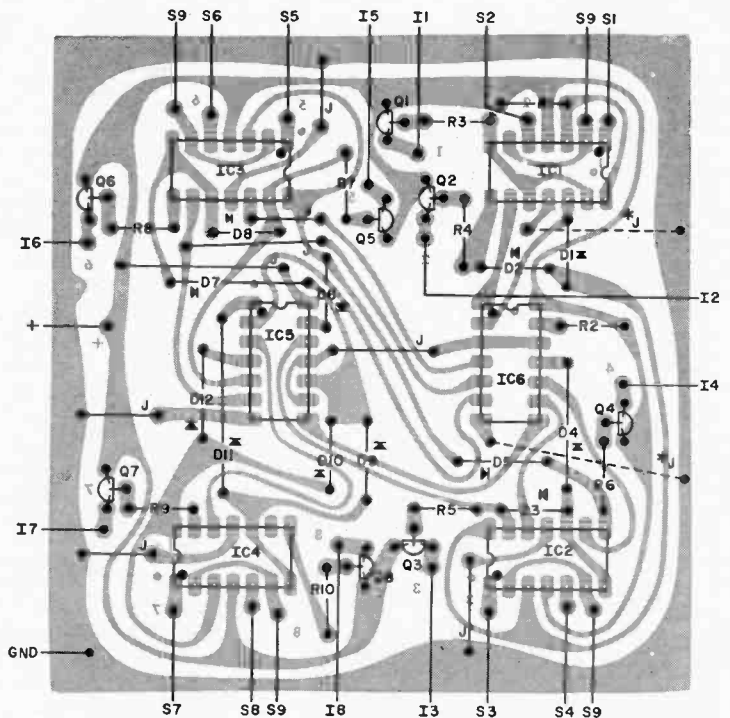
- C1-C8—0.05- μ F disc capacitor*
D1-D12—Small-signal silicon diode
I1-I8—6.3-volt, 50-mA pilot light
IC1-IC4—Dual JK flip-flop (Motorola MC-7473P)
IC5—Quad 2-input NOR gate (Motorola MC-7402)
IC6—Quad 2-input NAND gate (Motorola MC7400)
Q1-Q8—2N5129 transistor
R1,R2—4700-ohm, 1/4-watt resistor
R3-R10—1800-ohm, 1/4-watt resistor
R11—15-ohm, 1/2-watt resistor
S1-S9—Spst pushbutton switch (Switchcraft 103 or similar)
Misc.—Suitable chassis, plastic lens for lamp (8), line cord, grommet, mounting hardware, etc.
Note—The following are available from Southwest Technical Products, Box 32040, San Antonio, TX 78216: etched and drilled PC board at \$2.90, postpaid; complete kit of parts including board, chassis, and power supply at \$29.95, plus postage and insurance for 3 lb.

Construction. The electronic portion of Princeps Puzzle is assembled on a printed circuit board as shown in Fig. 2. Be sure to get the proper orientation on the IC's and the correct polarities on the diodes. Use a low-wattage soldering iron and fine solder to avoid damaging the semiconductors with heat. The eight lights and their associated pushbuttons and capacitors are mounted on the front panel along with the Reset button and R11. Once these are installed, the circuit board can be attached to the front panel as shown in the photographs.

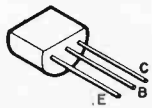
The wiring between the switches, lamps, and board is not critical but it should be color coded to avoid confusion. A line-operated power supply, delivering approximately 5 volts is shown in Fig.

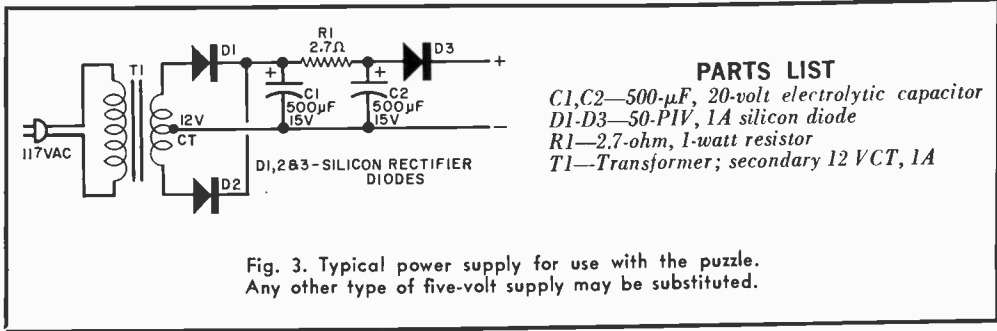


Fig. 2. Actual size foil pattern (left) and component installation (below) for the puzzle. Note that two insulated jumpers are shown and can go on foil side of the printed circuit board.



*INSULATED JUMPER





3. This supply may be assembled within the chassis using terminal strips to hold the components.

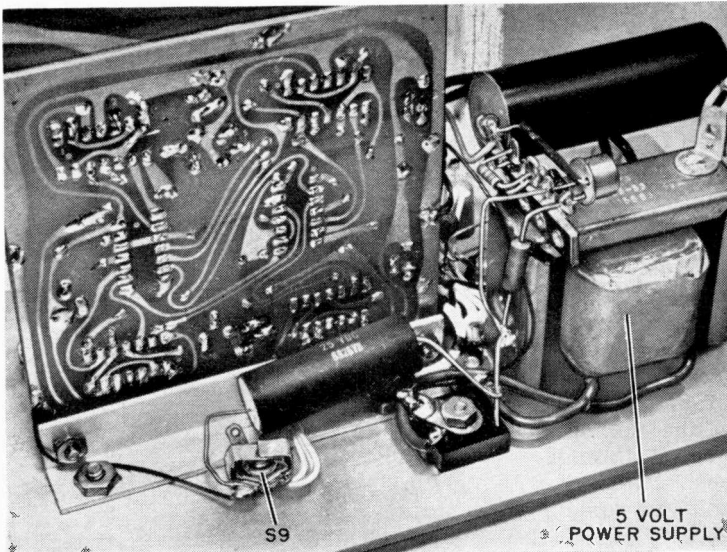
Theory of Circuit Design. The circuit uses four dual JK master-slave flip-flops, a quad two-input NAND gate, and a quad two-input positive NOR gate. The lamps are driven by emitter followers which are connected to the Q output of the flip-flops. In Fig. 1, the flip-flops are numbered to correspond to the lamps that they control.

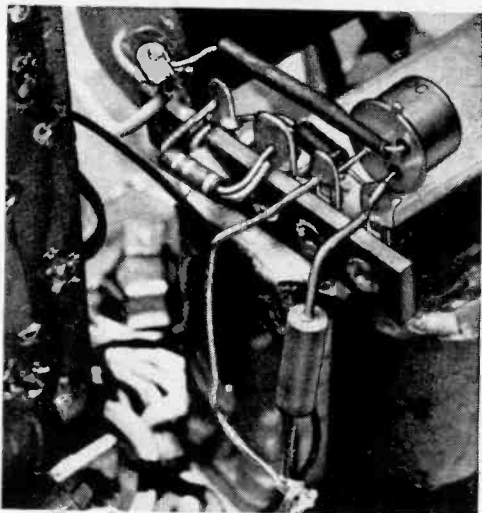
The JK inputs to FF1 are held at a high level at all times so that any pulse on the C input changes the Q output and turns I1 on or off. The \bar{Q} output of FF1 also controls the JK inputs to FF2.

Thus FF2 can be changed by a pulse on C only if the \bar{Q} output of FF1 is high—meaning I1 is on. The Q output of FF1 is coupled to FF3 through diode D1 and to one input of the NAND gate which is one of the controls for FF4 through FF8. Thus FF3 through FF8 are operative when I1 is off and the other control levels are correct. The \bar{Q} output of FF2 is coupled to FF3 through D2 so that FF3 can function only when I1 is off and I2 is on. The Q output of FF2 is coupled to FF4 through FF8 through a NAND gate so that they can operate only when FF2 is off and other conditions are met.

The \bar{Q} output of FF3 is coupled through D3 to FF4 so that the latter can only operate when I3 is lit. The \bar{Q} output of

The author elected to use a five-volt regulated dc supply in his prototype. The bridge rectifier, pass transistor, and filters can be seen above.





This view shows the value in using a terminal strip to mount off-board electronic components, in this case the regulated power supply. Such an approach can be used in any type of supply, or in any other project that requires outboard method of component mounting.

FF3 is also coupled to a NOR gate and its Q output to a NAND gate. These gates control FF5 through FF8 so that they cannot operate unless I3 is off. The \bar{Q} output of FF4 is coupled to FF5 through D5 so that FF5 can operate only when I4 is on. The Q output of FF4 is connected to one input of a NAND gate coupled to FF6, FF7, and FF8 so that they can operate only when I4 is off and other conditions are met.

The \bar{Q} output of FF5 is connected through D8 to FF6 so that FF6 can operate only when I5 is on. The \bar{Q} output of FF5 is also connected to a NOR gate while its Q output is connected to a NAND gate to control FF7 and FF8 so that they can operate only when I5 is off and other conditions are met. The Q output of FF6 is used only as a lamp drive but its Q output is connected to a NOR gate to control FF7 and to a NAND gate to control FF8 so that FF7 can operate only when I6 is on and FF8 can operate only when I6 is off.

The \bar{Q} output of FF7 is used only to drive lamp I7 and its Q output is connected to a NOR gate to control FF8. Thus FF8 can operate only if lamp I7 is on. The Q output of FF8 is used as a lamp drive only.

The clock input to each flip-flop requires that the input be held low, increased momentarily, and then returned to low. This condition is met by the normally closed pushbutton switches S1 through S8. A capacitor across each switch integrates the pulse and eliminates contact bounce.

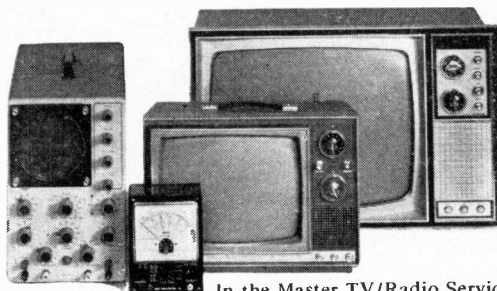
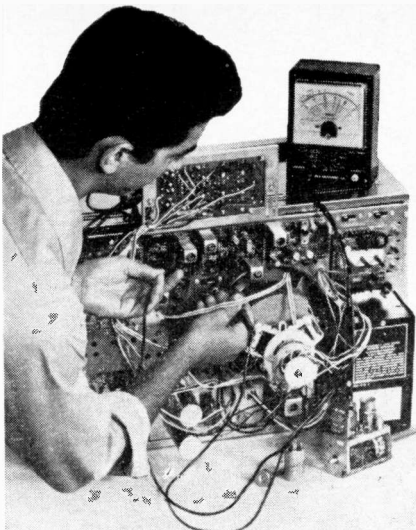
The overall logic circuit then controls the lamps so that I1 can be turned on or off at any time and to change the condition of any other lamp, the lamp immediately preceding the one to be changed must be on and all other lamps preceding that one must be off. This is the format that must be followed in solving the puzzle.

There are two modifications that can be tried. To make it easier, only the first six lamps and their associated circuits can be used—eliminating I7 and I8 and associated circuits. To make things more difficult, interchange the pushbuttons so that they don't line up with the lights—but be sure you know what's what or you may wind up on the puzzled side yourself. ♦



"Now don't worry, if something doesn't work right, remember—it's still in the design stage."

RCA Institutes Home Training may be your best investment for a rewarding career in electronics:



In the Master TV/Radio Servicing Program, you build and keep the all solid-state black and white TV set, the color TV set, the oscilloscope and multimeter shown above.

1 LEADER IN ELECTRONICS TRAINING

For over half a century, RCA Institutes, Inc. has been a leader in resident school technical training in electronics, and for many years, it has offered home study training in electronics.

2 RCA AUTOTEXT TEACHES ELECTRONICS RAPIDLY, EASILY

Beginner or refresher—"AUTOTEXT," RCA Institutes' own Home Training method helps you learn electronics rapidly, easily.

3 WIDE CHOICE OF CAREER PROGRAMS

Select from a wide choice of career programs, each of which starts with the amazing "AUTOTEXT" method of programmed instruction. Check over the attached card.

4 CASSETTE SYSTEM

An exciting concept — It's almost like having an instructor right in your home.

5 PERSONAL SUPERVISION THROUGHOUT

All during your program of home study, your exams are reviewed and commented upon and questions answered by RCA Institutes instructors personally involved in your efforts and ready to help you over any "rough spots" that may develop.

6 HANDS-ON TRAINING

To give practical application to your studies, a variety of valuable kits is included in many programs. In RCA's Master TV/Radio Servicing Program, you actually build and keep an all solid-state black and white TV set, and a color TV set. You also construct an oscillo-

scope and multimeter which are yours to keep and use on the job.

7 FCC LICENSE TRAINING — MONEY-BACK AGREEMENT

RCA Institutes' money-back agreement assures you your money back if you take and fail to pass the FCC exams within 6 months after completing the course.

8 CONVENIENT PAYMENT PLANS

You get a selection of tuition plans. And, we are an "Eligible Institution" under the Federally Insured Student Loan Program.

9 RCA INSTITUTES IS FULLY ACCREDITED

Accredited member National Home Study Council. Licensed by N.Y. State — courses of study and instructional facilities approved by the State Education Department.

Approved by N.Y. State Education Dept. for the training of Veterans.

RCA Institutes, Inc.

Home Study Dept. 222-303-0
320 West 31st Street
New York, N.Y. 10001

Name _____

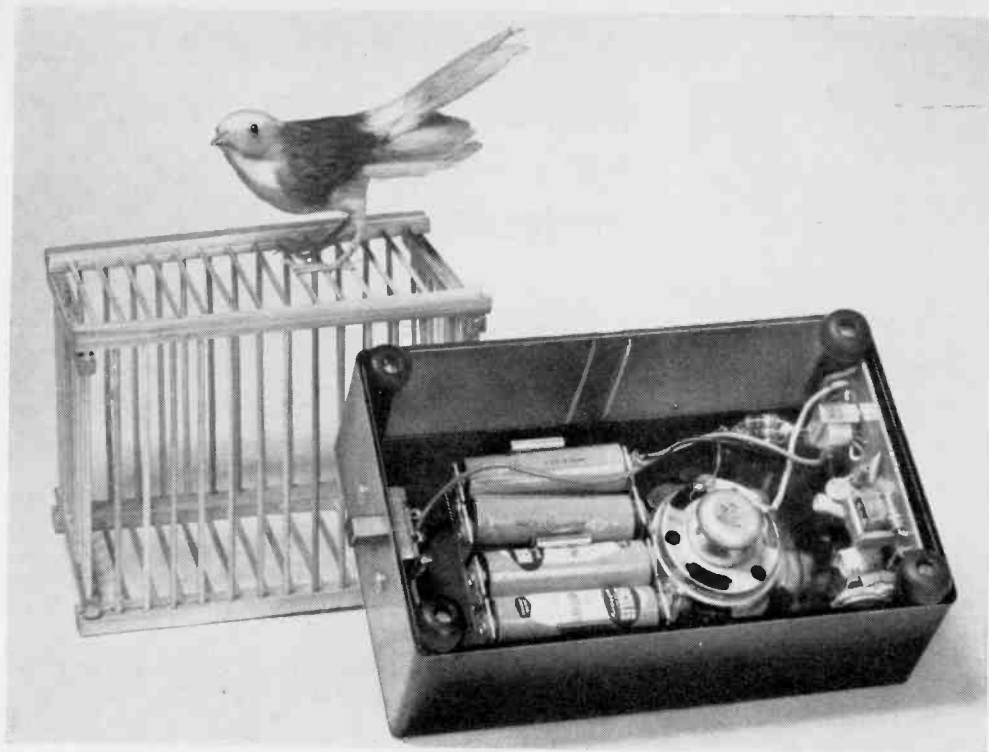
Address _____

City _____

State _____ Zip _____

Check here if interested in Classroom Training

CIRCLE NO. 14 ON READER SERVICE CARD



The Solid-State Bird

WHISTLES AND WARBLES LIKE A CANARY

BY JOHN S. SIMONTON, JR.

IF YOU LIKE the sweet, warbling song of a canary but don't dig that cage to be cleaned, try this electronic bird—a real solid-state, battery-operated singer. When turned on, the bird whistles down-scale for a few seconds, breaks into a warble, and, after several seconds, shuts off—only to start again automatically in a few more seconds.

The bird's circuit, shown schematically in Fig. 1, is deceptively simple in appearance. The most immediately obvious feature is an astable multivibrator made up of $Q1$, $Q2$, and their associated base timing circuits. Not so obvious is the blocking oscillator whose principal components are $Q2$, $C2$, and $T2$. The latter produces the warble.

When power is turned on, the bias circuits cause $Q1$ to be turned on and $Q2$ off. Capacitor $C1$ is initially discharged; but, as it begins to charge up through $R3$,

$Q2$ becomes forward biased by the current through $T1$ and $R4$. Eventually, the point is reached where $Q2$ acts as a blocking oscillator, and $Q1$ follows it because of coupling through $C5$.

During this oscillation, $C1$ is charged in a negative direction as a result of the half-wave rectification provided by $Q2$ (which is reverse biased during negative half cycles). Since the charging current is heavy at first and tapers off as $C1$ charges, the inductance of $T1$ goes from a low value to a high one because of the decreasing core saturation. The output tone then decreases in pitch.

Capacitor $C1$ goes rapidly negative with respect to ground, and its effect in the biasing of $Q2$ is replaced by the action of the oscillator itself during the positive half cycles and the charging current through $C4$ during the negative half cycles. Eventually, $C4$ charges to the

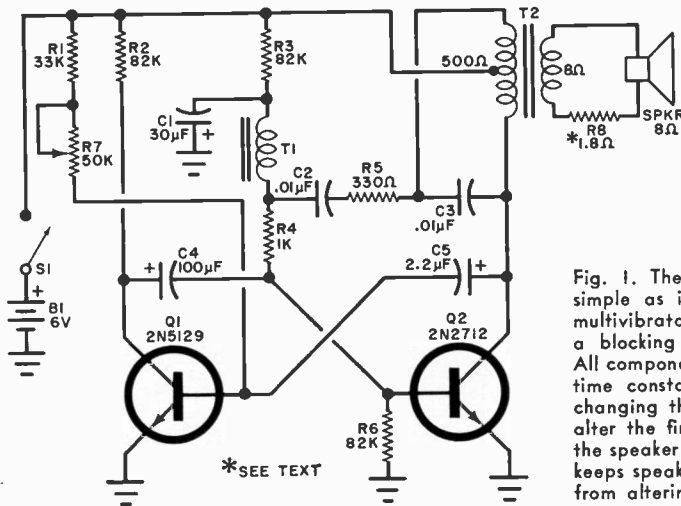


Fig. 1. The circuit is not as simple as it looks. Besides a multivibrator, there is also a blocking oscillator. All components are part of one time constant or another, so changing the value of one will alter the final sounds. Note the speaker damping (R8) that keeps speaker acoustic loading from altering the oscillator.

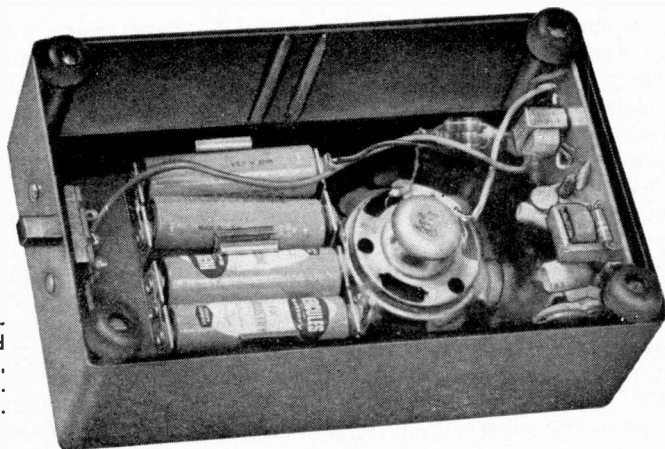
PARTS LIST

- B1—6-volt battery (4 AA cells in series)
- C1—30- μ F, 6-volt electrolytic capacitor
- C2, C3—0.01- μ F disc capacitor
- C4—100- μ F, 6-volt electrolytic capacitor
- C5—2.2- μ F, 6-volt electrolytic capacitor
- Q1—2N5129 transistor
- Q2—2N2712 transistor
- R1—33,000-ohm, $\frac{1}{2}$ -watt resistor
- R2, R3, R6—82,000-ohm, $\frac{1}{2}$ -watt resistor
- R4—1000-ohm, $\frac{1}{2}$ -watt resistor
- R5—330-ohm, $\frac{1}{2}$ -watt resistor
- R7—50,000-ohm trimmer PC potentiometer

- R8—1.8-ohm, $\frac{1}{2}$ watt resistor
 - S1—Spst slide or toggle switch
 - T1—10K:2K driver transformer (Lajayette TR-98, 99F61269 or similar)
 - T2—500-ohm CT:8-ohm output transformer (Lajayette TR-116, 99F61293 or similar)
 - Misc.—8-ohm speaker, plastic case, battery clips, wire solder, etc.
- Note—The following are available from PAIA Electronics, PO Box 14359, Oklahoma City, OK 73114: etched and drilled PC board, \$1.25; complete kit less batteries and case, \$6.95; both postpaid in USA.

point where its contribution to the Q2 biasing is small and the base/emitter junction of Q2 is reverse biased during a larger portion of each succeeding cycle. At some point, the blocking oscillator starts to "squegg," that is, the charge ac-

cumulated on C2 during negative half cycles is large enough that Q2 is turned off completely until the charge leaks off. Once the charge has leaked off, Q2 can oscillate once more. This charge-discharge cycle happens so rapidly that the audio



In prototype mounting arrangement, the speaker is mounted at the "bottom" of the box, while the "top" is left open. The rubber feet fit in cover.

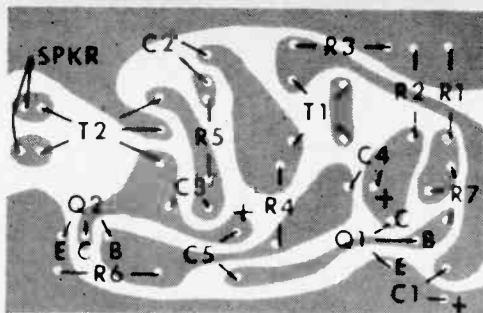
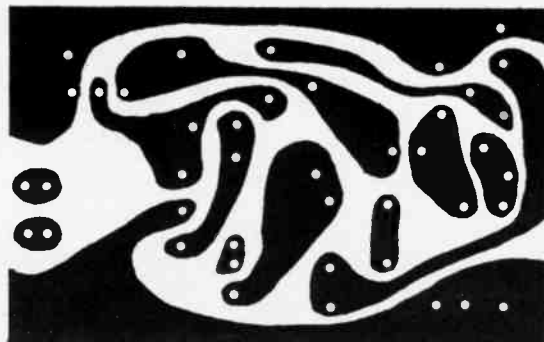


Fig. 2. Actual size foil pattern (right) and component installation (above). Note that miniature transformers must be used on this small PC board. It has been laid out so that it just fits in 6" x 3" x 2" plastic utility box.



tone generated sounds like a warbling bird. Finally, C4 discharges to the point where it makes no contribution to the biasing of Q2 and the latter turns off. With Q2 off, Q1 turns on and the cycle repeats.

Construction. Layout of the bird is not critical and any method of construction may be used. If you want to use a printed circuit board, the foil pattern and layout in Fig. 2 can be used. During assembly, be sure to observe the polarities of capacitors and semiconductors and do not overheat the components when soldering.

Component values are important. The circuit will work with the normal 10% tolerance of resistors and 20% tolerance of capacitors, but variations of any larger degree will throw it off. Every component determines some type of time constant, so if you change the value of one component, be prepared to change the rest.

Install leads on the board for the speaker and battery, making them long enough to reach when the board is located in the selected cabinet.

Since the output stage (Q2) works di-

rectly into the speaker without any buffering, any change in the speaker loading will be reflected back into the oscillator circuit, resulting in a change in the sound. This means that the selected enclosure (for board, batteries, and speaker) must have no resonant or antiresonant peaks. Resistor R8 is included as an option to isolate (partially) the speaker from the circuit.

The prototype was built in a conventional 6" x 3½" x 2" plastic case with the front cover not used. In the bottom of the case a hole was cut for the speaker. Make the hole slightly smaller than the diameter of the speaker and cement the speaker to the case behind the hole. Four rubber feet were attached to the holes on the opposite side (where the front panel was). The battery clips were mounted on the same side as the speaker with the PC board cemented to one wall and the power switch on the other wall.

The plastic case should be dressed up with a toy bird to complete the illusion. There are many garden supply houses that stock colorful stuffed birds—some even have small wood or metal cages to enclose the bird. ♦

BY DANIEL MEYER



BUILD THE

Five Forty

POWER AMPLIFIER

18 WATTS PER CHANNEL USING LATEST INTEGRATED CIRCUIT

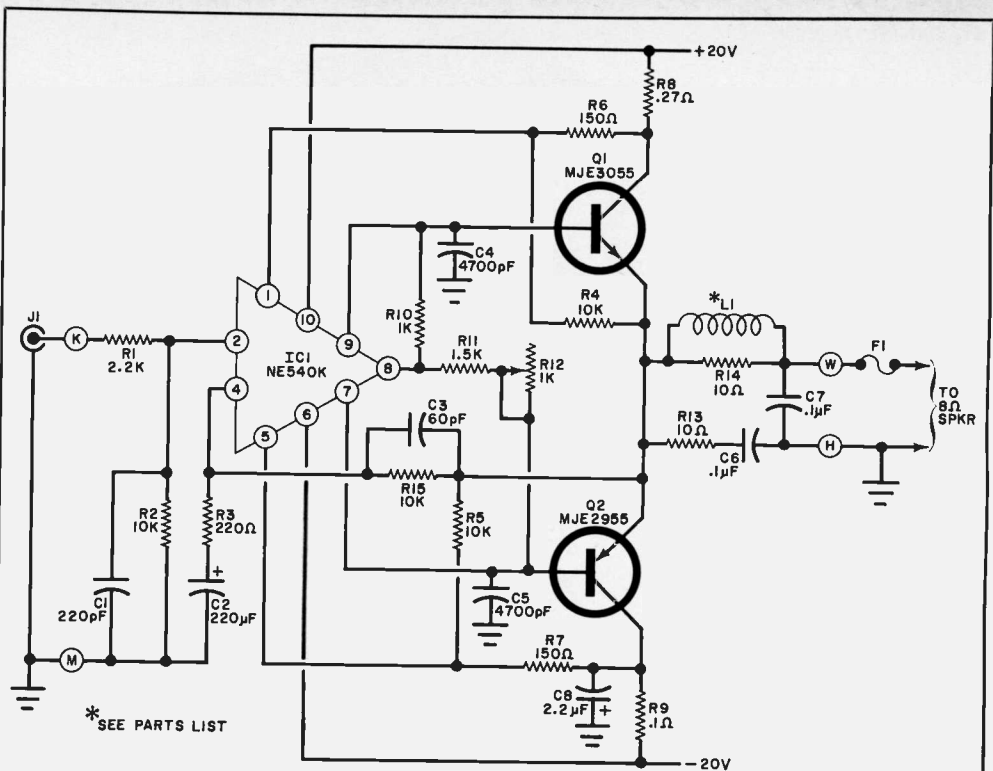
ALTHOUGH integrated circuits are used almost universally now in digital circuits, only recently have they begun to make serious inroads in linear circuits—especially in the area of high-performance audio devices. Most IC audio power amplifiers are restricted in power output and performance, thus limiting their use in quality music systems.

It is now possible to build an 18-watt (rms) per channel power amplifier using a new integrated circuit (the 540) coupled to a pair of output transistors. The total harmonic distortion of the amplifier is 0.1% at low levels, 0.6% at 10 watts and slightly over 1% before clipping. With an input impedance of approximately 10,000 ohms and requiring about 400 mV driving power, a pair of these amplifiers can be used in a stereo system to

deliver 15 watts per channel, with a power supply of modest size. With a larger supply up to 20 watts (IHF) is available per channel.

Tests show that the distortion level is consistent from 20 Hz to 20 kHz and actually decreases somewhat at higher frequencies—quite the opposite of conventional power amplifiers. Frequency response is within 1 dB from 5 Hz to 100 kHz. Square-wave tests show no trace of ringing or instability. This is quite good for an amplifier costing \$11 per channel—comparing favorably with many units of much higher price.

Theory of Circuit Design. The schematic diagram of the 540 Amplifier is shown in Fig. 1. A block diagram showing principles of operation is shown in Fig.



* SEE PARTS LIST

PARTS LIST

- C1—220- μ F, 5% polystyrene capacitor
 C2—220- μ F, 6-volt electrolytic capacitor
 C3—60-pF, 5% polystyrene capacitor
 C4,C5—4700-pF, polystyrene capacitor
 C6,C7—0.1- μ F, Mylar (or other film) capacitor
 C8—2.2- μ F, 50-volt electrolytic capacitor
 F1—1-ampere fuse (optional, see text)
 IC1—Integrated circuit (Signetics NE540K)
 J1—Phono connector
 L1—Single layer #24 or #26 insulated wire wound on R14
 Q1—Transistor (Motorola MJE-3055)
 Q2—Transistor (Motorola MJE-2955)
 R1—2200-ohm, $\frac{1}{2}$ -watt, 10% resistor
 R2,R4,R5,R15—10,000-ohm, $\frac{1}{2}$ -watt, 10% resistor
 R3—220-ohm, $\frac{1}{2}$ -watt, 10% resistor
 R6,R7—150-ohm, $\frac{1}{2}$ -watt, 10% resistor

- R8—0.27-ohm, 5-watt, 10% resistor
 R9—0.1-ohm, 5-watt, 10% resistor
 R10—1000-ohm, $\frac{1}{2}$ -watt, 10% resistor
 R11—1500-ohm, $\frac{1}{2}$ -watt 10% resistor
 R12—1000-ohm trimmer potentiometer (IR \bar{C} X-201 or similar)
 R13,R14—10-ohm, 1-watt, 10% resistor
 Misc.—Suitable chassis, terminal board for speaker connections, mica washers, silicone grease, heat sink for IC1, etc.

Note—The following are available from Southwest Technical Products, Box 32040, San Antonio, TX 8216: etched and drilled PC board #186b at \$2.30 postpaid; complete kit of parts for one channel amplifier (including PC board) #186c at \$10.50 plus postage and insurance for 6 oz; two amplifier kits and power supply #CA186 at \$37.50 plus postage and insurance for 6 lb.

Fig. 1. Having an input impedance of about 10,000 ohms, a single IC is capable of driving two power transistors to full output, requiring about 400 mV input.

2. The first stage in the IC is a differential amplifier having its own constant current source. Next is a pair of common-base amplifiers that present a low impedance to reduce any Miller effect that would impair high-frequency response. This stage is supplied with power through a zener diode and current source. In this way, power supply varia-

tions do not affect performance of the input stage.

The outputs of the common-base amplifiers drive a double differential amplifier which also has its own constant current source.

The next stage is composed of the actual output drivers of the IC, one operating on the positive half cycle, the

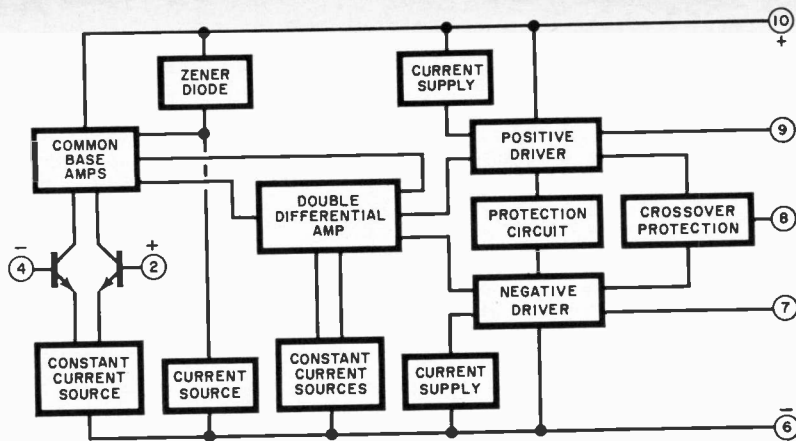


Fig. 2. There are 31 transistors and 26 resistors in 540K IC, making up the circuit shown here. Note how unique protection circuit provides maximum safety.

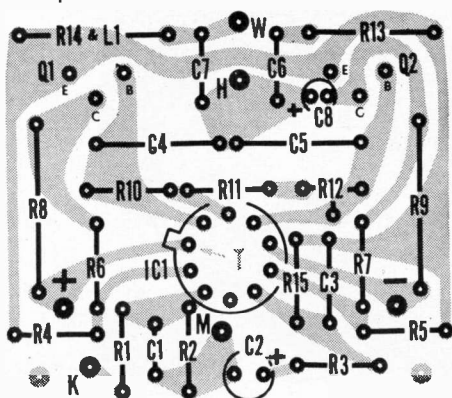
other on the negative half. The output circuit has a built-in protection arrangement to limit the current when the load resistance is too low. A transistor is used to bias the output so that crossover distortion does not occur.

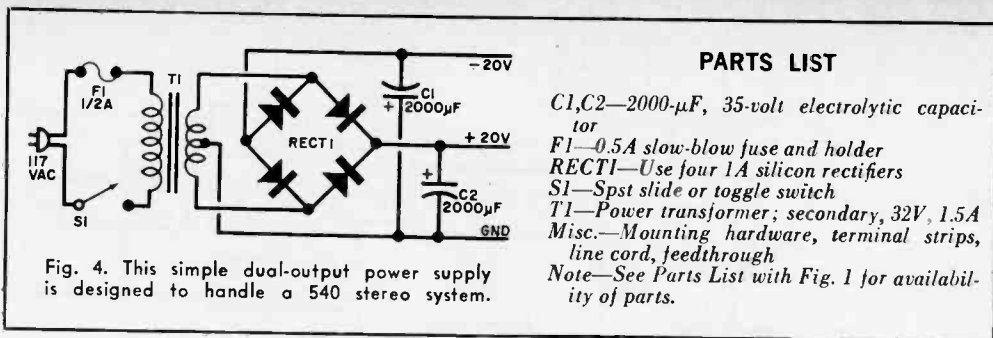
The protection circuit used here keeps the output transistors from being damaged by any type of load. Ordinarily current protection prevents damage if the load is resistive or slightly reactive, but it could not prevent destruction of the output transistors if the amplifier is driven hard with a highly reactive load. If you want to see how this happens (and can spare a pair of output transistors), take any transistor amplifier with ordinary overload protection and drive it to full output with a 100-Hz square wave. Do not use any load resistor on

the output terminals. Now begin adding 10- μ F capacitors across the load. At some point, perhaps with the first capacitor, the output transistors will heat up and probably be destroyed as the silicon chip goes into secondary breakdown. In the 540 amplifier, this cannot happen if the protection resistors are the correct value. Any voltage-current combination that is outside the safe operating area of the transistors clamps the drive current to the output stages.

The amplifier can be destroyed by overloading at frequencies above the audio range (over 30 kHz) for extended periods of time, but this is not a normal operating procedure. If there is any possibility of such an occurrence, a filter system should be used in the preamplifier. For good transient response, an audio amplifier

Fig. 3. Actual size foil pattern and component installation for the 540 amplifier.





PARTS LIST

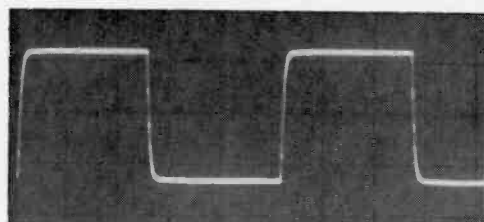
- C1, C2—2000-µF, 35-volt electrolytic capacitor*
- F1—0.5A slow-blow fuse and holder*
- RECT1—Use four 1A silicon rectifiers*
- S1—Spst slide or toggle switch*
- T1—Power transformer; secondary, 32V, 1.5A*
- Misc.—Mounting hardware, terminal strips, line cord, feedthrough*
- Note—See Parts List with Fig. 1 for availability of parts.*

Fig. 4. This simple dual-output power supply is designed to handle a 540 stereo system.

should have a bandwidth that goes beyond 100 kHz, but it must not be driven at high levels at these high frequencies or common-mode conduction will quickly overheat and destroy the output transistors.

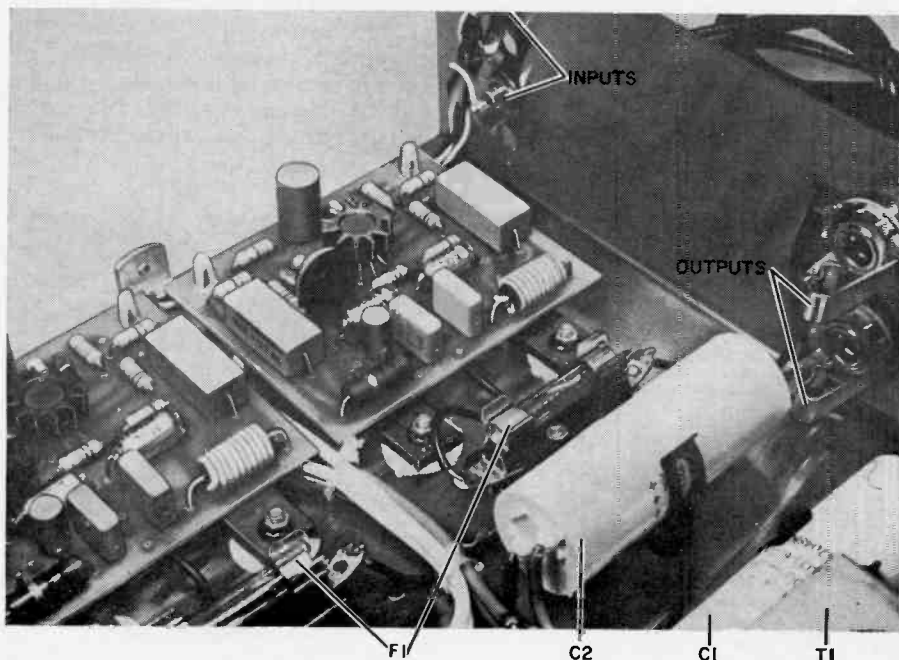
Construction. A single-channel power amplifier can be built on a printed circuit board as shown in Fig. 3. Note the position of the tab on the integrated circuit and the polarities of the electrolytic capacitors. Use a low-power soldering iron and fine solder to make all connections. The two power transistors (Q1 and

Q2) are mounted with their metal sides against the mounting surface. The board can be mounted using nylon clips and screws through the transistors. Use a



The output waveform of a 10-kHz square-wave input shows no sign of ringing or other instabilities.

The two channels are supported on plastic standoffs while the power supply components are mounted on the base of the chassis. A neat cable harness adds to the professional look.



HIRSCH-HOUCK LABORATORIES

Project Evaluation

This amplifier is an interesting demonstration of how simple such a device can be with the aid of current integrated circuit technology. It is a rather low-power unit by current standards, but could hardly be improved upon for its price.

With both channels driven, a realistic full-power rating would be about 10 watts per channel. However, at 10 watts, the distortion curve is quite flat across the entire audio frequency range—just below 1.0%. Similarly flat curves are obtained at reduced power: at half power the distortion is about 0.3% and at 1/10 power, just under 0.1%. All figures apply from 20 Hz to 20 kHz.

The 1000-Hz harmonic distortion, under 0.1% at low power rises smoothly to 0.15% at 2 watts, and more steeply to 1.75% at 15 watts. At higher powers it increases sharply. The IM curve has a similar shape, from 0.3% at 0.1 watt to 0.85% at 3 watts, and 4.2% at 10 watts.

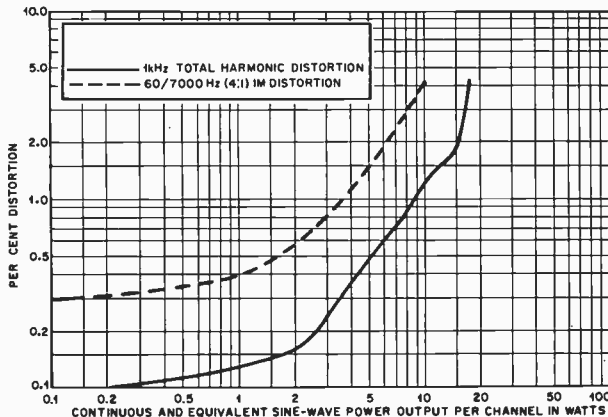
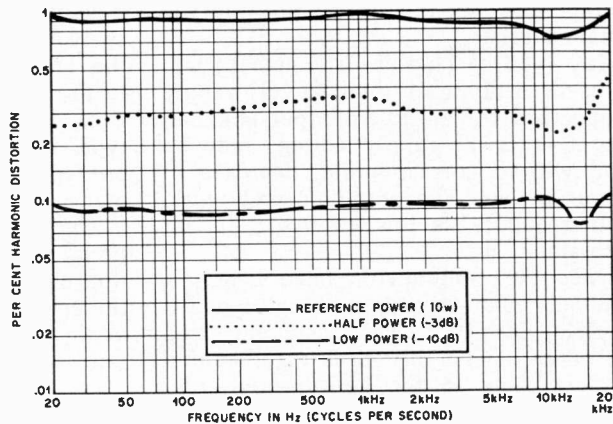
At the clipping point, the power output was 21.2 watts into 8 ohms and 12.1 watts into 16 ohms. The amplifier is not intended for use with a 4-ohm load.

The frequency response was excellent; down 0.2 dB at 10 Hz and 50 kHz, down 0.7 dB at 5 Hz, and down 3 dB at 170 kHz. Square-wave rise time was 2 microseconds. Noise level was a very low -87 dB referred to 10 watts.

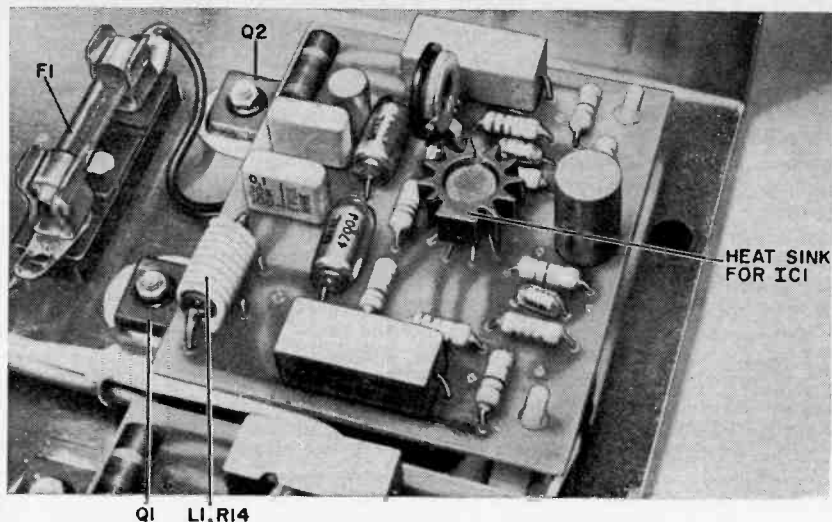
The preceding measurements were made with the bias controls set as received. Adjusting them did not produce any significant change in distortion. However, we did not observe the "glitch" in the waveform (referred to in the article) while adjusting the controls.

Subject to the above limitations, the 540 amplifier appears to be a very satisfactory low-power unit with low enough distortion for any installation where an amplifier of this power rating is likely to be used.

Very low percentages of harmonic distortion are present at all output power levels and across entire frequency range of the amplifier.



Total harmonic distortion and intermodulation distortion increase sharply at higher power outputs. Both channels driven with 8-ohm loads. One channel was measured.



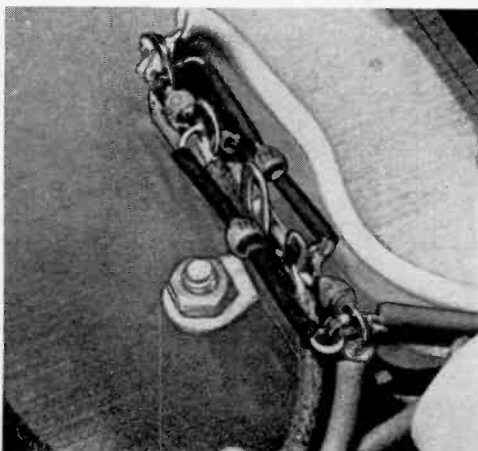
Note that Q1 and Q2 (of each channel) have their leads connected to the board, but are thermally (not electrically) affixed to the chassis to provide heat-sinking.

mica washer covered on both sides with heat sink compound to avoid electrical contact between the transistors and the metal chassis.

Any type of chassis arrangement can be used. Although a dual 20-volt supply is specified for an 18-watt (per channel) output, a lower supply voltage may be used with a corresponding decrease in output power. The amplifier will work, with a supply as low as five volts on each side.

Once the components have been assembled, connect a pair of color coded insulated leads to terminals K and M on the board. Twist the wires together and connect them to the appropriate input jacks. Connect terminal K to the "hot" terminal of the jack and M to the ground lug. Connect terminal H of the board

The four power supply rectifier diodes are mounted on a suitable terminal strip on the chassis base.

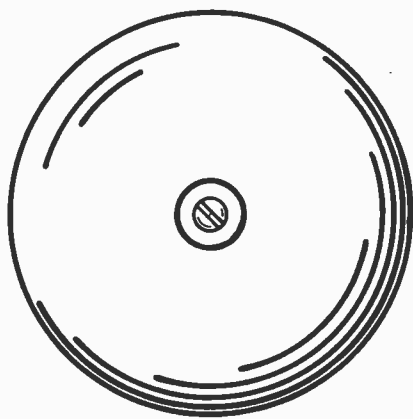


to the point on the power supply where the center tap on the secondary of T1 is connected. Connect terminal W to the speaker output point and terminal H and the ground side of the speaker output to the power supply ground. On a high-gain, wide-bandwidth amplifier of this type, it is very important that these input and output connections be properly made.

The output fuse (F1 in Fig. 1) is optional since the amplifier has a protection circuit, but it is advisable to protect the speaker in case of a high dc input or in the event an output transistor should fail.

Testing. To set the bias control, apply a 10-kHz signal to drive the amplifier to an output of 1 watt or less and connect the output to an oscilloscope. With R12 set for minimum resistance, there will be a small "glitch" or disturbance in the viewed waveform at the zero crossing. Adjust R12 until the glitch straightens out. Do not advance R12 beyond this point—to do so may cause excessive idle current in the output transistors. While the scope is connected, raise the sweep speed and check for any signs of high-frequency oscillation which, if present, may be cured by adding low-value capacitors to ground from the suspect points. Also check for heating of the output transistors. ♦

Professional Intruder/Fire ALARM



SELF-POWERED SOLID-STATE SYSTEM

HAS FEATURES OF A COMMERCIAL ALARM

BY GEORGE MEYERLE

DO YOU read an article about a burglar alarm kit with an inclination to say, "Oh, no, not another one of those things"—and move on to something else? Well, hold your horses and take a second look.

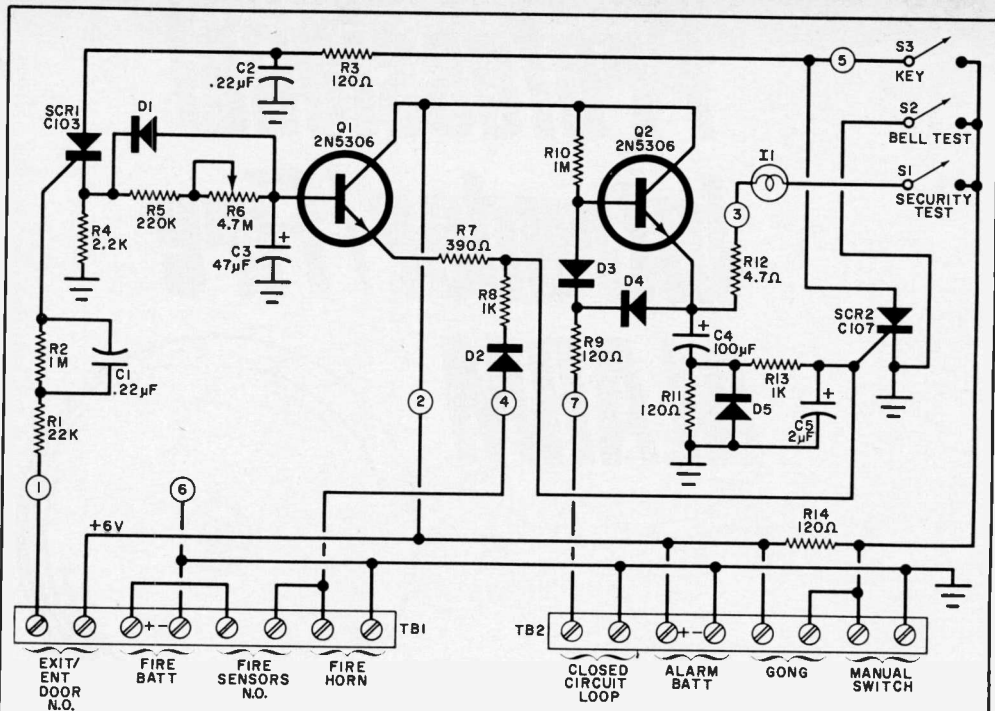
True, the alarm described here doesn't use a lot of new gadgets for detection devices or involve sophisticated things like ultrasonics or microwaves. Actually, it operates with breakwires and switches just as do most commercial units. The advantages of the alarm are in the circuit design itself—advanced solid-state features not found in most systems.

In addition, the alarm operates on lantern batteries for power, eliminating the possibility of having the wires cut to silence the alarm. Power consumption in the standby mode is extremely low so that almost shelf life can be obtained from the battery. This makes the system ideal for use in areas where primary power is not readily available.

In most commercial systems, a constant current flows through the closed protection loop to keep the various switch contacts in good condition. In this alarm, however, there is no wasteful loop current; the switch contacts are kept clean by a pulse of current which flows through the loop each time the system is activated.

In addition to intruder detection, the system can be used as a fire alarm. In this case, fire (actually heat) sensors are connected to the circuit to sound the alarm. It is also a simple matter to include such features as mat switches to indicate when anyone enters an open door or uses a staircase; and manual pushbuttons can be included to operate as panic alarms.

A 5-to-50-second delay is used to allow the owner to enter through any one selected door. Entry in any other way will cause the alarm to sound. For this type of use, the control panel must be located out of sight but convenient enough for



PARTS LIST

C1, C2—0.22- μ F capacitor
C3—47- μ F, 20-volt, tantalum capacitor
C4—100- μ F, 15-volt electrolytic capacitor
C5—2- μ F, 25-volt, electrolytic capacitor
D1-D5—1-ampere, 600-volt silicon diode
I1—6-volt, low-current incandescent lamp
Q1, Q2—2N5306 (Darlington) transistor
R1—22,000-ohm, 1/2-watt resistor
R2, R10—1-megohm, 1/2-watt resistor
R3, R9, R11, R14—120-ohm, 1/2-watt resistor
R4—2200-ohm, 1/2-watt resistor
R5—220,000-ohm, 1/2-watt resistor
R6—4.7-megohm PC potentiometer
R7—390-ohm, 1/2-watt resistor
R8, R13—1000-ohm, 1/2-watt resistor
R12—4.7-ohm, 1/2-watt resistor
S1, S2—Normally open pushbutton switch
S3—Key switch assembly

SCR1—Silicon controlled rectifier (GE C103YY)
SCR2—Silicon controlled rectifier (GE C107F12)

TB1, TB2—Eight-pin barrier strip

Misc.—Suitable chassis, lantern batteries (6-volt), battery connectors, mounting hardware, etc.

Note—The following are available from Metrotec Industries, Technical & Industrial Park, 33 Caine Dr., Plainview, NY 11803, etched and drilled PC board #602, \$2.00; control panel, chassis, key lock, PC board, all electrical and mechanical components, #601, \$29.95 plus \$1.60 postage; 10" gong, #607, \$15.95; fixed temperature heat sensors (specify 135° or 190°), \$1.90. The same firm can supply switches, break-wires, etc., used in professional alarms.

Fig. 1. Unlike other alarms, this one features a 5- to 50-second delay to allow legitimate entry without ringing the gong. This same circuit is also used for fire warning when used with the appropriate sensors.

the legitimate user to shut down the system by operating a key switch once he is inside. Both the control box and the gong enclosure can be fitted with normally open switches in the protective loop so that if anyone tries to remove either of these units from the wall, the alarm sounds.

Construction. The schematic of the elec-

tronic portion of the alarm is shown in Fig. 1. Assemble the circuit using the foil pattern and layout guide shown in Fig. 2. Silicon controlled rectifier SCR2 is mounted on the metal chassis and connected to the PC board terminals through three lengths of insulated wire. Be sure to get the polarities on the electrolytics and semiconductors correct. Use a low-power soldering iron and fine solder. Note that

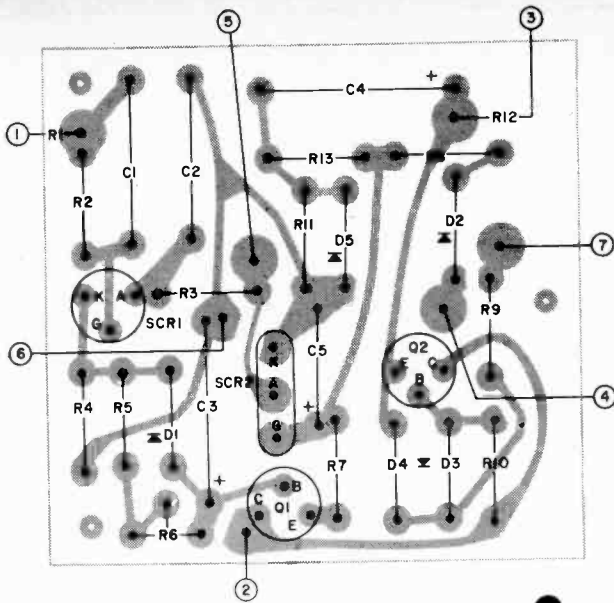
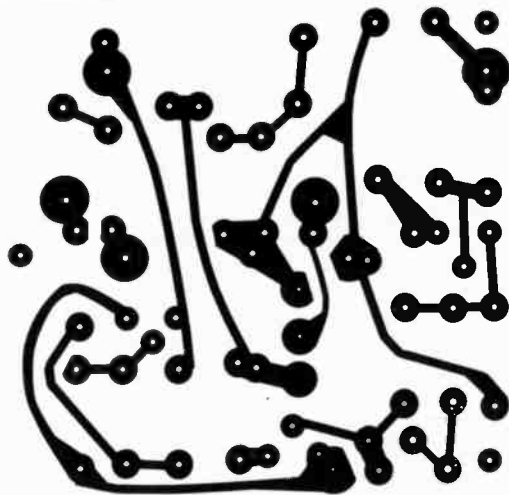


Fig. 2. The actual size foil pattern (right) and component installation (above). Note that SCR2 is mounted on the chassis and connected to its terminals via lengths of insulated wire. It should also be pointed out that both Q1 and Q2 are Darlington transistors for high input impedance.



R1 and R12 are mounted vertically with their top terminals serving as terminals 1 and 3 respectively. Terminals 2 and 4 through 7 on the board are made from L-shaped pieces of stiff copper wire inserted in the appropriate holes and soldered to the foil on the bottom.

Components such as the security test lamp *I1*, security test switch *S1*, bell test switch *S2*, and key switch *S3* should be mounted on the front panel of the enclosure and connected to the board with insulated wire.

Mount the components in a suitable enclosure similar to that shown in the photo. If the PC board is mounted on in-

ulated spacers SCR2 need not be isolated electrically from the metal chassis. If the board is metallically connected to the chassis, an insulating transistor mounting kit must be used, with silicone grease added to insure heat conduction.

Use some form of press-on type to identify the controls on the front panel. Connections to the outside circuit are made with insulated wiring passed through a hole punched on the side of the chassis.

Installation. When selecting a location for the control panel, remember that it should be mounted where it can be

THEORY OF CIRCUIT DESIGN

With the closed-loop protection circuit connected to the control panel, the emitter of *Q2* is at ground potential and *C4* is discharged. When the loop is broken in any way, *C4* is charged up to +6 volts through *Q2*. The positive voltage developed across *R11* during this charging period is applied to the gate of *SCR2*, turning it on. This completes the gong circuit through terminal 5 and the key switch.

To keep the alarm from sounding when the owner leaves or enters the premises, a unique 5-to-50-second delay is used. The switch on the exit/entrance door is open when the door is closed and closed when the door is opened. One side of the switch is connected to the battery supply.

Under normal conditions, before leaving, key switch *S3* is open so that, when the door is opened, the positive voltage applied to *C1* through *R1* cannot fire *SCR1* because there is no positive voltage on its anode. Capacitor

C1 discharges through *R2*. Now the key switch is closed and exit is made, closing the door. The next time the exit/entrance door is opened (the switch closes) *C1* is charged up and fires *SCR1*. The positive pulse across *R4* puts a charge on *C3* through *R5* and *R6*. As a result *Q1* is turned on and once it saturates, a positive pulse is applied to the gate of *SCR2*, turning on the alarm. The amount of time that it takes *C3* to charge up and turn on *Q1* is determined by the setting of *R6*.

The fire alarm system is a simple series circuit consisting of the heat sensor, the fire horn, and the fire battery. When the heat sensor closes, it completes the horn circuit. When the fire horn sounds off, a positive voltage at the junction of the fire sensor and the battery feeds through *D2* and *R8* to turn on *SCR2* and activate the intruder gong as well.

Diodes *D3* and *D4* protect the circuit from lightning spikes picked up on the relatively long closed loop. Diode *D5* removes the negative spike from the *SCR2* gate circuit when *C4* is discharged.

reached within 5 to 50 seconds (depending on the preset delay) after entering the premises. However, it should not be visible from outside the area being guarded. Also keep in mind that a number of leads have to be connected to the control panel, so be sure that you have cabling access.

Since the purpose of the system is to let you know when something happens, you should use a good, large, loud gong for the alarm. If mounted outside, the gong should be in a weatherproof louvered enclosure. The enclosure should have two normally open switches (one on the door and one between the enclosure and the wall) wired in series with the remainder of the closed-circuit loop. Mount and wire the switches so that if the gong enclosure is opened or it is removed from its mounting, one of the switches will open and cause the alarm to sound.

Intrusion Protection. Determine which door is to be used as the main entrance and exit. Fit the door with a switch that is open when the door is shut and closed when the door is open. This switch is connected to appropriate terminals on *TB1*. Determine the other points of entry that are to be protected and select the appropriate switch for each. In all cases, the switches must be normally closed

when all is OK, but open in the event of an intrusion. Connect them in series to form a closed-loop system to be connected to the appropriate terminals on *TB2*.

There are many different types of switches that can be used for this purpose. Some are spring-loaded and are held down by a finger arrangement attached to the door or window. In this way the switch opens when the door or window is opened. There are also magnetically operated switches, with the magnet attached to the door or window to keep the switch closed. Switches with mechanical variations can be obtained for doors and windows with unusual configurations and circumstances.

Large glass areas can be protected with self-adhering conductive frangible tape that can be very easily torn (open circuited) if a crack occurs in the glass. Electrical contact is made to the tape with a self-adhering contactor.

After all switches have been selected and properly installed—along with other protective devices—they must all be connected in series and brought to the appropriate terminals on *TB2*. To test the circuit, an ohmmeter should show a very low resistance for the entire loop when all doors and windows are closed. The resistance should go to infinity if any part of the loop is opened.

In the exit door circuit, the opposite is true. The circuit should be open when the door is closed and closed when the door is open.

To provide a manual alarm, connect a normally open pushbutton switch to the appropriate terminals on TB2. The switch can be mounted in any convenient location. Floor mat switches, if used, are connected to the same terminals on TB2.

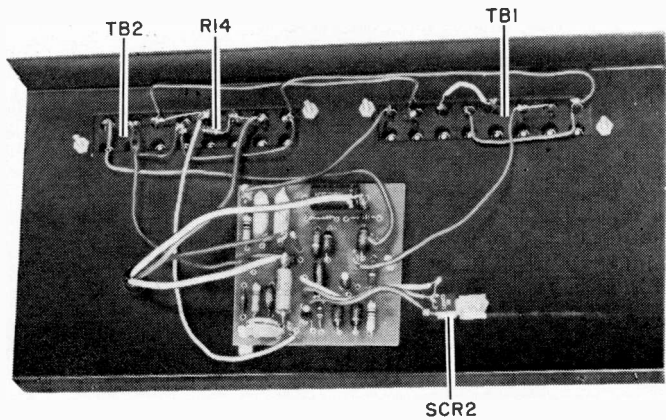
Fire Protection. This alarm system also makes an excellent fire or smoke alarm, when wired to suitable heat sensors. There are three basic sensors. One operates at a temperature of 135°F for use

normally open heat sensors are connected in parallel to the suitable terminals on TB1.

Test and Operation. To check the security of the system, with the key switch turned off, open any protected door or window as an intruder would. Depress the security test switch (S1) and note that the security test lamp (I1) comes on.

To test the closed circuit loop with the gong, make sure that the loop is closed and the key switch turned on. When any part of the closed loop is broken, the gong should ring until the key switch is turned off.

The PC board and the two barrier strips are shown mounted on the shelf that comes with the enclosure (see Parts List). Note how SCR2 is mounted to the metal shelf using a transistor insulator mounting kit.



in living areas; another switches on at 190°F for use in boiler rooms and attics; while a third is a rate-of-temperature-rise sensor that operates when there is a sudden change in the ambient temperature. The latter is what happens when a fire suddenly sweeps into a room. These

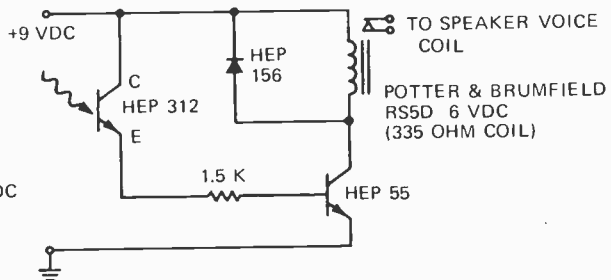
To check out the exit/entrance door system, open that door prior to turning the key switch on. Turn the key switch on and then close the door. The alarm should go off between 5 and 50 seconds after the door is opened again. The timing is set by adjusting R6. ♦

T-V COMMERCIAL KILLER

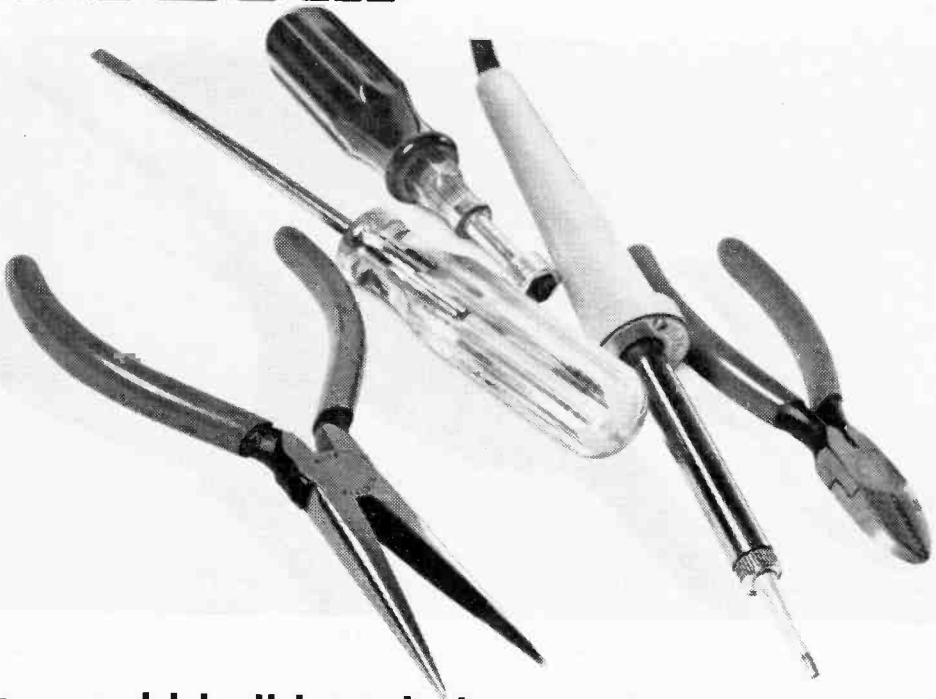
- FEATURES:**
- No interconnecting wires—use a flashlight to key relay
 - Low battery drain
 - Auto reset

PARTS LIST:

- 1 HEP 312
- 1 HEP 156
- 1 HEP 55
- 1 Resistor, 1.5K, 1/2 Watt
- 1 Relay, Potter-Brumfield RS5D, 6VDC
- 1 Battery, 9VDC

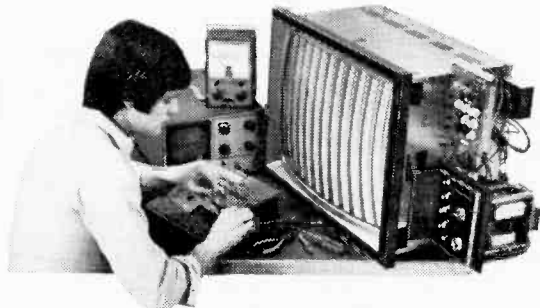


IF YOU CAN USE ANY OF THESE TOOLS...



...you could build a whole new future...

and build
yourself
a Bell & Howell
solid state
color TV while
you're at it!



If you're already handy with a set of tools, here's a way to pick up a pretty thorough knowledge of electronics: build yourself a solid state color TV as part of a complete learn-at-home program from Bell & Howell Schools.

This important project gives you valuable "hands on" experience with solid state circuitry—the kind of *practical* experience you'll need to build a successful career. It's a vital part of your total electronics education.

Once you've completed your program, you could be ready to build a new career—or start a business of your own—in home entertainment electronics.

Fix stereo systems . . . FM-AM radios . . . phonographs . . . tape recorders

With your new skills, you can build and service stereo-hi-fi systems—including FM-AM radios . . . phonographs . . . open reel tape recorders and cassette or cartridge player/recorders. You could even build yourself a complete "home entertainment communications center"—complete with the new gadgetry of cartridge television when it comes out. The skills you build up by following this brand-new program are more than enough to service almost any type of home entertainment electronic device.

A complete at-home learning program in home entertainment electronics

Don't confuse this program with an ordinary hobby kit. It's much more than that. It's a complete at-home learning program prepared by skilled instructors at Bell & Howell Schools.

It doesn't matter if you've never had any training in electronics before. Nobody's going to start throwing "diodes" and "capacitors" at you right off. You start with the basics. You take it one step at a time. You walk before you run. And you'll be amazed at how quickly you start to feel comfortable with things that seemed complicated at the beginning.

Attend special "help sessions" if you like

In case you should run into a sticky problem or two—one that you can't handle on your own—come in and see us. We've scheduled help sessions every few Saturdays at the Bell & Howell Schools and in many other cities throughout the U.S. and Canada. Drop by. Meet an expert instructor in person. Talk over any rough spots with him—and with other students. You'll enjoy the chance to "talk shop."

Master the most up-to-date solid state circuitry

Solid state is here to stay. Not just color TV but almost every type of electronic device will eventually move farther and farther in the direction of total solid state circuitry. Get to know the most advanced "trouble-shooting" techniques for these sophisticated circuits. You'll find an almost irresistible demand for your skills.

Why you should know electronics

No matter where you look, the amazing

technology of electronics is becoming a bigger and bigger part of the picture. More and more automotive parts and diagnostic instruments are electronic. Many large manufacturing plants use sophisticated electronic systems—controlled by a few skilled electronics technicians. The increasing use of two-way radio . . . the huge promise of cable television . . . the astonishing growth of electronic data processing all open doors to exciting new career opportunities for the man with thorough training in electronics. In fact, the day may come when the man who does not have electronic skills will be severely handicapped in many industries.

Why you should get your training from Bell & Howell Schools

Skilled instructors at Bell & Howell Schools—carefully selected for their knowledge, experience and teaching ability—plan each program with the utmost care and attention. Each year, they spend about \$200,000.00 improving programs and materials and keeping them in step with new developments in electronics. Thousands of people have used their Bell & Howell Schools training as the foundation for new careers and businesses of their own in electronics.

You build and keep the exclusive Bell & Howell Schools Electro-Lab®—a complete laboratory-in-the-home

To make sure you get practical experience with instruments used daily by professionals, you build and keep a Design Console, an Oscilloscope and a Transistorized Meter (see details at right). These are the three instruments you'll work with constantly—both during your program and thereafter.

CONSIDER THESE ADVANTAGES:

Help Sessions We've scheduled "help sessions" every few Saturdays at the Bell & Howell Schools and in many other cities throughout the U.S. and Canada. Top instructors give you expert guidance and you meet other students, too.

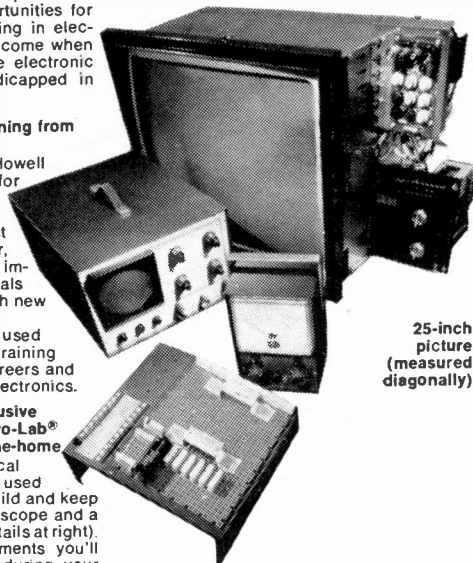
Resident Study After you complete your program, you can transfer to any of the resident schools for more advanced study, if you wish.

Lifetime National Placement Assistance When you complete your course, we help you locate a position in the field of Electronics that fits your background and interests. This unique service is available at any time after you graduate.

Veterans' Benefits We are approved by the state approval agency for Veterans' Benefits. Check the box for details.

Student Financial Aid We are an eligible institution under the Federally Insured Student Loan Program. Check the box for details.

Detach postage-paid reply card and mail today for free information



25-inch picture (measured diagonally)

■ **Bell & Howell Solid State Color TV.** Ultra-rectangular tube . . . 25-inch picture measured diagonally . . . full 315 sq. inch viewing area. Solid state modular circuitry . . . 4 advanced IC's . . . 100 transistors . . . 72 diodes . . . individual plug-in circuit boards. Special UHF/VHF tuning features . . . built-in self-service components.

■ **Design Console** Use this to rapidly "breadboard" circuits without soldering. Equipped with built-in power supply . . . test light . . . speaker . . . patented plug-in modular connectors.

■ **Oscilloscope** Portable 5-inch wide-band oscilloscope offers bright, sharp screen images . . . calibrated for peak-to-peak voltage and time measurements . . . 3-way jacks for leads, plugs, wires.

■ **Transistorized Meter** Combines most desired features of vacuum-tube voltmeter and quality multimeter. Registers current, voltage and resistance measurements on a large, easily-read dial. Features sensitive, 4-inch, jewel-bearing d'Arsonval meter movement.

For Free Information, Mail Card Today!

If card has been removed, write:

An Electronics Home Study School

DEVRV INSTITUTE OF TECHNOLOGY

ONE OF THE



BELL & HOWELL SCHOOLS

4141 Belmont, Chicago, Illinois 60641

347R3

**BY ROGER
MELEN
AND
HARRY
GARLAND**



**BUILD
THE**

FIL-OSCILLATOR

**IT'S A TWOSOME: SHARP AUDIO FILTER
& VERSATILE WAVEFORM GENERATOR**

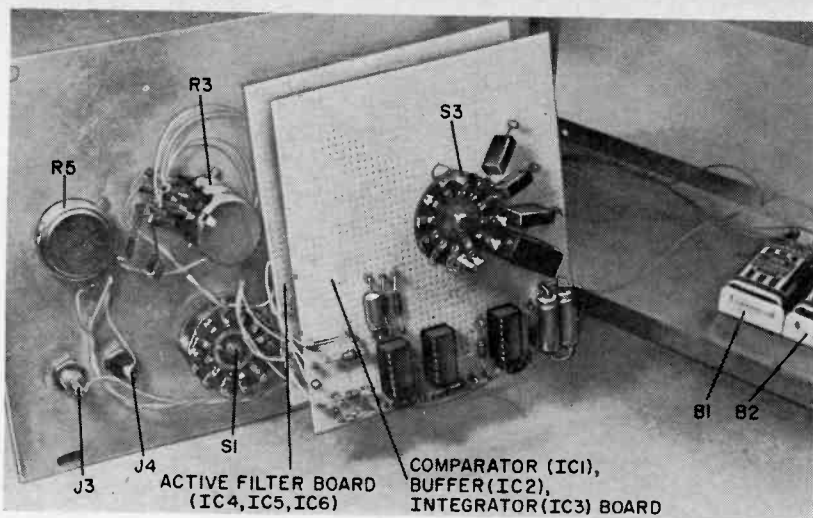
ACTING just as if it were born under the zodiacal sign of Gemini (the twins), the Fil-Oscillator is an unusual laboratory instrument having two distinct personalities: it is both a high-Q audio filter and a low-distortion sine, square or triangle wave generator. (Specifications are given in the Table.)

The heart of the Fil-Oscillator circuit (see schematic) is a sharp active filter (using three op amps) which can be tuned over the audio spectrum. Since all non-sinusoidal waveforms can be broken down into their constituent sine wave elements, it doesn't matter what shape is applied to the input of the filter. A sine wave of the frequency to which the filter is tuned appears at the output. Because of this sharp filtering action, the filter can be used in a wide number of

audio frequency applications, including measurement of the overtones (harmonics) of a musical instrument, charting the frequency spectrum of a complex waveform, measurement of the harmonic distortion of an amplifier or speaker system, or boosting the selectivity of a ham or SWL receiver.

As an oscillator, the device serves as a function generator of laboratory quality, developing low-distortion sine, square or triangle waves which are very useful in various test procedures. The Fil-Oscillator's active filter is used to derive the sine waves producing a purer waveform than is possible in conventional waveshaping circuits.

Six inexpensive IC op amps are used in the Fil-Oscillator, and its total cost is about \$35.



This photo shows how the prototype was constructed but this arrangement is not absolutely necessary. Circuit can be built on a PC or perf board and wired to front panel.

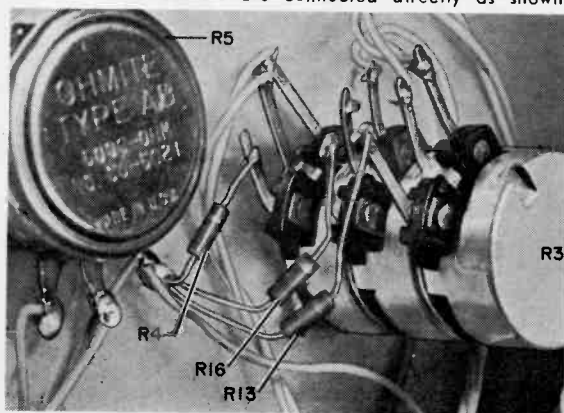
Theory of Circuit Design. The Fil-Oscillator is in four functional sections: an active filter consisting of IC4, IC5, and IC6; an integrator (IC3) which produces triangle waveforms; a comparator (IC1) to generate square waves; and a buffer output amplifier (IC2).

The frequency range of the active filter is selected by three-section switch S3, while three-section potentiometer R3 controls the frequency within the selected range. When mode switch S4 is in the FILTER position, an arbitrary input signal may be applied to the active filter input. When S4 is in the OSCILLATOR position, the active filter extracts the fundamental sine wave component from the

triangle wave output of IC3. The sine wave output of the active filter is applied to comparator IC1. When the sine wave voltage at the input to the comparator is positive, the comparator output swings negative, and vice versa. The amplitude of the square wave output is limited by diodes D1 and D2 before the signal is applied to IC3. Since the integral of a square wave is a triangle, the output of IC3 is triangular.

The input to the buffer amplifier (IC2) is selected by S1. Potentiometer R5 serves as the amplitude control. The output of the generator is taken directly from the low-impedance output of IC2.

Three-section frequency potentiometer is built up from add-on controls similar to IRC-CTS type 45. The resistors are connected directly as shown.



Construction. The prototype was built in a 9" x 6" x 5" aluminum cabinet, though any type of housing may be used. The components were assembled on two pieces of perf board mounted on switch S3. This switch is a conventional 11-position, 5-gang rotary switch which can be disassembled and the second and fourth gangs removed. These two portions of the switch were then replaced by two 4³/₄" square pieces of perf board.

The comparator (IC1), buffer amplifier (IC2), and integrator (IC3) and their associated components were mounted on the board that replaced the fourth gang of the switch; the active filter (IC4, IC5, and IC6) with its components was mounted on the board replacing the second gang. Dual in-line sockets were used for

HIRSCH-HOUCK LABORATORIES Project Evaluation

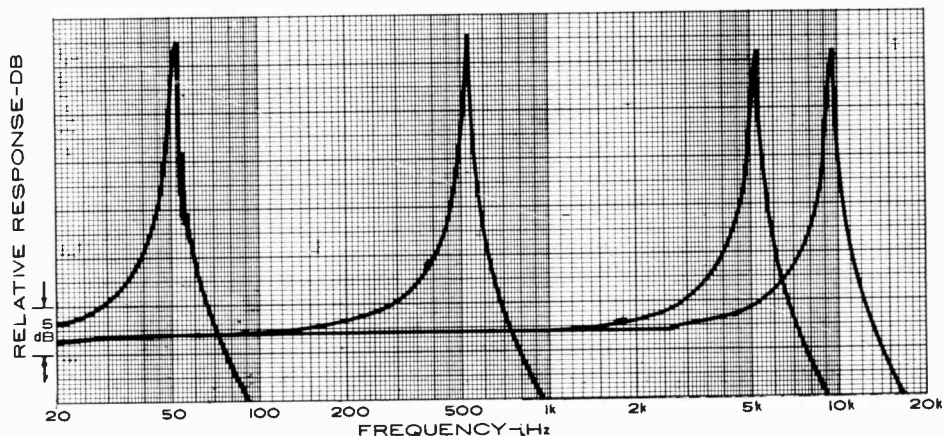
This is a very useful instrument for an audio engineering laboratory, and, in a simplified form (with just the filter), it would be a valuable addition to any amateur radio shack.

In the filter mode over the audio range, the pass-band gain of the filter varied less than 2.0 dB. Rejection of frequencies higher than that to which the filter was tuned was a little better than claimed with the third harmonic being attenuated by 49 dB at a fundamental of 1000 Hz. Rejection at lower frequencies was not as good as claimed by the authors. At one-third of the filter frequency, the response was down 29.5 dB versus 35.5 dB given by the authors. The noise output of the filter was 0.9 mV and appeared to be essentially independent of the level control setting. This would indicate that the noise is being generated after the level control in the output stage. An input of 0.38 volt is required for the filter to deliver 1.0 volt output at 1000 Hz. The maximum output before clipping in IC2 is 4.4 volts rms (high-impedance load).

To check the effectiveness of the filter in reducing distortion from a test oscillator, the output of a Radford low-distortion oscillator was fed through the Fil-Oscillator. At 1000 Hz, the input signal was 0.14% distortion, but after passing through the Fil-Oscillator, the distortion was 0.014%.

In the oscillator mode, the output amplitude varied from 1 to 2 dB over the full range and harmonic content was low at all frequencies—typically slightly under 0.05% up to 1000 Hz and about 0.07% in the 10-kHz to 20-kHz region. Distortion was essentially all third harmonic. The square wave does not have an ideal shape and has a noticeable tilt. The rise time was about 5 microseconds. At audio frequencies, the triangular wave appeared good, but at very high frequencies there was distortion visible.

The filter mode may be used to add audio selectivity to any communications receiver utilizing a narrow bandwidth. It is possible to copy CW signals through considerable QRM and QRN.



each of the IC's with perf board clips to hold the passive components.

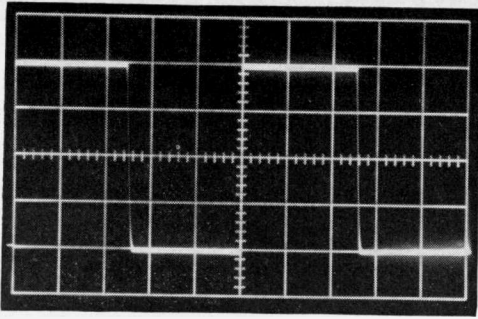
The various controls should be mounted on the front panel and the batteries on the bottom of the chassis.

Label the controls on the front panel with transfer type covered with a clear plastic spray. Add a handle and rubber feet to improve the appearance.

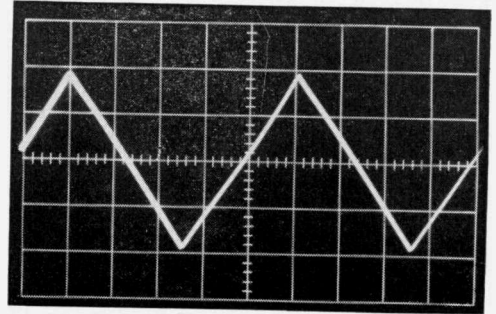
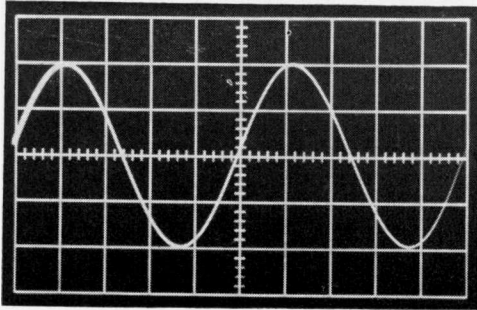
Calibration. Potentiometer R3 can be calibrated by comparing the output of the Fil-Oscillator with that of a known audio

frequency on an oscilloscope. A conventional audio generator and a frequency counter can be used to set the exact horizontal amplifier frequency if you want a more exact calibration. As each frequency is found, mark the position of R3. Once one range has been calibrated and, if high-quality Mylar capacitors have been used, the other ranges should fall in step with the markings.

Operation. The frequency range is selected by switch S3 (RANGE) with the



Of the three functions provided by the generator, the square wave (left) and the sine wave (below left) are the most useful in test applications. The triangle wave (below) is a special type of waveform used in vibration studies, servo applications, medical research, etc. Note that the 3 waveforms are clean and show no signs of distortion. The thickening of the trace on the left side is a malfunction of the oscilloscope used.



actual frequency determined by the setting of *R3*. Switch *S1* is used to select either a sine, square or triangle wave output, while *R5* determines the output amplitude.

When the Fil-Oscillator is set to the same fundamental frequency as that contained in the input and with *S4* on FILTER, the output displayed on an oscilloscope indicates the level of the fundamental waveform. For example, assume you

want to measure the second harmonic distortion of an audio amplifier. Apply a sine wave of known frequency to the input of the amplifier and connect the output to the Fil-Oscillator. Set the Fil-Oscillator to the second harmonic of the applied frequency and the output displayed on a scope will indicate the magnitude of the second harmonic in the amplifier output. This same procedure can be applied to higher harmonics or to a speaker system or musical instrument if a good microphone and preamplifier (if needed) are used to drive the Fil-Oscillator.

Anyone who has listened to the CW ham bands appreciates the importance of having a highly selective receiver. One disadvantage of using *Q* multipliers and similar circuits is that the selectivity control is very "touchy." Since the Fil-Oscillator has a constant, rather than a variable, *Q*, it is much easier to use. Simply connect the audio output of the receiver to the Fil-Oscillator input and set the filter frequency to obtain some pleasing tone. Only CW signals of that frequency (using the receiver BFO, of course), will pass through the filter—the others being rejected. This may show up drift in the receiver as well as the BFO. The output of the Fil-Oscillator can be connected to any external audio amplifier or to a headset. ♦

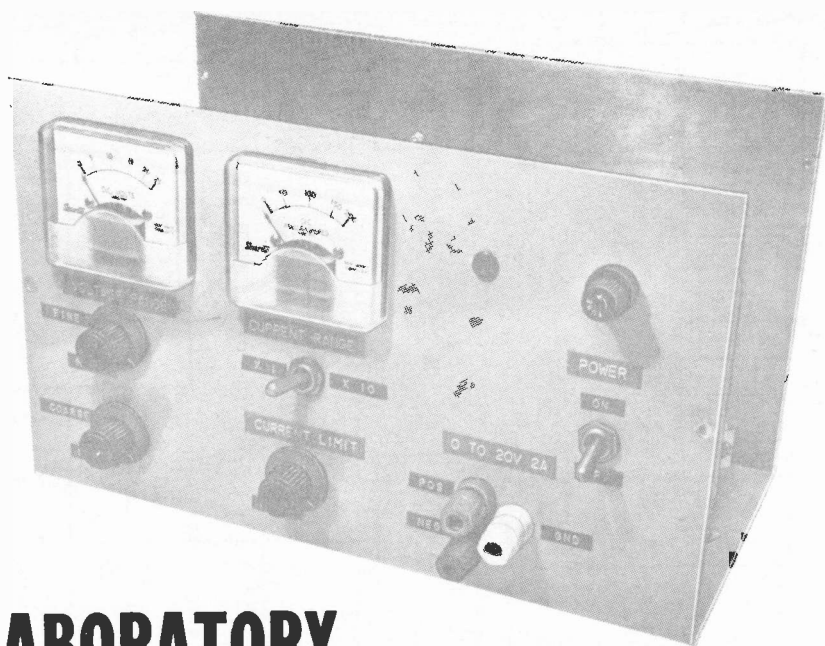
FIL-OSCILLATOR SPECIFICATIONS

Filter

<i>Q</i>	45 (nominal)
Frequency range	15 Hz to 32 kHz
Rejection at 3X resonant frequency (1-volt rms input)	200:1
Rejection at $\frac{1}{2}$ X resonant frequency (1-volt rms input)	60:1
Noise output	less than 0.5 mV rms

Oscillator

Output waveforms	sine, square, triangle
Frequency range	15 Hz to 32 kHz
Output amplitude	0 to 4 volts peak-to-peak
Output impedance	100 ohms
Output protection	short-circuit proof



LABORATORY IC POWER SUPPLY

Low-cost regulation: 0-20 volts, 0-2 amperes

BY RICHARD J. VALENTINE

LABORATORY-TYPE power supplies that include both voltage and current regulation usually come at a pretty high price. You can build one for yourself, however, that will hold its own against most commercial units; and it will cost you only about \$50. The final performance specifications for the power supply are given in the Table on page 97 so you can see how good it is.

Designed around a new regulator IC, the power supply has floating positive and negative outputs and can be adjusted from zero to 20 volts with fine and coarse voltage controls. The current range can be controlled continuously up to 2 amperes, and a short circuit on the output will not damage the supply. In addition, by setting the voltage output for maximum and adjusting the current limit for the desired level, you have a constant-current supply.

Construction. The schematic diagram of the power supply is shown in Fig. 1. Assemble the components on a printed circuit board as shown in Fig. 2. For the prototype shown in the photos, a 7" × 12" × 5 3/4" chassis was used. The circuit board was mounted vertically at one end of the chassis, with the heavy components, including *RECT1*, on the bottom. Power transistor *Q2* and its heat sink are on the rear panel. Operating controls and meters are mounted on the front panel. Construction is simple, but make sure that ample ventilation is provided for *T1* and *Q2*. Use at least #18 wire for connections to *RECT1*, *C9*, *Q2*, *M1*, *S2*, and the output jacks.

It is important to use the heat sink prescribed in the Parts List since it may be necessary to dissipate as much as 50 watts under certain short circuit conditions. To provide maximum heat transfer,

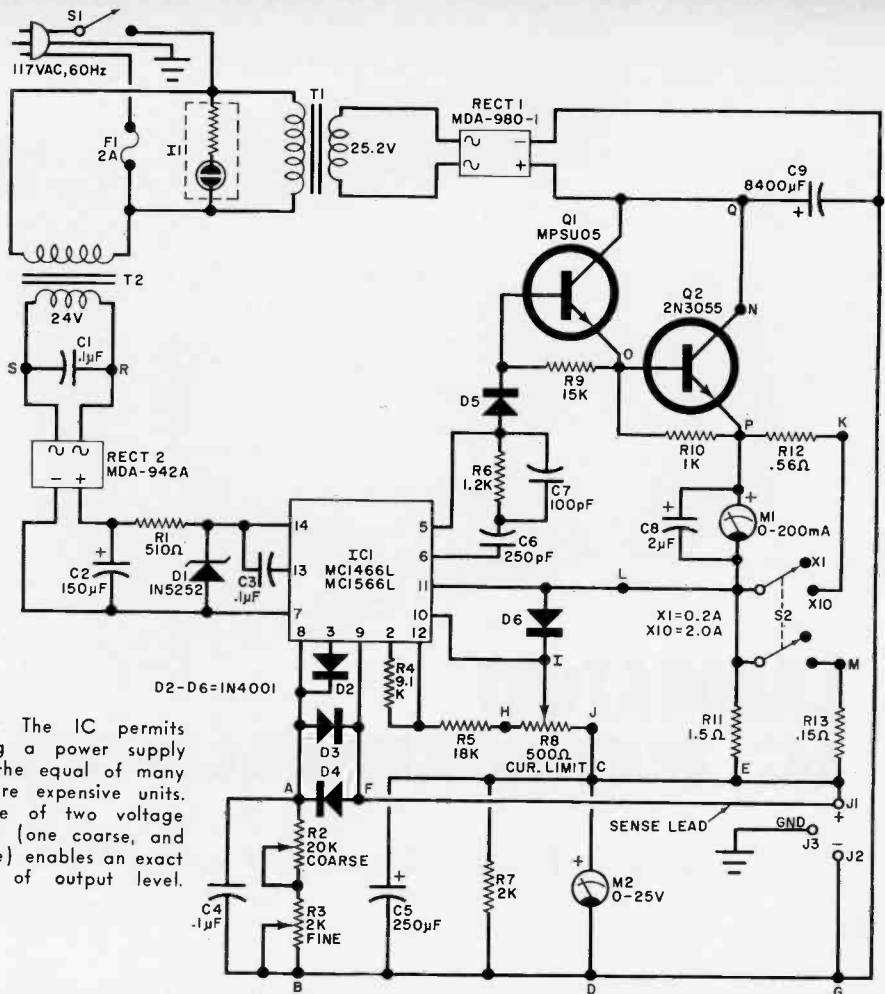
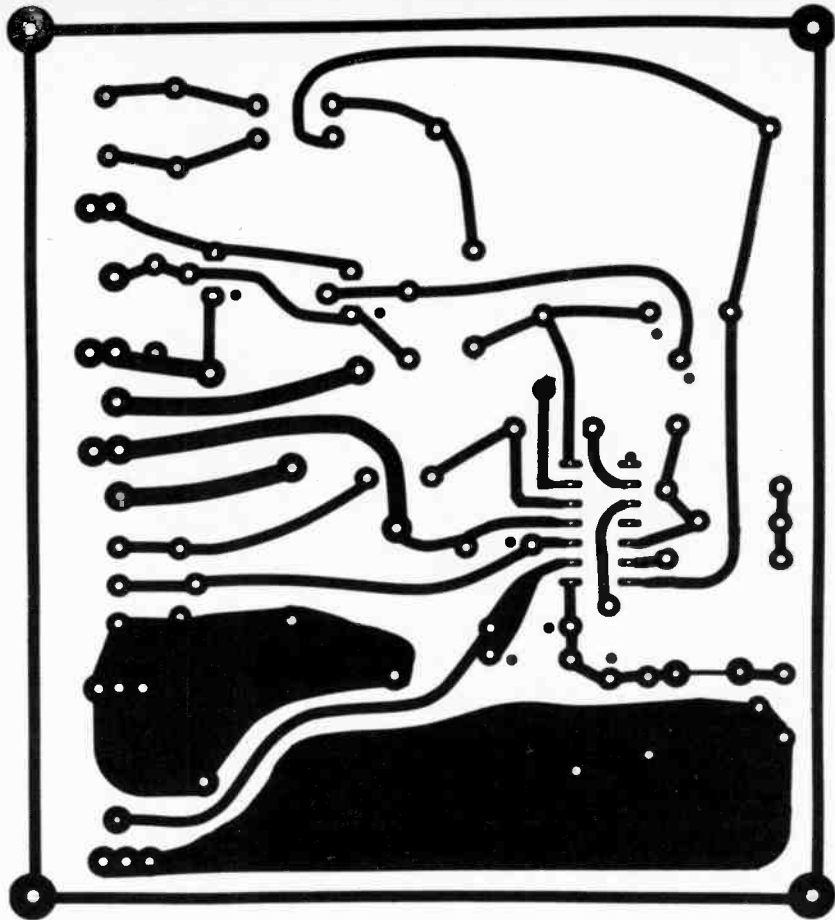


Fig. 1. The IC permits building a power supply easily the equal of many far more expensive units. The use of two voltage controls (one coarse, and one fine) enables an exact setting of output level.

PARTS LIST

- C1, C3, C4—0.1- μ F, 50-volt disc capacitor
 C2—150- μ F, 50-volt electrolytic capacitor
 C5—250- μ F, 50-volt electrolytic capacitor
 C6—250-pF mica capacitor
 C7—100-pF mica capacitor
 C8—2- μ F, 50-volt electrolytic capacitor
 C9—8400- μ F, 50-volt electrolytic capacitor
 D1—1N5252, 24-volt, 500-mA zener diode
 D2-D6—1N4001, 1-A, 50-volt silicon diode
 F1—2A fuse and holder
 I1—117-volt neon indicator
 IC1—Integrated circuit (Motorola MC1466L or MC1566L)
 J1-J3—Five-way binding post (red, black, and white)
 M1—0-200-mA meter (Shurite 8309)
 M2—0-25-volt meter (Shurite 8109)
 Q1—Transistor (Motorola MPSU05 or HEP S3020)
 Q2—2N3055 or HEP704 transistor
 R1—510-ohm, $\frac{1}{2}$ -watt 5% resistor
 R2—20,000-ohm wirewound potentiometer
 R3—2000-ohm wirewound potentiometer
 R4—9100-ohm, $\frac{1}{4}$ -watt 5% resistor
 R5—18,000-ohm, $\frac{1}{4}$ -watt 5% resistor
 R6—1200-ohm, $\frac{1}{4}$ -watt 5% resistor
 R7—2000-ohm, 2-watt 10% resistor
 R8—500-ohm wirewound potentiometer
 R9—15,000-ohm, $\frac{1}{4}$ -watt 10% resistor
 R10—1000-ohm, $\frac{1}{2}$ -watt 10% resistor
 R11—1.5-ohm, 2-watt 5% resistor
 R12—0.56-ohm, 2-watt 5% resistor (see text)
 R13—0.15-ohm, 2-watt 5% resistor
 S1—Spst slide or toggle switch
 S2—Dpst slide or toggle switch
 T1—Power transformer; secondary 25.2V, 2A (Triad F41X or similar)
 T2—Power transformer; secondary 24V, 0.035A (Triad F94X or similar)
 Misc.—14-pin in-line IC socket (optional), chassis (Bud SC-3030 or similar), knobs (3), 2°C/W heat sink (Thermalloy 6403B or Wakefield NC421A), mica insulator, silicone grease, mounting hardware, etc.

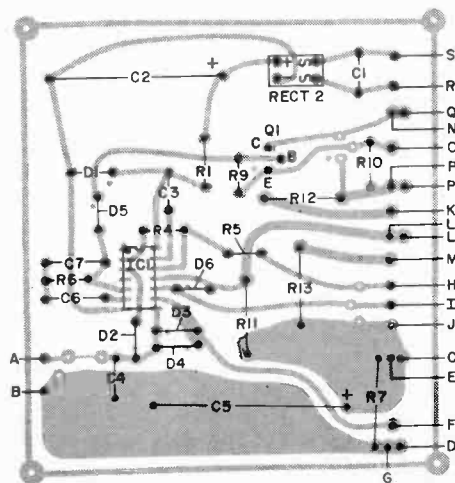


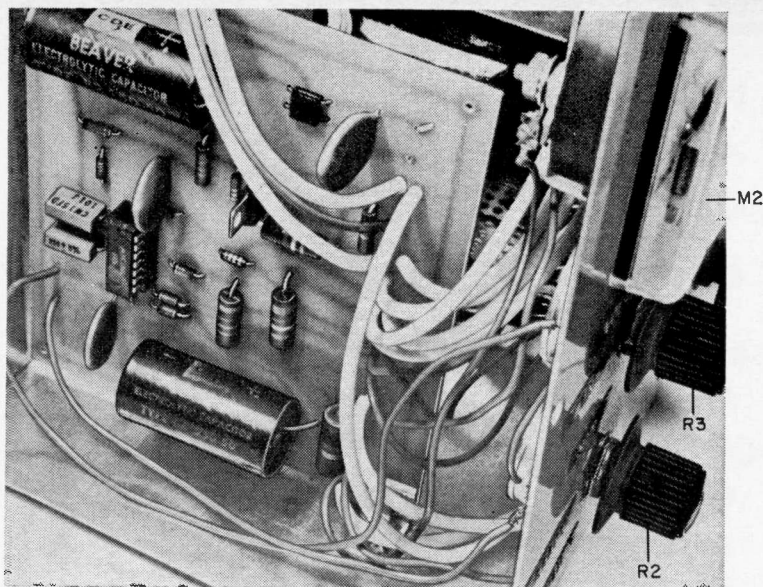
apply silicone grease to Q2, the mica insulator, and the portion of the heat sink covered by the insulator. A piece of plastic sheet can be used to keep the case of the transistor from shorting to ground through accidental contact with other objects.

If you use a meter other than that specified for M1, shunt resistor R12 must be changed to match the meter's internal resistance. The value of the shunt can be determined by multiplying the meter's internal resistance by 0.11.

Operation. With the current limit control set to maximum (rotor at the R5 end), adjust both voltage controls until the front panel voltmeter (M2) indicates the desired voltage. When the load is connected, the current meter will indicate the current being drawn by the load. When the current range switch S2 is in

Fig. 2. Actual size foil pattern (above) can easily be fabricated from one of the readily available commercial etching kits now sold by most distributors. Install various components as illustrated below.





Construction is not critical so any layout may be used. Don't forget to use heavy-gauge wire in all the current-carrying portions to avoid lead heating.

the X1 position, the meter will indicate to 200 mA. In the X10 position, the indication is to 2 amperes.

If the desired load current is known or must be limited to a safe value, set the current-limit potentiometer to maximum, adjust the two voltage-level controls to the desired voltage level and place a short circuit across the output terminals. Adjust the current-limit potentiometer

for the desired current level. Remove the short and note that the voltmeter goes back to the predetermined voltage.

By setting both voltage controls to maximum and adjusting the current limit for the desired level, the power supply can act as a constant-current source.

Theory of Circuit Design. The rectified power from *RECT1* is fed to the output

HIRSCH-HOUCK LABORATORIES Project Evaluation

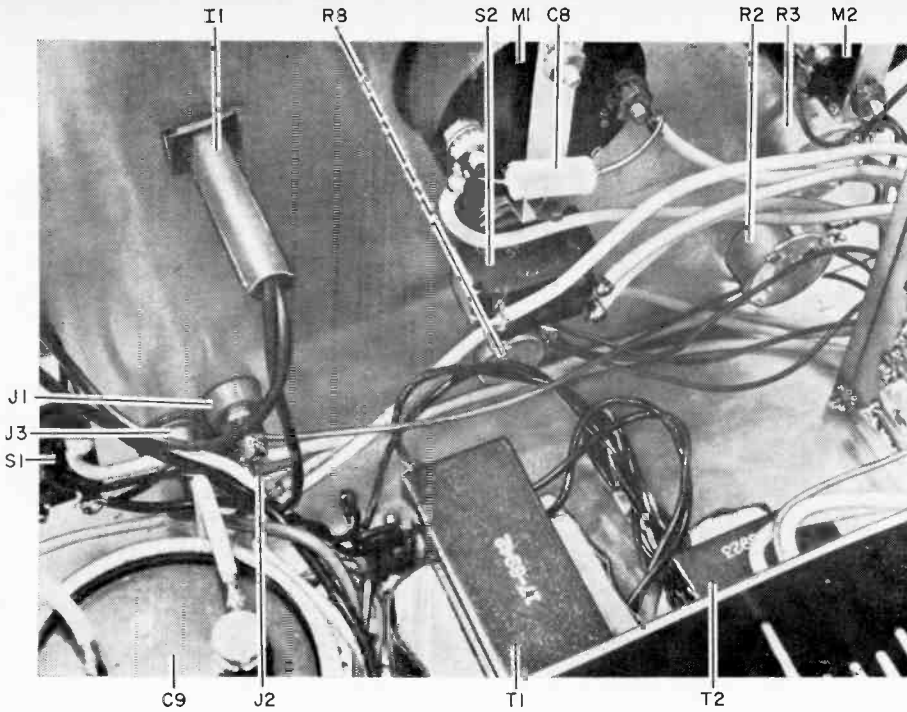
The supply seems to do just what the designer claims. The output voltage is adjustable from essentially zero to 21.3 volts, which is close enough to the rated 20 volts. The short circuit current is limited to 2.0 amperes with the current control set at maximum. The current limiting action is smoothly adjustable from zero to 2 A. With the coarse and fine voltage controls, it was easy to set the voltage as required. Of course, the meters on the prototype are rather crude—the ammeter reads about 10 to 15% high on the high range.

Set for constant current operation into a 4-ohm load, the ripple was about 0.4 millivolt at currents from 0.5 A to 2 A. In constant voltage operation, with

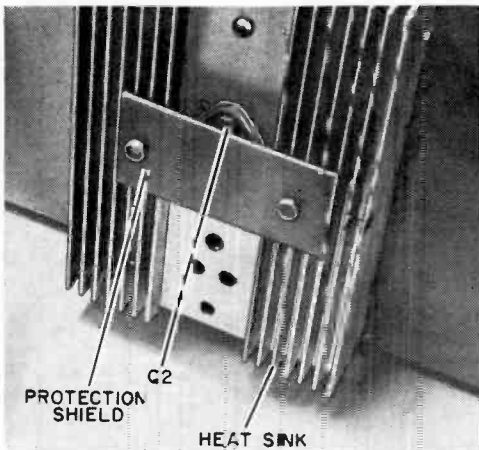
an 8-ohm load, ripple was between 0.120 and 0.127 millivolt for currents from 0.5 to 2 A. The ripple seems to be largely 60 Hz, not the expected 120 Hz, perhaps due to rectifier unbalance or internal pickup.

With a constant 120-volt line input and an 8-ohm load, the regulation was better than 0.01 volt at 15 volts out, from no load to 2 A. From full load with 108 volts input to no load with 128 volts, we could detect no output change. The specification of 0.03% would be a 5-millivolt change—about half the minimum we could detect.

When operating at 16-volt output with a 2-ampere load, for about 15 minutes, the temperature of the pass transistor case seemed to stabilize at 146°F (105°C), which is apparently within its safe operating range.



Note the large amount of room within the chassis. This, plus ventilation holes, permits the supply to run cool under almost all operating conditions.



Covering the metal case of the power transistor with a plastic shield reduces the possibility of accidental shorts from the rear of the supply.

through transistor Q2, which is controlled by Q1. The output is fed back through a sense lead to a differential amplifier which is part of IC1. The other side of this differential amplifier is supplied with a constant current through pin 14, while the two voltage control potentiometers

POWER SUPPLY SPECIFICATIONS

Voltage range	0 to +20 volts
Current range	0 to 2 amperes
Voltage regulation	0.03% (108 volts on line with 2 amperes load to 128 volts on line with no load)
Current regulation	0.2% in constant-current mode
Noise and ripple	Less than 0.0005 volt (0.001 volt in constant current mode)
Short circuit protection	Output may be shorted any voltage or current without supply failure

(R2 and R3) determine what the preset voltage should be. When the preset voltage is the same as the output voltage, the differential amplifier maintains the level of Q1 and Q2.

However, if a load is placed across the output and the voltage starts to go down, the differential amplifier allows Q2 to provide more voltage at the output. The opposite action takes place if the line voltage goes up. Resistors R11 and R13 provide current feedback for the IC and potentiometer R8 is set to fix the maximum load current. ♦

Single Sideband for CB is Now!

QUESTIONS AND ANSWERS ON THE
HOTTEST THING TO HIT CB

BY HERBERT FRIEDMAN

IF YOU'RE TIRED of paying for and experimenting with antennas, clippers, compressors, and other "talk power" devices, all in the hope of getting a little extra range out of your CB gear, then it's time to think of switching to single sideband—or SSB as it is called.

Advantages of SSB. Think in terms of SSB and you think in terms of twice the AM range, sharply reduced interference from other stations, less ignition noise interference, and most of all—46 CB channels in the same space occupied by the "old" 23 channels. (Just doubling the number of channels can cut interference up to 50%.)

Basically, SSB is simply a different way of getting your voice from one point to another. In an AM system, the transmitter consists of an r-f generator and an audio amplifier called a modulator. The r-f signal output from the generator serves no useful purpose other than to demodulate the signal at the receiver; and this could be done just as easily with a "carrier" injected in the receiver. Yet the

carrier uses 66% of the total available power. In a CB AM transmitter running the full legal input, the power to the r-f final amplifier is 5 watts. The maximum modulation that can be applied to an AM transmitter is 50% of the power input to the r-f final—or 2.5 watts. Add the 5 watts r-f input to 2.5 watts of audio and the total power input is 7.5 watts, yet the 2.5 watts of audio, which does all the work (producing intelligence) represents only 33% of the total power.

In an SSB transmitter, the carrier and one sideband are essentially eliminated and all the available power input goes into transmitting the modulation. This represents a substantial power gain over the modulation delivered by an AM system.

So without going one step further, we see that SSB provides at least 8 times greater effective output than a conventional AM CB transmitter. As far as the receiving station is concerned, the SSB signal is 8 times stronger than an AM signal.

The carrier needed for demodulation is

supplied by the SSB receiver, though the bfo (beat frequency oscillator) in a communications receiver can be used for carrier insertion.

Since there is no carrier in SSB transmission, there is no heterodyne interference if all stations on the channel are using SSB. And since SSB demodulation is essentially a single-tone conversion process by the injected carrier, ignition system impulse noise is not as annoying or signal-masking as it is on AM bands.

From a straight communications viewpoint, then, SSB is superior in every way to conventional AM. How SSB might affect your own CB operation is best illustrated by the following typical questions asked by other CB'ers.

Q. Is SSB compatible with AM?

A. No. AM signals sound like chatter on SSB receivers and vice versa. However, CB SSB rigs usually provide a standard AM detector for reception of AM signals.

Q. How bad is the interference when AM and SSB stations are using the same channel?

A. The interference is actually less than if the channel were all AM or all SSB. As far as AM is concerned, the interfering SSB signals have no carrier-caused heterodyne interference. To the SSB stations, the AM interference is chatter or an intermittent heterodyne. In practice, if the interfering AM station is on the exact frequency of the SSB station, there will be no intermittent heterodyne.

Q. What causes SSB signals to sound either too high or too low in pitch?

A. The frequency of the inserted carrier must be very precise. If it is not exactly matched to the suppressed carrier of the transmitter, the voice tone will be sharply altered. All SSB receivers have a "fine tuning" control or "clarifier" that matches the inserted carrier to the original carrier for proper voice reproduction.

Q. Exactly how does SSB provide 46 channels in the space of 23?

A. SSB uses only one sideband with the maximum sideband deviation equal to the highest modulating frequency of 5000 Hz. It is therefore possible to have two SSB transmitters on the same chan-

SAVE MONEY!

A Delta Mark Ten Capacitive Discharge Ignition (CDI) System On Your Car Slashes Maintenance Costs And Increases Performance.

Put a Mark Ten on your car and save by eliminating 3 out of 4 tune-ups. Save as gasoline mileage increases (up to 20%). The Mark Ten CDI system also extends spark plug life, promotes more complete combustion and assures instant starts in all weather. It operates on any 6 or 12 volt negative or positive ground system.

The Mark Ten B affords additional money saving advantages by drastically reducing combustion contaminants and restoring power lost by the use of smog control devices. Equipped with handy switch for instant return to standard ignition, the Mark Ten B works with ANY 12 volt negative ground engine. Both systems install in ten minutes without rewiring.

Order your Mark Ten or Mark Ten B today. Save money while you enjoy low maintenance and increased performance.

Mark Ten (Assembled) \$44.95 ppd.

Mark Ten (Deltakit) \$29.95 ppd.

Mark Ten B \$59.95 ppd.

(Kits available in 12 volt only, positive or negative ground)

(12 volt negative ground only)

Superior Products at Sensible Prices

Mfg. in U.S.A.



Dept. EEH

DELTA PRODUCTS, INC.

P.O. BOX 1147 • GRAND JUNCTION, COLORADO 81501

PHONE: (303) 242-9000

Please send me literature immediately:
 Enclosed is \$ _____

Ship ppd. Ship C.O.D.

Please send: _____ Mark Ten B @ \$59.95 ppd.
 ___ Standard Mark Ten (Assembled) @ \$44.95 ppd.
 ___ 6 Volt: Neg. Ground Only ___ Positive Ground
 ___ 12 Volt: Specify ___ Negative Ground
 ___ Standard Mark Ten (Deltakit®) @ \$29.95 ppd.
 (12 Volt Positive Or Negative Ground Only)

Car Year _____ Make _____
 Name _____
 Address _____
 City/State _____ Zip _____

CIRCLE NO. 4 ON READER SERVICE CARD

nel, one using the upper sideband and one the lower. The total bandwidth of both signals is 10,000 Hz—the space utilized by a single AM station.

Q. Wouldn't two SSB stations using the same channel interfere with each other even though they utilize different sidebands?

A. In a properly designed receiver, only one sideband per channel can be received at a time. All SSB rigs are equipped with a mode switch that selects either upper or lower sideband transmission and reception.

Q. Is it possible to work a station on the same channel but on the other sideband?

A. Yes. While there is no logic in doing so, the mode switch can be set to the opposite sideband when receiving. So far, all SSB rigs use a single switch for selection of the transmit and receive sidebands.

Q. Can I use a selective calling or tone squelch device with an SSB transceiver?

A. Theoretically, yes. Practically, no. The pitch of the audio output is determined by the frequency and stability of the inserted carrier and the receiver tuning control. The combined stability is not presently high enough to insure that the tone burst will come out of the receiver at exactly the same frequency it went into the transmitter. Nor is the transmitter stability presently high enough to insure that the transmitted tone is at the same frequency it went in.

Q. Do squelch controls work with SSB?

A. SSB has no effect on standard squelch operations.

Q. Why do all SSB units have r-f gain controls?

A. Under moderate-to-strong signal conditions, better SSB reception is obtained if the volume control is run almost wide open with the speaker level determined by the r-f gain control. For SSB, the lower the r-f gain, the better.

Q. Do SSB transceivers have automatic gain control to prevent receiver blasting on strong signals?

A. Yes, SSB receivers employ a fast-

acting agc which can generally follow a word rate. It is not a long-term agc such as that used in AM receivers. Unfortunately, if the agc is not properly designed—if it “hangs up” for a moment or two—the beginning of the following word can be lost.

Q. Since SSB is the transmission of only the modulation, couldn't greater talk power be realized by the use of a modulation booster device?

A. As a general rule, a modulation booster cannot be used with SSB since it can cause almost infinite power to be generated at the beginning of the modulation waveform. In a typical solid-state transmitter, the instantaneous drive to infinite power input could destroy the output stage. Instead, alc (automatic level control) is usually built directly into the transmitter by the manufacturer.

Q. What is meant by frequency shaping and speech processing?

A. Frequency shaping means that the SSB modulator responds only to the important intelligence-carrying frequencies: 300 to 3000 Hz (or 250 to 3500 Hz). This puts all of the transmitted sideband energy where it is needed. There is no power wasted in transmitting the low frequencies which only produce the characteristics by which we recognize who is speaking. Speech processing generally implies frequency shaping and/or compression or clipping. Shaping and processing are also used for AM.

Q. Why are SSB transmitters allowed 10 watts input when AM transmitters are limited to 5 watts?

A. The 10-watt PEP rating seen in SSB specifications is not measured in the same way as for AM transmitters. AM transmitters are rated in average power input—the final plate voltage times the final plate current. On the other hand, PEP means peak envelope power, which is the rms value of the instantaneous peak power input (or output) to the SSB final. As a rule, when using two-tone SSB modulation for tests, the equivalent average power input is half of the PEP input, though different measuring techniques can show a PEP equal to 3 times the average dc power input. There is no direct comparison. Ten watts PEP is not the equal of twice 5 watts; because it is

sideband, 10 watts PEP is at least 8 times as effective as 5 watts of average power at 100% modulation.

Q. What effect does a high standing-wave ratio have on SSB transmission?

A. The same as for any other transmitter. The losses due to a high SWR are the same for SSB, though a large mismatch between the transmitter and the line can cause modulation distortion. (A mismatch will not generally cause distortion in an AM transmitter.) Typical SWR's of 3:1 or less have no effect on SSB transmitters.

Q. Is an SSB transceiver more difficult to operate?

A. Not really. The mobile type of units might have one or two extra controls—such as r-f gain and mode (SSB-AM selector). Otherwise, they are operated in the same manner as any other transceiver, though fine tuning might be slightly more critical.

Q. Do SSB transceivers have the same features such as those on AM models: S-meters, public-address and remote

speaker outputs, among others?

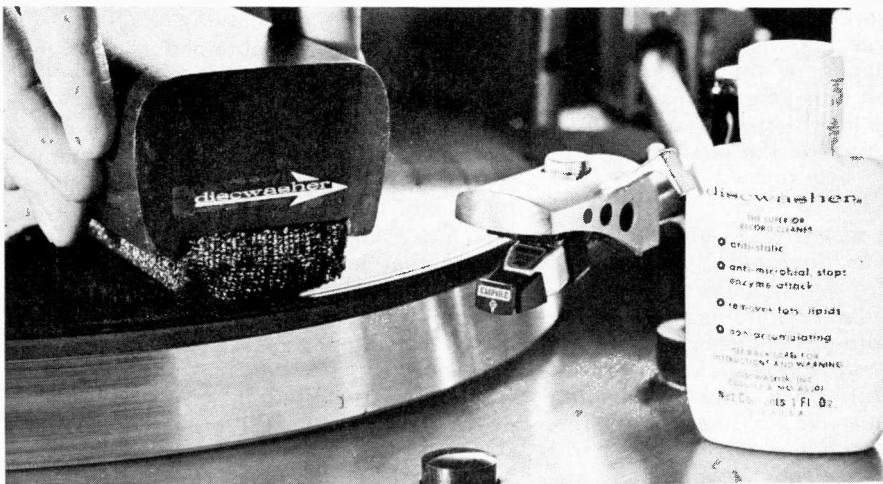
A. SSB does not affect the "extra" features. An SSB transceiver might have some or all of the advantages common to AM units.

Q. How does the overall performance of SSB equipment compare with AM equipment?

A. So far, SSB gear is similar in performance to the better quality AM units. Selectivity in terms of adjacent channel rejection is high (40 dB or better); image rejection is the same as for AM; and mechanical construction is good. Since SSB requires greater stability than AM, the SSB equipment receives a better factory alignment and adjustment.

Q. While I understand the power gain advantage in transmitting, how does SSB improve reception?

A. Rather than use the carrier for demodulation as in AM, SSB signals use an injected carrier whose level can be optimized for maximum sensitivity. Often, the SSB sensitivity is 3 to 6 dB higher than for AM. Also, SSB signal intelligence extraction of 80% can be obtained with



THE SUPERIOR COMBINATION

You have carefully selected your fine play back equipment. Now complete the system with Discwasher; the record cleaning system that safely removes fingerprints, dust particles,



and cigarette smoke which gradually degrade your record collection.

Discwasher: superior record care for daily use. \$12.95 from your audio specialist.

Discwasher Inc., Suite 316
909 University, Columbia, Mo. 65201
CIRCLE NO. 5 ON READER SERVICE CARD

DISCWASHER

a 6-dB $(S+N)/N$ ratio. AM requires a 10-dB $(S+N)/N$ ratio for 80% intelligence extraction.

Q. Would not a less expensive double sideband (DSB) transceiver deliver the same performance as SSB?

A. Yes, a real double sideband rig with fully suppressed carrier would deliver almost the same performance as SSB, but because there are two sidebands, the DSB signal would occupy the entire channel. Keep in mind that DSB is not the same thing as DSB with reduced carrier (DSBRC). The latter is almost the same as AM, with the carrier present but at a reduced level. DSBRC is received on a standard AM receiver. Its carrier still produces heterodyne interference—as with conventional AM. An SSB signal starts out as DSB, but one sideband is removed by a filter before the signal reaches the final r-f amplifier.

Q. Since an AM transmitter uses a class C amplifier with typical efficiencies of 80%, doesn't the SSB final amplifier, which is linear, have less efficiency and, therefore, less output?

A. The difference in efficiency between class C power amplifiers for AM and the linear amplifiers for SSB is about 12%, too small to have a significant effect in view of the much greater gain in effective power output at the modulating frequencies.

Q. What is meant when an SSB signal is referred to as "inverted"?

A. When transmitting the upper sideband, the modulation frequencies are in their natural order; the higher modulation frequencies correspond to a higher r-f frequency. But when transmitting the lower sideband, the high modulation frequencies are actually lower in r-f frequency than the low modulation frequencies, which are close to the carrier frequency. The lower sideband modulation is therefore termed "inverted." The receiver automatically straightens the whole thing out since the inserted carrier always represents the precise carrier frequency. Some confusion has come about over the term inverted because scrambler devices (such as those used for telephones) have an inverted speech process that can be decoded by inserting an audio

frequency carrier. But the term is really unimportant in narrow-band voice communications.

Q. How difficult is it to receive CB SSB on a communications receiver?

A. It's easy. Just run the volume control wide open, ride gain with the r-f gain control (with the avc off) and adjust the bfo until the signal clears into intelligible speech. However, both conversion oscillators and bfo must have good stability if you don't want the modulation to disintegrate into unintelligible chatter. SSB reception requires much greater receiver stability than AM.

To Summarize. As you can see, except for the incompatibility between AM and SSB, the latter has no disadvantages for the CB'er. Even under worst case conditions, SSB provides a stronger signal at the receiver in terms of recovered audio. Tests show that, as a general rule, the CB'er can expect at least twice the range over conventional AM transmission.

Channel splitting, a byproduct of SSB, really does result in a doubling of the available channel space. In metropolitan areas a substantial reduction in QRM interference could be obtained if a large number of CB'ers switched to SSB—or if specific channels were unofficially set aside for AM and SSB operation.

Admittedly, the cost of SSB equipment is greater than it is for AM; but judging by quality (comparing SSB to top-of-the-line AM equipment), the cost differential is not that much greater—especially if you consider the money that can be saved when you don't need talk power boosters and super antennas. (Of course, a super-antenna will give the same edge to SSB that it does to anything else.)

The one obvious difference between AM and SSB equipment is in size. There are no "pocket" SSB rigs. A compact SSB mobile unit is about $\frac{1}{3}$ to $\frac{1}{2}$ larger than an equivalent AM unit, so don't expect to hide it in the glove compartment. Base station SSB rigs are about equal in size to comparable AM units.

But price and appearance should really not be the basis for a decision. If you're interested in maximum communication effectiveness in terms of range and reduced interference, there is only one choice: single sideband. ♦

We've written the book on kits



You can get a copy FREE

Shown below are only a few of the more than 350 kits fully described in the 1973 Heathkit catalog. Kits for every interest, every budget...including color TV; stereo systems; electronic organs; marine equipment; a kitchen waste compactor; home intercoms and protection systems, garage door openers; table radios; portable radios and phonographs; guitar amplifiers and accessories; educational electronic workshops for youngsters and adults; tool sets; electronic test instruments; amateur and shortwave radio gear; radio-control equipment; metal locators.

Can you build a Heathkit? For 25 years people just like you have been doing it - armed with no more than a soldering iron and a few conventional hand tools.

No matter how complex the kit, the manual reduces assembly to a simple step-by-step operation. Add to that the availability of the technical correspondence department here in Benton Harbor, and service people in 36 retail stores across the country, and you see why we say "we won't let you fail." And finally, building a Heathkit is fun, pure and simple. The coupon below gets you started.

Here are just a few of the new kits in this new '73 edition



Heathkit 50-watt Stereo Receiver. \$169.95*

Heathkit Deluxe Metal Locator has submersible sensing head. \$89.95*



Heathkit VHF/FM Band-Scanning 8 channel Receiver. \$119.95*



Heathkit Dolby Cassette Deck. \$249.95*



Heathkit 6-Digit Electronic Clock-Alarm. \$54.95*



Heathkit 25V Solid-state Color TV with detent power tuning. \$599.95*



NEW Heathkit Ultrasonic Intrusion Alarm. \$49.95*



Heathkit 2 1/2 Digit VOM. \$79.95*



Heathkit Microwave Oven. \$379.95*



Heathkit Inductive Timing Light. \$29.95*



Heathkit CW QRP Transceiver - 40, 20 and 15 meters. \$69.95*



Heathkit Electronic Calculator. 8-digit readout. \$129.95*

Send Today for Your Free '73 Heathkit Catalog

HEATHKIT ELECTRONIC CENTERS

ARIZ.: Phoenix, 2727 W. Indian School Rd.; CALIF.: Anaheim, 330 E. Ball Rd.; El Cerrito, 6000 Potrero Ave.; Los Angeles, 2309 S. Flower St.; Pomona, 1555 Orange Grove Ave. N.; Redwood City, 2001 Middlefield Rd.; San Diego (La Mesa), 8363 Center Dr.; Woodland Hills, 22504 Ventura Blvd.; COLO.: Denver, 5940 W. 38th Ave.; CONN.: Hartford (Avon), 395 W. Main St. (Rte. 44); FLA.: Miami (Hialeah), 4705 W. 16th Ave.; GA.: Atlanta, 5285 Roswell Rd.; ILL.: Chicago, 3462-66 W. Devon Ave.; Downers Grove, 224 Ogden Ave.; IND.: Indianapolis, 2112 E. 62nd Ave.; KANSAS: Kansas City (Mission), 5960 Lamar Ave.; MD.: Baltimore, 1713 E. Joppa Rd.; Rockville, 5542 Nicholson Lane; MASS.: Boston (Wellesley), 165 Worcester St.; MICH.: Detroit, 18645 W. Eight Mile Rd. & 18149 E. Eight Mile Rd.; MINN.: Minneapolis (Hopkins), 101 Shady Oak Rd.; MO.: St. Louis, 9296 Gravois Ave.; N.J.: Fair Lawn, 35-07 Broadway (Rte. 4); N.Y.: Buffalo (Amherst), 3476 Sheridan Dr.; New York City, 35 W. 45th St.; Jericho, L.I., 15 Jericho Turnpike; Rochester, Long Ridge Plaza; OHIO: Cincinnati (Woodlawn), 10133 Springfield Pike; Cleveland, 5444 Pearl Rd.; PA.: Philadelphia, 6318 Roosevelt Blvd.; Pittsburgh, 3482 Wm. Penn Hwy.; TEXAS: Dallas, 2715 Ross Ave.; Houston, 3705 Westheimer; WASH.: Seattle, 221 Third Ave.; WIS.: Milwaukee, 5215 Fond du Lac.

CIRCLE NO. 9 ON READER SERVICE CARD

HEATHKIT Schlumberger
HEATH COMPANY, Dept. 110-3 Benton Harbor, Michigan 49022
<input type="checkbox"/> Please send FREE Heathkit Catalog.
Name _____
Address _____
City _____ State _____ Zip _____
Prices & specifications subject to change without notice. *Mail order prices; F.O.B. factory. CL-460R



An Under- ground SURVEY METER and Metal Locator

LOCATE WATER LEVELS OR BURIED TREASURE—
AT DEPTHS OF MANY FEET

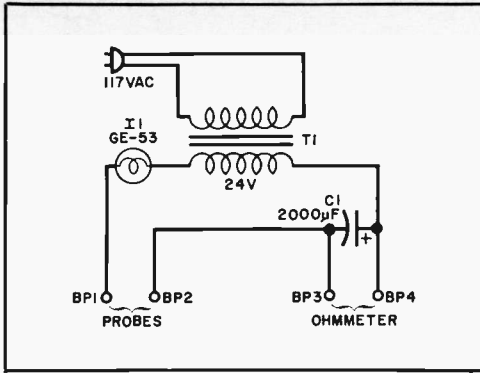
BY HAROLD PALLATZ

AT SOME TIME or other, you have undoubtedly read about or built and used an underground metal locator. Most of them work well when locating objects of a fairly good size that are not buried too far below the surface. Did you ever wonder what you would do if you wanted to find something that was really far down (say 100 feet) and perhaps non-metallic? How for instance, do geologists locate large ore deposits, underground

water sources, and oil pockets buried in the earth?

Any one of several different methods can be used—seismic shock, self potential, or resistivity profile. Obviously, each of these approaches operates in a different fashion but they are all quite capable of deep subterranean penetration.

In the seismic shock method, a series of transducers is positioned around an area and an underground shock wave is



Simple survey meter circuit can be easily assembled in a utility chassis.

initiated by conventional explosives. The transducers pick up both the original shock wave and the echoes from any underground strata having a different refraction index.

The self-potential method uses the potentials generated electrochemically in the earth to outline an ore body. A sensitive galvanometer—in conjunction with a set of conducting earth probes—measures the voltage gradients. Wooden stakes are driven into the ground at points of similar potential to outline the position of the ore body. A ground fault shows up as a sharp cutoff, or flat side, in such a pattern.

In the resistivity method, current is passed through the earth by inserting metal electrodes a known distance apart and variations in resistance are noted. The resistance can be related to the type of material existing at a certain depth (which is related to the spacing between electrodes). Water, as well as large metal pipes and ore bodies, have a low resistance, while oil has a high resistance.

Commercial geophysical equipment operating on the resistivity principle has been used to survey down to many hundreds of feet. With such equipment, four metal probes are stuck in the ground, equally spaced along a straight line and an electric current is passed between the rods. It can be shown that if two metal probes are spaced 100 feet apart, the current is a function of the average resistance 50 feet down at the center point between the two. Knowing the voltage and the current, the resistance at that point can be determined.

The survey meter described here is a

simplified version of the commercial equipment. It uses only two probes, but can locate such things as a water table 100 feet below the surface. A schematic diagram of the system is shown at left. It is assumed that the ground probes will maintain a more or less uniform resistance so that any change in resistance during measurements is due to the underground values. To eliminate the effects of polarization, an ac power source is used. However, since ac measurements made in the presence of stray fields can vary widely and are influenced by the capacitance and inductance effects in the earth, a dc metering signal is superimposed on the ac carrier. Although conventional, 60-Hz line frequency is used here, any other frequency can be used, but penetration of the earth is better with low frequencies.

Resistance readings are made with a conventional ohmmeter which should be capable of indicating from less than one ohm to about 100,000 ohms. No calibration is required since all readings made at the same place and time are relative to each other. Capacitor C1 bypasses the ac current and must be of a very low-leakage type. Lamp I1 is used to limit the short-circuit current to less than two amperes. The 24-volt rms carrier voltage can vary by 25% up or down.

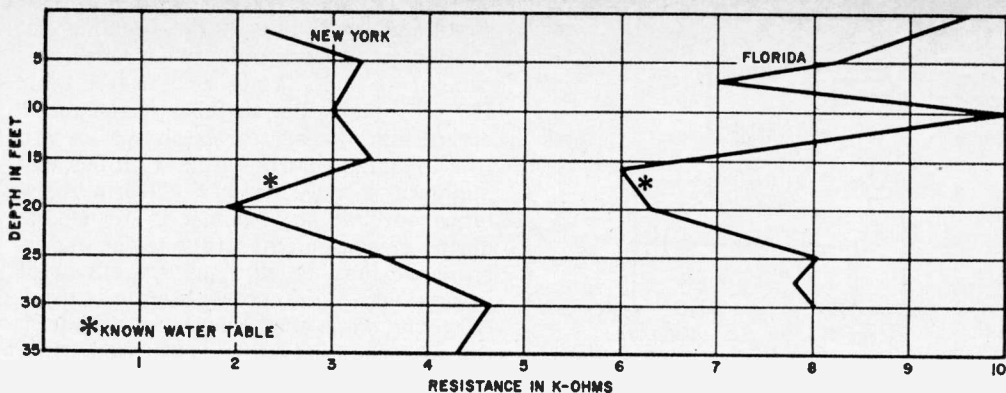
Construction. The components can be assembled in any convenient enclosure with a terminal strip to provide support and tie points. The probes can be iron, brass, copper, or aluminum (both the

EDITOR'S NOTE

Although we had no difficulty in locating a water table 20 feet underground and a water conduit 45 feet down, we did not have the opportunity of determining system "resolution"—how small an object can be detected at various depths. We leave this to the reader who is in better physical shape and handier with a shovel.

For readers in dry areas, the survey meter might be used to verify (or refute) the existence of a usable water table. It might also be valuable (more so than the metal locators that skim the surface) in locating buried treasure.

Try using a battery-powered oscillator to drive the transformer, remembering that the lower the frequency, the better.



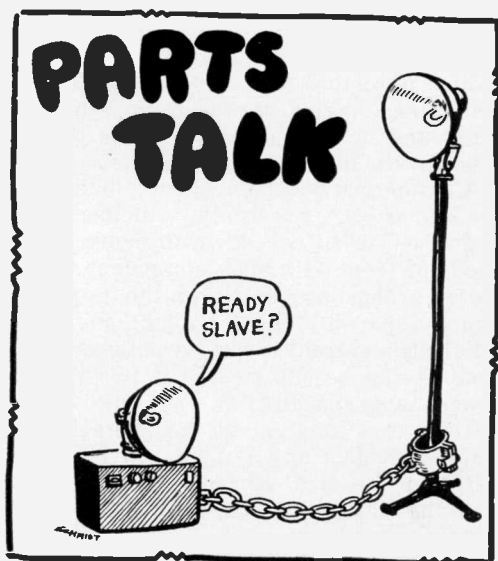
Two test recordings made in widely separated localities show striking similarities in that the resistance drops appreciably at depths where known water tables exist.

same) and should be between $\frac{1}{4}$ " and $\frac{1}{2}$ " in diameter and about 18" long. One end of each probe should be sharpened to make insertion easier. A length (50 to 100 ft) of #22 insulated (preferably plastic) wire is connected to each probe, with the other end connected to the appropriate binding post. The ohmmeter is connected (polarity not important) to BP3 and BP4.

Operation. With no ac power applied, short the two ground posts together. The ohmmeter should indicate a short circuit. When the posts are separated, the ohmmeter should deflect upscale as the capacitor charges. The maximum resistance is limited by capacitor leakage and must be over 50,000 to 60,000 ohms. Connect a known value of resistance across the ground posts and check that the ohmmeter reading indicates the correct resistance value (within tolerance). Turn on the ac power and note that the same resistance value is indicated. If it differs drastically, the problem is in the capacitor.

Use. Force the ground probes several inches into the earth in the area to be surveyed. You can start with a small separation (10 ft) or a large one (100 ft). With the ohmmeter connected and power on, record the probe spacing and the resistance value. Separate (or bring together) the rods at measured intervals (2 or 3 feet at a time) and record spacing and resistance. When you have sufficient data, plot them on graph paper.

Try to learn something about the area you want to survey. Charts and data are usually available from state or federal agencies concerned with mining and geology. Local well drilling companies also have data on land strata. Make your survey as near as possible to a location of which you have some knowledge. When you have succeeded in obtaining data of your own that checks with known data, you will begin to develop a "feel" for the system and variations in resistance will become meaningful to you. Just remember that dry rock, sand, oil, and gas have high resistance, while water shows up as a sharp low resistance. Two sample charts are shown above: ♦



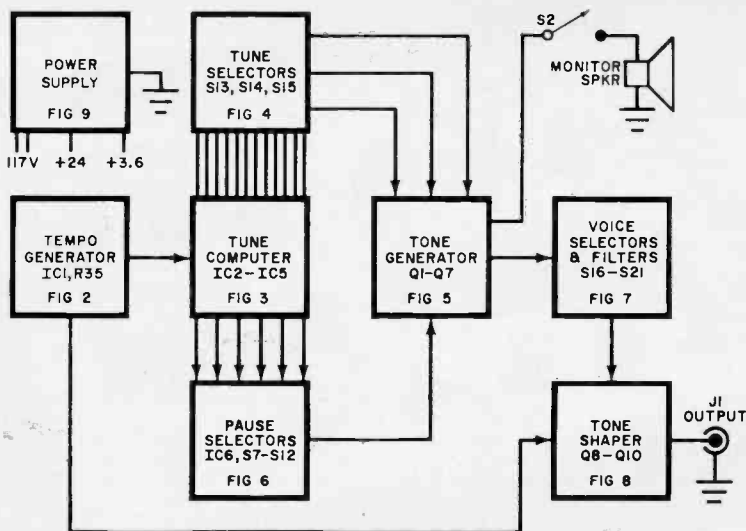


Fig. 1. The overall block diagram shows the signal flow for the system. Note that voicing filters and tone shaper are not linked to the monitor speaker.

PARTS LIST

- C1—4000- μ F, 6-volt electrolytic capacitor
 C2—0.1- μ F, 10-volt disc ceramic capacitor
 C3—500- μ F, 50-volt electrolytic capacitor
 C4—100- μ F, 25-volt electrolytic capacitor
 C5, C10—0.047- μ F, 50-volt Mylar capacitor
 C6, C8—0.22- μ F, 50-volt Mylar capacitor
 C7, C15, C16—47- μ F, 6-volt electrolytic capacitor
 C9, C12, C14—0.47- μ F, 50-volt Mylar capacitor
 C11—0.01- μ F disc capacitor
 D1-D3—1-ampere, 100-volt diode (1N4002 or similar)
 D4—24-volt, 1-watt zener diode (1N4749 or similar)
 D5-D7, D9—Silicon diode (1N914 or similar)
 D8—3.3-volt zener diode (1N747 or similar)
 IC1—Dual buffer (MC799P)
 IC2-IC4—Dual flip-flop (MC791P)
 IC5, IC6—Quad two-input gate (MC724P)
 J1—Phono jack
 Q1-Q3, Q7-Q9—Transistor (National 2N5129)
 Q4—Transistor (National 2N5139)
 Q5—Transistor (Motorola 2N4871, do not substitute)
 Q6—Transistor (Motorola MPS6523, do not substitute)
 Q10—Transistor (Motorola 2N4351, do not substitute)
 R1—330-ohm, $\frac{1}{2}$ -watt resistor
 R2-R4, R12, R31-R33, R36-R38—1000-ohm, $\frac{1}{4}$ -watt resistor
 R5-R7—22,000-ohm, $\frac{1}{4}$ -watt resistor
 R8-R10—100,000-ohm potentiometer
 R11—11,000-ohm, $\frac{1}{4}$ -watt resistor
 R13, R18—1500-ohm, $\frac{1}{4}$ -watt resistor
 R14—5000-ohm potentiometer
 R15—470-ohm, $\frac{1}{4}$ -watt resistor
 R16—20-ohm, $\frac{1}{4}$ -watt resistor
 R17, R20—100,000-ohm, $\frac{1}{4}$ -watt resistor
 R19, R28—4700-ohm, $\frac{1}{4}$ -watt resistor
 R21, R23—27,000-ohm, $\frac{1}{4}$ -watt resistor
 R22, R24, R25—1-megohm potentiometer
 R26, R30—3300-ohm, $\frac{1}{4}$ -watt resistor
 R27—1000-ohm potentiometer
 R29—2200-ohm, $\frac{1}{4}$ -watt resistor
 R30—3300-ohm, $\frac{1}{4}$ -watt resistor
 R34—8200-ohm, $\frac{1}{4}$ -watt resistor
 R35—10,000-ohm potentiometer
 R39, R40—3.3-megohm, $\frac{1}{4}$ -watt resistor
 S1-S12—Dpdtr rocker switch
 S13-S15—Single-pole, 12-position, non-short-
 ing rotary switch (Mallory 32112J)
 S16-S21—Interlocked six-station dpdt push-
 button switch assembly (Southwest Techni-
 cal SW-9678-stf or similar)
 T1—Power transformer; secondaries: 24 volts
 at 100 mA, 6.3 volts CT at 400 mA
 Misc.—Printed circuit terminals (47, optional),
 3.2-ohm speaker, suitable chassis, sub-
 chassis, grommets (3), line cord with strain
 relief, bottom plate with mounting hard-
 ware, rubber feet (4), switch hardware,
 ground lugs (3), $\frac{5}{8}$ " knobs (9), $\frac{1}{8}$ " knobs
 (3).

Note—The following are available from South-
 west Technical Products, Box 32040, San
 Antonio, TX 78216: etched and drilled
 printed circuit board at \$6.50, postpaid;
 complete kit with chassis, dialplate, and
 hardware at \$47.65; complete kit with
 chassis and black vinyl covered case 7"
 x10" x5" at \$53.15; plus postage and in-
 surance for 6 lb.

ever heard before. On occasion, the music may sound familiar but it is more likely to have a science-fiction flavor with many wild tonal sequences.

The Psych-Tone can be used with its internal monitor speaker; but, preferably, it should be connected to an external power amplifier to take advantage of the various voices and the sustain, attack, and decay provisions which are not available when only the monitor speaker is used.

General Circuit Operation. The Psych-Tone consists of seven operational blocks and a power supply as shown in Fig. 1. The tempo generator determines the reference beat (or clock) for the tune computer, which cycles through 63 different states in step with the clock pulse. The three tune selector switches convert the initial 63-note sequence into any one of 1728 different combinations. The tune computer also drives a pause selector circuit that decides when pauses are to be produced instead of tones. The selected sequence of notes and pauses then goes to a tone generator where it is converted into audio tones.

In the voice selector (filters) the tones are shaped into one of six selected voices, in a manner similar to the operation of an electric organ. The tones are further shaped in a

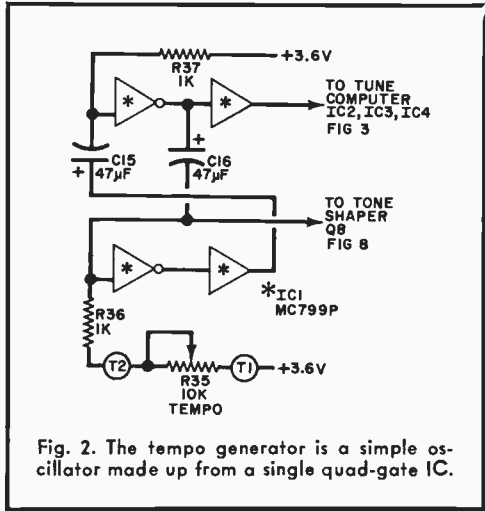


Fig. 2. The tempo generator is a simple oscillator made up from a single quad-gate IC.

variable-gain circuit that provides for adjusting the duration (sustain), attack (how fast the tone reaches full volume), decay (how fast the tone dies away from full volume), and loudness.

Tempo Generator. This circuit, shown in Fig. 2, contains a single integrated circuit (IC1) operating as an astable multivibrator. Two square wave outputs are produced—one

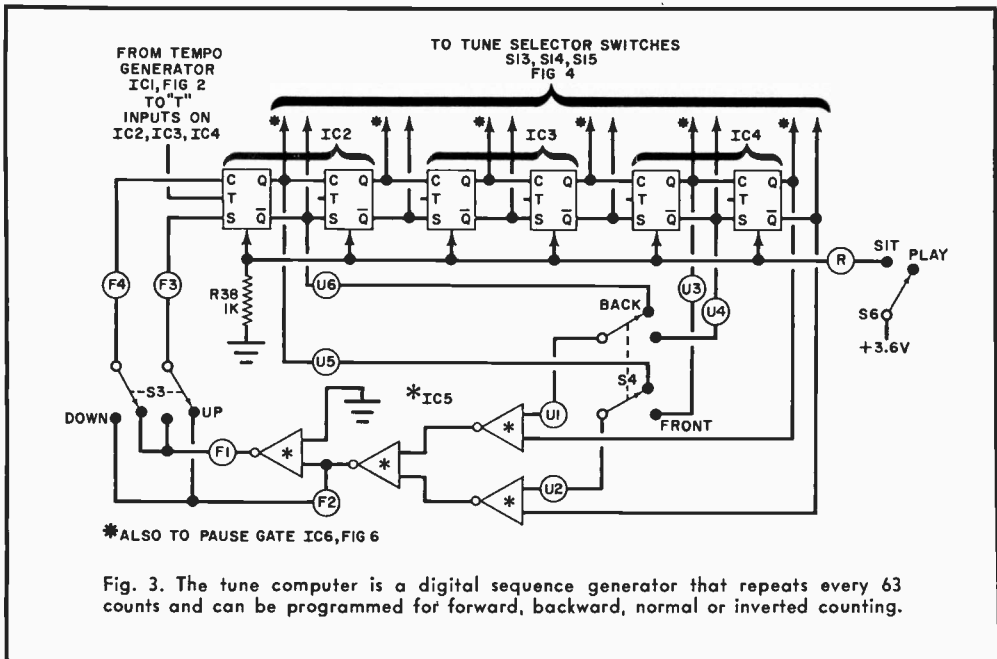


Fig. 3. The tune computer is a digital sequence generator that repeats every 63 counts and can be programmed for forward, backward, normal or inverted counting.

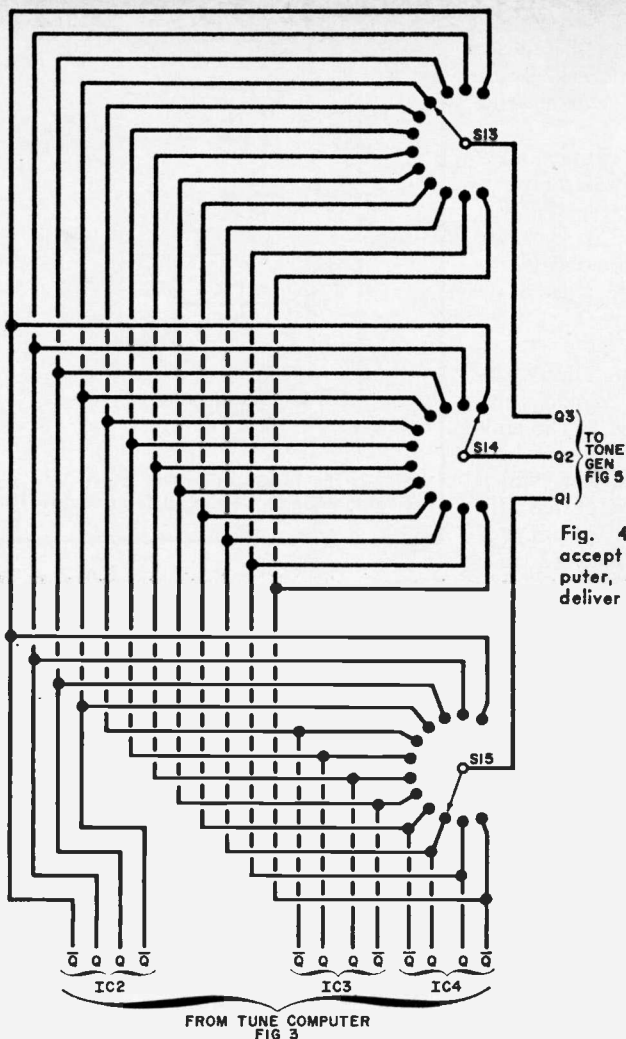


Fig. 4. Three tune-selector switches accept 12 outputs from the tune computer, and after the desired selection, deliver three signals to tone generator.

having a fast fall time and high drive capability for the tune computer, and the other for the tone shaper sustain circuit. The tempo (beat) is adjusted over a 5:1 range by potentiometer *R35*. If desired, the values of *C15* and *C16* can be increased or decreased to slow down or speed up the tempo.

Tune Computer. As shown in Fig. 3, the computer is a "pseudo random sequence generator." Like a random noise source, the computer sequences appear to be totally unrelated. However, this circuit can be programmed to return to exactly the same random sequence at any time. The logic consists of a six-stage shift register (*IC2*, *IC3*, and

IC4) and an EXCLUSIVE OR gate (*IC5*). The shift register is toggled by the tempo generator described above.

At each toggle pulse, each stage of the register shifts a 1 or a 0 to the next stage. The last two stages (*IC4*) drive the EXCLUSIVE OR gate. Switches *S3* and *S4* connect the logic so that the shift register goes forward, backward, with a normal scale, or with an inverted scale. The computer repeats every 63 counts. While any short sequence appears to be a random train of binary words, the same sequence repeats every time. Selector switch *S6* holds the computer in any interrupted state until the user is ready to restart the sequence.

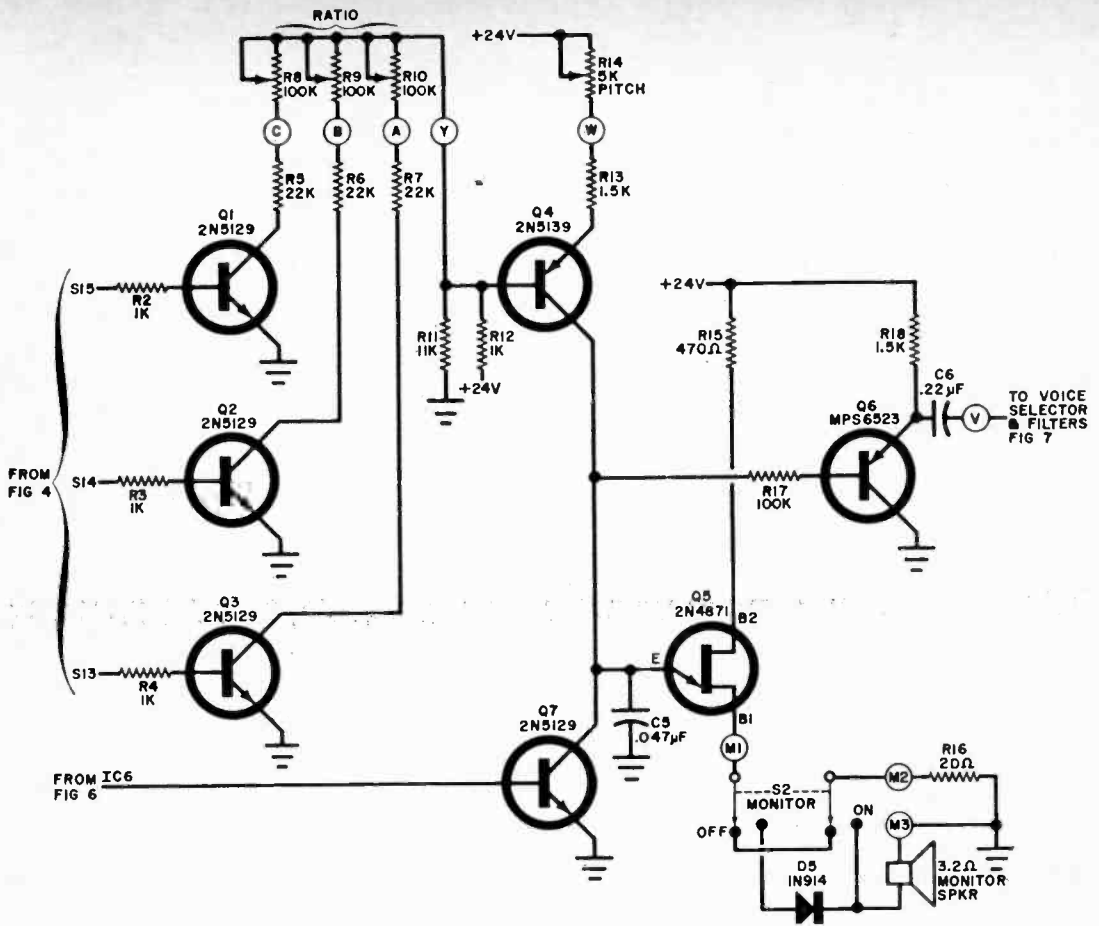
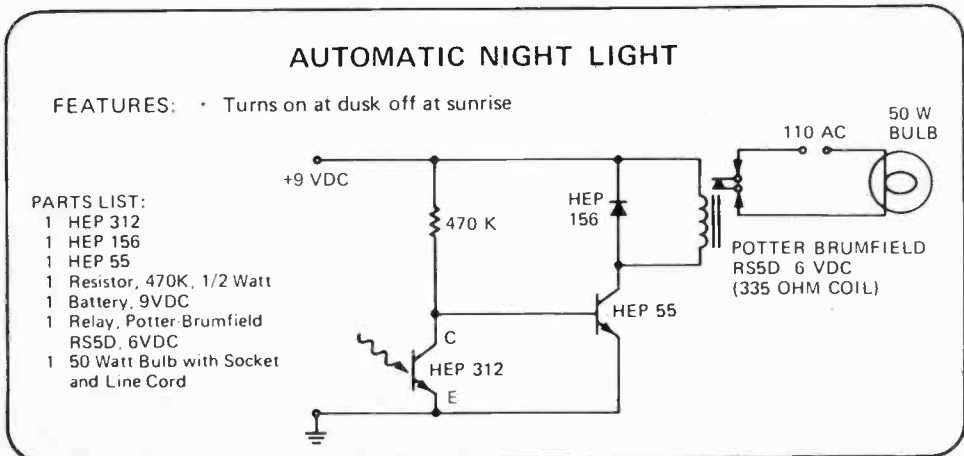


Fig. 5. The tone generator consists of a UJT oscillator whose frequency is dependent on the current flowing through Q4. This in turn is determined by the pitch control and operation of Q1 through Q3.

Each of the six stages has two possible outputs: a true or Q and the complement or not Q output. Thus there are twelve outputs which are selected by S13, S14, and S15,

shown in Fig. 4 so that three signals are supplied to the tone generator.

Tone Generator. The circuit shown in



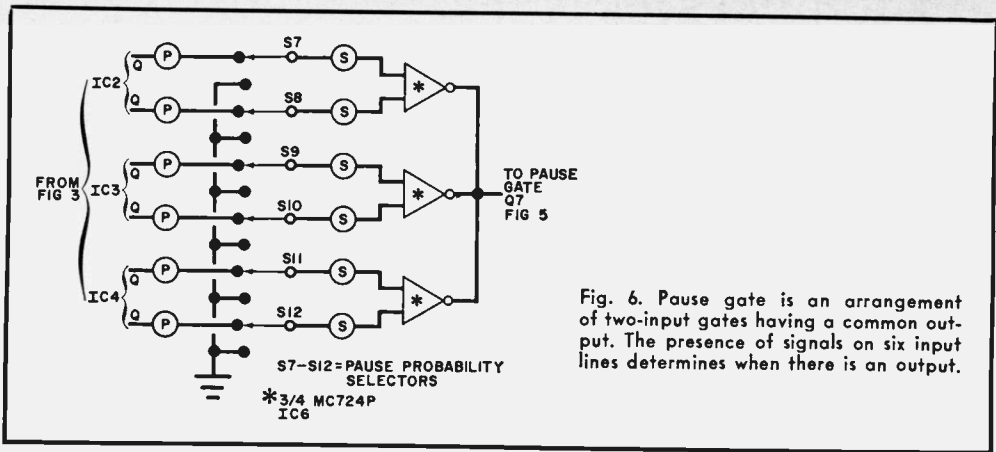


Fig. 6. Pause gate is an arrangement of two-input gates having a common output. The presence of signals on six input lines determines when there is an output.

Fig. 5 is basically a unijunction transistor oscillator (*Q5*) whose frequency is determined by the value of *C5* and the collector current of *Q4*.

Transistors *Q1* through *Q3* cause the base voltage of *Q4* to vary in accordance with the signals selected by *S13*, *S14*, and *S15*. The effect of the signals on *Q4* is determined by the collector loads on *Q1* through *Q3*. These are potentiometers *R8* through *R10*. Normally, one control is set near maximum, one at the midpoint and the other near minimum to get a weighted average and provide a wide spread of tonal values. The three ratio potentiometers permit an infinite variety of tonal forms for each of the basic sequences.

Pitch is controlled by *R14*, which, when combined with the tone-shifting base voltage applied to *Q4*, determines the frequency of

oscillation. Resistor *R17* and transistor *Q6* form a buffer amplifier having a low-impedance output for the voice selector without loading the UJT oscillator.

Pauses are provided by *Q7*, which shorts out *C5* and prevents a tone from being generated when a pause is desired.

The monitor speaker is switched in and out by *S2* while diode *D5* insures the same pitch whether the speaker is used or not. The speaker responds only to tone and pause sequences and is not affected by the sustain, attack, decay, and volume controls. However, the volume on the monitor is sufficient for practice sessions.

Pause Gate. As shown in Fig. 6, the pause gate consists of three two-input gates (*IC6*) arranged so that a logic 1 on any input allows

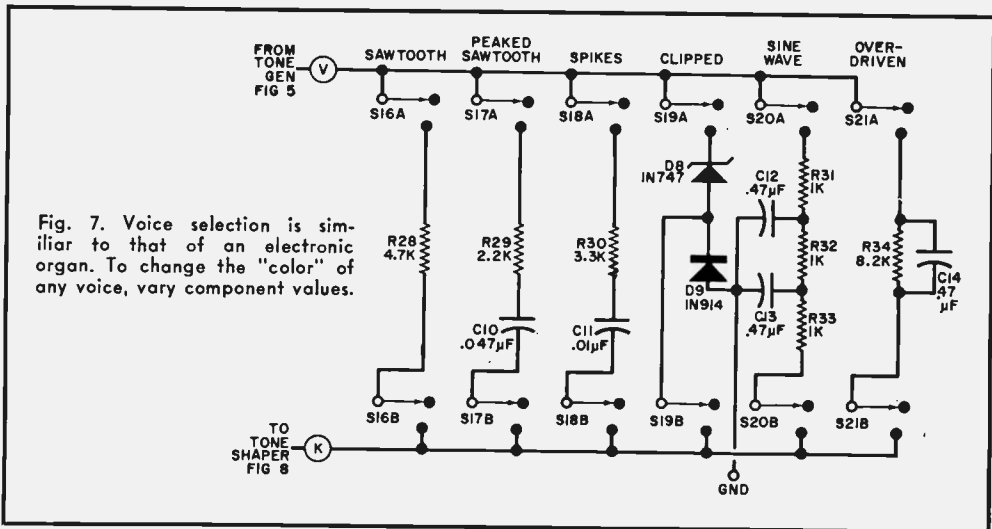
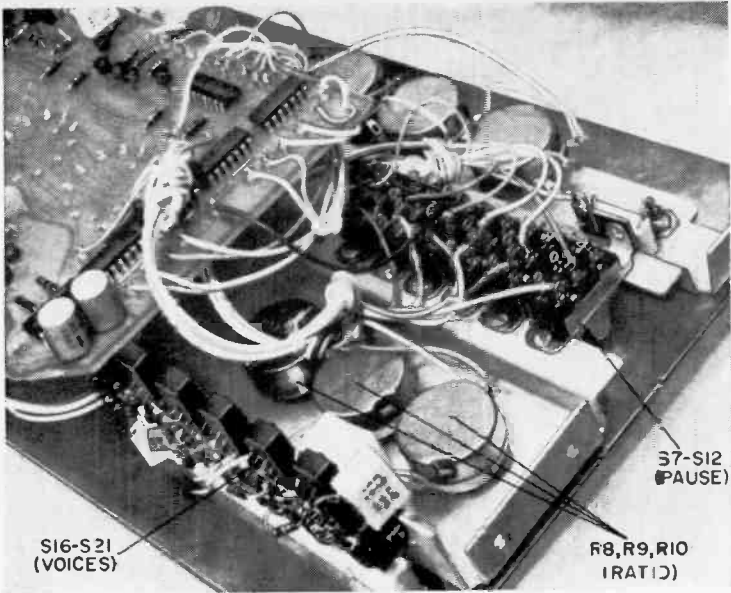
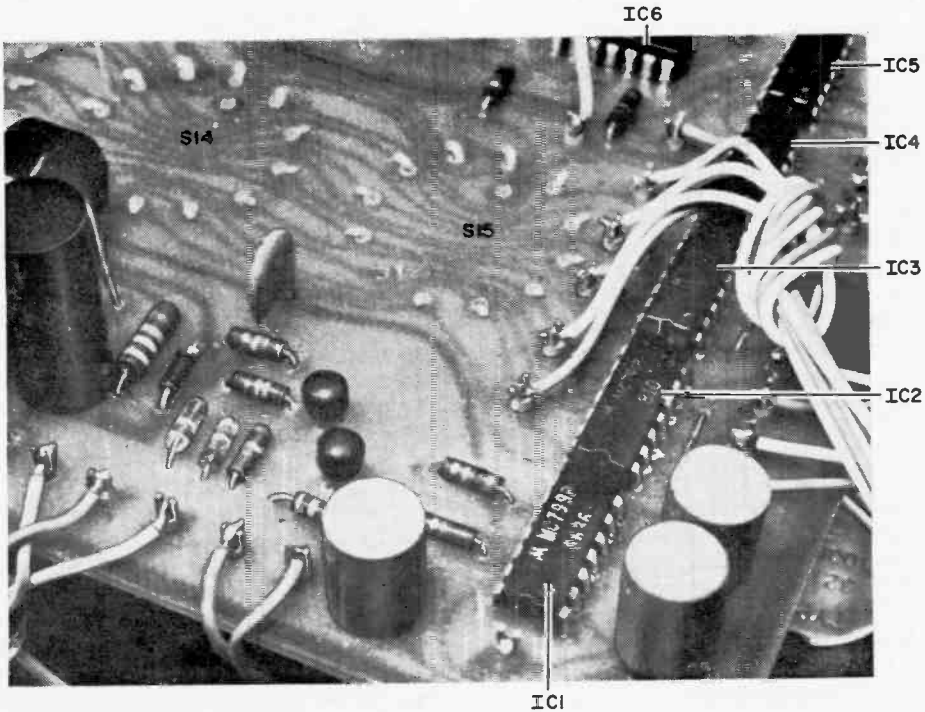


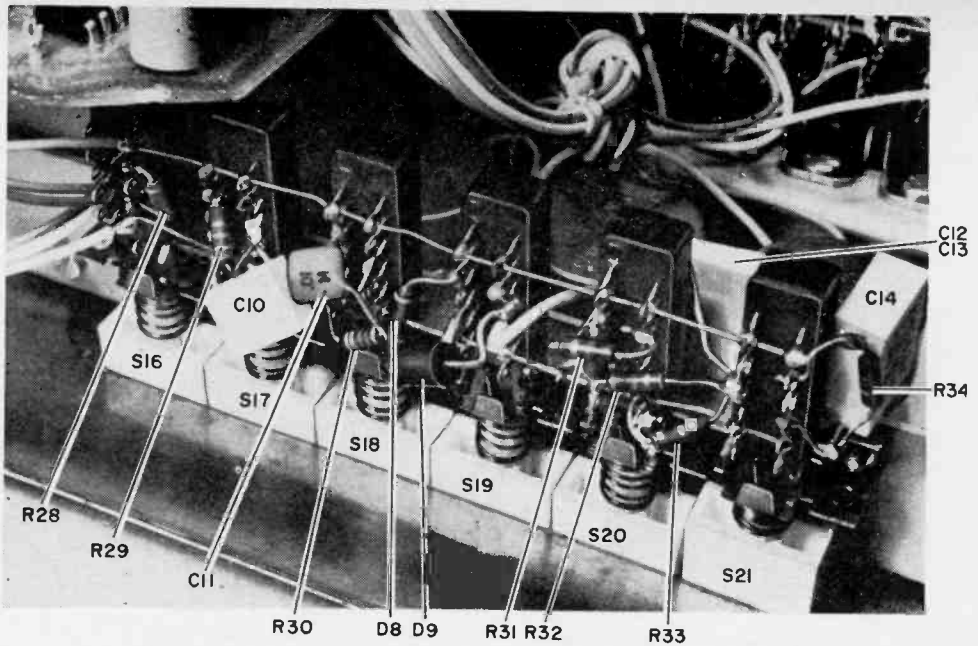
Fig. 7. Voice selection is similar to that of an electronic organ. To change the "color" of any voice, vary component values.



Although any mechanical arrangement can be used, the prototype was assembled to the front panel with a set of brackets and the potentiometer mounting hardware. The PC board is supported by the three tune-selector switches.

The tune-selector switch terminals fit through holes drilled in the PC board, and are soldered to the fail side of board. The three switches then support the board away from the panel.





The six voice switches are mounted on their own bracket with other components attached directly. The switch combination should be such that only one switch can be operational at any time.

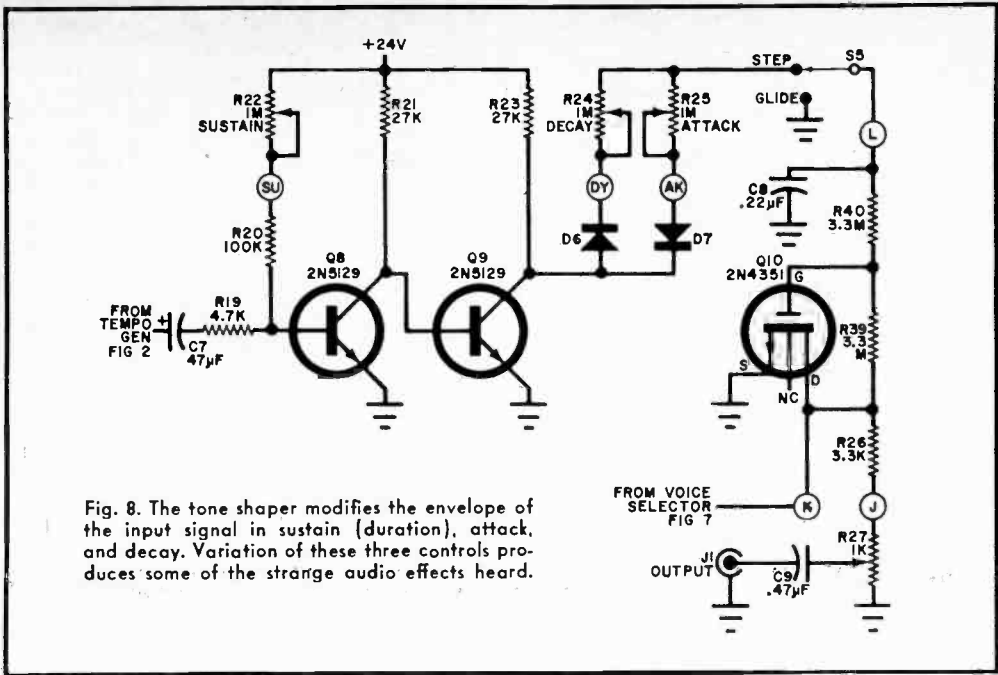
the tones to be produced (through *Q7*). The six inputs come through selector switches *S7* through *S12*, which provide either a *Q* or not *Q* signal, the latter being ground. If all the switches were grounded, there would be no tone generated since the common output would be high, saturating *Q7* and stopping the oscillation of the UJT circuit. If any five switches are grounded, the circuit plays about half the tones, with blanks or pauses at random intervals. With four switches grounded, $\frac{3}{4}$ of the tones are sounded; while grounding any three switches drops one note in eight (on the average). The combination of switches used determines the positions of the pauses. Thus, there are a total of 15 different ways to eliminate every fourth note on the average and 20 different ways to play the computer with an average of one note in eight missed.

Voice Selector. The circuit shown in Fig. 7 is controlled by a six-station interlocked pushbutton assembly (*S16* through *S21*). The switches determine the waveform of the tone produced: sawtooth, peaked sawtooth, spiked, clipped, rough sinusoid, or overdriven. The filters suggested here were chosen for economical reasons; filters such as those found in electronic organs may be used to obtain other tonal qualities.

Tone Shaper. The tone shaper (see Fig. 8) converts the filtered tones into individual notes. Transistor *Q10* is biased by *R39* and *R40* to act as a variable resistor which conducts both positive and negative portions of a waveform equally. This transistor acts as a shunt to ground from the output terminal.

The voltage across *C8* determines the operational mode of *Q10*. If this voltage is 6 or more volts positive (with respect to ground), *Q10* acts as a low resistance and shorts out the signal. If *C8* is grounded, *Q10* passes all the signal. Intermediate values of the control voltage will result in a controlled output level.

The rate at which *C8* goes from a positive voltage to ground determines how fast the output amplitude rises (the attack times); the length of time that *C8* stays near ground determines the sustain; and the rate of discharge on *C8* determines the decay time. The final output varies greatly for various values of attack, sustain, and decay. With a moderate amount of all three, a violin effect is obtained. With sharp attack, short sustain, and long decay, the percussive sound of a piano or chime is generated. A long attack, long sustain, and very short decay provide a totally unreal sound similar to a recording being played backward. Tremolo effects are obtained when the decay is set to overlap



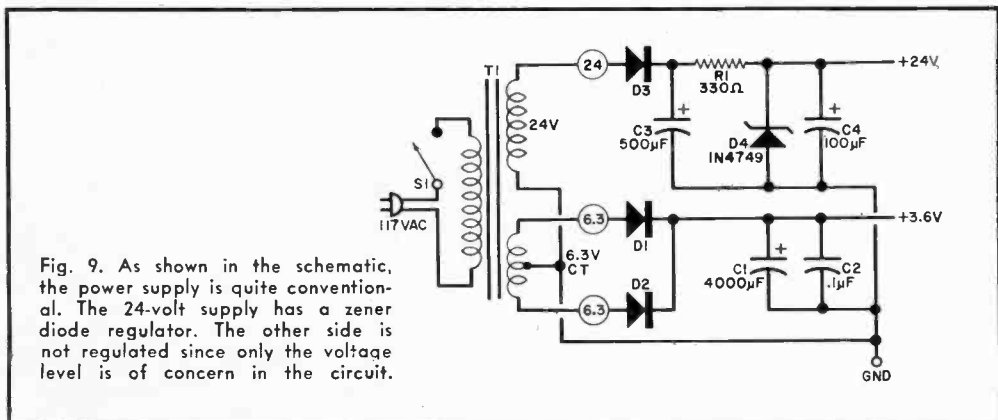
into the next tone, producing a "waa-waa". With *S5* in the glide position, *Q10* is disabled and the sound is similar to that of a bagpipe.

Transistor *Q8* is a monostable stage providing the sustain effect. Its output is controlled by *R22* and is inverted by *Q9*. The output of *Q9* is routed to *C8* for the attack effect or *R24* for decay.

Power Supply. The circuit of the power supply is shown in Fig. 9. It generates 24 volts dc for the tone generator circuit and 3.6 volts dc for the digital logic circuits.

Construction. An etched and drilled PC board is available commercially (see Parts List of Fig. 1) or you can make your own from a foil pattern that can be obtained by sending 25¢ to Editorial Department, ELECTRONIC EXPERIMENTER'S HANDBOOK, 1 Park Ave., New York, NY 10016.

Install the components on the board as shown in Fig. 10. Install the five jumpers next to the IC's using insulated sleeving on the two jumpers toward the center of the board. You may use PC terminals for the external connections to the board.



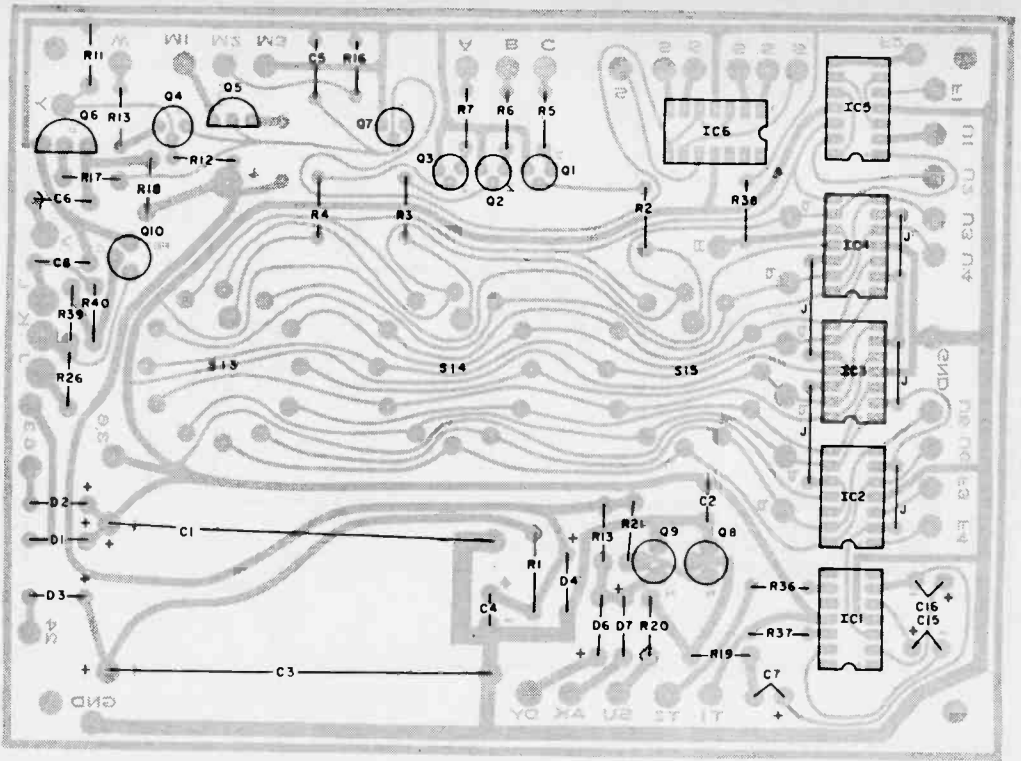


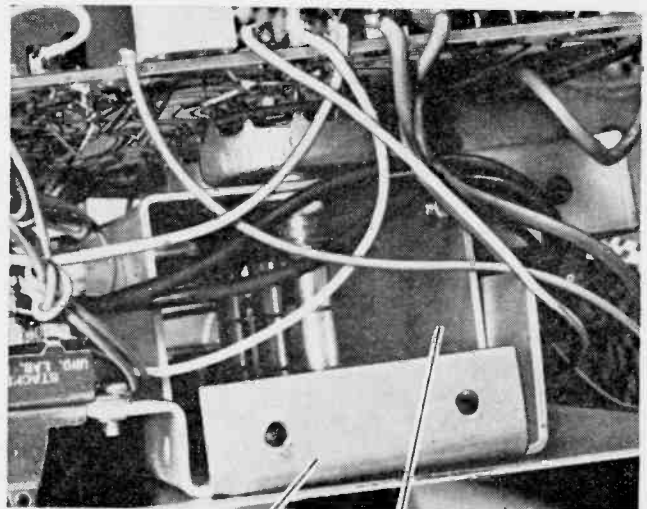
Fig. 10. Component installation. Unfortunately, the actual size foil pattern is too large for the page.

To save a lot of individual wiring, switches *S13* through *S15* are mounted directly on the foil side of the board, with the switch terminals inserted through the board. The inserted terminals may be crimped and fastened to the component side of the board with epoxy ce-

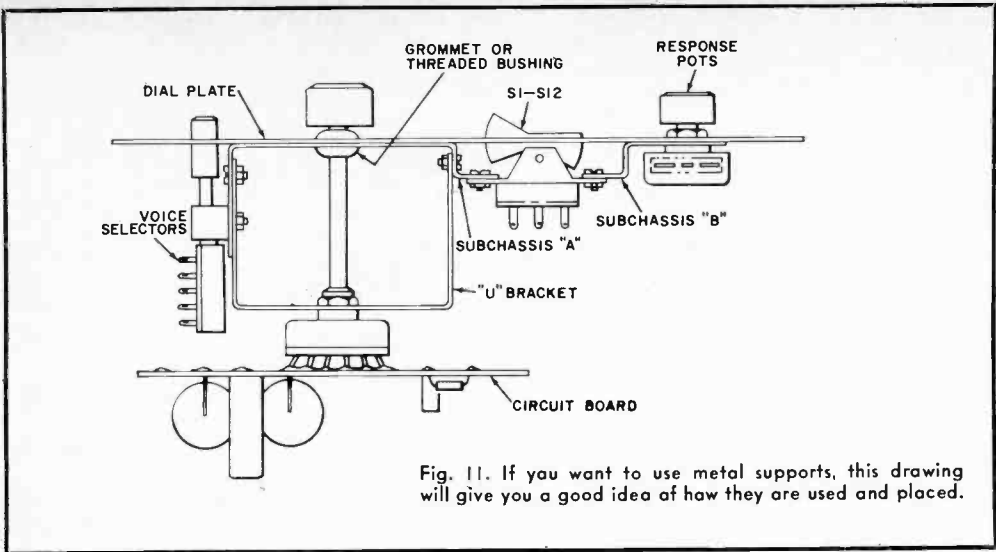
ment: then solder them to the pads on the foil side. A small wire jumper at the common terminal of each switch simplifies the final assembly.

When installing the components, use a low-wattage soldering iron and fine solder, and

Author used a set of brackets and subchassis to assemble prototype. With some ingenuity, any other mechanical arrangement can be used.



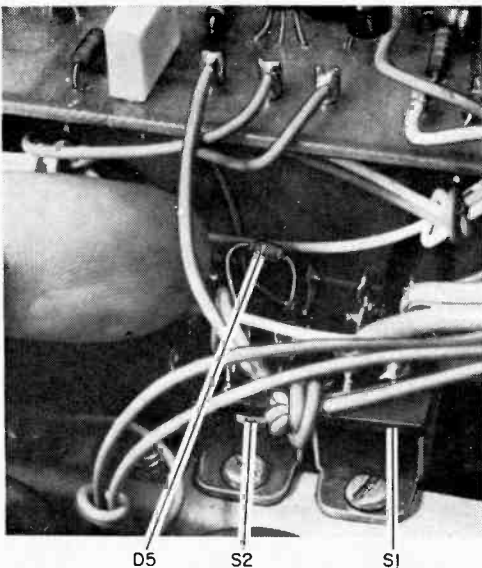
SUBCHASSIS A "U" BRACKET



observe the polarities of all components. Several different basing schemes are used on the transistors so be sure you get them installed properly.

Transistor *Q10* can be damaged by careless handling. To install this component, wait until all the other parts have been mounted on the board. Do not remove the shorting ring that comes with the transistor until you are ready to install it. Just before installation, wrap several turns of bare wire around the

In most cases, components directly associated with a switch are mounted on the switch terminals.



leads at the case, remove the shorting ring, and turn the substrate lead up (it is left unconnected). Install the transistor using a low-power soldering iron (not a gun). Once it is in place, remove the shorting wire.

Two subchassis brackets and a larger U-shaped bracket are used in the final assembly (see Fig. 11). The dialplate is secured to the brackets using the potentiometer hardware. The transformer is mounted wherever convenient. The bottom panel supports the speaker.

To avoid wiring confusion, it is best to use several colors of wire and group them into harnesses by tying them or slipping them through lengths of sleeving.

Preliminary Checkout. Double check all wiring, install the various knobs, identify the detents on the switches, and use some form of lettering to mark all controls and switch positions.

Plug the unit in, turn on switch *S1* and measure both supply voltages to make sure they are correct. Place the monitor switch (*S2*) in the ON position and set *S6* to PLAY. Set any three pause select switches (*S7* through *S12*) up and the other three down. The Psych-Tone should start to compose. Connect an external audio amplifier and speaker to *J1* and note the effects of the voice selectors (*S16* through *S21*) and all other controls.

There are no operating rules. Any and all of the 28 operating controls can be used in any sequence to produce any desired effect. ♦

A Substitute for Meters in Bridge Circuits

BY ED FRIEDMAN

ONE OF THE MOST common and useful electronic measurement circuits is the Wheatstone bridge (see Fig. 1A). In its usual form, a zero-center microammeter or milliammeter is used to indicate a null when the four legs of the bridge are balanced. There are, however, some disadvantages to this arrangement: the meter face must be relatively large to provide accurate readings, the meter cannot be subjected to much mechanical abuse, and a good-quality zero-center meter is fairly expensive.

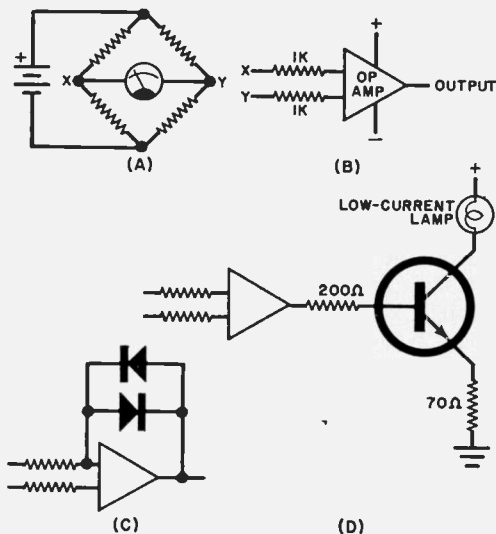
If an accurate null indication is all that

is required, there is a good, inexpensive way to avoid the zero-center meter. The idea is to use an operational amplifier integrated circuit as a high-sensitivity voltage comparator. The basic circuit is shown in Fig. 1B. Inputs X and Y to the op amp are connected to the same points on the bridge. Polarities are not important. A conventional VOM or VTVM can then be connected to the output of the op amp to indicate when the bridge is balanced (within a couple of millivolts in most cases). The null point is determined by the point that just causes the meter to change indication. The small amount of offset voltage within the op amp can usually be disregarded.

For extreme accuracy, however, a suitable offset voltage can be applied to make this minute correction. To limit the output swing, parallel back-to-back diodes can be connected from the output to the input of the op amp as shown in Fig. 1C. If germanium diodes are used, the swing will be limited to about 0.3 volt; with silicon diodes the swing will be about 0.7 volt.

If you want to eliminate the meter entirely, a lamp driver circuit such as that shown in Fig. 1D can be used. Any switching transistor, capable of handling the lamp current may be used. The emitter resistor which limits the cold filament current flow is optional. The base resistor limits the output current of the op amp when the transistor saturates. Of course, the lamp may be replaced by a low-current relay to control external equipment. The indication of null occurs just as the lamp changes states—that is, goes from off to on in one direction of the balance; and from on to off in the other direction. ♦

The zero-center meter in the standard Wheatstone bridge (A) can be eliminated by using an op amp as in (B) with a VOM. To limit output swing, two diodes are used as in (C). Circuit (D) eliminates a meter altogether by using another transistor and small lamp.



Enjoy a full year of Popular Electronics

INCLUDING Electronics World

at $\frac{2}{3}$ the current rate.

SAVE $33\frac{1}{3}\%$...AND ENJOY

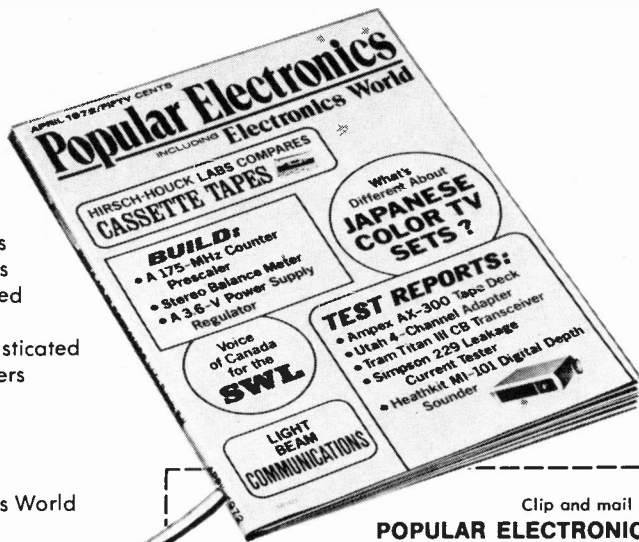
DIVERSE, CHALLENGING CONSTRUCTION PROJECTS

Popular Electronics Including Electronics World features up to 6 different projects per issue. Of course, they're all lab-tested for accuracy and "workability" . . . and they range from the simple to the sophisticated - from around-the-house helpers to lasers and computers.

NEWS AND INFORMATION

Popular Electronics Including Electronics World presents no-nonsense reporting on the latest developments in electronics . . . on careers in this fabulous field . . . on all the literature worth considering . . . and on everything of interest to the electronics enthusiast.

**SO PLUG INTO
POPULAR ELECTRONICS
INCLUDING ELECTRONICS
WORLD...SAVE $33\frac{1}{3}\%$ ON
THE CURRENT RATE.**



Clip and mail to:
**POPULAR ELECTRONICS
INCLUDING ELECTRONICS WORLD!**

Post Office Box 2774
Boulder, Colorado 80302

O.K., I want to plug into savings. Please enter my subscription to Popular Electronics Including Electronics World for one full year at \$3.97, $\frac{1}{3}$ off the current rate.

\$3.97 Payment enclosed

Please Bill Me

Name _____

Address _____ 0767

City _____

State _____ Zip _____

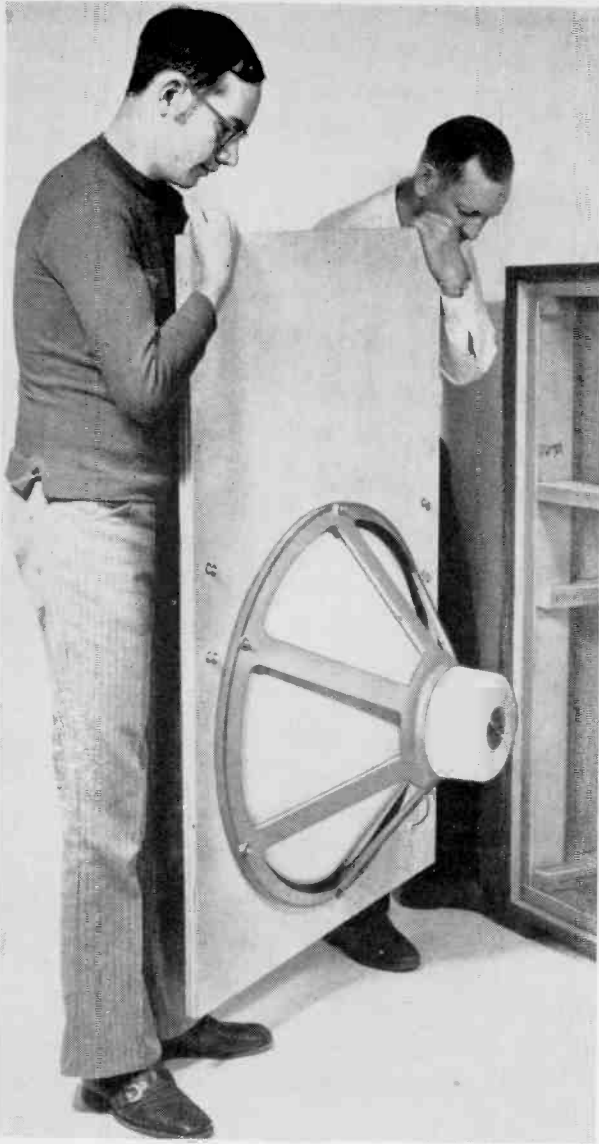
Please add \$1 for postage outside the USA,
its possessions and Canada.

BY DAVID B. WEEMS

The COLOSSAL WOOFER

*You
want
bass?*

This is it!



IN "The Case for the Single Woofer" (page 139) we discussed the benefits that can be obtained from using a mixed-signal woofer in a stereo system. The article made no mention of the relative quality of the speaker to be used, leaving its choice to the reader. However, if you want to try a really "different" mixed-signal woofer, you might investigate the Electro-Voice Model 30W woofer—a Super Colossal speaker measuring 30 in. in diameter. But if you do, have a second amplifier handy and be prepared to surrender about 27 cubic feet of space in your listening room.

The technical specifications for the

30W are as unusual as its size. For example, power handling capacity is listed at 100 watts with 200 watts peak. The frequency range is an uncommon 15-300 Hz, with a free air resonance of about 15 Hz. The Electro-Voice people also recommend setting the crossover at 100 Hz.

When the 30W is installed in the phase loaded box, described here, and the box is properly located with respect to one wall of the room, system resonance is about 30 Hz.

About the Woofer. The challenge of producing a response that is flat down to the lowest limits of the audio band has in-

spired several different approaches to ultra-low-frequency propagation of sound waves. The approach taken by Electro-Voice in designing the 30W for its top-of-the-line "Patrician" speaker system was to make the cone large enough to handle the lowest audio frequencies effortlessly.

The design of a woofer the size of the 30W presented some problems, particularly with respect to the material to be used for the cone. Paper, the conventional material, could not be used. A 30-in. cone made of paper stiff enough for piston action without cone break-up would have been too heavy for acceptable transient response. So the 30W cone is fashioned from low-mass bead foam polystyrene. This material does not exhibit cone breakup at frequencies below 250 Hz.

Impaired transient response can become a major disadvantage with woofers exceeding 15 in. in diameter due to the fact that large cones cannot be accelerated (controlled) as easily as smaller

cones. In the 30W, the use of polystyrene helps to alleviate the problem of cone mass. Also, since transient response becomes less of a problem with decreasing frequency, employing the lower than normal recommended crossover frequency reduces the response of the 30W to a range in which transient response is not problematical.

On the bright side, the large size of the 30W's cone has an inherent advantage. A bass frequency output level that would require a 12-in. cone to move $1\frac{3}{4}$ " could be duplicated by a 30-in. cone with only $\frac{1}{4}$ " of cone travel. It should be noted that distortion increases in proportion to the length of cone travel. Since the 30W requires a much shorter cone travel for a given output level, it stands to reason that distortion is considerably reduced as a consequence.

Woofer Box Assembly. The wall material recommended for the woofer box is 1"-thick plywood which is not generally

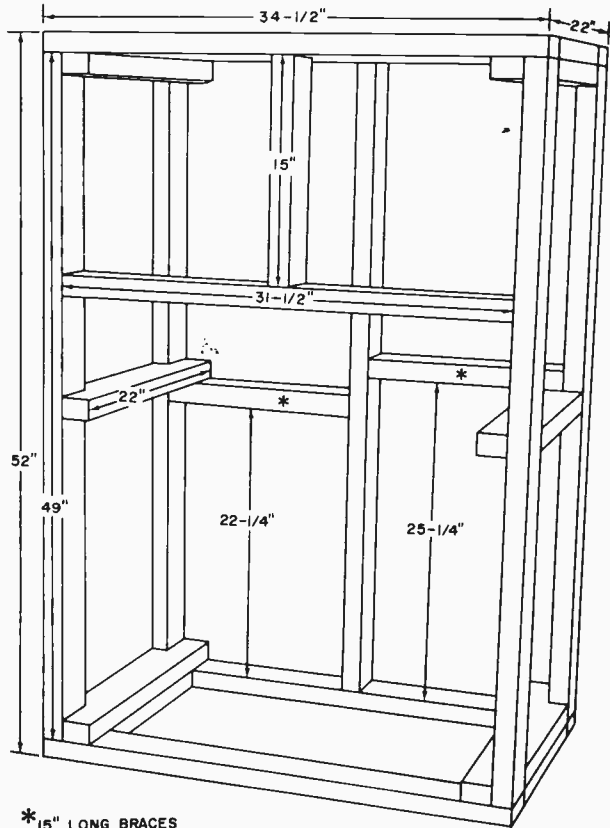


Fig. 1. Enclosure frame consists of 2" x 4" pine solidly anchored together with wood glue and 3" screws.

available. As an alternative, the walls can be fabricated from $\frac{3}{4}$ " fir plywood covered with $\frac{1}{4}$ " hardwood plywood. (If 1" plywood is available in your area and you choose to use it, you will have to make the appropriate dimension changes for the plywood sheets.)

Another thing to watch out for is the 2" x 4" framing stock. For years, 2" x 4" actually meant $1\frac{5}{8}$ " x $3\frac{5}{8}$ "—but on September 1, 1970, a new national softwood lumber standard became effective with the new dimensions fixed at $1\frac{1}{2}$ " x $3\frac{1}{2}$ ". Some lumberyards may have in stock both the old and new standard 2" x 4" stock. So, check the measurements of your framing stock before cutting it to size, particularly those pieces which are to be notched to receive another member.

Bearing in mind the varying dimensions, cut your 2" x 4" framing stock to the dimensions specified in the Bill of Materials. Drill $\frac{13}{64}$ " shank holes. Then clamp the pieces into position to drill $\frac{3}{32}$ " pilot holes in the proper locations to

receive #12 x 3" wood screws. Stagger the holes at the corners so that screws from two directions do not meet in the wood.

Start assembly by joining the members that make up the front frame, referring to Fig. 1. Use glue liberally on every joining operation with the single exception of mounting in place the back plate.

Next, assemble the corner pieces by attaching a length of plain 2" x 4" stock to the unnotched section of four of the notched pieces of lumber. If possible, use C clamps to hold the pieces together while seating the screws. Then anchor the corner pieces to the front frame. Finally, attach the corner pieces to the rear frame (assembled as shown in Fig. 2) in the same manner and add the center side braces. This completes the assembly of the frame.

Cut the front panel to size as specified. Attach this panel in place on the front of the frame with glue and #10 x $1\frac{1}{2}$ " flathead wood screws as follows. Lay the

BILL OF MATERIALS

- 1—Electro-Voice Model 30W woofer (available on special order at E-V dealers)
- 5—49" lengths of 2" x 4" pine for studs
- 1—36 $\frac{1}{2}$ " length of 2" x 4" pine for footing
- 4—34 $\frac{1}{2}$ " lengths of 2" x 4" pine for front and rear plates and sills
- 1—31 $\frac{1}{2}$ " length of 2" x 4" pine for rear cross brace
- 6—22" lengths of 2" x 4" pine, notched at ends, for spacers
- 2—20 $\frac{1}{2}$ " lengths of 2" x 4" pine for footing
- 7—15" lengths of 2" x 4" pine for front and rear braces and side sills
- 2—52" x 34 $\frac{1}{2}$ " sheets of $\frac{3}{4}$ " fir plywood for front and rear interior panels
- 2—52" x 23 $\frac{3}{4}$ " sheets of $\frac{3}{4}$ " fir plywood for side interior panels
- 2—36" x 23 $\frac{3}{4}$ " sheets of $\frac{3}{4}$ " fir plywood for top and bottom interior panels
- 1—52" x 36" sheet of $\frac{1}{4}$ " hardwood plywood for front exterior panel
- 1—52" x 34 $\frac{1}{2}$ " sheet of $\frac{1}{4}$ " hardwood plywood for rear exterior panel
- 2—53 $\frac{1}{2}$ " x 24" sheets of $\frac{1}{4}$ " hardwood plywood for side exterior panels
- 2—36 $\frac{1}{2}$ " x 24" sheets of $\frac{1}{4}$ " hardwood plywood for top and bottom exterior panels
- 1—38" x 5 $\frac{1}{2}$ " sheet of 1" hardwood trim, ends miter cut at 45°, for front interior base molding
- 2—24 $\frac{3}{4}$ " x 5 $\frac{1}{2}$ " piece of 1" hardwood trim, one end of each miter cut at 45°, for side interior base molding
- 1—39 $\frac{1}{2}$ " x 3 $\frac{1}{2}$ " piece of 1" hardwood trim, ends miter cut at 45°, for front exterior base
- 2—25 $\frac{1}{2}$ " x 3 $\frac{1}{2}$ " piece of 1" hardwood trim,

- one end of each miter cut at 45°, for side exterior base
- 2—48" x 2 $\frac{1}{2}$ " piece of 1" hardwood trim, one edge of each miter ripped at 45°, for front vertical corner trim
- 1—38" x 2" piece of 1" hardwood trim, ends miter cut at 45°, for front top molding
- 2—24 $\frac{3}{4}$ " x 2" pieces of 1" hardwood trim, one end of each miter cut at 45°, for side top molding
- 2—48" x 1 $\frac{3}{4}$ " pieces of 1" hardwood trim, one edge of each ripped at 45°, for side vertical corner trim
- 2—48" x 1 $\frac{3}{4}$ " pieces of 1" hardwood stock for rear edge side trim
- 4—48" lengths of 1" x 1" hardwood stock for center panel trim
- 60—#12 x 3" flathead screws for frame assembly
- 200—#10 x $1\frac{1}{2}$ " flathead wood screws for mounting $\frac{3}{4}$ " plywood panels to frame
- 50—#10 x 2" flathead screws for retaining rear panel
- 165—#8 x $\frac{3}{4}$ " flathead wood screws for fastening $\frac{1}{4}$ " panels in place
- 1 gal—Wood glue
- 2—Heavy-duty garage door pulls
- 8 sets—1 $\frac{1}{2}$ " x $\frac{1}{4}$ " round-head bolts, washers, and lugs for installing handles
- 6 sets—2 $\frac{1}{2}$ " x $\frac{1}{4}$ " round-head bolts, washers, and lugs for installing woofer
- 1—Two-lug screw-type terminal block or strip
- 1 qt—Contact cement for fastening hardwood panels to enclosure walls
- Misc.—Six-penny finishing nails for fastening trim in place; silicone rubber compound; Celotex; speaker wire; etc.

frame on its back on a level, flat surface and lower onto it the front panel. Use C clamps to prevent the panel from sliding around. Now, strike a line about 1" in from each edge of the panel. Locate and strike the center lines for the center brace as well. Making absolutely certain that the panel will not slip, use a $\frac{1}{16}$ " drill to sink $1\frac{1}{4}$ "-deep holes at 4" to 6" intervals along each line. (Note: Do not start at the corners; rather, start about 3" away from the points where the lines cross.)

Loosen the clamps and slide the panel off the frame assembly. Lay the panel on a flat surface and use a $\frac{3}{32}$ " drill to widen all holes drilled through the plywood. Then use a countersink to finish off the holes to a depth of about $\frac{1}{4}$ ".

Liberaly bead all front surfaces of the frame, including the center braces, with glue. Lower onto the frame the plywood panel so that each pair of holes is properly aligned. Tightly screw down the panel until the screw heads are flush with—or just slightly below—the level of the surface of the front panel. This is a rather time- and energy-consuming operation; so if you have a brace or electric drill with the proper screwdriver attachment, better haul it out.

After cutting the side panels to size, install them on the frame in the same manner described above. Take into account that the front edges of the panel should sit flush with the front surface of the front panel. This means that the lines for the screws must be located $2\frac{1}{4}$ " in from the front and rear edges of the side panels if they are to bite into the frame. The top and bottom lines are still 1" in from the edges.

Once the top and bottom panels are cut to size, strike a line $2\frac{1}{4}$ " in from each side edge, 3" in from the rear edge, and $2\frac{1}{2}$ " in from the front edge of each panel. Use the same procedures to fasten these panels to the frame.

The $\frac{1}{4}$ " hardwood panels, if used, are to be installed in the same sequence used for the plywood panels—front, sides, and bottoms. Delay mounting the top panel, for now.

Before installing the front panel, use a pencil to strike lines to locate straight rows of $\#8 \times \frac{3}{4}$ " screws which you will later cover with trim. Indent the lines 1" from each edge. Then strike two evenly

spaced lines down the middle of the panel, locating them so that the distance between vertical trim pieces will be equal. The distances between the vertical lines will be about $11\frac{3}{8}$ ".

Place the enclosure box on its back and set onto its front surface the hardwood panel. Use masking tape to hold the panel in place on the box while drilling. Chuck a $\frac{3}{64}$ " drill into your electric drill and sink pilot holes through the hardwood panel and about $\frac{1}{2}$ " deep into the plywood panel every 4" to 6" along each line. Remove the hardwood panel and use a $\frac{7}{64}$ " drill to ream through the already drilled holes in this panel. Finish up with a countersink, but avoid going clear through the holes.

Brush glue on both surfaces to be joined, spreading the glue as evenly as possible. Then lower the hardwood panel onto the glued box surface and carefully align the hole pairs. Press down on the hardwood panel until the excess glue bleeds out along the edges and through the screw holes. Use a dampened clean cloth rag to remove the excess glue. Fasten the panel down with #8 screws until the screw heads are flush with the surface of the hardwood.

Set the box, hardwood side down, on a flat, level surface and weight it with any heavy items you have around the shop until the glue sets solidly. If the surface on which the box rests is too rough to insure against marring the hardwood panel, a sheet of Celotex laid down first will provide the necessary protection.

Cut the side panels, which should overlap the side edges of the front panel, to size. Strike a line 1" in from both the top and bottom edges, $\frac{1}{2}$ " in from the front and rear edges, and $12\frac{3}{8}$ " in from the rear edges of both panels. Then proceed to fasten the hardwood panels to the sides of the box.

On the bottom panel, strike lines from front to rear for four rows of screws. Locate the front, rear, and side lines $\frac{1}{2}$ " in from the edges of the paneling. Then attach the panel to the bottom of the box with screws and glue.

Invert the box onto its unfinished plywood top and install with glue and $\#12 \times 3$ " flathead woodscrews a $2" \times 4$ " footing flush with the front and side edges of the box. Glue strips of heavy felt to the bottom surfaces of the footing

to protect the floor on which the box will be used.

While the box is inverted, cut the six base molding pieces to size from 1"-thick (actual dimension is $\frac{3}{4}$ ") hardwood stock, mitering the front edges of the side pieces and both ends of the front pieces at 45° to provide "invisible" joints. Smoothly sand all but the rear surfaces of the molding. Then attach the pieces flush with the bottom of the box with glue and six-penny finishing nails. Set the box in its upright position.

Cut to size the hardwood paneling and, using only contact cement, fasten it to the top of the box. Carefully follow the instructions supplied with the cement, and heavily and evenly weight the panel until the cement sets. Meanwhile, prepare the top molding pieces, cutting the appropriate ends at 45° to provide invisible joints. Smoothly sand the bottom surfaces.

After the contact cement has thoroughly set, use glue and six-penny nails to attach the top molding to the box. Rip two $2\frac{1}{2}$ "-wide pieces of hardwood trim at 45° and cut to exact length to fit between the top and bottom molding at the front edge of each corner of the box. Also, rip two $1\frac{3}{4}$ " pieces at 45° to complete the corners. Fasten these pieces to the box with glue and finishing nails.

Now, rip the two $1\frac{3}{4}$ "-wide pieces of hardwood for the side rear edges of the box and cut to length the four $1" \times 1"$ center side and front trim. Again, attach these pieces in place with glue and finishing nails after first sanding each piece. Stain and finish the box as desired.

Use the round pattern from the woofer's shipping carton to outline the speaker cutout. By sawing along the outside edge of the drawn circle, the cutout obtained with the pattern will be about $27\frac{3}{4}$ "—which is just about right.

Tightly clamp together the hardwood and plywood sheets that make up the speaker mounting board. Then use a sabre saw to make the speaker cutout, and drill holes for the speaker and handle mounting bolts. While the panels are clamped together, strike lines $\frac{3}{4}$ " in from the edges of the sheets and drill $\frac{3}{16}$ " shank holes along the lines, spacing the holes at 4" intervals. Then drill shank holes for each brace.

Separate the panels and drill seven

holes for "clamping" screws to hold the panels together while gluing. These holes ($\frac{7}{16}$ " shank in the $\frac{1}{4}$ " panel and $\frac{3}{16}$ " pilot in the $\frac{3}{4}$ " panel) should be located along a horizontal line 10" from and parallel to the top edges of the panels.

Coat the mating surfaces of the panels with glue and fit the glued surfaces together, aligning all hole pairs. Install the seven clamping (screws #8 \times $\frac{3}{4}$ "). Place clamps around the circumference of the woofer cutout as well as along the outer edges of the panels. If too few clamps are available, the handles and their bolts and the mounting bolts for the 30W can be installed to serve as clamps. But do not install the 30W itself at this point.

Mount a terminal strip with heavy-duty lugs and screw-type connectors in either lower corner, no less than 3" from the bottom or side edges. Use silicone rubber compound around the terminal strip to assure an airtight seal. You can locate the crossover components inside the box if external connections are provided for each crossover terminal so that changes in the wiring can be made without removing the 50 screws which secure the rear plate.

Set the speaker board temporarily into place in the rear of the speaker box and sink $\frac{3}{16}$ " pilot holes into the box frame through the perimeter holes already drilled through the board. Then lay the board on a flat surface and mount the 30W over the cutout with the bolts supplied. Use extreme care when handling the woofer and when tightening down the nuts on the mounting bolts. Test the speaker wiring and, if it is all right, install the rear panel in the speaker box.

No acoustical treatment of the inside of the box is necessary if a low-frequency (100 Hz or less) crossover point is used. Most damping materials are virtually transparent, having little or no effect, at such low frequencies.

If it is possible that the rear plate will be removed several times while testing, use #8 or #9 screws for the first installation. Reserve the #10 screws for the final assembly. If during testing, you find that the box is not airtight around the rear plate, remove the plate and apply a thick bead of silicone rubber compound to the frame members to which the panel fastens. Allow the compound to set completely before replacing the plate on the

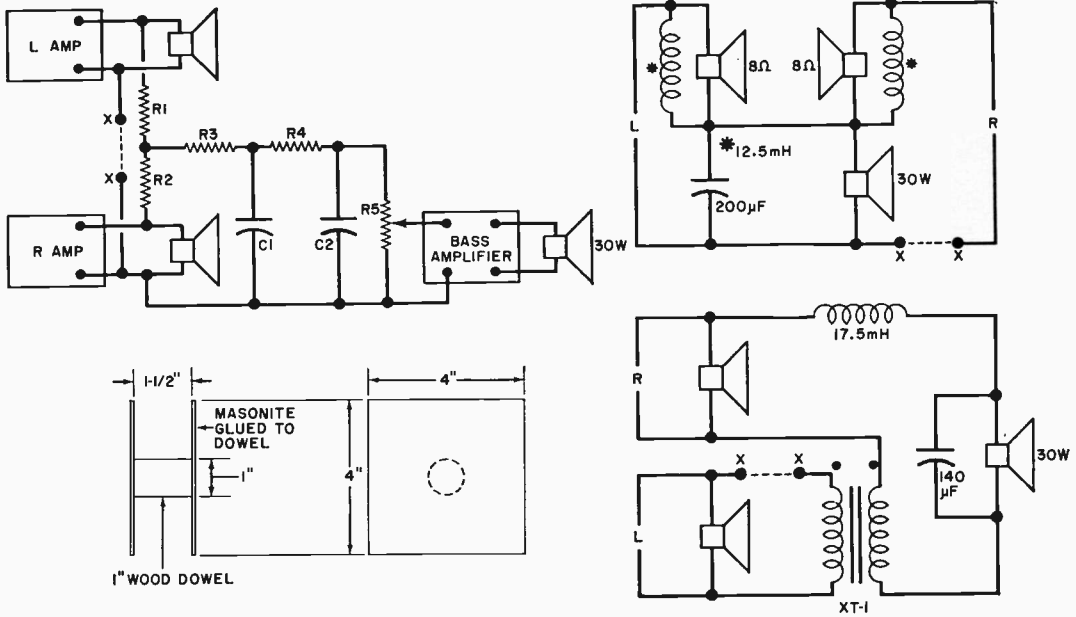


Fig. 2. Separate bass amplifier scheme is shown top left. Insert 500- μ F capacitor between X's if filter input is connected to solid-state amplifier. Wind 750 and 864 turns of #18 Formvar magnet wire onto spool (above left) for 12.5 and 17.5-mH coils, respectively, in diagrams above right.

rear of the box. The silicone rubber will then serve as an air-tight gasket.

Finally, tack a piece of grille cloth, open-weave burlap, etc., over the speaker opening. This is not required for any aesthetic reason since the woofer faces the wall and is out of sight. The covering simply serves to keep the dust and dirt away from the cone.

Phase Loading. In tests performed after the system was assembled, resonance was about 45 Hz with the box located in the center of a room. Moved to a position 10 in. from a wall, the system exhibited a 40-Hz resonance which dropped to 35 Hz at 4 in. from the wall. In the proper listening position, 2 in. from the wall, resonance fell to 31 Hz.

More important than the frequency of the resonance is the fact that the resonant peak was much less pronounced with the system located near the wall. In fact, the difference in sound quality between the middle of the room and near the wall locations was significant; a somewhat "boomy" low bass was changed by "phase loading" to a smooth response.

When placed 2 in. from a typical mod-

ern construction wall (gypsum dry wall), there was more vibration from the wall than from the panels of the box. However, the materials specified in the Bill of Materials should be taken as the minimum thickness for the box walls. If panel vibration is a problem, it can be dampened by gluing and screwing pieces of Celotex to the inside surfaces of the plywood panels in the areas not covered by the frame. And if you want to add acoustical treatment to the inside of the box anyway, it will do no harm.

For most speaker systems, the trick of obtaining correct polarity is accomplished by observing the polarity of each voice coil terminal and connecting positive to positive terminals. With the Super Colossal Woofer, the problem is complicated by the unorthodox position of the woofer in the box, the possibility of an unusual location for the box in the room, and perhaps phase shift in some kinds of crossover networks that might be used.

Instead of attempting to analyze the phase relationships of a particular installation, it is much easier and more accurate to switch the leads to the woofer and choose that connection which produces the best bass response. If a fre-



Woofer cone faces rear of enclosure. Grille cloth is used solely to protect cone from dust and dirt.

quency source such as a test record or an audio generator is available, use 100 Hz as the test frequency and listen for the greater output level at that frequency.

Woofer Hookup. The successful integration of the 30W system into a stereo setup requires attention to three problems: correct polarity of the woofer; proper balance between the woofer and the other speaker systems; and the choice of a circuit that is compatible with your amplifier.

The most flexible method of connecting the woofer to a stereo system is the use of a separate amplifier with an exceptionally good low frequency response. If the volume control on the bass amplifier is accessible, the output of the woofer can easily be matched to that of the full-range speaker systems. Also, the problem of an improper load on the stereo amplifier is avoided.

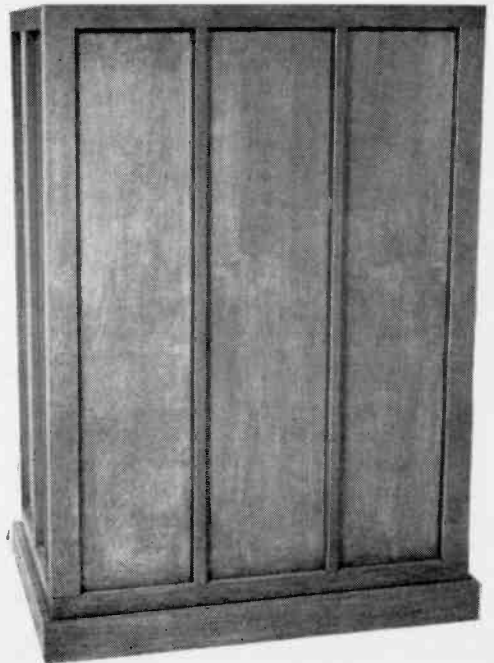
The bass amplifier requires a filter to roll off the response above 100 Hz. A passive filter, shown in the upper left diagram in Fig. 2 is the least expensive approach. Resistors R1 and R2 are 47 ohms, R3 is 390 ohms, R4 is 3900 ohms,

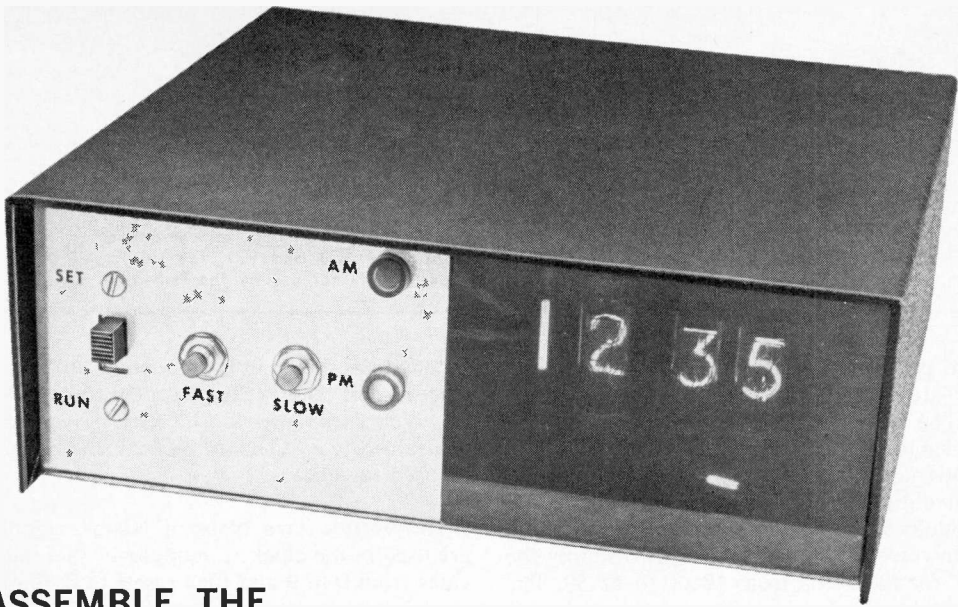
and R5 is 50,000 ohms. Capacitor C1 is 4 μ F, and C2 is 0.4 μ F. A possible disadvantage of this type of filter is insertion loss, which might necessitate an extra stage of amplification. Hookups that do not require a separate bass amplifier are shown to the right in Fig. 2. These, however, might require the use of pads on the full-range speakers to adjust their sound levels to that of the woofer.

The tendency at first is to adjust the volume level of the woofer too high. But in so doing, the whole system can sound "mushy." If used properly, the woofer adds a new depth that seems to improve the mids and highs. With a little experience and a careful hand on the volume control, the depth will become quite apparent.

At high power levels, objects that are not nailed down in the listening room begin to move around. In fact, acoustical feedback will require a damping pad under your turntable when playing records to prevent the feedback from making itself felt. But unless you live in the Mojave Desert or some equally isolated location, you will most likely get feedback from your neighbors before you reach the object-moving level. ♦

Enclosure sports modern design. Decorative molding covers screws that fasten wall panels together.





ASSEMBLE THE

Popular Electronics DIGI-VISTA

A TRUE ELECTRONIC DIGITAL CLOCK

This is the first of two very similar digital readout clocks. The basic difference is in the manner of handling "seconds." In this model, the seconds are not read; but an indication of clock operation is provided by an on-off neon lamp. A follow-up version of this design appears on page 31.

THERE ARE many types of digital clocks on the market today—most of them employing electrically or electronically driven mechanical displays. The latter are subject, of course, to the troubles which are inherent in precise mechanisms. What everyone wants is a totally electronic digital clock—including the readout.

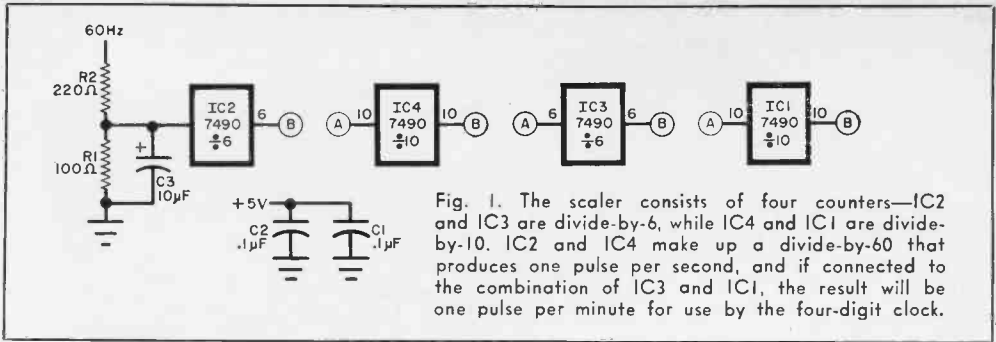
Recent reductions in the cost of transistor-transistor logic (TTL) devices and improvements in the reduction of noise to their operation have enabled the design of the "Digi-Vista" clocks described here. Two

models are presented. The first (which can be built for about \$110 and whose construction is detailed on page 31) has six digits indicating seconds, minutes, and hours with an a.m./p.m. indicator. The latter function is important when using the optional alarm circuit which is also described in this article. The second clock (about \$85 and described here) has four digits, indicating minutes and hours with an optional blinking seconds indicator as well as the a.m./p.m. feature.

Both versions of the Digi-Vista use the 60-Hz commercial power line as the timing source. This line frequency is usually very close to 60 Hz, though at any given instant it can be off by 0.1%. However, errors tend to cancel each other over a period of time. Unless you need extreme accuracy, the commercial power line is the best and most practical source of frequency.

The use of small printed circuit boards in the Digi-Vista keeps the overall size to a minimum and permits the builder to use almost

BY CHARLES G. KAY AND DANIEL MEYER



any type and, particularly, any size of enclosure for the finished clock.

The basic circuit for the clocks contains a scaler to generate the required timing information; a power supply; a combination of conventional Nixie® decade counters; a modulo-6 Nixie counter to indicate to 5 and then reset; and a “ten’s” board to supply the “1” for the hours from 10:00 to 12:59. The latter board also includes the a.m./p.m. indicator.

As shown in the block diagram in Fig. 1, the scaler uses the 60-Hz reference to drive a divide-by-6 counter (IC2). The other three IC’s in the scaler can be interconnected to divide-by-60 (divide-by-6 in series with a divide-by-10) to generate only one pulse per second for the six digit clock or to divide-by-3600 (divide-by-60 in series with a divide-by-60) to produce one pulse per minute for the four-digit clock. As an example of how this works, if the B6 output of IC2 is coupled to the A10 input of IC4, then the B10 output of IC4 is one pulse per second. If the B10 output of IC4 is coupled to the A6 input of IC3 and the B6 output of IC3 to the A10 input of IC1, then the B10 output of IC1 is one pulse per minute.

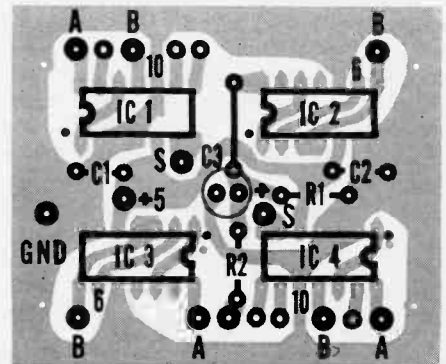
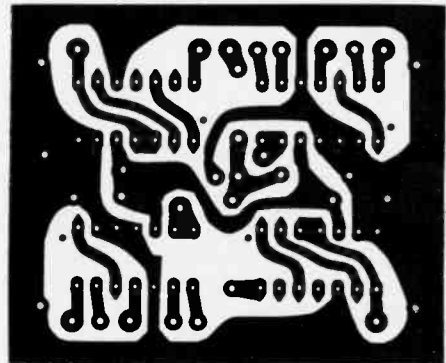
In either case, the same foil pattern (Fig. 2) is used for the scaler board. Figure 2 also shows the component and jumper installation on the top of the board. The three capacitors, two resistors, and jumper are used in both versions. If you are assembling the six-digit clock, install only IC2 and IC4, taking care to observe the notch and dot code on the IC’s. If you are making the four-digit version, install all four IC’s. Use fine solder and a low-power soldering iron. After construction, inspect the board for clean soldering and definitely make sure there are no solder bridges between foil sections.

Power Supply. The power supply, whose

schematic is shown in Fig. 3, can be built on a piece of perf board (except for the transformer which is mounted on the chassis) or you can fabricate a PC board. A heat sink should be used for Q2.

Readouts. Two types of Nixie readouts are used in the clock: a modulo-10 that indicates from 0 to 9 and then resets to 0, and a modulo-6 that indicates from 0 to 5 and then resets to 0. The two types are required to display such values as 59 seconds or minutes.

Fig. 2. Actual size foil pattern is shown at top and component installation for the scaler below.



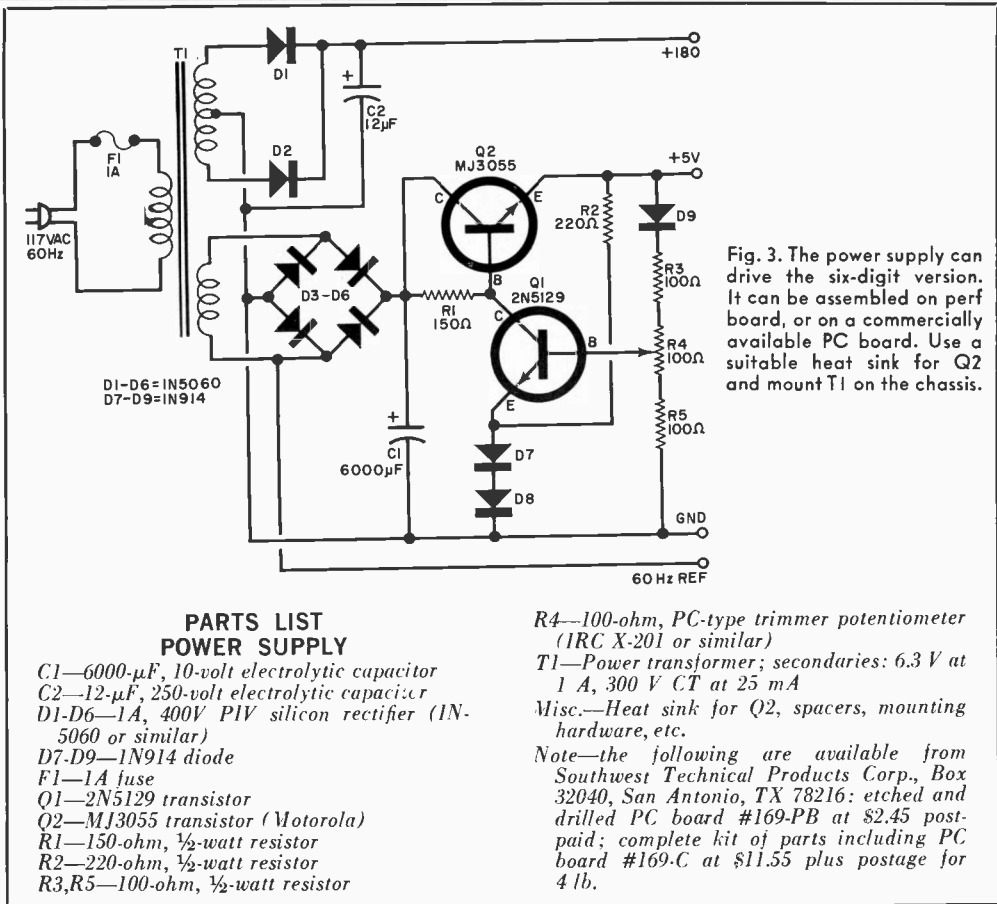


Fig. 3. The power supply can drive the six-digit version. It can be assembled on perf board, or on a commercially available PC board. Use a suitable heat sink for Q2 and mount T1 on the chassis.

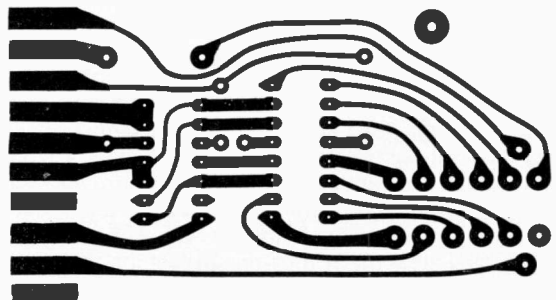
The modulo-10 readout is actually a conventional Nixie decimal counting unit and is readily available. The modulo-6 is the same except for some minor circuit changes shown in Fig. 4.

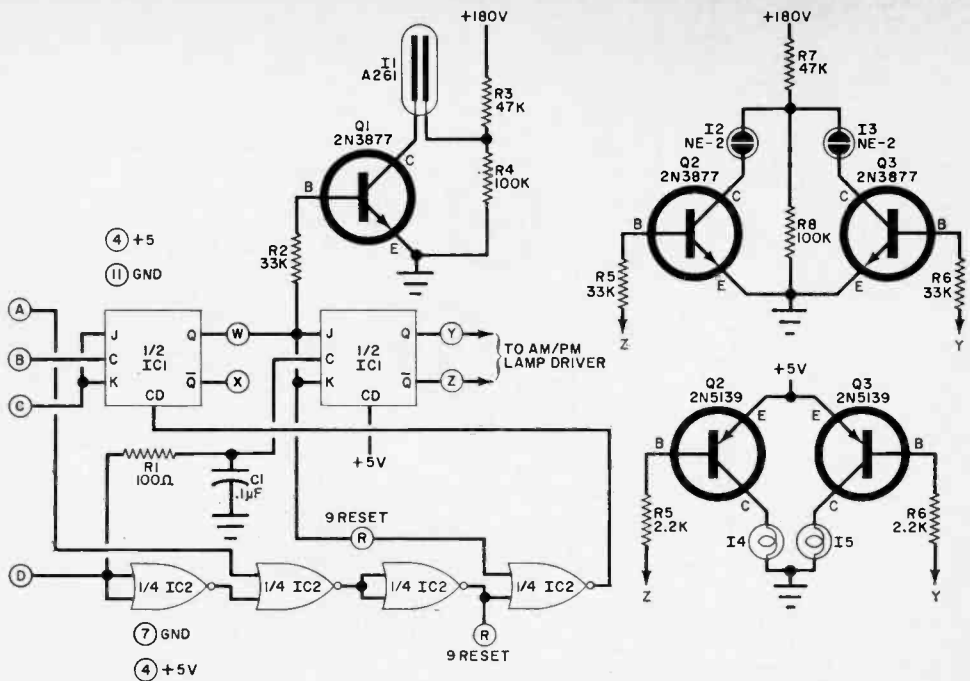
For the unit hours readout, the indicator must progress from 0 to 9, through 0, 1, and 2 and then back to 1 to pick up the count. In this way, the indicators can display 9:00, 10:00, 11:00, 12:00, and 1:00. To achieve this effect, you have to alter the wiring of the Nixie tube to the unit hour boards so that the

tube indicates ahead two digits. That is, the Nixie "2" should be connected to the "0" terminal of the board, with "3" on the "1", "4" on the "2", and so forth up the decade. When the unit hours board is so modified and properly connected to the tens counter board, the clock will indicate 12:59; and at the next pulse, 1:00.

The circuit for the tens-of-hours lamp and the a.m./p.m. indicator is shown in Fig. 5. Note that either of two types of indicator can be used for the a.m./p.m. function—

Fig. 4. For those who have back issues of Popular Electronics, the modulo-10 readout mentioned in text above is identical to the one described in the November 1968 issue. The foil pattern for the modulo-6 stage is shown at the right.





**PARTS LIST
TENS COUNTER**

- C1—0.1- μ F, 12-volt disc capacitor
- I1—Neon lamp (Signalite A-261 or similar)
- IC1—7473 dual flip-flop
- IC2—7400 quad two-input gate
- Q1—2N3877 transistor
- R1—100-ohm, $\frac{1}{2}$ -watt resistor
- R2—33,000-ohm, $\frac{1}{2}$ -watt resistor
- R3—47,000-ohm, $\frac{1}{2}$ -watt resistor
- R4—100,000-ohm, $\frac{1}{2}$ -watt resistor

For neon a.m./p.m. indicators

- I2, I3—NE2 neon lamp
- Q2, Q3—2N3877 transistor
- R5, R6—33,000-ohm, $\frac{1}{2}$ -watt resistor
- R7—47,000-ohm, $\frac{1}{2}$ -watt resistor
- R8—100,000-ohm, $\frac{1}{2}$ -watt resistor

For incandescent a.m./p.m. indicators

- I4, I5—6-volt, 50-mA miniature incandescent lamp
- Q2, Q3—2N5139 transistor
- R5, R6—2200-ohm, $\frac{1}{2}$ -watt resistor
- Misc.—Plastic covers for two lamps, mounting hardware, etc.

Fig. 5. The ten's counter accepts inputs from the unit hours board, and turns on the "1" neon lamp (I1) at the correct pulse. It also generates the correct reset pulse for the unit hours board. The constructor is given the option of using neon or incandescent lamps for the a.m./p.m. indicators.

neon lamps or conventional incandescent lamps. The foil pattern for this board, shown in Fig. 6, has provisions for the options. For neon indicators, omit the jumper at J1 and install jumpers at J4 and J5. For incandescent indicators, install jumpers at J1, J2 and J3.

Assembly. The overall schematic of the four-digit clock is shown in Fig. 7.

The prototype shown in the photographs was constructed in a conventional two-piece metal chassis with cutouts for the readouts. The cutout is covered with a piece of polarized plastic to reduce the glare and improve legibility. The a.m./p.m. indicator lamps are mounted in snugly fitting plastic holders with the letters marked or press-typed on the front window.

The power transformer and fuseholder are mounted on the bottom of the chassis with the PC boards mounted on spacers. In the prototype, the scaler and power supply were mounted horizontally, readouts vertically.

Each PC board should have its ground return and +5-volt supply connections made with individual leads to the power supply. Do not use the chassis as a common ground.

Note that the usual carry-to-input series circuit is used between the DCU's except for the connectors between the unit hours board and the tens of hours board. In this case, the A, B, C, and D logic line of IC1 (decade counter SN7490) of the unit hours DCU (pins 12, 9, 8, and 11 respectively) are connected to the A, B, C, and D inputs of the tens of hours board.

Fig. 6. Foil pattern and component installation for ten's counter board. Note that provisions are made for either neon or incandescent lamp indicators. Text explains where to connect required jumpers.

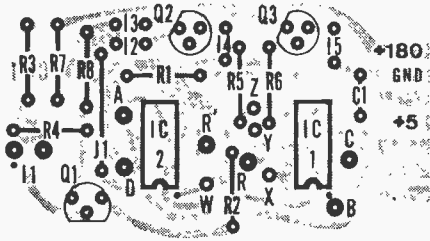
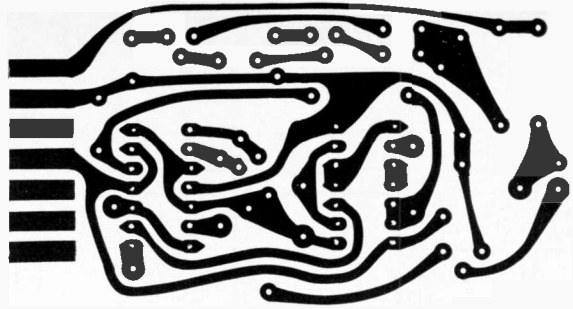


Fig. 7 does not make it completely clear that two separate "9 Reset" lines are used between the hours module M-3 and module M-5. There are two "9 Reset" points on the CL-1 board; R and R¹. These should be connected with separate wires to the two "9 Reset" pins on the decade counter's 7490. Split the copper pattern between pins 6 and 7 on the 7490 decade counter so that a connection may be made to each pin individually. It makes no difference which pin is used with R or R¹.

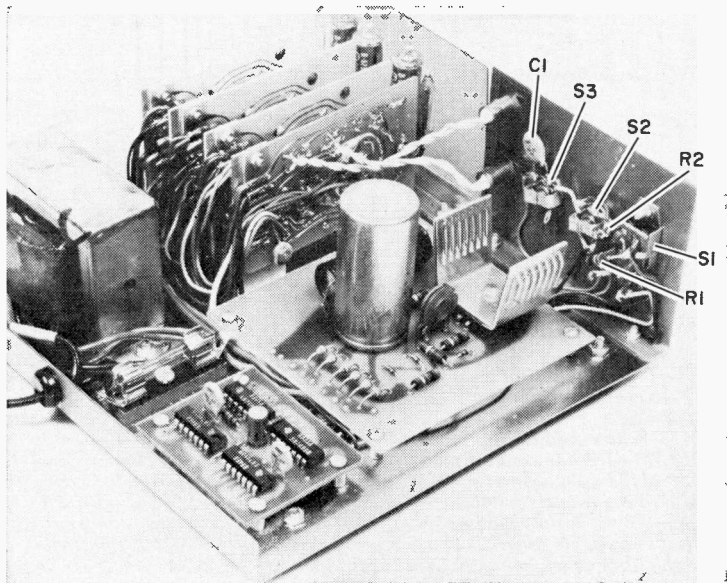
The "0 Reset" and "9 Reset" points on all

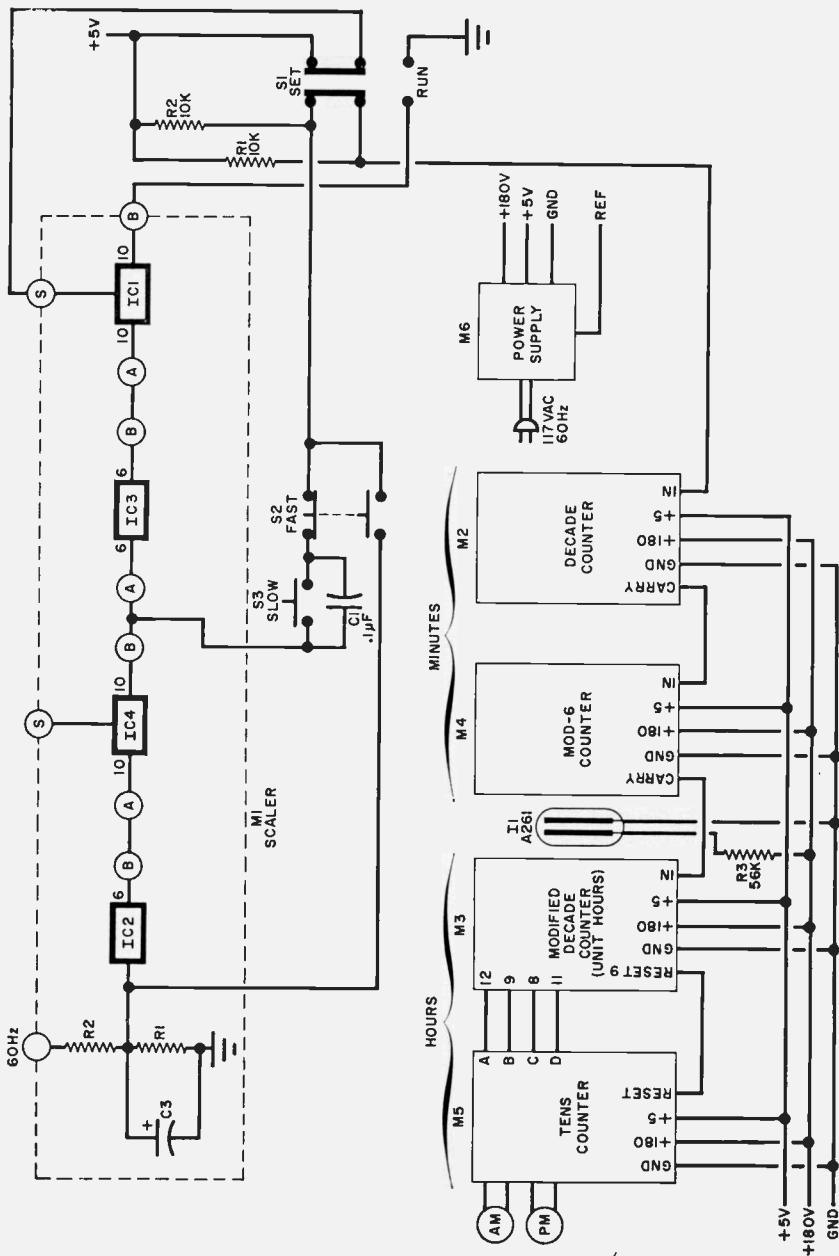
other counters must be grounded as must the "0 Reset" on the above decade counter. If this is not done, the counters may operate erratically, or it is possible that they will simply refuse to count.

The +180-volt line to the Nixie tubes should be very carefully installed as this voltage can damage components if wrong erratically, or it is possible that they will simply refuse to count.

Operation. Plug the power line into a 117-volt 60-Hz outlet and note that the Nixies come on and either the a.m. or p.m. lamp is glowing. Adjust R4 of the power supply so that the 5-volt supply is correct. Place the SET-RUN switch on SET and depress the FAST button. The minutes readouts in either clock will start to cycle and at 11:59, the a.m. and p.m. indicators will switch over. Cycle the clock through a 24-hour period to clear all of the counter units. With the SET-RUN switch on RUN, use the FAST button to bring the clock

The original clock was built in a conventional metal chassis having a cutout for the readouts, and the operating controls on front panel. Any other type of mounting may be used, and controls hidden; once set, they are not needed for clock.





PARTS LIST FOUR-DIGIT CLOCK

- C1—0.1- μ F capacitor
 I1—Neon lamp (optional) (Signalite A-261 or similar)
 M1—Scaler module
 M2, M3—Decade counter module
 M4—Modulo-6 counter module
 M5—Tens counter module
 M6—Power supply module
 Misc.—Suitable chassis, polarized plastic glare shield, spacers, mounting brackets, hookup wire, etc.

Note—The following are available from Southwest Technical Products Corp., Box 32040, San Antonio, TX 78216: decade counter module NX-10 at \$15, postpaid; modulo-6 counter module NX-6 at \$15, postpaid; tens counter module CL-1 at \$8.50, postpaid (specify neon or incandescent lamp); scaler module SC-10.4 at \$14.75, postpaid; power supply module 169 at \$11.55, plus postage for 4 lb; polaroid plastic at 25¢/sq in. (specify size required).

Fig. 7. Overall wiring of the four-digit clock. Lamp I1 is used to make a colon between the minutes and hours indications, and a narrow black band around the center of the lamp breaks up the neon glow into two glowing dots. In the slow set position, the clock is driven from the one-pulse-per-second point, while in the fast set, the drive is from the 60-Hz line. When the time shown is correct, place S1 to run.

Fig. 8. This optional electronic "tic-toc" is connected to the output of Scaler IC4 and blinks on and off to indicate that the clock is operating.

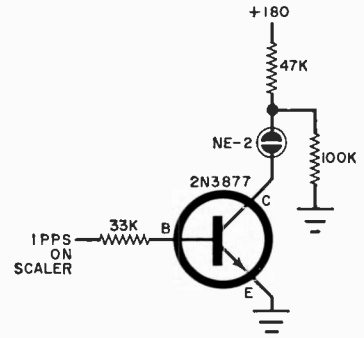
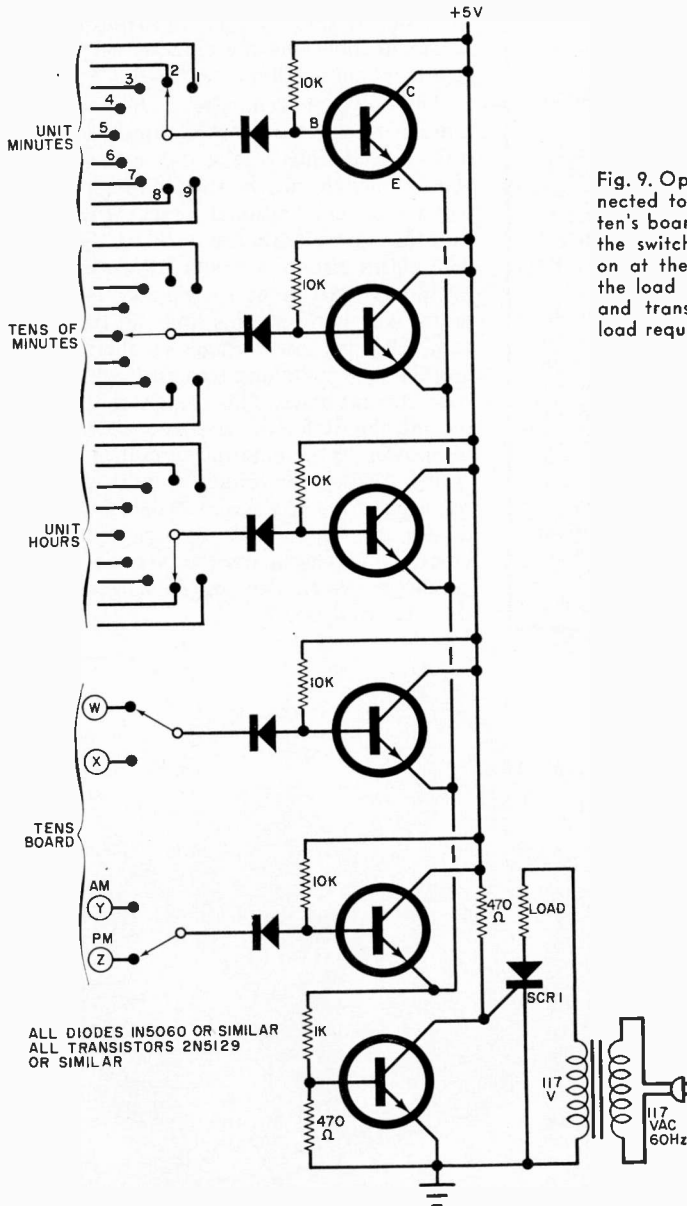


Fig. 9. Optional alarm system can be connected to the three readouts and to the ten's board as shown here. By positioning the switches properly, the SCR will turn on at the selected time, thus energizing the load (bell or other alarm). The SCR and transformer are selected to match load requirements of voltage and current.



The unit hours board is modified so that the Nixie-tube indicates ahead by two digits. This results in a "2" being shown when the counter would normally show a "0". This is done to simplify the logic needed to count to 12:59 and reset to 1:00. The operating cycle is as follows.

The counter is reset to "9" through the nine-reset input on the board. This results in a "1" being displayed. The count then proceeds up normally. After the count of "9", we must reset the counter to "0" and turn on the "1" lamp to indicate a "10". The "1" lamp is operated by the C and B lines coming into the tens counter board. When the displayed numeral on the unit hours board goes to "0", C and B both go to a logical zero state, and IC1 of the tens counter changes state. This turns on Q1 and ignites the "1" neon lamp. This then forms the number "10". The count then proceeds through 11 and 12. When the counter reaches 11:59, the next pulse causes the D line to go to a logical zero. This causes the second half of IC1 to change states and switch the AM and PM lights.

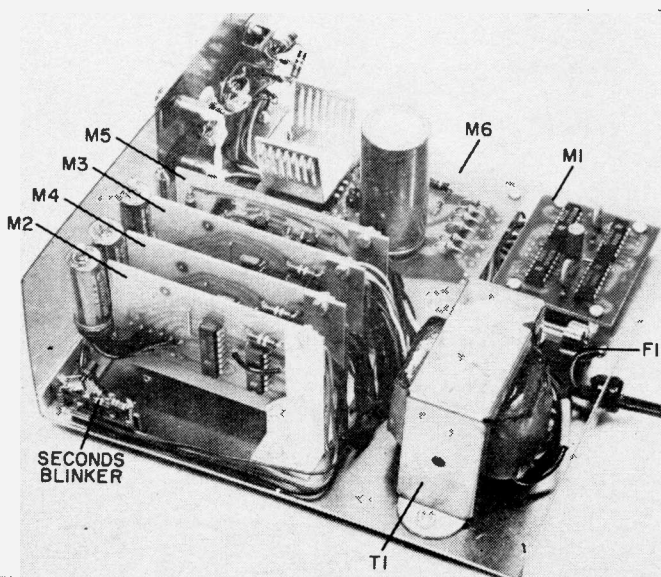
When the counter reaches 12:59, the system must be reset to 1:00. This requires a reset pulse to the "9" reset terminals of the unit hours counter, and to the first flip-flop of the tens counter, to reset the circuit and turn the "1" neon lamp off. This reset pulse is generated at the proper time by decoding the output of the first flip-flop of the tens counter which controls the "1" lamp, and lines A and D on the unit hours counter. When the output of this flip-flop is at logical 1, and A and D occur at the same time, a reset pulse is generated to reset the counter and the flip-flop.

to within a few seconds of the actual time, then use the SLOW button to set the time exactly. Place the SET-RUN switch on RUN.

Options. In building the four-digit clock, the optional seconds blinker circuit shown in Fig. 8 may be used. The circuit can be built on a terminal strip with the neon lamp lying horizontally below the actual time indicators. The input to this circuit comes from the B10 output of IC4 on the scaler board. Operation is such that the neon lamp glows for one second and is off for one second. Although it is an accurate time marker, this indicator only serves to show that the clock is working and is the optical version of a "tic-toc."

The optional alarm circuit shown in Fig. 9 can be used to turn on an external alarm at any desired time of the day or night. Any type of switch may be used, though the prototype used conventional rotary switches. The bottom two switches are ordinary dpst types. The alarm circuit is a NOR logic system and all inputs must be at a logic zero before the alarm will work. At this time, all the transistors will have low voltages on their emitters and the gate switching transistor will have no base current drive. This transistor then turns off and the SCR (or triac) conducts to supply power to the external circuit. The transformer secondary voltage should match the required drive for the external circuit. The diodes in series with the transistor bases block the voltages from the Nixies when they go above 5 volts. This prevents destruction of the NOR transistors. ♦

Arrangement used in the prototype may be duplicated or any other layout may be used. The optional neon lamp seconds blinker is mounted horizontally under the four indicators so that it is clearly visible when viewing the clock from the front.



Popular Electronics

INCLUDING Electronics World

1973 ELECTRONIC EXPERIMENTER'S HANDBOOK

Spring Edition

FREE

INFORMATION SERVICE

Here's an easy and convenient way for you to get additional information about products advertised in this Handbook. Just follow the directions below...and the material will be sent to you promptly and free of charge.

1. Tear out one of the perforated postage-free cards. Please print or type your name and address where indicated.
2. Circle the number on the card that corresponds to the key number at the bottom of the advertisement that interests you. (Key numbers for advertised products also appear in the Advertisers' Index.)
3. Simply mail the card. No postage is required.
4. This address is for our "Free Information Service" only. All other inquiries are to be directed to, 1973 ELECTRONIC EXPERIMENTER'S HANDBOOK, One Park Avenue, New York, N.Y. 10016.

1973 ELECTRONIC EXPERIMENTER'S HANDBOOK

Void after July 24, 1973

EEHS732

Please Print or Type

NAME _____

ADDRESS _____

CITY _____

STATE _____ ZIP _____

(ZIP CODE MUST BE INCLUDED TO INSURE DELIVERY)

Please tell us how many TV sets you service each month.

1. none 2. 1-2 3. 3-4
4. 5-8 5. 9-12 6. over 12

1 2 3 4 5 6 7 8 9 10
11 12 13 14 15 16 17 18 19 20
21 22 23 24 25 26 27 28 29 30
31 32 33 34 35 36 37 38 39 40
41 42 43 44 45 46 47 48 49 50

1973 ELECTRONIC EXPERIMENTER'S HANDBOOK

Void after July 24, 1973

EEHS73

Please Print or Type

NAME _____

ADDRESS _____

CITY _____

STATE _____ ZIP _____

(ZIP CODE MUST BE INCLUDED TO INSURE DELIVERY)

Please tell us how many TV sets you service each month.

1. none 2. 1-2 3. 3-4
4. 5-8 5. 9-12 6. over 12

1 2 3 4 5 6 7 8 9 10
11 12 13 14 15 16 17 18 19 20
21 22 23 24 25 26 27 28 29 30
31 32 33 34 35 36 37 38 39 40
41 42 43 44 45 46 47 48 49 50

FIRST CLASS
PERMIT NO. 217
CLINTON, IOWA

BUSINESS REPLY MAIL

NO POSTAGE NECESSARY IF MAILED IN THE UNITED STATES

POSTAGE WILL BE PAID BY—

**ELECTRONIC
EXPERIMENTER'S**

HANDBOOK Spring Edition

P.O. BOX 2907
CLINTON, IOWA 52732

FIRST CLASS
PERMIT NO. 217
CLINTON, IOWA

BUSINESS REPLY MAIL

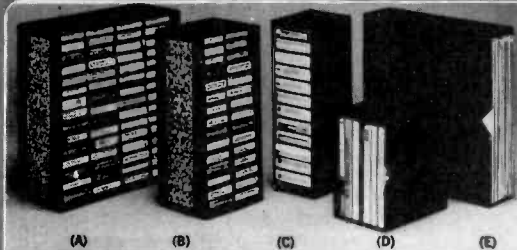
NO POSTAGE NECESSARY IF MAILED IN THE UNITED STATES

POSTAGE WILL BE PAID BY—

**ELECTRONIC
EXPERIMENTER'S**

HANDBOOK Spring Edition

P.O. BOX 2907
CLINTON, IOWA 52732



A COMPLETE SET OF MATCHED STORAGE CASES

Here's the ideal solution to the problem of keeping all your records and tapes stored neatly, safely, conveniently and attractively. A complete set of matched storage cases, designed by the editors of **STEREO REVIEW** magazine, for your records and all your tapes: cassette, cartridge and 7" reel. Now you can keep them side-by-side on your bookshelf or cabinet, easy to identify and readily available.

These cases are sturdily constructed and covered in a handsome leatherette. The outer case is elegantly embossed in gold and comes in your choice of three popular decorator colors—black, brown and green—so that they lend themselves readily to the decor of any room.

STEREO REVIEW large capacity storage cases are just what you've been looking for—they're the ideal solution to keeping your records and tapes neatly stored for easy use.

- (A) 60-unit cassette case. 13½" high x 12¾" deep x 5½" wide. \$14.75 each; 3 for \$42.
- (B) 30-unit cassette case. 13½" high x 6½" deep x 5½" wide. \$8.40 each; 3 for 24.00.
- (C) 12-unit 8-track cartridge case. 13¼" high x 6½" deep x 4¼" wide. \$5.25 each; 3 for \$13.75.

Units A, B and C have tilted compartments to prevent spillage and include pressure sensitive labels for titling.

- (D) 6-unit 7" reel case. 8" high x 7½" deep x 5" wide. Holds reels in original boxes. \$4.75 each; 3 for \$12.65.
- (E) 20-unit 12" record case. 13¼" high x 12½" deep x 3½" wide. Holds records in original jackets. \$5.25 each; 3 for \$13.75.

HERE'S HOW TO ORDER

Send your order to Ziff-Davis Publishing Co., Dept 23, One Park Ave., N.Y., N.Y. 10016. Be sure you identify the type of case ordered and indicate your color choice for the back of the case—black, green or brown (sides in black only). Print your name and address clearly and enclose the amount indicated above for the units being ordered PLUS an additional 50c per unit for postage and handling. Outside U.S.A. add \$1.00 per unit ordered.

THE CASE FOR THE SINGLE WOOFER

*PROS AND CONS ON AN OLD SUBJECT:
THE THIRD SPEAKER IN A STEREO SYSTEM*

BY DAVID B. WEEMS

THE IDEA of using a single woofer to reproduce the bass information present in the signals on both stereo channels is about as old as consumer stereo itself. Even today, there are audio authorities who maintain that, in some respects, one woofer can be better than two. To support their cases, they cite such advantages as extended bass response; better midrange and high-frequency performance; reduced turntable rumble; and much more flexibility in speaker arrangement.

Going back in history (stereo history, that is), you will find that the Electro-

Voice "Esquire-Stereon," Stephens "Stereadot," and Jensen "Galaxy" employed a mixed-signal speaker of one kind or another. All of these systems were essentially three-speaker setups in which the middle speaker carried the combined stereo signal, though it was not necessarily limited to operation in the bass range. Two small "satellite" speakers filled out these systems, providing left- and right-channel sound sources.

The Galaxy was a bit unusual. In it, the center speaker was used mainly for bass and low midrange reproduction, rolling off in response above 1000 Hz. Its

crossover point from satellites to woofer was about 350 Hz.

None of these three-speaker systems seemed to inspire any great loyalty from stereo buffs of the time; but there was one other system that might have succeeded where the others failed. It was the Weathers "Triphonic," which also had three speakers, but the third speaker did not have to be located in the middle. It contained a 10-in. woofer which had a falling response above 100 Hz, with a crossover point from satellites to woofer at 80 Hz—low enough to make the woofer's sound nondirectional.

Sometimes called the "camouflage" system, the Triphonic's satellite speakers were disguised as books, while the woofer box was small enough to be hidden under a piece of furniture. The system was probably the first attempt to exploit the unique advantages of single-woofer stereo.

Regardless of its originality, the Triphonic system was a commercial failure, which probably tainted the single-woofer concept for manufacturers and stereo buffs alike. Commercial success or failure

is an unreliable guide to what is good or bad, but one possible factor contributing to the failure of the Triphonic was the need for interchangeability between amplifiers and speakers. The period of transition from monophonic to stereophonic sound was also a time for change in amplifier design as transistors began to supplant vacuum tubes. Early transistorized amplifiers were often fussy about what was connected to their outputs. (Even today, certain precautions must be observed before connecting a mixed bass circuit to some amplifiers.) Most audio buffs took the easier method of using two separate speaker systems—including two woofers.

Some equipment buyers, following the reasoning that if one is good, two are better, automatically associated the idea of a single woofer with inferior quality. Department store salesmen, looking for a quick sale, were often responsible for perpetrating this misconception. Most of them use the ploy of emphasizing the number of speakers inside their system consoles as important advantages without reference to overall system quality.



The mixed-signal woofer in this design was located in the squat box shown in the center of the photo. The "totem poles" on each side contained the satellite speakers.

Nor did the Weathers system offer much in the way of a status symbol for the prospective buyers. Apparently, the only buyers interested in the Triphonic were impressed by the novelty of "invisible" speakers.

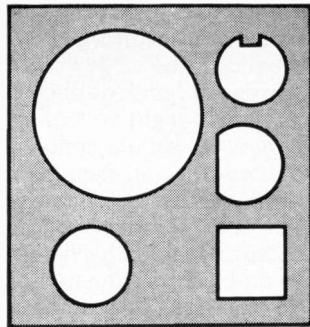
The return of interest in mixed bass is evident in the Infinity "Servo-Static I." Unlike the Weathers system, it is neither small in size nor moderately priced. This raises the question: Do the Infinity speakers demonstrate that a novel concept, once shot down by the \$100 competition, can make it in the \$1000 bracket? Of course, with their motional feedback and high overall quality, they have more going for them than just mixed bass. But whatever the reason, the fact that some audio fans are plunking down \$2000 for a common bass system suggests that single-woofer stereo is worth a careful second look.

The owner of two large speakers would gain little by adding a third woofer to rob power from the two already in use. But if going to a mixed bass permits the use of a significantly larger woofer, then one advantage seems certain—improved bass response.

Of course, some experts feel that extension of the bass range is insufficient reason for the switch to the single woofer, claiming that separate woofers are less likely to excite room resonances than one large woofer. Others contend that smaller woofers have the advantage of better transient response and bass detail over the bigger woofers. There are differences in sound character between a large woofer and a small one; but only a careful listening test will help you to determine which, if either, you prefer.

The second advantage is less obvious but just as important for some rooms. Stereo speaker systems, even small compacts, are often placed on the floor which enhances bass response but makes the high frequencies sound both unnatural and poorly dispersed. Here, the use of a separate woofer permits the placement of satellite speakers for optimum high-frequency sound dispersion and stereo effect. It also provides an opportunity for imaginative furniture arrangement.

With a properly chosen crossover frequency, the direction of the sound from the woofer will not be noticeable. The



Put more punch in your work.

With a Greenlee Chassis Punch you can punch clean, true holes in seconds. Round, square, key or D. In 16-ga. metal, hard rubber, plastic or epoxy. Available at radio and electronics parts dealers. Write for catalog E-730. Greenlee Tool Co, 1764 Columbia Ave., Rockford, Ill. 61101.

GREENLEE TOOL CO



A Unit of Ex-Cell-O Corporation 
 CIRCLE NO. 8 ON READER SERVICE CARD

DELUXE
MAGAZINE CASES

Designed Exclusively for
POPULAR ELECTRONICS

● The ideal way to save your valuable copies, keep them well protected and make it easy for you to refer to any issue at any time. Both decorative and attractive enough to enhance the decor of any room, each case holds a full year's copies. Constructed of reinforced fiberboard, these durable cases are covered in a rich-textured leatherette. The gold embossed back adds to its elegance and makes each case a welcome addition to your bookshelf or cabinet.

Magazine cases are available for any of your favorite magazines. They're only \$4.20 each, 3 for \$11.60, in any combination of titles ordered. Add 50c per case for postage and handling. Outside U.S.A. add \$1.00 per case ordered.

 **CHARGE YOUR AMERICAN EXPRESS OR UNI-CARD ACCOUNT.** 

Ziff-Davis Pub. Co., Dept. 23, 1 Park Avenue, New York 10016

My remittance in the amount of \$_____ is enclosed. Please send magazine cases for the titles indicated below.

CHARGE: American Exprss Uni-Card

Account # _____

Signature _____

EEH-S73	TITLE	QUANTITY
_____	_____	_____

Check One: All Black Maroon Back, Black Sides

Print Name _____

Address _____

City _____ State _____ Zip _____

PAYMENT MUST ACCOMPANY ORDER

woofer box can be tucked away under a piece of furniture, put in a closet, or even moved into an adjoining room. If the woofer is removed too far, discriminating listeners might detect a phase shift between the fundamental bass tones from the woofer and harmonics of those tones produced by the stereo satellite speakers. But the stereo effect itself will not be compromised. The listener will still hear some bass instruments on the left, others on the right, since the location of each instrument is recognized by its overtones which are produced by the upper range speakers.

The use of a common woofer for both channels also insures the physical separation of the low-frequency speaker from the treble speakers. Putting a tweeter in an enclosure designed for good bass, even if the tweeter is acoustically isolated, makes no engineering sense at all. The dangers of sound reproduction distortion and damage to small systems, which are not sealed off from the woofer, are well known. What is sometimes overlooked is the effect of the enclosure shape and size on high-frequency sound dispersion.

A large rectangular cross section enclosure has sharp corners at the front edge which produce diffraction effects, particularly when the midrange speaker or tweeter is installed in the front middle of the enclosure. These effects may cause

peaks or dips, up to as much as ± 5 dB in the response curve¹.

Enclosure diffraction, which produces interaction between the diffracted waves and the normal waves, was demonstrated by Dr. Harry F. Olson of RCA Laboratories some 20 years ago². But another shortcoming of the large enclosure when used for the middle and high frequencies, though not as well recognized, may be just as important to consider. The wider the front of the enclosure, the poorer is the dispersion of midrange and high-frequency sound.

It is an irony that speakers can be made to sound expansive and "big," due to good dispersion, by making them smaller. When the midrange and tweeter speakers are removed from the woofer's enclosure, the designer is free to make use of enclosures that fit the requirements of optimum upper frequency response and dispersion. An obvious example of one possible approach is the line source, or narrow midrange column, as described in "Totem Poles For Stereo" (January 1966 POPULAR ELECTRONICS).

Reducing turntable rumble through the use of a single woofer has often been suggested. The theory is based on the fact that rumble vibrations in a turntable tend to be in the vertical plane, to which the ideal stereo pickup will respond by

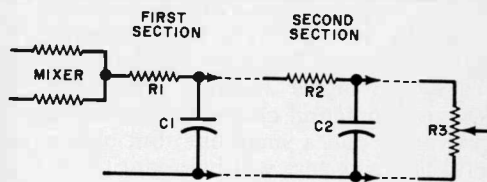
RC LOW-PASS FILTER

In the diagram (right), a single section filter consisting of R1 and C1 will produce only a 6 dB/octave slope in the response curve. By following the first section with a like section (R2 and C2), the rolloff slope is theoretically increased to 12 dB/octave. But R2 should be ten times the value of R1 to assure that the two stages operate more independently. Typically, a 50,000- or 100,000-ohm potentiometer, to control the level of the bass, is used to terminate the filter.

The following Time Constant Chart can be used to simplify the adjustment of RC values for various crossover frequencies:

F (Hz)	T (μ Sec)
60	2700
70	2300
80	2000
90	1800
100	1600
125	1300
150	1100

Since time constant T in microseconds is equal to resistance R in ohms times capacitance C in microfarads, the value



of C for various crossover points can be calculated by plugging the appropriate figures into the formula: $C = T/R$.

The typical tolerance of paper capacitors is ± 20 percent, hence, some variation in performance is to be expected. Also, when two or more sections are used in the filter, there is a chance of interaction between the sections, and the crossover point might occur at a frequency lower than that calculated.

The results obtained from the formula should be treated as only approximate values for the capacitors. The response of the network can be tailored to fit various situations by substituting various values of C to raise or lower the crossover point.

producing equal and out-of-phase voltages in each channel. These signals, if carried through the stereo system and reproduced by the speakers without phase shift differences, will cancel the rumble frequency. A stereo system with a woofer in each channel, when operated in proper balance, should theoretically cancel the rumble; but various factors, such as the listener's position with respect to each woofer, may prevent perfect cancellation.

When a single woofer is used for both channels, the unpredictable factor of room acoustics is canceled. Then rumble cancellation depends solely upon proper operation of the stereo cartridge and the amplifying system, components which are more subject to control than are speakers or the acoustical environment.

The claimed advantages of the single woofer do not rule out the question: What does it do to the stereo image? Does a single woofer improve the bass response at the expense of overall sound quality? There is no simple answer to this question. Several factors are involved—most critically, the choice of system crossover frequency.

If the crossover point is too high, the listener will detect the direction of the bass frequencies, and the stereo illusion will be impaired. There is a critical frequency, at least for a given listening environment, below which the direction of the sound is unimportant. To determine this frequency, we can rely on theory.

There is a scientific principle which states that two signal sources cannot be distinguished directionally if they are separated by less than one wavelength. So, assuming an average speaker separation of 8 ft, the critical frequency would be 140 Hz.

Another theoretical consideration concerns the size of the listening room itself. One authority on audio, Norman Crowhurst, states that if a room is large enough to hold a train of waves at crossover, the listener will be able to locate the direction of the bass sounds.³ According to his theory, a room 30 ft long could hold several wavelengths at 350 Hz (a typical crossover point) and the stereo effect will suffer.

But following theory alone is like re-

Special New Digital Multimeter Kit 3½ Digits—Volts—Ohms—Current—Capacity

Introductory Price \$89.95

**TREMENDOUS SAVINGS
ON FC KITS!**

Mod. 5	5V Power Supply	5.00
"	12AV 12V	5.20
"	15AV 15V	5.20
"	175 Nixie & IC Pwr Supply	8.00
"	13 Time Base Generator	
"	Crystal Controlled	12.00
"	7K Decade Counter Kit	
"	With 8754-0-9	
"	Without Latch	7.00
"	8K Same as above	
"	With Latch	8.00
"	Neon Readout Displays	Special
"	Limited Quantity	see Flyer

Send For Free Flyers On Linear,
Readouts, Resistors & Other Bargains

DIODES	
1N4148	100 for 3.00
1N4001	60 for 3.00
1N4004	40 for 3.00
1N4007	20 for 3.00
1N4729A	15 for 3.00
1N4734A	15 for 3.00

Min. order \$3.00. On orders less than \$10.00 enclose .50 for postage and handling. Send check or M.O.

EDWARDS ELECTRONICS

The John Edwards Electronics Co.
P.O. Box 465, Glen Ellyn, Ill. 60137

CIRCLE NO. 7 ON READER SERVICE CARD

free BA 1973 catalog

WRITE FOR
IT TODAY!



276 PAGE RADIO, TV & ELECTRONICS CATALOG

Your Buying Guide for
Everything in Electronics
... Stereo, Hi-Fi, TV's,
Radios, Tape Recorders,
CB, Kits, Tools, Books,
and Electronic Parts.

burstein-applebee

DEPT. PE 3199 MERCIER ST.
KANSAS CITY, MO. 64111

Name _____
Address _____
City _____
State _____ Zip Code _____

CIRCLE NO. 1 ON READER SERVICE CARD

lying on an insurance policy without reading the fine print. There may be aspects of the problem not covered by theory. For example, no filter network cuts off sharply enough to eliminate all frequencies above the crossover point. Typically, the attenuation slope is 6, 12, or 18 dB/octave. Because sharp cut-off filters cause phase shift, many authorities prefer the 6- or, at most, 12-dB filter. If the 6-dB/octave filter is chosen, it will be necessary to lower the frequency of the crossover in order to preserve the desired degree of separation at higher frequencies.

J. Gordon Holt, the author of the monthly "Stereo Scene" column, says the passband of the bass speaker should lie below 150 Hz. He further specifies that the signal to the woofer be down at least 15 dB at 200 Hz, if possible, to avoid directional cues. To satisfy these requirements, a 12-dB network should cross over at 80 Hz or lower, and a 6-dB network should cross over at 60 Hz or lower. Minor variations from these points will hardly be noticeable.

In hooking up a mixed-signal woofer, there are problems that go beyond the purely physical. As mentioned earlier, a major reason for the neglect of the single woofer concept is the necessity for choosing a circuit that is compatible with the amplifier you intend to use. Six methods of using a mixed-signal woofer with an existing stereo system are shown in the schematic diagrams in Fig. 1. One or more of these methods should work with just about any amplifier.

Circuit A would be the most versatile but for the fact that it requires a special woofer with dual voice coils which could be connected directly in parallel with the existing speaker systems. In circuits A, B, and C, it may be desirable to insert a capacitor in series with the left- and right-channel speakers. A properly chosen capacitor will offer sufficient reactance at low frequencies to prevent any possibility of a low-impedance load below the crossover frequency point. For example, if the crossover frequency is 150 Hz, University Sound engineers specify a series capacitor of 150 μF for each speaker and inductances of 8 mH in series with the woofer's voice coils.

A single woofer may be simply wired into the output of one of the channels of

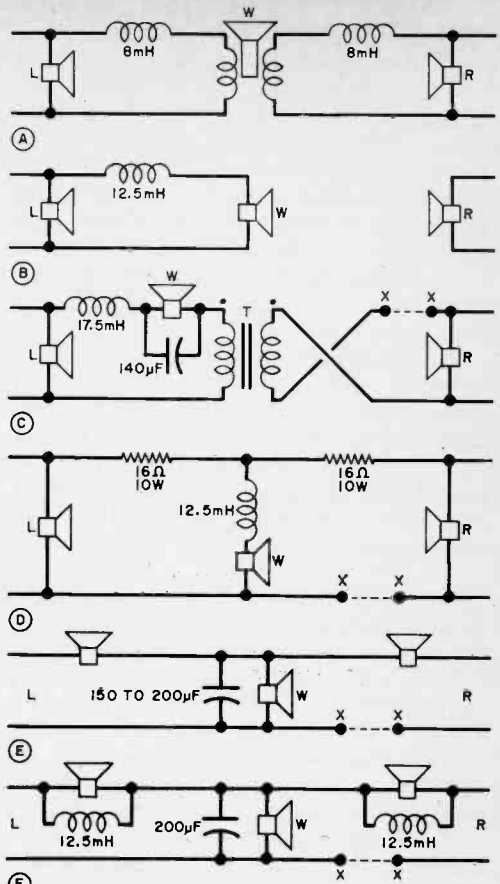


Fig. 1. Do not use circuits C-F with solid-state amplifiers unless a 500- μF capacitor is inserted between X's, and then only if the amplifier is known to be stable operating into capacitive load.

an amplifier (circuit B). While there is the possibility that the bass instruments on the other channel would be lost with a one-channel woofer, it is not likely for disc recordings which employ blended bass.

Another approach to incorporating the woofer into your system is to use a 1:1 mixing transformer (such as the Electro-Voice XT-1) as shown in circuit C. This setup is useful for tube-type amplifiers but can be used with solid-state systems only if a large-value capacitor—say, 500 μF —is inserted in the right channel line, and then only if the amplifier is known to be stable with a capacitive load.

If you own a solid-state amplifier, study the instruction manual and/or the schematic diagram to determine if the output connections for the left and right

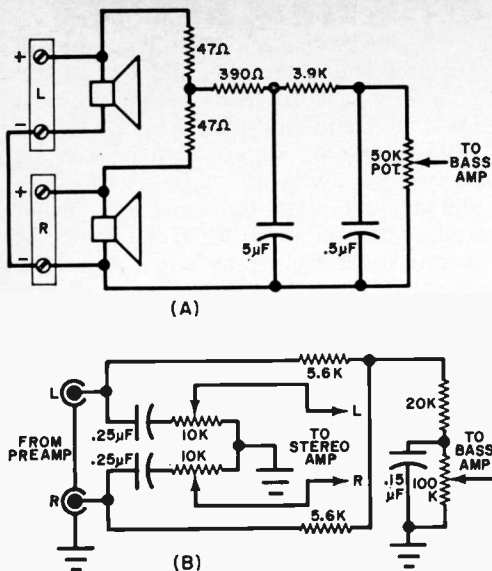


Fig. 2. Mixed signal for bass amplifier is derived from output terminals of stereo amplifier (top diagram) or from preamplifier output (directly above).

channel common points can be safely tied together before resorting to circuits D-F. A 500- μ F capacitor between the common terminals can be used with those amplifiers which are overparticular about direct hookups. Many amplifiers use a common ground line; and for these no problem exists.

Two low-cost methods of obtaining a sum signal from both stereo channels for driving a single woofer are shown in circuits D and E. The former is a typical method of deriving a third-channel sum signal in some amplifiers. Here, a series inductor has been added to the woofer line as a low-pass filter. The use of the

isolation resistors has some disadvantages, such as a loss of 6 dB in woofer output and reduced damping effect on the woofer itself.

Circuit E is a simple European setup mentioned by Baxandall¹ (who does not strongly recommend it). He cites the possibility of interaction of the three speakers because of the series arrangement between stereo speakers and woofer which could produce dips and peaks in the frequency response curve. Electro-Voice engineers offer a refinement of the circuit by adding a couple of inductors as shown in circuit F. The chokes offer a low-impedance path for the low frequencies, providing a bass rolloff in the left and right speakers. In this circuit, the full-range speakers appear in series with the woofer only near the crossover frequency.

The Fig. 1 circuits have one significant advantage. They do not require an extra amplifier to drive the woofer. But they also have common disadvantages. For one, the inductors and capacitors that make up the crossover networks operating at the proper low frequencies must have large values. The values stated in the diagrams are for 100 Hz or higher. Another type of filter should be used for operation at lower, and perhaps more desirable, crossover points.

J. Gordon Holt has a definite opinion on the best way to operate a common-bass system. He states, "I'm convinced that the only way to do this properly is via a separate amplifier. It would provide full woofer damping and complete control of woofer level without loss of side-speaker separation."

Holt offers two methods of crossing

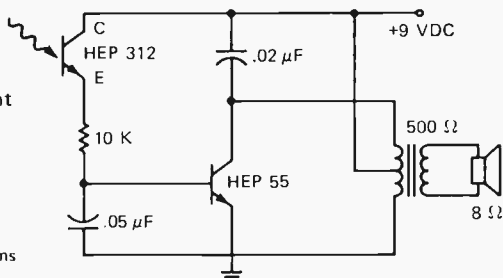
ELECTRONIC ALARM CLOCK: Sunlight Causes Audio Output

FEATURES:

- Ideal for hunting or camping trips — wake up at daybreak
- If car enters driveway at night headlights will sound alarm
- Fire alarm
- Musical toy—play with a flashlight

PARTS LIST:

- 1 HEP 312
- 1 HEP 55
- 1 Resistor, 10K, 1/2 Watt
- 1 Capacitor, 0.05 mfd
- 1 Capacitor, 0.02 mfd
- 1 Audio Output Transformer 500 to 8 ohms
- 1 Speaker, 8 ohms
- 1 Battery, 9VDC



over from a stereo amplifier to a bass amplifier, both of which are shown in Fig. 2. Circuit A in Fig. 2 is a passive filter network with crossover at 80 Hz and a 12 dB/octave slope. The frequency of the crossover can be raised to 100 Hz by changing the capacitor values to 4 μ F and 0.4 μ F, respectively. Passive filters work well but have inherent insertion losses which, in some cases, will most likely necessitate an extra stage of amplification.

Ideally, the crossover should be located between the preamplifier and main amplifier as shown in circuit B. The component values specified provide for a 6 dB/octave slope with a crossover at 60 Hz. The woofer cut-off point can be raised to 80 Hz by substituting a 0.1- μ F capacitor.

The crossover networks in Fig. 2 can be tailored to fit a particular installation simply by changing the values of the capacitors, working with the time constant chart and information in the box on page 142.

Another possible method of connecting a bass amplifier to a stereo amplifier is through an electronic crossover. Such crossovers were popular in pre-stereo times when the idea behind their use was to reduce intermodulation distortion with the aid of two or three amplifiers to cover the entire audio spectrum. Some

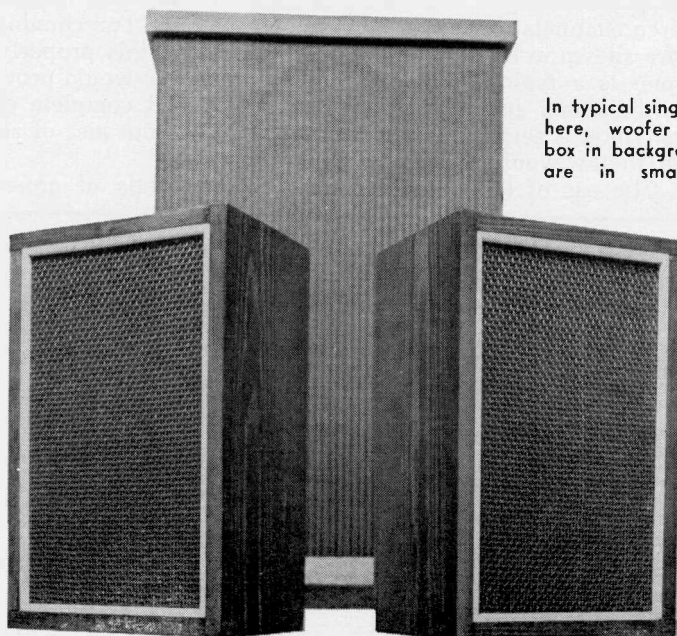
of those crossovers probably added as much distortion as the multiple amplifiers prevented, but they should be adequate for a low-pass filter if designed for a crossover frequency of 100 Hz or lower.

Single woofer stereo systems can be like the girl with the curl—very, very good or just plain horrid. Their design requires careful attention to the choice of the crossover frequency and the mixing circuit. If these two challenges are met and overcome, the concept opens all kinds of interesting possibilities for stereo systems that can be both practical and superb in performance.

Of course, the special problems of the single woofer can be avoided by going the well-traveled path of the easy-to-hook-up traditional two-speaker system stereo setup. But the easiest way to enjoy stereo would be to buy a department store portable "stereo" setup and forget the nuts and bolts. Well, if that's your answer to the problem, to each his own. ♦

References

1. *Radiotron Designer's Handbook*, F. Langford-Smith RCA 1953, p 850.
2. "Direct Radiator Loudspeaker Enclosures," H. F. Olson, *Audio Engineering*, November 1951.
3. *Stereophonic Sound*, N. H. Crowhurst, John F. Rider, 1961, p 92.
4. "L-C/H-Q Mark I" Part 2, P. J. Baxandall, *The Audio Amateur*, Summer 1970, p 14.



In typical single-woofer system shown here, woofer is located in large box in background; satellite speakers are in small foreground boxes.



BY W. L. GREEN

WITH A LITTLE PRACTICE, YOU MIGHT EVEN
BE ABLE TO IDENTIFY THE TYPE AND NUMBER OF FISH

IT IS an established fact that many marine creatures (especially porpoises) communicate with each other and use a form of sonar to locate and catch their food. Other fish seem to make noises for no particular reason while still others produce noises as a result of their movements. The latter is true of shrimp and other shellfish. (Schools of shrimp have been fouling up sonar operations for years.) So the underwater world is far from being the "silent deep" and, in some cases, is as noisy as a boiler factory.

If you would like to listen in on what goes on down there—and maybe spot a likely place for good fishing—you can build your own underwater fish detector for less than \$15. By lowering the detector into the water in various locations, you can determine whether there are any of the noise-making creatures about and, with a little practice, determine their type and approximate number. The commercial version of this detector is used—quite successfully—by professional shrimpers off the Florida coast.

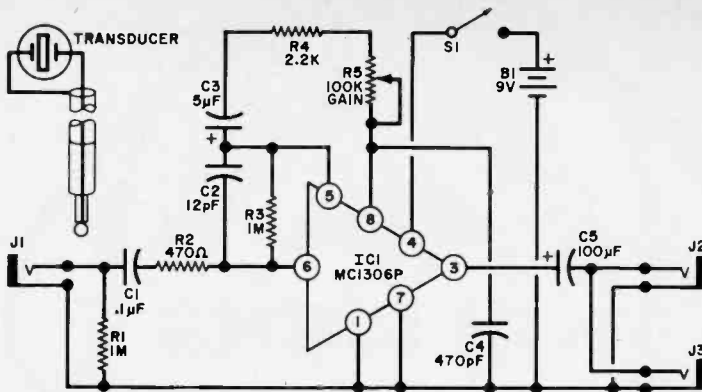


Fig. 1. The system is basically a ceramic transducer coupled to a high-gain amplifier. Only one output jack is actually required, the other can be used with an optional tape recorder.

PARTS LIST

- B1—9-volt battery
- C1—0.1- μ F disc capacitor
- C2—12-pF disc capacitor
- C3—5- μ F, 15-volt electrolytic capacitor
- C4—470-pF disc capacitor
- C5—100- μ F, 15-volt electrolytic capacitor
- IC1—MC1306P (Motorola)
- J1-J3—Miniature phone jack
- R1,R3—1-megohm, $\frac{1}{4}$ -watt resistor
- R2—470-ohm, $\frac{1}{4}$ -watt resistor
- R4—2700-ohm, $\frac{1}{4}$ -watt resistor
- R5—100 000-ohm miniature potentiometer with S1

S1—Spst switch on R5

Misc.—Suitable chassis, battery clip, battery mount, knob, mounting hardware, headset, speaker, transducer (see note) etc.

Note—The following are available from Alpha Electronics, Box 1005, Merritt Island, Fla. 32952: PC board, \$1.50; transducer UFD-50 (50-ft. cable), \$8.95; kit SFD-50 including transducer, PC board, components, and hardware but less battery, headset, and case, \$18.95 postpaid.

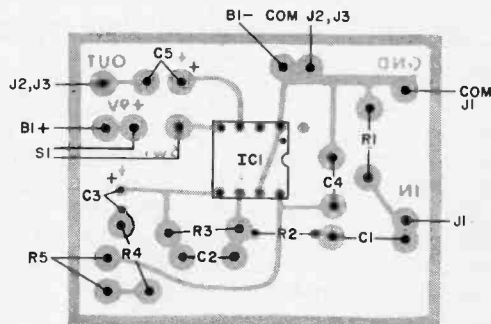
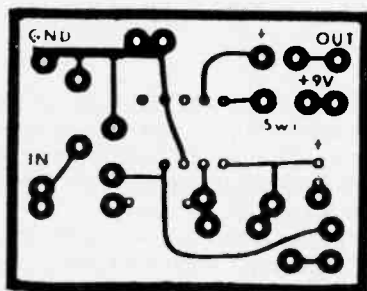


Fig. 2. Actual size foil pattern (left) and component installation (right).

EDITOR'S NOTE

The underwater fish detector was tested in various tanks at the New York Aquarium (with the aid of a helpful curator). Of course, the dolphins made the wildest underwater sounds, but the white Beluga whales came in a close second. Tests in some tanks did not reveal much noise, possibly, as the curator explained, because the fish had been there for some time and had few hunting instincts since they are fed on a schedule. The barking of a seal underwater is not to be believed, but these creatures tend to play with the transducer, which causes painful shocks on the ears.

Tests in the Great South Bay off Long Island, New York, revealed some strange noises (possibly flounder or mackerel, which were in at the time), but the noises from boats were usually overpowering.

Try the detector in your home fish tank, but be sure to turn off the aerator or pump while doing so.

Construction. The circuit, shown in Fig. 1, consists basically of an underwater transducer coupled to a high-gain audio amplifier (IC1). The response of the amplifier is down 3 dB at 200 Hz and 13 kHz, while maximum gain is 100,000. The output impedance is 0.5 ohm, making the system suitable for use with almost any type of speaker or earphones. It can also be used with another amplifier. Gain is controlled by R5 and there are two parallel output jacks—one of which can be used for a tape recorder.

It is recommended that a printed circuit board be used to prevent oscillations. A foil pattern and component layout are shown in Fig. 2. The board, with the battery, should be mounted in a small, metal shielded enclosure to prevent external electrical noise pickup. It is also suggested that the case be anodized to prevent corrosion when the detector is used near salt water. ♦

Free!
1973
Eico catalog
OVER 200 INSTRUMENTS • KIT & WIRED!

NEW! TR-410 Solid State Triggered Sweep Scope
NEW! 300C "Clamp-On" Current Tester
NEW! TD-8 8 Track Stereo Tape Deck
NEW! SS-200 "Time Delay" Burglar Alarm System
NEW! ASA-300 Electronic Siren Auto Alarm

Build all-professional Eico Kits and save up to 50%. The more you know about electronics, the more you'll appreciate Eico. Over 2500 local Eico dealers offer you all the top brands, personal technical counsel, fast off-the-shelf service. Free catalog includes Test Equipment, Stereo, Eico-craft Projects, Burglar/Fire Alarm Systems and name of nearest Eico distributor. check reader service card or send 25¢ for first class mail service.

EICO, 283 Malta St., Brooklyn, N.Y. 11207
Leadership in creative electronics since 1945



CIRCLE NO. 6 ON READER SERVICE CARD

PRINTED CIRCUITS

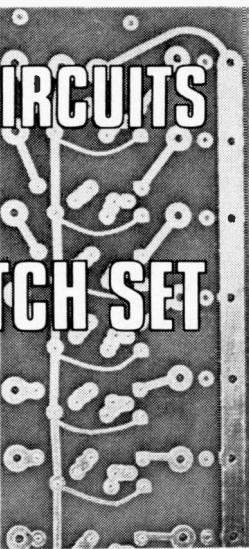
FAST — EASY
with DATAK's

DIRECT ETCH SET

EASY—patterns rub down directly on the copper board and connect with rub-down lines or tapes supplied.

FAST—safe new etchants will etch a 2 oz. copper board in 30 minutes.

ACCURATE— $\pm .002$ " print tolerance so parts and connectors mate with no errors.



Circuit Made With ER-1

COMPLETE ER-1 SET contains hundreds of dry transfer DIP, flatpack, TO-5, IC, and transistor patterns; $\frac{1}{16}$ " and $\frac{1}{32}$ " etch resist tapes; 4 copper clad boards; $\frac{1}{4}$ lb. dry etch; tray and instructions. \$4.95 ppd.

IN STOCK AT ALLIED AND OTHER DISTRIBUTORS
WRITE FOR FREE CATALOG listing this and many other dry transfer marking sets.

The DATAK Corporation

85 Highland Avenue • Passaic, New Jersey 07055
CIRCLE NO. 17 ON READER SERVICE CARD



SOLID-STATE LASER FOR THE EXPERIMENTER

SAFE SEMICONDUCTOR
LASER DIODE MAKES
AN IDEAL
SECRET COMMUNICATOR

BY FORREST M. MIMS

THANKS to a recent breakthrough in semiconductor (laser) technology, the serious electronics experimenter can now work with a solid-state gallium arsenide (GaAs) laser costing less than \$20. (One of the very first lasers suitable for experimentation was the HeNe device.)

Operating at 9050 Angstroms the laser beam is totally invisible—even when shone onto a sheet of white paper. It is suitable for many applications, including secret communications and intrusion detectors. Because both the transmitter and the receiver operate from self-contained batteries, any system using the laser can be independent of power lines.

Transmitter. The solid-state laser used

here requires a current pulse of at least 5 but not more than 10 amperes to reach the lasing threshold. If the maximum current rating is exceeded, the laser will be destroyed. Since the laser chip is only 3×9 mils, the current pulse must be very short (about 200 nanoseconds) to prevent damaging buildup of heat.

The circuit of the transmitter is shown in Fig. 1. Transistor Q1 can be any one of a number of switching transistors (such as HEP50) but it must be tested in the circuit to make sure that it avalanches properly. Capacitor C1 is charged up through R1 until the collector-to-emitter breakdown voltage of Q1 is reached. When Q1 breaks down (avalanches), the energy in C1 flows through Q1, R3, D1,

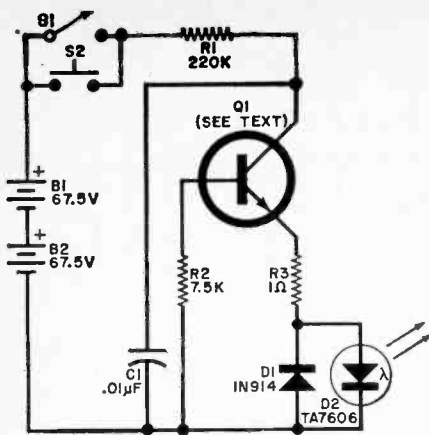


Fig. 1. The laser diode modulator is an npn switching transistor operating in the avalanche mode. One switch is for continuous operation, while the other is used for "burst" operation.

PARTS LIST TRANSMITTER

- B1, B2—67½ V battery
 - C1—0.01-μF, 1 kV capacitor
 - D1—1N914 fast recovery diode
 - D2—Laser diode (RCA SG2001, formerly 40856)*
 - Q1—Npn silicon switching transistor (see text)
 - R1—220,000-ohm, ¼-watt resistor
 - R2—7500-ohm, ¼-watt resistor
 - R3—1-ohm, ½-watt resistor
 - S1—Spst slide or toggle switch
 - S2—Normally open pushbutton switch
 - Misc.—3" × 4" × 5" aluminum utility box, battery clamps and clips, lens (see text), mounting hardware, wire, solder, etc.
- *Order from local electronics suppliers or RCA Electronic Components, Box 1140, New Holland Pike, Lancaster, Pa. 17604
- Note—For more information on diode lasers and pulser circuits, see "Semiconductor Diode Lasers" by Ralph Campbell and Forrest Mims (Howard W. Sams & Co., 192 pages, \$5.95). The book includes chapters on laser theory, optics, receivers, applications, and dozens of tested circuits.

and D2. To determine whether a transistor is avalanching, replace the laser diode (D2) with a conventional silicon rectifier. With a 135-volt source applied to the circuit, connect a scope across C1. When the circuit is oscillating (a small percentage of transistors may not), the amplitude of the displayed pulses is the breakdown voltage of the transistor. Do not use a transistor with a breakdown voltage greater than 45 volts since any higher

voltage will provide more than 10 amperes to the laser.

A foil pattern and component layout for the transmitter are shown in Fig. 2. Mount Q1, R1, R3, and C1 flush against the board to reduce stray inductance. Despite its low value, do not omit R3. It limits the laser current. Drill a 3/8" hole at the spot where D2 is to be mounted and use a hex nut to secure it in place. Its flat sides must be parallel to the nar-

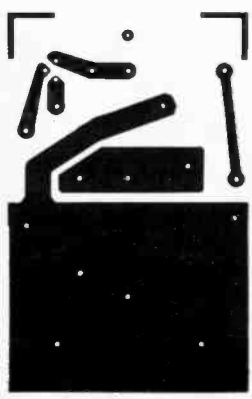
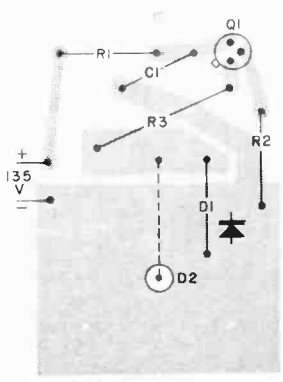


Fig. 2. Transmitter foil pattern and components. The cathode of the laser diode makes its connection via its mounting; the anode via a "flying" lead.



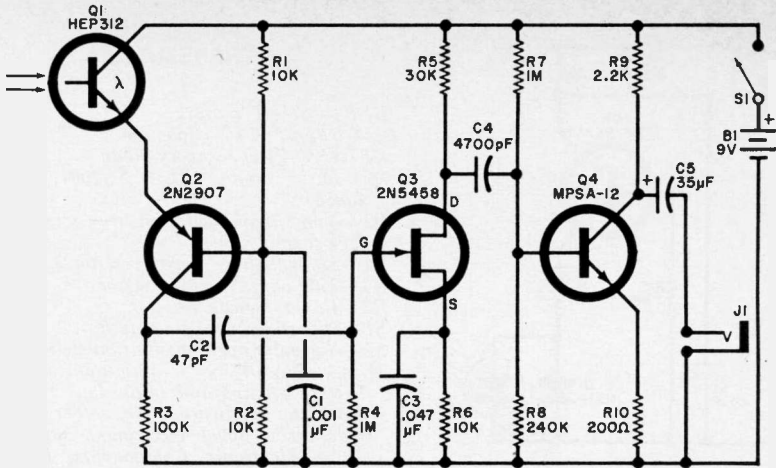


Fig. 3. The receiver is essentially a phototransistor driving a conventional audio system. Any phototransistor may be used as long as it will respond to the 9000-Angstrom laser output.

PARTS LIST RECEIVER

B1—9-volt battery
 C1—0.001- μ F, 10-volt capacitor
 C2—47-pF, 10-volt capacitor
 C3—0.047- μ F, 10-volt capacitor
 C4—4700-pF, 10-volt capacitor
 C5—35- μ F, 10-volt electrolytic capacitor
 J1—Earphone jack and plug
 Q1—HEP-312 phototransistor
 Q2—2N2907 transistor
 Q3—2N5458 or HEP801 FET

Q4—Darlington transistor (Motorola MP5A12)

R1, R2, R6—10,000-ohm, $\frac{1}{4}$ -watt resistor
 R3—100,000-ohm, $\frac{1}{4}$ -watt resistor
 R4, R7—1-megohm, $\frac{1}{4}$ -watt resistor
 R5—30,000-ohm, $\frac{1}{4}$ -watt resistor
 R8—240,000-ohm, $\frac{1}{4}$ -watt resistor
 R9—2200-ohm, $\frac{1}{4}$ -watt resistor
 R10—200-ohm, $\frac{1}{4}$ -watt resistor
 S1—Spst slide or toggle switch

Misc. 3" \times 4" \times 5" aluminum utility box, battery holder, lens (see text), mounting hardware, wire, solder, earphone, etc.

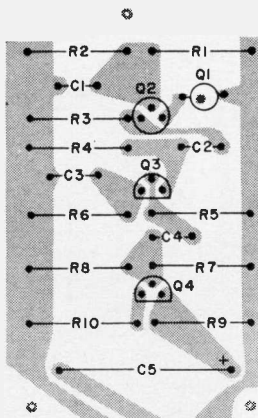
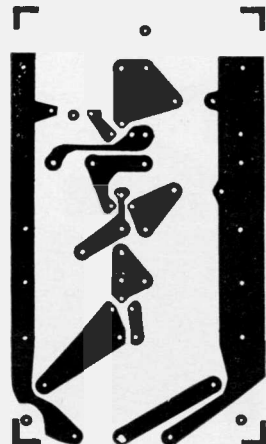
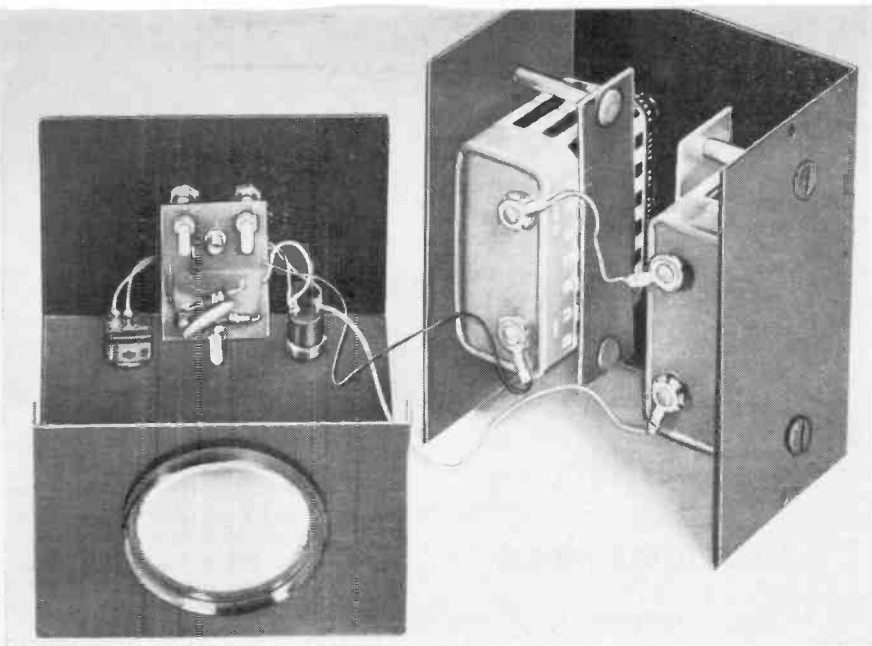


Fig. 4. The receiver foil pattern and component installation. Note that Q1 has only two leads; the light from the laser acts as the base input signal.





When mounting the transmitter, make sure the laser diode sits at the focal point of the lens. Three adjustable spacers are used to make this adjustment.

row end of the board. Be careful when connecting the laser anode lead to its hole in the foil.

To test the transmitter, place it close to an operating AM radio and depress the burst switch, S2. A tone of approximately

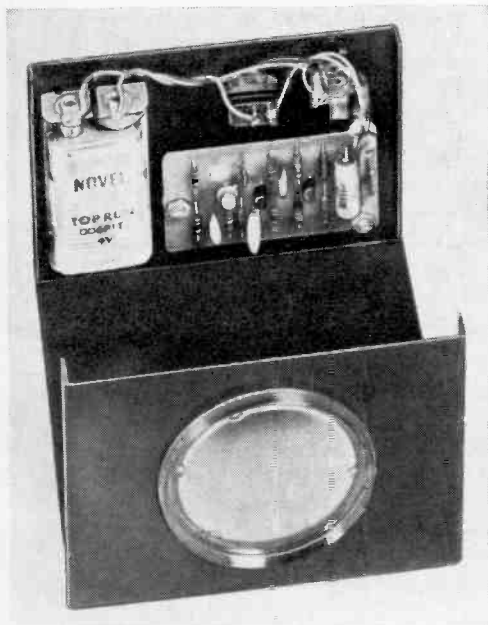
In the receiver, the phototransistor mounts at the focal point of the lens. In this case, the receiver, battery, switch and phone jack are mounted on one end of metal enclosure.

1 kHz should be heard from the radio.

Receiver. The circuit of the receiver (Fig. 3) is essentially a phototransistor (Q1) driving a conventional audio system. A foil pattern and component layout are shown in Fig. 4. The phototransistor is mounted on the foil side of the board and protrudes through a hole in the board. Clip the excess lead length from it before soldering it in place and make sure that it is level.

To test the receiver, turn it on and aim the phototransistor at a fluorescent lamp. Various noises will be heard as the receiver is aimed at different areas along the lamp.

Mounting and Optics. Using a 3" × 4" × 5" utility box, cut a 2" diameter hole for the lens in one narrow end. (See photographs.) Select a lens whose focal point is about 1/2" from the other end of the chassis. This can be done by using light from a distant source and moving a white card behind the lens until the distant light is focused. Make a note of this distance and, with the lens cemented to the chassis, mount the transmitter circuit board on the rear wall of the chassis using spacers so that the laser is at the focal point of the lens. Tighten the mounting and spacers but make sure that the laser anode lead does not touch the chassis.



**ELECTRONIC
EXPERIMENTER'S**

HANDBOOK

SPRING 1973

ADVERTISERS INDEX

READER SERVICE NO.	ADVERTISER	PAGE NO.
16	B & K Division, Dynascan Corporation	FOURTH COVER
	Bell & Howell Schools	84, 85, 86, 87
1	Burstein-Applebee	143
3	Cleveland Institute of Electronics	155, 156, THIRD COVER
17	Datak Corporation, The	149
4	Delta Products Inc.	99
5	Discwasher Inc.	101
6	EICO	149
7	Edwards Electronics	143
8	Greenlee Tool Co.	141
9	Heath Company	103, 104, 105
10	Lafayette Radio Electronics	6
11	Lee Electronic Labs, Inc.	SECOND COVER
12	MITS Micro Instrumentation & Telemetry Systems, Inc.	8
13	Meshna	59
	National Radio Institute	1, 2, 3
14	RCA Institutes, Inc.	67, 68, 69
15	Xcelite Inc.	21

SAFETY CONSIDERATIONS

The GaAs laser diode used here has a peak optical output of about 1 watt per pulse. That's a lot of light compared to the low-power helium-neon laser previously described in POPULAR ELECTRONICS, but since the optical pulses are so brief, the average power is far less than that of the helium-neon device.

It is impossible to operate a laser diode in a manner which will yield more than the rated power. Current pulses higher than the specified maximum cause heating effects which raise the laser's temperature. The temperature rise, which occurs almost instantly because of the laser's tiny physical dimensions, significantly increases the laser's lasing threshold and therefore reduces optical output. Very high, one-shot current pulses produce the same heating effect and usually destroy the laser chip.

According to the Air Force School of Aerospace Medicine, GaAs lasers ten times more powerful than the RCA SG 2001 used here are not capable of producing ocular damage. In fact, the SG 2001 output is far below the threshold for such damage. There are several reasons for this: absorption of the infrared in the eye's vitreous humor, imperfect focusing of the infrared, and the laser's low average power. But the main reason a single laser diode is incapable of inflicting ocular damage is that the power density at the retina is too far below the damage threshold.

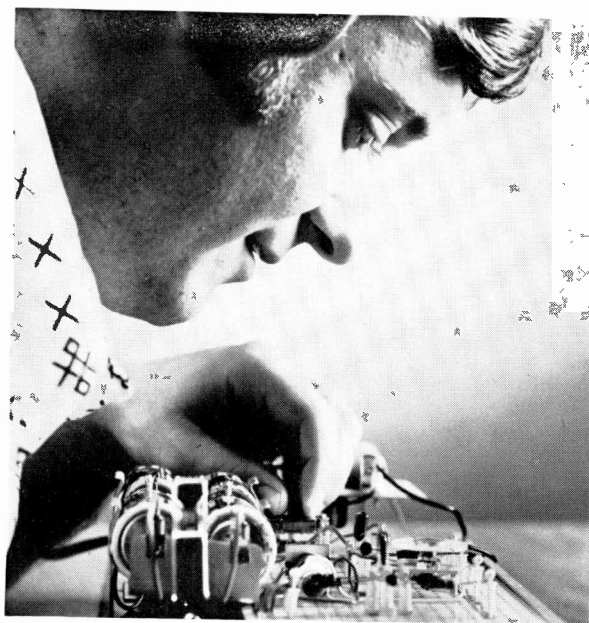
Nevertheless, follow a few basic precautions to insure utmost safety:

1. As with any source of bright light, do not look directly into the laser beam.
2. Avoid pointing the laser at very shiny surfaces (mirrors, unpainted metal, etc.).
3. Turn off the laser when it is not in use. (This preserves the lives of the batteries and the laser also.)

Follow the same procedure with the receiver, placing Q1 at the focal point of the lens.

Operation. To make a low-power CW transmitter/receiver system, aim the two units at each other (lenses facing). Transmission can be over quite a distance, depending on the lenses and the light.

To make an intrusion alarm, omit C5 and the earphone and replace R9 with a low-power relay to drive an externally mounted alarm. ♦



You Learn to Make Money ...with CIE's Electronics Laboratory!

Now you can learn Electronics by performing more than 200 practical, skill-producing experiments...with authentic industrial components...at home...in your spare time.

You learn by doing! This 161-piece Laboratory includes the up-to-date equipment you'll need — such things as an IC (integrated circuit), printed circuit board, FET (field effect transistor), photovoltaic cell, DC motor, microphone, multimeter, soldering iron and power supply.

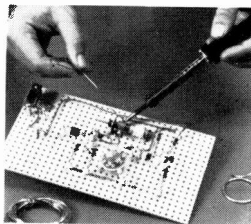
You put theory into *practice* right in your own home... in your spare time... while you go right on pulling down your present pay. It's CIE's exciting space-age "Electronics Technology with Laboratory" program... a unique combination of CIE's special AUTO-PROGRAMMED® Lessons and laboratory equipment. It is the *practical* way to learn Electronics!

Prepare for a High-paying Career

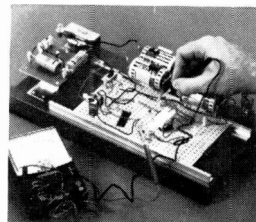
You see, when you "learn by doing," you're *ready to do*...you're *armed* with the know-how to meet the challenges of a high-paying career in Electronics... prepared to go after an exciting, relevant job in a growing field such as medical technology, pollution control, radio and TV broadcasting, computers...just to name a few. Once you have some experience, you can make \$12,000 a year or more.

But that's not all! When you successfully complete your Electronics Laboratory course, you'll get a CIE Diploma. And, you'll be able to pass the Government FCC examination or *be entitled to a full refund of all tuition paid!* CIE's Money-Back Warranty is valid during the completion time allowed for your course.

Send today for CIE's 2 FREE BOOKS about opportunities in Electronics. For your convenience, we will try to have a representative call. Mail reply card or coupon to CIE...or write: Cleveland Institute of Electronics, Inc., 1776 E. 17th St., Cleveland, Ohio 44114.



You learn how to construct circuits and connect them with a soldering iron, which is part of your CIE laboratory equipment. This "hands on" experience is extremely valuable.



Testing and troubleshooting are an important part of your learning experience. Your laboratory has a precision multimeter to diagnose electronic troubles quickly and accurately.

APPROVED UNDER G.I. BILL

All CIE career courses are approved for educational benefits under the G.I. Bill. If you are a Veteran or in service now, check box for G.I. Bill information.

CIE Cleveland Institute of Electronics, Inc.

1776 East 17th Street, Cleveland, Ohio 44114
Accredited Member National Home Study Council

Please send me your 2 FREE BOOKS — The CIE school catalog, "Succeed in Electronics" and "How To Get a Commercial FCC License."



Name _____ (Please Print)

Address _____

City _____

State _____ Zip _____ Age _____

Veterans and Servicemen:

Check here for G.I. Bill information.

EH-13

Introducing the expensive dual-trace scope that doesn't cost a lot.

The B&K Precision Model 1470.

A solid-state 5-inch scope that combines dual-trace triggered sweep with vectorscope capability.

Our DC to 10 MHz bandwidth with 10 mV/cm sensitivity makes the 1470 exceptionally versatile. And its TV-H and TV-V positions are a special plus.

Dual-trace lets you observe input and output wave forms simultaneously in the same circuit. And 16-position triggered sweep, from 1 sec/cm to 0.2 sec/cm lets you sync them instantly.

On the other hand, you might prefer our Model 1465 single-trace, triggered-sweep scope at \$359.95. It has many of the same features and our patented CALI-BRAIN® automatic voltage readout system.

Everything about our scopes is expensive — except their price.

For complete technical data, call your local B&K distributor. Or write Dynascan Corporation.

Very good equipment at a very good price. **B&K**

Product of Dynascan Corporation
1801 West Belle Plaine Avenue, Chicago, Illinois 60613

\$499.95

