

Projects you can Build!

GERNSBACK SPECIALTY SERIES 49604

WINTER
1994

ELECTRONICS EXPERIMENTER'S

Electronics **handbook**TM
NOW[®]

Unscrambling Descrambling

The truth on how
to put video
back in shape

Two Power
Antenna Projects
for AM & FM

Vacuum Tube Audio
Preamplifier

Bootable RAM Drive
For Your PC

How to Upgrade Your
Car's Stereo

Theory and Tips on
Building a Classic
Regenerative Radio

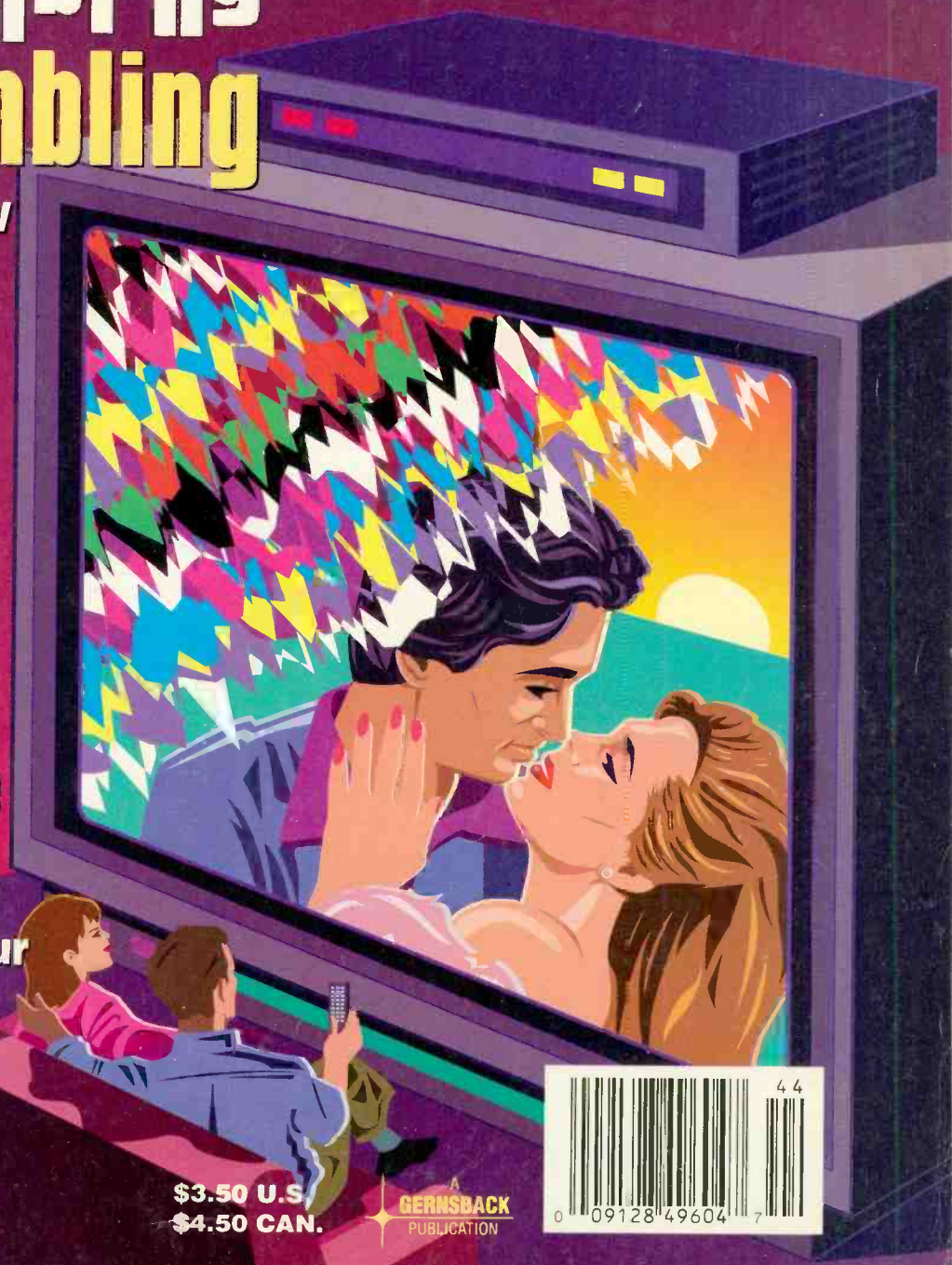

\$3.50 U.S.
\$4.50 CAN.

GERNSBACK
PUBLICATION



**24 HOUR
SHIPPING**

**ELENCO • HITACHI • B&K PRODUCTS
GUARANTEED LOWEST PRICES**

TO ORDER
CALL TOLL FREE
1-800-292-7711
1-800-445-3201 (Can.)

**AFFORDABLE - HIGH QUALITY
2 YEAR WARRANTY**

ELENCO OSCILLOSCOPES

Hitachi Compact Series Scopes



STANDARD SERIES
S-1325 25MHz \$349
S-1340 40MHz \$495
S-1365 60MHz \$849

DELUXE SERIES
S-1330 25MHz \$449
S-1345 40MHz \$575
S-1360 60MHz \$775

Features:

- High Luminance 6" CRT
- 1mV Sensitivity
- X-Y Operation
- Voltage, Time, + Frequency differences displayed on CRT thru the use of cursors (S-1365 only)
- Plus much, much more
- TV Sync
- 2 - x1, x10 Probes
- Complete Schematic

Features:

- Delayed Sweep
- Automatic Beam Finder
- Z Axis Modulation
- Built-in Component Test
- Plus all the features of the "affordable" series
- Dual time base
- Illuminated internal gradicule

V-212 - 20MHz Dual Trace	\$399
V-525 - 50MHz, Cursors	\$995
V-523 - 50MHz, Delayed Sweep	\$949
V-522 - 50MHz, DC Offset	\$895
V-422 - 40MHz, DC Offset	\$795
V-222 - 20MHz, DC Offset	\$649
V-660 - 60MHz, Dual Trace	\$1,149
V-665A - 60MHz, DT, w/cursor	\$1,325
V-1060 - 100MHz, Dual Trace	\$1,395
V-1065A - 100MHz, DT, w/cursor	\$1,649
V-1085 - 100MHz, QT, w/cursor	\$1,995
V-1100A - 100MHz, Quad Trace	\$2,495
V-1150 - 150MHz, Quad Trace	\$2,895

B&K OSCILLOSCOPES

2120 - 20MHz Dual Trace	\$389
2125 - 20MHz Delayed Sweep	\$539
1541B - 40MHz Dual Trace	\$695
2160 - 60MHz Dual Trace, Delayed Sweep, Dual Time Base	\$949
2190 - 100MHz Three Trace Dual Time Base, Delayed Sweep	\$1,395
2522A - 20MHz / 20MS/s Storage	\$875

Digital Capacitance Meter



CM-1550B
by Elenco
\$58.95
9 Ranges
.1pF-20,000pF
5% basic accy.

Big 1" Display Zero control w/ Case

Digital LCR Meter



LC-1801
\$125
Measures:
Coils 1uH-200H
Caps .1pF-200uF
Res .01-20M
by Elenco

Big 1" Display

Digital Multimeter



DVM-638
\$39.95
11 Functions with Case

FLUKE MULTIMETERS

Scopemeters (All Models Available Call)	
Model 93	\$1,225.00
Model 95	\$1,549.00
Model 97	\$1,795.00
10 Series	
Model 10	\$62.95
Model 12	\$79.95
70 Series	
Model 70H	\$65.00
Model 77H	\$149.00
Model 79H	\$169.00
80 Series	
Model 87	\$289.00

12A DC Power Supply



B+K 1686
\$169.95
3-14V @ 12A

Fully regulated & protected
Separate volt & current meters
with current limiting, low ripple

Quad Power Supply XP-580



\$79.95 2-20V @ 2A 5V @ 3A
12V @ 1A -5V @ .5A
Fully regulated and short circuit protected



B&K 390
\$139
3-3/4 Digit DMM
Bargraph
9 Functions
Including Temp, Freq
Rubber Boot



Dual-Display LCR Meter
w/ Stat Functions
B+K 878
\$239.95
Auto/Manual Range
Many Features
w/ Q Factor
High Accuracy

Sweep/Function Generator
with Freq. Counter



\$239
Elenco
GF-8026

Int/Ext operation
Sine, Square, Triangle, Pulse, Ramp
2 to 2MHz, Freq Counter .1-10MHz

Audio Generator



Elenco GF-800
\$59
20Hz-150KHz
Sine/Square
Waves
Handheld

2MHz Function Generator



B+K 3011B **\$219.95**
LED Display, Sine, Square, Triangle, Ramp
& Pulse Waves. TTL & CMOS

Digital Multimeter Kit
with Training Course



Elenco
M-2665K
\$49.95
Fun & Easy
to Build

Full Function 34 Ranges, Includes
Capacitance, Transistor/Diode Testing
20Amp AC/DC, Extra Large Display. Ideal
School Project **M-2661 (assembled) \$55**

**Learn to Build and Program
Computers with this Kit**

Includes: All Parts, Assembly and Lesson Manual



Model
MM-8000
\$129.00
by Elenco

Starting from scratch you build a complete system. Our
Micro-Master trainer teaches you to write into RAMs,
ROMs and run a 8085 microprocessor, which uses
similar machine language as IBM PC.

**Elenco Wide Band
Signal Generators**



SG-9000 **\$119**
RF Freq 100K-450MHz AM Modulation
of 1KHz Variable RF output
**SG-9500 w/ Digital Display &
150MHz built-in counter \$239**

TELEPHONE PRODUCT TESTER



B+K 1045A **\$499.95**
Provides basic operation tests for corded
& cordless telephones, answering
machines and automatic dialers.

Multi-Function Counter

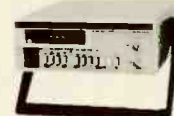

Elenco F-1200
1.2GHz
\$229
Measures Frequency, Period, Totalize
8 LED digits, Crystal oven oscillator,
.5ppm accuracy

WE WILL NOT BE UNDERSOLD
UPS SHIPPING: 48 STATES 5%. OTHERS CALL
IL RES add 7.75% TAX
PROBES INCL ALL SCOPES & METERS

C&S SALES INC.

1245 ROSEWOOD, DEERFIELD, IL 60015
FAX: 708-520-0085 • (708) 541-0710



15 DAY MONEY BACK GUARANTEE
FULL FACTORY WARRANTY
WRITE FOR FREE CATALOG

Other Schools Say Their Computer Repair Training Is The Best... At NRI, We Let Our Graduates Do The Talking:

"Just two years after finishing the NRI training in microcomputer servicing, I set up my own company. I contract myself out to several computer retailers as their service technician. I have control over my future and total confidence in my business"

V. Bender, Calgary, Alberta

"I recommend NRI to anyone looking for a change, success, and real challenge. The Action Learning Kits allow you to build on what you studied in the lessons - no better way exists to learn how to troubleshoot and service computers!"

R. Buda, Tenley Park, IL

"No doubt, the excellent back-up of your staff was a significant factor in my swift completion of my micro-computer repair training. Their helpfulness, either by phone or by letter, was nothing short of amazing."

J. Preusker, Angston, SA, Australia

Thousands of Successful NRI Graduates Are Proof of the Quality and Effectiveness of NRI Training

NRI's been successfully training people for new electronics careers for more than 80 years. Regardless of your previous experience, you can succeed with NRI, too.

Experience First-Hand the Intricate Electronics Inside Today's Computers

NRI's highly acclaimed Discovery Learning Method - the learn-by-doing approach that gives you first-hand experience with the intricate electronics behind microcomputers - is the most effective way to learn a new skill. You start with NRI's Discovery Lab - a complete breadboarding system that lets you design circuits, modify them, and then diagnose and repair faults.

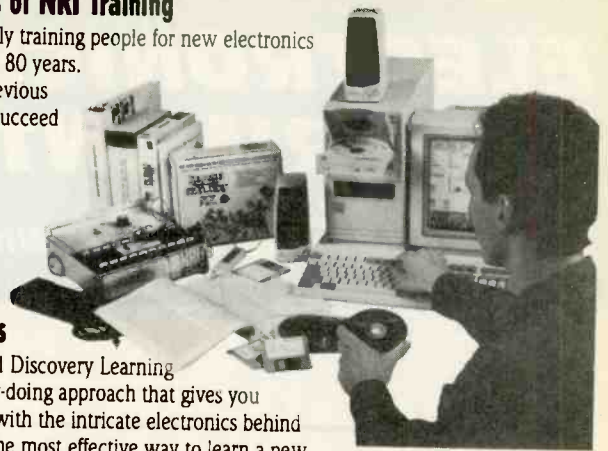

You then go on to build a state-of-the-art 486sx/25 MHz Intel-based computer from the keyboard up. You install the power supply, 3.5" floppy drive, 200 meg hard drive, and Super VGA color monitor. This powerful system, which also features a Pentium overdrive-ready motherboard and today's most sought-after peripherals - CD-ROM drive, sound card, and speakers - is all yours to train with and keep.

What's more, you perform diagnostic tests using the professional-level Ultra-X R.A.C.E.R. plug-in card and Quick Tech software, all included in your course.

Plus, NRI training includes fully integrated software packages - MS-DOS 6.21, QBasic, and Microsoft Works - and skill-building interactive projects to give you complete confidence in a wide range of applications.

Train in the Privacy of Your Own Home

No prior experience necessary - with your personal instructor and NRI's team of technical specialists behind you every step of the way, you learn at your own pace - no classroom pressures, no night school, no need to quit your present job until you're ready to make your move.

Take Advantage of Today's Money-Making Opportunities in Computer Repair

The Department of Labor forecasts over 220,000 jobs for computer service technicians by the year 2005. With the right training and skills, you can cash in on this wide-open opportunity. Only NRI prepares you so thoroughly for a full- or part-time job as a computer service technician - even a business of your own!

FREE Catalog Gives You the Whole Story—Call or Write NRI Today

Let us hear from you next! Send today for NRI's free, full color catalog. If the coupon is missing, write to NRI Schools, McGraw-Hill Continuing Education Center, 4401 Connecticut Avenue, NW, Washington, DC 20008.

Send today for FREE catalog or call 1-800-321-4634 Ext.1051

NRI Schools

McGraw-Hill Continuing Education Center
4401 Connecticut Avenue, NW, Washington, DC 20008



For career courses approved under GI Bill, check here for details.

Check one free catalog only

MICROCOMPUTER SERVICING

TV/Video/Audio Servicing

Industrial Electronics and Robotics

Basic Electronics

Computer-Aided Drafting

Computer Programming

Desktop Publishing & Design

PC Applications Specialist

Programming in C++

Name _____

(please print)

Age _____

Address _____

City _____

State _____

Zip _____

Accredited Member, National Home Study Council

32-1094

ELECTRONICS EXPERIMENTER'S handbook™ Winter 1994

An
**Electronics
NOW®**
Publication

Contents

SPECIAL THEORY/BUILD-IT SECTION

- Unscrambling Descrambling**85
Here's a basic look at what the cable companies do to premium channel signals and what you can do to learn about unscrambling descrambling.

SELECTED PROJECTS

- AM Power Loop Antenna**12
Now you can pull in distant AM broadcast stations while eliminating most of the heterodyne whistles and noise from nearby stations.
- Tunable FM Antenna Booster**20
Now you can pull in distant or weak FM broadcast signals that you have never been able to enjoy.
- High Tech Xmas Ornaments**30
Add a LED-electronics theme to your Christmas decorating with our Visible Components!
- Wave Shaping**34
Learn the basics of waveform generation and shaping with bipolar transistor circuits that you can build and put to work on your workbench.
- Radon Monitor**40
Build this radon monitor to detect a possible health threat in your home and, while doing it, learn more about radioactivity and how to measure it!
- Upgrade Your Car Stereo**52
Install a stereo in your car or remove one for servicing—it is easy to do and will save you money when you know how.
- Tube Head**56
Now you can bring back the warm, mellow ambiance to harsh, digital compact-disks sounds with this vacuum-tube preamplifier.
- Build the Digitizer**64
Here's a gadget that performs some digital analyzer functions, but it costs a lot less—and fits in the palm of your hand.
- SRAM II—Solid-State Disk Drive**71
Add a bootable 1.8 megabyte RAM drive to your personal computer.
- The Lost Art of Regeneration**78
Look again at the classic regenerative receivers and their importance in radio history, and then build these modernized, transistorized versions.

DEPARTMENTS

- | | |
|--|---|
| Editorial4 | Classified Advertising111 |
| New Products6 | Advertising Sales Offices112 |
| New Literature9 | Advertising Index112 |
| Free Information CardNext to page 9 | |

The Four-Year Electronics Degree Program That Really Hits Home!

Bring The Technology Home With A Bachelor Of Electronics Engineering Degree. No Hassles. No High Cost!

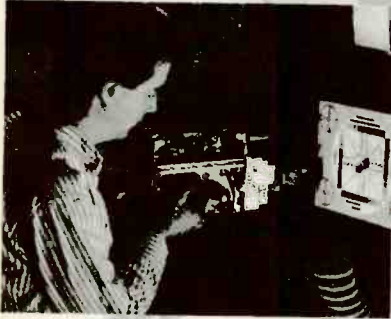

Now's the time to prepare for a profitable career.

We've lowered the cost of higher education.

It's true! You can earn a four-year Bachelor of Electronics Engineering Technology degree today ... and prepare yourself for a high-paying electronics career ... without quitting your job or ever leaving your home. Because World College, an affiliate of the Cleveland Institute of Electronics, offers you the total flexibility of independent study programs proven effective for people like you who truly want to succeed! World College independent study lessons help you build valuable skills

**Mail/Fax Today
or Call
1-800-696-7532**

step-by-step, and expert instructors are personally available to you with a toll-free call. What a way to earn an education!

A world of opportunity.

Where is your career headed? With a four-year bachelor's degree from World College, you call the shots, choosing from incredible, high-paying opportunities in electronics, telecommunications, computer, electrical power, and many other growing fields.

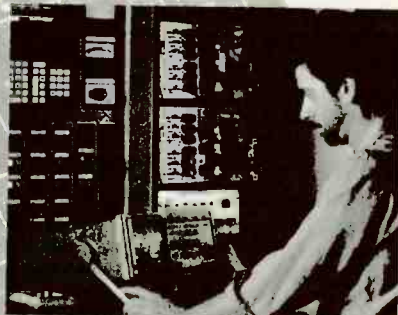

Take charge of your future in electronics.

World College gives you the skills, the knowledge, the power to take advantage of your best opportunity in electronics. And you can do it all at your own pace!

Without leaving home.

World College continually works to provide its students with the most advanced education tools. From the latest equipment and reference books to breakthrough computer-simulated experiments, students are exposed to the latest technological advancements.

All the equipment, parts, and software you need are included in your affordable tuition, including more than 300 hands-on lab experiments you can complete in your home.

Choose your own pace.

Earn your bachelor's degree on your time — and at your pace — because you pay tuition to World College only as you complete the upper-level semesters close to graduation. The faster you make it through, the less you pay. So you have an incentive to make your future happen quickly — yet the freedom to choose your own pace!

Send today for your FREE course catalog — and give yourself that future you've always wanted — with an electronics degree education from World College.

Four Powerful Reasons To Connect With World College Today:

1. Earn your four-year degree!
2. Self-paced training!
3. Independent study in your home!
4. Expert instruction!

Give Me The Power!

Send me a FREE World College course catalog today!



(Please Print Neatly)

Name _____

Address _____

City _____

State, Zip _____

Phone () _____

Age _____

**For faster service, call
1-800-696-7532,
or call
1-804-464-4600.**

**Or fax this coupon to
1-804-464-3687.**

**WORLD
COLLEGE**

Lake Shores Plaza
5193 Drive, Suite 113
Virginia Beach, VA 23455-2500



Affiliated with
Cleveland Institute of Electronics

WEH01

NEW PRODUCTS

DIGITAL MULTIMETER

The DM383 digital multimeter from *Universal Enterprises, Inc. (UEI)* measures up to 1000 VDC, 750 VAC, AC/DC current, resistance, diodes, and continuity. Its 200-mA range allows measurement of most flame safeguard systems. The DM383 offers a 0.91-inch, 2000-count

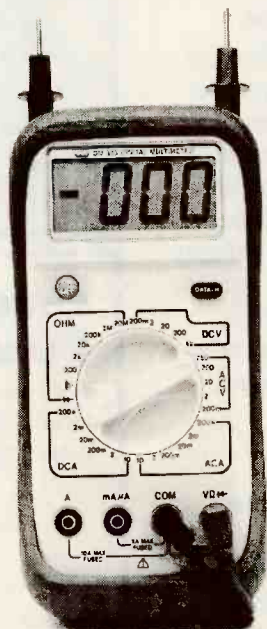

LCD readout and a color-coded front panel. Other features include auto-polarity, data-hold, overrange indicator, low-battery indicator, an audible continuity buzzer, and a diode-check function. The digital multimeter was designed to meet UL and IEC safety standards and to withstand a 10-foot drop. A unique "boot" that allows the user to hang the DMM or position it on a flat surface with an adjustable tilt stand also serves as a probe and lead holder. Probes snap into the boot and leads wrap neatly around it for storage.

The DM383 digital multimeter has a suggested trade price of \$49.95. For additional information, contact UEI, 5500 SW Arctic Drive, Beaverton, OR 97005; Tel. 503-644-8723.

CIRCLE 60 ON FREE INFORMATION CARD

WEATHER FAX PC INTERFACE

Available in kit form or fully assembled and tested, *A & A Engineering's Weather Fax PC-compatible interface* connects between the speaker of a satellite receiver (137 MHz or 1.69 GHz) or a HF SSB shortwave receiver and the computer's standard parallel printer port. Once connected, it will process HF ad satellite weather fax.

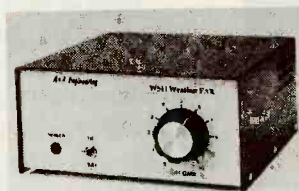

The interface consists of a satellite fax demodulator, a HF fax demodulator, a digitizer, a printer port, and a triple-output power supply. An optional 20-LED tuning indicator is available. The aluminum enclosure is pre-punched, painted, and lettered.

The included software will run on any PC/XT/AT/PS1/PS2-compatible computer with at least 640K of RAM and one floppy drive, parallel port, and a VGA display. To keep up with the satellite data stream in terms of real-time imaging, a 10-MHz 286 system or better is required.

The *WSH Weather Fax* interface costs \$159.95 in kit form or \$189.95 complete. The 20-LED tuning option adds \$40 to the price. U.S. shipping charges are \$6.50. For more information, contact A & A Engineering, 2521 West LaPalma, Unit K, Anaheim, CA 92801; Tel. 714-952-2114.

CIRCLE 51 ON FREE INFORMATION CARD

CAR AMPLIFIERS

The *Mean Machines* line of car amplifiers from *Autotek* includes nine models with larger chassis for increased emphasis on power, aesthetics, and improved heat dissipation. For simplified



installation and improved appearance, all controls and connections are located on the front panels of the two-channel amps. Gold-plated terminals are used for reduced resistance on power and speaker connections. The additional power capabilities are due to new circuit design and an exclusive transformer device that empowers a feature called Inductive Pulse Control.

The Mean Machines car amplifiers have retail prices ranging from \$279 to \$999. For additional information, contact Autotek, 855 Cowan Road, P.O. Box 4391, Burlingame, CA 94011-4391; Tel: 415-692-2444; Fax: 415-692-2448.

CIRCLE 77 ON FREE INFORMATION CARD

ENERGY-SAVING SURGE SUPPRESSOR

Designed to work with any PC or PC clone, *Tripp Lite's Iso-miser* is a combination surge suppressor and screen monitor. It saves electricity by automatically turning off power-hungry computer monitors. Keyboard activity automatically restores the monitor to its prior screen. The *Isomiser* is a member of the EPA's "Energy Star" program, which recognizes power-saving computers and accessories. Monitor shut-off time can be adjusted between five and



60 minutes with a convenient slide control. By powering down the connected monitor, the Iso-miser can provide savings up to \$190 a year per monitor, according to Tripp Lite.

The Iso-miser is also a four-outlet Isobar surge suppressor that provides spike and line filtering, as well as RFI and EMI filtering. Isolated filter banks provide up to 720 joules of surge suppression while preventing interference between connected equipment.

The Iso-miser screen monitor and surge suppressor has a suggested retail price of \$119.95. For more information, contact Tripp Lite, 500 North Orleans, Chicago, IL 60610-4188; Tel: 312-329-1777; Fax: 312-644-6505.

CIRCLE 97 ON FREE INFORMATION CARD

MULTIMEDIA PC'S

Two additions to Canon's line of multimedia PC's, have been designed to support serious multimedia applications. The *Innova Vision L50/340* and *L33/210* each offers a dual-speed, 680-MB CD-ROM drive, a Sound Blaster 16-bit stereo card, and an extensive software package. The L50/340 features the Intel 486DX2/50-MHz microprocessor with a 340MB hard drive. The L33/210 uses an Intel 486SX/33-MHz microprocessor and a 210MB hard drive. Each system includes 4MB of RAM (upgradeable to 36MB), a graphics accelerator, VESA local-bus architecture, and 1MB of video RAM (upgradeable to 2MB for faster playback and display performance). The multimedia computers also come with a fax



modem, shielded stereo speakers, and a 14-inch SVGA monitor. Pre-loaded software includes MS-DOS 6.2, Windows

3.11, MicroFAX, Microsoft Multimedia Works, Microsoft Encarta electronic encyclopedia, and two entertainment titles from Microsoft: Cinemania and Golf.

Estimated street prices for the Innova Vision Multimedia PC's range from \$1700 to \$2050. For more information, contact Canon Computer Systems, 2995 Redhill Avenue, Costa Mesa, CA 92626; Tel: 800-848-4123; Fax: 714-438-3317.

CIRCLE 83 ON FREE INFORMATION CARD

ROBOT KIT

You can build your own robot with the *ADR-1 Robot Kit* from *Aclypse Corporation*. The finished robot stands 27 inches tall, measures 14 inches in diameter, and weighs

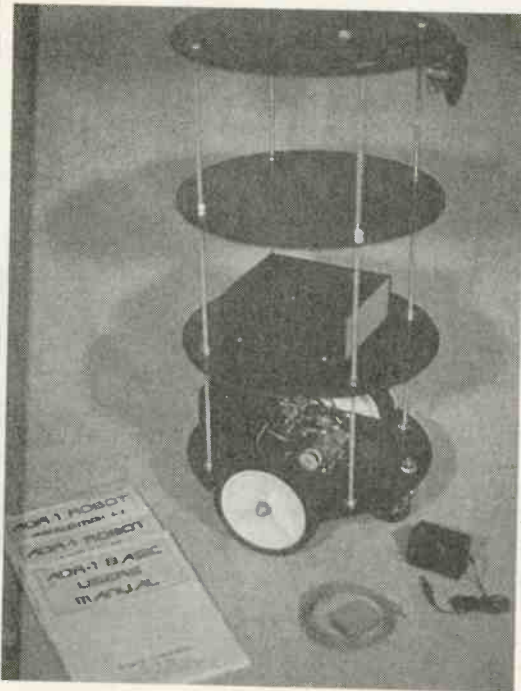

approximately 16 pounds. Its on-board computer system features voice-recognition capabilities, English speech output, power motor drive, and a battery with monitoring and recharge system.

It should take between two and six hours to build the ADR-1 Robot. No special tools or electronics experience is needed to build or use the robot.

The ADR-1 Robot has its own operating system, and a built-in BASIC programming language makes it easy to give the robot instructions. It can be pro-

Electronics
NOW[®]

ELECTRONICS EXPERIMENTER'S handbook™

Winter 1994

Hugo Gernsback (1884-1967) founder

Larry Steckler, EHF, CET,
editor-in-chief and publisher

Julian S. Martin
handbook editor

EDITORIAL DEPARTMENT

Brian C. Fenton, editor
Marc Spiwak, associate editor
Neil Sclater, associate editor
Teri Scaduto, assistant editor
Jeffrey K. Holtzman
computer editor

Dan Karagiannis, assistant editor
Robert Grossblatt, circuits editor
Larry Klein, audio editor
David Lachenbruch
contributing editor

Don Lancaster
contributing editor
Evelyn Rose, editorial assistant
Andre Duzant, art director
Russell C. Truelson, illustrator

PRODUCTION DEPARTMENT

Ruby M. Yee, production director
Karen Brown, advertising production
Kathy R. Campbell, production assistant

CIRCULATION DEPARTMENT

Jacqueline P. Cheeseboro
circulation director
Wendy Alanko, circulation analyst
Theresa Lombardo, circulation assistant
Michele Torrillo, reprint bookstore

Typography by Mates Graphics
Cover design by David Loewy
Cover art by Brad Hamann

Advertising Sales Offices listed on page 112.

Gernsback Publications, Inc.,
500-B Bi-County Blvd., Farmingdale, NY 11735. 516-293-3000

As a service to readers, *Winter 1994 Electronics Experimenter's Handbook* publishes available plans or information relating to newsworthy products, techniques and scientific and technological developments. Because of possible variances in the quality and condition of materials and workmanship used by readers, we disclaim any responsibility for the safe and proper functioning of reader-built projects based upon or from plans or information published in this magazine.

Since some of the equipment and circuitry described in *Winter 1994 Electronics Experimenter's Handbook* may relate to or be covered by U.S. patents, we disclaim any liability for the infringement of such patents by the making, using, or selling of any such equipment or circuitry, and suggests that anyone interested in such projects consult a patent attorney.

Electronics Experimenter's Handbook is published semiannually by Gernsback Publications Inc. All rights reserved. Printed in U.S.A. Single copy price \$3.95, Canada \$4.50. Canadian GST Registration No. R125166280. © Gernsback Publications Inc., 1993, 1994.



*From the Lab
to your
Living Room!*

Does your VCR have a "Head Cold?"

Probably not! However, through constant playing and using of degrading dry or wet cleaners, the output of your video tapes has slowly diminished to an unacceptable level and the VCR plays as if it has a head cold! The culprit is most likely clogged and dirty video and/or audio heads.

The **3M Black Watch™ Head Cleaner Videocassette** uses a patented magnetic tape-based cleaning formation to remove head clogging debris. No foreign substances such as cloth, plastics or messy liquids and no harsh abrasive materials are present. The cleaner's usable life is 400 cleanings or more!

It's easy to use. Place the **3M Black Watch™ Head Cleaner Videocassette** in the VCR and press the Play button. A pre-recorded message appears clearly on your screen and an audible tone is heard, telling you that the cleaning process is now completed. No guess work, you never over clean!

3M Black Watch™ Head Cleaner Videocassette **S**VHS **VHS**.....\$19.95

Once your VCR's head cold is cured, and the unit plays like new, consider using the finest videocassette you can buy—the **3M Black Watch™ T120 Hi Pro VHS 4410 Videocassette**. The 4410 is the highest performing videocassette available today for use with all standard format VHS recording hardware!

Here's what you hear and see....A sharp, clear picture—brightest colors—freedom from streaks, flashes and snow—outstanding high-fidelity audio reproduction—optimum camcorder performance—maintains recording integrity. **3M Black Watch™** video tape is 100% laser inspected to guarantee surface smoothness and drop-out free performance.

3M Black Watch™ T120 Hi Pro VHS 4410 Videocassette **VHS**.....\$8.00

CLAGGK INC. — 3M VHS Special Offer
P.O. Box 4099, Farmingdale, New York 11735

Yes, I like your offer and here is my order for 3M Black Watch™ products!

___ 3M Black Watch™ Head Cleaner Videocassette	(\$19.95 each)	___ \$
___ 3M Black Watch™ T120 Hi Pro VHS 4410 Videocassette	(\$8.00 each)	\$ ___
Shipping and handling per order		\$ 4.00
Total Amount in U.S. Funds only		\$ ___

New York State residents add local sales tax. Canadians add \$6.00 per order. No foreign orders. Do not send cash.

Bill my VISA MasterCard Expire Date ___/___/___

Card No. _____

Signature _____

Name (Please print) _____

Address _____

City _____ State _____ ZIP _____

NEW PRODUCTS

grammed by connecting it to almost any computer or terminal. Program and data files can be sent back and forth between the robot and a personal computer. The on-board computer is powered by a 16-bit 8086-compatible CPU with 256K of RAM. Optional expansion cards can be connected to add memory, sensors, motors, and other new devices.

The ADR-1 Robot Kit costs \$299. For further information, contact Aclypse Corporation, Rt. 2 Box 213H, Worthington, IN 47471; Tel: 812-875-2852; BBS: 812-875-2836.

CIRCLE 89 ON FREE INFORMATION CARD

GRAPHICS ACCELERATOR

Designed for power users of graphic programs such as Windows, Windows NT, OS/2, and AutoCAD, the *VideoBlitz II* graphics accelerator from



Genoa Systems is available in either PCI or VESA local-bus configurations. The PCI version is based on the Weitek P9100 GUI accelerator chip series and an IBM contemporary palette DAC. Equipped with 2MB VRAM standard, the graphics board is upgradeable to 4MB to meet the advanced requirements of Pentium-based PCI systems.

The *VideoBlitz II* can run at a maximum resolution of 1600 x 1200 pixels (up to 64K colors), and can deliver True Color (16.8 million colors) PCI graphics acceleration at 1280 x 1024 resolution. "FlickerFree" technology provides refresh rates that exceed VESA specifications at all resolutions.

The graphics accelerator includes high-performance drivers for Windows, Windows NT, and OS/2 2.1 environments, as well as for Ventura, Lotus 1-2-3, Microsoft Word, and WordPerfect. In addition, the Turbo DLD drivers from Panacea offer support for AutoCAD, AutoShade, AutoSketch, 3D-Studio, and other AutoDesk programs. An easy-to-use, menu-driven installation program is executable from either DOS or Windows.

The suggested list price for the PCI local-bus version of VideoBlitz II is \$589. The 2MB VESA local-bus version, which runs High Color (64K colors) at 1024 x 768 pixels and True Color at 800 x 600 pixels, has a suggested list price of \$549. For more information, contact Genoa Systems, 75 East Trimble Road, San Jose, CA 95131; Tel: 408-432-9090 or 800-934-3662; Fax: 408-434-0997.

CIRCLE 62 ON FREE INFORMATION CARD

PALM-SIZED WORLD-BAND RECEIVER

Whether you take frequent business trips, are planning a globe-trotting vacation, or prefer "arm-chair travelling" from the comfort of your own home, Sony's ICF-SW100S world-band receiver can help you keep up with news and events from around the world or around your town. The rugged, battery-powered receiver weighs just eight ounces, making it easy to take on the road. The ICF-SW100S can receive long-, medium-, and short-wave signals, as well as FM stereo. Its active antenna for shortwave reception helps pick up the clearest signal even in environments that typically have poor reception.

The receiver provides accurate information about time, broadcasting stations, and frequencies. Once the user inputs the local time, the built-in world clock can display the correct time of 24 major cities around the world. An LCD readout displays the names of broadcasting stations and their frequency numbers. Up to 50 different frequencies can be stored in the receivers memory,



so the user can preset several different frequencies for each station and call up the most suitable one depending on the time or the season. The receiver's stand-by function has two timer settings so that favorite programs won't be missed.

The ICF-SW100S world-band radio receiver, complete with AC adapter, has a suggested retail price of \$449.95. For more information, contact Sony, 1 Sony Drive, Park Ridge, NJ 07656.

CIRCLE 68 ON FREE INFORMATION CARD

TRUE-RMS BENCHTOP DIGITAL MULTIMETER

For use in electronics service and production tests, Wavetek's Model BDM40 4½-digit, true-RMS digital multimeter features AC and DC voltage measurement in six ranges to 20 megohms and a diode test range. The true-RMS measuring circuit is pushbutton selectable for AC or AC plus DC coupling to assure accurate measurements. All functions and ranges are selected using interlocking front-panel push-



45,736

ELECTRONIC COMPONENTS

Whether you order 1 part or all 45,736...MOUSER stocks and...ships same day!!

CALL... (800) 992-9943

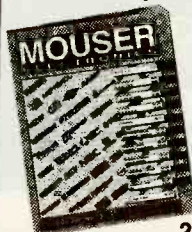

for your
FREE CATALOG

2401 Hwy 287 N.
Mansfield, TX 76063

MOUSER[®] ELECTRONICS

Sales & Stocking Locations Nationwide

CIRCLE 43 ON FREE INFORMATION CARD

FULL- OR PART-TIME JOB/BUSINESS:

Learn VCR repair!



Career-level home study. Master easy-to-learn, high-profit repairs without buying costly, high-tech instruments. **Free literature: send or call 24 hours a day.**

800-223-4542

Name _____ Age _____

Address _____ Phone () _____

City _____ State _____ Zip _____

The School of VCR Repair

PCDI, 6065 Roswell Road
Dept. VRL351, Atlanta, Georgia 30328

Be a computer repair expert!

Career-level home study course. Learn all about PC repairs, troubleshooting, installation, upgrading, servicing. Open your own business; become a more valuable employee. **For free literature: send or call 24 hours a day.**

800-223-4542



Name _____ Age _____

Address _____ Phone () _____

City _____ State _____ Zip _____

The School of PC Repair

PCDI, 6065 Roswell Road
Dept. JLL351, Atlanta, Georgia 30328

CIRCLE 44 ON FREE INFORMATION CARD

**IF COLLEGE
IS IN YOUR
CHILD'S FUTURE,
U.S. SAVINGS
BONDS
SHOULD BE
IN YOUR
PRESENT.**

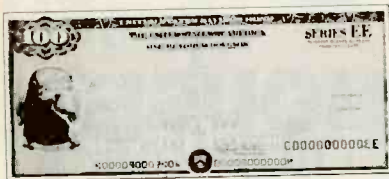

How can you be sure the money you save for college will be there by the time your child goes to college? Invest in U.S. Savings Bonds.

Ask your employer or banker about saving for college with U.S. Savings Bonds. Or write:

**U.S. Savings Bonds
for Education**

**Dept. of the Treasury
Washington, DC 20226**

**For a recorded message of
current rate information,
call 1-800-4US BOND
1-800-487-2663**



A public service of this magazine

NEW PRODUCTS

buttons. For user safety and convenience, input jacks are boldly labeled and the 2-amp jack is fully fused.

The Model BDM40 digital multimeter, complete with test leads, power cord, and a comprehensive instruction manual, costs \$429. For further information, contact Wavetek Corporation, 9045 Balboa Avenue, San Diego, CA 92123; Tel. 619-279-2955.

**CIRCLE 56 ON FREE
INFORMATION CARD**

WEATHER WIZARD II

You can monitor indoor and outdoor weather at the touch of a button with *Davis Instruments' Weather Wizard II*. The sophisticated, professional-quality weather station measures inside temperature from 32°F to 140°F,



outside temperature from -50°F to 140°F, records high and low temperatures, monitors wind direction and wind speed, records high wind speed, calculates wind chill to -134°, and records low wind chill. All highs and lows are recorded with time and date. Alarms can be set to sound when temperature, wind speed, or wind chill fall above or below preset levels.

The Weather Wizard II's functions can be easily expanded with optional add-ons. The Rain Collector allows you to measure daily and accumulated rainfall. Weatherlink allows you to link the Weather Wizard II to an IBM-compatible PC or Macintosh to process, analyze, and store weather data.

The Weather Wizard II, complete with an anemometer with 40 feet of cable, an external

temperature sensor with 25 feet of cable, a junction box with eight feet of cable, an AC-power adapter, and detailed instructions, costs \$195. For more information, contact Davis Instruments, 3465 Diablo Avenue, Hayward, CA 94545; Tel. 800-678-3669 or 510-732-9229; Fax: 510-732-9188.

**CIRCLE 64 ON FREE
INFORMATION CARD**

ELECTROCHEMICAL MARKING SYSTEM

The *IMG Electromark SS111*, available from *Jensen Tools*, is an electrochemical marking system that uses a low-voltage, low-amperage electrical current to etch permanent identification marks on metal. The SS111

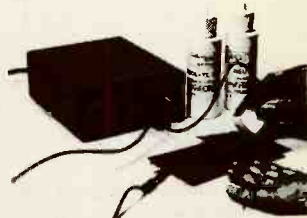

includes a 115-VAC, 50/60-Hz power supply, a stenciling tool, electrolyte, and neutralizer. When the electrolyte is applied to the stencil, it allows electrical current to pass through and onto the object being marked. Because the metal is etched away from the surface of the object, the mark is permanent. The entire process takes only a few seconds, and is a safe, easy, and economical way to mark metal objects for inventory control or security. Electrolyte will not damage skin, clothing, or surrounding equipment. Stencils can be made on any typewriter. Custom stencils are also available.

The IMG Electromark SS111, including instructions and carrying case, costs \$329. For additional information, contact Jensen Tools Inc., 7815 South 46th Street, Phoenix, AZ 85044; Tel. 800-426-1194; Fax: 602-438-1690.

**CIRCLE 75 ON FREE
INFORMATION CARD**

5 WAYS TO STOP WASTING TIME IN ELECTRONICS.

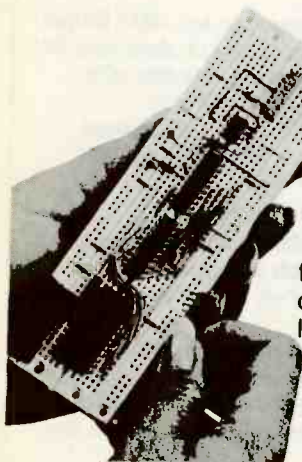

Stop wasting your time soldering. Save hours of soldering, desoldering, resoldering with Quick Test™ sockets and bus strips. Connect/disconnect resistors, capacitors, transistors, ICs, etc. as fast as you can push in/pull out leads. Interlock for limitless expandability. Priced as low as \$1.60, you'll wonder how you've done without them!

5-color coded binding posts and 17 sockets, for over 4,560 contact points. Lifetime guarantee. American-made. Affordably priced.

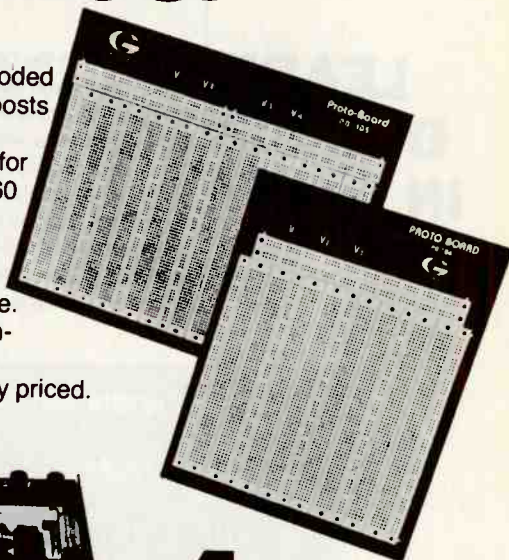

2.

Stop wasting your time breadboarding. Here

are three popular PROTO BOARD® Brand solderless breadboarding systems that meet any budget or time schedule. First the diminutive PB-10's 840 contact points and 3-color binding posts. PB-102 has 1,240 tie points, accepting up to 12 16-pin ICs. Finally, PB-103, with 2,250 contact points, and up to 24 16-pin capacity. They're affordable, American-made, lifetime guaranteed. You'll soon see why PROTO BOARD Brand is Today's Standard for Quality in Breadboarding.

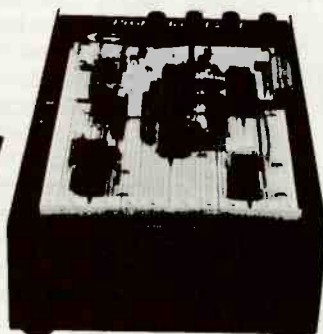
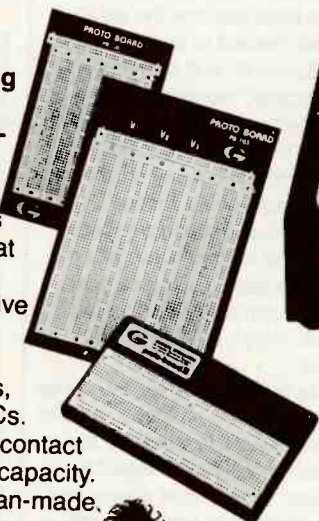

4.

Stop wasting your time plugging-in external power.

We've added the power to the breadboard. And, what power! Up to triple voltage power, +5V, +12V, -12V, regulated/current limited and DC. Up to 2,250 tie points, with 24 IC capacity and 14 pin DIPs. Now you can create, test and modify TTL, CMOS, Op-Amps and even microprocessor circuits. Plus, there is the standard Global Lifetime Guarantee on the sockets. And, wait 'til you see the modest prices!

3.

Stop wasting your time jury-rigging

large numbers of circuits. Here are two oversized PROTO BOARDS Brand, with expanded area, tie points, and more to keep your ideas together. PB-104 features 3,060 tie points, which can handle to 32 16-pin ICs with ease. Four color coded binding posts, and roomy 9.2" x 8" metal panel make it big...but simple. The humungous PB-105 lets you load up to 48 16-pin ICs, and much more onto its



5. NEW!

Stop wasting time designing computer circuits. Now you can use your solderless breadboard concepts for designing accessory circuits. PROTOCARD® is a PROTO BOARD Brand which fits any standard slot in your IBM, PC/XT or PC/AT computer. Some modules even include built-in basic decoder circuits for memory and I/O addressing. Breadboard areas up to 3,360 contact points. Buffered versions eliminate loading of pc buses.

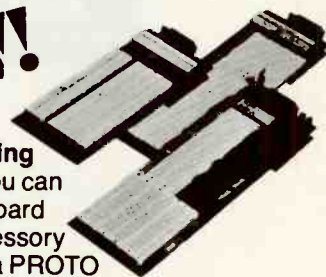

Easy does it!



Call toll-free for details
1-800-572-1028

GLOBAL SPECIALTIES

GLOBAL SPECIALTIES
70 Fulton Terrace, New Haven, CT 06512
(800) 572-1028 • Fax: (203) 468-0060

an **Interplex Industries** company

CIRCLE 47 ON FREE INFORMATION CARD

A0011

ELECTRONICS LIBRARY

LEARN DOS 6.2 IN A DAY

by Russell A. Stultz

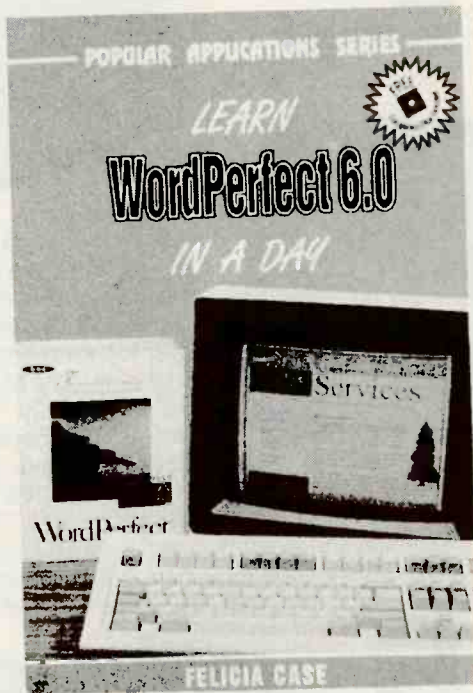

Designed with the beginner in mind, this tutorial makes it easy to master the most common DOS commands with practical, hands-on activities. It guides readers through the important commands that are found in every version of MS-DOS, and also explains how the new DOS 6.0 and 6.2 utilities can be used

to enhance computer operations. The book provides the means to quickly identify which commands are available in later versions, but unavailable in earlier versions, of MS-DOS. With an emphasis on learning by doing, the book has readers formatting disks, copying files, and displaying their contents within minutes after opening its cover.

Learn DOS 6.2 in a Day costs \$12.95 and is published by Wordware Publishing, Inc., 1506 Capitol Avenue, Plano, TX 75074; Tel: 214-423-0090.

CIRCLE 91 ON FREE INFORMATION CARD

THE COMPREHENSIVE GUIDE TO MILITARY MONITORING

by Steve A. Douglas

Ironically, the complexity that gives military monitoring much of its appeal also scares off many would-be listeners. This book aims to demystify the world of military monitoring, spelling out in simple terms—with no techno-jargon—how anyone can monitor military radio communications with a minimum of confusion and cost. The book explains the equipment needed to tune military frequencies, and provides a “milspeak” dictionary to help readers understand military lingo. The book also includes a base-by-base listing of all military frequencies, the top nationwide frequency listings, maps of military bases and refueling tracks, a source guide, and a complete listing of the U.S. Navy's FLTSATCOM channels.

In the final chapter, the author describes the shadowy world of stealth aircraft, which he has been monitoring closely for years. He includes photos and illustrations of secret aircraft, and a video still of the “TR-3A Black Manta,” which the Air Force still denies exists.

The Comprehensive Guide to Military Monitoring is available for \$19.95 plus \$4.00 shipping (Priority Mail) from Universal

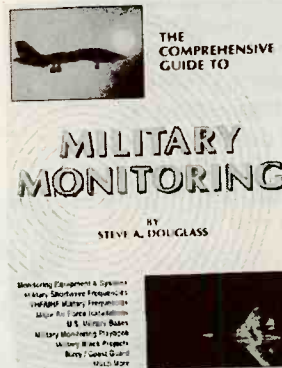

Electronics, Inc., 4555 Groves Road, Suite 13, Columbus, OH 43232; Tel: 614-866-4605; Fax: 614-866-1201.

CIRCLE 90 ON FREE INFORMATION CARD

LOTUS NOTES ANSWERS: Certified Tech Support

by Polly Russell Kornblith

The author teamed up with Corporate Software Inc., one of the world's largest providers of technical support, to produce this

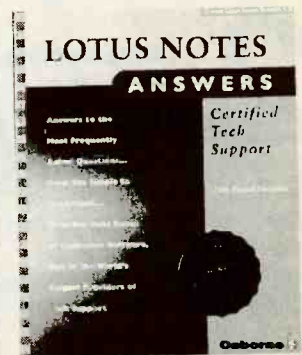

comprehensive, easy-to-use book. Handling 200,000 technical questions via phone each month, Corporate Software determined the questions most frequently asked by users of Lotus Notes. Both the questions and the answers appear in this book, eliminating the need to call the tech support helpline or waste time trying to find the answer in voluminous user's manuals. A wide range of Lotus Notes topics are covered, from adding and opening multiple databases, to using Views, to organizing and retrieving information. The book covers all the common pitfalls and trouble spots associated with Lotus Notes, including protecting and sending documents, and deciphering error messages. It explains how to use functions to look up information in other documents or databases, how to use encryption to protect your

mail, and how to import and export data to and from Notes. Finally, the book tackles the "Top Ten Tech Terrors" and offers "Frustration Busters" intended to help prevent problems before they occur.

Lotus Notes Answers: Certified Tech Support costs \$16.95 and is published by Osborne McGraw-Hill, 2600 Tenth Street, Berkeley, CA 94710; Tel: 510-549-6600; Fax: 510-549-6603.

CIRCLE 100 ON FREE INFORMATION CARD

HIDDEN HAM ANTENNAS

by Frank P. Hughes, VE3DQB

If you live in a neighborhood or apartment complex that places restrictions on ham antennas, this is the book for you. Following its "So long as what you put up does not look like a ham antenna, it's not likely to be questioned" motto, the book provides a wealth of ingenious ways to hide antennas—including placing them inside

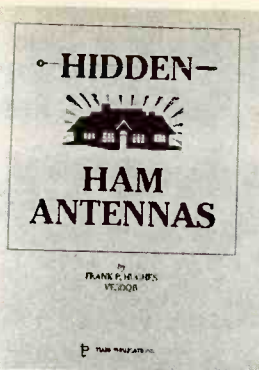

flagpoles or arbors, or disguising them as bird-house poles or tomato-plant supports! It covers outdoor, indoor, high-frequency, and VHF/UHF antennas, and presents methods to disguise them all. It also discusses antenna tuners, grounds, and counterpoises, and recommends some easily disguised commercial antennas.

Hidden Ham Antennas is available for \$12.95 plus \$2 shipping and handling (\$3 foreign) from Tiare Publications, P. O. Box 493, Lake Geneva, WI 53147; Tel: 800-420-0579.

CIRCLE 54 ON FREE INFORMATION CARD

FISHER WORLD TREASURE NEWS Volume 5, Issue 1

from Fisher Research Laboratory

This 28-page, magazine-format newsletter documents valuable discoveries made all over the world by people using Fisher metal detectors. The newsletter contains sections on archaeology, gold prospecting, underwater treasure hunting, and the use of metal detectors in law enforcement. It features stories on the lost legions of

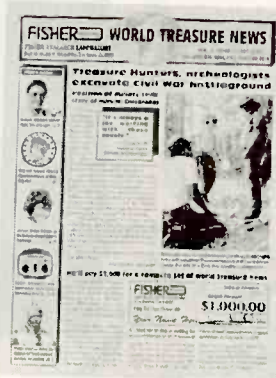

Rome, a 23-ounce gold nugget, a Civil War battle site, an 1874 key-date coin worth more than \$10,000, and a scuba-diving show.

The Fisher World Treasure News is free upon request from Fisher Research Laboratory, 200 West Wilmott Road, Dept. PE, Los Banos, CA 93635; Tel: 1-800-M-SCOPE-1.

CIRCLE 92 ON FREE INFORMATION CARD

THE VIRTUAL REALITY CONSTRUCTION KIT

by Joe Gradecki

Intended to provide "total immersion" in the virtual-reality experience, this book shows readers how to create virtual reality in their own homes. It offers plans for 14 inexpensive projects, designed to be hooked up to a home computer, that can be built even by those with no programming or electronics background. Projects include adapting existing hardware (such as Nintendo PowerGloves (Turn to page 109)



RECEIVING TUBES

OVER 3000 TYPES IN STOCK!

Also hard-to-find transformers, capacitors and parts for tube equipment. Send \$2.00 for our 32 page catalog.

ANTIQUE ELECTRONIC SUPPLY

6221 S. Maple Ave. • Tempe, AZ 85283 • 602-820-5411

Prototype it..... FAST!

with ProtoQuick 8051 or Z8

- Complete single board computers
- Up to 32K of PROM and DRAM
- 12 sq. in. plated through hole PCB
- RESET: 1 sec. at port or 100K 200K
- Op. exp. in EPROM or ROM code
- Assembled ready to run. \$5 only.
- MS-DOS cross assembler included.

ProtoQuick Z8 and 8051 **\$99.00** each

Software Selection: 2710 Heathkit Road, Channahon, IL 61614 (513) 561-2060

Run prototype applications or experimental hardware from the serial port. WITHOUT PROGRAMMING!

SURVEILLANCE & COUNTERSURVEILLANCE Electronic Devices

Transmitter Kits \$29.00 • Bug/Phone Tap Detectors
Covert Video Cameras • Books • Videos • Voice Changers
Shotgun Mics • Vehicle Tracking • Locksmithing • AND MORE!

7-Hour Telephone Recorder
Tapes incoming/outgoing phone calls automatically. **\$125.00**

FOR CATALOG SEND \$5.00 TO...
P.O. Box 337, Buffalo, NY 14226 (716) 691-3476

SUPPORT RESEARCH.

It Works Wonders.

CABLE TV DESCRAMBLERS

Best Prices in the U.S.A!
Guaranteed to Work!

QUANTITY DISCOUNTS



Jerrold, Scientific Atlanta
Pioneer, FTB-3, SA3

The Newest & the Latest

TVT-3K - Jerrold Impulse & Starcom series
SA3-DFA - Scientific Atlantas including 8536, 8536+, 8580, Drop-field
PN-3A - Pioneer systems

Panasonic TZPC145G 99 Ch Converters
Zentek XL2100 99 Channel Converters

30 DAY MONEY BACK GUARANTEE
FAST SHIPMENTS & FREE CATALOG

1-800-772-6244

M-F: 9-6 EST

U.S. Cable TV, Inc. Dept.: KEN094

4100 N. Powerline Rd, Bldg. F-4 Pompano Beach FL 33073

NO FLORIDA SALES!

CIRCLE 46 ON FREE INFORMATION CARD

FREE

Electronics & Computer Software
Education Catalog

*Fast-Track Individual Learning Programs
*State-of-the-Art Classroom Courses
*The Best Values in Electronics Education

New

Career-Level Courses
Personal Computer Servicing
TV and VCR Servicing

New

Computer-Aided Instruction

DC & AC Electronics
Semiconductors
Electronic Circuits

The stunning animations, hypertext
glossary, and easy-to-understand text make
learning electronics a breeze...and fun!

Learn the easy and affordable way from the
Masters in Electronics Training - **Heathkit**.
From Basic Electricity to Advanced Microprocessor
Applications and more, Heathkit will provide
you with an unparalleled learning experience at a
fraction of the cost of other programs.

Heathkit[®]
Educational Systems

For your FREE Catalog, call

Toll-Free 1-800-44-HEATH

please mention this code when calling 020-029

CIRCLE 42 ON FREE INFORMATION CARD

AM POWER LOOP ANTENNA

IF ANY OF YOUR FAVORITE AM RADIO stations is hard to receive because it is so far away, the Power Loop, an AM radio antenna booster, is the project for you. When coupled to your AM receiver, the improved signal-to-noise ratio it makes possible to boost the reception of any station in the 535 to 1705 kHz AM band. It will help out in poor reception areas, and you might even find yourself listening to AM stations that you never knew existed!

Here are some reasons you'll want to build this compact, easy to operate Power Loop:

- It eliminates the need to "jockey" your radio around to get the best signal from the AM station you want to hear.
- Its directivity reduces or eliminates most undesired interference, including radiated AC hum.
- It reduces or eliminates annoying heterodyne whistle.
- It compensates for AM receiver antenna circuit *tracking error*, assuring ideal RF tracking across the entire band.

The Power Loop is an easy to build, high-performance accessory for your AM radio. It contains no costly, hard-to-get components or critical wiring. Both circuit board construction and a modest amount of mechanical crafting are needed to build the project. Its power consumption is very low—a matter of milliwatts, and no special tools or test instruments are needed. However, a multimeter will be helpful for troubleshooting if the Power Loop does not work correctly when it is first turned on.

The high-Q loop can be remotely tuned with a rotary potentiometer control. The loop, the largest component in the system, can be attached to the wall above your AM radio. No electrical connections to your radio are needed because the loading coil, an important system component, is inductively coupled to the ferrite "stick" antenna in your radio. If the enclosure on your AM receiver is large enough, the loading coil can be placed inside.

Build this AM radio antenna booster and receive distant stations that you never expected!

ALLEN A. GAULT

Power Loop system

The Power Loop has four components and five functional sections, as shown in Fig. 1:

1. **Tuner amplifier**—includes the loop antenna and the tuner-amplifier. The varactor-tuned antenna is connected to the low-noise amplifier mounted at the base of the loop. The assembly consisting of the tuner amplifier and loop antenna can be attached to the wall near your AM receiver with a picture hook, suction cups or adhesive pads.
2. **Remote tuning control**—contains the power switch, tuning potentiometer and power indicator LED. Its rectifier-filter circuit converts the 24-volt AC input from the wall outlet-mounted transformer to filtered DC. The unit provides the variable voltage required to tune the loop to the desired frequency.
3. **Loading coil**—is placed near the AM receiver to couple the amplified RF signal to the host AM radio receiver inductively.
4. **Transformer**—a plug-in, wall-outlet-mounted transformer that supplies 24-volt AC to the remote tuning control from the 120-volt AC line.

Circuit operation

Figure 2 is the schematic for the tuner-amplifier. The loop antenna is connected to the gate input of transistor Q1, and it is tuned by varactor D1. Tuning voltage is available through R1, which is connected to the remote tuning control with a two-wire shielded cable and plug PL1. The drain output of Q1 is coupled to the gate of Q2 for ad-

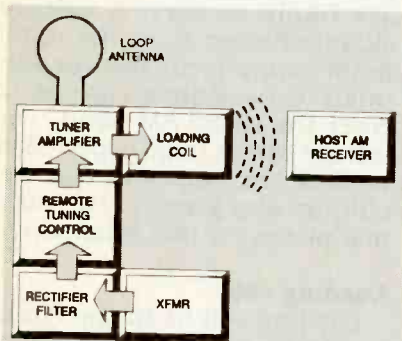

FIG. 1—AM ANTENNA POWER booster block diagram. The loop antenna can be mounted on or near the host AM radio. The loading coil field couples to the AM radio's antenna.

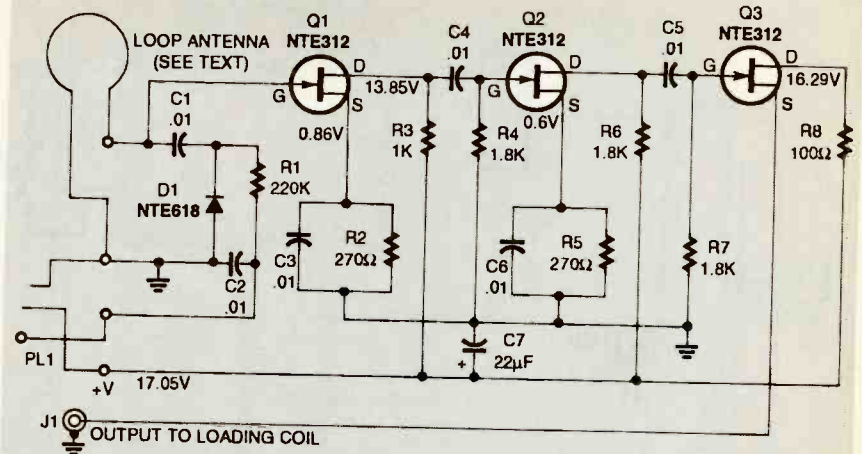

FIG. 2—TUNER-AMPLIFIER SCHEMATIC DIAGRAM: Three JFETs, Q1 to Q3, amplify the signal. Loop antenna tuning is performed by varactor diode D1.

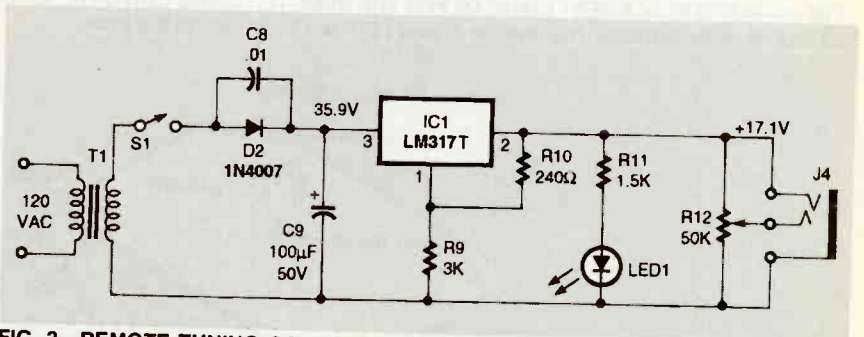

FIG. 3—REMOTE TUNING CONTROL UNIT SCHEMATIC DIAGRAM. Raw 24-volt AC input is rectified and regulated in this circuit designed for improved filtering. Potentiometer R12 permits fine tuning.

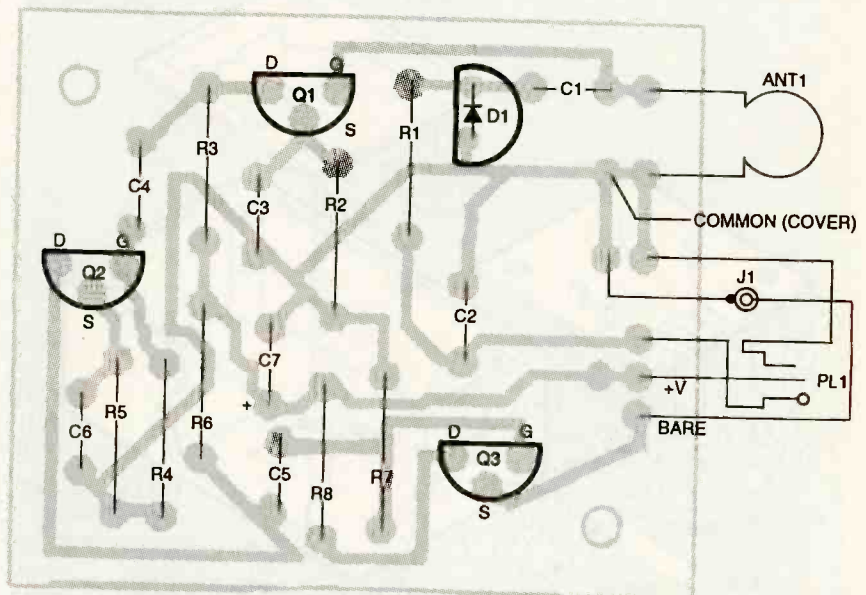

FIG. 4—PARTS PLACEMENT DIAGRAM FOR TUNER-AMPLIFIER. Jack J1 and plug PL1 are mounted on the case.

ditional amplification. The drain output of Q2 is coupled to the gate of Q3, which is connected as a source-follower.

The high input impedance of Q1 presents minimal loading on the tuned loop. The Q3 source-follower powers the loading coil

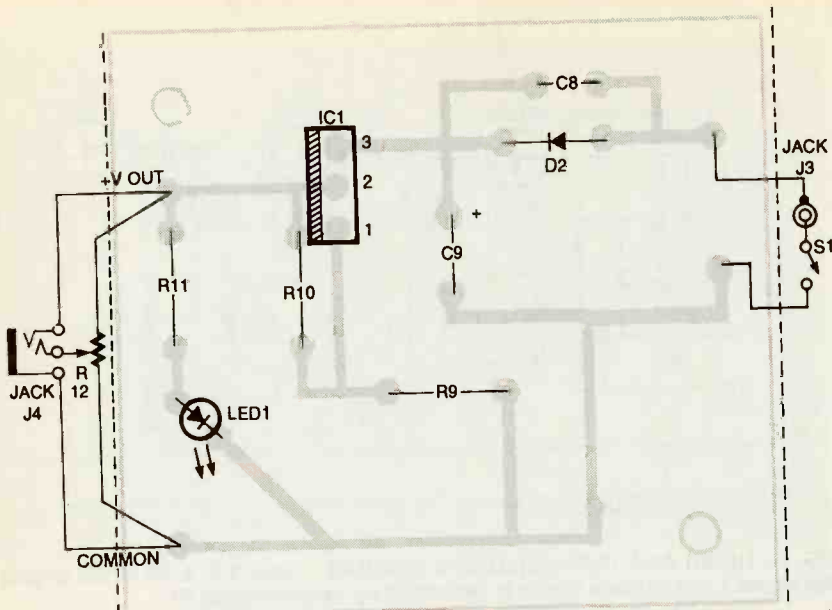
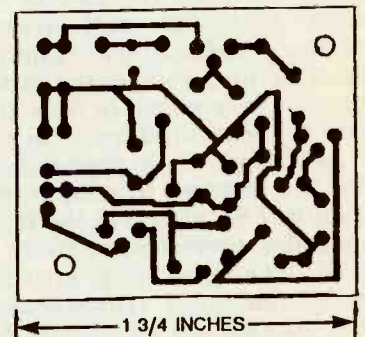

FIG. 5—PARTS PLACEMENT DIAGRAM FOR THE REMOTE TUNING CONTROL. Jacks J3 and J4, potentiometer R12, switch S1 and LED1 are mounted off the case.

Figure 3 is the schematic for the remote tuning control. The 24-volt AC from the wall-outlet transformer via cable can be turned on and off by switch S1. Diode D2 rectifies the input AC voltage, and C8 filters out AC line hum. Capacitor C9, part of the "L" input filter, filters the rectified voltage.

Three-terminal TO-220-packaged voltage regulator IC1 can be adjusted to provide about 17 volts DC by setting the ratio of the value of resistor R9 at pin 1 with respect to that of R10 shunting pins 1 and 2.

The rectification and filtering function are included in the re-



FOIL PATTERN FOR TUNER amplifier PC board.

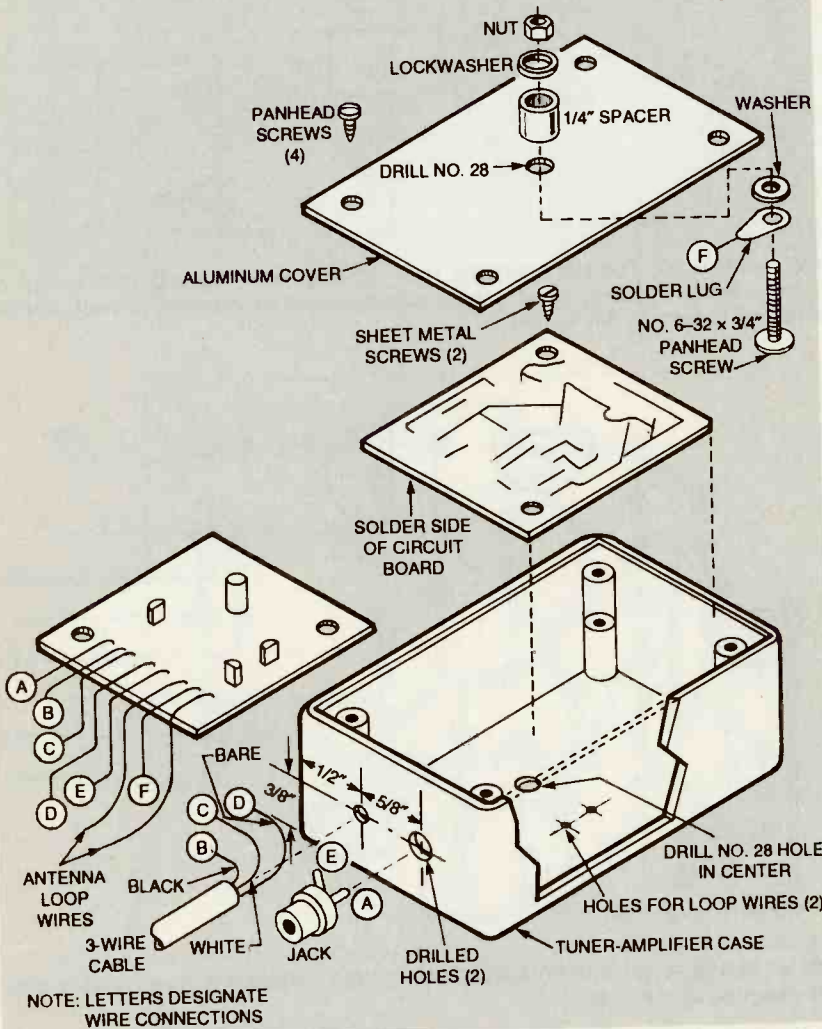

FIG. 6—ASSEMBLY DIAGRAM FOR THE TUNER AMPLIFIER. The circuit board is mounted in an inverted position, and the complete unit moves with the loop antenna.

mote tuning control to eliminate tunable hum likely to be present if a stock wall outlet-mounted AC-to-DC adapter were used. Capacitor C8, in parallel with diode D2, blocks tunable hum.

At least a 17-volt output is needed to tune the loop over the entire AM broadcast band, but the distributed capacitances of each system and the varactors like D1 (see Fig. 2) are likely to vary. A voltage slightly higher than the minimum requirement assures adequate capacitance change to cover the entire AM band. The voltage values to be expected at various test points in this circuit are also given to two decimal places on this schematic.

Loading coil

Loading coil L1 in the Power Loop is a ferrite-rod antenna. Typical of those found in most AM radio receivers today. It can be salvaged from a discarded radio or purchased from the

through a shielded phono cable. The voltage values to be ex-

pected at various test points in the circuit are given.

source given in the Parts List. Only the high impedance part of the winding is used.

Electronic construction

Tuner-amplifier—Refer to Fig. 2 and the tuner-amplifier parts-placement diagram Fig. 4. A foil pattern for the tuner-amplifier circuit board is included in this article if you want to make your own, but a finished board is available.

Insert and solder the components to the circuit board following conventional practice. Be sure the soldering iron is appropriate for the small size of this circuit board and that it is

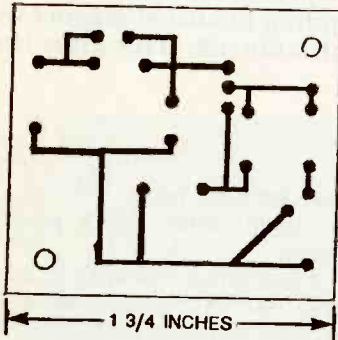

FOIL PATTERN FOR REMOTE tuning control PC board.

at the at the right temperature for melting rosin-core solder. Observe the orientation of the packages and pins on JFETs Q1, Q2 and Q3, and observe the polarity of electrolytic capacitor C7 when inserting them in the board.

Remote tuning unit—Refer to the schematic Fig. 3 and the remote tuning unit parts placement diagram Fig. 5. A foil pattern for the tuner-amplifier circuit board is included in this article if you want to make your own, but a finished and drilled board is also available from the source given in the Parts List.

Insert and solder the components to the circuit board, again following conventional practice. Again, be sure the soldering iron is appropriate and at the right temperature for melting rosin-core solder. Observe the correct positioning of the package and pins of voltage regulator IC1 and the polarities of electrolytic capacitor C9 and diode D2 when inserting them.

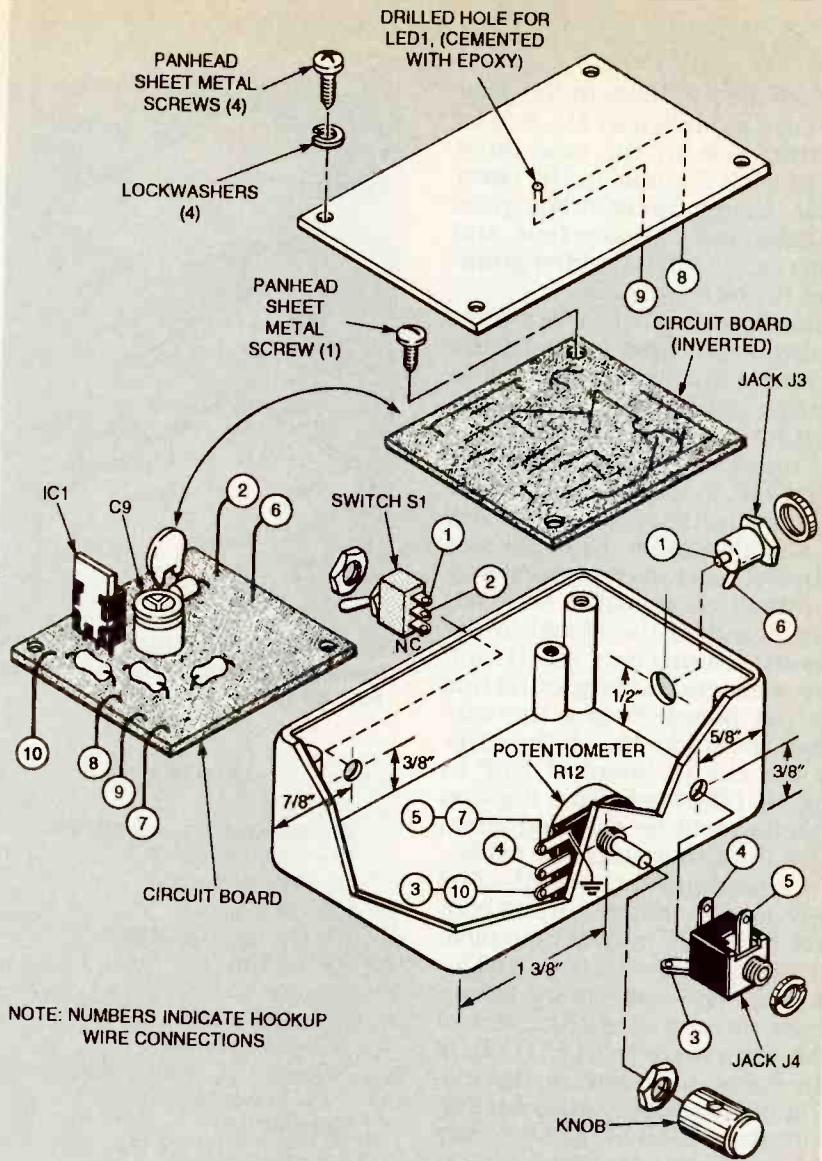
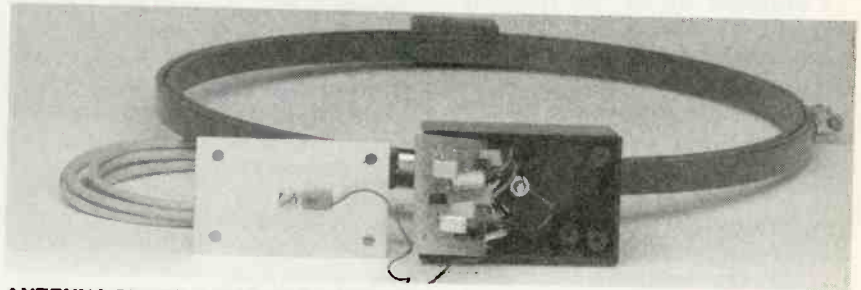

FIG. 7—ASSEMBLY DIAGRAM FOR THE REMOTE TUNING CONTROL. This unit includes the rectifier and filter for noise-free DC and the tuning potentiometer R12.



ANTENNA-TUNER AMPLIFIER ASSEMBLY.

Packaging the electronics

Tuner-amplifier. The tuner-amplifier case is a stock project case with an aluminum cover that measures $2\frac{1}{16} \times 1\frac{1}{16} \times 1\frac{3}{16}$ inches. Refer to the assembly diagram Fig. 6, and drill a hole in the center of the cover with a No. 28 drill.

Cut and strip both ends of a 4-inch length of insulated, No. 22

hookup wire and solder a lug to one end. Place the lug on a No. 6-32 $\times \frac{1}{4}$ -inch panhead machine screw as shown in Fig. 6, and assemble a washer before inserting it in the hole and fastening it with a $\frac{1}{4}$ -inch spacer, lockwasher, and nut, as shown. (The free end of the wire will be connected to the ground bus on the circuit board later.)

Drill the five holes in the plastic case as shown in Fig. 6. The central hole in the case must align with the hole in the cover plate. Install the RCA-type phono cable jack J1 in one hole, and insert a 1/4-inch ID rubber grommet in the other hole.

Insert the end of the ten-foot, two-wire shielded cable in the grommet and strip the jacket to permit making the three connections as shown in Fig. 6.

Connect the center conductor of jack J1 (A to A in Fig. 6) to the PC board with about 2 3/4 inches of shielded cable. Keep the unshielded part of the center wire as short as possible on each end. Connect the shield to the ground connection on J1 and the other end to the ground bus on the board. Solder the wire from the solder lug on the cover to the circuit board (F to F in Fig. 6). (The leads from the loop antenna will be soldered later.) SET the tuner amplifier aside.

Remote tuning control—The case for the remote tuning control is a stock project case measuring 2 1/16 x 1 1/16 x 1 3/16 inches. Drill a hole in the aluminum cover to admit the lens of the miniature red LED1. Drill the holes as shown in the mechanical assembly diagram Fig. 7 for the switch S1, jacks J3 and J4, and potentiometer R12. Mount those components in the walls of the case.

Complete all of the hookup wiring between the circuit board and the off-board components with No. 22 insulated wire. (Different colored insulation will make troubleshooting easier.) Cut and strip the ends of the wires to lengths that are long enough to permit removing the circuit board without breaking any connections.

When all of the soldering is complete, invert the board and fasten it to the inner stud with a single panhead sheet metal screw as shown in Fig. 7. Cement LED1 in place with its lens projecting through cover with epoxy, and clamp the leads to underside of the cover with an insulating adhesive strip. Close the cover and fasten it with four screws. Set the unit aside.

Loading coil. The plastic case

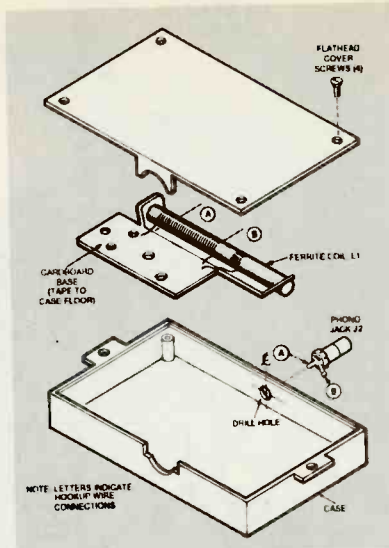

FIG. 8—ASSEMBLY DIAGRAM for the loading coil. Unit is located in or near the host AM radio.

for the loading coil measures 4 1/4 x 2 1/8 x 1-inch deep, and it has a plastic cover. Drill a hole for mounting RCA phono jack J2 in one wall of the plastic case, as shown in Fig. 8. Mount the jack in position as shown. Cut, strip, and solder the hookup wires as shown in Fig. 8 from the coil to J1.

Fasten the coil base in the bottom of the case as shown in Fig. 8 with double-sided adhesive tape. (The coil might or might not have a cardboard base.) Close the cover and fasten it with four screws. Set it aside.

Making the loop antenna

The loop antenna is made by winding insulated magnet wire on the outside of the inner hoop

PARTS LIST

All resistors are 1/4-watt, 5%.

- R1—220,000 ohms
- R2, R5—270 ohms
- R3—1000 ohms
- R4, R6, R7—1,800 ohms
- R8—100 ohms
- R9—3000 ohms
- R10—240 ohms
- R11—1,500 ohms
- R12—50,000 ohms potentiometer, PC board mounting

Capacitors

- C1, C2, C3, C4, Cr, C6—0.01µF, radial-leaded, Mylar, 50 volts
- C7—22µF, 35 volts, aluminum electrolytic
- C8—0.01µF, ceramic disk, 100 volts
- C9—100µF, 50 volts, aluminum electrolytic

Semiconductor

- IC1—LM317T voltage regulator, TO-220 package, Motorola or equivalent
- Q1, Q2, Q3,—N-channel JFET, NTE 312 or equivalent
- D1—varactor, NTE 618 or equivalent
- D2—1N4007 silicon diode
- D3—light-emitting diode, red, T1 or miniature axial lead.

Other components

- J1, J2—RCA jacks, panel mounting
- J3—audio jack for two-conductor shielded audio cable
- J4—jack to mate with 24-volt AC input plug from wall-outlet mounted transformer
- L1—loading coil, high-Q ferrite, (see text)
- PL1—plug for two-conductor

- shielded audio cable
- S1—toggle switch, SPST, panel mount
- T1—transformer, 120-VAC to 24-VAC, 100 mA or greater, wall outlet-mounted with output cable and plug

Miscellaneous: PC board for tuner-amplifier; PC board for remote tuning control; shielded phono cable terminated with RCA plugs, both ends, 6 feet; two-conductor shielded audio cable, 10 feet; metal shelf-mounting channel, 3 feet (see text); two spacers, 1/4 long; tuner-amplifier case with cover (see text); remote tuning control case with cover (see text); loading coil case with cover (see text); knob for potentiometer; No. 6-32 machine screws, nuts, lock-washers (see text), epoxy cement; wood glue; double-sided adhesive tape; solder; beeswax.

Note: The following parts are available from Allen A. Gault, 2012 Citrus Avenue, Jessup, MD 20794:

- Drilled PC boards for tuner amplifier and remote tuning-control unit—\$8.95
- High-Q loading coil with mounting tape—\$3.95
- No. 26 magnet wire, 50 feet—\$1.95
- Kit of all items listed above—\$13.95

Add \$1.50 for shipping and handling, Maryland residents add local sales tax.

of a pair of standard wooden 10-inch embroidery hoops. (They have an outside diameter of about 10 $\frac{3}{8}$ inches.) The inner hoop serves as the coil form, and the outer loop serves as a protective cover. These hoops are available in sewing supply and craft shops as well as five and ten and department stores, typically for less than \$2.

The complete loop antenna will be clamped inside a "C-" shaped support bracket with screws and nuts that will permit it to be moved through almost 360° in either direction, inhibited only by the interference of the attached cables. The antenna is fitted to the bracket with two adapters and screws that form poles 180° apart on the outer hoop, as discussed later.

Obtain a piece of soft wood that measures about $\frac{3}{4} \times \frac{3}{4}$ inch, about a foot long for making the two adapter blocks shown in the detail of Fig. 9. There are many ways to transfer the contour of the outside of the outer crochet hoop to the end of the wood stock. However, you can carefully position the hoop over the end of the wood and trace part of its circumference directly on the wood with a pencil to obtain an accurate pattern.

Clamp the end of the wood in a vise and carefully cut out the shallow arc with a sharp knife, coping saw or both. Then, using the hoop as a form, place sandpaper on the outside, grit side up, and carefully sand the cut-out arc so that it conforms closely to the hoop's outside diameter.

Measure in $\frac{3}{4}$ inch from the end of the wood and drill a hole at right angles to the flat edge of the wood through the center of the curved surface with a No. 28 drill bit. Countersink the hole as shown in Fig. 9 to admit a flat head No. 6-32 machine screw so that the end of the screw is completely below the contoured surface when seated.

Cut off a 1 $\frac{1}{2}$ -inch length squarely from the contoured and drilled end of the wood and mark it "A" lightly in pencil. Then repeat the entire process to make a second adapter. Mark

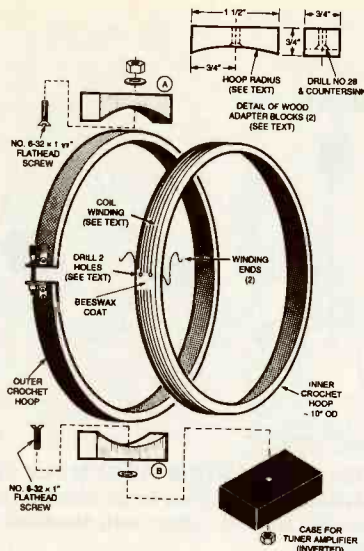

FIG. 9—LOOP ANTENNA construction. The outer hoop protects the coil windings.

the second adapter "B."

Insert a No. 6-32 x 1 $\frac{1}{2}$ -inch flat head machine screw in the adapter marked "A" and a No. 6-32 x 1-inch flat head machine screw in the hole of the adapter marked "B." Apply epoxy around the countersunk parts of the holes of both adapters to seat the screws. Avoid getting epoxy on the exposed external threads. Temporarily put a washer and nut on the ends of both screws until the epoxy sets.

When the epoxy has set, remove the clamping nut from adapter "A" and add a second washer, $\frac{1}{4}$ -inch standoff, lockwasher and nut on the screw. Glue the adapters to the outside surfaces of the outer hoop 180° apart but 90° away from the thumbscrew clamp with wood glue, as shown in Fig. 9. Clamp the adapters and set the outer hoop aside for at least 12 hours.

After the glue on the adapters has set, you can paint, lacquer, or varnish both the inner and outer loops. Be sure there is no metallic pigment in any of the finishes you choose.

Winding the coil

Drill two holes just large enough to accept the No. 26 AWG wire winding ends through the inner hoop as shown in Fig. 9. They should be drilled close to the outer rim but

not close enough to weaken the rim edges.

Before starting the coil winding, apply a coating of heated beeswax to the outer surface of the hoop to keep the winding from sliding off. The wax can be obtained from sewing supply stores.

Insert the first 6 inches of a 50-foot length of No. 26 AWG enameled magnet wire in one hole, and bend it back so that it will not slip out. Wind on 16 turns of wire (in either direction) around the outside of the hoop as shown in Fig. 9, pushing the turns close together in the wax layer as you wind.

After you have completed winding the turns on the rim of the hoop, insert the free end in the second hole and allow another 6 inches before cutting off the rest of the wire. Apply more heated beeswax to both ends of the two drilled holes to secure the wire in position.

Insert the inner hoop inside the outer hoop. Clamp the hoops together with the thumbscrew clamp mechanism on the outside of the outer hoop. Shape the two ends of the magnet wire so they lie over the side of the lower adapter.

Loop supporting bracket

Attach the tuner amplifier case to the No. 6-32 x 1-inch screw on adapter "B" with a lockwasher and nut. Thread the ends of the antenna loop wires through the holes drilled for them in the bottom of the case. Dress the wires to the sidewall of the case, opposite the jack J1 end, allowing enough slack to permit the circuit board to be removed and inverted, but keeping them as short as practical. When you have determined a satisfactory length, cut the wires and strip the insulating varnish back from their ends.

Secure the wires to the outside of the adapter and to the inside end wall of the case with hot beeswax. Solder them as shown in parts-placement diagram Fig. 4 and assembly diagram Fig. 6. Invert the circuit board and fasten it in position inside the case with two sheet

metal screws. (Use an insulating washer if the screw short circuits any traces on the circuit board when the board is fastened in position.) Assemble the cover to the case with the four panhead sheet metal screws.

Accurately measure the distance between the centers of the heads of the No. 6-32 nuts as shown in Fig. 9 by setting the completed loop antenna on a piece of paper and marking the points on the paper. This is the overall assembly height dimension. Record that measurement. (It should be approximately $13\frac{7}{8}$ inches with the 10-inch loop and case specified.)

Then measure the distance from the supporting screws to the rim of the loop antenna, add 1 inch and record that measurement. This dimension should be about $5\frac{1}{2}$ inches. Record that measurement.

Obtain a 3-foot length of $\frac{5}{8}$ -inch wide, stamped channel stock for mounting light shelving to walls from a hardware or building supply store. Measure off the two arm length dimensions and one length equal to the height of the antenna and tuner amplifier assembly on the channel stock and cut it to length.

Drill $\frac{1}{8}$ -inch holes close to both ends of the channel to accommodate No. 6-32 machine screws. Cut 90° vee-cuts $5\frac{1}{2}$ inches in from both ends on both edges of the channel stock so the ends can be bent into the C-shaped mounting bracket, as shown in Fig. 10. Carefully bend the stock into the right shape to form the bracket.

Temporarily assemble the

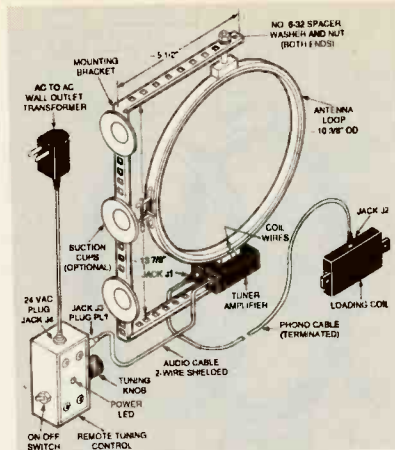

FIG. 10—SYSTEM ASSEMBLY DIAGRAM. The antenna-tuner amplifier assembly rotates within wall-mounted C bracket.

loop antenna-tuner amplifier assembly to the bracket to be sure that it fits correctly and there is no interference fit when the loop antenna is turned past the bracket. Once you have determined that the bracket is sized correctly and that the antenna loop-tuner amplifier assembly moves freely, you can remove the assembly from the bracket and paint the bracket.

After the paint is dry, apply either suction cups, a picture-hanging hook, or adhesive pads for mounting the completed assembly on the wall.

Interconnections

Refer to mechanical assembly diagram Fig. 10. Assemble the mounting bracket to the loop antenna and tuner-amplifier with washers and nuts. Be sure the connection is secure but loose enough to permit the loop to be rotated.

Terminate the two-conductor shielded audio cable with plug PL1 that mates with jack J3.

Plug the cable from the tuner amplifier in jack J3 of the remote tuning control. Plug one of the plugs of the six-foot length of shielded phono cable in jack J1 of the tuner amplifier and the one at the other end into jack J2 in the loading coil.

Operating the Power Loop

Plug wall-outlet transformer T1 into the 120-volt AC outlet and insert the 24-volt AC output plug into the jack J4 on the remote tuning control unit. Turn on the power switch. The LED power indicator should light at this time.

Tune in a weak AM station on your AM radio. Place the loading coil near the AM radio and rotate the knob on the potentiometer in the remote tuning control to peak the signal. Orient the loop to the best reception position.

Find the best location for the loading coil with respect to your AM radio. It could be taped to the back of the radio or fastened to the wall with the back of the radio positioned against it. Overall Power Loop gain should be about 350.

The received signal should be noticeably improved as long as the desired signal strength is less than the *desensitize* level of the receiver's automatic gain control (AGC), but greater than the existing "noise floor" level. When the AGC starts to reduce the sensitivity of the receiver, no additional signal enhancement will be evident.

To prevent possible oscillations due to feedback, position the loop antenna-tuner assembly on the wall at least two feet away from the loading coil.

If the system does not work as expected, carefully re-examine all of your work. Check to make sure that there are no loose or open connections.

You can also measure the voltages at the test points indicated by voltage readings in schematics Figs. 2 and 3. Compare your measurements with the values shown. Any significant variations should indicate a fault and help you to isolate it. Correct any faults revealed by this test.

Ω

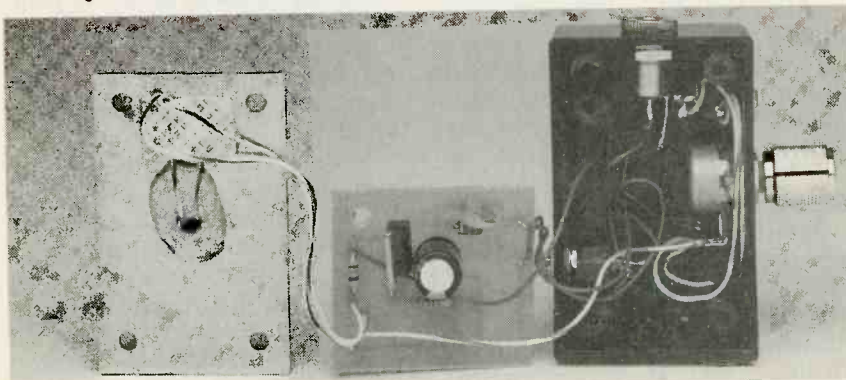

REMOTE TUNING CONTROL.

Artificial Life

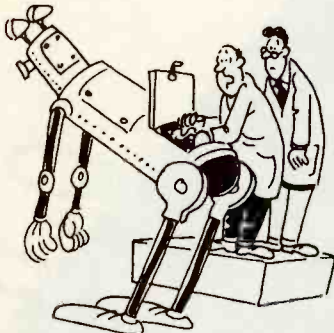

"There's the problem, Doctor Shapiro. Right here! In the lower lumbar region."

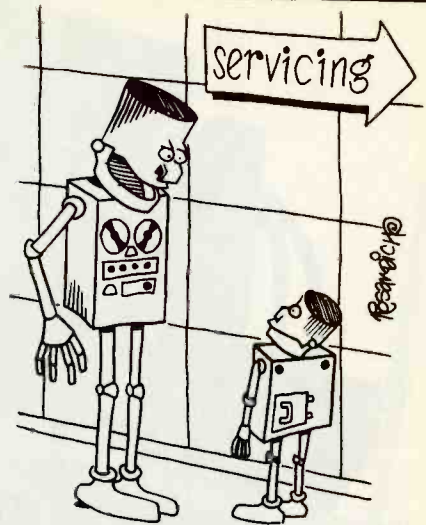
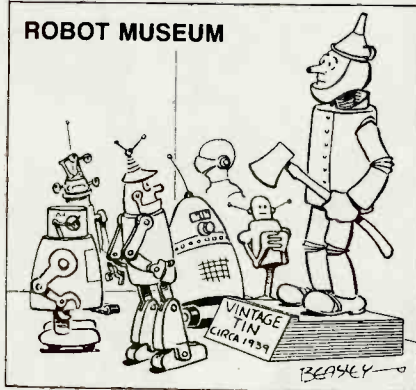

"Ajax, the computer brought you."

WE'VE GOT ENCLOSURES!

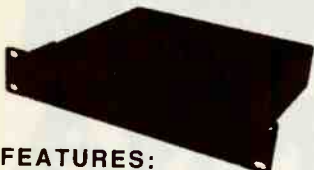

FEATURES:

- 1/2 RACK SIZE FOR COMPACT DESIGN
- CAN BE USED ON TABLE OR IN RACK
- FULL LINE OF ACCESSORIES
- THREE COLORS AVAILABLE: CLEAR STANDARD, FOR BLACK OR GOLD ADD \$5.00 PER BOX

RACKEM 'N' STACKEM™ Box		
MODEL	DESCRIPTION W x H x D (in)	PRICE \$
RSB-3	7.5 x 1.65 x 3	25.00
RSB-5	7.5 x 1.65 x 5	31.25
RSB-7	7.5 x 1.65 x 7	38.00
RSB-9	7.5 x 1.65 x 9	45.00
RSB-11	7.5 x 1.65 x 11	51.50
RSB-13	7.5 x 1.65 x 13	58.25

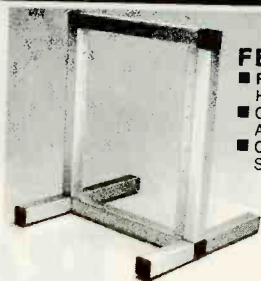

FEATURES:

- FOUR MODELS AVAILABLE IN HALF AND FULL RACK WIDTHS
- CLEAR, BLACK AND GOLD ANODIZED FINISHES
- CONSTRUCTED OF 1.0" SQUARE ALUMINUM TUBING

RACKEM 'N' STACKEM™ Table Top Racks		
MODEL	DESCRIPTION W x H x D (in)	PRICE \$
RSR-6	11.4 x 15.2 x 11	60.00
RSR-8	11.4 x 18.8 x 11	65.00
RSR-10	11.4 x 22.6 x 11	70.00
RSR-12	11.4 x 26.4 x 11	75.00
RSR-6-19	20.9 x 15.2 x 11	70.00
RSR-8-19	20.9 x 18.8 x 11	75.00
RSR-10-19	20.9 x 22.6 x 11	80.00
RSR-12-19	20.9 x 26.4 x 11	85.00

NEW

RACKEM 'N' STACKEM™ SERIES



BACK CHASSIS

PANELS ARE .063" ALUMINUM; STANDARD FRONT AND REAR PANELS ARE CLEAR ANODIZED, BLACK OR GOLD PANELS ALSO AVAILABLE FOR ADDITIONAL \$5.00

Rack Chassis

MODEL	DESCRIPTION W x D x H (in)	PRICE \$
1RU5	19 x 5 x 1.75	34.00
1RU7	19 x 7 x 1.75	36.50
1RU10	19 x 10 x 1.75	38.75
1RU12	19 x 12 x 1.75	42.75
1RU15	19 x 15 x 1.75	45.75
1RU17	19 x 17 x 1.75	48.75
2RU5	19 x 5 x 3.5	36.50
2RU7	19 x 7 x 3.5	38.75
2RU10	19 x 10 x 3.5	41.25
2RU12	19 x 12 x 3.5	45.25
2RU15	19 x 15 x 3.5	48.25
2RU17	19 x 17 x 3.5	51.25
3RU5	19 x 5 x 5.25	46.00
3RU7	19 x 7 x 5.25	48.50
3RU10	19 x 10 x 5.25	51.00
3RU12	19 x 12 x 5.25	54.00
3RU15	19 x 15 x 5.25	57.00
3RU17	19 x 17 x 5.25	60.00

Dual Slope Cabinets

MODEL	DESCRIPTION W x D x H (in)	PRICE \$
DS-1	4 x 6 x 4	62.00
DS-2	6 x 6 x 4	66.50
DS-3	8 x 6 x 4	70.75
DS-4	10 x 6 x 4	75.00
DS-5	12 x 6 x 4	79.75
DS-6	18 x 6 x 4	85.00
DS-7	4 x 8 x 6	72.50
DS-8	6 x 8 x 6	76.50
DS-9	8 x 8 x 6	82.00
DS-10	10 x 8 x 6	86.75
DS-11	12 x 8 x 6	92.25
DS-12	18 x 8 x 6	105.75

BOX-IT SYSTEM™

A NEW MODULAR SYSTEM FOR FAST AND EASY CONSTRUCTION WITH NO TOOLS

- OVER 180 PREPUNCHED ALUMINUM FRONT AND REAR PANELS TO MIX AND MATCH
- PANELS SUPPLIED WITH MARKING DECALS
- FULL RANGE OF BOXES AVAILABLE IN FULL AND HALF RACK WIDTHS; RACK MOUNT OR TABLE TOP STYLES
- ASSEMBLES WITH ONLY A PHILLIPS SCREWDRIVER
- ELECTRONIC COMPONENTS ALSO AVAILABLE
- THREE COLORS: CLEAR, BLACK AND GOLD



RF SHIELDED BOXES
HOT TIN-PLATED STEEL

RF Shielded Steel Boxes

MODEL	DESCRIPTION L x W x H (inches)	PRICE \$
SB-1	2.1 x 1.9 x 1.0	4.50
SB-2	3.3 x 1.9 x 1.0	6.00
SB-3	4.2 x 1.9 x 1.0	9.00
SB-4	6.3 x 1.9 x 1.0	10.50
SB-5	3.9 x 2.7 x 1.1	3.90
SB-6	4.8 x 2.7 x 1.1	11.50
SB-7	6.4 x 2.7 x 1.1	13.20
SB-8	2.6 x 2.7 x .83	7.00
SB-9	3.2 x 2.7 x .83	8.25
SB-10	4.8 x 2.7 x .83	9.00
SB-11	6.3 x 2.7 x .83	10.75
FTS-1	1000 pF 50VDC SOLDER TYPE	.85
FTS-11	1000 pF 50VDC SCREW-IN TYPE	3.50

PERFECT FOR RF AND CLOCK TYPE CIRCUITS AND ALLOW THE ELIMINATION OF SPILLOVER OF UNWANTED SIGNALS. THE BOXES COME WITH DIVIDERS AND THE LIDS CAN BE SOLDERED TO THE CASE. 1000 pF 50VDC FEED THRU CAPACITORS ARE AVAILABLE AS SOLDER OR SCREW-IN TYPES.



HEAVY DUTY RACK CHASSIS

PANELS ARE .080" ALUMINUM AND ARE FIELD REMOVABLE. STANDARD FRONT & REAR PANELS ARE CLEAR ANODIZED. BLACK PANELS AVAILABLE FOR ADDITIONAL \$15.00

Metal Cabinets

MODEL	DESCRIPTION W x D x H (in)	PRICE \$
MC-1A	4 x 3 x 2	17.25
MC-2A	6 x 3 x 2	20.00
MC-3A	8 x 3 x 2	22.00
MC-4A	4 x 4 x 3	22.00
MC-5A	6 x 4 x 3	22.00
MC-6A	8 x 4 x 3	24.25
MC-7A	4 x 7 x 4	22.00
MC-8A	6 x 7 x 4	24.25
MC-9A	8 x 7 x 4	27.00

Heavy Duty Rack Chassis

MODEL	DESCRIPTION W x D x H (in)	PRICE \$
3RU7 HD	19 x 7 x 5.25	120.75
3RU10 HD	19 x 10 x 5.25	127.00
3RU14 HD	19 x 14 x 5.25	140.75
4RU7 HD	19 x 7 x 7.0	127.00
4RU10 HD	19 x 10 x 7.0	135.50
4RU14 HD	19 x 14 x 7.0	140.75
5RU7 HD	19 x 7 x 8.75	132.25
5RU10 HD	19 x 10 x 8.75	139.75
5RU14 HD	19 x 14 x 8.75	150.25



METAL CABINET
PANELS ARE .063" ALUMINUM; STANDARD FRONT AND REAR PANELS ARE CLEAR ANODIZED. BLACK OR GOLD PANELS AVAILABLE FOR ADDITIONAL \$5.00

Quantity Discount

(per order, non-assortable)	Discount
10-99	10%
100 - UP	20%

NEW SIZES

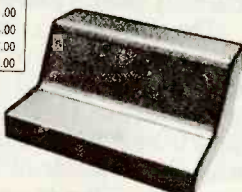

DUAL SLOPE CABINET
PANELS ARE .063" ALUMINUM



SESCOM, INC.
2100 WARD DRIVE
HENDERSON, NV 89015



CALL TODAY!
PREPAID ORDERS

SHIPPED SURFACE AT NO CHARGE
(48 STATES AND CANADA)



ORDERS (800) 634-3457
FAX ORDERS (800) 551-2749
OFFICE (702) 565-3400 ■ FAX (702) 565-4828
TECH LINE (702) 565-3993 M-Th 8 am to 4 pm (PST)
SESCOM, INC. is not responsible for inadvertent typographical errors
Prices and specifications are subject to change without notice.

CIRCLE 45 ON FREE INFORMATION CARD

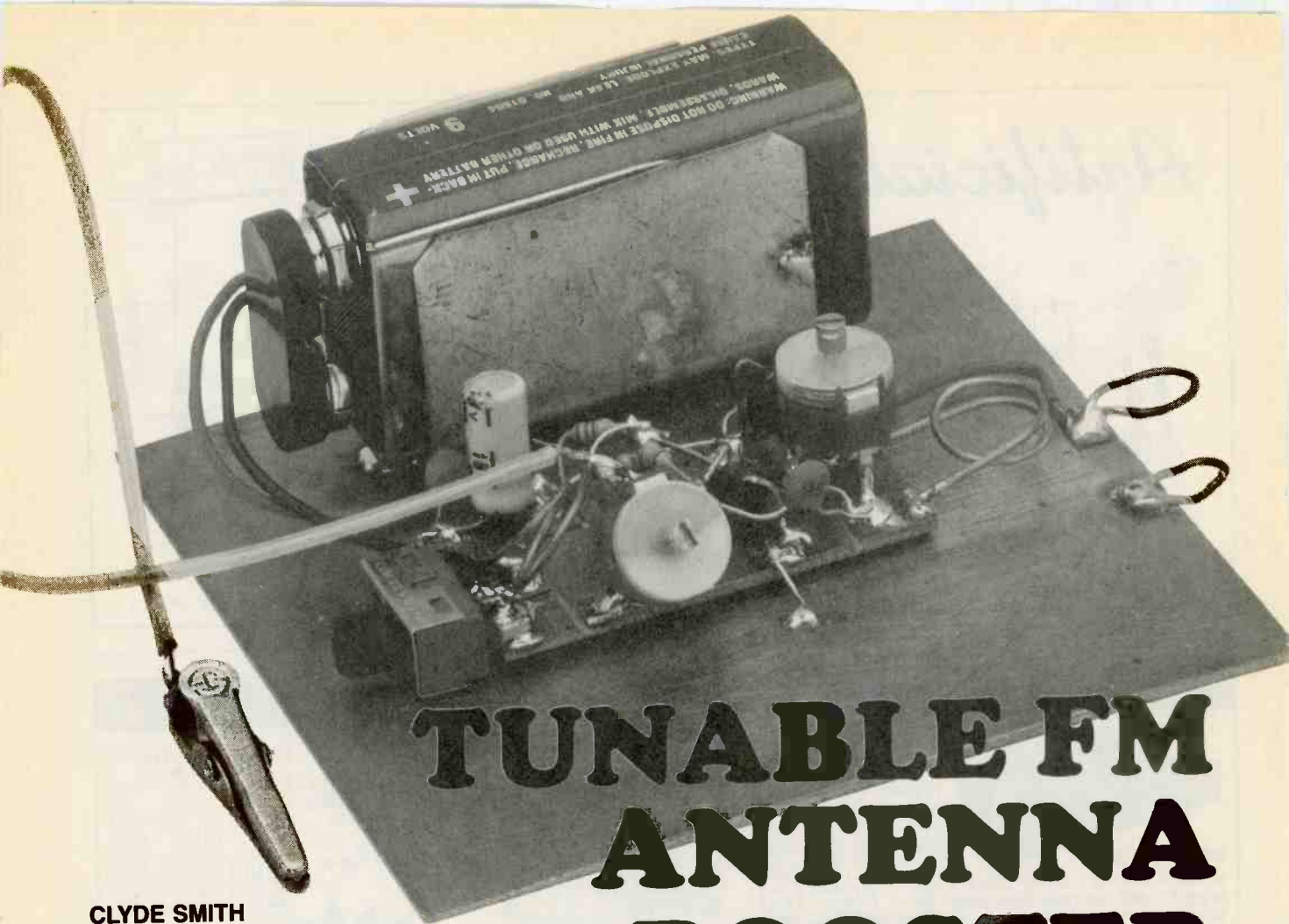

TUNABLE FM ANTENNA BOOSTER

CLYDE SMITH

HAVE YOU EVER HAD DIFFICULTIES in picking up or holding on to distant FM stations that were broadcasting programs you wanted to hear? Or maybe you know there are more distant stations out there that are beyond the range of your receiver. You could, of course, buy or build a better FM tuner. However, by building a tunable FM booster you will both save money and dramatically expand your FM listening reach.

It's true that factory-made FM boosters are available from electronics stores and mail-order houses, but they can cost as much as \$50. By contrast, the parts for our FM booster cost less than half that amount. The project should take only a few hours to complete, and you have many options for packaging the two-stage amplifier circuit.

You'll be amazed at the gain of this little circuit. The prototype has picked up stations more than 150 miles from the receiver! You'll need an indoor rabbit-ear antenna as shown in

Build this FM booster and enjoy broadcasts from distant FM stations that you've never been able to receive.

Fig. 1. The antenna is connected to the input side of the booster, and the boosted signal is sent via a single wire to the retracted antenna of the FM radio. Some simple adjustment procedures will be required after you hook up the circuit.

This FM booster improves selectivity when it is precisely tuned to a desired station that is close to others in frequency—a feature not found in broadband units. This selectivity is especially important for battery-powered, portable, Walkman-type receivers or low-performance FM receivers. This circuit also boosts weak signals to

a stereo lock-on level. However, when you are listening to strong local stations, you'll want to switch the booster off to prevent audio "swamping."

Circuit description

The booster circuit, whose schematic is shown in Fig. 2, is a two-stage radio-frequency amplifier. It includes two 2N3904 NPN transistors, Q1 and Q2, capable of 250-MHz operation. The signal from the rabbit-ears is fed to the first stage at the base of Q1, which is biased for optimum gain by R1. The circuit is tuned to the incoming signal frequency by the

combination of coil L1 and capacitor C1, which is coupled to the collector of the transistor through C3.

The preamplified signal is then applied to the base of Q2

through C4. The components in the second stage are identical to those in the first stage, and its frequency is determined by L2-C2 in the collector circuit. The fully amplified RF signal is then fed to the antenna of the FM receiver from the junction of L2-C2 with an insulated wire about 8 inches long terminated with an alligator clip. If the FM receiver has a telescoping antenna, collapse it to its retracted position.

The tunable FM booster is powered by a standard 9-volt transistor battery through switch S1. Capacitors C6 and C7 across the battery input perform filtering and stabilization on the power supply.

Booster construction

The circuit components are mounted on a copper foil-clad, 0.040-inch thick, glass-epoxy circuit board, as shown in parts-placement diagram Fig. 3. It is cut $1\frac{1}{2} \times \frac{3}{4}$ -inches. Six electrically isolated areas or pads are formed on the board for component mounting by removing thin strips of copper down to the substrate around the pads.

This construction method permits the components to be soldered securely to the copper foil of the board without drilling any holes in the board. A finished circuit board can be obtained from the source listed in the Parts List, but if you want to make your own, a foil pattern is included here.

Two hand-wound, air-core coils, L1 and L2, are included in the circuit. To form each coil, wind a $2\frac{1}{2}$ -inch length of No. 20 AWG bare copper wire $1\frac{1}{2}$ turns around a $\frac{3}{8}$ -inch diameter dowel or drill bit.

If you make your own board, remove the thin strips of copper foil to form the isolated pads with a handheld power tool with either a fine abrasive disk or circular saw in the tool chuck. You can also remove the copper manually by making parallel scores around the outlines of each pad with a sharp razor knife and carefully lifting out the thin strips between the scored lines.

Regardless of the method you use, inspect the fine channels with a magnifying glass and, with an ohmmeter, verify that there are no copper burrs between the isolated pads that could form an unwanted electrical path between them.

Position the leaded components as shown in parts placement diagram Fig. 3. The numbers on the diagram match the numbered pads on the circuit board. The "X" marks on the diagram indicate where lead terminations are to be soldered directly to the copper-foil pads, and the three stars indicate where lead terminations are to be soldered above the board, without making any contact with it.

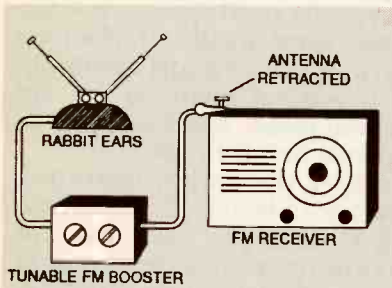
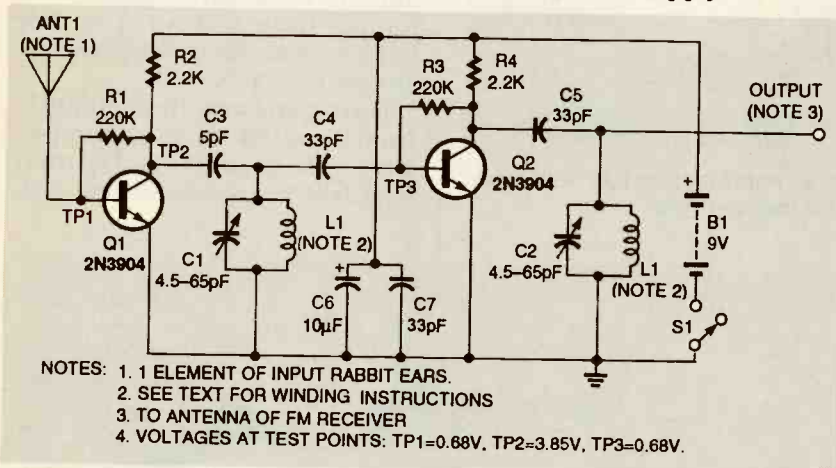

FIG. 1—TUNABLE FM BOOSTER is connected between rabbit ears and retracted antenna of FM receiver.



- NOTES: 1. 1 ELEMENT OF INPUT RABBIT EARS
 2. SEE TEXT FOR WINDING INSTRUCTIONS
 3. TO ANTENNA OF FM RECEIVER
 4. VOLTAGES AT TEST POINTS: TP1=0.68V, TP2=3.85V, TP3=0.68V.

FIG. 2—TWO-TRANSISTOR AMPLIFIER CIRCUIT with tunable tank circuits boosts the distant FM signals.

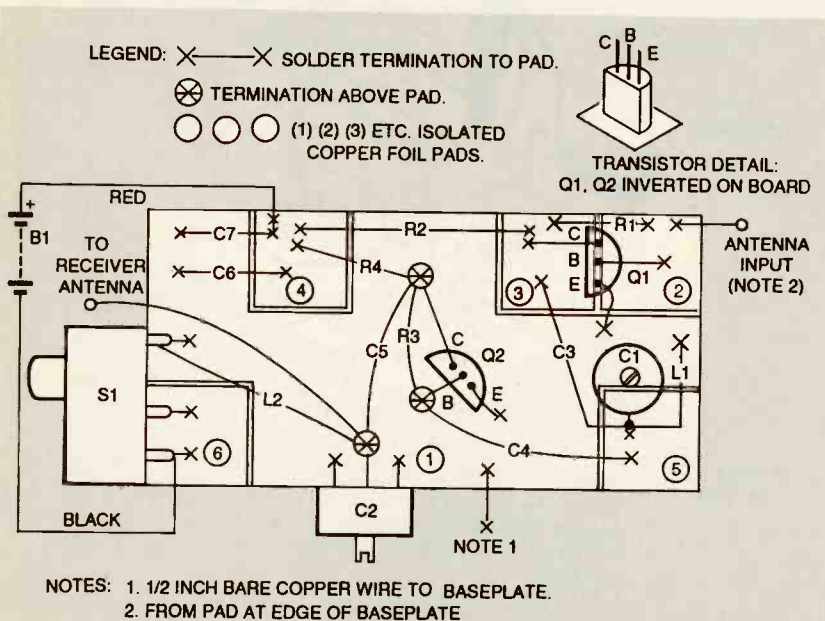

FIG. 3—PARTS PLACEMENT DIAGRAM. Components are soldered to pads on copper-clad board. Notice that the transistors are inverted.

PARTS LIST

All resistors are 1/8-watt, 5% carbon film

R1, R3—220,000 ohm

R2, R4—2200 ohm

Capacitors

C1, C2—4.5 to 65 pF variable trimmer, Sprague-Goodman or equivalent.

C3—5 or 7pF disc

C4, C5, C7—33 pF

C6—10μF, aluminum electrolytic

Semiconductors

Q1, Q2—2N3904 NPN transistor (TO-92 package)

Other components

L1, L2—air core RF coils (see text)

S1—miniature slide switch, SPDT

Miscellaneous: Rabbit-ear antenna with telescoping conductors, 1½ × 3-inch PC board (see text), 3 × 3-inch ground plane (see text), 3 miniature alligator clips, 9-volt battery clip assembly, insulated No. 22 AWG wire, bare No. 20 bare copper wire, 9-volt transistor battery, optional case, solder.

Note: The following items are available from Clyde Smith, 19 Christine St., Peters, MO 63376.

- Kit of all components and finished PC board except antenna, ground plane, and case—\$19.95
- PC board only—\$3.00

Add \$1.50 for shipping and handling. Missouri residents add local sales tax to all orders.

Notice that both transistors Q1 and Q2 are soldered in inverted positions. Solder the black and red leads from a 9-volt battery clip to the locations shown in Fig. 3. Cut an 8-inch length of insulated, stranded wire, trim the insulation from both ends, and solder one end to the junction of the leads from C2, C5, and L2.

After completing all soldering on the circuit assembly, check carefully at the points marked with the star to verify that no bare leads entering or leaving those junctions are in contact with any copper pads. Increase the spacing of the junctions above the board with a thin tool if they are too close to any copper pads.

Make a bracket for the 9-volt battery by cutting a 2½ × 1½-inch piece of tin-coated steel

from a flattened can. File the edges to remove any sharp burrs, and file a slight radius on each sharp corner to round it off. Then bend up the ends of the metal up 90° along the dotted line to form a "U-" shaped

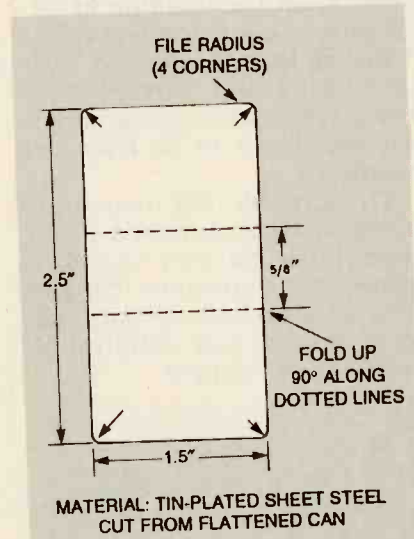

FIG. 4—PATTERN FOR BATTERY bracket cut from can metal.

channel. Leave a 5/8-inch spacing between the side pieces for inserting the battery.

Cut a second 3-inch square piece of copper foil-clad board for a ground plane, as shown in Fig. 5. Form an isolated ¼-inch copper foil pad with the method previously used along one edge of the board, as shown. Position the amplifier circuit assembly in a central position on the ground plane, and mark it with a pencil or felt-tip pen.

Solder the battery-mounting bracket to the 3 × 3-inch board adjacent to the circuit board "footprint" with solder beads at each end of the bracket channel. Then position the circuit assembly on the ground plane and solder a bare copper wire jumper from pad No. 1 on the circuit assembly to the plane, as shown in Fig. 5.

Form two loops from about 1-inch lengths of bare copper wire. Then solder a 1½-inch length of insulated, tinned cop-

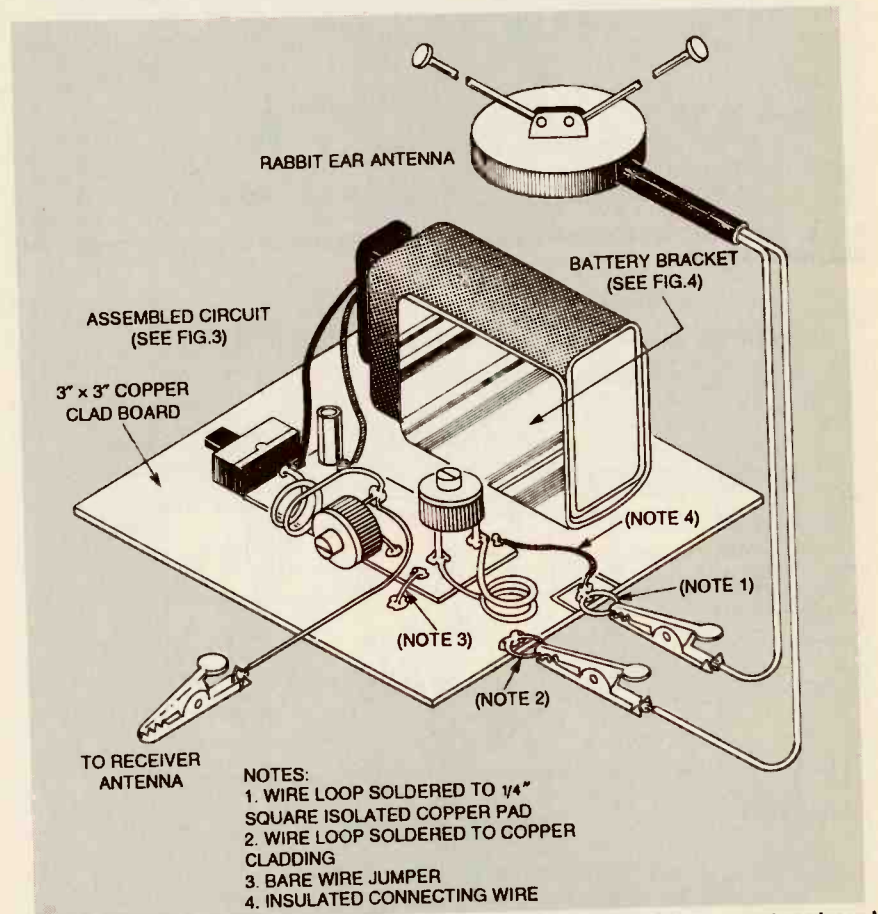
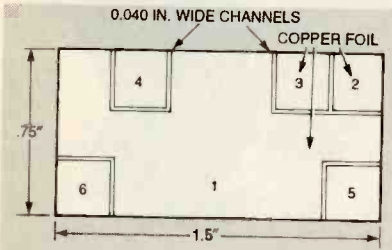

FIG. 5—BOOSTER ASSEMBLY DIAGRAM: 3 × 3-inch copper-clad ground-plane board holds a second board on which all components are mounted.

per wire from pad No. 2 on the circuit board to the pad on the edge of the ground plane while simultaneously soldering one of the copper loops to the pad. Then solder the second copper loop to a location adjacent to the pad, as shown in Fig. 5.

Solder miniature alligator clips to the terminations of the twin-lead from the rabbit-ear antenna, and solder an alligator clip to the end of the wire to the FM receiver antenna.

You might want to house the completed miniature circuit in a protective plastic case. Suitable project cases can be purchased from electronics stores or mail-order distributors that advertise in this magazine. If you put the circuit in a case, drill the holes for all external connecting wires and two access holes to tuning capacitors C1 and C2 before you position the assembly in the case.



CIRCUIT-BOARD FOIL PATTERN. Slits in the copper foil expose the insulating substrate.

The board can be fastened inside the case with beads of RTV silicone adhesive on the corners of the underside of the ground plane. You might also want to substitute small wire binding nuts and bolts for the wire loops on the ground plane for making the rabbit-ear antenna lead connections.

Be aware that the tunable feature of the booster increases gain, but it can also cause oscillation because the circuit is not neutralized. This drawback can be surmounted by placing and soldering circuit components precisely according to the parts placement diagram in Fig. 3 and closely following the adjustment procedures and any other suggestions that are given here.

Adjustment procedures

Perform the following adjustments:

1. Extend the rabbit ears to their limits, and position them with a separation angle of about 90°.
2. Connect the antenna leads to the 3 × 3-inch ground plane as shown in Fig. 5.
3. Switch the booster switch S1 OFF and the FM receiver's switch ON with its volume control set at a middle position.
4. Clip the alligator clip to the tip of the retracted antenna on

the FM receiver, and tune to a station near midband that is barely audible. Avoid loud, overpowering local stations that will make the adjustment procedures more difficult than is necessary.

5. Adjust capacitors C1 and C2, and then orient the rabbit ears until you obtain maximum output from the selected station. If the station is broadcasting in stereo, the stereo indicator should indicate when signal strength is at its maximum.

6. Turn switch S1 ON, and if the booster is working properly, you should hear an increase in signal strength. If the circuit is not working properly, measure the voltage at the points shown on schematic Fig. 1 with a voltmeter, and compare the readings with those shown on the schematic.

7. If signal strength decreases, the amplifier might be oscillating or it might be mistuned. Adjust C1 and C2 very slowly to obtain the clearest signal; repositioning the antenna while observing the stereo indicator might also prove helpful in obtaining the most optimum signal possible.

8. Repeat the preceding steps for each FM station of interest. Once you adjust the booster for one position of the band, others within 10 to 20 MHz should be received as well. Some tweaking of C1 and C2 might be necessary to achieve this result. Be patient until you get the knack of maximizing gain—after some experimentation, you should get it right.

Adjustment suggestions

The receiver must be tuned exactly to the station frequency. However, if the desired results are not obtained, alternately shorten one rabbit ear dipole or the other while changing the orientation or angle between the elements.

If you use the booster with a portable receiver in a fixed location, clip the booster output lead to the earphone wire insulation near the jack. Be patient and this circuit will reward you with many hours of listening enjoyment.

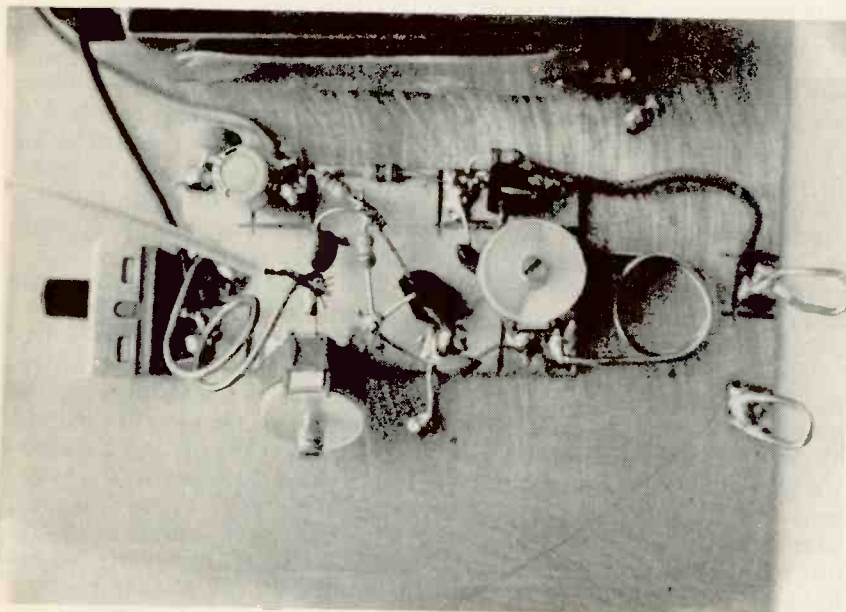

COMPLETED CIRCUIT ASSEMBLY mounted on the ground plane. The battery is at the top of the picture.

Long-Range BODY-HEAT DETECTOR

Build this instrument that detects the infrared emission of humans and animals for security or for performing science experiments.

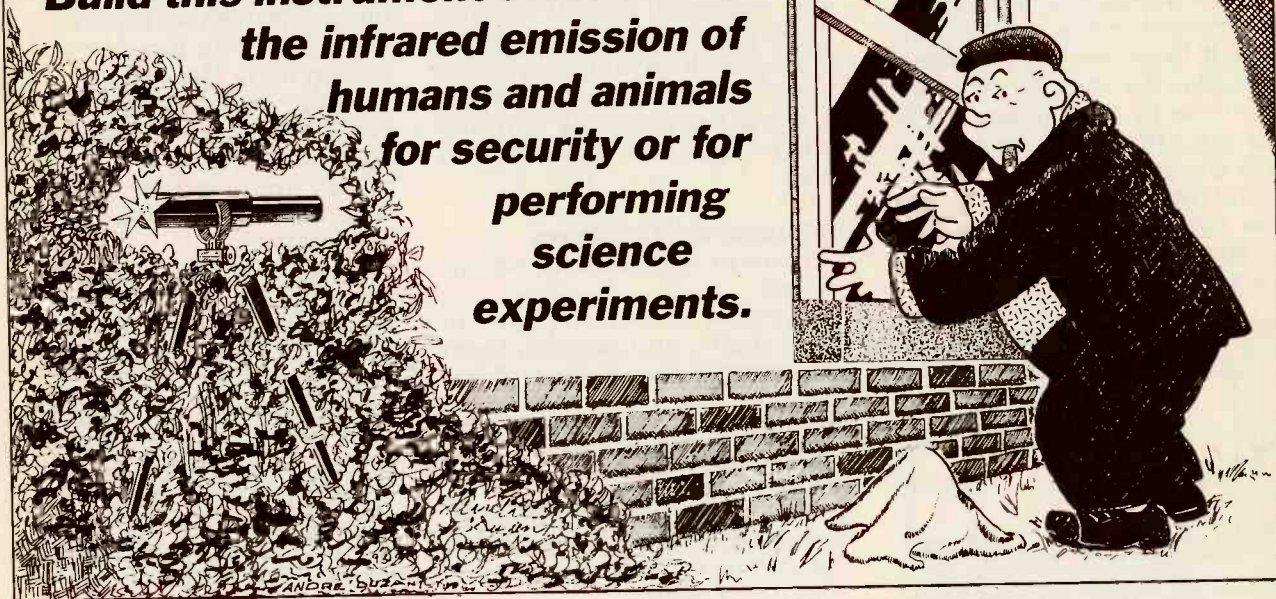

A PYROELECTRIC DETECTOR IN THIS battery-portable instrument detects the presence of animal or human intruders night or day by sensing their body heat. The detector can supplement your home security system, or you can monitor animals for nature study or find sources of heat loss.

This project will introduce you to the fundamentals of infrared emission and detection. The instrument could help you locate hidden or buried heat sources that could be wasting heat in your home. Detectors capable of "seeing" in the non-visible infrared region have proven themselves extremely useful in nighttime law enforcement and in military operations on land and in the air around the clock.

This instrument can detect the presence of humans or ani-

ROBERT IANNINI

mals up to several hundred feet away by sensing their body heat, which corresponds with a specific wavelength emission. Its narrow 8° field of view makes it suitable for detecting intruders passing through doors or moving along corridors inside a building. In addition, it can detect the presence of persons or animals entering the defined sensitive zone along roads or paths outdoors.

The best results will be obtained if the instrument is mounted on a camera tripod or other rigid support. When securely mounted, it can be panned manually or by electric drive over a wide sector to obtain a wider field of view. That makes it easier for the user to discriminate between true and false targets.

Pyroelectric detector

The heat sensitive elements in this instrument are two lithium tantalate (LiTaO_3) crystals within the TO-5 metal transistor case of the pyroelectric detector. The metal case has a rectangular silicon window in its cap for admitting infrared energy as well as a high-value resistor, and a low-noise field-effect transistor (FET).

The pyroelectric detector and pinout are shown in Fig. 1-a, and Fig. 1-b is a simplified schematic of the sensor circuit. Thermal compensation within the case prevents errors due to ambient temperature variations. The detector has a spectral range of 6 to 14 microns centered on 10 microns in the infrared band. This range is determined by the characteristics of the silicon window at the end of the TO-5 case.

The infrared emission from human and animal body heat is in the 10 micron infrared (IR) band that corresponds to the "black body" temperature of 100°F (300 K) and a frequency of 30,000 GHz. All objects whose temperature exceeds absolute zero (0 K) radiate energy as a function of the fourth power of temperature.

When the pyroelectric detector is exposed to infrared radiation in the 6 to 14 micron band, the temperatures of its lithium tantalate crystals change, unbalancing the charges on each crystal's surface. This unbalanced condition, which shows up as a voltage variation at the output of the sensor, indicates that infrared energy has been detected. The dual crystals in the detector cancel signals obtained from sunlight, open fires, or radiators because the crystals in the device are oppositely polarized.

To detect infrared emission, either the heat-emitting target

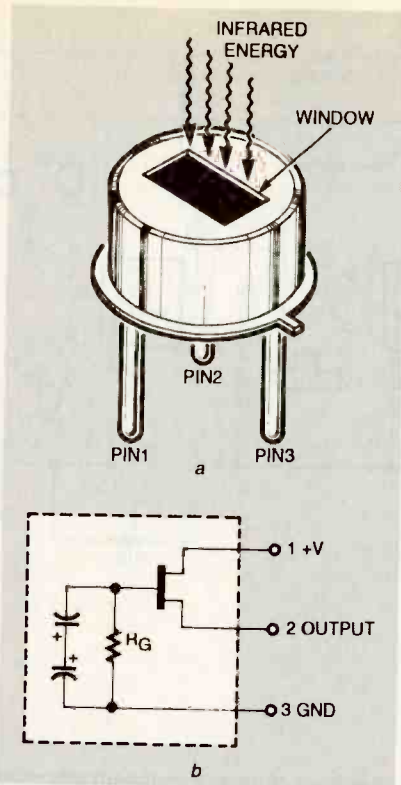

FIG. 1—DUAL-ELEMENT PYROELECTRIC detector pinout arrangement (a) and simplified schematic (b).

must be moving or a shutter must periodically break or "chop" the path between the target and sensor. In this detector, the path is chopped by a motor-driven shutter whose speed can be controlled.

Although a moving source will produce a changing signal, a rapidly moving object could be missed because of the instrument's narrow viewing angle and relatively slow detector response. As a result, you will probably want to operate the chopper motor for most object detection.

The infrared energy is focused on the sensitive rectangular window at the end of the detector case with a translucent plastic Fresnel lens, which has a focal length of approximately 5 centimeters. This translucent lens is transparent to infrared energy in the 10-micron region.

Operating modes

The thermal detector operates

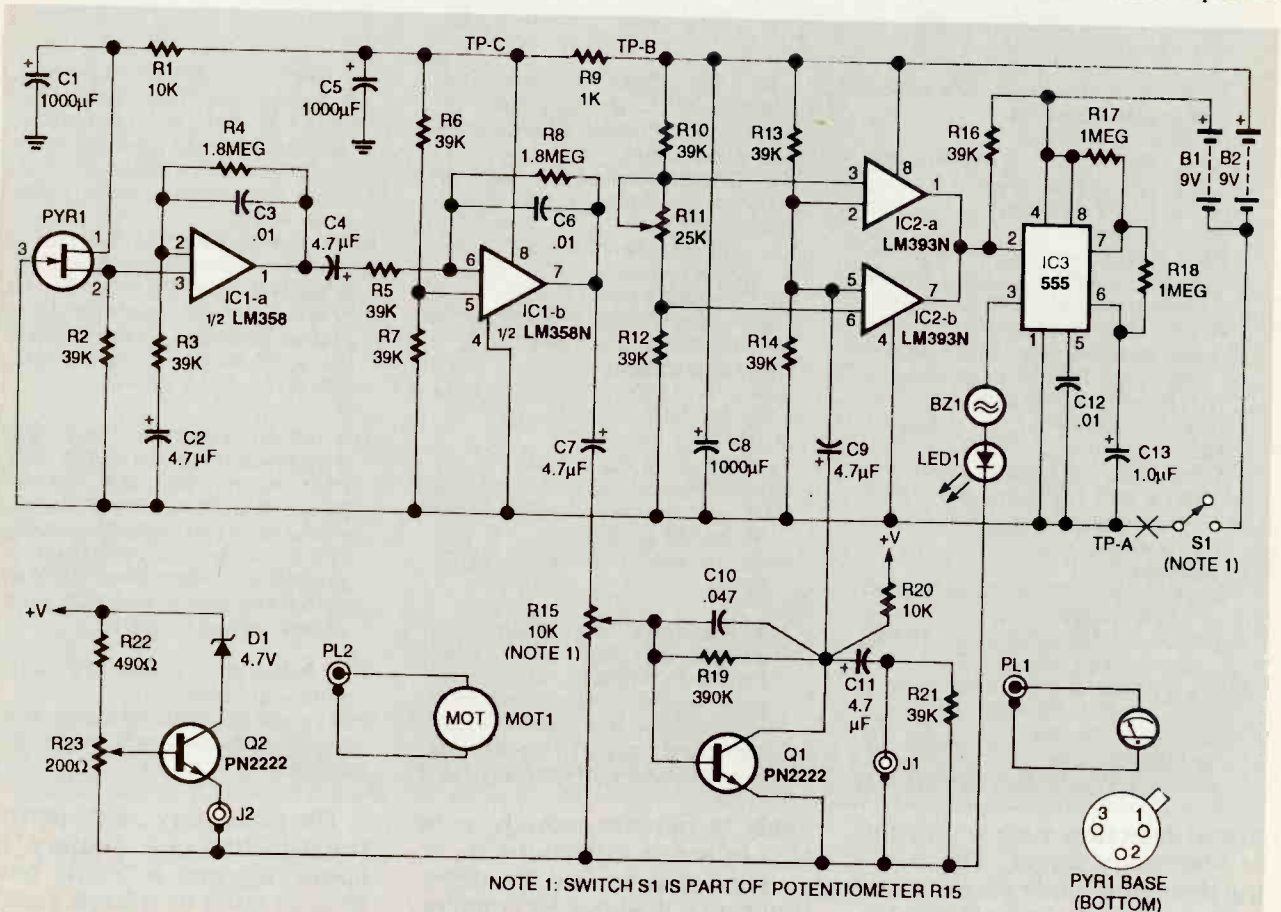

NOTE 1: SWITCH S1 IS PART OF POTENTIOMETER R15

FIG. 2—SCHEMATIC FOR THE INFRARED DETECTOR CIRCUIT. Panel potentiometer R15, J1 and J2, and LED1 are located on the end cap of the amplifier section.

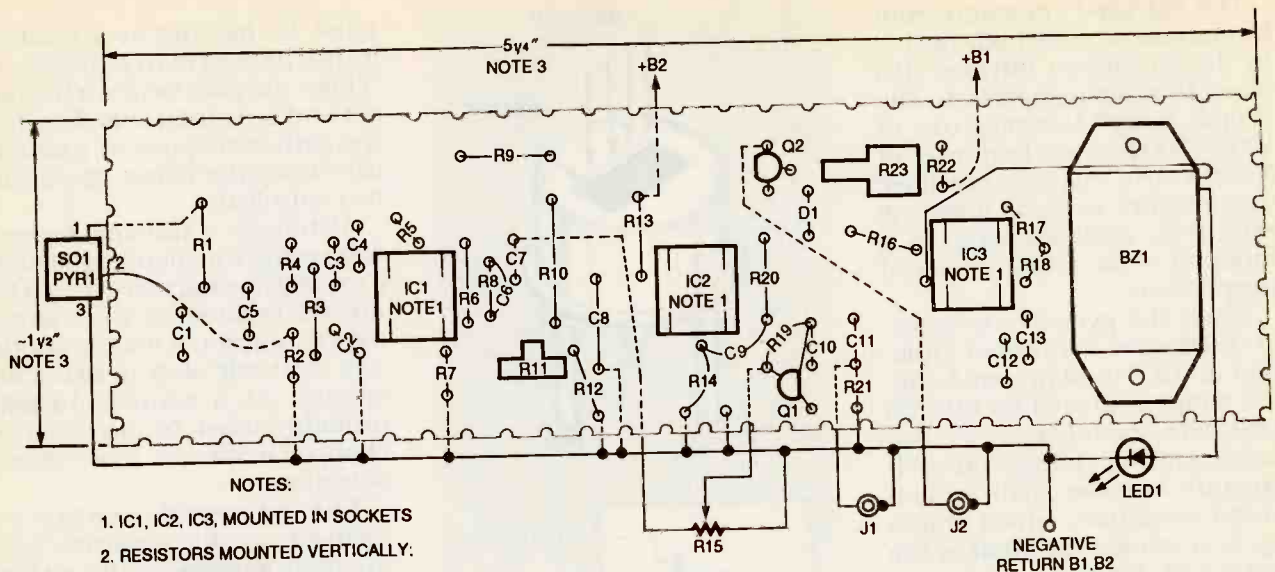

FIG. 3—LAYOUT OF THE CIRCUIT BOARD showing optimum component placement for point-to-point wiring. The circuit board width is determined by the inside diameter of the housing tube.

- NOTES:**
1. IC1, IC2, IC3, MOUNTED IN SOCKETS
 2. RESISTORS MOUNTED VERTICALLY:
R2, R4, R5, R6, R7, R8, R12
R14, R16, R17, R18, R19
R21, R22
 3. PERFORATED BOARD 0.42 IN HOLES,
0.1x0.1 IN GRID
 4. WIDTH DIMENSION TO FIT ID OF
TUBE (SEE TEXT)

All resistors are 1/4-watt, 10% unless otherwise specified.

- R1, R20—10,000 ohms
R2, R3, R5, R6, R7, R10, R12, R13, R14.
R16, R21—39,000 ohms
R4, R8—1,800,000 ohms
R9—1000 ohms
R11—25,000 ohms trimmer potentiometer, 8 mm vertical PC mount, Mouser Electronics 32RM403 or equivalent
R15/S1—1000 ohms control potentiometer, miniature panel mount, Mouser Electronics 31CT301 or equivalent
R17, R18—1,000,000 ohms
R19—390,000 ohms
R22—470 ohms
R23—200 ohms, trimmer potentiometer, 8 mm horizontal PC mount, Mouser Electronics 32RH202 or equivalent.

Capacitors

- C1, C5, C8—1000 μ F, 16 volts, aluminum electrolytic
C2, C4, C7, C9, C11—4.7 μ F, 25 volts, aluminum electrolytic
C3, C6, C12—0.01 μ F ceramic disc
C10—0.047 μ F, 100 volts
C13—1 μ F, 50 volts

Semiconductors

- PYR1—dual pyroelectric detector, 3-pin

TO-5 case, P2288 Hamamatsu Corp.
IC1—LM358N, dual operational amplifier, 8-pin DIP, National Semiconductor or equivalent

IC2—LM393N, dual comparator, 8-pin DIP, National Semiconductor or equivalent

IC3—NE555N timer, 8-pin DIP, Signetics or equivalent

Q1, Q2—N2222 NPN transistor
LED1—Light-emitting diode, T-1, yellow
D1—1N5230 Zener diode, 4.7 volts

Other components

- BZ1—Piezoelectric buzzer, 6 volts, Mouser 25MS060 or equivalent
J1, J2—Jack, 3.5 mm ID
PL1, PL2—Plug, 3.5 mm OD
MOT1—DC motor, 0 to 12 volts, low-torque, slow speed, MCM Electric No. 58-500 or equivalent.
SO1—transistor socket, 3-pin (for PYR1)

Miscellaneous: Fresnel lens, polyethylene, 0.77 focal length, 1 1/2-inch, Fresnel Technical No. IR2 or equivalent, perforated circuit board, 0.1-inch grid (see text), plastic or metal tubing, end cap and inserts (see text), two sockets for 8-pin DIP ICs, T-1 LED

snap-in holder, 28 AWG insulated tinned copper wire (nine-strand ribbon cable (see text), two 9-volt battery clips with insulated wires, two 9-volt alkaline transistor batteries, tinned copper wire, plastic adhesive, plastic screw, solder.

Note: The pyroelectric detector is available from Hamamatsu Corp. Bridgewater, NJ (201) 231-0960. The Fresnel lens is available from Fresnel Technical, 101 Morningside Drive, Ft. Worth TX 76110, (817) 926-7474.

The following items are available from Information Unlimited, Box 716 Amherst, NH 03031 (603)-673-4730, fax 603 672-5406;
● A kit of all parts including tubing cut to length, circuit board, pyroelectric detector, motor and all active and passive components except batteries—\$69.50

● Pyroelectric detector and motor—\$12.50
Please add \$5.00 for shipping and handling. Allow 4 to 6 weeks for delivery.

in two detection modes: moving or stationary target. The moving detection mode permits the user to detect intrusions by moving people or animals. The detector's field of view in this

mode is narrow enough to be able to sense intrusions in restricted spaces, and its detection range is about 100 meters. In this mode it rejects constant background thermal energy.

The stationary mode permits the detection of stationary "hot spots" against a "cold" background such as a back yard or open space at night. Preferred in a search for hidden persons.

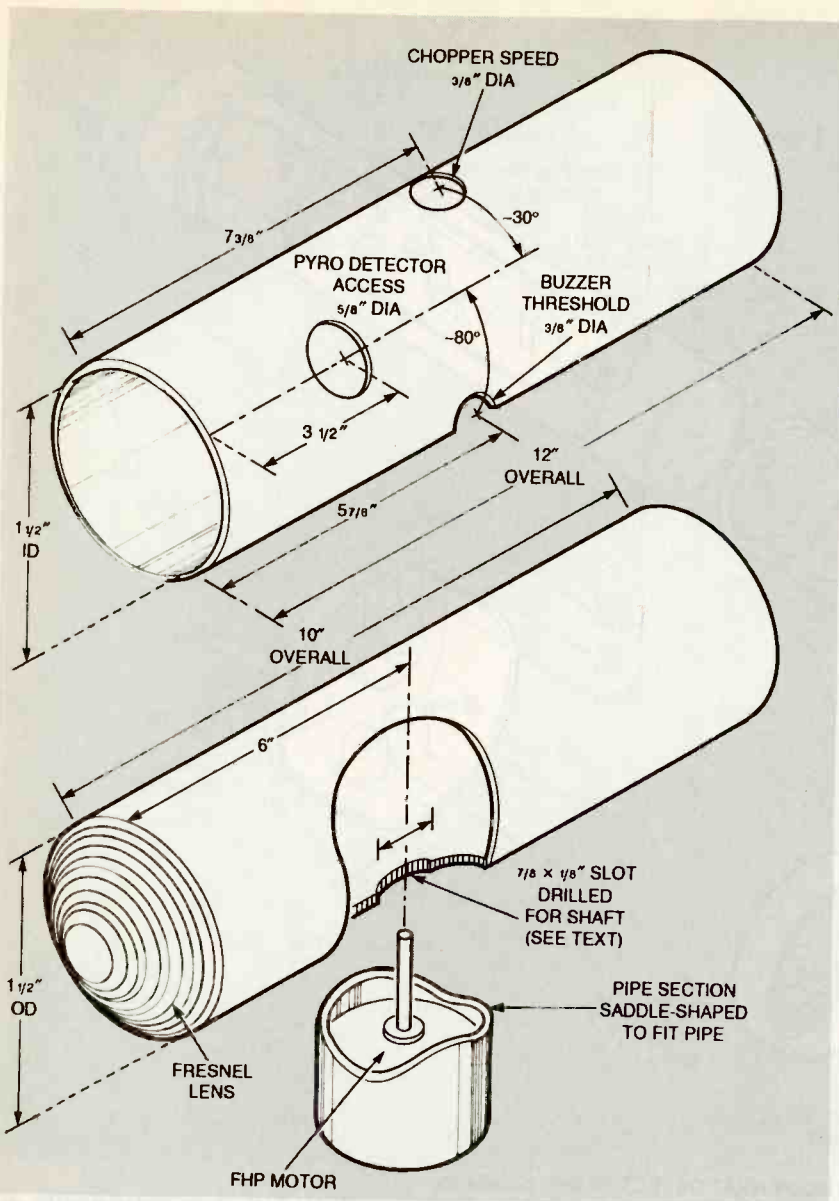

FIG. 4—CUTTING AND FORMING DIRECTIONS for the plastic or aluminum tubes for housing the sensor/amplifier and shutter/lens assemblies.

animals, or heat sources, this mode is so sensitive that some valid responses might seem to be false alarms.

System operation

Refer to the schematic, Fig. 2. The output of pyroelectric detector PYR1 is fed to the input of the low-frequency, dual-stage amplifier and filter IC1. The LM358N amplifier IC1-a, with a gain of about 2500, responds to a frequency of 0.1 to 10 Hz, peaking at about 1 Hz. This range matches the response of PYR1 to the infrared spectrum commonly generated by humans or large animals that is centered at about 10 microns.

The changing output of the filter IC1-b is further amplified by a factor of about 40 by PN2222 transistor Q1. This output can be capacitively coupled to an AC meter through EXTERNAL AC METER JACK J1. The output of J1 is an analog indication of signal strength, which should be between 20 and 100 millivolts.

The AC output of Q1 is also fed to IC2-a and b, an LM393N dual plus or minus "window" comparator. Trimmer potentiometer R11 sets the threshold activation level for buzzer BZ1. The output of IC2-a and b is sent to an AND gate, and its output is sent to the pin 2 TRIGGER

input of the NE555N timer IC3.

The output of IC3 can activate buzzer BZ1 and LED1 that are connected in series. LED1 illuminates when a target has been detected. Buzzer BZ1's on time is controlled by the 1-megohm timing resistors R17 and R18 across pins 8, 7 and 6, and capacitor C13 at pin 6. Panel potentiometer R15 (located on the end cap of the case) adjusts system temperature range and response to anticipated target size and temperature.

An optional chopper motor speed control consists of PN2222 transistor Q2 and trimmer potentiometer R23. Zener diode D1 provides a positive turn-on signal. Jack J2 provides DC drive for the shutter motor MOT1 through PL2.

External controls

Three access holes are formed in the tubular enclosure for the detector. One access port permits the lens position to be adjusted and the angle of PYR1 to be aligned for optimum results when the finished instrument is being set up. (This port is covered with an opaque band or tape to keep out ambient light when the instrument has been adjusted.)

Two other access holes are formed in the case to permit the two trimmer potentiometers R11 (buzzer threshold) and R23 (chopper motor speed adjust) to be set by a small insulated screwdriver or plastic trimmer adjusting tool. Panel-mount control potentiometer R15 can be set by a knob fitted on its shaft.

Chopper motor MOT1 speed can be set for optimum shutter chopping speed for detecting stationary objects by trimmer potentiometer R23. It produces the necessary "step function" in the infrared input signal.

Case material

Obtain a 12-inch length of aluminum or plastic tubing with an inner diameter of approximately 1.5 inches and a wall thickness of approximately 0.060 inch. Obtain a suitable plastic or aluminum cap with an inside diameter that will fit

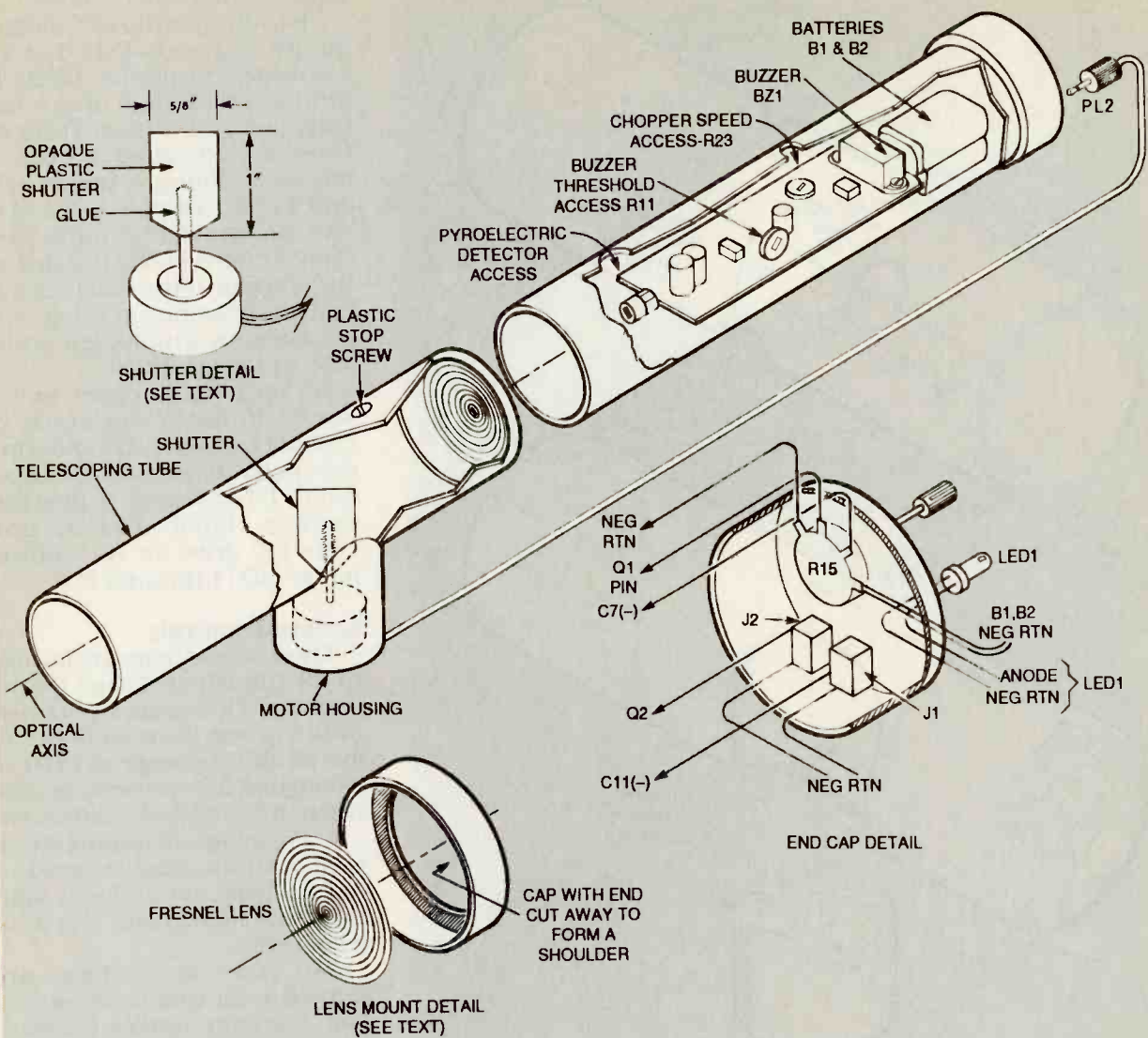

FIG. 5—CUTAWAY VIEW OF THE INFRARED BODY HEAT DETECTOR with details for making the shutter, lens mount, and end-cap assemblies.

snugly over the end of the tube.

Also obtain a 10-inch length of aluminum or plastic pipe with an exterior diameter of about 1.5 inches and a wall thickness of about 0.060 inch that telescopes snugly inside the larger tube. Then obtain an aluminum or plastic cap or cup about 1 inch deep that will fit snugly inside the smaller diameter tube.

Circuit board assembly

Refer to the electrical schematic Fig. 2 and the parts layout diagram Fig. 3. The amplifier circuit board was dimensioned to contain all of the electronic components and be able to slide inside the tubular case. The

prototype circuit board was cut from perforated board with a 0.1 inch grid to a length of 5¼ inches by 1½-inches, the approximate inside diameter of the housing tube. The width of the board should be cut slightly oversize. It can be sanded or ground down so that it can be press fit snugly inside the tube.

The parts layout as shown in Fig. 3 is intended to keep interconnection leads as short as possible. All connections are made with untrimmed component leads except for a bare wire bus that runs along the edge of the board on the wiring side. However, it might be necessary to solder tinned wire extensions on the ends of some sockets.

With Fig. 3 as your guide, insert the socket for pyroelectric detector PYR1 on the centerline of the board at the edge as shown. Then position the electronic components in the approximate positions shown in Fig. 3. In the prototype, resistors R2, R4, R6, R7, R8, R12, R14, R18, R19, R21 and R22 were all mounted vertically to conserve board space. One lead of each was bent back 180° to form a radial-leaded component.

Pay particular attention to the positions of the polarized devices and the pin 1 positions on the IC sockets. Bend the excess lead lengths on the wire side to form mechanical connections before doing any soldering.

Note the ground bus wire that connects pin 3 of SO1 with the negative sides of resistors R2, R7, R12, R14, R15, R21 and R23, as well as the negative sides of capacitors C2, C8, C12 and C13. In addition, this bus connects pin 4 of both IC1 and IC2 and the cathode of LED1 with one side of S1 (R15).

After completing all component insertion and soldering, check the circuitry visually against the schematic to be sure that all component placement is correct. Check for cold solder joints (dull gray color without evidence of solder flow), inadvertent solder bridges, or excessive solder on joints. Make all corrections before proceeding.

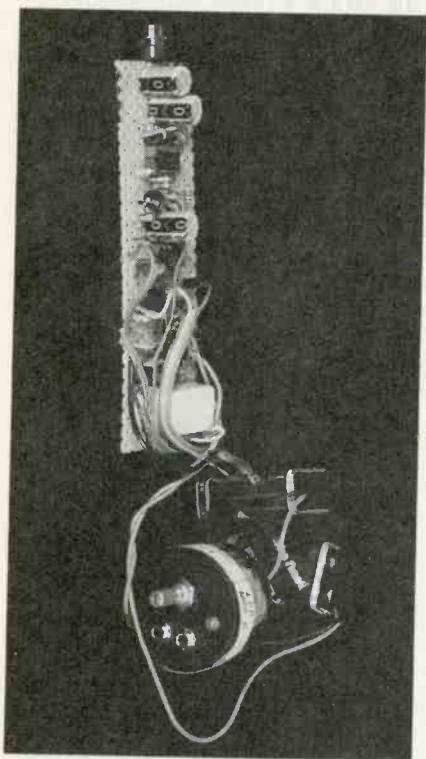

CIRCUIT BOARD AND END CAP assembly with batteries. The pyroelectric detector is at the top.

Mechanical assembly

Form the access holes in the 12-inch length of tubing as shown in Fig. 4. Then cut a slot that measures approximately $\frac{5}{8}$ -inch by $\frac{1}{8}$ -inch wide in the 10-inch tube as shown. Cut a small section of pipe that will accommodate the outside diameter of the DC shutter motor. Form a hole in the side of the section to accept the twin-wire

power cord, and shape the upper edge of the motor housing to form a saddle so that it will fit snugly against the pipe section.

Refer to the end cap detail in Fig. 5, and form the necessary holes in the tube cap to accommodate the two jacks J1 and J2, the light-emitting diode LED1 in a snap-in holder, and the combined potentiometer R15 and switch S1. Assemble those part in the cap and fasten them with the ring nuts provided.

End cap wiring

Cut approximate ten-inch lengths of No. 28 AWG insulated copper hookup wires required to connect the circuit board with the end cap components. The wires should be long enough to permit the end cap to be removed for replacing batteries B1 and B2 without removing the circuit board. In the prototype, nine-wire 28 AWG, multicolored flat-ribbon cable was used to make the nine connections from the circuit board to the cap.

Separate the individually color-coded insulated wires on both ends as necessary to make the appropriate connections. (If about an 8-inch length of flat cable remains bonded, it is easier to fold the cable back into the housing after final assembly.) Cut the black and red insulated wires from the 9-volt battery clips to about 10-inch lengths. Strip all wire ends, and twist all related pairs of wires before making the connections and soldering them.

Recheck the complete assembly looking for short circuits, cold solder joints, and improper location and orientation of polarized components. The circuitry can now be tested.

Electrical test

Install IC1 and IC2 in their sockets. Preset all potentiometers full counter clockwise with the pyroelectric sensor PYR1 out of its socket. Connect the 9-volt batteries B1 and B2 to their battery clips. Connect an ammeter on the 0 to 100-milliamperere scale in series with the common leads of both batteries across switch S1 at test point A (TP-A)

and measure the current. It should be between 15 and 20 milliamperes.

Turn the control knob of potentiometer R11 clockwise until the buzzer sounds. Expect to read a current of 60 milliamperes when LED1 is lit simultaneously. A voltage reading of 9 volts should be obtained at test point B (TP-B) and a voltage reading of 8.5 volts should be obtained at test point C (TP-C). Back off R11 slightly until the buzzer sound stops.

Insert pyroelectric detector PYR1 in its socket and slowly turn panel potentiometer R15 clockwise until the buzzer sounds. Keep PYR1 focused on a cold stationary background to prevent the detector circuit from responding erroneously to any movement. Make trial adjustments of R15 to verify the presence of a valid signal by passing your hand near the detector. Maximum sensitivity should be obtained when R15 is full clockwise and R11 is set to the critical activation point.

Connect a sensitive AC millivoltmeter set to the 500-millivolt range to jack J1, and watch for a response as an object or hand is placed in front of the detector.

Instrument housing

Refer to the lens-mount detail on Fig 5. Cut out the end of the aluminum or plastic cup that fits inside the 10-inch tube so that a shoulder about $\frac{1}{16}$ -inch wide is left as a retainer for the lens. Insert the lens in the aluminum sleeve and fasten it with one or two drops of a suitable adhesive. Then insert the lens assembly in the end of the tube as shown. Cement the assembly in place with an additional one or two drops of adhesive.

Refer to the shutter detail on Fig. 5. Assemble the chopper motor in the prepared housing. Then cut a thin piece of opaque plastic to the approximate dimensions shown, and glue it with suitable adhesive to the motor shaft as shown. After the adhesive has set, insert the shutter into the tube as shown in Fig. 5, and clamp the motor

(Continued on page 109)

HIGH TECH XMAS ORNAMENTS

Add an electronics theme to your Christmas decorating with the Visible Components.

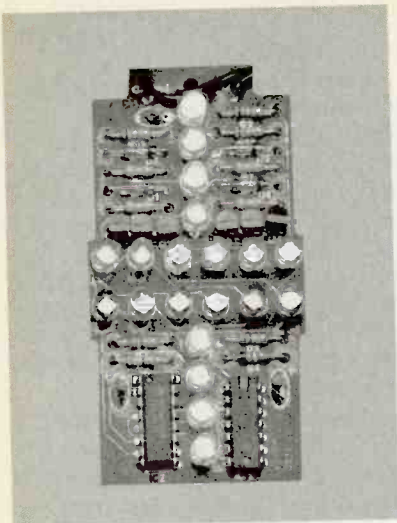

RON HOLZWARTH

CHRISTMAS WOULDN'T SEEM COMPLETE without at least one electronics project to add a little holiday spirit. This year, build the Visible Components, three light-up ornaments that take on the appearance of three common component symbols: a resistor, capacitor, and inductor. The Visible Components, and definitely worth adding to your Christmas ornament collection.

The Visible Components are surefire conversation pieces, and they are a great way to show off your Christmas spirit. After the holidays are over, the ornaments can decorate your workbench, office, or automobile, letting everyone know about your interest in electronics.

Flash patterns

Each visible component has several LEDs that light up in the pattern of the actual component's schematic symbol. But rather than each visible component having a simple flashing, alternating, or light-chasing illumination pattern, each one lights up in a way that mimics that component's operation in an actual circuit. Let's see exactly what that means.

In an actual resistor, current moves at a constant rate through the component. In other words, the component has a linear I-V relationship. That is represented on the visible resistor by having light

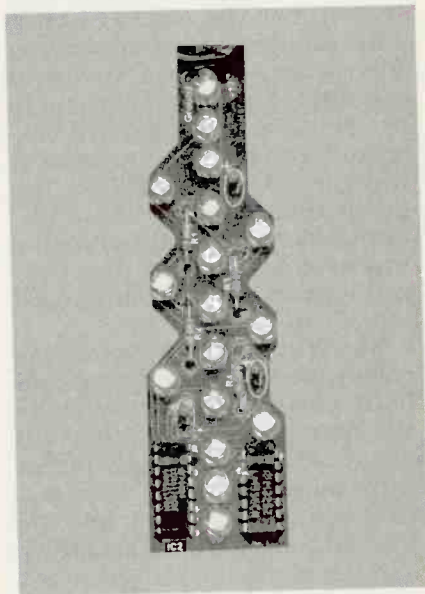

sweep through the LEDs at a continuous rate for three cycles and then turning off. The cycle then repeats again after a few seconds. The number of cycles during which light sweeps through the LEDs can be varied by changing certain component values.

Resistors do not store energy in an electric field, as do inductors and capacitors. To illustrate that, no LEDs are on during the off state.

A capacitor can store electrical energy while in a static state. This is illustrated on the visible capacitor by having the six LEDs that represent the lower plate of the capacitor remain lit during the off cycle. After a few seconds, the bottom

plate dims completely and the top plate then lights. The following clock cycles successively turn off the outer LEDs of the top plate, and the bottom plate begins to light again indicate a buildup of charge.

The visible inductor has two display sections, the coil itself and the leads. An electromagnetic field striking the coils of the inductor is illustrated by sweeping the ten coil LEDs sequentially.

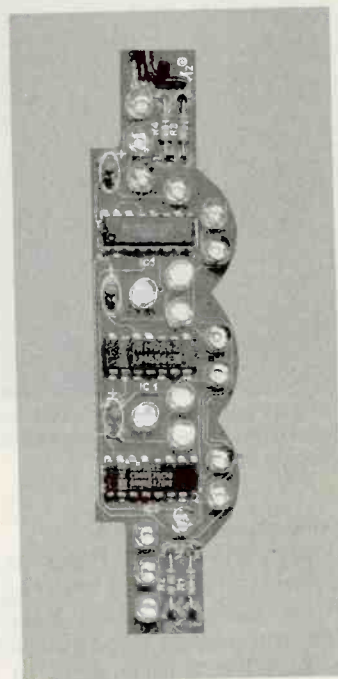

THE ORNAMENTS SHOWN in black and white photography become vividly alive with color when the completed boards are powered up!

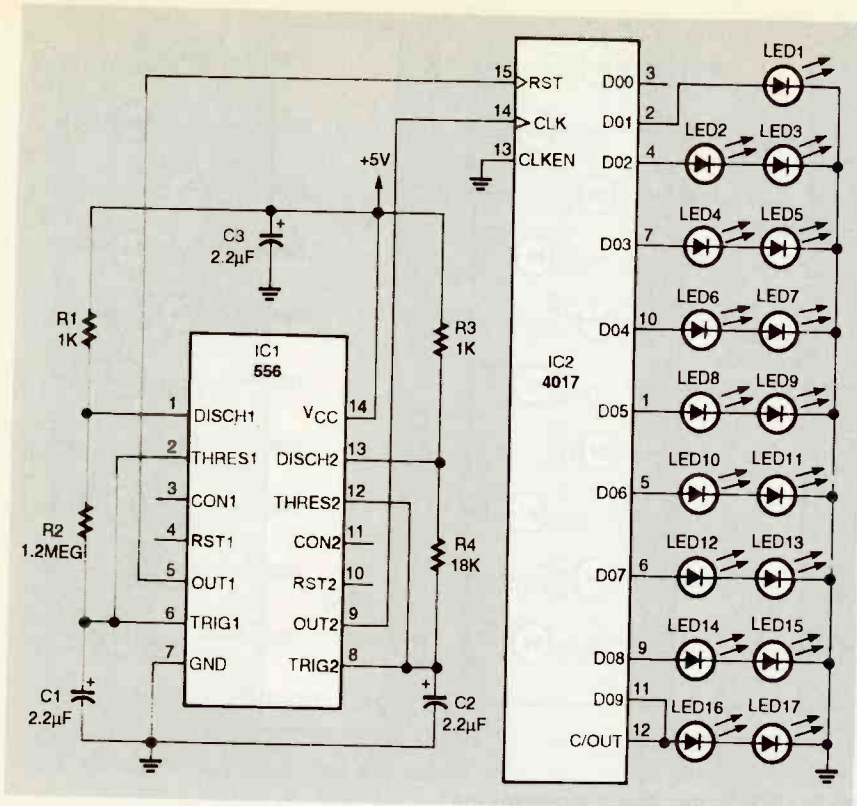

Circuitry

All three visible components share some common circuitry. Each is controlled by an LM556 dual timer IC and a CD14017 decade counter. Also, all three can be powered from a single 12-volt DC wall transformer. For the sake of discussion, we'll first examine the visible-resistor circuit shown in Fig. 1.

The reset time is controlled by one timer, IC1-a, whose timing components are C1, R1 and R2. The clock cycle time is set by the other timer, IC1-b, which uses timing components C2, R3, and R4.

The electrical differences between the visible components are the manners in which the decade counter is controlled by reset timer IC1-a.

In the visible resistor, the output at IC1-a pin 5 is connected to the RESET input (pin 15) of the decade counter (IC2). As long as the RESET line is held high, IC2 will not cycle and will keep pin 3 high. Since there is no LED connected to pin 3, no LEDs will be

FIG. 1—VISIBLE RESISTOR SCHEMATIC. This circuit drives 17 LEDs in a pattern that represents current flow through a resistor.

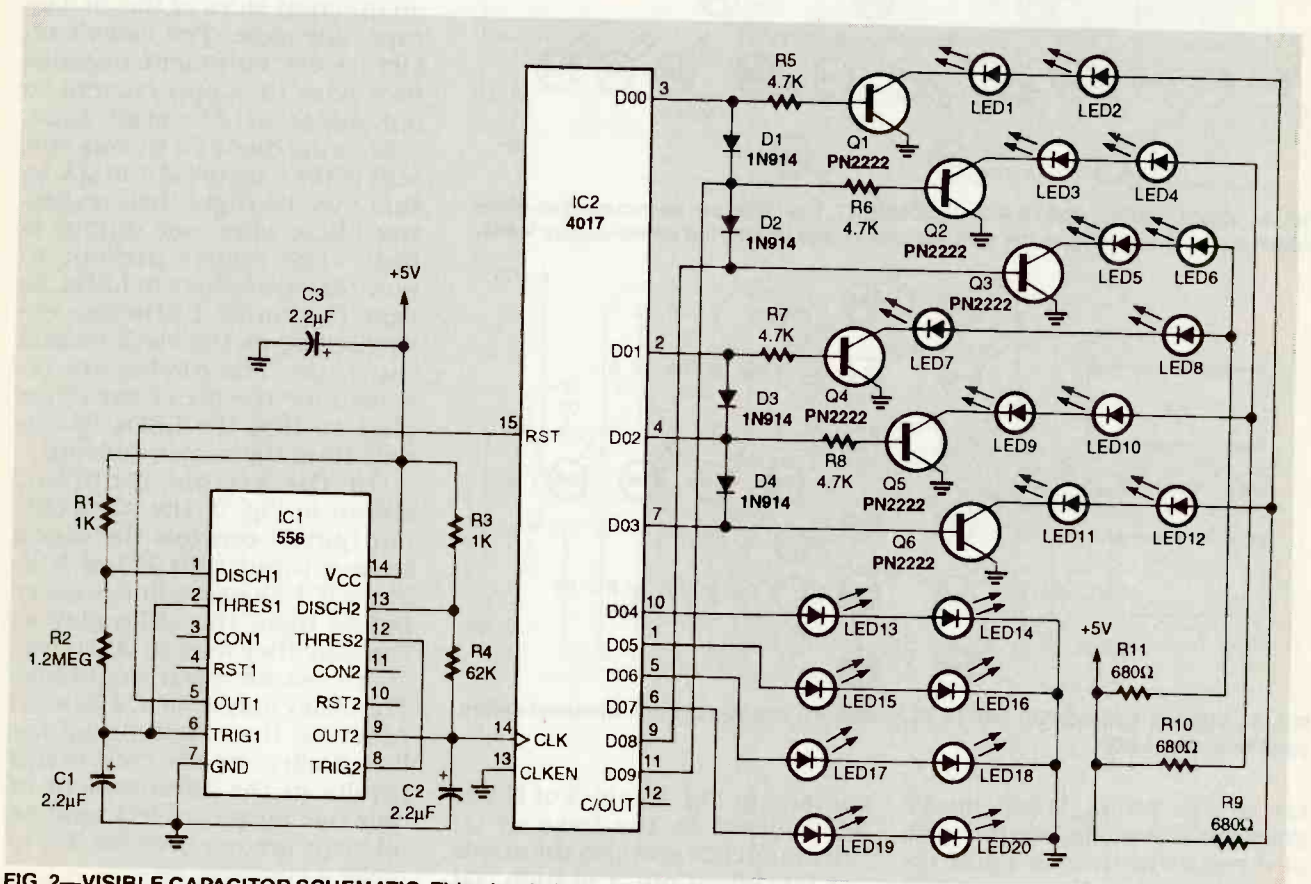

FIG. 2—VISIBLE CAPACITOR SCHEMATIC. This circuit drives 20 LEDs that are laid out in the pattern of a capacitor symbol.

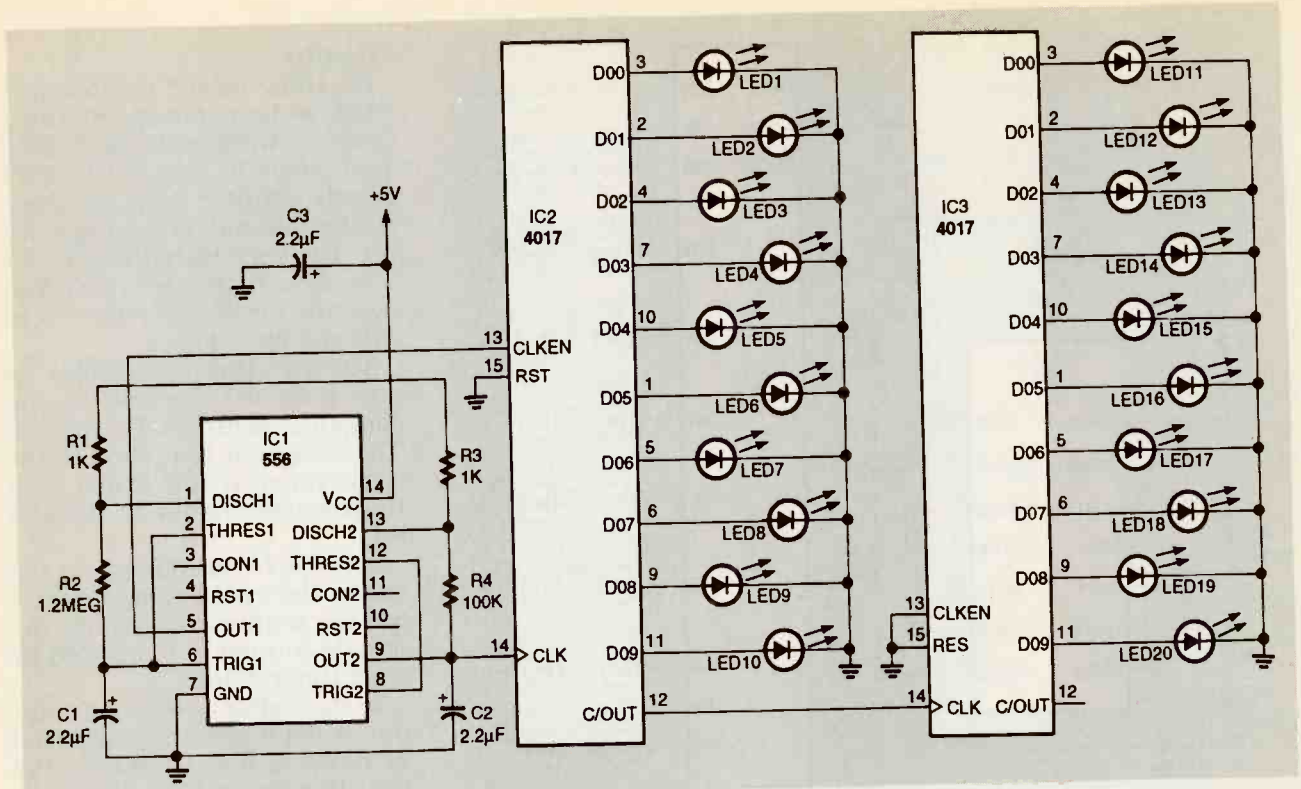

FIG. 3—VISIBLE INDUCTOR SCHEMATIC. The 20 LEDs in this circuit represent the coils of an inductor.

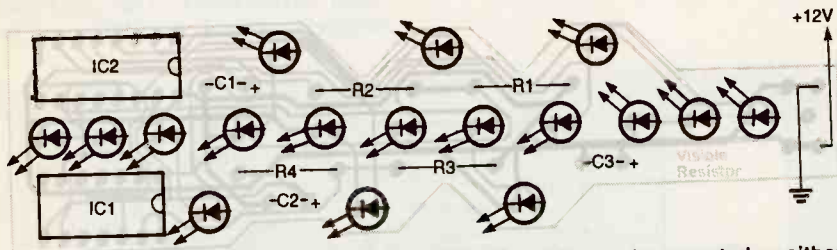

FIG. 4—VISIBLE RESISTOR PARTS PLACEMENT. The LEDs can be mounted on either side of the board as long as the cathode side points toward the power-supply leads.

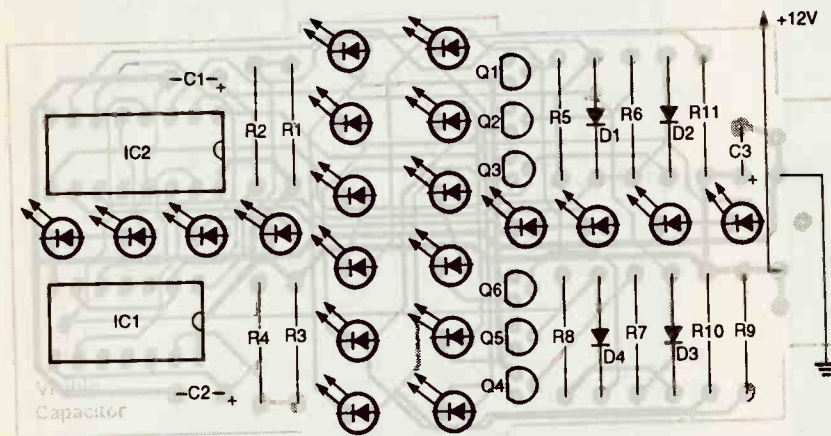

FIG. 5—VISIBLE CAPACITOR PARTS PLACEMENT. You can choose whatever colors you like for the LEDs.

LED2. Each of the current-limiting resistors (R9–R11) are shared by two sets of two LEDs on different sides of the visible-capacitor plate. The ¼-watt resistors are sufficient because they have to supply current to only one set of LEDs at any time.

Steering diode D1 directs current to the base of Q2 and Q3, so that they also light their respective LEDs when one output is high. The diodes prevent illumination of adjacent LEDs, so that the outer LEDs are extinguished as the clock counts continue. The diodes are reversed for the other capacitor plate so that the LEDs illuminate from the center outward.

On the visible inductor, shown in Fig. 3, the IC1-a output (pin 5) controls the CLOCK ENABLE input (pin 13) of IC2. Since IC1-a's RESET line is never pulsed high, the LEDs stay in the state they were in when the CLOCK ENABLE input went high. The CARRY output of IC2 (pin 12) provides the clock signal for IC3. Each complete cycle of IC2 results in the advancement of only one output of IC3, and so 99 steps are required for IC3 to make a complete cycle.

Timing resistors included in

on at this point. When RESET goes low, IC2 will begin its count and repeat until it is again reset.

On the visible capacitor,

shown in Fig. 2, pin 3 of IC2 is connected to the base of Q1 (through R5) and also the anode of D1. When pin 3 is high, Q1 will turn on, lighting LED1 and

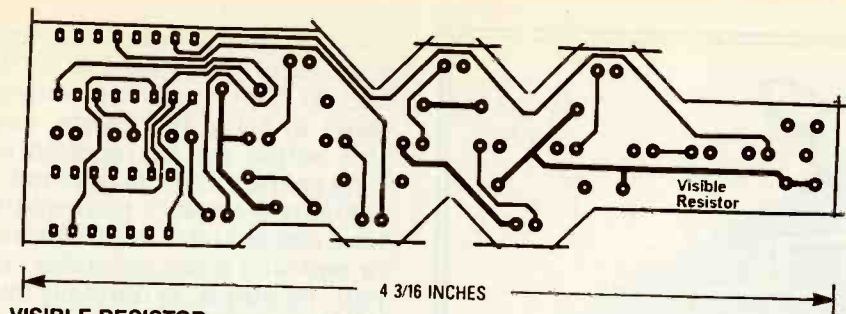

VISIBLE RESISTOR component side.

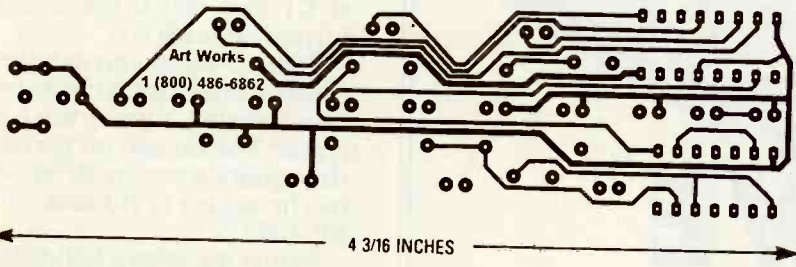

VISIBLE RESISTOR solder side.

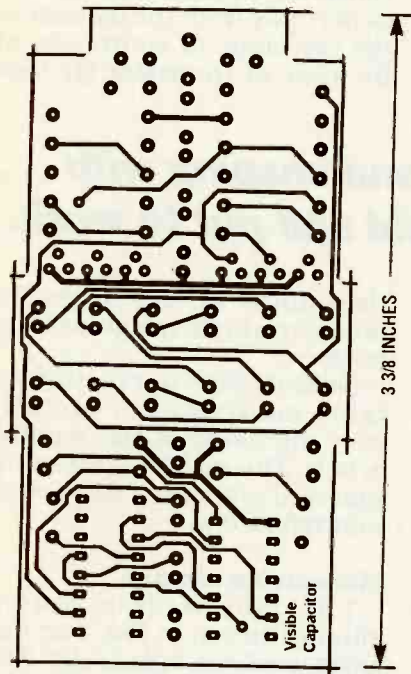

VISIBLE CAPACITOR component side.

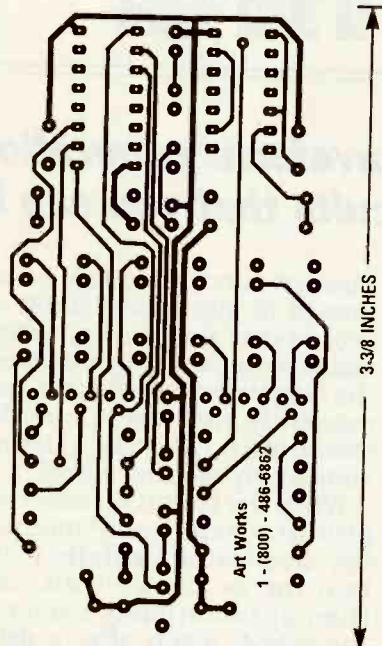

VISIBLE CAPACITOR solder side.

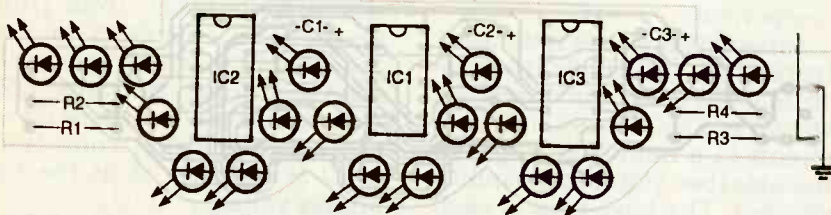

FIG. 6—VISIBLE INDUCTOR PARTS PLACEMENT. Mount the LEDs last, so they're not in your way when installing the other components.

the kit available from the source mentioned in the parts list are supplied as fixed units with the values specified in the parts list.

If you would like to experiment with different timing-resistor values, the kit also includes an adapter board that lets you sub-

VISIBLE RESISTOR PARTS

R1, R3—1000 ohms, ¼-watt, 5%
 R2—1.2 megohms, ¼-watt, 5%
 R4—18,000 ohms, ¼-watt, 5%
 C1—C3—2.2 μF, 25 volts, tantalum
 IC1—LM556 dual timer
 IC2—CD14017 decade counter
 17 LEDs (any color), 12-volt DC 300-mA wall transformer (one is sufficient to power all three visible components), PC board, wire, solder

VISIBLE CAPACITOR PARTS

R1, R3—1000 ohms, ¼-watt, 5%
 R2—1.2 megohms, ¼-watt, 5%
 R4—62,000 ohms, ¼-watt, 5%
 R5—R8—4700 ohms, ¼-watt, 5%
 R9—R11—680 ohms, ¼-watt, 5%
 C1—C3—2.2 μF, 25 volts, tantalum
 IC1—LM556 dual timer
 IC2—CD14017 decade counter
 D1—D4—1N914 diode
 Q1—Q6—PN2222 NPN transistor
 20 LEDs (any color), 12-volt DC 300-mA wall transformer (one is sufficient to power all three visible components), PC board, wire, solder

VISIBLE INDUCTOR PARTS

R1, R3, R4—1000 ohms, ¼-watt, 5%
 R2—1.2 megohms, ¼-watt, 5%
 C1—C3—2.2 μF, 25 volts, tantalum
 IC1—LM556 dual timer
 IC2, IC3—CD14017 decade counter
 20 LEDs (any color), 12-volt DC 300-mA wall transformer (one is sufficient to power all three visible components), PC board, wire, solder

ORDERING INFORMATION

Note: The following items are available from Transtronics, 3209 West 9 Street, Lawrence, Kansas 66049:

- PC board for any single visible component (specify choice of resistor, capacitor, or inductor)—\$12.00
- Set of three visible component PC boards (one of each)—\$30.00, or \$25 each when buying three or more sets
- Complete visible component kit including three PC boards, power supply, and 57 LEDs (specify choice of LED colors; red, green, yellow, or mixed)—\$65.00, or \$55.00 each when buying three or more kits
- Assembled string of three visible components (specify colors desired)—\$75.00

All prices include taxes, shipping, and handling. Visa/Mastercard orders call (800) 486-6862, 24 hours a day. For technical assistance call (913) 332-2726. Foreign orders require a bank check or postal money order in US funds and will be shipped air mail at no extra cost.

stitute multiturn potentiometers for fixed resistors. That will be useful if you are not sure what flash rates you want.

(Continued on page 110)

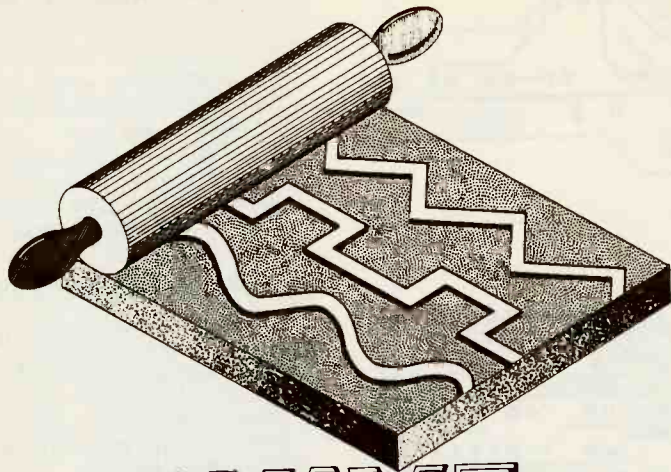

WAVE SHAPING

S1: the circuit locks into this state until Q2 is turned off by S2. At that time the output locks into the high state, and this action can be repeated as long as the circuit is powered.

Figure 2 shows a monostable (one stable state) multivibrator or one-shot pulse generator circuit. Its output is normally low, but switches high for a preset period (determined by the values of C1 and R2) if Q2 is briefly turned off with S1.

Figure 3 shows an astable (no stable states) multivibrator or free-running square-wave generator. The on and off periods of the square wave are determined by the values of R3 and C1 and R2 and C2.

Figure 4 shows a Schmitt trigger or sine-to-square waveform converter. Transistor Q2 switches abruptly from the ON state to the OFF state, or conversely, as the base of transistor Q1 base

Learn the basics of waveform generation and shaping with bipolar transistor circuits that you can build and put to work.

RAY MARSTON

THE SUBJECT OF THIS ARTICLE IS waveform generation and shaping as performed by various kinds of multivibrator circuits and special-purpose oscillators. It is a continuation of last month's article on transistorized RC and LC oscillator circuits, and the astable multivibrator. Previous articles in this series have covered the basics of the bipolar junction transistor (BJT) and have presented a general roundup of popular BJT circuits starting with those basic transistor amplifiers: common-collector, common-emitter and common-base.

Multivibrator basics

A transistor multivibrator is a cross-coupled, two-stage switching circuit. Each active transistor stage is regeneratively cross-coupled to its companion; thus, one stage automatically turns on as the other turns off, and conversely.

This cross-coupling can be arranged to give either stable or semistable switching. When stable cross-coupling is desired, the transistor switch locks permanently into the ON or OFF state until it is forced to change state by an external signal.

When the circuit is cross-coupled in a semistable manner, the transistor initially locks into the ON or OFF state, but then automatically becomes "unlocked" again after a delay period determined by the time constant of the cross-coupling components.

Schematics of the four basic transistor multivibrator circuits most commonly used are shown in Figs. 1 to 4. The Fig. 1 circuit is a manually triggered bistable (two stable state) multivibrator. The base-bias of each transistor is obtained from the collector of the other transistor, so that one transistor automatically turns off when the other turns on, and conversely.

The output can be driven low by briefly turning Q1 off with

risers above or falls below the predetermined trigger-voltage levels.

Several different practical astable multivibrator circuits were discussed in last month's article. This article will examine practical versions of three other multivibrators.

Monostable circuits

The monostable multivibrator circuit in Fig. 2 acts as a triggered pulse generator. Normally transistor Q2 is driven into saturation through R2, so the output (taken from transistor Q2's collector) is low. Transistor Q1, which derives its base-bias from transistor Q2's collector through resistor R4, is cut off under this condition, and its collector is at the full supply voltage.

When a START signal is applied to Q2 by momentarily closing switch S1, Q2 switches off, driving the output high and driving Q1 on through R4. Regenerative switching action is caused by the reopening of S1.

Transistor Q2's base is driven negative by the charge on C1, and as soon as the regenerative response is complete, C1 starts to discharge through R2. Eventually its charge falls so low that Q2 turns on again, thus initiating another regenerative response. Now both transistors revert to their original states, and the output pulse terminates, completing the action of the circuit.

Thus, a positive-going pulse is developed at the output of this circuit each time an input trigger signal is applied by momentarily closing switch S1. The pulse period is determined by the values of R2 and C1. The relationship is:

Pulse period = $\approx 0.7 \times R2 \times C1$
 Where the pulse period is in microseconds, C is in microfarads, and R is in kilohms.

The circuit in Fig. 2 can be triggered either manually by closing a momentary switch or by introducing an input trigger signal. That trigger signal can be either a negative pulse applied to the base of Q2, or a positive pulse applied to the base of Q1.

Figure 5-a is a practical schematic for a manually triggered monostable multivibrator. It can be triggered with momentary switch S1 by feeding a positive pulse to Q1's base through R2. Figure 5-b shows the circuit's waveforms.

In Fig. 5, the base-to-emitter junction of Q2 is reverse-biased during the operating cycle by a peak voltage equal to the supply voltage. This means that the maximum supply voltage should be limited to about 9 volts to prevent damage to the transistor. However, a supply voltage greater than the reverse base-emitter breakdown value of Q2 can be applied safely if silicon diode D1 is placed in series with Q2's base, as shown in Fig. 5.

This higher supply voltage provides the same kind of frequency correction that was described for the astable multivibrator in last month's article.

The value of timing resistor R3 in the Fig. 5 circuit must be large with respect to R1, but

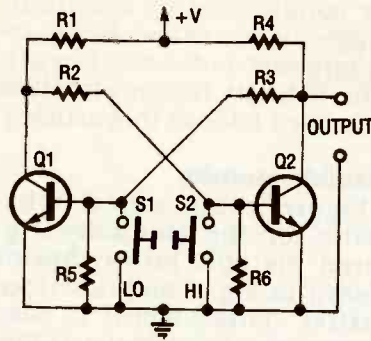

FIG. 1—A BISTABLE MULTIVIBRATOR intended for manual-triggering.

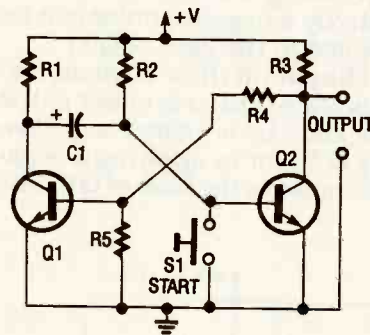

FIG. 2—A MONOSTABLE multivibrator designed for manual triggering.

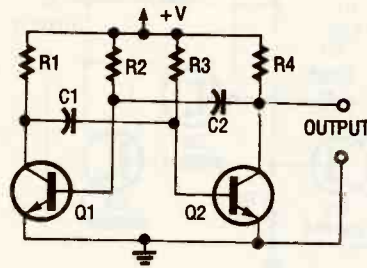

FIG. 3—AN ASTABLE MULTIVIBRATOR or free-running squarewave generator.

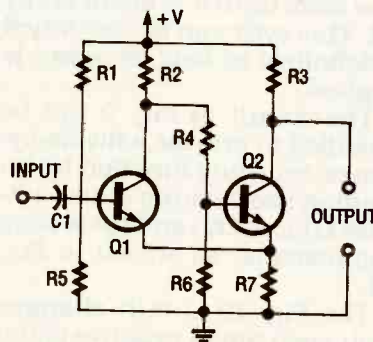

FIG. 4—A SCHMITT TRIGGER circuit is a sinewave-to-square wave converter.

must be less than the product of R5 and the h_{FE} of Q1. The pulse period for Fig. 5 equals 50 milliseconds divided by the value of capacitor C1 in microfarads; it will be 5 seconds with the value of C1 shown.

Long delays

If a Darlington transistor pair is substituted in place of Q2 in Fig. 5, the circuit will be able to provide very long timing periods. That substitution results in a very high effective h_{FE} , and permits the use of large values of R3, as shown in Fig. 6.

The Fig. 6 circuit can be powered from any DC source with an output between +6 and +15 volts to give a pulse output period of about 100 seconds with the values of the resistors and capacitors shown.

Keep in mind that a manually triggered monostable circuit such as those of Figs. 5 and 6 is dependent on the duration of the input trigger signal. The circuits trigger at the moment that a positive-going pulse is applied to the base of Q1 in Fig. 5 or Q3 in Fig. 6. If this pulse is removed before the monostable multivibrator completes its normal timing period, the period will end regeneratively, as previously described.

However, if the trigger signal has not been removed by the time the monostable completes its natural timing period, the timing cycle will end non-regeneratively. This means that the output pulse will have a longer period and falltime than if the trigger signal were removed earlier.

Waveform triggering

Figures 7 and 8 show alternative ways of applying input signal triggering to the monostable pulse generator. In each case, the circuit is triggered by a square-wave input signal with a short rise time. This waveform is differentiated by the differentiation circuit consisting of C1 and R1 to produce a brief trigger pulse.

In the Fig. 7 circuit, the differentiated input signal is rectified by diode D1 to provide a positive trigger pulse on the

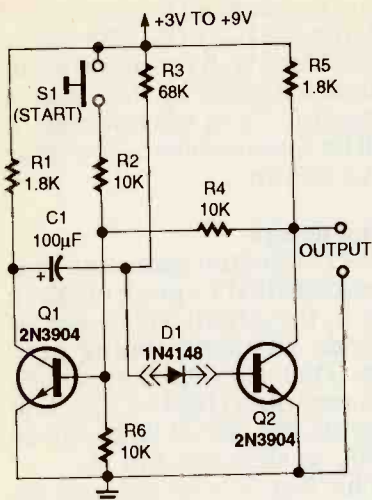

a

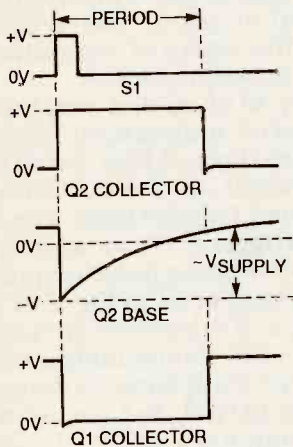

b

FIG. 5—A MANUALLY-TRIGGERED monostable pulse generator.

base of Q1 each time an external trigger signal is applied. In the Fig. 8 circuit, however, the differentiated signal is fed to the gate of transistor Q1. That change in the circuit makes the trigger signal independent of Q2. Notice that "speed-up" capacitor C3 in Fig. 8 is connected in parallel with feedback resistor R5 to improve the shape of the output pulse.

Both the circuits in Figs. 7 and 8 provide an output pulse period of about 110 microseconds with the values of resistors and capacitors shown. This period can be varied from a fraction of a microsecond to several seconds with a suitable choice of values for capacitor C2 and resistor R4.

The circuits in Figs. 7 and 8 can be triggered by sine or other

non-rectangular waves if they are conditioned by a Schmitt trigger or similar sinewave-to-squarewave converter circuit. (The Schmitt trigger circuit is discussed later in this article.)

Bistable circuits

Figure 9 is practical schematic for the manually-triggered bistable multivibrator shown in Fig. 1 and described earlier. This circuit is also known as a R-S (reset-set) flip-flop and, like a toggle switch, it is also an elementary digital memory. Its output can be SET to the high state by momentarily closing switch S2. (Alternatively a negative pulse can be applied to the base of Q2.)

The circuit then "remembers" this state until it is RESET to the low state by a momentary closing of S1 (or by applying a negative pulse to the base of Q1). The

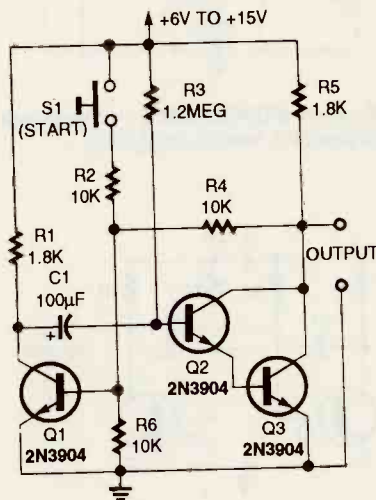

FIG. 6—A LONG-PERIOD (100-SECOND) monostable circuit.

circuit then "remembers" this new state until it is again set by S2. This cycle can be continued indefinitely as long as power is applied.

The circuit in Fig. 9 can be modified to provide a divide-by-two or counting function by including two steering diodes (diodes D1 and D2) and associated components, as shown in Fig. 10.

The Fig. 10 circuit changes state each time a negative-going trigger pulse is applied. If, for example, the input pulses are

derived from a squarewave input signal, the circuit will generate a squarewave output signal at half the input frequency.

The circuit generates a pair of output signals that are 180° out of phase, shown here as Q1 and Q2. The introduction of CMOS IC versions of the bistable counter circuit have largely eliminated any need for the construction of these circuits from discrete components.

Schmitt trigger

The last member of the multivibrator family to be discussed here is the Schmitt trigger circuit. It is a voltage-sensitive switching circuit that changes its output state when the input signal exceeds or falls below preset upper and lower threshold levels. Figure 11 shows how the Schmitt trigger converts sine waves to square waves.

The Schmitt trigger circuit is emitter-coupled and has cross-coupling between the base and collector of transistor Q1, which provides the required regenerative switching. Capacitor C2 speeds up the switching action by shunting R4. The sine-wave input signal is superimposed on a DC voltage. (The voltage is determined by trimmer potentiometer R8 and resistors R1 and R2) that is applied to the base of Q1.

A practical Schmitt trigger needs a sinewave input signal with an amplitude of at least 0.5

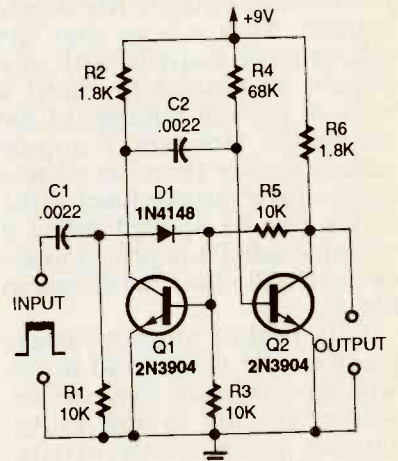

FIG. 7—A WAVEFORM-TRIGGERED monostable circuit.

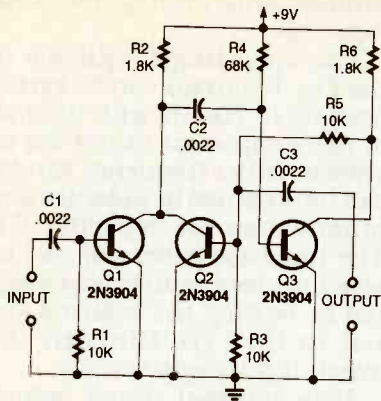

FIG. 8—A MONOSTABLE CIRCUIT with gate-input triggering.

volts, rms. The squarewave output signal symmetry varies with the input signal amplitude, so R8 must be adjusted to optimize that symmetry. The Schmitt trigger performs satisfactorily as a sinewave-to-squarewave converter at frequencies up to a few hundred kilohertz. The device produces squarewave output signals whose rise times are only a fraction of a microsecond.

Sawtooth generators

The astable multivibrator shown in Fig. 3 is one of a variety of circuits that can generate sawtooth waveforms. For example, it can generate negative-going sawtooth waves at the bases of both transistors Q1 and Q2. As a result, the astable multivibrator can be considered as another *free-running sawtooth generator*.

Similarly, the monostable multivibrators shown in Figs. 5 to 8 each generate a negative-going sawtooth on the base of Q2 during their active phases. They can be considered as *triggered sawtooth generators*.

Practical versions of Figs. 5 to 8 generate slightly nonlinear sawtooth waveforms because each of their timing capacitors charge exponentially (rather than linearly) through their timing resistors. This aberration can be easily overcome by replacing each timing resistor with a constant-current generator capable of generating linear waveforms.

A timing circuit based on the 555-type integrated circuit

timer offers the best way to generate positive-going triggered sawtooth waveforms. However, if you want to generate free-running, positive-going sawtooth waveforms, this can be done with a unijunction transistor or UJT, connected in the circuit shown in Fig. 12.

The UJT is a three-terminal

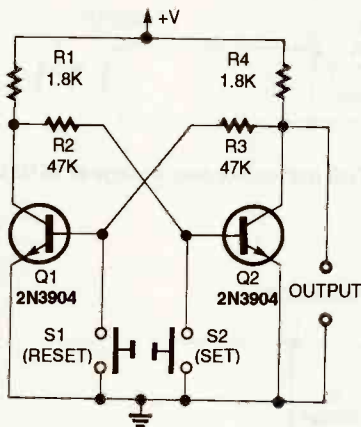

FIG. 9—A SWITCH-TRIGGERED FLIP-flop (R-S) bistable multivibrator.

abruptly to the ON state. When it is on, the emitter presents a low input impedance, and it draws a significant amount of current from the input circuitry. However, if this input current falls below a certain threshold value, UJT Q1 automatically switches back to its high input impedance state.

In Fig. 12, capacitor C1 charges exponentially towards the positive supply voltage through trimmer potentiometer R4 and R1 until the voltage on C1 reaches the firing value of the UJT Q1. At that time, the Q1 switches on and rapidly discharges C1. As soon as C1 is discharged, Q1 turns off again, so C1 starts to recharge again through R4 and R1.

This circuit generates a stable but nonlinear sawtooth waveform that can be varied from 25 Hz to 3 kHz by R4, with the value of capacitor C1 shown. Transistor Q2 and Q3 are connected as a Darlington emitter-follower

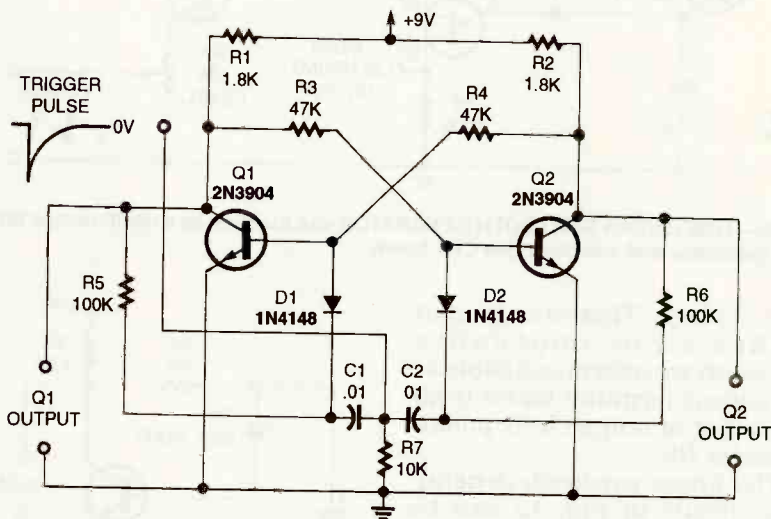

FIG. 10—A DIVIDE-BY-TWO BISTABLE circuit.

transistor whose terminals are identified as *emitter (E)*, *base 1 (B1)*, and *base 2 (B2)*. A UJT is connected as shown in Fig. 12 as Q1 with its B2 positive with respect to B1, and with the input applied to its emitter terminal.

The emitter of the UJT Q1 presents a very high impedance until the input (emitter) voltage reaches a specific *firing* voltage. At that time, UJT Q1 switches

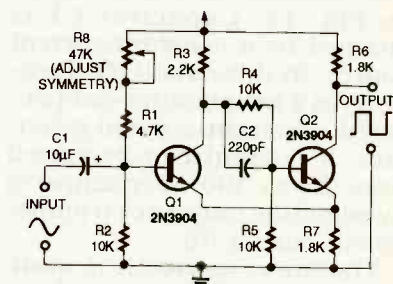

FIG. 11—SCHMITT TRIGGER sinewave-to-squarewave converter.

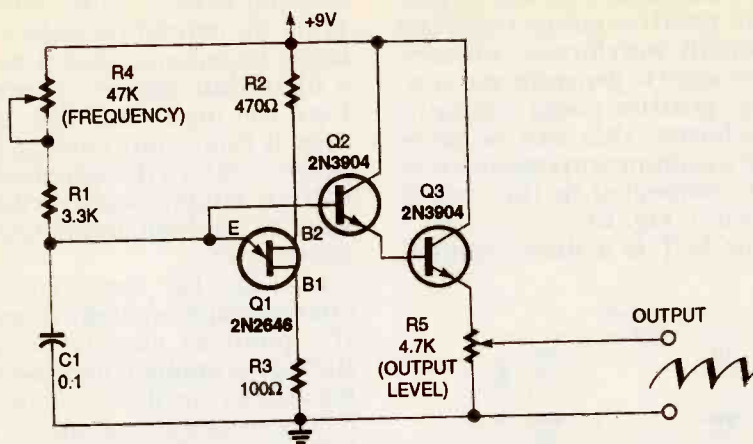

FIG. 12—A NONLINEAR SAWTOOTH GENERATOR that works over a range of 25 Hz to 3 kHz.

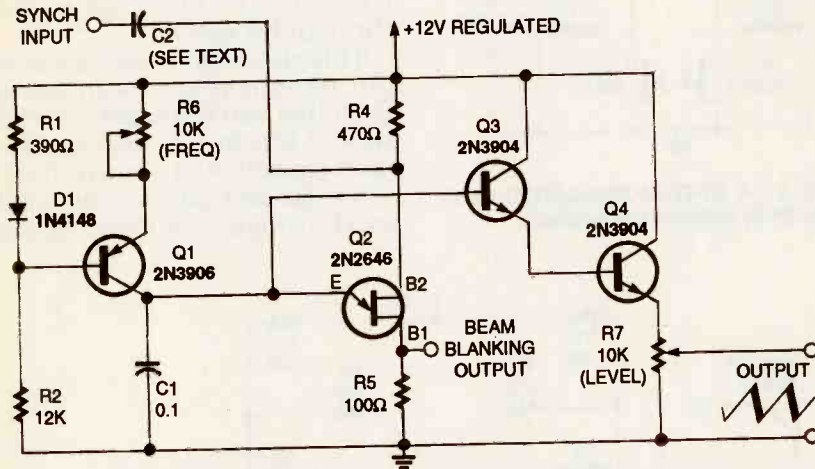

FIG. 13—THIS LINEAR SAWTOOTH GENERATOR can function as an oscilloscope timebase generator and can blank the CRT beam.

buffer stage. This arrangement makes a low-impedance sawtooth waveform available at an output terminal taken from the wiper of output level potentiometer R5.

The linear sawtooth generating circuit in Fig. 12 can be modified to become an oscilloscope timebase generator. The modified circuit is shown in Fig. 13. Capacitor C1 is charged by a constant-current source. In this circuit, Q1 functions as a temperature-compensated, constant-current generator. Its current can be varied from 35 to 390 microamperes by adjusting frequency trimmer potentiometer R6.

The linear sawtooth is available as a variable output whose amplitude can be varied by setting level potentiometer R7. The

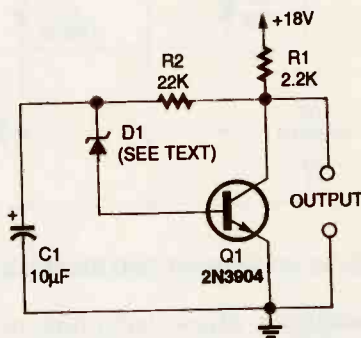

FIG. 14—A WHITE-NOISE GENERATOR has many applications.

output between R7 and ground can be fed via a coaxial cable to the external timebase jack of an oscilloscope.

Positive "flyback" pulses taken between resistor R5 and B1 of UJT Q2 at the beam-blanking output can be used to blank the oscilloscope beam if taken

through a high-voltage blocking capacitor.

The operating frequency of the Fig. 13 circuit can be varied from 60 to 700 Hz with R6 if all of the component values are as shown. Other frequency ranges can be obtained by substituting other values for capacitor C1. The timebase generator can be synchronized to an external signal by feeding the external signal to UJT Q2 through the sync input capacitor C2.

This external signal, which must have a peak amplitude between 200 millivolts and 1.0 volt, effectively modulates the supply voltage (and thus the trigger point) of UJT Q2. It causes UJT Q2 to fire in synchronism with the external trigger signal.

Capacitor C2 must have a lower impedance than resistor R4 at the sync signal frequency. Also, capacitor C2 must have a working voltage that is greater than the external voltage from which the external signal is applied. If the sync signal has a rectangular form with short rise and fall times, the value of C2 need only be a few hundred picofarads.

White-noise generator

"White noise" is another useful waveform. It is a signal that contains a full spectrum of randomly generated frequencies, each having equal mean power when averaged over a unit of time. White noise is useful for testing audio and radio frequency amplifiers, and it is widely used to mask background noise to serve as a sleeping aid.

Fig. 14 is the schematic for a simple, practical white-noise generator. It operates on the principle that all reverse-biased Zener diodes inherently generate white noise. In Fig. 14, R2 and D1 are connected in a negative-feedback loop between the collector and base of common-emitter amplifier Q1. Negative feedback stabilizes the DC working levels of the generator. Capacitor C1 serves to decouple alternating current from the circuit.

The Zener diode acts as a

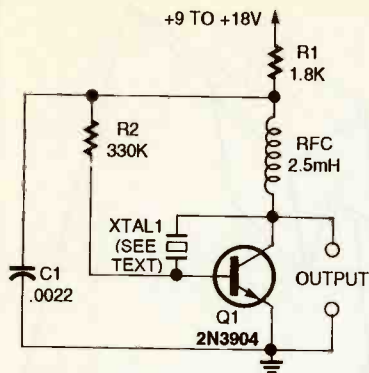

FIG. 15—A PIERCE OSCILLATOR with a parallel-mode crystal.

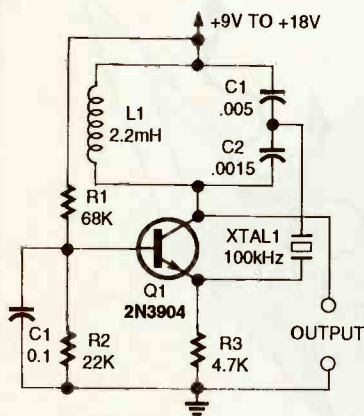

FIG. 16—A 100-kHz COLPITTS oscillator with a series-mode crystal.

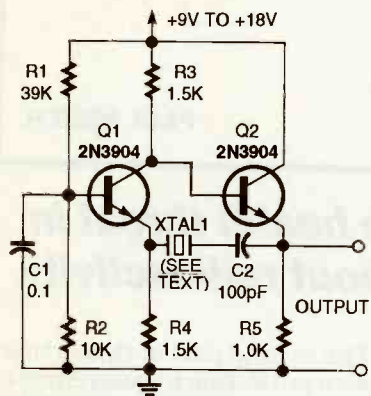

FIG. 17—THIS 50-kHz to 10-MHz oscillator will work with most series-mode crystals.

white-noise source that is in series with the base of transistor Q1. The Zener noise is amplified by the transistor to a useful level of about 1 volt peak-to-peak. Any Zener diode rated for 5.6 to 12 volts should work well in this circuit. Try different Zener diodes and compare the white-noise output.

Crystal oscillators

Crystal oscillator circuits generate accurate, stable frequencies because they include precisely cut piezoelectric quartz crystals which function as high precision electromechanical resonators or tuned circuits. The crystals in these circuits typically have Qs of about 100,000, and they can provide as much as 1000 times greater frequency stability than can conventional inductive-capacitive (LC) tank-circuit oscillators.

A piezoelectric crystal's operating frequency of a few kHz to 100 MHz is determined by its mechanical dimensions. The crystal, can be cut to provide either series or parallel resonant operation. Series-mode crystals present a low impedance at resonance, while parallel-mode crystals present a high impedance at resonance.

Figure 15 is a practical schematic for a crystal oscillator that is designed for a parallel-mode crystal. The circuit is actually a Pierce oscillator, and it will oscillate with most 100-kHz to 5-MHz parallel-mode crystals without any circuit modification.

Figure 16 shows an alternative 100-kHz oscillator that was designed for a series-mode crystal. It is known as a Colpitts oscillator.

Its tank circuit, consisting of L1, C1, and C2, is designed to resonate at the same frequency as the crystal. However, the tank circuit component values must be changed if any other crystal frequencies are desired.

Figure 17 is the schematic for a useful two-transistor oscillator that will work with most 50 kHz to 10 MHz series-resonant crystals. In this circuit, Q1 is connected as a common base amplifier, and Q2 is an emitter follower. The output signal (from Q2's emitter) is fed back to the input (Q1's emitter) through C2 and the series-resonant crystal. This is a versatile oscillator circuit that will work even with a low-cost, marginal crystal. Because of that, the circuit can form the heart of a simple crystal tester.

Whaddya Say To
A Guy Who's Had
The Same Job
For 50 Years,
Has Never Called
In Sick Or
Showed Up Late,
Never Taken A
Vacation Or A
Holiday, Never
Asked For A
Raise Or Griped
About His Bonus
And, Believe It Or
Not, Has No
Plans For
Retirement?



Thanks.

Remember - only you can prevent forest fires.

RADON MONITOR

Build this radon monitor to detect a possible health threat in your home and, while doing it, learn more about radioactivity.

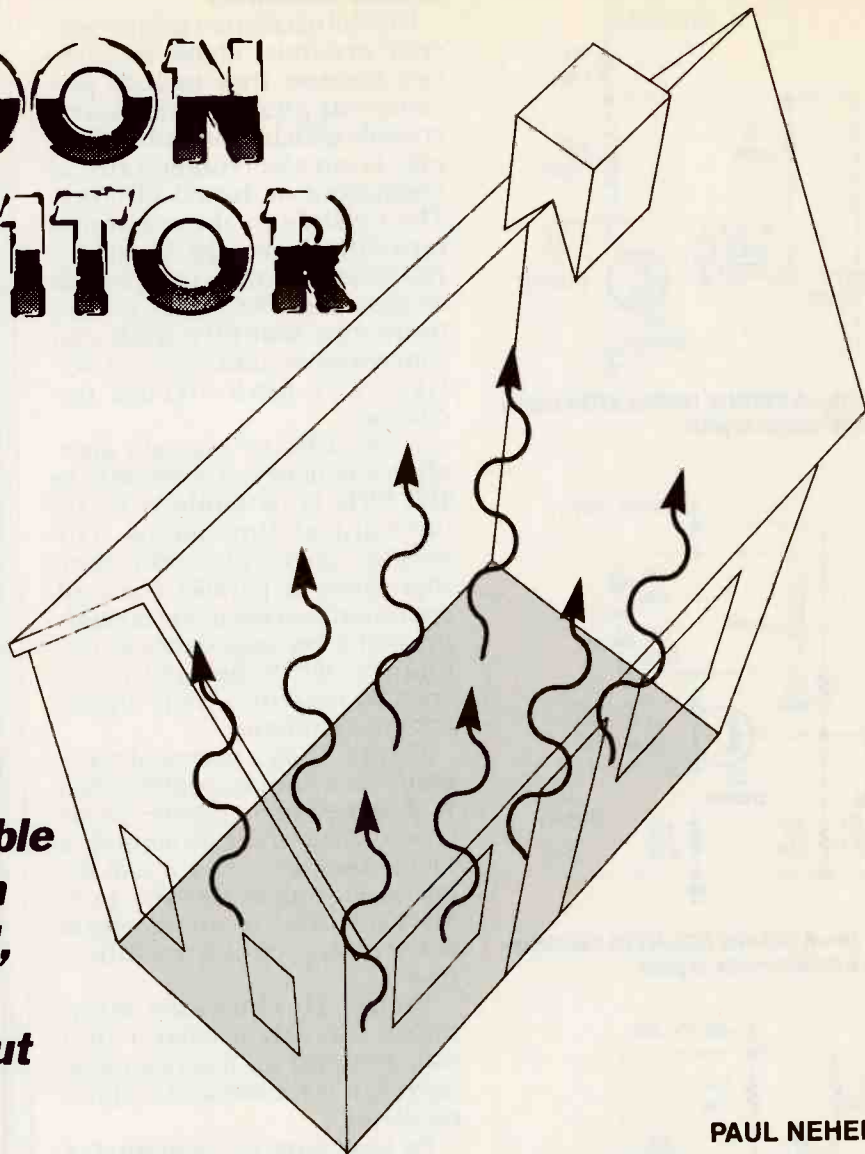

PAUL NEHER

Build this radon monitor to detect a possible health threat in your home and, while doing it, learn more about radioactivity.

THIS TWO-PART ARTICLE DISCUSSES the design, construction, and use of a simple, inexpensive environmental radon gas detector that you can build. It is called the beverage can environmental radon monitor or BERM because its ionization chamber sensor is made from a readily available aluminum beverage can. You will be given a choice of methods for measuring and recording events or rates that can be translated into units of radon density.

Most people are exposed to en-

vironmental radon in excess of the natural rate because of the time they spend indoors. This first article explains what radon is, why it is a health hazard, and the importance of knowing the level of radon in the rooms of your house where you spend most of your time while indoors. It also includes the information needed to build the ionization chamber, its amplifier circuitry, and alternative circuits for charging the chamber's internal high-voltage capacitor to 500 volts.

The second part of this article covers pulse-rate measurement, instrument calibration, and the conversion of pulse rates to radon density units. The article also offers alternative methods and circuits for performing these functions.

Even if the BERM is only crudely calibrated, it can warn you of unsafe radon levels in your home. However, when properly calibrated, it can give readings that compare favorably with those obtained from professional radon monitoring instru-

ments costing thousands of dollars. Constructing the BERM will give you "hands on" experience in measuring a common form of radioactivity, and give you a better understanding of how it produces isotopes, subjects not easily grasped in lectures or from reading.

The cost of parts to build the BERM, exclusive of a power supply, is typically less than \$20. Because most of the components are readily available, you might be able to reduce even that modest cost by making use of parts you already have on hand. You will need the standard electronic technician's set of hand tools as well as such basic electronic test equipment as a two-channel oscilloscope and either an analog or digital multimeter.

What is radon?

Radon is a natural, inert, radioactive gas emitted from the earth. Odorless, colorless, and invisible, it is a byproduct of the radioactive decay of uranium. Because it is inert and does not chemically bond to elements, it is released from the soil into the atmosphere. Radon is emitted almost everywhere on earth, but some geographical regions have higher concentrations than others, depending on the local geology and soil porosity.

Radon becomes a health problem when it decays and produces other short-lived isotopes called *daughter products* or *progeny*. These chemically active isotopes are usually formed as charged particles (ions). They bond readily to other substances such as dust and smoke particulates. Table 1 lists a portion of the decay chain of radon 222 and its short-lived progeny.

When radon decays, it releases alpha particles with an energy of 5.5 million electron volts (5.5 MeV). That would seem to be a large amount, but alpha particles travel only 4 to 7 centimeters (1.5 to 2.5 inches) in air before dissipating their energy in the ionization of air molecules. A piece of paper or even human skin is thick enough to stop alpha particles.

Direct exposure to radon, unlike direct exposure to beta particles, gamma rays, X-rays, or even ultraviolet light, poses little risk for humans.

The health threat from radon is indirect. Energetic alpha particles can cause chromosomal damage to the thin layers of lung tissue when humans breath air contaminated by radon and its progeny. That damage is a potential cause of lung cancer, especially when coupled with the effects of cigarette smoke in the lungs.

There are several different forms of radon, but radon 222 is the most prevalent form, and is of the most concern to health researcher. The number 222 refers to its isotope number. The alpha particles emitted by radon and its progeny are helium nuclei.

Most of the radon 222 that is inhaled is either exhaled directly or it diffuses into the bloodstream where its alpha emission does little detectable damage. However, radon's short-lived progeny such as polonium 214 and polonium 218 are more likely to emit alpha particles that are capable of damaging sensitive human tissue.

The alpha particles from the decay process of polonium 218 have 6.0 MeV of energy while those from polonium have 7.7 MeV, both higher than the 5.5 MeV of radon 222. For this rea-

son, researchers believe that they are the agents primarily responsible for inducing lung cancer in situations where radon 222 is present in amounts considered to be above the safe level.

Radon has been a constituent of the air for millions of years. We became aware of its existence only when instruments were developed that could detect and measure it. Its presence is of concern because of the alarming statistics on death due to lung cancer. Its presence has long been considered a contributing factor to those deaths. However, it is difficult to separate cancer attributable to radon alone from that attributable only to smoking or to smoking in the presence of radon.

The harmless concentration of radon in the outdoor air is about one-thousandth of its concentration in the ground. This can be demonstrated by placing an inverted bucket on bare ground over a suitable radon monitor. The radon emanating from the soil collects inside the bucket until an equilibrium condition is reached. The monitor will probably indicate a radon concentration that is several orders of magnitude higher than that in the surrounding air, but less than the soil concentration in the soil.

A house with a foundation, walls, floors, and a roof can be

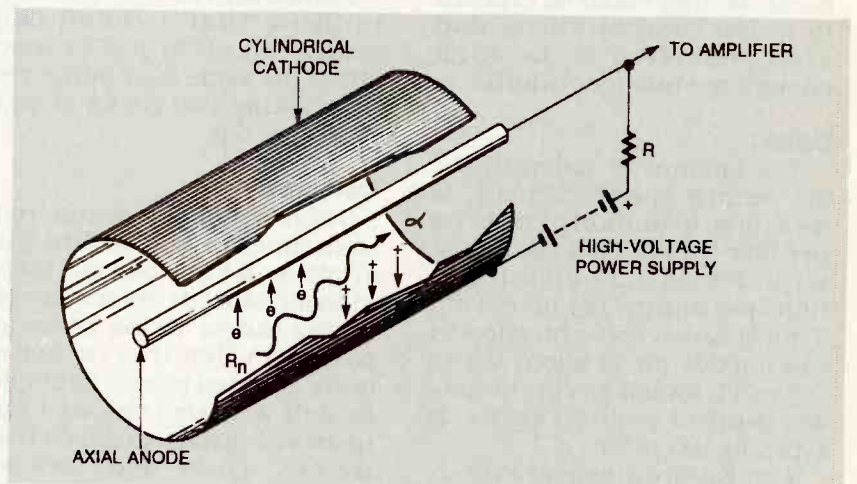

FIG. 1—THEORY OF RADON MONITOR IONIZATION CHAMBER. Positively charged anode wire attracts electrons and negatively charged cathode attracts positively charged ions. The recombination of electrons and ions causes a current that produces a voltage pulse.

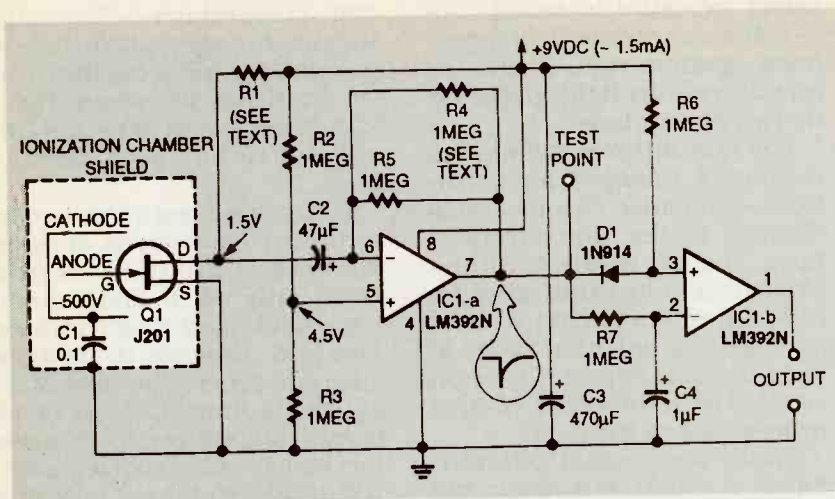

FIG. 2—RADON MONITOR AMPLIFIER amplifies voltage pulses across resistor R1 and then detects them for counting by separate pulse-rate counting circuitry.

TABLE 1
THE DECAY CHAIN OF RADON 222

Isotope	Name	Half life	Decay process	Energy
Rn 222	Radon	3.82 day	alpha	5.49 MeV
Po 218	Polonium	3.05 min	alpha	6.0 MeV
Pb 214	Lead	26.8 min	beta	1.0 MeV
Bi 214	Bismuth	19.7 min	beta	3.3 MeV
Po 214	Polonium	164 μ s	alpha	7.7 MeV

considered analogous to a bucket. It will also trap radon that leaks into the indoor airspace, especially if all the doors and windows of the house are closed. Under these conditions, the indoor radon might be 10 to 100 times more concentrated than outdoor radon. People in developed countries typically spend most of their time indoors at work, at school, or at home, so they could be exposed to radon concentrations that are considered to be high enough to endanger health.

Units

The amount of radon in the air, termed specific activity, is measured in units of picoCuries per liter (pCi/l). This can be interpreted as 2.22 disintegrations per minute per liter of air. Typical radon concentration in the outside air is about 0.1 to 0.2 pCi/l. Radon gas in the soil, at a depth of about 15 inches, is typically 100 pCi/l.

The Environmental Protection Agency (EPA) has stated that a radon level within a home of 4 pCi/l or less will present little or no health threat. It has

published recommendations for specific actions to be taken where higher concentration levels are found. These include follow-up testing in other rooms in the home. Nevertheless, it is ultimately up to the homeowner to decide what radon level is acceptable for his home in the absence of a scientifically established absolute safe threshold level for radon exposure.

Published risk comparisons indicate that a radon concentration of 30 pCi/l carries about the same cumulative risk as smoking two packs of cigarettes per day.

Detectors

There are many commercial instruments and techniques available for measuring radon indoors. Most detectors for evaluating indoor radon levels are passive in that they do not require external power. Examples include activated charcoal canisters or nuclear-track etch detectors. These detectors are exposed to indoor air under specified test conditions. After exposure, they are sent off to a laboratory for analysis, the

same approach used in detecting X-ray exposure with passive detection badges.

The principal drawback to passive detectors is that they measure radon concentration at only one specific location for a specified period of time. Many variables influence radon concentration levels; therefore, a single estimate of radon concentration is likely to have a significant error.

Obviously, radon concentration surveys based on two or more passive measurements will provide a more accurate assessment than a single measurement, but they are expensive because the price of a "one-time-only" passive detector can range from \$25 to \$100. If you conduct only one test, the EPA recommends that it be run under *worst-case conditions*.

By worst case conditions, the EPA means that the test should be made in any living space in the home or building that is closest to the ground (just above the floor slab, crawl space or basement) at a time of the year when ventilation is at a minimum—typically during the winter.

The air exchange rate and type of heating and cooling system in a house or building can cause wide variations in the amount of radon present due to differences in the way air is introduced, circulated and exhausted. There can also be daily variations in radon concentration. Because radon readings might exceed limits considered to be safe, it is recommended that radon concentration levels be measured over a one-year period in different locations in the home to obtain the best estimate of long-term risk.

Only an active radon monitor such as the BERM is capable of monitoring radon continuously. Commercial instruments capable of doing that typically cost several thousand dollars. The BERM radon monitor has many of the features of the expensive instruments at a far lower price.

BERM readings will be not be very accurate unless they are

compared against those of a properly calibrated test instrument. Nevertheless, even if it is not calibrated, the BERM will yield relative data that is accurate enough to indicate if a radon hazard exists in your home. You can use a BERM to locate the "worst case" room in your house where a follow-up test with a precisely calibrated monitor should be performed if you suspect excessive levels.

Ionization chamber theory

The easiest way to measure the presence of radon is to detect the high-energy alpha particles that it emits as a result of radioactive decay. As can be seen in Table 1, the alpha particle has a kinetic energy of about 5.49 MeV which ionizes the air passing through it. On average, about 34 eV is required to ionize air.

Therefore, assuming that an alpha particle dissipates all of

its energy ionizing air, about 100,000 (10^5) electron-ion pairs are generated over a path length of about 4 centimeters (1.5 inches). As a result, a charge of 10^{-14} coulombs can be collected by the electric field inside the ionization chamber.

The BERM ionization chamber, shown schematically in Fig. 1, has a cylindrical form factor because it is constructed from an aluminum beverage can. It has an axial, positively charged wire anode that extends the length of the can.

Negatively charged electrons (e) are attracted to the positively charged anode and arrive a few microseconds after an ionizing event while positively charged ions (+) are attracted to the negative cathode cylinder liner. A few milliseconds later the ions recombine with electrons from the high-voltage, DC-power supply.

The resulting current flow

produces a small voltage pulse across the resistor in series with the power supply. That pulse is then amplified, detected, and counted. The number of counts per minute can then be multiplied by a constant that includes the effective volume of the chamber to determine specific radon activity in units of pCi/l. The presence of radon "daughters" produced in the chamber increases the count rate.

The BERM ionization chamber design is based on the assumption that the air inside the chamber is a representative sample of the air in the room that is being monitored. The air in the BERM is slowly exchanged by diffusion through openings in the chamber.

Chamber size

A 12-ounce aluminum beverage can was selected for making the ionization chamber

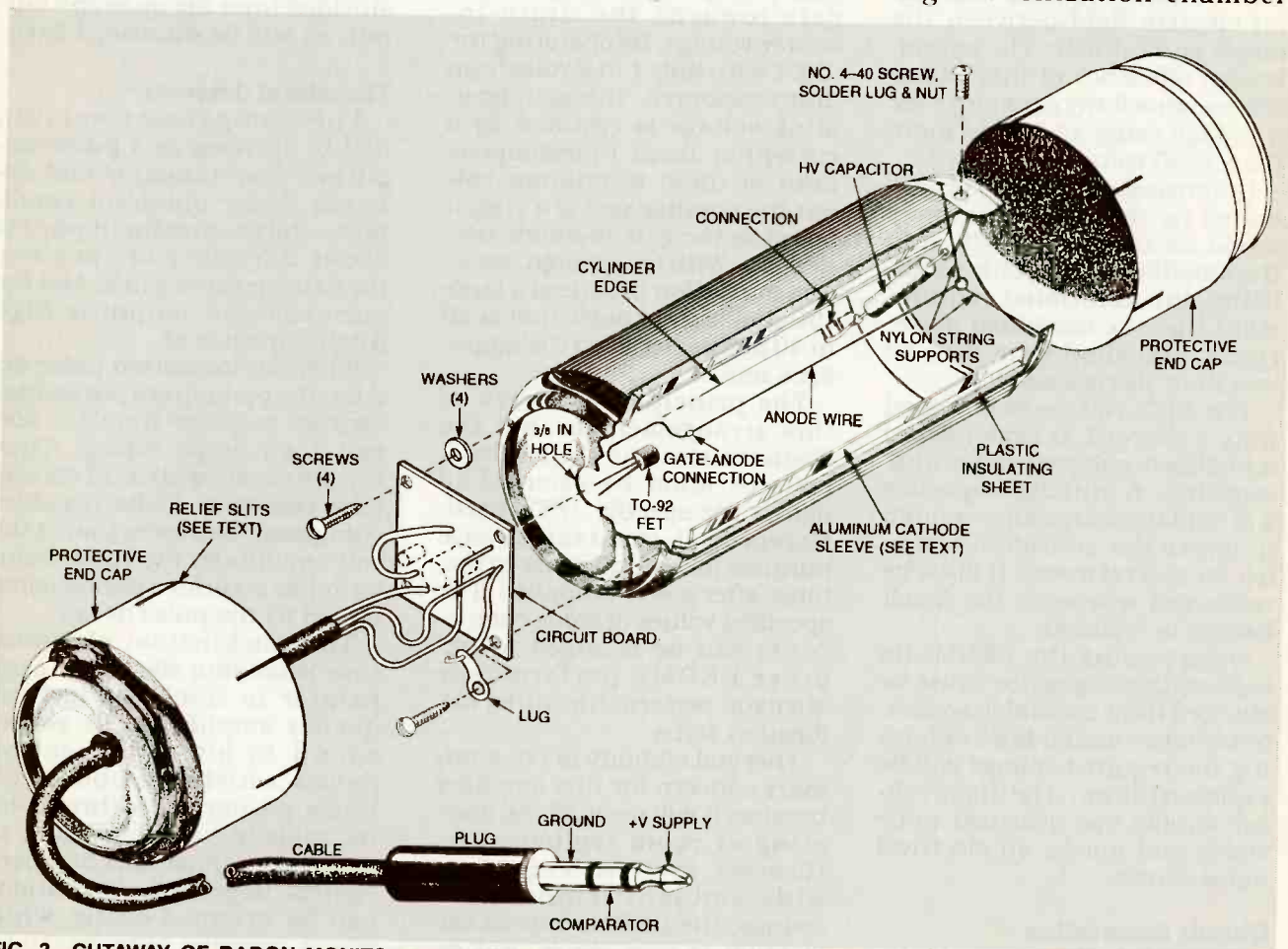

FIG. 3—CUTAWAY OF RADON MONITOR IONIZATION CHAMBER. A beverage can forms the chamber, an aluminum can forms the cathode, and half cans form protective end covers. Amplifier circuit board is shown left of center.

because, in addition to its ready availability, its size is standardized. This size uniformity permits BERM calibration based on chamber size. The can's dimensions are large enough for alpha particles to dissipate most of their energy ionizing air. As stated earlier, the amount of charge generated determines the amplitude of the current pulse collected on the anode.

Ionization caused by beta particles and other naturally occurring radiation, primarily gamma rays, causes lower amplitude pulses in a chamber of this size. This means that it is easier to discriminate the larger alpha ionization pulses from those caused by beta particles and gamma rays as well as by amplifier noise.

High-voltage supply

A nominal but stable 500-volt differential is required to set up an electric field between the anode and cathode. The ion collection efficiency of this chamber remains fairly constant over a voltage range of 200 to more than 1000 volts.

Unfortunately, any noise generated by the 500-volt supply would be coupled directly into the amplifier input. This establishes the additional requirement that the combined noise, ripple, and short-term drift be less than 100 microvolts.

The high voltage is obtained from a charged, 0.1-microfarad metallized-polypropylene-film capacitor. A suitable capacitor will hold its charge long enough to power the ionization chamber for several weeks. It must be recharged whenever the 9-volt battery is replaced.

Before using the BERM, its high-voltage capacitor must be charged from a suitable source. (Alternative methods for obtaining the required voltage will be explained later.) The high-voltage supply was designed to be stable and not be an electrical noise source.

Circuit description

Figure 2 is the schematic for the amplifier. To maximize the amplifier input signal, its ca-

pacitance must be minimized. This is done by connecting the chamber's anode wire directly to the gate of JFET Q1. The effects of excess capacitance and leakage current that would be present if a printed circuit had been used for the connection are eliminated. This approach holds total input capacitance to around 7 picofarads. An input pulse charges the gate of Q1 about 1 millivolt.

The charge must be kept on the gate long enough for the amplifier to respond. An input resistance large enough to maintain a long pulse width would introduce too much thermal noise for a good signal-to-noise ratio.

This problem was avoided by letting the gate float or self-bias. The result is that input impedance is maximized and noise is minimized.

A JFET can be self-biased because its gate leakage pulls the gate towards the drain-to-source voltage. By operating the JFET with only 1 to 2 volts from drain-to-source, the gate operating voltage is restored by a current of about 1 picoampere. Both of these techniques rule out the possible use of a circuit board as the gate-to-anode connection. With this design, an alpha ionization produces a large 100-millisecond pulse that is 20 to 40 dB greater than the amplifier's noise.

The principal drawback of this arrangement is that the drain resistor and the feedback resistor must be selected to match the specific JFET used. Moreover, it can take several minutes for the amplifier to stabilize after power is applied. The specified values of some components can be changed to improve BERM's performance after you perform the initial calibration steps.

Thermal stability is not a primary concern for this amplifier because it will normally be operating at room temperature. However, even with relatively wide ambient temperature swings, the BERM's overall calibration is very stable and remains unaffected by amplifier gain changes.

Operational amplifier

The LM392N is a low-power operational amplifier/voltage comparator performs as both an amplifier and comparator. The high-gain, internally frequency compensated op-amp is IC1-a, and the comparator is IC1-b. Both can operate from a single power supply over a wide range of voltages (3 to 32 volts). Current drain is 600 microamperes—essentially independent of supply voltage. The LM392N shown on Fig. 2 is in an 8-pin DIP package, but the LM392H in a metal can package can be substituted.

The op-amp functions as a current-to-voltage converter following the JFET's transconductance stage. Overall voltage gain is about 60 dB. However, amplifier power gain, due to the impedance transformation, is about 160 dB! To prevent regenerative feedback, the JFET's input must be electrically shielded from the op-amp's output, as will be discussed later.

Threshold detector

The comparator section (IC1-b) operates as a pulse-amplitude discriminator and detector. Under quiescent conditions, the positive input pin 3 is about 0.5 volt more positive than the negative pin 2, and the open collector output is high (high impedance).

When an ionization pulse occurs, the op-amp output swings sharply negative from its normal (half) supply voltage. Then it rises slowly with a 0.1 second time constant. If the negative-going peak has more than a 0.5 volt amplitude, the comparator switches state for a period determined by the pulse decay.

The combination of circuit time constants allows the comparator to track the low-frequency amplifier drift yet respond to alpha ionization pulses which are about five times greater than threshold. By adjusting amplifier gain to match the ionization chamber's signals, large alpha ionizations can be detected easily, while much smaller beta particle, gamma ray, and noise ionizations are rejected.

The comparator's output is an open collector which goes low (low impedance) whenever an alpha particle is detected. This output can be interfaced to any logic device, digital counter, or count-rate meter. This will be discussed in detail in Part 2 of this article.

Low-voltage power supply

The optimum low-voltage power supply for the amplifier is a 9-volt, battery. The BERM draws only a few milliamperes, so a 9-volt alkaline transistor battery should provide an effective life in excess of 50 hours—in addition to permitting it to be a portable instrument. However, if you would prefer to power your BERM from the AC line, a schematic for a suitably filtered 120-volt AC to 9-volt DC converter will be in Part 2 of this article.

Chamber arrangement

Refer to Fig. 3, a cutaway drawing of the ionization chamber. The amplifier is built by point-to-point wiring methods on a prepunched 1 $\frac{3}{4}$ -inch square circuit board with solder pads on one side. It can be seen, however, that all amplifier components except JFET Q1 are mounted and soldered on the component side of the board.

The drain and source leads of JFET Q1 are to be soldered onto the solder-pad side of the circuit board so that its plastic TO-92 package can extend into the can that forms the chamber through a hole formed in the bottom of the can. This arrangement effectively shields Q1's sensitive input from the rest of the amplifier circuit. As mentioned earlier, the anode wire is a direct extension of Q1's gate lead, bent 180° away from the other two leads.

Cathode sleeve

Refer to Fig. 3. The approximate 500 volts from charged capacitor C1 are applied between the aluminum can chamber, which is grounded, and a cathode made as an aluminum inner sleeve or lining separated from the can's inner wall by sheet plastic insulation. This

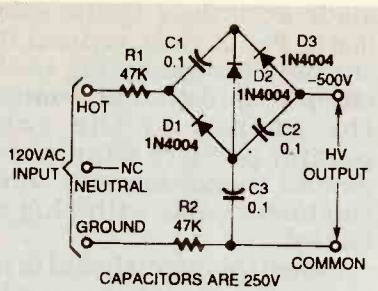

FIG. 4—VOLTAGE TRIPLER CHARGES ionization chamber capacitor. It is powered from the 120-volt AC line.

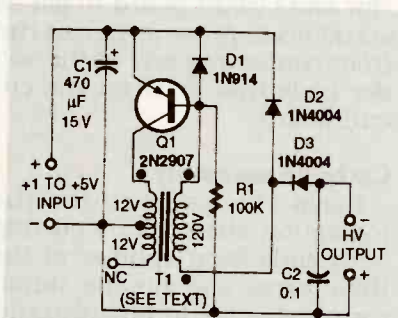

FIG. 5—BLOCKING-OSCILLATOR flyback circuit powered from DC is an alternative for charging the ionization chamber capacitor.

PARTS LIST

Figure 2 amplifier All resistors are 1/4-watt, 5%.

R1—selected value (see text)

R2—R7—1,000,000 ohms, carbon composition

All capacitors are aluminum electrolytic, 15-volts, unless otherwise specified

C1—0.1 μ F, 630 volts, metallized-polypropylene film, Sprague 730P104X9630 or equivalent

C2—47 μ F

C3—470 μ F

C4—1 μ F

Semiconductors

IC1—LM392N operational amplifier/voltage comparator, National Semiconductor or equivalent

Q1—J201 JFET, National Semiconductor or equivalent

Miscellaneous 3 aluminum 12-ounce beverage cans, 1 $\frac{3}{4}$ -inch square, punched circuit board with solder pads (Radio Shack No. 276-159 or equivalent), 4 No. 4 self-tapping sheet metal screws and matching washers, 1 4-40 screw and nut, polyethylene sheet (see text), 30-inch length of 3 conductor cable, 1/4-inch diameter phone plug, 9-volt alkaline transistor battery, solder lugs, electrical tape, solder.

sleeve-within-a can construction provides the unit with excellent shielding from electrical noise.

With this design, the effective volume of the ionization chamber is considerably reduced, compared to its physical volume, because the electric field includes the end surfaces of the can. These end-surface fields must be accounted for during instrument calibration.

Chamber assembly

Obtain three identical clean, undented, 12-ounce aluminum beverage cans. (They are 4.8 inches high.) Cut the top from the tab end of one can to form the ionization chamber with a can opener so that a crimped-on ring remains. Form a 3/8-inch hole in the center concave bottom of the can.

Then, using the blank 1 $\frac{3}{4}$ -inch square circuit board specified as a template, drill four small pilot holes on the rim at bottom of the closed end of the can, on top of its circular ridge. Later in the assembly procedure, self-tapping machine screws will be used to mount the circuit board on the end of the can as shown in Fig. 3.

Hold the circuit board in position on the end of the can with the solder tabs directed toward the can. Look in the open end of the can through the 3/8-inch hole and mark the locations of the solder pads that are suitable for Q1's drain and source pins. Plan your parts layout carefully so that one of those pads can be common to the ground or negative power supply pin on op-amp IC1-a.

Circuit assembly

Refer to Fig. 2. The selection of the value for drain resistor R1 will depend on the characteristics of the specific J201 JET (Q1) to be used in the circuit. Short the JFET's gate to its source and measure the drain-to-source current (I_{DS}) with a drain-to-source voltage of about 1.5 volts. Then calculate the drain resistor value based on this current and the voltage of the power source you intend to use:

Drain resistor $R1 = (V_s - 1.5)/I_{DS}$

For a J201 FET and a 9-volt battery, $R1$ should have a value between 10 and 33 kilohms.

When constructing the amplifier, use 1-megohm resistors for both parallel resistors $R4$ and $R5$. Form the axial leads of both resistors and solder them so that $R5$ will remain permanently in position while provision is made for the easy removal of $R4$ during the calibration process. By doing this, gain can be adjusted later by shunting 1-megohm resistor $R5$ with another value for resistor $R4$ until an optimum value is found.

Solder a short tinned wire to the output pin 7 of op-amp IC1-a to act as a test point to permit attaching an alligator clip lead or oscilloscope probe. Place a solder lug under one of the sheet metal screws holding the circuit board in position on the end of the can to act as a convenient circuit common or ground lug.

Other than this restriction on the placement of $Q1$ on the circuit board, the layout of the other components is not critical. Use the convenient pad locations bridged by the components you've selected and any necessary jumper wires to complete the wiring of the circuit. Complete the insertion and soldering of all components on the circuit board except for JFET $Q1$.

Insert and solder the source and drain leads of JFET $Q1$ on the solder-pad side of the board. Then carefully bend the gate lead directly away from the other two leads so that it is perpendicular to the solder-pad side of the circuit board.

Solder a length of bare copper wire (28 to 32 AWG) about 4 inches long to the gate lead of $Q1$, and straighten it so that it is perpendicular to the circuit board. Cut the free end of the anode wire to a length that is about $4\frac{1}{2}$ inches long. Twist a small loop (about $\frac{1}{16}$ -inch in diameter) on the end of the anode wire and solder the joint.

Carefully examine the circuit assembly to be sure that it was

made according to the schematic, Fig. 2. Next, connect the chamber can solder lug to the circuit-board ground, connect the output of the comparator, positive supply, and ground connection to a three-conductor cable with plug attached.

Fasten the circuit board to the end of the chamber can with four No. 4 self-tapping sheet metal screws. Use small matching washers between the can rim and circuit board to act as standoffs to prevent the can rim from contacting any of the solder pads that exist on the circuit board.

Cathode assembly

Form the cathode for the ionization chamber by cutting both ends from another of the three cans, and slit the aluminum cylinder longitudinally, being careful not to deform or flatten it. Trim, square the ends of this aluminum sleeve to a length of about 3.7 inches. File off any sharp edges or burrs that could cut through the thin plastic insulation layer to be applied later.

The aluminum in the can has intrinsic spring qualities, so that if its slit edges are overlapped about $\frac{1}{4}$ -inch they will retain their tendency to spring open. Cut two slots about $\frac{1}{4}$ -inch deep and about $\frac{1}{8}$ -inch apart at right angles to the slit edge of the aluminum cylinder. Those slots form a "digit" for later termination of one end of capacitor $C1$.

Wrap and crimp a short length of tinned lead wire around this digit as shown in Fig. 3 so that when the cathode sleeve is installed in the can, the lead can be soldered to one end of $C1$.

The inner wall and ends of these cans have a plastic coating, but it is not dependable as an insulator between the cathode sleeve and the chamber can. Cut a sheet of polyethylene plastic approximately 2 mils thick sheet so that it will extend about $\frac{1}{4}$ -inch beyond each end of the cathode sleeve and overlap its circumference. This material can be taken from sandwich

bags, cleaner's garment bags, or other sources.

Drill a small hole in the rim of the can and fasten a small solder lug inside with a No. 4-40 machine screw and a nut as shown in Fig. 3. After being sure that all the metal chips and filings have been cleaned from the chamber can, insert the insulating film and press it against the inner wall of the can and then insert the cathode sleeve. After the insulated cathode has been inserted, check to be sure that there is no metal-to-metal contact between the can and sleeve.

Capacitor installation

Carefully select high-voltage capacitor $C1$ to make sure that it is a high-quality, low leakage component. If left fully charged, it should retain at least 37% of its charge for at least a month at room temperature.

Solder capacitor $C1$ to the internal lug with as short a length of lead as possible, as shown in Fig. 3. Be sure to position the capacitor in the mouth of the can against the side wall as shown in Fig. 3.

Then solder the short wire stub on the cathode to the free end of capacitor $C1$. Clip its lead short and bend it toward the center of the can so that an alligator clip can be attached to it. Finally, check the resistance between the cathode sleeve and chamber can to be sure that it is effectively infinite.

Protective covers

Cut a third can in half and bend the tab of the top end back to its original unopened position. Carefully slip this top can half over the open end of the chamber can. Expect that it will form a tight "press fit." If the fit is too tight for easy removal, cut several longitudinal slits in the can half to permit slight expansion (see Fig. 3).

Drill a hole in the bottom of the other half can large enough to be able to insert a small rubber grommet which will pass the three-conductor cable. This can end will cover the circuit board and shield it from 60-Hz noise.

Initial checkout

Apply power to the ionization chamber with the cable and connect an oscilloscope to the op-amp test point shown in Fig. 2. After several minutes, JFET Q1 should have stabilized at its normal operating point with the drain at about 1.5 volts. The output of op-amp IC1-a should be half the 9-volt supply voltage with about 50 to 200 millivolts of low frequency noise riding on top of it.

When the amplifier is working properly, try to avoid bumping or vibrating the chamber because it is a sensitive vibration sensor, made even more sensitive as long as the anode wire remains unsupported. Shocks or vibrations will show up as large-amplitude, slow decaying sinewaves.

If the amplifier oscillates, produces square waves, or will not settle down after several minutes, check the drain voltage of JFET Q1 and the quality of the coupling capacitor C2. The amplifier circuit might have too much gain which can be reduced by substituting smaller values for resistor R4. Start with a 333 kilohm resistor which will reduce gain about 50%.

Anode support

Punch two small holes on the opposite sides of the can's rim as shown in Fig. 3. Insert a length of nylon monofilament fishing line through one hole, pass the free end through the loop at the end of the anode before passing it through the second hole. Pull both free ends of the line together around the outside rim of the can and, keeping tension in the line, tie them together with a knot. If the tension on the line is sufficient, the end of the anode will remain centered in the mouth of the can.

If a persistent 60-Hz waveform appears at the test point, pass a length of insulated hook-up wire through the cable grommet in the bottom of the end cap and hook it up to repeat the test. Press on the end cap and examine the waveform again. If this shielding doesn't cure the prob-

lem, check carefully for other construction errors such as a missing ground connection or a noisy power supply.

Gain adjustment

Assuming that the ionization chamber and amplifier comply with the initial checkout requirements, it should be ready to detect alpha particles. However, additional amplifier gain adjustments might be necessary. Charge the capacitor C1 to -500 volts, and put the end cap back on. If you have no means for charging the capacitor, this can be done with either the voltage-tripler circuit shown in Fig. 4 or the DC converter shown in Fig. 5.

The voltage tripler shown in schematic Fig. 4 operates directly from the 120-volt AC line. It will produce a voltage close enough to 500 volts for satisfactory operation of the BERM. Because of the shock hazard associated with line-powered circuits, the use of a grounded, three-wire plug and line core is strongly recommended. This circuit should be enclosed in a suitable protective case to prevent accidental contact with the power line and any of the three large electrolytic capacitors C1, C2, and C3.

The DC converter schematic shown in Fig. 5 is a blocking-oscillator flyback circuit which can be powered from an adjustable, low-voltage DC supply. It will produce an output of several hundred volts with an input as small as 1 volt. Measure the converter's output with any voltmeter capable of measuring 100 volts before connecting the output to capacitor C1. Transformer T1, used as a step-up transformer in Fig. 5, can be any stock 20 VA transformer with a 120-volt primary and a 12-volt secondary.

Apply power to the amplifier and wait for its activity to settle. Typically, it will take several minutes for JFET Q1's gate to charge up and probably will take another minute for the coupling capacitor to charge before amplifier output reaches half supply voltage.

With the oscilloscope set for 1

volt per division and very slow sweep (0.2 second per division), the test point voltage should vary slightly as you wait to see an event. Expect the appearance of a large negative pulse (see the waveform in Fig. 2) on the oscilloscope screen indicating that you have just been lucky enough to capture your first alpha particle.

In a typical home you will see a few of these pulses each minute. However, because you are observing a random radioactive process, you might see several pulses or none in any given minute. Watch the oscilloscope screen for a few minutes and estimate the pulse amplitudes.

If the BERM amplifier has too much gain, the amplifier's output will saturate. However, if most of the pulses have an amplitude less than ½-volt, gain must be increased. The optimum gain setting occurs when pulses with peak amplitudes of about 2- to 3-volts appear without saturating the amplifier. Adjust the values of feedback resistors R4 and R5 to accomplish this.

Comparator

The last step in the check-out procedure, after gain adjustment has been completed, is to verify comparator operation. With an external pull-up resistor (100 kilohm to 1 megohm) connected to the positive supply, check its output with the second channel of your oscilloscope.

You should be able to verify that pulses with amplitudes over ½ volt drive the output low. Then complete the assembly of the BERM by putting the circuit board end cap back on.

Counting techniques

To determine picoCuries per liter of activity, it is necessary to count the number of pulses over a period of time, say an hour, and determine the average count per minute. It will be necessary to divide this count by the effective volume of the chamber and factor in the effect of radon daughters, which also produce alpha ionizations, to come up with an estimate of the

being temporarily discharged.

Another alternative

You can also use a digital voltmeter with a constant 10-megohm input resistance and the pulse-rate circuit shown in Fig. 7. The five components of the rate circuit in Fig. 7 will fit on the amplifier circuit board with careful layout.

Typically, a full-scale count rate of 20 counts per minute will be suitable for most indoor air environments, so the values shown in Fig. 7 were selected to produce 200 millivolts into a 10-megohm resistance. Select the value of capacitor C5 to calibrate the circuit. In contrast to the previous approach, however, the DVM must remain connected at all times.

Rate meter calibration

To calibrate any of the rate meters, you will need a data point to adjust the gain or scale factor. You can build a pulse circuit based on the 555 silicon monolithic timer IC (e.g., NE555N or MC1455N) as shown in Fig. 8. It produces about 10 pulses per minute to establish the slope of the rate meter's response when input counts per minute are plotted against the rate meter output scale.

Calibrate the pulser's rate by counting oscillations for 10 minutes so it will be within 1% accurate. Connect this auxiliary pulse circuit to the rate meter and let it settle for at least an hour before adjusting gain potentiometer R11. It might be necessary to substitute an alternative value for capacitor C5, depending on which version of the rate meter you build. You should be able to calibrate the meter to within a few percent in this way.

Combine the two

The rate meter shown in Fig. 6 and the amplifier together draw a supply current of about 3 milliamperes. They will both work from a standard 9-volt transistor battery. If you want a portable radon monitor, you can put both circuits together in a common enclosure.

Reset pushbutton switch S1

across capacitor C6 will be useful if you should accidentally bump the ionization chamber against a solid object. The large number of false readings will overload the meter which will take a long time to settle unless switch S1 is pressed.

Periodically check the rate meter zero setting by resetting capacitor C6. Do not apply any input pulses to the rate meter circuit for about an hour to

display driver IC.

Computer interface

If you are a computer enthusiast you might want to use your PC to count the pulses, compute a running-time average, and display the results graphically. The interface to your computer probably makes use of a latched interrupt request. A separate RS flip-flop board, set by the active-low, open-collector output, can provide the latch that is reset by the interrupt handling routine. The count rate will typically be less than 10 counts per minute, so processing speed is not critical.

An advantage of the open-collector output from the ionization chamber is that it can be pulled up by the computer logic supply (5-volts, 10 kilohms) without the requirement that the noise-sensitive amplifier circuitry share a common (electrically noisy) positive supply voltage. The chamber ground should be connected to the computer ground.

The largest calibration error relates to the proper determination of the ionization chamber's effective volume. Compared with that uncertainty, most of the other contributing sources of error in the BERM are small—approximately 10%.

Gain equation

The specific activity of radon, $a(\text{Rn})$, as a function of system variables is given by the following equation:

$$a(\text{Rn}) = r \times k / (n \times \text{VE})$$

where $a(\text{Rn})$ is in units of picoCuries per liter

r = the count rate in counts per minute

k = a conversion factor from disintegrations per minute to picoCuries

n = the number of alpha counts per radon atom

VE = the effective volume in liters = physical volume \times efficiency.

The constants $k/(n \times \text{VE})$ equal 2.1 for a chamber equipped with a radon progeny filter. At 5 counts per minute, the radon concentration is 10.5 pCi/l.

If the construction instruc-

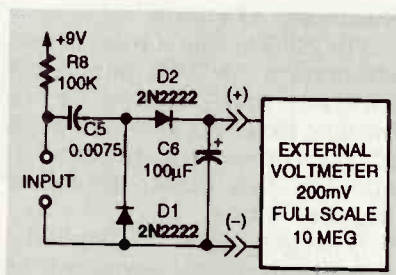

FIG. 7—AN ALTERNATIVE CIRCUIT for pulse-count determination if an external voltmeter is used in place of the meter.

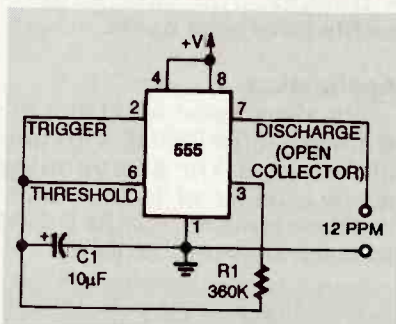

FIG. 8—THIS PULSE COUNT reference circuit can be used to calibrate the pulse-count rate circuit.

check capacitor C6 for memory effects.

Alternative counters

An electromechanical counter is capable of accumulating a raw count. The LM392 (IC1) cannot drive the solenoid directly, but it can trigger a 555 timer IC that provides both a sufficiently wide pulse and enough current to drive a low-voltage counter.

Some benchtop frequency counters include a scaler setting that will allow you to make a direct connection to the ionization chamber so you can accumulate counts. Alternatively, you can build a digital counter with an LSI counter/

tions given in part I of this article were followed, the result should be a BERM that will have the same calibration factor as the author's prototype. The basic accuracy of your instrument will be $\pm 25\%$, which accounts for the probable mechanical variations, the statistical uncertainty in the author's calibration, and any rate meter error.

Radon progeny error

Refer to Fig. 9. The conversion factor n , number of alpha emissions per radon atom, has a theoretical value of 3 because, for every radon disintegration, two more alpha particles are emitted from polonium 218 and polonium 214 (See Table 1) under equilibrium conditions.

As radon decays, the number of progeny atoms increases until their radioactive decay balances their rate of production. After radon is introduced into the chamber, the alpha production rate will stabilize in about two hours.

If the ionization chamber is open to the air so that radon and radon progeny can enter the chamber freely, there is a reading uncertainty caused by their unknown equilibrium state. Researchers have found wide variations in the ratio of short-lived daughter products compared to radon in indoor air.

This factor has been estimated to average $20 \pm 14\%$. A simple progeny filter made from a plastic or paper bag eliminates this source of error. However, even with a filter in place, radon diffuses slowly through the paper or plastic, and it might take up to eight hours for the reading to stabilize. The installation of a simple BERM filter is described later.

Rate meter error

Because rate meter gain is directly proportional to the power supply voltage, you should know that the calibration shifts with decreasing battery voltage. The voltage of a typical 9-volt battery will fall approximately 20% over its useful lifetime.

This has been found to permit about three days of continuous operation.

The rate meter, with a time constant (RC) of 1000 seconds, has an uncertainty that depends on the rate r , assuming the background rate is negligible, and as stated earlier, has a \pm half-scale error. If the count is accumulated by other means, the statistical uncertainty in N counts is \sqrt{N} .

Summary of errors

The BERM has a total probable error of $\pm 25\%$ plus a calibration drift caused by the battery. However, the total probable error can be reduced to about $\pm 13\%$ under the following conditions:

- A progeny filter is installed.
- A highly stable power supply is in use.
- The BERM is calibrated against a standard instrument with a $\pm 10\%$ error.
- Background rate adjustments have been made.

Application

The discussion on errors assumes that the BERM is in equilibrium with the surrounding air. A number of factors affect the time required for the BERM to reach this equilibrium.

PARTS LIST

Figure 6 ratemeter circuit.

All resistors are $\frac{1}{4}$ -watt, 5%.

R8—100,000 ohms, carbon composition

R9—100,000,000 ohms, carbon composition

R10, R13—2,200 ohms, carbon composition

R11—5000 to 10,000, 15-turn trimmer

R12—100 ohms, 15-turn trimmer

Capacitors

C5—470 pF silvered mica, selected (see text)

C6—10 μ F, 15 volts, aluminum electrolytic, radial-leaded, value tested (see text)

Semiconductors

Q2—2N5566 dual JFET

D2, D3—diodes formed from 2N2222 transistors

Other components

M1—0 to 20 μ A analog moving-coil panel meter (see text)

Filters

As discussed earlier, the installation of a simple radon progeny filter will limit the particles entering the ionization chamber to radon. Find a polyethylene plastic bag sealed on three sides that is large enough to hold the ionization chamber. Inflate it with air and tie it off at the neck with several turns of a wire tie. Observe the inflated bag over a period of about an hour to make sure that it has no pinhole leaks.

After you are satisfied that the bag is free of pinholes, open it and place the ionization chamber inside. Then inflate the bag again and again tie it off with several turns of the wire tie around cable this time. Attempt to hold as much air as possible inside the bag while you tie it off.

Response time

Theoretically, if a constant concentration of radon could be introduced into the chamber, the alpha count rate would increase over a few hours before reaching a stable rate. Figure 9 is a plot of short-lived radon progeny dynamics, which affect alpha count ratio until equilibrium conditions are reached. The BERM's ionization chamber will typically stabilize in a few hours. The shortest time constant of the rate meter is 17 minutes.

Background rate

Even when BERM is taken outdoors where radon concentration is very low, it is likely that there will be some alpha activity in the chamber. It will be caused by the materials in the chamber itself as well by residual isotopes from the surrounding air which have attached themselves to the chamber walls.

Because this background activity is variable, it is advisable to check the background rate after cleaning the chamber. This is done by discharging high-voltage capacitor C1 and flushing the chamber with clean outside air. If possible, allow the chamber to remain outdoors for a day before perform-

ing the indoor measurement.

The background rate of the chamber is typically 20 to 60 counts per hour. Use the net counting rate—gross indoor rate minus outdoor rate—to calculate radon concentration, especially if the rates are similar.

Making a measurement

Although the BERM has an assumed large scale factor or calibration error, the instrument is still sensitive enough to detect even small amounts of radon, perhaps only a few times greater than that in outdoor air. It has sufficient dynamic range to remain linear up to several hundred counts per minute. Without a filter which improves accuracy but slows down its measurement, the BERM can be used anywhere in a house to identify the highest levels of radon concentration and the conditions that cause that level.

Vibration effects

As stated in Part 1 of this article, the BERM's ionization chamber is a very sensitive vibration sensor that will also respond to loud, low-frequency noises. Be suspicious of any unusually high readings if the chamber had just been inadvertently bumped against a solid object. After you have gained experience with BERM while it is connected to an oscilloscope, you will be able to see for yourself what level of vibration causes false detections.

Natural background

You can modify the BERM so that it will be capable of measuring radon concentration in the soil. To do this the radon monitor must be capable of measuring up to 200 counts per minute. This is done by replacing resistor R9 with one having a value that is only 10 % of the specified R9 value. Then:

- Place the ionization chamber in the plastic filter bag as pre-

References

1. Brookins, Douglas G.: "The Indoor Radon Problem," Columbia University Press, New York, NY, 1990.
2. Lao, Kenneth: "Controlling Indoor Radon," Van Nostrand Reinhold, New York, NY, 1990.

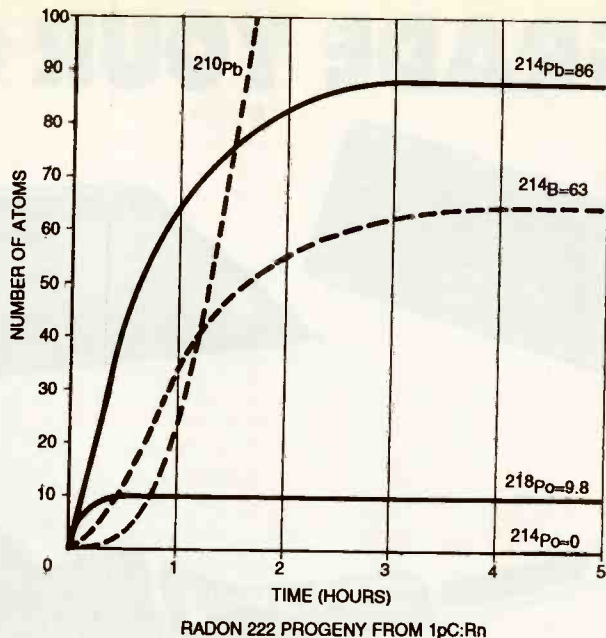

FIG. 9—PLOT OF RADON 222 PROGENY EMISSION OVER TIME VS. number of atoms.

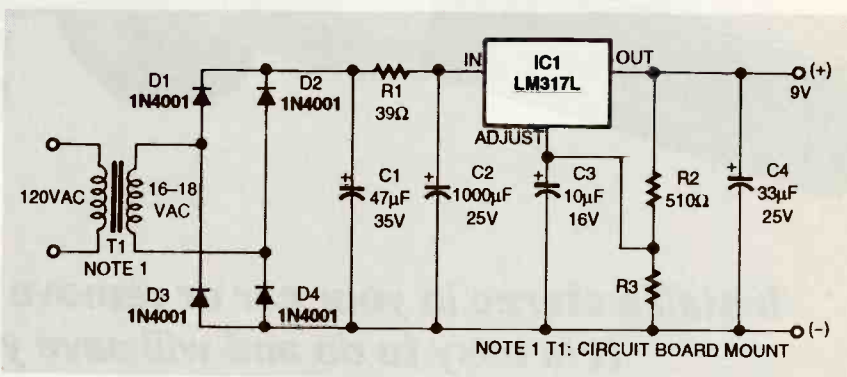

FIG. 10—THIS FILTERED POWER SUPPLY can replace a 9-volt transistor battery for powering the radon monitor.

viously described. (In this test the filter will act as a moisture barrier. The BERM is insensitive to changes in relative humidity, but condensation can provide a leakage path between the cathode lining and ground.)

- Dig a hole about 15 inches deep in dry ground.
- Place the bag-covered ionization chamber at the bottom of this hole to collect radon gas emitted from the soil and cover it with an inverted bucket. Then backfill the soil around the bucket to act as a seal.

This test should show that radon concentration in the ground is at least 100 times greater than that found in outdoor air. Compare the outdoor readings with those measured indoors with the same rate meter. If you have been unable

to calibrate your BERM against a professional instrument, the readings taken in the ground will act as a useful reference. *If the amount of radon collected indoors is as much as 10 % of the level determined from the soil test, it is probable that a radon hazard exists.*

Line power circuit

If you want to experiment with your BERM indoors or perform long-term testing, you might want to power it from the AC line rather than depend on disposable 9-volt batteries. An off-the-shelf AC-to-DC adaptor is not suitable for this application because it lacks the necessary filtering to eliminate noise interference. The circuit shown in Fig. 10 includes the necessary filtering.

UPGRADE YOUR CAR STEREO

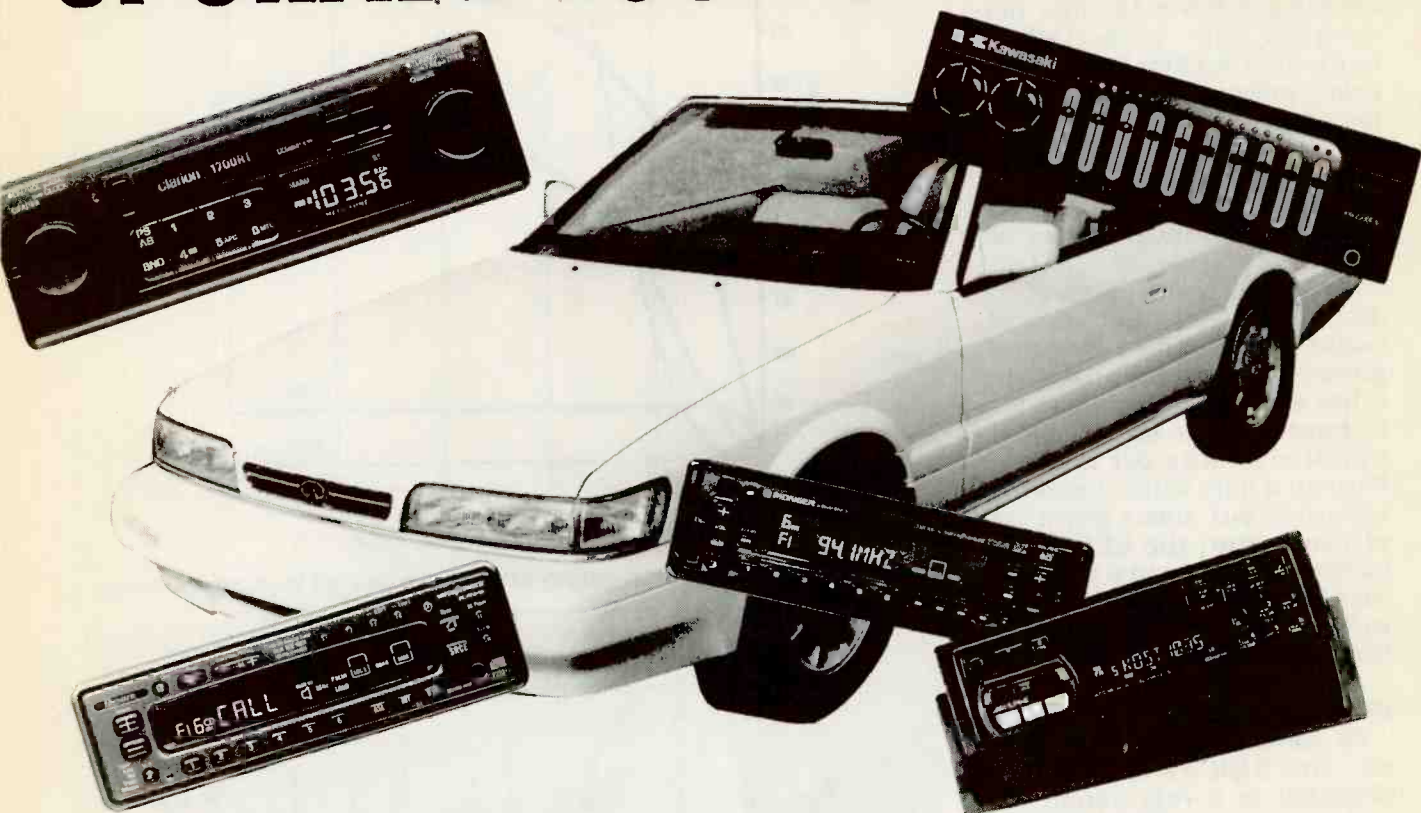

***Install a stereo in your car or remove one for servicing.
It is easy to do and will save you money
if you follow this procedure.***

MARC SPIWAK

IF YOU'VE HELD OFF FROM BUYING the car stereo you always wanted because of the high cost of custom installation work, you don't have to wait any longer. This article will take you step by step through a straightforward procedure. All you'll need to tackle the installation is basic knowledge of a car's electrical system, hand-tool skills, patience, and common sense. These requirements also apply equally if you want to remove your car's present radio or stereo system for repairs or upgrading to a better system, perhaps with a CD player in place of a tape cassette deck.

Standard installation

The circuitry in a car stereo

is, as you might expect, quite complex. The manufacturer has squeezed a receiver, amplifier, a tape cassette or compact-disc (CD) deck, and a lot of support circuitry into a small metal box. Its high component density and high percentage of parts that are not user serviceable suggest that internal servicing should be left to professionals. However, do-it-yourself installation is another story.

The external wiring required for installation is relatively simple. A typical external wiring scheme consists of four or more color-coded wires and an antenna cable. Your first task will be to identify the functions of all of the wires unless you are fortunate enough to find them labeled or called out in a service manual. Start by locating the

power and antenna terminals.

Most automotive stereo systems can be powered from any 12-volt DC source. However, be warned that you can encounter some units that are powered by +6 volts and -12 volts. The power wiring typically consists of a red wire for +12-volt DC and a black wire for chassis ground. The red wire must be connected to the car's accessory voltage terminal, which is activated by turning on the ignition switch. This scheme prevents inadvertent battery drain if you forget to turn off the radio.

The accessory voltage terminal and a ground connection can most easily be found in most cars by tracing the wiring from the car's factory installed radio, or from the fusebox. As a practical matter, any bare metal

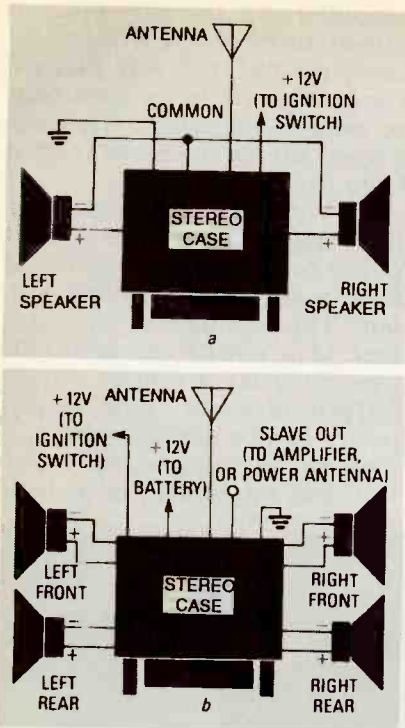

FIG. 1—BASIC STEREO WIRING schemes. A two-speaker stereo system a, and a four-speaker stereo system b.

part of the dashboard can be a satisfactory chassis ground.

Car stereos typically have two pairs of speaker-output wires, left and right. Nevertheless, you might encounter systems with only one wire for each channel and one common wire shared by both. But you'll find that most up-scale, expensive car stereos have four pairs of wires—left and right and front and rear. By convention speaker wires are typically colored green, brown, white, or gray—rarely red or black.

All car radios have an antenna cable terminated by a Motorola-type plug. The chances are that your car was equipped at the factory with an antenna for an installed radio. The cable from that antenna can be plugged into any new stereo system. In the unlikely event that your car was delivered without an antenna, you are faced with the task of installing one. This usually calls for drilling a hole in your car's fender, trunk, or roof for mounting the antenna. This a separate task that won't be discussed here.

Without labels or a manual, the identifying all of the wires

coming out of a replacement stereo or radio can be puzzling. Typically a car radio with digital tuning, memory presets, and perhaps even a clock, will have two power leads. It is common practice to use a red wire as the connection to the car's ignition switch. An orange or yellow wire is usually connected to an unswitched 12-volt DC source to preserve the radio's memory.

A connection to the terminal at the back of the cigarette lighter will usually meet this requirement. The lighter in most cars is permanently connected to the

memory wire directly to your car battery's positive terminal through an opening in the fire wall. If your car has a radio that can be removed and taken with you when you leave the car, it will have an internal memory-backup battery.

Some radios have a slave output wire that goes high when the radio is switched on. That wire can turn on an amplifier or activate a power antenna when the radio is switched on. There's a good chance that this wire will be colored blue.

The identification process can be complicated if your car has DIN-plug outputs specifically intended for connecting to other equipment. DIN is the abbreviation for *Deutsche Industrie Normenausschuss*, a German standards organization that sets standards for Germany that are recognized by most European countries.

If you are not sure about the functions of some of the wires

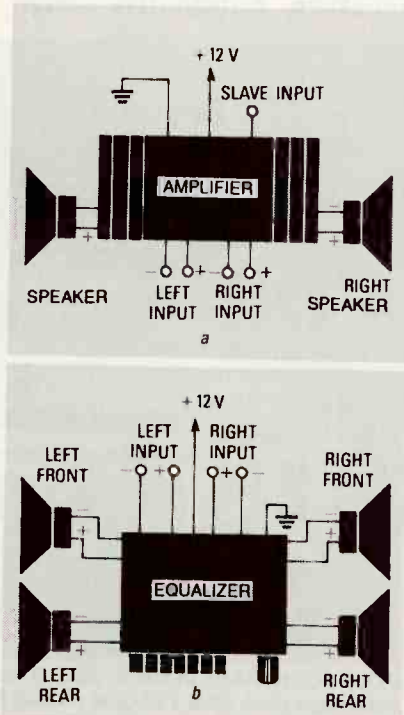

FIG. 2—AMPLIFIER AND EQUALIZER wiring. Amplifier wiring is shown in (a) and equalizer wiring is shown in (b). Both have wires for +12 volts, ground, and speaker input and output. An amplifier might also have a remote turn-on wire.

12-volt battery, and the lighter will work even if the ignition switch is off. Moreover, that terminal is usually easily accessible. However, if you are uncertain about that connection, try it out with the ignition switch off. If the lighter heats up, you have found a suitable terminal for the memory wire.

If the lighter does not heat up (or is inaccessible), search for an alternative with a voltmeter at the fuse box. If you are unsuccessful, you can always run the

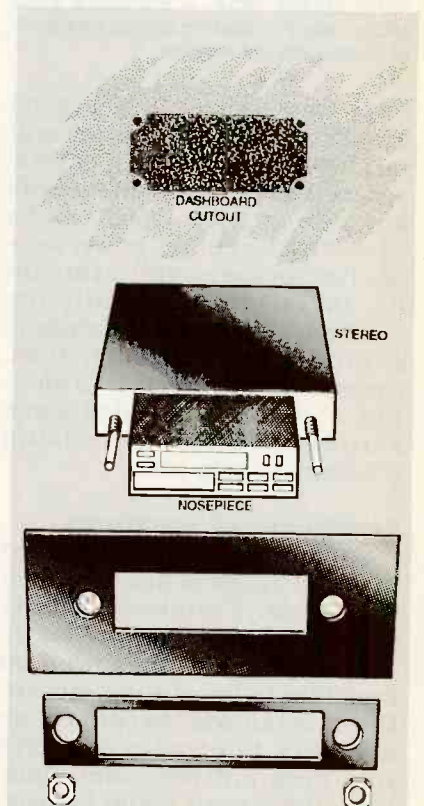

FIG. 3—INSTALLATION OF A TYPICAL radio/stereo. The two threaded control shafts that project through the dashboard mounting plate hold the case in position when fastened with nuts. A rear bracket might secure the back of the case to the dashboard.

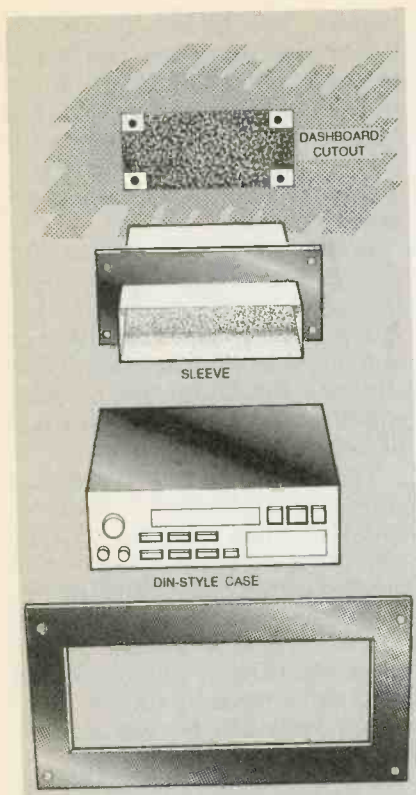

FIG. 4—INSTALLATION OF A DIN-style radio/stereo case. A standard case slides into a mounting sleeve designed to fit specific car models.

from your stereo, it is a good idea to set it up on a bench and test it before installing it in your car. In that way you can identify any mystery wires. You'll need a 12-volt battery or DC power supply, two speakers, and an antenna. Be certain to identify the +12-volt supply and the chassis ground wires first; after that, the others will be easier to identify. Figure 1 illustrates some standard automotive wiring schemes to help you.

Amplifiers and equalizers

Car stereos can be purchased in a wide range of price and performance. Premium quality stereos often have low audio output power so they need an amplifier to boost their output. But it is not wise to connect an amplifier to a radio or stereo that does not need amplification; the output could be overdriven and the sound degraded—and you could damage either the amplifier, speakers, or both!

Most amplifiers are designed to be impedance matched with

specific input circuitry and should be fed at the input level specified by the manufacturer. If you connect the speaker outputs from a car stereo to an amplifier that is designed to accept standard 1-volt, line-level inputs, you can overload and possibly damage the system.

Some stereos require two amplifiers—one for the car's front speakers and one for the rear speakers. Other automotive stereo systems are designed so that the receiver's output drives the front speakers and a separate amplifier drives the rear speakers. Automotive stereo

amplifiers are usually mounted out-of-sight of the driver and passengers, typically behind the dashboard, in the glove box, or even in the trunk. They are turned on by the slave output from the stereo.

An equalizer capable of enhancing the system's output power can usually be connected to any automotive stereo system. The purchase of an equalizer is a sound investment, especially for a system whose output is weak. The output power can be greatly enhanced even by an inexpensive equalizer that might sell for as little



FIG. 5—CONTRAST IN CASE SIZE. A modern automotive AM/FM stereo case with an audio tape deck atop a 23-year old AM/FM radio.

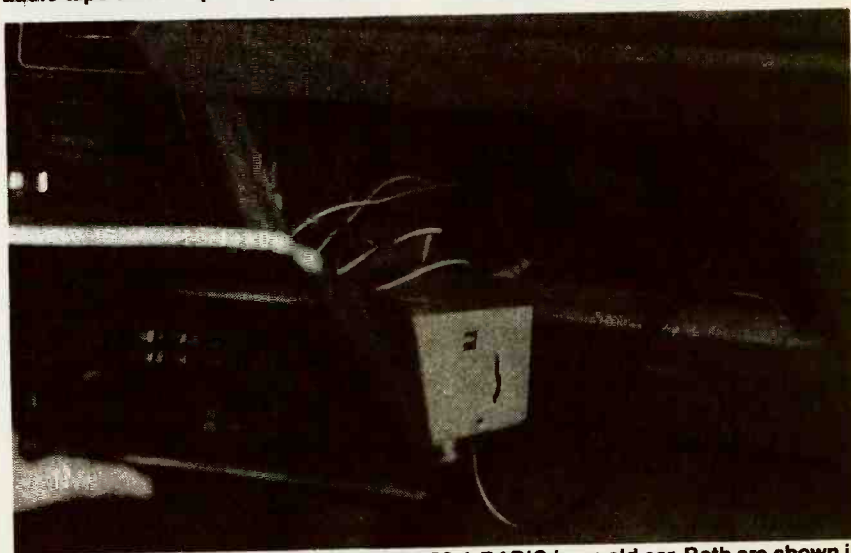

FIG. 6—MODERN CAR STEREO REPLACES A RADIO in an old car. Both are shown in Fig. 5. The stereo offers digital tuning, memory presets, a clock, a cassette deck, four speakers, and an equalizer.

as \$30.

If your original radio had only two speakers rather than a pair for the front and back of the car, an equalizer will give you two more outputs. Equalizers can be mounted behind the dashboard, but the easiest place to install it is under the dashboard. Equalizers are sold with all the necessary mounting hardware. The ON/OFF switch on an equalizer's front panel doubles as a bypass switch when the equalizer is turned off.

Amplifiers and equalizers must be connected to the +12-volt source, chassis ground, speaker input and output wires, and a remote turn-on wire as shown in Fig. 2. Be warned, however, that as you increase the number of components in a car-stereo system, the task of wiring it becomes more complicated. *Do not make any connections unless you are sure of what you are doing. Mistakes can be costly!*

Installation and removal

The first task that you must do when installing a new stereo is to remove the existing radio; this job calls for patience. Try to avoid damaging your car while making the installation. Consider taping protective cardboard or paper around any installation site to avoid scratching or scoring the finish during any material cutting or drilling operations. Separate all wire connectors carefully to avoid damaging them. The use of excessive force or tugging on the wires can rip them from their terminals and lead to costly repairs which might be beyond your skill level.

There are two different radio chassis styles, and they must be installed in different ways. A conventional car radio, as shown in Fig. 3, has two control shafts and a middle "nose-piece." The other more modern style, called a DIN chassis, has a flat, rectangular face with no control shafts, as shown in Fig. 4. In this instance, DIN refers to the case shape, size, and mounting requirements.

You might have to remove
(Continued on page 108)

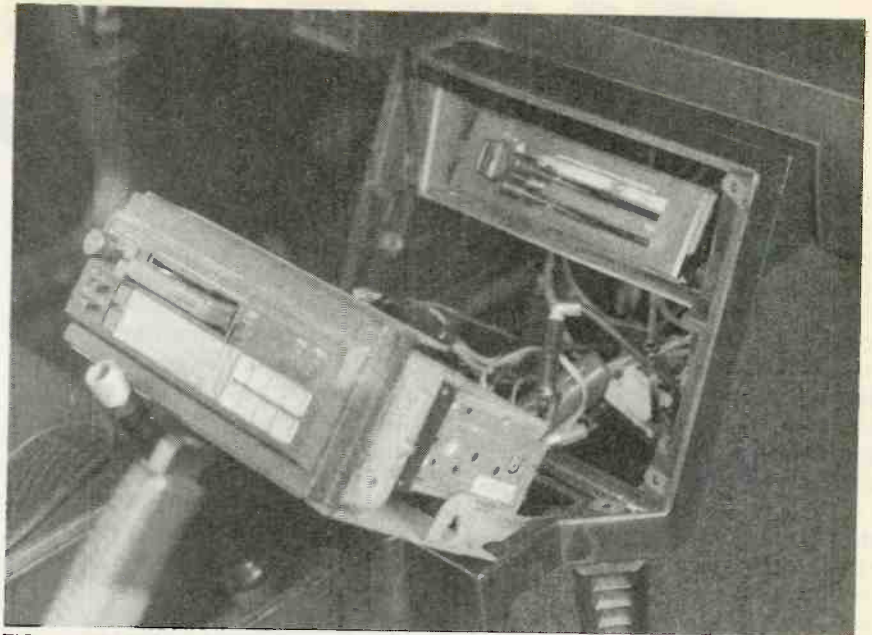

FIG. 7—DIN-STYLE STEREO requires a mounting kit to secure it in the console. Be sure that the mounting kit will fit your car.



FIG. 8—FRONT SPEAKERS can usually be mounted under the dashboard cover.

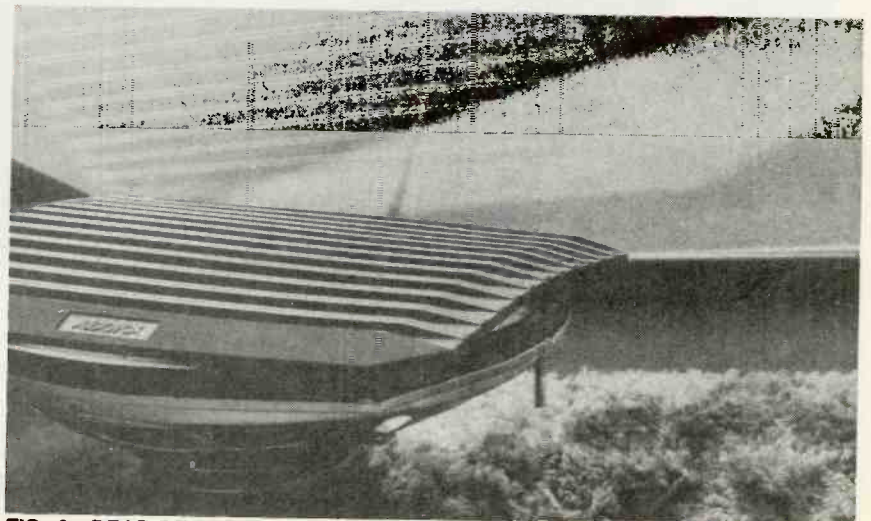

FIG. 9—REAR-DECK MOUNTED SPEAKERS can be installed from the trunk and positioned against the rear deck or mounted from above. Carpeting can cover the rear panel if it is soiled or warped.

TUBEHEAD

THE OPTICAL PITS ON COMPACT discs that store sound digitally are a remarkable technical accomplishment as far removed from the spiral grooves in vinyl records as ICs are from vacuum tubes. However, many audiophiles believe that compact discs are just the pits—nothing more than over-sampled, error-corrected digital records.

Opinions run so deep on this subject that the arguments rekindle the on-going dispute between lovers of vacuum tube amplifier "warmth" and proponents of solid-state amplifier "transparency."

For whatever reason, tube equipment will not go away. Is this just part of a retro trend that glorifies the past as a simpler, richer time? It could be.

but the differences between solid-state and vacuum-tube amplifiers are more than myth—they are real. To see (hear actually) how tube technology might improve the sound of your CDs, read on and take a close look at the TubeHead, a preamplifier with a twist. This hybrid circuit uses both low-noise solid-state op-amps and tubes together, so you can dial in the precise amount of sonic coloring you like—a combination of crisp solid-state transparency and the exaggerated car-

icature of tube-amp warmth.

Tube sound?

Many people believe that vacuum tube amplifiers sound "warmer," "fuller," or just plain louder than their solid-state cousins. There's wide, but not universal, agreement that those differences originate in the ways that solid-state and vacuum-tube amplifiers overload. Where solid-state circuitry tends to be linear over most of

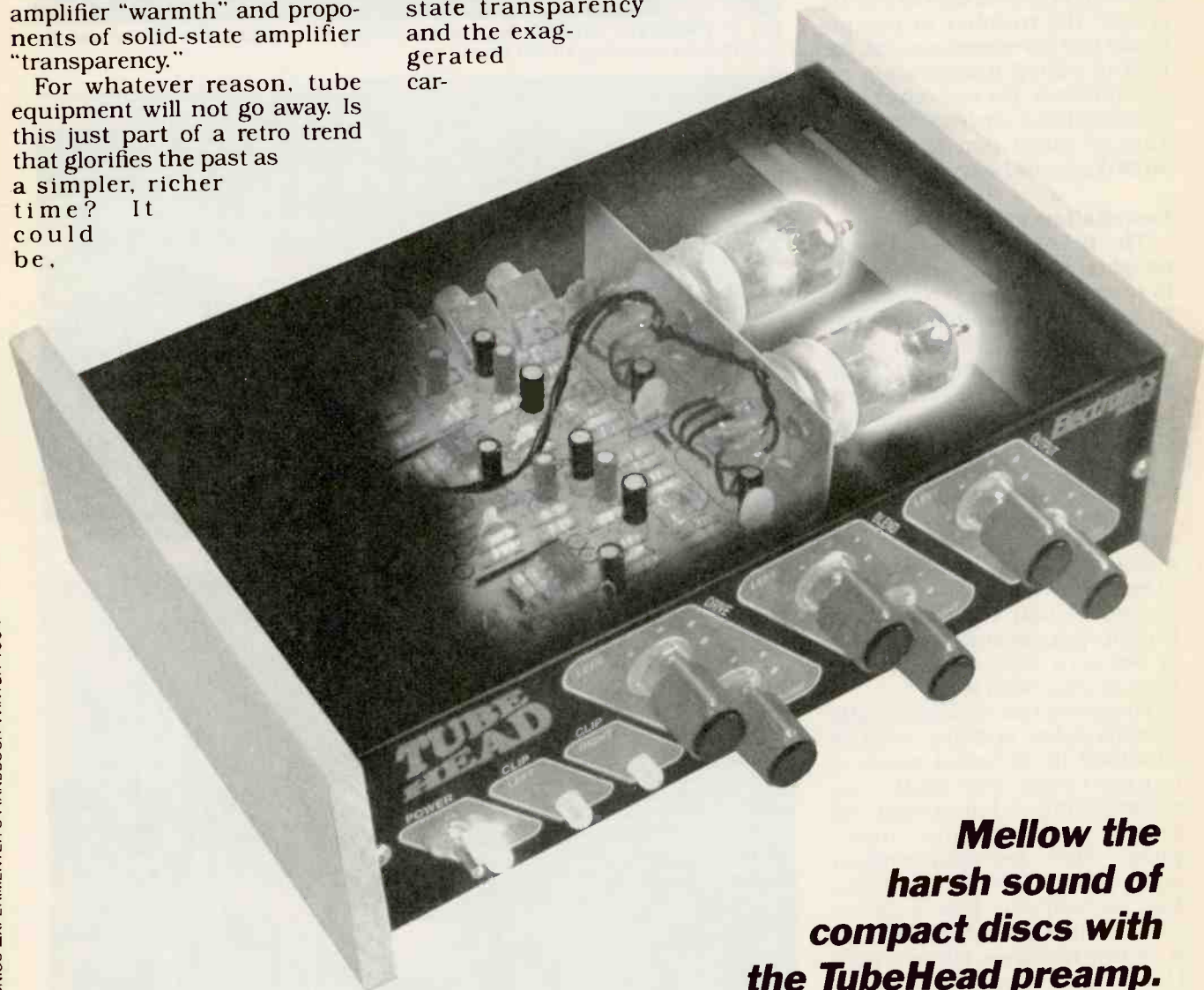

**Mellow the
harsh sound of
compact discs with
the TubeHead preamp.**

JOHN SIMONTON

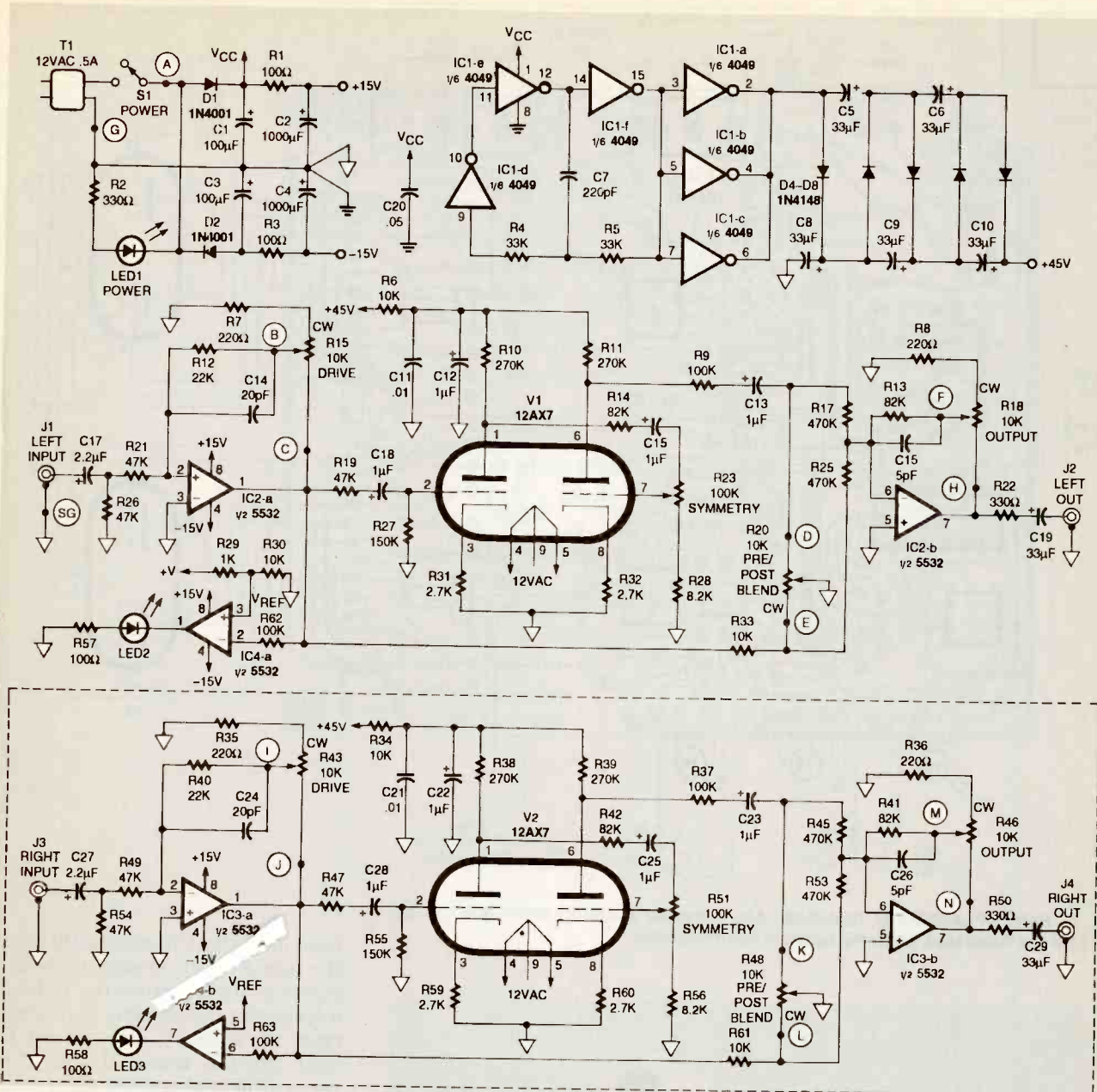

FIG. 1—TUBEHEAD SCHEMATIC. Output from transformer T1 is positive half-wave AC rectified by D1 and filtered by C1, C2, and R1 for a +15-volt supply. A -15-volt supply is available from D2, C3, C4, and R3. The plate supply for the 12AX7 tubes is produced by a voltage multiplier.

its operating range before it suddenly clips, tube amplifiers usually start "squashing" the signal well before they run out of headroom (see the "Clipping and Squashing" sidebar).

Both of those responses produce harmonic distortion, adding frequency components that were not in the original signal, but "squashing" generates much lower order harmonics. The result doesn't have the "buzzy fuzziness" that comes from the high-frequency components produced by clipping.

If the "squashing" is asymmetrical (more on the top than the bottom or vice-versa) the result can be strong second- and fourth-order overtones. These are musically benign in terms of producing dissonance, and more pleasing (though not necessarily more interesting) than the odd harmonics of clipping.

Consider this: All natural instruments generate an increasingly complex harmonic structure when they're played louder. They don't just produce higher sound pressure levels—

in a very real way they get "fuller." In fact, the increase in harmonic complexity gives the strongest indication to your ears (actually the brain attached to them) that one sound is louder than another. The squashing distortion of vacuum tubes extends this same principle to amplifiers. This might be the reason why tube amplifiers are so often subjectively judged to be "louder" than solid-state units.

Any preference for the warmer, fuller sound of tubes might be nothing more than habit. After all, even with vacuum tubes out of the picture, analog

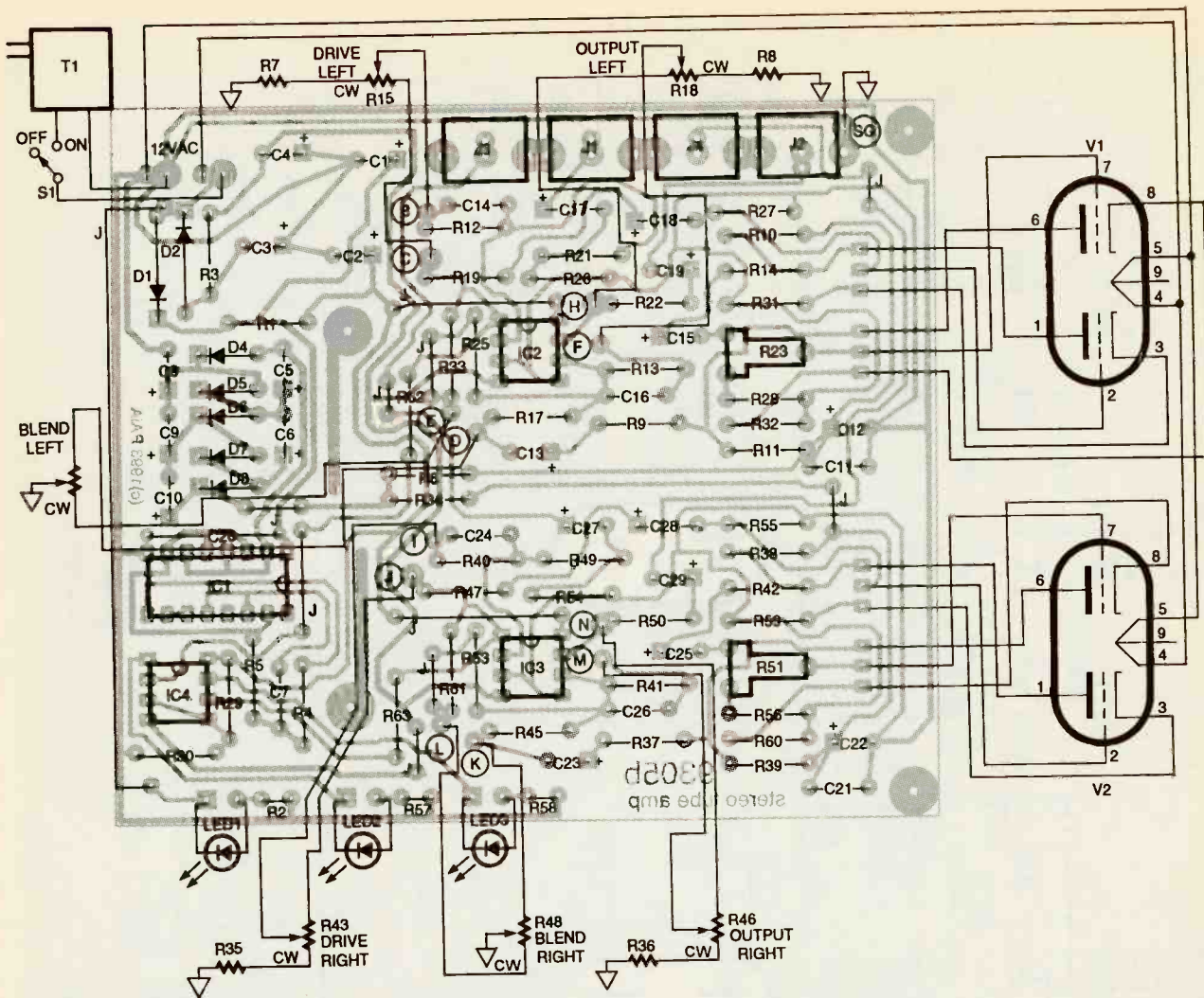

FIG. 2—PARTS-PLACEMENT DIAGRAM. Any accepted assembly technique can be used for the TubeHead, but a PC board is recommended.

tape and vinyl records still had the same compressing non-linearities. It's not unusual to find a listener expressing a preference for a taped copy of a CD over the CD itself. It was the general acceptance of CDs and digital sound recording that finally removed the last vestiges of natural "imperfection."

If tube preference is only habit, it is deeply ingrained. Even with the overwhelming editing and duplicating advantages of digital audio tape, many artists and engineers prefer to record on analog tape before transferring the sound to digital audio tape. Also, some of the most expensive condenser microphones used in professional recording have a vacuum-tube preamplifier built into the microphone. And if you don't know that tube amplifiers are *de-rigueur* in rock 'n' roll, it can only be because you don't care.

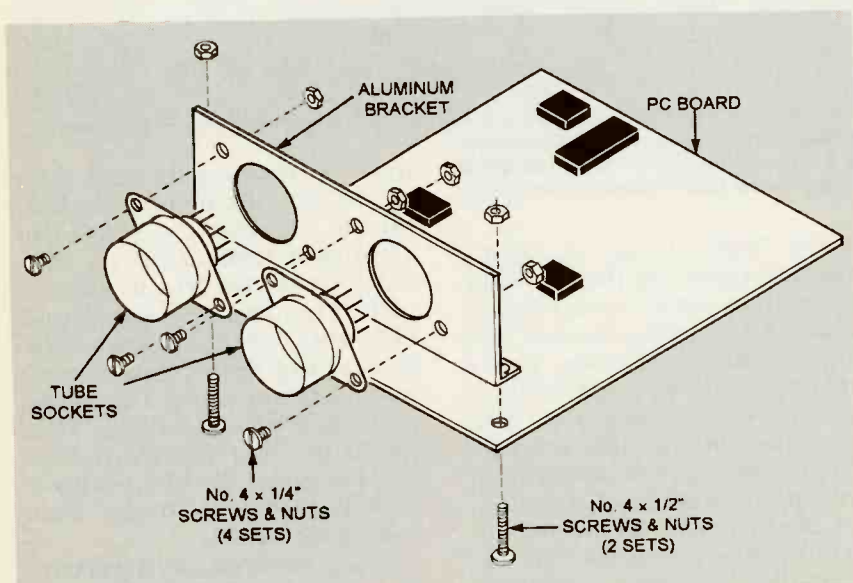

FIG. 3—THE TUBES ARE MOUNTED HORIZONTALLY to fit in a low-profile case. Four No. 4 × ¼ inch machine screws and nuts fasten the tube sockets to their mounting bracket. The right-angled aluminum bracket is fastened to the circuit board with four No. 4 × ½-inch screws and nuts that also hold the assembly in the case.

CLIPPING AND SQUASHING

All amplifiers become non-linear when they're driven hard enough, but tubes and transistors distort in distinctly different ways. An easy way to see these differences is with transfer curves such as those shown here. The input at the bottom responds to the curves to produce the outputs shown at right.

The transfer curve shown in Fig. 1-a is typical of a solid-state amplifier. Response is linear and wonderful until you

run out of headroom, and then the signal is suddenly clipped. The curve in Fig. 1-b shows what happens in the typical vacuum-tube amplifier. Because the ends of the curve roll over gradually rather than suddenly reaching a plateau, an increasing output is gracefully "squashed" rather than suddenly "clipped."

When you refer to the work of Fourier related to this clipping and squashing business, he tells us that a "discontinuity," such as the point where the output of the solid-state amplifier suddenly

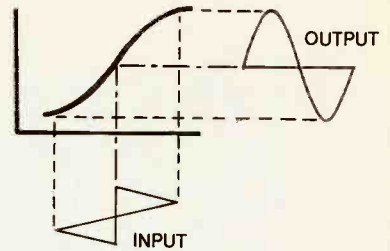

FIG. 2—A "SQUASHING" transfer function can decrease total harmonic content of a signal, such as the triangular wave shown here.

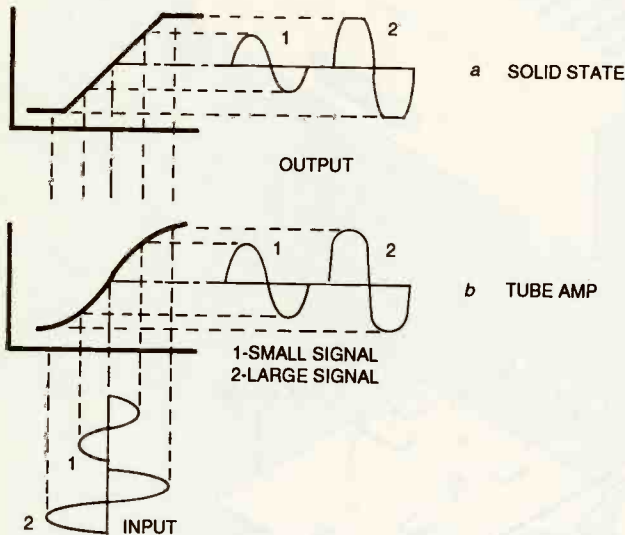

FIG. 1—TRANSFER CURVES show how an input is transformed into an output. The solid-state amplifier (a) is linear over most of its useful range before it suddenly plateaus. A tube amplifier (b) is never completely linear and goes into saturation gradually.

stops changing, splatters a spectrum of harmonics. These frequency overtones in the original waveform, both odd and even, easily extend into and beyond audible range. Even a guitarist's "fuzz box" doesn't generally produce harmonic structures like this because, in a musical context, the strong odd-order harmonics can lead to unplanned, unpleasant dissonances.

"Squashing," on the other hand, has no discontinuities and, because of this, the harmonics cluster within a few octaves of the fundamental. A particularly interesting observation is that while linear response leaves harmonics unchanged and clipping can only add harmonics, this squashing distortion can actually decrease total harmonic content. In Fig. 2, a triangular waveform is passed through a squashing function to produce a nearly sinusoidal output; the odd-order harmonics that made the input a triangle have been suppressed. Unlike a filter, this harmonic suppression is not frequency sensitive. Ω

The TubeHead circuitry exaggerates the natural non-linearities of the tubes by operating them at fairly low voltages and plate currents (see the Vacuum Tube Fundamentals sidebar). In addition to controlling how hard the tubes are driven, and consequently how much the signal is squashed initially, the circuit also features a blend control that sets the relative amounts of pre-tube or post-tube signal in the output.

How it works

The TubeHead schematic is shown in Fig. 1. The output from 12-volt AC transformer T1 is positive half-wave AC rectified by D1 and filtered by C1, C2, and R1 for a +15-volt supply. A -15-volt supply is obtained from D2, C3, C4, and R3.

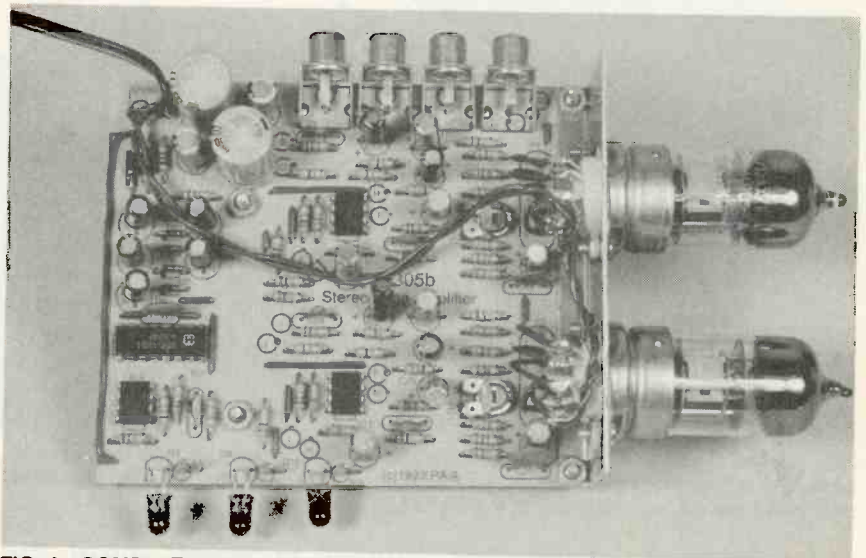

FIG. 4—COMPLETED PC BOARD and tube assembly.

Most tube circuits operate at high plate voltages, often hundreds of volts, and components needed to obtain those voltages

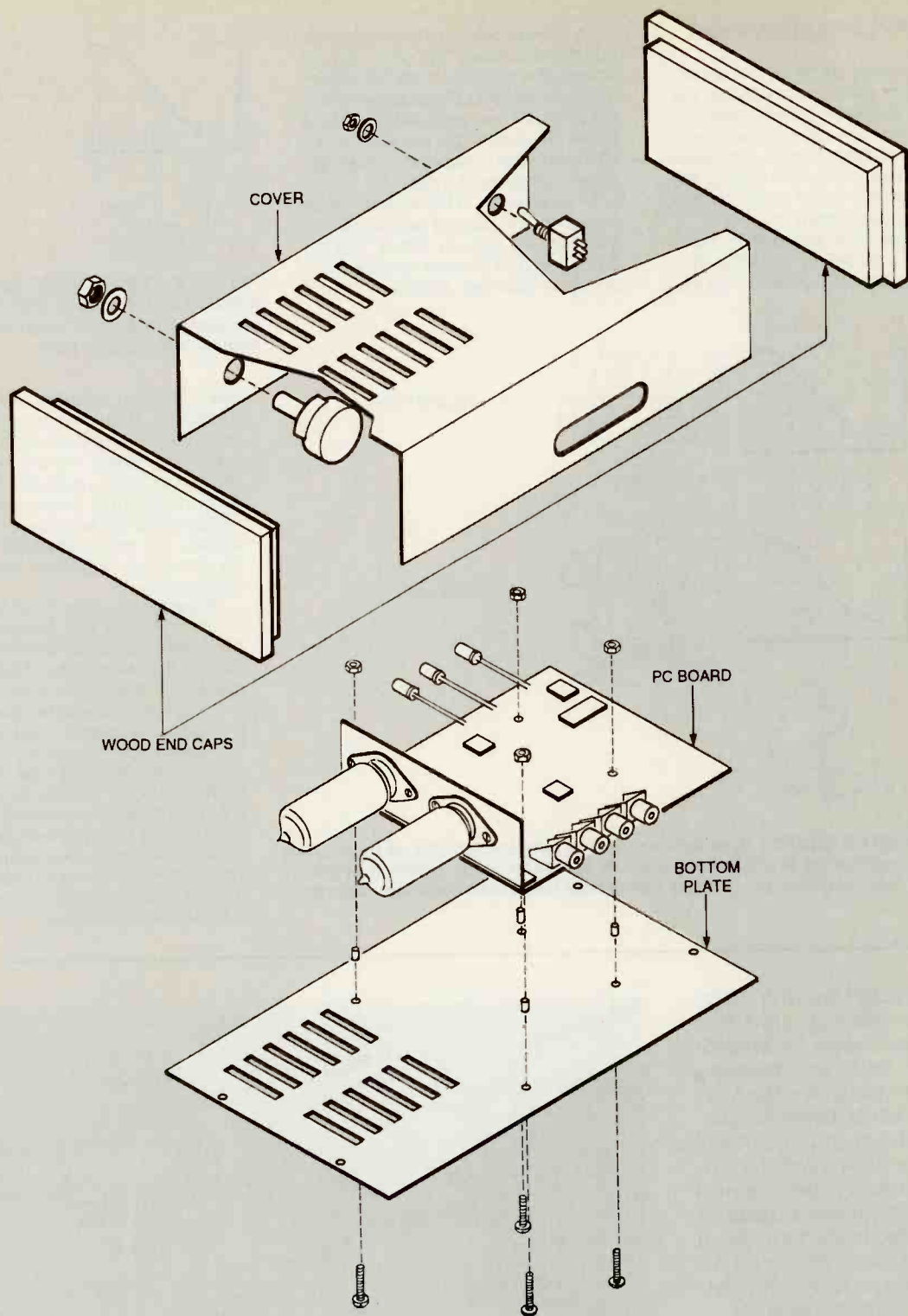

FIG. 5—THE CASE IS FORMED from 0.040-inch sheet aluminum with the top and bottom held together by screws driven into the wooden end caps. You can purchase this case from the source given in the Parts List.

can be expensive and difficult to find as well.

However, the method used to make a tube *really* sound like a

tube is to "starve" it with low plate voltage.

The 45 volts required for the TubeHead is higher than would

typically be found in solid-state circuitry. In place of an exotic multiwinding power transformer, the tube's plate supply is produced by a voltage multiplier. Capacitor C7 and resistors R4 and R5, together

25
K R | 1 meg R | 10 meg R | 2N3819 N-PET | 2N2222 TRANS | LED | Battery

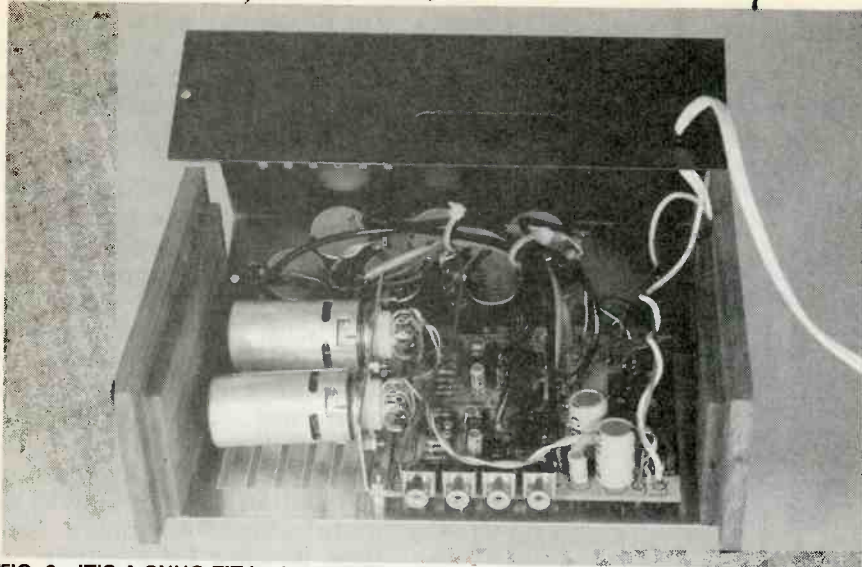
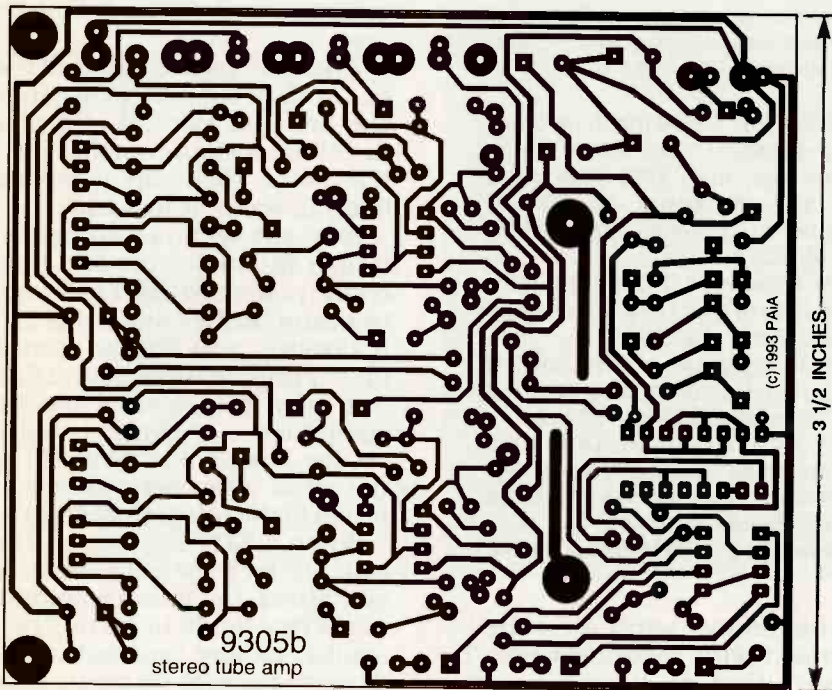

FIG. 6—IT'S A SNUG FIT in the prototype case.



TUBEHEAD FOIL PATTERN.

with three of the six inverters in IC1 form a 60-kHz, 15-volt, peak-to-peak, square-wave oscillator. The remaining three buffers in IC1 are wired in parallel to provide the greater output current necessary for driving a network of diodes (D4 to D8) and capacitors (C5, C6, C8 to C10) that multiply the 15-volt square wave to a DC voltage as high as 45-volts.

The stereo TubeHead consists of two identical preamplifier/tube/final amplifier sections. The left channel is built around a 12AX7 tube (V1) and a 5532

op-amp (IC2). The right channel is identical to this section.

The signal path begins with an adjustable gain stage built around op-amp IC2-a. Input signals are coupled by C17 and appear across R26. When the DRIVE control R15 is fully counter-clockwise, the voltage gain is set to a minimum of 1/2. At the clockwise end, the voltage gain is set to a maximum of 25. Capacitor C14 rolls off the high frequency response at a corner frequency of about 30 kHz. An op-amp wired as a comparator (IC4-a) turns on LED2 when the

output of the gain stage starts to clip.

Two tube stages provide maximum control of the output waveform's asymmetry. Both tube stages are within the envelope of V1, a 12AX7 dual triode. The output of IC2-a is coupled by R19 and C18 to R27, the grid resistor of the first tube stage. The output of the first tube stage appears across plate-load resistor R10, and is coupled by R14 and C15 to SYMMETRY trimmer R23. Trimmer output sets the amount of signal applied to the grid of the second stage. The output of the second stage appears across plate-load resistor R11.

A final output buffer stage built around op-amp IC2-b converts the relatively high impedance output of the tubes to a lower impedance consistent with contemporary audio equipment. Its operation is very similar to that of the circuitry around IC2-a.

Op-amp IC2-b also mixes the dry signal (pre-tube) with the post-tube processed signal using the BLEND potentiometer R20. At the clockwise end of R20's rotation, the final amplifier is fed exclusively with the output of the tube. At the counter-clockwise end, it's fed by the buffered input signal from the first gain stage. At intermediate settings of R20, a mix of the dry signal and the tube output drive the final buffer. The relative values of R37 and R61 compensate for the additional gain of the tubes so that the overall level is fairly constant as BLEND is varied from "pre" to "post."

Building the TubeHead

Any accepted conventional technique can be used for the assembly of the TubeHead electronics. The foil pattern for the PC board in the TubeHead is provided in this article if you want to make your own. However, ready-to-use PC boards and other components are available from the source given in the Parts List. Figure 2 is the parts-placement diagram for the PC board.

If you build the TubeHead from scratch, there are some

PARTS LIST

All resistors are 1/4-watt, 5%, unless otherwise noted.

R1, R3, R57, R58—100 ohms
 R2, R22, R50—330 ohms
 R4, R5—33,000 ohms
 R6, R30, R33, R34, R61—10,000 ohms
 R7, R8, R35, R36—220 ohms
 R9, R37, R62, R63—100,000 ohms
 R10, R11, R38, R39—270,000 ohms
 R12, R40—22,000 ohms
 R13, R14, R41, R42—82,000 ohms
 R15, R18, R20, R43, R46, R48—10,000 ohms, panel-mount potentiometer
 R17, R25, R45, R53—470,000 ohms
 R19, R21, R26, R47, R49, R54—47,000 ohms
 R23, R51—100,000 ohms, horizontal-mount trimmer potentiometer
 R27, R55—150,000 ohms
 R28, R56—8200 ohms
 R29—1000 ohms
 R31, R32, R59, R60—2700 ohms

Capacitors

C1, C3—100 μ F, 25 volts, electrolytic
 C2, C4—1000 μ F, 16 volts, electrolytic
 C5, C6, C8—C10, C19, C29—33 μ F, 25 volts, electrolytic
 C7—220 pF, ceramic disk
 C11, C21—0.01 μ F, ceramic disk
 C12, C13, C15, C18, C22, C23, C25, C28—1 μ F, 50 volts, electrolytic
 C14, C24—20 pF, ceramic disk
 C16, C26—5 pF, ceramic disk
 C17, C27—2.2 μ F, 25 volts, electrolytic

C20—0.05 μ F, ceramic disk

Semiconductors

D1, D2—1N4001 diode
 D3—not used
 D4—D8—1N4148 diode
 LED1—LED3—Red light-emitting diode
 IC1—CD4049 CMOS hex inverting buffer, Harris or equivalent
 IC2—IC4—NE5532 dual low-noise op-amp, Signetics or equivalent

Other components

J1—J4—RCA phono jack (PC mount)
 S1—SPST switch
 T1—12.5-volt AC, 500 milliampere wall-mount transformer
 V1, V2—12AX7 dual triode tube

Miscellaneous: tube sockets and mounting brackets, wire, solder, hardware, PC board, case, etc.

Note: The following items are available from PAiA Electronics, Inc., 3200 Teakwood Lane, Edmond, OK 73013, phone (405) 340-6300, fax (405) 340-6378:

- TubeHead PC board with tube-mounting bracket (9305pc)—\$22.50
- Complete kit of parts and PC board, less case, for 2-channel TubeHead (9305k)—\$78.25
- Punched, formed, and anodized case with 2-color leg-
ending and wooden end caps (9305cen)—\$19.50

Please add \$5 P&H to each order.

Fig. 3, and individual wires connect the socket's solder lugs to the rest of the circuitry. Figure 4 shows the completed PC board and tube assembly.

The prototype case was formed from 0.040-inch sheet aluminum with the top and bottom held together by screws driven into the wooden end caps (see Fig. 5). However, any case with interior dimensions greater than 7 × 5 × 2 inches will work well. If you make your own case, don't forget that tubes radiate a lot of heat. In the prototype, twelve 1 × 1/8-inch ventilation slots were cut in the metal above and below each tube to allow for adequate air flow. Figure 6 shows how all the components fit in the prototype case.

When you have completed the assembly and thoroughly checked your work, it's time for the all important "smoke" test. If any fault shows up, it is most likely to occur at this time.

Plug the wall-mount transformer into an outlet and turn on the power switch. The power indicator (LED1) should light; if it doesn't, you should immediately unplug the unit and find out why. Improperly placed components or solder bridges on the circuit board might be the cause. Also check the orientation of the integrated circuits.

When LED1 lights, let the unit idle for a few minutes while you check for passive components that might be getting hot, smoke, or any unusual smell. Observe the tube filaments to be sure they're glowing—if not, check the soldered connections on the tube sockets and the twisted pair that connects the filament circuit to the power supply.

If everything works well after a few minutes of operation, connect a low-impedance, line-level source to the left input (J1), and connect the corresponding output (J2) to an amplifier. Set the left channel DRIVE, BLEND, and OUTPUT controls to midrange and confirm that the signals flow correctly through the unit. Change the settings of the controls and observe that each one affects the sound. Notice that at

precautions to observe: Every ground in the system should return to a single point, but this is not always practical. Nevertheless, it is *very important* that there be separate wires for the ground of the audio circuitry and the power ground to IC1. The frequency of the 60-kHz square wave that drives the voltage multiplier is above the audio range, but if it leaks into the audio path it can cause unpleasant distortion. It is also recommended that you separate the voltage multiplier from the audio components (particularly the tubes and related components) by placing them at opposite ends of the board.

Connect the tube filaments directly to the points where the

transformer wires meet the PC board with separate wires. Be sure that no filament power passes through any part of the signal ground. Twist the filament wires together and route them away from all of the audio components.

When installing components, observe the polarity of electrolytic capacitors and diodes. Note that a single-channel version of the TubeHead can be built by eliminating all of the components drawn within the dashed lines on the schematic.

The TubeHead circuitry will fit into a low-profile case if the tubes are mounted horizontally. A right-angle aluminum bracket holds the tube sockets to the component board as shown in

VACUUM-TUBE FUNDAMENTALS

Figure 1 shows a typical triode vacuum tube. Because of the Edison Effect, heat from the filament drives free electrons from the oxide coating on the cathode. The positive voltage on the plate attracts the electrons, and the moving electrons produce a current flow. A negative bias voltage on the grid repels some of the electrons and prevents them from reaching the plate, resulting in lower current flow. In this way, a changing negative charge on the grid can modulate the plate current.

One source of non-linearity in vacuum tubes is "space charge;" electrons that are driven from the cathode but don't reach the plate simply accumulate. This cloud of negatively charged electrons has the same effect as a negative voltage applied to the grid—it decreases current flow. This is referred to as "self-biasing." This is a non-linear process because increasing negative grid voltage blocks electrons, which produces more space charge. This has the effect of making the grid even more negative.

Operating a vacuum tube at low plate voltages doesn't significantly affect the number of electrons that leave the cathode; that is primarily set by the filament temperature. So at low plate voltages and currents, space charge becomes a more important factor (just as many electrons are leaving the cathode, but fewer of them are reaching the plate). As a result, the non-linearity which is present in all tubes is exaggerated.

The TubeHead circuitry operates at

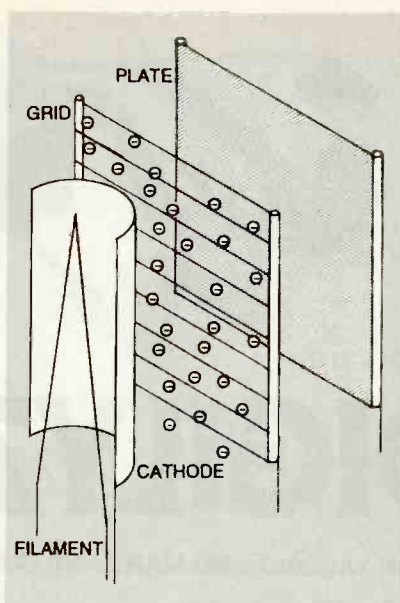

FIG. 1—TYPICAL TRIODE vacuum tube. Heat from the filament causes electrons to boil off the cathode. Any electrons not attracted to the positive plate voltage form a cloud that biases the tube.

such low voltage and current that it completely self-biases. To see this, measure the voltage between any of the grids and ground with a high-impedance scope or voltmeter. You will find that the grid is about 1 volt, negative. The negative voltage is the result of electrons boiling off the cathode and clustering around the grid. Ω

some point in the rotation of the DRIVE control potentiometer, CLIP indicator LED2 turns on.

Disconnect the source and amplifier from the left channel and connect it to the right channel. Confirm that this channel behaves the same way as the left channel.

Using the TubeHead

The 50:1 gain range available from the TubeHead's input buffer stage allows a wide range of signal sources to be processed. Typically, the signal source, such as a CD or tape player, can be plugged into the TubeHead inputs, and the outputs can plug into the main amplifier. The tape monitor input and output jacks on your integrated amplifier will provide a handy "effects" loop.

Each channel has three front-panel controls and one internal trimmer. The DRIVE control de-

termines how hard the tube is driven and, as a result, how much it "squeezes" the signal. The circuitry is designed so that with DRIVE set to minimum, the tube begins its non-linear response at about 0 dBV. With DRIVE at maximum, non-linearity onset occurs at about a 20-millivolt input.

The BLEND control sets the relative amounts of pre- and post-tube sound in the output. With the control fully counter-clockwise (the "pre" setting), only the clean signal appears in the output. Turning the control fully clockwise (the "post" setting) provides an exclusive output of tube sound.

The final panel control for each channel is the OUTPUT level. After setting the DRIVE and BLEND controls, set the OUTPUT level as needed for the best balance and lowest overall noise in the signal path.

As with the front panel controls, the SYMMETRY trimmer for each channel should be set to taste. These trimmers (R23 for the left channel and R51 for the right) are arranged so that at the clockwise end of their rotation, the output of the TubeHead is approximately symmetrical. Counter-clockwise rotation of these trimmers increases the asymmetry.

Notice that CLIP indicators LED2 and LED3 light when the first op-amp gain stage begins to clip; they are not intended to indicate distortion in the tube. If the CLIP indicator for a channel lights, reduce the DRIVE until the light goes off. Overloading the tube produces the desired effect, but overdriving the op-amps does not.

If you're involved in the production of music, either as musician or sound engineer, you'll find the TubeHead to be a useful addition to your bag of audio tricks. In addition to its warming ability, the TubeHead's "squashing" action makes it a useful substitute for an audio compressor or sustainer. The compression of an overloaded vacuum tube is not the same as a normal studio compressor. Compressors act on the average level of a signal over a relatively long time period. They affect the envelope of the signal without altering the harmonic structure. The tube's action is on a cycle-by-cycle basis, but with the exception of the subtle harmonic distortion that this produces, other effects are similar.

The nominal input impedance of the TubeHead is about 20 kilohms, consistent with most hi-fi equipment, synthesizers, and sound blasters. However, it is a little low for a proper match with high-impedance sources such as guitar pickups. A few minor changes will overcome this incompatibility; remove R26 and C14 and change the value of R21 to 680 kilohms and R12 to 100 kilohms. This increases the input impedance to 680 kilohms, making it compatible with such instrument transducers as piezoelectric microphones and guitar pickups. Ω

**Build the Digilyzer:
It performs some
digital analyzer
functions, but it
costs a lot less—
and it fits in the
palm of your hand.**

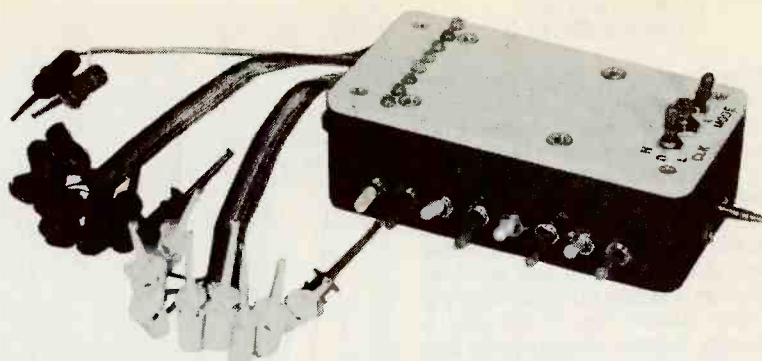

THE DIGILYZER

JOHN YACONO AND MARC SPIWAK

A DIGITAL ANALYZER IS AN EXTREMELY useful instrument for troubleshooting digital circuitry. Unfortunately, digital analyzers are usually priced beyond most hobbyists' budgets. However, the Digilyzer, the subject of this article, can perform some of the functions of a digital analyzer. And the best thing about the Digilyzer is that you can build it for less than \$50—a lot less than the purchase price of a factory-made analyzer.

The Digilyzer monitors the logic levels at eight of its inputs (called the *test inputs*), and when they match a user-set bit pattern, it latches the binary data present at its other eight inputs (called the *data inputs*). Once data has been latched, it is displayed on the unit by eight tri-colored LEDs. Digilyzers are end-stackable so that multiple units can monitor 16, 24, or 32-bit wide buses—this makes them quite versatile.

One of the most popular applications for the Digilyzer is monitoring the input and output from an integrated circuit to verify its operation. However, the Digilyzer performs many other complex tasks such as monitoring any memory location on a bus.

To use the Digilyzer you start by connecting the test inputs to the address bus, connect the data inputs to the data bus, and set the bit pattern for the address you want to observe.

When the Digilyzer next encounters that address, it latches onto the data.

The Digilyzer also offers other options that make it especially suitable for troubleshooting. For example, you don't have to define all the bits that make up the bit pattern. Some can be left in a "don't care" state. This is useful for checking computers with faulty buses that have an intermittent line. It also permits you to observe what is occurring over a wide range of addresses.

The Digilyzer has two modes of operation: *latch* and *free run*. In the latch mode, the unit latches onto data when the test inputs match the user-set bit pattern, and it ignores subsequent matches. In the free-run mode, the latched data is updated each time there is a match.

The Digilyzer is fitted with a BNC output that can trigger an oscilloscope when it detects a match. That feature allows the oscilloscope to display the serial data produced by a device such as an RS-232C port when its control- and data lines are at user-specified values. This feature is particularly useful for testing parallel-to-serial converters, checking the protocol of serial ports (you'll be able to "see" the stop, parity, and data bits), and determining the handshaking lines being used by a device.

The match detector

The schematic shown in Fig. 1 shows three main sections: a match detector, a match-signal processor, and a data buffer that performs double duty as a display driver. An 8-bit identity comparator, IC1, accepts two 8-bit words (denoted A and B) and compares them.

If each bit of the two words match, the output pin 19 goes low; if any corresponding bits in the words don't match, the output remains high. Moreover, when a match is found, the output will go low only if the enable input (EN pin 1) is low. When the enable input is high, the output remains high.

The bits that form the A word input to IC1 are supplied by TEST inputs TP1 to TP8. Each of the eight bits for the B word can be user set by switches S1 to S8. Each of the SPDT center-off switches can be set in one of three positions:

- the *low* position that ties a B input to ground
- the *high* position that allows a B input to float high through a pull-up resistor
- the "don't care" position that ties a B input to its corresponding A input, ensuring a match regardless of the A bit's value.

The ENABLE input functions as part of an optional clock input (TP9). If used, it gives IC1 the ability to sense the clock of the device-under-test (DUT). That feature can prevent false

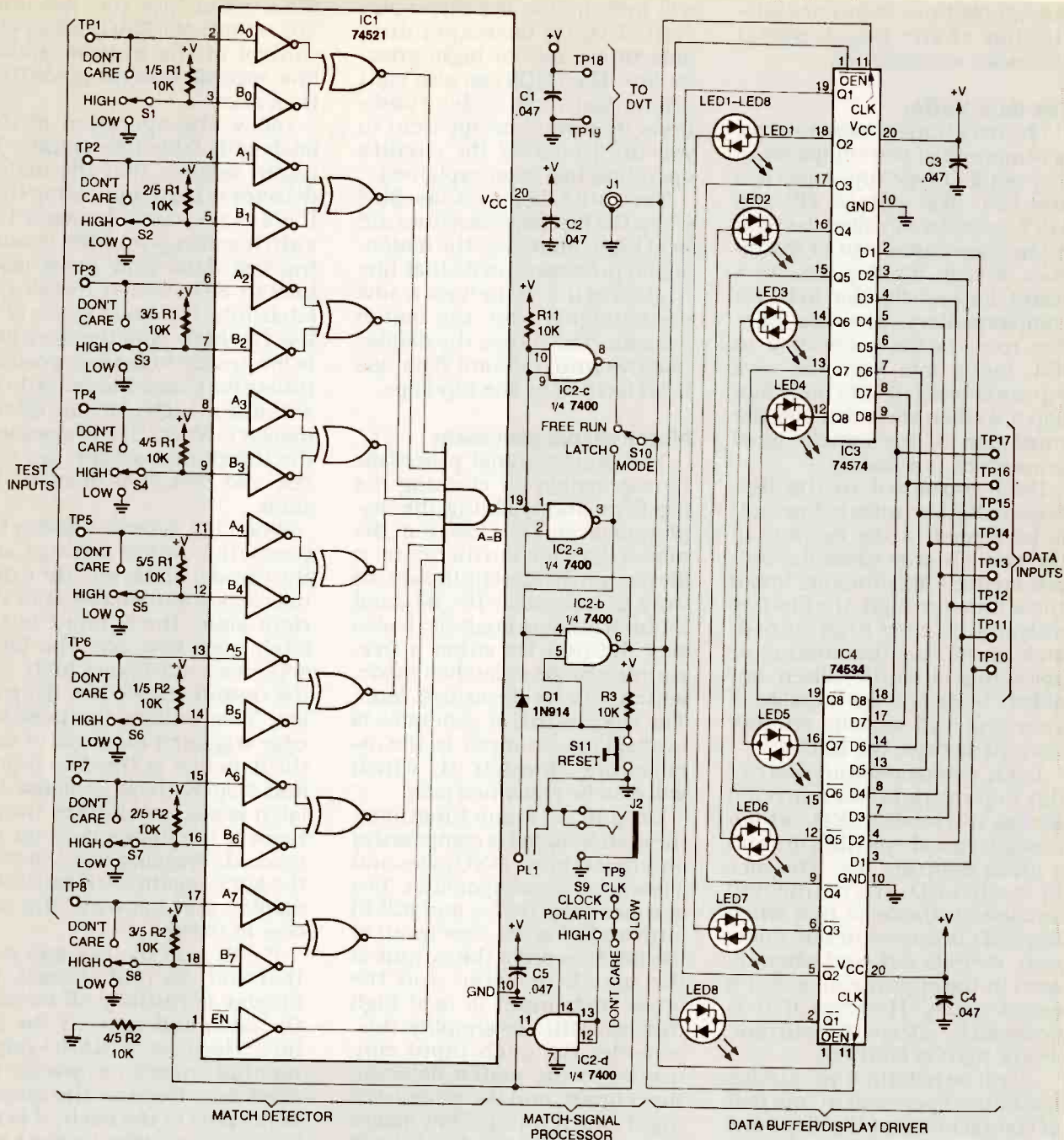

FIG. 1—THE DIGILYZER HAS THREE FUNCTIONAL SECTIONS: a match detector, a match-signal processor, and a data buffer that performs double-duty as a display driver.

triggering of the match detector because of the presence of *unsettled* test inputs, such as might occur when a parallel-printer port or a multiple-bit bus is being tested.

The clock pulses from TP9 enter SPDT center-off switch S9, which allows you to determine how the clock pulses will be treated. If a valid clock pulse is low-going, it can be passed di-

rectly to the enable pin by setting S9 to the low position.

If you want to ignore the clock input, placing S9 in the "don't care" position allows R9 to pull the enable pin low, causing IC1 to test data continuously. Putting S9 in the high position allows IC2-d to invert the incoming clock pulses so that a high clock signal will enable IC1.

The match-signal output

from IC1 is passed to the match-signal processor. It maintains an internal clock line (CLK) and an output-enable line (OEN) used by the data buffer. (The clock line generated by the match-signal processor should not be confused with the external clock pulses from the device under test or DUT.)

An explanation of the data buffer/display driver will be helpful in explaining the overall function of the clock and out-

put-enable lines before the discussion of the match-signal processor is completed.

The data buffer

The data buffer/display driver is composed of two complementary octal D-type flip-flops, IC3 and IC4. Test points TP10 to TP17, collectively called the DATA inputs, are connected to the inputs of both flip-flop ICs. As a result, for each flip-flop in IC3, a complementary (inverting) flip-flop receives the same data in IC4. Input data from the DATA inputs is clocked into both flip-flop ICs when there is a positive transition of the match-signal processor's CLK line.

Data contained in the flip-flops (whether inverted or not) is presented to the outputs of the two ICs only when the output-enable (\overline{OEN}) lines are low. If these lines are high, the flip-flop outputs go into high-impedance mode, neither sinking or sourcing current. When enabled, both ICs are capable of sourcing and sinking enough current to drive the LEDs.

Each complementary pair of flip-flop outputs is connected across a tri-color LED, which contains a red-emitting die and a green-emitting die. The dice in each LED are connected anode-to-cathode so that when the LED is biased in one direction, it emits red, and when biased in the opposite direction it emits green. However if it is powered by alternating current, yellow light is emitted.

It will be helpful if you understand the operation of one pair of complementary flip-flops and their associated LED. For example, if TP17 is low, that low is presented to D8 of IC3 and to D8 of IC4. When the flip-flops are clocked and the \overline{OEN} lines are low, Q8 of IC3 presents a low to LED8, while \overline{Q} 8 of IC4 inverts the data and presents a high to LED8. The LED is oriented so that its green element is forward-biased (emits) under those conditions.

Had TP17 been high when the flip-flops were clocked, the LED would have been biased in the opposite direction, thus turning it red. So the color of an LED

will indicate the logic level presented to its corresponding data input: red for high, green for low. The LEDs can also emit yellow, but only under conditions that won't be apparent to you until more of the circuit's operation has been explained.

The entire display is disabled when the flip-flop's \overline{OEN} lines are held high. Moreover, the match-signal processor holds that line high until it receives a low match signal from the match detector. That keeps the display inactive until relevant data has been latched by the flip-flops.

Match-signal processor

The match-signal processor is responsible for clocking the flip-flops and enabling the display on receipt of a low from the match detector. Furthermore, it allows multiple Digilyzers to work in unison for 16-, 24-, and 32-bit wide data analysis. It also sets the unit for either a free-running mode or latched mode, which will be described later. The clock signal it generates is available as an input to the oscilloscope through J1, which will also be explained later.

Despite its many functions, the match-signal is composed of only three NAND gates and a few support components. Two of those gates (IC2-a and IC2-b) form an R-S latch. One input of the latch receives the output of the match detector, and the other latch input is held high through R10. To simplify this, consider the latch input connected to the match detector, the S input, and the other latch input, the R input. That makes the output of IC2-a the Q latch output and the output of IC2-b the \overline{Q} latch output.

Consider that the mode switch S10 is in the latched position. That puts the output of

IC2-a in control of the clock line. The output of IC2-b is always in control of the output-enable line, regardless of the mode that is selected.

Follow the operation of the latch with Table 1 as a guide. To begin, assume that the match detector is high, indicating that there is no match between the switch settings and the incoming test data. Now press reset button S11, which forces the latch into the reset state: Q is low, \overline{Q} is high. Now the clock line is low (ready to make a positive transition), and the output-enable line is high (turning off the display). When S11 is released, the R input goes high, but the CLK and \overline{OEN} lines remain the same.

When IC1 detects a match between the switch settings and the test-data bits, and the external-clock input enable is in the right state, the S input to the latch goes low, and the latch sets; clock line Q goes high, and the output-enable line (\overline{Q}) goes low. That causes the positive-edge triggered flip-flops to take the data bits at the data inputs and display them. Because the latch is set, any further transitions of the match detector are ignored. Pressing S11 will reset the latch, again turning off the display and allowing the process to repeat.

If S10 is in the free-run position and the unit is reset, the display is initially off because the latch still controls the \overline{OEN} line. However, a NAND-implemented inverter controls the clock line. Because the inverter is not part of the latch, it is free to make a positive transition (a flip-flop clock pulse) upon receipt of each match signal. Thus in the free-run mode, the display is initially off; it turns on with the first match, and re-

TABLE 1—LATCH OPERATION

Input			Output		
Activity	Match Detector (S)	Logic At Pin (R)	CLK-Line Logic Level (Q)	OEN-Line Logic Level (\overline{Q})	Response
Depressing S11	High	Low	Low	High	Reset
Releasing S11	High	High	Low	High	No change
Data Match	Low	High	High	Low	Latch
Data Mismatch	High	High	High	Low	Still Latched

mains on to be updated by each match that follows.

If matches occur frequently while the Digilyzer is in the free-run mode, one or more of the LEDs might emit yellow. That means its corresponding data input(s) is changing rapidly from high to low and back again. This can't be achieved in the latched mode because the flip-flops are latched and cannot change state.

Whether or not the unit is in free-run or latch mode, the CLK line is available for external applications through BNC connector J1. The connector permits the Digilyzer to be connected to an oscilloscope's trigger input so that the oscilloscope can display serial data when user-set conditions have occurred.

Ganged operation

As explained earlier, the latch also allows two or more Digilyzers to be connected together and operated in unison. This feature is desirable when you want to monitor 16-, 24-, and 32-bit data/address lines. The units must be interconnected to prevent them from latching until all of them have found the right data at their respective test inputs. The Digilyzers are connected by means of plug PL1 and jack J2.

When connecting only two Digilyzers together, plug PL1 of one unit into J2 of the second, and vice versa. When connecting three units, mate the plug of the first unit with the jack of the second, and mate the plug on the second unit with the jack of the third, and connect the plug of the third unit with a short cable length back to the jack on the first Digilyzer.

Notice that the units are connected together in what amounts to a ring formation. You can insert a fourth unit into the ring 32-bit analysis.

Figure 2 shows the electrical connections made between the latches of two interconnected units. There can be more units in the series, but describing the operation of two should be sufficient to give you an understanding of what occurs when there

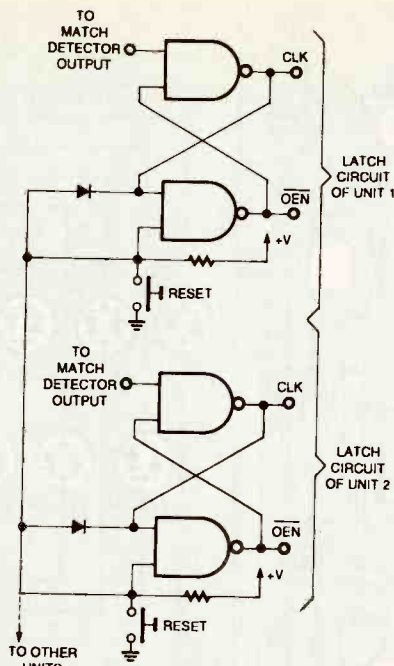

FIG. 2—THESE ELECTRICAL CONNECTIONS are made between the latches of two interconnected Digilyzers.

are three or four. The plugs and jacks were deliberately omitted from the drawing for clarity. Notice that the simplified wiring looks like a bus connecting one unit to another, but is actually not "ring-like" at all. That effect is achieved with clever wiring in the jacks.

Assume that one unit detects a match, but the other unit does not. It would not be desirable for either unit to latch because only one unit has detected a match; the latches must be inhibited in some way. For example, if unit 1 doesn't detect a match, the match-detector signal in that unit is high. The resulting CLK

signal must be low, regardless of the reset input value (examine Table 1 to verify this).

That action pulls the reset inputs of both latches low through the diode in unit 1, which puts both latches in their metastable state, effectively inhibiting them. As soon as both (all) units detect a match, the diodes will be reverse-biased, and all the latch-reset inputs will be pulled high via their 10K resistors. All the units will latch data, and their displays will be activated.

Some might find that technique objectionable because conventional wisdom suggests that applying two lows to a NAND-implemented R-S latch is forbidden or disallowed. In rigorous mathematical terms, those adjectives are correct because the state cannot be defined with the rigid rules of logic. In short, if you try to determine the output of a metastable latch, you will be unable to arrive at a definitive answer.

However, latches are not mathematical constructs; they are practical components. Therefore, they must produce an output, and they do. Moreover, that output is definitive and consistent. In this situation, both outputs are high. The high on the clock line latches new data into the flip-flops, but the high on the \overline{OEN} line prevents the display of the irrelevant data.

However, the output changes as soon as the latch is removed from the metastable state. This instability of the state justifies the term *metastable*. Thus the

LISTING 1

```

10 CLS
20 PRINT "If you want this procedure to auto-repeat press Y:"
30 AUTS=INPUT$(1)
40 INPUT "How many test values are there";N
50 DIM TEST(N-1)
60 FOR I= 0 TO N-1
70 PRINT "What's the #";I+1;"value";
80 INPUT TEST(I)
90 NEXT I
100 PRINT "Downloading dummy value. Press the reset button on the Digilyzer"
110 PRINT "to begin test procedure."
120 LPRINT CHR$(0)
130 FOR I= 0 TO N-1
140 LPRINT CHR$(TEST(I))
150 NEXT I
160 IF AUTS="Y" OR AUTS="y" GOTO 100
170 PRINT "The procedure has ended. To repeat the procedure press Y:"
180 ANSS=INPUT$(1)
190 IF ANSS="Y" OR ANSS="y" GOTO 100
200 END

```

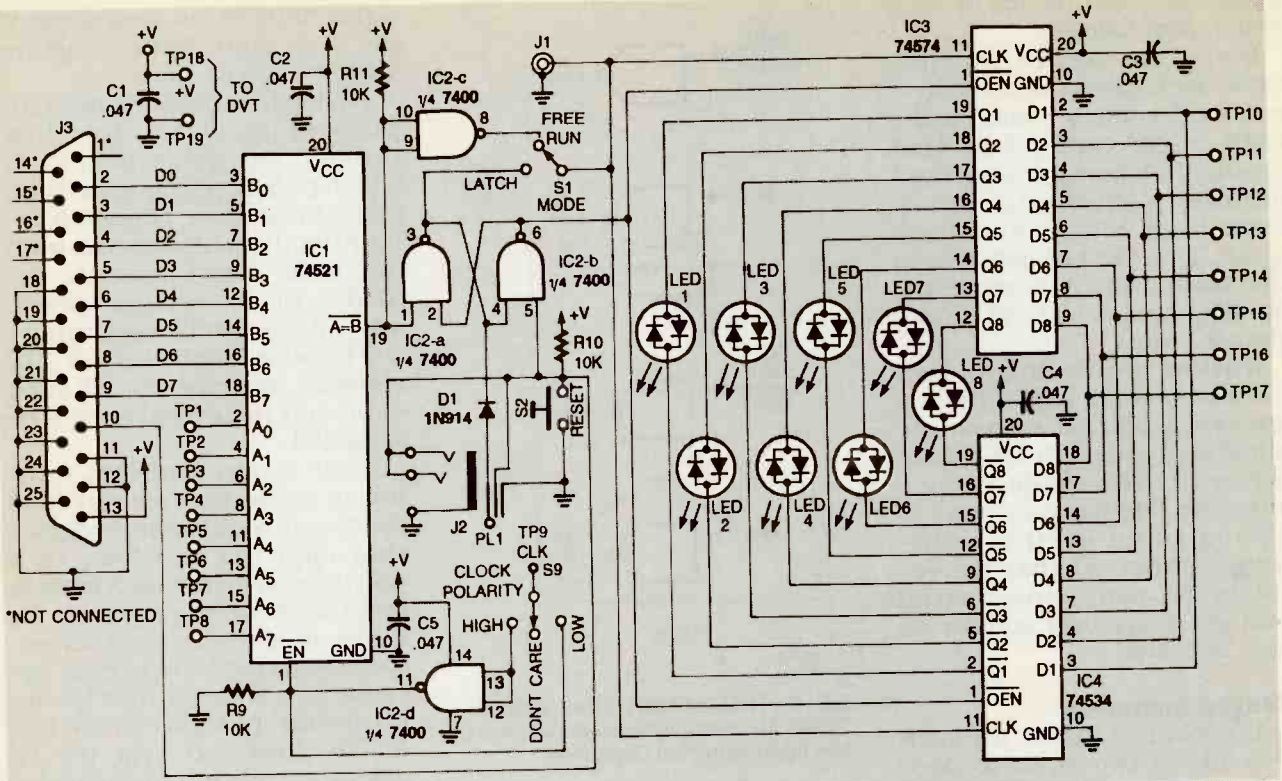

FIG. 3—AUTOMATED TESTING CAN BE PERFORMED: The Digilyzer can be controlled by a computer's parallel printer port. Here the computer downloads successive values of user-set test data.

instability allows the device to avoid premature latching so it can latch valid data.

Computer interface

If you plan to do automated testing, it will be easy to control the Digilyzer from a personal computer's parallel printer port. Figure 3 is a schematic diagram for computerized operation of the Digilyzer. In this application, the computer performs the often laborious task of downloading successive values of the user-set test data to the data-match detector. That permits you to avoid the need for setting the switches to one value after another.

The user-set (in this situation user-programmed) bits are sent to IC1 through pins 2 to 9 on the DB-25 connector shown. The 8-bit word contained on those lines provides the Digilyzer with the information that would have been provided by switches S1 to S8 in the manually-operated unit shown back in Fig. 1. Of course, none of those bits can be set to a "don't care state," but that restriction can be over-

come by judicious use of the program, as will be described.

Notice that the clock-polarity setting is still switch-operated. There is no reason for automating that feature. You will probably never want to use more than one clock-polarity setting on a given Digilyzer. It will usually be a "set and forget" switch.

Each time the computer provides the unit with the eight user-programmed switch values, it waits to see an acknowledge signal (a low-going pulse) on pin 10. Of course, the analyzer will only respond to it if you key the reset button.

That allows you to read the LED display and reset the unit before allowing the computer to download the next value. This, and some special features of the program, allow you to forego the computer keyboard after all the test values have been entered, and control the pace of the test procedure from the Digilyzer's console.

The program (shown as Listing 1) is a specialized data-entry procedure. While the program is running, it will ask you to enter

the decimal equivalent of the binary number that will be sent to the parallel port. Of course, each bit of that binary number will replace a switch, with D0 (the least-significant digit) as S1, and D7 (the most-significant digit) as S8. This data is called the *test data*.

Initially, the program asks if you want the list of test values you'll enter to be run automatically and repeatedly. That is a useful option for testing many identical Digilyzers because it frees you from having to return to the computer after you test each one.

Next, you will be asked how many test values you will be entering. That allows the program to allocate enough memory for all the values and set the size of two for/next loops: one for input and one for output. During the input loop, you will be asked to provide each of the test values in decimal form. That means that you will enter the decimal equivalent of the binary number formed by the eight user-set switches described earlier. If you are an adventurous programmer, you might want to create a subroutine that accepts binary values.

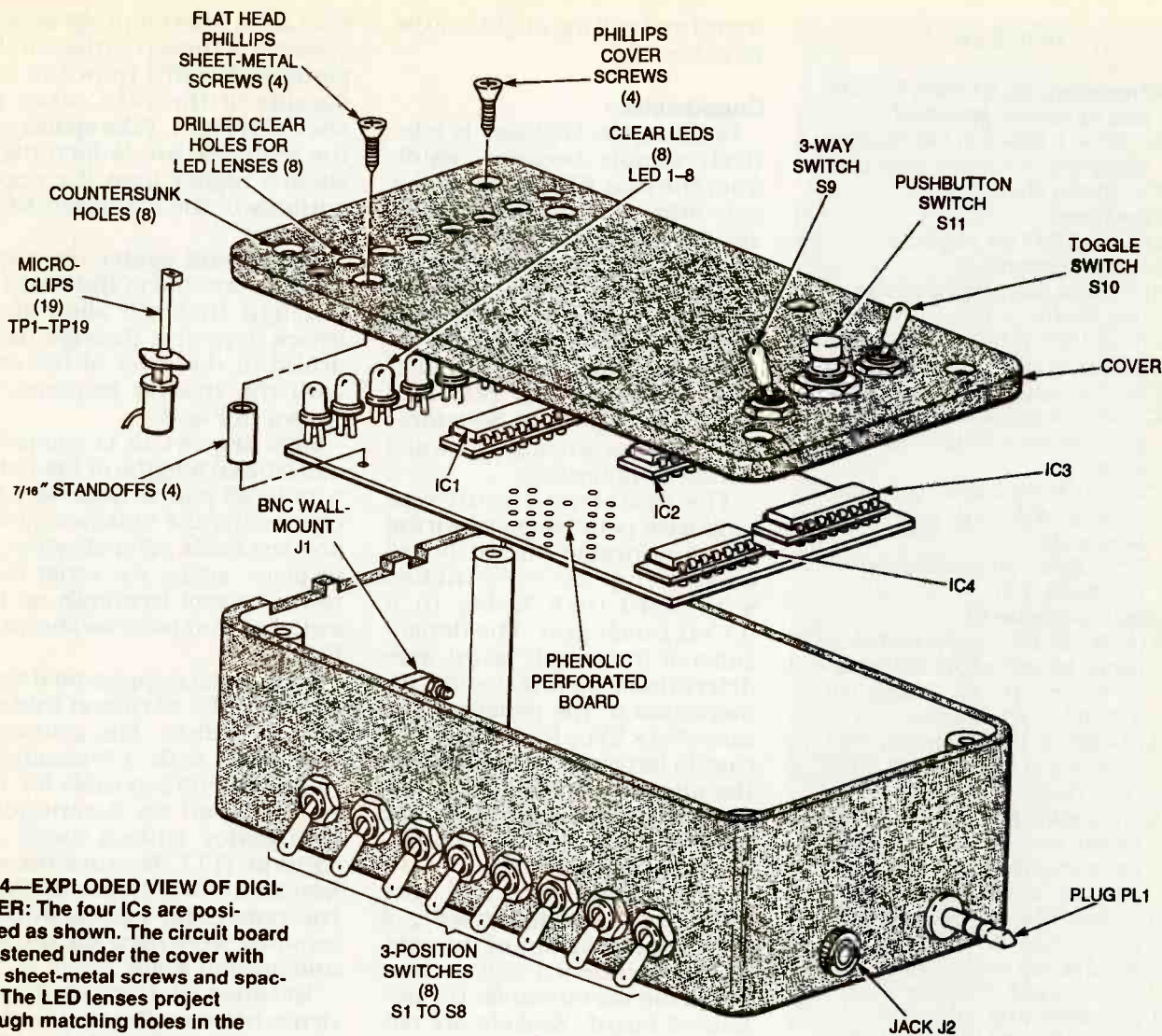

FIG. 4—EXPLODED VIEW OF DIGILYZER: The four ICs are positioned as shown. The circuit board is fastened under the cover with four sheet-metal screws and spacers. The LED lenses project through matching holes in the cover.

After all the test values have been entered, the program sends the NUL ASCII character to the Digilyzer. That action locks up the computer until you indicate that you want it to proceed by pressing the reset button. Once the button is pressed, the first test value is downloaded. When the LED display lights up, you can examine the latched data and get the next test value by depressing the reset switch.

If, for some reason, the DUT fails to generate a match to the programmed user setting in a reasonable length of time, the test value can be skipped by depressing the reset button. Thus, if the DUT fails, you can still continue your diagnosis without returning to the computer.

When all the test values have been run, the program checks to see if you chose the automatic mode of operation. If you did, the program produces the NUL character again. That locks up the computer and gives you a chance to connect another device that you want to test. Once you depress the reset button, it proceeds to run through the test values again, as before, and you don't have to return to the computer.

If you did not choose automatic mode, you are asked if you'd like to run through the list of test values again. It is a useful feature if you believe the results of the first test were unclear. If you don't want to rerun the procedure, the program will terminate. Although the computer might be locked, the program

can be terminated at any time by pressing CTRL-BREAK on the PC keyboard.

As was previously explained, you can test devices as if you programmed in a "don't-care state." Enter two test values for each bit in the "don't-care state." One test value should have the ambivalent bit low and the other should have it high.

While multiple don't-care bits can make data entry a chore because you must consider all the combinations, the program can be modified to handle don't-care states and arrive at suitable test values on its own.

Some other useful additions to the program that you might want to add include sub-routines to write the test data to a file or the printer. Similarly, some means of test-data re-

PARTS LIST

All resistors are 1/4-watt, 5%, unless otherwise specified.

R1, R2—10,000-ohm five-resistor, single-in-line network (see text)

R3—10,000 ohms

Capacitors

C1—C5—0.047 μ F, polyester

Semiconductors

D1—1N914 small-signal silicon diode, 75 PIV

IC1—74521 8-bit identity comparator circuit

IC2—7400 quad NAND gate

IC3—74574 flip-flop, D-type, octal, positive-edge triggered, three state

IC4—74534 flip-flop, D-type, octal, positive-edge triggered, inverting, three-state

LED1—LED8—tri-color light-emitting diode, T-1/4

Other components

S1—S9—SPDT toggle switch w/ center-off position, miniature panel mount, Radio Shack No. 275-375 or equivalent

S10—SPDT toggle switch, miniature, panel mount, Radio Shack No. 275-635 or equivalent

S11—momentary pushbutton switch, normally open, miniature panel mount, Radio Shack No. 275-1547 or equivalent

J1—male BNC connector, chassis mount, type 1094, Radio Shack No. 278-105 or equivalent

J2—stereo jack, miniature

PL1—stereo plug, miniature

TP1—TP19—test clips, miniature (see text)

Miscellaneous: Project case (see text), perforated phenolic circuit board, 0.1 \times 0.1 grid (see text), three 20-pin, one 14-pin wire-wrap IC sockets, ribbon cable (see text), wire-wrap wire, insulated wire 28AWG, four Phillips-flat-head sheet-metal screws, solder

retrieval and editing might also be valuable.

Construction

Building the Digilyzer is relatively simple because, aside from the four ICs specified, the only other circuit components are two single-in-line (SIP) resistor networks, one discrete resistor, and one diode. The SIP networks simplify wiring. With the exception of a single 10K resistor that has one grounded lead, all other 10K resistors function as pull-up resistors, making it a straightforward network application.

The prototype circuit was built with point-to-point wiring on a perforated circuit board measuring 2½ \times 3½-inches with 0.42-inch holes in a 0.1 \times 0.1-inch grid. The dimensions of the circuit board were determined by the inside dimensions of the construction case: 4¾ \times 2½ \times 1½-inches. The case is large enough to contain the circuitry and internal wiring without crowding, yet the package is small and convenient to handle.

Refer to schematic Fig. 1 for wiring and exploded view Fig. 4 for a general layout of the integrated circuits IC1 to IC4. Start by wiring the circuit on the perforated board. Sockets are recommended for all four ICs. Leave the insertion and soldering of the eight LEDs as the last step.

When the circuit-board assembly is complete except for

the LEDs, select four spacers to separate of the top surface of the perforated board from the underside of the case cover, as shown in Fig. 4. (The spacers in the prototype are 3/8-inch high, slightly higher than the upper surfaces of the ICs mounted in sockets.)

Mount and solder the eight LEDs at one end of the board at a height that will allow their lenses to project through holes drilled in the cover of the case with the spacers in place, as shown in Fig. 4.

After the circuit is complete, add labeled lengths of insulated wire to all points necessary for connecting the switches, jacks, and test leads. After all wiring is in place, solder the other ends to the correct terminals on the switches and jacks as shown in Fig. 1.

Next, solder approximately 7-inch lengths of ribbon cable to all test points. The prototype was wired with a 9-conductor multicolor ribbon cable for TP1 to TP9, and an 8-conductor multicolor ribbon cable for TP10 to TP17. Because the ribbon cable had 10 conductors, the remaining two-conductors removed were used for the V_{CC} and ground leads.

Because of the correspondence between the standard resistor color code and the colors of the wires bonded to the flat cable, the black wire in the nine-conductor cable, was assigned to test clip 1 (TP1) and the black wire in the eight-conductor cable was assigned to TP10.

Test the circuit at this stage in its construction before you mount any of the switches and jacks in the case. When you are satisfied that the circuit operates as described, complete the necessary hole drilling in the side walls of the case and its cover for mounting the switches and jacks.

Start first by marking the centers of the eight holes in a row in the side wall of the case for switches S1 to S8, as shown in Fig. 4. You can simplify the task of drilling an even row of holes in the case for the switches by applying a strip of drafting

(Continued on page 109)

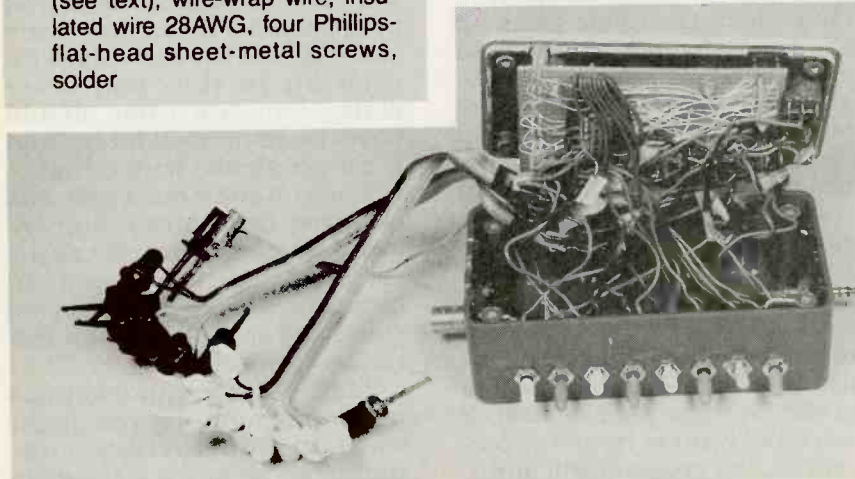
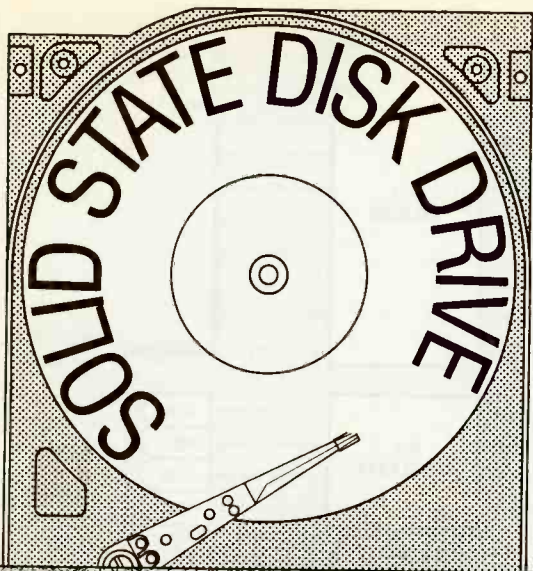

FIG. 5—DIGILYZER WITH COVER/CIRCUIT-BOARD ASSEMBLY REMOVED. The internal wiring is arranged so that the cover can be closed without interference.



SRAM II

Add a bootable RAM drive to your PC!

MARK HATTEN

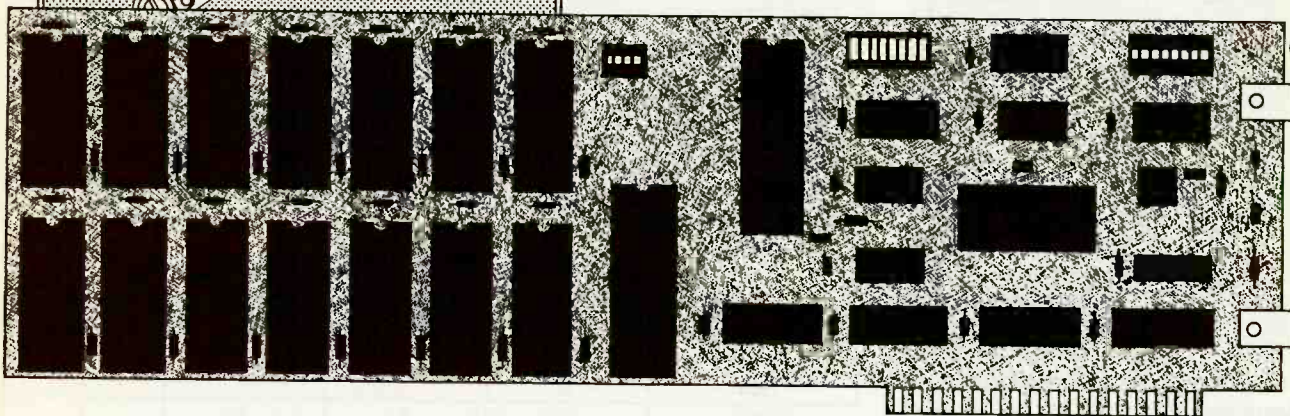

AS IN MOVIES. SO IN ELECTRONICS. This article is a sequel that details the construction of a PC expansion card called the SRAM II. In case you missed it, the original (**Radio-Electronics**, July and August 1990) provided an innovative circuit that allowed you to use a static RAM (SRAM) like an EPROM. You could write a program and copy it to a battery-backed SRAM, where it would remain even when the computer was turned off. With the appropriate code in the SRAM, you could even "hook" special software into the BIOS (basic input output system) during boot. The original design provided a password-protection feature that prevented the PC from booting unless the correct password was entered.

SRAM II extends the idea. It uses the SRAM-based boot-ROM concept, but this time a disk emulator is hooked into the PC's BIOS. In general, the SRAM drive functions like any other PC-based disk drive. It

does, however, have a few special features. For one, it's battery-backed, so its contents won't disappear when power goes off. Second, it can be made bootable!

SRAM II is designed to be the heart of an embedded system. Accordingly, it has enough semiconductor storage to hold a good-sized application: a maximum of 1.8 megabytes, supplied by fourteen 128K × 8 SRAMs.

The boot ROM can hold as much as 16 kilobytes of code, stored in either a common EPROM (27128 or 27256) or in a 43256 SRAM fitted in a special battery-backed "Smart Socket," made by Dallas Semiconductor. With the SRAM configuration being battery-backed, it is possible to enable and disable operation—and even change boot software—on the fly!

Partial and complete kits, as well as bare boards, are available. See the Parts List for pricing and other information concerning the kits.

How it works

The circuit consists of the following major components:

- PC-bus signal buffering
- I/O port decoding
- Upper memory segment-decoding unit
- Two 8255 peripheral interface controllers (PICs)
- An array of static memory.

The SRAM II buffers the PC address-bus signals with IC5, IC8, and half of IC4, as shown in Fig. 1. The circuit also buffers the data bus and several control signals, as shown in Fig. 2. Control signals include I/O Read (\overline{IOR}), I/O Write (\overline{IOW}), Reset (RST), and DMA enable (AEN). Note that Memory Read (\overline{MEMR}) is buffered (by IC10-c), but Memory Write (\overline{MEMW}) is not. This setup is not good practice, but it does not compromise signal quality here. (Cautious readers might want to buffer \overline{MEMW} using some of the spare gates shown in Fig. 5.—Editor)

The real heart of the circuit appears in Fig. 3. The gates, decoders, and DIP switches there

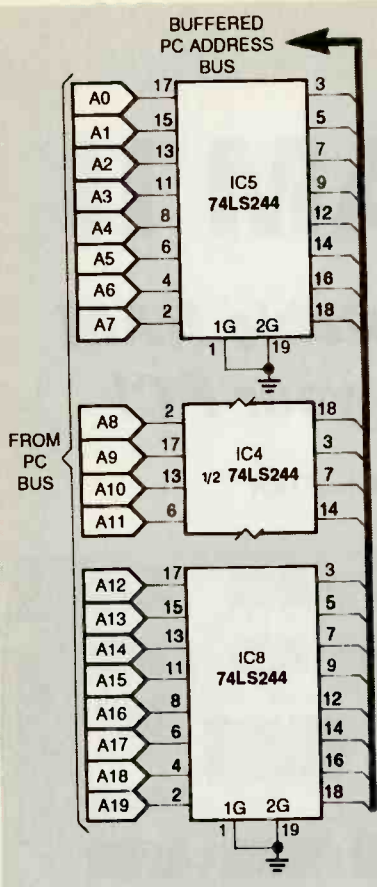

FIG. 1—ADDRESS BUS BUFFERING appears here. The other half of IC4 drives several control signals; that is shown in Fig. 2.

allow you to set board operation so it occurs at addresses that do not conflict with other equipment you might have installed in your PC.

I/O port decoding is accomplished by IC6, IC7, IC9, and IC10. Pin 3 of IC9-a is normally low, but whenever there is an I/O read or write, it goes high. If, in addition, AEN is low (there is no DMA activity), then IC9-b is high. In this case, both inputs to IC10-a are high, so its output also goes high.

Now look at IC7, a 4-bit comparator whose A = B output goes high when all four input bits, A0-A3, are equal to all four corresponding input bits, B0-B3. In practice, this means that the CPU address lines A5-A8 must be equal to the values set by the DIP switch S3. In addition, the PC bus address line A9 must be high.

The net effect of that circuitry is to define the base I/O port at which the SRAM circuitry will

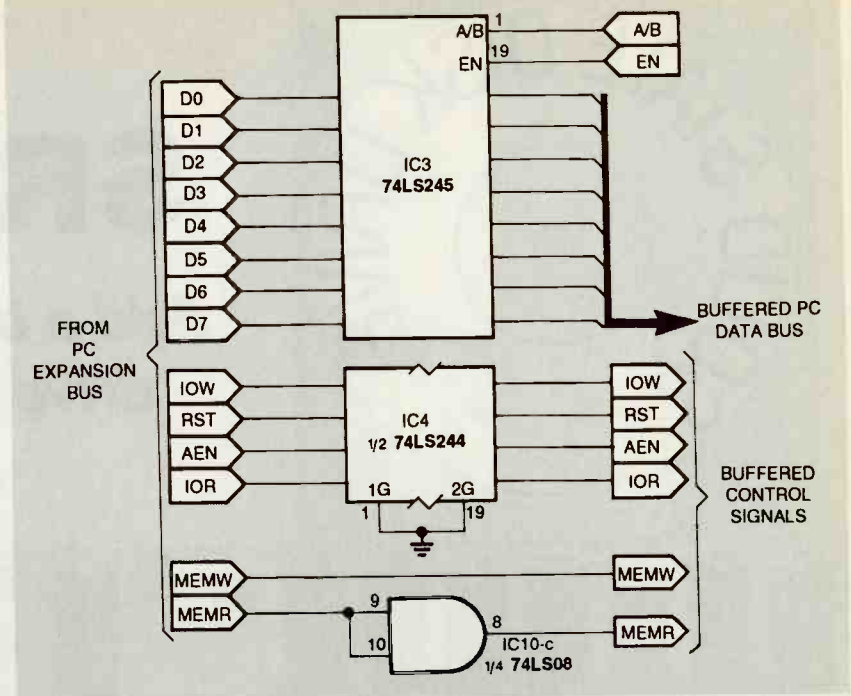

FIG. 2—DATA BUS AND CONTROL SIGNAL BUFFERING is shown here. Note that the memory-write line is unbuffered.

TABLE 1—S3 DETERMINES 32-BYTE BASE ADDRESS

Base Address	S3-a	S3-b	S3-c	S3-d
512	1	1	1	1
544	0	1	1	1
576	1	0	1	1
608	0	0	1	1
672	0	1	0	1
704	1	0	0	1
736	0	0	0	1
768	1	1	1	0
800	0	1	1	0
832	1	0	1	0
864	0	0	1	0
896	1	1	0	0
928	0	1	0	0
960	1	0	0	0
992	0	0	0	0

be decoded. The base address, as set by address line A9, is 512; depending on which switch positions of S3 are set, that values increase by 32 (512, 544, ... 992), as shown in Table 1. In conjunction with 1-of-8 decoder IC6, DIP switch S1 further narrows the decoded address to an eight-byte segment within the 32-byte block, as shown in detail in Table 2.

Now return to the decoding. When the address-bus value equals the value set by the DIP switches, and when either I/O

Read or I/O Write goes active, and AEN is inactive, IC9-c goes low, IC10-b goes low, and that in turn enables data-bus transceiver IC3 (shown in Fig. 2). Transfer direction (into or out of the CPU) is determined by the state of IC3 pin 1, which is in turn driven by IC10-d (refer to Fig. 3 now), which is normally thought of as an AND gate. However, in this case, IC10-d functions as a 2-input negative OR gate—when either input goes low, the output goes low. In other words, when the CPU

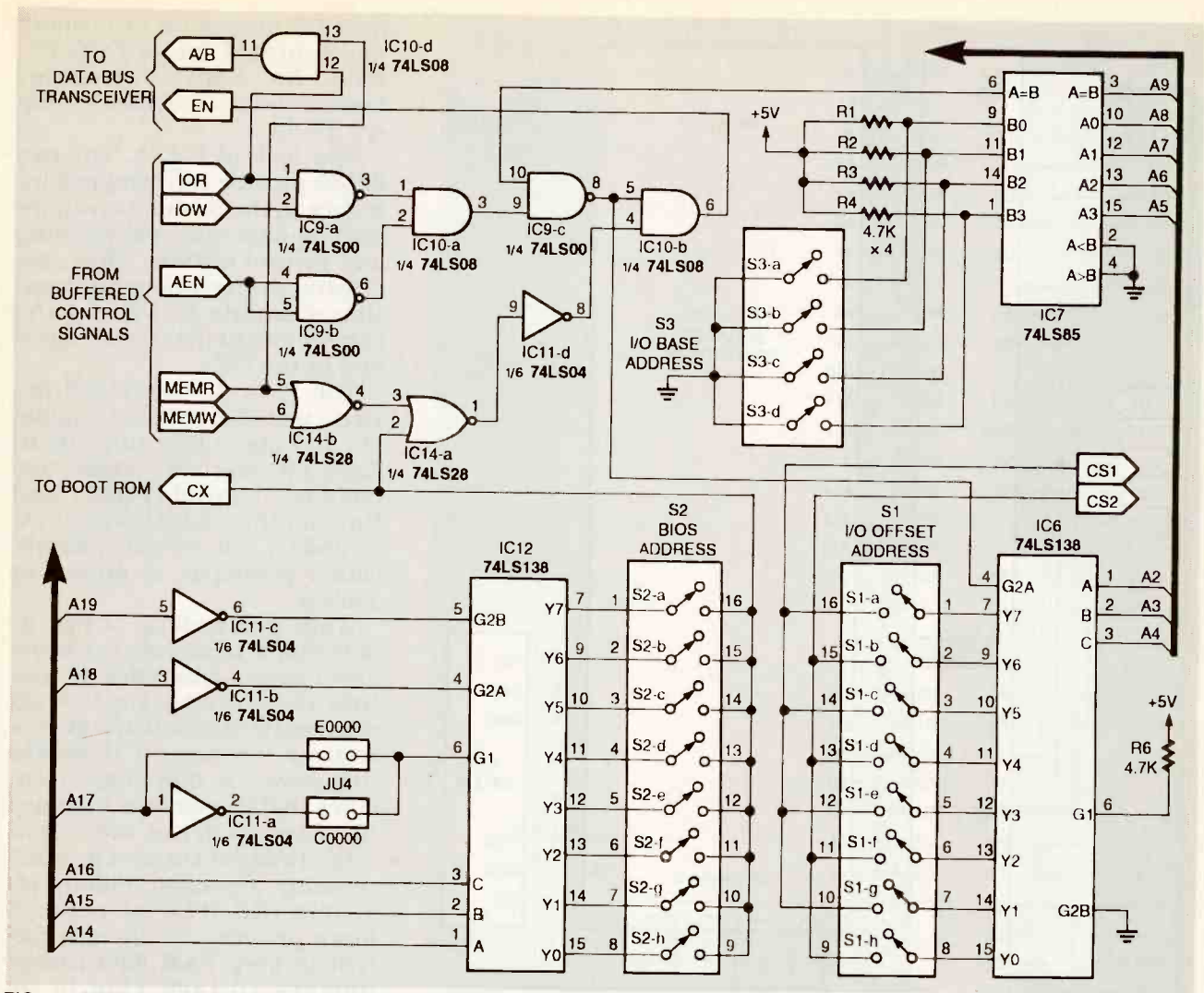

FIG. 3—ADDRESS AND I/O PORT DECODING occurs here. The DIP switches permit the selection of a base I/O address, an offset I/O address, and a memory-segment address to which the boot SRAM can be addressed. Logically, S1 is a 2P4T switch that provides the two chip selects that drive the 8255s shown in Fig. 4.

TABLE 2—S1 DETERMINES 8-BYTE OFFSET

On Positions				Standard Usage
1+2	3+4	5+6	7+8	
512	520	528	536	GAME PORT
544	552	560	568	
576	584	592	600	
608	616	624	632	
640	648	656	664	COMM2
672	680	688	696	
704	712	720	728	
736	744	752	760	
786*	776	784	792	HDISK CNTRL
800	808	816	824	
832	840	848	856	
864	872	880	888	
896	904	912	920	LPT
928	936	944	952	
960	968	976	984	MONO ADAPT
992	1000	1008	1016	
				CGA ADAPT
				FLOPPY/COMM1

reads either memory or an I/O port, and the proper decoding occurs as discussed earlier, the CPU can read whatever is on the SRAM II's data bus.

The other input to IC10-b comes from IC11-d, which is in turn driven by IC14-a. Its inputs come from two sources: high-order address decoder IC12 (by way of DIP switch S2), and the or'ed output of IC14-b. That gate goes high whenever there is either a read from or a write to system memory. Therefore, by tracing from IC14-b to IC14-a to IC11-d to IC10-b, you can see that data-bus transceiver IC3 can be enabled in a second way—when there is a system memory access.

I/O port decoding is done in two steps. DIP switch S3 sets a base address, and DIP switch S1 sets an 8-byte offset. Although S1 consists of eight individual

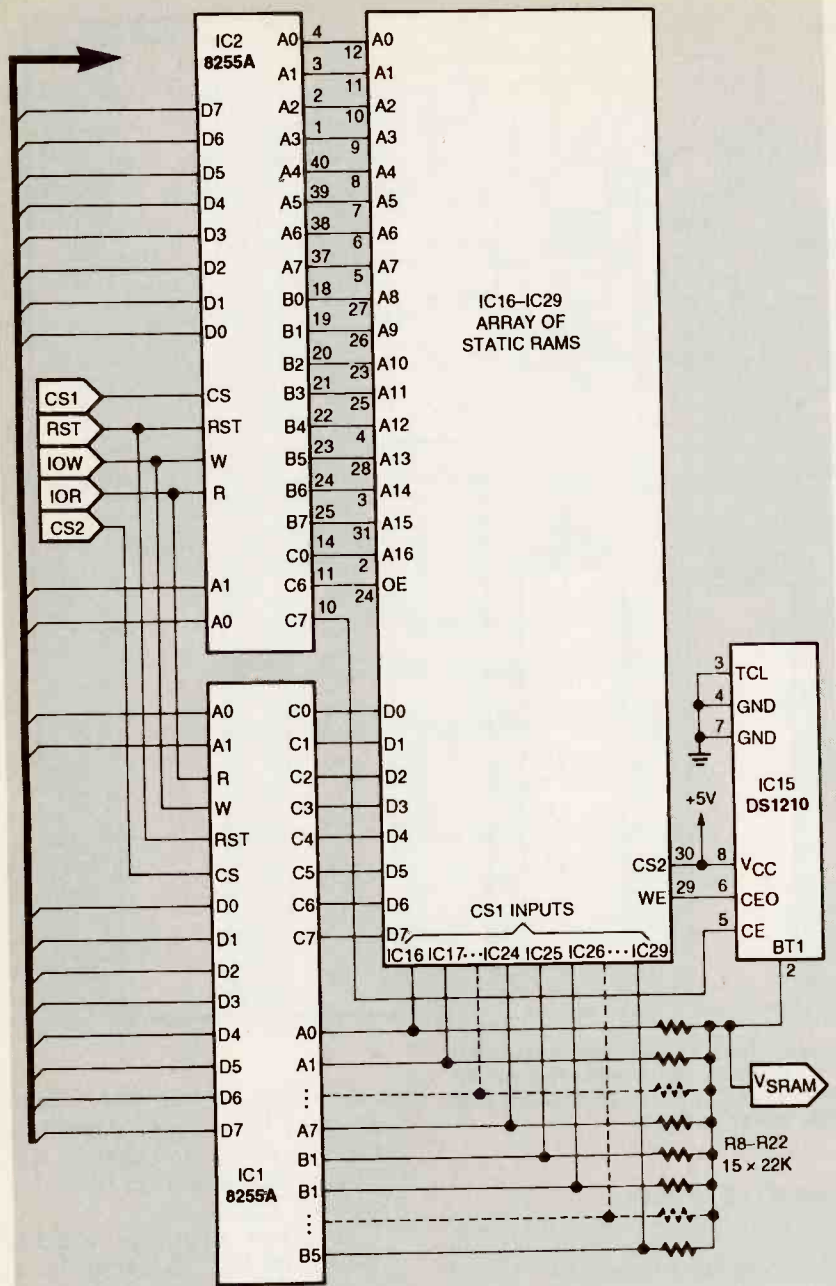

FIG. 4—TWO 8255s DRIVE ADDRESS AND DATA BUSES and control lines of an array of up to 14 static RAM's. IC15 is a data guard that disables the SRAM write line whenever power drops.

SPST switches, in logical terms it functions as a 2P4T switch; every other output is wired in parallel, so you can enable only two positions of S1 at once (1+2, 3+4, 5+6, or 7+8). The selected output pair provides two chip-select signals that enable the 8255 PICs, as shown in Fig. 4.

But first finish the address decoding in Fig. 3. Another 1-of-8 decoder, IC12, works with S2 to decode a 16K block of

high-address space, ranging from C8000 to EC000. Jumper JU4 selects either a low or a high start address (C000:0000 or E000:0000, respectively), and DIP switch S2 selects the desired 16K segment. Thus, when the system accesses the decoded address, IC13—the boot ROM/SRAM—is enabled by the signal that is labeled \overline{cx} .

On board memory addressing

You might have wondered

how 1.8 megabytes of memory was squeezed into a DOS PC. EMS. No. XMS? Try again. Custom bank-switched memory? That's it!

Now look at Fig. 4. The two 8255s provide the complete interface to the memory array, including data bus, address bus, and control signals. Thus, accessing a given memory location amounts to writing the correct bits to the correct registers in the PICs.

The PICs are standard devices, installed in IBM's original PC and many PCs since then. Each PIC has four addresses: one for a control register and three for three 8-bit I/O ports (A, B, and C). The I/O port identification is simple, as shown in Table 3.

While still looking at Fig. 4, note that IC15 serves as an intelligent power controller. It controls the WRITE ENABLE line (as delivered by IC2) into the memory array. Whenever IC15 senses that power is dropping, it ensures that \overline{WE} remains high until power switches over. That way, SRAM data cannot be inadvertently corrupted. Pull-up resistors (R8-R22) at each \overline{cs} input provide just enough current to keep RAM data intact. Battery voltage should be 2.0-4.0 volts. Use a 3.6-volt lithium battery or a pair of AA alkaline cells.

Figure 5 shows the remaining components of the circuit. Boot

TABLE 3—PIC PORT USAGE

PIC	Port	Usage
1	A	Memory bank chip selects 1-8
	B	Memory bank chip selects 9-14, 1 unused bit, and the memory bank read/write line.
	C	Memory bank data bus 0-7
2	A	Memory bank address bus 0-7
	B	Memory bank address bus 8-15
	C	Memory bank address bus 8-15, and memory bank output enable and write enable lines.

PARTS LIST

Resistors

R1-R7—4700 ohms, ¼ watt, 5%
R8-R22—22,000 ohms, ¼ watt, 5%

Capacitors

C1-C27—0.01 µF, mini DIP

Semiconductors

IC1, IC2—8255-A peripheral interface controller (Intel)
IC3—74LS245 octal bus transceiver
IC4, IC5, IC8—74LS244 octal bus buffer
IC6, IC12—74LS138 1-of-8 decoder
IC7—74LS85 4-bit comparator
IC9—74LS00 quad NAND gate
IC10—74LS08 quad AND gate
IC11—74LS04 hex inverter
IC13—43256 static RAM, 100 ns
IC14—74LS28 quad NOR gate
IC15—DS1210 intelligent power controller (Dallas Semiconductor)

IC16-29—static RAM, 128K × 8 (Sony 581000P-10L or equiv.)

D1, D2—1N4148

Other components

S1, S2—8 position SPST DIP switch

S3—4 position SPST DIP switch

JU1, JU4, JU5, JU6—2-pin, 0.1-inch header (with jumpers)

JU2, JU3—not used

B1—3.6-volt lithium battery (>0.5 mA/h)

IC13 socket—DS1213C Smart Socket (Dallas Semiconductor)

Miscellaneous: PC board, mounting bracket, IC sockets, solder, wire, etc.

Note: The following items are available from Hatronics, 145 Lincoln Street, Montclair, NJ 07042. (201) 783-7264:

- Bare PC board—\$62
- Kit of parts with OK—\$120
- 128 X 8 SRAM chips—please call

- Additional programmed EPROMs—\$5

All orders add \$6 S/H. NJ residents add sales tax. Check, money order, COD, AMEX accepted.

software is stored in IC13. Three jumpers control its operation: JU1 provides an overall enable/disable function for IC13; JU5 enables and disables writing to

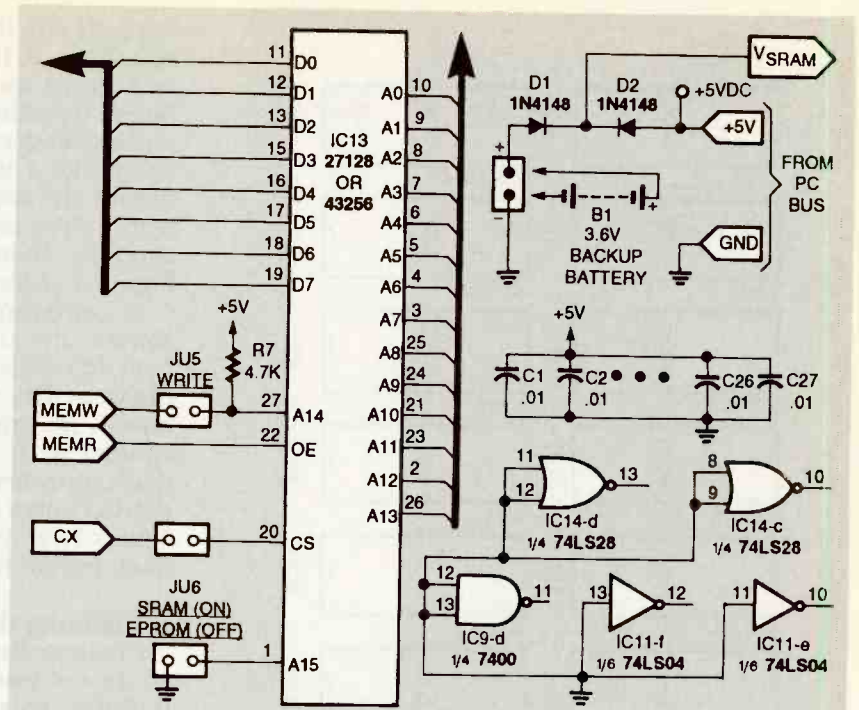

FIG. 5—MOUNT THE BOOT SRAM (IC13) in a Dallas Semiconductor Smart Socket, which has a built-in backup battery. The power supply has several 1N4148s that isolate the SRAM array back-up battery.

TABLE 4—JUMPER SETTINGS

Jumper	State	Description
JU1	On	Enable SMRAM II
	Off	Disable SRAM II
JU2	On	Not used
	Off	Not used
JU3	On	Not used
	Off	Not used
JU4	Upper	C8000-DC000
	Lower	E0000-EC000
JU5	On	Enable write to IC13
	Off	Disable write to IC13
JU6	On	IC13 = SRAM
	Off	IC13 = EPROM

an SRAM in the IC13 Smart Socket; and JU6 allows you to select between SRAM and EPROM operation. Table 4 summarizes the functions of all jumpers.

Part of SRAM II's appeal is its battery back-up capability. The circuit is wired so that PC-bus power (+5 volts) and the battery pack both feed the separate power line used by the memory bank. The power line is labeled V_{SRAM} . The two power sources are isolated from each other by diodes D1 and D2. Bypass capacitors C1-C27 also appear in Fig. 5, as do several unused gates, whose inputs are

grounded to avoid excess current drain.

Assembly and setup

Enough theory. Let's build something! First gather up all the tools you'll need, including a medium-power (35-watt) soldering pencil and some small-gauge solder. A Princess iron works well because of its small tip. Use thin diameter solder because thick solder can cause unwanted bridges.

The circuit is moderately complex, so a PC board is recommended for this project. Foil patterns are too large to print here, but they can be obtained by sending a self-addressed, stamped, business-size (No. 10) envelope to **Electronics Now**, SRAM PC Board, 500-B Bi-County Blvd., Farmingdale, NY 11735; you can also purchase an etched and drilled board from the author, as noted in the Parts List. The board components are not hard to assemble; the work can be completed in a few hours, depending on your experience. But haste makes waste, so don't rush!

Sockets are not mandatory, but they are recommended, par-

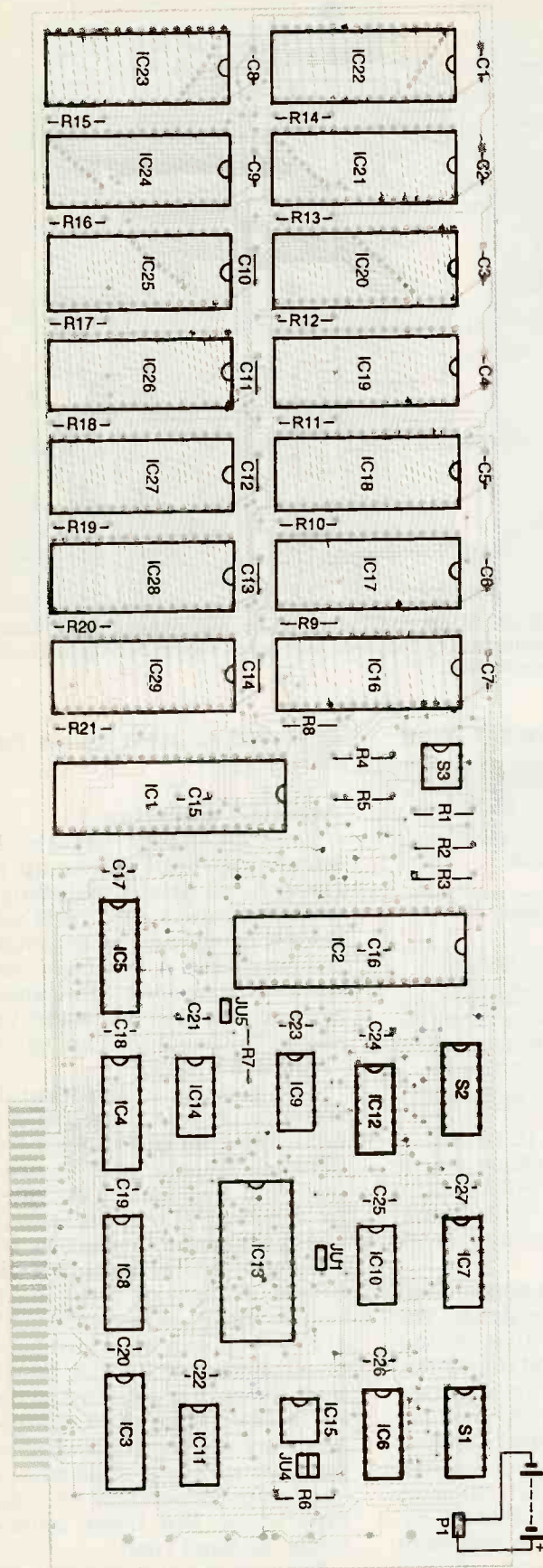

FIG. 6—MOUNT ALL COMPONENTS as shown here.

ticularly for the memory and LSI devices (IC1, IC2, IC13, IC15, and IC16–IC29). Refer to Fig. 6 as a guide for installing all components. Note: Before installing sockets for IC1 and IC2, mount and solder decoupling capacitors C15 and C16. If the sockets don't provide adequate clearance, mount the capacitors on the solder side of the board. After mounting all parts, check your work carefully. Some traces are *very* close together. Figure 7 shows the completed prototype.

To configure the board, you must define two things: the upper address segment where the boot ROM/SRAM will reside, and the base address of the eight I/O ports that control the board. Be sure the segment address does not conflict with any video card, network adapter, disk controller, or other device. Also, be sure that the I/O ports don't conflict either. Then refer to Tables 1, 2, and 4 to set the desired addresses. Last, install the board in your system.

Initializing the board

Create a directory on your hard disk and copy all the software from the distribution diskette to it. Software is also available from the *Electronics Now* BBS (516-293-2283, 9600, V32, V42bis) as a file called SRAM.ZIP. At a minimum, the following programs should be present: 128KZERO.EXE, ENABLE.COM, DISABLE.COM, 128SRAM1.SYS, and FLOPYIMG.EXE.

First initialize the board. Do this with the 128KZERO utility. To run this program type:

```
128KZERO xxx yy zz ["y"]
```

where xxx is the base port address, yy is the SRAM to start with, and zz is the number of SRAMs to initialize. The final parameter is optional. Normally the program asks for confirmation before clearing memory. But if you include a "y" at the end of the command line, the program will not request confirmation. The offset and number parameters allow you to specify individual SRAMs to erase; for now, erase everything. Following are several examples and explanations:

```
128KZERO 776 1 14
```

Initialize the board at I/O port 776. Require confirmation before proceeding.

```
128KZERO 512 5 1
```

Initialize a board at I/O port 512, starting and ending at SRAM 5. Require confirmation.

```
128KZERO 768 7 2 y
```

Initialize a board at port 768, starting with SRAM 7, and advancing to SRAM 8. Do not require confirmation.

Incidentally, for purposes of the software drivers, whenever you must specify an offset or SRAM number, IC16 corresponds to SRAM 1, IC17 to SRAM 2, and so on, until IC29, which corresponds to SRAM 14.

Creating a RAM drive

To address the SRAM ICs on the board as a disk drive, add a device driver to your CON%FGSYS file. The driver requires five parameters, each

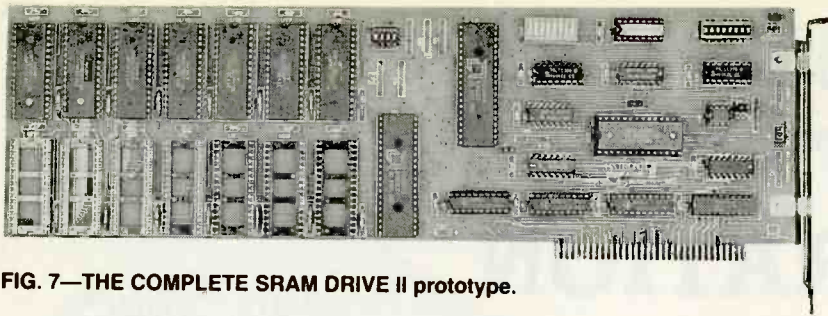

FIG. 7—THE COMPLETE SRAM DRIVE II prototype.

TABLE 5—S3 DEVICE DRIVER PARAMETERS

Prefix	Description	Note	Example
/	Base I/O port	Three-digit decimal value	/768
#	Number of SRAMs installed	Two-digit decimal value	#05
\$	Number of directory entries	Three-digit decimal value, must be power of 2.	\$016
%	Sectors per cluster	One-digit decimal value, must be power of 2. Default = 2.	%2
@	Number of sectors for FAT	One-digit decimal value, must be power of 2. Default = 6.	@6
&	SRAM offset	Two-digit decimal value. Number of SRAMs to skip before starting a drive.	&04

prefixed by a special character. Table 5 describes the parameters; Listing 1 shows a sample CONFIGSYS. Note that the sample defines two drives, each 256K in size. The first drive skips the first three SRAMs, which account for 384K bytes of memory. That area might, for example, be used to emulate a 360K boot diskette.

Creating a boot drive

To create a boot "drive" on the SRAM II, you must do three things: 1) Create a boot floppy disk that contains the precise configuration you want. 2) Create an image of that floppy disk in the first three SRAM ICs (IC16-IC18). 3) Install a driver in the BIOS. The driver reads the SRAM II emulated disk

LISTING 1—SAMPLE CONFIG.SYS

```
device = ansi.sys
stacks = 64,256
device = 128sram1.sys /768 #16 S016 12 503
device = 128sram1.sys /512 #03 S015 12 02
buffers = 20
files = 30
break on
```

LISTING 2—DEBUG DUMP OF BOOT SRAM

```
C800:0000 55 AA 0C E8 72 00 CB 00-00 00 0E 00 40 08 00 00
C800:0010 50 72 6F 6D 4B 69 74 00-00 00 00 00 00 00 00 00
```

rather than the A drive when booting (and subsequently). The software installation diskette includes several different BIOS drivers. The drivers are named xxxBOOT.DRV, where xxx corresponds to the three-digit decimal address where the board is installed.

To create a bootable SRAM drive, first create (and debug, if necessary) a bootable floppy disk that works exactly the way you want. Be sure to include the five SRAM II utility programs listed earlier. Then create the boot image on SRAM II with the utility FLOPYIMG, as follows:

FLOPYIMG xxx y

where xxx is the port address of the card, and y is a single digit corresponding to the floppy to use (0=A, 1=B). The program will then transfer, sector by sector, the contents of the specified floppy disk to the board.

Now load a driver into the boot ROM, with the utility INSTROM.

INSTROM xxxBOOT.DRV yyyy

where xxx is the port address

and yyyy is the memory address when IC13 is decoded by S2 and jumper JU4.

Now you should be able to boot from SRAM II. Reset or power-cycle your computer and allow it to boot normally. You should see a brief sign-on message; then the system should boot from the SRAM drive. When boot is complete, you should have a 360K A drive. If you loaded 128SRAM1.SYS to define any SRAM drives, it should appear when starting at drive C.

ENABLE.COM and DISABLE.COM are included in the floppy boot image so that SRAM II can be disabled. By typing the desired command with IC13's segment address, you can enable or disable the board. For example, if your board was installed at D0000, you could disable it by typing:

DISABLE D000

You could subsequently re-enable the board by typing:

ENABLE D000

Troubleshooting

If you can't get your computer to boot or to recognize SRAM II, first check the board construction.

If it passes inspection, check all jumper and switch settings. If these check out as well, the problem might be in the SRAM's or the boot SRAM. If there is a fault in the SRAM's, the clear utility (128KZERO) might tell you because it verifies all writes to memory.

To verify that the boot SRAM contains what it should where it should, use DOS's DEBUG program to dump the first few bytes. For example, if your board is located at C8000, start DEBUG. When the prompt appears, enter the following:

D C800:0

You should see a display like that shown in Listing 2. If not, your segment-decoding circuitry might not be working.

If all the hardware checks out, you could have a software problem. Create a boot floppy with no CONFIG.SYS or AUTOEXEC.BAT and install it in the SRAM. If this configuration will boot, you might have a path or command-line error.

THE LOST ART OF REGENERATION

Look again at classic regenerative receivers and their importance in radio history, and build these modernized, transistorized versions

CHARLES KITCHIN

IT IS NOT MUCH FUN TO BUILD A MODERN superheterodyne radio receiver these days because so much of the receiving circuitry is within a few ICs. Even if you do build one, you probably won't learn much about how they work—there is little opportunity to experiment and explore. Moreover, you can expect that the cost of parts will exceed the price of a radio at your local drug store. Nevertheless, educators agree that the best way to "get in touch" with the history of radio and enjoy electronics is to start by building a radio receiver from scratch.

This article will return you to those "thrilling days of yesterday" when almost anyone with an interest in radio could make his own receiver. It will retrace one of the important "roots" of modern electronics—regeneration or positive feedback. The schematics presented here are based on key circuits that were invented by geniuses whose names are only vaguely familiar to most people today.

The four regenerative detector receiver circuits discussed here were designed to give anyone from a novice to an expert "hands on" experience in building circuits that hold an impor-

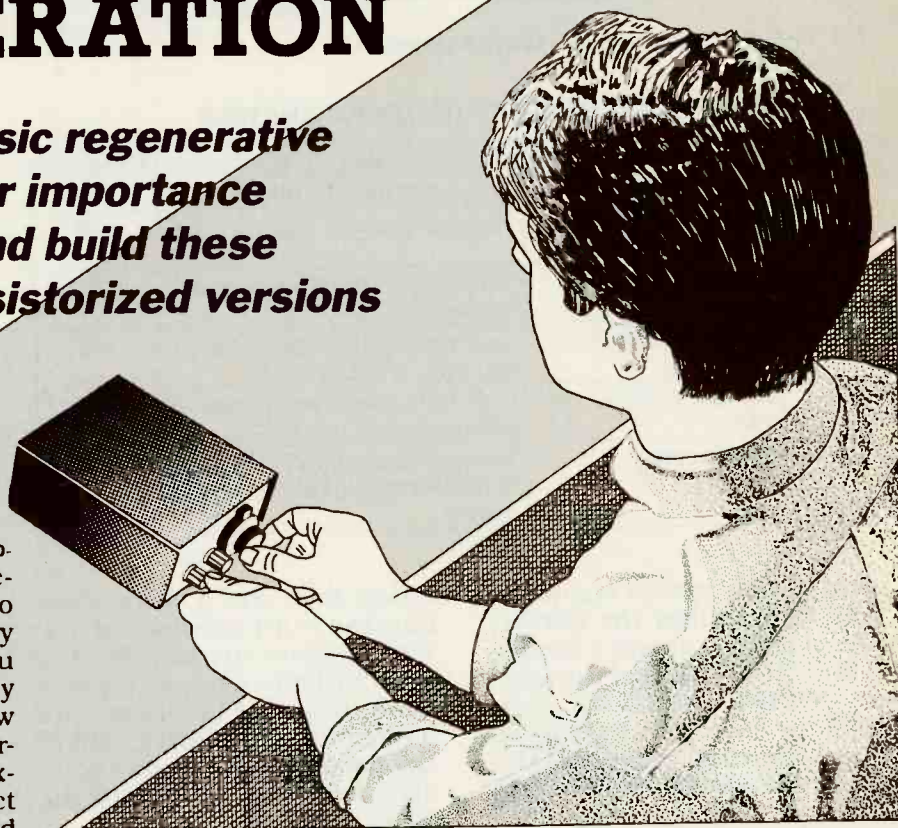

tant place in the history of radio communications. Transistors and ICs have replaced the vacuum tubes of the original circuits so you won't have to deal with 120-volt power. These "re-designs" have also minimized the number of "antique" components required.

This article differs from a typical **Electronics Now** "build-it" article—it does not contain parts placement diagrams nor does it contain complete parts lists. This means that if you want to build some or all of these circuits you'll have to be a bit more resourceful. However, the names of several companies offering the "hard-to-get" parts are included in the article.

You should also know that, although the performance of these modernized versions of classic circuits is quite good, skill and patience are needed to

get the most out of them. Also some post construction adjustments are called for.

Back in the 1920s and 1930s radio receivers were simple. If you did not want to buy one (they were expensive in those days), all you needed was a handful of parts, wire, solder, and wooden bread board. With a few hours of hand crafting, you could be listening to shortwave or your local AM station.

In those days radio fans were likely to know a lot more about the contributions of the great radio pioneers like Hertz, Fleming, Marconi, and Armstrong. These days their names are rarely mentioned in classrooms because the study of their accomplishments has been crowded out by such modern subjects as digital electronics, signal processing, and computer programming.

Radio-receiver history

Prior to the development of the vacuum tube, the most common radio circuit was the *crystal set* whose schematic is shown in Fig. 1-a. It was found that some natural minerals such as silicon and galena (lead-sulfide) had the ability to rectify current. Electromagnetic waves that intercepted the antenna caused a voltage to be developed across coil L1 between the antenna and ground. That voltage caused a current to flow through crystal D1 and the headphones on the positive half cycle.

When current flowed through the circuit, capacitor C2 was charged. When the polarity reversed, however, there was no current flow through the crystal because of its rectification property. During this half of the cycle, the capacitor discharged through the headphones. Figure 1-b shows an audio-frequency wave, Fig. 1-c illustrates an audio-modulated radio frequency wave, and Fig. 1-d represents a demodulated (detected) wave. The headphone diaphragms followed the audio-frequency wave to produce an audible signal.

Homemade versions of this circuit typically included a lump of galena fastened to a board along with a spring-wire contact called the "cat's whisker." One end of the brass wire was sharpened to point and pressed into the galena crystal. Together these parts formed the diode detector. (The modern Schottky diode also has a metal-to-semiconductor contact.)

A crystal set was easy to make, and the parts were inexpensive. However, the catch was that finding the right contact spot on the crystal with a pointed cat's whisker was likely to be a frustrating experience. Some probing around was necessary to find a location where rectification (detection) would be performed. Moreover, if you wanted the set to work, there had to be a radio station nearby that transmitted a signal strong enough to forward-bias the crystal "diode."

In those early days some hob-

byists used Quaker oatmeal boxes as coil forms, and even rolled their own capacitors from the foil-covered paper found in cigarette packs. The antenna was usually about a 100-foot length of bare copper wire strung out the window, suspended from glass insulators. A length of copper pipe was hammered into the earth below the window as a ground connection.

The diode vacuum tube, a simple two-element rectifier, offered little advantage over any of the crystal detectors—it still

could not amplify the incoming signal (see Fig. 2). Thus a tube diode circuit still needed a strong signal to detect, and it also it needed power to heat its filament (the early cathode).

The great leap forward in receivers occurred with the introduction of the triode vacuum tube. A small voltage variation on the triode's grid caused a large variation in the plate current, providing signal amplification. To receive undistorted signals, the triode amplifier-detector had to be operated on the linear portion of its characteristic curve; thus it needed a bias to put it at the tube's *operating point*. The input signal then caused the total grid voltage to vary above and below the bias value.

The *grid-leak detector* circuit shown in Fig. 3. was one of the early schemes for obtaining the necessary bias. In this circuit, the grid and cathode act as a diode. When an input voltage was applied to the grid, current flowed from the cathode to the grid through grid-leak resistor R1.

A voltage was then developed across the grid leak which provided a bias. The greater the input signal, the more the bias. This caused the voltage between the grid and cathode to vary with the input signal level. As a result, current flowing in the plate circuit was demodulated, and that signal could be heard with a headset.

The simple grid-leak-detector circuit required two power sources—a "B" battery for plate voltage and an "A" battery for the cathode heater combination. This was only one of several possible ways to develop a bias.

The operation of the triode electron tube has similarities to the operation of the N-type bipolar junction transistor (BJT). The cathode is analogous to the emitter, the grid to the base, and the plate to the collector. However, the triode more closely resembles the junction field-effect transistor (JFET). Here the cathode is analogous to the source, the grid to the gate, and the plate to the drain.

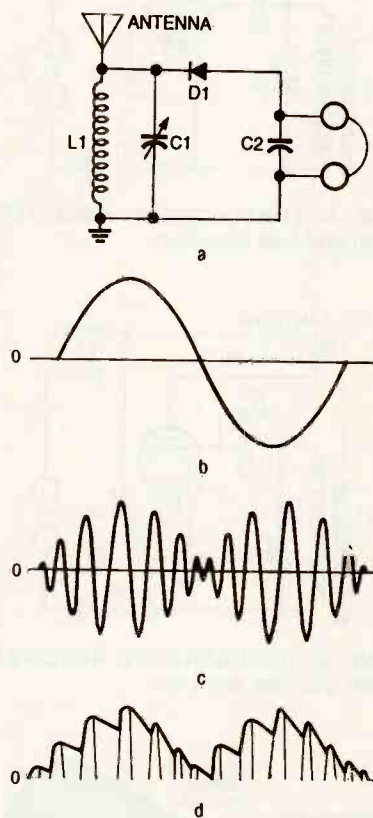

FIG. 1—CRYSTAL DETECTOR receiver with headphones (a), audio-frequency signal (b), modulated signal (c), and demodulated wave (d).

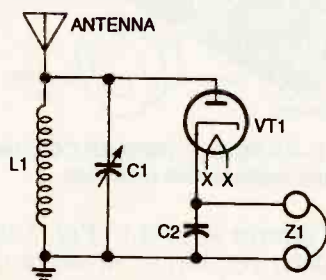

FIG. 2—VACUUM-TUBE DETECTOR receiver.

The substitution of JFETs or BJTs for the tubes in the original circuits permits the use of 9-volt transistor batteries as power sources, and generally results in performance that is better than that of tube circuits.

The tuned inductive-capacitive (LC) "tank" circuit in the receivers shown so far permitted discrimination between desired and undesired signals. Figure 4 is a simplified schematic for a tuned radio frequency (TRF) circuit with grid-leak detection. The voltage induced in the antenna caused a current to flow through the primary coil L1 of the radio frequency transformer. A voltage was induced in the secondary coil L2, which was tuned by variable capacitor C1 to resonance at the desired station frequency.

When the resonant frequency was reached, the voltage across L2 increased while the voltages from all other frequencies were reduced. Thus the detector operated most efficiently at the tuned frequency.

However, a principal drawback of the resonant tank circuit in the earlier crystal or diode detector receivers is that their detectors robbed energy from their input circuits. This occurred because their operation depended on rectifying the voltage induced in the secondary circuit. The unbuffered "loading" caused by crystal or diode detectors decreased the selectivity or sharpness (Q) of receiver tuning.

While the triode's gain improved the circuit's sensitivity and its buffering relieved the tuned circuit from headphone loading, the overall performance was still poor. Adding more than one stage of RF amplification ahead of the detector did little to improve that performance.

Regenerative detector

In 1914, a gifted radio engineer, Edwin H. Armstrong, discovered that by feeding a portion of the amplified signal in the plate circuit of a triode detector back into the grid circuit, there would be a significant increase in amplification.

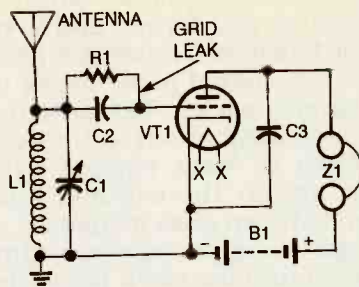

FIG. 3—GRID-LEAK-DETECTOR receiver.

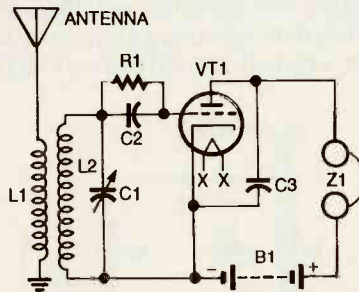

FIG. 4—TUNED-CIRCUIT RECEIVER with grid-leak detection.

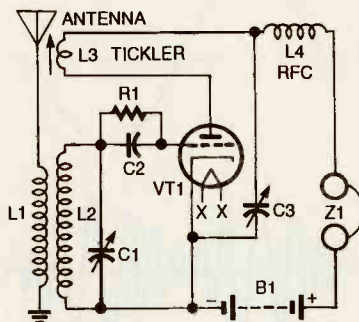

FIG. 5—REGENERATIVE RECEIVER with grid-leak detection.

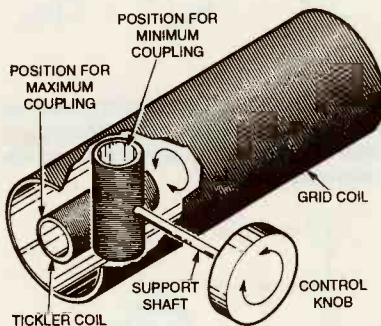

FIG. 6—VARIABLE TICKLER COIL used in early regenerative receivers.

The circuit shown in Fig. 5 is a modern version of Armstrong's original schematic for his regenerative receiver. There was no standard schematic symbol

for a vacuum tube.

A regenerative detector is basically a grid-leak detector in which a portion of the output signal is fed back to the tuned input circuit *in phase* with the input signal. The in-phase feedback lowers the resistance of the tuned input circuit, therefore raising its Q. This feedback also substantially increases the strength of input signals at or near the resonant frequency of the tuned circuit. As a result, both the amplification and selectivity of the stage are raised, especially for weak input signals.

The amplified signal in the plate circuit flows through tickler coil L3, which induces an increased current flow through the secondary coil L2. This increases the signal at the grid, causing an even greater signal at the plate. The input signal is therefore repetitively re-amplified providing very high single-stage amplification.

If enough of this energy were fed back into the grid circuit, the circuit would oscillate. This is not surprising: Remove the symbols for the antenna, coil L1, and the headphones, and you have a schematic for an *Armstrong oscillator*.

To prevent the receiver from becoming an unwanted oscillator, Armstrong invented a way to control the amount of positive feedback or regeneration. He did this by rotating the tickler coil L3 within the grid coil L2, as shown in Fig. 6. Coil L3 was mounted on a shaft at right angles to the axis of coil L2. (The shaft projects through the front panel of the radio, and a control knob is attached.)

When the knob is turned so that the two coils are in the same plane, maximum feedback is obtained. When the tickler coil is at right angles to the grid coil, feedback is minimum. By carefully rotating the tickler knob, the right amount of regeneration can be found.

This scheme fell into disfavor when receivers with interchangeable coils for several frequency ranges were introduced. The rotating tickler was also bulky and difficult to manufac-

ture, and the signal was detuned as regeneration was increased. However, it was soon discovered that regeneration could be also be controlled by substituting a variable capacitor for plate-bypass capacitor C3 shown in Fig. 5.

With this so-called "throttle condenser" in the circuit, the listener could simply remove two coils and plug in two alternatives to obtain a different range of broadcast frequencies. The fixed tickler with the right number of turns replaced variable tickler L3 within L2, permitting both L1 and L2 to be exchanged for another set.

The throttle condenser was able to transition the receiver more smoothly into oscillation than the rotating tickler, and regeneration had only a slight effect on tuning. Unfortunately, a second variable capacitor took up more space in the receiver and added to its cost.

However, it was found that varying the plate voltage was a simpler way to control regeneration. Figure 7 is a simplified schematic for a resistive-controlled regenerative detector. It was cheaper than earlier methods and resulted in only slight detuning. Tickler coil L3 was mounted permanently in a fixed position on the same coil form

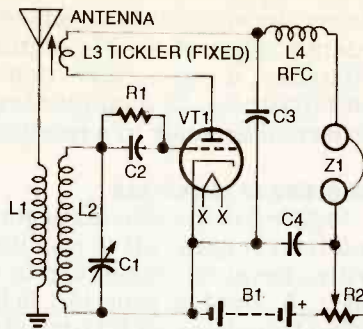

FIG. 7—VARIABLE-RESISTOR-controlled regenerative receiver.

as grid coil L2, and a fixed capacitor bypasses the plate. In this way, plate voltage (and regeneration) is controlled by varying the resistance with panel-mounted control potentiometer R2. Capacitor C4, across the battery, smoothes any sudden changes in plate voltage.

Regeneration principles

While the power gain of a tube or transistor is fixed, the voltage gain of a regenerative detector will approach infinity as it nears self-oscillation. Regeneration introduces a negative resistance into a circuit. Because the circuit's selectivity or "Q" is equal to its net reactance divided by its net resistance, the circuit's selectivity is increased with gain when regeneration is

introduced.

When regeneration is below self-oscillation, the circuit's negative resistance (produced by regeneration) is less than its fixed positive resistance. In this condition, regeneration has the effect of providing a stable increase in both gain and selectivity.

With more regeneration, a very dynamic region is reached, just at the threshold of self-oscillation. Here, the circuit's negative and positive resistances near equality. In this nonlinear operating region, minute changes in input level or circuit voltage produce very large (nonlinear) changes in output level.

The exact "balance" point between stable and unstable regeneration (when the circuit's net resistance is zero) can never be achieved; even the smallest amount of random noise will eventually build up enough to drive the circuit into sustained self-oscillation.

As regeneration is increased further, a strange "click" will be heard in the headphones. This indicates that the circuit has reached the negative-resistance transition point beyond which free oscillations will occur. If regeneration is increased beyond the oscillation starting point,

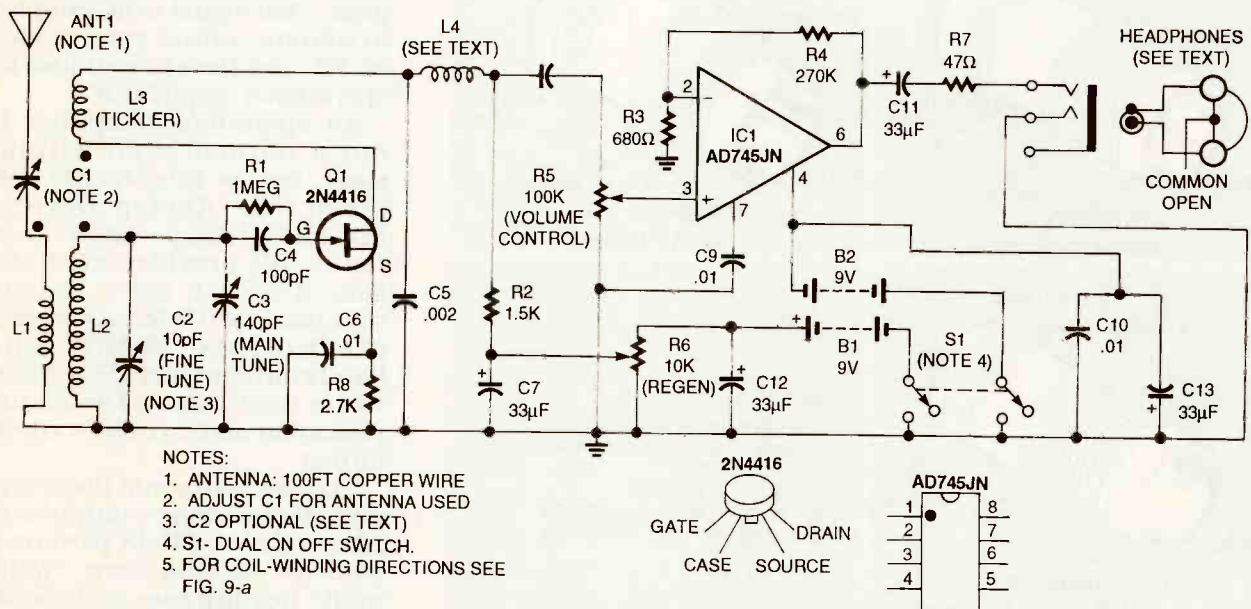

- NOTES:
 1. ANTENNA: 100FT COPPER WIRE
 2. ADJUST C1 FOR ANTENNA USED
 3. C2 OPTIONAL (SEE TEXT)
 4. S1- DUAL ON OFF SWITCH.
 5. FOR COIL-WINDING DIRECTIONS SEE FIG. 9-a

FIG. 8—REGENERATIVE SHORTWAVE receiver with JFET tuning and op-amp amplification. Frequency range is 6 to 17 MHz.

secondary oscillations at a lower frequency are generated. These oscillations tend to suppress or "quench" the main oscillation under certain conditions of input signal level and regeneration. This effect is called *super regeneration*.

Another property of a regenerative detector receiver is its ability to detect single sideband and frequency-modulated (FM) as well as amplitude-modulated (AM) signals. The single sideband signals are transmitted without a carrier; the carrier is restored in the regenerative detector by setting the regeneration threshold just above the level for free oscillation.

The listener's ability to adjust the effective "Q" of the circuit

allows a regenerative circuit to detect the amplitude versus frequency slope of an FM signal. Therefore, a regenerative detector circuit can be a single-stage universal detector in a receiver.

Shortwave receivers

Figure 8 is the schematic for a modern regenerative receiver with a frequency range of 6 to 17 MHz. A 2N4416 junction field-effect transistor (JFET) detector replaces the triode tube, and an AD745JN low-noise BiFET operational amplifier acts as the audio amplifier. A change in drain voltage alters the JFET's transconductance (and therefore gain), permitting the regeneration of the circuit to be controlled easily.

The amplitude-modulated

signal from the antenna is coupled to coil L1 through variable capacitor C1 whose value determines the coupling and antenna loading of the detector. Because C1 sets antenna coupling, its optimum value will depend on the length of the antenna selected and the capacitance of the antenna. A 100-foot antenna was used with the prototype.

Coils L1, L2, and L3 are wound on the same form, so the antenna signal developed in L1 is inductively coupled to L2. Capacitors C2 and C3, together with L2, form a resonant tank circuit that determines the receiver's tuned frequency. JFET Q1, a Motorola 2N4416, together with resistor R1 and capacitor C4 detect the amplitude of the incoming signal.

The JFET gate, serving as a diode detector, charges capacitor C4. The amplified drain signal is then coupled back to Q1's gate by tickler winding L3 and is repeatedly re-amplified. Regeneration is controlled by potentiometer R6, which adjusts the supply voltage applied to Q1 and thus its transconductance.

The detected audio output passes through the low-pass filter formed by capacitor C5 and radio-frequency choke (RFC) L4. This filter removes the radio-frequency component and allows only the audio signal to pass. That signal is AC-coupled to volume-control potentiometer R5, and then is amplified by operational amplifier IC1.

An operational amplifier is not a normal audio output stage, but for this receiver it is ideal. The Analog Devices AD745JN (IC1), packaged in an 8-pin DIP, provides an audio gain of 400. (It has a low-current noise of 6.9 femtoamperes per hertz and 20-MHz gain-bandwidth product.) It replaces two or three stages of audio amplification and an output transformer.

The low harmonic distortion and 30-milliampere output current of the AD745JN permits it to drive 32-ohm Sony "Walkman" headphones commonly used with personal stereos. at high-volume levels with low dis-

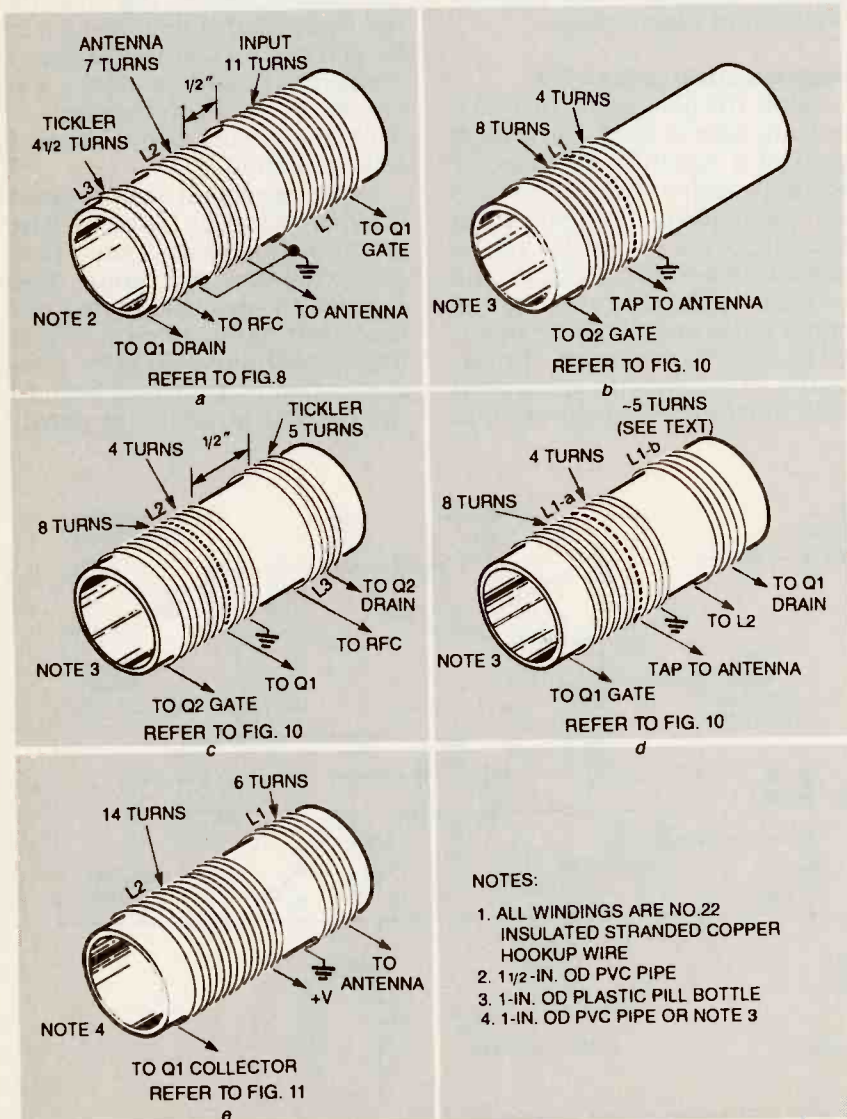
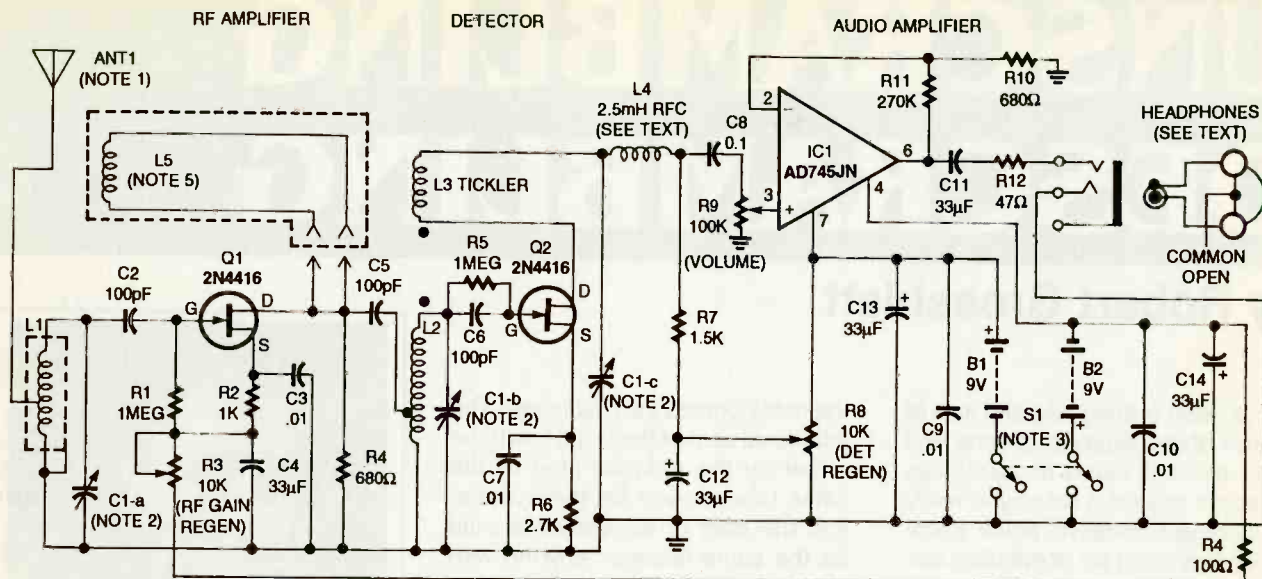

FIG. 9—COIL-WINDING DIAGRAMS for the four regenerative receivers.



- NOTES:
1. ANT 1 IS 100-FT COPPER WIRE
 2. C1 IS 3-SECTION GANGED VARIABLE: 10 TO 365pF EACH SECTION
 3. S1 IS DUAL GANGED SWITCH
 4. FOR COIL-WINDING DIRECTIONS SEE FIG. 9
 5. MODIFICATION FOR 2 CASCADED REGENERATIVE STAGES (SEE TEXT)

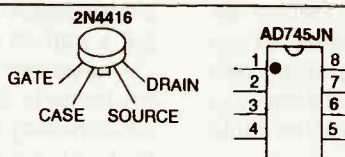

FIG. 10—REGENERATIVE SHORTWAVE RECEIVER with "throttling" capacitor," two JFETs, and an op-amp. An additional coil that adds a second regenerative stage is shown in the dotted box.

tortion. In this circuit, the headphones are series-connected, and their common terminal is floating. This wiring scheme doubles the headphone's impedance to about 64 ohms, making them much easier for the receiver to drive.

The excellent sound quality of this receiver will quickly become evident if you tune to such shortwave stations as BBC London which broadcasts music as well as voice. If a high-fidelity output is not desired, a 0.01 microfarad capacitor can be placed across volume control R5 to attenuate high frequencies.

The optimum number of turns on the tickler winding for a smooth transition into oscillation was found by trial and error. Coil-winding information is given in Fig. 9-a. (Figure 9 contains all the coil winding data needed to build the circuits described in this article). Too many turns will cause the circuit to break into free oscillation, making receiver tuning difficult; too few will restrict positive feedback, and receiver

sensitivity will suffer.

The main tuning coil for this receiver is wound on a 3-inch length of 1.5-inch outside diameter PVC pipe. Refer to the "Coil winding" section near the end of this article for useful suggestions in coil winding.

PARTS SUPPLIERS

Air-variable tuning capacitors, transformers and miscellaneous components can be purchased from:

- Antique Electronics Supply, 6221 S. Maple Ave. Temple AZ 85283.
- Fair Radio Sales Co. P.O. Box 1105, 1016 E. Eureka St. Lima, OH 45802
- Ocean State Electronics, P.O. Box 1458, 6 Industrial Drive, Westerly, RI 02891

Vernier dials are available from Ocean State Electronics.

The Analog Devices AD745JN operational amplifier and the Motorola 2N4416 JFET can be purchased from any stocking branch of Newark Electronics and many other distributors.

This shortwave receiver was designed to be easy to build. With the exception of the air-dielectric variable capacitors, all of the components are readily available from electronics mail-order houses or retail stores. The two variable capacitors can be purchased from the suppliers whose names and addresses are given in the Source List. The estimated price for all the components is about \$20. Stereo headphones add another \$7 to \$10.

There is nothing critical about the radio-frequency choke (RFC) for this receiver. You can buy a 2.5 microhenry RFC or make your own by winding several layers of turns of No. 30 AWG magnet wire around the entire length of a 470-kilohm, 1-watt, molded carbon composition (or carbon thick-film) resistor. Solder the wire ends to the resistor's leads.

Two 9-volt batteries power this receiver. It draws about 10 milliamperes from the positive battery and 8 milliamperes from the negative battery. The measured sensitivity of this receiver (50-ohm termination, 30%

(Continued on page 104)

UNSCRAMBLING DESCRAMBLING

By Robert Grossblatt

I've been getting lots and lots of mail about video in general and scrambled video in particular. For some reason a lot of you really get enraged because some cable companies insist on scrambling certain premium channels. Before we go any further on this, let me tell you that I don't see anything wrong with it. Now, wait a minute—before you write me off as a stooge of the cable industry, let me finish.

The cable companies have every right to scramble whatever they want, although the rumors that some companies are scrambling everything they transmit—including the standard VHF channels—is going much, much too far. Premium stations and the pay-per-view shows are okay to scramble. What's not okay are some of the regulations that a lot of the cable companies insist are their God-given right to impose on you.

To begin with, hitting you with an extra fee for putting in another outlet is ridiculous. Some years ago the phone company did the same thing—anyone who added an extension phone on his own was risking life imprisonment or, even worse, being regarded as a not-nice person in the eyes of Ma Bell. That all went out the window years ago, and I think it's only a matter of time before the same thing happens in the cable-TV business. And, as far as I am concerned, the sooner the better.

The most annoying part of the cable system is the whole business of sending me scrambled signals, and then telling me I can't do anything with them! As I said, if the cable companies don't want me to get a particular channel (because I'm not paying for it, or some other perfectly legitimate reason), then don't send it to me. Trap it out of the line before

the cable comes into my home. The additional cost of the traps has to be offset by the reduced cost of the cable box needed for the system, and the cost of installation should be the same because anyone with an opposable thumb and finger can put a trap on the line.

I agree that the signal coming into my home is the property of the cable company but, and this is important, at a certain time the real ownership of the signal becomes less clear. When the RF has been reduced to baseband video and has spent lots of milliseconds running around the inside of my TV set, I think things are a bit different and the cable companies' original claim of ownership is a lot weaker. And if I worked out a way to record scrambled signals and then descrambled them on playback, what then?

If I built a box that scrambled some of the channels currently sent to me in the clear, the cable company would look at me in a funny way, but I really doubt they'd care one way or the other.

Now that you know how I feel about this stuff, I'd like to show you how to descramble signals, but I

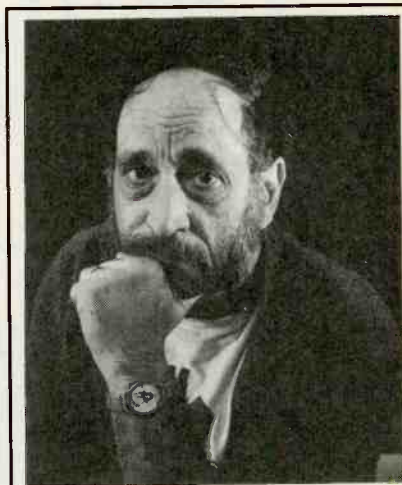

About Bob Grossblatt

Bob Grossblatt was raised in New York City and received a BS in Electrical Engineering from Rutgers University in the era of the sliderule. Although he planned on a career at IBM, he began working as an independent consultant shortly after graduating from college and has been doing that ever since. Most of his work in the electronics field has been in the conception and development of prototype devices for clients ranging from AT&T to NASA.

His career in electronics was interrupted at times by work in the movie business. He began writing about fifteen years ago and, in addition to the writing he has done for *ELECTRONICS NOW*, has also written several electronics books for Tab Books. Currently, his time is divided between circuit design, writing, and restoring old cars.

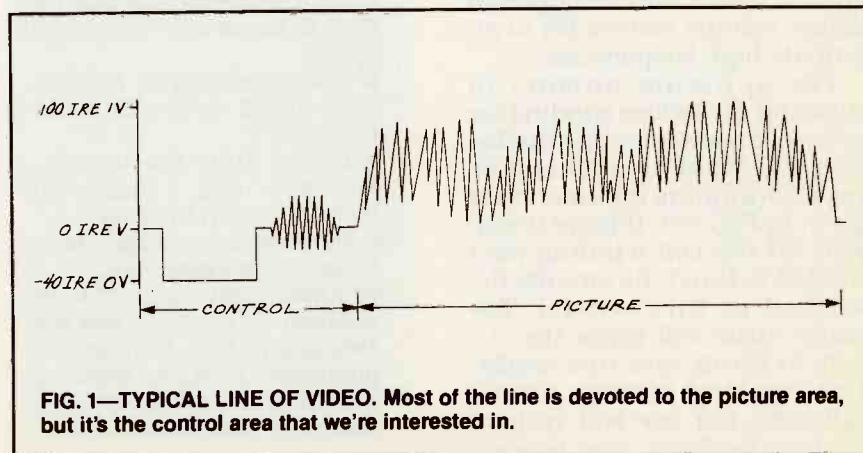

FIG. 1—TYPICAL LINE OF VIDEO. Most of the line is devoted to the picture area, but it's the control area that we're interested in.

can't because there are several ways that signals can be scrambled. It's sad but true that being able to descramble one system is no guarantee that you can descramble any other system.

The scrambling methods can be broken into two basic categories. The method you have in your home depends on the kind of cable service you have, how it's sent to you, and the economics of your viewing region. That last reason is important because the cable companies have to pay for the decoder boxes; the more sophisticated the way the signal is scrambled, the more the box costs. A cable company that has its franchise in a large city with lots of customers needs lots of boxes, and that translates into some serious numbers for the purchase of the boxes. And don't forget that the more extensive the scrambling method, the more expensive the equipment needed to scramble the signal in the first place.

Taking apart the video signal and turning it upside down and inside out is pretty simple, but putting it back together correctly is a different matter altogether. And the FCC keeps a careful watch on how close the reconstituted signal comes to real video. If the new signal is too messy, the FCC will give it a big thumbs down.

The most common approach to scrambling video involves manipulating the information in the horizontal interval. In the beginning, every cable company used the same method—they suppressed the horizontal sync pulse, which meant that the TV had no idea where each line of video started and ended. The sync pulse can be seen in the video waveform shown in Fig. 1. Without a sync pulse, the TV's horizontal circuitry will freewheel and you'll most likely see the horizontal weaving down near the center of your screen rather than being located discreetly off to the side. That also means that the TV won't see the transmitted colorburst signal in the right place, and the colors will be off as well.

To descramble the video, a decoding signal was sent, buried in the audio. It would restore the sync pulse at the proper time and for the

proper interval. I don't want to spend a lot of time on this because there's as much chance of seeing this as there is of seeing a mastodon. Once upon a time they were everywhere, but they're long gone today.

The best way to get a good handle on the whole business of video scrambling is to get into the theory and the circuitry needed to turn the theory into practice. I'll assume that you understand the basics of a clear video signal as we go through the methods that are often used to mess it up.

Every scrambling method depends on altering some or all of the control pulses that are included in the definition of the standard video waveform. That means that the most basic operation of any scrambling/unsrambling system is the separation of the control information from the picture information. That isn't such a complex job because the NTSC standard was devised with a strictly mathematical timing relationship between every individual part of the signal. Therefore, looking at a video signal is somewhat like reading a street map—if you know exactly where you are, you automatically know where everything else is. Or, in the case of scrambled video, just where everything else is supposed to be.

Over the following pages we'll be looking at various scrambling methods commonly used by the cable companies. I'll go through the theory and show you how you can find out what your cable company is shipping to the back of your TV set. And yes, we'll be looking at the circuitry needed to descramble the signals—practical examples with component values.

I'll be using standard ICs that meet all our usual criteria of price (low) and availability (everywhere), but this is one area where you're really going to need an oscilloscope. If you're serious about electronics you should have one of these things anyway, because they're just about the most basic and essential piece of test equipment you can own.

How They Scramble

You don't have to be a rocket sci-

entist to mess up video—that is true both aesthetically and scientifically. The hard part is to do it in such a way that you can put it back together again. This means that there has to be a rigorous approach to the task—almost a mathematical one—of tearing the video signal apart.

Take a look at—and get intimately familiar with—the typical line of video shown in Fig. 1. While most of the time on the line is devoted to the picture area, it's the control area where the real work is done. The video signal in the picture area determines what you'll be seeing on the screen but the stuff in the control area is what tells your TV where to put the picture and how it's supposed to appear.

The control area is blown up in Fig. 2, and the information in it is a graphed function of time and voltage. By the way, most video people like to talk about "units of video" rather than voltage for the same reason that audio people like to talk about decibels rather than voltage.

When the NTSC video standard was established, the two most basic decisions made were that it would range from 0 to 1 volt peak-to-peak, and that one voltage range would be reserved for picture and one would be reserved for control. As we go through our discussion on scrambled video, I'll talk sometimes about video in terms of IRE units and other times about voltage. The two are directly related as shown on the Y axis of Fig. 2.

The bottom line of the picture is 0 IRE units which is about 0.3 volts up the IRE scale. That point is important because it's both the defined level for black video (no picture on the screen) and the upper limit for any control signals. (There's a slight ambiguity here when you examine the colorburst.) For the moment, we can consider everything above 0.3 volts as picture and everything below that as non-picture.

That signal definition is the basis for most of the hardware in every NTSC-compatible TV ever made. Your TV contains circuitry that expects control information to be below 0.3 volts and picture information from 0.3 to 1 volt. That's important because it is the starting point for

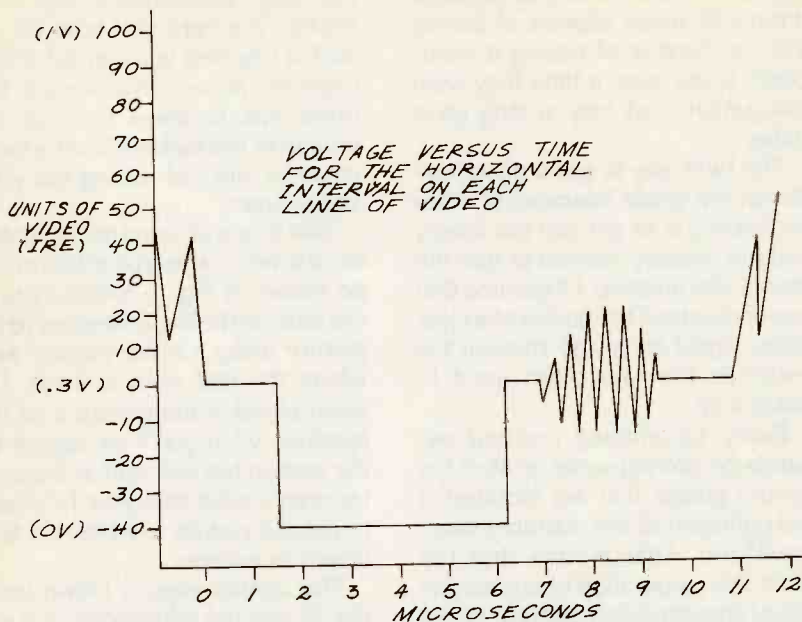

FIG. 2—THE CONTROL AREA. The NTSC video standard says that the signal can range from 0 to 1 volt peak-to-peak.

scramblers; when you get rid of some of the control information, a standard TV can't display the picture. Remember that the horizontal sync pulse defines the end (or, depending on your point of view, the beginning) of a line of video. If the TV doesn't see it, it won't know how to display the line on the screen, and the result will be that the TV will end one line and start another one at some random point on the screen.

The freewheeling retrace fre-

quency of the TV will come close to the one sent by the broadcaster, but it won't match exactly. What you'll see on the screen will be something like Fig. 3-a. The curved line running down the center of the screen is the horizontal interval sent by the broadcaster.

Three things are happening in Fig. 3-a. The first is that the line is curved because the horizontal circuitry in your TV runs at a frequency that's not exactly the same as the broadcast horizontal frequency. The TV can accept a certain amount of drift in the horizontal frequency. Once

upon a time a horizontal control was built into on the TV so you could hand tune the TV to the received signal. Although that control isn't around any longer (except sometimes as a trimmer on a circuit board inside the TV), the tolerance is still there. Modern TVs can automatically lock onto the broadcast horizontal frequency so there's no reason for the horizontal control to be accessible.

The second thing that's happening is that the line is in the center of your screen. The reason for that is simple. The TV's horizontal circuit uses the received horizontal pulse as an instruction to move the beam back to the left side of the screen. Because the scrambled signal has anything but a recognizable horizontal sync pulse, the TV zips the line back to the left side of the screen whenever it reaches the right side. Because that has nothing to do with the signal it's receiving, the line usually shows up at some random spot on the screen. The TV's freewheeling frequency is close to the broadcast horizontal frequency, so the TV will start a new line at about the same point in the broadcast line. That means you'll see the broadcast horizontal interval on each line at more or less the same horizontal location on the screen. The result is a curved line down the screen.

The third thing happening on the TV screen is that the colors are messed up. Because the horizontal sync is missing, the TV circuitry isn't seeing the colorburst in the right place, so there's no reference for either the intensity or color of the picture. The TV then uses whatever it sees in the colorburst location as a reference for both the intensity and color of the image.

You can see now that by simply getting rid of horizontal sync, the resulting video signal will be completely messed up. The best way to appreciate that, and a good way to get into video hardware, is to build something to demonstrate how all this stuff really happens. That's right, our first piece of hardware is going to be something that will let you scramble video. And, as far as the law is concerned, I'm pretty sure that nobody's going to become very upset.

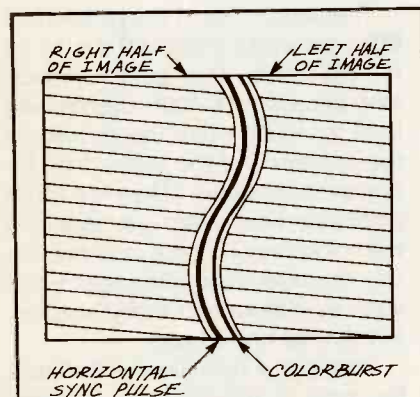

FIG. 3-a—A FREEWHEELING RETRACE won't match the frequency sent by the broadcaster. The curved line running down the center of the screen is the horizontal interval sent by the broadcaster.

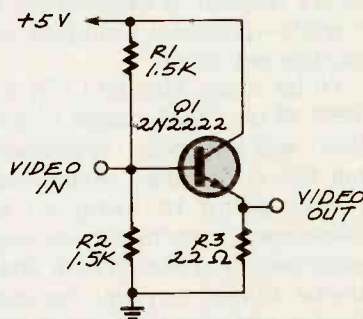

FIG. 3-b—A VIDEO BUFFER isolates one stage of hardware from another. The transistor is set up as a buffer and the level of the video can be controlled by the value of R2.

What we will need is a source of real live video.

That signal can be anything from an NTSC generator to a line-level video signal from the back of a VCR. You'll also need a scope to look at the video waveform and a TV to look at the picture. You can do without the latter but the former is a must. I'm not going to beat you up any more about getting a scope, but if you don't have one, get one.

To get started, because we're building circuitry that is going to use an external signal, the first thing we have to do is buffer it. That is done for two reasons. The first is that we have to be able to control the level seen by our video circuitry, and the second is so that a wiring error on the breadboard isn't going to send unpleasant voltages back to the signal generator or VCR. The results could be a bit nasty.

Video buffers are just like any other buffer—they're simple circuits that isolate one stage of hardware from another. Think of the circuit as being like an electronic fuse.

The easiest way to build a buffer is with a single transistor as shown in Fig. 3-b. The transistor is set up as a buffer, and the level of the video can be controlled by the value of R2. You can also put a potentiometer in series on the line feeding the video to the base of the transistor and trim the level that way.

Although the NTSC video standard calls for a signal that's 1-volt peak-to-peak, most VCR manufacturers don't strictly follow that standard when it comes to a video output signal. If you put the signal on a scope, you'll probably find that it's a bit higher than that. If that's the case, you should trim the level because the circuits we'll be building expect a 1-volt signal.

The only other thing to notice here—there just isn't much to the circuit at all—is that the video signal being fed to the base of the transistor is related to both positive voltage and ground through R1 and R2. The circuit is going to run on a regulated 5-volt supply; it must be steady because the level of the supply voltage is going to have an effect on the level of the video. Wire up the circuit show in Fig. 3-b and get the video source in place.

Side-tracking to SSAVI

The old suppressed-sync system was a one-way deal. If you got a box that could descramble one channel, it could descramble any channel. Which channels would be unscrambled was determined by one of the wafers on the channel selector dial. A position would be either jumped or open, which was a major cable company headache for two reasons. The first was that they had to open the boxes and solder or cut traces to configure the box for a given customer. The second was that some enterprising people realized what was going on, opened up their cable boxes, and reconfigured it themselves.

The only way the cable companies could guard against that was to use screws with oddball shaped heads to hold the box together. When that didn't work, they started using screws that had a left-hand thread. But enough history.

What the cable companies needed was a way to talk to each of the boxes individually, while they were in customer's homes. Making such addressable boxes also meant that several scrambling methods could be used; the boxes could be

told which method was in use at any one time. Since that information could be sent to the box during the vertical blanking interval (while the beam was off the screen), the cable operator could change the scrambling method from field to field—up to sixty times a second. The boxes could also keep a serial number in an EPROM or some other storage device, which meant that boxes could be addressed individually and the descrambling circuitry could be turned on and off for separate channels from the main cable company office. The cable companies loved it.

Understanding that kind of stuff is a bit more difficult than the old suppressed-sync system, but if you take the pieces one at a time, it all gets cut down to manageable, bite-sized chunks. Although the cable company's scrambling delivery system became much more sophisticated, it was still faced with the same cost restrictions when it had to decide which of the available scrambling techniques to use.

One of the most popular choices was the so called SSAVI system. That's an acronym for Sync Suppression Active Video Inversion. It

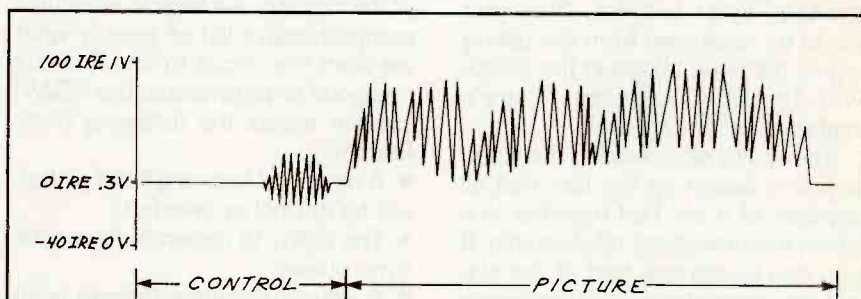

FIG. 4-a—THE SSAVI SYSTEM can deliver video with suppressed horizontal sync and normal video.

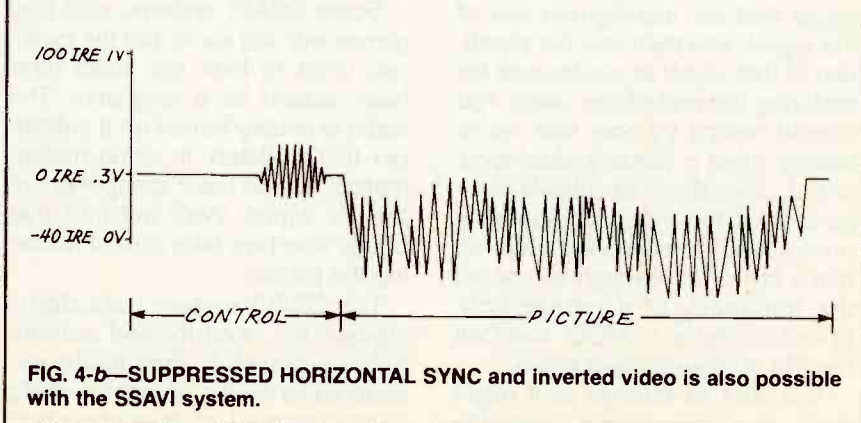

FIG. 4-b—SUPPRESSED HORIZONTAL SYNC and inverted video is also possible with the SSAVI system.

allows the video to be delivered to your doorstep in one of four flavors:

- Suppressed horizontal sync and normal video (Fig. 4-a).
- Suppressed horizontal sync and inverted video (Fig. 4-b).
- Normal sync and suppressed video (Fig. 5).
- Normal sync and normal video (we can forget this one).

Before we get into the nitty gritty of the SSAVI system, there are a few basic things you should know, because they tell you some interesting things about how the system works.

The first is that horizontal sync is never inverted—even if the picture is inverted. This means that any circuit designed to descramble it has to separate the two basic parts of the video line (control and picture first). We have to be able to turn the picture right side up (if needed) without inverting the control section as well.

The SSAVI system seems even more complex when you realize that the job of separating control and picture has to be done on lines that might very well have no horizontal sync pulse that can be used as a reference mark. In the older suppressed-sync system, the sync could be recovered from the gating signal that was buried in the audio; with the SSAVI system, there's nothing like that available.

The key to regenerating the video signal is based on the fact that all aspects of it are tied together in a strict mathematical relationship. If you can locate one part of the signal, you can determine where everything else has to be.

The broad picture for a descrambler, therefore, is to design a circuit that can identify one part of the signal, and then use the repetition of that signal as a reference for restoring the rest of the video. You should realize by now that we're talking about a phase-locked loop, or PLL. Even if the identifiable component of the video occurs only once a field (or even once a frame), that's still often enough to control the frequency of a voltage-controlled oscillator, or VCO, and lock the PLL to the received video.

This isn't as strange as it might seem. In a normal video signal, the

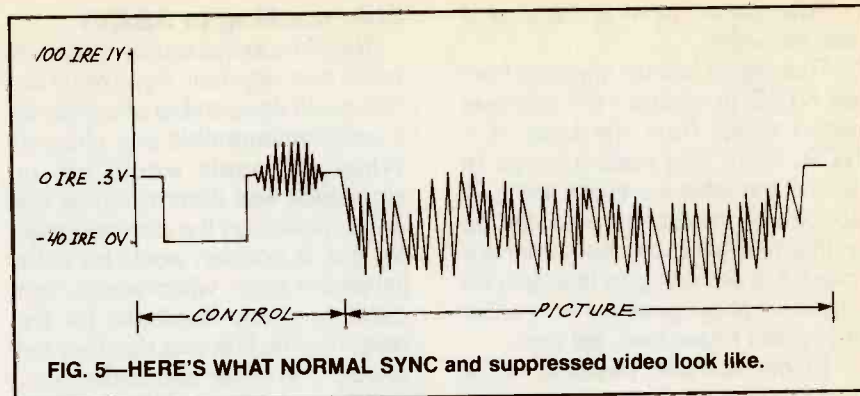

FIG. 5—HERE'S WHAT NORMAL SYNC and suppressed video look like.

reference for color is the colorburst signal that follows horizontal sync. The colorburst signal lasts only a bit longer than 2 microseconds, but it's used as a reference for the whole video line, which is about 63 microseconds long. As far as color correction is concerned, that means there's no real reference signal available for more than 95% of the line! The color phase for the rest of the line is based on the stand-alone 3.58-MHz generator that's a normal part of the TV set.

Building a SSAVI descrambler isn't as easy as building one to take care of suppressed sync, but it's not as difficult as you might think. Before we start to work out the details of the circuitry, we have to draw up a comprehensive list of exactly what we want the circuit to do. A circuit designed to descramble the SSAVI system needs the following basic features:

- A means of knowing if the picture will be normal or inverted.
- The ability to generate horizontal sync pulses.
- A way to identify a definite point in the received video.
- A circuit to place horizontal sync pulses at the right point.

Some SSAVI systems also play games with the audio, but the methods used to hide the audio have been around for a long time. The audio is usually buried on a subcarrier that's related, in some mathematical way, to the IF component of the TV signal. We'll get into that briefly when we take care of restoring the picture.

The SSAVI system uses digital signals for security and access rights—the stuff that cable executives lie awake all night thinking about (instead of less-important

things such as improving picture quality, increasing channel services, and widening the audio bandwidth). Because the first step in handling SSAVI scrambled signals is to locate a known point in the signal, we'll be using counters and other standard digital logic to keep track of where everything is supposed to be.

Build Your Own Scrambler

We haven't seen very much circuitry yet on our journey through videoland. That's to be expected, though, because video is a subject whose theory you should understand before you start building software. A video signal (shown in Fig. 6) is very complex, with many separate components that are mathematically related to one another.

If you look at a video signal on an oscilloscope, it will appear more or less like the lower waveform in Fig. 6. The most important component of the waveform is the horizontal sync pulse; if you do away with it, the TV won't have any reference for the beginning of a video line, and the image will be misaligned vertically.

Altering Horizontal Sync

Suppressing the horizontal sync is a simple, inexpensive, and relatively safe way to keep "unauthorized" viewers from receiving a coherent signal. So, to understand better how scrambling works, let's build a circuit that can alter the horizontal sync.

Because we're dealing with composite video, and we intend to play games with horizontal sync, the first thing we have to do is isolate the sync from the rest of the signal. That isn't very difficult—every TV in the universe can do it. Most modern

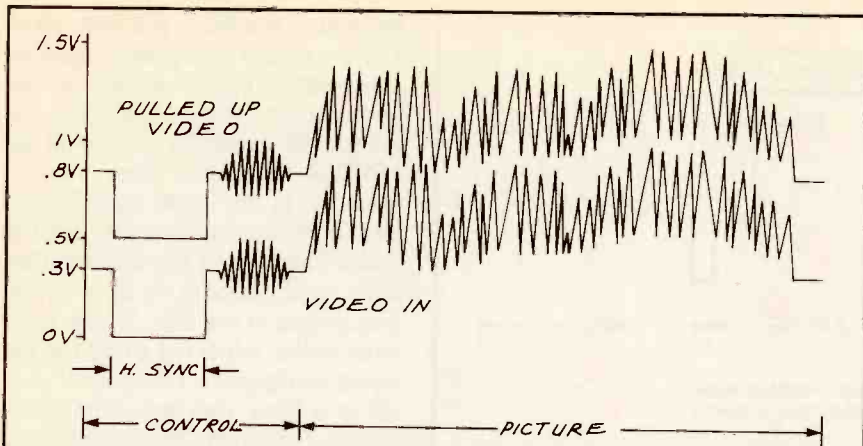

FIG. 6—A VIDEO SIGNAL is normally 1-volt peak-to-peak, but after buffering, the relative voltage level of the signal is raised by 0.5 volts. Then, the only part of the pulled-up signal that falls below the TTL threshold of 0.8 volts is the horizontal sync signal.

TVs either use a discreet sync separator chip or have the needed circuitry buried in the innards of some custom silicon. That makes things cheaper for TV manufacturers, but it's murder for people like us who have a hard time buying the chip in single quantities.

Fortunately, there's always more than one way to get the job done. In this case, it means looking at the voltage definitions inherent in the video signal, and seeing what we can do with them. Standard video has very strict voltage divisions; everything above 0.3 volts is picture information and everything below 0.3 volts has to be a control signal. (We haven't talked about vertical sync yet, but you'll find that the same voltage levels apply to it, too.)

When you have a 5-volt supply and a signal voltage with a 0.3-volt knee, you should immediately think

about standard TTL logic. In that family, everything below 0.8 volts is low, which is exactly what we're looking for. That might not be immediately obvious, so let's go through it.

A video signal is 1-volt peak-to-peak but, by buffering it, the relative voltage level of the signal is raised by 0.5 volts. So, instead of ranging from 0 to 1 volt, the signal ranges from about 0.5 to 1.5 volts. The translated level of the control/picture voltage point is now about 1 volt (see the upper waveform in Fig. 6). You can see that the only part of the pulled-up video signal that falls below the TTL threshold of 0.8 volts is the horizontal sync signal.

The bottom line here is that we can build a sync separator from a standard TTL gate—in this case we'll use a 7486 exclusive-or (XOR) gate. All we have to do, as shown in

Fig. 7, is feed the translated and buffered video from Q1 to one input of the gate, and tie the other input of the gate high.

Suppression Circuit

If you work out the truth table for yourself, you'll see that the only time the output of the gate is high is during horizontal sync. The output at pin 3 of the 7486 is a TTL-level inverted version of the horizontal sync. That output is fed to another XOR gate, which inverts the signal and gives us a negative-going sync signal. Ability to provide both a positive and negative sync signal is the key attribute of the suppression circuit. We want to build a switch that passes video during the picture portion of the signal and be able to alter the signal during the horizontal sync period. That's what the rest of the circuit does.

The first part of the circuit is a picture/sync separator, and the last part is a picture/sync combiner—sort of. Even though we can put the sync back in, we also have the option of sticking in just about anything else we want in place of horizontal sync.

The combiner uses half of a 4066 analog switch as a double-pole, double-throw switch. (The analog switch contacts close when the control voltage is high.) The outputs of the switch (pins 1 and 4) are combined, but because the control lines of the switches (pins 13 and 5) are connected to mirror images of the horizontal sync signal, we can route the picture portion of the video signal to the switch output when sync is low (pin 6 of the 7486) and route horizontal sync to the switch output when sync is high (pin 3 of the 7486).

The single-pole, single-throw switch (S1) controls the input to pin 3 of the 4066. While it's neat to see the effect S1 has on the video signal when seen on an oscilloscope, this is one of those cases when you're better off seeing the effect on a TV.

Whenever S1 pulls pin 3 of the 4066 high (anything above the expected sync level), the video signal loses its sync and the picture on the TV goes totally haywire. If you've seen scrambled pictures before, you'll recognize it immediately. The

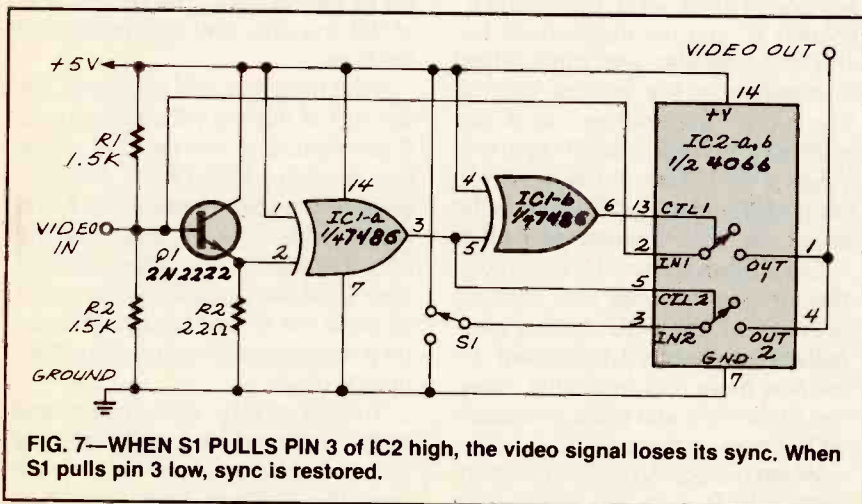

FIG. 7—WHEN S1 PULLS PIN 3 OF IC2 HIGH, the video signal loses its sync. When S1 pulls pin 3 low, sync is restored.

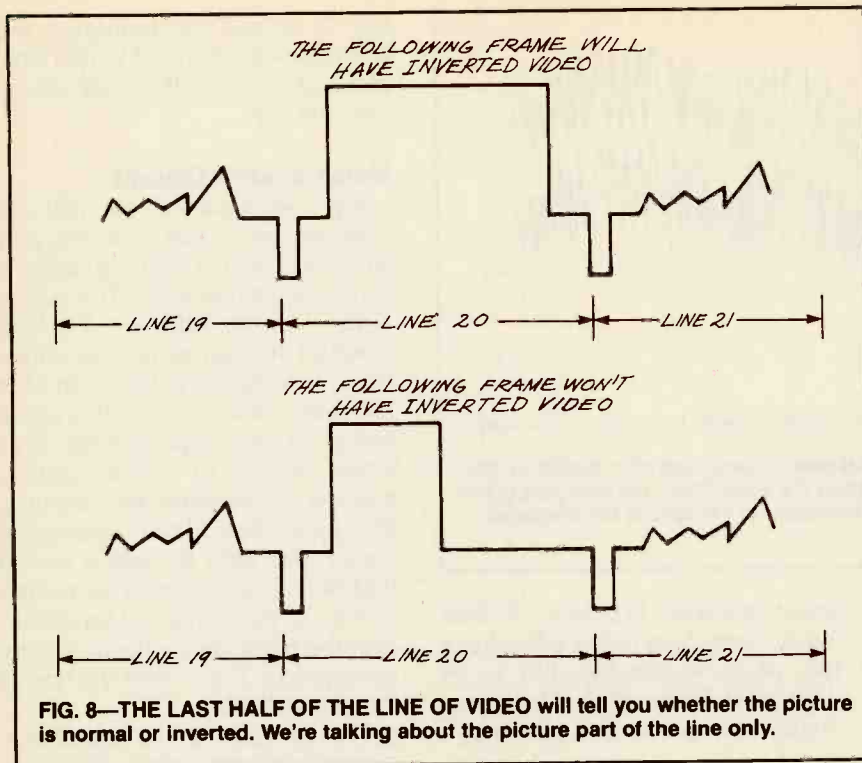

FIG. 8—THE LAST HALF OF THE LINE OF VIDEO will tell you whether the picture is normal or inverted. We're talking about the picture part of the line only.

left side of the picture will be on the right half of the screen, the right side of the picture will be on the left half. Down the middle of the screen will be the horizontal interval. When S1 pulls pin 3 low, sync is restored and so is the TV picture.

Putting It Together

We are not ready to go into the details of the scrambling business just yet, though. A successful scrambler not only has to take the video apart, but it also has to put it back together again. That is quite a bit more difficult. There has to be a way to encode the video signal so that the horizontal sync signal is restored at the right time, and for the right length of time. One outdated way that this can be accomplished is to bury the information in the 31.5-kHz audio subcarrier.

That's not so surprising when you realize that half that frequency is 15.75 kHz—exactly the same as the scan rate of the video lines on a standard color TV. There's not much point in going through all the gory details of recovering suppressed-sync video since it's about as useful as presenting a full tutorial on repairing telegraph lines.

Since suppressed-sync scrambling was figured out by signal pi-

rates about five minutes after it appeared, the people in the television signal scrambling business moved on to more complex methods of screwing up the video signal. The most common method now in use combines a variation on the suppressed-sync method, inverting the video, and performing a lot of other weird stuff.

Back to our SSAVI

When the SSAVI system first started, there were some constants in the video signal that could be used to descramble it. Remember that the picture can be messed up in any one of three ways. (See page 5, column 1), and the instructions for the descrambler are transmitted somewhere in the vertical interval. The word "somewhere" is a late addition to the SSAVI system. When it first started, the descrambling information was always on the same line. That's where we'll start.

Once upon a time, the sanctity of the vertical interval was closely guarded by the FCC, but as alternatives to standard broadcast TV became more popular (cable, satellite, etc), more and more junk started to show up there.

When the SSAVI system started, lines 0 to 9 were left alone by a

request of the FCC, but lines 10 to 13 were where the cable companies transmitted individual subscriber codes. Don't forget that there are unique ID numbers stored in an EPROM (or some other kind of memory) in the cable box. There's also logic circuits there to count the video lines, read the transmitted code, and match it up against the one stored in the box. These technical tricks are a big thing for the cable companies because it prevents a New York box from being used in California. The scrambling is the same, but the codes are completely different.

The decoder circuitry is also controlled by this coding process because a match between the transmitted bytes and the ones stored in the box will enable or disable the decoder. That is true for both the premium cable services and the pay-per-view events.

That kind of coding might be important to the cable companies, but it doesn't mean anything to us. We can build an experimental descrambler without paying any attention to them.

Since the video can be transmitted with either normal or inverted picture information, one of the tasks that has to be done by the descrambler is to tell the rest of the circuit what has been done to the picture. The place to find that information was originally in line 20, but it has been moved around since the system became popular. As you can see in Fig. 8, the last half of the line will tell you whether the picture is normal or inverted. Remember that we're talking about the picture part of the line only, and not the control section.

If the following field is normal, the last half of the line will be black, and if the picture is normal, the whole line is white. One of the things a decoder needs, therefore, is some way to detect the line and store the data it contains. The stored data is then used as a switch by the circuit to route the video through an inverter if the picture is being transmitted upside down.

This is pretty straightforward stuff. Since we're looking at only one piece of information, all we need is a place to store one bit of

information. Your basic piece of cake. The circuitry needed to detect the data, however, is a bit more complex. We need a reference in the signal. So establish a zero point for a line counter, and some counting circuitry to keep track of which line is being received.

You might be wondering what we can count if the signal is being scrambled. But remember, that in the vertical interval (the first 26 lines of video), the signal is being sent in the clear.

Now that we have an approach to handling the possibility of an inverted picture, the last problem to tackle is the one of varying horizontal sync pulses. Sometimes they're there, sometimes they're absent, and sometimes they're not at the proper level. Anything that unstable is a pretty poor choice for a reference signal. So, to avoid a mammoth circuit design problem, the best way to deal with it is to scrap the transmitted horizontal sync (even when it's there), and come up with a way to generate the signal ourselves.

That can also seem to be an insurmountable problem but, just as in the case of the inverted picture, the answer is going to be found in the vertical interval. Once again, remember that the first 26 lines of video are sent in the clear and, even during the rest of the video frame (no matter what's going on with the picture), the horizontal sync pulse is never inverted. It might be weak or missing entirely, but it's never upside down. That's important to keep in mind because if we generate our own horizontal sync, we don't want an upside down, positive-going sync signal present. If that was the case, the two sync signals would add together and cancel, which is not a good thing.

We've talked about how to regenerate sync where the signal being received is unreliable. Basically, the approach is to take the horizontal pulses sent in the clear during the vertical interval and use them as the reference for a phase-locked loop that will supply the missing pulses during the rest of the video frame. If you've got twenty or so reliable pulses per frame, you can accurately generate the missing two hundred and forty or so for

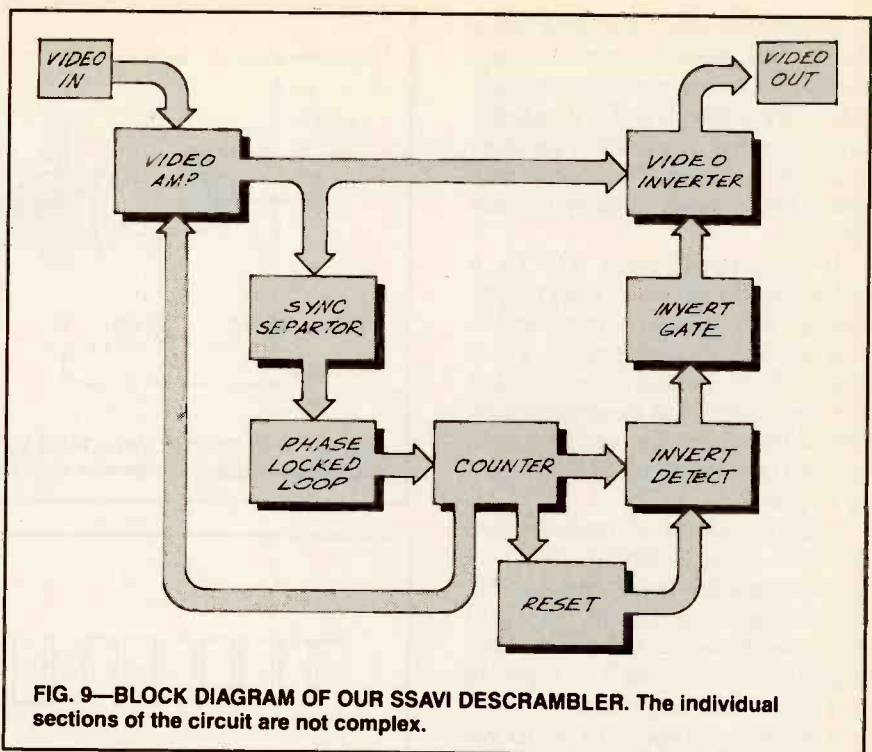

FIG. 9—BLOCK DIAGRAM OF OUR SSAVI DESCRAMBLER. The individual sections of the circuit are not complex.

the rest of the frame.

The block diagram of the circuit we need is shown in Fig. 9. In a nutshell, the job of the circuit is to make sure the picture is always present at the output in a non-inverted state, and that it has horizontal sync pulses present at the right level and the right position.

The scrambled video is fed to an op-amp and the output is sent to a sync separator—the same basic circuit that's found in every TV set in the universe. The sync pulses drive a phase-locked loop whose output is decoded to provide the missing sync pulses for the video lines outside the vertical interval (where most of the interesting stuff is found). These generated sync pulses are mixed with the incoming video and then sent, through a gated inverter, to the back of your TV set.

The gated inverter is controlled by a signal that tells it whether or not the picture portion of the video is upside down. The control signal is derived by watching the state of line 20, as we discussed before.

All this sounds incredibly complicated but, if you look over the block diagram, you'll see that it's just a collection of gates and counters—the same sort of stuff we've been messing around with for years.

Our Descrambler Takes Shape

Building a circuit that can make sense out of SSAVI-encoded signals isn't simple, but it's not impossible, either. Best of all, it can teach you a tremendous amount about basic video, too. We've reached the point where we start turning to hardware. If you look over the block diagram in Fig. 9, you'll see that the circuit we'll need is not complex.

The final thing we talked about was a reset pulse that's needed to initialize the various line counters that will be part of the SSAVI descrambler. We need to find something in the scrambled signal that's stable enough to use as a reset for our digital circuitry.

Remember that everything in the vertical interval is sent "in the clear." One of the components there is vertical sync—an ideal candidate for generating a reset pulse. When you look at scrambled video on a scope or waveform monitor, you may wonder how anything can be picked off the signal. (Incidentally, you stand a much better chance of successfully viewing the scrambled signal if you have a dual-channel scope. Feed standard video into one channel, use that for the trigger, and view the scrambled stuff on the scope's other channel.

Scrambled video may look like a mess, but even broadcast video that's sent in the clear is incredibly jittery. It's a tribute to TV designers and the video standard in general, that the TV set can lock onto anything that comes in over the airwaves.

If you tune your TV to a scrambled signal, you'll note that although the picture is messed up, the screen always shows a full frame. That's because, even though horizontal sync has been altered by the cable company, vertical sync can still be recognized by the circuitry in your TV.

The first piece of hardware we built was a simple demonstration circuit that enabled you to mess up the horizontal sync signal. The first thing we have to do to the video signal to descramble it is separate the sync from the picture.

The circuit shown in Fig. 10 will take video in at one end and give you two versions of the composite sync part of the signal out the other end: positive- and negative-going. The transistor is working as a simple buffer and, by adjusting the video level at its output, we can have the incoming negative sync fall below the high threshold of the TTL EXCLUSIVE-OR (XOR) gate. The first gate produces the composite sync and the second gate works as a simple inverter.

There are other ways to separate sync, but this one has the advantage of giving you an output that swings close to the supply rails, has a very low noise component, and is at TTL logic levels, which makes it much more reliable for feeding the digital circuits we'll be designing for the rest of the descrambler.

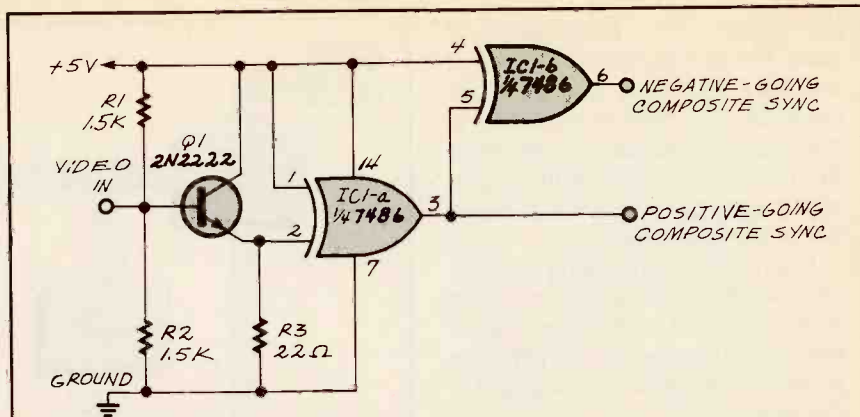

FIG. 10—THIS CIRCUIT WILL TAKE VIDEO in at one end and give you positive- and negative-going composite sync signals at the other end.

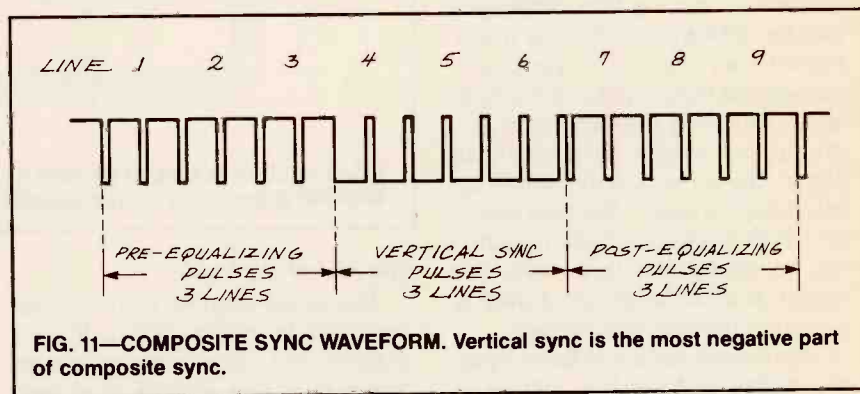

FIG. 11—COMPOSITE SYNC WAVEFORM. Vertical sync is the most negative part of composite sync.

While we're looking at the composite sync signal, this is a good time to work out the details of the reset circuit since it has to isolate vertical sync from the composite sync signal. The way to do that should be obvious when you look at Fig. 11, the composite sync waveform. Just as it's supposed to be, vertical sync is the most negative part of composite sync. To isolate the vertical sync, we need a simple low-pass filter; a suitable one is shown in Fig. 12.

The two gates after the filter

clean up the sloppy waveform produced by the R-C circuit. You'll notice that CMOS 4049 inverters square up the shoulders of the waveform. The low-pass filter (or vertical integrator, as it's sometimes called) is being fed with a positive-going version of composite sync and, since it's going through two inverters, it's producing a positive-going vertical sync pulse at the output of the circuit.

That's necessary because we a positive-going vertical sync for the rest of the circuit. As with most things electronic, there are several ways to do the same job, but bear with me until we've gone through the whole design before changing things around. Once you understand the circuit in its entirety, you can start modifying it to your heart's content.

Even though we haven't completed the design of the descrambler yet, the pieces we've finished can be put together as shown in Fig. 13 to produce some interesting and extremely informative waveforms. Video goes in at

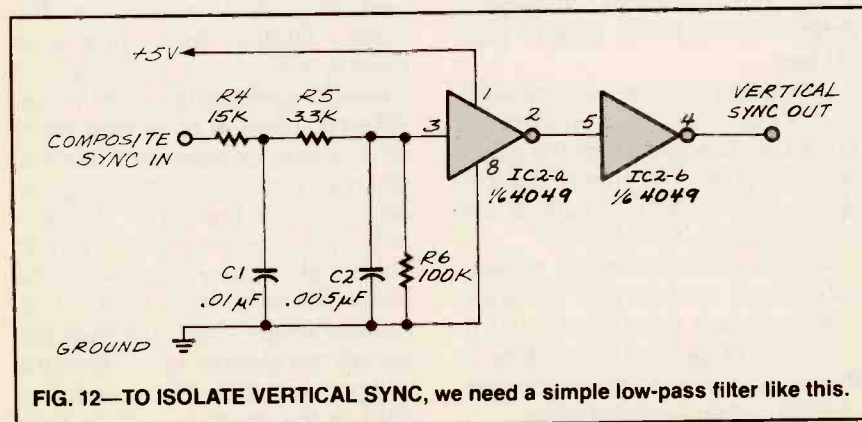

FIG. 12—TO ISOLATE VERTICAL SYNC, we need a simple low-pass filter like this.

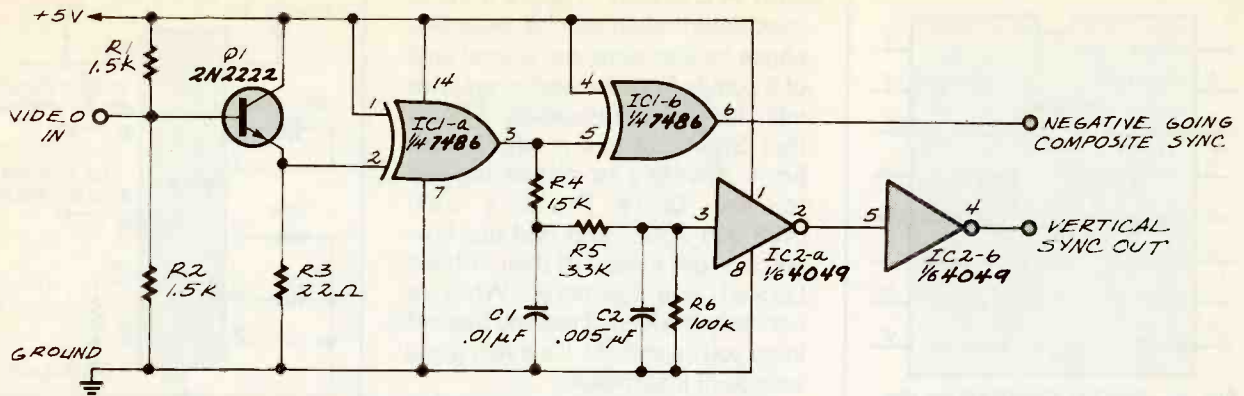

FIG. 13—THE FINISHED PIECES OF OUR DESCRAMBLER can be put together as shown here. Video goes in at one end and we're able to isolate the sync pulses at the other end.

one end and we're able to isolate the sync pulses at the other end. I leave it to you to imagine what a bit of creative gating can do—especially if you use these signals to control the switches in a 4066 as we did in the demonstration circuit in Fig. 7.

Now that we have vertical sync isolated, the next job to do (and the most critical for the descrambler) is to come up with a way of producing horizontal sync. That is obviously more difficult because we know that it won't be present all the time in the received video signal. As a matter of fact, it's a lot better if we operate under the assumption that it's never there at all.

PPL Lends a Hand

Once upon a time, when gated sync was the last word in video signal scrambling, it was relatively easy to descramble the system, as there were two constants you could count on. The first was that the missing

horizontal sync pulses were recoverable from information that was buried elsewhere in the RF signal. The second, more subtle, constant was that the horizontal sync pulses were always missing from each line of video.

The SSAVI system makes this part of the descrambling process a bit more difficult.

As we've discussed, the horizontal sync pulse in the SSAVI system is considerably sneakier than in any previous scrambling technique. In any given field of video, the pulses can be absent or at the wrong levels. They could be present, although the chances of that are small. The only constant in the SSAVI system is that the horizontal pulses will be there during the vertical interval—and that's while the electron beam is off the screen.

Given all that, our job is to come up with some way to generate horizontal pulses only when they're needed. Not only that, but we have

to be sure that the pulses we create are placed correctly on each line, and are produced at the exact same rate as the horizontal frequency of the incoming scrambled video signal. This sounds like an insurmountable design problem but, in fact, it's not really that difficult. The key to the design is the use of a phase-locked loop, or PLL.

Before we get into the details of how a phase-locked loop circuit is going to solve our sync problem, it's worth spending a few minutes on the basics of phase-locked loops. Since this is such an important part of our total circuit, it's impossible to understand how the descrambler works without a foundation in the theory of phase-locked loops.

The basic components of a standard phase-locked loop are shown in Fig. 14. There are two basic parts: the first is an input conditioning circuit that cleans up the signal applied to the phase detector, and the second is a local oscillator whose frequency is determined by a control voltage. That part is usually referred to as a voltage-controlled oscillator (VCO) or voltage-to-frequency converter.

The output of the VCO is compared to the input frequency, and the phase detector generates an error voltage that's proportional to the difference between the two frequencies. The error voltage controls the frequency of the VCO, and the result is that the VCO's output is always in-phase—or synchronized, if you prefer that term—with the input frequency.

By setting the VCO's base fre-

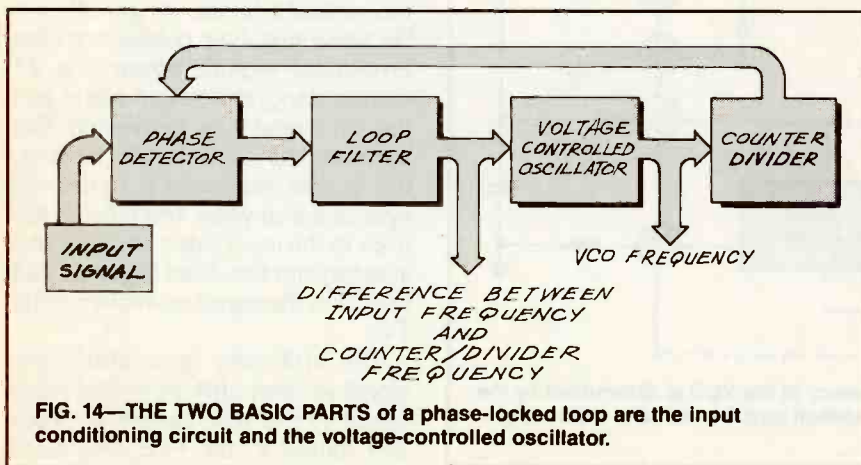

FIG. 14—THE TWO BASIC PARTS of a phase-locked loop are the input conditioning circuit and the voltage-controlled oscillator.

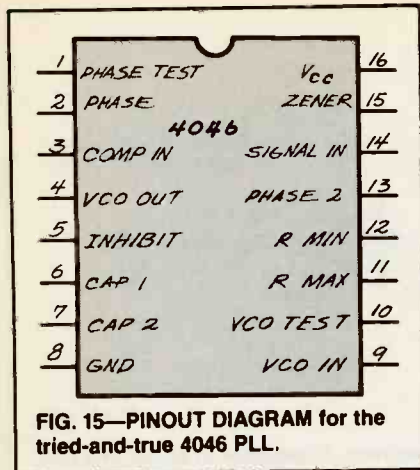

FIG. 15—PINOUT DIAGRAM for the tried-and-true 4046 PLL.

quency to some multiple of the input frequency, we can have the counter/divider chop the VCO frequency down to the input frequency and keep the VCO in sync with the input, even though the frequencies aren't the same. So, PLLs let us easily multiply frequencies, build filters, and—more to our point—keep signals in sync.

Phase-locked loops are basic building blocks in circuit design, and it's well worth your time to learn as much as possible about them. I strongly urge all of you out there to read about, experiment with, and

build PLL circuits. There's a lot of good information around regarding phase-locked loops and a good deal of it comes from the semiconductor manufacturers themselves. I know that Signetics has a whole data book devoted to phase-locked loops. Give them a call (408-991-2000) and find out how you can get a copy of their "Phase Locked Loop Handbook." While it's not really the kind of reading that will keep you up at night, it's a very good source of information.

The phase-locked loop we'll be using is the old tried-and-true 4046. The pinout for the chip is shown in Fig. 15, and a block diagram of the chip is shown in Fig. 16. The frequency of the VCO is determined by the RC constant of the resistors at pins 11 and 12, and the capacitor between pins 6 and 7. A second factor affecting the VCO is the control, or error voltage on pin 9.

The VCO will stay in sync with the input frequency that's applied to pin 14. If you put a divider circuit between the VCO output on pin 4 and the comparator input on pin 3, the VCO frequency will be the input frequency multiplied by whatever value you're using for the division.

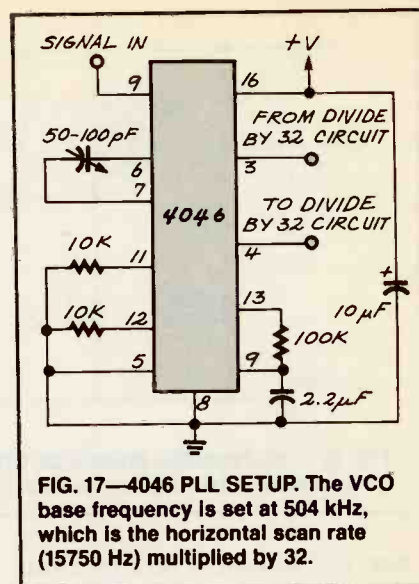

FIG. 17—4046 PLL SETUP. The VCO base frequency is set at 504 kHz, which is the horizontal scan rate (15750 Hz) multiplied by 32.

There are lots of things to watch out for when you're designing a circuit around a 4046, or any PLL for that matter, but we're more interested in the application than the theory.

In our descrambler, the PLL is the perfect solution for solving the horizontal sync problem. Remember that the only time we can be sure of receiving transmitted sync pulses is during the vertical-blanking interval. The question we had to answer is how any circuit could "know" when to generate a horizontal sync pulse if there's nothing that can be used as a reference. The way to make that happen is to do a couple of creative things with a PLL. To start off with, the 4046 setup we need is shown in Fig. 17.

The VCO base frequency is set at 504 kHz. That frequency is an even multiple of the standard horizontal scan rate (15,750 Hz \times 32). During the vertical interval, we get 26 usable horizontal sync pulses from the broadcast signal. When line 27 comes along, the picture starts and the horizontal sync is missing. But because the VCO is still running, the divider produces a horizontal sync signal anyway. The pulse is fed back to the input video amplifier and injected into the video signal so that line 27 is displayed correctly on the TV.

The artificially generated sync signal is then split from the video signal by the sync-separator circuit and routed to the PLL. The 4046

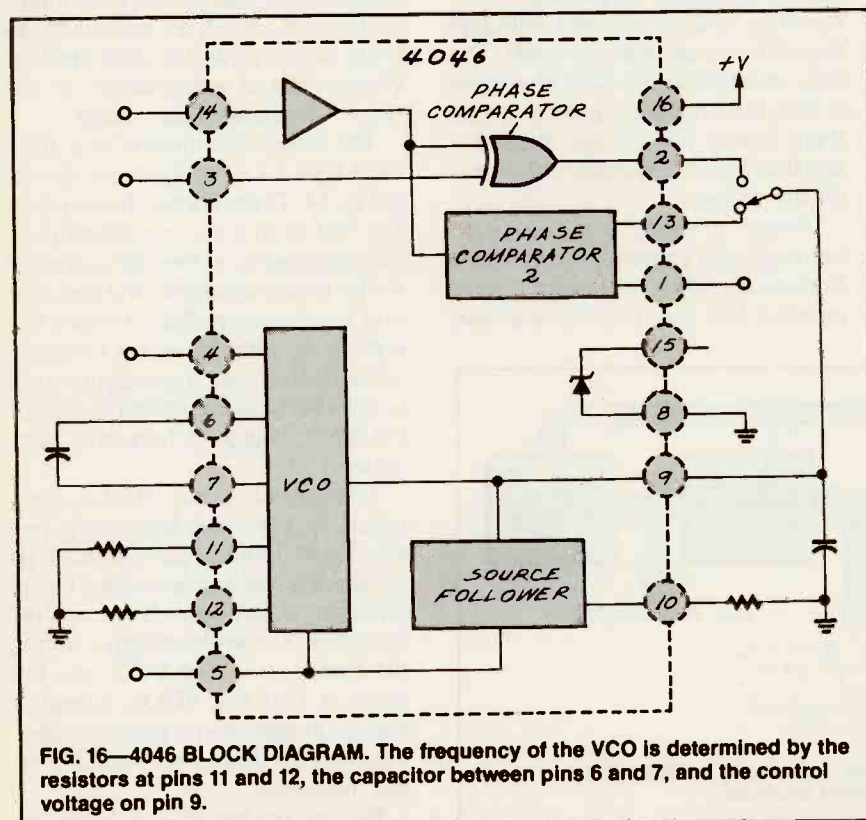

FIG. 16—4046 BLOCK DIAGRAM. The frequency of the VCO is determined by the resistors at pins 11 and 12, the capacitor between pins 6 and 7, and the control voltage on pin 9.

has no way of knowing that the sync pulse isn't a "real" one, so it treats it exactly the same as one obtained from the television broadcaster. This kind of self-bootstrap operation continues for the rest of the video frame until the next vertical interval is reached, when the whole thing starts all over again.

As you can see, the success of this whole scheme depends completely on the stability of the VCO in the phase-locked loop. In fact, while that might seem to be a real concern, it's really much less of a problem than you might think. I'm not going to go into the math, but your TV has a tremendous amount of tolerance, and even a ten percent drift in the VCO frequency won't cause much in the way of noticeable shakiness in the TV picture.

Get the phase-locked loop circuit working and closely examine the horizontal sync pulses on your scope. The demo scrambler we built before is the perfect circuit to shut off the transmitted horizontal sync signals periodically. Do that and then watch the results on the oscilloscope.

When we first started work on the SSAVI descrambler, the block diagram probably looked quite complex. But if you look at Fig. 9, you'll see that most of the work has been done. The most difficult job left for us is to come up with the counter that's needed by the phase-locked loop. It's a job we have to do carefully because the success of the descrambler depends on how well we can maintain the stability of the horizontal-sync signal.

The phase-locked loop in our design is driven by a 504-kHz clock based on an R-C network. That frequency was chosen for two basic reasons: The first is that it's exactly 32 times the NTSC line frequency of 15,750 Hz, and that makes it easy for us to do the division necessary to produce horizontal sync pulses. The second, and somewhat more subtle reason, has to do with the period rather than the frequency.

A 504-kHz clock has a period of 1.98 microseconds. That's interesting because, by using five of the counts, we can get a pulse that has a width of 9.92 microseconds, which is close enough to the

NTSC's established standard of 10.7 microseconds for a horizontal blanking pulse.

Before we go any further, I have to comment on my apparent disregard for precision. I've been using language and design techniques that are loaded with phrases like "close to," "pretty much the same as," "in the ballpark," and so on. Now, I'm as impressed with standards as anyone I know, but numbers have to work in the real world as well as on paper. You have to keep things like cost in mind when you're designing a circuit.

The NTSC standards for a video signal have a precision of several decimal points, and every broadcaster in the country spends a lot of time and effort making sure his signal adheres to that standard. The same is true of TV manufacturers, as well. The theory for standardization is terrific but, as is usually the case, what happens in reality is different. All you have to do to see what I mean is put a scope on the video signal received by your TV set; you'll find an overall similarity to the video standard, but you'll be amazed at how sloppy the signal really is. The average horizontal frequency might be 15,750 hertz, but there's considerable jitter from line to line in the signal. The same is true for burst, blanking, and all the other components in the line.

Despite these variations in the signal, the picture that shows up on your TV screen is apparently unaffected by them. The difference between studio-quality video (the stuff on the monitors in the broadcaster's control room) and received video (the stuff you see on your TV) is minimal.

Keeping all that in mind, let's design the rest of the descrambler.

The next thing we need is a divide-by-32 counter to complete the phase-locked loop section of the circuit. After my discussion of the relative importance of precision, you should understand why the phase-locked loop's oscillator is only RC-based, and not crystal controlled: It's just cheaper and easier.

The divide-by-32 circuit (the "Counter" in Fig. 9) can be built in several ways; as a matter of fact, we've designed a whole bunch of

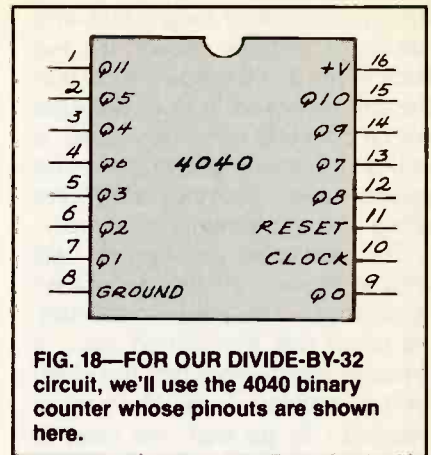

FIG. 18—FOR OUR DIVIDE-BY-32 circuit, we'll use the 4040 binary counter whose pinouts are shown here.

these things in the past. In order to keep the circuit as simple as possible, we'll use the 4040 binary counter whose pinouts are shown in Fig. 18. This is one of the earliest members of the CMOS family and still one of the best choices for general counting. It's a ripple counter, rather than a synchronous counter, so don't use it for applications where super accuracy is required. Remember that a ripple counter is a bunch of sequential counters, and each internal stage uses the output of the preceding stage as an input. This means that the outputs change in sequential order, and an incorrect count will be present briefly on the pins. Since the problem is caused by the propagation delay of each counter stage, the duration of the incorrect count on the outputs is, by and large, a function of the clock speed.

The 4040's clock input is fed with the 504-kHz signal generated by the 4046, and we're using a series of gates to decode the count and provide horizontal blanking and some other timing signals needed for the descrambler. The actual circuit is shown in Fig. 19. You should understand why each of these signals is needed before you start hooking everything up to the back of your TV set. To see what we need from the counter, let's use it to restore horizontal sync and then figure out what else we need to completely unscramble the incoming video.

Getting a horizontal sync clock for the phase-locked loop circuit is simple. All we have to do is pick off the Q4 output. That is a divided-by-32 version of the input clock from

the phase-locked loop's 504-kHz oscillator and, as shown, it's fed back to pin 3 of the 4046. Now that the phase-locked loop is provided with a constant reference signal, it will accurately generate sync pulses—even when they're not sent along with the transmitted video.

The remaining problem to deal with is turning off the generated sync pulses during the vertical interval when real transmitted sync is present. (Remember that the video isn't scrambled during the vertical interval.) To do that, we have to count the lines of video as they're received and make sure that transmitted sync is processed for the first 26 lines of each frame. The starting point for the count is the vertical sync signal and, as you recall, we've already isolated the signal. The sync separator we built earlier produces a positive-going version of vertical sync. If we use the rising edge of that signal as the zero point for the counter, we have to count a number of lines to reach the point where the lines of video are carrying picture information and are therefore scrambled.

The two lines in the frame that mark the beginning and end of the transmitted horizontal sync are 260 and 27, respectively. We need a circuit that can count the received lines and let the rest of the descrambler know when to use received horizontal sync and when to use the artificial sync generated by the phase-locked loop. The zero point for the counter will be the rising edge of our vertical sync signal. Since that occurs at line 3, we have to decode a count of 24 and 257.

We can use a 4040 to do that job as well. When the counter reaches 24 we have to enable a gate that will send the phony horizontal sync pulses to the video amplifier at the circuit's input. When we get to a count of 257, the gate has to be disabled to let the real horizontal pulses through to re-sync the phase-locked loop circuit.

Decoding those two numbers is a pain in the neck since it involves watching nine counter lines. You can do that with a bunch of gates, but a better way is to use an EPROM. The choice is yours although, if you haven't had much experience in this

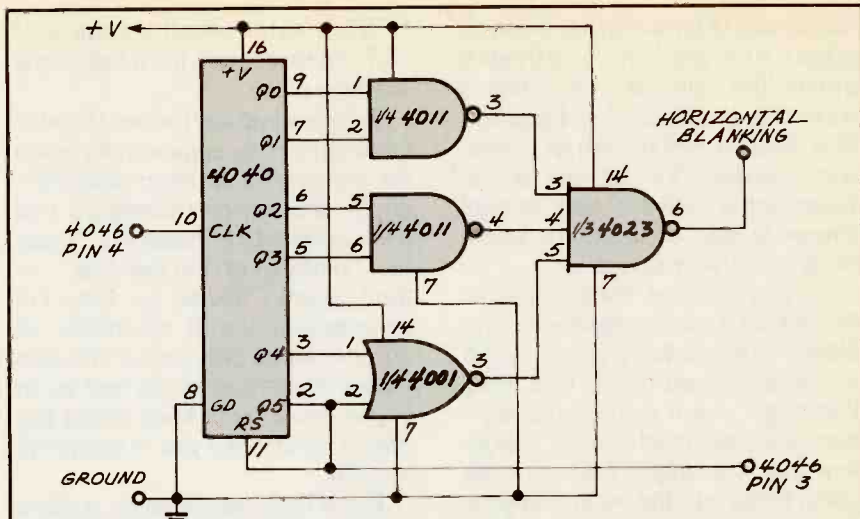

FIG. 19—THE 4040's CLOCK INPUT (CLK, pin 10) is fed with the 504-kHz signal generated by the 4046. We're using a series of gates to decode the count and provide horizontal blanking.

sort of decoding, it's probably a good idea to work out the logic and build the decoder with gates. Otherwise, an EPROM is the way to go. Assuming, of course, that you have programming capabilities.

Correct Sync

You can use any counter you want, and the 4040 is as good as any one of them. The tricky part of the design is that the decimal 257 is 100000001 in binary code. That means we need a counter/decoder that can handle nine lines. The 4040 can output the correct count, but the decoder must be able to "watch" nine lines. That's not a problem if you're using discrete log-

ic gates to do the decoding because you can have as many input legs as you want. If you're using an EPROM, it's obvious that the extra available address lines have to be tied to either power or ground.

Somewhere out there in designland, there's a combination of gates that will decode the two numbers (24 and 257), but finding it is pretty tedious and, to make matters worse, there's not a lot to be learned from doing it. I haven't given it a lot of thought, but it can probably be done with a handful of gates. I'll leave the rest of this as an exercise for some of you out there.

Don't get me wrong—decoding like this is sometimes necessary,

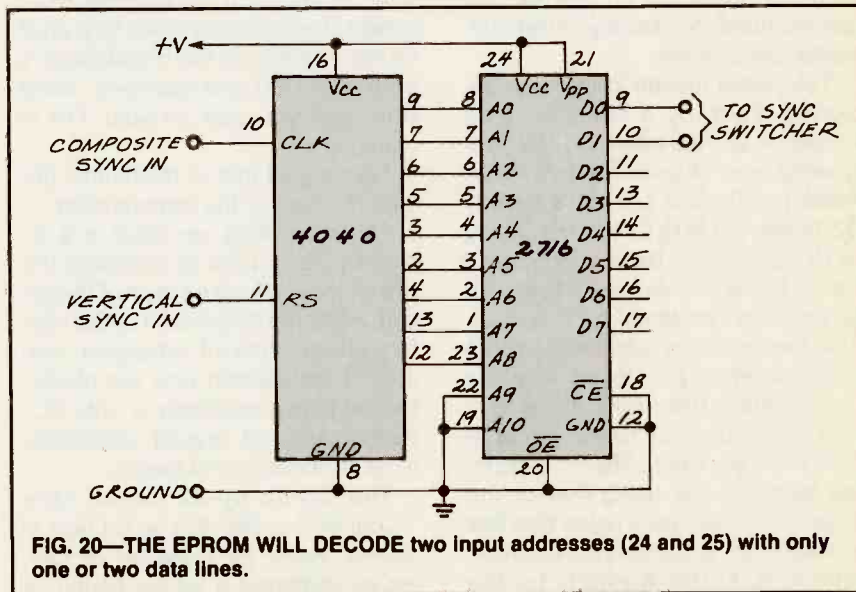

FIG. 20—THE EPROM WILL DECODE two input addresses (24 and 25) with only one or two data lines.

and if you're new to design, it's a good learning experience. But a smarter way to go about this is to use an EPROM, a one-chip solution to the problem.

You can use any EPROM you happen to have around, because we're interested in only two input addresses (24 and 257), and need only one or two data lines (depending on how we design the circuit that enables the manufactured or transmitted sync). The circuit is shown in Fig. 20, and the EPROM's truth table is shown in Table 1. I'm using two data lines to switch between sync sources, but a design could easily be worked out that uses only a single data line.

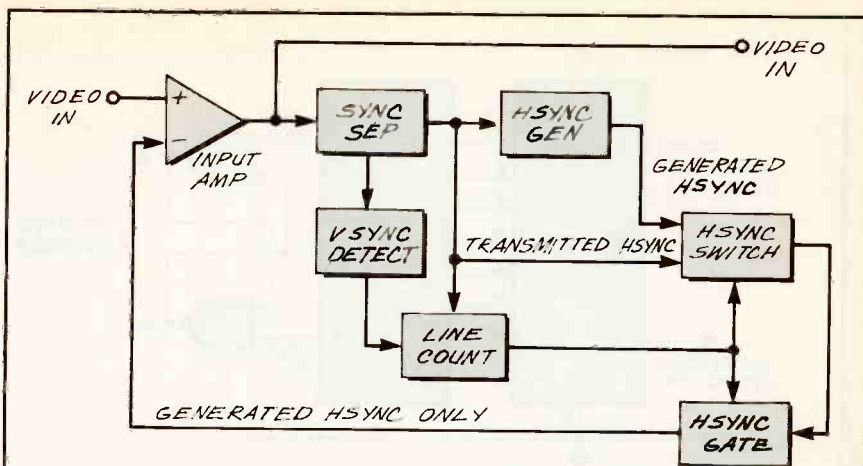

FIG. 21—SSAVI DESCRAMBLER BLOCK DIAGRAM. We use the transmitted sync during the vertical interval and the generated sync for the rest of the time.

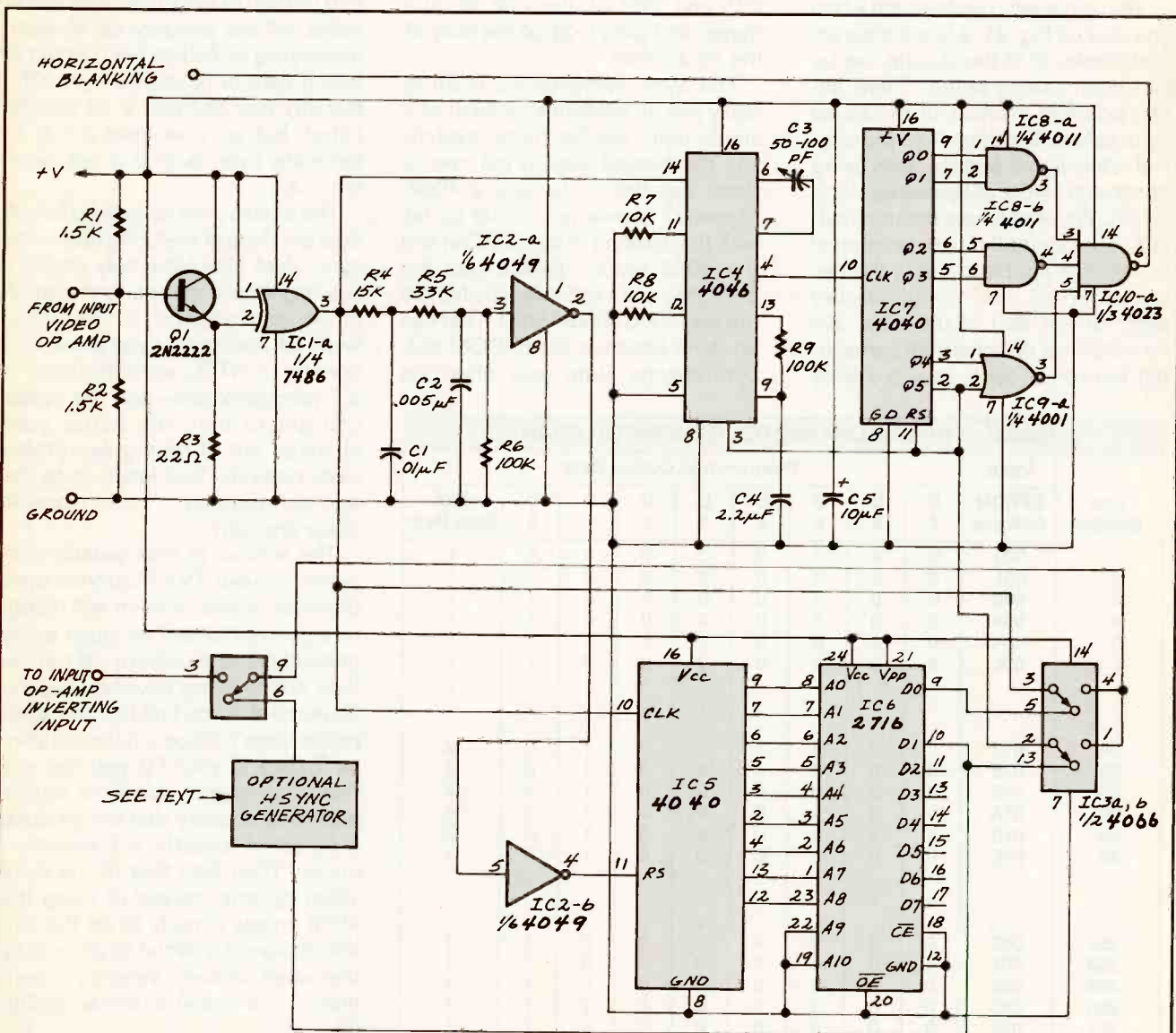

FIG. 22—THE SYNC SWITCHER is just an electronic single-pole, double-throw switch. Here we've added the EPROM and the 4066 switch. The EPROM's data lines directly control the two 4066 control lines.

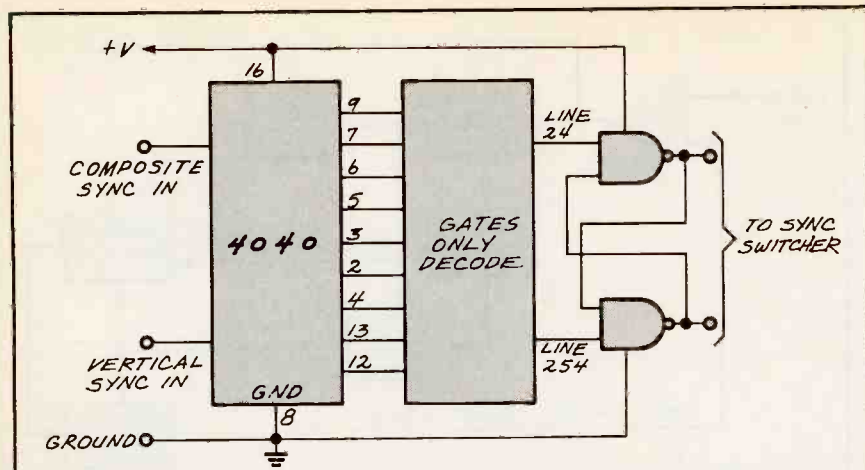

FIG. 23—INSTEAD OF AN EPROM, you can use some of the left-over gates to build a set/reset flip-flop.

This is easier to understand when you look at Fig. 21, a block diagram that shows all of the circuitry we've just been talking about. There are two possible sources of horizontal sync pulses: the ones from the original video signal, and the ones being generated by the phase-locked loop circuit. We want to use the transmitted sync during the vertical interval (it's sent in the clear during the vertical interval), and the generated sync for the rest of the time. We have 28 lines of signal with transmitted horizontal sync; they are lines

261 and 262 at the end of one frame, and lines 1–26 at the start of the next frame.

The sync switcher we need is really just an electronic version of a single-pole, double-throw switch, and the easiest way to put one of them together is to use a 4066. Figure 22 shows our circuit so far, with the addition of the EPROM and the 4066 switch. Notice that the EPROM's data lines directly handle the two 4066 control lines. That can be done because the EPROM outputs change state only when the

4040 counter signals the arrival of either line 24 or line 257. If you use gates to decode the counter output, you'll have to find a way to do the same thing. One approach would be to use some left-over gates to build a set/reset flip-flop whose control lines are triggered by the arrival of lines 24 and 257. The basic idea to effect this desired action is outlined in Fig. 23.

Back to Theory

Let's go over the general SSAVI theory for a minute. In the SSAVI system, there are two parts of the video signal that get messed up: the first is the horizontal sync pulse and the second is the polarity of the picture portion of each individual line of video. All the circuitry we've been developing so far has been aimed at taking care of horizontal sync. The circuitry has become a bit complicated, but we now have a way to generate sync even if it has been left out.

The circuitry we've built so far will do a good job of restoring horizontal sync. Just about the only problem you might have relates to the width of the generated pulse. The official width of horizontal sync pulse, according to NTSC specifications, is 4.7 microseconds—and the closer you get to that, the better your chances are of having everything work properly. That leads us to the age-old question, "How close is close enough?"

The answer to that question depends on your TV's horizontal sync detector: some of them will recognize pulses that are as much as 50 percent off, while others will turn up their noses at any deviation beyond 25 percent. If you find that the 4046 pulses aren't triggering the horizontal flyback in your TV, you can use those generated pulses to trigger additional circuitry that will produce a pulse of exactly 4.7 microseconds. Then feed that to the input video op-amp instead of using the 4046 pulses directly to do the job. We designed a circuit to do exactly that when we built a video-sync generator. The circuit is shown in Fig. 24.

Now let's address the problem of inverted video. When we first started this project, we talked about how

TABLE 1—EPROM CHARACTER GENERATOR CHART

Line Number	Input EPROM Address	Programmed Output Data								Hex Data Byte
		D 7	D 6	D 5	D 4	D 3	D 2	D 1	D 0	
1	000	0	0	0	0	0	0	0	1	1
2	001	0	0	0	0	0	0	0	1	1
3	002	0	0	0	0	0	0	0	1	1
4	003	0	0	0	0	0	0	0	1	1
5	004	0	0	0	0	0	0	0	1	1
6	005	0	0	0	0	0	0	0	1	1
.
.
24	017	0	0	0	0	0	0	1	0	2
25	018	0	0	0	0	0	0	1	0	2
26	019	0	0	0	0	0	0	1	0	2
27	01A	0	0	0	0	0	0	1	0	2
28	01B	0	0	0	0	0	0	1	0	2
29	01C	0	0	0	0	0	0	1	0	2
.
.
257	080	0	0	0	0	0	0	0	1	1
258	081	0	0	0	0	0	0	0	1	1
259	082	0	0	0	0	0	0	0	1	1
260	083	0	0	0	0	0	0	0	1	1
261	084	0	0	0	0	0	0	0	1	1
262	085	0	0	0	0	0	0	0	1	1

This EPROM can also be used to decode line 20 (see text) by programming one of the data lines high when line 20 (address 0Fh in the EPROM) is reached.

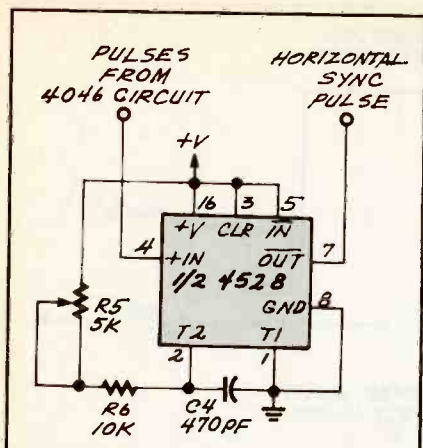

FIG. 24—IF THE 4046 PULSES WON'T TRIGGER the horizontal flyback in your TV, this circuit will generate 4.7-microsecond pulses when triggered by the 4046.

the SSAVI system encodes information about the polarity of the next frame of video. The original SSAVI system buried this information on line 20, as shown in Fig. 25. Now that we have circuitry to count the lines of video, it's a piece of cake to signal the arrival of line 20 and examine it.

Working with Video

When we built the divide-by-32 circuit (Fig. 26), we added some gates to the output of the counter to create a pulse that was approximately equal to the transmitted horizontal blanking pulse in both polarity and width. I also mentioned that the 2-microsecond period of the phase-locked loop's clock would turn out to be a very useful tool—and you will soon see why this is and what we can use it for.

Since we can identify the beginning of the horizontal blanking pulse, we can use the 504-kHz clock pulses to sample the video at any 2-microsecond multiple along the line. All we have to do is use the arrival of the horizontal blanking pulse (its falling edge) as a starting point, count the desired number of 504-kHz pulses, and sample the video to get the DC levels we want. Picking the points to sample for black-and-white DC levels is critical because they're needed to keep the picture brightness from changing when the signal switches between normal and inverted video.

The best line to use for this sam-

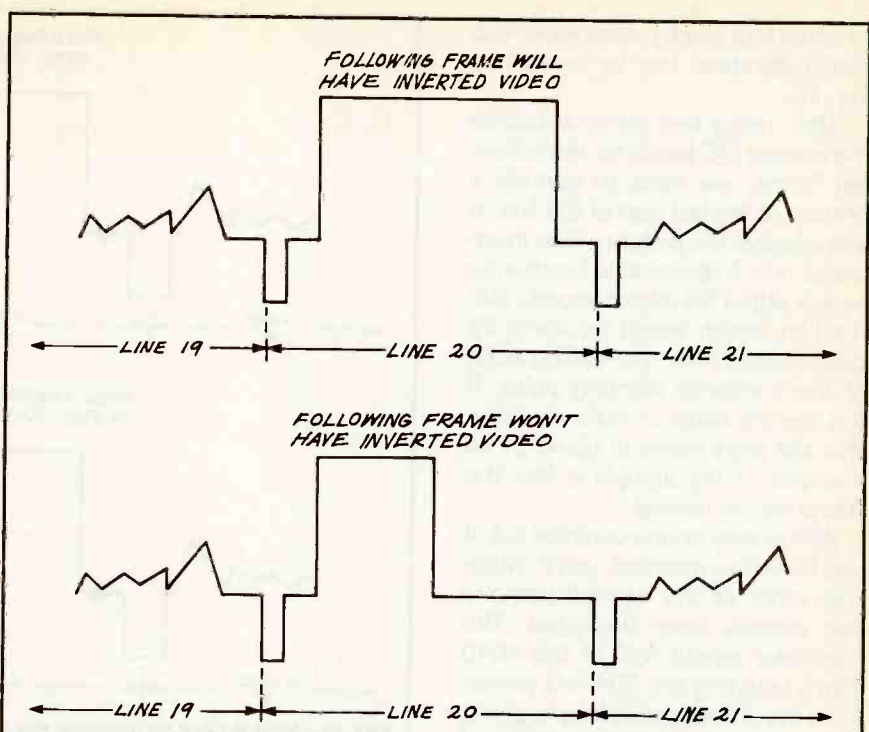

FIG. 25—TO CORRECT inverted video, we need the information buried in line 20.

pling is the same one that tells us whether the video is going to be inverted or not—I'm talking about line 20. As you can see in Fig. 27, when this line appears, the black level can be read from the back porch, and the correct white level can be gotten from the first half or so of the picture portion of the line (immediately after the rising edge of the horizontal blanking pulse).

Because the clock pulses from the phase-locked loop are slightly less than 2 microseconds wide, a single pulse sample can be taken four clock pulses after the leading (falling) edge of the horizontal blanking pulse to lock in the black level. The white-level sample can be taken two clock pulses after the end of the horizontal blanking interval (the rising edge of the pulse); it can be as

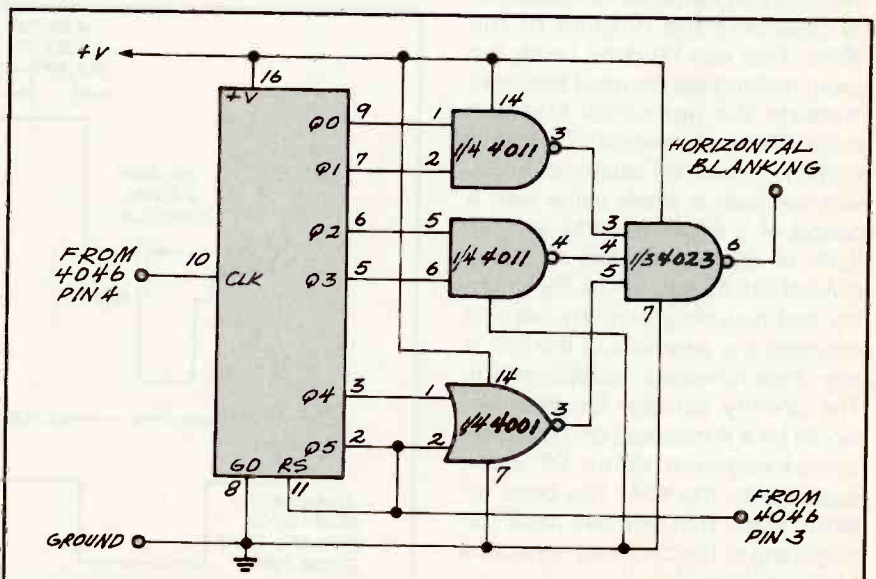

FIG. 26—THE GATES WE ADDED in the divide-by-32 circuit create a pulse that's approximately equal to the transmitted horizontal blanking pulse in both polarity and width.

much as four clock pulses wide. You can understand this by examining Fig. 28.

After using line 20 to establish the correct DC levels for the following frame, we have to sample a portion of the last part of the line to see whether the picture will be inverted or not. A reasonable location to pick is about 50 microseconds into the line, which would be some 25 clock pulses after the leading edge of the horizontal blanking pulse. If the sample taken is high, we know that the next frame is going to be inverted—if the sample is low, the frame will be normal.

All this may sound complex but, if you think for a moment, you'll realize that most of the needed circuitry has already been designed. The low-order output (oo) of the 4040 that's counting the 504-kHz pulses from the phase-locked loop is giving you a series of 2-microsecond pulses, and the gates hanging off the 4040 outputs are producing a synchronous analog of the horizontal blanking pulse. To sample the line as I just described, all you have to do is detect the leading or trailing edge of the blanking pulse (whichever one you need), count up the appropriate number of 2-microsecond pulses, and sample the video line.

All the signals you need to determine the DC levels and polarity of the following frame can be obtained by decoding the outputs of the 4040. That can be done using the same techniques we used earlier to recreate the horizontal blanking pulse. Since the period of a line of video is about 64 microseconds, and we have a clock pulse with a period of 2 microseconds, we can think of each video line as being divided into 32 segments. By counting and decoding properly, we can examine any segment of the line in any 2-microsecond multiple width. The polarity sample, for example, would be a 4-microsecond (2 clock-pulse) segment taken 25 clock pulses after the 4040 has been reset to zero. That will also mark the beginning of the decoded horizontal blanking interval.

Once the polarity sample has been taken, the same technique used to switch between generated

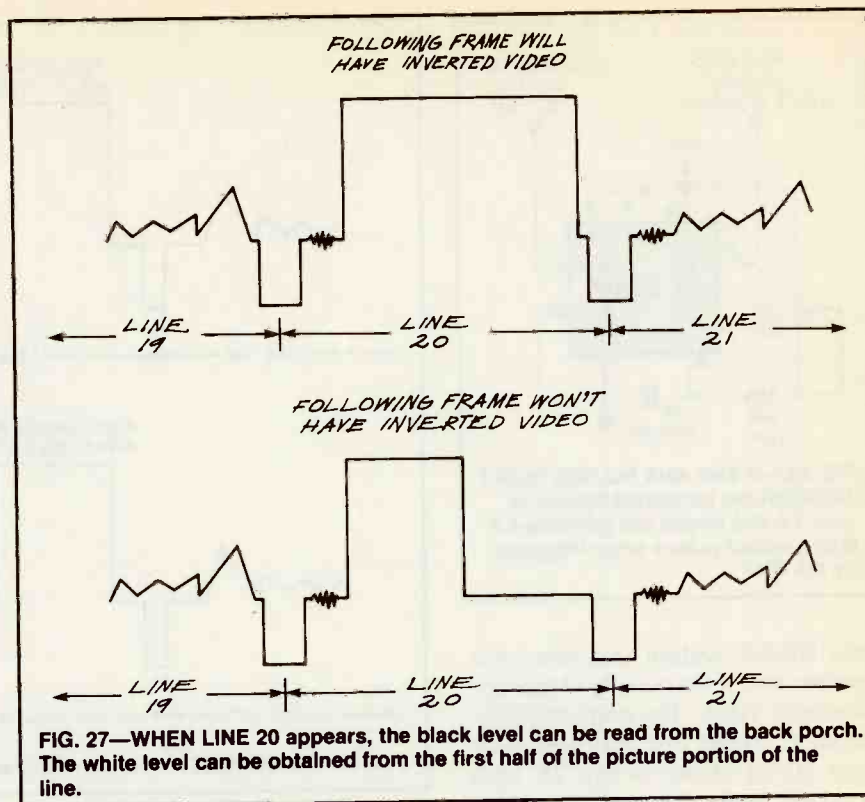

FIG. 27—WHEN LINE 20 appears, the black level can be read from the back porch. The white level can be obtained from the first half of the picture portion of the line.

and transmitted sync can be used to correct the video polarity if we find that it's been inverted. The two unused switches in the 4066 have to be configured, once again, as a single-pole, double-throw switch. The output of the gate that reflects the state of the polarity sample triggers a set/reset flip-flop that, in turn, toggles the SPDT switch.

The output of the amplifier at the front of the circuit contains both the received video and, except during the vertical interval, the generated horizontal sync signals created to stabilize each line of video. If the polarity wasn't a problem, we could send the signal off to the output stage of the descrambler and then directly to the back of a TV set.

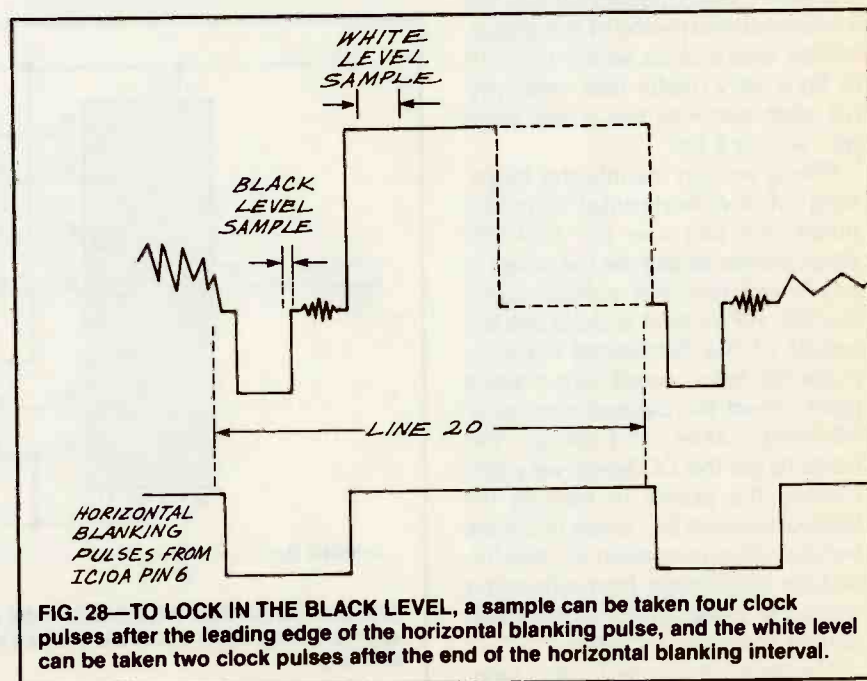

FIG. 28—TO LOCK IN THE BLACK LEVEL, a sample can be taken four clock pulses after the leading edge of the horizontal blanking pulse, and the white level can be taken two clock pulses after the end of the horizontal blanking interval.

Since, however, the "VI" part of SSAVI stands for "video inversion," we have to have available an inverted version of the video as well.

The received video with the corrected horizontal sync pulses is sent through an inverter that's built in exactly the same manner as the single-transistor buffer at the front of the decoder. This inverted version of the video is sent to one side of a polarity switch, and the plain video is sent to the other side of the switch. Each signal has its horizontal interval corrected by the circuitry that was designed to restore the sync signals.

The flip-flop built to indicate the presence of either normal or inverted video controls whether the normal or inverted video is routed to the descrambler's output.

Even though the descrambler's circuitry seems to have grown at an alarming rate, its overall operation is not hard to understand. If you've been following this from the beginning, you should have a pretty good handle on what's going on. We've regenerated horizontal sync and created a signal to tell us if the picture has been inverted. At the descrambler's output, we're using an electronic switch to make sure the video sent to the back of your TV set always has the correct polarity. This has been done by decoding the state of the transmitted video from line 20, and using that information to channel either a straight or an inverted version of the sync-restored video to the output of the descrambler.

The last piece of hardware business comes up because the horizontal sync is *never* inverted in the SSAVI system. Since the first thing we did to unscramble the video was to restore the horizontal sync pulses, the video coming out of our inverter (the video being sent to the invert side of the 4066 switch) will have the entire horizontal interval inverted as well. Fortunately, this is pretty easy to correct. We have to make sure that during the horizontal interval, only the non-inverted video is routed to the descrambler output.

The way to accomplish this is to gate the output of the polarity indicator (the flip-flop) with the horizontal blanking pulse. We want the normal video signal sent to the de-

scrambler output during the horizontal blanking interval, regardless of the polarity of the video signal.

When you're building a SSAVI descrambler like this, there are a few rules to keep in mind as you work your way through the design. We've gone over all of them, but listing them out will make it much clearer:

1. Since the vertical interval is always sent in the clear, the descrambler has to be disabled for this period of time.
2. During the horizontal interval, the transmitted video signal must be sent to the descrambler output.
3. If you don't have a scope, you won't be able to build a SSAVI, or any other video descrambler.

Go Build Your Own

You now have all the information you need to design and build a working descrambler. I admit that it's been a lot of work, but it's a low price to pay because the descrambler, when combined with the service manual for your TV, will let you use all the features in a cable-ready set.

I started writing on this subject because my local cable company began scrambling *all* the cable channels, not just the premium ones. A lot of people, myself included, have spent a lot of money to buy a TV that offers picture in picture, super stereo, and a bunch of other features. Using a box from the cable company completely wipes out most of those features, to say nothing about not being able to use the TV's remote control.

Because cable boxes are fairly expensive, even when purchased in quantity by the cable companies, the boxes provided with cable service don't provide the same range of functions as those built into a high-end TV set. Some boxes have audio and video outputs but, at least in my area, the audio is in mono—I didn't even know that mono was still a viable option.

The mentality of the cable companies today is on a par with that of the phone company twenty years ago. Not only were you charged for line service, but the phone company also insisted on billing you for all the hardware, wire, and installation as well.

It took a lot of legal work and lawsuits to convince the phone company that it was more profitable to concentrate on selling services than it was to keep a stranglehold on everything from your mouthpiece to my earpiece. For once, a bunch of lawyers did something that was worthwhile!

Until the cable companies learn the same lesson that was forced to the phone company, we're going to have to deal with the problem of the limitations of cable TV's proprietary hardware vs. the cable-ready TV set. If basic cable service includes 25 non-premium, non pay-per-view stations, I shouldn't need a cable box to get those channels. The big-brother, total-control mentality of the cable television companies is going to be ended, I fear, only by lawyers.

Real-world Considerations

In the original SSAVI system, horizontal sync was never inverted during active video (when the picture was showing up on the TV), but that has changed. The video waveform in Fig. 29-a shows the state of the horizontal interval as of fifteen minutes ago (as of this writing) on my cable. I've drawn it with an unscrambled horizontal interval so you can see how the scrambled signal relates in time to the normal one in Fig. 29-b. A change has been made to the 4-7-microsecond position normally occupied by the horizontal sync signal. There are also two 1-microsecond spikes at the very beginning and end of the horizontal interval. If you watch a scrambled picture, you can see these at both ends of the interval as it weaves its way down the middle of your screen.

These spikes peak at 100 IRE units but since they're not really in the horizontal interval, they don't cause any problem. If I had to make a guess as to why the "woop-dee-doo" has been added to the horizontal interval, I'd say that it's to keep people from doing what we're doing—adding a single sync pulse to restore the signal.

When I was designing the section of the descrambler that put the horizontal sync pulse back in the interval, I had to modify the circuit slightly to make it work. Basically, all

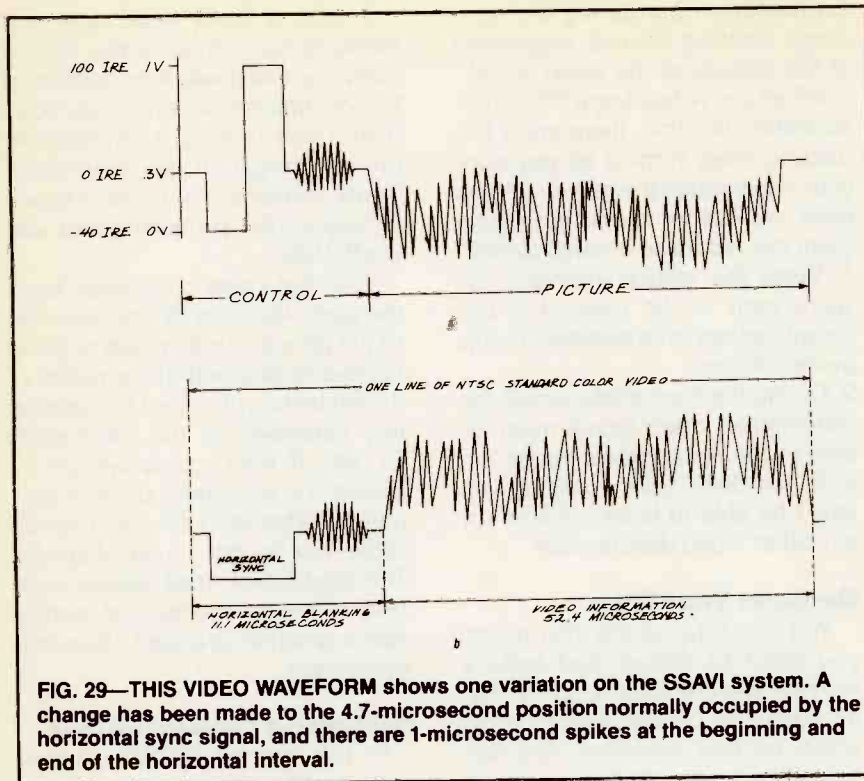

FIG. 29—THIS VIDEO WAVEFORM shows one variation on the SSAVI system. A change has been made to the 4.7-microsecond position normally occupied by the horizontal sync signal, and there are 1-microsecond spikes at the beginning and end of the horizontal interval.

I did was add some gates to the output of the 4040 line counter to create a pulse that started 2 microseconds into the horizontal interval and had a width of 4 microseconds—the approximate length of the horizontal sync pulse. I used it to gate the incoming video, completely eliminate the change from the transmitted signal, and make sure that the only thing that appeared in that section of the line was the generated horizontal sync from the phase-locked loop.

During the vertical interval, of course, this entire activity was disabled to allow the transmitted sync (which is still being sent in the clear) to be passed through the descrambler.

The polarity indicator for the picture still works as I described, but the newer SSAVI systems (at least the one in my area) move it around between lines 20 and 22. This is actually a dangerous thing for cable companies to do, since line 22 is usually considered to be active video.

The information as to where it will be is probably buried in the subscriber codes, which are difficult to decode. The code format is usually as a series of 32-bit words with bits that are about 2-microseconds wide

at a data rate of 504 kHz (which should be a somewhat familiar number).

How to handle this problem depends on the nature of the scrambled signal in your area. You can decode the marketing code and figure out which bits indicate the correct line to examine for determining the polarity of the following video frame, but that is an involved subject and there's just not enough room here to go into it. It's also not the best approach since there's nothing stopping the cable companies from putting the code somewhere else or, to make matters even worse, change the encoding algorithm.

A second way to deal with the problem is to examine the vertical interval on a scope, see where the polarity-indicating lines are, and work out some circuitry that examines them all. Remember that what has changed is the location of the line (it now moves around from place to place), and not the structure of the line. In essence, if there are three lines to examine, a high in the second half of any of them would indicate that the next video frame is inverted. That's the approach I took.

One interesting piece of informa-

tion I can pass along to you is that, again in my area only, the video is *always* inverted. Check the signal in your area and see if that's true for you as well. If it is, the design of the descrambler is much simpler.

Before you get to work, however, some thought has to be given to the things that might be done in the future. Since the SSAVI system has changed over the years, there's no guarantee that the way you go about detecting inverted video today is going to hold up tomorrow.

If you go through the trouble of building something to detect the state of video by looking at line 20, it can all be made useless if the cable company moves the information somewhere else. Restoring horizontal sync is pretty much locked in stone, but I can definitely think of a few ways that even that could be changed.

Remember that large-capacity EPROMs are cheap, and there's nothing stopping the cable company from putting several encoding techniques in the chip. To guarantee your work against obsolescence, the techniques you use to clear up inverted video have to depend on things that can't be easily changed by the cable company.

There's a much more interesting way to deal with the problem.

The vertical interval provides a lot of information. One thing we haven't talked much about is the white and black levels. I don't bother too much with these because the TV (or VCR) has excellent circuits to clamp the levels and condition the video signal before it reaches the sync separator. I've found that if I feed the video in at anywhere from 1.2 to 1.5 volts DC, the TV or VCR doesn't have any trouble working out the levels for itself.

The black level (0 IRE) should be about 0.3 volt and the white level (100 IRE) should be about 1 volt. Super black is the bottom of sync (-40 IRE) and is at 0 volts. Even if you can't find the polarity line to get the white level, you can always get the black and super-black levels from the unscrambled transmitted sync that's sent in the vertical interval. You can even get the black level of the video signal in the horizontal intervals during active video from

the 5-microsecond section containing the back porch.

Once you know the black level, you can integrate the picture part of the line to get the average DC voltage of the signal. That's the same sort of thing we had to do to isolate vertical sync from the composite sync signal. If it's below the black level, you know that the line has been inverted, and if it's higher, then you know that the line was normal. You'll probably have to filter out the chroma and look at the luminance (DC level) of the line, or else the circuit might have a hard time telling the difference between a dark normal video line and a bright inverted line.

If you do that, one other clue that will help detect an inverted line is that the picture's DC level should never get below about -20 IRE. If it does, the TV's vertical sync detector might sense it and falsely trigger a vertical retrace. That's the sort of thing that frequently happens when you try to view a scrambled video signal—even if the transmitted signal isn't doing anything to the original vertical interval.

Since video is inverted (or not) by the cable companies on a frame-by-frame basis, it's safe to assume that finding an inverted line means that the next one will be inverted as well. Remember that the descrambler is completely reset during the vertical interval when vertical sync is detected.

There's no way that I can provide you with an absolute method to descramble the video in your area—there are just too many subtle variations that can be added to the basic SSAVI system. The ones I just described are only a few of the many possible twists that can be done to a video signal.

The approach and circuitry we developed over the last few months—as well as the theory—should give you a good head start for working out the details that have to be added to deal with the particular scrambling method used by your cable company.

Some Reader Suggestions

Over the years, a lot of the projects we've worked on together have needed oddball decoders. I've said

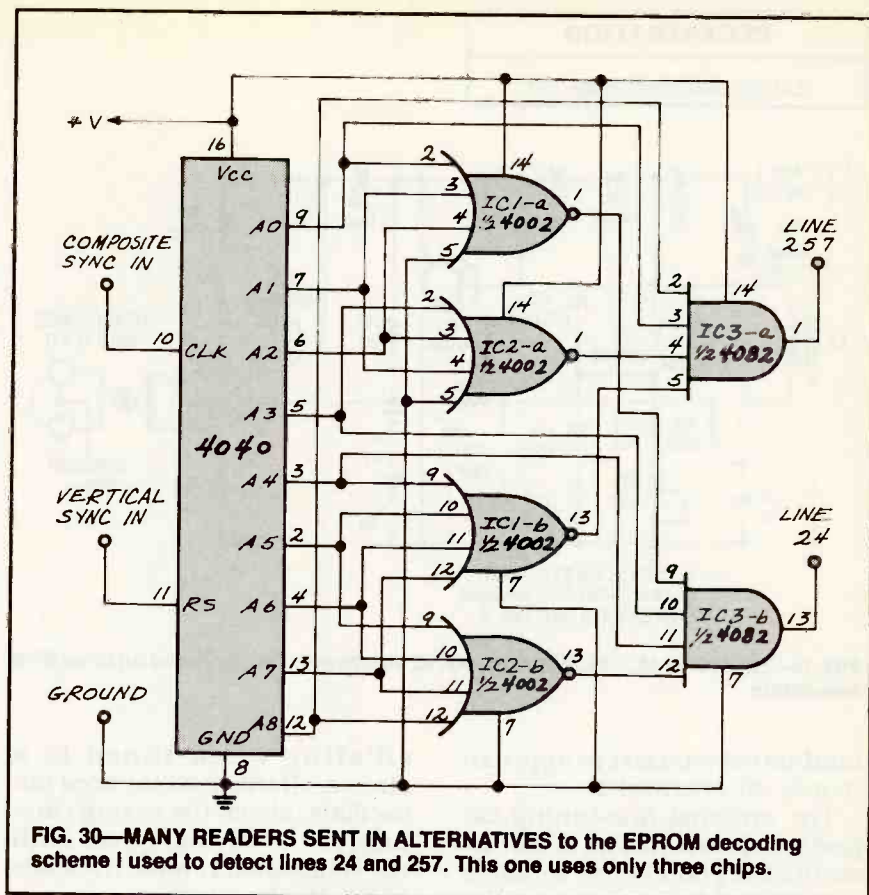

FIG. 30—MANY READERS SENT IN ALTERNATIVES to the EPROM decoding scheme I used to detect lines 24 and 257. This one uses only three chips.

over and over again that my preferred solution is an EPROM. I've used EPROMs for everything from custom character generators to state detectors for weird numbers. If you've got the time and patience to work out a gates-only solution, you might improve your logical thinking skills, but it will take you a lot longer to get something working, it will make PC board layout a lot more complicated, and it will lock you into a particular design. EPROMs are more versatile because any modifications to the hardware in the design can be accommodated simply by programming some new code in the EPROM.

When you're in the middle of designing some hardware, a gates-only decoder might seem more attractive if you can't program an EPROM right then and there. But if you do a lot of hardware design, an EPROM programmer is a piece of equipment that's just as essential as an oscilloscope.

I'm mentioning this because since we went through the basics of a SSAVI descrambler, I've received a lot of mail with alternatives to the

EPROM decoding scheme I used to detect lines 24 and 257. Since it seems that a lot of you out there either prefer to do stuff with gates or don't have access to EPROM programmers, I'm going to pass along some of the decoders I've received.

All the decoders that were sent in are built with standard gates, so you should have no trouble getting the parts. Even though I have the greatest faith in my readers, I'd be a bit remiss if I didn't tell you that I haven't tried these circuits myself.

Here is one from David Siegel of Livonia, Michigan and the schematic is shown in Fig. 30. It's a pretty slick design in that it's built with only three chips: two dual 4-input NOR gates and one dual 4-input AND gate. See if you can do better! Good luck. Ω

REGENERATION

Continued from page 83

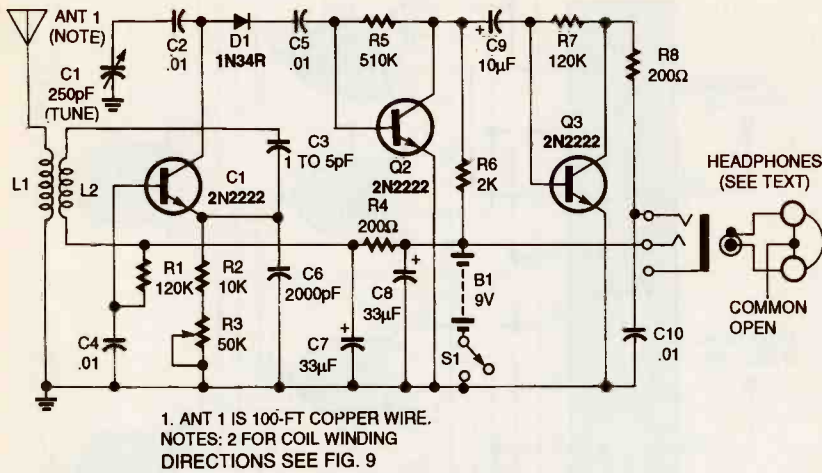

FIG. 11—ECONOMY MODEL REGENERATIVE shortwave receiver based on three NPN transistors.

modulated carrier) is approximately 40 microvolts.

The optional fine-tuning capacitor shown in Fig. 8 can be omitted if you choose to use a vernier dial for operating variable capacitor C3. The author's prototype for this shortwave receiver was built on an aluminum chassis with two side panels. The circuitry was point-to-point wired on a section of prepunched circuit board measuring about $2\frac{1}{2} \times 2\frac{1}{2}$ inches, with a ground plane on one side. It was mounted on stand-offs to the base of the chassis. The potentiometers, tuning dial, jacks, and terminals were mounted on the side walls. The two 9-volt batteries were snapped into clips attached to the side walls.

To operate the receiver, connect the antenna and ground to the set, back the regeneration control knob to the position for minimum regeneration, and turn on the power. With the volume control set in mid position, advance the regeneration control until a click is heard in the headphones.

Tune the receiver until a station is found, and again adjust the regeneration control knob, this time to a point just below oscillation. (There will be an audible howl if the receiver is os-

cillating when tuned to a station.) If the detector does not oscillate, check the wiring carefully. If the wiring agrees with the schematic, reverse the leads to the tickler winding.

The highest sensitivity and selectivity will be achieved if the receiver is operated at a point just below the threshold of oscillation. The regeneration control must be readjusted each time the receiver frequency is changed. Use one hand for tuning and the other for adjusting regeneration. Here are some tuning hints:

- If a station is being received with adequate volume, a decrease in regeneration will improve the sound quality.
- If more than one station is being received, and they cannot be separated by tuning, an increase in regeneration will provide more selectivity.
- The adjustment of capacitor C1 is important for receiver operation because it adjusts the loading the antenna presents to the detector. For best selectivity, coupling should be just enough to allow the detector to self-oscillate at the low end of its tuning range.
- Increasing the capacitance of C1 loads the detector. This will prevent free oscillation and detune the receiver slightly rather

than let it oscillate. (With less capacitance, the detector will oscillate intermittently as the signal level varies.)

- To avoid annoying oscillations, adjust C1 for its highest capacitance. This effectively provides automatic gain control (AGC). While it simplifies tuning, it also reduces receiver selectivity.

In general, for a 100-foot antenna, C1 should be set so that it provides about a third of its total capacitance (30 picofarads). If the antenna length is shorter, capacitance should be 50 to 100 picofarads.

Regenerative negatives

The regenerative receiver of Fig. 8 has its drawbacks. When receiving weak signals, the detector can self-oscillate if the regeneration level is too low to amplify the received signal satisfactorily. As a result, strong signals are amplified significantly with pronounced selectivity, while weak signals receive much less amplification.

When two received signals are close in frequency, it might be difficult to separate the weaker signal from the stronger one, and an audio "whine" occurs. In addition, "dead spots" are encountered as the receiver is tuned across the band because the antenna goes in and out of resonance as receiver frequency is varied. When the antenna is at resonance, it absorbs energy from the detector and loads it down, thus preventing re-

(Continued on page 106)

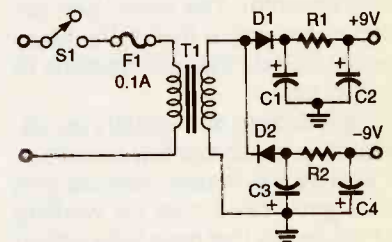

NOTES:

1. TRANSFORMER T1: PRIMARY 120VAC, SECONDARY 6.3VAC, 300mA
2. DIODES D1, D2: SILICON 2A, 200V
3. CAPACITORS C1, C2, C3, C4: 2000 μ F
4. RESISTORS R1, R2: 100 Ω

FIG. 12—FILTERED POWER SUPPLY for the transistorized regenerative receiver circuits.

GET THE LATEST ADVANCES IN ELECTRONICS

SUBSCRIBE TO—

Electronics NOW[®]



ENJOY THE WORLD OF ELECTRONICS EACH MONTH!

Subscribe to the best informed electronics magazine—the one that brings you the latest high-tech construction projects, feature articles on new technology, practical troubleshooting techniques, circuit design fundamentals, and much more.

Electronics Now looks to the future and shows you what new video, audio and computer products are on the horizon. You'll find helpful, monthly departments such as Video News, Equipment Reports, Hardware Hacker, Audio Update, Drawing Board, Computer Connections, New Products, and more. All designed to give you instruction, tips, and fun.

Electronics Now gives you exciting articles like:

- Buyer's Guide to Digital Oscilloscopes
- Build A Scanner Converter
- Single-Chip Voice Recorder
- Build A MIDI Interface for your PC
- Troubleshoot Microprocessor Circuits
- Build A High-Power Amplifier for your Car
- Add Music On Hold to your Phone
- All About Binaural Recording
- VGA-to-NTSC Converter



FOR FAST SERVICE CALL OUR TOLL-FREE NUMBER!

1-800-999-7139

DON'T DELAY — SUBSCRIBE TODAY!

If you prefer, just fill out the order card in this magazine and mail it in today.

7X446

REGENERATION

Continued from page 104

generation.

Probably the most annoying characteristic of the simple regenerative receiver is that if its detector free-oscillates, it radiates a signal from the receiving antenna at its tuned frequency. Because the antenna is also tuned to this frequency, it becomes a very efficient radiator.

Therefore, despite the fact that the JFET detector produces only a 10 milliwatt output, the generation of radio interference must be avoided. With the circuit of Fig. 8, the best way to prevent the detector from oscillating is to adjust the input coupling with variable capacitor C1 so that the detector never quite breaks into oscillation.

Throttle condenser

The JFET regenerative shortwave receiver circuit in Fig. 10 overcomes many of the drawbacks inherent in the Fig. 8 circuit. It includes a stage of RF amplification that provides about 30 dB of isolation between the detector and the antenna. It substantially improves the sensitivity to better than 0.5 microvolt over most of its operating range, makes some improvement in selectivity, and eliminates antenna "dead spots" caused by antenna resonance effects.

Resistors R1 and R2 set the bias level for RF amplifier Q1. The output of Q1 is coupled to the input of detector Q2 with a 100 picofarad capacitor and a tap on coil L2. This avoids excessive detector loading. Transistor Q1 is powered from the negative battery, while Q2 is powered from the positive battery. This balances the current drain from each battery so that both batteries will be discharged at the same rate.

Potentiometer R3 varies the negative supply voltage that, in turn, varies the RF gain and the signal level applied to Q2. To keep the signal-to-noise ratio high, set detector regeneration

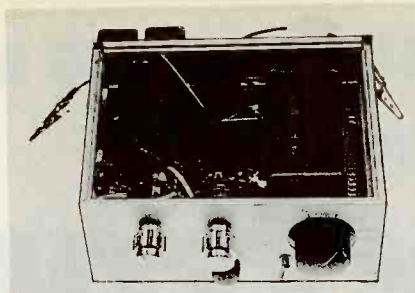

REGENERATIVE SHORTWAVE receiver. Note the shield between the RF and detectors.

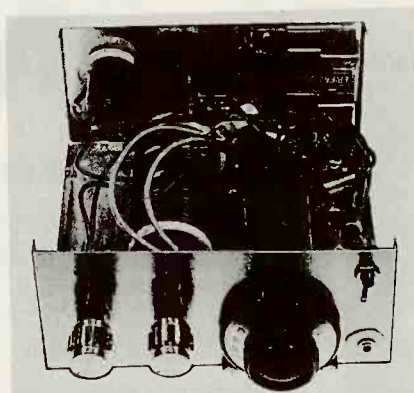

THIS SENSITIVE AND SELECTIVE receiver was built with a vernier dial for improved tuning accuracy.

control potentiometer R8 near midscale. This allows high RF gain to be adjusted before self-oscillation begins. Resistor R4 and capacitor C4 decouple the power supply between the RF and output stages.

Refer to Fig. 10 and notice that the coils for this receiver (Figs. 9-b and 9-c) are wound on 1-inch diameter plastic pill containers. The author's prototype was point-to-point wired on perforated universal circuit board with a ground plane on one side measuring 6 x 4½ inches that fit in a 6½-inch x 5 x 3-inch high metal case. Again, as in the Fig. 8 receiver, the manual controls with knobs, batteries, and headphone jack were mounted on the walls of the metal case.

Unfortunately, the additional gain of the RF stage makes it more difficult to maintain circuit stability. One way to overcome this is to be sure to connect the frame of the multi-gang tuning capacitor directly to ground with screws rather than relying on a length of wire sandwiched between it and the

chassis ground.

Connect the antenna directly to the tap on L1. Connect the gate of Q1, which is AC-coupled by C2, to the top of L1. To maintain its stability, solder a shield made from a small piece of copper-clad circuit board vertically between the RF and detector coils. This prevents strong detector signals from being fed back to the RF stage.

An innovative feature of this circuit is its *tracking* *throttler* capacitor. In a typical regenerative receiver, feedback or regeneration control must be constantly readjusted as the frequency is varied. However, one section of a three-gang tuning capacitor in this circuit forms a throttling condenser that helps to compensate for higher regeneration levels as the received frequency is increased.

The tracking of regeneration versus the received signal is not precise because the inductance of the tickler coil is less than that of the main tuning coils, while the capacitor values of both are equal. Here a compromise was introduced: additional turns were added to the tickler for better tracking, but the presence of a tickler with the same number of turns as the tuning coils would provide too much feedback. This excessive feedback would, in-turn, require the gain of Q2 to be reduced almost to cutoff, making regeneration difficult to control.

Cascaded regeneration

Two or more cascaded regenerative circuits will significantly increase overall receiver selectivity. The regenerative receiver in Fig. 10 can be modified to make both the RF and detector stages regenerative by adding a second tickler coil, L5, as shown in the inset of Fig. 10. Open the connection between the drain of Q1 and the junction between R4 and C5, and connect the coil shown as Fig. 9-d in the coil winding guide. One-inch diameter pill bottles were also used as the forms for this coil. Coils L2 and L3 remain the same.

For the highest selectivity and sensitivity, it is important that

both regenerative stages oscillate at the same time. "Regenerative tracking" can be accomplished with just the right number of turns on coil L5-a. (The \approx symbol indicates that from four to six turns might be required.) Nevertheless, to set both stages for continuous simultaneous oscillation over a useful frequency range, two separate regeneration controls are required: one for the detector and one for the RF stage.

This modification of Fig. 10 will result in a significant improvement in selectivity and some increase in sensitivity, but it involves a tradeoff. It will perform as well, if not better, than most modern superheterodyne receivers. However, there is a catch. If the RF stage is permitted to self-oscillate, it will radiate its signal from the antenna causing unwanted and illegal transmission, and you lose its principal benefit.

The detector could be set so that it oscillates first, but that will reduce the receiver's overall selectivity. Also, the tracking throttler capacitor is less effective now, and the receiver will need more frequent regeneration adjustment during tuning.

Low-cost receiver

Low cost and availability of components were important considerations in the "modern" regenerative receivers presented here. Nevertheless, the shortwave receiver in Fig. 11 is a "true" economy model. It offers a frequency range of 5.5 to 12 MHz. The prototype receiver was built with about \$8 worth of parts (less headphones). While its sensitivity is good, its selectivity and stability are not up to the standards of the receivers in Figs. 8 and 10.

The first thing that you'll notice in examining Fig. 11 is that bipolar NPN transistors have replaced the more expensive JFETs and op-amps. Transistor Q1 is part of a regenerative RF amplifier that provides high gain. The output of germanium detector diode D1 directly drives a two-transistor audio amplifier. (A germanium

diode was selected because its forward bias voltage—about half that of a silicon diode—gives the receiver increased sensitivity.)

The author's prototype was point-to-point wired on a 3½-inch square of copper-clad circuit board. This was mounted on a 4-inch square by ¾-inch square wood board. Sheet aluminum panels were attached to the wood base for mounting the control potentiometers, switches, jacks, and other components. The components were soldered onto two terminal strips attached to the end and center of the board. The coil form with coils L1 and L2 was mounted between the terminal strips and variable capacitor C1 was mounted on the other side.

The coil winding diagram that applies to this receiver is Fig. 9-e. The headphones are connected in series with the collector of Q3, eliminating the need for an output transformer.

Alternative power

Because a regenerative receiver includes an oscillating detector, it will amplify hum as well as radio signals. This makes it essential that it be powered with batteries or a very low-ripple power supply. Figure 12 is the schematic of a suitable supply.

Coil winding

Refer to Fig. 9, the coil winding guide, and study it carefully before winding any coils. Number 22 insulated, stranded-copper hookup wire was used for winding the coils.

Before winding the insulated hookup wire on a pipe section or pill bottle, it is recommended that you drill two small holes about ½-inch apart at one end where the turns are to begin. Feed one end of the insulated wire through both holes and tie a knot in it to secure the starting position, being sure to leave enough extra wire outside the knot for the external connections that are to be made.

Then complete that winding and drill two more holes in the coil where the winding ends and tie a knot there as well. Ω

3 NEW BOOKS for the Project Builder



Electronic Board Games

BP350—ELECTRONIC BOARD GAMES, \$6.00

Twenty novel electronic board games that you can build from the plans in this book. Whether you are interested in motor racing, searching for buried treasure on a desert island or for gold in Fort Knox, spinning the wheel of fortune, or doing a musical quiz—there is something for you to build and enjoy!

PCP119—ELECTRONIC MUSIC AND MIDI PROJECTS \$14.95

Save cash by building the MIDI gadgets you need. Want a MIDI THRU box, program change pedal, Metronome, analog echo unit, MIDI patchbay or switcher? Over 16 practical and very useful music and MIDI projects—all in this book! The projects are explained in detail with full instructions on assembly.

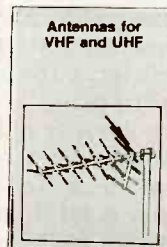
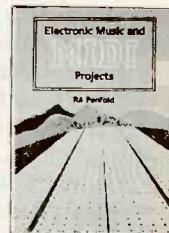

Antennas for VHF and UHF

BP301—ANTENNAS FOR VHF AND UHF \$6.00

From installing a TV or FM antenna to setting up a multi-antenna array for shortwave listening or amateur radio, this book explains the basics of VHF and UHF antenna operation and installation. The text describes in easy-to-understand terms the essential information about how antennas work, the advantages of different antenna types, and how to get the best performance from an antenna.

Mail to:

Electronic Technology Today, Inc.
P.O. Box 240
Massapequa Park, NY 11762-0240

Shipping Charges in USA & Canada

\$0.01 to \$5.00	\$1.50	\$30.01 to \$40.00	\$5.50
\$5.01 to \$10.00	\$2.50	\$40.01 to \$50.00	\$6.50
\$10.01 to \$20.00	\$3.50	\$50.01 and above	\$8.00
\$20.01 to \$30.00	\$4.50		

Sorry, no orders accepted outside of USA and Canada. All payments must be in U.S. funds only.

Number of books ordered.

Total price of books \$ _____
Shipping (see chart) \$ _____
Subtotal \$ _____
Sales Tax (NYS only) \$ _____
Total enclosed \$ _____

Name _____
Address _____
City _____ State _____ ZIP _____

Please allow 6-8 weeks for delivery.

CAR STEREO

Continued from page 55

knobs from either style before a dashboard installation can be removed. When you are working on late-model cars, you might need some special tools to fit unusual fasteners. You can usually obtain these from most automobile parts supply stores.

Most radios are installed with a bracket that is bolted to both the underside of the dashboard and to the back of the radio case. You can gain access to the bracket from under the dashboard, but you might have to remove covers or panels to get at the unit. Remove the bracket from the radio—not from the dash panel.

If it is not possible or practical to remove the radio through the front opening of the dashboard because of its size or interfering hardware, the radio must be removed from behind the dashboard. Oversize radios are more likely to be encountered in older cars that still have their original equipment in place.

Figure 5 shows a 23-year old Delco AM/FM monophonic radio with a more modern Kenwood AM/FM stereo with a cassette deck on top of it. This clearly illustrates the progress in miniaturization of automotive radios over the years—even with many additional features added.

It might be necessary to remove ventilation ducts and other interfering hardware to complete a job. The removal of a center-console-mounted radio, for example, might require the partial or complete removal of the console itself.

When all of the mechanical fasteners have been removed, permitting the radio to be pulled from its cutout, the next step is to disconnect any attached wires. Factory-installed radios typically have one or more connectors that can simply be unsnapped, and the antenna cable can be unplugged. You might want to identify the power supply wires that you will need at the connector with a

voltmeter at this time.

The other wires connect the factory-installed speakers which you will probably discard. There might also be a separate power wire attached to the

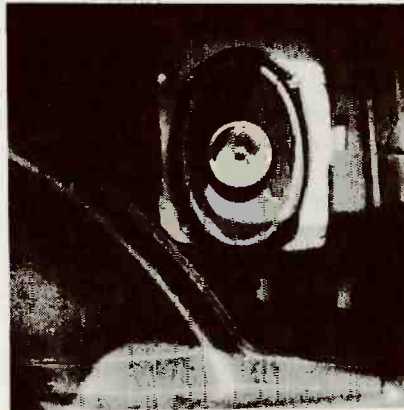

FIG. 10—REAR SPEAKERS can be mounted behind the back-seat side panels—if space permits.

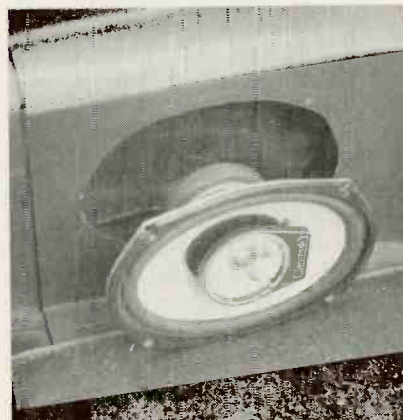

FIG. 11—IN A HATCHBACK CAR, rear speakers can be mounted on the panels in the hatch area.

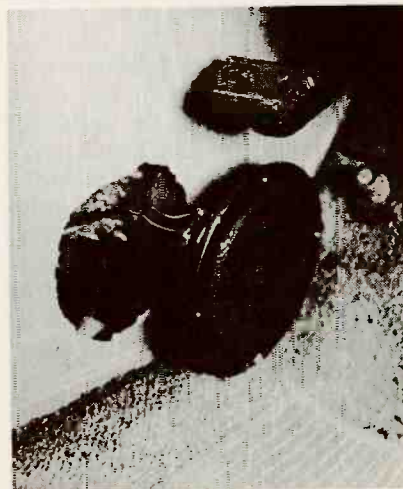

FIG. 12—CONFIRM THE CLEARANCE space when mounting speakers in door panels or front kick panels by removing the panel and making a measurement.

car's headlight switch. Power from that wire illuminates the radio's dial only when the car's headlights are on. The automobile's ignition switch must be on to enable the radio's ON/OFF switch. Many modern automotive stereos also have lights that illuminate the stereo's control buttons when the headlights are turned on, even if the radio is off.

When installing your new stereo system, avoid wherever possible, any unnecessary alteration of your car's interior. You might have to cut away some metal or plastic around the mounting hole in the dash panel to accommodate the new unit. Double check your measurements before you do any cutting that might be incorrect and irreversible, leaving the dashboard defaced.

The control-shaft spacing on conventional automotive stereos can usually be adjusted so that the case will fit through the original opening in the dashboard. Most of those radios are sold with bezels that fit securely over the dash panel's original trim plate.

The bezel might have grooves molded into its frame that allows pieces of it to be snapped off to adjust its size, as shown in Fig. 6. However, a DIN-type stereo usually requires a mounting kit to secure it in its intended location, as shown in Fig. 7. The installation of a removable radio is similar, but only the radio's mounting sleeve is installed. The radio then slides into the sleeve.

Speaker installation

Assume that you have removed your old radio successfully and are ready to install your new system. Now is the time to install the speakers. However, you first must decide if you want two speakers or four. The interior space in some cars is so restricted that it has room for only two speakers, so the decision has been made for you.

Unless you have some compelling reason for installing new speakers in another location, it makes sense to put them in the

(Continued on page 111)

DIGILYZER

Continued from page 70

tape to the case and marking the locations of the hole centers. Note: The ganged bodies of the eight switches selected occupied the space between the cover mounting posts inside the case.

Drill the eight holes for the switches as well as the holes for plug PL1 and jacks J1 and J2. Mount all the switches and the plug and jacks with the ring nuts provided or nut and bolt sets, as required.

Mark the locations of the eight holes in a row across the cover to admit the lenses of the LEDs. (In the prototype they were sized for the diameter of T1¼ LED lenses.) Tape a section of perforated board on the top surface of the cover and use the 0.1-inch matrix as a guide for locating the centers of the holes to be drilled. The spacing should correspond to the spacing of the LEDs on the circuit board.

Drill the eight holes for the LEDs, drill the four countersunk holes in the case cover for mounting the circuit to the underside of the cover, and drill the three holes in the cover for switches S9, S10, and S11, as shown in Fig. 4. You might want to apply decals to the cover to identify the switch functions.

Fasten the circuit board to the cover with the four spacers and suitable self-tapping screws. It will not be necessary to drill additional holes in the circuit board because the screws will pick up on matching holes in the board.

After fastening the circuit board to the case, attach the miniature test clips to the ends of the ribbon cables and separate twin lead. The test clips were color coded in the prototype: eight green clips on the eight-wire ribbon cable, eight white clips and one black and white clip on the nine-wire cable, and black and red clips to terminate the twin wires. The Digilyzer is now complete and ready on your test bench for the tasks you put to it! Ω

HEAT DETECTOR

Continued from page 29

housing assembly to the focus tube with plastic electrical tape. Then insert the focus tube in the larger circuit tube as shown in Fig. 5.

Operating instructions

Be sure to allow the detector to "soak" in the ambient temperature in which it will be operated until it becomes temperature stabilized. For example, if it is to be used outdoors in the winter or summer when the temperature is significantly lower or higher than room temperature (22°C), allow the unit to remain in that environment for at least one hour and possibly as long as two hours before attempting to detect objects.

The ability of the detector system to discriminate a heat-producing stationary object from its background environment will depend on chopper-motor speed. Maximum sensitivity is achieved with one-tenth chopper revolution per second, but a chopper speed of 1 to 3 rps is recommended.

However, if you elect not to use the chopper for some application or experiment, look into the open end of the tube and move the shutter so that it is aligned in the focal plane to minimize interference with the incoming infrared emission.

The field of view of this instrument with the Fresnel lens and pyroelectric detector specified is approximately 8°. Larger objects can be detected by panning the unit horizontally after mounting it on a rigid tripod.

After you are satisfied that the focus tube has been adjusted to the optimum focal length, mark the location of the end of the larger diameter tube on the smaller diameter tube. Drill a small hole in the end of the smaller diameter tube and insert a small plastic screw to act as a stop, as shown in Fig. 5. Either apply a patch of black plastic electrician's tape or slide an opaque plastic sleeve over the detector access port to keep out ambient light. Ω

LIBRARY

continued from page 11

and VictorMaxx 3D goggles) to work on your PC, and building your own 3D goggles, motion trackers, and 3D sound systems from scratch. The book comes with a disk that includes all the software needed to test, calibrate, and run the gear that you build. Even before you build any of the projects, you can

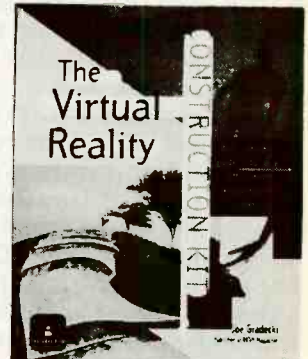

explore the virtual worlds included on the disk using just your mouse and monitor. Programmers will appreciate the C-code tips in the book and the source code on the disk. The disk also includes six virtual worlds in which you can tour a virtual park, play racquetball in a virtual court, fly a jet, battle a robot in a shooting game, construct an ancient Greek temple in three dimensions, and battle a friend via modem or cable hook-up in cyberspace combat simulation.

The Virtual Reality Construction Kit book and disk set costs \$27.95 and is published by John Wiley & Sons, Inc., 605 Third Avenue, New York, NY 10158-0012; Tel: 212-850-6336.

CIRCLE 93 ON FREE INFORMATION CARD

THE PIRATE RADIO DIRECTORY, Sixth Edition—1994

by Andrew Yoder and George Zeller

Since the beginning of broadcasting, there have been unlicensed, "pirate" radio stations, and their numbers are rapidly increasing every year. Although they are illegal in

HIGH TECH XMAS

continued from page 33

Construction

Assembly of the visible components is not difficult. Although you can build the circuits on perforated construction board, PC boards will provide a better appearance. Perfectly shaped component outlines are difficult to achieve when laying out the parts by hand. Parts-placement diagrams for the visible resistor, capacitor, and inductor are shown in Figs. 4-6.

A solder mask on the commercially available boards covers all runs and feedthroughs on both sides of the board, so that solder shorts are easily avoided. The solder mask gives the PC boards their color; the component sides of the boards are blue, and the solder sides are green.

Install the LEDs on each board last, as it will be more dif-

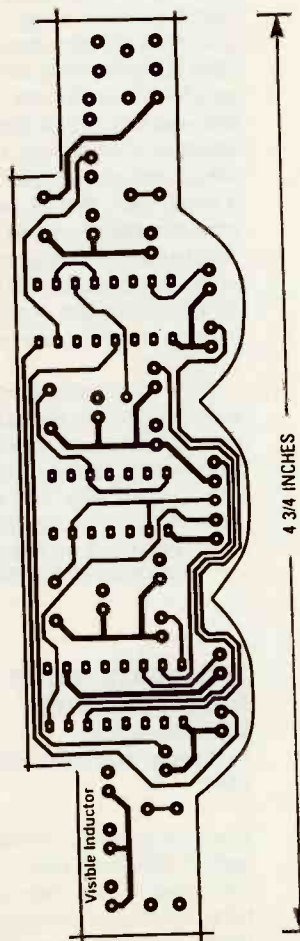

VISIBLE INDUCTOR component side.

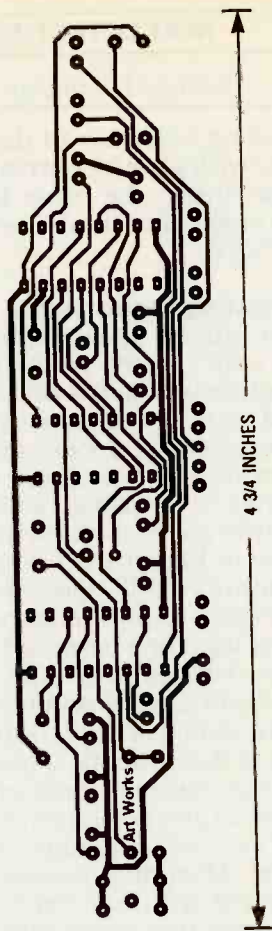

VISIBLE INDUCTOR solder side.

ficult to solder the other components in if you have to work around the LEDs. The LEDs are installed on all three boards with the cathode lead (the flat side) pointing away from the power-lead connections. The LEDs can be installed on either side of the board depending on whether you want your completed visible component to have a blue or green background. The LEDs can be any color available. You can specify LED colors when ordering.

Once the LEDs are in place, solder the +12-volt and ground wires to the appropriate points as labeled on the PC board. Two sets of power pads are included on each board, and either set of holes can be used. The extra pair of holes are for stringing all three (or more or less) visible components together so that they can be draped around a tree or along a wall. After you're done soldering, check for correct component placement and good solder connections. Ω

(Continued from previous page)

North America, such pirate stations often provide some of the most interesting, and amusing, programming on the airwaves. Unfortunately, the erratic and sporadic nature of pirate transmissions make them difficult to tune in.

This book details how to find clandestine stations on the shortwave bands, including broadcasts originating from organizations like the California Marijuana Growers Cooperative, businesses such as Friendly Freddy's Budget Burials, and even from someone in a leaky bathtub somewhere off the coast of North America. The book includes a witty introduction to pirate radio that explains how you can hear and QSL those stations on shortwave. The station section reviews dozens of pirate broadcasters who were active on shortwave last year, with details about their programming styles, relays, QSL addresses, and more. The book also includes a complete

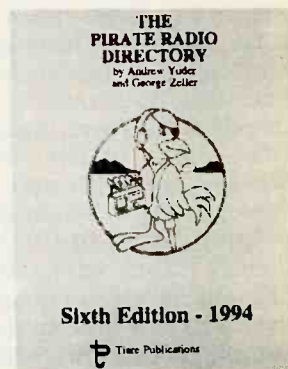

index of stations that have appeared in previous editions of the book.

The *Pirate Radio Directory* costs \$12.95 (plus \$2 shipping and handling; \$3 foreign) and is published by Tiare Publications, P.O. Box 493, Lake Geneva, WI 53147.

CIRCLE 58 ON FREE INFORMATION CARD

**ELECTRONICS
HOBBYISTS
handbook**
Spring 1995 Issue
On Sale, January 3, 1995

CAR STEREO

Continued from page 108

cutouts for the existing speakers. Obviously, this will save you the job of deciding on new locations and making new cutouts. Your task is limited to tailoring the existing cutout for the new speakers. Even this work can be minimized if you purchase new speakers that closely match the size of the existing units.

Speakers are available in a wide range of shapes and sizes, suitable for just about any automotive application. For example, there are low-profile speakers for door-panel mounting, flush-mount speakers, and oddly shaped speakers that will fit in narrow rear decks.

Front speakers can be mounted under the dash panel grille, as shown in Fig. 8, or in the doors. In a sedan, rear speakers can be installed from the trunk by mounting them against the rear deck or from above as shown in Fig. 9. In a hatchback car, the rear speakers can be positioned behind the back-seat side panels, as shown in Fig. 10, or on the panels in the hatch area of the car, as shown in Fig. 11.

When considering a speaker location such as the door panels or on the front kick panels, remove the panel first and check to be sure that there is enough clearance behind the panel to accommodate the speaker, as shown in Fig. 12. Then carefully mark and cut out the required opening. Avoid locating a speaker in a door in a way that will interfere with normal window opening and closing.

To install speakers on the top of the rear deck, examine the sheet metal panel underneath the rear deck from inside the trunk for round or oval cutouts. You might have to cut away some thin metal strips that span the cutouts to install a new speaker.

You should be able to cut through the rear-deck cover easily from inside the trunk with a utility knife or keyhole saw because the cover is usually made of cardboard or pressed

wood.

If you have trouble deciding where to place the speakers—or if you want to avoid doing any cutting, you can install flush-mount or stand-alone speakers. Flush-mount speakers, which can be mounted on any flat surface, are held in place with screws. Stand-alone speakers, which look like miniature home-stereo units, can be mounted with a simple bracket.

There is another alternative: Some manufacturers offer complete speaker systems in custom cases intended for certain models and years for installation in designated locations, such as in the hatch area. The cases might contain several speakers that offer excellent audio quality, but expect them to be expensive.

Speakers mounted in the dash panel are the easiest to wire. Just run the speaker wires directly from the stereo to the speakers. When wiring speakers in the back of the car, bury the wires under the carpet where necessary and pass them under rocker-panel covers and around the seats on their way to the speakers.

If you want to mount speakers in the doors, run the wires from inside the doors to the stereo at locations where they will not be damaged by or interfere with door opening and closing. The electrical wiring in the doors of cars with power windows is usually bundled and covered with a protective sleeve.

If you are unable to pass the speaker wires through the protective sleeve, wrap them with vinyl electrical tape and bind them to the outside of the sleeve.

To make future maintenance easier, try to make all connections to the stereo with one multi-connector plug. That way, the stereo can be removed easily. Permanent connections between wires can be made with approved electrical wire nuts or crimp-type sleeve connectors. Alternatively, they can be twisted together to form a mechanical bond and then soldered. All soldered connections should be isolated.

ADVERTISING SALES OFFICE

Gernsback Publications, Inc.
500-B Bi-County Blvd.
Farmingdale, NY 11735
1-(516) 293-3000

President, **Larry Steckler**

For Advertising ONLY
516-293-3000
Fax 1-516-293-3115

Larry Steckler
publisher

Christina Estrada
assistant to the President

Arline Fishman
advertising director

Denise Mullen
advertising assistant

Kelly Twist
credit manager

Subscriber Customer Service
1-800-288-0652

Order Entry for New Subscribers
1-800-999-7139
7:00 AM - 6:00 PM M-F MST

ADVERTISING SALES OFFICES
EAST/SOUTHEAST
Stanley Levitan

Eastern Advertising Sales
Electronics Now
1 Overlook Ave.
Great Neck, NY 11021
1-516-487-9357, 1-516-293-3000
Fax 1-516-487-8402

MIDWEST/Texas/Arkansas/Okla.

Ralph Bergen
Midwest Advertising Sales
Electronics Now
One Northfield Plaza, Suite 300
Northfield, IL 60093-1214
1-708-446-1444
Fax 1-708-559-0562

PACIFIC COAST/Mountain States
Hutch Looney & Associates Inc.
Blake Murphy
6310 San Vicente Blvd.
Suite 360
Los Angeles, CA 90048
1-213-931-3444
Fax 1-213-931-7309

EN Shopper
Joe Shere
National Representative
P.O. Box 169
Idyllwild, CA 92549
1-909-659-9743
Fax 1-909-659-2469

NOW Find the Right Part for Your VCR!

Only \$36.00 for pages
\$69.95 diskette

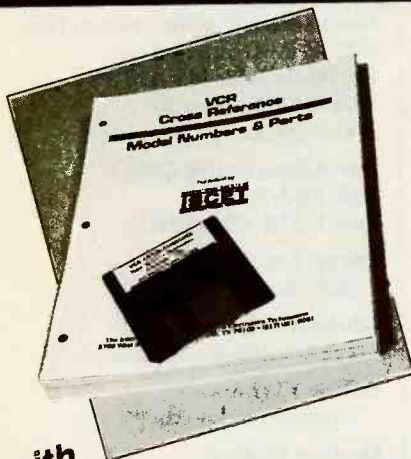

with the **ISCET VCR CROSS REFERENCE**

NEW! The Fourth Edition is contained on a diskette for IBM PC AT/XT compatibles, DOS 2.1 or higher. The disk software allows technicians to search by manufacturer for model numbers and description of part numbers. A parts editing sequence gives an on-screen view of all substitutes for parts entered. With the diskette, the technician can update files by adding model and parts

The 320-page, Fourth Edition of the VCR Cross Reference contains both model and part number cross references. Over 1300 new parts and 360 new models have been added.

VCR's are made in a few factories from which hundreds of different brand names and model numbers identify cosmetically-changed identical and near-identical manufactured units. Interchangeable parts are very common. An exact replacement part may be available only a few minutes away from you even though the original brand-name supplier is out of stock. Also, you may be able to cannibalize scrap units at no cost.

crosses of future models. The Fourth Edition can be printed on pages completely from the diskette.

The ISCET VCR Cross Reference, Fourth Edition, is on 8½ × 11-in., pre-punched pages and sells for \$36.00. The 3¼ inch diskette sells for \$69.95 and you can view listings from a monitor or printed page.

Claggk Inc. VCR CROSS REFERENCE OFFER P.O. Box 4099 Farmingdale, New York 11735

Name _____
Business _____
Address _____
City _____
State _____ Zip _____
Phone _____

Enclosed \$36.00 for the ISCET VCR Cross Reference, Fourth Edition.

Enclosed \$69.95 for the diskette containing the ISCET VCR Cross Reference, Fourth Edition. Please specify:

5¼ Diskettes (2) 3¼ Diskette (1)

Include \$3.00 for shipping each Cross Reference (Pages or Diskette)

The total amount of my order is \$ _____

Check enclosed—do not send cash.

Visa MasterCard Exp. Date ___/___/___

Signature _____

New York State residents must add applicable local sales tax to total.

ELECTRONICS BUYER'S MART

PLANS AND KITS

ALL-in-One catalog. AM/FM/Ham/Spy, transmitters, amplifiers, receivers. Voice scramblers/disguisers. Audio, TV, Tesla coils, plans, "secret" books, kits, imports, exports and more. Start your own licensed or unlicensed radio station. 60 full pages for \$1.00. **PAN-COM INTERNATIONAL**, PO Box 130-FH, Paradise, CA 95967.

60 SOLDERLESS Breadboard Projects in two easy-to-read pocket books. Complete with circuit descriptions, schematics, parts layouts, component listings, etc. Both books (BP107 & BP113) only \$11.90 plus \$3.50 for shipping. USA and Canada only. US funds. **ETT, INC.**, PO Box 240, Massapequa Park, NY 11762-0240.

CRYSTAL set Handbook — Visit antiquity by building the radios your grandfather built. Assemble a "Quaker Oats" rig, wind coils that work and make it look like the 1920's! Only \$10.95 plus \$3.50 for shipping and handling. **ELECTRONIC TECHNOLOGY TODAY, INC.**, PO Box 240, Massapequa Park, NY 11762-0240. US funds only! USA and Canada — no foreign orders.

BUSINESS OPPORTUNITIES

START your own technical venture! Don Lancaster's newly updated **Incredible Secret Money Machine II** tells how. We now have autographed copies of the Guru's underground classic for \$18.50. **SYNERGETICS PRESS**, Box 809-C, Thatcher, AZ 85552. (602) 428-4073. Visa/MC.

FOR SALE

THE Case Against the Patents. Thoroughly tested and proven alternatives that work in the real world. \$28.50. **SYNERGETICS PRESS**, Box 809-C, Thatcher, AZ 85552. (602) 428-4073. Visa/MC.

300 Experimenters Circuits—Complete in 6 practical books using diodes, relays, FET's, LED's, IC 555's, and IC CA3130's for building blocks. Only \$33.00 plus \$5.50 for shipping. USA and Canada only. US funds. **ETT, INC.**, PO Box 240, Massapequa Park, NY 11762-0240.

DESCRAMBLERS

UNIVERSAL descrambler. The only one you'll ever need! \$129.95, +\$5.00 S&H. **ELECTROMAN**, Box 24474, New Orleans, LA 70184. (504) 482-3017. MC/Visa.

RAIN FOREST RESCUE: SO THAT A CURE FOR CANCER MIGHT BE FOUND IN YOUR LIFETIME

To contribute to Rain Forest Rescue, call

1-800-222-5312

The National Arbor Day Foundation



ADVERTISING INDEX

Electronics Now does not assume any responsibility for errors that may appear in the index below.

RS #	Page
—	Antique Electronic Supply 11
41	C&S Sales, Inc. CV2
—	CLAGGK CV4
—	EDE 11
47	Global Specialties 9
42	Heathkit 11
—	Information Unlimited CV3
43	Mouser Electronics 7
—	NRI Schools 1
45	Sescom, Inc. 19
—	Software Science 11
44	VCR Repair 7
—	World College 3
46	Zentek 5

AMAZING Electronic and Scientific Products

Mystery Levitating Device!

Remember War of the World? Objects float in air and move to the touch. Defies gravity, amazing gift, conversation piece, magic trick or great science project.

ANT1K Easy to Assemble Kit / Plans \$19.50



Laser Ray Gun

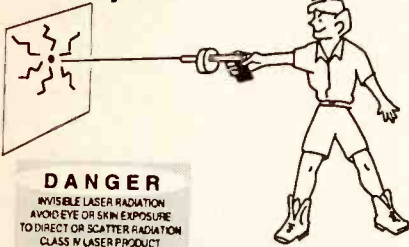

DANGER

AVOID EYE OR SKIN EXPOSURE TO DIRECT OR SCATTER RADIATION CLASS II LASER PRODUCT

Advanced project produces a burst of light energy capable of burning holes in most materials. Hand-held device uses rechargeable batteries. 500 joules of flash energy excite either a neodymium glass, yag or other suitable 3" laser rod. This is a dangerous CLASS IV project (individual parts/assemblies available). LAGUN1 Plans \$20.00
LAGUN1K Kit / Plans Price on Request

Extended Play Telephone Recording System

READY TO USE! Automatically controls and records on our X-4 extended play recorder, taping both sides of a telephone conversation. Intended for order entry verification. Check your local laws as some states may require an alerting beeper. TAP20X Ready to Use System \$129.50



Shocker Force Field / Vehicle Electrifier

Neat little device allows you to make hand and shock balls, shock wands and electrify objects, charge capacitors. Great payback for those wise guys who have wronged you!

SHK1KM Easy to Assemble Electronic Kit \$24.50



Blaster Pulsar

Pocket-sized wand produces 100,000 watts of power for personal defense, field and lab use, etc. BLS3 Plans \$10.00
BLS3K Kit / Plans \$69.50

Homing / Tracking Transmitter

Beeper device, 3 mile range. HOD1 Plans \$10.00 HOD1K Kit / Plans \$49.50

Listen Through Walls, Floors

Highly sensitive stethoscope mike. STETH1 Plans \$8.00 STETH1K Kit/Plans \$44.50

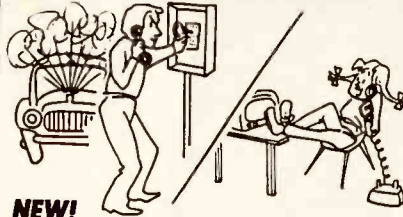

NEW!

INFINITY TRANSMITTER++ Room Monitor / Phone Line Grabber

ALL NEW! The Ultimate in Home or Office Security & Safety! Simple to Use! Call your home or office phone, push a secret tone on your telephone keypad to access either: A. On premises sounds and voices; or B. Existing telephone conversation with break in capability for emergency messages. CAUTION: Before assembly or use, check legalities with your state Attorney General's office as you may require "beepers" or other 3rd party alerts. TELEGRAB1 Plans Only \$10.00
TELEGRAB1K Kit / Plans \$99.50

Visible Beam Laser

Easy to build, RED Beam, visible for miles. Use for light shows, window bounce holography, cloud illumination and much more! LAS1KM Kit w/1mw Laser Tube, Class II \$69.50
LAS3KM Kit w/2.5mw Laser Tube, Class IIIA \$99.50

100,000V Intimidator / Shock Wand Module

Build an electrical device that is effective up to 20 feet. May be enclosed for handheld, portable field or laboratory applications. ITM2KM Easy-to-Assemble Electronics Kit \$49.50
ITM2 Plans only, credit-able to kit \$10.00

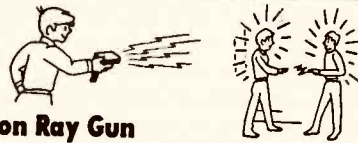

Ion Ray Gun

Projects charged ions that induce shocks in people and objects without any connection! Great science project as well as a high tech party prank. IOG3 Plans \$8.00
IOG3K Kit/Plans \$69.50

Invisible Pain Field Generator

Shirt pocket size electronic device produces time variant complex shock waves of intense directional acoustic energy, capable of warding off aggressive animals, etc. IPG7 Plans \$8.00 IPG7K Kit/Plans \$49.50
IPG70 Assembled \$74.50



1000 Ft++ Potato Cannon

NOT A TOY. Uses electronic or piezo ignition. CAUTION REQUIRED! POT1 Plans \$10.00 (Dangerous Product)

FireBall Gun

Shoots flaming ball - two shot capacity Great for special effects and remote fire starting. CAUTION REQUIRED! FIREBALL Plans (Dangerous Product) \$10.00



TV & FM Joker / Jammer

Shirt pocket device allows you to totally control and remotely disrupt TV or radio reception. Great gag to play on family or friends. Discretion required. EJ1KM Easy to Assemble Electronic Kit \$24.50



ATTENTION: High Voltage Fans!

4,000 volts in the palm of your hand! Experiment with anti-gravity, hovercraft, ion guns, force fields, plasma guns, shock devices, wireless energy and electrical pyrotechnics. Input: 9-14VDC.

MINIMAX4 Ready to Use \$19.50

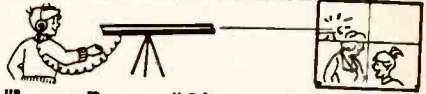

"Laser Bounce" Listener System

Allows you to hear sounds from an area via a lite beam reflected from a window or other similar objects. System uses our ready-to-use LATR1 Laser Terminator gun site as the transmitter. The receiver section is supplied as an easy-to-build kit, including our cushioned HS10 headsets. LLIST2 Plans \$20.00
LLIST1K Kit of Both Transmitter and Receiver \$199.50
LLIST20 Assemble with Laser Gun Site \$299.50

3mw Visible Red Pocket Laser Utilizes our touch power control! VRL3KM Kit / Plans \$74.50

Electronic Hypnotism

Puts subjects under control using highly effective electronic stimuli. Intended for parties and entertainment but must be used with caution. Includes valuable text book reference and plans. EH2 Plans and Text Book \$19.50

Automotive NEON!

Easy-to-Install 4-Tube Kit for Cars, Trucks, Vans! Available in Pink, Purple, Blue or Green - please specify color when ordering. RG4K (Specify Color) \$129.50

Flash-To-Music Option for above kit FMU1 \$29.50



3 MI FM

Wireless

Microphone

Subminiature! Crystal clear, ultra sensitive pickup transmits voices and sounds to FM radio. Excellent for security, monitoring of children or invalids. Become the neighborhood disk jockey! FMV1 Plans \$7.00 FMV1K Kit and Plans \$39.50



Telephone Transmitter - 3 MI

Automatically transmits both sides of a telephone conversation to an FM radio. • Tunable Frequency • Undetectable on Phone • Easy to Build and Use • Up to 3 Mile Range • Only transmits during phone use. VVPM7 Plans \$7.00
VVPM7K Kit/Plans \$39.50

INFORMATION UNLIMITED

Dept ENS17, Box 716, Amherst, NH 03031
Phone: 603-673-4730 FAX 603-672-5406
MC, VISA, COD, Checks accepted Please add \$5.00 Shipping & Handling

CATALOG
With many more items!
Free with Order or send \$1 P&H

Order by Mail or by 24 Hour Orders-Only Phone
800-221-1705

Countersurveillance

Never before has so much professional information on the art of detecting and eliminating electronic snooping devices—and how to defend against experienced information thieves—been placed in one VHS video. If you are a Fortune 500 CEO, an executive in any hi-tech industry, or a novice seeking entry into an honorable, rewarding field of work in countersurveillance, you must view this video presentation again and again.

Wake up! You may be the victim of stolen words—precious ideas that would have made you very wealthy! Yes, professionals, even rank amateurs, may be listening to your most private conversations.

Wake up! If you are not the victim, then you are surrounded by countless victims who need your help if you know how to discover telephone taps, locate bugs, or "sweep" a room clean.

There is a thriving professional service steeped in high-tech techniques that you can become a part of! But first, you must know and understand Countersurveillance Technology. Your very first insight into this highly rewarding field is made possible by a video VHS presentation that you cannot view on broadcast television, satellite, or cable. It presents an informative program prepared by professionals in the field who know their industry, its techniques, kinks and loopholes. Men who can tell you more in 45 minutes in a straightforward, exclusive talk than was ever attempted before.

Foiling Information Thieves

Discover the targets professional snoopers seek out! The prey are stock brokers, arbitrage firms, manufacturers, high-tech companies, any competitive industry, or even small businesses in the same community. The valuable information they filch may be marketing strategies, customer lists, product formulas, manufacturing techniques, even advertising plans. Information thieves eavesdrop on court decisions, bidding information, financial data. The list is unlimited in the mind of man—especially if he is a thief!

You know that the Russians secretly installed countless microphones in the concrete work of the American Embassy building in Moscow. They converted



CALL NOW!

1-516-293-3751

**HAVE YOUR
VISA or MC CARD
AVAILABLE**

what was to be an embassy and private residence into the most sophisticated recording studio the world had ever known. The building had to be torn down in order to remove all the bugs.

Stolen Information

The open taps from where the information pours out may be from FAX's, computer communications, telephone calls, and everyday business meetings and lunchtime encounters. Businessmen need counselling on how to eliminate this information drain. Basic telephone use coupled with the user's understanding that someone may be listening or recording vital data and information greatly reduces the opportunity for others to purloin meaningful information.

The professional discussions seen on the TV screen in your home reveals how to detect and disable wiretaps, midget radio-frequency transmitters, and other bugs, plus when to use disinformation to confuse the unwanted listener, and the technique of voice scrambling telephone communications. In fact, do you know how to look for a bug, where to look for a bug, and what to do when you find it?

Bugs of a very small size are easy to build and they can be placed quickly in a matter of seconds, in any object or room. Today you may have used a telephone handset that was bugged. It probably contained three bugs. One was a phony bug to fool you into believing you found a bug and secured the telephone. The second bug placates the investigator when he finds the real thing! And the third bug is found only by the professional, who continued to search just in case there were more bugs.

The professional is not without his tools. Special equipment has been designed so that the professional can sweep a room so that he can detect voice-activated (VOX) and remote-activated bugs. Some of this equipment can be operated by novices, others require a trained countersurveillance professional.

The professionals viewed on your television screen reveal information on the latest technological advances like laser-beam snoopers that are installed hundreds of feet away from the room they snoop on. The professionals disclose that computers yield information too easily.

This advertisement was not written by a countersurveillance professional, but by a beginner whose only experience came from viewing the video tape in the privacy of his home. After you review the video carefully and understand its contents, you have taken the first important step in either acquiring professional help with your surveillance problems, or you may very well consider a career as a countersurveillance professional.

The Dollars You Save

To obtain the information contained in the video VHS cassette, you would attend a professional seminar costing \$350-750 and possibly pay hundreds of dollars more if you had to travel to a distant city to attend. Now, for only \$49.95 (plus \$4.00 P&H) you can view *Countersurveillance Techniques* at home and take refresher views often. To obtain your copy, complete the coupon or call.

CLAGGK INC. EEHB
P.O. Box 4099 • Farmingdale, NY 11735

Please rush my copy of the Countersurveillance Techniques Video VHS Cassette for a total cost of \$53.95 each (which includes \$4.00 postage and handling)

No. of Cassettes ordered _____

Amount of payment \$ _____

Sales tax (N.Y.S. only) _____

Total enclosed _____

Bill my VISA MasterCard

Card No. _____

Expire Date _____ / _____

Signature _____

Name _____

Address _____

City _____ State _____ ZIP _____

All payments in U.S.A. funds. Canadians add \$4.00 per VHS cassette. No foreign orders.