

Popular Radio

20¢

AUGUST 1923

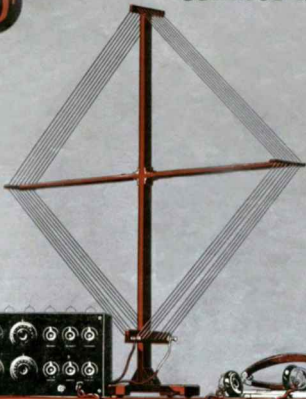

• The Winning Fight Against Static •

Aug 23

Please mention POPULAR RADIO when answering advertisements.

Brandes



This man knows Radio!

HE knows how to get the *best* out of his set. New hook-ups, new tubes, new parts—he tests them all and finds the best.

He was a wireless fan long before radio became the greatest indoor sport. Fifteen years ago he used Brandes. Today he still sticks to his Brandes *Matched Tone* Headset.

He knows that its *Matched Tone* assures clear and harmonious reception of the worldful of interesting news which his set picks up. He gets it all—perfectly—with a Brandes.

Made in Canada and England by

Canadian Brandes Limited, Toronto and London

C. BRANDES, Inc., 237 Lafayette St., N. Y. C.

Matched Tone

TRADE MARK REG. U.S. PAT. OFF.

Radio Headsets



POPULAR RADIO

EDITED by KENDALL BANNING



CONTENTS for AUGUST, 1923

(Cover design by Frank B. Masters)

VOLUME IV	NUMBER 2
The Foremost Radio Expert of France	Page 89
Lightning Has No Terrors for the Loop Antenna	90
The Winning Fight Against Static <i>John V. L. Hogan</i>	91
"Their Master's Voice"	101
"Thou Shalt Not Broadcast—" <i>Charles H. Kesler</i>	102
The New and Remarkable Alkali Vapor Tubes <i>Hugh A. Brown and Charles T. Knipp</i>	110
The New Voice That Is Being Heard Around the World <i>Stanford C. Hooper</i>	114
A Receiving Set in an Earphone <i>Frederic Siemens</i>	127
A Measurement Chart <i>Raoul J. Hoffman</i>	129
For Determining the Constants for a Loop Antenna—No. 5.	
How to Build a Tuned Radio Frequency Receiver . . . <i>Laurence M. Cockaday</i>	132
A Radio Station on Wheels <i>S. R. Winters</i>	142
How to Calibrate Your Wave Meter <i>E. L. Hall</i>	144
Radio—The New Farm Hand <i>Harry A. Mount</i>	150

DEPARTMENTS

Broadcasts	157
What Readers Ask	160
Listening In	166
Hints for Amateurs	173
"Stations I Have Heard"	175

VOLUME IV

AUGUST, 1923

NUMBER 2

Published monthly by Popular Radio, Inc., 9 East 40th Street, New York, N. Y., telephone number Vanderbilt 9985; H. B. Emerson, President; E. R. Crowe, Vice-President; F. C. Hemberger, Treasurer. Price, 20 cents a copy; subscription \$2.00 a year in the U. S., Canada and all countries within the domestic postal zone; elsewhere \$2.25 a year, payable in advance. The International News Company, Ltd., No. 5 Bream's Bldg., London, E. C. 4, sole distributors in England. Entered as second-class matter April 7, 1922, at the Post Office at New York, N. Y., under the act of March 3, 1879. Copyright, 1923, and title registered as a trade-mark by Popular Radio, Inc. Printed in U. S. A.

E. E. FREE, Ph.D., *Contributing Editor* LAURENCE M. COCKADAY, R.E., *Technical Editor*

New York: 9 East 40th St.

Chicago: 645 North Michigan Ave.

"Name is the follower
of reality."
Yu Tse.

The New Grebe

Broadcast
Receiver
earns great fame
through superior
performance.

Doctor Mu.

Seven Points of Satisfaction.

1. Requires no outdoor antenna—no loop.
2. Uses all kinds of tubes (4 of them) in any desired combination.
3. Employs the perfect combination of Regeneration and Tuned Radio Frequency Amplification with only two tuning adjustments.
4. Receives all broadcasting.
5. Tuning Dial graduated in wavelengths.
6. May be set up immediately, and successfully operated—anywhere—by anyone.
7. Complete, self-contained Receiver, in attractively finished walnut cabinet, with compartments for A and B batteries.

Write for Booklet

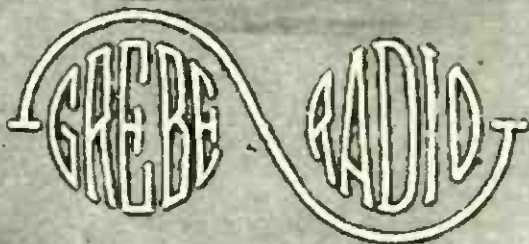

A. H. GREBE & COMPANY, Inc.
Richmond Hill, N.Y.
Weaver Branch, 451 East 3rd St., Los Angeles, Cal.

Licensed under Armstrong
U. S. Pat. No. 1,113,149

Type CR-12

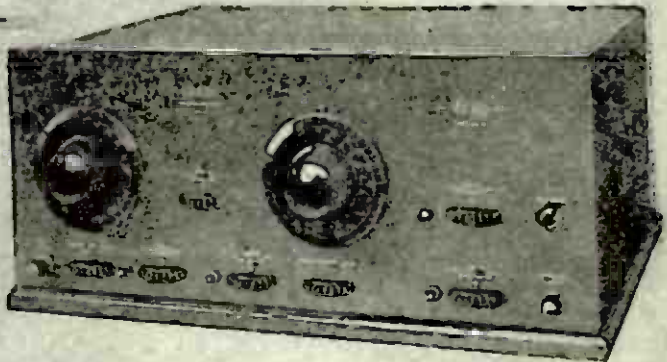

PAGES WITH THE EDITOR

REPORTS of the remarkable success of our Technical Editor's newest invention, the famous Cockaday Four-Circuit Tuner, continue to come not only from all over the United States but also from Canada, Mexico and now from England and Europe. One of the most impressive of these returns came from a group of typically alert fans down in Texas.

* * *

So intense was the interest of the amateurs of Waco in Mr. Cockaday's description of his receiver (in the May, 1923, issue) that they selected one of their number to make the journey all the way from Texas to the office of POPULAR RADIO and to obtain at first hand from the inventor all of the very latest working data that might be of value to them. And when Mr. Carl Bergstrom of Waco, walked unexpectedly into our office in New York, Mr. Cockaday laid aside his other work and filled up his visitor with enough "tips" about the new set to keep his Texas associates satisfied for some time to come.

* * *

Would you like to know what some of these "very latest working data" are? Turn to our *What Readers Ask* department in this number and you will find some of it; more will appear in our September and subsequent issues. Mr. Cockaday's experimental work in his laboratory is constantly revealing new and better ways for getting the most out of your apparatus, and this information is being, and will continue to be printed in the form of short, helpful, practical items in our departments.

* * *

HERE is a letter, picked from the hundreds that have come in—and are still coming in—from readers who have built the wonderful Four-Circuit Tuner. It is peculiarly significant because it comes from a self-confessed "hard-boiled ham" in New York.

"I have in the past used practically every circuit of any consequence, and almost every standard type of receiving apparatus. I am at present using a Reinartz, a super-regenerative and one of your justly famous DX hook-ups. For the last year I felt confident that we had reached the ultimate of selectivity and sensitivity in your DX receiver but since I have had the extreme pleasure of using the new Four-Circuit Tuner I have only realized what it is to receive broadcast as it should be received. Using two steps of amplification, *plus* a loud-speaker, the reception has been so perfect that it is beyond my limited vocabulary to do it justice.

"This morning, at about 1.30, through heavy static, I had the pleasure—with the accompanying thrill—to hear Chicago, Fort Worth and California. I had no trouble bringing in both Chicago and Fort Worth on a loud-speaker.

"I am not a rabid broadcast listener, but I must admit that the possession of one of your Four-Circuit Tuners will soften the heart of the most hardened ham to listen in for broadcast. I wish to thank you for the wonderful advancement you have made in radio communication."

—LEO JOHNSON

* * *

"THE man who discovered the electron," Sir Joseph J. Thomson (who is, naturally enough, one of the most distinguished of all living scientists), recently made a flying visit to the United States; during his stay he gave four talks on the electron before the Franklin Institute of Philadelphia. A coming issue of POPULAR RADIO will publish—for the benefit of such of its readers who could not attend the sessions—a contribution of Sir Joseph's that is based upon the first two of his talks.

* * *

It was Sir Joseph, by the way, who was once approached by one of his assistants in the Cavendish laboratories who asked:

"Why is it, Sir Joseph, that scientists like yourself, who contribute so much to human progress, have such small incomes while people like manufacturers and retailers in London make so much money?"

"Ah!" Sir Joseph replied, "but think of all the dirty work they have to do!"

* * *

OF all the indoor sports indulged in by the students at Princeton University, bridge was voted the most popular and radio second.

How does Princeton explain the local vogue of bridge?

* * *

"I CONSIDER POPULAR RADIO the best magazine published," reports H. A. Goesly of New York. "Your hook-ups are the clearest that I have seen, and the list of instruments, with their capacities, which you publish in connection with the hook-ups, is a feature of great value to the fan."

* * *

WHEN POPULAR RADIO initiated the project last summer of broadcasting the outdoor concerts of the New York Philharmonic orchestra it established a vogue that has spread rapidly—to the great benefit not only of radio fans but also of musicians and music lovers as well. Since the successful experiment of last August the music of many great orchestras has been broadcast from many stations by means of the "pick-up" system.

* * *

It is with particular gratification, therefore, we learn that the same project of broadcasting the concerts of the Philharmonic orchestra will be undertaken again this summer—and by the same station, WJZ.

(Continued on page 8)

Please mention POPULAR RADIO when answering advertisements.



The arrows point to the Dubilier Micadons used in the Fada one-sixty receiving set.

—and in FADA Receiving Sets

DUBILIER Micadons are an essential element in the efficient Fada one-sixty Neutrodyne receiving set because they are the only fixed condensers made of standardized, permanent capacity.

In the Neutrodyne circuit everything depends on constancy of capacity. And the standardized and calibrated Dubilier Micadon condensers alone meet that requirement.

Dubilier Micadons are used in De Forest, Freed-Eisemann, FADA and other receiving sets made by well-known manufacturers with reputations to maintain.

If a set is not equipped with Dubilier Micadons the broadcasted radio program is not heard at its best.

Price 35 cents to \$1.50. At all good dealers.

DUBILIER CONDENSER AND RADIO CORP.

48-50 WEST FOURTH ST., N. Y.

BRANCH OFFICES IN THE FOLLOWING CITIES:

Los Angeles, Cal. St. Louis, Mo. Atlanta, Ga. Huntington, W. Va.
Washington, D. C. Chicago, Ill. Pittsburgh, Pa.

Distributed in Canada by Canadian General Electric Company, Ltd., Toronto

DUBILIER PRODUCTS

PAGES WITH THE EDITOR

(Continued from page 6)

REPORTS about ourselves that reach us from sources that may rightly be regarded as prejudiced" either for or against us, may be just as rightly discounted. But here is a report about POPULAR RADIO that graciously comes to us from the publisher of a rival radio magazine—and even if it *does* emanate from an Esteemed Contemporary, the Editor just plumb refuses to discount it one iota. This report reads:

"You may be interested in knowing that the report turned in to me by a man whom I have just sent on a tour of some of the cities in what might be called the semi-rural district through middle eastern Pennsylvania show that POPULAR RADIO is growing in circulation faster than any other radio magazine and that his contacts with the advertisers also proved that their returns from your columns are better than those from any other magazine in the field.

"I am not at all surprised at this report because it was exactly what I thought myself."

—HENRY M. NEELY

* * *

AGAIN our subscription manager intrudes upon the Editor's pages with the following announcement—which the subscription manager apparently wants our readers to get for their own interest:

"We are constantly in receipt of requests for back copies of POPULAR RADIO. We now have a complete file beginning May, 1922. A single back number is \$.17 *postpaid*, May, 1922 to January, 1923, inclusive; other issues are \$.22 *postpaid*. All requests must be accompanied by remittance."

* * *

"I WAS very much enthused over your Four-Circuit Tuner as published in the May number. I believe that I am the first one to build the set in this city. The writer has read many radio magazines, but he has found none that is as full of facts or that can compete with POPULAR RADIO."

—EDWARD J. MEISTER

* * *

SLOWLY but inevitably the fame of POPULAR RADIO is spreading abroad. In a single mail recently the Editor received a handful of letters from English fans—none of whom seem to be suffering from that "reserve" that has been regarded as so typically British. For instance:

"POPULAR RADIO is simply splendid!" enthuses Mr. T. L. Blake of Essex, England. "The articles are so wonderfully concise and explicit and the pictures, drawings and items are so clear and simple and understandable that they are truly a great help to the amateur."

* * *

WHILE from Mr. Frank Kennedy of Lancashire comes a report of his remarkable suc-

cess with a single tube set that was described in POPULAR RADIO for April, 1923. He concludes with the enthusiastic comment:

"I want to congratulate you on your perfectly splendid magazine which is by far the best of all the American journals that find their way across to England."

* * *

AGAIN the Editor's holding files are crowded with manuscripts, diagrams and photographs that are of inestimable value to the radio fan everywhere. Most of this material describes new and improved receiving apparatus, recent inventions and discoveries of practical usefulness to the amateur, helpful hints for the assembling, installation and operation of radio equipment—all of it information of timely import that should be placed before our readers while it is still news and while it is of the greatest usefulness.

* * *

How can the Editor publish all of this new and valuable material—and keep on publishing new and valuable material as it becomes available—unless he adds materially to the number of pages in the magazine?

* * *

THE Editor believes that to enlarge the magazine is not only an obligation to our readers, but an inevitable development.

* * *

PLANS are now being worked out, therefore, for an important and significant announcement that will be made in our September number—an announcement that will be welcomed by all readers of POPULAR RADIO everywhere.

* * *

"THE article by Dr. Ernest Fox Nichols, *The Shortest Radio Waves Ever Produced by Man*, in your July number," a well-known scientist told the Editor, "is perhaps the most important contribution to the literature of radio since the announcement of the Hertzian waves in 1888. It is not only a real beat for POPULAR RADIO but an announcement of inestimable significance to science."

* * *

It was Dr. Nichols, incidentally, who, while he was Professor of Physics at Dartmouth College some years, flunked the Editor—properly enough, too—in sophomore Physics I. It is with peculiar satisfaction, therefore, that the Editor heaps coals of fire on the good doctor's head and awards him a "perfect recitation" on his famous article!

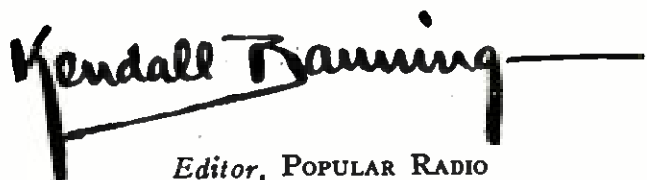
Kendall Banning

Editor, POPULAR RADIO

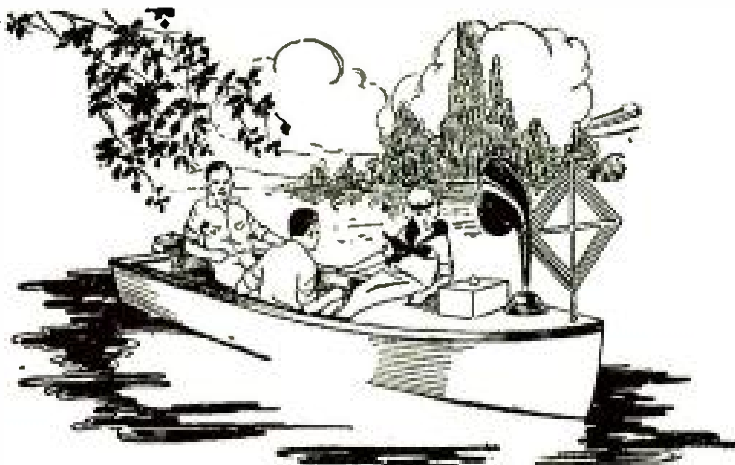

Vacation Time Is FIBERTONE Time

The FIBERTONE
is now

\$ 8

Your phone
plus a Fibertone
equals a beautiful musical instrument.

VACATION! In the heart of the mountains, on some distant lake or a sea-shore camp — wherever it may be, the entire party can enjoy Broadway's music, brought by your radio and amplified through the Fibertone horn.

The new low price makes it possible for everyone to own a loud speaker. A phone from any head set together with a Fibertone

horn makes a beautiful musical instrument.

Scientific manufacture, resulting from years of experience in the musical field, has developed the Fibertone into a faultless pure-toned amplifier. Made throughout of genuine fiber, the best material known to give volume of sound without distortion and metallic noises. A black crystalline finish gives it an outward beauty that rivals the beauty of its rich, mellow tone from within.

Dealers, write for proposition.

FIBER PRODUCTS COMPANY

240-C N. 10th Street, Newark, N. J.

FIBERTONE

Please mention POPULAR RADIO when answering advertisements.

"The World is Mine!" MU-RAD RECEIVERS

THE thrill of great distances — that is the special privilege of MU-RAD owners due to the extreme sensitivity and delightful efficiency of their sets. Cities for thousands of miles in every direction, a dozen states, ships at sea, far-away Hawaii, Cuba and Canada — all contribute to their entertainment.

Requires only a two-foot loop aerial. Professional results for the most inexperienced because MU-RAD RECEIVERS are so simply operated.

Absolute guarantee of 1000 miles reception.

Write for Literature.

MU-RAD LABORATORIES, INC.

809 FIFTH AVE. ASBURY PARK, NEW JERSEY

The New
Star in
the Radio
World





Kadel & Herbert

THE FOREMOST RADIO EXPERT OF FRANCE

The officer at the left is the famous General Gustave Ferrié, Inspector General of the Telegraph Service of the French Army, and one of the greatest authorities on radio in the world. An article by him will shortly be published in
POPULAR RADIO.

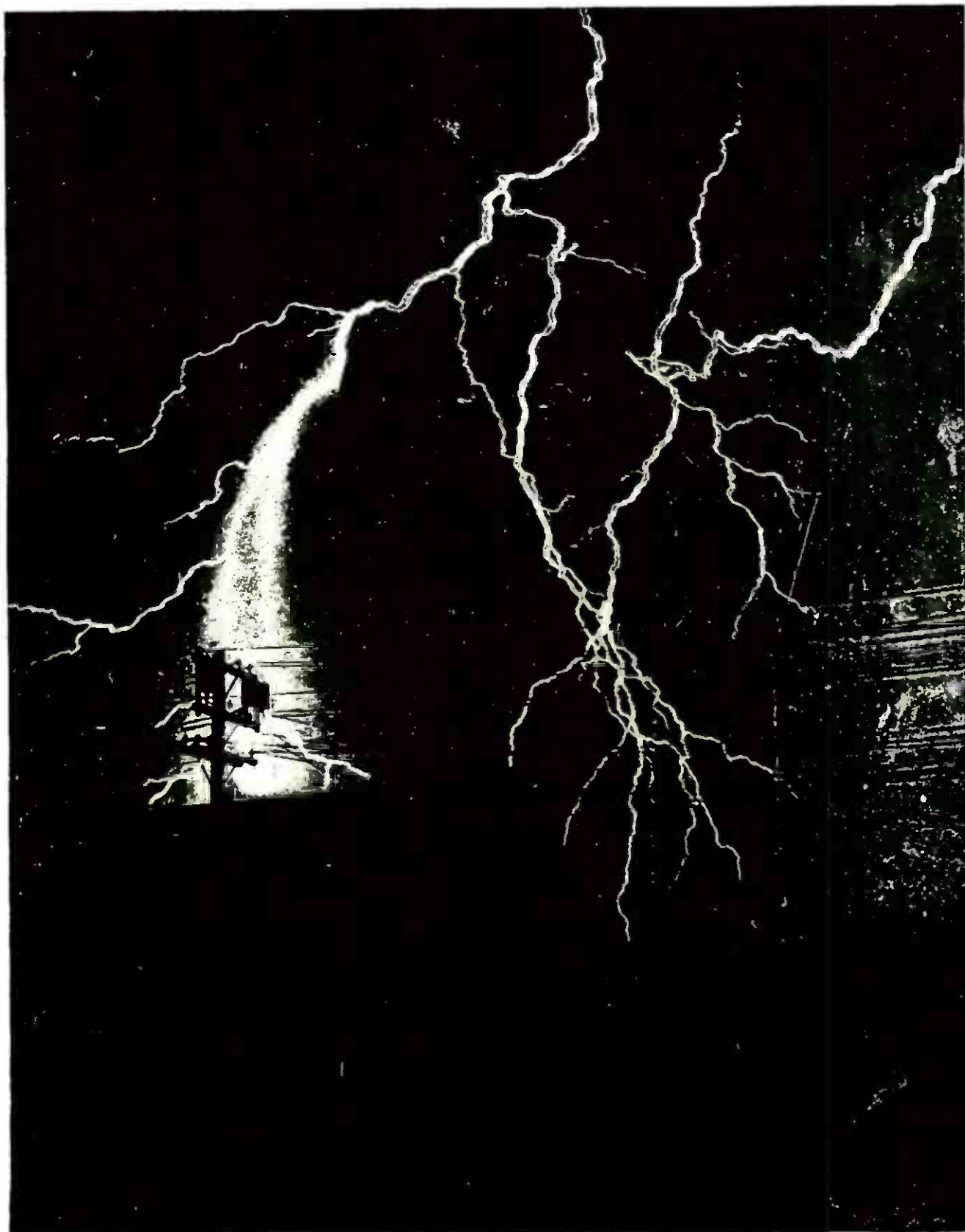

Brown Bros.

Lightning Has No Terrors for a Loop Antenna

Even during the most violent electrical storms the reception of broadcasting on a loop aerial is not greatly affected. And broadcasting may often be received on an outdoor antenna right up to the time that the storm hits the vicinity. The troubles due to "static" have been grossly exaggerated—as every experienced radio fan knows.



Popular Radio

VOLUME IV

AUGUST, 1923

NUMBER 2



THE WINNING FIGHT *against* STATIC

How Science Is Eliminating the Interference from "Strays"

This article has been written by one of the world's foremost authorities on radio. It has been written for the express purpose of dispelling some of the foolish illusions held by the more inexperienced radio fans concerning static—a subject that is becoming of less and less importance in radio work as science is slowly and surely devising means for overcoming it. Our "fear" of static diminishes as our knowledge of it increases. Read this article—and bury the static bugaboo once and for all!—EDITOR.

By JOHN V. L. HOGAN

ATMOSPHERIC interference with signal reception has always been the *bête noir* of radio from the earliest days of the practical art.

This interference goes by a number of names, "X's," "strays," "atmospherics," "static," and so on; perhaps more attention has been given to reducing its harmful effects than to any other single problem of radio engineering.

What is the net result of all this effort? Has the long-fought battle against the natural enemy of radio been at all effective? Has interference from strays been eliminated, and if not, why not? These are questions worth thinking about.

The simple fact is that stray trouble has been so greatly reduced that radio stations are today working over great

distances by the use of smaller transmitting power than would have been thought possible ten or even five years ago. The art of atmospheric interference reduction has progressed tremendously in the past decade.

Why, then, do we still hear of long-distance reception being interrupted by "static"?

The simple answer to that question is that while the radio engineers have been devising successful methods of reducing stray interference, they have also been producing new and marvelously sensitive radio receivers. These delicate instruments respond not only to exceedingly weak signals, but also to the much reduced stray waves that penetrate our best systems for minimizing atmospheric interference.

The radio art has reached the point where strays need not interrupt commercial communication services, except possibly during occasional short periods of extreme interference. A few years ago there was no commercial or other radio service that was free from frequent and extended serious interruption by strays. The summer, in these latitudes, was once a time when radio messages were received more by good luck than by good engineering; but matters are very different today.

Two Kinds of Atmospheric

Let us first consider, for a moment, what this atmospheric interference is and what effects it produces.

To begin with, there are at least two classes of "atmospherics." The word "static" is popularly used to cover all

sorts of naturally produced interference, but properly speaking it should be limited to the electric charges that are carried to a receiving aerial by particles such as dust, snow or moisture in the air. These particles, whether of smoke, steam or merely the motes that one sees in a beam of strong sunlight, are usually electrically charged. When they strike an antenna they transfer their charges to it. If the antenna is connected to a receiver, the charges will ordinarily pass silently to earth without producing any sounds in the telephones.

Series condensers in the antenna circuit of some receivers prevent this quiet discharge from the antenna to ground, and the charges pile up on the plates of the condenser. When the voltages so produced are not large (as is usually the case with small receiving antennas)

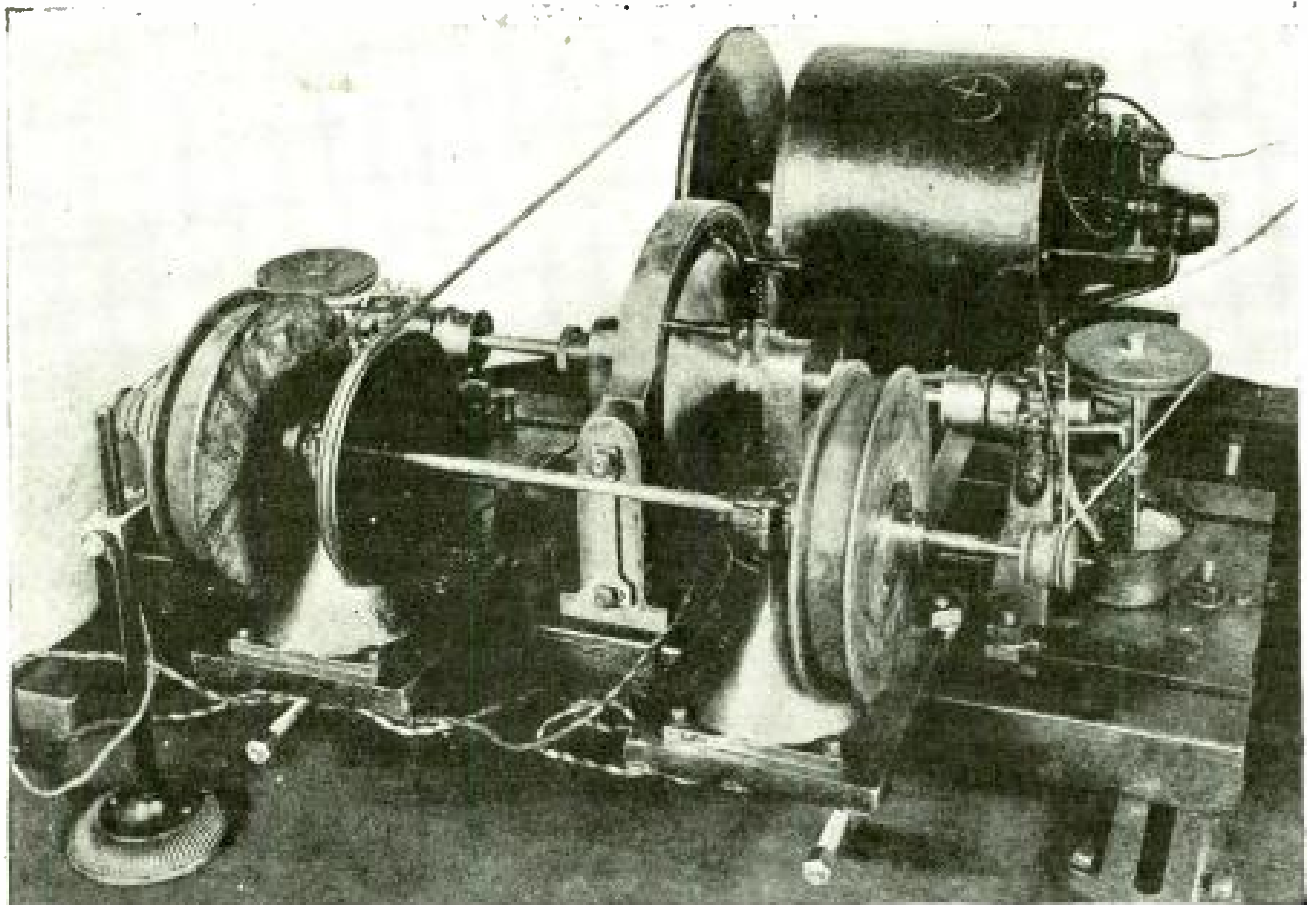

AN EARLY GUN IN THE FIGHT AGAINST STATIC

The first high frequency alternator to be developed as a method for producing the first C.W. signals. When it was used with a heterodyne receiver (such as illustrated in the photograph on page 94) it was found to be a reliable means of communication. It produced a high shrill note in the receivers which was easily distinguishable from the rasping noises of even heavy static.

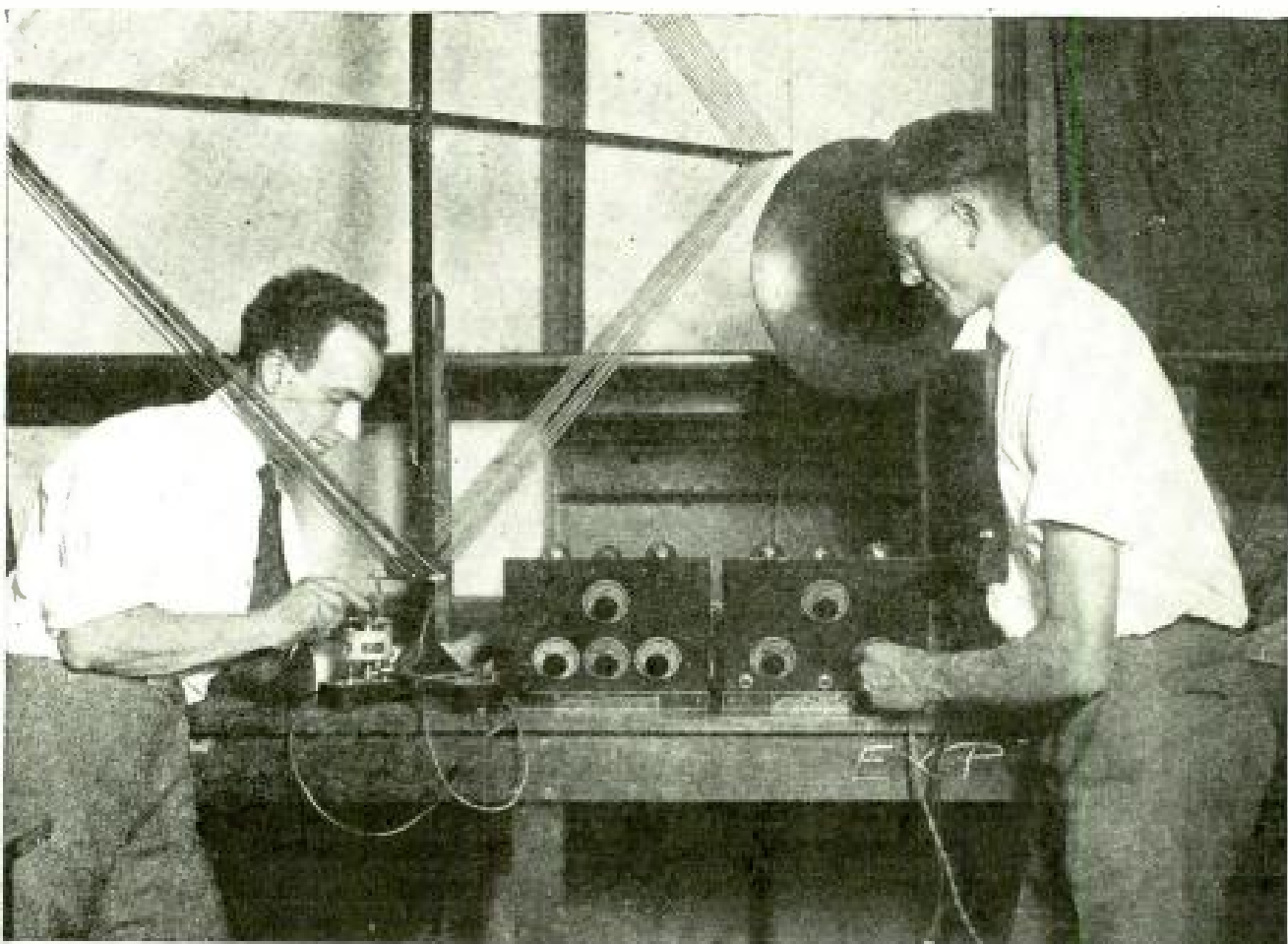

Kadel & Herbert

ONE OF THE BEST METHODS OF AVOIDING INTERFERENCE

Use a loop antenna and radio frequency amplification, not because radio frequency amplification itself reduces static, but because the loop increases the signal-stray ratio of your receiver, although but a small amount of signal strength is received. The radio frequency amplifier, however, plays its part in bringing up the signal strength of the signal that is received with the loop, without the accompanying disturbance from strays.

nothing happens to interfere with reception. However, if a large antenna is used the voltage may build up to a value high enough to cause sparking across the condenser at intervals of every few seconds, or even more frequently. For each spark across the condenser one hears a loud "bang" in the telephones.

There are four remedies for this condition (which is rarely encountered in broadcast reception):

First, use a condenser which is so well insulated that it cannot spark across;

Second, reduce the size of the antenna;

Third, connect a grid-leak of about $\frac{1}{4}$ megohm resistance across the condenser to keep it discharged;

Fourth, use an antenna circuit that

will tune *without* a series condenser.

Any one of these plans will eliminate this kind of static interference whenever it occurs.

Another effect produced by true "static" or the contact-charging variety of atmospheric interference, is a slight hissing noise heard in the receiver when heterodyne or oscillating beat-note reception is used. Ordinarily this hiss is so weak as not to interfere with telegraphic receiving, and it is entirely absent in the majority of radio telephone receivers.

Both of these interfering effects of true "static" can be completely avoided by using indoor antennas or coil antennas, or even by the use of outdoor antenna systems that have no ground connection.

"Stray Waves" and "Grinders"

The other class of atmospheric disturbance is the one that causes the most trouble; such troublesome impulses are properly called "strays."

There are at least two kinds of strays, each named by the sound it produces in the receiving telephones. The first kind, named "clicks," as a general rule gives less trouble than the second kind, which is called "grinders."

The clicks may sometimes be of rather great intensity, but they are usually separated by "quiet" intervals and so do not constitute serious interruptions unless they are so severe as to paralyze (for an instant) either the receiving apparatus or the operator's ears. It is often easy to identify a strong stray click with a distant but visible lightning discharge that is seen *at the same instant the click is heard*. This supports the theory that clicking strays arise directly from electrical storms near the earth's surface. Clicks are frequently heard during the stormy seasons even on clear days, but they are then much weaker than when

a thunderstorm is passing near by. The probability is that the stray electromagnetic waves generated by an intense lightning stroke travel outward in all directions for hundreds of miles, just as do the electromagnetic signal waves produced by a radio transmitter.

The second kind of strays, called grinders, are usually more disconcerting. A coffee-mill turned more or less continuously and at varying speeds is not a desirable accompaniment for either music or conversation, and intense grinder-type strays usually are just about as much of a disturbance. If some one, intent on bothering us, started to grind coffee in the living room, we should try to put him out or to curtail his activities. We *cannot* stop grinder strays at their source, however, for we don't know exactly what produces them or whence they come.

There is some ground for the belief that grinders are nothing more than irregular groups of clicks, piling one upon another in helter-skelter fashion and producing the characteristic more or less

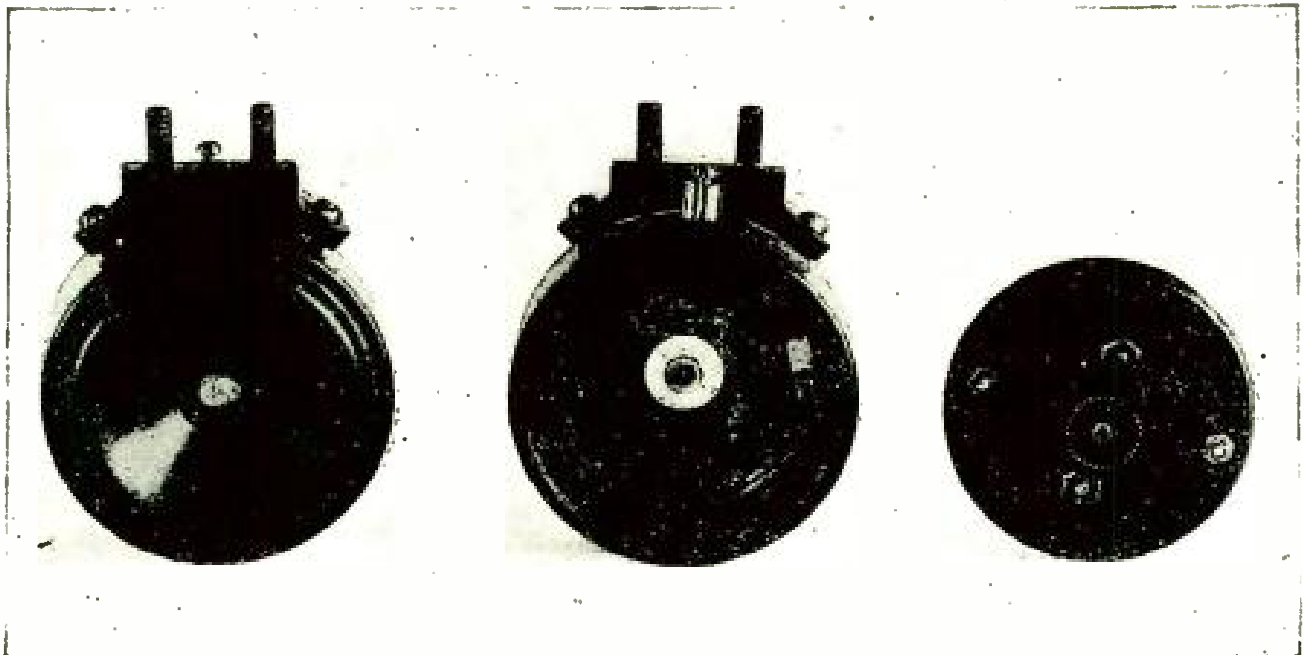

ONE OF THE FIRST "STATIC ELIMINATORS"

The earliest type of heterodyne telephones. This earpiece was used as a sort of combination detector and telephone; it contained a fixed coil through which circulated a current of slightly different frequency than the signal frequency which was lead through a moving coil attached to the diaphragm. The corresponding beat frequency which occurred between the two currents was used to actuate the diaphragm; it produced a high whistle which was easily read through static.

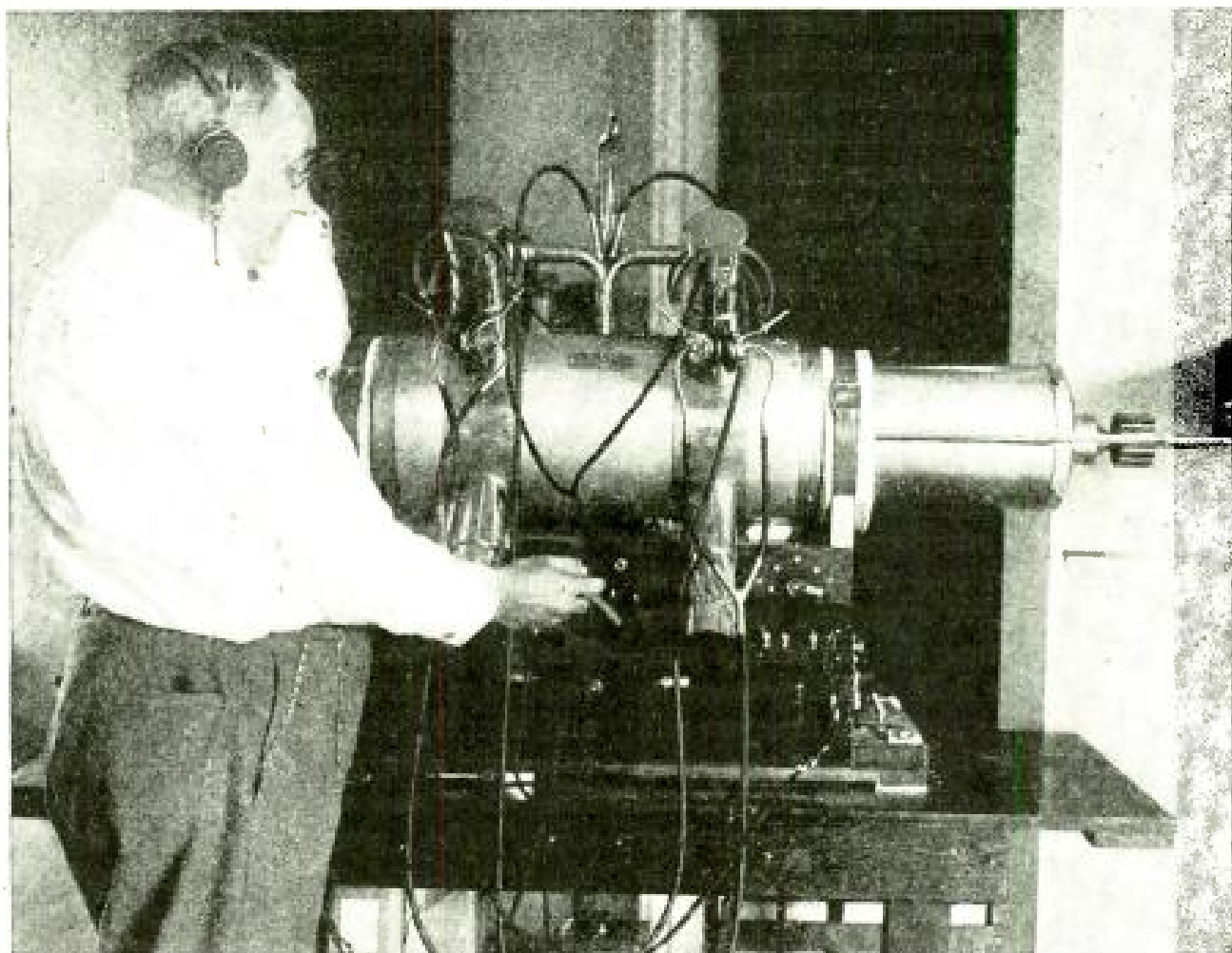

Pacific & Atlantic

A MODERN SPECIMEN OF ARTILLERY DEvised TO ATTACK "STRAYS"

This is one of the innumerable developments which come under the heading of "static eliminators." The device pictured above is the invention of W. J. Scott. It is being tested by the Navy Department at Washington.

continuous rattling and grinding sounds. There is also some experimental evidence to indicate that grinders usually arrive at our receiving stations from high altitudes, while clicks seem to come along the surface of the earth. However, no matter where either of them really do come from, it is certain that both reach our receiving antennas as abrupt and irregular electromagnetic waves that have many characteristics identical with the waves which carry radio signals. It is this approximate identity between stray waves and signal waves that has made it so hard to devise apparatus which is able to distinguish between them.

So much for our short summary of what static and strays are. Let us now think for a moment about the effects that

stray waves produce when they strike a receiving antenna system.

What Strays Do to Your Antenna

We know that radiant electromagnetic waves (in space) consist of electrostatic and electromagnetic forces that vibrate at certain frequencies and with certain intensities, and that increase or die away in accordance with certain power variations of the generating system. We know that these waves spread out in all directions from the point of origin traveling away from this central point with the speed of light—186 miles in each one-thousandth of a second. We know that whenever the wave-forces strike a conductor such as a receiving antenna wire they try to produce currents in that wire, and that by tuning

the receiving antenna system we can greatly increase the currents that will be set up in it by the arriving waves. We must make the natural frequency of the tuned receiving antenna circuit the same as the frequency of the waves we desire to intercept, if we are to have produced in it the greatest possible amount of current or power.

You can perhaps grasp the latter part of this idea, more clearly, by imagining a pendulum consisting of a weight suspended on a three-foot length of wire. Such a pendulum will swing from one side to the other and back again in a little less than two seconds. That is to say, it will have a natural frequency of a little more than thirty cycles a minute. If you take hold of the suspending wire a few inches from the top, you will find it difficult to make the weight swing unless you push and pull the wire at the natural frequency of about thirty per minute. On the other hand, if you do drive the pendulum at its natural rate of oscillation you will be able to build up a greater swinging of the hanging weight by little more than a slight push on

the wire applied at the proper instants.

The pendulum is a tuned *mechanical* system; the ordinary receiving aerial is a tuned *electrical* system.

Your hand in swinging the pendulum by regular impulses is a periodic driving force; so is a radio wave. When the frequency of the driving force agrees with the natural frequency of the pendulum, the largest swings are produced. So, when the frequency of the driving wave agrees with the natural frequency of the radio antenna system, the largest currents are produced.

Now for the effect of a stray wave. Suppose that you shot a revolver at the hanging weight, what would happen? The bullet would strike the weight and force it a certain distance to one side, and then the pendulum would commence to swing back and forth at its natural frequency, the swings gradually dying away. The larger the energy of the bullet, or the smaller the size of the hanging weight, the larger would be the swing of the pendulum before it commenced to die down.

In much the same way, when a stray wave strikes a receiving aerial it produces in it electric currents of the antenna system's natural frequency, and these currents gradually die away to nothing. The larger the energy of the stray wave, or the smaller the *persist-ence* of the antenna system, the larger will be the current before it commences to die down.

How to Distinguish Between Strays and Signals

If we bear in mind that the hand-swung motions of the pendulum correspond to radio signal currents in the antenna, whereas the shock excited, dying-away motions correspond to the undesired stray wave currents, we can see at once some of the difficulties that lie in the way of distinguishing one from the other. Once we let stray waves produce currents in our antenna systems, about the only differences we can

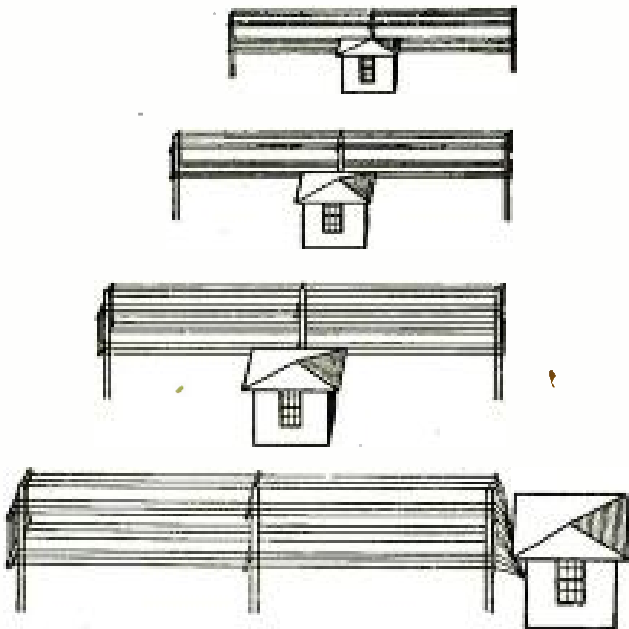

AN ELABORATE ANTENNA SYSTEM
FOR STUDYING STATIC

A schematic diagram of one of Dr. G. W. Pickard's early systems for reception during the static periods. This system was for use on long wavelengths.

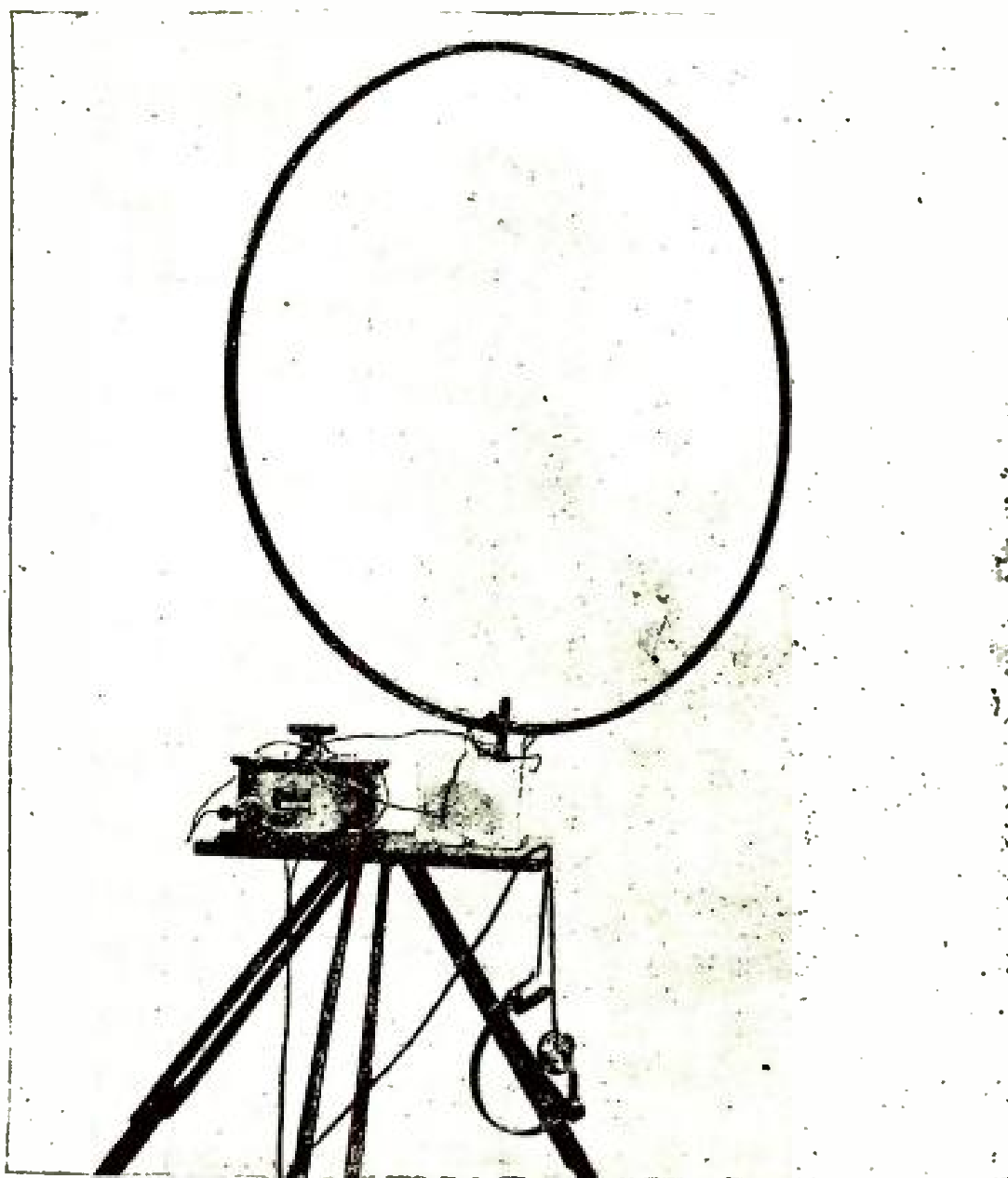

AN ANCESTOR OF THE LOOP ANTENNA

The first portable radio compass used in 1907 and 1908. It is with a development of this loop that many facts have been found out about static and its causes and effects. It has been used to determine the directional effects of static and much valuable and important data has been gathered by its aid.

detect between the unwanted stray currents and the desired signal currents is, that the latter may be uniform and regular whereas the former are always of the *damped* or dying-away variety and are always erratic and irregular.

Thus the problem of reducing interference from strays falls into two parts. The first is to keep stray waves from affecting the antenna system, and the second is to discriminate between signals and strays once they have both produced radio frequency currents in the

antenna wires. Substantial progress has been made in both divisions of the attack; and the advances have been cumulative and continuous for the past ten years or more.

It should be clear that we are not particularly interested in the *absolute* elimination of stray interference, except possibly as a theoretical ideal. So long as this kind of interference can be kept as small as or smaller than other unavoidable kinds of interference, we are satisfied. The easiest and best way to

measure the effectiveness of any scheme for reducing the harmful effects of strays is to study the ratio of signal intensity to stray intensity under various conditions for a long period of time. If the signal-stray ratio can be kept reasonably high for practical working, the scheme is a good one.

The Signal-Stray Ratio

Obviously the signal-stray ratio of any receiver varies from moment to moment even when listening continuously to some particular transmitter. Let us imagine that during some evening you are receiving from a broadcast station that is heard with an intensity of 200 (on an audibility meter), and that in the course of the evening the average stray intensity swings up and down irregularly between 20 and 400. Clearly enough, this means that the signal-stray ratio will be varying irregularly from $200/20$, or 10, down to $200/400$ or $1/2$. If you had instead been listening to a nearer station that was heard with an intensity of 600, the signal-stray ratio would have varied between 30 and 1.5. This means, of course, that at the worst moments the signals would have been $1\frac{1}{2}$ times as loud as the strays.

On the other hand, if you had been trying to receive from a far distant station that gave an intensity of only 40, the best ratio would have been only 2 and the worst 0.1—the strays ten times as loud as the signals.

Now consider that the signal intensity corresponds to the force with which you are keeping the pendulum swinging, whereas the stray intensity is analogous to the force exerted by the bullet that strikes the pendulum weight. Clearly enough, to keep the pendulum going regularly you need strong driving forces, and a large weight compared to the weight of the interfering bullet. Similarly, to receive messages regularly you should have strong incoming signals, and circuits not easily disturbed by the abrupt stray waves.

How to Reduce the Effects of Strays

What can we do to a radio circuit that will make it less subject to strays?

Merely increase its natural persistence of oscillation—which is another way of saying increase its inductance and reduce its capacitance and resistance. By using shorter antenna wires and adding low-resistance inductance coils to tune to the desired wave frequencies, or by putting a small series condenser (say of 0.00025 microfarad) in series with a larger antenna the persistence of the circuit can be substantially increased. Similarly, loop or coil antennas are generally much more persistent than ordinary antennas, hence are less subject to stray interference.

Of course, cutting down the size of your antenna is likely to weaken the signals you will receive from any particular station; the point is, however, that the stray interference will be weakened *still more*, or in greater proportion, and thus the signal-stray ratio will be improved. The numerical value of signal strength may be then regained by additional amplification, without bringing the strays up to their former intensity.

As an example of this, suppose that changing over from the plain antenna to the coil antenna brought the signal intensity above given as 200 down to 100, but at the same time reduced the stray intensity from between 20 and 400 down to between 2 and 40. Then the signal-stray ratio instead of varying between 10 and $1/2$ would lay between 50 and 25, and the signals would always be at least $2\frac{1}{2}$ times as loud as the strays instead of occasionally being only one-half as loud. A two-fold additional amplification would bring the signals back to the original intensity of 200, while preserving them much louder than the strays.

There are various and more elaborate ways of improving the signal-stray ratio of receivers, but although these rather complicated arrangements are of definite

value for radio communication using low wave-frequencies (long waves) they are not necessary for amateurs or broadcast listeners. The waves that have been set aside for amateur and broadcast transmission are largely free from the severe stray interference that is found at the wave frequencies used for long distance radio telegraphy. This fortunate state of affairs leaves matters so that radio broadcasting over reasonable distances is seldom interfered with seriously except when thunderstorms are nearby. By careful antenna design and the use of efficient amplifying circuits, and with skillful adjustment so as to keep the signal-stray ratio high, successful reception may even be carried on in the midst of local storms and reasonably long distance receiving is not tremendously handicapped by the customary quantity of summer-time short-wave stray interference.

The Regularity of Signals and the Irregularity of Strays

There remains for us to consider only the question of distinguishing between stray effects and signals, once the currents have been set up in the receiving system. The most useful plans for such discrimination are based upon the regularity of signals as contrasted against the irregularity of stray disturbances. The pure continuous wave used in radio telegraphy is exceedingly valuable in this respect, for its uniformity and persistence permit the use of highly selective circuits and loose couplings that tend to suppress strays in a way that is not attainable when spark or damped-wave transmission is utilized. With spark radio telegraphy about the best that can be done is to produce the wave-trains at a high and definitely regular audio frequency, so that the dots and dashes are heard as high-pitched, pure musical tones which sound very different from the clicks and grindings of the stray waves. With continuous waves, radio-telegraphic reception is best car-



Signal Corps, U. S. A.

A HIGHLY EFFICIENT LOOP

The use of the modern long-wave loop is one of the chief factors in obtaining unlimited and uninterrupted radio communication service in our military departments. Above is seen one of these loops used for long-wave reception by the Signal Corps of the army at Washington, D. C.

ried on by the heterodyne method, in the customary applications of which the desired signals not only are heard as high, pure musical tones but also are amplified in a selective fashion that does not magnify the stray-wave currents to the same extent.

Radio-telephone listeners are greatly aided in distinguishing speech and music from stray disturbances by the fact that the human ear has through many generations evolved into a wonderfully effective mechanism for sorting out and discarding irregular noises. Just as we can converse without great difficulty amid noises that would almost drown out the clicking of a telegraph sounder, so we can receive and understand radio telephone signals in spite of interference that would render dots and dashes unintelligible.

There have been produced various forms of acoustic and electrical filters for taking advantage of the difference in

regularity between strays and *telegraphic* signals, and some of these are very useful. Indeed, it is possible to aid even telephonic reception to some degree in this way, but as a rule such refinements are not essential in local broadcast work.

One last word as to irregular noises!

Don't think that all the clicks and rattles heard in some radio receivers are caused by strays. Many times interference blamed on "static" is really produced by *noisy tubes or batteries*, and may be completely eliminated by a few judicious replacements.

Don't get the idea that summer-time static can prevent useful radio work. Remember that golf played on links like a billiard table would be no sport at all; the hazards make the game.

Use your ingenuity and skill to build up the signal-stray ratio of your receiver, and you will *never* have to complain that stray-wave troubles have made radio less interesting.

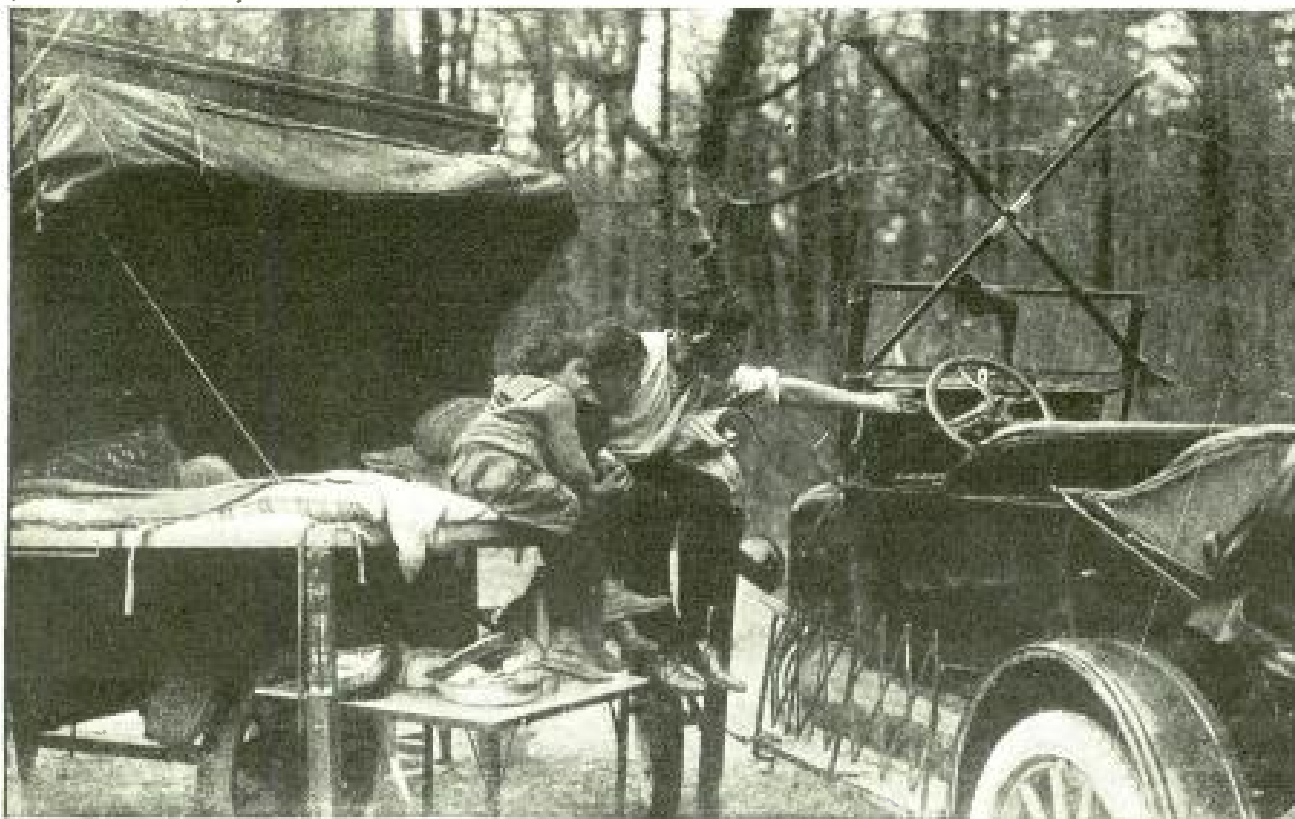

Travellette Photo News

A RECEIVER WITH A TIN LIZZIE ATTACHMENT

Here is one of the rapidly growing army of radio fans who carries his radio set along with him on his vacation jaunts. In this case the apparatus is such a prominent part of the Ford car that it has become, in effect, a radio set on wheels.



International

"Their Master's Voice"

As a demonstration of what may be done—and of what inevitably will be done—for reaching great masses of people by radio, this portable receiving apparatus, equipped with powerful loudspeakers, was recently set up in Battery Park, New York, during lunch hour. How many people could be reached by the President's voice if similar apparatus were operated in every city and town in the country?

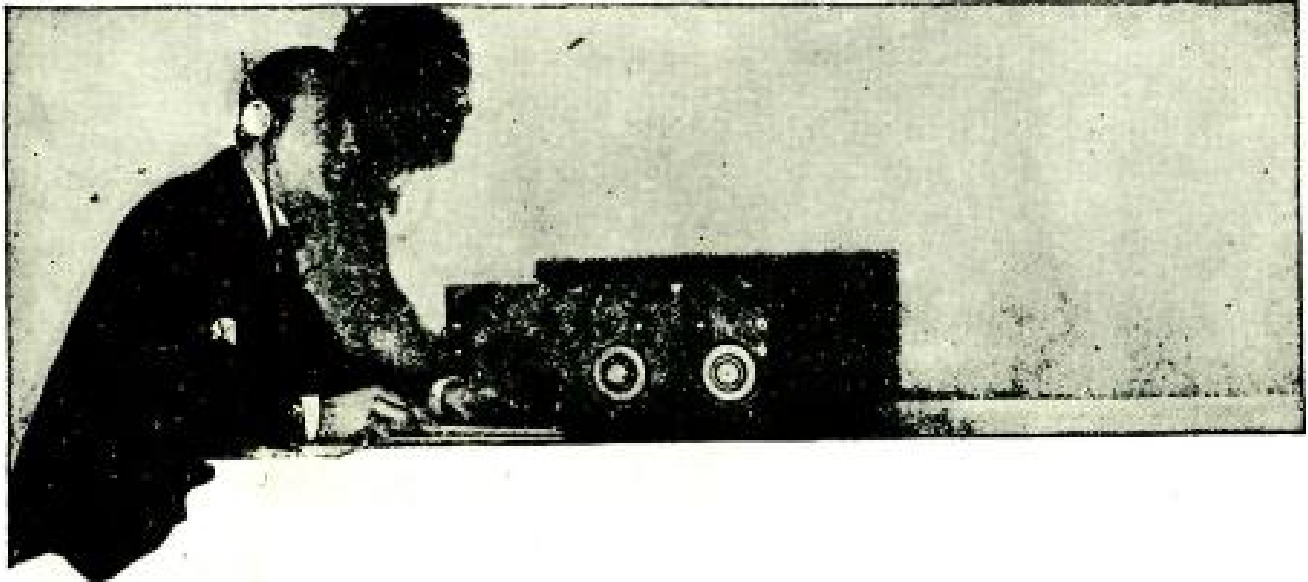

“Thou Shalt Not Broadcast—”

CERTAIN COPYRIGHTED MATERIAL HEREINAFTER SPECIFIED

THE American Society of Composers, Authors and Publishers is demanding fees from radio stations for broadcasting copyright material owned by its members. Some broadcasting stations may pay it; others are refusing on the ground that the Society includes only a portion of the composers. And the producing managers of musical comedies are also presenting their claims to both the Society and to the composers! How the law interprets these at present complicated rights is outlined in this article by an attorney who has made a special study of this subject.

By CHARLES H. KESLER

IF a broadcasting station wanted to broadcast a copyrighted, non-dramatic book it could do so. The copyright laws do not cover this method of presenting a book. One could indeed hire a hall, charge an admission fee and read a copyrighted book to the audience without any liability.

But who would want to go?

It is questioned if the broadcasting of books by radio, other than tales for children, be desired by the radio public.

There are, however, certain forms of writing or copyrighted matter which may be infringed if broadcasted by radio. Among such writings are lectures, sermons and addresses, dramatic and dramatico-musical compositions and musical compositions. In fact the American Society of Composers, Authors and

Publishers, an organization granting licenses for the public delivery of copyrighted songs, intends to charge fees ranging from \$250 to \$5,000 to radio stations for broadcasting its songs and musical selections.

This society has been formed for the purpose of granting licenses to persons who desire to render copyrighted musical selections in public. It is a lawful organization and a practical one, as it is apparent how difficult it would be for an artist or other person or company to secure licenses from each owner, author or composer individually, considering their great number and also the number of copyrighted songs there are. Of course a license from the Society of Authors and Composers gives no one the right to render copyrighted

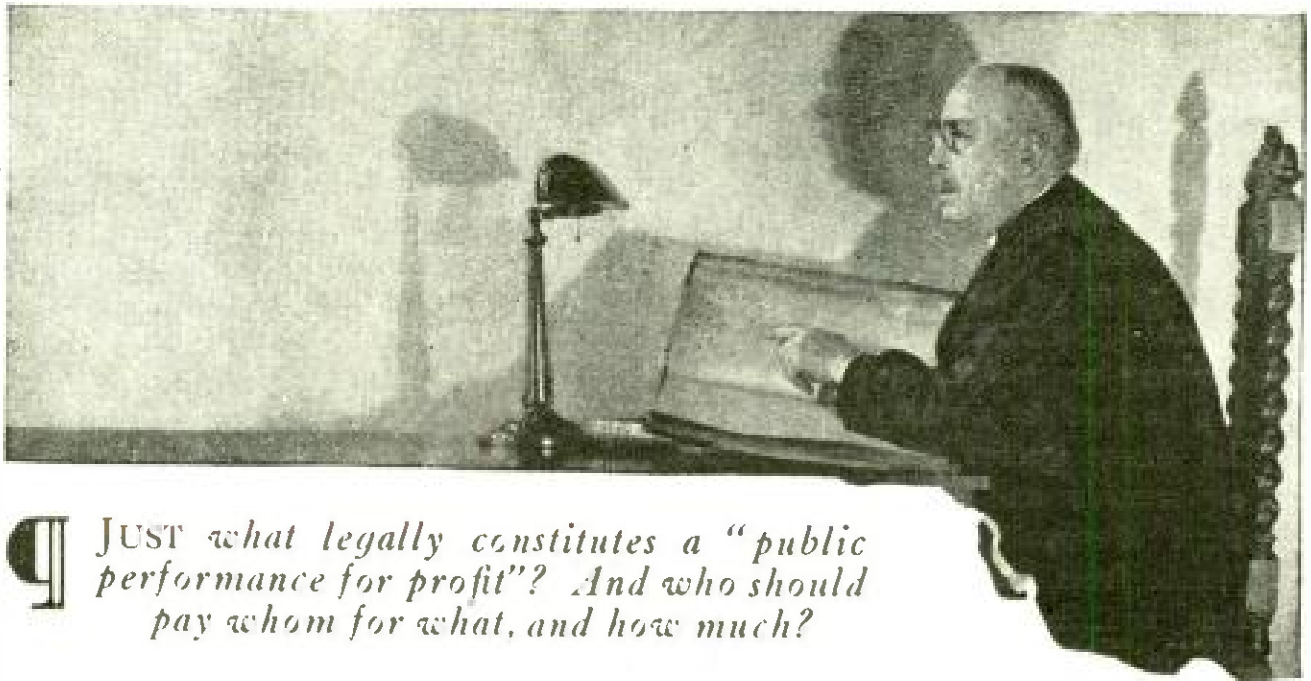

Q *JUST what legally constitutes a "public performance for profit"? And who should pay whom for what, and how much?*

songs owned by persons who are not members of this society.

It was not until 1909 that the copyright law conferred upon an author or owner of a copyright, the exclusive right "to perform or represent the copyrighted work publicly for profit if it be a musical composition," although there was then in force, and still is, a criminal statute prohibiting such performances.

The present law also confers upon the person entitled thereto the exclusive right "to deliver or authorize the delivery of the copyrighted work in public for profit if it be a lecture, sermon, address, or similar production."

The author or owner has the exclusive right to perform a drama (or dramatico-musical composition) publicly, whether for profit or not.

The copyright laws and the courts recognize two classes of musical selections; "dramatico-musical compositions" so called, and just plain "musical compositions."

The first class includes musical comedies, musical shows, operas and productions of similar nature.

The selections listed under the second class are published as single songs or musical selections, and are such as are not copyrighted as parts of a dramatic

work. The copyright on a musical dramatic production covers also any copyrightable component part of it and this part, if republished as sheet music with a suitable notice of the original copyright, should still retain all rights acquired as a copyrighted dramatico-musical composition.

The owner of a copyrighted drama (or "dramatico-musical composition") has the exclusive right "to exhibit, perform, represent, produce or reproduce it in any manner or by any method whatsoever," whether for profit or not.

It should be noticed that the language of the Act here is very broad—sufficiently broad, in fact, to give the copyright owner the exclusive right as to public performances "in any manner or by any method whatsoever," such as by moving pictures, phonographs, radio broadcasting or even where radio receiving is done publicly. This language is also sufficiently broad to cover moving picture films, phonograph records or music rolls of dramas or musical selections taken from the copyrighted dramatico-musical composition.

The reader, therefore, should bear in mind the distinction between mere "musical compositions," in which the element of "profit" must be present in the case of a public performance, and

technical "dramatico-musical compositions" which cannot be performed publicly even though not for profit.

Another right conferred by the copyright laws is the exclusive one "to make any arrangement or setting of a 'musical composition' or of the melody of it in any system of notation or any form of record in which the thought of an author may be recorded and from which it may be read or reproduced. . . ."

The clause quoted relates to phonograph records and music rolls. The payment of royalty on each record or roll made frees the record or roll from further contribution to the copyright except in case of public performance for profit. "The reproduction or rendition of a musical composition by or upon coin-operated machines shall not be deemed a public performance for profit unless a fee is charged for admission to the place where such reproduction or rendition occurs."

What then is meant by "public performance for profit"?

The Supreme Court of the United States answered this question in two cases considered at the same time: *Victor Herbert vs. Shanley Company*, and *John Church Company vs. Hilliard Hotel Company* (Vanderbilt Hotel).

Although the copyrighted music considered was taken from musical shows the facts peculiar to the two cases made it necessary for the Court to pass on the question of profit.

In the first case Herbert was the owner of a comic opera entitled *Sweethearts* which contained a song of the same title. This the Shanley Company caused to be sung by professional singers accompanied by an orchestra upon a stage in its restaurant on Broadway.

In the second case the Church Company owned the copyright of a lyric comedy in which is a march called *From Maine to Georgia*. The Hilliard Company caused this march to be per-



Westinghouse

A CONCERT THAT RAISES A DELICATE LEGAL PROBLEM

When Uncle Sam issues a copyright on a musical composition and an officer of Uncle Sam's Army orders a military band to play it in a broadcasting station, what can the composer do about it—in face of the fact that he cannot sue the government?

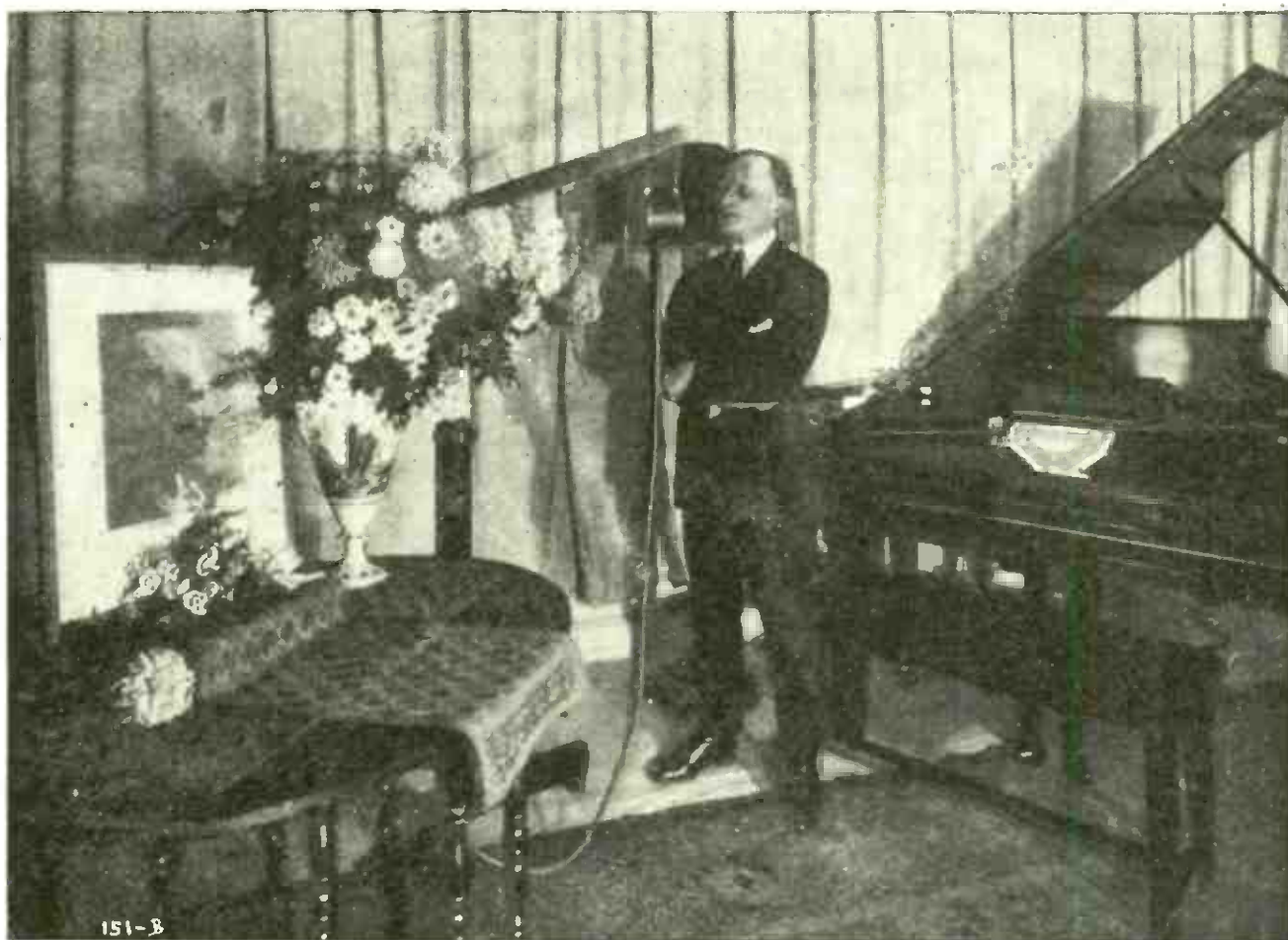

Westinghouse

THE MAKERS OF THIS PIANO-PLAYER ALSO OWN THE COPYRIGHT ON SOME OF ITS MUSIC

The law permits only those who own the copyright to make use of it. When a reproducing piano-player concern buys a copyright from a composer, therefore, it can broadcast the music at will.

formed in the dining room of the Vanderbilt Hotel for the entertainment of its guests, during mealtime, by an orchestra employed and paid by the Hotel Company.

These two cases present the question whether the performance of a copyrighted musical composition in a restaurant or hotel without charge for admission to hear it infringes the exclusive right of the owner to perform the work publicly for profit. Although it is easy to get in, as is well known to those of us who fortunately or unfortunately, have dined at Shanleys or at the Vanderbilt, it is not so easy to get out. The piper has to be paid.

Mr. Justice Holmes delivered the opinion of the Court in language worthy of the son of the *Autocrat of the Breakfast Table*. Justice Holmes said:

"If the rights under the copyright are infringed only by performance where money is taken at the door, they are very imperfectly protected. . . . The defendant's performances are not eleemosynary. They are part of a total for which the public pays, and the fact that the price of the whole is distributed to a particular item which those present are expected to order is not important. It is true the music is not the sole object, but neither is the food, which probably could be got cheaper elsewhere. . . . If music did not pay, it would be given up. If it pays it pays out of the public's pocket. Whether it pays or not, the purpose of employing it is profit, and that is enough."

According to this decision even the playing of a copyrighted "musical composition" in a restaurant by means of a phonograph or player piano would be considered an infringement, except if the instrument were coin-operated. The similar playing of a "dramatico-musical composition" would, of course, be an

infringement even though the purpose was not profit.

It is an erroneous impression which some have that, if they purchase an authorized sheet or a record or a music roll of a copyrighted song, they can use it to perform or render the song publicly. No right to so publicly perform it is implied by the purchase, except where the music purchased is a "musical composition" and the performance is not for profit, directly or indirectly, also excepting coin-operated devices.

The unauthorized broadcasting of "dramatico-musical compositions" is an infringement even in cases where the purpose is not profit. This means that neither schools, colleges, charitable institutions nor amateurs can broadcast such selections without license, not to mention radio manufacturers.

The language of the Act relating to such "dramatico-musical compositions" is very broad. There are no exceptions, no limitations circumscribing the exclusive right granted to the copyright owner when the selection is a dramatic musical composition.

When referring to mere "musical composition," however, the language of the statute is not as broad. The anti-limitation "in any manner or by any method whatsoever" is conspicuous by its absence. This seems to imply that the granted right to perform the mere "musical compositions" publicly has limits other than that as to profit. That is, the Act cannot be stretched beyond its elastic limits to cover all kinds of performances. This is a point for the defense. Whether or not the courts will draw the line more sharply between a musical selection which fortunately originated in a musical comedy and a similar selection which is a free lance, so to speak, remains to be seen. The broadcasting situation has clearly raised this issue. As far as broadcasting is concerned, the difference between one class of selections and the other, is the

difference between twelve and a dozen, merely logical. It is true their origins are different and they are made different by law.

But is the court going to say that one copyrighted song can be broadcast without infringing and another cannot?

Were such distinction made, it would be necessary for the copyright owner clearly to indicate or give notice that the piece or selection is covered as a dramatico-musical composition. If the court refuses to draw the line it will hold that even copyrighted "musical compositions" are infringed when broadcast for profit.

There remains, however, that doubt as to whether or not "musical compositions," as distinguished from "dramatico-musical compositions," can be broadcast for profit without infringement. Looking at it in what I do not hesitate to say is a reasonable manner, one should say, "certainly, broadcasting is a public performance." Yet we should consider and understand that courts are apt to look at such strictly statutory rights in a very technical manner, construing them narrowly, on the principle enunciated by the gentleman from the state just west of the Mississippi. It is not a cut and dried case for the copyright owner. The defense can offer argument the other way. It is a point the court might decide either way.

POPULAR RADIO for August, 1922, referred to the case of *White-Smith Music Publishing Company vs. Apollo Company*, in which the Supreme Court of the United States ruled under the old law that perforated music rolls which, when used with piano players to reproduce copyrighted musical compositions, do not infringe the copyright. The court held that the sale of such rolls (or records) was not a printing, publishing or copying of the copyrighted work within the meaning of the old Act. The copyright laws were strictly construed by the court. After that decision the laws were amended to give

POPULAR RADIO

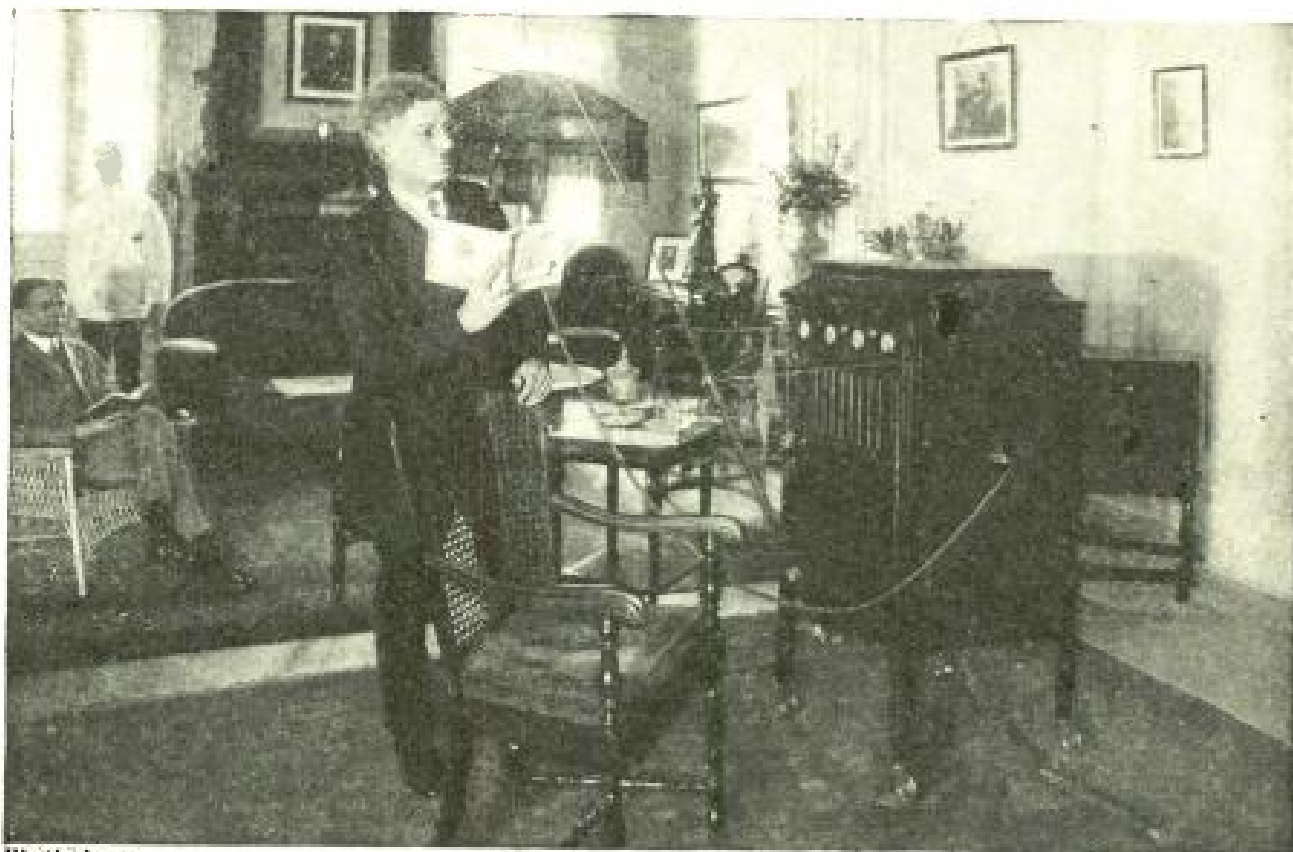

Westinghouse

AN AUTHOR DOES NOT NECESSARILY OWN THE RIGHTS TO HIS OWN WORKS

When Ralph Mayhew reads from his own "Bubble Books" and broadcasts the gramophone records of his own songs he can do so only with the permission of his publishers—who own the copyright.

the copyright owner the exclusive right as to records and music rolls also.

Similarly radio broadcasting is a new situation developed since 1909 when the present copyright laws went into effect although radio and telephoning were known at that time. Without giving the clause "to perform the copyrighted work (a musical composition) publicly for profit," a strained construction, just what does it mean? Can it be construed to cover a situation other than that of an artist in personal touch with his or her audience like the Vanderbilt and Shanley cases? The playing of a copyrighted musical composition on a phonograph or player piano is considered a "performance" if done publicly for profit. But is such a performance done "publicly" unless the audience is actually present to hear and see the phonograph or artist? Must not there be a place for the public to be other than in their homes?

Congress couldn't have had radio broadcasting in mind when it framed the copyright Act of 1909. Broadcasting as we know it was unknown then. It did, however, secure for the author of a "musical composition" the exclusive right as to instruments like the phonograph or player piano. This was intended. But any public performance had to be for profit. It is true that unqualified rights are given the author of a dramatic work but it is doubtful (although I have not studied the congressional proceedings) if Congress really intended that an author should have unlimited rights as to the public performance of a song merely because it was taken from a dramatic work. I believe it was the intent of Congress to place all songs as to public performance on an equal footing, the test to be whether or not the performance was for profit. In the endeavor to give the author of a dramatic work all



General Electric

A "PUBLIC PERFORMANCE FOR PROFIT" OF A DRAMA

Only the owner of a copyrighted play can legally authorize its presentation "whether for profit or not." (Question: Why do the actors who are broadcasting the scene illustrated above don their costumes and make-up?)

rights of performance, Congress apparently overlooked the fact that songs without dramatic action could be rendered separately from the dramatic work of which they formed a part. Granting that might have been the intent of Congress, nevertheless the law relating to dramatic works as it now stands does not express such intent. The law on the contrary is very broad. It covers all kinds of performances by all possible methods.

The point I wish to make, however, is that a Court might very well rule that radio broadcasting of "musical compositions" is not a public performance as commonly understood or within the meaning of the Act. If Congress had intended to include the public performance of musical compositions for profit "in any manner or by any method whatsoever" it would have so worded

the law as it did in the case of dramatic work. But it didn't do it. Congress did take pains to include record-operated machines. But can the Act be stretched to include this different way of rendering musical compositions—with radio apparatus? If under the old law a record or music roll was not considered a print or copy of a copyrighted musical composition, will the broadcasting of such compositions be considered a public performance under the present law?

Let us continue the argument for the defense by a philosophical consideration of what radio apparatus is. It is a hybrid among the sound-producing instruments. It is unlike a cornet or a violin which must be played by the artist. Moreover the receiver must be considered as part of the entire radio apparatus. The transmitter is useless without it.

Nor can we say that radio apparatus is like mechanical devices such as the phonograph or piano player. There is no record employed in transmitting. The transmitter is sound-operated. It is possible, however, to operate a transmitter directly from a record but it is not being done as yet in broadcasting. Radio apparatus is not mechanical. It is an electrical device dependent on the artist or on a separate sound producing agency. Nor is radio apparatus merely an amplifier of the sound, like a sounding board or other acoustical arrangement. The energy projected into space is not sound energy but electromagnetic waves. If there be amplification, it is amplification of electrical energy.

Here then is an instrument different from anything specifically mentioned in or contemplated by the copyright laws. The sound heard at the receiver is not the original sound produced by the artist. The artist's note is first transformed into electrical waves which in turn are changed into a new group of sound waves. If this be a public performance, as the Court may decide, it certainly is a new kind of performance.

The position for a plaintiff or copyright owner may be briefly stated. The broadcasting of copyrighted musical compositions is a public performance because such music is made available to the largest audience in the world. The copyrighted song is thus given the largest possible publicity. Should a broadcaster be allowed to profit without compensation to the copyright proprietor?

Assuming that the broadcasting of "musical compositions" is within the copyright laws also, only stations which broadcast such compositions without profit are free to do so. Such stations are those owned by charitable, eleemosynary or educational institutions or by governmental agencies. Furthermore, no action lies against the government for infringement of a copyright as such action is in tort and the government cannot be sued in tort without its per-

mission. Stations owned by manufacturers or dealers in radio apparatus and other goods or by agencies selling broadcasting service (not renting stations) are the ones which will be required to be licensed. As the Supreme Court said, if "the purpose is profit that is enough." Whether such purpose exists in any given case is a question of fact. Obviously the method of obtaining the profit here is different from the hotel and restaurant cases. In the latter cases the public paid on the spot. In the case of broadcasting, the profit may or may not be realized.

There is also the case of users of receivers. I passed a "radio restaurant" the other day in which the guests were being presumably entertained by radio. Some dealers also furnish radio concerts to attract the crowds. One can hear the music blocks away. If the broadcasters are liable under the copyright laws these users of receivers are also, unless they shut off the receiver every time a copyrighted song is announced. Nor would the fact that the broadcaster is licensed give such right to the user of the receiver, unless the license to the broadcaster specifically so provided.

Don't forget you can also be arrested for infringing copyrighted matter. Anyone who wilfully and for profit infringes a copyright or who knowingly and wilfully aids or abets such infringement is guilty of a misdemeanor.

In summary, no unauthorized radio station of any sort has the legal right to perform publicly musical selections known as "dramatico-musical compositions." It can't be done, even if not for profit. But there is some argument for holding that the radio rendition of "musical compositions" is not an infringement, even though the purpose is profit. If the courts decide the argument is not a good one, only such persons can broadcast or perform by radio such musical compositions, as do not do so for the purpose of profit.

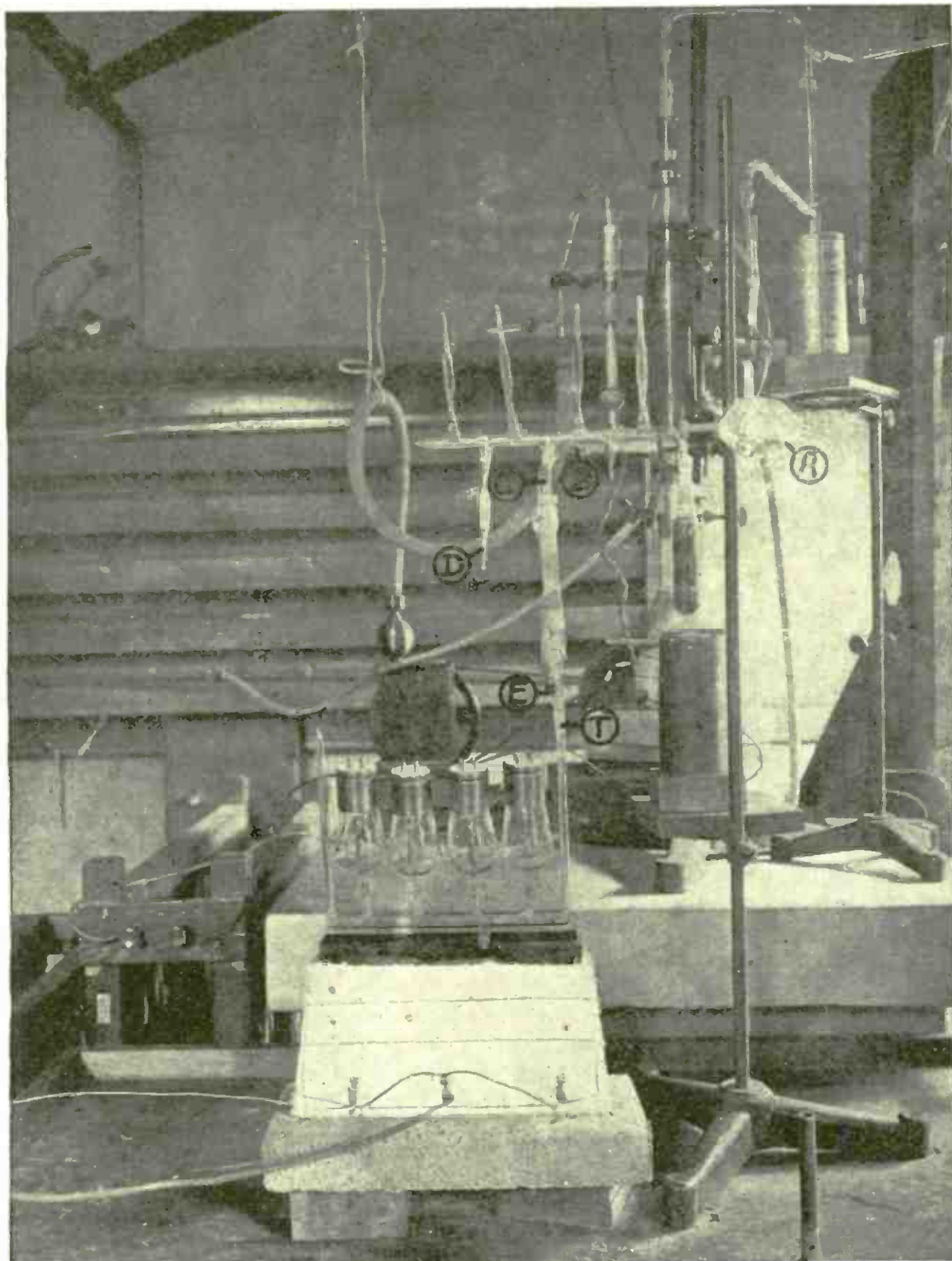

From a photograph made for POPULAR RADIO

THE APPARATUS USED FOR PUMPING AND PRIMING THE TUBES

FIGURE 1: *A*, is the glass bulb which holds the supply of K-Na; *B*, is the piece of blown-glass pipe that leads to the evacuating pumps; points *C*, *D*, and *E*, are points that are sealed off or opened during the process, and *T*, is the tube through which the vacuum tubes are exhausted and primed. The other apparatus consists of the pumps, the pressure gauges and the heater oven.

THE NEW AND REMARKABLE Alkali Vapor Tube

How the sensitivity of a vacuum tube is increased over 300 percent by the injection of potassium-sodium during the evacuation period.

By HUGH A. BROWN and CHARLES T. KNIPP

THE capacity of the new alkali vapor detector tube to function efficiently as a detector at low plate voltages is a matter of significance in the radio world. A description of the laboratory procedure in preparing these tubes, and a brief description of some newly discovered characteristics is of more than passing interest to the radio experimenter.

The material introduced into these tubes is an alloy of potassium and sodium, and has the appearance of mercury, which *must be prepared and handled only in a high vacuum.** A brief description of the method of filling the tubes follows:

Standard tungsten filament amplifier or detector tubes were connected to a "manifold" as shown in Figure 1. The glass bulb portion of two or more three-electrode tubes were fused in a vertical position onto a horizontal glass manifold. This manifold was connected through a "T" tube, one branch of which, B, led to the evacuating system, and the other to the *K-Na* alloy supply tube A. The evacuating system consisted of a charcoal tube in liquid air, a phosphorus pentoxide tube, a mercury vapor trap also immersed in liquid air, a McLeod gauge, a mercury condensation pump, and a supporting rotary oil pump, all shown in the illustration. The supply tube A, had a number of branch outlets, each branch being drawn down into a slender tube D, and also provided with a constriction, for the introduction

of the alloy into the manifold and for subsequent sealing off. Connection between the outlet tube and manifold was made by heavy-walled rubber tubing sealed with rubber cement and tightly wired down.

When a pressure of the order of 10^{-4} mm. of mercury was reached, the tip at D, which was previously nicked with a file, was broken off by sharply bending the rubber tubing. The evacuation was continued, and, in order to completely as possible evacuate the tubes, the filaments were kept incandescent and also, 150 volts were applied to the plates. This evacuating process was continued until the tubes (which had been previously connected to receiving circuits) functioned best as detectors with 60 to 80 volts on the plates. This test indicated that the tubes were fairly well evacuated.

The supply tube A, was then tilted up and a little of the alloy was allowed to run down into the manifold; after that, tube A, was sealed off at C. To guard against possible leaks, due to the rubber connecting tube, another seal off was made at E.

The oil bath with its electric heater attached was now raised so that the horizontal manifold was immersed in the oil. The bath was gradually heated, with the pumps going, and ultimately the temperature was raised to about 230°C ., at which temperature the alloy was fully vaporized. The vapor then passed through the capillary tubes, connecting the manifold to the electron tubes, and was condensed on the cool walls of the latter, forming a thin film.

*The preparation of this material is described in a paper by the authors published in the December, 1922, issue of the *Proceedings of the Institute of Radio Engineers*.

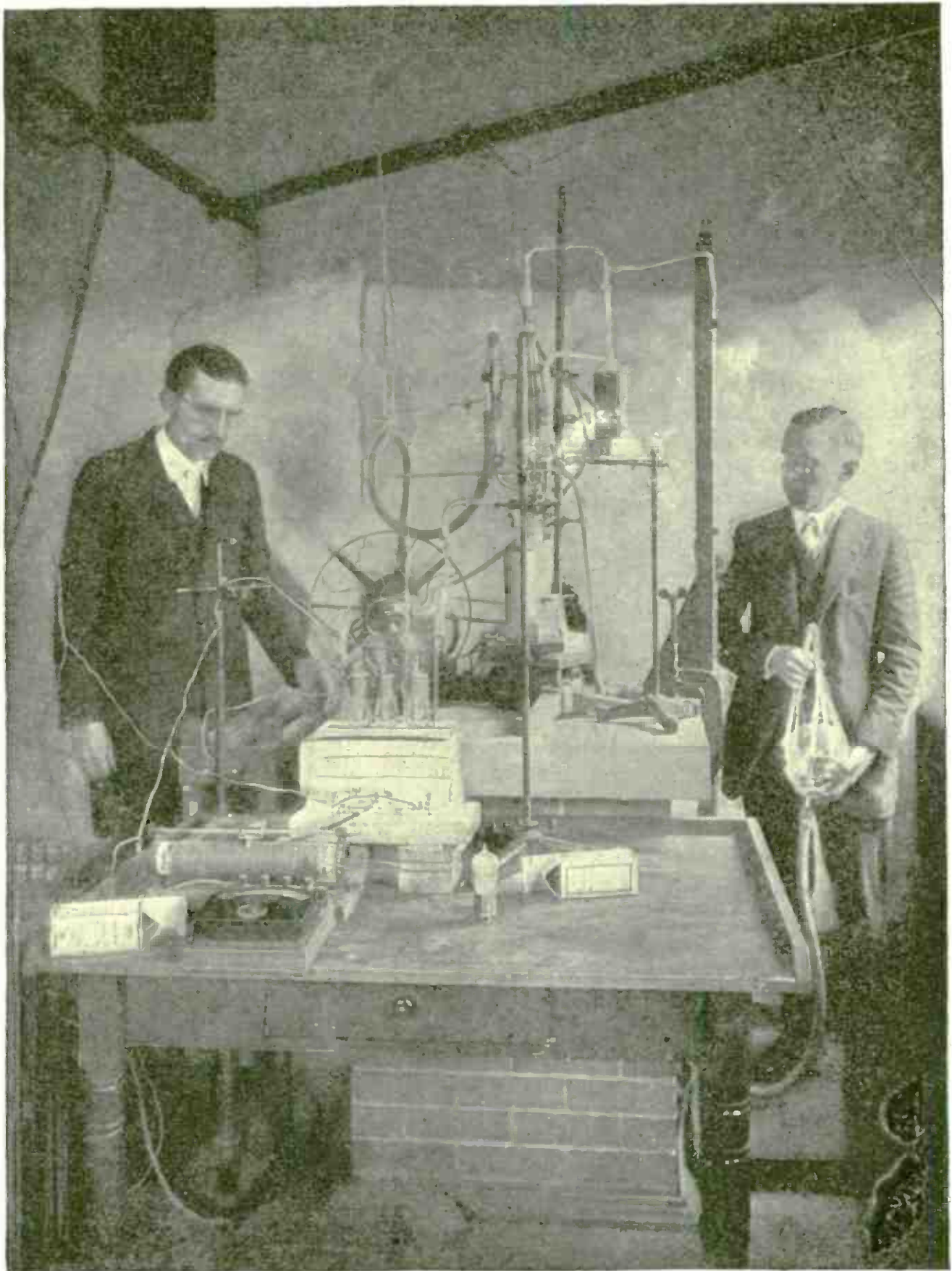

From a photograph made for POPULAR RADIO

THE AUTHORS DEMONSTRATE THE "SET-UP" FOR PRIMING
FIGURE 2: *At the left is Dr. Charles T. Knipp, head of the Physics Department of the University of Illinois, and at the right is Dr. Hugh A. Brown, associate of the Department of Electrical Engineering. They are injecting a small quantity of potassium-sodium alloy into the tubes during the process of evacuation.*

at first of varied purplish hues, but shortly becoming silvery white, when the deposited film became thicker. Heat, coming to the bulbs by reason of being mounted directly over the oil bath, was intercepted by strips of cardboard and by turning on an electric fan. The filaments were kept incandescent at nearly normal filament current during this distillation process, thus preventing a deposit of the alloy on the inner metal parts of the tube, as well as aiding in the process of evacuating. After the inner walls of the bulb were well covered with the alloy, the oil bath was removed, and the tubes were sealed off. The pressure throughout the final stages of priming was maintained at approximately .00004 mm. of mercury. The action of the alloy within the tube is to "clean up" the remaining traces of air, and hence the vacuum actually *improves* with time.

It is extremely important to clean all glass and rubber tubing with *aqua regia* and distilled water, otherwise the alloy will stick to the walls of the tubing. The authors prefer to construct new manifolds rather than attempt to clean the used ones, also to use fresh rubber tubing each time. In order to facilitate distillation in the bulbs, the sealing off strictures should be fairly large—about 1 to 2 mm. (inside diameter). Any of the alloy condensed in the stricture should be evaporated gently, before attempting to seal off, as excessive heat will burn the alloy and give it a brown color.

Figure 2 shows a photograph of the authors of this article at work "priming" some radiotron tubes in the research laboratory. The device on the right is the McLeod vacuum gauge, and when the photo was taken the mercury "cistern" of this gauge was being raised so as to read the pressure. The rheostat on the left was being adjusted so as to increase the temperature of the oil bath to allow the alloy to evaporate faster. The photographs give the readers some

idea of the complexity of the equipment that is required for such a seemingly simple job. The glass blowing requires long and tedious work. A tube that has already been primed is shown on the table beside the apparatus.

Note

A great deal of quantitative data has been obtained by the authors on the characteristics of these alkali vapor tubes, as is shown in the I. R. E. paper (see note above); a brief summary of the performance of the tubes as detectors and amplifiers will be of further value to our readers.

1. Alkali vapor tubes are *sensitive detectors at any plate voltage from 0 to 60 volts*, but are most sensitive at plate voltages ranging between 8 to 10 volts.

2. Laboratory tests have indicated that these tubes are *more than three times as sensitive* on weak damped-wave signals as the conventional gas-content detector tubes.

3. The adjustment of plate voltage and filament current for best results is far less critical than for gas-content tubes. A 50 percent change from the best plate voltage produces less than 20 percent decrease in audibility, as compared to 5 percent allowable variation for the gas-content tubes.

4. The tubes are steady, more selective as to wavelength than the ordinary vacuum tube, and *give absolutely distortionless reception*.

5. The high temperature of the filament is necessary to make the potassium-sodium alloy vapor active. A poorly evacuated tube can be made to perform like a high-vacuum tube by raising the filament temperature.

6. The best plate voltage to use is about 8 or 10 volts. With this voltage, users in the vicinity of Urbana-Champaign, Illinois (where the tests were made), report excellent results. When using only the positive filament-drop, with no additional "B" battery, the writers have often received broadcasting stations in Kansas City, Atlanta, Schenectady, and Pittsburgh, using a two-variometer type of regenerative receiver with an antenna 12 feet above the ground and 40 feet long, and with no amplifier. The reception from these stations was fairly loud and very distinct.

Again, using an antenna 40 feet high, and with no external "B" battery, broadcasting stations in Los Angeles, Cal., were received fairly loud. The above stations could even be heard faintly with the plate-circuit return connected to the negative filament lead, and with no "B" battery. With these conditions the tubes were also used as beat receivers of the autodyne type, receiving high-power stations on the coasts, when using the negative filament-drop as the sole plate potential.

—EDITOR



THIS STATION HAS BEEN HEARD THROUGHOUT
ALL NORTH AMERICA

Its owner is a typical amateur, Charles T. Asbury (3ADT) of Oak Lane, Pa. "My station has been heard in every state of the Union, Canada and Panama," he reports.

THE NEW VOICE THAT IS BEING HEARD AROUND THE WORLD

Amateur radio knows no geographical boundaries. The new and wonderful world of the ether has extended beyond the artificial barriers of countries and has become inter-continental in scope. Some of the remarkable long-distance work of amateurs has recently been checked up by the U. S. Navy; the results are published for the first time in the following article.

By COMMANDER STANFORD C. HOOPER, U. S. N.

BY the radio amateur of our distant Territory of Hawaii, the United States may be visualized as a vast honeycomb of amateur stations within a huge beehive of sound.

As he "listens in on the United States" from his vantage point out

near the center of the North Pacific Ocean, he overhears conversations in the "dot and dash language of radio" going on through space between his brother amateurs whose 17,000 odd licensed transmitting stations are scattered all over this broad land, ranging

in locations as they do all the way from the state of Washington on our Pacific seaboard to Florida on the Gulf of Mexico; from the Canadian border on the north to the Mexican border on the south; from California to Maine.

Not only is the dot and dash language of amateur radio telegraphy from all sections of the United States thus brought to him with lightning-like speed on those distant islands situated more than two thousand miles from the nearest point on our Pacific seaboard, but in some instances he also hears the *voices* of his brother amateurs conversing with one another through space by the medium of radio telephony.

Moreover, as a full fledged radio amateur, he is not restricted to "listening in" only. His station is equipped with a transmitting set as well as a receiving set and he can thus "talk" as well as listen.

Although the amateur radio trans-

mitting station, with its antenna suspended from the house top, may appear diminutive in dimensions as compared with the great high-power stations of the navy and of the commercial radio companies; although its juvenile transmitting wave is restricted by law to a length of 200 meters as against the waves ranging from 300 meters to the monster waves of 20,000 meters employed by the government and commercial stations; although he is also limited by law to an input power of only 1,000 watts (one kilowatt) with a consequent current value flowing in his antenna system rarely in excess of 10 amperes, whereas in the high-powered stations the input power has reached as high as 500,000 watts (500 kilowatts) with a consequent antenna current of 15 amperes to 700 amperes or more, yet in spite of all these handicaps he succeeds in covering remarkable distances through space, sometimes

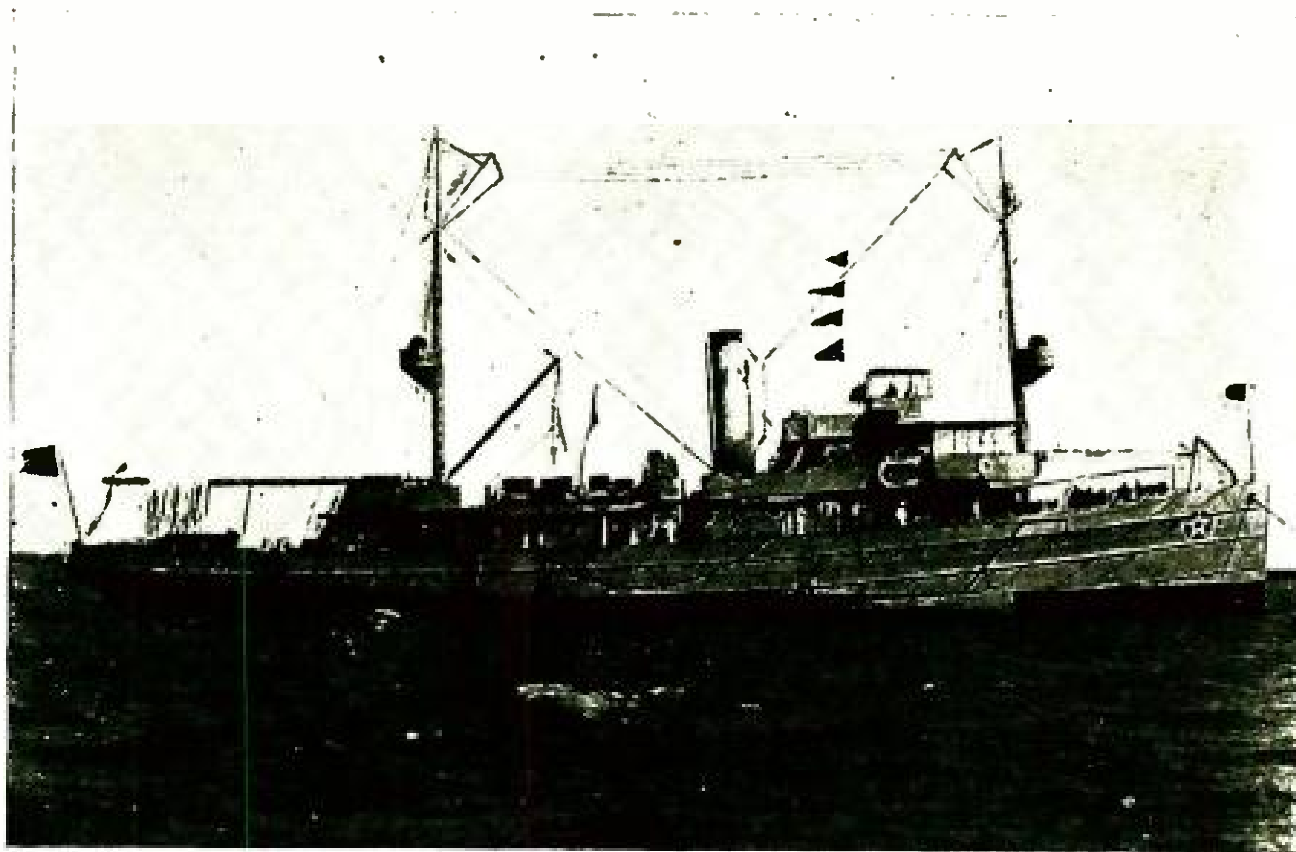

Official, U. S. Navy

HOW THE NAVY CHECKED UP AMATEUR RADIO STATIONS

The U. S. S. Sea Gull was fitted up with radio apparatus and was then dispatched to the east coast of the Island of Oahu in the Pacific—where the stations noted in this article were logged.

actually equalling those of the high-powered stations.

The amateurs have already successfully bridged the 2,000 odd miles of distance intervening between the Hawaiian Islands and our Pacific seaboard during the seasons of the year most favorable for radio communication—the autumn and winter months.

Communications are now exchanged back and forth during these months, with little, if any, difficulty, especially during the hours of darkness. Under exceptionally favorable conditions, communications are actually exchanged with inland stations situated as far eastward as Chicago and Detroit.

This will illustrate, on the one hand, the vagaries in radio communication, and on the other hand, the remarkable advances made by the amateurs in the development of the radio art within their restricted field of operation as regards wavelength and power input.

It is not intended to imply that the amateurs have thus far been *unnecessarily* restricted by governmental regulations. One need only to visualize the 17,000 odd amateur transmitting stations scattered all over the United States and to realize that under favorable conditions their signals may be effective for distances of 100 miles to more than 5,000 miles, to appreciate that restrictions as regards wavelength and power input *are necessary* in the interests of decreased interference to the essential government and commercial services.

Moreover, the amateurs of the United States are permitted far wider latitude than are those of any other country in the world, amateur radio operation being actually prohibited in most of the European and Asiatic countries.

As a result of the comparative freedom of action accorded the radio amateurs of America they have progressed in the development of the radio art within their sphere to such an extent that they now enjoy an acknowledged position of pre-eminence in

amateur radio throughout the world.

Their logical ultimate goal, however, is world-wide communication by amateur radio, and it is not inconceivable that they will eventually achieve this end.

Communications exchanged during the favorable autumn and winter months of the year between amateurs whose stations are situated along our Pacific seaboard and the amateurs in the Hawaiian Islands is not, of course, comparable with the reliable day and night service rendered every day in the year by the high-power stations of the navy and the commercial companies.

The high-power radio telegraphic service between our California coast and the Hawaiian Islands is absolutely reliable every day in the year, regardless of static conditions, except for the unaccountable brief sunrise and sunset "fading" periods which occur each day.

Of course the amateurs cannot render service of this quality but that they *have* succeeded in bridging the intervening distance between our Pacific seaboard and Honolulu with their low-powered, short-wave sets indicates that they are keeping not very far behind the high-powered services in the development of radio for long distance work.

During the autumn and winter months of the year 1921, an American amateur by the name of Dow, whose station is located in the town of Wailuku on the Island of Maui of the Hawaiian group, established communication, by radio, not only with amateur stations situated along our Pacific coast but also with others situated in our middle western states.

The juvenile 200-meter waves created by amateur stations thus not only effectually spanned the broad expanse of waters of the North Pacific Ocean but also the lofty peaks of the Sierra Nevadas and the Rocky Mountain ranges and the vast plains of our western states as the amateurs talked back and forth to one another. The

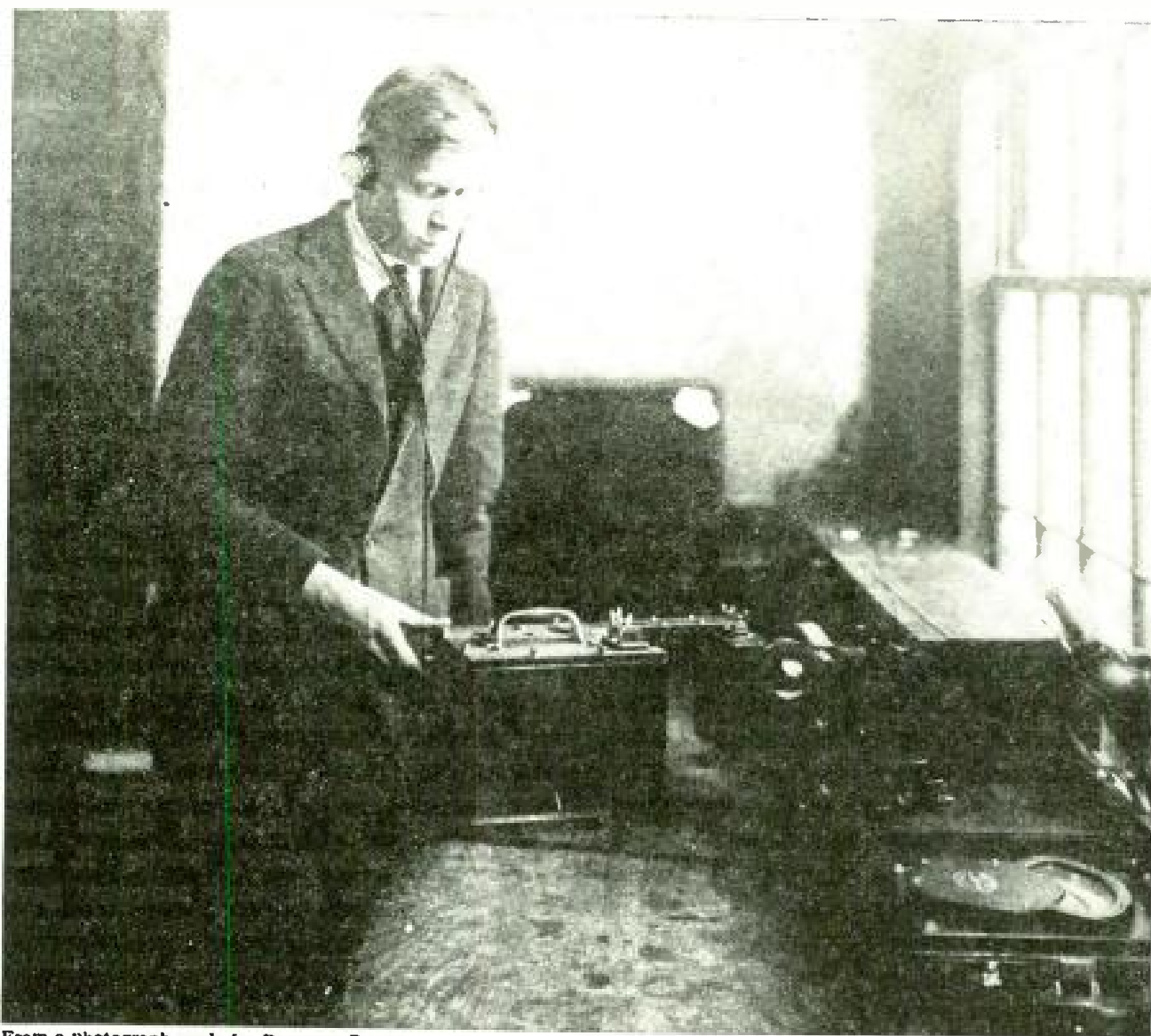

From a photograph made for POPULAR RADIO

AN AMATEUR STATION FAMED FOR LONG-DISTANCE TRANSMISSION

Experienced amateurs to whom the name of A. B. Tyrrell may be unfamiliar will be quick to identify him by his call letters 2BML. His station at Riverhead, Long Island, is known throughout the country for DX work.

performance was repeated during the year 1922 and among an ever widening circle of western amateur stations. In addition, amateur stations located along our Atlantic seaboard were also "picked up" at Wailuku, although communications were not actually exchanged between the Atlantic seaboard stations and the Wailuku station as was the case with the western stations.

These results were regarded as being so remarkable that experiments were undertaken during the month of October, 1922, by radio technicians attached to the navy's radio laboratory at Pearl Harbor on the Island of Oahu,

in order to ascertain whether receiving conditions on the Island of Oahu were equally as good as those on the Island of Maui, and to confirm the reports of previous amateur performances.

The experiments of the navy radio men were made during their leisure time after laboratory working hours between 3.00 P.M. and 3.00 A.M. Honolulu local time.

This enabled observations to be made during intervals when both daylight and darkness prevailed over the area under observation.

The Hawaiian Islands constitute one of the few favored areas of the world

for radio reception, as static is rarely experienced in these islands.

A radio peculiarity of the Hawaiian Islands is that the heaviest static season, such as it is, occurs there during the months of September and October instead of during the months of June, July and August as in the United States and elsewhere. Intense atmospheric disturbances such as prevail over the United States during the summer months are rarely experienced in Hawaii even during the months of September and October, although thunder storms with accompanying static occur from time to time regardless of the season of the year. These static storms prevail for not more than twenty-four hours duration and they are of infrequent occurrence. On the whole, static is far less prevalent in the Hawaiian Islands than it is in the United States.

A temporary receiving station was established on the shore line of the Island of Oahu with an unobstructed field between the station and the mainland of the United States.

The temporary installation was made in the buildings of the Makapu Lighthouse. Three different types of receiving antennas were temporarily installed for comparison as to their effectiveness.

One antenna consisted of the ordinary overhead antenna of one wire 150 feet long, suspended approximately 60 feet above the earth.

The other two consisted of Beverage antennas, one whose length was 656 feet, the other was 1,312 feet long.

The Beverage antennas consisted of single lengths of wire suspended 8 feet above the ground. The free ends of the Beverage antennas were connected directly to ground through resistances of about 540 ohms with the free ends pointing in the general direction of the United States.

It was found in connection with these experiments that the exact length of the Beverage antenna wire, the plane in which placed, its elevation above sur-

rounding earth, the effective insulation of the wires from their supports, and the value of the resistance in the free ends, all exerted a marked influence on the strength of incoming signals.

A simple regenerative circuit, audion and two stages of audio frequency amplification, was employed. Good results were obtained by the use of either of the three different antenna systems, and utilizing the ordinary overhead type antenna, amateur stations situated as far eastward as Chicago were readily picked up.

The 656-foot Beverage antenna, however, was found to be approximately 50 percent more effective than the ordinary overhead antenna, and the 1,312-foot Beverage antenna proved to be approximately fifty percent more effective than the 656 foot antenna.

However, the prevailing static increased in strength proportionately with the strength of incoming signal and after some preliminary testing it was found that the 656-foot antenna gave the more generally satisfactory results and the other two antennas were therefore discarded.

It may be well to explain here that this 656-foot antenna as finally utilized throughout the observations, extended from a small washhouse situated on a plateau about one thousand feet above the water and over the edge of the cliff to another point about four hundred feet above the water.

The antenna suspended at this elevation was generally from ten to seventy-five feet away from the edge of the cliff. The efficiency of the antenna as a collector was favorably influenced by this high location.

Experiments were made with different types of vacuum tubes which were available at the laboratory, and it was found that the type UV-200 tube, utilizing from twelve to sixteen volts on the plate, gave best results as a detector.

The navy standard C. W. 933 tube gave best results in the first stage of

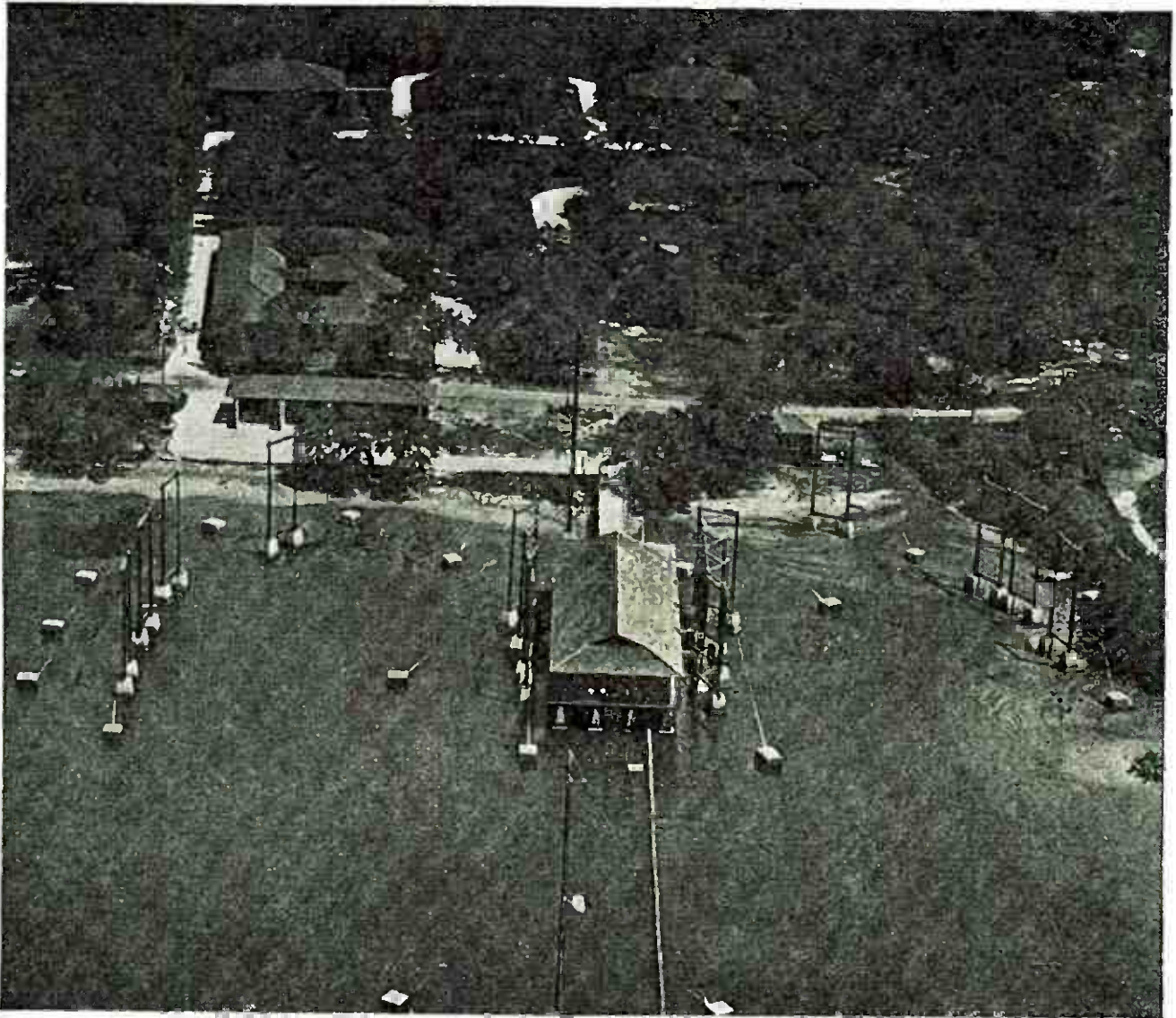

Bureau of Aeronautics, U. S. A.

WHERE THE NAVY LISTENED IN ON THE AMATEURS

During their spare time the officials of the naval radio station at Pearl Harbor in the Hawaiian Islands made a quiet study of the reception of amateur signals from the United States, 2,000 miles distant.

audio frequency amplification while the navy standard C. W. 931 five-watt power tubes gave best results in the second stage of amplification.

Experiments were also made with various types of audio frequency transformers available, the General Radio transformers finally being chosen for this work.

Using the installation and equipment as outlined in the foregoing, observations were begun during the daylight hours.

The following amateur stations along our Pacific seaboard were copied without difficulty during the daylight hours around 3.00 P.M. Honolulu local time.

Call	Location	Owner	Watts
6EN	Los Angeles, Cal.	H. A. Duvall	1,000
6BIG	San Rafael, Cal.	C. E. Walsh	1,000
6ARF	Woodlawn, Cal.	J. Duggan	500
6AK	Walnut Grove, Cal.	L. D. Mealer	1,000
6BCR	Alameda, Cal.	C. Foresman	500
7BJ	Vancouver, Wash.	Geo. Sturley	890
7SC	Aberdeen, Wash.	W. A. C. Hemerich	500

During the hours of darkness and up to 3 o'clock the following morning, 40 different stations situated in the United States within the comparatively "near-by" sixth radio district comprising the states of California, Nevada, Utah, Arizona and the Territory of Hawaii, were logged.

In addition the following distant stations were logged as the amateurs exchanged messages, conversed among themselves, or sent out conventional

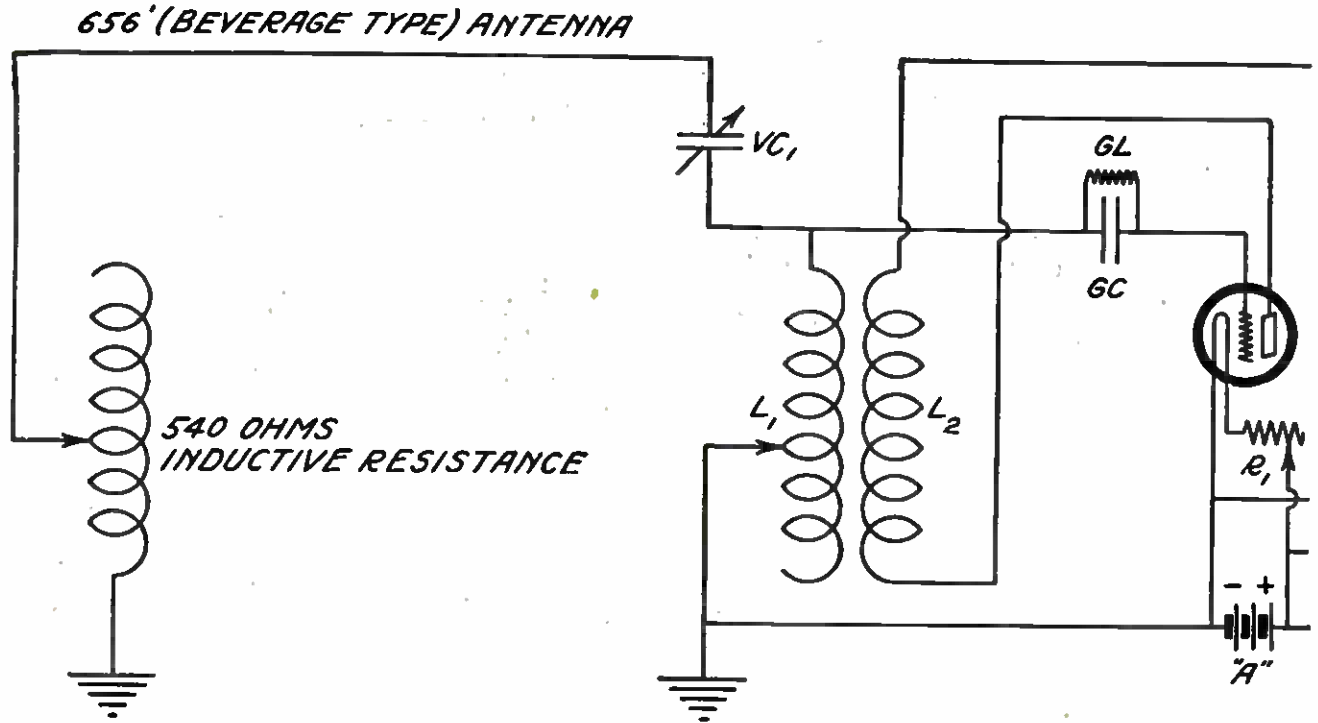

than 5,000 watts power have been established by the navy along our coasts at intervals of approximately every 200 miles, a distance which is considered as their reliable range.

To maintain constant service over the 2,000 mile stretch between San Francisco and Honolulu, both the navy and the commercial companies maintain stations ranging from 100,000 watts to nearly 500,000 watts.

Stations of such power are absolutely necessary for reliable continuous service. Yet, stations of only 1,000 watts power and sometimes even much less than 1,000 watts are effective not only for 200 miles or 2,000 miles but for approximately 6,000 miles, and judging from the strength of the incoming signals observed in the Hawaiian Islands, they were effective for still greater distances.

A review of the stations heard in the Hawaiian Islands during the observations described will show that signals from a number of stations of as low as 10 watts power were heard.

Let us segregate a few of the most notable cases of stations of extremely low power whose signals were effective for distances of 5,000 miles on the average. Their varying locations in-

dicade clearly that no freakish conditions prevailed with respect to any one station.

Call	Location	Owner	Watts
2BGM	New York City	W. P. Inman	10
2GO	Albany, N. Y.	H. G. Mulligan	50
4GH	Asheville, N. C.	E. A. Jackson	100
5UO	Wichita Falls, Tex.	J. R. Martin	20
5AEC	Oklahoma City, Okla.	R. L. Fish	24
8CAJ	Port Huron, Mich.	J. C. Fountain	50
8BXA	Ann Arbor, Mich.	E. W. Weslinger	27
8ANB	Cincinnati, Ohio	C. P. Goetz	20
8CF	Tiffin, Ohio	A. T. Gahrns	25
9DKY	Mason City, Iowa	M. H. Decker	21
9AWM	Sleepy Eye, Minn.	L. V. Berkner	120
9CCV	Courtland, Kan.	Ed. Barricklow	32
9CFY	Colorado Springs, Col.	C. O. Ford	100

In observations of this kind, where call letters consisting of a combination of one figure and several letters such as are assigned to all amateur transmitting stations, there is always the possibility of error on the part of the operator when "picking them out of the air." However, the radio men at the navy's radio laboratory at Pearl Harbor are expert radio operators as well as radio technicians; they are not likely to make mistakes "reading code."

Remarkable as these results are, therefore, they can doubtless be accepted as correct. In many cases the navy's radio men merely logged the call letters as they heard them, and did not know what the location of the station was, except as indicated generally by the figure in the call letter which de-

WIRING DIAGRAM USED IN THE TESTS OF AMATEURS

The circuit used at Hawaii by the Navy Department in the receiving tests with the amateurs on the mainland of North America. The proper way for connecting to the Beverage type antenna is also indicated.

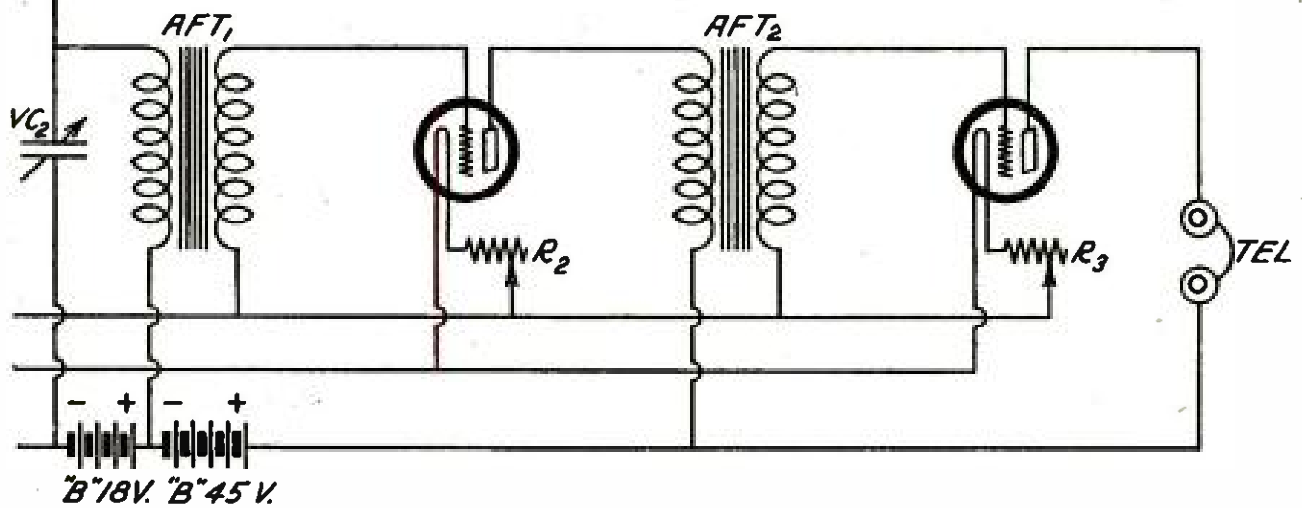

noted in what radio district it was located.

A peculiarity was noted in that the signals from the amateur stations situated along our Atlantic seaboard and within our middle western states reached their maximum aural strength about 8 P.M., local Honolulu time, while those from stations situated along our Pacific seaboard did not vary in strength but maintained a uniform strength throughout the hours of darkness in the Hawaiian Islands.

In order to observe the incoming amateur signals on board ship as well as on land and to compare the simple receiving circuit used at the Makapu Lighthouse experimental station when used in conjunction with the ship's overhead antenna, this receiving apparatus was installed on board *The Sea Gull*, stationed at the Pearl Harbor naval base.

After the installation had been effected, *The Sea Gull* left the harbor and proceeded to the east coast of the Island of Oahu.

As soon as the vessel cleared the east side of the island so as to afford a clear unobstructed field toward the mainland of the United States, signals from amateur stations in the United

States began coming in continuously.

Some of the stations which were logged on *The Sea Gull* during the hours of daylight, sunset, and darkness at Honolulu are given:

Call	Location	Owner	Watts
5HK	Dallas, Tex.	Robert W. Carol	1,000
5FV	Nashville, Tenn.	J. H. DeWitt, Jr.	1,000
5GV	Houston, Tex.	A. B. Ellis	500
5SK	Fort Worth, Tex.	M. R. Sanguinet, Jr.	150
5DI	Houston, Tex.	T. S. Depew	20
6AQJ	Tucson, Ariz.	J. H. Knost	1,000
7SC	Aberdeen, Wash.	W. A. C. Hemerich	500
7BV	Kelso, Wash.	C. Z. Kennedy	1,000
7TO	Medford, Ore.	H. H. Howell	40
7GK	Evanston, Wyo.	C. H. Linsley	1,000
7SY	Eugene, Ore.	G. M. de Broekert	175
8BXI	Utica, N. Y.	Thos. S. Batson	500
8CGP	Corry, Pa.	L. S. Gordon	960
9AWM	Sleepy Eye, Minn.	L. V. Berkner	120
9AVQ	Denver, Col.	F. A. Hechendorf	1,000
9ANF	Lincoln, Neb.	H. C. Harvey	500
9BJI	Denver, Col.	F. L. Hicks	100
9BOQ	Blair, Neb.	N. G. Garner	500

In addition to these, more than thirty amateur stations within the state of California were logged.

It was observed that the fading of the amateur signals was very much less pronounced than that experienced with the longer waves and this peculiarity was noted at both the Makapu Lighthouse experimental station and on board *The Sea Gull*.

The comparative absence of fading in this case may have been due in part at least to the fact that the experimental station was located directly on the waters edge and *The Sea Gull* was like-

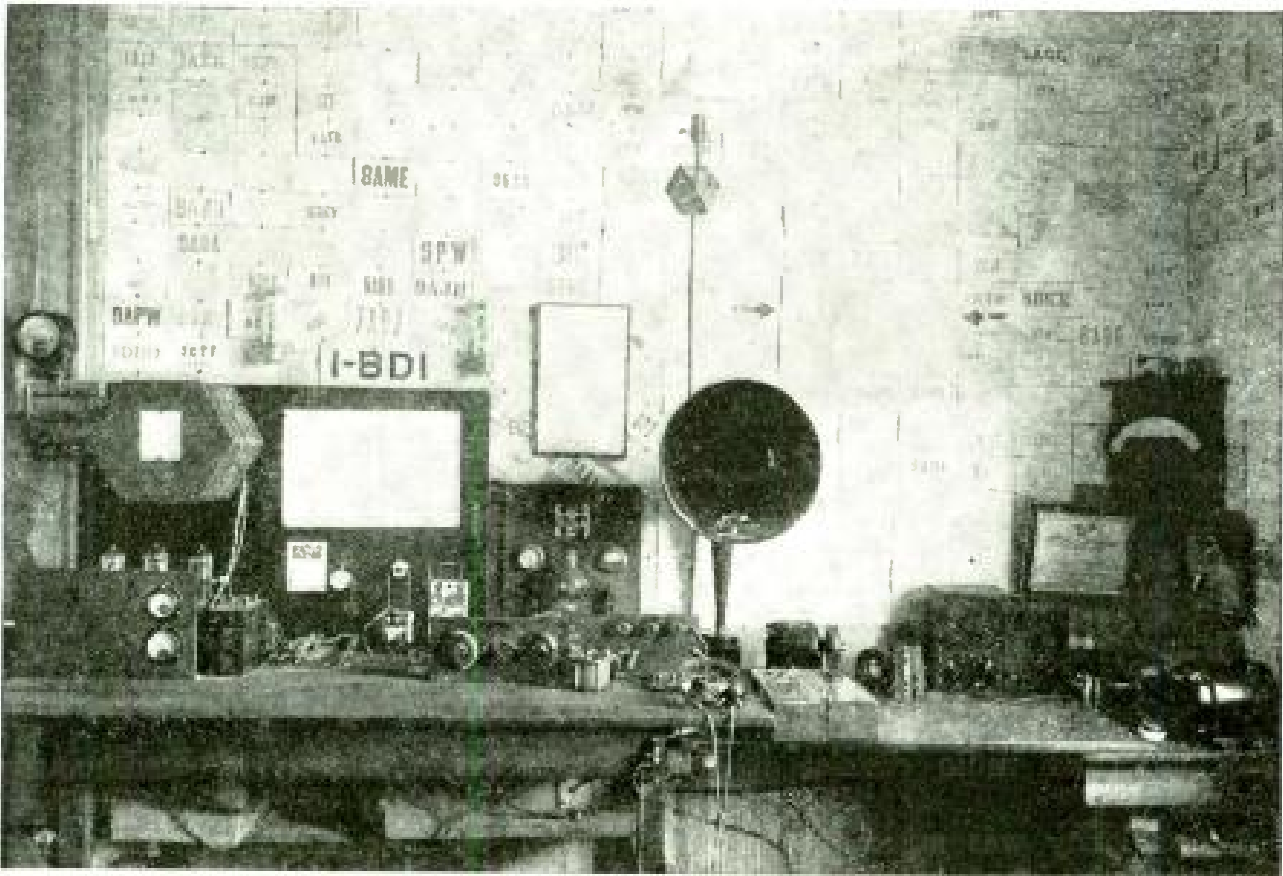

From a photograph made for POPULAR RADIO

AN IMPRESSIVE EXHIBIT OF LONG-DISTANCE WORK

The walls of F. E. Handy's station 1BDY at Orono, Maine, are literally covered with DX cards from fellow amateurs from all over the country.

wise favorably situated with respect to the incoming waves.

It is interesting to note in this connection that relatively less fading of signals on the long waves around 15,000 meters used by the navy and the commercial companies, occur at the navy's main receiving station at Wailupe than at the commercial station at Koko Head, although both of the stations are situated on the southeast coast of the Island of Oahu and are separated by an air line distance of only about three miles.

After observations had been made of the incoming amateur signals for two or three days with the results as outlined in this article, it was decided to make a temporary transmitting installation similar to that commonly employed by amateurs for the purpose of making brief experiments with a view to ascertaining whether or not contact could readily be made with amateurs on our Pacific seaboard, utilizing the amateurs'

government-authorized 200-meter wave.

A vacuum tube transmitter of only 250 watts power was hastily improvised, a circuit commonly employed by amateurs being utilized.

A Radio Corporation 50-cycle step-up transformer was used on the available 500-cycle alternating current radio power supply for exciting the filament and plate circuits, available coils and condensers of as near correct value as could be found being employed in the improvised transmitter.

This transmitter was installed on *The Sea Gull* and connected to that vessel's ordinary overhead antenna. After broadcasting a few "CQ's" or "general radio calls" and "signing off" with the call letters of *The Sea Gull*, several amateur stations situated within the state of California were immediately heard calling *The Sea Gull* in turn.

Contact was thus established without difficulty with amateurs in the United

States and the reports of previous amateur performances verified to the complete satisfaction of the navy's radio experts.

Conversations were exchanged with the following named amateurs during these brief tests:

Call	Location	Owner	Watts
6AWT	San Francisco, Cal.	B. Molinari	500
6KA	Los Angeles, Cal.	F. E. Nikirk	500
6JD	Los Angeles, Cal.	V. M. Bitz	500

By shifting to the ship's commercial wavelength of 600 meters, contact was also readily made with the commercial coastal station KPH at San Francisco.

It is performances such as described in this article that entitles the American amateur to the pre-eminent position he now holds in the radio of the world, and gives the "radio amateur" a status far different from that of the "radio fan."

Radio amateurs have a status in the radio world with respect to the radio fan comparable to that of the big league baseball player with respect to the baseball fan in the world of sport; to that of the motion picture star with respect to the movie fan in the realm of amusements.

To the radio amateur, the science of radio is a subject of study, investigation, experimentation and trial. To the radio fan it is primarily an agency for affording recreation and amusement.

The radio amateur speaks the dot and dash language of radio as fluently as he does the language of the spoken word. To him the dots and dashes coming through space comprising words, sentences and paragraphs, are as easily read as the layman reads a newspaper before his eyes.

To the radio fan the dots and dashes of the radio code merely constitute an unfathomable, unintelligible, jumble of meaningless sounds. The radio amateur understands the theory of radio and the functioning of the equipment and circuits. He knows how they function and why. He usually designs, assembles, and installs his own apparatus,

both transmitting and receiving, purchasing only such complete parts as he cannot readily build himself. He adjusts his transmitter and antenna circuits to the authorized wavelength setting of 200 meters and he measures the wavelength emitted to insure that his station is properly "tuned." When ready for operation, he undergoes an examination at the hands of the Department of Commerce and obtains a license from that department to operate his station, a combination of "official call letters" being assigned to him which designates his station from all others in the realm of radio.

Thus equipped with a government sanction to operate his "station" he broadcasts "CQ's" to attract the attention of other amateurs and explores the ether through his receiving equipment for answering signals from other amateur stations and proceeds to make acquaintances through space and discuss the relative merits of his invisible station as reflected by the aural strength and quality of his signals.

It may be taken for granted that he loses no time in trying to establish a long-distance record in amateur radio transmission.

Although all radio amateurs are not boys, boys constitute by far the greater number of the 17,000 odd "owners" of American amateur transmitting stations.

In the license issued to the amateur by the Department of Commerce he is recognized as the owner of his station, no questions being asked as to the legal status of the property on which it is situated.

Thus his antenna may be suspended between the chimney tops, or the roofs of his father's house and barn and his transmitting and receiving apparatus installed in the garret or basement of his home or even in his bedroom, but nevertheless he is the officially recognized proud owner of his station in the world of radio.

That the sphere of amateur radio is gradually being extended westward around the world by American amateurs is exemplified by the experiments described in this article. That it is also being extended eastward, has previously been demonstrated by tests as a result of which the Atlantic Ocean was successfully spanned.

The American amateur has continued to reach out in both directions until approximately one half the earth has now been spanned under the most favorable conditions for radio. And through his ingenuity and enthusiasm he has accomplished this noteworthy feat, in spite of the limited power on which he must operate and his restricted wavelength.

In view of the progress made by the amateurs since their advent into the world of radio about fifteen years ago, it is entirely logical to assume that they will eventually achieve world wide communication by radio.

It is obvious that when this result has been brought about, the American radio-phone broadcasting stations utilizing their wavelengths of about 400 meters and not being restricted as to power input, will also have achieved world-wide ranges.

These, with our radio amateurs, will doubtless cause the American derivation of the English language to become a popular course of study in the schools and homes of foreign lands.

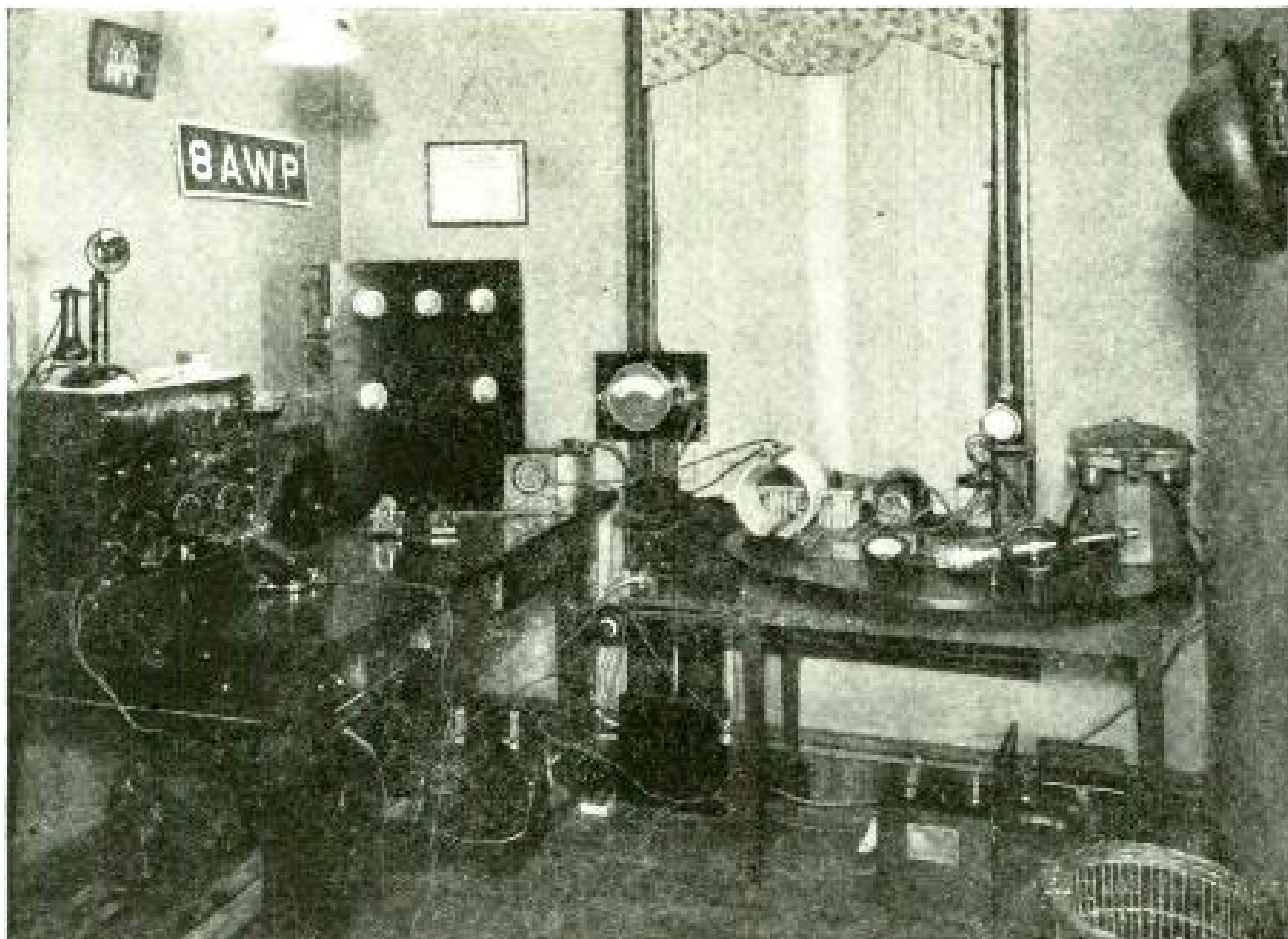

From a photograph made for POPULAR RADIO

A TYPICAL AMATEUR STATION THAT INDULGES IN INTER-CONTINENTAL COMMUNICATION

It is owned and operated by Samuel Woodworth of Syracuse, N. Y., whose call letters 8AWP have been heard throughout North America and abroad. The set in the corner underneath the license employs 5 50-watt tubes and has been heard repeatedly in Hawaii and off the coast of Chile. The large 250-watt tube set on the table by the window has been reported from England and France two or three times each month.

Q Some day, the scientists tell us, the "pocket radio set" will be as common as the watch is now. Here is a miniature set that shows what we may be coming to.



From a photograph
made for POPULAR RADIO

IT IS TUNED BY THE TWIST OF THE WRIST

A unique miniature crystal receiver that requires only an antenna to make it complete for the reception of broadcasting.

A Receiving Set in an Earphone

Tiny receivers—some of them so small as to be contained in finger rings—have fascinated radio fans to such a degree that some remarkably ingenious miniature sets have been devised. Here is a new one that has been found to be essentially practical.

By FREDERIC SIEMENS

THE development of the miniature receiving set is taking place so rapidly that it appears to be merely a matter of time when we shall be going about with vest-pocket radio devices in much the same way as we now go about with watches. The prospect certainly stirs the imagination. It brings up a vision of men and women going about their daily tasks with small black pill-box receivers strapped over one ear and small black cords extending from it to

sensitive midget machines hidden in their clothes.

As a matter of fact, several such miniature receivers have already been made. A set that has special claim to notice is shown in the illustrations. One of these sets was presented to each of three hundred guests at a recent dinner at White Sulphur Springs. The banquet hall was wired to receive broadcast programs, so that the guests merely had to "plug in" to enjoy the

entertainment that was provided for them.

This miniature set is fully equipped with a crystal detector and a single tapped coil, telephone ear-piece, flexible leads and plug. As shown in the illustration on this page, the whole set is mounted on a telephone headband; the telephone is fastened in the regular manner to one end and the set on the other end.

The detector is adjusted by means of the little knob on the set, and the wavelength is controlled merely by twisting the cap (which has not been shown in the picture) that contains the switch arm for making contact with the various contacts on the set.

All that is necessary to do to use the set is to connect it to a suitable antenna and ground.

It is not inconceivable that in the future we might have public antennas connecting to telephone jacks on the street lampposts; when that time arrives, all that the passerby would have to do, even with such a simple set as this, would be to take the plug out of his pocket and "plug in."

Then again, with the advent of the new miniature vacuum tubes which work on $1\frac{1}{2}$ volts from a dry battery, we may reasonably expect to hear of a new set which can receive long distance signals without any aerial at all, yet that will be no more cumbersome than the set described herein.

At all events this miniature set points the way. It is concrete evidence that the vest pocket set can be made a practical piece of apparatus and one that some day every one will own.

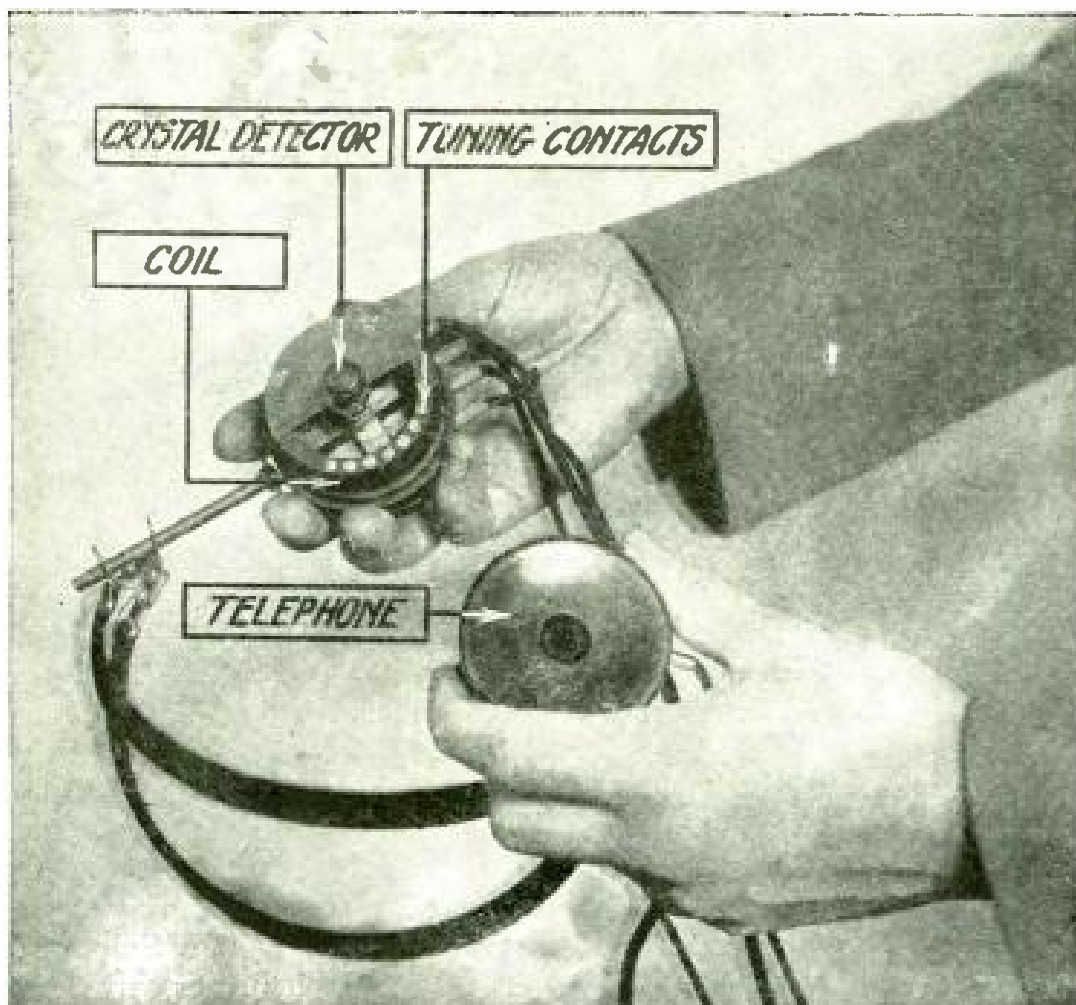

From a photograph made for POPULAR RADIO

HOW THE "EARPHONE" WORKS

Note the seven tuning contacts and the clever arrangement of the small coil and the crystal—all encased in a bakelite container the size of a watch.

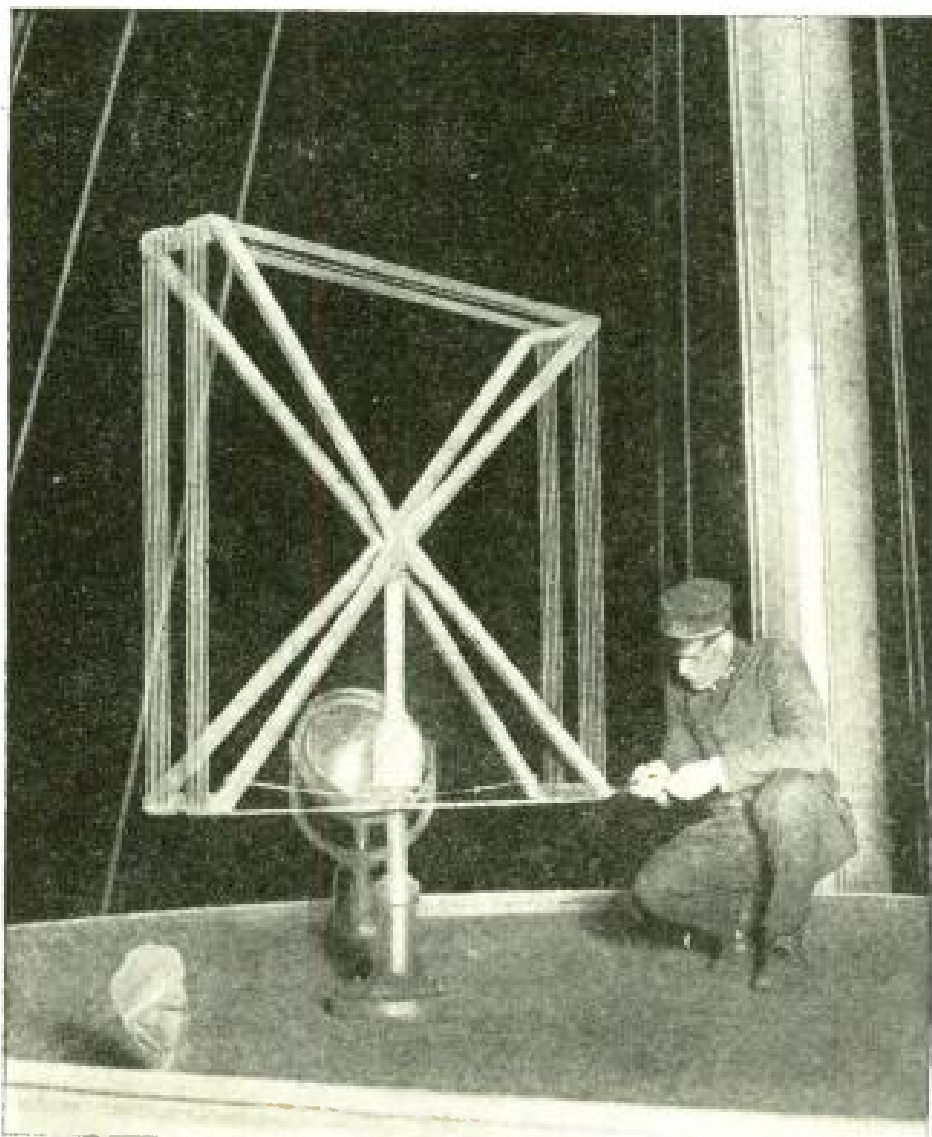

Kadel & Herbert

A LOOP ANTENNA INSURES HIGH SELECTIVITY

When used with supersensitive amplifying systems it is a valuable aid in doing away with static and interference. The loop shown here is located on the deck of a Navy compass station.

A MEASUREMENT CHART

FOR DETERMINING THE CONSTANTS OF A LOOP ANTENNA

ARTICLE No. 5

The previous articles contain charts *For Determining the Constants of Radio Circuits and Calculating Capacities of Condensers in Series*, in February, 1923; *For Determining the Dimensions of Your Coil*, in March, 1923; *For Determining the Capacity of a Condenser*, in May, 1923 and *For Determining the Capacity of Your Antenna*, in July, 1923.

By RAOUL J. HOFFMAN, A.M.E.

IN these days of modern radio when the multi-stage radio frequency amplifier, the super-heterodyne receiver, the super-regenerative receiver, and the various reflex circuit receivers have been coming

into more or less general use, the loop antenna for receiving has been brought more into prominence.

The three outstanding advantages of the loop type antenna—its directional ef-

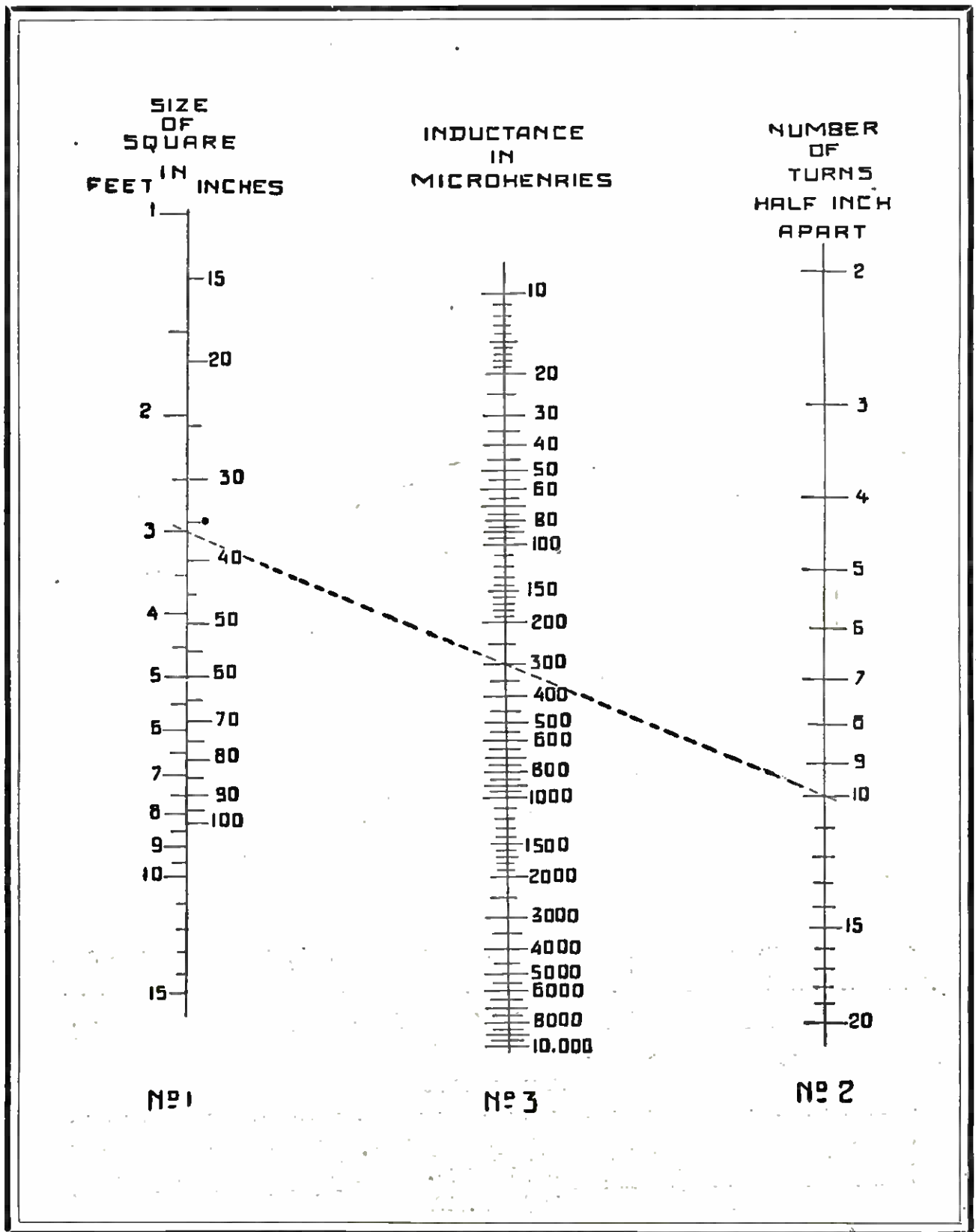

HOW TO USE THE CHART

PROBLEM: If you should want to build a loop antenna that would have a dimension of three feet to a side, and you wanted to incorporate in the loop enough turns of wire to give an inductance of 300 microhenries, how many turns would you wind on it?

SOLUTION: First, connect the value 3 on scale No. 1, with the value 300 on scale No. 3, with a ruler, and carry the line out over scale No. 2. Then observe the value on scale No. 2 where the line crosses the scale—which value would be the correct number of turns of wire to use.

fect, the simplicity of tuning and the absence of the troublesome and bulky outdoor antenna—are important to the city fan who is interested in receiving only.

There are several standard receiving sets now being placed upon the market that incorporate the loop antenna. However, there are many people who make their own sets, and who are experimenting with radio frequency amplification who have occasion to design and build their own loop antennas.

And the question "How many turns of wire shall I wind on the loop" is not often answered correctly.

For their benefit we have prepared this chart, that tells exactly how many turns of wire to use for a given wavelength range. A loop antenna is almost universally tuned by placing it in shunt to a good variable condenser and this is all that is necessary in the way of tuning.

First of all, the wavelength range should be decided upon.

Then the size of variable condenser should be chosen for use with the loop.

With these two points determined the prospective builder may easily calculate the necessary inductance which must be used in the loop to cover the wavelength

range chosen. The chart article in the February issue of POPULAR RADIO tells you how to do this.

When this inductance is known, you may then use the chart in the present article, for calculating the correct number of turns of wire to use to give the required inductance value.

The accompanying chart is based on the square form of loop, on which the wires are spaced $\frac{1}{2}$ an inch apart.

This form of loop should not be mistaken for the spiral loop.

When you use the chart, connect values on scale No. 1, with values on scale No. 3, with a ruler and read the number of turns required on scale No. 2.

Example:

To build a loop on a square form, 3 feet on each side, with the wires spaced $\frac{1}{2}$ inch apart to have a total inductance value of 300 microhenries. How many turns of wire should be used?

With a ruler, connect the size of the loop, (3 feet), on scale No. 1, with the desired inductance value (300 microhenries) on scale No. 3. If this line, connecting the two points is extended over to scale No. 2 it will cross at the correct number of turns, (10 turns).



Wide World

AN ANTENNA SYSTEM SMALLER THAN YOUR HAND

With eighty-five feet of wire wound into a spiderweb coil that measures only three inches in diameter, Kenneth Harkness, a New York radio engineer, has received as far as Schenectady. He claims he has the smallest antenna system in the world.

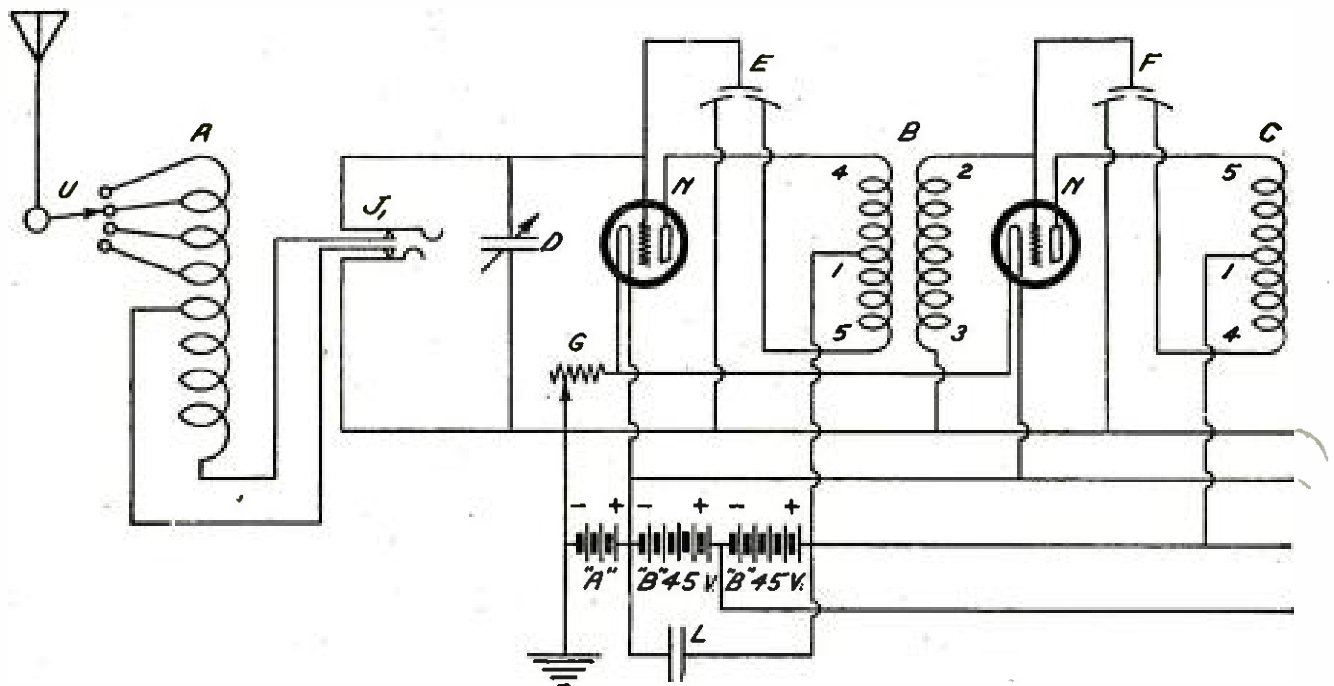

CIRCUIT DIAGRAM OF THE NEW 5-TUBE RECEIVER

FIGURE 1: The electrical connections for the instruments employed in this circuit are here shown and the parts are designated by letters which reappear in the text and also the list of parts, the photographs and the working diagrams.

HOW TO BUILD A TUNED RADIO FREQUENCY RECEIVER

—At a Cost of About \$60

The radio fan has heard much during the past six months of "radio frequency amplification." Perhaps he has also heard much of the troubles in getting it to work right. Nevertheless, the wonderful results obtained on "distance" by this circuit makes it popular. It is well known that tuned radio frequency amplification is much more efficient than the ordinary transformer-coupled method—but it is limited by "oscillation." This new method described here retains the extraordinary high amplification factor while at the same time it eliminates the possibility of oscillation.

By LAURENCE M. COCKADAY, R. E.

FOR summer reception there is no better method for receiving than the use of radio frequency amplification and a loop antenna—especially if the successive stages of amplification are tuned to the frequency of the incoming wave.

The reason is, that with a loop antenna, static is not picked up with such strength as it is with an ordinary antenna, and the loop tuning circuit has a low decrement when it is shunted by a condenser for tuning, whereas the ordinary receiving antenna may have a

resistance ranging from 10 to 40 ohms at the broadcasting wavelengths. This means that the loop will tune much sharper and therefore, much of the static can be eliminated. The tuned circuits in each stage of radio frequency amplification also act as "traps" which let only the signals of a certain wavelength (to which they are tuned) through. In other words, these circuits seem to act as filters to static which seems to have no specific wavelength.

The set described in this article employs two stages of radio frequency

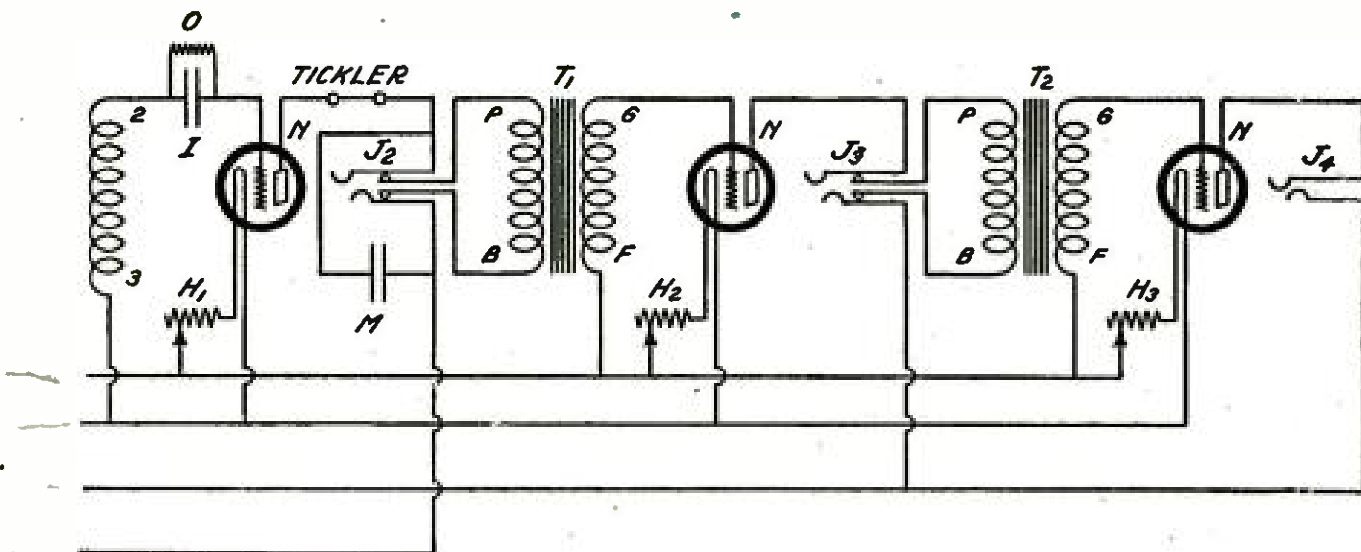

amplification and two stages of audio frequency amplification, with a vacuum tube detector. It can be used with a loop, with a short indoor antenna or with any type of outdoor antenna. The range with the loop or indoor antenna as far as tested up to the present writing seems to be about 1,000 miles. The range with the outdoor antenna has not been ascertained as yet but stations 3,000 miles away have been logged with a loudspeaker with good volume.

When used with an antenna, the primary circuit is semi-a-periodic, as there are only a few turns of wire used (with taps). The primary circuit is conductively coupled to the secondary circuit which is tuned by means of a small variable condenser. When a loop is used it is plugged into a jack, for that purpose, which disconnects the coils from the circuit and switches the variable condenser across the loop so that the same condenser may be used for tuning the loop. Each stage of amplification is tuned to the frequency of the incoming wave by means of an ingenious vario-transformer, a development by Lester Jones, former radio aide of the Navy Department at Washington, D. C. This transformer tunes the output circuit of the tube to which it is connected, and also the input circuit of the next tube, in a single operation. It has an extra plate winding

for inducing a neutralizing voltage on the grid of the preceding tube which, when used with the special compensating condenser, prevents oscillation in the circuits even when they are *exactly tuned*. When an ordinary radio frequency amplifier is exactly tuned the circuits will burst into oscillation and reception of voice signals is impossible; a stabilizer potentiometer is sometimes used to partly overcome this difficulty.

With the circuit described, however, a potentiometer is *not* necessary. By slightly unbalancing the circuits after a signal has been tuned in—this is done with the compensators—regeneration can be employed in the separate stages of amplification so that the signals may be built up to an enormous strength, even from distant stations.

There is also a provision made in the set for connecting a variometer in the plate circuit of the detector to make use of the heterodyne search method for picking up distant stations.

The set will not re-radiate.

The electrical circuit diagram is shown in Figure 1.

The Parts Used in Building the Set

In all the diagrams in this article each part bears a designating letter. In this way the prospective builder of a receiver may easily determine how to mount the instruments in the correct places and connect them properly in the electrical circuit. The same designating letters are used in the text and the list of parts below.



From a photograph made for POPULAR RADIO

DRAWING UP THE SPECIFICATIONS FOR THE CIRCUIT

In order to insure rigid accuracy in these "How to Build" articles in POPULAR RADIO, the technical editor and his staff of experts lay out the diagrams, from the actual set, and check and recheck the lists of parts used, the construction, the wiring and the operating hints until everyone is satisfied that the data is complete and correct.

The list of parts here given includes the exact instruments used in the set from which these specifications were made up; however, there are many other reliable makes of instruments which may be used in the set with equally good results.

If instruments other than the ones listed are used it will necessitate only the use of different spacing of the holes drilled in the panel and shelf for mounting them.

A—coupler-coil consisting of 60 turns of No. 24 DSC copper wire wound on a composition tube, 4 inches in diameter. Taps are taken off at the 3rd, 6th, 8th, and 9th turns.

B and C—Telos vario-transformers, 180 to 510 meters;

D—Haynes variable condenser, .00025 mfd.;
E and F—Amsco variable compensating condensers and knobs;

G—Fada rheostat, 5 ohms;

H1, H2 and H3—Amsco rheostats, 50 ohms;
I—Dubilier micadon fixed condenser, .00025 mfd.;

J1, J2 and J3—Pacent jacks, double-circuit;
J4—Pacent jack, single-circuit;

K—Fada tube sockets;

L—Dubilier fixed condenser, .1 mfd.;

M—Westinghouse fixed condenser, .0015 mfd.;

N—UV 201-A or C-301-A tubes used throughout;

O—tubular grid leak, 2 megohms;

P—composition panel;

Q—sub-panel made of well-dried hardwood;

R—Tait 4-inch dials;

S—Tait 3-inch dials;

T1—Amertran audio frequency transformer;

T2—Jefferson large type transformer;

U—four-point switch;

V—cabinet;

W—composition connecting-block with brass supports;

X—composition connecting-block with brass supports;
connecting wire;
binding posts, etc.

How to Construct the Set

After procuring all the instruments and materials for building the set, the amateur should set about preparing the panel P, (shown in Figures 2, 3, 4, 5 and 6).

First of all the panel should be cut to the correct size, 7 by 30 inches.

Then the edges should be squared up smoothly with a file. The centers for boring the holes (which are necessary for mounting the instruments) should be laid out on the panel as shown in Figure 4.

The holes outlined here with a double circle should be countersunk so that the flathead machine screws used for fastening the instruments will be flush with the panel. All the rest of the holes in this panel are straight drill holes. Sizes for the diameter of these holes have not been given, but the builder will readily decide what size hole is necessary by measuring the size of the screws and shafts of instruments that have to go through the holes.

When the panel is drilled, it may be given a dull finish by rubbing lengthwise with smooth sandpaper until the surface is smooth, then the same process should be repeated except that light machine oil should be applied during the rubbing. The panel should then be rubbed dry with a piece of cheese-cloth, and a dull permanent finish will be the result. Or the panel may be left with its original shiny-black finish, if care is exercised so that it is not scratched during drilling.

Next the sub-panel Q, should be cut to the correct size, 7 by 29 inches, and painted with

a dark *insulating* paint, and fastened to the main panel P, with wood screws running through the face of the main panel and into the edge of the sub-panel. (See Figures 5 and 6.)

Then, the two vario-transformers B and C, should be mounted on the panel P, in their correct places as shown in Figures 2, 3 and 5. Four screws are used to mount each transformer. The large dials R, are then secured to the shafts of the instruments by tightening up the knobs.

Next mount the four rheostats G, H1, H2 and H3, in their respective places, two screws to each rheostat, and affix the knobs and pointers. (See Figures 2, 3, 5 and 6).

Now fasten the two compensator condensers E and F, to the panel and attach the two small dials which are fastened with set screws. (Figures 2, 3 and 6).

The switch and contact points U, should be installed on panel P, in front and slightly to the left of the coupler-coil A.

The variable condenser D, should be fastened in its place with three screws and equipped with the 3-inch dials S.

The coil A, should be mounted on the sub-panel Q, by means of a small bracket, as shown in Figure 6, or it may be fastened flat to the sub-panel in any manner that the builder may prefer.

Next mount the jacks J1, J2, J3, and J4, in their respective places in the holes drilled for them and shown in Figures 3 and 6. The fixed condensers I, L, and M, may be screwed to the sub-panel in the positions indicated in Figures 2 and 3.

The connecting-block W, and the tickler connecting block X, should be made of composition panel and equipped with brass supporting

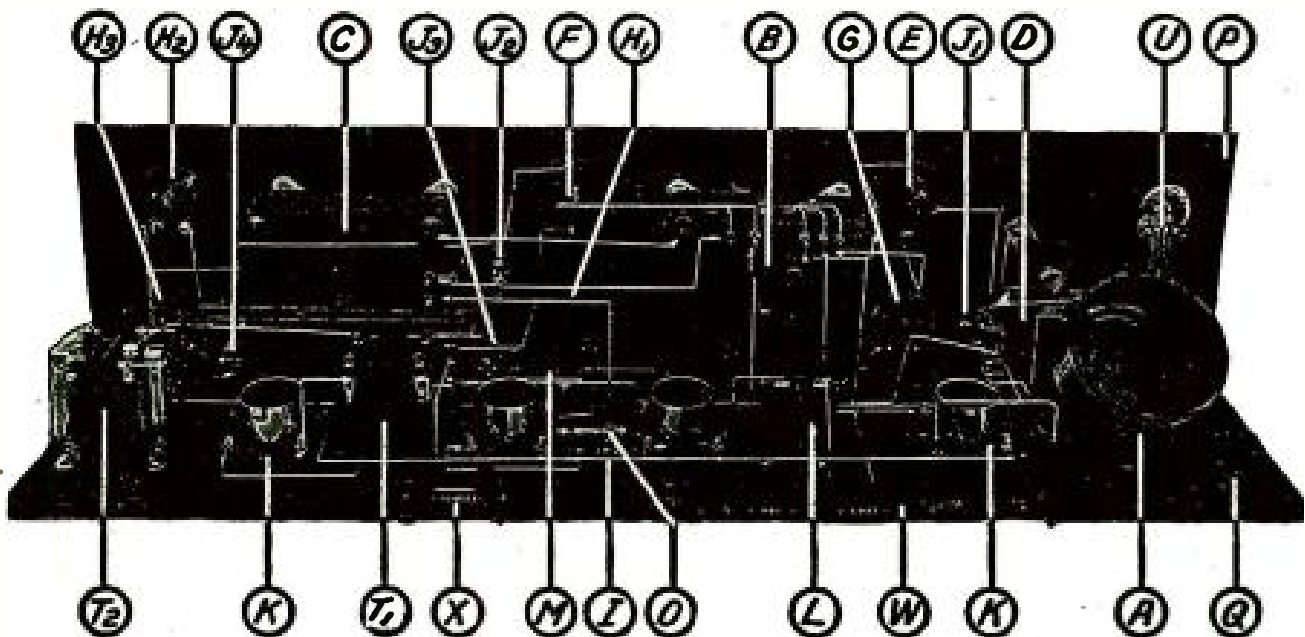

AN INTERIOR VIEW OF THE RECEIVER

FIGURE 2: This picture gives the general arrangement of the instruments as viewed from the rear and with the cabinet removed. For more specific details of construction the builder should refer to the diagrams in Figures 3, 5, and 6, which are mechanical drawings of the top and end views, and which are drawn to scale.

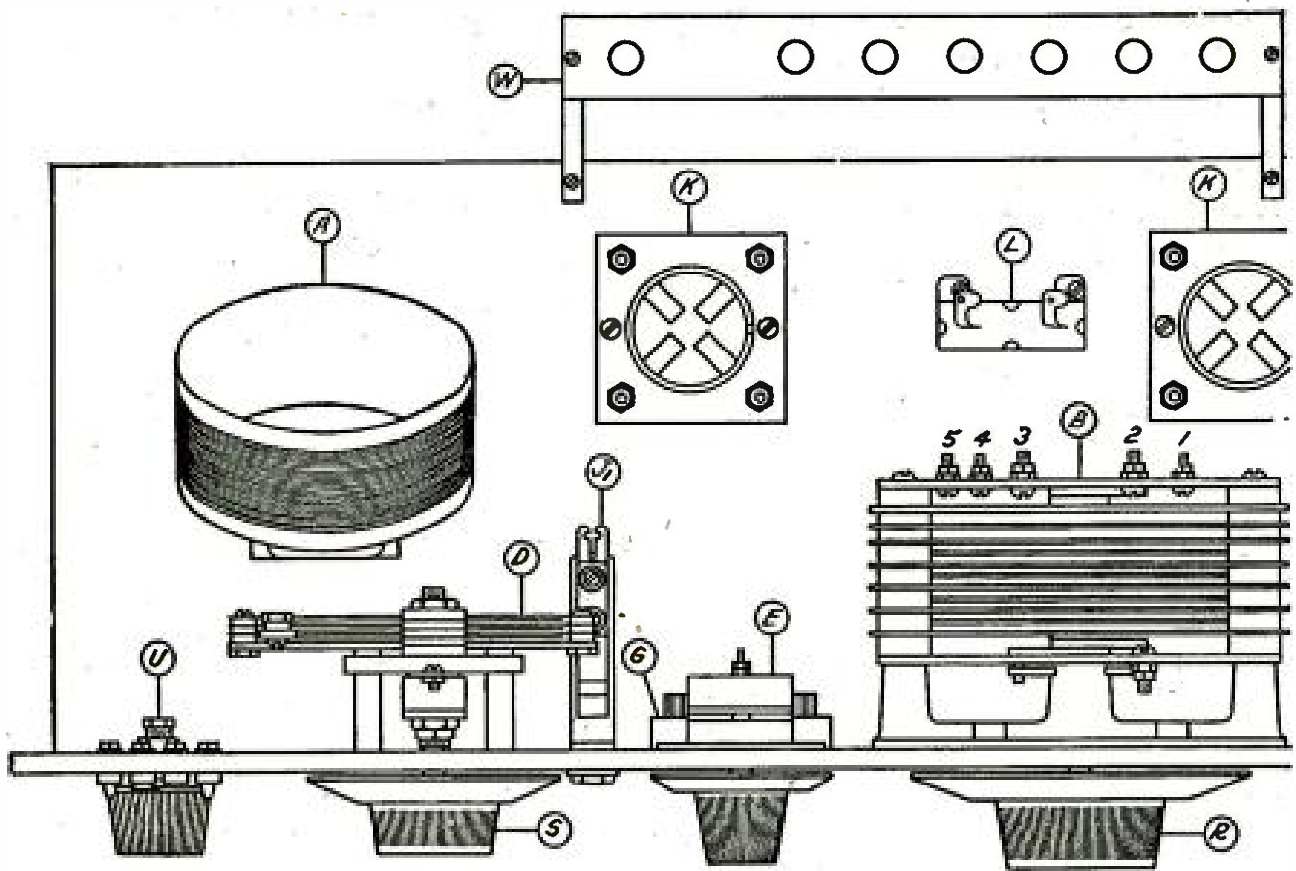

HOW TO PLACE THE INSTRUMENTS AND

FIGURE 3: When building a radio receiving set from printed instructions it is usual for the amateur to use up some of the parts which he has on hand which he thinks "might do" as well. He is also accustomed to arrange the instruments as he sees fit. But our

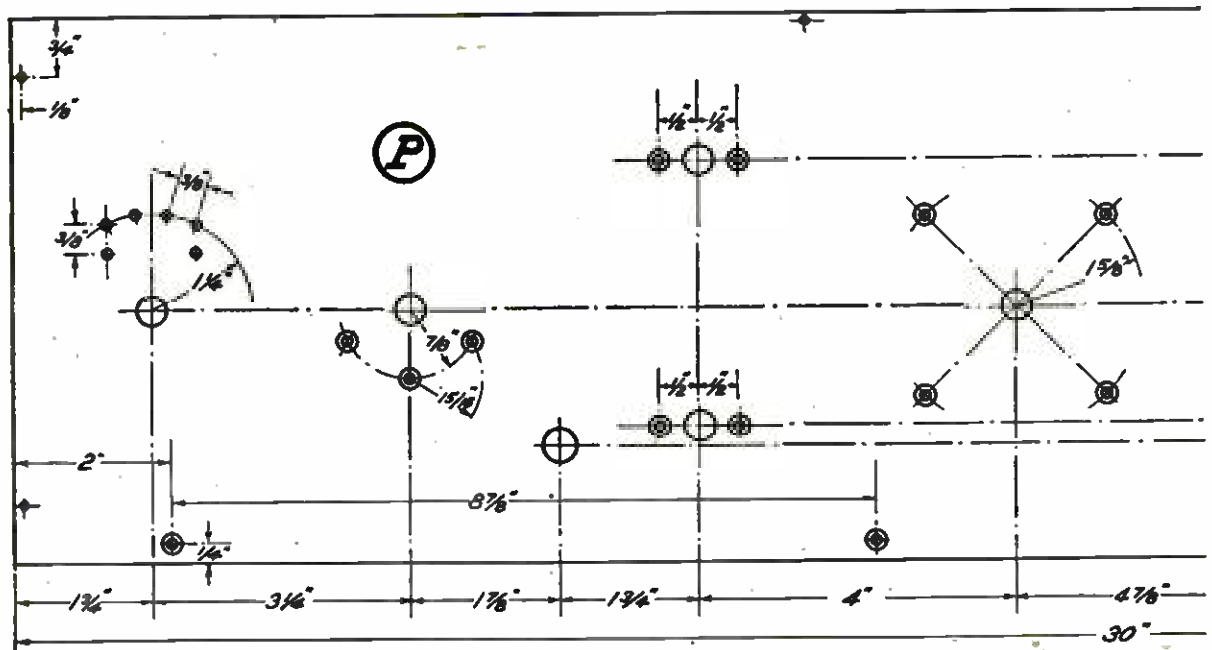

HOW TO PREPARE THE MAIN PANEL

FIGURE 4: The locations for the centers of the holes are given vertically and horizontally, as well as the proper arc for the centers of the switch points. The correct sizes

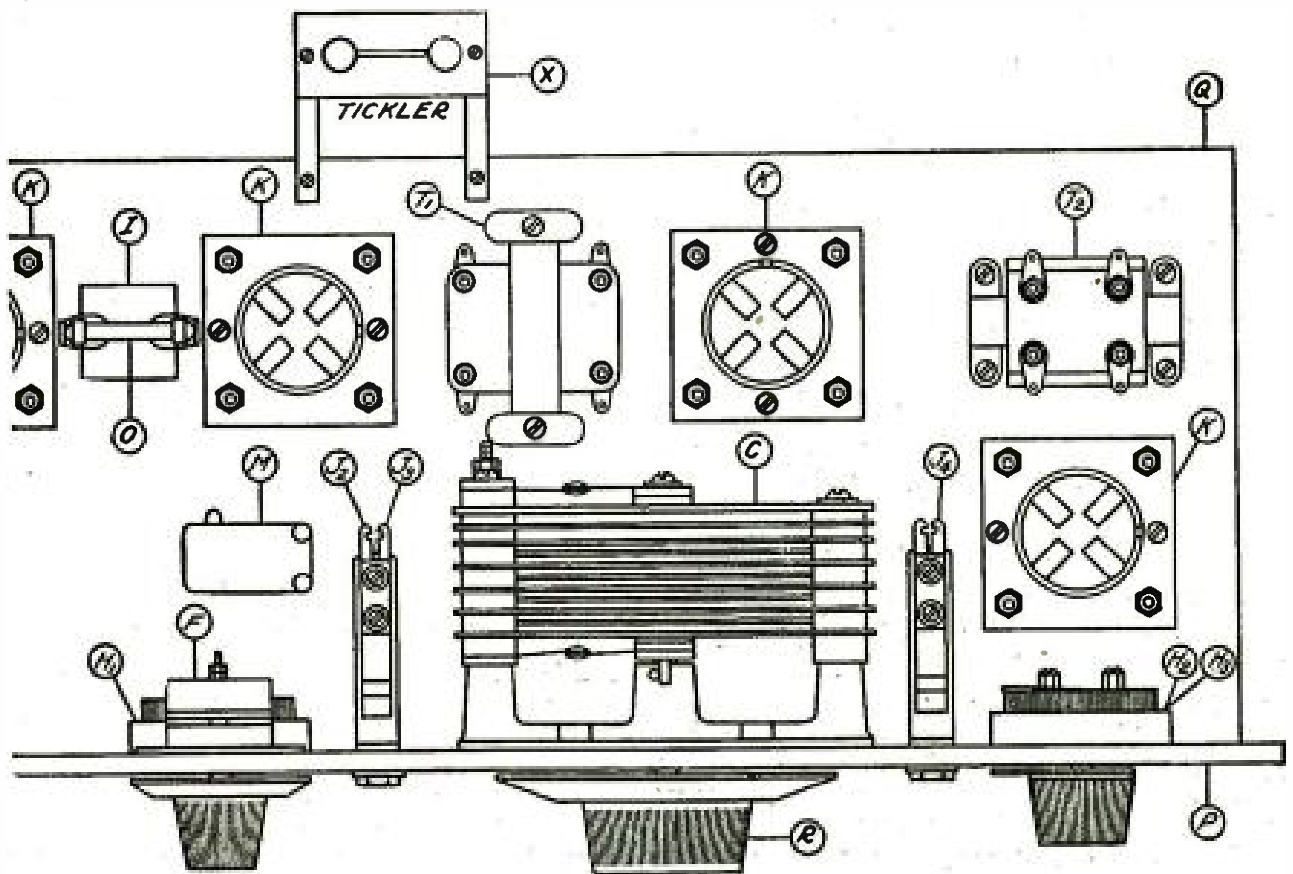

ASSEMBLE THE SET ON TWO PANELS

readers are advised to follow the arrangement shown above, as it has been carefully worked out.

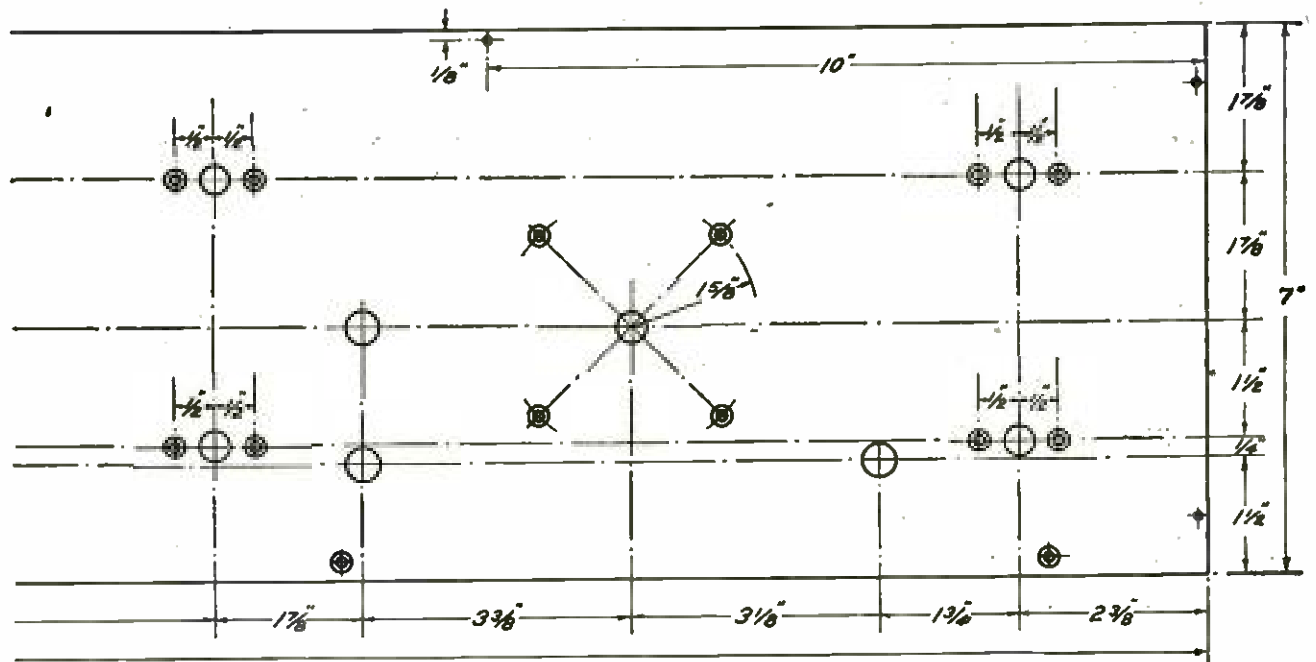

AND WHERE TO DRILL HOLES

for the holes will be decided by the builder by observance of the diameter of the shafts of the instruments and the supporting screws that go through the panel.

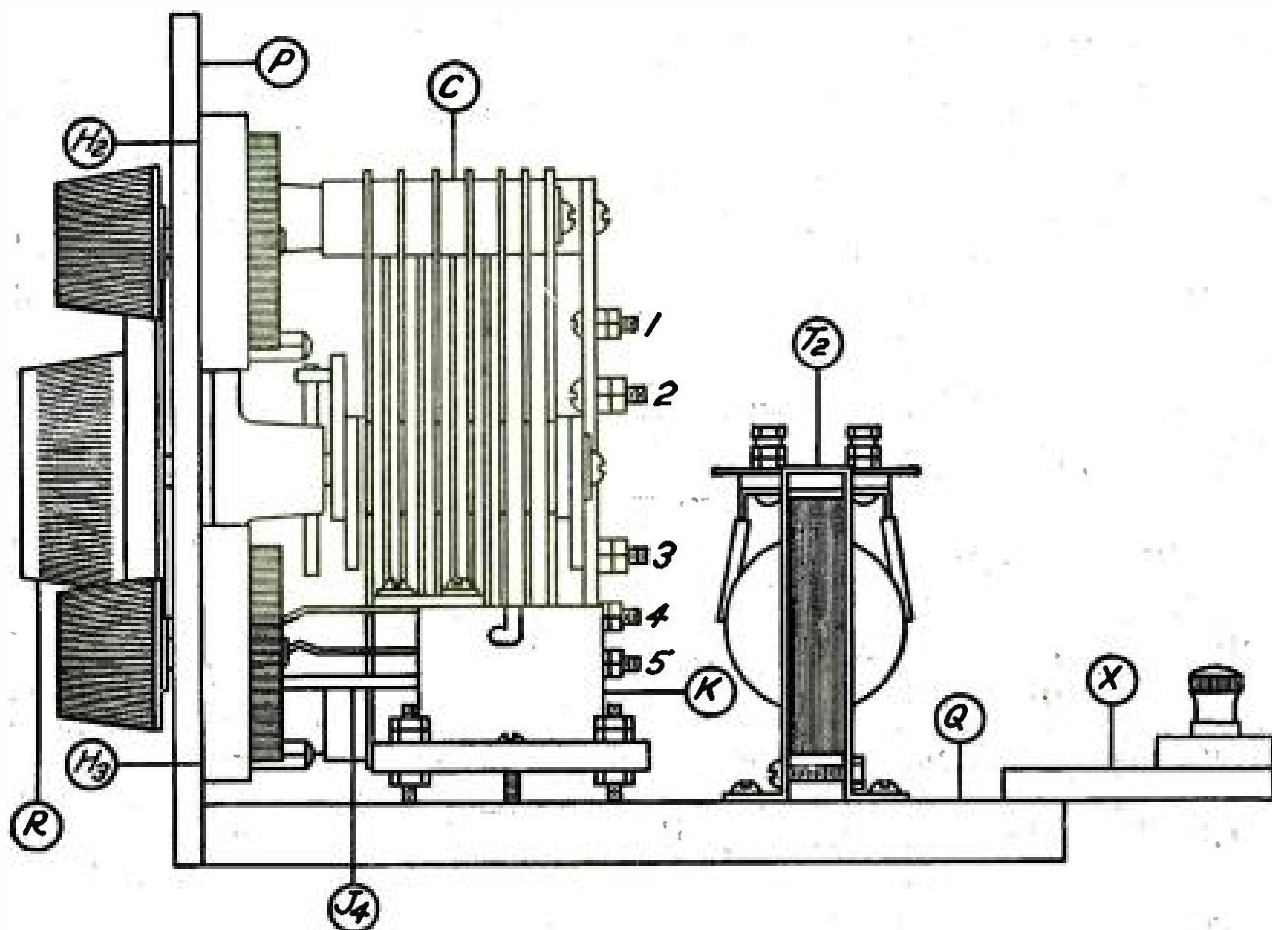

A VIEW OF THE SET FROM THE RIGHT

FIGURE 5: This drawing shows clearly the method of mounting the vario-transformers, the transformers, the rheostats the socket, the jack and the tickler block.

pieces. The blocks and the brass pieces should be of the dimensions given in Figure 8. When completed, the blocks should be fastened to the sub-panel Q, in the manner indicated in Figures 2, 3, 5, and 6.

The dimensions for the cabinet are given in Figure 7. It should be constructed of hardwood and polished in any style preferred by the builder.

How to Wire the Set

The grid wiring of the set should be kept as short as possible and should be isolated from the other circuit wiring as far as possible.

Start wiring with the antenna and ground binding posts (the first two left-hand posts, looking from the front in Figure 3) and connect up the coupler-coil A, and condenser D, as shown in the diagram in Figure 1. The first jack is used to "cut out" the antenna and ground and the coupler coil, when a loop antenna is used.

Wire up the first tube circuit to the vario-transformer B, and the compensator condenser E, as shown in the diagram, and continue on with the second tube circuit including the second vario-transformer C, and the condenser F. The connections for the posts on the vario-transformer are indicated in Figure 9.

Now wire up the detector circuit and the two stages of audio frequency amplification as shown, including the transformers T1 and

T2, the fixed condensers, and the other three sockets.

The "A" and "B" battery connections should be carefully traced through as well as the connections to the jacks to make sure that every connection is correct and that no circuits run foul of each other.

This will make sure that no tubes are destroyed when the circuit is put into operation.

A word of caution is here sounded against the use of excessive soldering paste on the jack connections and on and between terminals of condensers and other instruments. The paste contains acid and this causes leakage if allowed to remain between two connections. Only a very thin film of the paste is sufficient, and none should show on the insulation when the soldering is completed. If too much paste has been used by mistake, it should be removed by applying alcohol on a cloth; this will remove it readily.

Where the wires are fastened to binding posts and instrument terminals it is a good plan to use little copper tabs to which the wires can be soldered and then the tabs can be screwed down under the binding posts. Then if a mistake has been made in the wiring the posts can be loosened and the connection changed without leaving lumps of solder stuck all over the posts.

The third binding post from the left is the negative "A" battery, the fourth is for the

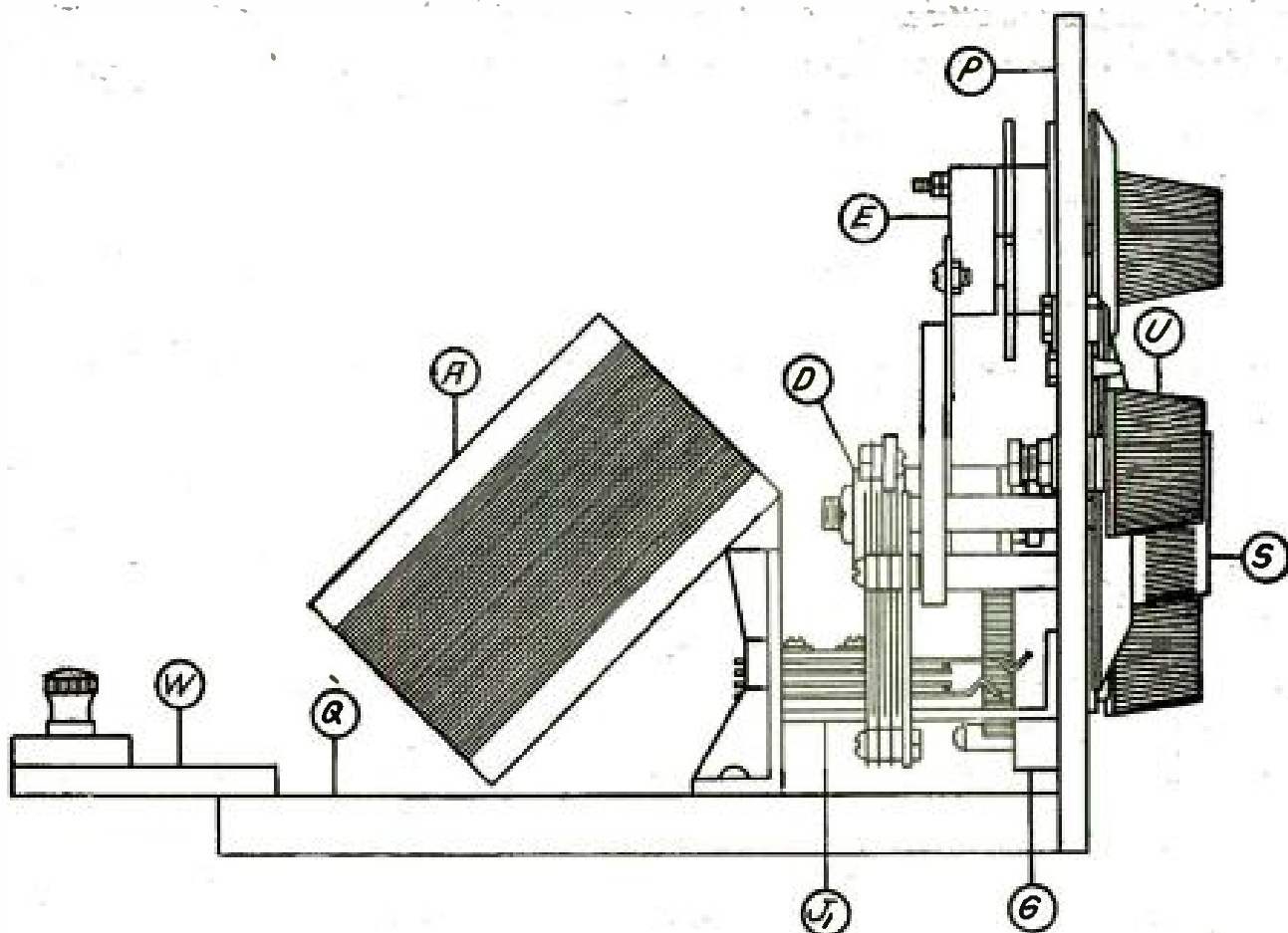

VIEW OF THE SET FROM THE LEFT

FIGURE 6: This drawing shows how to mount the variable condenser, the coupler-coil, the compensator condensers, the jack, and the battery connecting block.

positive "A" battery, the fifth the negative "B" battery, and the sixth and seventh are the detector plate 45-volt positive "B" battery tap, and the amplifier 90-volt "B" battery connection, respectively.

After you have finished the wiring job, sit down with some friend and check over the wiring once or twice before connecting up the batteries.

This will save you a lot of trouble in case you have made a mistake in the connections.

Operating Data

When using the set the following hints will be of practical value.

The set may be used with any antenna or "lighting plug" outfit, or it may be used with a loop antenna.

After the batteries are connected, the tube rheostats should be revolved in a clockwise direction until the tubes are all lighted to the correct brilliancy and the compensating condensers should be set at about 50.

The vario-transformer dials should be set at the proper wavelength, roughly, and the variable condenser tuned until the signal is picked up. Then the best tap on the antenna switch should be selected, and the finer tuning with the vario-transformer made. Then the compensator condensers should be adjusted for the maximum signal and the vario-transformers finally reset for the best results.

Amateur stations will tune between 0 and 40 on the vario-transformers, and low wavelength broadcasting stations will tune somewhere between 40 and 65. The medium and high wavelength broadcasting stations will tune between 65 and 100 on the vario-transformer dials.

If an extremely loud signal is desired it would be advisable to connect a variometer between the tickler binding posts and this will be rotated when a signal has been tuned in to obtain regeneration in the detector circuit. If the variometer is not used the two tickler binding posts, which are in series with the plate circuit of the detector tube, should be connected together with a short piece of wire.

When used with the loop antenna the set is tuned in the same manner as with the outdoor or indoor antenna with the exception that the tapped switch is not used.

The set will tune from about 180 meters to 515 meters.

The range with an outdoor antenna should be several thousand miles and several hundred (upwards) with a loop, according to the kind of building the set is located in.

The loop is especially suitable for summer use, as it cuts down the reception of interfering static, so that the broadcasting from nearby stations at least is clear and enjoyable.

Tuning is extremely sharp on both the loop and the regular antenna.

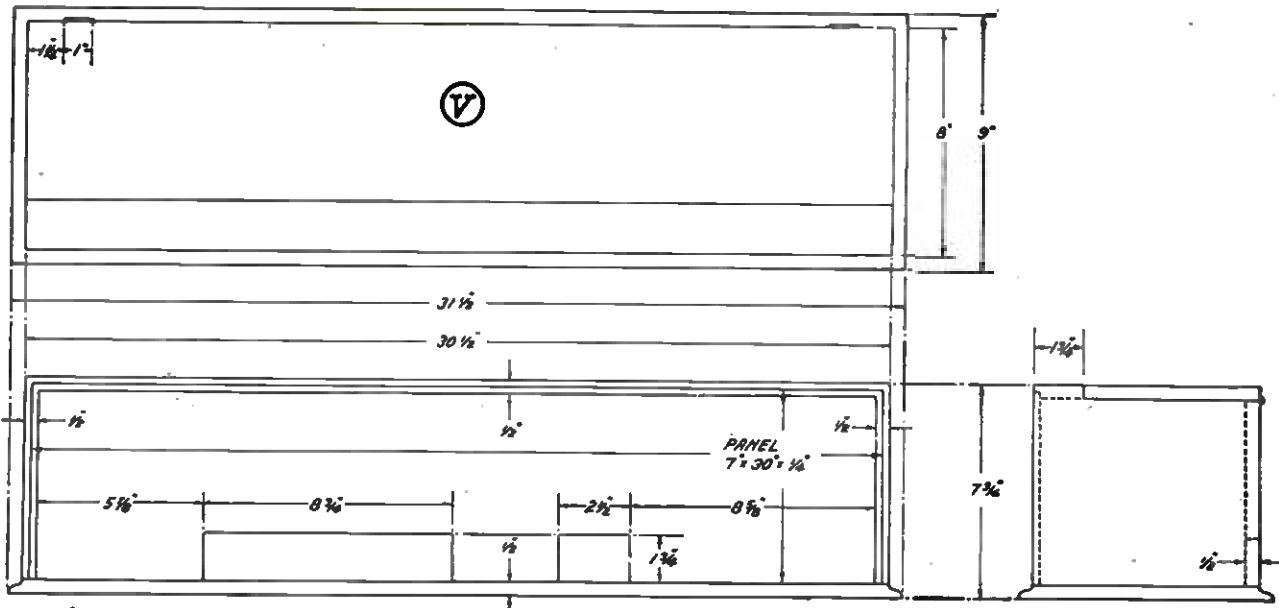

THE DIMENSIONS OF THE CABINET

FIGURE 7: Notice that the front of the cabinet is partly cut away so that the panel P sets flush with the cabinet. There are two rectangular holes cut in the back of the cabinet through which will project the two connecting blocks, so that all connections may be easily made in the rear and no unsightly wires will appear in front of the set when it is in operation.

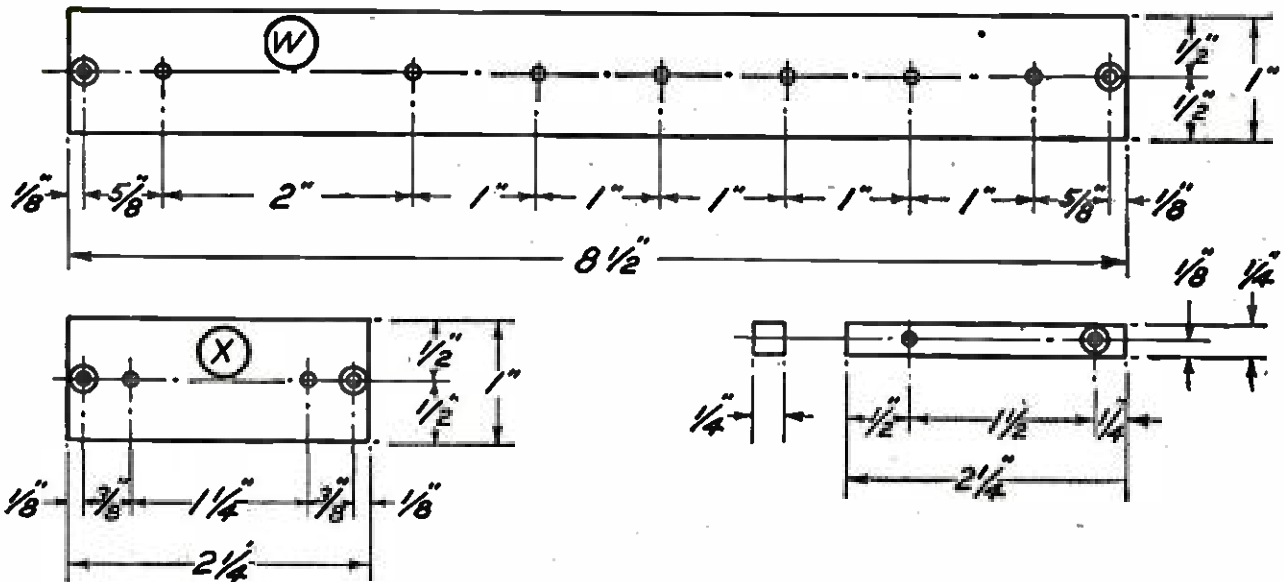

HOW TO MAKE THE CONNECTING BLOCKS

FIGURE 8: The sizes for the connecting blocks W and X and the brass supporting pieces. Two of the $2\frac{1}{4}$ inch brass pieces are used for mounting each block.

CONNECTION TERMINALS FOR THE VARIO-TRANSFORMERS

FIGURE 9: No. 1 is the "B" battery tap, No. 2 goes to the grid, No. 3 goes to the negative "A" battery, and Nos. 4 and 5 are the plate and compensator connections. The aluminum frame of the transformer is grounded on one of the screws as shown.

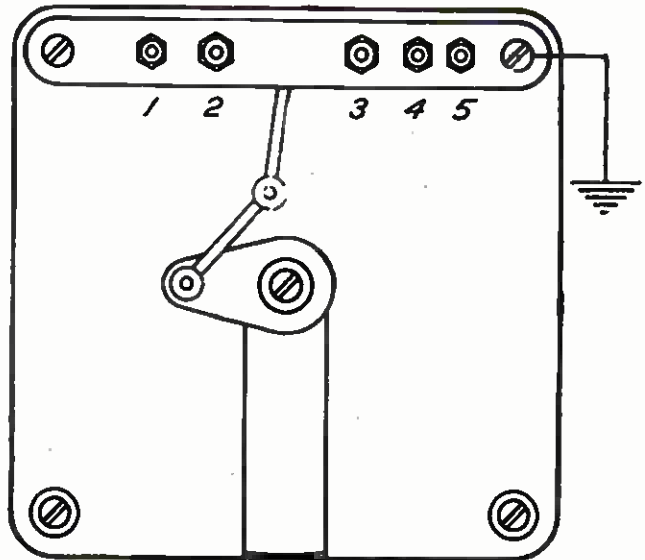

Kadel & Herbert

A NICKEL-IN-THE-SLOT RADIO SET

Parisian cafés, hotels and motion picture theaters are now being equipped with a device somewhat similar in outward appearance to a telephone pay-station apparatus that operates upon the insertion of a coin. Beside each instrument is hung a card on which the broadcast schedules are printed so that the pay-as-you-enter fan may know what to expect for his investment.



U. S. Signal Corps

A Radio Station on Wheels

By S. R. WINTERS

SPEED was a prime factor in the dash of the American troops into Mexico in 1914, in their pursuit of Villa and his bandit force. Good communication between the advancing columns and troop headquarters was another, for speed was dependent on the closeness with which these kept in touch with each other.

It is true that the army was equipped with radio apparatus for the purpose of communication, but the sets were carried by pack mules and could not be moved as fast as desired. Furthermore, the installation of a set, particularly the erecting of an antenna, took a lot of time. Radio could give neither quick nor effective service under these conditions.

The lack of results obtained in this emergency was the incentive upon which Brigadier General Edgar Russell set to

work to improve the radio branch of the Signal Corps. The result was the first "radio tractor," similar to the one pictured on this page.

Today these mobile radio units have become essential to army operations; each of the nine areas in the continental United States, as well as divisional units in the Philippines, the Panama Canal Zone and other provinces, is to be supplied with an outfit.

The latest design, SCR (Signal Corps Radio) 97, is being built for the Government by the General Electric Company and mounted on speedy White trucks which can transport the station to any point with facility. The radio equipment proper is carried inside the car; the aerial mast is divided into sections and set in a rack on the side, as shown in the illustration on this page. What appears

to be a trolley pole on top of the automobile is really an apparatus to aid in raising and lowering the mast. The actual setting up of these tractor aerials requires less than five minutes.

Recent tests, however, conducted by the Signal Corps have developed the fact that the portable aerial mast is not absolutely essential to the operation of the unit; any system of telegraph or electric light poles or even a tall tree may be used effectively as a support. The weight of the entire outfit, including the truck, is about five tons and thus the only real limitation to operation would be the necessity of staying on good roads or on fairly solid ground.

The above applies to the war-time use of the mobile radio station. To what purpose it will be put in peacetime is at present more or less a matter of conjecture. As a suggestion, in sections visited by tornadoes, earthquakes or prairie fires, communication might be maintained between the devastated areas and the outside world, in cases where all wires and stationary aerials were destroyed.

A SUBSTITUTE FOR THE ARMY MULE

Here the radio tractor is shown "set" for two-way communication. The antenna is in position, the counterpoise ground wires are spread out in fan formation on the earth's surface and the radio apparatus is tuned up ready for action. It takes just five minutes to accomplish this—including raising the antenna mast.

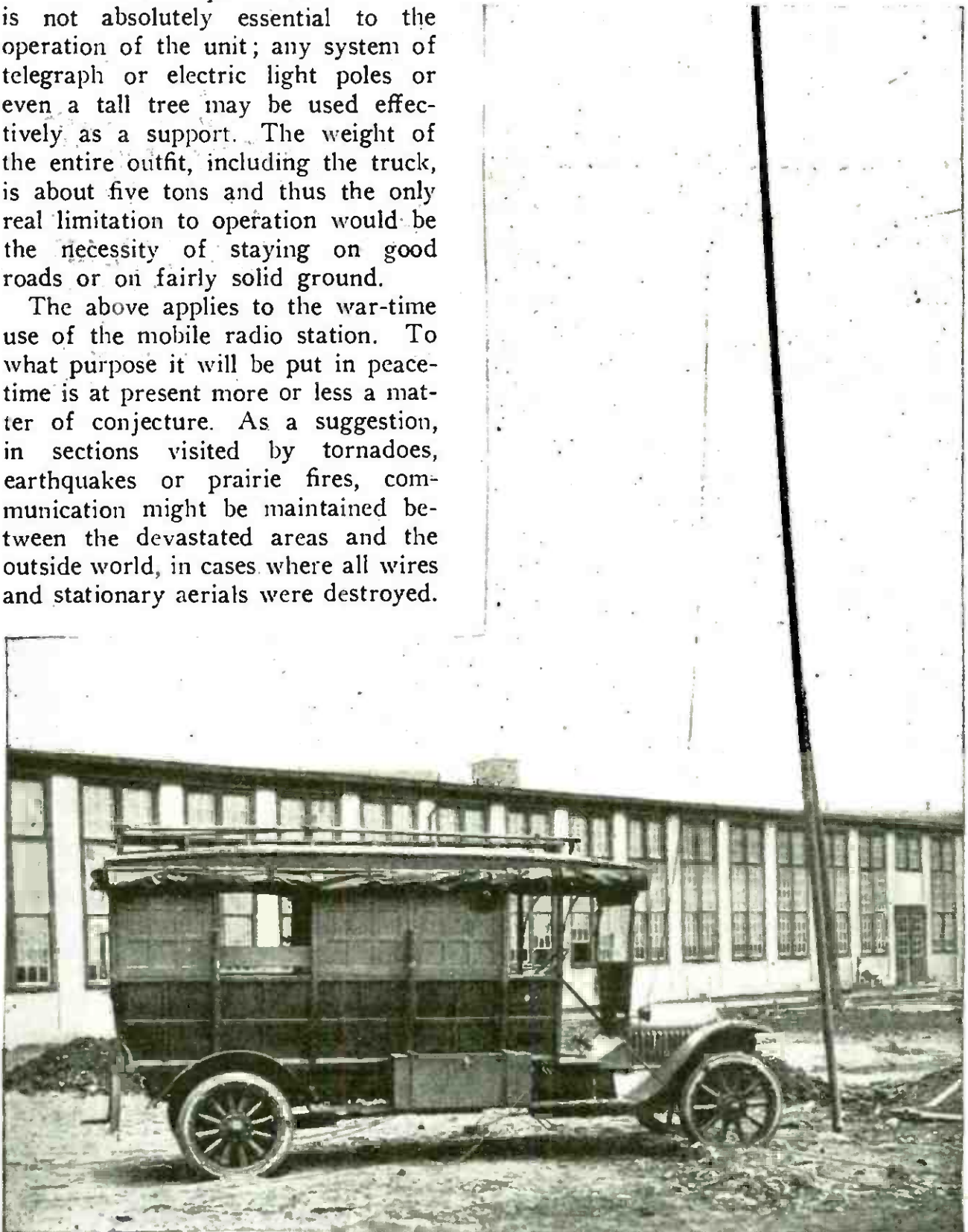

U. S. Signal Corps

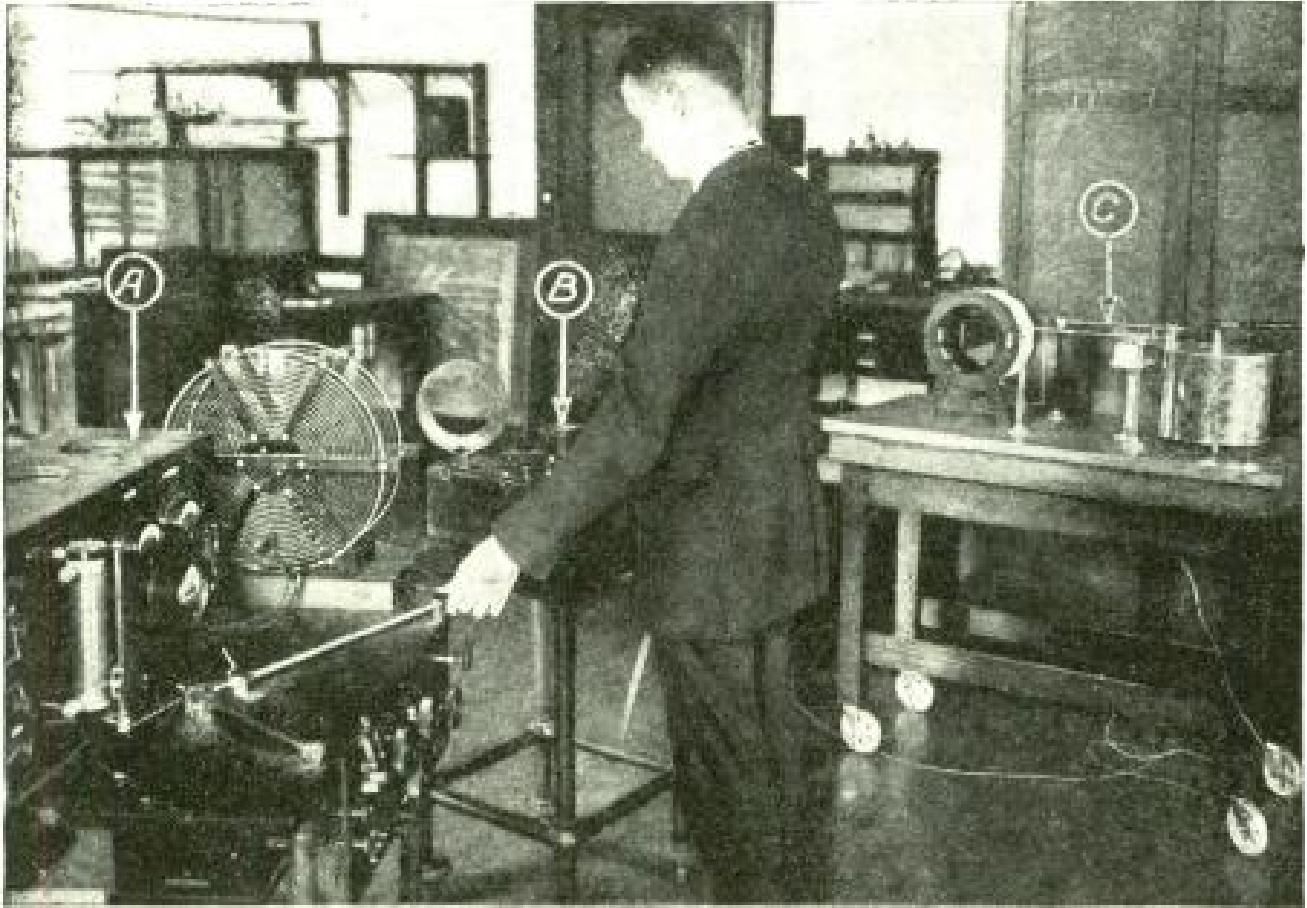

From a photograph made for POPULAR RADIO

TESTING A WAVEMETER IN THE LABORATORY OF THE BUREAU OF STANDARDS

FIGURE 1: *To calibrate an unknown wavemeter B, a high-frequency generator A, is used for generating a wave which is accurately measured by the standard wavemeter C. Then the unknown wavemeter B, is tuned to the frequency of the incoming wave and the setting of the instrument checked.*

How to Calibrate Your Wavemeter

To operate a transmitting station on the allotted wavelength is a problem that requires an accurate wavemeter for solution. How to calibrate this instrument correctly is here told by an expert of the Bureau of Standards, who has prepared this article for POPULAR RADIO by special permission of the Director.

By E. L. HALL

A WAVEMETER is one of the most essential instruments used in radio. Now that so many transmitting stations have been given wavelengths close together, the wavemeter assumes even greater importance than formerly.

As its name implies, the wavemeter is used to measure the wave emitted by a source of radio frequency oscillations.

The most important point to know about this wave is its length—how far it is from the crest of one wave to that of the adjoining wave. This distance is called the wavelength. The wavelength is related directly to the frequency or number of waves or impulses a second, by the relation $\lambda = V/F$ where $\lambda =$ wavelength in meters, $V =$ velocity of

electro-magnetic waves (about 3×10^8 meters a second) and F = frequency of electro-magnetic waves a second.

Radio frequency currents reverse the direction of their flow from (say) 10,000 to 30,000,000 times a second. Audio frequency currents reverse the direction of their flow from 16 to 10,000 or 15,000 times a second. It is possible to build a frequency indicator that will respond directly to each alternation up to 500 or 1,000 cycles a second, but beyond that other means for determining the frequency may be employed, such as comparing the audible note produced to that of a known source, such as a tuning fork.

When we consider radio frequency currents we see at once that some other method of determining the extremely rapid alternations is necessary. This is done by employment of the principle of resonance and by taking advantage of

the large current which flows in a radio circuit that is in resonance with a "driving" circuit—that is, a circuit that emits waves or impulses of the same frequency.

Wavemeters may be of two types: receiving or transmitting. Both contain an inductance and a capacity. The inductance is usually made up of one or more interchangeable coils of different sizes, and the capacity is a variable air condenser.

The receiving type of wavemeter employs a means for indicating when the maximum current is flowing in the circuit. This is sometimes a visual means (such as a thermal galvanometer of some type, a small battery lamp or a vacuum tube filled with some inert gas like neon which glows when an electric discharge passes through it), or it may be an audible means, such as a crystal detector and telephone receiver.

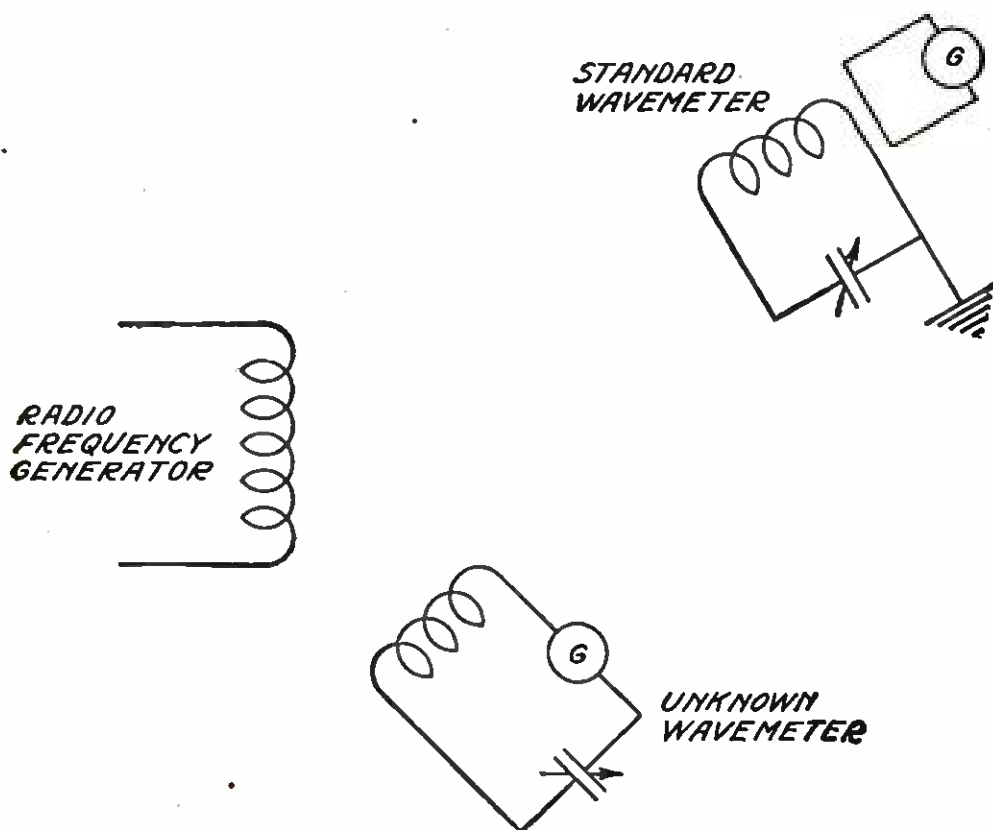

HOW TO CALIBRATE A WAVEMETER BY MEANS OF A HIGH-FREQUENCY GENERATOR

FIGURE 2: Here is a schematic diagram that illustrates the method of calibrating an unknown wavemeter by means of a high-frequency generator and a standard wavemeter as illustrated by the set-up shown in FIGURE 1. Resonance in this case is indicated by a galvanometer in the circuit of the unknown wavemeter.

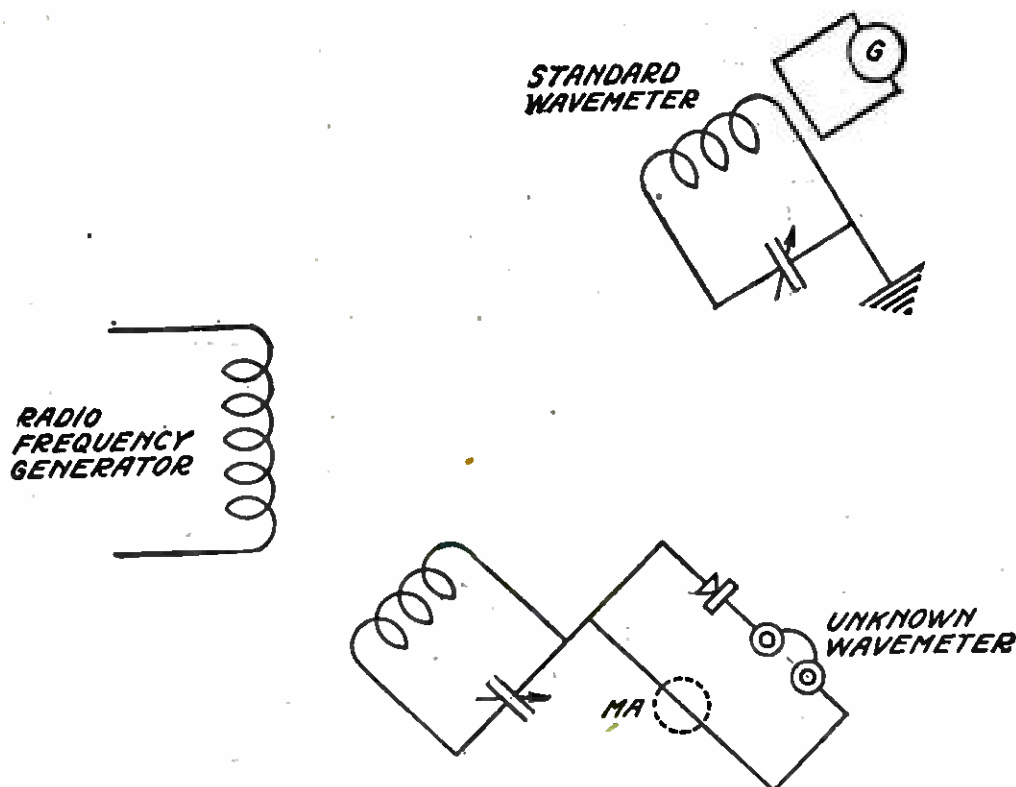

HOW TO CALIBRATE A WAVEMETER THAT HAS A UNI-LATERAL CONNECTION

FIGURE 3: To calibrate an unknown wavemeter employing a uni-lateral connection either a crystal detector may be used or else a milliammeter, as indicated by the dotted circle.

The transmitting type of wavemeter usually employs a battery-excited buzzer. The buzzer energizes the wavemeter circuit by impact, and the latter discharges, causing an oscillating current to flow in the wavemeter, the frequency of which is governed by the values of inductance and capacity in the electrical circuit.

There are several methods of connecting the various resonance indicators to the wavemeter; each has its own merits. The purpose of this article, however, is not to discuss the relative merits of the various connections, but to give a general idea of the method of calibrating a wavemeter.

The range of frequencies or wavelengths which a wavemeter will possess can be calculated readily beforehand, but an absolute calibration of the instrument can only be obtained by comparison with a wavemeter which has been calibrated or standardized.

The calibration of a wavemeter should not be considered to be exactly correct

without regard to the time when the calibration was made. That this may be assumed was shown by a request received some time ago from a manufacturer of wavemeters, who asked for a copy of the calibration of a certain wavemeter. Upon looking up the data for this wavemeter it was found that the calibration had been made six or eight years ago, so that it could not be depended upon after so long a time.

For accuracy, a wavemeter should be checked up at least once a year.

In calibrating a wavemeter the following apparatus is required: a radio frequency generator capable of emitting any desired frequency over the range of wavelengths covered by the wavemeter under test, a standard wavemeter which is calibrated in terms of frequency or wavelength, the wavemeter to be tested, and a sheet of paper upon which to take data.

Five or more points should be selected on the scale of the condenser of the

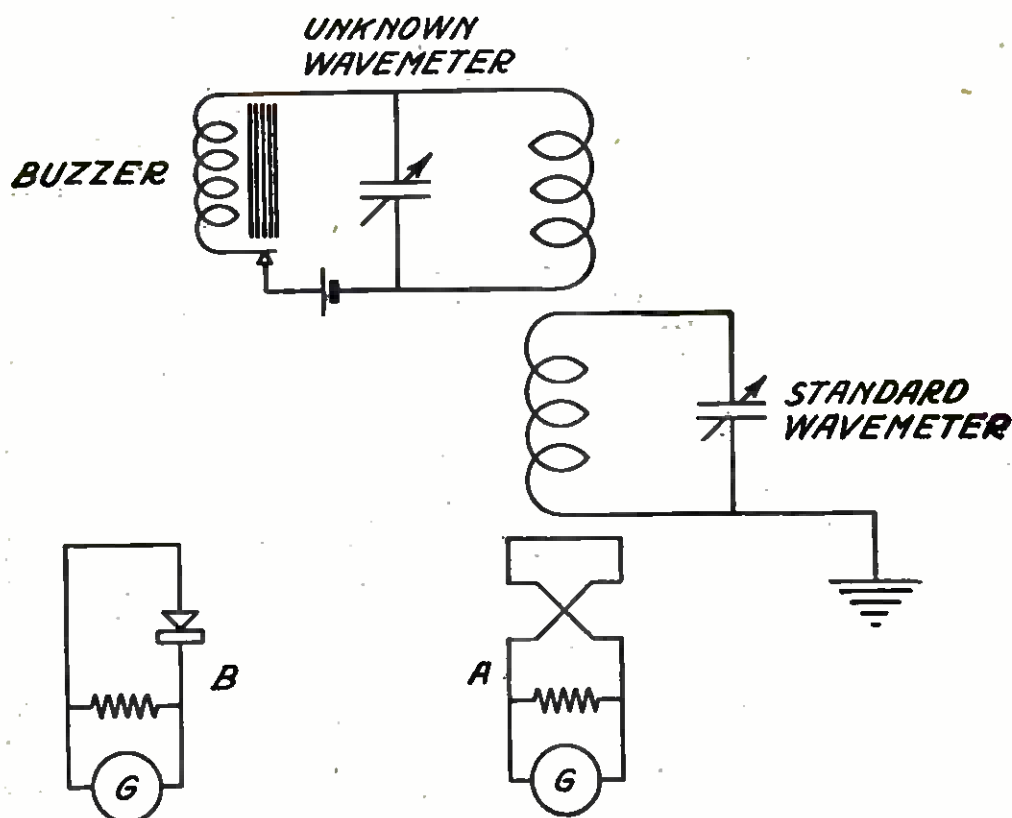

HOW TO CALIBRATE A WAVEMETER THAT EMPLOYS BUZZER EXCITATION

FIGURE 4: In this case no external generator is necessary. The standard wavemeter is moved up close to the generator; sometimes extremely close proximity is necessary on account of the small amount of energy emitted by the buzzer. The settings on the scales of the two instruments are then compared and the unknown meter is corrected to correspond to the standard.

wavemeter under test, at which tests are to be made. In selecting these points the extremes of the scale should be avoided. The lower ten degrees on the scale should not be used (except in extreme cases to obtain an overlap between two coils). This lower portion is avoided because of the small capacity in the wavemeter circuit in this region and the proportionally larger liability of introducing errors by reason of the proximity of other objects. The upper limit of the scale should be avoided because of the chance of error in the resulting calibration curve in case the scale is not set exactly correct with respect to the condenser plates.

In starting the calibration, the condenser of the wavemeter to be tested is set at the first point and the radio frequency generator is varied until resonance is indicated by the indicating instrument of the wavemeter. The condenser of the latter should then be varied slightly in each direction to determine

whether true resonance has been obtained.

At times it is possible to appear to have reached the resonance point by tuning the generator to the wavemeter, but if the wavemeter condenser is varied somewhat it may be found that resonance is obtained somewhat away from the desired point. This may be caused by a reaction of the wavemeter upon the generator owing to too close coupling between the two, or it may be due to the capacity existing between the wavemeter and the operator's body. If a wavemeter is properly shielded this latter difficulty will not be observed, except perhaps near the minimum setting of the condenser.

A wavemeter, whether used for measurement purposes or in calibrating, should be coupled as loosely as possible to the source of power. If the wavemeter is coupled too closely to the generator it will react upon the generator. This condition is more likely to occur on coils of large inductance which have a



Pacific & Atlantic

A "PRECISION WAVEMETER"

The Bureau of Standards has done some wonderful development work in designing and constructing standards of measurement. These standards include instruments for exact measurement of length, weight, velocity, pitch, and intensity in practically all fields where measurement can be made.

large distributed capacity and a high resistance. It may be observed on the wavemeter by obtaining two *apparent* resonance points, by turning the condenser in opposite directions. These two points may be a fraction of a degree to several degrees apart. The only thing to be done in such cases is to move the wavemeter away from the generator (loosen the coupling) until but one point is observed.

Another reason for keeping the coupling fairly loose when calibrating the wavemeter is because the power that exists in harmonics of the fundamental frequency may be picked up instead of the fundamental frequency. A radio frequency generator does not have its entire power output at one frequency; it is distributed upon several frequencies which bear certain relations to the fundamental frequency or that obtained from calcula-

tions of the inductance and capacity in the circuit. The fundamental frequency has the greater part of the power, but the harmonics may have sufficient power to operate a sensitive detector. Usually no difficulty is experienced from tuning to harmonics when a hot-wire ammeter or thermogalvanometer is used as the resonance indicator.

After the generator is accurately tuned to the wavemeter at the point desired, the wavemeter is detuned and moved away from the generator and the standard wavemeter is brought up and tuned to the generator. The condenser setting of the standard wavemeter is then read and is entered on the data sheet opposite the proper condenser setting of the wavemeter under test. The identification numbers of all apparatus used should be kept so that errors will be avoided in computing results.

The standard wavemeter is next detuned and moved away from the generator and the first one brought up and the generator tuned to the second point. All points throughout the series of coils are obtained in a similar manner. After the first complete test is finished it is repeated and the average of the two values for a given point is taken, unless there is too much of a difference between the values. In such a case a third reading is taken at the doubtful point, and it is likely that two of the three readings will agree sufficiently well. Errors in measurement or calculation are sometimes apparent when the calibration curve is drawn, because one or more points fail to lie on a smooth curve joining the majority of the determined points. The frequency or wavelength for other settings of the condenser than those at which tests are made can be obtained by reference to the calibration curve.

The calibration of a wavemeter that uses a crystal detector and telephone receivers as a resonance indicator is made in the same manner. If an electron tube radio frequency generator is used, undamped waves are produced and a means of modulation must be provided to produce a response in the telephone receivers, such as applying an alternating potential to the grid circuit of the generator. It will often be found that the resonance point is quite broad and that it is difficult to determine the exact point of resonance. Sometimes when the unilateral connection of the detector and telephone receivers is used a sensitive direct current milliammeter may be connected in the circuit (as shown by the dotted circle in Figure 3) without appreciably altering the resonance point. Then it is possible to obtain a sharp indication of resonance.

Before this method is used, the wavemeter should be tried out both ways to determine if the probable error in using the milliammeter is negligible. If the difference in resonance points by the two methods is significant, the milliammeter should *not* be used.

When calibrating a buzzer-excited wavemeter, the condenser of the latter is set at the desired point and the buzzer started. The standard wavemeter is brought up and tuned to resonance with the buzzer wavemeter. Difficulties are often encountered here owing to the extremely small amount of power emitted by the buzzer wavemeter. Extremely close coupling between the two wavemeters is often necessary. The resonance indicator of the standard wavemeter may be a thermo-element instrument of the crossed-wire type, with a couple of turns of wire connected to two terminals and coupled to the inductance coil of the standard wavemeter, and the other two terminals connected to a galvanometer, as shown at (a) in Figure 4.

Another indicator that is suitable consists of a coil of a couple of turns, a sensitive crystal detector and a wall galvanometer, all connected in series as shown at (b) in Figure 4.

Thus it is evident that in calibrating a wavemeter, whether of the receiving or the transmitting type, it is necessary to have a radio frequency current with a frequency or wavelength that corresponds to that of the wavemeter under test for the particular setting under consideration. This frequency will be determined by means of the resonance indicator of the calibrated wavemeter.

Wavemeters should be checked up with an accurately calibrated wavemeter at least once a year to be certain that the calibration has not changed.

"Testing the Einstein Theory with a Topaz"

That, in effect, is the purpose of the highly interesting experiments that are being made by Dr. Paul R. Heyl, who is using some of the most sensitive weighing devices ever made by man. Described in POPULAR RADIO for September.



U. S. Dept. of Agriculture

Q The daily contact between the farmer and the Department of Agriculture officials is doing much to insure better distribution of better produce—to the advantage of the farmer and the consumer alike.

Radio—the New Farm Hand

By HARRY A. MOUNT

ONCE I spent two weeks on a farm. It was in mid-winter and in one of the most thickly populated states of the middle west, yet this farm was eight miles from the nearest town and a mile from the nearest neighbor.

But it was a modern farm. Horses were still used in the fields, but there was not a buggy in sight; instead there was a garage with two automobiles. The nearest picture-show was eight miles away, but that was only a few minutes away by motor. And although the nearest neighbor was a mile away, in reality the whole countryside lived closer together than the inhabitants of a Harlem flat, thanks to the busiest telephone system I have ever seen.

Literature? The mail man brought a

great bundle of city newspapers and of come-on letters from the mail order houses every day.

Conveniences? A little gasoline engine in the wood-shed puffed away and furnished electric lights, and there was a tank in the cellar with water under pressure for the bathroom and kitchen.

The prospect of spending a week-end on such a farm as this, even in mid-winter, was not unpleasant, but—

No sooner had I arrived than it began to snow. It snowed all day and all night. The next day it snowed. Then it rained enough to put a crust of ice over everything and incidentally to pull down all the telephone wires. After that it snowed. Finally, on the morning



From a photograph made for POPULAR RADIO

Q The head of the government's radio service to farmers, Mr. J. C. Gilbert, of the Radio Market News Service of the U. S. Department of Agriculture in Washington. This service now covers the entire country.

To help the farmer plant, protect, harvest, pack, ship and sell his produce is the practical purpose of Uncle Sam in maintaining his Radio Service. Just how he does it is told in this article.

of the fourth day the sun came out on a world of marvelous beauty, if one had an eye for beauty, and marvelously depressing if one had an eye for business. We were snowbound, and there was nothing to do but wait until the snow melted or until some one from the outside dug through the drifted roads to us.

Things went along pretty well for a couple of days. By that time the subjects for conversation had narrowed down to one—the weather. Soon we all knew the contents of the last batch of mail order advertisements by heart. By the following Sunday I had finished the Sears Roebuck catalog and started on the Montgomery Ward catalog. At the end of ten days the whole house-

hold was on the verge of open hostilities, openly arrived at. I think it would have been a case of the survival of the fittest if a good old-fashioned slush-and-mud thaw hadn't set in then. By Sunday the roads were sufficiently cleared to reach the railroad station, and we only had to dig the car out of the mud twice on the way.

But that was away back in the year 1920 B.R.C. (Before Radio Came). A part of the modern equipment of that farm now is a radio set.

The other day I had a letter from one of those country cousins. Here is part of it:

We have scarcely been away from the farm, excepting for the necessary trips to town all winter. We would rather stay home and listen to the radio than traipse off eight miles to the

raising, dairying and the like. No, it was not an economic problem which caused this disaster, but the failure to solve a pressing human problem. The boys and girls raised on the farm preferred to its lonesomeness the bright lights and the companionship of the towns and cities.

Go into any farming community in the country today and you will hear that very same complaint: "The boys and girls won't stay on the farm." Permanent farm labor is hard to get for the same reasons. Will not radio, by taking the best that the city has to offer of music and thought, to the farmer's own fireside, help to solve this very real problem?

I think it will.

I know it is doing so in some specific cases, for I have before me as I write copies of half a dozen letters written by farmers to one of the big Eastern radio stations, in testimony of that fact.

But if the radio is helpful in solving the big social problem on the farm, it has become well-nigh indispensable as an instrument of practical usefulness. Take the matter of weather reports. All of us are interested in the weather, but to the farmer the weather is the biggest single factor in the success or failure of his business.

With this thought the government has perfected a wonderfully effective organization for gathering data and making weather forecasts, and it utilizes every means for getting this information to those who are particularly interested. But there has been no way to get a weather report to the isolated farmer within less than thirty-six hours from the time the prediction is made.

Now, weather may be predicted for any given locality with great accuracy for the next twelve hours, but predictions made thirty-six hours or more ahead will of necessity be less useful. Storm warnings, frost warnings and the like can of course only be given to those who can be reached quickly.

Radio provides, for the first time, a means for reaching practically the whole country within an hour or two, and accordingly the effectiveness of the government weather service has suddenly been increased a hundred fold. Weather reports are as vital to the farmer as stock reports to the stock broker and if nothing else came in over his radio receiver, it would be more than worth while.

Market reports are of scarcely less importance to the farmer. If there is anything more changeable and uncertain than the weather, it is markets. At nine o'clock in the morning, market reports on certain commodities are the liveliest of live news. At six o'clock in the afternoon they are ancient history. That is why the farmer, who has had no means of getting market reports up to the minute, has been at the mercy of the food speculator.

The farmer's complaint that he receives too little of the consumer's dollar is not entirely without foundation. To cite an example: of every dollar you spend for rolled oats, the farmer who grew the grain receives less than twenty cents. About the same proportion holds good in the case of bread and other grain products. One of the chief reasons that twenty cents worth of rolled oats is finally sold to you for a dollar is that between producer and consumer the oats passes through the hands of too many people who add nothing to the value, but much to the price.

A number of these speculators will automatically be eliminated through a better distribution of market information. The United States Department of Agriculture has long realized this fact and a large bureau of this department has for its specific job the collection and distribution of market information, with this very end in view.

The collection of market information is, and has been for a long time, remarkably efficient. The Department of Agriculture maintains an extensive leased



From a Photograph made for POPULAR RADIO

DAILY TIPS TO THE FARMERS OF THE WEST

Just where and when to market his products is a problem that always confronts the farmer. The Kansas City Board of Trade is helping him solve it by broadcasting up-to-the-hour prices every day.

wire telegraph system direct to the important large market centers, such as New York, Chicago, Kansas City, and St. Louis and all of these telegraph wires terminate in a room in one of the department buildings in Washington. Through this means hourly reports are received, and frequently during the day bulletins are prepared for the press and other agencies for distribution. In addition, daily and weekly as well as monthly and yearly market reviews are prepared and given the widest possible distribution.

All this is of value, but the market news of most value is that which reaches the man who wants to use it within a few minutes, or at most within an hour or two, after it is "news."

That is where radio comes in. It has tremendously increased the effectiveness of the market news service.

At first, when there were not so many radio receiving sets on the farms, an attempt was made to broadcast the information by sending it in code from government, army, navy and post office radio stations. To receive it a corps of volunteer radio amateurs was recruited who were to listen in at various times during the day and then to make the information they received available to their neighbors, country newspapers, granges, county agricultural agents, and the like. But the boys did not always finish their sessions at the old swimming-hole in time to receive the reports and the experiment was not very successful.

Only a little over a year ago the first market reports were broadcast by radiophone. As this is written ten government-owned and 76 private stations are broadcasting crop and market reports furnished by the Department of Agriculture and this so effectively fills the need that broadcasting in code has just been discontinued entirely.

In a few cases, especially in the East, market reports of local interest are furnished by State Departments of Agriculture to the broadcasting stations.

Recently Mr. J. C. Gilbert, who is in charge of this new activity of the Department of Agriculture, broadcast the request that farmers and others who were using the service write to him and tell him what specific uses were being made of it. Hundreds of letters poured in and an analysis showed that about half of them came from individual farmers, and the remainder from grain dealers, mills, elevators, banks, telephone companies, co-operative organizations, farm bureaus and other agencies which disseminate the reports among large groups of farmers.

The greater number of replies came from the Middle West. Missouri, Illinois and Iowa led in the number of responses to the inquiry. The letters indicate that nearly every farm in those states is radio-equipped with receivers

that average about \$85 in cost.

"A great many of the farmers," said Mr. Gilbert, "gave specific instances of savings resulting to them from the radio market reports. One farmer said he regarded the radio as the direct gift of God. Numerous general stores and banks in the small towns say their places of business have become headquarters for market news information, and a great increase in their own business results.

"At the present time the whole thing is in a formative state and it is difficult to say just how it will end up, but I think the need and demand for this sort of broadcasting has been fully established. Some of the stations which have been broadcasting market news are giving it up and we are adding others in their places. At present any farmer living east of the Mississippi or west of the Rockies is pretty sure to be within convenient distance of a good broadcasting station which two or three times during the day sends out our reports. The region between the Mississippi and the Rockies is not so well served, but we are gradually filling in that gap and we hope before long to place our radio service within reach of every farmer in the United States."

More power to Gilbert and his radio for Reuben!

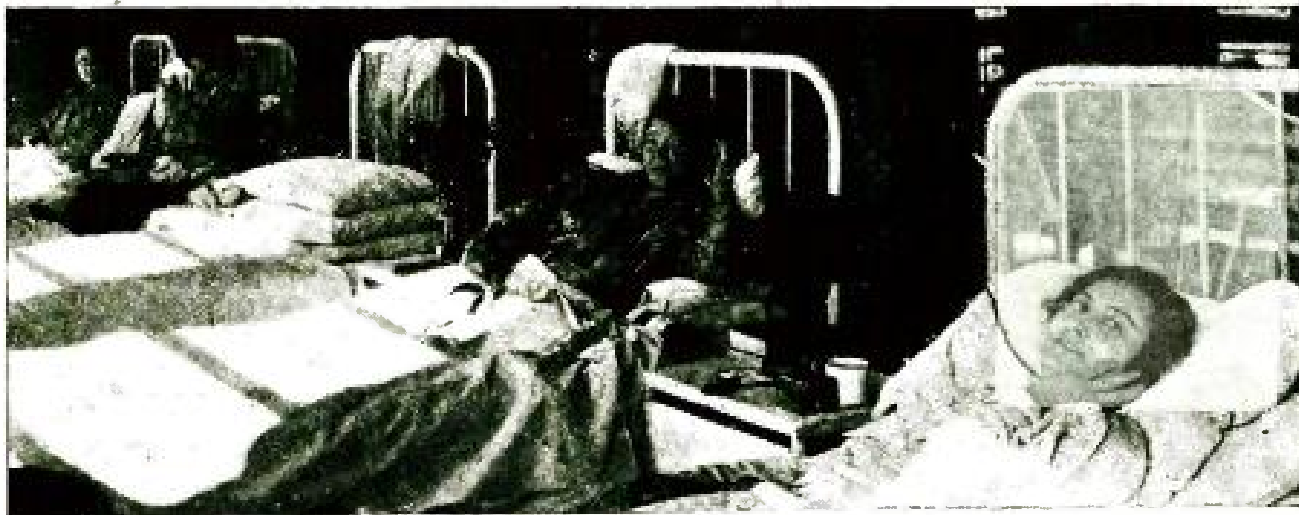

How radio is being used for alleviating human suffering will be told by Mrs. Christine Frederick in a coming issue of POPULAR RADIO.



BROADCASTS

ITEMS of general interest that you ought to know; bits of useful information that every radio fan ought to know.

A Chance Knowledge of Radio Saves 33 Lives at Sea.

WHEN seaman Addison Galligan, who is an ardent radio fan, picked up a little knowledge of the Morse code, he did it for his own amusement and with no idea that it would be the means of saving the lives of a whole ship's company at sea. But when the *S. S. Nika* caught fire off the coast of Washington, he was the only man on board who knew even a little code. Haltingly he spelled out "SOS," and then "f-i-r-e." The coastguard cutter *Snohomish* picked up the call and rushed to the *Nika's* aid in time to rescue everyone on board.

* * *

Over 250 Licensed Amateurs a Month

LEST some fans believe that the reception of broadcasts is the only popular phase of the radio art, be it known that amateurs are still entering the game of "key pounding" at the rate of over 250 a month. Since January 1, 1,334 amateur licenses have been granted by the Department of Commerce, and on June 5, there were 18,232 such stations in the United States.

The distribution of amateur stations by Districts on June 5th, was as follows:

District	Headquarters	Total
1	Boston	2,490
2	New York	2,629
3	Baltimore	1,994
4	Norfolk	444
5	New Orleans	941
6	San Francisco	2,172
7	Seattle	901
8	Detroit	2,932
9	Chicago	3,729

Total 18,232

The above table does not include special amateurs, of which class there are 201.

* * *

Radiophone Service from Ship to Shore

THE United Steamship Company of Copenhagen, Denmark, plans to install radio telephone equipment on all boats plying between Copenhagen and the provincial harbors for the

traveling public's convenience. Travelers will be able to secure direct communication through the land telephone service, with their own homes or offices.

* * *

Beer—or Radio?

A DECISION was handed down recently by an English court which declares that it is illegal for a public house (English for what we used to call a "saloon") to furnish their patrons with both liquid refreshment and radio music. From now on, evidently, the customers will have to choose between broadcasting and beer.

* * *

The Radio Information that the Farmers Want

A CANVASS made by the Department of Agriculture in regard to its broadcasting of market news reports indicated that the grain reports were most popular, with livestock reports and weather reports next in order.

* * *

A Silent Period for Amateur Transmitters

AT the suggestion of the amateurs themselves, who generously wish to co-operate with broadcast listeners all over the country, the government has issued an order which requires that all amateur stations keep off the ether from 7.30 until 10.00 P. M. All new amateur licenses will contain a clause which definitely restricts operators from encroaching on the ether during these hours.

* * *

A Chance for Amateurs to Visit the North Pole—by Radio

WHEN Donald B. MacMillan, the noted explorer, leaves Booth Bay, Maine, this summer for his seventh dash toward the pole, he will take with him a complete radio outfit and an amateur operator provided by the American Radio Relay League. By doing this it is expected that he will eliminate the loneliness that usually goes with such an expedition for he will probably be able to keep in touch with civilization until he is within twelve degrees of the Pole. Incidentally, amateur radio will benefit, as the operator chosen will send in a weekly log of the amateur stations that he hears while he is in the Arctic Zone.

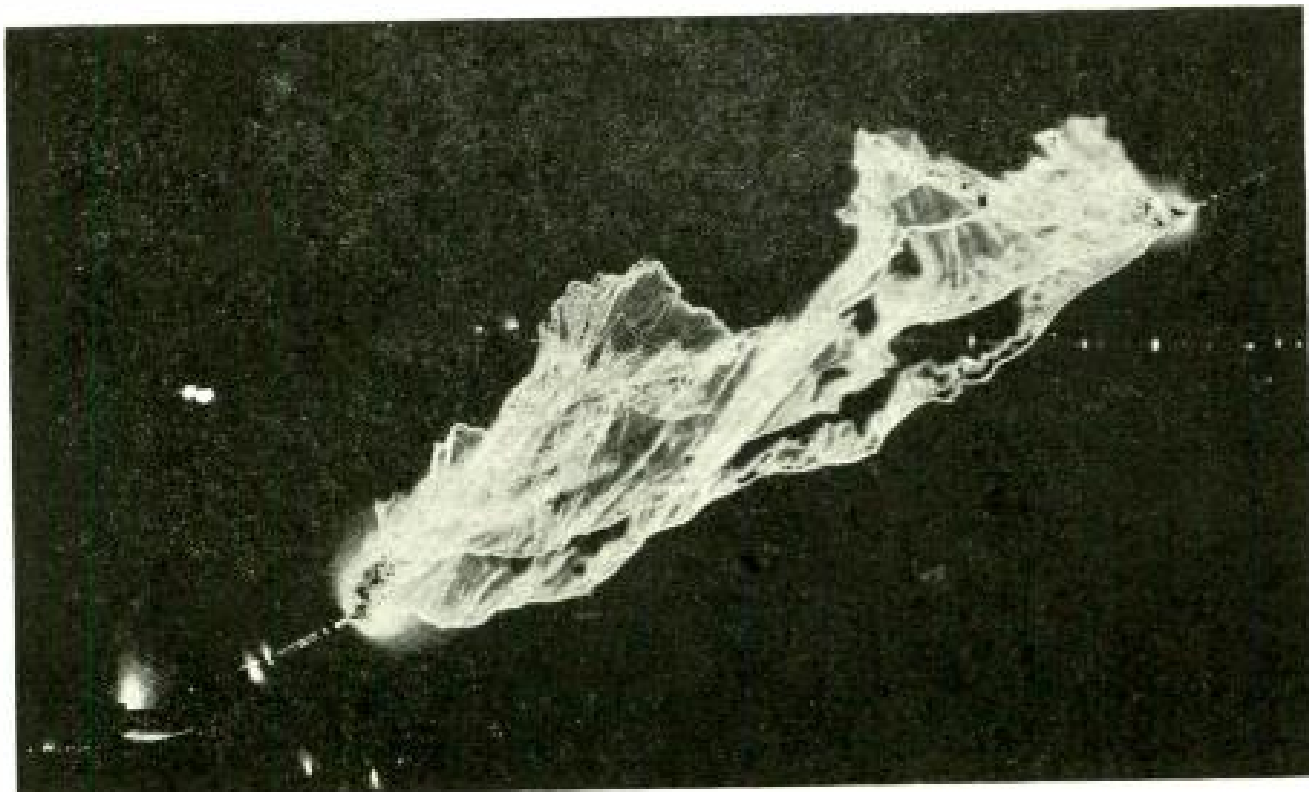

General Electric

THE MOST DANGEROUS LIGHTNING BOLT EVER FORGED BY MAN

This writhing shaft of electrical power, twenty-five feet long, has such tremendous force that in demonstration it not only shatters but practically eliminates a block of wood of 16 cubic feet. The flash pictured above was generated between the testing electrodes of 2,000,000-volt transformers—which are the highest voltage transformers in the world.

Will Radio Create a New Department of Government?

INTEREST in radio throughout the country is responsible for the fact that in a report for the reorganization of the government the only substantial change suggested was that the Post Office Department be renamed the "Department of Communications," and that it be provided with a bureau "to develop and extend telephone and telegraph service, particularly radio, throughout the country."

* * *

885 Radio Stations Operated by Uncle Sam

A RECENT report shows that there are at present 885 radio stations operated by the U. S. government. Of these the Navy has 533 ship and 52 land stations and the Army has 180 land stations. The rest are operated by the Post Office, Commerce, Interior and Treasury departments.

* * *

Radio Music that Comes by Telephone

WHAT appears at first to be an application of the recently-developed principles of "wired wireless" is now in effect in Backus, Minnesota. As a matter of fact, it is not "wired wireless" at all, but an ingenious device of the local telephone company. The loudspeaker of a receiving set located at the central office is placed in front of a transmitter which is connected to a farm line; the patrons of the line

are thus enabled to listen in on broadcast programs even if they have no apparatus of their own.

* * *

How a Radio Theory Worked Out in a Transatlantic Test

AN interesting example of how radio theories work out practically was afforded by the tests in transatlantic transmission which were recently carried out on signals from the station at Rocky Point, Long Island. The electric field strength which the signals should have when they had reached London was calculated in advance by means of the Austin-Cohen formula. Then the incoming signals were actually measured, and were found to have substantially this strength. This is only one case of many where this famous formula has worked out satisfactorily in practice.

* * *

Radio Carries to Mother Applause Given Her Son

WHEN the French consul Gaston Liebert conferred the Cross of the Legion of Honor upon Barre Ferre at the annual banquet of the Pennsylvania Society at the Waldorf-Astoria in New York, one of those who heard the applause was his mother, Mrs. S. P. Ferre, who was in Rosemont, Pa., where she listened in on the banquet by radio and heard her son receive his honor. Radio broadcasting is becoming a matter of public service.

A Record Long-Distance Reception

A RADIO message from the Naval station at Cavite, P. I., addressed to San Francisco for relay to Washington was picked up in the Washington Radio Central recently and copied before the San Francisco operator indicated its receipt. Needless to say, it was not relayed to Washington. This message was copied without error over 11,500 miles of sea and land.

* * *

The Legal Status of an Aerial on a Roof

ACCORDING to a recent decision by a Chicago magistrate, a landlord cannot legally destroy his tenant's radio aerial, inasmuch as the radio set is "an appurtenance to the home."

* * *

Radio in the Waiting Room

CALLERS upon Mayor Hylan of New York are not at a loss for entertainment even while waiting to be ushered into the sanctum, for a radio set has been installed in the reception room at City Hall. "It will be a welcome diversion for humble citizens who come daily and kick their heels while sitting on the benches in the lobby or in the reception room waiting to see the executive," observes one newspaper. "It is understood that a connection has been made with the Mayor's private office so that he can switch on a concert now and then to break the strain of his working hours."

* * *

The Charlie Chaplin of Radio

"The best known man in France today, not excluding President Millerand, is M. Radiolo, the official announcer of France's single wireless broadcasting firm," states *The Sun*, New York. "Six months ago he was discovered working in a railroad accountant's office. Manufacturers of a wireless apparatus offered him a contract at a salary of 1,000 francs a week to talk into the transmitter for three hours daily, his voice being considered to have a greater resonance than that of either Caruso or Jean de Reske at the height of their careers.

"But Radiolo is finding his fame irksome, as he can no longer attend theaters without having the audience rise and applaud just as if he were the President entering the official loge.

"The performance at a suburban theater was stopped in the middle of the first act last week until Radiolo, who had entered, satisfied the radio fans by repeating without a smile the phrase which introduces all French wireless programs: *Bon soir, mesdames, bon soir, messieurs.*"

* * *

Broadcasting in Japan

ALTHOUGH radio enthusiasts in Japan do not have all the advantages of their brother fans in the United States, from now on they will at least be able to enjoy regular broadcasting. The Japanese government has realized the wisdom of relaxing its rigid policy and has licensed a number of firms to broadcast music, speeches, and government reports. This ser-

vice will be paid for by a fee which will be collected by the government and handed over to the companies.

* * *

Learning Languages by the Ether Method

ONE of the most important factors in learning a new language is to have plenty of practice in hearing it spoken. A broadcasting station located in Sheffield, England, has realized this and is making an experiment in sending out French lessons by radio. As a matter of fact all that the European radio fan who wishes to learn a new language need do is to pick his headphones, tune in some broadcasting station of a foreign country, and listen in.

* * *

First Aid to a Ship's Engine by Radio

AN unusual example of the value of radio in an emergency was furnished by the motor ship *Sanguar*, which ran out of oil on her way from the Mediterranean to New York. She was obliged to put into Ponta Delgada where only heavy oil was found to be available. Not knowing how to use this, the captain sent a message by radio to the company's engineers and first aid—in this case, the necessary information—was returned *via* the ether.



Kadel & Herbert

THE FIRST "MINISTER OF RADIO"

When the Canadian Government recently appointed the Hon. Ernest Lapointe its Minister of Radio it established a precedent that may be followed by other countries. There are 150,000 receiving sets in Canada; they are taxed \$1 a year each.

WHAT READERS ASK



This department is conducted for the benefit of our readers who want expert help in unravelling the innumerable kinks that puzzle the amateur who installs and operates his own radio apparatus. If the mechanism of your equipment bothers you—if you believe that you are not getting the best results from it—ask THE TECHNICAL EDITOR.

THE flood of inquiries that has poured in upon the Technical Editor has not only furnished evidence of the need of this department, it has also necessitated a system of handling the correspondence that will insure the selection of and answer to only those questions that are of the widest application and that are, consequently, of the greatest value to the greatest number of our readers. Our correspondents are, accordingly, asked to co-oper-

ate with us by observing the following requests:

1. Confine each letter of inquiry to one specific subject.
2. Enclose a stamped and self-addressed envelope with your inquiry.
3. Do not ask how far your radio set should receive. To answer this inquiry properly involves a far more intimate knowledge of conditions than it is possible to incorporate in your letter.

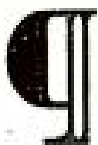

In justice to our regular subscribers, the Technical Editor is compelled to restrict this special service to those whose names appear on our subscription list. A nominal fee of 50 cents is charged to non-subscribers to cover the costs of this service and this sum must be enclosed with the letter of inquiry.

QUESTION: Would you advise me to build a single-circuit regenerative receiver or a regenerative receiver that makes use of inductive coupling? The reason I ask this is that there are four families in this apartment house who have receiving sets; when they heard that I was going to get a receiver they came down to see me in a body, and asked me *not* to buy or make a single-circuit set as it would interfere with their sets? Is this true? I have heard of so many single-circuit sets getting "distance" that I had almost decided to make a set of this type. After a while, I decided to write to you and ask your advice. They have agreed to let me abide by your decision.

BRUCE MCKARG

ANSWER: It would be better for you to make either a three-circuit regenerative set that employs loose coupling or if you must have a

single-circuit set one that has one stage of radio frequency amplification hooked in before your detector tube. This would prevent re-radiation and would keep you from interfering with the reception of your neighbors.

* * *

QUESTION: What is a good loudspeaker to use? I want one which will give little distortion and yet provide good volume in an apartment house.

V. C. SCOTT

ANSWER: Obviously we cannot tell you to buy any specific manufacturer's wares. To help you, however, we advise you to go to some responsible dealer and ask for a demonstration, and pick out an instrument which suits both your pocketbook and your sense of hearing. Most of the loudspeakers on the market are good in their respective fields, some cost but little and some seem to be high priced. Our advice, then, is for you to decide how much you will spend and then for you to obtain a demonstration of the various instruments which sell at that price. You can pick out the one you like best if you give it a comparative test with the others.

QUESTION: What is the function of the light in the bulb in my radio set? I have noticed that the brighter I turn up the light in it, the louder the music comes in. This is true of "my set" only, however, for my neighbor has a larger set and I can hardly see the light burning in it at all, and yet the music comes in much louder than in my own set, which has to be well lit up to work at all. This is a puzzling thing to me. But I know nothing of radio except to turn the dials until I hear something.

N. C. WHITE

ANSWER: The "light" in a vacuum tube, is actually only a "by-product." The real thing that makes the tube function is the stream of negative electrons which is given off by the filament when it is heated. In most tubes the filament is made of tungsten which has to be heated to almost a white heat before the electron stream given off from it is sufficiently strong for the tube to operate efficiently. This is evidently the type of tube you are using.

Your friend is probably using a tube which makes use of an oxide-coated filament which gives off the proper electron emission at a lower temperature. This is the reason that your friend's tube does not "light up" as much as yours and yet it works as well as yours. It is not the light in the tube that produces the results—it is the stream of electrons which flow from the filament to the plate which produces the sounds you hear in the telephones.

QUESTION: I am using a triple-coil set for listening to the broadcasting; since the wavelengths have been extended I have had trouble in getting the stations on the higher wavelengths. I am using an L-25 for the primary, an L-35 for the secondary, and an L-75 for the tickler. Will you kindly tell me what to do to increase my wavelength?

LESTER B. HILL

ANSWER: We suggest that you use an L-35, an L-50 and an L-75 coil in the respective circuits mentioned in your request. The antenna tuning condenser should be of .001 mfd. capacity (43 plates) and the secondary tuning condenser of .0005 mfd. capacity (23 plates). This will extend your range so that you will have no difficulty in getting the stations with the highest wavelengths. Be sure that you have a change-over switch for changing the antenna tuning condenser to multiple when tuning in these stations with the higher wavelength.

* * *

QUESTION: Please print a hook-up for a tapped coil, a variable condenser and a variometer, for use with a vacuum tube detector. I want to use a potentiometer control for the "B" battery.

J. KREUTZ

ANSWER: A circuit that may be used with your apparatus is given in Figure 1. The coil L, should be tapped at the 15th, 30th, 45th, 60th, 75th and 90th turns. A grid condenser GC, of .00025 mfd. capacity should be used and a grid leak GL, of 2 megohms. The condenser C, is a bypass condenser of about .001 mfd. The variable condenser VC, of .0005 mfd.

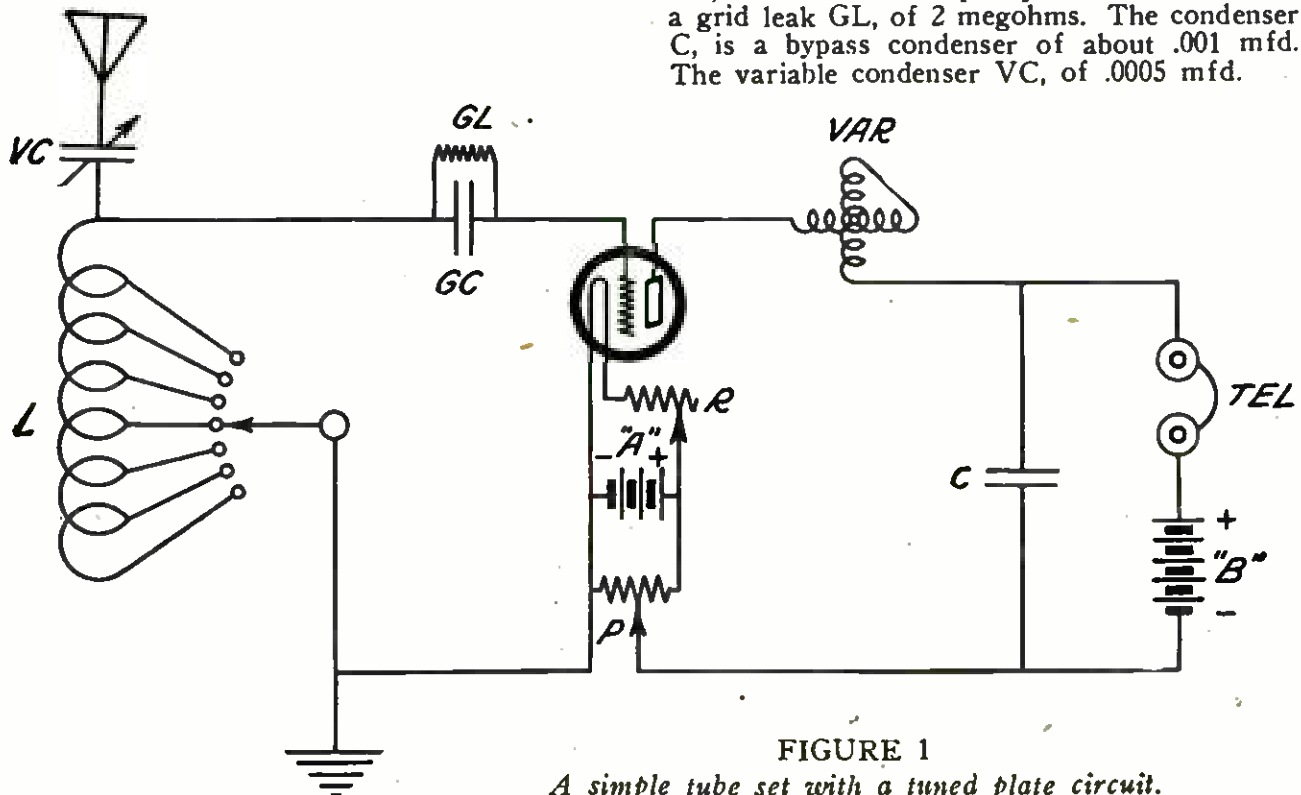

FIGURE 1

A simple tube set with a tuned plate circuit.

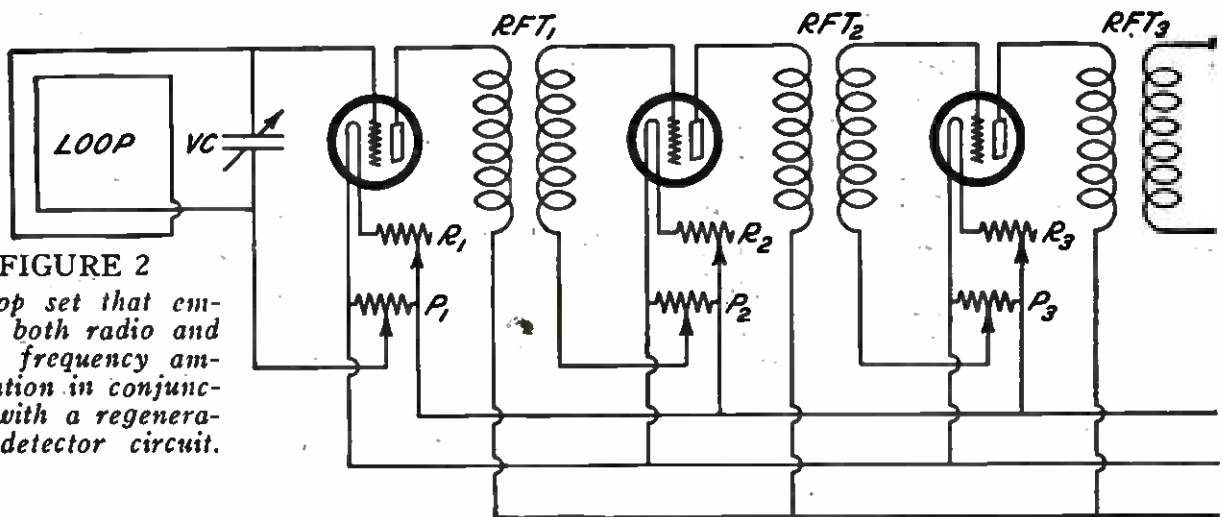

FIGURE 2
A loop set that employs both radio and audio frequency amplification in conjunction with a regenerative detector circuit.

QUESTION: I want to get a circuit that employs three stages of untuned radio frequency amplification with a regenerative detector circuit and two stages of audio frequency amplification. I want to use my set on a loop. Do I need to use potentiometers? If so please show how to connect them.

GEO. H. STONE

ANSWER: We have drawn out a circuit for you in the diagram in Figure 2. If reliable materials are used and the set is put together with care and wired correctly, you should have exceptionally good reception.

The parts to be used are the following:

VC—vernier variable condenser, .0005 mfd.;

GC—mica fixed condenser, .00025 mfd.;

GL—tubular grid leak, 2 megohms;

C—mica fixed condenser, .0005 mfd.;

VAR—variometer;

R1, R2, R3, R4, R5, and R6, filament rheostats;

P1, P2, and P3, potentiometers, 300 ohms;

RFT1, RFT2, and RFT3—radio frequency amplifying transformers;

AFT1 and AFT2—audio frequency amplifying transformers.

If ordinary tubes are used, the filament rheostats should be of 5 or 6 ohms resistance, but if the new thoriated filament tubes or dry-cell tubes are used, the filament rheostats should have a resistance of at least 30 ohms.

* * *

QUESTION: Is No. 30 enameled wire too small for winding a coupler?

H. S. NOBLE

ANSWER: Yes. You should use a larger size. Somewhere between No. 18 and No. 22 would be nearer right. The No. 30 wire would have too high a resistance and it would materially reduce the strength of the received signals.

This is particularly true for use on the coils of a coupler used in a non-regenerative receiver.

QUESTION: Is it all right to make the sub-panel in back of the main panel of the set for mounting the instruments on out of wood?

JOS. M. THIBEAU

ANSWER: Well dried wood which has been treated in paraffin can be used. Ordinary untreated wood, however, should not be used as it contains a large percentage of moisture; this would be liable to cause serious leakage.

* * *

QUESTION: I accidentally pushed my head telephones out of the window and they fell to the sidewalk. Although they did not appear to be damaged outside of a small dent in one side of the shell, they do not work as well as formerly. There are no parts bent or out of place. Will you kindly tell me what is the matter with them?

A. D. REYNOLDS

ANSWER: When a permanent magnet is hit a heavy blow, as with a hammer, a considerable part of its magnetism is lost. This is probably what happened to your telephones. In the fall to the sidewalk the magnets in the telephones were jarred and the permanent magnetism therefore was lost. Send the telephones back to the manufacturer and have them re-magnetized.

* * *

QUESTION: Will you please let me have a diagram of the two-tube Armstrong super-regenerative circuit for use with a loop antenna?

F. S. MASON

ANSWER: This circuit is given in Figure 1 on page 207 of the November, 1922, issue of POPULAR RADIO. A description of this type of receiver was also given in the September, 1922, issue. The new thoriated filament tubes work well with this hook-up.

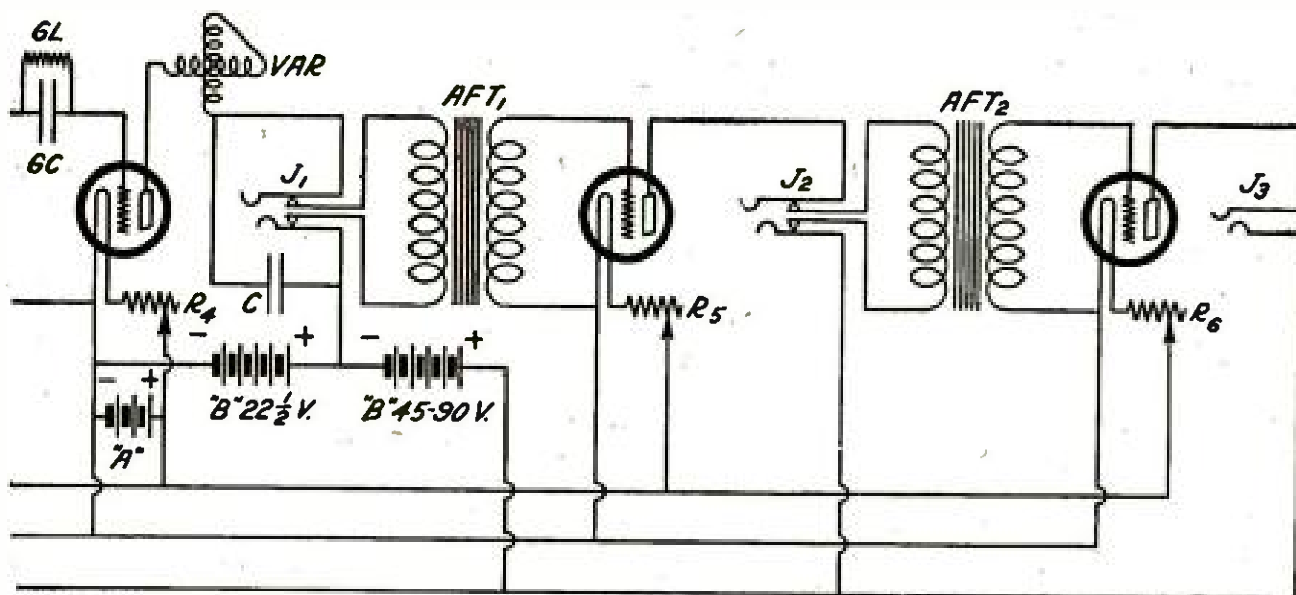

QUESTION: Is it possible to get a two-tube inverse reflex circuit that uses a crystal detector, which will have two stages of radio frequency amplification and two stages of audio frequency amplification and which will operate a loudspeaker when worked on a loop antenna? If so, will you please give me one? Please attach also a list of parts necessary so that I will know what to buy when I make the set. And please let me know the proper constants of the various instruments.

OLIVER WILLIS

ANSWER: The circuit for the two-tube crystal detector, reflex receiver is shown in Figure 3. You will need the following parts:

- VC—vernier variable capacitor, .0005 mfd.;
- C1—mica fixed condenser, .0025 mfd.;
- C2—mica fixed condenser, .0015 mfd.;
- C3—mica fixed condenser, .0015 mfd.;
- C4—mica fixed condenser, .0015 mfd.;
- C5—mica fixed condenser, .002 mfd.;
- P1—potentiometer, 300 ohms;
- P2—same as P1;
- R1—filament rheostat, 30 ohms;
- R2—filament rheostat, 30 ohms;
- RFT1—radio frequency transformer;
- RFT2—radio frequency transformer;
- AFT1—audio frequency transformer;
- AFT2—audio frequency transformer.

You may use either UV-201-A or C-301-A tubes or any of the dry-cell variety tubes.

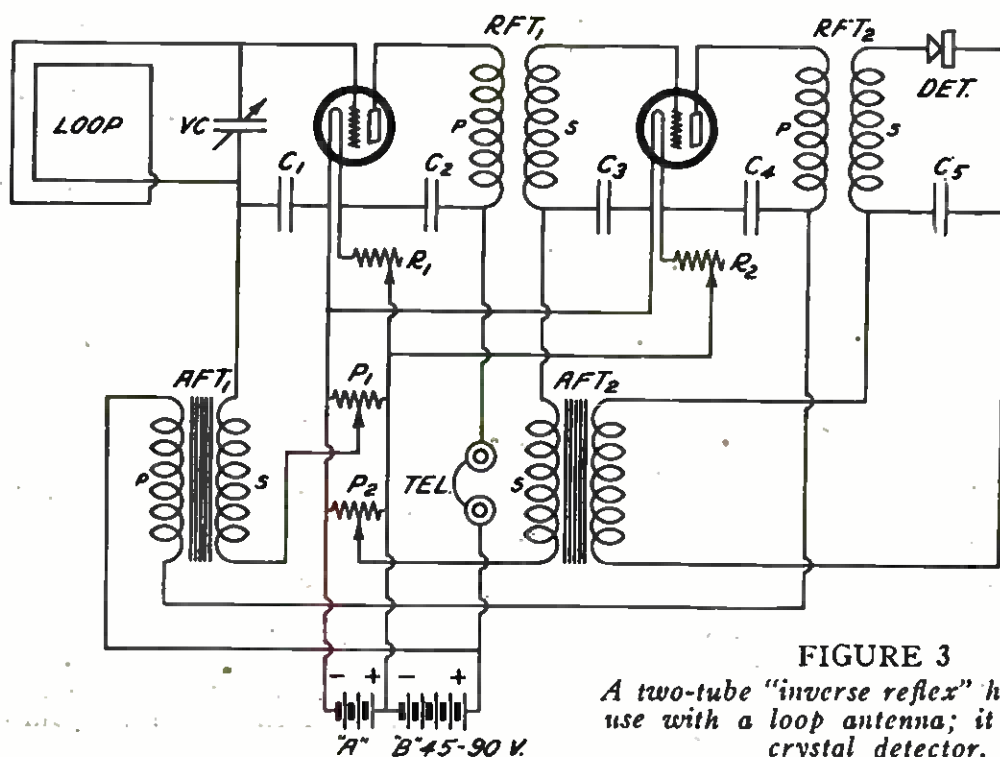
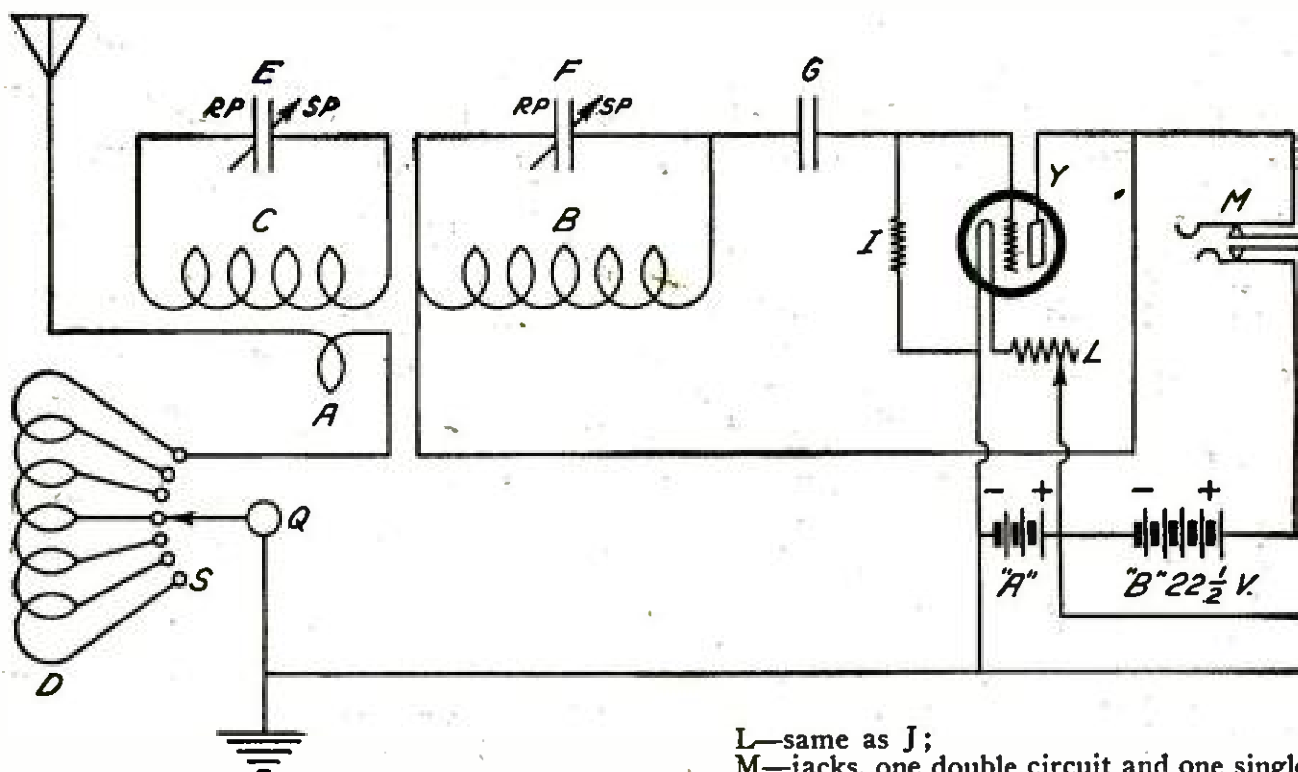

FIGURE 3

A two-tube "inverse reflex" hook-up for use with a loop antenna; it employs a crystal detector.



QUESTION: Please tell me what changes will be necessary to adapt the Four-Circuit Tuner for use with dry-cell tubes. I have tried out the circuit with the standard six-volt tubes and find that I can get practically any "DX" station with it even while the local stations are "on the air." Now I want to try the smaller tubes so that I can convert it into a portable set to carry on my car this summer and use with a portable antenna as suggested in the June issue of POPULAR RADIO.

R. LOWRY

ANSWER: In Figure 4 you will find a diagram of the Four-Circuit Tuner adapted for use with dry-cell tubes. The designating letters are the same as those used in the construction article in the May issue, but for the sake of clarity we give the following list of parts:

- A—single turn of wire;
- B—65 turns of No. 18 SCC wire;
- C—34 turns of wire wound close to B on the same tube. (A and B coils are both wound on a tube $3\frac{1}{4}$ inches in diameter);
- D—43 turns of same sized wire, double bank wound on same sized tube, and tapped at the 3rd, 7th, 13th, 21st, 31st turns;
- E—vernier variable condenser, .00035 mfd. (.0005 will be suitable for wavelengths up to 600 meters);
- F—same as E;
- G—mica grid condenser, .00025 mfd.;
- H—mica condenser, .001 mfd.;
- I—grid leak, 1 megohm;
- J—filament rheostats, 30 ohms;

- L—same as J;
- M—jacks, one double circuit and one single circuit;
- N—audio frequency amplifying transformers, high ratio in the first stage and lower ratio in the second stage;
- Q—switch lever;
- R—same as Q;
- S—taps (switch points).

The variable condensers should be arranged as shown in the diagram with the rotary plates and stationary plates connected as indicated.

A "C" battery in the grid circuit of the two amplifier tubes is necessary with this type of tube when any considerable amount of "B" battery voltage is used on the amplifier plates. The "C" battery should be an ordinary 3-volt flashlight battery connected with the negative side toward the grid.

* * *

QUESTION: What would be a safe plate potential for a radiotron UV-202 5-watt transmitting tube to be used with the Colpitts circuit? I am going to transmit with D.C. CW., and want to know what voltage my generator should give. I am going to use a 20-watt set with Heising modulation as described in Prof. Morecroft's article in the July issue of POPULAR RADIO.

LAWRENCE STUART

ANSWER: You may use a 150-watt, 500 volt D.C. generator on the four tubes in your new set. It would be good to have a field rheostat in the shunt field of the generator so that you can control the voltage of the output of the generator from 500 volts down to 150 volts. This would enable you to decrease power when working local stations so that you would give as little interference to your neighbors as possible.

FIGURE 4

An adaption of the Four-Circuit Tuner that will enable you to make use of dry-cell tubes.

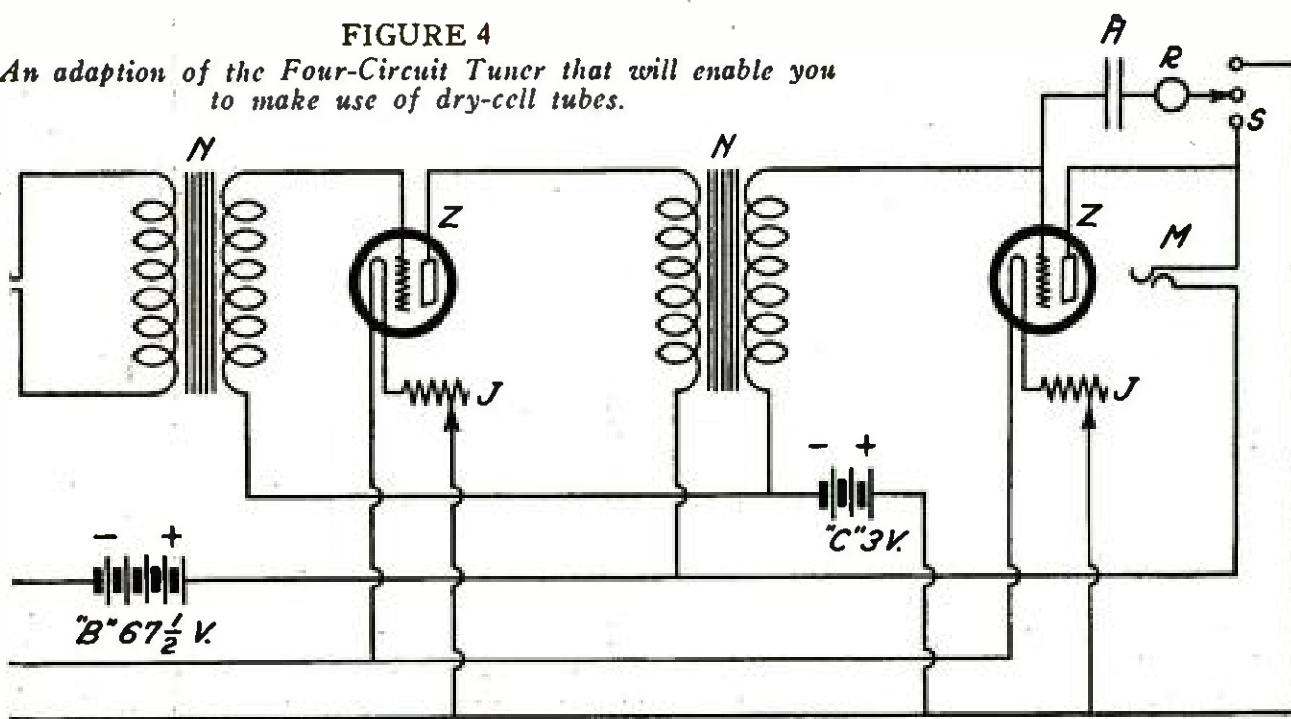

QUESTION: Is it possible to use all kinds of tubes on the Four Circuit Tuner, or are only the six-volt tubes suitable? I would like to use the new 1 1/2-volt tubes.

LEONARD CROUSE

ANSWER: The 1 1/2-volt tubes will work nicely in this circuit but the volume will not be quite as great as with tubes employing a greater filament energy.

QUESTION: What rheostat should be used with a UV-201-A or C-301-A tube when it is used as a detector? I am

using a 6-ohm rheostat now and I cannot keep my tubes from oscillating.

VICTOR DENNIS

ANSWER: It would be better to use a 30-ohm rheostat for the detector tube when this type of tube is used. You could then turn down the filament so that the tube would not oscillate.

QUESTION: Will you send me a hook-up showing how to add one stage of audio frequency amplification to the standard regenerative circuit shown in Figure 2 on page 60 of the May, 1922, issue of POPULAR RADIO?

A. C. HUBLEY

ANSWER: The circuit is shown in Figure 5. We have added a variable condenser in the ground lead. This will improve your tuning.

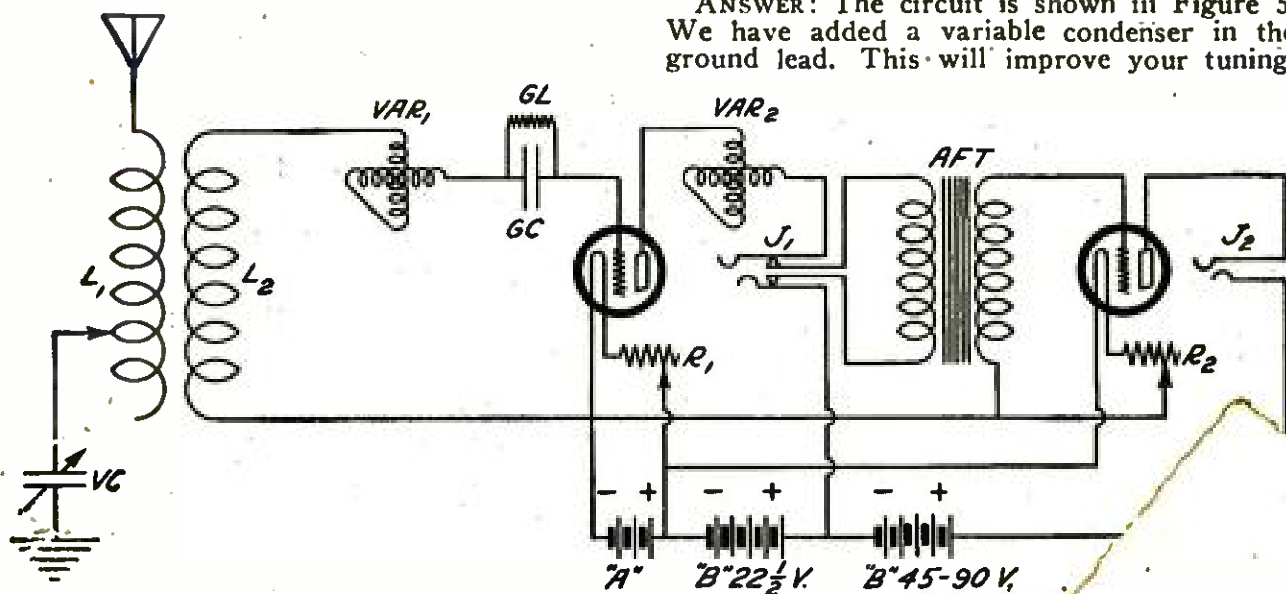

FIGURE 5

A hook-up that employs one stage of audio frequency amplification and regenerative circuit.



HELP your neighbor. If you have discovered any little Kink that helps to eliminate trouble in your radio apparatus, or if while experimenting with the connections of your set you should run across some interesting phenomenon, or if you should discover some new hook-up that gives better results—send it to the "Listening In" page.

A New Method of Eliminating Interference

THE progress that is being made toward the elimination of interference by means of short-wave transmission along a radio "beam" is indicated in the following report of experiments that are being conducted by Uncle Sam's scientists in Washington:

A possible solution of the problem of radio interference on point-to-point communication has been put forward by the Bureau of Standards as the result of recent experiments. It involves directional transmission on extremely short wavelengths.

In these tests a parabolic reflector of cylindrical type designed for a 10-meter wavelength was used. It was made by constructing a parabolic wooden frame with a 10-meter aperture. The frame was suspended in the air and 40 wires spaced one foot apart were suspended from it. The power source (located at the focus) consisted of a 50-watt electron tube. The output from the tube was coupled to an antenna, which was a linear oscillator of the Hertzian type tuned to a wavelength of 10 meters; the complete reflector system was arranged so that it could be rotated.

The receiving apparatus was located 170 feet from the reflector and consisted of a single turn loop antenna with a thermo-element in the loop circuit. A portable galvanometer was connected to the thermo-element.

Good directional transmission was obtained. With the reflector turned 20 degrees from the direct line to the receiver the received current dropped to one-half of what it had been with the reflector directed to the receiver. The larger part of the radiated power was confined to an angle of 20 degrees; at an angle of 270 degrees in a general direction away from the direction of the way the reflector was pointing there was practically no radiation.

Furthermore, good radiophone transmission was obtained by this system over a distance of as much as three miles.

* * *

Across the Continent in 0.0187 Seconds

WORDS spoken in a public hall in Schenectady, New York, reached a radio listener in San Francisco, California, 2,550 miles away, before they were heard by a listener only 150 feet from the speaker!

That statement looks a bit fantastic but it is mathematically true. The apparent absurdity becomes reasonable when it is realized that the speed of sound is only 1,126 feet a second at a temperature of 68 degrees Fahrenheit, while the speed of electrical vibrations or radio waves is 186,000 miles a second.

The listener in the back of the hall in Schenectady, 150 feet from the speaker, heard the words in 0.1332 seconds.

A microphone connected to the radio transmitting equipment of station WGY was two feet in front of the speaker and picked up the words in 0.002 seconds. The time required to transform sound waves into electrical energy was 0.002 seconds; the time required for electrical vibrations (or waves) to pass from Schenectady to San Francisco was 0.0137 seconds; the time required at the receiving end to convert the electrical vibrations into sound vibrations was 0.001 seconds.

Thus the total elapsed time from the speaker in Schenectady to the radio listener in San Francisco was 0.0187 seconds, while the listener in the hall heard the words in 0.1332 seconds.

In other words, the San Francisco man heard the words 0.1145 seconds sooner than the man in Schenectady.

C. H. HUNTLEY

Why We Cannot Hear Amateur Signals from Abroad

ONE sometimes wonders why so many American amateur signals are heard abroad while so few amateur signals from across the Atlantic have yet been picked up in this country. The reasons are told here:

Our English cousins have greatly profited by their government's limitations of amateur transmitting sets; indeed, they have been restricted to ridiculously small amounts of power for transmitting. But this very restriction has proved to be a blessing, for it has turned the efforts of the British amateurs to the improvement of their receiving sets. An amateur in England thinks nothing of using three, four, or even five or six stages of radio frequency amplification in his set, and he has mastered these complicated circuits in such a manner that

they are everyday practice in that country.

Here in America, on the other hand, the amateur has gone in for transmitting rather than for receiving. While it is true that he has done some extraordinary work in the development of the vacuum tube transmitter, at the same time he sticks to the one-tube regenerative circuit, with a couple of stages of audio frequency amplification added to it. As a general thing he steers clear of anything that looks like radio frequency amplification.

The American transmitter and the British receiver seem to make a rather good combination, in view of the fact that over a hundred American amateurs reached out across the Atlantic last winter and were heard in England by the British amateurs.

It is possible that if the amateurs of each country study the other's transmission and reception methods we might be able to get transmission from England to America, thus enabling us to talk both ways instead of only one way. That should be the next development in amateur radio.

FREDERICK SIEMENS

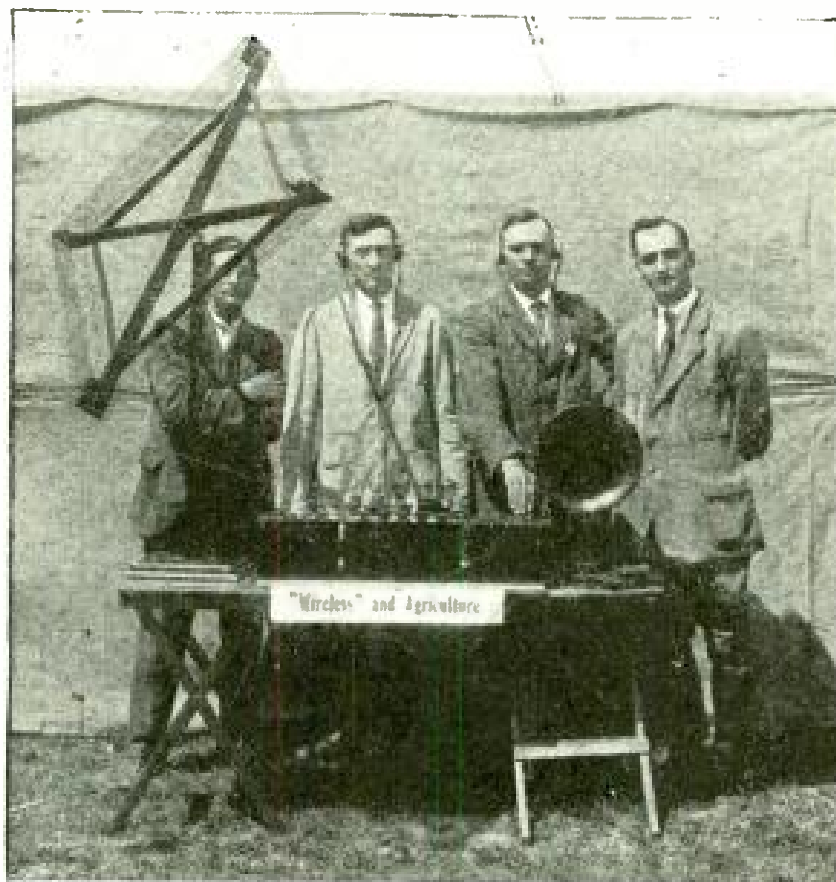

Dorien Leigh, London

BRINGING IN THE CROPS BY RADIO

The restrictions imposed by the British government upon the use of transmitters has turned the attention of the amateur in England to the receiving end of radio, which he has developed to a high grade of efficiency. With the five-tube radio frequency set shown above that employs a loop antenna (a typical British outfit) market reports from London can be brought in on a loudspeaker at the farm itself, thus enabling the farmer to take advantage of the most favorable prices. In England as in America this has already become one of the most important services that are performed by radio.

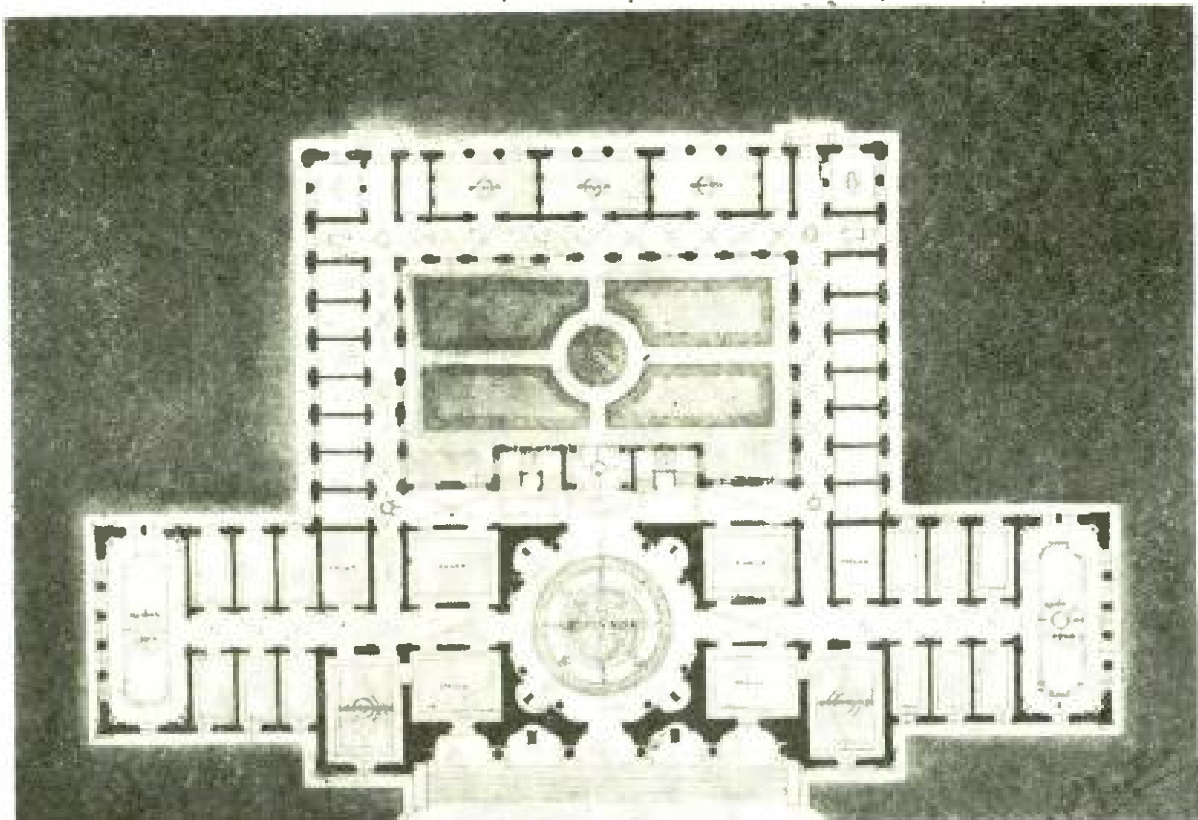
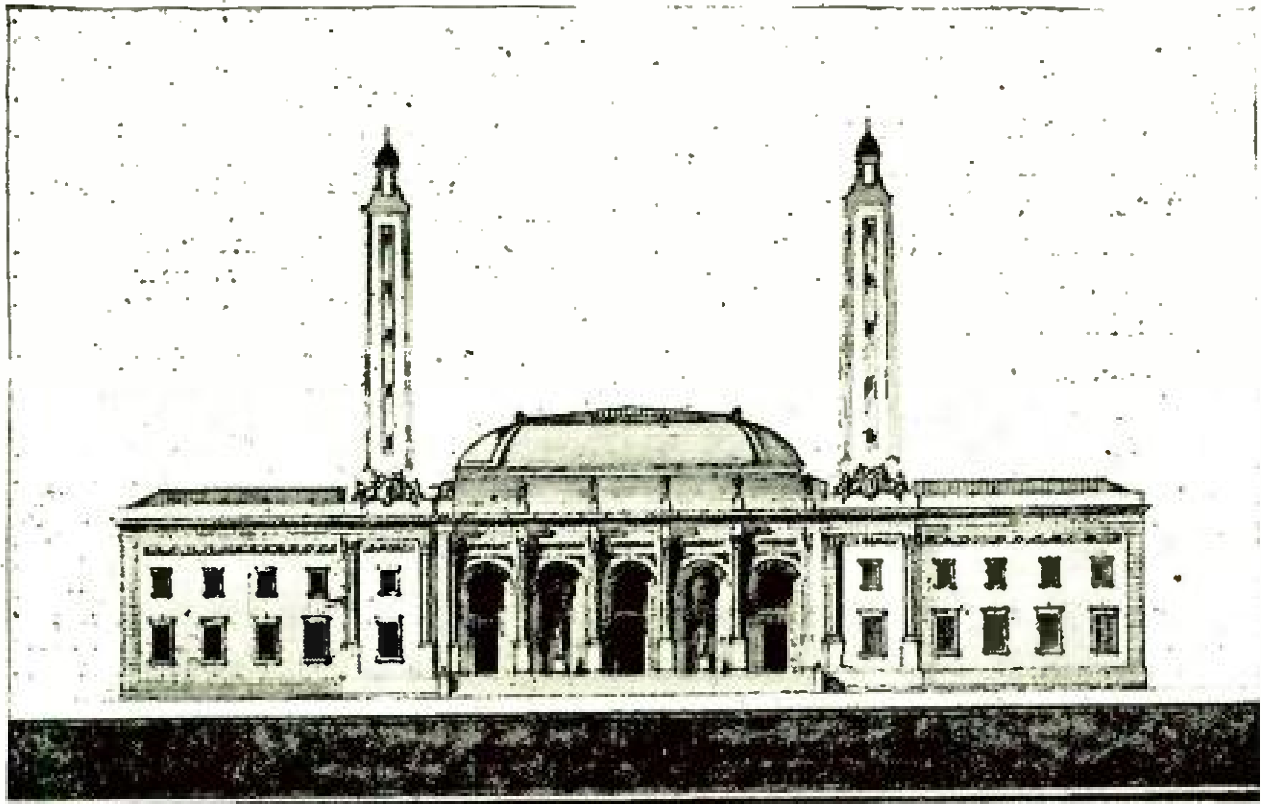

WILL THE BROADCASTING STATION OF THE FUTURE LOOK
LIKE THIS?

Here is the idea of a young architectural student, Harold H. Owen, of the kind of building that might be erected by a city of a million inhabitants which wanted a new home for its school of music, with full radio equipment. This design won First Mention Placed.

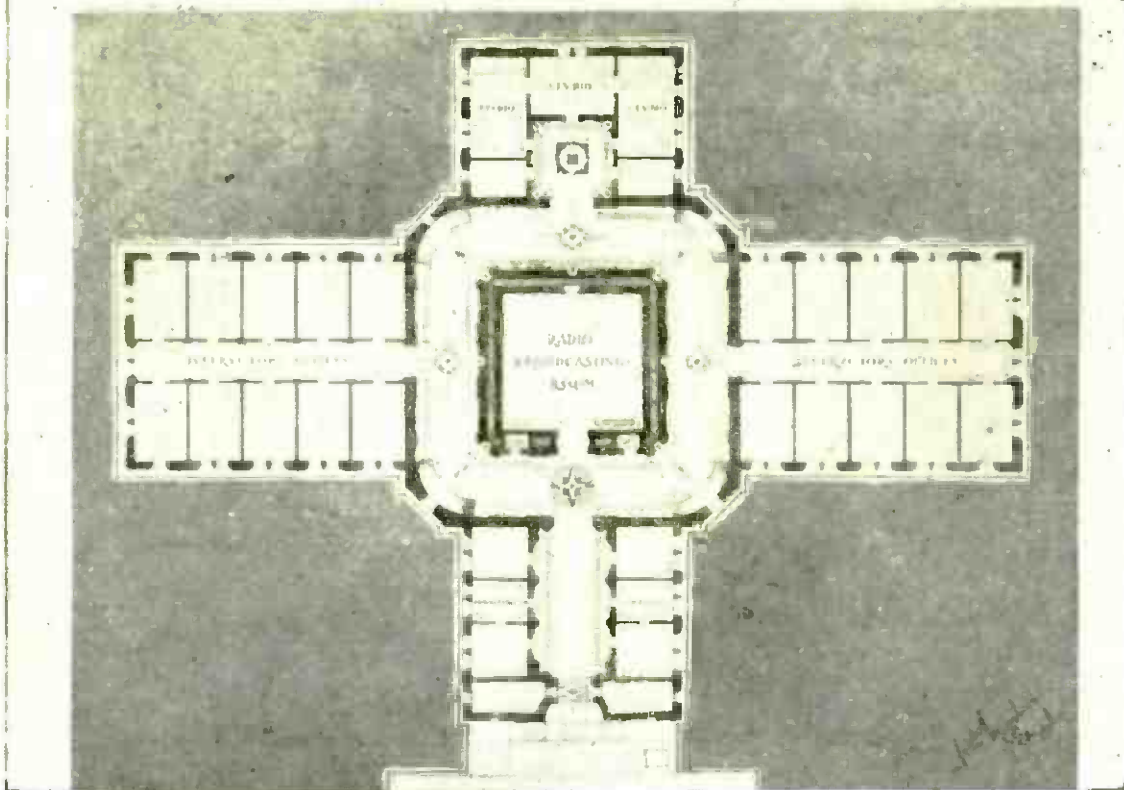
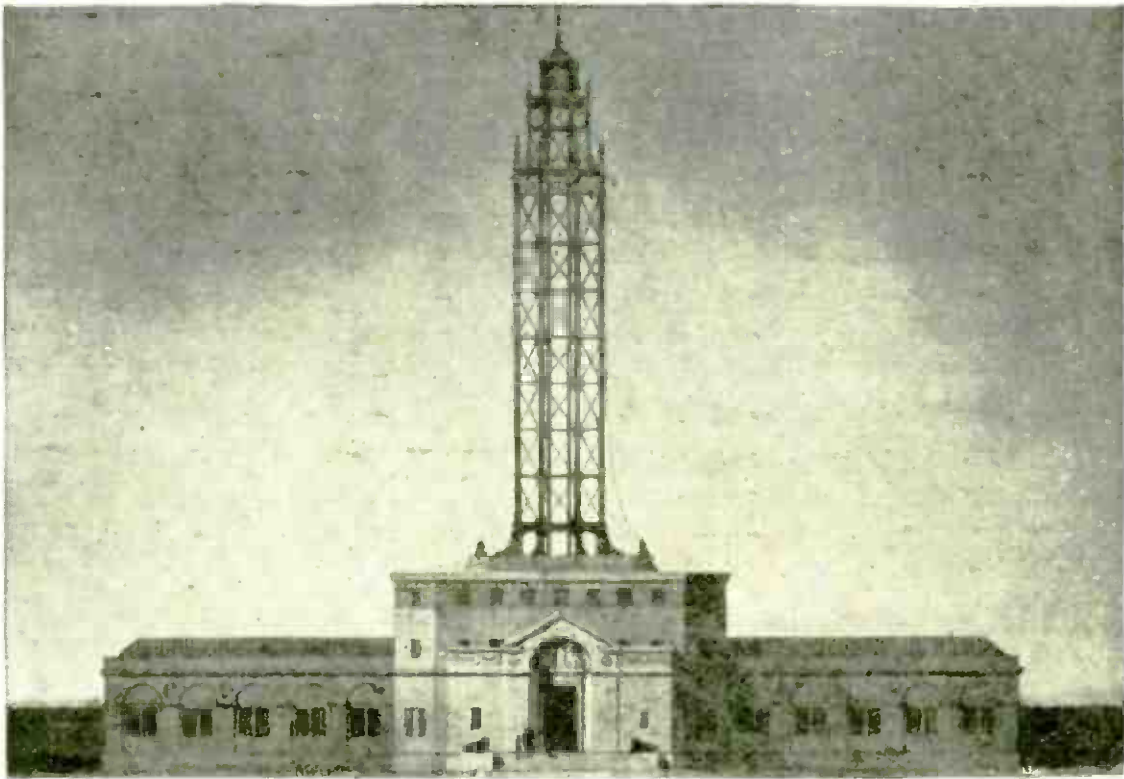

WILL THE CONCERT HALL OF TO-MORROW BE IN EFFECT A
BROADCASTING ROOM?

Such is the idea of directing heads of the School of Architecture at Columbia University in New York, whose recent "problem," devised for their students, brought forth some interesting ideas. The above design by José Fernández received First Mention.

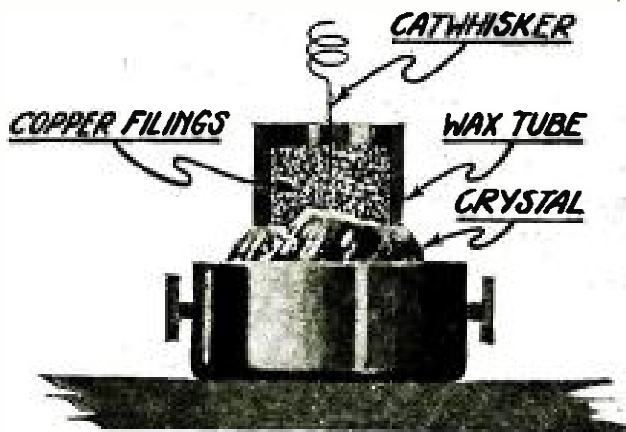

HOW THE ADJUSTMENT WORKS

By means of closely packed filings contact is made with the whole surface of the crystal, thus assuring a circuit through some sensitive spot.

How to Make a Permanent Adjustment for Your Crystal Detector

A RADIO fan in Pittsburgh, Pa., was bothered by the continued adjustments he had to make on the detector of his crystal set. The device he here describes overcame the difficulty for once and for all:

Roll out a flat piece of wax and form into a cylinder of a size to fit your crystal. Slightly heat one end and while soft fasten to the top of the crystal, as shown in the illustration. Then fill with copper filings and insert the catwhisker into the filing. The many small pieces of copper will make innumerable contacts with the crystal and there is sure to be a good circuit through one of the sensitive spots.

HARRY WERLING

* * *

Weather Reports by Radio from the Seven Seas

ACCURACY in weather forecasting can be attained only by complete and more or less simultaneous reports from all parts of the world. Radio has already established its value to weather forecasters by enabling stations located in heretofore inaccessible parts to send in reports; its next service in this line—according to this announcement that comes to us from Washington, D. C.—will be to extend the terri-

tory covered by the Weather Bureau so as to include even the high seas:

The extension of the daily weather forecasts to cover the entire North Atlantic ocean is characterized as an imminent development of meteorology by Major E. H. Bowie, chief forecaster of the U. S. Weather Bureau, who has recently returned to Washington after a round trip to France on the French merchant training steamship *Jacques Cartier*.

The trip lasted about six weeks and every day of it the forecaster was able to make a morning and night weather map which showed conditions over the whole North Atlantic, the whole of Western Europe and the whole United States and Canada. Reports were received by radio from vessels at sea, from the Navy station at Arlington, and from the French station at the Eiffel Tower.

Forecasts for the ocean between the tropics and the latitude of Iceland were made and broadcast every day from the *Jacques Cartier* at noon, Greenwich Time. The reports from vessels were relayed to Europe and to America where they were of great value to forecasters there by informing them of storms which were on their way across the ocean.

There was no difficulty in getting vessels to furnish the necessary data. They were all anxious to co-operate. This was true even of the big liners which hold their courses irrespective of the weather.

It is entirely practicable, Major Bowie says, to put out daily forecasts at sea and to broadcast them by radio for hundreds of miles.

Furthermore, the cost of this service would be inconsiderable if the principal maritime nations co-operated. Experienced meteorologists and forecasters could be distributed on vessels so that one or two would always be at sea; they would receive the reports from other vessels and from land stations, prepare the daily forecasts and broadcast them, and relay the vessel reports to land. The weather of the ocean can be charted just as easily as that on the land with results of great value both afloat and ashore. It is a field of work which up to now has been greatly neglected.

WATSON DAVIS

* * *

A Practical Indoor Antenna

IF you cannot put up an outdoor antenna, here is a suggestion for an indoor antenna that will bring in the signals and will not spoil the appearance of your room:

My landlord will not allow me to put up an outdoor antenna but I get very good results by running a wire in back of the picture molding down one side of the entry hall of my apartment and back on the other side to my apparatus. Only one end is connected, the other end being left free. I am using a single-tube set and I get all the local stations.

WILLIAM CASTRO

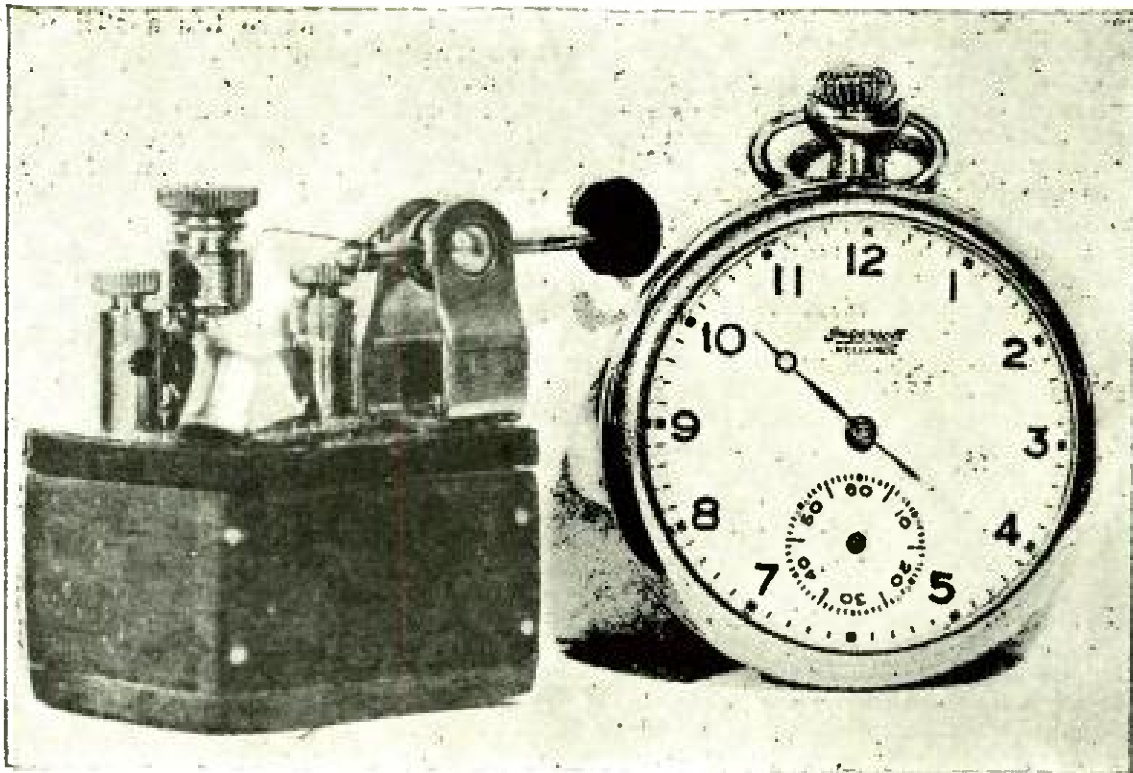

A COMPLETE RECEIVING SET THAT COSTS 35 CENTS

And that is made from materials which can be obtained at a five-and-ten-cent store. The coil (which is packed in the small box) is made of twelve feet of wire.

A Radio Set the Size of a Watch

IF an epidemic of incendiarism should break out in Boston, the local broadcasting stations would lose that part of their audiences that includes the fire department; indeed, the life of a fireman is peculiarly suitable to the development of a radio fan. One fireman, James J. Harrington, has recently built a miniature receiver that is literally "the size of a watch." How he did it is described below:

The set developed by Harrington is remarkable for its small size, low cost, and the loud clear reception which it gives. The material of which the set is made costs only 35 cents—exclusive of the headphones.

The wonderful results obtained with this set, which is small enough to fit in a vest pocket, are due to the manner in which the coil is wound.

Twelve feet of No. 26 wire is wound on a piece of cigar box $\frac{3}{8}$ inch by $\frac{1}{8}$ inch in size. There is about $\frac{1}{8}$ -inch space between each parallel wire and each layer is wound back over the preceding layer. The coil is contained in a box made of cigar box wood which is $1\frac{1}{2}$ inches long, $1\frac{1}{4}$ inches wide, and $\frac{7}{8}$ -inch deep.

On top of this box is mounted the crystal holder which may be bought for ten cents. This holder is made of fiber; the price in-

cludes a catwhisker and two binding posts. A third double binding post is placed between the single posts. This costs ten cents extra. A crystal may be bought for ten cents and the wiring and leads cost about five cents.

The coil is connected between the bottom of the crystal receptacle and the ground binding post. The top is then glued or screwed to the box. When this has been done the set is ready to use. A pair of headphones are obtained. The antenna and ground connections are made. All that remains is to adjust the catwhisker to the most sensitive spot of the crystal.

HARRY BELKNAP

* * *

How to Keep Your Crystal Detector Free of Dust and Grease

HERE are some practical hints for radio fans who use a crystal detector; they come from a New Jersey fan who is a veteran crystal user:

The greatest enemy to the sensitivity of a crystal detector is dust. The next greatest enemy is grease—especially grease from the hands of the operator. Grease and dust collect on the surface of the crystal and form a thin film which seriously affects the detector.

Trouble due to dust can be taken care of easily by enclosing the sensitive crystal in a glass case. This is generally done by the manufacturers of high-grade detectors, but

the cheaper detectors do not ordinarily have this feature.

In the old days when the crystal was used by almost every amateur, the enclosed detector was not known. It was up to the user, therefore, to protect his own crystal. He did it in this way: he went to the cellar or the attic and obtained a glass jar of some sort. This he took to the "wireless room" and inverted it slowly and carefully over the sensitively adjusted detector where it served as a dust cap.

This may still be done by the amateur whose set is equipped with an exposed detector. When he gets the cover in place, he will have a detector that keeps sensitive and stays in adjustment almost indefinitely.

Trouble due to the grease from the hands may be eliminated if the operator is careful not to touch the crystal. He should use a pair of surgeon's forceps or a pair of pliers for removing or replacing his crystals.

If a crystal detector has been covered with dust or grease and thus rendered insensitive, it need not be thrown away. Its original qualities may be restored merely by brushing it well with an old tooth brush that has been soaked in alcohol. Then allow the crystal to dry in some place that is free from dust.

Crystals for a detector should never be bought one small piece at a time; they should be bought by the pound or half-pound. In the long run it is cheaper to buy them this way. There are more sensitive pieces in a half-pound than in four or five "selected" boxes.

A quantity of crystal should be obtained and be broken up into pieces that will fit into the detector cup. These pieces should be placed on a piece of tin-foil which is connected to one side of the detector. The other side of the detector should be connected to

a flexible wire which has a stiff piece of bare wire soldered to it.

The sensitive crystals are found in this way: a station is tuned in on the crystal already in use and then the catwhisker is removed from the detector. After that each crystal on the tinfoil is gone over with the stiff bare wire. Pieces that do not test well are broken up and tested again. This operation is continued until all the sensitive pieces have been found.

LEROY WESTERN

* * *

How to Protect Your Tube Filament

THE radio fan who has cost himself both trouble and money by accidentally burning out the filament of his vacuum tube will appreciate this practical advice as to how to protect it:

Although the normal life of the average radiotron filament is more than 1,000 hours, it will be burned out in an instant if the high voltage leads from the "B" battery are connected across it. The burn-out requires but a fraction of a second; consequently it frequently remains unnoticed until the set is used again. This causes great inconvenience—particularly if a new tube cannot be obtained immediately.

Fortunately, however, it is an easy matter to protect the filament. Merely insert a 25-watt, 110-volt tungsten lamp in the circuit. The resistance of this automatically increases with the current and it becomes an effective ballast lamp that will prevent all injury.

J. L. BERNARD



ENTERTAINMENT FROM A TWO-INCH BOX

Although the set constructed by Harrington is less than two inches long, it brings in radio music from local stations strong enough to furnish entertainment to three fremen at once.

HINTS FOR

AMATEURS



ONE of the most annoying features of radio reception is the trouble due to body capacity. If you have to hold your hand near the dials in order to keep a distant station tuned in, you lose most of the pleasure of receiving. And this trouble is not necessary in any set. It can be eliminated in the following way: Connect the rotary plates of the variable condenser to the ground; if the variable condenser is in the secondary circuit, connect the rotary plates to the filament side of the circuit. If the trouble is experienced with the plate variometer, connect the stator windings to the plate and the rotor windings to the "B" battery.

* * *

A SMALL bit of sealing wax dropped on the edge of the winding of a coil will be sufficient to hold the wires from slipping. *Never use shellac on the windings.*

* * *

SOME beginners have their sets grounded on the water pipes, some on the steam radiator system, some on the fire escapes and some on the gas fixtures. It often improves reception to use all of these together, running a wire which connects them all to the ground terminal of the set.

The gas pipe should *not* be used, however, owing to the danger of fire.

MANY users of radio sets are not getting all they could out of them because they are not using the correct plate voltage on the detector tube. Try tuning in a weak and distant station and then changing the tap on the "B" battery until the best results are obtained.

* * *

START out in radio by making a small crystal set or a simple single-tube receiver. By doing this you will learn what goes into a set and you will understand more clearly what you are doing when you begin to tune in with more complicated instruments.

* * *

WHEN putting up your antenna do not forget to solder every joint; if you neglect to do so the joint will corrode and will offer great resistance to the feeble currents that are trying to flow in the antenna. Do not let your haste get the upper hand and cause you trouble in the end. The correct way to make a joint is shown in the accompanying diagram, Figure 1.

* * *

ERECT your antenna as high as possible and give your radio set a good start.

* * *

A RADIO set is no better than its weakest part.



HOW TO MAKE A JOINT IN YOUR ANTENNA

FIGURE 1: A poor antenna joint is a sure cause of loss of efficiency. Insure good results by making a neat workmanlike joint.

THE radio experimenter who builds the whole or even part of his set should provide himself with a set of tools to work with that will enable him to make a good job of the construction. The following is a list of the tools which he will find afe almost indispensable:

- 1 pair of 6-inch electrician's wire-cutting pliers;
- 1 pair of 4-inch electrician's wire-cutting pliers;
- 1 small breast drill capable of holding a 1/2-inch drill;
- 1 complete set of small drills up to 3/4 inch;
- 1 brace and bit;
- 1 set of -small files including round and triangular files;
- 1 countersink drill;
- 1 6-inch screwdriver with 1/4-inch spade;
- 1 6-inch screwdriver with 1/8-inch spade;
- 1 8-inch screwdriver with 1/4-inch spade;
- 1 electric soldering iron (1/2 pound);
- 1 can of soldering paste;
- 1/2 lb. of strip solder;
- 1 small center-punch;
- 1 pair of dividers;
- 1 15-inch brass-edge rule;
- 1 6-inch square;
- 2 small steel clamps;
- 1 small hand grindstone;
- 1 hacksaw and medium-sized blades.

If he provides himself with these tools he will never have to dig a hole

in his panel with a penknife, or whittle away at a piece of tubing with rising temperature and temper.

* * *

To enable your set to receive longer waves (and this will probably be necessary with the new assignment of wavelengths), insert a loading coil in series with the circuits that you are using or shunt them with a variable condenser.

* * *

OFTEN the contacts underneath your vacuum tubes become corroded and the circuit is not properly completed. It is a good plan to sandpaper the ends of the contacts occasionally, thus keeping them bright and shiny.

* * *

IF you use the small 1 1/2-volt tubes it is extremely important to mount the sockets on a piece of sponge rubber when more than one stage of amplification is used. If you neglect to do this you will be troubled by microphonic noises when you are tuning.

* * *

It is always a question with a beginner as to what kind of insulators to use with his receiving antenna. Suitable insulation may be obtained by using the ordinary glazed porcelain cleats shown in Figure 2. These may be purchased at any electrical store. Their cost is slight, but they are just as effective as any of the more expensive kinds. They should not be used for transmitting, however, unless two or three of them are connected in series.



A PRACTICAL INSULATOR THAT COSTS BUT A FEW CENTS

FIGURE 2: These porcelain cleats may be obtained at any electrical store. If you have a transmitter you should use two or three connected in series.

"STATIONS I HAVE HEARD"



If you are getting good results with your receiving set, tell your fellow-readers of **POPULAR RADIO** how you get them. Give the call letters of the stations you hear, the locations of them, the type of apparatus that you are using and **How YOU ARE USING IT.**

A REMARKABLE RECORD FOR A CRYSTAL SET

A HOME-MADE crystal set which receives from a station 800 miles away is reported by Henry Willier of Washington, D. C. He made the set himself, he states, and is but 12 years old. WWJ of Detroit, Mich., is the record station. Others are WJZ, Newark, N. J.; WEAJ, New York City; KDKA, Pittsburgh, Pa.; WHAS, Louisville, Ky.; 8HT, an amateur in Buffalo, N. Y., and WGY, Schenectady, N. Y.

The aerial used is made of one wire 110 feet long and 35 feet high. The instruments are, a variocoupler, a tuning coil, and primary and secondary condensers. The set cost less than \$20.

* * *

THREE SPIDER-WEB COILS BRING IN "DX"

A TOTAL of fifty-nine stations brought in by three spider-web coils and one tube is the record of Dewey Lee of Elwood, Ind., and he attributes his success to the use of a variometer in connection with the coils. The variometer is placed between the plate and the antenna and is used as a help to the tickler coil in controlling regeneration.

The most distant stations he receives are KHJ and KFI of Los Angeles, Cal.; CJCG, Winnipeg, Canada; CFCF, Montreal, Canada; PWX, Havana, Cuba, and KOY, Portland, Ore. His coils are made of 35 turns for the primary, 50 for the secondary and 50 for the tickler. Although he has had good results with similar coils of the honeycomb type, he likes the spider-web type better.

* * *

HE PICKS UP HALF THE COUNTRY ON ONE TUBE

EVERY large station in the eastern and middle western states comes in on one tube in the set of Robert E. Steele, of Brodhead, Wis.

WBAP at Fort Worth, Tex., 850 miles away, is received regularly and KHJ of Los Angeles, Cal., is frequently picked up.

The set is home-made. It consists of a variocoupler in a regenerative hook-up and a 43-plate condenser in the antenna circuit. The antenna is one wire 150 feet long and about 25 feet high, strung between trees.

* * *

FROM CANADA TO TEXAS ON A CRYSTAL

L. J. HOGG of Norwood, Canada, claims the record of receiving WBAP of Fort Worth, Tex., a distance of 1,225 miles, on his set, consisting of a crystal detector, variocoupler and 43-plate condenser.

"I do not think I get re-radiation from a tube set," he says, "because there is none within a mile of me and I never hear a whistling noise with the music."

He uses one wire 110 feet long and 35 feet high for an antenna, with a lead-in of 40 feet. On any cold night he can pick up WLAG, Minneapolis, Minn.; KSD, St. Louis, Mo.; WCX, Detroit, Mich., besides a number of others.

* * *

A FAN WHO "TUNES HIS EARS"

LEO R. FARBE, of New Orleans, La., hears CFCF, Montreal, Canada, using an aerial, counterpoise, and his radio frequency set of five tubes. His aerial has four strands, two feet apart, is 40 feet high and 100 feet long. The counterpoise has similar dimensions and is stretched eight feet from the ground.

The set tunes sharply and sometimes picks up as many as twenty-six broadcasting stations in an evening, as well as many ships at sea. Farbe says he has learned much about delicate tuning in order to establish his record, but he has also learned almost as much about careful listening and says he could not get along without his "sponge rubber ear caps."

2,225 MILES ON A SOAP BOX

WITH a few little things in a soap box, E. O. Knoch in Los Angeles, Cal., hears PWX of Havana, Cuba, about 2,225 miles away. He uses only one tube in a single-circuit regenerative hook-up and he hears over thirty distant stations, ten of which are more than 1,000 miles away. His panel and cabinet are made from the wood of an ordinary soap box. He has discarded his ordinary rheostat and his success is due, he thinks, to the carbon-disk rheostat, with which he has replaced it; before he could hear no farther than KFDL, Denver, Colo.

Some of his other records are WFAA, Dallas, Tex.; KFC, Seattle, Wash.; KSD, St. Louis, Mo.; WAAC, New Orleans, La., and WOC, Davenport, Ia.

* * *

A TWELVE YEAR OPERATOR OF A SINGLE-SLIDE "EXPRESS"

"If anyone can beat this, let him write me," says Geo. L. Merkel of Milwaukee, Wis., throwing down the gauntlet to all comers; he gives point to his challenge by announcing that he hears forty-two stations with a single-slide tuning coil and a crystal, and that he is only twelve years old.

The coil which does this is made of No. 20 enameled wire, wound on a cardboard tube $3\frac{1}{2}$ inches in diameter. He uses a two-wire antenna 45 feet long and 35 feet high.

He hears WSB, Atlanta, Ga.; WÉAF, New York City; WHAS, Louisville, Ky.; KDKA, Pittsburgh, Pa.; WHB, Kansas City, Mo.; WGY, Schenectady, N. Y. and WHAZ, Troy, N. Y.

* * *

A SET MADE OF STANDARD PARTS

By purchasing standard parts and connecting them himself, George C. Morgan of Ozark, Ala., has built a three-tube set with a variocoupler and two variometers which brings in 95 stations and covers the distance between

Los Angeles, Cal., and Medford Hillside, Mass. He is fifteen years old and says he did it all himself. His antenna is a single wire 100 feet long and 40 feet high.

WBAP, Fort Worth, Tex., and WHB, Kansas City, Mo., come in loud enough to be heard out in the street when he uses his loud-speaker. Others he hears are KHJ, Los Angeles, Cal.; WLAG, Minneapolis, Minn.; WBZ, Springfield, Mass.; WMB, Auburn, Me. and PWX, Havana, Cuba.

* * *

AN EXCELLENT RECORD FOR A SMALL SET

HAROLD J. O'CONNOR of New Rochelle, N. Y., receives 21 stations which are over 1,000 miles away, by using three spider-web coils and one stage of audio frequency amplification. He says his set is remarkably easy to tune and that almost all tuning is done with his secondary condenser. He uses a single wire 130 feet long and 25 feet high for an antenna.

KHJ, Los Angeles, Cal., comes in on the detector alone. Others he has heard are KYW, Chicago, Ill.; WKAQ, Porto Rico; WWJ, Detroit, Mich.; WSB, Atlanta, Ga., and WHAS, Louisville, Ky.

* * *

TO MEXICO CITY ON A DRY-CELL TUBE

BROADCASTING from Mexico City in Mexico was picked up by Cecil Sanner in Toledo, O., before he had been listening in a week, according to his letter which states that he uses only one dry-cell tube. He uses a tapped coil placed in inductive relation between his plate and grid variometers. The tuning is accomplished with the three inductances and a 23-plate condenser in the grid circuit.

Other stations he hears are PWX, Havana, Cuba; WMB, Auburn, Me.; WBAP, Fort Worth, Tex.; WGM, Atlanta, Ga.; WGY, Schenectady, N. Y., and WLAG Minneapolis, Minn.

His circuit is given in Figure 1.

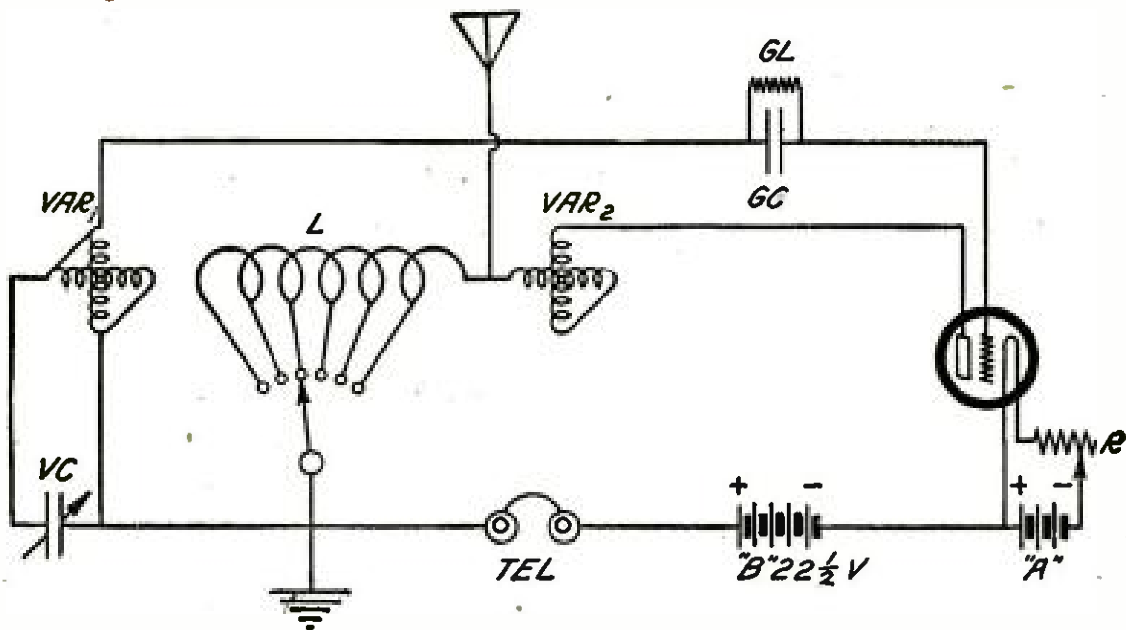

FIGURE 1

A single-tube circuit that employs a tapped coil placed in inductive relation between the plate and grid variometers. The rotor and stator windings of the grid variometer are connected in parallel.

WORKRITE RADIO PARTS WORK RITE

Hundreds of thousands of radio fans swear to the truth of this statement. Why? Because they use WorkRite radio parts and they know that the name "WorkRite" is a guarantee of perfection. No WorkRite Instrument is offered for sale until it has been thoroughly tested not only by our engineering department but also by outside laboratories and found to be perfect. Protect yourself from inferior parts by buying "WorkRite" radio parts all the time.



LIST OF WORKRITE PRODUCTS

WorkRite Super Variometer

Made from fine mahogany. Very sensitive and sharp to tune.....Price, \$3.50

WorkRite 180° Super Variocoupler

Made from moulded Bakelite. Has 12 taps. Wound with green silk. Range 150 to 705 meters.....Price, \$3.50

WorkRite Vernier Rheostat

50,000 possible adjustments. A turn of $\frac{1}{32}$ " will clear up a station. Made in three resistances. 6 ohm size,.....\$1.00

WorkRite Concert Head Set

Very sensitive. Try one and see. Price \$6.00

WorkRite E-Z-Tune Dial

Snappiest Dial on the market. Has a knurled flange on the rim for delicate leverage. Price 75c.

WorkRite Resistance Cartridge

Makes your 6 ohm Rheostat work with 15 and 30 ohm resistance Tubes. 15 or 25 ohms..40c.

WorkRite Nonmicrophonic Socket

For use with UV 199 Tubes. Has a sponge rubber base. Very efficient.....Price, 60c.

WorkRite Type "A" Hydrometer

You need one for your Storage "A" Battery. Full instructions with each instrument. Price 75c.

WorkRite Transformer. An aircore transformer for use in neutrodyne method of receiving. Moulded Bakelite tubes wound with green silk wire of proper size and carefully spaced, insure maximum efficiency. Price.....\$2.00

THE WORKRITE MANUFACTURING CO.

5525 EUCLID AVENUE

CLEVELAND, OHIO

(Branch Office, 536 Lake Shore Dr., Chicago)

Teleradio

(TRADE-MARK)



Supersensitive Headsets

Accurately reproduce the faintest signals on either crystal or tube sets and bring in voice or music with wonderful tonal quality. Equally satisfactory for local or distance work.

2000 Ohms	2200 Ohms	3000 Ohms
\$6.50	\$7.50	\$9.00

Another High Grade Instrument Has Been Added to the Popular "TELERADIO" Line of Wireless Equipment

Guaranteed Electrically and Mechanically Perfect

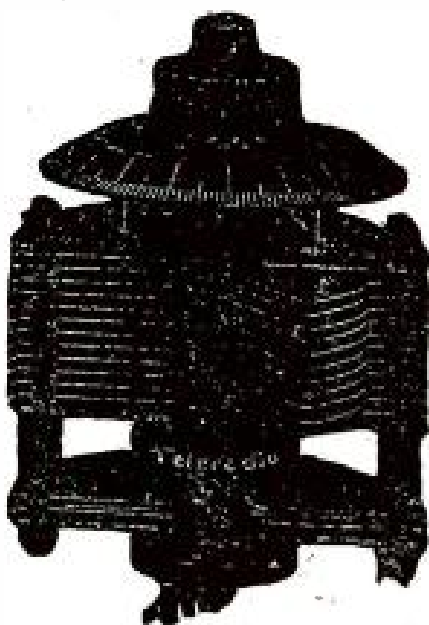

New Improved Vernier Variable Condenser

Makes Fine Tuning a Pleasure
All Metal Parts Nickel Plated

23 Plate \$4.50	43 Plate \$5.50
-----------------	-----------------

Lightning Arrestor, \$1.00
(Approved Type)

Rheostat (30 Ohms) \$1.00

Jobbers and Dealers Write for Our Attractive Proposition

Teleradio Engineering Corp.
484-490 Broome Street, N. Y. C.

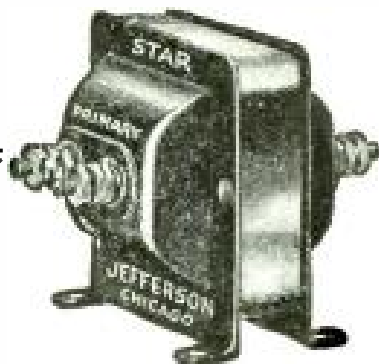

JEFFERSON

Amplifying Transformers

have gained an enviable reputation for audibility and amplifying power. In tens of thousands of receiving sets they are insuring 100% amplification—increased range, super-sensitivity, and the elimination of howling and distortion.

This positive preference rests on the unmistakable superiorities of design and operation which make Jefferson Amplifiers the choice of discriminating radioists.

FIVE JEFFERSON TYPES

The five Jefferson types meet the demand for an audio-frequency transformer for every requirement. In this assortment you are sure to find the transformer which will make your set super-sensitive, and enable you to tune in distant stations with ease, and freedom from distortion.

Radio Bulletin Sent Free

Jefferson Electric Mfg. Co.
427 S. Green Street Chicago

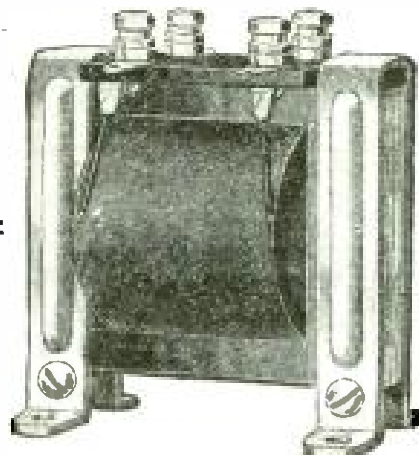

Please mention POPULAR RADIO when answering advertisements.



Speaking of Portable Sets—



AN ideal vacation set may be built with these units.

No special packing case is required, owing to the absence of protruding knobs and smooth surface of panel.

The concave dials, aside from adding attractiveness to a receiving set, increase its utility.

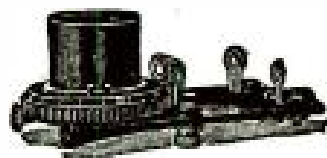
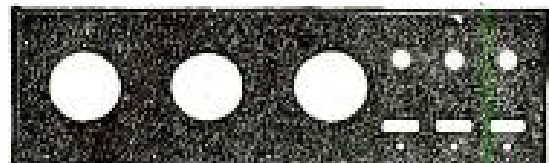
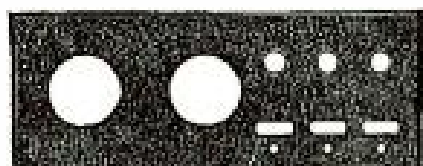
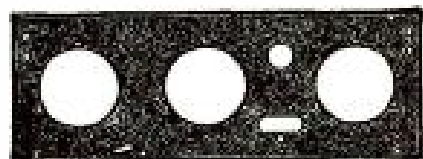
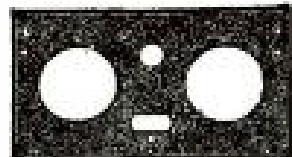

Descriptive literature on request.

EISEMANN MAGNETO CORPORATION

William N. Shaw, President
BROOKLYN, N. Y.

DETROIT

CHICAGO

SAN FRANCISCO

Please mention POPULAR RADIO when answering advertisements.

SPAGHETTI VARIOCOUPLER

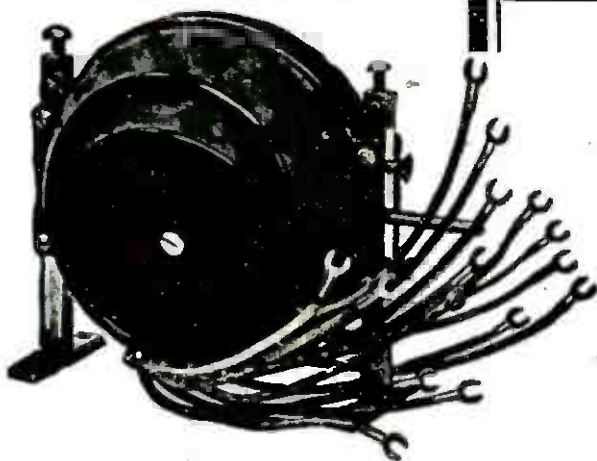

PIGTAIL CONTACT VARIOMETER



You'll Never Regret Buying

PEARLCO  PRODUCTS

For long distance stations, clear, full-toned tuning and sheer radio enjoyment you should select your set from Pearlco Products—offering a wide range of scientific equipment.

These molded-in-Bakelite devices couple rugged construction with excellent range and capacity. Each instrument is backed by a factory guarantee.

Pearlco Products are sold in the most modern and reliable radio shops everywhere.

If your dealer can't supply you, write to us.

PEARL RADIO CORPORATION

1033-35 Race Street

Philadelphia, Pa.

THE BEST HEADSET

HIGHEST AUDIBILITY
PERFECT MATCHING
GREATEST VOLUME



At Your
DEALERS
\$5.00

Why Strain Your Ears?

T. B. H. Headsets reproduce clearly and naturally. No "Fuzz" or "Tinny" tone. Extremely sensitive.

Aluminum cases—6 Foot cord—Weight 12 oz.
Type 6-A 17500 Turns (2200 ohms) Hard Rubber caps \$7.00
Junior 16000 Turns (2000 ohms) Composition caps \$5.00

*If your dealer does not carry them he will order them for you
Dealers and Jobbers write for discounts*

THE T. B. H. CORPORATION

DANVILLE, NEW YORK, U. S. A.

DISTRIBUTORS

The Eastern Specialty Co., Philadelphia, Pa.

Donaldson Radio & Service Station, Kansas City, Mo.

(Metropolitan District and South Atlantic States)

(Southwestern States)

Marie A. Alvarez, Havana, Cuba (Cuba)

Please mention POPULAR RADIO when answering advertisements.

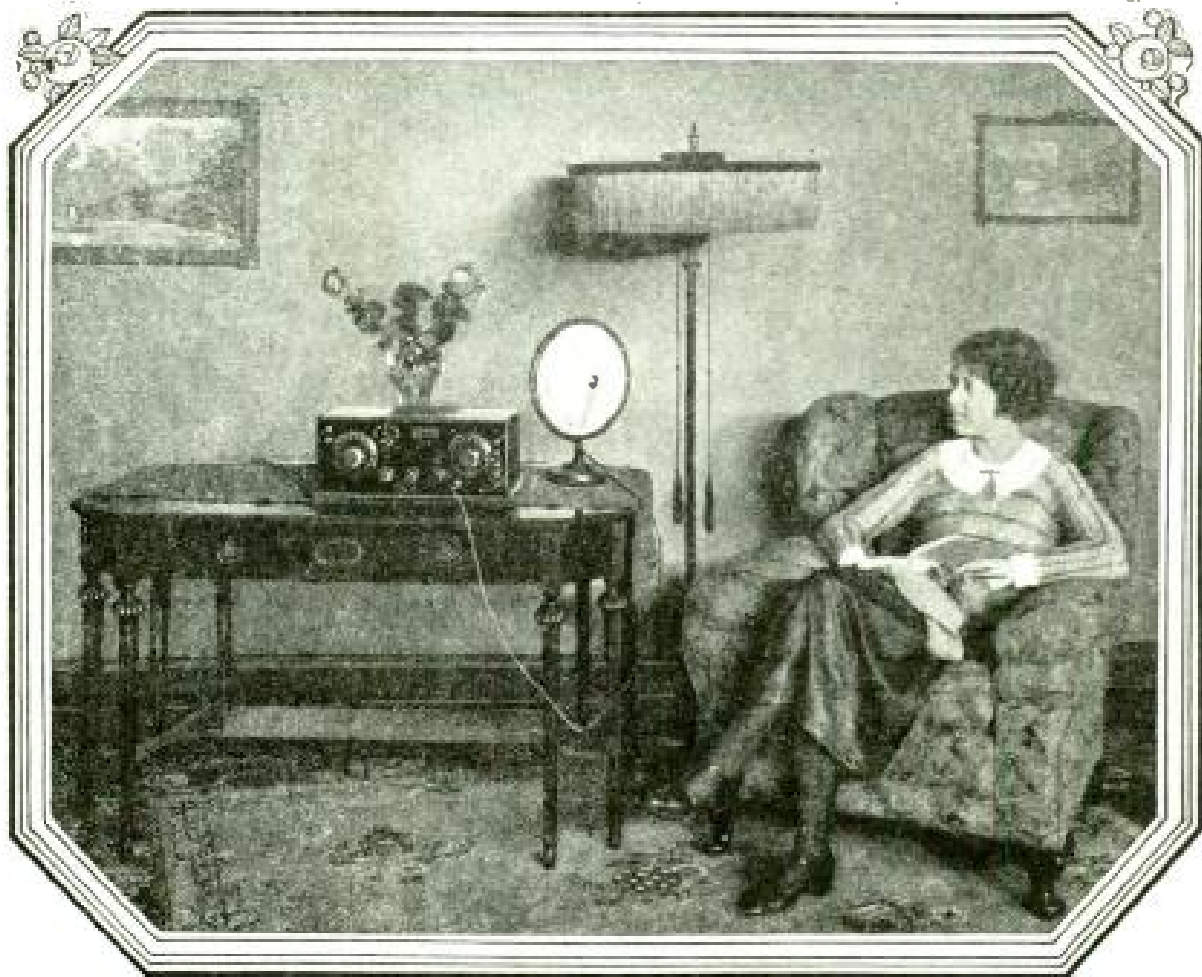

The SP2 Receiver Has "That Something"—

A Receiver that can be demonstrated with a world of satisfaction and sold with remarkable ease.

The SP2 is everything the radio-receiver purchaser anticipates in the ideal set of his fancy.

It brings in the local stations in all the fullness and clearness of the actual performance of the sender. Stations, broadcasting simultaneously, are tuned in and cut out at pleasure, readily and surely.

Noise and disturbance are practically eliminated. The SP2 is listened to with genuine delight. It gives a **QUALITY** performance; the entertainment as afforded by broadcasting stations **EVERYWHERE**—and at its best.

Long distance stations come in on the SP2 **clearly and distinctly** even to the "faintest" signals that mark the range of a highly efficient receiving set.

The SP2 Receiver has an unlimited range and is nationally known for its compactness of size, elegance of appearance, superiority of quality and scientific perfection.

Retails at \$100

CATALOG 101A—A complete catalog of radio equipment and valuable radio information, will be mailed on receipt of 10c in stamps

Dealers and Jobbers write for our attractive proposition

PITTSBURGH RADIO SUPPLY HOUSE

963 Liberty Avenue

Pittsburgh, Pa.

Distributors For

The SP2 Receiver—
Pathe Loud Speaker—
Amrad—
Cunningham—
Atwater Kent—
Sleeper—
Reflex Speaker—
Callophone—
Homcharger—
Autostat—
Radiall—
Frost—
Baldwin—
Pacent—
Jansen—
Dubilier—
E. M. P.—
A. B. C.—
Keystone—
Hafner—

and other reputable manufacturers.

GOOD RECEPTION EASY—

SUMMER OR
WINTER

—IF YOU OWN A LEFAX RADIO HANDBOOK

The man who owns a Lefax Radio Handbook gets good results from his set at all seasons of the year. Difficulties disappear readily. He can take instant advantage of every new development to improve his set and perfect reception—because Lefax Radio Handbook keeps pace with the new developments.

The ONE Best Book on Radio

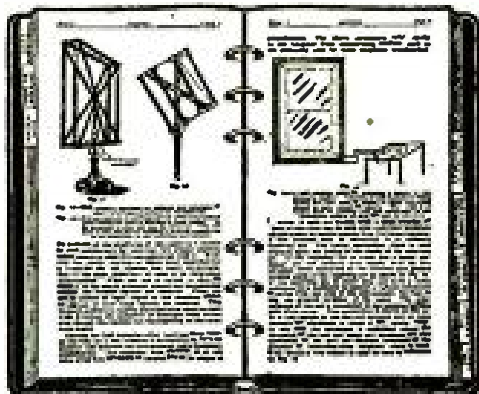

LEFAX NEVER GROWS OLD!

Lefax Radio Handbook is loose-leaf and every month additional pages are sent out covering the new developments. These pages fit the handbook and may be inserted in appropriate places in the handbook thus keeping it *perpetually up-to-date!* Written by the two chiefs of U. S. Bureau of Standards Radio Laboratory (Dr. J. H. Dellinger, and Mr. L. E. Whittemore). Get your copy now. Price, in U. S. A., \$3.50 including one year of the service which keeps it up-to-date.

For sale at all radio dealers and stationers.

LEFAX, INC.
139 S. 9th ST., PHILA., PA.

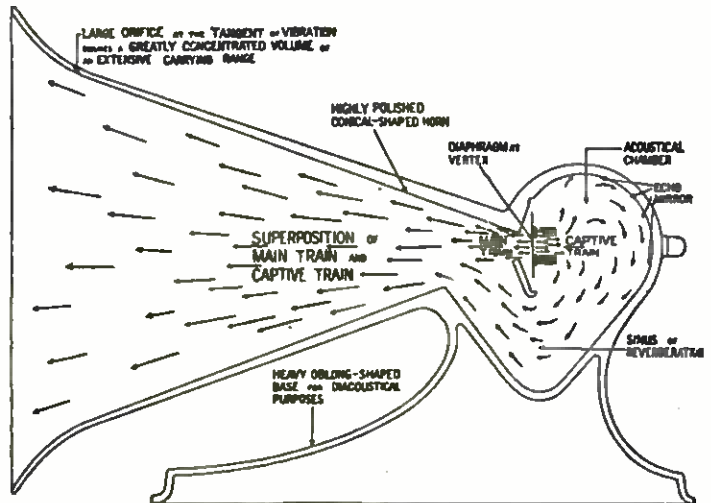

ECHO-JONG

GIVES FIBRE NEEDLE POINT TO THE RADIO HORN

A REAL PORTABLE LOUDSPEAKER

Unaffected by Climatic Conditions

NO PART TO BREAK OR JAR OFF

IDEAL FOR

Vacation, Outing or Travel

NO PULP to Crumble

NO WOOD to Warp

NO TIN to Bend

But

CASTED ALUMINUM for DURABILITY

Now Equipped With
A TONE REGULATOR

Retail Price \$35.00

WILLIAMS RADIO COMPANY

Radio Tone Specialists

1438 Washington Blvd., Detroit, Mich.

ELECTRIC SOLDERING IRON



EVERY RADIO FAN has been looking for this iron for both radio and home use. Operates on A. C. or D. C. current.

GUARANTEED one year. Sent anywhere in U.S. or Canada. Parcel Post prepaid on receipt of money order for \$2.28.

FANS Send 2c stamp for our list of RADIO BARGAINS

RADIO BARGAINS

17 N. LA SALLE ST. - CHICAGO

BARKELEW

FOUR-PHONE PLUG

for

STANDARD JACKS

The BARKELEW ELEC. MFG. CO.

MIDDLETOWN.

OHIO.



Please mention POPULAR RADIO when answering advertisements.

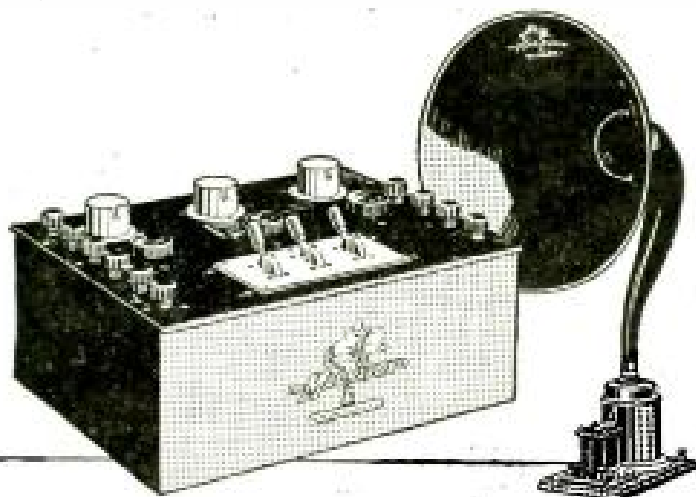

MAGNAVOX and FORMICA

THE radio engineers of the Magnavox Company have given their approval to Formica in the most sincere and convincing way—by using it exclusively in their apparatus for a long time.

Think over the list of great independent radio manufacturers whose standing and prestige in radio counts for something, and you will find almost every one among the regular users of Formica.

The only reason is that Formica is better looking, more uniform, more efficient than any other radio insulation of the kind. They have tested and tried them all and they *know*.

Your dealer will supply you promptly with a Formica panel in any of the standard sizes, or in any special sizes.

Dealers: Sell panels in the size your trade demands—not a few sizes that some one else wants you to carry. You will find Formica sales and advertising support and its wonderful nation-wide reputation a big help in building up your sales of panels and tubes.

THE FORMICA INSULATION COMPANY

4641 Spring Grove Ave., Cincinnati, Ohio

SALES OFFICES

50 Church Street . . . New York, N. Y.
422 First Avenue . . . Pittsburgh, Pa.
1042 Granite Bldg., Rochester, N. Y.
415 Ohio Building Toledo, Ohio

1210 Arch Street Philadelphia, Pa.
1819 Lyndale Ave., S. Minneapolis, Minn.
Sheldon Building . . . San Francisco, Cal.
Whitney Central Bldg New Orleans.

414 Finance Bldg. . . Cleveland, Ohio
9 S. Clinton Street . . . Chicago, Ill.
313 Title Building . . Baltimore, Md.
47 King Street . . . Toronto, Ontario

FORMICA

Made from Anhydrous Redmanol Resins
SHEETS TUBES RODS

AMPL-TONE PHONES



2200 Ohms—\$6.00

AT LAST, the public may have these EX-CELLENT Headsets at a popular price. Positively the equal of the expensive phones, for beauty, comfort, tone and durability. Money back guarantee protects you. "Wonderful value," "Equal to \$12.00 phones" and other testimonials on file.

Write for special prices for a limited period.

DEALERS: Get in on our special advertising and extreme discounts. One sample for \$3.25 cash.

C. M. FRENCH MFG. CO.
SEYMOUR, CONN

All-Ways
Better

MARCO

MARCO
RADIO
PRODUCTS

\$1.50



The Mar-Co Variable Grid Leak

Built to last a lifetime. A conservative range of from $\frac{1}{8}$ to 5 megohms. Unmatched in its field. Be sure to ask your dealer to show it to you.

Martin-Copeland Co.
Providence, R. I.

MARCO
RADIO
PRODUCTS

MARCO
RADIO
PRODUCTS

ATWATER KENT

RECEIVING SETS AND PARTS

are ideal for summer use due to their compact and rugged construction and the fact that they are moisture-proof.

Send for the illustrated folder

ATWATER KENT MFG. COMPANY
4933 Stenton Ave. Radio Dept. Philadelphia

Makers of
**THE WORLD'S HIGHEST GRADE IGNITION
STARTING AND LIGHTING**

RE-ORGANIZED HORNE MANUFACTURING COMPANY

Now Known as the
HORNE ELECTRIC & MANUFACTURING CO.

will continue the manufacture and sale of the well known Horne Radio Products consisting of 50 Radio Devices and will conduct an energetic summer sales campaign on the following new devices:

"PORTO-SET," \$43.00
(Trade-Mark)

Portable set in leather carrying case for vacationists, consisting of one stage radio and one stage audio on single tube, energized by flashlight battery.

"VARIO-LEAK," \$1.50
(Trade Mark)

A substantial Variable Grid Resistance Panel Mounted operated like a Rheostat.

"VERNIER CONDENSER," 90c

Two leaf type for either table or Panel Mounting. No moving contacts.

Write for latest catalog.

Write direct if your dealer can't supply you.

Horne Electric & Manufacturing Co.

Main Office and Works
Mercer and Colgate Sts. Jersey City, N. J.

New England Factory and Warehouse
54 Old Colony Ave., Boston



THE man who purchases a Magnavox for its *clearness* of reproduction, finds additional advantages in its use which contribute greatly to his enjoyment of Radio.

For instance, due to its extreme sensitivity, the Magnavox can reproduce distant signals which to ordinary reproducers would be indistinguishable. Ask your dealer for a demonstration.

Magnavox R2 Reproducer and 2 stage Power Amplifier (as illustrated) \$115.00

R2 Magnavox Reproducer with 18-inch horn: the utmost in amplifying power; requires only .6 of an ampere for the field \$60.00

R3 Magnavox Reproducer with 14-inch curvex horn: ideal for homes, offices, etc. \$35.00

Model C Magnavox Power Amplifier insures getting the largest possible power input for your Magnavox Reproducer
2 stage \$55.00
3 stage 75.00

Magnavox Products can be had from good dealers everywhere. Write for new booklet.

THE MAGNAVOX COMPANY
Oakland, California
New York Office: 370 Seventh Avenue

MAGNAVOX PRODUCTS

No Radio Receiving Set is complete without them

Confidence

These leading manufacturers of quality radio sets:

- Cutting & Washington
- Jones Radio
- Cleartone
- Zenith—(Chicago Radio Laboratory)
- Midwest Radio Co.
- Audiola Radio Co.
- Illinois Radio Eng. Co.

and others use

"ALL-AMERICAN"

Amplifying Transformers
Radio and Audio Frequency

as standard equipment in their sets. This is reason enough why any man building his own set should use "All-American" Transformers. The sales of these manufacturers depend on the efficiency of their apparatus. The Confidence they place in "All-American" Transformers to function properly under all conditions is proof of the quality of these instruments. Buy them—use them—and you, too, will endorse them. Every live radio dealer carries them. To help you get the best results from your radio set we offer FREE a book of twenty-five tested book-ups. Send 2c stamp for postage.



RADIO FREQUENCY TRANSFORMER



AUDIO FREQUENCY TRANSFORMER

RAULAND MFG. CO.
200 No. Jefferson St., Chicago, Ill.

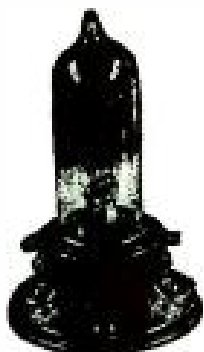

Na-ald Special Socket No. 499



De Luxe Contact



Na-ald De Luxe No. 400

It's the contact that counts

A careful examination will show that each contact in Na-ald sockets and adapters is of a wiping nature on a broad surface, and of sufficient tension, and so designed that tension is permanent, no matter how often the bulbs may be removed and how much the connecting prongs in the tubes vary.

Also it is little realized that sockets are being sold which, owing to faulty choice or control of material, develop current leakages from plate to grid that rob many otherwise well-made sets of their efficiency. Na-ald sockets in their design avoid all these troubles.

NA-ALD SOCKETS

- No. 499 Socket 199 tubes... \$0.50
- No. 429 Adapter 199 tubes... .75
- No. 400 De Luxe 200 tubes... .75
- No. 401 Small Spaca. 200 tubes... .35
- No. 411 W. D. 11 Tube... .75
- No. 450 Two in One W. D. 11 or 200 Tube... .50

Booklet with diagram of Hazeltine's Neutrodyne Circuit and other selected circuits, packed with each Na-ald product.

Alden Manufacturing Co.

Manufacturers of Sockets for Every Tube and Requirement
Dept. C 52 Willow St.

Springfield, Mass.

CABLE ADDRESS: ALDENCO

NA-ALD

Freshman FIX-O

A Fixed Resistance Leak Combination—4 in ONE

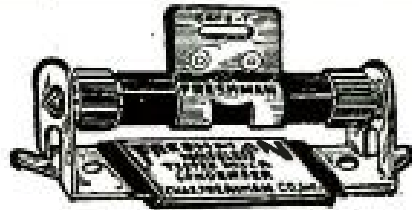

Freshman Condenser Leak Mounting

Freshman Fixed Leak SAFE-T HANDLE

Price Complete

65c

Furnished in any value of resistance from 1/2 to 10 Megohms

Separate Condenser and Mountings. 40¢

Separate Leaks with Safe-T Handle 30¢

At your dealers. Otherwise send purchase price and you will be supplied without further charge.

Chas. Freshman Co. Inc.
Radio Condenser Products

106 SEVENTH AVE.,

NEW YORK

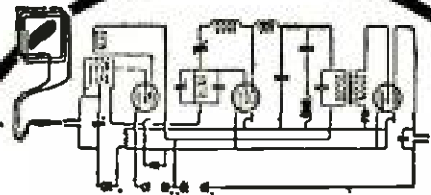

Supreme for Simple Sets or Super Stations

bakelite-dilecto!!

(A Laminated Phenolic Condensation Material)

The foremost radio engineers and the wiser amateurs rely on Bakelite-Dilecto (xx grade).

Its many amazing qualities make it the perfect material for radio panels, bases, frames and various insulation requirements.

Used in the U. S. Navy and Signal Corps nine years—and SATISFYING.

Any electrical man can get B D X X for you, shaped and drilled. Demand it for best results.

THE CONTINENTAL FIBRE CO.

Factory: Newark, Delaware

Dealer Service from:

- New York, 233 Broadway
- Pittsburgh, 301 Fifth Ave.
- Chicago, 332 S. Michigan Ave.
- San Francisco, 75 Fremont St.
- Los Angeles, 411 S. Main St.
- Seattle, 95 Connecticut St.

Be a Radio Operator

Earn Big Money

See the World

Without Expense



Learn at home to fill a REAL position in the world's fastest growing industry! Hundreds of big pay jobs waiting for trained men.

How often you've dreamed of travel—of being able to talk from experience of the gayness of Paris, the splendor of a Mediterranean sunset, the quaintness of a Chilean village, the poverty of Oriental settlements, the antiquity of Egyptian landmarks—these and a thousand other interesting scenes you've read about or seen in movies.

Now you can see the world—not as a hurried tourist who sees little and feels nothing, but with comfort and quietness, and earning splendid money all the while. You can be equally at home on a London tram or in a Venetian gondola; you can be as familiar with the native characteristics of the Chinese coolie as the Spanish peasant; you can in truth be a real citizen of the world, enjoying experiences rarely granted to men.

A Splendid Education The Life of an Officer

You will find that travel affords a splendid education. In your travels about the world you will learn much. You will meet the world's greatest variety of peoples. On board ship you will come into contact with the wealthy traveling public and the prosperous, active business class. In port you will be free to roam around and to explore all the interesting points both in the seaport towns and the surrounding country.

You travel in real style. On board ship you enjoy all the privileges of an officer. Your work is most fascinating. Messages to all corners of the world pass through your fingers. You occupy a position of great responsibility, a position which gives you a fine chance to make valuable connections in case you ever want to give up the sea and settle down.

Radio operators are in big demand on land as well

as sea. In case you want to give up the sea, you have a wonderful opportunity of stepping into a splendid land position—operator at a land station, at a broadcasting station or any one of hundreds of the more important big paying positions in radio. The splendid training you receive in qualifying as an operator will bring big money to you no matter where you decide to settle.

Send for New Booklet

Learn more about this world's fastest growing industry. Send for new illustrated booklet "Your Opportunity in Radio" which describes in detail the glorious opportunities in this field. Radio calls you from land and sea, and offers you more money than you could possibly earn in other fields.

Write now for this interesting booklet which tells you how you can become an operator or qualify for any other of the better positions in radio. It will be sent to you without cost. Mail coupon for it NOW. National Radio Institute, Dept. 32-H, Washington, D. C.

NATIONAL RADIO INSTITUTE

Radio Headquarters
Dept. 32-H, Washington, D. C.

Please send me your free catalog "Your Opportunity in Radio" describing your Home Study Course which will qualify me to become a Government Licensed Operator for land or sea positions.

Name.....

Address.....

City.....State.....

Please mention POPULAR RADIO when answering advertisements.

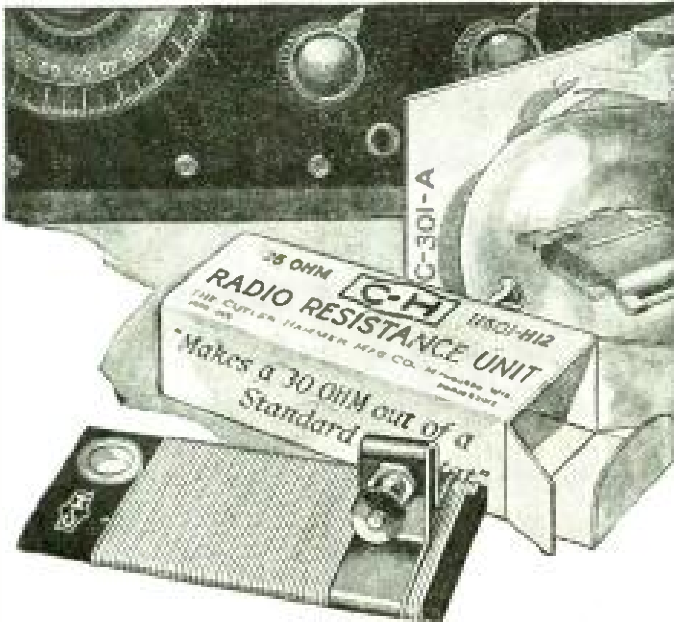

The C-H Radio Resistance Unit attaches instantly to your present rheostats for control of the "A" type tubes. Saves the cost of new rheostats, as well as the trouble of redrilling your panel. Buy one with each new tube and enjoy better reception tonight. Price 25c at dealers everywhere.

THE CUTLER-HAMMER MFG. CO.
Milwaukee, Wisconsin



More than one-half million C-H Radio Rheostats now in use.

CUTLER-HAMMER

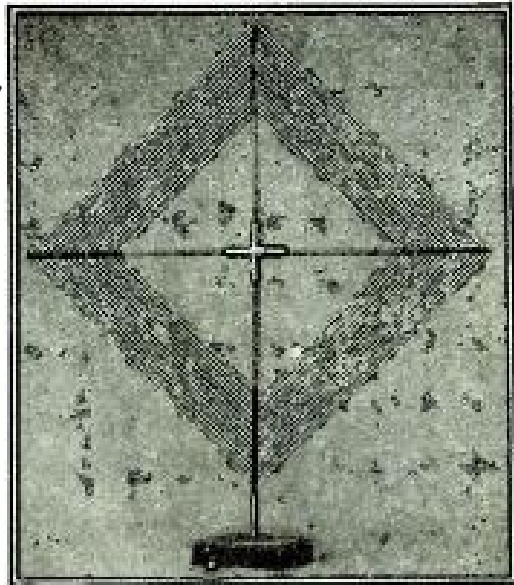

LOOP AERIAL \$10.00

Light—Substantial—Efficient—Directional
4 inch molded dial-detachable base.

Hartman loops stay taut and true.

33 1/2 in. wide—30 1/2 in. high—15 turns—4 in. dial.

Write for bulletins on Hartman Radio parts.

THE HARTMAN ELECTRICAL MFG. CO.
Mansfield, Ohio

Cotoco

TRADE MARK REG. U. S. PAT. OFF.

"Built First to Last"

The Audio Frequency Transformer that Combines ALL the Essentials for Complete Satisfaction.

Cotoco Transformers afford all the ideal features listed below and besides are of unusually handsome appearance.



1. High Amplification.
2. Minimum Distortion.
3. Low Interstage Linkage.
4. Convenient Mounting.
5. Compactness.

Sold by Reliable Dealers Everywhere.

COTO-COIL CO.

Providence, R. I.

Pacific Coast Branch, 329 Union League Bldg., Los Angeles

INSTRUMENT MAKERS

DEPENDABLE **TESCO** PRODUCTS

SINCE 1909

PRECISION HIGH EFFICIENCY
CRYSTAL SETS

Guaranteed to receive local broadcasts with volume and clarity equal to any sets manufactured

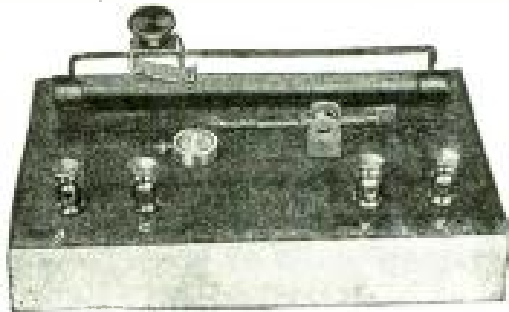

FREE FAMOUS TESCO RADIO Crystal Set (Shown in Cut)

To introduce the wonderful T-B-H radio headset we will give absolutely free of charge, the most efficient crystal receiver on the market.

Send \$5.00 for the headset and get this instrument free. Money refunded if not absolutely satisfied.

THE EASTERN SPECIALTY CO.
3552 N. Fifth Street, PHILADELPHIA, PA.

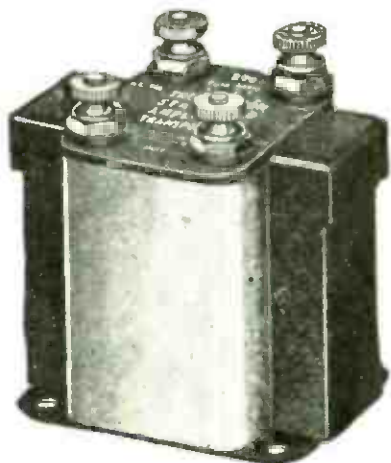

THORDARSON

Volume Selectivity Tonal Purity

Amplifying Transformers

Price, mounted only

6 to 1 ratio transformer \$4.50
(with Red Label)

3½ to 1 ratio transformer \$4.00
(with Blue Label)

The latest Thordarson developments in audio frequency transformers and variable condensers provide the experimenter and amateur with a positive means to increase the range, selectivity, and volume of broadcast reception. Distortion and internal interference are entirely eliminated through exclusive Thordarson scientific principles, constant supervision and tests at every stage of manufacture and assembly. Local stations and stations broadcasting simultaneously are tuned in or out at will.

Thordarson Built the First 1,000,000 Volt, 25 Cycle Transformer

He has also constructed mammoth transformers for central stations and leading Universities of the United States. No one man is more responsible for the present day efficiency of commercial A. C. transformers than he and that same genius, and 28 years of practical experience has developed audio frequency amplifiers and variable condensers to a degree of efficiency never before attained by any manufacturer. A folder describing their specifications will be sent on request.

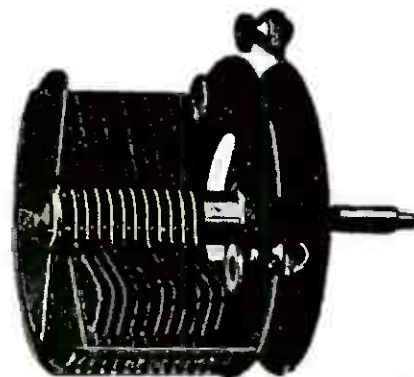

Variable Condensers

13 plate .00025 M. F. . \$2.00
with vernier, knob and dial 3.50
23 plate .0005 M. F. . 2.50
with vernier, knob and dial 4.00
43 plate .001 M. F. . 3.00
with vernier, knob and dial 4.50

Sold by all forward-looking radio dealers

THORDARSON

ELECTRIC MFG. CO.

Huron and Kingsbury Streets

Chicago

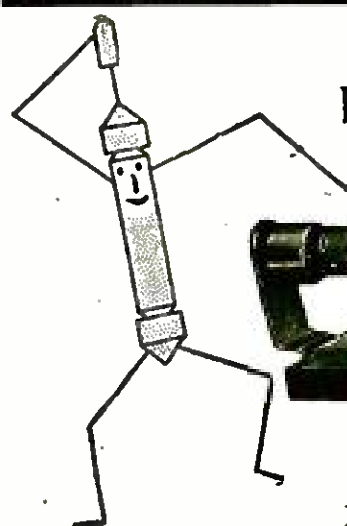

Two ways to better summer reception



DURHAM + DUBILIER

Finger-tip adjustment of grid resistance, accurate value and sturdy design of condenser—these will hold your tubes to quietest operation thru summer static noises.

Resistances:

No. 101 —to 5 megs.
No. 201A—to 10 megs.

Condensers:

.00025 mfd.
.00050 mfd.

Your dealer has them for \$1.10

Durham & Co., 1936 Market St., Philadelphia

DURHAM Variables High Resistance

Dealers:—Here's a number that will boost your whole line. For it keeps sets working through the summer months.

Wave Trap

TRADE MARK
PATENT APPLIED FOR

The Missing Link in RADIO

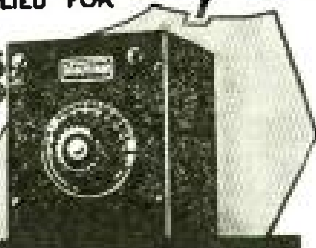

Stops Interference!

JOHN A. BURRICHTER, 207 E. Ohio Street, Indianapolis, Ind., says: My set is about ten blocks from one of the local stations and when they started broadcasting, it meant that ended everything for the evening. After your Wave Trap was installed, they were tuned out completely. Had expected with the approach of warm weather to take down my set until next fall but while other local "Listeners In" are almost entirely cut off by STATIC, I am enjoying the programs just as much as in the cold months. Have covered distances that heretofore have been impossible and really consider the Wave Trap the greatest invention since radio. Use the "FERBEND WAVE TRAP" for real results.
THE ORIGINAL WAVE FILTER



Ferbend Electric Co.
21 E. SOUTH WATER ST.
CHICAGO
Circular on request

50¢

THE PACENT 40



A perfect plug for every radio requirement at a price which enables you to have one on every phone cord. Just one of the many PACENT Radio Essentials affording you more efficiency, convenience and enjoyment from your radio equipment.

Don't Improvise—"PACENTIZE"

Write for Descriptive Bulletins (P-8)

PACENT ELECTRIC CO., INC.
22 Park Place New York, N. Y.

Pacent

RADIO ESSENTIALS

a Chi-Rad Special!



for W.D. 11 tubes -

Standard, threaded rubber, Willard's, specially adapted for use with W. D. 11 tubes. Supply current at 2 volts to one W.D. 11 tube for 210 hours on a single charge. Rechargeable. Brand new, size 4x5 1/2x7 inches—Chi-Rad guaranteed.

2-Volt Willard Charged . . \$7.50
2-Volt Willard Dry 6.50

These same Willards can be adapted to deliver 8 volts for pure D. C. for C. W. Transmitters. Better than a generator because no filter is necessary. Much less expensive.

In lots of 40 (320 volts) \$160.00

(Better prices on larger quantities.)
Specify dry or charged when ordering.

Chicago Radio Apparatus Co.
415 S. Dearborn St., Chicago, Ill.

HERE!

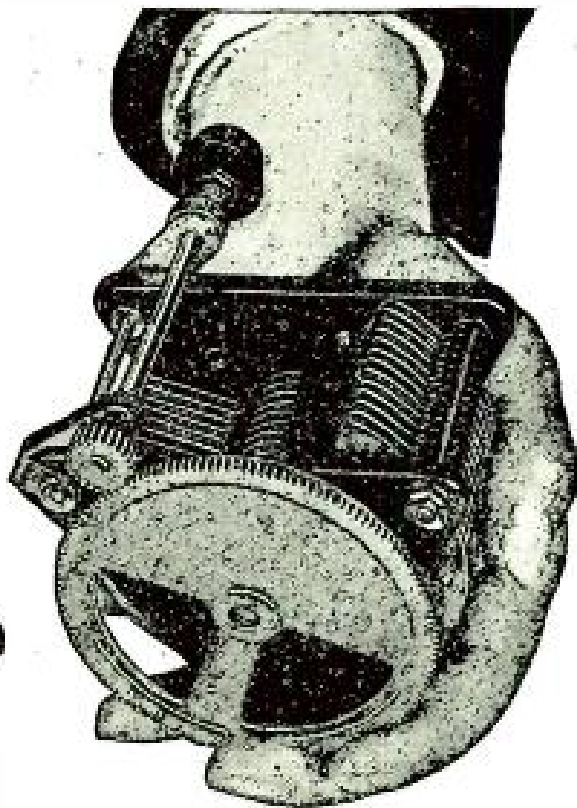

Use a Selective Condenser but a Non-selective Transformer

Good quality demands equal amplification for all frequencies within the voice range. The 3.7 to 1 ratio of the type 231A amplifying Transformer gives maximum amplification without distortion, in multi-stage as well as in single stage amplifiers.

High ratio amplifying Transformers are selective—and selective transformers have a resonant peak that causes serious distortion. Confine selection to the Condenser.

The General Radio Co.'s type 231A Transformer is suitable for use with UV-201A, 201, 199, WD-11, 12 and tubes of similar plate impedance.

\$5.00

A selective receiver is now a necessity. The new wave length allotments to broadcasting stations have helped to reduce interference, but the large number of broadcasting stations and the fact that the available band of wave lengths is limited, render a selective Condenser a necessity.

For selectivity, sharp tuning and fine adjustment, use a General Radio Co.'s type 247, 500 MMF geared Condenser.

Type 247 supplied mounted or unmounted, with or without gear.

\$3.25 to \$7.25

At your dealers, or direct from us: Two educational folders, "Quality Amplification" and "Quality Condensers." Ask your dealer or write us. Send for free Radio Bulletin 914U.

General Radio Company

Manufacturers of Radio and Electrical Laboratory Apparatus

Cambridge

Massachusetts

5420



*Natural
Re-PRODUCTION*

**Atlas
AMPLITONE**
LOUD SPEAKER

No blast or distortion. Its exclusive patented feature—the adjustable, double diaphragm—produces the radio programs in their original naturalness. Tuneable to your set and receiving conditions.

Let your ears be the judge. Hear the Atlas Amplitone at your dealer's. Write for interesting booklet "B." **\$25**

Letters from Users Requested

What have you accomplished with your Atlas Amplitone? Tell us about it.

Multiple Electric Products Co. Inc.
RADIO DIVISION
ORANGE ST. NEWARK, N. J.



Warren Radio Loop, cut away to show construction

**WARREN
RADIO
LOOP**

**Enjoy Your Set
All Summer
No Big Aerial Needed**

TAKE down your clumsy, dangerous, static attracting aerial and substitute a Warren Radio Loop. Flat as an atlas. Smallest size will fit inside your set, making it easily portable. Get the radio programs out of doors, wherever you go, this summer with a Warren Radio Loop. Sold by wide-awake dealers everywhere.

**A TYPE FOR EVERY SET
AT THE BEST DEALERS**

Type A-737 (800-700 meters) 6 inches square—non-directional..... \$10
 Type A-7236 (175-1000 meters) 6 inches square—non-directional..... \$12
 Type B-2537 (800-700 meters) 18 inches square—directional..... \$20
 Type BL-2520 (200-18,000 meters) with honeycomb coil. 18 inches square—directional..... \$25

Send for Bulletin I-102
V-DE-CO RADIO MFG. CO., Dept. F, Asbury Park, N. J.



KICO Storage "B" Batteries give long service at low cost

Alkaline type, will not sulphate or buckle. Life unlimited. Not harmed by short-circuiting, overcharging, or standing idle. Panel switches afford single cell variations. Easily re-charged from any 110-volt A.C. line by means of small home rectifier. One charge lasts three to six months in detector plate circuit.

Prices without rectifier:		Plain	(With Panels)
16 cell	22 volt.....	\$5.50	
24 cell	32 volt.....	\$7.25	\$11.75
36 cell	48 volt.....	\$9.50	\$14.00
50 cell	68 volt.....	\$12.50	\$17.00
78 cell	100 volt.....	\$17.50	\$22.50
108 cell	145 volt.....	\$23.50	\$28.50
Unmounted rectifier.....		\$1.00	
Mounted rectifier.....		\$2.50	

SATISFACTION GUARANTEED

All batteries are sold with the privilege of receiving your money back if not satisfied within a 30 day trial. Write for full information on "A" and "B" Batteries.

KIMLEY ELECTRIC COMPANY, Inc.
2667 MAIN STREET BUFFALO, N. Y.

**This "UNITED"
Audio Frequency
Amplifying
Transformer**

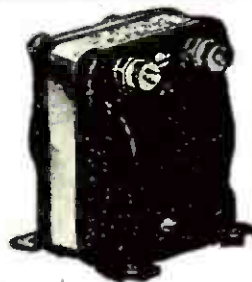

is a little "gem" of radio engineering—magnetically shielded. Ratio 5 to 1—a wonder-worker in producing loud, clear-toned signals, from any distance. At your dealer's, \$4.50.

"United" Variable Condensers have a new vernier dial assembly, original with us, that makes fine tuning a joy.

43 plate.. \$6.50	11 plate.. \$5.50	3 plate.. \$4.75
23 plate.. 6.00	5 plate.. 5.00	Postpaid

Vernier alone; can be attached to any \$250 plate condenser by drilling one hole



Show this ad to your dealer and ask him to supply your needs at the above prices. If he cannot do so, remit to us direct, under our money-back guarantee and give us name and address of dealer you wish to favor.

UNITED MFG. & DISTRIBUTING CO.

9705 Cottage Grove Ave.
Chicago, Ill.

New York Office:
50 Church St.
New York, N. Y.

San Francisco Office:
709 Mission St.
San Francisco, Cal.

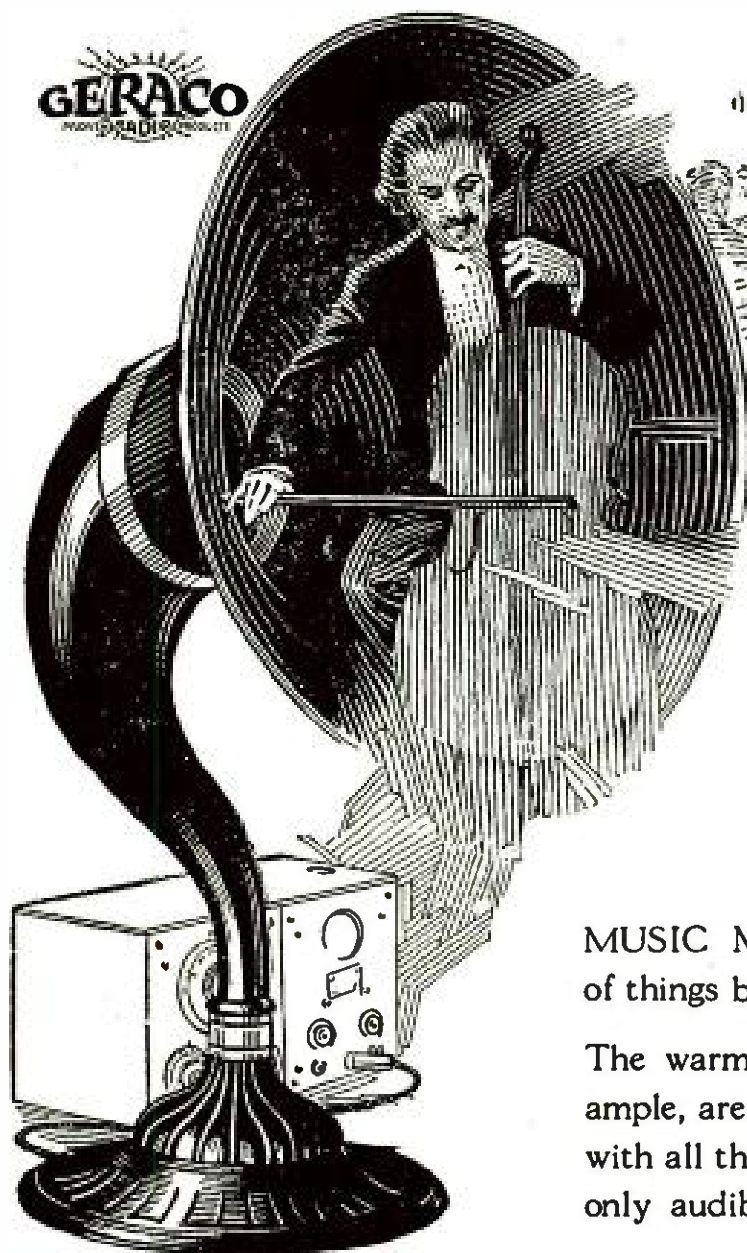

GERACO
MAKERS OF THE
POPULAR RADIO

Music Master

RADIO AMPLIFIER

Completes RADIO

MUSIC MASTER brings you *full* enjoyment of things broadcast.

The warm, human tones of the 'cello, for example, are revealed through MUSIC MASTER with all their expression and delicate coloring—only audible when the musician *himself* plays.

MUSIC MASTER does not influence the music's original quality but simply diffuses it in its true brilliance and richness. No tone-twisting!

A radio revelation! Allow your dealer to demonstrate MUSIC MASTER to you so you may make comparisons. This test never fails to establish MUSIC MASTER'S *pre-eminence*.

14" Horn, for the Home \$30
21" Horn, for Concerts \$35
Comes Complete, ready to attach
in place of headphones

**JOBBER'S
DEALERS**

A MUSIC MASTER will be sent you with full privilege of return. Write for full description of the GERACO Line and prices.

GENERAL RADIO CORPORATION

Makers and Distributors of High-Grade Radio Apparatus

CHICAGO

PHILADELPHIA
S. W. Cor. 10th and Cherry Streets

PITTSBURGH



Patent Applied For

THE FAVORITE RADIO CABINET makes a high class Radio Instrument.

It operates any good hook-up.

With one vacuum tube it operates a loud speaker.

No loop, no aerial, no ground, or other attachments necessary. It fills all vacancies.

THE FAVORITE has won the heart of the nation.

Everybody who see it, want one and those who have the price, buy one.

It is a beautiful piece of household furniture and adds to the appearance of the finest home.

A FAVORITE in operation on the floor of a dealer attracts all the attention of his customers.

Write for descriptive matter and prices.

Manufactured by

G. A. BARTHOLOMEW

409 Guardian Bldg.

Cleveland, Ohio

RHAMSTINE[★]

Victophone



\$7.50

Complete
with
cord

The quick popularity attained by the *Victophone* attests both the real need of a quality receiver built specially for use with the phonograph and the unexcelled tone and volume of this latest product of the Rhamstine[★] shops.

You'll like your *Victophone*.

Manufactured by

J. THOS. RHAMSTINE[★]

2162 E. Larned Street

Detroit, Mich.

★Makers of Radio Products

Coils and mountings
licensed under DeForest
patents

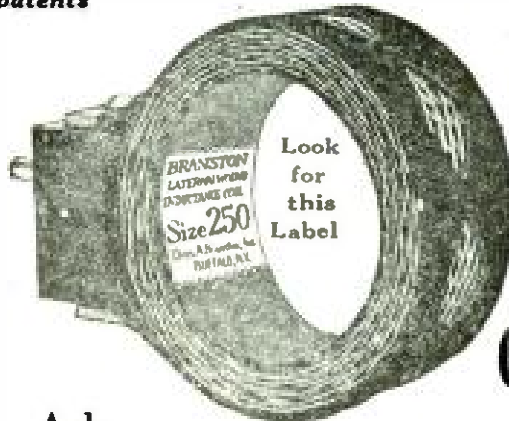

Insist
on
the
Genuine

Ask

Your "Old Timer" Radio friend why sets using Honeycomb Coils are best. Then ask your dealer for Branston Lateral Wound Honeycomb Inductance Coils and Coil Mountings.

Branston Coils are protected from injury and can not come loose from mountings. Positive contact assured. Guaranteed uniform maximum inductance with minimum distributed capacity.

Send 2c in stamps for Series 1 "Hook-Up" Circular showing five good Honeycomb Coil hook-ups and Catalog of Famous Branston Radio materials. Write today. Give us name of your Radio Dealer. If he can't supply you, let us know.

Chas. A. Branston, Inc.

811 Main St. Buffalo, N. Y.

In Canada—Chas. A. Branston, Ltd.
Toronto, Ont.



BRANSTON

In the new Cockaday
circuit, note

The AMERTRAN



It is also the standard audio transformer for the best NEUTRODYNE and REFLEX circuits. Its use is not limited to any particular audio circuit or with any particular tubes.

For pure tone quality with maximum volume, The Amer-Tran audio transformer has no equal.

Price \$7

Ask your electrical dealer, or sent carriage charges collect. (Wt. 1 lb.)

Turn ratio, 5:1

Amplification ratio is from 30-40 times audibility in a flat-top distortionless curve.

American Transformer Company

Designers and builders of radio transformers for over 20 years.

175 Emmet St., Newark, N. J.

Please mention POPULAR RADIO when answering advertisements.

Radio "Blind-man's Buff"

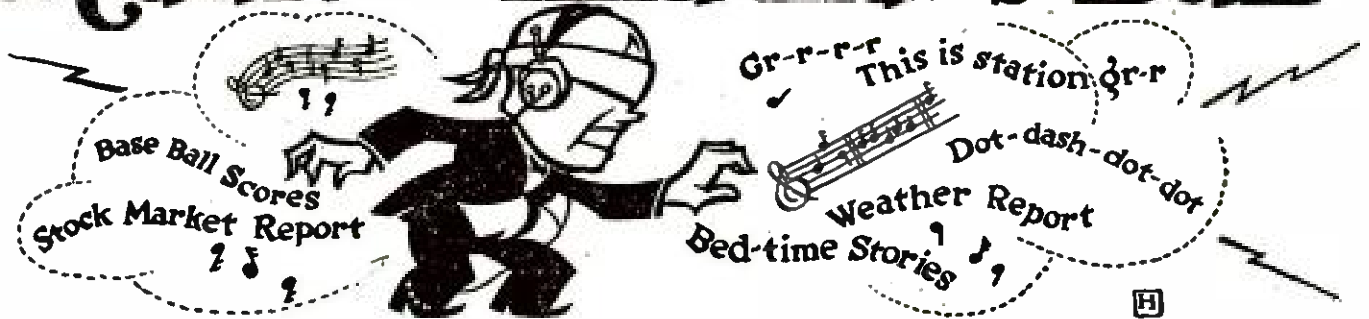

Picking your program with a single circuit receiver is a whole lot like playing blind-man's buff. You're not sure what you'll catch—nor how long you'll hold it.

In the midst of the entertainment you selected some other broadcasting station is quite likely to cut in and spoil the fun.

Selecting your radio equipment with your eyes open avoids this nuisance of jamming and scrambled messages.

Any radio-wise amateur will tell you that there's no comparison in genuine satisfaction between a single circuit instrument and the Paragon three-circuit receiver.

PARAGON

Reg. U. S. Pat. Off.

RADIO PRODUCTS

The amateur will tell you that the Paragon three-circuit receiver, because of its great superior selectivity and sensitivity, can pick and choose between broadcasting stations of about the same signal strength with less than one per cent differential.

This means that with a Paragon receiver you get what you want when you want it—complete messages and clear music from the station you tune in on, without interruption and jamming. Until you have listened in with a Paragon three-circuit receiver, you cannot guess the real pleasure and fascination of radio.

Long before broadcasting popularized radio with the general public, Paragon equipment was the choice of the experienced amateur. He will tell you today that if you want quality and satisfaction, Paragon Radio Products are the best and safest buy on the market.

An illustrated Catalog of Paragon Radio Products Is Yours For the Asking

DEALERS—The Adams-Morgan Company has an interesting proposition to make to reputable radio dealers who believe in quality merchandise. Details on request.

ADAMS-MORGAN COMPANY
20 Alvin Ave., Upper Montclair, N. J.

Type RD-5 Regenerative Receiver and Detector—\$75.00
Type A-2 Two-Stage Amplifier—\$50.00
(Licensed under Armstrong Patents.)

Also Manufacturers of PARAGON	
Radio Telephone	Amplifier
Transmitters	Transformers
V. T. Control Units	Control Dials
Rheostats	Amplifiers
Potentiometers	Receivers
V. T. Sockets	Switches
Detectors	Variometers

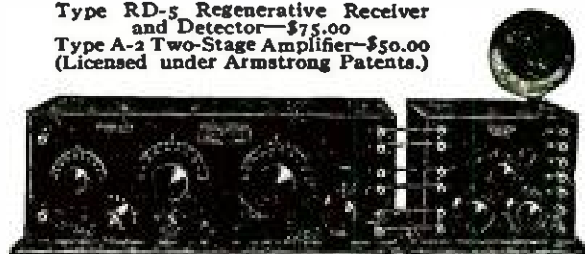

Your Choice!

—for Only 22 Cents in Stamps!

Hundreds of reliable hook-ups and circuit diagrams—practical hints and handy knacks—money-saving tips and pointers on how to make and improve your own sets. Take your pick of all this authoritative information on radio!

PERHAPS you haven't realized what a tremendous amount of information is available in the back issues of POPULAR RADIO. Since the first number was published, May, 1922, literally hundreds of requests have come to us for these valuable back issues of POPULAR RADIO which contain so many practical hints and worth-while suggestions.

There are still a few copies left of each of these back issues—with the exception of January, 1923. While they last you can take your pick of them at

only 22 cents each, to cover cost and mailing. Here's your opportunity to complete your files of POPULAR RADIO and to add to your store of information on just the subjects which interest you.

Glance over this partial list of contents of each issue. Then tell us which ones you want, enclosing stamps, check or money order to cover your requirements. Our stock is getting very low, so don't delay taking advantage of this offer!

May, 1922

- Harnessing waves to wire.
- How to make and install your own Receiving Set.
- How to tune a Regenerating Receiver.
- Symbols that help in reading diagrams.
- How to make soldered connections.
- How Radio waves are sent and received.

June, 1922

- Wireless that we can see.
- Can we talk to the dead by Radio?
- How to use your Radio Set in summer.
- How electricity is generated.
- Tones that do and don't broadcast.
- How to make a simple tube Receiving Set.

July, 1922

- Steinmetz on ether waves.
- How to learn the code.
- How to make a two-circuit Receiving Set.
- How high frequency currents are generated.
- Pointers for preventing interference.
- How to make a loose-coupler coil.
- How to use your Phonograph as a loud speaker.

August, 1922

- How machines are controlled by Radio.
- How Radio circuits are coupled and tuned.
- What "call letters" mean.
- Radio on your pleasure boat.
- How to make a variable condenser.
- The foolish fear of lightning.

September, 1922

- How to build the Armstrong Circuit Receiver.
- How the Vacuum Tube works.
- A resonance wave coil for reducing static.
- How to make a rotary plate condenser.
- The simplest receiving antenna.

October, 1922

- How to make a spider-web tuner.
- How the crystal detector detects.
- How to make your own grid condenser.
- Don'ts for Radio fans.
- How to use a Regenerative Set as a transmitter.
- How to restore worn-out crystals.

November, 1922

- Sir Oliver Lodge on ether waves.
- How to add a Vacuum Tube to your crystal set.
- Tricks with high frequency electric current.
- The most popular transmitting aerial.
- Right and wrong ways of adjusting the Regenerative Receiver.
- How to make a novel variocoupler.

December, 1922

- Radio on your motor car.
- How to select the best coil for your set.
- How to make and use a loading coil.
- How the Vacuum Tube detects.
- A Receiving Set that takes notes.
- How to make a series-antenna condenser.

January, 1923

(This issue, in which appeared Mr. Cockaday's full description of his "DX" Regenerative Receiver is completely exhausted. A circuit diagram of this 3-Circuit Tuner is found, however, in the Question and Answer Department of the April issue, 1923.)

February, 1923

- 20 tips on tuning.
- The Hoffman measurement charts.
- Shall I use a "hard" or "soft" tube?
- A novel tuner for shutting out interference.
- How the Audio frequency amplifier works.
- Pointers on aeriels.
- How to add an Audio-frequency amplifier.

March, 1923

- Making moving pictures talk.
- A Receiver without batteries.
- What really guides Radio waves.
- How to get the greatest efficiency out of your Radio circuits.
- How to make a one or two-step Audio-frequency Amplifier.
- How to make a Multi-Layer Coil.

April, 1923

- Ether waves and the Einstein Theory.
- How to use Regeneration without Radiation.
- How to make a crystal detector from a spool.
- How the Vacuum Tube detects and rectifies.
- How to make a simple single tube Receiving Set.

May, 1923

- Four ways to get good modulation.
- How the Radio frequency amplifier works.
- A simple buzzer test.
- How to make a light contact detector.
- How to build your own wavemeter.
- How to build the Cockaday 4-Circuit Tuner.

June, 1923

- How to use your Radio Set on your vacation.
- How the microphone transmitter works.
- How to build a good single tube receiver.
- How to make a crystal detector stand.
- How to determine the constants of your antenna.

July, 1923

- How to install your Radio Set on your boat.
- The ratio in size between your antenna and your coil.
- Useful facts about ear-phones.
- How to make a dry-cell tube Regenerative Set.
- How to keep up your storage battery.

POPULAR RADIO, INC.

9 East 40th Street

Dept. 84

New York City

Please mention POPULAR RADIO when answering advertisements.



AUDIOPHONE AND CANOE both go to camp

Nobody wants to wear head phones during hot, stuffy weather. A small efficient Loud Speaker ruggedly built will be welcome in any camp outfit. The AUDIOPHONE JR. is just the thing.



Bristol AUDIOPHONE made in two sizes—

Audiophone Sr.
Diameter of horn, 15 inches
Weight, 10 pounds
Price, \$32.50

Audiophone Jr.
Diameter of horn, 11 inches
Weight, 7 pounds
Price, \$22.50

Bulletin 3006-L describes them.

Light in weight and easily assembled or dismantled without tools. Doesn't require any battery. The tone quality is exceptional and will give enough volume to entertain the whole camp party.

See it at your dealers or write direct.

THE BRISTOL COMPANY
Waterbury, Conn.

BOSTON

CHICAGO

NEW YORK

PHILADELPHIA

ST. LOUIS

PITTSBURGH

SAN FRANCISCO

DETROIT

Please mention POPULAR RADIO when answering advertisements.

F-F BATTERY CHARGER

ALL TYPES But "B"
Charge AUTO
Batteries
Overnight
Right in
Your CAR

\$15

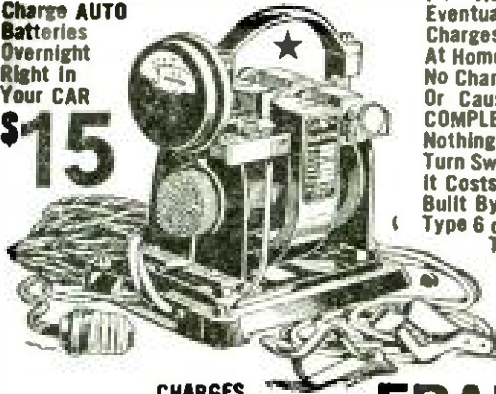

CHARGES
RADIO & AUTO BATTERIES.

F-F AUTOMATIC MAGNETIC TAPER CHARGE DESIGN made BATTERY CHARGING POPULAR Eventually You Will Buy An F-F CHARGER & The Sooner You Buy One; The More You Save. A-B Charges All 6 Volt & up to 120 Volts Of "B" & Loud Speaker Storage Batteries in Series inductively At Home Overnight. Disconnecting & Multiple Connections Unnecessary. Charging Circuits Separate. No Chance For Grounds, or Short Circuits. Nothing To Stop Over, Be Filled, Burn Out, Need Attention Or Cause Trouble. Infusible Rectifying Brushes Maintain Constant Efficiency Uninterruptedly. COMPLETE PORTABLE AUTOMATIC. No Skill Required. AMMETER eliminates Guess Work. Nothing Like It Made. Lasts A Lifetime. Screw Plug in Lamp Socket; Snap CLIPS on Battery Terminals; Turn Switch & Battery is Charged in Morning. Charged Batteries Mean Fewer Expensive Replacements. It Costs Less To Buy An F-F CHARGER Than To Be Without One. INSIST on The F-F CHARGER. Built By A Master Of The Art in 7 TYPES. Thousands Sold Make Possible These POPULAR PRICES:
Type 6 charges 6 Volt Battery At 6 amperes \$15 Type 12 charges 12 Volt Battery At 5 amperes \$15
Type B charges Radio "B" Batteries Up to 120 Volts \$15 Type A-B is Combination Of 6 & B \$20
Type 166 charges 6 Volt Battery At 12 amperes \$20 Type 1612 charges 12 Volt At 7 amps \$20
Type 1626 is a Combination Of Types 166 & 1612 and Charges Both 6 & 12 Volt Batteries \$20
Types B & A-B are RADIO Specials. Types 166, 1612 & 1626 are For Heavy & Rapid Charging.
SHIPPING WEIGHTS Complete with AMMETER & BATTERY CLIPS 11 to 15 lbs.
PURCHASE from DEALER; Mail Check, or WRITE us to Ship TYPE desired C. O. D.
ORDER Now, or WRITE immediately for FREE Descriptive CHARGER Bulletins 44 & 44A.

FRANCE MFG. CO., Cleveland, Ohio.

\$1.00

RITTER LOOP AERIAL

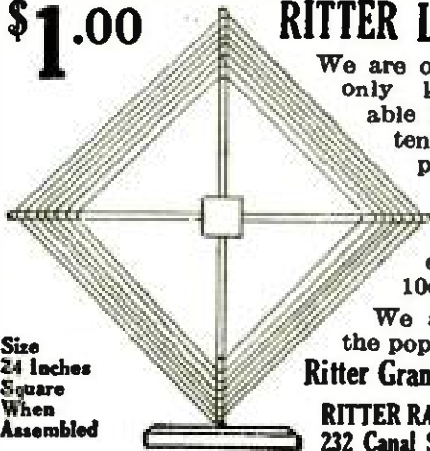

Size
24 inches
Square
When
Assembled

We are originators of the only knockdown portable loop aerial. Contents: wire, binding posts, wood parts and instructions on how to assemble and operate. By mail 10c extra.

We also manufacture the popular
Ritter Grand Crystal Set \$3.50

RITTER RADIO CORPORATION
232 Canal Street, New York City

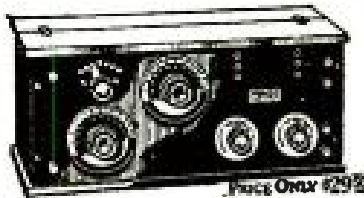

At this low price you get the efficiency of a \$50 set. It is a two tube radio frequency receiver—picks up stations 1500 miles away under good conditions—everywhere—any time. This outfit can be operated with a dry cell or storage battery. Cabinet is of solid mahogany and workmanship the finest throughout. Order direct or send for new Bulletin.

DEALERS—write for proposition—it's a winner.
AGENTS—wanted everywhere—write for territory
QUICKLY

THE MIDWEST RADIO COMPANY
812 Main Street Cincinnati, Ohio

POSITIVE RESULTS

are being obtained by thousands of satisfied users of the

EASTERN COIL SETS for the COCKADAY CIRCUIT

The remarkable features making this circuit more popular each day are its simplicity of construction and control—wonderful selectivity—distance records—clearness and loudness of reception, and the fact that all capacity squealing, interference, etc., are eliminated.

Made as per specifications of Mr. Cockaday, using No. 18 wire with D coil bank-wound.
Complete set of B, C & D coils—Price \$2.75.
Hook-up directions and material list furnished free with each set of coils.

Mail orders filled. Dealers communicate.

EASTERN RADIO MFG. CO.
22 Warren Street New York, N. Y.

WHY PAY MORE

GENUINE TUBES

W. D.-11 5.95 UV-199
W. D.-12 UV-201A

All New. No Stamps. Checks. C. O. D.

Send for our new price list
with hundreds of other items.

Save money. Order from us.

Cut Rate Radio Co.

P. O. Box 472

Newark, N. J.



**THE WORLD'S GREATEST
RADIO CRYSTAL**

GIVE YOUR CRYSTAL SET A FAIR CHANCE

A Crystal Set, when properly equipped, is the ideal method of radio reproduction—clear, musical, economical. But the best crystal set ever made will not reproduce properly with a poor crystal.

M. P. M. (MILLION POINT MINERAL) CRYSTAL

has made the Crystal Set successful. Unsolicited testimonials are constantly being received, reporting records up to 1200 miles. Don't discard

your Crystal Set until you have given "M. P. M." a trial.

Send 25c and name of your radio dealer for sample unmounted crystal.
35c for mounted. Insist upon M. P. M.

M. P. M. SALES CO., Dept. PR, 247 So. Central Ave., Los Angeles, Cal.

More Reasons Why



The new Crosley Duostat universal duo-wound rheostat for all makes of tubes is sold separately from Crosley radio sets if desired, complete as shown in the illustration above. Price—85c.

CROSLEY

Better - Cost Less
Radio Products
are
so Much Better

BY perfecting the new Crosley Duostat universal filament control rheostat, the Crosley Manufacturing Company has made giant strides in bringing within reach of all, the true reproduction of signals from the air. This rheostat (patent pending) properly controls all makes of tubes, including the new "A" and 199 and makes Crosley instruments even more efficient than ever before because of the:

1. Efficient, smooth, uniform control of all tubes duo-wound to low and high resistance 10 to 20 ohms.
2. Plunger type contact actuated by a special spring, insuring uniform pressure at all times.
3. Spring washers producing uniform tension.
4. Positive rugged stop at zero resistance or "on" position.
5. Circuit interrupted at "off" position.
6. Resistance material having zero temperature co-efficient.
7. Windings protected by a black moulded shell of high heat insulating material.
8. Electrical connections substantial in construction.
9. Design of parts to prevent warping.
10. Extremely low operating temperature with all tubes.

The outstanding performance of all Crosley instruments is due to the effective co-operation of the new filament control rheostat with the other parts.

For Sale at Best Dealers Everywhere

Write for free Catalog

CROSLEY MANUFACTURING CO.

816 Alfred Street

Cincinnati, Ohio

New York Office, C. B. Cooper, 1803 Tribune Bldg., 154 Nassau St.
Boston Office, B. H. Smith, 929 Blue Hill Ave., Dorchester.
Chicago Office, 1311 Steger Bldg., 28 E. Jackson Blvd., R. A. Stemm, Mgr.

Philadelphia Office, J. H. Lyte, 65 North 63d St.

St. Louis Office, Robt. W. Bennett Co., 1326 Syndicate Trust Bldg.



Crosley Radio Receivers have a universal appeal. The Model X pictured here is the last word in efficiency. It sells at \$55 in spite of its new features and advanced manufacturing cost.



NATURE

has given us many things to admire and use. But it requires "man made" devices to manifest the greatest wonders. For instance, RADIO.

In the Service Radio receiving set beauty and utility are exemplified in their highest form.

It adds beauty to your home and enjoyment through its loud, clear reception of distant music, speeches, etc.

The story of SERVICE RADIO will be told serially in this publication—or, if you prefer the entire story, write us for booklet, "The Story of Service."

SERVICE RADIO SETS

are simple to operate. They are made by a new concern composed of engineers and executives who have been connected with the most progressive producers.

Dealers: write for prices, terms and territory. Dealers' names will be published in our advertising.

"This Is a TELEFORCE Product"

SERVICE RADIO COMPANY

4727 Montgomery Road
NORWOOD, O.



*Make Your Set The Sensation
of Your Town!*
with

The RADIOXOR

Simple—Inexpensive—Certain

Can be attached to any set, operating head phones or loud speaker,—crystal or Vacuum Tubes,—Loop, Plug or Outdoor Aerial.

Send your name, address and type of set on a post card for details.

Selling like wildfire, so act promptly. Orders filled in order of receipt.

WILLART SALES COMPANY

Worlds Tower Building
110 West 40th Street New York City

Just In Time for All of the New Circuits B-T Universal Vernier Tuner

Replaces tapped coils and switches in the Reinartz and Ultra Audion Circuits, and improves reception wonderfully.

Takes the place of variocoupler in regenerative circuits with marked improvement in results.

Gives very fine vernier control when used as a variometer.

Adapted equally to all the old and new circuits. Ask your dealer or remit direct, sending dealer's name.

FREE Photo diagram of new B-T Reinartz hook-up. Send 2c stamp or postage and name of your dealer.

Bremer-Tully Mfg. Co. 534 South Canal St. Chicago

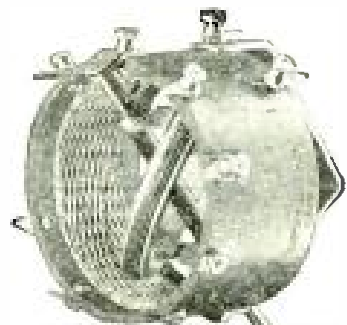

B-T. VERNIER TUNER

Price, Postpaid, \$5.00

Haynes-Griffin

RADIO SERVICE, Inc.

41 West 43rd St., N. Y. City



A. J. HAYNES

Assoc. Institute of Radio Engineers

MR. HAYNES has made many notable contributions to radio—among them the now world-famous Haynes Circuit. In this circuit Mr. Haynes answered for the first time in the history of radio the insistent demand for extreme long distance range at a reasonable cost. Employing only well known and proven principles of radio, but in a combination never before used, he has secured a most remarkable degree of selectivity and simplicity in operation.

Mr. Haynes' circuit has met with the enthusiastic approval and endorsement of the country's leading experts and amateurs. It is the first circuit on which any designer has been able to give an unqualified promise of 1,000 miles range.

Radio enthusiasts will find Mr. Haynes' booklet, describing his own personal receiving set, of absorbing interest and extremely helpful. Full diagrams and illustrations—and a complete description of how he came to build it, what he found out, and the surprising results obtained. Sent post-paid upon receipt of 50c.

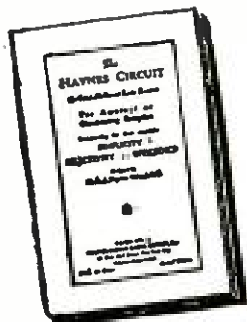

50c
Post
Paid

Local Interference Absolutely Eliminated

by the

HAYNES SELECTOR

"More Than a Wave Trap"

Designed by A. J. Haynes, Originator of the Haynes Circuit

OWNERS of radio sets located close to one or more broadcasting stations often find it impossible to eliminate entirely or to tune-out these stations. When nearby stations are operating they come in so strong as to drown out or interfere with programs from more distant stations.

The Haynes Selector was designed to eliminate this troublesome annoyance. Its success has been established beyond shadow of a doubt. In New York City with eight active broadcasting stations, thousands of users have found the Haynes Selector the final solution to all their interference troubles.

Special Filter Coil

The secret of the Haynes Selector lies in the special filter coil—never before used in any wave-trap. The interfering station is quickly and entirely trapped-out before it ever reaches your receiving set, and without the slightest loss in volume or signal strength of the station you wish to hear.

Used With Any Receiver

The Haynes Selector can be used with any type of receiver—single or double circuit—any type of antenna or loop aerial. Two or more Haynes Selectors may be used in series and all local stations eliminated successively. You can then work through to long distance with an unparalleled degree of selectivity. No knowledge of radio required for its use. You can connect it to your receiving set in an instant's time.

Be Sure to Send for Leaflet

Send a two-cent stamp for our 4-page illustrated leaflet giving in complete detail the many uses of the Haynes Selector, hook-ups, diagrams, theory and directions for use. We will be glad to mail these leaflets as long as supply lasts to readers of Popular Radio. Send two-cent stamp today.



Haynes Selector wired, showing Filter Coil

Complete in Cabinet \$8.50 Postpaid



Haynes Selector in Cabinet

HAYNES-GRIFFIN RADIO SERVICE, Inc. 41 W. 43rd St. New York City

New York's Largest Radio Store

DELICATE SOLDERING in RADIO

Both the manufacturers' and amateurs' problem on all fine work is readily solved by the instrument constructed for this particular purpose.

THE POST SOLDERING IRON

Platinum Heating Unit—Interchangeable Tips—Universal Current
(Large and Small)

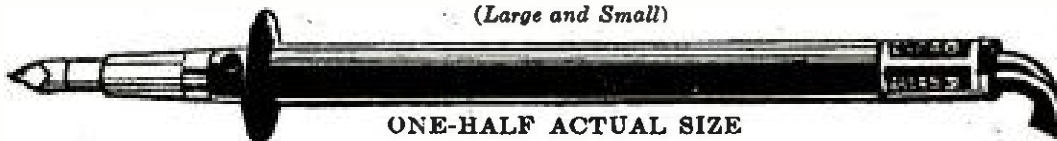

ONE-HALF ACTUAL SIZE

\$6.00

Awarded Certificate of Excellency, N. Y. Evening Mail Radio Institute
From your Dealer, or write

POST ELECTRIC COMPANY (Instruments Division), 30 E. 42nd St., New York

RT-A2

The Audio Frequency Transformer that gives you perfect Tone Quality and High Amplification without distortion.



Moisture-proof—it is ideal for the seashore. Letters received every day state that RT-A2 passes every test and fulfills the most critical requirements of experts and amateurs.

Use RT-A2 transformers at once and enjoy better radio reception.

Price \$6.50 at all good dealers

RASLA SALES CORPORATION

National Distributors

Dept. P, 10 East 43d St., New York City

BARKELEW
FOUR-PHONE PLUG
for
STANDARD JACKS
The BARKELEW ELEC. MFG. CO.
MIDDLETOWN, OHIO.

\$75 BUYS
The new Tuska Popular. Armstrong Regenerative Circuit, 3-tube, two dials tuning. Long range. Steamship officer reports hearing U. S. stations 2400 miles away clearly. Others \$35 to \$200. Ask for catalog.
THE C. D. TUSKA COMPANY, HARTFORD, CONN.

REG. U. S. PAT. O. F. **TUSKA RADIO**

Worth Sending For!

Circular describing Rheostat construction is sent free of charge upon request. Explains cut-out switch, constant contact principle, and minute adjustment of UNITY Vernier Rheostat. Write for it now.

THE UNITY MANUFACTURING COMPANY
224 N. Halsted St., Chicago

FREE Radio Catalog

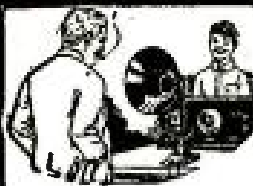

Our big stocks of standard makes of radio sets, parts and supplies enables us to make prompt shipment from stock. Play safe—buy standard equipment from a reliable house. No cut price material.

Send \$1.25 for Univernier for close tuning—mention size of

Condenser or Variometer shaft; \$2.00 for 6-phone plug.

JULIUS ANDRAE & SONS CO.

In Business since 1860

127 Michigan Street

Milwaukee, Wis.

"BUILD YOUR OWN"
With "RASCO" Parts!
If you need small radio parts in a rush, "RASCO" will supply them cheaper, better and quicker than any one. Be sure to get our great 68-page catalog. Over 500 different parts, 300 illustrations. This catalog contains 75 Vacuum Tube Hook-Ups, all values being shown. Due to great cost, catalog sent only upon receipt of 15c, stamps or coin.
Radio Specialty Co., Inc.
96a Park Place, New York

THE MOON RADIO CORPORATION
Manufacturers of
Ultra-fine Receiving Sets
12 Diagonal Street
Long Island City, N. Y.

Let Radio Experts Buy for You

This Service Is Free

Why hunt from store to store? Save time, trouble and money—a group of Radio Experts in New York will act as your personal representative, buy for you any standard make of radio equipment you want, from the smallest part to a complete set, either assembled or unassembled, and deliver it to you prepaid—all for less than if you did your own buying. Satisfaction guaranteed. Also disinterested advice on all radio problems—free. Write for plan.

PERSONAL SERVICE PURCHASING BUREAU
505 Fifth Ave., Desk 12, New York



The Boys Are the Buyers

Who has made radio an epidemic throughout the country? Who tinkers and fusses with sets, dismantling them and reassembling them, trying to better them? Who wants to learn all the latest improvements in radio equipment? Who buys most of it? The boys.

It's the boys who are spending the money. Every nickel goes for head sets, tubes, batteries and switches. When the price of the desired object exceeds their means, do they quit? Not a chance. They get to work on their parents and keep at it until they come across. That gets the grown-ups interested, and they go to their sons for information and advice.

THE AMERICAN BOY

"The Biggest, Brightest, Best Magazine
for Boys in All the World"

reaches this boy market as no other medium can. Over half a million boys, averaging from 15½ to 16 years of age, read it from cover to cover every month. Especially the radio department edited by Armstrong Perry, the world-known expert. It gives them the kind of stories and articles they like. From it they learn a surer and finer appreciation of values—personal and commercial. Because it has always played square with them it holds their confidence—particularly in its advertising.

Readers of THE AMERICAN BOY are the leaders of their gangs. And what these leaders do is done by the rest of the bunch; what they approve is right; what they buy, the others want.

Advertising in THE AMERICAN BOY is not only the logical way to reach boys—it's the only direct way. By winning their approval of your product you not only increase your present sales. You start a habit of buying your goods that lasts as long as you give them a square deal.

Copy received by August 15th will catch the October issue.

THE SPRAGUE PUBLISHING COMPANY, Detroit, Michigan
(Member A. B. C.)

Advertising Manager
548 Lafayette Boulevard

Branch Offices 286 Fifth Avenue, New York
1418 Lytton Building, Chicago



“How I Located My Trouble”

A Massachusetts radio enthusiast tells of a happy discovery that finally solved his difficulties.

“I COULDN'T figure out what was wrong with my radio set,” states a Fitchburg business man whose experience is interesting because it shows how one simple little adjustment will sometimes make such an amazing improvement in results.

“I had erected my antenna in just the right way, had connected up my different parts with the greatest care, had added improvements that were designed to bring my apparatus to the highest possible perfection,” he continues.

“I spent a good many hours talking over my problems with dealers and experts. I followed one suggestion after another. But still the same old trouble!”

Do You Have This Trouble?

“In spite of all my efforts, when I wanted to hear some particularly interesting broadcasting program, other stations kept breaking in; I found difficulty in getting long distance points; and intermittent squeals, whistles and howls would persist, no matter how I tuned or adjusted my dials.

“I was pretty nearly convinced I'd have to get some high-priced installation man to come out to

my home and set me right, when purely by chance I happened to pick up a copy of POPULAR RADIO—and thumbing through its pages I found the very answer to my problems!

“There in black and white, diagrammed and explained, was a simple, practical suggestion that turned the trick for me.”

The One Best Way to Get Results

Many other radio enthusiasts, too, who want to get the most out of their sets have found in POPULAR RADIO many an idea and practical suggestion that has made a world of difference in their enjoyment of this fascinating pastime, and saved them hours of experiment and costly error.

If you don't already *subscribe* to POPULAR RADIO, don't miss this opportunity of getting the magazine regularly at your permanent address.

A year's subscription will **save you money** over what you would pay on the newsstands, and will bring you the magazine every month, rain or shine.

Your Questions Answered **FREE!**

Then, too, as a regular subscriber, any questions you wish to ask of the Technical Editor will be answered **free of charge**. This is one of the most valuable features of POPULAR RADIO'S service, and is the same service for which non-subscribers pay 50 cents for each question asked, and they say it's worth many times what they pay. *Yet you can get this same added service absolutely free.*

The Coupon Entitles You to This Service

Simply fill out and mail the attached coupon today and your subscription will start with the very next issue. If you have some problem to put up to our Technical Editor now, send in your question with the coupon and he will be glad to straighten you out. This is a privilege to which all subscribers are entitled, and we want you to take full advantage of it.

But do not delay sending in your subscription. Get POPULAR RADIO regularly each month and don't risk missing any of its scores of helpful and practical suggestions.

POPULAR RADIO, Dept. 80,
9 East 40th Street, New York City

Please put me down for a year's subscription to POPULAR RADIO, beginning with the September issue. I am enclosing \$2 in full payment which also entitles me to free use of your Question and Answer Department.

Name

Address

.....
(No extra for Canada. Foreign countries
25 cents postage extra.)

RA

Please mention POPULAR RADIO when answering advertisements.



**SOME OF THE PARTS
SPECIFIED BY MR. COCKADAY
IN HIS FOUR CIRCUIT TUNER**

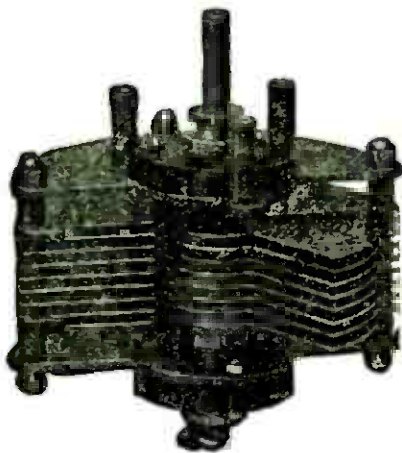

No. 185 VARIABLE CONDENSER . . . \$4.25
CAP. .00035 M. F. 17 PLATES

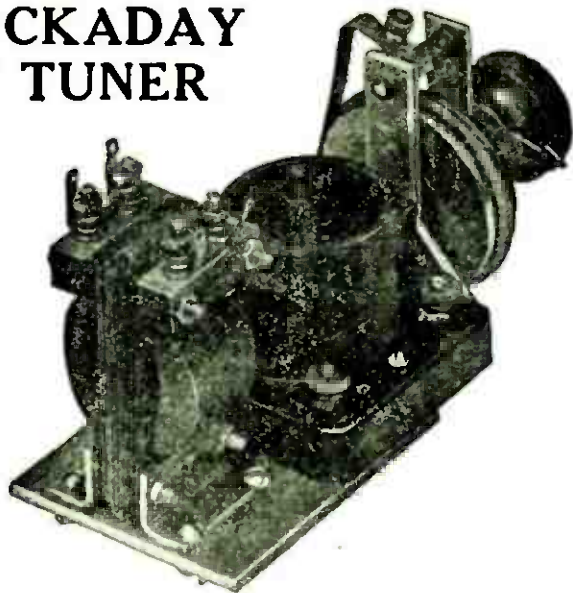

No. 198 AMPLIFYING UNIT . . . \$7.50
ACME TRANS.

No. 211 DETECTOR UNIT . . . \$2.40



No. 164 KNOB AND DIAL . . . \$0.75
MOLDED BAKELITE



No. 193 VERNIER ADJUSTER . . . \$0.35

R. MITCHELL & CO.

255 Atlantic Ave.

Boston, Mass.

*For 47 years Manufacturers of Scientific and other equipment
Look for trade mark on every piece
Jobbers and Dealers write for discounts*

Please mention POPULAR RADIO when answering advertisements.

NOVO "B" BATTERIES

NOISELESS **DEPENDABLE**

NOTE THE INSULATED BINDING POSTS AND 7/16 IN. WIRE CONNECTOR

NOVO M'FG CO.
 424 W. 33rd ST. NEW YORK
 531 SO. DEARBORN ST. CHICAGO

World Radio Batteries SAVE YOU 50%

WRITTEN 2 YR. GUARANTEE

SPECIAL 2-VOLT STORAGE BATTERY FOR W.D. 11-500
 WILL RUN 210 HOURS ON ONE CHARGE

RADIO PRICES:	
6 Volt, 60 Amps.	\$10.00
6 Volt, 80 Amps.	12.50
6 Volt, 100 Amps.	14.50
6 Volt, 120 Amps.	16.00

Thousands of users enjoy the dependable qualities of our battery. Our guarantee protects you. Will ship C. O. D. subject to inspection or will allow 5% discount for cash with order. Order today.

World Battery Co., 1219 S. Wabash Ave., Dept. 3, Chicago

RUSONITE

CRYSTAL RECTIFIER

(Patent Pending)
THE PERFECT SYNTHETIC CRYSTAL DETECTOR SENSITIVE OVER ENTIRE SURFACE
 No Hunting for "Spots." Loud and Clear. Endorsed by Thousands of Satisfied Users

Sensitiveness Guaranteed	Price Mounted	
		50c
14 K. Gold Supersensitive RUSONITE CATWHISKER, Permanent. Will not Oxidize		25c
RUSONITE REFLEX CRYSTAL Manufactured Expressly for Reflex Circuits. Will Stand Up Under Heavy Plate Voltage		\$1.00

Order from your dealer or direct from
RUSONITE PRODUCTS CORP.
 15 Park Row New York, N. Y.

Super-Sensitiveness!

THE crystal is the "bull's-eye" of your crystal receiving set. Unless it is super-sensitive you are wasting time and entertainment and cannot "hit" the combination for best results. Insist upon the genuine original Arlington Tested "NAA" Detector Minerals. They are carefully selected from bulk stock, individually tested and guaranteed super-sensitive.

Galena, Silicon or Goldite price per crystal, 25c. Same mounted in brass cup, 40c. Obtainable at your dealer's or sent direct (post-paid) on receipt of price.

The Newman-Stern Co.
 Newman-Stern Building Cleveland

LEARN RADIO

Here's your opportunity. Radio needs you. Win success in this fascinating field. Trained men in demand at highest salaries. Learn at home, in your spare time.

Be a Radio Expert

I will train you, quickly and easily, to design, construct, install, operate, repair, maintain, and sell all forms of Radio apparatus. My new methods are the most successful in existence. Learn to earn **\$1,800 to \$10,000 a Year**

FREE Wonderful, home-construction, tube receiving set, of latest design. Write for "Radio Facts" free. Engineer Mohaupt.

American Electrical Association
 Dept. 58 4513 Ravenswood Ave., Chicago

Something New

A real Loud Talking Detector made of B-Metal. 100 per cent. superior to any crystal. Puts new life into your Radio set. Guaranteed for ONE YEAR. CHEAPEST in the long run. If your dealer is unable to supply it, we will.

B-Metal Refining Co.
 3134 Trumbull Ave., Detroit, Mich.

LONG DISTANCE CRYSTAL SET

We receive programs from Atlanta, Minneapolis, Davenport, Fort Worth, Dallas, Kansas City, St. Louis, Denver on Crystal without batteries. Usual crystal set requires only easy, inexpensive changes. Send stamp for further information or \$1 for copyright drawings and instructions. Everything clearly explained. Satisfaction GUARANTEED.

LEON LAMBERT, 540 South Volusia, Wichita, Kan.

RADIO DEALERS

Write for consignment proposition and sample of the **CORYDON SNYDER CODE METHOD**

This is the most direct memory retaining method invented. Patent applied for. Anyone can learn the **WIRELESS CODE** in from one to three hours by this home study course. Retail at 50 cents. No samples sent unless request is made on business letter head.

CORYDON SNYDER, 1161 So. Ridgeland Av., Oak Park, Ill.

CHARGE YOUR BATTERY

(RADIO OR AUTO) at HOME for a NICKEL

The HOMCHARGER
 POPULARLY PRICED - PAYS FOR ITSELF
 SEND FOR THE AUTOMATIC ELECTRICAL DEVICES CO. FREE BOOK 100 W. THIRD ST. - CINCINNATI, OHIO

RADIO BOOK

only \$1

562 PAGES—Greatest book on Radio ever written. New — authoritative — complete. Packed with sound, practical information useful to every radio fan. Send \$1 today. Money back if not satisfied.

International Correspondence Schools
 Box 8252, Scranton, Penn.

W.T.501 DETECTOR TUBE

For tube sets, use our special Adaptor, 75c extra. To convert crystal sets into tube sets, use special socket, 40c extra.

RADIO RESEARCH GUILD
 40 Clinton Street, Newark, N. J.

Please mention POPULAR RADIO when answering advertisements.



Announcing— "BURGESS "A" Dry Battery"

"A Laboratory Product"

THIS new dry battery for the "A" or filament circuits of dry cell vacuum tubes is a Burgess achievement which will not soon be forgotten.

Burgess has perfected a dry "A" battery which will give over twice the life, on vacuum tube service, of any ordinary No. 6 Ignition dry cell. It has a rapid recovery to high voltage after short periods of rest and practically no voltage lost when not in use.

This Burgess "A" dry battery will lead the "A" battery field just as the Burgess dry "B" battery has led the field of "B" Batteries. Ask any Radio Engineer about Burgess "B" Batteries.

Made only in single cell units. This makes it possible to wire up convenient combinations for all types of dry cell tubes, and eliminates the hazards and expense of multiple cell units.

Ask for the Burgess "A" Battery

when you are equipping your new set or replacing your old dry batteries. Sold by all progressive radio dealers.

BURGESS BATTERY COMPANY

Engineers—DRY BATTERIES—Manufacturers
FLASHLIGHT—RADIO—IGNITION—TELEPHONE

General Sales Office: Harris Trust Bldg., Chicago
Laboratories and Works: Madison, Wisconsin

Branches:
New York Boston Washington St. Paul Kansas City New Orleans

In Canada: General Offices and Works, Niagara Falls, Ontario
Branches: Toronto Montreal Winnipeg St. John

"Ask Any Radio Engineer"

Radio's
New
Marvel



At Last Static Overcome

UNLIKE any other type of Antenna it will not bring in static and other outside interferences. Consequently your reception will be clearer and sweeter than ever before. And it will make your set portable.

The Short Cut Antenna will do away with and work better than an aerial—or cumbersome indoor loop.

The Short Cut Antenna does not even require electric light plug connections. Being absolutely non-directional, it will operate in any position.

It can be attached easily and quickly to any tube set. This time-tested, patented Short Cut Antenna is truly Radio's new marvel.

Send No Money

Send the coupon for one. *You risk nothing.* Test it out under the most adverse weather conditions. In case the Short Cut Antenna does not do all we claim it will do—send it back and your money will be refunded immediately.

The cost is much less than you expect—only \$5.00. Send the coupon today.

Short Cut Radio Corporation

Dept. C435

243 West 54th Street, N. Y. C.

Rush a Short Cut Antenna to me. I will pay \$5.00 to the Postman. In case it is not absolutely satisfactory, I will return it—and you are to refund my money.

I have aset.

Name.....

Address.....

Town.....

Big Values in Premiums!

These offers hold good until August 30th

Get the parts you want for your set—and get them FREE—by taking a few subscriptions for POPULAR RADIO from your friends.

If you've never tried it, you don't know how easy it is to get subscriptions for POPULAR RADIO. Just show this copy to some of your friends. Let the magazine sell itself to them. Then send us their names, with \$2 for each yearly subscription, and take your choice of any of the following radio parts. They'll come to you *free* as a reward for your efforts.

Any One of These for 2 Subscriptions:

Dubilier Ducon

Dubilier Tubular Grid Leak (any standard size) with Grid Condenser .00025 mfd.

DeForest Vacuum Tube Socket with Bingo Rheostat

DeForest Potentiometer

Teleradio Lightning Arrestor with 50 feet of No. 14 r.c. lead-in wire and ground clamp

Two memberships in The Radio Experimenters' League of Newark, N. J.

Manhattan Combination Volt-Ammeter

Diode Dry Cell Vacuum Tube

Your Choice for Only 5 Subscriptions:

Jefferson Audio Frequency Transformer (new style)

23 Plate Teleradio Variable Condenser, unmounted, with Alden-Napier 3 inch Dial

Bakelite Panel, size 7 x 24 inches

Set of DeForest Honeycomb Coils (Mounted) No. 35, No. 50 and No. 75

Lefax Loose Leaf Radio Handbook with full year's free supplement service

Big Values for 8 Subscriptions each:

Manhattan Genuine Bakelite Variocoupler

Manhattan Genuine Bakelite Variometer

Radiotron U. V. 200 and C. H. Vernier Rheostat

DeForest 3-Coil Honeycomb Mounting

R. C. A. Radio Frequency Transformer

U. V. 201 Vacuum Tube

Post Electric Soldering Iron

Manhattan Headset (3000 ohms)

Free with 10 Subscriptions each:

43 Plate United States Tool Vernier Type Variable Condenser

Brandes Phones

Atwater Kent Detector Unit. Complete with 22½ volt Ever Ready B. Battery

Moon Radio Horn

Atwater Kent Variocoupler

Atwater Kent Variometer

If you want some particular part that isn't listed here, write us and we'll tell you how many subscriptions you'll need to get it free. We'll tell you, also, how you can earn a complete Cockaday 4-Circuit Tuner *free*. Or you can get an Exide Storage Battery, type 3-LXL-9, 80 amp. hr. 6 volt, for only 25 subscriptions! Renewals count just as much as new subscriptions. A two-year subscription for \$4.00 counts the same as *two* one-year subscriptions.

Start today, and you'll have your required number of subscriptions in a jiffy!

POPULAR RADIO, Inc.

Dept. 83

9 East 40th Street

New York City

BUILD YOUR OWN HAZELTINE-NEUTRODYNE RECEIVER



With these FADA Neutrodyne Parts, one can successfully construct his own Neutrodyne circuit radio receiver

Use FADA Parts

The combination package pictured combines three FADA "Neutroformers," and two "Neutrodons" and a very complete booklet telling "How to Build Hazeltine Neutrodyne Receiver."

For only \$25.00 you can purchase these essential FADA Neutrodyne Parts, and be assured of success with your home-made Neutrodyne circuit Receiver.

Extra copies of the 32-page "How to Build Hazeltine Neutrodyne Receiver" booklet will be sent for 50c.

F. A. D. ANDREA, INC.
1581-D Jerome Avenue, New York City

BEST BY TEST STRAIGHT LINE VERNIER AIR CONDENSERS

Cast Aluminum Frame Plates and Formica Insulation

Tested and Endorsed by THE TRIBUNE INSTITUTE, New York
Awarded the Evening Mail's Radio Institute CERTIFICATE OF EXCELLENCE

POINTS OF SUPERIORITY

1. Stator plates instead of being loosely fitted are pressed into slots assuring perfect electrical contact.
2. Proper capacities and no over-rating of same.
3. Rigid construction so original adjustment is maintained.
4. Rotor and Stator plates of logarithmic curve type.
5. Formica insulation throughout.
6. Patented vernier arrangement eliminating body capacity.
7. Accurate and correct spacing of special spring aluminum plates.
8. Lowest dielectric losses proven by laboratory tests.
9. Independent Vernier Control. Vernier does not rotate with main rotor plates.

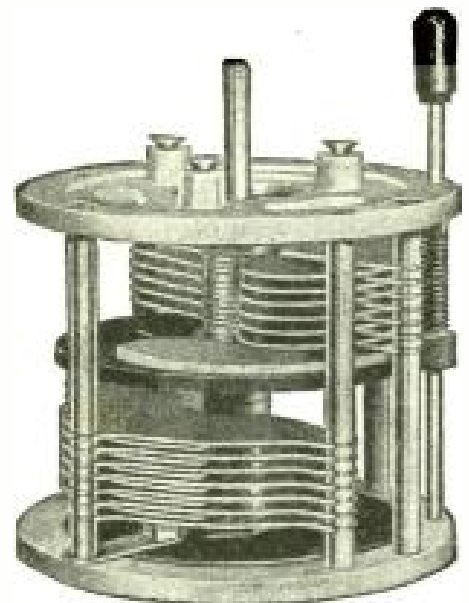

Type "A", .00047 M.F., \$6.00; Type "B", .00075 M.F., \$6.50; Type "C", .0015, M.F., \$7.50

Sold by All Leading Electric Firms and Radio Dealers
Jobbers and Dealers Write for Discounts
Special Prices to Set Manufacturers



MIGNON ELECTRIC MFG. CORP.
25-35 SOUTH WATER ST. ROCHESTER, N. Y.

Last Chance Offer! It Can't Be Beat!

MONEY saved is money earned. Radio enthusiasts want the most for their money. Here is an opportunity for you to get unusual value for your subscription dollars.

“POPULAR RADIO” and “RADIO” (San Francisco) known the nation over for the wealth of practical information they contain, in addition to a mass of most timely radio news, valuable constructional data for those who “roll their own,” feature articles by the leaders of the industry, the latest radio developments and discussions on everything worth-while

talking about, have joined forces in a great money-saving clubbing offer in order to give you these leading two radio publications at a cost very little more than the subscription price of either magazine alone. Just imagine—you can subscribe to both “POPULAR RADIO” and “RADIO” for a full year for only \$3.00—a saving to you of \$1.50 over what you would pay for them separately.

If you are already a subscriber to either magazine—or both—you can extend your subscription for another year at this unusually low rate.

This is undoubtedly one of the most liberal subscription offers yet made

“POPULAR RADIO” and “RADIO”
—one full year for only \$3.00
—a saving of \$1.50

POPULAR RADIO, Dept. 81,
9 East 40th St., New York City, N. Y.

Send me “POPULAR RADIO” and “RADIO” for one full year. I enclose \$3.00.

Name.....

Address.....

.....

Here's the little coupon that will save you big money if you mail it before August 20th.

Don't turn this page until you have clipped the coupon and started it on the way to “POPULAR RADIO.”