

THE STORY OF THE FIRST TRANS-ATLANTIC SHORT WAVE MESSAGE



PROCEEDINGS OF THE RADIO CLUB OF AMERICA INC.

1 BCG COMMEMORATIVE ISSUE, OCTOBER 1950

FOREWORD

IN November of 1948, the Awards Committee of the Radio Club of America brought to the attention of the President and Board of Directors a specific event of memorable importance which took place in December, 1921, involving seven members of the Club. The Committee in its report made reference to the group of men who got together and succeeded in communicating across the Atlantic on short waves, a step forward in the development of the radio communication art that is without equal to date—the amateur leading the professional. In commemoration of this accomplishment, it was recommended by the Committee that a marker be placed at the spot in the Town of Greenwich, Connecticut, where station IBCG, the station which transmitted the message was located, and that each of the seven members be given a replica of the Armstrong Medal in recognition of their achievements.

The Board approved this proposal, whereupon the president appointed a IBCG Memorial Committee to proceed with the selection and establishment of a marker, and the making of arrangements for the dedication ceremonies. This Committee has now completed its task and has recorded the story of the building and operation of Station IBCG and the sending and receiving of the first transatlantic short wave radio message in this specially authorized Commemorative Issue of the Club Proceedings.

The Club is deeply grateful to the Town of Greenwich for the generous cooperation in establishing the marker site, and particularly to First Selectman Wilbur Peck and Superintendent of Parks Joseph A. Dietrich for their keen interest and welcome assistance.

O. J. MORELOCK
President, Radio Club of America.

L. C. F. HORLE
Chairman, Awards Committee.



IBCG MEMORIAL COMMITTEE

GEORGE E. BURGHARD, Chairman
ERNEST V. AMY
EDWIN H. ARMSTRONG
PAUL F. GODLEY

JOHN F. GRINAN
HARRY W. HOUCK
L. C. F. HORLE
HARRY SADENWATER

360
4
57
52 7



IBCG MEMORIAL

The monument commemorating Radio Station IBCG stands at the intersection of Clapboard Ridge Road and North Street in Greenwich, Conn. It is some 200 feet east of the original station site. The marker was designed and built by Thomas H. Irwin of Old Greenwich, Conn.

NEAR THIS SPOT ON DECEMBER 11,
1921, RADIO STATION 1BCG SENT
TO ARDROSSAN, SCOTLAND, THE FIRST
MESSAGE EVER TO SPAN THE ATLANTIC
ON SHORT WAVES. 1BCG, AN AMATEUR
STATION, WAS BUILT AND OPERATED
BY MEMBERS OF THE RADIO CLUB OF
AMERICA.

DEDICATED
GREENWICH, CONNECTICUT
1950

1 B C G

INTRODUCTION

by
EDWIN H. ARMSTRONG

At the end of World War I, overseas communication by radio was universally carried out on wave lengths thousands of meters long. Costly antenna structures were a necessity, frequently including a multiplicity of towers not far from a thousand feet in height. Maximum ranges covered were of the order of four thousand miles; maximum speeds of transmission during good periods about fifty words a minute.

Today long distance communication is carried out on waves less than forty meters in length, antenna "towers" may be of the order of a hundred feet high supported by little more than outsize telegraph poles, distances have been increased to the ends of the earth and speeds into the hundreds of words per minute.

That this transition would occur became apparent about the end of 1926, after the inauguration of a practical short wave commercial circuit between England and Canada demonstrated a revolutionary superiority over all known methods of long distance communication, radio or wire. This, of course, is well-known radio history.

That the first step of the transition came about in December 1921 as a result of a series of transmission tests carried out between the United States and Great Britain by amateur radio stations is not well known. This episode in radio history is here recounted. Its part in shaping the course of subsequent events is now presented for the first time.

* * * *

This is the story of the transmission of the first radio message ever to cross the Atlantic Ocean on short waves. Specifically, it is the story of the construction and operation of amateur radio station 1BCG and the reception of its signals by Paul Godley at Ardrossan, Scotland. The story is known to few people outside of those who took part in the historic experiment of December 1921 organized by two amateur societies of the United States and Great Britain and carried out by a large group of amateurs of both countries.

The plan was simple. American amateurs were to transmit, British amateurs were to receive—and an American amateur, Paul Godley, was to be sent abroad with his own receiving equipment in an attempt to guard against a repetition of the failure of similar tests of the preceding year, when signals sent from the United States remained unreported from Britain.

The place which these tests have in radio history was appreciated by none of those concerned with them at the time. It is appreciated by few even now. But when what happened in December 1921 is compared with the records, published and unpublished, of what theretofore had passed as the "scientific knowledge" of the art, it becomes evident that the 1921 experiment marked a turning point in radio history.

Not only were the signals of 1BCG clearly readable for a large part of the time of the tests, but during one point of favorable transmission the call letters of many other American stations, including those of two "less than 50 watt" stations, were identified! Something not in the books—in fact, something contrary to what was in the books—had been turned up. The so-called knowledge of the art had been disproved and a new field of investigation opened up.

Here was taken the first step toward bridging the gap from the long wave transoceanic telegraph communication systems then in use to the present worldwide communication of today, an achievement that was ultimately brought about by a great discovery made through the imagination of Marconi and the engineering genius of C. S. Franklin.

It was the writer's good fortune to have had a hand in the design and construction of Station 1BCG, the first American station to be identified in Britain and the only station to send a message during that year. Those who read this story and who will take the trouble to compare it carefully with the state of the art of the time will find techniques of transmission used that were not to be found anywhere in commercial practice. They will find this to be true equally of the receiving equipment used by Paul Godley at Ardrossan, and they will find in the full account of the tests published in QST Magazine evidence in the reception of many signals at different locations of what must have been superbly skillful handling of equipment.

Today, with screen grid tubes, unicontrol tuning circuits, and permanently fixed and known frequencies of the transmitting station, the tuning skill of the old days has become an art as completely lost as the art of handling the clipper ships of a century ago.

In view of some attempts in the past to write the history of radio as the authors would like it to be, it is considered wise to fully document this account. The contemporaneous publications have therefore been reproduced, their present editors having very kindly given permission for this purpose.

It is seldom, indeed, that an account of an adventure of a quarter century ago can be set down with the accuracy which these records make possible. Beside the authentication of the dry facts of the case, the daily logs of events throw an interesting light on

and in fact go far to recreate the spirit of the time. That spirit was one of discovery and enterprise, a spirit which those who were there will never forget—which we know will live with us always—and which we hope will last until the end of time.

THE HISTORY OF 1BCG

by

E. V. AMY and G. E. BURGHARD

Radio station 1BCG was a special station built for a specific purpose. That purpose was to send radio signals across the Atlantic from Greenwich, Conn. to Scotland, on amateur wavelengths, and results proved that it served that purpose well. 1BCG won the prize as the best station in the Transatlantic Tests conducted by the American Radio Relay League in 1921 and its performance brought from the editor of Q.S.T. the comment: "1BCG seems an easy winner as the star station". Its signals were heard in England, France, Holland, Germany, and in every state in the Union. The greatest achievement was sending a complete twelve word message direct to Paul Godley, in Scotland. This established a new record for it was the first time in history that a radio message had been sent across the Atlantic on short waves. It must be remembered that early in 1920 all amateurs were restricted to wavelengths of approximately 200 meters, then called short waves. These wavelengths at that time were considered of little, if any, value, for long distance communication by government and commercial radio companies, and hence were assigned to American amateurs.

Many of the most outstanding advances in wireless telegraphy have been made, not along lines indicated by a study of principles and theory, but rather contrary to such indications, and the success achieved has then led to a revision of the principles and theory. It has been said by a well known authority that the reason Marconi and not Lodge was the first to transmit wireless signals across the English Channel was that Lodge was so well versed in electromagnetic theory that he knew it was impossible, whereas Marconi, not knowing it was impossible, went and did it.

If Marconi had consulted a board of leading experts in 1900 as to the feasibility of sending wireless signals across the Atlantic, it is doubtful whether he would have made his classic experiment. Principles and theory were all against him, but, fortunately, he made the experiment and gave those versed in the principles and theory the task of adjusting them to explain the facts which were commenced by Heaviside and Kennelly in 1902 and which have been advanced ever

since by a number of others with remarkable results.

However, the true explanation of the sky-wave phenomena was not possible until high frequency transmitters and sensitive short wave receivers became available to the thousands of amateurs. They explored this unknown band of frequencies and came up with remarkable and far reaching results. In the first few years preceeding 1920 surprising reports of amateur low-power contacts were being established with increasing regularity at ranges of around a thousand miles, far greater than that predicted by the well established ground wave transmission curve. This curve roughly represented the best known information, according to theory, about the range of radio waves at that time. It made low frequency or long wavelengths of 15 to 20 thousand meters look particularly attractive for long range transmission of 2,000 to 3,000 miles, and gave a maximum range of only 600 miles (over water) for amateur wavelengths of 200 meters.

To construct a quarter-wave vertical transmitting antenna for 15,000 meters (20 KC), a structure 2¼ miles high would be required. Since such construction was impossible, the government and commercial companies built their antennas as high as economic considerations allowed, with the result that the effective height was still a very small fraction of a wavelength and all such antennas were, therefore, a "brute force" method of generating radio waves and, at best, very inefficient. Furthermore, such a low frequency greatly limits the total number of frequency assignments available and limits each station to a narrow modulation band and relatively low speed transmission.

Although no complete official station log exists covering the construction and operation of station 1BCG, recollections are still vivid in the minds of the six Club members who built and operated it. Some are here related to give the reader a fair conception of the trials and tribulations, as well as an occasional humorous side of this historic project.

Building a radio station in 1921, even under the best of conditions with plenty of time to do the job, was quite a task. But to build one that had to do the



1BCG

General overall view of station 1BCG looking east and showing the antenna, counterpoise and operating shack, located on a field of the Elisha P. Cronkhite estate, Greenwich, Conn. Clapboard Ridge Road can be seen in left background running east and west. The Flat Top "T" type cage antenna is stretched between two steel masts 108 and 75 feet in height. The cage down lead can be seen connected to the roof of the shack and one of the counterpoise supporting poles is visible in the foreground.

impossible, to wit, transmit short wave signals across the Atlantic, and in the very short time of three weeks, was truly a courageous undertaking. This challenge we could not resist, particularly after hearing Paul Godley's parting words before he sailed for England as official representative of the A.R.R.L. to listen for American Amateurs in Scotland, when he pleaded: "Please build a station that Will get over there". Godley, no doubt, like ourselves, recognized the great odds against anyone getting a short wave signal across the Atlantic from an existing well established, perfectly designed station,—but we didn't even have a station! So we decided to build one and this is the story of how it was done.

Many and varied were the suggestions as to where the station should be located and what type of transmitter, how much power, and what antenna system to use. At first, Center Moriches on Long Island struck our fancy because there were two existing towers ready for use, but this site was discarded as being too far from the city where most of us lived. Burghard had a 75 foot guyed wooden mast on the roof of his five-story home at East 93rd Street in Manhattan, but this location wouldn't do because there was only D.C. power available. A piece of property was offered to us down near Atlantic Highlands, N. J. This was on high ground overlooking the ocean, but here there were no masts available and only a few hundred watts of A.C. power of doubtful voltage regulation.

We finally agreed that the site of Cronkhite's existing amateur station 1BCG would be the best location. It was situated near North Street on Clapboard Ridge Road in Greenwich, Conn. There was one 75 foot guyed steel mast available, also a small radio shack, plenty of A.C. power, a station license and a good clear ground space. All this with NO rent to pay just seemed ideal, so it became the station site.

Things really got started on November 19, 1921. On this Saturday afternoon, Amy, Inman and Cronkhite went to Greenwich to study the site and make plans for the antenna and ground system. It was decided to erect another mast 108 feet high to support a "T" type antenna and to move the shack to the open field and erect suitable posts to support a counterpoise ground system. Since time was short, arrangements were made to get construction help from the Greenwich Fire Company. Two members were present at the time and were more than willing to give us a hand.

The Fire Company was a great help to us, particularly in raising the 108 ft. steel pole. Unfortunately, during the early construction days of the station, weather conditions could not have been much worse, with rain, sleet, ice, snow or bitter cold most of the time. Several of the members of the local Fire Com-

pany loaned us their equipment, such as rubber boots and waterproof coats. Needless to say, this was most welcome when constructing the cage antenna and radial wire counterpoise in the rain and snow. Just when we were all hard at work, the inevitable had to happen. There was a fire in town and many of the lads were without their boots and coats. After a frantic phone call from the Fire-House, the missing equipment was rushed to the scene of the fire just in time to avoid any serious trouble, but it was a close call.

The design of the antenna and ground system was worked out by Amy and Cronkhite on November 20th for the purpose of building the most efficient transmitting antenna we could devise, using the best and latest technical knowledge then known. The antenna was to operate at a natural period of approximately 200 meters for maximum radiation efficiency. In order to keep the ground losses as low as possible, a radial counterpoise ground system was designed. A vertical wire, $\frac{1}{4}$ wavelength high, we knew should be a good antenna, but this would require a height of 156 feet for a wavelength of 200 meters. This was impossible to even hope for, so we had to do the best we could with one existing mast 75 feet high on the highest part of the land and erect another 108 ft. steel mast some 230 feet away in the low part, in order that the flat top section of the antenna would be approximately horizontal and the poles with their guy wires as far apart as possible and away from the induction field of the antenna. Calculations showed us that a "T" type antenna with a 100 ft. horizontal cage flat top made up in two sections, each 50 feet long, with eight #14 stranded phosphor bronze wires equally spaced around 18" diameter metal hoops and connected from the center point with a 70 ft. downlead to the counterpoise would have a natural period of approximately 190 meters.

In order to have as good a ground system as possible for the existing conditions, it was decided to use a radial wire counterpoise which is a form of capacity ground and very effective in rocky or sandy soils with poor conductivity.

It was well known that for a counterpoise to work properly, it must have sufficient size to have considerable capacity to ground. This means it should cover as much ground area as the location will permit. Its height is not critical, but should be high enough to be out of the way and allow clearance for a person to walk beneath it and at the same time not of such height as to noticeably reduce the effective height of the antenna. Since the function of the counterpoise is to act as a pure capacity ground, it should be free from self resonance effects.

The final design of the counterpoise as used at this

station consisted of thirty radial wires, each 60 ft. long, extending from a common central point at a height of seven feet above the ground. In order to reduce resonance effects of the counterpoise, it was made in two equal fan shaped halves, each with 15 wires. The end of each wire extending in a radial fashion was fastened to an insulator 60 feet from the central point. Each insulator was in turn connected by a wire to the heavy outer cable which ran between the eight counterpoise supporting masts which formed an outer square supporting cable approximately 120 ft. on each side. This made a very rigid and sturdy supporting arrangement for the counterpoise which was free from any noticeable change in capacity with the wind or heavy ice loading conditions.

As soon as the antenna and counterpoise construction was completed, an attempt was made to energize the system by a more or less new principle, namely, to excite the antenna and its counterpoise by means of a single wire non-radiating feed line directly connected from one end of the cage flat top to the trans-

mitter. The purpose of this method of exciting the antenna was to avoid any loading coil in the main downlead from the antenna to the center of the counterpoise and thereby excite the antenna at maximum efficiency without loading or coupling coils and thus avoid their inherent losses. Calculations indicated that for a current of approximately six amperes in the downlead at this point of connection to the counterpoise, a power input to the antenna of 800 watts would produce a voltage of approximately 1700 volts at the end of the antenna. Consequently, by feeding the end of the antenna with a single wire feed line at a voltage of 1700 and a current of 800 divided by 1700, or 0.47 amp., we could very effectively excite the antenna system. In addition to the main ammeter between the downlead and the counterpoise, this system required two additional R-F ammeters in the feed line, one near the top end of the antenna and the other at the end of the line coupled to the transmitter. Proper operation required that each meter read the same in order to avoid standing waves on this feed line.



Armstrong at right, supervising construction.

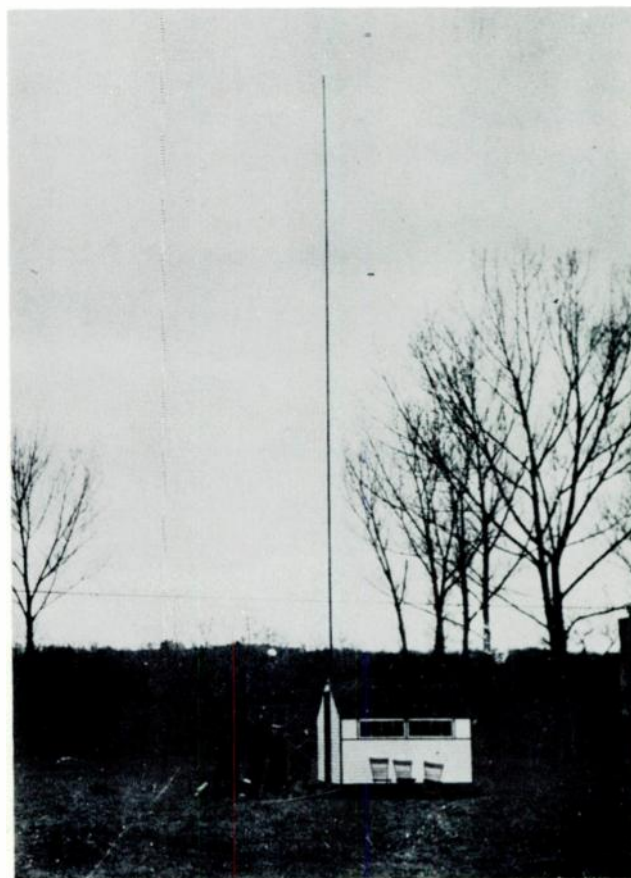

Overall view of station looking west. Counterpoise pole and wire in foreground, 108 foot mast in background.

1⁵⁰ - 1BCY says "Bi 1 hour"

1⁵⁵ 2EH CW "Test"

Lots jamming from Holland
stations

1⁵³ 2FP in strong, ECW

2⁰⁵ Am 2ARY ECW "Test"

Lots of @RM from
Poldhu's press on harmonics
Other press schedules
also going & all seem
to have harmonics makes
it difficult

2¹¹ 3FB 1PK "Test"

@RM FFU

2¹⁴ 2A9W cly 20E CW

2²⁴ 2EH CW cly 80XV.

VAT are jamming

2³⁵ 2EL calling Weak ✓

2³⁹ 1ARY CW weak

2²⁰ 2EH cly 8AFD very steady

2²⁰ 1BCY in with weak

2⁵² Am

"Nr 1 de 1BCG W-12

Newyork Date 11/12-21

To Paul Godley
Ardrossan Scotland

Hearty congratulations

Burghard

Inman

Erin

Armstrong

Amey

Crosswhite."

Rec'd from 1BCG finish-
ing at 3 Am.

He says "bi two hour"

3⁰³ 2FH working 2XQ

very steady x

3¹¹ 1RZ in CW. Resdove

Also many weaker ones

fanned by HP str.

THE FIRST MESSAGE

Facsimile of pages 44 & 45 from the original log kept by Paul Godley in Ardrossan, Scotland, showing the now famous message "Nr. 1," as he copied it from station 1BCG at 2.52 A.M., GMT on December 12th, 1921. This 12 word message was the first ever to be sent across the Atlantic on short waves.

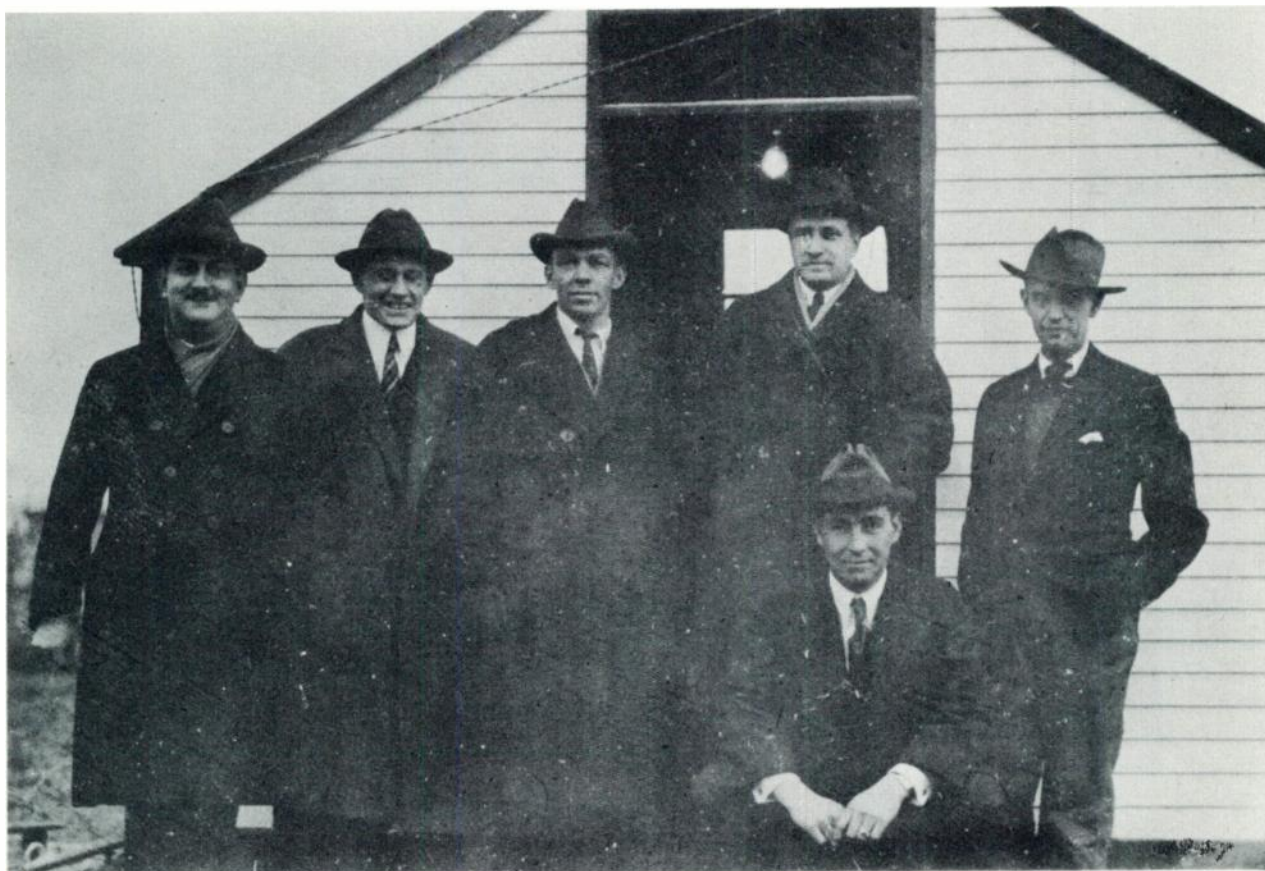

THE MEN WHO SENT THE MESSAGE

The six man operating and engineering staff of 1BCG posed outside the transmitter house after sending the now historic message to Scotland. Standing, left to right—John F. Grinan, Ernest V. Amy, Edwin H. Armstrong, George E. Burghard, Minton Cronkhite. Seated front—Walker P. Inman.

This method of feeding the antenna was found to be extremely critical and laborious as it required a telescope to read the meter up at the antenna, 70 feet off the ground, while another man read the meter in the shack during transmitter adjustments. These adjustments were made more difficult by the fact that the work was done at night and, since the allotted time to get on the air with the transmitter was rapidly passing, we decided to abandon this method of feeding the antenna in preference to the more conventional method as finally used.

In order to get a transmitter of approximately 500 watts put together in the shortest possible time, it was first decided to use two 250 watt UV-204 Radiotrons in a self-excited self-rectifying oscillating circuit. This required an 8,000 volt center tapped plate voltage transformer, with a primary to operate from 110 A.C., and a step-down filament transformer to light the filaments of the tubes requiring 11 volts at 3.75 amps each. The plate of each tube was connected through a choke coil to each end of the high voltage transformer secondary. The normal D.C. plate voltage of these tubes was rated at 2,000 volts, but this value could be safely increased 100% for alternating current without damaging the tube. A simple Colpitt's oscillating system was employed. Keying was accomplished by a relay in the primary of the high voltage plate transformer.

This transmitter was very easy to put into operation and produced strong signals in distant receivers, but it had several disadvantages, such as susceptibility to frequency changes with antenna swinging and line voltage fluctuations. It also produced a strong 120 cycle modulated signal tone. At Armstrong's suggestion, it was decided on December 5th to rebuild the transmitter, using a master oscillator power amplifier arrangement in order to avoid the self-excited oscillator disadvantages and produce a pure, steady C.W. signal for ideal heterodyne tone reception. This was no small job to undertake at this late date with the added burden of acquiring all the new equipment necessary to construct this transmitter. The shack had to be moved so as to be beneath the center of the antenna, which also entailed moving all the power lines. We procured and installed a 2000 volt D.C. motor generator set as well as a new filter system and high frequency condensers with two additional "P" tubes. If it had not been for the never ending persistence of Armstrong, we never would have had this master oscillator power amplifier set working in time to compete in the epoch making contest.

During the evening of December 6th, however, this new transmitter was put into operation. Using two 250 Watt "P" tubes as amplifiers and one as oscillator the antenna current was slowly increased to 4 am-

peres, and there it stayed for all adjustments until finally, having worked past 4 amps. it suddenly jumped to 6. A long CQ was sent out at 3.30 until the filter condensers began to boil and break down. We shut down at 4.30 A.M.

On December 7th, the first day of the transatlantic tests the entire staff was kept very busy making last minute improvements and adjustments. The control switches for filaments and motor generator were installed on the receiving table and another tube added to the power amplifier which was running much cooler now, but still not satisfactorily. During this time the tests had officially started and we heard many stations sending while we were still in a condition of more or less chaos. Finally with three amplifier tubes in parallel we increased the antenna current to 6½ amperes. Although we were still having some condenser troubles and keying difficulties we sent out a long C.Q. calling Godley until the condensers in the master oscillator circuit heated up and forced a shut down. Using a receiver which had been obtained in Greenwich and hastily rebuilt to receive long waves, we listened for W I I. but were disappointed when the message contained no news from Godley except that all reports will be delayed 24 hours.

On the second night of the tests, December 8th, we began transmitting at about 7:00 PM E.S.T. and continued during the special test period sending our code word Godly. Many other stations were working in their respective periods and we listened to them on our shortwave Paragon regenerative receiver. It had been arranged with the British Marconi Company by the sponsors of the transatlantic tests to send Paul Godley's daily message from its long wave station MUU at Carnarvon, Wales every night at a specified time, namely, 2:00 AM Eastern Standard. However, when some of the members of the Club were discussing this with W. A. Winterbottom, then Traffic Manager of the Radio Corporation of America, he made a most important suggestion—one that helped tremendously in building up the excitement of the event.

Since relatively few amateurs would have equipment capable of receiving the signal direct from Carnarvon, and in any event since reception was likely to be marred or destroyed by static, Winterbottom suggested that Godley send what was known as a TC message, that is, a repeat message, and that the Radio Corporation immediately after its receipt would then repeat it at slow speed from its long wave station WII at New Brunswick, New Jersey. In this way, everyone in the eastern half of the United States would be sure of getting a clean copy. Unfortunately, the message was always delayed 24 hours because of the machinery of handling it on the other side. The message came through that night at 2:05 AM EST.

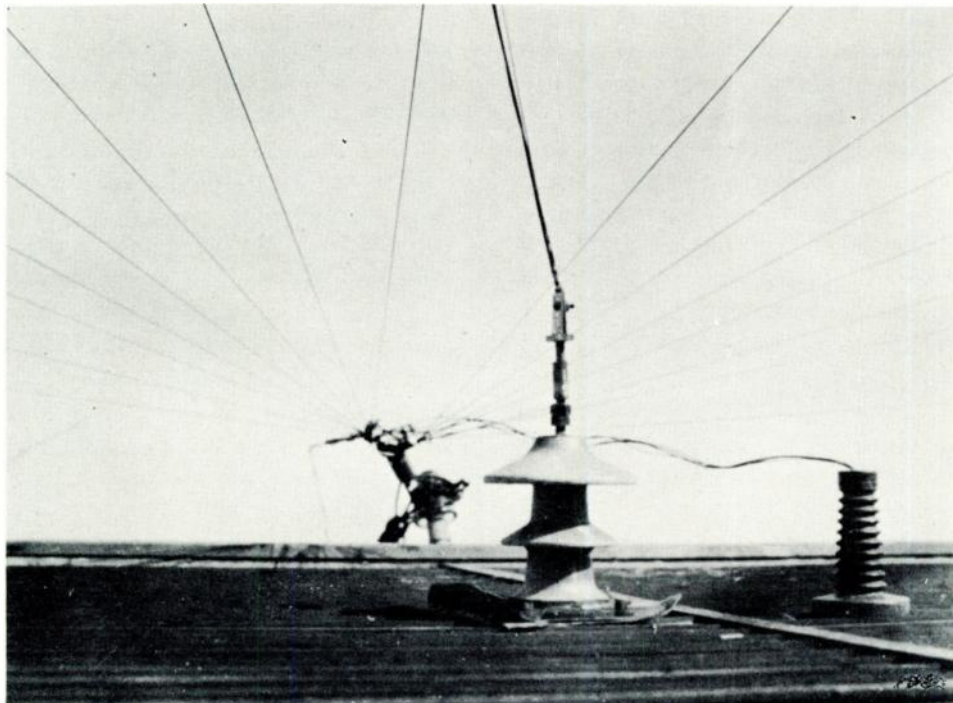

Roof of shack with antenna and counterpoise lead-ins.

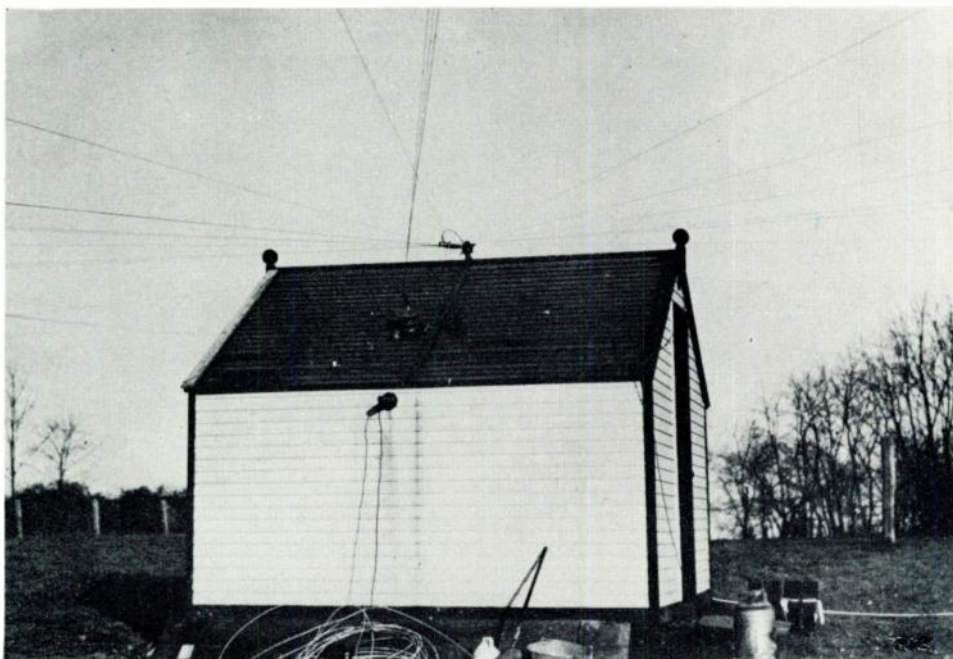

Exterior of shack with work nearing completion. Antenna and counterpoise connections as well as external ground for filaments and receiver, can be seen.

There we were with pencils and paper grouped around our special long wave receiver and loud-speaker ready to copy what Godley had to report. Fortunately for all, we had among us John Grinan, better known to the radio fraternity as "Johnny" or "JG". He has the distinction of being the first amateur to send a relay message to the Pacific Coast from his station 2 PM, New York City back in 1916 and also of getting the first direct signals across the continent in the same year. Besides this he had what is known to telegraphers as one of the prettiest fists in radio. So clear and so well known was his sending that Godley was able to recognize it at once when he heard the signals in Scotland and mentions it in his log. John and two other crew members had had commercial tickets for years and were experienced operators. But so great was the excitement when WII began sending, that hands trembled and the only clean copy was made by Armstrong who was head of the engineering staff and not supposed to copy at all.

The message stated that the only signal heard was from a spark station, 1AAY. This was most disconcerting news as we all felt sure we had made it. We were asking ourselves: "How could a spark transmitter outperform a high power CW with a pure heterodyne tone reception?", when the telephone rang. It was K. B. Warner from ARRL Headquarters at Hartford. He said that 1AAY was located in Bridgeport but could not raise him on the phone and asked if we would drive up there and check. It was a foul night, sleet and freezing rain, but Armstrong and Inman got into the old Packard and slid rather than drove to Bridgeport. They returned at 7:00 AM and reported that there was no radio station at the address given. Later reports proved that there had been an error in cable transmission and that the call letters should have been 1AAW. Further investigation was to disclose that he also was not transmitting that night. The full details are set forth in the official report of the ARRL by Warner in QST Magazine which is reproduced in the pages that follow. After this we decided to call it a day and get some sleep.

During the building of the station and throughout the tests the crew was quartered in the Maples Hotel in Greenwich, some two miles away by road. Many was the skiddy, icy ride we had in Armstrong's open Packard in zero weather, too sleepy to even notice the cold. When the time came to start the car to go to town and the cold was too much for the battery to buck, pushing was in order. By oscillating the Packard back and forth between two hills on either side of a hollow where the car was parked, we would finally get the motor running. Then we had to sit there until she warmed up enough to make the hill. One morning the radiator was frozen solid. There was

nothing to do but go in spite of it all and we arrived in town steaming like a locomotive, just making a garage before she stalled.

On December 9th, the third night, we again started up during the free for all and then sent on schedule calling Godley and signing 1BCG. The tubes were running cool and all was well with 6 amps. in the antenna, so we continued on fifteen minute shifts until 2:00 AM when we knocked off to listen to WII. The message stated that the weather was cold and clear and no signals had been heard. At 6:00 AM back to the Maples went six exhausted men. The Maples was a very nice quiet hotel patronized by a staid, elderly clientele and run on a strict system. Why they tolerated the motley crew who showed up in rubber boots and went to bed when respectable people were coming down to breakfast, and then left again in working clothes just when everyone was dressing for the evening meal, is still an unsolved mystery.

On the morning of the fourth day, December 10th, we received a cable from Godley saying: "Send MGES starting one Greenwich". This cable was to cause the loss of a great opportunity because of a misunderstanding. The staff discussed its meaning for many hours. There was no way of getting a confirmation from Godley, so we had to decide just what he meant by "send MGES". Those who were telegraphers said that if he wanted us to send messages he would have used MSGS as that is the proper American abbreviation for messages which he well knew. Cronkhite, who was an engineer and not an old Morse operator, was the only one who maintained that Godley wanted us to send messages. Finally he was voted down 5 to 1 and we decided that MGES was a code word and for some unknown reason that was what he wanted us to send. And send it we did from 8:00 PM until 3:00 AM all night long.

It was necessary to work in short shifts of ten minutes with three operators because of the extreme cold. There was only a small oil stove to heat the shack and with six large men and the stove using up the oxygen the door had to be opened once in a while to help keep us awake. This operation let in the icy blasts and would chill the sending hand of the operator using the key. We tried gloves, but they spoiled the style, so we rigged up a 120-watt lamp with reflector directly over the key which improved working conditions considerably. By the time the session was over, however, the operating staff was pretty well in the glass arm class. At 2:00 AM we shut down to get the WII report. This time there was no mistake. "Heard One Boy Cast George calling me strong steady congratulations" was the word. We had done it. The station rules were suspended and the "emergency" bottle was passed around. The exact time of recep-



Amy inspecting the counterpoise during construction.

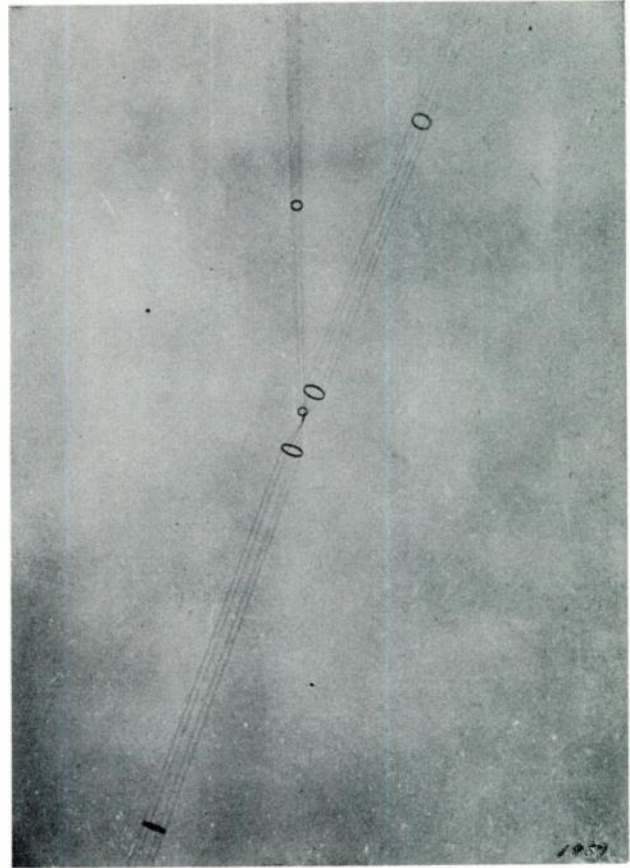

Looking up at the cage antenna and down lead.

tion—12:50 AM G.M.T.—is recorded in the article written by Godley and the entries in his log which follow. The record shows that 1BCG was the only signal heard that night.

On December 11th, the mystery of MGES was solved by cable. What Godley had said was "Send messages", and the British cable operator used the English abbreviation MGES. This story is told in Godley's log. Now we really prepared to send a message which was to be the first ever sent across the Atlantic on short waves with low power, or in fact with any power. The transmitter was checked from all angles and the very best adjustments made. By 7:00 PM the antenna current was 6.5 amps. with a total input of 990 watts and the wavelength 230 meters. Test signals were sent out in the Transatlantics according to schedule and further adjustments made. The following message was formulated:

"Nr. 1 de 1BCG words 12, New York December 11, 1921.

To Paul Godley, Ardrossan, Scotland.
Hearty Congratulations.

Burghard, Inman, Grinan, Armstrong, Amy,
Cronkhite."

At about 9:45 PM EST, Chief Operator Grinan took the key and began sending the now historic mes-

sage. The power input was still 990 watts and the wavelength unchanged at 230 meters. The message was repeated until 10:00 PM to insure its reception since there was no means of checking. Godley's log shows that it was received in full the first time it was transmitted. This was another record for Johnny Grinan and put the title of Champion Amateur Operator of the World in his hands. None of us realized at the time how important this message was to become, but we did feel fairly confident in view of the reported signal strength that the message would be received in Scotland.

At 2:00 AM we copied the report from WII. He was, of course, giving us what had happened the night before. We had again been heard together with several other CW and some spark stations, so that the success of the tests was definitely assured and everybody was happy. So to bed after cleaning up the set and checking all power. Looking back now it seems a miracle that during the seven days no one got mixed up with the high voltage. Six men, usually with wet feet, in a small shack ten by fourteen, with very little elbow room, and 2000 volts DC, was, to say the least, a dangerous situation. But luckily nobody was even burned.

On the morning of the twelfth, we received a cable



It wasn't all easy. Johnny Grinan, Chief operator, hauling on a guy wire wearing fire department boots and coat for protection.



Grinan and Amy taking out the snarls and kinks.



Time out during the building of the counterpoise to warm up. Left to right—Burghard, Inmann, Grinan, Alva B. See.

from Paul Godley acknowledging receipt of our twelve word message in full and congratulating us on the great work. We knew at the time that this was the first message ever sent under such conditions, but really didn't feel the true impact of it all until after the news got out and into the press. Then visitors began to arrive in Greenwich. Warner came down from Hartford to look us over and, of course, all the hams who could make the trip showed up. The commercial companies also sensed that something new had been accomplished. David Sarnoff, then General Manager of the Radio Corporation of America, made a trip with some of his aides to see how this could have been done with such low power and on such short waves. Prior to the tests, most radio engineers had pronounced the feat impossible. Our most distinguished visitor was Dr. Michael I. Pupin of Columbia University. He was accompanied by William Deegan of the Postal Telegraph Company. As he put it: "I came up to see what you boys were doing". Their interest is quite understandable when it is considered that Radio companies were spending millions at that time on long wave high power equipment, while the total cost of 1BCG, although it never was accurately figured, could not have been much over a thousand dollars.

The station continued in operation during the remaining days of the test, but by this time so many amateurs had heard us that practically every ham in the country was calling 1BCG. As a result, we spent a great deal of time answering their calls and sending messages.

Godley in Scotland, due to weather conditions or something beyond his control, never heard any amateur signals from the United States again after the morning of December 12th. The WII messages came in night after night reading: "Bright moon shine no reception", until the end of the transatlantic tests.

1BCG had done the job. Its achievements are recorded in the articles which follow, but let us quote from the official report of the tests in QST, the official organ of the ARRL:

"1BCG seems an easy winner as the star station. In addition to being heard all over the map, they got thru a coherent message on broadcast, at 3:00 AM G.M.T. on Dec. 12th, which was acknowledged by Godley by cable to this office. The first amateur transatlantic message ever sent read as follows: "Nr 1 NY ck 12 to Paul Godley, Ardrossan, Scotland. Hearty Congratulations. Burghard Inman Grinan Armstrong Amy Cronkhite".

Later reports were to show that an amateur operator in Holland using a regenerative receiver and two stage audio amplifier had copied all but one word in the signature of the now famous message, and a Brit-

ish amateur had heard the signals 15 feet from the phones. A ship operator at the dock in Cuxhaven, Germany, also copied 1BCG signals on December 9th, reporting great clarity. That is a distance of some 4000 miles. U. S. amateurs all over the country were contacted during the next few days. In fact, the traffic was so heavy that we used two operators, with two pairs of phones connected to one receiver. The incoming signals were tuned so that two stations were audible at the same time. One operator would read one and the second operator the other and then take turns at the key to answer. It worked very well, especially when the other hams got wise to what we were doing, and cooperated. On one of these nights we succeeded in getting a complete message thru direct to Catalina Island off the coast of California. This was followed by two more and also constitutes a first in radio transmission.

On December 29th, the station was dismantled and the transmitter as a unit transported to Columbia University to be exhibited at the reading of a paper before the Radio Club of America. It was never put into operation again. All technical data on the transmitter, antenna and counterpoise systems is set forth in this paper entitled "Station 1BCG", a reprint of which will be found in the latter part of this book.

In conclusion, let us add that this station was built and operated as a strictly non-commercial venture. The six of us couldn't resist the challenge to further our knowledge of the mysteries of radio and help blaze a new trail through the then scientific wilderness of long distance shortwave radio communication.



Getting ready to hoist the cage antenna.



General view of the station shack showing antenna and counterpoise leads with five crew members lined up in the snow. Left to right—Amy, Grinan, Burghard, Armstrong, Cronkhite. Inman was not present when this picture was made.

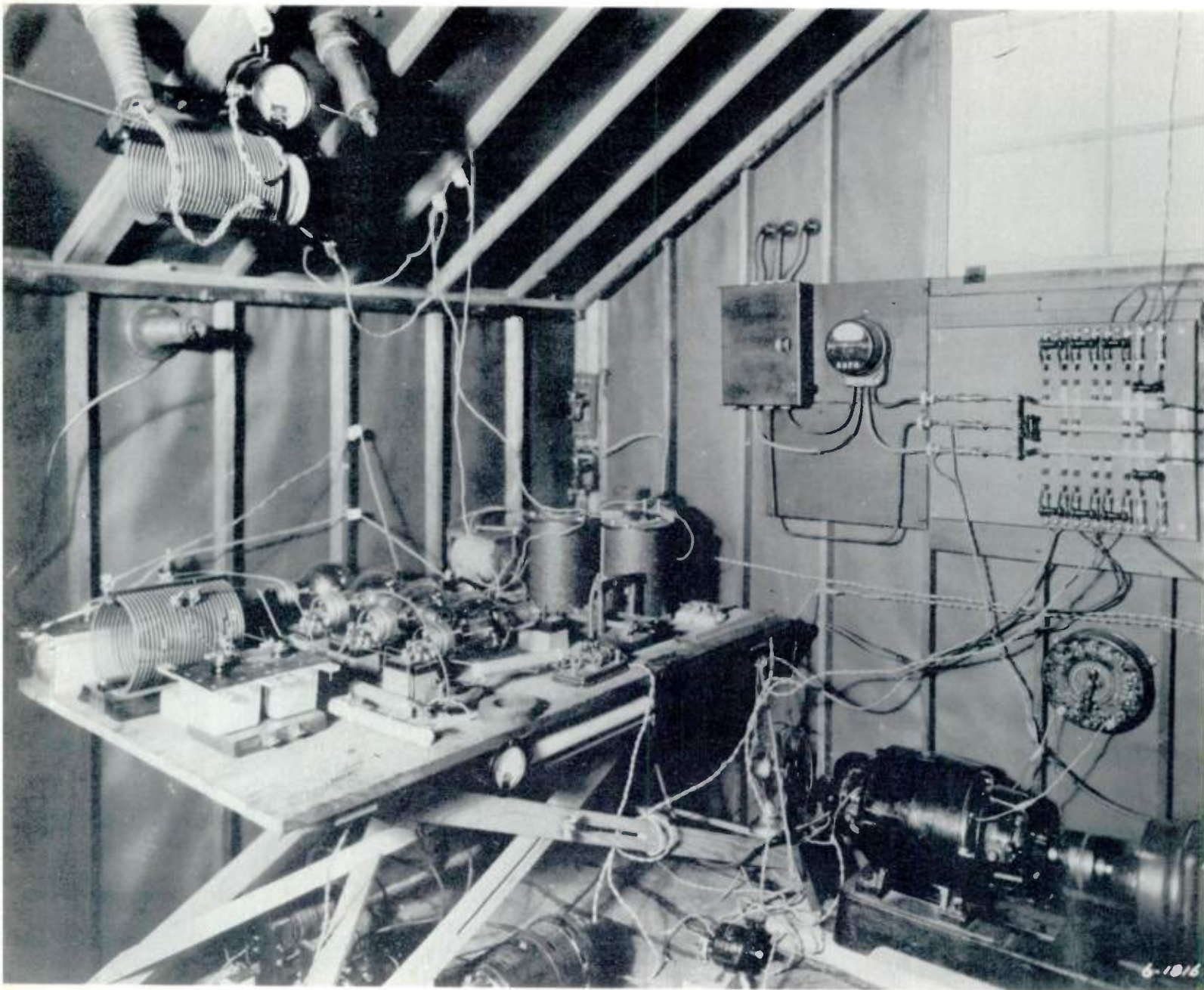

1BCG TRANSMITTER

Pictured here is the transmitter section of the shack. The four type "P" Radiotron UV204 Vacuum Tubes can be seen mounted on the center of the table, the oscillator tube on the right and the three amplifiers at the left. The oscillator circuit with ribbon inductance and mica condensers left foreground and the power amplifier variable plate tuning condensers rear center. One of the keying relays is on the table front center. A choke coil of the filter system is to the left of the plate tuning condensers just below the other keying relay mounted on the wall. Upper left—Counterpoise lead-in insulator, antenna coupling coil, radiation ammeter, and antenna lead-in. The 2000 volt DC. motor-generator set can be seen lower right and the filament transformer under the table left foreground. Note the electric fan for cooling the high voltage generator.

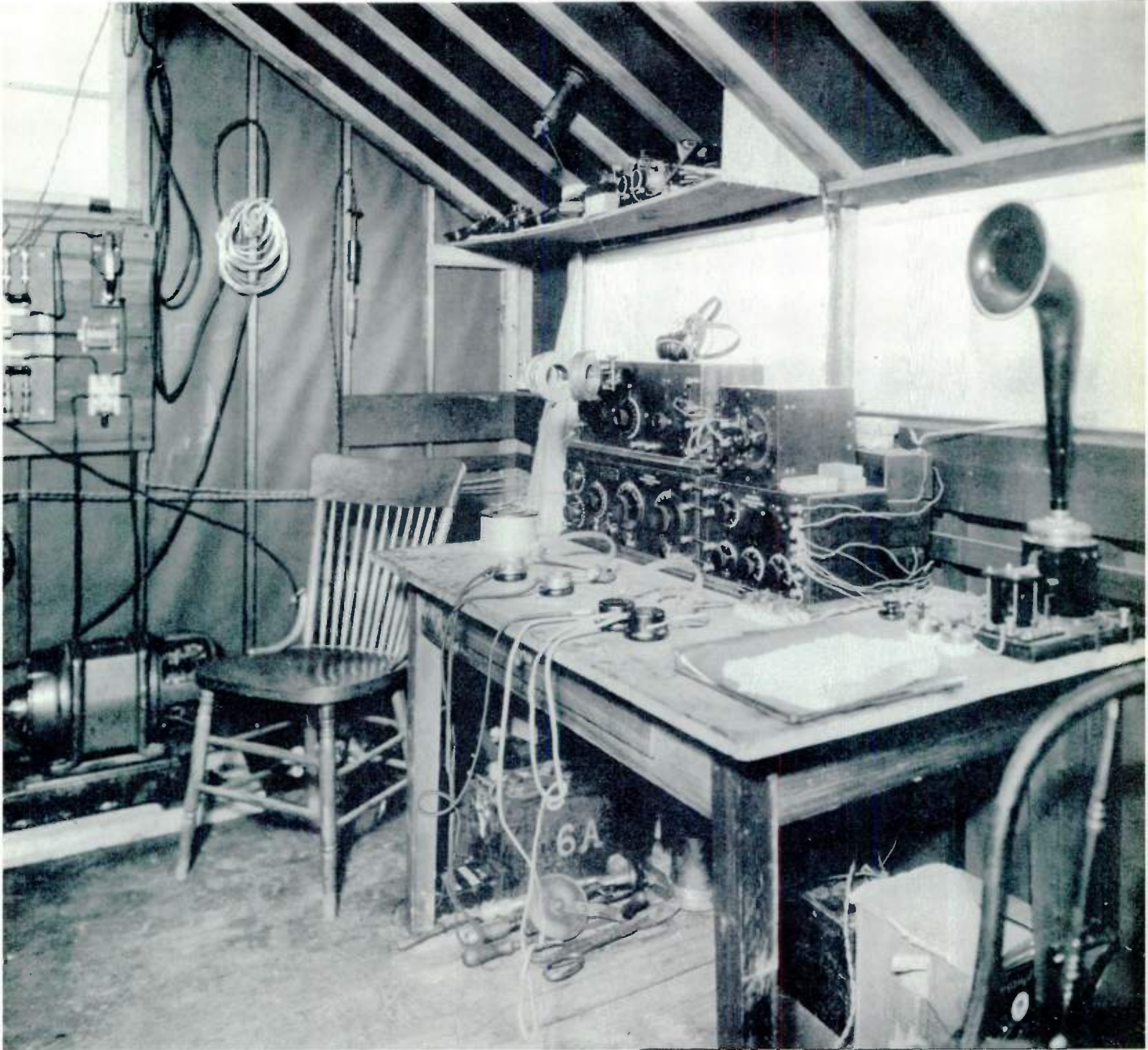

1BCG RECEIVER

This is the other half of the shack showing the receiver section. The short wave Paragon RA 10 regenerative receiver and amplifier are on the table right center. The long wave set for copying the nightly reports from WII is mounted on top of the Paragon. The small cabinet to its right contains the frequency monitor. The sending key and the two transmitter power control switches can be seen at the right in front of the Magnavox loud speaker.



PUPIN COMES TO VISIT THE STATION

Professor Michael I. Pupin of Columbia University came up to Greenwich with Mr. William Deegan of the Postal Telegraph Co. "To see what you boys are doing," as he put it. Front row, left to right—Armstrong, Burghard, Dr. Pupin, Cronkhite, Grinan. Standing rear, left to right—Tex Mc Bain of the Greenwich Fire Dept., George Brillhart, John Hobe, Carl Trube, William Deegan, R. H. Mc Mann, V. A. Hendrickson, Jack Mc Williams. Far rear—John Cullen, Fire Dept.

RECOLLECTIONS OF A MEMBER OF THE ENGINEERING STAFF OF IBCG

by
EDWIN H. ARMSTRONG

The engineer without experience with the transmitter art of 25 years ago may well look at the wiring diagram of IBCG and express wonder at the weird arrangements that were used. The engineering staff of IBCG might well counter with the remark: "Who else up to that time had ever built a transmitter to cross the Atlantic on a 200 meter wave length in less than one week's time?"—a good enough answer under the circumstances. Better answers lie among the recollections of the engineering staff to account for the things that were done.

The writer of this section became actively interested in the transmitter design shortly before the 5th of December, when an observation made in New York City of the roughness of the tone of the "self rectified A.C. self oscillator" used at IBCG recalled the success of a master oscillator power amplifier CW network that had been installed in the A.E.F. The superiority of the steady C.W. beat note over the I.C.W. and C.W. self oscillators then in use in all other nets had been observed throughout the Allied Armies.¹

Discussion of these results led to the serious decision to switch over to a master oscillator-power amplifier with DC motor generator power supply, despite the major operations that would have to be carried out in the three days left before the tests began.

The first step was taken without difficulty. A 2000-volt motor generator was quickly obtained from the Electric Specialty Company located in the nearby town of Stamford, and a P-tube master oscillator circuit tuned roughly to 200 meters put into operation. After some trouble caused by heating and a few burn-outs of components, a proper selection was made which gave fairly steady operation (over short periods of time, as we were to learn later). A couple of open iron core choke coils, located amidst the stores of the Hartley Research Laboratory at Columbia University, formed the filter which removed commutator ripple, so that the oscillator gave a clear, steady beat tone when listened to at an amateur receiver located in the neighborhood.

The second step was the one that was to cause the trouble. Bear in mind that at this time the art of neutralization was unknown, and that parasites, while known to exist, were looked on as a mysterious visitation of trouble which obeyed no known laws. The addition of two P-tubes in parallel as amplifiers

¹This was the first instance of master oscillator sets used in military communications.

produced all the strange effects that our present knowledge would enable us to anticipate. Tubes ran extraordinarily hot with much smaller plate currents than that current with which at other times they ran quite cool. Grid leads within the tube became suddenly incandescent, necessitating split second operation of the plate voltage switch to save the tube. Sometimes even the split second operation failed to save a tube.

For a period of about 36 hours of erratic behavior, the power stubbornly refused to appear in the antenna, but dissipated itself internally among the circuits, as evidenced by repeated component heatings and failures. None of us recall the number of "cut and try" changes that were made, but some time during the second day the important step was taken of including a series tuning condenser in the plate circuit of the multi-tube amplifier. Adjusting this condenser below a critical value produced an immediate stabilizing effect due, of course, as everyone now knows, to the introduction of a positive resistance reaction into the system through the medium of the plate-grid capacities.

From this point on the system was gradually stabilized and the power developed in the antenna rose steadily to an estimated 600 watts by the third day of the tests. The somewhat odd tap-on points of the various grids and plates shown in the diagram were arrived at experimentally, the test being the particular adjustment which stopped a particular parasite from playing around in the circuits.

The final problem was the keying of the transmission without spoiling the note. Attempts to key the master oscillator (with fixed bias on the amplifier grids) resulted in instability of the beat note due to heating, surges, etc. The oscillator was therefore kept permanently in operation and keying carried out by opening the amplifier grid leak circuit. A residual antenna current for open key conditions of about one-third that obtained with closed key conditions due to feed-through of oscillator power via the amplifier grid-plate capacity rendered the signal hard to read. This difficulty was solved for purposes of the test by arranging an auxiliary keying relay to alter the frequency of the master oscillator during the key-up conditions, the change in frequency being adjusted to carry the beat note out of the audible range of a receiver tuned to the main wave.

During the third day of the tests, after steady operating conditions had been established, our concern was principally with the steadiness of the note, and various troubles due to poor contacts caused by heating and the like were located. Information about the steadiness of the note was obtained by working various stations during the day, and the conflicting reports worried the staff no end. Finally it was observed that the reports of a good note came from stations at a distance, while the reports of a poor note were almost uniformly from stations in the local area. Subsequently the reason became clear—the high level of the signal was pulling the frequency of the self-heterodyne receivers into step with it! After that we rigged up to observe the frequency within the station on the third harmonic of the monitoring oscillator.

Of course after 1BCG got across three days running, the engineering staff were on top of the world. They let it be known that they were the boys who knew how to design transoceanic transmitters. Period! However, when for two days running the reports of no signals came through from Godley, the operating staff became critical. Suggestions were made that the transmitter must be wearing out, or that the signals must somehow be getting out of the groove that we thought we had worn through the ether to Ardrossan.

With the few days remaining of the tests, something

had to be done quickly. Recalling again that the CW net in the A.E.F. had been set up by connecting two motor generators in series to give twice the voltage on the plates of the tubes used for which they were rated, it was suggested that perhaps the tubes presently in use might also operate more “efficiently” if higher voltages were applied to the plates of the amplifier. Another motor generator was rushed in from Stamford—this time a 2500 volt affair. It was duly connected in series with the motor generator then operating, and the resulting 4500 volts applied to the plates of the P.A. It worked—and held together throughout the balance of the tests. It appears that the transmitter did operate more “efficiently”, but no check could be made due to the failure of the antenna hot wire ammeter to hold its calibration after a severe case of overheating.

However, the engineering staff received its first lesson in the vagaries of North Atlantic short wave propagation. The forces of Nature were not to be overcome by mere brute force methods, at least not by such amounts of power as could emanate from an “10 X 14 hut”. I believe the transmitter demonstrated its increased efficiency during the post-test period and that the engineering staff regained its standing with the operating staff when they were able to work every State in the Union without difficulty.

PROCEEDINGS OF THE RADIO CLUB OF AMERICA

PHONE FLATBUSH 7567

PECK & PECK

68 WOODRUFF AVENUE

RADIO SUPPLIES

INSTALLATIONS

March 6th 1922.

Operators of Station "1BCG"

Gentlemen;

Thinking that it may be of interest to you, I am sending this account based on entries made in my Diary which I kept on my recent trip around the world.

We left Hamburg December seventh and anchored at Cuxhaven, a small town on the Elbe river, to await the clearing of a very dense fog. We left Cuxhaven at about two AM the ninth and it was then that I listened in on Amateur waves. Knowing how inefficient the ships receiver was on short waves I scouted around for some junk to make up a set. A pillbox which had been bumming around for some time was used to support the inductance, which consisted of two windings one on the box and one on the cover and the whole thing used as a direct connected inductance and tickler respectively. This contraption with a variable condenser for tuning and a detector and two step comprised this very efficient (?) receiver.

I was called on watch about an hour before we raised anchor and it was about two AM before I was able to listen in. The static etc at that time was absolutely indescribable. After a few minutes I picked up a station calling test-PP and signing 1BCG. At that time I did not know that a Trans-Atlantic test was on, having been away from the States for over eight months.) You can imagine my enthusiasm at hearing a home station after being away for so long a time. It naturally follows that I would do every thing in my power to tune you in and the signal strength at times was so loud that you could be heard with ease any place in the shack.

I did not listen again on short wavelengths until December 16th at 12:15 AM when we where about 2020 miles from New York. I heard you again at that time along with perhaps a hundred other amateurs from all districts but 6's and 7's all unreadable with the exception of five or six spark stations and three CW. The spark stations were - 1ARY, 1CK, 2FP, 2PF and 9AK. The CW - 1AFV, 1ARY, and 2FP.

I hope this dope will be of some use to you and in closing send my best 73's to all,

Yours truly

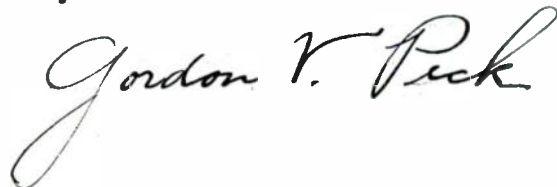

This letter was received from Mr. Gordon V. Peck, a ship operator who copied the signals from 1BCG in Cuxhaven near Hamburg, Germany on December 9th, 1921, a distance of over 4000 miles.

Springfield
 Thorold Grove
 Sale
 Cheshire
 England.

January 19th 1922.

Dear Sir,

I have at last got your address and hasten to write to you to congratulate you on being heard in this country.

As no doubt you will have heard I succeeded in hearing more of your DX men than any other British Amateur Station. My set was of home construction I mean that it was actually "made" by myself and one or two friends. We

When we heard you the first time on the Sunday morning we jumped round the room with delight. I had already heard 7X17, 1UN and 2B1K and another man but when we heard you calling 'TEST and GODLEY de 1BCG' we fairly rocked with excitement. I, of course had heard the others, and my two friends who were with me that night had only heard 2FP earlier in the morning working 2DA. We got his

radio OK and heard three calls from him. My friends were even then rather sceptical but when they heard you it was really funny. We were all getting somewhat drowsy and one "op" had gone to sleep. He had to work during the day and at the end of the test was nearly dropping as he sat up about four or five times with me. Well, suddenly I heard you. Then your letters followed and I yelled to my friend. The other "op" gave him a violent dig in the ribs, this waking him up. He ~~soon~~ immediately began to write for all he was worth. He still is teased ~~and~~ about how he jumped to it!

We were using a six valve H.F. amplifier when we heard you; using tuned transformer couplings. On the Monday morning we had a low frequency amplifier on top ^(1 stage) and your sigs were readable 15 feet from the phones. This is no exaggeration.

With Very Best wishes for the further success

I am, Yrs Very Sincerely,

W. R. Burne. J. K. W.

P.S. Is the station ¹⁵⁰⁰ still sending 9 if so would it be possible for you to give me a few calls over a period a day 10 days. W.R.B.



Station 1BCG



A Paper Presented by George E. Burghard at meeting of Radio Club of America,
Columbia University Dec. 30, 1921.

BEFORE going into the description of station 1BCG it may be well to consider for a moment the history of transatlantic amateur communication. The idea of transmitting American amateur signals to the Continent originated with one of the prominent members of the Radio Club of America before the world war when Mr. L. G. Pacent presented the matter for the consideration of the board of direction. Nothing definite was accomplished, however, and when Mr. Thomas Styles went to France after the war, Mr. Pacent suggested that the club erect a station to attempt communication, but the proposition was abandoned as too costly at the time. Some time after this Mr. Philip Coursey of "The Wireless World" took up the matter with Mr. White of the Wireless Press with like result, everyone being sceptical as to the success of the affair. Then Mr. M. B. Sleeper, at that time radio editor of "Everyday Engineering", took the

mission longer, and to send a representative to England to receive the American signals. Mr. P. F. Godley was selected as the logical man to go to England. He sailed for England in November, 1921, and it is here that the story of 1BCG begins.

On November 18th six members of the Radio Club of America at an informal meeting decided to build a transmitting station that would be heard in Great Britain. The six men were E. H. Armstrong, E. V. Amy, John F. Grinan, Walker Inman, Minton Cronkhite, and G. E. Burghard.

Various locations for the station were suggested and it was finally decided to build at Greenwich, Conn., on the site of Mr. Cronkhite's station 1BCG. Thru the courtesy of Mr. E. P. Cronkhite the necessary land and facilities were obtained. The antenna and transmitter were designed and decided upon and work was begun at Greenwich on November 19th. The

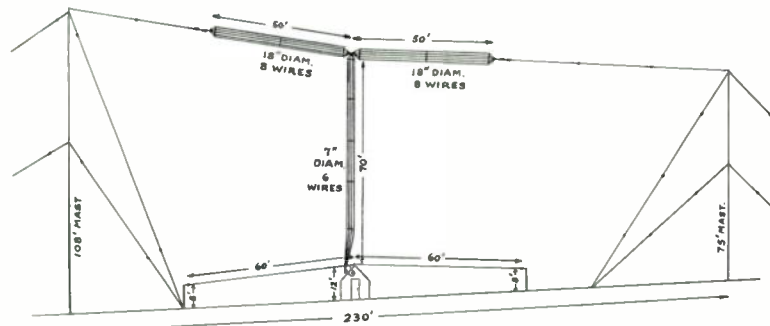

Antenna at 1BCG

idea up in earnest and laid the plans for the first amateur transatlantic test but was later forced to give it up. The American Radio Relay League took up the task at Mr. Sleeper's request, where he left off, and the first test was run under their auspices. The periods of transmission, however, were too short and no signals were heard in Europe. Then it was decided by the League to have another test the following winter, making the periods of trans-

mission longer, and to send a representative to England to receive the American signals. Mr. P. F. Godley was selected as the logical man to go to England. He sailed for England in November, 1921, and it is here that the story of 1BCG begins. On November 18th six members of the Radio Club of America at an informal meeting decided to build a transmitting station that would be heard in Great Britain. The six men were E. H. Armstrong, E. V. Amy, John F. Grinan, Walker Inman, Minton Cronkhite, and G. E. Burghard. Various locations for the station were suggested and it was finally decided to build at Greenwich, Conn., on the site of Mr. Cronkhite's station 1BCG. Thru the courtesy of Mr. E. P. Cronkhite the necessary land and facilities were obtained. The antenna and transmitter were designed and decided upon and work was begun at Greenwich on November 19th. The

Editor's note:

This paper was read before the Radio Club of America by its president, George E. Burghard, at the December 30th meeting at Columbia University in 1921. It gives a complete description of the station with circuit wiring diagrams of the transmitter and drawings with full dimensions of the antenna and counterpoise systems. The operation of the master oscillator power amplifier transmitter is fully explained and operating data such as input and output power together with circuit constants are accurately recorded. The distances covered and the various records established by 1BCG are also set forth in detail.

This system, which will be described in detail later, was made permanent and was used in the transatlantic tests and is still in use at IBCG at the present time.

The antenna system used is of the type T cage with a radial counterpoise. The dimensions are as shown in Fig. 1. The antenna proper is hung between two pipe masts 230 feet apart and 108 and 75 feet high, respectively. The two horizontal sections of the cage are each 50 feet long, 18 inches in diameter, and consist of eight phosphor-bronze wires. The vertical section is 70 feet over the top of the counterpoise, 7 inches in diameter, and consists of 6 wires. The counterpoise wires can be seen in relief stretching from the top of the transmitting shack which was located directly under the middle of the antenna, thus placing the transmitter in the center of the system. A bird's-eye view of the counterpoise is shown in Figure 2.

As can readily be seen the system is divided into two fan-shaped halves, each containing 15 wires all of equal length, i.e., 60 feet, and radiating from the transmitter as a center. The reason for this division of the counterpoise is of no im-

portance since it was intended to prevent harmonics in a predesigned system which was never put into practice. The natural period of this system of antenna and counterpoise from actual measurement proved to be between 190 and 195 meters.

The resistance of the antenna and counterpoise thru a range of wave lengths from 200 to 330 meters was found to be as follows:

Wave Length Meters	Resistance Ohms
200	40
210	31
215	18
225	16
230	15.5
240	14
270	12.5
290	17
310	12
330	9

Unfortunately no further readings were taken but since the working wave length of the station was 230 meters a fair idea of the antenna efficiency can be obtained from the figures at hand. The sudden rise in

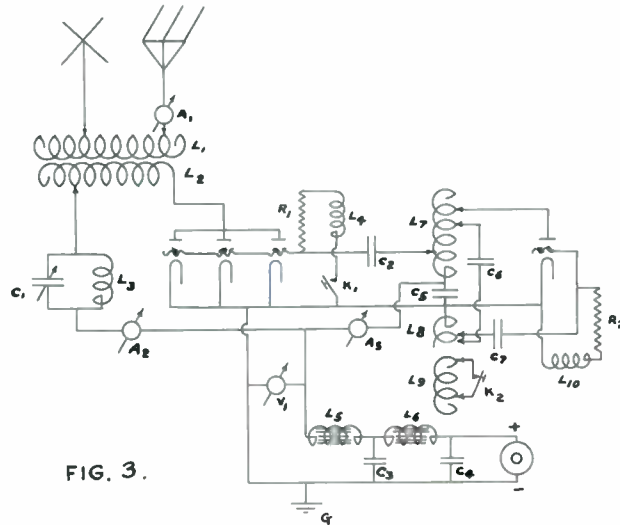

FIG. 3.

Constants for Fig. 3

A ₁	0-15 thermo-couple ammeter	L ₂	36 turns, 5" diam.
A ₂	0-3 ammeter	L ₃	3 millihenry choke
A ₃	0-500 milliammeter	L ₄	3 millihenry choke
C ₁	variable	L ₅	9 henries
C ₂	0.002 mfd.	L ₆	9 henries
C ₃	0.250 "	L ₇	16 turns, UL-1008
C ₄	0.0017 "	L ₈	3 turns, UL-1008
C ₅	0.250 "	L ₉	3 turns, UL-1008
C ₆	0.001 "	L ₁₀	3 millihenry choke
C ₇	0.002 "	R ₁	2500 ohms
L ₁	5 1/2 turns, UL-1008	R ₂	1000 ohms
		V ₁	3000 volt meter
		K ₁ , K ₂	relay signalling keys

resistance at 290 meters was later found to be due to the receiving antenna which had a fundamental wave length of approximately 290 meters.

No real earth ground was used in the station except to ground the filaments of the transmitting tubes, and for receiving; this consisted of several four-foot ground stakes driven into the ground.

The design of the transmitter centered about one main idea, the production of that type of 200 meter wave which would be most effectively handled by the super-heterodyne method of amplification and that type of audible signal which would be

within the narrow limits permitted by the resonance curve of the diaphragm and the physiological characteristics of the ear. There must be no variation in this frequency which will disturb the mechanical resonance of the diaphragm, nor flutter in note which will disturb what may be called the physiological resonance of the ear. The permissible limits of variation in frequency for a 1000 cycle note are well under 100 cycles. Hence for heterodyne reception at 200 meters or 1,500,000 cycles, a variation of frequency of less than 1/100 of one percent would be extremely disturbing to the operator and a variation of 1/20 of one

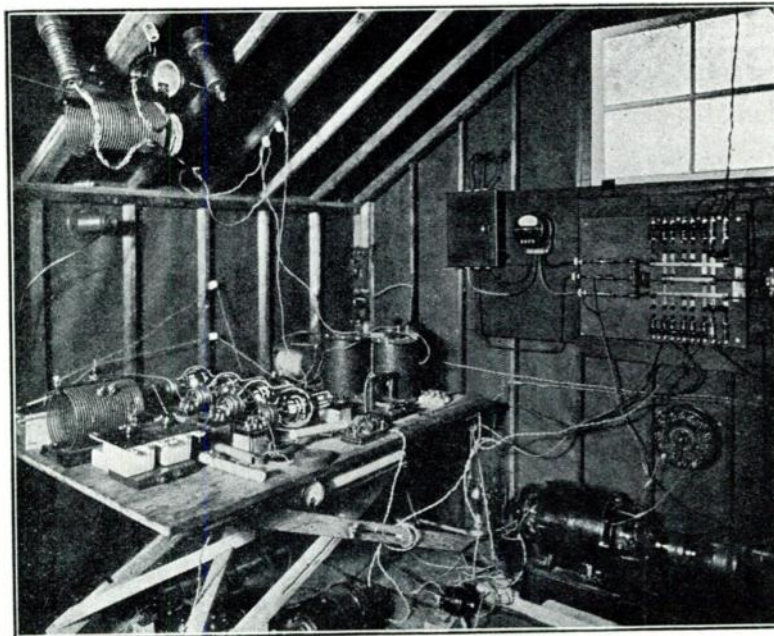

Interior view of the station

most effective on the combination of the telephone and the human ear.

To meet the first condition, that is, the electrical requirements of the super-heterodyne, a pure undamped wave must be used. It is obvious that the super-heterodyne with its great selectivity and highly resonant system cannot give its maximum response when there is any discontinuity or variation in amplitude in the transmitted wave. Undamped waves must be used, waves of a type which can be obtained only from a vacuum tube oscillator with a continuous current plate supply.

To meet the second condition (the combined electrical characteristics of the telephones and the physiological characteristics of the human ear) a current must be produced in the telephones which corresponds with the natural period of the diaphragms and which remains constant

percent would be sufficient to carry the note into an inaudible frequency.

The whole proposition therefore comes down to the construction of a vacuum tube transmitter producing undamped waves of an absolutely constant frequency which stays constant with an instantaneous application of a load of 1 K.W. There is but one type of transmitter which can possibly meet this condition—the master-oscillator-amplifier type with a motor-generator for the plate supply.

The general layout of the transmitter is illustrated by Figure 3. Four type U.V.-204 Radiotrons were used, one as the master oscillator, three in parallel as amplifiers. The filaments of these tubes were connected in pairs of two in parallel and each pair was lighted by A.C. obtained from the ordinary type of filament-lighting transformers. The plate supply was ob-

tained from a double-commutator 2200 volt 1.5 K.W. continuous current generator with A.C. drive.

The master-oscillator circuit employed was of the standard split inductance type with a fixed tuning condenser of the rather large value, for 200 meter work, of .001 mfd. The inductance consisted of a helix of 25 turns of copper strip wound edgewise, having a diameter of about 6" and a length of 9". This choice of constants was arrived at largely on account of an accident to several condensers of smaller

were of the open-core type, wound with No. 22 B. & S. wire, each having an inductance of 9 henrys and a direct current resistance of 85 ohms. The capacity of the two shunt condensers was .25 mfd. each.

The method of signalling used was as follows: The master-oscillator was connected permanently to the generator and ran continuously whenever the motor-generator was running. Its circuit was never broken. Signalling was accomplished by means of two magnetically-controlled keys. The first opened the grid leak circuit of the amplifiers. The

second simultaneously shortened the wave length of the master-oscillator about 5 meters by short-circuiting a couple of turns of a coil in inductive relation with the master-oscillator circuit. Under steady operating conditions this transmitter maintains 6 amperes in the antenna with an input of 990 watts into the plate circuits of all four tubes. The power in the antenna for this current is 558 watts, corresponding to an antenna resistance of 15.5 ohms. This gives a plate efficiency of about 56% with 2200 volts on the plates. On

account of various breakdowns in different parts of the apparatus this output was not obtained and the set was not in condition for steady operation until 1:10 A.M. of December 9th.

There are some points of interest about the set which are novel. Probably the most important is the stability of the master-oscillator. This is due to the type of oscillating circuit and the relatively large power of the master-oscillator, and to the tuning of the plate circuit of the amplifier which permits the neutralization of the reaction of the amplifier on the master-oscillator system. This is accomplished by adjusting the tuning of the amplifier plate circuit and the coupling with the antenna until the plate current of the master-oscillator tube remains unchanged when the key is closed.

In addition to this effect the series tuning system in the amplifier plate circuit has the very important advantage of increasing the transfer of energy to the antenna circuit when the antenna coil has but a few turns. It therefore assists in operating the antenna system close to its fundamental wave length.

It is interesting to note here that great difficulty was experienced in the first few days of operation in obtaining reliable information regarding the steadiness of the note. This was due to the fact that signals from IBCG were sufficiently strong to affect and alter to a considerable degree the frequency at which receiving sets with-

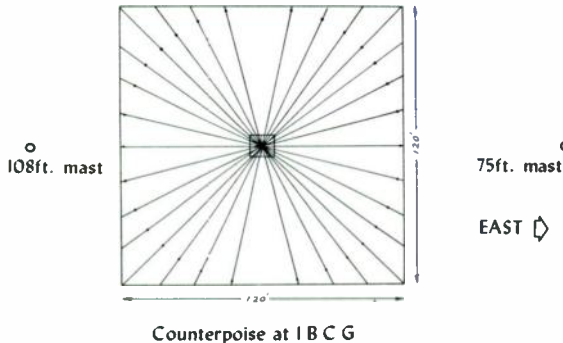

capacity in the master oscillator circuit on the first night of the tests. The only available condensers capable of standing the required voltage were two .002 mfd. mica condensers which were connected in series to give .001 mfd. The other constants of the circuit were then adjusted to fit this capacity. The usual grid condenser, with a high resistance leak and choke coil connected between grid and filament, was used.

The amplifier consisted of three tubes with their respective grids and plates connected in parallel. The grids were connected thru a series condenser to a tap on the plate side of the master-oscillator inductance. The usual grid leak and choke coil were connected between grid and filament. The plate circuit was coupled to the antenna thru a two-coil oscillation transformer. The primary or plate side of this transformer consisted of a coil of 36 turns of litz, having a diameter of 5" and a length of 3½". The secondary or antenna coil consisted of about 6 turns of edgewise-wound strip 6" in diameter. The plate circuit of the amplifier was tuned by means of a capacity consisting of three .005 mfd. variable air condensers connected in series to withstand the voltage. The path for the continuous current in the plate circuit was completed by a choke coil connected across the three condensers.

The filter circuit consisted of a two stage series inductance, shunt capacity filter, both inductances being placed in the positive generator lead. These inductances

in a radius of fifty miles were oscillating. This resulted in a bad note. The solution to this difficulty was found by setting up a self-heterodyne detector in the station with 150 volts on the plate, without a stopping condenser, and with a tuning circuit of small inductance and large capacity. By adjusting the frequency of this circuit to one third of the frequency of the station, beats were obtained between the fundamental of the station and the third harmonic of the receiver. This enabled the

cooler operation many stations are heard sending in Transatlantics. Finally sent CQ to Godley with 3 amps. in antenna. More tubes arrive—set is in operation until condensers in the master-oscillator circuit heat up so that it is advisable to shut down." "Dec. 8—Much trouble is experienced with condensers in master-oscillator circuit. Tested for adjustment all nite. 1:12 A.M. finally got condensers fixed with 6 amps. radiation and worked until 6:35 A.M. All OK now". From this it can be seen that

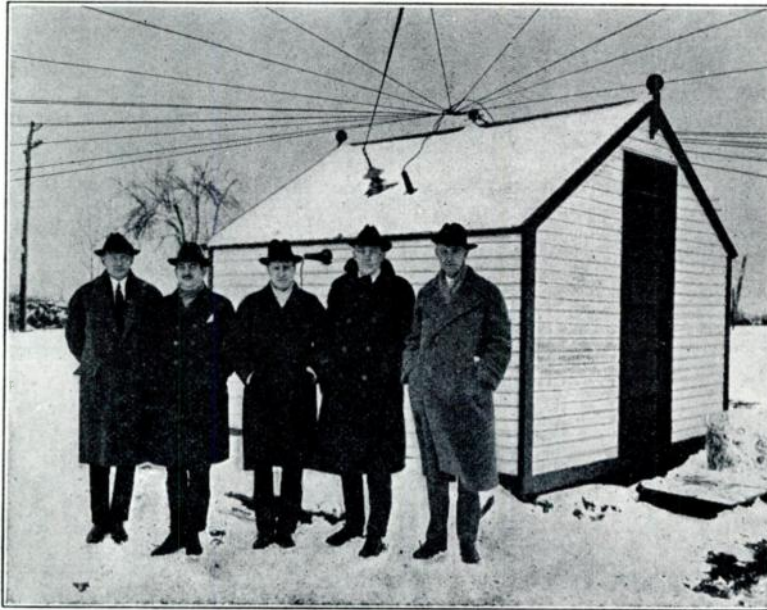

The station building at 1BCG and five of its owners. Left to right, Messrs. Amy, Grinan, Burghard, Armstrong, Cronkhite. Mr. Isman is missing in this photo. Note the counterpoise radiating from the top of the station, and the lead-in from it and the antenna.

frequency of the station to be observed perfectly. Observation on a windy night, when the notes of all C.W. stations heard were varying so badly as to be almost unreadable, showed the frequency to be absolutely unaffected by the motion of the antenna. The reports on this set from all parts of the country show beyond question that radiation of this kind is superior to very many times the energy radiated from the ordinary types of C.W. transmitters.

In connection with the actual operation of the station it will be interesting to quote from the engineering log in order to give an idea of the difficulties encountered: "Dec. 6th—During the evening the master oscillator is connected up. Two amplifiers in use. Tubes running very hot. A CQ was sent out at 3:30 A.M. and condensers boil over." "Dec. 7—One tube is found to be defective leaving only one amplifier. While we are adjusting the master-oscillator for

the station was actually not in operation until the 9th of December and in the short period of three weeks to date has accomplished some amazing long-distance feats.

1BCG's signals have been heard in practically every state in the Union; in Scotland on Dec. 9, 10 and 11; England, Holland, Porto Rico; Vancouver, B. C.; California and Washington. The greatest distance covered is to Amsterdam, Holland, approximately 3800 miles, mostly over water, and 2600 miles over land to Smith River, Calif. Last but not least 1BCG has established new records by sending three complete messages to 6XAD in Avalon, Catalina Island, Calif., and one 12-word message to Ardrossan, Scotland, at 9:45-10:00 P.M. Dec. 11, 1921; all with an input of 990 watts and wave length of 230 meters.

Photographs of 1BCG, thru the courtesy of Mr. J. Edw. Brown, of 1BKA, Glenbrook, Conn.

RETROSPECTIVE

by

PAUL F. GODLEY

In a rented tent in a farmer's field at the edge of the village of Ardrossan near the mouth of the Clyde in Scotland, I sat on a box, submerged in radio listening. Transcendental radio listening!—in the sense that it was beyond then commonly held notions; or, as many would have then insisted, contrary to common sense.

It was 12:50 AM., Greenwich Mean Time, December 9, 1921. The weather? "Wet and boisterous"!

Back home, through immersion, the call letters of just about every radio station in the States, especially those in easterly districts, had become familiar. Yet, here—startling, clear—were strange, seemingly New England call-letters . . . 1BCG! . . . (Or could they be "foreign"?) . . . And intermingled (was this pure coincidence?), the familiar, personal initial and "sine" letters PF, PF, PF!

Strange sounding call letters! Could they be "phoney"?

Of the station's American identity there was no certainty. And when, later, there could be no doubt, I knew not where it was, whose it was or the power used. Only much later—back in the States—was I told that 1BCG had come into being because of a chance, almost facetious, request made (and at once forgotten) as I was about to sail away toward "an unknown professional fate".

Those strange sounding signals were coming *from* Greenwich, Connecticut *into* the Greenwich Time Zone; and I was finding out just how Marconi must have felt 20 years before—almost to the day! In fact, I had reason to feel better than Marconi. The Poldu, Cornwall-to-St. John's, Newfoundland trip of his famous letter "S" on the 12th of December in 1901 was 2107 statute miles. On the same date in 1921 I copied from 1BCG a complete personal message. It was the first to hop the Atlantic via the "commercially useless" short waves; and it had travelled a great circle distance half again as far (3,169 miles). More important, the demonstration would set off speculation concerning broad horizons which augured well for world radio, amateur or otherwise.



THE MAN WHO RECEIVED THE MESSAGE

Paul Forman Godley who received the signals in Scotland and copied the epoch making message sent by 1BCG. His scientific knowledge, long experience and exceptional operating ability were largely responsible for the success of the transatlantic transmission.

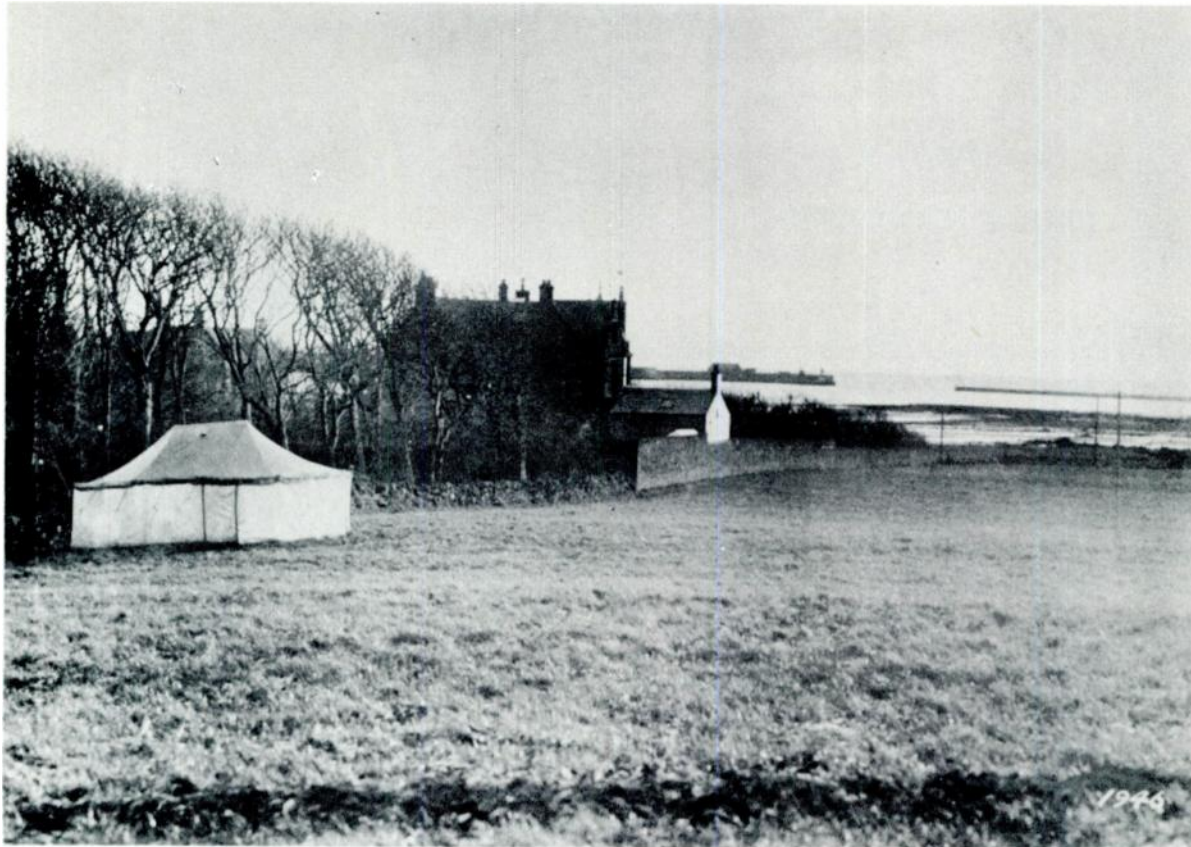

Exterior of the tent at Ardrossan, Scotland, which sheltered Godley and his receiving equipment. The Beverage wire was run from this tent down toward the beach.

In Central Iowa as a lad of seven I kept an ever-questioning watch at our front door upon the westward march of the telephone and thereby garnered first principles of electro-magnetism. I then first learned of the young Marconi, too; and, at the age of 12, by now steeped in the lore—and a skilled telegrapher to boot—I thrilled at the news of his Cornwall-to-Newfoundland letter “S.” Before leaving London for Ardrossan I met and talked with Marconi at length. He was deeply interested in all phases of our plans. Wished us luck. Asked that I carry a message to American Amateurs. Said: “I, too, am but an amateur.”

Marconi spoke more truly than we then could realize. Insofar as world radio worthy of such name was concerned, where was he who then was *not* an amateur?

Planned and projected by The American Radio Relay League, cheered on by the whole radio world, spark-plugged by the signals from the wonderful 1BCG, those trans-Atlantic short-wave tests and the high, world-round radio fevers which their success brought on, presaged the turn to the propagation techniques of the shorter waves upon which world radio is based; and I believe they engendered the further epochal short-wave tests in which Marconi, himself, was to soon take part.

Through the passing years I have often thought about how much fun and excitement might have been added to our “world’s greatest scientific sporting event” had we also had a 1BCG at Ardrossan and an Ardrossan set-up in Greenwich, U. S. A.

Editor's note:

These two articles are reproduced by permission of "Q.S.T." magazine, the official organ of the American Radio Relay League. They appeared in the February 1922 issue. The first was written by Kenneth B. Warner, the then editor, and tells the story of the Transatlantic Tests as conducted by the A.R.R.L., from December 7th to 16th, inclusive, 1921. It is followed by the official report of the tests by Paul F. Godley who did the actual receiving in Scotland. The report contains the complete log kept by Godley during the periods of reception together with his many very interesting comments.



A Magazine Devoted Exclusively to the Radio Amateur

The Story of the Transatlantics

By The Editor

THE signals of some thirty-odd American amateur radio stations, working on the short wave lengths and low power permitted amateurs, were heard across the Atlantic Ocean in the second series of Transatlantic Sending Tests conducted by the American Radio Relay League in December, 1921. This is a story of that achievement.

The First Attempt

The possibilities of transatlantic tests were first presented to the amateur world in 1920 by Mr. M. B. Sleeper, at that time radio editor of "Everyday Engineering". It is a subject that intrigues the amateur—his greatest desire in life is to get "distance" with his equipment. It has wonderful possibilities, too, in opening the way to world-wide amateur radio. The arrangements for the first tests in February of 1921 were going merrily along, then, when "Everyday Engineering" unfortunately was obliged to suspend publication. Mr. Sleeper requested the A.R.R.L. to take over the management of the tests, which it did in order that his splendid idea might not be lost. In the limited time remaining after our Operating Department took over the management it was not possible to perfect arrangements as we would have liked, and the tests failed. Looking back at them now we believe we can ascribe this to two causes: the length of time assigned the transmitting stations was altogether too short, and most of them were spark stations. At any rate no signals were received which unquestionably could be attributed to American stations.

American ship-operators on transatlantic runs had heard our signals on the other side, however, and we of the A.R.R.L. were still firmly of the belief that signals could be got over on schedule. Gradually the determination crystallized to try it again,

and we even made the boast in print that if a dyed-in-the-wool American ham could be sent across the water with a good American regenerator we knew signals could be copied; in fact, we bet our new spring hat on it. Ever since then we have been answering inquiries from England as to just what a "ham" is, particularly one who has been dyed while still in the wool. But we're used to questions.

To Try Again

And so the matter of additional tests was taken up with Mr. Philip R. Coursey, assistant editor of "The Radio Review", London, who had managed the British end of the first tests, and he, finding British amateurs desirous of giving the game a second go too, kindly agreed again to look after the reception end, which this year was perhaps to include France and Holland too. Plans went forward during 1921 and a brief announcement appeared in July QST, while an open invitation to all amateurs to enroll for the preliminary tests was published on page 12 of QST for September, in which the plan was explained and registration form appended.

About this time our First National A.R. R.L. Convention was held in Chicago and our Board of Direction had a meeting there at which plans for the forthcoming tests were considered. Since we were tackling the job we wanted to do a real good job of it and avoid any chances of a second failure. The desirability arose, then, of sending an American listener to Britain to supplement the efforts of the British amateurs, not only so that we might have a double chance of success and so that some comparisons might be made of the relative sensitivity of American and British amateur apparatus but also for a much more important reason—it would then be possible to make the tests really democratic,

as befits our organization, for if only picked stations were to transmit on schedule, obviously the number would be limited, whereas if we could have an A.R. R.L. man there, one used to twirling a mean variometer all night long, the tests could be made a great popular event with free-for-all periods in which the whole country could be invited to participate. This idea was favorably considered and funds were appropriated to send a man to England to make it possible. An invitation was extended Mr. Paul F. Godley, of Montclair, N. J., to undertake the mission in the name of American Amateur Radio, and he was kind enough to accept. Mr. Godley is the man who first adapted the Armstrong regenerative circuits to short-wave work; he originated the variometer regenerators which have made possible the wonderful short-wave DX work of American amateurs since 1914; and he was chosen to go overseas because in the unanimous opinion of the Board he was America's most expert operator in the practical reception of short wave signals. Let it be clearly understood that an American representative was not sent merely because we feared the English amateurs weren't seasoned operators or weren't able to get us with their equipment; instead it was in order that the tests might be expanded into a big popular event without asking the British amateurs to stay up *all* night every night; and Mr. Godley went over as an auxiliary to the British efforts. The French magazine "La T.S.F. Moderne", commenting on the arrangements, suggests that we feared the British weren't sufficiently the hard-boiled owls, but that wasn't it. Incidentally, fellows, you ought to see the French for boiled owls: "des oiseaux nocturnes durs a cuire", literally, "nocturnal birds hard to cook". Have a hi wid us on tt, you tough nocturnal ornithic persons! The big idea was to make sure that American signals got thru to Britain, so that the possibilities of transoceanic amateur work might be helped along, and that is why Godley was sent.

The Preliminaries

Altho it was decided to divide part of each test night into free-for-all periods it was obviously desirable to give our best stations individual schedules of considerable duration so that careful tuning could be done in Britain and positive reception be recorded. To pick the best stations which would be assigned such individual schedules, eliminating tests were conducted, and the announcement in September QST was an invitation to enter these preliminaries, the books being kept open until Oct. 12th. The hours being limited, there was time for only the better stations in these individual final schedules, and the preliminary qualification was that the

stations cover 1000 miles overland. Seventy-eight stations were entered in the preliminaries, which were conducted Nov. 1st to 5th, inclusive, an advance over the original dates made necessary by Mr. Godley's earlier sailing. The time being quite limited, arrangements for the preliminaries were conducted entirely by mail, without chronicle in QST. Instructions were given the transmitters and a thousand copies of the schedules distributed to picked receiving stations thruout our Operating Department with instruction to notify the Traffic Manager direct of all reception. Nov. 10th was set as the final date for the reception of qualifying reports, as the schedules had to be made up in advance of Mr. Godley's sailing. A station did not have to be reported by an official recorder to be eligible in the finals, however—any evidence that it had covered the requisite 1000 miles was sufficient. A number of stations participating in the prelims were heard over a thousand miles and have cards to prove it but still did not qualify, as the cards either came to them instead of to this office, so that no proof was offered, or came to this office too late. Some excellent stations, such as 1UN for example, failed of qualification thru such an accident. Other stations qualified at the last minute by rushing evidence to us, among which was 1AFV who, altho not reported a thousand miles by any of the recorders, filed a card with the Traffic Manager which showed he had covered the DX. Everyone who could show by Nov. 10th that they had made the grade was give a place in the finals, but for fairness' sake the Operating Department held rigidly to the original announcements.

The Finals

The complete scheme for the tests was published on pages 29-32, inclusive, of October QST. For six hours each night for ten successive nights, December 7th to 16th, inclusive, transmission took place and watch was kept on the other side. Each six-hour schedule was divided into two parts, the first part, from 7 p.m. to 9:30 p.m., Eastern Standard Time, being the free-for-all, consisting of ten periods of 15 minutes each and in each period of which all the amateurs in a given inspection district called "Test" and signed. The periods were rotated so that every night a district sent at a different time, sometimes early in the evening, sometimes late, so that if the hour mattered all would have an equal chance. The schedule for these periods appeared on page 30 of QST for October.

Then the second part of each of the six nights, from 9:30 p.m. Eastern Standard Time to 1:00 a.m. of the following date, was devoted to the individual stations who qualified in the preliminaries. Sealed secret

cypher combinations were assigned these stations, with a request that they not be opened until the first night of the tests, and no information was given out as to who had qualified except to the successful contestants themselves.

The following table lists the entrants in the finals:

Call	Location	Type	Wave	Cypher
1AFV	Salem, Mass.	C.W.	200	YLP MV
1TS	Bristol, Conn.	C.W.	200	AOTRB
1RU	W. Hartford, Ct.	C.W.	200	BPUSC
1DA	Manchester, Mass.	C.W.	200	CQVTD
1AW	Hartford, Conn.	Spk.	210	DRWUF
1BCG	Greenwich, Conn.	C.W.	230	GODLY
2BML	Riverhead, L. I.	C.W.	200	FSXVG
2FD	New York City	C.W.	200	GTYWH
2FP	Brooklyn	C.W.	200	HUZXJ
2OM	Ridgewood, N. J.	Spk.	200	JVAYK
2EL	Freeport, L. I.	C.W.	200	KWBZL
3DH	Princeton, N. J.	C.W.	210	LXCAM
4GL	Savannah, Ga.	C.W.	200	MYDBN
3BP	Newmarket, Ont.	Spk.	200	NZFCO
8DR	Pittsburgh, Pa.	C.W.	200	OAGDP
9KO	St. Louis, Mo.	Spk.	200	PBHFQ
9AW	Toronto, Ont.	C.W.	200	QCJGR
1ZE	Marion, Mass.	C.W.	375	RDKHS
2ZL	Valley Stream, L. I.	C.W.	325	TGMKU
8ZO	Parkeburg, Pa.	C.W.	360	UHNLY
5ZZ	Blackwell, Okla.	Spk.	375	VJOMW
6XH	Stanford U., Cal.	C.W.	375	WKP NX
7ZG	Bear Creek, Mont.	Spk.	375	XLQOY
8XK	Pittsburgh, Pa.	C.W.	375	YMRPZ
9ZY	Lacrosse, Wis.	C.W.	260	RZQMY
9ZN	Chicago, Ill.	Spk.	375	ZNSQA
9XI	Minneapolis.	C.W.	300	SFLJT

The three and a half hours for individual schedules was divided into fourteen periods of 15 minutes each, and times assigned to each station, the periods again rotating for fairness. At a suggestion from Mr. Godley the individual stations for the most part transmitted in groups on the same wave length, two stations sending at once permitting double the time for each without jeopardizing the chance of either to be heard. Most of the special schedule stations transmitted in pairs, three being the maximum going in any one period.

In England

These arrangements were by no means for the special benefit of Mr. Godley but were to govern the entire tests. The arrangements in England were entirely in Mr. Coursey's hands and the data on the schedules was communicated only to him. To avoid all criticism Mr. Godley was told nothing except the free-for-all schedule, which was public information, but Mr. Coursey supplied him with a schedule of the times and wave lengths on which to listen, the same as he broadcasted to all British listeners, and kept strictly to himself the identity and cyphers of the various stations. Mr. Coursey being in complete charge, Mr. Godley was on practically the same status as any British listener and was required to submit his reception to Mr. Coursey for verification and to report thru him.

Meanwhile the greatest enthusiasm seems to have greeted the preparations for the tests, on the other side. The Neder-

landsche Vereeniging voor Radiotelegrafie (Holland) wrote us for particulars and published them in their magazine, "Radio Nieuws", together with recommended Armstrong circuits for short-wave reception; and "La T.S.F. Moderne" did the same thing for the French amateurs. "Wireless World" was the bulletin for the British amateurs, and it was here, of course, that the highest interest centered. Many amateurs seem to have gone to great lengths in their preparations, making special sets with many stages of tuned-output radio amplification—and we are very happy that the outcome of the tests justified their labor.

Godley Prepares

While these arrangements were progressing "Paragon Paul" was busy too, building special amplifiers, testing various tuning arrangements, and experimenting with different aerials. When he succeeded in making 5ZA work a relay in New Jersey without interference from New York amateurs he felt he had things around where they belonged.

On Nov. 14th, the night before he sailed, a very impressive little dinner was given for him at The Engineers' Club in New York City, where our A.R.R.L. officers and our directors within hailing distance and the officials of other radio organizations gathered to wish him success and bid him Godspeed. While the trial was to be a severe one and no man could with surety predict the outcome, optimism was distinctly the keynote and everybody was certain that if it could be done at all Paul would get signals. At this meeting credentials and written instructions were given him, together with a sealed packet for Mr. Coursey in which the secret codes and final schedules were given. There were but two copies of these documents in existence and the duplicate was locked in the Hartford safe. Until the writing of the article it was seen by no eyes in this country save those of our Traffic Manager—not even by the present writer.

Godley sailed on the "Aquitania" on Nov. 15th, amid cheers and waving handkerchiefs of assembled radio friends and relatives, and for a couple of nights out the amateur air was thick with farewells and good wishes for 2ZE, Godley's home call, for everybody knew he would be in the static-room on the "Aquitania".

The second day out we radioed him:

"Bon voyage The entire radio world is pulling for you"—to which he replied:

Confidence increases as distance squared Broadcast my heartfelt appreciation".

Arrangements had already been made with the British authorities thru the kind co-operation of our own State Department and Department of Commerce for special authorization to Mr. Godley to bring in

apparatus and erect and operate a receiving station, and to one familiar with the British laws on radio it will be apparent that this was itself an accomplishment. Mr. Godley landed at Southampton on the 21st and proceeded to London, where he was shown every courtesy by the British radio men. He had originally planned to make use of the receiving station of Commander Phillips, near London, which was kindly placed at his disposal, but results there being discouraging he moved up into Scotland and located at Ardrossan, a thriving ship-building port and watering place on the coast to the west of Glasgow. There he erected his apparatus, accompanied by his official listener, Mr. D. E. Pearson, District Inspector of the Marconi company at Glasgow, who stood a constant watch

a.m. Eastern Standard Time, and do it slowly by hand, so that the amateur world could copy it direct and so get first-hand word from Godley at the earliest possible moment. November QST told of this and gave suggestions on the reception of MUU. Carnarvon's signals are not very easy to receive, however, and so it was arranged that Godley should send "PC" messages, which means that they were to be repeated back for verification, and on this side of the water the same brand of very interested co-operation which marked the attitude of the Marconi officials in England was evident in the Radio Corporation folks and special arrangements were made that WII, the Corporation station at New Brunswick, should slowly repeat Godley's messages upon their receipt immediately after 2 a.m. Eastern Time. This made it possible for every amateur to get the dope instantly, and altho announcement of the arrangements was not published it was telegraphed our Division Managers and broadcasted thru the divisions by radio, so that thruout the country there were watch parties every night of the tests.

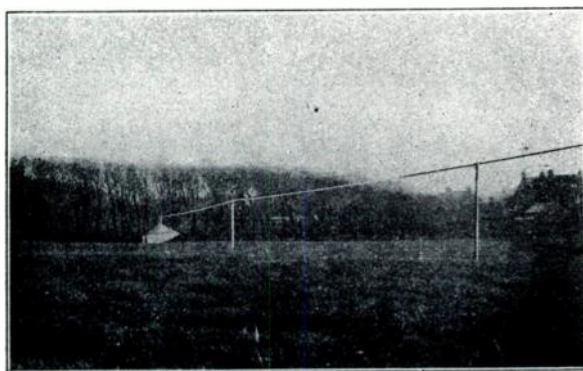

The Site at Ardrossan—Note the Tent.

with him during the tests and verified the reception of every signal.

Time was growing very short when Godley arrived at Ardrossan and there was no opportunity to build a shack or make any particular arrangements for comfort. Unfortunately the only good location was in an open field without buildings, and a tent was the only possible housing. This record-breaking reception, then, was done in just a tent, exposed to the elements, its only light a lantern and its only heat an oil stove, while the countryside rocked in the worst weather imaginable—cold and penetratingly raw, terrific down-pours of rain, and wild gales—the results of a cyclone which passed nearby. The physical strain and suffering must have been intense. What a debt we owe Godley for what he went thru for us!

Meanwhile it had been planned to file a message daily at Carnarvon, Radio MUU, addressed to the A.R.R.L. at Hartford and containing a brief report of reception or conditions. So great was the interest of the commercial companies in our undertaking that the Marconi officials very kindly arranged to send this report at a specified time daily, 7 a.m. British time or 2

which were delayed 24 hours thruout the tests, really told the story. These reports, by the way, were filed over his name by Mr. Coursey, Mr. Godley wiring coded reports of his reception to Mr. Coursey for checking, after which the latter passed them on to us.

Eight British amateurs were successful in copying American signals, and that is something that pleases us immensely. At this writing we have not yet received any detailed report from Mr. Coursey but he cables us that the secret codes were correctly copied by British amateurs from 1AFV, Salem, Mass.; 1BCG, Greenwich, Conn.; 2FP, Brooklyn; 2ZL, Valley Stream, L. I.; and 2BML, Riverhead, L. I.; that during the free periods they copied 1UN, Manchester, Mass.; 1RU, West Hartford, Conn.; 1XM, Cambridge, Mass.; and 2ZC, South Orange, N. J.; and that it is probable that 1ZE, Marion, Mass., and 2ZU were also heard; a total of eleven stations. Mr. Godley brings back the rumor that 1DA, Manchester, Mass., was also copied by the British amateurs but Mr. Coursey makes no mention of it. 1BCG was heard

The Results

by five British stations. It is very interesting to note that all of these stations are C.W.—not a spark was heard by the British amateurs.

The spark stations heard by Mr. Godley are Canadian 3BP, Newmarket, Ont.; 1ARY, Burlington, Vt.; 1AAW, not yet located; 1BDT, Atlantic, Mass.; 2BK and 2DN at Yonkers, N. Y.; 3FB, Atlantic City, N. J.; 9ZJ, Indianapolis; and 8BU of Cleveland. The C.W. stations reported by him are 1RU, West Hartford; 1RZ, Ridgefield, Conn.; 1ARY, Burlington, Vt.; 1BCG, Greenwich, Conn.; 1BDT, Atlantic, Mass.; 1BGF, Hartford; 1BKA, Glenbrook, Conn.; 1XM, Cambridge; 1YK, Worcester; 2EL, Freeport, N. Y. (spark or C.W.?); 2EH, Riverhead, L. I.; 2FD, New York City; 2FP, Brooklyn; 2ARY, Brooklyn; 2AJW, Babylon, L. I.; 2BML, Riverhead, L. I.; 3DH, Princeton, N. J.; 8ACF, Washington, Pa.; and 8XV, Pittsburgh.

Mr. Godley also brings back the rumor that on Dec. 9th British amateurs in London heard a phone signing WQM play the "Humoresque" at 10:45 p.m. G.M.T., and at 10:55 a piano solo, the wave length was 200 meters. WQM is listed as the broadcasting station of the Wichita Electric Light & Power Co., Wichita, Kansas, but at this writing they have made no response to our attempts at verification.

1BCG is reported from Holland and Germany during the tests, and we are informed that 2ZL was also heard in France. Some DX!

1AAW was originally reported as 1AAY, thru a mix-up in the separate code used between Messrs. Godley and Coursey, and was later corrected by cable to us. When the report of the first night came thru, advising that 1AAY had been heard, excitement reigned supreme at Hartford headquarters. Shown by our call-book to be in Bridgeport, Conn., he could not be located by telephone nor could any other Bridgeport amateurs. So we got E. H. Armstrong, from 1BCG, to drive there in an effort to locate him, which Mr. Armstrong did in the wee sma' hours of that same morning, only to find that 1AAY had moved to New Jersey. Radio Inspector Kolster was routed out and advised us that the call had been reassigned to Fitchburg, Mass. Later that day the Chief of Police of Fitchburg, whose name incidentally also is Godley and whose people are from New Jersey (wonder if he's red-headed?), located the Fitchburg lad and got him on the telephone wire for us, but he had only a quarter-inch coil and no aerial. With what fear and trembling he must have answered the summons to report to the

Chief of Police! Then the correction came from Godley and we were off again, this time after Roxbury, Mass., with Mr. Entwistle doing the Sherlock act. Meanwhile former 1AAY from Bridgeport comes in with the dope that he has moved to Belleville, N. J., where, altho it is the Second District, he operated on that test night with four amps in the aerial and signed 1AAY. But in view of Mr. Godley's correction he was very QRZ hr. And

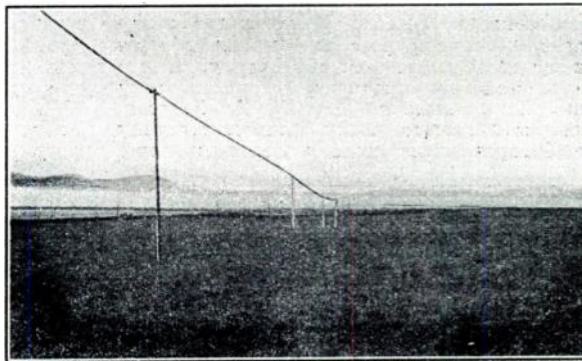

The "Beverage Wire," pointing out to sea across a low island.

1AAW in Roxbury hadn't operated a transmitter for six months! We thot we were up a tree at first but 1AAW and numerous Boston amateurs advise that the call *has been heard* on the air around there and that somebody else has appropriated the call. Whoever the would-be 1AAW is, he is sticking tight under cover now, as he knows he is a law-breaker, and to date he has not been located. It is a pity, too, for if he were within the law he could claim the honor of being the first station heard overseas in the tests.

1BCG seems an easy winner as the star station. In addition to being heard all over the map they got thru a coherent message on broadcast, at 3 a.m. G.M.T. on Dec. 12th, which was acknowledged by Godley by cable to this office. The first amateur transatlantic message ever sent read as follows:

"Nr 1 NY ck 12 to Paul Godley, Ardrossan, Scotland. Hearty congratulations. Burghard Inman Grinan Armstrong Amy Cronkhite."

Speaking of results of the tests, another result was that we won a perfectly nice spring hat from W. W. Burnham, of London, who took us up on our editorial bet before refered to, that a good U. S. ham could get signals over there. When the tests were over Burnham wired us:

"Congratulations Cable size of hat"

and we expect soon to publish a picture of our editorial self in the new London Lid.

Many prizes were offered by British firms to the successful receivers over there, and Messrs. Burnham & Co. have offered one of their Ultra III receivers to the most successful American contestant, the award of which has not yet been determined.

The Test Nights

It was wonderful to sit in on the tests. Goodness knows how many transcontinental records were broken, for an amateur never misses the opportunity to listen for fellows on the other side of the country when he knows they are sending on schedule. During the free-for-alls one could hear district after district start up, as regular as clock-work. First the air would be full of 2's, then it would change to 3's, and as the last 3-station shut down he would wind up with a "Go ahead, 4's, give her juice!"

Those were wild nights in Hartford. A little group of us were on the job every night at the Traffic Manager's static-room, waiting on a long-wave set for MUU to send the nightly report. The air was so thick with tobacco smoke that it was hard to see how a signal could get into the room, but WII with his tape transmitter could be heard tearing along in the background, and regularly at 2 o'clock he would slow down and say "Give me Godley's message". And then with what tenseness, with what wobbly hands and stifled breathing we listened as MUU started his hand-sent report! Here she comes, fellows! Will there be call-letters? Who has been heard? That was the absorbing question! Later in the tests we got so that we knew that a check of 17 or some such small number probably meant nothing but a report of weather conditions but you should have seen us when the big message came thru with a check of 94. Oh, Boy, that meant *signals!* And there were eighteen of 'em! And of course the same scene was being enacted in countless radio shacks all over the country.

About 2:05 the telephone line would be getting hot and what with press reports, telegrams to file, countless long-distance calls from everywhere, there was no use going to bed. The newspapers are wild for radio dope these days and our A.R.R.L. got lots of publicity and Amateur Radio a big boost up the ladder from these tests.

In Appreciation

Paul Godley returned to America on the "Olympic" on Dec. 28th, a conquering hero! He was met at the pier by many of those who saw him off and an informal luncheon was given in his honor at the Hotel Pennsylvania. The faith that his friends put in him had been more than justified. His niche in the Radio Hall of Fame is secure forever. With deepest gratitude we acknowledge our binding indebtedness to Mr. Godley, for the personal sacrifices he made to act as the representative of American amateurs overseas; for the suffering

he went thru in their name; for the wonderfully successful job he did in spite of difficulties. And our congratulations, Paul—long may you radiate!

Our deep thanks are also due to Mr. Coursey for the admirable way in which he organized the British end; to Mr. Coursey and numerous British radio men for the courtesies shown Mr. Godley; to the British listeners, one and all, for the interest that made the tests possible; to our own Secretaries of State and Commerce for their kind co-operation in getting Mr. Godley thru the miles of red tape; to the British post-office authorities for the permits so graciously granted; to the commercial companies on both sides of the water, Radio Corporation men in general, and in particular to Traffic Manager W. A. Winterbottom of the Radiocorp and Mr. Henry W. Allen, joint general manager of Marconi's, Ltd., for the co-operation that made the special MUU and WII broadcasting arrangements possible; and to Canadian and American amateurs themselves for their good sporting spirit—and our congratulations to the successful ones! All share in writing a glorious page in the history of Amateur Radio.

The Future

It is with much trepidity that we venture to talk of the future. Who can say? But surely these accomplishments open the road to broader field of Citizen Radio. The scientific world is startled at our A.R.R.L.'s achievement. In the most graphic way we have demonstrated the high radiation efficiency of the short waves. To put a message across the Atlantic on less than one kilowatt! *It was done.* To cross the Atlantic on antenna powers of fifty watts or less! *It was done.* To get over on wave lengths sometimes under 200 meters, with our aerials that are as grasshoppers to the commercial stations! *That too was done.*

Some of the stations had remarkably low power. But they used C.W. and one of the greatest lessons to be learned from these tests is how very much better C.W. is than spark.

We sincerely hope that as a result of these tests amateurs not only in Britain but on the Continent as well will be inspired with the ambition to get into the relay game and duplicate our feat in the reverse direction, giving us the opportunity to repay our debt to them; that, being shown possible, one-way amateur traffic to England and other countries may begin soon on schedule; and that the British authorities in particular will be so impressed by the potentialities of such work as demonstrated by our tests that the amateur restrictions in that country may soon be sufficiently modified to give hope of successful two-way amateur communication across the Atlantic.

That will be the fun, eh, fellows—to sit

at the old set on a cold winter's night, the bulbs burning cosily in front while the generator purrs sweetly in the corner, the old cob pipes neatly filled in advance and set in a row for a hard night's work—and then clear England, Scotland, France, and Holland in turn! (No, we never take a

drop of stuff like that, and we really believe that such things some day will come to pass.)

Surely radio has been given added impetus by these tests, and certainly the day of International Private Radio has been brought closer!

Official Report on the Second Transatlantic Tests

By Paul F. Godley

MENTAL processes during great moments are extremely complex and I shall never be able to fully recount those of mine, either upon the memorable occasion when, amidst the inspiring farewells of a host of renowned amateurs, the "Aquitania" bore me towards an unknown professional fate, or those of that other and greater moment, when without regard for the atrocities of the Scottish night the first American amateur signal finished its 3,500 mile journey at Ardrossan.

On the first occasion I was overwhelmed with a wish that some fairy power might sweep twenty thousand "hams" to a place beside me, while on the second it was with the utmost difficulty that I restrained a joy which cried for the slam of a switch, the mad whine of a motor, and the crazy stuttering of a key. No sinking tramp at sea ever bewailed its lack more than I bewailed it then.

The "Aquitania's" sailing marked the beginning of a short respite from a physical strain under which work, plan and preparation had placed me. No one else will ever know how much I needed sleep, and I began taking it in large doses. On the other hand, the first signal brought with it welcome and almost complete mental relief, for five nights of listening to static and high power station harmonics near London had left me in a somewhat dubious frame of mind, which may be judged from the fact that all thoughts of sight-seeing were dropped forthwith—a trip to Paris which had been planned was given up, and I began to muster meteorological "dope" from every quarter.

The first signal also ushered in a new period of physical strain, for it was found necessary to set up equipment under an indifferent tent, in an open field near the beach, and the test period was attended throughout by high, gusty, changing winds, heavy downpours, and a chill damp which drew heavily on one's reserve energies. So far as I know, for an American, there

is but one comfortable place in winter in all the British Isles. That place is in bed—with a hot water bottle at your feet. Hospitality, of which I found a plenty everywhere, will warm the cockles of your heart, but it's no good for the joints, so those whose hospitality I sampled secretly complained of gas bills.

It seems to me now that the most remarkable phase of the entire undertaking lay not so much in its complete success but rather in the thoroughly whole-hearted co-operation encountered at every step—both during the formation of plans and during their execution—and before following through this narrative every American relay man will be glad to recognize a debt of gratitude towards all those men and those organizations who seemed to find *pleasure* in doing *anything* to insure success.

It was generally known that various American manufacturers had lent their full support to the project. Sensitive, rugged Baldwin 'phones did their excellent bit. None in England could equal their ruggedness, and none were more sensitive. The small precision wave-meter of the General Radio Company checked to a hair on 200 meters with the unusually fine standard owned by Mr. Frank Phillips, of Wembly Park, London. Burgess batteries took to the wet and muck without a whimper. The A. P. amplifier tubes I had used in tests on this side were still intact and carried on throughout the whole procedure. The Radio Corporation's U.V.200 detectors functioned as gas content tubes in a way which was surprising to British amateurs who saw them working, while the Paragon Super-heterodyne and regenerative receivers pulled in signals in a manner which astounded everyone including Inspector D. E. Pearson, of the Marconi Marine Communication Company, Ltd., who was checking operator throughout the test.

During formation of plans, encouragement was offered by a full score of prominent radio engineers, and everyone was

February, 1922

QST

15

delighted with the generous attitude displayed by W. A. Winterbottom, Traffic Manager, Radio Corporation of America, whose efforts made possible the daily reports via Carnavon and New Brunswick—reports which passed as paid messages but which were never paid for, because Mr. Otto Rochs, Marconi's (England) able traffic manager, informed me there had been no intention of accepting payment. Messrs. Allen and Bradfield, Marconi's joint general managers, took a fatherly interest in the whole program. No amateur could wish for better friends, and tho very busy men they found time to be lavish with suggestion, assistance and real hospitality. Their assistance took the form of men and

In England Mr. P. R. Coursey, editor of "Wireless World," and his associates labored cheerfully to properly organize England, and Commander Frank Phillips opened his home and placed his very complete station at my disposal, while all manufacturers did their share toward boosting the interest in the tests in England by offering prizes.

I wish also to express my thanks for the assistance unwittingly given by one Mr. Louis Falconi, station 5ZA, of Roswell, New Mexico. It will probably be a great surprise to him when he learns that covering a period of about one week prior to my sailing, during which time the apparatus which I was to use was under test,

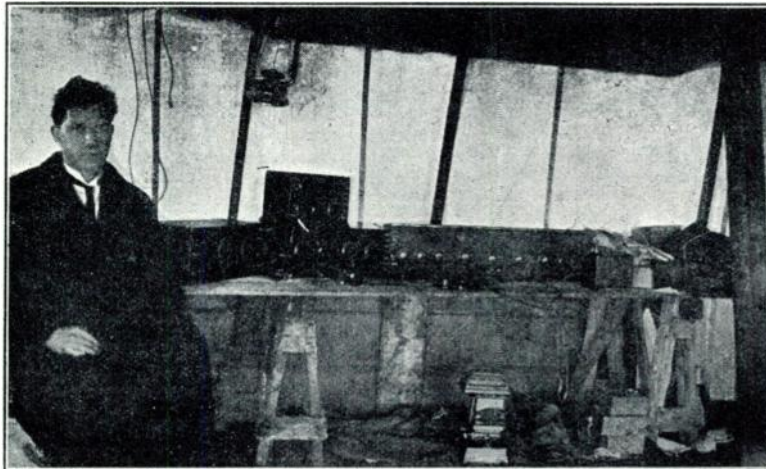

Inside the tent at Ardrossan—Mr. Pearson, checking operator.

materials at Glasgow, and the services of Mr. Pearson at Ardrossan. Capt. H. J. Round, of the same company, and whose valued contributions to the art are quite familiar to all American amateurs was also greatly interested in it all and offered anything he had in the way of equipment, such as a 22-stage amplifier, and proved an exceptionally fine host during my visit to the Chelmsford works of Marconi Co.

Of course, amateurs both in America and England were always ready with assistance. We dared to expect that, but certain amateur services stand out a bit from the rest. On this side it seems to me considerable credit should go to E. H. Armstrong for the keen interest he displayed prior to the tests, and the amount of time and energy which he expended in an effort to insure the success of this great undertaking. I feel that I should also call attention to the generosity displayed by the Adams-Morgan Company in releasing the writer's services for this work at a season, when, as all radio manufacturers know, every effort counts.

I used his very uniform signals to check and recheck the operation of the equipment. I not only received his signals during this period on the regenerative receiver, using the detector and two-stage amplifier, but also was able to get him nicely on a nine-turn loop in conjunction with a super-heterodyne receiver, when his signals were of such strength and regularity as to enable the operation of a four-ohm sounder by the insertion of relays in the circuit. The results of this reception greatly surprised several members of the Radio Association of Northern New Jersey, who chanced to visit my home very early one morning.

A thing which stands out in great prominence is this: the American amateur has given his British cousin a surprise. I am quite certain there wasn't an amateur in all Britain who thought it could be done. I can well imagine the glad surprise which must have spread out from London, when it became known that signals were being received. British men came in on it too, and as a result of all these signals from

America, there is a good deal of speculation in Britain at this moment on the endless possibilities of amateur radio on short waves. Whereas in the past they have been thinking in terms of 1,000 meters, they are now thinking in terms of 180 meters. They are limited to ten watts input, and their antennas must have no more than 160 feet of wire total.

Wasteful coils are necessary to load such a small antenna to 1,000 meters. Also, waves of this length do not travel at night like the shorter ones. Many will listen for us on 200 meters, and I hope soon we may be receiving *them* on 180. Good engineering on their part and a bit of luck will make it possible even with ten watts.

Good fortune seems to have followed everywhere. To begin with, there was that very impressive dinner the night preceding my departure, and the farewell party at the dock. An account of these doings has already been printed, but a part which was not staged was that I should meet on the deck of the "Aquitania" as she left New York Harbor, one H. H. Beverage, receiving engineer of the Radio Corporation of America, and by the way one who qualifies as being a "hard boiled ham." Needless to say, I had not been with Beverage long before we got around to that thing which is nearest his heart, to wit, the Beverage wire, as a static reducer.

Now, to those of you who are uninitiated an explanation of this term "Beverage Wire" will be necessary and it will be forthcoming later. The point I want to bring out here is that the thought of this Beverage wire served as a great buoy during the period previously mentioned when, after listening five consecutive nights near London, I had heard nothing but static and harmonics.

Before the "Aquitania" had been away many hours the great interest displayed in the undertaking began to be manifested by the radiograms sent by many amateur and professional radio men. The first of these came in over the signature of J. Andrew White, editor of "Wireless Age" and read:

Just an added slap on the back old man to emphasize my sincerest wish that this trip of yours will go down in radio history.

This was followed by several others among which was a greatly appreciated one from my old friend Harry Sadenwater, who, it will be remembered, served as radio officer on the ill-fated NC-3 during the transatlantic seaplane flights. He heartily wished me a "bon voyage and wonderful success."

Late in the evening of the first day I learned that Mr. H. M. Short, Superintendent, Marconi Int'l. Marine Communication Co., Ltd., had requested the Aquitania's

radio men to extend all courtesy to me and they proceeded to do all possible in making me feel at home, with the result that twenty-four hours later I found myself taking the following from WBF:

*From Hartford, Conn.
To Paul F. Godley, SS Aquitania via WBF.
Bon Voyage! The entire radio world is pulling for you!*

(Signed) Warmaxnell

while on the fourth day (Saturday) the High School Radio Club of Montclair, N. J. passed out a "73" via VCE (Cape Race).

Contrary to what may have been the general idea of this trip, at no time had I viewed it as anything even remotely resembling a lark, for there were sacrifices which had to be made. But, it was these radiograms—each bubbling over with sincerity and a *will* for success which first brought home to me the extent to which all these eyes reddened by long watches on the relay routes must be following me. As I tossed about in bed during the wee hours of Sunday morning the 19th of November I took note, too, of the veiled interest which had been shown in engineering circles, and before dropping away to sleep I remember mentally repeating over and over the resolve to *get signals or bust!*

The voyage was not rough—neither was it particularly smooth. Fortunately the state of the sea concerned me not at all. A good portion of my time was spent with the three very likable men in the radio cabin, Messrs. Maudesley, Farnam and Porter, respectively Chief, 2nd and 3d operators. It was impossible to do any real listening on amateur waves however. The vast quantities of radio traffic and book work which is to be found on the ocean greyhounds make this impossible, and I had, for the most part, to imagine the "bon voyages" and "73s" and "good luck" messages which were being passed out on short wave lengths, and I understand there were many of them.

As we neared the French coast I filed a message to a staunch League member, Mr. Leon Deloy, of Nice, France, extending greeting on behalf of his American contemporaries to which he promptly replied: "Radio greatly appreciated wish you complete success would be delighted to meet you".

I was very much surprised upon reaching the dock in Southampton to find Mr. H. J. Tattersall, Superintendent of the Marconi Company in Southampton, waiting to help me through the customs, and I was indeed glad to have him. It happens that a very heavy duty had just been placed on all radio equipment. Under these circumstances, British custom officials were inclined towards placing all of my apparatus in the warehouse in order that within the next two to four weeks some customs

officer might go over it at his leisure, place a proper valuation upon it, and exact duty accordingly. After considerable running around to various officials, and after a great deal of pleading with the Chief Customs officer of that port, we were told that if I cared to leave \$100 with the customs people, they would pass the equipment through, the \$100 to be returned at that time when the equipment was again taken from the country.

And so I finally reached London on a funny little train, and began to meet the various notables in and around London. I consider it of extreme fortune that it was possible for me to attend a meeting of the Wireless Society of London, and latter to hear an extremely interesting lecture by

met Marconi. He showed a flattering interest in a recital of the events which had led up to my visit and in amateur accomplishments in the States. He expressed every hope and seemed to feel confident that the tests would prove successful, and as I left him he asked me to pass on to American amateurs his good wishes, for, he said: "I, too, am but an amateur!"

As we passed out of the old building which had housed the Royal Society of Arts for many decades, I again felt myself being steered, and again we approached a long table in the balcony of a gaily colored restaurant. This, apparently, was to be a little dinner party in my honor, and so it proved—and it was a merry, long-to-be-remembered time we had while I managed

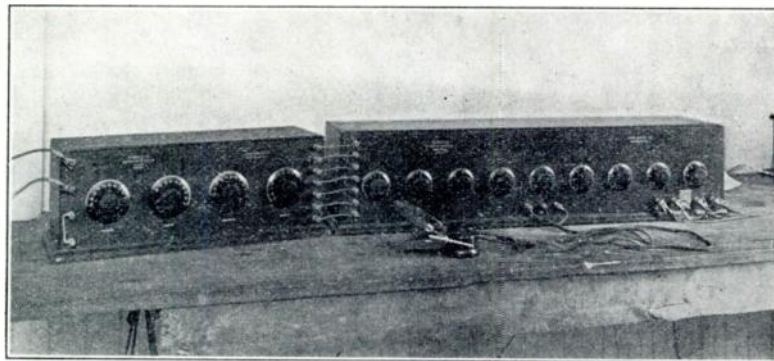

The tuner and amplifier which made up the Super-Heterodyne used at Ardara. As connected for use with Beverage antenna, the special regenerator shown on page 25 was inserted between this tuner and the antenna.

Dr. Fleming at a meeting of the Royal Society of Arts, and to meet and chat with such men as Senatore Marconi; Admiral Sir Henry Jackson, president-elect of the Wireless Society of London; Mr. Campbell-Swinton, past president of the society; Prof. E. W. O. Howe; Mr. E. K. Shaughnessy of the Wireless Section of the G. P. O.; Mr. F. Hope-Jones, Chairman of the Wireless Society of London, and many others.

Just prior to the meeting of the Wireless Society I was led into a large room adjoining the lecture hall and to my surprise found a long table heavily laden with various attractive things to eat and behind which several young ladies were wielding the tea things. It was time for a regular meal, so my stomach said, but it didn't quite look like a regular meal. However, after being assured that it was safe to do so I managed to personally superintend the rapid movement of a considerable portion of the commissary, notwithstanding that most everyone made great efforts to get me to talk.

At the close of Dr. Fleming's lecture I

to put away another big feed all in the same evening. And would you believe it—there were two "O.W's" in the gang! and they, too, joined in the toast to American Amateur Radio and to the success of the Transatlantic tests

As far as I was concerned, British hospitality had never been properly advertised. I had never expected so great an effort to make me feel at home, and while I was thinking this all over I was at the same time noting the glances on every hand which I understood as meaning that these British amateurs had been unable to decide whether I was just a "nut" or whether I was really confident of our ability to put the thing over.

Preliminary arrangements for an operating permit had already been made by Coursey and two days after arriving in London I set up the regenerative receiver and super-heterodyne at the station of Commander Frank Phillips above mentioned. British amateurs are very keen on radio-frequency amplification. Remember, most of their work is done on 1000 meters which

makes it a somewhat simpler matter. Phillips, the designer of the "Burndept III" receiver, thinks very highly of his fine little outfit. Before many hours, however, he agreed that the Paragon regenerative combination gave signals somewhat better than those obtainable on the outfit he was using, and that it was a thing not to be lightly passed by.

The vast numbers of harmonics from single circuit tube transmitters and Poulsen arcs, which one picked up at all times, struck me forcibly. Atmospheric conditions, too, were of an unusual type. I have never before encountered anything like it. During the winter time here in America we expect atmospherics will be negligible, or, if present at all, quite uniform in their habits. At Wembly Park I found them suddenly increasing during certain short periods of the night, and suddenly decreasing to appear again in another quarter, and in a new form.

Later, we got the Super-Heterodyne going, and it was quite apparent that all who saw it in operation were greatly impressed. Cmdr. Phillips showed particular delight when we picked up a 10-watt radio phone station at a distance of 18 miles on a coil having 8 or 10 turns and a diameter of 3 inches. We revolved the coil about on a pivot, and in this manner got the direction of the transmitting station. During our work with the super-heterodyne, I decided to make alterations in the mechanics of the capacitive feed-back. Accordingly, I put a bushing through the panel, placed a shaft in the bushing with a spring washer

and the idea which he got that oil was needed, and it may be that he is right; nevertheless, it is too good to keep.

London newspapers began to show a considerable interest in the tests very shortly after my arrival, and I was greatly amused to find the following printed on the editorial page of the "London Star" on November 30th:

THE FAR CALL

Prospects of the New Trans-Atlantic Wireless Test.
By "Nautacore."

"On December 8 there begins a series of Transatlantic wireless tests similar to those which took place last February. As then, American amateurs, using small power and short wave-lengths, will try to get into communication with this country.

"The stations taking part are purely 'amateur' but must be proved capable of bridging at least 1,000 miles in the States or Canada. With an amateur's small power, and short and theoretically inefficient wave-length, 1,000 miles is a big achievement; yet it has been done. In theory, a station can do little without a fair amount of power behind it, but, in fact, American stations, with a nominal maximum range of 250 miles, are often plainly heard in this country, whilst Valentia (west coast of Ireland) has kept up a brisk correspondence with British ships entering New York Harbour, although the official lists state that she cannot exceed 600 miles.

"Last February's tests were unsatisfactory from the point of view on both sides. In the States too many persons 'tried their hands.' On this side, the delicate, finely-tuned instruments employed were interfered with by wireless novices using receivers which acted as miniature transmitters—drowning the feeble pulsations of American aeriels. Americans, however, reject that excuse for our non-reception, declaring that incompetence had a lot to do with it; and to make certain of really good reception this time they are sending over one of their hardest of 'hard-boiled hams' with a brand-new bag o'tricks and their good wishes. He will show us how it should be done.

"The wireless magazines have made their last appeal to those not taking part in the contest to 'earth' their aeriels and go out for a walk during the specified hours and nights, so that interference may be reduced to a minimum. Those who have entered their names will conscientiously avoid 'regeneration.' Will all respect to the 'hard-boiled ham' I invite him to do likewise—avoid 'regeneration.' Then we all might get something."

(And now you know why I went to Scotland!!)

I was most anxious during all this period to gather what information I could concerning the handicaps under which British amateurs were working. The situation is something like this. Prior to the war British amateurs were allowed wave lengths of 180 meters and were limited to an input of but ten watts, licenses to use transmitters being granted only in a few cases. Subsequent to the war, due to some processes in the British Post Office which I was unable to analyze, British amateurs were given a choice between an operating wave length of 180 and 1,000 meters. There was a time during pre-war days when we ourselves no doubt would have welcomed operation on 1,000 meters, and it is I presume only natural that British amateurs availed themselves of this opportunity to choose the longer of the two. In view



to hold it firm, and so arranged this shaft that it controlled the small condenser. During the initial test of this little device the amplifier began to squeal vigorously. Phillips immediately jumped up from his chair and rushed to another room, to appear a few minutes later with an oil can from his wife's sewing machine, whereupon he proceeded to oil this shaft in its bearing. He maintains that there is no connection between the squeal of the amplifier

of what we have learned concerning the efficiency of antennas, and in view of the fact that the total length of wire in their antennas must be less than 160 feet, however, it is quite apparent that any transmitters operated by amateurs on a wave length of 1,000 meters would be operating at a very low efficiency. Further, our experience with short wave transmission has taught us that we may expect phenomenal distances under night-time conditions, particularly during the winter.

I believe that as the result of these tests, and as the result of some discussion during my visit to England concerning the relative merits of the two wave lengths, British amateurs are now studying the

time I suggested to him that amateurs could cause very little disturbance, even if given the greatest of freedom, provided they were kept to 180 meters. His reply was to the effect that the shorter the wave length the greater the number of stations there were which could be operated within a narrow band, at the same time overlooking the fact, apparently, that all waves below 275 meters are at present almost completely blanketed by harmonics from various high power spark, arc, and tube transmitters; and, in this connection, I was highly amused a day or so later to be able to count up to the 39th harmonic radiated by a G. P. O. station which is located in the north of Scotland. This station is trans-

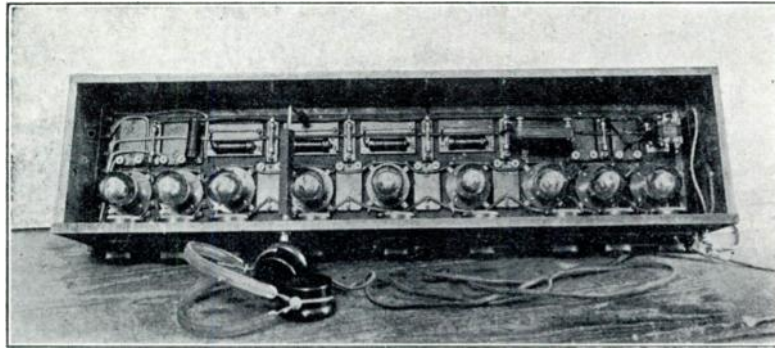

Interior arrangement of amplifier cabinet of Super-Heterodyne used at Ardrossan.

possibilities in connection with transmission on 180 meters, and in fact men repeatedly asked me for such pointers as it was possible for me to give them regarding transmission on short waves.

As mentioned previously, I met Mr. E. H. Shaughnessy, chief engineer, wireless section, G. P. O., and got, in an offhand manner, some of his views concerning amateurs and amateur work. Briefly, I should say that if Mr. Shaughnessy's attitude is representative of that of the G. P. O., British amateurs have a hilly road ahead of them. Mr. Shaughnessy showed great interest in amateur development in America—in fact, he seemed greatly surprised by the rapid strides which have been made in connection with radio-phone broadcasting since the war; but expressed the opinion that whereas American amateurs were so fortunate as to be situated on a large continent, set apart by itself, British amateurs found themselves on a small island, close to many foreign lands, with the result that no liberties could be given them without first considering what effect these liberties might have on various international radio communication problems. At this

mitting a great portion of every day.

It is most reasonable to assume that British as well as American men are able, eventually to get that thing which they go after, and there is no doubt in my mind that British amateurs are going after a more liberal G. P. O. policy. Neither can I believe that the British public can long remain blind to the almost limitless possibilities and advantages to be derived from a liberal radio-phone broadcasting program. I wonder if even here in America we amateurs realize that today the state of the art makes it possible for the President of these United States to speak directly to every citizen in the land? One's imagination cannot help but see the immense value of such an arrangement during times of national peril.

During the entire first week in London everything was blanketed with heavy fog. On one morning in particular upon coming from the "Underground" onto the Strand, the fog and smoke was so thick that it was impossible to see more than twenty feet ahead. Accidents of all sorts were occurring in the streets, and finally traffic had to be entirely abandoned, not withstanding

the fact that at all main street intersections huge flares were going continuously. At this time the fumes in the atmosphere were so violent as to make one cough continually, and the tears run down one's cheek.

Five nights of this sort of thing were quite enough. I was not at all at home under circumstances such as these, and since I could get no assurances from anyone that these conditions were not to continue indefinitely, I came to the fixed conclusion that the vicinity of London—even southern England for that matter—was no place for me, and arranged accordingly to proceed to Scotland, having previously chosen Ardrossan as the location providing conditions near London did not warrant remaining there.

Immediately my decision to change locations became known, wild tales of all sorts began to come to me, concerning the terrible Scotch climate—the rains, the mists, the chill temperatures, to say nothing of the ill effects of the Scotch whisky which one would most certainly be unable to dodge. Even taking all of this with a good grain of salt, I was not sure that I looked forward to the trip into the "Scotch wilds" with any particular pleasure, particularly in view of the fact that even after having been in England a week, I cannot remember at this time of having found a sufficiently warm spot.

The first problem which presented itself subsequent to this decision was the necessity for procuring an extension of the operating permit, or in lieu of that, a new permit which would allow the operation at Ardrossan. Messrs. Coursey, et al., were not at all enthusiastic concerning the possibilities of such extension within the few hours available, and were unable to see by what process such an extension could be pried out of the G.P.O. Several efforts were made to put me in touch with Capt. D. Loring of the G.P.O., and they failed, and finally deciding that we must have action, I myself went to the General Post Office Building, and by good fortune obtained an interview with Mr. J. W. Wissenden, Assistant Secretary, who proved to be a very good listener and a very amiable gentleman, but who was unable for some little time to see just how he could comply with my request. After an interview lasting about thirty minutes, he proved himself to be a thoroughly good fellow, and assured me that the required permit would reach Glasgow the first of the following week—in time to enable me to institute the program as scheduled. I remember telling him, after he had announced his decision, something to the effect that "I could expect no more from my own father", and I still feel that way about it. I do not know what sort of magic wand Mr. Wissenden waves, but I do feel sure

that he is apt to prove a real friend to British amateurs in the not too distant future. Coursey and the other men in his office at the time seemed greatly surprised to find me back so quickly with the good word, and someone remarked something to the effect that it must be great to be an American. I wonder what he meant?

The permit reached me in good time, via Coursey, and here it is:

184562-21 GENERAL POST OFFICE,
LONDON, E. C. 1.
2 December, 1921.

Mr. C. F. Phillips is hereby authorized to install and use for receiving wireless signals for experimental purposes during the month of December, 1921, at a station within 40 miles on land of Glasgow (but not within 1 mile of any Government Wireless Telegraph Station), apparatus for that purpose (including valves), and any aerial which may be considered necessary for the experiments. Mr. P. F. Godley may use the apparatus as the agent of Mr. C. F. Phillips.

It is necessary to stipulate that the apparatus shall be used in such a manner as to cause no interference with other stations, and that this permit is subject to withdrawal or modification at any time at the Postmaster General's discretion should occasion arise.

(signed) J. W. Wissenden
for the secretary.

About the time I was ready to shift for Scotland it began to look, as the result of cablegrams received from members of a committee of the Radio Club of America, which had been appointed to investigate the reported reception of station 2QR in Scotland, that it would be desirable for someone to go to Aberdeen, make the acquaintance of Messrs. Miller and Benzee, and learn what he could concerning this reception. Final conclusions reached partly as a result of this trip have already been reported, and I greatly admire the sportsmanlike spirit shown both by Messrs. Miller and Benzee, and by the Messrs. Robinson on this side. The tendency on the part of British amateurs near London is to believe that the gentlemen in Scotland had heard a *British* amateur phone, and this would seem quite likely.

The Miller brothers were located in Aberdeen at their attractive little general store where they carry a full line of handy electrical appliances, clocks, watches, etc. They had dismantled their original station, but had in operation sufficient paraphernalia to enable their getting time signals. And, after a long drive by motor into the country I found Mr. Benzee at work in his radio shack beneath two very fine looking 80-foot masts. He had the best looking amateur antenna which I saw in either England or Scotland, and as I entered his station and had a look around I wished it were possible to place in front of him some of the fine equipment which is available to American amateurs, for he seemed to be doing exceptionally good work with a great deal of ingeniously gotten up but clumsy and, I fear, rather inefficient home brewed "gear". He was greatly interested

February, 1922

Q S T

21

in everything we fellows over here are doing. He had the bug badly, and would come nearer to feeling at home were he to be suddenly dropped into the thick of amateur activities on this side than any other whom I met.

On Saturday evening Dec. 3d I arrived in Glasgow from Aberdeen and got quickly into bed at the Central Station Hotel. I had been nursing a cold, and was very desirous of resting up a bit, and shaking as much of it as possible.

On Sunday, December 4th, I came out to find the temperature about 30 degrees, and a very chillingly heavy fog. My log book reads as follows:

"Slept until noon in an effort to get warm. After mid-day meal, went out to look over Glasgow, but so chilled, gave it up after two hours. Returned to the hotel and hugged open grate fire in lounge, wrote a letter, had dinner, and went to bed to keep warm. No heat in hotel rooms. All shops in Glasgow closed tight on Sunday. During evening, also made schedules for following day, since tests began in 60 hours. To properly locate and make all necessary preparations calls for some hustling."

"Monday, December 5th, Central Station Hotel, Glasgow. Weather, 34 degrees and overcast. No fog. Present letter of introduction from Mr. Allen of Marconi house to Mr. J. A. Carswell of McNaughton Bros., Ltd., and found him busy, interested and agreeable. He sends his secretary with me to meet Mr. D. Sutherland, superintendent, Marconi International Marine Communication Company, Ltd., to whom I also have letter of introduction from Mr. Allen. Mr. Sutherland takes me in tow and I get tent, wire, insulators, accumulators, etc., etc., in very short order. Carswell, Sutherland and self lunch together. Very enjoyable. Leave Glasgow 4 P.M., Caledonia Railway for Ardrossan, arriving 5:30 P.M. (Eglinton Arms Hotel). Get large scale maps of Ardrossan, and try to choose likely site. A walk out in dark after tea shows all beach sites unsuitable account tides. Getting local color from Mr. Lee, proprietor of Eglinton, until 1 A.M.

Weather warmer and clear spots in sky when I turn in."

Mr. Sutherland was not particularly struck with the chances of my being able to secure the necessary materials and get them to Ardrossan within the time limits which I set. In fact, it took him about 20 to 30 minutes to get used to the idea, when suddenly he seemed to take great interest in the thing, and began to make the dirt fly. I was greatly pleased a few days later when he called me on the 'phone. The opening of the conversation ran something like this: "'Ello, 'ello, who are you? I say, Gadley, I want to congratulate you. I didn't think you would do it." (Meaning getting my equipment into operation

in so short a time.) Neither Mr. Sutherland's nor Mr. Carswell's interest stopped here, and they took advantage of every opportunity to get me on the telephone, to send mail and packages down by messenger, etc., etc., and they expressed a genuine delight when the good news reached them to the effect that our tests were successful.

I soon found myself with Mr. Wood, the town clerk of Ardrossan, and police officials, as well as several other worthy citizens enlisted in my cause. The day in Glasgow had been a foggy one, and I began to wonder whether or not my trip to Scotland was to be proved useless. At Ardrossan, however, the fog had cleared and was replaced by rain in great abundance. High, gusty winds were blowing, and although the tendency upon arrival was to sit tightly by the fire at the hotel, and bundle myself up, I went forth into the night in an effort to get the lay of the land. There remained but 30 hours before the tests commenced, and I was extremely anxious to locate that bit of ground upon which I might decide to erect the Beverage wire. The exploration of the night included a patrol of the beach south of Ardrossan, as well as the beach north of Ardrossan, both of which places on the map showed promise of being suitable for the purpose. I was very much downcast to return after three hours in this weather and after having found that both beaches were almost completely covered with water at high tide. The following morning further exploration was made, and at nine o'clock I met Mr. Carswell from Glasgow in the office of Mr. Wood, and the three of us proceeded to tramp around in an effort to locate a suitable site. The north beach was once more explored, and then at this point we were caught in an unusually heavy downpour and soaked to the skin, but not until I had finally decided that a certain field upon which we had had our eye would be suitable for the set-up. At this juncture we were invited into the home of Mr. Charles Murchie, and offered chairs beside a warm fire. I still shudder when I think of the awful thing we did to Mr. Murchie's rugs and polished hardwood floor.

We also used the telephone, got a Ford automobile, after some delay, and went off up into the country to locate the owner of the particular piece of farm land which I had chosen. I had been congratulating myself all along on the good fortune of having two interpreters with me, because I must admit I found considerable difficulty in understanding English as spoken in Scotland. When we finally reached the home of Mr. Hugh Hunter I greatly regretted my inability to talk the "brogue", because I was very grateful to Mr. Hunter for the great interest displayed by him in our project, which resulted in his allowing us to use the field.

At noon, Pearson, above-mentioned, came on the scene, and we immediately began transferring huge bundles of tent, storage batteries, trunks, floor boards, poles for the antenna, etc., etc., on to this field. It proved to be a very slippery field. It had been covered almost entirely with a heavy coating of seaweed which is used as fertilizer; and those who have had experience in walking over seaweed know that it is a very difficult matter. The one-horse wagon which we got to haul our paraphernalia on to the field was stalled several times, and it was only by unloading a portion of the equipment and carrying it, and



later by putting our shoulder behind the wagon that we were able to finally reach our destination. The poles were scattered down the field at 125-foot intervals, they having already been drilled to take insulators. Floor boards were spread on the ground, trunks and paraphernalia placed on them, and the tent erected. A laborer began digging holes for the poles, while Pearson, myself and one other man started erection of the tent. The tent had just been gotten nicely into position when an unusual heavy gust of wind lifted the whole affair and carried it away.

My log reads as follows: "Ardrossan, Scotland, December 6th. Weather warm, variable gales, with heavy squalls. Meet Mr. Carswell at office of Mr. Wood, Ardrossan Town Clerk, at 9 A.M., after further reconnoitering. Wood, personal friend of Carswell. We looked over maps, beaches and shoreward fields, and finally choose grass-covered fertilizer-covered field property of Mr. Hunter, about one and a quarter miles north of Caledonian Railway Station. Soaked in rain. See Police Sergeant and present credentials. Police find me a watchman. Arrange for transportation of tent, materials, trunks, etc., and order wire supporters from timber yards. Interview Mr. Hunter, and find him agreeable. Lunch. Inspector-operator Pearson arrived for checking results. Get men and all materials on field at 3 P.M., and attempt to erect 12 x 18 foot tent in gale and rain fails. Make very poor progress. Dark at 4 P.M. Continue work until 6:30. Distribute wire support poles, and lay out line for 1300 foot

wire, supported 12 feet above earth, on a line running approximately 26 degrees north of west (which is directly towards 9ZN). Rain and darkness finally drive us in. Pearson returns Glasgow for clothes, and I rig up small Western-Electric tube on Burgess batteries at hotel, and listen with makeshift regenerative receiver and an emergency 60-foot single wire antenna, and get gas pipe ground. Hear a good many 600-meter stations, and a great deal of heavy static on shorter waves. Small lighting battery expires after two hours and twenty minutes, and this, together with heavy cold and sore muscles, puts me to bed in a greatly depressed frame of mind, inasmuch as I had fully expected to get going full blast tonight. The chill and the whistle of a switch engine beneath my window prevents what should have been a sound sleep."

The following day, having enlisted additional labor, things were going in proper style. A line was laid out something under 1300 feet in length, and ten poles equally separated were erected, each pole being twelve feet above the ground and carrying a standard Post Office pattern insulator. A phosphor-bronze wire was then run the entire length of the line and grounded through a variable non-inductive resistance, the ground plates themselves taking the form of several short lengths of iron piping buried some four feet in the earth, at which depth we found one of the holes filled with water.

My log for December 7th reads as follows: "Weather warm, high winds, and driving rain with occasional slacking. All my clothes wet and heavy cold on chest. Two laborers meet me at hotel at eight (just getting light) and we proceed to the Lynn field. Rain has slackened to a drizzle, but walking on field extremely difficult because of its sogginess, and because the field is covered with slimy sea plants. By noon tent is erected, side walls up, and four poles up, the fourth one guyed. Pearson comes on the scene. We plant two more poles, and go to lunch. Darkness finds poles up and wire strung. We continue work in light rain, and bury several ground plates in wet, sandy soil at a depth of four and a half feet. End of line about 200 feet from telephone line (a good stone's throw from beach). Returned to tent, fixed lead-in, and then to hotel for late supper. Procured coffee, sandwiches and a bottle before returning to tent. Made table of boards, and trestles, chairs were boxes and apparatus trunk served as a back rest. A lantern and oil stove were set going, and we made ourselves as comfortable as possible, though small stove did little by way of heating big tent. Tubes, apparatus, high tension battery and storage battery unpacked and found all OK after their long and varied journey through

England and Scotland.

"By 11:30 the 3,000 meter amplifier, which will be used throughout in conjunction with super-heterodyne receiver, was going and "FL" (Paris) was picked up with no antenna connection. In completing set-up his time signals were missed but POZ (Nauen) at 12 midnight served as a check on timepieces. After time signals a 60-foot piece of wire was thrown into a tree for use in adjusting to short waves.

"Picked up many, many 600-meter stations immediately it is connected, and, using them, go through and carefully adjust all apparatus for maximum sensitivity. By about 1 A.M. we were on Beverage wire and feeling for short wave signals, and picking up harmonics from FL's spark and many high power continuous wave stations, although harmonics much less severe than near London, with the exception of Clifden-Ireland's, which are very strong.

"At 1:33 A.M. picked up a 60-cycle synchronous spark at about 270 meters, chewing rag. Adjusted for him, and was able to hear him say "C U L" and sign off what we took to be 1AEP; but atmospheric made sign doubtful! That this was an American ham there was no doubt! I was greatly elated, and felt very confident that we would soon be hearing many others! Chill winds and cold rains, wet clothes, and the discouraging vision of long vigils under most trying circumstances were forgotten amidst the overwhelming joy of the moment—a joy which I was struggling to hold within! I suggested hot coffee at once, and Pearson volunteered to warm it on our stove. He had pot and bottle in his hands when I called sharply to him to resume watch! Our welcome American friend was at it again with a short call for an eighth district station! His signal had doubled in strength, and he was booming through the heavy static and signed off clearly 1AAW, at 1:42 A.M.! Pearson only in time to get the AW on the tail end! We decided at once to leave settings and lay for him. About 1:50 he was in again, but recognizable only by virtue of his tone—totally unreadable!

"Having heard no more of him at 2:35, I returned from a five-minute run down the line to report a pole broken short off, and the line on ground at a point about 700 feet from tent. Winds very high.

"We shut down at 2:35 A.M., and repaired a break in wire, reset pole, and resumed watch at 3:10 A.M. Atmospherics were rising, and although no short wave signals from America, 600-meter signals were booming in with Cape Race readable with telephones on table at times. Closed watch at 6 A.M., after nearly twenty-one hours work of the worst sort.

"Wired Coursey: 'Rains, winds, atmospheric heavy. Working under tent.

Beverage antenna, which fell during night. Heard 1AAW calling eights 1:42 Greenwich, 270 meters, fading, sink gap. Ask him continue same time nightly. Keep all signals coming. Happy.'"

It might be well here to say something concerning equipment. I do not feel qualified at this time to enter into a technical discussion of the Beverage wire. I decided to use it because atmospheric, in the neighborhood of London, had been so strong as to make the use of the super-heterodyne impossible. The same atmospheric were encountered in Scotland, and although at one time I had intended to erect a fairly respectable vertical wire as a companion to the Beverage wire, thoughts of this were dismissed. For best reception at any given wave length, this wire should have a length equal to one wave length, and according to the dope given me by Beverage, should be grounded at the end toward the station at which the signal originates through a resistance of between 250 and 400 ohms. At the other end the wire is grounded through an inductance having an effective value of about 0.1 milli-henry (for 200 meters). This last inductance is coupled to the receiver, and adjustment of the resistance gives to the wire a decidedly directional characteristic, thus enabling the elimination of a great deal of interference and static. (I now doubt whether or not we ever had this wire properly adjusted for any wave length other than that on which station 1BCG was working, since in order that we might get proper adjustment it was essential that we have some signal to work on.) To make adjustments on this wire it was necessary to run back and forth from one end of the line to the other, and this was rather tedious work. But I have the satisfaction of knowing that we received the signals on the first night that the antenna was in operation, and that we had received a great number of signals prior to the time when British or Dutch amateurs had received any, notwithstanding the fact that according to calculations which Beverage has made, the effective of height of our antenna could not have been more than 65 or 70 feet.

The possibilities of the Beverage antenna in connection with reliable trans-continental and trans-Atlantic relay work are very well worth looking into. At this time I am satisfied that a goodly portion of my success is directly due to the use of this type of antenna. It is hoped that before long complete data concerning it will be available to amateurs.

As to the receiving equipment itself the only apparatus which I carried with me was a Paragon regenerative receiver, together with a Type DA-2 detector-amplifier, and a super-heterodyne receiver, which, including the external beat oscillator, had a total of ten tubes.

The Beverage wire was inductively coupled to the input circuit of No. 1 tube, which was a detector. The plate or output circuit of this tube was tuned regeneratively in order that advantage might be taken of regenerative radio-frequency amplification. The output circuit of this detector tube also included a closed oscillatory circuit, tuned to a frequency of approximately 100,000 cycles. The second tube was used as driver for an oscillatory circuit which, by virtue of its coupling to the input side of the first tube, supplied the detector circuit with oscillations of such a frequency as to produce beats of the order of 100,000 per second with incoming oscillations, this beat frequency being passed to tube No. 3, which is the first tube of the five-stage 100,000-cycle radio-frequency amplifier; all of the stages, excepting the last, are resistance-coupled, while the last is coupled through an air core transformer to a second detector, which in turn feeds one stage of audio-frequency amplification.

The complete circuit for the set-up as used is shown herewith. Inasmuch as various descriptions of this type of equipment have been printed in American magazines, no attempt will be made to go into great detail. Suffice it to say that the coupling resistances have a value of 100,000 ohms; the grid leaks a value of about 2 megohms, the grid condensers a value of about 250 micro-micro-farads. The air core transformer which couples the amplifier to the second detector is tuned to the frequency of amplification. Regeneration at the 100,000-cycle frequency is effected by capacitive back-coupling from the plate of the last radio-frequency amplifier to the grid of one of its predecessors. The cabinets containing the super-heterodyne equipment are lined with sheet copper. All condensers, resistances, leaks and tubes which go to make up this amplifier are selected with great care, and in addition it frequently proves advantageous to shield the cords and cases of the telephone receivers, the shield being connected to the negative terminal of the "A" battery.

For reception of continuous wave signals it will always prove more convenient to set up a tenth tube which drives an oscillatory circuit for this purpose. Usually it is better to set this oscillator so that the third or fifth harmonic of the oscillation which it produces falls near the frequency of amplification—this because it is difficult to control the amount of energy fed into the amplifier when the fundamental frequency itself is used for beat production.

On Dec. 8th my log reads as follows: "Weather: High winds and heavy rainfall, changing to clear with northwest winds at midnight. Star-filled heaven and a half moon—a welcome and beautiful sight.

Such a night should be ideal for our purposes.

"Line properly repaired during day and early evening spent trying to get dry at Hotel. Apparatus found in good shape, and constant watch kept until 6 A. M., with no amateur signals heard. Cape Race on 600 meters much weaker than last night. At 4:30 A.M. Pearson goes out and makes a shift in line to ground lead but no signals result.

"Attempt to receive C.W. stations blanketed by high power station harmonics, and the few breathing spells which Clifden takes are welcome ones. If poor weather instead of clear is required for signals it is to be hoped that we have poor weather.

"Clear spell brings greater chill and we shift table a bit and hang canvas to our backs to keep the wind off. A heavy cold which I have been fighting settles further into my lungs. Pearson being a Scotchman seems to be immune, and no doubt would suggest that I don't drink enough of Scotland's Honeydew.

"Wired Coursey: 'Cooler, clear; moderate atmospheric, no signals.' Closed down at 6 A.M., somewhat disappointed, but thankful for yesterday's great encouragement."

December 9th the log reads as follows: "Weather again wet and boisterous and at midnight on cutting in, find atmospheric very heavy, but wind dies away by 2 A.M.; rain continuing to fall, and atmospheric falling off to moderate strength.

"At 12:50, after listening some time for free-for-all sparks, we swing over to C.W. and it is indeed a thrill we get when 1BCG is picked on 230 to 235 meters. A harmonic from Clifden is jamming but after some adjustment this is partially nullified. Signals from 1BCG very steady and reliable. *Remarkable performance* and I wonder what power he is using. Lose him many times in an effort to 'feel out' the Beverage wire, but get him much better after adjustments terminated at 1:33. He is calling 'PF test' and signing. Sweetest song I have ever heard. Calls separated by (?). Changed operators at 1:45 A.M. His sending steady in all cases. He fades out for 30 seconds every 3 or 4 minutes, but always comes back strong and steady.

"At 1:59 A.M. he calls 2BGM and says 'Phone us now', then shuts off. Measures between 230 and 235 meters on little General Radio meter.

"Pearson and I relax, laugh with glee, and start looking for something to eat and drink.

"Continue through night to hunt for more, but without avail. Static fairly bothersome, and Clifden is sending a great deal, and am unable to shake him.

"Shut down 6 A.M. but start up again after talking it over, to copy MUU. MUU sends 'Godley's message'. It comes home

to me that ours is a history making set of tests—that American amateur radio has the world by the ears. I would give a year of my life for a 1-KW tube transmitter, a nice, upstanding aerial and a British Post Office license to operate it on 200 meters. To be forced to listen to a Yankee ham and *only* listen is a hard blow.

“Wired Coursey: ‘Burnham owes Warner new hat. Warm rains, calm, decreased atmospheric. 1BCG calling me ending two Greenwich. Undamped two thirty, strong, steady. Congratulations.’”

The performance of 1BCG had filled me with a lot of very wonderful feelings. Pearson and I spent considerable time in talking it over and trying to figure out what his equipment might be. It was hard

kindly mood! Signals were there! But, alas, I had not counted correctly on the vagaries of men’s minds! Some British telegrapher against whom I shall carry a grudge to my grave had “bulled” my cable, for it reached Armstrong reading “SEND MGES”, and he did! He sent “MGES” over, and over, and over until I was sick! He kept it up the entire night, regardless of schedule, and no earthly way of stopping him! I remember getting a laugh out of it by conjuring up pictures of the “Old Man” spitting on the cat, but I could not forgive myself for exercising so much thrift. I wished that I had sent cables to Hartford and home and to Warren G. himself apprising them of the facilities available, for then I am quite sure my ideas

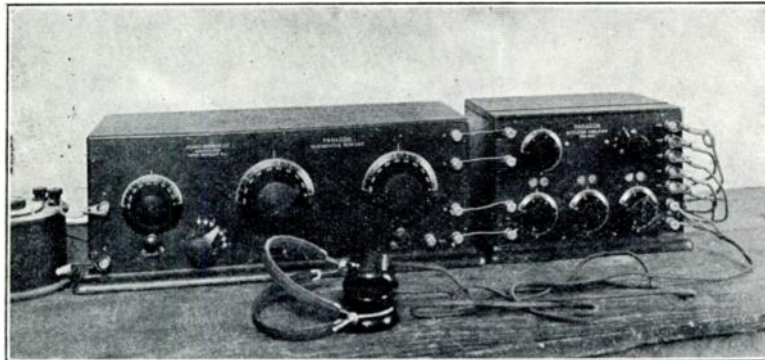

Special regenerative receiver, range 160 to 500 meters, used at Ardrossan and London.

for Pearson to believe that only 1 KW had been used, while I felt quite certain that the legal limit had not been exceeded. The frequency of the wave was *unusually* steady, and for this reason it had been possible to build up excellent signals by taking advantage of resonance in the telephones. To offset this belief, however, there remained the fact that we had not even heard indications of other stations after 1BCG shut down at 1:59 A.M. and I began to wonder whether or not 1BCG might be the only station which would get over in real style. I then decided that no one thing would forever redound to the credit of amateur radio more than the transmission and successful reception of a complete message and I wired Armstrong direct as follows: “Signals wonderful send messages starting one Greenwich” and went to bed with a singing heart and thoughts of the coming night when we would be copying (perhaps) messages via 1BCG from Hartford, and my home, and even from Warren G. Harding himself—who could say.

And, when we were on watch again it was “Allah be praised!” Nature was in a

on the subject would have been, finally, correctly interpreted.

My log for December 10th-11th reads: “Got on job a bit before twelve feeling very fit as a result of extra bit of sleep during afternoon and evening. Was most worn out. Take time signals from POZ and then do a bit of rearranging. I rig up external heterodyne for beating on my amplification frequency, hoping this will be better than using amplifier as autodyne, because of greater ease of adjustment.

“Get set at about 12:50, and at a few minutes past one, pick up 1BCG, sending ‘Mges’ over and over. Signal very strong and steady. Static very strong too, and have considerable difficulty to get signal-to-static ratio up. He fades more than last night. At 1:14 he says: ‘three minutes’. I expect him to start sending messages, so anchor on him, making adjustments for improvement from time to time, and am very thankful for such a fine signal to work on.

“Pearson makes frequent excursions up and down the line, and endeavors by every means to get the static out and get the signal, but at 1:15 he faded out.

1:16—There, but unreadable.
 1:17—There, but unreadable.
 1:18—Faded out.
 1:20—Returned a bit. Static getting heavier and adjust to reduce. Now have him saying "Mges" over and over.
 1:22—Faded out 10 seconds and back.
 1:23—Faded out 20 seconds and back.
 1:24—Faded out 10 second and back.
 1:25—Weaker.
 1:26—Weak but steady.
 1:27—Very weak and very steady.
 1:28 and 1:29—Coming up very strong and steady.
 1:30—Fades a bit.
 1:31—Long dash, very strong and steady.
 1:32—Fades a bit, but back again.
 1:33—1:45—Very strong and very steady. Says 'GE PF' and stops.
 1:50—Back again, after five minutes shutdown, and new operator now.
 1:51—Says "Minute, minute sn" and shuts off.
 1:53—Long, unsteady, bubbling dash, and immediately much stronger than at any other time. Can read him throughout tent with 'phones on table, and wind howling outside. "Tests VV Mges de 1BCG", etc., etc.
 1:57—Falls off a bit, but still good, saying "R R Mges de 1BCG."
 1:58—Fades to just audible for 20 seconds.
 1:59—Coming up
 2:00—Just audible and out five seconds.
 2:01 to 2:04—Strong and steady.
 2:05—Almost out for 20 seconds.
 2:06—Readable—back to normal and now reading 'phones down.
 2:07—Subnormal—slowly weaker, out five seconds, rising and falling. Static still quite severe, much worse than last night.
 2:08 to 2:12—Readable, rising, falling, weak. Suddenly jumps to normal for ten seconds, and fades to readable.
 2:14—Stronger.
 2:15—Says "Three minutes."
 2:18—In again, now another operator sending.
 2:21—Continuing good and steady.
 2:23 and 2:24—"PF PF de 1BCG Test Test", etc., etc. Fine, steady and strong, fading a bit, but never out.
 2:27—We jarred oscillator off setting and lost him, but back OK.
 2:31—Says "Min bi 3 mins" but starts immediately and says "QRV".
 2:32 to 2:38—Weaker but readable.
 2:40—Accumulator failed, lost him in making change.
 2:53—Going OK "Godley Mges."
 2:56—"QRV"
 2:59—He pauses. Very strong and steady during this period.
 3:02—We talk and miss a phrase.
 3:00 to 3:15—Very strong and steady.

Says "Bi 3 mins de 1BCG 30." We go out and stretch.
 3:27—He is just now starting with another long dash and says "QRK Godley?" Another operator now. Signals thoroughly uniform. He sends "PF" in American Morse, probably John Grinan.
 3:40—"PF" in American Morse twice.
 3:43—"2ZE" twice. He has been wonderfully uniform since 3 A.M.
 3:49—Pick up 1ARY, saying "QRV".
 3:53—1BCG comes in again. Also following from 1ARY: "From 1ARY to 2VA—we will play again at football next fall. No sig." "2AJF from 1ARY No sig. HW 2AJF de 1ARY ar."
 3:55—1ARY very slowly: "next fall no sig. 2AJF de 1ARY". Very steady.
 3:57—1BCG still going *strong*, steady, and sharply, says "30" at exactly 4 A.M.
 4:02—In again, very strong and steady.
 4:05—Decide 1BCG is not going to send messages so leave him. Static fallen off rapidly in last hour, and wind has gradually shifted from southwest to northwest. Getting colder. Clears up a bit, but begins raining again about 4 A.M.
 4:10—Some continuous wave calling 4GY. Can't read him for static.
 4:17—1BCG still steady and *strong*.
 4:18—Stops for a few minutes.
 4:19—1ARY calling 1UN (CW) weak.
 4:21—1ARY still calling 1UN.
 4:23—1BCG still in; sends few V's.
 4:26—1ARY calling 9BBF. "Here msg."
 4:30—1BCG says "Three minutes AS". Some spark in too, but unreadable.
 4:35—Several CW's and spark in, one CW quite loud but jammed. He is saying something about a message from "Richmond for West Palm Beach". From his fist suspect it is 4GL.
 4:37—"R R Hello, Godley de 1BCG." Still very steady and fine. 1ARY calling 9BBF again, *seems fully as strong and steady now as 1BCG*.
 4:43—"Hello Paul de 1BCG".
 4:49—2FD calling 9XAH (CW). Fine, clear and strong. Pearson marvels at proficiency of amateur operators.
 4:53—8ACF calling CQ (CW).
 4:54—2FD calling 9XAH, says "GE".
 4:58—1BCG still *very steady*. "Bi".
 5:03—1BDT (spk) calling 2OM says! "GE 73 QTC." 1ARY (now spk) calls 1BIS. Both above fading.
 5:09—Several sparks in too faint to read.
 5:10—1BDT calling 1DY.
 5:14—1BDT calling 1DY. (FFU jamming.)
 5:15—Some buzzer calling 3PU.
 5:18—2FP (ICW) in strong, very fine, steady signals. Sending his code word "HUZXJ."
 5:23—1RU (CW) in strong and clear sending his code word "BPUSC". 1RU signs off at 5:25 A.M. 2FP still going

February, 1922

QST

27

and can hear him all over tent. Very steady. Signs off at 5:30 A.M.

5:30—2BML in strong, steady, but his note varies considerably. Must be blowing at Rocky point and I wish Beverage could come up from Chelmsford and listen to his rotten note. However, Beverage is "there" on the antenna design. 2BML is sending his code word over and over very carefully and slowly, "FSXVG". He is much easier to read unheterodyned.

5:37—2BK is in (spark) working locals he says "OK tried anything yet OM".

5:40—1BDT in working a 3 station.

5:43—1BGF calling eight station.

5:44—1BCG still *going strong*. "V's".

5:49—8XV sending "Test" (CW.)

5:53—1YK calling 8AQV (CW). "LXCAM" coming through the QRM but cannot get his call due to jamming and his fades.

5:55—3BP (spark 60 cycle synchronous) Very strong.

5:57—LXCAM in again, but don't get his call. (500 cycle modulated CW).

6:00—1BCG "Test Godley". Still steady.

6:03—1XM signing off, ICW. 2EH (CW) calling 9ZJ—both good, but don't hear 9ZJ sign, although recognized his note and his fist.

6:05—2BK calling 8AYN. Strong.

6:19—2DN calling 8AYN; also strong.

6:23—1XM in, 500 cycle note, may be spark.

6:31—Someone says "Must put some wood on fire, old man." Think it is 2EH again.

6:39—A squeak box freaks in, and I am dumb-founded until I learn it is a French vessel. (FFV jamming.)

6:43—2EH (CW) calling 8AAH.

6:50—Close down to get a check on MUU. Colder; wind now in north. Very dark. A glorious night! And I hope that some of the English boys have had a look-in too. Surely, with their high frequency magnification they should do wonders on a night like this. I hope they have. I get a great deal of pleasure out of thinking about the glee with which MUU's message will be received tomorrow morning. How Warner will measure his head for the new spring hat! How old man Maxim will carry a face split from ear to ear. How Armstrong, Grinan, Burghard, King, Amy, Cronkhite and Inman will go around with chips on their shoulders and chests stuck out. 1BCG is *some* station, and Pearson and I both agree 1BCG was commercial signal 3 to 6 A.M. Some of the boys will be very much surprised too, because have heard some who never dreamed of getting over.

"The feature of the evening was the very fine and steady signalling from 1BCG. His continual transmission enabled a series of careful adjustments all along the line for a maximum effectiveness of antenna and

apparatus. Towards the last of test static had decreased, and was able to get "clear air."

"The patience and clocklike precision of shifts at 1BCG is deserving of great credit. Pearson is greatly impressed both by the enthusiasm displayed by all amateurs in America, and by the way this receiving outfit works.

"I am anxious for news from home, and cabled 1BCG as follows: 'Send home news.' Wired Coursey: 'Heard 1RU BPUSC, 2FP HUZXXJ, 2BML FSXVG, also spark 1ARY, 1BDT, 2BK, 2DN, 3BP; undamped. 1ARY, 1BCG, 1BDT, 1BGF, 1YK, 1XM, 2FD, 2EH, 8ACF, 8XV, strong, reliable, thrilling.'"

In connection with this night's results, the following is to be noted, that the reception of so many signals was a combination of adjustments resulting from having station 1BCG to work on, and of transmission conditions which seemed, after several hours' hesitancy, to have decided finally to let through a great number of stations. The extent to which this condition persisted is evidenced by the fact that, whereas during the early evening and prior to a series of adjustments of the Beverage wire it was just possible to read 1BCG through static, later the combination of static-eliminating adjustments and conditions made it possible to read *at least two stations whose output is not greater than 30 watts*.

Subsequent to 4:30, many sparks and CW signals would come flicking in for short periods of time and then go out again, before it was possible to get their signs, and in many cases to even hear what they were calling.

I cannot at this time too heartily condemn the practice of stations working locally without using their call letters. On at least a dozen occasions I very carefully tuned in stations to listen to them for periods ranging between one and three minutes, to find that my effort had gone for naught, since the stations in question suddenly stopped working without using their station calls.

Between 4:30 and 6 there were times when so many stations came in that it was impossible to read any. At such times as these I was very strongly reminded of the interference conditions near New York City. These conditions were duplicated exactly, excepting that the strength of signals was not as great. The number of stations audible; however, was fully equal to the number audible when listening in, in the vicinity of New York.

Monday, December 12th:

"1 A.M.—In late, account finishing up log. On at 1 A.M. adjusting on 600 meters. Partly cloudy, north wind all day, now southwest, but remains cooler. No rain today.

1:25—Go to short waves. Static intermittent, medium heavy clicks. Several American amateurs in too weak to read. 1BDT sending "Test", spark very strong and steady. "Transatlantic tests". Strong harmonic from some H.P. station, sending press and fading in and out. 1BKA sending "test" (CW). FFU jamming. 1XM (ICW sending "test". FFU jamming. Dozens of them in working, wonderful.

1:45—1XM in again.
1:50—1BCG says "Bi 1 hour."
1:55—2EH (CW) "Test." Lots of jamming from the Holland stations.

1:58—2FP in strong. (ICW).
2:05—2ARY (ICW) "Test". Lots of QRM from Poldhu's press on harmonic. Other press schedules also going, and all seem to have harmonics. Makes it difficult.

2:11—3FB spark. "Test." (QRM FFU.)
2:19—2AJW calling 2OE (CW). (30 watts.)

2:24—2EH (CW) calling 8AKV. (UAT arc jamming.)

2:35—2EL calling. (Weak.)
2:39—1ARY (CW) working.

2:50—2EH calling 8AFD very steady. 1BCG in with messages.

2:52—He starts: "Nr 1 de 1BCG words 12, New York. Date December 11, 1921, to Paul Godley, Ardrossan, Scotland. Hearty Congratulations. (Signed) Burgard, Inman, Grinan, Armstrong, Amy, Cronkhite." Received from 1BCG finishing at 3 A.M. He says "Bi two hours". (Last heard of him.)

3:03—2EH working 2XQ. Very steady.
3:11—1RZ in (CW), readable; also many weaker ones jammed by high power stations.

3:15—Shut down for slight shifts. Had small regenerative receiver in. Heard several CW stations faintly, but only one readable.

4:05—Back on super-heterodyne receiver. Apparently all faded out. Hear only an occasional 20-second amateur spark or continuous wave, and no more. Weather again changing here. FFU, who has been jamming all evening, is rising and falling rapidly, being very weak most of the time. Battery getting low, but do not blame it.

5:54—Heard nothing more.
6:05—Nothing more. Close down. Wired Coursey: 'Code LXCAM call jammed, also 1BKA, 1RZ, 2ARY, 2AJW and 3FB.'

"December 13, Tuesday—On 1:30 A.M. account oversleep, after up 24 hours straight. Partly cloudy. Bright moon. Wind northwest with occasional squall. A bit frosty.

1:30—Nothing in on short waves. Go through amplifier adjustment. Medium static. Medium to moderate clicks, and a good deal of interference from high power press-sending stations.

1:45—Wind begins rising rapidly and

cold getting intense. Ship stations going strong and static quite heavy on 200 meters, though much better than on vertical aerial. Nothing in on short waves which can be read.

2:10—Static growing worse. FL's arc jamming too.

2:15—Continuous wave station in on 225 meters, but can't make him out; and it is even difficult to get him turned on account of atmospherics. Atmospherics seem to have reached a sudden peak, and now are steady, louder crashes having flattened out into continuous roar.

2:40—Static killing everything, can't even read harmonics nearby from high power stations.

2:55—Swapping tubes for improvement of amplification. No marked improvement over those picked initially.

3:00—Static increasing, still bright moonlight, and partially cloudy. Wind still in northwest. Out for eats.

3:15—Static increasing and occasional squalls and cold rain.

3:22—Carefully tuning oil stove and succeed in increasing output 50 per cent.

3:25—On 600 meters, comparatively quiet.

3:30—FFU on 600 meters. Have not heard him on 240 tonight.

"Note: Although on all previous nights we have looked diligently for stations on 250, 275, 325, and 375, none are to be heard even when conditions seem at their best, at which time very fine signals are coming through from Cape Race on 600 meters.

3:30—Pearson calls this a "proper washout."

3:40—Harmonics from high power stations only. Clifden's very loud.

4:00—Static continues heavy and continual muffled roar. Hearing nothing on short waves.

4:01—Fairly strong, unsteady CW signal on 1BCG's wave, send V's; fading fairly strong at times. Lose him entirely trying to better him.

4:24—FFU begins floating in on 240 meters.

4:30—FFU faintly through static on 450 meters.

4:45—On 600 meters, static heavy there too, and not much doing. Hear no sign of Cape Race.

4:50—Some 500 cycle spark on 200 meters calling CQ, but do not get his sign.

4:52—Non-synchronous spark, loud, sounds like British commercial station, but don't get his call.

5:05—Nothing coming through, static falling off a bit, but rather severe yet.

5:15—Nothing doing.

5:30—600 meters very quiet. Static clicks coming in again. Pearson getting very sleepy. Shut down to go over the line and eat a bit.

(Continued on page 36)

Official Report of the Second Transatlantic Tests

(Continued from page 28)

6:00—Nothing in.

7:00—Copy MUU's report.

"Wired Coursey: 'Include yesterday's 8BU stop. Heavy atmospherics today.' (8BU logged by Pearson.) Coursey added to this: 'Many your stations heard by British amateurs. Details later.'"

December 13th—14th:

"In bed all day trying to keep warm and catch up on sleep. Get out a bit late. A cable from Clement via Coursey saying 2XB will transmit 450 meters continuously, CW, ICW and telephone 1 to 7 GMT this morning. A letter from Coursey saying 'They have been heard' in London, on British equipment and 'small British aerial'. I am very much pleased.

12:45—Find line and tent OK. Inspect grounds and start stove. Cold west wind, overcast, fleecy clouds. Static grinders. Clifden's harmonics particularly bad. POZ also has a strong harmonic going. FFU in good and strong and fading at 240 meters; also a harmonic from Poldhu, good and strong.

1:03—Some spark in, jammed by FUU and Clifden.

1:09—GMH in strong on 200 meters harmonic, also FFU.

1:25—Nothing of 2XB. Harmonics pretty bad on 450 meters.

1:30—GMH in. Also someone starting an arc.

1:45—Harmonics exceptionally bad; signals numerous on 300 and 600 meters. A great deal of intership work done on 300 meters in European waters. Dozens of ships near Firth of Clyde continually jammed everything near that wave.

2:00—Harmonics.

2:12—MFT's harmonics bad. GMH comes fading in and out on 200 meters; also JJT. Static comparatively light until now; increasing rapidly.

2:15—FBA on 500 cycle spark. FGR in on 320 meters.

2:30—GMH—PAF in, 450 meters.

2:40—PCB in, 450 meters.

2:45—Nothing in on 450 meters.

2:45—Static coming up; sounds like something charging and discharging, with a squeak. High west winds, quite cold.

2:50—Poldhu's harmonics freak on 200; also an American amateur freaking in and out. Non-synchronous gap. (Later more like GMH.) FFU fading in and out. This is a harmonic of his 600 meter wave, as is GMH's signal.

2:55—Very tired and sleepy.

3:02—Wind rising rapidly, and getting very cold.

3:10—Decide to turn in, nothing doing, and both greatly in need of rest.

"Wired Coursey: 'Colder, high winds, faint signals only. No reception.'"

It was on this night that Pearson had fallen asleep. The cold was particularly hard to bear. The wind whistled around our feet and came down in gusts on our heads. We pulled the oil stove around (it was directly underneath the table) and turned our boxes over so that our heads just stuck above the table. In this way the greatest possible portion of our bodies was exposed to what little heat was radiated by the stove.

Some time between 3:10 when we decided to turn in, and five o'clock, when we actually did turn in, I also threw my hands across the table and fell asleep. How long I slept I do not know, but I awoke suddenly with thoughts chasing around in my head to the effect that the "works" was on fire. In coming to I also awakened Pearson, who looked at me with eyes aghast. I immediately asked him if I had startled him, and he replied "What is the matter with your face? It is as black as ink."

The oil stove had taken a notion to smoke, and a good many of the papers, the log book, and a part of the apparatus; as well as the under side of the table, were thoroughly smoked up. My face laid across a crack, and when I had reached the hotel and had an opportunity to examine myself in the mirror, I could well understand Pearson's surprise.

It is growing rapidly difficult for me to remember the lack of enthusiasm on the part of both Pearson and myself to drag ourselves out of a warm corner by the open fire in the lounge at the hotel, in order that we might don rubbers, overcoats, and rain coats, and march out into the awfulness of the Scotch night, only to sit on a hard wood box in a very drafty tent. I remember several times wondering if this test would ever, *ever* be finished. As long as signals were coming in, there was plenty to keep one interested, and the nights passed very rapidly, but it was a continual fight against static and harmonics and cold and wet that drove one almost crazy.

In addition to this I was having to contend with a very heavy cold. I was subject to coughing spells which shook me from head to foot, and after which I felt as weak as a baby.

On Wednesday, December 14th, I almost decided to give it up. I had no hankering for an attack of pneumonia in Scotland, and I was advised on two occasions to forget all about radio and go to bed, unless I wished to be confronted with a serious illness of three or four weeks, with hospital attendance which was none too good. I am quite sure at this time if I had seen any weakening on Pearson's part I would have been only too glad to take advantage of it. I would like to say that I not only have the highest regard for Pearson's ability as an operator, but also for the courage—and

courage is the word—which he displayed in sitting up night after night, in a leaky tent, with high winds blowing, and heavy rains falling, and nothing but an occasional "wee drappie" and a very unreliable two-dollar oil stove to keep him warm.

At this time I was suffering from pains in the back, sore muscles, headaches, and a very stiff neck. However, towards the end of the week the weather was quite like summer, being very warm, and gentle southerly breezes were blowing, and we managed to carry on.

On Wednesday and Thursday, December 14-15, my log reads as follow:

"10:30—Very light static. Only thing to be heard on amateur waves are harmonics from 600 meter stations and harmonics from "Olympic's" tube set. Listening diligently on all waves, up to 12:10, nothing doing.

12:30—Dead silence, except for Clifden's harmonic, and an occasional 600 meter harmonic.

12:45—Go to vertical antenna. FFU's harmonic stronger and static heavier. No signals. Winds changing from west to north.

At 1 A.M. Poldhu's 200 meter harmonic comes in on his press schedules. Fading in and out. Static coming up rapidly since change of wind.

1:13—FFI in on 200 meters (harmonic.)

1:15—Static worse. Pearson goes to end of line and readjusts resistance, resulting in marked improvement in static.

1:30—MPD, FFU, and FFI in on harmonics. Nothing more.

1:45—Ditto.

2:00—Go to 450 for 2XB.

2:30—Nothing from 2XB. Static again getting stronger.

2:45—FFU in occasionally, nothing on short waves.

3:15—Absolute void of signals.

3:30—Both getting so sleepy we can hardly see.

3:45—Still sleepy. Still no signals.

4:00—Ditto. Ditto.

4:30—Conditions have been the same for hours. No signals. We decide to turn in.

"Wired Coursey: 'Bright moon shine, summery weather; only weak signals since the 12th.'"

Thursday and Friday, December 15th and 16th, log reads as follows:

"12 Midnight—600 meter signals more abundant than usual, but considerable static; go to 200 meters, and find static much worse. However, FFU's harmonic a bit stronger than usual, and FFI in occasionally on harmonic. Been like a summer's day here, and wind blowing from east and a bit south. Up all day getting photos of set-up; also had several visitors during afternoon, and for their benefit got signals from WKQ and POZ and several others.

12:30—Static heavy and no signals.
 12:45—Ditto.
 1 A.M.—600 meters going strong, static bad on 200.
 1:15—FFH and FFI in on harmonic. Clifden very noticeable account his absence tonight.
 1:30—Now raining hard, and wind rising. Static so bad can't read FFU, which is unusual.
 1:45—Static seems worse, but Poldhu's harmonic on his press schedule comes in very loud.
 2:00—Static very strong on 200.
 2:07—"Pace" and FFI working, also KBH working on 300 meters.
 2:11—Clifden starts up.
 2:15—Static so bad we shut down for a look around.
 3:30—Static very heavy. No signals.
 3:45—Clifden and FFU only, latter unreadable.
 4:05—FFU in—readable. Nothing else.
 4:11—GCC harmonics in, just readable through heavy atmospherics. Wind blowing fairly hard, and getting cold in tent.
 4:30—Harmonic from some Marconi CW ship-set in, swinging badly, but loud; also GCC's harmonic.
 4:35—YBV calling ZAZ; somebody calling YBV.
 4:40—Static continues heavy. No signals. Weeps! Shut down. Blowing and raining like Old Harry.
 5:15—Static continues to increase, and much colder, and blowing and raining hard.
 5:30—FFU in, and Clifden going, also bubbles from some arc. Can't read FFU, though his signals are fairly strong, at 5:45.
 6:00—Closed down. Wired Coursey: 'Atmospherics, no reception.'

When the original schedules were laid out, it was with a view to enabling me to complete tests and return home in time to be with my family on Christmas Day. These plans were made on the spur of the moment, and on the assumption that it would be possible for me to pack up my apparatus, get it aboard train, and reach Southampton by noon of Saturday, the 17th. After it was too late to change these plans it became obvious that such a course would be impossible, and so, before leaving London, I had booked passage on the Olympic, which sailed on the 21st. In order to catch the Olympic, pay proper respects to various men who had been of great assistance, and get my apparatus checked out by the Customs Officials in Southampton, it was necessary that I arrive in London not later than Monday.

In order to do this, it became more and more apparent that we would have to dismantle on Friday and forego the additional night of listening which should have come in according to schedule. All business houses in Glasgow close promptly at noon

on Saturday, and it would have been impossible for me to return batteries, tents, wire and other paraphernalia which we had borrowed, get my apparatus back and aboard train *prior* to Saturday noon. After considerable indecision, and after waiting most of Friday to see whether or not the summertime conditions which had been with us would change for more favorable ones, it was finally decided, after 3 P.M. on Friday, to dismantle. This we started to do, and by seven o'clock that evening we had everything packed and were loading it aboard a wagon. By nine o'clock everything was in Ardrossan, properly packed and labeled, and we were all set to take the first train in the morning for Glasgow.

During the night, Friday, the tail end of the cyclone which had passed across the Atlantic during our tests hit Scotland, and we were indeed happy that we *had* dismantled our equipment, because the winds that night were higher than at any time during our tests.

This same storm by the following morning had backed the waters in the English Channel up until the tide stood at a depth of two feet in the streets of Hull, this being the same storm which had battered the Olympic in her voyage across, resulting in the death of two men and the destruction of several thousand dollars' worth of equipment on board.

It may very well be that this storm played some part in the success of our Transatlantic Tests. Starting in the Gulf of Mexico on December 9th, the storm passed up our Atlantic Coast to Newfoundland, and then out to sea. A clipping from the London Daily Express, under date of December 20th, reads as follows:

"Cyclone breaks loose. Demon career of gales and floods. Hurricane and raging seas in the Atlantic! Tidal floods on the northeast coast of Britain, and destructive gales in Scandinavia were widely scattered. Weather phenomena that it is now possible to trace to one cyclone which swept across from America to Europe. It originated somewhere about December 9th in the Gulf of Mexico, and swept northwards out to sea, gathering in fury on its way, and then it continued its career to the northeast, and no more was heard of it until three days later. It was rediscovered on Friday evening, however, approaching from the southwest, and about 1 A.M. on Saturday morning the liner Megantic, steaming on a northerly course to pass the north of Ireland, was caught in its giant grip. It then flung eastwards, and swept across to Norway" * * *

Now, as it happens, all of the signals heard at Ardrossan were logged during the time when this cyclone lay between the receiving station and the United States. After it had passed to the north, no further signals were heard. Weather reports clipped from British newspapers during that period seem to give little bearing on this particular storm, although it has been admitted that the weather during the entire period was under its influence.

Some time during the test I received a

letter from London, which included the following poem:

If our climate is un-Godley,
If the weather seem to Paul,
If our static strikes you oddly,
If you hear no sigs at all,
If you get harmonics down the scale,
As far as tuners go,
If the dialect in Scotland,
Doesn't sound like Ohio,
If twenty thousand hard boiled hams
Are waiting on your word,
If but the thought of hearing them
Seems very near absurd,
If,—in the chilly morning hours,—
The faintest sigs come thru,
We'd like to hear about it,
If it's all the same to you !!

I met the fellow who wrote this. His name was Harris, but his initials I don't recall. He didn't look the poet either, although he does, I believe, edit one of Britain's best popular scientific magazines called "Conquest", at which he shows even greater proficiency than at writing poems.

And some chap in Belgium bravely showed his mastery of English by coming through with this:

A wise old owl lived in an oak.
The more he saw, the less he spoke.
The less he spoke, the more he heard.
"Hams" should imitate that old bird.

Which I had a great notion to forward to Harris with his name substituted for the first word in the last line.

Coursey began to "ride" me a bit about this time too, with: "Aren't you sorry you didn't stay down here in the warm? Signals have been heard here on our small aeriols", etc., ad nauseum!! I would have enjoyed nothing more than to have had the London crowd on that seaweed-covered field.

Congratulations began to come in too, not only from England and America, but also from France when our friend Delyoy showed that he was on the job by the following:

"Hearty congratulations for your success. Here atmospherics very bad especially last night".

Such things as this helped when we needed it. It was quite the rule to get on the job during the afternoon and find that, for some reason, several poles were flat on the ground. We were never able to ascertain whether they had been broken off by some "animal" or whether the winds had reached sufficient velocity to do it. On many occasions the wind was strong enough to bend the 2 x 4's which we used for poles several inches out of line, and their continual "working" in the soggy ground as the result of gusts probably had a great deal to do with their falling. We finally had four stays on each pole, after which no further trouble was experienced.

Prior to leaving Ardrossan, Mr. Martin of the "Ardrossan & Salt-Coats Herald" interviewed me concerning the import of the tests and their success. This interview

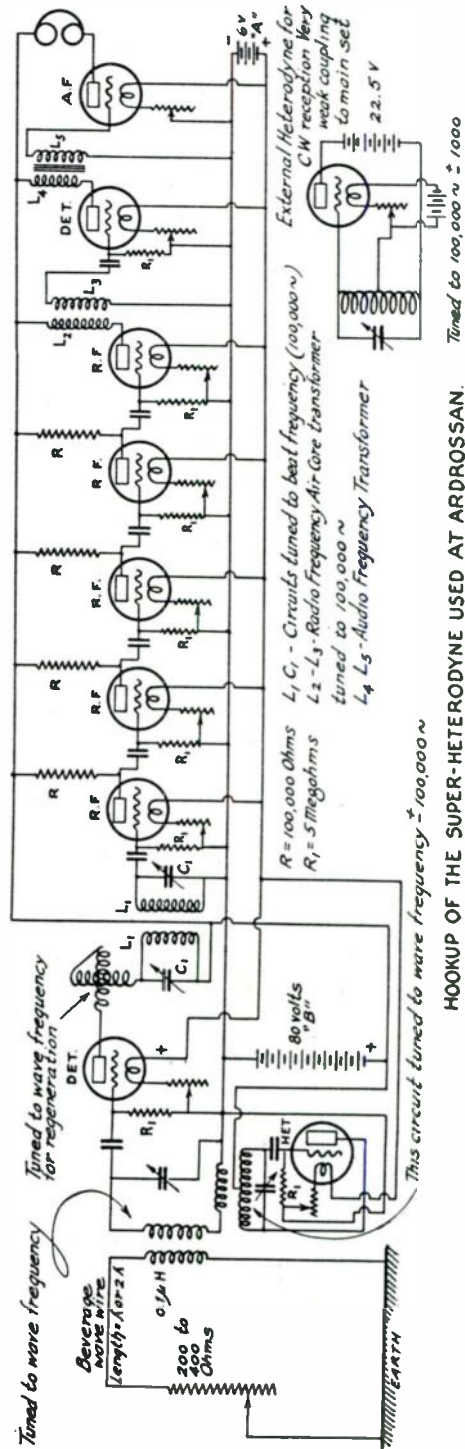

was followed by general publicity which pretty thoroughly covered the British Isles.

The hospitality shown at Ardrossan could not have been excelled. Everyone seemed anxious to do all within their power to make things easier for us. We were invited on two or three occasions to visit the Murchie home, which was quite near to the scene of operations, but we never had the nerve to drag our muddy selves into anyone's home again.

During one afternoon a very amiable Scotch gentleman, along with other of the town's people visited the test station. This particular gentleman possessed the enviable ability to consume large quantities of Scotch liquor. He listened during a period of several minutes to various high power stations picked up, having been told in each case "That is Berlin", and "Here is New York", etc. At the conclusion of the demonstration his remarks ran something like this: "'Sall right, young man, y'understand I know a bit o'American swank when I see it."

Some real enjoyment unexpectedly included itself in our program on the next to the last night that we were in Ardrossan. Mr. Lee of the Eglinton Hotel proved himself a real friend by producing three of Scotland's fairest lassies who entertained us during one entire evening, with songs, music and dancing. All had very excellent voices, and I shall ever feel grateful toward those who provided this entertainment. It came at the psychological moment, and its effects, I am quite sure, were reflected in subsequent work.

On account of the excellent signals of Friday, Saturday and Sunday nights, violent efforts were made to get hold of a dictaphone in order that records might be taken of the transatlantic transmissions. These records would have opened the eyes of American amateurs, had it been possible to make them on any of the above-mentioned nights. On Sunday night in particular signals were exceptionally strong, there being times when they could have been read at least 300 feet from the tent, with rains falling and winds howling. Both Pearson and I at one time got up off our boxes, with the intention of going out to see how far we could hear the signals, but after having poked our heads through the flap in the tent we gave this up. The rain was coming down in torrents, so we satisfied ourselves with turning the receivers face down on the table and walking to extreme corners of the tent, carrying on conversations in loud voices, and reading the signals just the same.

Through error in coding, the first station heard, 1AAW, was broadcasted as being 1AAY. A cable was received to the effect that 1AAY was a spark coil station and that the transmitter was not in operation. Immediate correction was sent by

cable to the effect that 1AAW, not 1AAY was heard.

On reaching London, it was possible for me to go over two or three of the logs which had been handed in by British amateurs to Mr. Coursey. From these logs, and from what additional information Coursey had, it was apparent that the following stations had been heard by British amateurs: 2ZL, 1DA, 2BML, 2FP, 1AFV, 1UN, 1XM, 2ZC, and 1BCG. 1BCG was also heard in Holland, and I understand that it is reported that this station has also been copied on board ship, while the ship was at anchor in the harbor at Hamburg, Germany. A postscript on one of Mr. Coursey's letters, received during the course of the test, read as follows: "1BCG seems to be the star turn! ——— Kilowatts?"

The Holland station copied No. 1 from 1BCG complete, with the exception of the first word in the text. He was using a regenerative receiver of the American pattern, together with two stages of audio-frequency amplification. British stations were using radio-frequency amplification, and one amateur had 18 tubes in operation.

On reaching London, I had only a few hours, which I had hoped to spend in looking around, providing the fog had lifted. The fog had lifted, but I found that it would be impossible for me to pass through London without giving Coursey a complete story on the test, and to this end I spent about ten hours in his office dictating. What time was left was spent in rushing around saying good-byes to those whom I could reach, and I shall always regret that it was impossible for me to reach everyone.

The return trip on the Olympic was rather an uneventful one, except for the reception of a radiogram dated Hartford, Conn., requesting information as to date of arrival and also advising me that a reception committee would be on hand at the dock.

In due time I found myself emerging from the side of the huge ship, and fell into the arms of press correspondents, photographers and friends. Needless to say, everything was confusion, and it was with considerable relief that I presently found myself at lunch in the Pennsylvania Hotel, recounting amusing incidents to these more than welcome American "hams".

We have just finished making a real bit of radio history. What we have done means, first of all, that it now lies within our power to communicate frequently with our British cousins, provided we show the will to do so. I feel quite certain that there will be every inclination on the part of the British to co-operate to this end. I strongly urge upon those men whose transmitters showed up so well during these

(Concluded on page 46)

OFFICIAL RECEPTION REPORT

(Concluded from page 40)

tests, to arrange for additional tests in conjunction with British amateurs, and as far as I am able to learn it will be possible at no distant date for British amateurs to transmit on 180 meters, signals which should have a good chance of reaching this side.

The part which British amateurs have played in the tests just completed has accomplished far more in the way of the creation of enthusiasm for this sort of thing than anything else could possibly have accomplished. It has been pointed out to them that American amateurs—all stations—are transmitting every night, day in and day out, and that what the British heard during the week of the test, they may hear again and again throughout the coming season, provided they listen with sufficient patience,—and, what is most significant, that some of the stations heard from in America were using an output of but 30 watts.

It is quite a common thing to read in the British daily papers of such, to them, unusual procedures as the broadcasting by radio-telephony of "The Evening Hour Story for Children by the Man in the Moon," or "A Wireless Church with an audience of 20,000 to 30,000 people," or "Grand operas which are available to any who care to listen."

Is it hopeless to expect that sooner or later Europe will follow with similar programs? Would it not be foolish to presume that Europe can much longer remain blind to the advantages of such programs?

At any rate, American amateurs are watching the progress of our British contemporaries with an interest which is far more real than it has ever been in the past. British amateurs have proven their mettle and there are a great many of them now ready to be welcomed into the great order of the "Hard-Boiled Ham."

WHAT THE PRESS HAD TO SAY AT THE TIME, ABOUT THE TRANSATLANTIC RADIO TRANSMISSION

N. Y. Telegram Dec. 16, 1921

Radio Amateurs in "Race" Send Messages to Scotland

Use Short Wave Transmission Sets, with Power Equal to That of Incandescent Lights.

By Associated Press.

More than twenty-five radio operators, working with short wave transmission sets, have succeeded in sending messages from the United States to Scotland as a result of the competitive experimental test begun last week.

This was announced here today by Prof. Alfred N. Goldsmith, head of the radio and electrical branch of the College of the City of New York. One of the successful contestants, he added, was located in Cleveland, and others in States bordering the Atlantic.

The test, he added, had aroused the keenest of interest among the more than 100,000 amateur enthusiasts in this country, and if British laws permitted amateurs of that country using a wave length similar to that permitted here, "the boys would be talking to each other as they now do from State to State in this country."

"The results show what efficient utilization of power will do," he added. "Messages have been exchanged over the Atlantic for some time by government and commercial stations, but the power they use, measured in technical terms, is about 10,000 times as much as permitted the amateurs."

POWER USED IS SMALL

Prof. Goldsmith compared the success of the amateurs with a feat whereby the rays from an ordinary incandescent light might be made visible to observers in Scotland.

"The power," he asserted, "is about the same, the only difference being light rays are visible, while the radio energy is not."

Among amateurs who have obtained

acknowledgment that their messages were received are Major E. H. Armstrong, E. V. Amy, John F. Grinan, Minton Cronkhite, Walter Inman and George E. Burghardt, of the Radio Club of America, who made a joint test.

For this purpose they set up a station in Connecticut, in the construction of which a nearby fire department assisted in setting the poles. For three nights they worked, sending repeatedly a certain number of words, and then came the cable announcing success.

The messages are being received in Scotland by Paul Godley, representative of the Radio Relay League of America, working in conjunction with Phillip Coursey, of the Amateur Wireless Society of Great Britain.

At stated hours Mr. Godley "listens in" with his receiving set tuned to pick up messages at the required wave length—200 meters. Mr. Coursey alone has the secret code words of identification, and by this means the sender is identified by his letter and number designation.

RULES LIKE SPORT EVENTS

Preparations for the contest took on the spirit of a sporting event. An elimination contest was held by which contestants were picked on their ability to transmit a certain distance. These contestants were given first chance to compete for the honor of being first to send their message over the Atlantic.

After a certain period the contest was opened to all, fifteen-minute periods being allotted to the various radio districts.

Transmission by a commercial radio company of an announcement from Mr. Godley giving names of stations heard is as eagerly listened for by the thousands of operators as would be the result of an international race or any other test of skill, Mr. Armstrong asserted.

N. Y. American Dec. 16, 1921

Amateur Radio Message Sent Across Atlantic

THE modern amateur wireless station recently built at Greenwich, Conn., has been successful in sending a message across the Atlantic in the test now under way under the auspices of the American Radio Relay League, it was announced last night.

Word came from Paul Godley, representative of the league in Scotland, that he heard the local station send its message on Friday night. The station is located on the Cronkhite estate at Greenwich and one of the owners is Minton Cronkhite. Major H. E. Armstrong, former commander of the United Army Radio Research Division, and George Burghardt, president of the Radio Club of America, supervised the construction of the station.

Eighteen amateur American radio relay stations had been heard in Scotland up until 2 o'clock this morning.

Greenwich News and Graphic Dec. 12, 1921

GREENWIC

BIG FEATHER IN GREENWICH CAP

Local Amateur Wireless Outfit Gets One of First Messages Across

Minton Cronkhite, son of Elisha P. Cronkhite of Greenwich, who with a number of New York associates, erected a radio station in a vacant lot on the Cronkhite estate at the corner of North street and Clapboard Ridge road here recently, and entered the contest for the sending of the first trans-Atlantic test ever planned, under the auspices of the American Radio League, have been successful in their efforts and so far as can be learned it is one of the first of the 15,000 or more amateur stations in the country to achieve the feat.

The successful message was sent last Friday night and Mr. Cronkhite received word Saturday morning at 2 o'clock from Paul Godley, the wireless inventor, who caught the message at a radio station in Scotland.

Again Saturday night the Greenwich amateurs put the message over, it being received by Mr. Godley in Scotland. Mr. Godley reported that the message was strong and steady. Associated with Mr. Cronkhite at the station is George Burghardt of New York, president of the Continental and Electrical company; Ernest Amy, Major E. H. Armstrong, Walker Inman and John Grinan, all of New York. All of the young men are members of the Radio Club of America.

It is their intention to continue the sending of messages every night for the next two weeks. The input of the station is one kilowatt, which is within the written amateur restrictions. It took the young men two weeks to erect the station, working nights and Saturdays.

(Continued on Page 6, Sec. 2)

GREENWICH SCORES

(Continued from Page 1, Sec. 1) day afternoons. Next week an additional station is to be constructed and these Greenwich amateurs intend to make a test in sending a wireless telephone message across the Atlantic.

Mr. Cronkhite and his wireless associates were assisted at the station by John Cullen, driver of the Amogger company.

ARTICLES IN MAGAZINES ABOUT THE FIRST MESSAGE

CIRCULATION OF THIS ISSUE OVER 75,000 COPIES



20 Cents
February
1922

Over 125 Illustrations
Edited by H. GERNSBACK

"THE 100% WIRELESS MAGAZINE"

Radio News for February, 1922

697

Amateurs Span the Atlantic

As reported by PIERRE BOUCHERON

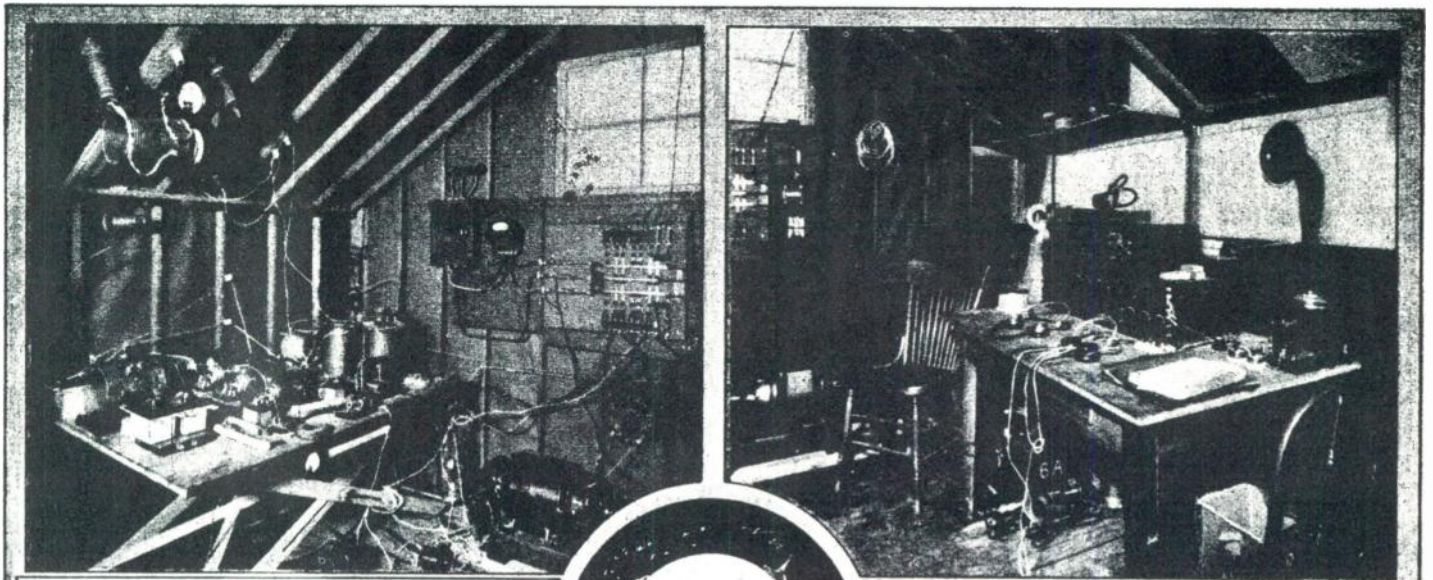

Above is the Transmitter at IBCG. It consists of Four 250-Watt Tubes Hooked up as Shown by the Diagram on This Page. The Radiation in the Aerials Was About Six Amperes.

The Long and Short Wave Receivers and Amplifier of IBCG Hooked up to a Special Aerial. This Set Was Especially Used to Listen to the Messages From Mr. P. F. Godley. Sent by MUU Everyday.



THE Continuous Wave method of transmission has conclusively won its laurels for twenty (20) of the twenty - five (25) identified American amateur radio stations heard by the official

The first amateur radiogram to be sent from the United States and to be received in Scotland during the great test is as follows:

- 2EH—C.W.—Radio Engineers' Club, Riverhead, L. I.
- 2FD—C.W.—J. DiBlasi, New York, N. Y.
- 2FP—C.W.—" " " " 252 Neptune

January, 1922

25 Cents

The WIRELESS AGE

Volume 9

Number 4

Amateurs Transmit Across Atlantic

Distinction of Sending First Message Across the Ocean Goes to Station 1BCG.
Twenty-four Other American Stations Also Heard in Scotland by P. F. Godley

TRANSMISSION of signals and messages across the Atlantic Ocean by an amateur radio station in the United States became an accomplished fact for the first time on the night of December 9 last, when undamped signals from the station of Minton Cronkhite, Greenwich, Conn., call letters 1BCG, were copied by Paul F. Godley, located at Ardrossan, near Glasgow, Scotland.

Mr. Godley made a special trip to Scotland, on behalf of the American Radio Relay League, for the purpose of determining whether or not the signals from amateur radio stations in the United States could be heard across the Atlantic. Definite periods of time for the operation of amateur stations were arranged, qualification trials were held prior to the trans-Atlantic tests, and all amateur stations which covered 1,000 miles or more overland in the preliminary tests were allotted fifteen-minute periods of transmission, and assigned five letters, arbitrarily, which were transmitted repeatedly for fifteen minutes.

The arrangement was, that should Mr. Godley be able to copy any of these transmitted groups he was to refer them to Philip R. Coursey, of London, who alone could determine the identity of the transmitting station by means of the code letters, as the American representative of the amateurs did not have a copy of the code combinations.



John Grinan, prewar 2PM (in the rubber coat) who operated the station

Provision was made for a period of 15 minutes on each night of the tests as a free-for-all transmission period, during which all stations not having a special period of transmission were invited to participate. This included stations which had not qualified in the 1,000 mile preliminary trials, or had not taken part in them. The first station, therefore, to be heard by Mr. Godley, was one which had not been in operation at the time of the preliminary trials, and which took part in the free-for-all period assigned to First District stations.

The trans-Atlantic tests took place

between 7 P. M. and 1 A. M. of the following morning, from December 7 to December 16, inclusive.

As a result of the first night's transmission, Mr. Godley reported having heard a First District station, Call 1AAY. It has not been possible to verify this, however, as inquiry at the transmitting station failed to show that the owner had transmitted during the time of the tests. No other station was reported on this night.

On the night of the 8th, a heavy rain and windstorm prevailed, with excessive static, and Mr. Godley reported no signals had been heard.

On the night of the 9th, trans-Atlantic transmission of signals on a 200 meter wave became an accomplished fact for the first time in the history of radio, when Mr. Godley reported the reception of signals from station "One Bay Cast George," meaning Station 1BCG. His advices, which came the following night by radio from MUU, stated that the signals of 1BCG were strong and steady. No other stations were reported by Mr. Godley as having been heard on the 9th, so that the distinction of having transmitted the first trans-Atlantic signals from an amateur station, conforming in every way with the Radio Laws and Regulations of the United States, clearly belongs to Mr. Cronkhite and those associated with him in the undertaking.

On the night of the 10th, Mr. God-

SCIENTIFIC AMERICAN

The Monthly Journal of Practical Information

35¢ a Copy



APRIL 1922



\$4.00 a Year

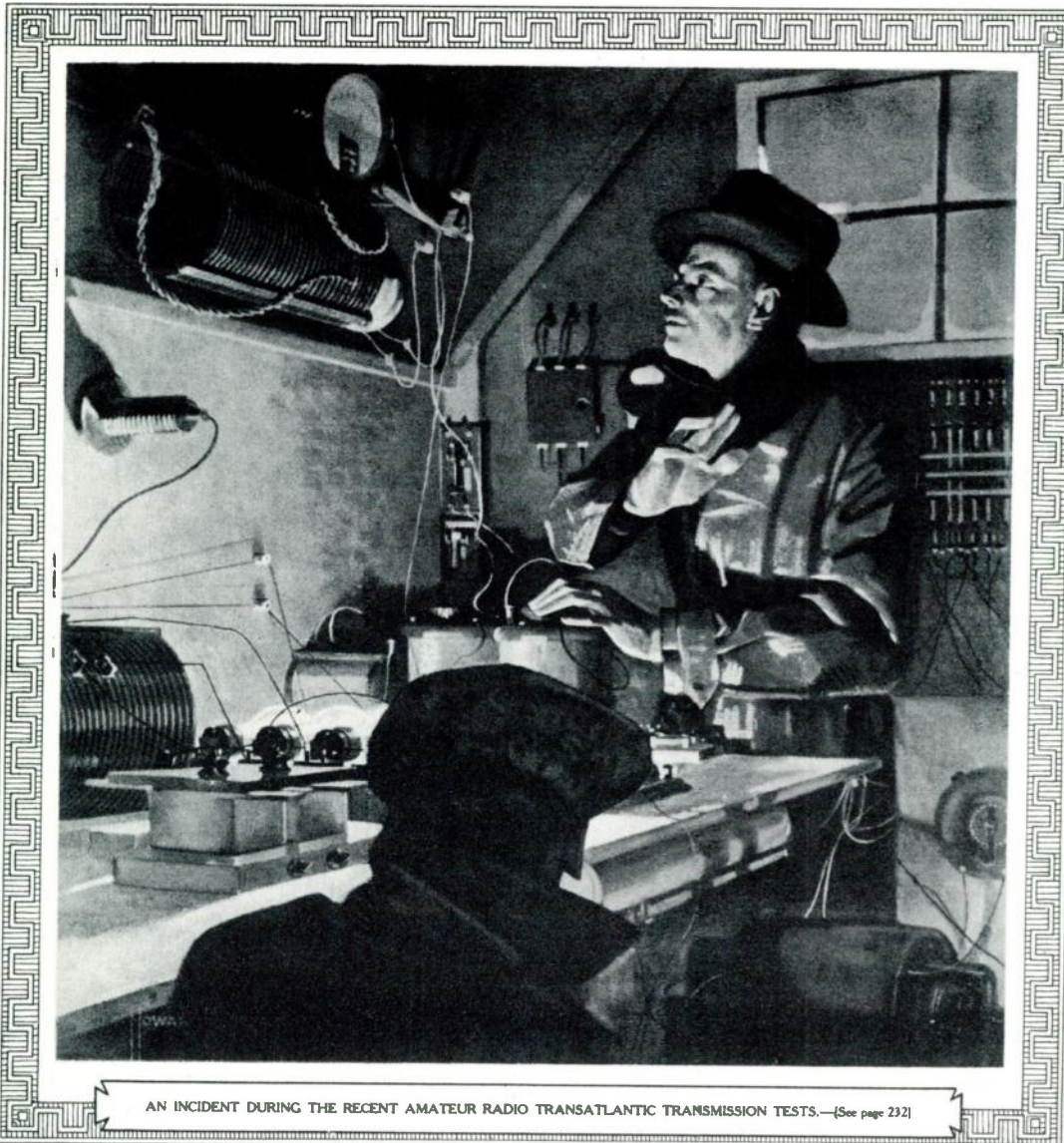

Scientific American Publishing Co., Munn & Co., New York

This article appeared in the April 1922 issue of Scientific American. The cover design was made from an original oil painting by Howard H. Brown who visited the station and made actual sketches during operation.

first man to send an amateur radiogram across the American continent, but who also was the first to send an amateur transatlantic message of congratulation, which was received in Scotland by Mr. Godley even to the last dot; while George E. Burghard, Minton Cronkrite and Walker Inman complete the personnel of IBCG.

This station is housed in a small portable building, and the long winter nights were cold, but not too cold to dampen the zeal of these dyed-in-the-wool radio men. Our cover illustration depicts a thrilling moment in the little shack during the transatlantic tests, as the writer, who attended these tests, recalls it.

An analysis of the report on the technical facts connected with these tests indicates that of the 27 stations heard across the Atlantic, 24 employed the new form of radio transmission known as the continuous-wave or "C.W." method, with power inputs ranging in most cases from 50 to 100 watts. This new system has made great strides within the past year, owing to its remarkable carrying powers, selectivity, simplicity and low cost, as compared with the older spark type transmitter.

Briefly, the difference between the continuous-wave and the discontinuous or damped-wave method is this: In C. W. we have a system of transmission which generates and propagates a perfectly uniform wave of constant amplitude. Such a wave, after leaving the antenna, travels through space without losing its form. The distance this kind of wave will travel is, of course, entirely dependent upon the amount of power at the initial source. Modern C. W. may be obtained by several distinctly different methods. The most popular method, at least among amateurs, is realized through the use of the oscillating vacuum tube. Here we have the somewhat magical performance of a glowing incandescent lamp generating a constant supply of high-frequency oscillations, which is ideally suited to radiation purposes through the simple expedient of controlling the electronic flow occurring between the lighted filament and a surrounding plate charged with positive electricity.

In the discontinuous or damped method the emitted wave is not continuous in its passage through the ether. Furthermore, the amplitude of its oscillations is not constant. Instead, after such waves have been given their first send-off by the initial power stroke of the transmitter, they rise to sudden great height and gradually fall lower and lower in amplitude until damped out completely. The next stroke of transmitter energy causes them to rise again, and the rising and falling process keeps on indefinitely, depending on the amount of energy back of it. Thus this sort of discontinuous or damped wave, as it is technically called, travels through space until exhausted; likewise, its "carrying" powers are entirely proportional to its initial amount of energy. It is produced by the spark type of transmitter and has been in use ever since the inception of wireless communication.

C. W., being constant in amplitude, does not dampen out and is, therefore, known as an undamped wave. The discontinuous wave, on the other hand, not being constant in amplitude, dampens out quickly and is, therefore, known as the damped wave. The first is a much better medium for bridging great distance at small cost, and, therefore, is slowly supplanting the older method. Then, too, it has decidedly selective qualities not readily attributed to the spark system. In other words, a radiated C. W., when intercepted by the receiving station, is so sharp and constant in character that the receiver must be tuned exactly to its wave length, otherwise it will not affect the instrument. When we consider that there are to date 13,835 amateur transmitting stations in the United States, and nearly 300,000 receiving units, this sharpness of tuning is a most important factor in eliminating interference between stations; indeed, in time to come it must supersede entirely other less selective methods of transmission.

Possibly the second most attractive feature of C. W. is its great economy in power consumption. For instance, power for power, C. W. will carry five times the distance spanned with the older spark method. Indeed, it is not uncommon for a 1-kw. vacuum tube transmitter to outdo a 5-kw. spark type set. By the same token, the over-all efficiency of a vacuum tube trans-

mitter is quite high as compared with the spark, the first being close to 70 per cent, while the latter is seldom over 35 per cent. This greater efficiency, please note, means considerable economy in power consumption, and quite naturally finds ready approval among communication engineers. Still another decided advantage of the C. W. method is its comparative simplicity of apparatus, eliminating, as it does, cumbersome transformers, huge condenser jars and ponderous spark dischargers of the stationary or rotary types. C. W. being practically noiseless, operating conditions are greatly improved. Moreover, the operator is enabled to send and receive almost simultaneously, without having to manipulate large change-over switches.

The use of vacuum tubes in transmission makes possible not only C. W., but also I. C. W., or interrupted continuous wave operation, as well as radio telephony. These three functions of the vacuum tube have played a most important rôle in the present-day usefulness of radio in general. C. W. has already been described. I. C. W. is practically the same form of transmission with the exception that a mechanical interrupter is inserted in the radiating circuit of the transmitter in

telephony, now so popular owing to the great success of the radio telephone broadcasting station.

The rôles which C. W. is capable of playing, combined with its inexpensiveness, simplicity, selectivity and carrying powers as recently and conclusively proved, make this the ultimate transmission system—the one which will supplant all other present-day systems for amateur short-wave, long-distance communication. In commercial work it also finds ready application, especially where dependable medium-power communication over medium distances is required. To this end, commercial transmitting units of the vacuum tube type are today fitted for C. W., I. C. W., and radio telephone operation, any one of which is instantly available simply by the turning of a master control switch.

The success of the recent amateur transatlantic tests had no sooner been reported than persons, not familiar with operating conditions, began to ask why it was possible for amateurs to operate overseas on such low-power outputs as 50, 100, 250 and 900 watts of electrical energy, when it took as much as 200,000 watts (200 kw.) for commercial stations to bridge similar distances; a quite natural question, and one that is easily answered. To begin with, for the amateur operator to span the Atlantic during a special prearranged period, at the most favorable season of the year, under particularly advantageous operating conditions, was one thing, and to furnish the public with reliable commercial service over the same distance during 24 hours of each day of the year, winter and summer, through heavy atmospheric disturbances and under the worst as well as the best operating conditions, is quite another thing. They compare as day with night: one means transatlantic communication at times; the other means transatlantic communication all the time.

In extolling the advantages of C. W. and its various applications, one fact stands out in bold relief, and that is the pre-dominating part played by the vacuum tube. Without this wonderful device, so young in years yet so old in its training and broad usefulness, many of our present radio achievements would not exist. Today the vacuum tube—call it the electrical acrobat or the modern Aladdin's lamp, if you will—finds many applications in the electrical industry, but certainly none so useful as in radio work, where it plays stellar rôles in both transmission and reception of radio telegraphy and telephony.

In a few brief years we shall see the vacuum tube responsible for feats of long-distance communication undreamed of today. But who is responsible for this wonderful achievement? The answer is to be found in the research laboratory, where year in and year out, unsung and seldom mentioned investigators toil quietly and indefatigably that mankind may be benefited.

The Last Glacial Epoch

MR. C. E. P. BROOKS (*Quarterly Journal R. Met. Soc.*, July, 1921) assigns the date 30,000 to 13,000 B. C., for the last great glaciation in northwest Europe (Ireland, Scotland, Scandinavia, and the Baltic). Some remains of glaciation continued until 6000 B. C.; after some intermediate

phases the date 1800 B. C. to A. D. 300 is assigned to the Peat-bog Phase, when the climate was cooler and more moist than at present. These changes are attributed chiefly to alterations of elevation; increased elevation has the double effect of producing glaciation on land and of closing the Straits of Dover and other channels for the warm currents from the Atlantic. Mr. Brooks also assigns considerable weight to the 1800-year cycle in tide-generating force announced by Mr. O. Pettersson. But it is very doubtful whether this cycle will explain any appreciable climatic changes. It does not mean that all the tides are higher at one of these 1800-year maxima, but merely implies that there are a few tides in the year very slightly in excess of those at other epochs, just as there are total solar eclipses of maximum duration at something like the same interval. Evidence of an approach to simultaneity in climatic changes in Europe and America indicate some cosmical cause; but the suggestion of a long-period variation in solar output (analogous to the short-period variations announced by Mr. Abbot) seems, to a commentator in *Nature*, more hopeful than the tidal cycle theory so long in vogue.

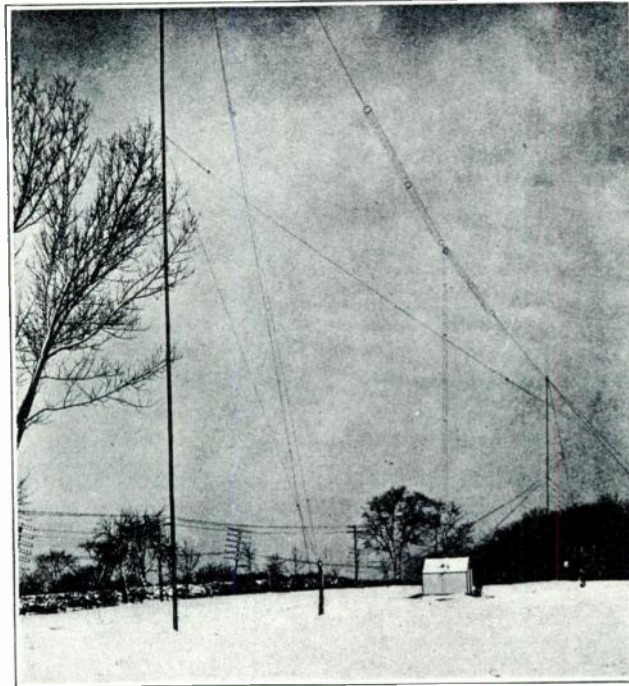

The mast to the right is 100 feet high, the one at the left is 80 feet. The antenna is of the so-called cage type, T-shape, a new form of aerial construction especially effective in continuous-wave transmission on account of its uniformity. The flat-top section of this antenna is 100 feet long and its down-lead is placed in the exact center, and measures about 80 feet long. Instead of a ground connection, a counterpoise forms the other part of the radiating system. The counterpoise is simply a secondary antenna system, located a certain distance below the actual antenna and a certain distance above the ground.

General view of IBCG, showing the station building, the masts and the antenna system

order to "break up" the emitted waves so that they will be heard at universal audible tones at the receiving end; otherwise, a special receiving circuit must be employed to render the waves audible, as is done in C. W. work.

Radio telephony is, so to speak, a combination of both C. W. and I. C. W. That is, a radio telephone transmitter is normally emitting continuous wave oscillations at radio frequencies—frequencies above 10,000 cycles per second. When speech takes place the oscillations are modulated by the characteristics of the voice, and these changes cause a superimposed rising and falling amplitude of the wave.

It is obvious that the continuous wave at once lends itself admirably to any requirement of the present-day radio art. First, it may be used in its natural wave form (C. W.) for long-distance radio telegraphy, whether for amateur or commercial purposes; secondly, it may be modified as in I. C. W. (interrupted continuous wave) to meet the receiving requirements of the older spark type installations still in use on thousands of vessels and land stations; and thirdly, it may be modulated by the human voice, thereby permitting radio

THE RADIO CLUB OF AMERICA

by

W. E. D. STOKES, JR.

Founder and First President

FORTY YEARS AGO—in an age of arc lights, horse cars and side wheel ferry boats—a few young boys teamed together their talents to tap Nature's hidden stores. In order to understand their motives and their aspirations, picture to yourself the American youth of that day. Of course every child believed implicitly in the glorious destiny of America and in his own capacity to play a leading part in America's development. In those days practically everyone was brought up to "play the game" for the very joy of living, and above all everyone was encouraged to invent.

The story of our team of young enthusiastic inventors begins with their attempts to improve upon Langley's flying machine and the Wright Brothers plane at Kitty Hawk. Several times a week flying meets were staged at the Broadway National Guard Armory where home-made model planes were put through their paces. About this time, Professor Reginald Fessenden of Brant Rock wireless fame appeared on the scene and the thought developed that the aeroplane models which were fast being destroyed in collisions against the Armory walls might in some way be guided by remote control with the aid of little known Hertzian Waves. Under the impetus of this Fessenden suggestion our team of young inventors quickly turned their attentions to the study of wireless. The lights in the back yard work shops burned into the small hours and in some instances, with the aid of relays and iron filing coherers, prodigious results were accomplished, such as turning off alarm clocks and closing windows by remote control.

The JUNIOR AERO CLUB OF U. S., which had been formed in 1907 was displaced on January 2nd, 1909 by the organization of the JUNIOR WIRELESS CLUB LIMITED, taking over the same members. On October 21st, 1911 the name was again changed to **The Radio Club of America** which title it bears to this day. With the passing years, added members in a swelling stream linked their lives and fortunes to carry forward the building of a worthy scientific club as well as an essential industry and a better America for ourselves and our children.

The most important characteristic of our club is its atmosphere of scientific research within the framework of non-commercialized friendships. In other words, club rooms are established where radio problems and advanced ideas are freely discussed without

fear of business competition. The members have notably respected each other's originality and there has developed a unity of purpose and an interdependence which has helped to stimulate the rapid growth of the radio industry itself. Thus, the 25th Anniversary Year Book was very properly dedicated to,

"The Spirit of Good Fellowship and the Free Interchange of Ideas Among All Radio Enthusiasts."

At the 17th Annual Banquet of the Club, Professor Pupin summed up the situation with this statement,

"You love this art for its own sake and not for what profit it brings you. If I thought otherwise I would not be with you this evening."

Space prevents my enumerating the long history of achievement by the Club and its members. On April 28th, 1910, a committee of young boys appeared before the sixteen U. S. Senators of the Commerce Committee in Washington to oppose the Depew Bill S. 7243—"To regulate Radio Communication." They believed that the bill was unreasonable and unfair to amateurs and students of wireless. They did however concede that some regulations might be enacted and offered constructive suggestions based on their technical knowledge of the art of wireless communication. This appearance of the boys and the common sense arguments they presented to the Committee received considerable newspaper notice and defeated the Depew Bill which was a punitive piece of legislation that would have entirely eliminated the amateur. A few years later, the Club, by pointing out the evil effects another bill, the Alexander Bill, would have had on the radio art and the amateur particularly helped convince the committee of the unsoundness of the proposed legislation. History will recognize the service performed by the Club in these efforts to preserve the rights of young American genius because the subsequent developments and ideas for radio advancement that flowed from the members of this organization had a really profound effect upon our way of life.

Many far reaching scientific discoveries were first announced at early meetings of the Club by youthful members, as when we heard a paper on the Hudson Coated Filament and when Armstrong discussed his fabulous ideas about the Audion. As early as 1911 two of our members demonstrated an arc telephone transmitter and actually transmitted music for the

benefit of the fleet then anchored in the Hudson River. Other early disclosures of importance that come to mind were Eltz's Square Law Condenser and Armstrong's Feedback Circuit which has made possible the broadcasting of today. Attendance at meetings soon grew so large that it became necessary to use the large lecture halls of Columbia University for the monthly gatherings. The small body of amateur operators gradually changed to a large organization of recognized scientific standing, before which the leaders of the radio world were pleased to deliver papers.

New developments have come thick and fast and numerous important papers have been presented to swell the bibliography of the radio art, but—what is all important, that enthusiastic spirit of the members for the original precepts of the founders continues undamped and undiminished in intensity.

The Radio Club of America, Inc.

11 West 42nd Street, New York City

Telephone — LOngacre 5-6622

Officers for 1950

President

O. James Morelock

Vice President

John H. Bose

Corresponding Secretary

Ralph R. Batcher

Treasurer

Joseph J. Stantley

Recording Secretary

Bernard D. Loughlin

Directors

Robert M. Aiken, Jr.
Ernest V. Amy
Edwin H. Armstrong
Salvatore Barone

P. S. Christaldi
Howard L. Cobb
Donald Fink
Alan Hazeltine
Harry W. Houck

F. A. Klingenschmitt
Jerry B. Minter
Harry Sadenwater
Paul Ware

Committee Chairman

Advertising

Paul Ware

Entertainment

F. A. Klingenschmitt

Papers

Frank H. Shepard

Affiliation

Ernest V. Amy

Medal

Lawrence C. F. Horle

Publications

Jerry B. Minter

Budget

Joseph J. Stantley

Membership

Perce B. Collison

Publicity

Austin C. Lescarboursa

Year Book

George E. Burghard

Legal Counsellor

George E. Burghard

MEETINGS

Technical meetings are held on the second Thursday evening each month from September through May at either Havemeyer or Pupin Hall, Columbia University, Broadway and 116th Street, New York. The public is invited.

MEMBERSHIP

Application blanks for membership are obtainable at the Club office. For the Member grade the invitation fee is one dollar and the annual dues are three dollars.

PUBLICATIONS

Subscription: Four dollars per year, or fifty cents per issue. Back numbers to members, twenty-five cents each.

PAST OFFICERS OF THE RADIO CLUB OF AMERICA, INC.

<i>Year</i>	<i>President</i>	<i>Vice President</i>	<i>Corresponding Secretary</i>	<i>Recording Secretary</i>	<i>Treasurer</i>
1909	W. E. D. Stokes, Jr.	George J. Eltz, Jr.	Frank King	W. Faitoute Munn	Frederick Seymour
1910	W. E. D. Stokes, Jr.	George J. Eltz, Jr.	Frank King	W. Faitoute Munn	Frederick Seymour
1911	W. E. D. Stokes, Jr.	George J. Eltz, Jr.	Frank King	W. Faitoute Munn	Ernest V. Amy
1912	Frank King	George J. Eltz, Jr.	David S. Brown, Jr.	George E. Burghard	Ernest V. Amy
1913	Frank King	George J. Eltz, Jr.	David S. Brown, Jr.	George E. Burghard	Ernest V. Amy
1914	Frank King	George J. Eltz, Jr.	David S. Brown, Jr.	Louis G. Pacent	Ernest V. Amy
1915	George J. Eltz, Jr.	Louis G. Pacent	David S. Brown, Jr.	Theophilus Johnson, Jr.	Ernest V. Amy
1916	Edwin H. Armstrong	Theophilus Johnson, Jr.	David S. Brown, Jr.	Thomas J. Styles	Ernest V. Amy
1917	Edwin H. Armstrong	Theophilus Johnson, Jr.	Thomas J. Styles	Walter S. Lemon	Ernest V. Amy
1918	Edwin H. Armstrong	Theophilus Johnson, Jr.	Thomas J. Styles	Walter S. Lemon	Ernest V. Amy
1919	Edwin H. Armstrong	David S. Brown, Jr.	Thomas J. Styles	Walter S. Lemon	Ernest V. Amy
1920	Edwin H. Armstrong	Louis G. Pacent	Thomas J. Styles	Walter S. Lemon	Ernest V. Amy
1921	George E. Burghard	Lawrence C. F. Horle	Renville H. McMann	Lewis M. Clement	John DiBlasi
1922	George E. Burghard	Ernest V. Amy	Renville H. McMann	Lawrence C. F. Horle	John DiBlasi
1923	George E. Burghard	Paul F. Godley	Renville H. McMann	Pierre Boucheron	John DiBlasi
1924	George E. Burghard	Paul F. Godley	Renville H. McMann	Arthur H. Lynch	John DiBlasi
1925	George E. Burghard	Paul F. Godley	Thomas J. Styles	Arthur H. Lynch	John DiBlasi
1926	Ernest V. Amy	John DiBlasi	Thomas J. Styles	Arthur H. Lynch	C. Randolph Runyon, Jr.
1927	Ernest V. Amy	C. Randolph Runyon, Jr.	Thomas J. Styles	David S. Brown, Jr.	Joseph J. Stantley
1928	Ernest V. Amy	Lewis M. Clement	J. L. Bernard	William T. Russell	Joseph J. Stantley
1929	Lewis M. Clement	Carl Dreher	Willis K. Wing	Charles E. Maps	Joseph J. Stantley
1930	Louis G. Pacent	Charles E. Maps	Willis K. Wing	Harry W. Houck	Joseph J. Stantley
1931	Harry Sadenwater	Lawrence C. F. Horle	Willis K. Wing	Harry W. Houck	Joseph J. Stantley
1932	Lawrence C. F. Horle	Charles W. Horn	Willis K. Wing	Harry W. Houck	Joseph J. Stantley
1933	Charles W. Horn	Harry W. Houck	Ralph H. Langley	F. X. Rettenmeyer	Joseph J. Stantley
1934	Harry W. Houck	Ralph H. Langley	F. A. Klingenschmitt	Keith Henney	Joseph J. Stantley
1935	Ralph H. Langley	F. X. Rettenmeyer	F. A. Klingenschmitt	J. K. Henney	Joseph J. Stantley
1936	Ralph H. Langley	John H. Miller	F. A. Klingenschmitt	J. K. Henney	Joseph J. Stantley
1937	John H. Miller	John F. Farrington	F. A. Klingenschmitt	J. K. Henney	Joseph J. Stantley
1938	John H. Miller	F. A. Klingenschmitt	Fred Muller	J. K. Henney	Joseph J. Stantley
1939	Paul F. Godley	J. K. Henney	John L. Callahan	Charles E. Dean	Joseph J. Stantley
1940	J. K. Henney	John L. Callahan	Charles E. Dean	Carl F. Goudy	Joseph J. Stantley
1941	John L. Callahan	Paul Ware	Lincoln Walsh	Harold M. Lewis	Joseph J. Stantley
1942	Paul Ware	Charles E. Dean	O. James Morelock	Lucius E. Packard	Joseph J. Stantley
1943	Paul Ware	Charles E. Dean	O. James Morelock	Lucius E. Packard	Joseph J. Stantley
1944	F. A. Klingenschmitt	O. James Morelock	Milton B. Sleeper	John H. Bose	Joseph J. Stantley
1945	F. A. Klingenschmitt	O. James Morelock	Milton B. Sleeper	John H. Bose	Joseph J. Stantley
1946	Alan Hazeltine	O. James Morelock	Harry Sadenwater	John H. Bose	Joseph J. Stantley
1947	Alan Hazeltine	O. James Morelock	Harry Sadenwater	John H. Bose	Joseph J. Stantley
1948	Jerry Minter	Robert M. Akin, Jr.	George C. Connor	John H. Bose	Joseph J. Stantley
1949	Jerry Minter	George C. Connor	John H. Bose	Perce B. Collison	Joseph J. Stantley

MEMBERSHIP OF THE RADIO CLUB OF AMERICA, INC.

Aceves, Julius G. (F)	529 West 179th St.	New York 33, N. Y.
Akin, Robert M. Jr. (F)	Evergreen Way	North Tarrytown, N. Y.
Alexander, Louis (F)	322 West 72nd Street	New York 23, N. Y.
Amerman, Edward A. (M)	60 Johnson Ave.	West Caldwell, N. J.
Amy, Ernest V. (F)	61 Bay Blvd.	Atlantic Beach, N. Y.
Anderson, Pierson A. (M)	Beech Drive, Medford Lakes	Medford, N. J.
Andrews, Raymond W. (M)	123 Willowood Court	Emporium, Pa.
Armstrong, Edwin H. (F)	435 East 52nd Street	New York 22, N. Y.
Arnold, John W. (F)	37 Washington Square	New York 11, N. Y.
Aron, Mitchell (M)	285 Lenox Road	Brooklyn 26, N. Y.
Aten, Dwight Cameron (M)	Consumers' Research, Inc.	Washington, N. J.
Aull, Wilson Jr. (F)	40-14—149th Street	Flushing, N. Y.
Ayer, Oliver G. (M)	18 Wiltshire Street	Bronxville, N. Y.
Bailey, George W. (M)	1 East 79th St.	New York 21, N. Y.
Baker, W. R. G. (F)	General Electric Co.	Syracuse, N. Y.
Barclay, R. H. (F)	80 Broad Street	New York 4, N. Y.
Barnett, A. Houston (M)	341 So. Canon Drive	Beverly Hills, Calif.
Barone, Salvatore A. (F)	290 Rose Street	Freeport, L. I.
Batcher, Ralph R. (F)	240-02—42nd Ave.	Douglaston, L. I.
Baum, Elmer (M)	375 Fifth Ave.	River Edge, N. J.
Baunach, Edward L. (M)	2 Westminster St.	Massapequa, L. I.
Bean, L. P. R. (F)	Box 3971V, G.P.O.	Sydney, Australia
Behr, Joseph (M)	118-44—223rd St.	St. Albans 11, N. Y.
Bernard, H. S. (M)	157 Cedarhill Ave.	Belleville, N. J.
Beverage, Harold H. (F)	RCA Communications, Inc., 66 Broad St.	New York 4, N. Y.
Biggs, J. Alan (M)	48 Curtis Lane	Yonkers, N. Y.
Binns, Jack (F)	Hazeltine Electronic Corp., 58-25 Little Neck Parkway	Little Neck, N. Y.
Blitzer, Richard (M)	845 Riverside Drive	New York 32, N. Y.
Bodnar, Charles J. (M)	106 Fisher Ave.	Tuckahoe, N. Y.
Bohman, Albert K. (M)	11705 N.E. 7th Ave.	Miami, Fla.
Borst, John M. (F)	194 Columbia Heights	Brooklyn 2, N. Y.
Bose, John H. (F)	204 Philosophy Hall, Columbia University	New York, N. Y.
Boucheron, Pierre (M)	Farnsworth—WGL	Fort Wayne 2, Ind.
Bradley, William D. (M)	Newman Sp. Road	Red Bank, N. J.
Brett, Harold M. (M)	53A Lovell Court	Nutley, N. J.
Brick, Frank R. (F)	37 West 57th St.	New York, N. Y.
Brigham, Cecil E. (F)	2480—16th St., N.W.	Washington, D. C.
Brociner, Victor (M)	310 East 75th St.	New York 21, N. Y.
Brown, David S. (F)	210 West 70th St.	New York 23, N. Y.
Brown, Reynolds D. Jr. (F)	Blue Bell	Montgomery County, Pa.
Brown, William J. (M)	641 Brown Street	Rochester, N. Y.
Brunet, Mead (M)	RCA International Div., 745 Fifth Ave.	New York 22, N. Y.
Burghard, George E. (F)	240 Central Park South	New York 19, N. Y.
Burke, Reginald (F)	602 West 139th St.	New York 31, N. Y.
Burlingame, Bruce O. (F)	103 Lafayette St.	New York 13, N. Y.
Buttner, Harold H. (F)	67 Broad St.	New York 4, N. Y.
Callahan, John L. (F)	67 Nassau Ave.	Malverne, L. I.
Campbell, Richard L. (F)	150 Causeway St.	Boston 14, Mass.
Canavaciol, Frank E. (F)	7119 Juno Street	Forest Hills, L. I.
Carini, Louis F. B. (F)	246 Wolcott Hill Road	Wethersfield, Conn.
Carlebach, Walter N. (M)	47 East 64th St.	New York 21, N. Y.
Cervantes, Howard F. (F)	274 Boulevard	Scarsdale, N. Y.
Chalfin, Norman L. (M)	720 Fort Washington Ave.	New York 33, N. Y.
Chambers, Albert B. (M)	2 Main Ave.	Passaic, N. J.
Cherry, Milton (M)	2129 Union St.	Brooklyn, N. Y.
Chittick, Kenneth A. (M)	RCA Manufacturing Co.	Camden, N. J.
Christaldi, P. S. (M)	132 Squire Hill Road	Upper Montclair, N. J.
Clark, Louis E. (M)	298 Highwood Ave.	Glen Rock, N. J.
Clement, Lewis M. (F)	Crosley Mfg. Co.	Cincinnati 25, Ohio
Cobb, Howard L. (F)	250 Rockaway Ave.	Boonton, N. J.

MEMBERSHIP OF THE RADIO CLUB OF AMERICA, INC.

Cockaday, Laurence M. (F)	Dept. of Electrical Engineering, U. S. Naval Academy	Annapolis, Md.
Cohen, Charles Leo (M)	House of Rest	Yonkers, N. Y.
Cohn, Hugo (M)	905 West End Ave.	New York 25, N. Y.
Collison, Perce B. (F)	9 Lorraine Drive	Tuckahoe, N. Y.
Connor, George C. (F)	145 No. Chatworth Ave.	Larchmont, N. Y.
Conrad, Matthew (M)	179 Weldon St.	Rochester 11, N. Y.
Cook, Lawrence (M)	610 William St.	Boonton, N. J.
Cooper, C. B. (F)	259 West 14th St.	New York 11, N. Y.
Cornelius, L. W. (M)	228 Iowa St.	Baytown, Texas
Crawford, John D. (M)	16 Lodge Road	Great Neck, L. I.
Crawford, Robert V. (M)	10 Manor Place	Dobbs Ferry, N. Y.
Cresser, James Joseph (M)	112-14 St. Marks Ave.	Brooklyn, N. Y.
Cronkhite, Minton	P. O. Box 805	Rancho Sante Fe, California
Crosby, Murray G. (F)	126 Old Country Road	Mineola, L. I.
Darrell, Robert D. (M)	524 West 24th St.	New York 11, N. Y.
Dart, Harry F. (F)	33 Burnett St.	Glen Ridge, N. J.
Day, Howard B. (F)	30 North Jefferson St.	Allentown, Pa.
Day, James R. (M)	Peconic Lane	Peconic, N. Y.
Dean, Charles E. (F)	Hazeltine Electronics Corp., 58-25 Little Neck Pkwy.	Little Neck, N. Y.
DeLano, Ralph B. Jr. (M)	20 West 69th St.	New York 23, N. Y.
DeVine, A. A. (M)	7 Bardon St.	Madison, N. J.
DiBlasi, John (F)	4310 Morgan St.	Little Neck, N. Y.
Dickey, Edward T. (F)	RCA Laboratories	Princeton, N. J.
Diehl, William F. (F)	9 Wallace St.	Clearfield, Pa.
Dietrich, Frederick (F)	1136 Fifth Ave.	New York 28, N. Y.
Dreyer, John F. Jr. (F)	24 Arthur Court	Oceanside, N. Y.
Dubilier, William (F)	72 Esplanade	New Rochelle, N. Y.
DuMont, Allen B. (F)	9 Bradford Parkway	Upper Montclair, N. J.
Dunn, Gano (F)	80 Broad Street	New York 4, N. Y.
Eastham, Melville (M)	General Radio Co., 30 State St.	Cambridge 39, Mass.
Easton, Ivan G. (F)	General Radio Co., 275 Massachusetts Ave.	Cambridge 39, Mass.
Edinger, John R. (M)	362 Henry St.	East Hempstead, L. I.
Egolf, Richard S. (M)	90 Eighth Ave.	Brooklyn, N. Y.
Engle, Karl D. (M)	1335 East 52nd St.	Chicago 15, Ill.
Erhard, John A. (M)	33 Moran Place	New Rochelle, N. Y.
Espenchied, Lloyd (F)	Bell Telephone Lab., Inc., 463 West St.	New York 14, N. Y.
Fairman, Harry E. (M)	41-41—41st St.	Long Island City 4, N. Y.
Farrand, C. L. (F)	Bronx Blvd. & 238th St.	New York, N. Y.
Felch, Edwin P. Jr. (F)	109 Fairmount Ave.	Chatham, N. J.
Felix, Edgar H. (F)	176 Franklin Ave.	Malverne, N. Y.
Fener, Alfred (F)	154 East 40th St.	Brooklyn, N. Y.
Fener, Howard (M)	Vertrod Corporation, 17 Williams Ave.	Brooklyn 7, N. Y.
Fink, Donald G. (F)	2 Knoll Road	Tenafly, N. J.
Finlay, Robert (M)	104 Brookside Ave.	Ridgewood, N. J.
Fogarty, John P. (M)	200 Lockwood Ave.	Yonkers 2, N. Y.
Forbes, Henry C. (F)	339 Central Ave.	Silver Creek, N. Y.
Freeman, Robert Lee (F)	A. C. Nielsen Co., 1791 Howard St.	Chicago 26, Ill.
Freitas, Manuel (M)	556 Bond St.	Elizabeth, N. J.
French, B. V. K. (M)	20-20 Carlton Road	Fair Lawn, N. J.
Gawler, Harry (F)	1060 Broad St.	Newark 2, N. J.
Gernsback, H. (M)	230 West End Ave.	New York 23, N. Y.
Gersch, A. E. (M)	1139-45 Main St.	Boonton, N. J.
Ghirardi, Alfred A. (F)	P. O. Box 906	Darien, Conn.
Gillette, E. C. Jr. (M)	Dept. of Physics & Chemistry, U. S. Military Academy	West Point, N. Y.
Glaser, Edward M. (M)	W 2 B R B, 14 Wallace Ave.	Bellmore, L. I.

MEMBERSHIP OF THE RADIO CLUB OF AMERICA, INC.

Glaser, Marcus (M)	35-15—37th Ave.	Long Island City, N. Y.
Godley, Paul F. (F)	10 Marion Road	Upper Montclair, N. J.
Goldsmith, Alfred N. (HM)	597 Fifth Ave.	New York 17, N. Y.
Goldsmith, Thomas T. Jr. (F)	519 Highland Ave.	Upper Montclair, N. J.
Goudy, C. F. (F)	Technical Appliance Corp.	Sherburne, N. Y.
Graham, Virgil M. (F)	67 Lincoln Ave.	New Hyde Park, N. Y.
Grim, W. Manning (F)	136 Davis Ave.	White Plains, N. Y.
Grinan, John F. (F)	May Pen	Jamaica, B. W. I.
Grogan, William F. (M)	243 East 39th St.	New York 16, N. Y.
Gruetzke, Charles P. (M)	1831 East 34th St.	Brooklyn 10, N. Y.
Gunther, Frank A. (M)	FM Cottage	Staten Island 6, N. Y.
Gustin, Harry Decker (M)	3204 Presbury St.	Baltimore 16, Md.
Guy, Raymond F. (F)	370 Tryon Ave.	Englewood, N. J.
Haas, John G. (M)	360 Hawkins Place	Boonton, N. J.
Hackbush, Ralph A. (F)	62 Douglas Ave.	Toronto, Canada
Hall, F. Sumner (M)	153 West 33rd St.	New York 1, N. Y.
Hamer, Warren G. (M)	Allen B. DuMont Labs., Inc., 1000 Main Ave.	Clifton, N. J.
Hanley, John F. (M)	57 Elliott Place	Rutherford, N. J.
Harley, John B. (M)	80 Sylvan Place	Valley Stream, N. Y.
Harnett, Daniel E. (F)	211 Pelham Road	DeWitt, N. Y.
Haynes, N. M. (M)	1115 Beach 9th St.	Far Rockaway, N. Y.
Hazard, Thomas T. (M)	Box #57, Woodland Road	Brookside, N. J.
Hazeltine, Alan (F)	15 Tower Drive	Maplewood, N. J.
Hees, George C. (M)	701 Fifth Ave.	New Hyde Park, N. Y.
Heising, R. A. (F)	232 Oak Ridge Ave.	Summit, N. J.
Helt, Scott (M)	53 West 72nd St.	New York 23, N. Y.
Henney, J. K. (F)	111 Fifth St.	Garden City, N. Y.
Hill, Edgar Burton (M)	541 West 180th St.	New York 33, N. Y.
Hinners, Frank A. (F)	233 Raymond St.	Rockville Centre, N. Y.
Hirsch, Charles J. (M)	Hazeltine Electronics Corp., 58-25 Little Neck Parkway	Little Neck, N. Y.
Hogan, John V. L. (HM)	155 Perry Street	New York 14, N. Y.
Hold, Henry W. (M)	147 Stiles Street	Elizabeth, N. J.
Horle, Laurence C. F. (F)	90 West Street	New York 6, N. Y.
Horn, Charles W. (F)	Calle Rincon del Bosque #2	Colonia Polanco, Mexico, D. F.
Houck, Harry W. (F)	Intervale Road	Mountain Lakes, N. J.
Huchberger, Alfred P. (M)	630 Fifth Ave.	New York 20, N. Y.
Huffman, Charles E. (M)	91 Wildwood Ave.	Upper Montclair, N. J.
Hughes, Matthew J. (M)	541 Park Place	Lyndhurst, N. J.
Hults, Ellsworth H. (M)	18 Milburn Court	Baldwin, L. I.
Hunkins, Harold R. (M)	81-A Alexander Ave.	Upper Montclair, N. J.
Inman, W. P. (F)	30 Rockefeller Plaza	New York 20, N. Y.
Ireland, Frederick (F)	General Radio Co. 950 North Highland Ave.	Los Angeles 38, Calif.
Jacob, Frederick N. (M)	5843 N. Rockwell Ave.	Chicago 45, Ill.
Jacobi, George T. (M)	3810 Greystone Ave.	New York 63, N. Y.
Jacobs, Charles F. (M)	P. O. Box 408 Church St. Station	New York 8, N. Y.
James, Wallace M. (F)	56 Francesca Ave.	West Caldwell, N. J.
Jarvis, Kenneth W. (F)	1140 Cherry Street	Winnetka, Ill.
Jenkins, Victor E. (M)	c/o John M. Forshay 27 Park Place	New York 7, N. Y.
Jennings, Malbon H. (M)	567 Palisade Ave.	Yonkers 3, N. Y.
Johnson, J. Kelly (F)	55 West 42nd Street	New York 18, N. Y.
Jolliffe, Charles B. (F)	RCA Laboratories	Princeton, N. J.
Jones, Cary B. (M)	P. O. Box 1059	Palo Alto, Calif.
Jones, Walter R. (F)	940 East State Street	Ithaca, N. Y.
Josephsen, Axel (M)	35 Runsey Road	Yonkers, N. Y.
Keim, Llewellyn B. (F)	825 Fifth Ave.	New York 21, N. Y.
Kellerman, Karl F. (M)	Brush Development Co. 505 Washington Bldg.	Washington 5, D. C.

MEMBERSHIP OF THE RADIO CLUB OF AMERICA, INC.

Kelley, Leo A. (F)	34-38—87th Street	Jackson Heights, N. Y.
Kennedy, R. E. L. (M)	1900 F Street, N. W.	Washington, D. C.
Kent, Roscoe (F)	155 Perry Street	New York 14, N. Y.
King, Frank (F)	45 East 85th Street	New York 28, N. Y.
Kishpaugh, A. W. (M)	10 Yale Terrace	West Orange, N. J.
Klingenschmitt, F. A. (F)	Hudson View Gardens 183rd St. & Pinehurst Ave.	New York 33, N. Y.
Knapp, Joseph F. (F)	640 Fifth Ave.	New York 19, N. Y.
Knoop, Walter (M)	1060 Broad Street	Newark 2, N. J.
Kranz, Fred W. (F)	Sonotone Corporation	Elmsford, N. Y.
Lafferty, Raymond E. (M)	12-05 Sumner Place	Fair Lawn, N. J.
Lamb, Francis X. (M)	Weston Electrical Instrument Corp. 614 Frelinghuysen Ave.	Newark, N. J.
Langley, Ralph H. (F)	40 Welwyn Road	Great Neck, N. Y.
LaPenna, Frank (M)	167 Chestnut Ave.	Staten Island 5, N. Y.
LeBel, C. J. (F)	370 Riverside Drive	New York 25, N. Y.
Lee, Richard H. (M)	44 Orchard Street	Pleasantville, N. Y.
Leiser, Walter A. (M)	598 So. 18th St.	Newark, N. J.
Lempert, Irving E. (M)	614 Valley Road	Upper Montclair, N. J.
Lescarbours, Austin C. (F)	International Tel. & Tel. Co. 67 Broad Street	Croton-on-Hudson, N. Y.
Lewis, Harold M. (F)	510 Blanchard Parkway	New York 4, N. Y.
Libby, Herbert L. (M)	30 Union Street	Allenhurst Park, N. J.
Lidbury, F. A. (F)	Oldbury Electro-Chemical Co. Hazeltime Electronics Corp.	Watertown, Mass.
Loughlin, Bernard D. (F)	58-25 Little Neck Pkway.	Niagara Falls, N. Y.
Loughlin, W. D. (F)	320 Morris Ave.	Little Neck, N. Y.
Loughren, A. V. (F)	Hazeltime Electronics Corp. 58-25 Little Neck Pkway.	Mountain Lakes, N. J.
Lynch, Arthur H. (F)	P. O. Box 466	Little Neck, N. Y.
MacDonald, William A. (F)	Hazeltime Electronics Corp. 58-25 Little Neck Pkway.	Fort Myers, Florida
MacDonald, Wm. Robert Jr. (F)	70 California Ave.	Little Neck, N. Y.
Mackay, John R. (M)	Wallace & Tiernan Prod., Inc.	Freeport, N. Y.
Macken, Patrick J. (M)	23 West Post Road	Belleville, N. J.
Maedel, George F. (M)	593 East 38th Street	White Plains, N. Y.
Manson, Ray H. (F)	100 Carlson Road	Brooklyn, N. Y.
Marriott, Robert H. (HM)	1470 East 18th Street	Rochester, N. Y.
Martin, Devereaux (M)	8 Ballard Place	Brooklyn, N. Y.
Martin, Edwin M. (F)	Farnsworth Tel. & Radio Corp. 3700 East Pontiac St.	Fair Lawn, N. J.
Marx, Ernest A. (M)	Allen B. DuMont Labs., Inc. 515 Madison Ave.	Fort Wayne, Ind.
Masin, Oldrich F. (M)	17 East 42nd Street	New York 22, N. Y.
Mayer, William G. (F)	404 Sixth Ave.	New York 17, N. Y.
Mayhew, Benjamin A. (M)	11 North Brae Court	Asbury Park, N. J.
McAinsh, Neville J. (M)	General Electric Co., Ltd.	Tenafly, N. J.
McCoy, Daniel C. (F)	R. R. #7, Normandy Lane	Stoke, Coventry, England
McDougall, Dugald S. (M)	209 South LaSalle St.	Dayton 9, Ohio
McGonigle, William J. (M)	146 St. James Place	Chicago 4, Ill.
McKenzie, Alexander A. (M)	245 Poplar Ave.	Brooklyn, N. Y.
McMann, Renville H. (F)	60 East 96th Street	Hackensack, N. J.
McMann, Renville H. Jr. (M)	60 East 96th Street	New York 28, N. Y.
Metzger, Frederick W. (M)	11 Montrose Ave.	New York 28, N. Y.
Meyerink, Kors G. (M)	9 Orchard Place	Rutherford, N. J.
Meyers, James G. (M)	1056 Sheridan Ave.	Cos Cob, Conn.
Miessner, Benjamin F. (F)	Sundown, R.F.D. 2	Bronx 56, N. Y.
Miller, Arthur G. (M)	Electronic Indicator Corp. 259 Green Street	Morristown, N. J.
Miller, Donald H. (M)	Electronics, 330 West 42nd St.	Brooklyn 22, N. Y.
Miller, John H. (F)	614 Frelinghuysen Ave.	New York 18, N. Y.
Minter, Jerry (F)	Box #1	Newark, N. J.
Montcalm, S. R. (M)	406 Hill Street	Boonton, N. J.
		Boonton, N. J.

MEMBERSHIP OF THE RADIO CLUB OF AMERICA, INC.

Morelock, O. James (F)	Weston Electrical Instrument Corp. 614 Frelinghuysen Ave.	Newark, N. J. New York 28, N. Y.
Morton, Alfred Hammond (F)	25 East 86th Street	
Muirhead, Robert Bruce (M)	Room 19, Conrad Hall Stetson University	Deland, Florida Ramsey, N. J.
Muller, Fred (F)	4 Gertzen Road	
Nason, Charles H. W. (M)	840 Hale Street	Beverly Farms, Mass.
Nicholas, E. A. (F)	Farnsworth Television & Radio Corp. 3700 Pontiac Street	Fort Wayne, Ind. New York 7, N. Y.
Nichols, Leroy C. (F)	50 Church Street	
Nygren, Arnold C. (M)	FM & Television Magazine 511 Fifth Avenue	New York 17, N. Y.
Offenhauser, Wm. H. Jr. (F)	Box 595	New Canaan, Conn.
Osborn, Perry H. (M)	Sunset Avenue	Haworth, N. J.
Osterland, Edmund (M)	Ballantine Labs., Inc.	Boonton, N. J.
Pacent, L. Gerard (F)	79 Madison Ave.	New York 16, N. Y.
Packard, Lucius E. (F)	Technology Instrument Co. 1058 Main Street	Waltham, Mass.
Page, Esterly Chase (M)	600 Bond Building	Washington, D. C.
Paine, Robert C. (M)	436 Cornelia Street	Boonton, N. J.
Palmer, Charles W. (F)	2429 Fairway Drive	Winston-Salem, N. C.
Panter, Philip F. (M)	6 Hooper Avenue	West Orange, N. J.
Papamarcos, George (M)	526 Bay Ridge Ave.	Brooklyn 20, N. Y.
Parkes, Alanson W. Jr. (M)	47 Cobb Road	Mountain Lakes, N. J.
Petry, Charles B. (M)	31 Brookside Ave.	Hawthorne, N. J.
Pickard, Greenleaf W. (F)	59 Dalton Road	Newton Centre 59, Mass.
Picone, John B. (M)	2016 West 8th Street	Brooklyn, N. Y.
Poppele, J. R. (F)	9 Crest Circle	South Orange, N. J.
Popkin-Clurman, J. Raymond (M)	46 Lee Street	Roosevelt, L. I.
Porter, H. F. (M)	Old York & Tetsen Roads Elkins Park	Philadelphia 17, Pa.
Potts, John H. (M)	1737 York Ave.	New York 28, N. Y.
Pratt, Haraden (F)	67 Broad Street	New York 4, N. Y.
Quist, Andrew H. Jr. (M)	317 Bath Avenue	Long Branch, N. J.
Randall, H. Douglas Jr. (M)	204 Burns Street	Forest Hills, N. Y.
Ranger, R. H. (F)	574 Parker Street	Newark 4, N. J.
Redington, John H. (M)	324 Cornelia Street	Boonton, N. J.
Replogle, Delbert E. (F)	300 Godwin Avenue	Ridgewood, N. J.
Rettenmeyer, F. X. (F)	Federal Telephone & Radio Corp. 740 Stanwick Road	Moorestown, N. J.
Richardson, Avery G. (F)	180 Vreeland Ave.	Boonton, N. J.
Rider, John F. (F)	480 Canal Street	New York 13, N. Y.
Robertson, John F. (M)	129 Soundview Ave.	Huntington, N. Y.
Rockett, Frank H. (M)	226 Sylvan Drive	Hempstead, N. Y.
Ronald, Thomas T. (M)	550 Piaget Avenue	Clifton, N. J.
Runyon, C. R. Jr. (F)	544 North Broadway	Yonkers, N. Y.
Runyon, C. R. III (M)	26 Willard Avenue	Hastings-on-Hudson, N. Y.
Russell, W. Gordon (M)	62 Farragut Avenue	Hastings-on-Hudson, N. Y.
Russell, Wm. T. (F)	62 Farragut Avenue	Hastings-on-Hudson, N. Y.
Sadenwater, Harry (F)	1165 Fifth Avenue	New York 29, N. Y.
Safir, Robert (M)	40 Argyle Road	Brooklyn 18, N. Y.
Sampson, Harvey (M)	6 Bixby Drive	Baldwin, L. I.
Sara, Joseph (M)	836 Bloomfield Ave.	Montclair, N. J.
Sarnoff, David (HM)	Radio Corporation of America 30 Rockefeller Plaza	New York 20, N. Y.
Schneider, Robert E. (M)	10 Wagg Avenue	Malverne, N. Y.
Schmidt, Fred W. (M)	10 Garret Street	Cedar Grove, N. J.
Schnoll, Nathan (M)	804 Anderson Ave.	Palisade, N. J.
Schumacker, Allan L. (M)	170 Aspinwall Street	Westbury, L. I.

MEMBERSHIP OF THE RADIO CLUB OF AMERICA, INC.

Seeley, S. Ward (M)	400 East 58th Street	New York 22, N. Y.
Seger, Ludwig (M)	1751 Filmore Street	New York 60, N. Y.
Seklemian, Robert S. (M)	66 Broad Street	New York 4, N. Y.
Shackelford, Benjamin E. (F)	745 Fifth Avenue	New York 22, N. Y.
Shea, Richard F. (F)	225 Twin Hills Drive	Syracuse, N. Y.
Shepard, Francis H. Jr. (F)	430 Morris Avenue	Summit, N. J.
Shepherd, James E. (M)	195 Nassau Blvd.	Garden City, N. Y.
Shortt, Hubert L. (M)	Polytron Corporation 133 Martine Ave.	White Plains, N. Y.
Sieminski, Edward (M)	134-14 Franklin Ave.	Flushing, N. Y.
Sievers, Edward S. (M)	4561 Hollywood Blvd.	Los Angeles, Calif.
Silver, McMurdo (F)	1240 Main Street	Hartford 3, Conn.
Simmons, M. Theodore (M)	285 Madison Avenue	New York 17, N. Y.
Simon, William C. (M)	Tropical Radio Telegraph Co. Pier 7, N. R.	New York 6, N. Y.
Singer, Charles H. (M)	Radio Station WOR 1440 Broadway	New York 18, N. Y.
Singleton, Harold C. (F)	2073 S. W. Park Ave.	Portland 1, Oregon
Skipper, Lionel C. (M)	5 Warner Avenue	Roslyn Heights, N. Y.
Skrotzki, Frederick H. (M)	75-01—60th Lane	Brooklyn 27, N. Y.
Slater, I. M. (M)	810 No. Bolton Ave.	Indianapolis 19, Ind.
Sleeper, Milton B. (F)	Monterey Road	Great Barrington, Mass.
Smith, J. E. (F)	1536 U Street, N. W.	Washington, D. C.
Smith, Myron T. (F)	Lowell Road	Concord, Mass.
Spencer, Benjamin F. (M)	515 Grove Street	Irvington 11, N. J.
Spies, David (M)	383 Amherst Street	East Orange, N. J.
Srebroff, Charles M. (F)	686 Maywood Ave.	Manhasset, L. I.
Stantley, Joseph J. (F)	686 Maywood Ave.	Maywood, N. J.
Stantley, Joseph J. Jr. (M)	Box 373, Halsey Road	Maywood, N. J.
Stanton, S. W. (M)	R.F.D. 1	Whippany, N. J.
Steen, Jerome Reed (M)	35 Hilltop Drive	Manhasset, N. Y.
Stevens, Archie McDonald (F)	400 West 119th Street	New York 27, N. Y.
Stockman, William (M)	Y.M.C.A.	Worcester 8, Mass.
Stokes, W. E. D. (F)	Lake Cottage	Lenox, Mass.
Stone, Clarence G. (F)	304 South 1st Ave.	Mount Vernon, N. Y.
Stone, G. E. (M)	413 W. Main Street	Boonton, N. J.
Styles, Thomas J. (F)	160-01—84th Drive	Jamaica, N. Y.
Suydam, C. H. (F)	451 Heywood Ave.	Orange, N. J.
Swanson, John W. (F)	Standard Oil Co. of N. J. 30 Rockefeller Plaza	New York 20, N. Y.
Swinyard, W. O. (M)	325 West Huron St.	Chicago 10, Ill.
Talley, David (M)	130 Martense Street	Brooklyn 26, N. Y.
Taylor, Willis H. Jr. (F)	Pennie, Davis, Marvin & Edwards 247 Park Avenue	New York 17, N. Y.
Tessohn, Meyer (M)	American Gas & Electric Corp. 30 Church Street	New York 8, N. Y.
Thomas, Leslie G. (M)	127 Erledon Road	Tenafly, N. J.
Thorp, Wilbur E. (M)	7371 West 83rd St.	Los Angeles 45, Calif.
Tittle, Hulburt C. (M)	Colonial Radio Corporation 254 Rano Street	Buffalo, N. Y.
Toegel, Burt J. (M)	725 Park Avenue	Plainfield, N. J.
Toth, Albert F. (F)	36-08—29th Street	Long Island City, N. Y.
Tuckerman, L. P. (F)	2480 - 16th Street, N. W.	Washington 9, D. C.
Tunick, Harry (F)	R.C.A. Laboratory	Princeton, N. J.
Tyne, Gerard F. J. (M)	340 East 66th Street	New York 21, N. Y.
Ulm, Ernest H. (M)	Sylvania Electric Products, Inc. 500 Fifth Avenue	New York 18, N. Y.
Ulrich, Vinton K. (F)	224 Lafayette Street	Salem, Mass.
Van Beuren, John M. (F)	Measurements Corporation	Boonton, N. J.
Van Den Meersche, A. J. (M)	22 St. Pieters AA1st Straat	Ghent, Belgium
Van Dyck, Arthur F. (F)	131 Sound Beach Ave.	Old Greenwich, Conn.

MEMBERSHIP OF THE RADIO CLUB OF AMERICA, INC.

Van Rensselaer, Henry C. (M)	Allen B. DuMont Labs., Inc. 1000 Main Avenue	Clifton, N. J.
Vogel, William H. Jr. (M)	59 Crane Street	Caldwell, N. J.
Volf, Christian A. (F)	International Hearing Institute Volfair Bldg.	Beverly Hills, Calif.
Vorperian, Harry (M)	505 East 175th St.	New York 57, N. Y.
Walsh, Craig (M)	13 Shadylawn Drive	Madison, N. J.
Walsh, Lincoln (F)	34 DeHart Place	Elizabeth, N. J.
Ware, Paul (F)	Boulevard & Sunset Road	Pompton Plains, N. J.
Watson, Paul G. (F)	27 Price Street	West Chester, Pa.
Wattson, Harry B. (M)	157 Prospect Place	Rutherford, N. J.
Weare, John (F)	457 West 57th Street	New York 19, N. Y.
Weber, Victor J. (M)	Bell Telephone Labs. 463 West Street	New York 14, N. Y.
Weed, Edgar M. (M)	53 Burnham Road	Morris Plains, N. J.
Wehrman, N. A. (F)	62-64 Saunders Street	Rego Park, N. Y.
Wheeler, Harold A. (F)	18 Melbourne Road	Great Neck, N. Y.
Williams, Roger (M)	41 Park Row	New York 7, N. Y.
Worthen, Charles E. (F)	51 Beaumont Avenue	Newtonville, Mass.
Wright, E. R. (M)	R-1 Div., Box 30, NAS	Jacksonville, Fla.
Yocum, Charles H. (M)	50 Church Street	New York 7, N. Y.
Young, Thomas J. (M)	Bell Telephone Labs., Inc. 180 Varick Street	New York 14, N. Y.
Zayac, Frank R. (M)	Boonton Lakes Road	Boonton, N. J.
Zenneck, Jonathan (HM)	Altheigenberg 67 Uber Mering (13b) Bayern, Deutschland	U. S. Zone
Zitniak, Walter (M)	515 Grove Street	Irvington 11, N. J.

Acknowledgment

Grateful acknowledgment is made to the following sponsors who, by their contributions, helped make possible this Commemorative Issue.

ALLIED RADIO CORPORATION
AMY, ACEVES & KING, Inc.
BALLANTINE LABORATORIES, Inc.
BOONTON RADIO CORPORATION
COMPONENTS CORPORATION
CONTINENTAL SALES CORPORATION
ALLEN B. DU MONT LABORATORIES, Inc.
ELECTRO MOTIVE MANUFACTURING CO., Inc.
GENERAL ELECTRIC COMPANY
GLOBE-UNION, Inc.
THE HALLICRAFTERS COMPANY
HEWLETT-PACKARD COMPANY
HUDSON WIRE COMPANY
DR. LEWIS M. HULL.
MEASUREMENTS CORPORATION
JAMES MILLEN MANUFACTURING CO., Inc.
MOTOROLA, Inc.
OPERADIO MANUFACTURING COMPANY
PHILCO CORPORATION
SYLVANIA ELECTRIC PRODUCTS CO., Inc.
WESTERN ELECTRIC COMPANY
WESTINGHOUSE ELECTRIC
WESTON ELECTRICAL INSTRUMENT CO.
ZENITH RADIO CORPORATION

