

OCTOBER 1951

RADIO — ELECTRONICS

LATEST IN TELEVISION • SERVICING • AUDIO

HUGO SKRNSBACK, Editor



30¢
U.S. and
CANADA

MOBILE TELEVISION SERVICE

SEE TELEVISION SECTION

**In this issue: Conversion to Color TV •
Intercarrier Buzz • A Signal Launcher**

You get *all five* ...with **RCA Batteries**



1. RADIO TRADE DISTRIBUTION

(less competition from non-radio outlets)

2. Radio-Engineered Quality

3. Top Brand Acceptance

4. Greatest Array of Selling Aids

5. Completely Rounded Line

You get 5-Way Help when you stock and sell RCA Radio Batteries . . . the line that's geared to the radio trade.

Radio Trade Distribution means less competition from non-radio stores in your area. It means your RCA Battery customers come back to you again and again. *More repeat sales. Better profits.*

Radio-Engineered Quality means increased customer satisfaction because of longer battery life . . . *extra listening hours. Satisfied customers are repeat customers. Bigger sales. Better profits.*

Top Brand Acceptance means faster sales because customers are pre-sold on the RCA name. People know and trust every product that bears the famous RCA monogram. *Bigger sales. Better profits.*

Greatest Array of Selling Aids means plenty of sales help right at the point of purchase. Signs, displays, merchandisers, and servicing aids . . . all these help you sell the RCA battery line. *Bigger sales. Better profits.*

Completely Rounded Line means you can fill practically every battery requirement. This complete line provides a type for almost every portable and farm radio need. *More sales. Better profits.*

Contact your local RCA Battery Distributor today. You'll find out how profitable it is to switch now to RCA . . . the battery line that's geared to the radio trade.

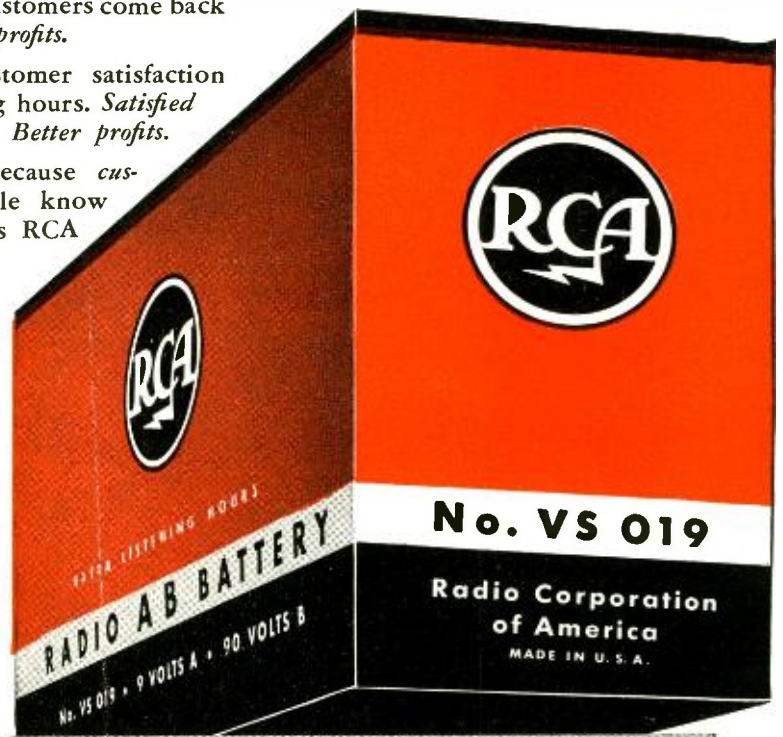

RADIO CORPORATION of AMERICA

RADIO BATTERIES

HARRISON, N. J.

NEW



I'LL TRAIN YOU FOR YOUR FCC LICENSE

A Federal Communications Commission Commercial Operator's License puts you in line for a good job in Radio or Television Broadcasting. Police, Marine, Aviation, Two-way, Mobile or Micro-wave Relay Radio. Mail coupon below for 64-page book FREE. It will give you complete facts about my NEW Communications course.



YOU BUILD THIS TRANSMITTER

with parts I send. With this Transmitter you practice how to put a station "on the air." You perform procedures demanded of Broadcast Station Operators, conduct many experiments, make many practical tests.

LEARN COMMUNICATIONS by PRACTICING at Home in Spare Time

with MANY KITS of RADIO EQUIPMENT I SEND



MY COURSE INCLUDES TELEVISION

Course Is New! Different!

Mail coupon now for facts about my NEW, intensely practical course in Radio-Television Communications. Let me send you FREE book. Read outlines of 78 lesson texts written by leaders in Communications and edited for you by my practical staff. See the nine big Kits of Parts I send that "bring to life" theory you learn. Read about the Transmitter you build and operate, about the Electronic Multitester you get. All equipment yours to keep. My NEW course covers Theory thoroughly and you get Practical Experience building units like those shown at the left. It's backed by N. R. I.—the world's oldest and largest home study Radio-Television school.



YOU BUILD this Transmitter Power Supply used in the basic experiments in RF and AF amplifiers, frequency multipliers, buffers, etc.

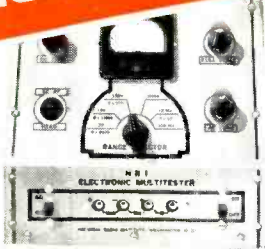

YOU MEASURE current, voltage (AC, DC and RF), resistance and impedance in circuits with Electronic Multitester you build. Shows how basic transmitter circuits behave; needed to maintain station operation.



YOU PRACTICE setting up code, amplitude and frequency modulation circuits (put voice, music, etc., on "carrier signals" you produce). You learn how to get best performance.

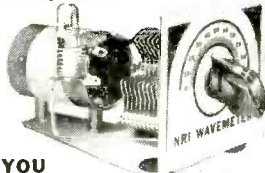

YOU BUILD this Wavemeter and use it to determine frequency of operation, make other tests on transmitter currents.

Ever think HOW FAST Radio-Television Communications is changing, developing, growing? Have you considered what this amazing progress can mean to you?

Look at these facts. In 1946 only 6,000 Television sets were sold. In 1950, over 5,000,000. By 1954, 25,000,000 Television sets will be in use, according to estimates. 100 Television Stations are operating in 35 states. Authorities predict there will be over 1,000 Television Stations. This rapid growth means new jobs, more jobs, good pay for qualified men all over the U. S. and Canada. Then add development of FM, Two-way Radio, Police, Marine, Aviation and Micro-wave Relay Radio! Think what all this means! New jobs, more jobs for beginners! Better jobs, better pay for experienced men!

Are you a beginner who wants steady work in this growing field? My NEW course can help you get an FCC License and prepare for the job you want. Are you a man with some training in Radio or Radar, or a Licensed Operator? My NEW course modernizes, increases the value of your knowledge and experience!

Servicing Training Also Offered by N. R. I.

If you prefer a good-pay job in Radio-Television Servicing or your own money-making Radio-Television Sales and Service Shop, I'll train you at home. My famous Servicing Course also includes many Kits of Radio Parts. You use them to get PRACTICAL EXPERIENCE with circuits common to Radio and Television. I also show you how to make \$5, \$10 a week or more EXTRA MONEY fixing neighbors' Radios while training. Full information in my 64-page book. Mail coupon.

Mail Coupon For Book FREE

Send today! See what my NEW course is like. Find out how I get you ready for a brighter future, better earnings, more security in Radio-Television. Send coupon now in envelope or paste on a postal. NO OBLIGATION. NO SALESMAN WILL CALL! My book, sent to you FREE, tells the full story. J. E. SMITH, President, Dept. IKF, National Radio Institute, Washington 9, D. C.

EXTRA PAY IN ARMY, NAVY, AIR FORCE

Knowing Radio, TV, Electronics can help you get extra rank, extra prestige, more interesting duty at pay up to several times a private's base pay. You are also prepared for good Radio-TV jobs upon leaving service. Mail Coupon TODAY.

I TRAINED THESE MEN



"N.R.I. has been my stepping stone from a few hundred to over \$4,000 a year as a Radio Engineer."—ALTON B. MICHAELS, Trenton, Georgia.



"I am employed by WKBO as transmitter operator. Have more than doubled salary since starting in Radio full time."—A. HERR, New Cumberland, Penna.



"Am Broadcast Engineer at WLPM. Your NEW Communications course shows the kind of equipment we use."—J. BANGLE, JR., Suffolk, Virginia.



"4 years ago, I was a bookkeeper with hand-to-mouth salary. Am now Radio Engineer with ABC network."—N. H. WARD, Ridgefield Park, N. J.

MAIL NOW-BOOK FREE

MR. J. E. SMITH, President, Dept. IKF, National Radio Institute, Washington 9, D. C.

Mail me your 64-page Book about Radio and Television Communications opportunities and training. (No salesman will call. Please write plainly.)

Name..... Age.....
Address.....
City..... Zone..... State.....
Approved Under G. I. Bill

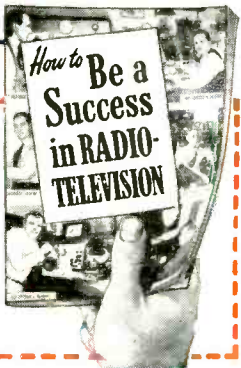

RADIO — ELECTRONICS

formerly RADIO-CRAFT

MEMBER
AUDIT BUREAU OF CIRCULATIONS

Hugo Gernsback, Editor-in-Chief

M. Harvey Gernsback, Editorial Director

Fred Shunaman, Managing Editor
Robert F. Scott, W2PWG, Technical Editor
Mel Kramer, Associate Editor

I. Queen, Editorial Associate
Angie Pascale, Production Manager
Wm. Lyon McLaughlin, Tech. Illustration Director

Lee Robinson, General Manager
John J. Lamson, Sales Manager

G. Aliquo, Circulation Manager
Robert Falath, Promotion Manager

CONTENTS — OCTOBER, 1951

Editorial (Page 21)	
Service Technicians' Evolution	by Hugo Gernsback 21
Television (Pages 22-31)	
Television Service on Wheels (Cover Story) ..	by Guy Slaughter 22
Intercarrier Buzz	by Marvin H. Kronenberg 24
Conversion to Color is Simple and Easy.....	by Matt Mandl 26
New Source of TVI	29
Television Service Clinic.....	Conducted by Matthew Mandl 30
Television DX Report	31
Servicing—Test Instruments (Pages 32-39)	
The Signal Launcher	by Robert E. Altomare 32
Notes on Meter Application	by Rufus P. Turner 34
Tube Replacement Tips	by John T. Frvo 36
Double Mystery Display.....	by Victor Fastenaekels 38
Novel Bench has Swing-Out Panel	by Harold Maxeiner 39
Audio (Pages 40-47)	
Audio Feedback Circuits, Part XII ..	by George Fletcher Cooper 40
Basic Intercom Units.....	by Eugene M. Hanafin, Jr. 42
Electronics and Music, Part XVI.....	by Richard H. Dorf 44
Construction (Pages 48-50)	
Old-Time Circuits	by John W. Straede 48
Garage Door Opener	by Theodore W. Hall 50
Foreign (Page 51-52)	
Which—AM or FM? England Ponders....	by Ralph W. Hallows 51
Electronics (Pages 53-55)	
How an Electronic Brain Works, Part XIII	by Edmund C. Berkeley and Robert A. Jensen 53
Theory and Engineering (Pages 56-72)	
Vibrator Circuit Fundamentals.....	by C. C. Erhardt 56
Limiting Amplifier	58
The Crystal Era Comes Back	by Wilbur J. Hantz 60
New Transistor Circuit Design Method	64
Rectifiers as Switches	68
Two Intermodulation Tests	70
New Design (Pages 74-80)	
V. H. F. Paging Calls Subscriber to Phone	74
Tubes of the Month	76
Broadcasting & Communications (Pages 84-85)	
Maintaining 2-way Mobile Equipment ...	by Lyman E. Gray 84
Amateur (Pages 86-98)	
Ham Station Control Rolls to Bedside....	by Jim Kirk, WJDEG 86
Automatic Dashes with Standard Bug.....	by Martin Crane 88
Department:	
Radio Month	10
Radio Business	14
New Devices	82
New Patents	100
Radio-Electronic	
Circuits	102
Try This One	106
Question Box	108
Miscellany	111
With the Technician	115
Technotes	119
People	120
Communications	123
Book Reviews	127

ON THE COVER:

The new mobile television service station of Appliance Distributors, Inc., Chicago, with technician Ben Schneider at the service bench. Ektachrome original by Fran Byrne

Use Sprague TELECAPS®
on TV replacement jobs.
Avoid costly callbacks!



Of course there's a reason why more Sprague Telecap molded tubular capacitors are used in leading television sets and by leading service shops than any other brand! Telecaps are especially designed for TV. They stand the gaff!

Write for Bulletin M-474

SPRAGUE
PRODUCTS COMPANY
DISTRIBUTORS' DIVISION OF THE SPRAGUE ELECTRIC COMPANY
81 MARSHALL ST., NORTH ADAMS, MASS.

October, 1951

RADIO-ELECTRONICS

Vol. XXIII, No. 1

Published monthly by Radcraft Publications, Inc., at Erie Ave., F to G Streets, Philadelphia 32, Pa.

EXECUTIVE, EDITORIAL AND ADVERTISING OFFICES: 25 West Broadway, New York 7, N. Y. Telephone REctor 2-8630. Hugo Gernsback, President; M. Harvey Gernsback, Vice-President; G. Aliquo, Secretary.

SUBSCRIPTIONS: Address correspondence to Radio-Electronics, Subscription Dept., Erie Avenue, F to G Sts., Philadelphia 32, Pa., or 25 West Broadway, New York 7, N. Y. When ordering a change please furnish an address stencil impression from a recent wrapper. Allow one month for change of address.

SUBSCRIPTION RATES: In U. S. and Canada, in U. S. possessions, Mexico, South and Central American countries, \$3.50 for one year, \$6.00 for two years; \$8.00 for three years; single copies 30c. All other foreign countries \$4.50 a year, \$8.00 for two years; \$11.00 for three years. Entered as second class matter September 27, 1948 at the post office at Philadelphia, Pa., under the Act of March 3, 1879. Printed in U. S. A. Copyright 1951 by Radcraft Publications, Inc. Text and illustrations must not be reproduced without permission of copyright owners.

BRANCH ADVERTISING OFFICES: Chicago: 520 N. Michigan Ave. Telephone Superior 7-1796. Los Angeles: Ralph W. Harker, 1127 Wilshire Blvd., Tel. MA 6-1271. San Francisco: Ralph W. Harker, 582 Market St., Tel. GARfield 1-2481. FOREIGN AGENTS: Great Britain: Atlas Publishing and Distributing Co., Ltd., London E.C.4. Australia: McGill's Agency, Melbourne. France: Brentano's, Paris 2e, Holland: Trilectron, Heemstede. Greece: International Book & News Agency, Athens. So. Africa: Central News Agency, Ltd., Johannesburg; Capetown: Durban. Natal: Universal Book Agency, Johannesburg. Middle East: Steimatzy Middle East Agency, Jerusalem. India: Broadway News Centre, Dadar, Bombay #14. K. L. Kannappa Mudaliar, Madras 2. Pakistan: Paradise Book Stall, Karachi 3.

POSTMASTER: If undeliverable send form 3578 to: RADIO-ELECTRONICS, 25 West Broadway, New York 7, N. Y.



Learn RADIO TELEVISION, ELECTRONICS *by* SHOP METHOD HOME TRAINING

Let NATIONAL SCHOOLS, of Los Angeles, a practical Technical Resident Trade School for almost 50 years, train you for today's unlimited opportunities.

You receive all parts, including tubes, for building this fine, modern Superheterodyne Receiver. This and other valuable standard equipment becomes your property.

these two FREE books will tell you how

WE BRING NATIONAL SCHOOLS TO YOU!

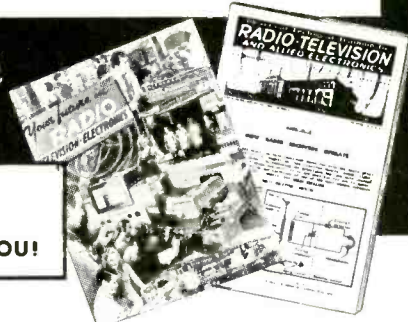

GOOD JOBS AWAIT THE TRAINED RADIO TECHNICIAN

You are needed in the great modern Radio, Television and Electronics industry! Trained technicians are in constant and growing demand at excellent pay—in Broadcasting, Communications, Television, Radar, Research Laboratories, Home Radio Service, etc. National Schools Master Shop Method Home Study Course, with newly added lessons and equipment, can train you in your spare time, *right in your own home*, for these exciting opportunities. Our method has been proved by the remarkable success of National Schools-trained men all over the world.

You Learn by Building Equipment with Standard Radio Parts We Send You

Your National Schools Course includes not only basic theory, but *practical* training as well—you learn by doing. We send you complete standard equipment of professional quality for building various experimental and test units. You advance step by step until you are able to build the modern superheterodyne receiver shown above, which is yours to keep and enjoy. You perform more than 100 experiments—build many types of circuits, signal generator, low power radio transmitter, audio oscillator, and other units. The Free Books shown above tell you more about it—send for them today!

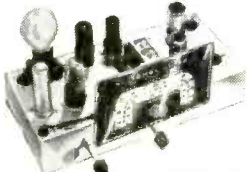

NOW! NEW PROFESSIONAL MULTITESTER INCLUDED



This versatile testing instrument is portable and complete with test leads. Simple to operate, accurate and dependable. You will be able to quickly locate trouble and adjust the most delicate circuits. You can use the Multitester at home or on service calls. It is designed to measure AC and DC volts, current resistance and decibels. You will be proud to own and use this valuable professional instrument.

GET THE DETAILS - SEND THE COUPON →

Lessons and Instruction Material Are Up-to-date, Practical, Interesting

National Schools Master Shop Method Home Training gives you basic and advanced instruction in all phases of Radio, Television and Electronics. Each lesson is made easy to understand by numerous illustrations and diagrams. All instruction material has been developed and tested in our own shops and laboratories, under the supervision of our own engineers and instructors. A free sample lesson is yours upon request—use the coupon below.

TELEVISION TRAINING A complete series of up-to-the-minute Television lessons is an integral part of your course, covering all phases of Television repairing, servicing and construction.

Here are just a few of the interesting facts you learn with the **FREE SAMPLE LESSON**

1. How radio receivers operate.
2. How the antenna circuit is constructed.
3. Converting signal currents into sound.
4. How the R-F transformer handles the signal.
5. How the tuning circuit functions.
6. The Radio "bands."

Both Resident and Home Study Courses Offered

NATIONAL SCHOOLS

LOS ANGELES 37, CALIFORNIA EST. 1905



MAIL OPPORTUNITY COUPON FOR QUICK ACTION

National Schools, Dept. 10-RE
4000 South Figueroa Street
Los Angeles 37, California

(Mail in envelope or paste on penny postcard.)

Mail me FREE the book "Your Future in Radio-Television" and the sample lesson of your course. I understand no salesman will call on me.

NAME _____ AGE _____

ADDRESS _____

CITY _____ ZONE _____ STATE _____

The Television and Radio Service

Dealer who can point with pride to his Raytheon Bonded Electronic Technician Certificate . . .



who can create

customer confidence with his Bonded, cash-



protected method of doing

business . . . who can instantly



identify himself to his customers with the

Raytheon Creed Display, the

Bonded Decal and the Raytheon

Bonded Identification Card



. . . is the Service Dealer whose business is booming.

If your business

is bogged down, better ask

your Raytheon



Tube Distributor if you can

qualify for this Raytheon



Bond that costs you nothing, but

adds plenty to your cash receipts.

RIGHT...FOR SOUND AND SIGHT®



RAYTHEON MANUFACTURING COMPANY

Receiving Tube Division

Newton, Mass., Chicago, Ill., Atlanta, Ga., Los Angeles, Calif.

Excellence in Electronics

RADIO AND TELEVISION RECEIVING TUBES, CATHODE RAY TUBES, SPECIAL PURPOSE TUBES, SUBMINIATURE TUBES, MICROWAVE TUBES



*How far ahead can you be
next year . . .*

IN TV AND ELECTRONICS?

◀ **Send for this free CREI booklet today...
and find out!**

THIS BOOKLET can mean the difference between small, t-w-i-d-e-l-y s-p-a-c-e-d salary increases—and rapid advancement. Between routine work—and challenging opportunity. Between constantly defending your job against better-trained men—and dynamic confidence. Between short-circuited hopes—and high-powered ambition.

An exciting new world has opened up with such super-speed that even the most optimistic electronic experts fall short in their predictions of expansion.

Think of the 1,500 TV stations within the next 5 years and the 2,500 stations within 10 years, as predicted by the Chairman of the FCC. Think of the 13,000,000 TV sets now in use. *Remember that we weren't supposed to reach that figure until 1954.* Think of the 100,000,000 radios in current operation. (95% of the nation's homes have one or more sets.) Think of the tremendous defense orders now being placed for electronic equipment and installations.

Think of the thousands of radio-equipped fire and police departments throughout the U.S. Of the many radio-equipped railroads, of the hundreds of cities with 2-way radio service for cars and cabs. Think of the wide-ranging field of aviation communications—radio-controlled aircraft, navigation-and-traffic control, airport stations.

Think of the maritime world with its navigational aids, fathometers, ship-to-shore and ship-to-ship communications and radar. Think of electronic heating, fax and ultra-fax, of electronic medicine, and all the other applications of electronic know-how.

Countless positions must be filled—in development, research, design, production, testing and inspection, manufacture, broadcasting, telecasting and servicing. Who will get those positions? You—if you prepare today—if you are alert and have the ambition to advance your knowledge. You—if you take 2 minutes to send for a free copy of "Your Future in the New World of Electronics."

This helpful book shows you how CREI Home Study leads the way to greater earnings through the inviting opportunities described above.

However, being an accredited technical school, CREI does not promise you a "bed-of-roses." You have to translate your willingness to learn into saleable technical knowledge

—via *study*. Since its founding in 1927, CREI has provided thousands of professional radiomen with technical educations. During World War II, CREI trained thousands for the Armed Services. Leading firms choose CREI courses for group training in electronics at company expense, among them United Air Lines, Canadian Broadcasting Corporation, Trans Canada Airlines, Sears Roebuck & Co., Bendix Products Division, All-American Cables and Radio, Inc., and RCA-Victor Division.

CREI courses are prepared by recognized experts, in a practical, easily-understood manner. You get the benefit of time-tested materials, under the personal supervision of a CREI Staff Instructor. This complete training is the reason why CREI graduates find their diplomas keys-to-success in Radio, TV and Electronics. CREI alumni hold top positions in America's leading firms.

At your service is the CREI Placement Bureau, which finds positions for students and graduates. Although CREI does not guarantee jobs, requests for personnel currently exceed supply by far.

Talk to men in the field and check up on CREI's high standing in electronics instruction. Determine for yourself right now that your earnings are going to rise with your knowledge—and that you get your rightful place in the Age of Electronics. All this CREI can promise you, provided you sincerely want to learn. Fill out the coupon and mail it today. We'll promptly send you your free copy of "Your Future in the New World of Electronics." The rest—the future—is up to you.

MAIL COUPON FOR FREE BOOKLET

CAPITOL RADIO ENGINEERING INSTITUTE

Dept. 1410C, 16th & Park Rd., N.W., Washington 10, D. C.

Send booklet "Your Future in the New World of Electronics" and course outline.

CHECK FIELD OF GREATEST INTEREST TV, FM & Advanced AM Servicing Aeronautical Radio Engineering Practical Television Engineering Broadcast Radio Engineering (AM, FM, TV) Practical Radio Engineering

Name.....

Street.....

City..... Zone..... State.....

If residence school in Wash., D. C. preferred, check here

Your voice

in Davy Jones' locker

To strengthen voices in the newest submarine cables between Key West and Havana amplifiers had to be built right into the cables themselves. With the cables, these amplifiers had to be laid in heaving seas; and they must work for years under the immense pressure of 5000 feet of water.

For this job, Bell Laboratories engineers developed a new kind of amplifier — cable-shaped and flexible, with a new kind of water-tight seal.

To serve far beyond reach of repair, they developed electron tubes and other parts, then assembled them in dust-free rooms.

The two cables — each has but two conductors — simultaneously carry 24

conversations as well as current to run the electron tubes.

With these deep-sea amplifiers, submarine cables carry more messages . . . another example of how research in Bell Telephone Laboratories helps improve telephone service each year while costs stay low.

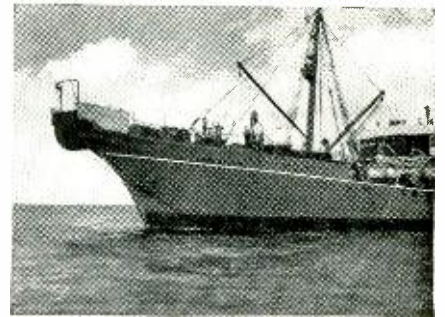

Cutaway view of deep-sea amplifier. Tubes and other elements are housed in plastic cases then enclosed in interleaved steel rings within a copper tube. Layers of glass tape, armor wire and impregnated fiber complete the sheath. Cable ship, shown right, payed out cable over large sheave at bow.

BELL TELEPHONE LABORATORIES

• Exploring and inventing, devising and perfecting, for continued improvements and economies in telephone service.

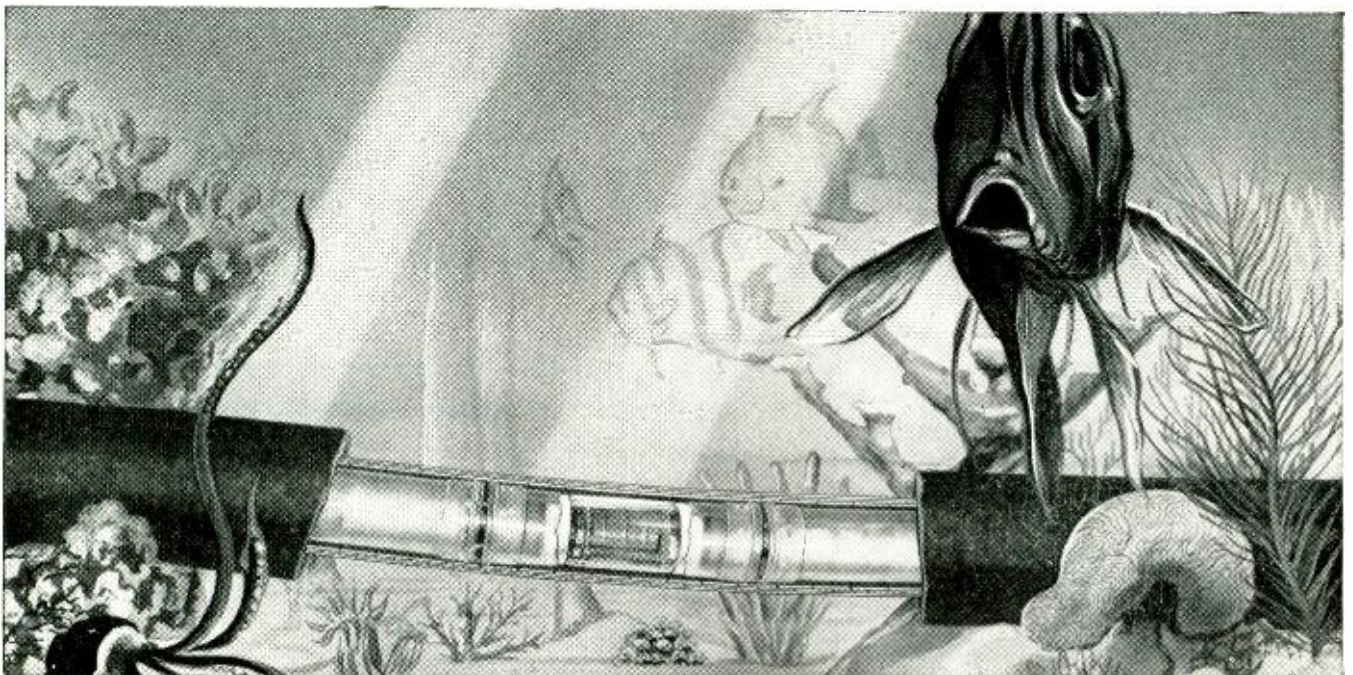

RADIO-ELECTRONICS for

NOW... GET EVERYTHING YOU
NEED TO LEARN AND MASTER

TELEVISION

RADIO-ELECTRONICS ...AT HOME!

Use REAL commercial-type equip-
ment to get practical experience



Here's the
REAL THING!

**SET UP YOUR OWN
HOME LABORATORY**

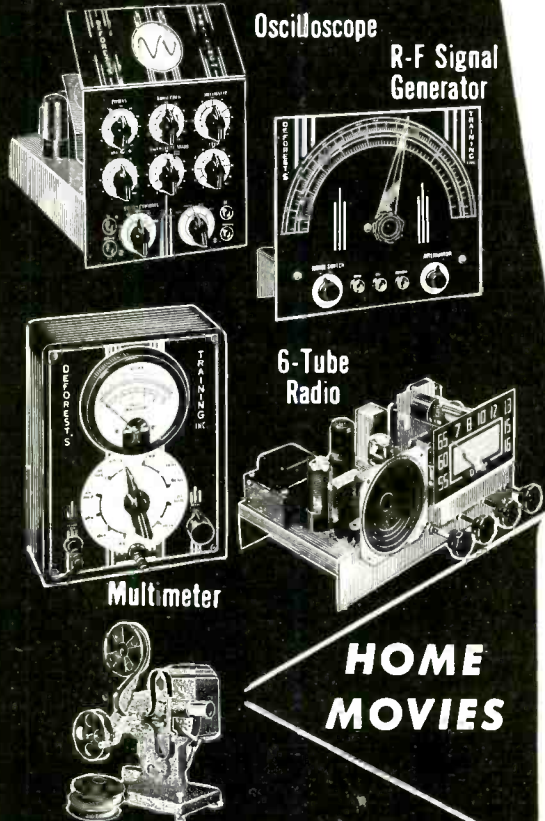

Oscilloscope

R-F Signal
Generator

6-Tube
Radio

Multimeter

**HOME
MOVIES**

ABOVE: Build and keep a real 16 INCH commercial TV receiver. Optional after completing regular training at slight additional cost.

D.T.I., ALONE, INCLUDES BOTH MOVIES and HOME LABORATORY
In addition to easy-to-read lessons, you get the use of HOME MOVIES — an outstanding training advantage — plus 16 big shipments of Electronic parts. Perform over 300 fascinating experiments for practical experience. Build and keep real commercial-type test equipment shown at left.

MODERN LABORATORIES
If you prefer, get all your preparation in our new Chicago Training Laboratories—one of the finest of its kind. Ample instructors, modern equipment. Write for details!

MILITARY SERVICE!
If you're subject to military service, the information we have for you should prove doubly interesting. Mail coupon today.

**Get BOTH of these
information packed
publications FREE!**



ACT NOW! MAIL COUPON TODAY!

DeFOREST'S TRAINING, INC., Dept. RE-10-H
2533 N. Ashland Ave., Chicago 14, Ill.

Without obligation, I would like your late News-Bulletin showing 89 ways to earn money in Television-Radio-Electronics ... and how I may prepare to get started in this thrilling field.

Name..... Age.....
Street..... Apt.....
City..... Zone..... State.....

De FOREST'S TRAINING, INC.
CHICAGO 14, ILLINOIS
A De VRY INSTITUTION

It's
Tung-Sol
for radio
and tv



Quality

-that keeps pace with the growth of the electronic industry

Quality

-that meets fully the performance requirements of all radio and tv set manufacturers

Quality

-that safeguards dealer service work

TUNG-SOL
RADIO, TV TUBES, DIAL LAMPS

TUNG-SOL ELECTRIC INC., Newark 4, N. J.
Sales Offices: Atlanta • Chicago • Dallas • Denver
Detroit • Los Angeles • Newark

HARBOR RADAR tests recently conducted at Boston by Raytheon Mfg. Co. used specially designed equipment including the world's largest commercial type antenna which is 41 feet wide and weighs about 5 tons.

The transmitter (which was located on Deer Island in Boston Harbor) used a selectable pulse length of 0.2 microsecond and 0.6 microsecond. Short pulse lengths give finer detail where two closely spaced objects must be separated; longer pulses when distant objects



Five-ton radar antenna is 41 feet wide.

must be seen. Ten-centimeter waves are used since sleet, fog, or sea return effects are least at this frequency. This large antenna produces a beam width of 42 minutes and has a power gain of approximately 10,000.

The signal was transmitted, received and retransmitted from Deer Island, providing a clear view of the harbor to Boston's Commonwealth pier. Microwave relay was used.

To meet special harbor demands a technique was developed to move land masses off the screen and put the radar station on the screen edge. This variable offset type indicator gives the effect of using a 32-inch tube where 16-inch tubes only are used. One standard indicator and three offset indicators were used. The offset indicators employed expanded the range out to sea, while the standard indicator checked all directions simultaneously.

A reflection plotter is used to project a pencil mark from the plotting surface directly on to the P.P.I. tube, using a semi-mirror. Continuous plotting is obtained this way, and the plots made on the board can be quickly erased or changed.

The first harbor radar system manufactured by Raytheon will be installed in the port of Le Havre, France, and one other engineering model is undergoing tests at the port of New York.

FIRING ELECTRONS with energies of 800,000 volts from a modified million-volt X-ray machine, scientists at G-E laboratories are making solid plastics

from liquid materials. This quickening of the process of polymerization (a process where short molecular chains in liquid form are combined to form longer chains and more rigid structures) may bring great changes in industry.

The joining together of the individual molecular units results from a rearrangement of the electrons in the atoms. Ordinarily this is done by chemical means. With this process high-speed electrons knock some electrons out of the atom or else stick to it. With a small proportion of the atoms thus altered, the reaction starts and proceeds to completion. In previous work castor oil was converted to a solid.

GOVERNMENT FREEZE on TV station construction in effect since September, 1948, because of shortage of channels, may be lifted in the near future. Nearby stations now operating on v.h.f. from 50 to 216 mc must now use widely separated frequencies or they interfere with each other. At present, 107 stations are in operation with tentative allocations pending on v.h.f. for 450 more.

The FCC proposals for the u.h.f. band would permit telecasts by thousands more. The chairman of the Commission, Mr. Coy, predicted recently that in five years there will be at least 1,500 TV stations in the country and 2,500 in ten years.

U.h.f. will use channels between 470 and 890 mc. A considerable number of these stations will be in cities of less than 100,000. They will be low-power, with a primary range of about one-fourth of the ordinary v.h.f. TV range which is now about 40 to 60 miles.

CRYSTAL CLUTCH with high speed of response was recently developed at the National Bureau of Standards as part of a program for development of fast-acting clutches suitable for use in high-speed computers.

Application of a d.c. voltage to the electrodes of three "Bimorph" crystals causes the crystals to bend; this bending process pushes the clutch output disc against the rotating input disc. The resonant frequency of the crystal sets the limit for the speed of response.

KEEN COMPETITION exists among several groups which are trying to control televising of events of special interest and importance. In an effort to outbid theater interests for TV rights to big sports contests (such as the Charles-Walcott fight) the Du Mont network will organize a "sports and special events" department.

It will be this department's job to secure telecasting rights to special events through the combined "buying power" of a TV industry group (eight manufacturers paid \$100,000 for the above fight rights).

Theater TV group opposition is stiff, including RKO, Loew's Inc., United Paramount, and Fabian. They have an advantage over Skiatron and Phonevision (which want subscription TV for the home viewer), since they operate over



ADD TECHNICAL TRAINING TO YOUR PRACTICAL EXPERIENCE

GET YOUR FCC LICENSE IN A HURRY!

THEN—Use Our Amazingly Effective **JOB-FINDING** Service

Get this Valuable Booklet FREE



TELLS HOW —

WE GUARANTEE

TO TRAIN AND COACH YOU AT HOME IN SPARE TIME UNTIL YOU GET

YOUR FCC LICENSE

If you have had any practical experience—Amateur, Army, Navy, Radio repair, or experimenting.

TELLS HOW —

Employers make

JOB OFFERS like These

to Our Graduates Every Month

Telegram, August 9, 1950, from Chief Engineer, Broadcast Station, Pennsylvania, "Have job opening for one transmitter operator to start immediately, contact me at once."

Letter, August 12, 1950, from Dir. Radio Div. State Highway Patrol, "We have two vacancies in our Radio Communication Division. Starting pay \$200; \$250 after six months' satisfactory service. Will you recommend graduates of your school?"

There are just a few examples of the job offers that come to our office periodically. Some licensed radiomen filled each of these jobs . . . it might have been you!

HERE'S PROOF FCC LICENSES ARE OFTEN SECURED IN A FEW HOURS OF STUDY With Our Coaching AT HOME in Spare Time.

Name and Address	License	Lessons
Lee Worthy, 2210 1/2 Wilshire St., Bakersfield, Calif.	2nd Phone	16
Clifford E. Vogt, Box 1016, Dania, Fla.	1st Phone	20
Francis X. Foerch, 38 Beucler Pl., Bergenfield, N. J.	1st Phone	38
S/Sgt. Ben H. Davis, 317 North Roosevelt, Lebanon, Ill.	1st Phone	28
Albert Schoell, 110 West 11th St., Escondido, Calif.	2nd Phone	23

CLEVELAND INSTITUTE OF RADIO ELECTRONICS
Desk RE-34, 4900 Euclid Bldg., Cleveland 3, Ohio

OCTOBER, 1951

TELLS HOW —

Our Amazingly Effective **JOB-FINDING SERVICE**

Helps **CIRE** Students Get Better Jobs

Here are a few recent examples of Job-Finding results:

GETS JOB WITH CAA

"I have had a half dozen or so offers since I mailed some fifty of the two hundred employment applications your school forwarded me. I accepted a position with the Civil Aeronautics Administration as a Maintenance Technician. Thank you very much for the fine cooperation and help your organization has given me in finding a job in the radio field."

Dale E. Young, 122 Robbins St., Owosso, Mich.

GETS FIVE JOB-OFFERS FROM BROADCAST STATIONS

"Your 'Chief Engineer's Bulletin' is a grand way of obtaining employment for your graduates who have obtained their 1st class license. Since my name has been on the list I have received calls or letters from five stations in the southern states, and am now employed as Transmitter Engineer at WMMT."

Elmer Powell, Box 274, Sparta, Tenn.

GETS CIVIL SERVICE JOB

"I have obtained a position at Wright-Patterson Air Force Base, Dayton, Ohio, as Junior Electronic Equipment Repairman. The Employment Application you prepared for me had a lot to do with me landing this desirable position."

Charles E. Loomis, 4516 Genesee Ave., Dayton, Ohio.

Your FCC Ticket is always recognized in all radio fields as proof of your technical ability.

OURS IS THE ONLY HOME STUDY COURSE WHICH SUPPLIES FCC-TYPE EXAMINATIONS WITH ALL LESSONS AND FINAL TESTS.



Get All 3 FREE

MAIL COUPON NOW

CLEVELAND INSTITUTE OF RADIO ELECTRONICS
Desk RE-34—4900 Euclid Bldg., Cleveland 3, Ohio

(Address to Desk No. to avoid delay.)

I want to know how I can get my FCC ticket in a minimum of time. Send me your FREE booklet, "How to Pass FCC License Examinations" (does not cover exams for Amateur License), as well as a sample FCC-type exam and the amazing new booklet, "Money-Making FCC License Information."

Name.....

Address.....

City..... Zone..... State.....

Paste on penny postcard or send air mail.

**From
Finest Studio
Equipment and
Servicemen's Needs
To Toughest
Military
Requirements...**

It's
Permoflux
"SOUND" IN DESIGN

Permoflux Royal Blue Line

Here's good news for every sound and serviceman! The famous Permoflux Royal Blue Line (with Alnico V magnets) is available for immediate delivery. This should be good news for your Hi-Fi customers too. So let them know about it! Remember the

Permoflux Royal Blue Line gives Big Speaker Performance—clean, brilliant, musical reproduction. Laboratory tests have proved over and over again that the Royal Blue Line Speakers produce a smooth, faultless flow of tone over an unusually large band of frequencies, up to 12,000 cycles in width. Averaged response curves show that these Speakers not only have excellent highs but also produce low frequency response, 50 cycles and lower depending on baffle, characteristic of much higher priced speakers.

For a quick sales clincher sell your replacement customers the Permoflux "Champion" Line. These top quality Speakers are available in all the popular sizes and are ideal as Radio, Television and Auto replacement Speakers. Popular sizes furnished with universal mounting brackets.

Replacements for Government Applications

Due to stepped up military requirements for Communications equipment, much of this equipment is today being de-mothballed and reconditioned by service organizations for government use. Permoflux, one of the largest speaker sources for this type of equipment makes available thru jobbers many replacement types of speakers for the above.

For further information on Permoflux Speakers send for these two attractively illustrated catalogs "Permoflux Royal Line No. J202 and Permoflux 'Sound' in Design No. J203."



PERMOFLUX
"SOUND IN DESIGN"

PERMOFLUX CORPORATION

4912-J W. GRAND AVE., CHICAGO 39, U. S. A. • 263 S. VERDUGO RD., GLENDALE 5, CALIF.

Canadian Licensee . . . Campbell Mfg. Company, Toronto, Canada

closed circuits. The FCC is withholding approval of subscription plans because "free" broadcasting has been traditional in the U. S.

ELECTRON ASTRONOMY is proposed by two French scientists to transform the 24-inch telescope of the Paris observatory to the equivalent of a 240-inch. Telescopes ordinarily catch light rays from distant stars and focus them on photographic plates. Instead of depending on the original starlight, the plan is to amplify the light's energy before it reaches the plate.

The image is first focused on a glass plate covered with an antimony and cesium compound which gives off electrons when struck by light. Electrons knocked loose by photon energy are accelerated and focused by a magnetic lens to form a new image, 100 times brighter, on a photographic plate.

Electronics in image intensification is not new; microscope images have been intensified by several similar methods in the past few years, and the method has been applied to star study. In June, 1949, RADIO-ELECTRONICS carried an article, "Television Helps Astronomy," describing such a light amplifier.

Principal disadvantage of image intensification is blurring or loss of resolution effected. New developments to offset this may be expected as research continues.

UNFILLED DEMAND for FM receivers was recently pointed up by Mr. Coy, chairman of the FCC, in an open letter to Mr. Horne of radio station WFMA. The principal barrier to faster recognition of FM's advantages is the lack of interest, he wrote:

"The approximately 700 stations now operating in the FM band is real testimony to the strength of the service, particularly when one considers that many manufacturers do not make sets and none of them has carried on continuously aggressive sales campaigns. In almost every area in the country there is an unfilled demand for FM receivers."

His statement also spiked rumors that the FCC intends to transfer part of the FM spectrum to other services: "As I have told you repeatedly, the FCC is not considering the deletion of the FM band or any part of it."

BEDROCK BOUNCE of Sonar signals told Chicago engineers how deep to put a tunnel for a new water distribution system. It replaced the lengthy and costly method of taking numerous rock borings along the proposed route.

Sonar was able to reveal the depth to the top of the mud and gravel layers just beneath the water and the depth of bedrock below the mud and gravel.

The distribution system tunnel has to go fifty feet below the top of bedrock to avoid seepage of water and mud. The survey found two hidden tunnels which will make it necessary to place the tunnel deeper than expected.

—end—

RADIO-ELECTRONICS for

the only complete catalog
for everything in Radio,
TV & Industrial Electronics

your 1952 free!
ALLIED 212-page
value-packed catalog

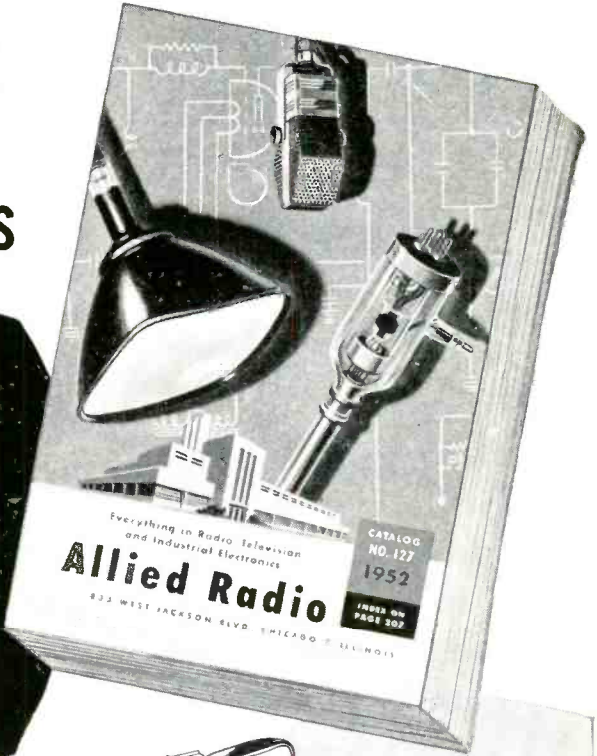

Send for it today!

Here's the *one* authoritative, complete, up-to-date Buying Guide to TV, Radio and Industrial Electronics. Make your selections from the world's largest stocks of quality equipment at lowest, money-saving prices. See the latest and most complete presentation of electronic apparatus: new TV, AM and FM receivers; High-Fidelity Custom Sound components; latest P.A. Systems and accessories; recorders; fullest selections of Amateur receivers and station gear; specialized industrial electronic equipment; test instruments; builders' kits; huge listings of parts, tubes, tools, books—the world's *most complete stocks* of quality equipment.

ALLIED gives you *every* buying advantage: speedy delivery, expert personal help, lowest prices, liberal time payment terms, assured satisfaction. Get the latest 1952 ALLIED Catalog. Keep it handy—and save time and money. Send for your FREE copy today!

the world's largest stocks

- Radio Parts Unlimited
- Test Instruments
- Television & Home Radios
- P.A. and Hi-Fi Equipment
- Amateur Station Gear
- Builders' Supplies
- Equipment for Industry

quick, expert service



ALLIED IS YOUR TV and HI-FI HEADQUARTERS
Count on ALLIED for the latest in TV! If it's made—we have it for quick delivery. We specialize, too, in High-Fidelity sound components—everything in amplifiers, speakers, tuners, phono gear and accessories. For TV or Hi-Fi—think of ALLIED!

ALLIED RADIO
the World's Largest Radio Supply House
EVERYTHING IN ELECTRONICS



free

SEND TODAY FOR RADIO'S LEADING BUYING GUIDE

ALLIED RADIO CORP., Dept. 2-K-1
833 W. Jackson Blvd., Chicago 7, Illinois

Send FREE 212-page 1952 ALLIED Catalog No. 127.

Name _____

Address _____

City _____ Zone _____ State _____

MERIT

Best for Better TV Service

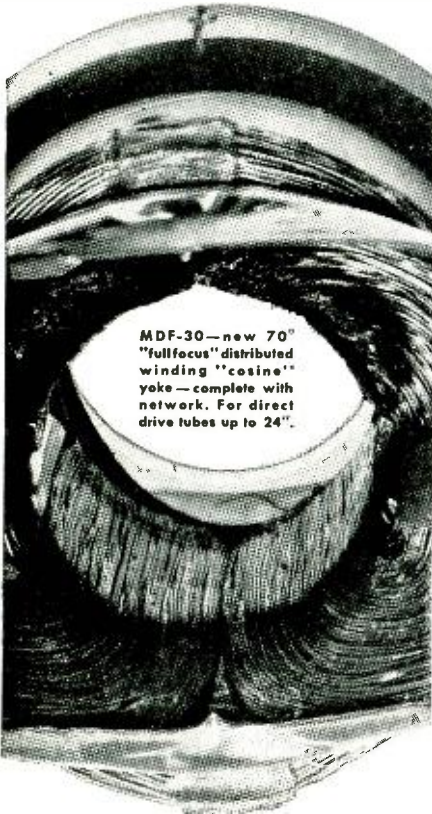

MDF-30—new 70" "fullfocus" distributed winding "cosine" yoke—complete with network. For direct drive tubes up to 24".

MeritTV full-line* Components For Conversion or Replacement

Merit... HQ for TV Service Aids

Keep ahead of TV conversion and component replacement service problems—write **MERIT, HQ for TV Service Aids.**



FREE
Sept. 1951
Issue #404

These 3 Merit extras help you:

1. Exclusive: Tapemarked © with all specifications and complete hook-up data.
2. Full technical data packed with every item.
3. Listed in Howard Sams's Photofacts.

HVO-8—air core "flyback" for direct drive systems.



*Merit is meeting the TV replacement component and conversion demand with a line as complete as our advance information warrants!
MERIT TRANSFORMER CORPORATION
4425 N. Clark St., Chicago 40, Illinois

Merchandising & Promotion

Sprague Products Co., North Adams, Mass., has designed a new transparent plastic "Slide-Pak" package for its Cera-mite disc capacitors and Bulplate



printed circuits and multiple capacitors. The slide-on cover permits easy removal of capacitors without destroying the package.

Merit Transformer Corp., Chicago, is sponsoring a new advertising-merchandising campaign, according to Bill Barron, Merit sales manager. Future advertising will concentrate on supplying complete information to the service technician. As a result of this aim, a special program called "TV Service Aids" has been developed, through which service technicians' questions on repair problems will be answered by Merit service engineers.

Littelfuse, Inc., Chicago, has published "The TV Fuse Guide" to aid in faster and easier fuse replacement. It lists

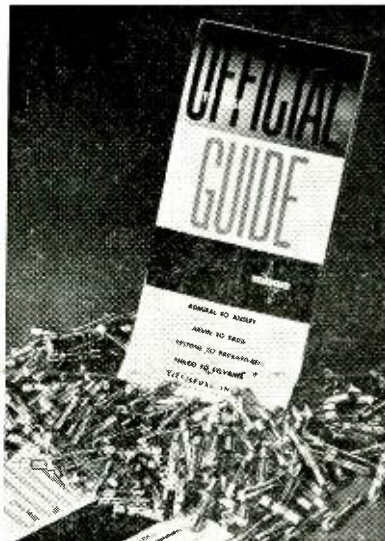

the brand name, model numbers, and corresponding fuse requirements for all makes and models. The Guide is available, free, through TV jobbers or directly from the company.

Ram Electronics Sales Co., Irvington-on-Hudson, N. Y., has begun a series of educational forums at which service technicians can obtain color TV product and conversion data.

Hickok Electrical Instrument Co., Cleveland, Ohio, issued a 4-page folder describing its new TV Videometer designed for fast and accurate testing in TV servicing.

Radio Merchandise Sales, Inc., New York City, reinstated a series of forums on the use of high-gain television antennas and open transmission line in fringe areas.

Ward Products Corp., Cleveland, has released a 4-page circular promoting its antennas as replacements for the improvement of TV pictures.

The RCA Tube Department, Harrison, N. J. has made available to parts dealers and service technicians a revised and enlarged edition of its "Television Components" book. It was previously limited to distributors, but now may be purchased from RCA distributors for twenty-five cents.

Burgess Battery Co. introduced a new counter display, the "Burgess Counter Merchant," to promote reminder sales of Burgess flashlight batteries. It is a permanent all-metal unit which puts a complete battery sales and service department right on the counter. Available through distributors.

Sylvania's Radio Tube Division is going to continue its million-dollar promotion for radio and TV service dealers; this program includes national advertising in weekly magazines, continuation of its TV show on 34 CBS



stations, point-of-sale promotional material, and direct mail material for service dealers and service technicians.

Concord Radio Corp., Chicago, has issued a free 48-page booklet, "Concert Hall Realism with High Fidelity."

Howard W. Sams & Co., Inc., Indianapolis, has published Volume II of the Television Tube Location Guide. The list price is \$2.00.

New Plants and Expansions

International Resistance Co., Philadelphia, has purchased the Hardy Instrument Co., of Forest Hills and Long Island City, N. Y., manufacturer of "Microstak" rectifiers. Future operations of the Hardy Co. will be carried on under the IRC name and transferred to the IRC Specialty Division in Philadelphia. Norman Hardy, founder of the Hardy Instrument Co., joined IRC as sales engineer.

RADIO-ELECTRONICS for

July 27, 1951

Hytron Radio & Electronics Co.
76 Lafayette Street
Salem, Mass.

Gentlemen:

We thought you would like to know just how fine we think the new Hytron "Easy Payment Plan" is. We had a set in our shop for estimation the day this plan was first introduced to us by a salesman from Ra-Tel, Inc. This set would require a new 19AP4A picture tube and some other parts and service. The total charge would amount to about \$100.00, and right then we thought we might lose the sale because our customer might not have the cash for such a repair. Then, we learned of the Hytron plan and immediately introduced it to our customer. He thought it was a wonderful plan to be able to get his set repaired without having to part with so much cash at one time. Needless to say, he accepted the job, and went away a happy satisfied customer.

We have used Hytron products for years, and have always thought them to be of the highest quality. The new rectangular picture tubes are wonderful. We feel that this new "Time Payment Plan" is another Hytron first, and will no doubt be a great asset to the serviceman as well as the customer. We recommend it highly to all.

Very truly yours,



B. W. Hodges

"HOW WE SAVED THE SALE"



B. W. Hodges,
owner of Air Park
Radio & Television,
Dallas, Texas

ANOTHER HYTRON "ASSIST" FOR YOU

Dropped a screw into an inaccessible chassis? No need to fuss. Just reach in with your Hytron-CBS Pick-Up Stick. A slight pressure of its special wax tip picks up screw pronto.

Trying to start a machine screw in a tight spot? Press head of screw into wax tip of your Pick-Up Stick. Push screw into position and start nut. As easy as that!

Use this Contest winner once and it pays for itself. Triples in brass as pencil too. Only 5¢ at your Hytron jobber. Get your Hytron-CBS Pick-Up Stick today!

STARTS SCREW
IN TIGHT SPOT

PICKS UP
SMALL PARTS

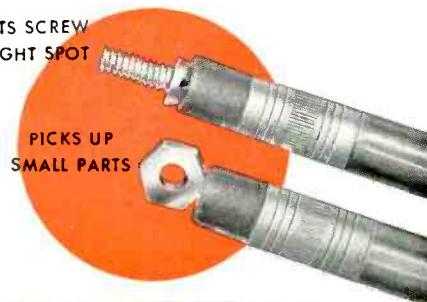

HYTRON-CBS

Pick-Up Stick 5¢ net

NINTH MEMBER OF
HYTRON SERVICE TOOL FAMILY!



MAIN OFFICE: SALEM, MASSACHUSETTS

OCTOBER, 1951



there's only ONE APPROVED POWER SUPPLY

New Low Cost "BJ" JUNIOR Save Time, Money Servicing DC Equipment

Demonstrate and test car and marine radios . . . relays, phone circuits, instruments, other low voltage devices. End costly storage battery failures with Electro's dependable filtered Power Supply. Exclusive conduction cooling doubles rectifier power rating, assures lowest cost per ampere output over other types and dissipates over 3 times the heat. Quality components withstand high overloads. 6 Volts, 1 to 12.5 amps. continuous power output.

Model "B" 6 Volt DC Power Supply 1 to 20 Amps. for Heavy Duty Applications

Convert Battery Radios to AC ALL-ELECTRIC



New Model "S" BATTERY ELIMINATOR with Selenium Rectifier

Converts any 1.4 volt, 4 to 6 tube battery radio to an efficient AC radio, plugs into a 115 volt 50/60 cycle outlet. Gives years of dependable hum-free reception at lowest cost. Guaranteed for three years.



Electro Products Labs. 4501-R Ravenswood Ave., Chicago 40, Ill.

Send literature, name of nearest source.

Name.....

Address.....

City.....State.....

IN CANADA: ATLAS RADIO CORP. LTD., TORONTO

Sarkes Tarzian, Inc., announced that its plant in Hawthorne, N. J., is now devoted to development and research work on all types of tubes. The production of picture tubes, formerly carried on at Hawthorne, will be concentrated in the company's Batavia, Ill., plant which has been recently expanded to double production.

National Union Radio Corp., Orange, N. J., has purchased a 45-acre tract in Philadelphia on which it plans to erect a \$1,500,000 tube manufacturing plant which is scheduled to be in operation by next spring.

Aero Products Co., manufacturer of transformers, moved its administrative and production divisions to 369 Shurs Lane, Roxborough, Phila.

Belmont Radio Corp., Chicago, manufacturer of Raytheon television sets, acquired a new 40,000-square-foot plant (its fourth), in Chicago's Northwest side. It will be devoted exclusively to research, engineering, and pilot production.

Sylvania Electric Products, Inc. organized a subsidiary, Sylvania Electric of Puerto Rico, Inc., to fabricate mica for radio tubes. The new company will be located in a 10,000-square-foot plant in Rio Piedras, a suburb of San Juan, Puerto Rico. Raymond R. Chapman, associated with the company's Parts Division for the past 17 years, will manage the new plant.

General Electric formed an Application Engineering Section within its Government Sales Department in Syracuse, N. Y. The new department, under the direction of J. W. Nelson, Jr., former sales manager for Air Force equipment, will assist the armed services in the use of present electronic equipment and the possible applications of and location for new electronic devices.

Business Briefs

. . . Allen B. Du Mont Laboratories, Inc., Cathode-Ray Tube Division, and Thomas Electronics, Inc., now give a replacement warranty for their TV picture tubes for six months from the date of installation in the user's set.

. . . La Pointe-Plascomold Corp., Windsor Locks, Conn., manufacturer of Vee-D-X TV antennas and boosters, entered the aircraft industry through the purchase of the Sculli Machine Co., East Hartford, Conn.

. . . Western Union Services, Inc., the new TV installation and servicing subsidiary of Western Union, expanded its servicing functions to include all standard television receivers. It also extended its territory to include two additional New Jersey counties. Previously the company limited its services to Du Mont receivers in three New Jersey counties.

. . . Brach Manufacturing Corp., Newark, N. J., completed arrangements for the assignment of a patent for u.h.f. master antenna systems designed by William J. Jones, microwave authority.

—end—

INDISPENSABLE! PHOTOFAC BOOKS



Photofac Television Course. Covers TV principles, operation and practice. 216 pages; profusely illustrated; 8½ x 11". Order **TV-1**. Only **\$3.00**

Television Antenna. New 2nd edition. Describes all TV antenna types; tells how to select, install, solve troubles. Saves time; helps you earn more. 200 pages; illustrated. Order **TAG-1**. Only **\$2.00**

Television Tube Location Guide. Volume 2. Accurate diagrams show position and function of all tubes in hundreds of TV sets; helps you diagnose trouble without removing chassis. 224 pages; pocket-size. Order **TGL-2**. Only **\$2.00**

Television Tube Location Guide. Vol. 1. Over 200 pages of TV receiver tube position diagrams on hundreds of models. Order **TGL-1**. Only **\$1.50**

1949-1950 Record Changer Manual. Vol. 3. Covers 44 models made in 1949, including multi-speed changers and wire and tape recorders. Original data based on actual analysis of equipment. 286 pages; 8½ x 11"; paper-bound. Order **CM-3**. Only **\$3.00**

1948-1949 Changer Manual. Vol. 2. Covers 45 models made in 1948-49. Paper bound. Order **CM-2**. Only **\$4.95**

1947-1948 Changer Manual. Vol. 1. Covers 40 post-war models up to 1948. Order **CM-1**. Only **\$3.95**

Recording & Reproduction of Sound. A complete authoritative treatment of all phases of recording and amplification. 6 x 9". Order **RR-1**. Only **\$5.00**



Audio Amplifiers. Vol. 3. Clear, uniform, accurate data on 50 important audio amplifiers, plus full coverage of 22 FM and AM tuners, produced during 1950. 362 pages, 8½ x 11". Order **AA-3**. Only **\$3.95**

Audio Amplifiers. Vol. 2. A complete analysis of 104 well-known audio amplifiers and 12 tuners made 1949-50. 368 pages, 8½ x 11". Order **AA-2**. Only **\$3.95**

Audio Amplifiers. Vol. 1. Covers 102 amplifiers and FM tuners made through 1948. 352 pages. Order **AA-1**. Only **\$3.95**

Auto Radio Manual. Complete service data on more than 100 post-war auto radio models. Covers over 24 mfrs. 350 pages, 8½ x 11". Order **AR-1**. Only **\$4.95**

Communications Receiver Manual. Complete analysis of 50 popular communications models. 246 pages, 8½ x 11". Order **CR-1**. Only **\$3.00**

Radio Receiver Tube Placement Guide. Accurate diagrams show where to replace each tube in 5500 radio models, covering 1938-1947 receivers. 192 pages, pocket-size. Order **TP-1**. Only **\$1.25**

Dial Cord Stringing Guide. Vol. 2. Covers receivers made from 1947 through 1949. Shows you the one right way to string a dial cord in thousands of models. Pocket-size. Order **DC-2**. Only **\$1.00**

Dial Cord Guide. Vol. 1. Covers sets produced 1938 through 1946. Order **DC-1**. Only **\$1.00**

Making Money in TV Servicing. Tested proved methods of operating a profitable TV service business. Covers all important phases. Authoritative, valuable guide to success. Over 130 pages. Order **MM-1**. Only **\$1.25**

Order from your Parts Jobber or write direct to HOWARD W. SAMS & CO., INC., 2201 E. 46th St., Indianapolis 5, Indiana

HOWARD W. SAMS & CO., INC.

RADIO-ELECTRONICS for

130,000 qualified TV servicemen needed

Here is how you can be one of them

INDUSTRY EXPERTS HAVE ESTIMATED over 130,000 qualified TV technicians will be needed for the installation, trouble-shooting and repairing of the television receivers in use by 1955.

There are far fewer than 50,000 fully trained TV technicians available today. This means more jobs, unrivaled future for security, greater earning power for thousands and thousands of additional TRAINED and EXPERIENCED TV Servicemen. Will you be one of them?

OUTSTANDING FUTURE FOR QUALIFIED TV SERVICEMEN

Men now in radio servicing as well as men in the radio-electronics industry with no experience in TV servicing . . . here is your opportunity. The RCA Institutes Home Study Course in Television Servicing makes it possible for you to convert your skill in radio servicing, or interest in radio-electronics, to the important money-making field of TV servicing.

The RCA Institutes Course gives you a sound knowledge of television fundamentals . . . intensive practical instruction in the proper maintenance and servicing of complex TV receiver circuits—including color TV and UHF . . . teaches you the "short cuts" on TV installation and trouble-shooting, saving you many hours of on-the-job labor.

TRAINING MEETS MODERN REQUIREMENTS

This course is in step with the progress of the television industry. It is backed by RCA—pioneer in television development. It is based on the actual experience of the RCA Service Company in servicing thousands of home television receivers. The

course is constantly being revised, improved and kept up-to-the-minute. It will help you to a more profitable and productive future in these ways:

PREPARE YOU to take the required technical examination with confidence, in those areas that require a license or permit to engage in TV servicing.

TRAIN YOU, if you are a serviceman in a non-TV area, to become a qualified TV technician by the time TV comes to your area. In TV areas, TV servicing has substantially replaced radio servicing as the chief source of income.

IF YOU ARE A QUALIFIED TV SERVICEMAN, it will keep you in step with the latest industry developments including color TV and UHF.

IT DEVELOPS the latent talents of installers into skilled trouble-shooting TV technicians.

TRAINS MEN in radio-electronics with no previous servicing experience to fill jobs as TV technicians, to win promotions and better pay.

RCA INSTITUTES HOME STUDY COURSE PLANNED TO YOUR NEEDS

You keep your present job in radio—television—electronics. In your spare time, you study at home. You learn "How-to-do-it" techniques with "How-it-works" information in easy-to-study lessons prepared in ten units. Cost of RCA Home Study Course in Television Servicing has been cut to a minimum—as a service to the industry. You pay for the course on a "pay-as-you-learn" unit lesson basis. You receive an RCA Institutes certificate upon completion of the course. The RCA Institutes Home Study Course in Television Servicing is approved by leading servicemen's associations.

RCA Institutes conducts a resident school in New York City offering day and evening courses in Radio and TV Servicing, Radio Code and Radio Operating, Radio Broadcasting, Advanced Technology. Write for free catalog on resident courses.



RCA INSTITUTES, INC.
A SERVICE OF RADIO CORPORATION OF AMERICA
350 WEST FOURTH STREET, NEW YORK 14, N.Y.

OCTOBER, 1951

Send for FREE BOOKLET

Mail the coupon—today. Get complete information on the RCA INSTITUTES Home Study Course in Television Servicing. Booklet gives you a general outline of the course by units. See how this practical home study course trains you quickly, easily. Mail coupon in envelope or paste on postal card.



MAIL COUPON NOW!

RCA INSTITUTES, INC.
Home Study Department, RE-1051
350 West Fourth Street, New York 14, N.Y.

Without obligation on my part, please send me copy of booklet "RCA INSTITUTES Home Study Course in TELEVISION SERVICING." (No salesman will call.)

Name _____ (Please Print)
Address _____
City _____ Zone _____ State _____



You Can't Miss

with these

TV PROFIT MAKERS

The perfect Rotator-Booster combination!



ALLIANCE TENNA-ROTOR is in a class by itself! No other TV accessory sold to the consumer can equal Tenna-Rotor in volume of sales, public acceptance or in proved performance in the field! More than 600,000 are in use! The new deluxe Model HIR (illustrated above) is fully automatic.

ALLIANCE TENNA-SCOPE is a Booster with one simple control. Gives maximum, uniform high gain on all channels—is instantly installed and makes an ideal companion item to Tenna-Rotor. Incidentally, Tenna-Scope, like Tenna-Rotor, is a favorite everywhere!

NATIONAL TELEVISION AND NEWSPAPER ADVERTISING PRE-SELLS! For more than two years, Tenna-Rotor has been backed by a powerful, continuous TV campaign in every major TV area. Hundreds of thousands of future customers see the eye-compelling Alliance TV spots right in their own homes. That's why Tenna-Rotor and Tenna-Scope offer an unbeatable team of profit makers. Preference for them is already established.

ALLIANCE MANUFACTURING COMPANY • Alliance, Ohio

RADIO-ELECTRONICS for



2-YEAR ALL-WEATHER TESTS

Show G-E Speakers Unsurpassed for Long-Life!

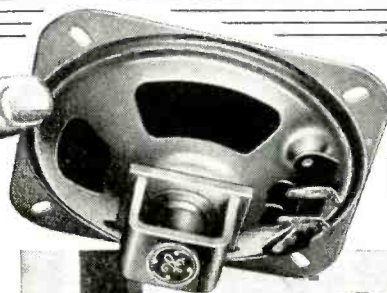

Twenty-seven sizes to choose from... and they're all G-E!

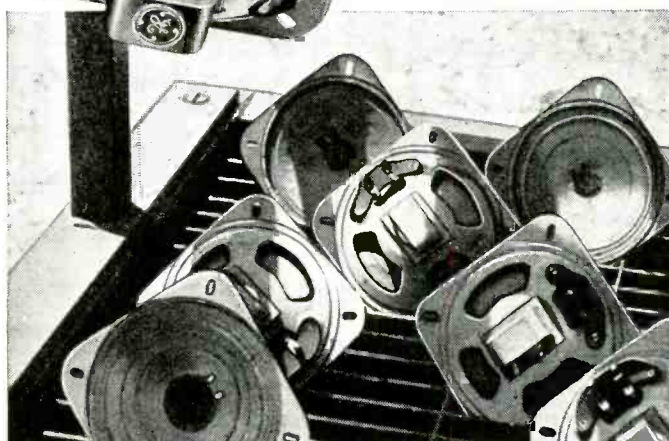

▲ **Unretouched photo** shows only slight tarnish on speakers. Special G-E plating gives excellent protection to steel frames, none of which were corroded after grueling tests.

★ After two years exposure to hot sun, rain, sleet and snow — with no shelter whatever in any season — 7 out of 8 General Electric speakers played well enough to perform in your radio set!

These recent tests at Electronics Park subjected the speakers to many times the abuse they would receive under years of actual playing conditions, indoors or out. It boils down to one more dramatic proof of this fact: *You can depend on General Electric quality — in design, in engineering, in construction.*

Your customers are entitled to this quality. How are your stocks of General Electric speakers?

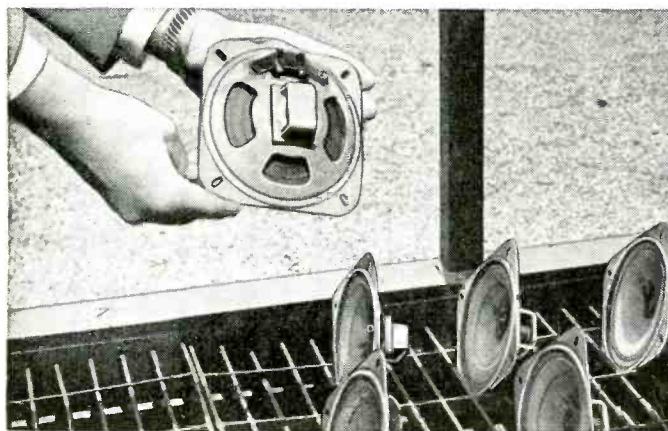

◀ **Racked on exposure tray**, speakers were checked at intervals for 2 years, then taken apart and examined for wear. Outdoor-type cones were warped only slightly, G-E aluminum voice coils were like new.

**STYLUS and
CARTRIDGE
REPLACEMENT
GUIDE**

General Electric Co., Section 45101
Electronics Park, Syracuse, N. Y.

Yes — send me latest speaker information plus new booklet on G-E Stylus and Cartridges.

NAME _____

ADDRESS _____

CITY _____ STATE _____

You can put your confidence in—

GENERAL  **ELECTRIC**

EICO
TEST INSTRUMENTS

Guard

CBS-Columbia Inc.
COLOR TELEVISION PRODUCTION QUALITY

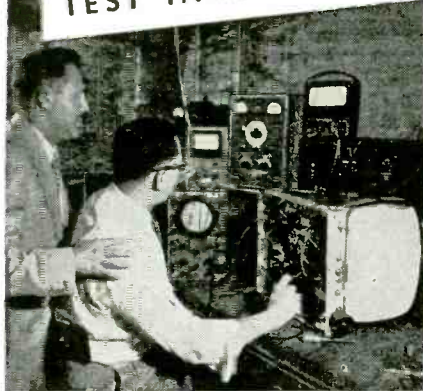

In the CBS-Columbia design laboratories, Al Goldberg takes some important readings with the EICO Model 221 Vacuum Tube Voltmeter and Model 555 Multimeter, as Harry R. Ashley looks on.



Mr. Al Goldberg, Assistant Chief Engineer of CBS-Columbia, and Harry R. Ashley, President of EICO, inspecting the use of the EICO Model 221 Vacuum Tube Voltmeter and Model HVP-1 High Voltage Probe at the Sweep Frequency Troubleshooting Position on the CBS-Columbia Color Television production lines.

KITS
WIRED INSTRUMENTS



NEW 555K MULTIMETER KIT \$29.95 WIRED \$34.95
20,000 ohms/volt



320K SIG. GEN. KIT \$19.95 WIRED \$29.95

NEW 322K SIG. GEN. KIT \$23.95 WIRED \$34.95

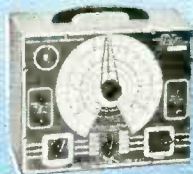

NEW 950K R-C BRIDGE & R-C COMP. KIT \$19.95 WIRED \$29.95



NEW 1040K BATTERY ELIM. KIT \$25.95 WIRED \$34.95



511K VOM KIT \$14.95 WIRED \$17.95



NEW 526K MULTIMETER KIT \$13.95 WIRED \$16.95
1000 ohms/volt



NEW 1171K RES. DECADE BOX KIT \$19.95 WIRED \$24.95



NEW 315K DELUXE SIG. GEN. KIT \$39.95 WIRED \$59.95



145K SIG. TRACER KIT \$19.95 WIRED \$28.95



NEW 625K TUBE TESTER KIT \$34.95 WIRED \$49.95



360K SWEEP GEN. KIT \$34.95 WIRED \$49.95

For Laboratory Precision at Lowest Cost—the Leaders Look to EICO!

WHY does CBS-Columbia, Inc., today's headline-maker in Color Television set production, use EICO Test Instruments on its new Color Television production lines and in its design laboratories?

BECAUSE — like Emerson, Tele-King, Teletone, and many another famous TV manufacturer coast to coast, CBS-Columbia knows that ...

Only EICO Test Equipment delivers All 10 EICO nomical Features!

1. Laboratory Precision
2. Lowest Cost
3. Lifetime Dependability
4. Speedy Operation
5. Rugged Construction
6. Quality Components
7. Latest Engineering
8. Super-Simplified Assembly and Use Instructions
9. Laboratory-Styled Appearance
10. Exclusive EICO Make-Good Guarantee

Before You buy any higher-priced equipment, be sure You look at the EICO line—in *Wired* as well as *Kit form*! Each EICO product is jam-packed with unbelievable value. YOU be the judge—compare, see EICO instruments today — in stock at your local jobber — and SAVE! Write NOW for FREE newest Catalog 10-C.

FOLLOW THE LEADERS... INSIST ON EICO!



NEW 221K VTVM KIT \$25.95 WIRED \$49.95



HIGH VOLTAGE PROBE \$6.95

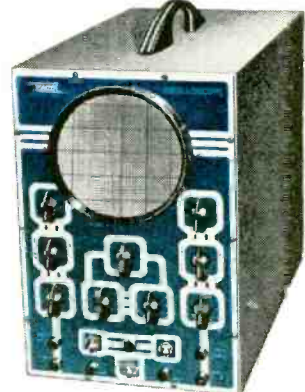

NEW 425K 5\"/>

©1953, Electronic Instrument Co., Inc.

Prices 5% higher on West Coast. Due to unstable conditions, prices and specifications are subject to change without notice.

EICO

ELECTRONIC INSTRUMENT CO., Inc.
276 NEWPORT STREET, BROOKLYN 12, NEW YORK.

RADIO-ELECTRONICS for

Service Technicians' Evolution

... *The service technician evolves slowly and painfully* ...

By HUGO GERNSBACH

THE radio and television service technician, like any other professional, is not born fully equipped. It takes long years of study and practice before he finally takes his place in the community as a full-fledged technician.

True, there are exceptions. Some highly-gifted men who have a sixth "techno" sense are mentally so highly organized that once they take up radio servicing they have become competent technicians in a few months. Like all people of the gifted, or genius type, they are uncommonly rare. Therefore we need not consider this special class in our present discussion.

How does one become a radio and television service technician? He may be taught by another technician, or he may be self-taught. In either case, he may have had theoretical training with a resident or correspondence school, or he may have learned his own theory with little or no outside help. It would be hard to say which of the two is the larger class, as there are no reliable statistics.

The service technician who is taught by another, proficient in the art, perhaps takes the easier course. His instructor can warn him of the various pitfalls, correct him, encourage him as he goes along, and by setting an example show him how to avoid the commoner beginners' mistakes.

The self-instructed technician must learn the hard way, by trial and error. There is one school which maintains that the self-taught technician is the better because he learns by hard experience, usually expensive to him. The lessons are also better remembered than if one tries to learn by someone else's experiences.

It is known that a very large group of radio technicians started out as radio experimenters or hobbyists—often very young. Experience gained in this manner is usually *never* forgotten. The young man, in his thirst for knowledge, accumulates a great deal of valuable experience, and whether he becomes a service technician, an engineer, or a physicist, he looks back on his early experience as an experimenter as his most valued period of training.

What really makes a *good* service technician? This is a complex question, but we shall try and answer it for the benefit of those who really aspire toward this goal.

First he must have a great deal of varied radio experience. This may sound trite. Nevertheless it is an important factor in the evolution of a first class service technician. But experience alone does not suffice if other qualities are missing. To be successful, a service technician must not only have a deep insight into all phases of his work but he must well-nigh know *all* about it, not only how it works, but *why* it works that way. He must know radio from the ground up and he certainly should be a good mechanic as well. He must know electrical theory

and know all the vagaries of the electric current. *Book knowledge and circuitry are of paramount importance.* Without these, no service technician will get very far nowadays.

More important than all of these is the service technician's "horse sense" plus intuition as applied to the mechanics of the radio or television set. These qualities are gained only by actual long experience in working with receivers. Some service technicians labor long and painfully to locate a certain failure in a receiver. Others guess the fault almost by intuition in a minimum of time.

These are all personal characteristics of various technicians. It is quite true that rarely will two men work the same way and tackle the same problem in the identical manner.

It must also be evident that the fast technician will nearly always be more successful economically than the slow-thinking one who has little or no intuition.

All of this presupposes that the modern successful service technician must know the ins and outs of his test instruments, analyzers, etc., because without these he will find the going exceedingly tough. Indeed, the screw-driver-and-plier technician is now a mere figure in radio history. The high complexity of the new receivers (particularly television sets) does not permit servicing without up-to-date test instruments. While it is true that once in a while a good technician, just by looking at a set that does not work properly, will guess the fault by intuition, this is decidedly not true for such other failures as intermittents, misalignments, delaying heat effects—which, after the set has been operating for several hours causes misfunction—and many others the reader can name immediately.

But even the world's best service technician will still be a complete failure if his public relations conduct is mediocre or bad. Today, with rising competition, the technician who can sell himself to his public is often successful, even if he may not be tops from a technical viewpoint.

We have often stressed this last point and will keep on stressing it because—as far as the public is concerned—the pleasant, courteous, neat-appearing, and honest-in-his dealings technician will *always* be tops. He must also keep his word. If he promises a repair set within a certain time that *promise must be kept* if the public is to continue having confidence in him.

Incidentally, it is these service technicians who are the successful ones, the ones who make money, the ones who will keep on being successful as the years roll on.

—end—



TELEVISION SERVICE ON WHEELS

By
GUY SLAUGHTER

A close-up view of the service position
in the rolling television service shop.

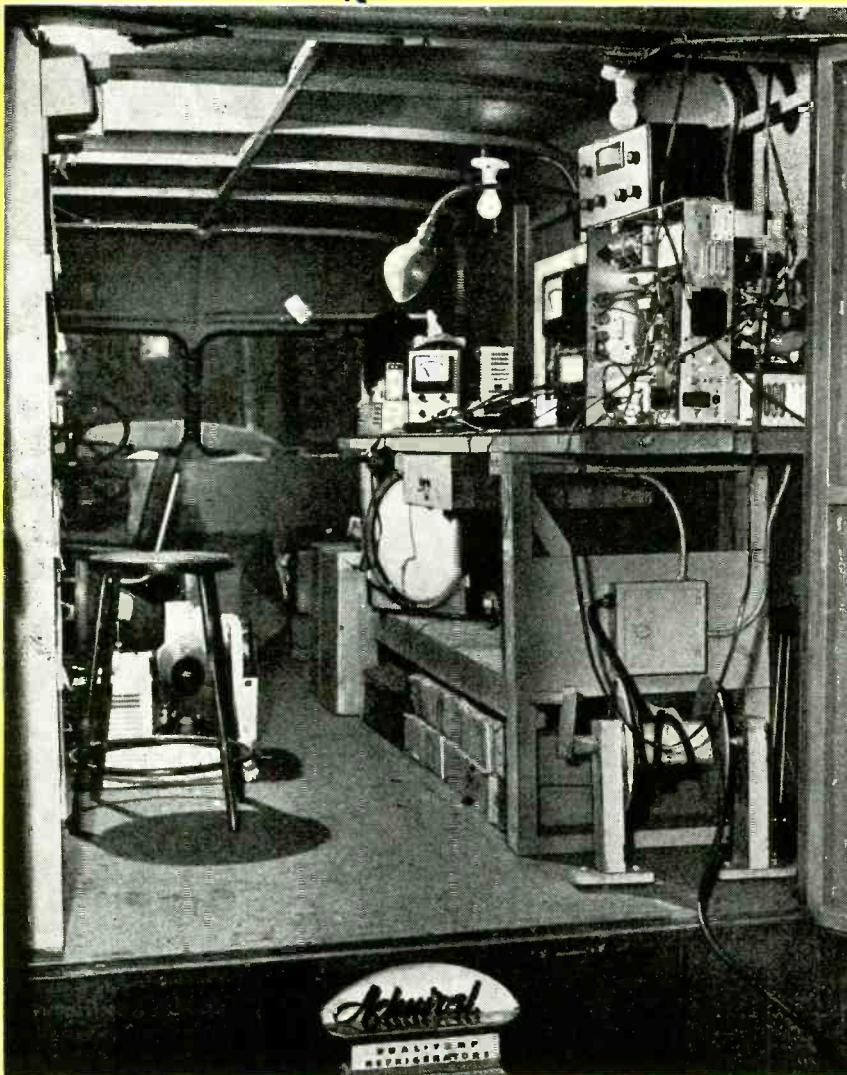

EVERY serious TV service technician has dreamed of owning a service lab on wheels. A Chicago organization, Appliance Distributors Inc., has made that dream a reality by installing complete repair facilities in each of three panel trucks, thus putting rolling laboratories on the road for door-to-door service.

Each of these TMU or Tele-Mobile Units is as well-equipped as most small shops. Bolted-down benches have: a Genescope; two multimeters (one v.t.v.m. and one 20,000-ohms-per-volt unit); a scope; a complete kit of hand tools; and a large assortment of parts and tubes likely to be needed in the field. The more fragile equipment is permanently fastened to the bench and is cushioned with foam rubber pads that provide adequate shock-protection. To date none of the equipment has been laid up because of shock damage.

Each TVehicle carries a length of cable which can be plugged into any convenient outlet to supply power to the bench. When the driver-technician arrives on the scene of a TV casualty he parks in front of the house, pulls the chassis, carries it to the bench, unreefs the power cable, and plugs it into the set-owner's house circuit. In case the repair job is to be done for an apartment-house cliff-dweller whose landlord frowns on donating the necessary kilowatts, the driver rolls his truck on to the nearest filling station, parks, and plugs in there. After chassis-surgery is completed, the TMU operator drives back to the apartment and reinstalls the set, time lost in transit being negligible.

Most of Chicago is in a high-signal area, so simple, indoor-type dipoles provide all the antenna normally required. In some cases, however, signal can be piped into the truck by clipping extension leads to the set-owner's antenna lead-in.

How TMU developed

TMU developed as a result of Appliance Distributors' city-wide TV servicing operation problems. During early stages of TV growth in Chicago, the organization was able to maintain adequate service, with multimeter-and-hand-tool-equipped technicians covering the city by auto. Only one in ten chassis had to be pulled, so each service technician was able to return the "pull" jobs to the home shop where bench men worked them over in time to be delivered and reinstalled in the customer's home a day or two later. Though the average number of sets pulled for bench service remained at the 10% mark, which seems to be an industry-wide figure, the total number of sets brought into the home shop began to hit the saturation point for the shop's facilities. The added confusion of a throng of technicians checking in each morning, drawing the day's call sheets and stocks of tubes and parts, as well as reporting back again each evening with reports, invoices, and pulled chassis was too much to handle.

RADIO-ELECTRONICS for

Also, Chicago is a sprawled-out, traffic-heavy metropolis, so sometimes a technician on a cross-town call spent more time driving than actually working. To solve these difficulties the TMU system was conceived.

Zoning the city

The city was divided into zones, and each zone was assigned a crew of *automobile-based* technicians plus a TMU. The truck was given a rendezvous point to which it returned after completing a call; usually this rendezvous was a gasoline station near the center of the zone. Service calls were accepted and classified at the special telephone switchboard located in the home shop building, dispatched by messenger to the rendezvous point, and passed out to the car-based technicians from there.

The car boys went out on their calls as usual, completed the 90 percent that didn't require chassis pulling, and notified the TMU of the 10 percent that did. The truck operator answered these calls, pulled and repaired the chassis, reinstalled them, and beat it back to the rendezvous to await his next call. The system worked admirably for a while, the only problem being the occasional intermittent chassis that required an unreasonable amount of time to repair as well as a long check period to make sure the trouble was cured. These intermits and the inevitable "dogs" that cropped up from time to time, were not ordinarily worked on in the field but were returned to the home shop for service.

But came the time when even this system got jammed up by the tremendous volume of service calls, and variations had to be worked out on the original plan. These variations have more or less resolved themselves into what might be called the "TMU Zone-Depot System."

TMU zone-depot system

Under this system, which handles upwards of 500 TV service calls (mostly on a service contract basis) per day in and around Chicago, the zone system is still in effect, and each zone has a depot or home base near the center of the zone, in addition to its crew of about 20 auto-based technicians and its TMU. This depot, either a small building or a partitioned-off section of a bigger one, has a supervisor and, in the case of one particularly large depot, a manager.

A messenger brings the day's service call sheets and stocks of parts and tubes. The supervisor, first thing each morning, assigns call sheets to the technicians, and issues each man his daily stock of components. The auto boys then take off on their calls. Each man is given only those calls from his own particular neighborhood, and is expected to handle at least eight to ten calls per working day. From the total of around 200 daily calls per depot-zone, some 20 will involve chassis pulls. The TMU will handle about half

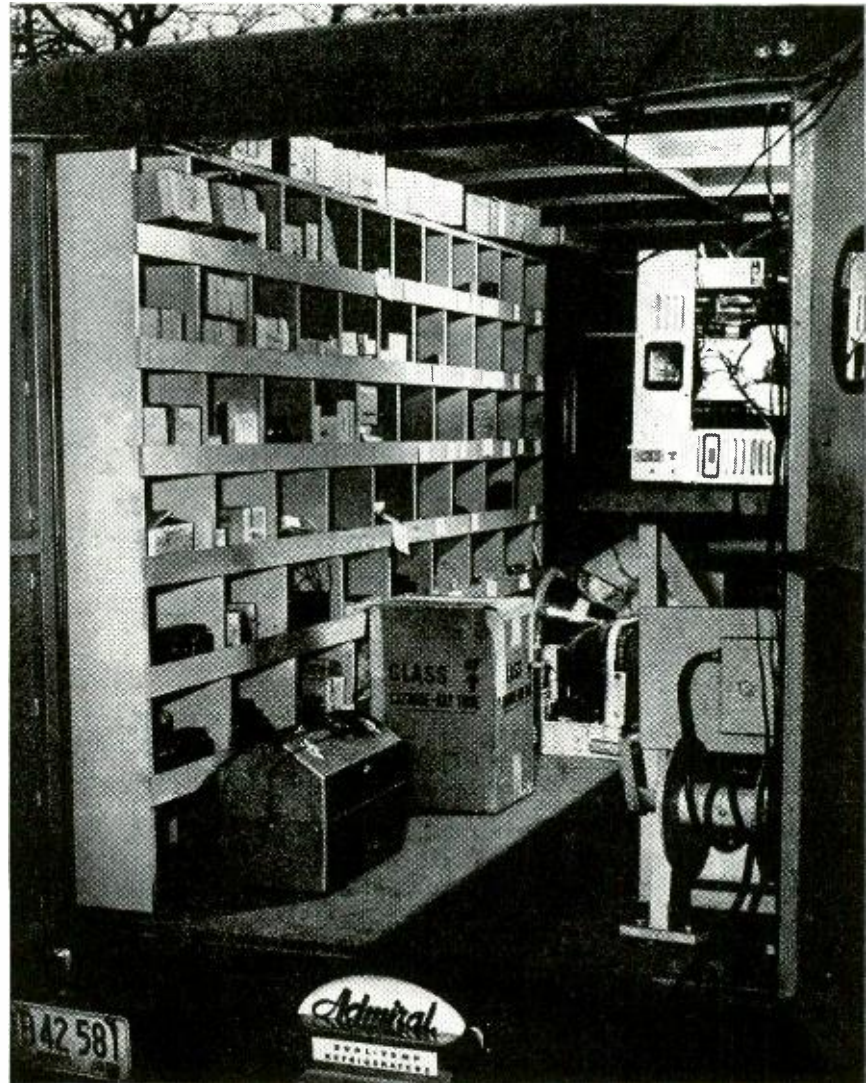

The mobile unit pulls chassis and repairs them on spot. Parts storage bins are shown at left, bench at right, and power cable reel at lower right of photo.

of these, and the remainder, intermits or "dogs" will be returned to the depot for proper servicing and bench checking there.

The depot is manned by the supervisor, his assistant, and one to four bench men, depending on the run of calls in that particular zone; floating bench men may be assigned to one depot for a few days to help catch up on a heavy volume of work, then transferred to another depot. The supervisor, in addition to his stints at the bench and his daily paper work, is also assigned certain house calls by the home office, usually those which involve an unhappy customer who requires soothing; the assistant supervisor, too, is pressed into this service on occasion.

The home shop, relieved of pressure, is able to function smoothly and do all non-TV servicing. Neither TMU, auto-based men, nor depot men will ordinarily handle radio or record-changer repairs. The theory is that the consumer will gladly wait a week or so for another appliance to be repaired if he knows his TV set will be fixed within two days; and under the TMU zone-depot plan,

one- and two-day service is the norm on all chassis-pull jobs except intermits. The home shop also handles large-screen-conversion jobs in quantity, and thus realizes an additional profit that couldn't be gone after if its facilities were completely tied up with straight service work.

While the home shop uses tube testers, the TMU's and the depots have no such equipment. Tube substitution is quicker and leads to fewer call-backs; if a tube is even suspected it is replaced with a new one. This policy has paid off and will be continued so long as tube shortages don't prohibit such practice.

The TMU system is making large-scale TV servicing operations efficient and profitable, and shows signs of catching on in other parts of the country with other service organizations. The next stage of the TV industry's development may make these mobile labs commonplace, with every TV dealer running one or more units, perhaps radio-despatched. And for now, TV curb service is already a reality, at least in Chicago.

—end—

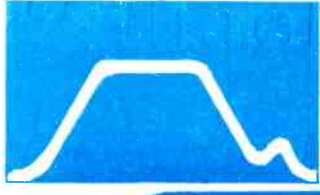

Intercarrier Buzz

By MARVIN H. KRONENBERG

THE sync buzz problem inherent in the intercarrier sound system is becoming more evident since more manufacturers are incorporating this circuit in their sets. It has always been recognized that use of intercarrier made it more difficult to provide "clean" sound. Circuits are being improved, but in the meantime service technicians face the problem of coping with annoying buzz.

No unusual circuits or circuit changes are necessary to minimize sync buzz. It is necessary first to classify the basic intercarrier circuits and find out how the trouble is caused.

In an intercarrier receiver, both the sound and picture carrier are amplified and applied to the video detector (see Fig. 1). This differs from usual TV receiver design in which the sound carrier is rejected by traps in the video i.f. so that there is no sound interfer-

ence to the picture. The intercarrier circuit requires that a definite ratio between picture carrier amplification and sound carrier amplification be maintained (Fig. 2). The reason for this is that picture carrier must not cause interference in the sound and the sound must not affect the picture. If the sound carrier is weak compared to the video carrier, variations in amplitude which normally occur on the video carrier will not appear when the two carriers beat together to form the 4.5-mc component used for sound reception in the TV receiver.

In analyzing the output of the video detector in an intercarrier receiver, two major frequency groups are found. First, the video signal obtained by detection of the video carrier; second, a 4.5-mc component which is the difference frequency between the sound and picture carriers. This 4.5-mc compon-

ent will be substantially free of amplitude modulation because of the high-ratio picture-to-sound carrier but will be frequency-modulated the same way as the sound carrier.

Sound detection

In current designs there are two places where the 4.5-mc sound component is selected for detection. Figs. 3 and 4 show these to be either at the video detector or the video amplifier. The takeoff circuits shown are those most generally used. In the earlier low-cost intercarrier receivers, 4.5-mc sound was usually taken off at the plate of the video amplifier, Fig. 3. This circuit is advantageous since the video amplifier has appreciable gain at 4.5-mc and therefore more 4.5-mc output is available compared to the takeoff point at video detector, Fig. 4. But the sync buzz in the sound is more difficult to eliminate when the 4.5-mc is taken off the plate circuit of the video amplifier.

Sync buzz in the sound of an intercarrier receiver is inherent in the system. The 4.5-mc component (result of a beat between the sound and picture carrier) is subject to amplitude variations even though a high picture-to-sound-carrier ratio is maintained. Even though the receiver is properly designed, local conditions may cause a very strong sound carrier and a weak picture carrier to be received on one or more channels. On these stations picture-to-sound-carrier ratio may be too small and the 4.5-mc component will be more subject to AM always present on the picture carrier.

In present TV broadcast practices the video transmitter signal (normally maximum during transmission of the sync pulse) instantaneously reaches nearly zero during white portions of the picture. This means that the transmitter is nearly 100% modulated, and when this occurs the 4.5-mc sound component, which depends for its existence on

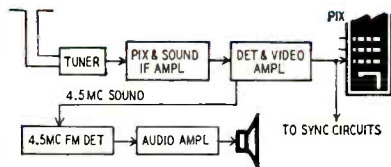

Fig. 1—Intercarrier receiver; sound and picture carriers are amplified.

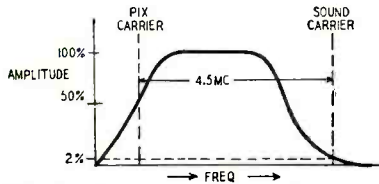

Fig. 2—Response curve of intercarrier receiver. Note position of two carriers which must not affect one another.

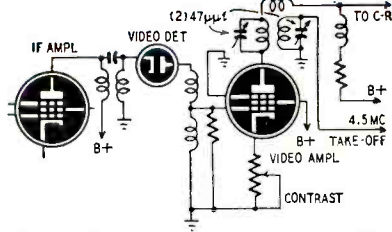

Fig. 3—The intercarrier circuit with sound takeoff at video amplifier.

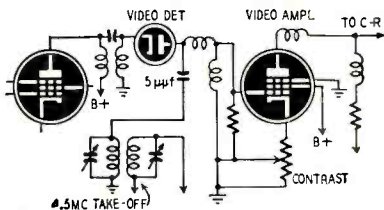

Fig. 4—Sound takeoff at video detector. There is less sync buzz here.

the picture (and sound) carrier, will vary in amplitude.

If the transmitter is 100% modulated there may be times when the 4.5-mc signal actually disappears. When this occurs at a rate coinciding with the transmission of the picture frames, a 60 c.p.s. buzz will appear in the sound output. Under severe conditions, where excessive modulation occurs and where the picture carrier is weak due to local conditions, receiver misalignment, etc., no amount of limiting action in the receiver will restore the holes in the 4.5-mc signal. However, this extreme is seldom realized, and more often it is possible to minimize if not entirely eliminate this troublesome buzz.

Thus the problem is mainly one of correct receiver alignment, and proper circuit design. Let us consider how the intercarrier circuits may be improved to give better rejection of amplitude variations on the 4.5-mc sound signal.

Adjustment procedure

Since the TV signal is ordinarily modulated about 85% the receiver must first be correctly aligned for proper picture-carrier-to-sound-carrier ratio. No distortion should be introduced which may increase the apparent modulation percentage of the video carrier.

Assuming these conditions, the first danger point to be considered in receivers that take 4.5-mc at the video-amplifier plate is the video amplifier. The polarity of the sync signal is usually negative at the grid of the video output stage. (This type of circuit can be recognized because video output is fed to the cathode of the picture tube). With normal contrast the set is adjusted so the tips of the sync pulses cause the video amplifier to almost reach cutoff. Turning the contrast control up too high or an extremely strong signal may cause the video amplifier cutoff, thus momentarily cutting off the 4.5-mc component in the plate circuit. This will produce a buzz in the sound system and no amount of limiting action will take it out.

Another source of trouble is an a.g.c. system which allows too strong a signal to be applied to the last i.f. stage or video amplifier. The overload condition increases the degree of picture-carrier modulation, thus placing a greater burden on the limiting circuits.

Inadequate rejection of amplitude modulation in the 4.5-mc sound circuits may also cause considerable buzz. A ratio detector (the most commonly used FM detection circuit in TV receivers) will not help in rejecting AM unless it is properly adjusted. Additional gain in the 4.5-mc driver stages will help considerably in improving the AM rejection properties of the 4.5-mc sound system and thereby increase receiver immunity to sync buzz.

Sync buzz usually results from a combination of these causes and the receiver therefore must be checked thoroughly before taking any steps to eliminate the buzz.

The more common symptoms and their most probable causes are:

(a) Severe buzz on most stations when contrast control is turned on full. Usually this is a result of overloaded video amplifier when sound is taken off video amplifier.

(b) Buzz on some channels and others clean. Some stations modulate more

put. If the ratio detector is correctly adjusted there will be no trouble. The ratio detector driver tube is also often used as a limiter.

To properly determine the performance of the 4.5-mc sound system, a signal generator capable of simultaneous frequency and amplitude modulation is required. A less accurate but satisfac-

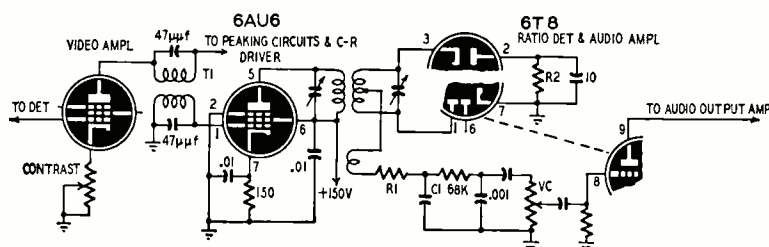

Fig. 5—Typical intercarrier sound circuit; the 6AU6 acts as straight amplifier.

heavily than others, particularly when sending test pattern; local conditions may cause some stations to be received with very strong sound carrier and weak picture carrier.

(c) Buzz occurs only at certain positions of fine tuning control. May be due to excessive tuning range of receiver or misalignment.

(d) Buzz occasionally during program or on certain types of stationary patterns. Usually indicates picture video harmonics getting into sound system. For example, a 2.25-mc video component may generate harmonics at 4.5-mc

tory means of testing would be with an on-the-air station.

Circuit changes

Fig. 6 is a modified version of Fig. 5, to improve rejection of unwanted AM components. Changes are:

1. Convert driver from linear amplifier to limiter by addition of R_g and C_g , ground the cathode, and reduce screen voltage to about 30.

2. Replace coupling transformer (T1) with capacitive coupling from video amplifier plate to secondary winding as in Fig. 6. (Short-circuit primary). This

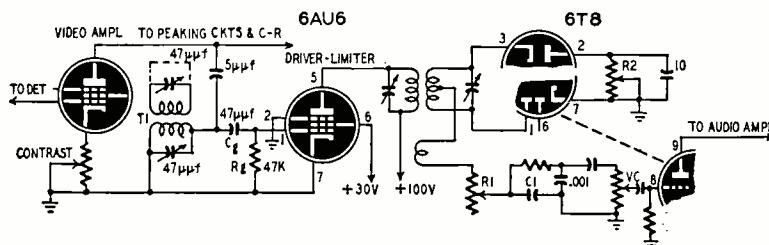

Fig. 6—Modified circuit of Fig. 5 to improve rejection of unwanted AM signals.

and interfere with normal sound signal.

If symptoms indicate an overload condition in the video or the last i.f. amplifier, increase the gain of the a.g.c. system so that for a given-strength signal more a.g.c. voltage is available. The gain of the receiver on strong signals will be reduced. This will result in reduced contrast range, but it is usually possible to effect a compromise to allow adequate contrast, yet limit the maximum signal at the video or last i.f. amplifier to prevent overload.

In sync buzz cases such as those in b, c, and d, it usually will be necessary to investigate the performance of the 4.5-mc sound system as a separate unit, determine its shortcomings, and make certain circuit adjustments and changes.

Fig. 5 shows a typical 4.5-mc intercarrier sound circuit including the sound takeoff point and audio amplifier. The function of the sound circuit is to amplify the frequency-modulated 4.5-mc. signal, reject any amplitude variations, and detect or convert the FM to audio. The most difficult problem is to effectively iron out AM so that no voice or sync buzz is present in the audio out-

put. will often increase amount of 4.5-mc signal available to driver grid, making possible better limiting action.

3. Adjustment of the ratio detector can be done if an FM-AM signal generator and oscilloscope are available. Follow manufacturer's alignment instructions. Variation in values of R_1 , R_2 and C_1 in Fig. 5 will affect the ratio detector's ability to reject AM. For example, reducing the value of R_2 will often materially improve AM rejection of the detector but may result in decreased audio output. When R_1 or C_1 is varied a sharply defined minimum in output due to AM will be found. If a potentiometer whose total resistance is about 500 ohms is substituted for R_1 , this null point will be found and may result in an improvement in AM rejection.

In the absence of adequate equipment, it is not recommended that adjustments be made on the ratio detector. However, a considerable improvement in reduction of sync buzz can be expected by making the circuit changes shown in Fig. 6, and by correct receiver alignment.

—end—

Conversion to Color is Simple and Easy

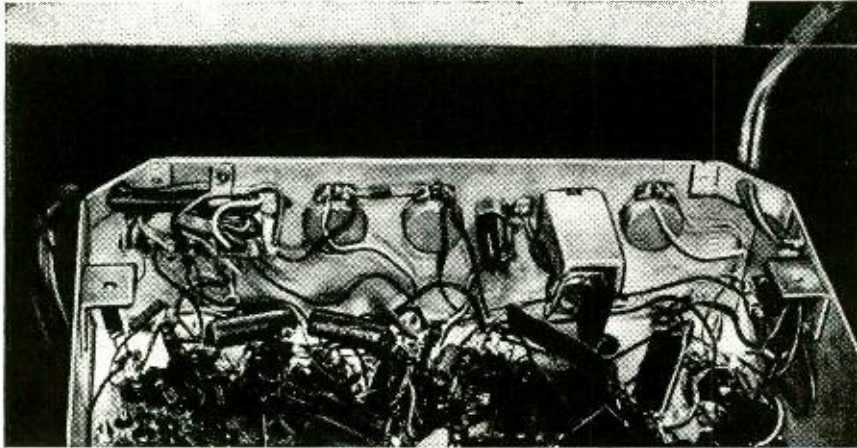

Note 6-p.d.t. color switch added in photo at right and controls placed as in Fig. 3.

By
MATT MANDL

The Admiral 30A1 rear panel before conversion for color is shown in the photo at left.

Few parts, slight circuit changes, give you color.

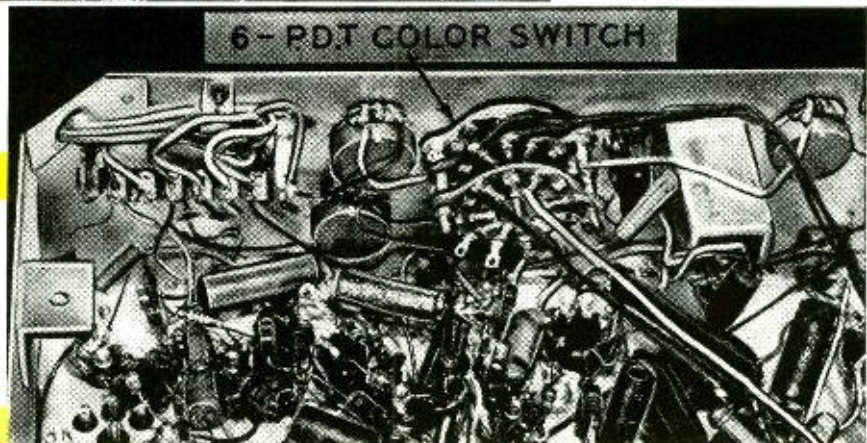

In adapting television receivers for color reception the vertical-sweep system must be altered to lock in with a 144-pulse-per-second sync, while the horizontal sweep must be changed for 29,160 sync. This is best done by a switch arrangement so that either black-and-white (monochrome) or color can be selected.

The vertical sweep circuits do not present much of a problem because adaptation means only a change of capacitor or resistor values in a blocking oscillator or multivibrator. With the horizontal sweep, however, special problems arise because of the automatic lock systems employed by modern receivers and because the high voltage is usually derived by kickback of horizontal sweep components. Besides, there are three primary lock systems used for horizontal sync, and each requires a different approach for color reception.

To investigate special color adaption problems, the author changed over three receivers, one with a phase-detector horizontal lock system, the second with a synchrolock type circuit, and

the third (most commonly used type) the synchroguide. Study all three adaptations because many of the problems are overlapping. Thus, even though you work on an Admiral 30A1 chassis as detailed herein, some of the problems you may run into will parallel those described for the RCA receiver.

Phase detector system

The Admiral 30A1 chassis was chosen because it employs a typical phase detector lock for the horizontal oscillator as shown in Fig. 1. A 6AL5 tube is used for the phase detector (discriminator) which regulates the bias on the control tube. The latter is a reactance circuit which develops an out-of-phase signal across the cathode resistor, which in turn shunts the oscillator coil via C413 and thus acts as a frequency control.

No changes need be made in the sync discriminator stage because it is a phase-detector type with no resonant-frequency sections. Because C413, in series with the signal across the cathode resistor of the 6J6, is a reactance

across the oscillator grid circuit, any change will influence oscillator frequency. Therefore C413 was disconnected from the cathode resistor and wired to one section of a six-pole, double-throw wafer switch.

A .004- μ f capacitor also was wired into the circuit as shown in Fig. 1. It is a critical value and must be found experimentally if the horizontal sweep is to remain locked in when changing from monochrome to color. Otherwise the frequency control must be adjusted each time the switch is thrown for color or black-and-white. Even with the same model number chassis this capacitor may be .0045 or .003 μ f, depending on the circuit characteristics peculiar to your receiver. A fixed capacitor may be used, shunted by a trimmer-type variable to simplify adjustment.

Another section of the switch was used to change over the sawtooth-forming circuit in the discharge stage. Here a 330- μ f capacitor replaces the 680- μ f one when on color, and the 8,200-ohm resistor is replaced by one of 3,000 ohms.

The vertical-sweep oscillator needed only an 80,000-ohm resistor to lock in with the 144-pulse-per-second sweep, Fig. 2-a. This value was found to be the best because it required only slight readjustment of the vertical-hold control when switching to color.

Because the higher sweep rate reduces the high voltage, beam velocity in the picture tube is reduced and the focus control range barely secured good focus. R437 in the focus-control circuit should be shorted out during color reception, as shown in Fig. 2-b. The focus control then gave a sharp picture at center setting and required no change on color.

In some receivers, particularly where tubes in the sweep system are fairly old, full width may not be secured on color. Resetting the drive control may help, but extreme settings may affect horizontal linearity with consequent picture distortion.

Additional sweep is obtained by shunting the 5,000-ohm horizontal oscillator plate resistor (R424, Fig. 1) by another of equal value when on color. One of the two remaining switch sections can be used for this purpose. Use a resistor having at least a 5-watt rating. If more width is needed, R426 (Fig. 1) in the grid circuit of the horizontal-discharge tube can also be shunted by an equal-value resistor for color, using the remaining switch section.

If the two switch sections are not used as above, they can switch two extra potentiometers into the circuit for height and vertical linearity. This will eliminate making slight adjustments on these controls when switching. These were not required on the receiver converted by the author. Duplicate-value potentiometers are used because the difference in the setting of these controls is slight when changing to color reception. This is an added refinement which may not always be necessary or desired.

Layout changes

Additional resistors or capacitors should be placed so that leads are as short as conveniently possible. The longest run necessary was the shunting wire for the R437 focus resistor which had to be wired to the focus control on the front chassis apron and run back to the color switch on the rear chassis apron. The .004- μ f (approx.) capacitor for color required only a short run, while the new discharge components were strung halfway across the chassis. Switch capacities or lead dress seem unimportant, though it is best to keep the vertical and horizontal circuit wires an inch or two apart.

To find room for the switch on the rear apron, a new hole was drilled above the vertical linearity control and the height control moved to this place. This left room for the switch to be mounted in the hole left by the height control and cleared the inside of the rear apron for the switch assembly. Fig. 3-a shows

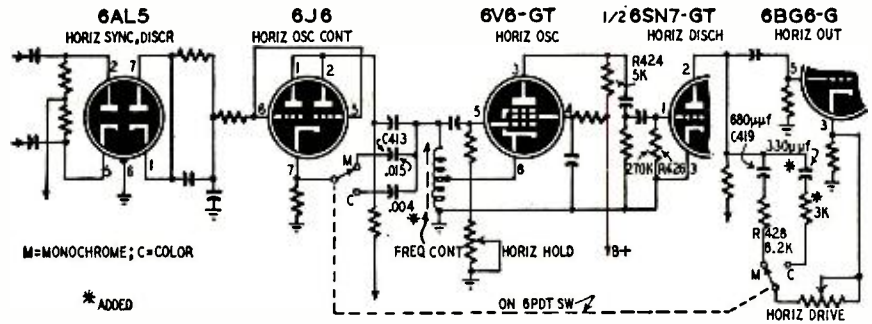

Fig. 1—Color horizontal sweep changes in Admiral 30A1; 6AL5 is phase detector.

the rear apron before the change. Fig. 3-b shows the new layout.

Another connection was made from the plate of the vertical oscillator to a newly installed insulated output terminal, Fig. 3-b. This is to secure pulses at the 144 repetition rate for use in the motor control circuit to keep the color wheel or drum rotating at a speed synchronized with the incoming sync.

This layout is included here to illustrate one of the many ways the new units can be placed on the chassis. If height and vertical linearity controls are included, they can be placed near the existing controls. Another method is to use dual type controls with the double shaft (one inside the other). These, while more expensive, save considerable space.

Synchrolock system

The synchrolock horizontal frequency control system is similar to the phase detector system of the Admiral 30A1, except that the discriminator section contains a resonant circuit which must be changed for color reception.

An RCA 8TS30 receiver was used (later model of the 630). This type of synchrolock is found in earlier Emersons as well as DeWald, Zenith, Du Mont, and a host of others. The switch was again mounted on the rear of the chassis and arranged to switch only four circuits.

The changes for the 8TS30, Fig. 4, are:

1. Two .005- μ f capacitors were used (Fig. 4-a)—one across the windings of the horizontal sync discriminator transformer primary, and the other across the secondary winding in the reactance tube circuit.
2. A 330- μ f capacitor and a 12,000-ohm resistor were wired into the discharge circuit, Fig. 4-b.
3. The only change in the vertical was to lower the blocking tube grid time-constant by switching in a smaller value grid resistor in the color position (620,000 ohms) Fig. 4-c.

When the switch was first thrown to the color position it was necessary to slightly readjust the horizontal frequency control on the rear chassis to permit lock-in at the color line rate. This did not need repeating during subsequent switching.

As with the Admiral, the value of

the horizontal-lock capacitors is critical and several combinations around the .005- μ f value may have to be tried to avoid constant readjustment of the frequency control.

When switching between monochrome and color rates the following controls had to be readjusted slightly each time the changeover was made: Horizontal hold, vertical hold, height, and focus. These controls had adequate range and

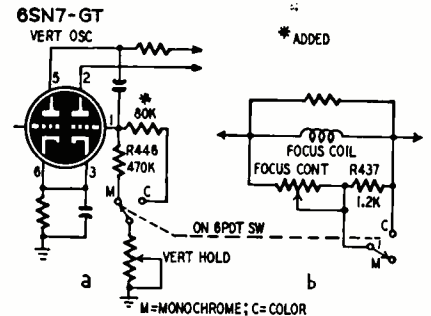

Fig. 2—Vertical sweep and focus circuit changes for color in the Admiral 30A1.

linearity was good. If height and vertical linearity are to be switched in, the circuits can be included as shown in Fig. 5.

If picture width is inadequate, the following should be tried:

1. Substitute horizontal oscillator and horizontal output tubes to find most effective pair.
2. Decrease horizontal output screen resistor on color position.
3. Decrease value of sawtooth-forming resistor (12,000 ohms). Add more supply voltage to discharge or sawtooth-forming circuit. Add positive to plate side or negative to cathode side (RCA 630 or 8TS30 models).
4. Add more negative supply voltage to cathode of horizontal output tube.

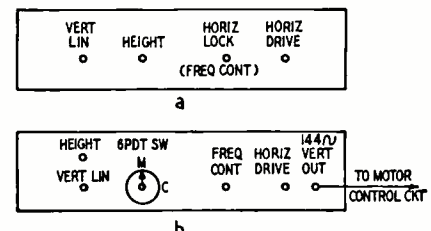

Fig. 3—Admiral 30A1 rear panel layout, (a) before; (b) after. Note 144 c.p.s. output terminal for color wheel sync.

Synchroguide system

For the synchroguide, another RCA (9T246 model) was used with changes as shown in Fig. 6. Here variable trimmer-type capacitors are used and these have the advantage that more accurate adjustment can be made so that lock remains stable during switching. Fixed capacitors can be tried experimentally, though it may mean that adjustments to controls are necessary each time the receiver is switched over.

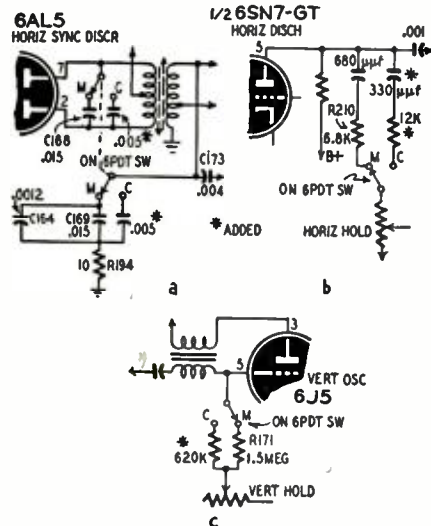

Fig. 4—STS30 changes, (a) horizontal sync, synchrolock system; (b) horizontal discharge; (c) vertical oscillator.

A Colortone adapter was tried on this RCA receiver, but a variety of adapters are available and include models for the synchrolock and for the phase-detector type horizontal circuits.

Adapter Circuitry

The Colortone adapter uses a circuit similar to that shown in Fig. 6. It is mounted externally and multilead cables are used. All color-position parts are located in the adapter and a few of the monochrome parts are removed from the receiver because they are duplicated in the adapter.

When such an adapter is used locate a clear place in the TV chassis where two holes can be drilled. These should be large enough to accommodate the two cable sections from the adapter. Two plug-receptacles can be used so the adapter can be detached from the receiver for convenience during servicing. (Remember the adapter contains some components removed from the receiver, so the latter will not function without the adapter.)

The adapter duplicates vertical linearity, height, and focus controls. This means standard receiver controls can be preset for monochrome and the adapter controls preset for color. Thus readjustment is not necessary when switching sweep rates. The adapter also has its own color horizontal and vertical frequency controls so they also can be preset on color. In switching only slight (or no) adjustment of hold controls is required.

Besides wiring the cables into the receiver, the following changes are made:

1. Removal of .0047- μ f time-constant capacitor (C145) in the grid circuit of vertical blocking oscillator. This capacitor is replaced by a similar capacitor in the adapter plus one of a lower value for the color field rate, Fig. 6-a.
2. Removal of the 180- μ f capacitor (C158) that sets the frequency of synchroguide oscillator. This capacitor is also replaced (at the factory) by a similar one in the adapter and a separate trimmer for color position, Fig. 6-b.
3. The .0022- μ f sawtooth-forming capacitor (C161) is removed from the horizontal circuit. This is duplicated by a similar capacitor in the adapter and one of a still lower value is switched in for color, Fig. 6-b.

After the adaptation, the receiver was first adjusted on monochrome by slight readjustment of the horizontal frequency control on the synchroguide transformer. If this control is off too far, no raster will appear, as opposed to the other systems previously discussed. If this happens after wiring in an adapter on the synchroguide, adjust horizontal frequency control first before rechecking wiring.

The adapter performs well and a minimum number of adjustments are required when switching rates. Width and brilliancy were adequate, though as with the other conversions, both the drive control and brilliancy had to be advanced. The amount of readjustment depends on the receiver, age of tubes, and general circuit efficiency.

Improving brilliancy

Because existing receivers are designed for maximum efficiency at the 60- and 15,750-c. p. s. sweep rates, it is reasonable to expect that color-adapt-

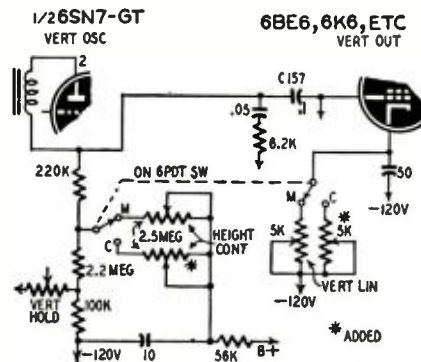

Fig. 5—Optional height and linearity additions to 8TS30 and most TV sets.

ed circuits will not perform comparatively as well when receiving color as they do on black-and-white. In particular the horizontal width is reduced because of the decline in circuit efficiency and with it there will be a decrease in brilliancy (most receivers utilize horizontal sweep for high-voltage generation.

A decrease in high voltage affects picture-tube beam velocity, and for this reason focus and beam bending (ion trapping) is also affected. Brightness during color reception can be recovered by adjusting the ion trap position. If brilliancy is down to an appreciable extent the ion trap should be readjusted each time a change from monochrome to color is made (and from color to monochrome). If this isn't done the gun structure of the tube eventually may be damaged. The old type ion trap coil can be used and coil current changed when switching between color and monochrome by use of switched resistors.

If picture width is improved by the methods previously detailed, brilliancy will also improve. Thus, recovery of proper width means high voltage has also been built up, and readjustment of focus and ion trap position is not required.

To pick up some additional brightness, the first high-voltage filter capacitor can be removed from ground and returned to the top of the damping circuit.

If specially designed horizontal output transformers and deflection yokes are used, little trouble will be experienced with foldover, insufficient width, and brilliancy, or with lack of linearity. These were just coming on the market when we were making our conversions, and we were not able to secure them before this was written. But they no doubt will be readily available soon.

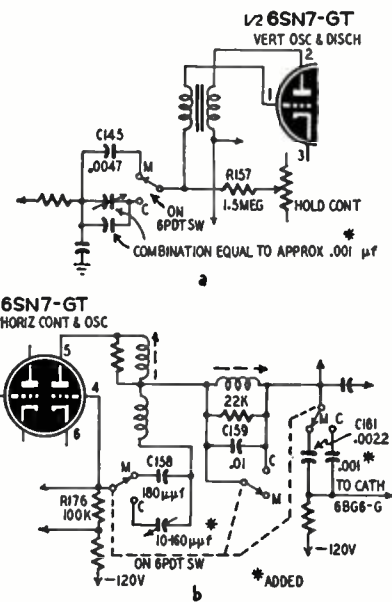

Fig. 6—Color changes, Synchroguide; Colortone unit uses similar circuits.

The same is true about color wheels and motors. The one used in this conversion was a home-built affair, but will soon be replaced by a manufactured job, and synchronized with a circuit which will use a saturable reactor motor control.

(A survey at press time showed that no complete kits were yet available, though some parts, such as a color wheel, were. Editor)

—end—

NEW SOURCE OF TVI

Many of the new TV receivers have their i.f. amplifiers tuned so the sound and video carriers are at 41.25 and 45.75 mc respectively. There are two basic reasons for the shift from 21 to 40 mc. First, oscillator radiation from sets having 21-mc i.f. amplifiers causes interference to nearby TV sets tuned to other channels. The use of a 40-mc i.f. raises the oscillator frequency sufficiently to prevent interference caused by radiation. Second, 21-mc i.f.'s are not suitable for sets designed for both u.h.f. and v.h.f. reception.

Although the shift to 40 mc eliminates a source of interference to other sets, and minimizes direct pickup of amateur signals in the bands below 30 mc, it leaves these sets wide open to interference from police service transmitters which operate in the 42.02-42.94, 44.62-45.06, and 45.10-46.02-mc bands. FCC regulations now permit plate power inputs up to 10 kw to the final amplifier of transmitters operating in the first two bands.

Since the FCC indicates these frequency allocations are permanent, the TVI from the source may increase as new TV stations go on the air and existing police transmitters continue to be replaced or modified for higher power.

It is possible that the interference can be reduced or eliminated by applying TVI reduction methods now commonly used by amateurs and some set manufacturers. However, the problem of eliminating interference from a 10-kw transmitter will be much harder than from amateur transmitters running a few hundred watts. The magnitude of the interference problem created by 40-mc police transmitters is evident from a report of actual field tests described in a recent issue of *The APCO (Associated Police Communication Officers) Bulletin*.

Interference tests

The tests were made to determine the distance over which interference was produced by 500-watt and 10-kw transmitters operating at approximately 45.75 mc. Both transmitters used antennas having a gain of 1.5. The antenna heights were 135 and 400 feet for the 500-watt and 10-kw transmitters, respectively. The test conditions were set up with a channel 2 TV station and a test transmitter in the same direction from the receiving dipole antenna 30 feet high. The r.f. and i.f. sections of the receiver were shielded as far as was practical. The receiver i.f. rejection—including traps—was 83 db. Measurements were made on the basis that interference stronger than 25 db below the desired signal is objectionable and an interfering signal more than 45 db below the desired signal is not noticeable.

In a fringe area where the strength of the desired signal was 70 microvolts per meter, the radius of objectionable interference was 0.84 mile and the radius of noticeable interference was

TV Puzzles Children - - and Experts, Too Sometimes

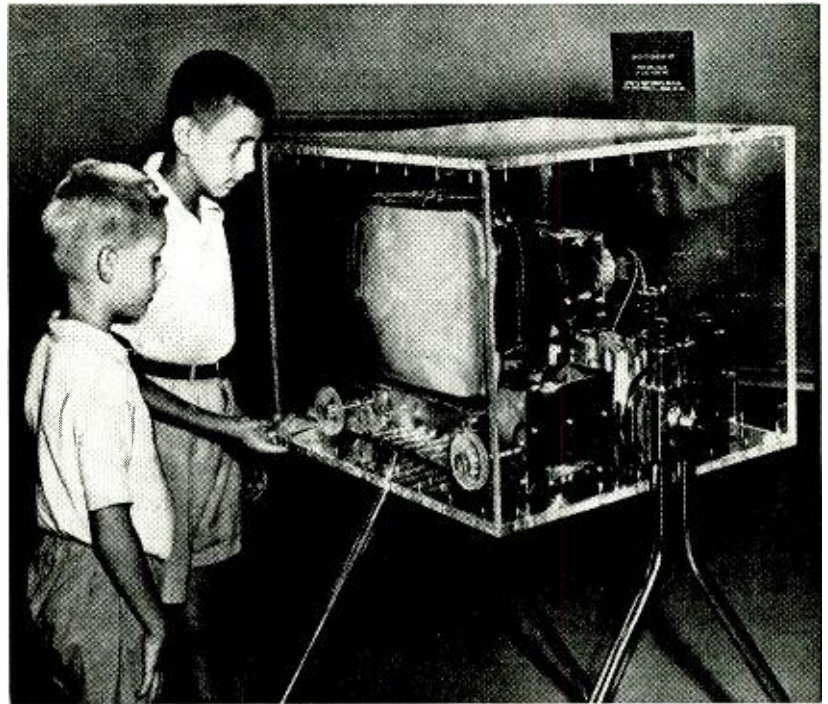

"Where does the picture come from?" These two kids are baffled at the very complex looking interior of a TV receiver mounted in a transparent plastic cabinet, on display at Philadelphia's Franklin Institute.

2.1 miles for the 500-watt transmitter. Under the same conditions, the radii of interference from the 10-kv transmitter were 3.4 and 8.4 miles respectively.

In an area where the TV signal strength was 225 microvolts per meter, the 500-watt transmitter caused objectionable interference over a radius of 0.46 mile and noticeable interference over a radius of 1.12 miles. The 10-kw transmitter produced objectionable interference at 1.9 miles and noticeable interference at 4.6 miles.

Changing any of the test conditions causes a reduction or increase in the interference level. For example, the range of objectionable interference from the 500-watt transmitter was reduced from 0.84 to 0.41 mile when tests were shifted from channel 2 to channel 5.

It is quite possible that many complaints of 40-mc TVI can be cleared up by using the new high-pass TV filters designed especially for use with sets having 40-mc i.f.'s. Their attenuation curve immediately below channel 2 is much sharper than that of the common high-pass filter designed for sets having lower intermediate frequencies. The sharper cutoff provides greater attenuation at 40 mc without affecting the strength of the channel 2 video carrier or sidebands.

It is believed that most of the super-power 40-mc police transmitters will be installed in suburban or rural areas well away from congested residential zones. We sincerely hope that this will become the general practice so as to minimize TVI interference.

—end—

TV INTERFERENCE

A home-wrecking motorist who drove his auto through the home of James Arata in Cincinnati, recently proved what it takes to wreck modern TV picture tubes—and sets.

Mr. Don Canady of Cincinnati sent us a clipping which said, in part: "Mr. Arata said he was talking to his wife in a far corner of the room when he heard timbers splintering. As the machine crashed through, the picture tube of the television set imploded and an iron radiator was hurled against an opposite wall."

Investigating, Mr. Arata found that his television set had "disappeared" . . . The crushed television set later was found inside the hood of the automobile.

The motorist, incidentally, was later fined \$55 for reckless driving, with the understanding that he was to pay for the repairs to Mr. Arata's home, conservatively estimated at \$5,000.

Television service technicians who have heard of the dangers of implosion have probably visualized somewhat similar results from a much milder shock. The fact is—TV tubes are getting better and better. These tubes must be rugged. On a 200-square inch glass viewing screen, the total atmospheric pressure is over 3200 pounds; on larger tubes it is even greater.

But there have probably been numerous TV viewers who, disgusted with their sets because of improper repair or servicing, poor programming, and hammy acting, pray for release from TV bondage some way, without breaking up their home—or their house.

Television Service Clinic

Conducted By MATTHEW MANDL

VERTICAL sync instability sometimes occurs for only one station of several that can be received. Picture contrast and quality is usually excellent and there is ample signal strength. Horizontal stability seems good, but for this one channel the vertical-hold control is critical and it is difficult to keep the picture from rolling vertically. This trouble is found where signal strength is high, as opposed to sync troubles which usually occur in fringe areas, or it occurs only when the strongest station is tuned in.

When vertical instability is present for only one channel the a.g.c. system is either defective or too critically adjusted for proper reception of stations with *highest* signal strength.

The result is insufficient negative bias on the r.f. and i.f. stages. Too much signal amplification results in the peaks of the carrier signal operating on the nonlinear (curved) portions of the characteristic curve of the tubes. The signal peaks may drive the i.f. amplifier grids

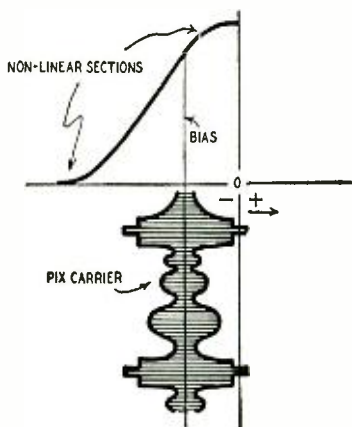

Fig. 1—Incorrect a.g.c. function. The grids of the i.f. amplifier go positive.

positive as shown in Fig. 1. With proper a.g.c. a strong signal will increase negative bias and thus cut down r.f. and i.f. gain.

Picture signal peaks represent sync pulses, and the clipped sync pulses could cause horizontal and vertical sync instability. However, automatic sync lock is used by most sets. Horizontal sync thus remains fairly stable, but vertical sync troubles will occur. If the a.g.c. system is too far out, *both* horizontal and vertical instability will occur and picture quality will suffer too.

The a.g.c. control should be adjusted while the strongest station is tuned in. Advance the control to where the picture starts to bend or pull horizontally, then back off until stability is secured. Even after this, sync instability may

occur for peaks of high modulation in the transmitted signal, particularly during film commercials. If too severe, the a.g.c. will have to be decreased, though this may give poor contrast for the weaker stations in the area.

If the a.g.c. control is ineffective, or if not present in some receivers, replace the a.g.c. tube and check capacitors and resistors in the a.g.c. circuit for off-value or defective.

In some cases the antenna should be reoriented. Low-ohm resistors or an attenuation pad can be switched across the antenna terminals of the receiver to cut down the signal for the strongest station. The value of the resistor or pad will have to be determined experimentally.

Retrace lines

I converted a small screen receiver to a larger one, using a new horizontal output transformer and matching yoke. I now have retrace lines on the screen and excessive stretching of the picture at the left of the screen. Also, what can be done for a noisy contrast control? H. H., Flushing, N. Y.

The following might help eliminate the difficulties:

1. Check ion-trap magnet adjustment. Incorrect setting will cause retrace lines to show because brilliancy has to be advanced too much and thus affects blanking. Check contrast control potentiometer for loose connections and clean shaft bearing and sliding contact with contact cleaning fluid. If this doesn't help, replacement will be necessary.

2. Reduce drive to horizontal output tube by adjusting drive control. Re-adjust linearity control as drive control is turned—also width control. If drive control does not reduce left stretch, check screen and plate voltages of horizontal output tube. See that the new transformer has not increased the voltage boost beyond that called for by original circuit.

3. As final resort, change voltage-boost filter capacitor (the one on the damper cathode side) to one of slightly different value than original. In the RCA 630 this is C186, .05 μ f. It may be defective or of incorrect value for the new transformer.

Sync loss

I have a Zenith 24H20 which has no horizontal synchronization. The picture rolls and tears and tube replacement has not helped. R. J. E., St. Louis, Mo.

This is caused by either an open circuit feeding sync to the control system or a defective component in the phase

detector and control circuit. Try the following: Replace the 100- μ f capacitor at the cathode of the 6AL5 phase detector. When this is defective, a positive voltage will appear at the plate (pin 7) of the 6AL5 instead of a normally negative voltage. Check the sync clipper stages feeding the horizontal system.

In some Zenith models loose rivets on the phonevision connector plug contribute to horizontal instability. If shorting bars are not soldered to the rivets, solder them. Check for a shorted capacitor at the plate of the control tube and an overheated resistor in the a.g.c. return. Also test resistors for incorrect values, and if not within 10% replace.

Echo effect

In an Admiral (21F1 chassis) I get several thin white-and-black lines following any vertical picture information. This is particularly noticeable for any abrupt change from black to white in the scene, or vice versa. W. J. McMahon, Valley Stream, N. Y.

This is known as "echo" or "ringing" effect and usually occurs for *every* station tuned in. Contrast this to ghost reception which will usually show up for only one or two stations, and has more pronounced picture displacement. Echo effect is caused by an overpeaked video amplifier or by a misaligned video i.f. section. High-frequency components of the signal pulse the offending stage into a transient oscillation which causes the repeat lines at sharply defined edges of picture images. If it only occurs on one or two stations it indicates that the r.f. alignment may be out. If the level of the video carrier is low with respect to the sound carried on some channels, this effect will occur.

Try a new 6AC7 video amplifier and also make sure that the peaking coils are well separated from other components and dressed away from the chassis. Test the coils to see they are not defective.

Check the alignment of the video i.f. stages to see that bandpass is not humped around the high-frequency sideband section of the response curve. Also check for a critical i.f. stage which might be near the oscillation point because of a bad tube or defective part. Check r.f. alignment if trouble is confined to one or two channels.

Wavy scan at left

On the left side of the screen in a Hallicrafters 810 receiver the scanning lines are wavy in what appear to be vertical sections as shown in the draw-

ing (Fig. 2). What causes this condition? P. E. B., Martinsville, Va.

This is produced by an open or defective capacitor across one-half of the horizontal deflection coils. This capacitor balances the distributed capacity of

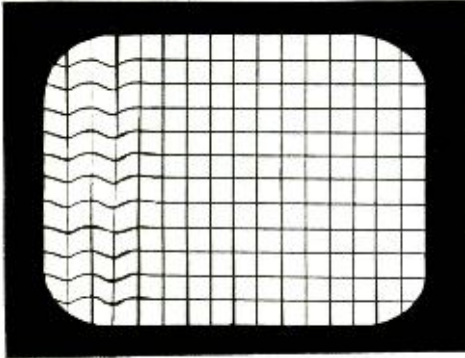

Fig. 2—Defective yoke capacitor will cause this vertical wavy-type distortion.

each coil section and prevents the distortion which looks like vertical sections of waviness. Replacing this capacitor will correct the trouble you are encountering.

Hum Bar

What causes a dark, horizontal bar to appear on the screen of the receiver? Along the edges of the bar the picture bends slightly. L. D. W., New York, N. Y.

The usual cause is a defective tube (cathode to filament short) in any of the following stages: tuner, video i.f. amplifiers, video detector, video amplifier, d.c. restorer, or a.g.c. tube. The edge of the picture bends because the sweep circuits are also affected by the defective tube.

Replace any filter capacitors which are not providing good hum filtering, for a ripple from the power supply can contribute to hum bar effects. Check the tubes in the stages mentioned, or replace one at a time until condition is corrected. Hum introduced into the picture signal affects bias at a 60-cycle rate and thus produces the horizontally shaded area.

Intercarrier buzz in Philco

The intercarrier buzz is very severe in a Philco 50-T1600. I've tried tube replacement but this did not help. The buzz decreases somewhat for critical fine tuning adjustment and proper contrast, but is still objectionable. J. E., Burbank, Cal.

This may be caused by a defective noise-filter capacitor in the FM detector system. This particular capacitor is the 2- μ f one across the output of the sound detector which absorbs the amplitude modulation components of the FM signal. If it does not provide adequate filtering the low-frequency sync components will be heard from the speaker in the form of audio buzz.

If replacement of this capacitor does not help, try a new 6T8 tube. If buzz persists, the trouble is probably due to

misalignment of the video i.f. section and this should be checked.

Picture positioning in Zenith

How can the picture be moved to the right on a Zenith H2447R receiver? What would also cause occasional picture instability in this receiver? H. H. H., Los Gatos, Cal.

The picture can be positioned to the right (or other directions) by using the centering control lever on top of the square plate of the focus-magnet bracket on the tube neck assembly. An up-down movement of the lever positions the picture horizontally, while a left-

right adjustment shifts it vertically.

For slight horizontal instability, adjust the hold control initially, and if instability still persists, try slight re-adjustment of the a.g.c. control, for the latter can cause picture bending and instability (as well as increased intercarrier buzz and poor picture quality). Finally, replace the 6AL5 horizontal phase detector, or the 6SN7-GT control tube. Also check the 6SN7-GT oscillator, and if this fails to correct the trouble, a general test will have to be made of all the parts in the horizontal lock system.

—end—

Television DX Report

TV reception during October will be similar to that experienced in September, to the extent that the weather for the two months is similar. Reception beyond normal distances will be governed almost entirely by weather conditions. Sporadic-E dx, as in September, will be rare, and if it develops at all, the openings will be of short duration and the signals will not approach those of summer in either strength or steadiness.

Signals coming from beyond the normal reception range because of tropospheric effects, will be, on the other hand, generally steady. The inexperienced viewer is sometimes misled by his results in the fall months, for tropospherically reflected signals may come in consistently for several evenings in a row, with such clarity and steadiness that he is led to think they should continue the year around.

If the TV antenna is shielded by dense foliage at close range, fall brings improved reception for another reason: The falling of the leaves reduces the screening effect of nearby trees. This effect is noticeable at considerable distances at times, particularly if the receiving location is behind a wooded hill.

Cool, calm evenings following the bright sunny days of October's "World Series weather" will be the best time to try for tropospheric dx. The effect will be most pronounced (though probably less frequent) on the high channels. In the more northern parts of the country the first part of the month will be generally better than the last, after the weather begins to turn consistently cool.

Auroral disturbances should be frequent in October, their effects being most marked in northeastern U.S.A. and adjacent portions of Canada. A communications receiver is helpful in checking for signs of coming auroral outbursts.

The National Bureau of Standards station, WWV, carries up-to-the-minute warnings of expected disturbances on all its frequencies: 2.5, 10, 15, 20, 25, 30, and 35 mc. During the tone-off periods of one minute's duration, at 20 and 40 minutes past the hour, letters are transmitted in code and are read-

ily deciphered. The letter N (dah-dit) means "normal" or no pronounced disturbance expected for 24 hours. The letter U (di-di-dah) indicates "unstable" or some disturbance possible. If W (di-dah-dah) is heard, disturbed conditions are prevalent or expected within 24 hours.

Disturbances pronounced enough to affect v.h.f. signals usually develop about an hour or so before sundown, fading out during the mid-evening

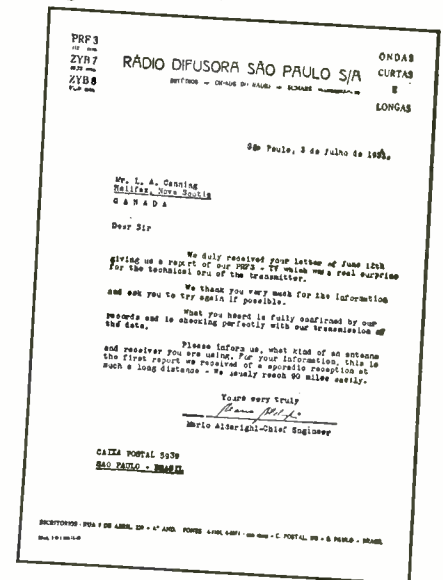

PRF3-TV, channel 3, Sao Paulo, Brazil, verifies a record-breaking report from a televiewer in Halifax, Nova Scotia! The distance is more than 5,000 miles.

hours, and frequently returning around 10 pm and lasting for several hours thereafter. The sound of the WWV signal, or any others between 2 and 10 mc, are a good tip-off. As an "ionosphere storm" is developing, signals in this range develop violent fading, sometimes with a fast flutter superimposed and easily detected.

Interested dx enthusiasts are asked to turn their rotatable arrays toward the north when auroral conditions are observed or expected. Reception up to 1,000 miles may be possible, and information as to the nature of such reception is earnestly solicited. Organized information aids dx analysis.

—end—

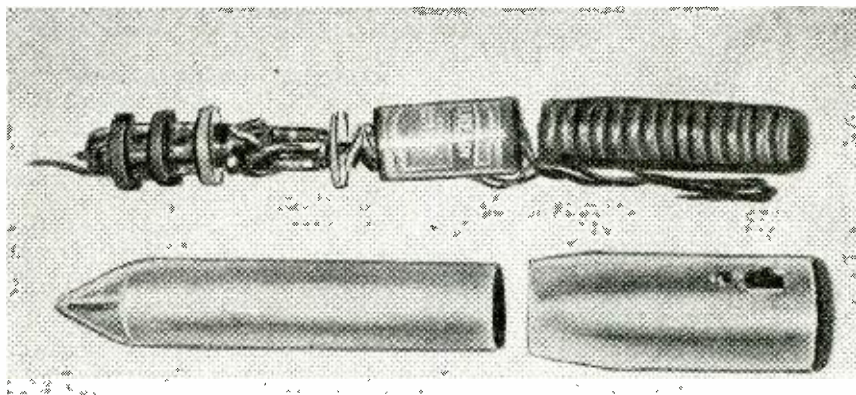
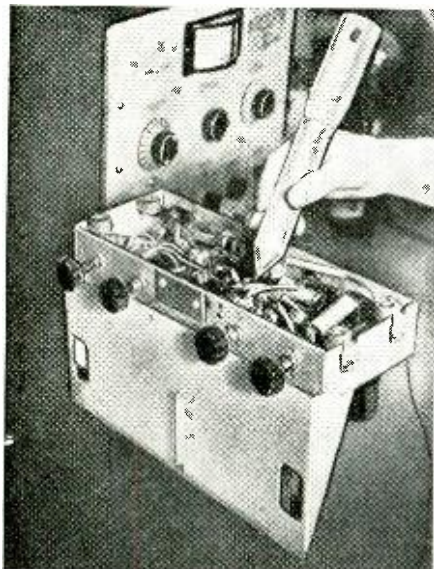

The compact Signal Launcher fits inside a shielded, two-piece aluminum case, easily made. A 3A5 miniature tube in a 1,120-cycle multivibrator circuit provides square-wave output for rapid trouble shooting by signal substitution. No dial twiddling is necessary, since harmonics are rich. I.f.'s can be aligned, too. Current drain is low. Left: unit is injecting a signal; note ease of handling.

pass through an a.f. amplifier. This principle can be used to simplify trouble shooting.

A suitable instrument

A test instrument of the universal-frequency type which can be used for trouble shooting and alignment too is described. A multivibrator circuit having a fundamental frequency of approximately 1,120 cycles is used. The output waveform provides strong signal energy over a wide frequency range.

The Signal Launcher unit is compact and self-contained, being mounted in a probe-projectile type housing. It is light, small enough (see photo) to be held in one's hand, and battery operated, necessitating no dragging wires or cable.

THE SIGNAL LAUNCHER

By ROBERT E. ALTOMARE

R.f. point source speeds servicing

SPEED is an essential characteristic of the modern servicing technique. To attain speed, the radio service technician must have a thorough knowledge of fundamental electronic theory and circuits. He must also have suitable test equipment and know its limitations and use.

One common trouble-shooting method is signal substitution (or signal injection). This requires a signal generator. Starting from the speaker end, a signal is applied to each stage or group of stages, and, progressively, the result is noted in some manner in the output. A limitation is that the signal generator and the receiver tuning dial must usually be preset. For rapid trouble-shooting, a universal-frequency signal source is desirable, since no dial-twiddling will then be necessary. Such a signal source can be had from any ex-

remely distorted low-frequency generator. Most often a square wave having a fundamental frequency approximating 1,000 cycles is used. Multivibrators have been used in the past to obtain this.

Such a signal source is useful since a distorted wave has not only fundamental frequency energy but harmonic energy as well. Any complex wave can be broken up into a Fourier series representing a series of sine waves harmonically related. The number of harmonics and their amplitude is a function of the original wave-shape. When the output of the distorted wave is applied to a circuit, the circuit will choose and pass only those frequencies it can handle.

Thus, an i.f. amplifier will pass essentially the intermediate frequency. Only audio-frequency components will

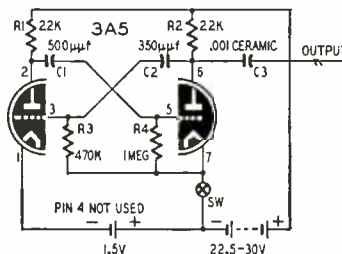

Fig. 1—Signal Launcher is a multivibrator. The ceramic capacitor C3 in the output was replaced by a 22,000-ohm resistor in one unit inspected.

Fig. 2—A complex square wave rich in harmonics is generated. It can be used as a universal signal source for shooting many types of troubles.

The life of each battery is practically equal to its shelf life. One of these units has been in operation for three years and the original batteries are still used. The unit might be kept in operation by using discarded batteries from battery portable receivers.

At the fundamental frequency, the r.m.s. output is 2.4 volts and less, of

RADIO-ELECTRONICS for

course for high harmonics. Most bands of an all-wave receiver and the i.f. stages of FM receivers are covered.

Fig. 1 shows the schematic circuit. A type 3A5 7-pin miniature battery tube is employed. A No. 1 flashlight cell provides filament voltage. Note that

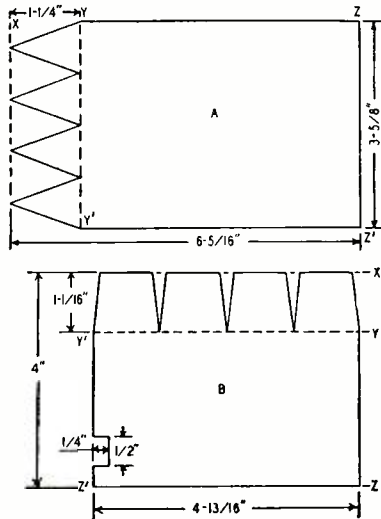

Fig. 3—The case dimensions; note cutout for switch. Use 1/16-inch aluminum.

the series filament connection is used although only 1.5 volts is applied. The B-supply is 22.5 volts, and can be one section of an Eveready type 467 (or 457) Minimax 67.5-v battery. Since first building this instrument, smaller batteries are being marketed. These provide more output, since they furnish 30 volts (Eveready 413, Burgess U20E). All resistors are 1/2 watt, although larger sizes are easier to obtain. The two blocking (coupling) capacitors are mica, postage-stamp size. The output is taken through a .001- μ f ceramic capacitor.

The output waveform is shown in Fig. 2. This wave-shape was selected to provide optimum output over a wide frequency range. The output signal is applied to the circuit under test in a single-ended manner; i.e., only the probe tip is used. No return connection is necessary.

Making the case

The housing may be any handy shape or design. Thus, a square could be used.

The container shown was made from 1/16-inch sheet aluminum in two sections. Fig. 3 shows the physical layout and dimensions of both sections before forming. The sawtooth edges are formed by cutting out with a hack-saw or tin-snips and finishing with a file. Part A is formed to have an inside diameter of approximately 1 inch by rolling around a 1-inch dowel or pipe, hammering lightly if necessary. Part B is formed around a 1 1/2-inch dowel. A section is cut out at S to provide space for mounting a slide switch. This can be riveted in place.

Aluminum soldering or welding of the outside seam of each piece prefera-

bly should be done with the forming dowel in place. Solder only along edges Y-Z and Y'-Z'. Aluminum soldering generally is difficult, but excellent results can be obtained by using aluminum solder and a small torch. Stearic acid is useful as a flux. The dowel forms now may be removed and the inside seam also soldered but only at the ends. The most difficult task follows. This is gently bending the triangular edges of section A between X and Y to a point, rounding at the same time. If a lathe is handy, the wooden dowel previously used may be turned to have approximately the same taper as the desired finished product. By properly inserting the dowel, the aluminum may be formed nicely by hammering. The four new seams should now be soldered.

If the unit appears rough at this point, sandpaper and a bit of elbow grease will miraculously transform it into a smooth, professional job.

Point X is now longitudinally filed toward point Y until a hole large enough to admit the lead from C3, insulated except at the very tip by means of a length of spaghetti.

The portion of section B between X and Y is now similarly formed except that the trapezoidal edges form a tapered cylinder which fits snugly around the pipe end of section A. This completes

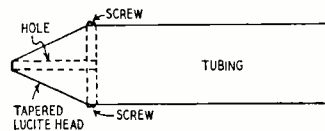

Fig. 4—Alternative generator housing.

the housing except that a cap or plug, as desired, may be fitted over the end of "B". Some constructors may prefer to use standard thin-walled brass tubing. The cylinder-forming process will then be unnecessary. Other alternate schemes such as the one depicted in Fig. 4 are possible. Here an 8-inch length of 1 1/2-inch tubing is used. A

small hole is drilled through the center of a short length of 1 1/2-inch lucite, plexiglas, or polystyrene rod. The rod is tapered as shown.

Wiring procedure

The entire unit (see photo) may be easily inserted in—or removed from—the housing. Fig. 5 shows a 7-pin button type socket mounted in a lucite ring of 1-inch diameter. C1 and C2 are arranged as shown and wired to the socket, their leads furnishing all the support needed. Now R1, R2, R3 and R4 are wired. Another lucite disk, having a 3/8-inch center hole, is now arranged. Three leads thread through the center hole and connect to the battery and small slide switch mounted in the cutout provided. This is all there is to the wiring. A 2-inch 6-32 headless screw should be arranged as shown to increase the rigidity of the unit.

Using the probe

If no wiring errors have been made the tube and support can be inserted in the housing and the unit should be ready to operate. Check the unit by touching its output to the input of an audio amplifier. A loud clear note should be heard from the speaker.

To become familiar with the operation of the Signal Launcher try it out on a receiver in operating condition. Touch the probe to the plate of the power amplifier. Note the sound and then move progressively toward the front end of the receiver by touching the power-amplifier grid, driver plate, etc., until the antenna is reached.

Having become familiar with the general operation, the final test can be made on an inoperative receiver. The unit cannot be used to check FM and TV front ends, however. Proceed as above until a point is reached where a very weak or no signal is heard. The trouble will usually be found between the last two points touched.

—end—

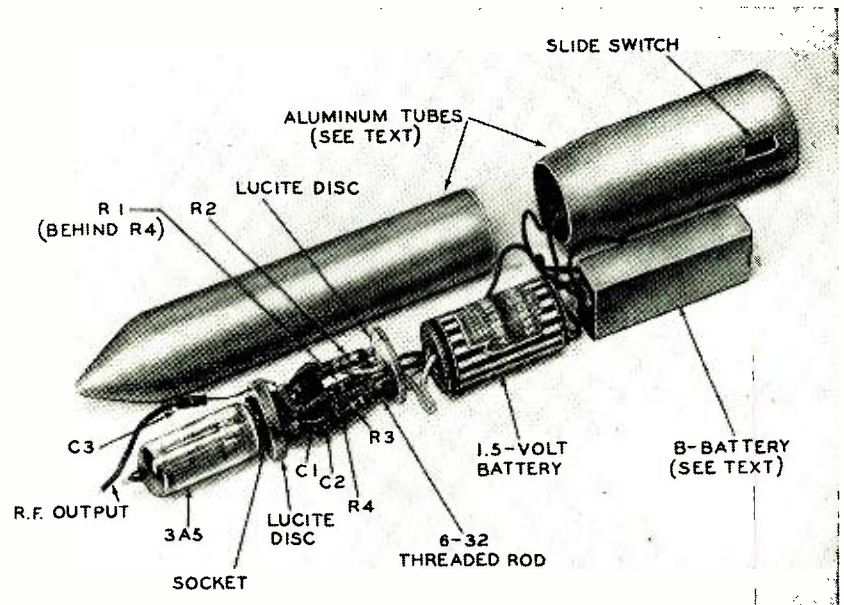
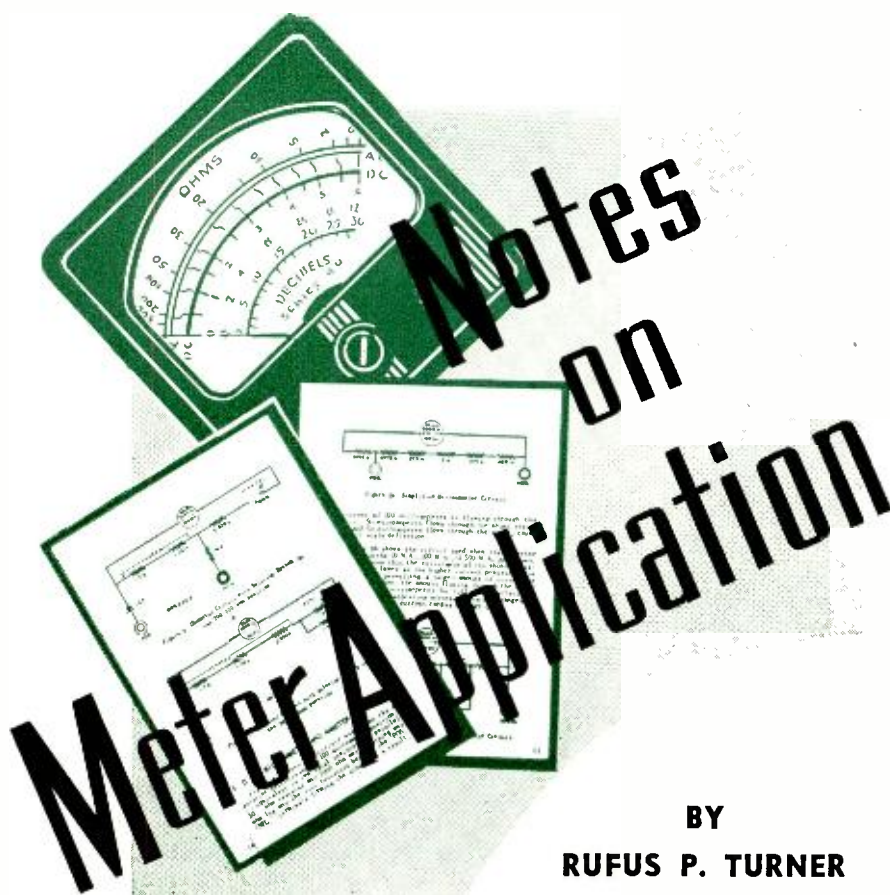

Fig. 5—An exploded view of the Signal Launcher showing the location of parts.



BY
RUFUS P. TURNER

CONSTRUCTIONAL articles rate high in reader interest. It is natural that they also should stir up the largest amount of reader-author correspondence. Most of the author's "fan mail" is from readers who have had trouble duplicating results claimed in the magazine. Precious few readers ever write letters for any other reason than to find out "how to make the thing work."

One of two things usually is responsible for the reader of a construction article being unable to make a piece of equipment work according to claims. Either some error crept into the text despite careful checking, or (more often) the reader has made circuit improvisations or substitutions for components specified in the article.

Most authors are familiar with the letter which confides, "The unit was built exactly as you described, except . . ." A list of substitutions then follows, and substituted meters cause the most trouble.

There is only one sure way to duplicate results in v.t.v.m. construction articles—use the *exact* milliammeter or microammeter specified. Other meters may be employed successfully only by making critical changes in the circuit design. For example, a typical single-tube d.c. vacuum-tube voltmeter circuit is shown in Fig. 1. Factors giving rise to trouble are:

Meter resistance

In Fig. 1, a bridge circuit is used to

zero-set the meter. This bridge contains four resistance arms: (1) the tube plate-cathode internal resistance R_p , (2) R_a and R_b in combination, (3) resistor R_c and (4) resistor R_d . The bridge is balanced, and the meter ac-

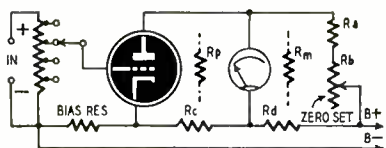

Fig. 1—A simple v.t.v.m. to measure d.c.

cordingly set to zero, when R_b is adjusted to make $(R_a + R_b)/R_p = R_d/R_c$. This is the condition for null, or zero bridge output.

The bridge is balanced for only one value of plate current. When an unknown voltage is applied to the input terminals of the instrument, a change in plate current occurs, and we want this change to cause a deflection of the meter. Now, unless the combination $R_a + R_b$ is made quite high compared to the internal resistance R_m of the meter, a large percentage of the plate-current change will flow through R_a and R_b instead of through the meter. The result will be a lower meter reading than desired. Or, the circuit is said to be insensitive. For best sensitivity, the circuit designer makes the total resistance of R_a and R_b at least 10 times the internal resistance of the meter. Also, to forestall loss of sensitivity due to high resistance in bridge

arms R_c and R_d , these latter two resistances are made low enough that their current is about 5 times the maximum tube plate current.

Along comes the reader (with all good intentions) who decides that this circuit is just what he has been waiting for, but the author shows a 0-1-milliammeter and the lowest voltage range is 0-1 volt. Now, reasons Mr. Reader, let us substitute a 0-100 microammeter (10 times as sensitive as the milliammeter) and get a basic instrument range of 0.1 volt.

Let us see what happens when this is done. The 0-1 milliammeter specified by the author has a resistance of 100 ohms, and $R_a + R_b = 1,500$ ohms—just 15 times R_m —a good design condition. The 0-100 microammeter, on the other hand, has an internal resistance of 2,500 ohms. So for this latter meter, the $R_a + R_b$ combination has less resistance than the meter! Most of the maximum-signal plate current now flows through the zero-set circuit instead of through the meter, and an *insensitive* condition results. The microammeter could be successfully substituted only by properly changing the values of R_a and R_b and possibly R_c and R_d as well.

Meter resistance assumes importance too when a meter of the same range but of different type or manufacture is used. For example, the author may specify circuit constants for a 50-ohm, 0-1 d.c. milliammeter. The manufacturer's name and the meter type number appear in the published parts list. Although the reader's meter may have the required 0-1 ma range, it may be a different make and with a different internal resistance. Also, the reader's meter could be of the same make and range but of a different type or model, and similarly with a different internal resistance. In this case, as before, the *identical* results specified by the author will not be obtained unless the reader uses a meter of the same make, range, type or model, and resistance recommended in the article.

Independent zero-set

An independent zero-set circuit, Fig. 2, is often specified in v.t.v.m. setups, especially in battery-operated instruments. It employs a separate battery and high-resistance rheostat for bucking the steady plate current out of the meter.

The reader, trying to escape the separate battery requirement, undertakes to design a bridge balancing circuit similar to Fig. 1 and will note immediately when the instrument is placed into operation that the sensitivity claimed in the article is not possible to obtain. But even in the best bridge zero-set circuits a little of the plate-current change will flow through the zero-set circuit, reducing the sensitivity of the instrument. In the battery-operated bucking circuit, on the other hand, greater sensitivity is obtained as long as a high battery voltage and high resistance zero-set rheostat are employed.

Meter drift and slam

Sensitive microammeters in v.t.v.m. circuits show considerable continuous zero drift unless extraordinary precautions are taken to stabilize the circuit. This effect is noticeable especially in meters having full-scale values less than 100 microamperes.

This drift shows conditions present in the circuit all the time but which are too slight to be shown up by the less sensitive meters normally used. One such condition is fluctuation of tube cathode temperature. Cathode temperature and operating voltage fluctuations easily can cause plate current changes of 2 to 10 microamperes. A change as small as this scarcely would be visible on the scale of a 0-1 milliammeter, but constitutes a large shift on the scale of a 0-20 or 0-50 microammeter. Similar meter drift is caused by heating in resistors. Momentary resistance shifts due to changing temperature conditions shift the meter deflection by a small amount. A sensitive microammeter displays this variation.

After a v.t.v.m. is switched on, the tube plate current increases slowly to its maximum operating level during the so-called warmup period. While the plate current is changing, the plate resistance of the tube passes through a number of corresponding values. The zero-setting bridge network consequently is unbalanced until the normal operating current level is reached.

This unbalance causes the meter to be deflected sharply while the instrument is heating up, after which the pointer settles slowly back to zero. In a carefully designed instrument, this initial deflection seldom exceeds one-third to one-half full-scale. When a more sensitive meter is substituted without redesigning the circuit, however, this initial false deflection may exceed full-scale and cause damage.

Multimeter circuits

The factor of internal meter resistance (R_m) is as significant in multimeters as it is in v.t.v.m.'s. In a high-range voltmeter, multiplier resistance usually is high compared to the internal resistance of the meter and has the sim-

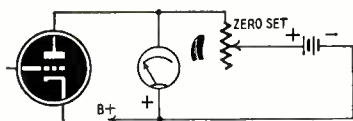

Fig. 2—Independent zero set for v.t.v.m.

ple ohmic value E/I , where E is the desired full-scale voltage deflection and I is the full-scale current deflection (in amperes) of the meter used. In a low-range voltmeter, on the other hand, the multiplier resistance becomes comparable to the meter resistance, and the multiplier resistance then correctly is equal to $(E/I) - R_m$.

A practical rule is: First calculate the multiplier value E/I , ignoring the meter resistance. If the value obtained

by this method is not greater than 10 times the meter resistance, then the meter resistance must be subtracted. This gives an odd multiplier value, but the off-size multiplier is necessary for maximum accuracy. If the author specified a multiplier requiring the series connection of several standard resistor values, don't substitute the nearest even-sized resistor and expect to obtain the specified instrument accuracy. The more sensitive the microammeter employed, the more important it is to subtract the R_m value from the calculated multiplier value.

Meter rectifier efficiency

When the author indicates a bridge rectifier, do not use a single-clement half-wave meter rectifier and expect to obtain the same calibration. Various rectifier circuits differ in efficiency—that is, the ratio of d.c. output voltage to a.c. input voltage. Fig. 4 shows five common circuits employed with rectifier-type meters. The efficiency of each circuit is given.

All rectifier-type meters tend to be nonlinear below about 2 volts a.c. So expect to be obliged to make a special low-range scale calibration. Meter rectifier response is affected noticeably by temperature and frequency. Unless crystal diodes are used, most rectifier-type meters will not hold calibration beyond 5,000 cycles. Some do not go that high. Germanium crystal diodes extend the frequency range to approximately 100 megacycles. Silicon crystal diodes will operate at several thousand megacycles, but they will not withstand the voltages at which germanium diodes can be operated. The combined errors of the rectifier-type current or voltmeter limit the accuracy of such instruments to about 5 percent. It is not uncommon for homemade voltmeters of this type to have errors higher than 5 percent.

When the circuit calls for a rectifier-type meter, do not substitute an a.c. voltmeter of the moveable iron-vane type without taking into consideration the high current required by the latter type of meter.

Mounting meters

Panel-type meters used in the construction of electronic test instruments usually are intended for mounting on nonmagnetic panels. Only when specially ordered are these meters ordinarily supplied for use on steel panels.

A panel of magnetic material, such as steel or iron, shunts the magnetic gap in the meter movement, changing the full-scale deflection and often affecting the linearity of response as well. When the author has employed a commercial meter of conventional type on a bakelite panel, you may be sure that your calibration will not be the same as his if you use the same meter on a steel panel. Order a meter which has been calibrated for installation on a steel panel to get his results.

When a regular meter is installed on a steel panel, the error introduced may be 2 percent or more. Thick panels are worse than thin ones. The panel effect has been responsible for a great deal of the unsatisfactory performance of

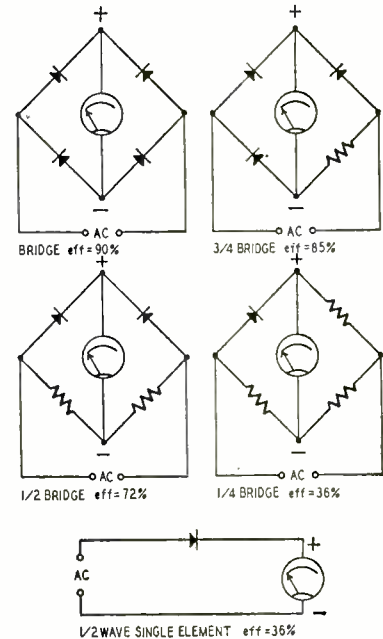

Fig. 3—Meter rectifiers may differ in efficiency, or ratio of a.c. into d.c. out.

multimeters, v.t.v.m.'s, indicating frequency meters, and similar direct-reading instruments built by experimenters and amateurs.

The indicating meter must be mounted out of the immediate vicinity of magnetic fields such as those set up by filter chokes and power transformers. Appreciable error can be introduced by such fields. The meter also must be kept away from excessive heat from tubes and other components. The complete instrument must be built to eliminate all vibration which might be transferred to the meter movement. Follow the author's layout of parts. He probably had your same trouble in the beginning and had to remount the parts on the chassis and panel several times before the finished layout was obtained.

The builder should consult meter manufacturer's specifications to determine the recommended position for mounting the meter. Some panel-type meters are calibrated for vertical mounting only, while others are guaranteed for both horizontal and vertical installation. Some meters are not intended to be mounted at an angle, such as in slant-front instrument cabinets or meter boxes.

If no information is available, and the reader calibrates his instrument with the meter in a certain position (for example, vertical or at a 45° angle), the instrument should be used thereafter only with the meter in that same position.

—end—

Tube Replacement Tips

Banish care: make tubes last longer, use adapters and proper substitutes

By JOHN T. FRYE

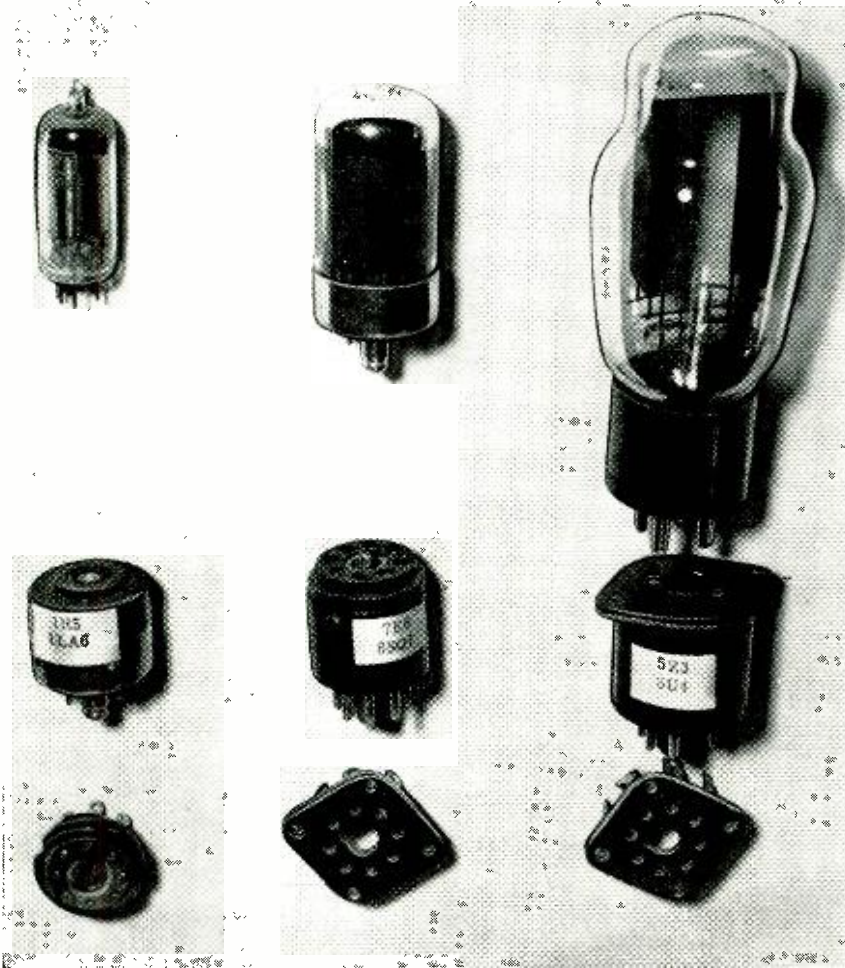

Loktal, octal, and miniature tube adapters. Use care in choosing proper tubes.

THE tube "shortage" of last winter is now an unhappy memory. Looking back, we can see that the shortage was largely artificial, caused chiefly by hoarding by speculators, and occasionally by the radio technician himself. Signs are not lacking at the present time that a much more gradual, but very real, shortage is growing on us. The continued step-up of military orders is approaching saturation for the tube plants—a situation that by no means existed last winter. Manufacturers are already cutting out production of some of the rarer tubes, "for a month or two," while concentrating on defense orders. Therefore it is time to begin thinking about means of preparing for and meeting eventual tight tube situations.

The word substitute always carries with it some idea of inferiority—and with good reason. Only rarely will a substitute tube equal completely the

appearance, the mechanical stability, and the performance of the tube it replaces; and even then the customer's pocketbook will suffer sharply for the change. That is why a tube substitution should be to the technician what telling a lie is to a gentleman: a last resort rather than a form of first aid.

There are several ways to secure enough replacement tubes so that you do not need to substitute. First, give up shopping around among several tube suppliers. Tube jobbers take care of their regular customers first, of course. Select a parts jobber large enough and well-established enough to receive sizable quantities of tubes for his quota, and let this dealer know you are concentrating *all* of your parts business with him and are depending upon him to see that you get your fair share of scarce tubes. He will very likely do just that.

Second, watch your tube inventory

like a hawk. Don't wait until you "are down to four" before ordering.

Third, don't hoard. My jobber says, "I don't want orders obviously dictated by the hoarding instinct. When a guy who has been using about twenty 50L6's a month suddenly asks for a couple of hundred, he is not fooling anybody—nor is he going to get the tubes. I want the fellows to order what they really think they will need—say in the next month. That gives me a chance to plan my own ordering and then to distribute the tubes so that they will really go into sets. All *unfilled* tube back-orders are *cancelled* at the end of each month; so a whole new up-to-date order should be sent in *every thirty days*." Ask your own tube dealer how he wants orders sent in and then follow his wishes.

Fourth, work out a "reciprocity" arrangement with one or more other service technicians in your community. Such an arrangement should be made only with a technician who gets his tubes from a different source than you do. Friendly technicians can sell tubes to each other at a discount of about half of that received from the jobber. This will prevent unnecessary delay in putting a receiver back into operation while a needed tube rests unused on the shelf of another shop. It will also insure against anyone's abusing the arrangement, for it will be to his financial advantage to get the tube from his own jobber if at all possible.

Making tubes last longer

See to it that tubes last as long as possible. During normal times many tubes are discarded when a little extra effort could extract many more months of useful life from it. For example, rectifiers such as the 35Z5, 35Y4, 35W4, etc., often develop a condition where they radiate a static-like noise into a nearby loop antenna when they are jarred, even by the vibrations of the speaker. A grounded shield quickly made from a piece of tin and placed around one of these tubes will stop the noise completely and allow the rectifier to live out its normal life span.

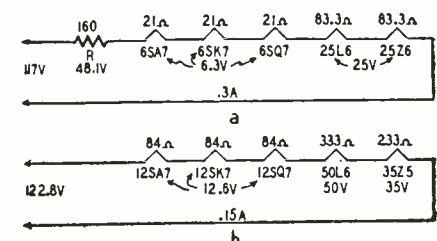

Fig. 1—E and R in typical filaments.
RADIO-ELECTRONICS for

Many grid-cap tubes develop a poor connection between the cap and the grid lead, causing noise and abrupt changes of volume. Remove the solder from the cap, thoroughly scrape the exposed end of the lead, and resolder. This will restore nine out of ten.

A microphonic tube can often be exchanged with a like tube in another circuit where the microphonic condition can cause no trouble.

Three-way portable tubes are often replaced unnecessarily. The vacuum tube or selenium rectifier furnishing the filament current for these tubes loses some of its current-passing ability with a resulting lowering of current through the 50-milliamper filament. Replacing the tubes (especially the one containing the oscillator) will often restore the set to operation for a short time because of the high initial emission of the filaments even under too-low-filament-current conditions, but as soon as emission drops to normal, the set will not operate again. But, if the filament current is raised to its normal value by replacing the weak rectifier (make sure voltage-dropping resistors in filament circuit are at rated resistance) the original tubes will work quite satisfactorily even on a line voltage as low as 100 volts.

Some customers, especially those who live on farms, will burn out a surprising number of 150-ma tubes in ac-dc sets. The fault is usually high line voltage. Inserting a 10-watt, 100-ohm resistor in series with the filament string will often double or triple the life span of these tubes without impairing the operation of the set in the least. The resistor should be mounted above the chassis if at all possible, and it should be cut into the filament circuit near the hot end, the one farthest from B-minus. Replacing a 35-volt filament tube with a 50-volt equivalent (such as a 50B5 for a 35B5) will also help, but this is not as effective.

In spite of all your efforts to make tubes last as long as possible, in spite of all the replacements you can buy, borrow, beg, or steal from your jobber and fellow repairmen, there is bound to come a time when a needed tube simply is not to be had. Then, if the customer's set is not to sit out the emergency, you must substitute tubes.

Substitution changes

Tube substitution is possible because over seven hundred different types of tubes are used in radio and television receivers to perform less than a dozen basic tube functions. These include oscillation, detection, conversion, voltage amplification, power amplification, rectification and visual indication.

However, tubes for a particular function, say oscillation, vary greatly. Filament voltage, filament current, number of elements, size, bias requirements, basing, power output, etc., must be considered in making a substitution.

A mistake in the filament needs of the substitute to be will probably result in the burning out of one or more

tubes. In transformer sets where the filaments are connected in parallel, it is necessary only to see that the rated filament voltage of the tube is the same as the voltage of the secondary winding supplying it. Current require-

the other tube filaments in the chain.

$$R = \frac{12.6}{.15} = 84 \text{ ohms.}$$

Figure 2-a shows these changes.

Figure 2-b pictures the even more complicated Rube Goldberg changes that must be made if a 6SK7 is substituted for a 12SK7. The reader can figure out for himself why the various values of series and shunt resistors must be employed to insure that a full 0.3 ampere passes through the 6SK7 and only 0.15 ampere goes through the other filaments. Such a substitution should be avoided. In addition to the excessive amount of heat released inside the set by the resistors, there is the sobering thought that if R2 or R3 fails, one or more tubes will go west *very pronto*. When at all possible, try to select a substitute tube for series-filament radio or TV sets that has the same filament current requirements as the other tubes in the set. If this is not possible, try to find one that has a lower current requirement so that it will need only a shunting resistor.

Using an adapter

Often such tubes can be found in a series with a different type of base and then the problem is whether to change the socket or use an adapter. Changing the socket makes a neater job. But, changing a socket in a crowded, compact set is often a difficult and tedious job. Adapters do not look so neat; they require more "head room", and increase the length of all leads. At the same time, they permit all of the work to be done outside of the set without disturbing the wiring. This writer prefers to use an adapter whenever possible.

They can be bought, but it is usually more convenient to make them yourself. A collection of bases from discarded tubes, a good variety of sockets, some wire, a few lengths of spaghetti, and some Duco cement are needed. RCA's *Triple Pindex* that permits you to have your choice of any three base diagrams

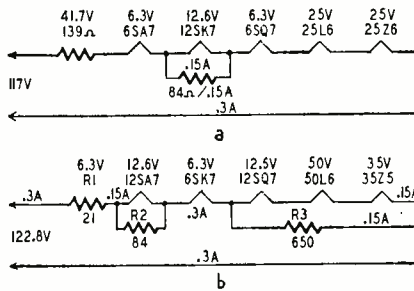

Fig. 2—Using a 12SK7 for a 6SK7 (a); difficulty (b) using 6SK7 for a 12SK7.

ments can be ignored, for as long as 6 volts is applied to a 6-volt filament, that filament is going to pass the proper current—at least until Ohm's Law is repealed! Of course current capacity of the transformer cannot be exceeded.

However, in transformerless sets where the filaments are connected in series, across the line, the current rating and resistance of the filament are important. Fig. 1-a and 1-b show the voltage and resistance distribution of typical filament circuits using 0.3- and 0.15-ampere tubes respectively.

Suppose it is necessary to substitute a 12SK7 for a 6SK7. First, the extra 6.3-volt drop across the filament will have to be subtracted from R by reducing that resistance to 139 ohms.

$$R = \frac{E}{I} = \frac{6.3}{.3} = 21$$

$$160 - 21 = 139 \text{ ohms.}$$

Then the filament of the 12SK7 will have to be shunted with an 84-ohm resistor so that 0.15 ampere can flow through it and another 0.15 ampere can go through the 12SK7 to make up the total of 0.3 ampere passing through

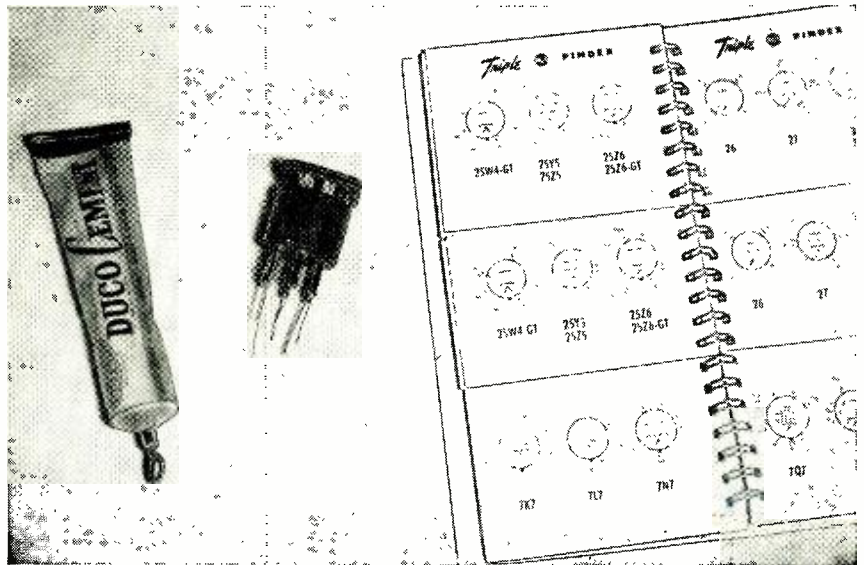

An adapter under construction. Socket is cemented to the bakelite tube base.

Double-Mystery Display

By VICTOR FASTENAEEKELS

USE a special device to attract attention to the display window of my radio shop. When anyone approaches the window, he automatically triggers a capacity relay which causes a 20-watt fluorescent lamp to glow. The fact that the lamp is suspended in space without any leads being connected to its terminals mystifies the onlooker. The circuit of the unit is shown in Fig. 1, and the complete unit is shown in Fig. 2.

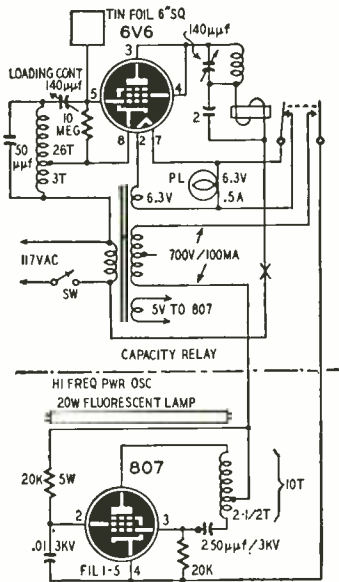

Fig. 1—The capacity relay schematic.

A 50B5 was used as the oscillator in the unit shown in the photographs because the power transformer we used had a 47-volt filament winding. The diagram is adapted to use a 6V6, 6AQ5, or similar tube as the oscillator in the capacity relay.

The grid coil is 29 turns of No. 24 or 26 wire close-wound on a ½-inch

form. The cathode tap is 26 turns from the grid end of the coil. The plate coil and its tuning capacitor were taken from an old 150-kc i.f. transformer. A sufficient number of turns was removed from the coil to permit the plate tank circuit to be tuned to resonance as indicated by minimum current dip read on a milliammeter inserted at X in the plate circuit. Vary the setting of the plate-tuning capacitor and the loading control for minimum current.

We used a telephone type d.c. relay which had a 2,000-ohm coil and two sets of contacts. One set is normally open and the other normally closed. The latter contacts open and insert a 6-volt, 500-ma pilot lamp in series with the heater lead to the oscillator when the circuit is triggered. The lamp serves two purposes. It lights and indicates when the relay is triggered, while at the same time it drops the heater voltage on the oscillator tube and causes a decrease in the plate current. This insures the relay releases when the person moves away from the window.

The normally open contacts are in series with the cathode return of the self-rectifying high-frequency oscillator which excites the fluorescent lamp. The coil for this circuit consists of 10 turns of ½-inch copper tubing wound with an inside diameter of 1 7/16 inch and spaced to occupy approximately 3 ½ inches. Plate voltage is fed into a tap 2 ½ turns from the grid end of the coil.

The components are mounted inside a large circle made of ¾-inch metal tubing as shown in Fig. 2. The high-frequency oscillator (Fig. 3) is mounted on a narrow platform mounted above the center of the circle. Two thin plastic straps suspended the lamp above the plate of the 807 oscillator. The capacity relay, Fig. 4, is mounted at the base of the circle. The free end of the coiled lead connected to the insulator normally

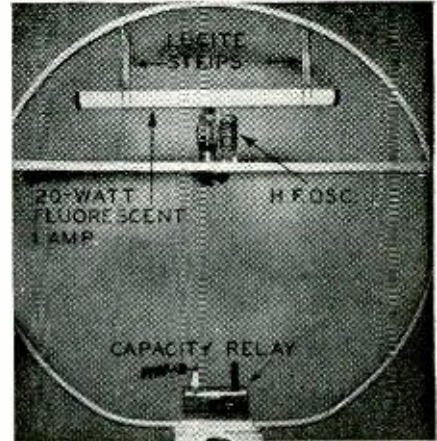

Fig. 2—Circular frame holds relay unit.

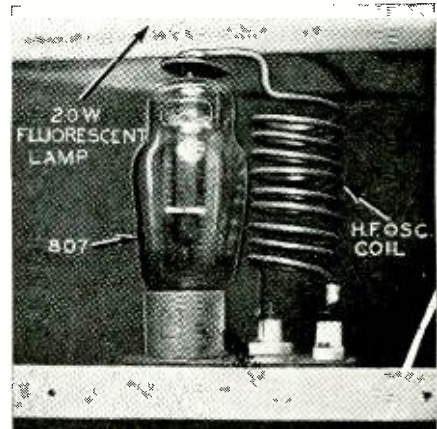

Fig. 3—R.f. oscillator lights lamp.

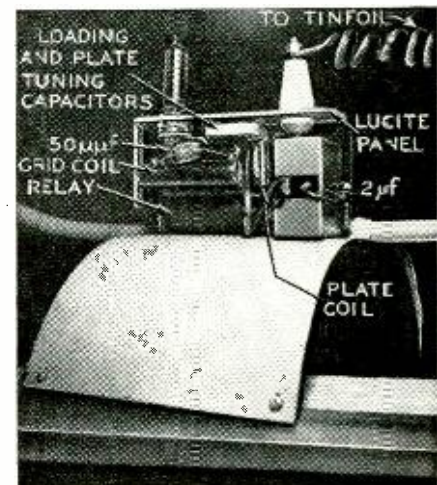

Fig. 4—Window tinfoil connects to relay.

connects to a 6-inch square of tinfoil fastened to the window. The power transformer is mounted under the bracket which supports the entire assembly.

Materials for eye-catcher

Resistors: 2—20,000 ohms, 5 watts; 1—10 megohms, 1 watt.
Capacitors: (Mica) 1—250 µf, 1—.01 µf, 3,000 volts; 1—50 µf, 500 volts. (Trimmers) 2—140 µf. (Paper) 1—2 µf, 600 volts.
Miscellaneous: Tubes: 1—807, 1—6V6, 6AQ5, or similar. Tube sockets. 1—Relay, 2,000 ohms, double-pole single-throw (one contact normally open, the other normally closed). 1—Power transformer, 700 volts c.t., 100 ma; 6.3 volts, 1 amp; 5 volts, 3 amp. 1—Pilot lamp, 6 volts, 50 ma. 1—Switch, single-pole single-throw. Hardware. Wire.

—end—

TUBE REPLACEMENT TIPS (Continued from page 37)

in front of you at the same time, is probably the handiest to use.

The photo shows an adapter under construction for permitting a 25Z6 tube to be used in a 25Z5 socket. Lengths of bare No. 22 wire have been soldered to the lugs of the octal socket and insulated with spaghetti. Each wire is threaded through the proper pin of the 6-prong base, the socket lugs are eased down inside the rim of the base, and then the wires are pulled tight and soldered. A little cement holds the socket firmly to the base.

When making an adapter from a loktal base, it will be found practically impossible to solder to the pins that formerly stuck up inside the tube. However, an inverted loktal socket can be shoved down over these pins; then the lugs of this socket can be connected

to the appropriate lugs on the socket of the substitute tube.

In some instances, it will be possible to solder heavy wires into the pins of an octal "button" pried from the bottom of a metal tube, and the substitute socket can be supported on them.

The subject of tube substitution is too vast to be covered in detail here. The average radio technician will do well to rely on the help given by the excellent books on this subject.

Two final admonitions: Always check alignment after making substitutions in r. f. and i. f. stages; paste a note or diagram on the chassis describing exactly what changes were made. This will help the next man and stamps you as a professional and ethical service technician.

—end—

TWENTY-FIVE years ago a service technician needed only a pair of pliers, screwdriver, tube tester, and volt-ohmmeter. Today even a one-man shop has much valuable equipment. Many service technicians still have their testing equipment scattered throughout the entire shop—on floors and shelves and stacked on the bench. By mounting test equipment on a panel, at easy eye level, one can save bench space, time, and energy, with less chance of damage to equipment.

I have mounted all my equipment on a single swing-out panel. Some instruments and ideas were taken from articles in *RADIO-ELECTRONICS*. As can be seen from the sketch, three hinges are necessary to support the whole assembly which swings out from another rear enclosure fastened to the wall.

(It might be advisable to make the panel in two sections, so that it swings out from each end, meeting in the middle or leaving a center piece for the oscilloscope. This will simplify construction. The photo showed more clearly than the printed cut that the third hinge differed from the other two. Apparently Mr. Maxeiner had trouble with his 6-foot door and had to add it later. —Editor)

The front framework for the panel is constructed from 1 x 6-inch material, in this case straight-grain No. 1 fir. It is screwed together and has four upright braces spaced according to the layout of the instruments; these braces are 1 x 2's and can be installed after the panel is fastened to the frame. The braces make the face of the panel rigid.

The paneling is tempered masonite $\frac{1}{4}$ x 30 x 72 inches and is fastened to the frame by 1 x 7 round-head wood screws, spaced at six-inch intervals. A similar framework of the same dimensions (height and length) is made for the rear on which the instrument panel frame is to be mounted, the depth of which depends upon the depth of the instruments. This rear framework is anchored to the wall, if possible, especially the upper left-hand corner and side as this must carry the weight of all of the instruments mounted on the panel. The left-hand side of the front panel is attached to the rear frame by three door hinges, thus allowing the entire front panel to be swung outward for easy servicing of test equipment.

When closed it rests upon a 1 x 6 upright attached to the rear framework. The height of this 1 x 6 upright depends upon the height the panel is to be from the top of the service bench.

When designing the layout of the instruments on the masonite panel, a well-balanced instrument panel can be obtained by making paper templates the same size as the instruments. The templates can be shifted around and placed where they will be suitable to your servicing needs.

Mounting instruments

Mount the instruments on the masonite by drilling the mounting holes smaller than the bolts to be used and

Novel Bench Has Swing-Out Panel

By HAROLD MAXEINER

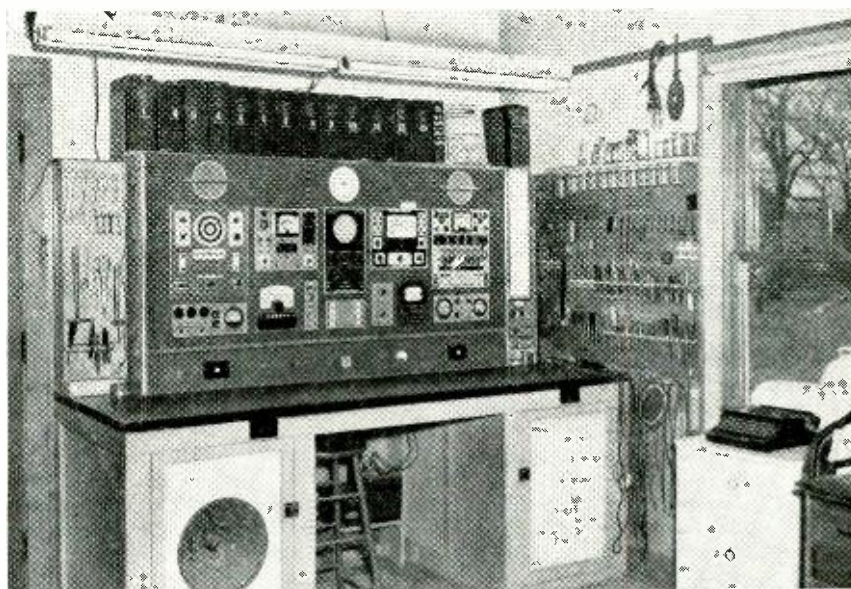

Panel swings out for instrument servicing. Note well planned equipment layout.

thread with a tap. The instruments are thus easily removed. Make each opening $\frac{1}{2}$ to $\frac{1}{4}$ inch smaller than the dimensions of the instrument to be mounted. For protection from dust in most instances the metal cases which originally housed the instruments can be placed over the instruments again and fastened to the rear of the panel by small metal angles. The oscillograph needs bracing.

The panel contains two rows of instruments. Above, from left to right they are: a SW generator and a high-fidelity 10-watt amplifier mounted on a single aluminum panel; another dual unit—capacitor checker, and 600 volt d.c. power supply which has a variable voltage from 0 to 90; Precision ES-500 oscillograph; Precision EV-10 v.t.v.m.; Precision 10-20 Tube Master.

The seven lower instruments are, from left to right: wattmeter used for appliances and TV sets which draw more than 150 watts; Jackson signal generator; speaker tester which connects to the two speakers on the panel top; switches and panel lamp indicators for the instruments, also the main switch for the entire panel; two substitution boxes, one for resistors ranging in value from 100 ohms to 1 megohm, the other for capacitors of 600-volt rating from .002 to 50 μ f; Triplet

model 1200-A volt-ohm-milliammeter; another wattmeter with a high and low range, used for a.c.-d.c. radios.

Below the main instrument panel is another narrow panel which does not swing out. It contains antenna and ground pin jacks, two special outlets for plugging in a flash soldering iron and an ampere meter connected to the 6-volt battery supply for checking auto radios. Note in photo the storage battery next to the stool.

The a.c. cords from all instruments were brought to individual switches on the switch panel (lower center). A d.p.s.t. master switch is used.

—end—

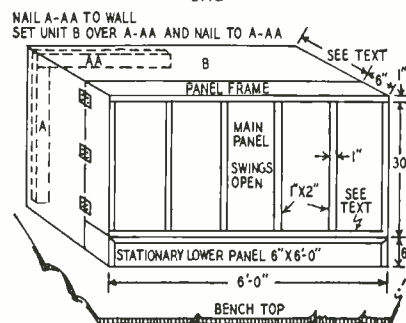

MAIN PANEL & LOWER PANEL ARE TEMPERED MASONITE

Dimensions of the frame. Door hinges are used to support panel weight.

Audio Feedback Circuits

Part XII—Problem—small bankroll and old amplifier; here's how to revamp properly

By **GEORGE FLETCHER COOPER**

WHenever I read in one of the technical journals articles describing how to construct something entirely new, I always wonder where the writer thinks the money is to come from. Most of us have some sort of audio amplifier around the house, and even if it isn't perfect, it is still not bad enough to junk completely. This month, I want to consider the problem of the old amplifier and the small bank roll.

Let us assume that you have an old amplifier, without negative feedback, which will give the power you need, and that you want to modernize it by adding feedback. The first step is to decide how much gain you have to spare; putting on feedback costs gain. Most amplifiers do have gain to spare. If you are unlucky there are two things you can try. First, get out that circuit diagram and see if there is any gain to be picked up around the stages. Maybe those plate loads in the early stages could be pushed up to scrape another 6 db. If you can't find any more gain, an extra input stage is the only solution. Most power-supply units will provide the extra power you need: 175 ma at 6 volts and about 1 ma at 200-300 volts for a 6AK5, for example. Since you want only about 20 db of gain at low level, practically any small tube will do, and to save money, connect it as a triode if you use a pentode.

I shall assume the output transformer is a small one, and it just about passes 50 to 10,000 cycles. Feedback improves the behavior at the low end. Not much can be done at the top or at very low frequencies and high level, either, once the transformer core reaches saturation. Feedback does not help then because the forward gain drops to zero during flux maxima, and the feedback vanishes for an instant. However, this just means that where you had intolerable distortion before, the distortion with feedback is unbearable. Any amplifier will overload if the level is too high.

Modification procedure

To begin the reform of the amplifier look back to Part II of this series and calculate the characteristic frequencies $1/RC$ for the coupling networks. The chances are that in a three-stage amplifier you will find you have two equal RC networks giving an ω value of about $1/RC = 300$, or even higher. Calculate the corresponding characteristic frequencies for the high frequency end,

too, guessing the stray capacitances: a carefully wired interstage will normally be about 20 μf . This will leave only the transformers as unknown elements. A word of warning here. If there is an interstage transformer you may as well give up at once. Trying to feed back round two transformers is no way to spend your spare time. Convert the whole circuit to an R-C system at once and save yourself trouble.

Now measure the over-all frequency response. Use a resistive load, not a speaker. You ought to take the response from 2 cycles to 200 kc. Take the top end as high as you can, anyway. We can try to find a trick to help out at low frequencies.

If you have a good oscilloscope, with wide-band amplifiers for X and Y plates, it is worth while to note the frequencies at which the phase shift is 90° and 180° . Put the input on one pair of plates, the output on the other: somewhere in the middle of the band you get a nice straight line, which you can arrange at 45° to the horizontal by altering the deflection amplifier gains. As you go up in frequency the figure

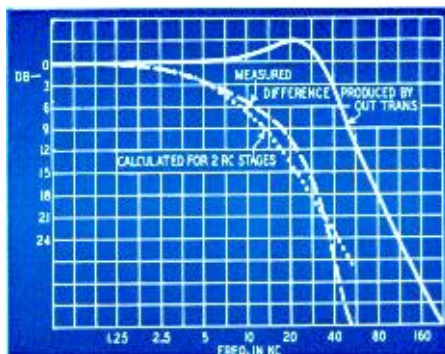

Fig. 1—Finding the output transformer response from measured overall response and calculated effect of RC coupling.

becomes an ellipse, which twists around and collapses to give a line sloping, when the gains are readjusted, 45° the other way. This is the 180° phase point and is obtained only with some care.

Before you reach this the ellipse will pass through a region in which one axis is horizontal, and if you readjust the gains here you will see a circle. The phase shift here is 90° . These two points (the 180° point is hard to get because of the reduced gain in the amplifier) are useful checks on the graphs we shall draw later. Even though I have a phase meter available I usually adopt this simple checking method.

Phase characteristics

Let us examine the high-frequency response. Plot the measured response on the same scale as you have been using for the amplifier and phase templates (Part II, Figs. 5, 8; Nov. 1950). Then plot the amplitude response corresponding to the calculated characteristic frequencies. The difference between these two curves represents the response of the unknown portion of the amplifier. I have done this for a particular example in Fig. 1.

There are now two possible approaches: The classical one is to use the straight-line approximations to the response curve for calculating the phase characteristic. The second is to use a smooth approximation from a set of suitable curves. The straight-line approximation method consists of drawing one or more lines which fit the observed amplitude response, and then using the rule that with a "semi-infinite slope" of 6x db per octave, the phase characteristic is that shown in Fig. 2. Usually with only an output transformer to worry about, x will be 2, and the over-all phase shift will be 180° . It seems to be more reliable to make use of some additional curves, however, if it is not too much trouble to find them.

By matching curves of this type to the amplitude response, the way is cleared for a calculation of the phase characteristic. In any normal circuit, the phase is completely determined by the amplitude response, and if you have been following this series you should be quite at ease with the way in which we combine the basic curves. The reason why we split off the calculable part was that this gives us more accurate results, and in addition makes it easier to see what happens when we modify the circuit.

This process is sufficient to enable a good guess to be made of the final performance of the system. Suppose that, as is almost certainly the case, that output transformer limits the response. You cannot expect the final response, with feedback, to extend much above the frequency at which the transformer gives 90° phase shift. Is it good enough, in your case? If you decide the answer is yes, or maybe, press on: if it is no, it means a new transformer, and then you can start the design from first principles.

Feedback

We now have all the facts and have decided to proceed with the design. How much feedback will the circuit accept as it stands? For home use, this is about 6 db less than the drop in amplitude response at the 180° point. Put on feedback and see if this is true. Probably you will not get the 20 db that professional amplifier designers regard as a minimum figure. It is then neces-

sary to process the response curves to enable more feedback to be used. Part V of this series, February 1951 (especially the extra RC across the plate load discussed there) contains the material needed to work this out.

It is easier to do the work on graph paper than physically try all imaginable combinations. I prefer calculating the shunt capacitance to bring the response down 3 db at the highest frequency allowable. This frequency is the 90° phase shift frequency in the output transformer (the equation $2\pi fCR = 1$ crops up again). Then put about one-third of the plate load in series with this capacitance: in Fig. 7, Part V, we have $R2 = R1/3$ and $C1R1 = 1/2\pi f$. The step in the response is then 12 db down, and the phase hump is about 38°. Two circuits of this kind give 24 db and 76°, and will normally do the job nicely. You can even make C1 two or three times bigger, because the feedback will flatten the response, and you don't expect high levels above about 1,500 cycles.

A few trial runs will determine the best values of these additional elements to be used. If you haven't been able to measure the response, start off by calculating C1 and R2 according to the one-third rule in the last paragraph and add these elements to each interstage coupling. The object of the mathematics in this patching work is to get the right order of magnitude at the beginning.

Low frequency

At the low-frequency end proceed in the same way: amplitude response, theoretical curves for the CR networks, resulting transformer response, calculated phase characteristics. If you have any measuring equipment, it is not difficult to find the transformer inductance. The impedance is 375 L ohms at 60 cycles, for example, so that a 60-h primary will pass just over 5 ma if you connect it in series with an a.c. meter across the 117-volt line. The other way of getting an idea of what the transformer is doing is to disconnect the load, working at a low level. If the output voltage rises 40% (3 db) the frequency is the characteristic frequency R/L. This is a quick and reasonably good way to get the answer you need, and you can calculate the phase and amplitude responses directly.

You will probably need to increase the RC product in the interstage couplings for low-frequency stability. You may do this by increasing the grid resistors, but do not go above 500,000 ohms here: the average tube will not take higher grid resistors. It is possible to increase the coupling capacitors, too, but large size and possibility of motorboating (positive feedback) may make it unfeasible if the coupling RC products are too big.

It saves a lot of trouble to jump straight to the use of the step circuit (Fig. 4 of Part V) with about a 12 db step in each stage. The rolloff can then begin at about 40-50 cycles and you get the protection you need against motor-

boating. This double RC circuit has been found to give extremely stable amplifiers, without forcing the use of large capacitors.

All you need to do now is to connect in the feedback resistor. In Part VIII, June, 1951, there is a table of the methods of connection. I favor a straight resistor brought back to the cathode. Provided the resistance is high, as it usually can be, there is no need to put a capacitor in to block the direct current. This helps the low-frequency stability conditions. A variable resistor, such as a half-megohm carbon potentiometer, is conveniently used as the feedback resistor. The value can be reduced until instability occurs: this test is best carried out with a signal applied.

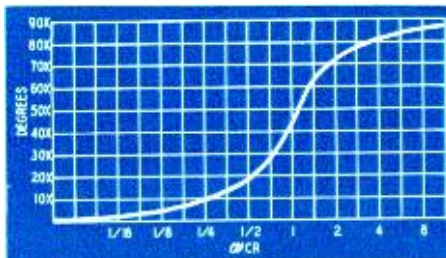

Fig. 2—The phase characteristic for a semi-infinite slope of 6x db per octave.

An oscilloscope is a great help here, because if instability occurs only during part of the cycle, the resulting fuzz is easily seen. Without the scope you can only listen for distortion. It is better to use a square-wave input with the scope. As feedback increases, ringing on the square waves increases: feedback can be adjusted to make sure that the amplifier is adequately damped. Using this method I have actually run amplifiers which were unstable with the input grid circuit open, and stable with it closed: the building up and dying away of oscillations was clearly seen.

Compromise solutions

The above design process has been a discussion in general terms capable of the widest possible solution. Poor output transformers always complicate things, and there are compromise solutions which are easier to apply.

Simplest of them all, in theory, is to feed back from the cathode of the output stage, so that the current through this tube is undistorted. This is a troublesome arrangement in practice, not because it becomes unstable, for the stability is usually very good, but because if the output tube is a tetrode, the cathode current usually includes the screen current. The feedback keeps the cathode current undistorted, but as the screen current is usually pretty distorted at high levels, the plate current is not at all what you expect. The distortion may even increase when feedback is applied.

At high frequencies, where this circuit is widely used, in coaxial cable repeaters, for example, it is easy to avoid this trouble by decoupling the screen back to the cathode. At audio this means an extra choke and electrolytic capacitor. Moreover, as we saw in

Part VIII, this increases the output impedance, which we do not want.

My usual compromise is to put on some feedback from the output tube plate, and the rest from the actual output winding. The low-frequency problems in this design are exactly the same as those discussed above. They can be made easier by feeding back only to the cathode of the last but one stage, because we do not expect much distortion in the input stages.

It is easy to put on about 10-15 db of feedback this way, and then add an extra 6-10 db round the whole amplifier. The inner feedback loop reduces the impedance of the amplifier, and includes the low frequency distortion behavior of the output transformer. The leakage inductance of the output transformer only appears in the outer feedback loop, so that a bad output transformer is much easier to keep under control. The high-frequency response is not improved by the inner loop feedback, but only by the over-all feedback.

Instead of considering the two final stages with their feedback loop as a sub-amplifier, using your mu-beta effect calculator (Part IX) to work out the response and calculating the over-all behavior, the simplest approach seems to be: put in a set of the double RC circuits, to save time in the long run. Add an inner loop feedback resistor to bring the gain down about 12 decibels. Measure the response to the plate of the output stage, and make sure that this response droops gently. If it shows a tendency to bump upward, put 50-100 μ f, or suitable capacitance across the feedback resistor. Then add the main feedback loop, and push the feedback to the instability point.

A year ago, when I began writing this series, I said I would not provide you with a cook book approach to the negative feedback amplifier. This article has quite consciously avoided the cook book approach. No quantities, just a hint of how they cook capon around Bayonne. If you are a cook, the rest is up to you. This article is meant to give you the general idea, and to set you on the right road. When it comes to adding feedback to your present amplifier, you can add some inside the speaker transformer, perhaps some positive round the first stages, and at least some of the negative feedback from the speaker winding itself. The more high-frequency resonances the transformer has, the less feedback you can take from the secondary winding.

One final word of warning: do not rush light-heartedly into the addition of feedback to Class B amplifiers. When the output transformer is not completely symmetrical you can get quite different phase and amplitude characteristics for the two halves of the cycle with a sine wave input. Cures are possible, but they take an enormous amount of trouble, and it is cheaper to get a new transformer. And, whatever the amplifier, plan what you are going to do before you start work.

—end—

Basic Intercom Units— Theory and Practice of Modern Systems

Small and large systems
described; only simple
amplifier theory needed

By EUGENE P. HANAFIN, JR.

MANY service technicians do not solicit intercom work because of the seeming complexity of the lines and switching systems. But intercom work is actually quite simple. The selling, installing, and servicing of such systems should be a natural for service technicians desiring additional income—particularly for those who do not wish to make the plunge into TV servicing, and whose over-all business is decreasing.

The modern multistation intercom system combines the principles of radio and telephony. The a. f. amplifiers and speakers are essentially those used in radio receivers or low-powered PA systems; The lines and switching arrangements are based on telephone circuits.

A very elementary two-station intercom system is shown in Fig. 1. Station 1 (the *master* station) is composed of a low-power amplifier and a small PM loudspeaker which serves as a mike also. Station 2 (the *remote* station) is only another PM speaker like the one at the master.

A person at the master communicates with the remote by talking into the speaker at the master. Sound waves, hitting the cone, move it and its voice coil, which moves in the magnetic flux across the permanent magnet gap and functions like a small a.c. generator. It produces an a.f. voltage which serves as the input signal to the amplifier. This can be demonstrated by connecting the voice coil of almost any PM loud-

speaker to a low-range a.c. voltmeter or millammeter. Speaking results in oscillation of the meter pointer, thus indicating the presence of small a.f. components. The amplifier drives the speaker at the remote station.

The circuit of Fig. 1 is hardly a complete intercom system, since it is a one-way arrangement. Communication can proceed in one direction (from the master to the remote) only—the remote cannot answer back.

A two-way system

A circuit permitting two-way communication between station 1 (master) and station 2 (remote) is shown in Fig. 2. This arrangement is identical with Fig. 1 except a double-pole double-throw switch has been added. It is called a "talk-listen" or T-L switch, and has two positions. The spring action of such a switch normally keeps it in listen position, Fig. 2. In this position, the amplifier input is connected to the remote station and the amplifier output is connected to the PM loudspeaker at the master. This setting permits speech to go from the remote to the master.

In operation, a person at the master wishing to communicate with the remote would press the T-L switch to talk position, Fig. 3, and speak into the master loudspeaker to attract the attention of a party at the remote. The T-L switch is then released, returning to listen position (Fig. 2) so the party at the remote might answer back. Two-

way conversation could then proceed, subject to manipulation of the T-L switch at the master.

A multistation system

The arrangement in Fig. 2 would be satisfactory for a system requiring only one remote station and a master (stations 1 and 2). Additional remote stations could be connected to the master of Fig. 2 by connecting them in parallel with the remote station. This would not be practical because it would require more amplifier power and because all conversations could be heard

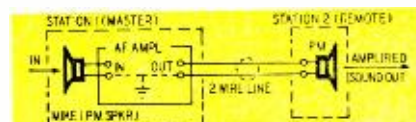

Fig. 1—A basic two-station intercom system for one-way communication.

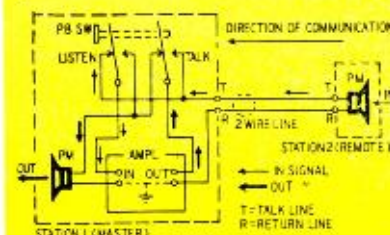

Fig. 2—Two-way communication circuit. A d.p.d.t. switch has been added.

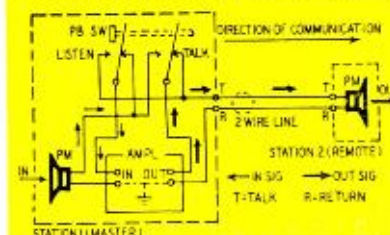

Fig. 3—In "talk" position, speech proceeds from the master to remote.

at all stations in the system. A practical way of incorporating more stations in the system is to add some form of selector switch to the master. A single-circuit six-position switch is shown in Fig. 4.

The selector switch as shown permits station 1 (master) to call and communicate with any of five remote stations, depending on whether the switch is set on contact 2, 3, 4, 5, or 6. A separate line for each switch point connects that point to its remote station. In Fig. 4 the selector switch has been set to permit communication between station 1 (the master) and station 3 (a remote). Manipulation of the T-L switch, as described and illustrated in connection with Figure 2, permits two-way communication between these two stations. Other stations in the system would not be affected by the conversation between stations 1 and 3, and could not overhear this conversation. Station 1 could call and communicate with any other remote by merely setting the selector switch to connect to that station.

Note that one tap on the selector switch of Fig. 4 is not used. This is customary because if the master was left connected to any remote station when the system was not being used for communication, sounds originating at or near that station would be picked up, amplified by the master, and reproduced by the master loudspeaker. This is prevented by returning the selector switch to the unused tap, such as tap 1 in Fig. 4, at the termination of each period of communication. This unused tap on the selector switch is used for other purposes in more elaborate systems, and will be explained later.

Fig. 4 shows two connections to each remote station. One of these connections is common to all stations in the system, or is connected to a line (the "R" line) which functions as a common return line to all other lines in the system. This common return line connects to the chassis of the master amplifier, as shown by the ground symbols in the block representation of this amplifier in Fig. 4.

Calling the master

While Fig. 4 shows a flexible and practical intercom system, all calls must originate at the master station. A separate buzzer system, with a pre-arranged code to identify the remote, could be combined with the intercom system, but a more practical way is a remote call arrangement in the system. This may be done by installing a single-pole double-throw switch in each remote, running an extra line ("call" line or "C" line) as a common line to each station, and connecting this C line to the unused tap (tap 1) on the selector switch at the master, as shown in Fig. 5.

The master T-L switch is normally in listen position, so the closing of any remote call switch will connect that remote station to the input of the master amplifier via the call line which connects to all stations. The person at the remote may actuate the remote call switch, speak into the remote station loudspeaker, and be heard by a person at the master. In calling, he would identify the remote by saying "Please call station 3," or some equivalent. The remote call switch would then be released to resume its normal position (as shown for station 2 of Fig. 5).

The person at the master answers the call from the remote by placing the selector switch on the tap for that station (station 3, in this instance) and actuate the T-L switch to talk position. Communication between the master and the remote would then proceed, subject to manipulation of the T-L switch, and without further use of the remote call switch.

As shown in Fig. 5, the call switch of station 3 (a remote) has been set to permit station 3 to call station 1 (the master), while the call switch of station 2 (a remote) is in released or normal position. A remote call switch is used only to call to the attention of

a party at the master the fact that communication is desired, and this switch and the common call line are not used after communication has been initiated.

Intercom amplifiers

An amplifier typical of those used in intercom systems is shown in Fig. 6. It is a conventional two-stage amplifier like the last two stages of almost every a.c.-d.c. receiver. In fact, the power and a.f. sections of such a receiver can be easily converted into a good intercom master station by removing the r.f. sections and installing the proper T-L and selector switches and a multi-plug or terminal strip for the lines to the remotes.

Isolation problems

The power supply is usually a.c.-d.c., which poses isolation problems. Most modern intercoms run the line to a negative bus, isolated from the metal cabinet used in many models. Cheaper and older types may have "hot" chassis. Special care is required in servicing or installing such equipment. No part of the system may be permitted to contact an actual ground, such as a water pipe, electrical conduit, or radiator.

Ground symbols in the diagram of Fig. 6 may represent connections to bus in some intercoms and to chassis in others. The average output power required is about 3 watts, and they draw about 35 watts from the power line. The input transformer has a winding L1 to match the voice coil impedance of the loudspeakers used, and a high-impedance grid winding, L2. Winding L3 on the output transformer matches the plate circuit of the output tube, and a sec-

ond winding L4 matches the loudspeaker impedance and is equal to that of L1. Intercom input transformers are available.

To reduce line losses, it is customary to use special PM loudspeakers which have 50-ohm voice coils, instead of the usual 2, 4, 6, or 8-ohm voice coils. Such loudspeakers are available, together with input and output transformers having voice-coil windings (L1 and L4 in Fig. 6) of the same impedance. However, low-impedance voice-coils are satisfactory for short lines. The line switch S1 would be in "on" position at all times to avoid warmup delay when communication is desired.

Although not shown in these schematics, a low cost, a.c.-d.c. intercom amplifier can be constructed using selenium rectifiers instead of tube type rectifiers. The advantages in this are low replacement cost and long life.

Between-station lines

All stations of an intercom system are connected by special intercom cable which is available with up to 72 conductors. Wire gauge is 22 A.W.G., tinned. Such cable is usually run from the master to the nearest remote, and continues throughout the system until all stations have been connected. This is termed "loop" wiring. It is entirely practical to run the cable directly from the master to various remotes in the form of branch wiring if, for any reason, that is the most practical method. The loop system, Fig. 7, is usually the easiest and most economical (with respect to the working time) required for installation.

—end—

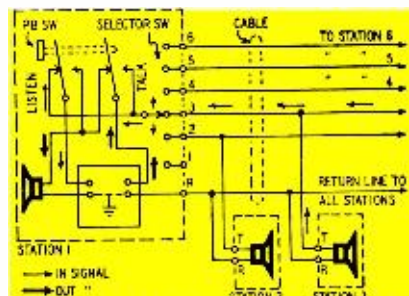

Fig. 4—Using a selector switch, the master station can call five remotes.

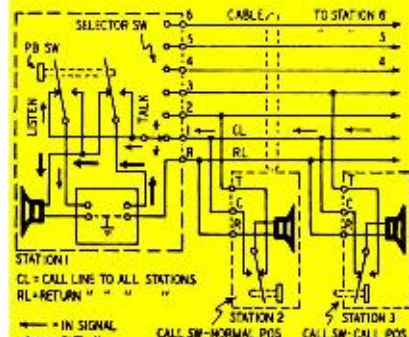

Fig. 5—Remotes initiate call to master with s.p.d.t. switch and common call line. Remotes must give identity.

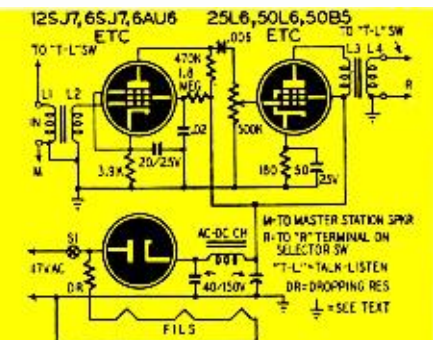

Fig. 6—An a.c./d.c. 3-watt amplifier for the intercom system.



Fig. 7—Loop wiring method is the easiest and most economical way to connect intercom system elements.

Electronics and Music

Part XVI—The Hammond organ continued; preamp, vibrato, reverberation, speakers

By

RICHARD H. DORF

THE only electronic sections of the Hammond organ are those following the tone-generator and harmonic-mixing circuits. Because the instruments do not contain vacuum tubes Hammond prefers to call it an *electric* rather than an *electronic* musical instrument.

Fig. 1 is a schematic of the entire Hammond electronic circuit. Parts of the circuits differ somewhat from model to model but this diagram gives a good over-all picture.

Fig. 8 in last month's article showed the tone-generator and drawbar system, ending at the primary of the matching transformer. Refer now to Fig. 1. The secondary of the matching transformer is connected to a rheostat box. It contains a rheostat which is operated by the foot pedal to control expression or volume; the shaft is connected to the pedal by a rod, which can be seen in last month's Fig. 2. The rheostat is across the transformer secondary, in series with a capacitor and coil. This

makes it impossible to lower the volume to zero. The rheostat box ends with a three-resistor voltage divider which has two taps brought out to terminals. When the organ is installed, the proper tap to give the desired amount of output signal is selected.

Fig. 2 shows one of the rheostat boxes used in models which have a tremulant. The tremulant varies the *volume* at a slow rate, approximately 6.33 cycles. It is in effect a rheostat in series with the high side of the circuit and it is mechanically varied from minimum to maximum resistance and back at the tremolo rate. It is actually a series of five resistors ranging in value from 15,000 to 450,000 ohms with their junctions connected to contacts. A laminated bakelite strip is positioned so it can slide between the contacts, one after another, and break them. The strip is alternately pushed in and out of the contact assembly by an eccentric geared to the shaft of the tone-generator motor. The gearing ratios are such that the action takes place at approximately 6 cycles per second. This varies the net resistance of the tremulant switch and the output volume from the rheostat box.

The 130,000-ohm tremulant control is directly in parallel with the varying tremulant switch. When the control rheostat is shorted (by adjusting the knob on the console) the switch is also shorted out and the volume remains constant. At maximum resistance, the tremulant switch works at maximum efficiency and the 6-cycle volume changes are maximum. At intermediate settings of the control, the switch has a smaller effect on volume. Thus the degree of tremolo can be controlled. There is no way of controlling the tremulant speed.

The preamplifier

Several preamplifier circuits have been used in various Hammond models. The one in Fig. 1 is representative. At its input there is a tone-control circuit, actually a mild bass booster, consisting of three series resistors and a series capacitor. This is adjusted at installation. It compensates for room acoustics.

The input stage of the preamplifier is a cathode-coupled phase inverter. The organ signal goes to the grid of the upper tube. The cathodes of both tubes are grounded through a common 3,300-ohm resistor. The signal on the upper tube causes a voltage drop across the cathode resistor, as in a cathode follower. The same cathode voltage

HARMONIC TABLE

Fund. Key	DB I Sub fund.	DB II Sub 3rd	DB III Fund.	DB IV 2nd H.	DB V 3rd H.	DB VI 4th H.	DB VII 5th H.	DB VIII 6th H.	DB IX 8th H.
C 16	4	23	16	28	35	40	44	47	52
C# 17	5	24	17	29	36	41	45	48	53
D 18	6	25	18	30	37	42	46	49	54
D# 19	7	26	19	31	38	43	47	50	55
E 20	8	27	20	32	39	44	48	51	56
F 21	9	28	21	33	40	45	49	52	57
F# 22	10	29	22	34	41	46	50	53	58
G 23	11	30	23	35	42	47	51	54	59
G# 24	12	31	24	36	43	48	52	55	60
A 25	13	32	25	37	44	49	53	56	61
A# 26	14	33	26	38	45	50	54	57	62
B 27	15	34	27	39	46	51	55	58	63
C 28	16	35	28	40	47	52	56	59	64
C# 29	17	36	29	41	48	53	57	60	65
D 30	18	37	30	42	49	54	58	61	66
D# 31	19	38	31	43	50	55	59	62	67
E 32	20	39	32	44	51	56	60	63	68
F 33	21	40	33	45	52	57	61	64	69
F# 34	22	41	34	46	53	58	62	65	70
G 35	23	42	35	47	54	59	63	66	71
G# 36	24	43	36	48	55	60	64	67	72
A 37	25	44	37	49	56	61	65	68	73
A# 38	26	45	38	50	57	62	66	69	74
B 39	27	46	39	51	58	63	67	70	75
C 40	28	47	40	52	59	64	68	71	76
C# 41	29	48	41	53	60	65	69	72	77
D 42	30	49	42	54	61	66	70	73	78
D# 43	31	50	43	55	62	67	71	74	79
E 44	32	51	44	56	63	68	72	75	80
F 45	33	52	45	57	64	69	73	76	81
F# 46	34	53	46	58	65	70	74	77	82
G 47	35	54	47	59	66	71	75	78	83
G# 48	36	55	48	60	67	72	76	79	84
A 49	37	56	49	61	68	73	77	80	85
A# 50	38	57	50	62	69	74	78	81	86
B 51	39	58	51	63	70	75	79	82	87
C 52	40	59	52	64	71	76	80	83	88
C# 53	41	60	53	65	72	77	81	84	89
D 54	42	61	54	66	73	78	82	85	90
D# 55	43	62	55	67	74	79	83	86	91
E 56	44	63	56	68	75	80	84	87	92
F 57	45	64	57	69	76	81	85	88	93
F# 58	46	65	58	70	77	82	86	89	94
G 59	47	66	59	71	78	83	87	90	91
G# 60	48	67	60	72	79	84	88	91	92
A 61	49	68	61	73	80	85	89	92	93
A# 62	50	69	62	74	81	86	90	93	94
B 63	51	70	63	75	82	87	91	94	95
C 64	52	71	64	76	83	88	92	83	76
C# 65	53	72	65	77	84	89	93	84	77
D 66	54	73	66	78	85	90	94	85	78
D# 67	55	74	67	79	86	91	83	86	79
E 68	56	75	68	80	87	92	84	87	80
F 69	57	76	69	81	88	93	85	88	81
F# 70	58	77	70	82	89	94	86	89	82
G 71	59	78	71	83	90	83	87	90	83
G# 72	60	79	72	84	91	84	88	91	84
A 73	61	80	73	85	92	85	89	92	85
A# 74	62	81	74	86	93	86	90	93	86
B 75	63	82	75	87	94	87	91	94	87
C 76	64	83	76	88	83	88	92	83	88

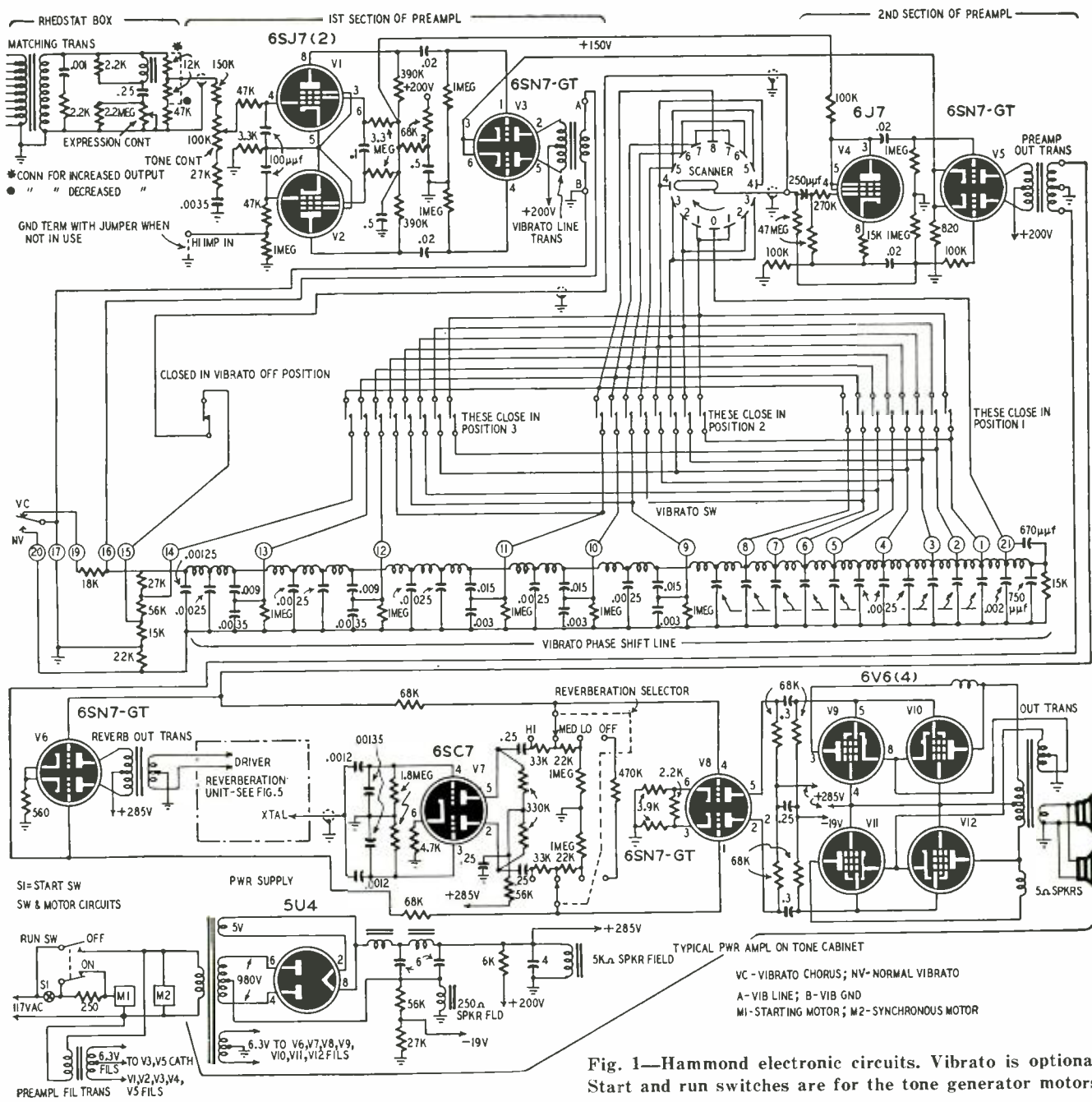

Fig. 1—Hammond electronic circuits. Vibrato is optional. Start and run switches are for the tone generator motors.

then appears between the cathode of the lower tube and its grid, which is effectively grounded through a 47,000-ohm resistor. Thus both tubes are excited equally and 180° out of phase by the one input signal. While the grid of the lower tube is normally grounded through a 47,000-ohm resistor, the ground jumper can be removed and a high-impedance phonograph signal connected. Not all preamplifiers are suited for high-impedance inputs. Before connecting external signals to a particular organ its instruction booklet should be consulted since even organs of the same model number may differ slightly.

Vibrato scanner

In models without vibrato, the output of the 6SN7 which immediately follows the 6SJ7's is transformed to low imped-

ance and a line is run from the transformer secondary to the power amplifier in the tone cabinet. Fig. 1, however, shows the circuit of later models, many of which have a unique vibrato circuit. Since there was no good way of varying the frequencies of the tone generators at the vibrato rate, the problem was solved by an interesting phase-shift system.

Fig. 3 is a block diagram of the vibrato circuits. A signal from the pre-amplifier 6SN7 is fed to the input of a delay line. A frequency-discriminating circuit shifts the phase of the signals going through it. A delay line is a compound low-pass filter made up of L-C components. The filter shifts the phase of signals passing through it by an amount depending on the frequency of the signal and the upper cutoff fre-

quency of the filter. Phase shift is 180° at the cutoff frequency.

A continuing shift in phase is effectively the same as a shift in frequency. While the phase is changing, frequency effectively changes as well, the amount of apparent frequency change depending on the speed of the phase change and the total phase shift. This method is well explained in an article beginning on page 71 of the June, 1950, issue of RADIO-ELECTRONICS.

Returning to Fig. 3, the signal passing through the delay line is shifted in phase slightly by each filter section. We have, then, the same signal at the junction between each pair of sections, but at increasing phase differences. A rotary scanner, Fig. 4, has a set of capacitor plates rotated at the end of an arm by a shaft. Around the housing

perimeter are stator assemblies, each a set of capacitor plates through which the rotor plates pass. Each stator is connected to one point along the delay line.

As the rotor goes around, it picks up signals capacitively from each stator in turn. The rotor is connected to the input of the second section of the pre-amplifier. The 6J7 therefore is fed the organ signals constantly shifting in phase and the effect is of a continuous small frequency change—a pulsing effect—like the tone a violinist gets by moving his finger quickly back and forth on a string.

The delay line is shown in detail in Fig. 1. Three degrees of vibrato are

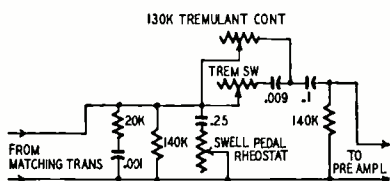

Fig. 2—Rheostat box in models with tremulant selects amount of output signal from the tone generators.

available and an additional “vibrato chorus” effect. With the switch in the “normal vibrato” position the input signal is fed directly across the input to the phase-shift line. With the switch in “vibrato chorus” position, a portion of the organ signal is fed right to the top of the delay line and appears on the scanner rotor without phase shift. Mixing with the phase-shifted signals, it produced an effect of a chorus of instruments since the same signal then goes through simultaneously with two different and constantly changing phase relationships.

The three degrees of vibrato are produced by scanning less than the entire delay line. They are selected by closing one of three 8-pole, single-throw switch assemblies, as shown in Fig. 1. For wide vibrato (position 3), 8 points of the filter are scanned between points 14 and 2. In position 2, the scanner picks up signals only between points 11 and 1; in position 1, only points between 8 and 1 are scanned. As can be seen by the numbering of the scanner stators in Fig. 1, although the rotor rotates continuously the scanning is carried on in a back-and-forth manner because there are two rotors for every switch point and they are cross-connected. When the vibrato switch is off, a contact connects the two sections of the preamplifier together directly, bypassing the delay line and scanner.

Reverberation control

“Live” music is usually heard in large halls, so most people are accustomed to a certain amount of reverberation caused by sound reaching the ear from the instrument and from echoes reflected from walls and ceiling. A limited amount of reverberation produces a more interesting effect than single-source music for the same reason that a chorus of instruments playing in

unison is more interesting than a single instrument.

Hammond organs are often used in homes and small halls where the room is either acoustically “dead” (sound is absorbed by rugs and draperies) or too small to allow long duration echoes. Hammond therefore created an artificial reverberation control unit, Fig. 5. The reverberation control is an electro-mechanical device which introduces multiple echoes by reflections within a network of coil springs. The unit is about 4 x 5 inches in cross-section and about 4 feet high. It is concealed within a tone cabinet such as the DR-20.

As Fig. 1 indicates, the signal from the preamplifier output is fed to the two grids of a 6SN7 in the tone cabinet. The plates of the 6SN7 are connected through a transformer to the reverberation unit driver. The same pre-amplifier output signal is also fed to the input grids of the 6SN7 preceding the power amplifier.

Reverberation action

The reverberation driver is a moving coil assembly similar to a dynamic speaker without a cone. The audio-frequency coil movement is transmitted to the stirrup directly under it (Fig. 5). The two enclosed springs (C, D) under the stirrup hold it in position but permit it to move freely up and down; the spring at the far left (A) balances the pull of the others. These three springs

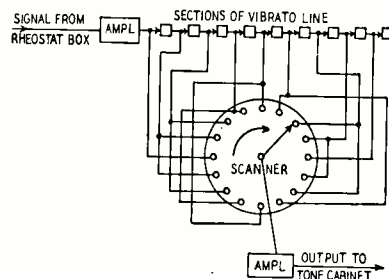

Fig. 3—Vibrato circuit block diagram. For wide vibrato (position 3), 8 points of the filter are scanned between points 14 and 2. In position 2, the scanner picks up signals only between points 11 and 1; in position 1, only points between 8 and 1 are scanned.

A sound wave from the stirrup travels down the open spring (E) at the far right to a crystal pickup, where it creates an electrical signal. This is the “first reflected signal” and is delayed about 1/15 second from the original signal which went directly to the power amplifier, because sound travels more slowly in the spring than in an electric circuit or in air. The output of the crystal is fed through a 6SC7 and a three-step attenuator to the power amplifier (Fig. 1). Thus, for a single, short, sharp musical note, the speaker will first emit the sound which comes to it directly in the form of an electrical wave, then about 1/15 second later it will again emit the same sound which came to it, this time via the reverberation spring.

The same wave from the stirrup (Fig. 5) also travels down the second spring from the left (B), which enters a short oil tube. From the bottom of

this spring the wave is reflected back along the spring, reduced in intensity by the oil damping. At the stirrup the horizontal lever transfers the wave to the right-hand spring (E) and it goes on to the crystal to produce a “second reflected signal” about 3/15 second after the direct signal.

Little of the energy of each wave is absorbed by the crystal, and the rest is reflected back up the spring (E). There it is transferred by the lever to the spring (B) in the short oil tube. It goes down that spring, is reflected up, and again goes down the crystal spring. The process continues over and over, giving a series of signals about 2/15 second apart until finally all the vibration is dissipated by the oil friction in the short tube. Just above the short oil tube a reflecting pin attached to the spring causes partial reflection and helps make over-all response uniform.

It is interesting to note that the amount of oil in the short tube varies the amount of energy loss at each repeated reflection, and therefore changes the total length of time during which the reflections keep going. Adjusting the level of oil is a simple way to simulate rooms of different sizes and reverberation characteristics. A reverberation selector switch operates a balanced pair of potentiometers to select the amount of reverberation signal to be added to the direct signal. The switch is in the tone cabinet and must be adjusted (usually at the time of installation).

Power amplifiers and speakers

The tone cabinets contain the loudspeakers and power amplifiers, as well as reverberation units in some models. Several tone-cabinet models are available, differing in power output, type of speakers, size, and shape. Two power outputs are used, 20 and 40 watts. The power amplifiers are similar and conventional; most employ push-pull parallel 6V6's as output tubes. The 40-watt units usually contain a pair of 20-watt amplifiers, sometimes on the same chassis.

The problem of fidelity here is not the same as in radio-phonograph systems. In the latter we need crispness and direct sound paths to the ear. In organs the necessity is for maximum diffusion of sound to avoid the point-source effect. Fidelity is not so important, for high

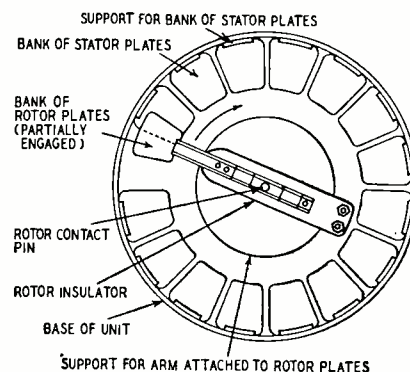

Fig. 4—Vibrato unit uses rotary scanner to shift the phase of organ signals.

transient frequencies and peaks are not present (though a good bass is necessary sometimes). As a result it is very rare to find tweeters used in tone cabinets and it is quite common to have loudspeakers pointed upward at the ceiling instead of at the listeners.

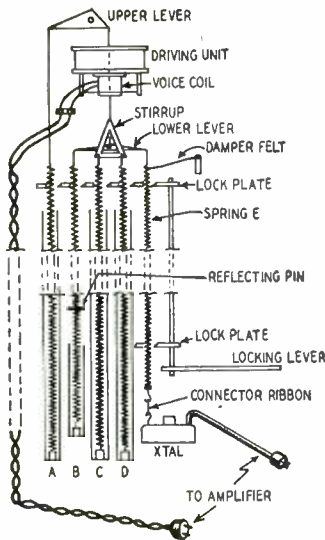

Fig. 5—Reverberation control unit. Springs delay sound, create "live" music.

The DR-20 tone cabinet contains a 20-watt amplifier and two 12-inch speakers directed toward the ceiling. It may also contain the reverberator. In the 40-watt tone cabinet, the treble is produced by two 12-inch speakers directed upward. Bass tones are produced by a bank of nine 10-inch speakers mounted on a vertical baffle and projecting sound through the front grill.

The ideal solution is to provide a tone chamber for the loudspeakers. If the chamber is very rigidly constructed, with reverberant walls made of concrete or tile, it provides a more desirable type of reverberation than the reverberation control. The chamber should be as large as possible, at least 800 cubic feet in volume for best results.

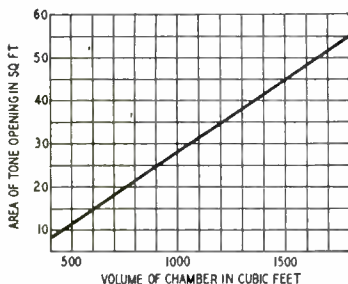

Fig. 6—Ideal openings for tone chambers of loudspeakers; the ratio is 2:3:4.5.

Ideal ratios for the chamber are about 2:3:4.5, and there is an ideal opening size for each chamber size (Fig. 6).

Harmonic synthesis

Readers have written asking questions about instruments in the planning stage. Many indicate that their instruments will use a harmonic synthesis system for tone coloring, like that in the Hammond. To help those with the

problem the Harmonic Table has been worked out.

The first column gives the 61 keys of a five-octave manual. The nine following columns show what frequencies are used for each of the harmonics and subharmonics in the coloring system and the Hammond drawbar controlling each.

In every case here, the number refers to the keys in the Frequency Chart on page 42 of the August, 1950, issue of RADIO-ELECTRONICS.* That chart shows the 88 piano keys, numbered from 1 to 88, with the frequency of each given to four significant figures. From the Frequency Table here and that Frequency Chart, the reader can tell, for example, that for the lowest manual key, C, the fundamental frequency is No. 16, 65.41 cycles; the subfundamental is No. 4, 32.70 cycles; and the 3rd harmonic is No. 35, 196 cycles, and so on. Note that most Hammonds have only 91 generators so that some doubling up is necessary at high frequencies and on higher harmonics. This can be avoided by providing additional generators, but the fact is that as the fundamental gets high the exact harmonic structure no longer is so critical to the ear. The extra generators, weighed against the economic and space requirements, are not usually worth while.

Fig. 7 is a sketch of one set of draw-

bars with their names and pitch lengths taken from standard organ phraseology. The pitch lengths in feet are: Suboctave, 14; Quint, 6 1/3; Fundamental, 6; Octave, 4; 12th, 2 2/3; Superoctave, 2; Tierce 1 3/4; Lariget 1 1/2; Top Octave, 1. The roman numerals indicate the ordinal numbers of the bars which are

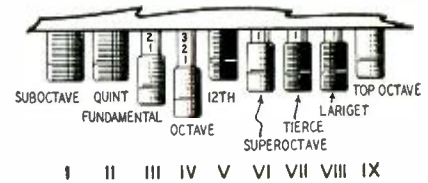

Fig. 7—Drawbars use organ terms. Numbers refer to the Harmonic Table.

noted at the heads of the columns in the Harmonic Table. For instance, the octave drawbar IV refers to DB IV, 2nd harmonic.

Another feature of some Hammond models is the pedal solo unit. This is very much like the Hammond Solovox and will be described along with the Solovox in a future article.

*Readers can obtain the August, 1950, issue for 35 cents from RADIO-ELECTRONICS, 25 West Broadway, New York 7, N. Y.

(continued next month)

Rockefeller Center Civilian Defense Control Board



Rockefeller Center has a major civil defense problem since it has a population equal to that of a good sized city. To control defense activities, a control board has been set up on the second floor of the 70-story RCA building. As shown in the photo, it is well equipped. Operation is simple. The man at the left in the picture will receive calls in any emergency from each of the building wardens in the Center. Instructions are relayed to specially trained first aid and fire fighting squads over the Motorola Uni-Channel Sensitive Dispatcher unit at the right. Outside phones link the Control Board to city facilities.

Old-Time Circuits

The graveyard of old circuits is still being robbed; we find that old hook-ups work well

By JOHN W. STRAEDE

Possibly the most famous hookup of antiquity—the Flewelling circuit—as shown in the original patent application.

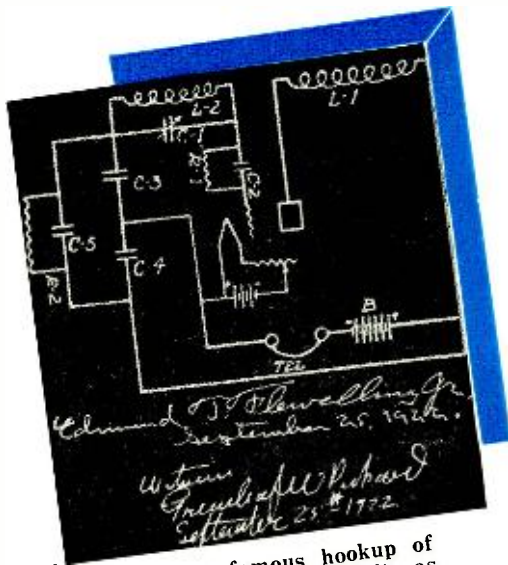

THE history of radio receiver design is full of splendid examples of ideas which were discarded only to be revived years later in improved form. Diode detection (if we exclude crystal detectors), probably had the longest lapse of any idea. Nearly all of us remember the early superheterodyne, which had a brief vogue in the early '20's and then disappeared for 10 years or so, and the Armstrong Flivver (superregenerative 1-tuber). These have been revived (see Fig. 1). The regenerative detector, Fig. 2-a, (remember Reinartz and Schnell?) has never vanished, for short-wave enthusiasts have kept it alive. In England it has remained as a standard type of broadcast receiver. Bandpass preselection (see Fig. 2-b), has also survived in England, and revived once (though only feebly) in Australia. Not every type of superhet has been revived—the stroboscopic converter is still in oblivion.

Early circuit designers and inventors concentrated on such things as one tuning circuit, automatic regeneration

control, improved sensitivity, freedom from whistles, simplicity of control, and getting as much as possible from the fewest tubes. A circuit could be put in one of three classes:

1. One-tubers (and 2- or 3-tubers) of high performance. These included the reflex receivers (many of which used crystal detection) and superregenerators, space-charge detectors, Megadyne, and others which used regenerative detectors.

2. Simplicity of control. Either regeneration was not used (or rather was not shown on the circuit diagram) or was controlled automatically. In this class we had the Neutrodyne, Isofarad, and Peridyne which used ganged tuning capacitors for "single control"; also the Lodge N in which regeneration was automatically set for the ends of the band.

3. Highly unorthodox. The circuits which ranged from the crazy Retrosonic (which so far as I can discover, never worked) through a 4-tuber "super" which was supposed to heterodyne straight from r.f. to a.f., to circuits of

high performance including the Interflex and Cockaday.

Now which of these old-timers have been revived, which are really dead, and which may reappear? From class 1, the reflex has already reappeared, mostly in low-priced superhets; an inexpensive FM-AM receiver consisting of only two or three tubes uses superregeneration, and the crystal diode is definitely back. Space-charge detectors and amplifiers may seem defunct at first sight, but the Philips (Australia), tube manual lists tetrode tubes specially made for space-charge operation.

Most of the highly unorthodox receivers have disappeared for good. Occasionally the interflex principle of crystal-in-grid-circuit is seen, usually in simple sets for beginners. The Cockaday (Fig. 3-a) essentially a regenerative detector with crude preselection and an absorption type regeneration control, is quite dead and likely to remain forever so. Likewise the Auto-plex with variometer tuning, the Tropadyne super and the Flewelling. One defect in all the last four was that at least one tuning circuit had both sides of the variable capacitor "hot," thus putting difficulties in the way of using modern grounded-rotor ganged capacitors.

The bandpass system of preselection never quite died, and may make a comeback. It has a big weeding-out of signal before the first tube, resulting in freedom from cross-modulation in t.r.f. receivers or image interference in a superheterodynes. See the circuit on page 33, July, 1949, RADIO-ELECTRONICS.

We come now to an entirely recent revival of the regenerative detector. This new circuit gets over the notorious "whistle" or "squeal" difficulty in a novel manner. A large amount of regeneration is used at all times—in fact an oscillator is kept going. But the circuit is arranged so that the oscillator

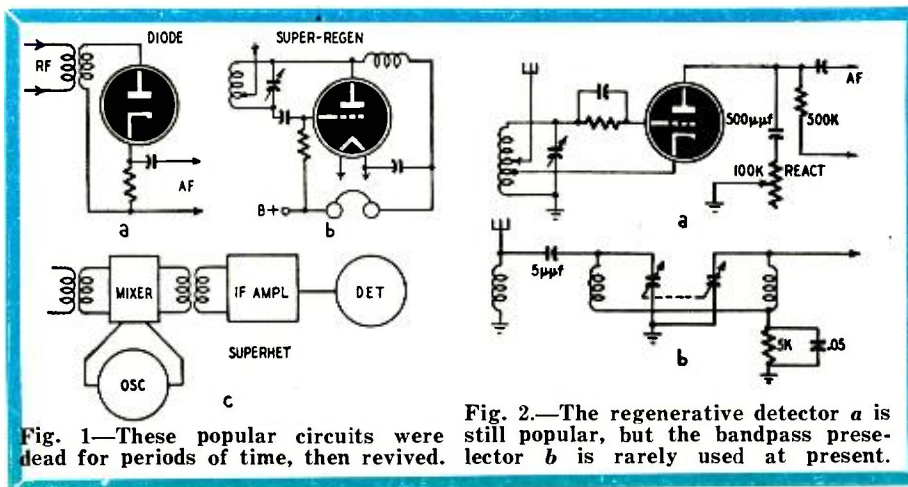

Fig. 1—These popular circuits were dead for periods of time, then revived.

Fig. 2.—The regenerative detector a is still popular, but the bandpass preselector b is rarely used at present.

frequency will jump into sync with that of any signal of usable intensity to which the oscillator is nearly tuned.

The principle is shown in Fig. 4. Provided the signal has a certain intensity there is absolutely no cutting of sidebands, so the circuit is very well suited for hi-fi reception. The hexode portion of a 6J8-G is used as a detector—either plate or grid-leak—while the triode is used as a separate oscillator (over 25 years ago people with tubes to spare used to try dividing a regenerative detector into two tubes). Through a potentiometer, part of the signal is fed into the oscillator circuit to “lock-in” much the same as the synchronization control of a cathode-ray oscilloscope works.

Note that the oscillator frequency of the 6J8-G is *not* different from the signal frequency; there is absolutely no heterodyning—the oscillator frequency is the signal frequency. The larger winding of the oscillator coil is the secondary of an ordinary r.f. or antenna coil and is tuned by a variable capacitor of full size. There is no padder, no i.f. transformer, and no alignment procedure.

The 6J8-G is the one and only detector. (Other triode-hexodes may be used, some English and Continental types being particularly suitable). Selectivity depends on the amount of synchronization applied to the oscillator (the amount required depends on the strength of oscillation, and sensitivity also depends on this strength). It is possible, in more elaborate circuits of this type, to obtain extreme selectivity without sacrifice of sideband quality. A complete constructional story on the synchrondyne appeared in the April issue of RADIO-ELECTRONICS (page 44).

Now let us look at another approach to receiver design. Suppose selectivity

and r.f. gain are separated. Suppose that *all* the selectivity is obtained by preselection circuits and that the resulting minute signal is amplified at radio frequency, then detected and amplified as usual. Complete freedom from cross-modulation and shock-effects is obtained, and by staggering the tuning of the various circuits a wide bandwidth with very sharp cutoff can be obtained. An early receiver in which tuning and amplification were separated was the Jones' Technidyne shown in principle in Figure. 5 The old Sparton Equasonne was an excellent example of this type of receiver. The modern “negative-mutual” coupling coils may be used in constructing a bandpass preselector. Of course the untuned r.f. amplifier must be carefully shielded and really aperiodic.

With modern tubes, resistance-capacitance coupling may be used, plate resistors being about 30,000 ohms, coupling capacitors about 20 μf , and grid resistors about 100,000 ohms. Ordinary a.v.c. can be applied to the r.f. amplifier.

A third “modern” circuit containing a large number of revivals is the “Scotchman's super,” an attempt to get everything for as little as possible. There is only one tuning circuit, the aerial-to-grid coupling being a resistance as in some of the old “hi-Q” receivers of 1928-30. A regenerative interflex (to new-timers, a crystal plus tube detector with regeneration), with fixed reaction acts as a power detector with sufficient output for a small speaker. This set will be described completely in a forthcoming article.

All-wave reception is possible by the use of either plug-in coils or a switch.

REFERENCES

- 1 Australian Band-Pass Receiver. *Listener-In Handbook*, No. 11. (The Mighty Atom).
- 2 A High-Fidelity Tuner-Amplifier. *Radio-Electronics*, July, 1949, page 33.

- 3 Methods of Band Pass Coupling. *Radiotron Designer's Handbook*.
- 4 Old-Time Circuits. *Radio-Craft*, July, 1945.
- 5 One-Circuit Super. *Australasian Radio World*, 1942.
- 6 Oscillodyne. *Radio-Craft*, Dec., 1949 (page 78).
- 7 A Practical Synchrondyne. *Radio-Electronics*, April, 1951, page 44.
- 8 Regenerative Interflex (Space Charge). *Popular Science*, May, 1939 (page 209).
- 9 Superregenerative Receiver. *R.C.A. Manual R.C.-15*, *Radio-Craft*, Dec., 1947 (FM), Jan., 1948.
- 10 Synchrondyne. *Electronic Engineering* (England) Sept., 1947.
- 11 Technidyne. *Drake's Radio Cyclopeda* (3rd. Edition).

(Readers may be interested in building the Flewelling circuit. They will need a bakelite or doped paper cylinder about 3 inches in diameter, inside which a 2 1/2-inch cylinder is free to rotate on a shaft. On the outside cylinder are wound 60 turns of No. 24 wire—on the inside one, 120 turns of No. 26 or 28. C1 is a 365- or 500- μf variable, C2 a 250- μf mica. C3, 4 and 5 are .006- μf mica. R1 and R2 are both 5-megohm potentiometers. The tube can be any convenient one, though one with high mutual conductance will work best. A 6C5 or 6J5 should work well, though a dry-cell tube could be tried. B-voltage for the 6C5 or 6J5 should be from 90 to 180. All-wave reception is possible by the use of eight plug-in coils or a switch.—Editor)

—end—

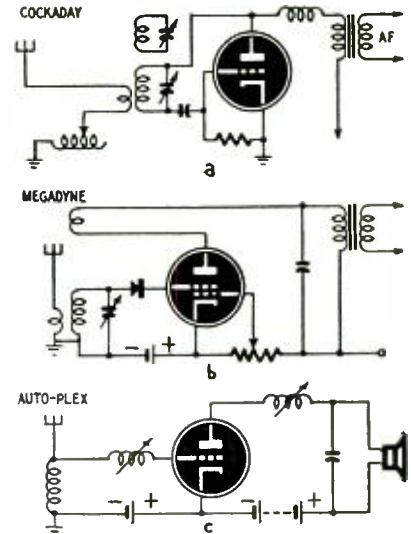

Fig. 3—Three famous circuits of old; the Cockaday, Megadyne and Auto-plex.

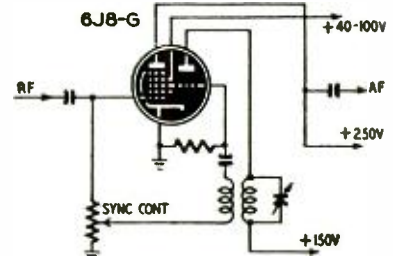

Fig. 4—No squeal in this regenerative.

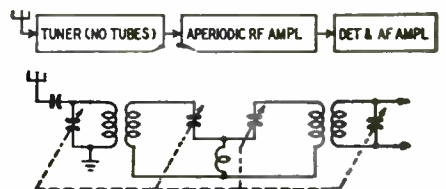
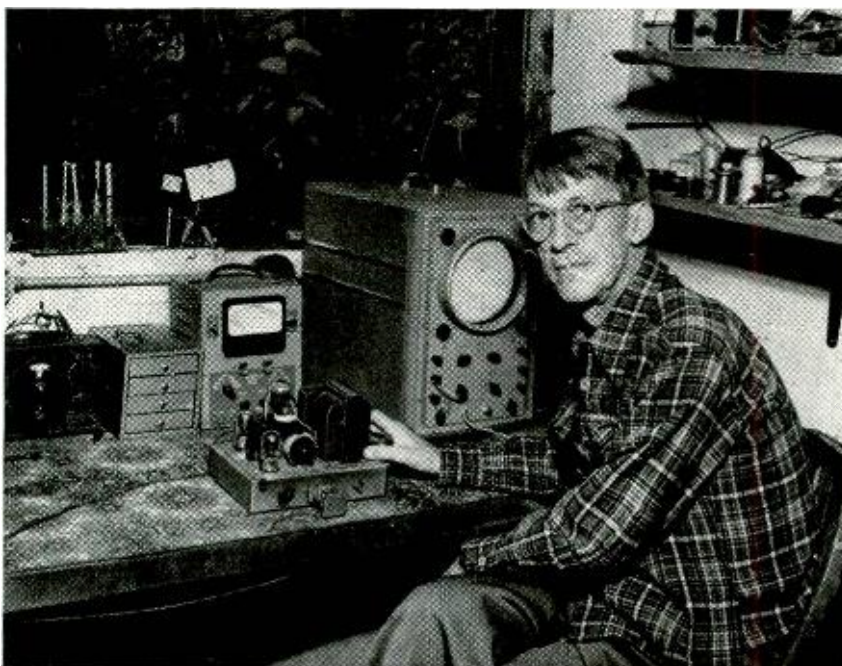

Fig. 5—Selectivity, r.f. gain separated.



E. T. Flewelling listens to Europe on a 1951 version of his superregenerative.

Garage-Door Opener

By THEODORE W. HALL

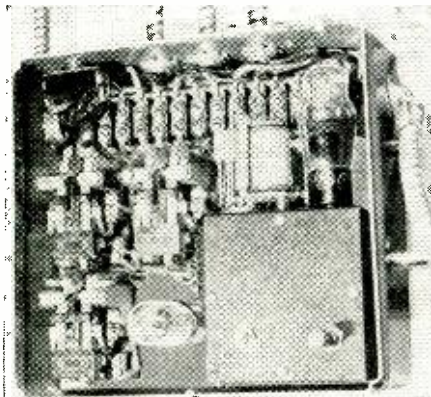

Receiver mounted in garage; note BX cable safety wiring and terminal strip.

THIS garage-door opener gives service as effective and reliable as far more complex types, and at a fraction of the cost. It uses a low-powered induction transmitter (an ordinary buzzer), thus reducing radio and television interference to a minimum. The receiver is also very simple, with a single 0A4-G and a d.p.s.t. relay. The motor and relays in the control circuit are protected in case of jamming or obstruction in the path of the opening or closing door.

Although several circuits can be used as an induction transmitter in this remote-control system, the circuit shown in Fig. 1 has the marked advantage of simplicity. It consists of a transmitting coil suspended under the car, a modified door buzzer, and a push-button, all connected in series and powered from the car battery.

In building this circuit, the original winding on the buzzer must be removed, and the coil forms refilled with No. 18 cotton-covered wire. This maintains the over-all circuit resistance at a minimum and produces a maximum output signal from the transmitter.

The make-and-break action of the buzzer contact causes an interrupted current to flow through the transmitting coil, and the resulting pulsating magnetic field induces the voltage into the pickup coil of the receiver.

A 0.5- μ f capacitor is connected across the buzzer contact to suppress the arc and insure an instantaneous interruption of current. The size of this capacitor may vary with the circuit constants in individual transmitters, and should be adjusted to the nearest nominal value which gives the best arc suppression at the contacts.

The receiver

Shown in Fig. 2 is the induction receiver. The starter-anode of a type 0A4-G control tube is biased to a point just below the trigger voltage of the tube by a resistance divider. The signal from the transmitter is picked up by the coil buried in the driveway and is added to the grid voltage to trigger the tube. This closes relay RY1, a 2,000-ohm, 15-ma relay, which initiates the motor-control circuit. The 12- μ f capacitor is needed to prevent contact chatter, un-

less the relay is designed for half-wave current operation.

The push-button connected as shown provides a convenient way of manually energizing the motor-control circuit for testing, and the R-C filter in the plate circuit is effective in preventing false operation from lightning or line transients.

A 5-watt universal output transformer serves as an impedance-matching device between the coil and the grid circuit. The transformer connections which result in the best sensitivity, and also the over-all system performance, can best be checked by making a temporary setup with the two coils separated approximately 18 inches. Adjustments can then be selected which will cause the receiver to operate with a minimum of bias voltage. In actual use this bias control, of course, will be set just below the

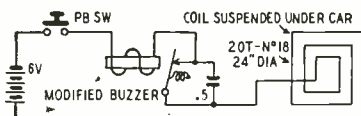

Fig. 1—Induction transmitter uses buzzer.

trip point, and will allow a radius of operation of two or three feet with this coil spacing.

Control circuit

The motor-control circuit Fig. 3 requires three medium power relays in addition to RY1 in the receiver. These relays were G-E type 2790 control relays, but any relay with a 117-volt a.c. operating coil and d.p.d.t. contacts heavy enough to handle the motor current will work satisfactorily. In a second set a Potter and Brumfield model MR11A relay with a 117-volt 60-cycle coil operated excellently. The limit switches are microswitches with s.p.d.t. contact arrangement.

In operation, with the door in the UP position, the UP-LIMIT switch is depressed. When RY1 in the receiver is closed momentarily, RY3 is energized and holds in through the normally closed contact on the DOWN-LIMIT switch. Relay RY3 applies power to one winding of the motor through a normally closed contact on RY2, and, at the same time energizes the reversing relay RY4. Reversing the connections to the second motor winding runs the door to the closed position where it depresses the DOWN-LIMIT switch. This breaks the hold-in circuit on RY3, removing power from the motor and the reversing relay RY4.

The operation of the door from the closed position is practically the same, except that RY2 is energized and held in by the UP-LIMIT switch, and the reversing relay RY4 does not close.

As a safety precaution, a 20-second heater-type time-delay relay is connected in the circuit as shown. In normal operation this heater is never energized long enough, or frequently enough, to open its normally closed contact. If, however, the garage door is obstructed and cannot complete its travel to the opposite limit switch, the time-delay relay will operate and disconnect the motor power by releasing RY2 or RY3. The time-delay relay may be a Ward-Leonard type 363, Leach 1157-T, or Advance type 350.

The accompanying photograph shows the receiver installation. The transmitter requires no additional explanation. The receiver and control equipment are

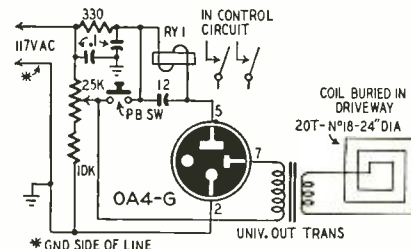

Fig. 2—Door-opener receiver circuit.

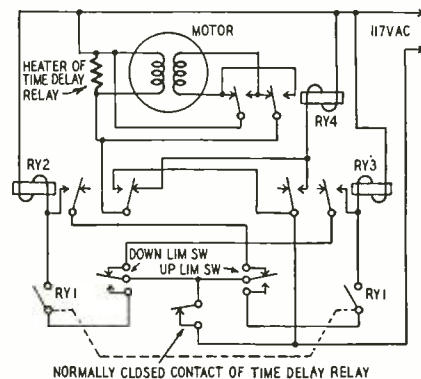

Fig. 3—The motor control schematic.

assembled on a panel and mounted in a steel knock-out box, with the receiver push-button extending through the cover of the box for manual operation. This arrangement provides a completely enclosed unit that can be wired with armored cable, but still allows ready access to the components for servicing and replacement.

Materials for door opener

Resistors: 1—330, 1—10,000 ohm, 1 watt; 1—25,000-ohm potentiometer.

Capacitors: (Electrolytic) 1—12 μ f, d.c. (Paper) 1—.5, 2—.1 μ f, 400 volts, d.c.

Relays: (Receiver) RY—1, 2,000 ohm, 15 ma, d.p.s.t. (Motor Control) 1, 20-second, heater-type, time-delay (see text); RY—2,3,4, 117-volt, a.c., d.p.d.t.

Miscellaneous: Tubes: 1—0A4-G and socket, 2—Pushbuttons, normally open, 1—5-watt universal output transformer, 1—Door buzzer, Wire: No. 18 for coils; hook-up. Solder. Hardware, Chassis.

—end—

Which—AM or FM?

England Ponders

Best system in doubt after year's test;
winner to be the standard v.h.f. system;
government may still enter a dark horse

By RALPH W. HALLOWS

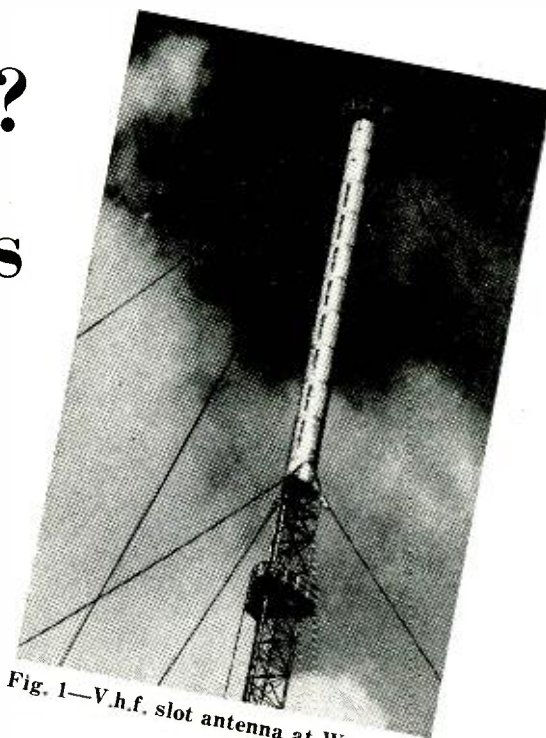

Fig. 1—V.h.f. slot antenna at Wrotham.

SOME TIME ago the British Broadcasting Corporation realized that it would have to provide a nationwide v.h.f. broadcasting service soon. The reason is simple: the medium-wave band is so overcrowded on this side of the Atlantic that interference-free reception can't be guaranteed even from high-powered transmitters at short range. For example, I have not been able for months to rely on receiving programs from the 100-kw London station which transmits on 247 meters (1214.5 kc), though it is barely 16 miles from my home.

If a full-sized v.h.f. network is planned, the first thing to decide is whether it will be AM or FM. No reliable or completely unbiased data was available, at any rate, not for high-powered services. The BBC concluded that the only recourse was:

1. Build AM and FM transmitters of approximately equal output power, each to be the best of its kind that could be designed and each to maintain the same standards of high fidelity.
2. Install both at a site which could serve the whole London area; when it would be decided which system was the best, the equipment not required would be dismantled.
3. Broadcast the same program simultaneously on AM and FM—with separate carrier frequencies, of course—from the same antenna.
4. Provide a large number of observers with a standard, specially designed, high-fidelity receiver, so arranged that the listener could switch instantly from FM to AM or vice-versa.
5. Conduct the tests for at least a year and arrive at no final decision until the mass of listeners' reports—and the economic aspects

of the FM-AM problem—had been fully considered.

The tests have now been going on for more than 12 months with carrier frequencies of 91.4 mc for FM and 93.8 mc for AM. It is expected that the report will appear shortly. I believe that report will be of worldwide importance. Completely free from any kind of political or commercial bias, it will show conclusively which of the rival systems has proved itself the better.

The transmitters

The dual transmitting station is at Wrotham (pronounced something like Rootum) in the county of Kent. The site is 730 feet above sea level, so that the 470-foot mast gives a total antenna height of 1,200 feet. Fig. 1 shows the v.h.f. aerial and part of the triangular

support mast. The aerial, which is shared by both transmitters, consists of 32 slots in the wall of a cylinder 110 feet long and 6½ feet in diameter. The slots are arranged in eight tiers, four slots in each tier.

The FM transmitter has a power output of 25 kw, and the AM is rated at 18 kw (unmodulated), which comes to just about the same thing. Both transmitters can deal faithfully with audio frequencies up to 15,000 cycles, but the normal range covered is 30 to 13,000 cycles, with a linearity better than ± 1 db. The maximum available deviation for the FM transmitter is ± 100 kc; ± 75 kc is generally used.

Fig. 2 shows the transmitter hall. In the foreground is the 25-kw FM transmitter, and beyond it is the 18-kw AM

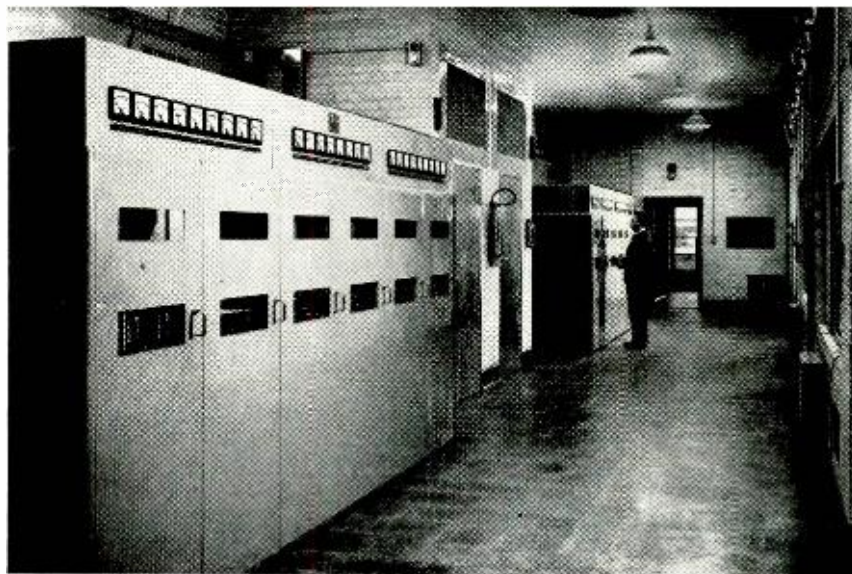

Fig. 2—V.h.f. transmitter hall, with 25 kw FM unit, foreground, 18 kw AM, rear.

transmitter. The kiosks, from which the transmitters are controlled, are behind the windows in the wall on the right. The two doors between the transmitters give access to the air ducts forming part of the tube cooling system.

The first thing that strikes you on going into the transmitter hall is the much smaller size of the FM assembly. The modulator of the AM transmitter has to supply a pretty large part of the total output power and is therefore rather large. The FM gear is thus more compact, since it requires no such giant modulator.

The AM transmitter needs no special comment; but its FM partner incorporates a new drive system, developed by the Marconi Company and known as F.M.Q. (Frequency Modulated Quartz). Fig. 3, another view of the v.h.f. transmitting station at Wrotham shows: top, the F.M.Q. drive for the FM transmitter, consisting of a directly modulated crystal oscillator and a series of frequency multiplying stages; bottom, first r.f. amplifier stage, consisting of one C144 double tetrode, and (above) second r.f. stage, consisting of two TT16 tetrodes.

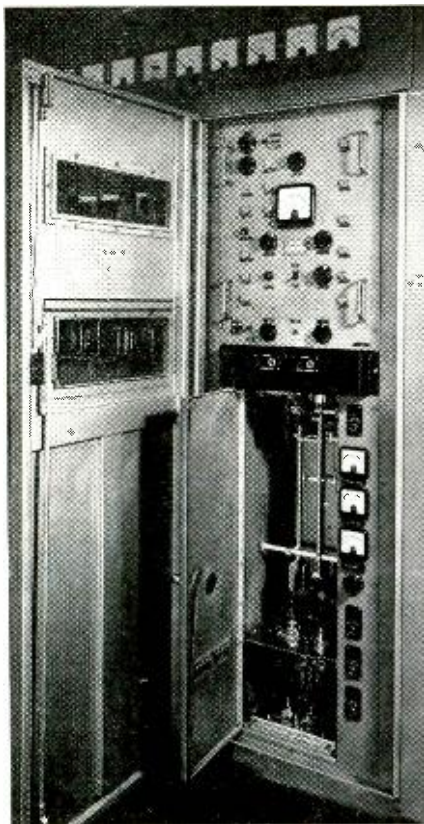

Fig. 3—The FM transmitter uses a new, frequency modulated quartz drive system.

The oscillating crystal is directly modulated and the carrier frequency is at all times crystal controlled. With 100 kc deviation, the center frequency change is less than ± 10 parts in one million. The crystal is cut so that it produces no harmonics inside the operating range of frequencies.

The modulating audio signal, after passing through a low-pass filter and

an attenuator, is fed to a balanced pair of push-pull modulator tubes, the output of which goes to the crystal oscillator by way of an amplifier. Part of the r.f. output of the crystal is fed through a phase-splitter to the modulator tubes. The susceptance of the balanced modulator is varied by the applied audio signal and the frequency generated by the crystal is correspondingly varied. In other words, the oscillations generated by the crystal, which controls the carrier frequency, are frequency-modulated by the a.f. signal; hence there is no instant at which the carrier and its deviation are not completely taken care of by the crystal.

The standard receiver

This receiver (see Fig. 4) is made to BBC specifications by R. N. Pitton and Company and was designed by F. H. Beaumont. It represents the finest FM/AM high-fidelity table radio (range 87.5-95 mc) that can be made, with little regard to cost. There are five controls in addition to the on-off switch on the right side of the cabinet. Reading from left to right these controls are: FM volume; AM/FM change-over (a 3-position switch; the middle position gives AM plus the noise limiter); AM volume; signal muting (this enables a dead quiet background to be obtained with the set on); tuning. The maximum undistorted output is 5 watts. A high-grade loudspeaker is fitted with a corrector network designed by the BBC.

The circuit uses 18 tubes (including two rectifiers and two stabilizers). The r.f. and i.f. stages are common to both systems, the intermediate frequency being 14 mc. The first FM limiter acts also as AM detector. The output of the AM detector is fed to one half of a double-triode a.f. amplifier, the output of the discriminator being fed to the other half. The noise limiter can be used, as we have seen, with both AM and FM. The oscillator is kept dead steady by temperature compensation and by the voltage-stabilizing circuit; a.f.c. is also provided to make doubly sure, the grid biasing voltage being taken from the discriminator.

The extended bass response of the receiver was an interesting problem, for it was found that with conventional circuit arrangements it tended to swing the whole high-voltage line stability. The answer was to isolate the output tube's plate circuit from this line and to provide it with its own plate-voltage supply by means of an auxiliary rectifier and smoothing circuit. The fidelity of the receiver for both FM and AM is ± 2 db from 30 to 12,000 cycles. For both, the sensitivity is 2 watts into the speaker for less than 150 μ v input (at ± 75 kc deviation in the one case and 40% modulation in the other) and the over-all distortion 1.8%.

Which system is going to be chosen? From my own experiences and those of friends who live at various distances from the transmitting station I'd be inclined to back FM so far as perform-

ance is concerned. Points are: the FM range is rather better—the carrier amplitude doesn't vary and you get good reception in any place where the signal is strong enough to operate the limiter; much less volume compression is needed—no fear of fading very soft passages right out, or of unsatisfactory signal-to-noise ratio in view of the dead quiet background; FM certainly seems to deal better with automobile ignition interference than AM, a serious problem in the region of 90 mc.

Performance, though, isn't the whole story. There are other considerations; the questions of initial cost and upkeep expenses. Some feel that if a popular priced FM receiver is produced it will need realigning at short intervals by the serviceman. This will cost the listener money. Those who hold this view claim that if AM reception is nearly as good as FM that it should be chosen out of regard for the pockets of the listener.

It will be a close thing between the two. All things considered, I back FM to scrape home by a narrow margin. But at present the problem still remains to be decided.

(From latest reports received from Mr. Hallows as we go to press, it seems that the issue is more in doubt than ever. He says, in part:

"The debate in the House of Commons has done no more than provide us with a new Radio Mystery. . . There is no possible doubt that FM proved itself the victor in the tests. The BBC has come out strongly in favor of it.

To everyone's surprise, the Postmaster General announced during the debate that a recent development made it inadvisable to decide in favor of either AM or FM.

Though he would give nothing away, the impression left was that he had another sort of modulation (possibly pulse) in mind.

Top BBC engineers are as mystified as the rest of us and know nothing of any such development. If there is a new development likely to compete with AM and FM, it is something produced by the engineering department of the post-office. There are some brilliant people there, and it is possible that they really have got something."—Editor)

—end—



Fig. 4—AM/FM receiver designed for tests is linear, ± 2 db, 30-12,000 c.p.s.

How an Electronic Brain Works

Part XIII—SEAC, the 800-tube Thinking Machine

By **EDMUND C. BERKELEY** and **ROBERT A. JENSEN**

IN the last five articles, we discussed the organization of an automatic electronic digital computer (for short, an electronic brain). In the seven before those, we described the organization of a similar machine made out of relays. Now in this article—the last one of the series—we shall take a good look at one of the big automatic electronic digital computers. This one is the National Bureau of Standards Eastern Automatic Computer, SEAC. It began to operate in May, 1950.

Fig. 1 is a picture of SEAC in one of the buildings on the grounds of the National Bureau of Standards in Washington, D. C. But, like any photograph of a machine that handles information, this photo does not tell very much.

SEAC came to be built as a result of three factors. The first of these was the demonstration that giant electronic computers could be built and made to work. ENIAC, now at the Ballistic Research Laboratory in Aberdeen, Md., proved that. ENIAC started working in 1946 and has been working ever since.

The second factor was the decision of the office of the Air Comptroller, Department of the Air Force, in early 1948, that it needed a big automatic computer for the study of supply programs for the Air Force. The question is: what sort of materials and personnel should be supplied and trained at what times, so that the United States should have the best possible Air Force? This is a prodigious planning problem, and it must be planned. The Air Force set up Project SCOOP (Scientific Computation of Optimum Programs) for this purpose.

The third factor was private industry's continuing delay in constructing giant automatic electronic digital computers. Two firms received government contracts for big electronic computers in 1946-47. One finished its first machine in 1951, the other company has not yet finished its first big computer.

So the Air Force and the Bureau of Standards got together in early 1948; and by the end of 1949, the machine system, the circuits, and the construction techniques had been settled on, and construction begun. The machine SEAC was completely assembled in March 1950. After some preliminary computing, it ran its first significant practical problem in May, 1950. This short period of 20 months was a fine

accomplishment. The main reason was the decision to stick to well-established techniques.

The appearance of SEAC

When you walk into the room where SEAC is, and see the front of the machine, it looks like Fig. 1. It is about 15 feet long, 5 feet deep, and 8 feet high. The nine racks are: 1, 2, 3, the control unit; 4 and lower 5, the arithmetical (or computing) unit; upper half of 5 and all of 6, the time pulse generator; rack 7, upper half, the clock pulse generator; rack 7 lower half, spare; racks 8 and 9, controls and power supplies, and also the circuits for the input-output systems using punched tape (this is the first of the planned input-output systems). But there is more to SEAC.

If you walk around the machine to the right, and go behind, you find another large bulky cabinet about 5 feet wide, 3 feet deep, and 7 feet high. This contains the machine's "memory," or rather the first installment of the memory of the machine, the "serial memory." This cabinet consists of 64 units like the one shown in Fig. 2—a long glass tube filled with mercury, mounted in an aluminum holder, and

connected to recirculation amplifiers; these units are "mercury delay lines" (see Article VIII). Each of these tubes stores eight units of information called "words." The words are usually numbers, but may be sets of logical indications, or instructions to the machine.

If you take a good look at a certain part of the machine, you will see an assembly like that shown in Fig. 3. This is an inside view of a section of the main part of SEAC. It shows, first, long fiber tubes containing short lengths of electrical delay lines—"rapid memory"; and, second, clusters of germanium diodes mounted in the tube bases—used as high-speed electronic switches.

The register which stores instructions (which we called the "program register" in our last article) is shown in Fig. 4. Fiber turrets support the resistors in the gating circuits; these turrets make the resistors accessible, and allow them to cool. In aluminum shields on the rear of the chassis, there is a coiled electrical delay line which can delay for 48 microseconds. When the computer is working, this delay line stores an instruction word (consisting of 48 binary digits) in continuous circulation.

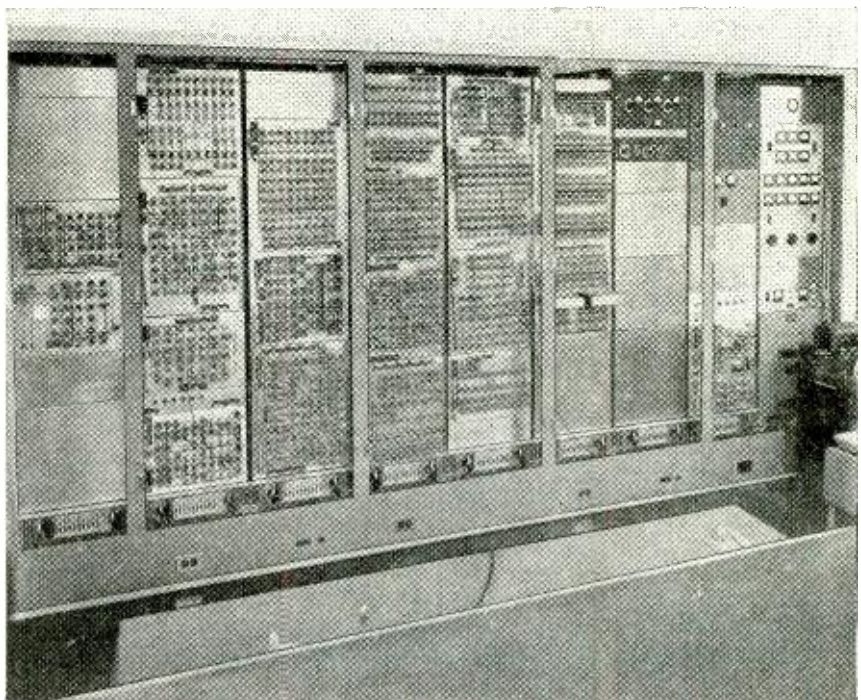

Fig. 1—Front view of SEAC shows nine racks holding all but the memory unit.

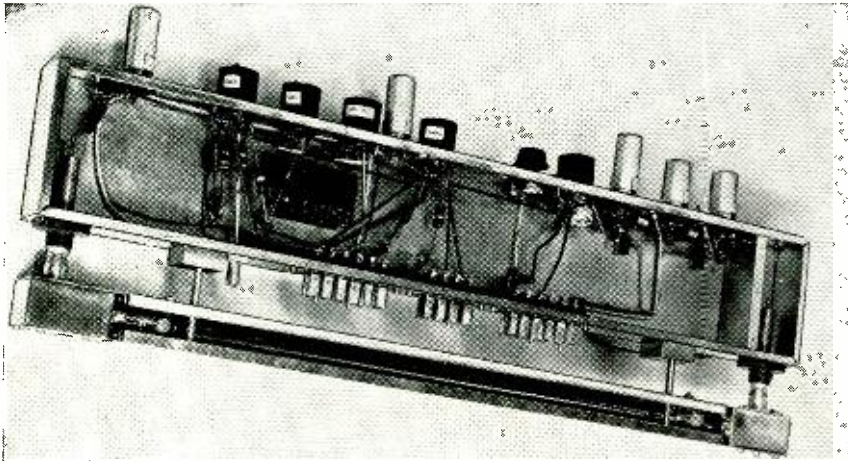

Fig. 2—One of 64 mercury delay lines in the serial memory section of SEAC.

How SEAC is organized

The over-all block diagram of SEAC is shown in Fig. 5, as drawn by the Bureau of Standards. The switch symbols indicate electronic operations performed automatically under the direction of the control unit of the machine. The time for switching is about 1 microsecond.

The usual five parts of the block diagram of an automatic computer are all here in the six blocks drawn. Input and output are shown at the top of the diagram in Fig. 5. In the machine, input consists of: (1) manual keyboard; (2) 5-hole paper-tape reader; (3) magnetic-wire reader, reading one channel of magnetized spots on wire. Output consists of: (1) a teletype printer; (2) paper-tape punch; (3) magnetic wire recording.

The next lower block in the block diagram is the "parallel memory unit." This unit was not in the machine when it started working in 1950, but at pres-

ent writing is under test, about to be completed. It consists of 45 "electrostatic storage tubes" (see Article VIII of this series), each able to store 512 spots. This added faster memory will speed up the machine considerably.

The next two blocks are the arithmetical (or computing) unit, and the control unit of the machine. The last block is the second part of the memory, "the serial memory unit," consisting of the cabinet of the mercury delay lines.

The flexibility of the machine is indicated in the diagram by the solid-line arrow going into the control unit. This means that information from its various parts can affect the control of the machine.

The basic pulse rate of the machine is a million cycles per second. It contains 800 vacuum tubes, 500 pulse transformers, 11,000 germanium diodes, and 100,000 soldered connections. When the parallel memory is added, another 300 vacuum tubes and 4,500 germanium

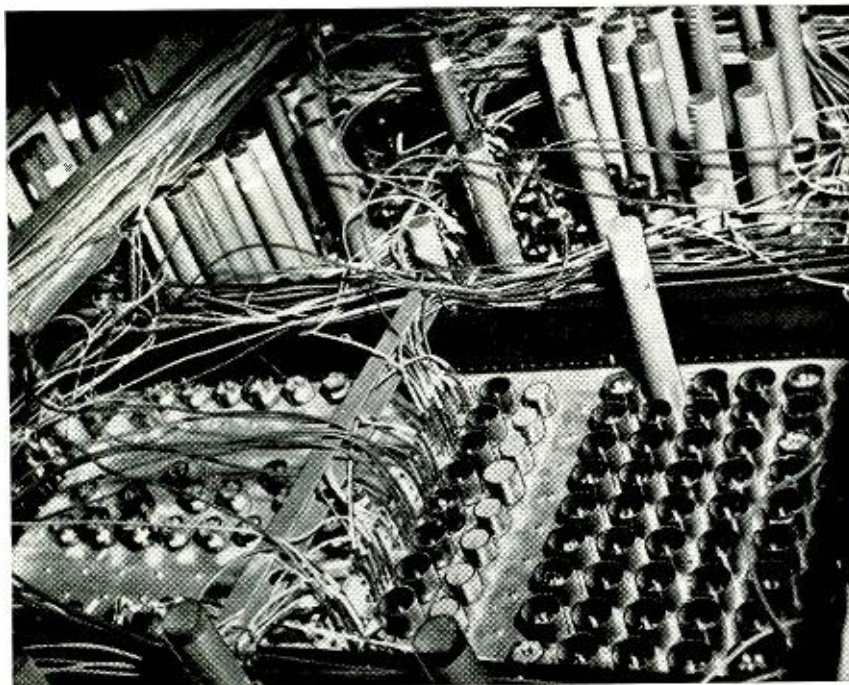

Fig. 3—Fiber tubes are the rapid memory; diode clusters are electronic switches.

diodes will be added to the figures above.

All the information-manipulating as such in this machine is done by circuits using germanium diodes—rectifier circuits such as those described in Article XII. So far as information-manipulating goes, vacuum tubes are used only to change positive pulses to negative ones or vice versa.

How information is handled

The regular piece of information in SEAC consists of 45 binary digits, ones or zeroes, and is called a word. A word may be a number of 44 binary digits, together with one more binary digit designating the sign (plus or minus). Or the word may be an instruction, or group of instructions. A 44-binary-digit number is equivalent to an ordinary number of about 13 decimal digits.

Two instruction systems may be used with SEAC. One is called a "four-address system." The machine is told the *address* (or register number, or memory location) of the first *operand* (number to be operated with); the address of the second operand; the address where the result of the operation is to go; and the address where the next order number is to be found. The other is a three-address system; and the address where the next order is to be found is normally the next consecutively numbered memory location (see the discussion of programming in Article XII of this series). Each instruction also includes four binary digits used to specify the operation that the arithmetical unit is to perform on the cycle when it is obeying such instruction (the letters of operations shown in Chart 1 are translated into machine language).

The operations, and the time in thousandths of a second they require, are shown in the chart. For example, take multiplication. Most of the time, if we multiply two 13-decimal digit numbers together, like 1.789789922981 and 2.566566783422, we want the answer to only 13 decimal digits. We shall be content to throw away the right-hand part, and we will use order R. Only when we are interested in 26 decimal digits of accuracy will we want the right-hand part. Only in that event will we use the M and N orders.

The time shown for addition is 0.9 milliseconds and for multiplication is 3.0 milliseconds. Hence SEAC will on the average perform about 1,100 additions per second or 330 multiplications per second.

SEAC handles numbers only in pure binary form. Hence if any decimal number is to be used, it must be converted into pure binary. But SEAC is clever. It will take in the decimal number, convert it to pure binary, calculate with it, and when the results come along, will turn them back into decimal number form.

This conversion and all other mathematical work is accomplished by programming the machine. Once a program or routine for a type of computation

has been worked out and translated into machine language, it can be stored on paper tape or magnetic wire, and given back to the machine whenever needed.

Even this labor can be reduced. For example, the Harvard Computation Laboratory has worked out a "coding machine" which will enable one to punch on a keyboard ordinary mathematical symbols, and let the machine prepare the detailed instructions for the automatic computer in machine language.

Problems worked on

What are the problems that SEAC has worked on? Up to the end of 1950, SEAC has put in 525 hours on problems for the Office of the Air Comptroller, solving large systems of linear algebraic equations in connection with planning of programs for the Air Force. It spent 72 hours in the study of the starting transient of a class C oscillator. It spent 68 hours determining sample sizes corresponding to the minimum variance in a census, using sampling methods. It spent 48 hours calculating the solution of a 27th-order system of ordinary differential equations relating to the neutron capture theory of the formation of the chemical elements in the universe. This problem was posed by the Applied Physics Laboratory of Johns Hopkins University.

Most of the problems are of course quite beyond the intelligent understanding of everyone but those few who have made a special study of the field in which they occur. We, the authors of this article, confess that we have to recite the above problems like parrots, repeating them from literature put out by the Bureau of Standards, with only a dim notion of what they mean!

But one problem we can understand is the following: SEAC calculated that the number 9,999,999,977 is a prime number, that is, has no factor except itself and 1. It did so by actually trying 80,000 trial divisors (the right trial divisors which would prove it) in 80,000 long divisions and finding that there was a remainder every time. It took SEAC 30 minutes to do that. A man with a desk calculator, working eight hours a day, would take about two months to do the same problem!

Operating experience

The operating experience on SEAC has been reported for October, November, and December, 1950. In those three months, the Bureau of Standards planned to operate the machine 24 hours a day, 7 days a week. Of each week's 168 hours, "preventive maintenance" was scheduled for 16 hours. Of the remaining time, half was devoted to the solution of problems, and the balance to computing machinery development and testing.

Now, in those three months, with regard to the part of the time allocated to problem solution, the average of "good" time was 76%. In fact, in the last week, the average was 96%. By

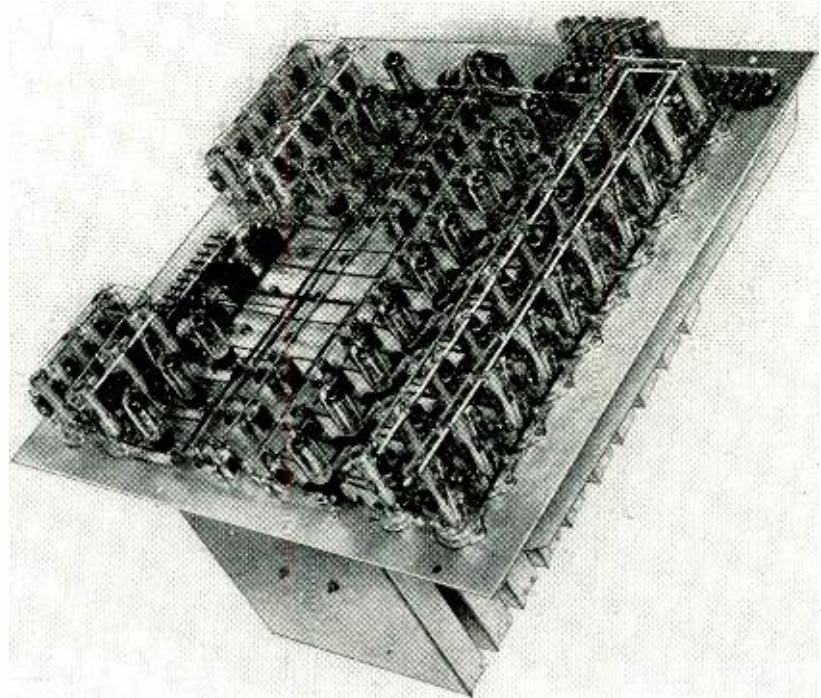

Fig. 4—Program registers were described previously. This is the SEAC unit.

CHART I		
Operation	Abbreviation	Time*
1. Addition	(A)	0.9
2. Subtraction	(S)	0.9
3. Multiplication		
a. Major or left-hand part, unrounded	(M)	3.0
b. Major part, rounded	(R)	3.0
c. Minor or right-hand part	(N)	3.0
4. Division	(D)	3.0
5. Comparison		
(This is a conditional transfer of the control of the machine based on the value of the arithmetical result in the arithmetic unit)		
a. Value taking into account the sign plus or minus	(C)	0.7
b. Value disregarding the sign plus or minus	(K)	0.7
6. Logical Transfer	(L)	
(This is an arbitrary partial word transfer, for the purpose of forming composite words)		
7. Input-Output Control		
a. Read-In	(T)	50.0
b. Print-Out	(P)	50.0
c. Reverse Motion	(7)	50.0
(This time is based on using input-output with a single channel magnetic wire, and handling words in blocks of 8 words)		

*In milliseconds for complete operation including average access time.

"good" time is meant time when either problem solutions or coding checks were produced correctly, or when the machine was in good operating condition but idle—as may happen when the machine is being changed from one problem to another.

Thus we can see that if a machine doing 1,000 operations a second is operating at 75% efficiency, it is still worth a good deal more than a machine that does 2 or 3 operations a second with 100% efficiency.

Achievements such as SEAC's are the pay-off, the end result of the long, fascinating road of computer design and construction and testing and opera-

tion, so that more of the mental drudgery in the world can be lifted off the minds of human beings. And we hope that many of the readers of RADIO-ELECTRONICS will take a good look into the field of electronic handling of information, and attack some of the big problems of today, such as lower cost,

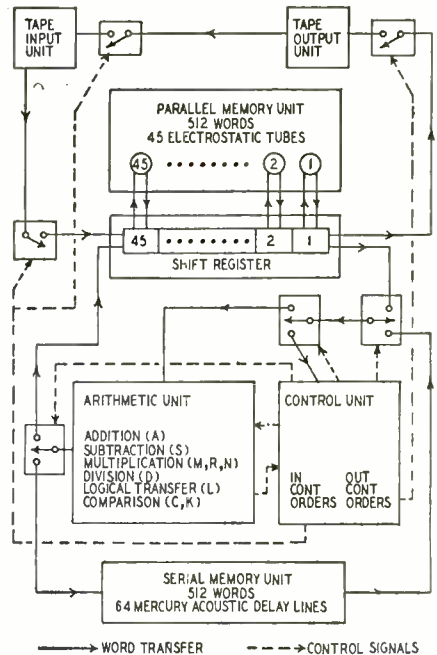

Fig. 5—How signals travel in SEAC.

more and cheaper memory, cleverer ways of programming machines, and the other great and interesting unsolved problems in this new field.

—end—



Courtesy: C. B. Mallory & Co.

A commercial 6-volt Vibrapak is shown above. The nonsynchronous vibrator changes 6 volts, d.c. into a.c. Stepped up, this voltage is rectified by 6X5.

Cutaway view below shows the parts in a nonsynchronous vibrator. Note vibrating reed and relative parts size.

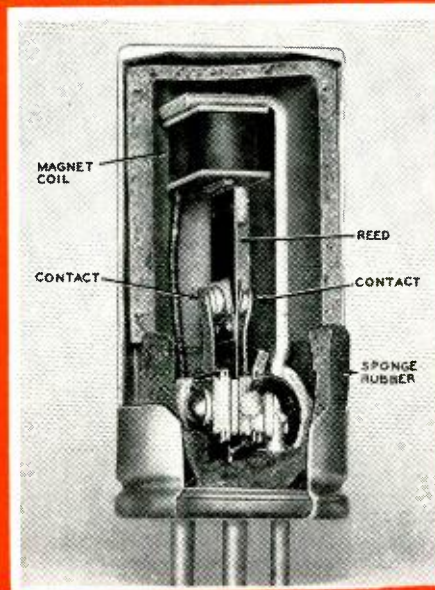

Courtesy: The Radiotek Corp.

Ingenious devices change d.c. to a.c., a.c. to d.c.—or both at same time



By

C. C. ERHARDT



Vibrator Circuit Fundamentals

VIBRATOR power supplies, far from being confined to car receivers, operate phono motors, farm receivers, public address systems, all types of electronic equipment, and even television sets. They have found wide acceptance in the police, forestry, marine radiotelephone, and amateur mobile services. A knowledge of the basic operation of vibrators and the frequently used circuits is a must today for every radio technician.

A vibrator is an electromechanical device which produces a square-wave alternating current from a direct-current source. The source may be dry cells, storage batteries or 115–230-volt power lines. It consists of a thin, springy metal reed, one or more sets of contacts, and a magnet coil, the entire structure being mounted in a metal container with a plug-in base. Sponge rubber lines the container to minimize mechanical vibration. The photo shows its construction. Most vibrators are designed to vibrate at a frequency of 115 cycles per second, although special types operate at frequencies as high as 250 c.p.s.

Used in a power supply, the vibrator is paired with a transformer in order to provide higher or lower voltages than that of the source. The interrupted input current produces a changing magnetic field in the primary which in turn induces a voltage in the transformer secondary. This voltage is higher, lower, or the same, depending

on the turns ratio of the transformer. The a.c. voltage of the secondary may be rectified by a vacuum tube or by an additional pair of vibrator contacts. Filtering is accomplished by standard means.

Basic vibrator circuits

Two basic vibrator circuits are shown in Figs. 1 and 2. Fig. 1 is the interrupter or *nonsynchronous* type of circuit. Here the vibrating reed is at rest between the two contacts when the battery is disconnected. When voltage is applied the magnet coil is energized, causing the reed to pull down to the lower contact A. Current then flows through the lower half of the transformer primary. At this instant the magnet coil is short-circuited and the reed springs back. Inertia causes the reed to continue past the neutral position and to hit against the upper contact B. A current will now flow in the upper half of the transformer primary in a direction opposite to that of the previous current flow. With the magnet coil again energized the cycle repeats itself. The full-wave rectifier tube V1 and filter components function as in a conventional power supply. The photo shows a commercial supply with this basic circuit, the Mallory type VP-553, 6-volt Vibrapak.

In the *synchronous*, or self-rectifying, type of circuit an additional set of contacts are added to the vibrator structure in order to provide d.c. for

the output circuit. Fig. 2 shows the complete over-all circuit. When the reed is attracted to point B it will also make contact with point D, putting terminals 2 and 4 at ground potential. In like manner when the reed contacts point A it will also contact point C, which in turn will put terminals 3 and 5 of the transformer at ground potential. Thus terminal 6 will always be positive with respect to the grounded side of the secondary, and current will flow in one direction through the load.

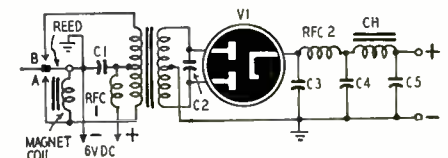

Fig. 1—Nonsynchronous vibrator use.

Just how this is accomplished may be seen from inspection of the two simplified circuits of Fig. 3. When current is flowing through the lower half of the primary, Fig. 3-a, a voltage will be induced in the secondary with the polarity as shown. If at this instant the bottom end of the secondary winding is grounded, current will flow through the load in the direction denoted by the arrows. Note that the secondary center tap is positive with respect to the negative end and negative with respect to the positive end.

Fig. 3-b shows what happens during the next half of the cycle when current

is flowing through the upper half of the primary winding. The induced secondary voltage will now be reversed—the upper terminal now being negative. If at this instant the upper secondary terminal is grounded, current will flow through the load in the same direction as before. Our vibrator then is nothing more than an *automatic switch* which keeps current flowing in the same direction despite reversals in polarity of the induced voltage.

Note the effects of a reversal of input polarity on both these circuits. Suppose the storage battery were connected with its leads reversed. In the nonsynchronous type a change of polarity will have no effect because the rectifier tube acts like an automatic valve in keeping the output polarized correctly. In the synchronous circuit, however, rectification is done mechanically, with the reed acting as a common switch. Under these circumstances a reversal of input polarity will cause B-plus to become B-minus and vice versa.

Vibrator manufacturers have gotten around this disadvantage by constructing a vibrator and socket arrangement which will act as a reversing switch. As shown in Fig. 4, the socket (b) will receive the vibrator (a) in either of two positions, 180° apart. This allows the secondary winding to be reversed, but the primary winding will stay the same. Output may then be corrected merely by turning the vibrator around. This feature is very useful in automobiles and boats where a grounded positive input is often encountered.

Timing capacity

Let us now examine the role of capacitor C1 in Figs. 1 and 2. In all vibrator circuits the transformer will act as an inductive load connected to the d.c. circuit through the vibrator contacts. At each make and break of the contacts high induced voltages will

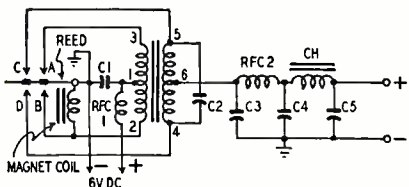

Fig. 2—Synchronous vibrator has two additional contacts which rectify a.c. h.v.

be formed which could cause severe arcing at the contacts with resultant damage to the vibrator. To control these high induced voltages it is necessary to connect a capacitor across the transformer primary or secondary.

Assuming a step-up transformer, it is better to connect capacitor, C2, across the secondary, as a smaller capacitor may be used with the higher voltage. This is because the capacitance reflected to the primary from the secondary increases as the square of the secondary-to-primary-turns ratio, and the same result is produced as connecting a high-value capacitance in the primary circuit. This timing capacitor is commonly called a buffer capacitor. The

value of C2 must be carefully selected to properly match the vibrator and transformer characteristics. Its function is to reverse the induced voltage so that it coincides with the voltage applied to the transformer on the *succeeding* half cycle.

The capacitor and transformer thus form a tuned circuit which cancels the inductive effect during the switching intervals. The breakdown voltage rating of this capacitor, C2, should be greatly in excess of the peak total secondary voltage. In supplies designed for radio receivers it has a rating of about 1,500 volts and a capacitance of about .05 μ f.

The "ideal" waveform of the vibrator-timing capacitor relationship is shown in Fig. 5. The horizontal lines above and below the zero axis represent the battery voltage minus the IR drop in the line. T1 and T2 represent the time interval when the contacts are closed. The sloping lines connecting points 1 and 2, and 3 and 4 represent the switching interval. During this interval one set of contacts is opening and another closing. The proper timing capacitor allows a smooth transition during this period. Incorrect values of timing capacitor result in high induced voltages and erosion of contacts.

Hash elimination

High-pitched hash noise radiates from vibrator power supplies. This hash, or r.f. interference, is caused by sparking at the vibrator contacts. It may be minimized by incorporating filters in the input and output circuits. The input filter may consist of a low inductance, high-current r.f. choke (RFC1 in Figs. 1 and 2), and a 0.5- μ f paper capacitor (C1). Their purpose is to keep the r.f. out of the battery leads where the noise might be radiated still further. The output filter consists of RFC2, which is a standard 2.5 mh. r.f. choke, and C3 which is a .01- μ f high-voltage paper or mica capacitor. Together they act to keep the r.f. out of the B-plus circuit.

Thorough shielding of all the components is necessary. Positioning of parts is important. Many times a different mechanical layout will result in considerably less noise radiation. A bottom plate on the chassis and a connection to a good earth ground will help.

Capacitors C4, C5, and choke CH comprise a standard brute-force filter to remove the a.c. ripple from the rectifier output. The input capacitor, C4, may have a value of 8 to 10 μ f, while the output, C5, should be from 20 to 30 μ f. Filter choke CH may be 10 to 30 henrys. A resistor may be used in its place if a large amount of ripple can be tolerated. Rectifier tube V1 may be a 6X5 with the heater voltage taken directly from the 6-volt battery, or a cold-cathode OZ4 may be used.

Other circuits

The circuits described above were for storage-battery operation. Converters (or inverters) operating from 115- or 230-volt d.c. mains have found wide

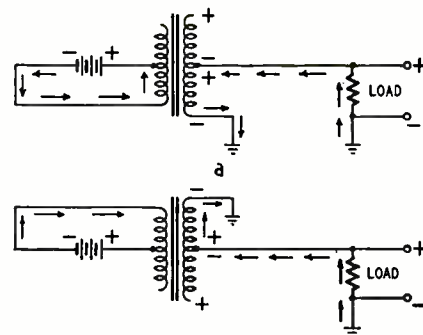

Fig. 3—Current flow, with reed in (a) "lower" position; (b) "upper" position.

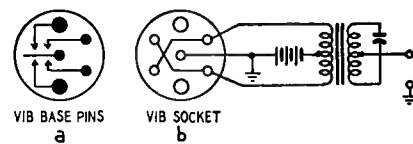

Fig. 4—(a) Vibrator base pin arrangement; (b) vibrator socket connections.

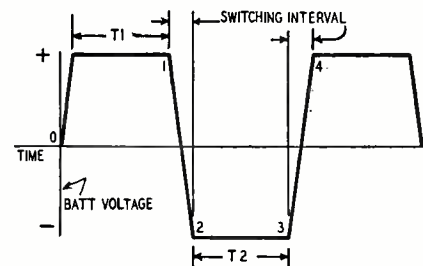

Fig. 5—The "ideal" vibrator wave form.

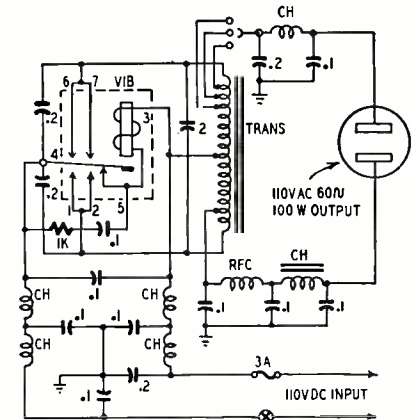

Fig. 6—Schematic for converter; input is 110 v.d.c.; output, 110 v.a.c. 60 cycles.

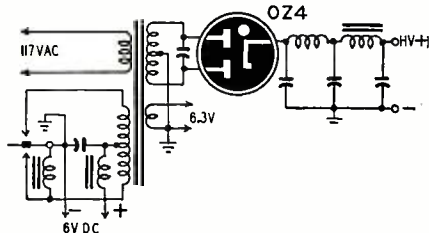

Fig. 7—A vibrator supply for use on both 117 volts, a.c., and 6 volts, d.c.

application for powering a.c. radio receivers, transmitters, television sets, etc. A commercial converter schematic (Radiant Vipower model 110R10) is shown in Fig. 6. A tapped autotrans-

Limiting Amplifier

A NEW limiting amplifier suitable for broadcast and recording—recently developed by RCA—incorporates many interesting features. Known as model BA-6A limiting amplifier, it uses three push-pull stages (Fig. 1) and has a maximum gain of about 54 db. The gain of the first stage is controlled by the amplifier output level. As long as this output is below a predetermined value, the stage has full gain. When this level is exceeded the gain is reduced.

Fig. 2 helps to explain the limiting action. Lead A is the grid return of the first stage. Normally the diode is blocked by its positive cathode voltage.

The threshold of limiting is at 29.5 dbm (decibel based on a 1-milliwatt zero level). At this point the diode blocking voltage is overcome. The tube conducts and passes current into C1, which charges in about .0006 second. Therefore the input grid negative bias is increased and the stage gain reduced. The quick charge means a short attack

time, which is needed to limit peaks of short duration. The diode blocks again after the output peaks have passed. Then C1 discharges through R11 in about 0.33 second. The longer recovery time prevents abrupt increase in gain after a loud passage.

With S1 closed, another time-constant network, R37-C18 is connected. Attack time remains the same as before since it is determined by the smaller capacitor C1. With S1 closed, however, there is a difference in recovery time. C18 requires about 0.9 second to charge through R37 and about 2 seconds to discharge through R37 and R11. If the peaks are short and arrive occasionally C18 does not acquire much charge, so the recovery time is nearly the same as with S1 open. If the peaks are prolonged, however, C18 becomes more fully charged, so the bias voltage remains for a longer period. The longer recovery time prevents fluctuations in gain during a series of peaks.

The way these components are used in the circuit is shown in Fig. 1. C1 and C18 are charged through a 6H6 full-wave rectifier coupled by capacitors to the output stage. The BALANCE-LIMIT SWITCH controls the recovery time. In SINGLE position C1-R11 is connected; DUAL adds the R37-C18 network.

The type of program determines whether single or dual limiting should be used or whether the switch should be left at off which provides no limiting at all. The setting of the input attenuator (with corresponding adjustment of the output attenuator) determines the degree of limiting. With greater attenuation the amplifier operates mainly below the verge of limiting. This supplies less average power to the output but greater dynamic range.

As the gain of the first stage is varied, there are plate current changes correspondingly. These produce low-frequency transients or thumps. Minimum thump is created if the stage is balanced. Two balancing controls are provided. With the *balance-limit* switch in position A, a 60-cycle voltage is applied through a capacitor to the 6SK7 grids in phase. The cathodes are returned through an added resistor. Then BAL. A is set for minimum output.

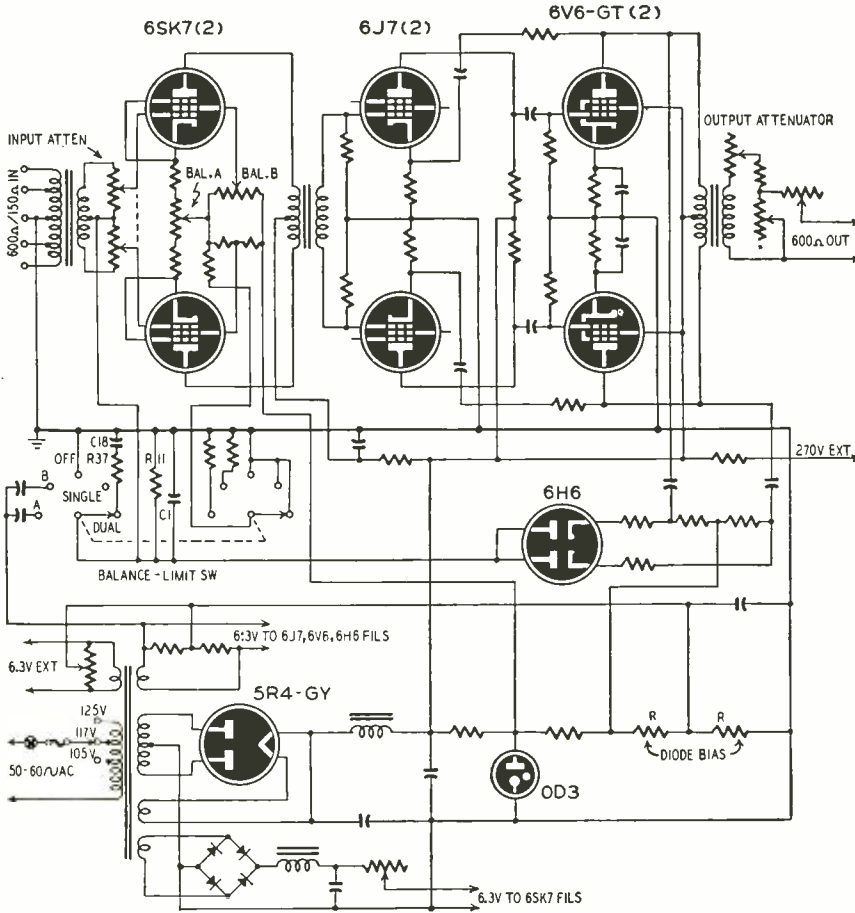

Fig. 1—Circuit of the BA-6A limiting amplifier which has maximum gain of 54 db.

VIBRATOR CIRCUIT FUNDAMENTALS (Continued from page 57)

former is used instead of the more conventional separate secondary type. Note that the magnet coil in the vibrator is connected in series with the input rather than in shunt and must be normally closed before operations can take place. Heavy contacts are used.

Converters are made in many power ratings. 350 watts is the largest size presently being manufactured for the general public. Vibrator supplies are manufactured which produce 117 volts a.c. from a 6-, 12-, or 32-volt d.c. input.

Fig. 7 shows a special dual primary

transformer which provides operation from a 6-volt battery (using vibrator) or 117 volts a.c. By installing a separate switch in each input circuit and arranging the output with separate plugs so that the filaments may be heated from either the battery or 6.3 volts a.c., flexible operation is achieved. The filaments should never be operated from the 6.3-volt secondary with battery input as this places too severe a load on the vibrator. Operate them direct from the battery.

—end—

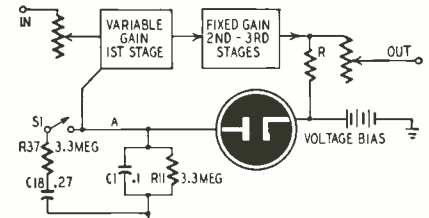

Fig. 2—The limiting action simplified.

Now switch to position B. This applies a larger 60-cycle signal to the grids and switches in a larger cathode bias. The BAL. B control is adjusted for minimum output. This process may be repeated. It balances the stage with both weak and strong signal inputs. The input stage filaments are supplied with d.c. to eliminate hum.

—end—



NOW-Be a Fully Trained, Qualified RADIO TELEVISION TECHNICIAN IN JUST 10 MONTHS OR LESS!

**I Send You
18 BIG
KITS
OF RADIO-
TELEVISION
EQUIPMENT**

**New "Package" Unit Training Plan
PAY AS YOU LEARN-YOU SET THE PACE!**

**No Monthly Payment Contract
to Sign!**

Now . . . be ready for Radio-Television's big pay opportunities in a few short MONTHS! Frank L. Sprayberry's completely new "Package" training unit plan prepares you in just 10 MONTHS . . . or even less! Equally important, there is NO monthly payment contract to sign . . . thus NO RISK to you! This is America's finest, most complete, practical training—gets you ready to handle any practical job in the booming Radio-Television industry. In just 10 months you may start your own profitable Radio-Television shop . . . or accept a good paying job in this fascinating expanding field at work you've always wanted to do. Mr. Sprayberry has trained hundreds of successful Radio-Television technicians—and stands ready to train you in less than one year, even if you have no previous experience. You learn by DOING . . . actually working with your hands with equipment of special design to illustrate basic theory instead of relying on books alone.

VALUABLE EQUIPMENT INCLUDED WITH TRAINING

The new Sprayberry "package" plan includes many big kits of genuine, professional Radio-Television equipment. While training you actually perform over 300 demonstrations, experiments and construction projects. In addition, you build a powerful 6-tube standard and short wave radio set, a multi-range test meter, a signal generator, signal tracer, many other projects. All equipment is yours to keep . . . you have practically everything you need to set up your own service shop. The interesting Sprayberry book-bound lessons and other training materials . . . all are yours to keep.

EARN EXTRA MONEY WHILE YOU LEARN!

All your 10 months of training is AT YOUR HOME in spare hours. Keep on with your present job and income while learning . . . and earn EXTRA CASH in addition. With each training "package" unit, you receive extra plans and ideas for spare time Radio-Television jobs. Many students pay for their entire training this way. You get priceless practical experience and earn generous service fees from grateful customers. Just one more reason why the Sprayberry new 10 MONTH-OR-LESS training plan is the best Radio-Television training in America today. If you expect to be in the armed forces later, there is no better preparation than good Radio-Television training.

**TRAIN AT
HOME IN
SPARE HOURS!**

FREE 3 BIG RADIO-TELEVISION BOOKS

I want you to have ALL the facts about my new 10-MONTH Radio-Television Training—without cost! Act now! Rush the coupon for my three big Radio-Television books: "How to Make Money in Radio-Television," PLUS my new illustrated Television Bulletin PLUS an actual sample Sprayberry Lesson—all FREE with my compliments. No obligation and no salesman will call on you. Send the coupon in an envelope or paste on back of post card. I will rush all three books at once!

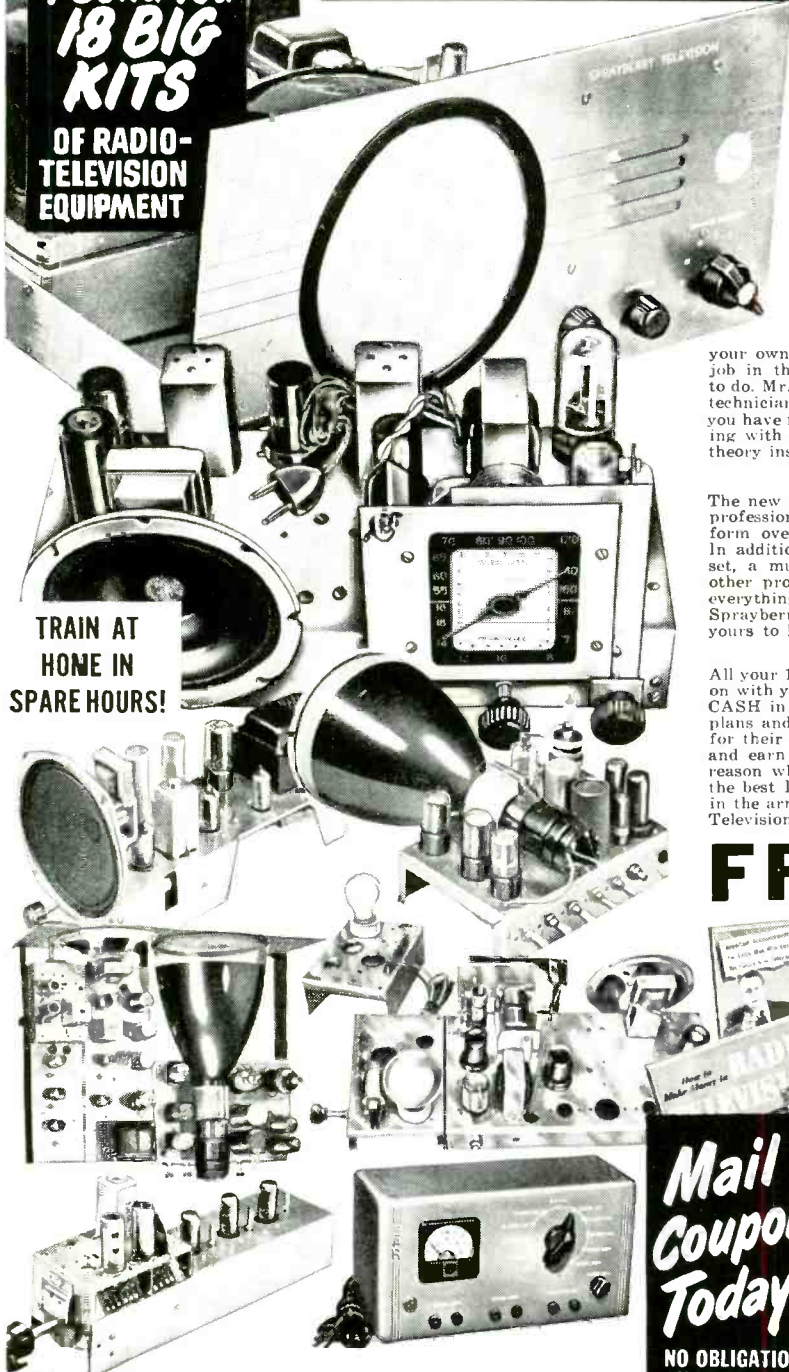

**IF YOU ARE
EXPERIENCED IN RADIO**

Men already in Radio who seek a short intensive 100% TELEVISION Training with FULL EQUIPMENT INCLUDED are invited to check and mail the coupon at the right.

**Mail
Coupon
Today!**
NO OBLIGATION
No Salesman
Will Call

**SPRAYBERRY ACADEMY OF RADIO, Dept. 20-B
111 North Canal St., Chicago 6, Ill.**

Please rush to me all information on your 10-MONTH Radio-Television Training Plan. I understand this does not obligate me and that no salesman will call upon me.

Name Age

Address

City Zone State

Please check Below About Your Experience

Are You Experienced? No Experience

The Crystal Era Comes Back

Germanium crystal diodes are taking over vacuum tube functions; common applications and new circuits used

By

WILBUR J. HANTZ

“HERE is the latest in television receivers. The marvelous model YR-1980 is to old-time television as the automobile was to the horse and buggy. Yes sir, Mr. Jones, you never will have to put out your hard-earned cash for bad tubes, because the model YR-1980 uses crystals instead.”

“Oh, you mean the kinescope viewing tube, Mr. Jones? The radio industry spent billions improving the old kinescope to give the public an unnatural picture. Then the public yelled for larger pictures, which meant still larger kinescopes. Finally the bubble

burst. Back in '60 my neighbor had to build an extra addition to his home just to house the TV receiver with its 100-inch viewing tube. But now we have completely eliminated the kinescope, as you can see. The YR-1980 uses a crystal-scope to transmit the picture signal in all directions from the receiver. To view the picture, you just wear this pair of spectacles. They are crystals that act as video picture converters, giving a three-dimensional true-color picture!”

Does this seem like a crackpot conversation? Perhaps—in our present era—but what about the future? Highly efficient crystals are rapidly replacing vacuum tubes, resulting in circuit simplification as well as economy. Some common applications of the crystal germanium diode are: noise limiters, speech clippers, FM and TV detectors, d.c. restorers for television, wave shapers, and meter rectifiers. Crystal diodes can also be used for television a.g.c. circuits, mixers, electronic counting circuits, frequency dividers, multipliers, and sideband generators.

Noise limiters are particularly effective against impulse noise of short duration where the instantaneous burst has a higher amplitude than the received signal. Usually such circuits use one-half a 6H6 or 6AL5 connected between the detector and the first audio amplifier so that the signal modulates the diode current. Crystals are used here. Figs. 1 and 2 are series type limiters, and Fig. 3 the shunt type. Fig. 1 is a circuit used with an infinite impedance detector. Sylvania type 1N54 crystals are recommended because of the high back resistance, but the 1N34 can also be used. To reduce hum, mount all noise-limiter parts in a shield can. In Fig. 3 adjust R1 and R2 for best limiting with the least distortion.

Speech clippers are peak-limiting

diode circuits similar to the type used as a noise limiter in receivers with the exception that they must clip both negative and positive peaks. The speech amplifier must have plenty of extra gain to stand the loss. Usually an additional stage of amplification is required. Fig. 4 shows a speech clipper using two crystal diodes. One clips the positive peaks and the other clips the negative peaks. Both diodes are biased so they do not conduct until the signal reaches a 2-volt level. Bias can be obtained from either a bleeder circuit in the power supply or from the cathode of the audio power output tube. The low-pass filter is necessary to remove harmonics and round off the waves. This circuit can also be used as a square-wave shaper for a sine-wave input. When used as a square-wave shaper the harmonic filter is omitted.

On the subject of clipping and wave shaping, Fig. 5 is another gadget that might be worth playing with. Two crystal diodes are connected in a positive and negative biased circuit to shape either sine or sawtooth waves. Either positive or negative pulses are available in the output, depending upon the position of the controls.

D.c. restorers. A crystal d.c. restorer is shown in Fig. 6. It detects or rectifies the sync pulse tips and develops a positive voltage. This counteracts the bias voltage set by the brightness control and maintains a picture brightness corresponding to the light level in the studio. However, if the video signal varies or the contrast control is changed, the level of the sync tips changes, which calls for a readjustment of the brightness control. The dependence of these two controls upon each other can be eliminated if the diode is adapted to detect at the base of the sync pulses instead of the sync tips. The level of the sync pulses sets the point where the electron beam

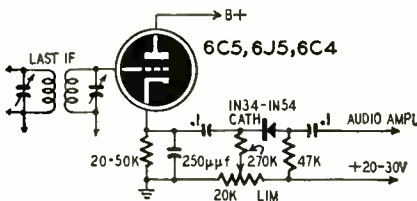

Fig. 1—Crystal used in noise limiter. Tube is an infinite impedance detector.

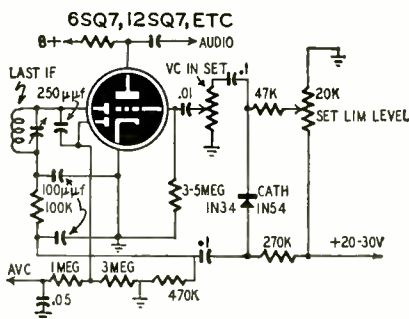

Fig. 2—Another series type noise limiter. Signal modulates the diode current.

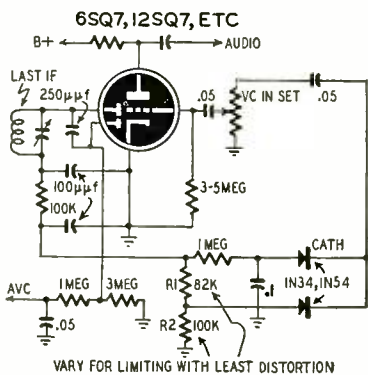

Fig. 3—A noise limiter of shunt type. Adjust R1, R2 for best limiting action.

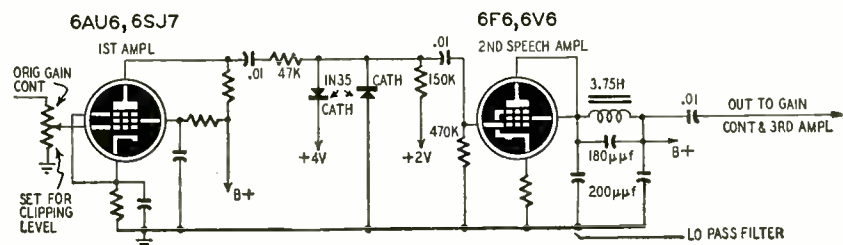

Fig. 4—Crystals used in the speech clipping circuit. Note the low-pass filter.

Double Barreled PROFITS with Louis Bros.

"picture perfect" antennas



NEW
"SELF-LOCK"
CONSTRUCTION
cuts time

NEW
ANTENNA
INSURANCE
makes sales



*No Tools, No Screws,
No Wing Nuts,*

**SWING-OUT ELEMENTS
LOCK INTO POSITION!**

With just a flick of the wrist, all elements swing out and automatically lock securely and permanently into place, giving positive electrical contact. You need absolutely *no hardware, no tools, no time!* So simple a *child* could assemble it!

This revolutionary new development in assembly design is an exclusive feature of Louis Bros. Series 400 Picture-Perfect Antennas.

*Look!
No Tools
Needed*

and they're insured

Every Louis Bros. "Picture Perfect" Antenna is covered by the St. Paul Mercury-Indemnity Co. at no cost to you. An individual insurance certificate is enclosed with each package. You'll find this *extra* protection to your customer a powerful talking point in selling more installations. We provide you with window decals and other effective point-of-sale display to help you get this important story across.

Order Louis Bros.
Picture-Perfect Antennas
from your jobber today!

Louis Bros.

"picture perfect" antennas

3543 E. 16th St., Los Angeles 23

*The Insured Antenna
With Assured Performance*



is cut off, regardless of where contrast is set.

This type circuit, the "automatic black level system," is used in the Stromberg Carlson model TS-125/15/16 television receiver. It can be added to

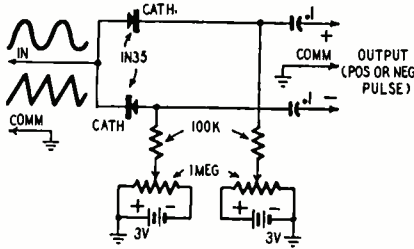

Fig. 5—Either positive or negative pulses are obtained with this shaping circuit.

most existing receivers. Fig. 7 shows a portion of a G-E 800 receiver with the necessary changes for automatic black level. A 6AL5 is originally used for the video detector and d.c. restorer. Remove this tube and substitute crystal diodes because the socket is needed for an extra sync amplifier. The additional 12AU7 provides negative sync pulses of greater amplitude than those appearing in the second video output circuit. The amplified sync pulses are fed into the negative side of the crystal diode to cut off the d.c. restorer when the video signal sync pulses are at the diode cathode. The d.c. restorer then conducts on the only remaining negative portion of the signal (the front and back porch pedestal) which is the black level as set by the transmitter.

The notations; B-minus 1, B-minus 2, in Figure 7 correspond to two different B-minus points which are common in transformerless receivers.

Frequency dividers usually employ a step-counter arrangement when a high degree of stability is required. A step-counter receives pulses of one frequency

and produces an output voltage at some submultiple frequency. Fig. 8-a shows a pair of crystal diodes used as step-counters. The working principle is voltage distribution across two capacitors connected in series (Fig. 8-b).

Positive pulses are applied to the input. Capacitors C1 and C2 charge through CR1 with the positive edge of the input pulse. The voltage across the capacitors is inversely proportional to the capacitance and equal to the input pulse amplitude. C2 is usually much larger than C1, so it charges to a small part of the applied voltage. When the trailing or negative edge of the input pulse arrives, C1 discharges through the diode CR2, driving its cathode negative. C2 cannot discharge because the plate side of CR1 is positive. C2 stays charged until another positive pulse is

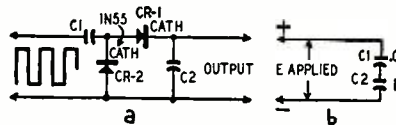

Fig. 8-a—Pair of diodes used as step counters; 8-b, the equivalent circuit.

applied to the input. C1 again discharges during the negative side of the input pulse. Thus, the voltage across C2 increases step by step with each input pulse. The steps become smaller as the voltage across C2 increases to the amount of the pulse amplitude. If the diodes are reversed in polarity, negative input pulses can be counted. For the purpose of experimenting with the counting diodes, some calculating information is given:

Let 100 volts be applied to the input. What voltage will be built up across C2 in Fig. 8-a after the source voltage is pulsed twice? The 100 volts is assumed to be signal voltage. The voltage

across C1 and C2 is: $E = 100 \times \frac{.05}{1.05} = 4.75$ volts after one pulse. At first, the negative charge on the plate of C1 will cut off CR2 and discharge through CR1. When the next pulse arrives, the voltage across C2, will oppose the applied voltage, since its negative plate is connected to the negative side of the circuit. The net signal voltage is then: $100 \text{ volts} - 4.75 \text{ volts} = 95.25 \text{ volts}$. The new voltage across C2:

$$95.25 \times \frac{.05}{1.05} = 4.52 \text{ volts.}$$

The total voltage across C2 after two pulses:

$$4.75 + 4.52 = 9.27 \text{ volts}$$

After an infinite number of pulses the final voltage across C2 approximates the applied input pulse voltage.

When the step-counter is used as a frequency divider, the output voltage triggers a flip-flop multivibrator or a single stroke blocking oscillator (6SN7-GT) as shown in Fig. 9. The control, R, in the cathode of the 6SN7 determines the point where the oscillator will be triggered. The oscillator is usually used as a frequency divider to divide down from the television transmitter's master oscillator frequency of 31,500 c.p.s., producing sync signals on down to the field frequency of 60 c.p.s. Several of these signals are used in the timing system. Therefore the master oscillator is locked with the 60 c.p.s. a.c. line frequency by frequency division instead of multiplication.

Some of the information contained in this article was obtained from:

Radio and Television Mathematics, by Bernhard Fischer—Macmillan Co.
40 Uses for Germanium Diodes, Sylvania Electric Products, Inc.
Basic Television, by Bernard Grob—McGraw Hill Book Co., Inc.

—end—

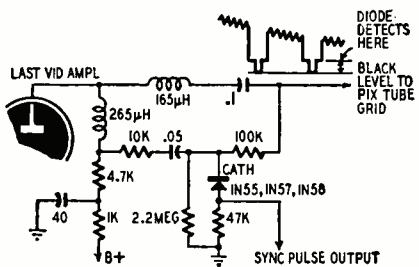

Fig. 6—Crystal in d.c. restorer circuit.

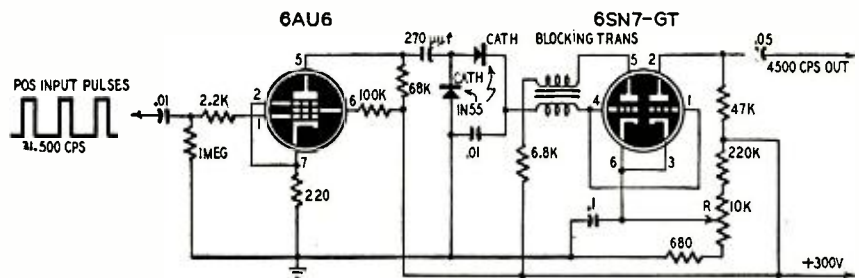

Fig. 9—Step counter as frequency divider. R controls oscillator trigger point.

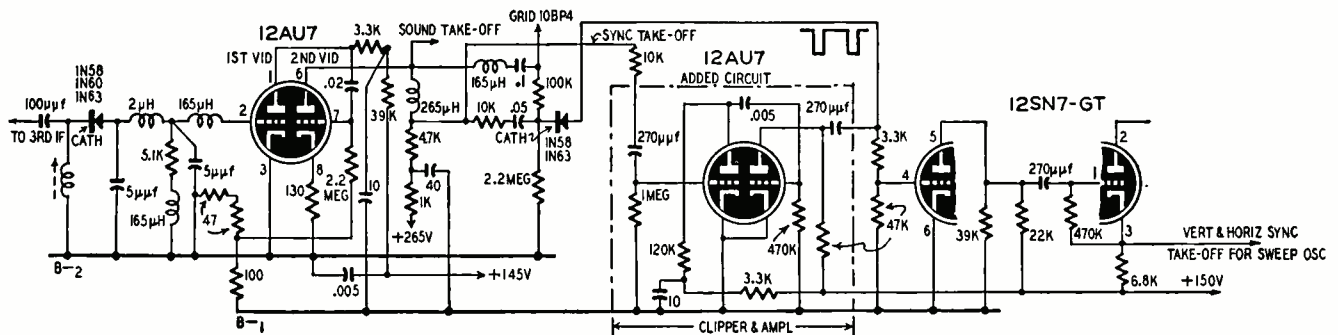

Fig. 7—A portion of G-E 800 receiver with changes for automatic black level; extra 12AU7 provides larger sync pulse.

A Guiding Beacon For
Quality-Electronic Parts

Your Local
RADIART
Distributor



NEW YORK

BUY OF THE MONTH

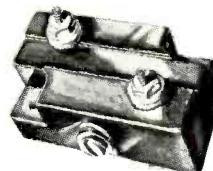

One of the newest developments at RADIART is a FULL SIZE LIGHTNING ARRESTER . . . at the price of a midget! It fits anywhere . . . handles all size twin leads and its sharp toothed cup washer eliminates wire stripping. Here is real protection against lightning and static charges . . . yet does not unbalance the line. Permanently sealed against temperature changes and humidity. See your RADIART DISTRIBUTOR, or write us.

These Are The Cities with RADIART DISTRIBUTORS in NEW YORK State serviced by BALL ASSOCIATES, Inc., Orchard Park, New York

State of New York:

ALBANY	JAMESTOWN
AMSTERDAM	KINGSTOWN
AUBURN	NIAGARA FALLS
BINGHAMTON	ROCHESTER
BUFFALO	SCHENECTADY
CORTLAND	SYRACUSE
ELMIRA	TROY
FREDONIA	UTICA
GLENS FALLS	WATERTOWN
ITHACA	

FOR NAME OF YOUR NEAREST RADIART DISTRIBUTOR

USE COUPON BELOW

BALL ASSOCIATES, INC. 58 Quaker St., Orchard Park, N.Y.

..... Please send names of the Radiart Distributors in my area stocking the following Radiart products in which I am interested: Tele-Rotors, Vibrators, TV and FM Antennas, "Spee-Dee" Chimney Mounts, Lightning Arresters, Auto Aerials, Power Supplies

..... Please have a Radiart Distributor call on me.

Name

Address

City State



THE RADIART CORPORATION CLEVELAND 2, OHIO

VIBRATORS • AUTO AERIALS • TV ANTENNAS • ROTATORS • POWER SUPPLIES

New Transistor Circuit Design Method

By I. QUEEN



NEW TELEVISION
Videometer



MODEL 650

**VISUALLY IDENTIFIES
TROUBLE IN ANY SECTION
OF A TV RECEIVER**

The HICKOK Model 650 Videometer is the first instrument of its kind to accurately and rapidly solve your servicing problems with the necessary tests to visually identify trouble in any section of a TV receiver.

FEATURES:

- An all-purpose video generator. Provides an electronically accurate bar or dot pattern on the screen of any TV receiver— independent of station operation.
- Can be used as a TV transmitter to simultaneously transfer a program to any number of TV receivers—on any desired channel.
- RF output, directly calibrated in microvolts for sensitivity measurements.
- Substitute Video Amplifier with gain of 0 to 10.
- Crystal controlled timer for greater accuracy.
- Fast, accurate, the ideal instrument for all area servicing.
- Increases TV maintenance profits—allows you to trouble shoot many more installations per day.
- Built only by HICKOK. Contains highest quality components throughout for lasting accuracy and dependability.

Write for the new, complete Hickok Test Instrument Catalog today.

THE HICKOK ELECTRICAL INSTRUMENT COMPANY
10531 Dupont Avenue • Cleveland 8, Ohio

Transistors can be substituted for tubes in oscillators, modulators, multi-vibrators, amplifiers, and other circuits. However, transistors and tubes have different characteristics, so circuits must be specially designed for each. Some experimenters have managed to obtain fair results from transistors by making slight modifications in standard hookups. Optimum performance can be obtained by following a new approach to transistor circuit design described in *The Bell System Technical Journal*. It shows that tubes and transistors are "duals" and that their respective circuits should also be duals."

What is a dual? Two circuits or components are duals if *voltage* in one behaves like *current* in the other, and conversely. Consider a series-resonant circuit. At resonance, maximum *current* flows through it. Its coil *voltage* is Q times the total network voltage. Now compare this with a parallel-resonant circuit. At resonance, maximum *voltage* appears across it. Its coil *current* is Q times the total network current. The interchange between voltage and current identifies these tuned circuits as duals.

Fig. 1 shows typical curves for a tube and a transistor which have equal dissipation and amplification factors. The two groups of curves are nearly identical when voltage and current are interchanged. For example, plate voltage (E_p) corresponds to collector current

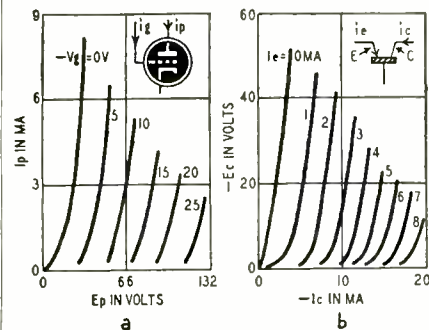
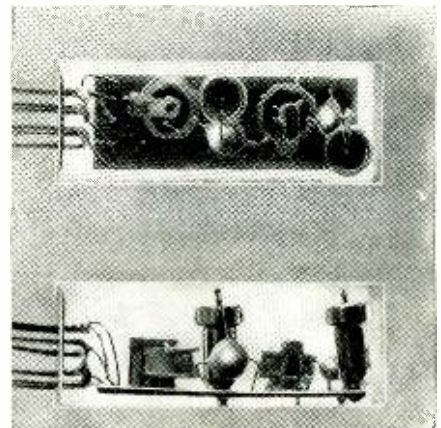

Fig. 1.—Comparison of static characteristics of vacuum tube (a) and those of its transistor dual shown in chart b.

(I_c). Similar relationships exist between a tube grid and a transistor emitter. Therefore tube and transistor are duals except for polarity. A tube reverses polarity, an N-type transistor does not. This is shown in the figure as a change in sign.

There is a definite relationship between the currents in a transistor and the voltages in a vacuum tube, and vice versa. This relationship is represented by r and is called *transformation resistance*. It is found by dividing the voltage at a given point on the axis of one curve (Fig. 1) by the current at the corresponding point on the axis of the other. In this particular tube-transistor combination, r is 6,600 ohms as found by 132 volts/.02 amp or 60 volts/.009 amp.



Example of amplifier using two junction transistors (plastic beads, center and right). It has a power gain of 90 db.

Because a tube and a transistor are duals, their respective circuits should also be duals. Efficient tube circuits are more or less standardized. When converted to dual form, we have equivalent transistor circuits of equal efficiency.

Unfortunately, it is not easy to determine a dual circuit. It is done as follows. Kirchhoff's equations are written for the known tube circuit. Then voltages are replaced by corresponding currents and vice versa. This gives a new set of Kirchhoff's equations. The transistor circuit is drawn from them.

Here are some important results of transforming a circuit to its dual. Each parallel circuit converts to a series circuit, and vice versa. The dual of a capacitor is an inductor, related to it through the equations $C = L/r^2$ or $L = r^2C$, where r is the transformation resistance. A resistor R converts to another resistor of value r^2/R . The dual of a circuit *loop* is a *node* (junction). Each component (or network) which meets at the junction is the dual of one of the loop components.

Fig. 2 shows a typical tube amplifier and its dual transistor circuit. The parallel-tuned circuit becomes series-tuned. The series-coupling capacitor converts to a shunt coil. The shunt grid leak becomes a series resistor. In the tube circuit the three original components are arranged around a loop. In the transistor circuit the three dual components meet at a junction. The constant tube voltage E converts to a constant current supply I shown by the curved arrows.

A phase-reversing transformer is shown in the transistor circuit. This is needed to make the two circuits exactly equivalent, since a transistor does not reverse phase. In most amplifiers the polarity is not important, so this transformer would be omitted.

Excellent results have been obtained by the method of duality. In one case, a pair of transistors was used in a class-B stage converted from a conventional tube circuit. The audio output was 400 mw. The same transistors gave

**A Giant Stride Toward
Good Television Everywhere!**



Above — For maximum efficiency, Tel-A-Ray Pre-Amplifiers are peaked at the factory to a single channel. This pre-amp is primarily designed for antenna mounting with the Tel-A-Ray "Reception Master" antenna. But when weaker constructed antennas are in use it may be mast mounted.

New, Improved TEL-A-RAY PRE-AMPLIFIER

gives clean, sharp reception beyond the fringe areas!

Here is an advance that can help sell many more television sets . . . that is a "must" installation wherever signals are weak and snow is a problem.

The only antenna-mounted device of its kind, the new, improved Tel-A-Ray Pre-Amplifier is now made in separate models for high and low channels . . . with a matched and tuned grid circuit that insures maximum gain and a stable signal. With it, television can now go beyond the fringe areas, and you have the simple, easily installed and economical means of insuring clear, sharp, snow-free television reception in many other locations. It is a tremendous advance with all the bugs worked out of it . . . ready for your use now in bringing good television to many more people.

USE WITH MODEL T OR TD ANTENNA for the best results

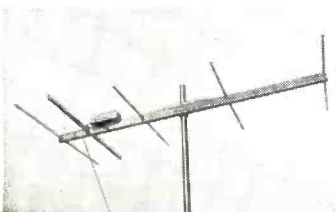

Installation of these famous long distance Tel-A-Ray antennas is the first step in getting clear, snow-free reception. With the Pre-Amplifier, they give up to 300 times gain over dipole.

- Gives maximum gain in signal.
- Insures stability of signal.
- Provides for vastly improved signal-to-noise ratio.
- Compensates for lead line loss.
- Eliminates or greatly reduces snow.
- An essential complement to the booster at the set in many locations, and can be used without a booster in numerous cases.
- Made of Dural and weather-sealed . . . completely guaranteed against weather damage.
- Inexpensive . . . speedily and easily installed to any mast or antenna.

Tel-a-Ray

ENTERPRISES, INCORPORATED

BOX 332E
HENDERSON, KENTUCKY



TRADE MARK

No fuss



When you use

Centralab's

Exact Replacement Controls



Why waste time "finkering" with kits . . .



when you can get exact, quickest-for-servicing,
custom replacement controls for TV - AM - FM . . .

There's a Centralab Custom Control — or Standard

***Blue Shaft* Unit that's Quickest for Service.**

Service Engineers! Centralab's famous Blue Shaft and Custom Controls are exclusive service items. You'll find Blue Shafts available in a complete line of plain and switch types with resistance ranges from 500 ohms to 10 megs. in a wide variety of tapers and

tapped units! All Centralab controls are packaged singly. Blue Shafts are also available in handy plastic boxes of 12 and in a special metal cabinet containing 22 controls. NO EXTRA charge for the cabinet.

Check These **LOW PRICES** on Popular Blue Shaft Controls!

Cat. No.	Ohms Max. Resistance	Taper	Circuit Location	List Price
B-60	500,000	C-2 (audio)	Volume or Tone	\$1.00
B-60-S*	500,000	C-2 (audio)	Volume or Tone	\$1.50
B-70	1 megohm	C-2 (audio)	Volume or Tone	\$1.00
B-70-S*	1 megohm	C-2 (audio)	Volume or Tone	\$1.50

*Switch Type

Ask your jobber or write direct for Bulletin 42-106 on Blue Shaft Controls. Send 25c for Centralab's TV and Custom Control Guide.

Centralab

Division of GLOBE-UNION Inc.

922 E. Keefe Ave. • Milwaukee 1, Wisconsin

RADIO-ELECTRONICS for

No CUSS

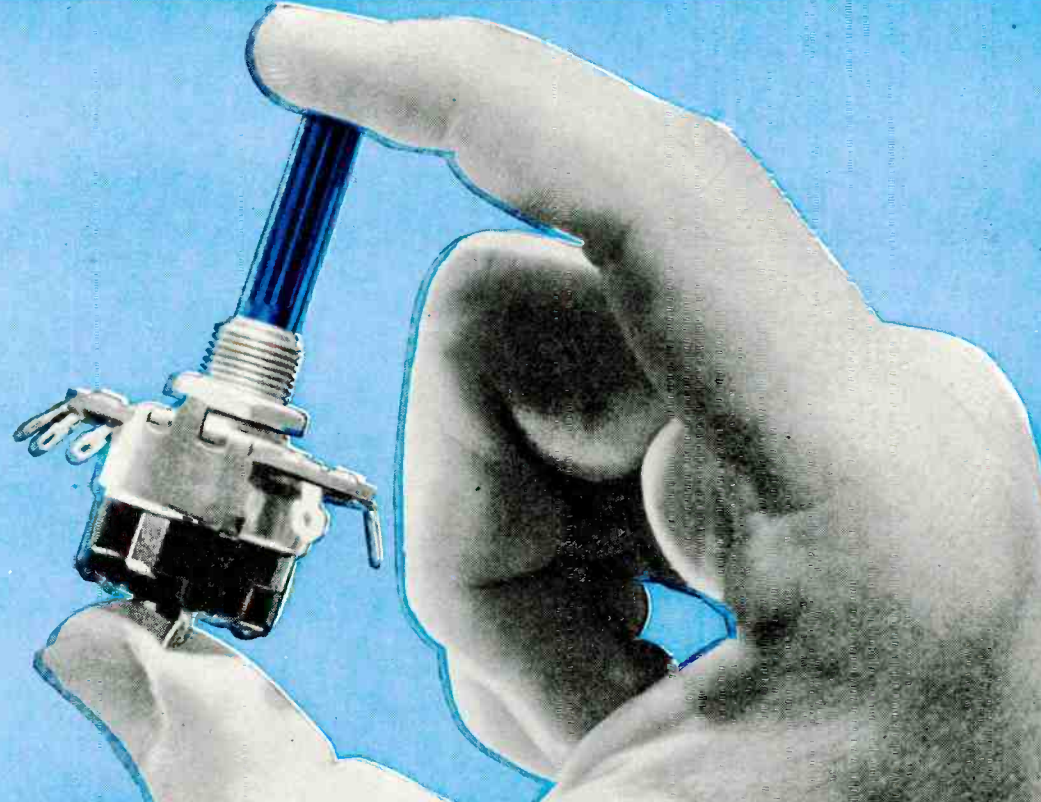
A detailed illustration of a hand holding a blue shaft control with an attached switch. The shaft is a vibrant blue, and the switch mechanism is silver and black. The background is a solid blue color.

Blue Shaft Controls with attached switches are your smartest service buy! Why? Because they save you valuable bench-working time — by being truly your quickest-for-servicing replacements. These factory attached and tested switches are high amperage, universal units. That means they can be used as SPST — DPST or 3 wire.

For quickest servicing, standardize on Centralab Blue Shaft and Custom Controls.



C-D's Tiny Mike

—the ceramic with the million dollar body!

Never before such uniformity, such dependability in ceramic capacitors! TINY MIKE is C-D through and through. Even the ceramic body is made by C-D, in its brand new ceramic body plant, electronically controlled at every stage!



Write for Catalog Dept. RC-101, Cornell-Dubilier Electric Corp. South Plainfield, N. J.

CONSISTENTLY DEPENDABLE CORNELL-DUBILIER CAPACITORS

Plants in South Plainfield, N. J., New Bedford, Worcester and Cambridge, Mass.; Providence, R. I.; Indianapolis, Indiana; Fuquay Springs, North Carolina, and subsidiary, The Radiart Corporation, Cleveland, Ohio.

Over 43,000 Technicians Have Learned

HOW TO GET THE MOST OUT OF BASIC TEST EQUIPMENT

Why Not You, Too?

SERVICING by SIGNAL SUBSTITUTION

A BEST SELLER FOR OVER 9 YEARS! (NEW, UP-TO-DATE, 12TH EDITION)

The Simple, Modern, Dynamic Speed Approach To Receiver Adjustment and Alignment Problems, AM-FM-TV.

- Nothing complex to learn
- Universal — non-obsolete
- No extra equipment to purchase
- Employs Only Basic Test Equipment

Ask for "S.S.S." at your local Radio Parts Jobber or order direct from factory.

PRECISION APPARATUS COMPANY, INC. • 92-27 Horace Harding Blvd., Elmhurst 4, N. Y.

only 40¢

100 pages. Invaluable information that will help you re-double the value of your basic test equipment.

only 25 mw in the conventional circuit.

Circuit transformation by duality is not easy. For that matter neither is tube circuit design. Fortunately tube circuits have become largely standardized and memorized. Certain components and voltages may vary with the tube type,

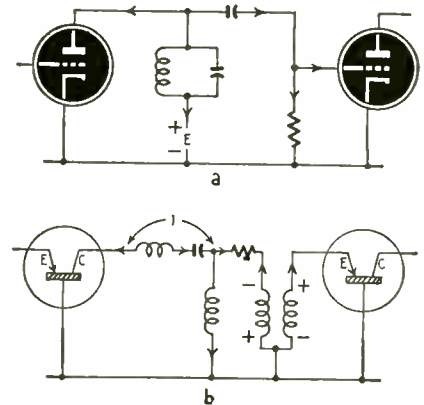

Fig. 2—A tuned vacuum-tube amplifier stage (a), and its transistor dual (b).

but these are readily available from manufacturers' data sheets. Eventually, transistor circuits will also become standardized, and recommended values will be given in data sheets. Until then experimenters will find that the duality principle is a great aid towards efficient design.

—end—

RECTIFIERS AS SWITCHES

Rectifiers are often considered valves. They permit current to pass in one direction but oppose reversed flow. At times it is better to consider rectifiers as "switches." If an impressed voltage puts a positive bias on an anode, the switch is closed and current can flow through the rectifier. With reversed polarity the switch is open, so no current flows.

In some circuits more than one voltage is applied at the same time to a rectifier. In such cases the switch anal-

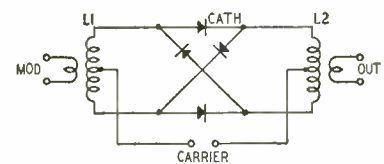

Fig. 1—The circuit of a ring modulator.

ogy is especially useful. For example, in some modulator circuits there may be two simultaneous inputs. One, the carrier, is usually relatively large in comparison with the other voltage, the audio. Then we can consider that the large carrier controls switch action.

Fig. 1 is the circuit of a double-balanced or ring modulator. The conductivity of the rectifiers is determined by carrier polarity since this is much larger than the audio. The carrier mixes with the audio to generate sidebands. Therefore the following signals exist in this circuit: the carrier C, the modulation M, and the sidebands S.

C is cancelled from the output be-



MISTER B. G. TO THE RESCUE!

(COURTESY OF SUPERIOR INSTRUMENTS CO.)



<p>"FOR CRYING OUT LOUD, STAND STILL"</p>	<p>"I'LL TRY ANOTHER CHANNEL"</p>	<p>"AH, A FILBUSTER — HE'LL KEEP (I HOPE)"</p>	<p>"THESE TV ORATORS ARE ALL ALIKE"</p>
<p>"I CAN'T CHECK THE PICTURE. WHAT'S THIS?"</p>	<p>"A CROSS-BAR GENERATOR, EH? WHAT DO YOU DO?"</p>	<p>"CONNECT TO ANTENNA POST, PLUG-IN — OK, NOW WHAT?"</p>	<p>"VERTICAL LINES! SAY, THAT'S GREAT!"</p>
<p>"TERRIFIC! HORIZONTAL LINES TOO!"</p>	<p>"WHAT A CINCH TO MAKE ADJUSTMENTS"</p>	<p>"WHY DIDN'T I MEET YOU BEFORE?"</p>	<p>"COME ON, PAL, YOU'RE BUNKING WITH ME"</p>



Do you want to do a fast, thorough T.V. service job?
Then don't wait another day! See your local jobber
and get the new, sensational time-saving, easy to use

SUPERIOR TV BAR GENERATOR

Throws a stable bar pattern on any TV Receiver Screen!!

Dealer's NET PRICE **\$39.95**

Write Dept. RC-10 for detailed descriptive circular
Superior Instruments Co. 227 Fulton St., New York 7, N. Y.



USE PHOTOFAC

the world's best Radio-TV service data—it pays for itself every working day

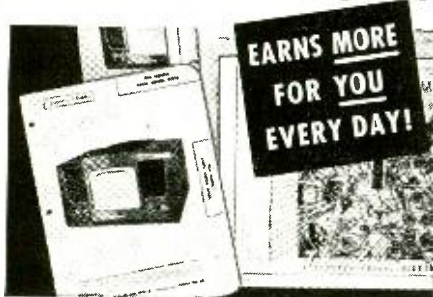

Try PHOTOFAC!

FREE We'll send you any Photofact Folder listed in the Photofact Cumulative Index *

WE'LL PROVE YOU'LL SAVE TIME and EARN MORE WITH PHOTOFAC

NOW—learn for yourself—at our expense—how PHOTOFAC makes your Radio and TV work *quicker, easier, more profitable!* Examine an actual PHOTOFAC Folder. Use it. You'll learn first-hand why over 35,000 successful service technicians use PHOTOFAC daily. You'll learn that no other service gives you PHOTOFAC'S *completeness, accuracy, uniformity, and lowest cost.* PHOTOFAC is the *only* radio and TV service data prepared from laboratory analysis of the actual equipment. Know the facts—get your **FREE** Folder now. Examine, use, compare—learn why no modern service shop can afford to be without PHOTOFAC!

* Except those followed by asterisk (*) or letter A.

WRITE FOR FREE INDEX

PAY AS YOU EARN! Ask your distributor about this amazing plan. Only \$18.39 puts the entire profit-boosting Photofact library in your shop now!

NOTE: Our **FREE** Folder offer is limited to Service Technicians only. Attach coupon below to your letterhead and mention your jobber's name. If you have no letterhead, send coupon to your jobber. Experimenters and others may obtain the Photofact Folder by remitting amount shown below.

HOWARD W. SAMS & CO., INC.
2201 E. 46th St., Indianapolis 5, Ind.

- Send **FREE** Photofact Cumulative Index
- Send Full Easy-Pay Details

I am a Service Technician:

- Send **FREE** Folder for set model.....

I am an Experimenter: Enclosed \$.....

- Send Folder for set model.....
- TV-\$1.00. Record Changer or Comm. Receiver-75c. AM/TM-50c

Name.....

Address.....

City.....Zone...State.....

cause it is fed through center-taps on L1 and L2. Equal and opposite carrier currents flow through each half of L1 and L2 so there is no carrier in either of these coils.

Fig. 2-a shows the equivalent circuit during one half the carrier cycle. Fig. 2-b shows conditions during the other half. In the first case the series rectifiers act like closed switches while the shunt rectifiers are blocked by the carrier. In the next case the opposite takes place.

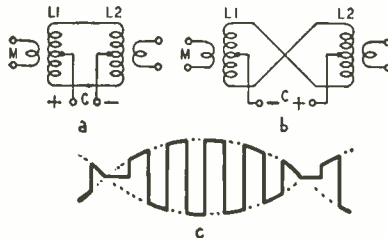

Fig. 2—(a) Equivalent circuit of ring modulator during one-half cycle; (b) during other half; (c) output wave.

In 2-a the input coil L1 is connected directly across the output coil L2. In 2-b the coils are also in shunt but the coil polarity is reversed. Therefore the modulation current flows continuously in the output coil but its polarity is reversed at the r.f. rate. Fig. 2-c shows this for one half the audio cycle. Note that there is a simultaneous positive and negative envelope with the result that the audio signal is cancelled out. Only sideband power can be obtained from this modulator circuit.

—end—

TWO INTERMODULATION TESTS

There are several ways of measuring a.f. distortion. Harmonic measurements are the simplest. Intermodulation tests are more satisfactory but they require more elaborate test equipment.

Intermodulation tests are not so well known but they show up distortion not indicated by the harmonic method. When 2 or more pure tones are fed simultaneously to any nonlinear a.f. circuit, the frequencies modulate each other. Since no amplifier or other a.f. equipment is perfect, some intermodulation exists.

Two standard intermodulation tests have been advocated. The SMPE test was standardized by the Society of Motion Picture Engineers. The CCIF test is recommended by the International Telephonic Consultative Committee, and is sometimes called the *difference-frequency* intermodulation test.

The SMPE method requires a l.f. and a h.f. test signal. Usually the first is 100 cycles and has 4 times the amplitude of the second which is 5 kc. Due to nonlinearity, sum and difference frequencies are created. They exist as sidebands at intervals of 100 cycles on both sides of the 5-kc "carrier" (see a). X and Y are the l.f. and h.f. signals, respectively.

Distortion due to the nth order sideband is then defined by the fraction:

Famous Products by

Jensen

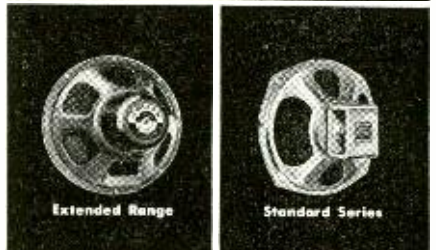
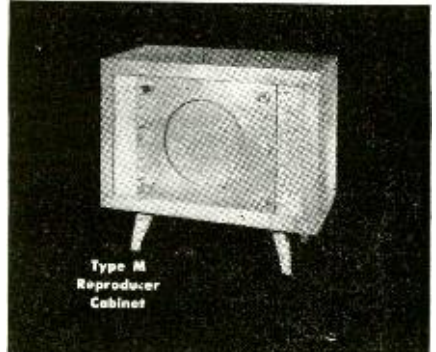
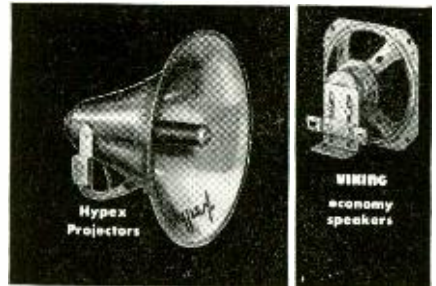
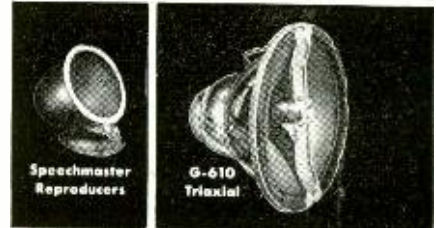
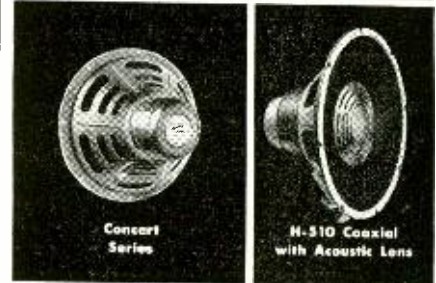

Jensen MANUFACTURING COMPANY

Division of the Motor Company
6601 S. LARAMIE AVENUE • CHICAGO 38, ILLINOIS

BURTON BROWNE ADVERTISING

RADIO-ELECTRONICS for

Sell Satisfaction... Sell TRIO TV Products

Yes, complete satisfaction all the way around results when TRIO TV products are sold. Jobbers know their dealers recognize quality of product — dealers know TRIO products mean satisfied customers. That's why TRIO products are the most wanted TV products on the market today.

TRIO YAGIS LEAD THE FIELD

TRIO 2-CHANNEL YAGIS

Models 445 & 479

Rapidly becoming the most popular — most wanted TV antenna in America. Available for channels 4 and 5, and channels 7 and 9. Provides gain on two channels equal to any two conventional 4-element yagis!

Features

- Full 10 db Gain On 2 Channels!
- One Bay Replaces Bulky Stacked Array!
- One Lead Replaces Old-Style 2-Lead Systems!
- Less Weight Per Gain Than Any Other TV Antenna!

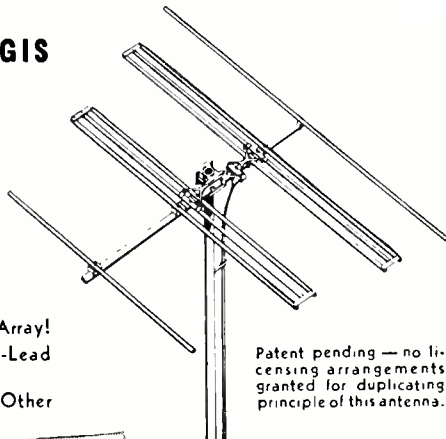

Patent pending — no licensing arrangements granted for duplicating principle of this antenna.

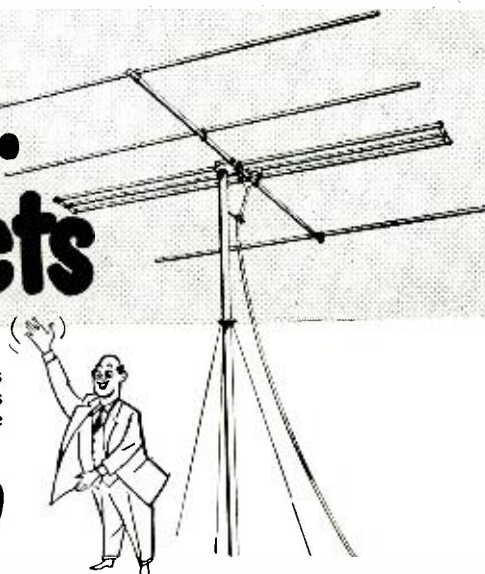

TRIO DOUBLE FOLDED DIPOLE

(Model 304)

Here is the popular TRIO Double Dipole TV Antenna. With 10 db forward gain and a front-to-back ratio of 25 db, it is unexcelled for extreme fringe areas. Available for each of 12 TV channels. Easily stacked for additional gain. Reinforced fittings for extra strength — extra rigidity!

Features

- Outperforms Conventional Large Arrays!
- Exact Impedance Match To 300 Ohm Line!
- Sturdy Construction — Light Weight!
- Partially Assembled!
- Gain Flat Over Entire Channel!

TRIO PHASITRON

Now Available Separately
(Model No. PC-600)

The TRIO PHASITRON, originally sold only as part of the TRIO Controlled Pattern TV Antenna System, is now available separately for TV set owners who want

to get the very best results from their sets and antennas, or to hams and other experimenters. PHASITRON acts as a continuously variable tuning stub and will provide an exact impedance match between line and booster and helpful in matching output impedance of booster to set input impedance. Due to exact matching, losses in line become negligible and set performance greatly improved.

May also be used to coordinate input from two or more antennas to provide added balanced output to set. Write for full details.

NEW TRIO TV ACCESSORY CONTROL UNIT

Model No. RY-1

A handy control unit that hides away inside or in back of the TV set and provides an automatic line switch for booster, rotator, TV lamp or other accessories. By plugging the line cords from these accessories into the TRIO Control Relay Unit, all accessories are turned on with the one switch controlling the TV set. Quickly installed without making any wiring changes in set.



New TRIO TV ROTATOR AND DIRECTION INDICATOR

Two heavy-duty 24 volt motors — instead of one — provide a reliability of operation that makes this rotator outstanding.

One motor turns antenna clockwise — the other counter-clockwise. Even if left on continuously, a motor cannot burn out since load on a single motor is never on more than 50% of the time!

The new TRIO TV Rotator provides the ultimate in trouble-free, dependable operation. Supports heaviest arrays, even in 80 M.P.H. winds.

Positive acting electrical stops at both ends of 360° turn eliminates lead damage.

Rotator Features

- Cast TENSALLOY aluminum mast holder, 11/16" steel shaft. Withstands 4500 lbs. bending movement.
- Automatic Electro-Mechanical Brake — reduces coasting to minimum.
- All-aluminum case — no cast zinc!
- Turns 1 RPM, lifetime lubricated.
- Ball-bearing end thrusts on shafts.
- Ideal for 10, 6 and 2 meter amateur use.



"TELEVISION TOPICS"

Write today for your free copy of "TELEVISION TOPICS" by G. N. Carmichael. It discusses items of interest to TV distributors, dealers and users, includes information on Antenna Types and Height, Lead-Ins, TV Signal Propagation, Interference, TV Set Limitations, Rotators, Mast and Towers and Future Trends in TV.



Trio

MANUFACTURING COMPANY
GRIGGSVILLE, ILLINOIS

Save Time
Save Money
with these...

New STANCOR REFERENCES

The big new Stancor 1951 Mid-Year Catalog lists 441 Stancor transformers ...the most complete catalog line in the industry. All transformers, including television components, are classified and indexed so you can easily locate the unit you need. Each listing includes electrical specifications, dimensions, weight and list price. Clear illustrations show each mounting type in detail.

The 8th Edition of the Stancor Television Catalog and Replacement Guide provides you with quick, easy-to-read replacement information on 1511 TV models and chassis made under 79 brand names. All manufacturers are listed alphabetically and the models and chassis are listed in numerical order. A separate section lists all Stancor TV transformers and related components by part number.

Both of these up-to-date references are now stocked by your Stancor distributor, or write Stancor directly for your free copies.

AUDIOPHILES—Use Stancor transformers to build the famous Williamson High Fidelity Amplifier. Circuit diagrams and complete parts lists are available in Stancor Bulletin 382 at your Stancor distributor.



Most Complete Line
in the Industry

STANDARD TRANSFORMER CORPORATION

3592 ELSTON AVENUE, CHICAGO 18, ILLINOIS

$$\frac{\text{nth harmonic of sidebands}}{\text{h.f. signal amplitude}}$$

The CCIF test uses 2 h.f. test signals of equal amplitude. The frequency difference between them is usually in the range 30-400 cycles. This difference frequency is one of the distortion products due to intermodulation. The distortion it creates is measured by

$$\frac{\text{difference-frequency amplitude}}{\text{sum of h.f. test signals}}$$

Intermodulation also exists between each h.f. signal and the second harmonic of the other (see b). This sideband distortion is defined by

$$\frac{\text{sum of both sidebands}}{\text{sum of h.f. signals.}}$$

According to Peterson*, the CCIF test is better than the SMPE, especially where the audio system has limited h.f. response. Hearing aids, filters, noise suppressors, etc., are systems

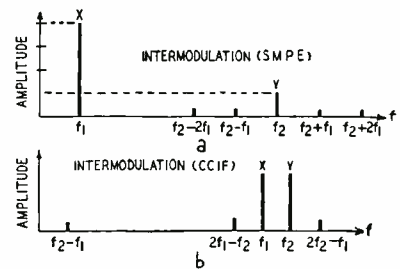

Two intermodulation measurement systems. Note the amplitudes of X and Y.

that fall in this category. A harmonic test on them would be misleading because of the limited h.f. response. The SMPE test cannot give a true picture because it has a strong l.f. test signal. This means that the h.f. end of the amplifier is not given a real check.

A pair of signal generators are required for intermodulation measurements. For the SMPE test the frequencies may be fixed at 100 and 5,000 c.p.s. as noted previously. For the difference-frequency test the oscillators may be ganged. This gives a constant beat through a wide range. With this setup X and Y may be moved up and down the scale while (f₂-f₁) remains stationary (see b).

*Arnold P. G. Peterson. *Technician*. Publication available from General Radio Co., Cambridge, Mass.

—end—

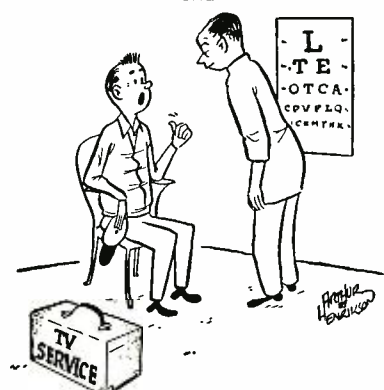

"I'm worried about my future, Doc. What can you do for color blindness?"

RADIO-ELECTRONICS for

NOW! COLOR TELEVISION \$1.25 ON YOUR PRESENT SET! 10 INCH

Sensational new Tri Colored Film, will bring you colored pictures on all black and white broadcasts
Brings in any TV program in glorious color, on any TV set
Anybody can attach in less than one minute
Greatest development since advent of television!

Send for yours today, start selling this red hot item at once, when your customers see colored programs with Ray Vision, you will be swamped with orders

RAY CO. 441 SUMMIT TOLEDO, OHIO Immediate Delivery

	RETAIL	YOUR COST
10 INCH	4.95	1.65
12 1/2 "	5.95	1.95
14 "	6.95	2.30
16 & 17 "	7.95	2.55
20 "	8.95	2.85

ADD 15¢ SINGLE ORDERS
WE PREPAY SIX OR MORE

JUST OFF THE PRESS! YOU CAN GET IT FREE!

FROM YOUR SYLVANIA DISTRIBUTOR

when you buy 100 Sylvania Receiving Tubes
or 2 Sylvania Picture Tubes!

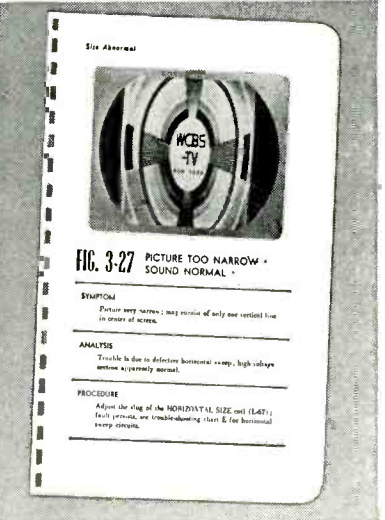
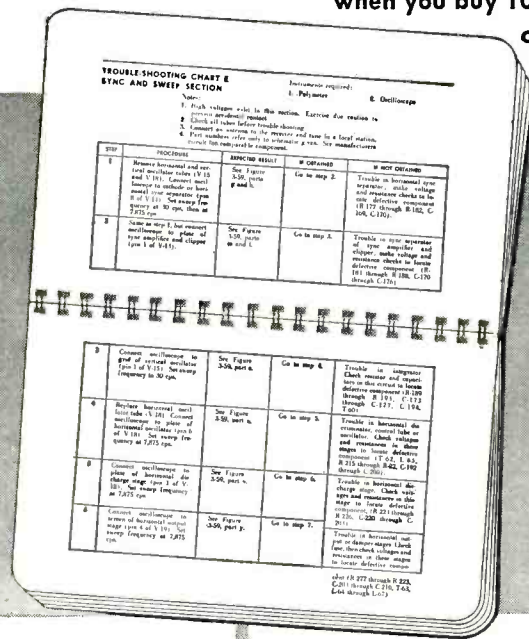
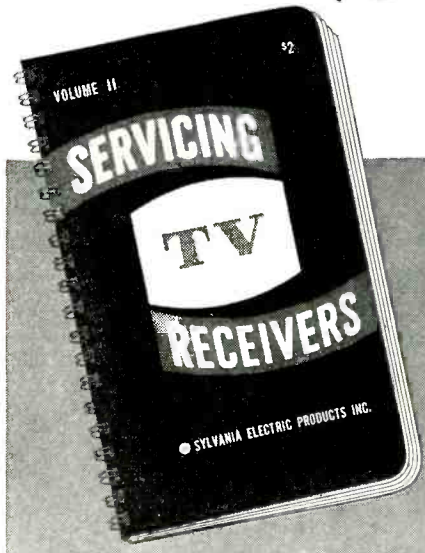

Offer good only Sept. 15, 1951 to Nov. 1, 1951. ACT NOW!

SERVICING TELEVISION RECEIVERS — VOL. II

Not just a revised, brought-up-to-date version of last year's book . . . but a completely new, reworked volume, prepared by an expert TV servicing-writing team!

Sylvania has long recognized your need for a more advanced, more complete, more systematically organized television service manual. Now, after months of careful preparation, this book is ready . . . VOLUME II, SERVICING TELEVISION RECEIVERS. It's yours FREE OF EXTRA CHARGE when you buy 100 Sylvania Receiving Tubes or 2 Sylvania Picture Tubes.

This new book, written around a popular 1951 TV receiver, contains servicing techniques for all the most recent circuits. Its information applies to most all TV sets in use today. In addition, it contains a systematic method of locating, isolating and correcting troubles . . . by far the clearest, easiest, simplest method yet devised for servicing present day receivers.

Get your FREE service book now. Offer expires Nov. 1. See or write your Sylvania distributor today!

Here's what this volume contains, how it helps you!

How to sectionalize trouble by picture analysis. For this, 41 photographs of abnormal TV pictures and their analyses are presented.

How to isolate faulty stage by use of 6 special trouble shooting charts—one for each section of receiver. Charts give step by step procedure, expected results, action required, instruments required. Charts provided for following sections: power supply, video, sound, sync., and sweep, high-voltage.

How to locate defective part—by trouble shooting charts based on voltage and resistance measurements and tube testing. Actual voltage and current readings to be encountered are listed.

Adjustment and alignment of television receivers. Alignment procedures for rf tuner, video if, sound if, and discriminator; adjustment of ion trap, focus coil, deflection coils.

- 150 PAGES! 5 BIG CHAPTERS!
- 80 PICTURES AND DIAGRAMS!
- WIRE-O-BINDING keeps book flat!
- HEAVY COVER, TOUGH, COATED PAGES to stand rough, constant handling!

SEE YOUR SYLVANIA DISTRIBUTOR FOR YOUR FREE COPY TODAY!

SYLVANIA

Sylvania Electric Products Inc., Emporium, Pa.

RADIO TUBES; TELEVISION PICTURE TUBES; ELECTRONIC PRODUCTS; ELECTRONIC TEST EQUIPMENT; FLUORESCENT TUBES, FIXTURES, SIGN TUBING, WIRING DEVICES; LIGHT BULBS; PHOTOLAMPS; TELEVISION SETS

V.H.F. Paging Calls Subscriber to Phone



THE
**MIGHTY
MIDGET**

THE BIGGEST
RECEIVER VALUE
IN AMERICA!

National's entire initial production run of the sensational new SW-54 receiver was exhausted in just a few short months after production! Now, at last, the "Mighty Midget" is once more available.

This amazing receiver tunes the entire frequency range from 540 kcs. to 30 mcs., voice and code, with big set sensitivity, yet measures only 11" x 7" x 7"! Has edge-lighted slide rule dial calibrated in 4 bands with foreign, ship, amateur and police frequencies clearly marked and unique plastic bandsread knob. Has new miniature tubes. Housed in smart modern metal cabinet with tough velvet-gray finish.

See and hear it today!

Write for name of nearest dealer.



Amateurs and v.h.f. enthusiasts in the New York metropolitan area have been mystified during the past few months by a station which recites a string of numbers in a woman's voice, followed by a man announcing "KEA627." They are hearing the Aircall Radiopaging station of the Telanserphone telephone-answering service, operating on 43.58 mc from the Hotel Pierre in New York City.

The radiopaging service, which was described in this magazine January, 1951, is a means of getting a person, who may be away from other means of communication, but within 25 miles of the station, to a phone. It is an extension of the telephone-answering service, and came into existence to meet a very special need.

Telanserphone found that some subscribers to the service could not be located, because they were out of reach of any phone. Some method of contacting such persons (doctors particularly) and bringing them to the phone was needed. A small portable receiver and a transmitter broadcasting only the numbers of subscribers for whom urgent calls were waiting, was the answer.

The Aircall subscriber

The number of people who require a system such as Aircall is not large, but those who do have use for it are likely to consider it a necessity. A doctor, for instance, can attend a play without leaving his name at the box office and waiting for a possible paging all through the evening. He (or the busy executive) can even go on a short fishing trip without fear of losing a life or a million dollars.

The Aircall subscriber has only to take from his pocket at intervals a specially designed receiver and listen to a program which consists merely of



The tiny hand-held Aircall receiver.

a string of numbers. If he hears the code number allotted to him by Aircall, he knows he is wanted on the phone, and calls Telanserphone by phone immediately. If his number is not on the program, he can relax for a while longer.

Superregenerative receiver

The little receiver which makes this possible is a clever v.h.f. design. Its size and actual working parts are shown very well in the two photographs. Two subminiature tubes, a special Sonotube for the oscillating detector, and a Raytheon CK522AX for the audio amplifier, are used.

Tuned to a frequency of 43.58 mc,

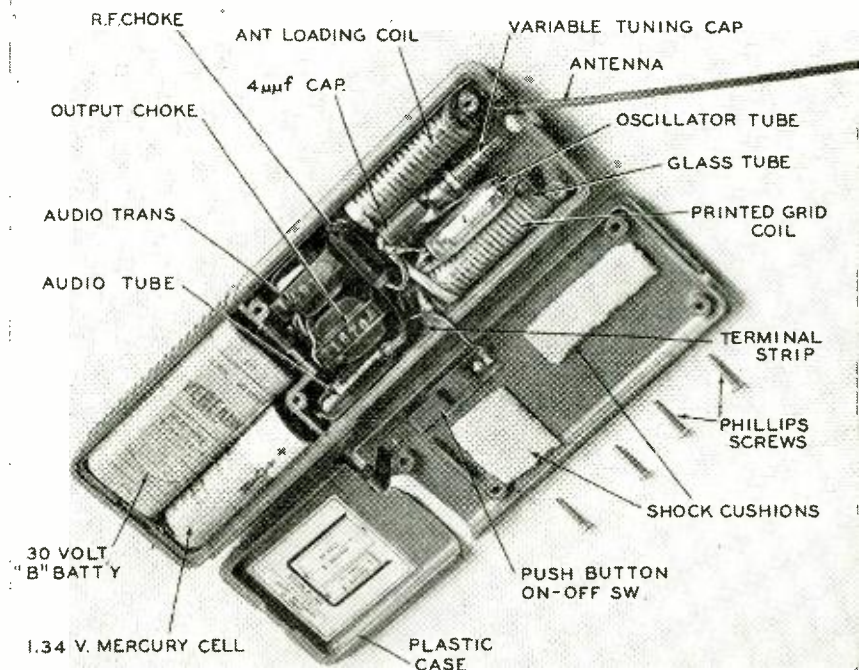

Printed circuits and miniature parts are secret of stable, sensitive, pretuned set.

the utmost stability is required to keep these little sets on frequency. Even a standard portable often gets pretty rough treatment, and a set of this type is likely to be carried in a briefcase or doctor's bag—or eventually, perhaps, even on a farmer's tractor—where it will receive more jolts and jars than the ordinary portable. To keep frequency changes within the narrowest possible limits, printed circuit techniques were used, the coils being silver deposited on glass tubes half an inch in diameter.

The receiver is a modified ultraudion superregenerator. The circuit as shown in the diagram may not be entirely complete, for in all high-frequency equipment, some capacitance resides in the spacing of components and between elements in tubes, instead of appearing on the diagram as measureable physical components.

Printed coils

An interesting feature is the antenna loading coil—something one would hardly expect to see in equipment operating above 40 mc. It is "wound" with 17 turns of silver deposited on the glass tube, a spiral of ribbon 3/64 inch wide, 1/32 inch between turns. It is connected to the 4-inch antenna at one end, and to the plate end of the tuning coil at the other.

The other coil—next to the subminiature tube in the photo—also has 17

turns of silver deposited on a glass form. The coil is a trifle shorter and the turns 1/64 inch narrower. It is tuned to the operating frequency by a tubular trimmer, across which is a 4- μ mf fixed capacitor. Adjustments are made through a hole in the end of the case, which is closed with a rubber grommet once the set is tuned in.

Any radio frequency remaining in the signal after detection is filtered out by the r.f. choke (40 turns on a 1/8-inch form) and a small ceramic capacitor—exact capacitance unknown—as well as the primary of the subminiature audio transformer.

In spite of its small size, the wiring is beautifully laid out. A small terminal strip runs across the case at the base of the coils and detector tube, below the r.f. choke. It has six eyelet terminals, which are soldering points to which leads are brought.

The set brings in a strong signal when held the proper distance from the head, body capacity affecting the super-regeneration slightly.

Operation is extremely simple. To listen, the user simply presses the push-button switch (see the cover section of the case in the photo) which turns on filament current. He is warned to take certain precautions, such as keeping the hand down on the battery section (away from the circuits) and not to hold the set too close to the head. As the receiver has no volume control,

the user soon learns to attenuate an overstrong signal by positioning the receiver closer to or farther from his ear.

Telanserphone maintains the little receivers, asking that they be sent to the office once monthly for checking and battery replacement. The owner is thus insured of trouble-free operation almost automatically.

Fees are very low, possibly due to the present experimental nature of the

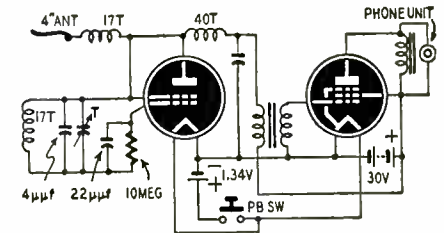

Circuit is a modified ultraudion type.

service. For \$10 per month the subscriber can lease a receiver and be paged any hour of the 24, besides having batteries replaced monthly, along with all other maintenance that may be necessary.

There is only one restriction—maintenance is strictly a shop proposition. The lessee must bring or mail his Air-call to the service department of Telanserphone—he cannot expect a technician to come to it.

—end—



RMS BOOSTER SP-5

America's best booster from America's oldest Booster manufacturer . . . gives you powerful gain over the entire television range. Can be peaked for operating channels without removal of chassis. Features gear-driven, velvet smooth single knob tuning. Has an edge in styling and simplicity!

Model SP-5, only **\$22.50**

RMS CORNER ARRAY ANTENNA COR-13

Features the characteristic curve and gain of a parabolic reflector antenna—one of the highest gain antennas in use today. In fringe or extreme fringe areas this antenna doubles the amount of stations you can receive. Cut to specific channels, down to channel 7. Reflectors 3/8" butt seam tubing; receiving element, 1/2" drawn aluminum tubing.

Model COR-13, for channel 13, only **\$15.95**
Additional charge for other channels.



AT FEDERATED . . .

THE MOST
POPULAR
THE MOST
POWERFUL

FOR
FRINGE AREA
TELEVISION

Federated Purchaser
INCORPORATED
CABLE FEDERPURCH
THE ONLY COAST TO COAST ELECTRONICS DISTRIBUTOR

- NEW YORK CITY 66 DEY ST. DiGby 9-3050
- LOS ANGELES 911 S. GRAND AVE. TRinity 7311
- NEWARK, N. J. 114 HUDSON ST. MARket3-4005
- ALLENTOWN, PA. 1115 HAMILTON ST. Phone 3-7441
- EASTON, PA. 925 NO. HAMPTON ST. Phone 4259

AVOID RESISTOR BREAKDOWNS



OHMITE Little Devil Resistors Provide EXTRA MARGIN of SAFETY

Although they are tiny in size, Ohmite Little Devil molded composition resistors have unusual ruggedness, stability, and current-carrying capacity. For example, they are rated at 70C instead of the usual 40C. They meet all test requirements of JAN-R-11, including salt water immersion and high humidity tests without wax impregnation. In addition to conventional color coding, the resistance value and wattage are clearly marked on each unit.

Available in 1/2, 1, and 2-watt sizes with $\pm 5\%$ or $\pm 10\%$ tolerance, in standard RTMA values—10 ohms to 22 megohms. The 1-watt size, $\pm 10\%$ tolerance, comes in values as low as 2.7 ohms.

OHMITE MANUFACTURING CO.
4894 Flournoy St., Chicago 44, Ill.

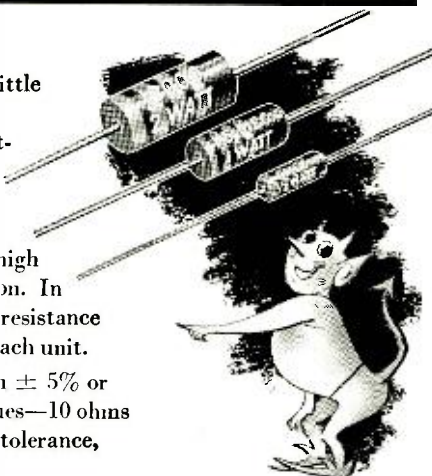

Available Only
From Your
Distributor

Be Right with **OHMITE**

RHEOSTATS · RESISTORS · TAP SWITCHES

TUBES OF THE MONTH

Du Mont is now offering to other receiver manufacturers and to the trade, the 30BP4, a 30-inch metal-cone round tube. It is claimed this is the world's largest picture tube.

The giant tube has a usable area of 536 square inches, uses a 90° deflection angle, and is 23 3/16 inches long, about 2 inches longer than the 20-inch type.

Sharp edge-to-edge focus is claimed. The anode is designed to operate at 20,000 volts. A single-magnet ion trap is required.

Two new 21-inch glass picture tube designs having a rectangular face and cylindrical front section are announced by National Union. The 21EP4, 21EP4A, 21FP4, and 21FP4A provide a picture 19 1/8 by 13 7/8 inches and reduce ambient light reflection two ways: a filter glass is used in the faceplate, and the cylindrical front surface eliminates reflection by scattering in an upward and downward direction the light incident on the tube face.

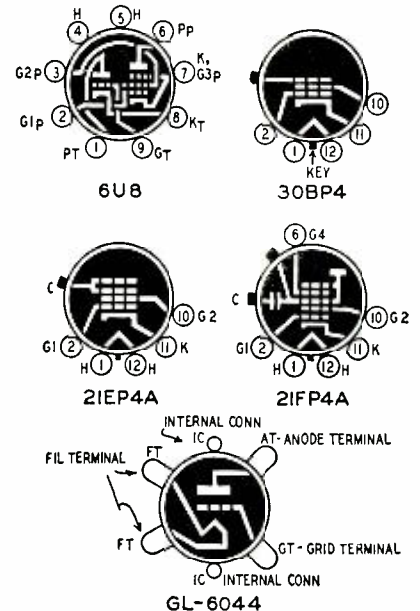

Base diagrams of new tubes described.

Type 21FP4 uses low-voltage (200 \pm 200 volts) electrostatic focus and magnetic deflection. 21EP4A uses magnetic focus and deflection. The tubes are also available without external conductive coating and do not bear the A designation, in this case. Both types use single-magnet ion traps, and 18 kv is the maximum collector voltage rating that is specified.

A miniature type triode-pentode, the 6U8, is being manufactured by Tung-Sol, and is intended as a local oscillator mixer for FM and TV receivers. The two sections are electrically independent: the triode has sufficient reserve emission to operate efficiently at widely varying supply voltage conditions; the pentode requires low local oscillator injection, with resultant low oscillator

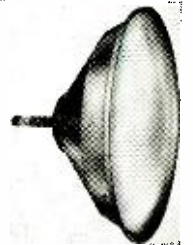

ACTUAL SIZE
Model 666-HH
TRIPLET
Volt-Ohm-
Milliammeter

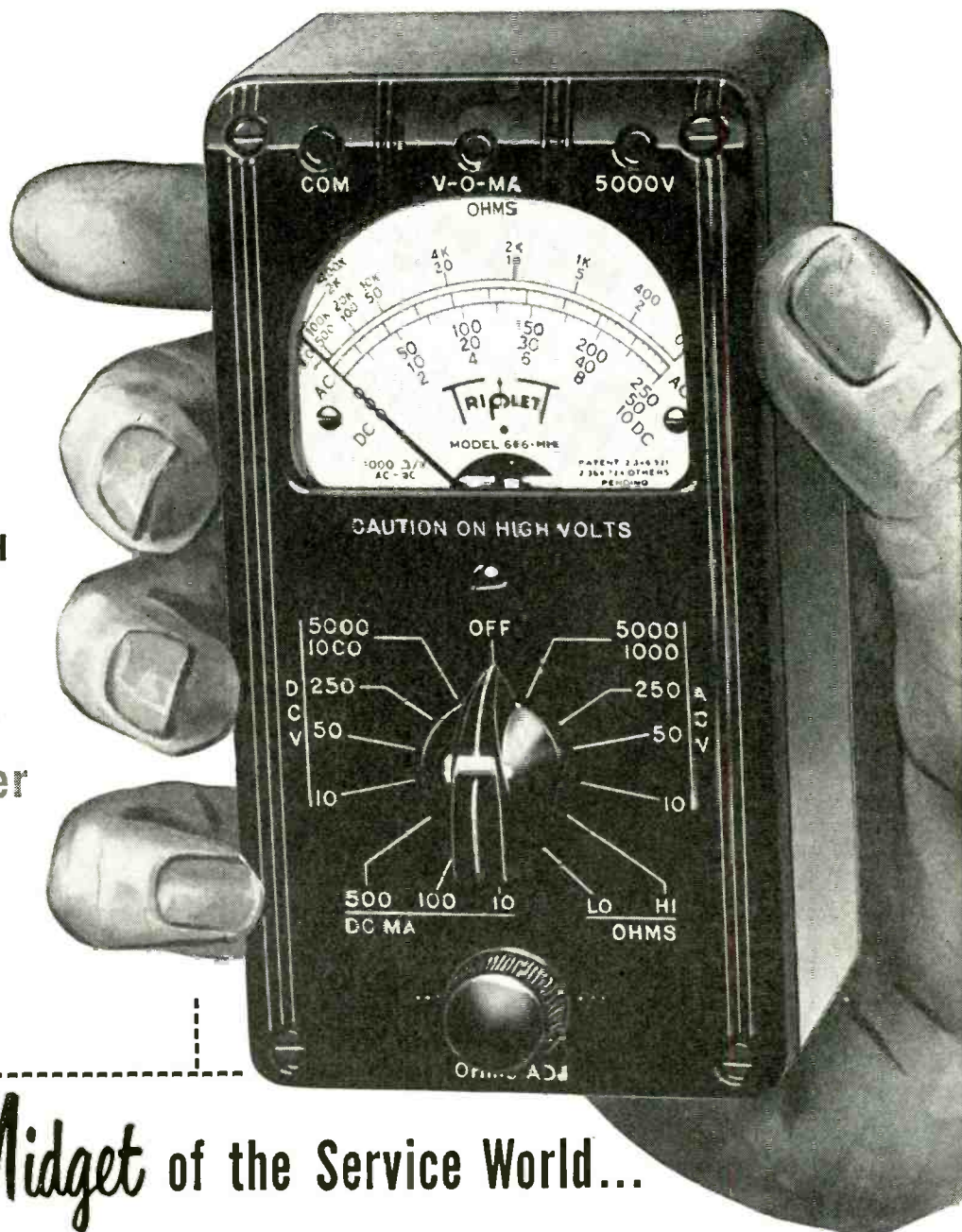

Mighty Midget of the Service World...

RANGES

D.C. VOLTS: 0-10-50-250-1000-5000,
at 1000 Ohms/Volt.

A.C. VOLTS: 0-10-50-250-1000-5000,
at 1000 Ohms/Volt.

D.C. MILLIAMPERES: 0-10-100-500,
at 250 M.V.

OHMS: 0-2000-400,000 (12-2400 at
center scale).

Slip this little V-O-M in your pocket and you become a walking laboratory for making complete D.C. and A.C. Voltage, Current, and Resistance Analyses. There's nothing "little" about this miniature marvel but its *size!* It's the mighty midget of the Service World—Truly a giant in performance.

Some of the things you get: a 3-color scale for quick-glance readability, only one switch for noticeable ease in correctly getting your range, the banana-type jacks that provide quick plug-in connections and lower jack contact resistance—and the remarkable stability on voltage ranges by use of special resistors throughout, and on current ranges with 250 M.V. instrument.

Buy Model 666-HH now—and remember, it carries the famous Triplet RED-DOT *Lifetime Guarantee*. Don't hesitate another day!

FOR THE MAN WHO TAKES PRIDE IN HIS WORK

Triplet

TRIPLET ELECTRICAL INSTRUMENT CO., BLUFFTON, OHIO, U. S. A.

ONLY \$24.50 AT YOUR DISTRIBUTOR

(Price Subject to Change)

LOOK-NO HANDS!



AUTOMATIC SELF-TUNING

SUPER Tune-O-Matic TV BOOSTER

- NO SEPARATE BOOSTER TUNING
- UNIFORMLY HIGH USABLE GAIN
- LESS "SNOW"—BETTER PICTURES
- EXCLUSIVE 4-STAGE BROADBAND CIRCUIT
- EASILY CONCEALED—HIGHLY STABLE

Connect it...and forget it! Anyone... even a child...can get his favorite programs with a clarity of picture and sound like never before...on any channel...automatically...without any booster tuning!

Exclusive E-V all-electronic broadband circuit gives superb low-noise performance...provides higher effective gain on all channels...works where others have failed, even in tough fringe areas. Furthermore, the booster can be easily concealed. Installation is quick and simple. Plugs into 50-60 cycle a.c. outlet. Thousands of installations have proved it completely trouble-free. There's nothing like it!

Model 3000 TUNE-O-MATIC. List. . . \$59.50

Electro-Voice

TV BOOSTERS • MICROPHONES • HI-FI SPEAKERS • PHONO-PICKUPS

Patent Pending

Electro-Voice, Inc., Dept. E10-51
421 Carroll St., Buchanan, Michigan
Send Free Bulletin No. 163

Name _____
(PLEASE PRINT)

Address _____

City _____ Zone _____ State _____

Serviceman Installer Dealer TV Fan

First all-channel, low-noise, antenna-mounted, self-tuning TV Booster! Mounts on antenna mast ahead of the lead-in. Automatically boosts the signal—not any local noise picked up by the lead-in. Clearly brings in telecasts you could never get before. Finest booster for tough fringe areas or noisy locations in primary areas.

Model 3010 TENNA-TOP.
List Price\$89.50

Send for

FREE BULLETIN TODAY!

radiation from TV receivers using it.

Some typical operating characteristics are; heater, 6.3 volts, 450 ma, a.c. or d.c., any mounting position; E_p triode, 150, pentode, 250; transconductance, triode, 8,500, pentode, 5,200 μ mhos; E_{c1} , triode, -12, pentode, -10.

A heavy-duty thyatron the GL-6044, is being produced for use in airborne electronic control equipment.



6U8, triode-pentode; rugged thyatron.

Instead of the conventional prong-type base for insertion into a socket, the tube has contact terminals extending at right angles from heavy support rods at the bottom. The tube can be bolted to a panel and thus will not work loose through equipment vibration.

It operates from -55 C° to 120 C° at normal atmospheric pressure, is inert-gas-filled, and has a current rating of 6.4 amperes. The indirectly heated cathode is rated at 2.5 volts, 17 amperes. —end—

Stable Frequency Divider

Highly stable frequencies in the audio- and radio-frequency ranges are often needed for aligning, testing, and calibrating some types of electronic circuits and devices. The equipment described here consists of three regenerative type frequency dividers which provide frequencies of 10 kc, 1 kc, and 100 cycles from a 100-kc frequency standard. These circuits are described in detail in *A Regenerative Frequency Divider of Improved Stability* (NRL Report No. 3653), published by the Naval Research Laboratory, Washington, D. C.

These dividers are stable and self-starting for input-signal voltages ranging from a volt or two to over 45 volts and for plate-supply voltages from 40 to 350. Output voltages usually are flat and do not fall below 10 volts for plate-supply voltages of 200 (or more) and inputs of 3 to 6 volts (depending on operating frequency and plate-supply voltage).

A block diagram of a single 10-to-1 divider system is shown in Fig. 1. The regenerative divider is designed around

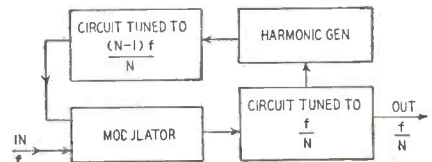

Fig. 1—A single 10-to-1 divider system.

two tubes and two selective tuned circuits. The input tube, the modulator, is a pentagrid converter type and the second tube, the harmonic generator, is a pentode.

The tuned circuit in series with the modulator plate is tuned to f/N while the plate circuit of the harmonic generator is tuned to $(N-1)f/N$. N is the factor by which the input frequency f is divided. Intermodulation between the input frequency f and the output of the harmonic generator, $(N-1)f/N$, pro-

The schematic of the 100-10-kc divider is shown in Fig. 2. The circuits of the 10-1-kc and 1-kc to 100-cycle dividers are identical to Fig. 2 except for the values of the coded components. Values for these components will be found in the accompanying table. Two 6V6 cathode-follower amplifiers are pro-

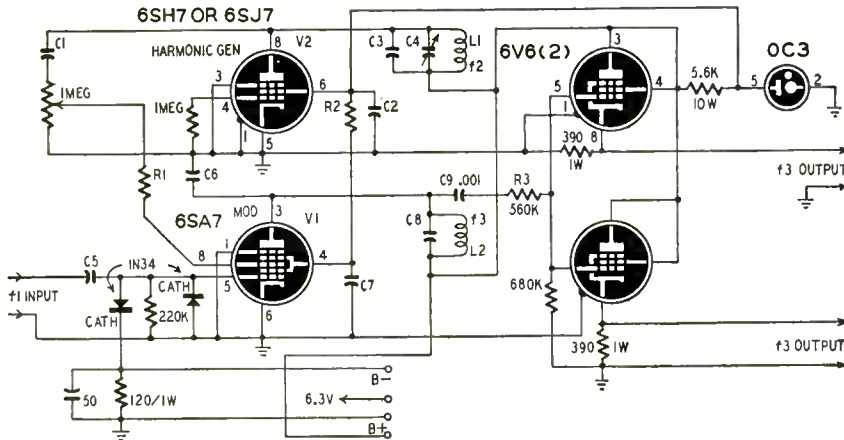

Fig. 2—Schematic of 100-10-kc divider. See table for other two divider values.

duces sum and difference frequencies of $(2N-1)f/N$ and f/N . Since the modulator output circuit is tuned to f/N , its output will of course be at this frequency. A continuous f/N signal will be produced as long as the input signal f is maintained.

TABLE

Part	Divider		
	100 kc to 10 kc	10 kc to 1 kc	1 kc to 0.1 kc
C1	25 μuf	50 μuf	.02 μf
C2	0.1 μf	1.0 μf	10 μf
C3	220 μuf^*	.0065 μf^*	#
C4	12-62 μuf	Not used	Not used
C5	150 μuf	620 μuf	.005 μf^*
C6	25 μuf	250 μuf	.025 μf
C7	0.1 μf	1.0 μf	10 μf
C8	.004 μf^*	0.25 μf^*	#
C9	.001 μf	.01 μf	0.1 μf
R1	100,000 ohms	Not used	Not used
R2	1,500 ohms	2,200 ohms	2,200 ohms
R3	560,000 ohms	180,000 ohms	180,000 ohms
V1	6SA7	6SA7	6SA7
V2	6SJ7	6SH7	6SH7
f1	100 kc	10 kc	1 kc
f2	90 kc	9 kc	900 c.p.s.
f3	10 kc	1 kc	100 c.p.s.
L1	13 mh	47.5 mh	#
L2	65 mh	100 mh	#

Notes: * Values not given in original data but calculated from frequency and inductance.
Values not given. Use L and C combinations which give desired frequency.

vided. One drives the following divider stage and the other is used for taking off voltages for testing and calibrating.

The input signal is square by two 1N34 diodes connected back-to-back. The square wave shock-excites the f/N circuit, causing it to ring and provide the type of signal needed to drive the harmonic generator.

The selectivity of the two tuned circuits must be high for efficient operation of the modulator and harmonic generator. Therefore, the coils' Q must be high. The in-circuit Q of the coils decreases with a decrease in the load shunting them. In each case, the load is the plate resistance of the associated tube and the resistance of the circuit being driven. The minimum in-circuit Q should be not less than 25.

Stability in any circuit, no matter how inherently stable the circuit itself is, depends greatly on the voltage regulation of the power supply. Although in this case an 0C3 is used, with consequent B-supply regulation, it might be advisable to meter the filament voltage. A Variac can then be used to vary line voltage and help insure proper calibration. —end—

New Devices Aid TV Viewing

The wave of color appears to have made more than one design engineer decide to see what could be done to make ordinary black-and-white more attractive. Two recent systems, Majestic's *Coloramic* and Sylvania's *Halolight*, are the most interesting steps in that direction.

Halolight is an application of the principle of "surround lighting," said to be used in some British moving-picture houses. In radio terms, a "matching section" is interposed between the bright screen and the dark surroundings. The wide mask of the Halolight receiver is translucent and can be made to glow with lights placed around the end of the viewing tube. Five intensities

are possible. Proper adjustment lies in keeping the "halo" brighter than the environment but darker than the picture's average brilliancy.

Persons watching Halolight screens for long periods report less eye fatigue than with standard screens. There is also an illusive feeling of largeness; pictures on a Halolight screen look bigger than those on a standard screen of the same size placed beside it for comparison.

Another system consists of a fixed 3-color filter in front of the standard screen. This device is being marketed by Majestic under the name *Coloramic*, and by filter manufacturers under a variety of names.

200
260
260
260



Simpson
volt-ohm-milliammeter that
outsells all others combined.

260
260

CENTER TV PICTURES in 3 seconds

with the **NEW**

BeamaJuster

This efficient and easily installed Perfection centering device makes possible the centering of TV pictures in 3 seconds instead of 20 to 30 minutes. The BeamaJuster eliminates costly and complicated centering controls of the resistor type.

It also replaces mechanical centering controls which tilt the focus coil to center the picture and require numerous springs, wing



nuts and special brackets. No drifting of picture. Perfect for conversions from small to large size tubes. Easily installed.

1. Snap BeamaJuster on back cover of tube yoke. (Fits any size tube.)
2. Rotate BeamaJuster as shown here for approximate centering of picture.
3. Make final adjustment by sliding outer plate of BeamaJuster vertically or horizontally.

Order today from your supplier!

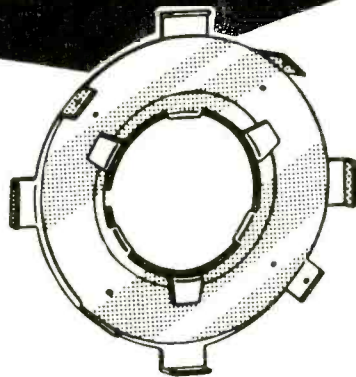

The filter is greenish at the bottom, blending into an orange-reddish color toward the center and going to blue at the top. There is no sharp line of demarcation in the filter, though one gets an impression of three bands blending into each other, and the color is faint enough to be unobtrusive. Some versions of the filter being marketed lack the green part in the foreground. Less eye fatigue is also claimed for this system, as well as a certain amount of depth and liveness.

—end—

TV IN "HIDDEN VALLEYS"

Equipment originally intended to supply TV programs to residents in large apartment buildings may solve the reception problem for "hidden-valley" dwellers, who may be within the range of one or more television stations but who are shielded by hills or mountains.

First installation reported was at Lansford, Pa. A tower was erected on Summit Hill, less than a mile away and in full "sight" of Philadelphia. A standard Jerrold multiple television amplifier unit was hooked in at the base, and the amplified signals were sent down the hill on a 72-ohm coaxial line mounted on poles. Three channels were amplified separately and sent along the same cable without interference. Another booster was inserted before reaching the village, and standard apartment distribution units were used at the houses of the subscribers.

RCA has installed a system at Pottsville, Pa., another mountain valley community. The antenna on Sharp Mountain catches TV signals from Philadelphia, 75 miles away, and sends them down the mountain and through Pottsville by coaxial cable strung on existing utility poles. Tap-lines run into subscribers homes. Pottsville residents, 275 subscribers at present, pay a \$135 initial fee and \$3.75 monthly.

—end—

PERFECTION ELECTRIC COMPANY

2637 South Wabash Avenue, Chicago 16, Illinois
MAKERS OF PERFECTION SPEAKERS AND TELEVISION COMPONENTS



COLOR TELEVISION PATENTS

Study first hand information, including Columbia system, by reading actual patents. Secure this comprehensive patent search report.

\$1 postpaid

PATENT SERVICE INSTITUTE
945-06 Pennsylvania Avenue
Washington 4, D. C.

PEN-OSCIL-LITE

Extremely convenient test oscillator for all radio servicing, alignment. • Small as a pen • Self powered • Range from 700 cycles audio to over 600 megacycles u.h.f. • Output from zero to 125 v. • Low in cost • Used by Signal Corps • Write for information.

GENERAL TEST EQUIPMENT
38 Argyle Ave. Buffalo 9, N. Y.

Largest Selling Booster

AT ANY PRICE !

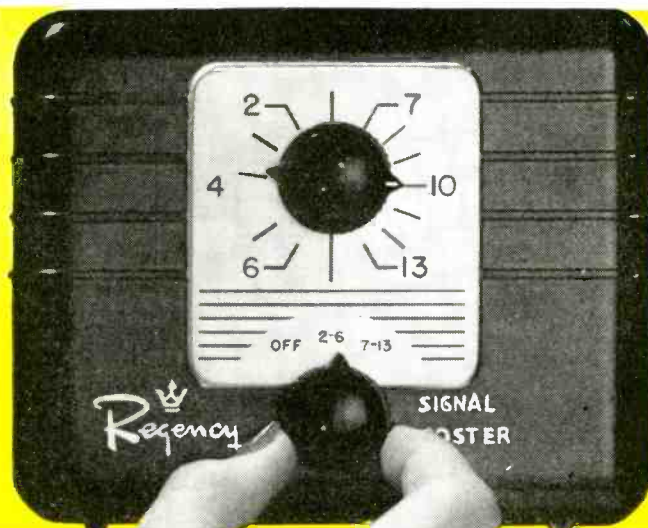

Regency

Let Us Put This Magnificent New 1952

MIDWEST TELEVISION

CONSOLE With Its MAMMOTH

20-Inch

PICTURE TUBE
IN YOUR HOME ON
30 DAYS TRIAL

FACTORY-TO-YOU

You be the judge! See and hear Mammoth-Picture Midwest Television right in your own home for 30 days. If you are not 100% satisfied, any money you have paid will be promptly refunded. Send today for the new 1952 catalog of the finest Midwest line in 32 years.

LOW FACTORY PRICES

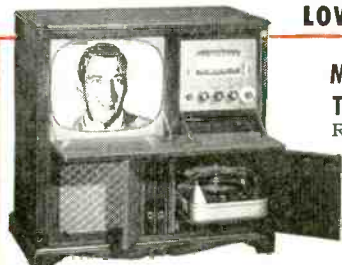

MIDWEST 20-Inch TELEVISION CHASSIS

Ready for easy installation in your own cabinet.

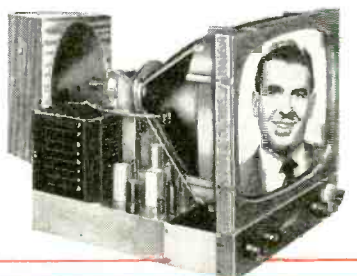

MIDWEST VIDEO GRAND

In addition to its mammoth 20-inch Rectangular Picture, this luxurious instrument offers a powerful, long-distance AM-FM Radio plus the newest-type 3-speed Automatic Intermix Record-Changing Phonograph.

Also—Powerful New 1952 World-Ranging
MIDWEST Series of RADIOS
For Beautiful Consoles and Complete Chassis:



An entirely new line of radios featuring the powerful Series 16 five wave band AM-FM Radio Chassis and the magnificent Symphony Grand Radio-Phonograph with 3-Speed Automatic Intermix Record Player.

Easy Terms

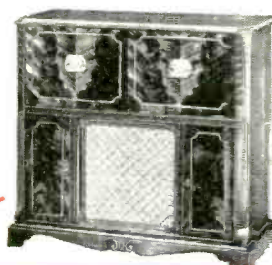

MIDWEST RADIO & TELEVISION CORP.

DEPT. 383, 909 BROADWAY, CINCINNATI 2, OHIO



EASY TERMS

WRITE or PHONE

For This NEW 1952

**FREE MIDWEST
TELEVISION
RADIO CATALOG**

If You Live In One of These Cities
Phone and Ask for Your Catalog

NEW YORK MURRAY Hill 2-6810
CHICAGO State 2-5600
PITTSBURGH Grant 1-0609
CLEVELAND PROspect 1-7450
DETROIT WOODward 3-1233
ST. LOUIS Grand 1161
PHILADELPHIA LOCust 4-1035

or Send Coupon Below

WRITE IN NAME AND ADDRESS (PLEASE
PRINT) ON COUPON OR 1c POSTCARD

MIDWEST RADIO & TELEVISION CORP.
Dept. 383, 909 BROADWAY • CINCINNATI 2, OHIO

Please send me your new FREE 1952 Catalog.

NAME _____

ADDRESS _____

CITY _____

ZONE _____

STATE _____

The single forward lobe of the
AMPHENOL

-INLINE*

ANTENNA

which receives peak signals from only
one direction . . .

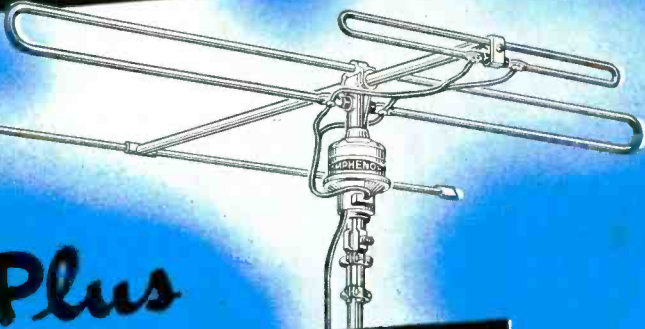

Plus

the accurate pointing of this
lobe in the direction of the
strongest signal by the

AMPHENOL
"AUTO-DIAL"
ANTENNA ROTATOR

Assures



Best PICTURE QUALITY

The Amphenol INLINE Antenna has no minor lobes to pick up reflected signals that create poor picture quality. When its single forward lobe is directed at the strongest signal, the best TV picture a set is capable of producing is received. When used in combination with an Amphenol "Auto-Dial" Rotator, the best picture possible can be received on all channels. The "Auto-Dial" performs so accurately the antenna positions which receive the best pictures on each channel can be recorded and exactly returned to when desired.

The best combination for the best TV picture on any channel — from any direction!

*Reissue Pat. No. 23,273

AMPHENOL

AMERICAN PHENOLIC CORPORATION

1830 South 54th Avenue • Chicago 50, Illinois

New Devices

DISTRIBUTION SYSTEM

Electro-Voice, Inc., Buchanan, Mich., is producing a model 3100 TV distribution system to provide simultaneous operation of more than one TV set from a common antenna. It provides isolation between the TV receivers to prevent interference from local oscillation. It also matches antenna impedance to each receiver.



One system will service four TV receivers. In large installations and in fringe areas, line amplifiers should be used in conjunction with the distribution system. 72-ohm coaxial cable is used.

It is housed in a well-ventilated steel case. Six coaxial sockets provide access to four receiver outlets, the signal input and the signal output. The unit includes an a.c. line cord and plug and a terminating resistor.

EFFICIENT TV ANTENNA

Ward Products Corp., division of the Gabriel Co., 1523 E. 45 St., Cleveland, Ohio, is distributing its Para-Con antenna, a unit that combines parabolic and conical designs in one antenna. The conical aerial supplies full audio and video bandwidth reception. The

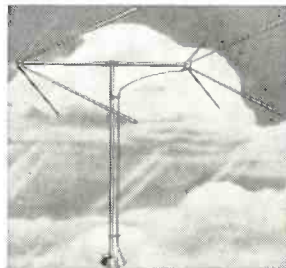

parabolic reflectors concentrate additional energy onto the driven elements. Having a high front-to-back ratio, channel interference is eliminated.

The Para-Con antenna is ruggedly built to withstand wind and weather and is easy to set up.

CRYSTAL CARTRIDGE

Astatic Corp., Conneaut, Ohio, is distributing the crystal model L-12 phonograph pickup cartridge for standard 78 r.p.m. records, which features low cost with high output. Output is approximately 4 volts at 1,000 c.p.s. on the Audiotone 78-1 test record. It

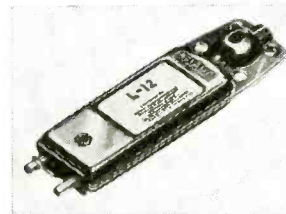

operates at a needle pressure of 1 ounce, has a total weight of 18 grams.

The housing is stamped steel, terminals are pin type and the crystal element is moistureproof coated. The L-12 comes without stylus and has a universal chuck to receive all standard type needles.

VERSATILE TESTER

Electronic Measurements Corp., 280 Lafayette St., New York, N. Y. is distributing a combination tube, battery, resistance, and capacitance tester, model 204.

It tests all tubes including the novel and subminiatures using the standard emission method. Its flexible switching

arrangement tests all tubes with .75-to 117-volt filaments, including cold cathode, magic eye, voltage regulator, and ballast types.

It also checks batteries under rated load; checks capacitor leakage to 1 megohm, and capacity from .01-1 μ f; it checks resistance up to 4 megohms. The unit is housed in an oak case which has a removable, hinged cover with carrying handle. Panel is 3-color hammertone. Line voltage control com-

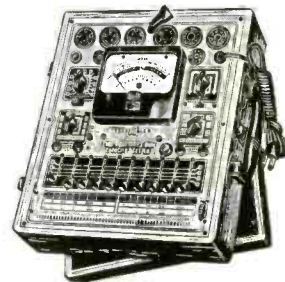

pensates for line variations between 105 and 135 volts. Built-in roll-chart is protected by heavy, nonbreakable, transparent plastic.

ANTENNA AMPLIFIER

Technical Appliance Corp., Sherburne, N. Y., is offering the TACO Antenna amplifier, to be located at the antenna and designed for use in fringe-area installations. The unit provides 14-db boost of the clear signal received, thus increasing the signal-to-noise ratio.

It is powered by a 24-volt transformer at the receiver. A relay energizes the transformer when the receiver is switched on. A TV set outlet is on the lower unit which plugs into a 117-volt wall outlet. Standard 300-ohm lead-in from the antenna to the

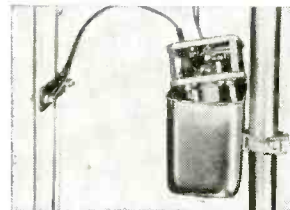

transformer is used. The TV signal and the 24 volts a.c. which travel the same lead-in are isolated by a network.

DX TV ANTENNA

Finney Corp., 4612 St. Clair Ave., Cleveland, Ohio, has brought out its TV Co-Lateral antenna with all-channel coverage in remote fringe areas up to 100 miles or more.

Elements consist of 12 driven and 12 parasitic on the high band and 8 driven and 4 parasitic on the low band. Co-linear arrangement produces high gain

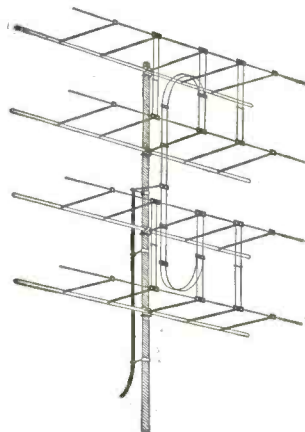

and high signal-to-noise ratio. Other features are one transmission line, light weight (8 lb.), rugged construction, and pre-assembly.

All specifications given are obtained from manufacturer's data

MAST COUPLER

Penn Television Prods. Co., 3336 Frankford Ave., Philadelphia 34, Pa., has introduced an aluminum antenna mast coupler for adding extra lengths to antennas.

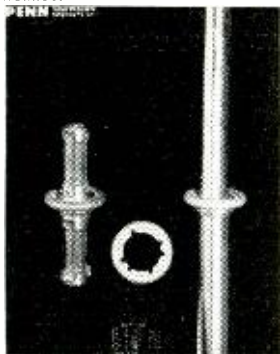

Designed with a floating guy wire ring to permit fastening the mast while antenna is oriented, this coupler fits into inside diameters of masts. The coupler and floating guy wire ring are manufactured of specially treated cast aluminum.

COLOR WHEEL

Deitz Sales Co., 120 South Orange Ave., Newark, N. J., is distributing its new color wheel, made especially for the CBS color television system.

The wheel is a solid, one-piece unit, 1/100-inch thick, not laminated. It is dynamically balanced to prevent vibration and to insure smooth, quiet performance.



Other features include true color reproduction (hue and density matched to the CBS color system), light-fast colors which will not fade, and pre-drilled mounting holes for assembly to either spindle or hub. Wheels are currently available for 7-, 10-, and 12 1/2-inch sets.

FLYBACK UNIT

Merit Transformer Corp., 4427 N. Clark St., Chicago, Ill., recently announced the HVO 8 air core horizontal output transformer designed for use in direct-drive systems. Used with the Merit MDF-30 cosine yoke, the HVO-8 provides wide replacement coverage.



HI-GAIN ANTENNA

Brach Manufacturing Corp., 200 Central Ave., Newark, N. J., announces its new fringe-area antenna, model TA-450 Air General, which is a 4-bay stacked 6-bar antenna with 24 dipole elements and 4 reflectors. It has an average gain of 12 db on channels 7 to 13 and 8 db on channels 2 to 6. This antenna is said to have a rugged mechanical structure featuring non-hygroscopic insulators, seamless tubing and seamless cross-arms, and is made with 35 hard aluminum which enables it to withstand high winds and ice loading.

SMALL CAPACITORS

Centralab, Division of Globe Union Inc., 900 East Keefe Ave., Milwaukee, Wis., is producing two new miniature feed-through ceramic capacitors, types FT-20 and FT-25. Both units are 0.135 inch maximum diameter; type FT-20 is 0.400 inch and type FT-25 is 0.690 inch, maximum length. Each is equipped with a 1/4-inch diameter eyelet which can be soldered to the chassis.

These capacitors are rated 500 volts d.c. working, 1,000 volts d.c. flash test. Type FT-20 is available in any standard capacitance tolerance from

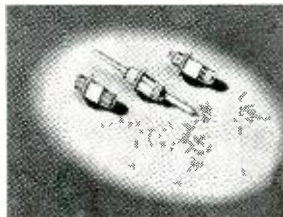

25 to 250 μmf , up to 650 μmf with $\pm 20\%$ tolerance; FT-25 ranges from 50 to 700 μmf in standard capacitance tolerances, up to 1,500 μmf in $\pm 20\%$ tolerance.

TINY MIKE

Astatic Corp., Conneaut, Ohio, announces a small, sensitive crystal microphone model DK-1, designed to give audiences the clearest, least distracting view of performers. The simple, curving lines of the DK-1 are said to conform to good principles of camouflage and the finish is brushed chrome, which reduces light reflection and glare and helps further to "hide" the microphone.

The mike is a nondirectional, high-impedance unit said to have excellent frequency range, with rising characteristics between 2,000 and 5,000 c.p.s. The crystal element has a moistureproof coating. Output level is approximately -55 db. The unit is available with or without an on-off switch.



SMALL FUSE POST

Littelfuse Inc., 4757 N. Ravenswood, Chicago, Ill., is offering a small fuse extractor post for type 3AG fuses which has a hole at the top of the knob for a test prod.



Over all length of the post is 1-11/16 inches. It is made of high-impact bakelite, with wide threads. The bakelite will strip the threads of the mounting nut before the post will break.

A leaf-spring tension lock in the knob of the post reduces voltage drop between the knob contact and the fuse, and the bottom contact cuts through any surface accumulation on the fuse cap to assure low-resistance electrical contact. An all-purpose terminal (solder, wrap-around, or quick disconnect) is used.

CONICAL ANTENNA

Radio Merchandise Sales, Inc., 1165 Southern Blvd., New York 59, N. Y., has added the Versacone, a new conical all-channel antenna, to their line.

The unit has a triple-nut locking device which secures the elements to the insulator. All elements are hardwood-dowel-reinforced to provide adequate strength under severe conditions.

Build 15 RADIOS AT HOME

With the New Improved 1951 Progressive Radio "EDU-KIT"

ONLY \$19.95

**ABSOLUTELY NO KNOWLEDGE OF RADIO NECESSARY
FREE TOOLS WITH KIT • NO ADDITIONAL PARTS NEEDED**

- EXCELLENT BACKGROUND FOR TELEVISION
- 10 DAY MONEY-BACK GUARANTEE

WHAT THE PROGRESSIVE RADIO "EDU-KIT" OFFERS YOU

The Progressive Radio "Edu-Kit" offers you a home study course at a rock bottom price. Our kit is designed to train Radio Technicians, with the basic facts of Radio Theory and Construction Practice expressed simply and clearly. You will gain a knowledge of basic Radio Principles involved in Radio Reception, Radio Transmission and Audio Amplification.

You will learn how to identify Radio Symbols and Diagrams; how to build radios, using regular radio circuit schematics; how to mount various radio parts; how to wire and solder in a professional manner. You will learn how to operate Receivers, Transmitters, and Audio Amplifiers. You will learn how to service and trouble-shoot radios. In brief, you will receive a basic education in Radio exactly like the kind you would expect to receive in a Radio Course costing several hundreds of dollars.

THE KIT FOR EVERYONE

The Progressive Radio "Edu-Kit" was specifically prepared for any person who has a desire to learn Radio. The Kit has been used successfully by young and old in all parts of the world. It is not necessary that you have even the slightest background in science or radio.

The Progressive Radio "Edu-Kit" is used by many Radio Schools and Clubs in this country and abroad. It is used by the Veterans Administration for Vocational Guidance and Training.

The Progressive Radio "Edu-Kit" requires no instructor. All instructions are included. All parts are individually boxed, and identified by name, photograph and diagram. Every step involved in building these sets is carefully explained. You cannot make a mistake.

PROGRESSIVE TEACHING METHOD

The Progressive Radio "Edu-Kit" comes complete with instructions. These instructions are arranged in a clear, simple and Progressive manner. The theory of Radio Transmission, Radio Reception and Audio Amplification is clearly explained. Every part is identified by photograph and diagram; you will learn the function and theory of every part used.

The Progressive Radio "Edu-Kit" uses the principle of "Learn By Doing". Therefore you will build radios to illustrate the principles which you learn. These radios are designed in a modern manner, according to the best principles of present-day educational practice. You begin by building a simple radio. The next set that you build is slightly more advanced. Gradually, in a progressive manner, you will find yourself constructing still more advanced radio sets, and doing work like a professional Radio Technician. Altogether you will build fifteen radios, including Receivers, Amplifiers and Transmitters.

The Progressive Radio "EDU-KIT" Is Complete

You will receive every part necessary to build 15 different radio sets. This includes tubes, tube sockets, variable condensers, electrolytic condensers, mica condensers, paper condensers, resistors, tie strips, coils, tubing, etc. Every part that you need is included. In addition these parts are individually packaged, so that you can easily identify every item.

TROUBLE-SHOOTING LESSONS

Trouble-shooting and servicing lessons are included. You will be taught to recognize and repair troubles, when you are learning in this practical way; you will be able to do many a repair job for your neighbors and friends, and charge fees which will far exceed the cost of the Kit. Here is an opportunity for you to learn radio and have others pay for it.

FREE EXTRAS IN 1951

- ELECTRICAL AND RADIO TESTER
- RADIO TROUBLE-SHOOTING GUIDE
- BOOK ON TELEVISION
- MEMBERSHIP IN RADIO-TELEVISION CLUB
- ELECTRIC SOLDERING IRON
- CONSULTATION SERVICE
- QUIZZES

THE PUBLIC APPROVES!

COMMENTS FROM SATISFIED USERS OF THE PROGRESSIVE RADIO "EDU-KIT":
VETERANS ADMINISTRATION, PHYSICAL MEDICINE REHABILITATION SERVICE, WASHINGTON, D. C.

"This Morning I was showing the Progressive Radio 'Edu-Kit' to one of our representatives from our Branch Office in Richmond, and already he wants me to purchase some for his hospital. . . . As indicated in previous correspondence, I took the Progressive Radio 'Edu-Kit' to our Veterans Administration Hospital at Fort Thomas, Kentucky; both instructors and patients worked them, and they proved quite satisfactory."

ROBERT L. SHUFF,
1534 Monroe Ave., Huntington, W. Va.

"Thought I would drop you a few lines to say that I have bought a Progressive Radio 'Edu-Kit' and was really amazed that such a bargain can be had at such a low price. I have already started repairing radios, and radio-phonographs. Friends were really surprised to see me get into the swing of it so quickly. The trouble-shooting tester that came with the kit is really swell, and finds the trouble if there is any to be found. Everything you say about your kit is true."

DOMINICK STRACUZZA
111 Clarence St., London, Ontario

"I am very satisfied with the Progressive Radio 'Edu-Kit' which I bought from you. I did not know anything about radio, but now I feel as though I have been in the radio business for years. Your kit is simple and educational, enjoy working with it."

Order your Progressive Radio "EDU-KIT" Today, or send for further information.

Postage prepaid on cash orders—C.O.D. orders accepted in U. S. A.

PROGRESSIVE ELECTRONICS CO.
497 UNION AVE., Dept. RE-52, Brooklyn 11, N. Y.

GET YOUR **BIG, NEW 1952** **CONCORD Catalog**

FREE!

Send for it NOW!

**ALL-NEW
COMPLETE
BUYING GUIDE
for Every Need!**

FAMOUS PRODUCTS—VAST STOCKS—LOWEST PRICES

TV • RADIO • ELECTRONICS

You save time and money—with this bigger, better 1952 Buying Guide! Here is page-after-page full of the latest and greatest values in Television, Radio and Electronics. It brings right to your finger tips one of the world's largest stocks of nationally known guaranteed quality parts and equipment. You find it quick and easy to get whatever you need—at the very lowest prices! Send for your **FREE Concord Catalog** today! Have it handy for quick reference!

Supplies for Industry, TV and Broadcast Stations, Schools, Servicemen, Hams, Government, Experimenters and Builders

CONCORD RADIO

901 W. JACKSON BLVD. • CHICAGO

Over 30 Years of Service to the Radio World

CONCORD RADIO CORP., Dept. JK-51
901 W. Jackson Blvd., Chicago 7, Illinois

Rush **FREE** Big, New 1952 CONCORD Catalog No. 951

Name _____

Address _____

City _____

Zone _____

State _____

**FREE
SEND FOR IT TODAY!**

**HIGH FIDELITY
TV & RADIOS
PHONOS & RECORDERS
SOUND SYSTEMS
HAM GEAR
TEST EQUIPMENT
ELECTRONIC TUBES
PARTS, BOOKS, KITS**

FAST DELIVERY
Large and varied stocks insure quick shipment on thousands of items.

HELPFUL SERVICE
Our technical experts give personal attention to your problems!

INDUSTRIAL DIVISION
Experienced staff and centralized efficiency speed service on supplies to Industry!

HIGH FIDELITY
Complete systems and custom components for finest reproduction!

EXPORT DIVISION
Special Export Division gives prompt service on orders and inquiries.

POSITIVE SATISFACTION
CONCORD'S policy of quality and value assures you of complete satisfaction!

Maintaining 2-Way Mobile Equipment

By LYMAN E. GRAY

An effective preventive maintenance schedule and procedure is necessary for reliable operation of the two-way communications equipment used by railroads, fire and police departments, public utilities, and similar services. Such a program requires that the technician be on the alert for items that may cause trouble or equipment failure before the next service call. The best way to do this is to prepare a check list for each piece of equipment to be serviced. The items on the check list will vary with different types of equipment. The following items appear on a typical one:

1. Battery or power connection.
2. Condition of antenna and lead-in.
3. Relays (contacts and springs).
4. Operation of vibrator.
5. Operation and output of dynamotor.
6. Transmitter alignment.
7. Receiver alignment.
8. Frequency check.
9. Stability of set's mounting.

The check list should be kept on each individual piece of equipment and filed as a permanent service record. If you include a list of materials used and note the time spent in servicing, you will have a complete expense record on the equipment.

Checking tubes

A tube checker is of little use in checking tubes used in high-frequency equipment. Most tubes in the receiver can be checked by measuring the grid current in the first limiter stage. All tubes in the transmitter except the power amplifier can be checked by measuring the grid current for each stage. Most transmitters have a metering circuit for this purpose.

Check the power amplifier by detuning its plate-tank circuit and noting the off-resonance plate current. Make this check as brief as possible to avoid damaging the tube or high-voltage supply. Replace the tube if the plate current does not rise at least 20% above the value at resonance. If the plate current is not 20% or more above the normal current at resonance after the tube is replaced, check the operating voltages.

Vibrator tests

Vibrators can be checked by measuring the B-plus voltage at the first input filter. Replace the vibrator if the voltage is as low as 15 volts below normal. Check the buffer capacitor at this point. In some cases of persistent vibrator trouble, the buffer capacitor may not show leakage, but may have lost capacitance or may have been replaced with the wrong size. This will cause excessive arcing at the points and lead to premature vibrator failure.

RADIO-ELECTRONICS for

In some types of Link equipment, the vibrator is used only for the receiver and not for transmitting. Sometimes, if the receiver has been operating long enough for the vibrator to get hot, it will not start when the push-to-talk button is released. This is caused by sticking vibrator contacts. Replace the unit.

Do not be too quick to replace the vibrator if it does not start when the set is first turned on. The trouble is likely to be in the A-plus circuit. Check the fuse and fuse holder. If this doesn't help, bring out the voltmeter and check the voltage across the battery terminals. If the battery is O.K., set the meter on its lowest d.c.-volts range and check the entire A-supply line. The trouble is likely to be located in a fuse holder, relay contact, or plug connection. There should be no voltage drops across any of these places. If you find a voltage drop across any two points in the line, you have hit the source of the trouble.

There is a very good reason for making these tests *before* replacing the vibrator. If the trouble is an intermittent connection or contact, changing the vibrator may jar the set enough to clear up the condition so the new vibrator will start when plugged in. When this happens, your trouble is far from cured and you may be miles away when trouble pops up again.

Other troubles

Other than tubes and power supply defects, the majority of the troubles are caused by vibration. Rubber shock mounts are used on most new equipment. They are supposed to suppress vibrations but they make conditions worse in most installations. I have found, from several years of experience, that we have less trouble from this source with solid-mounted equipment.

In other types of equipment, several circuits have no electrical ground returns. They depend entirely on the chassis and mechanical connections. This is a potential source of trouble. Connecting such components together with heavy bus bar soldered to the chassis at several points.

Most spring type antenna mounts have a flexible braid or wire to insure a good connection to the antenna. When this wire breaks—as it often does—the transmitter output is unstable and reception is noisy. In most types of mountings, the wire or braid has lugs soldered to each end and is connected by screws to the spring base and antenna socket. Solder hardens the wire and causes it to break much sooner than it would if no solder were used. I have found that it is best to use flat flexible braid approximately $\frac{1}{4}$ inch wide to replace the broken lead. Cut the braid about 3 inches longer than the spring, then use an ice pick or similar tool to punch a hole about $\frac{1}{2}$ inch from each end. Install a flat washer under the head of each mounting screw so the hole out in the braid will not tear when the screws are tightened.

—end—



YOU POINT TO GREATER PROFITS . . .

when you select the one source that puts authentic, authoritative information on every phase of television and radio servicing right at your fingertips. When you have the *complete* information on every set in every manufacturer's line, you take less time per call . . . and do a better job. There's only one place to get this wealth of information . . . Rider Manuals.

This is the only source of service data that really tells you everything. From complete wave-form data to factory parts lists, your knowledge of every set, every change, is accurate and complete. Ask your jobber to show you Rider Manuals — today!



JOHN F. RIDER Publisher, Inc.
480 Canal Street, New York 13, N. Y.

INCREASE

the efficiency of
your TV set
15 to 20%!

new

model B

revolutionary!**TURRET BOOSTER**

PATENT PENDING

Makes every TV Set as Efficient
as a Fringe Area Set!

**MONEY-BACK
GUARANTEE**

ONLY
\$9.95*
(list)

*Less additional tube and nominal installation charge

Here's a TV accessory everyone will
want — everyone can afford!

Dollar for dollar it's the biggest bargain in increased TV enjoyment ever announced. And, it's the hottest booster on the market today!

LOOK AT THESE FEATURES!

- Steps up Video output 15 - 20% — improves audio as well
- Improves "sinc". Will lock a picture that can barely be seen
- Actually improves signal to noise ratio by permitting TV clipper to function properly
- Quickly installed without changing wiring of set
- Fully concealed within set — no exterior units to tune
- Operates as soon as receiver is turned on — no extra switches to make tuning complicated
- Operates on intermediate frequency — one setting during installation for all channels at all times

model X21 and X45

... for sets having limited headroom. Plug oriented at six different positions: 2, 4, 6, 8, 10 & 12 o'clock, to permit insertion from easy access angle on crowded chassis. Model X21 for 21-25 MC, Model X45 for 45 MC, IF.

Order a **TURRET BOOSTER** from your TV Dealer today — start enjoying TV at its very best!

JOBBERS: Write for complete Details

BARB-CITY INDUSTRIES, Inc.
1151 FOURTH ST. DEKALB, ILLINOIS

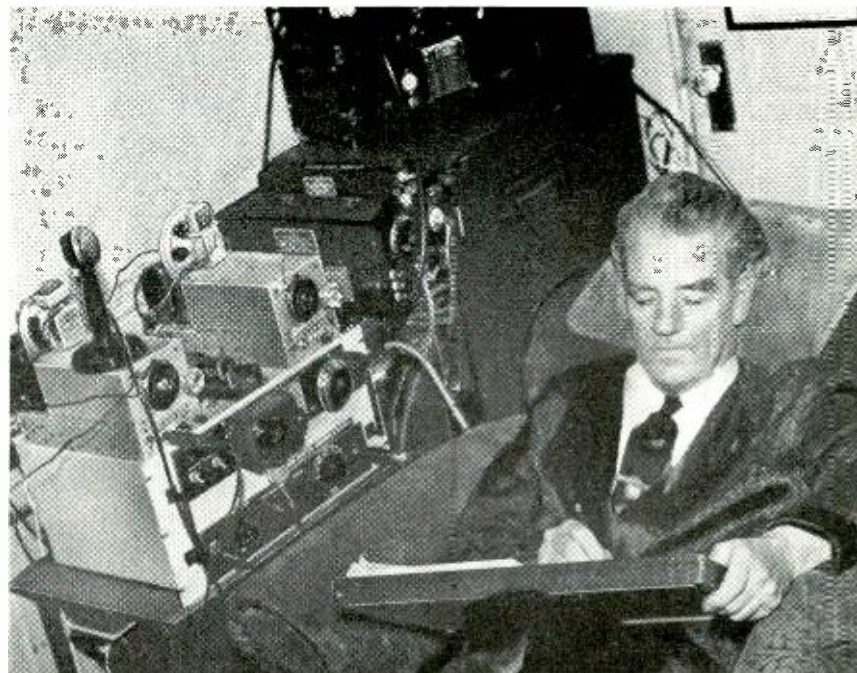

Working a station in comfort. Note the availability of controls, key, lap board.

Ham Station Control Rolls to Bedside

By **JIM KIRK, W6DEG**

THE object of this bedside ham station operating-control unit is to make life easier—and more enjoyable. Most inventions were sparked by the desire to enjoy life to a greater extent—and the writer pleads guilty to the charge of laziness.

The moveable table (roller casters) contains two receivers, remote control for a third, and a variable-frequency oscillator (see photos).

Full advantage was taken of junk box parts and surplus, so cost was low. For example, I have had that cart on hand for over twenty years. It is part of an old business filing system. The v.f.o. is in a surplus Navy low-frequency receiver cabinet, the RU17. Two command receivers (screwed to top of the lid) cover 40 and 80 meters; by using double conversion we have either a 20- or 40-meter receiver.

A remote-control dial (surplus) tunes an RU17 receiver which has plug in coils for all bands, but I use it for 80 meters and broadcast by leaving the double coil for this in place. Thus my three receivers cover 20, 40 and 80 meters plus broadcast.

The v.f.o. was constructed on the surplus RU17 chassis. Shields mounted in the base separate it into three compartments: oscillator; buffer and doubler; NBFM modulator and power supply. I use NBFM to avoid BCI.

The oscillator of the v.f.o. (complete circuit shown in Fig. 1) is stable and is left running all the time the station is used. It does not interfere with

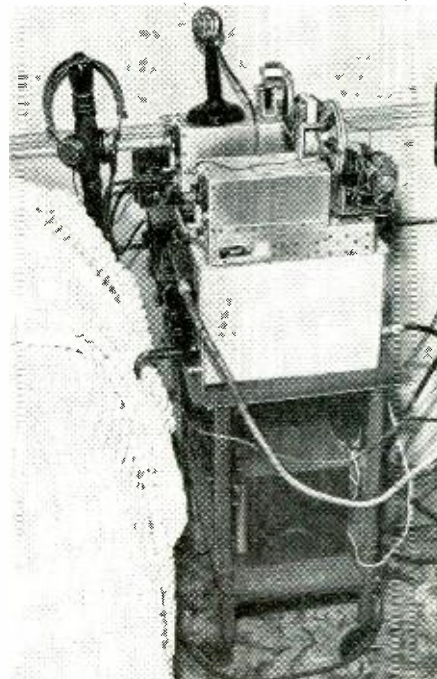
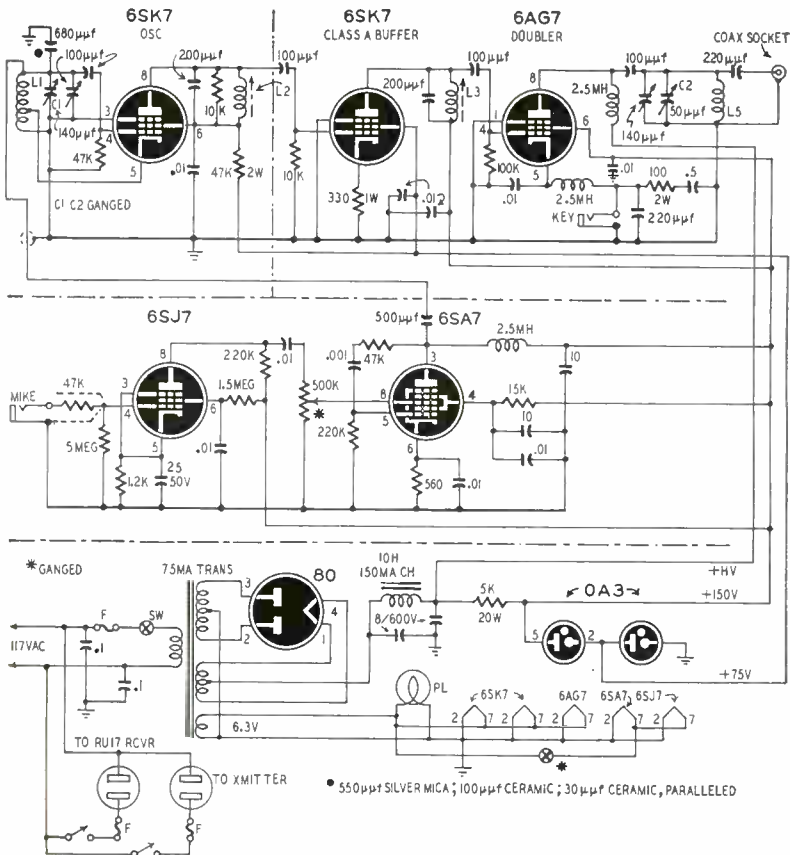

Table on wheels rolls to any location. Three receivers and v.f.o. can be used.

RADIO-ELECTRONICS for



Schematic of v.f.o. Doubler is keyed and key switch closed when using phone.

break-in operation because it is adequately shielded and is isolated from the power stages by a class-A buffer. The doubler is keyed. The switch on the key is closed when using phone. As shown on the diagram, three separate compartments are used to shield the oscillator; class-A buffer and doubler; modulator and power supply sections.

The output of the v.f.o. is connected by coaxial cable to the input of a rebuilt BC-375. It can be used, however, with most transmitters, the v.f.o. simply replacing the crystal-control stage. Reports have been T9X.

Material for v.f.o.:

Resistors: 1—560, 1—1,200, 2—10,000, 3—47,000, 1—

100,000, 2—220,000 ohms, 1/2 watt; 1—1.5, 1—5 meg-ohms, 1/2 watt; 1—330 ohms, 1 watt; 1—100, 1—47,000 ohms, 2 watt; 1—5,000, 1—15,000 ohms, 20 watt. Potentiometer: 1—500,000 ohms. Capacitors: (Electrolytic) 1—25 uf, 50 volts; 2—10 uf, 450 volts; 2—8 uf, 600 volts. (Oil-filled) 2—1 uf, 1,000 volts. (Mica) 4—.01, 1—.001, 4—.0001, 1—.005, 1—.00055 uf. (Ceramic) 1—30, 1—100, 2—200, 2—220 uf. (Paper) 5—.01, 1—.5 uf, 600 volts. (Variable) 1—50, 1—100, 2—140 uf. Miscellaneous: Tubes: 2—6SK7, 1—80 or 5Y3, 1—6AG7, 2—0A3, 1—6SJ7, 1—6SA7. Tube sockets: 1—coaxial, SO 239 Amphenol, 1—male a.c., 2—a.c., female. Switches, 3—s.p.s.t., 1—s.p.s.t. (on potentiometer). Jacks: 1—mike, 1—key. Fuses: 2—25 amp. (RU17 rcvr. and v.f.o.), 1—value depends on transmitter used. Coils: 1—oscillator, L1, 47 turns, No. 24 wire, close-wound on 1-inch diameter form, tap on 14 turn; 2—slug-tuned, L2, L3, Millen 74001; 1—plate coil, L5, 53 turns, No. 26 close-wound on 1-inch diameter form. Chokes: 3—r.f., 2.5 mh., 100 ma; 1—filter, 10 h, 150 ma. 1—RU 17 receiver box; 1 dial, vernier, with flexible shaft (surplus). Hardware, wire, solder.

—end—

NEW!
ALPRODCO
ECONOMY
ALUMINUM
"TOWER-PAC"
36' TOWER IN
ONE COMPACT

PACKAGE

Consisting of

- 4 ea. 6' ASSEMBLED TOWER SECTIONS
- 2 ea. 6' SECTIONS INTERLOCKING MAST
- 1 ea. HINGED BASE PLATE
- 1 ea. MAST KIT
- 3 ea. GUY BRACKETS

Complete Tower-Pac
 Part No. TP-36

TO DEALERS ONLY

\$37.40

ALSO AVAILABLE AS
 ROTATING TOWER-PAC
 Part No. TP-36-R

FOR ONLY

\$42.55

ALPRODCO, INC.

Kempton, Indiana
 Mineral Wells, Texas
 Dublin, Georgia

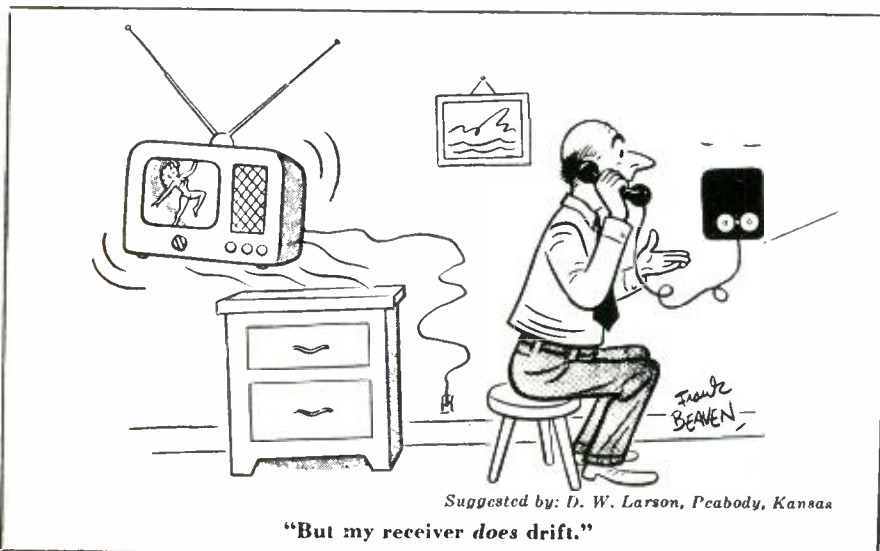

Suggested by: D. W. Larson, Peabody, Kansas

"But my receiver does drift."

NEW! VOL. 2

OF THE BOOK THAT SAVES YOUR TV SERVICING TIME!

HOWARD W. SAMS' "TELEVISION TUBE LOCATION GUIDE"



Gives Tube position and function in hundreds of important TV receivers... saves you hours of TV servicing time

FIND THE TROUBLE—REPLACE TUBES WITHOUT REMOVING THE CHASSIS

You've asked for more—and here it is—the second volume that brings you right up-to-date. There's nothing like it! The *only* book that shows the *position* and function of tubes in hundreds of TV receivers. Helps you save TV servicing time. Often an operational check in the customer's home—looking at the picture and listening to the sound—gives you a clue to the trouble. Many times only a tube failure is the cause. This invaluable Guide makes trouble diagnosis and tube replacement quick and easy, in most cases *without removing the chassis!* Each TV model has its own clear, accurate diagram. Book is fully indexed for quick reference. All new diagrams—takes up where Vol. 1 leaves off—no duplication. 208 pages, handy pocket size 5½x8½". Pays for itself on the first job!

ORDER TGL-2. Only... **\$2.00**



VOL. 1. "TELEVISION TUBE LOCATION GUIDE"

This is the initial volume owned and used daily by thousands of TV Service Technicians. Includes tube location and function diagrams of hundreds of important TV receivers made by 56 manufacturers. Saves hours of servicing time—permits diagnosis of trouble and tube replacement without removing chassis.

Over 200 pages; handy pocket size. Order copies for outside calls and for your bench. Own *both* volumes for complete TV tube location data! **\$1.50**

ORDER TGL-1. Only... **\$1.50**

HOWARD W. SAMS & CO., INC.

Order from your Parts Jobber today, or write direct to HOWARD W. SAMS & CO., INC., 2201 East 46th Street, Indianapolis 5, Ind.

My (check) (money order) for \$..... enclosed. Send the following books:

- TGL-2 "TV Tube Location Guide" \$2.00
- TGL-1 "TV Tube Location Guide" \$1.50

Name.....
 Address.....
 City.....Zone....State.....

Automatic Dashes With Standard Bug

By MARTIN CRANE

WHILE the usual electronic key circuit provides automatic dots and dashes, a simpler circuit may be used. A less complex but equally efficient keying device is described here.

The idea of this circuit was to take an ordinary bug and make it completely automatic by devising an electronic circuit which would make correctly spaced dashes. Thus the dot side of the key is employed as usual, and an electronic unit is connected to the dash side of the key in such a way as to make dashes automatically whenever the dash side of the key is depressed.

The circuit shown in Fig. 1 is simply an unsymmetrical multivibrator with a sensitive relay connected in series with one of the plate leads. The dash contacts of the bug are connected to one cathode of the multivibrator tube. As soon as the key is closed a square-wave-shaped current will flow through the relay coil.

The length of the dash, its speed and spacing are determined by the values of R1, R2, C1, and C2. Fortunately a characteristic of this type circuit is that the mark-to-space ratio (length of dash to space between dashes) remains constant if the ratio R1C1/R2C2 is held constant.

The speed of the dashes can be conveniently varied by means of a dual potentiometer for R1 and R2. The mark-to-space ratio will then be determined by the ratio of C1/C2 and will remain constant for a wide range of speed settings. A mark-to-space ratio of about 3 to 1 is desirable, but this can be adjusted to suit individual tastes by varying the C1/C2 ratio.

Modifying the bug

In applying this circuit to a bug it is necessary to isolate the dash from the dot contact on the key. Simply remove the connecting wire from the dash terminal, Fig. 2-a. Many semi-automatic keys, though, have a common arm which connects the dash and the dot contact. In this case a simple method of isolating the dash contact is shown in Fig. 2-b. The screw which ordinarily makes the dash contact was removed and replaced with a screw of much smaller diameter and insulated from the binding post as shown.

A suitable relay must be used to avoid adjustment difficulty. Requirements of the relay are first that it have adequate sensitivity and that it will respond to high keying speeds and not bounce. The inductance of the relay coil caused trouble at high keying speeds unless

the coil was considerably damped by R5. The reason is, when the current cuts off abruptly in the coil a sharp inductive kick of voltage across the coil produces a current causing the relay contacts to close prematurely. As a result the dashes run together. It may be

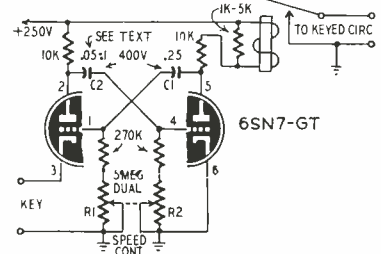

Fig. 1—Multivibrator type dash circuit.

necessary to experiment with the coil loading resistor relay contact and spring adjustments so that clean operation will be maintained over a wide range of speeds.

The usual adjustments on the dot side of the key must be made so that the dot and the dash speeds are correct. There is usually considerable lati-

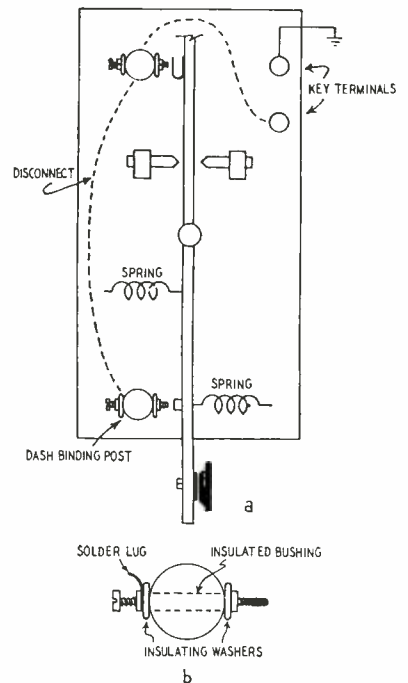

Fig. 2-a—Wiring changes on a standard bug; 2-b, isolating dash contact.

tude in dot speed so that for a fairly wide range of sending speed it will be necessary only to adjust the dash speed control.

(Continued on page 98)

Features OF THE NEW 1952

Heathkits



PROOF OF THE NEW O-7 OSCILLOSCOPE'S OUTSTANDING PERFORMANCE

Below are actual, unretouched photographs showing the outstanding frequency response characteristics of the NEW 1952 HEATHKIT OSCILLOSCOPE, MODEL O-7. To the left is a 10 KC square wave — to the right a 4 MC sine wave as they actually appear on the screen. Two highly severe tests to make on any scope (only the best of scopes will show traces like these) — and the O-7 really comes through.

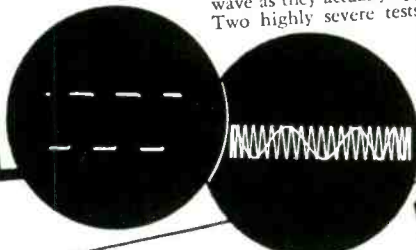

COMPANION VACUUM TUBE VOLTMETERS

Here are the two NEW 1952 VACUUM TUBE VOLTMETER COMPANION PIECES. Matched instruments of new design to open up the whole field of DC, AC, and resistance measurements for you. The new greatly reduced size combines style, beauty, and compactness — The V-5 and AV-1 have the new panel and cabinet construction as shown on the right. A tremendous pair of voltmeters. Small in size but virtual giants in the range of measurements they make.



NEW STYLE AND BEAUTY

Style that's modern, yet functional — that's the trend of today — and Heathkits are right up to the minute. Note the cut showing the new V-5 and AV-1 cabinet and panel construction. The front panel and rear cover slide right over the recessed flange of the case thereby eliminating sharp edges and pointed corners. The voltmeter kits aren't "shelf" or "mounted" instruments — they're moved about on the bench a lot and thus the new compact size and specially designed cabinets — Another 1952 Heathkit feature.

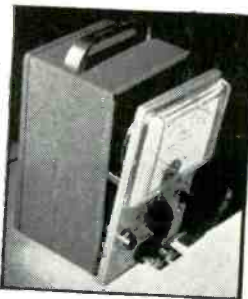

A STATEMENT FROM SIMPSON ELECTRIC CO.

In choosing Simpson Meters for their Heathkit VTVM, the Heath Co. has set a new high standard of kit meter quality. The same high quality of material, workmanship and design that has given Simpson the reputation for building "Instruments That Stay Accurate" is found in the Heathkit Meter Movement.

SIGNED
SIMPSON ELECTRIC CO.

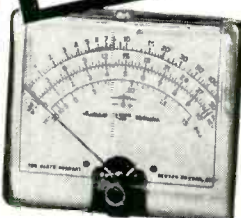

A STATEMENT FROM CHICAGO TRANSFORMER

It is indeed gratifying to note the outstanding sales records you are building with your Heathkits.

This sales success is readily understandable, since we are cognizant of the high quality standards you have established for your component suppliers.

We at Chicago Transformer are proud that our product has contributed to the recognized quality and increasing popularity of Heathkits.

CHICAGO TRANSFORMER DIVISION
Essex Wire Corporation

L. S. RACINE
Vice-President and Sales Manager

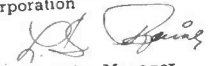

HEATHKIT PRECISION RESISTORS

Where exact resistance values are required for instrument accuracy, the Heath Co. has spared no effort in supplying the finest resistors available. Precision resistors as manufactured by Continental Carbon Inc., and Wilcor Corp., meet the rigorous JAN (Joint Army-Navy) specifications and are small in size, extremely non-inductive, highly stable, have a low temperature coefficient, and can be held to great accuracy. You'll find quality components in Heathkits.

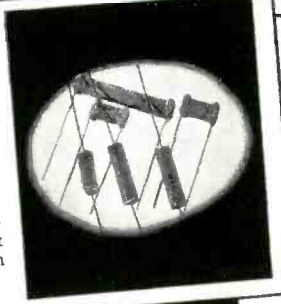

COLLEGES USE HEATHKITS

Colleges and Universities throughout the country are using Heathkits in their electrical engineering, radio, and physics laboratories — Heathkits are the answer to good test equipment at low cost, plus being rugged, dependable, and accurate. Trade schools are having their students build Heathkits to obtain a first hand working knowledge of test equipment and to get the practical experience gained by construction. Heathkits fill school needs.



YOU SAVE BY ORDERING DIRECT FROM MANUFACTURER—USE ORDER BLANK ON LAST PAGE

EXPORT AGENT
ROCKE INTERNATIONAL CORP.
13 E. 40th ST.
NEW YORK CITY (16)
CABLE: ARLAB, N. Y.

The HEATH COMPANY

... BENTON HARBOR 20, MICHIGAN

THE *New* 1952
Heathkit
**OSCILLOSCOPE
 KIT**

MODEL O-7
 SHIPPING WEIGHT 24 LBS.

\$43⁵⁰

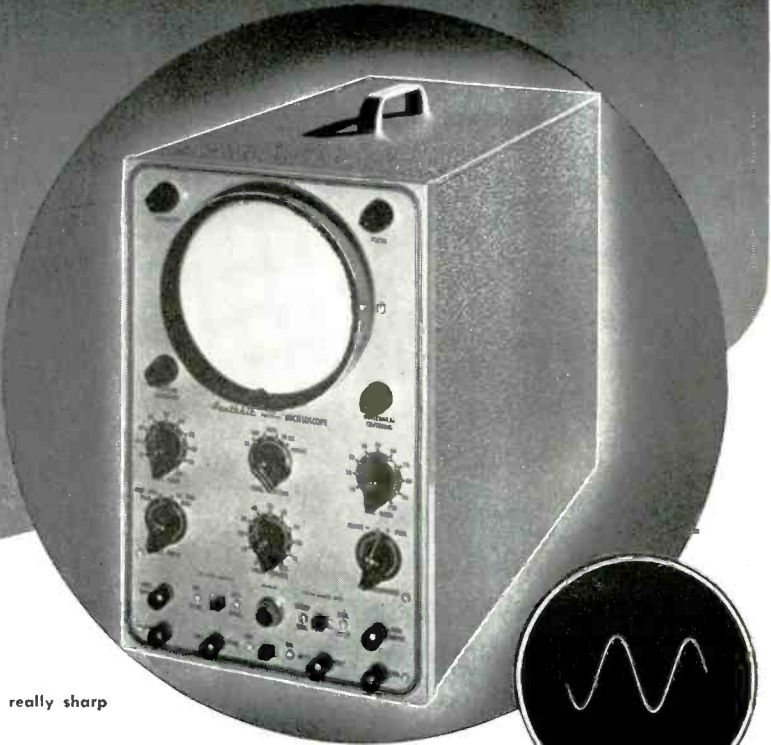

Features

- New "spot shape" control for spot adjustment — to give really sharp focusing.
- A total of ten tubes including CR tube and five miniatures.
- Cascaded vertical amplifiers followed by phase splitter and balanced push-pull deflection amplifiers.
- Greatly reduced retrace time.
- Step attenuated — frequency compensated — cathode follower vertical input.
- Low impedance vertical gain control for minimum distortion.
- New mounting of phase splitter and deflection amplifier tubes near CR tube base.
- Greatly simplified wiring layout.
- Increased frequency response — useful to 5 Mc.
- Tremendous sensitivity .03V RMS per inch Vertical — .6V RMS per inch Horizontal.
- Dual control in vernier sweep frequency circuit — smoother acting.
- Positive or negative peak internal synchronization.

The performance of the NEW, IMPROVED, HEATHKIT 5" OSCILLOSCOPE KIT is truly amazing. The O-7 not only compares favorably with equipment costing 4 and 5 times as much, but in many cases literally surpasses the really expensive equipment. The new, and carefully engineered circuit incorporates the best in electronic design — and a multitude of excellent features all contribute to the outstanding performance of the new scope.

The VERTICAL CHANNEL has a step attenuated, frequency compensated vertical input which feeds a cathode follower stage — this accomplishes improved frequency response, presents a high impedance input, and places the vertical gain control in a low impedance circuit for minimum distortion. Following the cathode follower stage is a twin triode — cascaded amplifiers to contribute to the scope's extremely high sensitivity. Next comes a phase splitter stage which properly drives the push-pull, hi-gain, deflection amplifiers (whose plates are directly coupled to the vertical deflection plates). This fine tube lineup and circuitry give a sensitivity of .03V per inch RMS vertical and useful frequency response to 5 Mc.

The HORIZONTAL CHANNEL consists of a triode phase splitter with a dual potentiometer (horizontal gain control) in its plate and cathode circuits for smooth, proper driving of the push-pull horizontal deflection amplifiers. As in the vertical channel, horizontal deflection amplifier plates are direct coupled to the CR tube horizontal deflection plates (for improved frequency response).

The WIDE-RANGE SWEEP GENERATOR circuit incorporates a twin triode multivibrator stage for producing a good saw-tooth sweep frequency (with faster retrace time). Has both coarse and vernier sweep frequency controls.

And the scope has internal synchronization which operates on either positive or negative peaks of the input signal — both high and low voltage rectifiers — Z axis modulation (intensity modulation) — new spot shape (astigmatism) control for spot adjustment — provisions for external synchronization — vertical centering and horizontal centering controls, wide range focus control — and an intensity control for giving plenty of trace brilliance.

The Model O-7 EVEN HAS GREAT NEW MECHANICAL FEATURES — A special extra-wide CR tube mounting bracket is provided so that the vertical cascade amplifier, vertical phase splitter, vertical deflection amplifier, and horizontal deflection amplifier can mount near the base of the CR tube. This permits close connection between the above stages and to the deflection plates; distributed wiring capacity is greatly reduced, thereby affording increased high frequency response.

The power transformer is specially designed so as to keep its electrostatic and electromagnetic fields to a minimum — also has an internal shield with external ground lead. You'll like the complete instructions showing all details for easily building the kit — includes pictorials, step-by-step construction procedure, numerous sketches, schematic, circuit description. All necessary components included — transformer, cabinet, all tubes (including CR tube), completely punched and formed chassis — nothing else to buy.

NEW INEXPENSIVE *Heathkit*
ELECTRONIC SWITCH KIT

The companion piece to a scope — Feed two different signals into the switch, connect its output to a scope, and you can observe both signals — each as an individual trace. Gain of each input is easily vidual trace. Gain of each input is easily vidual trace. Gain of each input is easily vidual trace. Gain of each input is easily vidual trace.



Model S-2
 Shipping Wt. 11 lbs.

Only
\$19⁵⁰

Use the switch to see distortion, phase shift, clipping due to improper bias, both the input and output traces of an amplifier — as a square wave generator over limited range. The kit is complete; all tubes, switches, cabinet, power transformer and all other parts, plus a clear detailed construction manual.

YOU SAVE BY ORDERING DIRECT FROM MANUFACTURER—USE ORDER BLANK ON LAST PAGE

REPORT AGENT
ROCKE INTERNATIONAL CORP.
 15 E. 40th ST.
 NEW YORK CITY (16)
 CASE 1, ARLAB N.Y.

The **HEATH COMPANY**

... BENTON HARBOR 20, MICHIGAN

THE *New* 1952

Heathkit VTVM KIT

MODEL V-5
SHIPPING WT. 5 LBS.

\$24.50

Features

- New styling, — to meet case for beauty.
- New truly compact size. Cabinet 4 1/8" deep by 4-11/16" wide by 7 3/8" high.
- Quality 200 microamp meter.
- New ohms battery holding clamp and spring clip — assurance of good electrical contact.
- Highest quality precision resistors in multiplier circuit.
- Calibrates on both AC and DC for maximum accuracy.
- Terrific coverage — reads from 1/2V to 1000V AC, 1/2V to 1000V DC, and .1 to over 1 billion ohms resistance.
- Large, clearly marked meter scales indicate ohms, AC Volts, DC Volts, and DB — has zero set mark for FM alignment.
- New styling presents attractive and professional appearance.

A real beauty — you'll have only highest praise for this NEW MODEL VACUUM TUBE VOLTMETER. Truly a beautiful little instrument — and it's more compact than any of our previous models. Note the new rounded edges on the front panel and rear cover. The size is greatly reduced to occupy a minimum of space on your workbench — yet the meter remains the same large size with plainly marked scales.

A set of specially designed control mounting brackets permit calibration to be performed with greatest ease — also makes for ease in wiring. New battery mounting clamp holds ohms battery tightly into place, and base spring clip insures a good connection to the ohms string of resistors.

The circuitry employs two vacuum tubes — A duo diode operating when AC voltage measurements are taken, and a twin triode in the circuit at all times. The cathode balancing circuit of the twin triode assures sensitive measurements, and yet offers complete protection to the meter movement. Makes the meter burn-out proof in a properly constructed instrument.

Quality components are used throughout — 1% precision resistors in the multiplier circuit — conservatively rated power transformer — Simpson meter movement — excellent positive detent, smooth acting switches — sturdy cabinet, etc.

And you can make a tremendous range of measurements — 1/2V to 1000V AC, 1/2V to 1000V DC, .1 to over 1 billion ohms, and DB. Has mid-scale zero level marking for quick FM alignment. DB scale in red for easy identification — all other scales a sharp, crisp black for easy reading.

A four position selector switch allows operator to rapidly set the instrument for type or reading desired — positions include ACV, DC-V, DC-V, and Ohms. DC — position allows negative voltage to be rapidly taken. Zero adjust and ohms adjust controls are conveniently located on front panel.

Enjoy the numerous advantages of using a VTVM. Its high input impedance doesn't "load" circuits under test — therefore, assures more accurate and dependable readings in high impedance circuits such as resistance coupled amplifiers, AVC circuits, etc. Note the 30,000 VDC probe kit and the RF probe kit — available at low extra cost and specially designed for use with this instrument. With these two probes, you can make DC voltage measurements up to 30,000V, or make RF measurements — added usefulness to an already highly useful instrument.

The instruction manual is absolutely complete — contains a host of figures, pictorials, schematic, detailed step-by-step instructions, and circuit description. These clear, detailed instructions make assembly a cinch.

And every part is included — meter, all controls, pilot light, switches, test leads, cabinet, instruction manual, etc.



Heathkit 30,000V DC PROBE KIT

A new 30,000 V DC Probe Kit to handle high voltages with safety. For TV service work and all other high voltage applications. Sleek looking — and guard — jet black handle — Red body with connector, cable, and PL55 type plug. Plugs into Heathkit VTVM so that 300V scale is conveniently multiplied by 100. Can be used with any standard 11 megohm VTVM.

No. 336 High Voltage Probe Kit • **\$550**
Shipping Wt. 2 lbs.

Heathkit RF PROBE KIT

This RF Probe Kit comes complete with probe housing, crystal diode detector, connector, lead and plug and all other parts plus clear assembly instructions. Extends range of Heathkit VTVM to 250 Mc. ± 10%. Works on any 11 megohm input VTVM. Specify No. 309 RF Probe Kit.

\$550
Ship. Wt. 1 lb.

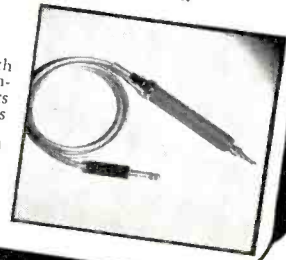

YOU SAVE BY ORDERING DIRECT FROM MANUFACTURER—USE ORDER BLANK ON LAST PAGE

EXPORT AGENT
ROCKE INTERNATIONAL CORP.
13 E. 40th ST.
NEW YORK CITY (16)
CABLE: ARLAB-N.Y.

The HEATH COMPANY

... BENTON HARBOR 20, MICHIGAN

Heathkit SIGNAL GENERATOR KIT

Model SG-6
Shipping Wt. 7 lbs.

The new Heathkit Signal Generator Kit has dozens of improvements. Covers the extended range of 160 Kc to 50 megacycles on fundamentals and up to 150 megacycles on useful calibrated harmonics; makes this Heathkit ideal as a marker oscillator for TV. Output level can be conveniently set by means of both step attenuator and continuously variable output controls. Instrument has new miniature HF tubes to easily handle the high frequencies covered.

Uses 6C4 master oscillator and 6C4 sine wave audio oscillator. The kit is transformer operated and a husky selenium rectifier is used in the power supply. All coils are precision wound and checked for calibration making only one adjustment necessary for all bands.

New sine wave audio oscillator provides internal modulation and is also available for external audio testing. Switch provided allows the oscillator to be modulated by an external audio oscillator for fidelity testing of receivers. Comes complete, all tubes, cabinet, test leads, every part. The instruction manual has step-by-step instructions and pictorials. It's easy and fun to build a Heathkit Model SG-6 Signal Generator.



\$19⁵⁰

Heathkit CONDENSER CHECKER KIT

Only
\$19⁵⁰

Model C-2
Shipping Wt. 6 lbs.



Checks all types of condensers — paper — mica — ceramic — electrolytic. All condenser scales are direct reading and require no charts or multipliers. Covers range of .00001 MFD to 1000 MFD. A Condenser Checker that anyone can read. A leakage test and polarizing voltage for 20 to 500 V provided. Measures power factor of electrolytics between 0% and 50% and reads resistance from 100 ohms to 5 megohms. The magic eye indicator makes testing easy.

The kit is 110V 60 cycle transformer operated and comes complete with rectifier tube, magic eye tube, cabinet, calibrated panel and all other parts. Has clear detailed instructions for assembly and use.

NEW Heathkit SIGNAL TRACER AND UNIVERSAL TEST SPEAKER KIT

\$19⁵⁰

Model T-2
Shipping Wt. 7 lbs.

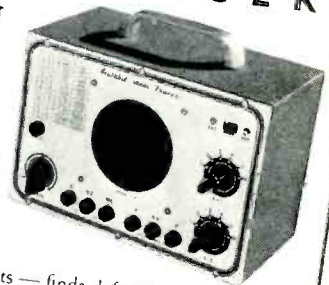

The popular Heathkit Signal Tracer has now been combined with a universal test speaker at no increase in price. The same high quality tracer follows signal from antenna to speaker — locates intermittents — saves valuable service time — finds defective parts quicker hour. Works equally well on broadcast, FM, or TV receivers. The test speaker has an assortment of switching ranges to match phones, pickups and PA systems. Comes complete: cabinet, 110V 60 cycle power transformer, tubes, test probe, all necessary parts, and detailed instructions for assembly and use.



Model TC-1
Shipping Wt. 12 lbs.

\$29⁵⁰

Heathkit TUBE CHECKER KIT

The Tube Checker is a MUST for radio repair men. Often customers want to SEE tubes checked, and a checker like this builds customer confidence. In your repairing, you will have a multitude of tubes to check — quickly. The Heathkit tube checker will serve all these functions — it's good looking (with a polished birch cabinet and an attractive two color panel) — checks 4, 5, 6, 7 prong Octals, Loctals, 7 prong miniatures, 9 prong miniatures, pilot lights, and the Hytron 5 prong types. AND IT'S FAST TO OPERATE — the gear driven, free-running roll chart lists hundreds of tubes, and the smooth acting, simplified switching arrangement gives really rapid set-ups.

The testing arrangement is designed so that you will be able to test new tubes of the future — without even waiting for factory data — protection against obsolescence.

You can give tubes a thorough testing — checks for opens, shorts, each element individually, emission, and for filament continuity. A large BAD?-GOOD meter scale is in three colors for easy reading and also has a "line-set" mark.

You'll find this tube checker kit a good investment — and it's only \$29.50.

YOU SAVE BY ORDERING DIRECT FROM MANUFACTURER—USE ORDER BLANK ON LAST PAGE

EXPORT AGENT
ROCKE INTERNATIONAL CORP.
13 E. 40th ST.
NEW YORK CITY (16)
CABLE: ARLAB-N.Y.

The HEATH COMPANY

... BENTON HARBOR 20, MICHIGAN

RADIO-ELECTRONICS for

New LABORATORY LINE HEATHKITS



MODEL AV-1
Shipping weight 5 lbs.

NEW *Heathkit* A.C. VACUUM TUBE VOLTMETER KIT

Now — as a Heathkit — at a price anyone can afford, an AC VTVM. A new kit to make possible those sensitive AC measurements required by audio enthusiasts, laboratories, and experimenters. Here is the kit that the audio men have been looking for. Its tremendous range of coverage makes possible measurements of audio amplifier frequency response — gain or loss of audio stages — characteristics of audio filters and attenuators — hum investigation — and literally a multitude of others. Ten ranges consisting of full scale .01, .03, .1, .3, 1, 3, 10, 30, 100, 300 volts RMS assure easy and more accurate readings. Ten ranges on DB provide for measurements from -52 to +52 DB. Frequency response within 1 DB from 20 cycles to 50 KC.

The ingenious circuitry incorporates precision multiplier resistors for accuracy, two amplifier stages using miniature tubes, a unique bridge rectifier meter circuit, quality Simpson meter with 200 microampere movement, and a clean layout of parts for easy wiring. A high degree of inverse feedback provides for stability and linearity.

Simple operation is accomplished by the use of only one control, a range switch which changes the voltage ranges in multiples of 1 and 3, and DB ranges in steps of 10.

The instrument is extremely compact, cabinet size — 4 1/8" deep x 4-11/16" wide x 7 3/8" high, and the newly designed cabinet makes this the companion piece to the VTVM. For audio work, this kit is a natural.

\$29.50

NEW *Heathkit* AUDIO FREQUENCY METER KIT

MODEL AF-1
Shipping weight 12 lbs.



\$34.50

A NEW Heathkit Audio Frequency Meter — the ideal instrument for determining frequencies from 20 cycles to 100 KC. Set the selector switch to the proper range — feed the signal into the input terminals — and read the frequency from the meter — completely simple to operate, and yet dependable results.

Quality Simpson 200 microampere meter has two plainly marked scales (0-100 0-300). These scales, read in conjunction with the seven position selector switch, give full scale readings of 100, 300, 1000, 3000, 10,000, 30,000, and 100,000 cycles. Convenient ranges for fast and easy readings.

For greatest accuracy, the 1-3-10 ratio of ranges is maintained and each range has individual calibrating control.

Input impedance is high (1 megohm) for negligible circuit loading. A signal and a change in signal voltage between these limits will not affect the meter reading. In addition, input wave shape is not critical (the unit will read the frequency of either sine wave or square wave input).

The tube complement consists of a 6SJ7 amplifier and clipper, 6V6 amplifier and clipper, 616 meter pulse rectifier, 6X5 power supply rectifier, and OD3/VR150 voltage regulator.

Construction is simple, and quality components are used throughout.

NEW *Heathkit* INTERMODULATION ANALYZER KIT

Intermodulation testing of audio equipment is rapidly being accepted by more and more engineers and audio experts as the best way to determine the characteristics of audio amplifiers, recording systems, networks, etc. — shows up those undesirable characteristics which contribute to listening fatigue when all other methods fail.

The Heathkit Intermodulation Analyzer supplies a choice of two high frequencies (3000 cycles and a higher frequency (60 cycles) and one low frequency (60 cycles). Both 1:1 or 4:1 ratios of low to high frequencies can be set up for 1M testing, and the ratios are easily set by means of a panel control and the instrument's own VTVM. An output level control supplies the mixed signal at the desired level with an output impedance of two thousand ohms. The Analyzer section has input level control and proper filter circuits feeding the instrument's VTVM to read intermodulation directly on full scale ranges of 30%, 10% and 3%. Built-in power supply furnishes all necessary voltages for operating the instrument.

You won't want to be without this new and efficient means of testing.



MODEL IM-1
Shipping wt. 18 lbs.

\$39.50

NEW *Heathkit* SQUARE WAVE GENERATOR KIT

The new Heathkit Square Wave Generator Kit with its 100 KC square wave opens an entirely new field of audio testing. Square wave testing over this wide range will quickly show high and low frequency response characteristics of circuits — permit easy adjustment of high frequency compensating networks used in video amplifiers — identify ringing in circuits — demonstrate transformer characteristics, etc.

The circuitry consists of a multivibrator stage, a clipping and squaring stage, and a cathode follower output stage. The power supply is transformer operated and utilizes a full wave rectifier tube with 2 sections of LC filtering.

As a multivibrator cannot be accurately calibrated, a provision is provided to allow the instrument to be accurately synchronized with an accurate external source when extreme accuracy is required.

The low impedance output is continuously variable between 0 and 25 volts and operation is simple. You'll really appreciate the wide range of this instrument, 10 cycles to 100 kilocycles — continuously variable. Kit is complete with all parts and instruction manual, and is easy to build.



MODEL SQ-1
Shipping wt. 14 lbs.

\$29.50

YOU SAVE BY ORDERING DIRECT FROM MANUFACTURER—USE ORDER BLANK ON LAST PAGE

EXPORT AGENT
ROCKE INTERNATIONAL CORP.
13 E. 40th ST.
NEW YORK CITY (16)
CABLE: ARLAB-N.Y.

The HEATH COMPANY

... BENTON HARBOR 20, MICHIGAN



Model 1B-1B
Shipping Wt. 15 lbs.

Heathkit IMPEDANCE BRIDGE KIT

This Impedance Bridge Kit is really a favorite with schools, industrial laboratories, and serious experimenters. An invaluable instrument for those doing electrical measurements work. Reads resistance from .01 Ohms to 10 meg., capacitance from .00001 to 100 MFD, inductance from 10 microhenries to 100 henries, dissipation factor from .002 to 1, and storage factor from 1 to 1000. And you don't have to worry about selecting the proper bridge circuit for the various measurements—the instrument automatically makes the correct circuit when you set up for taking the measurement you want. Bridge utilizes Wheatstone, Hay, Maxwell, and capacitance comparison circuits for the wide range and types of measurements possible. And it's self powered—has internal battery and 1000 cycle hummer. No external generator required—has provisions for external generator if measurements at other than 1000 cycles are desired. Kit utilizes only highest quality parts. General Radio main calibrated control.

\$69⁵⁰

Mallory ceramic switches, excellent 200 microamp zero center galvanometer, laboratory type binding posts with standard $\frac{3}{4}$ inch centers, 1% precision ceramic-body type multiplier resistors, beautiful birch cabinet and ready calibrated panel. (Headphones not included.)

Take the guesswork out of electrical measurements—order your Heathkit Impedance Bridge kit today—you'll like it.

Heathkit LABORATORY RESISTANCE DECADE KIT



\$19⁵⁰

Shipping Wt. 4 lbs.

An indispensable piece of laboratory equipment—the Heathkit Resistance Decade Kit gives you resistance settings from 1 to 99,999 ohms IN ONE OHM STEPS. For greatest accuracy, 1% precision ceramic-body type resistors and highest quality ceramic wafer switches are used.

Designed to match the Impedance Bridge above, the Resistance Decade Kit has a beautiful birch cabinet and attractive panel. It's easy to build, and comes complete with all parts and construction manual.

Heathkit LABORATORY POWER SUPPLY KITS

Limits:

No load	Variable	150-400V DC
25 MA	Variable	30-310V DC
50 MA	Variable	25-250V DC

Higher loads: Voltage drops off proportionally

Every experimenter needs a good power supply for electronic setups of all kinds. This HV supply and a 6.3 V filament voltage HV output desired (continuously variable within limits outlined), and a Volts-Ma switch provides choice of output metering. A large plainly marked and direct reading meter scale indicates either DC voltage output in Volts or DC current output in Ma. (Range of meter 0-500V D.C., 0-200 Ma. D.C.). Instrument has convenient stand-by position and pilot light.



\$29⁵⁰

Model PS-1...Ship. Wt. 20 lbs.

Comes with power transformer, filament transformer, meter, 5Y3 rectifier, two 1619 control tubes, completely punched and formed chassis, panel, cabinet, detailed construction manual, and all other parts to make the kit complete.

Heathkit ECONOMY . . . 6 WATT AMPLIFIER KIT



Model A-4
Ship. Wt. 8 lbs.

\$12⁵⁰

No. 304 12 inch speaker . . . **\$6.95**

This fine Heathkit Amplifier was designed to give quality reproduction and yet remain low in price. Has two preamp stages, phase inverter stage, and push-pull beam

power output. Comes complete with six tubes, quality output transformer (to 3-4 ohm voice coil), husky cased power transformer and all other parts. Has tone and volume controls. Instruction manual has pictorial for easy assembly. Six watts output with response flat $\pm 1\frac{1}{2}$ db from 50 to 15,000 cycles. A quality amplifier kit at a low price. Better build one.

Heathkit HIGH FIDELITY . . . 20 WATT AMPLIFIER KIT

Our latest and finest amplifier—the model A-6 (or A-6A) is capable of a full 20 Watts of high fidelity output—good faithful reproduction made possible through careful circuit design and the use of only highest quality components. Frequency response within ± 1 db from 20-20,000 cycles. Distortion at 3 db below maximum power output (at 1000 cycles) is only 8%. The power transformer is rugged and conservatively rated and will deliver full plate and filament supply with ease. The output transformer was selected because of its exceptionally good frequency response and wide range of output impedances (4-8-16-150-600 ohms). Both are Chicago Transformers in drawn steel case for shielding and maximum protection to windings. The unit has dual tone controls to set the output for the tonal quality desired—treble control attenuates up to 15 db at 10,000 cycles—bass control gives bass boost up to 10 db at 50 cycles.



\$33⁵⁰

Shipping Wt. 18 lbs.

Tube complement consists of 5U4G rectifier, 6SJ7 voltage amplifier, 6SN7 amplifier and phase splitter, and two 6L6's in push-pull output. Comes complete with all parts and detailed construction manual. (Speaker not included.)

MODEL A-6: For tuner and crystal phono inputs. Has two position selector switch for convenient switching to type of input desired.

MODEL A-6A: Features an added 6SJ7 stage (preamplifier) for operating from variable reluctance cartridge phono pickup, mike input, and either tuner or standard crystal phono pickup. A three position selector switch provides flexible switching. **\$35.50**

Shipping Wt. 18 lbs.

YOU SAVE BY ORDERING DIRECT FROM MANUFACTURER—USE ORDER BLANK ON LAST PAGE

EXPORT AGENT
ROCKE INTERNATIONAL CORP.
13 E. 40th ST.
NEW YORK CITY (16)
CABLE: ARCAD, N.Y.

The HEATH COMPANY

. . . BENTON HARBOR 20, MICHIGAN



NEW *Heathkit* T.V. ALIGNMENT GENERATOR KIT

Here is an excellent TV Alignment Generator designed to do TV service work quickly, easily, and properly. The Model TS-2 when used in conjunction with an oscilloscope provides a means of correctly aligning television receivers.

The instrument provides a frequency modulated signal covering, in two bands, the range of 10 to 90 Mc. and 150 to 230 Mc. — thus, ALL ALLOCATED TV CHANNELS AS WELL AS IF FREQUENCIES ARE COVERED.

An absorption type frequency marker covers from 20 to 75 Mc. in two ranges — therefore, you have a simple, convenient means of frequency checking of IF's, independent of oscillator calibration.

Sweep width is controlled from the front panel and covers a sweep deviation of 0-12 Mc. — all the sweep you could possibly need or want.

And still other excellent features are: Horizontal sweep voltage available at the front panel (and controlled with a phasing control) — both step and continuously variable attenuation for setting the output signal to the desired level — a convenient instrument stand-by position — vernier drive of both oscillator and marker tuning condensers — and blanking for establishing a single trace with base reference level. Make your work easier, save time, and repair with confidence — order your Heathkit TV Alignment Generator now!

\$39.50

Model TS-2
Shipping Wt. 20 lbs.

NEW *Heathkit* SINE AND SQUARE WAVE AUDIO GENERATOR KIT

Designed with versatility, usefulness, and dependability in mind, the AG-7 gives you the two most needed wave shapes right at your fingertips — the sine wave and the square wave.

The range switch and plainly calibrated frequency scale give rapid and easy frequency selection, and the output control permits setting the output to any desired level.

A high-low impedance switch sets the instrument for either high or low impedance output — on high to connect a high impedance load, and on low to work into a low impedance transformer with negligible DC resistance.

Coverage is from 20 to 20,000 cycles, and distortion is at a minimum — you can really trust the output wave shape.

Six tubes, quality 4 gang tuning condenser, power transformer, metal cased filter condenser, 1% precision resistors in the frequency determining circuit, and all other parts come with the kit — plus, a complete construction manual — A tremendous kit, and the price is truly low.

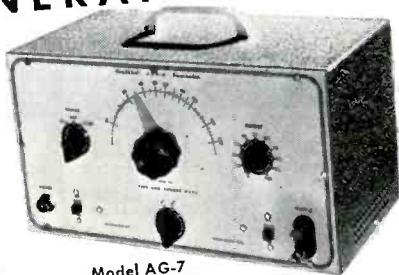

Model AG-7
Shipping Wt. 15 lbs.

\$34.50

THE NEW *Heathkit* HANDITESTER KIT

A precision portable volt-ohm milliammeter. Uses only high quality parts — All precision 1% resistors, three deck switch for trouble-free mounting of parts, specially designed battery mounting bracket, smooth acting ohm adjust control, beautiful molded bakelite case, 400 micro-amp meter movement, etc. DC and AC voltage ranges 10-30-300-1000-5000V. Ohms range 0-3000 and 0-300,000. Range Milliamperes 0-10 Ma, 0-100 Ma. Easily assembled from complete instructions and pictorial diagrams.



\$13.50

Model M-1
Shipping Wt. 3 lbs.

NEW *Heathkit*

BATTERY ELIMINATOR KIT

A few auto radio repair jobs will pay for the Heathkit Battery Eliminator Kit. It's fast for service. The voltage can be lowered to find sticky vibrators or raised to ferret out intermittents. Provides variable DC voltage 5 to 7½ Volts at 10 Amps. continuous or 15 Amps. intermittent.

Also serves as storage battery charger. A well filtered, rugged power supply uses heavy duty selenium rectifier, a husky choke, and a 4000 MFD electrolytic condenser for clean DC. 0-15V voltmeter indicates output which is variable in eight steps. Better be equipped for all types of service — it means more income

\$22.50

Model BE-2
Shipping Wt. 19 lbs.



YOU SAVE BY ORDERING DIRECT FROM MANUFACTURER—USE ORDER BLANK ON LAST PAGE

EXPORT AGENT
ROCKE INTERNATIONAL CORP.
12 E. 40th ST.
NEW YORK CITY 16
CABLE: ARIRAP-N.Y.

The **HEATH COMPANY**

... BENTON HARBOR 20, MICHIGAN

Heathkit RECEIVER & TUNER KITS for AM and FM



Model BR-1 Broadcast Model Kit covers 550 to 1600 Kc. Shipping Wt. 10 lbs.

\$19⁵⁰

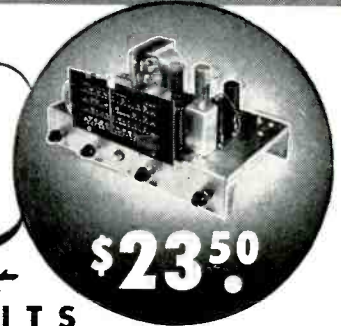

Model AR-1 3 Band Receiver Kit covers 550 Kc. to over 20 Mc. continuous. Extremely high sensitivity. Shipping Wt. 10 lbs.

\$23⁵⁰

TWO HIGH QUALITY *Heathkit* SUPERHETRODYNE RECEIVER KITS

Two excellent Heathkits. Ideal for schools, replacement of worn out receivers, amateur and custom installations.

Both are transformer operated quality units. The best of materials used throughout—six inch calibrated slide rule dial—quality power output transformers—dual iron core shielded. I.F. coils—metal cased filter condenser. The chassis has phono input jacks, 110 Volt output for phono motor and there is a phono-radio switch on panel. A large metal panel simplifying installation in used console cabinets is included. Comes complete with tubes and instruction manual incorporating pictorials and step-by-step instructions (less speaker and cabinet). The three band model has simple coil turret which is assembled separately for ease of construction.

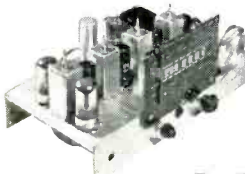

Model FM-2
Ship. Wt. 9 lbs.

\$22⁵⁰

TRUE FM FROM

Heathkit

FM TUNER KIT

The Heathkit FM Tuner Model FM-2 was designed for best tonal reproduction. The circuit incorporates the most desirable FM features—true FM.

Utilizes 8 tubes: 7E5 Oscillator, 6SH7 mixer, two 6SH7 IF amplifiers, 6SH7 limiter, two 7C4 diodes as discriminator, and 6X5 rectifier.

The instrument is transformer operated making it safe for connection to any type receiver or amplifier. Has ready wound and adjusted RF coils, and 2 stages of 10.7 Mc IF (including limiter). A calibrated six inch slide rule dial has vernier drive for easy tuning. All parts and complete construction manual furnished.



MAIL TO THE
HEATH COMPANY
BENTON HARBOR 20,
MICHIGAN

ORDER BLANK

From _____

SHIP VIA

- Parcel Post
- Express
- Freight
- Best Way

Quantity	Item	Price	Quantity	Item	Price
	Heathkit Oscilloscope Kit — Model O-7			Heathkit H.V. Probe Kit — No. 336	
	Heathkit VTVM Kit — Model V-5			Heathkit R.F. Signal Gen. Kit — Model SG-6	
	Heathkit FM Tuner Kit — FM-2			Heathkit Condenser Checker Kit — Model C-2	
	Heathkit Broadcast Receiver Kit — Model BR-1			Heathkit Handitester Kit — Model M-1	
	Heathkit Three Band Receiver Kit—Model AR-1			Heathkit Power Supply Kit — Model PS-1	
	Heathkit Amplifier Kit — Model A-4			Heathkit Resistance Decade Kit — Model RD-1	
	Heathkit Amplifier Kit — Model A-6 (or A-6A)			Heathkit Impedance Bridge Kit — Model IB-1B	
	Heathkit Tube Checker Kit — Model TC-1			Heathkit A.C. VTVM-KIT — Model AV-1	
	Heathkit Audio Generator Kit — Model AG-7			Heathkit Intermodul. Analyzer Kit—Model IM-1	
	Heathkit Battery Eliminator Kit — Model BE-2			Heathkit Audio Freq. Meter Kit — Model AF-1	
	Heathkit Electronic Switch Kit — Model S-2			Heathkit Square Wave Gen. Kit — Model SQ-1	
	Heathkit T.V. Alignment Gen. Kit — TS-2				
	Heathkit Signal Tracer Kit — Model T-2				
	Heathkit R.F. Probe Kit — No. 309				

On Parcel Post Orders, include postage for weight shown and insurance. (We insure all shipments.)

On Express Orders, do not include transportation charges—they will be collected by the Express Agency at time of delivery.

Enclosed find Check Money Order for _____

Please ship C.O.D. Postage enclosed for _____ lbs.

ALL PRICES SUBJECT TO CHANGE WITHOUT NOTICE

EXPORT AGENT
ROCKE INTERNATIONAL CORP.
13 E. 40th ST.
NEW YORK CITY (16)
CABLE: ARLAR-N.Y.

The HEATH COMPANY

... BENTON HARBOR 20, MICHIGAN

RADIO-ELECTRONICS for

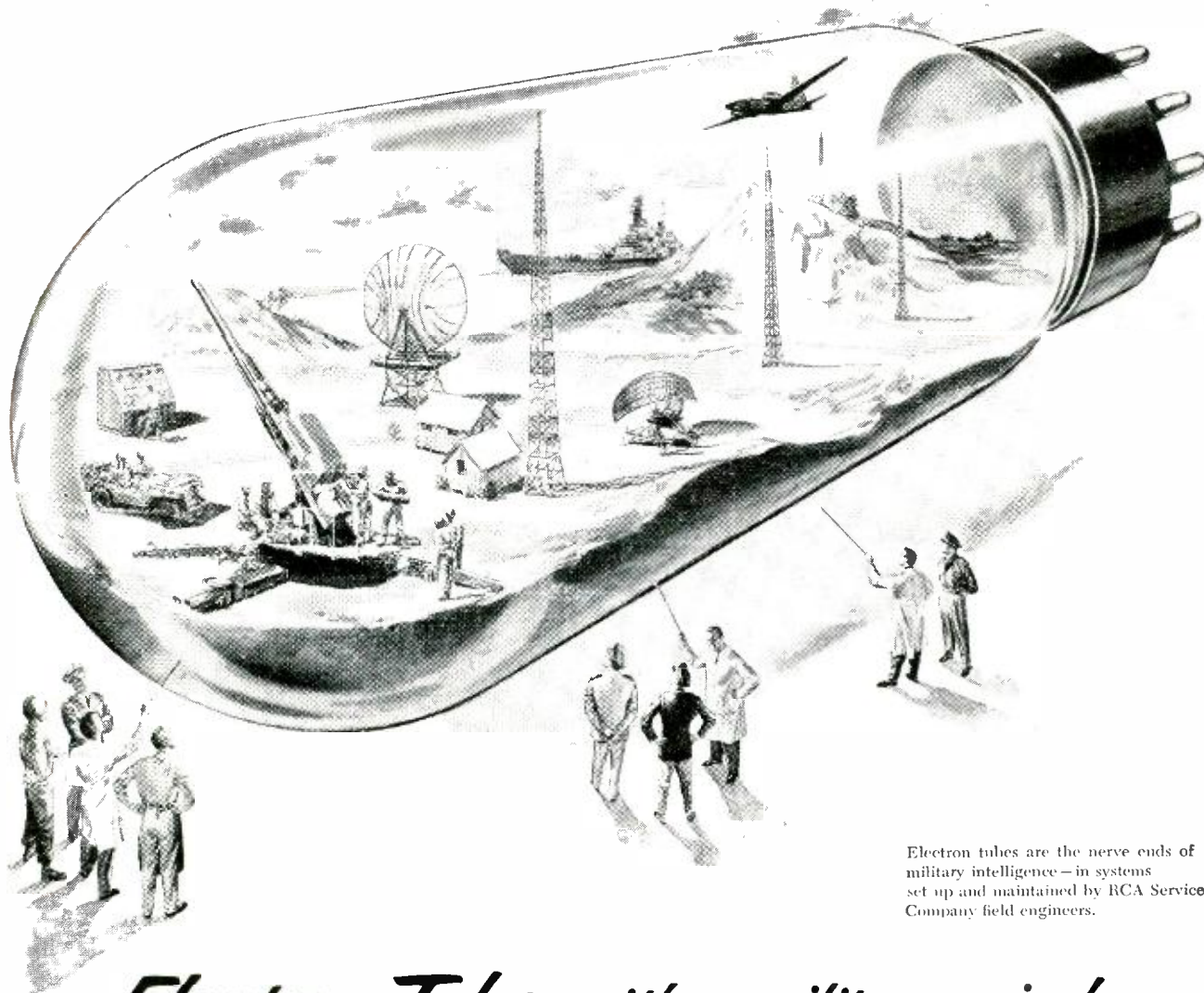

Electron tubes are the nerve ends of military intelligence—in systems set up and maintained by RCA Service Company field engineers.

Electron Tube with a military mind

With the rapid advance of airplanes, tanks, fast ships, and mechanized weapons of war, a swift, sure means of *communication* and *detection* is as important as are the new weapons themselves. It is provided—by electron tubes and electronics.

So important is this area of military intelligence that RCA Service field engineers—here and abroad—have lifted their efforts to new peaks. Working with our Armed Forces, they install and maintain such *communications systems* as short-wave radio and portable radiotelephones.

They work with systems of *detection*, such as radar. They help ships and planes *navigate* with loran and shoran. These engineers are the link between research developments made at RCA Laboratories—and America's military strength.

The number of RCA field engineers has *tripled* since World War II. And they serve where needed, wherever an electron tube's "military mind" can be of military use.

* * *
See the latest wonders of radio, television, and electronics at RCA Exhibition Hall, 36 West 49th Street, N.Y. Admission is free. Radio Corporation of America, RCA Building, Radio City, N.Y. 20, N.Y.



Practical training of military personnel—in classes, factory, and the field—is a basic part of RCA Service Company's work with our Armed Forces.



RADIO CORPORATION of AMERICA

World Leader in Radio — First in Television

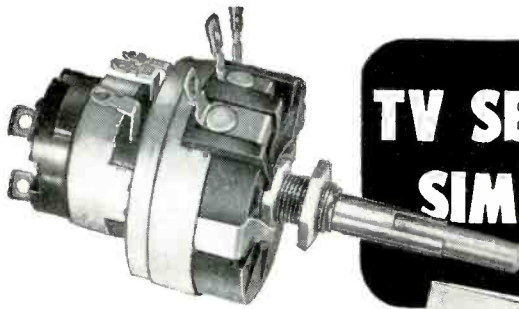

TV SERVICING SIMPLIFIED

Use this big Clarostat TV Control Replacement Manual! Almost 3000 control listings of all the popular TV set models and chassis. You can spot the correct replacement for any wornout or defective TV control.

Best of all, your Clarostat jobber has that right replacement in stock. No delay. And it fits — electrically and mechanically — without fussing or cussing. Stays put, too, for a profitable job.

GET THAT TV CONTROL REPLACEMENT MANUAL NOW!

Supply is running out. Send your dollar bill and start saving time, trouble, money, in TV servicing. Or get your copy from your Clarostat jobber.



Controls and Resistors

CLAROSTAT MFG. CO., INC. • DOVER, NEW HAMPSHIRE

IN CANADA: CANADIAN MARCONI CO. LTD., MONTREAL, P.Q., AND BRANCHES

Many hams who have had experience with electronic keys prefer a circuit which provides a self-completing dash so that the keying characteristic will be more uniform and less subject to the

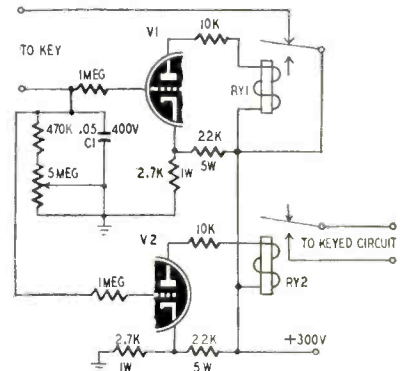

Fig. 3—The self-completing dash circuit.

peculiarities of the individual operator. The circuit shown in Fig. 1 will make uniformly spaced dashes only if the key is held down for the duration of the last dash. In other words, if the key is lifted up too soon some chopping of dashes will occur and the result will sound more like a manually operated dash. This will depend on the skill of the operator, and considerable practice may be required before the letters come out with precision.

Self-completing dash

In a self-completing dash circuit the dash will complete itself even though the key is opened too soon. The self-completing dash circuit (Fig. 3) operates as follows: C1 charges to a high positive voltage the instant the key is closed. This charge overcomes the blocking bias applied to the cathodes and causes V1 and V2 to conduct, thus actuating the relays. The contacts of RY1 in series with the charging voltage open and allow C1 to discharge through R1. When the voltage across C1 falls low enough V1 cuts off and the relay returns to normal. V2 conducts as long as its grid voltage (determined by C1) is above cutoff point. If the key remains closed the cycle begins again and dashes will continue to be sent.

As can be seen from the above, only a tap on the dash side of the key will cause a complete dash to be sent. A little practice will result in clean tape-like sending. The relay and key requirements, however, are necessarily more complicated, since an extra set of relay contacts is required and the dash lever on the key as well as the dash binding post must be isolated.

Some bugs are so light that all sorts of gadgets have been devised to hold them in place on the operating desk. Since you must modify the key to use it with this circuit, why not consider building the dash-maker in a small metal utility box with the parts arranged so the bug can be mounted in the base with the paddle protruding from the front? The added weight of the electronic components will hold the key in place on almost any surface.

—end—

SURPLUS
BOUGHT & SOLD
GOULD GREEN 252 Greenwich St.
Worth 4-8044—NYC 7

Soldering Iron CONDITIONER
Cleans and will keep your soldering iron point (tinned and shiny) bright as new. Lasts for years without filing. Just rub the point of the hot iron in the compound each time you use it and it will keep it in perfect condition for soldering. The compound will last for years and it is not necessary to "dress" the point of the iron. The compound is absolutely non-corrosive. Price \$1.00 (first half for stamps).
REVCO, Dept. E 7520 Crandon, Chicago 49, Ill.

SAVES TIME-MONEY ON EACH CALL

N.U. VIDEOTRON

PICTURE TUBE CHECKER 28⁷⁵
Net to Dealer

- PORTABLE • RUGGED
- ACCURATE
- Checks all magnetically and electrostatically deflected tubes.
- Uses beam current principle of test.
- Checks electron gun for continuity and shorts.
- Checks tubes in carton or set without removal.

AVAILABLE AT LEADING DISTRIBUTORS OR WRITE FOR CATALOG

NATIONAL UNION RADIO CORP.
350 SCOTLAND ROAD • ORANGE, N. J.

New Supreme 1951 TV Manual

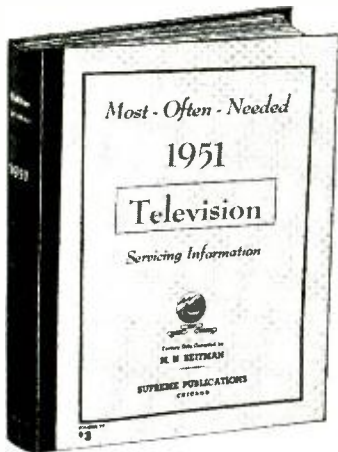

INCLUDES ALL POPULAR SETS

The new 1951 TV manual has complete service material on every popular television set of every important manufacturer. Here is helpful, practical, factory-prepared data that will make servicing and adjustment easy for you. This new giant manual, as well as the previous volumes listed at left, has complete circuits, alignment facts, test patterns, response curves, service hints, voltage charts, waveforms, recommended changes for improvement, and many double-spread diagram blueprints. Here is your TV service material to help you become an expert, and at only \$3 and \$2 per manual.

AMAZING BARGAIN OFFER

The new 1951 TV manual is the most remarkable value offered by Supreme Publications in their 18 years of business. This giant-size television servicing manual at only \$3, or the TV manuals for previous years for only \$3 and \$2 each, are amazing bargains and defy competition. There is nothing else like them. Each manual is a virtual treatise on practical television repairs. By normal standards, each such large manual packed as it is with practical facts, hundreds of illustrations, diagrams, charts, photographs and expensive extra-large blueprints, should sell for \$10—but as SUPREME special values they are priced at \$3 and \$2 each. Only a publisher who sold over one million television and radio manuals can offer such bargains based on tremendous volume-sales.

FIND—FIX ALL T-V FAULTS

Use the new 1951 TV manual and the earlier volumes (see listing at left) to help you with all TV repairs. Cuts hour-wasting jobs to pleasant moments. Use test patterns for quick adjustment, or look up probable cause of trouble in the pages of hints after simply observing fault in video picture. No equipment needed with these tests. Or use your voltmeter and compare values with many voltage charts included. With an oscilloscope you can get waveforms similar to hundreds illustrated using test points suggested and in a flash locate what used-to-be a hard-to-find fault. Order at our risk for a 10-day trial. Use coupon at bottom of page.

YOURS TO USE ON TRIAL

Be ready to repair any TV set by having in your shop all five Television Manuals described at left. Or try the new 1951 TV manual to see what an amazing bargain you get for only \$3. Order on no-risk trial by using coupon at bottom of page.

New 1951 Television Manual

This newest giant volume of the series covers 1951 factory data on all popular television sets of all makes. There are circuit explanations, 192 pages of alignment procedure, test patterns, response curves, pages of waveforms, voltage charts, service hints, and dozens of large double-page circuit diagrams. Manual style binding. At your parts jobber or by mail, special price, only **\$3**

1950 TV Manual. Includes service information on all popular TV sets of all makes from Admiral to Zenith. Large size: 8 1/2" x 11", plus ten mammoth 11x15" blueprints. **\$3**
Amazing bargain at only

1949 TV Manual. Similar to the volume listed above. Has 192 extra-large pages, plus 9 double-spread giant blueprints. **\$3**
To order see coupon below, only

1948 TV Manual. Earlier volume has material on all popular TV sets of this period. Large size: 8 1/2" x 11". Remarkable value. **\$3**
Including 8 fold-out blueprints, only

1947 FM and TV Manual. Data covers all needed FM and television sets including popular R.C.A. 630TS. Size: 8 1/2" x 11". **\$2**
Service material on 192 pages. Only



All Supreme Publications TV and Radio manuals are compiled by M. Beitman, radio engineer, teacher, author, and serviceman.

SUPREME RADIO MANUALS

Just Out

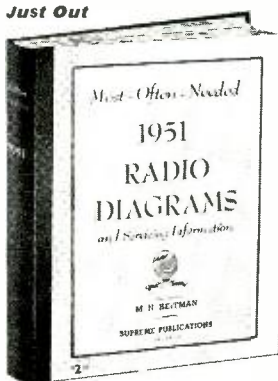

New 1951 Radio Diagrams

Now you can benefit and save money with Supreme amazing manual scoop. This one giant volume has all the service data you need on all recent radio sets. Here you have clearly-printed large schematics, needed alignment data, parts lists, voltage values, and information on stage gain, location of trimmers, and dial stringing illustrations. This is the help you need to find tough faults in a jiffy. The new 1951 radio manual is a worthy companion to the 10 previous volumes used to an advantage by over 132,000 shrewd radio men.

RADIO-ELECTRONICS HOME-STUDY COURSE

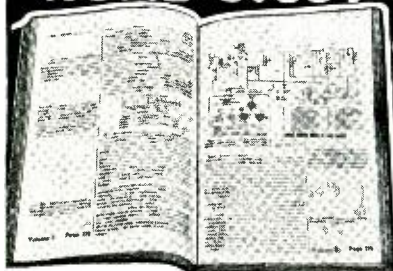

ONLY \$3.95
COMPLETE 3 VOLUMES
53 Lessons

NEW AMAZING OFFER

Here is the most amazing bargain in radio training. The price scoop of the year. For only \$3.95 (full price) you receive a complete radio-electronics course of 53 extra-large, fact-packed lessons. Covers every topic of radio fundamentals, practical servicing, TV, FM, audio, and industrial electronics. Published in three giant books, bound in one super-mammoth volume. Printed in 1951. Compares lesson by lesson with the best \$200 home-study correspondence courses; but here you get all lessons at one time at the unheard-of bargain price of only \$3.95; nothing further to pay or buy.

THREE COURSES IN ONE

The complete training of these 53 large lessons is really THREE distinct courses on: (1) Practical Radio, (2) Applied Electronics, and (3) Radio Servicing. The lessons are clear, practical, easy to master and use. Early lessons will make fundamentals clear even to a beginner, while other lessons will give you the practical "know-how" of an expert. Notice in the illustration of the manuals, at top, that the wide column on each page has the text, while the narrow column contains pertinent explanations usually supplied by a teacher. These teacher comments guide you over the hard parts, stress points of importance, tell you how to perform practical experiments using any home radio. There are hundreds of review self-testing questions, 427 drawings, pictures, diagrams, and over a thousand service hints.

YOURS TO TRY FOR 10 DAYS

Just send no-risk coupon, at right, and receive the 3-volume COURSE for a free examination. Use all this material a full 10 days in your own home. Read a few lessons, examine the hundreds of illustrations, apply some of the hints to fix a couple of radios. Only then, if you are pleased, the complete course of 53 lessons, in three volumes, is yours to keep for only \$3.95, full price; otherwise, it costs you nothing for the use and examination. Fair enough? The available quantity is limited. Please rush coupon or ask your jobber while your special price is still only **\$3.95**

Supreme Publications

Sold by all Leading Radio Jobbers

OCTOBER, 1951

BIGGEST BARGAIN IN SERVICE DATA

Wise servicemen know that Supreme Publications manuals have all the material needed at the lowest prices. For the remarkable bargain price (only \$2 for most volumes) you are assured of having on hand needed diagrams and all other essential repair facts on almost all sets you will ever service. Every popular radio of all makes, from old-timers to new 1951 sets is covered. Select manuals wanted, see list below.

SUPREME RADIO MANUALS for PREVIOUS YEARS



1950 1949 1948 1947 1946 1942 1941 1940 1939 1926-1938
SUPREME Most-Often-Needed RADIO DIAGRAMS
Each Manual only \$2 ('50, '49, \$2.50); 192 pages of diagrams, alignment data, voltage, values, parts lists, and service hints; large size, 8 1/2" x 11". To order see coupon below. **RADIO DIAGRAMS 240 PAGES PRICE \$2.50**

NO-RISK TRIAL ORDER COUPON

SUPREME PUBLICATIONS, 3727 W.13 St., Chicago 23, ILL.

Send on trial the manuals checked below and at right. You guarantee complete satisfaction.

- New 1951 Television Service Manual \$3.
- 1950 Television Manual. \$3. 1949 TV. \$3.
- 1948 TV. \$3. 1947 TV & FM, only \$2.00
- Radio & Electronics Course, 53 lessons. ... \$3.95
- I am enclosing \$..... Send postpaid.
- Send C.O.D. I am enclosing \$..... deposit.

Name:

Address:

- RADIO Diagram Manuals**
- New 1951 Manual, \$2.50
 - 1950 Radio
 - 1949 Manual } **\$2.50**
 - 1948
 - 1947
 - 1946
 - 1942
 - 1941
 - 1940
 - 1939
 - 1926-1938 Manual, \$2.50
- PRICED AT ONLY \$2 EACH**



It's the newest convenience in soldering. *Twin Spotlights* on your new 135-watt WELLER Soldering Gun completely eliminate shadows; you see clearly even in the darkest chassis.

Pull the trigger of your WELLER Gun, heat and light come on together—in just 5 seconds! No more waiting, wasted current, or blind soldering. Your WELLER Gun pays for itself in a few months!

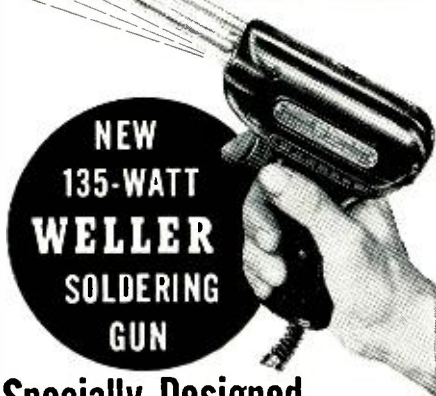

Specially Designed for TV and Radio Work

- **DUAL SOLDERLITE**—Two prefocused spotlights completely eliminate shadows — let you see clearly what you are soldering.
- **OVER/UNDER DESIGN**—Tube construction braces tip and improves visibility.
- **5-SECOND HEATING**—No waiting. Saves power. Pull the trigger and you solder!
- **LONGER REACH**—Slides easily into deep chassis, reaches the tightest corners.
- **GREATER CAPACITY**—Smaller, lighter, with greater soldering capacity.
- **TRIGGER-SWITCH CONTROL**—Adjusts heat to the job. Saves current—no need to unplug gun between jobs.
- **DUAL HEAT**—Single heat 100 watts; dual heat 100/135 watts; 120 volts, 60 cycles. Handles all light-duty soldering.

See new Models WS-100 and WD-135 at your distributor, or write for bulletin direct.

• **SOLDERING GUIDE**—Get your new copy of "Soldering Tips"—revised, up-to-date and fully illustrated 20-page booklet of practical soldering suggestions. Price 10¢ at your distributor, or order direct.



WELLER
ELECTRIC CORP.
828 Packer Street, Easton, Pa.

PHOTOCELL AMPLIFIER

Patent No. 2,548,176

Paul T. Semm, Batavia, and Robert T. Nakasone, Chicago, Ill.

(Assigned to Wheelco Instruments Co.)

This is a form of magnetic amplifier. Coils L1 of the saturable transformer T1 form one arm of a bridge network. The other 3 arms are L2, R1, and R2. The middle leg of T1 has 2 control windings which oppose each other. The bridge is set for balance when PE, the photocell, has zero output.

When current flows through the upper control winding, the core is partly saturated. This reduces the reactance of L1 and unbalances the bridge. An a.c. voltage appears across A and is

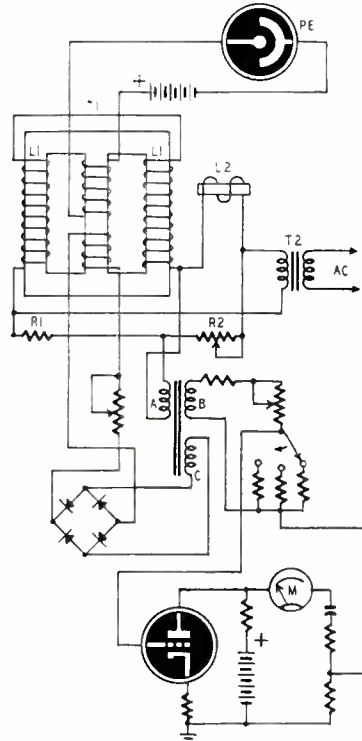

stepped up in B. A divider feeds part of the voltage to a triode amplifier. The a.c. component is indicated by M. This component is proportional to the PE output flowing through T1.

Voltage from the winding C is rectified and fed back to oppose the upper control voltage. This stabilizes the amplifier. If desired, one of the control windings may be reversed. Then the feedback is *positive*. This increases amplifier sensitivity but may reduce stability.

SECRET PULSE COMMUNICATION

Patent No. 2,543,907

Paul François Marie Gloess and Louis Joseph Libois, Paris, France.

This invention deals with pulse communication. Systems of this type use a modulator to form pulse groups in accordance with sounds or other information. When the pulse groups are intercepted and detected, they yield the original message. This invention permutes or rearranges the order in which the pulses appear in each group.

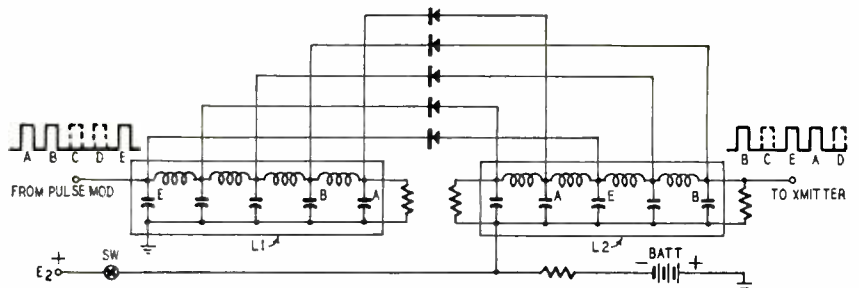

Unless the groups are restored to their original form before detection, the messages are garbled and have no meaning.

It is assumed that the modulator forms groups having 5 pulse positions each. Not all positions need be occupied in any group. The typical group here has pulses in the first, second, and fifth positions, marked A, B, E, respectively. This group feeds a delay line L1, composed of series-inductance and shunt capacitance. Each section of L1 produces a time delay equal to the interval between pulse positions. At a particular instant, therefore, the first pulse A has passed through L1 and charges capacitor A. At the same time the second pulse B is at capacitor B. The next 2 capacitors have no charge because no pulses occupy the third and fourth pulse positions. Capacitor E is charged by the last pulse in this group.

Each capacitor in L1 is connected in any desired arrangement to a capacitor in L2. Thus, when the rectifiers conduct, L1 transfers the entire group to L2 in a predetermined pulse position order. For example, the output of L2 is shown as BEA instead of the original ABE.

Normally the crystal rectifiers are blocked by a negative voltage (from the battery) on each anode. Under this condition L2 provides no output. When the auxiliary positive voltage E is switched in, the battery voltage is balanced out and the rectifiers conduct. Then pulses are available from L2.

This invention contemplates the use of several lines like L2, each with its own battery and auxiliary supply. As soon as the first pulse group occupies L1, E2 is switched in. Therefore a permuted pulse group is available for transmission. When the second group arrives at L1, another line, say L3, is made effective. This is done as before by switching in its auxiliary supply. E3. L3 permutes the second group in some different manner. In the same way, the third group fed to L1 is permuted by still another line L4, etc.

This system of coding pulses is so complicated that it is hardly likely to be decoded by unauthorized persons who do not know the key.

SQUELCH FOR PUSH-BUTTON RECEIVER

Patent No. 2,546,401

Madison G. Nicholson, Jr., Snyder, N. Y. and Maxwell C. Scott, Lancaster, N. Y.

(Assigned to Sylvania Electric Products Inc.)

Receivers are easily converted to include this squelch system. It eliminates noise and clicks during tuning. Typical component values are given in the schematic. C2, R2 form part of the a.v.c. When the set is turned on, C1 charges from the high-voltage source.

Contacts A are arranged to close momentarily when any push-button is operated. These contacts may be part of the button assembly or on some external relay added for the purpose. While the contacts are closed, C2 shunts C1 (through

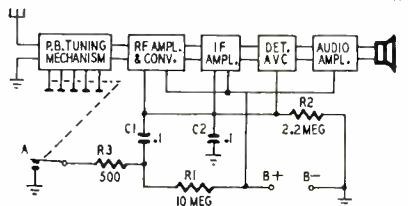

low resistance R3). Therefore a large negative bias builds up on C2 and blocks the receiver. Normal operation is restored after C2 discharges through R2.

R2 and C1 may be chosen to provide any desired squelch interval but the values shown have been found effective. R3 is not essential to the squelch action but it reduces sparking at A.

—end—

Lafayette HOME OF TOP NAMES IN RADIO

FEATURING RCA TEST EQUIPMENT

NEW WV-77A JUNIOR VOLTOHMYST
 —Here again . . . at an amazing low price! Includes all the features of previous models, plus greater voltage range, wider frequency response, higher overall accuracy and complete electronic operation. High input resistance on all ranges; 11 megs for DC, 0.2 to 2 megs for AC. Flat frequency response 30 cps to 3 mc (50 kc to 250 mc with WG-264 probe not included). AC & DC volt ranges: 0.3/12/60/300/1200. High impedance vacuum tube diode used as signal rectifier, 5 Ohmmeter ranges from 0-1000 megs with center scale values of 10, 1000, 10,000 ohms; 1 meg and 10 megs. Uses only one 1.5V. battery. Safely measures continuity of filaments of battery-operated receiving tubes. 8"H., 5 3/8"W., 4 1/2"D. Supplied with tubes, battery, probes, cable and instructions. For 105-125V, 50/60 cycles AC. Shpg. wt. 6 lbs.
RCA Model WV-77A..... \$47.50
RCA Model WG-264 Probe..... \$7.75

WV-97A SENIOR VOLTOHMYST — A professional tool for efficient troubleshooting of critical TV service work. Reads peak-to-peak voltages of complex waves directly up to 2000 volts, with frequency response flat to 3 mc. 7 DC volt ranges with readings from 0.02 to 1500. 7 AC volt ranges with readings from 0.2 to 2000 peak-to-peak and 7 RMS ranges with readings from 0.1 to 1500. 7 resistance ranges 0-1000 megs with center scale 10, 100, 1000, 10,000 ohms; 1, 1, 10 megs. Input resistance 11 megs for DC, .83 to 1.5 megs for AC. Accuracy $\pm 3\%$ on DC, $\pm 5\%$ on AC. Push-pull DC amplifier bridge circuit with inverse feedback provides excellent linearity, stability and high input impedance. Reads AC with DC present and vice versa. Blue-gray hammeroid case 7 7/8"H., 5 3/8"W., 4 1/2"D. For 105-125V., 50/60 cycles AC. With tubes, WG-218 direct probe and cable, WG-217 DC probe, ohms lead and probe. Shpg. wt. 10 lbs.
RCA Model WV-97A..... \$67.50

WO-56A 7" OSCILLOSCOPE—A precision designed laboratory instrument with extremely high sensitivity, sharp, bright trace, superior high and low frequency response, three push-pull stages of direct-coupled amplification and excellent square-wave response. Exclusive new sync-limiter circuit keeps steady pattern on screen even with large changes in gain signal level and frequency. Vertical amplifier sensitivity: 10.6 RMS mv/inch and 30 mv/inch peak-to-peak. Response flat within 2 db from DC to 500 kc; within 6 db at 1 mc; useful beyond 2 mc. Both amplifiers equipped with frequency-compensated and voltage-calibrated attenuators. Preset fixed positions for TV vertical and horizontal waveforms, "plus" and "minus" sync for easy lock-in of wave-forms, and line-frequency sweep and sync phasing. Variable sweep frequency 3-30,000 cps. Blue-gray hammeroid case 13 3/4"H., 9"W., 16 1/8"D. For 105-125V., 50/60 cycles AC. Supplied with 7JPI CRT, all tubes, WG-218 and WG-216A probes, cable and ground lead. Shpg. wt. 35 lbs.
RCA Model WO-56A..... \$217.50

WO-57B 3" OSCILLOSCOPE—Built to handle every TV and radio service job. Features a direct-coupled, 2-stage push-pull vertical amplifier with deflection sensitivity of 30 mv RMS/inch. Frequency response flat within 2 db from DC to 500 kc; within 6 db at 1 mc; useful beyond 2 mc. Square-wave response with negligible tilt and overshoot. Vertical input resistance 1 meg. no probe, 35 mmf; with WG-218 probe, 90 mmf; with WG-216A probe, 9.5 mmf. Has preset fixed sweep positions and sweep reversal switch for left-to-right or right-to-left traces. Positive and negative synchronizing for easy "lock-in" of waveforms. 60-cycle phase controlled sweep. Linear sweep range 15-30,000 cps. Trace expansion two times screen diameter for sweep alignment applications. Peak-to-peak calibrating voltage source. Portable steel case 10"H., 13 1/2"W., 7 1/2"D. Complete with tubes, WG-218 and WG-216A probes, cable, leads, and instructions. Shpg. wt. 20 lbs.
RCA Model WO-57B..... \$145.00

AUTHORIZED

DISTRIBUTOR



free!

New, big 1952 Lafayette Catalog is value-packed with thousands of radio, television and electronic parts . . . PLUS an up-to-the-minute High Fidelity Section with the latest audio equipment for custom installations. Send for your FREE COPY. Just fill in and mail the handy coupon today.
 Make sure to visit your nearby salesroom — you'll save time and money.

COUPON

RADIO WIRE TELEVISION INC. Dept. JJ
Lafayette Radio
 100 Sixth Ave., N. Y. 13, N. Y.
 Please ship the following:
 WV-77A WV-97A WO-57B WO-56A WG-264
 Enclosed \$.....
 Send additional literature on.....
 Send FREE Lafayette Catalog.
 Name.....
 Address.....
 City..... Zone..... State.....



Radio Wire Television Inc.

NEW YORK 13, N. Y.
 100 SIXTH AVENUE
 REctor 2-8600

BOSTON 10, MASS.
 110 FEDERAL STREET
 HUbbard 2-7850

NEWARK 2, N. J.
 24 CENTRAL AVENUE
 MArket 2-1661

BRONX 58, N. Y.
 542 E. FORDHAM RD.
 FOrdham 7-8813

VARIABLE-SELECTIVITY I.F. IN COMMUNICATIONS RECEIVER

In most communications receivers, the selectivity of the i.f. amplifier strip is increased in several ways: by using crystal filters; by increasing the number of tuned circuits; by making one of the amplifiers regenerative; or by using special variable-selectivity transformers.

An unusual variable-selectivity system is used in a double-superheterodyne communications receiver described in *Radio and Electronics* (Wellington, New Zealand). The first i.f. channel operates at 455 kc and the second at 100 kc. The variable-selectivity circuit used in the 100-kc i.f. is shown in the diagram.

to approximately one-eighth its normal value. The amount of feedback is adjusted by varying the value of R3.

A portion of the output of V2 is fed back to the grid of V1 as *positive feedback*. The voltage on the grid is produced by a voltage divider, consisting of the impedance of the secondary of T1 in series with R1. Since the impedance of the parallel-tuned secondary is greatest at resonance, positive feedback is maximum at 100 kc and tapers off rapidly for frequencies on either side of resonance. By adjusting the value of R1, the positive and negative feedback voltages are equal at 100 kc and the gain of the amplifier is the

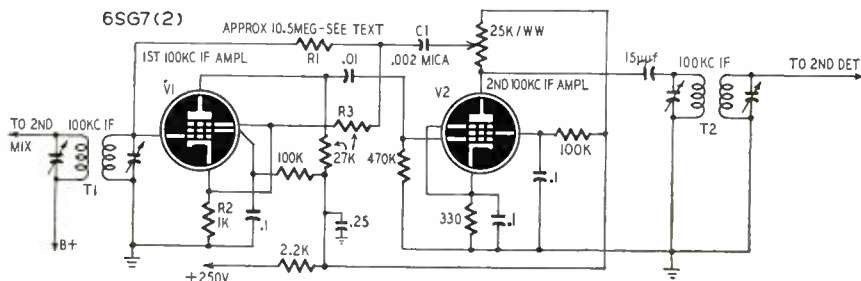

The 100-kc i.f. amplifier uses two resistance-coupled 6SG7's coupled to the second mixer through T1 and to the 100-kc second detector through T2. If C1, R1, and R3 were omitted, the circuit would be a straightforward resistance-coupled i.f. amplifier.

The plate-load resistor of V2 is a potentiometer from which feedback voltages are tapped off and fed to the cathode and control grid of V1. C1 is a blocking capacitor which prevents d.c. from appearing in the feedback network. When the arm of the potentiometer is at the end nearest the plate, R2 and R3 act as a voltage divider which supplies *negative feedback* voltage to the cathode of V1. This negative feedback is constant at all frequencies and reduces the gain of the amplifier

same as it would be without feedback.

The impedance of the tuned circuit decreases off resonance and causes a corresponding decrease in positive feedback. Since the negative feedback is constant, it predominates and greatly attenuates all signals except those coming in at 100 kc.

As the arm of the control is moved toward B-plus, both feedback voltages are reduced equally so the gain is constant at resonance. Off resonance, there is less negative feedback voltage available, so the response of the amplifier is broader. When the arm of the potentiometer is at the B-plus end there is no feedback voltage, so the gain of the amplifier is constant and the selectivity is determined solely by the tuned circuits.

WIDE-RANGE EQUALIZER FOR HIGHS OR LOWS

A wide-range equalizer which permits boosting or cutting of both highs and lows provides more pleasing response than the high-cut type of tone control used in many receivers and amplifiers. A description of such an equalizer which can be added to existing equipment was published in *Radio Con-*

structor (London, England). Its circuit appears here.

The equalizer reduces the over-all gain of the amplifier to which it is added, so an extra amplification stage is necessary. This can be had by installing a medium-mu triode such as a 6J5, 6C4, or one-half of a 12AU7, or by

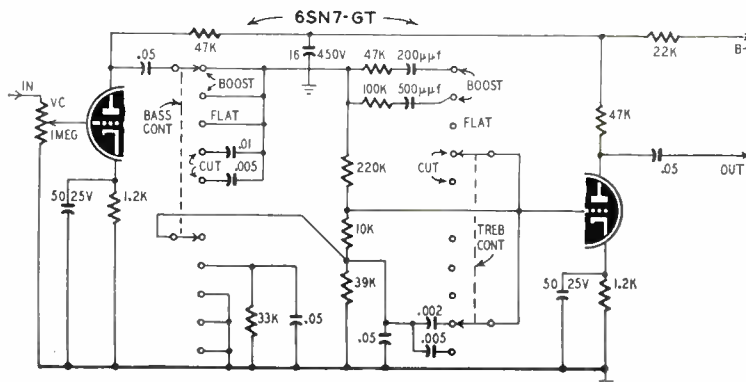

**MOST
POWERFUL
COMBINATION
for
SINGLE
CHANNEL
RECEPTION**

VEE-D-X

THE LaPOINTE-PLASCOMOLD CORPORATION
Windsor Locks, Conn.

substituting a double triode for one of the triode amplifier tubes in the amplifier circuit.

The controls are two 5-position double-pole rotary switches. These controls switch in the resistors and capacitors which determine the response of the circuit. The switches, R-C networks, and associated leads must be kept short to avoid hum and feedback difficulties.

VOLUME EXPANDER

The most common types of volume expanders incorporate an amplifier stage in which the gain increases when the peaks of the signal voltage exceed a predetermined level. This type of circuit is a variable-gain expander. An expander of the constant-gain, variable-output type is used in the Masco model MA-10EX amplifier. This circuit is shown in the diagram.

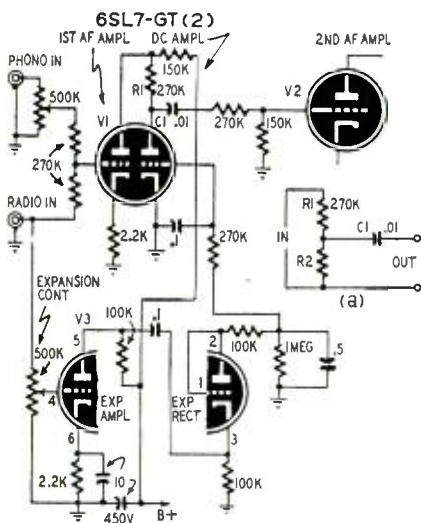

The signal applied to the radio input is amplified by the first a.f. amplifier V1, and by the expander amplifier V3. The output of the latter is rectified and applied as negative bias to the grid of the d.c. amplifier. The d.c. amplifier is connected as one leg of a voltage divider which receives the full output of V1. This voltage divider is shown at a where the internal resistance of the d.c. amplifier is represented by R2. The voltage across R2 is applied to the grid of the second a.f. amplifier V2.

When the bias is low, R2 is low and only a small percentage of the voltage developed by V1 reaches the grid of V2. The output voltage and the effective value of R2 increase as the bias voltage increases. When the bias is high enough to cut off the d.c. amplifier, R2 approaches infinity and the grid of V2 receives the full output of V1.

In this type of amplifier, the volume control is set for the desired average volume level with the expansion control turned down, then the expansion control is turned up to the point where the expander cuts in on volume peaks.

The advantage of this type over the variable gain type is especially noted in the reproduction of transients. A pulse might trigger the remote cutoff type tube usually used, and ringing, or hangover might result.

Buy Appeal

For Home Entertainment Units

High in quality . . . yet low in price . . . General Industries' Model 250 Tape-Disc Recorder Assembly meets every need for an all-purpose sound recorder. It is simple to operate, foolproof and dependable —built to the same high quality standards which identify all GI Smooth Power phonomotors and turntable assemblies.

Now is the time to investigate the tremendous profit possibilities offered by this versatile recording assembly. Write today for catalog sheet describing both recording and playback features of the GI Model 250.



Model 250—TAPE-DISC RECORDER ASSEMBLY

Suggested amplifier circuit and complete amplifier parts list is contained in a comprehensive service manual which accompanies each unit.

The GENERAL INDUSTRIES Co.

Department C • Elyria, Ohio

FREE ENERGY—Harness the Power from Radio Broadcasts

A RADIO MOTOR EARN \$10,000
in Royalties
Put Your Ingenious Mind to Work

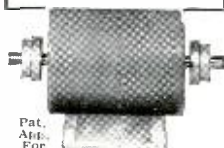

Pat. App. For

The radio motor pictured here has already been developed and has run for two months on the free energy from broadcast programs. We've already done the so-called impossible. Now we want ingenious experimenters who can improve on this motor and show us how it can be applied to practical uses.

A LIBERAL ROYALTY PLAN

Liberal royalties to the alert and ingenious person who develops a way of increasing the power of the radio motor for practical application using only radio energy from broadcast programs. We send you a royalty income agreement which amply protects you on any developments you make increasing the power of this radio motor for practical applications.

Complete plans including Royalty income agreement—all for \$5.00. Rush cash or money order.

HOW TO DO IT

You can get copyrighted instructions from us and detailed "How to do it" drawings showing how to build an actual running model of the radio motor pictured. You also receive a list of complete sources of supply for the few inexpensive materials you need.

NO CONNECTION WITH ANY OUTSIDE RADIO—NO ELECTRICITY—NO BATTERIES—NO TUBES

Radio Motor is started by turning shaft until music or talking is heard from within the motor housing. Yet when motor is not running you can enjoy it as a radio which costs absolutely nothing to run.

SCIENTIFIC PRODUCTS OF INDIANAPOLIS

P.O. Box 6331-H—42nd Street Station, Dept. RE-10 Indianapolis 5, Ind.

ILLINOIS ELECTROLYTIC CAPACITORS

of "Time Tested Quality"

For Every Electronic Application

Seventeen years of production experience, making millions of quality capacitors, has created this complete, outstanding ILLINOIS CONDENSER line. There's a full Jobber line of capacitors for every TV and radio replacement purpose; capacitors for the entire electronics industry—capacitors that meet the highest standards of dependability.

This engineering and manufacturing experience enables ILLINOIS CONDENSER COMPANY to meet every demand for new capacitor types, whether for peace or defense applications.

Write for catalog or tell us your needs. There is an ILLINOIS ELECTROLYTIC CAPACITOR exactly suited for the job—a capacitor of "Time Tested Quality."



ILLINOIS CONDENSER CO.
1616 NORTH THROOP STREET • CHICAGO 22, ILL.

EXPORT DIVISION: 15 Moore St., New York 4, N.Y. U.S.A.
CABLE ADDRESS: "MINTHORNE"



PULSES FROM A CRO

Next time you need a sawtooth or pulse generator don't overlook your oscilloscope as a source. A sawtooth generator feeds the horizontal plates D1, D2. These plates are accessible through terminals usually located at the rear of the scope. Frequency is determined by the sweep-frequency control.

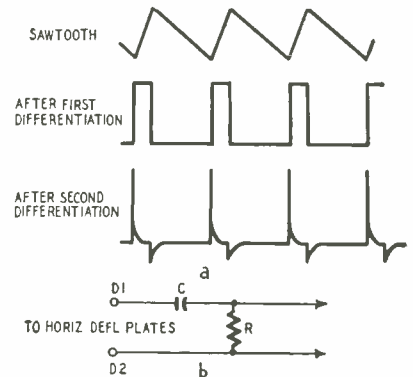

When the deflection circuit is balanced to ground, the output may be taken off in three different ways. Leads directly to D1 and D2 provide an unbalanced output. Grounded output is available by connecting one lead to ground (of the scope) and the other to one of the terminals. Polarity is reversed by interchanging terminals D1 and D2.

The sawtooth may be converted to a pulse by differentiation networks. One stage converts it to a rectangular wave. A second stage results in a sharp, rapidly decaying pulse (see a).

The time constant (RC) of the differentiation network (b), should be small relative to the period of the sawtooth or pulse wave. For proper differentiation R should be small in comparison with X_c. However, if R is made too low, a weak pulse will result. For medium frequencies R may be 25,000 ohms and C may be .002 μ.

ADAPTER FOR SLAVE SCOPES

Schools, radio and TV service clinics, and lecturers often use an oscilloscope to display waveforms being discussed. In many instances, a large percentage of the audience is seated where it is impossible to clearly observe the patterns on the screen. In *Sylvania News*, Allen White describes an adapter for "piping" signals from a master or pilot

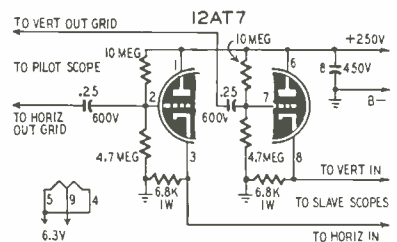

scope into other scopes placed at strategic points throughout the lecture hall.

The adapter shown in the diagram uses two cathode followers to pick up the signals from the vertical and horizontal deflection circuits of the pilot scope and feed them to the vertical and

TECH-MASTER

TELEVISION

New TECH-MASTER developments!

LO-PRICED
Universal KIT



FOR TUBES UP TO 14" RECT.

First LOW-COST TV Receiver Kit completely engineered exclusively by TECH-MASTER. Features 2-knob control and small, lightweight chassis.

Model 5116 ... \$89.50

Set of circuit-matched TUBES tested with each individual kit... \$16.25

Advanced
630 Type KIT

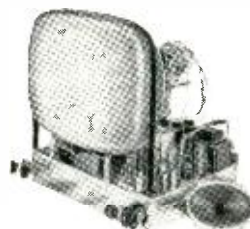

FOR ALL TUBES 12" Rd. to 20" Rect.

The greatest advance in TV Kits developed by TECH-MASTER!

Model 630D19 (De-Luxe) Principal components assembled.

Resale Price \$159.50

Model 630S19 (Standard) Unassembled

Resale Price \$154.50

Above Kits supplied with tubes, parts, speaker and pix tube mounting brackets (less Kine, wire and solder). CONTACT YOUR JOBBER or write Dept. RC-10 for literature.

TECH-MASTER PRODUCTS CO.

443-445 Broadway, New York 13, N. Y.

More leading engineers and technicians have built Tech-Master for their own use than any other Television Kit.



horizontal input terminals of the slave scopes.

The input terminals of the adapter connect to the control grids of the horizontal and vertical output tubes in the master scope. The high input impedance of the cathode followers (5 megohms or more) minimizes loading of the amplifier grids. The output impedance of the cathode follower is approximately

180 ohms. Tests proved that ordinary lamp cord up to 75 feet long could feed the signals to the remote scopes without affecting the waveshapes.

After the slave units have been initially adjusted for focus, gain, and position of the trace, they will faithfully reproduce the master scope pattern even when gain and sweep master controls are varied.

SIMPLE ELECTRONIC BUG

Most semiautomatic keys which produce automatic dashes as well as dots are either cumbersome mechanical gadgets or multivibrator-type circuits which require high- and low-voltage supplies and a number of resistors and capacitors. A novel electronic bug which uses only two relays, two capacitors, one resistor, and a gas-filled diode is described in *Short Wave Magazine* (London, England). The circuit is shown in the diagram.

The tube used in the original model was a type CV188 voltage-regulator tube which is not available in this country. It is somewhat similar to the 0C3/VR105. Its characteristics are:

- Maximum starting voltage... 140
- Normal working voltage... 190
- Maximum cathode current... 10 ma
- Average cathode current... 4 ma
- Minimum cathode current... 1 ma

The circuit can be made to work with most of the common types of voltage-regulator tubes.

The circuit must be supplied with a d.c. voltage equal to or slightly greater than the minimum starting voltage required for the tube you use. When the voltage is applied, C1 charges to full supply voltage through the normally closed contacts of RY1 and resistor R1. This voltage is applied to the plate of the tube through the coil of RY1. When the key paddle is pushed to the right, the cathode of the tube is returned to ground to complete the circuit. When the tube conducts, the current energizes the coil of RY1, thus opening the normally closed contacts and applying power to the coil of keying relay RY2.

C1 discharges through R1, the coil of RY1, and the internal resistance of the tube. The discharge continues until the current drops below the hold-in current level of the relay. RY1 releases and C1 again charges to the striking voltage of the diode. If the key is still pressed to the right, a chain of dots will be sent until the key is centered again.

Push the key to the left to make dashes. One side of C2 and the cathode of the tube are simultaneously connected to B-minus. In this position, C1 and C2 are in parallel. The added capacitance increases the R-C time-constant of the circuit to the point where RY1 holds in long enough to make dashes three times the length of a dot.

The value of C2 must be determined experimentally because the value of R in the R-C time-constant is complicated by the fact the resistance of the tube varies as a function of the current through it. The transmitting speed

can be varied by switching in additional capacitance across C1 and C2. A rotary wafer switch can be used for this.

Relay RY1 should pull in at 1.5 ma or less. Its coil resistance should not be so high that the total resistance

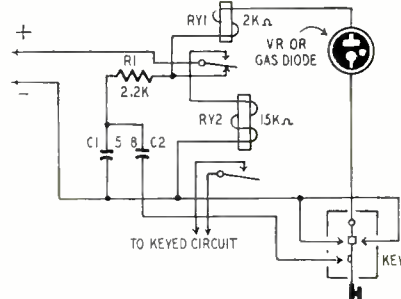

The circuit of the electronic bug. Tube can be an 0C3/VR105 or similar type.

is great enough to limit the current to a level below that required to operate RY1. This relay may be an Advance, type 1200, or equivalent. The keying relay may be any s.p.s.t. d.c. relay which will operate at the applied supply voltage with a minimum current drain.

The key can be made by modifying a standard semiautomatic key or side-swiper.

TV ALIGNMENT BIAS PACK

Most TV manufacturers specify that a small fixed d.c. bias voltage must be applied to the a.g.c. line of the set while the i.f. circuits are being aligned. Small dry batteries are usually used for this purpose. However, the variable-

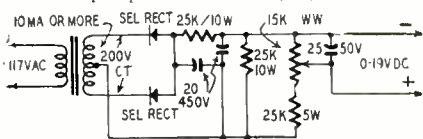

voltage bias pack described in Stromberg-Carlson's *Current Flashes* is a handy substitute for bias batteries on busy TV service benches. The circuit of the pack is shown.

The power transformers used in the original models were replacement units for the VoltOhmyst, but you can use almost any small power transformer which will deliver 75 to 120 volts d.c. into the filter. Values of the components are not critical. Substitutions can be made freely as long as the unit delivers pure d.c. with negligible ripple and the output can be varied over the desired level. An added refinement which will prove useful is the addition of a voltmeter across the output terminals. The meter should have fairly high sensitivity to minimize circuit loading.

—end—

25 DB GAIN

(BEFORE NOISE PICKUP)

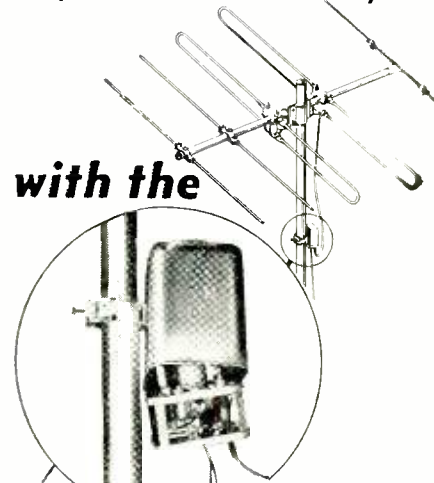

with the

TACO ANTENNA AMPLIFIER

- Amplifies only the signal from antenna — does not amplify noise pickup as ordinary boosters do.
- Operates completely automatically. Relay turns amplifier on when receiver turns on.
- Single 300-ohm line carries both signal and power. No extra wiring needed.
- No special wiring at receiver.

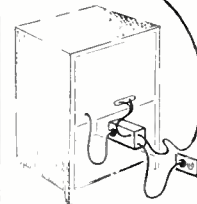

ASK YOUR TACO JOBBER FOR COMPLETE INFORMATION



TECHNICAL APPLIANCE CORP.
SHERBURNE, N. Y.

TV, FM, and AM Antennas and Antenna Systems.

In Canada: Stromberg-Carlson Co., Ltd., Toronto 4, Ont.

Practical, Popular-priced Books on RADIO•AUDIO•SERVICING



A NEW BOOK ON RADIO TUBES!

RADIO TUBE FUNDAMENTALS—No. 45. By George J. Christ. 96 pages, 74 illustrations. Just off the press—the first and only low-priced book to give you such a complete picture of the how, what and why of radio tubes—the heart of any set. The author, an engineer and teacher, gives the radio man the information he wants about tubes in the way he's accustomed to using it. Here's a practical book that will increase your understanding of radio whether you're a 25-year man or just starting out. Covers tubes from the electron theory to a working analysis of the different types of tubes. You'll find this new Gernsback Library Book as valuable as your soldering iron! Order your copy today. Only \$1.00.

TWO TOP FLIGHT \$1.00 BOOKS

MODEL CONTROL BY RADIO—No. 43. By Edward L. Safford, Jr., 112 pages. An authority in the field of radio control gives you the first complete book on the subject. For beginner and expert. Tells you what radio control is, how it works and how to construct not only component parts but a complete system as well. Illustrations explain each step.

HIGH-FIDELITY TECHNIQUES—No. 42. By James R. Langham, 112 pages. You've never seen a technical book like it! Just as he'd talk to you across the work bench, RADIO-ELECTRONICS' popular audio writer tells you how to design your own equipment and how to get top performance from it. Takes the double talk out of high-fidelity work.



THREE IMPORTANT 75¢ BOOKS



PUBLIC-ADDRESS GUIDE—No. 41. 80 pages. This handy book shows the service technician the way to extra income in big-paying PA work. Covers installation, maintenance and construction.

THE CATHODE-RAY OSCILLOSCOPE—No. 40. 112 pages. A "must" for servicing TV, FM and AM receivers and in amateur operation! Tells in simple, but technically sound language, how the 'scope works and how to use it.

PRACTICAL DISC RECORDING—No. 39. 96 pages. Tells you how to make good disc recordings. Covers every phase, theory as well as technique. A full chapter is devoted to each component.

9 POPULAR 64-PAGE BOOKS — 50¢ EACH

HANDY KINKS AND SHORT CUTS—No. 29. A treasury of time savers! Antennas, power supplies, test equipment, phonographs, amplifiers. Easy reference. Illustrated.

UNUSUAL PATENTED CIRCUITS—No. 30. A gold mine of important hook-ups. Control circuits, detectors, amplifiers, power supplies, foreign circuits.

RADIO QUESTIONS & ANSWERS—No. 31. Answers the tough ones on circuit diagrams, amplifiers, receivers, transmitters, meters and test equipment.

ADVANCED SERVICE TECHNIQUE—No. 32. A "must" for the advanced service technician! Covers specialized problems of servicing not usually found in ordinary textbooks.

AMPLIFIER BUILDER'S GUIDE—No. 33. For the designer and builder of audio equipment.

Covers a variety of amplifiers with power outputs from 8 to 30 watts.

RADIO-ELECTRONIC CIRCUITS—No. 34. For the experimenter—circuit diagrams of intercom systems, power supplies, voltmeters, electronic relays, receivers, etc.

AMATEUR RADIO BUILDER'S GUIDE—No. 35. For the "ham" who builds his own. Receivers, transmitters, antennas, converters, etc. Practical construction data.

RADIO TEST INSTRUMENTS—No. 36. Practical construction data on signal tracers, capacity meters, portable and bench multi-checkers, voltmeters, etc.

HOW TO BUILD RADIO RECEIVERS—No. 38. Describes 18 modern sets including short wave, broadcast, vhf, portable, ac-operated, ac-dc, miniatures—types for every fan.

THE GERNSBACK LIBRARY

SEE YOUR DISTRIBUTOR OR MAIL THIS COUPON TODAY

RADCRAFT PUBLICATIONS, INC. Enclosed is \$..... for which please send me postpaid, the books checked below.
25 West Broadway, New York 7, N. Y.

- 29 30 31 32 33 34 35 36
 38 39 40 41 42 43 45

Name.....
Street.....
City..... Zone..... State..... 101

COMPENSATED SCOPE PROBE

Shielded cable is often required to prevent pickup of hum and other spurious signals when using a scope for visual alignment and TV waveform analysis. When the signal is taken off a high-impedance circuit, cable capacitance and input capacitance of the scope cause changes in the amplitude and shape of signals such as pulses and square waves which have high-frequency components.

Losses due to capacitance can be overcome by using a shielded, frequency-compensated probe. Construction of the probe is shown at *a*, the schematic at *b*. Stock numbers (Philco)

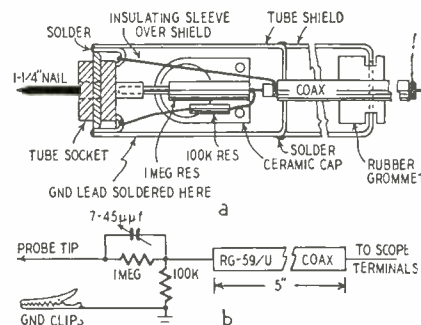

The physical layout of the compensated probe is shown at *a*; the schematic at *b*.

of the special components are given at the end of this item.

Probe construction

Bend the socket lugs back to contact the socket mounting ring. Connect the 1-megohm resistor across the capacitor terminals, insert one end into the center socket shield and solder in place. Connect the 100,000-ohm resistor between the output end of the capacitor and one of the socket lugs as shown at *a*. Wire the center conductor of a 5-foot length of RG-59/U to junction of the resistors and capacitor. Slide tube shield over coax and solder to the socket mounting ring. Drill hole in shield opposite capacitor adjustment screw. Cement grommet to second shield. When dry, slide over coax and solder to first shield. Solder a 1¼-inch finishing nail to socket center shield. The ground lead is an 8-inch lead with an alligator clip on one end and the other end soldered to the tube shield.

To adjust the probe, connect it to the video detector of a TV set known to be working properly. Set scope to view composite video signal. Adjust padder so vertical and horizontal sync pulses are the same height. *Reset the compensating capacitor if probe is used with a scope other than the one for which it was compensated.*

The compensated probe attenuates the signal by as much as 10 to 1 so it should not be used in applications where full sensitivity rather than wide-band response is required.

Special components are: 1—tube socket (27-6226), 1—capacitor, 7-45 µf (31-6480-3), 2—tube shield (56-5629-FA3), 1—resistor (66-5104340), and 1—resistor (66-4109340).—Philco Serviceman

FINDING LEAD-IN BREAK

Long TV lead-ins often develop close-gap breaks which affect the performance of the receiver. Since the wire usually breaks while leaving the insulation intact, it is often more economical to replace the line than to spend the time required to locate the breaks by carefully going over every inch of line.

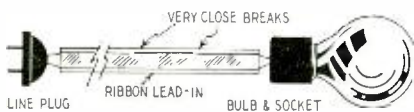

Breaks are easy to locate if you put a standard a.c. line plug on one end of the line and a socket and 115-volt bulb on the other. When you insert the plug into the power line, the current will jump across the gaps and develop enough heat to burn the plastic insulation. The break can then be spotted by inspection. The breaks should be cleaned, soldered, and taped to restore normal service.—*Alfred Huntington*

BANDSPREAD CAPACITORS

If you are building a communications receiver and are wondering what to use as a bandspread capacitor, try using an FM tuning capacitor. These have capacitance ranges which are just right for bandspreading. They are available in two- and three-gang types which are less expensive than other ganged capacitors of similar size and construction.—*Charles Erwin Cohn*

STRIPPED SCREW HOLES

The next time you have trouble tightening the back on a receiver cabinet because the wood-screw holes are stripped, slip a small piece of small-diameter rosin-core solder into each hole before inserting the screws. The original screws will usually hold securely. This method eliminates the possibility of splitting the wood with a larger screw.—*Westinghouse Service Hints*

LOCATOR FOR OPEN HEATERS

An open heater in a series string is easy to locate with a tester made by connecting a set of test prods to a 10-watt, 115-volt lamp. Touch the prods to the heater pins of each tube. The lamp lights when it is across the open heater.—*Manuel E. Silva*

—end—



"Aha—Now I see a tall dark man in a convertible"

OCTOBER, 1951

RIGHT!

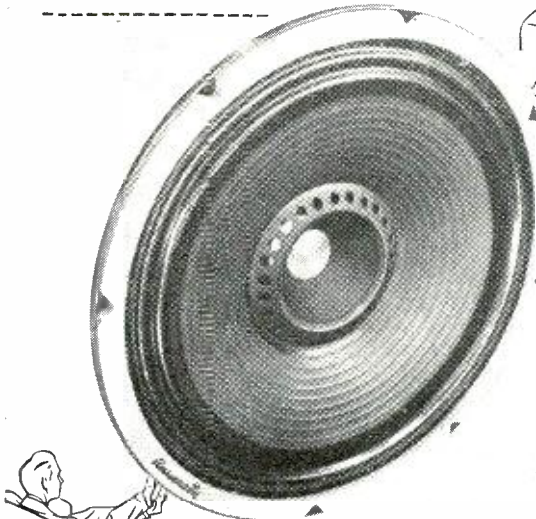

— from any angle

A challenging answer to low cost, wide-angle high fidelity reproduction. Diffusicone-12 is a newly engineered speaker with exclusive dual concentric cone design, which diffuses the normally beam-like high frequencies. Results in exceptionally uniform response . . . assures full range reception over the entire listening area.



Write today for Bulletin 62N73 — address inquiries to Desk 69.



THE NEW

University DIFFUSICONE-12

An Engineering Achievement of UNIVERSITY LOUDSPEAKERS INC. 80 So. Kensico Ave., White Plains, New York

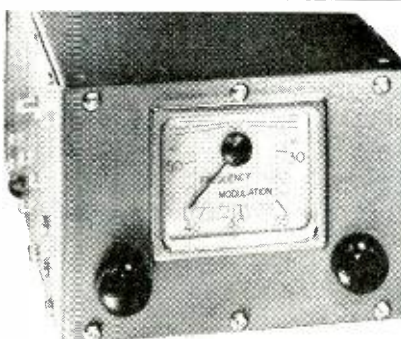

Model
M-51
\$72.50

for emergency communications

USED BY HUNDREDS OF MUNICIPALITIES FROM BOSTON, MASS., TO ALHAMBRA, CAL.

POLICeALARM MONITORADIO

5 Models For All Systems

6 VOLT MOBILE

M-51

Tunable 30-50 MC

M-101

Tunable 152-163 MC

RCC-1

Fixed Frequency in both bands

115 VOLT AC-DC

PR-31

Tunable 30-50 MC

PR-8

Tunable 152-163 MC

AIRCRAFT

AR-1

AM Tunable 108-132 MC

115 Volt AC-DC

Says S. L. Grant, City Manager, Winchester, Virginia . . .

"I think you have a receiver that is well built, and I see no reason why it should not be in demand by all public works departments that have a transmitter available."



Users of FM 2-Way Radio Communications equipment throughout the entire nation, find Polic-Alarm and Monitoradio a welcome innovation to low-cost mobile communications radio .

For Complete Information: See Your Jobber—Or Write Us Today

RADIO APPARATUS CORPORATION

55 N. NEW JERSEY ST., INDIANAPOLIS 4, IND., PHONE: ATLANTIC 1624

**Replace Your Old TV Aerial
With The NEW Snyder
360° MOTORLESS
TV AERIAL**

**SAME CLEAR PIX
AS MOTOR ROTAT-
ING AERIAL SYS-
TEMS COSTING
TRIPLE THIS PRICE!**

Only \$10.35
*Less
Must*

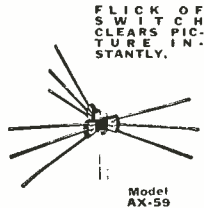

Electronically beams in complete 360° rotation to give clear picture on all channels. You choose direction with Directronic selector switch, mounted on or near TV set. Complete with 9 hi-tensil 3/8" aluminum alloy elements 75 ft. of 3 conductor cable, and beam selector switch.

**ORDER STACKED ARRAY MODEL AX-599
FOR ULTRA FRINGE AREAS**

Electronically rotates 360° same as above. 18 elements. Complete with 75 ft. of 3 conductor cable and beam selector switch. **\$16.95**
Less Must

STEEL MAST SECTIONS weather treated.	
10 Ft. 1/2" di.	\$2.19
5 Ft. 1/4" di. crimped end	1.35
Chimney Mount Brackets CM-100	1.59
Wall Mount Brackets WB-2. Adj. to 18"	
Heavy Duty	3.75

Order from Dept. RE-10 or call Mulberry 2134
WRITE FOR FREE F.Y.I. BULLETIN

**WHOLESALE
RADIO PARTS CO., Inc.**
311 W. Baltimore St.
BALTIMORE 1, MD.

LEARN

**Television
-Radio
OR
Electricity**
IN THE GREAT SHOPS OF **COYNE**



**TRAIN QUICKLY!
OLDEST, BEST EQUIPPED
SCHOOL OF ITS KIND IN U.S.
Young and Older Men**

Come to the Great Shops of Coyne in Chicago. Get practical training in TELEVISION-RADIO or ELECTRICITY — vital in Defense Program. Prepare now for a better job or better service rating.

START NOW — PAY LATER

You can finance most of your tuition, pay for it later in easy monthly payments. Special plan for men of Draft Age. Part time employment service available. **GI APPROVED**

FREE BOOK Clip coupon for Big Free Illustrated Book. Indicate below, course that interests you. No salesman will call. Act NOW.

An Institution not for Profit

B. W. COOKE, Pres.
COYNE Electrical & Television-Radio School,
500 S. Paulina St., Chicago 12, Ill. Dept. 71-81H
Send FREE BOOK and full details on:

TELEVISION-RADIO ELECTRICITY

NAME.....

ADDRESS.....

CITY..... STATE.....

ADDING CARBON MIKE TO HI-IMPEDANCE PA INPUT

? I have a surplus T-32, desk microphone which I would like to use with my PA system which has two high-impedance input circuits. The input circuits use 6J7's with their cathodes grounded and the grids biased with Mallory bias cells. Please prepare a diagram showing how I can add a parallel input circuit or replace one of the present circuits so I can use the T-32.—J. L. C., Petal, Miss.

A. The diagram shows how a carbon microphone can be added to an amplifier having a high-impedance input circuit like that shown. Add parts shown at left of circuit, and connected to the input by dashed lines. You can mount the input transformer close to the input jack or grid of the tube.

If cathode bias is used on the output stage, you can use the voltage across the cathode resistor to supply current for the microphone. If the voltage on the cathode does not exceed 8 volts, connect the lead from the primary of

the transformer directly to the cathode of one of the tubes. If the cathode voltage is higher, replace the present cathode resistor with a wire-wound adjustable resistor having the same resistance and wattage rating. Connect the

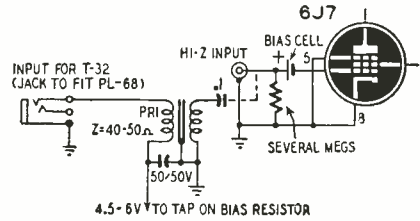

transformer lead to the tap and adjust the tap for 3 to 8 volts. Use the lowest voltage that will produce the required output without overloading the input stage.

The T-32 has a resistance of 40 ohms. The transformer should be designed to match a 40-50-ohm microphone or line to a high-impedance grid circuit.

RC-2 AMPLIFIER MODIFIED FOR PA USE

? I am enclosing the diagram of my Radio Craftmen model RC-2 amplifier.

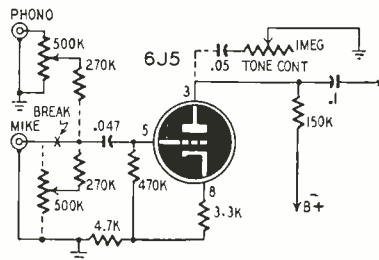

I want to use it on PA jobs. I have enough gain for a crystal microphone or pickup, but I can't use the unit because it does not have a volume control. Please show how I can add a simple mixer for microphone and phono and a simple, high-cut type of tone control.—L. F., Onarga, Ill.

A. The diagram shows the input circuit of your amplifier. Add those components which are shown connected to the main circuit by dashed lines. Break the input circuit at the point indicated.

CORNER SPEAKER CABINET CONSTRUCTION DATA

? Can you supply construction data on a corner-type speaker enclosure for a pair of 12-inch woofers and a multi-cell tweeter. The cabinet should be of the bass-reflex type. Can I use 1/2-inch lumber for constructing the cabinet?—E. O. C., Mamaroneck, N. Y.

A. The enclosure shown in the diagram was made available to us through University Loudspeakers, Inc. It is designed for a tweeter and a pair of 12- or 15-inch woofers.

The openings for the speakers are determined by the speakers which you have. Average openings are 10 1/2 and 13 1/2 inches for 12- and 15-inch speakers, respectively. The port should be fairly large—56 to 64 square inches—to facilitate tuning the enclosure. The best lumber for the job is plywood at least 3/4 inch thick. Reinforce the corners with corner blocks and use screws and glue in the final assembly.

The port must be tuned to match the resonant frequency of the enclosure to that of the speaker. Connect a 100-ohm noninductive resistor in series with one of the leads between the output transformer and the crossover network, or between the amplifier and voice coil

in a single-speaker system. Connect a variable-frequency a.f. oscillator to the input of the amplifier and feed in a signal.

Adjust the controls for 2 volts on a v.t.v.m. or a.c. voltmeter across the input to the crossover network or voice coil. Plot the voltage readings as the frequency is varied from about 20 to 200 cycles. The voltage will peak at two frequencies. If the peaks are unequal, place a movable plywood panel behind the port and vary the port area until the peaks are of equal amplitude.

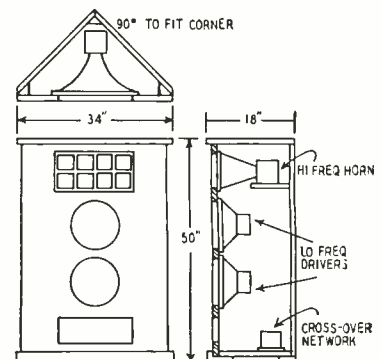

GE THYRATRON FG-105



Brand New MERCURY RECTIFIER

Individually boxed in factory sealed cartons. List Price \$60.00. Your cost... **\$18.95** each
While They Last!
For continuous rectifier and welder control service. Tetrode type, indirectly heated cathode; 10000 V peak, 10000 V peak inverse, Av. Max. current 6-4 amps continuous; 2.4 to 4 amps welder control service.

1B3	1.25	6K8	1.25	12SK7	.88
1H5GT	.99	6L6G	1.75	12SL7	.95
1LA4	1.12	6L6M	2.65	12SN7	1.25
1LA6	1.20	6Q7	.65	12SQ7	1.10
1LB4	1.22	6SA7	1.10	12SR7	.90
1LC5	1.05	6SC7	1.10	12Z3	.85
1LC6	1.15	6SF5GT	.90	14A7	1.05
1LD5	1.22	6SF7	.95	14B6	1.05
1LE3	1.15	6SG7	.85	14F8	1.10
1LG5	1.10	6SJ7	1.00	14F7	1.05
1LM4	1.45	5SK7	.85	14J7	1.10
1LN5	1.22	6SL7GT	1.15	14M7	1.05
1NSGT	1.20	6SN7GT	1.45	14N7	1.10
1Q5GT	1.15	6SQ7	.80	14Q7	1.00
1R5	.95	6SS7	.85	14R7	1.05
1S4	.95	5T8	1.25	19	.85
1S5	.95	6VAGT	1.05	24A	.79
1T4	.95	6W4	1.05	25L6	.90
1T5GT	1.15	6X5	.75	25Z5	.85
1U4	.95	6Y6G	1.10	25Z6GT	1.00
1V	.75	/A4/XXL	1.05	26	.59
2A3	1.45	7A5	1.05	27	.59
2A5	.95	7A6	1.05	28D7	.90
2A6	.75	7A7	1.05	30	.75
2A7	.75	7A8	1.05	31	.65
2B7	.95	7B4	1.05	32	.75
2X2A	.88	7B5	1.05	33	.79
3Q5GT	1.15	7B6	1.05	34	.89
3S4	.90	7B7	1.05	35 51	.75
3V4	.90	/B8	1.05	35A5	.90
5T4	1.45	7C4	1.05	35B5	1.00
5U4G	.75	7C5	1.05	35C5	1.05
5Y4G	1.65	7C6	1.10	35L6	1.10
5W4	.95	7C7	1.00	35W4	1.00
5X4G	1.10	7E8	1.00	35Y4	.95
5Y3GT	.75	7E7	1.00	35Z3	.88
5Y4G	.75	7F7	1.00	35V4	.75
5Z3	.95	/F8	1.75	35Z5	.95
5Z4	1.15	7H7	1.40	36	.65
6A3	1.25	7K7	1.10	37	.65
6A6	1.15	7L7	1.10	38	.65
6A7	1.05	7M7	1.25	39 44	.65
6A8	1.10	7Q7	1.00	41	.75
6AC5GT	1.35	7Y4	.89	42	.82
6AC7	1.35	7Y4	.89	43	.75
6AG5	1.25	117L7	1.45	45	.85
6AH6	1.65	117N7	1.45	46	.85
6AJ5	1.65	117P7	1.45	47	.95
6AK5	1.65	117Z6	.85	48	2.25
6AK6	1.25	117Z6	1.05	49	.95
6AL5	.90	12A	.85	50A5	1.00
6AL7	1.60	12A6	.70	50B5	1.15
6AQ5	1.15	12A8GT	.95	50C5	1.10
6AT6	.99	12AH7GT	1.25	50L6	1.00
6AU6	.90	12AT6	1.00	50Y6	1.25
6AV6	1.00	12AT7	1.45	53	1.05
6BA6	1.00	12AU6	1.20	56	.70
6BE6	1.00	12AU7	1.20	57	.85
6BC6G	2.20	12AV6	1.05	58	.85
6BH6	1.05	12AW6	1.75	59	1.05
6C4	.95	12BA6	.95	70L7	1.10
6C6	.85	12B6	.95	71A	.85
6D6	.85	12J7	.95	75	.85
6E5	.95	12K7	.95	76	.85
6F5	.70	12K8	1.00	77	.85
6F6	1.05	12Q7	.75	78	.85
6F6G7	.95	12S7	.95	80	1.05
6J5	.70	12SC7	1.25	82	1.10
6J6	1.25	12SF7	.85	83	1.25
6J7	1.05	12SG7	.90	83V	1.15
6K6	.85	12SH7	.95	34 LJ4	.90
6K7	.80	12SJ7	.95	85	.95

WILLARD 2-VOLT STORAGE BATTERY
Exact replacement for GE Portables for I.B.-500— **\$2.69**
BRAND NEW, Each.

WILLARD MIDGET 6-V STORAGE BATTERY
3 amp hour rating. Transparent plastic case. Brand new, 3 3/8" x 1 13/16" x 2 3/8" high. Uses standard electrolyte. **\$2.65**
Each.

ONE-QUART BOTTLE BATTERY ELECTROLYTE
Made by Willard, for above storage batteries. 1 quart sufficient for two 2-volt cells. Hermetically sealed. SPECIAL. **\$1.45**
per qt. bottle.

7-PRONG 2-VOLT RADIO VIBRATOR
for Portable and Farm Sets Replacement for GE I.B. 530 **\$1.95**

Please include 25% Deposit with order—Balance C.O.D. MINIMUM ORDER \$3.00. All Shipments F.O.B. Our Warehouse, N.Y.C.

G & G SERVICE MAJESTIC
RADIO PARTS SERVICE
53 VESEY STREET - NEW YORK 7, N.Y.

HARD-TO-FIND COMPONENTS

? An audio-frequency choke rated at 1,080 henries was specified as the plate load for a 6SJ7 regenerative detector in a recent article ("3-Tube Receiver For Wired Radio" in the December, 1950, issue). Most radio parts dealers either tell me that I am crazy or they try to sell me a r.f. choke rated in millihenries or a standard filter choke. I have also seen a number of diagrams which have a selenium rectifier working out of a small isolation transformer. Whenever I try to purchase one of these for a small power supply, some jerk tries to sell me a transformer costing more than \$10. Can you give me the manufacturer's name and stock number on suitable a.f. chokes and isolation transformers?—F. R., Vicksburg, Miss.

A. High-inductance (1,000 henries or more) audio chokes have been rather scarce for the last few years, but you may be able to find one still on the shelf of some dealer. You will probably have better luck if you ask for a Stancor type C-2300. Thordarson type T20C50, or any choke having an inductance of approximately 250 henries or more when the current through it is 5 ma or more. You can also use the secondary of an interstage a.f. transformer or you can connect the primary and secondary in series.

Jobbers are just beginning to stock small, half-wave type 117-volt power transformers, but you can obtain them in several brands. Among them are the Merit P-3345 (120 volts, 50 ma, and 6.3 volts, 1.5 amp.), Thordarson T-22R12 (120 volts, 75 ma, and 6.3 volts, 1.5 amp.), Stancor PS8415 (125 volts, 15 ma, and 6.3 volts, 0.6 amp.), and Triad N-51X (115 volts, 3.25 amp. approx.) These are actually more satisfactory than straight isolation transformers, which are hard to get in the low- or medium-price range.

If you cannot find any of these transformers, you can connect two duplicate filament transformers back-to-back as an isolation transformer.

ADDING A RECORD PLAYER

? Please print a diagram showing how I can connect a record player to a Zenith 8G005 Transoceanic portable receiver.—A. G., New York, N. Y.

A. It is comparatively simple to add a crystal pickup to your receiver. If you do not care to add a phono-radio switch, merely connect the pickup across the outside terminals of the volume control. If you want to do a real job, add a

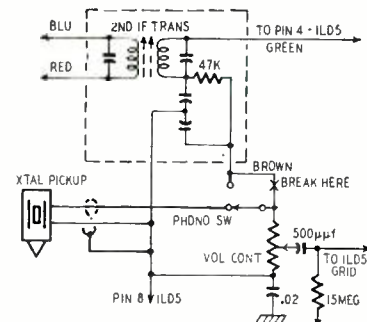

ARMY - NAVY - AIR FORCE - MARINES Here's Help!

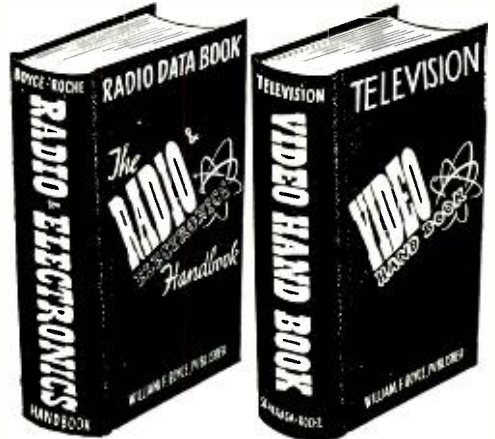

GET AHEAD FASTER IN RADIO TELEVISION ELECTRONICS

TWO great books assist you in every operation in radio, television and electronics. Give you the fundamentals, complete ground work, understanding of all types of radio, television, electronic gear and their circuits, including theory of operation.

Show you expert methods of planning, building, installing, operating, testing, adjusting, and servicing. The know-how of radio, television and electronics presented in plain language and simple terms with easy to understand pictures and working diagrams.

You get 1800 pages of basic knowledge, methods and data of radio, television, electronics completely illustrated with over 2000 pictures, drawings, codes, charts and graphs. Written by the Boyce-Roche experts who make electronic manuals for the U. S. Signal Corps.

SPECIAL OFFER - Save Two Dollars

Send for both books together and get them at the special combination price of only \$12.00!

RADIO & ELECTRONICS HANDBOOK provides instruction and reference on fundamentals, parts, tubes, circuit elements, receivers, transmitters, amplifier systems, power supplies, antennas, meters, test equipment, and accessories, with complete Data Section.....\$7.00

VIDEO HANDBOOK teaches television and provides complete handbook reference on all phases with full sections on principles of television, receivers, antennas, test equipment, servicing, pattern interpretation, transmitters, show production and more.....\$7.00

SEND NO MONEY - 10-DAY FREE EXAMINATION COUPON (Good only while special combination offer lasts.)

BOYCE-ROCHE BOOK CO. CALDWELL 50, NEW JERSEY

Send () Both books together @ \$12.00
() Radio & Electronics Handbook @ \$7.00
() Video Handbook @ \$7.00

In ten days I will send you price plus postage or I will return book(s) postpaid. (Offer good only in U. S.)
Name.....
Address.....
City, Zone, State.....
Employed by.....
SAVE POSTAGE. We pay postage if you enclose full price now. Money back on same return privilege.

RADIO AND ELECTRONIC MANUFACTURERS

- ★ INCREASE YOUR SALES
- ★ EXPORT YOUR PRODUCTS

We can export your Radio and Electronic merchandise and handle all details.



Call or write us for information

JAMIN INTERNATIONAL CO.

Importers & Exporters

50 Broad Street

New York 4, N. Y.

HAover 2-4196

Trained men always welcome in RADIO • TV • ELECTRONICS

CREI trains you for better jobs, higher pay—in minimum time!

Industry approves CREI by (1) welcoming our graduates, and (2) using CREI training for their technicians (e.g., RCA-Victor Division, United Air Lines, Sears Roebuck). Win your lifetime career with CREI Residence School training in historic Washington, D.C. Average time required: 22 months.

SEND FOR ILLUSTRATED FREE CATALOG

Get your copy of new descriptive catalog, with survey of opportunities, and details of course and school. New classes start twice a month. Act now!

CAPITOL RADIO ENGINEERING INSTITUTE

An Accredited Technical Institute Founded in 1927
Dept. 3010C, 16th & Park Rd., N.W., Wash. 10, D.C.

\$52,000.00 AVAILABLE

TO BUY NEEDED SURPLUS ELECTRONIC EQUIPMENT

Top Dollar Paid! Send description, condition and asking price. Prompt replies!

URGENT! NEEDED AT ONCE: BC-611 or BC-721 Handie-Talkies. Complete units or parts.

WEST REGION ELECTRONICS
1437 S. Norton Ave., Los Angeles 19, Calif.

HUGO GERNSBACK'S

GREAT SCIENCE FICTION NOVEL IS MUST READING

Listen: "NO BOOK in two generations, no book since Jules Verne, has undertaken to do what Hugo Gernsback in the first decade of our century has here so outstandingly achieved."

LEE DE FOREST, Father of Radio.

Forty years ago, Hugo Gernsback, Father of Modern Science Fiction, in this book, **RALPH 124C 41+**, predicted and described in startling detail, radar, the learn while you sleep method, television, televised operas, plastics, night baseball, blood transfusion, wire recording, micro film and a host of other scientific achievements—all undreamed of in 1911—but part of everyday life today.

All of these and scores more, not as yet realized, are found in his remarkable prophetic book. For Hugo Gernsback's prophesies are based not on

fantasy but on the logical projections of established scientific facts.

RALPH 124C 41+ is the first and most remarkable true science fiction novel ever written! A whacking good adventure story that takes place in 2660 AD—but it is far more than fiction!

To technically minded people, **RALPH 124C 41+** is the most complete and accurately documented catalog of scientific prophesy ever published. It was originally written in 1911 and published in book form in 1925. Now, because of its tremendous importance as a work of accurate, scientific prediction of the future, it has been reissued in a new, second edition.

Hugo Gernsback's writings were the spark that started many of today's top radio engineers and scientists on their way. Now again, this new edition of **RALPH 124C 41+** may well be the inspiration for a new generation of pioneers of science.

RALPH 124C 41+ is the kind of book you should read. Order your copy now, only \$2.50 postpaid. The supply is limited.

RADIO PUBLICATIONS

25 West Broadway New York 7, N. Y.

MAIL THIS COUPON TODAY

RADIO PUBLICATIONS

25 West Broadway, New York 7, N. Y.

Gentlemen:

Send me a copy of **RALPH 124C 41+** postpaid, at once. My remittance of \$2.50 is enclosed.

NAME

STREET

CITY.....ZONE...STATE.....



phono input jack and change-over switch. The diagram shows the input to the first a.f. amplifier. To connect the phono-radio switch, break the circuit at the point shown and insert the switch and phono input leads as shown by heavy circuit lines.

UNUSUAL TV TROUBLE

? *Recently I tapped our TV lead-in and ran a length of transmission line to the FM receiver. The extension lead was fitted with an insulated plug so it could be disconnected when the TV set is in use.*

When tried, the FM reception was excellent and the TV picture normal. When I pulled the plug to disconnect the lead from the FM set, the volume on channel 4 dropped to a whisper. Performance on other channels was normal. Can you explain the cause of this peculiar condition and tell me how to remedy it?—D. C., Cleveland Heights, Ohio

A. From the information you have given, we conclude that your extension

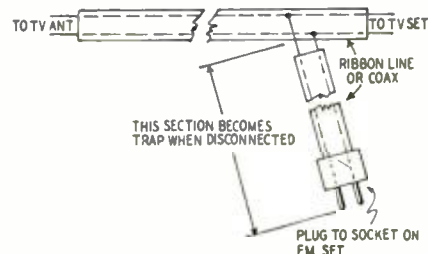

from the lead-in to the plug at the FM set is an odd multiple of a quarter wavelength long at approximately 71 mc. Thus, when the plug is disconnected from the set, you have in effect a one-quarter wavelength open stub across the TV lead-in. Such a trap has a very low impedance at its resonant frequency. The drawing shows the condition as we visualize it.

Try shorting the pins of the plug together. If this clears up the trouble, get a matching socket and tie its terminals together. Use this to short-circuit the line when the FM set is not used.

V-BEAM TV ANTENNA

? *I am interested in erecting the V-beam antenna described on page 36 of the July, 1951, issue, but before I do, I want to know if two boosters are absolutely necessary. If I can get away with a single booster, shall I put it at the set or at the antenna?—H.A.M., Sheboygan, Wis.*

A. According to the author, he uses the booster at the antenna to compensate for the loss produced by the mismatch between the 800-ohm antenna and the 300-ohm transmission line. You can probably obtain comparable results by substituting a quarter-wavelength matching stub for the booster at the antenna. The stub should be 13 3/4 inches long. It may be made from No. 12 wire spaced 2 1/2 inches center to center. Connect one end of the stub to the antenna terminals and the other to the 300-ohm lead-in. Use a booster between the lead-in and receiver in fringe areas or when trying for dx stations.

—end—

STAN-BURN SPARKS

**CONDENSER SPECIALS
BY PASS—ALL GUARANTEED**

.001-400 Stan Burn .04	.002-600 Stan Burn .08
.01-600 Stan Burn .07	.005-600 Stan Burn .12
.02-600 Stan Burn .09	.005-600 Stan Burn .59
.05-600 Stan Burn .10	1-600 Stan Burn .19
.001-600 Stan Burn .07	20x20-150 Stan Burn .49
.25-600 Stan Burn .15	40x40-150 Stan Burn .97
.005-200 Stan Burn .07	50x30-150 Stan Burn .59
.004-200 Stan Burn .07	40-150 Stan Burn .81

CHASSIS—630—K2—Famous make 129.50

CATHODE RAY TUBE SPECIALS

12LP4 \$19.95	17BP4A 27.00	
12LP4A 19.95	20CP4 39.95	
14BP4 19.95	G. E. TUBES	
16DP4A 26.00	19AP4A \$47.95	
16GP4 33.00	19DP4A 47.95	
16AP4A 39.00	24AP4A 83.20	
16RP4A 26.00	Single ion traps39	
	Double ion traps59	

SPEAKER SPECIALS

4" P.M. \$1.64	4x6 P.M. 2.19
5" P.M. 1.75	6x9 3.73
6" P.M. 2.41	5x7 3.43
8" P.M. 3.41	10" P.M. 5.48
12" P.M. 6.33	

ANTENNAS

Conicals, less mast \$ 2.98
Circle X, less mast 2.98
Double V, less mast 2.98
Chimney Mounts—1-1295
12 or more 2.98
100 ft. roll strapping03
Mast standoffs 1.59
10 ft. masts, each 1.49
12 or more, each 1.97
55 mil. 300 ohm wire white or black, 1000 ft.

We carry a complete line of popular makes of Radio and TV tubes, at 50% discount. Also many other special purpose and transmitting types, and all electronic parts and equipment at lowest prices. Send us a list of your requests for quantities and prices. Terms: 20% with order. Balance C.O.D. All prices FOB, New York Warehouse. Minimum order \$5.00. Write for our latest price list to Dept. RE-10.

STAN-BURN RADIO and ELECTRONICS CO.
(C.S.S. THEATRE BLDG.)
1697 BROADWAY • NEW YORK 19, N.Y.

IF YOU BUY ON SPECIFICATIONS



and tops in value, you'll buy the

TWIN-TRAX* TAPE RECORDER
"Choice of Engineers Everywhere"

Compare the guaranteed specifications of a Twin-Trax Tape Recorder with any other recorder in any price class. You'll find that Twin-Trax gives you more features, better all-around performance and more value for your money. Complete specifications, performance ratings and direct factory prices in our catalog 5109. Send for it today.

*Trademark Reg.
AMPLIFIER CORP. of AMERICA
398 Broadway, New York 13, N. Y.

TELEVISION RECEIVER—\$1.00
Complete instructions for building your own television receiver. 16 pages—11"x17" of pictures, pictorial diagrams, clarified schematics. 17"x22" complete schematic diagram & chassis layout. Also booklet of alignment instructions, voltage & resistance tables and troubleshooting hints.—All for \$1.00. Write for free catalogue.
CERTIFIED TELEVISION LABORATORIES
Dept. C, 5507-13th Ave., Brooklyn 19, N. Y.

ELECTRONIC LITERATURE

Any or all of these catalogs, bulletins, or periodicals are available to you on request direct to the manufacturers, whose addresses are listed at the end of each item. Use your letterhead—do not use postcards. To facilitate identification, mention the issue and page of RADIO-ELECTRONICS on which the item appears. All literature offers void after six months.

SOLDERING GUIDE

A 16-page booklet, National Bureau of Standards Circular 492, discusses compositions used and procedures followed in soldering. Available from U. S. Government Printing Office, Washington 25, D. C. Fifteen cents.

TRANSFORMER CATALOG

Standard Transformer Corp.'s mid-year catalog lists the complete Stancor line. Illustrations show each mounting type in detail. Available from the Standard Transformer Corp., 3580 Elston Ave., Chicago, Ill. Gratis.

MAGNETIC TAPE BOOKLET

An illustrated booklet, Form 2J8024, describing new magnetic tape recording equipment for professional broadcast use, is being released by RCA. Available to broadcast engineers requesting it on letterhead from Engineering Products Dept., RCA, Camden, N. J. Gratis.

SOLDER CATALOG

A 36-page booklet being distributed by Federated Metals lists types, applications, and distribution of solders. Available from Federated Metals Division, American Smelting and Refining Co., 120 Broadway, New York 5, N. Y. Gratis.

PARABOLIC ANTENNAS

The parabolic antennas of The Workshop Associates are listed in their new catalog. Photos and specifications are included. Available from The Workshop Associates, Division of the Gabriel Co., 135 Crescent Road, Needham Heights 91, Mass. Gratis.

VIBRATOR REPLACEMENT GUIDE

This guide has just been published and covers the complete line of vibrators plus other cross-reference information. Available from distributors or by writing the James Vibrapowr Co., 4036 N. Rockwell Ave., Chicago 18, Ill. Gratis.

ASTATIC CATALOG

General catalog No. 51 has been released by the Astatic Corporation. An up-to-date price list is included. Available from the Astatic Corp., Conneaut, Ohio. Gratis.

MANUALS AND TEXTS

The spring, 1951, catalog of John F. Rider includes a complete listing of the company's texts and manuals. Available from John F. Rider Publisher, Inc., 480 Canal St., New York 13, N. Y. Gratis.

TRAIN FOR TELEVISION

in 3 easy steps!



ONLY \$1550
for the complete training (all 3 books)

5 Months to Pay!
...pay while you learn



These three really great books make it easy for you to train for television—at absolute minimum cost. No lessons to wait for! No wasted time! Read singly, each book is an authentic, easy-to-understand guide to an essential phase of modern TV. Add all three together and you have a specialized training that can help you win better pay, a bigger job or even a business of your own in the fastest-growing industry of all!

The famous
RINEHART TV LIBRARY

1—FREQUENCY MODULATION

This great, 448-page book with over 300 illustrations provides up-to-the-minute training in the circuit system by which TV sound is transmitted. You learn all about FM theory, circuits, transmitters, receivers, mobile units, tuning indicators, antennas, test equipment, alignment, service, etc. Price \$5.00 separately.

2—TELEVISION SERVICING

After studying this great book, you'll find even the most puzzling TV service problems greatly simplified. You'll work better, faster—more profitably! Actual service case histories make things amazingly clear. Illustrations explain details step by step. Subjects range from testing, repair and component replacements, antennas, testing, improving picture linearity to fringe area reception, vital service data, and many others. Price \$4.00 when purchased separately.

3—TELEVISION ENGINEERING

This 700-page book can help guide you to good pay in manufacturing, lab or broadcast studio work and other advanced phases of TV. Includes transmission fundamentals, a full explanation of the cathode ray tube, TV camera chains, telecasting techniques, lenses, oscilloscopes, synchronizing generators, video amplifiers, power supplies and many more. Contains 385 helpful illustrations. Price \$7.50 separately.

YOU CAN'T LOSE on this offer!
Read this famous RINEHART TV LIBRARY for 10 full days before you decide! Bought singly, these 3 fact-packed books cost \$16.50. Under this offer you save \$1 and have the privilege of paying in easy monthly installments while you use the books. Use coupon!

10-DAY FREE EXAMINATION

Dept. RE-101, RINEHART BOOKS, INC., Technical Division, 232 Madison Ave., New York 16, N. Y.

Send me the famous RINEHART TV LIBRARY (3 books) for 10-DAY FREE EXAMINATION. If the books are not what I want, I will return them postpaid in good condition at the end of 10 days without any further obligation on my part. If I decide to keep them, I will then enclose \$3.50 as my first payment and will send you \$3 a month for 4 months until the total special price of \$15.50 is paid.

NOTE: Any of these books may be bought separately at prices indicated for each.

Name

Address

City, Zone, State

Your employer

**WHERE HEAVY DUTY PERFORMANCE COUNTS,
INSTALL PENN TV
ANTENNA MOUNTS...**

**UNIVERSAL BASE
MOUNT BMA-138**

Built for heavy duty flat roof installations, mount secures masts from 1" to 2" with exclusive locking bearing. Special tongue supports base for mast. Complete with cadmium plated nuts and bolts.

Write today for full information on the Penn TV Products line.

PENN TELEVISION PRODUCTS CO.
3336-38-40 Frankford Ave., Phila. 34, Pa.

Every RADIOMAN can use these SERVICE HINTS!

Valuable Manual Yours—FREE Write today—no obligation.

FEILER ENGINEERING CO. Dept. 10RC11
8026 N. Monticello Ave., Skokie, Ill (Suburb of Chicago)

Every page of "How to Simplify Radio Repairs" is packed with on-the-bench, practical ideas.

ON-THE SPOT BATTERY RECORDER

WALKIE-RECORDALL 8 lb. miniature BATTERY RECORDER-PLAYBACK

Continuous, permanent, accurate, indexed recording at only 5¢ per hr. Instantaneous, permanent playback. Picks up sound up to 600 ft. Records conferences, lectures, dictation, 2-way phone & sales talks, while walking, riding or flying. Records in closed briefcase with "sho-lon-mike". Write for details.

MILES REPRODUCER CO., INC.
812 BROADWAY Dep't RE10 NEW YORK 3, N. Y.

TUBE SHORT TESTER

A new dodge in circuit checking for the layman appears in this little short and open tester for tubes, which is advertised for sale to television set owners.

Circuitwise the device is an ordinary continuity tester to be plugged into the 117-volt circuit. A 7-watt lamp is inserted in one side of the circuit and a pair of partly insulated test prods close the circuit when brought together, thus lighting the lamp.

The ingenious part of the system is the 38 cards supplied with it. These are partly perforated for the pins of the tube to be tested.

The tester uses 38 punched, coded cards.

On the bottom are pin numbers, with a tabulation of pins which should show continuity. If the lamp lights between any other pairs of pins, a short is indicated.

While the largest source of trouble in television receivers is tubes, it must be noted that the television set owner will run into certain difficulties in attempting to use it. Even the service technician has been known to have trouble getting miniatures out of (and back into!) certain sockets in some TV receivers. And every service technician knows that a large portion of the trouble-causing tubes are neither shorted nor open.

**TUBES Price - Slashed!
Receiving & Transmitting**

RMA Guaranteed—All Standard Brands			GENUINE MOLDED CONDENSERS		ELECTROLYTIC CONDENSERS	
			Fresh Stock—All Mineral Oil Filled—100% Centigrade—Meets Jan. C91 Tests All 600 Vals		All Guaranteed Fresh Stock!	
3EP1	\$ 5.39	024 S .59	7C4/1203A	.89		
3HP7	3.49	1R5 .89	12A7	1.19		
5FP14	16.99	5U4 .79	12AU7	1.19		
78P7	7.89	5V4 1.39	12BH7	1.19		
7CP1	12.49	5Y3 .49	12SA7	.79		
803	2.49	6AC7 1.29	12SK7	.79		
805	2.99	6AG5 1.29	12SQ7	.69		
885	1.29	6AL5 .79	35A5	.98		
905	2.29	6AU6 .79	35L6	.89		
954	.29	6BC5 .89	35W4	.69		
1624	1.49	6BG6 1.89	35Y4	.89		
1629	.35	6BN6 1.39	35Z5	.59		
7193	.29	6BQ6 1.59	50A5	.98		
8020	1.25	6K7 .59	50B5	.98		
GL471A	2.75	6SA7 .69	50L6	.75		
		6S7 1.09				
		6V6 .89				

Special Sale! 630 SUPER CHASSIS
30-Tubes—Licensed by RCA

High efficiency high voltage circuit
For all picture tubes up to 24"
Keed AGC • Automatic brightness control
Special extra high gain standard coil tuner
Complete, ready to play
Including all hardware & knobs

\$133.95 (less CRT)

FREE! Set of brackets for tube with any TV chassis!

630 DX Chassis—3 times normal reception—designed expressly for fringe areas. Needs no complicated booster or antenna.

\$149.95 (less CRT)

FREE: Write for catalog... tubes, parts and accessories for radio and TV. Also special electronic instruments catalog.

TV PICTURE TUBES
All Black Face

Brand New, Standard Brands, Sealed Cartons

10BP4	22.95	19AP4A	24.95
12LP4	22.95	20CP4	33.95
14BP4	22.95	24AP4	69.95
16GP4	29.95		
16HP4	31.95		
17BP4	24.95		

Minimum order \$5.00, in C.O.D. include postage with order. All merchandise subject to prior sale. E.O.B. New York, N. Y.

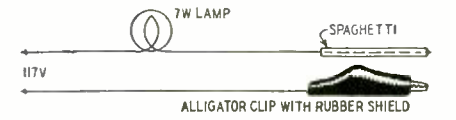

Simple schematic of the test device.

There is also the ever-present danger of electrocution from the 117-volt line. This last is very real, though guarded against to some extent by insulating the probe tips as far as practical, and advising caution.

However useful the device may be technically, it is a safe bet that it will be a breeder of good-will between set owner and television service technician. After trying to check the 20 or so tubes of a television receiver and replace them, the average set owner will realize that there is more to this business of television servicing than he had ever realized.

THE ROSE COMPANY

98 Park Place Dept. E10 New York 7, N. Y. Cortland 7-6195

THE FUND TOPS \$8,500.



HELP-FREDDIE-WALK FUND

It is with pleasure that we report the following collections made during the past month.

We trust now, with the advent of cooler weather, our readers will get behind the Help-Freddie-Walk Fund in earnest once more.

As most of our readers know by this time, little three-year-old Freddie is the son of the Arkansas radio technician, Herschel Thomason. Little Freddie was born completely without legs and arms and will be dependent all his life on mechanical appliances by which it is hoped that in time he will be able to become a useful citizen. This, of course, will run into a terrifically large amount of money, as you must realize. For this reason, please do not let up on your contributions. They are needed desperately. The fund has been doing well, but there is still a long way to go before Freddie's future is assured.

Please send your contributions from time to time—even the smallest donation will be greatly welcome.

Make all checks, money orders, etc., payable to Herschel Thomason. Please address all letters to:

Help-Freddie-Walk Fund
c/o RADIO-ELECTRONICS
25 West Broadway
New York 7, N. Y.

FAMILY CIRCLE CONTRIBUTIONS

Balance as of July 19, 1951.....	\$420.45
Juanita Addison—Washington, D. C.	3.25
G. G. Halley, Mgr. of the Dixie Home Store—Batesburg, S. C.....	1.00
Mr. & Mrs. W. Wallace Cashwell and Wolly Jr.—Tampa, Fla.....	2.00
Mrs. H. Losky—Brooklyn, N. Y.....	2.00
Jackie Martin—Glendale, Ohio.....	1.00
Jill Smalling—Philadelphia, Pa.....	5.00

FAMILY CIRCLE contributions received up to August 20, 1951.....\$434.70



Trains are fun to watch, but more fun to handle. Freddie needs arms. Please help.

OCTOBER, 1951

#630 TV PARTS...TOP QUALITY...LOW PRICES

FOR KIT BUILDERS, REPLACEMENTS AND EXPERIMENTERS

The following television parts list comprises all the components needed to build the famous #630 television chassis plus added features. PRICES UNLESS MARKED PER SET ARE PER ITEM. Parenthesis indicate amounts of parts needed in lots of two or over. THE PRICES SPEAK FOR THEMSELVES.

RCA FRONT END TUNER, compl. w/tubes	\$22.49	PUNCHED CHASSIS PAN, cadmium plated	\$4.87
STANDARD TURRET TUNER, com. w/tubes	22.49	630-KIT, screws, nuts, rivets, washers	1.69
ESCAPCHEON PLATE, for either tuner	1.69	HI VOLTAGE CAGE ASSEMBLY, complete	3.73
DUMONT INPUT TUNER, compl. w/tubes	22.49	VOLTAGE DIVIDER SHIELD & COVER,	1.79
COMPLETE SET OF KNOBS, incl. decals	1.34	ELECTROLYTIC COND. SUB-CHASSIS	.94
COMPLETE SET OF KNOBS, Gold incl. decals	2.49	SOUND DISCRIMINATOR SHIELD	.19
POWER TRANSFORMER, 295ma.	201T6	TUBE CRADLE BRACKET	.57
VERTICAL OUTPUT TRANS.	204T2	DEFLECTION YOKE BRACKET	.29
HORIZONTAL OUTPUT TRANS.	208T2	DEFLECTION YOKE MOUNTING HOOD	.59
VERTICAL BLOCKING TRANS.	211T1	FOCUS COIL BRACKETS	.49
HORIZONTAL OUTPUT TRANS.	211T3	CATHODE TRAP COIL SHIELD	.39
HORIZONTAL OUTPUT TRANS.	211T5	CHASSIS MOUNTING BRACKETS	.44
FOCUS COIL, 247 ohms	202D1	BRIGHTNESS & HOLD CONTROL BRACKET	.59
FOCUS COIL, 470 ohms	202D2	WIDTH CONTROL BRACKET	.16
DEFLECTION YOKE, 60°	201D1	TUNER SHAFT BRACKET	.17
DEFLECTION YOKE, 70°	206D1	TERMINAL STRIP KIT, set of 18	.59
SOUND DISCRIMINATOR TRANS.	203K1	CORONA TERMINALS & RING	.17
1st PIX I.F. TRANSFORMER	202K2	TUBE SHIELD & CLIP	.22
2nd PIX I.F. TRANSFORMER	202K3	MINIATURE WAFER SOCKET (10)	.07
1st & 2nd SOUND I.F. TRANS. (2)	201K1 ea.	MINIATURE MOLDED SOCKETS (2)	.12
HORIZONTAL DISCRIM. TRANS.	208T8	OCTAL WAFER SOCKETS (3)	.07
FILTER CHOKE, 62 ohms	202K4	CATHODE RAY TUBE SOCKET, 18" leads	.39
CATHODE TRAP COIL	201R1	HV KINESCOPE LEAD, with clip	.39
WIDTH CONTROL COIL	201R4	AMPHENOL CONNECTOR PLUGS, set of 2	.48
WIDTH CONTROL COIL	AGC	OVAL PM SPEAKER, 5" x 7"	2.49
WIDTH CONTROL COIL, keyed	201R5	8" PM SPEAKER, heavy alnico #5 magnet	3.97
HORIZONTAL LINEARITY COIL	202L1	12" PM SPEAKER, heavy alnico #5 magnet	6.94
HORIZONTAL LINEARITY COIL	202L2	SPEAKER CONNECTOR PLUGS, set of 2	.18
3rd & 4th PIX COILS, (2)	202L3	12 1/2" CRT MOUNTING BRACKET SET	1.96
FILAMENT CHOKES, (5)	203L1	16" CRT MOUNTING BRACKET SET	2.98
VIDEO PEAKING COIL	203L2	UNIVERSAL MTG. BRACKET SET, 12 1/2" to 20"	6.97
VIDEO PEAKING COIL	203L3	24" CRT MOUNTING BRACKET SET	6.97
VIDEO PEAKING COILS, (2)	203L4	PLASTIC RING, for insulating rim 16" CRT	1.97
VIDEO PEAKING COILS, (2)	203D1	PLASTIC SLEEVE, for insulating 16AP4	1.88
ION TRAP BEAM BENDER, (single)	203D3	PLASTIC SLEEVE, for insulating 16GP4	1.88
ION TRAP BEAM BENDER, (double)	203D3	PLASTIC RING, for insulating rim 17" CRT	2.04
AUDIO OUTPUT TRANSFORMER (6K6)		PLASTIC SLEEVE, for insulating 17CP4	1.92
HV RECTIFIER, SOCKET ASSEMBLY, single		PLASTIC RING, for insulating rim 19" CRT	2.08
HV RECTIFIER, SOCKET ASSEMBLY, double		PLASTIC SLEEVE, for insulating 19AP4	1.96
TV 6' LINE CORD, with both plugs		PLASTIC RING, for insulating rim 24" CRT	3.89
INTERLOCK SAFETY CONNECTOR (input)		PLASTIC SLEEVE, for insulating 24AP4	2.94

VARIABLE CONTROLS

PICTURE & SOUND, 10K ohms 1 meg. & switch	1.14
VERTICAL & HORIZ, 50K ohms 1 meg.	1.04
BRIGHTNESS CONTROL, 50K ohms	.44
HORIZ. CENTERING, wirewound, 20 ohms	.57
HEIGHT CONTROL, 2.5 megohm	.48
VERTICAL LINEARITY, 5000 ohms	.44
VERTICAL CENTERING, wirewound, 20 ohms	.96
FOCUS CONTROL, wirewound, 1500 ohms	.98
HORIZONTAL DRIVE, 20K ohms	.44

MICA CONDENSERS—85°C Operation

270 MMFD — 500 V.W. (7)	ea. .12
390 MMFD — 500 V.W.	.12
470 MMFD — 500 V.W.	.12
680 MMFD — 500 V.W.	.16
4700 MMFD — 500 V.W.	.29

ELECTROLYTIC CONDENSERS—85°C

40/10/80MFD — 450/450/150 VOLTS	1.37
40/40/10MFD — 450/450/450 VOLTS	1.49
80/50MFD — 450/50 VOLTS	1.49
40/10/10MFD — 450/450/350 VOLTS	1.37
20/80MFD — 450/350 VOLTS	1.49
250/1000MFD — 10/6 VOLTS	.98

TUBULAR CONDENSERS—85°C

.002 — 600V	.09	.005 — 400V (3)	ea. .07
.0025 — 600V (2)	ea. .09	.01 — 400V (5)	ea. .09
.004 — 600V	.11	.015 — 400V (2)	ea. .11
.005 — 600V	.11	.05 — 400V (5)	ea. .12
.01 — 600V (2)	ea. .12	.1 — 400V (2)	ea. .14
.05 — 600V (6)	ea. .15	.001 — 1000V	.14
.1 — 600V	.17	.004 — 1000V (2)	ea. .14
.25 — 400V (2)	ea. .21	.035 — 1000V	.18
		.05 — 1000V	.18

CERAMIC CONDENSERS

10 MMFD, 10% Tolerance	.12
51 MMFD, 10% Tolerance	.12
56 MMFD, 10% Tolerance	.12
82 MMFD, 10% Tolerance (2)	ea. .12
1200 MMFD, not less than rated capacity	.14
1500 MMFD, not less than rated capacity (21)	ea. .14
6800 MMFD, not less than rated capacity	.19

H.V. FILTER CONDENSERS—(Cartwheels)

10KV — 500 MMFD	.48
15KV — 500 MMFD	.67
20KV — 500 MMFD	.79

WIREWOUND RESISTORS

5000 ohms, 5 watts	.22
VOLTAGE DIVIDER, 1360/250 ohms	.74
VOLTAGE DIVIDER, 5300/2500 ohms	.89
VOLTAGE DIVIDER, 6750/12/93 ohms	.72

CARBON RESISTORS

1/2 WATT, 5% TOLERANCE, 10, 150(5), 390, 470, 5600, 10K(2), 18K, 680K(2), 820K OHMS, 1.2 & 1.5 MEG	ea. .09
1/2 WATT, 10% TOL., 3.3 39(3), 330, 560(3), 680, 1800, 2700(2), 3300, 4700, 6800(4), 8200(4), 10K(3), 22K, 27K(2), 47K, 56K, 100K(3), 150K, 270K, 470K(3) OHMS, 1(2), 2.2(2), 4.7, 6.8 MEG	ea. .07
1/2 WATT, 20% TOL., 100(2), 1000(9), 3300, 22K(3), 100K, 150K, 220K(2), 330K, 470K(3) OHMS, 1(3), 10 MEG	ea. .05
1 WATT, 5% TOL., 2.2, 39K, 47K OHMS	ea. .14
1 WATT, 10% TOL., 180, 3300, 4700(2), 10K(2), 18K, 22K, 27K, 39K OHMS, 1 MEG	ea. .12
1 WATT, 20% TOL., 10K OHMS	ea. .10
2 WATT, 10% TOL., 100, 270 OHMS	ea. .18
2 WATT, 20% TOL., 2200(2) OHMS	ea. .14

#630 TV TUBES—STANDARD MAKES

6J6	R.F. Amplifier	1.39
6J6	R.F. Oscillator	1.39
6J6	Converter	1.39
6BA6	1st and 2nd Sound I.F. (2)	ea. .84
6AU6	3rd Sound I.F.	.84
6AL5	Sound Discriminator	.94
6AT6	1st A.F. Amplifier	.69
6K6GT	Audio Output	.77
6AG5	1st, 2nd, 3rd 4th Pix I.F. (4)	ea. 1.27
6AL5	Pix. Det. & DC restorer	.94
6AU6	1st Video Amplifier	.84
6K6GT	2nd Video Amplifier	.77
6SK7	1st Sync. Amplifier	.84
6SH7	Sync. Separator	1.04
6SN7	2nd Sync. Amp & Hor. Dis.	1.04
6J5	Vert. sweep osc. dis.	.69
6K6GT	Vertical sweep output	.77
6AL5	Hor. Sync. Discriminator	.94
6K6GT	Hor. Sweep Oscillator	.77
6AC7	Hor. Sweep Osc. Control	1.39
6BG6G	Horizontal Sweep Output	2.32
5V4G	Reaction scanning	1.14
1B3/8016	High Voltage Rectifier	1.27
5U4G	Power Supply Rectifier (2)	ea. .69

BROOKS RADIO & TELEVISION CORP.

84 VESEY ST., Dept. A, NEW YORK 7, N.Y. Cortlandt 7-2359

Compare!
PROVE
EMC
SUPERIORITY!

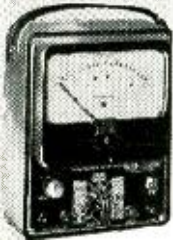

Model 104
 (20,000 ohms
 per volt meter)
 • 4 1/2" SQUARE METER (50
 micro-amperes-Alnico
 magnet)
 • Includes carrying strap
 5 DC Voltage Ranges at 20,-
 000 ohms volt to 3,000 V.;
 5 AC Voltage Ranges to 3,-
 000 V.
 3 Resistance Ranges to 20
 megs.
 Also 3 AC & DC Current
 Ranges at
 5 DB Ranges **\$26.95**



Model 102
 (1000 ohms
 per volt meter)
 • 3" SQUARE METER
 • 3 AC CURRENT RANGES
 (0-30/150/600 ma.)
 • Same zero adjustment for
 both resistance ranges
 (0-1000 ohms, 0-1 meg-
 ohms)
 5 DC & 5 AC Voltage Ranges
 to 3,000 Volts
 Also 4 DC
 Current
 Ranges **\$14.90**



Model 103
 (1000 ohms
 per volt meter)
 • 4 1/2" SQUARE METER
 • 3 AC CURRENT RANGES
 (0-30/150/600 ma.)
 • Same zero adjustment for
 both resistance ranges
 (0-1000 ohms, 0-1 meg-
 ohms)
 Same Ranges as Model 102.
 Also
 5 DB Ranges **\$18.75**
 Model 103-S with plastic
 carrying straps **\$19.25**

All of the above have molded bakelite cases.
 Write Dept. RE-10 for Free Complete Catalog
 of these and other instruments.
 — See them at your Jobbers —

Electronic
Measurements Corp.
 280 Lafayette St., New York 12, N. Y.
 Export Dept., 303 W. 42nd St., N. Y. C.

WILL BUY OR TRADE

NEED BC-611 or BC-721 Handie-Talkie
 (or any part); ART-13; ARC-1; ARC-3;
 DY-17; TS-12; TS-13; MN-26 J or K;
 BC-342; BC-312; I-100; BC-348; BC-788
 A, AM, B or C; I-152A, AM, B or C;
 TS-67; Teletype, test or any other
 equipment. Cash or trade. What have
 you?

Write: **BOB SANETT (W6REX)**
 4668 Dockweiler, Los Angeles, California

RADIO-ELECTRONICS CONTRIBUTIONS

Balance as of July 19, 1951.....\$8,060.18

Amateur Radio Station VE6WX— Consort, Alta., Canada.....	3.00
Anonymous—Lake Odessa, Mich.....	1.00
Anonymous—Philadelphia, Pa.....	11.00
W. J. Bluhm—Jamaica Plain, Mass.....	5.00
H. Christensen—Chicago, Ill.....	1.00
M/Sgt. Thomas R. Davenport—Fort Bragg, N. C.....	10.00
Mrs. Thelma Gunn—Germiston, Union of South Africa.....	1.00
R. J. McDermott, U.S.N.—Norfolk, Va.....	5.00
George Mackey—The Dalles, Oregon.....	6.75
John A. Shaffer—Aspinwall, Pa.....	5.00
John G. Trainor—West Hempstead, L. I., N. Y.....	5.00
James K. Wilson, Wilson Radio Serv- ice—Riverview, Mich.....	5.00

RADIO-ELECTRONICS contributions 8,118.93
 FAMILY CIRCLE contributions..... 434.70
 Total received to August 20, 1951..\$8,553.63

CORRECTION

A feedback network for providing additional picture width is mentioned in the article "Profitable Conversions with Rectangular Tubes" in the August 1951 issue. The text describes two 10-μuf, 1,500-volt capacitors in series between pin 4 of the horizontal output transformer and the grid of the horizontal output tube.

Both of these 10-μuf capacitors should have 2,500-volt ratings instead. Since these special capacitors are not generally available, try the low-capacitance, high-voltage capacitors used in some keyed a.g.c. circuits or approximately 10 inches of 300-ohm transmitting-type transmission line.

Radio Thirty-Five Years Ago
 In Gernsback Publications

HUGO GERNSBACK
 Founder

Modern Electrics	1908
Wireless Association of America	1908
Electrical Experimenter	1913
Radio News	1919
Science & Invention	1920
Television	1927
Radio-Craft	1929
Short-Wave Craft	1930
Television News	1931

Some of the larger libraries still have copies of **ELECTRICAL EXPERIMENTER** on file for interested readers.

OCTOBER, 1917
ELECTRICAL EXPERIMENTER

- Radio-Controlled Torpedo
- Brown University Trains Radio Experts
- The Amateur's Opportunity, by Hugo Gernsback
- A Radio Controlled Model Boat, by H. C. Van Benthuysen and Max I. Black
- Measurements of Radio Antenna on Shipboard, by F. A. Hart
- A Simplified Variable Condenser, by R. U. Clark, 3rd
- A Key That Will Handle 1 K.W. for \$1.00
- Porcelain Knobs as Antenna Insulators, by Benjamin L. Team
- An Arcless Magnetic Radio-Relay, by Loren Anslow
- A Simple Potentiometer Control, by Burt Clark
- Adjustable Loud Talking Receiver, by Thos. W. Benson

—end—

IMMEDIATE DELIVERY
ON
AUTO RADIOS

Custom built for all popular 1949-1950 and 1951 automobiles: Chevrolet, Ford, Plymouth, Dodge, Studebaker, Henry J, and Hudson.

Every radio is a powerfully built, 6 tube, super-heterodyne with RF stage and 3 gang condenser for sensitive, long distance reception. Latest miniature tubes used, with beam-power output and oversize Alnico V loudspeaker, giving plenty of volume with excellent tone. Includes Automatic Volume Control and has low battery drain.

Each model radio is Custom-Built, designed for the individual automobile and can be mounted within 4 minutes with no cables, no brackets, no holes to drill.

When ordering, indicate type automobile:

Write for big discount prices

YOUR MONEY
RETURNED IN FULL—

If the New Regency Television Booster fails to improve your television enjoyment! Bring your picture out of the snow and reduce interference!

- Push-Pull Neutralized triode design assures high gain without adding noise.
- No external impedance matching devices required.
- Inductive tuning assures some high-gain wide-band operation on all channels.
- Single knob tuning control.
- Underwriters approved with 90 day RMA guarantee.

LOWEST Price—ONLY **\$19.11**

MODEL NFRD—RADIO NOISE FILTER

If it doesn't work, send it back!

We absolutely guarantee that our Model NFRD will eliminate all line noises when properly connected to radios, television sets, short wave sets, motors, electric shavers, refrigerators, vibrators, oil burners, transmitters, and all other sources of interference. This unit will carry up to 12 amperes or 1 1/2 KW of power and may be used right at the source of interference or at the radio.

Small size only 3"x1 1/2"x7 1/2". Very low price only
 Each **\$1.95**

A SCIENTIFICALLY DESIGNED
PHONO SCRATCH FILTER

Resonated at approximately 4500 cycles effectively reducing objectionable needle scratch without altering the brilliancy of reproduction.

Contains a HI-Q SERIES resonated circuit. Tested by means of an audio oscillator and an oscilloscope to give 22 db attenuation with very low signal loss.

EASY TO ATTACH

Just two wires to clip on. Compact **\$1.98**
 Price

THREE TUBE PHONO AMPLIFIER

An assembled unit ready for installation using tone and volume control and six feet of rubber cord **\$2.95**

(Not including Tubes)

With Complete Set of Tubes\$3.95

PHONO OSCILLATOR

Wireless phono oscillator transmits recording for crystal pick-ups or voice from carbon mike through radio without wires. Can also be used as an inter-comm by using P.M. speaker as mike. **\$2.95**
 Price (excluding tubes)

With Complete Set of Tubes\$3.95

AUTOMATIC RECORD CHANGERS \$11.95

Standard well-known brands. Single speed 78-RPM types guaranteed to be in good working condition. Order while they last!

Satisfaction guaranteed on all merchandise
 All prices subject to change without notice.
WRITE FOR FREE CATALOGUE C10

RADIO DEALERS SUPPLY CO.

154 Greenwich St. New York 6, N. Y.

DETROIT TSCA MEETS

The Television Service Contractors Association of Detroit held a dinner meeting August 15, at which a number of speakers, including Hytron distributor Fistner and Philadelphia TCA representative, Paul V. Forte, were heard. Mr. Fistner discussed Hytron's new sales plan, and Mr. Forte spoke on the problems of associations and their value to their membership and the public.

The Detroit association has been offered the cooperation of TV and radio stations and the newspapers in a program of TV shorts, radio spots and newspaper items of an educational nature on the subject of television. These will be directed at the television and radio set owner and the general public. During his visit, Forte met with the Association's committee handling the program to answer questions and offer suggestions based on experience with similar programs in Philadelphia.

PROPOSED L. A. LEGISLATION

Legislation to safeguard the television and radio set owner was proposed for Los Angeles County by its sheriff, Eugene Biscailuz, as an aftermath of the recent arrest and imprisonment of dishonest repairmen.

The law requested by Sheriff Biscailuz would follow an existing ordinance which controls auto mechanics. It would call for an investigation of the applicant's character and record before granting the license. About 10% of all applicants for auto mechanic licenses are turned down, the sheriff stated.

The licensed repairman would be required to keep a record of all repairs for which a charge of \$5 or more was made; keep records of the names and addresses of all persons from whom he obtained second-hand parts; furnish on demand an itemized statement of parts and labor used in any repair job and inform the customer whenever any second-hand parts were used in the repair of his receiver.

The county Board of Supervisors could revoke the license of any repairman who made false statements, charged for parts not installed, charged for new parts when installing old, or conspired with any person to defraud the owner or other person or persons financially interested in the cost of the repairs. A dishonest technician would not be able to stay in business long.

NETSDA APPOINTS

The National Electronic Technicians & Service Dealers Associations (NETSDA) have appointed Paul H. Wendel, managing director of the Television Technicians Lecture Bureau (TTLB), as chairman of its Education and Program Committee. Clarifying the functions of the Bureau under this arrangement, Max Leibowitz, president of NETSDA, stated that all material designed for the education of service technicians and dealers would be cleared and disseminated by TTLB in accordance with the requirements of NETSDA.

STAY TUNED IN!

Always

There's a NEWS Program from the TELETOWER!



Teletower always has... does... and always will... place "high priority" upon development engineering. It was constant design study that pushed Teletower to top position in sales. *Continuing* design study will keep it "the tower in your future".

Penn's newest development is a "revolution"—a *new* self-supporting tower that carries two hundred and fifty pounds of head-load without using a single strand of guy wire! You'll be hearing *plenty* more about this one soon... from Penn... from dealers... from set owners.

Watch this publication for our advertising... and watch your mail for timely messages from Teletower.

STAY TUNED IN... WITH TELETOWERS!

A FEW DEVELOPMENT ENGINEERING ACHIEVEMENTS OF JUST ONE YEAR!



Pole Base Mount.
Durable aluminum base with adjustable socket to accommodate 1" O.D. tubing to 2" pipe. Competitive priced.



Universal Motor Mount.
Easy to adapt to all antenna rotors.



Built-In Base permits raising tower on slope after base is fastened to roof.



PENN

Teletowers
Hrftowers
enna-Mast
Hardw...

PENN BOILER & BURNER MFG. CORP., L R, PA.

BE SURE

REPLACE WITH

QUAM
Adjust-A-Cone
SPEAKERS



You can be sure when you sell Quam Adjust-A-Cone Speakers. They are designed right for top performance—they are built right for trouble-free service and they are backed by more than a quarter century of speaker building experience.

Always sell the speaker that is first in original equipment—first in the replacement field. It costs no more and provides more satisfaction.

Also makers of Quam Focalizer Unit and Ion Traps

QUAM-NICHOLS COMPANY

521 E. 33rd PLACE, CHICAGO 16, ILLINOIS

MAKERS OF QUALITY SPEAKERS FOR 27 YEARS, UNDER THE SAME MANAGEMENT

HAVE YOU A JOB FOR A TRAINED TECHNICIAN?

We have a number of alert young men who have completed intensive training in Radio and Television Repairing. They learned their trades thoroughly by working on actual equipment under personal, expert supervision. If you need a trained man, we invite you to write for an outline of our course, and for a prospectus of the graduate. No fees, of course. Address:

Placement Manager, Dept. P108-10

COMMERCIAL TRADES INSTITUTE
1400 Greenleaf Chicago 26

ARSD NEWS

Associated Radio Service Dealers of Columbus, Ohio, held their July meeting with John Graham presiding in the absence of Charles Dykes, president, and Fred Colton, v.p., who were away. The meeting turned into a Round Table discussion with kick-backs, service pricing and collection; some subjects covered.

A family picnic was held for members of the ARSD and 138 attended and enjoyed the full program of events, contests and entertainment provided.

FRSAP ELECTS SECRETARY

The Federation of Radio Servicemen's Associations of Pennsylvania named William J. Lansberry, of Hollidaysburg, recording secretary, to succeed John Grimme, of Altoona, according to an announcement by Dave Krantz, FRSAP chairman.

At a Wilkes-Barre outing of state associations, 100 representatives went on record as protesting credit controls on appliance purchases, favoring relaxing the controls, since many of the members sell TV and radio receivers as well as service them.

CODE OF ETHICS

A Code of Ethics prepared by the National Appliance and Radio Dealers Association (NAARDA) for its members who install and maintain television receivers resembles in many points those followed by many electronic technicians' associations. Some differences will be noted in the approach:

All work shall be done only by competent *qualified* technicians. Only the *best materials*, which have been approved by the standards of the radio and television industry, shall be used.

All local safety regulations and building codes shall be strictly adhered to by CTIS (Certified Television Installation and Service) members of the NAARDA. Ample *protection* against lightning damage shall be provided on all installations.

The television owner's person and property shall be fully protected by *liability* and *property damage insurance* while installations are in progress. *Special care* shall be taken to make each installation safe, both electrically and mechanically.

The clause on compliance with safety regulations is an important one often overlooked in associations' Codes of Ethics.

FAIR TRADE PROTEST

Protests against "Fair Trade" contracts have been registered by three New York television dealer associations, who have jointly resolved that such agreements are "fair only for the manufacturer." The associations were the New York (City) Television Dealers Association, the Westchester Gas and Electric Appliance Dealers Association, and the Nassau County Appliance Dealers Association.

ALL IN ONE!

with RCP's new
MODEL 8773

SERVISHOP



EQUIVALENT TO A COMPLETE SERVICE SHOP!

- TUBE TESTER
- SET TESTER
- A.M. GENERATOR
- F.M. GENERATOR
- A.F. GENERATOR
- CONDENSER TESTER
- FUSE PROTECTED METER

\$ 99⁹⁵

Every square inch solid-packed with value! Look what you get in this phenomenally low priced tester: a complete latest model obsolescent proof tube tester with approximately 1000 listings on improved roll chart together with an elaborate multimeter for measuring all AC & DC voltage DC currents—resistance in ohms and megohms—output in decibels—condenser leakage—signal generators for audio—radio AM and radio FM signals.

- DC Voltmeter: 0-10-50-500-1000-2500
- AC Voltmeter: 0-10-50-500-1000-2500
- DC Milliammeter: 0-10-100-1000
- DC Ammeter: 0-10
- Decibel Meter: -8 to +15, 15 to 29, 29 to 49, 32 to 55
- Ohmmeter: 0-500-5000 ohms, 0-0.1-1-10 meg-ohms

Complete with tubes, batteries, test leads, output leads, etc., in beautiful natural finish oak case, BUY FROM YOUR JOBBER. INSIST ON RCP INSTRUMENTS • WRITE FOR CATALOG RE-10

RADIO CITY PRODUCTS CO., INC.

152 West 25th St. New York 7, N. Y.

RHOMBIC TV ANTENNAS

Power Gains of 100 and More for consistent extreme fringe area reception

BUILD YOUR OWN—USE OUR RHOMBIC TV ANTENNA BOOK

- Complete Simplified Building instructions and drawings for 24 sizes.
- Use and Design of open wire lines.
- Information on Stacked Rhombics.

\$1.50 Richard J. Buchan
Postpaid WOTJF Bricelyn, Minn.

HELP THE DEFENSE EFFORT

by turning over old copies of RADIO-ELECTRONICS and all other waste paper to paper collecting agencies in your community.

**An Open Letter
TO TELEVISION SET
MANUFACTURERS**

From an Independent
Television Service Technician

Mr. Manufacturer:

You no doubt feel that the television sets that you manufacture can best be serviced by factory-trained service technicians, who know all the tricks and quirks necessary to keep your set in its best operating condition. And you are probably right! However, the major portion of the television servicing in this country is being capably handled by independent service organizations, who work on all makes and types of sets. Whether they are large organizations or one-man establishments, it does not take them long to compare the various makes of television sets they service as to design, ease of repair, and other features.

This letter discusses some of the author's "pet peeves," accumulated over a period of four and one-half years of television servicing as an independent one-man organization. No manufacturers' names are mentioned—it's not necessary. Service technicians know the sets—and you manufacturers know also. Even consumers are getting "maintenance minded." Just ask some of the retail television sales organizations.

The following "pet peeves" are offered to you for what they are worth, as suggestions for the improvement of your relations with the television servicing industry.

1. Tubes are manufactured as "plug-in" devices because of the frequent need for replacement. Let's keep them on top of the chassis!! When a chassis must be pulled to check or replace a 1B3GT (or a 6AL5), the customer is going to be told why the extra two or three dollars is on his bill. He will remember why, too. The same applies to high-voltage cages with side entrances only—the chassis must be pulled to inspect or replace the tubes therein. And please, Mr. Manufacturer, locate the tubes in your set so they may be reached from the back of the set. It is O.K. to hide them behind other parts—we'll find them. But if you must hide a miniature type tube, use a guide type tube socket so the tube may be "felt" back into place. *Plain flat miniature sockets hidden from view are time-wasters and temper-shorteners.*

2. Contrary to the apparent opinion of some manufacturers, it does not take a shorted capacitor, or wires touching, to blow a fuse. Fuses will open up from fatigue, or will blow if the set is slightly underfused and is turned on immediately after being turned off, or if there is a shorted tube. In any event, if the cause of the blown fuse does not require the chassis to be removed from the set to be repaired, it seems reasonable that the fuse itself be replaceable without removing the chassis. *So let's keep fuses on top of the chassis.* Hide them in the high-voltage cage if you wish, but *not* underneath the chassis.

3. Several of you manufacturers make provision on your sets for removing the safety glass front on the set to facilitate cleaning of the pic-

Let MILTON S. KIVER Help You
Prepare For COLOR TV
And...



Easy to TRAIN AT HOME This Practical Way!

Men with the right training in Television Servicing are in big demand... pull down big pay. T.C.I. TRAINS YOU RIGHT with easy-to-follow technical training designed by servicemen, for servicemen! You learn practical, professional type Television Servicing without leaving your present job. Included are money-making extras such as set conversion, master antenna installation, COLOR TV and field servicing short cuts. You can start earning Television money after the first few lessons. You learn to test, trouble shoot and repair all types of TV sets. You learn COLOR CONVERSION too!

HERE'S HOW YOU GET EXPERIENCE!

You train on your own large screen modern television receiver, furnished as part of your course. This set is yours to keep! As an optional feature you can get two weeks of actual field experience out on service jobs and on the repair bench for Chicago's largest independent servicing organization. You learn Television Servicing by actually doing Television Servicing... you get the practical know-how you need to qualify for BIG MONEY in this fast-growing field. Age is no barrier. Many TCI students are over 40!

ACT NOW! Fill out and mail coupon for FREE Catalog and SAMPLE LESSON. Write TODAY!

TELEVISION COMMUNICATIONS INSTITUTE
205 W. Wacker Dr., Dept. RE-5, Chicago 6, Ill.

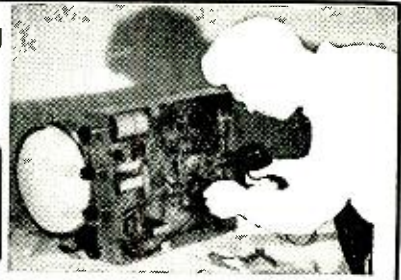

YOU GET and keep modern large screen Television receiver.

YOU DO actual testing, servicing, trouble shooting and repairing

FOR THE BEGINNER
TCI offers a low-cost Pre-Television Course in Radio, especially designed to prepare you for television in just 5 to 7 weeks. Everything you need from basic radio through servicing... to Television.

MAIL NOW FOR FREE BOOKLET

MILTON S. KIVER, President
TELEVISION COMMUNICATIONS INSTITUTE
205 W. Wacker Dr., Dept. RE-5, Chicago 6, Ill.
O.K. Mr. Kiver! Rush FREE Catalog on your practical home study course in Television Servicing, including COLOR TV. Include FREE Sample Lesson. I am not obligated. Salesman will not call.

Name.....Age.....
Address.....
City.....Zone.....State.....
() BEGINNERS check here for information on Pre-Tel Radio Course.

NEW CONDENSER TESTER



Finds Intermittent
Condensers Instantly

Pres-probe's sliding tip with variable resistance prevents condenser heating. Tests with power on. Requires no adjustment. Stops guesswork. Saves time. Convenient probe size (7/8" long). Satisfaction guaranteed.

NET
795
Postpaid
U.S.A.

See Your Dist. or Order Direct

PRES-PROBE CO.

4034 N. Sixth St., Milwaukee 12, Wisc.

EASY TO LEARN CODE

It is easy to learn or increase speed with an Instructograph Code Teacher. Affords the quickest and most practical method yet developed. For beginners or advanced students. Available tapes for beginner's alphabet to typical messages on all subjects. Speed range 5 to 40 WPM. Always ready—no QRM.



ENDORSED BY THOUSANDS!

The Instructograph Code Teacher literally takes the place of an operator-instructor and enables anyone to learn and master code without further assistance. Thousands of successful operators have "acquired the code" with the Instructograph System. Write today for convenient rental and purchase plans.

INSTRUCTOGRAPH COMPANY

4701 Sheridan Rd., Dept. RC, Chicago 40, Ill.

You can't beat
Radio-Electronics
for complete coverage of
RADIO, TELEVISION
and **AUDIO**

**TELEVISION SERVICING
CYCLOPEDIA**

A "MUST" FOR
EVERY RADIO-TV MAN!

Hundreds of time-saving, money-making TV facts at your finger-tips... 750 fact-packed pages cover every phase of Television! Over 400 illustrations, charts and diagrams! All complete, easy-to-understand... all in alphabetical order and cross-indexed for quick reference. It's yours for 7 days' Free Trial!

BRAND NEW
750
PAGES
450
ILLUSTRATIONS

HELPS YOU GET
AHEAD FASTER IN TV

The NEW 1951 COYNE TELEVISION SERVICING CYCLOPEDIA tells you why things happen... how to handle any TV problem... and does it quickly! Covers alignment, amplifiers, antimas, frequency... IFT and COLOR TV... converters and adapters... television r-f... ion traps... hundreds of TV facts. Includes a complete explanation of Test Patterns... how to use them to adjust TV sets... with dozens of actual Test Patterns... Mathematics limited to easy, grade-school arithmetic. Formulas simplified. Everything explained in detail. **SEND NO MONEY!** Just mail coupon for this book. Have TV Cyclopedias for 7 days. Then send either \$5.95 plus postage or return book and owe nothing. Act now!

Yours on
**7-Day
FREE
TRIAL**

FREE TRIAL COUPON

Educational Book Publishing Division
COYNE ELECTRICAL & TELEVISION-RADIO SCHOOL
500 S. Paulina St., Dept. A-1-T-1, Chicago 12, Ill.
Send me the 1951 Coyne Television Servicing Cyclopedias for 7 days' FREE Trial per your offer.

Name.....Age.....
Address.....
City.....Zone.....State.....

Where employed.....
() Check here if you are enclosing \$5.95. We pay postage. 7-day Money-Back Guarantee.

G-E MODEL 12T3

The complaint was an intermittent raster. We checked all voltages, socket connections, and tube heaters for intermittents without finding the trouble. The trouble was traced to an intermittent heater-to-cathode short in the 6SQ7, which short-circuits the heater of the picture tube.

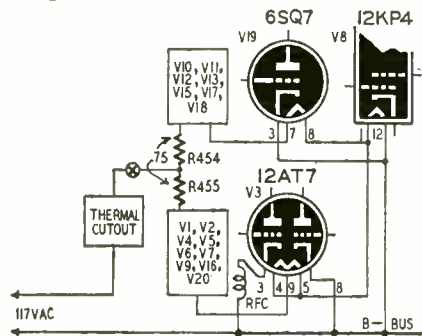

This same condition can be caused by a short between heater and cathode of the 12AT7 in the front end. The same trouble can occur in the 12T4, 12C107, 12C108, and in other models having similar series-parallel heater strings. The diagram shows how the heater of the picture tube can be shorted out by a heater-to-cathode short in the 6SQ7 or 12AT7.—John Scaglione

STROMBERG-CARLSON TV SETS

Improper action of the brightness control (the control seems to operate in reverse) in sets of the 24 and 119 series is often due to an open 2.2-megohm resistor (R291) in the grid return of the

picture tube.

To increase the range of the contrast control in these models, short-circuit or remove the 220-ohm cathode resistor of the 6AR5 video amplifier.

To increase the range of the brightness control in the model 24 series receivers so as to reduce the picture illumination properly, the 150,000-ohm resistor (R294) in series with the feed side of the brightness control should be decreased to 100,000 ohms.—Stromberg-Carlson TV Service Dept.

EMERSON 3-WAY PORTABLES

The model 523 and similar 3-way portables may work O.K. on batteries, yet blow out one of the 1.4-volt tubes as soon as the set warms up on a.c. or d.c. The heaters of the 1.4-volt tubes are in series across the cathode resistor of the 50B5 a.c.-d.c. output tube. Measuring the cathode voltage, we found that it was 7.3 volts instead of 6.2 volts as listed in the service manual. If all resistors check O.K., replace the 50B5 to cure the trouble.—Roy Brandt

(There are two capacitors in the output circuit of the model 523 which can cause tubes to blow if either is leaky. One of these is the coupling capacitor between the plate of the first a.f. amplifier and the paralleled grids of the output tubes. The other is connected between plate and cathode of the 50B5. Leakage in either will cause an excessive voltage drop across the cathode resistor and the series-connected filaments.—Editor)

—end—

THE BROOK

High Quality

AUDIO AMPLIFIER . . .

ALL TRIODES

- Distortion and intermodulation extremely low
- Wide frequency range, flat from 20 to 20,000 cycles within .5 db
- Attractive remote-control pre-amplifier
- Compensation for various inputs; Phono, Tuner, Television or Microphone
- Exclusive BROOK circuits and transformers

YES, ALL THESE FEATURES . . . but primarily LISTENING PERFORMANCE heretofore not achieved

Write for free Technical Bulletin, detailed Distortion Analysis & booklet "Better Listening"

BROOK ELECTRONICS, INC. Dept. EK-1
34 DeHART PLACE, ELIZABETH 2, NEW JERSEY

NOW! The KLIPZON MINI-PROD CONNECTOR

CLIPS ONTO WIRES IN HARD-TO-REACH PLACES

NEEDLE-SHARP POINT PIERCES INSULATION

FITS INTO PIN-JACKS

CLIPS ONTO MINIATURE SOCKET TERMINALS

IT'S A MINIATURE CLIP . . . it's a MINIATURE TEST PROD, too!

STREAMLINED FOR MODERN ELECTRONICS

FOR LABORATORY, SERVICE SHOP, PRODUCTION LINE TESTING

3X

25¢ ea. RED or BLACK

Only one year old, but over 250,000 in service!

Used by Leading TV, RADIO and ELECTRONIC MANUFACTURERS

SOLD NATIONALLY BY MORE THAN 600 RADIO PARTS DISTRIBUTORS

Ask for KLIPZONS at YOUR Local Distributor
Write for FREE FOLDER #1, describing MINI-PRODS and Other KLIPZON Products.

FITS INTO BINDING POSTS

CLIPS ONTO CLOSE SPACED LUGS AND TERMINALS

CONNECT EASILY TO EACH OTHER FOR EXTENSION OF LEADS

EASY TO WIRE. SOLDERLESS CONNECTION IN PLASTIC HANDLE

Engineers UNITED TECHNICAL LABORATORIES Manufacturers
MORRISTOWN, N. J.

SOUNDTRONICS SPECIALS

FAMOUS MAKE

13 Channel T.V. Tuner
Same type used by leading mfrs.
—West., Magnavox, Telesing,
Mech., etc. Ideal for schools,
mfrs., etc. Uses 6C4 Osc., 6AG5
Mixer, 6BH6 R.F. Amp.

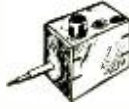

GUARANTEED

Less tubes, with shields and diagram..... \$3.95

3 TUBE KIT FOR TUNER

6C4, 6AG5, 6BH6..... \$2.88

14 PIN TV SOCKETS for 3BP1, 7JP4, etc.

Black Bakelite..... 15¢ Mica Filled..... 28¢

TOP BRAND TUBULAR CONDENSERS

.1 MFD 1000 Working Volts.....	6¢
.05 MFD 400V.....	7¢
.035 MFD 600V.....	6¢
.25 MFD 400V.....	7¢
.035 MFD 1000V.....	8¢

MUTER CERAMIC CONDENSERS, 600 VOLT

15, 22, 33, 56, 75, 82, 180, 220 MMFD
5¢ each..... \$4.50 per C

U.T.C. CHOKES P.A. CASES

10 HY @ 66 MA \$.97	10 HY @ 110 MA \$1.40
5 HY @ 150 MA \$ 1.85	10 HY @ 150 MA \$ 2.25

SPECIAL ASSORTMENTS

50 new pop. type coded res. 50 small / YOUR CHOICE
pop. ceramic cond., all voltages \$1.49 each asst.
& cap. 50 postage stamp mica cond. }

F. W. SEL. BRIDGE RECTIFIERS

18 V. IN. 14 V. OUT	40 V. IN. 34 V. OUT
1.3 Amps..... \$ 2.90	.6 amps..... \$ 3.30
2.4 Amps..... 3.85	1.2 Amps..... 4.40
6.6 Amps..... 5.45	3.2 Amps..... 6.55
13.0 Amps..... 9.80	6.0 Amps..... 11.70
17.5 Amps..... 12.50	9.0 Amps..... 13.75

SHURITE 2" SO. METERS

D. C. AMPS		D. C. VOLTS	
0 - 1.....	\$1.60	0 - 1.....	\$1.55
0 - 3.....	1.60	0 - 3.....	1.60
0 - 5.....	1.60	0 - 5.....	1.60
0 - 10.....	1.60	0 - 10.....	1.65
0 - 15.....	1.70	0 - 15.....	1.75
0 - 25.....	2.00	0 - 25.....	1.75
0 - 50.....	2.30	0 - 50.....	1.90

WIRE KIT—OVER 100 FT.

Contains over 100 ft. of #12, #14, #16 H.D. wire for Pri & Fil. Wiring..... ONLY 69¢

POWER TRANSFORMER SPECIALS

700 V. CT @ 70 MA, 6.3 V @ 2.5 A, 5 @ 2 Amp \$2.29
700 V. CT @ 150 MA, 6.3 V @ 3.5 A, 5 @ 2 Amp \$4.95

TV OR SCOPE TRANSFORMERS

1800 V @ 5 MA, 2.5 V @ 2 Amps..... \$3.95
435/870/1625 @ 35 MA, 6.3 V @ 600 MA, 6.3 V @ 1.3 A, 2 V @ 2.5 Amps, 5 V @ 2 A..... \$4.95

3600 V @ 2 MA, 1.25 V @ 300 MA, 750 V CT @ 200 MA, 6.3 V @ 8.7 Amps, 5 V @ 3 Amps..... \$7.95
8 HY @ 75 MA CHOKE—500 OHM D.C.R..... 49¢

TRANSFORMER POWER SUPPLY

115 V. 60 CY., 300 V. @ 55 MA., 6.3 V. @ 2 Amps. Has 5Y3, 2-BHY, Chokes, 3-30 MFD Filters, Pilot Term. Strip, Meas. 5"x5"x8". Completely wired..... \$6.85

TERMS—25% w/order, balance C.O.D.

SOUNDTRONICS LABS.

632 Arch St., Phila. 6, Pa.—MA 7-2775

J. J. Kahn, president of the STANDARD TRANSFORMER CORP., was appointed chairman of the new RTMA Promotion Committee. Other members of the committee included: Max F. Balcom, SYLVANIA ELECTRIC PRODUCTS, INC.; Paul



J. G. Kahn

V. Galvin, MOTOROLA, INC.; Leslie F. Muter, THE MUTER CO., and ex officio, Glen McDaniel and James D. Secrest, RTMA president and general manager and secretary, respectively.

Other RTMA committee appointments included A. D. Plamondon, Jr., president of INDIANA STEEL PRODUCTS, INC., as chairman of the newly formed Small Business Survey Committee, and H. N. Henrye Saller of JOHN E. FAST & Co., as chairman of the Credit Committee.

John H. Cashman, president of THE RADIO CRAFTSMEN, INC., Chicago, was elected chairman of the Association of Electronic Parts and Equipment Manufacturers. Francis F. Florshiem, president of COLUMBIA WIRE & SUPPLY Co., Chicago, was elected vice-president, and Helen Staniland Quam of the QUAM-NICHOLS Co., Chicago, was re-elected to her sixteenth consecutive term as treasurer. Kenneth C. Prince was renamed executive secretary of the association.



J. H. Cashman

P. M. Pritchard joined SYLVANIA ELECTRIC PRODUCTS, INC., as general sales manager of the Parts Division. Mr. Pritchard joined the sales staff of Sylvania in 1937 but left the company in 1948 to serve as director of sales for the Victor Electric Products, Inc.



P. M. Pritchard

Dr. Ivan A. Getting was elected vice-president, Engineering and Research, of RAYTHEON MANUFACTURING Co., Waltham, Mass. Dr. Getting is an authority on radar and for the past year has held the highly strategic post of chief scientist of the U. S. Air Force.



Dr. I. A. Getting

Ray Simpson, chairman of the board of the SIMPSON ELECTRIC Co., Chicago, was appointed to the position of chairman of the Subpanel on Indicating Instruments, a part of the Panel of Components of the Research and Develop-

"Jumbo Radio Parts Kit" VALUE-PACKED. 17 FULL LBS. OF COILS, WIRE, SOCKETS, RESISTORS, CONDENSERS, ETC., ETC. ONLY \$3.95

Leotone

Radio Hardware Treasury FULL LBS. CAN of Nuts, Screws, Lugs, 6V. Buzzer & Key (W.E.E.)..... 1.49
Mercury Switch..... 1A/115V..... 39c 3/1.00
DPDT Bat Toggle..... 6A/125V..... 49c 6/2.49
20 Push-Back Wires, Red, Yel., Blue, BK..... 100/89c
74 Ohm Coax Cable (16-13 U)..... 20 ft. length 1.39
High Fidelity Crystal Mike..... Hi-imped. rubber mid. 1 3/4"x1/4". Less housing..... 1.29
Aluminum Housing for crystal mic..... 1.49
Nandy Carbon Mike (RS-83)..... Press-to-talk..... 1.49
Changer Mtg. Springs..... 2 deck, 1/2" shaft..... 39c 6/1.98
Rotary Switches..... 2 deck, 1/2" shaft..... 39c 6/1.98
3 pos., D.P. or 6 pos. S.P..... 39c 6/1.98
Tube Cartons..... Plain white. Prices per 100:
Min. (1" sq) \$1.20; GT (1 1/2" sq) \$1.34; 7"..... \$1.45; Med. (1 1/2" sq) \$1.65; Large (2" sq) \$1.85
Rubber Shock Mounts..... 2 1/2" mtg..... 12¢ 10/1.00
Heavy duty 100 lbs. 2 1/2" mtg..... 49c 6/2.49
Magnet Wire..... 230 P.E., 400 ft. roll 23c 5/1.00
255SCE, 500 ft. roll..... 29c 4/1.00
W-1008 Field Wire..... rolls 100-400 ft..... 4¢ per ft.
Radio-Amplifier Steel Cabinet, also for Test Eqp., Power Supply, Medical Or Industrial Eqp., Hinged front. Walnut, 14"x8" sq..... \$2.49
2 Volt Trickle Charger Kit for 2V. p'table batts. Cap. 2 Amps. With ass'ly instructions..... 6.95
W.E. Headphones..... Hi-imped. 5 ft. cord..... 3.49
A.C. Blower (Delco)..... 5400 RPM, 3" impeller. Less Hsg. 2" 1/2" A. Dim.: 2 1/2" O.D.x5"..... 3.49
5" Speaker Baffle Mount..... 1/4" masonite 19¢ 6/1.00
Generator Voltage Reg. (GBD-1A-18)..... 24 cont. adj. relay. Shock-mtd..... 1.98

Speaker Cone Kit..... 4" to 12" incl. Tree-edge, Less voice coils. Kit of 12 asstd. \$1.98
Speaker Repair Kit..... Liberal assortment of Spiders, Felt, Rings, Cement, V.C. Forms, Shim, Kit, Chamois Pthr., & Instruct's. 2.49
ALL FOR BOTH CONE & REPAIR KITS!..... 3.95

25W-250 Ohm Rheostats..... 1/4" shaft..... 49c 6/2.49
50W-15 Ohm Rheostats..... 1/4" shaft..... \$1.29 6/5.98
Dynamic Headphones & Hand-Mike (B-10-MH)..... 2.49
HS-30 Card & Clip (CD-020)..... 9c 6/1.00
HS-30 Steel Headband..... 15c 8/1.00
HS-30 Matching Transformer..... 49c
HS-30 Replacement Phone Units..... Less housing..... 49c
20" Flexible Shaft & housing..... 1/4" tips..... 69c 3/1.98
G.E. Plate Relay..... 8,000 ohms, dble brk. 98c 6/5.00
SPEAKERS..... "ALNICO MAGNET SPECIAL"..... "U" type, polished. 3 1/2"x3 1/2"..... ea. 49c 6/2.49
Alnico Magnet Kit..... powerful Bar, Block, U, Rod, etc. 10 asstd. for..... 1.98

(WRITE FOR "ALNICO MAGNET" SUPPLEMENT)
"FACTORY SPEAKER REPAIRS SINCE 1927"
Min. Order \$3.00..... 20% deposit on all COB's
Please add sufficient postage—excess refunded
Full remittance with foreign orders

LEOTONE RADIO CO.
67 Day Street, New York 7, N. Y.

AUTOMATIC M-90 AUTO RADIO



- Six Tube Superheterodyne • Three Gang Condenser • Powerful, Long-Distance Reception • Fits All Cars, Easy Installation
- Mounting Brackets Included
- 6 Tube model M90..... \$533.87
- 5 Tube Model A-15..... \$28.76

*Above price includes Federal Excise Tax
Approx. shipping weight either radio (11) eleven pounds
MAIL US YOUR ORDERS
All orders filled within 24 hours.
Standard Brand tubes 50% off list

Bill Sutton's Wholesale Electronics
Fifth at Commerce Fort Worth, Texas

500 FORMULAS TO SUCCESS

MANY million dollar firms started with a single formula, for which they paid a big price. Here you have 500—no less—tried and tested formulas, recipes and processes for making things..... all at the ridiculously low price of 25¢. Here is your opportunity to start a business with but a few dollars' capital and with undreamed profits in prospect. You can also use these formulas in your own home to cut household expenses to the bone, or you can put them to use in your workshop to cut costs as much as 100%. Quit paying out many dollars in profits to manufacturers, wholesalers, and dealers, when you can make the same thing yourself for a few cents. It's so easy when you follow our simple instructions.

66 PAGES, 47,000 WORDS IN TEXT
Send for "500 FORMULAS AND RECIPES" today. Enclose 25¢. That's all you want be asked for another cent now or later. Sold on a money-back guarantee.

NATIONAL PLANS COMPANY
1966R Broadway, New York 23, N. Y.

RADIO-ELECTRONICS for

★ **WANTED** WE NEED YOUR SURPLUS ELECTRONIC EQUIPMENT ★
★ **WE PAY TOP \$\$\$ FOR:** ★
★ RADIO RECEIVERS ★ CLAMPS ★
★ TRANSMITTERS ★ PLUGS ★
★ ARC-1 ★ CORDS ★
★ ARC-3 ★ RELAYS ★
★ ART-13 ★ TELEPHONE ★
★ CONTROL BOXES ★ MATERIALS ★
★ INDICATORS ★
★ AN CONNECTORS ★ **WE BUY ANYTHING!!** ★
★ Write, Wire Today! ★
★ Tell us what you have ★
★ **TALLEN COMPANY, INC.** ★
★ Dept. RE, 562 Atlantic Ave. ★
★ Brooklyn 17, New York ★

7 HARD TO GET ITEMS AT BIG SAVINGS TO YOU

AMAZING BLACK LIGHT



250-watt ultra-violet light source. Makes fluorescent articles glow in the dark. Fits any lamp socket. For experimenting, entertaining, unusual lighting effects. Ship. wt. 2 lbs. ITEM NO. 87 A SAVING AT **\$2.45**

POWERFUL ALL PURPOSE MOTOR



Sturdy shaded pole A.C. induction motor. 15 watts, 3000 rpm. 3"x2"x1 3/4"; 4 mounting studs; 7/8" shaft, 3/16" diameter; 110-120 volts. 50-60 cycles. A.C. only. When geared down, this unit can operate an 18" turntable with a 200 lb. dead weight. Use it for fans, displays, timers and other purposes. Ship. wt. 2 lbs.

ITEM NO. 147 UNUSUAL BUY **\$2.45**

WATTHOUR METER

Leading makes — completely overhauled, ready for service. 100-110 volts, 60 cycles, 2-wire A.C. 5 amp. Heavy metal case 8 1/2" x 6 1/4" x 5". Easy to install. Ship. wt. 14 lbs.



ITEM NO. 33 NOW ONLY **\$4.50**

WESTERN ELECTRIC BREAST MIKE

Lightweight 1 lb. carbon microphone. Aircraft type. Breastplate mounting, adjustable 2-way swivel. Easily fastened straps. For home broadcasts, communications etc. Complete with 6 foot cord, hard rubber plug. Sheradized plate, non-rusting finish. Ship. wt. 2 lbs.

ITEM NO. 152 NEW LOW PRICE **\$1.75**

TELEPHONE TRANSMITTERS

Genuine transmitters made by Kellogg, Western Electric, Stromberg Carlson. Work on two dry cells. For P.A. systems, intercoms, other practical uses. Shipping weight 1 lb.



ITEM 160 REAL VALUE **\$2.45**

250 POWER TELESCOPE LENS KIT

Make your own high powered 6 ft. telescope! Kit contains 3" diam., 75" focal length, ground and polished objective lens and necessary eye pieces. Magnifies 50x to 250x. Full instructions. Ship. wt. 1 lb. ITEM NO. 123 YOU SAVE AT **\$2.95**



HUDSON SPECIALTIES CO.
40 West Broadway, Dept. RE-10-51
New York 7, N. Y.

I am enclosing full remittance for items circled below. (Be sure to include shipping charges.)

OR, my deposit of \$..... Ship balance C.O.D.
MINIMUM C.O.D. ORDER \$5.00.
C.O.D. ORDERS ACCEPTED ONLY WITH 20% DEPOSIT
INCLUDE SHIPPING CHARGES.

Circle items wanted
87 147 33 152 160 123

Name..... Please Print Clearly

Address.....

City..... Zone..... State.....

Please mention
RADIO-ELECTRONICS
when writing to advertisers

ment Board. The group was organized to co-ordinate the efforts of military and commercial organizations with scientific achievement.



R. F. Sparrow

Dr. Henry M. O'Bryan was appointed manager of the Physics Laboratories of SYLVANIA ELECTRIC PRODUCTS, INC., at Bayside, N. Y. He joined the company after having served as assistant executive secretary of the Research and Development Board in Washington since 1947.

Gardiner G. Greene was appointed vice-president of the GABRIEL CO., Cleveland, in charge of the Electronics Divisions which include WARD PRODUCTS CORP., Cleveland, and WORKSHOP ASSOCIATES, Needham, Mass. Mr. Greene has been president of Workshop Associates, which became a Gabriel division early this year, for the past nine years.

H. B. Nelson, Jr., was appointed assistant to the sales manager of replacement tubes for the Tube Divisions of GENERAL ELECTRIC Co. in Schenectady, N. Y. He was formerly supervisor of co-operative advertising for the Electronics Department, Receiver Division.

Dr. W. R. G. Baker of GENERAL ELECTRIC was re-appointed chairman of the RTMA Television Committee for the coming year. Thirteen Committee members were also appointed. They included:—Benjamin Abrams, EMERSON RADIO; Robert S. Alexander, WELLS-GARDNER; Max F. Balcom, SYLVANIA; W. J. Barkley, COLLINS RADIO; H. C. Bonfig, ZENITH; John W. Craig, CROSLLEY; Allen B. Du Mont, DU MONT LABORATORIES; J. B. Elliott, RCA; E. K. Foster, BENDIX RADIO; Paul V. Galvin, MOTOROLA; W. J. Halligan, HALLICRAFTERS; L. F. Hardy, PHILCO and W. A. McDonald, HAZELTINE ELECTRONICS.

Personnel Notes

V. S. Mameyeff of RAYTHEON MANUFACTURING Co. was reappointed chairman of the RTMA Export Committee. W. M. Adams, SPRAGUE ELECTRIC Co., will serve as vice-chairman. The RTMA also announced the reappointment of E. W. Merriam, ALLEN B. DU MONT LABORATORIES, INC., as chairman of the Service Committee. F. L. Granger of STROMBERG-CARLSON was named vice-chairman.

Harold G. Cheney was appointed sales manager of the Electronic Tube Division of the WESTINGHOUSE ELECTRIC CORP. He had been headquarters

Ray F. Sparrow was elected executive vice-president of P. R. MALLORY & Co., INC. Indianapolis, Ind. He had been vice-president in charge of sales.

Dr. Henry M. O'Bryan was appointed manager of the Physics Laboratories



H. M. O'Bryan

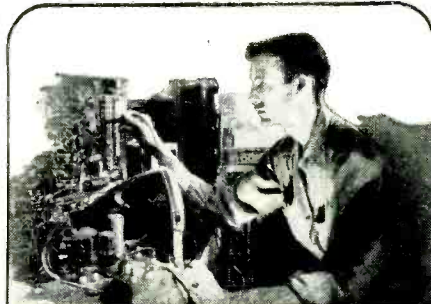

Learn Radio TELEVISION

through this UNIT CHASSIS SYSTEM

The exclusive "Unit Chassis System" of teaching television was developed at this 48-year-old College of Electrical Engineering. The TV set is divided into stages on separate chassis. You study one stage at a time, intimately learning the functions of every component of all types and makes of receivers. You are fully prepared to cope with future design changes, including the advent of color television. By enrolling NOW you will be ready for engineering employment opportunities predicted to reach a new high level in 1954.

You can become a Radio Technician in 12 months

The first third of the College Electrical Engineering program trains you for such positions as Radio Shop Operator or Serviceman, Supervisor of Service Personnel. The Radio Technician's certificate is awarded. You may then advance immediately or at a future date into courses described below.

Radio-Television Certificate in 6 additional months

Be prepared for such work as Radio TV Service—Audio, Transmitter or Communication Technician—and Broadcast Operator (upon passing FCC examination).

Also Your Technician Courses are credited toward the B. S. Degree in ELECTRICAL ENGINEERING.

The Radio Technician course, while complete in itself, is one-third of the college program (major in electronics). Further, you may select as an elective: design, research, manufacturing and production, or engineering sales and management.



B.S. Degree in 36 months. Military, practical or prior academic training evaluated for advanced credit. Terms open Oct., January, April, July.

MILWAUKEE SCHOOL of ENGINEERING

Technical Institute • College of Electrical Engineering

FREE—Write for "Occupational Guidance Manual" and 1951 Catalog.



MILWAUKEE SCHOOL OF ENGINEERING
Dept. RE-1051, 1025 N. B'way,
Milwaukee, Wisconsin

Without obligation, mail Occupational Guidance Manual,

1951 Catalog, Your Career Bulletin on Radio-TV, Electrical Engineering, B.S. Degree in Electronics, Electrical Power. Also bulletin on Electrical Service, Welding, Refrigeration, Heating, Air Conditioning.

Name..... Age.....

Address.....

City..... State.....

DID YOU GET IT? IF NOT
**SEND NOW FOR B-A's
 136 BIG PAGE
 FREE CATALOG**

**1952
 RADIO TELEVISION
 ELECTRONICS**

BURSTEIN-APPLEBEE CO.
 1012-14 McGee St.
 Kansas City 6, Mo.

FREE

Send your 1952 catalog to:

Name.....
 Address.....
 City.....State.....

BURSTEIN-APPLEBEE CO.

SURPLUS

**OCTOBER SPECIALS
 BARGAIN! NEW!**

CRAMER TIMER
 ADJUSTABLE TIME DELAY RELAY. RELAY adjustable from 1/30 sec. S.P. D.T. with starting relay for remote control motor and contacts separate. Stock No. R-246. Operating voltage 115V. AC. Coil resistance. Contacts SPST (NO) or (NC) 10 Amps. **EACH \$9.95**

**VERTICAL ANTENNA
 MAST KITS**
 Fully Adjustable 5 to 35 Feet
 Easy to Set Up

FOR FM, TELEVISION AND ROTARY BEAM
 Doublet Antenna Kit used with the famous Hallcrafters BC-610, consisting of 7 steel-alloy mast sections in a handy canvas bag. Each section is 5'6" long, 1 1/2" O.D. with the last 6" rolled to a smaller O.D. to telescope into the end of the preceding section. No taper. Assemble into mast up to 35' high or shorter by any multiple of 5'. Finished in weatherproof olive drab. Ideal for erection of FM and Television Beams! Drop your coaxial cable right through the center! Brand new. **EACH \$12.95**

TUBE SPECIALS

1626	49	1616	69	12S17G7	99
1629	38	81	49	41	49
FG104/5561	919		99	837	99
	29.95	2K2	99	2051	1.29
RK73	99	843	39	G.E. 211	.98
15R	79	803	2.95	12A6	.69
801	79	901	99	65J7	.69
6AK5	1.49	5BP4	1.95	307ARK75	4.95
250R	3.95	1625	39	1E7G	.69
HY615	49	10Y	39	EF50	.69

MANY OTHER ITEMS NOT LISTED
 FUSES 3c each, \$1.95 per C 3AG—1 amp, 4 amp, 15 amp
 4AG—35 amp, 40 amp 5AG—20 amp, 40, 50, 70 amp

GP-7 TRANSMITTER

TUNING UNITS
 Ideal Basis for E.C.O. Rig
 Tuning units for TCE & GPT in the following frequencies: kes A—350 to 800 kes; B—400 to 1500 kes; C—1500 to 3000 kes; E—4525 to 6500 kes; F—8200 to 9050 kes. Contains all coils, etc., for these frequencies. Used units are in A-1 condition. **Write C.F. each \$3.95**

Write for our Bargain Bulletin

DOW RADIO, INC.
 1759 E. Colorado St. Pasadena 4, Calif.
 Phone: SYcamore 3-1196

\$2.00 min. order 25% deposit with orders
 Send full remittance to save C.O.D. charges
 All merchandise fully guaranteed. Subject to prior sale.

administrator of lamp sales.

... Lee Golder, pioneer radio sales executive, was appointed chief of the Radio and Television Section of the NATIONAL PRODUCTION AUTHORITY (NPA) with headquarters at Washington, D. C.

... Richard E. Laux resigned as president and treasurer of the GENERAL INSTRUMENT CORP., Elizabeth, N. J. Monte Cohen, president of the F. W. SICKLES DIVISION, was elected executive vice-president in charge of operations, and Abraham Blumenkrantz, chairman of the Board, assumed the additional duties of treasurer. Mr. Laux will continue as director.

... Raymond K. Burnet was named Cleveland district sales manager for the Radio and Television Division of SYLVANIA ELECTRIC PRODUCTS. Mr. Burnet rejoins Sylvania after three years with SUE, YOUNG AND BROWN, Los Angeles distributors.

... George R. Faustman, chief industrial engineer of BENDIX RADIO DIVISION, was promoted to the post of general factory manager. He succeeds Edward F. Kolar who was recently named general manager of the Red Bank division of Bendix.

... W. W. Hamilton returned to AVIA PRODUCTS Co., Los Angeles, as head of the new Two-Way Radio Communications Division. He had been vice-president of VETRIC, INC.

... Malcolm V. Fields joined the LA POINTE-PLASCOMOLD CORP., Windsor Locks, Conn., manufacturer of Vee-D-X TV antennas and boosters, as head of the Special Products Division. Mr. Fields has had more than 15 years of experience in production engineering and subcontracting with various New England manufacturers. The company also announced the appointment of Lincoln N. Kinnicut as advertising manager.

... Henry Geyelin, former advertising manager for the Receiver Sales Division of ALLEN B. DU MONT LABORATORIES, INC., was named to help coordinate the various advertising activities of the company. He will also work on creative phases of Du Mont advertising. George Hakim, former co-operative advertising manager of the division, succeeded Mr. Geyelin as advertising manager of the division. The company also announced the appointment of Frederick W. Timmons, Jr. as regional sales manager of the Cathode-Ray Tube Division. Mr. Timmons has been with Du Mont since 1946.

... Nathaniel B. Nichols, an authority on servomechanisms and automatic controls, was appointed manager of the Research Division of RAYTHEON MANUFACTURING Co., Waltham, Mass.

... William Patterson was named sales manager for Sky-Hi television masts manufactured by the THOMAS MOLD & DIE Co., Wooster, O. He was previously with Philco.

—end—

**TECHNICIANS
 YOU CAN PROFIT
 FROM THIS BOOK!**

**Basic
 Radio
 Course**

Only \$2.25

176 Pages 130 Illustrations

**First Gernsback Library Book with
 Durable hard-cloth cover**

One of the finest books on fundamentals ever written for the practical service technician. BASIC RADIO COURSE starts with Ohm's law, then takes you through the circuits of a modern radio set and tells you how and why they work. It's actually a pleasure to read because the author believes learning should be fun. He talks the service technician's language and isn't afraid to make you smile once in a while. But BASIC RADIO COURSE doesn't skimp on facts. It gives you all the technical information you'll find in a higher priced book. But, you'll enjoy reading it and you'll save money.

PUBLISHED BY REQUEST

BASIC RADIO COURSE was published at the request of many radio men who read, enjoyed and learned from John Frye's series on the fundamentals of radio servicing which concluded only recently in RADIO-ELECTRONICS. It can help the experienced technician as well as the beginner. Order your copy today.

TWENTY-SIX CHAPTERS

The Electron Theory • Ohm's Law and the Resistor • What is Induction? • Capacitance • How Capacitors are Made • Reactance, Impedance and Phase • Resonant Circuits • Transformers—How They Work • The Diode Vacuum Tube • Triode and Tetrode Tubes • The Pentode Vacuum Tube • Vacuum Tube Characteristics • The Power Supply • Power Supply Types • Sound and Loud-Speakers • The Power Output Stage • The Voltage Amplifier • Demodulating the R. F. • Receiver Selectivity • The Converter Stage • Some Oscillator Circuits • How To Trap a Signal • Signals in Space • Receiver Refinements • Instruments and Tools • Service Techniques.

**Order your copy from your distributor or
 MAIL THIS COUPON TODAY**

Radcraft Publications, Inc., Dept. 101
 25 West Broadway
 New York 7, N. Y.

My remittance for \$2.25 is enclosed. Please send me a copy of Book No. 44, BASIC RADIO COURSE postpaid.

NAME _____
 STREET _____
 CITY _____ ZONE _____ STATE _____

WATTS SHOWING

Dear Editor:

While checking for ideas for a good audio amplifier, I ran across the "Engineered Amplifier Brings Audio Realism" in the February, 1951, issue . . .

While the amplifier incorporated a number of excellent ideas in the amplifier I finally built, there is one place in which the "engineering" done by the authors appears to have been left with its watts showing.

Fig. 4, Page 27, shows a circuit to provide heater current for the pre-amplifier tubes. In the text the authors also state that R8 should be adjusted to about 7,000 ohms, and in operation, "resistor R8 gets rather hot."

According to James Watt there appears to be good reason: the power dissipated in this case is $(.15)^2 \times 7,000$, or 157.5 watts. Using a 50-watt resistor, as the authors recommend, indicates a supreme faith in the quality of the parts produced by American radio manufacturers. For resistor R8 I used three 2,500-ohm, 50-watt resistors. After hours of continuous service the temperature of these resistors is normal.

MERVYN RATHBORNE

Half Moon Bay, Cal.

SORRY—OUR ERROR!

Dear Editor:

Referring to page 25 of the August issue of RADIO-ELECTRONICS I note that in my article "Slave Unit," under the heading "Other Uses" six paragraphs have been added to the original manuscript as submitted by me. Unfortunately you failed to inform me of the contents of this editorial addition with the result that a gross error has crept in and now appears under my by-line.

The error concerns the statement that the slave unit can be operated with leads up to fifty feet. Such long leads are bound to introduce loss of the higher video frequencies, phase shift, radiation and other undesirable effects.

In all fairness to your readers and to myself I request that you print suitable errata in your next issue, pointing out specifically that this error was not included in my original manuscript and does not originate with me.

WALTER H. BUCHSBAUM

Bellerose Manor, N. Y.

CHANGED THOUGHT

Dear Editor:

Like anyone else, I enjoyed looking over my article in your June issue. To see one's thoughts in print is always pleasurable.

But suddenly I came upon a sentence which I was sure I had not written. For, in fact, I did not agree with it. One could accept the various small editorial changes in sentence structure, punctuation, etc.—but this was a stranger in our midst. Then came realization that you changed the sentence I wrote because you thought I was in error—technically—and you were setting me right!

The paragraph near the top left of

OCTOBER, 1951

NIAGARA IS
RADIO PARADISE!

EVERYTHING FOR THE RADIO-MINDED MAN

NEW • BETTER • PRECISE VTVM KIT

The V. T. V. M., known as the model 909, is available in kit form or factory wired. And, according to the manufacturer, it incorporates the Precise reflex circuit which allows for greater accuracy and stability. The ranges are:

- DC: 0-5-25-250-500-1000 volts
- DC: 0-5-25-250-500-1000 volts
- AC: 0-5-25-250-500-1000 volts
- Ohms: RX1, RX10, RX1000, RX10.000, RX1.000.-000 ohms (from .01 to 1 ohm to 1 billion ohms)
- DB: From -20 to -55 DB

The frequency range, with accessory probes (not included) goes over 250 megacycles; top voltage is 30,000 volts. The DC accuracy of two percent or better is assured by 1% ceramic precision resistors. Special two-color "rapid-construction" instruction books are included with each kit. The step-by-step directions also contain the purpose of each circuit which enables the builder to more fully understand his instrument.

- KIT FORM**
- K907 VTVM—7½" Meter 15 lbs. \$38.98
 - K909 VTVM—4½" Meter 10 lbs. 25.98
 - K914 RF PROBE ½ lb. 3.98
 - W907 VTVM—7½" Meter 15 lbs. \$57.98
 - W909 VTVM—4½" Meter 10 lbs. 44.98
 - W914 RF PROBE ½ lb. 4.98
 - W999 HIGH VOLTAGE PROBE 1 lb. 6.98



Test leads, wire and batteries are included with each instrument, no extras are required.

MINIATURE O-I D. C. MILLIAMETER

New Shipment—New Low Price! Perfect for mobile. Requires 1" hole. Flange mounting. Completely enclosed. Satin aluminum finish. While they last. Only **\$4.75**



BC 652-A MOBILE RECEIVER

2 to 6 MEGS-IDEAL for Aircraft, Yachts, Amateur, Fire, Police, Taxicabs, Trucks, etc. (Super sensitive one full microvolt) 11 tube superhet circuit, including a crystal calibration check system. Continuously tuned range—noise limiter—each unit is brand new, complete with Dynamotor. Tubes, Circuit in original sealed cartons, wgt. **\$29.95** 40 lbs.

SOUND POWER PHONES

Model No. RCA M1-2475 Navy type "Q," 10 miles without Batteries. Rubber cushioned earphones, mouthpiece microphone attached, 22 ft. rubber cord, push-to-talk switch, navy water-proofing plug. Excellent condition. One complete unit as illus. . . . **\$9.95** Each
Same as above with mike on chest plate type "O," RCA M1-2454B **\$4.95**



WEBSTER CHICAGO AUTOMATIC 3 SPEED RECORD CHANGER

TYPE 100—SERIES A fortunate purchase makes it possible for us to offer these fine, new record changers at less than regular manufacturer's cost. Made by Webster-Chicago and only introduced on the market a few months ago as one of their latest models. Plays 12, 10 or 7 inch records at 33 1/3, 45, or 78 R. P. M. New spindle carefully lowers unplayed record stack. Balanced arm assures light needle pressure and long wear. Needle-tip (included) for standard or micro-groove records. Inside-out records played without any adjustment. Pickup arm comes to rest position after last record has played. Complete factory packed and sealed record changers, normally listing at \$47.50—While they last. **\$24.85** Shipping Wgt. 15 lbs. . . .



80 MTR TRANSMITTING STATION FOR THE NOVICE

- 1-TRANSMITTER KIT \$15.95 (as described in May QST)
 - 2-POWER SUPPLY KIT (for above) 9.95 (see June QST)
 - 3-ANTENNA KIT (80 mtrs) 2.95
- \$28.85**

COMBINATION SPECIAL

ALL THREE KITS **\$25.95**
All kits are available separately at prices indicated beside each kit. Complete instructions with each kit.

REMOTE CONTROL FOR THE THING!!
(PLUS \$1.00 BOOK FREE)

The answer to the "Remote Control" experimenter's dream! A completely wired, 3 tube remote control unit, originally used as Electronic Brain for remote thermo-static control of electric blankets. Can be used, with slight modification, to control model trains, planes, trucks, remote on-off for radios, open and close garage doors from your car, or to remotely control any device in accordance with your own ingenuity. And that's not all! With each unit we will give you absolutely free, one copy of Gernsback Library's popular new book "Model Control by Radio," 112 pages, containing more than 125 illustrations, diagrams, tables and practical uses for Electronic Remote Control. Remote Control Unit, including Fil. Xfmr., 300 ohm plate circuit, "trigger" relay, completely wired, circuit diagram and above described book—less tubes **\$5.50** ALL FOR ONLY Shipping Wgt. 3 Lbs.

WESTERN ELECTRIC 25 WATT AUDIO REPRODUCER

AMAZING FREQUENCY RESPONSE! 25 WATT RECEIVER Made by W. E., no D-173246, for the famous BEECHMASTER 250 watt P. A. systems used in guiding blind aircraft in for landings and for P. A. from flying aircraft. These P. M. dynamic receivers have an impedance load of 8 ohms to the output of any amplifier. DUAL CO-AXIAL MAGNETS weigh 23 ounces. Perfect for use as horn type drive speaker or co-axial high power tweeters. Shipping wgt. 7 lbs. **\$12.50** Each



ONE OF AMERICA'S GREAT RADIO STORES

Niagara

RADIO SUPPLY CORP. Dept. C-101

160 Greenwich Street, New York 6, N. Y.

Digby 9-1132-3-4

The New
**GONSET FM
COMMUNICATIONS
TUNER**

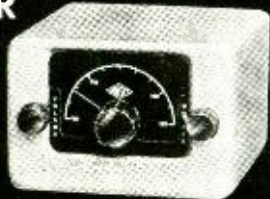

**PROVIDES A SENSITIVE RECEIVER
FOR 2 WAY FM RADIO-TELEPHONE
COMMUNICATIONS**

- Excellent for mobile or fixed operation
- Used with your auto or fixed radio
- Receives police, fire, taxi, etc.
- Compact (5 1/4" x 3 1/4" x 5 1/4")
- High sensitivity
- 5 tubes

\$59.50 net

Models available
30-40 MC
40-50 MC
88-108 MC
152-162 MC



see your distributor or write direct

GONSET CO., BURBANK, CALIF.

**SHOOT TV TROUBLE
FAST!**

With **H. G. CISIN's**
Copyrighted Rapid

"TV TROUBLE SHOOTING METHOD"
EARN more money! Locate television troubles by this quick, entirely new method. Rapid checks applied in simple, logical steps enable you to classify, sub-classify, diagnose and locate all faults in record-breaking time regardless of make or model!

H. G. CISIN is well-known to radio and television men as a recognized electronic engineer, inventor, technical author and educator. He has trained thousands of television technicians, many of them now owning their own prosperous TV service organizations or holding important positions in television. The results of his years of experience are embodied in this remarkable **TV TROUBLE SHOOTING METHOD**.

HERE'S PROOF! J. B. Seiler, Chicago, writes: "Rush another copy. Am tickled to death with results. Your book hasn't failed me yet." G. E. Hirsch, Jamaica, N. Y., writes: "Congratulations! Your book extremely underpriced. Very ingenious in its logical use of cause and effect, should be in every TV tool kit."

Guaranteed, Money Back in 5 Days If Not Satisfied!
INCREASE your earning power with the most valuable aid to TV servicing ever written! SEND YOUR NAME AND ADDRESS TODAY.

POSTPAID **\$1.**

RUSH COUPON NOW!

H. G. CISIN—CONSULTING ENGINEER,
Dept. E-6
200 CLINTON ST., BROOKLYN 2, N. Y.
Enclosed is \$_____ for which please rush _____ copies (postpaid) of your **TV TROUBLE SHOOTING METHOD**.

Name.....
Address.....
City..... Zone..... State.....

page 41 starts, "A tuned signal tracer . . ."

Then the sentence, "Of course, if the set has been aligned on a wrong frequency, you may have difficulties, but wrong tracking will show up that trouble immediately."

My original copy read: "If the set has been aligned on a wrong frequency, you know it immediately."

As a result of your editorial revision, not only has my thought been completely altered, in fact, turned on its head, but you have hit me below the belt in a sense.

I have a set which was aligned on a wrong frequency on the bench before me now. It reminded me to get down to the letter writing.

The set is an Emerson Model 1003. The complaint: Weak.

Now—and this is very important—when that chassis is pulled, the dial escutcheon *remains in the cabinet*. All we have on the chassis is a pointer sliding along a blank piece of metal. But with tuned signal tracing we have no need for the dial.

All I did was: 1.—Turn on the set, and tune in a local station. 2.—Turn on my revised Hickok Traceometer, and place the pick-up lead from the tracer near the under-side of the set. 3.—Turn the tracer's dial to pick up the set's i.f. signal as it was passing through the set. 4.—Discover that the set was operating on an i.f. of about 400 kilocycles. 5.—Realize that 400 kc is obviously wrong for any modern set.

To complete the repair I then: 1.—Tuned my signal tracer to 455 kc. 2.—Moved the tuning gang slightly up in frequency. 3.—Adjusted four i.f. screws until both the set, and the tracer were operating in unison at 455 kc. 4.—Adjusted the oscillator parallel trimmer, and the r.f. trimmer, for tracking at the high end of the dial.

The job was done. No signal generator used. . . .

JOHN D. BURKE

*Jack's Radio Shop
Jamaica, N. Y.*

(The change was made after carefully considering the problem. Mr. Burke is quite correct in saying that 400 kc is obviously wrong for any modern set, and in implying that a frequency in the vicinity of 455 kc would be correct in practically all cases. What he overlooks is, that the technician is more likely to be puzzled by sets which do not follow the rule than by standard, modern sets.

For example, suppose a technician on the Pacific coast runs into a set tuned to 262 kc, but which shows all the symptoms of poor or incorrect alignment. He retunes it to 455 and finds an improvement, but not enough. The Pacific coast technician will know exactly what the situation is, and will try to find out from his data just what frequency that particular Patterson receiver is tuned to.

But what would an East Coast man, who may never have seen a Patterson, do? And what would he do with the

OPPORTUNITY AD-LETS

Advertisements in this section cost 35¢ a word for each insertion. Name, address and initials must be included at the above rate. Cash should accompany all classified advertisements unless placed by an accredited advertising agency. No advertisement for less than ten words accepted. Ten percent discount six issues, twenty percent for twelve issues. Objections or misleading advertisements not accepted. Advertisements for Dec. issue must reach us not later than October 21, 1951. Radio-Electronics, 25 W. Broadway, New York 7, N. Y.

SPEAKERS REPAIRED at wholesale prices. Guaranteed workmanship. Fast service. Amprito Speaker Service. 70 Vesey St., New York 7, N. Y.

RAPID RADIO REPAIR by John D. Burke—88-14 168 Street, Jamaica, N. Y. Postpaid \$1.25.

MAGAZINES (BACK DATED)—FOREIGN, DOMESTIC—Arts, Books, booklets, subscriptions, etc. Catalog 10¢ (refund). Ciccone's, 86-22 Northern Blvd. Jackson Heights, N. Y.

WILL BUY ALL ART13/47A \$200.00, ART13/47 \$150.00, RC348 \$85.00, ARC-3 complete \$750.00, R77 Receivers only \$400.00, ARC-1's \$600.00, BC312 \$60.00, BC312 \$65.00, Ship Via Express C.O.D., subject to inspection to H. Finnegan, 49 Washington Avenue, Little Ferry, New Jersey.

WE REPAIR, EXCHANGE, SELL, ALL TYPES OF electrical instruments, tube checkers and analyzers, Hazleton Instrument Co. (Electric Meter Laboratory), 140 Liberty Street, New York, N. Y. Telephone—BARclay 7-4239.

WANTED: AN/APR-4, other "APR-," "ARR-," "TS-," "LE-," ARC-1, ARC-3, ART-13, everything Surplus. Special tubes, Tech Manuals, Lab quality Test Equipment, etc. Describe, price in first letter. Littell, Farhills Box 26, Dayton 9, Ohio.

RADIO—TELEVISION—ELECTRONICS—TUTORING \$5 per lesson—Mo. Tech., 3907 North 25th Street, St. Louis 7, Missouri.

Five Element TV Yagi Beams, Aluminum Tubing Etc. Write for prices. Willard Hadcliff, Fostoria, Ohio.

AMATEUR—RADIO AND ELECTRICAL RESEARCH Engineering. Ily Twillmann, R.R.#1, Chesterfield, Mo.

ANTENNAS AND EQUIPMENT FOR TV AND FM. All Types, lowest prices. Wholesale Supply Co., Lunenburg, Mass.

EVERY RADIOMAN Can Use These SERVICE HINTS! Valuable Manual Yours—FREE!

Every page of "How to Simplify Radio Repairs" is packed with on-the-bench, practical ideas. Contains photos, charts, diagrams—no fluff—no vague theory. In plain every-day language it gives you priceless suggestions—new servicing ideas. You'll use and benefit from the experience of experts. Partial list of contents: How to Localize Trouble; How to Service Amplifiers; How to Test for Distortion; How to Test Audio Circuits; How to Test Speakers; How to Find Faults in Oscillators; How to Test Radio Parts—and it's all yours—FREE! No obligation.

FEILER SEND COUPON OR PENNY POSTCARD FOR YOUR FREE COPY TODAY!

FEILER ENGINEERING CO., Dept. 10RC17
8026 N. Montross Ave.
Skokie, Ill. (Suburb of Chicago)
Please RUSH my FREE copy of "How to Simplify Radio Repairs."
Name.....
Address.....
City..... Zone..... State.....

\$3.00 FOR CARTOON IDEAS
RADIO-ELECTRONICS prints several radio cartoons every month. Readers are invited to contribute humorous radio ideas which can be used in cartoon form. It is not necessary that you draw a sketch, unless you wish.
Address
RADIO CARTOONS, RADIO-ELECTRONICS
25 West Broadway, New York 7, N. Y.

THE FAMOUS "630"

By Regal

Here is the famous "630"—at a new low price. Tried, tested and proven in millions of homes to be the most efficient TV layout yet. It's completely assembled with picture tube. Choose the model and tube size below.

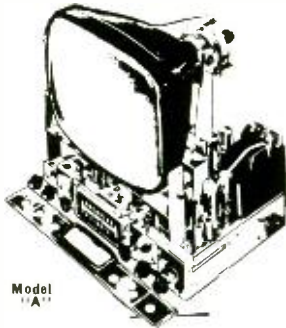

Model "A"

Your choice of model and tube size.



Model "B"

\$149.50

Complete With 16 or 17 Inch Tube

10% Cash With Order

ALMO RADIO CO.
509 ARCH ST. & 6205 MARKET ST.
Philadelphia, Pa.
6th & ORANGE STS. • Wilmington, Del.
4401 VENTNOR AVE. • Atlantic City, N. J.
1133 HADDON AVE. • Camden, N. J.

WANTED TO BUY

Large and small quantities of new or used electronic government or manufacturers' surplus tubes and equipment. Highest prices paid. State quantity, condition and best price in first letter.

Box No. F-2 c/o Radio-Electronics
25 West Broadway
New York 7, N. Y.



ALL GLASS **16"** ALL GLASS

16FP4 BENT-GUN C R TUBE
Fully Guaranteed, in Factory-Sealed Carton

SPECIAL **\$19.95** SPECIAL

READY for SHIPMENT—ORDER NOW!

Federated Purchaser
INCORPORATED

66 DEY ST., NEW YORK 7, N. Y.
DIZBY 9-3050

NEWARK, N. J. 114 Hudson St.
ALLENTOWN, PA. 1115 Hamilton St.
EASTON, PA. 925 Northampton St.
LOS ANGELES, CALIF. 911 S. Grand Ave.

odd, freak set which appears on the Atlantic seaboard? Some of the old Pilots—for example—had an i.f. of 115 kc! And it is more than possible that some of the younger generation, who believe that the correct i.f. is *always* 455, might work for some time over a set before discovering it should be aligned at the one-time "standard" frequency of 175 kc!

Our apologies to Mr. Burke for altering the sense of his article, and we believe he will agree that in talking to the radio service technician, it is necessary to watch for the exceptions. He can be depended on to take the more reasonable "standard" jobs in his stride. —Editor)

LICENSES ARE NECESSARY

Dear Editor:

My job is instrumentation—gauge development—but as to licensing: a number of our people will bring their radios or TV sets to us as a last resort. We can scarcely refuse even though it means lost lunch periods.

But how can you blame them? A fellow with a neon probe and a pair of jeweler's diagonals comes along, looks at the TV set and says, "It won't play—I'll have to take it into the shop." Estimate: \$35. Actual cost: one 3-cent fuse, one \$1.02 resistor, and the time spent in chasing down several leads.

Three more of the same type (in the past month) are still bad after a \$75 expenditure . . .

Now, what protection is available to either the customer or to the honest technician except licensing?

WILLIAM C. ROBERTSON

Alexandria, Va.

(The weakness of the above argument is, of course, the assumption that licensing *will* offer protection to the customer or the honest technician. No doubt it will offer protection against unskilled workers masquerading as service technicians. What the customer chiefly requires to be protected from is the dishonest worker—the over-charger—as this letter and other evidence abundantly proves. While theoretically a proven dishonest technician could have his license revoked, it is known that this has not eliminated the crooked fringe in other licensed trades, such as electricity and plumbing. Licensing may be a step in the right direction, but if accepted as the whole solution to the problem, will inevitably do far more harm than good.—Editor)

BIG BRAIN

Dear Editor:

I am enjoying your series on electronic brains very much. I hope you go on to analog computers after you finish the present series. Then I would like to see a series on control circuits which could be used in guided missiles. Also, I like the New Patents page and the various new and unusual circuits which you print.

RAYMOND T. CARPENTER

San Francisco, Cal.

—end—

WESTINGHOUSE RCA
MULTI-RANGE METER for
RCA Advanced Voltohmist
or Battery Voltohmist
0-200 MICROAMPS

4 scales—ohms, milliamps VDC, VAC and db 2-color scale. 4 1/2" square meter, calibrated, sealed, and made specifically for RCA TVM BRAND NEW **\$12.95**

RCA METER PANELS for the above **\$1.19** CHASSIS partially assembled for Volt-ohmist **\$1.49**
METER BOX for Battery Voltohmist, with strap **\$1.69** former **\$2.89**

DUMONT 4-CIRCUIT INPUTUNER

Featuring FM BAND reception, as well as 13 TV channels. Fits into dual channel IF system. Type 430 receivers, with alteration. Higher gain 2-to-1 ratio on high channels, low noise, input impedance 300 ohms 21.25 mc sound center IF. Continuous tuning. Complete with TUBES and KNOBS. Dramatically reduced to . . .



\$19.95

A COMPLETE INSTRUMENT—NOT A KIT!

5" OSCILLOSCOPE

• HIGH GAIN **\$119.95** • BRAND NEW
• WIDE BAND
• REDUCED to **\$79.95** • Reg. Value \$279

- 1: Vertical Bandwidth 10 Cy to 2 Mc., 3db down
 - 2: Vertical Sensitivity .66 RMS volts/inch
 - 3: Decade Type Frequency Compensated Attenuators
 - 4: Horizontal Bandwidth 2 Cy to 900 KC 6 db down
 - 5: Horizontal Sensitivity .15 RMS volts/inch
 - 6: Push Pull Deflection Amplifiers
 - 7: Direct Connection to Deflection Plates Available
 - 8: Internal Synchronization of Either Polarity
 - 9: X-axis input (Intensity Modulation)
 - 10: Calibrated 60 Cy Test Signal
- Tube Complement:
2-6AG7, 3-6SN7, 1-6AC7, 1-5Y3, 1-2X2, 1-884, 1-5CP1

CARTER DYNAMOTOR

Stock No. 4037AS
DC Input 6VDC;
output 400 V @
37a rails DC. Perfect
for mobile communications in car,
plane or boat.
BRAND NEW. List
\$71.40. Our Price

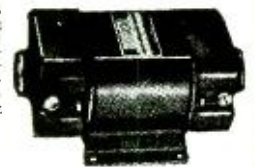

\$34.95

STEP-DOWN TRANSFORMER

Pri. 110-220 V; Sec. 1.5v, 30.5v, 33.5v,
30.5v @ 5 amps. Cased and hermetically
sealed. 4" x 4" x 2", 9 lbs. **\$3.95**

TERMS: 20% cash with order, balance C.O.D. unless rated. Prices F.O.B. our warehouse in N. Y. C. Minimum order \$5. NOTE: Due to conditions beyond our control, prices are subject to change.

Phone Worth 4-3270

ACORN ELECTRONICS CORP.

76 Vesey St., Dept. R-10, New York 7, N. Y.

SCARCE IMMEDIATE DELIVERY

RADIO and TV TUBES

TUBES BOUGHT, SOLD and TRADED
Send Your Want and Trade List!

Complete Line of TELEVISION PICTURE TUBES

Radio and TV service men, experimenters, amateurs . . . we have many types of scarce tubes ready for immediate shipment. Don't use make-shifts or spend valuable time looking for tube sources. Try Electro FIRST . . . and get the tubes you need without delay. Get complete list and Electro's low prices. It's FREE . . . write today!

ELECTRO-SALES 425 W. Randolph St., Chicago 6, Ill.

RADIO SCHOOL DIRECTORY

RADIO ENGINEERING

B. S. DEGREE IN 27 MONTHS

Complete Radio Engineering course incl. Telev., U.H.F. and F.M. BS Degree Courses also in Mech., Civil, Elect., Chem. and Aero Eng.; Bus. Adm., Acct. Extensive campus, modern buildings, well equipped labs. Low cost. Prep. courses. Personalized instruction. Heavy demand for graduates. Placement service. Founded in 1884. Prepare now for the civil and military opportunities ahead. Enter Jan., March, June, Sept. Write for Catalog.

TRI-STATE COLLEGE
24101 COLLEGE AVE. ANGOLA, INDIANA

LEARN DAY and EVENING CLASSES TELEVISION

ELECTRONICS-RADIO

Modern Laboratory instruction in

- SERVICING
- BROADCAST OPERATING
- ELECTRONIC and TV ENGINEERING



WRITE FOR ILLUSTRATED CATALOG
ELECTRONICS INSTITUTE, Inc.
21 HENRY, DETROIT 1, MICH.

- COMPUTING MACHINERY
 - SYMBOLIC LOGIC
- and other subjects

Courses or guided study, by mail—Beginning or advanced—individuals or study groups—Fitted to your interests and pocketbook. Write

EDMUND G. BERKELEY AND ASSOCIATES

MAKERS OF SIMON

World's Smallest Electric Brain

Author "Giant Brains or Machines That Think"

John Wiley & Sons, 1949

36 West 11 St., R10, New York 11, N. Y.

TELEVISION

PREPARE FOR A GOOD JOB!

COMMERCIAL OPERATOR (CODE)
RADIO SERVICEMAN

TELEVISION SERVICING
BROADCAST ENGINEER

Approved for Veterans
SEND FOR FREE LITERATURE

BALTIMORE TECHNICAL INSTITUTE
1425 Eutaw Place, Dept. C, Baltimore 17, Md.

RCA and TELEVISION

Thorough Training For Men and Women in All Technical Phases
APPROVED FOR ELIGIBLE VETERANS
DAY—EVENINGS WEEKLY RATES
FREE PLACEMENT SERVICE FOR GRADUATES
For Free Catalog Write Dept. RC-51

RCA INSTITUTES, Inc.
A Service of Radio Corporation of America
350 WEST 4TH STREET NEW YORK 14, N. Y.

CODE SENDING RECEIVING SPEED

Be a "key" man. Learn how to send and receive messages in code by telegraph and radio. Commerce needs thousands of men for jobs. Good pay, adventure, interesting work. Learn at home quickly through famous Candler System. Qualify for Amateur or Commercial License. Write for FREE BOOK
CANDLER SYSTEM CO.
Dept. 3-L, Box 928, Denver 1, Colo., U.S.A.

F.C.C. COMMERCIAL RADIO OPERATOR'S LICENSE

CRITICAL SHORTAGE OF LICENSED OPERATORS EXISTS

A wonderful future is yours with an F.C.C. commercial radio telephone or telegraph operator's license, leading to top-salaried jobs in aviation, broadcasting, transportation and Civil Service. Sensational new streamlined HOME STUDY course teaches you in the shortest possible time at lowest possible cost. NO OTHER COURSE LIKE IT! Proven valuable during World War II in speedily training thousands of men, eliminates tedious schooling, exam, papers, wading through books. Each page of text directly related to official F.C.C. exam questions, thus assuring you of all theory requirements.

The entire course, nothing else to buy, containing 230 pages of complete material, diagrams, etc., yours for only \$9.95. Send check or money order; or pay postman \$9.95 upon receipt, plus C.O.D. charges. Complete satisfaction guaranteed or money refunded within ten days.

STREAMLINED SELF STUDY COURSES
509 5th Ave. Dept. A New York, N. Y.

ATTENTION...

A NEW department of the DON MARTIN SCHOOL OF RADIO AND TELEVISION ARTS AND SCIENCES . . . for instruction and training in—TELEVISION—Incorporating:

Production: Writing, Directing, Producing, Acting, Staging, Lighting.

Engineering: Transmission, Receiving, Camera and Studio, Operation, Theory of Video, Pickup and Reproduction.

Approved for veterans.

THE DON MARTIN SCHOOL OF RADIO AND TELEVISION ARTS AND SCIENCES

1655 No. Cherokee, Hollywood 28, Calif. HU. 23281.

Approved for Veterans

Bachelor of

Science Degree Engineering

Offered in 18 Mo.

Enroll today. Unlimited opportunity for good paying positions in these rapidly expanding professions.

AUDIO ENGINEERING • RADIO & TELEVISION ENG. • MOTION PICTURE FILM ENG. • BROADCASTING • SOUND RECORDING • UNIVERSITY of HOLLYWOOD

STATE CHARTERED NONPROFIT EDUCATIONAL INSTITUTION

4918 SANTA MONICA BLVD. HOLLYWOOD CALIF.

RADIO ENGINEERING

FM—Television—Broadcast

Police Radio, Marine Radio, Radio Servicing, Aviation Radio and Ultra High mobile applications. Thorough training in all branches of Radio and Electronics. Modern laboratories and equipment. Old established school. Ample housing facilities. 7 acre campus. Small classes, enrollments limited. Our graduates are in demand. Write for catalog.

Approved for Veterans

VALPARAISO TECHNICAL INSTITUTE
Dept. C VALPARAISO, INDIANA

BECOME A RADIO AMATEUR

Complete Home-Study Course for Passing FCC Amateur Radio Examinations

• **LOW COST** •
PERSONAL COACHING
MONEY-BACK GUARANTEE
Write for Details

FEDERAL ELECTRONICS INSTITUTE
34 East Putnam Ave., (Dept. F), Greenwich, Conn.

AUDIO (SOUND) ENGINEERING HOME STUDY TRAINING

Practical, easy-to-understand lessons, written by competent Audio Engineers and Educators, prepare you for a better job and a good future in the Television, Radio, Motion Picture, and Recording Industries.

Write today for details—Learn while you earn!!

HOLLYWOOD TECHNICAL INSTITUTE
Div. RE
4925 Santa Monica Blvd. Hollywood 27, California

RADIO COURSES

Preparatory Mathematics, Service, Broadcast, Television, Marine Operating, Aeronautical, Frequency Modulation, Radar.

Classes now forming for the
Fall term beginning October 1st
Entrance exam. Sept. 17th.

Veterans. Literature.

COMMERCIAL RADIO INSTITUTE
(Founded 1920)
38 West Biddle Street, Baltimore 1, Md.

RADIO ENGINEERING DEGREE IN 27 MONTHS

Intensive, specialized course including strong basis in mathematics and electrical engineering, advanced radio theory and design, television, modern lab. Low tuition. Self-help opportunities. Also 27-month courses in Aeronautical, Chemical, Civil, Electrical, and Mechanical Engineering. Approved for G.I.'s. Enter, Dec., March, June, Sept. Catalogue.

INDIANA TECHNICAL COLLEGE
1510 E. Washington Blvd., Fort Wayne 2, Indiana

The Book that takes Drudgery out of Mathematics

Only **\$1.** postpaid

SOLVES EVERYDAY PROBLEMS HELPS YOU GET AHEAD IN LIFE

How many times have you lost money because of a mistake in figuring? Do you know how to figure quickly and correctly? Can you figure discounts, interest rates, taxes and all the other calculations you meet up with in your daily life?

Are you having trouble qualifying for Civil Service Exams or Armed Services Promotions, because you're not up on mathematics?

Here is the book that gives you a good background in mathematics; that takes all the irritation and drudgery out of it. You don't need to be scared of mathematics, because here's the subject explained without frills, without useless computations. Here's the book for men in radio jobs; for business men; technicians and craftsmen, explaining and answering everyday mathematical problems in easy-to-understand words and illustrations.

The Radio Technician will find information on the following: Ohm's Law—Resistance—Reactance—Capacities—Inductances.

The valuable tables are multiplication and division table, Squares, Square Roots, Cubes and Cubic Roots, Tables, Areas of Circles, Table, Common Fractions reduced to Decimal Table, Factors and Prime Numbers Table, Table of Multiples.

Yes, it's the key to a simple understanding of mathematics. It's a real home-study course in mathematics for the man who's alert to its importance in the world today.

ELEMENTARY MATHEMATICS

• EASY — SIMPLIFIED — PRACTICAL •

CONTENTS OF BOOK

CHAPTER I. Arithmetic—Addition—Subtraction—Multiplication—Division.
CHAPTER II. Factoring and Cancellation—Fractions—Decimals—Percentage—Ratio—and Proportion.
CHAPTER III. The Metric System.
CHAPTER IV. How to Measure Surfaces and Capacity (Geometry).
CHAPTER V. Powers and Involvement—Roots and Evolution.
CHAPTER VI. Mathematics for the Manual and Technical Craftsman—Thermometer conversions—Graphs or Curve Plotting—Logarithms—Use of the Slide Rule.
CHAPTER VII. Special Mathematics for the Radio Technician.
CHAPTER VIII. Commercial Calculations—Interests—Discounts—Short Cut Arithmetic.
CHAPTER IX. Weights and Measures—Useful Tables.

Send Stamps, Cash or Money Order.
Send Today for Your Copy of This Indispensable Book. It Can Be Carried Readily in Your Pocket. (Size 6 x 9 in.)

ONLY \$1. POSTPAID

TECHNIFAX, 520 N. Michigan Ave. Chicago 11, Ill.

Enclosed find \$1.00 for which send me ELEMENTARY MATHEMATICS prepaid.

Name _____

Address _____

City & State _____

RE-10-51

RADIO-ELECTRONICS for

RADIO AMATEUR LICENSE MANUAL (27th edition). Published by American Radio Relay League, West Hartford, Conn. 6½ inches x 9½ inches, 96 pages (including 32 pages of advertising). Price 50¢.

This latest revised issue of the well-known amateur guide has special importance because of the new novice and technician licenses now being issued. These classes of license require a code speed of only five words per minute. The theory test for novice license is very simple. A more advanced examination is given for technician license which permits operation on ham bands above 220 mc. The manual describes all classes including these new ones.

Separate chapters are devoted to each amateur class license. Clear language describes who is qualified, how to obtain a license, regulations which apply, and operating information. Each chapter carries its own sample questions and answers, with schematic diagrams included where needed (except for the extra class which is not yet effective).

The guide also includes a map of U.S. zone areas, schedule of times and places where license exams are given, U.S. and international regulations, and an index.

ULTRASONICS, by P. Vigoureux, Published by John Wiley & Sons, Inc., 440 Fourth Ave., New York 16, N. Y. 6½ x 10 inches, 163 pages. Price \$4.00.

The object of this work is to introduce the reader to the technique and simpler aspects of the theory of propagation of ultrasonics in fluids. Unlike many texts, this explains, in clear, simple English, basic and advanced concepts of propagation in liquids and gases. Math is held to a minimum, with special relations explained clearly by numerous graphs. A good bibliography is appended.—*MMK*

ELECTRON MICROSCOPIC HISTOLOGY OF THE HEART, by Bruno Kisch and Joan Bardet. Published by the Brooklyn Medical Press, P.O. Box 99, Cathedral Station, New York 25, N. Y. 6¾ x 10 inches, 106 pages. Price \$5.00.



Bob Sch

Suggested by Joe E. Buresch, Venetia, Pa. "This theatre shows movies only to television fans."

OCTOBER, 1951

Microphotographs taken of heart tissue, using the RCA model B electron microscope, reveal new structures of sarcosomes and sarcoplasm granules. This is a careful report, with numerous microphotographs, but lacks an index.—*MMK*

TELEVISION TUBE LOCATION GUIDE (TGL-2). Published by Howard W. Sams, Inc., Indianapolis, Ind. 5½ x 8½ inches. Pages not numbered, 219 diagrams. Price \$2.00.

Second volume in the *Television Tube Location Guide* series, this book enables the TV service technician to identify all tubes and their circuit functions from the top of the chassis. This feature often makes it possible to repair a TV set speedily when the trouble is limited to a defective tube.

The new volume takes up where the earlier one leaves off. It contains tube placement data on most new models as well as on some earlier models not covered in the first volume.

RCA VICTOR SERVICE DATA—Volume V (1949) and Volume VI (1950), prepared by RCA Service Co., Inc. for Radio Corp. of America, Harrison, N. J. Both volumes are 9 x 11½ inches. Volume V has 330 pages and Volume VI has 472. List prices at RCA distributors, \$5.00 and \$5.50 respectively.

These volumes are compilations of service data sheets previously issued for RCA Victor receivers, TV sets, record players and changers, phono preamplifiers, and battery eliminators during 1949 and 1950.

The sheets have been corrected and revised to include production changes. They contain such information as schematic and wiring diagrams, electrical and mechanical specifications, alignment and adjustment procedures, complete parts lists, chassis layouts, and other useful servicing data.

TV AND OTHER RECEIVING ANTENNAS (Theory and Practice), by Arnold B. Bailey. Published by John F. Rider Publisher, Inc., New York. 5¾ x 8¾ inches, 595 pages. Price \$6.00.

Those who have been wading through such nebulous terms as "all-band" and "superdirectional" in search of practical knowledge and performance data on antennas will find the end of their search in this book. As implied in the title, the stress is on TV antennas, but the approach is such that the material presented is readily applied to antennas in general as used in the higher frequency ranges.

After a brief review of terminology and the nature of the television signal and its reception problems, the author goes directly into the theory of antennas minus the high-powered mathematics so often used in books of this type. About half the volume deals with antennas that are actually used, and an outstanding feature of the book is a number of data sheets which give performance characteristics, patterns, and a simple sketch of the more common antenna types. These enable the technician to select the most suitable antenna for any given situation.

NOW! BECOME EXPERT AT RADIO-TELEVISION IN 4 EASY STEPS!



Complete Self-Training Course in RADIO and TV by Famous Experts—Takes You BY SIMPLE STEPS From Basic Theory to Problems of Repair, Installation, Color TV, etc.

NOW you can do ANY Radio-TV installation, service, or repair job like an expert; operate field-testing equipment; understand problems of TV, FM-AM transmission, etc. Step into a good-paying job—or start your own service business. Train yourself AT HOME... IN SPARE TIME... with the McGraw-Hill Basic Course in Radio and TV.

2296 Pages—1611 Illustrations

The men who wrote this complete 4-volume course are among the outstanding radio and TV instructors in America today. Every detail is clearly explained in over TWO THOUSAND PAGES of step-by-step instruction and over SIXTEEN HUNDRED "how-to-do-it" illustrations, cross-section diagrams, etc. The review questions and answers "nail down" everything you learn. At-a-glance "trouble-shooting" charts show how to diagnose instantly any radio or TV breakdown... and how to repair it expertly and quickly.

The course will pay for itself many times over. It can qualify a beginner for FCC's 1st-Class License test; gives an experienced technician more confidence and skill.

SEND NO MONEY

Mail coupon below to examine complete four-volume course FREE for 10 days. No obligation. Or you may examine individual books FREE for 10 days by checking the proper boxes in coupon.

PARTIAL CONTENTS ESSENTIALS OF RADIO. 800 pages, 433 illus. Circuit Analysis • Vacuum Tubes • Circuits • Detector • Amplifier • Tube Oscillator • Power Supply • Transmitting Receiving • Etc.

ELEMENTS OF RADIO SERVICING. 475 pages, 375 illus. Multimeters • AC Power Supply • Speakers • Antennas • Auto Radios • Push-Pull Output Stage

BASIC TELEVISION. 592 pages, 415 illus. Scanning • Synchronizing • Video Signal • Brightness Control • DC Reinsertion • Picture • FM Alignment • Picture Tubes • VHF and UHF transmission • Reception

TELEVISION SERVICING. 429 pages, 388 illus. Antennas • Transmission Lines • Test-pattern and Picture Analysis • Localizing Reception Troubles • Interference Remedies • Deflection Circuits... AND MUCH MORE

FREE 10-DAY TRIAL COUPON

McGraw-Hill Book Co., Inc., Dept. RE-10-51, 327 West 41st St., New York 18, N. Y.

Send me for 10 day free examination the Basic Course in Radio and TV, 4 Vols. (Regular retail price is \$23.75; Special Course Price only \$19.95 in easy installments.) If not satisfied with Course, I will return it, pay nothing. Otherwise, I'll send \$1.95 plus delivery then and only \$3.00 in monthly installments.

If you wish to examine any of these books individually, check below the ones you wish us to send you for 10 Days' FREE EXAMINATION:

<input type="checkbox"/> Essentials of Radio, \$6.50	<input type="checkbox"/> Elements of Radio Servicing, \$4.75
<input type="checkbox"/> Basic Television, \$6.50	<input type="checkbox"/> Television Servicing, \$6.00

For any book I keep, I'll send \$2.00 plus delivery in 10 days, balance in easy monthly installments.

Name.....

Address.....

City..... Zone..... State.....

Position.....

RE-10-51

Company.....

WE PAY FOR DELIVERY if you send first payment of \$1.95 when ordering Course or full price when ordering individual books (prices above). Same return privilege.

TAB That's A Buy!

ELECTRONIC THRIFT-LITE Sensational Lightweight Photoflash with Lifetime Flash Tube, Works with any Camera. New... \$44.50

TUBES NEW-GUARANTEED

Table of vacuum tubes with columns for tube type (e.g., 19c, 2C26, WE215A), price, and other specifications.

Infrared Snooperscope Image-Converter Tube High-sensitivity simplified design 2" dia. Willemite screen Resolution up to 350 lines/in. Complete data & tube, each. \$4.98; 2 for \$9.49

Table for 6-VOLT INPUT CARTER GENERATORS with columns for Output, List, and Each price.

Table listing various electronic components and their prices, including US Navy Version, Radio Comp, and various tube types.

Sell Your SURPLUS TUBES & Gear To 'TAB'—Send List & Best Prices

Advertisement for 'TAB' featuring images of electronic components and contact information for Dept. 10RE, 6 Church Street, New York 6, N. Y.

ADVERTISING INDEX

Table listing various companies and their advertising rates, including Acorn Electronic Corp., Alliance Manufacturing Co., Allied Radio Corp., etc.

Table listing various companies and their advertising rates, including Radiant Corporation, Radio Apparatus Corp., Radio City Products Company, Inc., etc.

RADIO SCHOOL DIRECTORY Page 126

Table listing various radio schools and their locations, including Baltimore Tech. Inst., Berkeley & Associates, Martin School, Don Candler System Company, RCA Institutes, Inc., Streamlined Study Course, etc.

Advertisement for JFD Manufacturing Co. featuring 'The Largest Selling LIGHTNING ARRESTER At Any Price!' and 'JUNBO' brand lightning arresters. Includes UL logo and 'APPROVED' text.

Table listing various electronic components and their prices, including 0Z4, 0Z4C, 1B3GT, 1R5, 1U4, 3A4, 3A5, 3D6, 3S4, 3Q4, 5U4C, 5Y4C, 5Y3GT, 6B4, 6AL5, 6AG5, 6A6, etc.

DYNAMOTORS BRAND NEW — BOXED

Table listing dynamotor specifications and prices: 6 V. INP—400 V. out @ 375ma. \$28.00; 6 V. INP—570 V. out @ 250ma. \$33.00

New Selenium Rectifiers Full Wave Bridge Types

Table listing selenium rectifier specifications: Current (1 Amp, 2 Amp, 4 Amp, 6 Amp, 8 Amp, 12 Amp, 24 Amp), Volts (18/14, 36/28, 54/40, 110/100), and Price (\$3.75, \$7.50, \$10.50, etc.).

We have an interesting inventory of End-Equipment—write BARRY ELECTRONICS CORP. 136 Liberty St., N. Y. 6, N. Y. Recto 2-2563

ELECTRONS AND HOLES IN SEMI-CONDUCTORS, by William Shockley. Published by D. Van Nostrand, Inc., 250 Fourth Ave., New York, N. Y. 6 1/2 x 9 1/4 inches, 558 pages. Price \$9.75.

Written by one of the team who developed the device, this book provides a practical theoretical and working knowledge of transistors describing in clear language the concept of the positive hole and its negative counterpart, the excess electron.

This difficult subject is handled in a remarkably lucid fashion, with fully one-half of the book presenting the theory in pictorial and descriptive terms easily understood. Basic quantum and statistical mechanical principles are handled, and the reader is "led along" to more difficult concepts.—*MMK*

BASIC RADIO COURSE, by John T. Frye. Published by Radcraft Publications, Inc., 25 West Broadway, New York 7, N. Y. 5 3/4 x 8 3/4 inches, 176 pages. Price \$2.25.

The radio worker has seen too many books on radio and television servicing which continually digress into works on theory instead of sticking to the main job of explaining repair techniques. A book with the opposite emphasis may be welcomed.

Frye, while writing on basic radio fundamentals, does not hesitate to throw in a few hints on servicing the circuits under discussion, drawing on his experience as a service technician. This should make it more readable to the average technician or radio student.

The contents of the book are known to many readers of this magazine, in which it appeared as a serial from February, 1949, to April, 1951.

AN INTRODUCTION TO LUMINESCENCE OF SOLIDS, by Humboldt W. Leverenz. Published by John Wiley & Sons, Inc., 440 Fourth Ave., New York 16, N. Y. 6 1/4 x 9 1/4 inches, 569 pages. Price \$12.00.

This book is intended for nonspecialists in luminescence, and provides in orderly fashion a fairly complete and useful description of luminescent solids, particularly artificial (man-made) phosphors. The book is packed full of useful information presented on a graduate level. Particularly valuable are the almost 100 pages covering references and the Formula, Name, and Subject indexes.—*MMK*

—end—



1% PRECISION RESISTORS				GIBSON GIRL	
.6	468	33,000			
1.01	800	40,000			
5	920	55,000			
5.05	1100	57,000			
10.1	1400	75,000			
18	5000	84,000			
43.5	7500	30c ea.			
50	8500	10 For			
75	10,000	\$2.50			
82	10,000	100,000			
124	10,000	129,000			
125	12,000	120,000			
128	12,000	150,000			
150	17,000	220K			
128	17,300	250K			
250	20,000	40c ea.			
300	25,000	10 For			
430	30,000	\$3.50			
1 Meg. 75c ea.					

The Emergency Radio Transmitter. Send S O S signals automatically on 500KC. 150-mile range. No batteries required. Has hand-driven generator tubes, wire. New. It's only...\$5.95

DYNAMOTORS						
Type	Input Volts	Input Amps.	Output Volts	Output Amps.	Radio Set	Price
PE86	28	1.25	250	.060	RC 36	\$2.95
DM416	14	6.2	330	.170	RU 19	6.95
DM33A	28	7	540	.250	BC 456	4.95
DM42	14	46	515	.110	SCR 506	4.95
			1030	.050		
			2/8			
PE101C	13/26	12.6	400	.135	SCR 515	5.95
BD AR 93	28	6.3	800	.020		4.45
23356	27	1.75	285	.075	APN-1	3.50
35C0458	28	1.2	250	.060		
ZA-085	12/24	4/2	500	.050		
ZA-056	12/24	8/4	12/275	3/110		
B-19 pack	12	9.4	275	.110	Mark II	8.75
D-104	12		500	.050		12.69
			440	.200		
DA-3A	28	10	300	.060	SCR 522	8.45
			150	.010		
			14.5	.5		
5053	28	1.4	250	.060	APN-1	3.95
PE73CM	28	19	1000	.350	BC 375	9.95
CW21AAX	13	12.6	400	.135		
	26	6.3	800	.020		
			9	1.12		
BD 77KM	14	40	1000	.350	BC 191	12.95
PE94	28	10	300	.200	SCR 522	
			150	.010		
			14.5	.5		

CAPACITORS CERAMICON		
MMF.	MMF.	MMF.
3	35	82
3.1	35	125
4	47	200
5.4	50	240
6.4	50	250
6.4/6A	60	345
3A, 1.25/	150	350
3A, 115V 2.0 cv	65	500
input. Price. \$.395	70	1000

T.V. Transformer, 7" or 9" scope, 3000 v/5 MA, 720vct / 200 MA. 6-4/8-7A. 6-4/6A. 5/3A, 1.25/3A, 115V 2.0 cv input. Price. \$.395

Rated Concerns Send P.O. Minimum Order \$3.00
Send N.O. or CHK. Mds. Guartd. Shpg. Charges
Sent C.O.D. Price F.O.B. N.Y.C. Phone Di. 9-4124

COMMUNICATIONS EQUIPMENT CO.
131 Liberty St. Dept. C-10 New York City 7, N. Y.

Valuable guides for television technicians

Check the ones that can help you most and see them on approval

1. **Movies for TV**

By Battison. All the information you need to choose the best equipment, operate it efficiently and make the most effective use of films on TV. Shows what may go wrong and how to avoid it; how to edit film, produce titles, special effects, commercials, newsreels, combine live scenes with film, and all other techniques. \$4.65

2. **Television & FM Antenna Guide**

By Noll and Mandl. Complete data on all VHF and UHF antennas, including information on new types given here for the first time. Shows how to select the right type for the site, where and how to install it, how to minimize noise from transmission line, and all other techniques needed to insure getting the most out of any antenna system. \$5.50

3. **Television for Radiomen**

By Noll. Clear, non-mathematical explanation of the operating principles and function of every part and circuit in today's TV receivers and the basic principles of transmission. Full instruction in installation, alignment, testing, adjustment, trouble-shooting. \$7.00

4. **Radio and Television Mathematics**

By Fischer. 721 sample problems and solutions show you what formulas to use, what numerical values to substitute, and each step in working out any problem you may encounter in radio, television or industrial electronics. Conveniently arranged for quick reference. \$6.00

YOUR COPY of NEW 1951 COMPLETE GREYLOCK CATALOG

IS NOW **READY!**

Send for it Today!

68 Pages crammed full of Radio—Electronic—Television quality merchandise at terrific savings! Many standard lines carried, including:

- BOGEN Challenger Line, Boosters
- JACKSON Instruments
- RIDER Publications
- CORNELL-DUBILIER Vibrators, Converters, Rotators
- SPRAGUE
- REGENCY
- HYTRON
- BURGESS
- ELECTRO-VOICE
- JENSEN

High quality Greylock Tubes still available at some of Today's best prices.

If you sell or service Radio, TV or Electronics equipment, you can't afford to be without this GREAT BUYING GUIDE! Write NOW for your copy (unless already on our mailing list).

GREYLOCK ELECTRONICS SUPPLY CO.
115 Liberty Street • New York 6, N. Y.

USE THIS COUPON

The Macmillan Co., 60 Fifth Ave., New York 11

Please send me the books checked by number below. I will either remit in full or return the books in 10 days.

1. 2. 3. 4.

Signed

Address

SPECIAL MOTORS

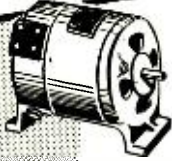

SELSYNS

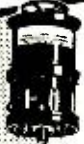

DYNAMOTORS



POWER UNITS



BLOWERS



THIS EQUIPMENT IS THE FINEST AVAILABLE, BUILT BY LEADING MANUFACTURERS AND UNCONDITIONALLY GUARANTEED BY WELLS. MANY TYPES NOT LISTED ARE IN STOCK. SEND US YOUR REQUIREMENTS FOR IMMEDIATE QUOTATION.

MANUFACTURER	TYPE OR NO.	VOLTAGE	RPM	DIMENSIONS	SPECIAL INFORMATION
Stewart Warner		6VDC		2 1/4" x 2 3/4"	1/4" x 1/2" Lg. shaft
John Oster	B-9-2	12VDC 1.4A	5600	2 1/4" x 3 3/4"	1/4" x 1/8" Lg. shaft. Shunt Wd.
General Ind.	62800	13VDC 9A	6800	2 1/8" x 4"	1/4" x 3/4" Lg. shaft. 1/12 HP
Emerson	D-26-BT	24VDC 24A	100	2 1/4" x 5 1/2"	160 Ft.-Oz. torque
Redmond	7-N	24VDC .96A	6000	2 3/4" x 3 1/4"	Complete blower assembly
F. A. Smith	40H	115VAC 60 Cy		6" x 5 1/2" x 5"	100 CFM blower (\$12.95)
Western Elect.	FL	115VAC 400 Cy	6700	3 1/4" x 4" x 4 1/2"	25 CFM blower
Signal Elect.	D-4272	24VDC .66A	2100	2 1/4" x 2 1/2"	3/4" x 1" shaft. 1/190 HP
General Elect.	5 BA50M164	24VDC 13A		3 3/8" x 7 1/2"	Shunt wound
Stromberg	D-4496	24VDC .45A		2 1/2" x 3 1/4"	1/4" x 3/4" shaft. .003 HP
Amglo		24VDC		1 1/2" x 2 1/2"	Telephone ringing circuit motor
John Oster	A-16B-26R	26VDC		1 1/2" x 2 1/2"	3/16" x 3/16" shaft. Series Rev.
John Oster	DEST-8-1R	27VDC 1.4A	3800	2 1/4" x 4 5/8"	3/8" x 3/4" shaft. 1/40 HP
Delco	5069267	27.5VDC .25A	6000	1 1/2" x 2 1/2"	1/4" x 1 1/4" shaft. 1 1/2 Oz.-In Tq.
Western Elect.	KS5996-LO4	28VDC		2" x 2 1/2"	3/16" x 3/8" shaft. Series Rev.
Bendix	M05B	28VDC 1.75A	3200	1 1/2" x 2 1/2"	1/4" x 1 1/8" shaft. Series Rev.
Bendix	E-11500-1	28VDC 1A	9000	1 1/2" x 2 1/2"	1/4" x 1 1/8" shaft. Series Rev.
Fractional Mtrs.	SH-280	28VDC 3.1A	3900	3 1/4" x 5 1/2"	1/4" x 5/8" shaft. Used in ART 13
Electrolux	20100	28VDC 1A		2" x 2 1/2"	3/8" x 5/8" shaft. 20 Deg. rotation
John Oster	A-21-E-12R	28VDC .4A		1 1/2" x 2 3/4"	3/8" x 3/8" shaft. Series Rev.
Emerson	D-26-BV	28VDC 3.1A	3900	2 1/2" x 3 1/4"	1/4" x 5/8" shaft. 1/20 HP
Electrolux	16876	28.5VDC 1.8A	2200	3 3/4" x 5"	1/4" x 1 1/4" shaft. 1/35 HP
Western Elect.	KS 9303	50-60VAC 175 Cy		2 1/2" x 3 1/4"	
General Elect.	21JH1	57.5VAC 400 Cy		2 1/4" x 3 1/4"	Selsyn differential
General Elect.	21JG1	57.5VAC 400 Cy		2 1/4" x 3 1/4"	Selsyn transmitter
General Elect.	5BN38HA10	80VDC .25A	3000	2 1/8" x 5 1/2"	1/4" x 3/4" lg. shaft
General Elect.	21JF1	115VAC 400 Cy		2 1/4" x 3"	Selsyn generator
Diehl	11-1	110VAC 60 Cy		4" x 5 1/2"	Synchro repeater selsyn
Bendix		110VAC 60 Cy		3 1/4" x 5 1/2"	Synchro differential selsyn
Bendix		110VAC 60 Cy		3 1/4" x 5 1/2"	Synchro transmitter selsyn

MANUFACTURER	TYPE OR NO.	INPUT	OUTPUT	DIA.	LGTH.	SPECIAL INFORMATION
Eicor	ML3415-254	27.5VDC 1.5A	250VDC .060A	4"	8 3/4"	With bracket mounting
Eicor	ML3412-42	13.8VDC 2.45A	220VDC .070A	3 3/8"	5 1/2"	No mounting
Western Elect.	DM53AZ	14VDC 2.8A	220VDC .080A	2 3/4"	4 1/2"	With base plate
Westinghouse	1171187A	27VDC 1.4A	285VDC .060A	2 1/4"	4 1/4"	No mounting
General Elect.	5DY82AB52	27VDC 1.5A	285VDC .060A	2 3/4"	4 1/2"	No mounting
Western Elect.	1171091B	27VDC 1.6A	285VDC .075A	2 3/4"	4 1/2"	No mounting
Redmond	5047	27VDC 1.75A	285VDC .075A	2 3/4"	4 1/2"	No mounting
Eicor	ML3415-254	27.5VDC 1.5A	100VDC .150A	3 1/2"	5 1/2"	With base plate.
Eicor	ML3420-194	27.5VDC 4.0A	325VDC .200A	3 3/8"	6 1/2"	With base plate
C.Q.R.	355D2BA	27.9VDC 1.25A	220VDC .070A	3 3/8"	5 1/2"	No mounting
Continental	DM310A	28VDC .5A	100VDC .01A	2 3/4"	4 1/2"	No mounting
C.A.Y.	DM32A	28VDC 1.1A	250VDC .060A	2 3/4"	4 1/2"	With base plate
Pioneer	PE86M	28VDC 1.25A	250VDC .060A	2 3/4"	4 1/2"	With base and filter
Bendix	DA-1A	28VDC 1.6A	230VDC .100A	3 3/8"	5 1/2"	No mounting
Redmond	DM5 3A	28VDC 1.4A	220VDC .080A	2 3/4"	4 1/2"	With base plate
Redmond	5056	28VDC 1.4A	250VDC .060A	2 3/4"	4 1/2"	With base plate.
Eicor	ML-3420-90	28VDC 3.3A	400VDC .125 A	3 1/2"	6 1/2"	With base plate
Continental	DM33A	28VDC 5A	575VDC .160A	3 1/2"	7 1/2"	Cont. duty. No mounting
Winco	41S6	13VDC 13A	250VDC .060A	4" x	8 3/4"	With base plate
		13VDC	300VDC .225A			Intermittent
Continental	DMX310A	12VDC 2.8A	150VDC 100A	2 3/4"	4 1/2"	Cont. Duty. No mounting
Airs	VA 137	115VAC 60 Cy	90-135VAC 7.6A	3 3/4"	5 3/4"	3/8" x 1" Shaft. Ind. Volt Reg.
				DIMENSIONS		
Pioneer	PE 55	12VDC .16A	500VDC 0.2A	7 1/4" x 12 1/2" x 13 1/2"		Pwr. Unit W/DM 19G DYN, Filter and Mounting
Westinghouse	PE 94C	28VDC 10.5A	300VDC .260A	8 1/4" x 6 1/2" x 12 1/2"		Pwr. Unit W/DA3A DYN, Filter and Mounting
			150VDC .010A			
			14.5VDC 10A			

CHECK WELLS' HUGE STOCK FOR IMMEDIATE DELIVERY OF QUALITY COMPONENTS AT SUBSTANTIALLY LOWER COST

- Resistors • Condensers • Wire and Cable • Relays
- Co-ax Connectors • Rectifiers • Transformers • Chokes
- Micro Switches, Toggles • Antennas • Accessories
- Electronic Assemblies • Dial Light Assemblies

Seeley 8-4143

MANUFACTURERS AND DISTRIBUTORS: WRITE FOR CATALOG

ORDER DIRECT OR THROUGH YOUR LOCAL PARTS JOBBER

WELLS SALES, INC.

833 W. CHICAGO AVE., DEPT. Y, CHICAGO 22, ILL.



You wouldn't want a car that drives only in circles!

Of course not. What you want is a car that will go where you want it to go. And so it is with volume controls, too... a survey of hundreds of servicemen revealed the importance you place on adaptability to the job at hand. Naturally, you want a control that is easily tailored to *any* job.

Make Sure! Make it Mallory!

Using the Mallory Midgetrol* helps you make sure that the installation is exactly as you want it... easier for you and insuring complete customer satisfaction.

There are three big reasons why the Midgetrol $\frac{15}{16}$ " control does a better job... because the *permanently fixed tubular brass shaft* can be adapted for any popular knob in a few seconds... because AC switch attachment is simple and positive... because the precision-controlled carbon element gives

smoother taper, quieter operation, more accurate resistance value and less drift in TV sets.

These same advantages are available in the Dual Concentric Midgetrol, tailor-made on the job to match each specific requirement. It is assembled in five easy steps, in less than five minutes, using complete, *factory-inspected* control sections. You can make over 10,000 different combinations from sub-assemblies available in distributor stocks.

Make it Mallory and make sure! Ask your distributor to show you the Mallory Midgetrol... with the features that make installation faster and surer than ever.

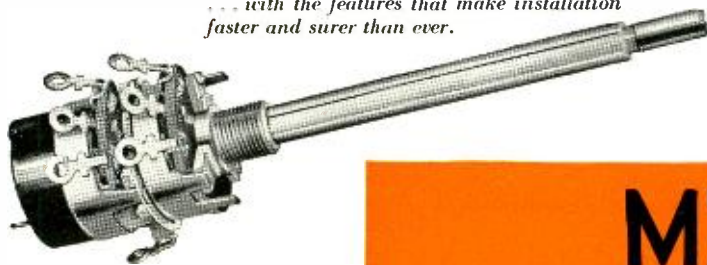

Complete Dual Concentric Midgetrol illustrated. Single section control available in complete line of resistance values.

P. R. MALLORY & CO. Inc.
MALLORY

CAPACITORS • CONTROLS • VIBRATORS • SWITCHES • RESISTORS
• RECTIFIERS • VIBRAPACK* POWER SUPPLIES • FILTERS

*Reg. U.S. Pat. Off

APPROVED PRECISION PRODUCTS

P. R. MALLORY & CO., Inc., INDIANAPOLIS 6, INDIANA

THE QUALITY OF RCA TUBES IS UNQUESTIONED



It's fundamental...

**the best established brand name
is your biggest stock in trade**

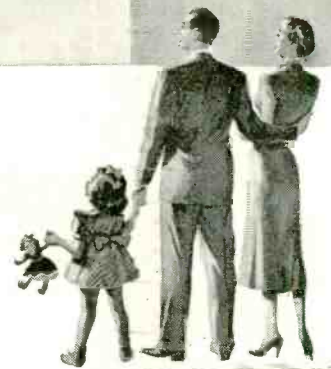

Every RCA picture tube you install sells the idea of long-term, high-quality performance . . . and helps develop a permanent customer. Stocking and recommending RCA picture tubes is good business, because no other brand enjoys greater customer confidence . . . and customer confidence is your stock in trade.

Remember—more RCA picture tubes are now in active service than those of any other manufacturer . . . over 5 million since the advent of commercial tele-

vision, when RCA pioneered the first large-scale production of picture tubes. Yes, RCA picture tubes of all types have consistently given outstanding performance.

And, today, RCA kinescopes carry a factory warranty that guarantees your customers against any defect for six months from the date of installation.

Your local RCA Tube Distributor carries a complete line of RCA kinescopes. Whether you want one or a hundred . . . he's ready to serve you.

Keep informed . . . keep in touch with your RCA Tube Distributor



RADIO CORPORATION of AMERICA
ELECTRONIC TUBES HARRISON, N. J.