

DECEMBER 1951

# RADIO — ELECTRONICS

LATEST IN TELEVISION • SERVICING • AUDIO

HUGO GERNSBACK, Editor

LIGHT-SENSITIVE  
ELECTRONIC BEAST

SEE ELECTRONICS



30¢  
U.S. and  
CANADA

*In this issue:* Measuring Distortion • Scotsman's Super •  
New Life for Old Radios

# You get all five

## ...with RCA Batteries

### 1. Radio-Engineered Quality

(for extra listening hours)

2. Radio Trade Distribution

3. Top Brand Acceptance

4. Greatest Array of Selling Aids

5. Completely Rounded Line

### What is "radio-engineered quality"?

It's the extra performance you get from batteries that are specifically designed for radio use and built to exacting quality standards of RCA's tube and battery engineers.

For your customers, "Radio-Engineered Quality" means extra listening hours, greater satisfaction.

For you, it means more repeat sales, greater profits.

You get *plenty of other benefits*, too, when you stock and sell the RCA line . . .

**You get Radio Trade Distribution . . .** RCA Battery distribution steers customers back to radio dealers and servicemen . . . away from the non-radio outlets. Repeat sales come back to *you*, again and again.

**You get Top Brand Acceptance . . .** a *pre-sold* name that's known to every radio and TV set owner in America, a *name that sells itself*.

**You get the greatest array of Selling Aids . . .** signs, displays, merchandisers, servicing aids . . . all helping you to make sales right at the point of purchase.

**You get a Completely Rounded Line . . .** for example, there are seven batteries designed to meet most of your demand. The complete line provides a type for almost every portable and farm radio need.

• • •

**Call your local RCA Battery Distributor now.** Get full details on how you too can join in the *radio-trade* switch to RCA *Radio-Engineered* batteries. Hundreds of other radio dealers and servicemen are finding they are the *batteries geared to their radio trade*. You will too. So call your RCA Battery Distributor. Get lined up for more battery sales, better profits . . . *today*.



**RADIO CORPORATION of AMERICA**  
RADIO BATTERIES

HARRISON, N. J.

**NEW**



**I'LL TRAIN YOU FOR YOUR FCC LICENSE**

A Federal Communications Commission Commercial Operator's License puts you in line for a good job in Radio or Television Broadcasting, Police, Marine, Aviation, Two-way, Mobile or Micro-wave Relay Radio. Mail coupon below for 64-page book FREE. It will give you complete facts about my NEW Communications course.

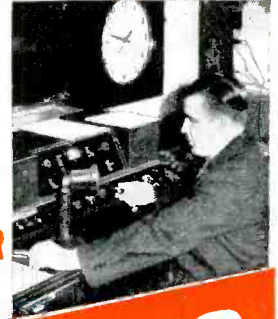

**YOU BUILD THIS TRANSMITTER**

with parts I send. With this Transmitter you practice how to put a station "on the air." You perform procedures demanded of Broadcast Station Operators, conduct many experiments, make many practical tests.

**LEARN COMMUNICATIONS by PRACTICING at Home in Spare Time**

**with MANY KITS of RADIO EQUIPMENT I SEND**



**MY COURSE INCLUDES TELEVISION**

**Course Is New! Different!**

Mail coupon now for facts about my NEW, intensely practical course in Radio-Television Communications. Let me send you FREE book. Read outlines of 78 lesson texts written by leaders in Communications and edited for you by my practical staff. See the nine big Kits of Parts I send that "bring to life" theory you learn. Read about the Transmitter you build and operate, about the Electronic Multitester you get. All equipment yours to keep. My NEW course covers Theory thoroughly and you get Practical Experience building units like those shown at the left. It's backed by N. R. I.—the world's oldest and largest home study Radio-Television school.

**Mail Coupon For Book FREE**

Send today! See what my NEW course is like. Find out how I get you ready for a brighter future, better earnings, more security in Radio-Television. Send coupon now in envelope or paste on a postal. NO OBLIGATION. NO SALESMAN WILL CALL! My book, sent to you FREE, tells the full story. J. E. SMITH, President, Dept. INF, National Radio Institute, Washington 9, D. C.



**YOU BUILD** this Transmitter Power Supply used in the basic experiments in RF and AF amplifiers, frequency multipliers, buffers, etc.



**YOU MEASURE** current, voltage (AC, DC and RF), resistance and impedance in circuits with Electronic Multitester you build. Shows how basic transmitter circuits behave; needed to maintain station operation.



**YOU PRACTICE** setting up code, amplitude and frequency modulation circuits (put voice, music, etc., on "carrier signals" you produce). You learn how to get best performance.

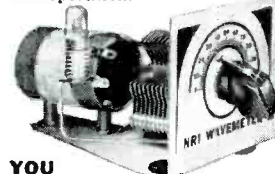

**YOU BUILD** this Wavemeter and use it to determine frequency of operation, make other tests on transmitter currents.



**EXTRA PAY IN ARMY, NAVY, AIR FORCE**



Knowing Radio, TV, Electronics can help you get extra rank, extra prestige, more interesting duty at pay up to several times a private's base pay. You are also prepared for good Radio-TV jobs upon leaving service. Mail Coupon TODAY.

**I TRAINED THESE MEN**



"N.R.I. has been my stepping stone from a few hundred to over \$4,000 a year as a Radio Engineer."—ALTON B. MICHAELS, Trenton, Georgia.



"I am employed by WKBO as transmitter operator. Have more than doubled salary since starting in Radio full time!"—A. HERR, New Cumberland, Penna.



"Am Broadcast Engineer at WLFM. Your NEW Communications course shows the kind of equipment we use."—J. BANGLEY, JR., Suffolk, Virginia.



"4 years ago, I was a book-keeper with hand-to-mouth salary. Am now Radio Engineer with ABC network."—N. H. WARD, Ridgefield Park, N. J.

**Servicing Training Also Offered by N. R. I.**

If you prefer a good-pay job in Radio-Television Servicing or your own money-making Radio-Television Sales and Service Shop, I'll train you at home. My famous Servicing Course also includes many Kits of Radio Parts. You use them to get PRACTICAL EXPERIENCE with circuits common to Radio and Television. I also show you how to make \$5, \$10 a week or more EXTRA MONEY fixing neighbors' Radios while training. Full information in my 64-page book. Mail coupon.

**MAIL NOW-BOOK FREE**

**MR. J. E. SMITH, President, Dept. INF, National Radio Institute, Washington 9, D. C.**

Mail me your 64-page Book about Radio and Television Communications opportunities and training. (No salesman will call. Please write plainly.)

Name..... Age.....

Address.....

City..... Zone..... State.....

Approved Under G. I. Bill

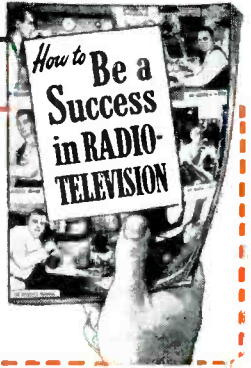

# RADIO - ELECTRONICS

Incorporating  
**SHORT WAVE CRAFT\* TELEVISION NEWS\***  
**RADIO & TELEVISION**  
 \*Trademark registered U. S. Patent Office

formerly **KADIO-CRAFT**  
 MEMBER  
 AUDIT BUREAU OF CIRCULATIONS

Hugo Gernsback, Editor-in-Chief  
 M. Harvey Gernsback, Editorial Director  
 Fred Shunaman, Managing Editor

Robert F. Scott, W2PWG, Technical Editor  
 I. Queen, Editorial Associate  
 Angie Pascale, Production Manager  
 Wm. Lyon McLaughlin, Tech. Illustration Director  
 Lee Robinson, General Manager  
 John J. Lamson, Sales Manager  
 G. Aliquo, Circulation Manager  
 Robert Follath, Promotion Manager

## CONTENTS ————— DECEMBER, 1951

<b>Editorial (Page 23)</b>			
Is the Vacuum Tube Doomed? .....	by Hugo Gernsback 23		
<b>Audio (Pages 24-33)</b>			
Important Factors in High-Quality Audio .....	by Wallace Waner 24		
Shut-in's Ear Extender .....	by E. E. Youngkin 26		
Three-Channel Amplifier .....	by J. Zoucas 27		
Portable Mixing Pre-Amp. ....	by Charles L. Hansen 28		
Electronics and Music, Part XVIII .....	by Richard H. Dorf 30		
Ionophone Circuitry .....	by E. Aisberg & M. Bonhomme 33		
<b>Servicing—Test Instruments (Pages 34-41)</b>			
Measuring Distortion .....	by Rufus P. Turner 34		
Uses for the 6BN6 .....	by Wilbur J. Hantz 37		
A Question for the Technician .....	by Nicholas B. Cook 37		
Carrying Case for Home Service .....	by Andrew E. Jackson 38		
New Life for Old Radios .....	by Jack Darr 40		
<b>Television (Pages 42-45)</b>			
Formula for TV Success .....	by John D. Burke 42		
Improved Audio for the 630 .....	by Charles B. Remer 43		
Television Service Clinic .....	Conducted by Matthew Mandl 44		
TV Predictions .....	45		
<b>Electronics (Pages 46-48)</b>			
Light-Sensitive Electronic Beast .....	by Edmund C. Berkeley 46		
<b>Theory and Engineering (Pages 50-58)</b>			
Harmonic Oscillators .....	by Norman L. Chalfin 50		
Transistor Amplifier Circuits .....	by I. Queen 56		
<b>Construction (Pages 60-66)</b>			
A Scotsman's Superhet .....	by John W. Straede 60		
TV Components Make this 14 KV Generator ..	by Harold Pallatz 62		
<b>Amateur (Pages 68-70)</b>			
Low Drift V.F.O. Allows Multi-Brand Break-in ..	by Otto Wooley 68		
<b>New Design (Page 71)</b>			
Tubes of the Month .....	71		
<b>Departments</b>			
Radio Month .....	10	Try This One .....	94
Radio Business .....	17	Question Box .....	96
New Devices .....	72	Miscellany .....	99
With the Technicians .....	74	Technotes .....	104
New Patents .....	80	People .....	106
Radio-Electronic .....		Communications .....	108
Circuits .....	91	Book Reviews .....	110

**ON THE COVER:** Squee, the electronic squirrel, prepares to follow a lighted flashlamp held by one of his builders, Jack Koff.  
*Ektachrome original by Avery Slack*

WATCH FOR THE 5TH ANNUAL TELEVISION NUMBER NEXT MONTH

December, 1951 **RADIO-ELECTRONICS** Vol. XXIII, No. 3  
 Published monthly by Radcraft Publications, Inc., at Erie Ave., F to G Streets, Philadelphia 32, Pa.  
**EXECUTIVE, EDITORIAL and ADVERTISING OFFICES:** 25 West Broadway, New York 7, N. Y. Telephone  
 REctor 2-8630. Hugo Gernsback, President; M. Harvey Gernsback, Vice-President; G. Aliquo, Secretary.  
**SUBSCRIPTIONS:** Address Correspondence to Radio-Electronics, Subscription Dept., Erie Avenue, F to G Sts.,  
 Philadelphia 32, Pa., or 25 West Broadway, New York 7, N. Y. When ordering a change please furnish an address  
 stencil impression from a recent wrapper. Allow one month for change of address.  
**SUBSCRIPTION RATES:** In U. S. and Canada, in U. S. possessions, Mexico, South and Central American countries,  
 \$3.50 for one year, \$6.00 for two years; \$8.00 for three years. Entered as second class matter September 27, 1948 at the post  
 office at Philadelphia, Pa., under the Act of March 3, 1879. Printed in U. S. A. Copyright 1951 by Radcraft Publica-  
 tions, Inc. Text and Illustrations must not be reproduced without permission of copyright owners.  
**BRANCH ADVERTISING OFFICES:** Chicago: 520 N. Michigan Ave. Telephone SUperior 7-1796. Los Angeles:  
 Ralph W. Harker, 1127 Wilshire Blvd., Tel. MA 6-1271. San Francisco: Ralph W. Harker, 582 Market St., Tel.  
 GARfield 1-2481. **FOREIGN AGENTS:** Great Britain: Atlas Publishing and Distributing Co., Ltd., London E.C.4.  
 Australia: McGill's Agency, Melbourne. France: Brentano's, Paris 2e. Holland: Trilectron, Heemstede. Greece:  
 International Book & News Agency, Athens. So. Africa: Central News Agency, Ltd., Johannesburg. Capetown: Durban  
 Natal. Universal Book Agency, Johannesburg. Middle East: Steimatzky Middle East Agency, Jerusalem, India: Broadway  
 News Centre, Dadar, Bombay #14. K. L. Kannappa Mudaliar, Madras 2. Pakistan: Paradise Book Stall, Karachi 3.  
**POSTMASTER:** If undeliverable, send form 3579 to: RADIO-ELECTRONICS, 25 West Broadway, New York 7, N. Y.



# SPRAGUE

## TV CAPACITOR

### REPLACEMENT MANUAL



When others are just coming out with their *first* TV capacitor manual, Sprague is bringing out its **FOURTH** edition.

This brown-covered serviceman's bible lists TV replacement capacitors for 1561 television sets, far more than in any other manual. And it lists them set by set as well as by receiver manufacturers!

### GET YOURS... TODAY!

Ask your Sprague distributor for a FREE copy of this new Manual M-481. Or, write your name on the attached coupon and enclose 10c to cover handling and mailing and we will rush your copy directly to you!

Mail to:

#### SPRAGUE PRODUCTS COMPANY

81 Marshall Street, North Adams, Mass.

Enclosed is 10 cents for your M-481 TV Manual.

Name \_\_\_\_\_

Street \_\_\_\_\_

City \_\_\_\_\_ Zone \_\_\_\_\_

State \_\_\_\_\_

RADIO-ELECTRONICS for

# TRAIN for Security! Good-Paying Jobs!

## MAKE THE MONEY YOU'VE ALWAYS DREAMED OF!



# LEARN RADIO -TELEVISION

## AND ELECTRONICS BY EASY SHOP METHOD TRAINING AT HOME!

**You get all the parts—even tubes!—** for this modern Superheterodyne Receiver. You learn to build it step by step. And you keep it! Get all the facts. Mail coupon now.

Let **NATIONAL SCHOOLS**—a resident-training school for nearly 50 years—train you at home for today's unlimited opportunities in Radio-Television-Electronics. National Schools is one of the largest schools of its kind. It is located in Los Angeles—the center of Radio and TV world! It has four large buildings of modern shops and labs. Its faculty is considered tops in the business.



You learn from lessons prepared by experienced instructors and engineers. Men who are successful Radio and Television technicians. Men who have trained 1000's of men like YOU!

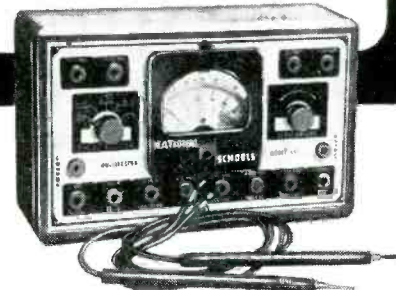

### Only National Schools Gives You This Professional Multi-Tester!

You get this amazing, new testing instrument—factory-made and tested—complete—ready to use! Simple to operate. Accurate and dependable. An instrument every Radio-TV man needs. Light enough to carry around—so you can use it at home or on service calls. You'll be proud to own this valuable equipment.

### Here are only a few of the Good-Paying Jobs You Can Choose

Radio Station Engineer, District Service Manager, Aircraft Radio Inspector, Own Your Own Repair Shop, Inspector Technician, Service Specialist, Special Government Jobs, Complete TV Service, Sound Truck Operator. Many more! National Schools graduates have secure, good-paying jobs like these! So don't wait—mail the coupon today. Now—while you're thinking about it!

### Attention! Men Going into Service Soon!

National Schools' course quickly prepares you for many important jobs in the Armed Services. With National Schools Training you have an opportunity to get into special service classifications—with higher pay and grade—immediately!

### FREE SERVICE FOR GRADUATES

National Schools uses its great influence and prestige to help you find your place in the field of your choice. Don't put it off! Start yourself toward a skilled trade! Get the big pay you've always wanted!

**NATIONAL SCHOOLS**  
LOS ANGELES 37, CALIFORNIA • ESTABLISHED 1905

### You Train At Home—In Your Spare Time

National Schools Shop Method Home Training gives you basic and advanced instruction in all phases of Radio-TV-Electronics. And remember—your training is based on resident school training principles. You learn fast from hundreds of diagrams and pictures. All instructions are written by experienced technicians who work in Radio and TV every day. All instructions have been developed and tested in National Schools' own labs and studios, which are equipped with the latest RCA equipment. No wonder this National Schools course is so up-to-date, practical, interesting. And so easy to learn! And no wonder it is held in such high regard by leaders of American industry! Approved for eligible Veterans.

### We Teach You How To Make Welcome Extra Money—While You Learn!

Many National Schools students—men like you—make plenty of extra dollars each week in spare time! Fixing neighbors' radios, appliances—and other ways we teach you. You start learning and earning from the day you enroll. From the very first lesson!

### WE SEND YOU LOTS OF PARTS LIKE THIS!

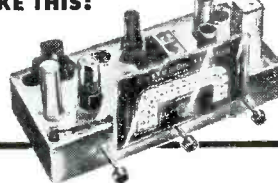

With National Schools Shop Method Home Training, you get basic principles and plenty of practical training. You learn by doing. No wonder you learn so fast! We send you many parts—all of professional, modern quality. You do lots of practical experiments. You advance day by day, step by step. Until you can even build the modern Superheterodyne Receiver you see above—plus other important testing units. The free book tells you all about it. The free sample lesson shows how easy the training is. Use the coupon. Send today—without fail!

**DON'T PUT IT OFF!  
GET THE BIG SALARY YOU HAVE ALWAYS WANTED!**

## FREE BOOK TELLS YOU HOW!

Page after page—in color—tells you everything you want to know. Mail the coupon. Get this valuable book today. And if you hurry—YOU GET A FREE SAMPLE LESSON, TOO! Shows how easy National Schools Home Training is. Mail the coupon today.

### Today's Shortage of Trained Technicians Creates Chance of a Lifetime For You!

Think of it! With guided missiles, radar, and other electronic devices so important to national defense! With big, new developments in TV. With over 90,000,000 home and auto radios, over 12,000,000 TV sets. With more than 3100 radio stations...over 100 TV stations—and more building every day...yes, imagine the great opportunity you have today!

~~They~~ **you** are wanted in Radio-Television-Electronics! America's ~~fastest-growing~~ **fastest-growing** field. High-pay jobs—the kind you've always ~~wanted~~ **wanted**—are waiting for YOU!

### Job Security! Big Money! For YOU! in Today's Expanding Industries!

Trained Radio and Television technicians really make important money these days. Thousands of National Schools graduates—men just like you—are earning good money all over the country. Why not you? And—National Schools graduates get the personal satisfaction of being highly-skilled technicians. Men people respect. Men who enjoy their work—rather than having to drag along in just any old job.

### National Schools Has Trained 1000's of Successful Men! Why Not YOU?

In almost every state—and many foreign countries—National Schools graduates are filling big jobs with famous companies. Or running their own successful businesses. What are YOU waiting for? National Schools training is complete training. So when you graduate you can take advantage of today's big opportunities in Radio-Television-Electronics—fast.

### MAIL THIS COUPON TODAY—WITHOUT FAIL!

NATIONAL SCHOOLS, Dept. GR-121  
4000 South Figueroa Street  
Los Angeles 37, California

Mail in envelope or paste on post card.

Mail me FREE the book mentioned in this ad. Also a free sample lesson. I understand no salesman will call on me.

NAME \_\_\_\_\_ AGE \_\_\_\_\_

ADDRESS \_\_\_\_\_

CITY \_\_\_\_\_ ZONE \_\_\_\_\_ STATE \_\_\_\_\_

Check here if you were released from the Service less than 4 years ago.



*Right for Sight!®*

*Announcing*  
**CORONA INHIBITOR**

**N**ow, for the first time, you can get television picture tubes that are *not affected by atmospheric conditions*. Ordinary picture tubes may lose as much as one-tenth of their brightness on humid or rainy days, but RAYTHEON made Tubes with CORONA INHIBITOR are 100% efficient *rain or shine*.

This amazing new weather-proofing is so effective, that even when tested with a water spray on the high voltage contact, RAYTHEON Tubes with the CORONA INHIBITOR showed *no loss of brightness* due to arcing around the high-voltage connection.

Ask your RAYTHEON Tube Distributor for Raytheon Picture Tubes with CORONA INHIBITOR. Your customers will like them... and so will you.

the new



**development that keeps**

**TELEVISION  
PICTURE TUBES**

**at peak performance**

*Rain or Shine*



*Excellence in Electronics*

**RAYTHEON MANUFACTURING COMPANY**

Receiving Tube Division

Newton, Mass., Chicago, Ill., Atlanta, Ga., Los Angeles, Calif.

RADIO AND TELEVISION RECEIVING TUBES, PICTURE TUBES, SPECIAL PURPOSE TUBES, SUBMINIATURE TUBES, MICROWAVE TUBES

*This Christmas*  
Give yourself a share of  
the Multi-Billion Dollar  
**RADIO TV  
ELECTRONICS**  
Industries



**Choose the "gift" of CREI Home Study—  
for technical training that leads to  
money in the bank, job security and a lifetime career**

**C**HRISTMAS DAY friends and relatives may remember you with handsome gifts of jewelry, men's wear or what not. Some extra-thoughtful person may buy you a special piece of equipment you've wanted.

But nobody, this Christmas or any other day, will give you big paychecks, security, or a real career. These are "gifts" you must acquire yourself. There is no time like this Christmas to make yourself a present of the training you need . . . to get the high pay, the security and the profitable career waiting for you in radio, TV and electronics.

These industries are gobbling up all the qualified manpower America's schools can train. They are calling desperately for more men to man TV stations; to develop, design, test, inspect, manufacture and service the millions of TV sets to come and the 13,000,000 now in use; to service the 100,000,000 radios in current operation; to handle the tremendous defense orders now being placed for electronic equipment and installations.

There are gaping openings. Do you know who will get them? **MEN WITH SPECIALIZED TECHNICAL TRAINING!** In other words, YOU . . . if you prepare now. To get this training, you must select a school equipped by experience to teach you thoroughly, and that's what you find at CREI, a fully accredited technical Institute which, since 1927, has trained thousands of professionals on a high technical level.

CREI courses are prepared and taught by recognized experts in a practical, easily-understood manner. Our courses are constantly under revision in light of new industrial developments. With CREI Home Study, you get the benefit of personal supervision by a CREI staff instructor. By personal supervision we mean a person-to-person relationship which results from the individual way in which your queries are answered and examinations are graded. This thorough method guarantees that you know all of the subject matter, not just the fraction that usually shows up in a test or quiz.

Because CREI training is so thorough and scientific, CREI diplomas are keys to success in radio, TV and electronics. CREI alumni hold top positions with some of America's lead-

ing firms. Further evidence of industry's approval of CREI methods and results lies in the fact that leading firms choose CREI courses for group training in electronics, at company expense. Among them are United Air Lines, Canadian Broadcasting Corporation, Sears Roebuck & Co., RCA-Victor Division and Bendix Products Division.

When you choose CREI Home Study, you qualify for the services of the CREI Placement Bureau, which finds positions for students and graduates. Although CREI does not guarantee jobs, requests for personnel currently exceed supply.

We have prepared for your guidance an interesting free booklet which describes your possibilities in radio, TV and electronics. It shows you how CREI Home Study leads the way to greater earnings. You will enjoy reading "Your Future in the New World of Electronics." From it you will be able to determine:

(1) whether you will plod along, untrained, waiting for a stroke of luck to propel you into a big job . . . or

(2) if you will give yourself CREI Home Study to get the technical training which will move you closer to the top in your field.

*Just fill out the coupon and mail it today. We'll promptly send you your free copy. The rest—the future—is up to you.*

**MAIL COUPON FOR FREE BOOKLET**

**CAPITOL RADIO ENGINEERING INSTITUTE**

Dept. 1412C, 16th & Park Rd., N.W., Washington 10, D. C.  
Send booklet "Your Future in the New World of Electronics" and course outline.

CHECK FIELD OF GREATEST INTEREST  TV, FM & Advanced AM Servicing  Aeronautical Radio Engineering  Practical Television Engineering  Broadcast Radio Engineering (AM, FM, TV)  Practical Radio Engineering

Name.....

Street.....

City..... Zone..... State.....

If residence school in Wash., D. C. preferred, check here

## They're headed for new frontiers

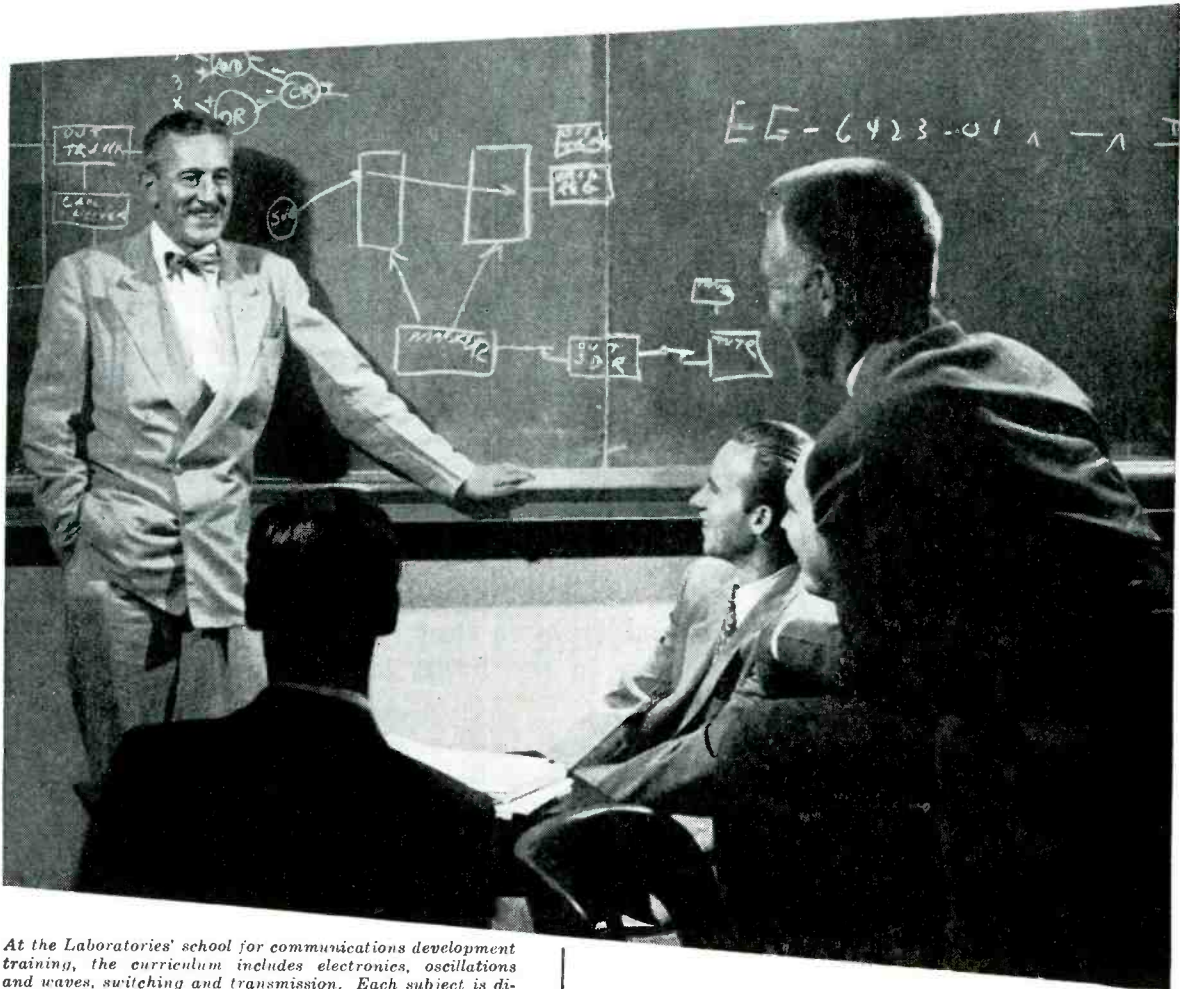

*At the Laboratories' school for communications development training, the curriculum includes electronics, oscillations and waves, switching and transmission. Each subject is directly keyed to the latest fields of telephone research.*

EACH year the Bell System selects hundreds of engineering graduates from technical schools, to find the answers to communications problems through the application of science and technology. A specifically qualified group joins Bell Laboratories to develop *tomorrow's* telephone system — also, in the present emergency, more powerful electronic devices for the armed services.

They come — thanks to the competence of our nation's educators—with an excellent grounding in fundamentals. To equip them still further, the Laboratories operate a school at graduate level for advanced communications.

The new men receive an intensive course in the latest theory and techniques. At the same time they take their places as members of the Technical Staff doing responsible work which, with their classroom instruction, reveals where they can make the most of their aptitudes.

● More than ever America's future must depend on men and women who are trained to think far ahead in technology whether for tomorrow's telephones or national defense. By helping them, Bell Telephone Laboratories help make America's telephone system the world's best, help the armed forces keep our country strong.

## BELL TELEPHONE LABORATORIES

*Exploring and inventing, devising and perfecting, for continued improvements and economies in telephone service.*



RADIO-ELECTRONICS for



**NOW... GET EVERYTHING YOU NEED TO LEARN AND MASTER**

# TELEVISION

## RADIO-ELECTRONICS ...AT HOME!

Use REAL commercial-type equipment to get practical experience

Your future deserves and needs every advantage you can give it! That's why you owe it to yourself to find out about one of the most COMPLETE, practical and effective ways now available to prepare AT HOME for America's billion dollar opportunity field of TELEVISION-RADIO-ELECTRONICS. See how you may get and keep the same type of basic training equipment used in one of the nation's finest training laboratories... how you may get real STARTING HELP toward a good job or your own business in Television-Radio-Electronics. Mail the coupon today for complete facts—including 89 ways to earn money in this thrilling, newer field.

**D.T.I., ALONE, INCLUDES BOTH MOVIES and HOME LABORATORY** In addition to easy-to-read lessons, you get the use of HOME MOVIES—an outstanding training advantage—plus 16 big shipments of Electronic parts. Perform over 300 fascinating experiments for practical experience. Build and keep real commercial-type test equipment shown at right

**Get BOTH of these Information packed publications FREE!**

**89 WAYS TO EARN MONEY IN TELEVISION RADIO ELECTRONICS**

**YOU GET ALL 6**

### MODERN LABORATORIES

If you prefer, get all your preparation in our new Chicago Training Laboratories—one of the finest of its kind. Ample instructors, modern equipment. Write for details!

### MILITARY SERVICE!

If you're subject to military service, the information we have for you should prove very helpful. Mail coupon today.

### ACT NOW! MAIL COUPON TODAY!

DE FOREST'S TRAINING, INC., DEPT. RE-12-H  
2533 N. Ashland Ave., Chicago 14, Ill.

Without obligation, I would like your Opportunity News Bulletin showing "89 Ways to Earn Money in Television-Radio-Electronics"; also, the folder showing how I may prepare to get started in this thrilling field.

Name \_\_\_\_\_ Age \_\_\_\_\_  
Address \_\_\_\_\_ Apt. \_\_\_\_\_  
City \_\_\_\_\_ Zone \_\_\_\_\_ State \_\_\_\_\_



**Here's the REAL THING!**

### SET UP YOUR OWN HOME LABORATORY

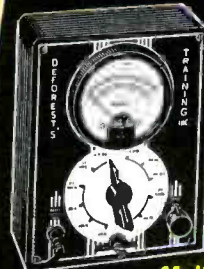

Multimeter



Oscilloscope

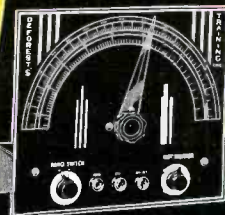

R-F Signal Generator

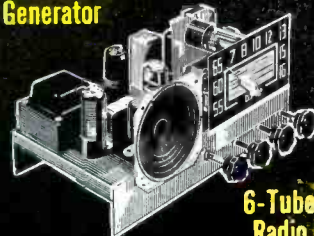

6-Tube Radio

### HOME MOVIES

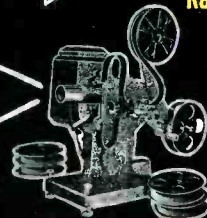

**De FOREST'S TRAINING, INC.**  
CHICAGO 14, ILLINOIS  
A De VRY INSTITUTION

**LONG-RANGE RADAR** installations on the Arctic frontier network may now be manned either by Canadian or United States operators, reports the Air Force. Previously, Canada's law required its radio and radar operators to be British subjects, but an Order-in-Council by Canada's Department of Defense has cleared the way for joint operation of the long-range warning network by nationals of either country.

The new installations, built by the General Electric Company, require 400 men to operate the multiple positions on a 24-hour basis at each location.

**460-MC TWO-WAY RADIO** communication has been inaugurated by the

City of Miami in its police radio system.

Miami was also the first to initiate police operations on the 160-mc band, which is the currently accepted police communication band in many parts of the country. From the first units in the 160-mc band, the City of Miami police system has been developed until today it includes 6 two-way radio base stations and 270 two-way mobile radios. Motorola developed and built both systems for the City of Miami.

**EXPERIMENTAL U.H.F. TV** station is being built by Sylvania Electric Products, Inc., at Emporium, Pa. The application to transmit monoscope and test patterns on 870 to 890 megacycles was

granted by the Federal Communications Commission on October 2.

**SECRET TV SYSTEM** will be used by the Navy in its new giant carrier, the *Forrestal*. The flush deck of the carrier, without the superstructure of present-day carriers, will enable her to handle many types of planes, including atomic bombers. The new television system is said to be designed to help the planes to land.

**ULTRASOUND** may aid in the preparation of new and better vaccines against bacteria and viruses, according to Dr. Nelson Newton, of the Battelle Memorial Institute. Specimens of tobacco mosaic virus exposed to ultrasound for 3½ minutes lost 95% of its infectivity. It is believed that the rod-shaped viruses are broken up by the sonic waves.

Dr. Newton has been experimenting with ultrasonic waves at the extremely high frequency of 7 megacycles per second. He reports further that another series of tests with reduced intensity and varied exposure times to the radiation produced, among other effects, an increased infectivity of "aged," or old, viruses. This, he suggests, might be applied to reactivating and possibly extending the period of usefulness of aged vaccines.

**NEW RADIO-CONTROLLED** robot jet guided missile, the B-61 Matador, has been developed for the Air Force by the Glenn L. Martin Co. Although intended as a weapon of offense, the bomber cannot exceed a horizon-to-horizon operating radius due to the nature of the high-frequency radio waves used in controlling its flight.

A piloted mother plane equipped with an intricate electronic and radar system is used in guiding the pilotless plane to its tactical destination. A series of spaced relay control stations may also be used in lieu of the piloted mother plane for control purposes over long distances.

Radar signals from the controlling stations are used to keep track of the Matador's flight course and its exact location.

**THE LOUDEST SIGNAL** on the world dial is the goal sought by George Q. Herrick, chief of the facilities of the Voice of America. A \$4,188,000 appropriation by Congress has cleared the way for construction at six locations of ten super-power curtain antennas which will have a width of 755 feet between towers. The towers supporting the curtain will be 290 feet tall on one side and 250 feet on the other.

Up till now, the executive reported, the long transmission distances involved, coupled with Russian jamming tactics, have reduced the effectiveness of our Voice broadcasts. Mr. Herrick believes that the new installations will bring our Voice up to the strength of Radio Moscow in a considerable area of the Iron Curtain states and will add millions of listeners to those now hearing the Voice.

RADIO-ELECTRONICS for



**THE** *Aristocrat*

**WORLD'S FINEST**

**DYNAMIC MICROPHONE**

**THE TURNER COMPANY**

933 17th Street N.E., Cedar Rapids, Iowa

IN CANADA:  
Canadian Marconi Co.,  
Toronto, Ont., and Branches

EXPORT:  
Ad. Auriema, Inc.,  
89 Broad Street, New York 4

# FREE

**TELLS HOW—**

**WE GUARANTEE  
TO TRAIN AND COACH YOU AT HOME  
IN SPARE TIME UNTIL YOU GET  
YOUR FCC LICENSE**

If you have had any practical experience—Amateur, Army, Navy, radio repair, or experimenting.

**TELLS HOW—**

**OUR AMAZINGLY EFFECTIVE JOB-FINDING SERVICE HELPS CURE STUDENTS GET BETTER JOBS. HERE ARE JUST A FEW RECENT EXAMPLES OF JOB-FINDING RESULTS:**

**GETS CIVIL SERVICE JOB**

"Thanks to your course I obtained my 2nd phone license, and am now employed by Civil Service at Great Lakes Naval Training Station as an Equipment Specialist."  
Kenneth R. Leiser, Fair Oaks, Mtd. Del., McHenry, Ill.

**GETS STATE POLICE JOB**

"I have obtained my 1st class ticket (thanks to your school) and since receiving same I have held good jobs at all times. I am now Chief Radio Operator with the Kentucky State Police."  
Edwin Healy, 264 E. 3rd St., London, Ky.

**GETS BROADCAST JOB**

"I wish to thank your Job-Finding Service for the help in securing for me the position of transmitter operator here at WCAE, in Pittsburgh."  
Walter Koschik, 1442 Ridge Ave., N. Braddock, Pa.

**GETS AIRLINES JOB**

"Due to your Job-Finding Service, I have been getting many offers from all over the country, and I have taken a job with Capital Airlines in Chicago, as a Radio Mechanic."  
Harry Clare, 4537 S. Drexel Blvd., Chicago, Ill.

**HERE'S PROOF FCC LICENSES ARE OFTEN SECURED IN A FEW HOURS OF STUDY WITH OUR COACHING AT HOME IN SPARE TIME:**

Name and Address	License	Lessons
Lee Worthy, 2210 1/2 Wilshire St., Bakersfield, Cal.	2nd Phone	16
Clifford E. Vogt, Box 1016, Dania, Fla.	1st Phone	20
Francis X. Foerch, 38 Beucler Pl., Bergenfield, N. J.	1st Phone	38
S/Sgt. Ben H. Davis, 317 North Roosevelt, Lebanon, Ill.	1st Phone	28
Albert Schoell, 110 West 11th St., Escondido, Cal.	2nd Phone	23

**CLEVELAND INSTITUTE OF RADIO ELECTRONICS**  
Desk RE-36, 4900 Euclid Bldg., Cleveland 3, Ohio

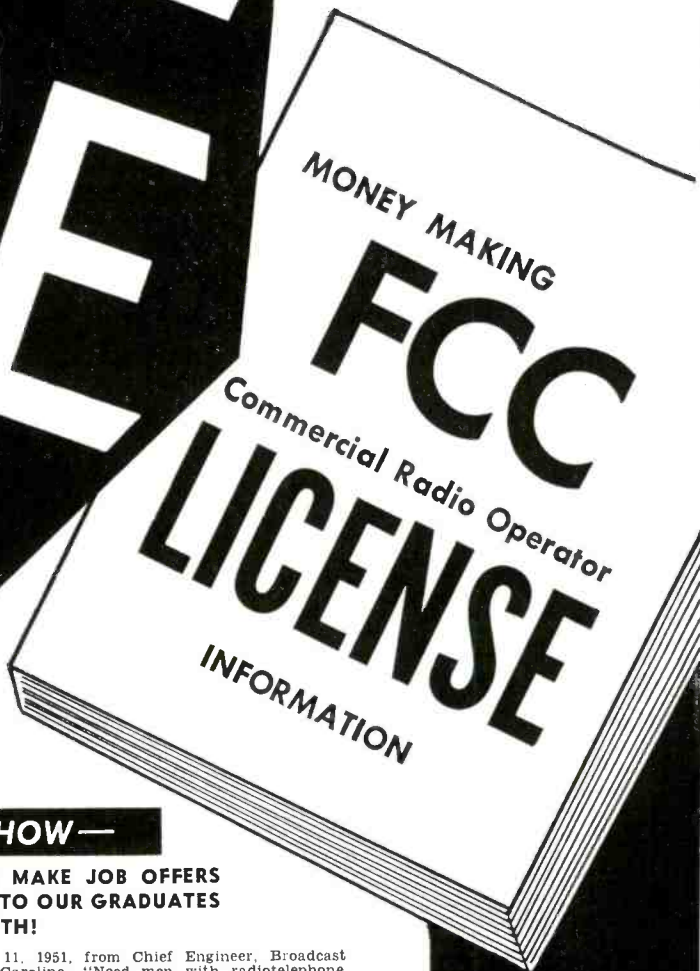

**TELLS HOW—**

**EMPLOYERS MAKE JOB OFFERS LIKE THESE TO OUR GRADUATES EVERY MONTH!**

Letter, October 11, 1951, from Chief Engineer, Broadcast Station, North Carolina. "Need men with radiotelephone 1st class licenses, no experience necessary. Will learn more than at average station for we are equipped with Diesel Electric power, transmitting and studio equipment".

Telegram, October 2, 1951, from Chief Engineer, Broadcast Station, Wyoming. "Please send latest list available first class operators. Have November 10th opening for two combo men".

Letter, October 8, 1951, from Chief Engineer, Broadcast Station, Texas. "Please send list of latest licensed graduates".

These are just a few of the examples of the job offers that come to our office periodically. Some licensed radioman filled each of these jobs; it might have been you!

Ours is the only home study course which supplies FCC-type examinations with all lessons and final tests.

**ACT NOW!**

**Get All 3 FREE**

Your FCC ticket is Always Recognized in All Radio Fields as Proof of Your Technical Ability.



**MAIL COUPON NOW**

Cleveland Institute of Radio Electronics  
Desk RE-36—4900 Euclid Bldg.  
Cleveland 3, Ohio  
(Address to Desk No. to avoid delay.)

I want to know how I can get my FCC Ticket in a minimum of time. Send me your FREE booklet, "How to Pass FCC License Examinations" (does not cover exams for Amateur License), as well as a sample FCC-type exam and the amazing new booklet, "Money-Making FCC License information."

Name.....  
Address.....  
City.....Zone....State.....

Paste on penny postcard or send air mail.

# MERIT

TV full-line\* Components For  
Improvement, Replacement, Conversion



## SELL IMPROVED RECEPTION

MERIT "TV" Kit #1000 for edge to edge focus—contains MFD-70 Cosine Yoke, HVO-7 Universal Flyback and MWC-1 Width Linearity Control. Keep a Kit handy — you'll get plus business and a reputation for "know-how."



MFD-70 . . . original of the "cosine" series—low horz, high vert inductance. Used by such famous sets as

Radio Craftsman. Cosine Yokes will improve 10,000,000 sets now in use!

## MERIT...HQ for TV Service Aids

MERIT's 1952 Catalog #5211 now available . . . introducing MERIT IF-RF Coils, includes Coil & Transformer data, listings. Other MERIT service aids: TV Repl Guide #404, Sept. '51 issue—covers 3000 models, chassis of 82 mfrs; Cross Ref Data on IF-RF Coils, Form #14. Write: Merit Coil and Transformer Corporation, 4425 North Clark Street, Chicago 40.

## These three MERIT extras help you:

- Exclusive: Tape-marked with specs and hook-up data 
- Full technical data packed with every item
- Listed in Howard Sams Photo-facts



\*Merit is meeting the TV improvement, replacement and conversion demand with a line as complete as our advance information warrants!

BURTON BROWNE ADVERTISING

**ROBERT H. MARRIOTT**, one of radio's earliest pioneers, died October 31 at the age of 72. His radio career dated back to 1897.

Mr. Marriott was one of the moving spirits in the formation of the Institute of Radio Engineers in 1912, and is often referred to as the founder of that organization. He was a former president of the Institute, as well as of the earlier Wireless Institute. His career included work as active or consulting engineer for most of the earlier wireless concerns and the U.S. government. He was also the holder of many radio patents.

**UNDERWATER AMPLIFIER**, operating 1,700 feet below the ocean surface and 200 miles from land, will speed the transmission rate of the Western Union cable in which it is inserted from 500 to 1,500 letters per minute. It was exhibited recently aboard the cable ship *Lord Kelvin*. The amplifier is contained in a steel tube roughly a foot in diameter and four feet long. The interior of the cylinder is filled with oil to equalize the pressure of 700 pounds per square inch at sea bottom.

The most remarkable thing about the amplifier is that it receives its power from a supply source located 1,200 miles away. The circuit is similar to that of a d.c.-type radio (a.c.-d.c. without rectifier and filter). The required 0.3 ampere is sent along the cable, where it interferes in no way with the messages, and a dropping resistor between the positive input lead and filaments provides the plate voltage, as in a standard a.c.-d.c. or d.c. receiver. Voltage drop along the cable is fantastic, of course, and more than 2 kilowatts must be supplied at the shore station, in this case in Long Island, to furnish the 50 watts or so used by the repeater submerged off the

coast of Newfoundland.

The amplifier is a push-pull resistance-capacitance coupled type. It has three stages, with four tubes in the third stage. Tubes are Western Electric long-life type, expected to give 20 years continuous service. The tubes themselves and closely associated components are placed in a depressurized, sealed cylindrical case of heavy metal inside the main cylinder, as the tubes would not stand the heavy underwater pressure. A standby amplifier forms part of the equipment.

**ILLEGAL TV RELAYING** by two brothers of Shadyside, Ohio, was charged by the Government in a Federal Grand Jury action.

Walter S. and Earl N. McGuire allegedly boosted signals from stations outside their area and relayed them over an antenna they set up for reception by persons who could not otherwise have received TV programs.

**AN ABRUPT RECESS** was given to color television, as our readers are aware, by the recent government order halting commercial color broadcasts to conserve scarce materials. Some slight dislocation was occasioned a number of sections of the industry, notably those producing color conversion kits, adapters, and to CBS-Columbia and others who were commencing to make complete color receivers.

It was first believed that the order would prevent all developmental as well as commercial operations, but further clarification indicated that the ban would not apply to experimental work.

Not least affected was this magazine. We had on hand a number of articles on color conversion and servicing, which will now be held up till color broadcasting again becomes a live issue.

—end—

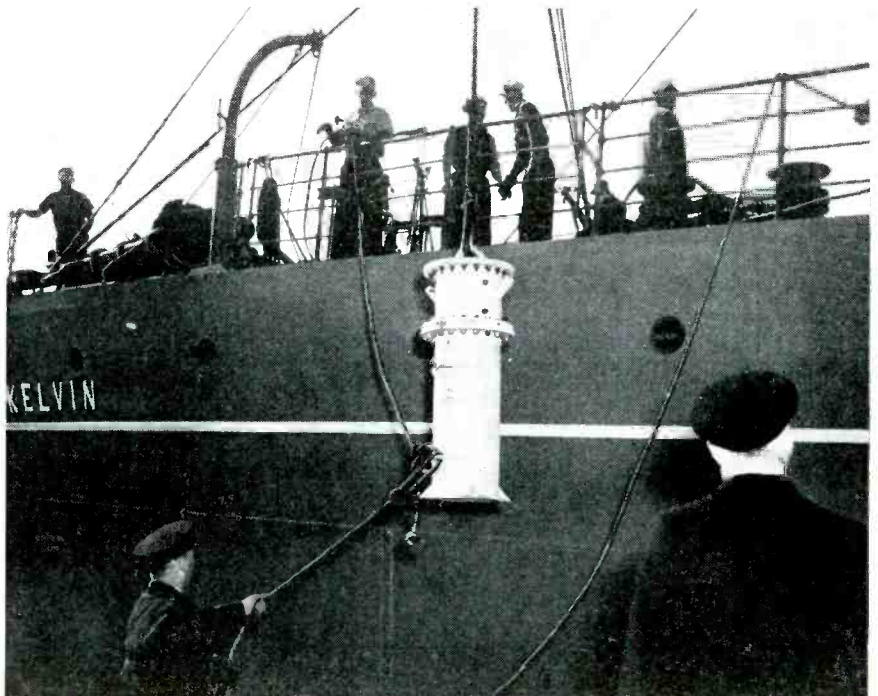

The cable amplifier starts out on its journey for service in the silent depths.

RADIO-ELECTRONICS for

Courtesy Western Union

the only complete catalog  
for everything in Radio,  
TV & Industrial Electronics

your 1952 **free!**  
**ALLIED** 212-page  
value-packed catalog

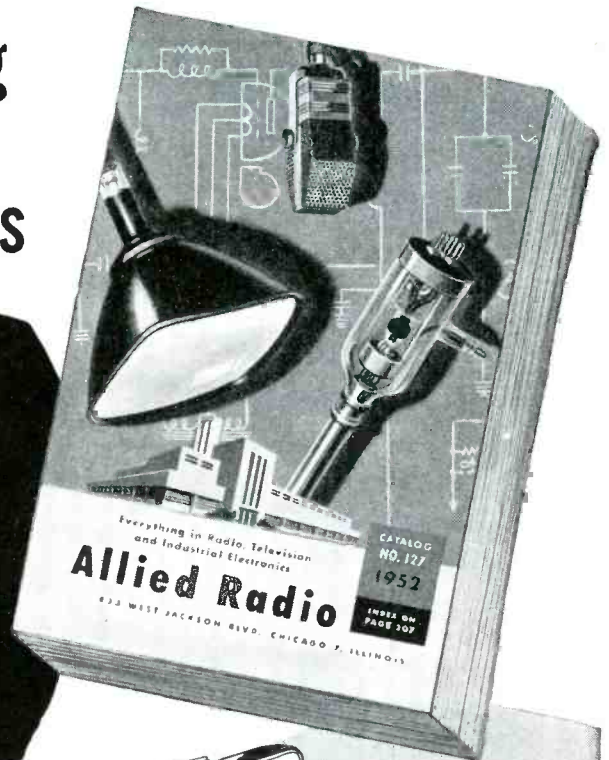

**Send for it today!**

Here's the *one* authoritative, complete, up-to-date Buying Guide to TV, Radio and Industrial Electronics. Make your selections from the world's largest stocks of quality equipment at lowest, money-saving prices. See the latest and most complete presentation of electronic apparatus: new TV, AM and FM receivers; High-Fidelity Custom Sound components; latest P.A. Systems and accessories; recorders; fullest selections of Amateur receivers and station gear; specialized industrial electronic equipment; test instruments; builders' kits; huge listings of parts, tubes, tools, books—the world's *most complete stocks* of quality equipment.

ALLIED gives you *every* buying advantage: speedy delivery, expert personal help, lowest prices, liberal time payment terms, assured satisfaction. Get the latest 1952 ALLIED Catalog. Keep it handy—and save time and money. Send for your FREE copy today!

the world's  
largest stocks



- Radio Parts Unlimited
- Test Instruments
- Television & Home Radios
- P.A. and Hi-Fi Equipment
- Amateur Station Gear
- Builders' Supplies
- Equipment for Industry

quick, expert service

**ALLIED IS YOUR TV and HI-FI HEADQUARTERS**

**TV** **HI-FI**

Count on ALLIED for the latest in TV! If it's made—we have it for quick delivery. We specialize, too, in High-Fidelity sound components—everything in amplifiers, speakers, tuners, phono gear and accessories. For TV or Hi-Fi—think of ALLIED!



**free**

**SEND TODAY FOR RADIO'S  
LEADING BUYING GUIDE**

ALLIED RADIO CORP., Dept. 2-M;1  
833 W. Jackson Blvd., Chicago 7, Illinois

Send FREE 212-page 1952 ALLIED Catalog No. 127.

Name \_\_\_\_\_

Address \_\_\_\_\_

City \_\_\_\_\_ Zone \_\_\_\_\_ State \_\_\_\_\_

**ALLIED RADIO**

*the World's Largest Radio Supply House*

EVERYTHING IN ELECTRONICS

# Only G-E Tube Dealers

**G-E Aluminized Tube makes your picture better than new!**  
Here's proof in black and white

Is there a difference between the picture you see on your TV set and the picture you see on a regular TV set? The answer is yes. The picture on a G-E Aluminized Tube set is sharper, brighter, and more lifelike. The picture on a regular TV set is dull, flat, and lifeless. The picture on a G-E Aluminized Tube set is the picture you want to see.

It's not just the G-E Aluminized Tube, up to 20% brighter and sharper than the regular TV set. It's the G-E Aluminized Tube that makes the picture on your TV set so much better. You get that sharp, bright, lifelike picture that makes the picture on your TV set so much better. You get that sharp, bright, lifelike picture that makes the picture on your TV set so much better.



**"What a difference a GE tube makes! Now our picture is better than new!"**

Is there a difference between the picture you see on your TV set and the picture you see on a regular TV set? The answer is yes. The picture on a G-E Aluminized Tube set is sharper, brighter, and more lifelike. The picture on a regular TV set is dull, flat, and lifeless. The picture on a G-E Aluminized Tube set is the picture you want to see.



You can put your confidence in—  
**GENERAL ELECTRIC**

are backed up by regular full-page tube advertisements in LIFE and the POST!

**LIFE**

THE SATURDAY EVENING  
**POST**

**"The most eye-opening proof I've ever seen!"**



**GE Aluminized Tube made our set BETTER THAN NEW!**

Is there a difference between the picture you see on your TV set and the picture you see on a regular TV set? The answer is yes. The picture on a G-E Aluminized Tube set is sharper, brighter, and more lifelike. The picture on a regular TV set is dull, flat, and lifeless. The picture on a G-E Aluminized Tube set is the picture you want to see.

It's not just the G-E Aluminized Tube, up to 20% brighter and sharper than the regular TV set. It's the G-E Aluminized Tube that makes the picture on your TV set so much better. You get that sharp, bright, lifelike picture that makes the picture on your TV set so much better.

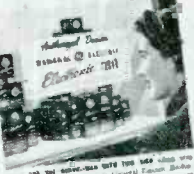

Is there a difference between the picture you see on your TV set and the picture you see on a regular TV set? The answer is yes. The picture on a G-E Aluminized Tube set is sharper, brighter, and more lifelike. The picture on a regular TV set is dull, flat, and lifeless. The picture on a G-E Aluminized Tube set is the picture you want to see.

It's not just the G-E Aluminized Tube, up to 20% brighter and sharper than the regular TV set. It's the G-E Aluminized Tube that makes the picture on your TV set so much better. You get that sharp, bright, lifelike picture that makes the picture on your TV set so much better.

You can put your confidence in—  
**GENERAL ELECTRIC**

**READ BY  
24,000,000  
PEOPLE!**



# Only G-E Tube Dealers

can write letters like these, proving how powerfully  
G-E tube advertising helps at point-of-purchase!

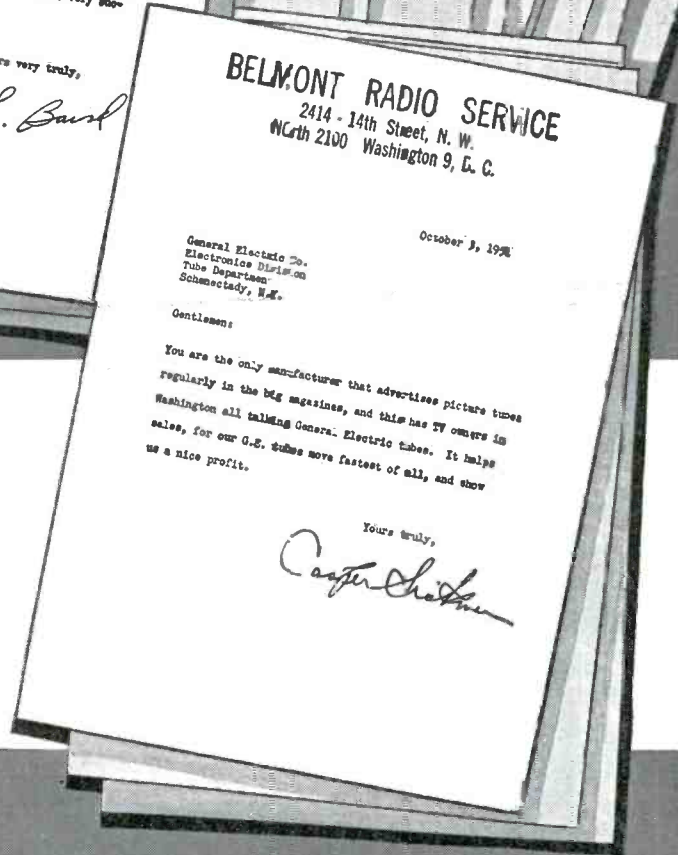
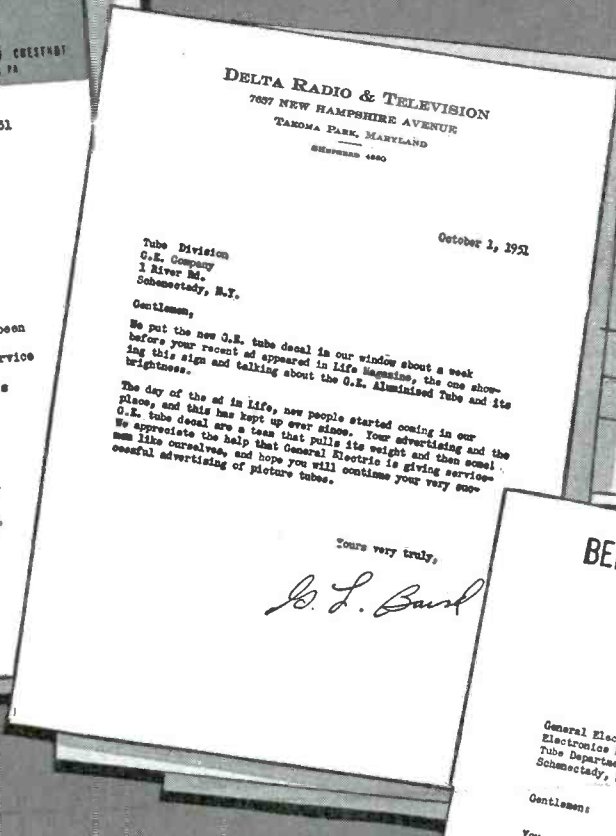
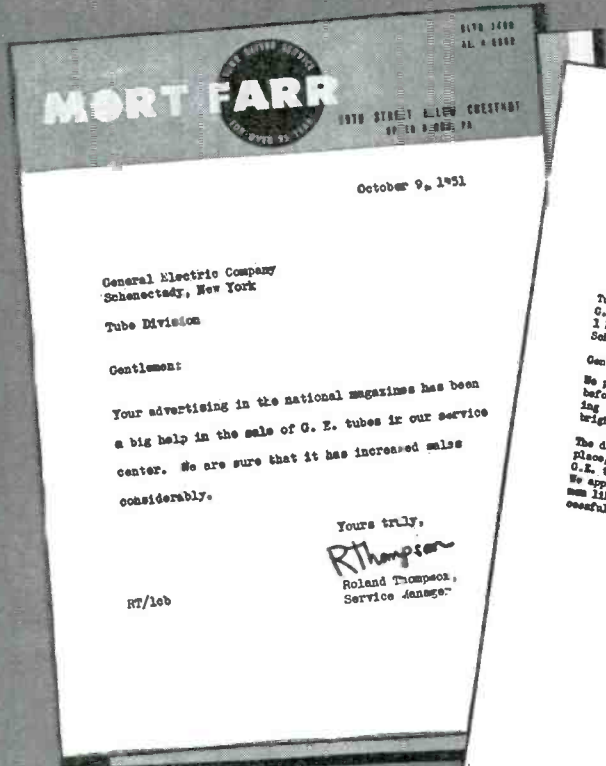

Increase your profits—speed turnover  
—by handling the tubes that *national advertising pre-sells for you!* Your local General Electric tube distributor will be glad to assist. Phone him today!

*You can put your confidence in—*

**GENERAL**



**ELECTRIC**

there are  
many  
chinese copies

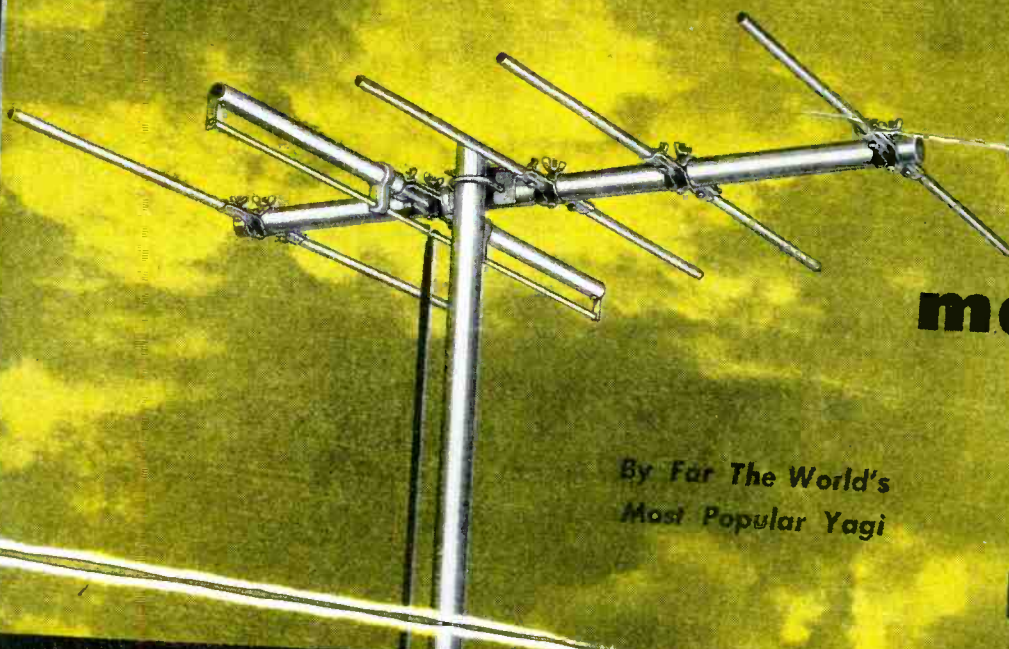

...but  
**ONLY**  
**VEE-D-X**  
makes the  
**JC**

By Far The World's  
Most Popular Yagi

also  
VEE-D-X  
Originals

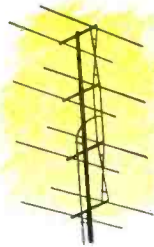

THE COLINEAR



LIGHTNING ARRESTER

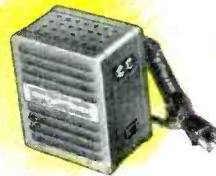

OUTBOARD BOOSTER



ROCKET BOOSTER

BEWARE OF CHINESE COPIES.

INSIST ON

*Genuine*

**VEE-D-X**

ORIGINATORS

of The World's Most Powerful  
Antenna Systems

限  
防  
假

冒



**Merchandising and Promotion**

I.D.E.A. has designed a new yellow-and-black counter card to display its Regency TV signal booster on counters and shelves or in windows.

The Hallicrafters Co., Chicago, is offering a merit award for outstanding achievement by new novice-class radio amateurs who work all states between 12:01 a.m. September 8, 1951, and 12:00 p.m. September 7, 1952, and have obtained their regular ham licenses. The first ten novices to qualify will receive a Hallicrafters S-76 receiver and all others will receive \$25 in cash.

Littelfuse, Inc., Chicago, has designed a space saving metal rack for wall or counter displays of its "One Call TV Kit". The kit is a hinged, plastic box which provides service technicians with

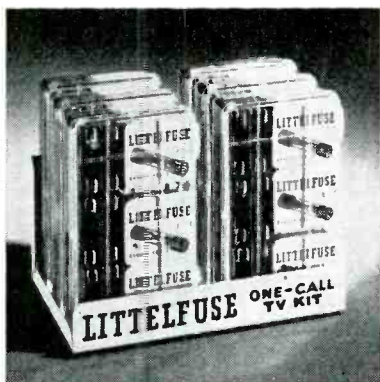

nine of the most needed types of TV fuses and six "Snap-On" TV fuse holders. There are 45 fuses in all, packed five each in vest pocket size metal boxes.

Javex, Garland, Texas, is distributing new counter, window, or wall sales display aids. One card displays a 300-ohm wall plate with plug and twin lead. Another card shows Javex high-voltage probes.

Acme Electric Corp., Cuba, N. Y., has prepared a special catalog illustrating its facilities for producing transformers and other components for electronic and electrical equipment. The catalog is meant primarily for contractors engaged in producing military equipment.

Radio Merchandise Sales, Inc., New York City, has reactivated its technical service forums for television distributors and their customers. The first of the series was held before the Syracuse TV Accessory House at Elmira, N. Y.

General Electric's Tube Department sales and engineering personnel is bringing the G-E tube development story to its customers with a series of tube application clinics. G-E engineers visit plants of major industrial, transmitting and receiving tube customers and conduct half-day meetings with their engineering staffs.

Helipot Corp., South Pasadena, Cal., has issued a new three-color catalog showing the facilities of its two potentiometer manufacturing plants.

Tetrad Co., Los Angeles, has released a new bulletin illustrating its copper-wire windings and the specialized electronic components in which they are used. In line with current trends, the bulletin emphasizes miniaturization.

**Production and Sales**

NBC TV Sales Planning and Research Department announced that there were 14,003,500 television sets installed in the U.S. as of October 1. A breakdown of this figure showed that New York had 2,550,000; Los Angeles, 1,025,000; Chicago, 995,000; Philadelphia, 903,000; and Boston, 787,000. Hugh M. Beville, director of the department, announced that half of all the families in TV reception areas throughout the country already own television sets. This total represents about 31% of all U.S. homes.

The RTMA reported that 23,761,253 radio receiving tubes were sold during the month of August, an 80% increase over July sales. This brought the total for the first eight months of 1951 to 252,849,145 as compared with 227,773,373 for the same period of 1950. An analysis of the August figure showed 12,917,526 tubes were sold for new equipment, 7,230,419 for replacements and the balance for export and for government agencies.

The RTMA also reported that 210,043 TV picture tubes valued at \$4,327,234 were sold to set manufacturers during the month of August. This brought the total sales for the first eight months of 1951 to 2,851,222, valued at \$72,714,437. Of the tubes sold in August, 98% were 16 inches or larger in size, and 93% were rectangular in shape.

**Radio & Television Set Production**

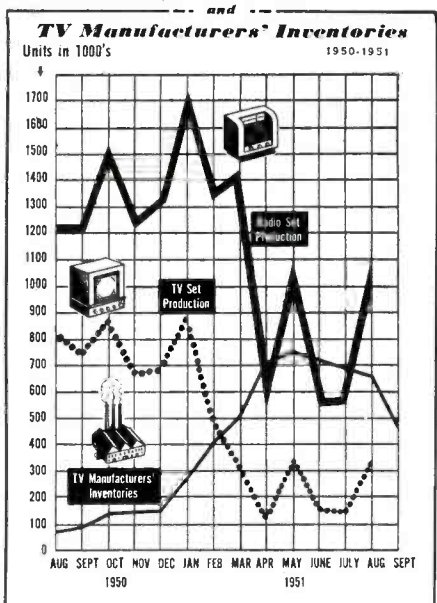

**New Plants and Expansions**

Allen B. Du Mont Laboratories television receiver manufacturing plant in East Paterson, N. J., has been partially converted for military production. Paul Eshleman, Du Mont's production control manager during World War II,

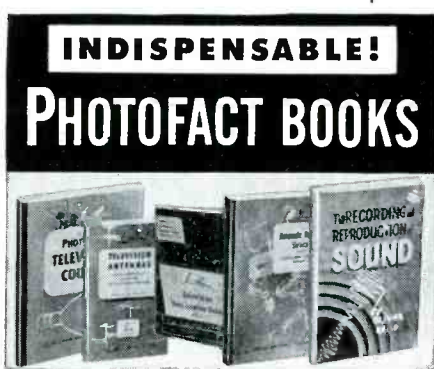

**Photofact Television Course.** Covers TV principles, operation and practice. 216 pages; profusely illustrated; 8 1/2 x 11". Order **TV-1**.....Only **\$3.00**

**Television Antenna. New 2nd edition.** Describes all TV antenna types; tells how to select, install, solve troubles. Saves time; helps you earn more. 200 pages; illustrated. Order **TAG-1**.....Only **\$2.00**

**Television Tube Location Guide. Volume 2.** Accurate diagrams show position and function of all tubes in hundreds of TV sets; helps you diagnose trouble without removing chassis. 224 pages; pocket-size. Order **TGL-2**. Only **\$2.00**

**Television Tube Location Guide. Vol. 1.** Over 200 pages of TV receiver tube position diagrams on hundreds of models. Order **TGL-1**.....Only **\$1.50**

**1949-1950 Record Changer Manual. Vol. 3.** Covers 44 models made in 1949, including multi-speed changers and wire and tape recorders. Original data based on actual analysis of equipment. 286 pages; 8 1/2 x 11"; paper-bound. Order **CM-3**.....Only **\$3.00**

**1948-1949 Changer Manual. Vol. 2.** Covers 45 models made in 1948-49. Paper bound. Order **CM-2**. Only **\$4.95**

**1947-1948 Changer Manual. Vol. 1.** Covers 40 post-war models up to 1948. Order **CM-1**.....Only **\$3.95**

**Recording & Reproduction of Sound.** A complete authoritative treatment of all phases of recording and amplification. 6 x 9". Order **RR-1**.....Only **\$5.00**



**Audio Amplifiers. Vol. 3.** Clear, uniform, accurate data on 50 important audio amplifiers, plus full coverage of 22 FM and AM tuners, produced during 1950. 362 pages, 8 1/2 x 11". Order **AA-3**.....Only **\$3.95**

**Audio Amplifiers. Vol. 2.** A complete analysis of 104 well-known audio amplifiers and 12 tuners made 1949-50. 368 pages, 8 1/2 x 11". Order **AA-2**.....Only **\$3.95**

**Audio Amplifiers. Vol. 1.** Covers 102 amplifiers and FM tuners made through 1948. 352 pages, Order **AA-1**.....Only **\$3.95**

**Auto Radio Manual.** Complete service data on more than 100 post-war auto radio models. Covers over 24 mfrs. 350 pages, 8 1/2 x 11". Order **AR-1**.....Only **\$4.95**

**Communications Receiver Manual.** Complete analysis of 50 popular communications models. 246 pages, 8 1/2 x 11". Order **CR-1**.....Only **\$3.00**

**Radio Receiver Tube Placement Guide.** Accurate diagrams show where to replace each tube in 5500 radio models, covering 1938-1947 receivers. 192 pages, pocket-size. Order **TP-1**.....Only **\$1.25**

**Dial Cord Stringing Guide. Vol. 2.** Covers receivers made from 1947 through 1949. Shows you the one right way to string a dial cord in thousands of models. Pocket-size. Order **DC-2**.....Only **\$1.00**

**Dial Cord Guide. Vol. 1.** Covers sets produced 1938 through 1946. Order **DC-1**.....Only **\$1.00**

**Making Money in TV Servicing.** Tested proved methods of operating a profitable TV service business. Covers all important phases. Authoritative, valuable guide to success. Over 130 pages. Order **MM-1**.....Only **\$1.25**

Order from your Parts Jobber or write direct to  
**HOWARD W. SAMS & CO., INC., 2201 E. 46th St., Indianapolis 5, Indiana**  
**HOWARD W. SAMS & CO., INC.**

**HIGH  
FIDELITY**  
*is here!*

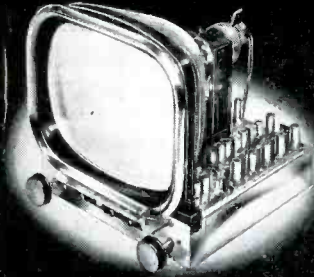

**TWO BRILLIANT NEW  
CUSTOM CHASSIS —**

Now, for the first time, you can enjoy the finest television and FM—plus high fidelity audio—all in one superbly-designed instrument! Now, at last, custom builders and electronics enthusiasts can choose the Craftsman Television which best suits their needs. **SEE them! HEAR them!** Above all—**COMPARE them!**

**The RC-101**

An outstanding new high fidelity custom video tuner with the same fine, big-picture quality and sensitivity as its famous predecessor, the RC-100. Features include keyed AGC and booster switch, plus new, double-shadow tuning eye for precision tuning. 20-20,000 cycle audio output permits remote hook-up with high fidelity audio and FM-AM tuners. Turret-type channel selector.

**The RC-200**

Here, at last, is a TV-FM-high fidelity audio receiver which, in one chassis, combines true high fidelity television and FM reception! Has all features of RC-101, plus 5-watt, push-pull high fidelity audio system and coverage of FM band. Continuous-type tuner and tuning eye permit 1-knob control of TV, FM or phono. Both chassis finished in polished chrome.

Write for information—**or send 50c for instructions and schematics.**

**THE RADIO  
craftsmen  
INCORPORATED**

Dept. G-12, 4401 N. Ravenswood Ave., Chicago 40, Ill.

heads the manufacturing operations in East Paterson. Mr. Eshleman personally designed and supervised the conversion of this former Wright Aeronautical plant into a television receiver manufacturing operation.

**Thompson Products, Inc.**, Cleveland, manufacturer of aircraft and automotive parts, recently purchased the Antenna Research Laboratory, Columbus, Ohio. The company plans to manufacture a complete line of antenna products for communications, aircraft, and navigation purposes. An official of the firm stated that there were no immediate plans for home TV antenna manufacturing.

**Radio Receptor Co., Inc.**, Brooklyn, N. Y., manufacturer of radio and electronic equipment, is increasing its plant's capacity and will manufacture germanium diodes.

**General Electric** has begun shipment of two-way radio equipment from its new Utica, N. Y., plant. The plant will be devoted exclusively to the production of this equipment. Production is being transferred gradually from the company's Electronics Park plant, Syracuse, N. Y.

**Copperweld Steel Co.**, Glassport, Pa., has purchased the outstanding stock of the Flexo Wire Co., Inc., Oswego, N. Y. It will be operated as a wholly owned subsidiary of Copperweld for the production of small and fine sizes of Copperweld wires and cables for the electronics and electrical appliance industries.

**The Esquire Radio Corp.**, Brooklyn, N. Y., was recently established for the production of clock-controlled radios. A. R. Lieberman, formerly chief engineer and general manager of Jewel Radio Corp., is president.

**Thomas Mold & Die Co.**, Wooster, Ohio, has announced plans to expand its present production facilities to meet the growing demand for its "Sky-Hi" masts.

**Crest Laboratories, Inc.**, Far Rockaway, N. Y., recently increased its floor space to accommodate increased production brought by additional government orders.

**Phalo Plastics Corp.**, Worcester, Mass., has renovated its testing laboratories and added new equipment.

**Business Briefs**

... **Thomas Electronics Inc.**, Passaic, N. J., has begun production of small vacuum tubes for original equipment and replacement. The company previously limited its production to TV picture tubes.

... **The RTMA Board of Directors** approved membership applications of the following companies, bringing its membership to 329: L. H. Frost & Co., Grand Rapids, Mich.; Hardwick, Hindle, Inc., Newark, N. J.; Hughes Aircraft Co., Culver City, Cal. and Jeffers Electronics, Inc., DuBois, Pa.

... **RCA Victor Division** announces plans to enter the home air-conditioning field in January, 1952, when it will

place its first unit on the market.

... **Tung-Sol Lamp Works Inc.** has changed its corporate name to Tung-Sol Electric Inc., to give a more accurate description of its activities and products.

... **General Electric's Tube Department**, Schenectady, N. Y., has announced an advanced course in television service, including set conversion. Radio and TV service technicians may sign up for the course through their distributors.

... **The 1952 Electronic Parts Show's** corporation manager, Kenneth C. Prince, announces that contract forms and brochures have been mailed to member exhibitors. The show, which will be held in the Hotel Stevens in Chicago on May 19 through 22, will be the only industry-wide national parts show to be held in 1952.

... **The NPA** has issued an order, M-85, granting priority assistance to FCC-licensed amateur radio stations and stations used by the Civil Air Patrol in obtaining supplies for maintenance and repair for existing stations and for building new stations.

... **Sarkes Tarzian, Inc.**, Bloomington, Ind., held a symposium on u.h.f. at Bridgeport, Conn., at which it demonstrated its new v.h.f. tuner, TT16. This tuner features 12-channel v.h.f. performance plus a u.h.f. position in which the tuner is changed to an amplifier for u.h.f. i.f. systems. It is available for receivers with either 21- or 41-mc i.f's.

... **RCA Service Co.**, Camden, N. J., announces that 25 field engineers and technicians have completed the second postgraduate training course in theater television installation and service techniques.

... **Kaye-Halbert Corp.**, Los Angeles, has formed a new national service company for providing better service to its distributors and dealers.

... **The Eidophor-CBS** large-screen theater color television, shown earlier this year in Switzerland, will be demonstrated in the U. S. before the end of the year by the 20th Century-Fox Film Corp.

... **The Radio and Electronics Society of India** will hold an International Exhibition in Bombay from February 9 to 29, 1952. The exhibition will afford manufacturers and distributors all over the world a chance to study the needs of Indian and Asian electronic buyers.

... **Sightmaster Corp.**, New Rochelle, N. Y., was issued two new patents involving the processing of glass for TV picture tubes to permit a true transmission of all colors evenly.

... **The Electrovox Co., Inc.**, East Orange, N. J., announces that replacement data on its "Walco" needles have been made available through the Howard Sams Photofact folders.

... **L. S. Thees**, General Sales Manager of the RCA Tube Department urged the industry's radio battery dealers to capitalize on the popularity of portable radios with aggressive merchandising and promotion. He said portables now account for about 20% of all radio sales.

—end—



**DAVE MARKS, President**  
 Fort Orange Radio Distributing Company, Inc.  
 Albany, New York

# "OUR FASTEST SELLING SPEAKER LINE FOR THE PAST 7 YEARS!"

## Quality Product Plus Smart Promotion Spell Success for Aggressive Parts Jobber

"MY dealer customers don't bother to open the cartons — as they do with other brands — before buying G-E speakers. They know that General Electric factory-packed Alnico units come to them in perfect shape, ready for use. Customer confidence pays off. Because I stock all 27 G-E models, my dealers know I can fill any speaker need."

What Dave Marks does not mention is that his merchandising skill has made him one of the top parts distributors in the East. He makes frequent and profitable use of all G-E sales tools: catalogs, booklets, envelope stuffers, display pieces of all kinds. They're available to you, too, through your General Electric distributor or representative. Call him today for your share of these sales helps.



**Drive-In Theatre Speaker Sales Hot!** With G.E.'s special weather-tested outdoor speaker, Dave Marks, shown here with general manager Ted Sharaf, has increased his drive-in business four times over in two years!

### DEALERS AND SERVICEMEN

Here's a complete new service manual on all General Electric television receivers — 102 models manufactured since 1945! You get 80 pages packed with circuit diagrams, symbols and numbers, tube locations, top and bottom chassis views. Plus photographs and lists of service aids. Mail coupon for it today. Only \$1.00.



General Electric Company, Section 45121  
 Electronics Park, Syracuse, New York  
 Send me \_\_\_\_\_ copies of the new 80-page service manual on General Electric TV receivers at \$1.00 each. I enclose \$\_\_\_\_\_

Check     Money Order

NAME \_\_\_\_\_  
 ADDRESS \_\_\_\_\_  
 CITY \_\_\_\_\_ STATE \_\_\_\_\_

**GENERAL ELECTRIC**

# Know "WHY" Ceramic Capacitors . . .

**Here are the facts about Ceramic Capacitors — why they are the most permanent capacitors . . . why they do a better job . . . give a better performance . . .**

Up until a few years ago, capacitor design was based on one idea — "the bigger the better." Paper and mica, etc., were cheap, readily available materials, and their use was the only known art for making commercial capacitors (or "condensers" as they used to be called).

Now don't misunderstand us . . . those old condensers were really OK as far as they went. *But today there's something more to talk about . . . CERAMIC CAPACITORS.*

Actually, the idea of ceramic capacitors isn't new. They've been used as electronic components for more than 20 years. We call them new because it's only in the last few years that service-engineers have paid any attention to them . . . and because some of these modern ceramic capacitors really are new . . . with new higher voltages, new and better physical characteristics. So if ceramic capacitors were overlooked by service-engineers during the last few years . . . we feel it's because you didn't know about just how good they really are—or because what you needed wasn't available.

Let's take a look at modern ceramic capacitors and the story behind them. It was in the early 1900's when German scientists discovered the dielectric properties of ceramic materials. In the U.S.A., we had an abundant supply of mica and other materials, so U.S. research men never bothered with ceramics. Then came World War I, and ceramics became mighty important in European radio manufacture. Ceramics were a long way from perfected but they did the job . . . and continual improvement made them increasingly important in the electronic field. Meanwhile, at Centralab, we had started to investigate these new materials. It was soon found that U.S.A. had a bigger source of raw ceramic materials and that our stocks were of vastly superior physical and electrical characteristics.



Then one of our foreign representatives supplied us with a complete set of foreign-made ceramic components. Result — Centralab developed a ceramic research program. The program was big and thorough . . . and it's still going on.

In a few years, Centralab put on the market its first ceramic capacitors. With World War II, came tremendous developments in electronics. Radio, radar and other electronic equipment demanded the finest in component parts . . . and ceramic capacitors came into their own. *In fact, independent research has shown that during World War II, in some classes of military equipment, there was not a single known instance of a failure of a ceramic capacitor!*

Thus, through the lessons learned over a period of 20 years of intensive research — Centralab Ceramic Capacitors have today become the best capacitor buy for safe guaranteed servicing. For when you use CRL ceramic capacitors, you're using the benefits of hundreds of thousands of man-hours of research—experiments with over 20,000 different ceramic compounds!

That's why any ceramic isn't the best ceramic for the job. Each of those 20,000 ceramic mixes had definite physical and electrical characteristics . . . and when we say that Centralab today uses only 250 of those 20,000 tested compounds, you can be sure that those discarded did not perform to the exacting requirements of sensitive electronic circuits.

Yes, and if you compare the old-style paper and mica capacitors with modern ceramic capacitors . . . point for point, based on your own technical experience, you'll see why ceramics are vastly better . . . the safe, dependable way to assure a good service job.

For example, every serviceman is aware of the moisture absorbing quality of paper condensers . . . and how moisture can seep in along the leads on mica units. Compare these old designs with modern ceramic tubular and disc types . . . Centralab's Ceramic-X capacitor bodies are nonhygroscopic . . . moisture absorption being only .007% or less! That fact alone means Centralab Capacitors give you and your service customer the ultimate in reliability—even under severe tropically humid conditions.

Old-timers in the service field . . . yes, and young ones, too, will recall the bulky size . . . the difficulty of handling old-fashioned large size capacitors . . . when size seemed to be an important factor in design. Now, look at modern ceramic capacitors. They're less than 1/4 the size . . . you can fit them anywhere!

When you look at this chart of the development of capacitors using various materials . . . the tremendous improvement of the dielectric con-

stant "K" with the entry of ceramics into the field is dramatically evident.

One of the most serious problems with old-time capacitors was that they broke down under high temperatures. Here again, ceramics have more than proven their superiority. 85° C. will not harm the modern ceramic capacitor. In fact, the ceramic body itself can easily withstand any temperature encountered in electrical apparatus. High capacity is

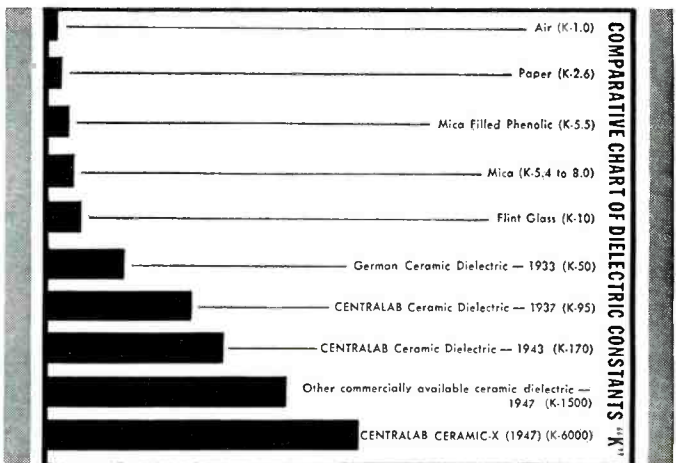

well maintained under wide temperature variation. What's more, the copper-silver electrodes are electro-bonded to the ceramic with a tensile strength of 30,000 lbs. per square inch — thus preventing any possible change of the relative position of the electrodes.

A typical example of the high degree of perfection and performance offered by ceramic capacitors is contained in CRL Hi-Vo-Kaps. These units are rated at 10 — 20 and 30 KV and are intended exclusively for TV. You'll find that practically the entire TV industry has standardized on these CRL units as original equipment for this most exacting application.

When it comes to low power factors—check ceramics against all others. With ceramics, initially it's .1% to .6%. After 100 hours at 95% humidity, it's .5% to 3% and they'll return to normal! That's ceramic high efficiency! If it's accuracy you want, ceramic capacitors can give you unusually close tolerances in wide range of values.

In r.f. circuits, where drift is critical, one of the likely causes is temperature change. Stabilization can be effected by capacitors which compensate for temperature variations. Centralab pioneered ceramic capacitors for this purpose. This important research resulted in Centralab's famous TC-Hi-Kaps Zero Temperature and Negative Temperature Compensating units. These are a Centralab exclusive "First". For service-engineers they are the industry's last word in accurate stabilizing capacitors.

Service-engineers today are called upon for more exacting work — more downright customer satisfaction. Every job that comes into your shop is a challenge to your reputation. Regardless of the care in workmanship, no service job is better than the components you put into it. To stay in business tomorrow — you can't take chances today.

Field research shows that smart service-engineers everywhere are replacing all old-fashioned or dangerously old capacitors with ceramic capacitors, within the capacity ranges available. Particularly if there is any indication of possible failure within a reasonably short period. For by-pass and coupling applications . . . they're using Centralab BC Hi-Kaps. For tuning applications, they're using temperature compensating TC Hi-Kaps. It's their own assurance of a good job well done . . . and their customer's insurance of complete satisfaction. What's more, to the serviceman and customer alike . . . *there's little or no premium in price.*

You'll find Centralab ceramic capacitors are available in a wide variety of capacities from any recognized better radio parts distributor. Ask him. And remember, Centralab is the pioneer in the field of electronic ceramics. That fact alone is your best assurance of engineering know-how, production know-how, and performance know-how that permits no compromise with quality.

# and you'll Buy Ceramic Capacitors

Choose the exact capacitors you need from the world's widest line of ceramic capacitors — for jobs that demand the best in guaranteed TV-AM-FM servicing . . .



**CERAMIC DISC HI-KAP CAPACITORS** — provide very high capacity in extremely small size, with minimum thickness. For by-pass, coupling and general applications. Superior power factor and low inductance.



**CERAMIC BC TUBULAR HI-KAP CAPACITORS** — for by-pass or coupling applications and most general circuit work. Smallest size on the market. Remarkable stability under high temperatures or humidity.

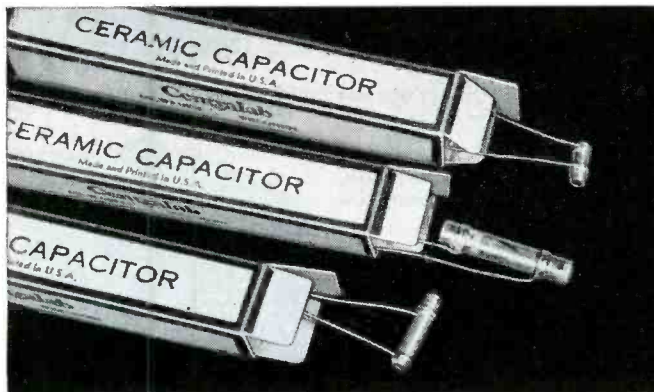

**TC TEMPERATURE COMPENSATING CERAMIC CAPACITORS** — stable units that do not change in capacity under wide temperature variations—or may be selected to correct for frequency drift in resonant circuits caused by temperature changes. Also superior replacement for close tolerance micas.



**CAPACITOR KITS** — several are available. Illustrated is assortment of 200 units of most generally used values, supplied in a four-drawer metal cabinet. Often assures required values will be on hand when needed in labs or for service. No charge for cabinet.

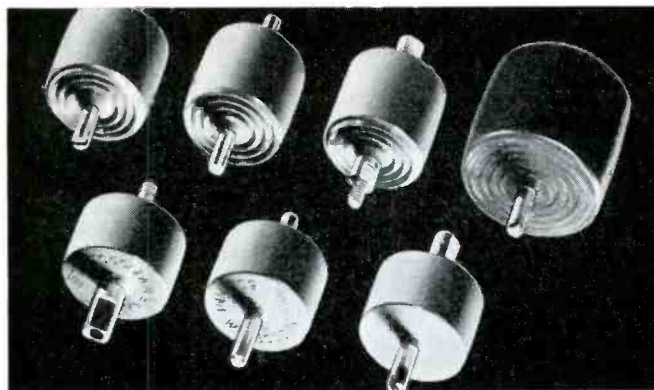

**TELEVISION HIGH VOLTAGE CAPACITORS** — the accepted standard for the TV industry. Used for filter and by-pass in TV high voltage power supply and pulse filter for cathode ray tubes. Ask for Centralab Hi-Vo-kaps.

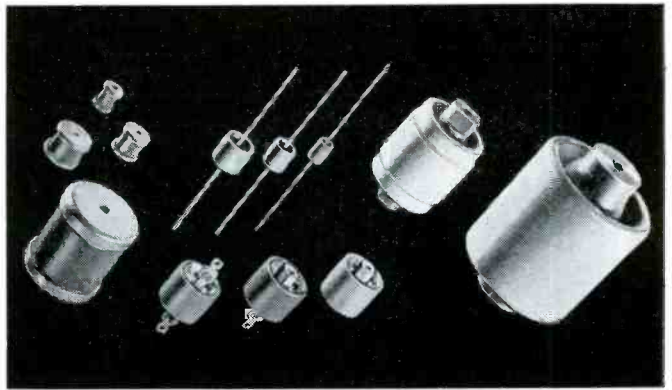

**TRANSMITTING AND HIGH ACCURACY CERAMIC CAPACITORS** — for applications involving rigid frequency control. Used for holding oscillator frequencies to close limits. Excellent as secondary Standards.

Yes, for the safest, quickest guaranteed servicing . . . standardize on Centralab Ceramic capacitors. You'll have the world's widest line to select from — as made by Centralab, America's pioneer builder of ceramic capacitors. You can get complete information on all the capacitors described here — plus other valuable service information from Centralab's Catalog 27 . . . available at your distributor's.

## Centralab

Division of Globe-Union Inc.  
922 E. Keefe Avenue • Milwaukee 1, Wis.

**EICO**  
TEST EQUIPMENT

*guards*

**Tele King**  
HIGH STANDARDS OF  
TELEVISION PRODUCTION QUALITY



Tele-King Production Test Foreman James Adler and Harry R. Ashley, President of EICO, inspecting the use of the EICO Model 425 Oscilloscope and Model 221 Vacuum Tube Voltmeter at one of the important constant-duty alignment positions on the Tele-King television production line, New York City.

**EICO KITS and INSTRUMENTS**



**New 555K MULTIMETER**  
KIT \$29.95 Wired \$34.95



**320K SIG. GEN. KIT \$19.95**  
Wired \$29.95

**New 322K SIG. GEN.**  
KIT \$23.95 Wired \$34.95



**New 950K COND.-RES. COMP. BRIDGE KIT \$19.95**  
Wired \$29.95



**New 1040K BATTERY LIM.**  
KIT \$25.95 Wired \$34.95



**HV PROBE**  
\$6.95



**511K VOM**  
KIT \$14.95  
Wired \$17.95



**New 1171K RES. DECADE BOX KIT**  
\$19.95 Wired \$24.95

**New 526K MULTIMETER KIT**  
\$13.90 Wired \$16.90

**EICO**

ELECTRONIC INSTRUMENT CO., Inc.  
276 NEWPORT STREET, BROOKLYN 12, NEW YORK



**New 315K DELUXE SIG. GEN.**  
KIT \$39.95 Wired \$59.95



**New 625K TUBE TESTER KIT** \$34.95  
Wired \$49.95



**360K SWEEP GEN. KIT** \$34.95  
Wired \$49.95



**145K SIG. TRACER-KIT** \$17.95  
Wired \$26.95



**New 221K VTVM KIT** \$25.95  
Wired \$49.95



**New 425K 5" SCOPE KIT** \$14.95  
Wired \$29.95

**For Laboratory Precision at Lowest Cost—  
the Leaders Look to EICO!**

**WHY**

does Tele-King Corp., one of America's leaders in quality television set production, use EICO Test Instruments on its television production lines and in its design laboratories?

**BECAUSE**

like Emerson, Tele-Tone, CBS-Columbia, and many another famous TV manufacturer coast to coast, Tele-King knows that . . .

**Only EICO Test Equipment delivers  
All 10 EICO nomical Features!**

- |                           |   |
|---------------------------|---|
| 1. Laboratory Precision   | 7. Latest Engineering                             |
| 2. Lowest Cost            | 8. Super-Simplified Assembly and Use Instructions |
| 3. Lifetime Dependability | 9. Laboratory-Styled Appearance                   |
| 4. Speedy Operation       | 10. Exclusive EICO Make-Good Guarantee            |
| 5. Rugged Construction    |   |
| 6. Quality Components     |   |

Before You buy any higher-priced equipment, be sure You look at the EICO line—in Wired as well as Kit form! Each EICO product is jam-packed with unbelievable value. YOU be the judge—compare, see EICO instruments today — in stock at your local jobber — and SAVE! Write NOW for FREE newest Catalog 12-C.

**FOLLOW THE LEADERS...INSIST ON EICO!**

Prices 5% higher on West Coast. Due to unsettled conditions, prices and specifications are subject to change without notice.

# Is The Vacuum Tube DOOMED?

. . . The Vacuum Tube's Competitor Is Rising Fast . . .

By HUGO GERNSBACK

ONE of the foremost, if not the greatest, invention of recent times was Dr. Lee de Forest's three-element vacuum tube. It would be difficult to cite a single other invention that has benefited man in so many different ways as has the vacuum tube, which gave birth to a new giant—radio-electronics.

Since the first vacuum tubes appeared on the market, not long after the turn of the century, many billions of such tubes have been manufactured all over the world. This tempo has been accelerated from year to year, is still increasing, and will probably continue to increase during the present decade. The world annual output of vacuum tubes is colossal, reaching about half a billion. They are made in all sizes, from the miniscule types, smaller than a pea, to huge transmitting types weighing hundreds of pounds each. Vacuum tubes have been well standardized during the past two decades and their life is usually quite long. Thus many radio receiving sets with their original tubes, from the early twenties—when broadcasting started—are still in use. Some of these ancient tubes have an astonishingly long life and if not used continuously still perform well.

One would think that such a fragile instrument as a vacuum tube would have a very short life, but such is not the case. The average tube giving normal service lasts long, if not electronically worn out by a current overload.

Nevertheless, the vacuum tube has serious shortcomings, the foremost of these being:

- (1) Bulkiness. (2) Electric current drain. (3) Vulnerability to severe shock.

There are also many other disadvantages of a technical nature, which we need not go into here. Before the vacuum tube came into active use there was a fascinating device which was widely used in wireless communication—the crystal detector. It was also a rectifier which needed no current of any type, neither A nor B—it supplied its own current from the rectified radio waves. It operated efficiently, was light in weight, and was practically everlasting.

It had, however, several inherent disadvantages. It was easily put out of commission, even by slight shocks or jars; it was insensitive, and it could not be used as an amplifier, and it did not oscillate, as did the vacuum tube.

Later, in 1924, a Russian experimenter, O. V. Lossev, invented an oscillating crystal which actually worked. This achievement was first reported in the American press in one of the writer's former magazines in September, 1924. This oscillating crystal, however, did not come into general use because it was highly temperamental. It was difficult to adjust and keep going. The "bugs" were never ironed out.

It was not until the end of World War II that the scientists, J. Barden and W. H. Brattain, of the Bell Telephone Laboratories, after years of painstaking work, developed a perfect crystal which in all practical respects

duplicates the vacuum tube. This is the *transistor*. The modern transistor has three terminals, just as the original vacuum tube, but as it does not require a filament current, it becomes much more flexible, is very much lighter, and, as now manufactured, is impervious to the most violent shocks. As there is nothing to wear out, it should last practically forever. The transistor, which is smaller than a pea, is also an amplifier. But when connected in cascade with transformers for power purposes, electric current must be used to energize it.

The new transistors, for certain purposes, are ideal, particularly where weight and space are at a premium, such as in airplanes, many important war devices, etc. When the transistor is used with printed or applique wiring, weight and space are still further reduced. Certain radio components, such as variable resistors, switches, relays, etc., have recently been miniaturized to such an extent that the size and weight of these devices have been reduced astonishingly. The only component which has not been greatly miniaturized is the transformer, although advances have been made.

Using the new molecular loudspeaker reported in the last issue of RADIO-ELECTRONICS, it would seem possible that during the next few years an excellent superheterodyne radio receiver, no larger than a wrist watch, could be designed.

Will the transistor make the vacuum tube obsolete in the near future? This is much to be doubted. The vacuum tube will always have certain advantages over the transistor. It must also not be forgotten that for many years to come people will still use their present radios and television sets. Vacuum tubes therefore will still have to be manufactured by the billions to take care of replacements. This is true not only of home devices but for industrial, maritime, commercial, and military devices.

What keeps the transistor from displacing the vacuum tube in the immediate future? This is mainly an economic question, because the cost of the transistor today is much greater than that of the vacuum tube. At the time we go to press, the price of the transistor is \$18.00. Also the transistor so far does not operate on all frequencies. Mass production has not yet been evolved. There are still many manufacturing "bugs" to be straightened out. This may take some years.

What also, in the writer's opinion, will hold back the transistor is its present name. The public never has taken kindly to it and probably never will. The word "crystal," from the Greek "Krystallos" is the basis for a popular name. I would seriously suggest that, particularly for public consumption, a new name should be adopted. I advance the term "crystron" (crys=crystal; tron=electron). This

is what the device is—an electronically operating crystal. The adoption of this designating name *now* will do away with a great deal of confusion in the future.

Radio-Electronics wishes its readers a  
Happy Christmas and prosperous New Year



Courtesy Underwood and Underwood

# Important Factors in HIGH-QUALITY AUDIO

By WALLACE WANER

**T**HE high-fidelity fan is always seeking a new and better circuit from which to build that "perfect" amplifier. His choice of a good schematic usually can be taken for granted, but there is little assurance that the finished product will come up to his high expectations. Too often a number of factors not indicated on the wiring diagram are overlooked. They may be just the factors that make the difference between complete satisfaction or keen disappointment with the finished product.

These factors apply with equal importance to any type of audio amplifier. For this reason no specific circuit is analyzed in this article. By modifying existing amplifiers, or by incorporating these essentials in proposed construction, it will be easier to achieve the type of true high fidelity which gives the listener a sense of "presence" and of on-the-scene realism.

## The output transformer

Perhaps the most misused component in an audio amplifier is the output transformer. This unit definitely should be on the husky side. Instead, it is often too skimpy for the output of the ampli-

fier. The result is that the core saturates with only a few watts of audio power. Besides the distortion usually introduced by the small transformer, the undersize core and inadequate copper content of the windings not only limits power output but gives unequal amplification over the desired frequency range.

A good example of the variation in output transformers is shown in the photograph. The smaller transformers are each rated at 20 watts. Each saturates and has a high distortion factor long before this power is reached. Actually, such a 20-watt rating is more indicative of how much these transformers can handle before burning out rather than how much *audio power* they will deliver with high fidelity. By comparison, the high-quality transformer at the left is rated at 15 watts of audio power, yet is larger than the two which are rated at 20 watts! Obviously, ratings do not always tell us the whole story about an output transformer.

Many new audio enthusiasts have found, to their surprise, that a good-quality audio-output transformer with a rating of 10 or 15 watts is as big as a power transformer.

## Advantages of large size

The need of a big output transformer can be understood more easily when we consider what the audio amplifier wants from it. Suppose two 6L6 tubes are used in push-pull class A1, which will furnish approximately 18 watts of audio power with only 2% total harmonic distortion. Each half of the primary winding will have over 50 milliamperes of current flowing through it, besides the audio-signal current variations.

Using a power-supply voltage of about 250 volts for the 6L6 tubes, the a.c. audio signal will swing up to 400 volts peak value with full grid input. Plate current will run over 70 ma per tube. With such current and voltage values you can get best results and proper performance at high output levels only with large diameter wire and plenty of core. The larger core increases permeability, which in turn increases the inductance of the windings. This means that the number of turns can be reduced by the manufacturer in both primary and secondary windings and still hold the inductance to the desired value.

The immediate benefit of fewer turns is a reduction of distributed capacitance



between the windings. Less capacitance means less shunting effect on the higher audio frequencies. The reduced number of turns also decreases the resistive component of the windings and thus cuts down on audio power dissipation in the transformer.

The temptation to buy the cheapest output transformer (or to use that odd one lying around) must be shunned if high fidelity with reasonable power output is the goal. The extra cost of the bigger job pays off in improved performance.

**Impedance matching**

The load resistance for the output tubes and the voice coil must be properly matched. Neglect here can undo the benefits of the larger size transformer. Unless the impedance match is correct, maximum power output cannot be obtained from the audio amplifier power output tube. If too low an impedance is reflected to the tube, quality may drop, too.

and measure the stepped-up voltage across the secondary. Dividing the secondary voltage by the a.c. voltage applied to the primary gives the turns ratio. As an example, if 2 volts is applied to the voice-coil winding of an output transformer and 60 volts is read across the plate winding, the turns ratio would be 30 to 1. (It is preferable to use a small value of a.c. voltage on the voice-coil winding to prevent overheating.)

**The loudspeaker**

A common fallacy is that the larger the cone the better the speaker. This is far from true. Loudspeaker efficiency and power-handling capabilities depend on several factors other than mere cone size.

Regardless of make or price, the amount of undistorted power the loudspeaker is capable of delivering depends on the smallness of the gap between the pole pieces surrounding the voice coil and the strength of the mag-

**Hangover reduction**

Hangover—in audio discussions—refers to the blending of one tone with the next—an effect similar to holding down the sustaining pedal of a piano. Musical notes which are supposed to be sharply separated in staccato fashion, blend and slur together.

The amount of hangover depends very much on the design and quality of the output section of the amplifier. Sometimes it is so slight that it is hardly noticeable, and not until it has been entirely eliminated can one appreciate the decided improvement in musical crispness and definition.

Hangover is caused by improper damping of the output circuit. It may be due to power tubes with high plate resistance (pentodes and beam tubes) or to a cone which moves too freely. When the speaker cone is pulsed by an audio field in the voice coil it moves sharply forward and back. When the musical note ends and there is a sudden absence of signal in the voice coil, the speaker cone should stop as suddenly. The laws of physics and inertia remind us, however, that the cone will not come to sudden rest, but will continue its motion for a little while—depending on its stiffness and mass. This extra movement shifts the voice coil back and forth in a magnetic field and a.c. voltage is, of course, induced in the voice coil.

This unwanted voltage reappears in the speaker and adds a trailing tone to the one just reproduced, thus destroying any possibility of sharp reproduction. Hangover can be reduced by a stiff-cone speaker and a high concentration of magnetic energy around the voice coil, for both have a damping effect. The high plate resistance of pentode tubes can be reduced by negative feedback (also called inverse feedback) as shown in Fig. 2. R can be a 500,000-ohm variable which can be replaced by a fixed resistor once the correct value has been established. C should be

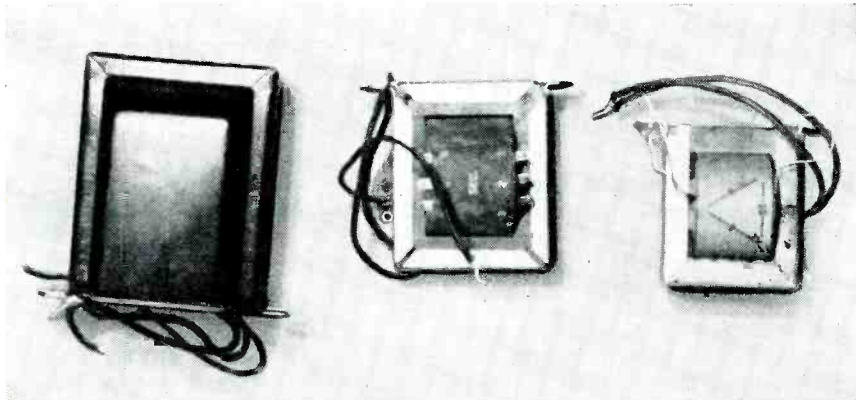

A good 15-watt and two so-called 20-watt output transformers compared for size.

The necessary turns ratio between the primary and secondary can be calculated by the simple formula:

$$\text{Turns ratio: } \sqrt{\frac{\text{Primary } Z}{\text{Voice coil } Z}}$$

The primary impedance actually refers to the preferred load resistance. This information can be found in the tube manual. If, for instance, the load resistance is 2,500 ohms (typical for a triode 6A3) and the voice-coil impedance is 5 ohms, we get the following:

$$\sqrt{\frac{2500}{5}} = \sqrt{500} = 22.5 \text{ (approx.)}$$

This would mean that a satisfactory transformer would have 22.5 times as many turns on the primary as on the secondary.

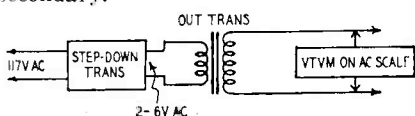

Fig. 1—Setup for finding turns ratio.

The turns ratio of a transformer can be found by measuring its voltage step-up ratio, which is the same as the turns ratio. Fig. 1 is a typical setup. Apply a small known voltage to the primary

netic field in that gap.

The frequency response may depend on cone construction, suspension, and other contributions of careful design, but the amount of power the speaker can handle without distortion depends in a large measure on the size of the magnetic alnico slug in the PM types or the magnetic field built up by the dynamic types. A small magnet slug or an undersize field coil will limit the amount of power the speaker can handle, and severe distortion will result above a few watts. Thus, a 16-inch speaker which has the same size slug as an 8-inch cannot be expected to give much better performance than the smaller one.

Understand, of course, that the larger speaker with a proportionally larger magnetic field will outperform the smaller. Too often, however, the larger speaker is used merely because of its size, and if it has an inadequate magnetic field it will be unable to deliver the required or expected audio power. This alone would not be too serious except for the fact that the large cone with the small magnet is more prone to produce such undesirable effects as cone resonance and hangover.

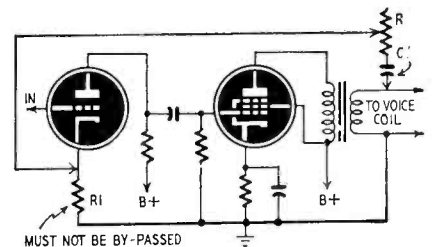

Fig. 2—This simple feedback circuit reduces the effects of a number of faults.

.05 μf or larger; it serves to prevent shorting any d.c. developed across R1. If the amplifier oscillates, reverse the tap and ground connections at the output transformer secondary, or reverse primary leads.

This type of inverse feedback can be used over several stages and will help reduce distortion and tube noises. It is particularly useful with pentode output tubes. When triode output tubes are used, their low plate impedance makes damping to reduce cone resonance and hangover effects unnecessary. Most

triode power amplifiers have very low plate resistance, so a free-moving cone speaker can be used to secure better low-frequency response from the speaker.

### Output equalization

One serious disadvantage of an output transformer is that the inductive reactance of the primary varies to a considerable extent with frequency, as indicated by the inductive reactance formula:

$$X_L = 6.28 \text{ frequency inductance } (2\pi fL).$$

As can be seen, with a constant inductance, each change of frequency will produce a corresponding change in the ohmic value of the reactance. This means that high tones find a higher reactance and get more amplification than the low tones which produce a much lower reactance. An equalizing circuit as shown in Fig. 3 will help compensate for this undesirable effect, for

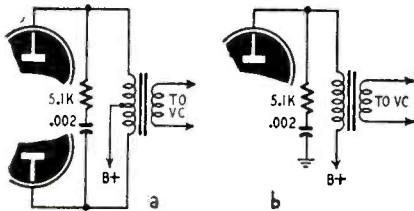

Fig. 3—The equalization circuit, for push-pull and single-ended amplifiers.

the impedance across the circuit formed by the resistor and capacitor will act in fashion opposite to the coil reactance. Find the exact values of capacitance by experiment. This type of compensation is seldom needed with triode output tubes, due to their lower output impedance as compared with that of the output transformer primary.

### The sound source

Radio tuners, microphones, and

phonograph pickups often introduce considerable distortion in the upper frequency ranges. The response characteristics of recordings by the various phonograph record companies also vary to a considerable extent. For these reasons reproduction can be improved by using some sort of tone control. Not the usual bypass type of tone control, however. An actual R-C low-pass filter network as shown in Fig. 4 is a much more satisfactory method of equalization and high-frequency noise attenuation.

The one at *a* is variable and can be adjusted so that attenuation begins at the upper ranges of the phono pickup or radio tuner. The nonvariable type shown at *b* can be used after experimenting with C1 and C2 values for proper reduction of noise and distortion. These could range from .002 to .005  $\mu\text{f}$ . The larger values attenuate most. Once the proper values have been established, the filter network can be inserted in the grid input circuit of an amplifier stage as shown. The coupling capacitor value and the grid leak are left undisturbed.

The values of R1 and R2 should be approximately 47,000 to 56,000 ohms. In Fig. 4-a, a knob can be brought out on the front panel for manual control.

### High-frequency audio losses

The foregoing does not imply that a wide-frequency-response amplifier is not desirable, for it is. With a high-quality pickup extending to well above 15,000 cycles with little noise, the high tones should not be diminished.

The same holds true for an FM tuner where audio ranges to 15,000 will be received. In such instances a flat-response amplifier to 15 or 20 kc is highly desirable to reproduce the overtones so essential to definition and presence.

One oversight which often has a serious effect on the frequency range of a good amplifier is the use of too long

shielded leads from the phono pickup to the input of the amplifier. It is, of course, necessary to use shielded cable from the sound source to the amplifier input, because the high gain of the first stage will pick up hum or introduce squeals and whistles. The input cable, however, must be kept as short as possible, for the capacitance losses between inner conductor and outer shield are high for just a few feet of length. Even if we have an amplifier with a response flat to 15,000 cycles, we can easily spoil this range by using an excessively long shielded cable between the sound source and the grid of the input tube. Every foot or so that is eliminated makes a pronounced difference in high-frequency output.

On new construction it is advisable to guard against running signal-carrying wires too close to chassis. If grid and plate leads, or load resistors, are positioned too close to chassis or circuit wiring, capacitance will again hamper high-frequency reproduction.

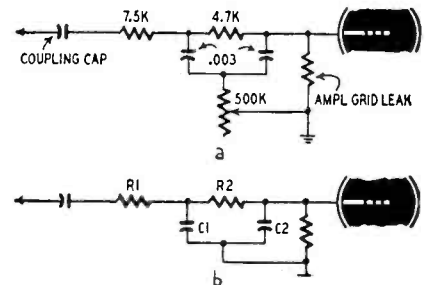

Fig. 4—The filter type tone control.

All the foregoing will become meaningless if you try to get too much out of your amplifier. You must have a well-designed circuit, capable of handling the amount of audio power you desire without distortion. Pushing an amplifier beyond what it can handle will undo the best design and workmanship.

—end—

## Shut-In's Ear Extender

An invalid or shut-in who is confined to one room soon tires of the sameness of radio programs and phonograph recordings, and longs for the sounds he heard before being confined. His hearing range can be greatly increased and life can be made less boring if a few small PM speakers and a high-gain audio amplifier are available.

The speakers are used as microphones and are placed near the source of the sounds he wants to hear. Much of the normal family life can be brought to him through microphones placed in the kitchen, living room, near the family dining table, or on the front porch. Outdoor sounds such as bird songs, children at play, and the arrival of the newsboy with the evening paper can be picked up by microphones that are placed in nearby trees or under the eaves of the house.

A telephone pickup should not be overlooked. You can make one by mounting a Ford spark coil—which can still be bought at Sears or Montgomery Ward, or at many auto supply houses—under the phone with its secondary connected to the amplifier input through shielded cable.

There are a number of ways in which you can rig up a suitable amplifier. A preamplifier can be rigged up to feed the microphones into the audio circuit of the radio set or you can use a small 3-tube phono amplifier with an extra 12SQ7 or similar tube added to supply the gain required. A single-pole multi-position rotary switch can be used to connect one microphone (speaker) at a time to the input of the amplifier. A more elaborate system can be worked out by using separate input circuits with gain controls for each. In this way,

the listener can pick up a variety of sounds and blend them in their normal proportions.

Outdoor speakers should be mounted in metal cans—1-pound coffee cans are O.K.—with a number of small holes punched in front of the speaker. The assembly should be weathertight at the top and tilted so water cannot run or be blown into the speaker cone. Speakers mounted in trees can be concealed in a weatherproof case which can be constructed to look like a rustic bird house.

A slightly better system can be built with crystal microphones instead of the small PM speakers. The results will not in most cases pay for the extra cost of the better microphone equipment, however, though if it is available it will add somewhat, especially to the quality of the transmissions. —E. E. Youngkin

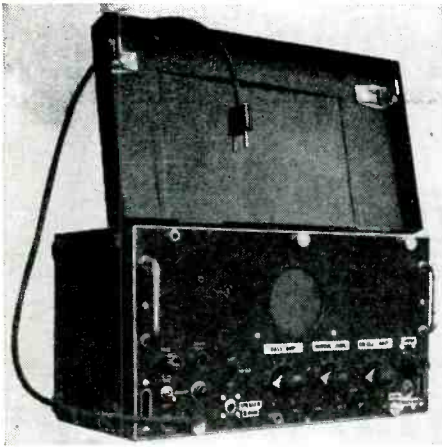

Left—Mr. Zoucas' amplifier viewed from the front. Hinged lid covers the panel. Center—Chassis view. Note that oil-filled capacitors were used in the original version. Right—The underchassis wiring. The output transformer is at the right.

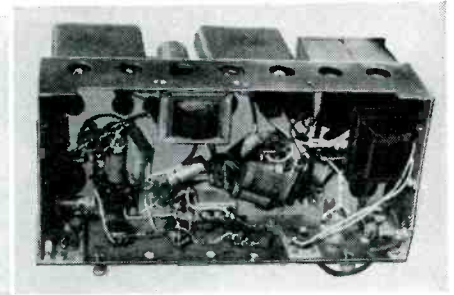
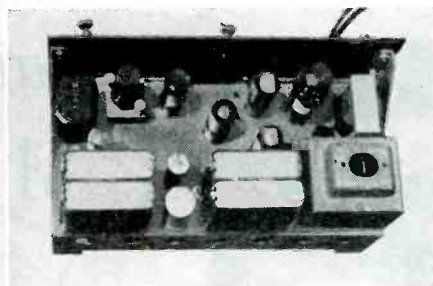

# Three-Channel Amplifier

By J. ZOUCAS

**A** FLEXIBLE tone-control system is an important part of any phonograph amplifier. Most high-quality amplifiers use more or less complex networks of L, C and R. They usually also require one or more supplementary tubes to compensate for the loss of gain in the compensating network.

I decided that it was simpler to split the input stage into three independently controlled channels. Two cover only a part of the audio frequency spectrum (bass and treble). The third channel covers the whole spectrum.

There are six separate tone controls. (The photos show only two, P4 and P6. The other four, S1, S2, P2, and P3, were added after the photos were taken.)

As the amplifier was designed for my living room, 8 watts was judged sufficient output. A pair of 6V6's in class A1:1 deliver this at the plate voltage chosen. To lower the output impedance, negative feedback is used from the voice-coil winding of the output transformer over three stages to the 6J5 ca hode circuit.

The input of the amplifier is designed for a crystal pickup. R1 is selected to limit signal voltage at point X to 0.5 volt on peaks. From here the signal goes through the volume control P1 and then divides into three parts, going to a 6SJ7 and each half of a 6SL7. The output of the 6SJ7 has a low-pass filter in its plate circuit. The crossover frequency of this filter can be adjusted by S1. The amount of bass boost is regulated by P2. The over-all gain of the bass boosting channel is controlled by the potentiometer P4 in the grid circuit of the 6J5.

One half of the 6SL7 functions as the uncompensated stage which amplifies all frequencies. P5 controls the gain of this channel.

The other half of the 6SL7 is used as the treble channel. This channel has a variable high-pass filter in its plate circuit. S2 selects the frequency at which the channel's response begins to

fall. Potentiometer P3 regulates the amount of fall. The over-all gain of the treble channel is controlled by potentiometer P6.

The output of the three separate channels is combined at the grid of the 6J5 amplifier. The 6SN7 which follows the 6J5 functions as the phase inverter using a cathode-coupled circuit. In this circuit, only one of the triode grids is driven. The other triode's grid is at ground potential as far as a.c. is concerned. The signal is fed through the cathode which is connected to the cathode of the first half of the 6SN7. Since both cathodes are well above ground,

they vary at an audio rate when a signal is fed to the first triode grid. Because of the grounded grid, the second triode's plate has the same phase as the cathode, and differs by 180° from the plate of the first triode.

The 6V6 push-pull output stage is connected in conventional fashion. However, each tube has a separate cathode bias resistor (a 600 ohm, 4-watt potentiometer). A closed-circuit jack in each cathode permits metering cathode current of each 6V6. Adjust the bias to give a cathode current of 35 ma for each tube.

To get the maximum quality from

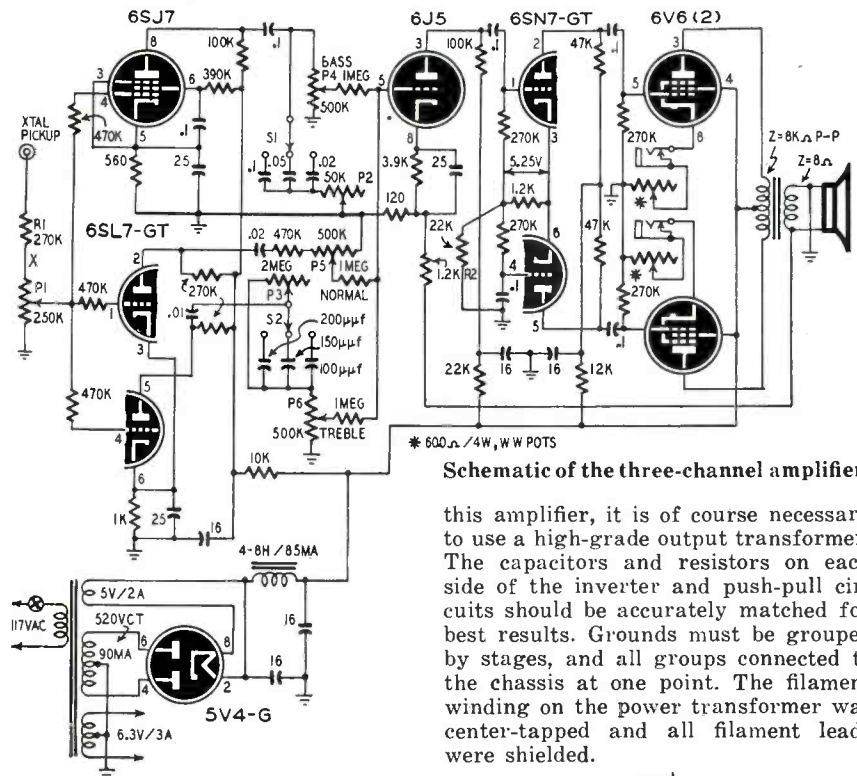

Schematic of the three-channel amplifier.

this amplifier, it is of course necessary to use a high-grade output transformer. The capacitors and resistors on each side of the inverter and push-pull circuits should be accurately matched for best results. Grounds must be grouped by stages, and all groups connected to the chassis at one point. The filament winding on the power transformer was center-tapped and all filament leads were shielded.

—end—

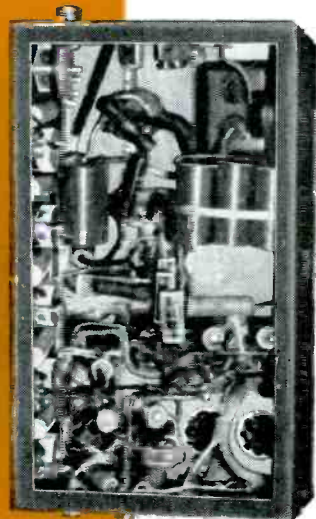
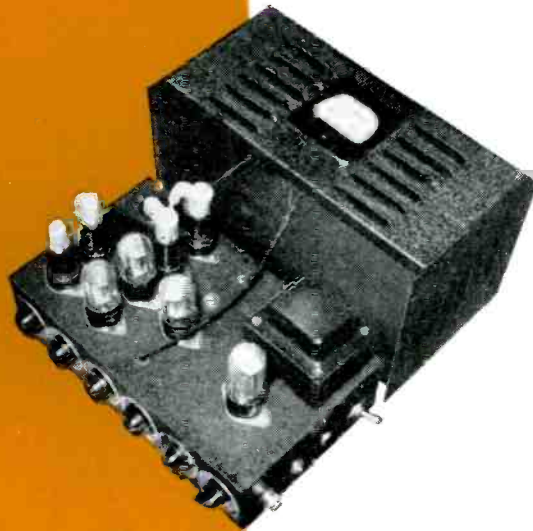
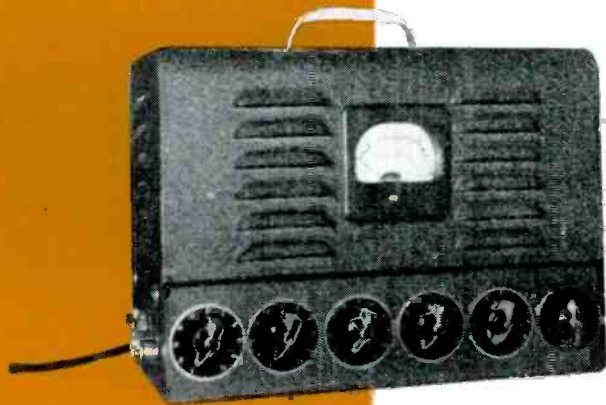

## *Portable* MIXING PRE-AMP

High-impedance pre-amp. designed to work with tape recorders, but applicable, with slight modifications, to a wide variety of uses.

By CHARLES L. HANSEN

RECORDING companies and users of tape and wire recorders have a need for a microphone pre-amplifier if the recorder is to be used to its maximum capabilities. Our small recording company discovered this when we purchased two Brush portable tape recorders. Commercially available mixing preamplifiers are all excellent; however very few of the portable units are priced less than \$400. Four hundred dollars will buy a lot of equipment, and expensive commercial preamplifiers are financially out of reach of our small recording company. The total cost of this home-constructed unit is approximately \$60, including all parts, plus about 10 hours of labor, a worthwhile saving.

This preamplifier is designed to permit four high-impedance inputs and one high-impedance output. It is used in the studio for studio recording and is portable enough to be used for on-location recording. Dubbing from records is accomplished by use of a pickup equalizer and lossy pad ahead of one or more of the inputs. More than enough gain is available when using dynamic and ribbon mikes on long cable

runs with low-impedance settings on mikes. Necessary level indicator and monitoring facilities are included and add little to the cost. In the interest of economy and good performance high-level mixing is used and there is no cross-talk between channels.

The unit has been in constant use for six months and has not developed a single case of trouble. It has been able to fill any recording requirement and has definitely proved its worth over and over again. Our latest job was recording an hour-long program of a school choral group and miscellaneous piano duets and solos. Two pianos were used and each required a mike, as they were at different stage locations. The other two mikes were used to cover the choral group.

Our job called originally for one set of records covering all selections of the group for the school record library. But after the records were heard by the group we had orders to make 79 additional 10- and 12-inch records.

**Construction**

Common judgment is used in parts layout and placement. The power supply is located on one end away from the low-level equipment on the other end of the chassis. The mixing tubes are next to the high-gain input tubes. All filament wires are run in shielded cable and the center tap of the filament winding is grounded. It is important to use double shielding in the grid leads of the input 6J7 tubes, and the grid resistor is contained in the shielded grid lead and located above chassis. The back covers of all potentiometers are strapped together and are then grounded to the main bus.

Filter chokes are unnecessary; there is no trace of hum in the unit. 6J7's were used in the input because the grid lead is not subject to a.c. which would have been the case if a 6SJ7 were used. Previous experience had taught us to avoid most tubes which have the grid connection on the bottom of the socket when used in low-level, high-gain circuits. We also had in mind substituting 1620's for the 6J7's if there was any heater-to-cathode hum. Note the wiring order of tube filaments. This may mean the difference between a preamplifier with hum or without hum. Shielding of the coupling capacitors between the preamp and the mixer was unnecessary. We did attempt to use two low-impedance input transformers, of the plug-in type, contained within the unit. The hum pickup was intolerable even though the transformers were the best type obtainable. Cable transformers are used, as they are less expensive than the better well-shielded mike transformers. The unit is less subject to hum pickup if the mike transformers are located a few feet away from the a.c. power transformer field. It is more versatile if all inputs are high-impedance.

The monitoring circuit makes use of one half of a 6SN7-GT. Enough gain is available for loud headphone volume

for monitoring near a pickup source to override the direct sound. The original design called for switching the monitoring amplifier to various channels for sampling purposes. A single monitoring connection is used and is sufficient. The VU meter makes use of the other half of the 6SN7-GT and is a conventional 1-ma movement. A 1N34 diode is used as meter rectifier.

Tests with a Western Electric 2B measuring set and a 19-C oscillator indicated the preamplifier to be substantially flat from 50 to 15,000 cycles, which is well beyond the range over which it is expected to be used. Input-output comparison tests with a square-wave generator and oscilloscope were very favorable. Means to check distortion were not available, but listening tests indicated that the audio quality was excellent, and records made with the equipment bore out the observations.

This preamplifier was designed for use in connection with recording equipment. It can of course be used for other applications. In some situations it might

be advantageous to incorporate equalization in the first stage. Thus one of the sections might be compensated for the output of a tape puller, another for a reluctance pickup, etc.

Amplification is sufficient to permit such a modification in most of the cases which would arise, and certain types of work can better be done with a unit which combines the preamplifier and equalizer in one portable case.

**Materials for preamplifier:**

**Resistors:** 4—820, 4—22,000, 2—47,000, 4—470,000 ohms, 1/2 watt; 4—1, 5—1.5 megohms, 1/2 watt; 1—470, 2—820, 1—2,200, 1—10,000 ohms, 1 watt; 1—4,700 ohms, 2 watts; 1—4,500, 1—9,000 ohms, 10 watts. Potentiometers: 1—5,000 ohms, wire-wound, screw-driver adjustment; 5—500,000 ohms.

**Capacitors:** (Paper) 9—.05, 4—.05 uf, 400 volts; (Electrolytic) 6—16, 2—20, 1—40 uf, 450 volts; 6—25 uf, 25 volts.

**Miscellaneous:** Tubes: 4—6J7, 3—6SN7-GT, 1—5Y3-GT. 8—octal sockets; 1—1N34 germanium diode; 1—0-1-ma d.c. meter; 4—coaxial connectors, female; 4—shields for 6J7; 1—power transformer, 700 volts c.t., 70 ma, 5 volts c.t., 2 amp. 6.3 volts c.t., 4 amp; Chassis and cover; hookup wire; knobs; dial plates; hardware, etc.

—end—

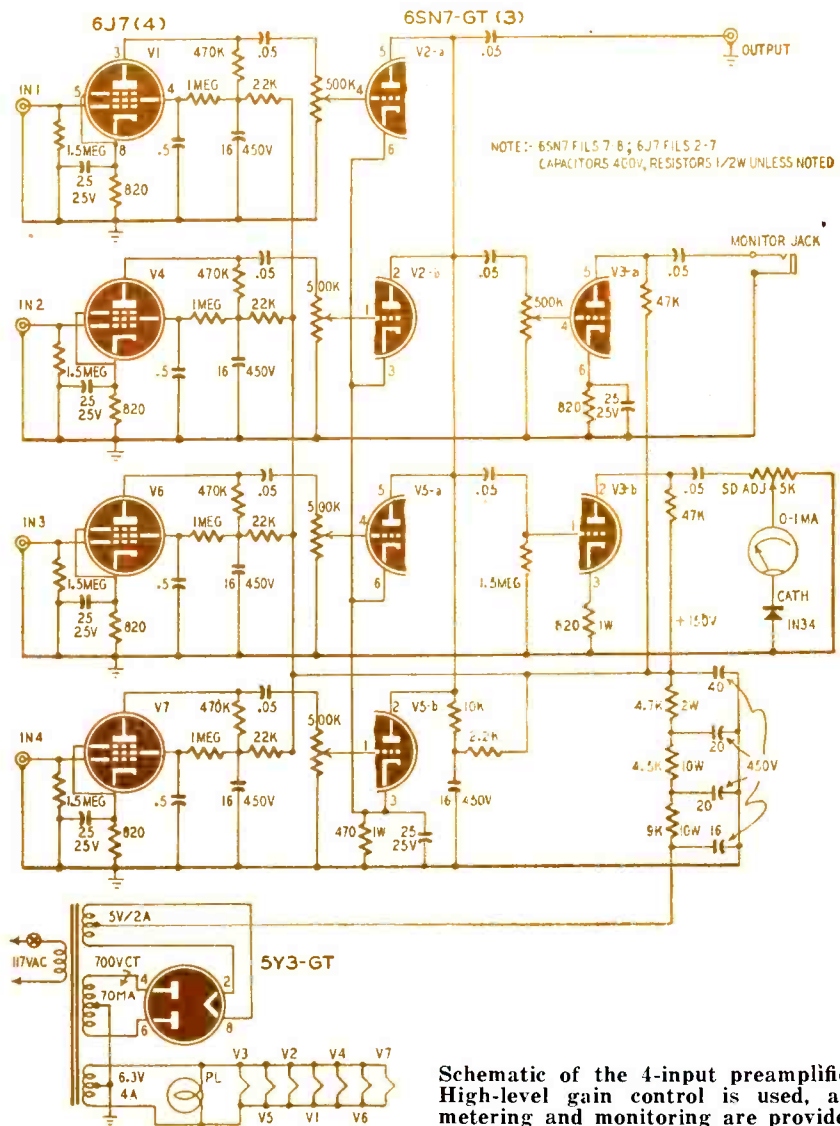

**Schematic of the 4-input preamplifier. High-level gain control is used, and metering and monitoring are provided.**



# ELECTRONICS and MUSIC

## part XVIII The Baldwin organ . . . its keying and tone color circuits

By RICHARD H. DORF

ONE of the most interesting features of the Baldwin electronic organ and one which contributes greatly to its outstanding performance is the keying sys-

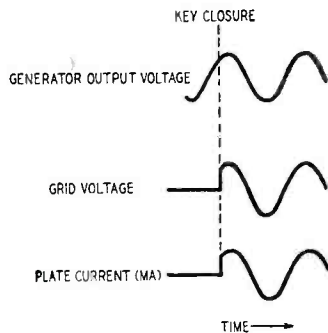

tem. Every designer of an instrument using continuously running tone generators—and that means all instruments with synchronized octave-generator chains of any kind—is faced with the problem of key switching.

The chief cause of the trouble is key clicks. The average voltage represented by any recurrent a.c. waveform is zero, and, unless there is another source of d.c. involved, the a.c. has no d.c. component. Keying a source of a.c. should therefore create no sudden rush of plate

Fig. 1, left—Sudden switching of a continuous sine wave causes effects resembling those produced by square waves, with accompanying key clicks.

current in a following class A amplifier stage, since the average plate current in such a stage does not vary (ideally) with a change in input-signal level.

The fact is, however, that there is no way of knowing at what part of the a.c. cycle the key will close. And if it closes at any part of the cycle except one of the two instants when it is passing through zero, there is a sudden instantaneous change in tube plate current from its resting value to some higher or lower value. This is illustrated in Fig. 1. Note that at the instant of key closure, the plate current rises in a very short time, and the vertical line looks like the leading edge of an excellent square wave. This very short rise time is in the nature of a part of a narrow pulse containing a very large number of harmonics at very high amplitude and the result is a loud click in the loudspeaker. The noisiness of ordinary switching in electronic music is further aggravated by any dirt or corrosion on the contacts or any lack of positiveness in the contact, since either of these result in making and breaking the contact several times in quick succession, each time with a click.

The loudness of the click depends on the rise time of the plate current and the amplitude of rise. There are thus three possible solutions. The first, an impractical one, is to see that the switch closes only when the voltage is passing through zero. The second is to place a low-pass filter after the switch somewhere in the system, eliminating the high harmonics which create the click. The third method, especially good when the waveform is sharply peaked, causing high-amplitude plate-current excursions, is to use a device which acts as a volume control and closes the circuit gradually. Then the initial plate-current excursion is very small, since the initial input signal itself is very small, and clicks are inaudible, while the waveform, once it has come to maximum amplitude, is unimpaired.

A second and equally important advantage of a device of this kind is that

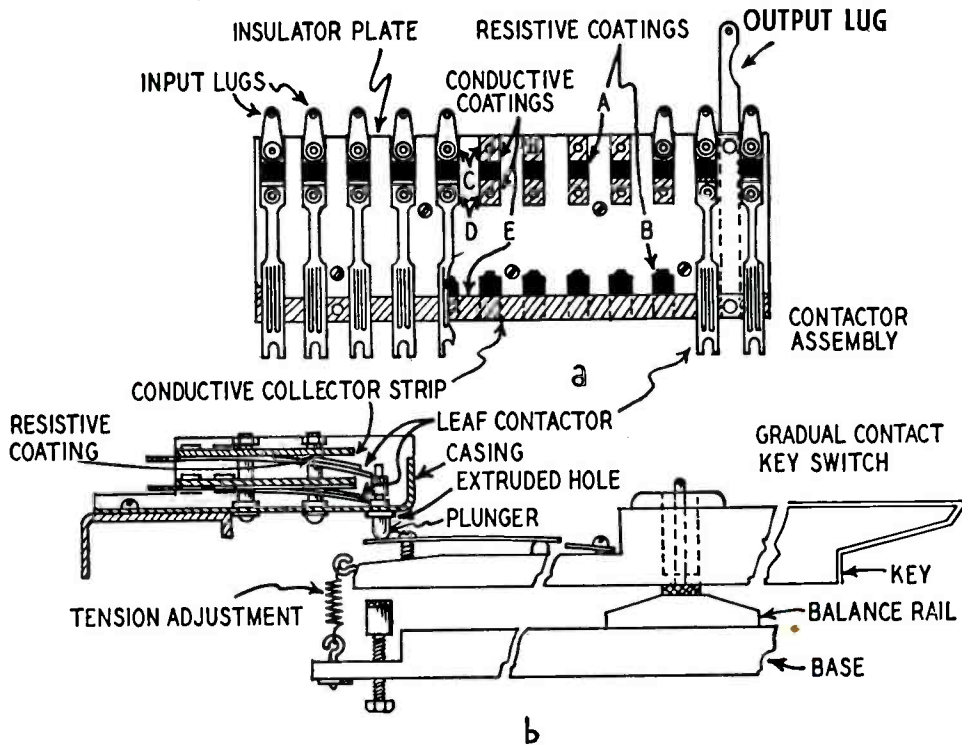

Fig. 2—In the equipment above, gradual contact is made through resistive coatings. Slow current rise eliminates clicks and produces pleasant musical attack.

it duplicates in some degree the action of conventional acoustic musical instruments, the attack of which is (except for a few plucked and struck instruments) gradual.

The special switches employed in the Baldwin for gradual attack are drawn in Fig. 2 and pictured in Figs. 3 and 4. Note first the contactor assembly at *a* in Fig. 2. This is a flat insulator plate with conductive and resistive coatings applied by printed-circuit techniques. Resistive coating A has a resistance of about 5,000 ohms. Resistive coating B has a resistance of about 25,000 ohms. A signal-input lug is fastened to conductive coating C, and one end of a leaf contactor is secured to conductive coating D. A third conductive coating E contacts all the resistive coatings B and is connected to an output lug.

The scheme is diagrammed in Fig. 5. With the silver-plated beryllium copper-leaf springs in the resting position as shown, no signal from the generator passes to the following circuits. As pressure is exerted upward on the end of the spring, the spring first contacts the left end of resistive coating B, and gradually passes along it until it contacts conductive coating E, when the circuit is complete except for the permanent 5,000-ohm isolating resistance. Under these conditions, the plate currents of any following tubes will look like the waveform in Fig. 6. The steep initial rise is still there, at point X, but its amplitude is very small and the a.c. output builds up smoothly to the maximum, as the envelope shows.

The details of the gradual-contact switch are shown in *b* of Fig. 2. There are actually 24 or 36 of them on each assembly, depending on whether the assembly is to be used in the great or swell manual. This is in two or three horizontal lines of 12 each. We shall explain the reason for the two or three groups later. The photograph of Fig. 3 shows the upper side of the key switch assembly, with the 36 input lugs (this is a 3-stack assembly for the great manual) and the 3 output lugs. The ends of the leaf contactors, with their wooden actuators, can be seen peeking from under the insulator plates at the top. The two extruded holes at the bottom are for cables. Fig. 4 shows the bottom of the assembly, with the actuator buttons coming through the extruded holes. At the left of the 12-key switch assembly is a single-key assembly consisting of two gradual switches, one above the other, used, as will be explained later, in the stop switches and for the pedal clavier.

**The keying circuit**

The generator assembly provides 73 tones, from the third C below middle C to the third C above middle C. Fig. 7 shows the switching schematic for the 8-foot register on one of the manuals; this means that when the middle-C key, for example, is struck, the tone switched is actually middle C, 261.7 cycles, not an octave above or below that. Since a manual includes only five octaves of keys, only five of the six octaves of

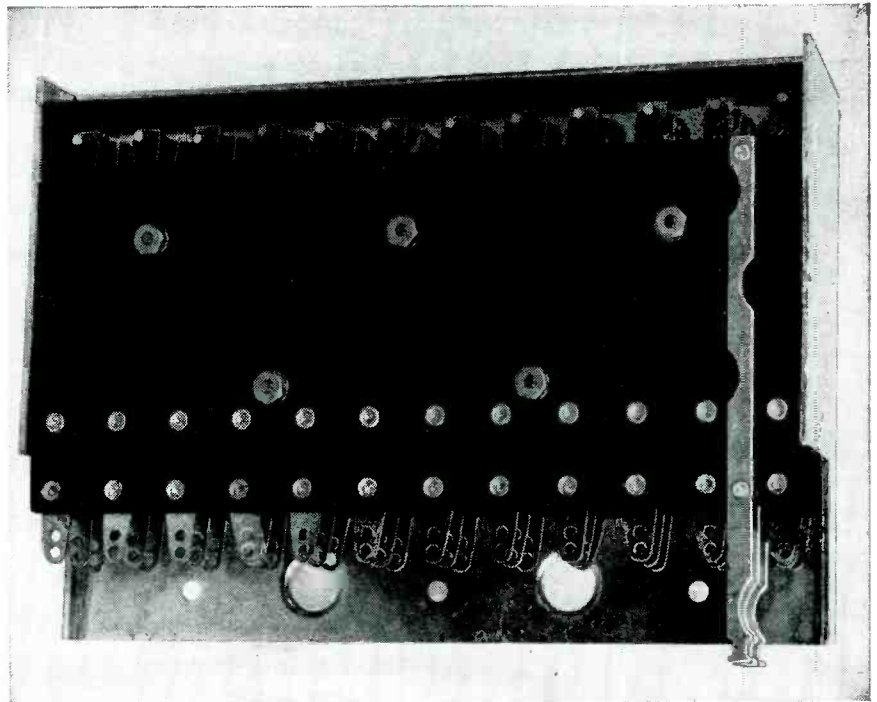

Fig. 3—Upper side of switch assembly reveals input and output solder lugs.

tones generated are used here, octaves 2 through 6.

The tone from each generator is brought to the upper end of the 5,000-ohm isolating resistive coatings, thence to the leaf-spring contactor. Any of the tones of octave 4 which are switched in by pressing a key in that octave go to the common octave 4 collector strip. The collector strips of all the 8-foot switch assemblies go to a resistive network. The purpose of the network is to attenuate the tones from each octave in increasing degree. At the output in Fig. 7 the highest tones have the largest amplitude and the lowest tones the smallest. The reason for this will become apparent when we discuss the tone-coloring system.

Each manual has a switching system like this, each system using one bank of 12 gradual-contact switches for each octave (and a single switch for the uppermost C). The great manual has two more of these switching systems, using the other two banks of switches in its octave assemblies. One system is a 16-foot register, meaning that when middle C is keyed, the tone actually heard is one octave below middle C, and so on. The 16-foot system makes use of the tones generated in octaves 1 through 5. The third switching system is for the 4-foot register, and uses octaves 3 through 6. Since there is no seventh octave, normally necessary to provide tones one octave above the highest keys on the manual, the upper octave of 4-foot switches simply repeats the tones of

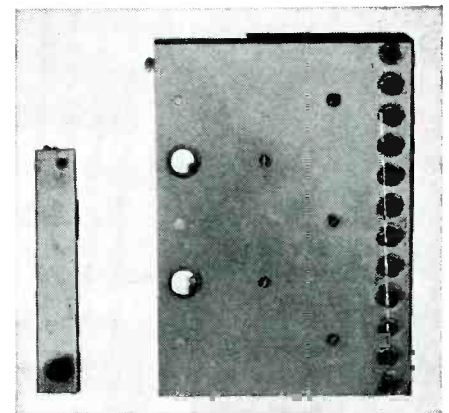

Fig. 4—A 12-note gradual-contac key switch assembly. Single switch at right.

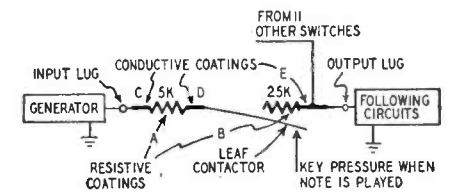

Fig. 5—Schematic diagram of switch system shows method of gradual attack.

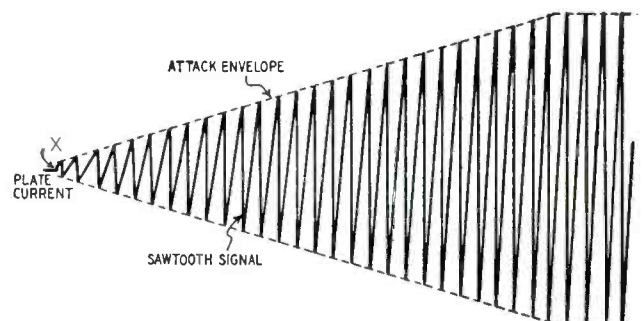

Fig. 6—The sudden rise of plate current at X is very small.

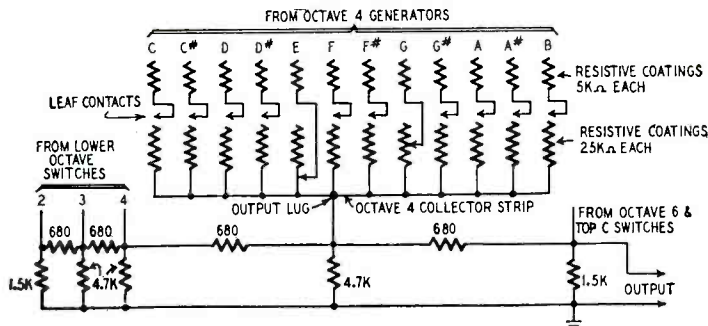

Fig. 7—Schematic of 8-foot swell or great keying system. Because output is taken from high-frequency end of attenuator network, highs predominate.

the octave below in the 4-foot register. We thus have three separate switching systems in the great manual, though all are actuated every time a key is pressed. Each system has an output so there are three outputs in all (plus an

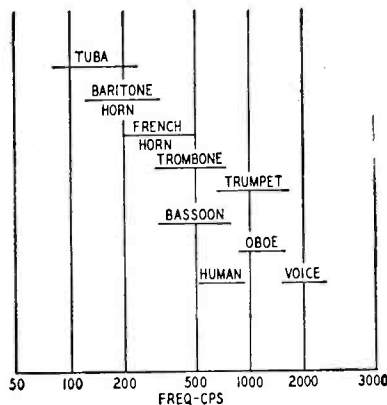

Fig. 8—Formant ranges of some typical orchestral musical instruments.

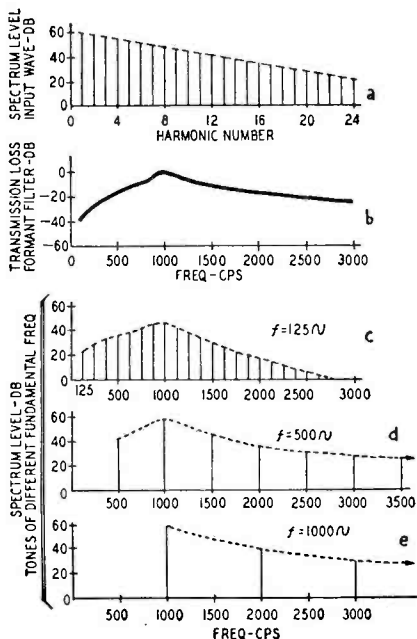

Fig. 9—How 1,000-cycle formant would affect spectrum of theoretical instrument. (a) Harmonic content of tone generated at reed or mouthpiece. (b) Response of filter to produce required spectrum characteristic. (c) Harmonic content of 125-cycle tone. (d) Same for 500-cycle tone. (e) Strongest harmonic of 1,000-cycle tone is fundamental.

extra 4-foot output taken from the low-frequency end). The swell manual has only 8- and 4-foot registers, with a total of two outputs. The pedal clavier has only 16- and 8-foot registers, making a total of two outputs. All these outputs are fed to the tone-color box and each output provides sawtooth waves.

**Tone-color principles**

The method of tone coloring in the Baldwin is built solidly on the theory of formants. A formant may be defined simply as a frequency range in which the harmonic components of a complex wave are prominent relative to the harmonics in other frequency ranges. Any tone color may have more than one formant, due to the physical properties of the instrument which produces it, as we explained in the July issue of RADIO-ELECTRONICS. The tone color as it appears to the ear is influenced not only by the formant frequency range but also by the amount of emphasis in that range and the width of the frequency band involved. Fig. 8 is a chart showing the formant frequencies of some typical instruments. The instruments in the chart all have quite pronounced formants; many others have much less emphasis of the harmonics which fall in those ranges. The generalized difference to the ear is that the latter sound rather bland, while the instruments in the chart sound fairly sharp and are easily identified.

Notice the formant frequencies of the brass instruments; the frequency becomes higher as the size of the horn bell decreases. Note, too, the human voice as shown in the chart. The voice has two formants caused by the size and resonances of the oral cavity (not by the difference between male and female voice pitches, which is accounted for by the difference in fundamental pitch generated as the result of differences in the vocal chords). Speech is intelligible because in speaking we change the shape of the oral cavity to give different formants within the ranges shown. All vowels have a formant in the lower range and most also have one or more in the upper range.

Fig. 9 shows the effect of a formant range on the spectrum of a musical instrument. Let us assume that we wish to imitate a type of tone color

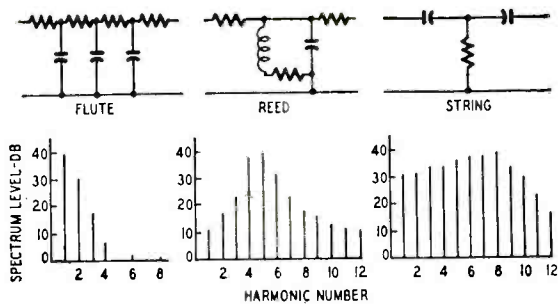

Fig. 10—Filters (above) to produce correct harmonic structure of three kinds of musical tones shown below.

whose formant is at and around 1,000 cycles. At *a* appears the harmonic content of any tone produced initially at, say, the reed or the mouthpiece. It may closely resemble a sawtooth, which means that succeeding harmonics will be present with amplitudes inversely proportional to their orders. To duplicate it, therefore, let us set up a sawtooth oscillator of variable frequency.

In *b* we see the desired bandpass characteristic of the following circuits, with a rise in response at 1,000 cycles and a drop in response at each side of 1,000. This can be achieved with a simple L-C tuned circuit of moderate Q. In *c* we see what happens when we pass a tone of 125 cycles through the system. The most prominent harmonic, due to the response of the filter, is the eighth, at 1,000 cycles.

In *d* we observe what happens to a 500-cycle note—the most prominent harmonic is the second. And in *e*, with a fundamental frequency of 1,000 cycles, the most prominent harmonic is the fundamental itself.

This is a simplified example, for actually the "response curve" of the spectrum of an organ stop or other instrument does vary somewhat, depending on the fundamental frequency—the formant shifts to some extent as the instrument is played over its fundamental range. There are, however, very much larger differences between the spectra of some other instruments, so providing a single filter over the entire range of an electronic instrument makes a satisfactory approximation. Fig. 10 shows typical spectra for flutes, reeds, and strings in the octave above middle C, together with the basic electrical filters which will give the correct frequency response to imitate these spectra. In practice, the basic filters shown may be followed by others which help to produce the desired boost and rolloff characteristics. Notice the sharp dropoff in upper flute harmonics, the highly resonant character of the reed spectrum, and the much softer emphasis at the string formant. Strings in general have a number of formants.

Next month we shall complete our description of the Baldwin electronic organ with schematic diagrams of the tone filters and descriptions and diagrams of the power amplifiers and other details.

(to be continued)



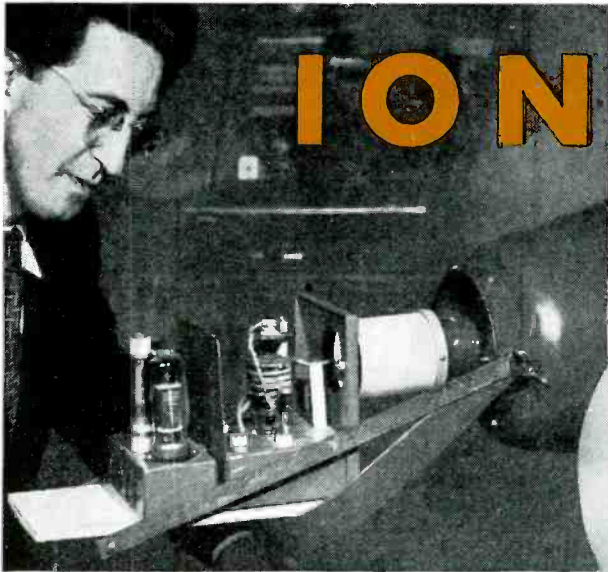

# IONOPHONE CIRCUITRY

By E. AISBERG\*

and M. BONHOMME\*\*

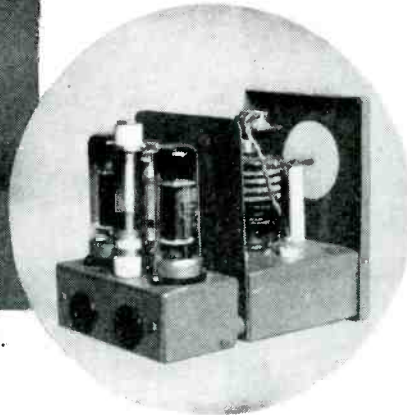

Ionophone, with two views of its driving equipment.

“YESTERDAY’S dreams make tomorrow’s inventions.”

To couple yesterday’s dream with future reality, it was necessary to strike out into new and unexplored areas—to do things as they had never been done before. Thus the young French physicist Klein found it advisable to abandon the whole audio amplification system and excite the speaker described in last month’s article with *modulated radio-frequency waves*.

The high-frequency, high-voltage oscillator used to excite the speaker, and which can be modulated by a low frequency, is shown in our schematic, Fig. 1. A form of plate modulation is used. Grid modulation could, of course, just as well have been used, or any of the standard modulation systems.

We have a small transmitter of classical design except for the output, which is through a high-ratio r.f. transformer, to obtain the necessary high voltage. The 40-meg resistor in shunt with the secondary of the transformer serves to damp out peaks. It is made of a small plastic rod, with a diameter of about 3/8 of an inch and is about 8 inches long.

The power produced by the prototype here described is equal to that of an electrodynamic speaker rated at around 10 watts. The response curve (Fig. 2), which is the result of tests made by the Centre National d’Etudes des Telecommunications, shows its wide range. As a matter of fact, it can reach much higher frequencies. However, its output diminishes in the supersonic range because the transit time of the ions becomes an appreciable quantity in relation to the oscillation cycle.

Its acoustic output (the relation of the low-frequency electrical energy and the acoustical energy measured in a soundproof room), is 7%—much higher

than the better type of present electrodynamic loudspeakers.

The special characteristics of this new loudspeaker suggest interesting possibilities. Though it can be used in conjunction with present-day radio receivers without any modification, it may be predicted that the future will see sets specially adapted to the new loudspeaker. Receivers may even be designed *without detection stage*, but with the intermediate frequencies, adequately amplified, serving as the source of excitation for the loudspeaker. Elimination of the detector stage, which is a source of distortion, would be a great advantage. At the same time, a special oscillator as a source of high-frequency excitation for the speaker would no longer be needed, as the modulated i.f. would fit the specifications exactly. However, there are certain difficulties to be overcome before such a receiver can be created.

Aside from use in the radio, an interesting application of the ionic loudspeaker might be made in the field of supersonics. Of all the known supersonic transducers (piezoelectric, magnetostrictive, etc.), it is the only one that is aperiodic and which can with equal ease generate all the supersonic frequencies and frequency-modulate them.

It should not be overlooked, on the other hand, that all electrical phenomena are reversible. Like all other loudspeakers, the ionic model can be used also as a *microphone*. Sound waves penetrating to the vicinity of the cathode disturb the movement of the ions and thus modify the electrical resistance of the ionized space. Thus we have a microphone with variable conduction, comparable, in a certain measure, to the carbon microphone.

However, it is not safe at present to predict the practical realization of such a microphone, as the background noises

due to the irregular flow of the ions—hardly perceptible when the device is operating as a loudspeaker—would act the same in a microphone, but would also be amplified in all the successive stages which follow the microphone and might reach a quite disturbing level.

It is still difficult to foretell all of the applications that the future may hold for the Ionophone. It is within the realm of possibility that therapeutic uses might be discovered. The possibility of simultaneously producing supersonics of controllable frequencies and intense ultraviolet rays modulated by the same frequency might be of great value. Meanwhile researchers have before them a new and fertile field of investigation.

—end—

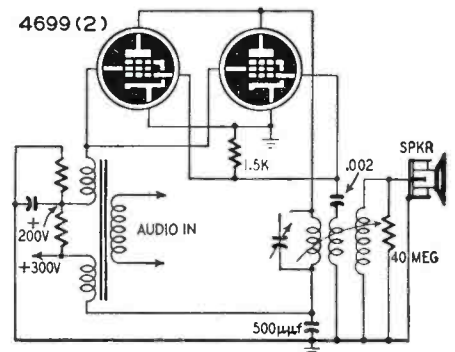

Fig. 1—The Ionophone driving circuit.

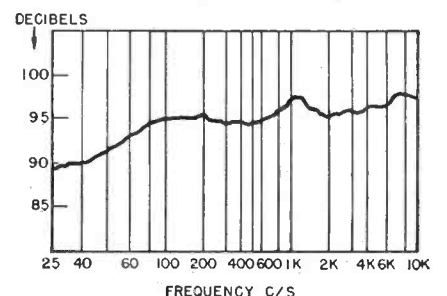
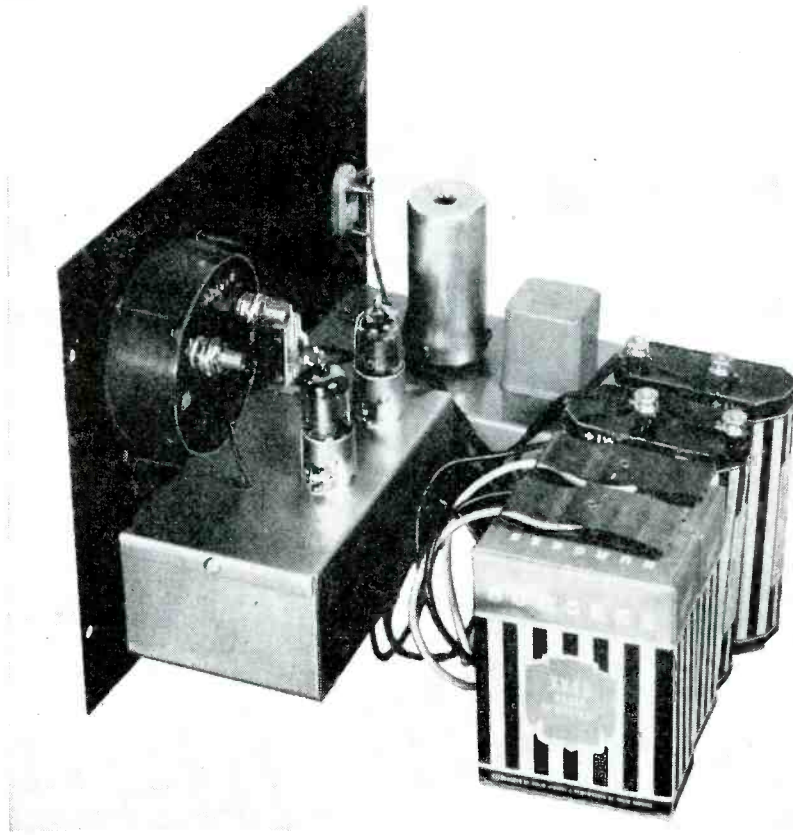

Fig. 2—Response curve of the speaker.

\*Publisher of *Toute La Radio*, Paris  
\*\*Chief Editor of *Toute La Radio*

# MEASURING



Distortion meter. Audio inductor and plug-in tuning unit are seen at rear.

**O**NE of the most important considerations in appraising amplifier performance is how faithfully the system transmits audio impulses. Only distortion measurements can establish quantitatively the degree of fidelity.

Distortion tests enable the designer to check the effects of circuit changes on reproduction. They are invaluable also to the service technician in determining the effectiveness of repairs and adjustments. In routine maintenance work, the sudden appearance of small amounts of distortion, usually not detectable by ear, usually points to the start of trouble in some component.

## Testing methods

There are several methods of measuring audio distortion. Of these techniques, the fastest, as well as the one most favored in service and maintenance, is that of checking *total distortion*. The technician usually is not as much interested in the strength of separate distortion components (for example, second harmonic, third harmonic, fourth harmonic, etc.) as he is in the answer to his question, "How much distortion is present?" Furthermore, there seldom is time to check individual harmonics and to calculate

the square root of the sum of their squares when distortion must be checked after each of many amplifier adjustments.

A widely-used basic distortion-measuring circuit is shown in Fig. 1. This is the bridged-T network which is the foundation of the distortion meter described in this article. The network components (L, C1, C2, and R) are chosen to provide a sharp null (zero transmission) at the test frequency. R is made variable and is preset closely for sharp null. When the Q of the circuit is kept reasonably high, the fundamental test frequency is eliminated completely and only the total harmonic voltage (E2) appears across the a.c. millivoltmeter. In use, the amplifier or audio network to be tested is supplied with a signal from an audio oscillator or signal generator having very low distortion. The output of the amplifier then is connected to the input terminals of the network. The meter is switched first across the network input terminals, as shown by the dotted lines, to read the amplifier output voltage (E1). This voltage contains fundamental and harmonics. The meter finally is switched to the output of the bridged-T network, and the small voltage (E2) due to harmonics is read. The distortion then is

the ratio of E2 to E1 and is expressed in percentage as  $100 (E2/E1)$ . If the input voltage, E1, always can be set to a predetermined level for reference, the millivoltmeter can be made direct reading in distortion percentage, and no calculations will be required.

## Complete instrument

Many amateurs and professionals have employed this method of distortion measurement, using homemade equipment. However, there are several difficulties common to almost all setups: (1) The a.c. meter must be capable of checking very small voltages at the output of the bridged-T network. These often are millivolts which cannot be read on the scales of ordinary v.t. voltmeters. For example, 1 volt may be obtained from the amplifier under test and applied to the input terminals of the distortion-checking circuit. In order to measure 1% distortion, the meter then must show 10 millivolts (0.01 volt) when connected to the bridged-T output. (2) Coil L (Fig. 1) must have a higher Q than customarily is obtainable with the power-supply filter chokes often used in the circuit by experimenters. If the Q of the bridged-T circuit is not high, harmonics will be attenuated and the meter will not give a true indication of distortion. (3) Usually, no provision is made for easily changing the operating frequency to a new value. (4) Considerable inaccuracy can occur from hum generated by the power supply of the v.t.v.m. and picked up by the bridged-T choke.

We have made the following improvements to remove these shortcomings: (1) A sensitive electronic millivoltmeter circuit has been provided. This circuit requires no zero adjustment. The indicating meter is a comparatively inexpensive 0-1 d.c. milliammeter (reading linearly direct in distortion percentage—1, 10, and 100% full scale), and only 10 millivolts at the output of the bridged-T network is required for full-scale deflection when the range switch (S2 in Fig. 2) is in its 1% position. (2) Hum has been eliminated by powering the voltmeter

# D I S T O R T I O N

By RUFUS P. TURNER

**Service technicians as well as high-fidelity men  
need a quantitative means of checking distortion;  
it is one of the two commonest faults in receivers**

circuit with small, self-contained A- and B-batteries. Since the drain is low, long battery life may be expected. Battery operation also provides complete isolation. (3) Coil L is a special audio inductor (U.T.C. type VI-C15) which has good Q and adjustable inductance. (4) The test frequency may be changed at will with plug-in frequency units C1, C2, R1. The values given for C1, C2, and R1 in Fig. 2 are for a test frequency of 400 cycles, since this frequency is supplied by most AM signal generators. Table I gives capacitance and resistance values for other common test frequencies between 50 and 5,000 cycles. There is little point in checking beyond 5,000 cycles, since the harmonics of higher frequencies lie out of the range of most hearing. Usually, three test frequencies, selected in the low, middle, and high portions of the audio spectrum (e.g. 50, 1,000, and 5,000 cycles), will give a satisfactory practical picture of amplifier behavior. The author found it convenient, for compactness and simplicity, to use plug-in frequency units. However, the reader, if he desires, may incorporate a switching "tuner" and enclose all components for 10 or more frequencies within the instrument case.

The complete circuit is shown in Fig. 2. The input gain control allows the meter to be set to a reference level (such as 100%) when the meter is switched to read input voltage. Switch S1 is a spring-return switch resting normally in the position shown, to con-

nect the meter across the output of the bridged-T network. For initial adjustment, this switch is thrown to the right to connect the meter to the input.

The range switch, S2, gives the indicating meter three ranges—0-100%, 0-10%, and 0-1%. At the 100% setting of the switch, the meter has a full-scale deflection of 1 volt, at the 10% setting 0.1 volt, and at the 1% setting 0.01 volt.

The millivoltmeter circuit is simple, employing a high-gain 1U4 pentode resistance coupled to a triode-connected 3S4 driver amplifier for the meter circuit. The full-wave meter circuit consists of a crystal bridge employing two 1N34 germanium diodes and two 100-ohm resistors. If a pair of matched 1N34's aren't available, use a 1N35 duo-diode. The 100-ohm resistors must be matched within at least 1%.

Since the 3S4 must be cathode-biased, the A-battery must be operated above ground. That is the reason for the separate A-battery for the output stage. There is no B-battery drain when the tube filaments are not lighted, so no switching is needed in the high-voltage circuit.

### Construction details

The photographs show construction details of the distortion meter. The instrument is housed completely in a 10 x 7 x 8 inch standard metal cabinet. Tuning and millivolt-amplifier units are mounted on separate small box-type chassis. The chassis holding the

amplifier measures 5 1/4 x 3 x 2 inches. The tuning unit chassis is 5 1/2 x 3 x 1 1/4 inches. Both of these chassis are enclosed on all sides and accordingly provide good shielding.

On page 34, small, shielded inductor L may be seen on the rear of the farther chassis. Directly in front of the inductor is the plug-in can containing C1, C2, and potentiometer R1. The latter is provided with a slotted shaft for adjustment through the hole seen in the top of the plug-in can. The plug-in foundation is a Millen 74001 assembly which has an octal base. The coil form is removed from this unit and the two capacitors and potentiometer are installed in its place. In order to fit into the small can, Mallory *Midgetrol* potentiometers (15/16 inch diameter) were used. If the reader is compelled to use larger potentiometers, the larger Millen 74400 plug-in cans may be employed. The latter are rectangular cans and, like the type 74001 used in our instrument, are provided with octal bases for plugging into a standard 8-pin tube socket.

The A- and B-batteries fit snugly into the cabinet just to the rear of the amplifier chassis in approximately the position they are shown in the first photo. They stand vertically.

The leads from the input binding-post terminals are shielded with braid.

Keep all leads in the meter amplifier as short as possible and use point-to-point wiring. Resistors R2, R3, and R4 must be of close tolerance, varying not

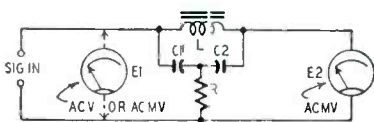
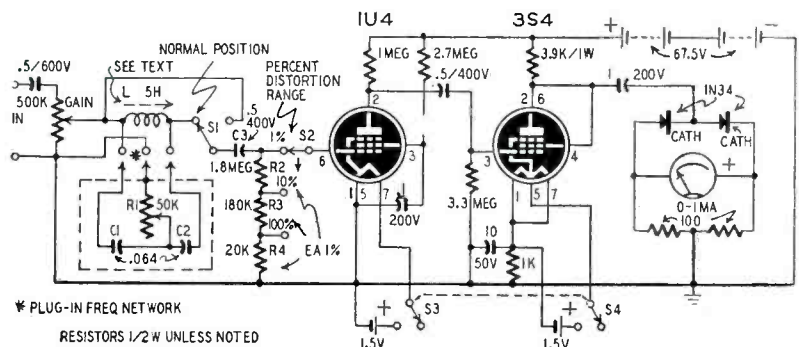

Fig. 1, above—Basic distortion meter circuit. It is the familiar bridged-T.

Fig. 2, right—Schematic of a distortion meter which combines sensitivity, low hum level, complete suppression of the fundamental signal and ability to operate on several audio frequencies.



more than 1% from specified values. Aside from these points, no special precautions are necessary in construction of the amplifier. In the plug-in units, capacitors C1 and C2 must be matched carefully and should be as close to specified values (see Table I) as can be obtained. A glance at the list shows that a number of the capacitances are not stock values, but must be made up with suitable units connected in parallel (e.g., 0.028  $\mu\text{f}$  required for the test frequency of 600 cycles would be made by paralleling 0.02 and 0.008). These ca-

TABLE I  
PLUG-IN BRIDGED-T NETWORK  
COMPONENTS

Test Frequency (cycles)	Capacitors C1, C2 ( $\mu\text{f}$ each)	Potentiometer R1 (ohms)
50	4	10,000
100	1	10,000
200	0.250	50,000
300	0.11	50,000
400	0.064	50,000
500	0.04	100,000
600	0.028	100,000
700	0.020	100,000
800	0.016	100,000
900	0.0125	100,000
1000	0.010	500,000
2000	0.0025	500,000
3000	0.0011	500,000
4000	0.00064	2 meg.
5000	0.00040	2 meg.

pacitors must be high-grade, to insure high Q in the bridged-T network. By using metallized tubulars for the high capacitances, smallest physical size may be secured.

### Initial adjustment

If the instrument has been wired correctly and good components used throughout, the voltmeter section will require no adjustment whatever. However, if desired, this part of the instrument circuit may be checked for voltage calibration and linearity. Remove temporarily the lead between C3 and S1 and feed a series of accurately known calibration voltages between C3 and ground, checking the corresponding meter readings. A 1,000-cycle source, such as an audio oscillator, is recommended. In some instances, higher sensitivity might be obtained—full-scale deflection with less than 10 millivolts input with switch S2 at 1% position. However, the absolute voltage level is unimportant in this application. The important thing is that the voltage, whatever its level, be divided *exactly* by 10 and 100 by successive settings of switch S2.

Next, the frequency units must be adjusted to the corresponding operating frequencies. We will give one example, that of the 400-cycle unit. (1) Switch on the distortion meter and allow about 5 minutes warmup time. (2) Set an audio oscillator to 400 cycles and connect its output to the distortion-meter input terminals. (3) Plug the 400-cycle frequency unit into the distortion meter. (4) Set switch S2 to its 100% position

and advance the gain control until a healthy meter deflection is obtained. (5) Adjust potentiometer R1 in the frequency unit for lowest obtainable meter reading (complete null). (6) With an 8-32 Allen wrench, adjust the inductance set-screw in inductor L for further improvement of this null. (7) Do not touch the setting of R1 at any time afterward unless a routine recalibration is made. Also, do not retouch the setting of the inductance screw in the inductor L. (8) Successively plug in each frequency unit and adjust it to its particular frequency by adjustment of its potentiometer R1 only.

### Operating the meter

**Checking oscillator distortion:** After warming up both the oscillator and distortion meter for at least 5 minutes, connect the oscillator to the distortion meter and set the oscillator output to the desired level. (1) Set switch S2 to its 100% position. (2) Plug-in a frequency unit for the desired test frequency and set the oscillator dial to that frequency. (3) Set switch S1 to its right-hand (input) position and adjust the gain control for full-scale meter deflection. (4) Return switch S1 to its normal (output) position. (5) Set switch S2 successively to lower ranges until an accurately readable meter deflection is obtained. This deflection, together with the setting of switch S2, will indicate the oscillator distortion percentage directly. (6) Rock the oscillator dial back and forth slightly for an improvement in the meter dip. (7) Repeat the procedure at several settings of the oscillator output control, since oscillator distortion often varies with output.

**Checking amplifier distortion:** Measuring the distortion of an amplifier is similar to the procedure just given for checking an oscillator. There is an important preliminary point, however, and that is to check carefully the distortion of the oscillator which is to be used to supply a test signal to the amplifier. The oscillator distortion figure then must be subtracted from any distortion figure obtained for the amplifier. When checking a complete amplifier system, connect the distortion meter across the loudspeaker voice coil (if you can stand the noise), since the speaker is the normal load of the amplifier. If quietness is a necessity, however, the voice coil may be replaced temporarily with a resistor having the same ohmic value and rated at twice the power output of the amplifier.

To check the amplifier: (1) Connect a low-distortion audio oscillator (whose distortion has been checked and recorded at each intended test frequency) to the amplifier input. (2) Connect the amplifier output to the distortion meter. (3) Allow the oscillator, amplifier, and distortion meter to warm up. (4) Plug-in a distortion meter tuning unit for the first test frequency. (5) Set the oscillator to the same frequency. (6) Set switch S2 to its 100% position. (7) Set switch S1 to its right-hand (input)

position, set the amplifier gain control to the desired test point, and advance the gain control of the distortion meter for full-scale meter deflection. (8) Return S1 to its normal (output) position and change the setting of switch S2 for a readable meter deflection. (9) Rock the oscillator dial to deepen the null. (10) Read the distortion percentage from the meter deflection and the setting of range switch S2. (11) Subtract from this figure the distortion of the audio oscillator, previously determined. (12) Repeat the procedure at as many test frequencies and at as many settings of the amplifier gain control as desired.

**Special note regarding low test voltages:** When the amplifier or oscillator under test delivers an output voltage of 1 or higher, the distortion meter can be set initially to 100%. Under this condition, 1% distortion then can be read at full scale when the range switch is at its 1% setting. On the same range, the first major division of the meter scale (0.1 milliamperes) indicates 0.1% distortion, and the first small division 0.02% distortion. If the test voltage is lower than 1 volt but sufficient to allow the meter to be set to full scale with switch S2 in its 10% position, then 10% distortion is indicated at full scale when S2 is switched to its 10% position. When the test voltage is too low to permit setting the meter to full scale, simply divide the final indicated distortion figure, indicated by the meter, by the distortion indicated in the initial setting. Example: With switch S2 at its 100% setting, the meter can be set initially only to the 50% point. In the distortion measurement, with S2 subsequently set to its 1% position, the meter indicates 0.5% distortion. The true indicated distortion then is 0.5 divided by 50, or 1%.

### Materials for Meter (400 cycles)

**Resistors:** 2—100 ohms, 1/2 watt (matched within 1%); 1—1,000 ohms, 1/2 watt; 1—3,900 ohms, 1 watt; 1—1, 1—2.7, 1—3.3 megohms, 1/2 watt; 1—20,000, 1—80,000 ohms, 1%, 1/2 watt; 1—1.8 megohms, 1%, 1/2 watt. (Potentiometers) 1—500,000 ohms; 1—50,000 ohms (Mallory U33).

**Capacitors:** (Electrolytic) 1—10  $\mu\text{f}$ , 50 volts. (Miniature metallized tubular) 2—.06, 2—.05  $\mu\text{f}$ , 400 volts; 2—1.0  $\mu\text{f}$ , 200 volts; 1—.05  $\mu\text{f}$ , 600 volts. (Mica) 2—.004  $\mu\text{f}$ .

**Miscellaneous:** 1—Adjustable inductor (UTC VI-C15). Batteries: 2—67.5 volts, Burgess XX45 or equivalent; 2—1.5 volts, Burgess 2FBP or equivalent. Switches: 1—s.p.d.t., spring-return rotary; 1—single-circuit, 3-position, non-shorting. Meter: 1—0-1 ma d.c., Triplett 327-T or equivalent. Chassis; cabinet; dial knobs; input terminals; hookup wire; tubes; sockets, etc.



A front view of the distortion meter.  
—end—



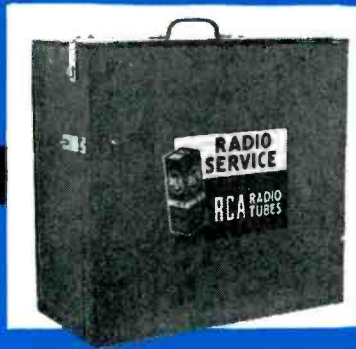

# carrying case for home service

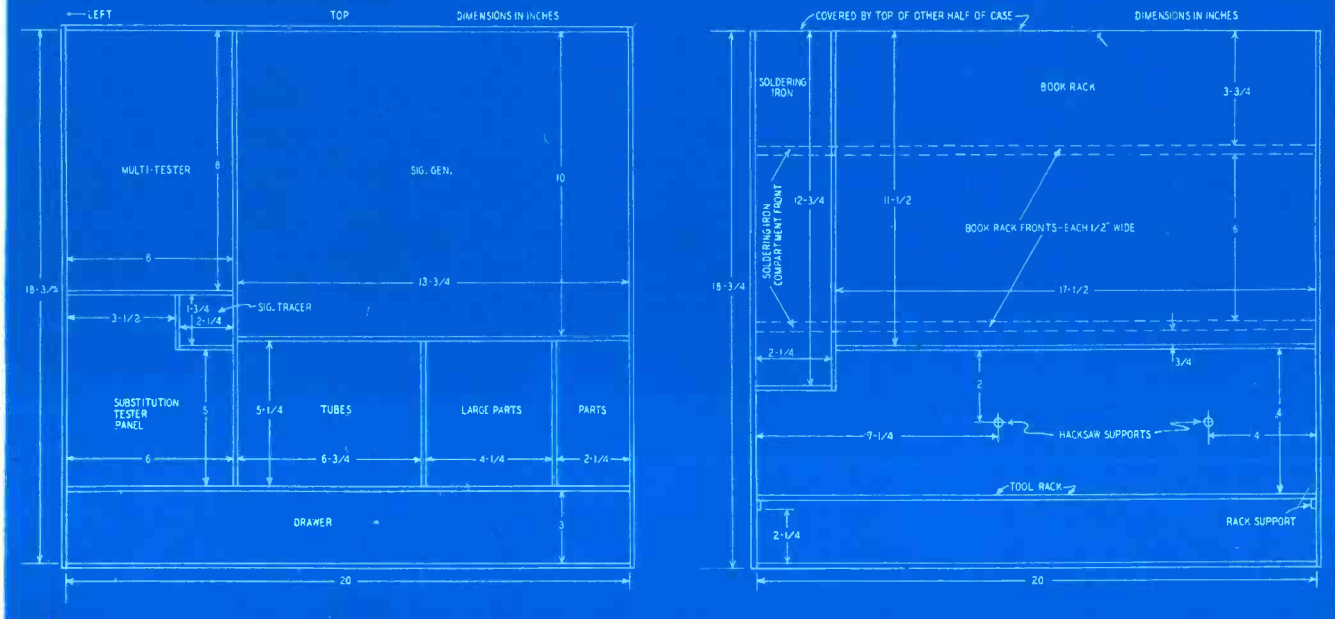

Figs. 1 and 2—Dimensional diagram. Compartment at left holds tubes, equipment; cover section carries tools and data.

**H**OME servicing—unpopular in the past—is increasingly becoming necessary because of television. The technician can do many jobs in one trip with a representative selection of radio parts and tools, which can be carried in the case to be described. If the model number of the set is known (from previous servicing records or from inquiry to the owner) practically all service needs may be anticipated. Service data can be carried in the book rack. Home servicing becomes more efficient and profitable.

The carrying case is 20½ inches wide, 19¼ inches high, and 10 inches deep. It will hold a volt-ohm-milliammeter, signal generator, signal tracer, substitution tester, soldering iron, tools, books, 40 GT or metal tubes, and most of the other parts needed for radio and TV servicing. Weight is only 15 pounds empty. Cost is about five dollars. The design is extremely flexible so that, while primarily for the service technician, the case makes a complete workshop for the amateur or experimenter.

Fig. 1 shows the various compartments in the case. The signal-generator compartment will hold most of the

## By ANDREW E. JACKSON

smaller size AM or FM models, including the RCA line. (It also makes an excellent place to carry demonstration receivers.) The drawer serves as a holder for all small parts and will hold 20 additional tubes, if desired. A large, heavy cloth upon which to lay parts and tools also may be carried. Fig. 2 is the inside of the door. A hacksaw is mounted on right-angle hooks behind the tool rack, which is removable. The signal-tracer compartment is made for a tracer probe of the crystal-diode type which can be used with a pair of headphones. The headphones are mounted in the test-lead compartment which is behind the volt-ohm-milliammeter compartment. The parts, test unit panels, books, etc. are accessible by opening the door which covers the front of the case. Test equipment, test leads, and headphones may be removed by opening the top lid.

The case is made of quarter-inch plywood because it is inexpensive, requires a minimum of tools, and has much more strength for its weight than regular wood. Saw crossgrain cuts slowly and

carefully to avoid chipping the wood.

Assemble the parts of the case as shown in Figs. 1 and 2 according to the general rules given below. Check with the photos. All joints of the construction are glued, and are reinforced with nails wherever possible. Parts should be fitted together temporarily to determine where glue and nails go. When nails are used, space them evenly, driving them from the side opposite that from which glue will be applied and until their points are seen on the surface which will be glued. Then apply glue, fit the glued surfaces together, and drive the nails all the way in.

Figs. 1 and 2 show inside dimensions of compartments. The double solid lines on these figures should be drawn on the inside of the back and door front respectively as a guide for spreading glue. Draw light pencil lines, as a guide for driving nails, on the outside of the back so that they fall between double lines (given dimensions plus ¼ inch).

Start construction by fastening the ends to the end edges of the bottom so that the pieces are perpendicular to each other. The back then may be secured to the unit just made. Now the

pencil lines previously drawn on the back may be extended to the sides to aid in assembling the shelf and the bottoms of the test-equipment compartments. Drive nails into the sides of the shelf first to hold it in place while driving nails into the back.

Draw parallel pencil lines 8 and 8 1/4 inches down on the multimeter side of the partition to aid in gluing the partition to the multimeter compartment bottom. Where the partition joins the bottom of the signal-generator compartment use a 1 1/2 x 1 1/2-inch right-angle bracket for reinforcement. Drill 3/16-inch holes for the bracket in the partition and the compartment bottom 1 1/4 inches from their front edges. Insert bolts with their heads inside the signal-generator compartment. Place the bracket *outside* the compartment. Another bracket holds the partition to the back of the case. Bolt it on the volt-ohm-milliammeter side of the partition with the bolt nuts facing in.

The back of the multimeter compartment is the front of the test-lead compartment as shown in the top view photograph. Draw two parallel lines for glue, as before, placing the first one back from the front of the case the thickness of the instrument which will occupy the space plus a quarter of an inch. Finish the multimeter and signal-

set on its supports so as to be easily removable when the hacksaw is needed. If necessary, brace the tool rack with a 3 1/4 x 1-inch plywood piece to prevent sagging. Use glue only in fastening the bottoms of the book rack and soldering iron compartment and their partition to the door front. Secure the fronts of the soldering iron compartment and the book rack flush with the front edges of the door sides and partition to complete the door.

Begin constructing the drawer by fastening its front and back outside its bottom as was done for the sides and bottom of the case proper. Make the front and back extend 1/4 inch farther to the right (front view) than the bottom and the end to allow space for door bolts, making cutouts in the drawer front where necessary to pass them. Space drawer partitions as desired. After the glue has dried, rub the sides and bottom of the drawer with beeswax or soap to make it slide easily. A drawer pull may be made by screwing 3/8-inch screw-eyes into the drawer front 1 1/2 inch from the drawer bottom and 7 inches from each end. Connect the screw-eyes with hookup wire.

In fastening the top to the case, drill 3/16-inch holes in the top 3/8 inch from its back edge and 3 1/2, 4 1/2 and 9 3/4 inches from each end. Drill holes in the back 3/8 inch from its top edge and the same distances from each end. (The 3/8-inch dimension will vary—check your hinges.—*Editor*) Bolt one half of each of the three hinges to the outside of the back with the bolt heads and hinge pins facing outside the case. The other halves of the hinges are bolted to the inside of the lid. Bolt heads and washers for these go outside the top as shown in the top view photo.

Drill 3/16-inch holes for the door hinges in the right side of the case and the right door side (front views) 1/2 inch from their front edges (again depending on the hinges—*Ed*) and 2 1/2, 3 1/2, 9 and 16 1/2 inches from the top edge of the case. Places where holes are not drilled because of interference with shelves may be filled with screws. Place hinges and bolt heads outside the case.

The hasp on the left side of the door and its associated eye on the left side of the case should hold the door tightly to the case proper. Fasten the hasp to the outside of the case with screws. The hasps fastening the top to the sides of the case are placed 2 1/4 inches from the front with the hinge on the top and the eye on the side of the case. Notch the eyes of the hasps with a file so that they will hold their hinges without a padlock.

A special feature of the case is the

right-angle bracket and eye fastener on the door and top. This combination holds much of the case's weight and

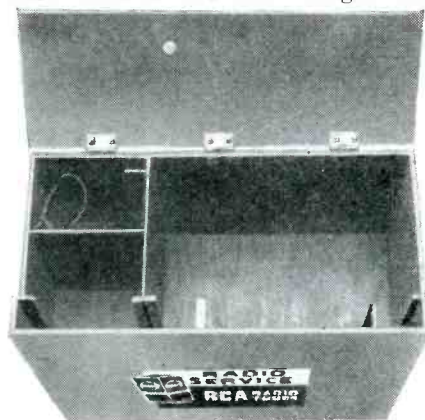

The test leads are reached from the top.

acts as a safety feature because the top can't be opened unless the door is open. When the door is closed the bracket on it slides into the slightly flattened eye-bolts on the lid. Fasten the bracket to the inside of the door 9 1/8 inches from the right outer edge (inside view) and even with the top of the door. Locate the eyes 9 1/8 inches from the left edge of the top and 1/2 and 1 1/4 inches from the front edge.

Bolt the handle to the center of the top and reinforce with washers on the under side. Give the case two or three coats of clear varnish, wax and polish. You now have a very useful carrying case for service calls. The substitution tester in the lower left compartment is (to the author) one of the most important features of the equipment. However, every service technician has his own pet "substitutionalyzer" or other personal test instrument. Put it in that compartment to complete your equipment!

### Bill of Materials Quarter-inch plywood (Dimensions in inches)

- 2—20 1/2 x 19, front and back
  - 1—20 1/2 x 10, top
  - 2—19 x 1 1/2 for door sides
  - 2—19 x 8, left and right ends
  - 2—17 1/2 x 1/2, book compartment fronts
  - 2—1 1/2 x 1/2, tool rack holders
  - 1—20 x 1 1/2, door bottom
  - 1—20 x 8, bottom
  - 2—20 x 2 7/8, front and back of drawer
  - 1—20 x 7 3/4, shelf
  - 1—20 x 1, tool rack
  - 1—14 x 8, sig. gen. compartment bottom
  - 1—6 x 8, v-o-m compartment bottom
  - 1—17 1/2 x 1 1/2, book rack bottom
  - 1—2 1/4 x 1 1/2, soldering iron compartment bottom
  - 1—19 3/4 x 7 1/4, drawer bottom
  - 7—2 5/8 x 7/4, drawer sides and divisions
  - 1—1 1/2 x 6, v-o-m compartment lower facing strip
  - 2—1/2 x 2 1/4, soldering iron compartment fronts
  - 1—10 x 8, partition between v-o-m and sig. gen. compartments
  - 1—8 x 6, v-o-m compartment back
  - 1—7 x 6, substitution tester panel
  - 3—5/4 x 7, divisions of shelf
  - 1—2 x 7, sig. tracer compartment side
  - 1—7 x 2 1/4, sig. tracer compartment bottom
  - 1—13 x 1 1/2, partition between soldering iron compartment and book rack
  - 2—9 1/2 x 1/2, sig. gen. compartment side facings
  - 1—14 x 1/2, sig. gen. compartment bottom facing strip
  - 2—9 1/2 x 1/2, sig. gen. compartment side facings
- Hardware and miscellaneous**
- 6—1 1/2" x 1 1/2" butt hinges; 3—hasps (about 1" wide by 3 1/2" long; 30—1/2" x 9/32" bolts with nuts; 1—handle for top; 24—3/8" x 5 flat-head wood screws; 3—metal washers 3/4" diameter; 6—metal washers, 3/8" in diameter; 3—right-angle screw hooks 3/4" longest way; 2—3/4" over-all eye bolts with a 3/8"-in-diameter eye; 1—service decal; 1/2 pt.—clear varnish; small box 3/4-inch No. 17 flat-head wire nails; 1/4 pt.—good quality liquid glue.

—end—

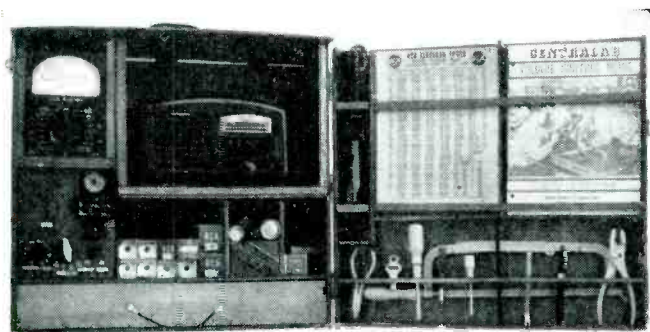

The carrying case and its contents are ready for a job.

generator compartments by installing facing strips to the outer quarter inch of their sides and bottoms. Install the lower strips first. Corrugated cardboard, if placed around the multimeter and signal generator, will cushion these instruments against damage.

Draw the proper parallel lines on the shelf to aid in gluing its partitions in place.

Fasten the side of the signal-tracer compartment perpendicularly to the outside edge of its bottom. Then fasten this unit to the rest of the case.

The door sides and bottom are assembled to the front just as was done for the main part of the case. Space and drive nails very carefully into the front to avoid denting the wood. Fasten the tool rack holders to the door sides and screw the right-angle hooks for the hacksaw into the door front slightly less than a quarter of an inch. Then the tool rack, after being drilled with various sized holes for tools (use two 1/2-inch holes 1 inch apart for pliers), is



# New Life for Old Radios

By JACK DARR

The author at his bench, working over one of the old-timers.

**A**LMOST every family has a couple of older sets somewhere. These old jobs may not look very pretty, and they may not play very well when you get 'em, but with a little patience and some careful service work, they'll furnish lots of good entertainment. Many of them are surprisingly well constructed, and you'll be astonished at the circuits you'll find in them. (The first push-button tuner the writer ever saw was on a Fada, back in 1928, and it was about three years old then!) Lots of them used triodes in a push-pull audio stage, with a generous-sized speaker, and the tone quality excels most present-day models.

The tubes used in these sets are often easier to obtain in shortage periods than the miniature and octal-locctal tubes used in the later models. In fact, you've probably got several full sets of good tubes in your junk-box right now. I have. All you need is a little brushing-up on some of the circuits common to the older models which aren't encountered in the 1940-1951 sets.

## Power supplies

Most of the 1929-1939 sets used a straight transformer power supply, with an 80 rectifier. Any of the 5-volt full-wave rectifiers may be substituted for it, if there is any reason to do so, by changing to an octal socket, and wiring to fit the tube available. Types 5Y3, 5Z3, 5R4, 5U4, and several others will work.

If the set was built before 1935, the chances are that the original filters were wet electrolytics, from 8  $\mu$ f up, at 450 volts, or less; 4- and 2- $\mu$ f filters were found in many of them, and some had paper units. These will have long since gone the way of all flesh, and the replacements themselves probably won't be too good. Check them carefully, and replace with new dry electrolytics, from 8  $\mu$ f on up, at 450 working volts.

Watch out for the hot-negative circuits on quite a lot of these. The filter chokes, speaker fields, and bleeder resistors were occasionally connected in

the negative return lead, and the resultant voltage drop was used for the high bias voltage required on the triode power stage. You can't use a common-negative filter on these, and the common-positive units are sometimes hard to locate. Use single tubular units, and you can connect them in any way necessary. See Fig. 1.

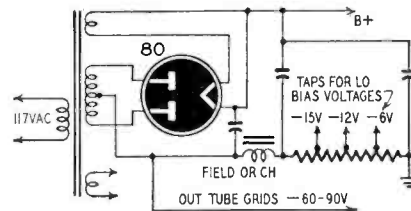

Fig. 1—A common old-time bias system.

A number of the older designs used a filter choke, or the speaker field, or both. Check these for opens and grounds. If a speaker field shows an open circuit, check the outer layer of wire. Often the trouble occurs here, where the lead wires are connected to the fine wire of the winding. If it's not repairable, use a separate filter choke. You'll usually find room to mount this on the chassis. Then use a PM speaker.

Bleeder resistors will be found across the power supply, to improve regulation, and to provide taps for the various screen and plate voltages. See Fig. 2. These were either *Candohms* or wire-wound ceramic units. If one section is open, the rest of the voltages will be upset and some stages deprived of all voltage. Replace the open section with a 10-watt resistor of the correct size, fastened across the terminals of the old resistor. If this is a *Candohm*, run the tip of a knife-blade through the old resistor or remove it, to insure that it will not heal up and upset the voltages. When repairs are finished, tap the whole resistor briskly, to locate any more possible open sections.

## Audio stages

These radios used triode class A audio stages regularly. The tubes used,

45's, 2A3's, etc., require a bias voltage that seems astonishingly high to us now, accustomed as we are to the 10-15 volts required on pentodes. The 45's, for instance, require at least 60 volts of negative bias, with a plate voltage around 300. If bias voltage is low, plate current will run much too high, causing low plate voltage, loss of volume, and possible overheating of power transformers and other components. You will find numerous cases where previous repair jobs have resulted in improper connections in the bias supply. This can result in loss of bias, distortion, and other troubles. Check bias resistors, input transformer secondary windings, and bleeder resistors, for continuity and proper resistance.

You'll find resistors and capacitors mounted on terminal boards and strips. This makes servicing easy, but there is always a possibility of leakage through the insulating material of the terminal board itself. We found one set with heavy leakage from the high-voltage terminal to the first audio grid, resulting in a severe loss of volume.

Watch for leaky or intermittent capacitors, especially in audio coupling circuits and screen or plate bypasses. Even micas aren't immune, if they're old enough. Check grid and plate-load resistors for correct values, replacing those which have shifted too much.

Lots of these old-timers used "block" bypass capacitors with as high as seven or eight bypasses in a single can. Returns often changed inside the can, too, making them difficult to trace. If you

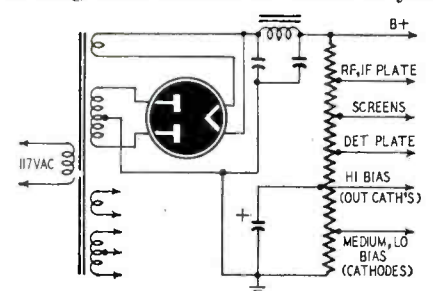

Fig. 2—Bleeder resistors were common.



find one defective, cut the lead close to the can, and install a separate unit at the tube socket. It's not a bad idea to check the rest of the capacitors in the can, too.

The size of capacitors used in these sets varies somewhat from modern practice. Screen bypasses ran up to 0.1  $\mu$ f, and the E-plus or plate-return bypasses were 0.25  $\mu$ f, or even 0.5–1.0  $\mu$ f. Bypasses in a.v.c. circuits were in the vicinity of .02–.05  $\mu$ f, and the a.v.c. filter resistors were 0.1–1.0 megohms. Cathode bypasses when used were from 0.25 to 0.5  $\mu$ f.

Coupling capacitors ran from .02 to 0.1  $\mu$ f. Check these carefully for leakage and capacitance. Most sets used input transformers for the power stage, and the coupling capacitors were found only in the driver or first audio input.

Output and input transformers were about the same then as now, with the exception of their physical size. Modern units will be less than half the size of the original units. Plate-load impedance of the triodes is rather low, so the d.c. resistance of the windings will be correspondingly less. Watch out mostly for balance between the two halves.

Input transformers will be found with open primaries, mostly. Secondaries are rarely found opened, but they deserve a check, especially if the set has not been used for a few years. If the secondary is good, but the primary open, with no replacement available, try shunting the primary with a resistance equal to the plate-load resistance of the tube, and coupling the signal into one of the output grids with a capacitor, about .05  $\mu$ f. Leave the secondary connected as it is. This is a fairly good emergency repair. If you want to play with it, remove the transformer, and make a simple phase inverter out of the driver tube. This depends mostly on how much time and money you want to spend on the set.

### R.f., i.f. and oscillator stages

Intermediate frequencies in these sets ranged from 175 kc and even lower about 1929–1932, some 370 kc, some 265 kc, and some in the 450-kc band used so widely now. The correct i.f. can be easily identified with a signal tracer, by connecting the i.f. probe to the detector, and tuning in some noise. Maximum response will be found in the vicinity of the proper i.f., no matter how badly the set is mistuned. For instance, if you get the highest reading around 200 kc, it's very likely a 175 kc i.f.

Watch out for electrolysis damage to r.f. and i.f. primaries, and oscillator plate windings. Any winding carrying high-voltage d.c. is liable to this trouble. In the older radios, breakdowns due to this cause are frequent. You can check all coils for continuity, or wait until you start aligning. Trouble of this type will show up instantly, by severe flattening of the response, or the complete absence of a peak while tuning.

If the set displays over-all weakness, with good tubes, it very likely needs aligning. Look up the correct i.f. and

the location of trimmers in service manuals. If you don't have a schematic for this particular set, sometimes the i.f. can be found by measuring the resistance of the i.f. transformers, although this is a rather rough way. Old service data is pretty complete, and you can find the i.f.'s of many of these sets listed in manuals of the period.

If you are in the habit of using a signal tracer for aligning, connecting the i.f. probe to the diode plate, you may encounter trouble in the older sets, which sometimes used triode "power detectors," etc. If you get erratic indications or oscillations, especially in the older auto radios, go back to the output meter across the voice coil.

Check up on antenna coils. Lots of these were shielded, in large cans, and damage may go unnoticed. If the line bypass capacitors, from the a.c. line to chassis, have shorted out, the antenna coil primary will burn up if the antenna post is grounded. This will lower the sensitivity quite a bit, even if the coil does not open up. They may be replaced by the separate primary coils, or the whole unit changed to a modern type iron-core coil.

When testing the oscillator section, be sure that the oscillator is delivering sufficient voltage over the entire band.

The most common pentagrid converters used in these sets (often 6A7's or 6A8's) should develop at least 15 volts d.c. at the low-frequency end of the band. With the sets using a separate triode oscillator, such as a 76 or 37, the readings will be about the same. Watch for shifting of the grid and plate-load resistors, also the cathode-bias resistor used in some circuits. Mica capacitors used in grid circuits will develop intermittent connections.

Mica insulation in trimmer capacitors on the older sets sometimes causes trouble by moisture absorption or physical damage. Oscillator drift and intermittent operation may sometimes be traced to this. While we're on the subject, look out for the little gimmicks used in lots of these sets—two pieces of wire, connected to the oscillator and r.f. sections of the tuning gang, and twisted together to make a small capacitor. If these are made of braid-covered wire, dampness will sometimes cause a leakage and a very puzzling intermittent.

Tuning capacitors used in the old sets are quite a bit larger than modern units. Check carefully for bent or damaged plates, also for proper grounding. Noise while tuning is often caused by loose grounds. Clean and check the grounding springs, and install pigtail grounds of flexible wire if necessary. You can get most of the dust out with an air-hose, or with the high-voltage test of your capacitor tester. Disconnect the lead wires from the gang, and connect the high voltage across one section at a time. Rotate the plates until sparking ceases.

### Volume controls

Several unusual volume-control circuits were found in the older sets. Vol-

ume control in the screen-grid circuit (Fig. 3-a), in the r.f. cathode, and in the antenna, or a combination of the last two (Fig. 3-b) were common. Any of these may be changed to our more usual audio-grid circuit, if the original control is defective. However, many of these sets lack a.v.c. Relocating their volume controls will cause the r.f. stages to overload and distort on strong signals.

With the screen or cathode type of control, of the proper size to give maximum gain. This is easiest found by experimenting, or cut-and-try. Then install an audio-grid control in an appropriate place. The antenna control may simply be removed and a new control installed, as most of these were low-resistance pots, shunted across the antenna coil primary. Where irreplaceable dual volume controls were used, a potentiometer may be used in place of one of them and a fixed resistor substituted for the other. If additional control is required, it can be put in the audio end. Watch out for single controls used as combination antenna shunt-r.f. bias controls; the slider was grounded in this type, and the antenna connected to one end the cathode to the others, as in Fig. 3-b.

### General hints

These sets are old! They've been stored for some time, and have probably accumulated quite a cargo of dust and dirt, and perhaps visited by several families of mice. Apply a vacuum cleaner or a brush to the set and clean it up as much as possible. This will make the service job a great deal easier, and neater.

Watch out for mouse damage to wiring, transformers, coils, speaker cones, etc. Mickey Mouse loves to gnaw on wires, and he may have cleared himself a space to build a little home right in the middle of the chassis.

Tune it up carefully, give the cabinet a good going-over with polish, and you'll probably have a set that will surprise both you and the customer. It'll make him very happy. And don't forget, if he's happy, your streaks will be quite a bit thicker than they will if he isn't!

—end—

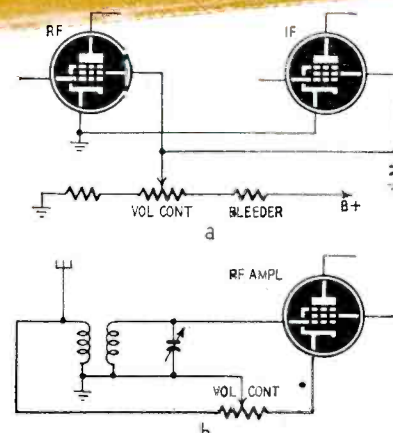
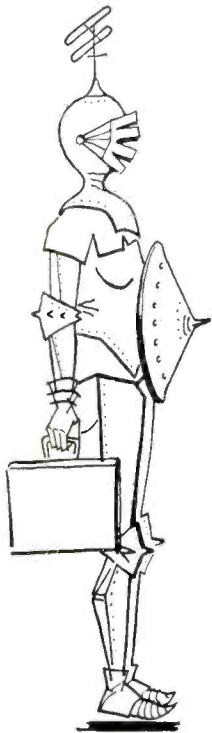

Fig. 3—Control circuits of yesteryear.



# Formula for TV Success

By JOHN D. BURKE

Video receiver service demands new techniques but the old fundamentals of good business and common sense are needed more than ever before



**M**Y experience is similar to that of thousands of men who are keeping the world's TV's going. We were radio repairmen. TV was thrust upon us.

Others are leaping directly into TV. Their road has been harder. They bit off more than they could chew. Some have gone bankrupt. Others are on the way now.



Once upon a time radio sets had only a 90-day warranty. This was the responsibility of the dealer, with the factory replacing parts or tubes. But—TV is a very different story. Much more complicated than radio sets; containing expensive components; involving special type aerials and lead-ins; requiring sometimes two men on service calls; involving complex customer instruction problems; and all this for *one year!*

TV contracts have satisfied neither the customers nor the contractors.

## This is not for me

TV sales are not for me—for a number of reasons. The main one is subjective. I do not like the relationship of merchant to customer. Such relation-

ships all too often lead to mistrust. Even when the merchant is actually giving away his merchandise at a small profit—or even a loss!

Antenna installation and repair requires special equipment, courage, and agility. One of my friends gets all my aerial work. He makes some nice money.

He can have it. He would prefer to be able to repair TV receivers and stay on the ground. He's still up in the air!

I used to heartily endorse three makes of sets. "This one is best; this second best; and that one third." In line with these endorsements I took people to a very nice dealer who sold a few sets on my suggestion. For about a year I continued this practice.

The result? I lost the friendship of those who took my suggestions. With over 80 manufacturers building TV's, is there not room for terrific conflict in every family, and groups of friends, as to which is best? More fools we to express any opinion!

I also had a strained relation for a time with my dealer friend. One of my prospects showed interest in an \$800 model. The dealer ordered it. The customer changed his mind.

When asked, I *now* tell people the names of those makes which I think are *no good*. So far, this advice has not boomeranged. Otherwise, "Take your choice!" say I.

In confessing one of the reasons for my hesitation over plunging into TV work, a couple of years back, perhaps I will help you also.

Frankly, I was scared of the picture tubes. They could explode! (Imply, they say. Same result.) They involve very high voltages. (I've been

nipped a few times.) They cost too much.

Many a time I've broken out into a cold sweat while, as gently as possible, I tugged and pulled and twisted and turned, trying to ease the neck of a big hunk of tube out of a tight yoke.

Brother—if you have had that experience—you know what I mean. Where else would the tube be, while this goes on, except smack up against your chest?

"Wear goggles and gloves," they say. Give me a suit of armor!

That fear is not as great now—but I shall always handle those babies with the respect they deserve.

After a while you learn to discharge the tube itself, as well as other capacitors, before getting near them. But—who let those engineers loose who put metal picture tubes in certain sets, and then put a knob for setting up the stations right alongside that killer—a knob we are supposed to reach like contortionists from the back of the set.

Ah, well! At least the high voltage on most sets carries little power nowadays, since the introduction of flyback transformers.

As you may have surmised, mine is a one-man shop. My approach is to regard myself as similar to a doctor. Some of my patients come to the office. Where possible I treat them in their home. No use to make a hospital case out of each headache.

This *does not mean* taking tubes out and replacing them, one by one, blindly. It does mean taking along on every call not only a complete set of tubes, but the *diagram* of the set, soldering iron, a few capacitors and resistors, a meter, tube

substitution book (very necessary nowadays). In each case I try to get the model number at the time of the first phone call. Most people have no idea what it is—they have to hunt for it while you hold the phone.

So, you arrive. Since it is to your interest to do the job fast, you come prepared. You do not forget your "cheater cord." Tubes account for the greatest percentage of TV troubles. The defective one usually can be determined quickly. Many other jobs can be done at home, including capacitor and resistor replacements.

There is a psychological point, however, where it is best to call a halt and propose taking the set to your shop.

To my shop come three types of jobs: Those I bring in; those brought me by other repairmen; those people bring in.

Tough repair jobs have included: one or more bad capacitors; open sweep transformers; bad selenium rectifiers; wrong-value resistors; bad switch contacts; poorly soldered connections; a few burned-out transformers.

"Hey, there!" you cry, "what about alignment?"

What about it? Leave those screws alone, say I. It is a rare case where I have to do any alignment. Do I use a sweep generator, then? No. Sorry. I have no sweep generator. I use the test pattern. My oscilloscope tells me the cause of poor synchronization.

Here's a couple of examples of my rough-and-ready method: A Du Mont, with picture and sound separated too far so that on weak stations you could only get one or the other. I simply adjusted sound i.f. down to meet the picture. Simple. Another case: the set used several 6J6's. All channels were off frequency indicating a changed oscillator tube characteristic. Simply switched 6J6's in the customer's home. Everybody happy.

### Keep the bills down

Long before the tube situation got tight I had a policy of changing very few tubes. You make more money, and charge the customer less. If a tube is working, why replace it? If your charges are moderate, they will call you back again.

Try to demonstrate that TV sets can be kept operating on a job-to-job basis at less than they would pay for contracts—and with better service. Far better—three or four calls per year—totalling less than a year's contract.

Results of these policies? No arguments on the phone. Everyone is friendly. Recommendations spread your fame. In time, you will have to limit your customer list—or expand.

But then other troubles will start.

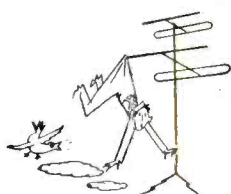

I leave that to those who want to get rich. Just give me enough work to make a good living, and enough leisure to live a good life.—end—

# Improved Audio For The 630

By CHARLES B. REMER

RECENTLY I purchased a television chassis, one of the popular 630 type. It came equipped with a Du Mont Inputuner, as I had planned to use the set for FM as well as television. It also had a 12-inch speaker.

The audio fell far short of desirable FM quality, but I decided that by making a few changes, adding treble and bass boost, it could be improved.

First it was determined that there was not enough gain to work with. The answer was to replace the 1st audio tube, 6AT6, with a pentode. A number of miniature tubes could be used, but since 6AG5's were on hand they were selected. Other tubes such as 6AU6, 6BH6, 6AK5 would be satisfactory.

A boosting network designed to give a moderate amount of treble and bass boost was inserted between the 6AL5 detector load and volume control.

This network was tried before the feedback was used, and although it worked well it still lacked enough bass. More boost could not be used because of the gain limitations. There was also some high-frequency distortion.

Feedback between the cathode of the 6AG5 and output transformer was then tried. The amount of feedback was adjusted to the gain available by a voltage divider across the secondary.

The amplifier was very stable and more feedback could have been used had there been more gain.

### Rewiring the audio

The actual changeover is easy. First, remove grid capacitor C3 and grid leak R4 from pin 1 of 1st audio tube socket (6AT6) and rewire pin 1 to center of volume control. Coupling capacitor C3 can be used between the 6AL5 output lead and the network. Mount on unused terminal above the 6AL5 shield.

Coupling capacitor C5 is rewired from pin 7 to pin 5, and plate bypass C4 is removed.

A new plate-load resistor R11 and 6K6 grid resistor R12 are wired in. Don't disconnect R6 from terminal strip over the 6AL5 shield. It can be used for part of the bias voltage divider for the 6AG5. Rewire grid end of R6 to bottom of volume control with R9.

The cathode lead may be pushed through a hole that is already in the chassis next to pin 7 and run to voice-

coil terminal strip directly above hole. The two resistors making up the feedback voltage divider can be mounted on this terminal strip.

Keep cathode lead as short as possible. Don't forget to disconnect ground from pin 2. The 6AG5 screen resistor R19 and capacitor C8 can now be wired, and network resistors R7 and R8 with capacitors C1 and C7 can now be put in between volume control and 6AL5 to complete the conversion.

If after all wiring is finished the set should oscillate when turned on, reverse voice-coil leads on output transformer.

By using both feedback and the treble-bass boost network the audio now sounds good and the time and effort put into the conversion has paid off.

(It appears that Mr. Remer may have had conditions, either due to his speaker, cabinet, room, or some other factor or combination of factors, that cut his treble exorbitantly. He has removed C4—which formed part of the original 630 treble de-emphasis circuit—and has added treble boost with C7. His reception should be screechy indeed. If other readers, using other components, find this to be the case, they may find it advisable to again cut the treble, by omitting C7 or by putting another (but smaller) capacitor between ground and R1-C3 junction.—Editor)

### Parts List

**Resistors:** (Original parts) R1, R2—22,000 ohms; R3—1 megohm, variable (volume control); R4—10 megohms; R5—330,000 ohms; R6—270,000 ohms. (New parts) R7, R10, R12—1 megohm; R8—70,000 ohms; R9—47,000 ohms; R11—500,000 ohms; R13—100 ohms; R14—5,000 ohms.

**Capacitors:** (Original parts) C1, C4—.0025  $\mu$ f; C2, C3—.01  $\mu$ f; C5, C6—.005  $\mu$ f. (New Parts) C7—200  $\mu$ f; C8—0.1  $\mu$ f; C9—50  $\mu$ f, 25 volts electrolytic. New resistors may have 1/2 watt rating; capacitors are paper, 400 or (better), 600 working volts except where noted.

—end—

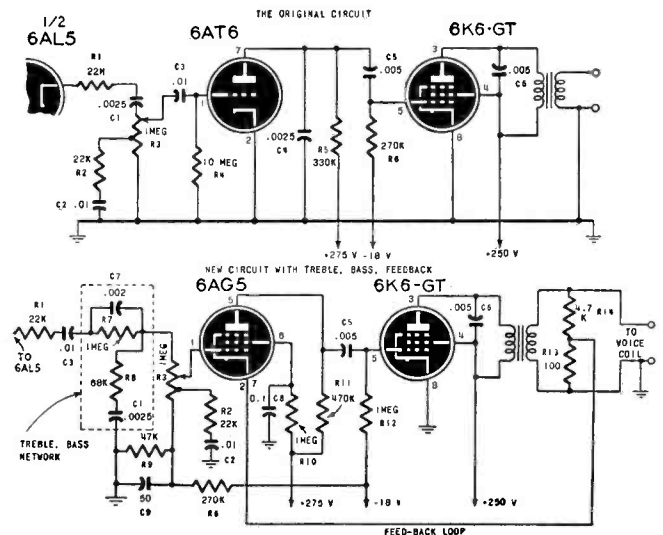

# Television Service Clinic

Conducted by MATTHEW MANDL

A LARGE number of the queries received by the Television Clinic relate to problems which arise after converting to large-screen receivers. (As with most of the letters which are sent to the Clinic, the answers are sent directly to the readers and only those of greatest general interest are published each month.)

One particular trouble which occurs after conversion merits discussion here because it occurs often with many types of receivers. That is the horizontal (and sometimes vertical) instability which occurs after rewiring the high-voltage system for the bigger tube.

Theoretically the sweep stability of the receiver should not be affected, because during conversion no changes are made in either the vertical or horizontal oscillator. What does happen, however, is that the increase in sweep necessary for the larger picture tubes will usually increase the voltage supplied by the voltage-boost system.

With many receivers the voltage-boost output is used to furnish B-potentials for either the horizontal oscillator tube or the discharge tube. In some receivers both such tubes receive their voltage from the boost system and sometimes the vertical circuits also are supplied with plate voltages from this source. A typical voltage-boost circuit of this type is shown in Fig. 1.

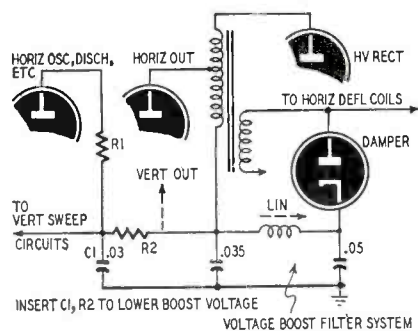

Fig. 1—Commonly used booster circuit.

When the high voltage and sweep output are increased during conversion, the transient-pulse amplitude increases and the damper tube rectifies a higher voltage and passes greater current. The output of the voltage-boost system will therefore increase. This increase is usually welcome to the horizontal output tube because it aids in getting more sweep amplification. However, when this increase in boost voltage is applied also to vertical and horizontal oscillator plate circuits it can upset circuit specifications sufficiently to cause instability.

Attempts to re-establish stability by adjusting hold controls are usually of

no avail, and upsetting the frequency or phase control settings of the horizontal lock system will only entail complete realignment after the plate voltages have been brought back to normal.

The method for reducing the boost voltage to the sweep oscillators while retaining the increased amplitude for the horizontal output tube is shown in Fig. 1, where R2 and C1 have been inserted. The series resistor R2 should be chosen by trial and error while taking a voltage reading at the plate of one of the circuits fed by the boost system. Check for proper voltage with the manufacturer's schematic and change the value of R2 until values are correct.

To prevent R2 from acting as part of the load resistor (R1) of any of the circuits which are fed by the boost, a capacitor (C1) is inserted to ground as shown. If the final value of R2 is too low, linearity may be upset slightly and will have to be adjusted a little.

In receivers where the vertical output stage voltage is also secured from the voltage-boost system the circuit should be so arranged that full boost is applied to vertical output. This can be done by making sure the feed line to the vertical output is taken off *prior* to the newly installed dropping resistor as shown by the dotted line in Fig. 1. This will aid in getting increased height for the larger picture tube.

## Sweep instability

*A Garod 920 receiver develops severe vertical and horizontal instability after operating about an hour. Changing tubes in both sweep circuits did not help. E. S. R., Morgantown, W. Va.*

Both horizontal and vertical sync loss indicates trouble in the sync separator system preceding both vertical and horizontal circuits. There may also be a defective tube in any stage prior to sync take-off, from the tuner through picture stages. Check these tubes by direct substitution, for often a tube will change characteristics slightly and clip sync levels while still giving a good picture in terms of general quality. Such tubes often check O.K. in an ordinary emission type of tester. If tube substitution does not clear the trouble, check for a faulty part in the separator.

## Vertical foldover

*In a Hallicrafter T-54 there is pronounced foldover at the bottom of the picture. This is accompanied by poor vertical linearity. G. P. O., Richmond, Va.*

A leaky coupling capacitor between

the vertical oscillator and the output tube is the usual cause for poor vertical linearity accompanied by foldover. The degree by which this condition can upset linearity and cause foldover is shown in Fig. 2. The pattern on this receiver was perfectly formed prior to a defect



Fig. 2—What a leaky capacitor can do.

developing in the coupling capacitor feeding the vertical output tube. When the coupling capacitor which caused this condition was checked, it was found to have a leakage resistance of 400,000 ohms.

Replace defective coupling capacitors with the same type and capacitance rating. Defective tubes and other capacitors also can cause such troubles and should be checked throughout the entire vertical circuits if the trouble persists.

## Horizontal smear

*I am experiencing difficulty locating the cause for horizontal smearing of objects in the picture. The appearance somewhat resembles that of ghost reception, except that poor definition is also present. The picture really appears out of focus. E. R. W., Washington, D. C.*

Horizontal smear, or "trailing smear" as it is sometimes called, is caused by poor low-frequency response in any picture section of the receiver (usually in the video-amplifier stages). The most common cause for this is a defective capacitor in the decoupler circuit. The latter is the resistor-capacitor combination between the B-plus supply and the load impedance of a tube. It isolates stages from interaction between each other and also boosts low-frequency response. Check all tubes and parts (particularly decoupling and coupling capacitors) from video detector to video amplifier inclusive.

Finally the picture i.f. stages should be checked, because any abrupt change in tube characteristics or in component

parts which might affect low-frequency picture sideband response will produce similar symptoms.

### Hum bar in slave unit

*What would cause 60-cycle hum bars in a slave unit but not in the master receiver? The remote unit consists of video, audio, and sync amplifiers, sync circuits, power supply and picture-tube circuits. R. P., Fort Madison, Iowa.*

The dark and light hum-bar interference is caused by 60-cycle ripple voltage entering the video amplifier and sync circuits of the remote unit. This is usually caused by a defective tube which has a cathode-to-filament short, though occasionally a poorly filtered low-voltage power supply will cause this trouble. If the latter is at fault, however, hum will be heard also from the speaker. The fact that the hum bars are not present in the master unit localizes the trouble to the slave unit. Check tubes by direct substitution.

### Picture shrinkage

*On a Craftsmen RC-200 the picture shrinks in from the side about one-half inch after the first 10 minutes of operation. Replacing the horizontal output tube did not help. When the trouble first appeared the picture shrank in all around equally, but I was able to remedy this with vertical linearity and vertical size controls. What can now be done for the horizontal shrinkage? M. L., Amboy, Ind.*

Normally you should expect a slight change in picture size in any receiver after the first five or ten minute warm-up period. Until the high-voltage system reaches correct amplitude, slight blooming occurs, and then the picture assumes the proportions it will keep while the set is in operation. It is only if the picture size reduces beyond the point where the width or height controls can give full masking that other troubles might be indicated.

You stated that you cured vertical shrinkage by adjustment of vertical controls, yet these two controls would not affect intermittent vertical size unless the controls are defective. If, as in your case, size changes only during warmup, it is more likely that you increased the vertical size beyond the picture mask and thus did not notice the slight shrinkage during warmup. The same can be done with the horizontal, by adjusting horizontal width until the picture is properly masked after warmup.

Wait until a station pattern is on the air and readjust all controls after the set has reached proper temperature, and with the contrast set for normal viewing.

### Poor picture in remote unit

*After installing a 10HP4 in parallel with the 7JP4 in an Admiral 19A1, I get a very weak picture on the remote*

*tube (located 50 feet from the master unit). When brightness or contrast is advanced, the picture turns negative on the 10HP4 but the 7JP4 operates normally. How can I correct this trouble? S. S., Philadelphia, Pa.*

The 50-foot run to the remote is excessive for good reception and will introduce considerable loss. The negative picture results because the long connecting cable introduces too much stray capacitance and cuts down on the high-frequency components of the picture signal by acting as a low-reactance shunt.

With just the lower frequency picture signal components left, an advance of controls will result in a negative picture because sync, blanking, etc., are all out of proportion to the higher frequency signal amplitudes. Paralleling tubes is not good practice even with ones having similar characteristics such as the 7JP4 and 10HP4. A much better arrangement is to employ a slave unit as described in RADIO-ELECTRONICS in the August, 1951 issue.

### Projection changes

*What changes are required for substituting a 3NP4 projection tube for a TP400 in a Philco model 48-2500? C. H. B., New Orleans, La.*

Such a change would have to include new deflection and high-voltage systems as well as changes in the optical system because of the difference between these two tubes. The 3NP4 has a 2.5-inch face, a 5-prong base, and uses 25,000 volts in the high-voltage system. The TP400 has a 4-inch face, requires 20,000 volts for the 2nd anode and uses a different type of deflection yoke.

The best way to change the receiver over is to use a complete "package" unit such as the *Protelgram* put out by the North American Philips Co. This unit comes complete with a yoke, corrector lens, mirror, and other components in a small housing. Another compact unit contains a separate power supply. The old unit and optical system would have to be removed and replaced with the new. It could be mounted in the cabinet at an angle to throw the picture on the present Philco tilted screen if it should be desired.

—end—

## TV PREDICTIONS

Though sporadic ionization in the E-layer region of the ionosphere may bring about dx propagation of low-band TV signals occasionally at any season of the year, there are two periods when such dx is much more frequent than at other times. These are spread either side of the shortest and longest days of the year. The winter season is the shorter of the two, but the TV dx enthusiast will find it well worth while to keep a close watch on the lower channels from about the middle of December through the first week of January.

In the northern half of the country, where December means winter, in fact as well as in name, the reliable reception range for all channels will average considerably less than for the previous eight months. This will mean generally poor fringe-area reception, but in locations where co-channel or adjacent-channel interference was a problem in the warmer months the lessened tropospheric bending may bring about some improvement in reception.

Tropospheric bending can be pronounced in December, too, but the average signal strengths observed for the next few months will be considerably below those of the April-November period. Times when tropospheric conditions will be good can be predicted readily at this season by no more than observation of local weather and a daily look at the weather map. "Increasing cloudiness and warmer" is the weather prediction that means tropospheric dx in the winter months, particularly after a slow-moving high-pressure center has passed or is in the process of passing.

Aurora borealis is less likely to occur in December than in the other cold months, though the northernmost portions of the country will probably experience a few disturbances of sufficient severity to affect at least the lower TV channels. Very few aurora observations have been received to date, and TV dx-ers are asked to turn their arrays to the north and check reception carefully whenever an aurora is seen. Most likely to result in observable effects on TV reception are the displays in which well-defined vertical rays or curtains are seen

—end—

## LOOK FOR THE SPECIAL 160 PAGE JANUARY TELEVISION ISSUE!!

Next month's issue of RADIO-ELECTRONICS will be a special TV number featuring special articles on UHF conversion, new TV circuits, transmission line tuning, TV Dx data, additional conversion information, and other TV servicing aids. Complete directories on TV receivers, antennas, boosters, and other items will be published. All this in addition to our regular sections devoted to audio circuits and design, servicing, latest test instruments, and data on new and special units.

**RESERVE JANUARY FOR YOUR VERY OWN!**

Some important lessons for radiomen are carried by this



*Light Sensitive . . .*

# ELECTRONIC BEAST

By EDMUND C. BERKELEY

ON the cover of this issue of RADIO-ELECTRONICS is a picture of a small robot which has four sensing organs, three acting organs, and a small electronic and relay brain. His name is Squee, the Robot Squirrel. What he does is roll along the floor, hunt for "nuts," pick up a "nut" in his scoop, take it over to his "nest," leave it there, and then hunt for more nuts.

Although Squee is not a very clever robot, he does have a small amount of memory and of reasoning ability, and he is a close cousin of his predecessor, Simon, the Midget Electric Brain. Simon was the main subject of a series of thirteen articles in RADIO-ELECTRONICS from October, 1950, to October, 1951, by Robert A. Jensen and this author.

There are a number of interesting things about Squee, himself, but the most important of them is that he is in many ways a good illustration of a powerful new method for the design of

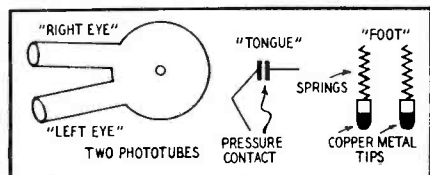

Fig. 1—The electronic sensory organs of Squee.

circuits for mechanical brains and robots. This method is the *algebra of logic*, also called *Boolean algebra*. The engineers at Northrop Aircraft Co. in California, who designed the electric brain Maddida, say they have given up drawing circuit diagrams in many places because Boolean algebra does a better job.

In this series of two articles the main emphasis will be on Boolean algebra: what it is, how you can calculate with it, and how it can be used in practice. The secondary emphasis will be on Squee. But first a few more words about Squee.

Why did Edmund C. Berkeley and Associates build Squee? Well, last year Bob Jensen and I read some articles about a mechanical tortoise made in Bristol, England, by Dr. W. Grey Walter at the Burden Neurological Institute. We said to ourselves, "Let's make a robot like that—but have him do something a little more clever." So we came up with the idea of a squirrel gathering nuts, and decided to make a robot squirrel.

Squee was constructed mainly through the efforts of three men—Robert A. Jensen (until he re-entered the Air Force in June, 1951), William Szabo, and Jack Koff. Bob Jensen made the skeleton, a framework holding a front wheel for driving, a pivoted column

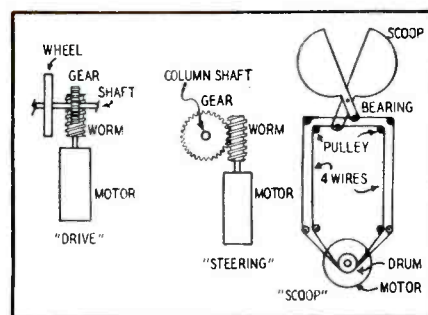

Fig. 2—These are the squirrel's motor organs.

holding and steering the wheel, and two rear wheels rolling free. He mounted tubes, relays, and batteries. By October, 1950, the machine was responsive to light (but only to one kind of light). It still had no "hands." In March, 1951, we made a commitment to exhibit Simon and Squee at the Minnesota State Fair, August 25 to September 3, under the auspices of The Dayton Co., a large department store of Minneapolis. The project that had started as fun became good business. We undertook in earnest the work of making the machine sensitive to a second kind of light, and to give it the needed hands. The scheme for the scoop and the nest light was the main contribution of Szabo, and the final completion, testing, and modi-

fication of the machine was due to Jack Koff. Squee was exhibited ten hours a day for ten days in Minneapolis, and probably 50,000 people saw him.

**The design of Squee**

The physical design of Squee is based on hitching together the sensing organs (see Fig. 1) and the acting organs (see Fig. 2) with appropriate hardware. The logical design of Squee is based on the Boolean algebra relating the conditions expressed by the sensing organs and the conditions expressed by the acting organs.

The first two sensing organs are the *right eye* and the *left eye*, the two photocells. They enable Squee to scan the surrounding environment; as Squee turns his steering column, the photocells look in one direction after another for nuts or nest. A nut (currently a golf ball) is lighted from above by a steady light, a d.c. light. The nest (currently a 12 x 18-inch sheet of aluminum) is lighted by a 60-cycle a.c. gas-filled lamp giving 120 flickers a second.

In Squee the physical circuit using electronic tubes connected to each photocell reports at any time three logical conditions. These are: darkness; a.c. light; and either d.c. or a.c. light or both a.c. and d.c. light. The possible logical reports from the circuit, for each phototube are:

Condition	Darkness	A.C.	Any light
No.	Report	Report	Report
1	1	0	0
2	0	1	1
3	0	0	1

Here the 1 designates "yes" or "reported" or "on," and the 0 denotes "no" or "not reported" or "off." Notice particularly that this circuit, which we called the Amplifying Circuit, was unable to report "d.c. and not a.c."; there will be a lot to say about this point later.

The third sensing organ of Squee is a contact-reporting switch taken from a vending machine, and installed at the base of the scoop. We called this the "tongue." When the nut (ball) entered the scoop, it would roll against this contact switch and close a relay, thus telling Squee that it had taken hold of a nut.

The fourth sensing organ of Squee is a "foot," consisting of two copper tips mounted on springs, which trail along the floor. If and when both of them touch a metal plate (the "nest"), a relay is closed, and Squee "knows" that it has found the nest.

The possible logical reports from these two sensing organs are:

Tongue Report	Foot Report
1	1
0	0

We come now to the acting organs. After a lot of pondering over various ways of giving energy to the acting organs, and the problems of clutches,

we finally decided on the simplest, though crudest method: We hitched a separate motor to each part that had to be moved, and we provided that it could be de-energized, run forward or backward.

For the drive wheel, we mounted a gear on the drive shaft, and turned that gear with a worm wheel mounted on the shaft of the drive motor. For steering, we mounted a gear on the column shaft, and turned the gear with a worm wheel mounted on the shaft of the steering motor. In the case of the scoop, we had a problem. There was room to put a motor at the bottom rear of the chassis. But the scoop was at the front of the chassis, even ahead of the column, and it had to be opened and closed like two cupped hands held together at the wrists. So we ran pulley lines made of light, flexible wire string, from the base of the scoop to the drum mounted on the shaft of the scoop motor; and we adjusted the amount of

turning of the motor by means of limit switches, so that there would be two positions and the scoop would be either open or closed.

The possible logical reports about each of these three acting organs is:

Condition	Motor On	Motor Forward	Motor Backward
1	0	1 or 0	0 or 1
2	1	1	0
3	1	0	1

We have now reduced the sensing (or input) of Squee to a set of yes's and no's, or 1's and 0's. We have reduced the acting (or output) of Squee to a set of yes's and no's, or 1's and 0's. We now have left the problem of hitching the input and the output together, so as to express the desired behavior of Squee.

Ordinarily, up to this time, this kind of problem has been solved by the practical method of drawing circuits on paper, using prior rule-of-thumb experience with that method. But there

**CHART 1—THE IDEAS OF BOOLEAN ALGEBRA**

ELEMENTARY ALGEBRA	QUESTION	BOOLEAN ALGEBRA	
<b>1. What symbols are used to stand for any things being talked about?</b>			
a, b, c, . . . , x, y, . . .		a, b, c, . . . , x, y, . . .	
<b>2. What can the things be that are talked about?</b>			
Numbers, like: 4, 8.57, -3, 1/8, √2, 3.14159. . . . .	(A) Classes, like: "Horses, Animals, Cows, Mammals, . . ." (B) The truth values (i.e., yes, no; or 1, 0) of statements such as: "Motor A is off." "Motor B is on." "Photocell C registers light."		
<b>3. What operations are there?</b>			
PLUS: a + b MINUS: a - b TIMES: a × b, ab DIVIDED BY: a ÷ b, a/b ROOT: √a, etc.		OR: a ∨ b AND: a • b, ab NOT: a', -a EXCEPT: a • b' OR ELSE: a ∨ b	
<b>4. What special constants are there?</b>			
ZERO, 0, such that a + 0 = a for every a (and a • 0 = 0, a ≠ ∞) ONE, 1, such that a • 1 = a for every a, a ≠ 0 INFINITY, ∞, such that a + ∞ = ∞ for every a (and a • ∞ = ∞ for a ≠ 0)		NULL CLASS, 0, such that a ∨ 0 = a for every a (and a • 0 = 0) UNIVERSE CLASS, 1, such that a ∨ 1 = 1 for every a (and a • 1 = a)	
<b>5. How many are all the things that are talked about?</b>			
INFINITY, ∞		2, or 4, or 8, or 16, or . . . , or ∞	
<b>6. What is an example of a rule?</b>			
"The reciprocal of the reciprocal of a number is the number itself." 1/(1/a) = a		"The truth value of the denial of the denial of a statement is the truth value of the statement itself." (a')' = a	
<b>7. How do you represent graphically the things talked about?</b>			
(A) By points on an infinite line: See drawing on page 48 (B) By tables of numbers:		(A) By areas in a finite rectangle: (See drawing below) The areas No. 1 to 8 are: No. 1: ab'c' " 2: abc' " 3: a'bc' " 4: a'b'c " 5: ab'c " 6: a'bc " 7: abc " 8: a'b'c' The null class has no location. (B) By tables of truth values:	
a	b	c	d
0	0	0	1
0	0	1	0
0	1	0	0
0	1	1	0
1	0	0	0
1	0	1	0
1	1	0	0
1	1	1	1

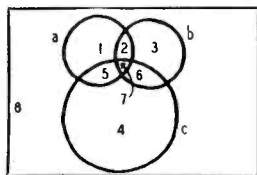

is beginning to be a change: Designers have begun to use the methods of Boolean algebra to effect the logical design of circuits to express behavior. For connecting the input and output yes's and no's, 1's and 0's, is a problem in Boolean algebra. What is Boolean algebra?

### Boolean Algebra

Boolean algebra is a kind of algebra named after a great English mathematician, George Boole, who lived 1815 to 1864. He wrote a famous book called *The Laws of Thought*, in which he laid

out quite completely the design of a new algebra. It was somewhat like ordinary algebra but was adapted to the ideas and operations of logic, of reasoning.

Other mathematicians and symbolic logicians have since then considerably improved and extended the algebra which Boole devised.

### Ideas of Boolean algebra

What are the ideas of Boolean algebra? In Chart 1 is a comparison of the main features of:

Elementary algebra, which we all

learn in school, for handling numbers, and which is essential for all computations in radio, electronics, electricity, etc., and

Boolean algebra, the newer algebra, which is useful for handling statements, classes, conditions, and circuit elements.

A great deal of information has been packed into this chart, and it is worth much attention.

A reader may say: "There seem to be two ways in which Boolean algebra can be represented, by classes and by the truth values of statements." Yes—and there are more ways besides. Boolean algebra is an interesting mathematical framework that applies to quite a variety of different situations.

For example, take the number 30 and its factors 1, 2, 3, 5, 6, 10, 15, 30; let  $a, b, c, \dots$  be any factors; let  $a \vee b$  mean the least common multiple of  $a$  and  $b$ ; let  $a \cdot b$  be the highest common factor of  $a$  and  $b$ ; and  $a'$  be  $30/a$ . You will find this to be a Boolean algebra.

For another example, consider sets of contacts, switches or relays; let  $a, b, c, \dots$  be any switch contacts;  $a = b$  if  $a$  is closed when  $b$  is closed and open when  $b$  is open;  $a \vee b$  means  $a$  and  $b$  in parallel;  $a \cdot b$  means  $a$  and  $b$  in series; and  $a'$  is any contact open when  $a$  is closed and closed when  $a$  is

CHART 2—THE RULES OF BOOLEAN ALGEBRA

TOPIC	ELEMENTARY ALGEBRA	BOOLEAN ALGEBRA
<b>1. Commutative Law</b>	$a + b = b + a$ $a$ PLUS $b = b$ PLUS $a$ $a \cdot b = b \cdot a$ $a$ TIMES $b = b$ TIMES $a$	$a \vee b = b \vee a$ $(a \text{ OR } b) = (b \text{ OR } a)$ $a \cdot b = b \cdot a$ $(a \text{ AND } b) = (b \text{ AND } a)$
<b>2. Associative Law</b>	$(a + b) + c = a + (b + c)$ $a$ PLUS $b$ PLUS $c$ is the same, whatever order you take them. $(a \cdot b) \cdot c = a \cdot (b \cdot c)$ $a$ TIMES $b$ TIMES $c$ is the same, whatever order you take them.	$(a \vee b) \vee c = a \vee (b \vee c)$ $a$ OR $b$ OR $c$ is the same, whatever order you take them. $(a \cdot b) \cdot c = a \cdot (b \cdot c)$ $a$ AND $b$ AND $c$ is the same, whatever order you take them.
<b>3. Distributive Law</b>	<b>ONE LAW:</b> $a \cdot (b + c) = ab + ac$ $a$ TIMES $(b$ PLUS $c) = (a$ TIMES $b)$ PLUS $(a$ TIMES $c)$	<b>TWO LAWS:</b> (1) $a \cdot (b \vee c) = a \cdot b \vee a \cdot c$ $a$ AND $(b$ OR $c) = (a$ AND $b)$ OR $(a$ AND $c)$ (2) $a \vee (b \cdot c) = (a \vee b) \cdot (a \vee c)$ $a$ OR $(b$ AND $c) = (a$ OR $b)$ AND $(a$ OR $c)$
<b>4. Combining</b>	$a + a = 2a$ $a$ PLUS $a =$ TWO $a$ $a \cdot a = a^2$ $a$ TIMES $a = a$ SQUARED There are no numerical coefficients and exponents.	$a \vee a = a$ $a$ OR $a = a$ $a \cdot a = a$ $a$ AND $a = a$ There are no numerical coefficients or exponents.
<b>5. Special Elements</b>	0, ZERO; 1, UNITY $a + 0 = a$ $a \cdot 0 = 0$ $a + 1 = a + 1$ $a \cdot 1 = a$	0, NULL, NOTHING; 1, UNIVERSE, ALL $a \vee 0 = a$ ( $a$ OR NOTHING = $a$ ) $a \cdot 0 = 0$ (WHAT IS BOTH $a$ AND NOTHING = NOTHING) $a \vee 1 = 1$ ( $a$ OR ALL = ALL) $a \cdot 1 = a$ (BOTH $a$ AND ALL = $a$ )
<b>6. Opposites</b>	<b>TWO OPPOSITES:</b> $a + (-a) = 0$ $a$ PLUS (MINUS $a$ ) = 0 $a \times (1/a) = 1$ $a$ TIMES (RECIPROCAL OF $a$ ) = 1 $-(-a) = a$ $1/(1/a) = a$	<b>ONE OPPOSITE:</b> $a \vee a' = 1$ $a$ OR NOT $a =$ ALL $a \cdot a' = 0$ BOTH $a$ AND NOT $a =$ NOTHING $(a')' = a$ (NOT-NOT- $a = a$ ) $1' = 0$ $0' = 1$
<b>7. Laws Involving Opposites</b>	$a + b = -(-a - b)$ $a \cdot b + a(-b) = 0$ $-(a + b + c \dots) = (-a) + (-b) + (-c) + \dots$	$a \vee b = (a' \cdot b)'$ $a$ OR $b =$ NOT (NOT- $a$ AND NOT- $b$ ) $a \cdot b = (a' \vee b)'$ $a \cdot b \vee a \cdot b' = a$ $(a \vee b) \cdot (a \vee b') = a$ $(a \vee b \vee c \dots)' = a' \cdot b' \cdot c' \dots$
<b>8. Absorption</b>	$a + ab = a(1 + b)$ $a(a + b) = a^2 + ab$	$a \vee (a \cdot b) = a$ $a$ OR $(a$ AND $b) = a$ $a \cdot (a \vee b) = a$ $a$ AND $(a$ OR $b) = a$
<b>9. Relation of Less Than or Included In</b>	<b>LESS THAN OR EQUAL:</b> $a \leq b$ if and only if $a +$ (zero or some positive number) = $b$	<b>INCLUDED IN (LIES IN):</b> $a \subset b$ if and only if: $a \vee b = b$ , or $a \cdot b = a$ , or $a \cdot b' = 0$ , or $a' \vee b = 1$

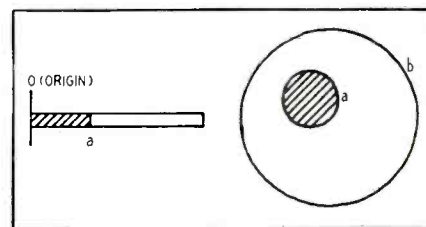

The drawings above indicate what  $a$  and  $b$  mean in standard and Boolean algebra.

open. This is typical Boolean algebra. How it is applied in practical electric circuits will be shown later.

### Rules of Boolean algebra

But the ideas of Boolean algebra, interesting though they may be, are not enough; we also need the rules. We could work out the rules on the basis of ordinary reasoning. In fact, most ordinary reasoning is Boolean algebra, and is done by means of words and experience. But the rules of Boolean algebra expressed in mathematical form are potent and helpful. They are given in Chart 2, set into comparison with the rules of ordinary elementary algebra.

Here then is an introduction to the ideas and rules of Boolean algebra. Some of the ways to use them for dealing with circuit elements that can be "on" or "off," and some of the ways to use them for connecting input and output to express the behavior of a robot or mechanical brain, will be explained in the next article.

—end—





**I Send You  
18 BIG  
KITS  
OF RADIO-  
TELEVISION  
EQUIPMENT**

# NOW-Be a Fully Trained, Qualified RADIO TELEVISION TECHNICIAN IN JUST 10 MONTHS OR LESS!

**New "Package" Unit Training Plan  
PAY AS YOU LEARN-YOU SET THE PACE!**

**No Monthly Payment Contract  
to Sign!**

Now . . . be ready for Radio-Television's big pay opportunities in a few short MONTHS! Frank L. Sprayberry's completely new "Package" training unit plan prepares you in just 10 MONTHS . . . or even less! Equally important, there is NO monthly payment contract to sign . . . thus NO RISK to you! This is America's finest, most complete, practical training—gets you ready to handle any practical job in the booming Radio-Television industry. In just 10 months you may start your own profitable Radio-Television shop . . . or accept a good paying job in this fascinating expanding field at work you've always wanted to do. Mr. Sprayberry has trained hundreds of successful Radio-Television technicians—and stands ready to train you in less than one year, even if you have no previous experience. You learn by DOING . . . actually working with your hands with equipment of special design to illustrate basic theory instead of relying on books alone.

**VALUABLE EQUIPMENT INCLUDED WITH TRAINING**

The new Sprayberry "package" plan includes many big kits of genuine, professional Radio-Television equipment. While training you actually perform over 300 demonstrations, experiments and construction projects. In addition, you build a powerful 6-tube standard and short wave radio set, a multi-range test meter, a signal generator, signal tracer, many other projects. All equipment is yours to keep . . . you have practically everything you need to set up your own service shop. The interesting Sprayberry book-bound lessons and other training materials . . . all are yours to keep.

**EARN EXTRA MONEY WHILE YOU LEARN!**

All your 10 months of training is AT YOUR HOME in spare hours. Keep on with your present job and income while learning . . . and earn EXTRA CASH in addition. With each training "package" unit, you receive extra plans and ideas for spare time Radio-Television jobs. Many students pay for their entire training this way. You get priceless practical experience and earn generous service fees from grateful customers. Just one more reason why the Sprayberry new 10 MONTH-OR-LESS training plan is the best Radio-Television training in America today. If you expect to be in the armed forces later, there is no better preparation than good Radio-Television training.

## FREE 3 BIG RADIO-TELEVISION BOOKS

I want you to have ALL the facts about my new 10-MONTH Radio-Television Training—without cost! Act now! Rush the coupon for my three big Radio-Television books: "How to Make Money in Radio-Television," PLUS my new illustrated Television Bulletin PLUS an actual sample Sprayberry Lesson—all FREE with my compliments. No obligation and no salesman will call on you. Send the coupon in an envelope or paste on back of post card. I will rush all three books at once!

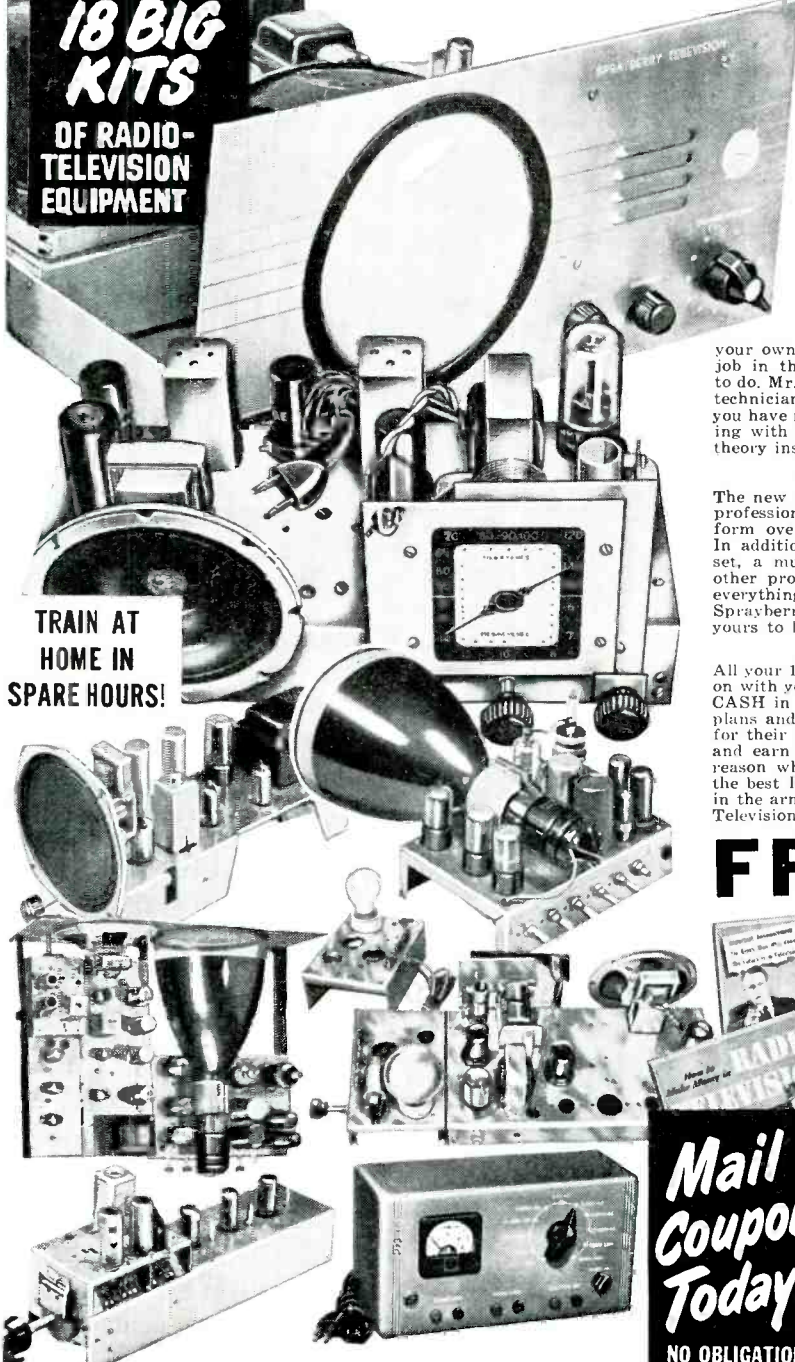

**TRAIN AT  
HOME IN  
SPARE HOURS!**

**IF YOU ARE  
EXPERIENCED IN RADIO**

Men already in Radio who seek a short intensive 100% TELEVISION Training with FULL EQUIPMENT INCLUDED are invited to check and mail the coupon at the right.

**Mail  
Coupon  
Today!**

**NO OBLIGATION  
No Salesman  
Will Call**

**SPRAYBERRY ACADEMY OF RADIO, Dept. 20-D  
111 North Canal St., Chicago 6, Ill.**

Please rush to me all information on your 10-MONTH Radio-Television Training Plan. I understand this does not obligate me and that no salesman will call upon me.

Name.....Age.....

Address.....

City.....Zone.....State.....

Please check Below About Your Experience

Are You Experienced?  No Experience

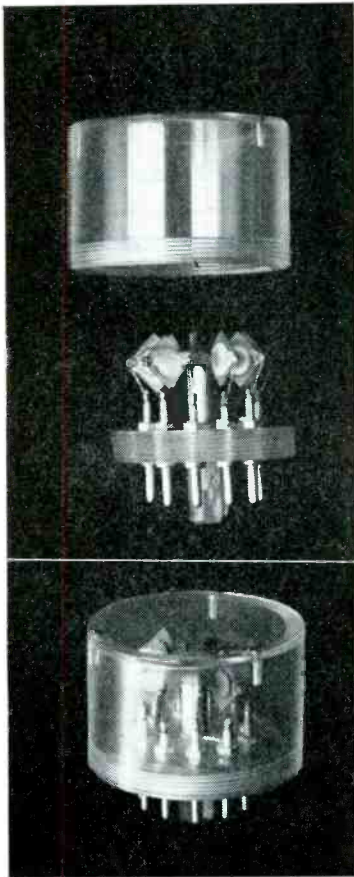

Multiple holder for 10 overtone units.

# Harmonic Oscillators

Photo  
Courtesy of  
Western Electric Co.

By NORMAN L. CHALFIN

**D**IRECT crystal-controlled oscillators at 50 megacycles have been available commercially for the last few years. They have been rather expensive. This is a necessary result of the great care required in their manufacture.

Mason and Fair<sup>1</sup> first demonstrated direct crystal-controlled v.h.f. oscillators in 1942. The circuits and the crystal units were of special construction as shown in Fig. 1. Their physical appearance was somewhat as in 1-a and their equivalent bridge circuit is shown in 1-b. The basic idea was that when the holder and crystal capacitances were balanced out at a frequency near an odd harmonic of the crystal thickness frequency, the crystal circuit placed in the output-to-grid feedback path of an oscillating circuit will control the oscillator at an odd crystal harmonic (Fig. 1-c). The fascinating point of this arrangement is that the fundamental is not present, nor is any other related frequency below the desired odd harmonic.

To appreciate the mechanical nature of the phenomenon that makes the harmonic-mode crystal oscillator possible, one must first observe the operation

of a crystal oscillator plate of the familiar AT or BT cut. In Fig. 2 is shown the motion an oscillating crystal of this type undergoes. Note that the action is a forward motion of the top surface while the bottom surface moves backward, pivoting at the center. This would be one half-cycle. The second half-cycle will have the forward motion in the bottom half and the backward motion in the top half.

The motion described is *thickness-shear vibration*. The result is a piezoelectric polarity as shown in the figure. Now picture the same crystal with its thickness divided by three as shown in Fig. 3. In the harmonic-mode oscillator the shear vibration breaks up this way. A fifth harmonic oscillation will show a breakup of five sections of equal thickness, a seventh harmonic oscillation seven sections, and so on. This harmonic excitation occurs only at the odd harmonics. You can see why it is that the even harmonics are not possible if you examine the breakup diagram in Fig. 3. Note the upper pair of sections and see that if they alone made up a crystal the polarity of the opposite surfaces would be the same. For a piezoelectric crystal to sustain oscillation,

the piezoelectric polarities of the opposite surfaces must be of opposite sign. At any odd number of thickness-shear breakups the opposite faces will always have opposite piezoelectric polarities.

## Some overtone circuits

The simplest of the harmonic-mode oscillating circuits is the familiar plate-tuned crystal oscillator shown in Fig. 4-a. While the author has never suc-

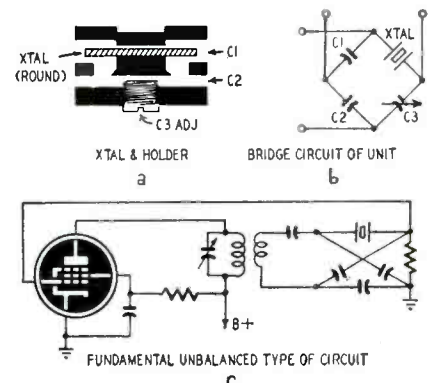

Fig. 1—Basic Mason and Fair circuit.  
RADIO-ELECTRONICS for

# IT'S STARTED!



**4,000,000  
PICTURE TUBE  
REPLACEMENTS  
COMING!**

## Get YOUR Share!

### MOST HYTRON TOOLS AVAILABLE AGAIN!

Materials shortages are tough. But most of the Hytron tools are available now. Only the 7-Pin and 9-Pin Straighteners will be scarce. Aluminum and stainless steel are tight . . . and we won't give you an inferior tool.

A word to the wise: order now while these famous tools are available. Put them to work for you. They'll save your time . . . temper . . . dollars. Order today from your Hytron jobber.

HYTRON TOOLS

Pick-Up Stick, 5¢ net



Probing Tweezers, 35¢ net



Tube Tapper, 5¢ net



Soldering Aid, 49¢ net



Tube Lifter, 15¢ net



Tube Puller,  
75¢ net



7-Pin and 9-Pin  
Straighteners,  
55¢ ea. net



Auto Radio Tool,  
24¢ net

Over 4,000,000 TV sets are now over two years old. Just as electric-light bulbs dim with age, the picture tubes in these sets are failing.

A tremendously profitable replacement market (conversions too) is now yours for the selling. And you have lots to sell when you sell CBS-Hytron picture tubes: The original *studio-matched* rectangular — made in the world's most modern picture-tube plant.

You get better than new set performance with greatly improved tubes. A new black face for better contrast. Convenience of the Hytron Easy Budget Plan. And a generous six-months-from-date-of-sale guarantee. A guarantee you can depend on . . . because it is backed by CBS-Hytron.

Go after your share of this tempting business now! Remember: demand for TV picture and receiving tubes is expected to exceed supply. Military requirements and serious materials shortages are the reason. Tubes in your stock will be better than gold. Don't over-buy, but buy enough. CBS-Hytron will do its utmost to help you.

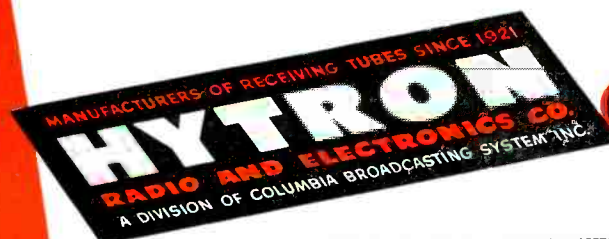

MAIN OFFICE: SALEM, MASSACHUSETTS



A Guiding Beacon For  
Quality Electronic Parts

Your Local  
**RADIART**  
Distributor

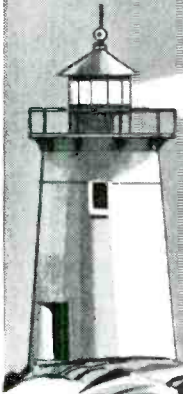

These Are The Cities With  
**RADIART DISTRIBUTORS** in CALIFORNIA  
Served by **ROBERT M. HARDIE**  
Los Angeles, California

- |                 |                      |
|-----------------|----------------------|
| <b>BERKELEY</b> | <b>SACRAMENTO</b>    |
| <b>FRESNO</b>   | <b>SAN FRANCISCO</b> |
| <b>OAKLAND</b>  | <b>SAN JOSE</b>      |
| <b>STOCKTON</b> |                      |

**BUY OF THE MONTH**

The TELE-ROTOR "CUB", second ONLY in power to the "Heavy Duty" TELE-ROTOR, features the same powerful motor that has helped to make the "Heavy Duty" TELE-ROTOR so famous! The "CUB" incorporates a sensitive meter for utmost accuracy in tuning. Model 502B (uses 5 wire cable)... \$44.95. See Your Radiart Distributor, or write us.

**FOR NAME OF YOUR NEAREST RADIART DISTRIBUTOR**  
USE COUPON BELOW

**ROBERT M. HARDIE** 1127 Wilshire Blvd., Los Angeles 17, Calif.

..... Please send names of the Radiart Distributors in my area stocking the following Radiart products in which I am interested:  Tele-Rotors,  Vibrators,  TV and FM Antennas,  "Spee-Dee" Chimney Mounts,  Lightning Arresters,  Auto Aerials,  Power Supplies

..... Please have a Radiart Distributor call on me.

Name .....

Address .....

City ..... State .....



**THE RADIART CORPORATION** CLEVELAND 2, OHIO

VIBRATORS • AUTO AERIALS • TV ANTENNAS • ROTATORS • POWER SUPPLIES



Tel-a-Ray's

BIG

FOUR

of TV reception

For television that's  
bright and clear  
Wherever you are . . .  
far or near



**Good reception up to 200 miles or more!**

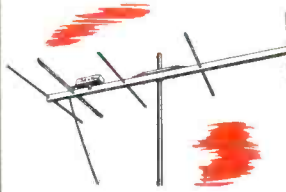

1

Models T and TD Antennas . . . famous for providing clear, stable, interference-free reception at almost unbelievable distances. With the Pre-Amplifier, they give up to an amazing 300 times gain over dipole. Rugged, weatherproof construction.

**Signal amplification without noise!**

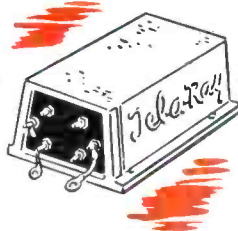

2

The unique, research-perfected Pre-Amplifier . . . the only device of its kind . . . an antenna- or mast-mounted installation that dramatically multiplies the signal gain while keeping noise at a minimum. Eliminates snow and makes signals strong and stable. Sold as a weather-sealed unit and guaranteed against weather damage.

**Middle-distance champions!**



3

Models R and RD Antennas . . . designed to give the finest TV reception to the outer service areas at low cost . . . America's champion middle-distance performers. Same quality construction features as Models T and TD.

**Now, primary area reception benefits from Tel-a-Ray Antenna know-how!**

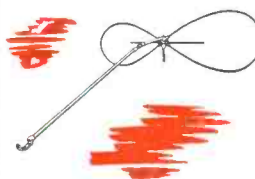

4

Butterfly Swivel-Positioned TV Antenna . . . low cost, high gain . . . easy to adjust for best primary area reception . . . self-mounted on three-way bracket for quick installation almost anywhere . . . an all-channel antenna designed and priced for the mass market.

**HOW TO INCREASE VOLUME AND PROFITS NOW**

A huge market is opened up for you by Tel-a-Ray long-distance antennas and the Pre-Amplifier. With them, you can sell television in areas where it could not otherwise be sold successfully. For the big, established primary area market, the Butterfly has the features needed for capturing replacement sales . . . for building profits and volume against the strongest competition. These are products of the finest construction and appearance . . . ruggedly made of corrosionproof materials and unconditionally guaranteed against wind and weather damage. Let us send you full details.

*Tel-a-Ray*, America's most progressive antenna manufacturer, has applied to the FCC to operate a UHF television station on Channel 50 . . . Tel-a-Ray's research engineer is keeping pace with America's fastest-growing industry, has developed an effective UHF antenna. Such progress assures you finer television.

Send the coupon  
for full information and  
free sales literature



**Tel-a-Ray ENTERPRISES, INC.** P. O. Box 332E, Henderson, Kentucky

Yes . . . send me full information and descriptive literature on  
 Models T and TD Antennas;  Models R and RD Antennas;  
 Butterfly Swivel-Positioned Antenna;  The Pre-Amplifier.

NAME.....  
 COMPANY.....  
 ADDRESS.....

# HICKOK

Latest Design  
**VACUUM TUBE  
VOLTMETER**

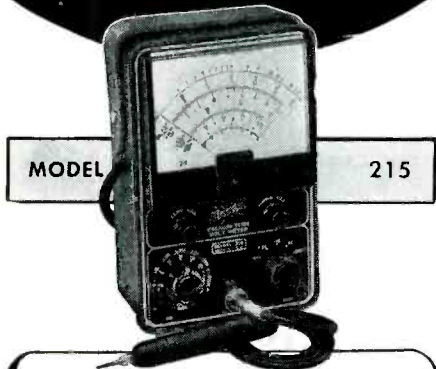

MODEL

215

**INCLUDES:**

Exclusive, New Single-Unit  
AC-DC Probe

**FEATURES**

- Accurate Peak-to-Peak measurements
- Portable, shock-resistant case
- Large 5", easy-to-read meter
- Zero-Center scale

**RANGES**

**DC VOLTMETER**

Volts: 0-1200 in 7 ranges  
Input Resistance: 10 megohms

**OHMMETER**

Design Center: 10 ohms  
Readability: 0.2 ohm to 1000 meg.

**AC VOLTMETER**

AC, RMS: 0-1200 in 7 ranges  
AC, Peak-to-Peak: 0-3200 in 7 ranges  
Frequency Characteristics: 40 cps to 3.5 MC,  
and to 250 MC with crystal probe.  
input Impedance: 30 meg. shunted by 150  
uuf with dual-probe furnished.

This new HICKOK Model 215 provides laboratory quality, accuracy and dependability. Ideal for the radio-television manufacturer or service shop. Has wide applications in the electronic or industrial fields. Contains the sensitivity and ranges for fast, accurate measurements of sine or complex waves of electronic devices. Test leads are included. Write today for complete information.

**THE HICKOK ELECTRICAL INSTRUMENT CO.**  
10531 Dupont Ave. • Cleveland 8, Ohio

ness for this arrangement is probably to be found for receiver applications in the u.h.f. region. The identical circuit has been used in experimental TV local oscillator control.

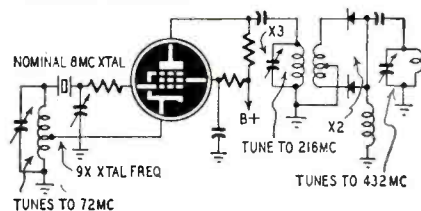

Fig. 9—432-mc output with 8-mc crystal CR-9 units, operating at 40 and 45 mc.

Photographs are shown of a crystal-holder assembly developed for multiple frequency selection such as in a TV tuning turret, applying harmonic-mode oscillators. Wherever many frequencies are required, as in a multichannel receiver, a holder of this type is useful. The author has constructed FM receivers and TV receivers, <sup>4</sup>, <sup>5</sup>, employing harmonic oscillator circuits. Reference is made to these in the bibliography.

Any carefully made crystal of the AT or BT cut works in a harmonic oscillator under the proper conditions.

Circuits must be wired with care and the well-known techniques of high-frequency construction must be observed. The crystal must have very flat surfaces and very rectangular edges for best results. Acid-etched surfaces have been found better for harmonic-mode crystals than abrasive-ground surfaces.

—end—

<sup>1</sup> Mason and Fair, A New Direct Crystal Controlled Crystal Oscillator for Ultra-Short-Wave Frequencies, *Proc IRE*, Oct., 1942, p. 464.  
<sup>2</sup> Lister, Overtone Crystal Oscillator Design, *Electronics*, Nov., 1950, p. 88.  
<sup>3</sup> Thurston, Direct Crystal Control at 50 Megacycles, *Western Electric Oscillator*, July, 1946, p. 30.  
<sup>4</sup> Chalfin, Crystal Stabilization of Television Receivers, *Radio-Electronic Engineering Section, Radio News*, May, 1946, p. 9.  
<sup>5</sup> Chalfin, Crystal Control for Stability on VHF Receivers, *Tele-Tech*, Jan., 1947, p. 71.  
Butler, Series Resonant Crystal Oscillators, *Wireless Engineer*, June, 1946.  
Sells, VHF Crystal Oscillators, *QST*, Nov., 1947, p. 44.  
Goldberg and Crosby, Series Mode Crystal Circuits, *Tele-Tech*, May, 1948, p. 24.  
Johnson and Bernstein, Simple Crystal Control on 144 Megacycles, *QST*, Oct., 1948, p. 22.  
Tilton, So It's Hard to Get on VHF! *QST*, Nov., 1948, p. 44.  
Treuke, A Regenerative Oscillator for Harmonic Type Crystals, *QST*, Dec., 1949, p. 46.  
Tilton, Overtone Crystal Oscillator Circuits, *QST*, April, 1951.

## Transistor Amplifier Circuits

By I. QUEEN

**T**RANSISTORS have been improved remarkably since they were first developed just a few years ago. They are now available to experimenters (at \$15 to \$18 apiece) and will, no doubt, find wide use in the future.

The unusual properties of the germanium crystal are due to impurities. Some, like antimony or arsenic, cause it to release excess electrons. Such crystals are called N-type. Other impurities, like aluminum, cause the crystal to absorb electrons. These crystals are P-type.

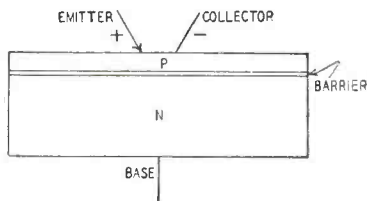

Fig. 1

The conductivity of N-type germanium is due to electrons which are free to hop from atom to atom under the force of an electric field. P-type germanium conducts because of the "holes" or atoms which have lost electrons.

A typical transistor may be made of a small block of N-type germanium approximately .05 inch square and .02 inch thick. One surface is heat-treated to give it P characteristics. The other surface is metal-plated for low resistance. This becomes the base of the transistor.

Two catwhiskers 2 or 3 mils apart contact the P surface. One (called the emitter) is biased positively with re-

spect to the base. The other is negative—the collector—(See Fig. 1.)

The positive potential on the emitter repels holes into the P layer. These diffuse through the layer which has lower resistance than the barrier. Since the base is negative it partly neutralizes the positive charges on the P surface. The greater the voltage between emitter and base, the more holes diffuse through the P surface. The base then neutralizes more of the positive space charge and permits greater flow of holes.

Holes moving away from the emitter flow laterally through the P zone and may come under the influence of the collector. Therefore they flow into the load circuit (Fig. 2). The concentration of charges near the collector reduces the potential near this area and may also permit the flow of electrons in the high-voltage circuit between collector and base. The combination of electrons moving out of the collector and holes moving into it constitutes the total collector current. The ratio of collector current to emitter current depends upon the construction of the transistor and the circuit in which it is used.

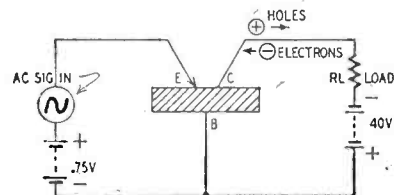

EMITTER ARROW POINTS TOWARD TRANSISTOR TO DENOTE N-TYPE

Fig. 2



# There's No Comparison!

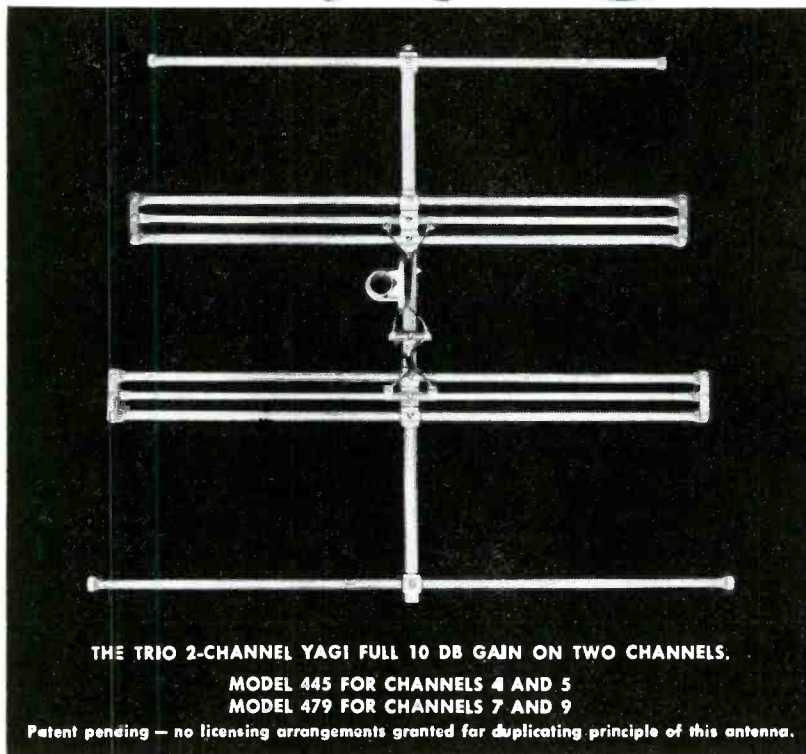

THE TRIO 2-CHANNEL YAGI FULL 10 DB GAIN ON TWO CHANNELS.

MODEL 445 FOR CHANNELS 4 AND 5  
MODEL 479 FOR CHANNELS 7 AND 9

Patent pending — no licensing arrangements granted for duplicating principle of this antenna.



Yagi elements of .035" thick seamless aluminum, are full 5/8" in diameter. Ends are crimped for greater strength and to cut down vibration. Prevents entrance of dirt and moisture.

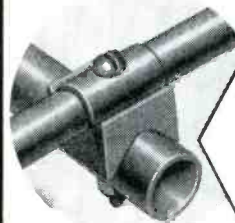

An extra clamping member permits taking up bolts tight without putting undue strain on element. Cast aluminum V block assures perfect right angle alignment. No detail of design or construction has been overlooked to make the TRIO 2-Channel Yagi the finest fringe area TV antenna available anywhere — at any price!

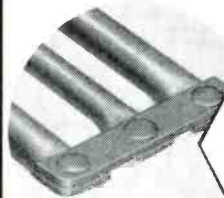

Double-folded dipole sections have heavy gauge aluminum brace bars securely riveted to element ends thus providing positive electrical connection and extreme rigidity. Workmanship throughout is of the highest order.

## TRIO — TOPS ALL IN DESIGN, CONSTRUCTION, PERFORMANCE

*The Original*  
**2-CHANNEL YAGI**

One of the most widely imitated antennas on the market today, the TRIO 2-Channel Yagi still stands alone in efficiency and strength.

TV buyers — and sellers — are discovering that "look alike" is not enough — that imitations are never as good as the original.

There is no secret to TRIO's marked superiority. The simple truth is that TRIO slights no construction detail, overlooks no design feature. This means unparalleled

efficiency — rugged dependability for both installer and TV set owner.

Installers! Avoid profit eating call-backs caused by poorly made imitations! Set owners! Enjoy years of dependable, efficient TV reception! Compare the TRIO 2-Channel Yagi with any other TV antenna at any price. Yes, compare — then you, too, will insist on an original TRIO — the 2-Channel Yagi that set the standards.

## TRIO the "Trouble-proof" TV Rotator



For years of dependable, un failing service — in good weather and bad — you can't beat the new TRIO TV Rotator and Direction Indicator.

Sturdy and completely weatherproof, the TRIO Rotator will support the heaviest TV arrays — even in 80 MPH winds! Its sound design and construction has been proven by 3 years of extensive field testing under every extreme of weather. The TRIO Rotator will not freeze up!

### 2 HEAVY DUTY MOTORS

Two separate 24 volt motors are used — one for each direction of rotation. Thus, each motor operates just 50% of the time — cannot burn out. Positive acting electrical stops at both ends of 360° turn eliminates lead damage.

Housing is die-cast aluminum for greater strength, lighter weight and perfect alignment of parts. The TRIO Rotator is precision built throughout.



**SMARTLY STYLED  
DIRECTION  
INDICATOR**

The TRIO Direction Indicator is housed in a sturdy plastic cabinet of graceful lines. It is a beautiful instrument that will blend harmoniously with any furniture style.

Utmost ease in selecting the desired antenna direction is provided by a new "finger-tip" control that operates at a light touch and the easy-to-read dial face that clearly and instantly indicates the exact antenna position.



*TRIO*

**MANUFACTURING COMPANY**  
GRIGGSVILLE, ILLINOIS

ARMY—NAVY  
AIR FORCE—MARINES  
SERVICEMEN  
TECHNICIANS  
**Here's Help!**

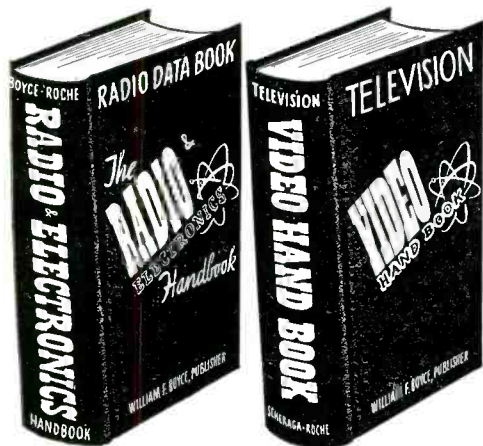

Now in 1800 PAGES  
THE BASIC KNOWLEDGE  
AND DATA OF

**RADIO & TELEVISION**

DIGESTED INTO 32 SECTIONS  
... IN A COMPLETE, QUICK-  
TO-FIND, EASY-TO-READ  
HANDBOOK FORM.

You can plan every operation in TV—Radio & Electronics with the Library Set. These handbooks are your lifelong tools—use them every day on the board, at the bench, or in the field—for construction, production, servicing, installation or operation—for adjusting, troubleshooting, measuring and testing. Your invaluable aid in service, research, development, design, manufacturing and maintenance. With all data & servicing procedures, these handy books work better, faster and easier.

In addition, you get complete coverage of everything you need in TV, Radio & Electronics—in practical form—everything presented in plain talk, all terms explained; schematics, working diagrams and pictures all clearly illustrated for your quick and easy reference. These books are works of complete authority prepared by the well known engineers, Joseph J. Roche and Morton Scheraga, under the direction of William F. Boyce, famous for the preparation of hundreds of handbooks and manuals for the U. S. Signal Corps, U. S. Navy, U. S. Air Force, Western Electric Co., General Electric Co., Bell Laboratories, National Radio Co. and many others.

These Handbooks are endorsed by leading schools for instruction and reference. The armed services make them available to their technicians in libraries, schools, and in the field. Engineers, Draftsmen, Laboratory and Production men in every industry have purchased over 50,000 of these books for use in their work.

500 Radio Jobbers keep them constantly in stock for the convenience of their service and industrial customers. These are the most commonly used books in Radio & TV. Whether you use these Handbooks for general reference, scientific instruction or education, one thing is certain; the practical help, the daily usefulness you will derive from them will prove to be worth many times their price.

Contents are too long & complete to describe here, so see the books at your Radio Jobber, your bookstore, or

SEND FOR TEN DAY  
FREE TRIAL EXAMINATION.

RADIO ELECTRONICS HANDBOOK ..... \$7.00  
VIDEO HANDBOOK ..... \$7.00  
— SPECIAL OFFER! SAVE \$2.00 —  
The LIBRARY SET (both books)..... \$12.00

BOYCE-ROCHE BOOK CO.  
Caldwell 52, New Jersey

Send  Library Set (2 books) @ \$12.00  
 Radio Electronics Handbook @ \$7.00  
 Video Handbook @ \$7.00

In ten days I will send price plus postage, or I will return books postpaid.  
(Offer good in U.S.A. and to men in Armed Services overseas only.)

Name.....

Address.....

Employed by.....

Save postage—we pay postage and packing if you send money NOW. Money back on same return privilege.

A new transistor type is now being developed at Bell Telephone Laboratories. It is called the N-P-N-type. It consists of a single piece of germanium, each end of which has N-type conductivity. Between them is a thin P-type layer less than .001 inch thick (Fig 3). Like any P-type transistor, this one requires a negative emitter and a positive collector.

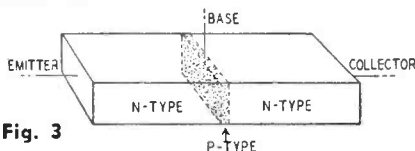

Fig. 3

This transistor has improved gain and noise characteristics. It operates with very low collector input. In class A its efficiency approaches the theoretical limit of 50%. Collector input may be anything from 0.1 to 39 volts and between 20 microamperes and 5 milliamperes.

The N-P-N can give a gain of over 44 db up to a limit of 3.4 kc. Response may be maintained to 220 kc when the gain is reduced to 27.8 db (by decreasing input and output impedances). The new transistor is completely described in the Bell System Technical Journal, July, 1951.

Compare the operation of a vacuum tube and a transistor. In a transistor, the emitter is the source of charged particles. As the particles move away they are controlled by the voltage between emitter and base. The collector gathers them and they flow to the output circuit. Unlike the vacuum tube, the input circuit of a transistor has low impedance. Considerable power is absorbed from the signal source. The transistor is essentially a power amplifier.

Just as with tubes, there are three basic circuits for transistors. They are: grounded base, grounded emitter, and grounded collector. The word "grounded" signifies that an element is common with the other two. There need not be a direct connection with earth in any case.

Fig. 4 shows the grounded base circuit.

Fig. 5 shows the grounded-emitter circuit. With average constants the input impedance is greater and the output impedance smaller than in the previous circuit. This makes it convenient when matching for maximum gain. With ordinary values, this circuit can provide considerable current amplification and the output phase is reversed.

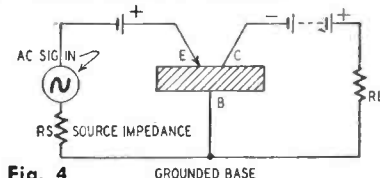

Fig. 4

A grounded collector or "cathode follower" is shown in Fig. 6. This can be used to give very low output impedance and relatively high input impedance. Amplification is essentially current since the output voltage is less than the input. Phase is not reversed.

In the various circuits shown above it

may be noted that the emitter bias is rather inconvenient. It is generally a fraction of a volt and very critical. For this reason efforts have been made to eliminate need for a separate bias sup-

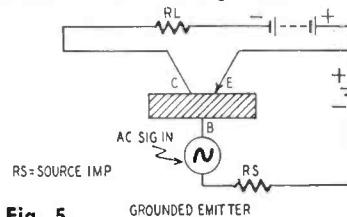

Fig. 5

ply. An effective method has been invented by H. L. Barney and R. C. Mathes.\* These circuits are shown in Fig. 7.

The high voltage between collector and base results in a small current flow

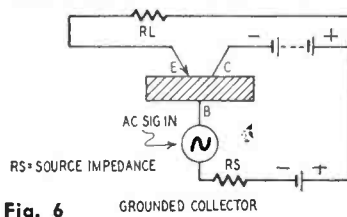
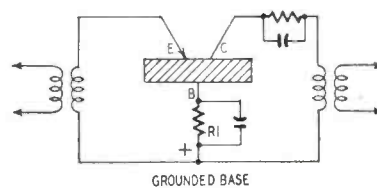

Fig. 6

of about 2.5 ma between the elements. Electrons flow from collector to base within the transistor. In Fig. 7-a, a resistor R1 is connected in the base circuit and bypassed for signal currents. It sets up a bias voltage with polarity as shown. If R1 is about 300 ohms, the bias will be about 0.75 volt, which is usually satisfactory.

Fig. 7-b shows a grounded collector circuit. The bias resistor R1 is used as described in the previous circuit. A grounded-emitter circuit is shown in 7-c.



7-a

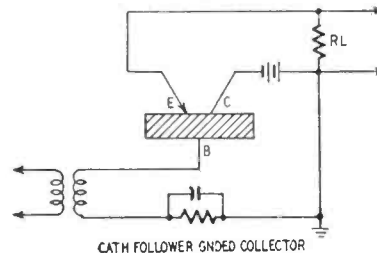

7-b

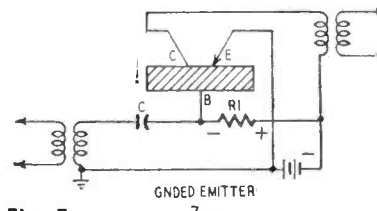

7-c

A capacitor C blocks the base. Base current therefore flows through R1 and sets up the required bias. This resistor may be several hundred thousand ohms and should not be bypassed.

\*Patent No. 2,517,960

—end—



*Sensationally NEW for 1952!*  
**MIDWEST TELEVISION**

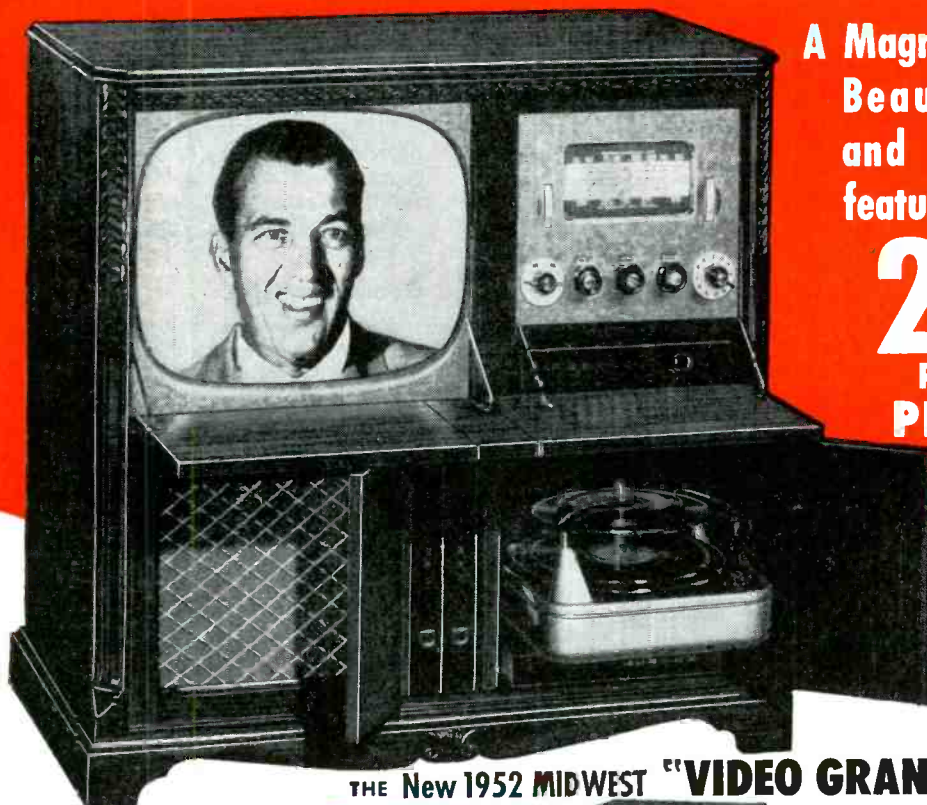

A Magnificent New Line of Beautiful CONSOLES and Complete CHASSIS featuring the Mammoth

**20-Inch**  
 RECTANGULAR  
 PICTURE TUBE

FACTORY-TO-YOU

**Special Bonus**  
  
**GIFT!**  
 Illuminated  
**TELEVISION CLOCK**  
 Given With Every  
 Purchase of a MIDWEST  
 RADIO or TELEVISION  
**LIMITED TIME ONLY!**

THE New 1952 MIDWEST "VIDEO GRAND"

20-Inch Television-Radio-Phono

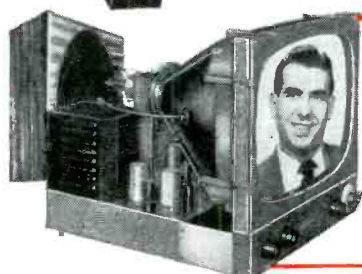

**MIDWEST**  
**20-Inch**  
 TELEVISION  
 CHASSIS  
 and SPEAKER  
 —for easy installation  
 in your own cabinet.



We Pay Transportation Charges

**WRITE or PHONE**  
 For This NEW 1952  
**FREE MIDWEST**  
**TELEVISION**  
**RADIO CATALOG**



If You Live In One of These Cities  
 Phone and Ask for Your Catalog

- NEW YORK Murray Hill 2-6810
- CHICAGO State 2-5600
- PITTSBURGH Grant 1-0609
- CLEVELAND Prospect 1-7450
- DETROIT Woodward 3-1233
- ST. LOUIS Grand 1161
- PHILADELPHIA LOcust 4-1035

or Send Coupon Below

WRITE IN NAME AND ADDRESS (PLEASE PRINT) ON COUPON OR 1c POSTCARD

MIDWEST RADIO & TELEVISION CORP.  
 Dept. 385, 909 BROADWAY • CINCINNATI 2, OHIO  
 Please send me your new FREE 1952 Catalog.

NAME \_\_\_\_\_  
 ADDRESS \_\_\_\_\_  
 CITY \_\_\_\_\_ ZONE \_\_\_\_\_ STATE \_\_\_\_\_

**30 DAYS TRIAL**

New 1952 MIDWEST "CONSTELLATION"  
 20-Inch TELEVISION CONSOLE

Also—Powerful New 1952 World-Ranging  
**MIDWEST Series of RADIOS**  
 For Beautiful Consoles and Complete Chassis

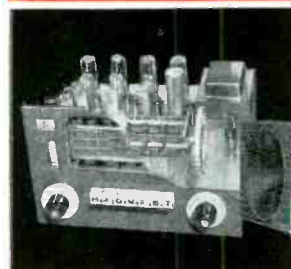

An entirely new line of radios featuring the powerful Series 16 five wave band AM-FM Radio Chassis and the magnificent Symphony Grand Radio-Phonograph with 3-Speed Automatic Intermix Record Player.

*Easy Terms*

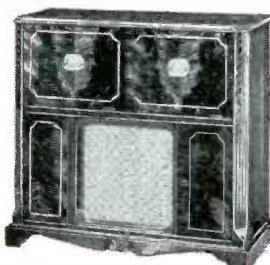

**MIDWEST RADIO & TELEVISION CORP.**  
 DEPT. 385, 909 BROADWAY, CINCINNATI 2, OHIO

# A Scotsman's Superhet

By JOHN W. STRAEDE

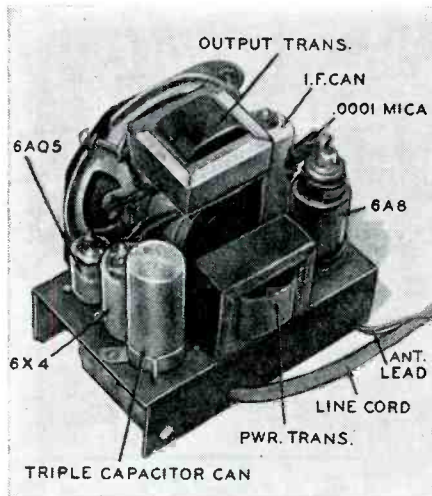

Junior-sized chassis packs all parts.

WONDER how many "Scotch" sets have been described! Since the early twenties, economically minded set designers have turned out the Scotsman's one-valver, his 2-tuber, his 3-tuber, etc. Well, here's a baby superhet that's fairly inexpensive and has a number of interesting features. It operates a loudspeaker on locals, and some of the stronger short-wave stations also can be received at reasonable speaker strength. The usual radiation, an antisocial feature of most regenerative receivers, is absent, as regeneration is limited to the second detector. No regeneration adjusting is required when tuning the receiver, as the amount of feedback is fixed. The set therefore is simple to operate and is compact.

Economy is achieved by having no padder, no trimmer, no aerial coil, no intermediate-frequency stage, and only three tubes (two if a dry rectifier is used). See Fig. 1. If you buy a loudspeaker for the job, get one with long leads (you won't have to buy any hookup wire).

## Tube functions

Although sensitivity is somewhat low due to the lack of i.f. stage and untuned aerial circuit, it is not as low as might at first be feared. The second detector is a real "power" detector using a 6AQ5, midget equivalent of the 6V6. It performs three functions: i.f. amplifier because it is regenerative; diode detection, the grid and cathode acting as a diode; and a.f. power output. About 1 to 1½ watts is obtained with a high voltage supply of 250 volts. Combining these functions enables a smaller rectifier to be used.

The second tube operates under con-

ditions of high sensitivity, high anode load (25,000 ohms) and low grid bias (bias is due to the rectification of the i.f. signal applied to the grid).

## Regeneration

Fixed regeneration is obtained by linking the anode of the output tube through a small capacitor to the anode of the converter tube. The capacitor is extremely small and consists in practice of a "gimmick"—a length of insulated hookup wire, each end of which is looped once around the leads from each of the anodes. Possibly a double loop may be required if the Q of the i.f. transformer or the line voltage and therefore B-voltage is low. This regeneration does not usually have to be adjusted to a maximum; only a small amount is required. In some locations none at all may be needed unless short-wave operation is required

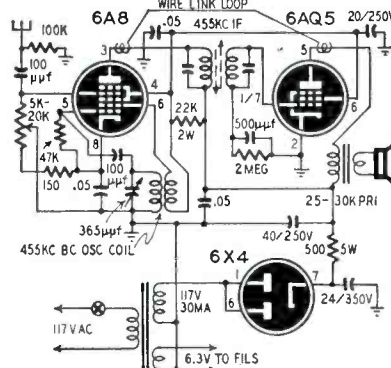

Fig. 1—The basic superheterodyne set.

If the set is to be used seriously for short-wave reception, a regeneration control is advisable (Fig. 2) so that the set can be kept at maximum sensitivity. (The set shown is for broadcast band only but other models had plug-in coils.)

## Pepping it up

Greater sensitivity for short-wave reception can be obtained by increasing the plate load of the output tube. Even 55,000 ohms can be used for B-plus supplies as low as 100 to 125 volts and 30,000 ohms for supplies up to 250 volts. Too high a load may cause sparking at the tube pins or a breakdown in the speaker transformer.

Another way to obtain a slight rise in sensitivity is to use audio-frequency regeneration (in addition to i.f. regeneration!), on the output tube. The necessary feedback, see Fig. 3, is obtained by grounding one side of the secondary of the speaker transformer

(and of course the voice coil), and connecting the cathode of the output tube to the other side.

If such an alteration results in a decrease in volume, then reverse the transformer secondary. This positive feedback causes only a very slight increase in distortion (usually not even noticeable).

## Component size

Midget tubes and small parts are used. The speaker is a PM job. A midget variable capacitor using a solid dielectric of plastic, saves space, but an air-dielectric capacitor is advisable if short-wave reception is required.

Further space could have been saved by omitting the 6.3-volt filament transformer and using a 12A8-GT and a 50L6-GT as tubes with a series resistor.

In any version of this circuit careful alignment of the single i.f. transformer is necessary to avoid whistles, a common fault in any superhet that has no tuned circuit before the converter. Fig. 4 shows how to connect parasitic suppressors to prevent whistles.

## Materials for baby superhet

Resistors: 1—2 megohms, 1—100,000, 1—47,000, 1—150 ohms, ½ watt; 1—22,000 ohms, 2 watts; 1—500 ohms, 5 watts. Potentiometers: 1—5,000-20,000 ohm. Capacitors: (Mica) 2—100, 1—500 µmf. (Paper) 3—.05 µf, 250 volts. (Electrolytic) 1—triple unit, 20, 40 µf, 250 volts, 1—24 µf, 350 volts. Miscellaneous: Tubes: 1—6A8, 1—6AQ5, 1—6X4. Tube sockets. Coils (see text). 1—6.3-volt power transformer, 2 amperes. 1—Speaker, 25,000-30,000-ohm primary, 6-8-ohm secondary. Chassis. Hardware. Solder. Wire.

—end—

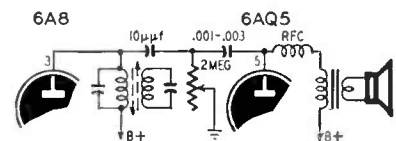

Fig. 2—Circuit for r.f. regeneration.

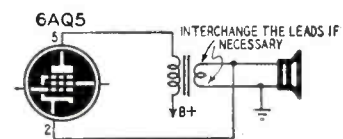

Fig. 3—Positive feedback aids gain.

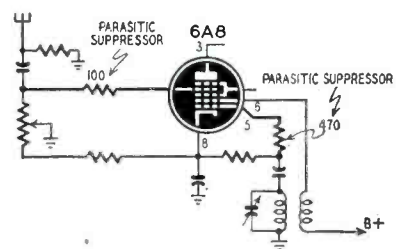

Fig. 4—Suppressors help kill birdies.

# Now this precision-matched miniature Pliers Kit yours **FREE**



IT'S SYLVANIA'S  
GREATEST  
PREMIUM YET!



...with every 100 Sylvania  
Receiving Tubes or 3 Picture Tubes  
purchased between Nov. 15th and Dec. 15th

Here's exactly the tool kit every radio and TV serviceman  
has always needed. A complete miniature pliers kit.  
It contains:

**Slip-Joint Pliers:** 4¾ inches long with adjustable  
two-position slip-joint.

**Needle-nosed Pliers:** 5¼ inches long for inaccessible  
wiring and terminals.

**Parrot-nosed Pliers:** 4½ inches long, with adjustable  
three-position slip-joint.

All have precision-matched jaws with finely-  
milled teeth, forged from the finest steel by a  
leading manufacturer of surgical instruments.  
Regular \$4.50 value!

This kit, packed in sturdy plastic case, is  
yours absolutely free when you buy just 100  
Sylvania Receiving Tubes or 3 Sylvania TV  
Picture Tubes from your Sylvania Distributor.  
But, please hurry! Offer closes Dec. 15th.  
Your regular Sylvania Distributor has these  
kits now. Call him TODAY!

MAN, WHAT A  
TIME AND WORK  
SAVER!



## WHY YOU'LL WANT THESE PLIERS

1. Especially designed for radio and televi-  
sion service work.
2. A craftsman's tool... forged from high-  
est quality steel, not cold-rolled or  
stamped.
3. Precision-matched jaws... sure grip,  
finely-milled teeth.
4. Needle-nosed and parrot-nosed pliers  
wonderful for inaccessible wiring.
5. A regular \$4.50 value.



# SYLVANIA



RADIO TUBES; TELEVISION PICTURE TUBES; ELECTRONIC PRODUCTS; ELECTRONIC TEST EQUIPMENT; FLUORESCENT TUBES, FIXTURES, SIGM TUBING, WIRING DEVICES; LIGHT BULBS; PHOTOLAMPS; TELEVISION SETS

DECEMBER, 1951

A Real  
Aid to a

**STRONGER  
TV SIGNAL**

for ANY Receiver

**WINCHARGER**  
REG. U.S. PAT. OFF.

## TV Roof Mount Tower

The world's leading producer of towers presents a new superior TV ROOF MOUNT TOWER

**UTILITY**—Adjustable feet for any roof slope. Adjustable clamps for pipe or fittings— $1\frac{1}{4}$  to  $1\frac{3}{4}$  inches. Ten foot tower plus ten foot pipe provides a 19 foot SELF-SUPPORTING installation. Ten foot tower plus 30 foot pipe provides a 40 foot installation with guys at 20 and 40 foot levels. May be used as a ground installation.

**APPEARANCE**—Baked-on black enamel finish. All hardware electro-plate galvanized.

**SAFETY**—All steel, sturdily braced construction. Weight is evenly distributed on all four feet.

**CONVENIENCE**—Will fit any roof. One man can easily and quickly erect either the five or ten foot tower plus mast and antenna. Mount is easily climbed for service and maintenance. Comes packed in a flat carton for easy storage.

**ECONOMY**—Low erection costs. No special tools required. *Low in Price.*

America's top distributors and dealers carry the Wincharger TV Roof Mount Tower. For complete distributor and dealer information, write to: Wincharger Corporation, Department (1), Sioux City 2, Iowa.

Write today.

**NOW!**

**Wincharger Corp.**  
SIOUX CITY, IOWA

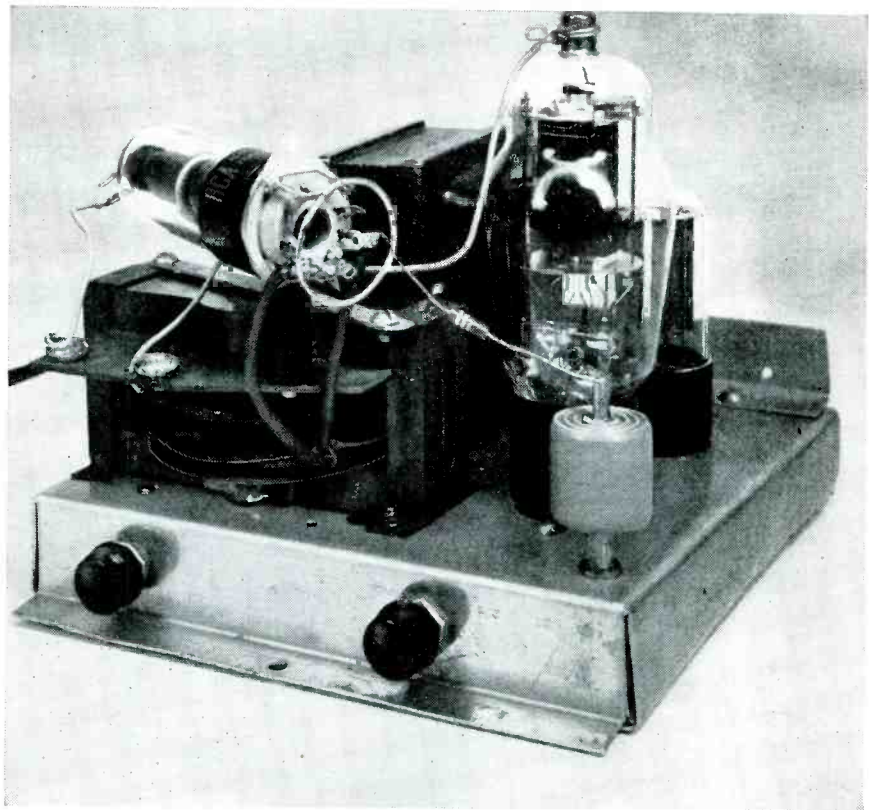

Using less than 60 watts of power and standard TV components and tubes this handy little unit can put out fourteen kilovolts with plenty of microamperes.

# TV Components Make This 14-KV Generator

By HAROLD PALLATZ

A few of the uses of these power supplies are: electrostatic paint spraying, dust removing, electret charging, and breakdown testing of television components.

Electrostatic paint spraying operations in industry are in much demand. The hookup is simple. A light potential is applied between the muzzle of the sprayer and the object to be painted. The fine paint particles which ordinarily were lost are now attracted to the object, their paths being changed so that none are wasted. Paint savings may amount to hundreds of gallons to a large manufacturer. A more even and smoother coating is achieved at the same time.

Dust removing is a necessity in hospitals and in many factories. Filtering methods which use fine-mesh screens result in restriction of the flow of the air. By arranging many pairs of parallel plates, each of which is highly charged, any particles of dust in the air stream are immediately pulled by electric fingers to the plates. The clean air flows freely between them. The instruments you are now using in your shop may well owe part of their trouble-free operation to use of one of these

electrostatic dust removers in the factory where they were made.

### For the experimenter

For those of us who like to experiment and tinker a little, a high-voltage power supply finds many applications. A Kerr cell (light modulator) will operate directly off the output of the supply. By proper switching circuits, a fast-acting electronic camera shutter can thus be made. Electret construction and charging requires high potentials. The adjustable output feature of these power supplies will prove handy for this task. The upper limit of 14 kilovolts should be sufficient to meet most size and charge requirements.

Instruments should be tested and calibrated at the conditions under which the equipment is designed to operate. The direct comparison of kilovoltmeters is a simple task with these power supplies. Instruments can be checked against a meter which is built into the power supply or compared against others of known accuracy. The fineness that the voltage output may be set to will help in these tests. Make sure that both instruments are grounded properly.



German crowd, part of the 1,250,000 from East and West Berlin, sees a typical RCA television program.

## "Freedom's window in the Iron Curtain"

You've read the story of last summer's TV demonstrations in Berlin. It attracted a million and a quarter Germans—including thousands who slipped through the Iron Curtain to see Western progress at work.

Behind this is another story: How RCA engineers and technicians broke all records in setting up these Berlin facilities. The project called for a TV station and studio, a lofty batwing antenna, and the installation of 110 television receivers at strategic points. Such a program would normally take several months to complete. It was

installed and put to work by RCA in a record-breaking 85 hours!

Programs witnessed by Berliners included live talent shows, sports events, news commentaries, and dramatizations of the Marshall Plan. Observers pronounced reception fully up to American standards—another impressive demonstration of democracy's technical ingenuity and leadership.

\* \* \*

See the latest wonders of radio, television, and electronics at RCA Exhibition Hall, 36 West 49th St., New York. Admission is free. Radio Corporation of America, RCA Building, Radio City, N. Y. 20, N. Y.



Part of the 401 cases of RCA equipment shipped to Berlin for television demonstrations.



**RADIO CORPORATION of AMERICA**

*World Leader in Radio — First in Television*

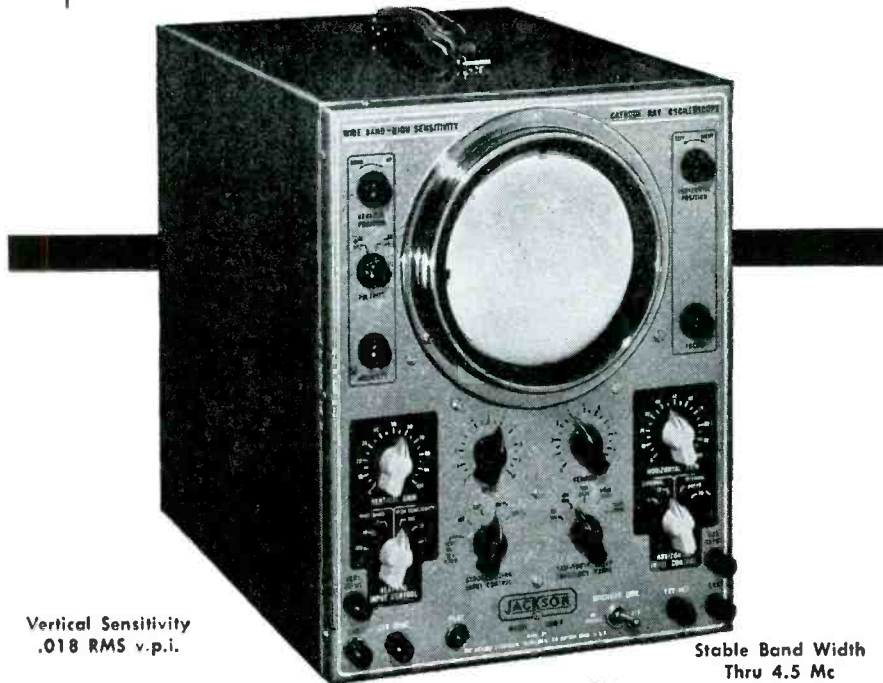

Vertical Sensitivity  
.018 RMS v.p.i.

Stable Band Width  
Thru 4.5 Mc

# JACKSON Oscilloscope gives you "dual service"

This is a high-quality, laboratory-grade 5" Oscilloscope that provides the "dual service" of both high sensitivity and wide band width.

## specifications

**Vertical Amplifier**—Video-type frequency compensation provides flat response within 1.5 db from 20 cycles thru 4.5 Mc, dropping smoothly to a still useful value at 6 Mc.

**Sensitivity Ranges**—With a band width of 20 cycles thru 100 Kc, the sensitivity ranges are .018, 18, 18 RMS volts-per-inch. The wide band position 20 cycles thru 4.5 Mc has sensitivity ranges of .25, 2.5, 25 RMS volts-per-inch.

**Horizontal Amplifier**—Push-pull with sensitivity of .55 RMS volts-per-inch.

**Input Impedances**—Vertical: 1.5 megohms shunted by 20 mmfd. Direct to plates, balanced 6 megohms shunted by 11 mmfd. Horizontal: 1.1 megohms.

**Linear Sweep Oscillator**—Saw tooth wave, 20 cycles to 50 Kc in 5 steps. 60 cycle sine wave also available, as well as provision for using external sweep.

**Input Voltage Calibration**—Provides a standard voltage against which to measure

volts of signal applied to vertical input.

**Vertical Polarity Reversal**—For reversing polarity of voltage being checked or for choosing either positive or negative sync. voltages.

**Return Trace Blanking**—Electronic blanking provides clear, sharp trace to prevent confusion in waveform analysis.

**Synchronizing Input Control**—To choose among INTERNAL, EXTERNAL, 60 CYCLE, or 120 CYCLE positions.

**Intensity Modulation**—60 cycle internal or provision for external voltage for intensity modulation uses.

**Additional Features**—Removable calibration screen—Accessory Model CR-P Demodulation Probe for Signal Tracing—All-steel, gray Ham-R-Tex cabinet. Total net weight only 26 pounds. Same height as other Jackson TV instruments: 13" H x 10 1/4" W x 15 1/8" D.

**Prices:** Model CRO-2, Users' Net \$197.50. Model CR-P Probe, Users' Net \$9.95.

Breakdown tests can be made of television parts while actually mounted in the set or on the bench. For all such tests, a resistor of approximately 1 megohm should be connected in series with high-voltage terminal. Breakdown can be observed either visually or with a neon bulb or voltmeter.

### The high-voltage power supply

Our high voltages are obtained by using a flyback (television horizontal output) transformer. It works both as the oscillator and the high-tension transformer. To secure d.c. output we use a 1B3-GT rectifier tube. This tube cannot be replaced by a 1X2. The 1X2 is a fine, well-designed tube, but cannot stand up well in the severe service demanded by experimental voltage supplies.

The oscillator (Fig. 1) is fed by a simple power supply which delivers d.c. Several attempts were made to secure operation directly off the raw a.c. from the power transformer. All resulted in lowered high-tension output or excessive tube heating.

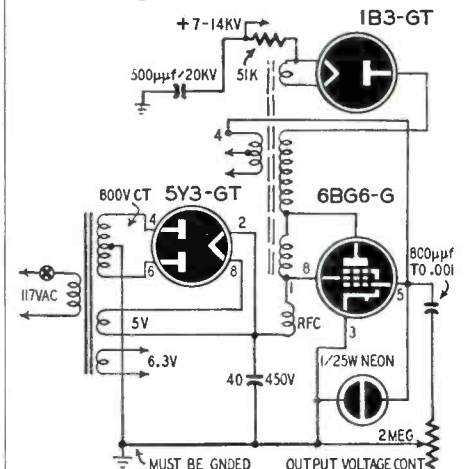

Fig. 1—The schematic. The neon bulb drives the 6BG6 tube to rated output.

The d.c. low-tension supply is full-wave operated and is unusual in that no resistor or choke is used. A single 40-µf, 450-volt capacitor does all the filtering. Output should be 250 to 400 volts at approximately 100 ma.

The high-voltage capacitor should be rated at 20 kilovolts minimum. Our first attempts resulted in blowing out a television capacitor rated at 10 kilovolts. Capacitance is 500 µf, which provides sufficient filtering for most applications. If very large capacitors such as photo-flash types are used, a resistor should be placed in series to prevent excessive current drains through the 1B3-GT tube.

The socket of the 1B3-GT must have a corona ring (see photo), and its insulation to ground should be adequate for the voltages. Most plastics such as plexiglas, bakelite, lucite, etc., will do very well. Ceramic insulators are also useable. None of the socket-prong clips should extend beyond the ring.

Dust particles will be attracted to all the high-potential points. Clean these areas regularly to prevent excessive leakage.

**TWO OTHER FINE JACKSON INSTRUMENTS**

**Model 655 Audio Oscillator**

Sine-wave 20 cycles to 200,000 cycles. Less than 5% harmonic distortion between 30 cycles and 15,000 cycles. Frequency calibration accurate within 3% or 1 cycle. Hum level down more than 60 db of maximum power output. Output impedances of 10, 250, 500, 5000 ohms or Hi Z resistive output.



**Model TVG-2 TV Generator**

Sweep Oscillator in three ranges from 2 Mc thru 216 Mc, all on fundamentals. Reversible sweep direction. Sweep width variable .1 Mc thru 18 Mc. Marker covers 4 Mc thru 216 Mc. Crystal Oscillator to use as Marker or Calibrator. Video Modulation, from external source for using actual video signal for check, or for use with Audio Oscillator to produce bars for linearity checks.



See your electronics distributor for more information, or write

**JACKSON ELECTRICAL INSTRUMENT CO. • DAYTON 2, OHIO**

"Service Engineered" Test Equipment  
IN CANADA: THE CANADIAN MARCONI CO.



# This is it!



the ***NEW*** ***Thomas***

**Automatic Selffocusing Phototron picture tube . . .**

available with sensational glare-reducing cylindrical surface face plate...the latest THOMAS engineering achievement!

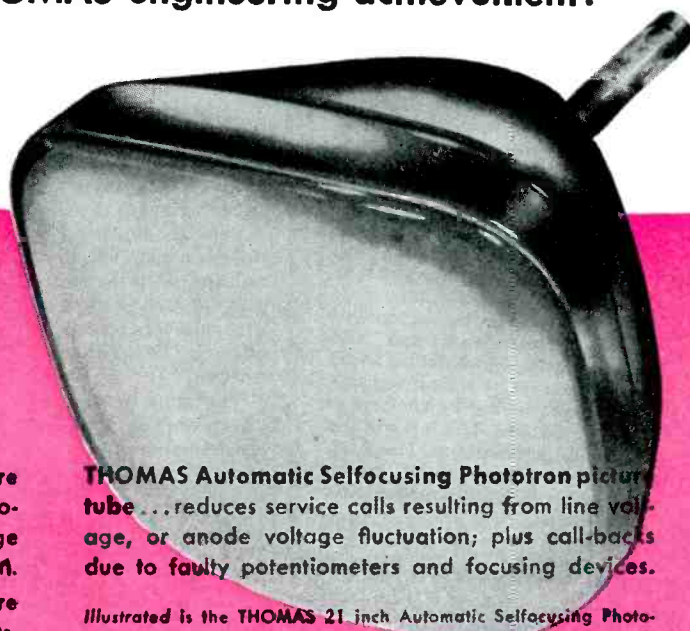

**THOMAS Automatic Selffocusing Phototron picture tube . . .** replaces either electromagnetic—or electrostatic—focusing tubes. Gives sharp focus edge-to-edge for the entire tube life . . . without focus deterioration.

**THOMAS Automatic Selffocusing Phototron picture tube . . .** requires no focusing circuits or components. And is directly replaceable without circuit changes.

Contact your jobber or distributor for the complete THOMAS Phototron line . . . or write THOMAS direct.

**THOMAS Automatic Selffocusing Phototron picture tube . . .** reduces service calls resulting from line voltage, or anode voltage fluctuation; plus call-backs due to faulty potentiometers and focusing devices.

Illustrated is the THOMAS 21 inch Automatic Selffocusing Phototron picture tube with glare-reducing cylindrical surface face plate. The selffocusing feature is available in other sizes and types.

Thomas Phototrons are *Exact* original equipment with these 20 TV set makers and many others . . .  
 ADMIRAL • HOFFMAN • OLYMPIC • MECK • PILOT • STEWART-WARNER • KAY-HALBERT • MAGNAVOX • IMPERIAL • STARRETT  
 HALLICRAFTERS • WESTINGHOUSE • SCOTT • CALBEST • BENDIX TELEVISION • PACKARD BELL • CROSLY • TELE KING • MOTOROLA

## Thomas

### ELECTRONICS Inc.

PASSAIC, NEW JERSEY



**NEW** a "must" book for every TV Service Technician

**"Servicing TV in the Customer's Home"**

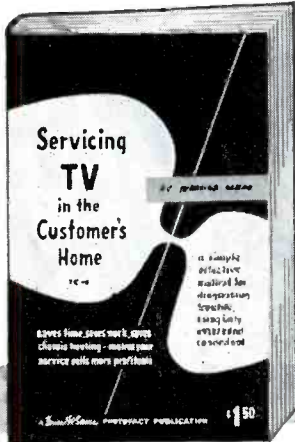

**SAVES TIME SAVES WORK Earns More for You on Outside Service Calls**

shows how to diagnose trouble using capacitor probe and VTVM

Here's the book you've been asking for—practical, proved help to make your outside TV servicing really effective and profitable. Saves time, work and chassis hauling... shows you how to make successful repairs on the spot. You learn the following: 1. A simple, effective method for tracing down trouble, using your VTVM and a simple capacitor probe. 2. Methods for finding your way around a strange circuit—shows you how to "pull tubes" and diagnose trouble by observing audio and picture effects. 3. How to judge TV set performance by analysis of the test pattern. 4. Methods for making adjustments in the field. You'll want this essential, profit-building book. Handy pocket size; sturdy cover.

ORDER TC-1. Only \$1.50 Pays for itself on the very first job.

**HOWARD W. SAMS & CO., INC.**

Order from your Parts Jobber, or write direct to HOWARD W. SAMS & CO., 2201 E. 46th St., Indianapolis 5, Ind.

**ORDER TODAY**

Send... copy(ies) of "SERVICING TV IN THE CUSTOMER'S HOME," \$1.50 per copy.

(Check) (money order) for \$..... enclosed

Name.....

Address.....

City..... State.....

Lick stubborn cases of corona discharge by applying several coats of polystyrene cement to the offending surfaces and letting dry fully before applying power.

**Meter circuits**

Microammeters with a number of high-resistance series-multiplier resistors may be wired across the output terminals to show actual output voltage. The meter itself must be at the ground terminal. Stray r.f. fields must not be present near the meter, or damage to the meter, shock, or improper

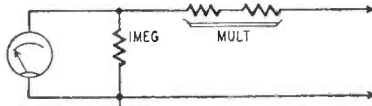

Fig. 2—Circuit for metering the generator. Ground the case of the meter!

readings may result. The meter should of course load the circuit as lightly as possible. We suggest a 0-25-microampere movement. The circuit appears in Fig. 2. For a 25- $\mu$ a movement the multiplier MULT should be 600 megohms; for a 50- $\mu$ a movement, 300 megohms. Although our circuit uses a 6BG6 tube, you are by no means limited to this one type. The popular 807 and television horizontal output tubes should all work well. The circuits may vary somewhat with changes in tubes.

Output of the circuit shown in Fig. 1 is adjustable between 7 and 14 kilovolts. This may be doubled with a voltage-doubling circuit.

To secure these high potentials it is necessary to have the oscillator operate in a nonlinear mode. We secure this circuit requirement with a neon bulb in the grid circuit. Ionization of the bulb causes sharp voltage pulses in the grid circuit which build up the high potentials in the flyback transformer. A small pigtail 1/25-watt neon bulb does the job. The method of varying the voltage is quite simple, as only a rheostat and capacitor are required. These are connected across the neon bulb and change the grid-circuit operating conditions.

The type of oscillation has a marked effect on the breakdown of the flyback transformer. The transformer will

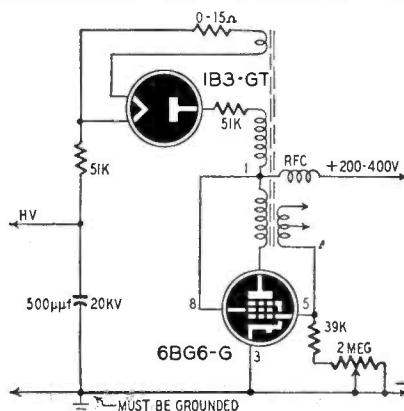

Fig. 3—A feedback oscillator circuit.

break down if the neon bulb is replaced with a resistor which approaches a critical value. Circuits can be construct-

ed that use this principle instead of the neon bulb, but care must be observed in construction. (A suggested circuit appears in Fig. 3.) Grid coupling is accomplished by using one of the yoke taps on the transformer. Try all taps and select the best one. Usually the one marked "4" works best.

A small radio-frequency choke placed in series with the B-plus lead will improve the operation many times. The choke should be at approximately 8 millihenries and rated for 100 milliamperes. Use of choke depends upon the particular flyback transformer and tubes used.

As can be seen in the photographs, the layout and wiring is simple, and the supply can be put together quickly and easily. One word of warning! The chassis is shown "out in the open" for purposes of photographing. Don't try to use it that way! Keep it in a standard cage and keep it grounded as indicated in the schematic. Fourteen kilo-

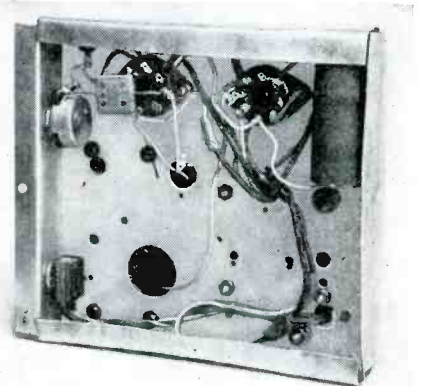

There is little below-chassis wiring.

volts is not *always* lethal, but electronic Russian roulette is no game for the serious radio experimenter or television technician.

**Materials for high-voltage supply**

**Resistors:** 1—51,000 ohms, 1—2-megohm potentiometer.

**Capacitors:** (mica or high-quality paper) 1—800  $\mu$ f to .001  $\mu$ f; (electrolytic) 1—40  $\mu$ f, 450 volts; (high-voltage) 1—500  $\mu$ f, 20 kv.

**Tubes:** 1—6BG6-G, 1—1B3-GT, 1—5Y3-G or -GT.

**Miscellaneous:** 1—power transformer, 400-400 volts, 100 (or more) ma, 5 volts 3 amperes, 6.3 volts, 2 (or more) amperes; 1—flyback (horizontal output) transformer, 14-kv type; 1—neon lamp, .04 watt; 1—RFC, 8 mh app., 100 ma; sockets; chassis; cage; hardware; wiring; etc.

—end—

**CORRECTION**

We have been informed of two errors appearing on page 57 of the October, 1951, issue. The value of C2, of Fig. 2, specified as .05  $\mu$ f is much too large to be considered as typical. The average buffer capacitor in a circuit of this type has a capacitance of about .005  $\mu$ f and a working-voltage rating of 1,600 volts.

In the text, Fig. 6 is described as being a schematic of the model 110R10 Radiant Vipower. The correct name for this device is, of course, the Radiant Vipower. It is manufactured by The Radiart Corp., Cleveland, Ohio.

We thank Mr. Milton S. Roth, Jobber Sales Manager of Radiart, for these corrections.

# A PAGEFUL OF BARGAINS

EVERYTHING BRAND NEW  
**PRICES SLASHED!** 40%/60%/90%  
 SALE LASTS THIS MONTH ONLY

NEVER EVER . . . HAVE SUCH VALUES BEEN OFFERED—We are *not* in the mood for taking inventory this year-end . . . Instead we are sacrificing this gigantic stock at ridiculously LOW PRICES. This sale is without limit or reserve, first come first served . . . ACT FAST!

## TELEVISION

- U.S. PROJECTION (22 1/2" x 30") TV SETS**  
 3—Floor Samoles—gold as is, leatherette cabinet, H-78" W-43" D-24", inspection allowed, list price \$1995.00. Complete, only **\$97.18**
- DEWALD 20" CONSOLE TV SET**  
 In factory sealed cartons, list price \$424.45. Complete **254.67**
- DEWALD 14" TABLE TV SET**  
 Showroom Sample, perfect, list price \$219.95. Complete **109.98**
- DEWALD 10" TABLE TV SET**  
 Showroom Sample, perfect, list price \$169.95. Complete **84.97**
- #630 16" CONSOLE TV SET**  
 Standard Make, in factory carton, list price \$395.50. Complete **237.30**

## RADIOS

- 3-Way ROUND THE WORLD PORTABLE**  
 Dewald A.C. D.C. 3-hand, leatherette case, whip ant. list price \$60.75. Complete **38.84**
- 5-TUBE SUPER TABLE MODEL**  
 Walnut, A.C.-D.C. Style, quality performance, built-in antenna. Complete **13.77**
- SAME SET IN IVORY** Complete **15.38**
- RADIO WITH SESSIONS CLOCK**  
 Goes ON & OFF automatically, quality reception. Complete **18.97**
- CUSTOM-BUILT AUTO RADIOS**
- FORD . . . 1949-50-51 | PLYMOUTH 1949-50-51
- DODGE . . . 49-50-51 | CHEVROLET 49-50-51
- STUDEBAKER . . . 50-51 | HUDSON . . . 48-49-50-51
- HENRY J. . . . . 51 | **All List at \$59.95**
- Your Price . . . (Any Model) **\$36.97**  
 Complete ready to install  
 Including Easy Instructions.

**AUTO ANTENNA** All brass, 3 section! **\$2.49**  
 (Catalogs on above merchandise on request)

## RADIO & TV SPEAKERS

- DYNAMIC SPEAKER, 4"—450 ohms** . . . \$ .79
- DYNAMIC SPEAKER, 5"—450 ohms** . . . .89
- PM SPEAKER, 5"—Alnico #5 1-oz. mag.** . . 1.29
- PM SPEAKER, 12"—Alnico #5 heavy mag.** . 4.98

## NO-GLARE TV FILTERS

- For Better, More Clearly Defined Pictures, Improves Contrast, Eliminates TV Glare, Sharpens Picture Image, Sizes To Fit All Sets In Smoke Or Blue Colors.
- 10" . . . . . 8" x 10 1/2" . . . . . \$ .79
  - 12 1/2" . . . . . 9" x 12 1/2" . . . . . 1.12
  - 14" . . . . . 10 1/2" x 15" . . . . . 1.33
  - 16" . . . . . 12" x 16 3/4" . . . . . 1.72
  - 17" . . . . . 13 3/4" x 17 3/4" . . . . . 1.96
  - 19" or 20" . . . . . 15 1/2" x 19 1/2" . . . . . 2.14
  - 24" . . . . . 20" x 24" . . . . . 3.27

## CRYSTAL-CLEAR LUCITE MASKS

- Framed in Beautiful Rich Gold Leaf Finish (Overall Dimensions)
- 16"—Round . . . . . 13-11/16" x 16 1/4" . . . \$ 5.37
  - 16"—Rectangular . . . . . 12 3/4" x 16 1/8" . . . . . 5.24
  - 17"—Rectangular . . . . . 13-9/16" x 16 7/8" . . . . . 5.37
  - 19"—Round . . . . . 15 3/4" x 19 3/8" . . . . . 7.18
  - 20"—Rectangular . . . . . 15 3/4" x 19 7/8" . . . . . 7.18
  - 24"—Round . . . . . 20 1/2" x 26 1/4" . . . . . 13.97
- (Including Set of Rosettes)

## TUBE CARTONS in Lots of 1000

- SMALL PEANUT 1" x 1" x 2 1/8"** **\$8.01**
- LARGE PEANUT 1" x 1" x 2 3/4"** **8.96**
- GT TYPE 1 1/4" x 1 1/4" x 3 3/8"** **9.54**
- SMALL G 1 1/2" x 1 1/2" x 4 1/2"** **12.51**
- LARGE G 1" x 2" x 5"** **14.39**
- EXTRA LARGE 2 1/4" x 2 1/4" x 6 1/2"** **26.73**

## STANDARD RADIO & TV TUBES

- |       |       |       |       |       |      |
|-------|-------|-------|-------|-------|------|
| 37    | ..... | \$.19 | 12SJ7 | ..... | .72  |
| 80    | ..... | .49   | 6SK7  | ..... | .72  |
| 5Y3   | ..... | .49   | 6AT6  | ..... | .72  |
| 6J5   | ..... | .54   | 6C5   | ..... | .72  |
| 43    | ..... | .54   | 6AB4  | ..... | .74  |
| 6K7   | ..... | .54   | 25W4  | ..... | .74  |
| 6X5   | ..... | .57   | 6SH7  | ..... | .76  |
| 6SQ7  | ..... | .59   | 1LE3  | ..... | .84  |
| 6AL5  | ..... | .59   | 6AG5  | ..... | .88  |
| OZ4   | ..... | .62   | 50A5  | ..... | .88  |
| 5U4   | ..... | .59   | 6SN7  | ..... | .88  |
| 35Z5  | ..... | .49   | 6AC7  | ..... | .99  |
| 12SQ7 | ..... | .59   | 1B3   | ..... | .99  |
| 12SK7 | ..... | .69   | 117Z5 | ..... | .99  |
| 12SA7 | ..... | .69   | 12AU7 | ..... | .99  |
| 50L6  | ..... | .69   | 6J5   | ..... | .99  |
| 35L6  | ..... | .72   | 6BQ6  | ..... | .99  |
| 6AU6  | ..... | .72   | 6AH6  | ..... | 1.38 |
| 6BA6  | ..... | .72   | 6BG6  | ..... | 1.77 |

## TV CONDENSERS—85°

- |              |                    |       |        |
|--------------|--------------------|-------|--------|
| .01          | — MFD — 400 Volts  | ..... | \$ .06 |
| .1           | — MFD — 400 Volts  | ..... | .09    |
| .035         | — MFD — 1000 Volts | ..... | .09    |
| .05          | — MFD — 1000 Volts | ..... | .12    |
| .05          | — MFD — 2500 Volts | ..... | .37    |
| .1           | — MFD — 2500 Volts | ..... | .39    |
| .25          | — MFD — 2500 Volts | ..... | .42    |
| .03          | — MFD — 3000 Volts | ..... | .42    |
| .05          | — MFD — 3000 Volts | ..... | .46    |
| .003         | — MFD — 6000 Volts | ..... | .38    |
| .01          | — MFD — 6000 Volts | ..... | .47    |
| .05          | — MFD — 6000 Volts | ..... | .49    |
| .005         | — MFD — 7500 Volts | ..... | .42    |
| .0005        | — MFD — 7500 Volts | ..... | .39    |
| .003         | — MFD — 7500 Volts | ..... | .44    |
| .03          | — MFD — 7500 Volts | ..... | .49    |
| 250/1000 MFD | — 10/6 Volts       | ..... | .68    |
| 40/10/80 MFD | — 450/150 Volts    | ..... | .99    |

## 1/2 WATT RESISTORS 10% TOL.

- 3.3, 39, 330, 560, 680, 1800, 2700, 3300, 4700, 6800, 8200, 10K, 22K, 27K, 47K, 56K, 100K, 150K, 270K, 470K OHMS, 1, 2.2, 4.7, 6.8 MEG  
 Your Choice **\$3.97** per Hundred

## WIREWOUND RESISTORS

- 5000 ohms, 5 watts . . . . . \$ .14
- 1360/250 ohms . . . . . .58
- 5300/2-500 ohms . . . . . .58
- 6750/12/93 ohms . . . . . .54
- KANDOHM, 1000 ohms . . . . . .11
- 2500 ohms, 100 watts . . . . . .19

## RADIO TUBULAR CONDENSERS

- |           |                    |       |        |
|-----------|--------------------|-------|--------|
| .005      | — MFD — 1700 Volts | ..... | \$ .09 |
| .02       | — MFD — 1700 Volts | ..... | .14    |
| 5         | — MFD — 35 Volts   | ..... | .07    |
| 10        | — MFD — 25 Volts   | ..... | .08    |
| 10        | — MFD — 50 Volts   | ..... | .10    |
| 16        | — MFD — 150 Volts  | ..... | .16    |
| 50/50 MFD | — 150 Volts        | ..... | .24    |
| 8         | — MFD — 450 Volts  | ..... | .34    |

## MICA CONDENSERS—85°

- 25, 250, 390, 470 MMF. . . . . each \$ .06

## CERAMIC CONDENSERS

- 2, 10, 51, 56, 82, 1500 MMF. . . . . each \$ .06

## MISCELLANEOUS ITEMS

- LOCTAL SOCKETS, molded, push on **\$.01**
- \$5 SAPPHIRE PHONO NEEDLE . . . . . .58
- 1 POUND ROSIN CORE SOLDER . . . . . .59
- 100 ASST. KNOBS, screw & push-on **2.97**
- 100 ASST. SOCKETS, oct., loct., min. **3.92**
- 100 ASST. COND., .001 to .05 . . . . . **4.69**
- 100 ASST. RESISTORS, 1/2 watt . . . . . **3.58**
- 100 ASST. PIL. LTS., 44, 46, 47, 51 **4.83**
- OUTPUT TRANSFORMER (50L6) . . . . . .52
- OUTPUT TRANSFORMER (6K6) . . . . . .89
- UNIVERSAL OUT. TRANS. (any tube) . . . . . **.49**
- IF TRANSFORMER, 456KC . . . . . .58
- IF TRANSFORMER, FM-10.7MC . . . . . .58
- VARIABLE COND., 2 gang, super . . . . . .59
- VOL. CONT. L/S, 1/4, 1/2, 1, 2 meg. . . . . **.47**
- VOL. CONT. W/S, 1/4, 1/2, 1, 2 meg. . . . . **.19**
- AC-DC OVAL ANTENNA LOOPS . . . . . .08
- ANTENNA HANK, 15' on handy spool . . . . . **.19**
- RESISTANCE CORD, 150 ohms . . . . . .16
- 6' LINE CORD, complete with plug . . . . . **.46**
- TOGGLE SWITCH, DPDT . . . . . .59
- SELENIUM RECTIFIER, 75 mills . . . . . .69
- SELENIUM RECTIFIER, 100 mills . . . . . **27.49**
- G.I. 3-SPEED REC. CHANGER . . . . . **16.74**
- VM 2-SPEED RECORD CHANGER . . . . . **3.18**
- PHONO MOTOR, 78 RPM, complete **4.97**
- PHONO MOTOR, 78, 45, 33 RPM, **4.63**
- UNIVERSAL PICKUP, 78, 45, 33 RPM **2.44**
- FAMOUS MAKE CRYSTAL PICKUP . . . . . **1.42**
- CRYSTAL CARTRIDGE, popular type . . . . . **.49**
- MICROPHONE TRANS. in-put . . . . . **3.87**
- PHONO AMPLIFIER, incl. 3 tubes . . . . . **8.95**
- BROOKS INVERTER, DC to AC, 50 W **5.76**
- QUALITY STAND MICROPHONE . . . . . .49
- GRILL CLOTH, gold, 14" x 13" . . . . . **1.47**
- GRILL CLOTH, gold, 36" x 23" . . . . . **1.18**
- UNIVERSAL BALLAST TUBES, (3) . . . . . .19
- JFD ADAPTER, type 202 . . . . . .39
- AUTO VIBRATORS, 4 prong, 12 volt . . . . . **.02**
- PILOT LIGHT ASSEMBLIES . . . . . .02
- VOLUME CONTROL SWITCHES . . . . . **2.97**
- 300 OHM TWIN-LEAD WIRE, 100' **6.11**
- TV POWER TRANSFORMER, 295 ma **4.84**
- 72 OHM CO-AX CABLE WIRE, 100' **1.99**
- TV TABLE ANTENNA . . . . . **4.97**
- TV WINDOW ANTENNA, Gyro Tenna **5.86**
- TV CONICAL ROOF ANTENNA . . . . . **.79**
- TV 16" PLASTIC RINGS, (16AP4) **2.00**
- \$20.00 ELECTROASTER, as is . . . . . **1.69**
- 67 1/2 V. BATTERY, 3 5/8" x 2 3/4" x 1 3/8"

## #630 TV PARTS

- FOCUS COIL, 247 ohms . . . . . \$1.98
- DEFLECTION YAKE, 60° . . . . . 1.86
- 16" CRT BRACKET SET . . . . . 1.84
- HV FILTER CONDENSER, 10KV . . . . . .39
- VERT. LIN. CONTROL, 5000 ohms . . . . . **.29**
- HORIZ. DRIVE CONTROL, 20K . . . . . **.29**
- FOCUS CONTROL, 1500 ohms . . . . . .57
- FLYBACK TRANSFORMER, 211T3 **2.17**
- CRT SOCKETS, 18" leads . . . . . .19

## COLOR TELEVISION

- Take advantage of the present color situation at prices lower than factory cost.
- COMPLETE COLOR CONVERTER **\$97.49**
  - RUSSELL COLOR MOTOR . . . . . **19.78**
  - POPULAR COLOR MOTOR . . . . . **11.62**
  - COLOR ADAPTER, specify TV make **7.34**
  - 7" COLOR WHEEL, 15 1/2" diam. . . . . **6.27**
  - 10" COLOR WHEEL, 22" diam. . . . . **10.99**
  - 12 1/2" COLOR WHEEL, 27 1/2" diam. **16.83**

**BROOKS RADIO & TV CORP., 84 Vesey St., Dept. A, New York 7, N. Y.** TELEPHONE Cortlandt 7-2359

**TRIAD**  
**High-Fidelity**  
**Output**  
**Transformers**  
**Give you Highest**  
**Performance at**  
**LOW COST!**

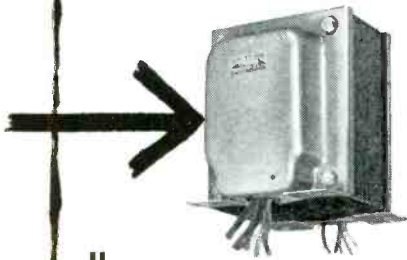

HIGHEST PERFORMANCE is assured when using Triad high-fidelity output transformers through the use of highest quality core material and interleaved windings of low resistance. LOW COST is maintained by use of mass produced die-stamped cases and flexible leads. Coils have a frequency response within 1 db from 30-15,000 cycles; deliver full-rated output within 3 db over entire frequency range. These transformers, having high open circuit inductance and low leakage reactance, may be used in feedback circuits having as much as 30 db of neg. feedback.

**Compare these Specifications and Prices**

Type No.	Primary Impedance	Secondary Impedance	Output Watts	List Price
S-31A	8000 C.T.	4-8-16	15	10.50
S-32A	8000 C.T.	500/250/125	15	11.00
S-33A	3000 C.T.	4-8-16	15	10.50
S-35A	5000 C.T.	4-8-16	18	11.50
S-36A	5000 C.T.	500/250/125	20	12.00
S-38A	9000 C.T.	4-8-16	25	15.20
S-39A	9000 C.T.	500/250/125	25	16.00
S-40A	2500 C.T.	4-8-16	30	15.20
S-42A	4500 C.T.	4-8-16	50	21.25
S-45Z	4000/2000/4-8 1000/500		10	5.80
S-46A	2000/1000/4-8-16 500/250		20	12.95

These Triad High-Fidelity Output Transformers afford a standard of performance second only to Triad's "HS" Series.

Write for Catalog  
**TR-51**

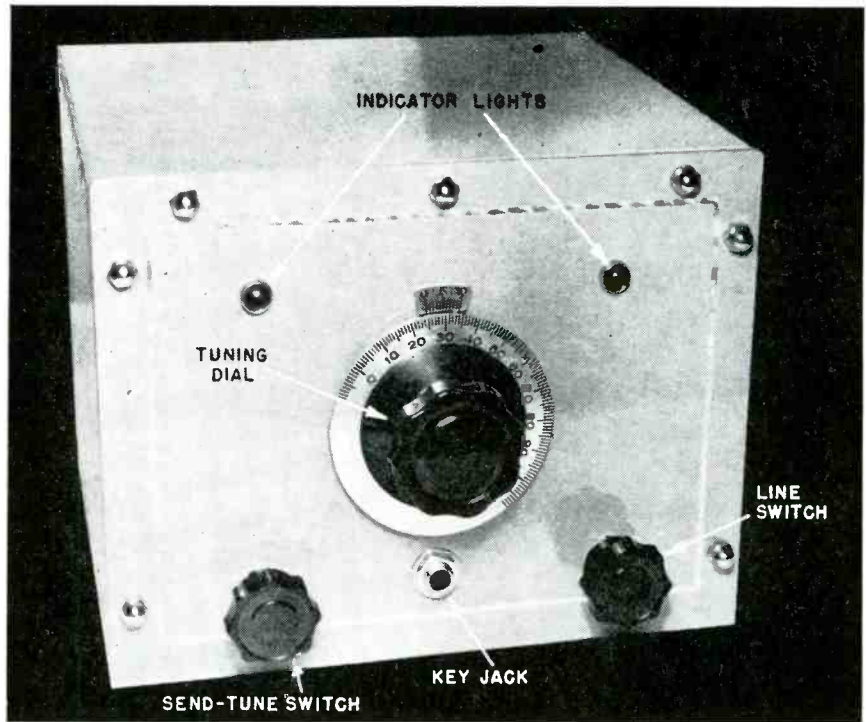

Front view of v.f.o. Both send-tune and off-on switches are of the rotary type.

# Low-Drift VFO Allows Multi-Band Break-In

By OTTO L. WOOLEY

THE miniature tubes used throughout this v.f.o. permit a stable unit of moderate power output to be built in a minimum of space. The r.f. section consists of three 6AK6's: an electron-coupled oscillator, buffer and power amplifier stage. Compound voltage regulation is secured with an 0A2 and 0B2 complement, and the rectifier

is a 6X4. In the unit shown the output is in the 80-meter band, but with plug-in coils could be used on any frequency desired. Following usual practice in this type of equipment, the oscillator operates on a submultiple of the output frequency and the output stage is a doubler.

Oscillator keying allows full break-in

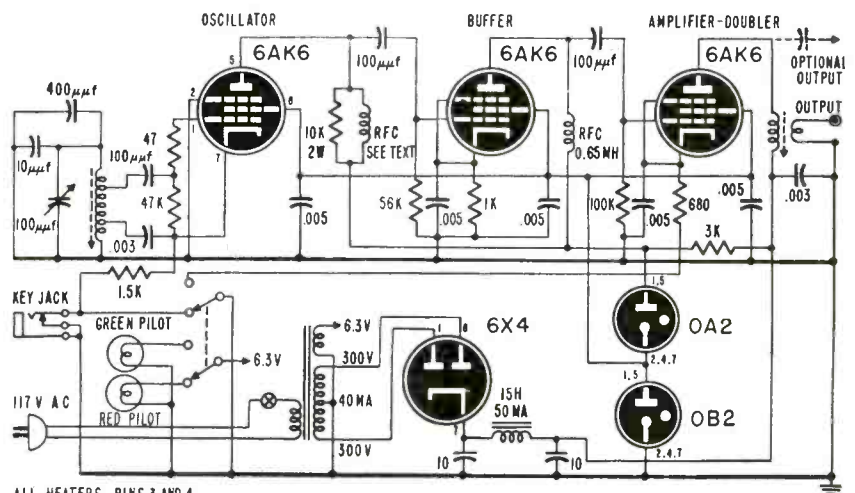

ALL HEATERS: PINS 3 AND 4

The miniature-tube v.f.o. All coil details are fully explained in the text.

operation. With the circuit used, keying is crisp and clean. For good oscillator efficiency, the tube is operated with 255 volts on the plate, but total cathode current is held to a low 6.5 ma. Stability is improved by the resistor-loaded, broadly resonant choke in the plate circuit. This choke is constructed by scrambling about 275 turns of No. 34 d.s.c. wire on a 10,000-ohm, 2-watt composition type resistor (Ohmite "Little Devil" series or equivalent).

Note that the oscillator cathode is coupled for r.f. to the coil in the grid circuit through an .003- $\mu$ f capacitor, while the d.c. return is made through the 1,500-ohm resistor. The oscillator grid tank is not required to carry any direct current, and is thus relieved of a possible heat source.

The buffer stage is operated at the same voltages as the oscillator. Its total cathode current is 8 ma. A 0.65-mh r.f. choke is used in its plate circuit.

The output tube is run with 325 volts on the plate and 105 on the screen, with a cathode current of 12 ma. Under these conditions the v.f.o. delivers sufficient r.f. to drive the usual crystal oscillator stage as an amplifier or as a doubler. A slug-tuned, low-C output coil provides substantially constant power across the operating range. The output link shown was selected to couple into the cathode circuit of the transmitter crystal stage. If it is desirable to feed a grid, the alternative capacitance coupling from the output plate may be necessary for full output.

The 0A2 and 0B2 tubes provide simple regulation for the oscillator and buffer plates and compound regulation for all the screens in the r.f. section. This makes the unit practically immune to any changes in supply voltage. The power supply employs full-wave rectification and capacitor input to the filter.

One feature will interest most operators; that is the tuning switch which makes it possible to spot the v.f.o. frequency in the receiver without putting the transmitter on the air. The position of this switch is shown by the indicator lamps on the front panel. These lamps also show when the a.c. supply is turned on. In the tuning position the oscillator is operating, the output tube cathode circuit is open, and the red indicator lamp is on. Throwing the switch to the sending position closes the output cathode circuit, puts the oscillator across the key, and lights the green indicator lamp. When used for phone operation the keying plug can be removed and the v.f.o. will operate under key-down conditions through the closed circuit jack. If break-in operation is not contemplated the design can be simplified by omitting the tuning switch and keying in the output cathode lead. (Keying in the output stage is somewhat less critical as to click filtering than oscillator keying.)

A 7 x 7 x 2-inch aluminum chassis is used for a foundation, with a 6 x 8-inch panel. The cabinet is made to fit the panel and is 7½ inches deep, folded

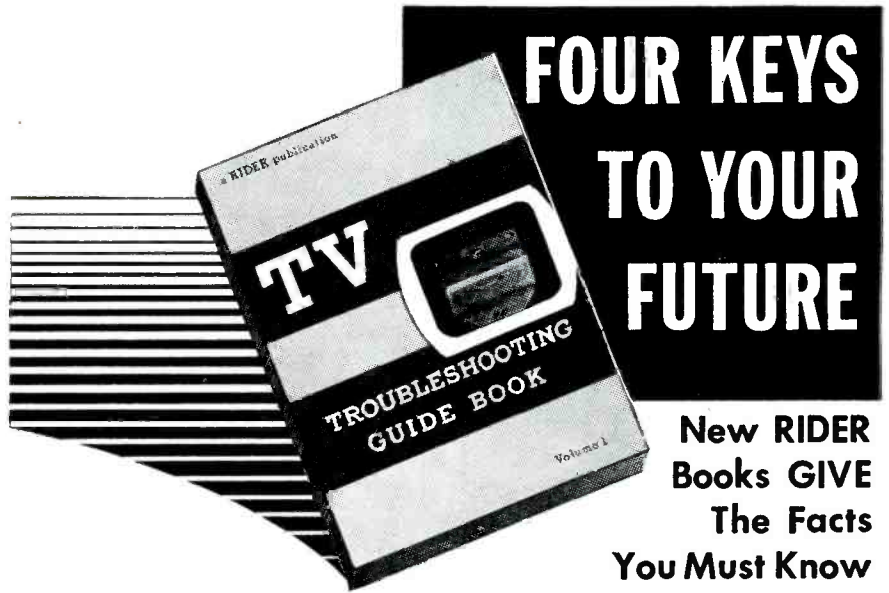

**New RIDER Books GIVE The Facts You Must Know**

**TV TROUBLESHOOTING GUIDE BOOK**

A new, practical, easy-to-use guide book that is the final word on television troubleshooting. It tells how to spot receiver troubles and correct them. Contains actual information right from the manufacturers. Five information-packed chapters, durably bound.

More than 200 pp., 8½" x 11" ..... **\$3.90**

**RECEIVING TUBE SUBSTITUTION GUIDE BOOK**

First Supplement by H. A. Middleton

An indispensable addition to the original book. Illustrating 650 completely new radio-television tube substitutions in numerical sequence with accompanying wiring instructions, original and substitute tube socket illustrations. If you own the original edition, you need this supplement for complete coverage.

48 pp., 8½" x 11" ..... **\$.99**

**TV AND ELECTRONICS AS A CAREER**

by Ira Kamen and Richard H. Dorf

Here is an interesting, informative book important to your future. Written by top authorities of the industry as an authentic guide to the career possibilities offered by all phases of the electronics industry.

326 pp., 5½" x 8½" ..... **\$4.95**

**BROADCAST OPERATOR'S HANDBOOK**

by H. E. Ennes, Second Edition

A practicing broadcast operator tells veteran and student operators all the procedures of AM and FM studio operating practices. A valuable, easy-to-read book for anyone wishing to make a career of broadcasting or to increase present knowledge if already active in the field.

440 pp., 226 ill. .... **\$5.40**

**Coming Soon... UHF PRINCIPLES, by Allen Lytel... Don't Miss This!**

CLIP AND MAIL THIS COUPON - TODAY!

**JOHN F. RIDER, Publisher, Inc., Dept. RE-12**  
480 Canal Street • New York 13, N. Y.

Please send me book(s) checked. It is understood, if not satisfied, I may return them within 10 days and receive full refund.

( ) TV TROUBLESHOOTING GUIDE BOOK, \$3.90  
 ( ) RECEIVING TUBE SUBSTITUTION GUIDE BOOK, 1st Supp., \$.99  
 ( ) TV AND ELECTRONICS AS A CAREER, \$4.95  
 ( ) BROADCAST OPERATOR'S HANDBOOK, \$5.40

Name.....  
 Address.....  
 City..... Zone..... State.....  
 (Please Print)

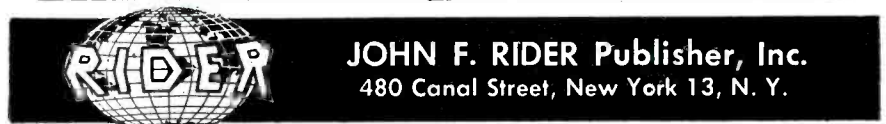

# NO SHADOWS

with new  
**DUAL SPOTLIGHT**  
Soldering Gun

Pull the trigger of your new light-duty Weller Soldering Gun, and *instantly* twin spotlights focus on the job—banish every shadow. Five seconds later the tip is at soldering heat! No waiting. No wasted current. This streamlined 135-watter—newest of the famous Weller line—is *fast!* Built compactly for working in crowded chassis, too. And the time and power you save pays for your Weller Gun in a few months.

**New**  
**135-Watt**  
**Weller**  
**Soldering**  
**Gun**

**Specially Designed**  
**for TV and Radio Work**

- **DUAL SOLDERLITE**—Two prefocused spotlights completely eliminate shadows.
- **OVER/UNDER DESIGN**—Tube construction braces tip and improves visibility.
- **5-SECOND HEATING**—Pull the trigger and you solder!
- **LONGER REACH**—Slides easily into deep chassis; reaches the tightest corners.
- **GREATER CAPACITY**—Smaller, lighter, with greater soldering capacity.
- **TRIGGER-SWITCH CONTROL**—Adjusts heat to the job. No need to unplug gun between jobs.
- **DUAL HEAT**—Single heat 100 watts; dual heat 100/135 watts; 120 volts; 60 cycles. Handles all light-duty soldering.

See new Models WS-100 and WD-135 at your distributor, or write for bulletin direct.

• **SOLDERING GUIDE**—Get your new copy of "Soldering Tips"—revised, up-to-date, fully illustrated 20-page booklet of practical soldering suggestions. Price 10¢ at your distributor, or order direct.

**WELLER**  
ELECTRIC CORP.

828 Packer Street, Easton, Pa.



from sheet aluminum. Ventilation holes are drilled along the top and lower edges of the cabinet. The chassis is treated the same to allow the components mounted underneath to cool. The power supply is mounted externally on the rear of the cabinet where the heat will have little effect upon the frequency-determining elements. The general parts layout is apparent from the photographs, and provides very direct leads in all the critical portions of the circuit.

The oscillator padding capacitor is a 400- $\mu$ f, 2,500-volt mica taken from a TU-10 tuning unit. These seem to be very stable in all respects, and the threaded inserts make it possible to use machine screws for mounting. This makes the installation very solid. An insulating feedthrough bushing brings the hot capacitor lead through the chassis to the stator plates of the tuning capacitor.

Only a small amount of temperature compensation is necessary. It consists of a 10- $\mu$ f negative-coefficient Ceramicon mounted on the oscillator coil form inside the shield. The actual amount of compensation will vary with different units and can be determined only by experiment.

Final amplifier output is doubled in the output coil, consisting of 120 turns of No. 32 d.s.c. on the Millen 74001 form. The pickup link is 12 turns of 24 d.s.c. wound on the cold end. Do not ground the tuning-slug screw in this coil. It is desirable to keep coil-to-ground capacitance at a minimum.

A 6-prong socket is used to receive the plug from the power supply. At first glance it might appear that a rule of safety is being violated by having the plug on the power supply. However the socket supplies the a.c. to energize the supply so the method shown conforms to usual practice.

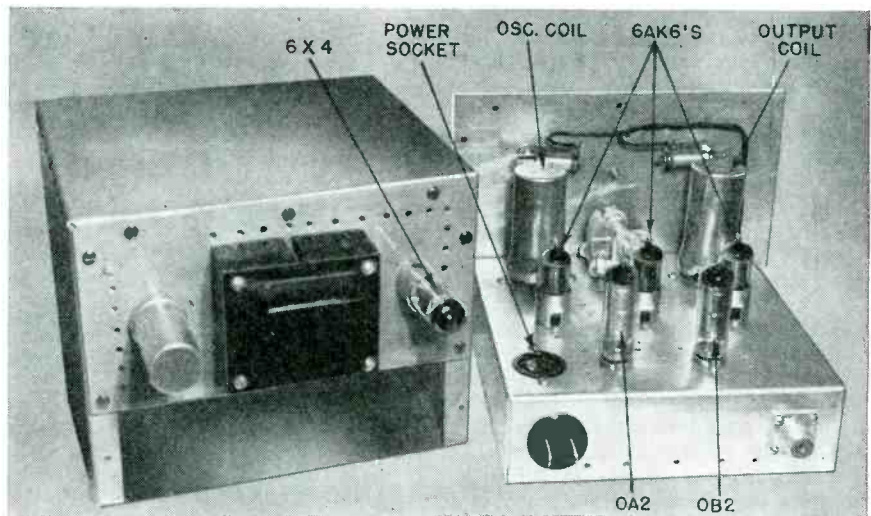

The power supply is so mounted as to minimize heating. Filter choke is inside.

The oscillator grid tank coil consists of 45 turns of No. 28 d.s.c. on a National XR-50 form mounted on a Millen 74001 base. Do not attempt to use the polystyrene form with which the Millen base is furnished. It expands and shifts the coil in relation to the tuning slug, thus causing a large frequency shift as the v.f.o. warms up. The coil is tapped 10 turns from bottom for the cathode lead and 12 turns from the top for the grid lead. The 47-ohm resistor in series with the oscillator grid suppresses any parasitic tendencies that might result from the tapped coil arrangement.

With the values used in the oscillator circuit the tuning range is somewhat more than 300 kc on 80 meters. The tuning slug is used to set the band edges, so no handset capacitor is needed. For c.w. the v.f.o. will cover from 3500 to 3800 kc, or can be set to cover a similar amount in the phone band.

After the band edges are set to the desired spot slip a narrow shim of stiff cardboard down between the tuning slug and the inside wall of the coil form so that the slug will not be able to move or shift from vibration or handling of the unit.

The output of the v.f.o. may be increased by simply exchanging the regulator tubes, thus raising the voltage on all screens to 150. However, in the interests of stability it is always best to run at the lowest potentials consistent with satisfactory output. The total d.c. input to the v.f.o. as shown is 27 ma, a low figure that results in cool, stable operation.

Nickel-plated crown nuts for the front panel and a coat of gray enamel give a commercial finish that will improve the appearance of the operating position.

#### Materials for VFO

**Resistors:** 1—47, 1—1,000, 1—47,000, 1—56,000, 1—100,000 ohms, 1/2 watt; 1—680 ohms, 1—1,500 ohms, 1 watt; 1—10,000 ohms, 2 watts; 1—3,000 ohms, 10 watts, wire-wound, adjustable.

**Capacitors:** 1—100  $\mu$ f, 1—400  $\mu$ f, 2—.003  $\mu$ f, mica; 2—100  $\mu$ f, 6—.005  $\mu$ f, ceramic tubular; 2—10  $\mu$ f, 450 volt working electrolytic; 1—10  $\mu$ f, negative temperature coefficient, ceramic; 1—100  $\mu$ f, variable tuning.

**Inductors:** 1—45 turns No. 28 d.s.c. on XR-50 form (see text); 1—120 turns No. 32 d.s.c. on Millen 74001 form, with 12-turn No. 24 d.s.c. link; 1—RFC, 275 turns No. 34 d.s.c. scramble-wound on 10,000-ohm resistor; 1—RFC, 0.65 mh.

**Other components:** Transformer, 300-300 volts, 40 ma. 6.3 volts filament; filter choke, 50 ma; 1—d.p.d.t. rotary switch; 1—s.p.s.t. rotary switch. Miscellaneous hookup material, chassis, panel, etc.

—end—

TUBES OF THE MONTH

General Electric Co. has announced the development and release for general sales of a new low-cost miniature television receiver tube designed to reduce snow in fringe-area reception. A somewhat similar tube, the 6BQ7, has been released by RCA.

The new tube, the 6BK7, a 9-pin miniature type, is a duo-triode with a shield between sections and high transconductance. As a cascode amplifier in TV front ends at 216 mc it has a noise factor of only 7 decibels. The tube also has been suggested as a low-noise first-i.f. amplifier in u.h.f. circuits.

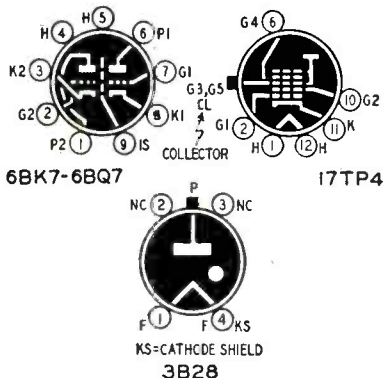

Typical operation (two tubes) is: Plate volts, 150; cathode bias resistor, 56 ohms; amplification factor, 40; plate resistance, 4,700 ohms; transconductance, 8,500  $\mu$ mhos; plate current, 18 ma.

The 6BQ7 characteristics under typical operating conditions are: Plate volts, 150; cathode bias resistor, 220 ohms; amplification factor 35, plate resistance 5,800 ohms; transconductance, 6,000 micromhos; plate current, 9 ma. Noise factor in a television front end at 220 mc is given as 6 db.

A new 17-inch rectangular metal-shell kinescope, the 17TP4, and a high-power gas-filled half-wave rectifier, the 3B28 are other RCA contributions.

The 17-inch television tube features magnetic deflection, low-voltage electrostatic focusing and a frosted filter-glass faceplate to reduce ambient light reflections. The low-voltage focusing element is brought out to a separate pin on the duodecal 6-pin base. Focusing voltage from the receiver B-supply may be either fixed or adjustable.

Operating conditions are: Heater, 6.3 volts at 0.6 amp.; ultor (grids Nos. 3 and 5), 16 kv max.; grid No. 2, 500 volts max.; grid No. 4 (focusing), 0-400 volts; horizontal and vertical deflecting angles, respectively, 66° and 50°; single-field ion-trap magnet.

The 3B28 tube uses a small 4-pin base, a coated filament and is xenon-filled. It will withstand inverse anode peak voltage of 10 kv when delivering 0.25 amp or 5 kv with 0.5 amp anode current. Ambient temperature ratings are -75° to +90° C.

Operating data: Filament, 2.5 volts at 5 amp; anode voltage drop, 14 volts max.; heating time before application of anode voltage, 10 seconds min.

—end—

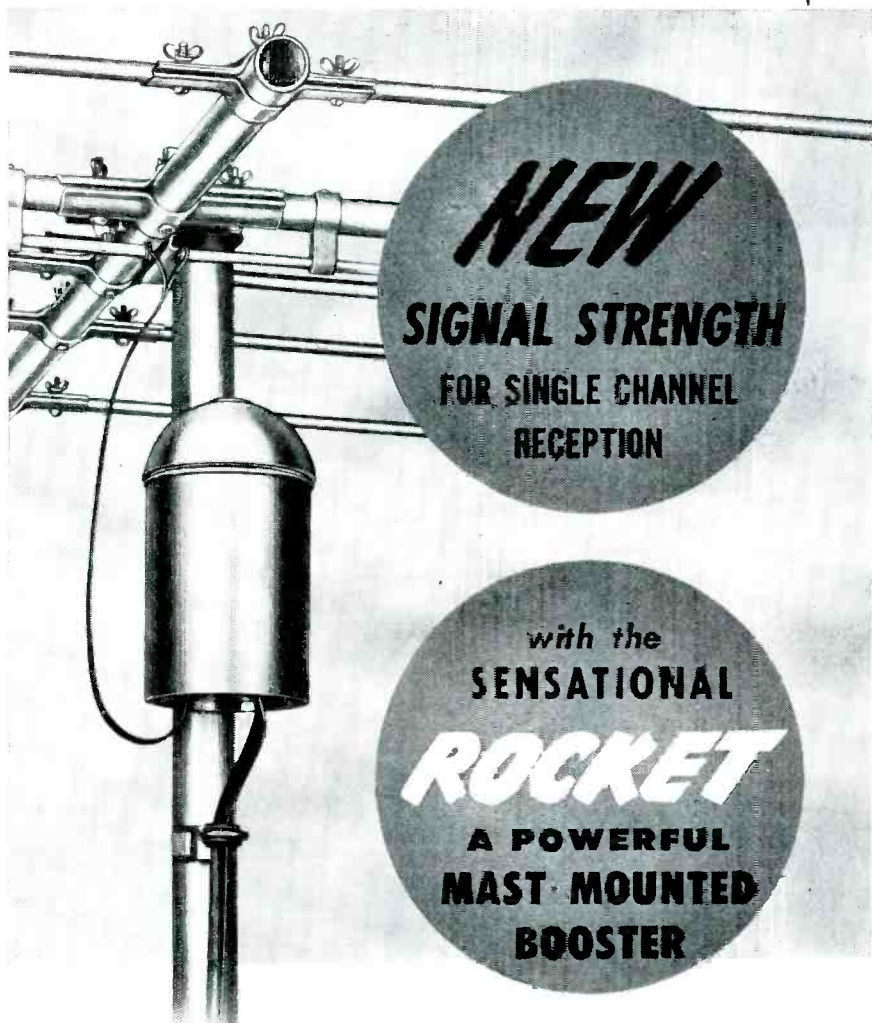

Research and laboratory tests have long proved that the best point to boost a TV signal is at antenna height — where the most favorable signal-to-noise ratio exists. But it remained for VEE-D-X engineers to perfect the extremely powerful Rocket Booster that delivers on 18 db gain with full 5 megacycle band width. The Rocket Booster has two components — (1) the booster itself, and (2) a control unit. It is factory preset for peak performance on any desired channel and once installed needs no further adjustment. For complete information on the sensational new Rocket Booster see your distributor or write to The La-Pointe-Plascomold Corporation, Windsor Locks, Conn.

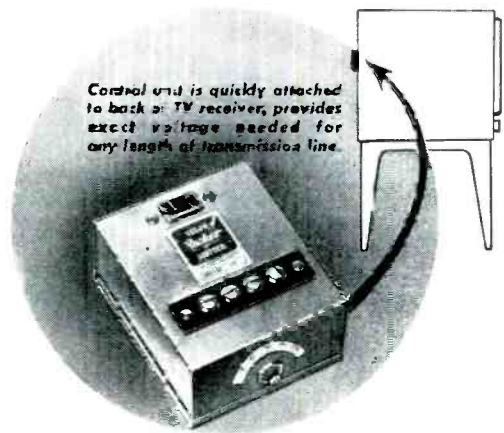

**VEE-D-X**

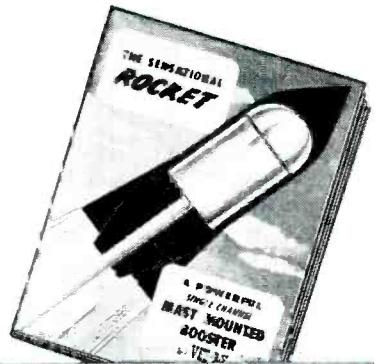

MAKERS OF THE WORLD'S MOST POWERFUL ANTENNA SYSTEMS

# Protect YOUR CUSTOMER'S HOME and TV SET



## with an AMPHENOL LIGHTNING ARRESTOR

The National Fire Protection Association has set up the National Electrical Code to prevent needless loss of life and property by fire. The Code states: "Each conductor of lead-in from an outdoor antenna shall be provided with a lightning arrester approved for the purpose, . . ." Are you doing your part in this campaign?

The Amphenol Lightning Arrester meets all the requirements of the National Electric Code and carries the Underwriters' Laboratories Seal of Approval. It combines the best qualities of two basic arrester principles — the gap type, for unflinching protection against lightning, and the shunt-resistance type which prevents loss of signal strength and at the same time improves TV reception by carrying static discharges to ground. It is compact, easy to install inside or outdoors.

To protect the home owner, recommend a lightning arrester as part of the antenna installation. To give your customer the best installation, specify AMPHENOL!

# AMPHENOL

AMERICAN PHENOLIC CORPORATION  
3830 SOUTH 54TH AVENUE • CHICAGO 50, ILLINOIS

## New Devices

### CORNER SPEAKER BAFFLE

Permoflux Corp., 4900 W. Grand Ave., Chicago, Ill., has produced a new corner-type speaker baffle designed to accommodate an 8-inch speaker. The baffle provides a frequency range of from 30 to 12,000 cycles. Finished in maroon leatherette, the unit is 14 inches wide, 24 inches high, and 9 1/2 inches deep.

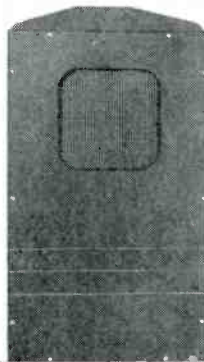

### SUBMINIATURE CONTROLS

Clarostat Mfg. Co., Dover, N. H., has announced the series 48A subminiature variable-resistance controls. Measuring only 3/8 inch in diameter, the body depths are 7/16 and 53/64 inch respectively, for single and dual units. The 1/8-inch shaft, obtainable as flattened or slotted tube or standard rod, extends 1/2 inch beyond the 1/4-inch-long bushing.

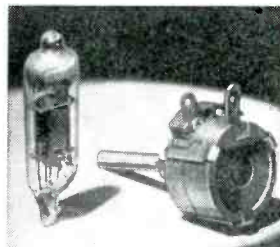

The controls are available in tapered or linear resistances. The linear ranges are from 1,000 ohms to 5 megohms, and tapered resistances range from 5,000 ohms to 2.5 megohms.

### TV LEAD FEED- THROUGH BUSHING

Mosley Electronics, 2125 Lackland Road, Overland, Mo., announces their new Roof-Thru, a weatherproof feed-through bushing designed to permit TV lead-ins to be brought in through the roof without allowing moisture to enter. The device consists of a plastic bushing combined with a copper flashing plate. It is readily installed by

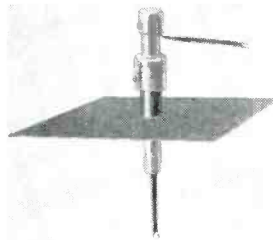

lifting a few shingles, drilling a 1-inch hole, inserting the Roof-Thru, and then replacing the shingles. The flashing prevents water from entering the drilled hole and the design of the device prevents leakage through the bushing. The unit makes possible more efficient and less expensive installations by reducing the length of lead-in required.

The Roof-Thru is especially applicable to new-construction work but is almost as easily installed on roofs of old buildings.

### TV FOCUS COIL

Standard Transformer Corp., 3592 Elston Ave., Chicago, Ill., has recently added the FC-11 focus coil to their line of TV replacement components.

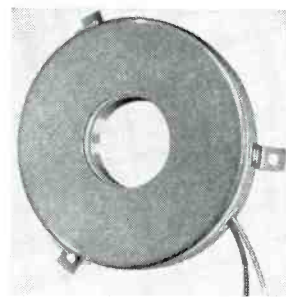

The unit, equivalent to the RCA 202D2, is made for direct-view picture tubes designed for external magnetic focusing. The FC-11 has a resistance of 470 ohms and carries a maximum current of 140 ma. It is 4 1/4 inches in diameter, with mounting centers set 120 degrees apart on 2-11/16-inch radii. This and other TV replacement components are described in the Stancor TV Transformer Catalog and Replacement Guide No. 338.

### CARBON RESISTORS

The Phaostron Co., 151 Pasadena Ave., South Pasadena, Cal., has introduced a new deposited-carbon resistor known

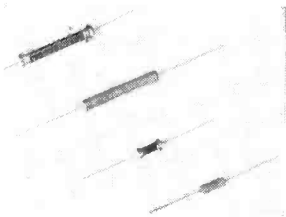

as the Carb-ohm. It is designed especially for high-frequency applications, particularly where high values of resistance or wattage ratings up to 2 watts are required. The resistors are recommended for use in circuits where matched units are required, and for applications where equipment is subjected to extreme temperatures. They may be used as replacements for wire-wound types in many applications.

The resistors are available either in hermetically sealed glass tubes or clad in a special humidity-impervious casing. Both types of construction provide long-time stability and freedom from variations caused by climatic changes. They are available with the axial leads, as shown, as well as with threaded-stud and tapped-hole terminals. Power dissipation ratings range from 1/3 to 2 watts. Resistances range from 20 ohms to 200 megohms.

### WIRED TV CHASSIS

Tech-Master Products Co., 443 Broadway, N. Y., has added three new custom-built models for 24-inch picture tubes to their line of TV chassis. Model 2430 has been designed specifically for all picture tubes requiring from 65 to 70 horizontal degrees deflection (such as 24AP4, 20CP4, 19AP4, etc.) and is supplied with a 5 x 7-inch PM speaker. Model 2431P is similar to model 2430 but contains, in addition, push-pull audio and a phono input jack. 2431P is supplied with a 12-inch PM speaker and universal picture-tube mounting brackets. Model 2431C is basically the same 2430, but with continuous tuner

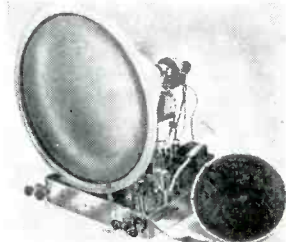

All specifications given on these pages are from manufacturers' data.

RADIO-ELECTRONICS for



covering TV and FM bands, push-pull audio, and a phono input jack. It is supplied with 12-inch PM-type loud-speaker.

All three models include horizontal a.f.c. and FM sound employing discriminator-type detector. Also featured are noise-saturation circuits; three-stage audio i.f. system; full 4-mc bandwidth; adjacent-channel traps; keyed a.g.c. circuits and universal picture-tube mounting brackets. Special color-converter connections are provided. U.h.f. channels can be accommodated by interchanging tuner strips. All chassis are supplied completely wired, aligned, and tested, with all tubes except picture tubes.

**PHONOGRAPH CARTRIDGES**

Shure Brothers, Inc., 225 W. Huron St., Chicago, Ill., announces two new replacement phono-cartridges. The model W22AB-T turnover cartridge is an extended-range vertical-drive unit used as replacements for single-needle

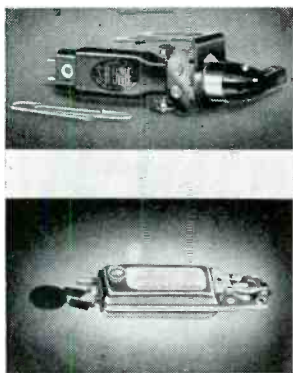

all-purpose cartridges and other types of turnover and dual needle cartridges. It replaces the cartridge and turnover mechanism. Its features are frequency response to 10,000 cycles; tracking with 8 grams; needle pressure, and a standard 1/2-inch bracket mount with elongated holes for quick installation.

Model W42BH, dual-voltage cartridge is a lever-type unit for 78-r.p.m. records. Equipped with a slip-on capacitor-harness for dual-voltage output, 1.5 or 3.75 volts is obtainable in one cartridge. This cartridge replaces old-style 78-r.p.m. cartridges. Special needle guard protects the crystal from breakage.

**TV MAST MOUNTING BRACKET**

Kenwood Engineering Co., Inc., Kenilworth, N. J., has introduced their model 106 parapet mounting bracket for antenna masts up to 1 1/2 inches in diameter. Made of heavy-gauge galvanized steel, the frame has four claw-like members which clear the coping and extend to the wall. Each claw is tipped with a pointed set-screw which provides positive anchorage to the wall. The unit provides for positive vertical support of the mast regardless of wall contour. It can be quickly installed on walls up to 13 1/2 inches thick. The photo shows the method of mounting and the truss like construction of the model 106 bracket.

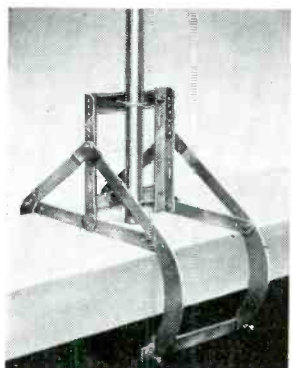

**4- AND 5-BAY YAGIS**

JFD Manufacturing Co., Inc., 6101 16th Ave., Brooklyn 4, N. Y., is now producing double-stacked four- and five-element Yagi arrays for channels 7-13. The double-stacked arrays include low-

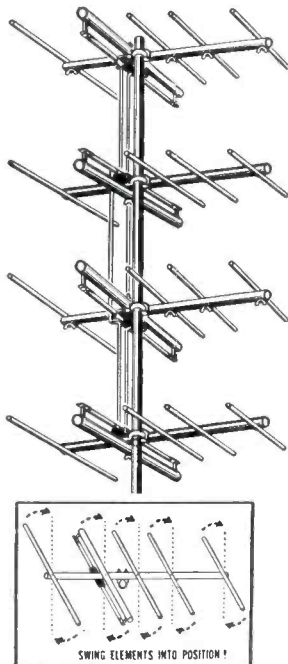

loss jumper-feeder systems which provide a perfect match to 300-ohm impedance. The stacked design boosts the gain up to 20 db over a tuned dipole and also improves directivity in the vertical plane, resulting in clearer pictures, free from interference caused by sources below the antenna plane. Half-wave spacing increases signal pickup and takes advantage of gain increases resulting from in-phase interaction between bays. The Sky-Ranger Yagis are constructed of all-aluminum tubing and incorporate high-impedance collector elements.

**108-132-MC RECEIVER**

Radio Apparatus Corp., 55 N. New Jersey St., Indianapolis, Ind., has de-



veloped a new a.c.-d.c. receiver for monitoring AM aircraft communications in the 108-132-mc band. The receiver, Monitoradio model AR-1, receives tower instructions to incoming and outgoing private, commercial, and military aircraft. It is housed in a black plastic cabinet measuring approximately 7 x 6 x 10 inches.

**SHIELDED LEADS**

United Technical Laboratories, Morristown, N. J., has developed a new line of shielded test leads with proportioned air and polyethylene dielectric for unusually low capacitance and losses, even at u.h.f. The leads have the durability and flexibility required for laboratory and electronic service work. The new type S Klipzon shielded leads eliminate stray pickups, feedback, or other undesirable coupling effects. They are supplied in 3-foot lengths with an approximate outside diameter of 9/32-inch, and have a maximum capacitance of only 25 pF. Black and red Mini-Prod connectors are supplied at each lead end for grounding the shield and for circuit or instrument connection, respectively.

—end—



# Build 15 RADIOS AT HOME

With the New Improved 1951 Progressive Radio "EDU-KIT"

## ONLY \$19.95

FREE

- ELECTRICAL AND RADIO TESTER
- RADIO TROUBLE-SHOOTING GUIDE
- BOOK ON TELEVISION
- MEMBERSHIP IN RADIO-TELEVISION CLUB
- ELECTRIC SOLDERING IRON
- CONSULTATION SERVICE
- QUIZZES

ABSOLUTELY NO KNOWLEDGE OF RADIO NECESSARY

FREE TOOLS WITH KIT • NO ADDITIONAL PARTS NEEDED

- EXCELLENT BACKGROUND FOR TELEVISION
- 10 DAY MONEY-BACK GUARANTEE

WHAT THE PROGRESSIVE RADIO "EDU-KIT" OFFERS YOU

The Progressive Radio "Edu-Kit" offers you a home study course at a rock bottom price. Our kit is designed to train Radio Technicians, with the basic facts of Radio Theory and Construction Practice expressed simply and clearly. You will gain a knowledge of basic Radio Principles involved in Radio Reception, Radio Transmission and Audio Amplification.

You will learn how to identify Radio Symbols and Diagrams; how to build radios using regular radio circuit schematics; how to mount various radio parts; how to wire and solder in a professional manner. You will learn how to operate Receivers, Transmitters, and Audio Amplifiers. You will learn how to service and trouble-shoot radios. In brief, you will receive a basic education in Radio exactly like the kind you would expect to receive in a Radio Course costing several hundreds of dollars.

THE KIT FOR EVERYONE

The Progressive Radio "Edu-Kit" was specifically prepared for any person who has a desire to learn Radio. The Kit has been used successfully by young and old in all parts of the world. It is not necessary that you have even the slightest background in science or radio.

The Progressive Radio "Edu-Kit" is used by many Radio Schools and Clubs in this country and abroad. It is used by the Veterans Administration for Vocational Guidance and Training.

The Progressive Radio "Edu-Kit" requires no instructor. All instructions are included. All parts are individually boxed, and identified by name, photograph and diagram. Every step involved in building these sets is carefully explained. You cannot make a mistake.

PROGRESSIVE TEACHING METHOD

The Progressive Radio "Edu-Kit" comes complete with instructions. These instructions are arranged in a clear, simple and progressive manner. The theory of Radio Transmission, Radio Reception, Audio Amplification and servicing by Signal Tracing is clearly explained. Every part is identified by photograph and diagram; you will learn the function and theory of every part used.

The Progressive Radio "Edu-Kit" uses the principle of "Learn By Doing". Therefore you will build radios to illustrate the principles which you learn. These radios are designed in a modern manner, according to the best principles of present-day educational practice. You begin by building a simple radio. The next set that you build is slightly more advanced. Gradually, in a progressive manner, you will find yourself constructing still more advanced radio sets, and doing work like a professional Radio Technician. Altogether you will build fifteen radios, including Receivers, Amplifiers, Transmitters, Code Oscillator and Signal Tracer.

The Progressive Radio "EDU-KIT" Is Complete

You will receive every part necessary to build 15 different radio sets. This includes tubes, tube sockets, variable condensers, electrolytic condensers, mica condensers, paper condensers, resistors, tie strips, coils, tubing, hardware, etc. Every part that you need is included. In addition these parts are individually packaged, so that you can easily identify every item.

TROUBLE-SHOOTING LESSONS

Trouble-shooting and servicing lessons are included. You will be taught to recognize and repair troubles. While you are learning in this practical way, you will be able to do many a repair job for your neighbors and friends, and charge fees which will far exceed the cost of the Kit. Here is an opportunity for you to learn radio and have others pay for it. You build a professional Signal Tracer, which alone is worth more than the complete price of the kit.

THE PUBLIC APPROVES!

COMMENTS FROM SATISFIED USERS OF THE PROGRESSIVE RADIO "EDU-KIT":

**VETERANS ADMINISTRATION, PHYSICAL MEDICINE REHABILITATION SERVICE, WASHINGTON, D. C.**

"This morning I was showing the Progressive Radio 'Edu-Kit' to one of our representatives from our Branch Office in Richmond, and already he wants me to purchase some for his hospital. As indicated in previous correspondence, I took the Progressive Radio 'Edu-Kit' to our Veterans Administration Hospital at Fort Thomas, Kentucky. Both instructors and patients worked them, and they proved quite satisfactory."

**ROBERT L. SHUFF, 1534 Monroe Ave., Huntington, W. Va.**

"I thought I would drop you a few lines to say that I have bought a Progressive Radio 'Edu-Kit' and was really amazed that such a bargain can be had at such a low price. I have already started repairing radios and radio-phonographs. Friends were really surprised to see me get into the swing of it so quickly. The trouble-shooting tester that came with the kit is really swell, and finds the trouble if there is any to be found. Everything you say about your kit is true."

Order your Progressive Radio "EDU-KIT" Today, or send for further information. Postage prepaid on cash orders—C.O.D. orders accepted in U. S. A.

PROGRESSIVE ELECTRONICS CO.

497 UNION AVE., Dept. RE-54, Brooklyn 11, N. Y.

REPORT CALLED "LETDOWN"

Reaction of the service technicians' groups to the RTMA service committee's report—described in the November issue, page 113, has been sharp and generally unfavorable.

First to react was the veteran Federation of Radio Servicemen's Associations of Pennsylvania (FRSAP) whose chairman, Dave Krantz, in a letter to Glenn MacDaniel, president of the RTMA, stated:

"It is almost impossible to describe that 'let down feeling' that overcame those in attendance. Its broad phraseology and completely inadequate attempts at solution to some of the many points and problems presented by the service industry to your committee at the meeting in Chicago, exemplify a complete lack of any attempt of the radio and television industry at the manufacturing level to do any more for the service industry than they have done in the past—a big blank zero . . ."

Frank Moch, president of the National Alliance of Television and Electronic Service Associations (NATESA) states in an official bulletin, RTMA answer to NATESA proposals:

"It is nice to know you realize the interdependence of the various segments of the industry. It is, however, unfortunate that despite the apparent awareness of mutual problems, RTMA has taken almost four months to say nothing on the major problems of the industry."

Both letter and bulletin go into the report in some detail, using almost the same words in some cases, especially in regard to the educational proposals. Both believe that the RTMA proposal

of technician training through vocational schools—as opposed to the proposal to train today's technicians in the newer aspects of electronic servicing, including color television and u.h.f. would produce results in four or five years instead of meeting the immediate and pressing needs of television.

The National Electronic Technicians and Service Dealers Associations, in its October meeting in New York, stated (as reported on P. 77) that the report was "inadequate and empty of any promise."

A more conciliatory note was struck by the Television Contractors Association of Philadelphia, who in the course of a three-page letter to the chairman of RTMA's Service Committee, says:

"It became clear to us in Chicago, and later in New York, that your Committee is not a policing organization, and that its primary function is to exchange ideas intended to improve conditions in the television industry. The acceptance of these ideas, no matter how desirable, is not mandatory with the individual manufacturers, and we find we have a similar situation in our own organization. We realize that under existing laws the situation could not be otherwise. . . ."

"You can depend on us to work along with your Committee, so long as it continues to display this spirit of cooperation. We know you need a little time to erase the problems created over the years, and we shall look for and appreciate each sign of progress. Our only request, at this time, is that you keep us fully informed on what is accomplished."

PENNSYLVANIA PROGRAM

The Federation of Radio Servicemen of Pennsylvania has completed its speaker schedule for 1951 and is now starting to schedule meetings from January to June 1952.

Mr. A. G. Petrasek conducted a series of lectures for RCA Tube Department at all the chapters in September. In October Mr. F. Wendell Tietsworth of the G-E Electronics Department lec-

tured on New Trends in TV Design. The November program featured Mr. Gill, Chief Field Service Engineer of Raytheon TV and Raytheon Tube Divisions, followed by John F. Rider.

The Federation suggested to members that they return to sender or place in waste paper baskets all the parts catalogs that are being received daily, and give full patronage to local distributors.

TELEVISION CONTRACTOR ATTACKS LICENSE MOVE

In a circular opposing the Pennsylvania licensing bills No. 1464 and 1465, Albert M. Haas, president of the Television Contractors Association of Philadelphia, emphasizes the customer's right to choose his own technician.

"As the public begins to learn more and more about television," he says, "the customer begins to exercise his own police powers. There is no greater law than that which permits a consumer to select his technician, contractor or dealer. The fact that a technician is licensed does not gainsay a poor job by the technician and the customer, invoking his prerogatives, refuses to have him back again."

Mr. Haas makes the point that legitimate complaints represent a very small

proportion of the servicing jobs, and refers to a recent meeting called to discuss such complaints. He reports:

"During the meeting a few questions developed the fact that many of the alleged complaints were merely inquiries. Most of them were based on dealer or contractor failures which left the consumer at a loss on the unexpired portions of service contracts. Only a small number of these were chargeable to a lack of competence in the technician.

"But, lumping all the complaints together, and assuming they were all received in one month, and comparing them to the 800,000 receivers we had in the city at that time, they amount to the infinitesimal figure of 1/16 of 1%!

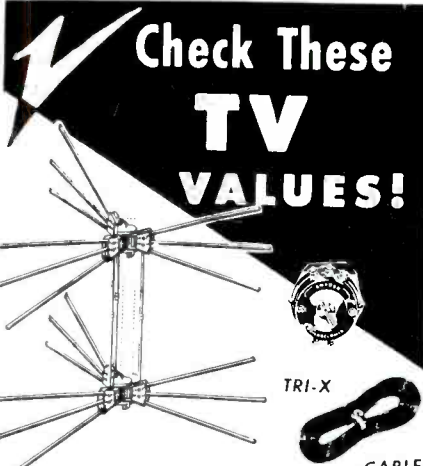

TRI-X

CABLE

DIRECTRONIC MOTORLESS

360° Electronically Switched Beam  
 • No Motors • No Electric Power  
 • No Roof Orientation • No Ghosts  
 The Directronic 18 element, 360° antenna is the finest for ultrafringe or metropolitan reception. The HI-PAC molded insulator is a material of extreme tensile strength not affected by weather or temperature, either mechanically or electrically. Included in the AX-599 'Servicemen's Array' are:  
 78 hi-tensile aluminum alloy elements  
 1 set of connecting stubs (3)  
 Universal U Clamps for masts to 1 1/2"  
 Directronic Beam Selector  
 75 feet of Tri-X Cable  
 1 stacked array per carton  
 AX-599 Directronic . . . . . \$15.90  
 AX-56 Directronic, 6 element Single . . . . . 9.05  
 Weight 4 3/4 lbs.  
 AX-566 Directronic, 12 element Stacked . . . . . 14.25  
 Weight 7 lbs.  
 AX-59 Directronic, 9 element Single . . . . . 9.95  
 Weight 5 1/4 lbs.  
 All above antenna prices include Tri-X Cable and Switch.

5 ELEMENT TV ANTENNA

Excellent Pictures in Fringe Areas  
 Here is a highly directive antenna that is the real solution to perfect pictures in fringe areas because it is closely tuned to each channel and cuts interference and noise to the minimum. Five elements include one folded dipole, three directors and one reflector. Supplied less mast. Specify number of channel desired. Channels 2 to 6—\$6.95 Channels 7 to 13—\$3.95 Shipping Weight—5 1/2 lbs. Low Band. Shipping Weight—3 lbs. Hi-Band.

ALL CHANNEL CONICALS

This conical TV is designed for broad-band reception on all TV channels plus F.M. The conical has proved high signal-to-noise ratio and excellent front-to-back ratio; matches 72, 150 or 300 ohm input impedance. This metropolitan area, high quality TV antenna is engineered for superior performance. The all-aluminum construction provides maximum strength and eliminates rust and weight problems. The AA-4 is built solid and cannot slip or twist on the mast.  
 3-3/5 each Stacked Array with Tie Rods \$8.20 each  
 Shipping Weight 3 1/2 lbs. Shipping Weight 7 1/2 lbs.  
 Lots of 6, single cartons Lots of 6, single cartons \$23.10  
 Shipping Weight 18 lbs. Shipping Weight 19 lbs.

1 1/4" O.D.		
Mast Steel (Dualcoated) 5' Crimped . . . . .	\$ 1.05	
Mast Steel (Dualcoated) 10' . . . . .	1.95	
Mast Steel (Zinc Plated) 10' . . . . .	1.59	
Mast Connectors for 1 1/4" O.D. Mast . . . . .	.39	
10" Long . . . . .	20.53	
Motors—Alliance AR . . . . .	26.33	
Alliance DR . . . . .	29.70	
Radiart TR2 . . . . .	28.50	
Waleo WHO-4 . . . . .	.03 ft.	
Motor Wire . . . . .	.06 ft.	
3—Conductor (Waleo) . . . . .	.04 ft.	
4—Conductor (Alliance) . . . . .	.06 ft.	
8—Conductor (Radiart) . . . . .	1.49	
Peak Roof Saddles (will take up to 1 1/2" O.D.) . . . . .	.02 ft.	
Twin Lead 300 Ohm—270 Mil—Solid . . . . .	1.49	
Twin Lead 300 Ohm—2 60 Mil—7/28 Stranded . . . . .	.92 1/2 ft.	
Side Wall Mounts—3" Extension . . . . .	1.25	
Side Wall Mounts—6" Extension . . . . .	2.25	
Side Wall Mount—12" Extension . . . . .	7.50	
Side Wall Mounts—18" Adj. . . . .	1.70 pr.	
The Rods for Stacking Antennas . . . . .	1.70 set	
Double Stacking Assembly—for stacking 2—XX arrays . . . . .	4.95	
Aluminum Guy Line 7/18—Stranded—300' coil . . . . .	.69	
Arrestors (TV—Lightning) . . . . .	34.97	
Auto Radio (6 tube Universal Underdash) Chimney Mount—Complete with Straps . . . . .	1.19	
Coax—72 Ohm . . . . .	.06 ft.	
Elements 3/4" x 44" or 48" . . . . .	1.20 pr.	
Elements 1/2" x 45" or 48" . . . . .	.00 3/4 ft.	
Guy Wire—Galvanized—4 Strand #20 . . . . .	.01 1/2 ft.	
Guy Wire—Galvanized—6 Strand #20 . . . . .	1.75	
Guy Wire—Galvanized—11 Strand #20 . . . . .	19.50	
Indoor Antennas (Popular Brands) Rabbit Ears . . . . .	26.97	
Boosters—Anchor—101-75 . . . . .	2.75 C	
Astatic—BT-1 . . . . .	5.50 C	
Tec—S-505 . . . . .	8.50 C	
Stand-off Screw Insulators—3" for 300 Ohm . . . . .	5.50 C	
7" for 300 Ohm . . . . .	8.50 C	
Strap Clamp Stand-off Insulators—3" . . . . .		

PRICES SUBJECT TO CHANGE WITHOUT NOTICE.  
 ALL PRICES F.O.B. CLEVELAND, OHIO  
 Desk RE-12  
**NATIONAL ELECTRONICS OF CLEVELAND**  
 DELCO BUILDING CLEVELAND 3, OHIO

# ROSE Co's SENSATIONAL FREE GIFT OFFERS

## TUBES

RMA GUARANTEED—STANDARD BRANDS ONLY

Receiving	
0Z4	\$ .59
1A5	.69
1A7	1.09
1B3	1.19
1R5	.79
1X2A	1.19
5U4	.79
5V4	1.39
5Y3	.49
6AB4	.99
6AC7	1.29
6AG5	1.29
6AH6	1.89
6AK5	1.89
6AK6	1.19
6AL5	.79
6AQ5	.89
6AT6	.69
6AU6	.79
6AV6	.69
6BA6	.79
6BC5	.89
6BD6	1.09
6BG6	1.89
6BH6	.89
6BJ6	.89
6BN6	1.39
6BQ6	1.59
6C4	.79
6CB6	.89
6CD6	2.79
6H6	.79
6J6	1.19
6K6	.69

SPECIAL SAVINGS ON ALL NUMBERS

### Transmitting

OB2	\$1.69
OC3/VR105	1.29
OD3/VR150	1.19
2X2	.79
3EP1	5.39
3HP7	3.49
5FP14	16.99
7BP7	7.89
7CP1	12.49
211	.79
304TH	12.49
GL471A	2.75
12A6	.69
717A	1.99
803	2.99
805	3.49
807	1.79
809	1.79
813	7.49
872A	2.39
885	1.29
905	2.29
954	.29
1616	1.19
1624	1.49
1629	.35
2051	1.19
7193	.29
8020	1.25
9006	.29

## FREE!

This Superior Electric SOLDERING IRON. What every serviceman needs! Yours absolutely FREE!

- ★ Nickel Chrome Wire Heating Element
- ★ Handsomely Plated Shaft
- ★ Replaceable Tips
- ★ U.L. & C.S.A. Approved

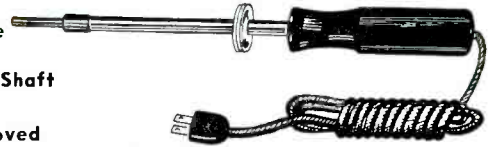

For a limited time, the ROSE Co. is offering, absolutely FREE, this wonderful new soldering iron to its customers. With each order of \$25, you get FREE this 75 Watt electric soldering iron. A \$50. order brings you a 100 Watt Soldering Iron or two (2) 75 Watt Irons. A 75W. Iron for each \$25. order. Be sure to mention which iron you want with your order. Act quickly—order Now! GET THIS SUPERIOR ELECTRIC SOLDERING IRON NOW... ABSOLUTELY FREE. We're sorry that this offer cannot include TV chassis, Picture Tubes, or complete radios.

### Terrific Value!

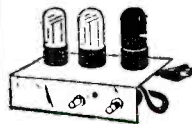

### 3-TUBE PHONO AMPLIFIER

For all type records. 2 1/2 Watt output. Completely wired with full range tone and volume controls, plus switch. \$2.95 (less tubes)

SET OF TUBES FOR AMPLIFIER (above) \$2.95  
 Output, 50L6 .49  
 Pickup, single speed 1.89  
 Pickup, 3-speed 4.95  
 Motor, 78 I.P.M. & Turntable 2.89  
 Motor, 3-speed & Turntable 4.95

## TV PICTURE TUBES

Full Year's Guarantee Not Pro-Rata—Black Face—Brand New—Standard Brands Sealed Cartons

10BP4	\$24.95	16GP4	\$31.95	19AP4A	\$37.95
12LP4	24.95	16HP4	33.95	20CP4	37.95
14BP4	24.95	17BP4	29.95	24AP4	69.95

## The Great 630 Super Chassis

Bargain Priced for Terrific Savings! 30-Tubes—RCA lic.—For 16" to 24" Picture Tubes

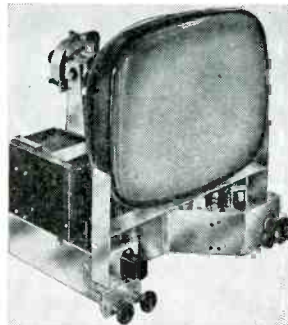

- High efficiency high voltage circuit
- Keyed AGC
- Automatic brightness control
- Special extra-high gain standard coil tuner
- Directly adaptable for color
- 12" Quality speaker
- Factory wired, aligned & tested
- Complete, ready to play
- Including hardware & knobs

Complete \$144.50 (less CRT)

**Special:** With Dumont Inputuner, FM Radio and RCA 12" Speaker only \$154.50 (less CRT)

630DX Chassis, 3-times normal reception of regular chassis. Needs no complicated antenna or booster. \$159.50

Reduced to less-CRT  
 FREE OFFER: Schematic diagram FREE with any chassis ordered!

### Special! GENUINE MOLDED CONDENSERS

Special Savings  
 Now! 10 for \$1.89

Special! DEDUCT 5¢ from the price of each in lots of 10 or more!

### AC LINE CORDS

Special Savings  
 Now! 10 for \$1.89

VOLUME CONTROLS  
 1 Meg. & Switch 42¢  
 1/2 Meg. & Switch 42¢  
 1 Meg. less switch 23¢  
 1/2 Meg. less switch 23¢

## SPECIAL CHRISTMAS SALE 5-Tube, AC/DC, Superhet RADIOS

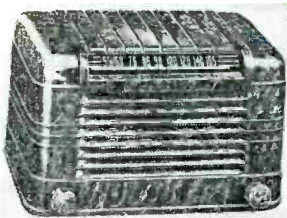

Brand New Famous make, table model radio with illuminated slide-rule dial, highly polished walnut plastic cabinet with streamlined grille, delivers greater wattage output for finer, undistorted tone and with automatic volume control to maintain uniform volume, prevents blasting on strong signals and reduces fading.

Licensed by RCA!

### Look at these Specs!

- 5 Tubes, incl. rectifier
- AC/DC Superheterodyne circuit
- Alnico V Speaker for true tone
- 540" x 1650 K (560 to 182 meters)
- 6 Tuned Circuits
- Built-in loop antenna
- 10 1/4" x 6 1/4" x 5 1/2"
- 7 lbs., 3 oz., shipping weight

lots of 3 complete Dealer Net, \$13.95 \$15.95 ea.

### ROSE SLASHES PRICES AGAIN!



## SPEAKERS

All Alnico V—Every one a Buy!

4" P.M.	\$1.59 ea.
5" P.M.	1.69 "
6" P.M.	1.89 "
12" P.M.	5.95 "
4"x6" P.M.	1.79 "
6" 62 ohm with output	3.75 "
4"x6" 1500 ohm with output	3.49 "

DEDUCT 5% from price of any Speaker in lots of 10 or more. May be assorted. ORDER NOW before cobalt freeze advances prices!

### Rose Saves You Plenty! ELECTROLYTIC CONDENSERS All Guaranteed Fresh Stock

	ea.	lots of 10	lots of 100
20x30—150 V.	\$0.39	\$3.70	\$34.95
40x40—150 V.	.45	4.30	39.95
50x30—150 V.	.45	4.30	39.95
50x50—150 V.	.49	4.50	41.95
40x40x20—150 V.	.69	6.70	59.95
50x30x20—150 V.	.69	6.70	59.95
50x50—150 V. (200-25 V.)	.79	7.70	69.95
25—25 V.	.19	1.50	13.50
25—30 V.	.19	1.50	13.50
20—250 V.	.29	2.59	23.95
8—150 V.	.39	3.69	32.50
10—150 V.	.39	3.69	32.50
16—450 V.	.59	5.69	49.50

Order Now! Save Now! Maybe Ass't. for 100 Lot Price!



# THE ROSE COMPANY

100 Park Place

Dept. E-12, New York 7, N. Y.

CORtland 7-6195

High-Fidelity • TV • Radio  
Phonographs • P.A. • Parts  
Test Equipment • Tools • Books  
Ham Gear • Electronic Tubes

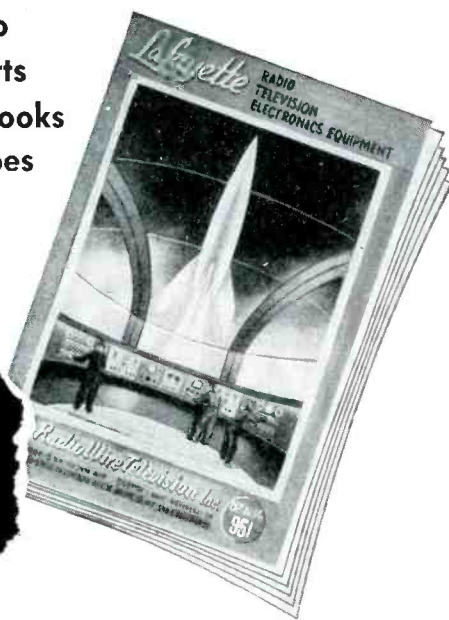

31st year

# New Lafayette

# Catalog

NOW  
READY!

A practical encyclopedia used by economy-minded servicemen, hams and technicians throughout the world because they know they have a complete "one-source" guide. For quality equipment, for hard-to-get items, for nationally-advertised merchandise, for low prices, it's Lafayette.

IMMEDIATE SHIPMENTS  
★  
COMPLETE STOCKS  
★  
TECHNICAL SERVICE  
★  
30-DAY MONEY BACK GUARANTEE  
★

*Lafayette*  
DIV. RADIO, WIRE, TELEVISION, INC.

**RADIO & TELEVISION**

**RUSH THIS COUPON AT ONCE**

VISIT LAFAYETTE SHOPPING CENTERS at  
100 Sixth Ave. New York 13, N. Y.  
•  
110 Federal St. Boston 10, Mass.  
•  
24 Central Ave. Newark 2, N. J.  
•  
542 E. Fordham Rd. Bronx 58, N. Y.

Lafayette Radio, Dept. JL  
100 Sixth Avenue  
New York 13, N. Y.

*I need the 1952 catalog. Please rush!*

Name.....

Address.....

City..... Zone..... State.....



PASTE ON POSTCARD

Is THIS why we must have technicians licensed?

"Just a few months ago a national magazine told us a story of some scandals in the medical profession. It was pointed out that there were a great number of 'quacks' in the profession . . . but . . . it was also pointed out that the number of quacks in relation to competent physicians was very small. . . . All the vaunted power of our States cannot keep them out!

"I have heard and listened carefully," said Mr. Haas further on in his letter, "to the arguments advanced by the supporters of these laws. The words are gilt-edged and, all put together, they promise Utopia without undue effort on the part of anyone. That they have been, apparently, accepted by technicians in general seems only to prove that they have an unusually high degree of gullibility.

"What is better than licensing? A real appreciation of our very important position in the radio-television industry, and constant efforts to improve our status in the eyes of the consumer upon whom we all depend for our livelihood. The continuance of our efforts to educate the public as to the nature of his television receiver and just what he can expect from it."

**EMBLEM OF NATESA**



This emblem of the National Alliance of Television and Electronic Service Associations is available to members.

**PITTSBURGH ACTIVITY**

The members of the Radio and Television Servicemen's Association of Pittsburgh heard a full report from their president, George Sharpe, on the State Federation meeting which he attended as a delegate. He brought back an especially complete account of the 50-point program presented by the Federation to Philadelphia's Joint Electronic Radio Committee on Service, and also a detailed report on the revised State licensing bill. Acceptance of the 50 points as an association goal and of the revised licensing bill was approved practically unanimously.

**SCHOOL OPENS AGAIN**

Courses at the regular radio and TV school of the Blair County (Pennsylvania) Association of Radio Service Engineers were resumed after a summer vacation, with Mr. Brubaker as instructor.

Several manufacturers meetings have been conducted in Altoona, through the cooperation of the Federation of Radio Servicemen of Pennsylvania and distributors. The open meetings conducted by RCA and Taco were very well attended.

RADIO-ELECTRONICS for

**LACKAWANNA INSTALLS**

The Lackawanna, Pennsylvania, Radio Service Technicians Association installed its new officers at a recent meeting.

The officers are: president, James Jerome, Olyphant; vice president, Raymond Rogers, Peckville; secretary, Howard Greene, Scranton; treasurer, Henry Govan, Olyphant; directors, Leon Helk, Carbondale; Merrill Greene, Scranton, and Fay Maynard, Scranton. Merrill Greene, Scranton, is the retiring president. The officers were installed by Mr. Helk, a past president.

The following committee chairmen were named: Public relations, Mr. Helk; complaint, Merrill Greene; membership, Joseph Kuzmac, Scranton; ways and means, Mr. Maynard; technical, Karl Mead, Scranton. William Slavinskis, Scranton, was made chairman of arrangements for the State Federation meeting at which the local association acts as host.

**LECTURE AT HARRISBURG**

Mid-State Radio Servicemen's Association had a very interesting lecture meeting, sponsored by the local distributor, D & H of Harrisburg, Pa. The principal speaker, Mr. A. G. (Slim) Petrsek of RCA, who spoke on servicing problems, demonstrated his lecture with a live chassis and RCA's latest test equipment. Several new members were taken into the Association.

Members of the MSRSA have been furnished, at a small charge, with the keystone emblem stamp intended for use on contracts or repair bills. This stamp informs the customers that they are dealing with an Association member.

**ESFETA'S FALL MEETING**

The quarterly meeting of the Empire State Federation of Electronic Technicians Associations (ESFETA) was held in New York City at Toots Shor's on October 7th under the chairmanship of Wayne Shaw of Ithaca. All chapters were present. The delegates spent a great deal of time discussing educational programs, membership drives, the RTMA report and the dues structure to be paid NETSDA. The Empire State Federation will promote programs with the intention of helping the local chapters build larger memberships.

**NETSDA MEETS IN N. Y.**

More than 50 delegates and visitors were present at the October 7 meeting of the National Electronic Technicians and Service Dealers Associations in New York City. In addition to the chapter members, there were delegations from Westchester, Rochester, and Buffalo, New York, and from Fall River and Boston, Mass.

Dues per capita were discussed and referred to the finance committee headed by Vance Beachley, Treasurer.

The RTMA Service Committee's report was presented at completion of the reports of the representatives present at this meeting. NETSDA went on rec-

**Now! TRAIN QUICKLY AT HOME for RADIO-TV**

*... at lowest price in history!*

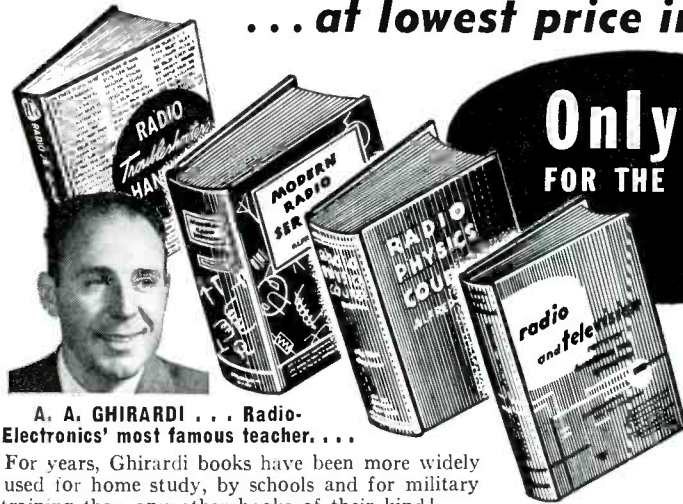

**Only \$19 FOR THE 4-VOLUME COURSE**

**5 Months to Pay!**

A. A. GHIRARDI . . . Radio-Electronics' most famous teacher. . .

For years, Ghirardi books have been more widely used for home study, by schools and for military training than any other books of their kind!

**Ghirardi's FAMOUS-4 Library**

**COMPLETE TRAINING FOR BETTER JOBS IN THE WORLD'S FASTEST GROWING INDUSTRY**

These 4 fact-packed books so clearly and fully cover radio, television and general electronic theory, troubleshooting and servicing that, in short order, you can train at home to handle repairs on practically any type of home equipment. Ask the men who already have good-pay jobs in Radio-Television Electronics! They'll tell you Ghirardi training is the finest—at any price—because it is so amazingly complete—because it

makes even the toughest subjects so easy to understand. Thousands of leaders in the business got their own basic training from earlier editions of some of these same world-famous Ghirardi books! Send coupon today! Read them for 10 days on our free examination plan. Then, if you decide to keep them, buy on easy monthly installments at a saving of \$2 on the complete set!

**1—COMPLETE BASIC TRAINING FOR BEGINNERS**

(Ghirardi's "RADIO PHYSICS COURSE")

The world's most widely used basic training book for beginners! Starts with Basic Electricity—carries you step by step through radio-electronic theory developments and equipment. 36 courses in one! 972 pages; 508 illustrations; 856 review questions. Price \$5 if bought singly.

**2—COMPLETE PROFESSIONAL SERVICE TRAINING**

(Ghirardi's "MODERN RADIO SERVICING")

This giant 1300-page book teaches you to work by professional methods that command highest pay. Explains instruments. Tells how to analyze circuits, test components, locate troubles and make repairs, adjustments and installations—even how to start a service business. Price \$5 if bought singly.

**3—SERVICE SHORTCUTS AND HELPFUL HINTS**

(Ghirardi's "TROUBLESHOOTERS' HANDBOOK")

This 744-page book covers common troubles, their symptoms and repair methods on over 4800 older receivers on which data is so often lacking. Saves time—avoids useless testing. Includes over 300 pages of charts, data and service helps. Price \$5 if bought singly.

**4—YOUR A-B-C GUIDE TO MODERN RADIO-TV CIRCUITS**

(Ghirardi's "RECEIVER CIRCUITRY AND OPERATION")

The latest Ghirardi book—and the one that brings you fully up-to-date on modern radio, FM and TV circuits, exactly how they operate and why. You learn how to recognize each circuit—how to locate troubles—how to handle tough jobs in 1/2 the usual time! 669 pages. Price \$6 if bought singly.



Dept. RE-121, RINEHART BOOKS, INC., Technical Division, 232 Madison Ave., New York 16, N. Y.

Send me the Ghirardi FAMOUS-4 LIBRARY (all 4 books) for 10-day examination. If not wanted, I will return them post-paid in good condition after 10 days, and will owe you nothing. If I decide to keep them, I will then send \$4 as my first payment and will send \$3 a month for the next 5 months until the total price of \$19 is paid.

(Outside U.S.A. cash only—same return privilege)

**TO ORDER BOOKS SINGLY . . . check here**  
Send cash. Return books postpaid in 10 days for money back if not satisfactory.  
 No. 1—Radio Physics Course (\$5)  
 No. 2—Modern Radio Servicing (\$5)  
 No. 3—Troubleshooters' Handbook (\$5)  
 No. 4—Receiver Circuitry and Operation (\$6)

Name \_\_\_\_\_  
Address \_\_\_\_\_  
City, Zone, State \_\_\_\_\_ Employer \_\_\_\_\_  
Employer's address \_\_\_\_\_

## how to choose a high fidelity loudspeaker



**Jensen**  
WIDE RANGE



G-610  
TRIAXIAL  
3-WAY

SINGLE-UNIT  
DIRECT RADIATOR  
TYPES (5"-15")

"Genuine Jensen Wide Range" means much more than wide frequency range—it means superior performance all the way—in every attribute that makes for enhanced listening pleasure: 1. Wide Frequency Range . . . 2. Balanced Frequency Response . . . 3. Smooth Response . . . 4. Wide Angle Distribution . . . 5. Low distortion . . . 6. Good Efficiency . . . 7. Adequate Power-Handling Capacity.

Whatever the cost or size, a choice from the Genuine Jensen Wide Range series insures a maximum of performance to today's new high fidelity standards.

Write for free booklet—"Let Music Come to Life"—it includes a listing of Genuine Jensen Wide Range loudspeakers.

# Jensen

MANUFACTURING COMPANY  
Division of the Muter Company  
Export Department at the Factory  
6601 S. Laramie · Chicago 38, Illinois

BURTON BROWNE ADVERTISING

ord rejecting it as inadequate and empty of any promise to meet the present day servicing problems.

A committee was appointed to focus public attention on the New York City and Pennsylvania licensing bills and supply information to all other servicing associations and persons interested.

A nominating committee was ap-

pointed to select a list of candidates for elective offices during the coming year.

The body approved the following resolution. "NETSDA representatives will not attend any future meetings called by the industry unless duly authorized representatives only of National or State groups are in attendance."

### TV GYP FINED \$1,000

Television Associates, Los Angeles, California, was ordered to pay a \$1,000 fine after having pleaded guilty to charges of petty theft. A former president of the corporation was also sentenced to 50 days in the county jail. Judge Paul McIver was more sympathetic to the present president, Mrs. Patricia Smith, whom, he stated, "went almost overnight from clerk to president and who appears to be the victim of others designing to run for cover." She was put on probation for two years, with the proviso that she serve the first five weekends in the county jail, and that she "cooperate with those investigating the TV racket without reservation in order to bring those responsible

for this conspiracy to justice."

Television Associates had been accused of a number of offenses ranging from overcharges to assault and battery, including—believe it or not—twisting a customer's arm. According to the customer, the latter offense occurred when an employee of the company, allegedly acting under the orders of the president of the company, demanded her warranty contract when returning her repaired set. On her refusal, she charged that he started to take away the set, and the arm-twisting occurred when she (unsuccessfully) attempted to prevent the delivery man from taking away the repaired receiver in lieu of the contract.

### DROP LICENSE PROPOSALS

Proposals to license TV technicians in Milwaukee were dropped at a public hearing before the licensing committee of the Milwaukee Common Council, according to a recent story in *Retailing Daily*.

Chief objections to the proposed ordinance centered about its provisions for an annual license fee ranging from \$100 to \$500, the amount of experience required before a technician could be licensed, the minimum size requirement for a television repair shop, and the quantity of test equipment each service organization would be compelled to have.

### BBB REPORTS COMPLAINTS ARE DOWN IN COLUMBUS

The September meeting of the Associated Radio-Television Service Dealers of Columbus, Ohio, which was also the year's third quarterly Associate Jobber Meeting, featured an address by Mr. Gordon Kilmer of the Better Business Bureau. Mr. Kilmer reported that the TV complaints at the Better Business Bureau had dropped off con-

siderably during the past year—a trend exactly opposite to that in many other large cities.

Two of the factors which were cited as contributing to this desirable trend were: the better understanding by the layman of the many problems of TV, and the efforts of ARTSD to "Keep Columbus Clean."

### L.A. PREPARES ORDINANCE

The city attorney and the Building and Safety Department of the city of Los Angeles were instructed to draw up an ordinance, "which in their opinion will give due process by law to stop this gypping in the TV repair business."

The action, which took place late in September, followed one by the Los Angeles County supervisors in ordering preparation of a licensing ordinance for TV repair shops in unincorporated areas in Los Angeles County. Unlike the city license, which was apparently to be under the Building and Safety Department, the county plan proposed that the licensing be under the control

of the county sheriff, whose representatives would inspect repair shops regularly "for recovery of lost or stolen sets or parts, and to assist in eliminating fraudulent practices."

According to Administrative Officer Wayne Allen, licensing of TV repair shops "is necessary for the same reason as is licensing of auto repair shops, auto wreckers, auctioneers and others he listed.

The type of licensing proposed for the city is not as clearly foreshadowed, but it is likely that it will follow somewhat similar lines to those proposed in the unincorporated areas.

**VANCOUVER BULLETIN REAPPEARS**

After a lapse of some months the official organ of the Radio Electronic Technicians Associations of Vancouver and British Columbia has resumed publication with its September number. Much of the news concerns a recent meeting of the Vancouver chapter, at which delegate Jim Baird reported on the meeting of the national association, The Radio Electronic Technicians of Canada (RETA), in Regina, Saskatch-

ewan. A meeting of the Victoria chapter at which a "free tube testing" envelope stuffer sent out by a large advertiser was discussed and strongly deprecated; also, a report that many qualified electronic technicians have left for other fields. The editor feels that the explanation for the desertions from the ranks of the technicians is that top wage in Victoria is only \$1.40 per hour.

**PATERSON, NEW JERSEY, ACTIVE**

The Radio Servicemen of New Jersey, Inc. have announced their affiliation with the National Alliance of Television & Electronic Service Associations (NATESA).

The association, which is located in Paterson, has made arrangements with the Allen B. Du Mont Laboratories for a series of lectures on u.h.f. and color, beginning in November. H. B. Rhodes, the president of RSNJ, indicated that other service organizations in the vi-

cinity would be invited to these meetings.

RSNJ is also working on a plan for a legal and foolproof escrow system, which will probably take the form of a trust fund to which the members will subscribe—with the object of protecting service contract holders in the event that any one of the member service organizations should, through financial reverses, encounter difficulties in carrying out its contract obligations.

**SHORTAGE OF TECHNICIANS IMMINENT?**

Shortage of trained service technicians may become television's main problem in the near future, according to Paul V. Forte of the Philadelphia Television Contractors Association.

Service contractors were compelled to retrench drastically during last summer's slow period, Mr. Forte pointed out. Every technician who was not absolutely necessary was let go. These

men got jobs in the expanding electronic defense production, usually at higher wage rates. Therefore they have been lost to the service industry.

The industry itself has failed miserably to train service technicians, Mr. Forte said, and no present or proposed plan will provide sufficient numbers of trained men in the next few years.

—end—

**NEW!**

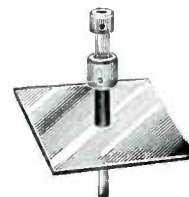

**MOSLEY ROOF-THRU**  
The Leak-Proof Roof Entrance for TV and FM Transmission Line and Rotator Control Cable

Here's the new ROOF-THRU, another MOSLEY product for BETTER TV PICTURES Through More Efficient Installation. ROOF-THRU provides the easiest and most practical method of bringing in lead-in for concealed-in-wall installations using MOSLEY Flush Mounted Sockets.

Why the ROOF-THRU Way Is Best:

- Permits shorter lead-in line resulting in less loss of signal energy—less interference pick-up!
- Copper flashing and plastic bushing provides perfect seal against leaks!
- Prolongs life of transmission line by keeping it out of weather!
- Eliminates unsightly wires on outside of house!
- Long lasting—weather can't hurt ROOF-THRU!
- Easy to install on new or old buildings!

Cat. No. 624 MOSLEY ROOF-THRU

List Price \$5.84

See the ROOF-THRU and MOSLEY Flush Sockets at your jobber

**MOSLEY ELECTRONICS**  
2125 Lackland Road, Overland, Missouri

Get This Valuable Book

Just for Examining COYNE'S New 5-Volume Set

**FREE**



*Applied Practical Radio-Television*

**ON 7 DAYS FREE TRIAL!**

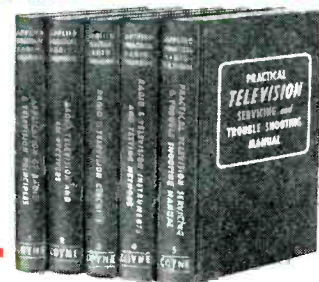

Yes, you get this big, brand new book, "150 Radio-Television Picture Patterns and Diagrams Explained", absolutely FREE! Just off the press! Gives complete wiring circuits and diagrams on the latest Radio and Television Sets. Easy-to-read, large 8½ x 11" pages, with full instructions on how to read and use the diagrams. A "must" in every Radio and Television service-man's repair kit. You get this valuable book as a FREE Gift for asking to see Coyne's great new 5-book set, "Applied Practical Radio-Television"!

**Here's "Know How" that Makes You Worth More!**

Coyne's new "Applied Practical Radio-Television" is written for men who want to get ahead fast in big pay TELEVISION and RADIO work . . . men who know that a practical working knowledge helps bring top earnings. Over 1500 pages, 5000 subjects, of the latest Radio and Television "know how"—with 1000 crystal-clear illustrations and diagrams.

**Color Television Included**

COMPLETE SECTION ON COLOR TV AND UHF! How to install, service, align, balance ALL radio and TV sets . . . how to use testing instruments . . . latest data on UHF adapters and converters, and much MORE. Step-by-step photographs "break down" equipment to show you what makes it "tick". Fully indexed for ready reference on the job or to study at home, Up-to-the-minute, complete, easy to understand!

**SEND NO MONEY!** Just mail coupon. We'll send you 5-volume set on 7 DAYS FREE TRIAL. With it we'll include the book of 150 Radio-TV Diagrams. If you keep set, pay \$3 in 7 days and \$3 per month until \$16.90 is paid. (Cash price \$15.40.) Return the set alone and you OWE NOTHING. Either way, the book of Diagrams is yours to keep. Coupon is just a request to see Set free and get FREE BOOK. Offer is limited. Act NOW!

**FREE BOOK—FREE TRIAL COUPON!**

**COYNE Electrical and Television-Radio School**

500 S. Paulina St., Dept. C1-T1, Chicago 12, Ill.

YES! Rush "Applied Practical Radio-Television" for 7 days FREE TRIAL per your offer. Include 150 Radio-TV Picture Patterns & Diagrams Book FREE!

Name ..... Age .....  
Address .....  
Town ..... Zone ..... State .....  
Where employed .....

**COYNE** ELECTRICAL & TELEVISION-RADIO SCHOOL  
500 S. Paulina St., Dept. C1-T1, Chicago 12, Ill.

## FOR PERFECTION



in TV INSTALLATIONS  
in any locality use the new  
**Simpson** MODEL 488  
TV FIELD STRENGTH METER

Ideal for antenna orientation, comparison of antenna systems, adjustment of TV signal boosters, checking antenna and lead-in installations and many other functions . . . the 50 microvolt full scale range is an outstanding feature for those concerned with fringe area installations where maximum efficiency must be attained . . . the 500, 5,000 and 50,000 microvolt ranges extend the usefulness of the Simpson Model 488 into areas of higher signal strength.

**SIMPSON ELECTRIC COMPANY**  
5200 WEST KINZIE STREET, CHICAGO 44, ILL.  
Phone: COlumbus 1-1221  
In Canada: Bach-Simpson, Ltd., London, Ontario

BURTON BROWNE ADVERTISING

## Reserve Your Television Issue NOW!

Our Special Annual Television Issue comes out next month. This will be the biggest issue we have ever printed—160 full pages of information and data on receivers, antennas, boosters, u.h.f., conversions, servicing, and other articles of the TV technician, as well as our full complement of audio and radio articles and departments.

## TRANSISTOR MICROPHONE

Patent No. 2,553,491

William Shockley, Madison, N. J.

(Assigned to Bell Telephone Laboratories, Inc.)  
This inventor, who has done much work with transistors, has a new application for semiconductors. He uses a germanium filament connected so that its output varies with vibration. By attaching a diaphragm it becomes a microphone or sound-level instrument.

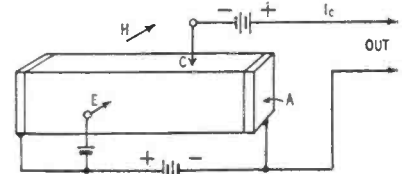

The figure shows an N-type germanium filament or elongated body of square cross-section connected as a transistor. The emitter E and collector C are biased by batteries. Holes emitted by E tend to flow through the filament to A which is negative. Their motion is also controlled by a magnetic field H transverse to the filament. (The body is placed between the poles of a strong magnet.) Therefore the holes also have an upward component. At some critical value of H, the holes move directly toward C and the output current is maximum. The output drops as H is increased.

## STANDARD CELL CIRCUIT

Patent No. 2,565,892

Leonard Stanton, Philadelphia, Pa.

(Assigned to Minneapolis-Honeywell  
Regulator Co.)

This invention decreases the peak load of a standard cell. A simplified circuit is shown. A vibrator reed switches between cell SC and a source of variable voltage E. When the voltages are unequal, a.c. output exists across C1. Output phase depends upon whether E is larger or smaller than the constant potential SC. The output a.c. may be used as desired: to indicate, control, etc.

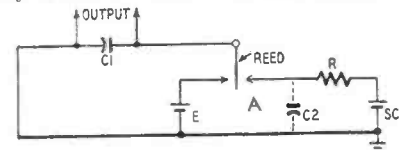

It is important to limit the peak current flowing from SC. This peak occurs at the instant the reed contacts terminal A. Thereafter, the flow decays exponentially as C1 charges. This inventor uses a clever yet simple method. He merely adds a very large capacitor C2. With this connection, peak current is taken from C2, not the cell. SC supplies a more constant current during the entire vibrator cycle.

# regency boosters are still being allocated!

They have been for 13 months! While we are striving to end this condition, most distributors are also filling orders on an allocation basis. For your supply of genuine Regency Boosters, get your orders in early!

Edward C. Tudor *president*



**INSTRUMENT DAMPING**

Patent No. 2,560,257  
 Frederick R. Sias, Marblehead, Mass.  
 (Assigned to General Electric Co.)

An electrical meter may indicate incorrectly if it is moved about while a reading is taken. For example, the meter may be aboard a moving airplane or it may be an exposure meter carried in the hand. This new design eliminates error due to this cause.

The new instrument consists of two similar meters placed back-to-back. They have a common axis of rotation and are connected in parallel across the source being measured. When current

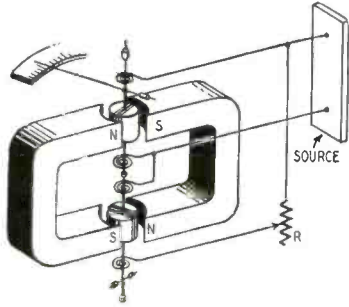

is applied, the front meter deflects clockwise as usual. The rear meter will deflect counter-clockwise. Both deflections are "up-scale," of course.

Now if an external acceleration is imparted to this dual instrument, each armature tends to move in the same direction, for example clockwise. Each coil generates an emf when it cuts through its magnetic field. Because of the back-to-back arrangement, the induced voltages are additive so current flows through the two coils and R in series. The motion is damped out by being converted to electric power. R controls the damping.

During normal measurement of current, the two coils move in opposite directions. Therefore the induced voltages oppose and there is no damping of this component of the motion.

**ARC-BACK COUNTER**

Patent No. 2,557,848  
 George L. Usselman, Port Jefferson, N. Y.  
 (Assigned to Radio Corp. of America)

This counter records the number of arc-backs which occur in a high voltage rectifier system. During a flash-over an instantaneous high current flows from anode to cathode of a rectifier tube. If the flashes occur repeatedly or frequently, the rectifier tube should be replaced to prevent damage to the other components.

The counter includes a selenium rectifier S,

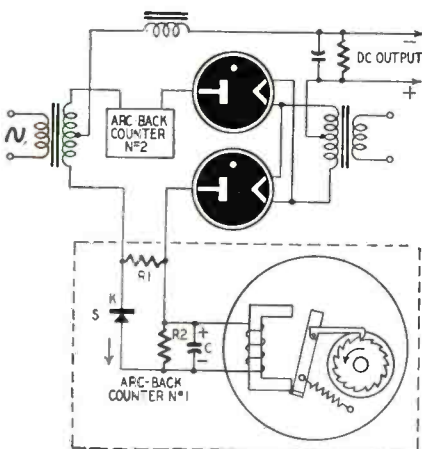

resistors R1 and R2, and a capacitor C. There is also a relay mechanism as shown within the circle. Normal rectifier current flows through R1 from the rectifier plate. Should an arc-back occur, current will flow through S and R2, charging C with polarity as indicated. The relay coil is energized and its armature is attracted. The ratchet wheel is moved forward one tooth by each flash-over. After an arc-back, C discharges through R2 and the counter is ready for the next breakdown.

# FOR PERFECT PICTURE CENTERING IN ELECTRO-STATIC TUBES

## Use the **NEW** PERFECTION *Kine-Center*

Here is the simplest of all centering devices for the new electrostatic tubes. It is also the most efficient and positive—as your own tests will prove.

- **Quickly Mounted.** Slip the Kine-Center over the tube neck and tighten the holding screw. It stays firm. No wobble. No wiggle.
- **Finger-Tip Control.** Picture is centered by rotating the two rings either independently or together.
- **Positive Centering.** Once adjusted, the rings stay put.
- **No Distortion of Focus** as with many other centering devices.

**MORE EFFICIENT**  
 Rings are closer to deflection yoke (the most effective operating area) and to the tube neck. They are stabilized magnetically.

Order today from your supplier!

**PERFECTION ELECTRIC COMPANY**  
 2635 South Wabash Avenue, Chicago 16, Illinois  
 MAKERS OF PERFECTION SPEAKERS AND TELEVISION COMPONENTS

## TV SERVICING SIMPLIFIED

Use this big Clarostat TV Control Replacement Manual! Almost 3000 control listings of all the popular TV set models and chassis. You can spot the correct replacement for any wornout or defective TV control.

Best of all, your Clarostat jobber has that right replacement in stock. No delay. And it fits — electrically and mechanically — without fussing or cussing. Stays put, too, for a profitable job.

**GET THAT TV CONTROL REPLACEMENT MANUAL NOW!**

Supply is running out. Send your dollar bill and start saving time, trouble, money, in TV servicing. Or get your copy from your Clarostat jobber.

**CLAROSTAT**

*Controls and Resistors*

CLAROSTAT MFG. CO., INC. • DOVER, NEW HAMPSHIRE

IN CANADA: CANADIAN MARCONI CO. LTD., MONTREAL, P.Q., AND BRANCHES

# USE PHOTOFAC

the world's best Radio-TV service data—it pays for itself every working day

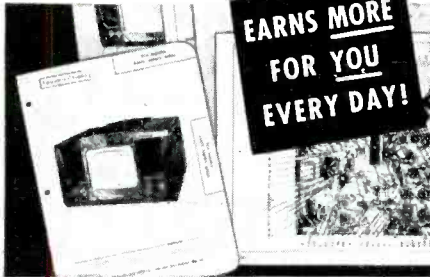

## Try PHOTOFAC!

**FREE**

We'll send you any Photofact Folder listed in the Photofact Cumulative Index \*

WE'LL PROVE YOU'LL SAVE TIME and EARN MORE WITH PHOTOFAC

NOW—learn for yourself—at our expense—how PHOTOFAC makes your Radio and TV work *quicker, easier, more profitable!* Examine an actual PHOTOFAC Folder. Use it. You'll learn first-hand why over 35,000 successful service technicians use PHOTOFAC daily. You'll learn that no other service gives you PHOTOFAC's completeness, accuracy, uniformity, and lowest cost. PHOTOFAC is the *only* radio and TV service data prepared from laboratory analysis of the actual equipment. Know the facts—get your FREE Folder now. Examine, use, compare—learn why no modern service shop can afford to be without PHOTOFAC!

\* Except those followed by asterisk (\*) or letter A.

**WRITE FOR FREE INDEX**

**PAY AS YOU EARN!** Ask your distributor about this amazing plan. Only \$18.39 puts the entire profit-boosting Photofact library in your shop now!

**NOTE:** Our FREE Folder offer is limited to Service Technicians only. Attach coupon below to your letterhead and mention your jobber's name. If you have no letterhead, send coupon to your jobber. Experimenters and others may obtain the Photofact Folder by remitting amount shown below.

HOWARD W. SAMS & CO., INC.  
2201 E. 46th St., Indianapolis 5, Ind.

- Send FREE Photofact Cumulative Index
- Send Full Easy-Pay Details

I am a Service Technician:

- Send FREE Folder for set model.....

I am an Experimenter: Enclosed \$.....

- Send Folder for set model.....

TV-\$1.00. Record Changer or Comm. Receiver-75c. AM/1M-50c

Name.....

Address.....

City.....Zone...State.....

## Magnetic Field Strength Meter

Patent No. 2,562,120

Gerald L. Pearson, Millington, N. J.

(Assigned to Bell Telephone Laboratories, Inc.)

This sensitive instrument is based on the Hall effect. It needs no amplifiers or high-voltage supplies. A flat probe is utilized to explore a magnetic field. A calibrated meter indicates the field strength in kilogauss.

The probe consists of germanium deposited on a flat quartz plate. Such a probe may be as thin as .0025 inch, for example, to explore narrow

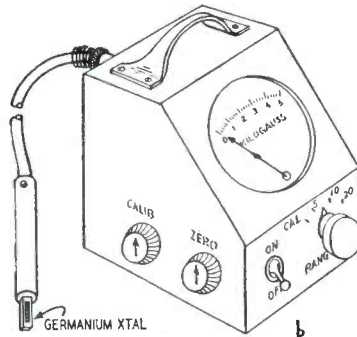
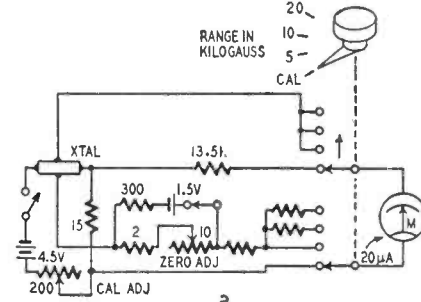

gaps. The probe is held transverse to the field. The Hall effect requires a d.c. flow through the germanium in a direction at right angles to the field. Under this condition a voltage is generated which is proportional to the current and the field and is at right angles to each.

The crystal current is supplied from a 4.5-volt battery in series with a calibrating resistor. See a in the figure. The current is adjusted to the desired value by throwing the range switch to CAL and noting the meter M. To make a measurement, the switch is thrown to one of the three kilogauss ranges. The zero adjustment is set for null reading when the field is zero. Now M is a voltmeter in series with a multiplier resistor, and it indicates the Hall voltage output.

Probe polarity must be observed. If it is incorrectly inserted into a gap (that is, facing the wrong magnetic pole) M will read backward.

This instrument was described in the Review of Scientific Instruments, April 1948. A portable model is shown at b in the figure.

## STATIC DETECTOR

Patent No. 2,556,458

Raymond C. Webster, Kansas City, Mo.

(Assigned to W. E. Anderson, Inc.)

A vacuum tube makes a sensitive detector of negative static charges. A pentode detector is shown in the figure. When the probe is brought near a charged body, part of the charge is transferred to the grid by induction. There is a proportionate drop in plate current as will be indicated by the microammeter.

The instrument is not so effective for measuring positive charges. A positive grid attracts electrons which are trapped (since SW is left open during a measurement). In a short time the positive charge on the grid is neutralized.

Before testing for a charge, the grid should be brought to ground potential to remove any charges on it. This is done by momentarily closing SW.

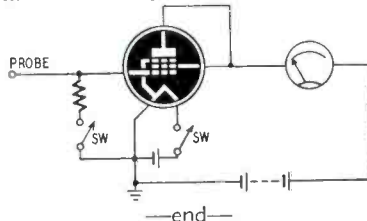

# STAN-BURN E-D-A-R-K-E

Condenser Specials	Speaker Specials
BY PASS—	ALL GUARANTEED
ALL GUARANTEED	ALL GUARANTEED
20x20-150 Stan Burn .49	4" P.M. \$1.64
50x30-150 Stan Burn .49	5" P.M. 1.75
20x150 Stan Burn .32	6" P.M. 2.41
8-450 Stan Burn .41	8" P.M. 3.41
16-450 Stan Burn .49	12" P.M. 6.33
4 Prong Vibrators	4 x 6 P.M. 2.19
each \$1.29	6 x 9 3.73
Lots of 12 or more 1.19	5 x 7 3.43
	10" P.M. 5.48
Turret TV Tuners \$18.95	

## NEW for '51 AUTOMATIC RADIOS

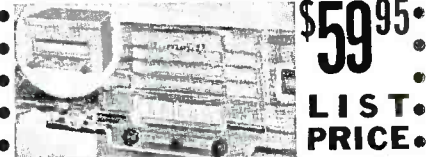

**\$59.95**  
**LIST PRICE**

Each auto radio is specifically designed to fit all 1949, 1950 and 1951 cars for Ford, Plymouth, Dodge, Chevrolet, Hudson, Henry J and Studebaker. All incorporate the same outstanding features: Six-tube superheterodyne. Six-tube storage battery operation. Two dual-purpose tubes. Eight-tube performance. Installation in a few minutes. Three-gang tuning condenser and tuned R.F. stage for extreme sensitivity. Permanent magnetic dynamic speaker with Powerful Alnico #5 magnet. Low battery drain. Weight 10 lbs.

### ATTRACTIVE DISCOUNTS TO DEALERS

CHASSIS 630 K3B Video Product \$139.50

### CATHODE RAY TUBE SPECIALS

7JP4	\$15.00	16RP4A	26.00
10BP4	14.95	17BP4A	27.00
12LP4	19.95	20CP4	39.95
12LP4A	19.95	19AP4A	47.95
14BP4	19.95	19DP4A	47.95
16DP4A	26.00	21AP4A	73.00
16BP4	33.00	Double ion traps	.59
16AP4A	39.00	Single ion traps	.39

### RAM TRANSFORMERS

RCA type for 16" to 24" X032	\$3.85	70° DEFLECTION YOKES	
G.E. Type for 16" to 24"	\$3.85	Todd wired replacement for RCA, GE, etc.	
X045	\$3.85	Special	\$3.85

These are very special prices while they last!

### ANTENNAS

Conicals, less mast, 10 element	\$ 2.98
Circle X, less mast	2.98
Double V, less mast	2.98
Chimney Mounts—1-12 .95 12 or more	.89
100 ft. roll strapping	2.98
Mast standoffs	1.59
12 ft. masts, each	1.49
12 or more, each	1.09
55 mil. 300 ohm wire white or black, 1000 ft.	19.97

**AUTHORIZED DISTRIBUTORS for:** General Electric, Kenrad, Tung-Sol, National Union, Jewel, De Wald, Regal, Automatic and Setchel Carlson.

We carry a complete line of popular makes of Radio and TV tubes, at 50% discount. Also many other special purpose and transmitting types, and all electronic parts and equipment at lowest prices. Send us a list of your requests for quantities and prices. Terms: 20% with order. Balance COD All prices FOB New York Warehouse. Minimum order \$5.00 Write for our latest price list to Dept. RE-12

# STAN-BURN RADIO and ELECTRONICS CO.

(C.B.S. THEATRE BLDG.)  
1697 BROADWAY • NEW YORK 19, N.Y.



# Features OF THE NEW 1952



## PROOF OF THE NEW O-7 OSCILLOSCOPE'S OUTSTANDING PERFORMANCE

Below are actual, unretouched photographs showing the outstanding frequency response characteristics of the NEW 1952 HEATHKIT OSCILLOSCOPE, MODEL O-7. To the left is a 10 KC square wave — to the right a 4 MC sine wave as they actually appear on the screen. Two highly severe tests to make on any scope (only the best of scopes will show traces like these) — and the O-7 really comes through.

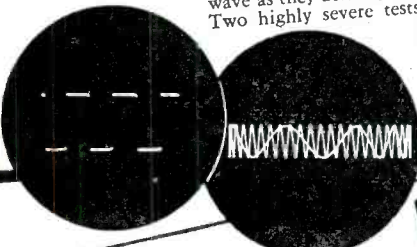

## COMPANION VACUUM TUBE VOLTMETERS

Here are the two NEW 1952 VACUUM TUBE VOLTMETER COMPANION PIECES. Matched instruments of new design to open up the whole field of DC, AC, and resistance measurements for you. The new greatly reduced size combines style, beauty, and compactness — The V-5 and AV-1 have the new panel and cabinet construction as shown on the right. A tremendous pair of voltmeters. Small in size but virtual giants in the range of measurements they make.

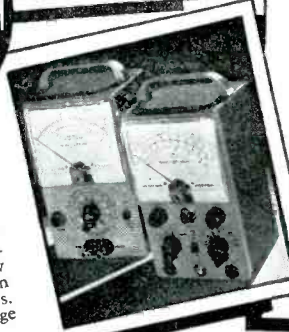

## NEW STYLE AND BEAUTY

Style that's modern, yet functional — that's the trend of today — and Heathkits are right up to the minute. Note the cut showing the new V-5 and AV-1 cabinet and panel construction. The front panel and rear cover slide right over the recessed flange of the case thereby eliminating sharp edges and pointed corners. The voltmeter kits aren't "shelf" or "mounted" instruments — they're moved about on the bench a lot and thus the new compact size and specially designed cabinets — Another 1952 Heathkit feature.

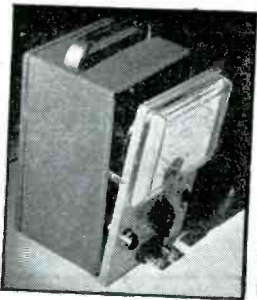

## A STATEMENT FROM SIMPSON ELECTRIC CO.

In choosing Simpson Meters for their Heathkit VTVM, the Heath Co. has set a new high standard of kit meter quality. The same high quality of material, workmanship and design that has given Simpson the reputation for building "Instruments That Stay Accurate" is found in the Heathkit Meter Movement.

SIGNED  
SIMPSON ELECTRIC CO.

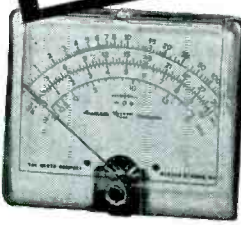

## A STATEMENT FROM CHICAGO TRANSFORMER

It is indeed gratifying to note the outstanding sales records you are building with your Heathkits.

This sales success is readily understandable, since we are cognizant of the high quality standards you have established for your component suppliers.

We at Chicago Transformer are proud that our product has contributed to the recognized quality and increasing popularity of Heathkits.

CHICAGO TRANSFORMER DIVISION  
Essex Wire Corporation

L. S. RACINE  
Vice-President and Sales Manager

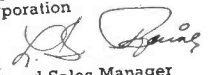

## HEATHKIT PRECISION RESISTORS

Where exact resistance values are required for instrument accuracy, the Heath Co. has spared no effort in supplying the finest resistors available. Precision resistors as manufactured by Continental Carbon Inc., and Wilcor Corp., meet the rigorous JAN (Joint Army-Navy) specifications and are small in size, extremely non-inductive, highly stable, have a low temperature coefficient, and can be held to great accuracy. You'll find quality components in Heathkits.

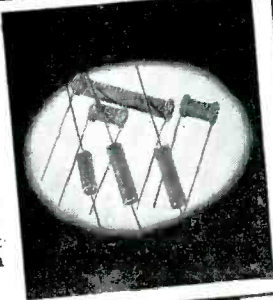

## COLLEGES USE HEATHKITS

Colleges and Universities throughout the country are using Heathkits in their electrical engineering, radio, and physics laboratories — Heathkits are the answer to good test equipment at low cost, plus being rugged, dependable, and accurate. Trade schools are having their students build Heathkits to obtain a first hand working knowledge of test equipment and to get the practical experience gained by construction. Heathkits fill school needs.

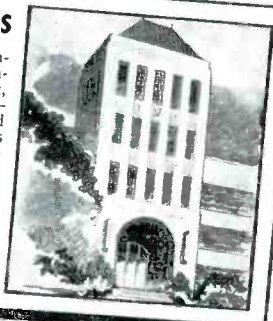

YOU SAVE BY ORDERING DIRECT FROM MANUFACTURER—USE ORDER BLANK ON LAST PAGE

EXPORT AGENT  
ROCKE INTERNATIONAL CORP.  
13 E. 40th ST.  
NEW YORK CITY (16)  
CABLE: ARLAB N.Y.

# The HEATH COMPANY

... BENTON HARBOR 20, MICHIGAN

THE *New* 1952  
*Heathkit*  
**OSCILLOSCOPE  
 KIT**

MODEL O-7  
 SHIPPING WEIGHT 24 LBS.

**\$43<sup>50</sup>**

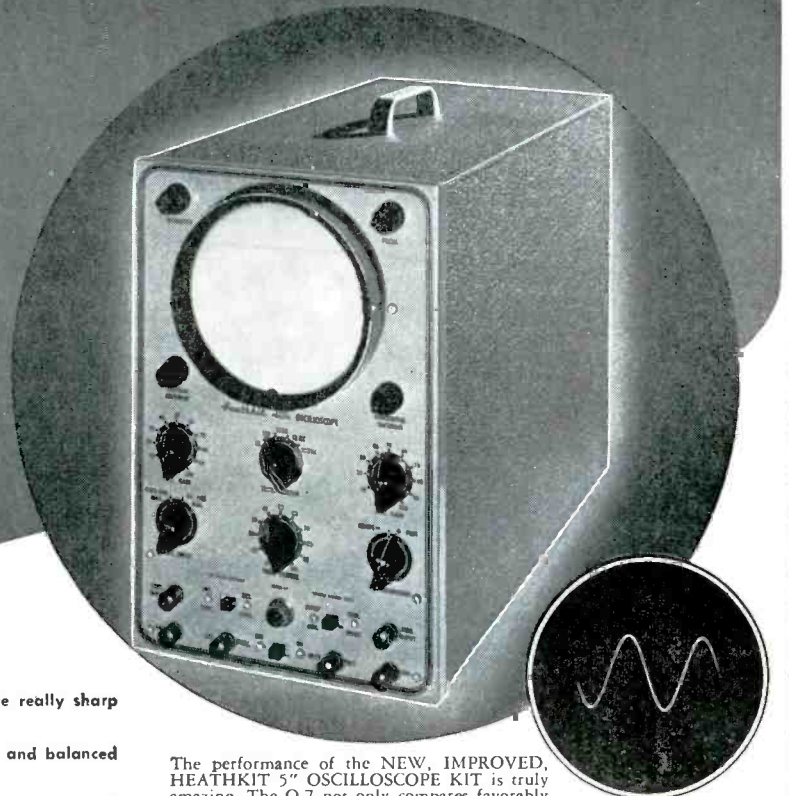

*Features*

- New "spot shape" control for spot adjustment — to give really sharp focusing.
- A total of ten tubes including CR tube and five miniatures.
- Cascaded vertical amplifiers followed by phase splitter and balanced push-pull deflection amplifiers.
- Greatly reduced retrace time.
- Step attenuated — frequency compensated — cathode follower vertical input.
- Low impedance vertical gain control for minimum distortion.
- New mounting of phase splitter and deflection amplifier tubes near CR tube base.
- Greatly simplified wiring layout.
- Increased frequency response — useful to 5 Mc.
- Tremendous sensitivity .03V RMS per inch Vertical — .6V RMS per inch Horizontal.
- Dual control in vernier sweep frequency circuit — smoother acting.
- Positive or negative peak internal synchronization.

The performance of the NEW, IMPROVED, HEATHKIT 5" OSCILLOSCOPE KIT is truly amazing. The O-7 not only compares favorably with equipment costing 4 and 5 times as much, but in many cases literally surpasses the really expensive equipment. The new, and carefully engineered circuit incorporates the best in electronic design — and a multitude of excellent features all contribute to the outstanding performance of the new scope.

The VERTICAL CHANNEL has a step attenuated, frequency compensated vertical input which feeds a cathode follower stage — this accomplishes improved frequency response, presents a high impedance input, and places the vertical gain control in a low impedance circuit for minimum distortion. Following the cathode follower stage is a twin triode — cascaded amplifiers to contribute to the scope's extremely high sensitivity. Next comes a phase splitter stage which properly drives the push-pull, hi-gain, deflection amplifiers (whose plates are directly coupled to the vertical deflection plates). This fine tube lineup and circuitry give a sensitivity of .03V per inch RMS vertical and useful frequency response to 5 Mc.

The HORIZONTAL CHANNEL consists of a triode phase splitter with a dual potentiometer (horizontal gain control) in its plate and cathode circuits for smooth, proper driving of the push-pull horizontal deflection amplifiers. As in the vertical channel, horizontal deflection amplifier plates are direct coupled to the CR tube horizontal deflection plates (for improved frequency response).

The WIDE-RANGE SWEEP GENERATOR circuit incorporates a twin triode multivibrator stage for producing a good saw-tooth sweep frequency (with faster retrace time). Has both coarse and vernier sweep frequency controls.

And the scope has internal synchronization which operates on either positive or negative peaks of the input signal — both high and low voltage rectifiers — Z axis modulation (intensity modulation) — new spot shape (astigmatism) control for spot adjustment — provisions for external synchronization — vertical centering and horizontal centering controls, wide range focus control — and an intensity control for giving plenty of trace brilliance.

The Model O-7 EVEN HAS GREAT NEW MECHANICAL FEATURES — A special extra-wide CR tube mounting bracket is provided so that the vertical cascade amplifier, vertical phase splitter, vertical deflection amplifier, and horizontal deflection amplifier can mount near the base of the CR tube. This permits close connection between the above stages and to the deflection plates; distributed wiring capacity is greatly reduced, thereby affording increased high frequency response.

The power transformer is specially designed so as to keep its electrostatic and electromagnetic fields to a minimum — also has an internal shield with external ground lead.

You'll like the complete instructions showing all details for easily building the kit — includes pictorials, step-by-step construction procedure, numerous sketches, schematic, circuit description. All necessary components included — transformer, cabinet, all tubes (including CR tube), completely punched and formed chassis — nothing else to buy.

NEW INEXPENSIVE *Heathkit*  
**ELECTRONIC SWITCH KIT**

The companion piece to a scope — Feed two different signals into the switch, connect its output to a scope, and you can observe both signals — each as an individual trace. Gain of each input is easily varied (gain A and gain B controls), the set (gain A and gain B controls), the switching frequency is simple to adjust (coarse and fine frequency controls) and the traces can be superimposed for comparison or separated for individual study (position control).

Use the switch to see distortion, phase shift, clipping due to improper bias, both the input and output traces of an amplifier — as a square wave generator over limited range.

The kit is complete; all tubes, switches, cabinet, power transformer and all other parts, plus a clear detailed construction manual.



Model S-2  
 Shipping Wt. 11 lbs.

*Only*  
**\$19<sup>50</sup>**

**YOU SAVE BY ORDERING DIRECT FROM MANUFACTURER—USE ORDER BLANK ON LAST PAGE**

SOLE AGENT  
**ROCKE INTERNATIONAL CORP.**  
 12 E. 40th ST.  
 NEW YORK CITY (16)  
 CABLE: ARKAB-N.Y.

*The* **HEATH COMPANY**

**... BENTON HARBOR 20, MICHIGAN**

THE *New* 1952*Heathkit*  
**VTVM  
KIT**MODEL V-5  
SHIPPING WT. 5 LBS.**\$24.50***Features*

- New styling, — formed case for beauty.
- New truly compact size. Cabinet 4 1/8" deep by 4-11/16" wide by 7 3/8" high.
- Quality 200 microamp meter.
- New ohms battery holding clamp and spring clip — assurance of good electrical contact.
- Highest quality precision resistors in multiplier circuit.
- Calibrates on both AC and DC for maximum accuracy.
- Terrific coverage — reads from 1/2V to 1000V AC, 1/2V to 1000V DC, and .1 to over 1 billion ohms resistance.
- Large, clearly marked meter scales indicate ohms, AC Volts, DC Volts, and DB — has zero set mark for FM alignment.
- New styling presents attractive and professional appearance.

A real beauty — you'll have only highest praise for this NEW MODEL VACUUM TUBE VOLTMETER. Truly a beautiful little instrument — and it's more compact than any of our previous models. Note the new rounded edges on the front panel and rear cover. The size is greatly reduced to occupy a minimum of space on your workbench — yet the meter remains the same large size with plainly marked scales.

A set of specially designed control mounting brackets permit calibration to be performed with greatest ease — also makes for ease in wiring. New battery mounting clamp holds ohms battery tightly into place, and base spring clip insures a good connection to the ohms string of resistors.

The circuitry employs two vacuum tubes — A duo diode operating when AC voltage measurements are taken, and a twin triode in the circuit at all times. The cathode balancing circuit of the twin triode assures sensitive measurements, and yet offers complete protection to the meter movement. Makes the meter burn-out proof in a properly constructed instrument.

Quality components are used throughout — 1% precision resistors in the multiplier circuit — conservatively rated power transformer — Simpson meter movement — excellent positive detent, smooth acting switches — sturdy cabinet, etc.

And you can make a tremendous range of measurements — 1/2V to 1000V AC, 1/2V to 1000V DC, .1 to over 1 billion ohms, and DB. Has mid-scale zero level marking for quick FM alignment, DB scale in red for easy identification — all other scales a sharp, crisp black for easy reading.

A four position selector switch allows operator to rapidly set the instrument for type or reading desired — positions include ACV, DC+V, DC-V, and Ohms. DC- position allows negative voltage to be rapidly taken. Zero adjust and ohms adjust controls are conveniently located on front panel.

Enjoy the numerous advantages of using a VTVM. Its high input impedance doesn't "load" circuits under test — therefore, assures more accurate and dependable readings in high impedance circuits such as resistance coupled amplifiers, AVC circuits, etc. Note the 30,000 VDC probe kit and the RF probe kit — available at low extra cost and specially designed for use with this instrument. With these two probes, you can make DC voltage measurements up to 30,000V, or make RF measurements — added usefulness to an already highly useful instrument.

The instruction manual is absolutely complete — contains a host of figures, pictorials, schematic, detailed step-by-step instructions, and circuit description. These clear, detailed instructions make assembly a cinch.

And every part is included — meter, all controls, pilot light, switches, test leads, cabinet, instruction manual, etc.

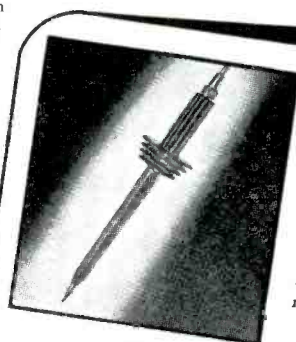
*Heathkit*  
**30,000V DC  
PROBE KIT**

A new 30,000 V DC Probe Kit to handle high voltages with safety. For TV service work and all other high voltage applications. Sleek looking — and guard — jet black plastic — Red body with connector, cable and PL55 type plug. Plugs into Heathkit VTVM so that 300V scale is conveniently multiplied by 100. Can be used with any standard 11 megohm VTVM.

**\$5.50**No. 336 High Voltage Probe Kit  
Shipping Wt. 2 lbs.*Heathkit*  
**RF PROBE KIT**

This RF Probe Kit comes complete with probe housing, crystal diode detector, connector, lead and plug and all other parts plus clear assembly instructions. Extends range of Heathkit VTVM to 250 Mc. ± 10%. Works on any 11 megohm input VTVM. Specify No. 309 RF Probe Kit.

**\$5.50**

Ship. Wt. 1 lb.

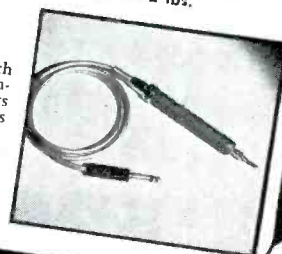
**YOU SAVE BY ORDERING DIRECT FROM MANUFACTURER—USE ORDER BLANK ON LAST PAGE**

EXPORT AGENT  
**ROCKE INTERNATIONAL CORP.**  
13 E. 40th ST.  
NEW YORK CITY (16)  
CABLE: ARLAB-N.Y.

**The HEATH COMPANY****... BENTON HARBOR 20, MICHIGAN**

# Heathkit SIGNAL GENERATOR KIT

Model SG-6  
Shipping Wt. 7 lbs.

The new Heathkit Signal Generator Kit has dozens of improvements. Covers the extended range of 160 Kc to 50 megacycles on fundamentals and up to 150 megacycles on useful calibrated harmonics; makes this Heathkit ideal as a marker oscillator for TV. Output level can be conveniently set by means of both step attenuator and continuously variable output controls. Instrument has new miniature HF tubes to easily handle the high frequencies covered.

Uses 6C4 master oscillator and 6C4 sine wave audio oscillator. The kit is transformer operated and a husky selenium rectifier is used in the power supply. All coils are precision wound and checked for calibration making only one adjustment necessary for all bands.

New sine wave audio oscillator provides internal modulation and is also available for external audio testing. Switch provided allows the oscillator to be modulated by an external audio oscillator for fidelity testing of receivers. Comes complete, all tubes, cabinet, test leads, every part. The instruction manual has step-by-step instructions and pictorials. It's easy and fun to build a Heathkit Model SG-6 Signal Generator.



## Heathkit CONDENSER CHECKER KIT

Only  
**\$19.50**

Model C-2  
Shipping Wt. 6 lbs.

Checks all types of condensers — paper — mica — ceramic — electrolytic. All condenser scales are direct reading and require no charts or multipliers. Covers range of .00001 MFD to 1000 MFD. A Condenser Checker that anyone can read. A leakage test and polarizing voltage for 20 to 500 V provided. Measures power factor of electrolytics between 0% and 50% and reads resistance from 100 ohms to 5 megohms. The magic eye indicator makes testing easy.

The kit is 110V 60 cycle transformer operated and comes complete with rectifier tube, magic eye tube, cabinet, calibrated panel and all other parts. Has clear detailed instructions for assembly and use.



## NEW Heathkit SIGNAL AND UNIVERSAL TEST SPEAKER KIT

**\$19.50**

Model T-2  
Shipping Wt. 7 lbs.

The popular Heathkit Signal Tracer has now been combined with a universal test speaker at no increase in price. The same high quality tracer follows signal from antenna to speaker — locates intermittents — finds defective parts quicker — saves valuable service time — gives greater income per service hour. Works equally well on broadcast, FM, or TV receivers. The test speaker has an assortment of switching ranges to match phones, pickups and PA systems. Also tests micro-60 cycle power transformer, tubes, test probe, all necessary parts, and detailed instructions for assembly and use.

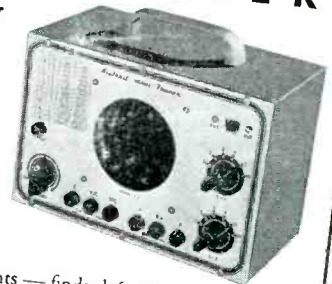

Model TC-1  
Shipping Wt. 12 lbs.

**\$29.50**

## Heathkit TUBE CHECKER KIT

The Tube Checker is a MUST for radio repair men. Often customers want to SEE tubes checked, and a checker like this builds customer confidence. In your repairing, you will have a multitude of tubes to check — quickly. The Heathkit tube checker will serve all these functions — it's good looking (with a polished birch cabinet and an attractive two color panel) — checks 4, 5, 6, 7 prong Octals, Loctals, 7 prong miniatures, 9 prong miniatures, pilot lights, and the Hytron 5 prong types. AND IT'S FAST TO OPERATE — the gear driven, free-running roll chart lists hundreds of tubes, and the smooth acting, simplified switching arrangement gives really rapid set-ups.

The testing arrangement is designed so that you will be able to test new tubes of the future — without even waiting for factory data — protection against obsolescence.

You can give tubes a thorough testing — checks for opens, shorts, each element individually, emission, and for filament continuity. A large BAD-?-GOOD meter scale is in three colors for easy reading and also has a "line-set" mark.

You'll find this tube checker kit a good investment — and it's only \$29.50.

YOU SAVE BY ORDERING DIRECT FROM MANUFACTURER—USE ORDER BLANK ON LAST PAGE

EXPORT AGENT  
ROCKE INTERNATIONAL CORP.  
13 E. 40th ST.  
NEW YORK CITY (16)  
CABLE: ARLAB-N.Y.

The **HEATH COMPANY**

... BENTON HARBOR 20, MICHIGAN

New LABORATORY LINE HEATHKITS



MODEL AV-1  
Shipping weight 5 lbs.

NEW *Heathkit*  
A.C. VACUUM TUBE  
**VOLTMETER KIT**

Now — as a Heathkit — at a price anyone can afford, an AC VTVM. A new kit to make possible those sensitive AC measurements required by audio enthusiasts, laboratories, and experimentors. Here is the kit that the audio men have been looking for. Its tremendous range of coverage makes possible measurements of audio amplifier frequency response — gain or loss of audio stages — characteristics of audio filters and attenuators — hum investigation — and literally a multitude of others. Ten ranges consisting of full scale .01, .03, .1, .3, 1, 3, 10, 30, 100, 300 volts RMS assure easy and more accurate readings. Ten ranges on DB provide for measurements from -52 to +52 DB. Frequency response within 1 DB from 20 cycles to 50 KC.

The ingenious circuitry incorporates precision multiplier resistors for accuracy, two amplifier stages using miniature tubes, a unique bridge rectifier meter circuit, quality Simpson meter with 200 microampere movement, and a clean layout of parts for easy wiring. A high degree of inverse feedback provides for stability and linearity.

Simple operation is accomplished by the use of only one control, a range switch which changes the voltage ranges in multiples of 1 and 3, and DB ranges in steps of 10.

The instrument is extremely compact, cabinet size — 4 1/8" deep x 4-11/16" wide x 7 3/8" high, and the newly designed cabinet makes this the companion piece to the VTVM. For audio work, this kit is a natural.

**\$29.50**

NEW *Heathkit*  
**AUDIO FREQUENCY METER KIT**

MODEL AF-1  
Shipping weight 12 lbs.



**\$34.50**

A NEW Heathkit Audio Frequency Meter — the ideal instrument for determining frequencies from 20 cycles to 100 KC. Set the selector switch to the proper range — feed the signal into the input terminals — and read the frequency from the meter — completely simple to operate, and yet dependable results.

Quality Simpson 200 microampere meter has two plainly marked scales (0-100 0-300). These scales, read in conjunction with the seven position selector switch, give full scale readings of 100, 300, 1000, 3000, 10,000, 30,000, and easy readings.

For greatest accuracy, the 1-3-10 ratio of ranges is maintained and each range has individual calibrating control.

Input impedance is high (1 megohm) for negligible circuit loading. A signal and a change in signal voltage between these limits will not affect the meter reading. In addition, input wave shape is not critical (the unit will read the frequency of either sine wave or square wave input).

The tube complement consists of a 6SJ7 amplifier and clipper, 6V6 amplifier and clipper, 6H6 meter pulse rectifier, 6X5 power supply rectifier, and OD3/VR150 voltage regulator.

Construction is simple, and quality components are used throughout.

NEW *Heathkit*  
**INTERMODULATION ANALYZER KIT**

Intermodulation testing of audio equipment is rapidly being accepted by more and more engineers and audio experts as the best way to determine the characteristics of audio amplifiers, recording systems, networks, etc. — shows up those undesirable characteristics which contribute to listening fatigue when all other methods fail.

The Heathkit Intermodulation Analyzer supplies a choice of two high frequencies (3000 cycles and a higher frequency (60 cycles) and one low frequency (60 cycles). Both 1:1 or 4:1 ratios of low to high frequencies can be set up for IM testing, and the ratios are easily set by means of a panel control and the instrument's own VTVM. An output level control supplies the mixed signal at the desired level with an output impedance of two thousand ohms. The Analyzer section has input level control and proper filter circuits feeding the instrument's VTVM to read intermodulation directly on full scale ranges of 30%, 10% and 3%. Built-in power supply furnishes all necessary voltages for operating the instrument.

You won't want to be without this new and efficient means of testing



MODEL IM-1  
Shipping wt. 18 lbs.

**\$39.50**

NEW  
*Heathkit* **SQUARE WAVE GENERATOR KIT**

The new Heathkit Square Wave Generator Kit with its 100 KC square wave opens an entirely new field of audio testing. Square wave testing over this wide range will quickly show high and low frequency response characteristics of circuits — permit easy adjustment of high frequency compensating networks used in video amplifiers — identify ringing in circuits — demonstrate transformer characteristics, etc.

The circuitry consists of a multivibrator stage, a clipping and squaring stage, and a cathode follower output stage. The power supply is transformer operated and utilizes a full wave rectifier tube with 2 sections of LC filtering.

As a multivibrator cannot be accurately calibrated, a provision is provided to allow the instrument to be accurately synchronized with an accurate external source when extreme accuracy is required.

The low impedance output is continuously variable between 0 and 25 volts and operation is simple. You'll really appreciate the wide range of this instrument, 10 cycles to 100 kilocycles — continuously variable. Kit is complete with all parts and instruction manual, and is easy to build.



MODEL SQ-1  
Shipping wt. 14 lbs.

**\$29.50**

YOU SAVE BY ORDERING DIRECT FROM MANUFACTURER—USE ORDER BLANK ON LAST PAGE

EXPORT AGENT  
ROCKE INTERNATIONAL CORP.  
13 E. 40th ST.  
NEW YORK CITY (16)  
CABLE: ARAB-N.Y.

**The HEATH COMPANY**

... BENTON HARBOR 20, MICHIGAN



Model 1B-1B  
Shipping Wt. 15 lbs.

## Heathkit IMPEDANCE BRIDGE KIT

This Impedance Bridge Kit is really a favorite with schools, industrial laboratories, and serious experimenters. An invaluable instrument for those doing electrical measurements work. Reads resistance from .01 Ohms to 10 meg., capacitance from .00001 to 100 MFD, inductance from 10 microhenries to 100 henries, dissipation factor from .002 to 1, and storage factor from 1 to 1000. And you don't have to worry about selecting the proper bridge circuit for the various measurements—the instrument automatically makes the correct circuit when you set up for taking the measurement you want. Bridge utilizes Wheatstone, Hay, Maxwell, and capacitance comparison circuits for the wide range and types of measurements possible. And it's self powered—has internal battery and 1000 cycle hummer. No external generator required—has provisions for external generator if measurements at other than 1000 cycles are desired. Kit utilizes only highest quality parts. General Radio main calibrated control. Mallory ceramic switches, excellent 200 microamp zero center galvanometer, laboratory type binding posts with standard 3/4 inch centers, 1% precision ceramic-body type multiplier resistors, beautiful birch cabinet and ready calibrated panel. (Headphones not included.)

**\$69<sup>50</sup>**

Take the guesswork out of electrical measurements—order your Heathkit Impedance Bridge kit today—you'll like it.

### Heathkit LABORATORY RESISTANCE DECADE KIT



**\$19<sup>50</sup>**

Shipping Wt. 4 lbs.

An indispensable piece of laboratory equipment—the Heathkit Resistance Decade Kit gives you resistance settings from 1 to 99,999 ohms IN ONE OHM STEPS. For greatest accuracy, 1% precision ceramic-body type resistors and highest quality ceramic wafer switches are used.

Designed to match the Impedance Bridge above, the Resistance Decade Kit has a beautiful birch cabinet and attractive panel. It's easy to build, and comes complete with all parts and construction manual.

### Heathkit LABORATORY POWER SUPPLY KITS

*Limits:*

No load	Variable	150-400V DC
25 MA	Variable	30-310V DC
50 MA	Variable	25-250V DC

Higher loads: Voltage drops off proportionally



**\$29<sup>50</sup>**

Model PS-1...Ship. Wt. 20 lbs.

Every experimenter needs a good power supply for electronic setups of all kinds. This unit has been expressly designed to act as a HV supply and a 6.3 V filament voltage source. Voltage control allows selection of HV output desired (continuously variable within limits outlined), and a Volts-Ma switch provides choice of output metering. A large plainly marked and direct reading meter scale indicates either DC voltage output in Volts or DC current output in Ma. (Range of meter 0-500V D.C., 0-200 Ma. D.C.). Instrument has convenient stand-by position and pilot light. Comes with power transformer, filament transformer, meter, 5Y3 rectifier, two 1619 control tubes, completely punched and formed chassis, panel, cabinet, detailed construction manual, and all other parts to make the kit complete.

### Heathkit ECONOMY . . . 6 WATT AMPLIFIER KIT

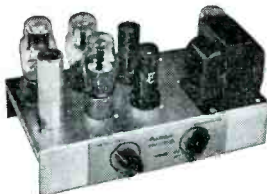

Model A-4  
Ship. Wt. 8 lbs.

**\$12<sup>50</sup>**

No. 304 12 inch speaker . . . **\$6.95**

This fine Heathkit Amplifier was designed to give quality reproduction and yet remain low in price. Has two preamp stages, phase inverter stage, and push-pull beam power output. Comes complete with six tubes, quality output transformer (to 3-4 ohm voice coil), husky cased power transformer and all other parts. Has tone and volume controls. Instruction manual has pictorial for easy assembly. Six watts output with response flat  $\pm 1\frac{1}{2}$  db from 50 to 15,000 cycles. A quality amplifier kit at a low price. Better build one.

### Heathkit HIGH FIDELITY . . . 20 WATT AMPLIFIER KIT

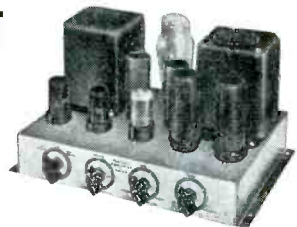

**\$33<sup>50</sup>**

Shipping Wt. 18 lbs.

Our latest and finest amplifier—the model A-6 (or A-6A) is capable of a full 20 Watts of high fidelity output—good faithful reproduction made possible through careful quality design and the use of only highest quality components. Frequency response within  $\pm 1$  db from 20-20,000 cycles. Distortion at 3 db below maximum power output (at 1000 cycles) is only .8%. The power transformer is rugged and conservatively rated and will deliver full plate and filament supply with ease. The output transformer was selected because of its exceptionally good frequency response and wide range of output impedances (4-8-16-150-600 ohms). Both are Chicago Transformers in drawn steel case for shielding and maximum protection to windings. The unit has dual tone controls to set the output for the tonal quality desired—treble control attenuates up to 15 db at 10,000 cycles—bass control gives bass boost up to 10 db at 50 cycles. Tube complement consists of 5U4G rectifier, 6SJ7 voltage amplifier, 6SN7 amplifier and phase splitter, and two 6L6's in push-pull output. Comes complete with all parts and detailed construction manual. (Speaker not included.)

**MODEL A-6:** For tuner and crystal phono inputs. Has two position selector switch for convenient switching to type of input desired.

**MODEL A-6A:** Features an added 6SJ7 stage (preamplifier) for operating from variable reluctance cartridge phono pickup, mike input, and either tuner or standard crystal phono pickup. A three position selector switch provides flexible switching.

**\$35.50**  
Shipping Wt. 18 lbs.

**YOU SAVE BY ORDERING DIRECT FROM MANUFACTURER—USE ORDER BLANK ON LAST PAGE**

EXPORT AGENT  
**ROCKE INTERNATIONAL CORP.**  
13 E. 40th ST.  
NEW YORK CITY (16)  
CABLE: ARLAB-N.Y.

*The* **HEATH COMPANY**

**. . . BENTON HARBOR 20, MICHIGAN**





## NEW 1952 *Heathkit* BATTERY ELIMINATOR KIT

- Can be used as battery charger.
- Continuously variable output 0 - 8 Volts — not switch type.
- Heavy duty Mallory 17 disk type magnesium copper sulfide rectifier.
- Automatic overload relay for maximum protection. Self-resetting type.
- Ideal for battery, aircraft and marine radios.
- Dual Volt and Ammeters read both voltage and ampereage continually — no switching.

The new Heathkit Model BE-2 incorporates the best. Continuously variable output control is of the variable transformer type with smooth wiper type contacts.

There are no switches or steps and voltage between 0 and 8 Volts is available at 10 Amperes continuous and 15 Amperes intermittent. Maximum safety from overloads and shorts provided by automatic overload relay which resets itself when overload is removed.

The new rectifier is a 17 plate Mallory magnesium copper sulfide type. This is the most rugged type available for long trouble-free use.

Output is continuously metered by both a 0 - 10 Volt Voltmeter and a 0 - 15 Amp Ammeter. Shorted vibrators indicated instantly by ammeter.

Equip now for all types of service — aircraft — marine — auto and battery radios — this inexpensive instrument vastly increases service possibilities — better be ready when the customer walks in.

**\$24<sup>50</sup>**

Model BE-3  
Shipping Wt. 17 lbs.

## NEW *Heathkit* SINE AND SQUARE WAVE AUDIO GENERATOR KIT

Designed with versatility, usefulness, and dependability in mind, the AG-7 gives you the two most needed wave shapes right at your fingertips — the sine wave and the square wave.

The range switch and plainly calibrated frequency scale give rapid and easy frequency selection, and the output control permits setting the output to any desired level.

A high-low impedance switch sets the instrument for either high or low impedance output — on high to connect a high impedance load, and on low to work into a low impedance transformer with negligible DC resistance.

Coverage is from 20 to 20,000 cycles, and distortion is at a minimum — you can really trust the output wave shape.

Six tubes, quality 4 gang tuning condenser, power transformer, metal cased filter condenser, 1% precision resistors in the frequency determining circuit, and all other parts come with the kit — plus, a complete construction manual — A tremendous kit, and the price is truly low.



Model AG-7  
Shipping Wt. 15 lbs.

**\$34<sup>50</sup>**

## THE NEW *Heathkit* HANDITESTER KIT

A precision portable volt-ohm milliammeter. Uses only high quality parts — All precision 1% resistors, three deck switch for trouble-free mounting of parts, specially designed battery mounting bracket, smooth acting ohm adjust control, beautiful molded bakelite case, 400 micro-amp meter movement, etc.

DC and AC voltage ranges 10 - 30 - 300 - 1000 - 5000V. Ohms range 0 - 3000 and 0 - 300,000. Range Milliampères 0 - 10 Ma, 0 - 100 Ma. Easily assembled from complete instructions and pictorial diagrams.



**\$13<sup>50</sup>**

Model M-1  
Shipping Wt. 3 lbs.

## NEW *Heathkit*

## T.V. ALIGNMENT GENERATOR KIT

Here is an excellent TV Alignment Generator designed to do TV service work quickly, easily, and properly. The Model TS-2 when used in conjunction with an oscilloscope provides a means of correctly aligning television receivers.

The instrument provides a frequency modulated signal covering, in two bands, the range of 10 to 90 Mc. and 150 to 230 Mc. — thus, ALL ALLOCATED TV CHANNELS AS WELL AS IF FREQUENCIES ARE COVERED.

An absorption type frequency marker covers from 20 to 75 Mc. in two ranges — therefore, you have a simple, convenient means of frequency checking of IF's, independent of oscillator calibration.

Sweep width is controlled from the front panel and covers a sweep deviation of 0-12 Mc. — all the sweep you could possibly need or want.

And still other excellent features are: Horizontal sweep voltage available at the front panel (and controlled with a phasing control — both step and continuously variable attenuation for setting the output signal to the desired level — a convenient instrument stand-by position — vernier drive of both oscillator and marker tuning condensers — and blanking for establishing a single trace with base reference level. Make your work easier, save time, and repair with confidence — order your Heathkit TV Alignment Generator now!

Model TS-2  
Shipping Wt. 20 lbs.

**\$39<sup>50</sup>**

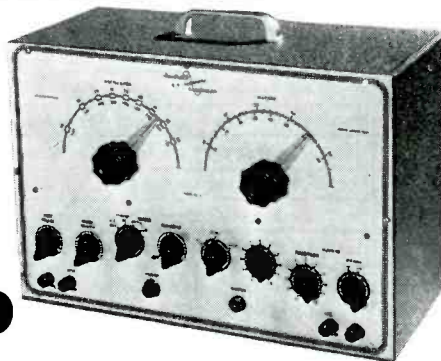

**YOU SAVE BY ORDERING DIRECT FROM MANUFACTURER—USE ORDER BLANK ON LAST PAGE**

REPORT AGENT  
ROCKE INTERNATIONAL CORP.  
13 E. 40th ST.  
NEW YORK CITY (16)  
CABLE: ARLAB-N.Y.

*The* **HEATH COMPANY**

**... BENTON HARBOR 20, MICHIGAN**

# Heathkit RECEIVER & TUNER KITS for AM and FM

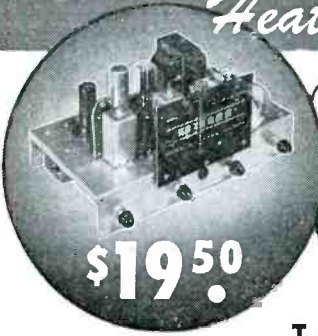

Model BR-1 Broadcast Model Kit covers 550 to 1600 Kc. Shipping Wt. 10 lbs.

**\$19<sup>50</sup>**

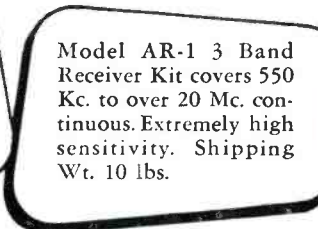

Model AR-1 3 Band Receiver Kit covers 550 Kc. to over 20 Mc. continuous. Extremely high sensitivity. Shipping Wt. 10 lbs.

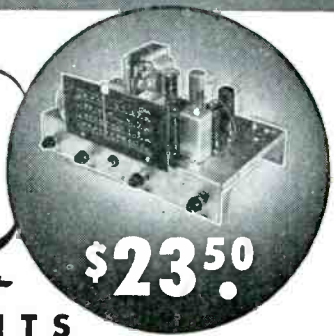

**\$23<sup>50</sup>**

## TWO HIGH QUALITY *Heathkit* SUPERHETRODYNE RECEIVER KITS

Two excellent Heathkits. Ideal for schools, replacement of worn out receivers, amateur and custom installations.

Both are transformer operated quality units. The best of materials used throughout—six inch calibrated slide rule dial—quality power output transformers—dual iron core shielded. I.F. coils—metal cased filter condenser. The chassis has phono input jacks, 110 Volt output for phono motor and there is a phono-radio switch on panel. A large metal panel simplifying installation in used console cabinets is included. Comes complete with tubes and instruction manual incorporating pictorials and step-by-step instructions (less speaker and cabinet). The three band model has simple coil turret which is assembled separately for ease of construction.

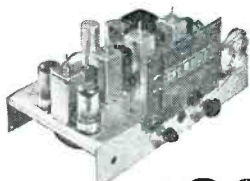

Model FM-2  
Ship. Wt. 9 lbs.

**\$22<sup>50</sup>**

## TRUE FM FROM *Heathkit* FM TUNER KIT

The Heathkit FM Tuner Model FM-2 was designed for best tonal reproduction. The circuit incorporates the most desirable FM features—true FM.

Utilizes 8 tubes: 7E5 Oscillator, 6SH7 mixer, two 6SH7 IF amplifiers, 6SH7 limiter, two 7C4 diodes as discriminator, and 6X5 rectifier.

The instrument is transformer operated making it safe for connection to any type receiver or amplifier. Has ready wound and adjusted RF coils, and 2 stages of 10.7 Mc IF (including limiter). A calibrated six inch slide rule dial has vernier drive for easy tuning. All parts and complete construction manual furnished.



## ORDER BLANK

From \_\_\_\_\_  
 \_\_\_\_\_  
 \_\_\_\_\_

SHIP VIA

- Parcel Post
- Express
- Freight
- Best Way

Quantity	Item	Price	Quantity	Item	Price
	Heathkit Oscilloscope Kit — Model O-7			Heathkit H.V. Probe Kit — No. 336	
	Heathkit VTVM Kit — Model V-5			Heathkit R.F. Signal Gen. Kit — Model SG-6	
	Heathkit FM Tuner Kit — FM-2			Heathkit Condenser Checker Kit — Model C-2	
	Heathkit Broadcast Receiver Kit — Model BR-1			Heathkit Handitester Kit — Model M-1	
	Heathkit Three Band Receiver Kit—Model AR-1			Heathkit Power Supply Kit — Model PS-1	
	Heathkit Amplifier Kit — Model A-4			Heathkit Resistance Decade Kit — Model RD-1	
	Heathkit Amplifier Kit — Model A-6 (or A-6A)			Heathkit Impedance Bridge Kit — Model IB-TB	
	Heathkit Tube Checker Kit — Model TC-1			Heathkit A.C. VTVM-KIT — Model AV-1	
	Heathkit Audio Generator Kit — Model AG-7			Heathkit Intermodul. Analyzer Kit—Model IM-1	
	Heathkit Battery Eliminator Kit — Model BE-2			Heathkit Audio Freq. Meter Kit — Model AF-1	
	Heathkit Electronic Switch Kit — Model S-2			Heathkit Square Wave Gen. Kit — Model SQ-1	
	Heathkit T.V. Alignment Gen. Kit — TS-2				
	Heathkit Signal Tracer Kit — Model T-2				
	Heathkit R.F. Probe Kit — No. 309				

On Parcel Post Orders, include postage for weight shown and insurance. (We insure all shipments.)

On Express Orders, do not include transportation charges — they will be collected by the Express Agency at time of delivery.

Enclosed find  Check  Money Order for \_\_\_\_\_

Please ship C.O.D.  Postage enclosed for \_\_\_\_\_ lbs.

ALL PRICES SUBJECT TO CHANGE WITHOUT NOTICE

EXPORT AGENT  
 ROCKE INTERNATIONAL CORP.  
 13 E. 40th ST.  
 NEW YORK CITY (16)  
 CABLE: ARLAB-N.Y.

# The HEATH COMPANY

... BENTON HARBOR 20, MICHIGAN

## GLow-LAMP COUNTING RING

One of the simplest electronic counters yet designed has recently been patented by Russell Sydnor Crenshaw, Jr., of the U.S. Navy. It utilizes the flip-flop characteristics of an ordinary neon or other glow-lamp. The lamp fires when fed with a voltage higher than its striking potential. Then conduction is maintained at some lower operating voltage. The lamp is triggered from one stable state (conductive or nonconductive) to the other by the pulses to be counted.

it reduces the voltage across T0 so that it cannot sustain conduction. For a moment all lamps are extinguished so the voltage across each tends to rise. Note, however, that the charge on C2 is in a direction which adds to the supply voltage on T1. Therefore this lamp is fired first. As soon as it passes current the voltage across the other lamps drops too low for conduction.

Now R3 and R4 are passing current. The drop across R3 biases X2 to conduction. C2 is discharged. The voltage

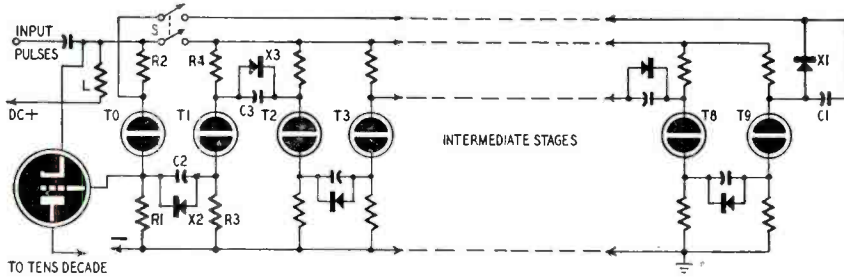

Each of the counter stages needs only one neon or other glow-lamp, a rectifier, several resistors, and a capacitor. The power supply may be 115 volts d.c. The counter is more compact than vacuum-tube types and does not need a filament supply. Furthermore the lamps automatically indicate the progress of the count. However, gas tubes require time to de-ionize. This limits the counting speed of the instrument.

The counter's schematic is shown above. Each decade counting ring requires ten stages, of which six are drawn here. The others are connected in a similar manner and need not be shown. Initially, only T0 conducts. This is assured by momentarily opening switches S. When they are closed again, T0 continues to pass current. Due to the voltage drop across the limiting resistor L there is insufficient potential across the other lamps to fire them.

While T0 conducts, current flows through R1 and R2. The voltage drop across R1 is in a direction to block rectifier X2 so capacitor C2 becomes charged. The direction of the voltage across R2 causes X1 to conduct so C1 cannot charge.

When a negative signal pulse arrives,

across R4 blocks X3. This permits C3 to take a charge (positive terminal toward T2).

When a second negative pulse is impressed on the counter, T1 is extinguished. Again all lamps are off momentarily. The voltage on all lamps begins to rise but T2 is fired first because it is fed by the d.c. supply in series-aiding with the charge on C3. With T2 passing current, the voltage on the other lamps is reduced below the striking value.

In this way the count progresses down the ring. Each successive negative pulse ignites the next lamp in line and extinguishes the previous one. The tenth pulse ignites T0 again and blocks T9. This produces a positive pulse at the T0 cathode and the control grid of the triode tube. The triode output is a negative pulse which triggers the tens decade. The latter is operated once for every ten pulses to the units decade. Additional decades may be added for hundreds, thousands, etc.

This counter will probably replace presently used circuits for many applications. It is covered by patent No. 2,549,779 and may be used by the U.S. Government without royalties.

## SENSITIVE BATTERY-POWERED RELAY

Amateurs, experimenters, and builders of radio-controlled models often have need for a sensitive battery-operated d.c. relay like the one described here through courtesy of the Cornell-Dubilier Electric Corp. The relay closes when a d.c. control signal of 1 to 1.5 volts is applied to its input terminals. The control signal can be taken from a phototube, the a.v.c. line of a receiver, from a microphone and rectifier combination, or any source delivering 1 or 2 volts at a few microamperes.

To adjust the relay, set the 50,000-ohm control to the point where the relay just drops out with no signal applied to the input terminals. The relay should pull in when a control signal

is applied. If it does not, adjust the setting of the 500-ohm cathode biasing resistor to the point where the relay closes when the signal is applied. Keep the input leads short and well shielded to prevent stray a.c. fields from tripping the relay.

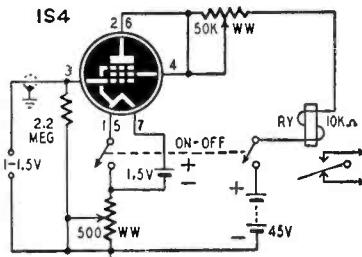

# Learn Radio TELEVISION

through this UNIT CHASSIS SYSTEM

The exclusive "Unit Chassis System" of teaching television was developed at this 48-year-old College of Electrical Engineering. The TV set is divided into stages on separate chassis. You study one stage at a time, intimately learning the functions of every component of all types and makes of receivers. You are fully prepared to cope with future design changes, including the advent of color television. By enrolling NOW you will be ready for engineering employment opportunities predicted to reach a new high level in 1954.

## You can become a Radio Technician in 12 months

The first third of the College of Electrical Engineering program trains you for such positions as Radio Shop Operator or Serviceman, Supervisor of Service Personnel. The Radio Technician's certificate is awarded. You may then advance immediately or at a future date into courses described below.

## Radio-Television Certificate in 6 additional months

Be prepared for such work as Radio TV Service—Audio, Transmitter or Communication Technician—and Broadcast Operator (upon passing FCC examination).

## Also Your Technician Courses are credited toward the B. S. Degree in ELECTRICAL ENGINEERING.

The Radio Technician course, while complete in itself, is one-third of the college program (major in electronics). Further, you may select as an elective: design, research, manufacturing and production, or engineering sales and management.



B.S. Degree in 36 months. Military, practical or prior academic, training evaluated for advanced credit. Terms open January, April, July, October.

# MILWAUKEE SCHOOL of ENGINEERING

Technical Institute • College of Electrical Engineering

FREE—Write for "Occupational Guidance Manual" and 1951 Catalog.

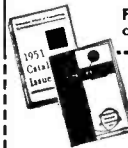

MILWAUKEE SCHOOL OF ENGINEERING Dept. RE-1251, 1025 N. B'way, Milwaukee, Wisconsin

Without obligation, mail  Your Career Bulletin,  1951 Catalog, Occupational Guidance Bulletin on Radio-TV,  Electrical Engineering, B.S. Degree in Electronics,  Electrical Power. Also bulletin on Electrical Service,  Welding,  Refrigeration, Heating, Air Conditioning.

Name..... Age.....

Address.....

City..... State.....

If Veteran, indicate date of discharge

# 4 SENSATIONAL VALUES

for immediate delivery from stock

NOT KITS but completely wired and factory guaranteed instruments

## TEST-CRAFT Model TC-10 Quality Multitester

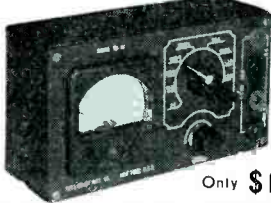

Only \$12.85

AC and DC Voltage Ranges: 0-5/15/150/1500/3000 Volts. DC Current Ranges: 0-5/50 ma. 0-1.5 Amps. Resistance Ranges: 0-100 ohms, 0-100 K. Size: 6"x3 1/2"x2". Complete with batteries and full instructions.

## TEST-CRAFT Model TC-75 Combination Test Speaker and Signal Tracer

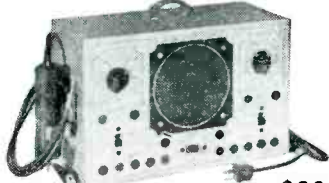

Only \$29.50

plus speaker substitution plus resistor tester plus condenser tester plus output indicator plus field substitutor plus voice coil substitution Complete with full instructions

## TEST-CRAFT Model TC-50 Tube and Set Tester

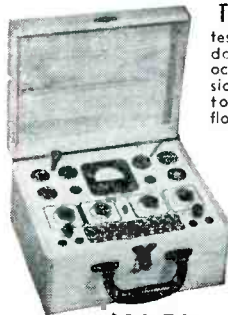

tests all tubes up-to-date incl. 4, 5, 6, 7L, octals, loctals, television, magic eye, thyristors, single ended floating filament, mercury vapor, new miniatures, etc.

Multimeter Specifications: AC and DC Voltage Ranges: 0-1-100-1000-5000 DC Current Ranges: 0-10/100/1 Amp Low Resistance Range: 0-10,000 Ohms Medium Resistance Range: 0-100,000 Ohms.

Only \$39.50

High Resistance Range: 0-1 megohm. Complete with test leads and full instructions

## MODEL 999 Combination Television, F.M. and A.M. Signal Generator and Signal Tracer

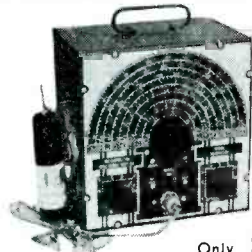

Only \$28.85

Generates R.F. frequencies from 150 kilocycles to 50 megacycles. Battery operated, no external source of current required. Positive action attenuator provides effective output control at all times. R.F. is obtainable separately or modulated by the Audio Frequency. Complete with test leads and full instructions. 25% with order, balance C.O.D. or full check with order.

METROPOLITAN ELECTRONICS & INSTRUMENTS CO. Dept. D 106 Fifth Ave., New York, N.Y.

## AUGUST TV FIELD STRENGTH METER MODIFIED

Readers who constructed the TV field-strength meter described on page 72 of the August issue will probably find it difficult to obtain an RK62 for the second detector. Raytheon abandoned this tube in favor of the RK61 which is the miniature version. Unfortunately production of the RK61 has been temporarily suspended because of high-priority military orders. Since there is no direct substitute which will provide the sensitivity of the RK61 or RK62, the field-strength meter has been modified to permit the use of a 957 like that used in the local oscillator circuit.

A recent issue of *Aerovox Research Worker* describes changes which permit a 957 acorn-type triode to be substituted for the RK62. The modified circuit works almost as well as the original when the original 1-ma meter is replaced by a unit having full-scale deflection of 100  $\mu$ a or less. If such a meter is not available, the instrument may be fitted with pin jacks for connecting the low-current range of a multimeter. A meter having a sensitivity of 10,000 ohms per volt can be used. The revised circuit of the super-regenerative i.f. amplifier and second detector is shown.

Maximum sensitivity requires careful selection of the value of the grid resistor and careful adjustment of coupling between L2 and L3. The average value of the grid resistor is 1 megohm. Try slightly higher and lower values and vary the coupling between coils. Use the values producing greatest change in plate current for a given input signal. Two turns were added to the detector coil to compensate for the lower grid-to-filament capacitance of the 957. L3 now has 21 turns. Wire size, coil diameter, and winding length are the same as in the original model.

Because the meter in the revised circuit is more sensitive than the one used in the original circuit, special precau-

tions must be observed to protect it against excessive current. Before installing the meter and bucking-voltage battery, connect a 1- or 2-ma meter in place of the meter shown in the diagram. Connect this meter with its positive terminal going to the arm of the regeneration control. Close both switches and adjust the regeneration control so the meter reads close to 500  $\mu$ a. Carefully mark this position on the scale

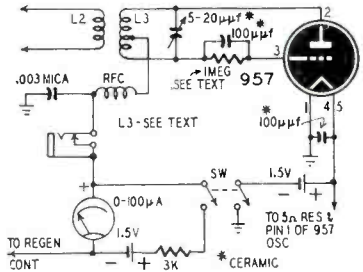

of the regeneration control. Open both switches and install the 100- $\mu$ a meter and battery which supplies the bucking voltage through the meter. Be sure that both meter and battery are polarized as shown in the diagram.

When operating the instrument, always close the standby switch and advance the regeneration control to the predetermined 500- $\mu$ a point before closing the filament switch. When the switch is closed, plate current flows but it is bucked out by the 500- $\mu$ a current flowing through the meter from the opposite direction. This produces a near-zero reading on the meter. Touch-up the adjustment of the regeneration control to bring the meter to zero. An incoming signal will cause the meter to read upward. A strong one will produce a reading of 50 to 75  $\mu$ a when the value of the grid resistor and the coupling between L2 and L3 are optimum.

## "HOT" BASIC OSCILLATOR UNIT

This crystal oscillator circuit is recommended by the Petersen Radio Company, Inc., of Council Bluffs, Iowa. It gives generous harmonic output of the crystal as high as the fourth.

The 15- $\mu$ mf and 500- $\mu$ mf capacitors, with the crystal acting as an inductor, make a Colpitts oscillator. The screen is used as the anode for the oscillator section. The plate circuit is tuned to the desired harmonic. The crystal oscillates at its fundamental regardless of whether the plate is tuned to a harmonic or not. A pronounced plate-current dip appears when the plate circuit is tuned to the fundamental and lesser dips when harmonics are tuned in.

This oscillator provides sufficient output on the fourth harmonic to drive a 2E26 or equivalent.

If you plan to use this oscillator on its higher harmonics, it is advisable to use link coupling rather than the impedance (capacitive) coupling shown in the diagram. Link coupling provides a

means of efficient impedance matching between the stages and makes possible higher voltages on the grid of the following stage. In addition to minimizing

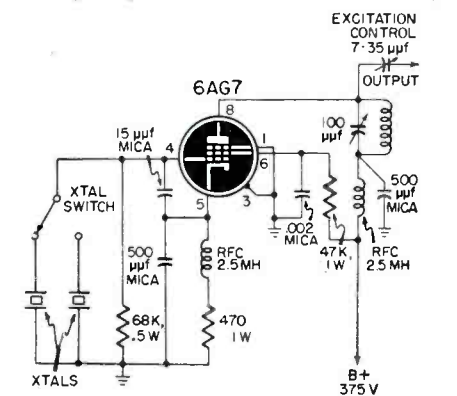

power losses, link coupling is a convenient means of reducing radiation of spurious signals. The latter factor is important in TV areas.



**FREE!** **BIG NEW 1952 CONCORD CATALOG**



Send for it NOW!

**YOUR COMPLETE BUYING GUIDE for every need in— TV • RADIO • ELECTRONICS**

You save time and money—with this bigger, better 1952 Buying Guide! Here is page-after-page full of the latest and greatest values in Television, Radio and Electronics. It brings right to your finger tips one of the world's largest stocks of nationally-known guaranteed quality parts and equipment—High Fidelity, TV, and Radios, Phonos, and Recorders, Sound Systems, Ham Gear, Test Equipment, Electronic Tubes, Parts, Books, Kits, and Tools. You find it quick and easy to get whatever you need—at the very lowest prices. Send for your FREE Concord Catalog today! Have it handy for quick reference.

**LOWEST PRICES — FAST DELIVERY POSITIVE SATISFACTION**

Supplies for Industry, TV & Broadcast Stations, Schools, Servicemen, Hams, Government, Experimenters & Builders.

**HIGH FIDELITY**—Complete systems and custom components.

**INDUSTRIAL DIVISION**—Experienced staff and centralized efficiency.

**EXPORT DIVISION**—Prompt service on orders and inquiries.

**CONCORD RADIO CORPORATION**  
901 W. JACKSON BLVD. • CHICAGO 7

CONCORD RADIO CORP., Dept. JM-51  
901 W. Jackson Blvd., Chicago 7, Ill.

Rush FREE Big, New CONCORD Catalog

Name \_\_\_\_\_

Address \_\_\_\_\_

City \_\_\_\_\_ Zone \_\_\_\_\_ State \_\_\_\_\_

**HANDY TOOL FOR COAX**

A Gillette office knife is a handy item to keep around the shop or shack. This rugged knife is constructed like a scalpel and its replaceable blades are razor sharp. Its full-size handle fits the palm so you can apply enough force to make a clean cut in or through coax—even RG-8/U. If you have previous experience at cutting RG-8/U, I'm sure you will appreciate the clean cuts which can be obtained.

The knife can be purchased at most stationery and office-supply stores for about a dollar, and replaceable blades are only a few cents each.—Milton Kalashian, W1NXT

**CAPACITOR SUBSTITUTION BOX**

For the past several months, I have been using a capacitor substitution box which I find very useful in TV and radio servicing. Using only 21 capacitors and an equal number of s.p.s.t.

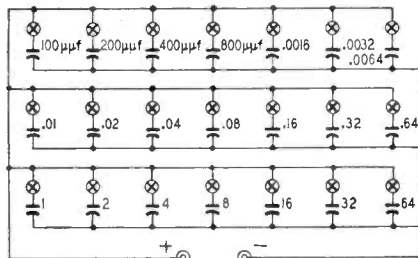

switches in the circuit shown, I can cover a range of 54 different capacitances. The components are mounted in a 4 x 5 x 9-inch metal box with switches and terminals on the front. Connections are made so stray capacitance is minimized.

You won't realize how handy one of these little gadgets can be till after you have used it for a few weeks.—George E. Row

**TV CHASSIS SUPPORT**

When servicing TV sets, it is often necessary to stand the chassis on end to expose the wiring underneath. When the picture tube and deflection yoke are mounted on the chassis, the assembly is very top-heavy, making it difficult to keep the chassis in a position convenient for under-chassis servicing.

I have solved the problem by using stiff wire hooks suspended by adjustable straps fastened to the ceiling or a shelf above the workbench. The chassis can be safely supported in any convenient position by engaging the hooks at the top end. This system permits the assembly to be pivoted when making adjustments on both the top and under sides of the chassis.—Hyman Herman

**USING 160-METER XTALS**

If you have any crystals from the old 160-meter band, you can probably put them to work on 6 meters if they are between 1852 and 2,000 kc. Most of these crystals will oscillate on their third harmonic without any special multiplier or feedback circuits. Thus, you can hit 6 meters by using a simple oscillator followed by two low-power triplers.—S. H. Beverage, W1MGP

**Replace Your Old TV Aerial With The NEW Snyder**

**360° MOTORLESS TV AERIAL**

**SAME CLEAR PIX AS MOTOR ROTATING AERIAL SYSTEMS COSTING TRIPLE THIS PRICE**

**Only \$18.95**

Complete with 3 1/2" mast sections, 75 ft. of 3 cond. cable. Electronic beam selector switch. Connecting stubs, guy ring mounting base, "U" clamps.

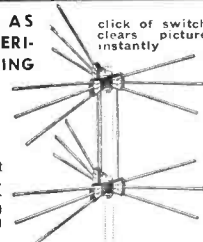

For Ultra Fringe Electronically beams in complete 360° rotation to give clear picture on all channels. You choose direction with Directronic selector switch. Mounted on or near TV set. 18 hi-tensil 3/8" aluminum alloy elements. Complete ready to install.

**AX-599 DIRECTRONIC ARRAY FOR FRINGE** Same as TX-599 less mast . . . . . 16.95  
**AX-56 DIRECTRONIC ARRAY FOR CITY AREA** 6 element array with switch, lead-in less mast \$9.50

**STEEL MAST SECTIONS** weather treated,  
10 Ft. 1 1/4" di. . . . . \$2.19  
5 Ft. 1 1/4" di. crimped end . . . . . 1.35  
Chimney Mount Brackets CM-100 . . . . . 1.59  
Wall Mount Brackets WB-2, Adj. to 18" Heavy Duty . . . . . 3.75

Order from Dept. RE-12, or call Mulberry 2134  
WRITE FOR FREE F.Y.I. BULLETIN

**WHOLESALE RADIO PARTS CO., Inc.**  
311 W. Baltimore St.  
**BALTIMORE 1, MD.**

**REK-O-KUT presents a New Continuously Variable-Speed Turntable of Broadcast Quality**



**Plays at any speed from 25 to 100 R. P. M., without "wow!"**

**Speed can be varied while in operation to produce sound effects.**

Now for the first time . . . a continuously variable turntable of Broadcast Quality at a popular price. Ideal for record collectors, musicians, singers, disc jockeys, broadcast stations, music schools, dance studios, skating rinks, gymnasiums, etc. Plays through amplifier, radio, TV set or phonograph. Operates on 50 or 60 cycles.

**Model CVS-12 (illustrated)**  
Chassis, motor and turntable . . . \$84.95 net.  
**Model CVS-12P**, mounted in portable case with 16" dual stylus pickup . . . \$124.95, net.

\*\*\*\*\*  
**3-Speed 12" Transcription Turntable**

Recommended by outstanding music critics. Induction-type motor designed for smooth, quiet, vibration-free operation. 3 speeds, 78, 45 and 33 1/3.

**Model LP-743** . . . \$54.95 net.  
\*\*\*\*\*

Write for Illustrated Catalog of REK-O-KUT Line of Hi-Fidelity Recording Instruments, Phonographs, Transcription Tables, Accessories.

**REK-O-KUT CO.**  
38-11 A Queens Blvd., L.I.C., N. Y.

**FILE CARD TUBE DATA**

Being tired of having my tube manual closing up or its pages turning over while in use, I bought another copy and a set of file cards and proceeded to cut up this copy and paste the base diagram and characteristics on the cards. Now, I slide out each card as I need it and it stays put.—*Fred F. Davis*

**SIMPLE BANDSPREAD TUNING**

My receiver covers the 550 to 1600-kc broadcast and 5 to 18-mc short-wave bands. Tuning was so critical on 14 mc that it was almost impossible to separate the stations until I installed a small bandspread tuning capacitor in the oscillator circuit. The capacitor was

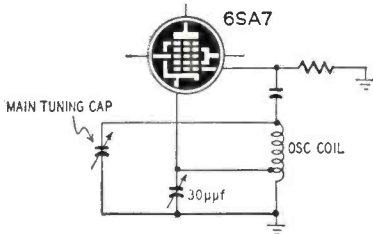

first connected in parallel with the oscillator section of the main tuning gang, but I found that considerably more spread was obtained by connecting it between ground and the cathode tap on the coil as shown in the diagram. The capacitor was installed close to the oscillator coil and a flexible coupling added to bring the control shaft through the front panel on the set.—*M. Dalla*

**THREADING RODS**

Short lengths of threaded brass, copper, and fiber rods are often needed in experimental work. If you do not have a die which will do the job, you can often use a steel nut of the proper size and with a clean-cut thread. With the unthreaded rod held tightly in a vise, you can, by applying considerable pressure, screw the nut onto the rod. When the nut is backed off, it will leave a perfect thread.—*Oscar E. Malech*

(It helps to file or grind a conical end on the rod so the nut can be slipped over it, making the cut easy to start. Another trick is to select a nut one size larger than normal and cut a slot through one side with a hacksaw. Slip the nut over the rod, then grip the nut tightly in a vise so that the pressure closes the gap, causing the threads to bite into the rod.—*Editor*

**OSCILLATOR CIRCUIT KINK**

When wiring in the grid leak of a superhet oscillator or converter, do not ground the bottom end of the resistor; bring it to a tie point and connect a resistor of 500 to 1,000 ohms between that point and ground. You now have a test point for checking oscillator grid current without breaking the circuit to insert the meter. The added resistance is large enough to prevent it from affecting the meter reading, yet so small it will not affect circuit operation.—*Charles Erwin Cohn*

—end—

**NEW!  
STANCOR**



Here are three of the newest additions to the most complete transformer replacement line in the industry.

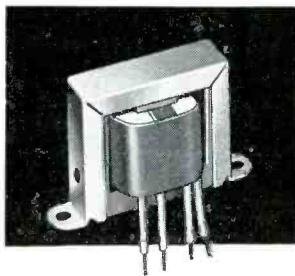

**A-8124, VERTICAL BLOCKING-OSCILLATOR TRANSFORMER**

A three winding transformer for replacement in 7 Dumont models, 9 Crosley models and Stromberg-Carlson model TV-125. See Stancor Bulletin 384.



**FC-11, FOCUS COIL.**

For use with picture tubes up to 24". Equivalent to RCA 202D2. See Stancor Bulletin 383.

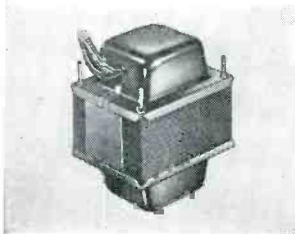

**P-8163, TV POWER TRANSFORMER**

Equivalent to RCA 75508 (971316-1), used in 28 RCA models. See Stancor Bulletin 388 for a complete list.

Your Stancor distributor has data sheets on these new Stancor TV transformers. Ask him for the latest Stancor Bulletins.

Other new Stancor TV components include **DY-8, DY-9, and DY-10**, 70° deflection yokes with ferrite cores, nylon coil bobbins and anti-astigmatic focusing (resulting from "cosine" distributed windings) for tubes up to 24". **A-8131**, an air core "flyback" for direct drive circuits, to be used with **DY-10**.

**STANCOR TV TRANSFORMER CATALOG AND REPLACEMENT GUIDE** lists transformer replacements for over 1500 TV models and chassis. Available **FREE** from your Stancor Distributor.



**STANDARD TRANSFORMER CORPORATION**

3592 ELSTON AVENUE, CHICAGO 18, ILLINOIS

Over 43,000 Technicians Have Learned

**HOW TO GET THE MOST OUT OF BASIC TEST EQUIPMENT**

Why Not You, Too?

**SERVICING by SIGNAL SUBSTITUTION**

A BEST SELLER FOR OVER 9 YEARS! (NEW, UP-TO-DATE, 12TH EDITION)

The Simple, Modern, Dynamic Speed Approach To Receiver Adjustment and Alignment Problems, AM-FM-TV.

- Nothing complex to learn
- No extra equipment to purchase
- Universal — non-obsolete
- Employs Only Basic Test Equipment

Ask for "S.S.S." at your local Radio Parts Jobber or order direct from factory.

**only 40¢**

100 pages. Invaluable information that will help you re-double the value of your basic test equipment.

PRECISION APPARATUS COMPANY, INC. • 92-27 Horace Harding Blvd., Elmhurst 4, N. Y.

## SPECIAL!! 6 TUBE AC-DC KIT

At Last! A low-priced kit designed for high sensitivity, excellent selectivity and good tone quality. Uses 25L6, 25Z6, 6SQ7, 6SA7, 6SK7, 6SK7 in an easily constructed circuit. The 6 Tube Kit is shipped with all parts, including punched chassis, resistors, condensers, coil, sockets, PM Speaker, hardware, etc.

And at a closeout price of only **\$6.95**  
X182 less tubes and cabinet

X183 Extra for matched set of six tubes for kit **\$3.25**

### 5 TUBE AC-DC SUPERHET KIT

Five tube superheterodyne kit, A.C.-D.C. contains all components required to construct this latest design, highly sensitive superheterodyne broadcast receiver complete with black bakelite cabinet (excludes wire and solder) Price \$7.95

Extra for a kit of five tubes (1-12SK7, 1-12SA7, 1-12SQ7, 1-35Z5 and 1-50L6) \$2.95.

### YOUR MONEY RETURNED IN FULL—

If the New Regency Television Booster fails to improve your television enjoyment! Bring your picture out of the snow and reduce interference!

- Push-Pull Neutralized triode design assures high gain without adding snow.
- No external impedance matching devices required.
- Inductive tuning assures same high-gain wide-band operation on all channels.
- Single knob tuning control.
- Underwriters approved with 90 day RMA guarantee.

LOWEST Price—ONLY **\$19.11**

### MODEL NFRD—RADIO NOISE FILTER

If it doesn't work, send it back!

We absolutely guarantee that our Model NFRD will eliminate all line noises when properly connected to radios, television sets, short wave sets, motors, electric shavers, refrigerators, vibrators, oil burners, transmitters, and all other sources of interference. This unit will carry up to 12 amperes or 1 1/4 KW of power and may be used right at the source of interference or at the radio.

Small size only 3"x1 1/2"x7 1/2". Very low price only  
Each **\$1.95**

### A SCIENTIFICALLY DESIGNED PHONO SCRATCH FILTER

Resonated at approximately 4500 cycles effectively reducing objectionable needle scratch without altering the brilliancy of reproduction.

Contains a HI-Q SERIES resonated circuit. Tested by means of an audio oscillator and an oscilloscope to give 22 db attenuation with very low signal loss.

EASY TO ATTACH

Just two wires to clip on. Compact **\$1.98**

### THREE TUBE PHONO AMPLIFIER

An assembled unit ready for installation using tone and volume control and six feet of rubber cord **\$2.95**

(Not including Tubes)

With Complete Set of Tubes **\$3.95**

### PHONO OSCILLATOR

Wireless phono oscillator transmits recording for crystal pick-ups or voice from carbon mike through radio without wires. Can also be used as an inter-camm by using P.M. speaker as mike.

Price (excluding tubes) **\$2.95**

With Complete Set of Tubes **\$3.95**

### CRYSTAL DIODES

Std. makes

IN34.....75 IN34A.....75 IN23B.....2.25

Satisfaction guaranteed on all merchandise  
All prices subject to change without notice.

## RADIO DEALERS SUPPLY CO.

154 Greenwich St. New York 6, N. Y.

### S-METER FOR S-38 RECEIVER

? Please print a diagram of an S-meter which I can add to my S-38 receiver. I do not have a diagram of the set, so please show the points to which I must connect the meter circuit.—J. L. S., New York, N. Y.

A. The S-meter circuit shown in the diagram was described in detail in the August, 1948, issue. It has been modified slightly to permit its use in the Hallicrafters S-38 receiver. Since this set has series-connected heaters, it is simpler to use a small filament transformer for the 6C4 meter tube than it is to rewire the heater string in the set. The grid of the 6C4 connects to the a.v.c. line in the set. This connection can be made to terminal 2 of the antenna transformer. A drawing of the transformer and its terminal numbers is shown below the schematic of the S-meter.

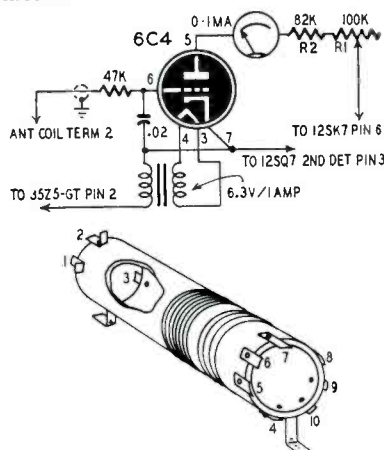

Short-circuit the antenna terminals and adjust R1 so the meter reads full scale. The needle should fall to zero on a strong local station. If it does not, try varying the value of R2.

### AUDIO PREAMP POWER SUPPLY

? Please design a power supply which will deliver d.c. plate and heater voltages for the preamplifier and equalizer described in the article "Engineered Amplifier Brings Audio Realism" in the February, 1951, issue.—O.R.N., Jr., Cornwells Heights, Pa.

A. The power supply shown delivers well-filtered plate voltage for the plates

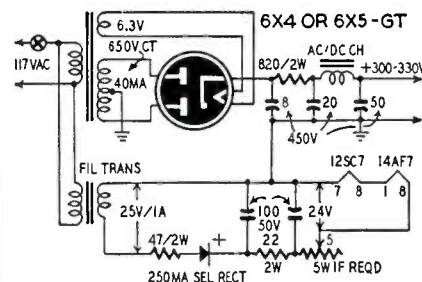

of the tubes as well as 24 volts d.c. at 150 ma for the heaters. The 5-ohm variable resistor is required only if the output from the heater supply exceeds 24 volts. The filament transformer may be a Stancor type P-6469 or equivalent.

### TUBE BASE AND DATA

? I have a Raytheon CK1013/5517 tube which I want to use in a strobe flash unit. Please print pin connections and the voltage and current ratings on this tube.—O. C. A., Holloman AFB, New Mexico.

A. The CK1013/5517 tube mounts in a 7-pin button socket with pin connections as shown. The plate connects to the top cap. The exhaust tip comes out

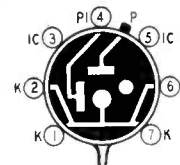

IC=INTERNAL CONN PI=STARTER ANODE  
CK1013/5517

the side of the envelope in the sector between pins 1 and 7. Pins 3 and 5 are internal connections which cannot be used as tie-points and must not be connected to any external circuit except the cathode.

The tube is a half-wave, cold-cathode, gas-filled rectifier. Maximum r.m.s. supply voltage is 1,200 and the minimum is 550. Average cathode current is 6 ma. The maximum safe cathode current (steady state) is 50 ma and the maximum surge current is 150 ma. A resistance of about 10,000 ohms should be used in series with the plate so the plate current will not exceed these values. The starter anode connects to the plate through a 10-megohm resistor to limit its current. Plate-to-cathode drop is 100 volts at 6 ma cathode current.

### ANTENNA FOR 152-162 MC

? I have a receiver for use in the 152-162-mc band and would like to have construction details on a vertical antenna to use with it. Can you help me?—C. C., Newark, N. J.

A. A number of vertical antennas can be used for v.h.f. communications. Perhaps the simplest is the "J" antenna shown in the diagram. It consists of a vertical half-wavelength radiator fed at the base through a quarter-wavelength matching section. If the antenna is to be used for reception throughout the band, the total length of the longer section should be approximately 54 1/4 inches and the shorter leg should be 19 inches long. The antenna may be made from rods 1/4 to 1/2 inch in diameter. They should be spaced 3 to 4 inches apart for use with coaxial cable between 50 and 80 ohms. The inner conductor of the radiator line connects to the base of the radiator and the outer conductor to the bottom of the shorter element. This point may be connected to a

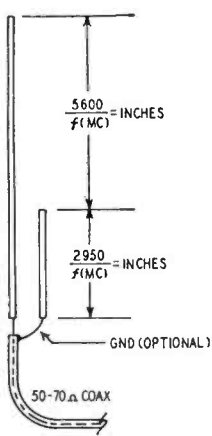



grounded metal mast to provide protection against lightning.

If the antenna is to be used mainly for reception on one frequency, use the formulas shown on the diagram to compute the lengths of the radiator and matching stub.

**AUDIO FOR FM TUNER**

? I have a Meissner model 8C FM tuner to which I would like to add a power amplifier which can be operated from the tuner's power supply and will supply enough power for a small PM speaker. Can you tell me how to do this? —H. D., New York, N. Y.

A. The power supply of the tuner is operating close to maximum capacity, so

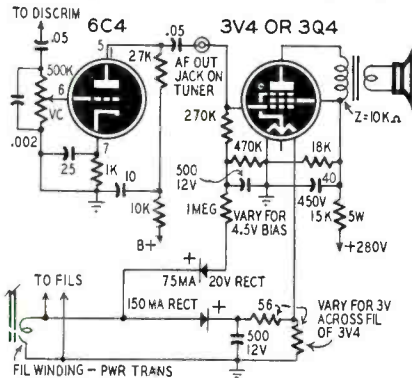

we have designed a power amplifier using a battery-type amplifier tube instead of one of the 6-volt types which draw considerably more plate and screen current. The 3V4 or 3Q4 draws a total of about 10 ma as compared to 40 ma or more for 6-volt tubes. Filament and bias voltages are obtained by rectifying voltage obtained from the heater winding on the power transformer.

**PHILCO 38-116 AS TUNER**

? I have a Philco model 38-116 receiver which I want to convert to a tuner for use with a high-fidelity amplifier and speaker system located in the basement. Please tell me how I can remove the audio circuits in the set without disturbing the fixed bias applied to the other tubes.—O.M.B., Flint, Mich.

A. With the set operating normally, measure the cathode currents of the 6J5 driver and push-pull 6L6-G output tubes. Add the cathode currents. Now measure the voltage on the screen grid of one of the 6L6's. Remove the 6J5 and 6L6's from the circuit along with all resistors and capacitors immediately associated with their plate and grid circuits. Do not remove the resistors which supply grid bias for the 6J5, as this network also supplies bias for the 6R7-G first a.f. tube.

A bleeder resistor must be connected between the output side of the 85-ohm filter choke and ground. The value of the resistor must be adjusted so the bleeder current equals the total cathode currents of the 6J5 and 6L6 tubes. Bleeder resistance is found by dividing the normal B-plus voltage by the bleeder current. Its wattage rating should be about 25% higher than the

HEART OF A *good* RECORD-CHANGER

It's General Industries' turret-type, 3-speed motor, currently being supplied to record-changer manufacturers.

In this highly efficient design, turntable speeds of 33 1/3—45 and 78 RPM are secured through three separate pulleys mounted on a turret plate. By means of a simple lever, the desired pulley is brought into contact with the idler wheel. The two pulleys not in contact with the idler wheel remain stationary.

In addition to this turret-type motor, General Industries also offers the popular Model TR turret-type, manual 3-speed motor, as well as the Model TS belt-driven 3-speed motor for both manual and record-changer applications. Write today for full information on all models.

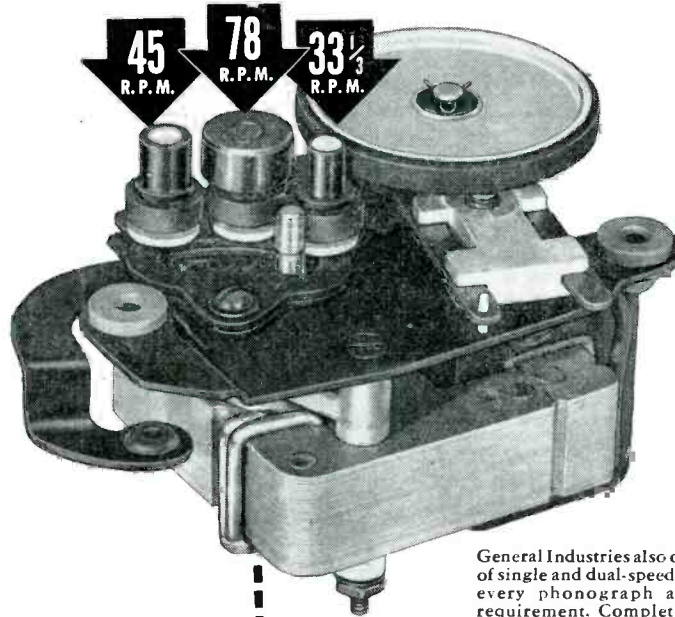

General Industries also offers a complete range of single and dual-speed phonomotors to meet every phonograph and record-changer requirement. Complete details on request.

**The GENERAL INDUSTRIES Co.**

DEPARTMENT C • ELYRIA, OHIO

**WILL BUY OR TRADE**

NEED BC-611 or BC-721 Handie-Talkie or any part: ART-13; ARC-1; ARC-3; DY-17; TS-12; TS-13; MM-26; J or K; BC-342; BC-312; I-100; BC-348; BC-788 A, AM, B or C; I-152A, AM, B or C; TS-67; BC-1016 Tape Recorder; TS-45; TS-35; TS-33; TS-102; TS-120; TS-146; TS-147; TS-148; BC-344; APR-4; TS-47; ARN-7; teletype, test or any other equipment. Cash or trade. What have you?

**BOB SANETT (W6REX)**

4668 Dockweiler, Los Angeles, California

**TELEVISION RECEIVER—\$1.00**

Complete instructions for building your own television receiver. 16 pages—11"x17" of pictures, pictorial diagrams, clarified schematics. 17"x22" complete schematic diagram & chassis layout. Also booklet of alignment instructions, voltage & resistance tables and troubleshooting hints.—All for \$1.00. Write for free catalogue.

**CERTIFIED TELEVISION LABORATORIES**  
Dept. C, 5507-13th Ave., Brooklyn 19, N. Y.

**\$3.00 FOR CARTOON IDEAS**

RADIO-ELECTRONICS prints several radio cartoons every month. Readers are invited to contribute humorous radio ideas which can be used in cartoon form. It is not necessary that you draw a sketch, unless you wish.

Address  
**RADIO CARTOONS, RADIO-ELECTRONICS**  
25 West Broadway, New York 7, N. Y.

**Every RADIOMAN can use these SERVICE HINTS!**

Valuable Manual Yours—FREE  
Write today—no obligation

**FEILER ENGINEERING CO. Dept. 12RC-1**  
8026 N. Monticello Ave., Skokie, Ill (Suburb of Chicago)

Every page of "How to Simplify Radio Repairs" is packed with on-the-bench, practical ideas.

# Compare!

PROVE  
**EMC**  
SUPERIORITY!



**Model 300**  
vacuum tube-volt-ohm-cap.  
meter  
• 4½" Meter • Complete with leads • Input resistance to 30 Meg-ohms • 5 AC Volt Ranges to 1,000 volts • 6 DC Volt Ranges to 1,000 volts • 4 capacity Ranges • 6 Resistance Ranges to 1,000 Megs.  
Model 300—Open Face.....**\$41.50**  
Model 300 in Kit Form.....**\$24.95**  
Model 300—Portable Case with cover.....**\$46.60**



**Model 500**  
r.f. signal generator  
Provision for external modulation with 400 cycle internal modulation available. Employs electrostatically shielded transformer for 115 V. 60 cycle operation.  
Ranges from 150 KC to 36 Megs. on fundamentals — over 100 Megs. on harmonics.  
Model 500—Two color gray ham-mertone. Panel and case.....**\$29.75**  
Model 500 in Kit form.....**\$19.75**

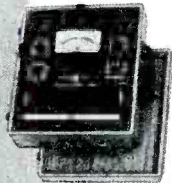

**Model 203**  
tube-ohm-capacity tester  
• Tests all tubes including Noval and sub-miniatures! • Emission testing method gives easy, direct readings • Tests all tubes from .75V to 117 filament volts. Individual sockets for each type tube base.  
Built-in roll chart. Three color ham-mertone panel.  
Model 203—Portable Oak case, Removable Cover.....**\$49.50**

All of the above have molded bakelite cases.

Write Dept. RE-12 for Free Complete Catalog of these and other Instruments.

See them at your Jobbers—

**EMC** Electronic Measurements Corp.  
280 Lafayette St., New York 12, N. Y.  
Export Dept., 303 W. 42nd St., N. Y. C.

## NEW CONDENSER TESTER



**Finds Intermittent Condensers Instantly**

Pres-probe's sliding tip with variable resistance prevents condenser heating. Tests with power on. Requires no adjustment. Stops guesswork. Saves time. Convenient probe size (7/8" long). Satisfaction guaranteed.

NET **795** Postpaid U. S. A.

See Your Dist. or Order Direct

**PRES-PROBE CO.**

4034 N. Sixth St., Milwaukee 12, Wisc.

value found by multiplying the B-plus voltage by the bleeder current in amperes.

Replace the 51,000-ohm plate-load resistor for the 6R7-G with a high-fidelity transformer designed to match a medium-mu triode to a 500-ohm line. Use a good grade of audio cable to connect the secondary of the plate-to-line transformer to the 500-ohm input of your amplifier.

If the amplifier does not have a 500-ohm input, a good line-to-grid transformer must be used between the line and the input to the amplifier.

### LOOP ANTENNA DATA

? Please print constructional details on a loop antenna for use between 1600 kc and 3.8 mc. I would like to be able to use the loop for direction finding.—R. R. R., Brentwood, L. I.

A. The number of turns in the loop depends on the frequency range, stray capacitance, proximity and type of shield, and many other factors. The larger you make the loop, the better it will work.

Wind a few turns of wire on the form or frame and connect the loop in the circuit of a Colpitts oscillator. Use a frequency meter or short-wave receiver to determine the frequency range.

Note that in a Colpitts circuit, each section of the tuning capacitor must have twice the value of the capacitor which will be used to tune the coil when used as a loop antenna. Thus, if you plan to tune the loop with a single-section 365-µmf capacitor, each section of the oscillator-tuning capacitor should have a capacitance of 730 µmf. You can use a four-section broadcast capacitor with the sections connected in pairs. After determining the range of the coil in the oscillator, you can add or remove turns to get the exact range that you want.

### MIDGET MODIFICATION

? In the article "Heat Reduction in Midget Sets" in the June, 1949, issue, the author suggests the addition of an untuned r.f. amplifier to the circuit of a 4-tube superhet. Please prepare a diagram showing how this can be done.—G. G. M., Oak Ridge, Tenn.

A. In most cases, we consider an untuned r.f. amplifier as being one in which the antenna is connected to a broad-band input circuit. Tuning takes

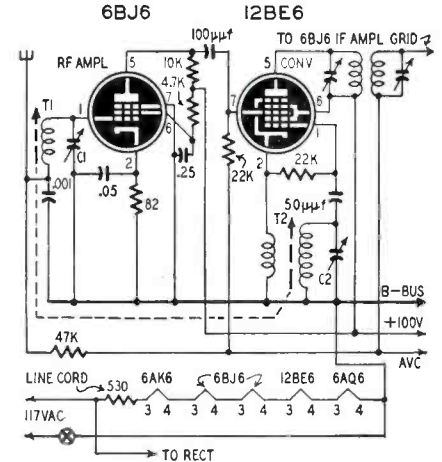

place after the r.f. amplifier. In areas where there are a number of strong local stations, all are amplified equally before reaching a tuned circuit. This condition often causes severe heterodyning and cross-modulation. Such troubles can be minimized by tuning the antenna input circuit and using resistance-capacitance coupling between the r.f. amplifier and converter as shown in the diagram. A 6BJ6 is used as the r.f. amplifier. The line-dropping resistor is decreased to 530 ohms to compensate for the r.f. tube which has been inserted in the heater string.

—end—

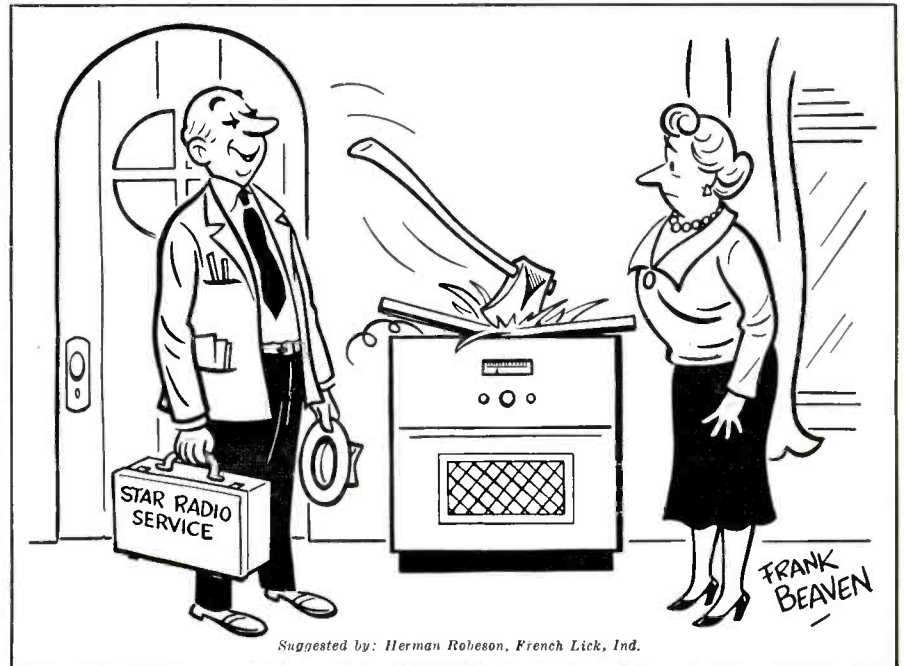

Suggested by: Herman Robeson, French Lick, Ind.

"Neighbors been complaining about its volume again?"

**A RADIO MOTOR**

It has been many years since a motor designed to operate on the power delivered by a broadcast antenna has been announced. Previous ones described in Gernsback publications operated on the electrostatic principle. Consequently the editors of RADIO-ELECTRONICS were much interested when the inventor brought to us the device pic-

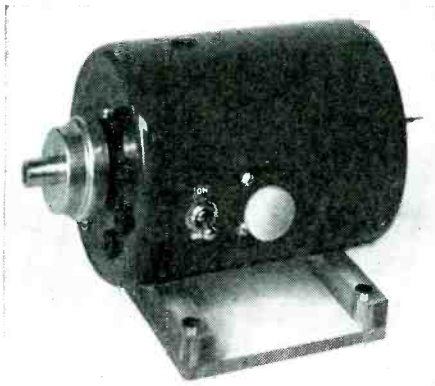

"Pulley" is the radio dial—motor shaft may be seen extending from the far end.

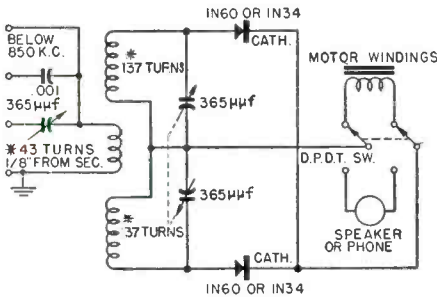

\* NO. 32 ENAMEL ON 1" TUBE  
COPYRIGHT 1951 E. H. PATRICK PATENT PENDING

A schematic of the radio power source.

tured here—a genuine dynamic motor designed to operate off a broadcast antenna. The motor itself is in the right-hand section of the case (in the photo of the opened motor). It is—as can be seen in the photo—a D'Arsonval movement; a microammeter with a pair of light-contact commutator wires instead of the fixed connections of the standard meter. Consequently, when a strong station is tuned in and the meter coil swings over, instead of bringing the indicator over against the pin, it simply turns it far enough to reverse the connections to the commutator, causing it to move another half turn—in other words, to behave like a true motor.

The inventor claims to have obtained enough power from this unique device—when used close to a broadcast station—to operate a microswitch through the reducing-gear train shown in the right foreground. Thus it could (for example) start the breakfast coffee as the local station started its morning program.

The receiver consists of a push-pull crystal rectifier, efficiently coupled to an antenna circuit. Both antenna and secondary circuits are tuned, and an antenna about 200 feet long and as high as possible is recommended.

The main tuning knob is at the end; the small one at the side operates the antenna tuner. The switch changes the



**FLASH** Merry Christmas  
BARGAINS FROM **Niagara**

ONE OF AMERICA'S GREAT RADIO STORES

**DOES YOUR TV DROOP FROM TVI\* BLOOP?**

**BANISH INTERFERENCE WITH NIAGARA'S FAMOUS HIGH PASS FILTER**

Positive protection against interference from amateur transmitters, diathermy, and all other devices generating radio frequency interference below 40 MCS. Designed for 300 ohm leadin. No loss in brightness or clarity.

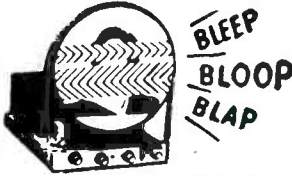

Wired and tested... **\$2.95**  
Postpaid if entire amount is included with order.  
\* Television interference



**\$129.00**

**BRAND NEW "30 TUBE" ORIGINAL 630 TYPE 16"-20" TV RECEIVER**

Completely Wired, Aligned and Tested—Ready to Install With Big 12" High Quality PM Speaker.

- 30 TUBES (including 3 Rectifiers)!
- High Efficiency High Voltage Circuit!
- Advanced Model 12 Channel Tuner!
- AGC for Fringe Area Reception!
- Magnificent TV Performance!

**WEBSTER CHICAGO AUTOMATIC 3 SPEED RECORD CHANGER TYPE 100-16 SERIES**

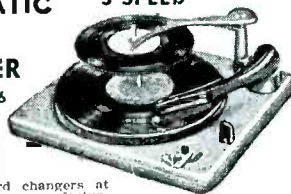

A fortunate purchase makes it possible for us to offer these fine, new record changers at less than regular manufacturer's cost. Made by Webster-Chicago and only introduced on the market a few months ago as one of their latest models. Plays 12, 10 or 7 inch records at 33 1/3, 45, or 78 R. P. M. New spindle carefully lowers unplayed record stack. Balanced arm assures light needle pressure and long wear. Needle-tip (included) for standard or micro-groove records. Inside-out records played without any adjustment. Pickup arm comes to rest position after last record has played. Complete factory packed and sealed record changers, normally listing at \$47.50—While they last. Shipping Wgt. 15 lbs. .... **\$24.85**

**12 VOLT VIBRATOR POWER SUPPLY**

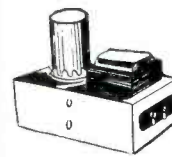

Vibrator power supply delivering 300 V. D. C. at 80 Ma. Filter Built-in fully wired, tested and guaranteed new.

**\$5.95**

**THE HEART OF BC-221 FREQ. METER**

This VFO sub-assembly, used in BC-221 freq. meter, is ideally suited for home construction or: 1—Amateur VFO, 2—Frequency meter foundation, 3—Portable Transmitter, 4—Replacement for BC-221. Unit contains two temperature and moisture compensating coils, water switch, three variable condensers, carbon resistors, and silver mica condensers. FULLY WIRED and mounted on sturdy aluminum sub-chassis, ready for installation. Brand new—in original packing. New, low price .....

**\$4.95**

**REMOTE CONTROL FOR THE THING!!**

(PLUS \$1.00 BOOK FREE)

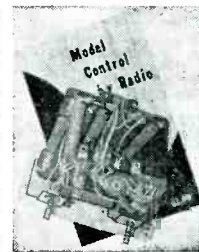

The answer to the "Remote Control" experimenters' dream! A completely wired, 3 tube remote control unit, originally used as Electronic Brain for remote thermo-static control of electric blankets. Can be used, with slight modification, to control model trains, planes, trucks, remote on-off for radios, men and close garage doors from your car, or to remotely control any device in accordance with your own ingenuity.

And that's not all! With each unit we will give you absolutely free, one copy of Gernsback Library's popular new book "Model Control by Radio," 112 pages, containing more than 125 illustrations, diagrams, tables and formulas, crammed full of theory and practical uses for Electronic Remote Control. Remote Control Unit, including P.H. Xfmr., 300 ohm plate circuit "trigger" relay, completely wired, circuit diagram and above described book—less tubes. **\$5.50**  
ALL FOR ONLY..... Shipping Wgt. 3 Lbs.

ONE OF AMERICA'S GREAT RADIO STORES  
**Niagara** RADIO SUPPLY CORP. Dept. 12-E1  
160 Greenwich Street, New York 6, N. Y.

Digby 9-1132-3-4

LEOTONE • LEOTONE • LEOTONE • LEOTONE •

**Leotone**

Color TV Wheel Parts!  
1/16" Clear Lucite Disc  
foundation for 10" screen  
wheel ..... 5.95  
For 7" screen wheel ..... 3.95  
Red, Green & Blue Trans-  
parent Acetate for TV Color wheel, per sq. foot 1.00  
Experimental Tubes . . . Fil. tested, 40 asstd.  
receiving types ..... 1.98  
RCA UX-200 Tubes . . . brand new tubes, ea 6/1.00  
Radio Builders Library for both Beginner &  
Advanced Ham . . . 15 sets of Short Wave Re-  
ceiver & Transmitter Construction Data for only .98  
Phono Turntable Felts . . . brown 10" .29c 12" .39c  
6V PILOT BULBS . . . screw base, 10/39c 100/ \$3.49  
#20 Push-Back Wire . . . Red, Yel, Blue, Blk, 100 ft., 89c  
H5-30 Headset . . . Brand New 1.45  
H5-30 Matching Transformer . . . ea 1.49  
H5-30 Headband only . . . ea 19c 6/1.00  
H5-30 "W" Cords (CD-620E) & clip, ea 19c 6/1.00  
Sound Power Phone Units . . . use as Revr or  
Xintr. Perfect for TV & Intercom work. Metal  
hsg. . . 1.95 2/3.49  
1/20 H.P. GE Motor . . . 1725  
RPM, dble. 3/8" shaft, 110-  
Volts, 7A O. D. 43/4" x 3 1/2"  
W-110B Field Wire . . . rolls  
100-400 ft. only . . . 1/2c ft.  
Plastic Cabinet & Chassis  
Handsome, Red, Yel, Walnut  
or Ebony & 5 tube punched  
chassis, 14 1/2" x 7 1/2"  
Reflector type, new . . . 1.79  
Tank Periscope . . . 1.69  
Midget Relay . . . (RSM) 24V DC  
SPST, N.O., 280 . . . 3/4" x 1" x 1 1/4" .79  
SPST, N.O., 8A. conds., (dble. brk, 230  
1" x 1 1/2" x 1 3/8" . . . .85  
SPDT, 280 . . . 3/4" x 1" x 1 3/8" .98  
3PST, N.O. 280 . . . 5/8" x 1 1/4" x 1 3/8" 1.29  
Rotary Power Switch . . . SPDT, 15A/125V. . . 1.29  
Tube Carbons . . . plain white, prices per 100:  
Min (1 1/2" sq.) \$1.20; GT (1 1/4" sq.) \$3/4  
1.45; Med (1 1/2" sq.) \$4/4—1.65; Large (2" sq.) \$5/4  
Bargain Kits! Speaker Cones . . . 4" to  
12" incl. free-edge. Less Voice Coils . . . 12/1.98  
Speaker Repair Kit . . . Liberal assortment of:  
V.C. forms, felt, Chamois leather, Rings,  
Spiders, Cement, Shim Kit & Instructions  
All for only . . . 2.49  
Special—Both Cone & Repair Kits . . . only 3.95  
Jumbo Radio Parts Kit . . . 17 Full Lbs. of:  
Coils, Sockets, Wire, Resistors, Condensers,  
Switch, Jacks, Chassis, etc. etc. SHIP  
wt. 21 lbs. . . 3.95  
High Fidelity Crystal Mike . . . Hi-imped. rubber  
sheek mid. 1 3/4" x 1/4". Less housing . . . 1.29  
Hand mike case . . . Sturdy molded bakelite for  
crystal mike. Rubber mouth piece . . . 98c  
Aluminum Housing for crystal mike . . . 1.49  
HANDY CARBON MIKE (HS-83). Press-to-talk  
"Alnico Magnet Special". "U" type. ea 49c 6/2.49  
Alnico Magnet Kit . . . powerful Bar, Block, "U".  
Rod, etc. Kit of 10 asstd. (supplement)  
(Write for new "Alnico Magnet" supplement)  
Radio Hardware Treasure . . . Full lb. can of  
Nuts, Screws, Washers, Lugs, etc. . . 69c 3/1.98  
(WRITE FOR "ALNICO MAGNET" SUPPLEMENT)  
"FACTORY SPEAKER REPAIRS SINCE 1927"  
Min. Order \$3.00 . . . 20% deposit on all COD's  
Please add sufficient postage—excess refunded  
Full remittance with foreign orders

**LEOTONE RADIO CORP.**  
67 Dey Street  
New York 7, N. Y.

set from speaker to motor. The speaker mounted just below the hole in the top consists of a large 2,000-ohm phone unit, of the case.



Receiver (left) and motor (right) with reducing gears, horn and other equipment. Courtesy Scientific Products of Indianapolis

### "Transatlantic Crossing" Remembered

30 years ago on December 11, 1921, a group of six amateurs sent the first shortwave message across the Atlantic Ocean. The message, which was picked up in Ardrossan, Scotland, by Paul Godley, opened the door for intensive work and developments in shortwave communications and forever killed the theory that "wavelengths below 200 meters are useless."

Exactly 20 years before (December 12, 1901) Marconi—also using short wavelengths—had received a single letter across the Atlantic. Since then there had been no verified report of successful communication at such short wavelengths and the exploit had dropped to the status of a legend in the minds of communication engineers. But by 1921 reports of British reception of American amateur signals had been seeping through with enough insistence to persuade the American Radio Relay League to check and to make an official test. Paul

Godley, one of America's leading amateurs, was sent to Scotland, and the hams on this side set about building a station that "would get across."

The site of Minton Cronkhite's station 1BCG was chosen and a "T" antenna 100 feet long and 70 feet high at the center was erected. The transmitter used two 250-watt tubes of the then standard UV-204 type.

Till the last minute the operating staff were busy making final adjustments and they sent out the first messages while "we were still having some condenser troubles and keying difficulties." Nevertheless, the signals got through, and on the fourth night of the tests "transatlantic message Nr. 1" was transmitted to Godley.

Last year, the Radio Club of America erected the stone shown in the photograph to commemorate one of the most decisive transmissions in the history of radio.

## SHOOT TV TROUBLE FAST!

With H. G. Cisin's Copyrighted Rapid "TV RAPID TROUBLE SHOOTING METHOD"

Without experience or knowledge, this guaranteed new method of servicing TV sets enables you to DIAGNOSE TV troubles as rapidly as an expert. NO THEORY—NO MATH—you can locate all faults in record-breaking time, regardless of make or model. TV TROUBLE SHOOTING METHOD is the most valuable aid to TV servicing ever written. Be a TV Trouble Diagnostician. Increase your present earnings. Open your own Profitable Business or get a high-paying skilled job.

It's all in this book . . .  
Nothing more to Pay—Nothing else to Buy  
Alphabetically listed, there are 85 picture troubles, over 58 raster and 17 sound troubles and by this unique copyrighted method you know EXACTLY WHERE the trouble is; plus step-by-step instructions, including 69 RAPID CHECKS, enabling you to find the faulty part.  
13 IMPORTANT PRELIMINARY CHECKS NEED NO INSTRUMENTS! Of the 69 Rapid Checks, OVER 65 ALSO REQUIRE NO INSTRUMENTS! Rapid checks include emergency checks for distorted pictures, defective tubes including PIX tube, plus 57 others. ALL EXPLAINED IN SIMPLE LANGUAGE. PERFORMED WITHOUT INSTRUMENTS. MANY CHECKS USE THE PICTURE TUBE AS A GUIDE.  
H. G. Cisin, the author, is the inventor of the AC/DC midget radio. He licenses RCA, AT&T, etc. He has also trained thousands of technicians now owning their own prosperous TV service organizations or holding highly paid TV positions. His years of experience are embodied in this remarkable new TV TROUBLE SHOOTING METHOD.  
Guaranteed, Money Back in 5 Days if Not Satisfied!

Send your name and address today with \$1. for your post-paid copy, you'll say it's worth hundreds! RUSH COUPON NOW!

**H. G. CISIN—CONSULTING ENGINEER**  
Dept. E-8, 200 Clinton St., Brooklyn 2, N. Y.

Name \_\_\_\_\_  
Address \_\_\_\_\_  
City \_\_\_\_\_ Zone \_\_\_\_\_ State \_\_\_\_\_



Four original operators of IBCG, first shortwave station to transmit a trans-Atlantic message, were present at the dedication of a memorial to that station (Radio-Electronics, Sept., 1950). From left to right the men are: Major Edwin H. Armstrong, George E. Burghard, Paul F. Godley, and Ernest V. Amy.

**ELECTRONIC LITERATURE**

Any or all of these catalogs, bulletins, or periodicals are available to you on request direct to the manufacturers, whose addresses are listed at the end of each item. Use your letterhead—do not use postcards. To facilitate identification, mention the issue and page of RADIO-ELECTRONICS on which the item appears. All literature offers void after six months.

**RADIO-TV CATALOG**

The 1952 Catalog No. 95 has been issued by Concord Radio Corp. It features a wide variety of electronic components, sound units, tuners, test equipment, and reference books. Gratis from Concord Radio Corp., 901 W. Jackson Blvd., Chicago 7, Ill.

**CONSERVATION HANDBOOK**

RCA's "Handbook on Conservation Materials" discusses a number of subjects, including stretching antenna installation material and future possibilities in material economy. Possibly the most interesting part to the TV and radio repair technician is the 10-page section, "Alternate Tube Types," which is followed by a shorter section, "Alternate Replacement Parts," giving alternate component numbers for a large number of RCA parts.

Available from E. C. Buurma, RCA Service Company, Inc., Camden, N. J.

**COMPONENT INFORMATION**

Centralab has published two catalogs—one on switches, describing its various types of multipole gang and other switches for all electronic devices, and one covering its line of *T. C. Hi-Kaps* (temperature compensated ceramic capacitors)—as well as a number of leaflets on special high-frequency and small-space capacitors, miniature printed-circuit mounting assemblies, etc.

Available to interested parties on letterhead request to Centralab, 922 E. Keefe Ave., Milwaukee 1, Wis.

**ALLIED RADIO CATALOG**

The new 1952 Allied Radio catalog contains 212 pages, with comprehensive listings of the items familiar to Allied customers. Of especial interest are the sections on Geiger counters, sound equipment, and amateur radio supplies.

Available from Allied Radio Corp., 833 West Jackson Blvd., Chicago 7, Ill.

**RADIO-TV CATALOG**

The Burstein-Applebee Co. 1952 Catalog No. 521 features a wide variety of electronic components, test equipment, home and auto communication sets, TV sets, shop tools, reference books, and household appliances.

Copy is gratis by writing to Burstein-Applebee Co., 1012-14 McGee St., Kansas City, Mo.

**TV ANTENNA CATALOG**

The line of Louis Bros. antennas and chassis cradle is covered in a booklet put out by Louis Bros., 3543 East 16th St., Los Angeles 23, Cal. It lists all-band and Yagi-type antennas. Gratis.



**YEARS AHEAD**



**Directronic**  
MOTORLESS  
**TV AERIAL SYSTEMS**

**360° ELECTRONICALLY SWITCHED BEAM**

**GIVES SAME CLEAR PIX AS MOTOR DRIVEN AERIALS AT 1/3 THE COST**

**SIMPLE FLICK OF SWITCH  
CLEARS PICTURE** *INSTANTLY  
NO WAITING*

**OPENS BIGGEST  
REPLACEMENT MARKET  
IN TV HISTORY**

**MAIL THIS COUPON TO-DAY!**  
SNYDER MFG. CO.  
23rd & Ontario Sts., Phila. 40, Pa.

Please send me free copy of authoritative booklet **TENNA TIPS** on Directronic and all other types of aerials, plus catalogs.

NAME \_\_\_\_\_  
ADDRESS \_\_\_\_\_  
CITY \_\_\_\_\_ ZONE \_\_\_\_\_ STATE \_\_\_\_\_

**NO** MOTORS OR MOVING PARTS

**NO** ROOF ORIENTATION

**NO** ELECTRIC POWER

**NO** GHOSTS

**FREE**

**TENNA TIPS**

PRICE 50¢

**"NO COME-BACKS"**  
when you **REPLACE** with

**QUAM**  
*Adjust-A-Cone*  
**SPEAKERS**

**LOOK FOR**  
the  
**U-Shaped**  
**COIL POT**

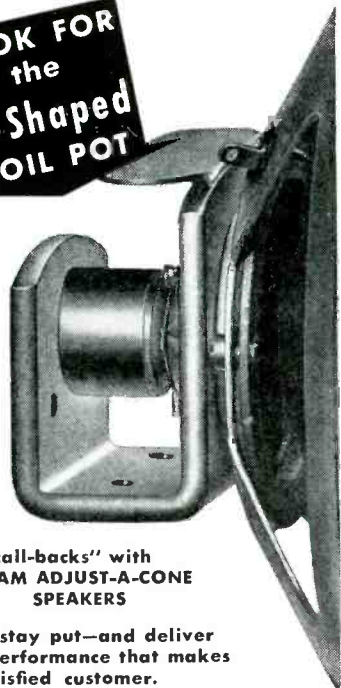

No "call-backs" with  
**QUAM ADJUST-A-CONE**  
**SPEAKERS**

they stay put—and deliver  
the performance that makes  
a satisfied customer.

Quam Speakers are built right  
and designed right by the  
world's largest speaker man-  
ufacturer—builders of the speaker  
that's first for Original Equipment  
—first in the Replacement Field.

Also makers of Quam  
Focalizer Unit & Ion Traps  
**WRITE FOR CATALOG**

**QUAM-NICHOLS COMPANY**

521 E. 33rd Place, CHICAGO 16, ILL.

MAKERS OF QUALITY SPEAKERS FOR  
27 YEARS, UNDER THE SAME MANAGEMENT

**HAVE YOU A JOB FOR A  
TRAINED TECHNICIAN?**

We have a number of alert young men who have completed intensive training in Radio and Television Repairing. They learned their trades thoroughly by working on actual equipment under personal, expert supervision. If you need a trained man, we invite you to write for an outline of our course, and for a prospectus of the graduate. No fees, of course. Address:

Placement Manager, Dept. P108-12

**COMMERCIAL TRADES INSTITUTE**  
1400 Greenleaf Chicago 26



**THE FUND  
REACHES \$8,877**

**HELP-  
FREDDIE-WALK  
FUND**

We are happy to report that the interest of our readers in little Freddie Thomason, the armless and legless three-year-old son of radio technician Herschel Thomason, continues to be evidenced by their contributions to the Help-Freddie-Walk Fund, which this month reaches a grand total of almost \$8,900.00.

Freddie and his mother have just returned from another visit to the Kessler Institute, and he continues to make progress. However, it will be an "uphill climb" for many years to come before Freddie will be able to confidently face the world around him, and many thousands of dollars will be needed to assure him those mechanical appliances upon which he will be dependent throughout his life. We are certain that the diligent and unselfish efforts of Freddie's parents and doctors will be matched by the wholehearted cooperation of our many readers who are able to contribute to such a worthy cause.

We are pleased to note the following group contributions received this month:

- Donated by Sigma Tau Omega members, San Francisco, California, through the efforts of Mrs. John R. Skinner.....\$5.00
- Donated by the Toll Operators, New York Telephone Company, Buffalo, New York, through the efforts of I. McAllister....\$15.50

Another "group contribution" received this month was that of \$12.00 donated by the Airborne Communications, 71st Ftr. Intcp. Sq., Coraopolis, Pennsylvania, through the efforts of Lt. Edward T. Kosok, who says that his men responded readily to Freddie's appeal when he brought it to their attention.

No contribution is too small for our notice and each is acknowledged with sincere thanks and appreciation; please send them from time to time, whenever you are able.

Make all checks, money orders, etc., payable to Herschel Thomason. Please address all letters to:

Help-Freddie-Walk-Fund  
c/o RADIO-ELECTRONICS  
25 West Broadway,  
New York 7, New York

**FAMILY CIRCLE CONTRIBUTIONS**

Balance as of September 19, 1951	\$457.50
M. Finkelstein, Brooklyn, New York	2.00
Lillian Jung, Brooklyn, New York	5.00
Leonora V. Murphy, North Syracuse, N. Y.	5.00
Mrs. D. Newton, El Cajon, California	1.00
Mrs. Mary F. O'Dwyer, Hartford, Conn.	1.00
Sigma Tau Omega Members, San Francisco, Calif.	5.00
Helen White, Bois D'Arc, Missouri	1.00

FAMILY CIRCLE Contributions Received up to October 18, 1951 .....\$477.50

**Trained Men Urgently Needed in  
RADIO-TV-ELECTRONICS**

Let CREI train you for better jobs,  
higher pay—in minimum time!

Industry wants trained men desperately, and will pay well to get them. CREI training offers you what industry needs—quickly and thoroughly. (Average time required: 22 months.) Win your lifetime career with CREI Residence School training in historic Washington, D. C.

**SEND FOR ILLUSTRATED FREE CATALOG**  
Get your copy of new descriptive catalog, with survey of opportunities, and details of course and school. New classes start twice a month. Act now!

**CAPITOL RADIO ENGINEERING INSTITUTE**  
An Accredited Technical Institute Founded in 1927  
Dept. 3012C, 16th & Park Rd., N.W., Wash. 10, D.C.

**OPPORTUNITY AD-LETS**

Advertisements in this section cost 35c a word for each insertion. Name, address and initials must be included at the above rate. Cash should accompany all classified advertisements unless placed by an accredited advertising agency. No advertisement for less than ten words accepted. Ten percent discount six issues, twenty percent for twelve issues. Objectionable or misleading advertisements not accepted. Advertisements for Feb. issue must reach us not later than December 21, 1951. Radio-Electronics, 25 W. Broadway, New York 7, N. Y.

Offers over 20 years experience and large following of electrical and electronic equipment manufacturers in Chicago and Midwest. Open to one or possibly two additional lines. Send full particulars to Box D12-51, Radio-Electronics, 25 W. Broadway, New York 7, N. Y.

**RADIO OFFICERS.** \$600+ monthly earnings, plus top union conditions. Men with 6 months American Merchant Marine radio operating experience since Jan. 1935 can obtain special FCC license to sail immediately. Men with FCC radiotelegraph 2nd class license and 6 months sea time on Navy ships as radiomen can also qualify. Phone, wire, or write American Radio Ass'n CIO, 5 Beekman St., NYC. Cortlandt 7-6397.

**SPEAKERS REPAIRED** at wholesale prices. Guaranteed workmanship. Fast service. Amprite Speaker Service, 70 Vesey St., New York 7, N. Y.

**MAGAZINES (BACK DATED)—FOREIGN, DOMESTIC**—Arts, Books, booklets, subscriptions, etc. Catalog 10c (refunded). Cicerone's, 86-22 Northern Blvd. Jackson Heights, N. Y.

**WE REPAIR, EXCHANGE, SELL, ALL TYPES OF** electrical instruments, tube checkers and analyzers. Hazleton Instruments Co. (Electric Meter Laboratory), 140 Liberty Street, New York, N. Y. Telephone—BARclay 7-4239.

**WANTED: AN/APR-4, other "APR", "ARR", "TS", "IE", "ARC-1, ARC-3, ART-13, everything "Surplus." Special tubes, Tech Manuals, Lab quality Test Equipment, etc. Describe, price in first letter. Littell, Fairhills Box 26, Dayton 9, Ohio.**

**MEISSNER ANALYST LIKE NEW \$50.** L. Miller, 2106 Hildarose, Silver Spring, Md.

**AMATEURS — RADIO ENGINEERING QUESTIONS** Answered \$1.00 With Schematics \$2.50. Henry Twillman, R. R. #1, Chesterfield, Missouri.

**STATEMENT OF THE OWNERSHIP, MANAGEMENT, AND CIRCULATION REQUIRED BY THE ACT OF CONGRESS OF AUGUST 24, 1912, AS AMENDED BY THE ACTS OF MARCH 3, 1933, AND JULY 2, 1946 (Title 39, United States Code, Section 233) OF RADIO-ELECTRONICS, published monthly at Philadelphia, Pa., for October 1, 1951.**

1. The names and addresses of the publisher, editor, managing editor, and business managers are: Publisher, Radercraft Publications, Inc., 25 West Broadway, New York 7, N. Y.; Editor, Hugo Gernsback, 25 West Broadway, New York 7, N. Y.; Managing Editor, Fred Shunaman, 25 West Broadway, New York 7, N. Y. Business Manager, none.

2. The owner is: Radercraft Publications, Inc., 25 West Broadway, New York 7, N. Y.; H. Gernsback, 25 West Broadway, New York 7, N. Y.

3. The known bondholders, mortgagees, and other security holders owning or holding 1 percent or more of total amount of bonds, mortgages, or other securities are: None.

4. Paragraphs 2 and 3 include, in cases where the stockholder or security holder appears upon the books of the company as trustee or in any other fiduciary relation, the name of the person or corporation for whom such trustee is acting; also the statements in the two paragraphs show the affiant's full knowledge and belief as to the circumstances and conditions under which stockholders and security holders who do not appear upon the books of the company as trustees, hold stock and securities in a capacity other than that of a bona fide owner.

H. GERNSBACK, Publisher.  
Sworn to and subscribed before me this 28th day of September, 1951. [Seal] Maurice Coyne, Notary Public. (My commission expires March 30, 1952.)

RADIO-ELECTRONICS CONTRIBUTIONS

Balance as of September 19, 1951	\$8,250.93
George Adams, Jeado, Pa.	1.00
Airborne Communications, 71st Ftr. Intcp. Sq., Coracopolis, Pa.	12.00
The Alotrico, Jrs., Yonkers, N. Y.	3.00
Anonymous, Dudley, Mass.	2.50
Anonymous, Glens Falls, N. Y.	1.00
Cpl. Eudarel C. Bastian, Cherry Point, N. C.	2.00
W. G. Chandler, Lemon Grove, Calif.	2.00
Guy S. Cornish, Cincinnati, Ohio	1.00
E. C. Faust W9POG, Paducah, Ky.	2.00
Van H. Ferguson, Tallahassee, Fla.	5.00
Pvt. Herbert S. Friedman, Port Monmouth, N. J.	1.00
Frank Gabinowitz, Long Branch, N. J.	2.00
W. M. Gale, Merriam, Kan.	5.00
Pfc. Charles J. Hefner, Randolph AFB, Texas	1.00
P. Leone, Mount Vernon, N. Y.	1.00
Arnold F. Liska, Richmond, Calif.	2.00
F. Michenfelder, Beaumont, Texas	2.00
W. L. Murdock, Indianapolis, Ind.	2.00
Norman H. Nixon, Ellettsville, Ind.	3.67
Mr. & Mrs. W. A. Oetzell, Chicago, Ill.	5.00
Wilburt J. Purrington, Windom, Minn.	3.00
Radio Parts Company, San Diego, Calif.	25.00
Radio Quality Control, Sioux City, Iowa	6.00
The Radio Shop, Tooele, Utah	13.00
Reiss, Flushing, N. Y.	1.00
Schroeders, San Antonio, Texas	1.00
Joe Selan, Ecorse, Michigan	1.00
Bobby & Landy Small, Long Beach, Calif.	10.00
Wesley W. Smith, Philadelphia, Pa.	1.00
W. H. Strupper, New Vienna, Ohio	5.00
Toll Operators, N. Y. Tel. Co., Buffalo, N. Y.	15.50
William E. Tucker, Pittsburgh, Pa.	5.00
Edward F. Wielgot, Chicago, Ill.	5.00
Mr. & Mrs. Maurice J. Wilson, Del Paso Heights, Calif.	1.00

RADIO-ELECTRONICS Contributions Received up to October 19, 1951... \$8,399.60  
 FAMILY CIRCLE Contributions .... 477.50

TOTAL RECEIPTS to October, 1951... \$8,877.10

Radio Thirty-Five Years Ago  
 In Gernsback Publications

HUGO GERNSBACK Founder	
Modern Electrics	1908
Wireless Association of America	1908
Electrical Experimenter	1913
Radio News	1919
Science & Invention	1920
Television	1927
Radio-Craft	1929
Short-Wave Craft	1930
Television News	1931

Some of the larger libraries still have copies of ELECTRICAL EXPERIMENTER on file for interested readers.

**DECEMBER, 1917**  
**ELECTRICAL EXPERIMENTER**  
 Locating the Submarine by Radio by H. Winfield Secor  
 How I Telegraph Pictures by J. H. Leishman  
 Women Radio Operators  
 Interesting New Radio Apparatus  
 Phonograph Teaches Wireless Code Quickly  
 Dr. L. W. Austin on the Audion  
 The Audion and the "Edison Effect" by George Holmes  
 The How and Why of Radio Apparatus  
 How to Operate Audion on 110 Volts D.C. by Norman A. Woodcock  
 —end—

DECEMBER, 1951

# 3

New  
Custom-Built  
Deluxe  
TV Chassis

by **TECH-MASTER**

for  
16"  
to  
24"  
Picture  
Tubes



**MODEL 2430**—Designed specifically for all picture tubes requiring from 65 to 70 degrees horizontal deflection, (such as 24AP4, 20CP4, 19AP4, etc.) Supplied with 5X7 speaker and Universal Picture Tube Mounting Brackets. .... **\$189.50**

**MODEL 2431P**— Similar to model 2430, but with Push-Pull Audio, Phono Jack, 12" PM Speaker and Universal Picture Tube Mounting Brackets. .... **\$199.95**

**MODEL 2431C**— Basically same as Model 2430 but with Continuous Tuner, Push-Pull Audio, Phono Jack, 12" PM Speaker and Universal Picture Tube Mounting Brackets. Allows complete coverage of both TV and FM bands. .... **\$199.95**

The new **Gold Medal Series** incorporates all the latest Tech-Master features which have made this improved 630 type chassis the standard by which custom-built TV is measured... performance and service are assured because Tech-Master design and construction are as fine as human hands and brains can produce. All chassis are supplied completely wired, aligned and tested with all tubes (less picture tube).

**LOOK** for your Tech-Master registration and guarantee card attached to each chassis... it is your assurance that you are buying a genuine Tech-Master receiver.



See the Gold Medal Series and other quality Tech-Master products at your favorite Radio Parts Jobber or write direct to Tech-Master Products Co., Dept. RE-12 for complete descriptive literature.

**TECH-MASTER PRODUCTS CO.**  
 443-445 Broadway • New York 13, N. Y.

## -here's what you call *RUGGED*



90-10000 CPS  
EXTENDED  
RESPONSE



30 WATTS  
CONTINUOUS  
DUTY





MATCHES ANY  
SYSTEM OR  
AMPLIFIER



SELF-ALIGNING  
RIM-CENTERED  
ASSEMBLY



RUGGED DIE-CAST  
ALUMINUM  
HOUSING

Additional exclusive features include Bakelite Screw Type Terminal Strip, Gland Nut Type Cable Entrance, Special 45 ohm Transformer Tap, and Equalized Palate Type Breakdown Proof Diaphragm Assembly - write Desk 21....

*An Engineering Achievement of* **UNIVERSITY LOUDSPEAKERS INC.**  
 80 So. Kensico Ave., White Plains, New York

**THE NEW MODEL 706A RCP**  
**"WIDE RANGE"**  
**SIGNAL GENERATOR**  
**FOR BETTER, OVERALL PERFORMANCE**



**MODEL 706A**  
**SIGNAL GENERATOR...\$67.50**

RCP now makes available to you this brand-new, precision-packed "WIDE RANGE" SIGNAL GENERATOR Model 706A for BETTER OVERALL PERFORMANCE in your SERVICE TESTING. New all-exclusive features including continuously variable modulation from 0% to 80%. Excellent for FM alignments. Provides high stability and accuracy with sharp, easy-reading calibrated dial, eight scales from 150 KC to 220 MC. Planetary drive gives vernier tuning with no backlash. Marker calibration—accurate to within 1%. Thorough shielding of all critical circuits and components, including oscillator tube, coil assembly, attenuator, switching circuit. Transformer is electrostatically shielded. Output—high and low level. Ladder-type Step Attenuator. Tube Complement: 6BA6, 6SJ7, 6X4. A high-quality instrument in performance, construction and appearance—the NEW MODEL 706A is handsomely finished in Grey and White. Comes complete with tubes and accessories, ready to operate on 105-130 Volts 60 Cycles. Sizes: 15" x 9" x 7". Weight 14 lbs.

BUY FROM YOUR JOBBER • INSIST ON RCP INSTRUMENTS • WRITE FOR CATALOG RE-12

**RADIO CITY PRODUCTS CO., INC.**  
 152 West 25th St.  New York 7, N. Y.

**EASY TO LEARN CODE**

It is easy to learn or increase speed with an Instructograph Code Teacher. Affords the quickest and most practical method yet developed. For beginners or advanced students. Available tapes for beginner's alphabet to typical messages on all subjects. Speed range 5 to 40 WPM. Always ready—no QRM.



**ENDORSED BY THOUSANDS!**

The Instructograph Code Teacher literally takes the place of an operator-instructor and enables anyone to learn and master code without further assistance. Thousands of successful operators have "acquired the code" with the Instructograph System. Write today for convenient rental and purchase plans.

**INSTRUCTOGRAPH COMPANY**  
 4701 Sheridan Rd., Dept. RC, Chicago 40, Ill.

**WESTINGHOUSE H-626T16, H-630T14**

Due to variations in characteristics of 6K6-GT vertical output tubes, a change has been made in the height-control circuit of later production models to provide increased control over picture height.

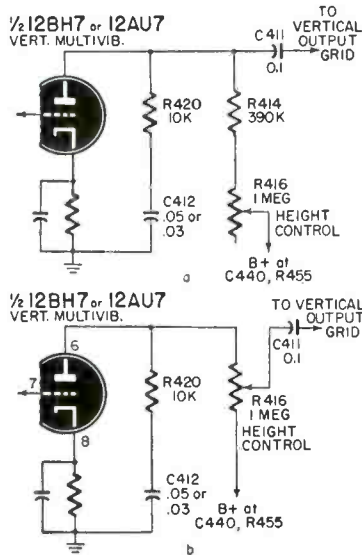

The original circuit is shown at *a* and the modified circuit at *b*. R414 is removed from the circuit and the height-control wiring changed as shown. In later production, capacitor C412 was changed to .03  $\mu$ f in the V-2172 chassis only.—Westinghouse Service Dept.

**PHILCO 46-350**

If the volume is low and the sound distorted, check the 1U5 screen-dropping resistor. This resistor is likely to be open or it may have increased its resistance to a value far above the 3.3-megohm normal value.—Andrew Ordog, Jr.

**RCA 6T74 RECEIVER**

After the set had been in operation for a few minutes, the picture would shrink, leaving a dark strip at top and bottom of the mask. Suspecting trouble in the vertical deflection circuit, we interchanged the 6K6-GT audio-output and vertical-sweep tubes. This cleared up the trouble and the picture filled the screen. After a short period of normal operation the picture shrunk again; this time from the sides. Replacing the 5U4-G low-voltage rectifier cleared up the trouble permanently, although again interchanging the 6K6-GT's caused a return in the vertical output circuit. Since one of the tubes did not work well in the sweep circuit, we replaced it rather than have trouble later in the audio circuit.—James H. Bell

**DU MONT RA-113**

If a set of this model comes in with no high voltage, turn on the set and remove the damper tube (6W4-GT) from its socket. If the raster appears with heavy foldover on it, the trouble can be traced to a leaky capacitor (C291) in the boosted-voltage circuit. Replace this with a .02- $\mu$ f, 600-volt capacitor to prevent future breakdown of this component.—James T. Smith

**PICTURE DIM?**

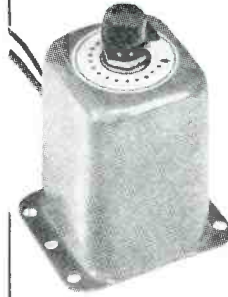

**New Life for Old TV picture tubes with Pictboost**

Exciting new accessory. Restores brightness to dim TV tube. Peps up emission. Extends tube life. **EASIER, FASTER, EASIER, QUICKER, CHEAPER** than installing new tube. Just the thing for service contractors.

10% Cash With Orders Your Cost **\$7.95**

**HOW TO ORDER**

Model #1 for most sets  
 Model #2 for series heater circuits  
 Model #3 for loss of brightness control—picture tube heater to cathode short.  
 10% cash with orders

**ALMO RADIO CO.**

509 ARCH ST. & 6205 MARKET ST.  
 Philadelphia, Pa.  
 6th & ORANGE STS. • Wilmington, Del.  
 4401 VENTNOR AVE. • Atlantic City, N. J.  
 1133 HADDON AVE. • Camden, N. J.

**SURPLUS**

BOUGHT & SOLD  
**GOULD GREEN** 252 Greenwich St. WOrth 4-3044—NYC 7

DID YOU GET IT? IF NOT  
**SEND NOW FOR B-A's 136 BIG PAGE FREE CATALOG**

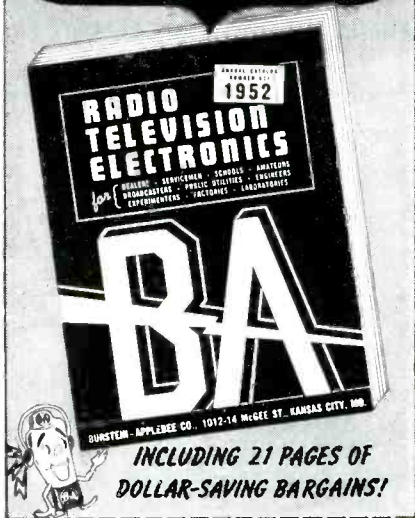

**BURSTEIN-APPLEBEE CO.**  
 1012-14 McGee St.  
 Kansas City 6, Mo.

INCLUDING 21 PAGES OF DOLLAR-SAVING BARGAINS!

**FREE**

Send your 1952 catalog to:

Name.....  
 Address.....  
 City..... State.....

**BURSTEIN-APPLEBEE CO.**



**SENTINEL 400-TV**

If the set is dead with no sound or video, the trouble is likely to be caused by a shorted screen bypass capacitor in the video i.f. circuit. This trouble occurs most frequently in the third i.f. amplifier but it can occur just as easily in the others. Use a 600-volt, .005- $\mu$ f capacitor as a replacement.—*Wilbur J. Hantz*

**VIBRATOR POWERED SETS**

When a vibrator has not been used for several months, it may fail to start when placed in service. This may be caused by an insulating film which forms on the contacts. The vibrator may be restored to normal operation by applying momentarily twice the normal operating voltage to the magnet through a 5-ohm resistor. The vibrator should start to operate immediately (listen for vibration). It should then

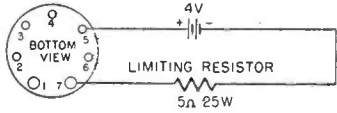
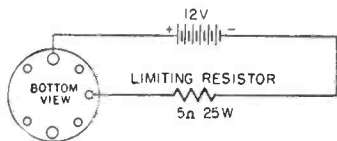

operate on normal voltage in the receiver. Be sure that the battery is fully charged and that terminals are clean and bright.

The drawing at *a* shows connections for the vibrator (stock No. 35543) used in the RCA QB11, QB12, and QB13. The drawing at *b* is the test setup for the vibrator used in the RCA 65BR9.—*RCA Service Bulletin*

**TRUETONE C2906**

Some of these models have 35W4 and the others have 35Z5-GT rectifiers. In some of the latter types, the heater string begins at the pilot-light tap (pin 3) of the 35Z5-GT instead of pin 2. This causes excess voltage to be applied to the heater string, thereby reducing the normal life of the tubes. Connecting the line to pin 2 instead of pin 3 will result in longer tube life.—*Howard McCall, W8TNF*

**TVI FROM CHRISTMAS TREE**

Last year during the Christmas holidays, we received a number of complaints of flutter and dark moving horizontal lines on TV sets which had built-in antennas or were used with indoor antennas.

The trouble was traced to the use of metallic tinsel as decoration on Christmas trees. Any slight movement of the tree set the tinsel in motion, causing reflections which produced the symptoms. The trouble was cleared up by moving the set or antenna into another room.—*William R. Brown, Jr.*

—end—

**OUR QUALITY THE FINEST  
OUR PRICES THE LOWEST**

All Tubes are Standard Brand. Each Tube Individually Boxed and Fully Guaranteed or Your Money Back.

1B3GT	1.12	6SQ7 or GT	.72	25L6GT	.89
1X2-1X2A	.96	6T8	1.19	25W4GT	.98
5U4G	.72	6V6	1.69	25Z6GT	.78
5V4G	1.29	6V6GT or G	.88	35A5	.96
5Y3GT	.47	6W4GT	.66	35B5	.99
6AC7	1.29	6X4	.74	35L6GT	.86
6AG5	.86	6X5G or GT	.74	35W4	.88
6AH6	1.49	12AL5	1.19	35Y4	.86
6AK5	1.59	12AT6	.65	35Z5GT	.59
6AL5	.68	12AT7	1.09	50A5	.96
6AS5	.99	12AU7	.96	50B6	.96
6AU6	.78	12BA6	.84	50L6GT	.79
6BC5	.86	12BE6	.86	11Z3	.77
6BF6	.89	12BH7	1.17	5B1P	4.69
6BG6G	1.89	12SA7GT	.79	5CP1	4.69
6BH6	.99	12SG7	1.21	304TH	12.95
6BJ6	.76	12SK7GT	.77	304TL	11.95
8B06GT	1.44	12SL7GT	1.20	803	3.20
8CB6	.89	12SN7GT	1.49	805	3.25
6D06G	2.85	12SQ7GT	.78	807	1.98
616	1.09	14A7	1.03	813	8.25
6K6GT	.77	14B6	1.03	832	7.95
6SA7 or GT	.79	14Q7	.99	832A	12.95
6SK7 or GT	.90	19B6G	2.99	866A	1.69
6SL7GT	1.89	19T8	1.89	2051	1.22
6SN7GT	1.69	25B06GT	1.69		

**All American 5 Tube Kit**  
(50L6, 35Z5, 12SA7, 12SQ7, 12SK7)  
Stand. Brand Tubes only \$3.60 per kit!

**TV PICTURE TUBES**

All Black Faced—Non Glare Sheldon, Zetko, and other famous makes. All Guaranteed.

14BP4	\$21.95	17HP4	24.95
16HP4	28.95	19AP4	32.95
16KP4	28.95	19EP4	32.95
16GP4	30.95	19DP4	39.50
16LP4	32.95	20CP4	32.95
17BP4	22.90	24AP4	65.50

**FREE CATALOG** Over 600 types of Tubes listed.  
All at 50% to 85% off list price

For a complete listing on receiving television, transmitting and special purpose tubes not listed here, check back to last month's issue. Nearly every type of tube on hand. Write for free catalog on all types of tubes, radio and television parts, electronic equipment, etc.

**BUYER'S DIVIDEND**

**FREE FREE**

With every \$25.00 purchase, 1-10" Speaker with a 3.16 oz. Alnico 5 Magnet.

With a \$50.00 Purchase or more, 3-10" Speakers.

Terms: 20% cash with order, balance C.O.D. Prices F.O.B. N.Y. City warehouse. Min. order \$5. (Allow for postage) NOTE: Availability of merchandise subject to prior sale. Prices subject to change without notice.

**STEVE-EL ELECTRONICS CORP.**  
Dept. E-12, 61 Reade St., N.Y. 7, N.Y. COrtland 7-0086

Visit Our New Store

**LATEST 30 TUBE 630 TV CHASSIS**

**\$141.50**  
Less C.R.T.

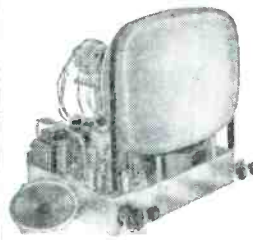

Finest for fringe area reception. Will work where most receivers fail to operate. The new and improved super 630 TV chassis, is a 30 tube high quality television-receiver manufacturer under license by RCA. The "630" chassis is universally recognized by leading Electronic Engineers as the highest standard of television excellence. This chassis is the standard by which all other TV sets are measured.

Standard R.M.A. Guarantee. Free replacement on all defective parts and tubes.

Complete, ready to work with a 12" R.C.A. Speaker and standard coil tuner. All knobs and hardware included. Fed Tax paid—Net \$141.50 (Less C.R.T.)  
With DuMont Input Tuner and F.M. Radio Fed. Tax Paid—Net \$146.50 (Less C.R.T.)

Brackets for Picture Tube mounting on chassis \$4.95 extra.

**AUTOMATIC 3 SPEED CHANGER SPECIALS**



Webster Chicago Model 100-16  
Plays 12-10-7 inch records at 33 $\frac{1}{3}$ , 45 or 78 R.P.M. Light, balanced arm assures light needle pressure and long wear. Needle tip included for standard or microgroove records. Pick-

up arm comes to rest-position after last record is played. New and in factory sealed cartons. Base 12 x 12 $\frac{1}{2}$ . Shipping Wt. 14 lbs. Net. \$24.90

Milwaukee—Model 11600



Plays 12-10-inch records at 33 $\frac{1}{3}$ , 45 or 78 R.P.M. Light pick up arm has twist needle tip (included) for standard and micro-groove records. Extra spindles included for the 7"-78 R.P.M. record and the 45 R.P.M. record. New and in factory sealed cartons. Base 12x12. Shipping Wt. 12 $\frac{1}{2}$  lbs. Net. \$22.95

V.M. Model 406-20



Plays all records at all speeds, 33 $\frac{1}{3}$ , 45 or 78 R.P.M. Intermix records of the same speed—has a light pick up arm with a twist needle for standard or micro-grooved records. New and in factory sealed cartons. Base 12 $\frac{1}{2}$  x 13. Shipping Wt. 12 lbs. Net. \$21.95

**FREE ENERGY—Harness the Power from Radio Broadcasts**

**A RADIO MOTOR EARN \$10,000**

in Royalties Put Your Ingenious Mind to Work

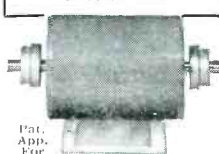

The radio motor pictured here has already been developed and has run for two months on the free energy from broadcast programs. We've already done the so-called impossible. Now we want ingenious experimenters who can improve on this motor and show us how it can be applied to practical uses.

**A LIBERAL ROYALTY PLAN**  
Liberal royalties to the alert and ingenious person who develops a way of increasing the power of the radio motor for practical application using only radio energy from broadcast programs. We send you a royalty income agreement which amply protects you on any developments you make increasing the power of this radio motor for practical applications.

Complete plans including Royalty income agreement—all for \$5.00. Rush cash or money order.

**HOW TO DO IT**  
You can get copyrighted instructions from us and detailed "How to do it" drawings showing how to build an actual running model of the radio motor pictured. You also receive a list of complete sources of supply for the few inexpensive materials you need.

**NO CONNECTION WITH ANY OUTSIDE RADIO—NO ELECTRICITY—NO BATTERIES—NO TUBES**

Radio Motor is started by turning shaft until music or talking is heard from within the motor housing. Yet when motor is not running you can enjoy it as a radio which costs absolutely nothing to run.

**SCIENTIFIC PRODUCTS OF INDIANAPOLIS**

P.O. Box 6331-H—42nd Street Station. Dept. RE-10 Indianapolis 5, Ind.

## TRIPLEX WAVE MASTER

**TRIPLE DIRECTORS**

**TWO BAY STACKED CONICAL**

**NO BOOSTER REQUIRED**

**MATCHES ANY OHM WIRE**

**75-150-300**

1/4 Wavelength Stacked

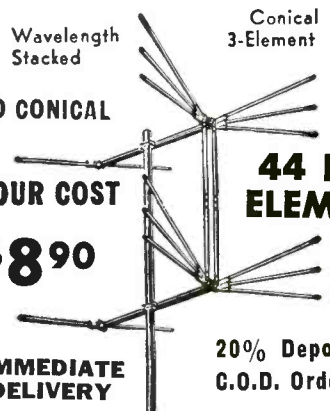

**44 INCH ELEMENTS**

20% Deposit C.O.D. Orders

Conical with 3-Element Dipole

**GHOST FREE RECEPTION ALL CHANNELS**

**INSTANT ASSEMBLY**

**EASY INSTALLATION APPROX. WT. 7 POUNDS**

**YOUR COST \$890**

**IMMEDIATE DELIVERY**

**UNDER ACTUAL TESTS... PROVED!**

- Most advanced design to date.
- Easier tuning, added selectivity on any receiver.
- 30% more gain than former 4X antennas.
- These tests conducted in fringe areas and locations up to 250 miles from transmitting stations—not by meter or laboratory tests, but under average home installation.
- Reception available in fringe and formerly unsatisfactory locations, all channels.

**SOLD DIRECT—WRITE—WIRE—CALL—FAIRFAX 9171**

# RAY CO.

441 SUMMIT ST. TOLEDO, OHIO

Price List **\$2690**

Harold Harris, sales manager of CHANNEL MASTER CORP., was elected president of the Antenna Manufacturers Association, succeeding M. S. Hoth, jobber sales manager of The Radiart Corp. Kenneth S. Brock, advertising and sales promotion manager for WARD PRODUCTS



H. Harris

and WORKSHOP ASSOCIATES, Divisions of the Gabriel Co., was elected vice-president of the Association. Edward Finkel, JFD MANUFACTURING Co., continues as treasurer.

Michael D. Kelly, former assistant television sales manager of THE HALLICRAFTERS Co., Chicago, was promoted to the position of television sales manager. Other Hallicrafters executive appointments include: William J. Halligan, Jr., radio sales manager; William S. Wright, operations manager; Fred T. Page, controller; Randolph W. Westfield, executive staff member, and J. C. Matthews, chief purchasing agent. Hallicrafters also announced the appointment of John S. Mahoney, sales promotion manager, to the position of advertising manager, succeeding Charles J. Nesbitt who resigned to join the creative staff of Critchfield & Co.

Ricardo Muniz was appointed vice-president in charge of operations of the TRAD TELEVISION CORP., Asbury Park, N. J. He will be in complete charge of engineering and production functions. Mr. Muniz, formerly general manager of the Television Receiver Manufacturing Division of Du Mont Laboratories, is known to our readers as the author of several articles for RADIO-ELECTRONICS and other Gernsback publications.



R. Muniz

Charles A. Hansen, JENSEN MANUFACTURING Co., president of the Radio Parts and Electronic Equipment Shows, appointed the following committee chairmen for the 1952 Electronics Components and Equipment Show to be held in Chicago the week of May 18: Credentials, Arthur C. Stallman, Stallman of Ithaca; Budget, Lew W. Howard, Triad Transformer Manufacturing Co.; Entertainment, W. D. Jenkins, Radio Supply Co.; Housing, John H. Cashman, Radio Craftsmen, Inc.; Publicity, Jerry Kirshbaum, Precision Apparatus Co.; Educational, Jack A. Beriman, Shure Brothers, Inc.

John H. Cashman, RADIO CRAFTSMEN, INC., chairman of the Association of Electronics Parts and Equipment Manufacturers, named the following chairmen for EP & EM committees for the coming year: Catalog, W. J. Barron, Merit Transformer; Credit, Joe Morin, Shure Brothers; Social, Ken Hathaway, Ward-Leonard; Educational, Les Thayer, Belden Manufacturing; Publicity, Frank Florsheim, Columbia Wire; Mo-

## 14 Ram Parts

**Exact Replacement:**  
You need only 14 Ram parts to cover over 94% of TV sets now in the country—because Ram specifications are identical to those of the original parts!



Flybacks

## cover over 94% of

**Performance-Proved:**  
Ram makes transformers, yokes, and coils for such leading TV set manufacturers as DuMont, CBS-Columbia, Olympic, Tele-Tone, Majestic, Fada, Silvertone, Starrett, Regal, DeWald, etc.—surpasses their every laboratory, production and field test!



Yokes

## TV replacement needs

**Lowest-Priced:**  
for highest profits for you.



width coils  
linearity coils

SIMPLIFY your TV parts stock with Ram's complete, universal line! Ask your distributor for Ram components —today! Write NOW for FREE latest TV Replacement & Conversion Guide, #E-12.

# Ram

**ELECTRONICS SALES CO.**  
51 South Buckhout St.  
Irvington-on-Hudson, N. Y.  
Irvington 9-5700

TEST-PATTERN TESTED COMPONENTS FOR TV

## PEN-OSCIL-LITE

Extremely convenient test oscillator for all radio servicing; alignment • Small as a pen • Self powered • Range from 700 cycles audio to over 600 megacycles u.h.f. • Output from zero to 125 v. • Low in cost • Used by Signal Corps

• Write for information.

**GENERAL TEST EQUIPMENT**  
38 Argyle Ave. Buffalo 9, N. Y.

## TUBES at Mfr's. COST

Standard Brands—Unbranded—Guaranteed

*1B3	\$.135	6BE6	\$.49	6W4QT	\$.49
1L4	.60	6BF5	.60	6X4	.36
1L6	.60	6BQ6A	1.48	6X8	.36
*1LB4	1.05	6C7	.94	*12A6	.70
*1LN5	1.05	6C86	.94	*12A7	.70
1R5	.60	6C97	1.95	12AT6	.40
1U4	.60	6C97	1.95	12AU7	.58
1U5	.50	6CB6	.56	12AV7	.75
*2A3	1.45	6CD6A	1.93	12AX7	.65
*2X2	.60	6G6M	1.09	12BA6	4.95
3Q4	.66	6J5GT	.44	12X7	.65
3V4	.62	6J6	.73	12AY7	.49
*5V4	1.20	*6J8	1.09	12BA6	.48
5Y3GT	.33	*6K6	.65	12BE6	.49
*5Z3	.85	*6K7M	.85	*12BE6	.49
*6AC7	1.25	*6J7GT	.85	12SK7GT	.58
6AG5	.57	6L6G	1.05	12SN7GT	.58
*6AC7	1.65	6L6GA	1.05	19T8	.86
*6AF8	1.75	*6N7M	1.20	25L6GT	.50
6AK5	1.10	*6R6	1.50	*25W4	.90
6AL5	.44	6S4	.51	35L6GT	.53
6AQ5	.91	*6SCT	1.10	35W4	.37
6AT6	.40	*6SF5GT	.75	35Z5GT	.39
6AU6	.48	6SK7GT	.53	50B5	.53
6AV6	.40	6SL7GT	.65	50C5	.53
6AB5/6NB	1.25	6SN7GT	.58	50L6GT	.53
6BA6	.48	6T8	.86	59	1.50
6BC5	.56	6V6GT	.51	*89V	.75

UNBRANDED—Lots of 50 only  
\*STANDARD BRANDS—Any Quantity

## SPECIAL PURPOSE TUBES

1N23A	\$.275	350B	\$.550	5749	\$.495
1N23B	4.95	394A	5.30	5814	4.95
2C51	2.95	715B	18.00	8025	5.75
2E25	5.95	721A	3.95	9001	1.75
2O21	1.65	723AB	14.50	9002	1.50
2K25	2.95	807A	1.95	9005	3.95
304TL	12.49	809	2.25	CK70	4.95
304TH	12.49	829B	13.95	CK1005	.79
3B24	5.50	832A	3.15	RK73	1.50
3C24/24E	1.50	837	1.95	T20	2.25
6J4	6.75	884	1.70	T200	16.95
44A	2.25	931A	6.75	TUF20	3.95
75TH	6.75	9003	1.75	T220	3.25
2110/VT40	1.75	1633	.65	TZ40	3.25
		5670	5.95		

**IMMEDIATE DELIVERY!**

Write for quotations, many other types available. 20% Deposit with order, balance C.O.D. All tubes subject to prior sale.

**WRITE, WIRE, CALL—TODAY!**  
We Buy Anything in Electronics—large or small Quantities!

## Nat Adelman

168 Washington St. New York 6, N. Y.  
CO. 7-6091

## ON-THE-SPOT BATTERY RECORDER

**WALKIE-RECORDALL** 8 lb. miniature BATTERY RECORDER-PLAYBACK

Continuous, permanent, accurate, indexed recording at only 5c per hr. Instantaneous, permanent playback. Picks up sound up to 60 ft. Records conferences, lectures, dictation, 2-way phone & sales talks, while walking, riding or flying. Records in closed briefcase with "hidden mike"! Write for details.

## MILES REPRODUCER CO., INC.

812 BROADWAY Dept RE12 NEW YORK 3, N. Y.

bilization, S. N. Shure, Shure Brothers; Industrial Relations, Jerome J. Kahn, Standard Transformer Corp.; Membership, Charles Hansen, Jensen Manufacturing Co.

**Personnel Notes**

... W. L. Parkinson, GENERAL ELECTRIC, and Fred D. Wilson, DuKane Corp., were named chairmen of the RTMA Service and School Equipment Committees, respectively.

... Mrs. Douglas Horton, who commanded the WAVES in World War II, has been elected to the Board of Directors of RCA. She is the first woman to serve on the board. She succeeds Arthur E. Braun who resigned.

... James Lippman has rejoined the NATIONAL Co., Malden, Mass., in the newly created position of customer service manager.

... Jack Thomas has joined the engineering staff of TECHNICAL APPLIANCE CORP., Sherburne, N. Y., in the Government Contract Division. He was formerly with the Antenna Laboratories of Ohio State University.

... Robert T. Borth has been appointed to the newly created position of manager of employee relations for the Tube Department in GENERAL ELECTRIC, with headquarters in Schenectady, N. Y. He was previously manager of community relations in New York City.

... Don Haines has joined BELMONT RADIO CORP. in an administrative capacity as assistant to William Garstang, administrative director of engineering and research. He was formerly chief engineer at Sentinel Radio.

... Dr. Newbern Smith, chief of the Central Radio Propagation Laboratory of the NATIONAL BUREAU OF STANDARDS in Washington, D.C., was awarded the 1952 Harry Diamond Memorial Award by the Board of Directors of the Institute of Radio Engineers. The award is made annually to a person in Government service who has made outstanding contributions to the field of radio and electronics.

... David Gnessin has been appointed sales manager of TRANSVISION, INC., New Rochelle, N. Y. Mr. Gnessin, formerly factory representative in Columbus, Ohio, has been a frequent contributor to RADIO-ELECTRONICS.

... Arthur W. Burten has joined the ASTRON CORP., East Newark, N. J., as advertising manager and a member of the Sales Department. He has been associated with the radio industry for a number of years in both sales and advertising.

... George Wedemeyer, president of NEDA, appointed the following distributors to the Board of Directors of the Radio Parts and Electronic Equipment Shows, Inc.: Byron Deadman, Green Bay, Wis.; Anthony Dybowski, Buffalo, N. Y.; Louis W. Hatry, Hartford, Conn.; W. D. Jenkins, Richmond, Va.; H. E. Ruble, Dayton, Arthur C. Stallman, Ithaca, N. Y.; L. F. Waelterman, St. Louis.

... Louis Selsor has joined the NATIONAL VIDEO CORP., Chicago, as jobber sales manager. He formerly held sales positions with Du Mont and Thomas Electronics.

... Myer Fried, retired U.S. Army colonel, has been retained by the RCA SERVICE Co., Camden, N. J., as special advisor to P. B. Reed, vice-president in charge of the Government Service Division.

... Ray R. Hutmacher was elected vice-president in charge of the Contract Division of SOUND, INC., Chicago. The firm, with its affiliated companies, Star Products Co. and The Pentron Corp., is a manufacturer of magnetic tape recorders, tape players, amplifiers, and other electronic products. Mr. Hutmacher was formerly with Permoflux Corp., Chicago.

... Dale Cropsey recently joined POTTER AND BRUMFIELD, Princeton, Ind., as works manager.

—end—

**THE JUNIOR SUPER-METER**  
**THE MOST COMPLETE AND COMPACT**  
**MULTI-SERVICE INSTRUMENT EVER DESIGNED!**

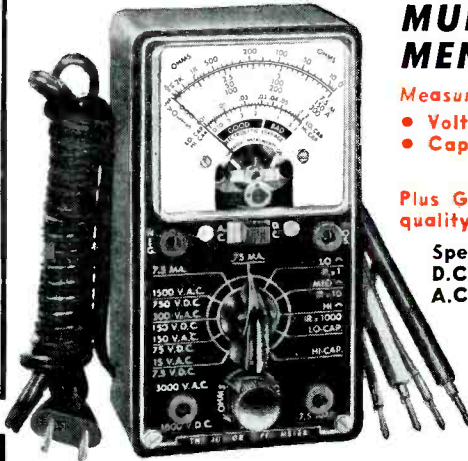

**Measures:**

- Voltage
- Current
- Resistance
- Capacity
- Reactance
- Inductance
- Decibels

Plus Good-Bad scale for checking the quality of electrolytic condensers.

**Specifications:**

D.C. Volts: 0-7.5/75/150/750/1500 Volts.  
 A.C. Volts: 0-15/150/300/1500/3000 Volts.

**Resistance:**

0-10,000/100,000 ohms. 0-10 Mgsms.

D.C. Current: 0-7.5/75 Ma. 0-7.5 amps.

Capacity: .001 Mfd.—2 Mfd. .1 Mfd.

—20 Mfd.

**Electrolytic Leakage:** Reads quality of electrolytics at 150 Volt test potential.

**Decibels:** —10 Db. to +18 Db. +10 Db. to +38 Db. +38 Db. to +58 Db.

**Reactance:** 15 ohms—25 K ohms 15 K ohms—2.5 Megohms.

**Inductance:** 5 Henry—50 Henries 30 Henries—10 K Henries.

Handsome round cornered molded bakelite case 3 1/8" x 5 7/8" x 2 1/4" complete with all test leads and instructions.

**\$21.40**

**SOLD ON EASY PAYMENTS**  
**AT THE NET CASH PRICE**

No interest or carrying charges added. Simply remit \$5.40 with order, pay balance \$4.00 per month for four months.

**MOSS ELECTRONIC DIST. CO., INC.**  
 Dept. B-6, 38 Murray St., New York 7, N. Y.

more TV  
 set outlets  
 per dollar!

with  
 easy-to-install  
 BLONDER-TONGUE

**ALL-CHANNEL  
 MASTER  
 ANTENNA  
 SYSTEMS**

- No signal loss
- For systems supplying up to 2000 TV sets
- No "Extras"—Transformers built in, Coax Connectors not needed

**Required for Installation**

- 1 good antenna
- 1 screwdriver
- 1 pair of pliers

Literature on Request write Dept. D



Distribution Amplifier  
 8 TV Set Outlets  
 Model #DA8-1-M  
 List Price \$87.50



Distribution Amplifier  
 2 TV Set Outlets  
 MODEL #DA2-1-M  
 List Price \$39.50

Model #CA-1-M  
 List Price \$77.50



Commercial Antensifier  
 (30 Times Gain)  
 Use As Pre-Amplifier, Line Amplifier or de-luxe Booster

**BLONDER-TONGUE LABS.** 38 N. Second Ave., Mt. Vernon, N.Y.

for dependable sound,  
**INDUSTRY** relies on  
**ATLAS**



DR Double-Reentrant Projectors



Paging & Talk-Back Speakers



ALNICO-V-PLUS Driver Units



Dual Speakers



FULL-GRIP, VELVET-ACTION Mike Stands

**DEPENDABLE QUALITY:**

The latest electro-acoustic research and engineering—and over 20 years of manufacturing know-how—are behind every ATLAS product.

**DEPENDABLE SERVICE:**

Coast-to-coast and around the world today—in every Industrial, Marine, Railroad, Military, Educational, Civic, U.S. and Foreign Government application—under every kind of climate and noise condition—ATLAS sound equipment is famous for highest efficiency and durability. That's the proof of ATLAS performance dependability.

**DEPENDABLE DELIVERY:**

Yes, ATLAS gives our Government highest priority. And yes, we too feel the pinch of material shortages. But our customers will continue to get our usual dependable delivery—because we believe in equitable and dependable distribution to all ATLAS users.

**DEPENDABLE PROFITS:**

Completeness of line, excellence of product, dependable delivery, right prices—that's the ATLAS combination that means high, steady Industrial Sound profits for You!

JUDGE for yourself, COMPARE ATLAS at your local Jobber today. See why ATLAS is the preferred line for utmost dependability. Write NOW for FREE latest Catalog 551.

**ATLAS SOUND CORP.**  
1443-39th Street, Brooklyn 18, N. Y.  
In Canada: Atlas Radio Corp., Ltd., Toronto, Ont.

**COLOR TONE! TELEVISION!**  
ON YOUR  
Simply attach TELECOLOR FILTER to front of set and enjoy programs in glorious color tones instead of dull black and white. GUARANTEED to give genuine color tone. Can also be used with any other filter. Once tried, you will never go back to old black and white. Write for FREE information. ORDER BY MAIL. NEW REDUCED PRICES!  
Send check, M.O., cash, COD to Dept. RE-2  
10 in. \$1 16, 17 in. \$3  
12, 14 in. \$2 19, 21 in. \$5  
**HARVARD LAB.** 659 FULTON ST. BROOKLYN, N. Y.

**WEED OUT THE CROOKS?**

Dear Editor:

There has been much talk around here lately of licensing TV technicians. The twofold purpose of doing so is supposedly to weed out the crooks and the technically unfit.

Let me remind the advocates of licensing that the medical profession, despite having the most strictly enforced licensing plan in the world, is cursed with frauds and quacks.

LEONARD LEE LAMASCUS  
Los Angeles, Cal.

**CONVERSIONS OUTDATED?**

Dear Editor:

I do not intend to renew my subscription to RADIO-ELECTRONICS. Here's why! Over 50% of the August issue of the magazine was devoted to big-picture TV conversion. Thirteen months ago, when these conversion jobs were in demand, and there was a real need for the material, RADIO-ELECTRONICS carried practically no articles on this topic. Now, when all progressive service technicians are well acquainted with the problems of conversion, you devote several issues to the subject. In short, your magazine is way behind the times.

LAWRENCE W. LECHTRECK  
Creve Coeur, Mo.

(Our reader has slightly overstated the case for the August TV Conversion Issue. Ten pages—10% of the 100-page magazine—were devoted to conversion in that issue. He has, however, equally understated the case for earlier numbers. True, we did not run any articles thirteen months before the one he complains about. In July, 1950, conversion was an extremely new thing, and reliable information about methods and pitfalls was nonexistent. As soon as a skilled operator had obtained enough experience in successful conversion, it was incorporated in an article, and published in January, 1951. At the same time, we offered information on big-tube conversion in brochure form and have since sent out several thousand brochures on the subject. Our main article (cover story) in May was also on conversions.

So far are we from believing that the subject is played out that we intend to continue printing articles on it whenever we feel that their excellence and originality merit publication. What do our TV technician readers think about it? Can you use more information on conversion problems?—Editor)



Suggested by: Arthur Henrikson, Chicago 5, Ill.

**SURPLUS**

**DECEMBER SPECIALS**  
**BARGAIN! NEW!**

**CRAMER TIMER**  
ADJUSTABLE TIME DELAY RELAY. RE-LAY adjustable from 1/30 sec. S.P.D.T. with starting relay for remote control motor and contacts separate. Stock No. R-246. Operating voltage 115V, AC. Coil resistance. Contacts SPST. (NO) or (NC) 10 Amps. EACH \$8.50

**VERTICAL ANTENNA MAST KITS**  
Fully Adjustable 5 to 35 Feet Easy to Set Up  
FOR FM, TELEVISION AND ROTARY BEAM Doublet Antenna Kit used with the famous Hallcrafters BC-610, consisting of 7 steel-alloy mast sections in a handy canvas bag. Each section is 3/4" long, 1 1/2" OD with the last 6" rolled to a smaller OD to telescope into the end of the preceding section. No taper. Assemble into mast up to 35' high or shorter by any multiple of 5'. Finished in weatherproof olive drab. Ideal for erection of FM and Television Beams! Drop your coaxial cable right through the \$12.95 center! Brand new.

**TUBE SPECIALS**

1626	.49	1616	.69	12S17QT	.99
1629	.39	81	.49	41	.49
FG104 5561	.919		.09	837	.99
	29.95	2X2	.99	2051	1.29
RK73	.99	843	.39	G.E. 211	.98
15R	.79	803	2.95	12A6	.69
801	.79	9001	.99	65J7	.69
6AK5	1.49	WLE30	7.95	307ARK75	4.95
250R	3.95	1625	.39	1E7Q	.69
HY615	.49	10Y	.39	EF50	.69

**MANY OTHER ITEMS NOT LISTED**  
FUSES 3c each, \$1.95 per C 3AG—1 amp, 4 amp, 15 amp  
4AG—35 amp, 40 amp 5AG—20amp, 40, 60, 70amp

**GP-7 TRANSMITTER**

**TUNING UNITS**  
Ideal Basis for E.C.O. Rig  
Tuning units for TCE & GPT in the following frequencies: A—350 to 800 kc; B—800 to 1500 kc; C—1500 to 3000 kc; E—4525 to 6500 kc; F—8200 to 40500 kc. Contains all coils, etc., for these frequencies. Used units are in A-1 condition. Units C & F each \$3.95

Write for our Bargain Bulletin

**DOW RADIO, INC.**  
1759 E. Colorado St. Pasadena 4, Calif.  
Phone: Sycamore 3-1196  
\$2.00 min. order 25% deposit with orders  
Send full remittance to save U.O.D. charges  
All merchandise fully guaranteed. Subject to prior sale.

**WHY WILL YOU CHOOSE YOUR TAPE RECORDER?**

- Higher Fidelity and Smoother Performance?  
**A. THEN BUY TWIN-TRAX!\***
- Longer Continuous Playing Time?  
**A. THEN BUY TWIN-TRAX!\***
- Professional Specifications at Popular Price?  
**A. THEN BUY TWIN-TRAX!\***
- Wider Selection of Models?  
**A. THEN BUY TWIN-TRAX!\***

No matter which of these features you consider most important. You'll find them all—and many other exclusive features—in our Twin-Trax Recorders. Send today for your free copy of our Catalog #272. \*Reg. U. S. Pat. Off.

**AMPLIFIER CORP. OF AMERICA**  
398 Broadway, New York 13, N. Y.

**\$52,000.00 AVAILABLE**  
To Buy Needed Surplus Electronic Equipment

Urgently need BC-611, BC-344, BC-1016 Tape Recorder, ARC-1, ART-13, T-152C, BC-788C, BC-348, TS-45, TS-35, TS-33, TS-152C, BC-788C, BC-348, TS-45, TS-35, TS-33, TS-102, TS-120, TS-146, TS-147, TS-148, TS-13, TS-12, APR-4, TS-47, ARN-7—complete units or parts. Send description, condition and asking price to:

**WEST REGION ELECTRONICS**  
1437 S. Norton Ave., Los Angeles 19, Calif.

TV AIDS RETARDED

Dear Editor:

Your editorial in the September issue was inspired. As a matter of fact, television is already unintentionally adding to the educator of retarded children who are forced by lack of school facilities to remain in their homes. Since they are shunned by their contemporaries, in many cases, the only contacts these backward children have are their parents.

As a secretary for the Association for the Help of Retarded Children, Inc., I have learned of several children who were able to recognize the alphabet and read the advertising because of its constant repetition. A case of one man's poison! Where television itself may be retarding to the average child because of its distracting influence when there is homework to be done, it is a broadening influence to the children who have no other instructors than their own mothers.

At the next opportunity you have to plug Television as an educational feature, please don't forget to mention the mentally retarded children at home as well as those in private and public schools.

CHARLOTTE P. DONNELLY  
New York, N. Y.

(Television's inherent educational possibilities are so great that they show up in spite of the unfavorable environment of our present type of television programs.—Editor)

—end—

*The Original!*  
**LOW LOSS OPEN WIRE LINE**  
*(lowest loss lead-line mfd.)*

**"GONSET LINE"**

- 1/2 THE LOSS OF NEW MOLDED RIBBON
- 0.5 DB LOSS PER 100 FT. AT 200 M.C.
- POLYSTYRENE SPACERS

*Ideal for*

- TELEVISION
- AMATEUR
- COMMERCIAL
- FRINGE AREAS
- LONG RUNS
- BEACH AREAS

send for latest bulletin

**GONSET CO., BURBANK, CALIF.**  
72 E. TUJUNGA AVE.

*Miller*  
BUILDERS OF QUALITY RADIO INDUCTANCES SINCE 1924

**NOW AVAILABLE TO THE SERVICEMAN AND EXPERIMENTER**  
**THE FAMOUS K-TRAN**

- THE FINEST MINIATURE I. F. TRANSFORMER EVER MANUFACTURED!
- ONLY 2 1/4" HIGH BY 3/4" SQUARE
- SHELL CORE PERMEABILITY TUNED. STABLE SILVER MICA FIXED CONDENSERS — NOT MICA COMPRESSION TUNED.
- UNIQUE SNAP CLIP MOUNTING FOR ROUND HOLES IN CHASSIS.

455 KC input transformer gain 50. Band width at 2 times 16 KC; at 10 times 40 KC.  
455 KC output transformer gain 110. Band width at 2 times 18 KC; at 10 times 50 KC.  
262 KC input transformer gain 65. Band width at 2 times 9 KC; at 10 times 23 KC.  
262 KC output transformer gain 130. Band width at 2 times 10 KC; at 10 times 27 KC.

CAT. No.	ITEM	NET PRICE
12-H1	262 KC Input I. F. Trans.	1.50
12-H2	262 KC Output I. F. Trans.	1.50
12-C1	455 KC Input I. F. Trans.	1.32
12-C2	455 KC Output I. F. Trans.	1.32

The "K-TRAN" is distributed nationally to the jobber only by J. W. Miller Company.  
\*Manufactured under "K-TRANS" Patent Numbers 2435630 and 2429468 of Automatic Manufacturing Corp.

**J. W. MILLER COMPANY**  
5917 S. MAIN ST. LOS ANGELES, CALIF.

**GREYLOCK TELEVISION VALUES**

**HIGH VOLT. FLYBACK TRANSFORMER 14K VOLTS**



Used for 16", 17" round or rectangular tubes. Good for conversion and replacement use. Many set mfrs used this flyback transformer in their sets and paid more than this for them!  
Order #B-2612 Each, ONLY **\$2.99**



**CHIMNEY MOUNTS**

We overstocked on our regular chimney mount—our loss, your gain! WHILE THEY LAST! Order #E-1585 Each, ONLY **99c**



**4 ELEMENT CONICAL ANTENNAS**

Constructed of reinforced butt seam aluminum elements and strong steel cross bars; ruggedized insulators.

SINGLE Order #P-003 **\$3.99**  
STACKED Order #P-004 **\$8.29**  
Extra elements for conicals make fan-flector type.  
P-009 Low Band Elements, each **49c**  
P-010 High Band Elements, each **35c**

TERMS: Net C.O.D., F.O.B. New York City. 25% Deposit on all C.O.D. Orders.

For your convenience Graylock will be open on Saturdays from 9:00 am to 2:00 pm.

**GREYLOCK RADIO VALUES**

**NEW! ESQUIRE CLOCK-RADIO**



IN BAKELITE EBONY  
**ONLY \$19.60 each**

WAKE UP TO MUSIC!

Sensational Esquire Clock-Radio, will awaken you, or lull you to sleep, and then shut off automatically! Check these features!

- On-Off Switch
- Sessions Automatic Electric Movement
- Automatic Turn-on
- Automatic Shut-off
- Sweep second Hand
- Built-in Antenna
- Alarm set control
- Station Selector
- Volume Control
- Alarm Set Pointer
- Superheterodyne Receiver
- 105-120 V. 60 cy. AC.
- RTMA 90 Day Warranty

Please include 25% deposit with C.O.D. Orders

PREPAID XMAS SPECIAL!  
Include remittance with order and we'll ship Clock-Radio PREPAID, anywhere in continental U.S., Alaska, or Puerto Rico.

"A Trusted Name in Radio!"

**GREYLOCK ELECTRONICS SUPPLY CO.**  
115 Liberty Street - New York 6, N. Y.

**GREYLOCK REC. TUBE VALUES**

All tubes listed below, carry standard RTMA 6 month Guarantee—excepting only burn-outs and breakages.

At these sensationally low prices, these tubes must be ordered in quantities of AT LEAST 10 TUBES (may be assorted)—no orders for less than 10 tubes accepted.

All individually boxed in attractive Greylock Cartons.

1L4	6BA6	6W4GT
1U4	6BE6	6X4
1U5	6CB6	25Z5
3Q4	6C6	117Z3
3V4	6J7	
6AL5	6S4	
6AQ5	6SK7GT	<b>49c each</b>
6AU6	6SN7GT	
6AV6	6V6GT	

6AK5	.79	12AU7	.59
6AS5	.69	12AV7	.79
6BG6G	1.09	12AX7	.59
6BQ6GT	.79	12SK7GT	.79
6CD6G	1.29	12S8GT	.69
6SA7GT	.59	19BG6	1.09
6U4GT	.79	25L6GT	.59
		35Z5GT	.59

FOR ADDITIONAL VALUES

Radio Hams, Radio & TV Servicemen, Electronics Experimenters—write for Greylock's Great New Catalog C-12, crammed full of money-saving values for YOU!

# TUBES

Every  
Critical  
Type

WE BUY FIRST QUALITY TUBES FOR CASH!

Fully Guaranteed • Brand New • Immediate Delivery

.59	.69	.79	.99	1.29
5U4G 5Y3GT 6AL5 6AU6 6AV6 6BE6 6J5GT 6K5GT 6K6GT 6W4GT 35W4 35Z5GT	1R5 1U4 354 3V4 6BA6 6SA7GT 6SK7GT 6SN7GT 6V6GT 6X5GT 6BJ6 12AT6	1B3GT 3Q4 12AU7 12SA7GT 12SK7GT 12SN7GT 12SQ7GT 35L6GT 50L6GT 6CB6 6BH6 25L6GT	1X2A 5V4G 6BC5 6AG5 6AC7 6J6 6T8 6AB4 12AV7 12BH7 12SC7 12SG7	6AH6 6BG6 6CD6 6BQ6 6BN6 6AK5 12AT7 19C8 19T8 25BQ6 19BG6 70L7GT

300-ohm twin lead, pure copper and polyethylene, \$19.50 per thousand feet. 1500 feet to a roll.

TERMS: Orders for less than \$25.00, add 10% to above prices. 25% deposit with order, balance C.O.D. F.O.B. New York City.

All Merchandise Subject to Prior Sale.

## Supreme Radio & Television Co.

136 Liberty Street, New York 6, N. Y.

**STOP!**  
**TV INTERFERENCE**

Eliminates interference caused by Short Wave...F.M. Hams...Diathermy...Atmospheric disturbances, etc.

With a **TELEMATIC** Full Range **FILTER KIT**

**SIMPLE — SPEEDY — EFFICIENT**

- Eliminates antenna-fed interference!
- Covers full-range both I.F. and R.F. Sharper, steadier picture!
- Fewer service recalls!
- Any filter in kit replaceable separately!

**FILTER KIT** contains 2 Hi-Pass Filters, 4 WAVE TRAPS covering full range of interference signals. Send for FREE Booklet on TV-INTERFERENCE

ONE JORALEMON ST. BROOKLYN 2, N. Y.

### DYNAMOTORS

Type	Input Volts	Input Amps.	Output Volts	Output Amps.	Radio Set
PE86	28	1.25	250	.060	RC 36
DM41S	14	6.2	330	.170	RC 19
DM33A	28	7	540	.250	BC 456
DM42	14	46	515	.110	SCR 506
			1030	.050	
PE101C	13/26	12.6	400	.135	SCR 515
		6.3	800	.020	
BD AR 93	28	3.25	375	.150	
23350	27	1.75	285	.075	APN-1
ZA0515	12/24	4/2	500	.050	MARK II
B-13 pack	12	9.4	275	.110	
			500	.050	
D-104	12		225	.100	
			440	.200	
DA-3A	28	10	300	.089	SCR 522
			150	.010	
			14.5	.5	
5053	28	1.4	250	.060	APN-1
PE73CM	28	19	1000	.350	BC 375
CW21AAX	13	12.6	400	.135	
	26	6.3	800	.020	
			9	1.12	
PE94	28	10	300	.200	SCR 522
			150	.101	
			14.5	.5	
DY2/ARR-2					DY22/ARC

### INVERTERS

PE 218-E: Input: 25 28 vdc. 92 amp. Output: 115 v. 350-500 cy 1500 volt-amperes. Dim: 17"x6 1/2"x10". New \$49.50

PE-218-H: Same as above except size; 10 1/2"x6"x10". New \$49.50

PE-206: Input: 28 vdc. 38 amps. Output: 80 v 800 cy. 500 volt-amps. Dim: 13"x5 1/2"x10 1/2". New.

### 1% PRECISION RESISTORS

1.01	128	2230	30000
3	150	4300	33000
5	200	5000	35000
5.05	250	7500	40000
10.1	300	8500	50000
18	430	10000	55000
43.5	468	12000	57000
50	800	17000	75000
75	920	17300	75000
82	1000	20000	type in
120	1100	25000	stock
125	1450		
Above Ea. .30¢	Ten For		\$2.50
100000	150000		200000
120000	170000		220000
Above Ea. .40¢	Ten For		\$3.50
1,000,000 ohms			Each 75¢

Send M.O. or CHK. Mdse. Guardt. Shpg. Charges Sent C.O.D. Price F.O.B. N.Y.C. Phone Di. 9-4124

**COMMUNICATIONS EQUIPMENT CO.**  
131 Liberty St., Dept. C-12 New York City 7, N. Y.

**ELECTRIC TRANSMISSION LINES**, by Hugh Hildreth Skilling. Published by McGraw-Hill Book Co., Inc., 330 W. 42 St., New York, N. Y. 6 x 9 inches, 438 pages. Price \$6.50.

This text is the result of a happy combination. The author has had years of college teaching experience. He has also consulted many practical specialists in the field. The result is a good book on theory, yet one practical enough for engineers and technicians. Algebra is used as well as circular and hyperbolic functions. There is a sprinkling of more advanced concepts.

The first half of the book deals with basic theory. The remainder is more specialized, with separate chapters on telephone lines, power lines, r.f. lines, filters, and wave guides. Diagrams and impedance charts add clarity.

Practical problems are given at the end of each chapter. They are chosen to explain and review chapter material. (We have encountered other texts with problems so complicated as to require a more advanced book to solve them.)

Wire characteristics, circular and hyperbolic functions are given in the appendix. Useful equations are printed on each inside cover.—IQ

**SHORT WAVE WIRELESS COMMUNICATION (Fifth Edition)**, by A. W. Ladner and C. R. Stoner. Published by John Wiley & Sons, Inc., 440 Fourth Ave., New York, N. Y. 5 1/2 by 8 1/2 inches, 717 pages. Price \$8.00

This is the work of two British authorities on high frequencies. It is a comprehensive text on theory and principles. The discussions are largely non-mathematical, although equations and diagrams are provided. A high technical level is maintained.

In general the subject matter is well chosen, but there are a few exceptions. About 30 pages are devoted to properties of crystals and angle cuts. Only three pages are set aside for crystal circuits. The ratio detector is not mentioned at all. In view of the large number of circuits and components in the book, a more detailed index might have been advantageous.—IQ

**TELEVISION ANTENNAS (Second Edition)**. Published by Howard W. Sams, Inc., 2201 E. 46th St., Indianapolis, Ind. 5 3/4 x 8 1/2 inches, 223 pages. Price \$2.00

Written with the needs of the practical technician in mind, this publication, containing 174 illustrations, presents an orderly treatment of TV antenna principles, construction, installation and reception problems. Simple computations and clear construction data, with radiation patterns and charts, are lucidly presented for a wide variety of TV antennas, from rhombics and conicals to multi-element Yagis.

Many commercial antennas are listed and described as to types and manufacturers.

The intensive coverage on installation techniques makes up to some extent for the somewhat skimpy treatment given to actual antenna and transmission line troubleshooting.—CM

You can't beat **RADIO-ELECTRONICS**  
for complete coverage of  
**RADIO, TELEVISION and AUDIO**

# RADIO SCHOOL DIRECTORY

**AUDIO (SOUND) ENGINEERING COURSE HOME STUDY TRAINING**

Prepare yourself, in your spare time for a **BIG PAY JOB** as an **AUDIO ENGINEER**. Practical, easy-to-understand lessons, written by nationally recognized Audio Engineers and Educators.

Prepare for a **SUCCESSFUL CAREER** in the **TELEVISION, RADIO, DISC AND TAPE RECORDING, ELECTRONICS AND MOTION PICTURE INDUSTRIES**.

Training will not interfere with present employment.

**EARN WHILE YOU LEARN  
WRITE FOR COMPLETE DETAILS—TODAY**

B. M. Klekner, D.Sc., Ph.D.  
*President*

**HOLLYWOOD TECHNICAL INSTITUTE**  
3359 Cahuenga Boulevard  
Hollywood 28, California

**LEARN  
AMATEUR RADIO**

- Radio • Television
- Communications • Electrical inspector courses.

FCC License preparation. Amateur Radio Station on premises.

Build your own equipment in our Laboratories.

C. Gallo W2AWI (Director)

**LINCOLN SCHOOL OF RADIO & TV INC.**  
1851 B'way (61st St.) New York, N. Y.

**F.C.C. COMMERCIAL  
RADIO OPERATORS LICENSE**

Critical Shortage of Licensed Operators Exists!!!

A wonderful future is yours with an F.C.C. commercial radio telephone or telegraph operators license, leading to top-salaried jobs in aviation, broadcasting, transportation and Civil Service. Sensational new simplified HOME STUDY course teaches you in the shortest possible time at lowest possible cost. **NO OTHER COURSE LIKE IT!** Proven valuable during World War II in speedy training thousands of men, eliminates tedious schooling, exam papers, wading through books. Each page of text directly related to official F.C.C. exam. questions, thus assuring you of all theory requirements.

The entire course, nothing else to buy, containing 230 pages of complete material, diagrams, etc., yours for only \$9.95. Send check or money order; or pay postman \$9.95 upon receipt, plus C.O.D. charges. Complete satisfaction or money refunded within ten days.

**STREAMLINED SELF STUDY COURSES**  
509 5th Ave. Dept. A New York, N. Y.



**RADIO COURSES**

Preparatory Mathematics, Service, Broadcast, Television, Marine Operating, Aeronautical, Frequency Modulation, Radar.

Classes now forming for the Mid-Year term beginning Feb. 1, 1952  
Entrance exam, Jan. 21, 1952  
*Veterans' Literature.*

**COMMERCIAL RADIO INSTITUTE**  
*(Founded 1920)*  
38 West Biddle Street, Baltimore 1, Md.

**ATTENTION...**

A NEW department of the **DON MARTIN SCHOOL OF RADIO AND TELEVISION ARTS AND SCIENCES** . . . for instruction and training in—**TELEVISION**—Incorporating:

Production: Writing, Directing, Producing, Acting, Staging, Lighting.

Engineering: Transmission, Receiving, Camera and Studio, Operation, Theory of Video, Pickup and Reproduction.

Approved for veterans.

**THE DON MARTIN SCHOOL OF RADIO AND TELEVISION ARTS AND SCIENCES**  
1655 No. Cherokee, Hollywood 28, Calif. HU. 23281.

**LEARN DAY and EVENING CLASSES  
TELEVISION**

**ELECTRONICS-RADIO**  
Modern Laboratory Instruction in

- SERVICING
- BROADCAST OPERATING
- ELECTRONIC and TV ENGINEERING

**G.I. APPROVED**

**WRITE FOR ILLUSTRATED CATALOG**

**ELECTRONICS INSTITUTE, Inc.**  
21 HENRY, DETROIT 1, MICH.

**Prepare Now!**

**RADIO ENGINEERING**

**B. S. DEGREE IN 27 MONTHS**

Complete Radio Engineering course incl. Telev., U.H.F. and F.M. BS Degree Courses also in Mech., Civil, Elect., Chem. and Aero Eng.; Bus. Adm., Acct. Extensive campus, modern buildings, well equipped labs. Low cost. Prep. courses. Personalized instruction. Heavy demand for graduates. Placement service. Founded in 1884. Prepare now for the civil and military opportunities ahead. Enter Jan., March, June, Sept. Write for Catalog.

**TRI-STATE COLLEGE**  
24121 COLLEGE AVE. ANGOLA, INDIANA

**CODE SENDING RECEIVING SPEED**

Be a "key" man. Learn how to send and receive messages in code by telegraph and radio. Commerce needs thousands of men for jobs. Good pay, adventure, interesting work. Learn at home quickly through famous Candler System. Qualify for Amateur or Commercial License. Write for FREE BOOK.

**CANDLER SYSTEM CO.**  
Dept. 3-0, Box 928, Denver 1, Colo., U.S.A.

**RCA RADIO and TELEVISION ELECTRONICS**

Thorough Training For Men and Women in All Technical Phases

New Classes (Day & Eve.) Start NOVEMBER 30, 1951  
FREE PLACEMENT SERVICE FOR GRADUATES  
For Free Catalog Write Dept. RC-51

**RCA INSTITUTES, Inc.**  
A Service of Radio Corporation of America  
350 WEST 4TH STREET NEW YORK 14, N. Y.

**LEARN**

**Television-Radio Electricity**

**REFRIGERATION-ELECTRONICS**

IN THE GREAT SHOPS OF **COYNE**

**TELEVISION**

**PREPARE FOR A GOOD JOB!**  
COMMERCIAL OPERATOR (CODE) RADIO SERVICEMAN

**TELEVISION SERVICING  
BROADCAST ENGINEER**

Approved for Veterans  
SEND FOR FREE LITERATURE

**BALTIMORE TECHNICAL INSTITUTE**  
1425 Eutaw Place, Dept. C, Baltimore 17, Md.

**V RADIO ENGINEERING**

**FM—Television—Broadcast**

Police Radio, Marine Radio, Radio Servicing, Aviation Radio and Ultra High mobile applications. Thorough training in all branches of Radio and Electronics. Modern laboratories and equipment. Old established school. Ample housing facilities. 7 acre campus. Small classes, enrollments limited. Our graduates are in demand. Write for catalog.

Approved for Veterans

**VALPARAISO TECHNICAL INSTITUTE**  
Dept. C VALPARAISO, INDIANA

**TRAIN QUICKLY! OLDEST, BEST EQUIPPED SCHOOL OF ITS KIND in U.S.**  
*Young and Older Men . . .*

Come to the Great Shops of Coyne in Chicago. Get practical training in TELEVISION-RADIO or ELECTRICITY—vital in Defense Program. Prepare now for a better job or better service rating.

**START NOW—PAY LATER**

You can finance most of your tuition, pay for it later in easy monthly payments. Special plan for men of Draft Age. Part time employment service available.

**FREE BOOK** Clip coupon for Big Free Illustrated Book. Indicate below, course that interests you. No salesman will call. Act NOW.

**COYNE SCHOOL**

B. W. Cooke, President  
A TECHNICAL TRADE INSTITUTE CHARTERED NOT FOR PROFIT  
Established 1899  
500 S. Paulina, Chicago

**ELECTRICITY ★ TELEVISION  
RADIO ★ REFRIGERATION ★ ELECTRONICS**

**RADIO ENGINEERING IN 27 MONTHS DEGREE**

Intensive, specialized course including strong basis in mathematics and electrical engineering, advanced radio theory and design, television. Modern lab. Low tuition. Self-help opportunities. Also 27-month courses in Aeronautical, Chemical, Civil, Electrical, and Mechanical Engineering. Approved for G.I.'s. Enter, Dec., March, June, Sept. Catalogue.

**INDIANA TECHNICAL COLLEGE**  
1512 E. Washington Blvd., Fort Wayne 2, Indiana

**BECOME A RADIO AMATEUR**

Complete Home-Study Course for Passing FCC Amateur Radio Examinations  
ALSO CODE COURSE FOR COMMERCIAL EXAMINATIONS

- LOW COST
- PERSONAL COACHING
- MONEY-BACK GUARANTEE

Write for Details

**FEDERAL ELECTRONICS INSTITUTE**  
34 East Putnam Ave., (Dept. F), Greenwich, Conn.

B. W. COOKE, Pres.  
COYNE School  
500 S. Paulina St., Chicago 12, Ill. Dept. 91-81H

Send FREE BOOK and full details on:

TELEVISION-RADIO  ELECTRICITY

NAME .....

ADDRESS .....

CITY .....

STATE .....

# "TAB" That's A Buy!

**"WILLIAMSON" 10W HI-FI KIT**  
 10 to 20000 cycles with Ease! Internationally Famous: For Hi-Fi enthusiasts, Incl Pwr supply, RCA Chassis, Less Pre-Amp & output Xfmr. Pre-selected parts, Balanced resistors, Power Supply & 5 tubes. \$29.95  
 Wilson Preamp Kit & Tone boost Amplifier, chassis, parts, pwr supply & 5 tubes. \$34.95  
**SUPER-Wide-Range HI-FI TRIODE 10W KIT**  
 10 to 20000 cycles, 60dB Max Harmonic Distortion 1 1/4% at full output & only 1/2% at 5W output. Includes Bass & Treble tube boost & Tone ckt & Preamp 4 G.E. pickup 4 dual & 2 output (?) tubes, Parts, RCA chassis & info., less output xformer. \$29.95  
 UTC Hi-Fi Output Xfmr for P.P. 2A3, 6BA, 6A5 & 6L6. Csd cap 30V; Sec 5 taps 2 1/2 to 250 ohms. \$6.95  
 GE Reluc Cartridge perm needle. \$1.98  
 GE Dual Reluc Cartridge RFX 050. \$7.29  
 GE Reluc Cartridge RFX040 of 494. \$7.29  
 GE S120D Hi-Fi Hvy dty 12" PM Spkr. \$18.98

**MERCURY THERMO REGULATOR**  
 Dual Ckt 105°F & 32°F, extremely sensitive & accurate for most exacting requirements—research, fire prev., freeze pt. control, or max.-min. temp. control. Brand new, indiv. boxes w/ data & ckt. \$20.00. SPECIAL 98c. \$12 for \$10.00

**866A KIT and XFORMER**  
 2 Tubes, Sekts. Xfmr 115v 60cye Impt. output 2.5vct/10A/Kvins. \$6.98

**DIODE PROBE TUBE!**  
 Unexcelled for NO-LOSS UHF Testing. Ultra-Sensitive Sub-Minature—Envelope Element & Probe at 15' cord. Low Pwr. 1W. BRAND NEW w/ Data, VR92. ONLY 25c 5 for \$1.00.

**TAB "SUN-FLASH" LAMPS**

No.	Replaces	W.-Sec.	Max.	Each
U10	GE FT110	100	\$ 9.98	
No. 1	GMLO 5804X	100	10.98	
23ST	GE FT114	200	10.98	
53GT	GE FT403	500	16.98	
V1	5Y1	200	11.98	
R4340	FLASH TUBE—Tab Special		\$36.00	
X-400	Air Corps Lamp P/O 1168 An Equip.		\$14.98	

**NEW THRIFT-LITE LIFETIME PHOTO-FLASH**  
 Not a kit, Incl Pwr pck, Life Rtl Lamp, filter & 15' cord. 1/1000 Sec flash every 7 sec. True dayvile color. All cameras, oper 115V AC w/ lite Type AC40. \$41.98  
 Complete outfit for AGC & Battery opt. Incl AC40&BP25 portopak & all access for KODAK&COMPUR Shutters Complete \$49.95  
 Write for Complete "THRIFT-LITE" Data Booster-packs, Ext lites, Units for focal plane shutters & accessories. **WE BUY, SELL & SWAP**

**TRANSFORMERS**  
 115 V 60 Cye Input CR Pwr Xfmr for 7" to 20" Tubes. 10 VOLTS to 20KV (w/ quadrupler ckt). ALL Tubes, PL & FIL wndgs divrng; 300 VDC/275Ma Full-Wave, 6.4V/10.3A, 5.4V/8A, 2.5V/3A Hypertal Core, Oil impreg. \$7.98  
 2500V for CRT, 6.3V/6A, 2.5V/1.75A Csd Kenyon 4 BC412 Repimnt. \$7.98  
 1400VCE 90ma, 6.3V/3A, 5v/3A H'sid. \$5.98  
 1320V & 375VCT 110ma, 5V/3A, 2.5V/3.25A, 6.3V/2.75A H'sid. H. Vinsld. \$5.98  
 1000vcs/150ma, 2x5v/3a, 6.3v/5a, 5v/3a, 2x5v/3a, 6.3v/1.25a H'sid. \$4.98  
 1000vct/45ma, 795 vct/80ma & 380 vct/55ma, 3x5v/3a, 6.3vct/1a, 6.3vct/1a, 3H Vinsul, USN, conl. use USN Rating Hypertal Core. \$4.98  
 900V/35ma, 2x2.5v/2a, Xcellent 1800 Vdblr, two 2x2 Hl. wndgs, H'sid HVins. \$2.98  
 840vct/110ma, 2x2.5v/2a, 2x5v/3a, 6.3v/1A, 6.3v/3A Csd Hvins Raytheon. \$4.98  
 700vct/125ma, 6.3vct/4A, 5v/3a, 2x5v/3a, 600vct/120ma, 5v/3a, 6vct/5a, 6.3v/3a, wndg Insul 2200V, Thoridaron Csd. \$4.49  
 570V/150ma, 5v/3a, 2v/4a, H'sid. \$4.49  
 420vct/90ma, 6.3v/1.25a, H'sid. 6-12-24-115vct & 115 230vct. \$1.98 2 for \$3.49

**FILAMENT TRANSFORMERS**  
 6.3vct/4A (quad 6.3) H'sid HVins. \$2.69  
 6.3v/2A \$3.99 6.3v/6A HVins. 1.98  
 2.5v/2A, 79c 7.5vct/12A HVins csd. 4.98  
 12.6vct 1.25A, \$1.98  
**PLATE TRANSFORMERS**  
 7500 V or 15000 V Dblr/35ma. \$19.95  
 3000V 10 ma. Csd HVinsul. \$ 8.95  
 — WRITE IN YOUR REQUIREMENTS.

**Sell Your SURPLUS TUBES & Gear To "TAB"—Send List & Best Prices!**

APS13/RT34 30 mc IF, Less Tubes As Is. \$7.98  
 Radio Compass Revr Less Tubes As Is. \$5.98  
 Tuning MTR GE 2-1/2" Sq. \$1.25  
 ANT KITS ARRI with Coax-Cnetn. 4 for 1.00  
 RSTR KIT 100 assld 1/2" & 1W to 2 megs. 100 for 3.98  
 Circular Slide Ruler Plastic Rtl equiv. 9.98  
 6" Sharpening Stone Carbide Co. \$2.25 Spl. .25  
 PI 259 Coax Plug. 55 50239 Coax Jack. .55

**MOTORS & SELSYNS**  
 211G1 G.E. Selsyns U Fix No Returns 2 for 49c  
 211H1 G.E. Selsyns 110V/60 Cye. 2 for \$6.98  
 211F3 G.E. Selsyns, New 115V/400 Cye. each \$9.75  
 C78248 Hvy Dty Synchro-trans 115V/80Cye 2for \$18.00  
 Other Types Available—Write for List

**SNOOPSCOPE**  
 Image Converter Tube Hi Sensitivity simplified design 2" dia; Wilhelmite Screen—Resolution up to 350 lines/in. Complete dntc & Tube, ea. 4.98 2 for \$9.49  
**RADIOACTIVE Meters** 1 1/2" OD. 5 for \$25  
**DIAG CUTTERS** 6 1/2" Hvy dty Eng. Shld steel 1.69  
 IN34 Xtals @ 69c IN34A @ 89c IN35 @ 1.95  
 616 @ \$1 or 12 for \$10; 6K4 @ 49c or 12 for \$5.00

**METER SPECIALS**  
 BEST BUY—5MA DC Tuning Meter GE 2 1/2". \$1.29  
**DC MICROAMMETERS**  
 0-150 UA Weston Sq. \$16.98  
 0-500 MA 2 1/2" Dejar. 6.98  
**AC VOLTMETERS**  
 0-8V 3 1/4" RD Model 476 Weston. \$3.49  
 0-15V AC Weston 476 Sq Model 476. \$9.95  
 0-130V Weston 476 3 1/2" RD. 7.49  
 0-150V Weston 3 1/2" Sq 1000 Ohms/V. 8.98  
**VOLUME LEVEL INDICATOR**  
 -20 to +3 VU Weston 3" Square. \$16.98  
 0.1 Amp R.F. 2 1/2" GE, USN Bklt CSD. 3.95  
 0-8 Amp R.F. 3" Triplet Hi-Freq; Int Couple 4.98  
 0.9 Amp R.F. 2 1/2" USN. 2.49  
**DC AMMETER**  
 0-1A 3 1/2" Westinghouse. \$4.98  
 0-10A 3" Sq. Triplet. 3.98  
 0-30A 2 1/2" Weston, Type 202P Shunt. 2.98  
 Many Other Types—Write in Your Requirements.

**FULL-WAVE BRIDGE RECTIFIERS**

18VAC INPUT	14VDC OUTPUT
2 Amps. \$2.40	12 Amps. \$ 7.50
4 Amps. 3.85	24 Amps. 14.00
8 Amps. 5.65	

36VAC INPUT	28VDC OUTPUT
2 Amps. \$3.75	8 Amps. \$ 9.95
4 Amps. 7.00	12 Amps. 14.00

Dept. 12RE, 6 Church Street New York 6, N. Y. Room 200  
 Worth 2-7230 \$5. Min 25% Dep. Prices subject to change

## ADVERTISING INDEX

Adelman, Nat	106
Allied Radio Corp.	113
Almo Radio Co.	104
American Phenolic Corp.	72
Amplifier Corporation of America	108
Atlas Sound Corp.	108
Barry Electronics Corp.	112
Bell Telephone Labs.	8
Blonder-Tongue Labs.	107
Boyce-Roche Book Co.	56
Brooks Radio & Television Corp.	67
Burstein-Applebee Co.	104
Capitol Radio Engineering Institute	7, 102
Centralab—Div. of Globe Union	20, 21
Certified Television Labs.	97
Cisin, H. G.	100
Clarostat Manufacturing Co.	100
Cleveland Institute of Radio Electronics	11
Commercial Trades Institute	102
Communications Equipment Co	110
Concord Radio Corp.	94
Coyne Electrical & TV Radio School	79, 111
DeForest's Training, Inc.	9
Dow Radio, Inc.	108
Electronic Products Lab.	54
Electronic Instrument Co., Inc.	22
Electronic Measurements Corp.	98
Electronic Specialty Supply Co.	113
Failler Engineering Co.	97, 113
General Electric Co.	14, 15, 97
General Industries Co.	97
General Test Equipment	106
Genset Company	109
Gould Green	104
Greylack Electronics Supply Co.	109
Harvard Laboratories	108
Heath Company	83, 84, 85, 86, 87, 88, 89, 90
Hickok Electrical Instrument Co.	58
Hytron Radio & Electronics Co.	51
Instrutograph Company	104
JFD Manufacturing Co., Inc.	112
Jackson Electrical Instrument Co.	64
Jensen Manufacturing Co.	78
Lafayette Radio	76
La Pointe-Plasemold Corp.	16, 71
Leotone Radio Co.	100
Mallory & Co., Inc., P. R.	Inside Back Cover
McGraw-Hill Book Co.	113
Merit Transformer Corp.	92
Metropolitan Electronics & Instrument Co.	12
Midwest Radio & Television Corp.	59
Miles Reproducer Co., Inc.	106
Miller Company, J. W.	109
Milwaukee School of Engineering	91
Mosley Electronics	79
Moss Electric	107
National Electronics of Cleveland	74
National Radio Institute	3
National Schools	5
Niagara Radio Supply Corp.	99
Opportunity Adlets	102
Perfecton Electric Co.	81
Precision Apparatus Co., Inc.	85
Pres-Probe Co.	98
Progressive Electronics Co.	73
Quam-Nichols Co.	102
RTA Victor Division (Radio Corporation of America)	Inside Front Cover, Back Cover
Radiart Corporation	53
Radio City Products Company, Inc.	104
Radio Corporation of America	63
Radio Craftsmen, Inc.	18
Radio Dealers Supply Co.	96
Radio Wire & Television, Inc. (Lafayette)	76

## RADIO SCHOOL DIRECTORY

Page 111

Baltimore Tech. Inst.  
 Candler System Company  
 Commercial Radio Inst.  
 Electronics Institute, Inc.  
 Federal Electronics Inst.  
 Hollywood Technical Inst.  
 Indiana Technical College  
 Lincoln School of Radio & TV, Inc.  
 Martin School, Don  
 RCA Institutes, Inc.  
 Streamlined Self-Study Course  
 Tri-State College  
 Valparaiso Technical Inst.

Ram Electronics Sales Co.	106
Ray Company	106
Raytheon Manufacturing Co.	6
Regency Div. (I.D.E.A., Inc.)	80
Rek-O-Kut Company	94
Relay Sales	114
Rider, John F., Publisher Inc.	69
Rinehart Books, Inc.	77
Rose Company	77
Sams & Co., Inc., Howard W.	17, 66, 82
Sanett, Bob	97
Scientific Products of Indianapolis	105
Simpton Electric Co.	105
Snyder Radio Manufacturing Co.	101
Siragusa Products Co.	4
Sirayberry Academy of Radio	49
Stan-Burn Radio & Electronics Corp.	82
Standard Transformer Corp.	95
Steve-EI Electronics Corp.	105
Supreme Radio & Television Co.	110
Sutton's Wholesale Electronics, Bill	113
Sylvania Electric Products, Inc.	61
Tab	112
Tallen Company, Inc.	93
Tarzian Inc., Sarkes	93
Tech-Master Products Co.	103
Tei-A-Ray Enterprises, Inc.	55
Telematic Industries, Inc.	110
Thomas Electronics	65
Triad Transformer Mfg. Co.	68
Trio Manufacturing Co.	57
Turner Company	113
University Loudspeakers, Inc.	103
Vee-D-X	71
Weller Electric Corp.	70
West Region Electronics	108
Wholesale Radio Parts Co., Inc.	94
Winchenger Corporation	62

Radio-Electronics does not assume responsibility for any errors appearing in above index.

## The Largest Selling LIGHTNING ARRESTER At Any Price!



NO. AT102

APPROVED

**JUMBO**

Protects Home and TV \$225 Set Against Lightning Hazards LIST

U.S. Patent No. D-4664

- Installs anywhere
- No wire stripping, cutting or splicing

(Complete with strap and ground wire.)

**OVER 1,000,000 IN USE TODAY!**

See Your Jobber or Write for Form No. 84

**JFD MANUFACTURING CO., Inc.**  
 6101M 16th AVENUE, BROOKLYN 4, N. Y.  
 FIRST in Television Antennas and Accessories

## CARTER, 6 Volt Dynamotors • Compact, Brand New In Sealed Cartons Type 4037-AS—400 Volts DC out @ 375 mills. Only \$28.00 (List price \$71.40).

- TV "Cheater" Cord—6 Ft. Complete—U.L. App'd.
- ART-I—75 Meter Deluxe Mobile AM XMT—Complete—NEW @ \$25.00
- AR-II Complete, Ultra Compact XMT-R-RCVR—Write For Details

### QUALITY, TESTED TUBES

New and guaranteed in stock now; many others not listed—complete line of receiving tubes at low prices. Submit your requirements on any types for our quotation. Call us on WESTINGHOUSE Industrial & Special-purpose Tubes.

0A2	\$1.49	6AG5	\$.85	12A6	\$.75
0B2	1.55	6AH6	1.50	12AT7	1.00
0Z4	.65	6AU6	.65	12AU7	.85
1B3GT	.85	6BA6	.70	12AV6	.55
1N21B	3.50	6BE6	.70	12AY7	3.00
1N23	1.45	6BG6G	1.20	12BA6	.70
1N23A	2.50	6BQ6GT	.90	12BE6	.70
1N23B	4.00	6C4	.65	12BH7	1.00
1N34	.68	6CB6	.85	12BHT	.95
1R5	.65	6CD6G	1.75	12J57	.75
1U4	.65	6J5GT	.55	12K57	.75
2B7	.75	6J6	1.10	12L57	.75
3A4	.85	6K6GT	.79	12O57	.75
3A5	1.10	6R8	.90	25L6GT	.65
3D6	.50	6H7	.70	35C5	.60
3Q4	.55	6SK7GT	.75	35Z5GT	.55
3S4	.90	6SL7GT	.75	50C5	.60
5U4G	.59	6SN7GT	.70	50L6GT	.60
5V4G	1.05	6T8	1.25	80	.60
5X4G	.85	6U4GT	.80	304TL	11.50
6AB4	.75	6V6GT	.60	304TH	11.50
6AC7	.98	6W4GT	.50	807	1.65
6AJ5	1.95	6X4	.45	813	7.75
6AK5	1.25	6X5GT	.45	872A	2.25
6AL5	.40	6Y6G	.75	955	.45

### SELENIUM RECTIFIERS—FULL-WAVE BRIDGE TYPES

Current (cont.)	18/14 Volts	36/28 Volts	54/40 Volts	110/100 Volts
1 Amp.		\$1.98		
2 Amps.	\$2.40	3.75	\$6.95	\$10.50
3 Amps.	3.85	7.00	9.00	
6 Amps.	5.65	9.00		
10 Amps.	6.95	10.95		48.00
12 Amps.	8.50	14.00		58.00
20 Amps.	13.25	20.00		
24 Amps.	14.00	20.00		
30 Amps.	15.00	30.00		
36 Amps.	25.00	35.00		

All our Rectifiers are new & Guaranteed one year. We manufacture special types of rectifiers and rectifier supplies to your specs. **FAST DELIVERY.**

## BARRY ELECTRONICS CORP.

136 Liberty Street, N. Y. 6, N. Y. Rector 2-2563  
 Terms: 25% with order, balance C. O. D.—Send a few cents for postage—All merchandise guaranteed, F. O. B. N. Y. C.



**AUTOMATIC M-90 AUTO RADIO**

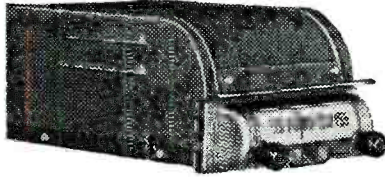

- Six Tube Superheterodyne • Three Gang Condenser • Powerful, Long-Distance Reception • Fits All Cars, Easy Installation

- Mounting Brackets Included
  - 6 Tube model M90.....\$533.87
  - 5 Tube Model A-15.....\$28.76
- \*Above price includes Federal Excise Tax  
Approx. shipping weight either radio (11) eleven pounds

**MAIL US YOUR ORDERS**

All orders filled within 24 hours.  
Standard Brand tubes 50% off list

**Bill Sutton's** Wholesale Electronics  
Fifth at Commerce Fort Worth, Texas

**\* BUY WITH CONFIDENCE \***  
**\* 5 DAY MONEY BACK GUARANTEE \***  
**\* ELECTRONIC SURPLUS MATERIALS \***

- Component Kits of Quality**
- ★ 100 INSULATED RESISTORS—name brands RMA color coded 1/4, 1/2, 1, 2 Watt, many 5%. Over 50 values.....\$2.75
  - ★ 100 (CARBON NON-INSUL. RESISTORS) RMA color coded, 1/4 to 2 watt. Contains over 50 values.....1.75
  - ★ 50 RF CHOKE COILS—all sizes for plate, grid, fil. circuits Xmitter, TV, Oscill., etc.....1.75
  - ★ 50 MICA CONDENSERS—over 20 values, incl. popular silver mica types.....1.95
  - ★ 25 PRECISION WIRE WOUND RESISTORS—name brands, Over 50 values.....2.95
  - ★ POTENTIOMETER KIT—15 types, Carbon & W.W. S.D. & shaft types. Includes 1/2 & 1 meg. with switches.....2.25
  - ★ 50 CERAMIC CONDENSERS—Over 25 values, Color coded.....2.45
  - ★ 50 BY-PASS CONDENSERS—Tubular Pop. Values.....2.75
  - ★ 20 ELECTROLYTIC CONDENSERS—Tubular, Flt & upright types. Popular values for service or set building.....2.95
  - ★ 40 TUBE SOCKETS—4-5-6-7-8 prg., Ceramic, molded & bakelite water types, 7 pin miniature, acorn, klystron, etc.....1.95
  - ★ 50 TIE POINT STRIPS—2-3-4-5-6-7-8 term.....1.45
  - ★ 20 BATHTUB CONDENSERS—assorted values, voltages, terminals.....1.95
  - ★ HOOKUP WIRE ASSORTMENT—Cut lengths, 24 to 120" Stripped ends, some tinned. Mixed colors, 2 lbs., approx. 400 ft......89
  - ★ EXTRA BONUS—1 wire kit free with 5 assorted kits.

*Na C.O.D.'s*  
**ELECTRONIC SPECIALTY SUPPLY CO.**  
56 Lisenard Street New York 13, N. Y.  
Dept. RED

**BASIC ELECTRON TUBES**, by Donovan V. Geppert. Published by McGraw-Hill Book Co., Inc. 330 W. 42 St., New York, N.Y. 6 1/2 x 9 1/4 inches, 332 pages. Price \$5.00.

Designed for use in conjunction with electronics courses on a college level, this book covers the physical and electrical characteristics of basic types of vacuum and gas tubes. Higher mathematics, while desirable, is not absolutely necessary for an understanding of this readable book.

Full chapters are given to such industrial types of tubes as mercury-pool rectifiers and ignitrons. Thyratrons, glow-discharge tubes, and cathode-ray tubes also receive a chapter each.

Circuit theory is excluded to concentrate solely on tubes. The book is well indexed as well as being well illustrated.

**PRINCIPLES OF ELECTRICAL ENGINEERING**. Fourth Edition, 1951, by William H. Timbie and Vannevar Bush. Published by John Wiley and Sons, Inc., 440 Fourth Ave., New York, N. Y. 6 x 8 1/2 inches, 626 pages. Price \$6.50.

This book will appeal to the more advanced student of electrical engineering. Advanced methods for analyzing electrical and magnetic problems are shown, including circuit analysis, the fundamental problems of electric and magnetic fields, and the relation of these problems to circuit analysis. The examples presented are developed from mathematical physics, the basis being the English, CGS and MKS unit systems.

The field covered is broad and includes: Kirchoff's laws; electric power and energy; simplification of electric networks; conductors and resistors; conduction in solids and liquids; transients in electric circuits; alternating-current circuits; the magnetic circuit; interaction between electric and magnetic fields; magnetic properties of iron and steel, and other subjects. Two closing chapters deal with electronics and electromagnetic waves.

A table of useful conversion factors is included, together with an index. To fully assimilate this book one should have a good mathematical background.

—HWS

—end—

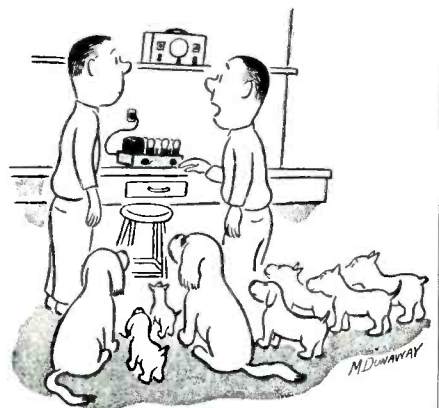

Suggested by: M. B. Dunaway, Omaha, Nebraska

"There must be a high frequency whistle in it somewhere."



**NEW! ENLARGED! REVISED!**

**Special Offer On This Complete RADIO ENGINEERING LIBRARY**

*New, Up-To-Date Editions of Famous Library Covers Whole Field of Radio Engineering. Places Latest Facts, Standards, Data, Practice, and Theory At Your Fingertips*

The five big volumes of the new edition of the Radio Engineering Library now include the very latest facts, standards, data, and practice. This Library will help solve hundreds of problems for designers, researchers, engineers, and students in any field based on radio.

Written by leading radio engineers, these books cover circuit phenomena, networks, tube theory, vacuum tubes, amplification, measurements, etc.—give specialized treatment of all fields of practical design and application. They provide you with a complete and dependable encyclopedia of facts.

- 5 Volumes, 3872 Pages, 2770 Illustrations
- Eastman's FUNDAMENTALS OF VACUUM TUBES, 3rd Edition.
- Terman's RADIO ENGINEERING, 3rd Edition.
- Everitt's COMMUNICATION ENGINEERING, 2nd Edition.
- Hund's HIGH FREQUENCY MEASUREMENTS, 2nd Edition.
- Henney's RADIO ENGINEERING HANDBOOK, 4th Edition.

**SEND NO MONEY**

Special Low Price—Easy Terms

On this special offer you get this Library for \$34.50, instead of \$39.00. You save \$4.50 and may pay on easy terms. Mail coupon below to examine the Library FREE for 10 days. No obligation. These books are recognized as standard works; you are bound to need them. So take advantage of this special money-saving offer. *Mail coupon at once!*

McGraw-Hill Book Co., Dept. RE-12-51  
327 West 41st St., New York 18, N. Y.  
Send for 10 days' FREE trial, the RADIO ENGINEERING LIBRARY. If not satisfied I will return books. Otherwise I will send \$4.50, plus delivery charges, then; and \$5 a month for 6 months. (Reg. price \$39.00; you save \$4.50).

Name .....

Home Address .....

City & State .....

We'll Pay Delivery Charges if you enclose \$4.50 first payment WITH coupon. Same return privilege for full refund.

**EVERY RADIOMAN**  
Can Use These SERVICE HINTS!  
Valuable Manual Yours—FREE!

Every page of "How to Simplify Radio Repairs" is packed with on-the-bench, practical ideas. Contains photos, charts, diagrams—no fluff—no vague theory. In plain every-day language it gives you priceless suggestions—new servicing ideas. You'll use and benefit from the experience of experts. Partial list of contents: How to Localize Trouble; How to Service Amplifiers; How to Test for Distortion; How to Test Audio Circuits; How to Test Speakers; How to Find Faults in Oscillators; How to Test Radio Parts—and it's all yours—FREE! No obligation.

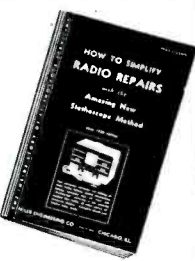

**FEILER** SEND COUPON OR PENNY POSTCARD FOR YOUR FREE COPY TODAY!

FEILER ENGINEERING CO., Dept. 12RC1  
8026 N. Monticello Ave.  
Skokie, Ill. (Suburb of Chicago)  
Please RUSH my FREE copy of "How to Simplify Radio Repairs."  
Name .....

Address .....

City ..... Zone ..... State .....

# RELAYS FOR EVERY PURPOSE

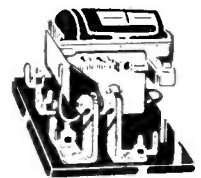

**Over a Million in Stock!**

Each relay is brand new, standard make, inspected, individually boxed and fully guaranteed.

The following list represents only a portion of our relay stock. Write or wire us for information on types not shown.

Stock No.	D.C. Voltage	Ohmage	Contacts	Unit Price	Stock No.	D.C. Voltage	Ohmage	Contacts	Unit Price	Stock No.	D.C. Voltage	Ohmage	Contacts	Unit Price	
<b>STANDARD DC TELEPHONE RELAYS</b>															
R-806	115*	900	1A	\$2.05	R-817	24	150	1A/50 Amps.	\$3.45	R-169	24	200	1A	\$2.45	
R-161	6	10	2B & 1A	1.10	R-534	14	45	1A/30 Amps.	2.05	R-570	24	230	1B Dble. Brk.	2.70	
R-518	85/125	6500	1C	3.60	R-223	28	150	1A/40 Amps./48 VDC.	1.70	R-960	24	230	3C/15 Amps.	2.95	
R-633	180/350	10,000	1C & 5 Amps. Oet. Skt.	2.90	R-680	6	3	1A/50 Amps.	3.90	R-529	24/48	1020	2C	3.10	
R-667	6	75	1B/10 Amps. 1A/3 Amps.	2.45	R-677	6	3.5	1A/50 Amps.	3.90	R-715	24	—	2 C Ceramic	3.70	
R-632	6	12	5A & 1C	1.45	R-532	6	15	1A/50 Amps.	3.90	R-584	6	20	1A Dble. Brk.	1.30	
R-154	6/12	200	1A	1.50	R-676	12	16	1A/50 Amps. 1AUX/25A	3.90	R-192	12	44	3C/10 Amps.	1.70	
R-517	12	250	2A	1.50	<b>ROTARY RELAYS</b>										
R-116	85	3000	1B	3.05	R-712	24	200	2B	\$2.05	R-224	12	85	1A	1.45	
R-631	100/125	3500	2A	1.90	R-711	24	200	2C & 1B	2.05	R-221	18/24	5000	1A	2.00	
R-545	110/250	7000	1C	2.40	R-573	28	200	1C & 1B	2.05	R-205	24	260	2C	1.55	
R-124	300	12,000	1A	1.55	R-766	24	230	12 Pos. 8 Deck	4.90	R-891	24	475	1C/5 Amps.	1.45	
R-160	6	12	3C & 3A	1.30	R-809	28	7	1B & 12 Pos. W/ 7" Shaft for Wafera.	2.45	R-858	27	230	2C	1.55	
R-155	12	100	4C & 4B	1.45	<b>DIFFERENTIAL RELAYS</b>										
R-520	200/300	14,000	2A	3.45	R-208	120	2000	2C/3 Amps.	\$2.45	R-833	6.5	1300	2A	3.05	
R-159	6	50	2A	1.35	R-209	220/250	8000	1C/3 Amps.	3.10	R-220	75	5000	1C	1.50	
R-153	12	200	1C & 1A	1.55	<b>SEALED RELAYS</b>										
<b>SHORT TELEPHONE RELAYS</b>															
R-635	12	100	1C & 1A	\$1.35	R-261	12/24	1900	1C/5 Pin Plug	\$3.75	R-828	6/8	42	1A	1.50	
R-826	12	150	2C, 1B	1.55	R-673	48/150	7500	1C/5 Amps.	2.80	R-927	115*	—	1B Dble. Brk.	3.10	
R-770	24	150	1A/10 Amps.	1.45	<b>VOLTAGE REGULATORS</b>										
R-771	24	200	1A/10 Amps.	1.45	R-745	6	2	1A/10 Amps.	\$1.05	R-784	24	150	3C/10 Amps.	1.30	
R-603	18/24	400	2A	1.55	R-780	24	350	1C/6 Amps.	1.05	R-598	28	185	2C	1.30	
R-575	24	500	2C	2.40	R-509	6/12	35	1B/2 Amps.	1.05	R-622	20/30	200	3A & 2C/10 Amps.	1.45	
R-764	48	1000	2C & 2A	2.00	<b>SPECIAL RELAYS</b>										
R-563	60/120	7500	1A	1.70	R-503	12/32	100	3A, 2C	\$13.50	R-144	18/24	250	2A	1.45	
R-801	115*	—	None	1.45	R-749	600	—	Max. 28 Amps.	7.45	R-298	21	300	1A	1.25	
R-213	5/8*	—	2A	3.10	R-804	550*	—	1B/38 Amps.	4.35	R-296	21	300	1A	1.25	
R-589	12	125	2A	1.30	R-250	115	—	Adj. Cir. Bk. -04-16A	17.50	R-586	21	300	1A & 1C	1.25	
R-113	12	150	4A	1.55	R-579	220*	—	1B	8.70	R-137	24	300	1C	1.45	
R-689	12/24	255	1C	1.55	R-294	27.5	200	1B	5.35	R-142	21	400	2C	1.50	
R-799	24	500	None	1.00	R-686	115*	—	2C	6.10	R-785	24	200	2C/10 Amps.	2.00	
R-115	24	500	1C	1.70	R-246	115*	—	1B	11.20	R-607	24*	—	1A	1.20	
R-110	24/32	3500	1C	1.70	R-216A	115*	—	1A	11.20	R-606	24*	—	1A & 1B	1.20	
R-121	150	5000	2A & 1C	2.05	R-611	24*	—	1A 30 Amps.	11.20	R-605	24*	—	3A	1.20	
R-654	150/250	6000	1A & 1B	2.45	R-283	12	125	1C/10 Amps.	4.35	R-149	6/8	45	1B	1.50	
R-800	12	150	2C & 1A	1.55	R-614	18/24	60	1A/15 Amps.	4.35	R-732	12	120	1A	1.45	
R-537	12/24	150	2C & 1B	2.00	R-215	12	25	4" Micalex Lever In Series	3.20	R-281	18	12	25	2A	1.30
R-750	24	400	1A	1.60	R-527	6/12	50/50	1C	1.20	R-135	24	250	1B	1.45	
<b>CONTACTORS</b>															
R-650	24	100	1A/50 Amps.	\$3.70	R-544	12/24	60/60	1C	2.05	R-133	24	300	None	.75	
R-312	24	7	1A/200 Amps.	5.50	R-255	12/24	60/60	1A	3.50	R-138	24	300	4A	1.45	
R-333	98/120	975	1A/200 Amps.	5.50	R-669	75*	400 Cy.	1B, 1A	1.20	R-132	24	300	2C	1.50	
R-334	115	1200	3A/Size 2	5.50	R-660	6	—	3/4" Stroke Solenoid Valve	1.20	R-731	24	300	2C	1.55	
R-338	6	7.5	1A/50 Amps.	3.45	R-651	24	100	Annunciator Drop	3.10	R-292	24	350	1C	1.25	
R-353	65*	—	2A	3.95	R-295	12	275	2A, 1C	2.70	R-626	24	400	1A/5 Amps.	1.55	
R-358	18/29	200	1A/Dble. Brk.	2.00	R-230	5/8	2	Water	5.35	R-786	60	1300	2C	2.00	
R-445	14	12.5	1A/50 Amps.	4.05	R-813	12	12	Water	5.35	R-588	90/125	6500	4C	2.70	
R-446	12	18	1A/50 Amps.	3.90	R-716	24	70	1A, 1B, 1C	3.45	R-755	24	300	1A	1.45	
R-448	24	67	1A/50 Amps.	3.90	R-620	6/12	35	2C, 1A	1.80	R-150	6	30	1A	1.50	
R-449	28	160	1A/50 Amps.	3.90	R-629	9/14	40	1C/10 Amps.	1.55	R-803	14	150	1A, 1C	2.50	
R-450	24	75	1A/50 Amps.	3.90	R-720	20	50	2C Ceramic	1.70	R-895	14	150	2A, 1B, 1C	2.50	
R-188	24	200	1A/75 Amps.	3.70	R-500	12	10/10	2C/6 Amps.	3.55	*AC. **AC/DC.					
R-183	24	60	1A/50 Amps.	3.45	R-816	12	10/15	2C/6 Amps.	3.55						
R-187	24	100	1A/50 Amps.	3.70	R-524	24**	—	150 Coll Only	1.00						
R-554	24	85	2A/100 Amps.	5.90	R-566	115*	—	150 Coll Only	.75						
R-788	100*	—	3B & 2A	5.45	R-710	—	—	—	—						
R-682	115*	35	5A/10 Amps.	6.10	<b>KEYING RELAYS</b>										
R-767	24	20	2A/10 Amps.	4.95	R-714	9/14	65	2C/5 Amps.	\$1.55	R-714	9/14	65	2C/5 Amps.	\$1.55	
R-180	12	25	1A/50 Amps.	4.05	R-850	12	150	1A/1.5 Amps.	1.50	R-850	12	150	1A/1.5 Amps.	1.50	
R-265	24	60	1A/100 Amps.	3.45	R-721	18/21	290	2C/5 Amps.	1.55	R-721	18/21	290	2C/5 Amps.	1.55	
R-535	24	70	1A/100 Amps.	4.80	R-694	24	300	1A/5 Amps.	1.50	R-694	24	300	1A/5 Amps.	1.50	
R-556	24	70	1A/100 Amps.	4.80	R-935	28	1000	1C/1.5 Amps.	1.65	R-935	28	1000	1C/1.5 Amps.	1.65	
R-557	24	100	1A/50 Amps.	3.85	R-949	2.4*	60 Cy.	1A/5 Amps.	1.95	R-949	2.4*	60 Cy.	1A/5 Amps.	1.95	
R-178	24	100	1A/100 Amps.	4.80	R-704	2/6	25	2B/5 Amps.	1.35	R-704	2/6	25	2B/5 Amps.	1.35	
R-608	24	125	1A/200 Amps.	2.80	R-173	1/7	17	1A	3.00	R-173	1/7	17	1A	3.00	
R-184	28	50	1A/100 Amps.	4.90	R-280	6/8	77	1A Dble. Brk.	2.45	R-280	6/8	77	1A Dble. Brk.	2.45	
R-719	24	10	1A/200 Amps.	4.95	R-647	6/12	15	1B/20 Amps.	1.45	R-647	6/12	15	1B/20 Amps.	1.45	
R-182	26	80	1A/25 Amps.	2.40	R-273	20	160	2A/15A Dble. Brk.	3.55	R-273	20	160	2A/15A Dble. Brk.	3.55	
R-244	75*	265	1A/20 Amps.	2.20	<b>BASIC CONTACT ASSEMBLIES SHOWN IN UNOPERATED NORMAL POSITION</b>										
R-244	75*	265	1A/20 Amps.	2.20											
R-659	22	2	2A/20 Amps.	1.70											
R-552	24	70	4A/50 Amps.	5.35											
R-185	24	100	1A/50 Amps.	3.45											
R-186	24	132	1A/50 Amps.	4.35											

**SPECIAL!**

**CO-AXIAL RELAY**

D153766 SPDT, 6 VDC.

19 Ohm coil. Designed to accommodate 75 watts maximum. Perfect for all types of antenna switching. Designed for using standard 83-1SP coaxial fittings. Part of RAX-1 equipment. No. R-846—\$6.95 Ea.

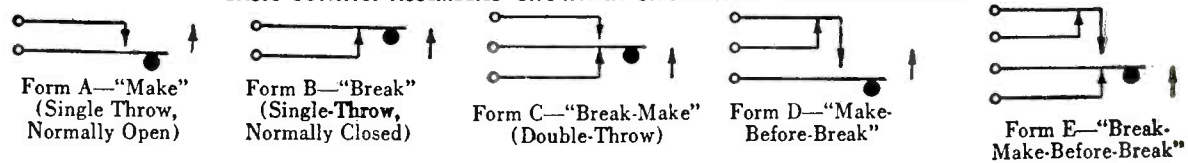

**RELAY SALES**

MANUFACTURERS AND DISTRIBUTORS:  
WRITE FOR THE  
NEW CATALOG

Telephone  
SEeley 8-4146

833 W. CHICAGO AVE. DEPT. Y, CHICAGO 22, ILL.



# Don't take chances with misfits!

In a field survey of servicemen on the subject of desirable volume control features, by far the most comments concerned easy adaptability and installation. If you want a control that is tailored for the job... and one that will deliver thousands of hours of smooth, quiet performance...

## Make Sure! Make it Mallory!

When you use the Mallory Midgetrol\* you are using a control designed to make your job easier and at the same time give your customer outstanding performance. Here is the unbeatable combination of Midgetrol features:

First, you get a permanently fixed, tubular brass shaft that can be adapted for split-knurl or flatted type knobs in a few seconds by inserting one of the steel shaft ends supplied in every package. This means utmost convenience without sacrificing the stability

of permanent, two-point shaft suspension.

Second, you get the convenience of AC switch design that permits secure attachment, without removing the control housing. Positive indexing assures proper position.

Third, you get exceptionally accurate resistance values and taper curves.

Fourth, you can be sure of years of quiet, satisfactory service life through extremes of humidity and temperature.



*Make it Mallory and make sure! Ask your distributor to show you the time-proved Mallory Midgetrol with the new features that make installation faster and simpler than ever.*

In addition to single controls, dual concentric Mallory Midgetrols can be made up easily by combining factory-assembled front and rear sections of desired resistance values. Ask your Mallory Distributor for details!

\*Reg. U.S. Pat. Off.

P. R. MALLORY & CO.

# MALLORY

CAPACITORS • CONTROLS • VIBRATORS • SWITCHES • RESISTORS  
 • RECTIFIERS • VIBRAPACK\* POWER SUPPLIES • FILTERS

APPROVED PRECISION PRODUCTS

P. R. MALLORY & CO., Inc., INDIANAPOLIS 6, INDIANA

THE QUALITY OF RCA TUBES IS UNQUESTIONED



*It's fundamental...*

**the best established brand name  
is your biggest stock in trade**



Every RCA picture tube you install sells the idea of long-term, high-quality performance . . . and helps develop a permanent customer. Stocking and recommending RCA picture tubes is good business, because no other brand enjoys greater customer confidence . . . and customer confidence is your stock in trade.

Remember—more RCA picture tubes are now in active service than those of any other manufacture . . . over 5 million since the advent of commercial tele-

vision, when RCA pioneered the first large-scale production of picture tubes. Yes, RCA picture tubes of all types have consistently given outstanding performance.

And, today, RCA kinescopes carry a factory warranty that guarantees your customers against any defect *for six months from the date of installation.*

Your local RCA Tube Distributor carries a complete line of RCA kinescopes. Whether you want one or a hundred . . . he's ready to serve you.

*Keep informed . . . keep in touch with your RCA Tube Distributor*

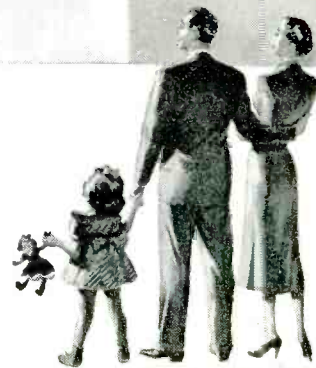

**RADIO CORPORATION of AMERICA**  
ELECTRON TUBES

HARRISON, N. J.