

RADIO - ELECTRONICS

JUNE 1952

LATEST IN TELEVISION • SERVICING • AUDIO

HUGO GERNSEACK, Editor

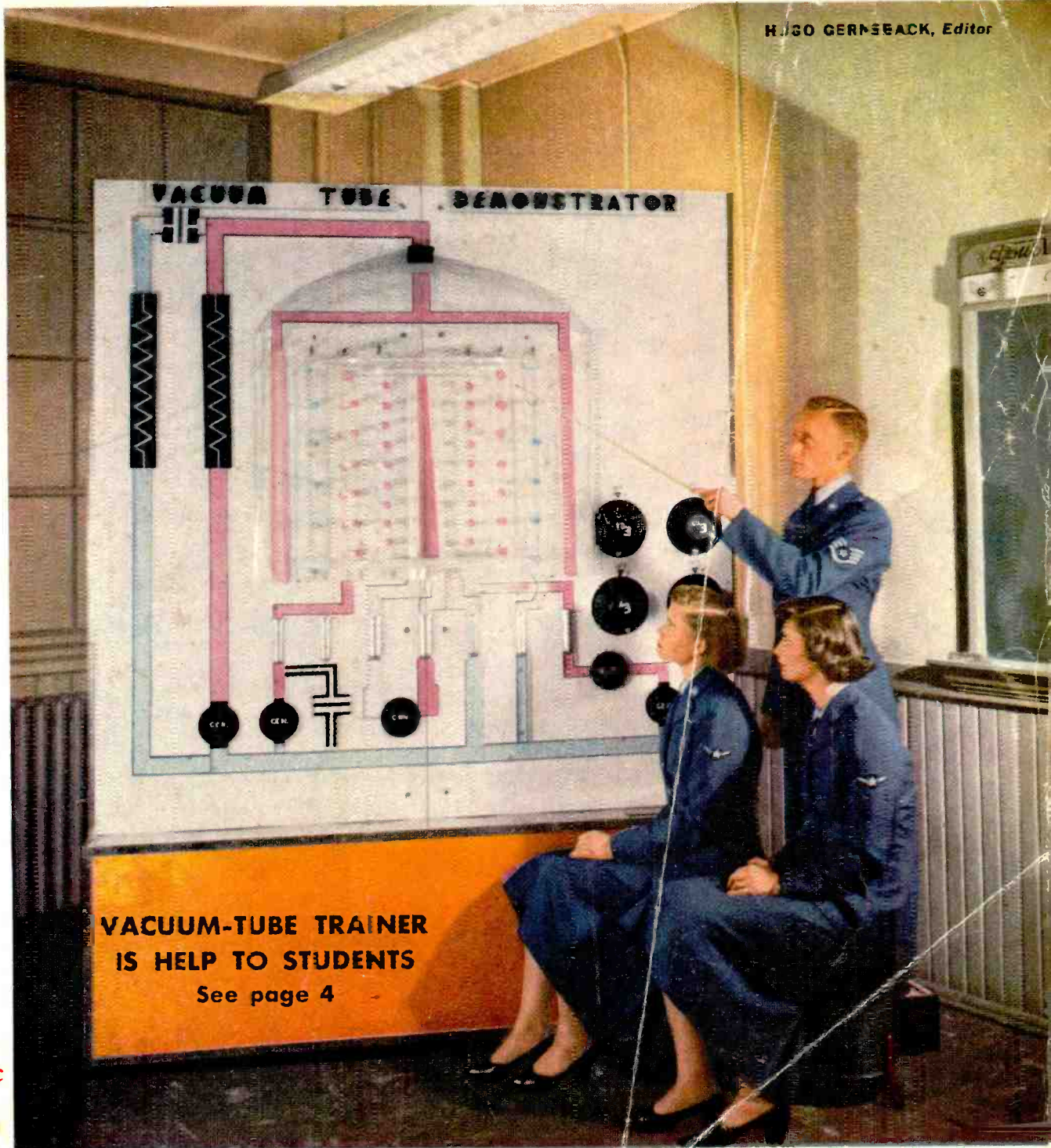

**VACUUM-TUBE TRAINER
IS HELP TO STUDENTS**
See page 4

30¢

U. S. and
CANADA

**In this issue: Hard-to-Locate TV Troubles •
Radio-Controlled Plane • Dynamic Signal Tracer**

You're top-man on our Totem Pole



You...
the Local Radio Dealer
and Serviceman

...here's why:

You're in the *Radio Business*. So are we.

You're interested in promoting the sale and use of *radio products*. So are we.

If You prosper, so do we!

That's why we are so anxious to *give you help* when you stock, sell and promote the *RCA Battery Line*.

That's why we continue to channel our principal battery distribution to *You, the radio dealer-serviceman*, thereby assuring *You* the repeat business for **RCA RADIO BATTERIES**.

That's why we advertise *You, The Radio Service-Dealer*, on national network radio and TV programs . . . and tell millions of listeners that *You are best qualified to sell and install* **RCA RADIO BATTERIES**.

We also help *You advertise for repeat sales on the RCA Battery carton itself!* Millions of volume-type RCA Batteries carry a printed message directing the user to *return to You* for replacements. Below this message is a space where you can stamp *your own name and address* with a personalized stamp which you may obtain from your RCA Battery Distributor.

We will continue to provide speedy, dependable service, backed by the *only* nation-wide warehousing and distribution organization geared to the needs of the radio trade.

With all this to back you, your best move is to stock, sell and promote *the RCA Battery Line*.

Remember: You're a *Radio Man*.
We're a *Radio Company*.
If You prosper, so do we!

That's why you're tops on our totem pole. And that's why *you'll do better . . . make more money . . .* with the *RCA Battery Line*.

So call your RCA Battery Distributor. Let's get started selling *RCA Batteries together . . . right now*.



RADIO CORPORATION of AMERICA

RADIO BATTERIES

HARRISON, N. J.

TRAIN

for Security! Good-Paying Jobs!

MAKE THE MONEY YOU'VE ALWAYS DREAMED OF!



LEARN RADIO -TELEVISION

AND ELECTRONICS BY EASY SHOP METHOD TRAINING AT HOME!

You get all the parts—even tubes!—for this modern Superheterodyne Receiver. You learn to build it step by step. And you keep it! Get all the facts. Mail coupon now.

Let **NATIONAL SCHOOLS**—a resident-training school for nearly 50 years—train you at home for today's unlimited opportunities in Radio-Television-Electronics. National Schools is one of the largest schools of its kind. It is located in Los Angeles—the center of Radio and TV world! It has four large buildings of modern shops and labs. Its faculty is considered tops in the business.



You learn from lessons prepared by experienced instructors and engineers. Men who are successful Radio and Television technicians. Men who have trained 1000's of men like YOU!



FREE BOOK TELLS YOU HOW!

Page after page—in color—tells you everything you want to know. Mail the coupon. Get this valuable book today. And if you hurry—YOU GET A FREE SAMPLE LESSON, TOO! Shows how easy National Schools Home Training is. Mail the coupon today.

You Train At Home—In Your Spare Time

National Schools Shop Method Home Training gives you basic and advanced instruction in all phases of Radio-TV-Electronics. And remember—your training is based on resident school training principles. You learn fast from hundreds of diagrams and pictures. All instructions are written by experienced technicians who work in Radio and TV every day. All instructions have been developed and tested in National Schools' own labs and studios, which are equipped with the latest RCA equipment. No wonder this National Schools course is so up-to-date, practical, interesting. And so easy to learn! And no wonder it is held in such high regard by leaders of American industry! Approved for eligible Veterans.

We Teach You How To Make Welcome Extra Money—While You Learn!

Many National Schools students—men like you—make plenty of extra dollars each week in spare time! Fixing neighbors' radios, appliances—and other ways we teach you. You start learning and earning from the day you enroll. From the very first lesson!

WE SEND YOU LOTS OF PARTS LIKE THIS!

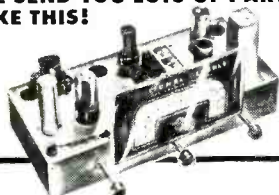

With National Schools Shop Method Home Training, you get basic principles and plenty of practical training. You learn by doing. No wonder you learn so fast! We send you many parts—all of professional, modern quality. You do lots of practical experiments. You advance day by day, step by step. Until you can even build the modern Superheterodyne Receiver you see above—plus other important testing units. The free book tells you all about it. The free sample lesson shows how easy the training is. Use the coupon. Send today—without fail!



Only National Schools Gives You This Professional Multi-Tester!

You get this amazing, new testing instrument—factory-made and tested—complete—ready to use! Simple to operate. Accurate and dependable. An instrument every Radio-TV man needs. Light enough to carry around—so you can use it at home or on service calls. You'll be proud to own this valuable equipment.

Here are only a Few of the Good-Paying Jobs You Can Choose

Radio Station Engineer, District Service Manager, Aircraft Radio Inspector, Own Your Own Repair Shop, Inspector Technician, Service Specialist, Special Government Jobs, Complete TV Service, Sound Truck Operator. Many more! National Schools graduates have secure, good-paying jobs like these! So don't wait—mail the coupon today. Now—while you're thinking about it!

Attention! Men Going into Service Soon!

National Schools' course quickly prepares you for many important jobs in the Armed Services. With National Schools Training you have an opportunity to get into special service classifications—with higher pay and grade—immediately!

FREE SERVICE FOR GRADUATES

National Schools uses its great influence and prestige to help you find your place in the field of your choice. Don't put it off! Start yourself toward a skilled trade! Get the big pay you've always wanted!

Today's Shortage of Trained Technicians Creates Chance of a Lifetime For You!

Think of it! With guided missiles, radar, and other electronic devices so important to national defense! With big, new developments in TV. With over 90,000,000 home and auto radios, over 12,000,000 TV sets. With more than 3100 radio stations...over 100 TV stations—and more building every day...yes, imagine the great opportunity you have today! YOU are wanted in Radio-Television-Electronics! America's fastest-growing field. High-pay jobs—the kind you've always wanted—are waiting for YOU!

Job Security! Big Money! For YOU! in Today's Expanding Industries!

Trained Radio and Television technicians really make important money these days. Thousands of National Schools graduates—men just like you—are earning good money all over the country. Why not you? And—National Schools graduates get the personal satisfaction of being highly-skilled technicians. Men people respect. Men who enjoy their work—rather than having to drag along in just any old job.

National Schools Has Trained 1000's of Successful Men! Why Not YOU?

In almost every state—and many foreign countries—National Schools graduates are filling big jobs with famous companies. Or running their own successful businesses. What are YOU waiting for? National Schools training is complete training. So when you graduate you can take advantage of today's big opportunities in Radio-Television-Electronics—fast.

DON'T PUT IT OFF! GET THE BIG SALARY YOU HAVE ALWAYS WANTED!

NATIONAL SCHOOLS
LOS ANGELES 37, CALIFORNIA • ESTABLISHED 1905
In Canada - 193 E. Hastings St., Vancouver, B. C.

MAIL THIS COUPON TODAY—WITHOUT FAIL!

NATIONAL SCHOOLS, Dept. GR-62
4000 South Figueroa Street
Los Angeles 37, California

Mail in envelope or paste on penny post

Mail me FREE the book mentioned in this ad. Also a free sample I understand no salesman will call on me.

NAME _____

ADDRESS _____

CITY _____

Check here if you were released from the Service

Makeshift replacements...reduce picture quality

Replacements with Raytheon Television Tubes assure picture quality

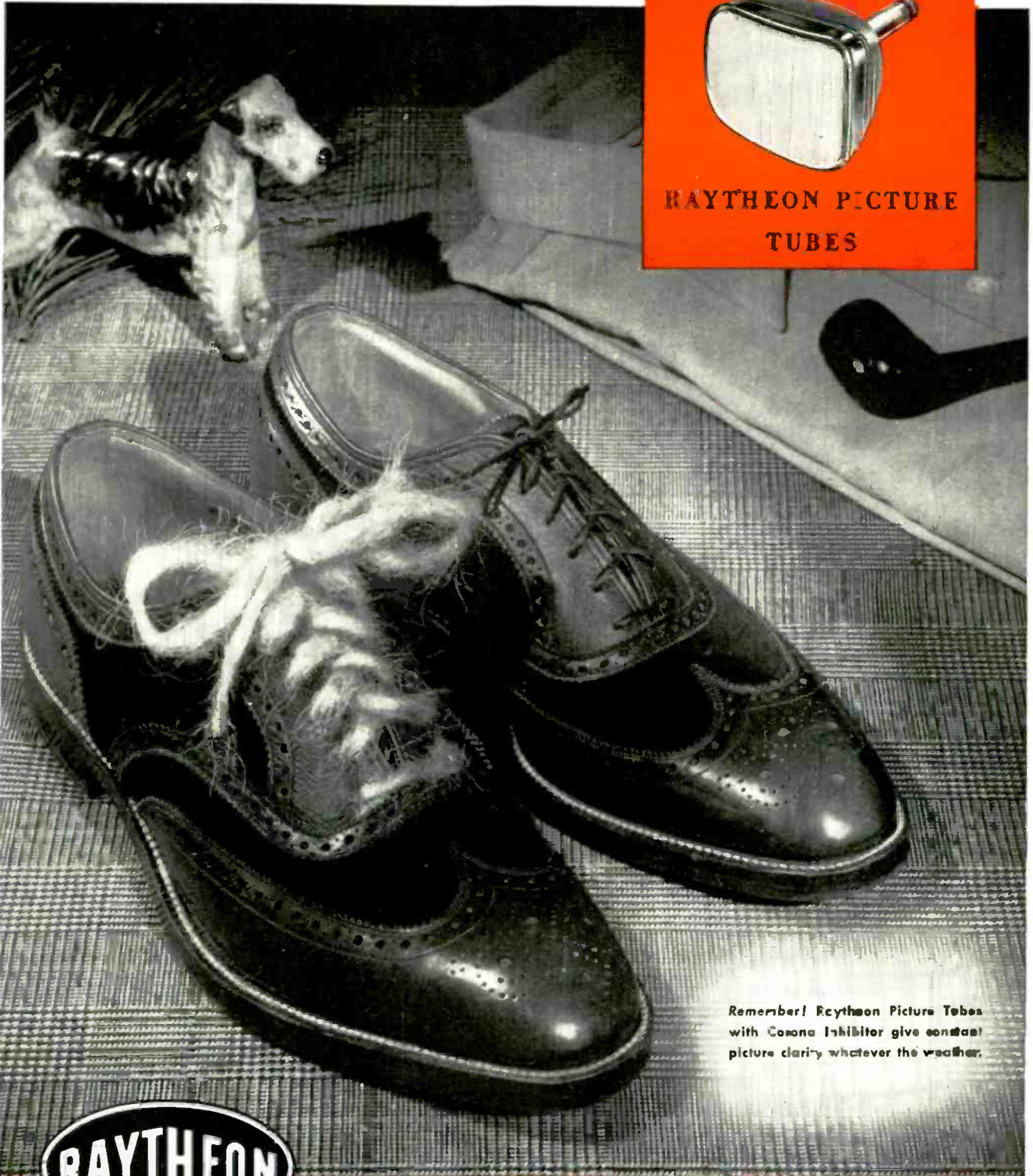

Right for Sight



RAYTHEON PICTURE TUBES

Remember! Raytheon Picture Tubes with Cosona Inhibitor give constant picture clarity whatever the weather.



Excellence in Electronics

RAYTHEON MANUFACTURING COMPANY

Receiving Tube Division

Newton, Mass., Chicago, Ill., Atlanta, Ga., Los Angeles, Calif.

AND PICTURE TUBES - RELIABLE SUBMINIATURE AND MINIATURE TUBES - GERMANIUM DIODES AND TRANSISTORS - RADIC TUBES - MICROWAVE TUBES



*How far ahead can you be
next year . . .*

IN TV AND ELECTRONICS?

◀ **Send for this free CREI booklet today...
and find out!**

THIS BOOKLET can mean the difference between small, w-i-d-e-l-y s-p-a-c-e-d salary increases—and rapid advancement. Between routine work—and challenging opportunity. Between constantly defending your job against better-trained men—and dynamic confidence. Between short-circuited hopes—and high-powered ambition.

An exciting new world has opened up with such super-speed that even the most optimistic electronic experts fall short in their predictions of expansion.

Think of the 109 TV stations now in operation, and the 2,053 new TV stations which the recent freeze-lifting will make possible. Think of the 16,785,044 TV sets now in use and the millions more soon to come. Think of the 100,000,000 radios in current operation. (95% of the nation's homes have one or more sets.) Think of the tremendous defense orders now being placed for electronic equipment and installations.

Think of the thousands of radio-equipped fire and police departments throughout the U.S. Of the many radio-equipped railroads, of the hundreds of cities with 2-way radio service for cars and cabs. Think of the wide-ranging field of aviation communications—radio-controlled aircraft, navigation-and-traffic control, airport stations.

Think of the maritime world with its navigational aids, fathometers, ship-to-shore and ship-to-ship communications and radar. Think of electronic heating, fax and ultra-fax, of electronic medicine, and all the other applications of electronic know-how.

Countless positions must be filled—in development, research, design, production, testing and inspection, manufacture, broadcasting, telecasting and servicing. Who will get those positions? You—if you prepare today—if you are alert and have the ambition to advance your knowledge. You—if you take 2 minutes to send for a free copy of "Your Future in the New World of Electronics."

This helpful book shows you how CREI Home Study leads the way to greater earnings through the inviting opportunities described above.

However, being an accredited technical school, CREI does not promise you a "bed-of-roses." You have to translate your willingness to learn into saleable technical knowledge

—via *study*. Since its founding in 1927, CREI has provided thousands of professional radiomen with technical educations. During World War II, CREI trained thousands for the Armed Services. Leading firms choose CREI courses for group training in electronics at company expense, among them United Air Lines, Canadian Broadcasting Corporation, Trans Canada Airlines, Sears Roebuck & Co., Bendix Products Division, All-American Cables and Radio, Inc., and RCA-Victor Division.

CREI courses are prepared by recognized experts, in a practical, easily-understood manner. You get the benefit of time-tested materials, under the personal supervision of a CREI Staff Instructor. This complete training is the reason why CREI graduates find their diplomas keys-to-success in Radio, TV and Electronics. CREI alumni hold top positions in America's leading firms.

At your service is the CREI Placement Bureau, which finds positions for students and graduates. Although CREI does not guarantee jobs, requests for personnel currently exceed supply by far.

Talk to men in the field and check up on CREI's high standing in electronics instruction. Determine for yourself right now that your earnings are going to rise with your knowledge—and that you get your rightful place in the Age of Electronics. All this CREI can promise you, provided you sincerely want to learn. Fill out the coupon and mail it today. We'll promptly send you your free copy of "Your Future in the New World of Electronics." The rest—the future—is up to you.

MAIL COUPON FOR FREE BOOKLET

CAPITOL RADIO ENGINEERING INSTITUTE

Dept. 146D, 16th & Park Rd., N.W., Washington 10, D. C.

Send booklet "Your Future in the New World of Electronics" and course outline.

CHECK TV, FM & Advanced AM Servicing Aeronautical Radio Engineering
FIELD OF Practical Television Engineering
GREATEST Broadcast Radio Engineering (AM, FM, TV)
INTEREST Practical Radio Engineering

Name.....

Street.....

City..... Zone..... State.....

If residence school in Wash., D. C. preferred, check here

MERIT

tv full-line*

components give

universal coverage

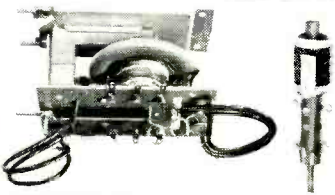

NEW IMPROVED HVO-7 FOR GREATER COVERAGE
Tapped AFC Winding. Covers Admiral Chassis 21-24 Series.

MWC-1 UNIVERSAL WIDTH COIL
(3-27 MH) A Tapped Secondary For AGC or AFC.



IF-RF COILS
Only complete line of TV replacements.



"COSINE" YOKES
Complete with leads & network.

MATCHED FOR DIRECT DRIVE



MDF-30 HVO-8
A-3080 Vert. Mtg.
A-3081 Horiz. Mtg.
Autotformer



KIT NO. 1000
MATCHED SET FOR SPEEDY PROFITABLE SERVICE!

MERIT . . . HQ for PRACTICAL TV Service Aids

MERIT'S 1952 Catalog No. 5211 with new MERIT IF-RF Coils.

Other MERIT service aids:
TV Repl Guide No. 404, 3500 models & chassis.

Cross Ref Data, IF-RF Coils, Form No. 14.
See your Jobber or write: Merit Coil and Transformer Corp., 4425 Clark Street, Chicago 40.



These three MERIT extras help you:
Exclusive: Tapemarked with specs and hook-up data.
Full technical data packed with every item.
Listed in Howard Sams Photo-facts.



*Merit is meeting the TV improvement, replacement and conversion demand with a line as complete as our advance information warrants!

DR. LEE de FOREST, the "Father of Radio", was honored on April 8 by a banquet at the Hotel Waldorf-Astoria, New York City. The banquet, held under the auspices of *The Radio Pioneers*, an organization of persons who have worked with or for Dr. de Forest during his career, commemorated the 45th anniversary of his invention of the Audion, or 3-electrode vacuum tube.

The principal speakers were a former president of the U.S. and a former governor. Ex-president Hoover began his speech by listing de Forest as one of the five inventors of modern times whose work has had the greatest impact on modern civilization. He pointed out parallels in his own life and de Forest's, revealing that they had spent part of their boyhood within 15 miles of each other, in Iowa, and that they had graduated as engineers only a year apart, de Forest from Yale's Sheffield School, and Hoover from Stanford. However, Mr. Hoover said, de Forest had taken the better road from there on, staying with science and making vast contributions, each with incomparable benefits to humanity, while he had "deserted the technical field for the slippery paths of public life."

Ex-president Hoover admitted that de Forest's invention had not been an unmixed blessing, and that possibly its worst result was the singing commercial. But, he continued, Dr. de Forest could redeem himself by inventing "a push button with which we could transmit our emotions instantly back to the broadcasters" at any time during a program.

Charles Edison, former governor of New Jersey, cited de Forest as the holder of more than 300 patents, and compared him as an inventor with his own illustrious father, Thomas A. Edison, recalling a meeting between the two at which, according to de Forest's autobiography, Edison had borrowed (and kept) his pencil. He concluded his

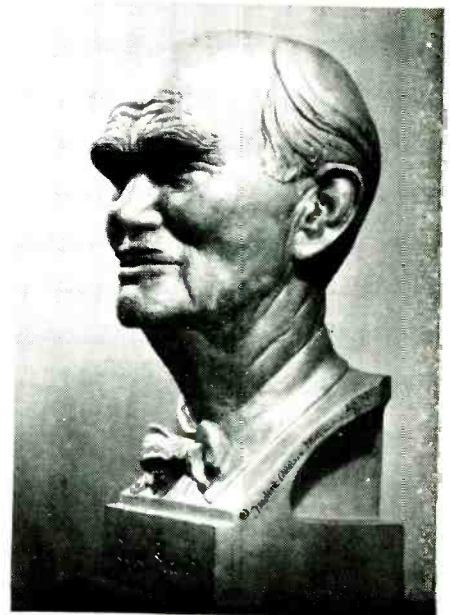

Sculptor—Frederic Allan Williams

speech by returning the pencil (or its equivalent) to de Forest.

A highlight of the affair was the presentation of a bust of de Forest to Yale University, which numbers him among its greatest graduates of the first half of the 20th Century.

De Forest, in replying to the speeches, reminisced about the old days and the old-timers, naming many of his co-workers present and absent, and admitted that, far from resting on his laurels at 77, he was still actively inventing, and had in fact recently taken out a patent on what some people considered the nemesis of the audion—an improved transistor!

NEW BRITISH TV STATION, opened in March, links Scotland with London and provides the longest television relay system in Europe. It is situated at Kirk o'Shotts, roughly mid-

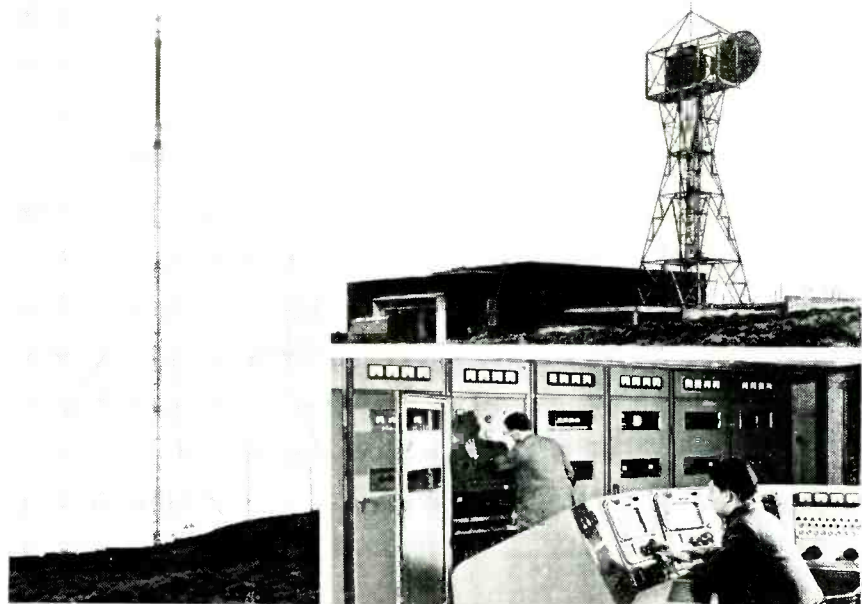

The BBC TV transmitter at Kirk o'Shotts, Scotland. Left: The 750-foot transmitting antenna. Upper right: TV programs relayed from London are received on these microwave parabolic antennas. Lower right: The 5-kw picture transmitter undergoing adjustments. The main operating console is in the foreground.

RADIO-ELECTRONICS

Prepare Now... in spare time at Home ... for a New,

PROFITABLE, INTERESTING FUTURE

TELEVISION RADIO - ELECTRONICS

RADIO CHIEF OF ILE DE FRANCE
FRENCH LUXURY LINER PRAISES D. T. I.

Radio Chief—Jean Desmas Says:

"DeForest's Training, Inc., of Chicago, is known not only throughout Europe, but also in many parts of the world as one of America's finest Television, Radio and Electronics training centers."



JACK DEMPSEY
Former World's Heavyweight Champion
TELLS WHY HE'S PROUD
TO BE WITH **D.T. I.**

- I have been greatly impressed with D.T.I.'s wonderful spirit of friendliness and sincere determination to help its students make good in Television-Radio-Electronics.
- I admire its remarkable 20 year record of helping men build brighter futures.
- I also admire the business policy of its management and the thoroughness of its large faculty of instructors.
- Never have I heard young men praise a school as enthusiastically as do the students and graduates of D.T.I. They are its best boosters.



Prepare At Home Or In Our Chicago Laboratory!

See for yourself how readily you may prepare at home, or in our modern Chicago laboratories, for a better job or business of your own in one of America's fastest-growing fields—TELEVISION-RADIO-ELECTRONICS.

If you train at home you get (1) the use of a 16-mm. movie projector and 16 reels of animated movies to help you learn important points faster... easier, (2) modern lessons and (3) sixteen shipments of electronic parts enabling you to get valuable practical experience from over 300 projects—including building and keeping the electronic equipment shown below. And upon completing training, you have the optional privilege of building and keeping a big 17-INCH TV set at moderate added cost. Get the full story. Mail coupon today!

LAUD D. T. I.'s HOME MOVIES IN CONGRESS

D.T.I.'s remarkable home training benefit of visual training MOVIES has been praised from the floor of the House of Representatives in Washington, D. C. and recorded in The Congressional Record.

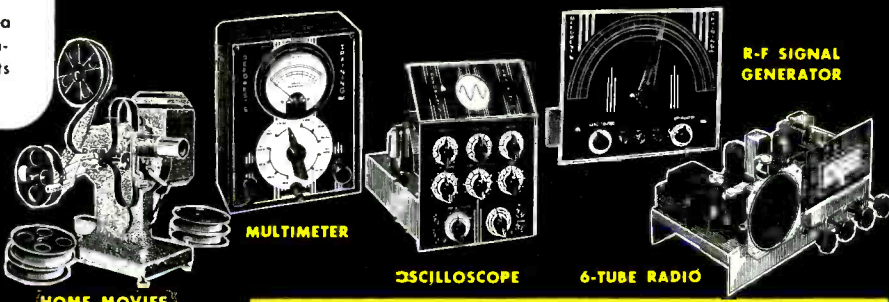

R-F SIGNAL GENERATOR

MULTIMETER

OSCILLOSCOPE

6-TUBE RADIO

HOME MOVIES

MILITARY SERVICE!

If subject to military service, the information we have for you should prove very helpful. Mail coupon today.

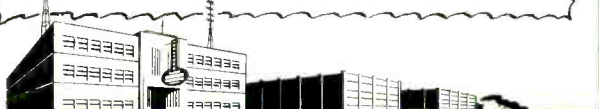

De FOREST'S TRAINING, INC.
AFFILIATED WITH
De VRY Technical INSTITUTE
CHICAGO 14, ILLINOIS



MAIL COUPON TODAY!

Dept. RE-6-1
DE FOREST'S TRAINING, INC.
2533 N. Ashland Ave., Chicago 14, Ill.

I would like your Opportunity News Bulletin showing "89 Ways to Earn Money in Television-Radio-Electronics"; also, the folder showing how I may prepare to get started in this thrilling field.

Name _____ Age _____
 Address _____ Apt. _____
 City _____ Zone _____ State _____

Famous Guns

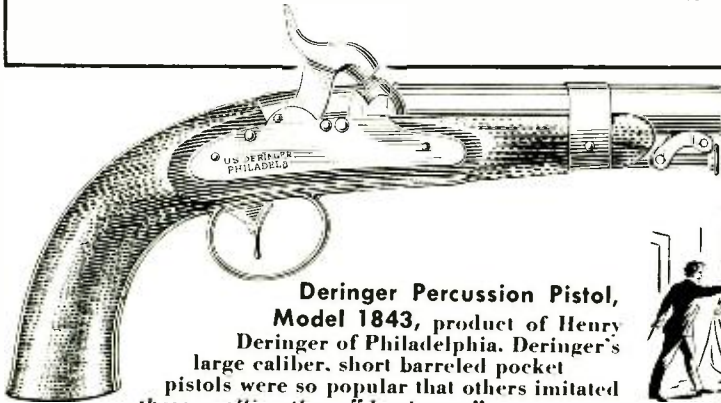

Deringer Percussion Pistol, Model 1843, product of Henry Deringer of Philadelphia. Deringer's large caliber, short barreled pocket pistols were so popular that others imitated them—calling them "derringers".
John Wilkes Booth used a Deringer to assassinate Lincoln.

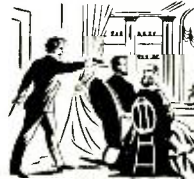

Trap or Doorjamb Pistol, Caliber .31, made by North & Couch, Middletown, Conn. This lethal little device protected householders against burglars. Fixed to the doorjamb, with a cord running from muzzle rod to door, the pistol fired all its barrels into any intruder.

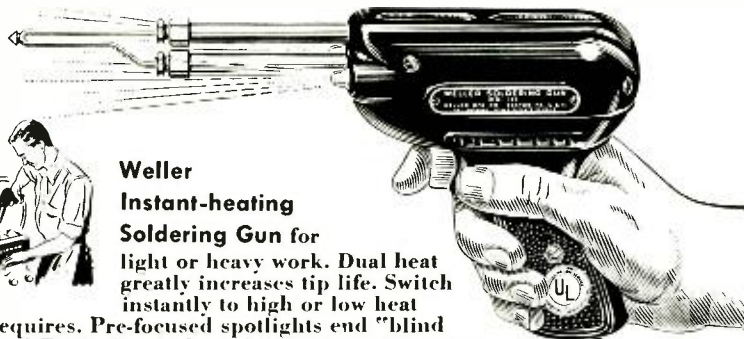

Weller Instant-heating Soldering Gun for light or heavy work. Dual heat greatly increases tip life. Switch instantly to high or low heat as job requires. Pre-focused spotlights end "blind soldering". Exclusive tip-fastening arrangement assures full, constant heat. High-impact plastic housing. Perfect balance. Low-cost replaceable tips. Pays for itself in a few months. See at your Distributor or write for Bulletin direct.

Get **SOLDERING TIPS**, new Weller Handy Guide to faster, easier soldering. 20 pages fully illustrated. Price 10c at your Distributor or order direct.

Weller BETTER FROM GRIP TO TIP!

SOLDERING GUNS 828 Packer Street, Easton, Pa.
The Finest Soldering Tool for the Finest Craftsmen

way between Glasgow and Edinburgh, and will provide television service over a wide area in Scotland.

Kirk o'Shotts will receive programs from London, over 400 miles away, by a transmission network divided into three main parts. Programs can be transmitted in both directions over any or all of the three network sections.

Extra-wide-band coaxial cable is used on the first section, which carries programs underground from London to Birmingham. The second section runs from Birmingham through Manchester to the transmitter at Holme Moss, using a smaller type coaxial cable. The final section of the network carries pictures by a microwave radio link.

The 750-foot height of the antenna, combined with the natural elevation of the site, gives an effective height of more than 1,600 feet. The mast and aerial system can withstand gales of 120 miles per hour.

LOUIS GERARD PACENT, noted radio pioneer, died April 6th at the age of 58. A wireless experimenter as early as 1906, Mr. Pacent became one of the world's first radio amateurs, and suggested the tests which led to the first successful amateur transatlantic transmissions.

After the first World War he established the Pacent Electric Company which produced many of the components used in early broadcast receivers and electric phonographs.



Mr. Pacent was the author of a number of technical books and a contributor to several technical journals. His last article in this magazine appeared January 1948.

The Pacent Engineering Corporation, which he founded in 1933, is engaged in research and development engineering in military and civilian electronics.

In 1951 Mr. Pacent was cited by the Department of the Army for his services during the second World War, and received the Marconi Memorial Medal of Achievement from the Veteran Wireless Operators Association. He was a Fellow of the IRE and of the Society of Motion Picture and Television Engineers, a Fellow and past president of the Radio Club of America, and a member of the Institute of Electrical Engineers, and the Engineers Club.

NEW AMATEUR BAND of 21 to 21.45 mc. opened May 1, may cause interference in television receivers whose i.f.'s are lower than 21.5 mc, warn officials of the American Radio Relay League.

Tests carried out by the League indicate that such interference may be eliminated or minimized by re-aligning the receivers at a sound i.f. of 21.9 mc if possible, and not lower than 21.7.

—end—
RADIO-ELECTRONICS

Which Do You Want?



Better Pay



A Nice Home



A New Car



Greater Security



Happy Vacations and Travel

Get Your FCC Ticket Then Use Our Amazingly Effective Job-Finding Service To Get a Better Job



EDW. H. GUILFORD
Vice President

I can train you to pass your FCC License Exams in a minimum of time if you've had any practical radio experience—amateur, Army, Navy, radio servicing, or other. My time-proven plan can help put you, too, on the road to success.

Just fill out the coupon and mail it. I will send you free of charge, a copy of "How to Pass FCC License Exams," plus a sample FCC-type Exam, and the amazing new booklet, "Money Making FCC License Information."

How to Pass FCC License Exams

Commercial Radio Operator



FREE

Tells where to apply for and take FCC examinations, location of examining offices, scope of knowledge required, approved way to prepare for FCC examinations, positive method of checking your knowledge before taking the examinations.

Get this Amazing Booklet FREE

TELLS HOW — WE GUARANTEE — TELL HOW —

TO TRAIN AND COACH YOU AT HOME IN SPARE TIME UNTIL YOU GET

YOUR FCC LICENSE

If you have had any practical experience—
Amateur, Army, Navy, Radio Repair or Experimenting

TELLS HOW — Employers Make

JOB OFFERS Like These to Our Graduates Every Month

Long distance Phone from Chief Engineer, Broadcast Station, Georgia. "Need 1st class licensed man immediately; salary \$65 for 49 hour week."
Letter from Chief Engineer, Broadcast Station, Penna. "We are in need of a broadcast engineer with first class license. Experience not necessary and starting pay is \$53 per 49 hour week."
These are just a few examples of the job offers that come to our office periodically. Some licensed radio men filled each of these jobs. . . . it might have been you!

HERE'S PROOF FCC LICENSES ARE OFTEN SECURED IN A FEW HOURS OF STUDY WITH OUR COACHING AT HOME IN SPARE TIME

Name and Address	License	Lessons
Lee Worthy 2210 1/2 Wilshire St., Bakersfield, Cal.	2nd Phone	16
Clifford E. Vogt Box 1016, Dania, Fla.	1st Phone	20
Francis X. Forch 38 Beucler Pl., Bergenfield, N. J.	1st Phone	38
S Sgt. Ben H. Davis 317 North Roosevelt, Lebanon, Ill.	1st Phone	28
Albert Schoell 110 West 11th St., Escondido, Cal.	2nd Phone	23

CLEVELAND INSTITUTE OF RADIO ELECTRONICS
CARL E. SMITH, E. E., Consulting Engineer, President
Desk RE-42, 4900 Euclid Bldg., Cleveland 3, Ohio

Our Amazing Effective JOB-FINDING SERVICE

Gets Better Jobs for Graduates

Here is just one recent example of Job-Finding Results

OURS IS THE ONLY HOME STUDY COURSE WHICH SUPPLIES FCC TYPE EXAMINATIONS WITH ALL LESSONS AND FINAL TESTS.

GETS FIVE JOB-OFFERS FROM BROADCAST STATIONS
"Your 'Chief Engineer's Bulletin' is a grand way of obtaining employment for your graduates who have obtained their 1st class license. Since my name has been on the list I have received calls or letters from five stations in the southern states, and am now employed as Transmitter Engineer at WMMT."
Elmer Powell, Box 274, Sparta, Tenn.

Your FCC Ticket is recognized in all radio fields as proof of your technical ability.



TELLS HOW YOU CAN GET A FREE TELEVISION ENGINEERING COURSE



Get All 3 FREE

MAIL COUPON NOW

CLEVELAND INSTITUTE OF RADIO ELECTRONICS
Desk RE-42, 4900 Euclid Bldg., Cleveland 3, Ohio
(Address to Desk No. to avoid delay)

I want to know how I can get my FCC ticket in a minimum of time. Send me your FREE booklet, "How to Pass FCC License Examinations" (does not cover exams for Amateur License), as well as a sample FCC-type exam and the amazing new booklet, "Money Making FCC License Information."
 Tell me how I can get your Free Television Course.

NAME

ADDRESS

CITY.....ZONE.....STATE.....

Paste on 2 cent postcard or send air mail



Your best picture tube and set tester ... an RCA VoltOhmyst*

Save time and money—be sure—by pre-checking TV chassis and picture tubes in the home with an RCA "VoltOhmyst". Here's how . . .

Bringing your RCA "VoltOhmyst" into the customer's home on every service call is more than good psychology—it's good business—because the features of an RCA "VoltOhmyst" permit you to make a rapid and systematic check of the chassis as well as the picture tube—right in front of the customer.

Here's how you go about it (no picture or a dim picture, but sound okay):

1. Turn on set and visually check that picture-tube heater is lighted. Check adjustment of ion-trap and focusing magnets.
2. If picture-tube heater is not lighted, remove the socket from the tube and check heater continuity with "VoltOhmyst". Also check heater-to-cathode leakage.
3. Measure socket-terminal voltages to ground with "VoltOhmyst." Note action of Brightness Control on grid or cathode voltage.
4. Check for video voltage at grid or cathode terminal of picture-tube socket with "VoltOhmyst" AC Probe.
5. Replace picture-tube socket and measure high voltage with WG-289 High-Voltage Probe. Note effect of Brightness Control on high voltage.
6. If high voltage is lower than normal, measure "B plus" and "boosted B plus" voltages with "VoltOhmyst" DC Probe. If B-plus voltage is normal and boosted B-plus voltage is low, try a new damper tube.
7. If "B plus" and "boosted B plus" voltages are both normal, try new tubes in the horizontal output, horizontal oscillator, and HV rectifier.
8. If none of these tests indicate the trouble, then it may be concluded that the picture tube is at fault.

These simple tests permit you to give the customer an immediate and positive diagnosis of the trouble . . . and in many cases, permit you to correct the fault on the spot. Most important—you know immediately whether a new picture tube is needed, or whether it will be necessary to take the chassis to the shop.



WG-289 High-Voltage Probe with WG-206 Multiplier resistor, \$9.95 Suggested User Price.

WV-77A Junior "VoltOhmyst," only \$47.50 Suggested User Price.

Only RCA makes the "VoltOhmyst"

RCA "VoltOhmysts" measure DC voltages in high-impedance circuits, *even with rf present*, without the ill effects of heavy circuit loading, regeneration, or frequency shift. They also measure AC over a wide frequency range, *even in the presence of DC* . . . and detect leakage resistances as high as 1000 megohms.

See the WV-77A and the WG-289 as well as the WV-87A and WV-97A "VoltOhmysts" at your local RCA Distributor, or write for bulletins to Commercial Engineering, Section FX 49, Harrison, N. J.

*Reg. U.S. Pat. Off.



RADIO CORPORATION of AMERICA
TEST EQUIPMENT
HARRISON, N. J.

RADIO-ELECTRONICS

**BIG
VALUES
NEW
RELEASES**

**FREE
SEND FOR IT!**



**you'll find them in the latest
ALLIED Supplement**



"SKY ROVER" PORTABLE KIT

Build this powerful 3-way superhet portable for AC, DC, or battery operation. Covers 535-1650 kc AM broadcast band; has built-in antenna, PM speaker, automatic volume control. Easy to assemble from 8-page illustrated manual. High-quality kit includes all parts, tubes and carrying case (less batteries). Shpg. wt., 6 lbs.
83-276. Only.....\$17.95
80-596. Battery Kit.....\$2.11



DEWALD 3-BAND PORTABLE

Powerful broadcast and "round-the-world" Short Wave at low cost! Tunes 540-1600 kc; 2.0-5.45 mc; 5.45-16.7 mc. Operates from AC, DC or batteries. Superhet circuit; loop AM antenna. 53" collapsible SW whip; handsome tan-brown case. 9 1/2 x 11 1/2 x 5 1/2". Complete with tubes, less batteries. 9 lbs.
4J-708. Only.....\$42.50
80-619. Battery Kit.....\$4.74



WELLER SOLDERING IRON

Squeeze the trigger—you're ready to solder in 5 seconds! Double-tube electrode and long tip; with 2 spotlights that light up working area. Air-cooled transformer. 100-135 watt dual-heat type. Shpg. wt., 3 lbs.
46-589. Only.....\$10.73



CHAMPION SPRAY GUN

Smooth-working all-metal electric gun for spraying lacquer, paint, varnish, chemicals, insecticides, etc. No compressor—has motor right in handle—develops over 90 lb. pressure. Pistol trigger. 25-ounce glass jar. With 8 ft. cord. For 110-120 v., 60 cy. AC. Shpg. wt., 5 lbs.
46-139. Only.....\$9.57



MICRO-VOX WIRELESS MICROPHONE

Mike with built-in midget radio transmitter plays through any radio within 50 feet for home entertainment or as small P.A. System. Complete with built-in batteries. Shpg. wt., 3 lbs.
99-485. Only.....\$5.85



WHEELER SELF-POWERED PHONE

Self-contained, self-powered telephone handset—no batteries or line voltage needed. Fine for inter-room use. Use with No. 16 or No. 19 twisted wire. With 3 1/2 ft. cable, test clips, insulators. Shpg. wt., 1 1/2 lbs.
59-350. Only.....\$9.62

All Prices F. O. B. Chicago



E-Z-I TV LIGHT AND CLOCK

Combination TV light and numeral-type clock. When placed on top of TV cabinet, helps reduce viewing eyestrain. Walnut plastic case. 5 x 5 1/2 x 7 1/2". For 110 v., 60 cy. AC. Shpg. wt., 2 1/2 lbs.
78-328. Only.....\$7.66



4 X 6" OVAL SPEAKER VALVE

Ideal for replacement use in portable and table radios, TV sets and intercom. Fine buy for builders, experimenters. With 1.47 oz. Alnico V magnet. Voice coil imp. 3.2 ohms. Wt., 12 oz.
81-640. Only.....\$1.69

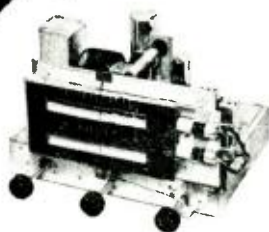

PILOT HI-FI AM-FM TUNER

Best buy in a quality tuner covering standard AM broadcast and 88-108 mc FM. Flat response within 2 db. 20-15,000 cps. Slide-rule dial; separate 3-gang condensers for AM and FM; input for phono and TV, with bandswitch; power supply; tuned RF on AM and FM; ceramic loop stick antenna for AM, FM line antenna. Size, 11 1/2 x 6 x 9"; with 9 tubes and rect. For 110-120 v., 50-60 cy. AC. Shpg. wt., 8 1/2 lbs.
97-944. Only.....\$42.95



NEW REGENCY TV BOOSTER

Features maximum stability on all TV channels by providing inductive and capacitive neutralization. Single tuning knob for easy operation. Fine tracking accuracy. Improves both picture and sound for greater TV enjoyment. Mahogany plastic cabinet. 4 1/2 x 6 x 4 1/2". For 110-120 v., 60 cy. AC. Shpg. wt., 7 lbs.
97-211. Only.....\$19.11



NEW TV TUBE BRITENER

Extends useful life of older, dull-looking TV picture tubes; increases electron emission, thus adding brightness. Installs inside cabinet in minutes; automatic; 3 boost positions to select desired tube brilliance.
80-179. Only.....\$5.73



KNIGHT 3-SPEED PHONO-RADIO

Complete home entertainment at new low cost. Has V-M 3-speed intermix changer, with turnover cartridge—plays all records, all sizes and speeds—intermixes 10" and 12" records. Superhet radio covers 540-1730 kc; Alnico PM speaker, tone control. In attractive cabinet, 15 x 9 1/2 x 19 1/2". With all tubes and loop antenna. For 105-125 v., 60 cy. AC. Shpg. wt., 35 lbs.
5G-563. Only.....\$56.75



NEW TV CLARIFIER

Tunes out antenna-fed interference which causes annoying TV picture distortion. Eliminates FM, diathermy, SW, ignition, amateur interference, etc. Matches any antenna. Easy to install and operate. Brown case, 4 x 3 1/4 x 1 1/2". Shpg. wt., 1/2 lb.
77-566. Only.....\$4.41



PLASTIC SPRAY

Provides tough coating of clear flexible plastic on any surface. Guards against rust, tarnish, etching. Dries hard in an hour. Automatic spray. Shpg. wt., 1 1/4 lbs.
43-136. Only.....\$1.03



NEW "TENNA-BOAT" TV INDOOR ANTENNA

Beautiful, practical. Ceramic boat hull is base; mast and boom are the antenna. Plastic sail is rotatable for best reception; has built-in tuning condenser.
97-047. Dark Green
97-048. Crimson
97-049. Harvest Moon
Each, Only \$8.25

ALLIED RADIO

ALLIED RADIO CORP. Dept. 2-F-2
833 W. Jackson Blvd., Chicago 7, Ill.

FREE SEND FOR IT

Send Free ALLIED Supplement No. 130.

Enter order for.....
.....\$.....enclosed

Name.....

Address.....

City.....Zone.....State.....

PHILCO Custom Styled Auto Radios

Stainless Steel Kitchen Tools

PHILCO "Easy Out" Ice Cube Trays

PHILCO POLISH Refrigerators Furniture, Automobiles

PHILCO Freezer and Refrigerator Bags

For QUICK June Profits
Nationally Advertised
PHILCO
Accessory Products

ADVERTISED IN JUNE
to the millions of
readers of the
SATURDAY EVENING POST
and
BETTER HOMES AND GARDENS

GET YOUR summer selling season *off to a flying start* with these Philco Accessory products your customers will see advertised in June national magazines. Take a free ride to profits by giving them special display in your store and windows. Feature them in your promotions. *Drive it home* to the buyers of your area . . . that *your store* is the place to buy the Philco Accessories they need.

"HIT OF THE MONTH" OFFERS

NEW FOR JUNE! Ask about the new *extra profit* "June specials" on Philco Parts and Accessories.

NOW AT YOUR PHILCO DISTRIBUTOR

RADIO-ELECTRONICS



"Let Me Tell You How It Happened..."



Carl Vineglass,
Al's Radio,
Lawrence, Mass.

"FOR YEARS I'VE BEEN BUYING TUBES... A LOT OF THEM CBS-HYTRON. But I didn't know too much about CBS-Hytron. Sure, I'd seen their ads. Read about their original rectangular tube. Their 1X2A, 6BQ6GT, 12BH7, 12BY7, etc. Their handy service tools. (I just couldn't get along without my Soldering Aid.) Their Budget Plan. And so on.

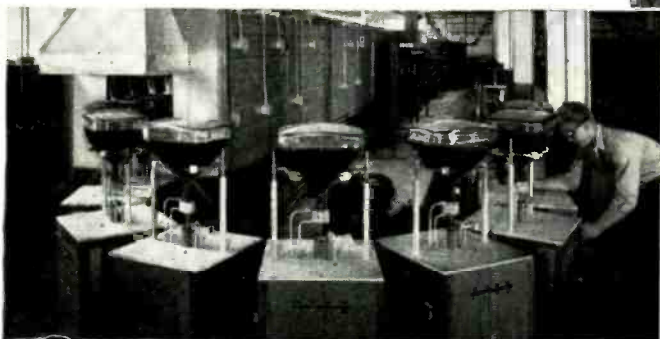
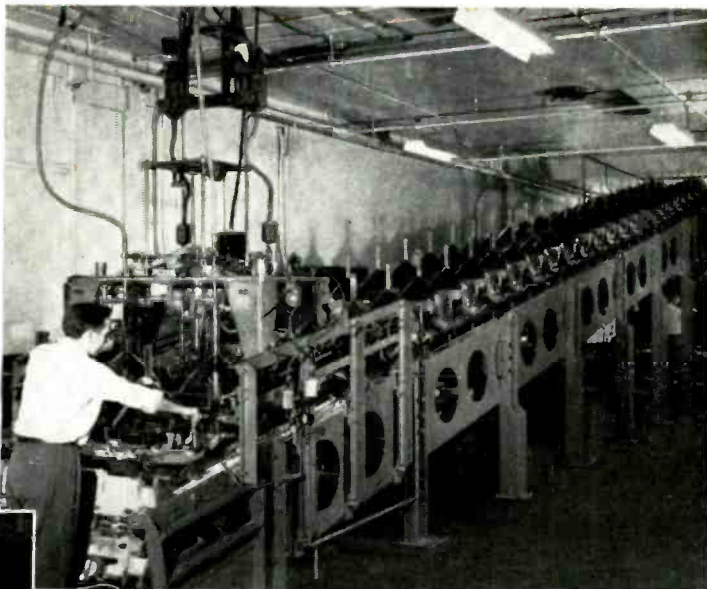

"I like to know the fellows I buy from though. So last week I drove over to Salem. The CBS-Hytron gang, from President Bruce A. Coffin down, gave me a real welcome. Also the low-down on CBS-Hytron tubes, and what's behind them.

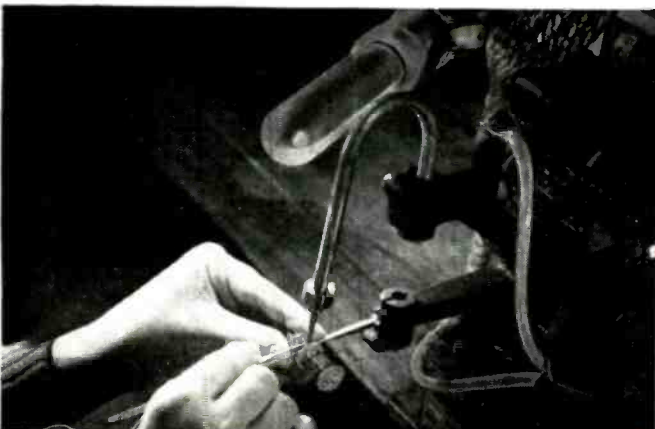

"First off, I discovered that CBS-Hytron is big... and getting bigger fast. I saw receiving tubes rilling out of their combined Salem and Newburyport plants at 300 a minute. With their new Danvers plant, it'll be 600 a minute! And their picture tubes run at 5000 a day! You may already know that CBS-Hytron is now a division of Columbia Broadcasting System, Inc.



"CBS-Hytron has a saying, 'Tubes are known by the company they keep.' In their shipping rooms, I saw tubes being rushed out to most of the top manufacturers and jobbers I ever heard of... and lots I don't even know.

"The reason for all the popularity wasn't hard to find. I never saw such painstaking manufacturing and testing in my life. From raw materials to finished tube. Every single tube gets the works.

"And is making tubes complicated! That ingenious machinery does everything but talk. The flying fingers of the girls assembling the tubes, though, are what caught my eye. I just couldn't believe you could get that watch-like precision with that amazing speed. And talk about engineers! I saw electronic, mechanical, chemical, metallurgical, production, industrial engineers by the score.

"I've read that CBS-Hytron's picture-tube plant is the most modern in the world. I believe it. It's really something the way that push-button, automatic plant handles those big bottles. And that new Danvers receiving-tube plant is more of the same. Floor space covers approximately five acres. Main production floor is longer (500 feet) than the longest home run ever hit by Babe Ruth. That plant has everything. They tell me the whole idea was to produce at economical top speed the finest receiving tubes in the world. To my way of thinking, they succeeded.

"Believe me, I'm glad I made that trip to CBS-Hytron. They're a real on-their-toes outfit. Before I never was too fussy what standard brand of tube I bought. But now I want CBS-Hytron, and that's that! You would, too, if you'd seen what I have."

AN OPEN INVITATION...

to all service-dealers and their distributors. You are mighty welcome to drop in at CBS-Hytron any time. How about this summer?



MAIN OFFICE: SALEM, MASSACHUSETTS

VEE-D-X

Single Channel BOOSTERS

Engineered for
GREATER POWER
and
SUPERIOR PERFORMANCE

The Sensational MAST-MOUNTED ROCKET

- 18 DB Gain
- Easy to Install
- Low in Price



Amplifies signal at antenna height where most favorable signal-to-noise ratio exists. Delivers 18 db gain. Easy to install and low priced. Uses 300 ohm transmission line. Compact control unit fits snugly against back of TV set.

\$34⁹⁵ LIST

original OUTBOARD BOOSTER

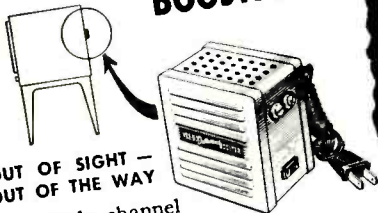

OUT OF SIGHT —
OUT OF THE WAY

For single channel use. Delivers powerful 18 db gain with full 5 megacycle band width. No special tuning tool required.

\$19⁹⁵ LIST

THE LaPOINTE-PLASCOMOLD CORP.
Windsor Locks, Conn.

Gentlemen:
Please send me details onthe Rocket
.....the Outboard.

NAME
STREET
CITY ZONE ... STATE

Merchandising and Promotion

Cornell-Dubilier Electric Corp., Jobber Division, South Plainfield, N. J., is delivering a two-piece lightning-arrester merchandiser to stimulate point-of-purchase sales of its new UL-approved lightning arrester for TV and radio



protection. The merchandiser consists of a wall dispenser which holds 12 individually-cartoned arresters and a 24-unit self-service counter display.

The RCA Tube Department, Harrison, N. J., designed a flip-type index as a finger-tip reference on RCA radio-television speakers. Less than six inches square, and suitable for mounting on

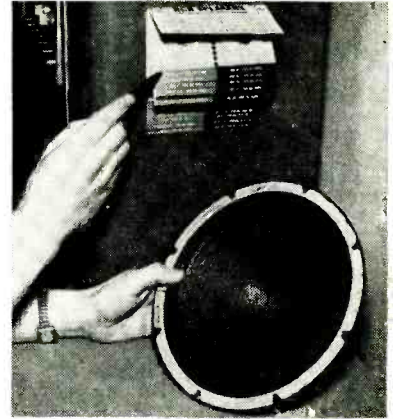

the wall or service bench, the index provides all data necessary for the installation of any one of 22 different RCA speakers. It is available to service technicians through distributors.

Radio Merchandise Sales, Inc. (RMS), New York City, is continuing its series of forums on TV antennas and allied products. A meeting was held recently in Albany, N. Y., under the sponsorship of the Fort Orange Radio Supply Co.

Littelfuse, Inc., Des Plaines, Ill., released its first completely illustrated list-price sheet on fuses. It is a 4-page sheet containing actual-size drawings of 25 fuse types.



BAROMETER of the PARTS INDUSTRY

During April, 53 of the leading 400 manufacturers of Radio-Television-Electronic parts and equipment made changes in their lines. Actually there was a decrease in "change activity" as compared to the previous 3 months. In price revisions by the number of manufacturers and products affected, the following summary illustrates the comparative trend for the months of March and April.

	No. of Manufacturers	
	March	April
Increased prices	12	10
Decreased prices	28	14

	No. of Products	
	March	April
Increased prices	482	179
Decreased prices	492	321

As evident now for the second month, price decreases still predominate. For a summary of the most active product categories, see the following table:

Products Group	Increased Prices		Decreased Prices		New Products		Discontinued Products	
	No. of Mfrs.	No. of Products	No. of Mfrs.	No. of Products	No. of Mfrs.	No. of Products	No. of Mfrs.	No. of Products
Antennas & Access.	1	8 ↑	4	25 ↓	6	43 ↓	5	21 ↓
Capacitors	2	41 ↑	1	6 ↑	3	48 ↓	None	None
Controls & Resistors	1	10 ↓	None	None	2	420 ↑	None	None ↓
Sound & Audio	1	1 ↓	1	1 ↓	7	40 ↓	9	25 ↓
Test Equipment	None	None ↓	None	None ↓	4	7 ↓	1	1 ↓
Transformers	None	None ↓	None	None ↓	1	22 ↓	None	None ↓
Tubes	5	119 ↓	7	153 ↓	11	74 ↑	1	6 ↓
Wire, Cable, etc. Connectors	None	None	1	36 ↓	3	75 ↑	2	3 ↓

↑ Increase over March
↓ Decrease

↑ Increase over March
↓ Decrease

Comment: Tube prices continue to show the most activity without any apparent trend.

Comment: With the exception of 1 manufacturer of Controls, there is no apparent change in the trend of new and discontinued products.

This data is prepared by the staff of United Catalog Publishers, Inc., 110 Lafayette Street, New York City, publishers of RADIO'S MASTER, the Official Buying Guide of the Parts Industry.

Permo, Inc., Chicago, inaugurated a complete merchandising service for its *Fidelitone* special type replacement needles. The ten-point plan includes inventory, packaging, installation, and advertising aids. Among the promotional materials supplied are broadsides, needle and cartridge data sheets, dis-



play packages, etc. Permo also announced that the manufacturing processes used in the production of its phonograph needles would be featured on one of the "Industry on Parade" TV shows, sponsored by the National Association of Manufacturers.

Snyder Manufacturing Co., Philadelphia, designed a self-service merchan-



dising kit for its indoor *Directronic* TV antenna system. The components for the antenna are packed in a box which may be opened and folded as a counter display.

The Ward Products Corp., Division of The Gabriel Co., Cleveland, designed a new counter display for its line of auto antennas. The new blue, orange and



black display mounts three types of the company's antennas, the *8-Ball*, *Phantom* and *Air King*. It is available through distributors.

Vaco Products Co., Chicago, is underway on a campaign promoting its line of Lynn Lightning Solderless Terminals. A catalog showing the com-

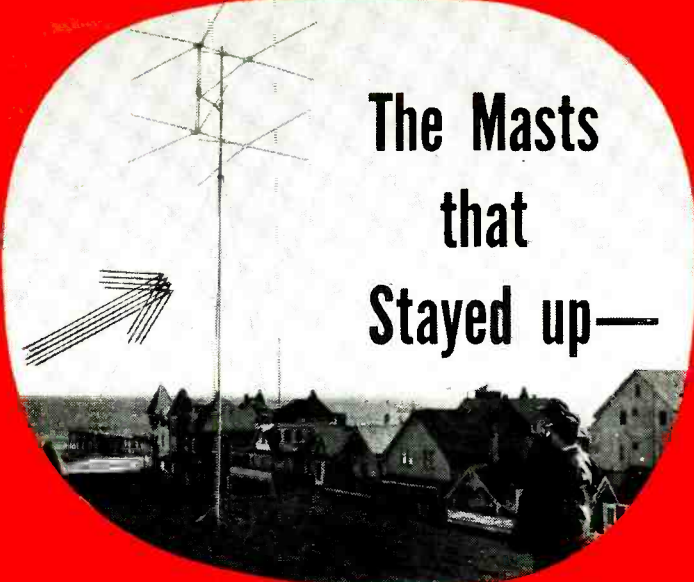

The Masts that Stayed up—

when others
went
DOWN!

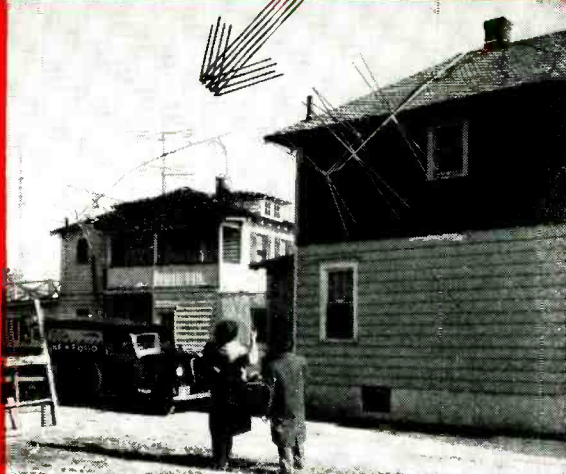

PERMA-TUBE

... the Steel Television Mast that's UP to STAY!

... it was a *big blow*—the hurricane of November 1950 that hit the New York area with devastating force. Television masts were crumpled and flattened like straws in the path of the wind ... all but those made of PERMA-TUBE. PERMA-TUBE Masts *Stayed Up!* ... and why did PERMA-TUBE Masts *stay up?* For the very good reason that they're made of sturdy, corrosion-resistant steel ... Jones & Laughlin Tele-

vision grade PERMA-TUBE Steel ... a product that is pre-treated with Vinsynite and coated with a metallic-pigmented vinyl resin base *inside and outside.*

... what's more, they're easily, quickly and economically installed. Their new Fitted Joints can be slipped together in a matter of seconds. And you can obtain PERMA-TUBE in standard lengths, diameters and wall-thicknesses.

FOR COMPLETE INFORMATION—MAIL THIS COUPON TODAY!



Jones & Laughlin Steel Corporation
495 Jones & Laughlin Building
Pittsburgh 30, Pennsylvania

Without charge please send me:—

- Name of nearest distributor
- Complete information on Perma-Tube

NAME _____

COMPANY _____

ADDRESS _____

INDISPENSABLE!

PHOTOFACT BOOKS



Photofact Television Course. Covers TV principles, operation and practice. 216 pages; profusely illustrated; 8½ x 11". Order **TV-1**.....Only **\$3.00**

Television Antennas. New 2nd edition. Describes all TV antenna types; tells how to select, install, solve troubles. Saves time; helps you earn more. 200 pages; illustrated. Order **TAG-1**.....Only **\$2.00**

Television Tube Location Guide. Volume 2. Accurate diagrams show position and function of all tubes in hundreds of TV sets; helps you diagnose trouble without removing chassis. 224 pages; pocket-size. Order **TGL-2**.....Only **\$2.00**

Television Tube Location Guide. Vol. 1. Over 200 pages of TV receiver tube position diagrams on hundreds of models. Order **TGL-1**.....Only **\$1.50**

Making Money in TV Servicing. Tested proved methods of operating a profitable TV service business. Covers all important phases. Authoritative, valuable guide to success. Over 130 pages. Order **MM-1**.....Only **\$1.25**

Servicing TV in the Customer's Home. Shows how to diagnose trouble using capacitor probe and VTVM. Short-cut methods help save time, earn more on outside service calls. Order **TC-1**.....Only **\$1.50**

1949-1950 Record Changer Manual. Vol. 3. Covers 44 models made in 1949, including multi-speed changers and wire and tape recorders. Original data based on actual analysis of equipment. 286 pages; 8½ x 11"; paper-bound. Order **CM-3**.....Only **\$3.00**

1948-1949 Changer Manual. Vol. 2. Covers 45 models made in 1948-49. Paper bound. Order **CM-2**.....Only **\$4.95**

1947-1948 Changer Manual. Vol. 1. Covers 40 post-war models up to 1948. Order **CM-1**.....Only **\$3.95**

Recording & Reproduction of Sound. 2nd Edition. New, completely revised and vastly enlarged edition of the outstanding original volume. The most authoritative treatment of all phases of recording and amplification ever written. Over 800 pages. 6 x 9". Order **RR-2**.....Only **\$7.95**



Audio Amplifiers. Vol. 3. Clear, uniform, accurate data on 50 important audio amplifiers, plus full coverage of 22 FM and AM tuners, produced during 1950. 362 pages, 8½ x 11". Order **AA-3**.....Only **\$3.95**

Audio Amplifiers. Vol. 2. A complete analysis of 104 well-known audio amplifiers and 12 tuners made 1949-50. 368 pages, 8½ x 11". Order **AA-2**.....Only **\$3.95**

Audio Amplifiers. Vol. 1. 102 amplifiers and FM tuners made through 1948. 352 p. Order **AA-1**.....Only **\$3.95**

Auto Radio Manual. Complete service data on more than 100 post-war auto radio models. Covers over 24 mfrs. 350 pages, 8½ x 11". Order **AR-1**.....Only **\$4.95**

Communications Receiver Manual. Complete analysis of 50 popular communications models. 246 pages, 8½ x 11". Order **CR-1**.....Only **\$3.00**

Radio Receiver Tube Placement Guide. Accurate diagrams show where to replace each tube in 5500 radio models, covering 1938-1947 receivers. 192 pages, pocket-size. Order **TP-1**.....Only **\$1.25**

Dial Cord Stringing Guide. Vol. 2. Covers receivers made from 1947 through 1949. Shows you the one right way to string a dial cord in thousands of models. Pocket-size. Order **DC-2**.....Only **\$1.00**

Dial Cord Guide. Vol. 1. Covers sets produced 1938 through 1946. Order **DC-1**.....Only **\$1.00**

Order from your Parts Jobber or write direct to
HOWARD W. SAMS & CO., INC., 2201 E. 46th St., Indianapolis 5, Indiana
HOWARD W. SAMS & CO., INC.



plete line of solderless terminals, connectors, crimping tools, self-service display boards, etc., has been released. A two-color kit counter display holding a complete service kit in a plastic box is also included.

Channel Master Corp., Ellenville, N. Y., is telling the complete technical and sales story of its **Z-Match** Yagi



antennas in a give-away promotion involving giant-size matchbooks available from its distributors.

Perma-Power Co., Chicago, has prepared catalog sheets, technical data, etc., on its **TV Tube Britener** which, it states, increases the brilliance of older picture tubes.

JFD Manufacturing Co., Brooklyn, N. Y., prepared a four-color display featuring its **Sky-Streak** line of automobile antennas. The company also announced it is working on three new catalogs covering its entire line for service technicians, representatives and distributors.



Production and Sales

The RTMA issued a 29-page booklet giving radio and TV set production statistics for the past five years. The report showed there were 75,117,262 radio sets and 17,002,169 TV sets produced from 1947 through 1951. Manufacturers' dollar value of the radio output was estimated at \$2,175,936,597 and of TV at \$3,166,986,300.

New Plants and Expansions

National Electronic Products Corp., Pittsburgh, announced the establishment of an Electronics Division with headquarters at Ambridge, Pa. The new

division will consist of two departments: Television and Radio at Ambridge, and Radar at the new million-dollar Elizabeth, N. J., plant. The new Division will manufacture and distribute Nepco Yagi TV antennas, Nepco TV masts, and allied products.

Workshop Associates, division of Gabriel Co., Needham Heights, Mass., took a long-term lease on two additional buildings, a one-story structure which will include offices and production facilities, and a four-story plant housing production and production testing equipment. The new buildings are located in Norwood, Mass.

Hycon Manufacturing Corp., Pasadena, purchased control of Arcturus Electronics Corp., Newark, N. J. New officers were installed, including Trevor Gardner, president; Alden Acker, vice-president; and Jack Sheehan, general manager.

Radion Corp., Chicago, announced the completion of its plant modernization program, including a new plant at 1130 W. Wisconsin Ave., and the refinishing of its Plant No. 2 at 1137 Milwaukee Ave. Completion of the program gave the company nearly 40,000 square feet of space.

Sylvania Electric Products Inc., Electronics Division, announced expanded facilities for the production of electronic tubes. New division headquarters will be located at Woburn, Mass., and another new building in Newton, Mass., has been purchased. This brings the number of Electronics Division plants to three.

Business Briefs

... **Standard Transformer Corp., Chicago,** established a 21-member Serviceman Advisory Board composed of selected service technicians to advise the company on replacement transformer problems and to represent the servicing industry in Stancor's product planning.

... **Centralab** electronic components for the Canadian market will now be manufactured by Globe Union, Ltd., a wholly-owned subsidiary in Toronto.

... The RTMA voted to amend its by-laws on three points: Changing the name of the Transmitter Division to Technical Products Division; increasing the number of directors representing the Amplifier and Sound Equipment Division to two; and giving the Board of Directors more flexibility in calling special meetings.

... **Milton S. "Mike" Roth,** former jobber sales manager of Radiart Corp., established his own representative firm, Mike Roth Sales Co., Cleveland. Among the companies he will represent are JFD Manufacturing Co., Brooklyn, N. Y., and United Transformer Co., New York City.

... **Radar-Radio Industries of Chicago, Inc.,** president, Leslie F. Muter, reported that although employment in the Chicago area's electronics plants was off 27.3% from last year, the region had not been classified as a "distressed area," and therefore was at a distinct competitive disadvantage.

—end—

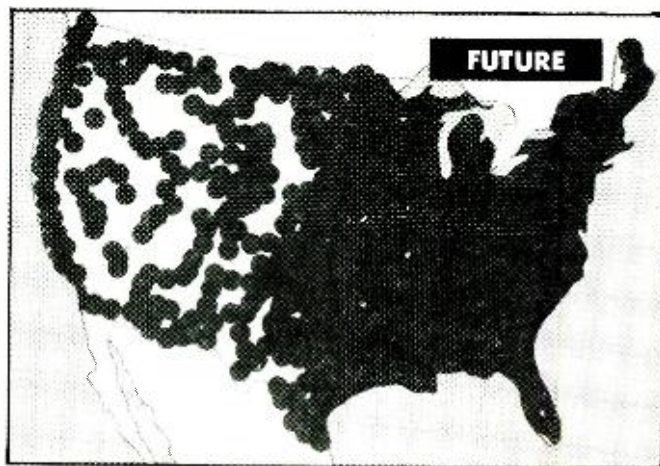
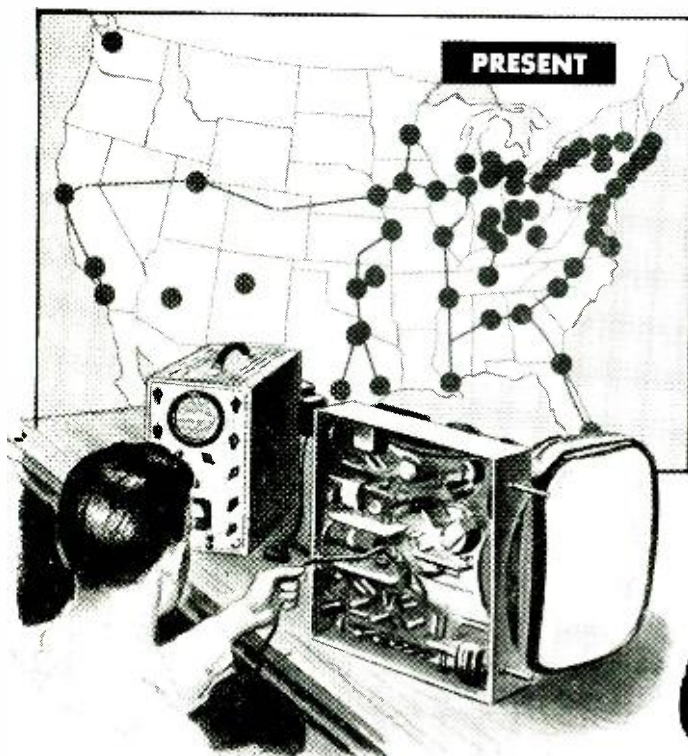

FUTURE—How new TV stations are expected to cover the nation.
PRESENT—Chart shows extent of current coverage.

Cash in on this Great Opportunity

... for good-pay jobs in TV SERVICING

YES, thousands of opportunities are going begging right now for good-pay jobs in TV Servicing.

The lifting of the "freeze" on new television stations clears the way for the expansion of the industry for 2,053 new stations, in 1,291 communities in the United States, its territories and possessions. There are only 108 stations telecasting now.

This is your golden opportunity to get all set for a good job that can mean employment security and a bright future for years to come. It's a great opportunity that can lead you, as a trained and experienced TV Serviceman, into establishing a profitable business of your own.

Big shortage of TV Technicians creates opportunities—NOW

Industry experts have estimated over 130,000 experienced TV technicians will be needed for the installation, trouble-shooting and repairing of television receivers in use by 1955. There are fewer than 50,000 fully trained TV service technicians available today. What an opportunity this creates for you!

Here are some of the good-pay jobs you can

choose—installation and trouble-shooting of TV receivers in homes . . . bench technician in radio-TV service shops . . . inspector, tester, repairman, field serviceman for TV receiver manufacturers, distributors and dealers . . . testing and servicing with electronic instrument manufacturers and companies with military contracts for electronic equipment . . . civilian serviceman with U. S. Military Bases . . . your own TV service shop—and many more.

RCA Institutes home study course trains you in your spare time

If you are associated with the radio-electronics industry, with no experience in TV servicing, the addition of the RCA Institutes Home Study Course in TV Servicing to your present experience will quickly qualify you to step out and grasp the good jobs now open in television.

The RCA Institutes course gives you a sound knowledge of television fundamentals . . . intensive practical instruction on the proper maintenance and servicing of TV receiver circuits . . . teaches you the "short cuts" on TV installation and trouble-shooting. Learn TV servicing (based on actual experience of hundreds of skilled technicians) from RCA engi-

neers and experienced instructors—pioneers and leaders in radio, television and electronic developments.

RCA Institutes home study course planned to your needs

You keep your present job. In your spare time, you study at home. You learn "How-to-do-it" techniques with "How-it-works" information in easy-to-study lessons prepared in ten units. Cost of RCA Home Study Course in Television Servicing has been cut to a minimum—as a service to the industry. You pay for the course on a "pay-as-you-learn" unit lesson basis. You receive an RCA Institutes certificate upon completion of the course. The RCA Institutes Home Study Course in Television Servicing is approved by leading servicemen's associations.

Don't pass up this lifetime opportunity for financial security and a bright future in TV.

SEND FOR FREE BOOKLET

Mail the coupon—today. Get complete information on the RCA INSTITUTES Home Study Course in Television Servicing. Booklet gives you a general outline of the course by units. See how this practical home study course trains you quickly, easily. Mail coupon in envelope or paste on postal card.

RCA Institutes conducts a resident school in New York City offering day and evening courses in Radio and TV Servicing, Radio Code and Radio Operating, Radio Broadcasting, Advanced Technology. Write for free catalog on resident courses.



RCA INSTITUTES, INC.
 A SERVICE OF RADIO CORPORATION of AMERICA
 350 WEST FOURTH STREET, NEW YORK 14, N.Y.

JUNE, 1952

MAIL COUPON NOW!

RCA INSTITUTES, INC., Home Study Department RE-652
 350 West Fourth Street, New York 14, N. Y.

Without obligation on my part, please send me copy of booklet "RCA INSTITUTES Home Study Course in TELEVISION SERVICING" (No salesman will call.)

Name _____ (please print)

Address _____

City _____ Zone _____ State _____



"It pays to replace with the BEST" Federal-

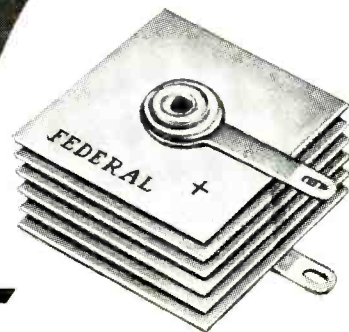

The Original Miniature Selenium Rectifier!

IT PAYS YOUR CUSTOMERS in finest quality and dependable, long-life performance—proved by over 30,000,000 units shipped to the field!

IT PAYS YOU, Mr. Serviceman, in customer satisfaction and goodwill—and a good profit on every job!

Here Are Other Specific Reasons Why "Federal" Is Your No. 1 Choice for Servicing the Big, Growing Radio-TV Replacement Market:

- Tests by receiver manufacturers show a life expectancy of well over RTMA guarantee.
- Over 250,000 tests prove superior immunity to shelf-aging.
- Federal's synthetic barrier layer stops change during long storage.
- Quality rigidly controlled. All units fully tested before release.
- Units available either packed in the attractive Federal resale box or in bulk.
- Constant research keeps you up-to-date on rectifier progress.

SAVE TIME—SERVE YOURSELF

from *Federal's* **NEW**

RECTIFIER DISPENSER



**LOOK FOR IT
ON YOUR
DISTRIBUTOR'S
COUNTER!**

America's Oldest and Largest Manufacturer of Selenium Rectifiers

Federal Telephone and Radio Corporation



SELENIUM-INTELIN DIVISION
100 KINGSLAND ROAD, CLIFTON, NEW JERSEY
In Canada: Federal Electric Manufacturing Company, Ltd., Montreal, P. Q.
Export Distributors: International Standard Electric Corp., 67 Broad St., N. Y.



RADIO-ELECTRONICS

way out yonder in the fringe areas...



WALSCO

MODEL M ANTENNA OUT-PERFORMS ALL OTHERS

BEYOND the city limits... way out where the tall grass grows, WALSCO Model M Antennas are producing sharper, crystal-clear TV pictures. Almost anywhere in the fringe areas, the amazing Model M will out-perform, out-last any competitive all channel antenna.

Once you install... *that's all*. No costly call-backs that eat up your profit. Guaranteed sturdier, more dependable in any climate. Chromate-coated magnesium cross-arms have a structural strength almost equal to steel, yet are $\frac{1}{3}$ lighter than aluminum. Positive corrosion resistance anywhere, any time of the year. Elements are made of high-conductivity, super-strength aluminum alloy, reinforced with Swiss "Permalum." Install the WALSCO Model M... the most dependable all-channel fringe area antenna.

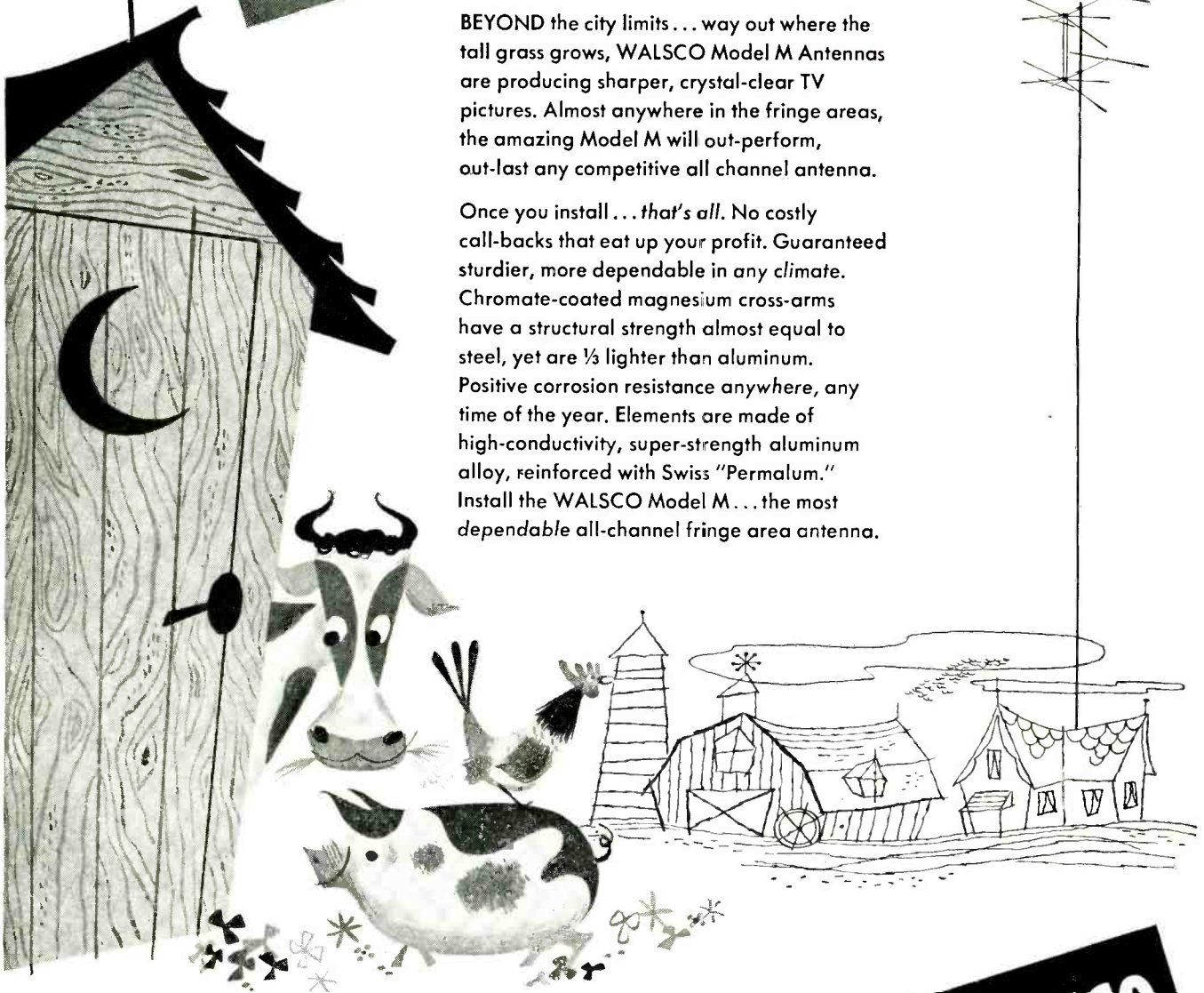

walSCO quality earned its reputation

WALSCO

THE TRANSISTOR

A picture report of progress

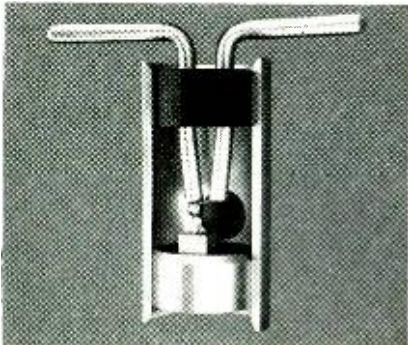

FIRST TRANSISTORS were of this point contact type (picture three times life size). Current is amplified as it flows between wires through a wafer of germanium metal. These transistors are now being made at the Allentown plant of Western Electric, manufacturing unit of the Bell System. They will be used in a new selector which finds the best routes for calls in Long Distance dialing.

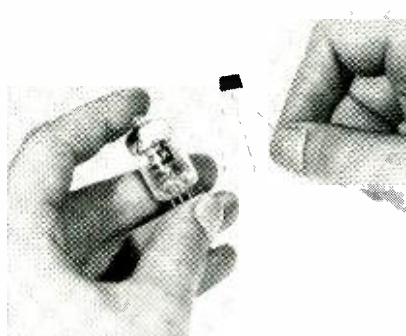

NEW JUNCTION TRANSISTORS, still experimental, also use germanium but have no point contacts. Current is amplified as it flows through germanium "sandwich"—an electron-poor layer of the metal between two electron-rich ends. This new transistor runs on as little as *one-millionth* of the power of small vacuum tubes.



MUCH HAD TO BE LEARNED, especially about the surface of germanium and the effect of one part in a million of alloying materials. Transistors promise many uses—as amplifiers, oscillators, modulators...for Local and Long Distance switching...to count electrical pulses.



ASSEMBLY PROBLEMS, such as fixing hair-thin wires to barely visible germanium wafers, have been solved through new tools and mechanized techniques. Finished transistors withstand great vibration and shock. Engineers see many opportunities for these rugged devices in national defense.



MOIST PAPER AND COIN generate enough current to drive audio oscillator using junction transistors. Half as big as a penny matchbox, an experimental two-stage transistor amplifier does the work of miniature-tube amplifiers ten times larger.

A tiny amplifying device first announced by Bell Telephone Laboratories in 1948 is about to appear as a versatile element in telephony.

Each step in the work on the transistor... from original theory to initial production technique... has been carried on within the Laboratories. Thus, Bell scientists demonstrate again how their skills in many fields, from theoretical physics to production engineering, help improve telephone service.

BELL TELEPHONE LABORATORIES

Improving telephone service for America provides careers for creative men in scientific and technical fields.



RADIO-ELECTRONICS

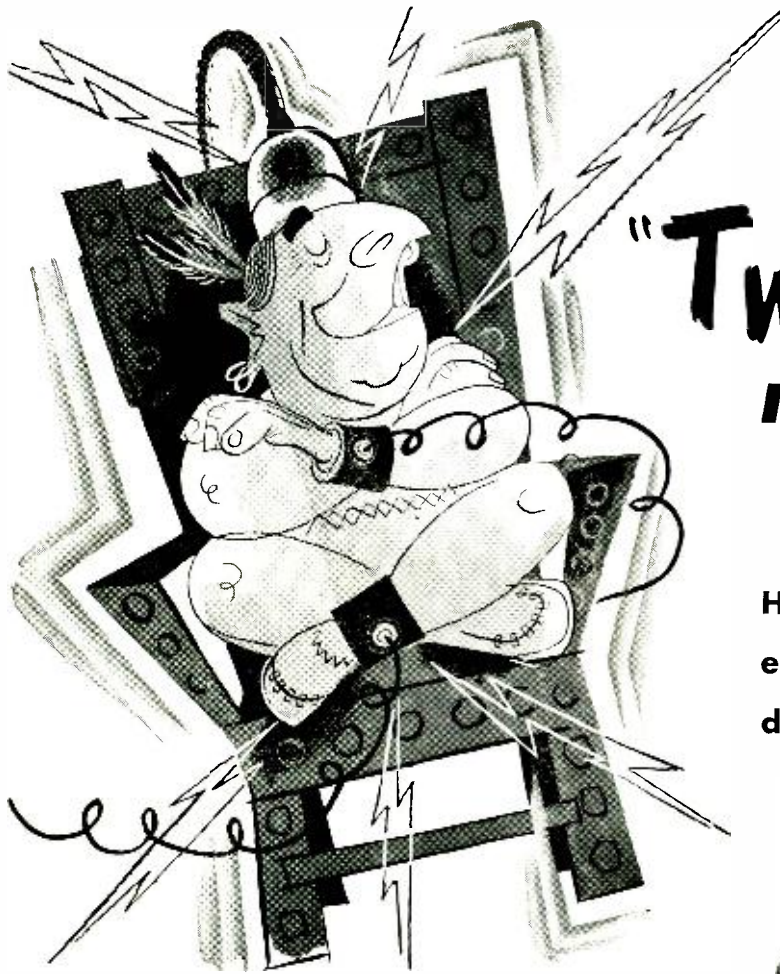

Sangamo "Twist-Tabs" never flinch in a hot seat!

High surge voltages and
extreme ripple currents
don't faze them...

*Type PL Electrolytic Capacitors

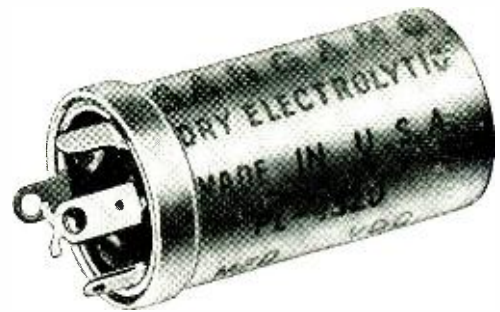

Sangamo "Twist-Tab" (Type PL) Electrolytic Capacitors are designed particularly for all television and electronic applications that demand long life and dependable performance at 85° C under conditions involving extreme ripple currents and high surge voltages.

These quality components are sealed in round aluminum cans and have twist prong tabs for washer or direct chassis

mounting. All connections from the capacitor are securely fastened to the terminal lugs, providing permanent low resistance connections. The aluminum cans are negative, and the mounting ring provides the negative connection. Sangamo "Twist-Tabs" offer a selection from the largest listing of capacities and voltages available from any single source. Write for full information.

Those who know ...choose Sangamo

SANGAMO ELECTRIC COMPANY

MARION, ILLINOIS

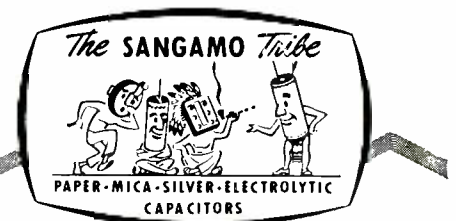

IN CANADA: SANGAMO COMPANY LIMITED, LEASIDE, ONTARIO

JUNE, 1952

SC52-1

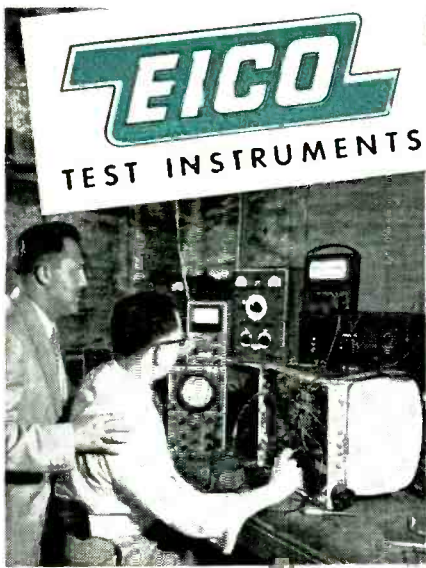

CBS-Columbia Inc.
HIGH STANDARDS OF
TELEVISION PRODUCTION QUALITY

In the CBS-Columbia design laboratories, Al Goldberg takes some important readings with the EICO Model 221 Vacuum Tube Voltmeter and Model 555 Multimeter, as Harry R. Ashley looks on.

Mr. Al Goldberg, Assistant Chief Engineer of CBS-Columbia, and Harry R. Ashley, President of EICO, inspecting the use of the EICO Model 221 Vacuum Tube Voltmeter and Model HVP-1 High Voltage Probe at the Sweep Frequency Troubleshooting Position on the CBS-Columbia Television production lines.

KITS
WIRED INSTRUMENTS

For Laboratory Precision at Lowest Cost—
the Leaders Look to **EICO!**

WHY does CBS-Columbia, Inc., another one of America's leading TV manufacturers, use EICO Test Instruments on both its production lines and in its design laboratories?

BECAUSE — like Emerson, Tele-King, Tele-Tone, Majestic, and many another famous TV manufacturer coast to coast, CBS-Columbia knows that . . .

Only **EICO** Test Equipment delivers
All 10 **EICO** nomical Features!

1. Laboratory Precision
2. Lowest Cost
3. Lifetime Dependability
4. Speedy Operation
5. Rugged Construction
6. Quality Components
7. Latest Engineering
8. Super-Simplified Assembly and Use Instructions
9. Laboratory-Styled Appearance
10. Exclusive EICO Make-Good Guarantee

Before You buy any higher-priced equipment, look at the EICO line — in *Wired and Kit form!* Each EICO product is jam-packed with unbelievable value. Compare, see *EICO instruments today*—in stock at your local jobber—and **SAVE!** Write **NOW** for **FREE** newest Catalog 6-C.

FOLLOW THE LEADERS
... **INSIST ON EICO!**



NEW
221K VTVM KIT \$25.95
WIRED \$49.95



HIGH VOLTAGE
PROBE \$6.95



NEW 425K 5" PUSH-PULL
SCOPE KIT \$44.95. WIRED \$79.95



NEW 555K MULTI-METER
KIT \$24.95. WIRED \$29.95
20,000 ohms/volt



320K S.G.
GEN. KIT \$11.95. WIRED \$29.95

NEW 320K S.G. GEN.
KIT \$23.95. WIRED \$34.95



NEW 37K Sine & Square Wave
AUDIO GEN. KIT \$3.95. WIRED \$49.95

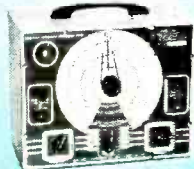

NEW 950K R-C BRIDGE &
R-C COMP. KIT \$19.95
WIRED \$29.95

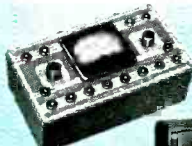

511K VOM
KIT \$14.95
WIRED \$17.95

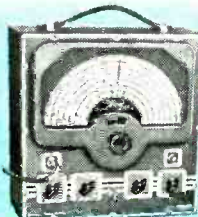

NEW 312K DELUXE SIG.
GEN. KIT \$39.95
WIRED \$59.95



NEW 625K
TUBE TESTER KIT \$34.95
WIRED \$49.95

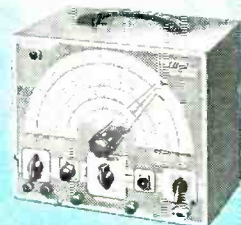

360K SWEEP GEN. KIT \$34.95
WIRED \$49.95



NEW 1040K BATTERY ELIM.
KIT \$25.95. WIRED \$34.95



NEW 536K MULTI-METER
KIT \$12.90
WIRED \$14.90
1000 ohms/volt

NEW 117K RES.
DECADE BOX KIT
\$19.95
WIRED \$24.95



145K SIG.
TRACER KIT
\$19.95
WIRED \$28.95



ELECTRONIC INSTRUMENT CO., Inc.
84 WITHERS STREET, BROOKLYN 11, N. Y.

©1951, Electronic Instrument Co., Inc. Prices 5% higher on West Coast. Due to unstable conditions, prices and specifications are subject to change without notice.

1,945 New Television Stations

... The second U.S. Television boom is now on.

By HUGO GERNSBACH

THE long interdict of new TV station construction was rescinded by the Federal Communications Commission on April 14, 1952. The so-called television "freeze" had run for three and one-half years, during which time only the 108 television stations, now on the air, went into operation.

The future transmitter construction program will eventually put on the air in continental U. S. a total of 2,053 v.h.f. and u.h.f. television stations.

When this program is completed, there will be almost 350 cities with television stations instead of the 65 cities operating transmitters now. Recognizing the great power of television in the educational field, the FCC has assigned 242 channels to non-commercial educational stations, 115 in the present v.h.f. band and 127 in the u.h.f. band.

The FCC wisely inaugurated the television station freeze in 1948 because of the then-prevailing great interference of the low-band v.h.f. channels and to forestall the otherwise inevitable chaos of interference between television stations.

It should be realized that the coming second television boom which the unprecedented number of projected TV stations is bound to bring, will not come overnight. Fortunately for the economy of the country, it will be extended over many years. The reasons for this are simple. To begin with, completely equipped television stations are not built overnight. Moreover, prospective television station owners must first be licensed by the FCC in Washington. This means hearing after hearing to ascertain who is entitled to get such a practically priceless license, and what the prospective owners in turn will do for the public's good. A television station nowadays is a tremendous responsibility, and it cannot be one hundred percent commercial. It must render a valuable service to the public. Hence, long extended hearings are in prospect in Washington.

It should also be noted that the majority of the new stations will not be connected with present networks—and may never be—on account of their geographical location. This means that most of the new stations will have to be independent, using local talent and motion pictures almost exclusively.

It is felt that within about five years, all the 1,945 new stations will be operating full blast, blanketing the entire country with television. This contrasts with the fact that only 60% of the U. S. population has television today. In the future there will be few sizable towns that will not have one or more television outlets.

Fortunately, there is at present no freeze or shortage of television equipment. The manufacturers of television transmitter equipment had foreseen the lifting of the freeze and had made preparations to meet it. The prospective television station operators therefore will have no difficulties in building their stations as fast as they have been licensed by the FCC. According to the *Radio and Television Manufacturers Association*, more than 20 stations in cities not now served by TV will be operating before the end of the year.

What does the second television boom mean to the country's economy? Benjamin Abrams, president of the Emerson Radio and Phonograph Corporation, predicted in the middle of April that the industry's present annual turn-

over of two billion dollars would reach five billion to six billion dollars within three years. All sources agreed that the new boom will be one of the important factors in the national economy, and is certain to last for five years and in our own estimation perhaps longer.

The reason for the last statement is that it is fairly certain that the boom will be extended beyond five years, when color television has come into its own.

Up to the present time, American manufacturers have produced 17,000,000 television sets. Spokesmen for the industry assert that by the time all of the new television stations are operating, there will be over 50,000,000 TV sets in continental U. S.

From the servicing, converting or adapting standpoint of television sets now in use, it is interesting to note that for once American manufacturers had foreseen what was ahead. Many of them had for years designed their sets in such a manner that they could be adapted to the new u.h.f. stations with little additional cost. Tuning strips will be supplied—they are even available now—by many of the television set manufacturers whose sets use turret tuners. Thus the service technician can convert a receiver to receive one or two u.h.f. stations in a matter of fifteen minutes to one-half hour by means of a tuning strip supplied by the manufacturer. The cost in many cases will not be much more than \$10.00 per set. Converters will be available for sets which do not use turret tuners, or where a larger number of u.h.f. stations are to be received.

Set manufacturers also say that the u.h.f. sets will give better pictures in some instances, for the reason that these frequencies are not so sensitive to man-made static caused by home appliances, X-ray, diathermy and other electrical apparatus.

In the past, the radio press has been criticized by some members of the radio servicing industry who felt that radio magazines and the press in general have devoted too much space to television. Inasmuch as a large part of the country from which such complaints originated was not served by television, this criticism was understandable. All such objections have now been removed and radio technicians who have not had a chance to service television receivers before, now have the opportunity of their lives. They should immediately get ready for the coming boom in their sections of the country if they wish to share in the new prosperity.

We have mentioned before, and we now reiterate, that radio technicians in areas soon to be equipped with television must immediately take active steps to become expert in television servicing. The best way to do this is to get a television chassis and go to work on it and familiarize oneself with its intricacies. Nor is it necessary to work on a "dead" set. Even if there is no television station in the neighborhood, many tests can be made with a signal generator, which all service technicians possess. And with a good, high antenna some excellent dx is bound to be received in all parts of the country during the summer season. Nor is it necessary to buy a brand new television set. Many dealers in the larger cities all over the country have second-hand 10-inch chassis for sale at low prices. They are ideal for the purpose.

START YOUR TV HOUSECLEANING NOW

"Now is the time—"

This will be a busy summer for TV. Sell maintenance for slack-time profit



By JOHN B. LEDBETTER

EVERY TV receiver, regardless of age or make, should be given a thorough inspection, tube-check, and cleaning at least once a year. In a year's time, the cumulative effects of heat, tube-aging, vibration, and dirt invariably degrade the picture.

Normally, the most logical time for cleaning and overhauling a set is in summer, when the average owner uses it least. This summer, however, the presidential nominating conventions and the following campaigns will stimulate televiewing to an all-time high.

Start your own campaign, by mail, newspaper advertising, or phone, reminding your customers of what the summer will mean on TV. When you get a receiver, be sure to cover *everything*. Make a brief but thorough inspection of the chassis for corrosion, loose mountings, dust, and wax. Examine the wiring, terminal strips, components, and sockets for evidence of overheating or arcing, poor terminal contacts, and poorly-soldered joints. After this, you can proceed with the cleaning chores.

Cleaning the picture tube

Wear protective goggles when you remove the picture tube. As soon as the tube is exposed, lay a heavy canvas cloth or towel over the top and sides as added protection. This may seem repetitious or over-cautious, but take a look at page 114 in the February issue of *RADIO-ELECTRONICS*. This shows what *can* happen when a kinescope implodes.

Clean the tube face with a soft, lint-free cloth dipped in mild soapy water (or use regular window cleaner). *Do not* wipe the glass with a dry rag—it may scratch the surface and pave the way for a subsequent implosion. Clean the inside of the safety glass in the same way and dry with a soft paper

towel or lint-free tissue. If lint collects on the safety glass, remove it with the furniture-cleaning attachment of a vacuum-cleaner. This is much more effective in removing lint than blowing or attempting to wipe it off with a cloth or brush. Several portable-type vacuum cleaners are now available which will serve this purpose very well.

In restaurants and taverns, nicotine- and grease-laden smoke deposits a yellowish coating on the safety glass and face of the picture tube. Owners of these sets should have them cleaned regularly (at least twice a year, and oftener if required). Check the position of the mask—it should fit snugly around the picture-tube face as dirt and grease will accumulate very quickly. In many cases this can be corrected by sealing the mask to the picture-tube face with masking tape. Sealing the edges of the tuner shield compartment in the same way will keep grease from getting into the head end and seriously affecting reception.

For cleaning rubber ring masks or gaskets, use a piece of soft cotton saturated with carbon tetrachloride. Be careful not to get the liquid on any plastic mask or insulating sleeve.

Cleaning the receiver chassis

A layer of dust on the chassis reduces normal air circulation around the tubes and other components. In addition, it increases the danger of arcing and breakdowns (especially in the high-voltage power supply) by absorbing moisture. The best way to clean the set is with the vacuum-cleaner attachment mentioned above. A blower is *not* recommended because it only blows the dust *into* the set where it may cause trouble on switch contacts and other moving parts. After cleaning, make sure all tubes, tube shields, con-

nectors, and leads are in place and properly seated.

Refinishing wood cabinets

After the picture tube and chassis have been cleaned, start on the cabinet. Usually the finish will show some damage, but with a little effort it can be made to look like new. Here are a few hints on cabinet rejuvenation—*BUT*—if you have never done any cabinet refinishing don't practice on TV receivers! Learn the game on some of those old radio sets the customers didn't call for. Strange and irreversible things can happen when a green man and a rag of furniture stain get together on a good cabinet.

Wax spots, polish marks, cloth burns. For high-gloss finishes use Johnson's new liquid cream wax polish. Rub gently with a soft cloth. For satin finishes, saturate a soft cloth with rottenstone and light machine oil and rub lightly *with* the grain until the marks disappear. Another method is to use a soft cloth saturated with Simoniz cleaner. Rub gently with the grain. *Never use circular motions or rub across the grain.*

Minor scratches. Use regular furniture polish, a polish stick, or analine dye (available at most furniture repair shops). If the scratch has not completely penetrated the finish, take a fine needle and carefully scratch through the surface to the wood. This allows the stain to soak *into the wood* instead of merely filling in the hard top finish. Analine dye should be applied carefully with a small water-color or camel's-hair brush. Apply several times if necessary until the scratched area matches the cabinet finish in color. Wipe the excess from the surface and allow a few minutes for drying before wax or polish is applied.



Deep scratches. If not too deep or conspicuous, try filling in with varnish stain or a polish stick. (One of the furniture touch-up kits now on the market will help here). If the scratch is deep or if it has chipped off any veneer, stripping, or inlay, *leave it alone or turn the job over to an experienced furniture repairman.* Wood fillers seldom produce satisfactory results in these cases.

Liquid marks, cigarette burns, other "party hazards." These usually damage the finish permanently and make it necessary to call in a cabinet refinisher. (Some dealers and distributors maintain their own cabinet repair departments—you might check on this in your own locality.) Small, slightly-damaged areas may respond to one of the wax-spot treatments already described.

Finger-marks. Remove with warm water, mild soap, and a soft cloth. Dry quickly. In some cases blowing on the spot and quickly wiping with a soft, dry cloth will remove them. Do *not* use carbon tetrachloride or similar cleaners on any plastic surface.

Candy marks, food marks, grease spots. Use warm water, a soft cloth (and mild soap if necessary). Do *not* scrub, but rub gently *with* the grain. Dry and polish with soft tissue or a soft, lint-free cloth, and finish with furniture polish or cabinet wax.

Pencil marks, crayon marks. Remove with Simoniz cleaner and polish with a soft cloth. Carbon tetrachloride, benzine, gasoline, or other available cleaning agents can be used on *wood* cabinets if removed immediately and the surface polished with a good wax or furniture polish. An art gum eraser is effective on pencil marks if they have not dented or punctured the finish.

Fingernail polish. If damage is not too serious, try softening with nail-polish

remover. (Extreme care is required to prevent further damage to the finish.) Remove with Simoniz cleaner and polish to the desired luster. If the finish is damaged, try one of the wax-spot methods to smooth out the surface. If the damage is extensive or too noticeable, turn the cabinet over to a professional refinisher.

Refinishing plastic cabinets

To clean: Use mild soap and a soft cloth dampened with warm water. Do *not* use carbon tetrachloride or any kind of cleaning powder which contains fine abrasives or chemicals. These will ruin the finish and roughen or even dissolve the plastic.

To polish: Use Simoniz Kleener, Johnson's Carnu, Wright's Silver Cream, or equivalent. Apply with a soft, lint-free cotton cloth or tuft of absorbent cotton.

Soft drinks, liquids. These will roughen or pit plastic surfaces. To restore the finish, try rubbing with No. 0000 steel wool, moistened with light sewing-machine oil. (Do *not* use this method on lacquered or enameled surfaces.) Polish with Johnson's new liquid cream wax or a similar high-luster wax.

Aerosol bombs, DDT, similar liquids. Direct application may attack the surface of plastic cabinets and plastic safety masks. If the mask is fogged or roughened, it must be replaced. If the damaged area is small, try rubbing it *gently* with Bon Ami or similar cleaner and then buff with jewelers' rouge. Apply these with a soft, damp cloth. Apply pressure with the tips of the fingers. If this smoothes the area, finish by polishing with Glasswax.

Scratches on plastic cabinets. Extreme care is required in removing these scratches. The following method will be satisfactory in many cases:

a. Use No. 400 sandpaper; apply with a

generous amount of water. Use free, easy, circular motions in applying. Finish with very light strokes.

- b. When the area has been sanded, clean thoroughly with wet cotton, then dry with a clean tuft of cotton.
- c. Apply polish generously and rub vigorously with rapid circular motions. Several minutes may be required to give a good luster.
- d. Remove the polish with a damp piece of cotton and dry with another piece. Go over the entire area if necessary with another piece of dry cotton.

Materials for touch-up work

You can do these jobs faster and more efficiently if you have the following items arranged in a portable case.

1. Hand-type vacuum cleaner with furniture-cleaning attachment.
2. Assortment of small camel's-hair brushes
3. Small bottle of carbon tetrachloride.
4. Several clean, lint-free cloths.
5. Touch-up kit for cabinet work.
6. Small-size Johnson's new liquid cream wax.
7. Small amount of rottenstone.
8. Small can of 3-in-1 machine oil.
9. Small jar of Simoniz Kleener.
10. Small bottle of furniture polish.
11. Polish stick.
12. Small vials of aniline dye (mahogany, walnut, etc.).
13. Small bottles of walnut and mahogany varnish stain.
14. Razor blades (single-edge for safety).
15. Several small pins or needles.
16. Small can of benzine.
17. Small bottle of nail-polish remover or solvent.
18. One-half bar of mild (vegetable) soap.
19. Small jar of Wright's Silver Cream.
20. Small roll of absorbent cotton.
21. No. 0000 steel wool. Wrap to prevent mixing with other items.
22. Several sheets of fine sandpaper (No. 400).
23. Small can of Bon Ami.
24. Small jar of jewelers' rouge.
25. Small bottle of Glasswax.
26. Small bottle of window cleaner.

Assembling all these items and fitting them into a small bag may represent quite a job. It is entirely practicable, however, and will save you many steps as well as providing you with materials *when you need them!*

—end—

hard-to-locate TV TROUBLES

There's a solution to every TV service problem —often of the "Why didn't I think of that before?" variety. Here are a few that had an expert guessing.

By WALLACE WANER

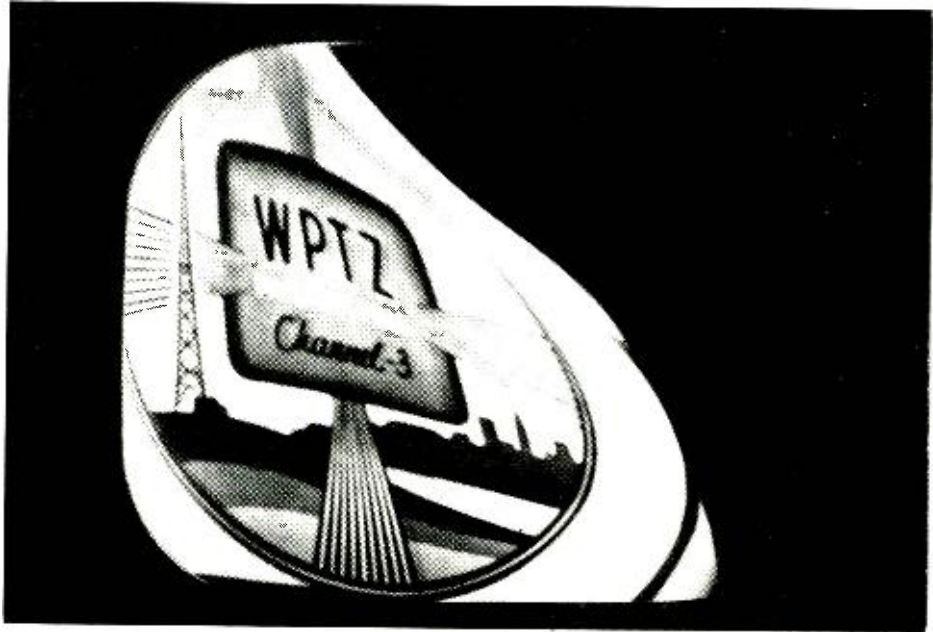

Picture distortion caused by proximity of speaker magnetic field.

WHEN the experienced television technician runs across a "toughie" in his daily servicing, he usually sets it aside until he has gone through the receivers that have lesser troubles. Then his procedures usually include signal tracing, voltage and resistance checks, and other tests until the fault is finally located.

On occasion, however, he runs into a real sticker which taxes not only his ingenuity but his patience. Ordinary checks often fail to localize the defect and the problem child defies time-tested and usually reliable methods of diagnosis. Eventually, after endless chain-smoking and head scratching, he stumbles on some simple little item that takes only a few minutes to correct. Admirably refraining from throwing his v.t.v.m. through the picture tube, he sits down and wonders how he can avoid this time-consuming and nerve-racking experience in the future.

Unfortunately, however, he rarely comes up with any pat solution. Next time he may get an entirely different set of symptoms and find the same part responsible as in the previous case. The only thing he really learns is to be suspicious of *every symptom* in such instances and to exhaust every possible cause and effect. Swallowing his pride

and consulting other experienced men also helps. After all, if doctors need an occasional consultation, the television technician should not feel any hesitation in doing likewise. Maybe the other fellow doesn't have the answer either, but he probably can add to your "could it be this or that" routine, and between the two of you the trouble can often be found in much shorter order.

Just to nudge you into adopting such an open-minded attitude, let's run over a few of the tougher problems which had to be solved recently by one eastern service shop. Perhaps you will be smarter than we were, and put your finger on the sore spot right away. To us, however, these and many prior toughies no doubt contributed to the distinguished gray which now graces our temples. While this may capture the adoring glances of the female of the species, we'd rather dispense with the charm and knock these television headaches out in quicker time.

Check the line voltage!

One problem which defied routine checks was a Hallcrafters T-54 7-inch receiver which had developed severe vertical and horizontal sync instability. The condition seemed to be intermittent and on occasion the receiver would be perfectly stable. The set was re-

moved to the shop and thoroughly checked. All tubes, parts, and voltages were found to be normal. The set was run for two days yet developed no horizontal sync instability. It was returned to the customer and immediately the sync instability returned.

At first it was suspected that the line voltage was below normal, but inasmuch as the customer had a 17-inch receiver in the same home which was working perfectly, no a.c. voltage check had been made. This oversight was, of course, our first mistake. Upon checking the line voltage in the evening it was found to be less than 100. After additional thought the solution became apparent. The Hallcrafters, like many other receivers, uses a low-voltage tripling system to develop the proper plate potentials for the vertical and horizontal sweep oscillators. (See Fig. 1.) A voltage tripling system suffers more severely than a conventional power supply during line voltage fluctuations. Thus, if the line voltage is 115 volts, an unloaded voltage tripler develops over 460 volts because the capacitors charge to the peaks of the rectified a.c. signal. Under load, however, the voltage may drop to about 30%. If the line voltage decreases to 90 (a 25-volt difference) the final voltage in the tripling process may reach only

200, a 100-volt difference. This was the cause of the instability. A line regulator transformer solved this problem.

A tube teaser

Another case of unstable horizontal sync occurred in an Emerson receiver using Synchroguide horizontal lock. The vertical was relatively unaffected, though the hold control seemed critical. Again, all parts, tubes, and voltages were normal. The step-by-step alignment procedures for the Synchroguide were undertaken with an oscilloscope but this was no help. The sync separa-

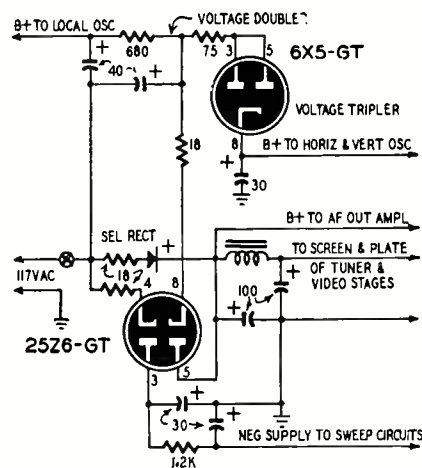

Fig. 1—Voltage tripling system used in Hallicrafters TV models T-54 and T-55.

tor and amplifier tubes and their associated resistors, capacitors, and voltages were checked. Again, nothing seemed amiss. Finally, even though the tubes checked well in an emission-type tube tester, the tubes in the sync-separator and amplifier circuits were replaced. This cured the trouble. It was found that the sync amplifier tube had varying characteristics which caused intermittent output amplitude.

The Synchroguide responds to the area of the signal at the grid of the control tube. For this reason, manufacturers strive to present a constant amplitude sync level to the Synchroguide circuit. This solution also helped the vertical system, although this does not rely as much on sync amplitude as on the repetition rate of the incoming pulses.

Laying a ghost

Another job which consumed considerable time before a solution was found was an Admiral 20A1 with intermittent ghost reception. Pictures were often ghost-free, but at other times pronounced ghosts were present. As there were no high buildings or water towers in the neighborhood, our first thought was that the characteristics of the tuner or video i.f. stages were changing and causing an unsymmetrical bandpass. If the bandpass of the

video i.f. stages is such that it is humped at the high-frequency sidebands of the television carrier, it will often pulse video-amplifier stages into momentary transient oscillation at the higher modulating frequencies. This can simulate ghost reception.

A check at the shop showed the i.f. response to be correct and the set operated normally. When the set was returned, the intermittent ghost reception appeared again. Upon further checking it was found that the reflections were coming from another receiving antenna off the path of the stations in the area.

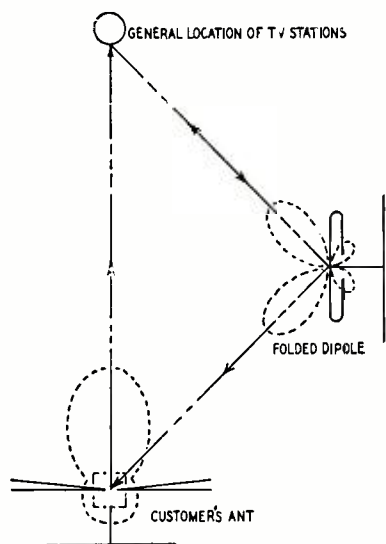

Fig. 2—Ghost signals were caused by re-radiation from a distant rotary antenna.

This is shown in Fig. 2.

The offending antenna was motor-driven. When rotated, it would, in certain positions, reflect sufficient signal to cause ghost reception. Additional checks indicated that this condition is much more pronounced when the two antennas have the same physical length. This condition is also aggravated by antennas having two primary lobes, such as a folded-dipole with reflector working on the higher channels.

There was nothing that could be done except to ask the owner of the offending antenna to keep it stationary or to erect a screen between the customer's antenna and the remote antenna. It was found that a small section of chicken-wire screening, erected eight feet away from the antenna, and grounded to the roof, was sufficient to suppress the undesired reflections.

The perfect alibi

Manufacturers are sometimes at fault. They will bring out a new model and publish complete service notes for it. Often, however, field tests and reports from dealers indicate that certain circuit changes should be made. Future runs of this model are modified, and supplementary service notes covering the changes are issued. Thus, unless such design changes and corrections are made by the servicing technician,

a characteristic trouble may never be entirely corrected. The technician should always check to see if supplements have been issued.

Possible faults or omissions in the original assembly should not be overlooked. In one instance, a pronounced buzz was traced to the speaker. It was found that the leads running to the speaker terminals were mechanically fastened but not soldered.

Another instance which proved particularly troublesome occurred recently in a receiver of a well-known make. The picture and raster were intermittent but the sound was all right. Checks were made at the grid of the picture tube and the associated controls. All voltages were normal and remained stable for hours of operation. Even the picture tube socket was inspected and found to be all right. A new picture tube was about to be installed when one of the technicians applied pressure to the base of the original tube and found that it was loose. A closer inspection revealed that some of the socket pins were not cleanly soldered. As the base cement was not holding to the glass neck, the pin leads were unsoldered and the base removed. Two of the wires were found badly tarnished and had been cold-soldered during the tube assembly.

Each lead was cleaned and tinned and the base reconnected and re cemented. This cured the trouble.

Divide and conquer

Some cases are recurrent and eventually are recognized for that reason. Earlier, we had a habit of replacing only one of a pair of parallel 5U4 rectifiers if one of the tubes went bad. This often resulted in the new tube carrying most of the load. Manufacturers use paralleled low-voltage rectifiers for the prime purpose of distributing the load evenly between the two tubes. When one is replaced, it will have greater emission than the old one and the current will be unevenly divided. The new tube will have a much shorter life than if both tubes were replaced. This is also good practice in high-voltage systems where two 1B3 or 1X2 tubes are used in voltage-doubling circuits.

Mistakes are costly in terms of wasted time. One of our men had placed a chassis on its side to replace a low-voltage filter capacitor. When finished he checked the receiver without putting it right side up, and got the picture shown in the photo on the opposite page. After an hour of frantic (and useless) linearity and centering-control adjustment he found the trouble. The speaker was wedged under the glass picture tube and its magnetic field was distorting the beam. Fortunately the tube was not metal, or we would have had a demagnetizing job to perform. Which just goes to show, you never know what you'll run up against next in this TV business. Never a dull moment, though.

—end—

A discussion of new features in the circuits of modern television sets and 3-way portables

short circuits

By ROBERT F. SCOTT

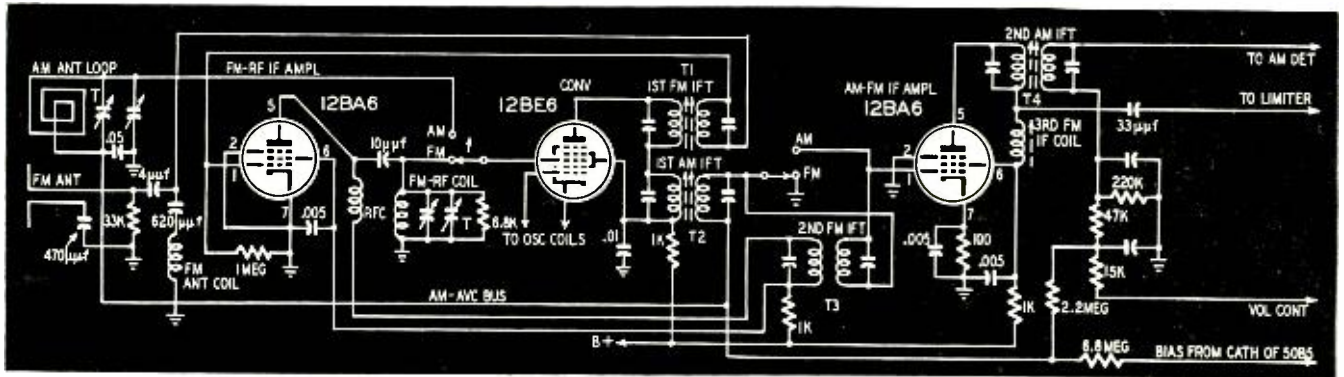

Fig. 1—A partial schematic showing the operation of the reflexed r.f.-i.f. amplifier used in the G-E model 218 receiver.

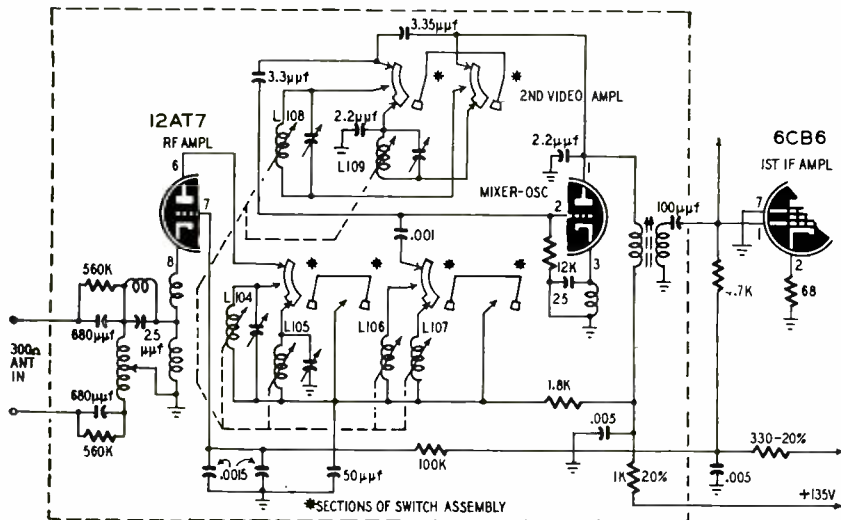
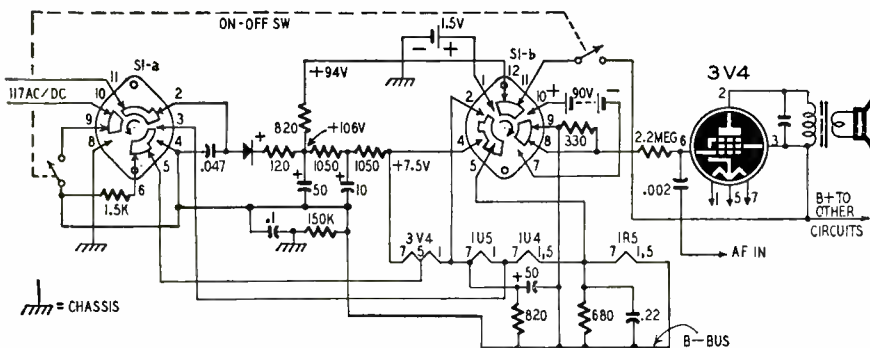

Fig. 2 (above)—Diagram of the 1-tube TV tuner used in some Tele-Tone chassis. Fig. 3 (below)—Diagram of the filament switching circuit in the Philco 51-629.



SOMETIMES we feel that a title like "The Unexpected" or "Surprise!" would be far more descriptive than the one which we have chosen for this column. The drawing-board wizards and assembly-line Houdinis are certainly coming up with some shockers. We have been keeping an eye on foreign receiver circuits for a few years and are not too surprised when we see an r.f. or i.f. amplifier also used as an audio amplifier. But when we find a set in which the r.f. amplifier serves as a reflex i.f. amplifier, as in the G-E 218 6-tube AM-FM receiver, it's time to swear off and reach for an aspirin. The reflex circuit of this set is shown in Fig. 1.

On FM operation, the 12BA6 acts as both r.f. and i.f. amplifier. The signal from the antenna is developed across the antenna coil and fed through the secondary of the first FM i.f. transformer T1 to the grid of the 12BA6 amplifier. The r.f. signal is amplified and fed through a 10- μ f coupling capacitor to the grid of the 12BE6 (The r.f. choke has sufficient reactance to prevent the FM r.f. signal from straying into the primary of the second FM i.f. transformer.) The r.f. signal is reduced to 10.7 mc and appears in the primary of the first FM i.f. transformer. The signal in the secondary is fed back to the grid of the first 12BA6 now operating as first FM i.f. amplifier.

From the plate of the 12BA6, the signal passes through the r.f. choke to the primary of T3, the second FM i.f. transformer. The signal then passes from the secondary of T3 to the grid

of the second 12BA6 which is used as the first AM and second FM i.f. amplifier. The amplified 10.7-mc signal next appears across the third FM i.f. coil where it is coupled into the grid of a 12AU6 limiter (not shown) through a 33- μ f capacitor.

On AM, the circuit is more conventional. The signal is fed from the AM loop antenna directly to the grid of the 12BE6 converter. The 455-kc AM i.f. signal passes through T2 to the 12BA6 i.f. amplifier, then through T4 to the AM detector and a.v.c. diode of the 19T8. The a.f. signal follows the same path as it does during FM operation.

closed one side of the power line connects to B minus through the on-off switch and contacts 9 and 10 of S1-a. The other section of the line connects through contacts 2 and 11 to the selenium rectifier which supplies A and B voltages. Contacts 5 and 6 connect a shunting resistor between the center-tap of the 3V4 and ground. Pin 1 of the 3V4 is 4.5 volts positive with respect to the grid. This voltage provides fixed bias for the 3V4 during line operation.

Approximately 94 volts from the B supply is fed to the plates and screens through contacts 11 and 12 of S1-b. Part of the output of the selenium rec-

TV DX IN JUNE

If you've had the idea up to now that TV dx is something that happens to somebody else, June is your month. Sporadic-E dx occurs somewhere in the United States practically every day.

June, 1951, reports received by RADIO-ELECTRONICS showed 26 days of dx, and there is every reason to expect that 1952 will be at least as good; perhaps better, as there is some evidence to indicate that sporadic-E dx is more prevalent in years of low sunspot number.

Dx reception will be frequent in the mid-morning hours, dropping out usually around the middle of the afternoon, and often returning in the early evening. The best dx will usually be over by 10 to 11 p.m., local time, but as the month wears on, late-evening reception will become more common. In fact, there will be times in the latter part of June when dx will be receivable during just about any hour that there are stations on the air in the right places.

The most frequently logged distances will be 600 to 1,100 miles, but intense ionization will bring the skip distance down to as little as 300 to 400 miles at times. Ionization over wide areas simultaneously will make multiple-hop effects possible, and the distance you can cover will be limited only by the number of stations on a given channel. Eastern viewers who don't mind staying up until their nearer stations have left the air should be able to log some West Coast stations, though the multiple-hop reception will not generally be as good as the single hop. Reports of reception in excess of 1,500 miles, particularly, are solicited.

Though the main item of interest to the TV dx enthusiast will be the sporadic-E skip sessions, we should not overlook the possibilities of tropospheric dx, particularly on the high channels. Along both our coasts, all across the southern part of the country, and in the region around the Great Lakes, June will provide the kind of weather that makes for considerable extension of the normal reception range. Look for excellent high-band reception in the early morning hours, particularly on fair calm days. Late evening hours will also provide good hunting on the high channels. (The normal range will be extended on the low bands, too, but tropospheric reflected signals may often be obscured by sporadic-E dx on channels 2 through 6.)

While all this early-summer dx will be fun for the viewer who is interested in long-range propagation, it will be a source of trouble for TV technicians. A high percentage of TV set owners are interested only in entertainment. Few of them will know what causes the pile-up of signals that is almost certain to occur when stations a thousand miles away start rolling in with almost local signal strength.

—end—

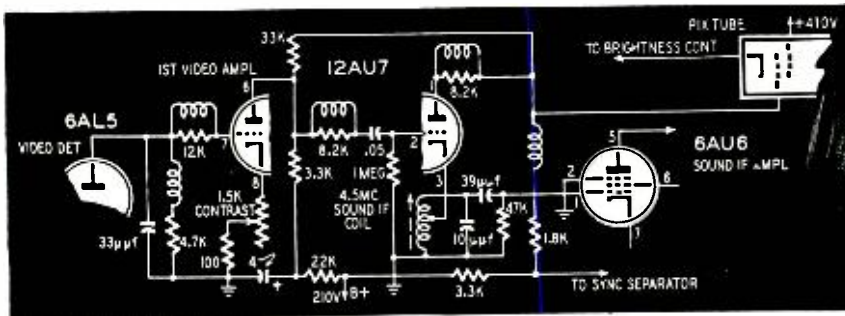

Fig. 4—Interesting sound take-off employed in a number of Majestic models.

One-tube TV tuner

Have you ever seen a one-tube TV tuner? If you haven't, take a close look at the next Tele-Tone TV set that comes in. If it uses a TAM or TAP chassis, you are likely to see one lone 12AT7 on the tuner chassis. This tube performs the functions of r.f. amplifier, mixer, and oscillator. The TV band is covered in two ranges, channels 2 through 6 on one, and 7 through 13 on the other.

One triode of the 12AT7 is a grounded-grid r.f. amplifier—a circuit which minimizes oscillator radiation through the tube into the antenna while generating comparatively little noise. See Fig. 2. The remaining triode is the oscillator and mixer. The various channels are selected by a combination of variable-inductance and variable-capacitance tuning. The r.f. amplifier plate coils L104 and L105, mixer coils L106 and L107, and oscillator coils L108 and L109 are stamped into bakelite sheets sandwiched between movable brass plates which act as the rotor plates of a capacitor. The oscillator is a modification of the familiar ultradion. The sound i.f. is 21.25 and the picture i.f. is 25.75 mc.

Three-way filament operation

The filament switching circuits of many 3-way portables are complex and are likely to cause trouble for the service technician who is not too familiar with them. Therefore, we will discuss the switching circuits of a typical 3-way portable.

Fig. 3 is the circuit used in Philco's 51-629. The voltage-selector switch S1-a and S1-b is shown in the LINE position. When the on-off switch is

tifier is dropped to 7.5 volts for the filaments. The 820- and 680-ohm resistors carry the cathode currents of tubes between the dropping resistor and B minus. Contacts 8 and 9 of S1-b ground the grid return of the 3V4.

For battery operation, sections 8 and 9 of S1-a connect the B minus bus to the chassis through the on-off switch. Sections 4 and 5 connect the 3V4 center tap to B minus. One of the filament pins of the 1U4 and 1U5 is connected to B minus through sections 3 and 4 of S1-a. The ungrounded filament pin of each tube in the string is connected to the positive side of the 1.5-volt filament battery through contacts 1, 2, 4, and 5 of S1-b. The negative side of the filament battery connects to the chassis so the line switch must be on and S1 set for battery operation before current can be drawn from it.

Sections 10 and 11 of S1-b connect the positive side of the 90-volt B battery to the B plus line in the set. Sections 7 and 8 connect the negative side of the battery to the junction of the 330-ohm and 2.2-megohm resistors so the smaller resistance is between B minus and ground. This resistor biases the 3V4 during battery operation.

Novel sound take-off

In most intercarrier TV sets, the sound is taken off either at the output of the video detector or the plate circuit of a video amplifier. The novel arrangement shown in Fig. 4 is used in the Majestic 700, 712, and 801. These sets have a 2-stage video amplifier using a 12AU7. The sound take-off is in the second video amplifier stage which has its cathode grounded through a tap on the 4.5-mc sound i.f. coil.

—end—

TV SERVICE CLINIC

Conducted By
MATTHEW MANDL*

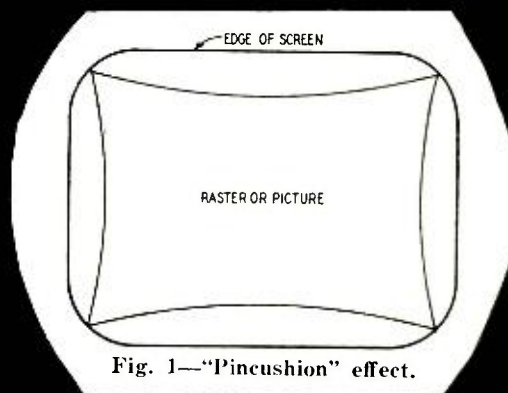

Fig. 1—"Pincushion" effect.

MANY of the new receivers use the curved-face (or so-called "cylindrical") rectangular tubes designed to eliminate room glare. These include the 17LP4, 17QP4, 21EP4A, 21FP4A, and 21KP4A. When a cosine-wound yoke is used with these tubes for sharp edge-to-edge focus, pincushion effects are set up.

To eliminate them, two magnet slugs are placed above and below the tube at the beginning of the flare. These magnets extend slightly beyond the frame of the yoke housing and are suspended by an adjustable wire support.

When replacing defective picture tubes of this type, the magnets may have to be readjusted, particularly if they are accidentally moved from their original position.

Unless a station pattern is on, or a cross-bar generator used, the pincushion effect may not be too noticeable. But when viewing televised scenes with vertical or horizontal sections, the viewer would notice the bending effect and distortion. Adjustments are simplified if the picture size is reduced slightly so the pincushion effect is noticeable as shown in Fig. 1. The magnets should then be adjusted until the picture is perfectly rectangular, after which the size can be increased to fill the mask properly.

This adjustment will not correct poor sweep linearity or overdrive conditions. Such defects must still be overcome with the usual controls.

Another factor important in servicing such television receivers: Adjustments of the centering ring may disturb the edge-to-edge focus procured from the cosine yoke. Thus, after positioning the picture with the centering ring adjustment, check the edge-to-edge focus by closely observing whether the horizontal line trace is sharp along its entire length.

If this is difficult to see, misadjust the vertical hold control slightly until the picture rolls slowly. This will eliminate interlace and cause line-to-line pairing. Under this condition the line structure is heavier and edge-to-edge

focus is easier to check. Readjust the focus control and recheck picture centering, for the focus control has a slight effect on picture position. Finally, readjust the focus control until full beam clarity is regained.

Also check the ion trap magnet. Too weak a magnet will make it difficult to eliminate corner shadows at the setting which gives maximum brightness. Incorrect ion trap magnet position will cause ion burns eventually—the length of time depending on how far off true position it is. (See the article on that subject in the February, 1952, issue.) If the magnet is weak it may have to be placed closer to the focus unit. The fields of the latter will influence the ion trap and make it difficult to adjust either one correctly. A new ion trap magnet is relatively inexpensive and can save costly picture tubes as well as permit you to make proper adjustments for better performance.

Intermittent interference

In a location across the street from a high-voltage substation there is an intermittent roaring noise from the speaker, accompanied by sync loss. Could this noise and interference originate in the substation? J. P. F., Roan's Prairie, Texas.

It is quite possible that an intermittent high-voltage arc at the substation could cause the symptoms you describe. When this condition again occurs, remove the antenna lead-in from the receiver to see if the interference decreases. If the noise is still present, the a.c. mains are feeding it into the receiver. A line filter would then help.

This test, however, could also indicate that the trouble might be a loose or intermittent connection within the receiver itself. This can be verified by trying another receiver in the same house.

If the interference is from a radiated source the solution is more difficult. You will have to get the power company to check their equipment to eliminate the arcing condition, for at such a close distance little can be done in the way of antenna line filtering.

High-voltage rectifier troubles

In a Sylvania model 7120BF receiver I've had to replace the 5642 high-voltage rectifiers repeatedly. Some picture blooming now occurs. R. L. B., Canton, N. Y.

The high voltage circuit of this receiver uses the voltage-doubling principle with two 5642 rectifiers. Try a 3.3-ohm resistor in series with the filament wire to the tube which burns out more frequently. You could also rewire the circuit to accommodate the more rugged 1B3.

Replacement tuners

Would fringe area reception be improved by the installation of one of the new type front ends using the cascode circuits? Would the receiver or tuner require alignment after installation? C. E. C., Lynchburg, Va.

The new front ends containing the cascode tuner have exceptional characteristics for fringe areas. They have considerably more gain and much less snow effect than the older tuners. Most of these replacement tuners are accurately tracked at the factory, so extensive realignment procedures would not be needed. Usually all that is required is a slight retouching of the output picture and sound coils. Complete installation information is usually furnished with the new replacement tuners. Make sure you get one to match your present i.f.

Booster oscillation

I have three boosters hooked up to an RCA 630TS. All the boosters are of different makes but all use 6AK5's. I have trouble keeping them from oscillating between each other. Would you tell me how to keep them from oscillating? R. D., Washington, D. C.

Your boosters oscillate because of overloading the inputs to the second and third booster. Virtually all boosters are designed for the specific purpose of building up a very weak signal. When you inject the output of one booster into another, the second booster (and third) receive signals far in ex-

* Author: Mandl's Television Servicing.

cess of those for which they were designed. This trouble often occurs when two boosters are placed in series and would be even more likely with your combination of three.

You could install gain controls in the first two boosters so the output of each one does not overload the next one. These could be potentiometers in the cathode circuits. They would regulate the bias, and thus the gain. The potentiometers should have slightly more resistance than the existing cathode resistors. With sharp-cutoff tubes the control would not be as effective as with remote-cutoff types.

Tuner trouble

I have installed a new Standard tuner in an RCA 8-T-243. The tuner works all right except for channel 5. For this station there is a difference of about 3 or 4 turns of the oscillator screw between the sound and picture. How can I correct this trouble? B. D., Knowlton, Quebec, Canada.

As there is an appreciably greater difference in the trimmer adjustments of the oscillator screw on channel 5 than on other channels, it may indicate improperly adjusted coils. Since the coils are of the snap-in type, you can remove the two and increase the coupling between the coil sections. This will increase the band-width and might give you both picture and sound for one setting of the oscillator trimmer adjustment.

This receiver is of the split-sound type and will always receive best picture and best sound at slightly different settings. The receiver should be adjusted for best sound for both the os-

illator set-screw and the fine-tuning control.

If coil correction cannot cure the trouble, you can get coil replacements for channel 5.

Interference traps

What can be done to reduce diathermy interference? I have tried homemade traps, but these had little effect except to reduce signal strength. E. M., Ottawa, Ontario, Canada.

Probably your homemade traps were tuned within the television band and therefore diminished the desired signals instead of the interference. Try commercial traps; these are calibrated at the factory and are more effective. They are made by several companies, including Drake, JFD, and Telematic. The JFD BR 106-10-30 is for short-wave and diathermy from 30 to 60 megacycles. The BR 106-60-90 is for diathermy or other interference from 60 to 90 megacycles, as is also the Telematic WT-16. The Drake model is the TV-300-50HP. A number of manufacturers will now supply traps gratis for any of their models subject to such interference.

Stacking Yagi antennas

We are located in an extreme fringe area and receive channels 3 and 6 from Omaha and channel 4 from Kansas City. The five-element tuned Yagi antennas have proved satisfactory, but I would like to stack this type. What is the best spacing? W. H. K., Mankato, Kansas.

For best reception with the Yagi antennas you should stack them one-half wave-length apart. In this manner you will get true broadside reception with a gain increase of approximately 4 db. Often, broadband antennas are stacked less than this to favor the higher channels, but, since you are using a single channel Yagi, a half-wavelength spacing is recommended. Use parallel bars to interconnect the two and feed them in the center. See Fig. 2. The impedance of the matching section should be 425 ohms. This may be $\frac{1}{4}$ -inch tubing spaced $4\frac{1}{2}$ inches or No. 12 wire spaced $1\frac{1}{2}$ inches. You'll get additional gain if you use the double-stacked Yagis for one channel because stacking gives the 4-db gain mentioned above.

Antenna choice

In this area all channels (2 through 13) are broadcast from Mount Wilson, about 90 miles away. Evidently a Yagi would not be suitable because it is not broadband. What suggestions do you have for an antenna system? J. J. D., Edwards, Calif.

If all your channels are broadcast from Mount Wilson, 90 miles from your receiver, you could use a stacked biconical antenna array with reflectors. If it is mounted high enough you should get good results. Use an open-wire transmission line for minimum lead-in loss. Use the biconical with three rods each side of the insulator, for this helps

broadband reception and increases impedance. A Yagi would give some 5 db greater gain but—as you stated—would be narrowband. Some Yagis are available for two-channel operation but are not much use beyond that. Several Yagis, of course, could be used with separate lead-ins and a switch arrangement for antenna selection. If more gain is desired, use a booster.

TV conversion for Europe

I am planning to send a television set to my brother in Sweden. He is located 12 miles from a TV station which is transmitting on a frequency similar to channel 3 here. They use FM for the sound and AM for video but they are using a system of 625 lines and 25 frames.

The set I expect to send is an RCA Victor, model 17T172.

I am wondering how many changes would be necessary to make this set work over there. G. A., North Wildwood, N. J.

You mention that the receiver is to be used in an area where a system of 625 lines and 25 frames is used. This would give a horizontal sweep frequency of 15,625 in contrast to the 15,750 in use in the United States. This would be close enough so that no changes need be made in the horizontal sweep circuit. Possibly, slight readjustment of the hold control or the frequency control in the Synchroguide system may assure better stability.

The vertical sweep of the RCA is designed for 60 cycles, using the interlace principle. Our standards of transmission utilize 30 frames per second, interlaced 2:1, which results in 60 fields per second. We are using 525 lines per frame (525 times 30 equals 15,750). If this receiver is to be used with interlaced scanning at a 50-cycle rate, no vertical changes would be necessary either.

You should ascertain whether the power supply requirements in Sweden can be satisfied. Many parts of that country use 25 cycles. Is this receiver to be used in an area where 110-117 volts, 50 cycles is available?

Another factor would be the r.f. tuner. You mention that transmission is from a station on a frequency "similar to" channel 3. Possibly, slight oscillator slug adjustments would have to be made if there is a slight frequency difference. Other factors are bandwidth and type of transmission. The RCA is designed for a bandwidth of transmission in the tuner of 6 mc. U. S. TV standards call for vestigial sideband transmission and spacing of 4.5 mc between video and sound carriers, with the sound carrier 4.5 mc above the video.

Note: Letters addressed to this Clinic are answered directly and those of general interest are published. When writing to this department enclose a stamped, self-addressed envelope and give model number of receiver, name of manufacturer, and chassis number. Include such information as antenna type, channel numbers of stations which can be received in your area, and what preliminary checks you have undertaken prior to writing us. Explain in detail exactly what the trouble symptoms are.

—end—

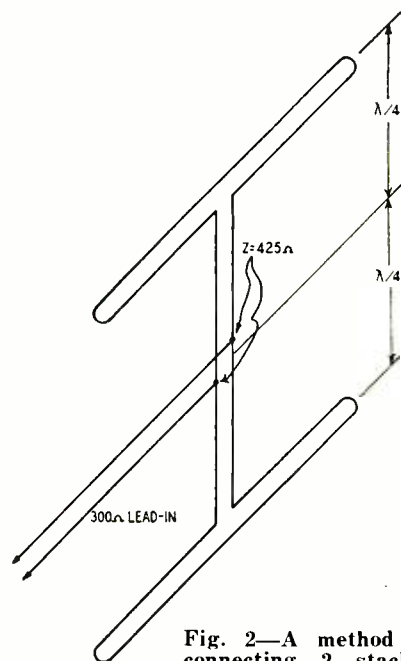

Fig. 2—A method of connecting 2 stacked antennas to a common transmission line. Although folded dipoles are shown, the method and impedance values shown in the drawing apply equally to vertically-stacked Yagi antenna arrays. Matching section is described in the text.

though folded dipoles are shown, the method and impedance values shown in the drawing apply equally to vertically-stacked Yagi antenna arrays. Matching section is described in the text.

BEWARE THAT INSTALLATION

Every chimney and party wall carries an invisible sign—"NO TRESPASSING!" Here is some advice that may help you avoid costly liability.

By H. L. MATSINGER

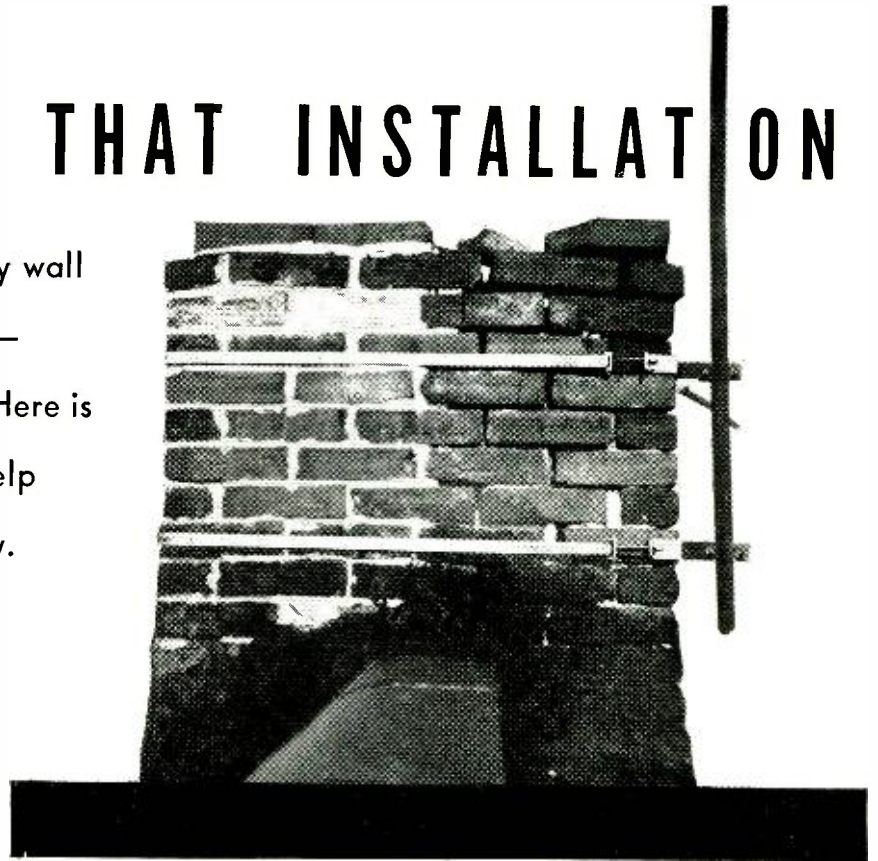

Two costly mistakes for the installer: The antenna mounting straps cross the property line (marked by the parapet); the brickwork tells its own story.

SUPPOSE that one morning while you are tangling with the innards of a recalcitrant receiver a customer dashes into your shop and excitedly announces that he is being sued because of an antenna installation that you made. Would you consider his remark preposterous and impossible? If you would, read on, brother!

On November 9, 1951, the Philadelphia *Evening Bulletin* carried the headlines: "Neighbor Sues Over TV Antenna; Court Suit Says That Mast Is On Wrong Roof." The article goes on to state that Robert and Maria Egizi of 913 South Delhi filed an injunction suit in Common Pleas Court against Alex and Ida Giordano, who live at 911 South Delhi, charging them with maintaining the antenna despite repeated requests to remove same, including a written request made on June 29, 1951. The suit asks relief from a number of retaliatory measures taken by the Giordanos, asks for removal of the antenna, and for \$1,500 as punitive damages, holding that the presence of the antenna is a "continual trespass."

Unfortunately, this is not an isolated case, although few ever are brought to court. Normally, the aggrieved neighbor just goes to work on the moorings with a hacksaw or tinsnips. Dual chimneys, of the type commonly found in row-house construction, belong only in part to any individual owner. It is apparent, therefore, that when you use chimney straps to support a TV antenna on such a chimney, you are trespassing on the other man's

property. This is true, not only of the straps but of any part of the antenna structure which may extend over the property line. The abutting owner, at his discretion, may insist upon the removal of all parts so offending, or trim them back to the property line.

If, in the process of trimming back the chimney straps, the antenna mast happens to fall down (and it likely will), your customer has no redress unless the straps have been trimmed too far. If you have failed to get a signed easement from the adjoining owner you have no recourse but to erect a new mast for your customer, since you were negligent in the original installation.

Aside from the legal aspects of chimney mounts, certain mechanical considerations are also involved. Brick chimneys, being a layer type of masonry, do not offer very high resistance to a bending moment or torsional type of strain. This means that when straps are used, the continual swaying of the antenna and mast will loosen and eventually ruin any such chimney. Even the practice of inserting lead plugs in a top and bottom brick of the chimney is bad, for the strain is concentrated on these two bricks, and in a very short time the mast is likely to be leaning at a precarious angle.

Then, too, when the antenna and lead-in are mounted over the flue, hot corrosive gases play over the elements and connections, while soot deposits create a low-resistance short circuit. Naturally, this will reduce the efficiency,

To be on the safe side, it is always best to mount the antenna in the center of the roof if possible. Mount the mast on a plank or block of wood to prevent piercing the roofing, and use a floor flange or a base collar to keep the end of the mast from kicking out. Add a mast ring, and at least four guy wires, with turnbuckles to permit adjustment, and anchor the ends with adequate screw-eyes. If you do this you can feel reasonably certain that you will have no nasty come-backs. It is highly improbable that this type of mounting will blow down, even in an extremely heavy wind, but if it does the antenna will remain solely on the property of your client.

(In many localities, building department and fire department regulations may require installation of an antenna in such a manner that its movement or collapse will not endanger, damage, or obstruct access to adjoining property. Deeds and leases on semi-detached or row-type structures often contain restrictive clauses of the same character. Even if the antenna structure is to be entirely on your customer's building, and there is no normal trespass on adjacent property, you should check the possibility of existing restrictions for your own protection. Remember that the liability is yours, and that lawsuits are expensive even if you win them.—*Editor*)

The photograph accompanying this article serves to accentuate the main points made, and to act as a signpost for your guidance. —end—

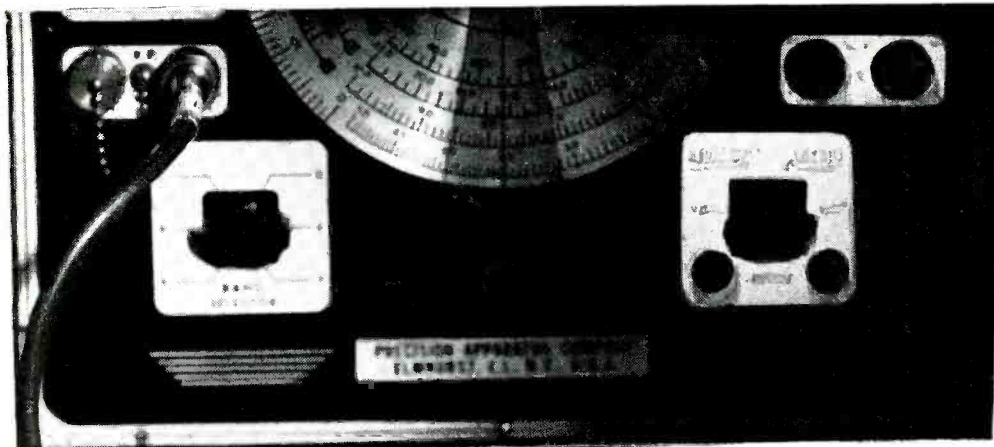
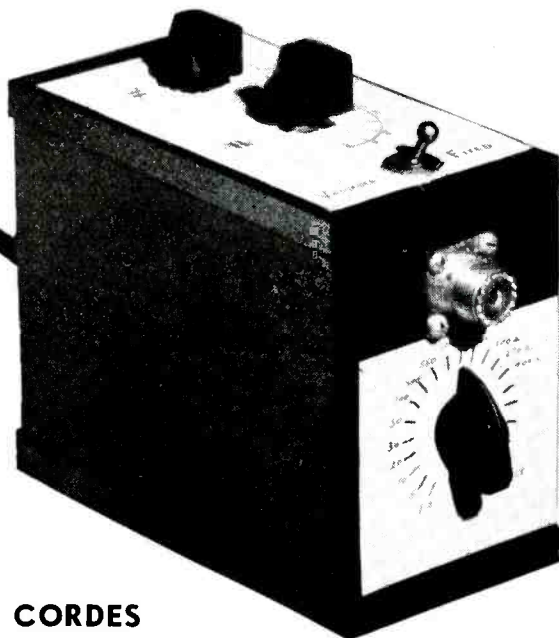

Fig. 1—The completed dummy antenna selector. The coax connector is for the receiver input cable.



DUMMY ANTENNA SELECTOR

By HENRY C. CORDES

EVERY receiver alignment job calls for the use of one or more different dummy antennas between the signal generator and the receiver. Most technicians have an assortment of made-up dummy antennas lying around *somewhere*. These usually consist of a resistor, a capacitor, or an unmounted combination, with a clip at one end for connecting to the receiver, and a fragile bare wire lead at the other end for the signal generator cable clip.

Whenever one is needed, the technician generally has to dig it out of a box of miscellaneous junk, only to find that one of the leads is broken.

Since the number of types required is already large and is constantly increasing, the well-equipped service shop should have some device for quickly selecting the right unit and automatically connecting it in the generator output circuit. An additional advantage of such a device would be to simplify

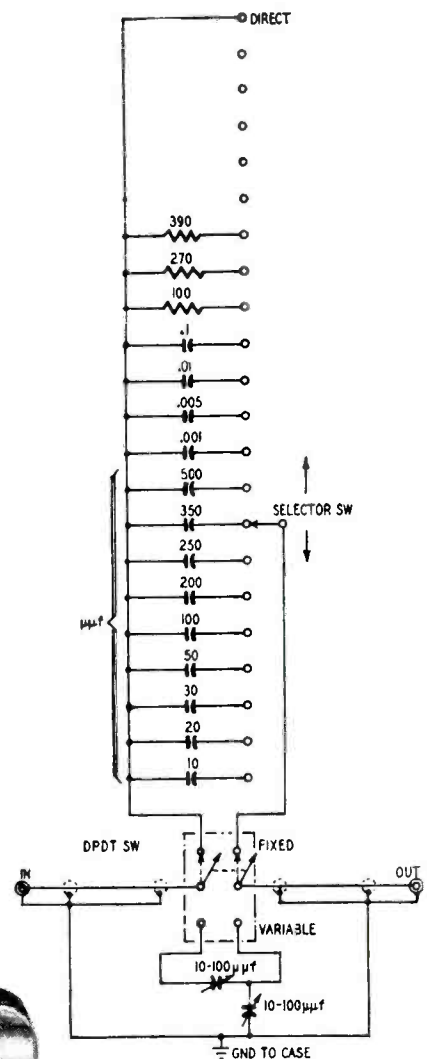
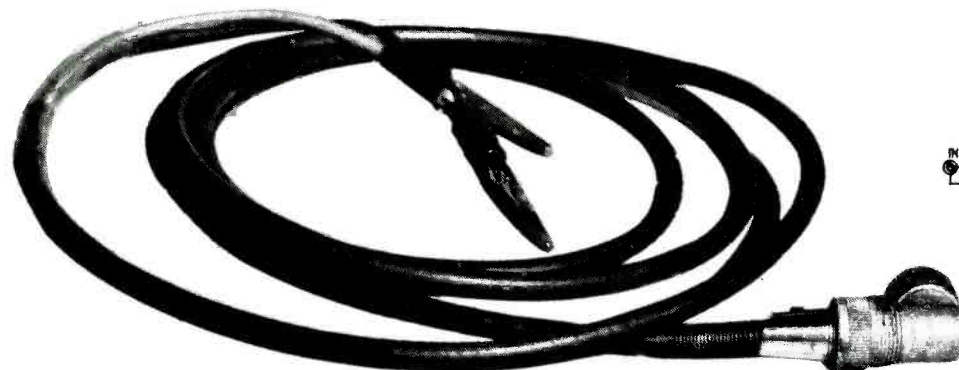

Fig. 2—Schematic of selector unit.

the connections to the receiver. Instead of cluttering up the chassis with a bulky network and an assortment of clips (especially when working with miniature tubes), the dummy antenna selector could be installed at or near the signal generator, and only a single cable run to the receiver. This would also reduce the radiation problem.

After much planning and experimenting, this versatile dummy-antenna selector was born. It was built in a metal can from an old auto-radio power supply. Any enclosed metal box large enough to accommodate the components without too much crowding may be used.

Fig. 1 shows the completed unit and the locations of the controls. On the front panel are the dummy-antenna selector switch and the output jack. On the top are two variable-capacitor control knobs and a d.p.d.t. VARIABLE-FIXED switch. These variable capacitors are connected in a series-parallel arrangement required only for aligning the front ends of some late-model auto radios. Technicians who do not handle this type of work can omit these capacitors and the VARIABLE-FIXED switch.

The circuit diagram is given in Fig. 2. The dashed lines show the connections with the VARIABLE-FIXED circuit eliminated. With the d.p.d.t. switch in the FIXED position the selector switch connects the desired dummy antenna in series with the hot side of the signal-generator output cable. The selector switch used in this model had 22 taps, but any nonshorting switch with at least 17 taps may be used.

The sizes of the fixed capacitors and resistors were selected after a detailed search through many volumes of service manuals, as representing the most commonly needed values. Special dummy antenna networks can be inserted in the external circuit, as described later.

In the VARIABLE position of the d.p.d.t. switch, the special series-parallel combination for auto-radio use is connected between the generator and the receiver. The variable capacitors are of the straight-line-capacitance type, to simplify calibration.

Construction details

If used, the variable capacitors should be mounted at least one-half inch apart at their nearest points to minimize interaction. Leads to the variables should be dressed away from each other and from all other wiring and the case. Do not use shielded wire for these leads. The series-connected variable capacitor must be completely insulated from the case.

For best results and minimum size the fixed capacitors (up to .01 μf) should be of the ceramic type. Half-watt resistors are adequate. One lead from each fixed capacitor and resistor is soldered to a common bus from the d.p.d.t. switch. Their respective opposite ends are soldered to taps on the selector switch, with the values increasing in the clockwise direction as viewed from the knob end of the shaft. Note

that the last tap on the selector switch is connected directly to the bus bar. This feeds the generator output directly to the circuit under alignment, or permits the insertion of special dummy antennas between the output cable and the receiver. Unused taps on the switch may come in handy later if additional dummy antennas are required.

Drill a hole in the metal housing for the shielded input cable, and ground the shield to the housing. The hot lead is connected directly to the d.p.d.t. switch. Also ground the shielded lead to the output jack. A jumper wire between the shields of the input and output cables inside the unit insures good ground continuity.

The dial scales were made from white card stock cemented to the top and front of the case and marked with India ink. The variable-capacitor circuit was drawn on the top scale to show the function of each control.

Based on the manufacturer's rating of the variable capacitors, the low point on each calibration scale was marked 10 μf , and the high point 100 μf . The mid-point was marked 55 μf . Other capacitance values were marked off uniformly in proportion. *(These markings may be inaccurate, especially at the low end of the scale, because they do not include stray capacitances. If possible, the actual values should be measured on a bridge after the unit has been completed.—Editor)*

The unit is connected to the generator via the new input cable. The original generator test cable is connected to the selector output jack.

Testing the selector

The selector unit can be tested with a signal generator, an ordinary radio, and an output meter.

Turn on the generator and the radio and allow time for thorough warmup. Set the generator and radio to the same frequency and connect the output cable from the selector unit to the receiver antenna post. See that the switch is in FIXED position. Set the selector switch on the .1- μf tap. Connect the output meter across the receiver voice coil and adjust generator and volume control for normal output.

Switch the selector to the next lower sized dummy. A lower reading should be noted on the output meter. Each successive reduction in the size of the dummy antenna capacitors should result in a lower output reading.

The resistor dummies can be checked with an ohmmeter between the input and output cable ends.

There may be a few types of sets which require dummy antennas which cannot be simulated by this selector. Even in these cases it will be useful, as the setup usually will call for only one or two resistors or capacitors in addition to those in the unit.

One point should be checked regardless of which selector you decide to build. The selector-switch arm must make perfect contact with all taps for trouble-free operation.

Materials for dummy antenna selector

Resistors: 1—390 ohms, 1—270 ohms, 1—100 ohms, 1/2 watt.

Capacitors: (Paper) 1—0.1 μf , 400 volts. (Ceramic) 1—10 μf , 1—20 μf , 1—30 μf , 1—50 μf , 1—100 μf , 1—200 μf , 1—250 μf , 1—350 μf , 1—500 μf , 1—001 μf , 1—005 μf , 1—01 μf . (Variable) 2—100 μf max. midjet air trimmers (National UM-100, Hammarlund APC-100, Bud LC-2081, or equivalent.)

Miscellaneous: 1—single-circuit rotary switch, 17 or more contacts, nonshorting type (Mallory 13124L or equivalent); 1—d.p.d.t. toggle switch; 1—coaxial output connector, chassis type; 1—coaxial input connector, cable type (see text); 2 feet signal generator cable; 1—6 x 5 x 3-inch metal box; wire, solder, hardware, knobs.

—end—



Suggested by Burton J. Teague, Canton, Ohio

"The set fades a lot."

AVOID LAW\$UITS\$



By LEO T. PARKER*

Costly legal pitfalls may trap the service technician or dealer. Some recent adverse decisions should serve as warning guideposts.

RADIO and television technicians and dealers will do well to keep informed of new higher court cases involving others in the same business. A great deal of money, time, and effort may be saved by *avoiding adverse lawsuits*.

In the following higher court decisions, various points of law are discussed which may help readers avoid suits, or win those which are unavoidable.

Law of warranties

Higher courts now consistently hold that a seller who breaches his warranty or guarantee must take back the subject of the sale and refund the *full purchase price*, plus interest. Therefore, sellers of radio and television sets must avoid making unreasonable guarantees such as that "the set will operate satisfactorily to the purchaser," or that "satisfaction is guaranteed."

For example, in *Keeler v. General Products*, 75 Atl. (2d) 486, the testimony showed facts as follows: A restaurant owner bought a television set from General Products for \$1,523.25. The purchase was made in reliance upon the assurances of the seller's president and vice-president, and one of its salesmen, that the set would operate satisfactorily in his town. However, it failed to provide good reception, and the seller replaced it with another model. The same officials renewed their assurances of satisfactory performance by the substitute set. The second set proved to be no better than the first. The purchaser then demanded the return of the purchase price and offered to return the set, which was in substantially the same condition as when delivered. Although the demand was repeated on numerous occasions, the seller refused to accept the set or to refund the money. The restaurant owner

sued the seller to recover the full purchase price of \$1,523.25 plus legal interest.

The higher court promptly ordered the seller to take back the television set and refund the full purchase price. The higher court said:

Several remedies were available to the plaintiff upon the breach of warranty. He elected to rescind the sale. When the defendant refused to take the set back, the plaintiff held it as bailee and acquired a lien thereon to secure repayment of the purchase price.

The seller could have avoided an adverse decision in this litigation by proving that its officers and salesman had merely represented that the television set would operate *as satisfactorily as other sets at the same price*. However, when the officers and the salesman made a positive statement and guaranteed that the set "would be satisfactory," the purchaser had a legal right to sue and recover the full purchase price upon proof that the set did not operate *satisfactorily to him*.

Uncertain sale contract

Higher courts now consistently hold that all contracts of sale are void if made through error, violence, fraud, or menace. Hence, where a purchaser proves that he did not receive *what he thought he was purchasing*, there is no valid contract, and the purchaser may compel the seller to take back the merchandise and refund the purchase price.

For example, in *Jake v. Blem Electrical Company*, 46 So. (2d) 631, these facts were proved: The Blem Electrical Company, a retailer of television receivers and other appliances, had in its employ a salesman who was learning to sell television sets. He sold the plaintiff a television set for an agreed price of \$1,095.00, plus an installation charge

of \$200.00, and taxes and freight charges of \$48.85, or a total amount of \$1,343.85, to which were to be added finance or carrying charges. The purchaser made a deposit of \$100.00, and verbally obligated himself to pay a further sum of \$350.00 cash when the set was delivered, and to execute a note for the unpaid balance. It is important to observe that two disinterested witnesses were present when the order was placed with the salesman.

When the television set was delivered it was not in a cabinet, but was mounted on a chassis and enclosed by a steel frame. Later a service technician volunteered suggestions as to the manner in which a cabinet might be constructed to enclose the set. It was then that the purchaser realized that a misunderstanding might have occurred, and he immediately telephoned the seller, stating that he was rescinding the contract because he had been under the impression that a "beautiful cabinet" would enclose the set.

In subsequent litigation the higher court held that the seller must take back the television set and refund the payments. This court said:

"After carefully considering the record, our opinion is that there was never a meeting of the minds as between plaintiff and defendant's representative, with respect to the sale and purchase of the television receiver. We are impressed by the fact that plaintiff testified that C and S (the disinterested witnesses) were present during the entire negotiations leading up to the sale . . . The testimony convinces us that he did not get delivery of what he intended to buy . . ."

This court explained that sellers of merchandise may eliminate controversies of this nature by having a written contract signed by the purchaser.

Therefore, the seller could have avoided taking back this television set if the salesman had been provided with a *printed* order form which the purchaser would have signed. Under these circumstances the court would *not* have listened to the testimony of the two disinterested witnesses in favor of the plaintiff. Verbal guarantees, statements, and assertions are *not* good evidence nor acceptable by the court when a written contract determines the legal rights and liabilities of the contracting parties.

Motto: Never sell any merchandise on a verbal agreement. Always have the purchaser sign an agreement printed, typewritten, or written in ink.

Repairman liable for tax

According to a recent higher court decision owners of television service shops must render bills to customers, *clearly separating material charges from labor charges*. Failure to do so renders the technician liable for the state's sales tax on the *full amount* of the bill.

For example, in *Muench v. Glander*, 93 N.E. (2d) 606, it was shown that a technician failed to charge any sales

*Attorney at Law, Cincinnati, Ohio

tax to customers for repairs. In subsequent litigation the higher court held that he was liable to the state for the sales tax on the full amount charged, notwithstanding the repairman had made no deliberate attempt to evade the sales tax law. The court said:

Where a person sells material and in connection therewith furnishes labor or service in applying such material to his customer's property, the entire transaction shall be considered a sale and subject to tax, unless there is a clear separation, in the making or billing of a charge therefor, of the material furnished and the labor or service performed.

Here is a specific example: Assume that a television technician installs a part for which he charges 25¢. If he charges the customer \$3.25, that is: 25¢ for the part and \$3.00 for labor, *without separating the part cost from the labor cost*, he must pay the state a sales tax on \$3.25. The technician *cannot* go back over his books and correct or separate the cost of materials from the labor cost. On the other hand, if the technician makes out a bill to the customer, or if the customer pays cash, the technician may enter the account as 25¢ for parts; \$3.00 for labor, and he may pay the state's sales tax on only 25¢, instead of \$3.25.

Don't forget this! If you do, two, three, or four years from now the state's tax collector may go back over your books and collect a considerable amount of delinquent taxes, plus heavy penalties.

Minor cancels contract

Recently a higher court held that if a television dealer sells to a minor, the latter can rescind the contract, return the set at any time and demand refund of the *full* purchase price. This is so, although the minor's father may have signed the purchase contract, mortgage, or notes.

In *Davis v. Clelland*, 92 N.E. (2d) 827, minor sued a dealer alleging that as a minor he was entitled to rescind the purchase contract and recover the full purchase price.

The dealer defended the suit by contending that the appliance was purchased by the father of the minor. However, since the testimony showed that the title was made to the minor, the higher court held that the dealer must refund the full purchase price to the minor. The court said:

If the father purchased it, the dealer was required by law to deliver to him the title. The source of the purchase money was immaterial as to the right of the defendant (dealer) and did not fix the identity of the purchaser.

In other words, irrespective of who pays the purchase price, the minor may rescind the contract and recover the full purchase price if the testimony shows that the seller delivered the merchandise to the minor.

—end—

Battery failures in portable equipment can be costly and aggravating. Here are some methods of preventing them.

MONITORING BATTERY INSTRUMENTS

By RUFUS P. TURNER

IT'S often a good idea to use test instruments with self-contained batteries. Battery power allows operation at locations remote from power lines. It also provides complete isolation from the a.c. line and thus prevents introducing hum into either the instrument or the device under test. The battery unit is portable—often an important feature. Instruments in which battery operation frequently offer advantages include electronic voltmeters, oscillators and signal generators, distortion meters, frequency meters, wave-shapers, field-strength meters, and instrument amplifiers.

One of the annoying drawbacks of battery operation is the rapid rundown of batteries due to needlessly leaving the power switch in its ON position during periods when the instrument is not actually in use. This costly nuisance has caused much concern to users and designers of battery-operated equipment, and often prompts the sacrifice of the obvious advantages of battery operation in favor of more foolproof a.c. operation.

There are several practical ways in which battery power supplies can be monitored, and often protected, to prevent untimely exhaustion of the batteries. With civilian battery supplies still in uncertain condition and with high prices prevailing, it will pay builders and users of battery-operated equipment to utilize these schemes. The particular method chosen will depend upon a number of factors, mainly electrical and mechanical feasibility. The

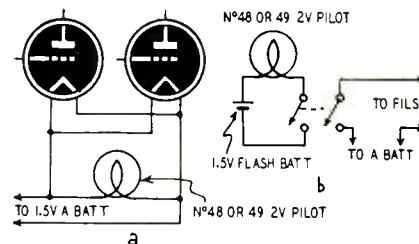

Fig. 1—Protection with low-current lamps.

writer makes no claim to originality, since each scheme has been used in some piece of battery-operated electronic equipment. Our aim is to call attention to what can be done.

Pilot lights

The mere thought of a current-consuming pilot light in a battery power supply ordinarily creates horror. However, there are instances where the drain of an A-battery pilot light is not unreasonable. An example is the case of 1-volt tubes operated from a large-size dry cell. Type 48 (screw base) and 49 (bayonet base) lamps draw only 60 milliamperes at 2 volts and around 50 ma at 1.5 volts. This current drain is small for the protection provided, and a large-size cell will handle the load. The pilot light is connected in parallel with the tube filaments (See Fig. 1-a) and glows only when the A battery is switched on. For designers who do not favor the shunt connection, there are other methods of pilot-light operation.

Pilot light with separate battery

To remove extra drain from the A battery, a separate flashlight battery



may be provided for a type 48 or 49 pilot lamp. This lamp gives adequate light on 1.5 volts. By using a d.p.s.t. on-off switch, a separate set of contacts is provided for the pilot-light circuit. This arrangement is shown in Fig. 1-b.

Pilot light in series with tube

The pilot lamp may also be operated in series with the tube filament so that it lights only when the switch is on.

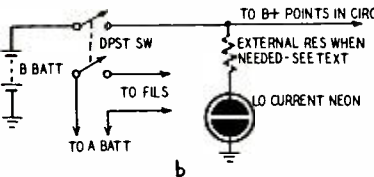
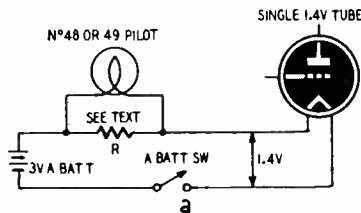

current and attracts more attention than a steady light.

Switch flags

Where no extra current may be drawn from the batteries, on-off switches may be provided with eye-catching "flags" of one sort or another to signal the ON position. Individual mechanical ingenuity can provide many variations of this scheme.

Fig. 3-a shows a simple flag arrangement. A rotary on-off switch is pro-

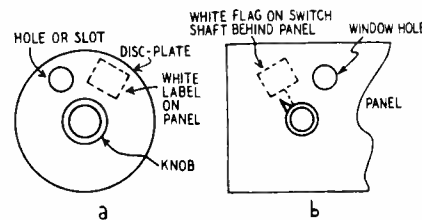

Fig. 2 (left)—Series pilot-lamp and shunt neon-lamp methods of monitoring.

Fig. 3 (above)—Eye-catching indicators mounted on the battery on-off switch.

switch contacts and disconnects the batteries.

The on-off switch may be wired in series with the lid-operated switch.

Additional methods

Where cost is not a factor, a miniature panel-type d.c. voltmeter may be connected in parallel with the tube filaments or wired from a B plus-circuit point to ground. This meter will serve the dual purpose of warning when the batteries are on, and also of showing

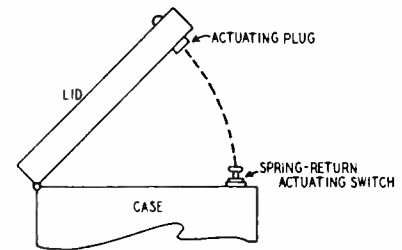

Fig. 4—Automatic protection for cased instruments with a lid-operated switch.

This arrangement is shown in Fig. 2-a and is best applied to instruments and devices employing one tube.

A 3-volt A battery supplies the lamp and tube filament in series. When a 0.1-amp filament is employed, the lamp must be shunted with a 27-ohm, ½-watt resistor R. When using a tube with 0.05-ampere filament, no resistor is required across the lamp, but a 140-ohm, ½-watt resistor must be connected in parallel with the tube filament. In either case, burnout of the lamp will not damage the tube.

Neon B-battery pilot light

When at least 90 volts of B battery are available, a low-power neon lamp (¼-watt or 1/25-watt size) may be connected as shown in Fig. 2-b to glow when the on-off switch is closed. Types NE-2 and NE-51 1/25-watt lamps, each require a 200,000-ohm external series resistor. In the ¼-watt group, types NE-17 and NE-48 require external series resistors of 30,000 ohms. All other ¼-watt types have built-in resistors. The technician who desires a more elaborate and economical set may use the blinker system described in RADIO-ELECTRONICS, October, 1949. The neon lamp, flashing only at intervals, uses negligible

provided with a disc-plate in which a hole or slot is cut. A piece of brilliant white paper or plastic is cemented to the instrument panel in such a position as to be visible through the hole when the switch is in its ON position.

Another scheme which may be used with a rotary switch is shown in Fig. 3-b. Here, a small white flag is attached to the switch shaft behind the instrument panel by a stiff wire or blade. A window-hole is drilled through the panel at a point where the flag will show through when the switch is on.

Lid-operated switch

A scheme used by several instrument manufacturers, which makes it impossible to store the instrument with batteries running (provided the cover or lid of the instrument case is closed), is the lid-operated switch (See Fig. 4). The switch is a spring-return pushbutton type with normally-closed contacts. This switch is wired in series with the battery power supply and may be provided with two sets of contacts, one for the A battery and the other for the B battery. A small dowel or plug is attached to the inside of the lid so as to push down on the switch button when the lid is closed. This action opens the

continuously the condition of the batteries. In order to minimize drain, the meter circuit must have as high resistance as possible. Under no circumstances should this be less than 1,000 ohms per volt. In lieu of a voltmeter a plate current milliammeter in one B-battery lead may be used if desired.

A small clockwork-driven switch may be employed as the regular on-off switch in battery-operated equipment. These mechanical timers may generally be set for any running time up to one hour, which would appear to be ample for most testing operations. Its timing action will be started automatically when the instrument is switched on, and the batteries will be switched off automatically at the end of the interval.

Undoubtedly, there are numerous other methods of signaling to the operator that his batteries are switched on. Only a representative few could be covered in this space, but the methods suggested should provoke thought on the part of technicians. Battery-operated instruments are preferable to line-operated devices in many applications, and their advantages should not be sacrificed because of fear that the batteries will run down through carelessness.

—end—

A DYNAMIC SIGNAL TRACER

By W. CARL MARSH

Extra-sensitive
r.f.-a.f. tracer has
valuable features,
many service
uses

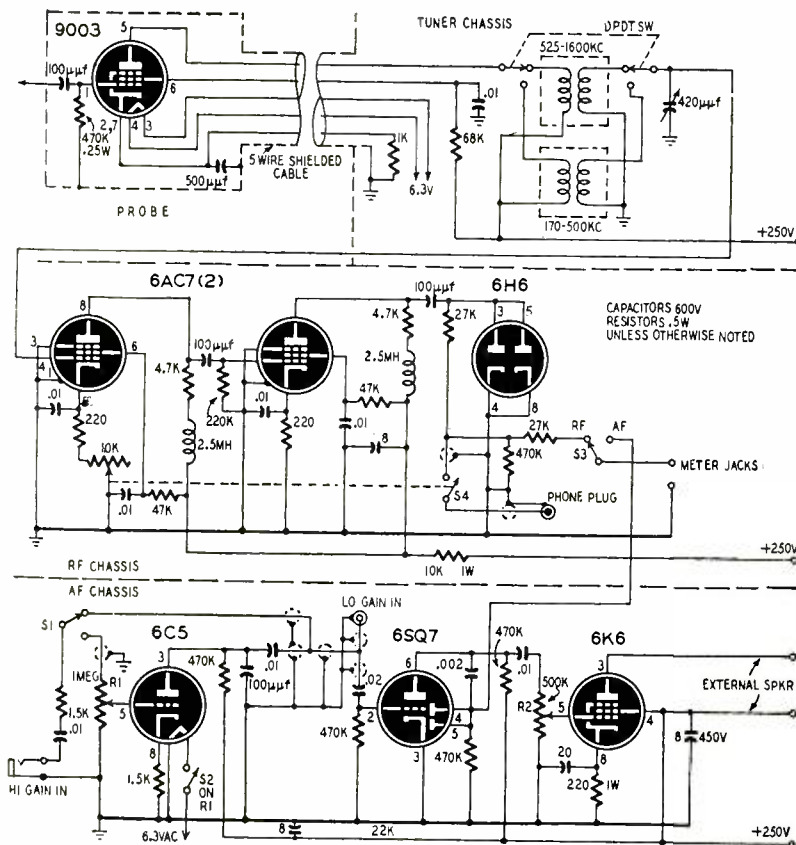
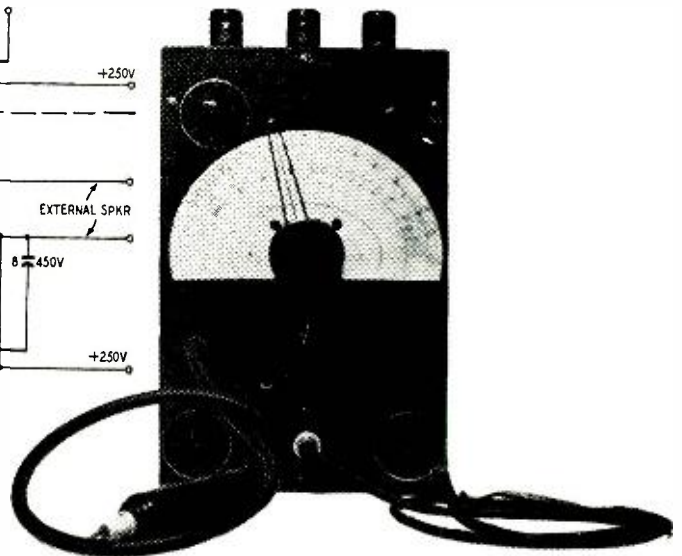

Fig. 1—Signal circuits of the tracer. Probe and tuner sections are at the top; the r.f. amplifier-detector unit is in the center; the audio amplifier at the bottom. The completed tracer is shown at the right. Its housing may be enlarged to accommodate the power supply and speaker.



SERVICE technicians have been offered many signal tracers which claim to trace the signal "from the antenna to the speaker", but they neglect to tell you that *you* have to furnish that signal, either from a strong local station or a signal generator.

We have no local stations where I am located. The nearest stations, WSM Nashville and WREC Memphis, are more than 100 miles away, so a signal tracer that will follow a signal from antenna to speaker has to be a sensitive one. With this in mind I have, through an evolutionary process, arrived at a practical and extremely flexible signal tracer. It has been used in my shop for approximately twelve months and is invaluable in saving time and eliminating some tough jobs of hunting with voltmeter and soldering iron. As proof of its sensitivity I can place the contact point of the prod

against the insulation of my antenna lead-in and tune in half a dozen stations, including WSM and WREC.

The signal tracer is built in a steel cabinet $7\frac{1}{2} \times 12 \times 7$ inches. The schematic is shown in Fig. 1. Power supply and speaker were not included because I already had both built into my bench. Any power supply delivering 6.3 volts a.c. at 2.5 amps and 250 volts d.c. at 100 ma will serve the purpose.

The audio section is a straightforward 3-stage high-gain amplifier. Metal tubes should be used in the first two stages for maximum stability. The main volume control (R2) is in the grid circuit of the 6K6 with an auxiliary control (R1) at the input to the first amplifier. Where extremely high gain is not required switch S1 can be used to bypass the input stage. S2 is ganged with R1 and opens the 6C5 heater circuit when this stage is not used. A low-gain input connection is

also provided for direct connection to the second stage.

A portion of the audio signal is rectified by the diode plates of the 6SQ7, and fed to one terminal of S3 for signal voltage measurements. Be sure to take proper precautions to eliminate feedback by liberal shielding and separation of grid and plate leads. The audio section is placed in the bottom of the signal tracer cabinet.

The r.f.-i.f. section uses two untuned 6AC7 amplifiers and a diode detector. The control in the cathode of the first 6AC7 is a sensitivity control. Switch S4 disconnects the output of the r.f. unit when only the audio section is being used, to prevent spurious sounds issuing from the speaker.

Each stage of this unit is completely isolated from the next by interstage shields. The interstage coupling-capacitor leads run through small holes in the shields. Be sure to use a bottom

shield as well to eliminate the possibility of pickup from the audio amplifier. The r.f.-i.f. amplifier is placed in the upper part of the cabinet with the tubes projecting through holes in the top.

After this unit has been completed and connected to the audio amplifier it can be tested by connecting an antenna, through a 100- μ f mica capacitor, to the input. (*Editor's note:* Temporarily connect a 10,000-ohm resistor from the grid of the first 6AC7 to ground.) As there is no selectivity in this unit several stations should be heard simultaneously.

The coils for the tuner were made from i.f. transformers with enough turns removed to bring the frequency up to the proper range and the primaries wound over the secondary. The tuning capacitor is a war surplus job and has a capacitance of 420 μ f, but any coil and capacitor combination that will cover the desired frequency ranges can be used. The ranges of this tracer are 170–500 kc on the i.f. band and 525–1600 kc on the r.f. band.

The probe assembly is shown in Fig. 2. The housing was made from the shell of an old MG type 6F6 tube. The crimps holding the shell to the base were pried out and the inside glass tube removed from the base. The guide pin was broken off and the hole enlarged to pass a 5-wire shielded cable. The base of another tube was also used as an insulating washer by grinding it down until it fit inside the shell. The cable was passed through the holes in the base piece and washer and connected to a 7-pin miniature socket for the 9003 pickup tube. A hole was made in the closed end of the shell to take a small feedthrough insulator. A long bolt through this insulator serves as the probe tip and connects to the 100 μ f mica isolating capacitor. Be sure to ground the shielding on the cable to the shell of the probe and connect an external ground lead and clip.

The tuner was calibrated with a signal generator. Broadcast stations can be used for the 525–1600 kc range if enough are available.

After calibration you are ready to use one of the handiest test instruments you will ever own. The possible uses are limited only by the ingenuity of the operator.

Due to the high sensitivity of this tracer it is not necessary to make actual contact with the circuits being tested. Thus there is no detuning of critical circuits.

To check a receiver oscillator, turn S3 to the RF position and connect a v.t.v.m. set to the 10- or 15-volt range to the meter terminals. Tune the receiver to the low end of the dial and

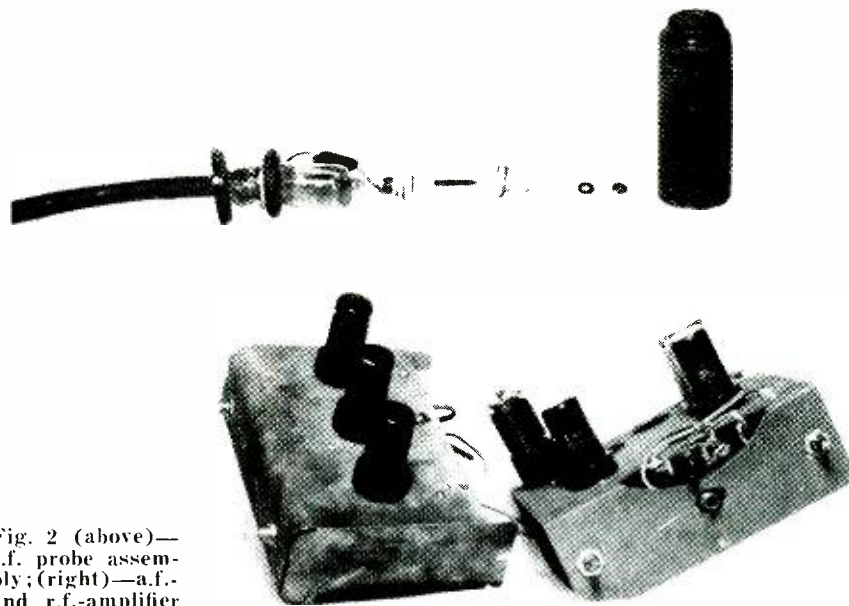
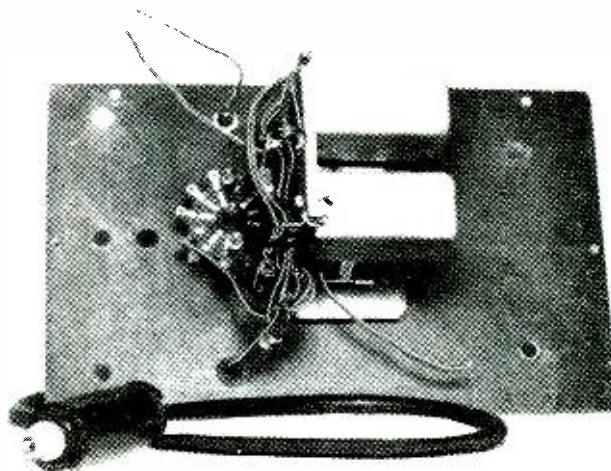

Fig. 2 (above)—r.f. probe assembly; (right)—a.f. and r.f. amplifier unit sub-chassis.



The r.f.-i.f. selector unit sub-assembly, shown mounted to the tracer panel, and the completed r.f. probe unit.

add the i.f. to the dial reading. Tune the signal tracer to this frequency and hold the probe tip near the oscillator coil or tuning capacitor. If the oscillator is operating on or near the correct frequency, the meter needle will kick strongly as the tracer is tuned back and forth across this frequency.

To locate trouble in a dead receiver where supply voltages are normal, simply tune the receiver to the frequency of a strong station and trace the signal from grid to plate through each stage. Use the correct tuning range of the signal tracer for the r.f. and i.f. sections of the receiver. Only the audio section of the tracer is needed when you have passed the detector.

For testing phono pickups and microphones, simply feed the output into the proper stage of the audio amplifier. For crystal pickups use the low-gain input and volume control R2. If the crystal is good you will be able to hear the output with plenty of volume. With a standard test record and a good

crystal pickup you can calibrate the v.t.v.m. for comparison checks. The high-gain input should be used for dynamic (variable-reluctance) pickups, and microphones.

If proper precautions and good workmanship are used in constructing this signal tracer, you will have an instrument that you will depend on more and more as time goes by. Many new uses will suggest themselves as you become more accustomed to handling your tracer.

Materials for the signal tracer

- Resistors:** 2—220 ohms, 1/2 watt; 1—220 ohms, 1 watt; 1—1,000, 2—1,500, 2—4,700 ohms, 1/2 watt; 1—10,000 ohms, 1 watt; 2—27,000, 2—47,000, 1—68,000 ohms, 1/2 watt; 1—220,000, 6—470,000 ohms, 1/2 watt; Potentiometers: 1—10,000 ohms; 1—500,000 ohms; 1—1 Megohm, with s.p.s.t. switch.
- Capacitors:** (Mica) 4—100, 1—500 μ f; (Paper) 1—0.002, 8—0.01, 1—0.02 μ f, 600 volts; (Electrolytic) 2—8 μ f, 450 volts; 1—20 μ f, 25 volts. (Variable) 1—420 μ f (max).
- Miscellaneous:** Tubes: 1—6H6, 2—6AC7, 1—6C5, 1—6SQ7, 1—6K6-GT, 1—9003. Tube sockets. Coils (see text). Switches: (Wafer) 2—s.p.d.t.; 1—d.p.d.t. Cabinet. Chassis. Connectors. Hardware. Wire. Solder.

—end—

VACUUM TUBE TRAINER HELPS STUDENTS



Checking the circuits of the vacuum-tube trainer.

Air Force trainees
learn electronic principles
from huge animated
tube model.

By M/S FORREST C. WOLFERD

THE problem of constructing a classroom trainer that would clearly and swiftly demonstrate electronic activities of the radio vacuum tube was presented to me in March, 1948, while I was stationed at Chanute Air Force Base, Illinois. The "poser" was handed me by Major General Charles C. Chauncey, then deputy commander of the United States Air Force's technical training program. His decision to seek a new-type trainer was the result of advice from instructors that existing trainers and charts were hopelessly inadequate in helping a student to understand the elusive behaviorisms of the vacuum tube.

To assist in the construction of the trainer, I called on Technical Sergeant Robert C. Williams, a man with five years experience designing training aids for Army and Air Force schools. We decided on a device that would demonstrate every vacuum tube operation, from the diode to the pentode tube.

We wanted to show current and voltage variations, space charges, erratic movement, grid action, and secondary emission. We wanted everything that happened in an actual tube to occur clearly and simply on the face of our trainer.

To present these effects in a way that would appeal to students, we decided to use moving lights, similar to those seen on a theater marquee. These lights would vary in brilliancy to show changes in the amount of voltage; change colors to demonstrate polarity and increase or decrease in number to illustrate the strength of current. Lights would move about, imitating electron flow exactly.

In addition, all parts of the tube were

to be included in the trainer, looking as much like themselves as possible.

Planning these effects was one thing—achieving them another.

We began construction with the face panel. Williams suggested all parts be made of Plexiglas, as it was durable, light, and easy to work and handle.

For our filament, we used a V-shaped rod, inside a half-cylinder representing the cathode. This was cut away in front so the filament could be seen.

Next came the grids—1-inch tubing curved like a coil. To reveal the lights demonstrating electron flow, they were also cut away.

We made the external circuits of half-inch plastic strips with corners beveled and outlined in black.

The plate element was a large half-cylinder which fitted over the other elements and grids.

All these parts were mounted on a translucent Plexiglas panel. The external circuits and grids were detachable and could be added one at a time to build in succession a diode, triode, tetrode, and pentode tube. The filament, cathode, and plate circuits, were cemented to the panel.

Behind the panel glowed the lights. Because of the translucence of the Plexiglas, the lights could be seen, but not as distinct individual bulbs. This gave a more realistic effect.

We then drew up the arrangement of all bulbs within the tube. We arranged the bulbs in 43 horizontal rows, 44 to a row. Even-numbered rows showed normal electron flow and odd-numbered rows demonstrated space charge, erratic movement, and secondary emission.

Each of the even-numbered rows was

cut in half, placing 22 bulbs on each side of the cathode. Each side was then divided into four circuits of 5 to 6 bulbs each. The divisions were: (1) cathode to control grid; (2) control grid to screen; (3) screen to suppressor; and (4) suppressor to plate.

In the odd-numbered rows we used 24-bulb circuits to demonstrate erratic movement and secondary emission. All remaining bulbs showed space charges.

External circuits for the filament, control grid, and screen grid came next. They contained 5- to 6-bulb circuits and were arranged in their proper positions.

Next came the plate circuit. To show greater variations in current, it contained 24 bulbs per circuit.

The final step in the lighting system was the design of lights inside the elements. These were 110-volt lamps mounted behind the Plexiglas pieces representing the filament, cathode, grids, and plate. To make the moving lights flow smoothly, we spaced our bulbs only five-eighths inch on centers.

We searched six months before finding enough bulbs to do the job. We finally discovered what we needed: 23-volt, miniature screw-base, type T lamps. Getting suitable commercial sockets to fit the bulbs proved impossible, so all sockets were designed and built by Sergeant Williams.

After designing and building our lighting system, we began wiring. This was the toughest part of the project. It took us two years, and it required 60,000 feet of wire to connect the maze of bulbs so they would operate the way we wanted.

First, we went to work on the marquee flow. On the 5- and 6-bulb circuits, we connected each bulb to four rings of spiral-wired breaker points. Every ring contained six points, one for each bulb.

A cam revolved continually inside the rings, activating the six points in succession. Thus, by energizing one ring, one light moved across the circuit. By energizing another ring we put another light in motion. In this way up to four lights in each circuit flowed. This

gave us our marquee effect plus a varying number of bulbs to show changes in current.

To achieve both these effects in the 24-bulb circuits we used a commutator switch with 24 brushes. The commutator contained 16 segments, each energized by a slip ring. This gave us up to 16 bulbs in motion.

Changes in polarity were shown by passing cellophane shields in front of bulbs, while variations in the amplitude of voltage were illustrated by changing the brilliancy of the lights, using variacs.

All these effects—current, polarity, voltage, and marquee-flow—were regulated by only four front-panel controls. Five motor-control systems, interconnected with bridges and micropositions, enable proper interaction throughout the trainer. Wafer switches connected to the motor controls automatically energize the rings of breaker points, brushes of the slip rings, and sections showing space charge.

Because of the automatic interlocking controls, a change in one element is always followed by the proper reaction elsewhere.

In use, the filament control is turned on and one side of the filament circuit glows red (positive), the other side green (negative).

As the voltage is turned up, brilliancy of the lights increases. As current increases, more lights appear.

After a short time delay, the filament and cathode glow red, indicating heat. As their glow becomes more intense, white lights representing electrons move away from the cathode.

At first, these electrons form no definite pattern, demonstrating erratic movement. As more are emitted, however, they form clusters representing space charges.

Next, the plate control is turned on, causing the plate circuit to glow red (positive). As voltage increases, the plate becomes brighter and electrons move toward it from the cathode in definite patterns.

At the same time red lights in the plate circuit become brighter and increase in number, illustrating stepped-up voltage and current. Space charges diminish, erratic movement stops.

By applying a negative voltage to the plate control, lights in the plate circuit change to green and movement ceases. The ground circuit, represented by blue lights, automatically increases as current becomes greater.

When the diode demonstration ends, the Plexiglas control grid is attached to the face panel and a triode tube is formed. By regulating the next front panel control, all activities in a triode tube take place on the trainer's face.

Tetrode and pentode demonstrations are given in the same way: successively adding a grid and turning on another control panel for each one.

By the end of March, 1951, we had ironed out the last of the bugs and our project was ready for display.

—end—

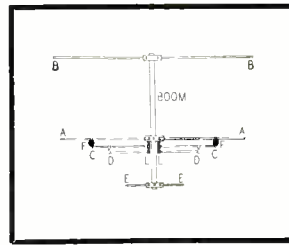

NEW ANTENNA IDEA

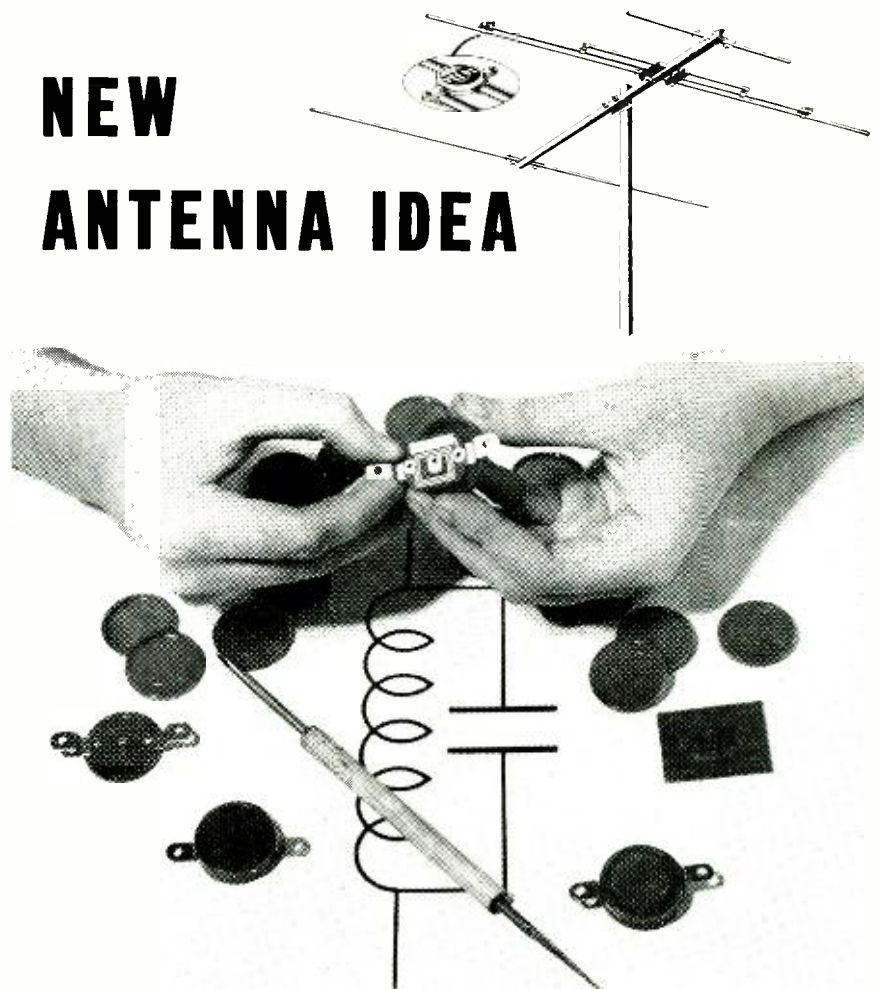

The printed circuit has now reached the top in its advance as a radio and TV component! It is used by Vee-D-X as an integral part of their new *Q-Tec* antenna, whose driven element consists of a series of T-matched dipoles which provides a 300-ohm match on both the high and low channels. The printed circuit is a part of the matching system and prevents detuning effects between the high- and low-channel elements, while providing a driven element of extremely low Q. The close proximity of the high and low elements and the elimination of the adverse interaction by the printed circuit results in an exceptionally broadband driven element. A high-channel director and a low-channel reflector give it the desirable front-to-back ratio and gain characteristics of parasitic type antennas such as the Yagi.

The printed-circuit matching unit is shown in the photo and the complete antenna in the diagrams above. Operation fundamentals can be understood easily with the help of the

figure. On the low channels, B-B acts as a reflector for dipole A-A. F and F are the printed circuit isolation filters in weatherproof plastic housing—on the low channels they have low reactance and connect A-A through sections C-C and D-D to the 300-ohm line at L and L. Thus C-C and D-D act as a T-match between the line and dipole A-A. The printed circuit filters F and F are antiresonant at the center of the high channels (195 mc) and effectively isolate A-A from the 300-ohm line at these frequencies. However, C-C forms a fullwave antenna in this range, coupled to the 300-ohm line through the T-match of sections D and D. In these high channels, E-E acts as a director for optimum forward gain and directivity.

The multiple T-match further adds to the broadband characteristics of the antenna because the proximity of A-A and C-C provides capacitance coupling that makes the elements appear to be "fatter" and thus have a lower Q and consequent broader frequency response.

—end—

ELECTRONICS and MUSIC

Part XXIV—The simple
Minshall electronic organ—
Ingenious circuitry
produces true organ tones
with few components.

BY RICHARD H. DORF



Fig. 1—The Model J Minshall Electronic Organ has two manuals, pedal clavier, and built-in amplifier and speaker. Other models have external tone cabinets rated at 20 and 40 watts. The instrument is all-electronic, with tube generators; tones are colored by formant method.

THE Minshall electronic organ (Minshall-Estey Organ Co., Inc., Brattleboro, Vt.) is one of the most interesting instruments in the electronic music field. It is capable of producing excellent organ tones and is used with great success in churches, homes, and radio stations; yet its circuits and mechanical construction are remarkably simple. It contains just about the minimum of circuitry and materials necessary to produce a genuine musical instrument, a goal which is not easy to achieve. Electronic organ design tends to become complex if for no other reason than that there must be at least 61 tone generators and a multiplicity of tonal effects. It is not really difficult to design an instrument that will sound good and have good flexibility. To get the same results with economy is hard but very desirable—it makes possible a low price and easier servicing, as well as reduced bulk.

The simplicity of the Minshall centers first in the ingenious frequency dividers, each of which employs only half of a duo-triode tube, five capacitors, and three resistors. The tone-color circuits (of the formant type), instead of using a separate filter for each stop, have several of the filters "collapsed" into a few groups so that any one filter component is used for more than one

tone color. A unique type of vacuum-tube filter is employed. All of this will be explained in detail and diagrammed.

Fig. 1 is a photograph of the Minshall model J, a two-manual instrument with a 25-note radiating pedal clavier. This type has a built-in loudspeaker for maximum compactness. Where space is not at a premium model E is usually installed. The E is similar to the J but has a solid wood front and requires a separate tone cabinet (model C-20 or C-40, giving 20 or 40 watts output). A single-manual organ, model H, is also in wide use. Its circuitry is even simpler than that of the J and E. In this article we shall describe models E and J.

(Readers should note that the present-day Minshall organ is entirely electronic, with vacuum-tube tone generators. It should not be confused with an amplified-reed organ (model B) which was made by this company shortly after the war. The reed organ is no longer manufactured.)

The block diagram of Fig. 2 illustrates the scheme of operation of the Minshall electronic organ. The tone-generator assembly produces five octaves of notes. The tones go to the two key manuals and the pedal clavier, thence to the tone filters through the tablet-board control switches. The re-

sulting tones are amplified and fed to a loudspeaker.

Tone generators

Each of the 12 tone-generator chassis contains three 12AX7 duo-triodes, power and output plugs, and a tuning control. It produces five octavely related notes. One of these chassis strips is shown in Fig. 3.

The topmost tone for each chassis is generated by a phase-shift oscillator, illustrated schematically in Fig. 4, using half of the first tube. The usual phase-shift oscillator has series capacitors and shunt resistors; the opposite arrangement, however, appears to be

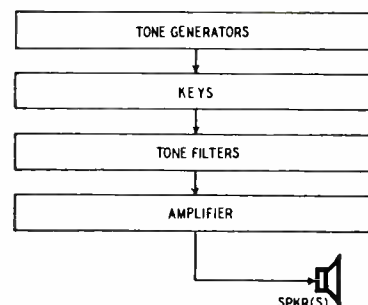

Fig. 2—Simplified block diagram of the Minshall organ operation scheme.

more stable. The 5,000-ohm variable resistor between the bottom of the network and ground permits tuning each oscillator over a range of slightly more than one semitone above and below the desired frequency. The .0015- μ f capacitor across the control minimizes leakage between oscillators.

Eight different oscillators are manufactured on the Minshall assembly lines, differing in the values selected for C1, C2, C3, and C4. The capacitors used are standard high-quality micas with 10% tolerance. As they come off the production line the oscillators are tested for center frequency and are then inserted into appropriate generator chassis. This is an economy which would not be possible if very small component tolerances were necessary or if each component had to be individually selected and measured.

The remainder of a generator chassis is shown schematically in Fig. 5. The first triode, which is the second half of the 12AX7 used in the oscillator of Fig. 4, is a buffer stage used to isolate the highest-note output connection from the oscillator itself. It is also used to feed the first frequency divider.

The circuitry of the frequency dividers is unique in commercial electronic musical instruments. With only a single tube per divider, they produce sawtooth output waveforms, the type best suited for use with formant filters because of their progressive harmonic content.

The output of the master oscillator, which is approximately sinusoidal, is fed to the buffer grid through blocking capacitor C1. Because the triode is

operated at zero bias with a fairly large grid-leak resistor R1, the grid draws current on positive input half-cycles. As a result the tube is biased to cutoff over most of the input cycle. When the tube is cut off, its plate is at maximum voltage, since no current is drawn through plate resistor R2. Plate shunt capacitor C3 therefore charges at a rate determined by the R-C time constant. During the small portion of the cycle when the tube conducts, it acts almost as a short circuit across C3 and discharges it quickly. The result of the slow charge and fast discharge is a sawtooth potential across C3, at the same frequency as the master oscillator. The sawtooth signal is taken through blocking capacitor C2 to the keying circuits, as the highest of the five notes generated on the chassis. The circuit of this buffer is extremely interesting since it transforms a sine wave to a sawtooth.

The first divider has been redrawn in Fig. 6 to make its operation clearer. C4-C5 is a capacitive voltage divider which reduces the amplitude of the input signal. If C_x were omitted, the divider would operate in the same way as the buffer. The reduced signal fed to the grid is large enough to cause the tube to cut off after the initial input peak. While the tube is cut off capacitor C6 will charge through R3. On the next positive peak of the input cycle the tube will conduct, C6 will discharge, then charge slowly again as the tube again is cut off. Output is taken from the plate, just as in the buffer, both for the keying circuits and for the next divider.

However, the presence of the feed-

back path from plate to grid through C_x changes all this and makes the tube respond only to *every other* input peak, so that the output is at half the input frequency.

C_x is a large capacitor whose only function is to provide a feedback path from plate to grid. At the initial peak of grid voltage from the buffer, a negative pulse appears at the plate of the tube. (This is the time at which C6 discharges through the tube.) This pulse is fed back to the grid through C_x . However, the feedback voltage reaching the grid is delayed by the series circuit of R2 and C5. For this reason the feedback negative pulse does not reach the grid in full strength until the second input peak from the buffer arrives. Now the grid is so negative—due to the feedback negative pulse—that this second input peak cannot make the tube conduct. Therefore C6 continues charging.

When the third input peak comes along C6 is almost fully charged. The charge on C5 due to the feedback negative pulse has leaked off through R1 and R2. Again the grid is excited by the input pulse, the tube conducts momentarily, and C6 discharges. And again the tube is quickly cut off by the drop across R1-R2 caused by the grid current.

Because the tube is sensitive to the first, third, fifth, and following *odd* input pulses, while the even input pulses do not affect the charging of C6, the output taken from the plate for the keying circuit and the next divider input is one-half the frequency of the input from the buffer. And because the output is the potential across a slow-charge, fast-discharge capacitor—as in

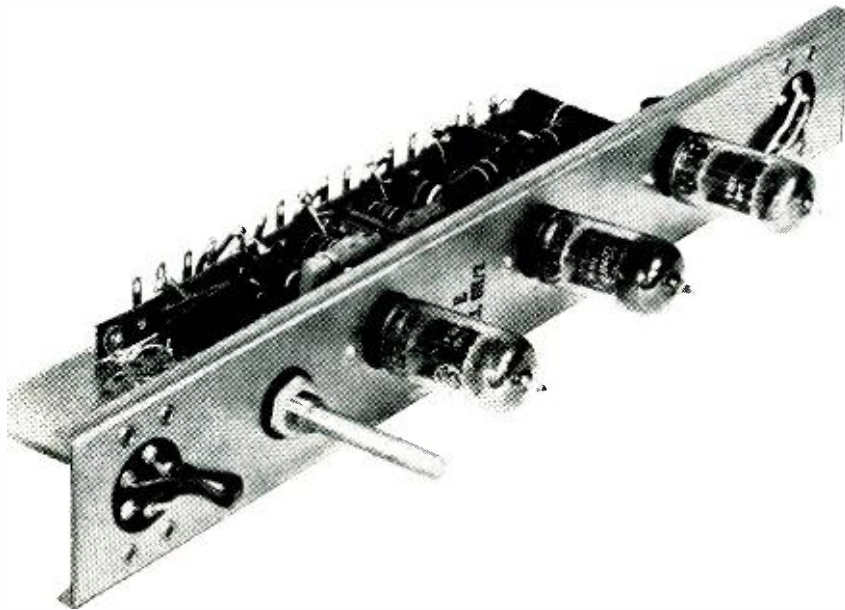

Fig. 3—Each of the 12 generator chassis holds four tubes, two connectors and tuning control.

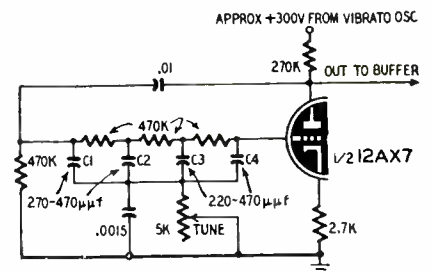

Fig. 4—Special phase-shift circuit used to generate the highest frequency for each oscillator-frequency divider chassis unit.

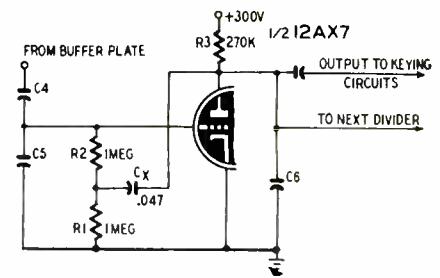
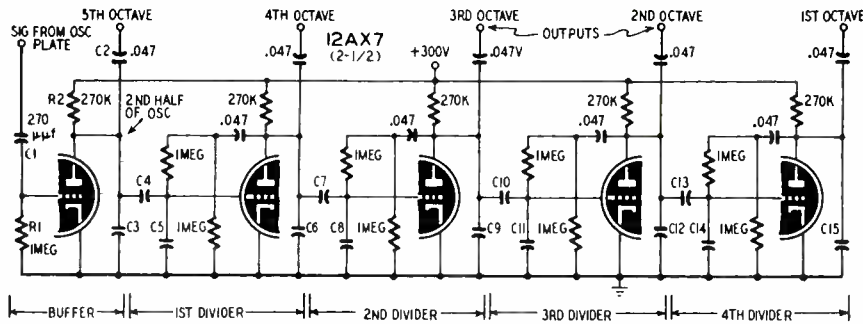

Fig. 5 (left)—Schematic of an oscillator-divider chassis. Fig. 6 (right)—A single frequency-divider circuit redrawn.

the buffer—the waveshape is a sawtooth.

The succeeding three dividers work in exactly the same manner, each energized by input waves from the previous divider, each having sawtooth output of half the input frequency. In order to understand this circuit thoroughly it is helpful to remember that the outputs are *not* voltage drops across resistors due to tube plate current, as in ordinary vacuum-tube circuits. They are potentials appearing across a charging and discharging capacitor. The tube is used merely to control the charge and discharge of the capacitor between plate and ground.

This unusual frequency divider can be explained in another way, which analyzes its operation in a more exact manner. Fig. 7 shows waveforms at various points in the circuit. The input waveform is represented by *a*, the sawtooth from the buffer or previous divider. If we assume initially (leaving the proof until later) that the tube conducts on alternate input-wave peaks,

the plate current waveform is as shown in *b*—with pulses at half the input frequency.

The solid line in *c* of Fig. 7 shows the plate voltage—which is the voltage across the charging and discharging capacitor *C*₆ (Fig. 6). The capacitor discharges each time the tube conducts, and the solid line shows the accompanying fall of plate voltage. After each pulse of plate current (in the figure) the capacitor again charges slowly and the plate voltage (in the figure) rises. Notice that this plate-voltage waveform is a sawtooth at half the frequency of the input (*a*).

The sawtooth voltage—appearing across *C*₆—is a complex wave consisting of a fundamental and even harmonics. Because the output network is capacitive the fundamental component of the output voltage lags almost 90 degrees behind the pulse of plate current. This fundamental component (which cannot of course actually be seen with an oscilloscope) is shown by the dashed line in *c* of Fig. 7. It is

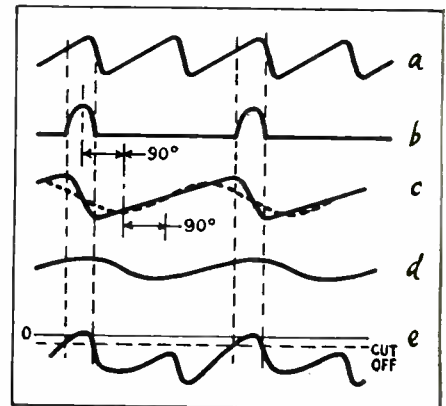
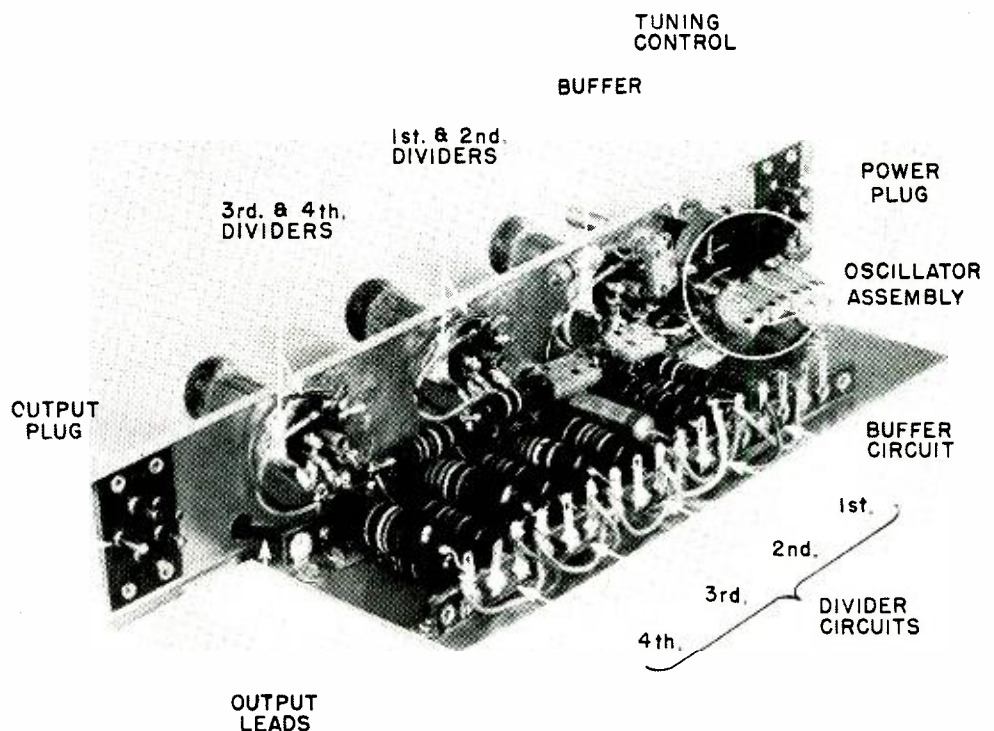

Fig. 7—Waveforms in the frequency-divider circuits of the Minshall electronic organ. Their derivation is explained in the text.

important because of the feedback. Feedback from the plate takes the path through *C*_x (a blocking capacitor of large value which has no effect on phase or waveform), and the series

This underside view of one of the 12 divider chassis shows the compact, yet accessible arrangement of the resistors and capacitors. The oscillator assembly at right is a separate unit and is selected and added as the last operation in divider manufacture.



S-METER FROM SURPLUS

By **GEORGE H. HAGUE**

AS the owner of a low-priced communications receiver I have come to realize the advantages of a signal-strength indicator. The prospects for adding one looked poor since there is no suitable space on the front panel. A cable-connected S meter mounted in its own cabinet or chassis seemed a likely alternative.

During the process of designing an S meter a glance across the work-bench, discovered, bold as brass, a BC-442-A antenna relay. Here was a neat looking unit, with a fairly sensitive meter already mounted in a small metal box. The current required for full-scale deflection was checked. This was between 4.5 and 5 ma, but 1 ma swung the needle to the point marked 6 on the meter scale. (It apparently has a non-linear movement with a linear scale.)

Construction was started by removing all parts except the local-remote switch from the relay. The meter was remounted so it could be read in a horizontal position. When the antenna standoffs were taken out the three large holes were concealed by mounting the zero-set control in such a position that the dial plate would just cover them. Another hole was drilled in the bottom plate for the connecting cable.

Because of the current requirements of the meter, I preferred the circuits that use the plate current of an i.f. tube connected to the a.v.c. The basic circuit shown in Fig. 1 makes the meter read backward and hard to calibrate.

After mulling it over I decided to use the circuit shown in Fig. 2. This allows the meter to read up-scale. It is the familiar bleeder type using the meter in a balanced bridge circuit. Since the value of the bleeder resistor R will

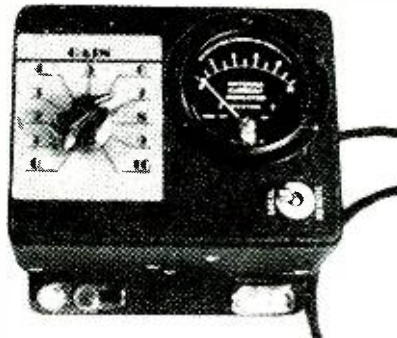

Complete cable-connected S meter.

vary with the tube types and voltages used in other receivers, the constructor should try different values until the proper size is found. I use a 25,000-ohm 2-watt resistor. It gives the S meter fairly good sensitivity and does not impose too heavy a load on the power supply. It would be a good idea to insert a milliammeter in the B+ lead of the connector cable to check the actual current drain. In my receiver this amounted to only 3.5 ma, and allowed a weak signal to register on the meter.

The local-remote switch shunts the meter and disconnects the bleeder from the B supply when the meter is not being used. A 3-wire cable from the receiver to the meter is required. A terminal strip at the back of the receiver and lugs at the ends of the cable leads facilitate connection. The brackets on the relay case make it possible to mount the instrument on the wall.

The S meter could be calibrated with

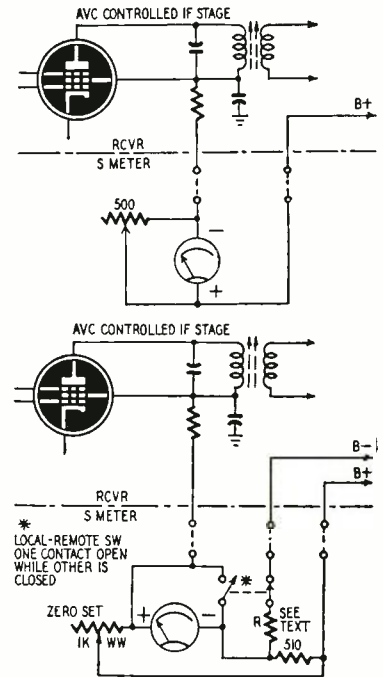

Fig. 1 (above)—Fundamental circuit. Fig. 2 (below)—Final meter circuit.

an accurate signal generator but since the object is merely to compare relative signal strengths, this is, of course, unnecessary. The zero-set control is adjusted by shorting the antenna post on the receiver to ground and setting the meter to zero. Taking the ground off the antenna post puts you in business with an S meter, which should not cost you over four dollars.

Materials for the S meter

Resistors: 1—510 ohms, 2 watts, 1—24,000 ohms (see text) 2 watts, 1—1,000 ohms, wire-wound potentiometer
Miscellaneous: 1—dial plate and knob; 1—3-wire connector cable and terminal strip; 1—BC-442-A antenna relay or a metal box-chassis and a 0-5 milliammeter; rubber grommet, hardware, wire, solder, etc.

—end—

combination of R2 and C5. The C5-R2 combination will be recognized as a low-pass filter or simple integrating network and has two effects. The harmonic content of the sawtooth plate voltage which is fed back through it is almost completely attenuated, so that

TABLE I
Capacitor Values for Fig. 5

Cap.	C	D	F	A
	C ₁	E	G	A ₂
	D	F	C ₂	B
C3	.015	.012	.010	.0082
C4	330	270	220	180
C5	.0027	.0222	.0018	.0015
C6	.018	.015	.012	.010
C7	680	560	470	390
C8	.0047	.0039	.0033	.0027
C9	.013	.027	.022	.018
C10	.0015	.0012	.0010	.00082
C11	.0032	.0068	.0056	.0047
C12	.068	.056	.047	.039
C13	.0039	.0033	.0027	.0022
C14	.018	.015	.012	.010
C15	0.12	0.10	.082	.068

Decimal capacitances in microfarads; others in micromicrofarads. Tolerance ±10%.

what appears across C5—and is fed to the grid—is almost a sine wave. This sine wave is the fundamental component of plate voltage shown in the dashed line of c. Second, it introduces an additional lag of almost 90 degrees in the phase of the fed-back signal. As a result, the feedback voltage reaching the grid is of the shape and phase indicated in d of Fig. 7.

Note the relation between wave a, the input signal, and fed-back voltage d. The fed-back signal reaches its negative peak at the same time as the input signal reaches every other crest. Combining the input and the fed-back voltages gives the form of e in Fig. 7. Every even crest is negatively displaced, preventing it from bringing the tube's grid voltage above the plate-current cutoff point; while every odd crest is displaced positively, aiding tube conduction. Thus it is easy to see that our original assumption—that the tube conducts only on alternate peaks of the input signal—is justified, and a frequency division of 1 to 2 takes place.

The frequency-sensitive capacitor val-

ues for the divider strings are given in Table I and refer to the numbered capacitors in Fig. 5. Standard 10%-tolerance capacitors are used. The resistor values are constant, since either R or C may be varied.

A single divider usually works well over a range of six to eight semitones, or more than half an octave. In an actual generator string, however, the ranges of the four dividers are staggered to some extent by parts tolerances, and the over-all range through which all four dividers work successfully may be limited to five semitones or less. The most important value is the plate (output) capacitor since it affects not only frequency but also level, which must be the same from note to note. In the Minshall plant four different generator string designs are manufactured, as Table I indicates, each useful for three notes.

In next month's article we shall discuss the vibrato, keying, and control circuits of the Minshall organ, the tone-color system, and the amplifier.

(to be continued)

MODEL PLANE CONTROL . . .

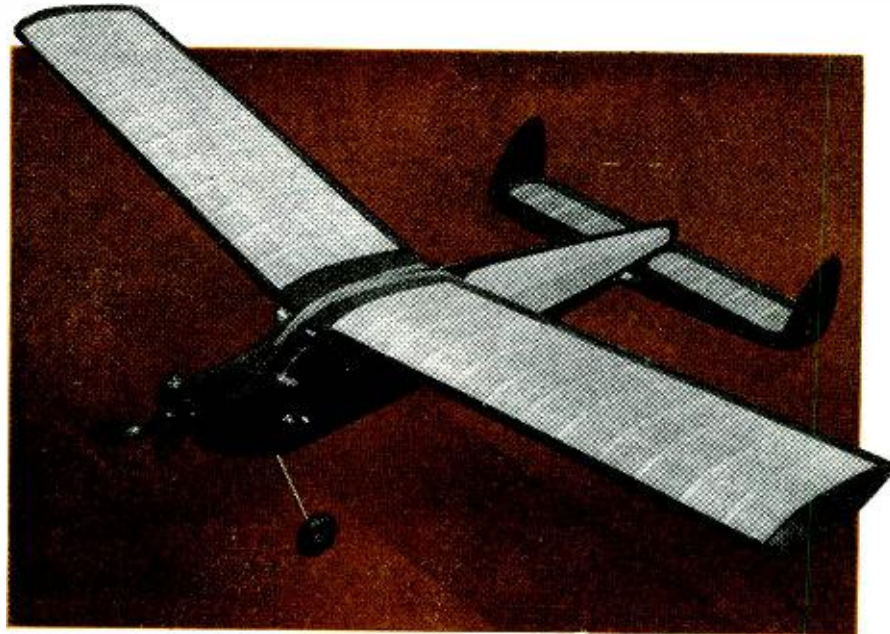

. . . with 27-mc signals . . .

A fascinating hobby—
combining the techniques of
electronics and flying—
now open to non-amateurs
too, with the assignment of
an exclusive Citizens'-Band
spot frequency. Simple
equipment gets you started.

By E. J. BROWN

MILITARY use of guided missiles and radio-controlled miniature planes for targets and test purposes has become a part of everyday news. The use of radio control has spread to amateurs who build and fly small gas-engined planes as a hobby. The development of miniature components and compact hearing-aid batteries have reduced the size of radio-controlled model planes to half that of prewar types.

The opening of the Citizens band and the marketing (by the Vernon McNabb Co.) of a complete Citizens band control unit, including a transmitter, receiver, and escapement control, has greatly expanded the number of radio-controlled-model builders.

One of the most valuable aids to radio control of plane models is the Raytheon RK-61 tube. This tube, a gas thyatron triode, requires so little operating current that it is possible to reduce the weight of the airborne radio equipment to only 7½ ounces. The RK-61 was in short supply for a while, but is now available again. A British tube, the XFG-1, also may be used without any circuit changes.

This article describes a complete model-control system which can be easily constructed in the home. It is intended for use in the amateur bands above 26,960 mc., and on the new Citizens band radio control frequency of 27.255 mc. While much radio control work is also being done on the 460-470-mc Citizens band, the RK-61 thyatron

is not considered suitable for use at frequencies above 100 mc. (Editor's note: No attempt should be made to use radio control for any purpose until the necessary licensing requirements have been met. Consult the FCC for latest regulations.)

The schematic of the superregenerative receiver which is mounted in the plane or other controlled unit is shown in Fig. 1. A spiral-wound inductor L1 is used to reduce space requirements. L1, consisting of 9½ turns of No. 16 enameled wire with a tap at about 3½ turns from the inside, can be seen in Figs. 2 and 3. The relay and the escapement-type control unit (Fig. 4), which moves the rudder, are separate,

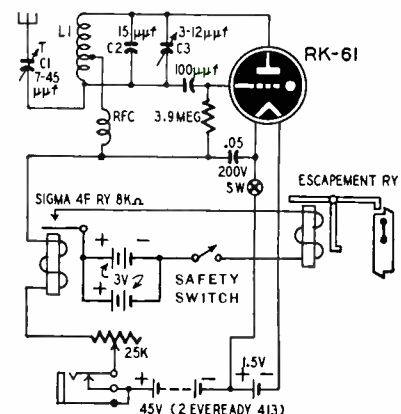

Fig. 1—Schematic of the receiver. An incoming signal closes the relay contacts.

RADIO-ELECTRONICS

Fig. 2 (below)—Close-up view of the receiver tuning assembly, showing the special spirally-wound tuning inductor. The underside of the control relay for the escapement mechanism appears at the left.

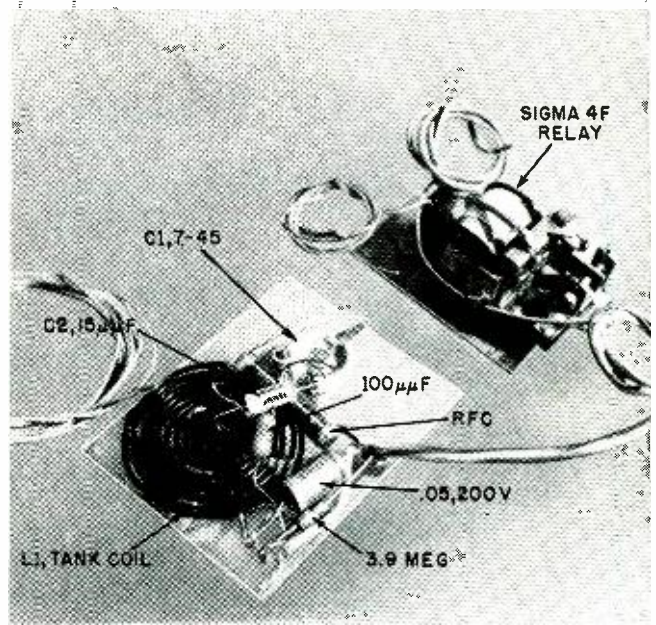
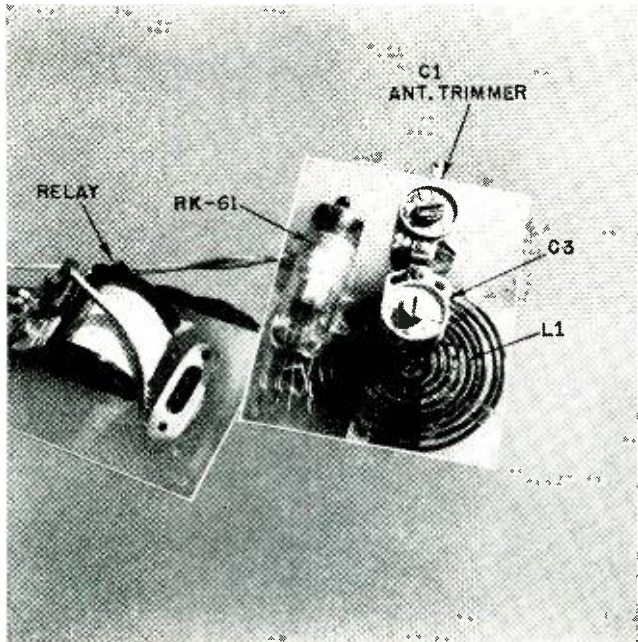

Fig. 3 (above)—The opposite side of the receiver mounting plate, showing the placement of related components and the connecting cable to the control relay unit.

and may be mounted in any convenient location in the model.

The receiver is constructed on a base of polystyrene as shown in the photos. Do not solder the tube wires directly to components, as it may damage the tube and would prevent quick removal. All parts are standard except the r.f. choke, which is made from a burned-out tubular glass fuse, close-wound with a 1-inch long, single layer of No. 32 enameled wire. The three-wire

cable connects the receiver to the relay and the batteries.

If dimensions vary from those shown it may be necessary to change the value of the fixed band-spread capacitor C2 to keep the receiver in the band. The L-C ratio of the tank is not critical, but if trouble is experienced try varying the number of turns on the coil and try changing the point of the choke connection to control regeneration.

A 25,000-ohm potentiometer is used

to control plate current. Filament current is supplied by two penlite cells wired in parallel. A switch in the A plus-B minus lead turns the receiver on or off.

A closed-circuit jack is used in the B plus lead for plugging in a 0-5-ma d.c. meter to tune the receiver. The no-signal plate current should read between 1.3 and 1.5 ma, dropping to 0.1 to 0.3 when a signal is received. The receiver antenna should be a piece of stranded wire about 60 inches long. Lengths as short as 18 inches will work at short ranges. The antenna-tuning capacitor, C1, will compensate for incorrect lengths.

The relay used in the receiver is a Sigma 4F, 8,000-ohm unit, obtainable on the surplus market or from Control Research Co., P.O. Box 9, Hampton, Virginia, who carry other radio control supplies and specialize in kits for radio-control equipment. This relay is the heart of the set and must be super-sensitive and have adjustable contact spacing and armature spring tension.

Adjust the relay to pull in the armature at 1.1 ma and release it at 0.7 or 0.8 ma. The armature spring tension and contact spacing must be reduced from the original settings. The contact spacing should not be over 10 one-thousandths of an inch to start with, and the armature must not touch the pole piece when pulled in.

The control units may be of the escapement type, pulse type (which rotates back and forth 180°), or small electric motors with self-centering limit

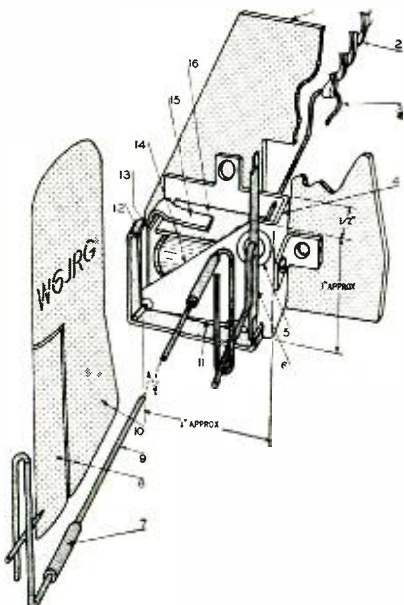
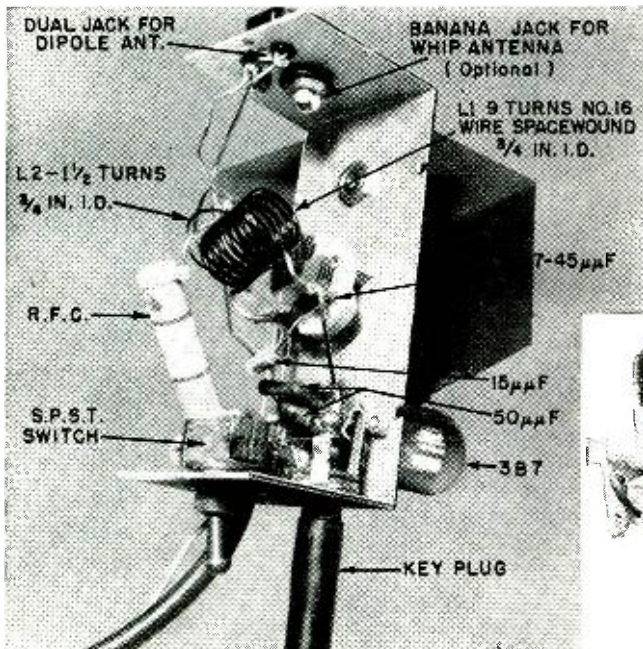
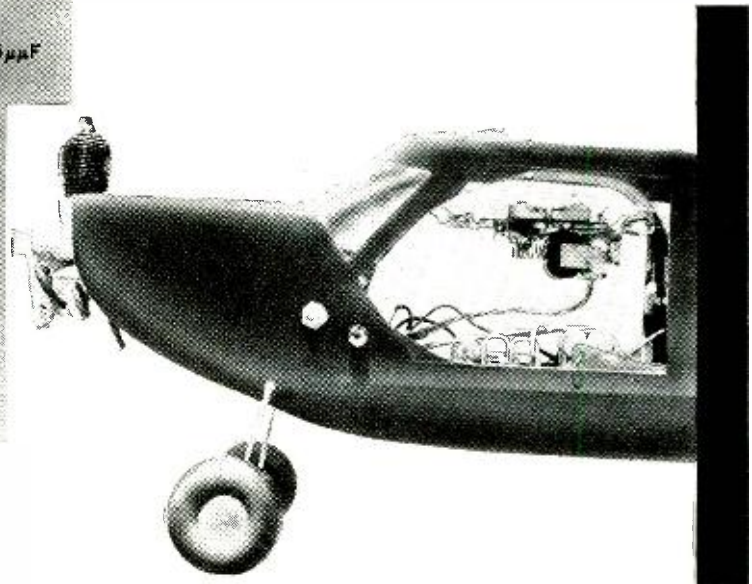

Fig. 4—The escapement mechanism. The parts are identified and described below.

1. Bulkhead.
2. Rubber loop, 1/8-inch flat rubber.
3. Crank-pin hook, 1/16-inch music wire.
4. Frame, .025-inch hard brass sheet.
5. Bearing, model airplane type.
6. Control arm, 1/8-inch brass rod.
7. Bushing, brass tubing.
8. Rudder.
9. Yoke shaft, 1/16-inch music wire.
10. Fin.
11. Spring, .012-inch music wire.
12. Pawl.
13. Armature, 1/16-inch soft iron.
14. Coil: 90 ft. No. 32 enameled wire (or equivalent in No. 31 to give resistance of 6-10 ohms), wound on soft iron core 3/16-inch diameter, 3/4 inch long. This coil draws 300-500 ma at 3 volts.
15. Armature stop.
16. L-shaped coil bracket.



(Left)—The 27-mc transmitter assembly (Below)—A typical receiver installation in the cockpit of a flying plane model.



switches. These may be covered in a future article.

The escapement shown in Fig. 4 is also from Control Research Co., available in kit form. The dimensions shown will produce a slightly larger unit with more reliability for operation in a large plane or boat model. This unit should weigh from 1/2 to 1 ounce completed.

The escapement is wired to the relay so the relay opens the circuit when energized by the no-signal plate current. The circuit closes when the relay opens as a signal is received. A s.p.s.t. switch is required in the escapement circuit to open the circuit when the receiver is turned off.

The batteries used are a factor in weight. Eveready 413E B-batteries will last three to four months, and two penlite batteries in parallel will provide

filament current for a month or more. The batteries used to control the escapement or control unit draw the most current and should be as large as possible. The author uses four to six penlite batteries in series-parallel to develop 3 volts. They are usually good for 12 to 20 flights of 5 to 10 minutes duration each. The weight of the complete installation with above batteries will be about 12 ounces. Smaller batteries may be used to reduce weight, with a corresponding reduction in life and reliability.

The transmitter, diagrammed in Fig. 5, is a conventional push-pull circuit and may use a 3A5 or a 3B7. A 6J6 may be used if operation from a car battery is desired. The author started with a dry-battery-operated 3A5 unit but now uses a 6J6 transmitter with a surplus-bargain dynamotor for B-supply. Both units were equally reliable, but the dynamotor eliminates the worry of battery drain affecting signal strength.

The grid-leak resistors R1 and R2 shown in Fig. 5 were reduced to 6,800 ohms for the 6J6 to increase output.

The transmitter is constructed on the U-frame part of a standard 2 1/4 x 2 1/4 x 5-inch aluminum box, as shown in the photo above. The tube socket is at the bottom of the U with the tube outside for better cooling.

The control switch in the B plus lead can be any type of push-button switch mounted either on the transmitter or at the end of a 5- or 6-foot cord to

permit moving around while operating.

The r.f. choke is an Ohmite Z-14, but one similar to the type used in the receiver will do as well. L1 is 9 turns of No. 16 center-tapped, with an inside diameter of 3/4 inch. Turns are spaced one wire diameter. L2 is 1 1/2 turns with 3/4-inch inside diameter.

A folded dipole antenna has been found to be the most effective for transmission over distances up to three miles. The dipole is a piece of 300-ohm ribbon line 14 feet, 5 inches long, shorted at the ends. A 300-ohm lead-in connects to the center of one of the antenna conductors. The mast must be mounted in a piece of pipe or other support to permit rotation. A 9-foot vertical rod antenna may also be used if operation is limited to ranges of one-half mile or less. One side of L2 is grounded when using this type of antenna.

Tune the transmitter with an absorption-type wavemeter or grid-dip meter and then tune the receiver to the transmitter frequency as described above.

The transmitter and receiver circuits shown may be used also for operation in the 50- to 54-mc amateur band with the advantage of shorter antennas.

The equipment described above provides an excellent beginning for the newcomer to radio control. The author wishes to thank the Control Research Co. for permission to use the transmitter schematic and the receiver circuit (as modified by the writer with the spiral coil).

—end—

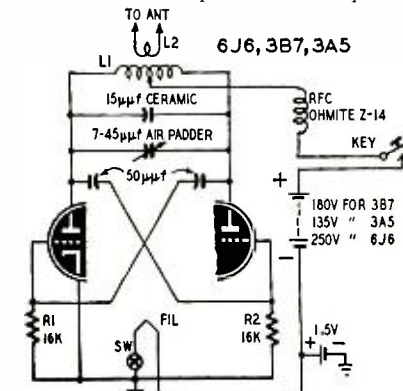

Fig. 5—Schematic of the transmitter. For a 6J6, heater battery should be 6.3v.

Fig. 1—Interior layout of the frequency spotter.

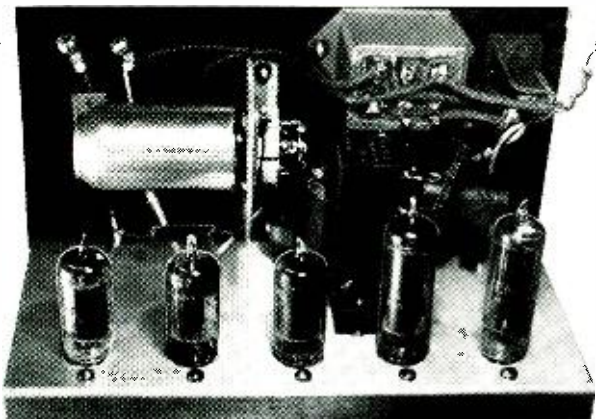
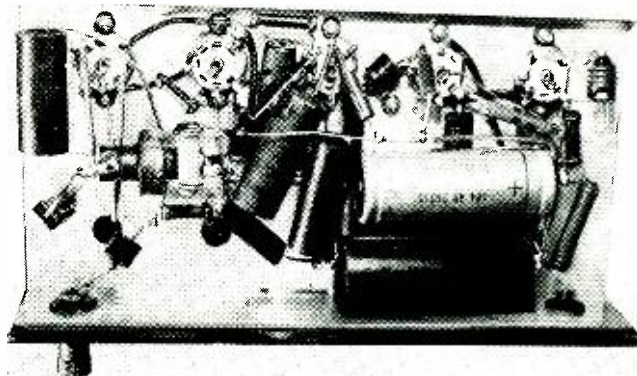

Fig. 2—Component placement beneath the chassis.



CRYSTAL FREQUENCY SPOTTER

By ALFRED HAAS

THE increasing need for v.h.f. and u.h.f. signal sources calls for critical marker frequencies, having fractional megacycle values.

It is not easy to build a highly accurate signal generator with wide frequency coverage, and very few service-type oscillators have the required stability, or scales readable in decimal fractions of a megacycle.

It is possible, however, to build a relatively simple crystal oscillator of high accuracy and stability. Its harmonics provide a great many check points that can make even a poor signal generator temporarily accurate.

A diagram of such an instrument for a.c.-d.c. operation is shown. It consists of a 50B5 crystal oscillator, a 12BA6 harmonic amplifier, a 12BE6 mixer with two inputs, and a 12AT6 audio amplifier. The 35W4 rectifier provides B plus voltages.

In practice, a crystal having a relatively high fundamental frequency (1500 kc in this case) is used first.

Harmonics of this frequency are fed into the mixer along with the output of the signal generator. If the generator is tuned close enough to one of the crystal harmonics, the difference becomes audible. As the generator approaches the exact frequency of the harmonic, the audible difference decreases in pitch, and at zero difference disappears entirely.

When a sufficient number of check points 1500 kc apart have been marked on the generator dial a 100-kc crystal is switched on. Harmonics of this crystal should zero-beat at each of the original check points and produce 14 additional check points between each original pair.

The parts layout is shown in Fig. 1 and Fig. 2.

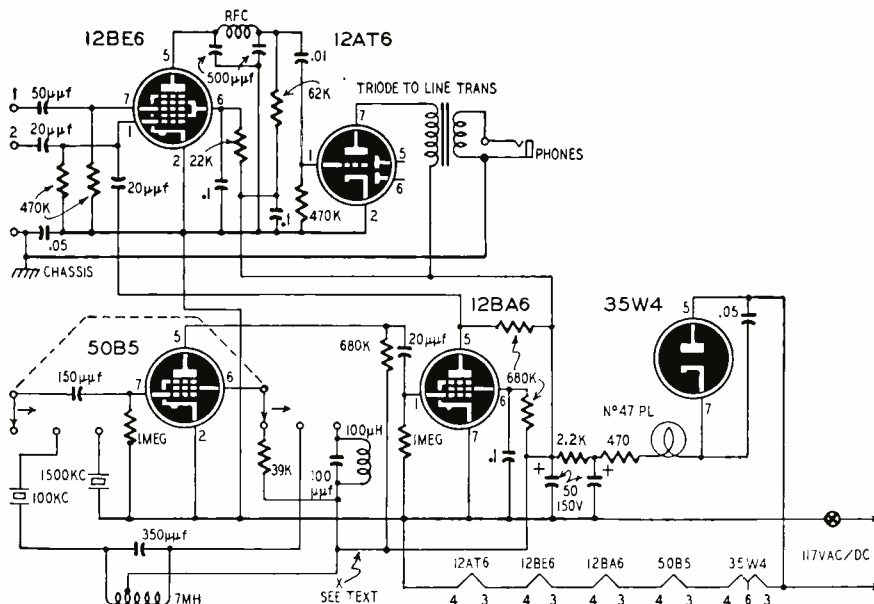

Circuit details

Precision crystals are sometimes sluggish in starting. For this reason ringing-type oscillator circuits are used. The 100-kc oscillator requires a 7-milli-henry coil, tapped at one-tenth the total number of turns. The coil is tuned by a capacitance of approximately 350 µf. The 1-mc circuit is tuned by a 100-µh coil and a 100-µf capacitor. (Sluggish r.f. chokes suitable for this circuit are available from several manufacturers—Editor.)

The three-position selector switch allows use of either crystal, or a standby position in which the oscillator is disabled by reducing the screen voltage. The mixer can then be used for comparing two external oscillators.

The type 47 pilot lamp in the rectifier cathode circuit acts as a fuse and indicates failure of the oscillator circuit by an increase in brightness.

Tuning procedure

To tune the oscillator ringing circuits, a 0-10 d.c. milliammeter shunted

by a 0.1-µf capacitor is inserted at X in the diagram. Each circuit should be tuned for a screen current of about 2 ma. Lower currents may cause instability.

An accuracy of approximately 1% can be obtained by this method. For utmost accuracy terminal 2 should be coupled loosely to the antenna post of a receiver tuned to one of the standard frequency transmissions from WWV. By adjusting the tank circuits to zero beat in the receiver speaker, a short-time accuracy of one part in ten million may be obtained.

Materials for frequency spotter

Resistors: 1—2,200, 1—470 ohms, 1 watt; 2—1 meg-ohm, 3—680,000, 2—470,000, 1—62,000, 1—39,000, 1—22,000 ohms, 1/2 watt.

Capacitors: (Electrolytic) 2—50 µf, 150 volts. (Paper) 3—0.1 µf, 1—0.05 µf, 1—0.01 µf, 400 volts. (Ceramic or mica) 2—500 µmf, 1—350 µmf, 1—150 µmf, 1—100 µmf, 1—50 µmf, 3—20 µmf.

Miscellaneous: 1—50B5, 1—35W4, 1—12AT6, 1—12BA6, 1—12BE6 tubes; 1—triode-to-line low-level output transformer; 1—2-pole-3-position waver switch; 1—s.p.s.t. toggle switch; 1—1500-kc crystal; 1—100-kc crystal; 2—crystal sockets; 5—7-pin miniature sockets; terminals, chassis, wire, solder, hardware.

—end—

This view shows the six 4,000-ohm units that form the 807 screen-dropping resistor. Above-chassis mounting aids heat dissipation.

Economical,
simple, efficient,
this unit swings
an 807 to 90 watts
peak output

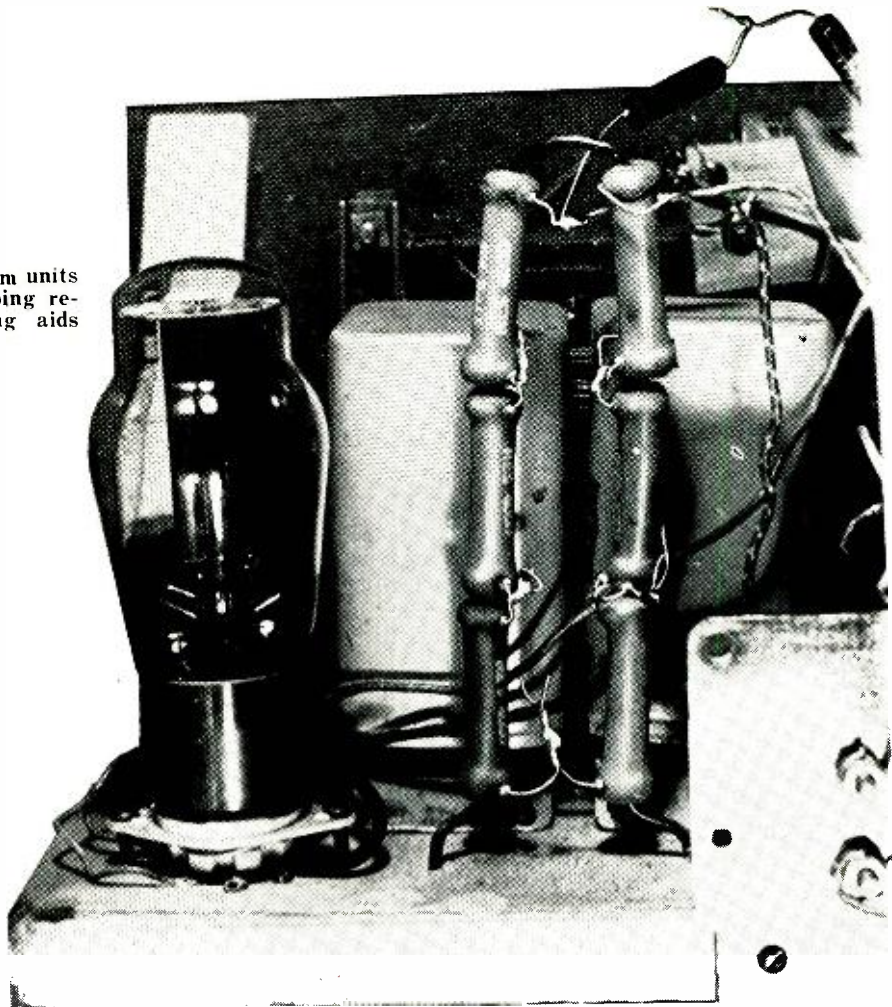

CLAMP TUBE MODULATOR

By FRED J. LINGEL, W2ZGY

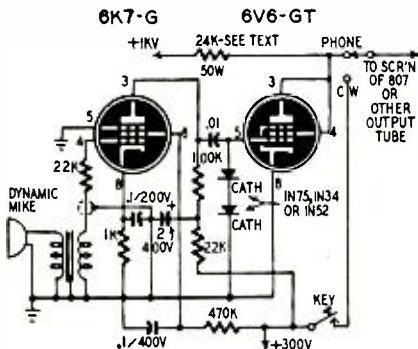

Fig. 1 (above)—Circuit of the clamp-tube modulator. Use of crystal diodes in the 6V6 grid circuit reduces hum modulation.

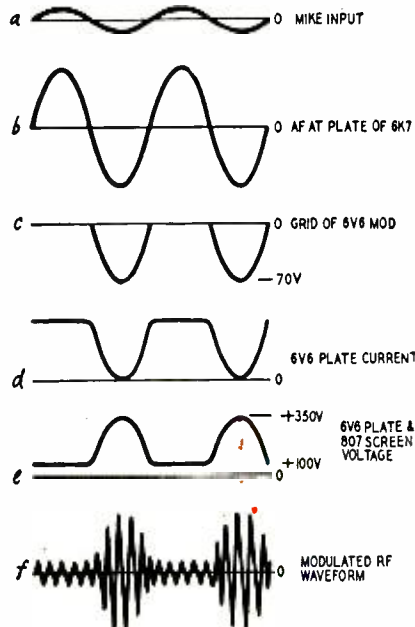
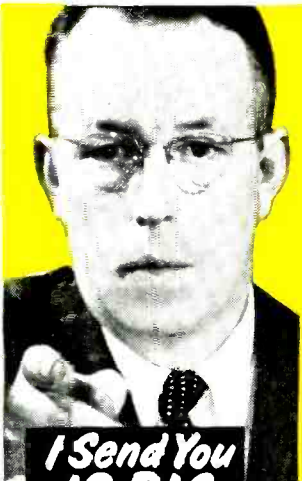

Fig. 2 (right)—Controlled-carrier modulation waveforms from microphone to transmitter output. Details in text.

THIS article describes a two-tube controlled-carrier modulator using two germanium diodes as the audio rectifier. The unit was designed around the intercom amplifier used in the No. 19 Mark II surplus tank transmitter-receiver. Normal telephone speech level at the dynamic mike fully modulates an 807 to 90 watts peak power output. The two-tube assembly reduces r.f. feedback and gives a much simpler modulator than any previously described.

Controlled-carrier modulation is popular in amateur transmitters for a number of reasons:

- Few parts—no transformers.
- Low cost—uses receiving type tubes.
- Small size.
- Higher power—phone operation at maximum c.w. ratings.
- Easy to adjust—impossible to over-modulate.
- Ideal for portable rigs—modulated amplifier plate and screen power on only when speaking.
- Simple power-output control—speak low for locals, loud for distance.



Learn RADIO TELEVISION

**—New Package Unit Plan—PAY AS YOU LEARN
NO MONTHLY PAYMENT CONTRACT TO SIGN!**

**I Send You
18 BIG
KITS
OF RADIO-
TELEVISION
EQUIPMENT**

**APPROVED
FOR VETERANS
UNDER
THE
G.I. BILL**



**IF YOU ARE
EXPERIENCED IN RADIO**

Men already in Radio who seek a short intensive 100% TELEVISION Training with FULL EQUIPMENT INCLUDED are invited to check and mail the coupon at the right.

**TRAIN IN 10 MONTHS OR LESS
At Home in Your Spare Hours**

Now . . . be ready for Radio-Television's big pay opportunities in a few short MONTHS! Frank L. Sprayberry's completely new "Package" training unit plan prepares you in just 10 MONTHS . . . or even less! Equally important, there is NO monthly payment contract to sign . . . thus NO RISK to you! This is America's finest, most complete, practical training—gets you ready to handle any practical job in the booming Radio-Television industry. In just 10 months you may start your own profitable Radio-Television shop . . . or accept a good paying job in this fascinating expanding field at work you've always wanted to do. Mr. Sprayberry has trained hundreds of successful Radio-Television technicians—and stands ready to train you in less than one year, even if you have no previous experience. You learn by DOING . . . actually working with your hands with equipment of special design to illustrate basic theory instead of relying on books alone.

VALUABLE EQUIPMENT INCLUDED WITH TRAINING

The new Sprayberry "package" plan includes many big kits of genuine, professional Radio-Television equipment. While training you actually perform over 300 demonstrations, experiments and construction projects. In addition, you build a powerful 6-tube standard and short wave radio set, a multi-range test meter, a signal generator, signal tracer, many other projects. All equipment is yours to keep . . . you have practically everything you need to set up your own service shop. The interesting Sprayberry book-bound lessons and other training materials . . . all are yours to keep.

EARN EXTRA MONEY WHILE YOU LEARN!

All your 10 months of training is AT YOUR HOME in spare hours. Keep on with your present job and income while learning . . . and earn EXTRA CASH in addition. With each training "package" unit, you receive extra plans and ideas for spare time Radio-Television jobs. Many students pay for their entire training this way. You get priceless practical experience and earn generous service fees from grateful customers. Just one more reason why the Sprayberry new 10 MONTH-OR-LESS training plan is the best Radio-Television training in America today. If you expect to be in the armed forces later, there is no better preparation than good Radio-Television training.

FREE 3 BIG RADIO-TELEVISION BOOKS

I want you to have ALL the facts about my new 10-MONTH Radio-Television Training—without cost! Act now! Rush the coupon for my three big Radio-Television books: "How to Make Money in Radio-Television," PLUS my new illustrated Television Bulletin PLUS an actual sample Sprayberry Lesson—all FREE with my compliments. No obligation and no salesman will call on you. Send the coupon in an envelope or paste on back of post card. I will rush all three books at once!

SPRAYBERRY ACADEMY OF RADIO
Dept. 20-K, 111 N. Canal St., Chicago 6, Ill.

**Mail
Coupon
Today!**
NO OBLIGATION
No Salesman
Will Call

SPRAYBERRY ACADEMY OF RADIO, Dept. 20-K
111 North Canal St., Chicago 6, Ill.

Please rush to me all information on your 10-MONTH Radio-Television Training Plan. I understand this does not obligate me and that no salesman will call upon me.

Name..... Age.....

Address.....

City..... Zone..... State.....

Please check Below About Your Experience

Are You Experienced? No Experience

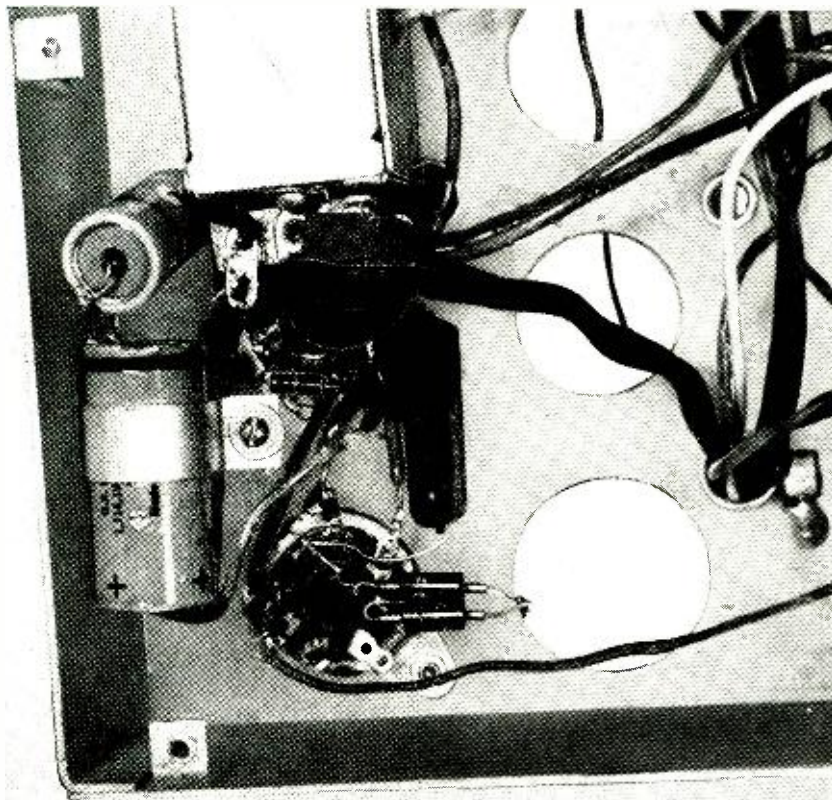

Underside of the clamp tube modulator, showing the compactness of the layout. The microphone transformer is at the top, partially concealing the 6K7-G socket. The series-connected germanium-crystal diodes are at the bottom.

Automatic speech clipping—more complete modulation.

The complete circuit diagram is shown in Fig. 1.

The modulator operates as follows:

The 6K7 is the a.f. amplifier, and the 6V6-G is the clamp tube, operated with zero bias. With no audio signal input, the 6V6 draws enough current through the 24,000-ohm resistor to drop the voltage on the 807 screen and the 6V6 plate to 50–100 volts. The reduced screen voltage on the 807 drops the plate current to about 20 ma, and the plate power input is limited to about 20 watts.

When an audio signal (*a* in Fig. 2) is applied to the 6K7, the positive half-cycles of the amplified signal (*b*) cause the series-connected germanium diodes to conduct and short-circuit the audio to ground so it does not affect the operation of the 6V6.

On the negative half-cycles, the audio signal drives the 6V6 grid to a maximum of about 70 volts negative with the voltage following the negative half of the speech envelope (*c* in Fig. 2). This negative audio voltage causes a corresponding drop in the clamp-tube plate current (*d* in Fig. 2), which decreases the drop across the 24,000-ohm 807 screen and 6V6 plate resistor. The screen voltage rises as shown at *e*.

The r.f. output is modulated by the varying screen voltage.

Although the audio modulating component includes harmonics generated by the clipping action on positive speech half-cycles of the series-connected crystal diodes, and by the non-linearity of the screen characteristic, the halves of the modulated r.f. envelope are symmetrical (see waveform *f* in Fig. 2) because of the flywheel effect of the tank circuit.

By connecting the two diodes across the grid, we eliminate the two grid resistors sometimes used in this type of modulator. The two series-connected diodes provide a high grid resistance with a greater control action. If only one diode is used, the rectified grid voltage is roughly half the value obtained with two.

The 807 screen dropping resistor consists of six 4,000-ohm, 10-watt resistors connected in series. By connecting the 6V6 plate to a tap on the resistor string, you can vary the ratio between the strengths of the unmodulated and fully-modulated carrier.

For c.w. operation and for tuning up on phone, the screen of the 807 is connected to a 300-volt d.c. supply rather than to the modulator resistor. This is preferred to cathode-biasing the 6V6, since the plate of the 6V6 is then not

held at an abnormally high voltage for an appreciable period of time with eventual tube failure.

I have used this arrangement very successfully for several months on my "souped-up" No. 19, Mark II surplus transmitter. It runs approximately 10 watts idle carrier and 100 watts peak. The germanium diode rectifier helps keep a.c. hum at a low level, since there is no heater supply in this sensitive portion of the modulator system.

The 807 final amplifier of the Mark II is run with 1,000 volts on the plate. The resting plate current is about 20 ma. It rises to 100 ma on modulation peaks. The screen-grid is run at 50–100 volts in its quiescent state and rises to a maximum of 350 volts under modulation. The modulation is limited to about 80% because the final plate current is not completely cut off on peaks. The 807 plate-current meter indicates comparative r.f. output, audio level, and tank-circuit resonance.

When answering a CQ, I have found it best to switch to the c.w. position for a couple of seconds before modulating. During this interval I check plate current and tuning of the final amplifier. The full carrier power also gives the calling station a more definite indication that he is being answered.

—end—

A Guiding Beacon For Quality Electronic Parts

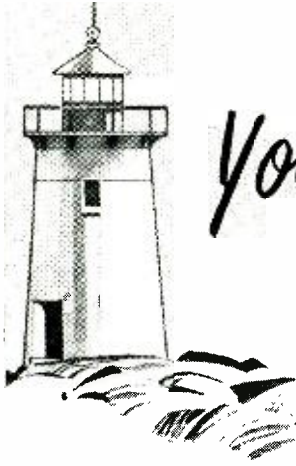

Your Local
RADIART
Distributor



RADIART Sales Offices Across The Nation



These Are The Cities With RADIART Distributors
In Delaware, Maryland, Virginia, New Jersey,
Pennsylvania and Washington, D. C.

Delaware
WILMINGTON

District of Columbia
WASHINGTON

Maryland
BALTIMORE
CUMBERLAND
HAGERSTON
SALISBURY

New Jersey
ATLANTIC CITY
BRIDGETOWN
CAMDEN
PHILLIPSBURG
PITMAN

Pennsylvania
ALLENTOWN
BETHLEHEM
EASTON

HARRISBURG
HAZELTON
LANCASTER
NORRISTOWN
PHILADELPHIA
POTTSVILLE
READING
SCRANTON
SUNBURY

Virginia
WILKES-BARRE
WILLIAMSPORT
YORK

Virginia
DANVILLE
LYNCHBURG
MARTINSVILLE
NEWPORT NEWS
NORFOLK
RICHMOND
ROANOKE
STAUNTON
WINCHESTER

BUY OF THE MONTH



The NEW — ALL NEW... "CDR" ROTATOR is far and away the very last word in antenna turning devices! Boasting many new outstanding features, this new rotator begins where others leave off! Easy to install — fool-proof in operation... the control cabinet features full view indicating meter with finger tip lever control instantly reversible. See it at your jobber — or write for literature.

FOR NAME OF YOUR NEAREST RADIART DISTRIBUTOR
USE COUPON BELOW

RADIART SALES CO. 50 E. Wynnewood Road, Wynnewood, Penn.

.....Please send names of the Radiart Distributors in my area stocking the following Radiart products in which I am interested: Tele-Rotors, Vibrators, TV and FM Antennas, "Spee-Dee" Chimney Mounts, Lightning Arresters, Auto Aerials, Power Supplies

.....Please have a Radiart Distributor call on me.

Name

Address

City State



THE RADIART CORPORATION CLEVELAND 2, OHIO

VIBRATORS • AUTO AERIALS • TV ANTENNAS • ROTATORS • POWER SUPPLIES

SIMPLE MAGNETIC AMPLIFIER

Comparative newcomers to the field of electronics, magnetic amplifiers now play important roles in equipment design.

By ERWIN LEVEY

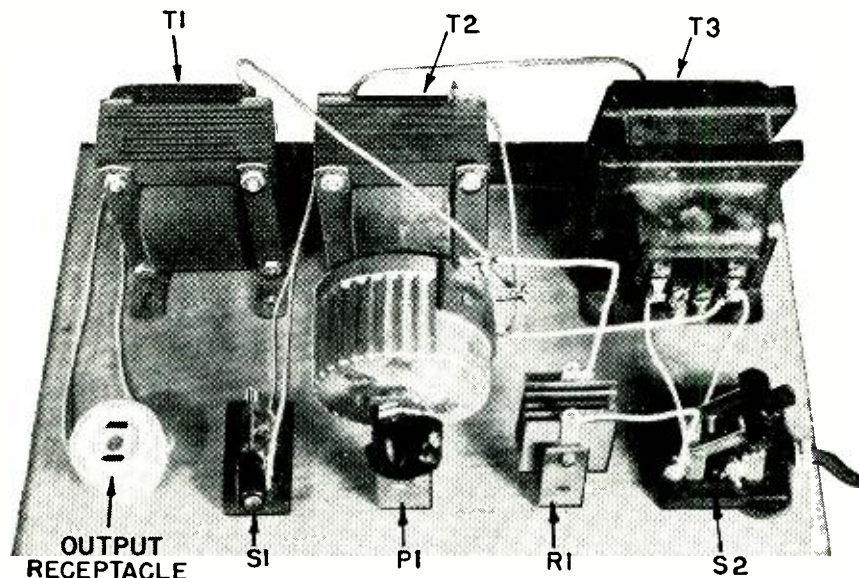

Fig. 1—Layout of the magnetic amplifier. The large potentiometer controls its gain.

THE growing use of magnetic amplifiers in military and industrial electronic equipment has stimulated considerable interest in these relatively unfamiliar devices. This article describes a simple setup for demonstrating the basic principles of magnetic amplification and applying them to controlling the speed of a small a.c. motor.

The equipment requires only three standard filament transformers and a few other readily available parts, all of which are mounted on a 7 x 12-inch wood baseboard.

The layout and all parts are clearly seen in the two photographs, Figs 1 and 5.

Magnetic amplification

In its simplest form a magnetic amplifier is a magnetic core with two windings (Fig. 2). One of these, the *d.c. or control winding*, usually has a large number of turns and is connected across a source of variable d.c. The other, called the *a.c. or load winding*, is connected in series with the load and an a.c. supply line. A small amount of power applied to the d.c. winding will control a larger amount of power in the a.c. winding.

This is because varying the amount of current in the d.c. winding can vary the inductance of the a.c. winding over a wide range. As its inductance is varied, so is its impedance to a.c. and consequently the amount of power which can be applied to the load.

When the d.c. is zero the self-inductance of the windings is high and little power is applied to the load. As the amount of d.c. through the control

winding is increased, the impedance of the secondary goes down, because the core is becoming saturated magnetically, and variations in the a.c. field no longer have any effect on it. Hence these variations do not set up the bucking voltages which keep the secondary impedance high.

With a large amount of d.c. in the winding, the secondary has practically no impedance, and the load is, in effect, connected directly across the a.c. supply.

The apparatus is an *amplifier* because the amount of power applied to the control winding is less than that controlled in the a.c. winding. This unit—built with ordinary transformers for demonstration purposes—has a gain in the order of two, but magnetic amplifiers made with special core material have extremely high gains. For a more complete and highly understandable treatment of this subject, see the article "Magnetic Amplifiers" in the September, 1951, issue of RADIO-ELECTRONICS.

This model uses a two-core arrangement. Since a low-voltage control system was desired, two 6.3-volt filament transformers were used. These are transformers T1 and T2 in Fig. 3. The type of transformer used does not matter but the two must be identical or they will not function as a saturable reactor when connected. When used in this way no physical changes are required; it is necessary only to interconnect the windings so that certain phase relations exist.

Phasing procedure

To phase the transformer windings

correctly the following simple test is used. (A schematic of the arrangement is shown in Fig. 4.) Connect the two primaries in *parallel*. Designate one side of the line as S (start) and the other as F (finish). Mark the leads on each of the transformers accordingly. (It doesn't matter at this point which leads are used, as this coding will be the starting point.) Next, connect the secondaries of the two transformers in *series* and connect a 6.3-v pilot light across the two outside terminals. If the bulb glows brightly when the primaries are connected to the a.c. power line, connection is correct. Under this condition the two coils are in "series-aiding", which means that the total terminal voltage is 12.6. If the bulb is extinguished the connections are incorrect and *one* of the two secondary windings should be reversed.

When the proper connections have been made, mark the two windings as shown in Fig. 4. It is extremely important that this be done correctly, otherwise the unit will not operate in the final circuit.

The transformers can now be connected together to function as a saturable reactor. The 110-volt primaries are used as the d.c. control winding and are connected in "series-opposing" as shown in Fig. 3. The 6.3-v secondaries are used as the a.c. winding and are connected in parallel.

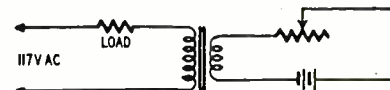
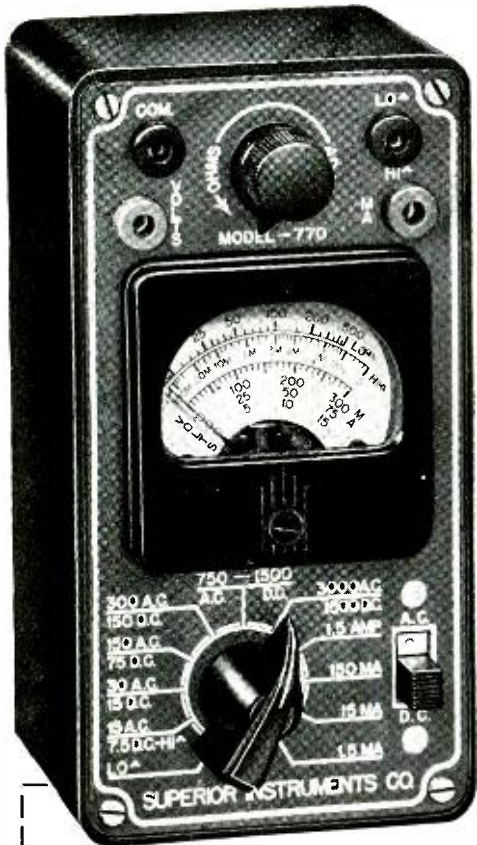

Fig. 2—Basic magnetic amplifier circuit. The magnetizing effect of the d.c. controls the permeability of the iron core.

WORLD'S FASTEST SELLING VOLT-OHM MILLIAMMETER



Superior's Model 770

is an accurate pocket-size V.O.M.
Measures only 3 1/8" x 5 7/8" x 2 1/4".

- ★ Uses latest design 2% accurate 1 Mil. D'Arsonval type meter.
- ★ Same zero adjustment holds for both resistance ranges. It is not necessary to readjust when switching from one resistance range to another. This is an important time-saving feature never before included in a V.O.M. in this price range.
- ★ Housed in round-cornered, molded case.
- ★ Beautiful black etched panel. Depressed letters filled with permanent white, insures long-life even with constant use.

The Model 770 comes complete with self-contained batteries, test leads and all operating instruments.

\$14⁹⁰
NET

SPECIFICATIONS

- 6 A.C. VOLTAGE RANGES:
0—15/30/150/300/1500/3000 Volts.
- 6 D.C. VOLTAGE RANGES:
0—7.5/15/75/150/750/1500 Volts.
- 4 D.C. CURRENT RANGES:
0—1.5/15/150 MA. 0—1.5 Amps.
- 2 RESISTANCE RANGES:
0—500 Ohms. 0—1 Megohm.



SEND FOR YOUR FREE COPY OF OUR CATALOG TODAY!

— THE "SUPERIOR" LINE —

We have been manufacturing Test Equipment for twenty years . . . rugged instruments designed for all 'round use—in the shop—in the basement—in the house. Our units can be piled in the back of your car with the rest of your gear. Accurate? We must make our units accurate to required tolerances to stay in this business. Not the 1/10th of 1% required by laboratory technicians but the 2% accuracy required for service work. Price? Compare the dealer's price of **any** model in our line with the price of any comparative unit. Ours is **always** lower priced.

Write Dept. RE-6 for your FREE catalog



Manufactured and Guaranteed by
SUPERIOR INSTRUMENTS CO.
227 Fulton Street, New York 7, N. Y.

**BUY IT AT YOUR
RADIO
PARTS
JOBBER**

high
HICKOK
sensitivity

5 Inch
OSCILLOGRAPH
with DC
AMPLIFIERS

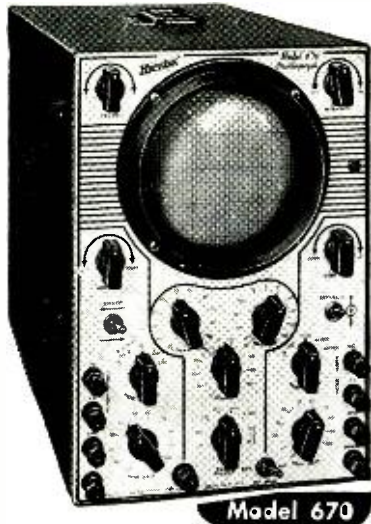

Accurate television service requires a GOOD "Scope". This HICKOK 670, designed with D. C. amplifiers provides perfect square wave response on low frequency. The extra sensitivity—to 10 MV per inch—in this HICKOK 670, properly shows the response curve, even when TV receiver is far out of alignment.

Features . . .

Wide band vertical amplifier useable beyond 2MC. Polarity reversing switches. Push-pull amplifiers. Direct connections to horizontal and vertical plates. Fixed sweep frequency for accurate viewing of wave forms 30 and 7875 cycles. Recurrent linear sweep 3 to 50,000 cycles. Astigmatic focus control for sharper trace. Horizontal amplifier 0 to 100 KC. Sweep oscillator 3 to 50 KC.

You'll like this Model 670. It's a perfect companion to the 610A for accurate TV alignment; or the Model 630 for accurate wave form analysis. Write for complete technical details.

THE HICKOK ELECTRICAL INSTRUMENT CO.
10531 Dupont Avenue · Cleveland 8, Ohio

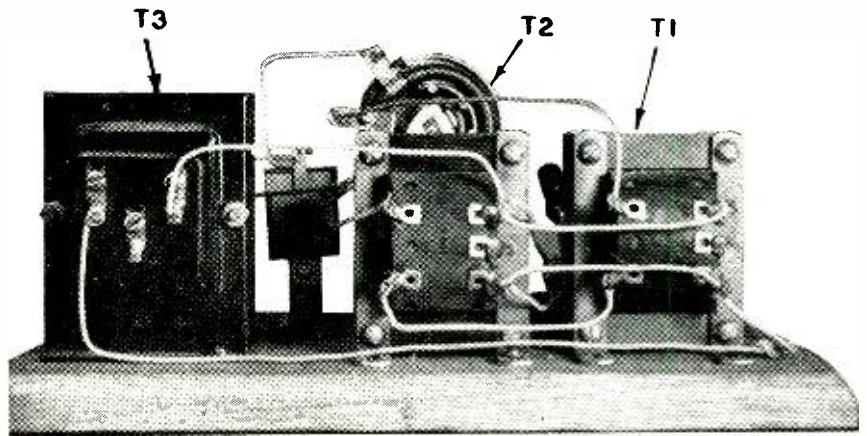

Fig. 5—Rear view of the magnetic amplifier. The two control transformers are at the right. The shielded transformer provides power for a small motor load.

A third transformer (T3) is needed to provide proper voltage for the load. Any small low-voltage motor will serve if the proper operating voltage is obtainable.

A much higher line current is required to start a motor than to keep it running. In this circuit even the minimum inductance of the a.c. windings would limit the current to such a small value that the motor could not start. A shorting switch (S1) is connected across these windings to allow full current to be applied to the motor when the power is first turned on. Once the motor is running the switch is opened, transferring control to the magnetic amplifier.

A half-wave selenium rectifier supplies the d.c. control current. The inductance of the d.c. windings provides good smoothing action, and no additional filtering is necessary. A 5,000-ohm, 50-watt potentiometer controls the current to the d.c. coils.

After the circuit has been assembled and all connections checked it can be put in operation. For this test the motor should not have a load attached. First close the shorting switch S1; then set the potentiometer so that full d.c. will flow when the power is turned on. Next close switch S2 to energize the circuit. The motor should start immediately. When it is up to full speed open S1. The motor speed can then be varied by turning the potentiometer. If the d.c. falls below a certain value the motor will stop because of the high inductance of the a.c. windings. It may be started again by closing S1.

The motor speed may be varied over wide limits. A little experimenting will

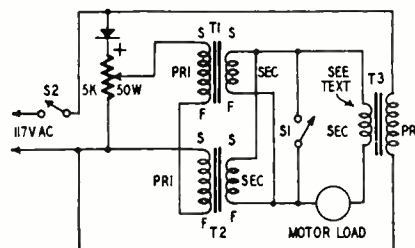

Fig. 3—The magnetic amplifier circuit. Characteristics of the three transformers and rectifier are given in the text.

show the best control ranges for different operating conditions.

If the motor stops when S1 is first opened, vary the potentiometer slowly over its full range since it may have been hooked up backwards. If the motor still will not operate, shut off the power. If wiring is correct, transformers T1 and T2 should be checked and the phasing test repeated.

If transformers T1 and T2 do not have adequate current rating they may burn out or give only limited control. If too heavy a load is placed on the motor the control range will be reduced since a larger amount of d.c. will be needed. In this case, two similar rectifiers may be paralleled and the power rating of the potentiometer doubled.

The power gain of this unit is fairly low because ordinary 4% silicon steel is used as the core material of the transformers. In commercial magnetic amplifiers high-permeability core materials

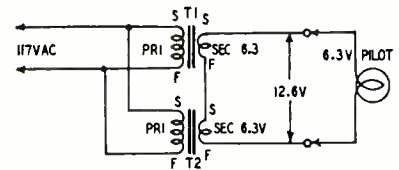

Fig. 4—Connections and polarity markings for the transformer phasing test.

give extremely high amplification. The power gain may be calculated from the formula:

$$\text{gain} = \frac{\text{a.c. power output}}{\text{d.c. power input}}$$

The simple magnetic amplifier described here will help to understand some of the basic operating principles of these units. For clarity the information in this article has been limited to only one application of a specific type of circuit. By varying the circuits and parts almost any amount of a.c. power may be controlled at any voltage desired.

PARTS LIST

- 1—200-ma selenium rectifier; 1—5,000-ohm, 50-watt potentiometer;
- 2—double-pole, single-throw switches; 3—6.3-volt, 5-amp filament transformers (see text for T3);
- 1—motor (see text).

—end—

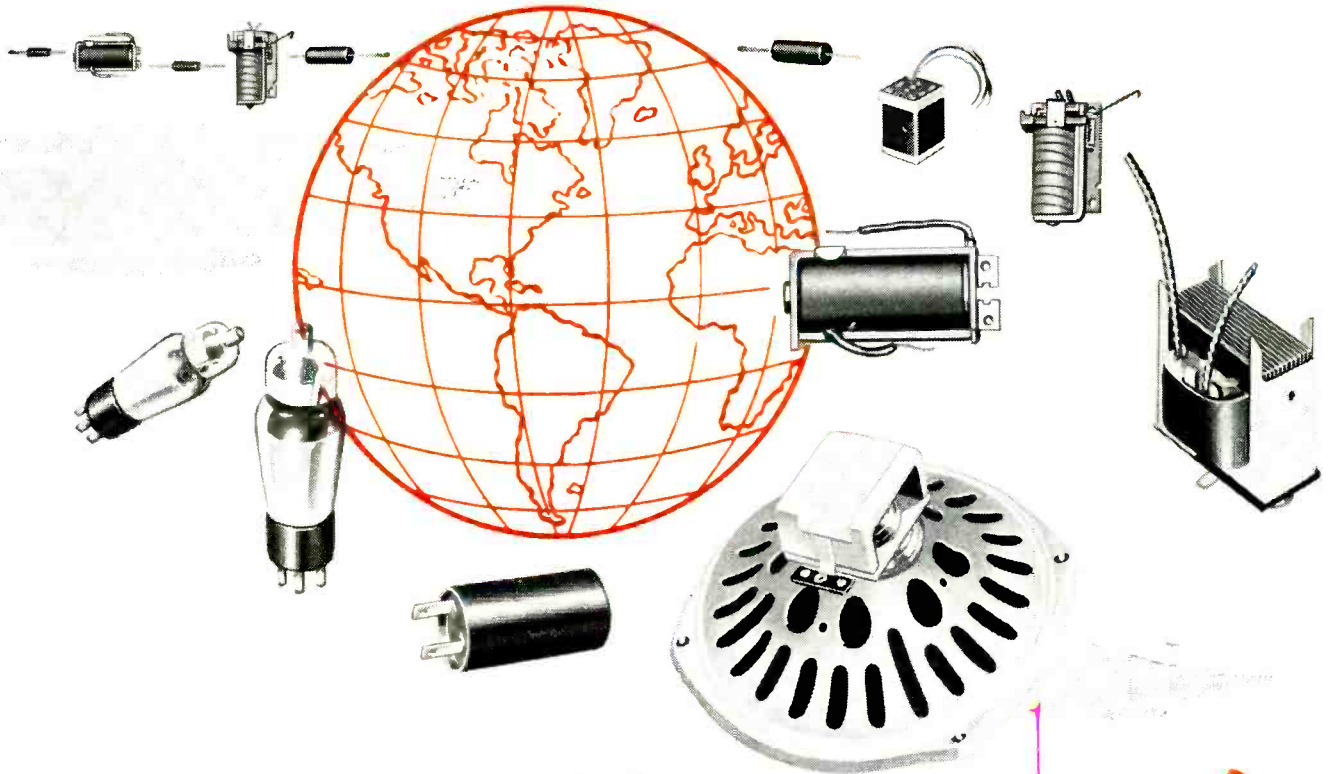

Have a Look at some of the

World's Finest Radio Parts!

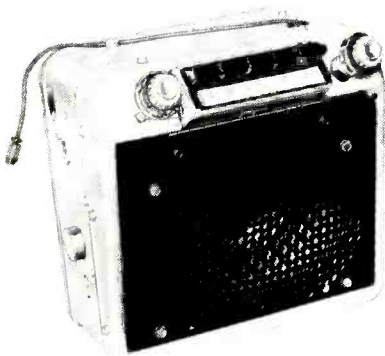

Ordinary radio parts? Not at all! You see, these automobile radio parts—like thousands of others bearing the Delco Radio name—are of uniform high quality.

More than half of all radio-equipped cars are equipped with Delco Radios—*seven million* in all. Think of the volume-building opportunity for you!

**THINGS TO REMEMBER ABOUT
DELCO RADIO SERVICE PARTS**

1. Offer largest market for original-equipment replacement parts.
2. Made in the world's largest factory devoted exclusively to automobile radios.
3. Designed by one of the largest and most forward-looking engineering groups devoted exclusively to automotive radio.

DELCO RADIO PARTS

A GENERAL MOTORS PRODUCT



A UNITED MOTORS LINE

DISTRIBUTED BY WHOLESALERS EVERYWHERE

DELCO RADIO

DIVISION OF GENERAL MOTORS CORPORATION
KOKOMO, INDIANA

This instrument provides complete sweep and marker frequencies

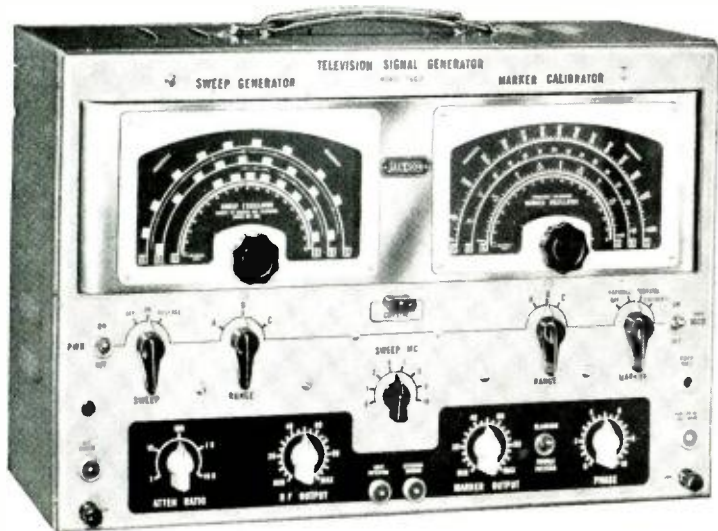

Jackson Model TVG-2 Television Generator

Both industrial and service technicians the world over use the Model TVG-2. Years of experience have proved that Jackson Signal Generators STAY accurate. Just ask the "ole timer" who owns one.

Continuously variable sweep frequencies over all TV and FM bands . . . Reversible single response pattern with base line or double pattern . . . Adjustable sweep width from 100 KC thru 18 MC . . . Marker Calibrator continuously variable from 100 KC thru 216 MC . . . Separate Crystal Oscillator for use either as a marker or calibrator . . . Video Modulation Jack provides for picture or pattern

modulation . . . Marker Calibrator IF frequencies all on highly stable fundamentals . . . RF Output completely controllable with variable and step attenuator . . . Multiple shielding of attenuators and circuits insures low leakage . . . Complete Sweep and Marker Generators in one beautiful instrument . . . Styled to match the famous Jackson Model CRO-2 Oscilloscope.



MODEL CRO-2
OSCILLOSCOPE



MODEL 655
AUDIO OSCILLATOR

5-inch oscilloscope having a vertical sensitivity of .018 RMS v.p.i. and band width flat within 1.5 db from 20 cycles thru 4.5 Mc. Linear sawtooth sweep oscillator 20 cycles thru 50 KC per second in 5 steps. A standard voltage provided for determining unknown Peak to Peak potentials of all waveforms. Has reversible vertical polarity and return trace blanking.

Sine-wave 20 cycles to 200,000 cycles. Less than 5% harmonic distortion between 30 cycles and 15,000 cycles. Frequency calibration accurate within 3% or 1 cycle. Hum level down more than 60 db of maximum power output. Output impedances of 10, 250, 500, 5000 ohms or Hi Z resistive output.

See your electronics distributors for more information, or write

JACKSON ELECTRICAL INSTRUMENT CO.
 "Service Engineered" Test Equipment DAYTON 2, OHIO In Canada: The Canadian Marconi Co.



The RCA 7WP4 is a new projection kinescope for use in theater-television equipment. It is capable of providing a clear, bright picture 20 feet by 15 feet when used with a suitable reflective optical system. Contributing to the brightness is a high-efficiency, metal-backed, white fluorescent screen developed especially for theater-projection service.



The 7WP4 is designed with a faceplate curvature for use in an optical system having an 80-foot throw.

The 7WP4 employs electrostatic focus and magnetic deflection. Electrostatic focus facilitates use of the tube with a reflective optical system. Magnetic deflection provides essentially uniform focus over the entire picture area.

Operating with a maximum ultor voltage of 80,000 volts and a maximum focusing-electrode voltage of 20,000 volts, the 7WP4 incorporates high-voltage design features including a bulb with corrugated side walls with insulating coating to provide a long leakage path over its external surface, an inner cone-neck section to provide adequate vacuum insulation between internal ultor coating and outer neck section, and only one high-voltage envelope connection—all other connections are made through a plastic-filled diheptal 14-pin base (see diagram below).

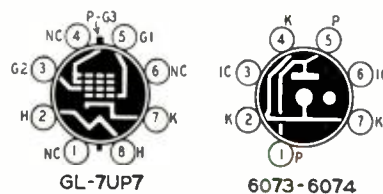

GL-7UP7

6073-6074

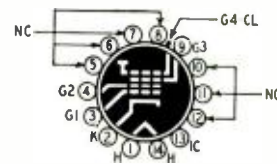

7WP4

RADIO-ELECTRONICS

Announcing

the New TRIO 'MINIT-UP'

STRONGEST TV ANTENNA EVER DESIGNED...

PLUS-ONE MAN/MINUTE ASSEMBLY!

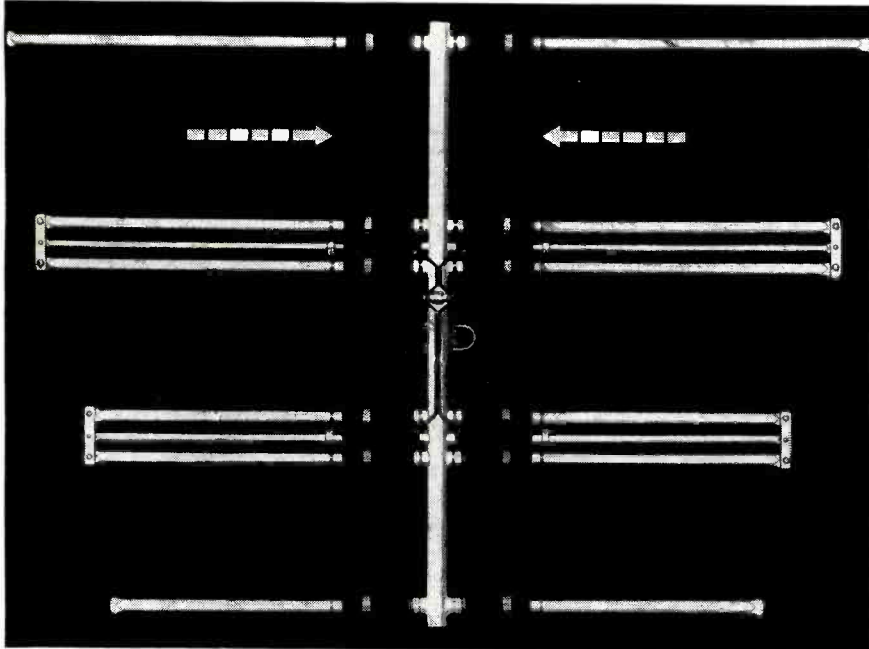

This "exploded" view graphically illustrates the extreme simplicity of MINIT-UP's assembly. Note the color code bands that show instantly where each element is attached. Note the serrated connectors that provide a firm grip with hand or glove — in any weather. Here, indeed, is the last word in TV antennas. Featuring easy assembly, rugged strength — it's the New TRIO "MINIT-UP"!

Model 445MU High Gain MINIT-UP for channels 4 and 5
Model 479MU High Gain MINIT-UP for channels 7 and 9

(TRIO's conventional single channel yagis also available with "MINIT-UP" construction)

Patent pending — no licensing arrangements granted for duplicating principle of this antenna.

MINIT-UP STOPS ANTENNA "CALL BACKS"!

TRIO TV Antennas have long been recognized as "leaders in performance"! Now — with new design features and "minute quick" assembly — TRIO is, easily, the "leader in construction"!

Dealers and Installers will find TRIO's MINIT-UP the most profitable TV antenna they can install. MINIT-UP goes up fast — and stays up! Every detail of design and construction is employed to make MINIT-UP the most rugged TV antenna on the market today!

This — is it!

The new TRIO MINIT-UP . . . a revolutionary TV antenna that combines "minute quick" assembly with strength never before attained in *any* TV antenna!

Strong statements, to be sure — but absolutely true. Take a good look at the illustrations . . . see how simple, how fool proof, how "minute quick" assembly is! Note well, also, the many superior construction details that make the new TRIO "MINIT-UP" a veritable tower of strength!

Feature upon feature makes this new TRIO MINIT-UP the biggest good news in TV antennas yet!

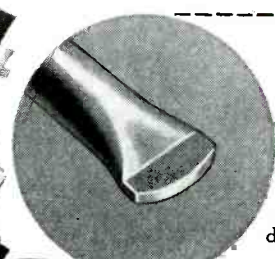

Yagi elements of .035" thick seamless aluminum, are full 5/8" in diameter. Ends are crimped for greater strength and to cut down vibration. Prevents entrance of dirt and moisture.

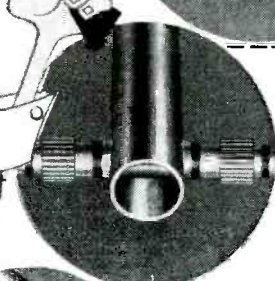

End view of the heavy gauge 1 1/4" boom showing how element inserts are swaged to completely eliminate vibrations and to provide tremendous strength.

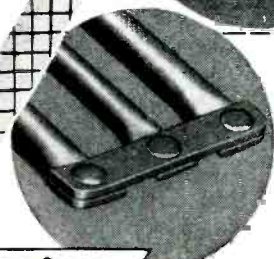

Double-folded dipole sections have heavy gauge aluminum brace bars securely riveted to element ends thus providing positive electrical connection and extreme rigidity. Workmanship throughout is of the highest order.

ONE MAN



MINIT-UP



TRIO Manufacturing Company
GRIGGSVILLE, ILLINOIS

for High
Fidelity



← New High Fidelity
Speaker



→ New Coaxial Speaker

it's
OXFORD
Speakers

Preferred for original equipment
... Proven for replacement!

Other Oxford Speakers for: Radio and Television •
Portable Sets • Auto Radios • P.A. Systems • Out-
door and Weatherproof Applications • Intercom

OXFORD
ELECTRIC CORPORATION

3911 S. Michigan Ave. • Chicago 15, Ill.
EXPORT: ROBURN AGENCIES, NEW YORK CITY

A copy of our
latest catalog
will be sent
upon request.

Available at
leading jobbers!



The G-E Tube Department has announced a new cathode-ray tube for radar indicator service and oscilloscope applications which reduces undesirable screen charging.

The new tube, the 7UP7, employs magnetic focus and magnetic deflection and can be used as a replacement for the 7BP7 or the 7BP7-A.

Use of a reflective aluminized screen reduces undesirable screen charging, permitting more accurate plotting directly from the face of the tube.

The aluminized screen also improves resolution and definition, reduces screen burns, and increases tube life.

The new tube also uses an improved anode contact design, permitting operation at higher altitudes. A recessed small-cavity cap has been used on the anode contact instead of the conventional recessed small-ball cap.

Basing is shown in the accompanying diagram.

Special types

The RCA Tube Department has announced a new, high-perveance, pencil-type diode designed especially for pulse-detection and pulse-power-measuring service at frequencies up to 3,300 mc.

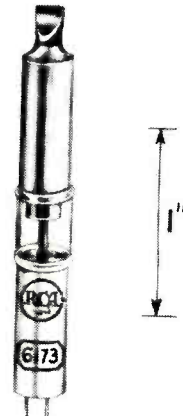

The design of this new tube, the 6173, features a coaxial electrode structure of the double-ended, metal-glass type having minimum transit time, low lead inductance, low plate-to-cathode capacitance, and high resonant frequency. It has a 6.3-volt heater, drawing only 0.135 amp. It is of very small size, and weighs only 1/5 ounce. These electrical and mechanical features make the 6173 particularly suitable for use with coaxial and wave-guide-type transmission lines, and in r.f. probes for u.h.f. measurements.

The new RCA 6073 and 6074 are cold-cathode, glow-discharge tubes of the 7-pin miniature type intended for voltage-regulator service under excessive shock and vibration.

These new types are military versions of the 0A2 and 0B2. They can withstand an instantaneous impact acceleration of 900 g, and a vibrational acceleration for extended periods of 2.5 g. Furthermore, they are processed to have very stable characteristics.

The 6073 and 6074 have an operating-current range from 5 to 30 milliamperes. The 6073 regulates at an

RADIO-ELECTRONICS

average value of 108 volts, whereas the 6074 regulates at an average value of 151 volts. Both types have the basing shown in the accompanying drawing.

Transmitting tubes

RCA type 6166 is a new, forced-air-cooled power tetrode designed for v.h.f. service in television and cw applications. It has a maximum plate dissipation of 10 kilowatts, is rated for operation up to 220 mc, and utilizes an economical thoriated-tungsten filament.

The 6166 can deliver a synchronizing-level power output of 12 kilowatts in broad-band television service at 216 mc; and a power output of 9 kilowatts in class-C FM-telephony service in circuits operating at 216 mc.

The electrode structure of the 6166 is designed especially for use with high-power circuits of the coaxial-cylinder type. The design provides low-inductance, large-area, r.f. electrode terminals for insertion into the cylinders, and facilitates the multiple use of the 6166 in cavity circuits. An external radiator provides for cooling by forced air.

The Lewis and Kaufman *Los Gatos* type 719A is a clipper diode recommended for use in pulse generators where the pulse-repetition rate is 2,000 per second or less, and peak forward current is 10 amperes. Peak-inverse rating is 25,000 volts.

Rated at 75 watts, the tube incorporates a new black-body heat-dissipating anode surface called *Sintercote*. The heater draws 7 amperes at 7 volts. The tube has a maximum height of 5 7/8 inches and a maximum diameter of 2 1/16 inches. It fits a standard No. 234 socket.

—end—

NEW MARINE - RADAR PLOTTER REDUCES COLLISION HAZARDS

Marine Radar may become far more useful as a navigation aid and saver of lives at sea with the help of a new *Reflection Plotter* recently announced by Raytheon.

While radar has been extremely useful in showing the position of other ships as well as stationary objects, it

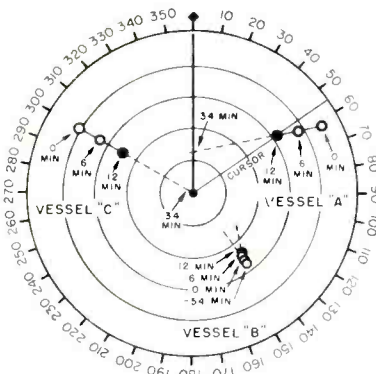

Typical reflection-plotter situation. Dot in center is radar-equipped vessel; heavy line (360°), its course. Plot shows vessel "A" will pass ahead; collision with vessel "C" will occur in 34 minutes unless either vessel changes course sooner.

JUNE, 1952

A STAR IS BORN

TV "DO-ALL" GENERATOR

OVERALL ACCURACY BETTER THAN 1/2 OF 1%
SINGLE BAND ACCURACY TO 1/10 OF 1%

\$69⁵⁰
NET

One compact, accurate, efficient instrument—which gives the performance of several combined instruments—each of which is higher priced and all of which are needed for properly servicing Television and FM receivers.

The only single, easily portable instrument that provides for alignment of: Front Ends, IF's Horizontal Linearity, Vertical Linearity, Picture Size, Picture Position, Focus Coil, Ion Trap.

Range: 9 Megacycles to 220 Megacycles with skips ALL FUNDAMENTALS—Bands 9-11 Megacycles 21-47 Megacycles; 54 to 220 Megacycles.

Pattern Generator: Modulation can be either Horizontal Bar—Vertical Bar or Cross Hatch.

Tuning: Dial continuously calibrated through 340°, giving extremely long calibration scale; enables easy reading and tuning. Each TV channel is marked specially, on the dial.

Audio Output: Both 540 Cycles and 220.5 KC are available.

Attenuation: Complete variation through 200 ohm control

Extreme stability—unusually fine circuit design—rugged mechanical construction.

Never such an investment at such a low price! Stock this new item now—a concerted advertising program on this item will bring you greater sales.

Write for Catalog RE-6.

RADIO CITY PRODUCTS CO., INC.
152 WEST 25th ST.—NEW YORK 1, N. Y.

PARTS LISTS

Bills of material for most of the pieces of equipment described in RADIO-ELECTRONICS construction articles are on hand at all radio parts jobbers and distributors who sell the magazine. See your dealer for a complete parts list of any of this apparatus you wish to construct.



C-D's Tiny Mike

takes 30,000 volts with a grin!

The famous ceramic body made by C-D with an original engineering job inside and out! More dependable, longer lasting than any previous TV high-voltage ceramic capacitor! Can be used at *full rated voltage*, because it's *conservatively* rated for DC flash test up to 2x rated working voltage!



Send for
Bulletin 2-614

Dept. RC-62

**CORNELL-DUBILIER
ELECTRIC CORP.**

South Plainfield, N. J.



Plants in So. Plainfield, N. J.; New Bedford, Worcester and Cambridge, Mass.; Providence, R. I.; Indianapolis, Ind.; Fuquay Springs, N. C.; and subsidiary, The Radiant Corp., Cleveland, O.

CONSISTENTLY DEPENDABLE
CORNELL-DUBILIER
CAPACITORS

has been necessary to take two or more observations of the position of a moving ship, then plot its course and speed to determine if it is on a safe heading or if there is possibility of collision. This takes time and there are occasions when the officer cannot leave the bridge to do such plotting.

The Reflection Plotter provides a plotting surface, made of non-reflecting plastic, which is fitted over the radar screen. Edge-lighting around the plotter illuminates any objects placed in con-



Marking positions on plotter screen.

tact with it, so that by using a grease pencil, marks made on the plotter become luminous. Through an optical arrangement, these notations appear as though they actually are being made on the face of the radar screen below, so that the luminous radar "pips" can be marked and their actions observed. Their movements away from the original marked positions enable the operator to determine the direction and speed of each vessel in relation to his own ship.

The watch officer merely makes a mark indicating the position of the ship, noting the time beside the mark. A given number of minutes later, he makes another mark, again noting the time. These two would be sufficient to determine the other ship's course and speed, but the reflection plotter makes it unnecessary to do so. It is only necessary to draw a line through the two points, showing the course of the strange ship. If that line passes through the center of the screen (the position of a ship is always in the center of its own radar pattern) there is danger of collision. If it does not pass through the center, the ships will pass each other safely.

It will be noted that this method (as well as earlier methods for plotting with the help of radar) assumes that the radar-carrying ship is at a fixed point, and all motion is attributed to the strange ship. This makes for simpler plotting than the traditional method of plotting the course of both ships with relation to the earth, and is the secret of the reflection plotter's operation.

—end—

RADIO-ELECTRONICS

Over 43,000 Technicians Have Learned
**HOW TO GET THE MOST OUT
OF BASIC TEST EQUIPMENT**
Why Not You, Too?

SERVICING by SIGNAL SUBSTITUTION
A BEST SELLER FOR OVER 9 YEARS! (NEW, UP-TO-DATE, 12TH EDITION)

The Simple, Modern, Dynamic Speed Approach To Receiver Adjustment and Alignment Problems, AM-FM-TV.

- Nothing complex to learn
- No extra equipment to purchase
- Universal — non-obsolescent
- Employs Only Basic Test Equipment

Ask for "S.S.S." at your local
Radio Parts Jobber or order direct from factory.

PRECISION APPARATUS COMPANY, INC. • 92-27 Horace Harding Blvd., Elmhurst 4, N. Y.



only 40¢

100 pages. Invaluable information that will help you re-double the value of your basic test equipment.

the most convenient TV tower ever made

THE TEL-A-RAY

SWING-OVER*
TOWER

*swings over
to the ground
for servicing . . .*

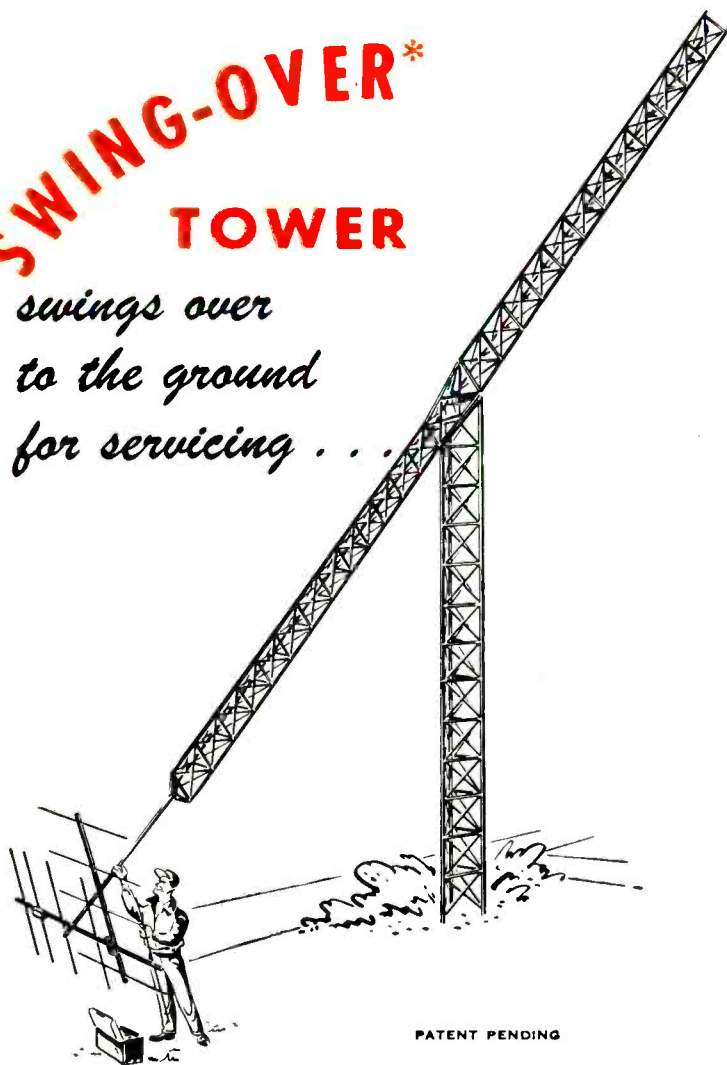

The biggest new idea in television — the Tel-a-Ray Swing-Over Tower* — swings over to the ground for easy servicing! One man can raise or lower this counterbalanced tower in three minutes!

Model TT1, for ground installations, is 50 feet high when a recommended 10 feet of water pipe is added — can be quickly erected with no guy wires.

Model TT2 is designed for roof tops, reaches up 24 feet with the addition of an eight-foot pipe.

Although light in weight, the Swing-Over Tower is ruggedly built with steel angles and welded construction.

Simple to assemble . . . no machinery necessary . . . low in price.

Write today for information.

JUNE, 1952

FOR WONDERFUL
TV RECEPTION
WHEREVER YOU ARE

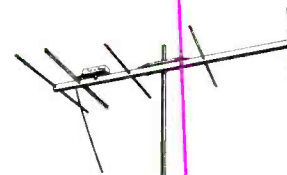

The weatherproof Model T antenna . . . brings in wonderful reception up to 200 miles.

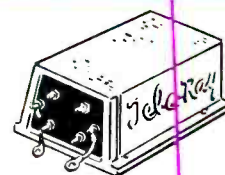

Only low-priced Pre Amplifier on the market, the T₅. Multiplies signal gain . . . holds noise to a minimum.

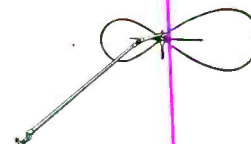

Butterfly Swivel-Positioned TV and FM antenna . . . designed to give the finest reception in primary areas.

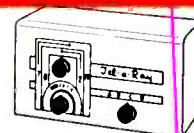

Tel-a-Ray's new Switching Booster (Model PTB1) — one switch changes channels and antennas. Eliminates the need for a separate booster for each antenna . . . for as many as four antennas. Automatic features make this outstanding.

FOR COMPLETE INFORMATION WRITE

Tel-a-Ray

ENTERPRISES, INC.



BOX 332E
HENDERSON, KY.

LIGHTWEIGHT HEADSET

Telex, Inc., Telex Park, St. Paul 1, Minn., has announced a new addition to the line of Telex headsets.

The new Dynaset model with under-the-chin styling and light weight (1.25 oz.) is designed to be worn all day without fatigue.

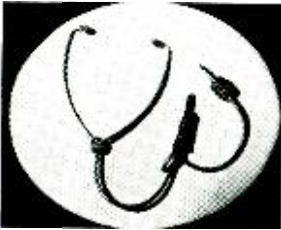

Among additional features is a higher fidelity range, permitting more exact reproduction of highs and lows of both music and speech.

The Dynaset is suitable for office transcribing machines, telecasting, radio monitoring, amateur radio, record stores, theaters, phone-order boards, electronic laboratories, and commercial communications of all kinds.

TV ANTENNA MOUNT

Channel Master Corp., Ellenville, N. Y., has announced the *Super Mount*, a new ready-made mounting structure which permits side-by-side stacking of any 4 antennas, regardless of make, and opens the way to many new stacking arrangements.

The structure is heavy-gauge, seamless steel tubing, bright zinc plated. Full-wave spacing for each channel is clearly marked.

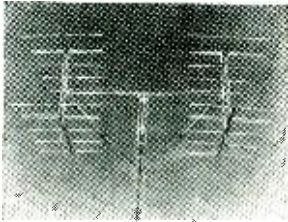

Featuring a unique sliding arrangement which simplifies installation, the mount may be either assembled at the top of the tower or assembled on the ground and swung up into position.

A 4-bay array of Channel Master 5-element Z-Match Yagis, installed on the *Super Mount* produces over 15 db gain on the low band.

WEATHERPROOF SPEAKER

RCA Victor Division of Radio Corporation of America, Camden, N. J., has designed a new speaker, the MI-6441, which performs equally well as a high-efficiency microphone in talk-back systems or as a re-entrant speaker in low-powered voice paging systems. Ruggedly constructed and completely weatherproofed, the speaker can be used in outdoor or indoor industrial sound installations, and is designed to replace cone-type speakers in intercommunication systems where maximum acoustic output is required.



The removable diaphragm unit is enclosed in a weatherproof spun aluminum cover. It has a spun-aluminum flared bell and reflector, which can be locked in the desired position. The distribution angle is 120 degrees. The speaker is finished in a baked dark amber gray enamel.

Electrical specifications show a power handling rating of 12 watts; sensitivity of 105 db; frequency response of 350 to 10,000 cycles; and impedance of 16 ohms. It is 6 1/2 inches long, with a bell diameter of 6 3/4 inches. The speaker weighs 2 1/2 pounds.

HIGH-VOLTAGE JACK

Insuline Corp. of America, 36-02 35th Ave., Long Island City 1, N. Y., has introduced a new high-voltage tip jack for electronic test equipment. The nylon insulation withstands 10,000 volts, and has negligible moisture absorption. The one-piece contact is phosphor bronze and takes all standard phone tips and test prods. The jack is furnished with a molded washer that affords positive protection against shorts to a metal panel.



TELEVISION BOOSTER

Regency Division, I.D.E.A., Inc., 7900 Pendleton Pike, Indianapolis 26, Indiana, has incorporated an exclusive circuit stabilizer, for which patent application has been made, in the new Regency television signal booster model DB-520. The stabilizer provides both inductive and capacitive neutralization to assure maximum stability on all channels.

The new model also features a single off-on switch for booster and TV receiver; single tuning knob; push-pull triode circuit; link coupling for optimum impedance matching; improved tracking accuracy; a compact cabinet; and broadband response which insures equal enjoyment of both video and audio on all channels. The model is approved by Underwriters' Laboratories.



AUTO SPEAKERS

Quam-Nichols Co., Chicago, Ill., has announced two new rear-seat auto speakers. The economy model, AS-1 kit includes a Quam 6 1/2-inch PM *Adjust-A-Cone* Speaker with capacity to handle the full output of any single-ended auto set. The de luxe model, AS-2 kit includes a Quam heavy-duty 6 x 9-inch PM *Adjust-A-Cone* speaker with capacity to handle the most powerful auto set made.

The economy model features a 1.47-oz. Alnico V magnet; 3-position switch for dash mounting; ample cable for any installation; flocked grill screen; baffle plate; miscellaneous hardware and installation instructions.

The de luxe model features a 2.15-oz. Alnico V magnet; three-position switch for dash mounting; sufficient cable for any installation; flocked grill screen, baffle plate, sponge rubber gasket for easy and trouble-free installation; miscellaneous hardware and installation instructions.



ANTENNA ROTATOR

Brach Manufacturing Corporation, of 200 Central Ave., Newark, N. J., announces its new Diamond antenna rotator No. 470.



The rotator features a special aluminum alloy casting whose streamlined design reduces wind resistance and precludes ice formation. The weather-proof, moisture-sealed drive unit is capable of clockwise and counterclockwise 365-degree rotation, and uses simple 3-wire rotator lead.

The indicator is styled to match the decor of any room, and it houses a light to signal change of direction of rotation.

FM PHONO CARTRIDGE

Weathers Industries, 510 Richey Ave., West Collingswood 6, N. J., has introduced a new FM phonograph cartridge, operating on a variable capacitance principle.



With a good transcription arm, the Weathers cartridge tracks at a stylus pressure of 1 gram. When installed in modern record changers the stylus pressure can be adjusted to 3 grams or less. Frequency response is 20 to 20,000 cycles per second.

The cartridge requires an auxiliary oscillator unit using one 6AT6 tube. Filament and plate current may be taken from the audio amplifier, or from a separate power supply.

CRT REACTIVATOR

Crest Laboratories, Inc., Whitehall Building, Far Rockaway, N. Y., announces a plug-in type cathode-ray tube rejuvenator. Its simplicity of installation permits quick salvage of weak picture tubes.



FERRITE CORE KIT

Grayburne Corp., 103 Lafayette St., New York 13, N. Y., has announced a special experimenter's ferrite-core kit to enable engineers to familiarize themselves with ferrite cores.

The kit, type FCK, consists of 27 var-

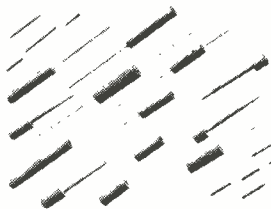

ious-size cores adapted for experimentation in i.f. and r.f. coils, solenoids, linear, or width controls and in other electromechanical applications.

SUPER-TWEETER

Jensen Manufacturing Company, 6601 So. Laramie Ave., Chicago 38, Ill., has developed a new high-frequency unit which makes a three-way system of any coaxial speaker, or a 2-way system of a single-unit direct radiator. The RP-302 "super-tweeter" is adapted from the h.f. channel of the Jensen G 610 Triaxial speaker. Installation is simple—atop cabinet or flush on baffle in a 1-11/16-inch hole. The RP-302 provides response from 4,000 cycles up, extending speaker range to approximately 18,000 cycles, with extremely low distortion. The small Hypex horn disperses sound with a useful coverage angle of 120 degrees in both horizontal and vertical planes. A special plastic diaphragm gives



freedom from breakup. Impedance is 16 ohms, maximum power rating 30-40 watts when used with the Jensen A-402 crossover network. The unit can be connected with a 2-µf series capacitor across any low-impedance speaker line up to 16 ohms.

MARKER GENERATOR

Precise Development Corp., Ocean-side, N. Y., has introduced an unusual r.f.-a.f.-TV marker generator. Available complete or in kit form, the Precise model 630 reaches 110 mc on fundamentals and 330 mc on harmonics.



A built-in Wien-bridge audio oscillator covering 20-20,000 cycles provides controllable-percentage modulation or may be used independently. The r.f. circuits are individually tuned and load-compensated for constant output on all ranges. A separate crystal-controlled marker oscillator is included.

Other features of the generator are: cathode-follower output, with step-type attenuator; complete shielding and line filtering; and vernier tuning of both r.f. and a.f. oscillators. External modulation may be used, with the internal modulator acting as a speech amplifier.

Kits are available with or without the r.f. sections completely prewired and aligned.

POCKET V-O-M.

Trade Associates, 128 South 1st St., Brooklyn, N. Y., is producing a pocket volt-ohm-milliammeter, measuring only 2 1/4 x 2 1/4 x 4 inches. The instrument has the following ranges: Volts (a.c. or d.c.): 1, 10, 50, 100, 500, and 1,000 at 1,000 ohms per volt; d.c. ma: 1, 10, and 100; ohms: 1 megohm (22,500 ohms mid-scale). A crystal-diode rectifier is used for a.c. voltage measurements.



PORTABLE TAPE PLAYER

Pentron Corporation, 221 E. Cullerton St., Chicago 16, Ill., is producing a portable playback machine for standard magnetic tape recordings.

It is available either as a self-contained unit with speaker and amplifier, or with preamplifier only, ready to plug into any existing amplifier, radio, or TV set. Both feature double-track operation and tape speeds of 3 3/4 and 7 1/2 inches per second. Both types are also available with single-track (full-width) heads for broadcast applications.

Frequency response is 50-8,000 cycles at 7 1/2 inches per second and 50-3,000 cycles at 3 3/4 inches per second. Flutter is less than 0.5%.

Model PB-1 (with preamplifier only) weighs 19 pounds and is 11 3/8 x 10 x 9 3/4 inches. Model PB-A2 has a 5-watt amplifier, 6-inch Alnico V speaker and weighs 22 pounds. Its dimensions are 11 3/8 x 12 1/4 x 9 3/4 inches.

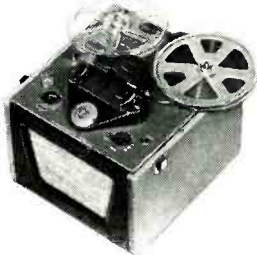

MULTIPLE SPEAKER ENCLOSURE

Permoflux Corporation, 4900 West Grand Ave., Chicago, Ill., is marketing a new corner horn enclosure for four 8-inch speakers.

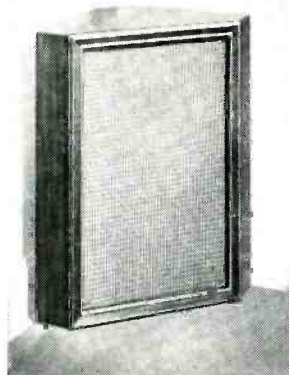

Special features of the new corner horn include: Smooth over-all response, achieved by proper low-frequency loading in an enclosure of reasonable proportions; decreased distortion due to limited cone travel; corner placement, giving response from 30 to 12,000 c.p.s.

Two models are available, CH-8M in mahogany finish for traditional settings, and CH-8B in blond mahogany

for modern interiors. The enclosure is 25 inches high, 20 inches wide, and 11 inches deep. Shipping weight (without speaker) is 20 pounds.

BATTERY ELIMINATORS

The Schauer Manufacturing Corp., 4500 Alpine Ave., Cincinnati, Ohio, is distributing improved models of its Electroxx battery eliminators.

The Electroxx AR-5, featuring adjustable output voltage, replaces the AR-2. Principal changes include complete redesign of the case and the addition of an ammeter.

The AR-5 is hum-free and delivers 6 volts d.c., at any load current up to 15 amperes. The case is finished in metallic grey and is 7 1/2 inches wide, 9 1/4 inches deep and 9 inches high.

Model AR-4, which replaces the AR-1, is similar to the AR-5, except that the output voltage is not adjustable. Output is 6 volts d.c. at approximately 15 amperes. Case dimensions are the same.

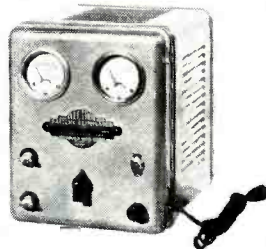

MULTIMETER

Electronic Instrument Co., Inc., 84 Withers St., Brooklyn 11, N. Y., manufacturers of EICO test instruments, have announced a new 1,000-ohms-per-volt multimeter.

Available either wired or in kit form, model 566 uses a 4 1/2-inch, 400-ua meter movement, and has the following

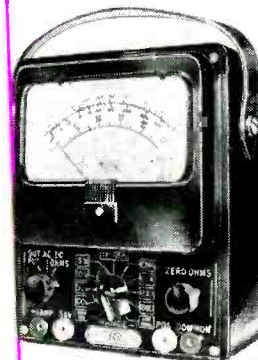

ranges: volts (a.c. or d.c.): 1, 5, 10, 50, 500, 5,000; current (a.c. or d.c.): 1 ma, 10 ma, 0.1 amp, 1 amp; resistance: 500 ohms, 100,000 ohms, 1 megohm; db: minus 20 to plus 69 (6 ranges).

Model 566 is housed in a high-impact bakelite case 6 3/4 x 5 1/4 x 3 inches.

TeleSound CUSTOM-BUILT TV CABINETS

DIRECT FROM MANUFACTURER TO YOU—COMPARE PRICE and QUALITY!

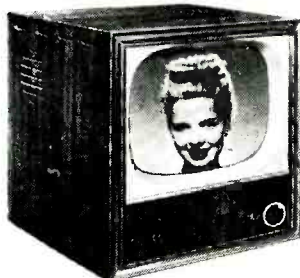

H: 25", D: 21 1/2", W: 25" Wgt: 50 Lbs.
TABLE MODEL 500 **\$42.00**

As above, for 24" Picture Tube
H: 31", D: 24", W: 27" **\$55.80**
Wgt: 60 lbs.



H: 40 1/4", D: 22 1/2", W: 25 1/4"
Wgt: 60 lbs.
CONSOLE MODEL 200 **\$45.50**



H: 40 1/2", D: 24", W: 25"
Wgt: 100 lbs.
CONSOLE MODEL 800 **\$82.50**



H: 40 1/2", D: 24"
W: 25", Wgt: 100 lbs.
CONSOLE MODEL 1000 **\$87.50**

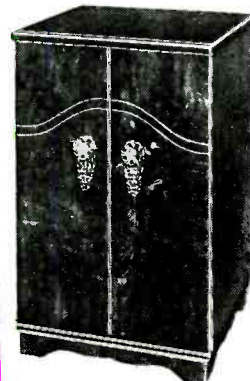

Be price conscious! TELE-SOUND Wholesale Prices enable you to sell more, make a BETTER PROFIT for yourself!

ALL PRICES TAX INCLUDED

All TeleSound cabinets illustrated are available in Ribbon Stripe Mahogany. Model 200 also available in Walnut. All cabinets can be had in Blonde Korina at 10% additional. These cabinets are custom built and drilled to fit standard 630 type chassis. We can supply them with undrilled panel to fit any other chassis you specify.

FAMOUS SUPER 630 CHASSIS

Terrific! low priced!
30 tubes—for 16" to 24" Picture Tubes
• High Efficiency High Voltage Circuit
• Keyed AGC
• Automatic brightness control
• Special extra high gain Cascade Standard Coil Tuner
• Directly adaptable for UHF.



\$139.50

FREE OFFER! Schematic Diagram and complete 24 page service manual FREE with above chassis!

DUMONT TV PICTURE TUBES — 6 Months' Guarantee

12 1/2" Black or White	\$20.50	19" Round (Bik)	\$35.50
14" Glass Rect. (Bik)	\$20.50	20" Rectangular (Bik)	\$35.50
16" Glass Round (Bik)	\$30.50	21" Rectangular (Bik)	\$39.50
16" Glass Rect. (Bik)	\$30.50	24" Metal	\$69.50
17" Rectangular (Bik)	\$29.50		

SPECIAL COMBINATION OFFERS!

SAVE MONEY! Order the cabinet of your choice from the TeleSound models illustrated, in combination with the famous 630 TV Chassis, 12" speaker, and your choice of picture tube. Check these sensationally low prices:

CABINET STYLE	COMBINED WITH Super 630 chassis, 12" speaker, and			
	17" CRT	20" CRT	21" CRT	24" CRT
500	\$205.75	\$211.60	\$215.50	\$258.20
200	209.15	215.00	218.90
800	245.10	251.05	254.95
1100	250.10	255.95	259.95
1000	245.10	251.05	254.95	284.20

TeleSound CORPORATION

421 West 28th Street
New York 1, N.Y.
Phone: WI 7-0719

Picture Proven!

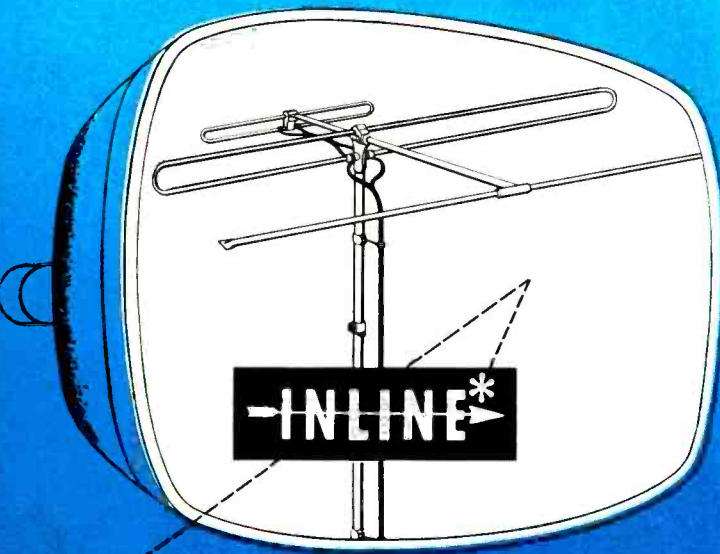

*U. S. PATENT NO. 23,273

RECOGNIZED PERFORMANCE

Even after four years in the highly competitive television market, in which many antennas have come and gone, the Amphenol Inline Antenna is still recognized as the best all-channel TV antenna. Proven by every mechanical and electrical test, the Inline Antenna is established as the *quality* TV antenna on the market today!

Point by point, even when compared with competitive manufacturers' own test data, the Amphenol Inline is indisputably the superior TV antenna.

see this Book...

for a complete presentation of the various types of antennas, their test reports and performance charts. Your Authorized Amphenol Distributor has a free copy of this book for you, get yours today!



AMPHENOL

AMERICAN PHENOLIC CORPORATION
3830 SOUTH 34th AVENUE • CHICAGO 30, ILLINOIS

New Devices

V-M CHANGER

V-M Corporation, Benton Harbor, Michigan, has introduced a de luxe version of the V-M tri-o-matic record changer, especially designed for high-fidelity applications.

Called the V-M tri-o-matic 956-GE, this newest model features a hum-free four-pole motor, muting switch, and G-E variable reluctance cartridge, in addition to the tri-o-matic standard features.



The 956-GE is mounted on a metal base and is equipped with 6-foot a.c. cord and 4-foot phono cord. The 951-GE is the same unit without the base, for custom installations and for replacement. Precut mounting boards are available.

Both models shut off automatically after the last record plays. Arm set-down is automatic for any size record.

SCOPE CALIBRATOR

Simpson Electric Co., 5200 W. Kinzie, Chicago, Ill., has introduced the model 276 direct-reading oscilloscope calibrator. Model 276 provides sine-wave output up to 250 volts peak-to-peak,



in six ranges. The meter is calibrated directly in r.m.s., peak, and peak-to-peak values. Each range is continuously adjustable from zero to full-scale value.

The calibrator comes in a black molded-bakelite case identical to models 260 and 303.

POCKET TESTER

Neo-Lite Manufacturing Company, Rockford, Ill., has introduced the *Dandy-Lite* pocket-size circuit tester. Operating on the neon glow lamp principle, the *Dandy-Lite* will test for grounds or polarity on lines from 90 to 550 volts a.c.-d.c., and can be used to check automotive cables and circuits, fuses and spark plugs. In addition, electric fences, radios, and television sets can be checked.



BATTERY-POWERED TAPE RECORDER

Amplifier Corp. of America, 398 Broadway, New York 13, N. Y., has announced the *Interviewer* battery-operated midget tape recorder as the latest model in its series of Magne-mite recorders.

The *Interviewer* carries its own power supply of small dry-cell flashlight batteries, so that it may be operated anywhere, regardless of the availability or type of current on hand. Its detachable nondirectional microphone plugs directly into the microphone input jack, and is supported by its own rigid tubing. A table stand, complete with extension cable, is also available.

The *Interviewer*, in a two-tone leatherette-covered cabinet, measures only 11½ x 8½ x 5½ inches, and weighs 9¾ pounds, including batteries which last 100 operating hours.

The spring-wound drive motor runs 15 minutes on a single winding and may be rewound during operation. A warning light goes on approximately one minute before rewinding is necessary. A special governor assures constant tape speed and vibrationless control.

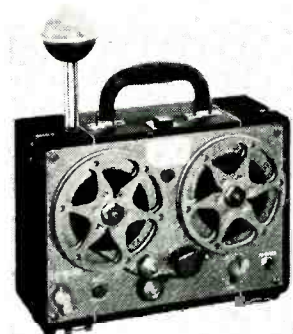

Two hours of recording are accommodated on a 5-inch reel of standard ¼-inch tape. Tape speed is 1½ inches per second. The frequency range, up to 3,000 cycles, permits accurate recording of individual speech characteristics for absolute recognizability. Sensitivity is sufficient to pick up normal conversations at a distance of 100 feet from the microphone.

Headphone monitoring while recording is possible. The *Interviewer* also contains its own playback preamplifier, which will feed directly into earphones or into an external amplifier and speaker.

SPEAKER ENCLOSURE

Electro-Voice, Inc., Buchanan, Mich., has developed a new folded-horn corner enclosure for 8-inch speakers.

Utilizing the Klipsch principle of folded-horn corner loading, the *Baronet* conceals the throat of a horn formed by the walls of the room. With a volume of 1½ cubic feet, it provides response down to 35 cycles, with direct front radiation of high frequencies. Proper air-loading of the driver cone holds the voice coil in the flux gap and reduces distortion.

The *Baronet* is conservatively modern in design and is available in mahogany and blond hand-rubbed finishes. Height 23½ inches; width 14½ inches; depth (bottom) 14½ inches; depth (top) 10½ inches.

—end—



All specifications given on these pages are from manufacturers' data.

RADIO-ELECTRONICS

With the Technician

HOME REPAIR GUIDES

Since our recent article, "Fix It Yourself" (April, 1952, issue) the situation on the home repair guide front has become considerably more tense. Sales of these books have skyrocketed almost into a major national industry. Full-page ads from newspapers in several of the larger cities have been sent us by readers, and one book's publisher had a three-color, four-column ad in a syndicated comic section which presumably appears in the Sunday papers of most large and medium-sized cities in the country. Two of the books have come out with new editions (one looks in vain for "condensers" and "lack of electronic power" in the new versions).

The ads scream that "Thousands of TV Owners (are) Being Swindled!", and that the non-owner of the magic book "will probably waste \$30-\$100" on his set during the next year, presumably in payments to service technicians for unnecessary repairs and adjustments.

And the remedy is easy. All the TV owner needs is "5 minutes a week for perfect reception!" (Whether this is straight repair-and-adjustment time or whether it includes time spent studying the book is not stated.) With "A TV Expert at Your Elbow 24 Hours a Day" he can "Avoid 90% of All TV Repair Calls," as well as "Save \$50 to \$150 on New, Giant-Screen Set." All the new homeowner has to do is buy this book and he can complete his library with a five-foot-shelf bought from the savings he'll accumulate!

Service associations are blasting the ads and in many cases have persuaded newspapers that their publication is contrary to set-owners' interests. Radio stations have been even quicker to grasp the danger to unskilled owners and their receivers, and have cancelled or refused advertising.

One of the most striking cases is reported by *Retailing Daily* from St. Louis. According to that paper, the *Post-Dispatch* and the *Globe Democrat* have promised not to run advertising on the "TV Owners' Guide" until the ad is cleaned up. This action was taken at the instigation of the Association of Television Service Companies of Greater St. Louis. Not only did the city's two important papers refuse the ad, but Radio Station KMOX, which ran two tape recording advertisements on the book, has promised not to repeat the ad until it has been changed "to meet truthful requirements", according to Vincent Lutz, president of the Association. Promoters of the book were then said to have approached the local program guide, the *TV Review*. That publication also declined to sell them advertising space.

Philadelphia TV technicians protest the contents of the book as much as the advertising. While it is held in some quarters that such books will promote rather than harm service business, the technicians are not happy over the prospect of handling the traditionally mean owner-botched job, which promises to be a worse mess in television than it ever

JUNE, 1952

SIMPSON ELECTRIC COMPANY, 5200 W. KINZIE ST., CHICAGO 44, COLUMBUS 1-1221

Simpson

perfectly

designed

for proper servicing

of all tv and fm

receivers



model 479

tv-fm

signal generator

\$269 dealer's net

Simpson

BEHIND BARRAGE ADVERTISING

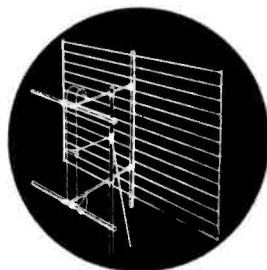

"Positively Amazing Performance!"

is what they are all saying about the new ALL-CHANNEL

GONSET "RADARRAY"

"Model C"

High gain and front-to-back ratio on all 12 channels. No side lobes. Ideally suited where maximum gain is required on several channels, or where ghosts, co-channel or adjacent channel interference problems exist in combination. Eliminates or greatly reduces oscillator interference troubles.

Ruggedly constructed yet light enough to be used on a rotator. Another engineering achievement by the originators of prefabricated open-wire line for T-V. Write for our "Fringe Area" brochure.

available at most dealers

GONSET CO. 801 S. MAIN ST. BURBANK, CALIF.



Better than Ever!

the new
CORNELL-DUBILIER

Seal-Vent

VIBRATORS

★ You'll agree that this is the greatest advance in vibrator design in the past 17 years. This new CORNELL-DUBILIER vibrator is SEALED until used, to prevent oxidation of the vibrator contacts, and VENTS itself when needed! Heat generated when the vibrator is put into service melts the wax out of the sealed vent and permits air circulation . . . for LONGER LIFE and EVEN GREATER PERFORMANCE!

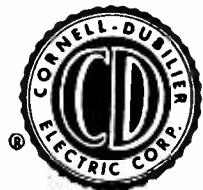

CONSISTENTLY DEPENDABLE
CORNELL-DUBILIER
SOUTH PLAINFIELD, NEW JERSEY



- ROTATORS
- CAPACITORS
- VIBRATORS
- ANTENNAS
- CONVERTERS

TELEPHONES
Intercommunication telephones
2 for \$29.95—Dealers Wanted

Telephone Parts—Extensions, dial telephones, switchboards, handsets, components etc., Write—
TELEPHONE ENGINEERING CO.
Main St., Simpson, Pa.

RADIOS
2 & 3 band Electric and/or battery
TELEVISION
AC, DC Operation
TEST INSTRUMENTS
Write for FREE Catalog

ARKAY—Radio Kits, Inc.
120 Cedar St., New York 6, N. Y.

From the earliest days of Radio . . .
to the present era of Television . . .

CORNISH WIRES

"Made by Engineers for Engineers"

CORNISH WIRE CO., Inc. — 50 Church St., N. Y. C. 7

ACCURATE COMPONENT TESTER

Just Published! Measuring Bridge Design Booklet
Gives complete details of a new circuit which permits rapid precision measurements of resistances, capacities and inductances. Complete plans—simple, easy text, tables, diagrams—which guide the technician, amateur or engineer in developing instrument with linearity of indicating scale according to own requirements! Money Back if not satisfied. Send only \$1.00 to

TECHNOLOGICAL DEVELOPMENTS
475-C Fifth Avenue, New York 17, N. Y.

was in radio. The chairman of the Pennsylvania Federation, Dave Krantz, points out that attempts by the owner to repair his own set "will result in a violation of the safety underwriters' instructions" as well as in ultimately higher repair bills. Frank Moch of the National Alliance of Television and Electronic Service Associations reports that his organization has sent out more than 75 telegrams to manufacturers, newspapers, radio stations, and others, and reports that "Philco, Capehart, G-E, Belmont and Hallicrafters have offered positive support, as have Howard Sams and John Rider." The Radio Television Manufacturers Association has also condemned the books, but declined the request of a Philadelphia meeting to engage in a national advertising campaign denouncing them. Local action, believes the RTMA, is the most effective approach. A New York service technician has printed at his own expense a book called "Why You Should Not Try to Fix Your Own TV" which he hopes to sell to at least part of the public who have read the other books. (See *Book Reviews*)

The reaction of John TV Owner is not readily discovered, except in the fact that he has flocked to buy the books. Whether or not he has attempted to put the instructions into effect after reading his book is unknown. However, the more articulate section of the public—the writers and cartoonists—have expressed themselves as being at least mildly doubtful. The strip printed on page 39 of our May issue (which appeared originally in the *New York Herald Tribune*) is typical of the cartoonist's reaction to the books. A number of one-picture cartoons with the same general theme have also appeared. Cartoonists—like most other technicians with a special skill—are highly skeptical about the possibilities of learning a skilled craft at a cost of \$1.98 and a few minutes of time.

COLUMBUS STOPS AD

One of the speakers at the March meeting of the Association of Radio-Television Service Dealers of Columbus, Ohio, was Mr. William Schmitt of the *Columbus Citizen*. He explained the attitude of the paper toward advertising, stated that insertion of certain unethical advertising had occurred as a mistake and guaranteed that it would not recur. He also informed the meeting that the editor of the paper would be interested in printing an editorial presenting the ARTSD point of view as an answer to the offending ad. The *ARTSD News* did not explain the nature of the "unethical ad" but readers will have little difficulty guessing it correctly.

PARTS SHOW AND LICENSING

A proposal presented by the Board of Directors of the Chicago Electronic Parts Show which stated that "the question of servicemen's licensing laws requires the concerted action of the entire industry" and which would have placed Show funds at the disposal of a serviceman-dealer advisory committee

for the purpose of "aggressively pursuing this activity," was voted down by a majority of the organizations sponsoring the Show.

Two of the associations who voted down the measure expressed themselves as being opposed to licensing of service technicians. One of these, the Sales Managers Club, expressed itself as being "extremely sympathetic to the non-licensing of radio servicemen," but felt that no funds should be diverted from the Show corporation's treasury except for the purpose of distributor education. The other, the Association of Electronic Parts and Equipment Manufacturers, felt that the industry could best be served by combating local efforts to license independent radio and television service technicians. Only one of the groups, the West Coast Electronic Manufacturers Association, did not express its opinion on the merits or demerits of licensing, but voted bluntly that the Show corporation confine its activities to Show problems.

N. J. OPPOSES BONDING

The Radio and Television Servicemen of (Paterson) New Jersey, Inc., has registered objection to Assembly Bills 222 and 227, which were introduced in the 1952 session of the Legislature.

Bill 222 would create a system to guarantee performance of television contracts by creating special trust funds under the State Department of Banking and Insurance. Bill 227 would require that a performance bond be issued with every service contract sold.

J. Palmer Murphy, secretary of RTSNJ and manager of the distribution division of the Paterson Chamber of Commerce, stated that filing of performance bonds for each contract would cause endless complications and trouble. A general surety bond for each company would not be as expensive, he said, and he did not believe that even such a bond would be necessary.

The organization's president, H. B. Rhodes, said that the two bills, while designed to protect the public, were not properly drawn for that purpose, and instead would increase the cost of service to the customer and would drive reputable companies out of contract servicing.

CAPITAL PLANS CAMPAIGN

Television service companies and dealers are planning a campaign of education for the Washington, D.C. consumer. Its keynote will be to urge set owners to know the firms with which they deal.

According to Norman Sellinger of the local TV technicians' association, the campaign will be aimed at firms who advertise cut-rate service.

OBJECTIVES SET

The new Television Service Association of Pittsburgh, Pa., gives as its objectives:

1. To develop a consumer education program which will tell the set buyer and user what he can reasonably expect

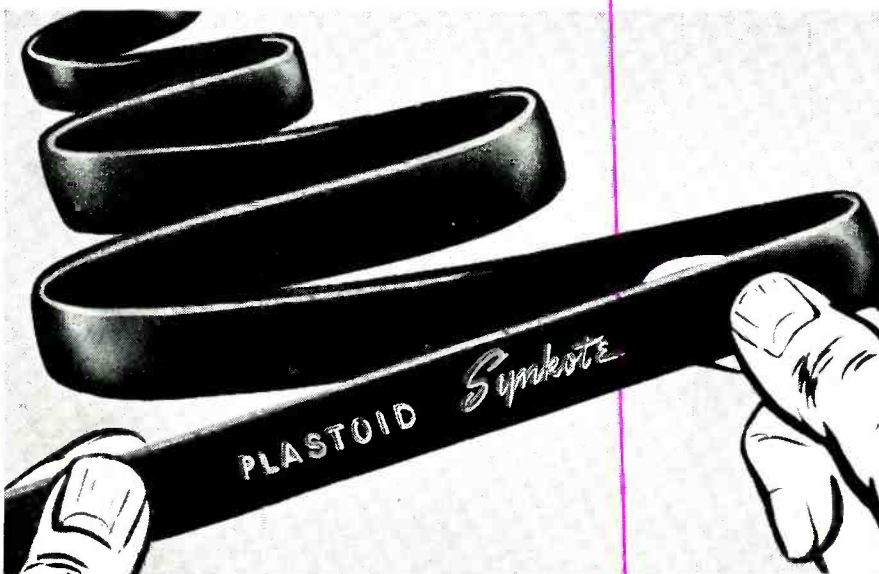

HEAVY WEB TV LEAD-IN WIRE CUTS DOWN COSTLY "CALL-BACKS"

Have you seen the new SYNKOTE 300 ohm TV lead-in? It has a .100 web with a maximum variance of five thousandths of an inch! Tough polyethylene construction that stands up against sun, snow, rain, cold and abrasion.

Ask your jobber to show you this as well as the complete SYNKOTE line of dependable wires . . . used and recommended by leading manufacturers everywhere.

Synkote

SYNKOTE .100 web twin-lead—cat. #PP1376

DEPENDABLE

HOOK-UP WIRE • COAXIAL CABLE • TV LEAD-IN WIRE



"manufactured by the mile — tested by the inch"

SYNKOTE—Reg. Trademark of PLASTOID CORP., Long Island City 1, N. Y.

A SMALL AD—BUT BIG MONEY!

Here's What I'll Pay for the Following:
 RC-348 or BC-312..... up to \$70.00
 ATC or T-17 Type ART-13..... up to 250.00
 RC-221 or R5/ARN-7..... up to 45.00
 TS-251..... up to 175.00
 FL-30 or F-21/ARA-9 audio filters..... up to 6.00 ea.
 Also want TS-147, TS-148, MG-149, RTA-1B or parts.
 I'll buy almost anything—and I'm not kidding.
 Write or wire:

BOB SANETT 4668 Dockweiler,
 Telephone: YOrk 4637 Los Angeles, Calif.

REDI-VOLT PLUG IN D.C. POWER SUPPLY UNITS

A thousand uses, fluid heater equipment. Selenium rectifier type with filtered output. Plugs into acal socket. 115V. A.C. Input.

NEW LOW PRICES

Model 60—60 ma. at 140V.....\$2.30
 Model 120—120 ma. at 110V.....\$2.90

Postpaid U.S.A. Satisfaction guaranteed.
Z-LAB CO., Box 48, Grand Rapids, Mich.

PLEASE MENTION RADIO-ELECTRONICS WHEN WRITING ADVERTISERS

SENSATIONAL VALUE!

#630 SUPER 30 TUBE CHASSIS
Mfr. Licensed under R. C. A. Patents
EASILY ADAPTABLE to U.H.F.

Complete with
21" first quality
tube

AND
Beautiful hand-
rubbed Mahog-
any Console
Cabinet.

COMPLETE PRICE

\$259.95

slightly higher
with full doors



the latest 1952 model with all the newest
electronic improvements . . .

- peak sensitivity for fringe areas
- synchrolock tuning
- keyed A G C
- 15,000 volts under load
- 12-inch RCA speaker
- can be adapted to color & UHF
- high quality parts

A set—NOT A KIT

Completely wired, Factory Engineered, aligned
and tested. RMA Guaranteed

1 YEAR GUARANTEE ON TUBE

A half-hour to mount; ready for operation.
Saves up to \$150.

Compare this anywhere for high quality—
low price!

Write Dept. H for further information. Phone
and mail orders filled on receipt of money
order for 25% as deposit . . . the balance
C.O.D., f.o.b. N. Y.

NEW ENGLAND TELEVISION CORP.
75 CHURCH STREET NEW YORK, N. Y.

150 **FREE!** Just for
Examining
COYNE'S
New 6-Volume Set

Get This New Book
R F E
150 Radio-Tele-
vision Picture Patterns and Dia-
grams Explained. Gives wiring
circuits and diagrams on latest
Radio and Television sets. Also
dozens of TV Test Patterns and
trouble-shooting short cuts. A
"must" in every serviceman's
kit. It's yours FREE!

Helps You Get Ahead!
This book is our gift to you for
examining Coyne's brand new 6-
volume set, APPLIED PRACTI-
CAL RADIO-TELEVISION. Here
is the most up-to-date set of re-
ference books in America! 2350
easy-to-understand pages; 1200
illustrations. Covers all
phases of radio and televi-
sion. Tells you how to in-
stall, service, shoot trou-
ble, align all types of
radio and television sets.
"Break-down" photos help
you understand quicker.
Set includes new 762 page
quick reference Cyclopedic
of Television Servicing.

**Sensational
Free Book Offer—Send No Money!**

Mail coupon now to get this great new
6-volume set and the FREE Book of
Radio-TV Diagrams and Test Patterns.
Use the set 7 days. If you keep the
set, pay just \$1.00 after 7 days and
\$3.00 a month until \$24.00 plus post-
age is paid. (Cash price \$22.00.) If
not 100% satisfied with set send it
back and owe us nothing. EITHER
WAY THE BOOK ON TV PICTURE
PATTERNS AND DIAGRAMS IS YOURS FREE. Coupon is
just a request to see set and get Free book. This offer
is limited. ACT NOW!

**FREE
ON
7 DAYS
TRIAL**

MAIL COUPON NOW!

COYNE ELECTRICAL & TELEVISION-RADIO SCHOOL
500 S. Paulina St., Dept. 62-T1, Chicago 12, Ill.
Rush "APPLIED PRACTICAL RADIO-TELEVISION" on
7 days' FREE TRIAL, per offer above. Include FREE
Book.

NAME..... Age.....
Address.....
City..... Zone... State.....
Where Employed.....
() Check here if you want set sent C.O.D. You pay
postman \$22.00 plus C.O.D. postage. Same money-
back guarantee of satisfaction.

pect from his television receiver.
2. To create a means whereby the
consumer can recognize the responsible,
ethical, service technician.
3. To develop an understanding of
warranty problems locally and through-
out the industry. This should result in
abatement of practices which have
been found objectionable by the service
industry.

4. To find a suitable method for resolv-
ing customer complaints as quickly as
possible and to develop means for avoid-
ing their undue repetition.

Robert A. Laneve was elected tem-
porary chairman of the association
and Penny Martin secretary and public
relations director. L. C. Reed, M. J.
Reich and Thomas Ulrich were ap-
pointed members of the acceptance com-
mittee, with the task of setting tech-
nical qualifications and standards for
membership eligibility.

CALIFORNIA TO LICENSE?

A copy of Assembly Bill No. 26,
entitled Radio and Television Service,
has been forwarded to us by Harry F.
Ward, public relations director of the
Long Beach Radio Technicians Associa-
tion. In many respects it resembles bills
recently introduced in Pennsylvania and
New York City.

The proposed law would create a 5-
member state board of radio and televi-
sion examiners.

One member would be connected with
radio-TV manufacturer or distributor
factory service, one an independent
radio and television dealer, one affiliated
with the broadcasting industry, one a
journeyman radio and television repair-
man not employed by any manufac-
turer or distributor organization, and
one a member who is not affiliated with
either the radio or television industries.

It would be illegal to operate as a
servicing dealer or service organization
without a license from the board, and no
dealer or service organization would be
permitted to employ other than regis-
tered technicians to install, repair,
maintain or adjust radio or television
sets or electronic record players.

Service dealers and service organiza-
tions would be charged a license fee of
\$25 for the first year and \$15 for each
succeeding year. Technicians would be
charged an annual registration fee of
\$5 and apprentices one of \$2. In addi-
tion, technicians and apprentices would
pay application fees of \$5 and \$2 re-
spectively.

There would be three classes of tech-
nicians: radio technician, television
technician, and installation technician.
Applicants would be required to have
taken a course of training in a trade,
vocational, or technical school, or have
completed a four-year apprenticeship,
and would be given an examination in
technical knowledge and practical skill.
Apprentices would also be registered,
but would not need technical quali-
fications. Examinations might be waived
if the applicant could submit evidence
of sufficient education, training, and
experience to meet the required quali-
fications.

The bill would also prohibit any
servicing dealer, service organization,
technician, or apprentice from making
any fraudulent statements or using
misleading advertisements, with respect
to the skill of technicians or quality of
materials used in servicing electronic
equipment.

INSTRUCTION BOOKLETS

A bill recently introduced in Congress
by Representative Walter Horan of
Washington would make it compulsory
for manufacturers of electrically op-
erated household appliances to supply
instruction booklets with their products.
The booklets would contain "an ade-
quate explanation of the operation and
care of the appliance, an adequate
description of the functions of the var-
ious parts of the appliance, including
the names of such parts, and adequate
instructions for the making of such
repairs and adjustments as do not
normally require the services of expert
technicians."

There has been objection to the bill
from both electrical-appliance and
radio-television service associations.
Objections appear based on the fear
that such booklets would encourage the
owner to repair his own appliances
and radio or TV receivers, with damage
to the customer and equipment and loss
of business to service organizations.
A reading of the bill shows no ground
for such fears. Since the booklets are
to be prepared by the manufacturer,
there is little reason to believe that any
repairs or adjustments would be recom-
mended beyond those now recommended
in operating manuals or leaflets put
out by better manufacturers with their
equipment. Nor is there any reason to
believe that the Federal Trade Com-
mission (whose approval the instruc-
tion booklets would be required to have)
would have any reason to suggest
amendments or changes to a reason-
ably competent instruction book.

The effect of the law, if passed, would
simply be to make universal a practice
which has always been followed by the
more reputable manufacturers of both
mechanical and electrical appliances.

The reaction of the radio-TV tech-
nicians, (most of whom have at least
one piece of equipment in the shop
which is useless or of limited use be-
cause no information on it can be ob-
tained) is likely to be that the bill
should be broadened to:

Provide that additional instruction
booklets be obtainable from the manu-
facturer at a reasonable price in cases
where the old ones are lost or damaged;
and

Extend the Act to cover radio and TV
test equipment as well as household ap-
pliances!

NEW MICHIGAN GROUP

The Television Technicians of Mich-
igan was formed recently at a mass
meeting of technicians from Detroit,
Flint and Pontiac. A series of technical
and practical tests has been set up and
must be passed by all applicants whose

qualifications are not such as to make entrance tests superfluous.

Membership cards that will serve also as identification cards are being issued, and will be renewable every three months. Members will follow a code of ethics that will include refusal to carry out orders of unscrupulous employers.

TISA HOLDS FORUM

A proposal to police the service industry was made at the open forum held under the auspices of the Television Installation Service Association in Chicago, March 26. According to president Frank Moch, within 30 days TISA will begin an advertising campaign, inviting set owners to present all complaints about poor television servicing directly to the Association.

A secret vote was taken on the subjects of unionization and licensing. The forum was neutral on the subject of unionization, but a strong vote was cast in favor of a state law which would license both technicians and shops. It was suggested that it might be based on the state's Medical Profession Bill.

TISA has organized a company known as Western United Services, in an attempt to forestall possible penetration of the Western Union Telegraph Co. into the Illinois television servicing picture. It would presumably go actively into business under that name should the Eastern TV service subsidiary of WU start operations in the area.

—end—

THE FIRST TRULY PORTABLE TAPE RECORDER

For All Remote and Field Recording

Tiny, Lightweight, Battery-Operated Spring-Motor

MAGNEMITE*

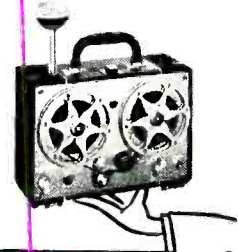

Model 610-B

Compare the Size
World's smallest tape recorder, only 11½ x 8½ x 5½ in.

Compare the Weight
World's lightest tape recorder, only 10 lbs. including batteries.

Compare the Playback
Yes, a playback pre-amplifier actually built in.

Net Price: \$225

*Trade Mark Reg.

Every feature you want for field recording! No larger than a shoebox, the Magnemite* is a complete tape recorder-playback instrument, with self-contained inexpensive dry cells that last 100 hours without replacement. Why bother with old-style heavy, bulky, fluttery field recorders with their converters and storage batteries? Lose up to 50 lbs. of excess weight by using the Magnemite*

Choice of 4 models, for speech or music recording, including unit with NAB standards. Write today for literature, including complete specifications and direct factory prices.

AMPLIFIER CORP. of AMERICA • 398-10 Broadway • New York 13, N. Y.

5000 ROLL LABELS
Printed with your copy on white gummed paper in Red or Blue ink..... 2½ x 4" Per 1000
\$1.65
Merit Label Co 515 Greene Ave. B'klyn 16, N. Y.

PEN-OSCIL-LITE
Extremely convenient test oscillator for all radio servicing, alignment • Small as a pen • Self powered • Range from 700 cycles audio to over 600 megacycles u.h.f. • Output from zero to 125 v. • Low in cost • Used by Signal Corps • Write for information.
GENERAL TEST EQUIPMENT
38 Argyle Ave. Buffalo 9, N. Y.

LEARN Practical RADIO AT HOME  **COMPLETE ONLY... \$19⁹⁵**

BUILD 15 RADIOS

**ABSOLUTELY NO PREVIOUS TRAINING NEEDED
EXCELLENT BACKGROUND FOR TELEVISION**

10-DAY MONEY-BACK GUARANTEE

WHAT THE 1952 PROGRESSIVE RADIO "EDU-KIT" OFFERS YOU:

This is a practical home radio course. You learn theory, construction, operation, trouble shooting, code. You build RECEIVERS, TRANSMITTERS, AMPLIFIERS, CODE OSCILLATOR, SIGNAL TRACER.
You start with a simple radio circuit, and gradually advance to more complex circuits. No previous background is required. No instructor is needed. All parts and instructions are included and every single step is clearly explained.
All parts are guaranteed, individually packaged, identified, and explained.
There is nothing extra to buy. You receive all parts, tools and instructions at once. You keep everything; there is absolutely nothing you return to us.
You can easily pay for the kit in a short time by repairing radios. Use the tester and signal tracer for servicing. The signal tracer alone is worth more than the price of the entire kit.

USED BY RADIO SCHOOLS AND GOVERNMENT AGENCIES!

The Progressive Radio "Edu-Kit" includes tubes, paper condensers, mica condensers, electrolytic condensers, variable condensers, selenium rectifiers, chassis, hardware, tie strips, tube sockets, solder, wire, soldering iron, tubing, coils, instruction book, radio tester, etc.; in brief, everything you need in a practical radio course.
Send for further information and receive FREE Radio & TV Trouble Shooting Guide. Or order direct from this ad and receive FREE Code Oscillator Key (Value \$2.95) in addition to Radio & TV Trouble Shooting Guide.
Postage prepaid on Cash orders—C.O.D. orders accepted in U.S.A.

FREE RADIO TESTER & SOLDERING IRON

GET A WELL-PAYING JOB

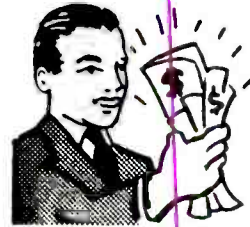

GO INTO A PROFITABLE BUSINESS AND PLAN FOR A FUTURE



PROGRESSIVE ELECTRONICS CO.
497 UNION AVE. DEPT. RE-60 BROOKLYN, NEW YORK

DOUBLE-YOUR-MONEY- FOR SATISFACTORY FIT AND

No Shafts Too Short • No Switches Where Not Needed • No Reversing of Connections
• No Improper Tapers • No Overlong Shafts • No Unsatisfactory Resistance Values

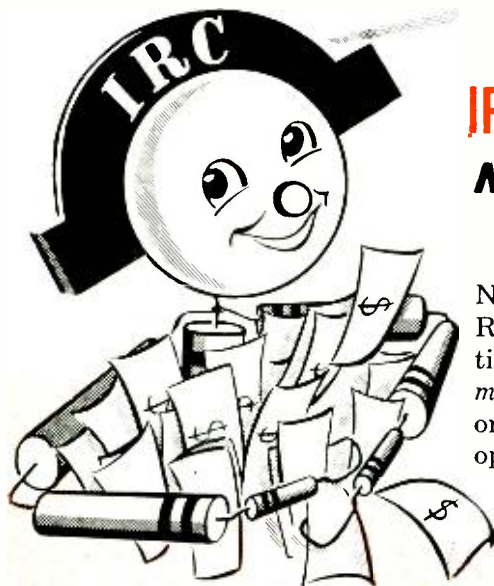

IRC'S NEW UNIVERSAL REPLACEMENTS

**Must Fit and Operate Satisfactorily or
Double Your Money Back!**

Never before has any manufacturer dared to guarantee Universal Replacements for satisfactory fit *and* electrical operation—without cutting or filing of shafts. IRC makes that guarantee now—*double your money back* if any IRC new Universal Replacement, employing K-2 or K-3 CONCENTRIKITS with Exact Duplicate Shafts, fails to fit and operate satisfactorily!

LESS-THAN-A-MINUTE ASSEMBLY OF CARBON OR WIRE WOUND REPLACEMENTS USED IN OVER 5,000 TV MODELS

With IRC's two new, simplified, four-piece CONCENTRIKITS, you can actually assemble carbon or wire wound concentric duals in *less than a minute*—in home or shop—without special tools! And with a small stock of new CONCENTRIKITS—plus our Exact Duplicate Shafts and Base Elements—you can cover 416 Manufacturers' Concentric Dual Parts Numbers used in over 5,000 TV Models!

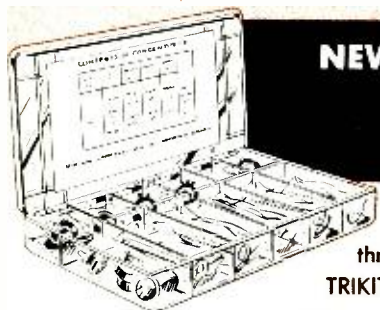

NEW IRC DEALER ASSORTMENTS GIVE WIDEST COVERAGE AT LOWEST STOCK COST

You'll tie-up less money in inventories—and lose less stock through obsolescence—when you buy IRC's new CONCENTRIKITS in low-cost, easy-to-stock CONCENTRIPAKS. These handy assortments include Base Elements, Exact Duplicate Shafts and Switches to suit specific brands of TV sets. And with them you get wide coverage at a fraction of the cost of factory-assembled controls. For example . . .

CONCENTRIPAK for Philco—KC-1. Replaces any of 13 Philco concentric dual controls—plus 21 others. Costs only \$10.20.

CONCENTRIPAK for RCA—KC-2. Replaces any of 14 RCA concentric dual controls—plus 38 listings among 15 other makes. Costs only \$7.44.

CONCENTRIPAK for Admiral—KC-3. Replaces any of 14 Admiral concentric duals plus others. Costs only \$7.80.

IRC DEALER ASSORTMENT #14. Wide-coverage, low-cost dealer stock of CONCENTRIKIT parts. Gives coverage of 240 concentric dual listings (which would require 149 different concentric duals). Supplies replacement coverage among 59 trade names, including the most popular and widely sold.

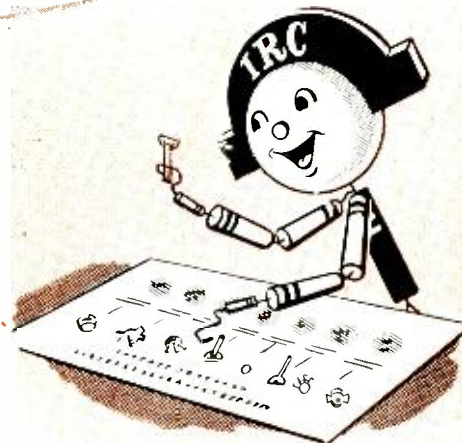

IRC's new pictorial instruction sheet makes Concentrikit assembly a snap.

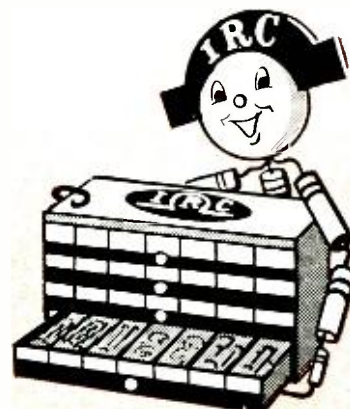

BACK GUARANTEE

OPERATION OF IRC TV CONCENTRIC DUALS

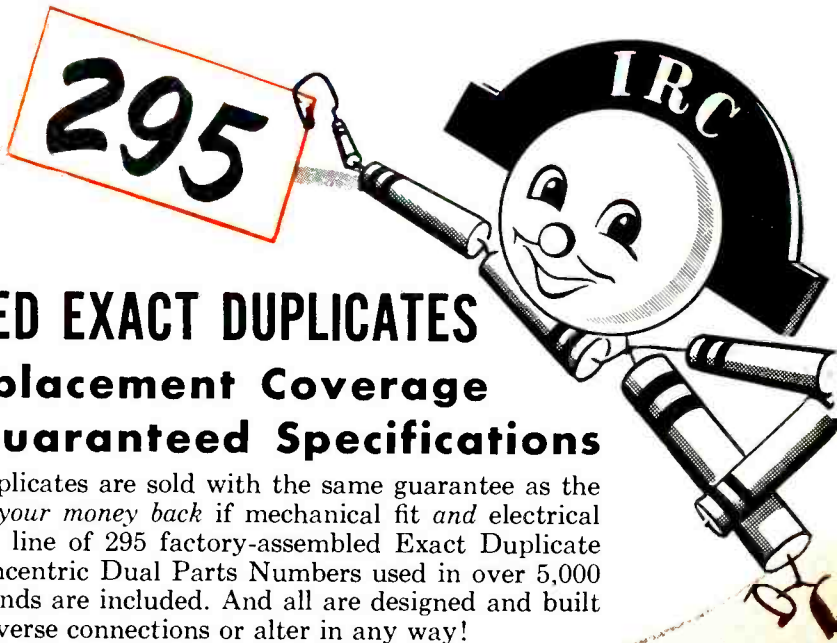

IRC FACTORY-ASSEMBLED EXACT DUPLICATES

Give Widest Replacement Coverage with Dependable, Guaranteed Specifications

IRC's new factory-assembled Exact Duplicates are sold with the same guarantee as the new IRC CONCENTRIKITS. *Double your money back* if mechanical fit and electrical operation are not satisfactory! The full line of 295 factory-assembled Exact Duplicate Controls covers 416 Manufacturers' Concentric Dual Parts Numbers used in over 5,000 TV Models. Both carbons and wire wounds are included. And all are designed and built to accurate specifications. No need to reverse connections or alter in any way!

COMPLETE CONCENTRIC DUAL COVERAGE

FROM ONE RELIABLE SOURCE

Whether you prefer Universal Replacements or Exact Duplicates, you can get your choice now from a single, dependable source. That's time and money saved—for now you can schedule your trips to your IRC Distributor. And regardless of the concentric dual units you buy, IRC's guarantee protects you—*double your money back if fit or operation are unsatisfactory!*

GET THE FULL STORY TODAY

Mail the coupon today for full details of IRC's new, improved CONCENTRIKITS and FACTORY-ASSEMBLED EXACT DUPLICATE CONTROLS. Catalog Data Bulletin DCIC contains stock numbers, prices, TV sets covered and parts numbers. Yours without obligation.



INTERNATIONAL RESISTANCE CO.

401 N. Broad Street, Philadelphia 8, Pa.

in Canada: International Resistance Company, Ltd., Toronto, Licensee.

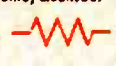
Wherever the Circuit Says 



INTERNATIONAL RESISTANCE COMPANY
417 N. Broad Street, Philadelphia 8, Pa.

Please send me full details of:—

- IRC's new, improved CONCENTRIKITS, with Exact Duplicate Replacement Shafts, Base Elements and Switches.
- IRC's 295 new Factory-Assembled Exact Duplicate Replacement Controls.

NAME

COMPANY

ADDRESS

CITY

STATE

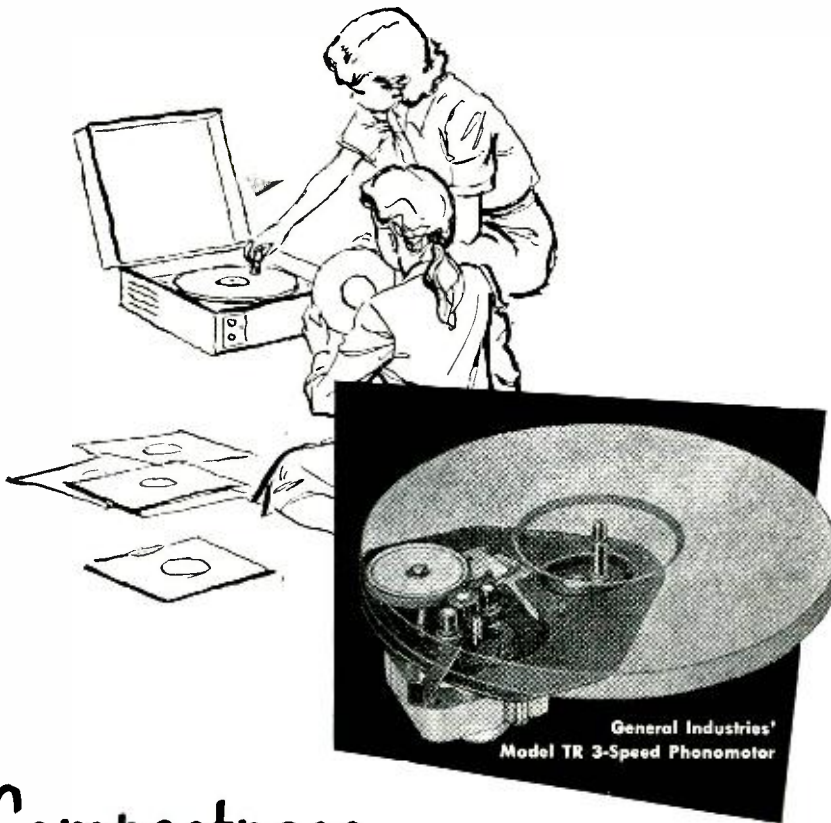

Compactness...

another reason why leading manufacturers prefer General Industries' 3-Speed Phonomotors

Because of their clean compact design, General Industries' *Smooth Power* Phonomotors are ideally suited for any phonograph application—portable record player, table-model combination or full-size console.

Write *today* for complete information about these trouble-free, performance-proved phonomotors, including specifications, design features and dimensions.



THE GENERAL INDUSTRIES CO.
Department ME • Elyria, Ohio

So You Want To Be A Writer!

That idea you may have for writing a technical book is absolutely no good unless you do something about it. If you're dying to reveal all you know about TV; if you feel the world is wasted without your words on servicing, or if you nurture a secret ambition to out-theorize all the books on TV theory, then start your writing career by writing to us. Just send us a letter outlining your ideas. Our reply will contain a copy of our author's guide and details of royalty payments.

Book Dept.
RADCRAFT PUBLICATIONS, INC.

25 West Broadway,
New York 7, N. Y.

"EDISON EFFECT" FINDS A NEW USE

By IRVING GOTTLIEB

Interesting and useful effects may result from using vacuum tubes in unconventional ways. Commonly all the tube elements are parts of closed circuits, with proper external voltages applied. But there are cases where an element may be left "open." A capacitance-operated "floating-grid" relay was described in this magazine in June, 1943, and a biological microvoltmeter with a normally-open grid circuit in the May, 1944 issue. As can be seen from the dates, these accounts are rare.

The long known but little used Edison Effect (flow of current in a vacuum tube between a hot cathode and any other element having a lower temperature, but no applied a.c. or d.c. potential) may also have its uses. The author worked out this simple circuit to demonstrate a possible use of this effect—measurement of very high resistances. It has the great advantage that it does not require the high potentials found in most equipment designed for high-resistance measurement.

The circuit will measure resistance values of 10 to 1,000 megohms. When applied to composition and film type resistors used in conventional electronic equipment, and to the measurement of surface leakage of insulating materials it yields good accuracy over a far greater range than the average ohmmeter. It is not suitable for determining the insulation resistance of dynamos or other devices in which the capacitance between measuring points exceeds about 15 μf . This circuit is shown below.

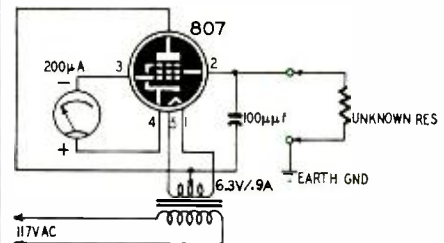

The principle of operation is: Electrons are emitted from the heated cathode. Some of these electrons are intercepted by the control grid and return to the cathode through the meter circuit. Others, which have higher velocities or are emitted at different angles, pass the control grid and accumulate on the screen grid. If these electrons are not removed from the screen grid, their cumulative negative charge will deflect free electrons back to the control grid and increase the current in the meter circuit.

On the other hand, if the negative charge on the screen grid is removed, fewer electrons will be intercepted by the control grid. This will reduce the current circulating between cathode and control grid. If any of the inter-grid electrons are deflected back to the

RADIO-ELECTRONICS

control grid, the external current will have a proportional value.

The best way to remove the charge from the screen grid is by means of an earth-ground. The meter should be calibrated by using known resistors. The scale calibration will not be linear. The 100- μ f capacitor reduces the effects of distributed or lumped capacitance in the resistance being measured. A capacitor larger than 100 μ f will reduce the sensitivity. An air-dielectric capacitor connected by short, heavy leads will give best results.

The 807 tube should be mounted inside a metal box and the screen grid connection should be brought out through a large porcelain feed-through insulator. Most effective shielding is obtained by connecting the plate terminal of the tube and the metal box to the center-tap of the filament winding.

SIMPLE PULSE INVERTER

Electronic counters, radar, loran, and many other electronic devices often require pulses of a specific polarity for proper operation of a particular circuit. In some instances, the pulse provided by the source is of opposite polarity to that required by the circuit. In such cases, a transformer or tube is usually used as a phase inverter. Leonard Reiffel, in *The Review of Scientific Instruments*, describes a simple circuit which may be used for phase inversion when the pulse does not require further amplification.

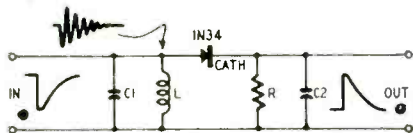

The inverter is shown in the diagram. When a negative pulse is applied to the input terminals, it shock-excites the tuned circuit (L-C1) and sets up a train of damped oscillations. The positive half-cycles of the oscillations are rectified by the 1N34 and integrated by R and C2 into a positive pulse with a gradual decay.

The voltage across the output terminals is a positive pulse having a decay corresponding to the positive half of the envelope of the damped oscillations. The output pulse is delayed one-half cycle with respect to the input cycle. To invert positive input pulses, reverse the connections to the 1N34. —end—



Television is Amazing
Suggested by Robert W. Glueckstein

JUNE, 1952

Harry M. Neben,
chief of Amphenol's Electrical Testing Laboratory,
recommends

Simpson

Model 303 Vacuum Tube Volt-Ohmmeter



\$58.75 DEALER'S NET
SIMPSON ELECTRIC COMPANY
3200 W. KINZIE ST.
CHICAGO 44
COLUMBUS 4-3221

SEEK BROWNE ADVERTISING

BE YOUR OWN BOSS!

MAKE MORE MONEY



\$1.00 VALUE

25c

40,000 WORDS IN TEXT

NO ADS ALL "MEAT"!

In "CASH IN" you now get THE real money-makers — dozens of profitable tested mail order plans, confidential business secrets, dozens of practical tested formulas, successful tested schemes — actual experiences of men who have started on a shoestring — with less than \$10 capital. 25c a copy postpaid. Send U. S. stamps, money order, or coin.

Money Back Guarantee

NATIONAL PLANS COMPANY
1966R BROADWAY, NEW YORK 23, N. Y.

EASY TO LEARN CODE

It is easy to learn or increase speed with an Instructograph Code Teacher. Affords the quickest and most practical method yet developed. For beginners or advanced students. Available tapes for beginner's alphabet to typical messages on all subjects. Speed range: 5 to 40 WPM. Always ready — no QRM.

ENDORSED BY THOUSANDS!

The Instructograph Code Teacher literally takes the place of an operator-instructor and enables anyone to learn and master code without further assistance. Thousands of successful operators have "acquired the code" with the Instructograph System. Write today for convenient rental and purchase plans.

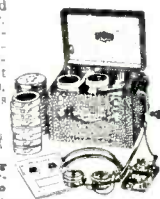

INSTRUCTOGRAPH COMPANY

4201 Sheridan Rd., Dept. RC, Chicago 40, Ill.

For better, quicker servicing



USE

Mandl's Television Servicing

Here are detailed, illustrated instructions for locating and correcting EVERY flaw or failure that may occur in each stage of today's TV receivers. You'll learn simple signal tracing procedures; trade tricks in diagnosing troubles in minimum time; the essentials of successful VHF and UHF servicing; how to trouble-shoot A.G.C. circuits, synchroguide circuits, and all other circuits, including the latest improvements. A complete master trouble index enables you to QUICKLY find the cause of and procedures for correcting any trouble, including those hard-to-find troubles. Hundreds of diagrams, original photographs of flaws as they appear on the TV screen, oscilloscope patterns and other illustrations further aid you in locating trouble, testing, and making adjustments.



Noll's

Television for Radiomen

Very clear, thorough, non-mathematical explanations of the function and operating principles of every element and circuit in TV reception; how the receiver is constructed; basic principles of transmission; and the techniques of installing, adjusting, and aligning today's receivers, with full instruction on test equipment and its use. Here, in the simplest, clearest terms, is the basic knowledge that is a MUST for good TV work.

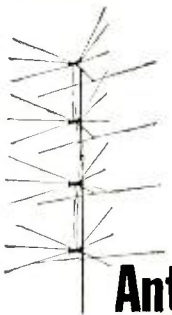

AND

Noll & Mandl's Television and FM Antenna Guide

Are fringe area reception, ghost reception, interference your problems? This book shows you how to overcome them—how to improve gain; minimize noise on the transmission line; get the MOST out of the antenna system at any location. It tells how to determine the right type of antenna for the site and the best position for it; gives full data on all types of antennas including those for the new UHF and VHF locations, yagi antennas, stacking, boosters, and other fringe area aids.

NOW MORE THAN EVER, YOU'LL NEED THESE EXPERT SERVICE AIDS.

SEE THEM ON APPROVAL

The Macmillan Co., 60 Fifth Ave., N. Y. 11

Please send me the books checked below. I will either remit in full or return the books in 10 days.

- Mandl's TV Servicing \$5.50
- TV & FM Antenna Guide \$6.25
- TV for Radiomen \$7.75

Signed

Address

(This offer good only within continental limits of U.S.A.)

THICKNESS GAUGE

Patent No. 2,572,908

Irving R. Brenholdt, Chicago, Ill.
(assigned to Standard Oil Co., Chicago)

This instrument measures iron or steel from 1/41 inch to one inch thick. Accuracy is not affected by rust or dirt on the metal. A practical form of the device is shown at a and the basic schematic is drawn in B.

An oscillator generates a frequency of 50 cycles which is fed to an LC circuit. L is the inductance of a laminated core probe. Its coil may have about

1500 turns. LC is tuned to slightly below 50 cycles. When the probe approaches magnetic material, its inductance drops and resonance is reached. LC may be designed for resonance when the probe is about 1/8 inch from a mass of metal.

To measure thickness, the probe is brought near the metal. When the gap is 1/8 inch, peak probe voltage occurs. This peak is rectified and stored on C1 which is unloaded. The v.t.v.m. indicates C1 voltage. The probe may be moved about, but only the peak voltage (at 1/8-inch probe distance) is indicated.

Although the peak always occurs with the same probe gap, the maximum depends upon metal thickness. The thicker the metal, the greater the eddy current loss, therefore the lower the peak. The instrument is calibrated by potentiometer P on a metal sample of known thickness. After completion of a measurement, SW is closed to discharge C, and bring M to zero.

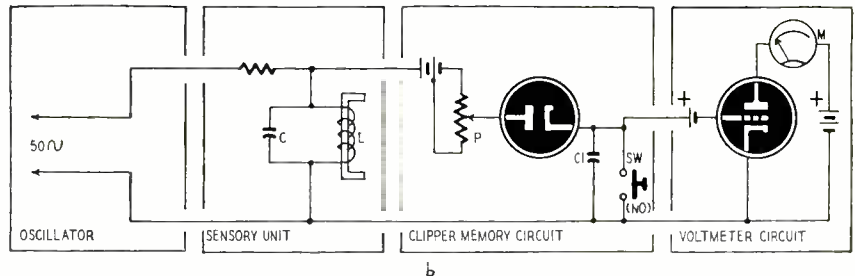
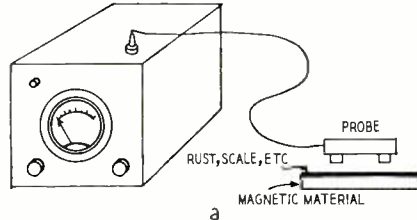

AID TO THE BLIND

Patent No. 2,582,728

Joseph B. Walker, Hollywood, Calif.

This invention detects obstacles by means of light beams. Reflected light from an obstacle is converted to sound to warn the blind person. The apparatus is portable and powered by batteries.

Essential parts are shown in the illustration. Lamps 1 and 2 project light beams through perforations in revolving disc D. Another view of D appears in the insert. Light from 2 passes through the inner perforations and is deflected upwards toward A. Therefore this beam can detect obstacles several feet above ground. If reflections occur at this level, the light falls on mirror AA and photocell PE. As the reflected light is interrupted at an audio rate by the perforations in the rotating disc, the photocell current

is modulated and its amplified output heard in the reproducer.

Light from 1 passes through the outer perforations and is projected downward by the lens. This detects obstacles nearer the ground. Reflections (if they occur) fall on mirror BB and on PE.

Note that the outer ring of perforations has twice as many holes as the inner ring. Therefore the 1 beam is interrupted at twice the rate and is responsible for a higher frequency than the beam from 2.

Output from PE may operate an ear-phone or other reproducer. When the blind person hears a low-pitched tone he is warned of an obstacle several feet above ground. A high-pitched tone indi-

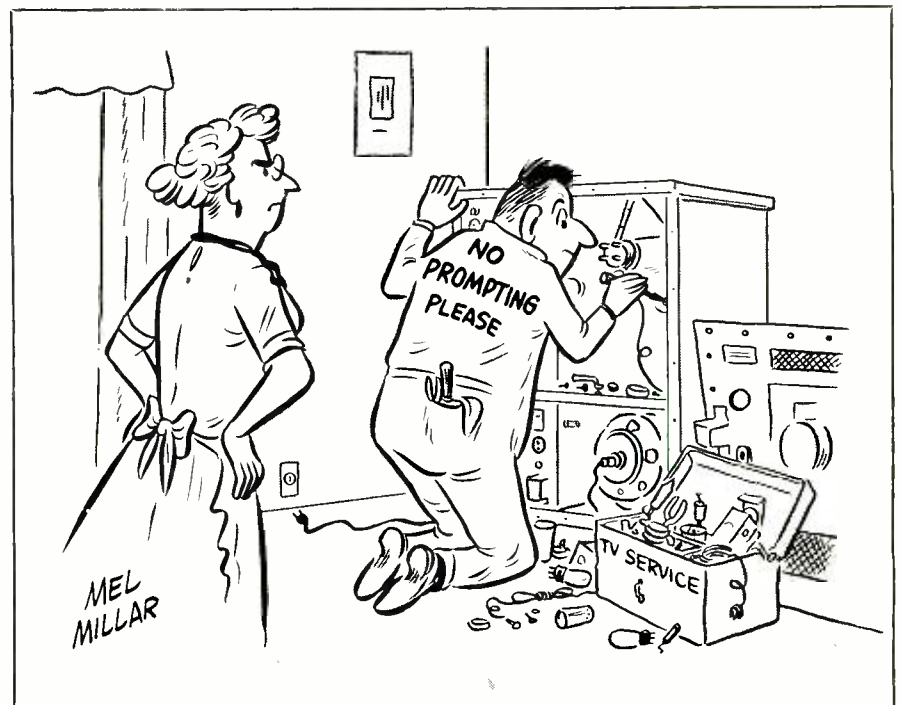

THE MIRACLE OF ELECTRONIC CONTROL

Yours to Command!



ADVANCED **THYRATRON** CIRCUIT
REMOTE CONTROL

FOR 110 VOLTS 60 CYCLES AC

Engineers — Hams — Students
Servicemen — Hobbyists

Here's the chance of a lifetime to own a genuine Thyatron Electronic Remote Control of your own at a fraction of its regular price! This mighty handful (only 5 3/4 x 5 x 3 1/4") of miracle control can be made to perform hundreds of practical, fascinating feats of remote control.

PRECISION THYRATRON CIRCUITRY

These amazing Thyatron precision thermostatic controls can easily and quickly be modified by you for electronic remote control of: Transmitters; Turn Radio and TV on and off; Open and Close Garage Doors from your car; Remote Control of Appliances, Machinery, Power Tools; Remote Controls for Model Railroads, Planes, Boats, Trucks; Burglar, Fire, Temperature and Rain Alarm Systems; Poultry Brooder Controls, etc., etc.

Your own ingenuity and inventiveness can devise many more interesting and practical uses which this remarkable unit can control for you. A complete schematic is furnished with each control.

PARTS ALONE WORTH TWICE THE COST
Each control unit contains a highly sensitive plate circuit trigger relay, a 110 volt 60 cycle AC filament transformer, many condensers and resistors (including 1% precisions) and a host of other valuable parts worth twice or more our low, low bargain price. No matter how you use it it's a great buy!

Kit of 3 Tubes for Remote Control Unit, consisting of 6SN7GT, 6SL7GT and a GE Thyatron GL-5662 (net \$3.30 by itself). All 3 plus Bakelite Cabinet, only \$4.95
No. C.O.D. Postpaid in U.S.A. Only
(10 Days Net to Rated Firms)

Send Check or Money Order to Dept. R.

ATTENTION: Electronic Alarm Manufacturers! These Thyatron controls are ideal for adaptation by you for FIRE, BURGLAR and other alarm systems you make. Increase your profits, make a better product by using this control or its components in your products. Let your engineers check a few and see for yourself. Terms: Net 10 days to rated firms.

\$2.88
only

(Less Cabinet & Tube Kit)
No. C.O.D. Postpaid in U.S.A. Only

Complete With Cabinet and Thyatron Tube Kit **\$7.50**
No. C.O.D. Postpaid in U.S.A. Only

POPULAR REMOTE CONTROL USES

- ON-OFF for Transmitters, Radio or Television Sets
- Open and Close Garage Doors From Inside Your Car
- Model Railroads, Boats, Planes, Cars, Trucks
- ON-OFF for Appliances, Machinery, Power Tools
- Burglar, Fire, Temperature or Rain Alarm Systems
- Poultry Brooder Temperature Controls
- Remote Thermostatic Control

MANUEL KLEIN COMPANY

94-R Chambers Street, New York 7, N. Y.
Rector 2-6460

SO IMPORTANT — it was
Featured in Special Article
in

The New York Times

Jan. 28, 1952
FREE copy
of article on request

**UNIT REACTIVATES
TV PICTURE TUBES**

Small Electronic Device Tests
Sets at Home and May Add
Year or More of Use

By T. R. KENNEDY Jr.

A small electronic device that can be applied to home television receivers to test and reactivate the picture tube without removing it from the set, resulting in renewed brightness in many and considerably longer useful life, has been placed on the market for the first time by a New York manufacturer.

In some cases it was said, the picture tube may be made almost as good as new and given as much as a year's useful life before replacement is necessary.

The instrument is small and compact. It weighs three pounds and is as large as the average lunch box. It costs little and is simple to operate.

Picture tubes, some of them new and never in a receiver, have shown remarkable improvement in brilliance and definition after a few minutes of reactivation in the last few days.

Although the principle of its operation is not new—cathode-ray tube manufacturers have used it for years in the initial making of picture tubes—its incorporation in a small instrument

The almost immediate urgent need for such an instrument which also soon may be produced in kit form for home assembly, is apparent to ten million TV parents. Eight to ten million picture tubes, Transvision engineers estimate, have now been in use for three to four years or more, and "probably are in need of test and reactivation to renew their brightness." Unfortunately, loss of brightness, it was pointed out, seldom can be detected short of comparing the old tubes with new ones in lately produced sets.

Furthermore, picture tubes may have lost some of their brightness which has been described as a "kind of aging process" to which all large cathode-ray tubes and similar devices are subject. Back-

upset of the current uses most of use today, cost from \$25 to \$45.

New picture tubes can be tested and reactivated without removing them from their cartons, and tubed in TV sets without removing the tubes from the receiver. It is done by attaching a standard picture tube socket to the tube, and by turning a switch on the tester reactivator, and noting the glow of a small neon bulb as a condition of the tube is indicated which is plugged into an AC home electric socket. The receiver, meanwhile, is not turned on.

In some cases the test and reactivation is accomplished in less than two minutes.

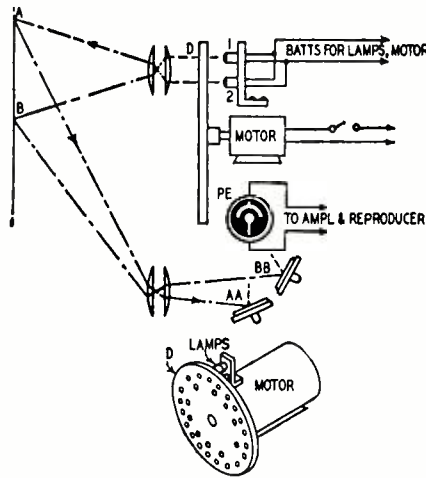

creates a lower obstacle. With experience, obstacles may be judged as to height, distance and even approximate outline by manipulating the device in various ways.

In another form of the device covered in the same patent, a single light source is used. By an interlocking lever arrangement, the light beam and a reflecting mirror are made to scan the area to be covered. The rotating light-modulator disc has several concentric rings of perforations, each ring containing a different number of holes. As the beam moves vertically, reflections pass through different rings, modulating the output according to the height of an obstacle.

PULSE REGISTER CIRCUIT

Patent No. 2,582,480

Thomas L. Dimond, Rutherford, N. J.
(Assigned to Bell Telephone Laboratory, Inc.)

This device stores a pulse or voltage, and subsequently registers it. It can be used in computing machines, telephone switching networks, and similar devices. No heater type tubes are used. No stand-by power is wasted.

The circuit shown here can store a positive voltage and register it. When RY1 is energized (even momentarily) a positive voltage fires the gas tube V1 (similar to a neon lamp) and therefore charges C. As the charge grows, the potential drops across V1. Finally V1 is extinguished and the charge is trapped on C.

Later, RY2 may be energized to test for a positive charge on C. The negative voltage from B2 adds to the positive charge on C. The total is large enough to trigger V1 again. A pulse of current flows through R and this transmits a voltage pulse (through a capacitor) to thyatron V2. If desired, the output from V2 may be fed to a mechanical register or counter.

Additional relays and associated circuits may be used to store and read negative voltages. The circuits are like those shown except for reversal of power-supply polarities. For example, negative pulses are read by a circuit like that of RY2, except for a reversal of B polarity.

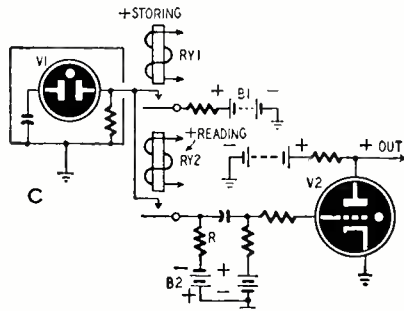

ULTRASONIC MICROPHONE

Patent No. 2,579,136

Leslie J. Anderson, Moorestown, N. J.
(assigned to Radio Corp. of America)

This microphone is designed specifically for ultrasonic frequencies used in secret signalling, obstacle detection, and similar applications. It does not respond to audible waves which may also be present.

The invention utilizes a flat metal bar fixed at its center. End A is inside a metal vacuum tube and may be used as the anode. End B is outside

TUBES at Mir's. COST

Branded — Standard Brands
RTMA Guaranteed

1A7GT	\$0.79	8RF5	\$0.65	12A6	\$0.70
1B3	.85	8BF6	.70	12AT6	.40
1L4	.60	6B6G	1.48	12AT7	.95
1L6	.60	6BQ6	.94	12AU6	.55
1LC6	1.05	6BQ7	1.95	12AU7	.75
1LN5	1.05	6C4	.60	12AV7	.95
1N34	.69	6CB6	.65	12AX7	.75
1R5	.60	6CD6G	1.93	12BA6	.48
1R4	.85	6E5	1.05	12BA7	.80
1R5	.80	6F6	.70	12BE6	.55
1T4	.85	6H6M	.65	12BH7	.50
1U4	.60	6J5M	.65	12J5GT	.30
1U5	.50	6J6	.73	12SA7G	.70
1X2A	.85	6K6	.65	12SF5M	.65
3A4	.75	6K7	.70	12SG7	.90
3Q4	.55	6K8	1.35	12S17	.80
3V4	.62	6L6GA	1.05	12SK7	.65
3S4	.80	6S4	.51	12SQ7	.70
5U4G	.55	6S7M	.85	12SN7GT	.75
5V4	.95	6SA7GT	.70	12SR7	.65
5Y3GT	.39	6SC7	1.10	14B6	.95
5Z3	.85	6SH7	.65	14E6	.95
6A7	1.00	6S17	.70	19T8	.86
6AB4	.65	6SK7GT	.53	25A5	.95
6AB5 6N5	1.25	6SL7GT	.65	25BQ6	1.60
6A7	.95	6SN7GT	.85	25L6GT	.60
6AG5	.65	6SQ7GT	.65	25W4	.80
6A17	1.40	6T8	.86	35L6GT	5.1
6AH6	1.75	6V6GT	.60	35W4	.47
6AK5	.95	6W4GT	.49	35Y4	.89
6AK6	1.20	6X4	.43	35Z5GT	.49
6A15	.54	6X5	.43	45Z5	.80
6AQ5	.65	6Y6	.85	50B5	.53
6AT6	.45	7AD7	1.25	50C5	.55
6AU6	.65	7C5	.70	50L6GT	5.3
6AV6	.50	7C7	.85	59	.75
6AX5GT	.85	7E7	1.30	89Y	1.30
6B4	1.50	7F7	.95	9001	1.25
6BA6	.55	7G7	1.30	9002	1.05
6BC5	.56	7Q7	.89	9003	1.25
6BE6	.49	7W7	1.25	9006	.35

BRANDED—STANDARD BRANDS

Minimum Order \$15.00

IMMEDIATE DELIVERY!

Write for quotations, many other types available. 20% deposit with order, balance C.O.D. All tubes subject to prior sale. Prices subject to change without notice.

WRITE, WIRE, CALL—TODAY!

We Buy Anything in Electronics—large or small quantities!

Nat Adelman

168 Washington St. New York 6, N. Y.
CO. 7-6091

**TRANSVISION CR TUBE
TESTER - REACTIVATOR**

performs 2 vital functions:

- Tests Picture Tubes
- Renews Brightness of Dim Picture Tubes

It's a **TESTER**:

Without removing picture tube from set, you apply this precise instrument to:—

- Measure Cathode emission
- Locate shorts between elements
- Locate high resistance shorts or leakage as high as 3 megohms

It's a **REACTIVATOR**

for dim CR Picture Tubes

Revives dim TV Picture Tubes, without removal of tubes from sets. Reactivation works on tubes with low light output, if there's no mechanical break in tube. 110 V—60 cycles. Weighs only 3 lbs. One or two applications pays for instrument.

SATISFACTION GUARANTEED or money refunded if you return the instrument in 10 days in good condition. **\$19.95 NET**

RUSH THIS COUPON—
TRANSVISION, INC.

DEPT. RE6 NEW ROCHELLE, N. Y.

() Send me CR Tube Tester-Reactivator(s).

() Enclosed find \$ deposit. Balance C.O.D.

() Enclosed find \$ in full. Send prepaid.

Name _____

Address _____

City _____ State _____

Operate 2 sets
from 1 Antenna

with the

**TELE Matic
ADD-A-SET**

TV Receiver Coupler



SAVE money! labor! materials!

- Highest efficiency transformers used.
- Operates in fringe areas.
- High pass filter action.
- No inter-set coupling.
- Eliminates soldering, screw terminal.
- Compact, mounts inside cabinet.

Sold by leading Jobbers Everywhere
Send for FREE booklet on TV INTERFERENCE



the tube. K is the cathode. A cylindrical shield S surrounds these elements and the heater.

Ultrasonic waves set end B into vibration and the energy is transmitted to A. When the anode vibrates, it causes corresponding variations in

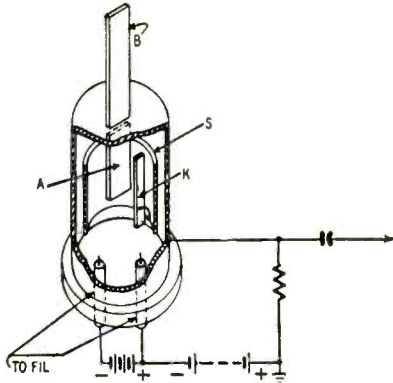

tube current. The signal is then amplified as required.

Bar dimensions depend on the frequency of operation. As an example, the bar may be 2.54 cm long and .1 cm thick. The top of the tube (which supports the bar) may be .2 cm thick and 1 cm in diameter. The bar may be of stainless steel or beryllium. Under these conditions, the resonant frequency will be about 26 kc.

The bar is bidirectional. Each side is sensitive to supersonic waves.

AREA MEASUREMENT

Patent No. 2,578,882

George H. Eash, Toledo, Ohio

(Assigned to Selby Shoe Company, Portsmouth, Ohio)

This is a form of light-measuring circuit. An opaque pattern is placed in the path of a steady light beam. It partially blocks the light falling on a photocell and there is correspondingly less cell output. The unknown pattern area is determined from the cell output either by calibration or comparison with a known area.

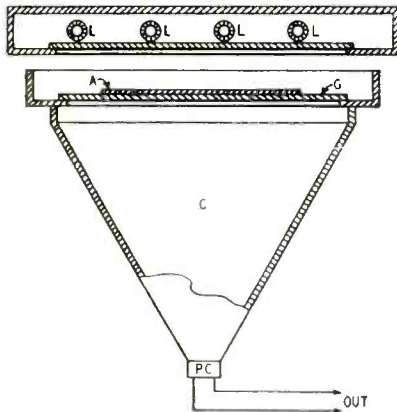

The figure shows a recommended arrangement. L is a bank of lamps, fluorescent or incandescent. The lighting must be uniform. Light from the lamps falls upon G, a layer of translucent glass which diffuses and equalizes the light. The area to be measured (A) is placed in front of G. At the other end of C is photocell PC. Cell output corresponds to light transmission through G.

Without A, maximum light falls upon PC and the output current is noted. Now if a flat object of any shape is placed in front of G, it blocks part of the light. For example, if A has half the area of G, output from PC will be reduced to one-half (assuming proportional output).

—end—

TV DIRECT FROM THIS GREAT TO YOU FACTORY
BRINGS YOU
Finest Quality at Lowest Prices



TRANSVISION

TV KITS, WIRED CHASSIS, and SETS
CABINETS, COMPONENTS, INSTRUMENTS, and ACCESSORIES
SENSATIONAL OFFER

on top quality TV Picture Tubes.

• FREE—VALUABLE PREMIUMS:

With every Transvision tube you buy, you get a Merchandise Premium Coupon of real value. Write for list today.

• TRADE-IN ALLOWANCE on old tubes: Make from \$2.50 to \$5.00 glass allowance on each "dud."

• FULL 2 YR GUARANTEE:

Only Transvision gives you a Guarantee for 24 months.

COMPARE: Get the full details on the Transvision tube deal today.

FREE BOOKLET: "INSIDE CRT, or What You Should Know about Picture Tubes". Written by CRT experts, illustrated. It will **MAKE MONEY FOR YOU. WRITE FOR IT.**

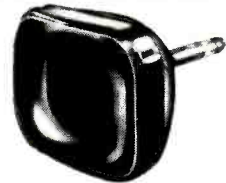

TRANSVISION Picture Tube PRICES

Type	Your Cost if no old tube is traded in— DEALER PRICE—	Allowance for old tube	Your FINAL COST, if old tube is turned in— DEALER NET—
10BP4	\$17.95	\$2.50	\$15.45
12IP4	17.95	2.50	15.45
12LP4	19.95	3.00	16.95
14RP4	19.95	3.00	16.95
16DP4	27.95	4.00	23.95
17BP4	25.95	4.00	21.95
19AP4	37.00	5.00	32.00
20CP4	35.95	5.00	30.95



SPECIAL!



REMOTE CONTROL TV CHASSIS

Here's the finest buy in Remote Control TV. Unit is all-electronic; no troublesome mechanical parts. Gives complete operating control of set. Plus—the latest Transvision A-4 Wired TV Chassis; completely aligned; ready to plug in. Has AFC and AGC. Top quality reception, even in fringe areas. 17" A-4 TV Chassis, remote control, and CRT, net \$199. 20" A-4 TV Chassis, remote control, and CRT, net 219. With Du Mont Tuner and FM radio, add..... 10

BEAUTIFUL TV CONSOLES

Ideal for Custom-Building or Conversion. Factory prices start from \$49. Send for Cabinet Catalog now.

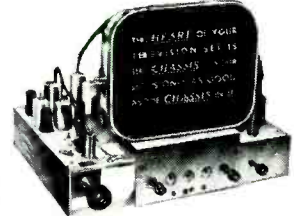

FIELD STRENGTH METER AT NEW LOW PRICE

Improve TV installations; save half the work with the Transvision Field Strength Meter. Especially good for fringe areas—measures field strength as low as 10 microvolts. **\$59 net**
Model FSM-1, complete with tubes.



U. H. F. ADAPTERS

will be available for all Transvision Sets and Kits.

Write for Factory Agent Plan

MULTI-SET CONNECTORS

feed up to 5 TV Sets from 1 Antenna

Prices: Multi-Set Conn. for 2 sets \$4.95 list*
For 3 or 4 sets 7.95 list*

*Dealers, write for discounts

FREE: EXTRA INCOME EVERY MONTH from hints in "TV and Electronics Notes." Request or send 50c to cover cost of sample copy, addressograph plate and mailing for FREE Subscription. Monthly issues are gold mines of info on New Products, Sales, Service, Conversion, etc. **WRITE DEPT. REG TODAY!**

TRANSVISION, INC. NEW ROCHELLE, N. Y.

ANTENNA DESIGN DATA

The data in the table is based on material in an Admiral radio course and was prepared as an aid to antenna installation crews and experimenters. Adding radiators or reflectors to an antenna causes a sharp reduction in the antenna impedance and makes it necessary to use a matching section to couple the array to standard transmission lines. The impedance of the matching section can be found by finding the square root of the product of the an-

tenna and transmission line impedances or, $Z_2 = \sqrt{Z_1 \times Z_3}$, where Z_1 , Z_2 , and Z_3 are impedances of the antenna, matching section, and line, respectively. The length of the matching section or stub is

$$L = \frac{246}{f} \times VP,$$

where L is the length of a quarter-wavelength section in feet, f the operating frequency in megacycles, and VP the velocity of propagation. VP is 0.77 for 150-ohm lines and 0.68 or 0.71 for 75-ohm coaxial lines.—*W. G. Eslick.*

(See "Transmission-Line Constants" in the January 1950 issue. The folded-dipole impedances are approximately correct only when the dipole conductors are the same size. If the driven conductor is smaller than the other, the impedance will be higher. The stepup in impedance over a dipole depends on the conductor diameters and spacing.—*Editor*)

TYPE	IMPEDANCE	GAIN (DIPOLE AS ZERO)
DIPOLE	72	0
FOLDED DIPOLE	300	0
DIPOLE WITH REFLECTOR	60	2-2 1/2
FOLDED DIPOLE WITH REFLECTOR	250	2-2 1/2
DIPOLE, REFLECTOR & DIRECTOR	20	2-1/2-5
FOLDED DIPOLE, REFLECTOR & DIRECTOR	80	2-1/2-5
DOUBLE DOUBLET, REFL. & DIR.	225	4
DOUBLE STACK "TWO OVER TWO"	300	5

RECEIVING FM ON TV SETS

If you are using a TV set which has a turret-type tuner, it is quite possible that you can modify it so you can receive a few of the local FM broadcast stations. Channel 6 must be vacant in your locality. Sets with intercarrier sound won't work.

You simply adjust the channel 6 oscillator-tuning slug until you receive FM stations in the low-frequency half of the band. The printed-circuit tuner can be adjusted to bring in stations between 88 and about 94 mc. The Standard Coil tuner can be adjusted to bring in stations a few megacycles higher. The fine-tuning control can be used to tune in stations adjacent to the one on which the oscillator is centered.

The mixer and antenna circuits are not tuned to the FM band, so this trick works best for local stations.—*M. G.*

Get RID of BARKHAUSEN OSCILLATION



with the

PERFECTION B. O. ELIMINATOR



(Actual Size)

To eliminate the vertical black bars which appear in TV pictures as a result of Barkhausen Oscillation in the horizontal sweep output tube (such as the 25BQ6, 6BQ6, 6EV5, 25EV5, 6AU5 or 25AU5, etc.) — use the Perfection B. O. Eliminator.

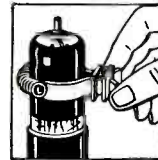

Easy to Install

Because it brings a concentrated magnetic field near the screen grid it usually eliminates the oscillation. Just slip the B. O. Eliminator over the tube, move down, or up, or turn until the dark vertical bars disappear.

Write today for full details!

PERFECTION ELECTRIC CO.

2635 South Wabash Avenue, Chicago 16, Illinois
Makers of Perfection Speakers, Ion Traps and BeamJuster TV Picture Centering Controls

CODE SENDING SPEED

Be a "kev" man. Learn how to send and receive messages in code by telegraph and radio. Commerce needs thousands of men for jobs. Good pay, adventure, interesting work. Learn at home quickly through famous Candler System. Qualify for Amateur or Commercial License. Write for FREE BOOK.

CANDLER SYSTEM CO.
Dept. 3-G, Box 928, Denver 1, Colo., U.S.A.



Regency



Largest Selling Booster

AT ANY PRICE!

RADELCO

LIGHTNING ARRESTOR



MODEL R-116

IT'S THE LOWEST PRICE UNDERWRITERS' LISTED ARRESTOR ON THE MARKET

ORDER FROM YOUR NEAREST PARTS JOBBER

LIST PRICE **90¢**

OPPORTUNITY AD-LETS

Advertisements in this section cost 35¢ a word for each insertion. Name, address and initials must be included at the above rate. Cash should accompany all classified advertisements unless placed by an accredited advertising agency. No advertisement for less than ten words accepted. Ten percent discount six issues, twenty percent for twelve issues. Objectionable or misleading advertisements not accepted. Advertisements for Aug. issue must reach us not later than June 21, 1952. Radio-Electronics, 25 W. Broadway, New York 7, N. Y.

SPEAKERS REPAIRED at wholesale prices. Guaranteed workmanship. Fast service. Amprite Speakers Service, 70 Vesey St., New York 7, N. Y.

MONOTUBE RADIOKIT COMPLETE! Nothing else to buy. Broadcast-hand battery set with 5" speaker, batteries, tube, full instructions. No technical knowledge required—only \$5.75 postpaid. Barry Electronics Corp., 136 Liberty Street, New York 6, N. Y.

WE REPAIR, CONVERT, SELL, ALL TYPES OF electrical instruments, tube checkers and analyzers. Hazleton Instrument Co. (Electric Meter Laboratory), 128 Liberty Street, New York, N. Y. Telephone—BARclay 7-4235.

"NEEDLE-BRUSH" AUTOMATICALLY REMOVES fuzz during phonograph change cycle. 79¢ postpaid. Henry Industries, Ames, Iowa.

WANTED—TOP PRICES PAID—Navy Selsyns IP, IG, ICT, 5P, 5G, 5C and BC-348, BC-221, AN/ART-13, AN/ARC-1, AN/ARC-3, RTA-1B. Electronic Research, 719 Arch St., Philadelphia.

WANTED: AN/APR-4, other "APR-", TS-", "IE-", ARC-1, ARC-3, ART-13, BC-348, etc. Microwave Equipment, everything Surplus, Special tubes, Tee Manuals, Lab Quality Equipment, Meters, Fast Action, Fair Treatment, Top Dollar! Littell, Fairhills Box 26, Dayton 9, Ohio.

Five Element TV Yagi Beams, Aluminum Tubing Etc. Write for prices. Willard Radcliff, Fostoria, Ohio.

TV AND FM ANTENNAS, YAGI, CONICAL, BOW-TIE. Mounts, accessories. Lowest prices. Wholesale Supply Co., Lunenburg 2, Mass.

JUNE, 1952

IMPROVING IMAGE REJECTION

Many sets which use external antennas have poor image rejection on the broadcast band. The region between 550 and 800 kc is often filled with heterodynes and garbled speech. A simple remedy for this is to insert a 2.5-mh r.f. choke in series between the antenna lead and the top of the primary of the antenna coil. If the set has short-wave bands, install a switch to cut out the choke because it will attenuate signals in the short-wave range. On band-switching receivers, install the choke between the broadcast antenna coil and the band-switch.—*Charles Erwin Cohn*

HANDY SERVICING LIGHT

Time after time, I have run into TV sets which have flat, wafer-type miniature sockets mounted behind i.f. cans, capacitors, transformers, and other components where they cannot be seen without pulling the chassis. Taking the tubes out for checking isn't so bad, but

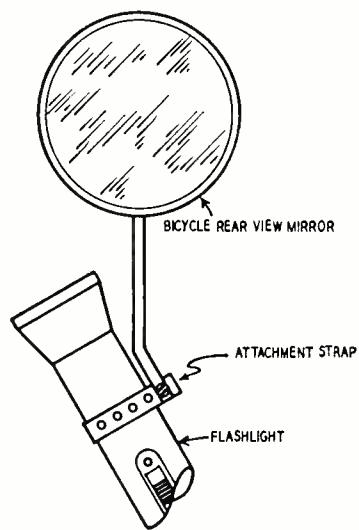

getting them back into the sockets can be a time-consuming, frustrating job. The same problem also arises frequently in seating alignment tool tips in tiny tuning slug slots.

After several such experiences, I devised the flashlight-mirror combination shown in the drawing. A bicycle rear-view mirror is fitted to the barrel of the flashlight with a metal strap clamp. With this arrangement, I can throw light into the socket and see the reflection clearly in the mirror. The swivel on the mirror permits it to be set at the most convenient angle.—*Harry E. Brooks*

HUM REDUCING KINK

Sometimes, you may find that hum in an audio amplifier is originating in a push-pull driver or output stage which uses directly heated tube types such as the 45, 47, 2A3, 6A3, 6B4-G, and 6B5. In this case, try transposing the filament leads of one tube and use the connection which gives the least hum. This connection is the one which makes the hum voltages in phase in the plate circuits so they cancel out.—*John Sareda*

"PACKAGED ENGINEERING"
at Its Best!
For the TV Technician

The B-T MIXER-AMPLIFIER SYSTEM



Model MA4-1

For All VHF and UHF Multi-Antenna Problems

Designed for the Service Technician to enable him to plan and make any installation . . . whether a single receiver or a complete 2000-set Master Antenna System . . . of lower cost, and without outside engineering.

The B-T MA4-1 is a wide-band, oil-channel TV signal mixer for feeding 5 antennas to 1 TV receiver or distribution system. One input is broad-band for signals requiring no pre-amplification, and the remaining 4 accommodate separate plug-in strip assemblies. All terminals have 75 and 300 ohm connections. Several units may be ganged to serve any number of antennas.

B-T PLUG-IN STRIPS

Channel Strip CS-1 is a 2-tube (6AB4-6CB6), single channel, highly selective amplifier with a gain of at least 17 db., one strip for each TV channel.

The UHF Converter, UC-1 is designed for lowering UHF signals to existing TV frequencies, permitting UHF reception on present TV receivers.

Eliminates all need for rotators, separate boosters, converters, and other costly projects.

Once connected the MA4-1 performs without further attention . . . no switching . . . no adjustments.

LIST PRICES:

Model MA4-1 (less plug-in strips) **\$52.50**
Channel Strip CS-1 (specify channel) **19.50**
UHF Converters UC-1 to be announced
Standard RTMA Warranties Apply.

For the Complete "Packaged Engineering" story, ask about B-T Signal Amplifiers and B-T Distribution Amplifiers at your local Distributor, or write to Service Department, F



BLONDER-TONGUE LABS, inc.
Mount Vernon 1, New York

The NEW 1952 Heathkit OSCILLOSCOPE KIT

MODEL O-7
SHIPPING WT. 29 LBS. **\$435.00**

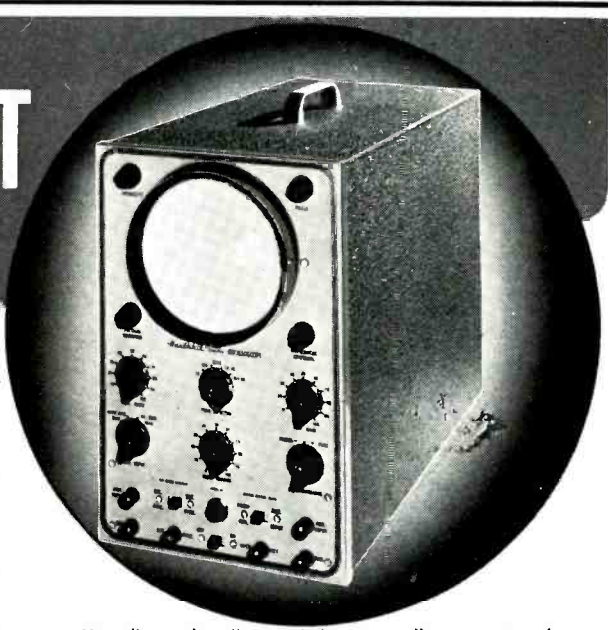

The Heathkit O-7 Oscilloscope with its 10 tube lineup (including CR tube) and carefully engineered circuit using highest quality components is truly the most outstanding scope value on the market today.

The "spot shape" (astigmatism) control working in conjunction with the focus control assures clear, sharp focusing . . . extended sweep range and faster retrace time permits the study of high frequencies . . . step-attenuated frequency-compensated cathode follower vertical input contributes to the excellent frequency response of the vertical channel03V RMS per inch vertical sensitivity makes weak input signals easy to study . . . push-pull operation of both vertical and horizontal deflection plates reduces pattern distortion . . . specially designed extra-wide CR tube mounting bracket places vertical cascade amplifier, vertical phase splitter, and deflection amplifiers near base of CR tube to reduce distributed wiring capacity and increase high frequency response.

Ideal for TV servicing—steep wavefronts encountered in TV work are easily handled. Fine for production line testing—rugged quality components can stand up under continuous hour-after-hour use. Excellent for laboratories—electrical performance comparable to scopes costing 4 and 5 times as much.

You'll like the complete instructions showing all details for easily building the kit—includes pictorials, step-by-step construction procedure, numerous sketches, schematic, circuit description. All necessary components included—transformer, cabinet, all tubes (including CR tube), completely punched and formed chassis—nothing else to buy.

- New "spot shape" control for spot adjustment—to give really sharp focusing.
- A total of ten tubes including CR tube and five miniatures.
- Cascaded vertical amplifiers followed by phase splitter and balanced push-pull deflection amplifiers.
- Greatly reduced retrace time.
- Step attenuated—frequency compensated—cathode follower vertical input.
- New mounting of phase splitter and deflection amplifier tubes near CR tube base.
- Increased frequency response—useful to 5 Mc.
- Tremendous sensitivity .03V RMS per inch Vertical—.6V RMS per inch Horizontal.

MODEL S-2

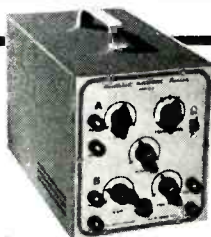

Heathkit ELECTRONIC SWITCH KIT

SHIPPING WT. 11 LBS.

\$19.50

The companion piece to a scope—Feed two different signals into the switch, connect its output to a scope, and you can observe both signals—each as an individual trace. Gain of each input is easily set (gain A and gain B controls), the switching frequency is simple to adjust (coarse and fine frequency controls), and the traces can be superimposed for comparison or separated for individual study (position control).

The kit is complete with tubes, switches, cabinet, power transformer and all other parts, plus a clear detailed construction manual.

NEW Heathkit AUDIO FREQUENCY METER KIT

MODEL AF-1
SHIPPING WT. 15 LBS.



\$34.50

The ideal instrument for determining frequencies from 20 cycles to 100 KC. Set the selector switch to the proper range—feed the signal into the input terminals—and read the frequency from the meter—completely simple to operate, and yet dependable results.

Quality Simpson 200 microampere meter has two plainly marked scales (0-100 0-300). These scales read in conjunction with the seven position selector switch, give full scale readings of 100, 300, 1000, 3000, 10,000, 30,000, and 100,000 cycles. Convenient ranges for fast and easy readings.

For greatest accuracy, the 1-3-10 ratio of ranges is maintained and each range has an individual calibrating control.

A signal voltage anywhere between 2 and 300V can be fed directly into the instrument and a change in signal voltage between these limits will not affect the meter reading. In addition, input wave shape is not critical (the unit will read the frequency of either sine wave or square wave input).

The tube complement consists of a 6SJ7 amplifier and clipper, 6V6 amplifier and clipper, 6H6 meter pulse rectifier, 6X5 power supply rectifier, and OD3/VR150 voltage regulator.

Construction is simple, and quality components are used throughout.

Heathkit INTERMODULATION ANALYZER KIT



MODEL IM-1
SHIPPING WT. 18 LBS.

\$39.50

Intermodulation testing of audio equipment is rapidly being accepted by more and more engineers and audio experts as the best way to determine the characteristics of audio amplifiers, recording systems, networks, etc.

The Heathkit Intermodulation Analyzer supplies a choice of two high frequencies (approx. 3000 cycles and 7000 cycles) and one low frequency (60 cycles). Both 1:1 or 4:1 ratios of low to high frequencies can be set up for IM testing, and the ratios are easily set by means of a level control and the instrument's own VTVM. An output panel control and the instrument's own VTVM. An output panel control supplies the mixed signal at the desired level with level control supplies the mixed signal at the desired level with an output impedance of two thousand ohms. The Analyzer section has input level control and proper filter circuits feeding the instrument's VTVM to read intermodulation directly on full scale ranges of 30%, 10% and 2%. Built-in power supply furnishes all necessary voltages for operating the instrument.

YOU SAVE BY ORDERING DIRECT FROM MANUFACTURER—USE ORDER BLANK ON LAST PAGE

EXPORT AGENT
ROCKE INTERNATIONAL CORP.
115 E. 40th ST.
NEW YORK CITY (16)
CABLE: ARLAB-N.Y.

The **HEATH COMPANY**

... BENTON HARBOR 20, MICHIGAN

THE *New* 1952 Heathkit VTVM KIT

MODEL V5-A
SHIPPING WT. 7 LBS.

\$24.50

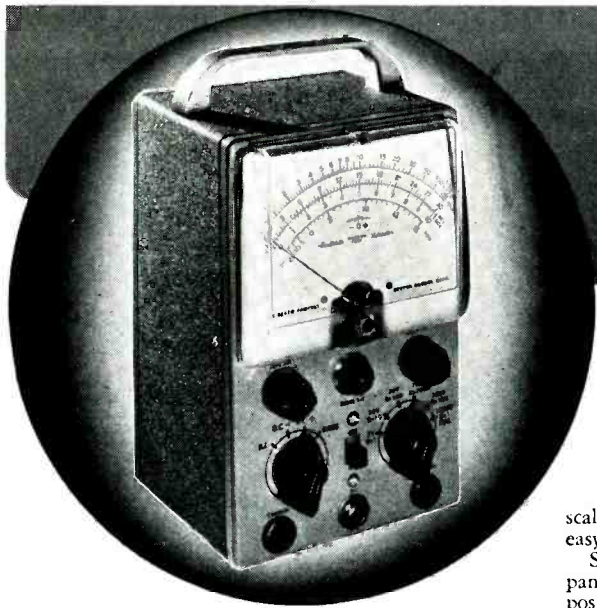

Designed to take up a minimum of space, yet designed to be the most important and useful instrument on your workbench. Really handsome looking — note the rounded edges on front panel and rear cover. New compact size has cabinet dimensions of only 4 1/8" deep x 4 1/16" wide x 7 3/8" high.

Tremendous coverage — will read from 1/2V to 1000V AC, 1/2V to 1000V DC, .1 to over 1 billion ohms resistance, and Db. Meter scale has zero-set mark for FM alignment — all scales clearly marked for easy and fast readings and Db scale is in red for easy identification.

Simple to operate. Ohms adjust and zero adjust controls located on front panel along with selector and range switches. Selector switch has four positions: AC, DC-, DC+, and Ohms to set up the instrument for type of reading desired. DC- position allows negative voltages to be taken without reversing test prods. AC and DC voltage ranges are full scale 3V — 10V — 30V — 100V — 300V — 1000V and resistance ranges are RX1, X10, X100, X1000, X10M, X1 Megohm. Convenient ranges for fast and accurate readings.

Strictly highest quality components used throughout — 1% precision resistors in multiplier circuit, Simpson 200 microampere meter movement, sturdy cabinet, excellent positive detent smooth acting switches, etc. New miniature tube used in meter balancing circuit and new battery holding clamp and spring clip assure good contact to ohms string of resistors.

Kit comes complete — and the instruction manual with its step-by-step instructions, pictorials, figures, and schematic makes assembly a pleasure.

- New styling, — formed case for beauty.
- New truly compact size. Cabinet 4 1/8" deep by 4-11/16" wide by 7-3/8" high.
- Quality 200 microamp meter.
- New ohms battery holding clamp and spring clip — assurance of good electrical contact.
- Highest quality precision resistors in multiplier circuit.
- Calibrates on both AC and DC for maximum accuracy.
- Terrific coverage — reads from 1/2V to 1000V AC, 1/2V to 1000V DC, and .1 to over 1 billion ohms resistance.
- Large, clearly marked meter scales indicate ohms, AC Volts, DC Volts, and DB — has zero set mark for FM alignment.

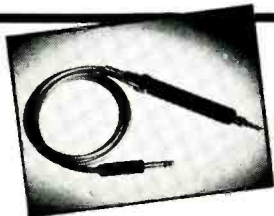

Heathkit R F PROBE KIT

Extends range of Heathkit VTVM to 250 MC ± 10%. Designed for taking RF measurements. All parts furnished including probe housing and crystal diode detector. Shipping Weight 1 lb.

\$5.50

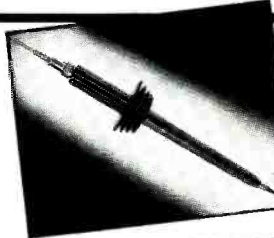

Heathkit 30,000V DC PROBE KIT

For taking readings up to 30,000 V DC when used with the Heathkit VTVM (or any standard 11 megohm VTVM). Comes with two color molded plastic probe body and all parts. Shipping Wt. 2 lbs.

\$5.50

Heathkit A. C. VACUUM TUBE VOLTMETER KIT

Now — as a Heathkit — at a price anyone can afford, an AC VTVM. Makes possible those sensitive AC measurements required by audio enthusiasts, laboratories, and experimentors. The kit audio men have been looking for. Ten ranges consisting of full scale .01, .03, .1, .3, 1, 3, 10, 30, 100, 300 volts RMS assure easy and more accurate readings. Ten ranges on DB provide for measurements from -52 to +52 DB. Frequency response within 1 DB from 20 cycles to 50 KC.

The ingenious circuitry incorporates precision multiplied resistors for accuracy, two amplifier stages using miniature tubes, a unique bridge rectifier meter circuit, quality Simpson meter with 200 microampere movement, and a clean layout of parts for easy wiring. A high degree of inverse feedback provides for stability and linearity.

Extremely compact, cabinet size — 4-1/8" deep x 4-11/16" wide x 7-3/8" high. Newly designed cabinet makes this the companion piece to the VTVM.

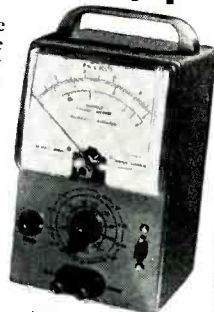

MODEL AV-1
SHIP. WT. 5 LBS.

\$29.50

Heathkit SQUARE WAVE GENERATOR KIT

The Heathkit Square Wave Generator is an excellent square wave frequency source with features you won't want to be without. Especially notable is the wide range of the instrument — 10 cycles to 100 kilocycles continuously variable. This wide range makes it useful for television and wide band amplifier work as well as audio experimentation. The output impedance is low, and the output voltage is continuously variable between 0 and 20 volts. Because a multivibrator stage cannot be accurately calibrated, terminals on the front panel can be used for synchronization to an external source should it be desired.

The circuitry consists of a multivibrator stage, a clipping and a squaring stage, and a cathode follower output stage. The power supply is transformer operated and utilizes a full wave rectifier tube with 2 sections of LC filtering.

For a good, wide range, and low priced square wave generator, the SQ-1 just can't be beat.



MODEL SQ-1
SHIP. WT. 14 LBS.

\$29.50

YOU SAVE BY ORDERING DIRECT FROM MANUFACTURER—USE ORDER BLANK ON LAST PAGE

EXPORT AGENT
ROCKE INTERNATIONAL CORP.
17 E. 40th ST.
NEW YORK CITY (16)
CABLE ARLAB N.Y.

The **HEATH COMPANY**

... BENTON HARBOR 20, MICHIGAN

Heathkit SIGNAL GENERATOR KIT

Model SG-6
Shipping Wt. 7 lbs.

The new Heathkit Signal Generator Kit has dozens of improvements. Covers the extended range of 160 Kc to 50 megacycles on fundamentals and up to 150 megacycles on useful calibrated harmonics; makes this Heathkit ideal as a marker oscillator for TV. Output level can be conveniently set by means of both step attenuator and continuously variable output controls. Instrument has new miniature HF tubes to easily handle the high frequencies covered.

Uses 6C4 master oscillator and 6C4 sine wave audio oscillator. The kit is transformer operated and a husky selenium rectifier is used in the power supply. All coils are precision wound and checked for calibration making only one adjustment necessary for all bands.

New sine wave audio oscillator provides internal modulation and is also available for external audio testing. Switch provided allows the oscillator to be modulated by an external audio oscillator for fidelity testing of receivers. Comes complete, all tubes, cabinet, test leads, every part. The instruction manual has step-by-step instructions and pictorials. It's easy and fun to build a Heathkit Model SG-6 Signal Generator.



Heathkit CONDENSER CHECKER KIT

Only
\$19.50

Model C-2
Shipping Wt. 6 lbs.

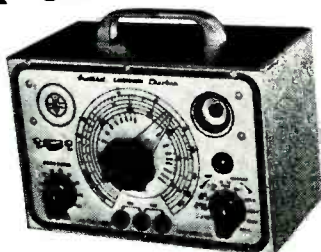

Checks all types of condensers — paper — mica — ceramic — electrolytic. All condenser scales are direct reading and require no charts or multipliers. Covers range of .00001 MFD to 1000 MFD. A Condenser Checker that anyone can read. A leakage test and polarizing voltage for 20 to 500 V provided. Measures power factor of electrolytics between 0% and 50% and reads distance from 100 ohms to 5 megohms. The magic eye indicator makes testing easy.

The kit is 110V 60 cycle transformer operated and comes complete with rectifier tube, magic eye tube, cabinet, calibrated panel and all other parts. Has clear detailed instructions for assembly and use.

NEW Heathkit SIGNAL TRACER AND UNIVERSAL TEST SPEAKER KIT

\$19.50

Model T-2
Shipping Wt. 7 lbs.



The popular Heathkit Signal Tracer has now been combined with a universal test speaker at no increase in price. The same high quality tracer follows signal from antenna to speaker — locates intermittents — saves valuable service time — finds defective parts quicker hour. Works equally well on broadcast, FM, or TV receivers. The test speaker has an assortment of switching ranges to match either push-pull or single output impedances. Also tests microphones, pickups and PA systems. Comes complete: cabinet, 110V 60 cycle power transformer, tubes, test probe, all necessary parts, and detailed instructions for assembly and use.

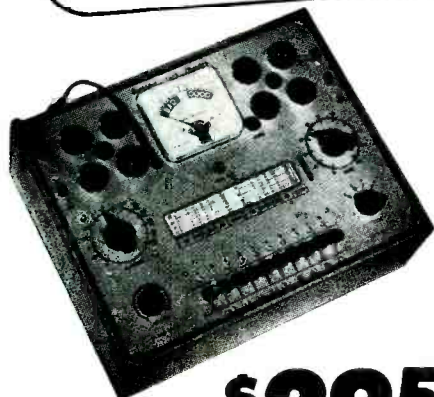

Model TC-1
Shipping Wt. 12 lbs.

\$29.50

Heathkit TUBE CHECKER KIT

The Tube Checker is a MUST for radio repair men. Often customers want to SEE tubes checked, and a checker like this builds customer confidence. In your repairing, you will have a multitude of tubes to check — quickly. The Heathkit tube checker will serve all these functions — it's good looking (with a polished birch cabinet and an attractive two color panel) — checks 4, 5, 6, 7 prong Octals, Locals, 7 prong miniatures, 9 prong miniatures, pilot lights, and the Hytron 5 prong types. AND IT'S FAST TO OPERATE — the gear driven, free-running roll chart lists hundreds of tubes, and the smooth, acting, simplified switching arrangement gives really rapid set-ups.

The testing arrangement is designed so that you will be able to test new tubes of the future — without even waiting for factory data — protection against obsolescence.

You can give tubes a thorough testing — checks for opens, shorts, each element individually, emission, and for filament continuity. A large BAD-?-GOOD meter scale is in three colors for easy reading and also has a "line-set" mark.

You'll find this tube checker kit a good investment — and it's only \$29.50.

YOU SAVE BY ORDERING DIRECT FROM MANUFACTURER—USE ORDER BLANK ON LAST PAGE

KOLM INTERNATIONAL CORP.
131 40th ST.
NEW YORK CITY 10

The **HEATH COMPANY**

30000 HARRIS RD., MICHIGAN

NEW 1952 *Heathkit* BATTERY ELIMINATOR KIT



Model BE-3
Shipping Wt. 17 lbs.

- Can be used as battery charger.
- Continuously variable output 0 - 8 Volts — not switch type.
- Heavy duty Mallory 17 disk type magnesium copper sulfide rectifier
- Automatic overload relay for maximum protection. Self-resetting type.
- Ideal for battery, aircraft and marine radios.
- Dual Volt and Ammeters read both voltage and amperage continually — no switching.

The new Heathkit Model BE-2 incorporates the best. Continuously variable output control is of the variable transformer type with smooth wiper type contacts. There are no switches or steps and voltage between 0 and 8 Volts is available at 10 Amperes continuous and 15 Amperes intermittent. Maximum safety from overloads and shorts provided by automatic overload relay which resets itself when overload is removed.

The new rectifier is a 17 plate Mallory magnesium copper sulfide type. This is the most rugged type available for long trouble-free use.

Output is continuously metered by both a 0-10 Volt Voltmeter and a 0-15 Amp Ammeter. Shorted vibrators indicated instantly by ammeter.

Equip now for all types of service — aircraft — marine — auto and battery radios — this inexpensive instrument vastly increases service possibilities — better be ready when the customer walks in.

NEW *Heathkit* SINE AND SQUARE WAVE AUDIO GENERATOR KIT

Designed with versatility, usefulness, and dependability in mind, the AG-7 gives you the two most needed wave shapes right at your fingertips — the sine wave and the square wave.

The range switch and plainly calibrated frequency scale give rapid and easy frequency selection, and the output control permits setting the output to any desired level.

A high-low impedance switch sets the instrument for either high or low impedance output — on high to connect a high impedance load, and on low to work into a low impedance transformer with negligible DC resistance.

Coverage is from 20 to 20,000 cycles, and distortion is at a minimum — you can really trust the output wave shape.

Six tubes, quality 4 gang tuning condenser, power transformer, metal cased filter condenser, 1% precision resistors in the frequency determining circuit, and all other parts come with the kit — plus, a complete construction manual — A tremendous kit, and the price is truly low.

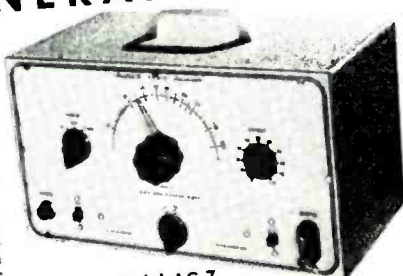

Model AG-7
Shipping Wt. 15 lbs.

\$34.50

THE NEW *Heathkit* HANDITESTER KIT

A precision portable volt-ohm milliammeter. Uses only high quality parts — All precision 1% resistors, three deck switch for trouble-free mounting of parts, specially designed battery mounting bracket, smooth acting ohm adjust control, beautiful molded bakelite case, 400 micro-amp meter movement, etc.

DC and AC voltage ranges 10 - 30 - 300 - 1000 - 5000V.
Ohms range 0 - 3000 and 0 - 300,000. Range Milliampères 0 - 10 Ma, 0 - 100 Ma.
Easily assembled from complete instructions and pictorial diagrams.

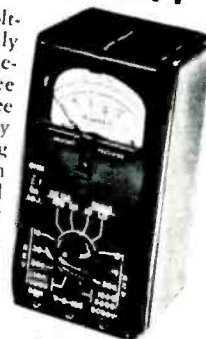

\$13.50

Model M-1
Shipping Wt. 3 lbs.

NEW *Heathkit*

T.V. ALIGNMENT GENERATOR KIT

Here is an excellent TV Alignment Generator designed to do TV service work quickly, easily, and properly. The Model TS-2 when used in conjunction with an oscilloscope provides a means of correctly aligning television receivers.

The instrument provides a frequency modulated signal covering, in two bands, the range of 10 to 90 Mc. and 150 to 230 Mc. — thus, ALL ALLOCATED TV CHANNELS AS WELL AS IF FREQUENCIES ARE COVERED.

An absorption type frequency marker covers from 20 to 75 Mc. in two ranges — therefore, you have a simple, convenient means of frequency checking of IF's, independent of oscillator calibration.

Sweep width is controlled from the front panel and covers a sweep deviation of 0-12 Mc. — all the sweep you could possibly need or want.

And still other excellent features are: Horizontal sweep voltage available at the front panel (and controlled with a phasing control — both step and continuously variable attenuation for setting the output signal to the desired level — a convenient instrument stand-by position — vernier drive of both oscillator and marker tuning condensers — and blanking for establishing a single trace with base reference level. Make your work easier, save time, and repair with confidence — order your Heathkit TV Alignment Generator now!

Model TS-2
Shipping Wt. 20 lbs.

\$39.50

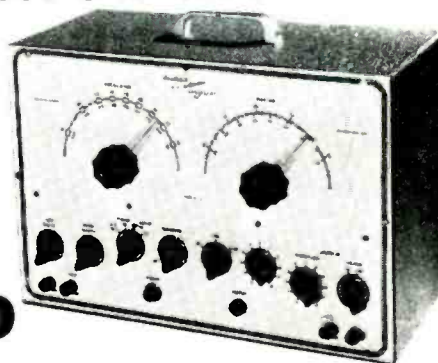

YOU SAVE BY ORDERING DIRECT FROM MANUFACTURER—USE ORDER BLANK ON LAST PAGE

EXPORT AGENT
ROCKE INTERNATIONAL CORP.
12 E. 40th ST.
NEW YORK CITY (10)
CABLE AREA 8 N Y

The **HEATHKIT COMPANY**

... BENTON HARBOR 20, MICHIGAN



Model 1B-1B
Shipping Wt. 15 lbs.

Heathkit IMPEDANCE BRIDGE KIT

This Impedance Bridge Kit is really a favorite with schools, industrial laboratories, and serious experimenters. An invaluable instrument for those doing electrical measurements work. Reads resistance from .01 Ohms to 10 meg., capacitance from .00001 to 100 MFD, inductance from 10 microhenries to 100 henries, dissipation factor from .002 to 1, and storage factor from 1 to 1000. And you don't have to worry about selecting the proper bridge circuit for the various measurements—the instrument automatically makes the correct circuit when you set up for making the measurement you want. Bridge utilizes Wheatstone, Hay, Maxwell, and capacitance comparison circuits for the wide range and types of measurements possible. And it's self powered—has internal battery and 1000 cycle hummer. No external generator required—has provisions for external generator if measurements at other than 1000 cycles are desired. Kit utilizes only highest quality parts. General Radio main calibrated control.

\$69⁵⁰

Mallory ceramic switches, excellent 200 microamp zero center galvanometer, laboratory type binding posts with standard 3/8 inch centers, 1% precision ceramic-body type multiplier resistors, beautiful birch cabinet and ready calibrated panel. (Headphones not included.)

Take the guesswork out of electrical measurements—order your Heathkit Impedance Bridge kit today—you'll like it.

Heathkit LABORATORY RESISTANCE DECADE KIT



\$19⁵⁰

Shipping Wt. 4 lbs.

An indispensable piece of laboratory equipment—the Heathkit Resistance Decade Kit gives you resistance settings from 1 to 99,999 ohms IN ONE OHM STEPS. For greatest accuracy, 1% precision ceramic-body type resistors and highest quality ceramic wafer switches are used.

Designed to match the Impedance Bridge above, the Resistance Decade Kit has a beautiful birch cabinet and attractive panel. It's easy to build, and comes complete with all parts and construction manual.

Heathkit LABORATORY POWER SUPPLY KITS

Limits:

No load.....	Variable 150-400V DC
25 MA.....	Variable 30-310V DC
50 MA.....	Variable 25-250V DC

Higher loads: Voltage drops off proportionally. Every experimenter needs a good power supply for electronic setups of all kinds. This HV supply and a 6.3 V filament voltage source. Voltage control allows selection of HV output desired (continuously variable within limits outlined), and a Volts-Ma switch provides choice of output metering. A large plainly marked and direct reading meter scale indicates either DC voltage output in Volts or DC current output in Ma. (Range of meter 0-500V D.C., 0-200 Ma. D.C.). Instrument has convenient stand-by position and pilot light.



\$29⁵⁰

Model PS-1.....Ship. Wt. 20 lbs.

Comes with power transformer, filament transformer, meter, 5Y3 rectifier, two 1619 control tubes, completely punched and formed chassis, panel, cabinet, detailed construction manual, and all other parts to make the kit complete.

Heathkit ECONOMY . . . 6 WATT AMPLIFIER KIT



MODEL A-7
Shipping Wt. 8 lbs.

\$14⁵⁰

- Choice of 4-8-15 ohm output impedances.
- Response flat $\pm 1\frac{1}{2}$ db from 20—20,000 cycles.
- 6 watts output.
- Good fidelity at low cost.
- Output tubes working in push pull.
- Volume, bass, and treble controls.
- Two separate inputs.

The purpose of this kit is to provide to the kit builder a low cost amplifier with excellent fidelity. The circuit consists of four tubes with following functions: a 12SL7, one section working as an amplifier and one as a phase splitter, two 12A6 output tubes working in push pull, and a 5Y3 rectifier in a full wave rectifier circuit.

The unit operates from a husky power transformer, and has good output transformer with a choice of 4—8—15 ohm output impedances. (Speaker not included).

The kit provides excellent listening pleasure and the price is really low. Compare it with all others. You won't find a better buy.

MODEL A-7: For tuner and crystal phono inputs. Has two position selector switch for convenient switching to type of input desired.

Model A-7-A: Has a 12S17 preamplifier stage with special compensation network for operation with reluctance phono input. Shipping Wt. 8 lbs. **\$16.50**

Heathkit HIGH FIDELITY 20 WATT AMPLIFIER KIT

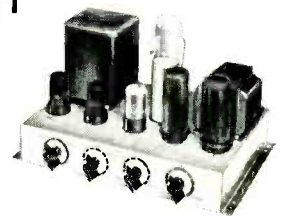

MODEL A-8
Shipping Wt. 18 lbs.

\$33⁵⁰

The A8 (or A-8A) is a high quality amplifier for those who want high fidelity output at moderate cost. Frequency response within ± 1 db from 20 20,000 cycles. Distortion at 3db below maximum power output (at 1,000 cycles) is only .8%. Kit has a Chicago power transformer in drawn steel case and a Peerless output transformer with output impedances of 4—8—16 ohms. Bass and treble controls permit listener to select output with tonal qualities of his own liking.

The tube lineup is composed of a 6SJ7 voltage amplifier, a 6SN7 amplifier and phase splitter, two 6L6's in push-pull output and a 5U4G rectifier. All parts furnished (speaker not included) and the construction manual makes assembly easy.

MODEL A-8: For tuner and crystal phono inputs. Has two position selector switch for convenient switching to type of input desired.

MODEL A-8A: Features an added 6SJ7 stage (preamplifier) for operating from variable reluctance cartridge phono pickup, mike input, and either tuner or standard crystal phono pickup. A three position selector switch provides flexible switching. Shipping Wt. 18 lbs. **\$35.50**

YOU SAVE BY ORDERING DIRECT FROM MANUFACTURER—USE ORDER BLANK ON LAST PAGE

EXPORT AGENT
ROCKE INTERNATIONAL CORP.
12 E 40th St.
NEW YORK CITY (16)
CABLE: ARIAN Y

The HEATH COMPANY

. . . BENTON HARBOR 20, MICHIGAN

Heathkit RECEIVER & TUNER KITS for AM and FM



\$19.50

Model BR-1 Broadcast Model Kit covers 550 to 1600 Kc. Shipping Wt. 10 lbs.

Model AR-1 3 Band Receiver Kit covers 550 Kc. to over 20 Mc. continuous. Extremely high sensitivity. Shipping Wt. 10 lbs.



\$23.50

TWO HIGH QUALITY Heathkit SUPERHETRODYNE RECEIVER KITS

Two excellent Heathkits. Ideal for schools, replacement of worn out receivers, amateur and custom installations.

Both are transformer operated quality units. The best of materials used throughout — six inch calibrated slide rule dial — quality power output transformers — dual iron core shielded. I.F. coils — metal cased filter condenser. The chassis has phono input jacks, 110 Volt output for phono motor and there is a phono-radio switch on panel. A large metal panel simplifying installation in used console cabinets is included. Comes complete with tubes and instruction manual incorporating pictorials and step-by-step instructions (less speaker and cabinet). The three band model has simple coil turret which is assembled separately for ease of construction.

TRUE FM FROM Heathkit FM TUNER KIT

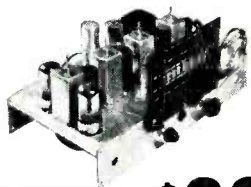

Model FM-2
Ship. Wt. 9 lbs.

\$22.50

The Heathkit FM Tuner Model FM-2 was designed for best tonal reproduction. The circuit incorporates the most desirable FM features — true FM.

Utilizes 8 tubes: 7E5 Oscillator, 6SH7 mixer, two 6SH7 IF amplifiers, 6SH7 limiter, two 7C4 diodes as discriminator, and 6X5 rectifier.

The instrument is transformer operated making it safe for connection to any type receiver or amplifier. Has ready wound and adjusted RF coils, and 2 stages of 10.7 Mc IF (including limiter). A calibrated six inch slide rule dial has vernier drive for easy tuning. All parts and complete construction manual furnished.



MAIL TO THE
HEATH COMPANY
BENTON HARBOR 20,
MICHIGAN

ORDER BLANK

From _____

SHIP VIA

- Parcel Post
- Express
- Freight
- Best Way

Quantity	Item	Price	Quantity	Item	Price
	Heathkit Oscilloscope Kit — Model O-7			Heathkit H.V. Probe Kit — No. 336	
	Heathkit VTVM Kit — Model V-5			Heathkit R.F. Signal Gen. Kit — Model SG-6	
	Heathkit FM Tuner Kit — FM-2			Heathkit Condenser Checker Kit — Model C-2	
	Heathkit Broadcast Receiver Kit — Model BR-1			Heathkit Handitester Kit — Model M-1	
	Heathkit Three Band Receiver Kit—Model AR-1			Heathkit Power Supply Kit — Model PS-1	
	Heathkit Amplifier Kit — Model A-4			Heathkit Resistance Decade Kit — Model RD-1	
	Heathkit Amplifier Kit — Model A-6 (or A-6A)			Heathkit Impedance Bridge Kit — Model IB-1B	
	Heathkit Tube Checker Kit — Model TC-1			Heathkit A.C. VTVM-KIT — Model AV-1	
	Heathkit Audio Generator Kit — Model AG-7			Heathkit Intermodul. Analyzer Kit—Model IM-1	
	Heathkit Battery Eliminator Kit — Model BE-2			Heathkit Audio Freq. Meter Kit — Model AF-1	
	Heathkit Electronic Switch Kit — Model S-2			Heathkit Square Wave Gen. Kit — Model SQ-1	
	Heathkit T.V. Alignment Gen. Kit — TS-2				
	Heathkit Signal Tracer Kit — Model T-2				
	Heathkit R.F. Probe Kit — No. 309				

On Parcel Post Orders, include postage for weight shown and insurance. (We insure all shipments.)

On Express Orders, do not include transportation charges — they will be collected by the Express Agency at time of delivery.

Enclosed find Check Money Order for _____

Please ship C.O.D. Postage enclosed for _____ lbs.

ALL PRICES SUBJECT TO CHANGE WITHOUT NOTICE

EXPORT AGENT
ROCKE INTERNATIONAL CORP.
12 E. 40th ST.
NEW YORK CITY (16)
CABLE: ARLAB N Y

The HEATH COMPANY

... BENTON HARBOR 20, MICHIGAN

Picture Tube Rejuvenator

- Simple Plug-in
- Permanent Hook-up
- Applicable to All Size Tubes
- Save on Service Contracts
- Automatically Operated
- Only \$6.45 List

*Hermetically Sealed
Miniature and
Sub-miniature*

Audio Transformer

- **MANUFACTURED** to meet most exacting MIL-T-27 specifications
- **STYPOL** impregnation prior to potting assures quiet operation and long life under all adverse conditions
- **MU-METAL** core assures light, compact unit with full efficiency, wide frequency response
- **TRANSISTOR APPLICATION.** Stock items designed for Transistor circuitry.

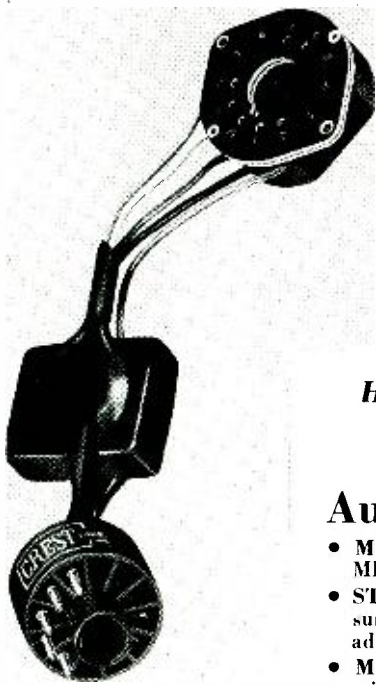

Jobbers Inquiries Invited

CREST

LABORATORIES, INC.

Whitehall Building, Far Rockaway, N. Y.

See Us at the Electronics Parts Show in Chicago

Men who know *Quality*...know **TECH-MASTER**



C. G. McPROUD,
Editor of **AUDIO**
Engineering, writes:

"I assembled my own home TV receiver from a standard Techmaster kit. I was amazed at the speed and simplicity with which this could be done. So gratifying was the result, that I have since

for Top TV Performance!

been obliged to assemble several more Techmaster receivers for friends who marvelled at the picture quality of my own. In each case the results were excellent and have provided their owners with uninterrupted top quality, trouble-free performance..."

Experts Everywhere Concede the Superiority of the Techmaster 630 Type Circuit!

The TECHMASTER 630 has been advanced in every detail of modern engineering and design. Every component is the best available, and rigid factory and test standards are your assurance of years of trouble-free performance. Prefabricated unit construction, factory pre-adjusted and pre-aligned make assembly an utterly simple and enjoyable procedure with a minimum of tools.

More leading engineers and technicians have chosen Techmaster Kits and Techmaster Chassis, than any other television.

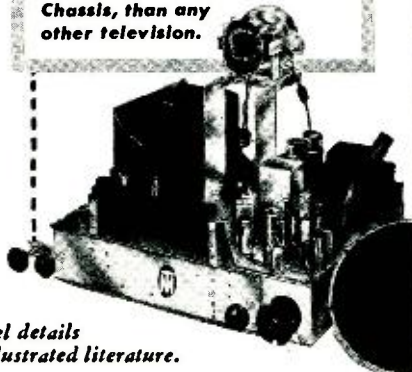

See your local Jobber for model details
or write direct to factory for illustrated literature.

TECH-MASTER PRODUCTS COMPANY • 443-445 BROADWAY, N. Y. 13, N. Y.

PEAKING TWO-BAND SET

A fisherman friend wanted to hear the marine band on an old two-band broadcast set which uses 6D6's and other tubes of that vintage. (The set was insensitive on short waves; only a few mushy police calls could be heard.) To further complicate matters, he wanted to use a 6-foot wire as the antenna.

Realigning the set did not improve its sensitivity on short waves. The detector trimmer couldn't be peaked without disturbing calibration on the broadcast band. We hooked the 6-foot antenna wire to one end of a 10-turn scramble-wound loop of No. 28 c.c. wire. The loop was just large enough to pass over the antenna coil. We tuned the set to ship frequencies and moved the loop down the coil until a sensitive spot was found where signals and noise peaked up. Then we scramble-wound 10 turns of wire around that spot and cemented it tight with coil dope. The end of the new antenna coil was left ungrounded as a precaution against shock because set was an a.c.-d.c. type with one leg of line going to chassis. Previous signal strengths of R1 and R2 are now R9. Broadcast signals are louder and more stations are received.—B. W. Welz

STICKY VIBRATORS

New vibrators and those which have not been used for a long time often fail to start on d.c. because of oxidization of the contacts. The usual method of clearing up this trouble is to connect a 50-watt lamp in series with the vibrator and run it on 117 volts a.c. for a few minutes.

I find it more convenient to plug the unit into a tube tester and operate it on 12 volts a.c. from the filament transformer. If the tube tester does not have a flexible switching arrangement, test leads fitted with banana plugs can be inserted in the filament pins of a 4- or 6-prong socket and the other ends clipped to the vibrator pins.

This method does not harm the tester. Usually a few seconds of running on a.c. is all that is needed to remove the oxidization. When the hum of the vibrator changes to an unsteady buzz, this is an indication that the contacts have cleaned up and that the vibrator will start without trouble on d.c.—Frank Greene

TOOL FOR COAX CABLE

A standard copper-tubing cutter, available at most hardware stores for less than a dollar, is a handy tool for preparing coaxial cable to receive fittings. In using the tool, the first step is to twirl the cutter around the plastic jacket, cutting through it to the outer braid.

After removing the jacket, cut through the outer braid and remove it. The cable can now be finished with a pocket knife and the fitting can be installed in a professional manner—Clyde C. Cook, W6GBV

—end—

RADIO-ELECTRONICS

STABLE OSCILLATOR

The stability of a heavily loaded, modulated, tuned-plate tuned-grid oscillator may be greatly improved by installing a carefully chosen cathode biasing resistor. Moving the grid-leak and its bypass capacitor from the normal position to the grounded end of the grid coil provides more constant output over the tuning range when the cathode biasing resistor is correctly adjusted. A variable potentiometer is recommended. When it is adjusted for best modulation quality, and antenna loading is optimum, the band-width and audio quality of the modulated oscillator compares favorably with a well-designed AM transmitter running the same power input.

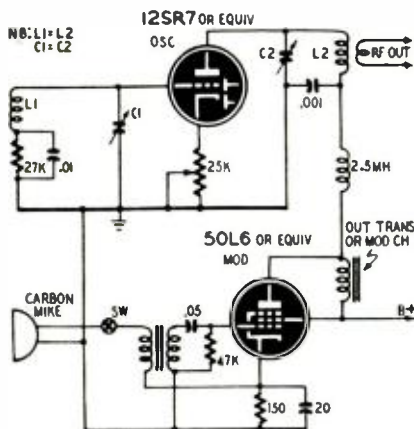

When loaded with a dummy antenna, the oscillator performed well on the broadcast band as well as on 2 and 3 mc. The basic circuit of the modulated oscillator is shown in the diagram. It may be used as a phono oscillator, home broadcaster, or carrier-current transmitter. The tuning range depends on the inductance of the coils and the values of the variable capacitors. Power output may be raised by using heavier tubes and raising the power input to the oscillator plate and modulator. For phonograph and home broadcast use, antenna length and power input should be held to a minimum, to avoid illegal radiation.—G.P. Oberto

HEAR YOUR OSCILLOGRAM

An oscilloscope is a highly useful instrument. However, when working on a radio receiver or audio amplifier, it is often difficult to interpret the oscillograms, because the signals which they represent are intended for the ear instead of the eye. When using an actual signal for servicing, it is often difficult to tell whether the observed waveforms are normal or not. The obvious solution is to connect a headphone jack somewhere in the vertical deflection circuit of the oscilloscope, enabling the waveform to be heard as well as seen. However, such a direct connection is useful only for audio-frequency signals. The circuit shown is capable of making audible audio-frequency signals, and the modulation on rf. signals.

Its operation is simple. Throwing the switch to the AF position connects the

40 New Crystal Diode Circuits for Radio-TV Servicemen, Hams

This book belongs in the file of every Radio and TV Serviceman and Ham. Shows 40 new, tested ways of using Sylvania Crystal Diodes. Contains a special chapter on Radio and TV service devices, including instructions for making an Antenna Orientation Meter, a Tuned Crystal-Type Signal Tracer, and numerous other

helpful circuits. Other chapters give circuits for hams and experimenters. Detailed directions and easy-to-follow diagrams. We know this little book can save you a lot of time . . . and money, too. For your copy just send a quarter with your request to: Sylvania Electric Products Inc., Dept. E-3106, Emporium, Pa.

IT'S GOT everything FOR profitable servicing--

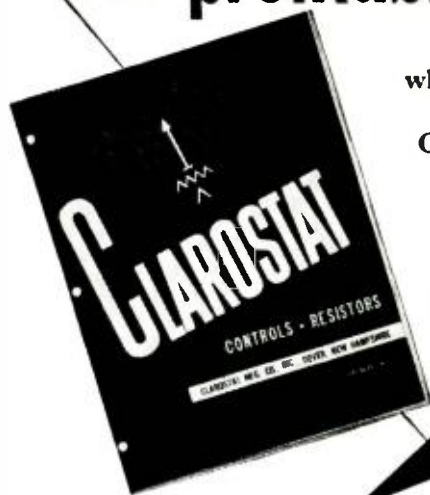

Your time is money! That's why Clarostat's latest catalog gets right down to what's-what in **CONTROLS and RESISTORS**. Instead of lengthy sales blurb, you get better listings of more values to meet the greatest range yet for servicing and initial-equipment needs. Proved easier, faster, safer and more profitable to work with this latest Clarostat catalog.

Ask for your copy...

Your Clarostat distributor has your copy waiting for you. Ask for it. Or if you prefer, write us directly.



Controls and Resistors

CLAROSTAT MFG. CO., INC., DOVER, NEW HAMPSHIRE

In Canada: Canadian Marconi Co., Ltd., Toronto, Ontario

POWERFUL RECEPTION
...from Any Direction
JUST FLICK THE SWITCH!

FAMOUS "4-WAY"
Wavemaster
TV ANTENNA

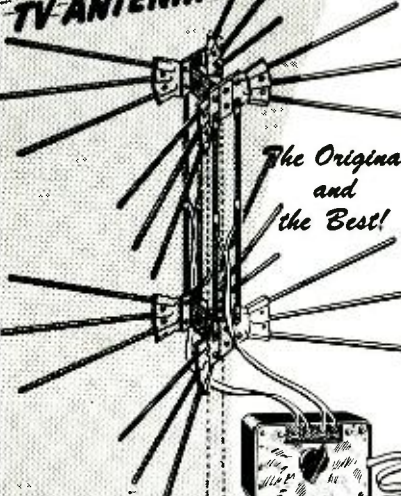

The Original and the Best!

- NO BOOSTER!
- NO ROTOR!
- NO TURNING!
- ALL CHANNELS!
- NO GHOSTS!

RAY-X CONTROL BOX INCLUDED!
 Retail \$22.95

YOUR COST
\$11.90

LOTS OF 3 \$11.25 EA.

Simply place control box near set. Each of 4 positions opens up one complete antenna in the direction you want. Strong reception on all channels.

ORDER NOW! DIRECT FROM MANUFACTURER

RAY MFG. CO. Phone Fa. 9171
 441 Summit St., Toledo, Ohio

Please rush 4-Way (double-stacked) Wavemaster Antenna(s), ready for any mast. Ray-X Control Box included. Check Money order for \$..... is enclosed.
 Send C.O.D. (20% deposit required)

Name.....
 Address.....
 City..... Zone..... State.....

\$3.00 FOR CARTOON IDEAS

RADIO-ELECTRONICS prints several radio cartoons every month. Readers are invited to contribute humorous radio ideas which can be used in cartoon form. It is not necessary that you draw a sketch, unless you wish.

Address
RADIO-CARTOONS,
RADIO-ELECTRONICS
 25 West Broadway,
 New York 7, N. Y.

tube as a cathode follower, while the RF position connects the tube as an infinite-impedance detector. The input is connected through the .001- μ f capacitor to the vertical deflection plate or the output of the vertical amplifier, thus getting plenty of signal. The output is controlled by the potentiometer which also acts as the tube load resistor. The oscilloscope circuit should be checked carefully to make sure that the signal take-off point is not at a dangerously

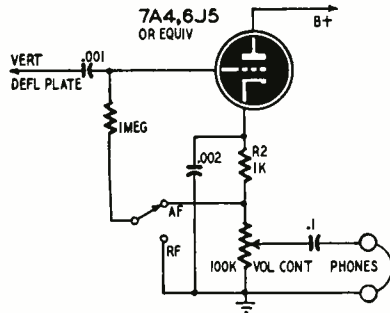

high potential. In any event, the .001- μ f coupling capacitor must have a voltage rating high enough to withstand the peak potential at the point of signal takeoff.

Although it requires a little work to add this circuit to an oscilloscope, it can make a great improvement in the instrument's usefulness. It makes it possible to use the ears to detect troubles such as distortion, noise, or hum, which are difficult to detect from oscillograms, especially when they are slight. Then, a close examination of the oscillogram of the defective signal can be used to determine the electronic nature of the defect.—Charles Erwin Cohn

VOLUME EXPANDER

Various types of volume expanders and their relative merits have long been the subject of debate among sound engineers and high-fidelity music lovers. Expanders of different types have been incorporated in PA and high-fidelity amplifiers and in some of the more elaborate receivers. They may be classified into variable-gain and variable-output types. A new expander design of the former type is described in patent No. 2,556,692, granted to V. L. Holdaway and assigned to Bell Telephone Laboratories.

The circuit of the variable-gain amplifier is shown at *a*. The 6K7 is the main amplifier and the 6F8-G is the side or control amplifier. The cathode of the 6K7 and the plates of the 6F8 are tied together and connected to point A on a voltage divider which sets the bias on the 6K7 cathode at 25–30 volts. The 6F8 is biased to (or nearly to) cutoff by the battery in series with its grid return. The signal which is applied to the 6F8 control tube appears across the 500,000-ohm expansion control. The signal to the 6K7 is taken from the junction of the 750,000- and 250,000-ohm resistors which make up a voltage divider.

When no signal is applied to the input terminals, the 6F8 is cut off and



your ear will tell you

the performance of the TRIAD Hi-Fidelity Amplifier is equal to that of amplifiers costing much more

Listening tests conducted before groups of critical music lovers have proved that the difference in reproduction qualities between the low cost Triad Amplifier and the other higher priced units is undistinguishable. Available in kit form only, with complete assembly instructions, the Triad HF-10 Amplifier provides valuable experience while affording substantial savings. In quality and performance it is a fitting companion to the finest sound system components available today.

prices

HF-10 Kit — Includes S-31A, R-14A, A-74J and C-10X Triad transformers, chassis, prints and assembly instructions..... **\$43.00**

HF-10A Kit — Same as above except for substitution of HS-81 output transformer for S-31A. **\$63.50**

Both of above available with 500/250/125 ohm output

Write for Catalog **TR-52**



TRIAD
 TRANSFORMER MFG CO

2254 So. Sepulveda Blvd.
 Los Angeles 64, California
 RADIO-ELECTRONICS

no current flows through the 1-megohm cathode biasing resistor. Point *B* remains substantially at ground potential, thus holding the bias on the 6K7 to that value supplied by the tap at *A*.

When a signal of increasing amplitude is applied to the expander, the 6F8—if initially biased to cutoff—conducts on the positive half-cycles and develops a positive voltage across the 1-megohm resistor. The positive voltage thus developed at *B* biases the grid of the 6K7 and opposes the positive bias supplied to its cathode from point *A*. The effective bias of the main amplifier will decrease, thus increasing its gain. The gain-grid-bias curve is shown at *b*.

The drop between plate and cathode of the 6F8 insures that the maximum

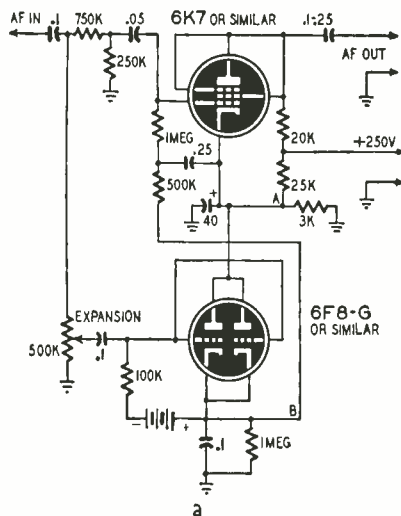

voltage developed at *B* can rise to within a volt or two of point *B* but cannot exceed it. Therefore, the grid of the 6K7 always operates with negative bias, preventing any distortion

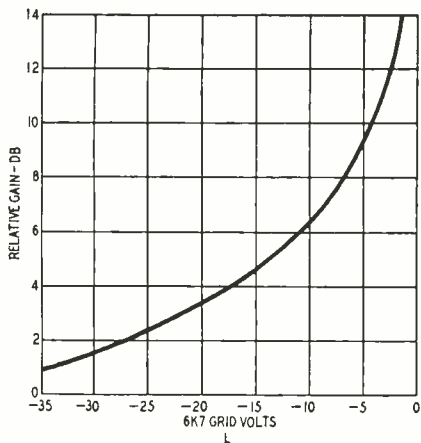

which would occur if the tube were operated with positive grid bias. Since the 6K7 operates with only one or two volts of bias with high input signals, the voltage divider in the input circuit holds the maximum signal drive below this value.

The sizes of the resistors and capacitors in the 6F8 cathode circuit and in the 6K7 grid return determine the attack and decay times of the expander action. These values may be varied to control the rate of expansion.

—end—

New
WILLIAMSON TYPE
AMPLIFIER Features

- First Williamson Type Amplifier supplied with matching preamplifier
- Uses Altec Lansing Peerless output transformer.
- Practically distortionless—Harmonic and intermodulation distortion both less than 1/2 of 1% at 5 watts output.
- Frequency response
- ± 1 db from 10 cycles to 100 kc.
- Output impedance 4, 8, or 16 ohms.

The new Heathkit Williamson Type Amplifier kit is the best obtainable in amplifiers today—the choice of the really discriminating listener. You can hear the difference and measurements actually bear out the superb performance. Frequency response ± 1 db from 10 cycles to 100 kc allow you to hear the highs and lows with equal crispness and clarity. Harmonic and intermodulation distortion both less than 1/2 of 1% at 5 watts output eliminate the harsh and unpleasant qualities which contribute to listening fatigue.

The present is similar to the one published in Audio Engineering Magazine for November, 1949, and is considered by engineers throughout the audio field as one of the best ever developed. The Main Amplifier (which may be purchased separately) consists of a voltage amplifier and phase splitter using a 6SN7—a driver stage using a 6SN7, and a push-pull output stage using a pair of 807 tubes. The output transformer is manufactured by the Peerless Division of Altec Lansing and is built to their highest standards. Output impedances of 4, 8, and 16 ohms are available. The power supply uses a separate chassis with husky Chicago Transformer power transformer and choke, and 200V Military filters for long hum-free operation. A 5V4G rectifier is used. The main amplifier and power supply are each on a chassis measuring 3 1/2" high by 5 1/2" wide by 11" long.

PREAMPLIFIER AND TONE CONTROL UNIT KIT
The preamplifier kit consists of a 12AX7 or 12AY7 dual triode first amplifier stage with a turn-over control for LP or 78 record types, and a 12AU7 amplifier stage with equalized bass and treble tone controls which each provide up to 1 db. of boost or attenuation. A switch on panel selects either magnetic, crystal, or turner inputs. Preamplifier also is well suited to custom installations—it will operate in either vertical or horizontal position, and special milled shafts of the controls and switches allow a variety of shaft lengths to be selected. Dimensions: 2 1/4" high by 10 1/4" wide by 7 1/4" deep.

WA-A1 Amplifier kit — Combination 1 — (Main Amplifier and Power Supply) complete with WA-P1 Preamplifier kit. Total Ship. Wgt., 34 lbs. (Shipped Express only) \$69.50

WA-A1 Amplifier kit only — Combination 4 — (Main Amplifier and Power Supply). Less WA-P1 Preamplifier. Total Ship. Wgt., 29 lbs. (Shipped Express only) \$49.75

WA-P1 Preamplifier Kit only. (Less power supply) (Tubes included). Total Ship. Wgt., 7 lbs. (Shipped Express or Parcel Post) \$19.75

WRITE FOR Free CATALOG

The
HEATH COMPANY
BENTON HARBOR 20, MICHIGAN

You SAVE BY ORDERING DIRECT

AMPERITE
Studio Microphones
at P.A. Prices

Ideal for BROADCASTING RECORDING PUBLIC ADDRESS

"The ultimate in microphone quality," says Evan Rushing, sound engineer of the Hotel New Yorker.

- Shout right into the new Amperite Microphone—or stand 2 feet away—reproduction is always perfect.
- Not affected by any climatic conditions.
- Guaranteed to withstand severe "knocking around."

Models
RBLG—200 ohms
RBHG—Hi-imp.
List \$42.00

"Kontak" Mikes
Model SKH, list \$12.00
Model KKH, list \$18.00

Special Offer: Write for Special Introductory Offer, and 4-page illustrated folder.

AMPERITE Company, Inc.
361 BROADWAY • NEW YORK 12, N. Y.
Canada: Atlas Radio Corp., Ltd., 540 King St. W., Toronto

AUDELS TV SERVICE TELLS HOW TO SOLVE TV TROUBLES AND ANSWERS TV QUESTIONS

AUDELS TELEVISION SERVICE MANUAL covers T.V. information at your finger ends. Shows good receiver adjustment and How to Get Sharp, Clear Pictures, How to Install Aerials—Avoid Blurs, Smears, Interference and How to Test. Explains Color Systems and Methods of Conversion. IT PAYS TO KNOW! Over 380 PAGES & 225 ILLUSTRATIONS explaining operating principles of Modern Television Receivers.

Just Out!

1001 FACTS 19 CHAPTERS

Placement of Television Receivers—Receiver Controls—Test Patterns & Adjustments—Television Interference—Interference Traps—Television Antennas & Transmission Lines—Master Antenna Systems—Antenna Installation Procedure—Television Broadcasting—Television Receiver Fundamentals—Circuit Description of Typical Receiver—Television Picture Tubes—Projection Type Receivers—Television Testing Instruments—Television Servicing—Trouble—Television Terms.

\$2 POST PAID

Shooting—Color Television—

7 DAYS FREE TRIAL
GET THIS PRACTICAL ASSISTANCE FOR YOURSELF — MAIL COUPON TODAY —

AUDEL, Publishers, 49 W. 23rd St., N.Y.
Mail me postpaid for 7 Days examination AUDELS TELEVISION SERVICE MANUAL (Price \$2). If O.K. I will mail you \$2, otherwise I will return book.

Name: _____
Address: _____
Employed by: _____

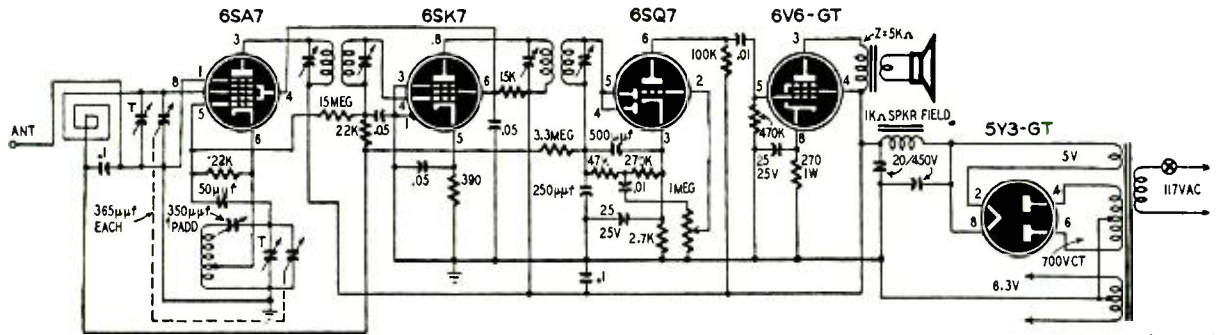

Schematic of a 5-tube, a.c.-operated broadcast receiver, following standard commercial circuit practice throughout.

5-TUBE BROADCAST SET

? I would like to construct a 5-tube AM broadcast receiver using a 6SQ7 detector, a.c., and a.f. amplifier, 6SK7 i.f. amplifier, 6SA7 converter, and a 6V6-GT power amplifier tube. I would like the diagram to show a loop antenna and connections for a speaker with a 1,000-ohm field.—E.S.T., New York, N.Y.

A. The diagram of the receiver is shown. All components are conventional and the circuit should work nicely after alignment. The intermediate frequency may be anywhere in the range of about 450-470 kc. The oscillator padder capacitor is correct for most broadcast oscillator coils, but consult the coil manufacturer's recommendations for exact value.

5-INCH OSCILLOSCOPE

? I have a high-voltage transformer which has a 700-volt, 40-ma low-voltage secondary, a 2,250-volt, 2-ma half-wave high-voltage secondary, and filament windings delivering 5 volts at 3 amp, 6.3 volts at 3.5 amp, and 2.5 volts at 1.8 amp. Please show how I can use this in a general-purpose scope using a 5BP1 or 5BP4 tube.—G. H. K., Chicago, Ill.

A. The scope diagram is shown. The power transformer and filter chokes should be placed well away from the amplifiers and the picture tube to prevent hum pickup. The centering, focus, and intensity controls should be insulated from the chassis and driven from the front panel through insulated shafts. The deflection-signal leads and

interstage coupling capacitors should be dressed well away from the chassis to minimize wiring capacitance which causes loss of high frequencies. Shield the scope against external fields with a steel case. Be sure to discharge the high-voltage filter capacitors before beginning work under the chassis.

I.F. INTERFERENCE

? I live on the coast where there are a number of marine and commercial stations operating on the low-frequency side of the broadcast band. Their fundamentals and harmonics fall within the i.f. range of my superhet-type high-fidelity tuner and spoil reception with cross-talk and whistles. Please tell me how to eliminate this trouble.—A. R. G., Atlantic City, N. J.

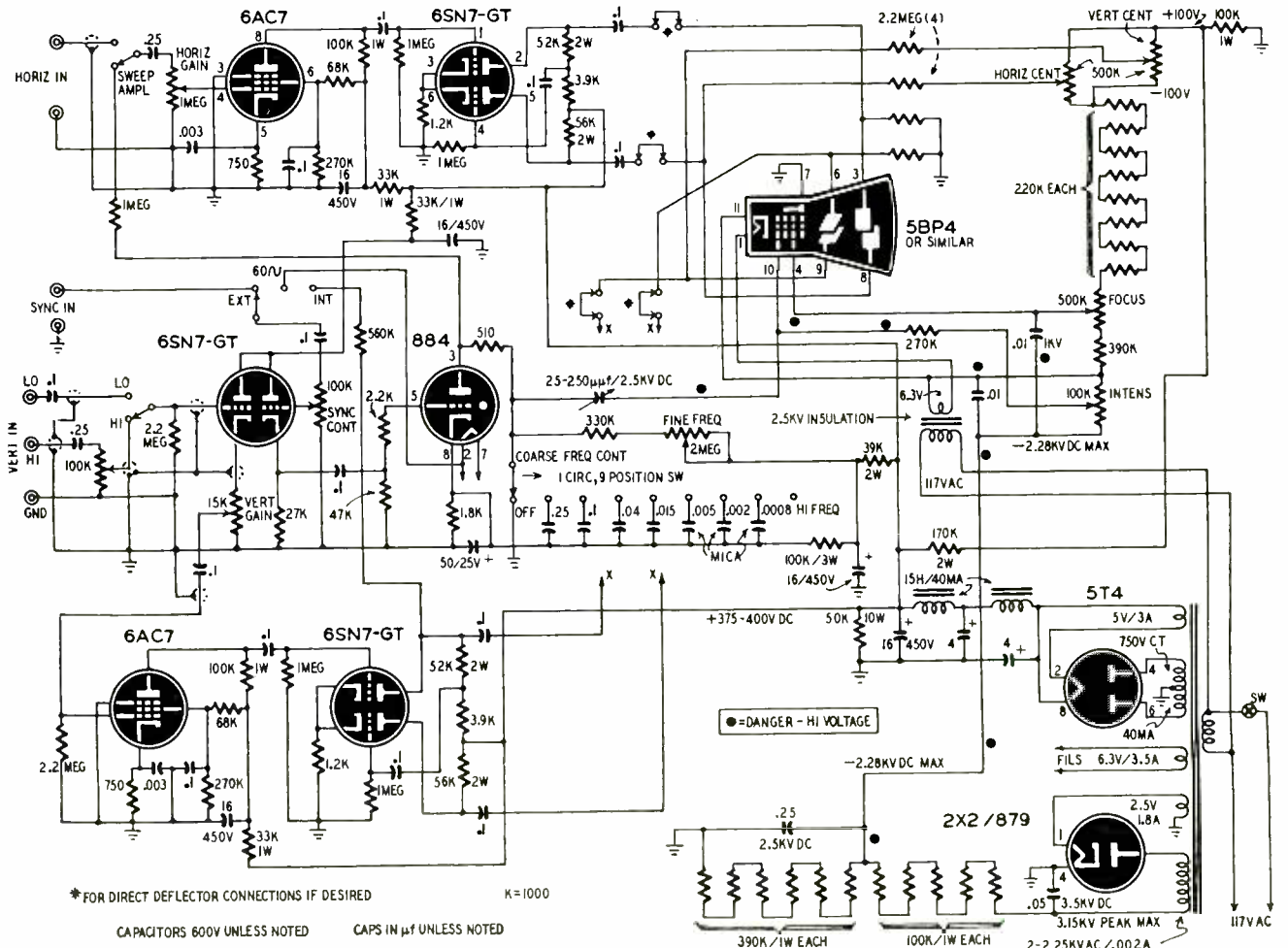

Circuit diagram of the 5-inch cathode-ray oscilloscope. A steel or iron case should be used for magnetic shielding.

HOW EASY

can YOU make tv servicing?

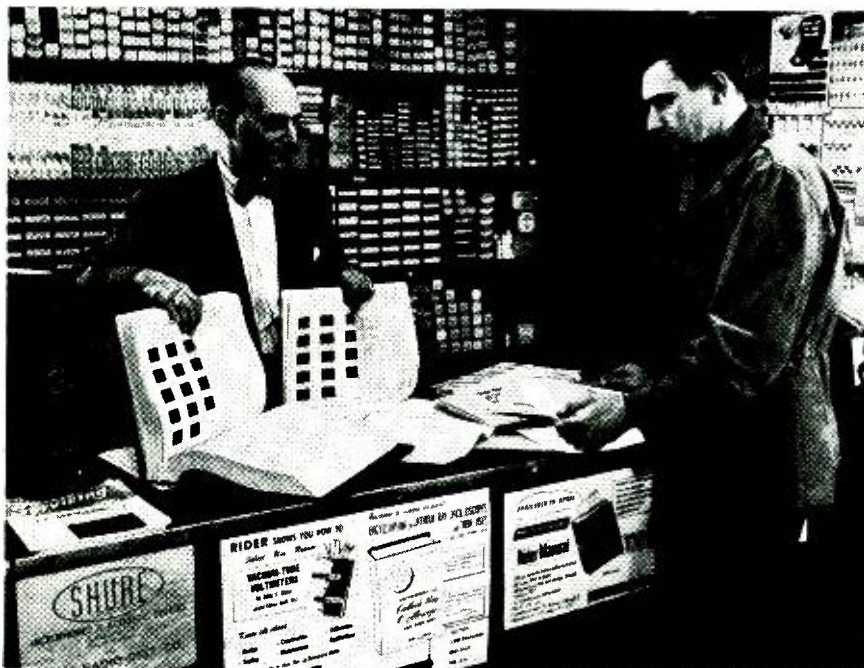

Rider TV TEK-FILES Packs 1 to 56

The contents of a typical TEK-FILE Pack are pictured below. In TEK-FILE Packs you buy complete Rider servicing data for only one, two, or a few manufacturers according to your needs. Notice that each pack is made up of standard file folders for easy use. Only \$2.00 each pack.

TEK-FILE EXTRA.

Many packs contain TEK-FILE Handies...3 x 5" index cards giving manufacturer's trouble cures plus production changes. Vital data for permanent repairs!

DON'T BE SWITCHED!

Rider TEK-FILE is *Not* the same as any other publisher's service. If your jobber doesn't carry their DON'T BE SWITCHED. Write us direct...We'll sell you. (Please include your jobber's name.)

TRY A PACK

To judge TEK-FILE'S superiority, buy one pack for the next receiver you service. If you don't agree it's best...return

Try this simple rule used successfully by thousands of service technicians.

Take advantage of the set manufacturer's service literature.

This is the key to easy, successful servicing which is overlooked by a surprising number of service technicians. They believe, strangely enough, that the more oversimplified the data they purchase the less their servicing problems. They think that because the servicing information on a set is condensed, that data will be easier to work with. How wrong this approach is can be measured by the fact that servicing data *in itself* is worthless. Its only value comes from its use as a guide to receiver diagnosis and repair. Doesn't it make sense then that the most complete data will be the best because it makes your diagnosis and repair job easier?

Rider data is complete data with a bonus!

For 22 years Rider has been the only publishing source for complete, factory issued, official servicing data. From large, easy to follow schematics...circuit explanations...stage by stage alignment curves...page after page of troubleshooting test patterns...waveforms...

clear, enlarged chassis views...circuit changes...to complete unpacking instructions; Rider gives you the complete story including all manufacturer's production changes...in accurate, organized, unedited form. PLUS A NEW FEATURE: A LISTING OF ABSOLUTELY GUARANTEED REPLACEMENT PARTS. The parts listed must meet the physical and electrical performance ratings of the original equipment used in the receiver...or you get your money back. (Look for this new Rider feature beginning with Rider TV Manual 10 and Rider TV TEK-FILE Pack 57.)

Rider Servicing data available two ways!

Rider TV Manuals Vols. 1 to 9

Complete data for manufacturer's receivers produced during a certain period. (The newest, TV 9, (just published) covers October 1951 through February 1952.) Each manual contains over 2000 (8½ x 11) pages in permanent binder, with an index covering the contents of all manuals. Manuals are perfect for shop use and permanent reference. Price \$24.00 each.



the pack to us within seven days and we'll send you a full refund. TRY ONE TODAY!

FREE Rider TEK-FILE indexes are at your jobber's. If he's out, write us.

OUT SOON!

Rider RADIO TEK-FILES! Same style as TV TEK-FILES. Now, get your complete radio servicing data this easy, economical package way. Ask your jobber.

John F. Rider Publisher, Inc. 480 Canal St. New York 13, N. Y. West Coast office: 4216-20 W. Jefferson Blvd. Los Angeles, Calif.

Become an Electrical Engineer



MAJOR IN ELECTRONICS



- B. S. Degree in 36 Months
- Radio-Television Technician Certificate in 18 Months

Experts predict that by 1954 there will be at least two positions for every engineering and technician graduate. This College offers a tested plan that permits you to enter these vast employment opportunities at an early date. First—you save a valuable year through optional year-round study. Second—you can receive advanced credit for prior training gained in the armed forces, other schools or field experience.

Enter Both Radio and Television Through This Plan

12 months or one-third of the B. S. degree course (Electronics major)—also brings you the Radio Technician's certificate. An added 6-month course qualifies you for the Radio-TV Technician's Certificate.

The Famous "UNIT CHASSIS SYSTEM"



of teaching was developed here. It "breaks down" the TV set by stages. You learn every component of all types and makes—and are prepared for future design changes, including the advent of color.

SPECIAL! Television Clinics

Ambitious Radio and TV Servicemen can enroll now in special one-month clinics in July and August—to handle latest field service problems. Write for full details.

Over 48,000 former students from all states and 23 overseas countries. Faculty of trained specialists. Modern laboratories and equipment. Nonprofit technical institute and college 49th year.

MILWAUKEE SCHOOL OF ENGINEERING

• Founded 1903 •

Terms open July, October, January, April

FREE — Write for "Occupational Guidance Bulletin," "Your Career" booklet, and Catalog.

Milwaukee School of Engineering
Dept. RE 552, 1025 N. Milwaukee
Milwaukee, Wisconsin

Without obligation send Catalog for Electrical Engineering, B. S. Degree, major in Electronics; Power; "Your Career"; Occupational Guidance Bulletin on: Radio-TV; Electrical Power; Welding; Heating, Refrigeration Air Conditioning; TV Service Clinic.

Name.....Age.....

Address.....

City.....Zone.....State.....

If veteran, indicate date of discharge.....



A. Most likely, the interfering signals are coming in on the antenna. If so, you

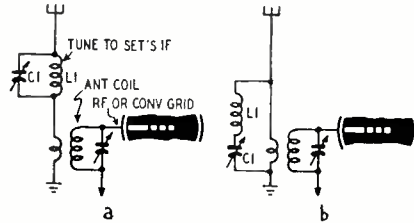

can eliminate them by inserting one or more tuned traps in the antenna circuit of the set. The drawing at *a* shows a parallel-tuned trap, and the drawing at *b* shows one which is series-tuned. If the interference is severe or is from two stations, it may be necessary to use both types of traps. In any case, the traps should tune to the i.f. range of your set. L1 and C1 may be one winding and tuning capacitor from a standard i.f. transformer.

RECEIVER-TRANSMITTER QUERY

? I have a model 11-UF-ED-6 Link receiver and a model 32-UFM-ED-2 transmitter. Both are crystal controlled on 39.46 mc. I want to shift the frequency to 33.86 mc. The transmitter crystal is at 1,059.25 kc. The receiver uses two crystals: one at 5.456 and the other at 6.892 megacycles. What crystals must I use for the new frequency? —G. F. B., College Park, Md.

A. The transmitter output is on the 32nd harmonic of the crystal frequency. Therefore, the new crystal frequency is 33.86/32, or 1.05812 mc (1,058.12 kc).

The receiver is a double superheterodyne with the first i.f. at 5 mc and the second at 456 kc. The 5.456-mc crystal is in the oscillator circuit of the second converter and is not changed. The heterodyning frequency for the first converter is 5 mc below the signal frequency and is the fifth harmonic of the 6.892-mc crystal. Therefore, at the new frequency, the heterodyning signal is 33.86 minus 5, or 28.86 mc. Since the 5th harmonic of the crystal is used, the new crystal for the receiver must be 28.86/5 or 5.772 mc.

Some of the tuned circuits may not have sufficient range to tune down to the new frequencies, so you may have to shunt the coils with small padders or add a few turns to the coils. A grid-dip meter will be helpful in checking the tuning range of the coils and in making sure that you don't pick up the wrong harmonic of the crystal.

TUBE NUMBERING SYSTEM

? I am preparing for an amateur examination and have been studying the various types of tubes used in transmitters. I find it difficult to compare different types of tubes without referring to the tube manual or the handbook. Is there any way that I can determine pertinent data on a tube from its number? —E. E. K., Bronx, N. Y.

A. This can't be done under the old numbering system in which we have

SPECIAL!! 6 TUBE AC-DC KIT

At Last! A low-priced kit designed for high sensitivity, excellent selectivity and good tone quality. Uses 25L6, 25Z6, 6SQ7, 6SA7, 6SK7, 6SK7 in an easily constructed circuit. The 6 Tube Kit is shipped with all parts, including punched chassis, resistors, condensers, coil, sockets, PM Speaker, hardware, etc.

And at a closeout price of only **\$6.95**

X162 less tubes and cabinet

X183 Extra for matched set of six tubes for kit **\$3.25**

5 TUBE AC-DC SUPERHET KIT

Five tube superheterodyne kit, A.C.-D.C. contains all components required to construct this latest design, highly sensitive superheterodyne broadcast receiver complete with black bakelite cabinet (excludes wire and solder) Price \$9.95 Extra for a kit of 5 tubes (12A16, 12BA6, 12BE6, 35WA, 50C5). Price \$3.25.

Electronic Code Practice Oscillator & Blinker Kit AC/DC or Battery Operated!

One of the most practical Code Practice Oscillators ever designed, yet one of the simplest to build and operate.

Can be used with any number of headphones. Adjustable Pitch Control—Any type of headphone can be used.

No warmup time—ready to operate instantly simple and safe to operate

Operates anywhere—with AC or DC power, or from a 90 volt Miniature Battery

Learn Blinker Code with flashing light blinker can be used as signaling device

International Morse Code included

Kit each **\$2.95** Assembled **\$3.95**

MODEL NFRD—RADIO NOISE FILTER

If it doesn't work, send it back!

We absolutely guarantee that our Model NFRD will eliminate all line noises when properly connected to radios, television sets, short wave sets, motors, electric shavers, refrigerators, vibrators, oil burners, transmitters, and all other sources of interference. This unit will carry up to 12 amperes or 1/4 KW of power and may be used right at the source of interference or at the radio. Small size only 2 1/2" x 1 3/4" x 4 1/2". Very low price only

Each **\$1.95**

A SCIENTIFICALLY DESIGNED PHONO SCRATCH FILTER

Resonated at approximately 4500 cycles effectively reducing objectionable needle scratch without altering the brilliancy of reproduction.

Contains a HI-Q SERIES resonated circuit. Tested by means of an audio oscillator and an oscilloscope to give 22 db attenuation with very low signal loss

EASY TO ATTACH

Just two wires to clip on. Compact

Price **\$1.98**

THREE TUBE PHONO AMPLIFIER

An assembled unit ready for installation using tone and volume control and six feet of rubber cord **\$2.95**

(Not including Tubes)

With Complete Set of Tubes..... **\$3.95**

PHONO OSCILLATOR

Wireless phono oscillator transmits recording for crystal pick-ups or voice from carbon mike through radio without wires. Can also be used as an intercomm by using P.M. speaker as mike. Price (excluding tubes) **\$2.95**

With Complete Set of Tubes..... **\$3.95**

Grab Bag Special, 10 pounds of Misc. Electronic Material — Transformers Condensers, resistor, wire, etc. Price **\$1.95** ea.

Satisfaction guaranteed on all merchandise All prices subject to change without notice.

Write for FREE Catalog.

RADIO DEALERS SUPPLY CO.

154 Greenwich St. New York 6, N. Y.

such tubes as the 812, 813, and 815. There is no similarity between them.

A new numbering system is in use by Eimac and other manufacturers. Many of the older types are now identified under a dual numbering system. The new number enables the user to determine the type, plate dissipation rating, and amplification factor. The old familiar 250TH now bears the numbers 3-250A4/250TH. The number ahead of the dash indicates the number of elements in the tube, the number or numbers between the dash and the letter gives the plate dissipation rating in watts, and the letter stands for the version of the tube. The letter A is used on the original design; B, C, and so on indicate later modifications. The modified versions of a given basic type are not necessarily interchangeable either physically or electrically.

The number (if any) following the letter indicates the mu of the tube. The number 1 is used for a mu of 10 or less, 2 is for a mu of 11 to 20, 3 for 21 to 30, and so on. The new 4E27A's are now marked 4E27A/5-125B. The 5- stands for pentode or 5-element tube; 125 is the plate dissipation in watts; and B is the version of the tube.

In some receiving-transmitting types, such as the 6L6, the first numeral(s) gives heater voltage to the nearest lower whole number; the letter (s) shows the type; the last numeral gives the number of independently-connected elements in the tube.

—end—

Coin Radios PAY OFF!



Here is a profitable business, year in and year out, in any locality. You only put in a little time and you'll really earn the profits.

Console-type limed oak finish. Height 24", width 15", depth 13". Unconditionally guaranteed for 90 days. Each **\$59.95**

Sample \$74.50 each

F.O.B. Chicago (in lots of 5)

20% deposit—balance C.O.D.

BRADLEY ASSOCIATES

1652 N. Damen Ave., Dept. RE, Chicago 47, Ill.

Stage a
"Music Festival"
in your own LIVING ROOM



For "Live" Symphony reproduction

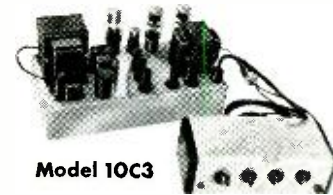

Model 10C3

the **BROOK** High Quality All-Triode
AUDIO AMPLIFIER

Write for free Technical Bulletin, detailed Distortion Analysis & booklet "Better Listening"

Brook Electronics, Inc., Dept. EF-2

• • 34 DeHart Place, Elizabeth, New Jersey

MANUFACTURER'S CLOSEOUT!

Every reader knows this famous maker of Wire Wound Fixed & Variable Resistors Marked General Electric.

We've bought up a tremendous supply of these and now you can buy them below manufacturer's 5000 list prices.

10 WATT FIXED		10 WATT ADJ.	
1-1000 ~ List	.75	1-1000 ~ List	1.47
1100-5000	.80	1250-5000	1.53
6000-10,000	.92	6000-10,000	1.63
11,000-20,000	1.03		
22,500-25,000	1.08	Your Cost. Each	.39
30,000-50,000	1.22		
Your Cost. Each	.24	20 WATT FIXED	
		5-10000 ~ List	.95
		1200-5000	.97
		6000-10,000	1.12
		12,500-20,000	1.20
		25,000-40,000	1.37
		45,000-60,000	1.58
		65,000-80,000	1.83
		85,000-100,000	2.11
Your Cost. Each	.47	Your Cost. Each	.36
25 WATT ADJ.		100 WATT ADJ.	
1-1000 ~ List	1.87	1-1000 ~ List	3.58
1250-5000	1.88	1500-5000	3.67
6000-10,000	2.03	10,000	3.87
12,000-20,000	2.08	15,000-20,000	4.12
25K	2.28	25,000-40,000	4.37
Your Cost. Each	.47	50,000-60,000	4.53
		75,000	4.75
		100,000	4.95
Your Cost. Each	.69	Your Cost. Each	.79

Deduct 10%—Lots of 100 or more. Deduct 20%—Lots of 1000 to 10,000. Minimum Order—\$2.00

TERMS: All items F.O.B., Washington, D.C. All orders \$30.00 or less, cash with order. Above \$30.00, 25 per cent with order, balance C.O.D. Foreign orders cash with orders, plus exchange rate.

SUN RADIO

OF WASHINGTON, D. C.

938 F STREET, N. W. WASH. 4. D. C.

XTALS FOR ALL PURPOSES!

LOW FREQ. XTALS—FT 241A	SCR 522 Xtals	BC-61 Xtals
For SSB, lattice filter, etc. 1/2" spc. 54th or 72nd harmonic channels listed by fundamentals. Fractions omitted.	1/8" ins 1/2" spc.	2 banana plugs 3/8" spc.
374 407 483 508	400 464	2030 2435
375 408 484 509	440 466	2045 2442
377 409 485 511	441 468	2105 2532
379 411 487 514	442 470	2125 2545
380 412 488 515	446 472	2145 2557
381 413 490 516	447 474	2155 3202
383 414 491 518	450 475	2220 3215
384 415 492 519	452 476	2258 3237
385 416 493 520	461 477	2280 3250
386 418 494 522	462 479	2282 3322
387 419 495 525	463 480	2290 3510
388 420 496 526		2300 3520
390 422 497 530		2305 3550
391 423 498 531		2320 3580
392 424 503 533		2360 3945
393 425 504 537		2300 3955
394 426 506 538		2415 3995
395 427 507		
396 431		
397 433		
398 435		
401 436		
403 437		
404 438		
405 481		
	49c ea. 10 for \$4.50	
	SPECIAL 230 Kc xtals without holders 69c each 3 for \$2.00	
		\$1.29 each

HAM XTALS—FT 243 HOLDERS—1/2" pin spc.		
4190 6773 7873	1015 5900 6306 6573	7506 7673
5030 6873 7906	1126 5806 6325 6575	7540 7706
5485 6906 7940	2045 5825 6340 6600	7573 8240
6040 7240 7973	3735 5840 6373 6606	7606
6073 7273 8273	5305 5850 6406 6625	7640
6106 7806 8306	5677 5873 6440 6641	7650
6125 7840	5706 5875 6450 6673	
6140	5725 5936 6473 6706	
6173	5740 5940 6475 6740	
6175	5760 5973 6506 7440	
6206	5773 6273 6540 7473	
		99c ea. 10 for \$9.00
		Ad 20c for each 10 xtals or less for postage and handling.

SPECIAL PURCHASE Record Changer
Gen. Instruments 3-speed Automatic
Reg. \$34.95
Brand New
\$19.97

With all purpose cartridge & needle. Plays 33 1/3-45 RPM records automatically.

HERE'S A REAL BUY!



Two-Station INTERCOM SYSTEM

Less than half the original price. Built for America's leading dept store chain, whose name we cannot mention because of this low price. Consists of master station, remote station and 20 ft. of 3 conductor wire. Can be used as a private or non-private system. 115V AC or DC. Brand New. Now only \$17.95. Additional wire per ft. .05.

BRAND NEW
now only **\$17.95**

VARIABLE CONDENSERS

From SCR-522



2 Gang 25 MMF \$1.29 per section



3 Gang 25 MMF \$1.59 per section
Brand New with Concentric Air Trimmers

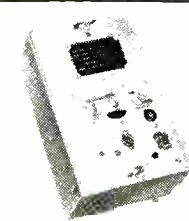

NAVY VHF-CW Transmitter

Battery operated (67 1/2 V. "B") and (1 1/2 V. "A")
Frequency 80 to 105 MC. uses 2 1G4 Tubes—with instruction manual—less tubes and batteries.

\$4.95

SENTINEL MODEL 312

When these sets are inoperative on line operation, replace the 1R5 oscillator tube and the selenium rectifier. If the tube and rectifier are good, the set will operate at line voltages as low as 105. If either unit is weak, the 1R5 is likely to stop oscillating when the line voltage drops to 112 or lower.

A three-way set which operates on the service bench may not operate correctly in the customer's home if the line voltage is low. Before returning such sets to the owner, always check their operation on low line voltage. A Variac or other voltage-reducing device can be used for this purpose.—*Sentinel Radio Service Dept.*

STROMBERG-CARLSON TV-12

The 12JP4 picture tube in these sets is directly replaceable with a 12RP4. The operating characteristics of these tubes are identical and the latter type can be used as a replacement in any set using the 12JP4. When making the substitution, be sure to use an ion trap on the 12RP4.—*Stromberg-Carlson Current Flashes*

HOWL IN FM SETS

When using superregenerative-type FM receivers like the Fremodyne, a howl may be heard during commercials on some stations. The stations which cause the howl are storecast stations which transmit ultrasonic tones to con-

trol the volume of storecast receivers. The ultrasonic tone is not heard on standard superhets but it beats with the ultrasonic quench frequency of the superregenerative detector and produces an audible howl. This is one of the inherent disadvantages of these circuits and cannot be eliminated.—*Charles Erwin Cohn*

(Some listeners of course will prefer the howl to the commercial.—*Editor*)

AIRLINE 94WG-3006A, -3009A

In some sets, the trimmer capacitor strip consisting of C-55A, C-55C, and C-55B is physically reversed. This places C-55A at the bottom instead of the top. These capacitors were wired normally. Therefore the 10-160- μ f capacitor was connected in the HORIZONTAL FREQUENCY CONTROL circuit and the 40-370- μ f capacitor in the HORIZONTAL LOCKING RANGE circuit. The correct positions of these capacitors are shown in the drawing.

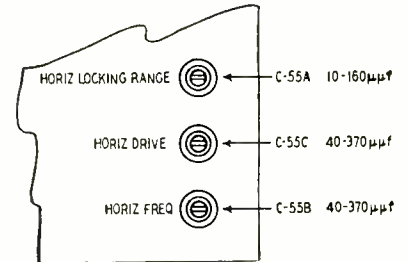

This error does not affect the operation of the sets as long as all circuit constants remain normal. Variation of some components with age may make it necessary to run the horizontal-lock capacitor at extreme minimum capacitance and the frequency control at maximum. If it is difficult to set these two controls, check the positioning of the capacitor strip. The low-capacitance unit (10-160 μ f) should be at the top and the two 40-370- μ f units at the bottom.—*Montgomery Ward General Service Letter*

AIRLINE 84BR-3004 TV SETS

The high-voltage winding of the r.f.-power-supply coil extends through a bakelite subpanel and cannot be removed without first removing the rectifier filament winding. The latter winding is not considered a part of the high-voltage oscillator coil and new coils do not have this winding on them.

- To remove the coil:
1. Unsolder the vinylite-covered filament leads from the 1B3-GT socket. Use minimum heat to prevent damage to the insulation on the leads.
 2. Loosen the fiber spacer on the fil-

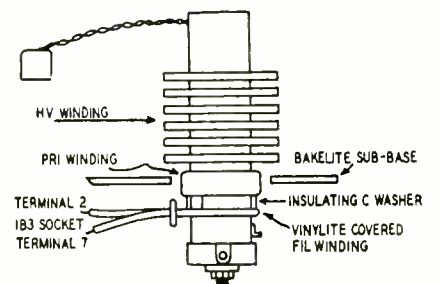

the **BIG 10** *is terrific!*

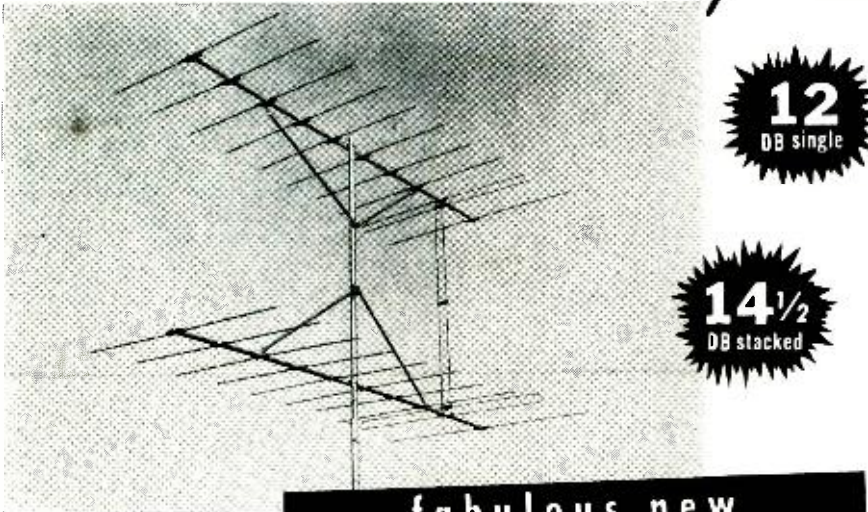

12
DB single

14½
DB stacked

CHANNEL MASTER'S

fabulous new
10 Element Yagi

COMPARE these 10 Terrific Features!

- | | |
|--|--|
| <ol style="list-style-type: none"> 1. 10 Elements — more signal, less noise, less rear pickup. 2. Highest gain of any Yagi ever developed. 3. Over 30% more gain than any 8 element Yagi. 4. This antenna can be stacked, with 78% additional gain over single bay. 5. Includes the famous Z-Match system. 6. You don't pay for stacking bars. | <ol style="list-style-type: none"> 7. Excellent 300 ohm match in all installations. 8. "Boom Braced" to prevent crossboom "bounce" which causes picture flicker.* 9. Two piece "Sweij-Lok" crossboom for simplified stocking, handling, and installation.* 10. Completely pre-assembled. |
|--|--|

*Low Band only

LIST PRICES	
ch. 7—13	ch. 2 or 3 31.94
\$1388	ch. 4 or 5 28.47
	ch. 6 25.69

CHANNEL MASTER CORP. MEMBER
ELLENVILLE, N. Y.

Technotes

ament winding and enlarge the loop to clear the coil form.

3. Remove the C-washer. Take care to avoid damaging the primary winding (See diagram.)

4. Unsolder the other leads to the coil form and remove the coil.

The replacement coil is installed in the reverse order. Place the original filament winding in the same position on the new coil.—*Montgomery Ward Service Letter*

DUMONT RA-109A

To reduce snow on weak signals, increase the a.g.c. delay bias so the signal level at the grid of the first i.f. stage is high enough to override the tube noise of the i.f. amplifiers. To do this, substitute an 8.2-megohm resistor

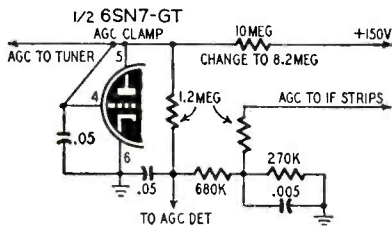

for the 10-megohm unit connected in the 150-volt line to pins 4 and 5 of the 6SN7-GT a.g.c. clamp and horizontal saw-tooth forming (discharge) tube. The position of this resistor is shown in the partial schematic above. This change has been made in all chassis beginning with No. 0959931.—*DuMont Service News*

OLYMPIC 762, 783, 967, 968, 970

Horizontal oscillator drift which causes the picture to deteriorate into bars sloping downward to the left is caused by the 150- μ f mica capacitor in the oscillator circuit. Replace this capacitor, C75, with a 150- μ f, 10%, N750 negative temperature coefficient ceramic capacitor. This capacitor is connected from terminal F of the horizontal oscillator coil to pin 4 of V18, the 6SN7-GT tube. Reset the horizontal oscillator as described in the service manual.—*Olympic Service Bulletin*

BUZZ IN TV SETS

An annoying buzz is sometimes present in the audio of TV sets which use a 6T8 as a discriminator and first-audio tube. This buzz, which can be heard with the volume control turned all the way down, is comparatively common when the 6T8 is located under or close to the picture tube. The trouble can be eliminated by placing a well-grounded shield over the 6T8.—*Hubert L. Frazier*

FARNSWORTH GV-260

Flashes of light or unsteady background illumination can be traced to trouble in the d.c. restorer circuit. This is usually caused by an increase in the value of R40, a 10,000-ohm resistor, which changes the time-constant of the d.c. restorer. This resistor connects to the grid of the picture tube.—*Wilbur J. Hantz*

—end—

JUNE, 1952

outsells all others combined MODEL 260 VOLT-OHM-MILLIAMMETER



\$38.95 DEALER'S NET

SIMPSON ELECTRIC COMPANY

5200 W. KINZIE ST.

CHICAGO 44

COLUMBUS 1-1221

Simpson

NEW! MOSLEY DUAL-MATCH TV COUPLER . . .

. . . OPERATES 2 TV SETS FROM 1 ANTENNA!

IDEAL FOR:

- Two Family Homes
- Apartments
- Other Multi-Set Installations

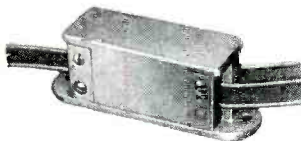

The Dual-Match is available at most TV Dealers and Jobbers. Ask for Catalog Number 902—the New MOSLEY Dual-Match TV Coupler. List Price, only \$3.95

Here's a real convenience for folks who have an extra TV set in their play-room, den, or elsewhere. It's the new MOSLEY Dual-Match TV Coupler that permits two TV sets to operate from just one antenna—without one set interfering with the other. The Dual-Match is efficient, compact and low in price. It is easily installed without solder to standard 300 ohm transmission line.

MOSLEY ELECTRONICS
2125 Lackland Road Overland, Missouri

USE PHOTOFAC

the world's best Radio and TV Service Data...

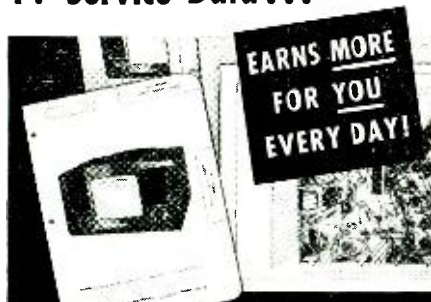

WE'LL PROVE YOU'LL SAVE TIME and EARN MORE WITH PHOTOFAC

FREE Service Technicians: We'll send you any Photofact Folder listed in the "PF INDEX and Technical Digest." If you haven't an Index, get a free copy from your local Photofact distributor or write for it today. To obtain Free Folder, be sure to state Photofact Set and Folder Number as shown in the Index.

NOW—learn for yourself how PHOTOFAC makes your Radio and TV work quicker, easier, more profitable! Just get and use an actual PHOTOFAC Folder. Discover why over 35,000 successful service technicians count on this invaluable data daily. No other service gives you PHOTOFAC'S completeness, accuracy, uniformity and lowest cost. PHOTOFAC is the only Radio-TV service data prepared from laboratory analysis on the actual equipment. Get your FREE Folder now. Examine, use, compare. See why you can't afford to be without PHOTOFAC!

NOTE: Our FREE Folder offer is limited to Service Technicians only. Attach coupon below to your letterhead and mention your jobber's name. Experimenters and others may obtain the Photofact Folder by remitting amount shown below.

HOWARD W. SAMS & CO., INC.

HOWARD W. SAMS & CO., INC.
2201 E. 46th St., Indianapolis 5, Ind.

I am a Service Technician. Send me Free Folder No. which appears in Photofact Set No. (as listed in the PF Index).

I am an Experimenter. Enclosed \$..... Send me Folder No. which appears in Photofact Set No. (TV—\$1.00. AM-FM—50c. Record Changer or Communication Receiver—75c)

Name.....

Address.....

City.....Zone.....State.....

EASY PAY PLAN!

PAY AS YOU EARN! Ask your distributor about this amazing plan. Only \$18.39 puts the entire profit-boosting Photofact library in your shop now!

ELECTRONIC LITERATURE

Any or all of these catalogs, bulletins, or periodicals are available to you on request direct to the manufacturers, whose addresses are listed at the end of each item. Use your letterhead—do not use postcards. To facilitate identification, mention the issue and page of RADIO-ELECTRONICS on which the item appears. All literature offers void after six months.

SUN RADIO CATALOG

Sun Radio's Catalog No. 52 is a large (8½ x 11-inch) book containing 164 pages. Special attention is called to the comprehensive transformer and capacitor sections covering 50 pages, to the listings of connectors which take up 10 pages, and to the industrial sound section, containing 12 pages. There are also very complete listings of tubes and crystals, including special, transmitting and industrial types and transistors, as well as a great number of small hardware items. There are two indexes—one by product and one by manufacturer—and the user is told on the cover just where the index is.

Gratis from Sun Radio & Electronics Co., Inc., 122-124 Duane St., New York 7, N. Y.

SELENIUM RECTIFIERS

A 28-page booklet which describes rectifier fundamentals, the process of manufacturing rectifier stacks, design details and applications of these increasingly important devices. A complete glossary of rectifier terms is included.

Gratis from General Electric Co., Schenectady 5, N. Y.

PRODUCT INDEX

A condensed catalog of P. R. Mallory products, including mercury batteries, capacitors, contacts, rectifiers, resistors, switches, vibrators, resistance welding necessities, metals and ceramics, and tuners. Considerable descriptive material, in language designed to be equally readable by engineer and layman, is devoted to each set of items, thus making the publication considerably more valuable than an ordinary catalog.

Gratis from P. R. Mallory & Co., Inc., 3029 E. Washington St., Indianapolis 6, Indiana.

1952 HEATHKIT CATALOG

The Heathkit line now includes 6-volt power supplies, intermodulation analyzers, audio-frequency meters and Williamson audio-amplifier kits as well as the older and more familiar pieces of test equipment advertised in earlier catalogs. All these items are described in a 16-page catalog, which also carries some information on Heath Company facilities.

Gratis from Heath Co., Benton Harbor, Michigan.

COUNTER TUBES

The radiation counter tubes manufactured by Amperex are described in a 22-page loose-leaf catalog. A six-page introduction reviews briefly the history

ARC-5 XMTR. COILS MASTER OSCILLATOR

#6029	3-4 MC	\$1.85
#6030	4-5.3 MC	1.75
#6031	5.3-7 MC	1.65
#6032	7-9 MC	2.35

POWER AMPLIFIER

#7247	3-4 MC	2.19
#7250	7-9 MC	2.98

ANTENNA LOADING

#6033	3-4 MC	1.39
#C034	4-5.3 MC	1.25
#6035	5.3-7 MC	1.65

AND 7-9.1 MC

AUDIO TRANSFORMERS

AT501 HI-FI Special: Pri: 3000 ohms P-P/Sec: 1.16; 12-20 200 ohms 60-10,000 CY. 1 lb 70W. \$2.49
AT152 HI-FI Driver Pri: 10,000 ohms Sec: 10,000 ohms PP Grids 50-15 KC/1 db. \$1.49
AT063 Output to ILS or Line Pri: 11,200 ohms SEC: 8000 600 ohms \$1.10
AT449 HI-FI Driver (5000 ohms) to P-P output grids (1,000 ohms) 100-10,000 CY. 10 W. 6V6 to P1 807's. \$2.39
AT686 Intercon Input: Spkr 4-1.8 ohms to grid (250-000 ohms) \$0.69
AT415 Plate (18,000 ohms C.T.) to line (125 ohms) 175 w. 500-600 CY. \$1.95
AT858 Plate (10,000 ohms C.T.) to line V.C. (500/125130 ohms HI-FI—20 W. \$6.95
AT070 Mike-or-Line (250 ohms) to grid (250,000 ohms C.T.) \$1.20
AT765 Mike-or-Line (600 ohms) to grid (50,000 ohms C.T.) \$0.89

AT871 Universal Output 10W HI FI Pri: 20,000 Ohms P-P/16,000 Ohms P-P also 5000 1000 ohms, Single End. SEC: 500 15 7.5/3 75/1.25 ohms. Response Flat P.M. 1 db. 50-20,000 Cycles. \$4.75
--

AT-694 HI-FI Output: 3 Watts, 8500 Ohms P-P to V.C. (15 ohms) 15-15KC P.M. 1 db. \$1.49
AT-4-A1: Mike (35 ohm Carbon) to Line 600 ohm/200 ohm \$1.19
AT-649: Line (500 ohms) to Grid (75K ohms) \$1.19
AT-448: Line (600 ohms) to V.C. (6 ohms) 17 db. Level. \$1.19
AT-631: Mike-or-Line (200 ohms) To Single or P-P Grids (10K Ohms) \$0.95
AT-718 Line (500 ohms) to Line (600 30 Ohm) Response: 50-20KC P.M. 1 db. \$0.49c

Send M.O. or CHK. Mdse. Guardt. Shpg. Charges Sent C.O.D. Price F.O.B. N.Y.C. Parcels in Excess of 20 Lbs. Will Be Shipped Rwy. Express or Motor Freight.

COMMUNICATIONS EQUIPMENT CO.
131 Liberty St. Dept. C-6 New York City 7, N. Y.
Phone DI. 9-4124

FOR YOUR CUSTOMERS!

"WHY You Should NOT TRY to Fix Your Own TV" 44 Page book—50¢ each \$1 for 3 Postpaid

JOHN D. BURKE
88-14 168th St., Jamaica 32, N. Y.

EVERY RADIOMAN Can Use These SERVICE HINTS!

Valuable Manual Yours—FREE!

Every page of "How to Simplify Radio Repairs" is packed with on-the-bench, practical ideas. Contains photos, charts, diagrams—no fluff—no vague theory. To plan every-day language it gives you priceless suggestions—new servicing ideas. You'll use and benefit from the experience of experts. Partial list of contents: How to Localize Trouble; How to Service Amplifiers; How to Test for Distortion; How to Test Audio Circuits; How to Test Speakers; How to Find Faults in Oscillators; How to Test Radio Parts—and it's all yours—FREE! No obligation.



FEILER SEND COUPON OR GOVERNMENT POSTCARD FOR YOUR FREE COPY TODAY!

FEILER ENGINEERING CO., Dept. 6RC2
8026 N. Monticello Ave.,
Skokie, Ill. (Suburb of Chicago)
Please RUSH my FREE copy of "How to Simplify Radio Repairs."

Name.....
Address.....
City.....Zone.....State.....

SPECIAL TV ITEMS for ASSEMBLIES, CONVERSIONS and INSTALLATIONS



INDOOR TV ANTENNA

- Newest, panorama high-gain type
- Brass 3-section chrome plated dipoles
- Absolutely tilt and tip-proof

list price \$5.95 special at **\$1.99**

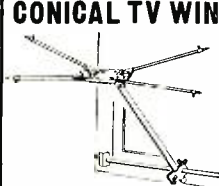

CONICAL TV WINDOW ANTENNA

- Approved type
- Fine reception
- Easy to install

\$4.97

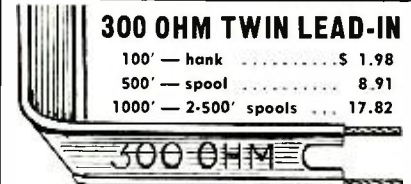

300 OHM TWIN LEAD-IN

100' — hank \$ 1.98
 500' — spool 8.91
 1000' — 2-500' spools ... 17.82



72 OHM COAXIAL CABLE

100' — hank \$ 4.84
 500' — spool 22.99
 1000' — 2-500' spools ... 43.86

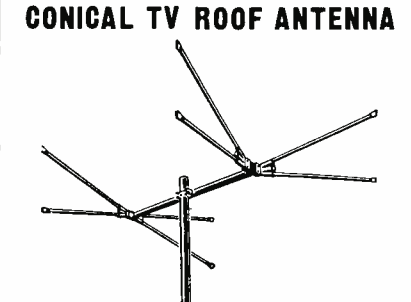

CONICAL TV ROOF ANTENNA

Sturdy, Efficient, covers all TV and FM channels. Uniform spacing between dipoles and reflectors insures greater concentration of signals reaching the dipoles and reduces the number of reflected rays. Made of seamless aluminum, assembles in a jiffy.

Complete with 10' mast **\$9.42**
 Same in double, stacked array... **15.84**



FAMOUS REGENCY BOOSTER

Largest Selling Booster AT ANY PRICE!

NEW MODEL

- Greater Pickup
- Greater Stability
- One Knob Control
- Easy To Install

Underwriters' Approved

list price \$32.50 special at **\$19.11**



CRYSTAL-CLEAR LUCITE MASKS

Framed in Rich Gold Leaf Finish

Tube Size	Overall Dimensions	
12 1/2" — Round	11 1/2" x 13 3/8"	\$4.78
14" — Rect.	10 1/2" x 13 1/4"	4.52
16" — Round	13 1/2" x 17"	5.97
16" — Rect.	12 1/2" x 15 3/4"	5.84
17" — Rect.	13 1/2" x 17"	5.97
19" — Round	15 3/4" x 20"	7.98
20" — Rect.	15 3/4" x 20"	7.98
21" — Rect.	15 3/4" x 20 3/8"	8.84
24" — Round	20 1/2" x 24 1/4"	14.65

(Including Set of Rosettes)



PLASTIC OPEN MASKS

Used in conjunction with safety glass

16" — Rect.	14 1/8" x 17 1/2"	\$1.87
17" — Rect.	14 1/8" x 17 1/2"	1.87
20" — Rect.	17 1/8" x 23 3/8"	2.98
21" — Rect.	18" x 22 5/8"	3.36
24" — Round	20" x 27"	6.74

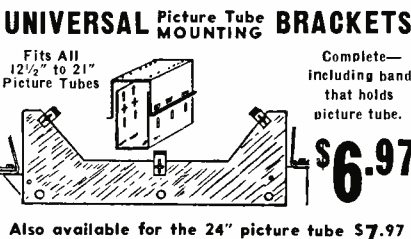

UNIVERSAL Picture Tube MOUNTING BRACKETS

Fits All 12 1/2" to 21" Picture Tubes

Complete—including band that holds picture tube.

\$6.97

Also available for the 24" picture tube \$7.97

NO-GLARE TV FILTERS

Far Better, More Clearly Defined Pictures
 Improves Contrast ... Sharpens Picture Image

AVAILABLE in SMOKE or BLUE COLORS

10" — 8" x 10 1/2"	\$.89
12 1/2" — 9" x 12 1/2"	1.26
14" — 10 1/2" x 15"	1.47
16" — 12" x 16 3/8"	1.92
17" — 13 1/8" x 17 3/8"	2.16
19" — 15 1/2" x 19 1/2"	2.44
20" — 15 1/2" x 19 1/2"	2.44
21" — 16" x 20"	2.78
24" — 20" x 24"	3.87

SAFETY GLASS in POPULAR SIZES

16" — 13 3/8" x 16 1/4"	\$2.96
17" — 13 3/8" x 16 1/4"	2.96
20" — 15 1/8" x 20 1/4"	3.72
21" — 16" x 22"	4.29
24" — 22 3/4" x 25 3/8"	6.83

PULSE KEYED AGC KIT

Finest, most accurate and the easiest Kit to install in a #630 or in any other make TV receiver. Improves performance, eliminates airplane flutter and picture jumping and insures a steady picture on all channels.

COMPLETE SET OF PARTS \$4.59
 including 6AU6 tube & instructions

CONVERT ANY 10" OR LARGER TV SET TO A 16" to 24" RECEIVER

With a new **DELUXE VOLTAGE DOUBLER KIT** — scientific ••• accurate ••• eliminates guess work. Anyone with even a limited knowledge of TV can follow the simple step by step instructions and produce a perfect conversion in as little as one hour.

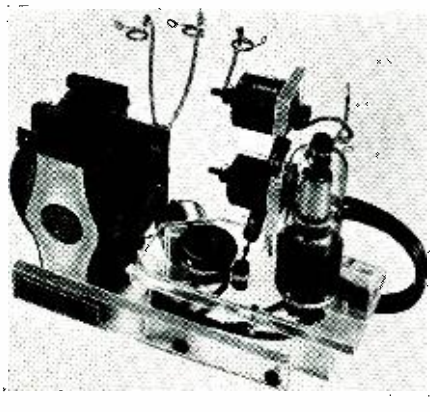

DEFLECTION YOKE 70"206D1	\$3.98
FOCUS COIL, 470 ohms202D2	3.42
ION TRAP BEAM BENDER, (single)	203D1	.79
PLASTIC RING, for insulating rim 16" CRT		1.97
PLASTIC SLEEVE, for insulating 16AP4	1.88
PLASTIC RING, for insulating rim 16" CRT		1.88
PLASTIC SLEEVE, for insulating 16CP4	1.88
PLASTIC RING, for insulating rim 17" CRT		2.04
PLASTIC SLEEVE, for insulating 17CP4	1.92
PLASTIC RING, for insulating rim 19" CRT		2.08
PLASTIC SLEEVE, for insulating 19AP4	1.96
PLASTIC RING, for insulating rim 24" CRT		3.89
PLASTIC SLEEVE, for insulating 24AP4	2.94

ASSEMBLED KIT FOR THE 630 CHASSIS

- Sub-Assembly (illustrated)
 - Flyback Transformer #211T5
 - Rectifier Tube #1B3
 - Resistors & Condensers
 - Set of 16" to 17" Mounting Brackets
- \$15.98**

UNASSEMBLED KIT FOR ANY TV CHASSIS

(SAME SET OF COMPONENTS AS LISTED ABOVE)

Electrically the circuit remains the same. Unassembled form allows for modifications in mounting and wiring.

\$13.98

ILLUSTRATED CONVERSION MANUAL
 SUPPLIED WITH EACH KIT
 (add \$3.99 for Universal Mounting Brackets)

Modernize Your #630 TV Set
 With a New
STANDARD CASCODE TUNER
 For better all around performance

Complete w/tubes, instructions **\$22.49**

Depend On . . .

Insist on . . .

ASTRON

CAPACITORS



You can depend on Astron for a complete line of multi-tested dry electrolytic and molded paper tubular capacitors for every radio, and television replacement job. For quality next time . . . insist on Astron.

Write for catalog AC-3

ASTRON CORPORATION
255 Grant Avenue, E. Newark, N. J.

OSCILLOSCOPES ARE "GOLD MINES"!

. . . if you learn how to use them fully on all types of service jobs!



Learn to handle the oscilloscope fully on all types of AM, FM and TV service work—and watch your efficiency and earnings soar!

MODERN OSCILLOSCOPES AND THEIR USES, a fact-jammed 326-page book by Jacob H. Ruter, Jr., of the Allen B. DuMont Laboratories, contains exactly the help you need—written in a way you can clearly understand. It shows you how to use your scope for fast accurate work on all types of jobs from troubleshooting to realigning; how to make connections; how to adjust circuit components; how to set controls and how to analyze patterns fast and accurately. 370 helpful illustrations including dozens of pattern photos make things doubly clear.

No other type of specific service training stands to mean so much to you in terms of being able to do better, faster and more profitable work!

- ✓ When, where why and exactly how to use your oscilloscope
- ✓ How to interpret patterns
- ✓ How to handle tough jobs in less time

MAIL ORDER 10-DAY FREE EXAMINATION

Dept. RE-62, RINEHART BOOKS, Inc. Technical Division, 232 Madison Ave., New York 16, N. Y. Send MODERN OSCILLOSCOPES AND THEIR USES for 10-DAY EXAMINATION. If I decide to keep the book, I will then remit \$6.00 plus a few cents postage in full payment. If not, I will return book postpaid and owe you nothing.

Name _____
Address _____
City, Zone State _____
Employer's Name & Address _____

OUTSIDE U.S.A.—Price \$6.50, cash only. Money back in 10 days if book is returned.

of the counter tube and explains its characteristics. Following this is a series of data sheets on the various types of tubes made by the company. *Gratis from Ampere Electronic Corp., 25 Washington St., Brooklyn 1, N. Y.*

N. T. C. RESISTORS

An 8-page booklet describing the characteristics of Keystone negative temperature coefficient resistors, some basic application information, and answers to the most commonly asked questions about this type of resistor. *Gratis from Keystone Carbon Co., St. Marys, Pa.*

FOLDED HORN DESIGN DATA

Drawings and instructions for building the backloading folded horn which is used with the new Jensen G-610 Tri-axial speaker are being offered would-be speaker-enclosure constructors. The horn can be mounted in a 5 x 3 x 2-foot cabinet, utilizing all of it. The manufacturer claims that this new horn design reduces loudspeaker resonant frequency by almost an octave, increases efficiency 4 to 6 db over the entire piston range, improves transient performance and allows doubling the loudspeaker power rating for a given amount of distortion. *Gratis from Jensen Manufacturing Co., 6601 South Laramie Ave., Chicago 38, Ill.*

Radio Thirty-Five Years Ago

In Gernsback Publications

HUGO GERNSBACK Founder

Modern Electrics	1908
Wireless Association of America	1908
Electrical Experimenter	1913
Radio News	1919
Science & Invention	1920
Television	1927
Radio-Craft	1929
Short-Wave Craft	1930
Television News	1931

Some of the larger libraries still have copies of ELECTRICAL EXPERIMENTER on file for interested readers.

JUNE, 1918 ELECTRICAL EXPERIMENTER

- The Phenomena of Electrical Conduction in Gases, by Rogers D. Rusk, M.A.
- Television and the Telephot, by H. Gumslacht
- The Dynatron—a New Vacuum Tube
- A "Fountain Pen" Radio Receiving Set
- Radio Signal Generator For Teaching Students, by Geo. F. Paul
- Radio Key With Ball Bearing Contacts
- Radio Operating in Alaska, by Howard S. Pyle
- Code Buzzer Tricks, by E. Duskis
- Design and Use of the Wave-Meter, by Morton W. Sterns
- Preventing Burning Out Audion Filaments, by E. T. Jones
- A Detector Hint, by P. B. Kingsley
- A Simple Ball-Joint Detector, by Clarence Sausley
- Improved Tickler Coil Hook-up, by E. T. Jones
- Variable Condenser Control for Panel Sets, by Walter Peterson

SERVICEMEN NEED PIX-EYE

Speeds TV Trouble Shooting! Saves Vital Time and Money!

Check TV Circuits On—The—Spot

Model TE-5 **\$5.97**



No more yanking picture tubes. Just plug Pix-Eye into CRT socket. Quickly analyzes the picture tube for shorts, intermittents and opens. Makes instant check of brightness control circuits, contrast control circuits, video circuits, low voltage circuits, filament voltage circuits. Take Pix-Eye on the call . . . keep one at the bench. Order Today!

SAVE \$14! BRAND NEW
General Electric FRONT END
COMPLETE WITH TUBES Reg. \$27
Pre-aligned RF head end unit
Brand new GE replacement for GE models: 810; 814; 820; 830; 835 840 **12.95**

Address Orders To Dept. RE-6
WRITE FOR FREE FYI FLYER

WHOLESALE RADIO PARTS CO., Inc.
311 W. Baltimore St.
BALTIMORE 1, MD.

FASTER STURDIER
Lower Installed Cost

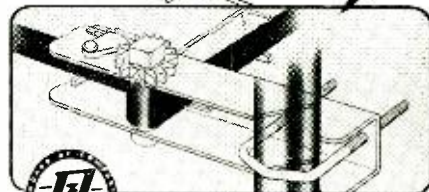
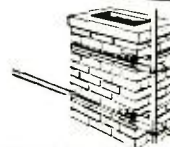

RADIART SPEED-DEE CHIMNEY MOUNT

Model AK 85 The fastest-installed chimney mount ever devised for TV antennas! Rugged in design—simple to install. Simply thread strapping through ratchet, around chimney and back through ratchet—wind up ratchet tight—and the job's done! Heavy gauge, zinc-plated steel with large "U" bolt for up to 1 1/4" O.D. mast and full length galvanized steel strapping.

THE RADIART CORPORATION
CLEVELAND 13, OHIO
RADIO-ELECTRONICS

Government Surplus Outstanding Values



**SCR-27N
COMMAND and
ARC-5 Equipment**



RECEIVERS		
	USED	NEW
HC-453-190 to 550 KC	\$22.95	\$42.50
HC-453-3 to 6 MC	11.95	18.95
HC-453-8 to 9 MC	11.95	18.95
TRANSMITTERS		
HC-457-1 to 5.3 MC	12.95	21.95
HC-458-5.3 to 7 MC	12.95	21.95
HC-696-3 to 4 MC	20.95	39.95
HC-459-7 to 9 MC	16.95	27.50
ADDITIONAL EQUIPMENT		
BC-156, Modulator	3.95	6.95
BC-150 Control Box (3 Receiver)	1.49	2.95
BC-4-1 Control Box (Transmitter)	1.29	2.49
HC-442 Relay Unit (ANT)	2.95	3.95
Plugs: PL-147, 148, 151, 152, 153, 154, 156—EACH	1.25	
Flexible Shafting with gear to fit Receivers		1.69
3 Receiver Rack	2.25	
2 Transmitter Rack	1.69	

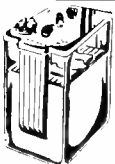

**WILLARD 2-VOLT
STORAGE BATTERY
20 Ampere-Hours**

Exact replacement for GE portables for LB-500—**\$2.69**
BRAND NEW. Each

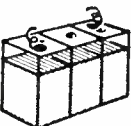

**WILLARD MIDGET
6-V STORAGE BATTERY**

3 amp hour rating. Transparent plastic case. Brand new. 3 3/4" x 1 1/2" x 2 3/4" high. Uses standard electrolyte. Each **\$2.85**



**ONE-QUART BOTTLE
BATTERY ELECTROLYTE**

Made by Willard, for above storage batteries. 1 quart sufficient for two 2-volt cells. Hermetically sealed. SPECIAL. **\$1.69**
per qt. bottle

7-PRONG 2-VOLT RADIO VIBRATOR
for Portable and Farm Sets Replacement for GE. LB 530 **\$1.95**

**GOULD 6-VOLT
STORAGE BATTERY**
Navy Standard. Black Rubber Case. BRAND NEW. 15 Amp. Hour Rating **\$7.95**



4 VOLT NAVY STORAGE BATTERY 10 amp. hrs. @ 16 hr rate. Plastic case, housed in crackle finished metal case. Brand New. Very special **\$7.95**



**BC-645 XMTR RECEIVER
15 Tubes 435 To 500 MC**

The electronic equipment that saved many lives in the war. Set can be modified to use for voice communications, voice or code, on following bands: ham band 420-450 mc, citizens radio 460-470 mc, fixed and mobile 450-460 mc, television experimental 470-500 mc. 13 tubes (tubes alone worth more than sale price!); 4-7E7, 2-7H7, 2-7EA, 2-6F5, 2-955 and 1-WES7GA. Now covers 460 to 490 mc. Brand new BC-645 with tubes, test power supply in factory carton. Shipping weight 25 lbs. **\$49.50** each

PE-101C DYNAMOTOR for above BC-645 **\$4.95**
UHF ANTENNA ASSY. for above BC-645 **\$2.45**



11-TUBE SUPERHET RECEIVER
Model BC-652-A—2000 to 6000 KC (75-80 Meters) BRAND NEW IN ORIGINAL CRATE. SMASHING LOW PRICE **\$59.50**

Complete with Crystal Tubes and Dynamotor.
For those of you "sailors" in need of a good radio receiver aboard ship, the Model BC-652-A made by General Electric Co., will fill your needs! It is a rugged, good performing receiver which will give fine service for a long long time. This set is designed for 12-24 volt DC operation, which is ideal for shipboard use. It needs absolutely no conversion, just connect it into your batteries. Technically this set is an 11-tube superhet receiver with a freq range of 2000 to 6000 Kc (75-80 meter band), a crystal freq standard, and a 12-24 volt dynamotor, on two chassis combined into one case. The sensitivity is one microvolt or greater.

Please include 25% Deposit with order—Balance C.O.D. MINIMUM ORDER \$3.00. All Shipments F.O.B. Our Warehouse N.Y.C.

G & G RADIO PARTS SERVICE
51 VESEY STREET • NEW YORK 7, N.Y.

THE FUND NEARS \$9,500



HELP - FREDDIE-WALK FUND

Those of our readers who have been following the growth and progress of little Freddie Thomason, the armless and legless son of Herschel Thomason, radio technician of Magnolia, Arkansas, will be interested in learning that he celebrated his fourth birthday a short while ago with a barbecue given by the Kiwanis Club. Soon afterwards, he made another visit to the Kessler Institute, West Orange, New Jersey, where necessary adjustments were made in the mechanical appliances on which he is so dependent.

Others who are meeting Freddie for the first time will want to know that it



has been largely through the Help-Freddie-Walk Fund, instigated by RADIO-ELECTRONICS many months ago and enthusiastically supported by hundreds of its readers, that Freddie and his appreciative family have been able to look forward to the future with optimism and hope. Although the Fund now totals almost \$9,500, many thousands more will be needed before the job of rehabilitating the unfortunate child can be considered as complete as human ingenuity can make it.

The continued support from people in all stations of life all over the world is very encouraging. With a donation of \$5.00, Frank C. Okleberry, c/o Fleet Post Office, San Francisco, writes: "... I am greatly relieved to know that people are doing what they can for Freddie. You can count on me!" Eugene A. Tracy, of the S.S. Edwin Booth, Yokohama, Japan, sent \$25.00, and commented: "I wish I could send a million, but I hope that the enclosed will swell the fund." And we should also like to take special note of a \$4.00 contribution received from Sgt. A. L. Howell, in the name of the personnel of the U.S. Armed Forces Blood Donor Center, Fort Leonard Wood, Missouri.

ENGINEERS



Make this your home for important work under ideal conditions

- TV Receiver Design Eng.
- Test & Inspection Eng.
- Electronics Eng.
- Field Engineers
- Lab Technicians

TO WORK ON:

Radar, G. C. A., Mobile Radio, Auto Radio, Airborne Communication & Navigation Equipment, Television, Antennas, Microwave Equipment, Servo Mechanisms, Guided Missiles and Test Equipment.

YOU BENEFIT

from high wages, a modern, air-conditioned plant, paid vacations and holidays, group insurance and a good chance for advancement. Housing immediately available in the beautiful suburban and country areas that surround the Bendix plant.

Write Wire, Phone Mr. E. O. Cole, Dept. 5

Bendix Radio
DIVISION OF BENDIX AVIATION CORP.
BALTIMORE-4, MD.
Makers of the World's Finest Electronic Equipment

ON-THE SPOT BATTERY RECORDER
WALKIE-RECORDALL 8 lb. miniature BATTERY RECORDER-PLAYBACK Continuous, permanent, accurate, indexed recording at only 5c per hr. Instantaneous, permanent playback. Picks up sound up to 80' ft. Records conferences, lectures, litigation, 2-way phone & sales talks; while walking, riding or flying. Records in closed briefcase with "hidden mike"! Write for details.
MILES REPRODUCER CO., INC.
212 BROADWAY Dep't RE-6 NEW YORK 3, N. Y.

Every RADIOMAN can use these SERVICE HINTS!
Valuable Manual Yours—FREE
Write Today—no obligation
Every page of "How to Simplify Radio Repairs" is packed with on-the-bench, practical ideas.
FEILER ENGINEERING CO. Dept. 6RC2-1
8026 N. Monticello Ave., Skokie, Ill. (Suburb of Chicago)

New—Different—Powerful

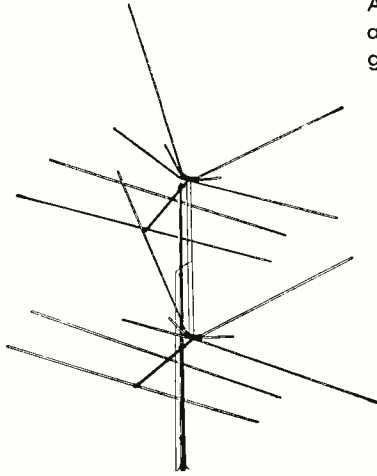

Model C-2

Radiation Lobe:

High Band—
6° left to right

Low Band—
10° left to right

A completely new large conical type antenna designed for highest maximum gain on all channels—2 to 13

- Rugged Construction
- Double plate dipole holders
- 7/16" Aluminum Tubing
- Oak dowel pins
- Crimped ends
- Micarta insulators
- Cast aluminum mast clamps
- Mast clamp assembly will take 1" to 1 3/4" O.D. mast or pipe

Signal strength in comparison to dipoles cut to station.

High band:
7 times dipole.

Low band:
4 times dipole.

Contact your distributor for prices.

Manufactured by

KAY-TOWNES ANTENNA CO. P.O. Box 586 Rome, Ga. 1511 Dean Ave.

LEARN

Television-Radio Electricity

REFRIGERATION-ELECTRONICS

IN THE GREAT SHOPS OF **COYNE**

TRAIN QUICKLY! OLDEST, BEST EQUIPPED SCHOOL of ITS KIND in U.S. Draft Age and Older Men..

Come to the Great Shops of Coyne in Chicago. Get practical training in TELEVISION-RADIO or ELECTRICITY—vital in Defense Program. Prepare now for a better job or better service rating.

START NOW—PAY LATER

You can finance most of your tuition, pay for it later in easy monthly payments. Special plan for men of Draft Age. Part time employment service available.

FREE BOOK Clip coupon for Big Free Illustrated Book. Indicate below course that interests you. No salesman will call. Act NOW.

COYNE B. W. Cooke, President
A TECHNICAL TRADE INSTITUTE CHARTERED NOT FOR PROFIT
Established 1893
500 S. Paulina, Chicago

ELECTRICITY ★ TELEVISION RADIO ★ REFRIGERATION ★ ELECTRONICS

B. W. COOKE, Pres. COYNE School
500 S. Paulina St., Chicago 12, Ill. Dept. A2-81H

Send FREE BOOK and full details on:

TELEVISION-RADIO ELECTRICITY

NAME.....

ADDRESS.....

CITY..... STATE.....

Send for these Bargains & SAVE MANY DOLLARS

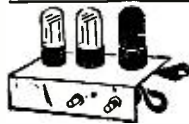

3-TUBE PHONO AMPLIFIER

Designed for use with all types of records. 2 1/2 watt output—completely wired with full range tone control. \$2.95 ea.

ROSE Cash Saver! lots of 3 \$2.49 ea.

- TUBES (for above), set of 3.....\$1.95
- 50L6 OUTPUT TRANSFORMER.....ea. .49
- SPEAKER, 4" P.M.....ea. 1.39
- SPEAKER, 5" P.M.....ea. 1.49
- SPEAKER, 6" P.M.....ea. 1.69
- PHONO PICKUP, 78 RPM.....ea. 1.95
- MOTOR & TURNTABLE, 78 RPM, complete.....2.89
- MOTOR & TURNTABLE, 3-Speed complete.....4.95
- HI-FIDELITY PICK UP with turnover cartridge & 2 permanent needles, complete.....4.95

Terrific Value! RECORD PLAYER BASE

Teakwood, beautiful leatherette cover with cutout for motor. Can also be used for speaker baffles. Holds 4" to 7" speaker. Size: 13" x 8 1/4" x 3 1/2".

SAVE! only 98c ea.

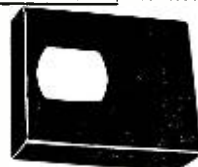

Save More! Order 3 for \$2.49!

- Save More Than Half! JEWEL TIPPED PERMANENT NEEDLES
- Ruby tip, list \$2.50 ea. \$ 98
 - Sapphire tip, list \$5.00 ea. 1.49
 - 3-Speed, jewel tip, list \$2.50 ea. 98

VIBRATORS, 4-prong, 6 V., Universal type, on \$1.29 Save! Get 10 for only \$11.90

FREE! Write for new parts & tune floor!

Low Priced For Quick Sale TUBES

- | Standard Brands—All Guaranteed! | | |
|---------------------------------|----------------|-------------------|
| 024.....\$ 69 | 6AT6.....\$ 69 | 6V6.....\$ 89 |
| 1B3.....\$ 59 | 6A6.....\$ 70 | 6X5.....\$ 69 |
| 1X2A.....\$ 99 | 6C85.....\$ 89 | 12A07.....\$ 1.19 |
| 5U4.....\$ 69 | 6K6.....\$ 79 | 12SK7.....\$.79 |
| 5V4.....\$ 1.09 | 6SA7.....\$ 79 | 12SQ7.....\$.69 |
| 6AC7.....\$ 1.19 | 6SK7.....\$ 79 | 35Z5.....\$.59 |
| 6AG5.....\$ 1.09 | 6SQ7.....\$ 69 | 50L6.....\$.69 |
| 6AL5.....\$ 69 | 6SN7.....\$ 99 | 8J.....\$.59 |

MINIMUM ORDER: \$5.00. 25% deposit with order. balance C.O.D. Include postage with order. All merchandise subject to prior sale. F.O.B. New York City. Prices subject to change without notice.

THE ROSE CO. 100 Park Place, Dept. E-6
New York 7, N. Y. Cortlandt 7-6195

Please send your contributions, large or small, from time to time. Make all checks, money orders, etc., payable to Herschel Thomason. Address all letters to:

Help-Freddie-Walk Fund
c/o RADIO-ELECTRONICS
25 West Broadway
New York 7, N. Y.

FAMILY CIRCLE CONTRIBUTIONS

Balance as of March 18, 1952	\$ 521.50
Mrs. Edna Bachmann, Chicago, Ill.	2.00
Eugene A. Tracy, S.S. Edwin Booth, Yokohama, Japan	25.00
Mrs. Addie Schlenck, Oxford, Ohio	2.00

FAMILY CIRCLE Contributions Received to April 18, 1952.....\$ 550.50

RADIO-ELECTRONICS CONTRIBUTIONS

Balance as of March 18, 1952	\$8,855.96
Alliance Radio & Television Repair Shop, Claymont, Delaware	2.00
Anonymous, San Antonio, Texas	.20
V. A. Boker & Sons, Minneapolis, Minnesota	10.00
Sven Bourghardt, Gateborg, Sweden	1.00
Chester's Radio Sales & Service, Winnipeg, Manitoba, Canada	5.00
Ned Fleishman, Fayetteville, North Carolina	1.00
C. A. Fleming, Lafitte, Louisiana	10.00
W. N. Gurnee, WOJG, Fort Bliss, Texas	5.00
Mr. & Mrs. Robert Gray, Richmond, Indiana	1.00
C. T. Haley, Chicago, Illinois	1.00
George F. Jephson, Bloomfield, New Jersey	5.00
Norman C. Jones, Ballston Spa, New York	5.00
Mr. & Mrs. Thomas F. Malone, Arlington, Virginia	2.00
C. R. Mitchell, Newark, Ohio	2.00
Frank C. Okleberry ATI, F.P.O., San Francisco, California	5.00
Personnel of the U.S. Armed Forces Blood Donor Center, Fort Leonard Wood, Missouri	4.00
John Piotkiewicz, North Chicago, Ill.	2.00
A. V. Predki, Detroit, Michigan	2.00
Paul Trinker, Orleans, Indiana	1.00

RADIO-ELECTRONICS CONTRIBUTIONS.....\$8,920.16

FAMILY CIRCLE CONTRIBUTIONS.....550.50

TOTAL CONTRIBUTIONS to April 18, 1952.....\$9,470.66

MODERN XTAL SET DX REPORT

The following report is published through the courtesy of Dr. W. H. Grace, Jr., of Bronxville, N. Y.

The past winter was a favorable one for xtal-set dx reception in Richmond, Va., according to Mr. Joseph Amorose. Using a homemade receiver with only a germanium-diode detector, headphones, a single-wire antenna, and ground, Mr. Amorose heard the following stations:

- | | |
|-----------------------|--|
| WOR—New York, N. Y. | WJR—Detroit, Mich. |
| WJZ—New York, N. Y. | WGY—Schenectady, N. Y. |
| WNBC—New York, N. Y. | WBZ—Boston, Mass. |
| WCBZ—New York, N. Y. | WWSM—Nashville, Tenn. |
| WRBW—Buffalo, N. Y. | WWSW—Washington, W. Va. |
| WCKY—Cincinnati, Ohio | WTAR—Cleveland, Ohio |
| WLW—Cincinnati, Ohio | WBAL—Baltimore, Md. |
| WRT—Charlotte, N. C. | KTHS—Little Rock, Ark. |
| WSB—Atlanta, Ga. | A station in Miami and one in Salt Lake City were also heard but their calls could not be obtained. Reception from the more or less local stations was normal. |
| WLWL—New Orleans, La. | |
| WHAS—Louisville, Ky. | |
| KMOX—St. Louis, Mo. | |
| WBBM—Chicago, Ill. | |
| WGN—Chicago, Ill. | |
| WHO—Des Moines, Ia. | |

—end—

People

George E. McAllister was appointed Division manager of the Norwood plant of WORKSHOP ASSOCIATES, Division of The Gabriel Co. Mr. McAllister served over eighteen years with Gabriel as industrial engineer, plant manager, purchasing agent, and for the past five years general manager of The Ward Products Division.



G. E. McAllister

George L. Loomis succeeds Walter A. Weiss as manager of SYLVANIA ELECTRIC PRODUCTS' radio tube plant at Burlington, Iowa. Mr. Weiss was appointed general manufacturing manager of the Radio Tube Division. Before his promotion, Mr. Loomis was engineering manager of the Division's Products Development Section.



G. L. Loomis

H. R. Letzter was appointed sales manager of the Industrial Division of WEBSTER-CHICAGO CORP., manufacturer of record changers, phonographs, and magnetic wire and tape recorders. Mr. Letzter has been with Webster-Chicago for the past four years in various executive sales capacities, including sales to the government.



H. R. Letzter

Harold L. Herndon, former service manager of the RAYTHEON MANUFACTURING COMPANY'S Cleveland district, was promoted to the post of district manager in charge of sales and service for the Cleveland district. Albert R. Wolfe, who assisted Mr. Herndon as field engineer, succeeded him as service manager.



H. L. Herndon

Raymond Rosen, president and senior member of the RAYMOND ROSEN Co., distributors of RCA Victor products and president of Raymond Rosen Engineering Products, Inc., died of a heart attack in his home in the Germantown section of Philadelphia.

Personnel Notes

John J. Radigan, Jr., recently assumed duties as newly appointed vice-president in charge of industrial relations at P. R. MALLORY & Co., INC., Indianapolis. He came to Mallory from E. W. Bliss Co.

Stanley R. Andrews was elected vice-president in charge of STANDARD COIL PRODUCTS Co., INC., Chicago pro-

MODEL 480 GENESCOPE

Simpson

RECOMMENDED

by service managers of leading manufacturers:

don anderson
frank smolek
floyd makstein
norm cooper
max schinke
tim alexander

hoffman
zenith
emerson
hallcrafters
admiral
motorola

\$395 dealer's net

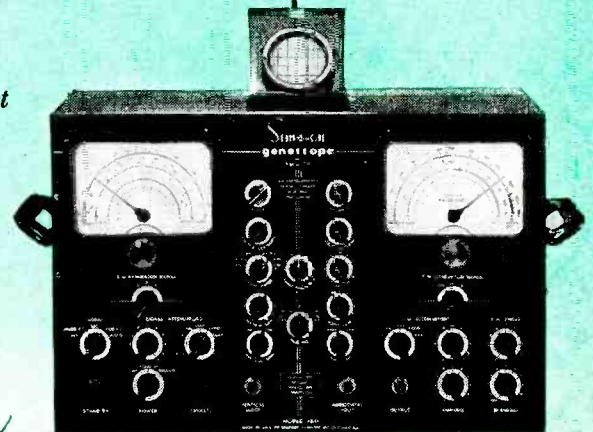

Simpson

SIMPSON ELECTRIC COMPANY, 5200 W. KINZIE ST., CHICAGO 44, COLUMBUS 1-1221

BURTON BRONK ADVERTISING

WEAR This Tested Cimier 10 Days FREE

World Famed Swiss Cimier

Originally made as a military watch. NOW, here in America . . . a real he man's watch! For time of day or split-second stop-watch timing. The Genuine Cimier "remembers" results indefinitely, while movement keeps going. Separate dials record minutes and seconds. A true precision time-piece.

GUARANTEED

Guarantee certificate for one FULL YEAR with each watch. SATISFACTION OR MONEY BACK.

Act NOW while we can hold this price. Send check or money-order for \$14.95, and we will pay postage. (Or we will ship COD, and you pay the postman \$14.95 plus COD charges.)

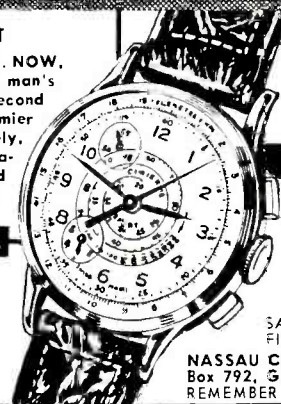

Only

14.95 Tax Incl.

8 STAR FEATURES

- A sweep-second stop-watch
- Three separate dials
- Tachometer (for speed)
- Telemeter (distance)
- A precision watch
- Shatterproof crystal
- Genuine leather strap
- Radium dial and hands
- Black or white dial available

SAME WATCH IN RICH GOLD FINISH . . . \$15.95 Incl. Tax

NASSAU CO., Dept. 211
Box 792, G.P.O. New York 1, N. Y.
REMEMBER HIM FOR FATHER'S DAY

**IT'S REVOLUTIONARY
DAVIS SUPER-VISION
ALL-CHANNEL ANTENNA
FOR FRINGE AREA or DX
with ELECTRONIC DIAPOLE SEPARATORS
"THE ONLY TV ANTENNA SOLD WITH A
MONEY-BACK GUARANTEE"**

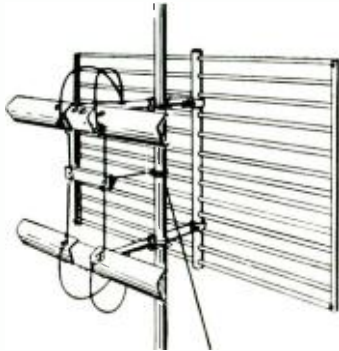

10 OUTSTANDING FEATURES:

1. EXCELLENT FOR FRINGE AREA and DX RECEIVING—and broad band receiving with high gain on all channels—2 through 13.
2. CLEARER PICTURES UP TO 125 MILES OR MORE—from the station.
3. GHOST PROBLEMS REDUCED or eliminated due to excellent pattern.
4. PROVIDES 10 DB OR MORE GAIN ON HIGH CHANNELS where gain is needed most.
5. EXCELLENT FRONT TO BACK RATIO on all channels. Eliminates co-channel interference.
6. MINIMIZES INTERFERENCE: Airplane Flutter—Diathermy and Ignition—F.M.—Neon Signs—X-Ray—Industrial—Etc.
7. ELIMINATES DOUBLE STACKED ARRAYS, and out-performs 2 bay yagis on low band and 4 bay yagis on high channels.
8. ONLY ONE TRANSMISSION LINE NECESSARY.
9. NO WORRY OVER POSSIBLE CHANNEL CHANGES on either high or low channels.
10. CAN BE TIPPED WITHOUT TILTING MAST to take advantage of horizontal wave lengths.

AT YOUR JOBBERS, OR WRITE TO:

DAVIS ELECTRONICS 1-10
3047 W. Olympic Blvd., Los Angeles 6, California
SIRS: RUSH INFORMATION TO ME AS CHECKED BELOW:

Send Free Technical Data on new SUPER-VISION ANTENNA.
 Send Name and Address of NEAREST JOBBER.

Name _____
Street _____
City _____ State _____

duction facilities. He was previously works manager of Standard Coil's three Chicago plants.

... David Hughes joined the industrial sales staff of SIMPSON ELECTRIC Co., Chicago. He was formerly director of the instrument school of the Industrial Training Institute.

... Donn F. King was appointed east central district sales manager of the Parts Division of SYLVANIA ELECTRIC PRODUCTS, INC., with headquarters in Cincinnati. He was previously on the supervisory sales staff of the division. Sylvania also announced the appointment of A. W. Keen as manager of Application Co-ordination. He was formerly assistant to the manager of Sylvania's Product Development Laboratory at Kew Gardens, N. Y.

... Donald G. Fink joined the PHILCO CORP. as co-director of Research-Operations. Mr. Fink was formerly editor of *Electronics* magazine.

... A. M. Repsumer was promoted to the post of television supervisor for the BAKER MANUFACTURING Co., Evansville, Wis., manufacturer of television masts, towers, and roof mounts.

... Edward Cappucci was appointed plant superintendent for RADIO MERCHANTISE SALES (RMS), New York City. He was previously with the George S. May Co. Gene Reich, previously with Magnavox, will head the company's Quality Control Section. Rubin Agdern continues as production manager. Mal Greenberg joined the company's sales engineering staff, and Harold Merson was appointed chief electronic engineer.

... Edward S. Hill, Sam R. Alexander, and Oscar K. Leisher were appointed district sales managers for CHANNEL MASTER CORP., Ellenville, N. Y., in the southeast, the southwest, and the Maryland and central Pennsylvania territories, respectively.

... Joseph Holzman was appointed industrial sales engineer for the INSULINE CORPORATION OF AMERICA, Long Island City, N. Y.

... J. D. Ceader was re-elected president of the OXFORD ELECTRIC CORP., Chicago. Hugo Sundberg was re-elected vice-president and general manager, and David E. Davis secretary-treasurer. All members of the board of directors were also re-elected.

... Leo Brook was appointed industrial and broadcast sales manager of ALLIED RADIO CORP., Chicago distributor, in a move to expand the Sales Division. Other appointments included: Dave Kennedy, sales development manager; Gordon Hough, inside sales administration; George Kelly, government sales manager; Jack Lizars, dealer sales manager; Fred Prehn, Chicago Store sales manager; Eugene Carrington, general product promotion; and Julian McBarron, general account promotion.

... Russell J. Tinkham was named manager of the newly established Chicago office of AMPLEX ELECTRIC CORP., Redwood City, Cal., manufacturers of magnetic tape recorders.

—end—

**For A Clearer Sharper Picture
Replace Your Old TV Antenna**

with the Famous
**Rocket
DIRECTRONIC**
MOTORLESS TV
ANTENNA

360° Electronically Switched Beam
• No Motors
• No Roof Orientation
• No Electric Power
• No Ghosts
Flick of Switch Clears Picture Instantly

The Directronic 18-element 360° antenna is the finest for ultra-fringe or metropolitan reception. The Hi-PAC molded insulator is a material of extreme tensile strength not affected by weather or temperature, either mechanically or electrically. Included in the AX-599 "Service" array are: 18 hi-tensile aluminum alloy elements; Universal U Clamps for masts to 1 1/2"



AX-599 Directronic As shown \$16.95
Directronic Beam Selector 75 feet of Tri-X Cable AX-59 Directronic 9-element Single..... \$10.35

Where Else Can You Find Bargains Like These

**Rocket YAGI
5 ELEMENT TV ANTENNA**

Excellent Pictures in Fringe Areas
HIGH GAIN. Minimum interference from ghosts and noise due to a directive pattern. Five elements include one folded dipole, three directors, and one reflector. Supplied less mast. MATCHES 300 OHMS IMPEDANCE. Molded insulator provides additional strength. Exclusive design mast clamp prevents antenna turning or canting under any conditions. STRIP-ON, TROUBLE-FREE CONSTRUCTION. Stands the test of severest weather. Elements of extra heavy aluminum-clamped top and bottom. Completely pre-assembled. Just swing elements into line and tighten wing nuts.

Channels: 2 or 3..... \$7.95 each 4, 5 or 6..... \$8.95 each
7 to 13..... \$3.95 each
EACH CHANNEL requires a DIFFERENT Yagi. When ordering specify exact channel number desired.

BIG PRICE CUTS ON CONICALS

All Channel Conicals—Single Bay.....	\$2.95
All Channel Conicals—Stacked Array with The Rods.....	\$ 6.00
Mast Steel (Ductalco) 5' Crimped 11 1/2" O.D.....	1.05
Mast Steel (Ductalco) 10' 11 1/2" O.D.....	1.95
Mast Steel (Zinc Plated) 10' 11 1/2" O.D.....	1.59
Mast Connectors for 1 1/2" O.D. Mast—10'.....	49c
Chimney Mount Complete with Straps.....	1.19
Peak Roof Saddle (will take up to 1 1/2" O.D.).....	1.49
Lightning Arrestor—TV.....	69c
Galvanized Guy Wire—6 strand @ 20'.....	1 1/2c ft.
Galvanized Guy Wire—11 strand @ 20'.....	1 1/2c ft.
300 ohm Twin Lead—7 22 stranded—500' Reel.....	\$7.50
300 ohm Open Line Twin Lead—500' Reel.....	2c ft.
Mast Stand-off Insulators—3".....	8.50 C
Stand-off Screw Insulators—2".....	2.75 C
Stand-off Screw Insulators—7".....	5.50 C

ROCKET PRODUCTS SOLD ONLY BY MAIL BY NATIONAL ELECTRONICS
Prices Subject to Change Without Notice
ALL PRICES F.O.B. CLEVELAND, OHIO
Do not remit more than complete purchase price. Pay shipping charges on receipt of goods. 25% deposit on C.O.D. orders, please. Money-back guarantee.

FREE CATALOG

of TV antennas, accessories at lowest prices. Tells about our fast service, free installation help. Send name, address now.

National Electronics
OF CLEVELAND
THE HOUSE OF TV VALUES
206 Delco Building Cleveland 3, Ohio

WANTED TO BUY

Large and small quantities of new or used electronic government or manufacturers' surplus tubes and equipment. Highest prices paid. State quantity, condition and best price in first letter.

Box No. F-2 c/o Radio-Electronics
25 West Broadway
New York 7, N. Y.

★ **WANTED** ★
★ WE NEED YOUR ★
★ SURPLUS ★
★ ELECTRONIC ★
★ EQUIPMENT ★
★ WE PAY TOP \$\$\$ FOR: ★

RADIO RECEIVERS	CLAMPS
TRANSMITTERS	PLUGS
ARC-1	CORDS
ARC-3	RELAYS
ART-13	TELEPHONE
CONTROL BOXES	MATERIALS
INDICATORS	
AN CONNECTORS	

WE BUY ANYTHING!!
Write, Wire Today!
Tell us what you have
TALLEN COMPANY, INC.
Dept. RE, 159 Carlton Ave.
Brooklyn 5, New York

FLASH! Tube Prices SMASHED!

ALL TUBES listed below carry 6-month guarantee—exception only burnouts and breakages. At these sensationally low prices, these tubes must be ordered in quantities of AT LEAST 10 ASSORTED TYPES. Add 10% for orders under 10 tubes. All individually boxed in attractive Greylock Cartons.

SPECIAL OFFER: Additional 5% discount on all shipments of 100 tubes or more assorted!

0Z4M	\$.59	6BH6	\$.79	TN7	\$.79
1A7GT	\$.89	6BJ6	\$.79	TX7	\$.79
1B3GT	\$.89	6BL7GT	1.09	807	1.79
1H5GT	\$.69	6BN6	1.09	12A8GT	\$.49
1L4	\$.49	6BQ6GT	\$.79	12AL5	\$.79
1LA4	\$.89	6BQ7	1.49	12AT6	\$.49
1LC5	\$.79	6C4	\$.49	12AT7	\$.79
1LD5	\$.99	6C5GT	\$.49	12AU6	\$.49
1LN5	\$.89	6C6	\$.49	12AU7	\$.59
1N5GT	\$.69	6CB6	\$.49	12AV6	\$.59
1R5	\$.59	6CD6G	1.49	12AV7	\$.69
1S5	\$.49	6E5	\$.79	12AX4GT	\$.69
1T4	\$.59	6F6GT	\$.59	12AX7	\$.59
1U4	\$.49	6H6	\$.59	12AZ7	1.29
1U5	\$.49	6J5	\$.49	12BA6	\$.49
1X2	\$.89	6J6	\$.89	12BA7	\$.99
3A4	\$.59	6J7	\$.49	12BE6	\$.49
3A5	\$.79	6K6GT	\$.59	12BH7	\$.99
3LF4	\$.99	6L6G	1.19	12J5GT	\$.59
3Q4	\$.49	6L6GA	1.19	12Q7GT	\$.69
3S4	\$.59	6S4	\$.49	12SATGT	\$.79
3V4	\$.49	6S8GT	1.29	12SK7GT	\$.59
5U4G	\$.69	6SATGT	\$.69	12SN7GT	\$.79
5V4G	\$.89	6SC7	\$.99	12SQ7GT	\$.69
5X4G	\$.59	6SD7GT	\$.79	12S8GT	\$.79
5Y3GT	\$.49	6SG7	\$.89	14A7	\$.89
5Y4G	\$.69	6SH7	\$.79	14B6	\$.79
6AB4	\$.69	6SJ7GT	\$.69	14Q7	\$.99
6ACTM	1.09	6SK7GT	\$.49	19B6G	1.29
6AG5	\$.79	6SL7GT	\$.69	19T8	\$.99
6AGTM	1.19	6SN7GT	\$.59	25B6GT	\$.79
6AH6	1.29	6SQ7GT	\$.59	25L6GT	\$.59
6AK5	\$.89	6SR7	\$.89	25W4GT	\$.49
6AL5	\$.49	6T8	\$.79	25Z5	\$.49
6AQ5	\$.49	6U4GT	\$.59	25Z6GT	\$.69
6AQ6	\$.69	6U5	\$.89	35B5	\$.59
6AR5	\$.59	6V3	1.59	35C5	\$.59
6AR6	2.49	6V6GT	\$.49	35L6GT	\$.69
6AS5	\$.69	6W4GT	\$.49	35W4	\$.49
6AT8	\$.49	6W6GT	\$.79	35Y4	\$.69
6AU8	\$.49	6X4	\$.49	35Z5GT	\$.49
6AV6	\$.49	6X5GT	\$.49	41	\$.69
6AX4GT	\$.69	6Y6G	\$.79	45	\$.69
6AX5GT	\$.79	7A4	\$.89	50B5	\$.59
6BA6	\$.49	7A8	\$.89	50C5	\$.59
6BC5	\$.69	7B6	\$.59	50L6GT	\$.49
6BD5GT	1.09	7B7	\$.89	80	\$.49
6BE6	\$.49	7C8	\$.89	117Z3	\$.49
6BF5	\$.89	7C7	\$.89	FM1000	\$.89
6BG6G	1.29	7L7	\$.99	7JP4	16.50

MANY ADDITIONAL VALUES, in Radio, TV and Electronic components and accessories! Send for our Great New Bargain Catalog (1-106-3). All Prices F.O.B. NYC. Please include postage and insurance with your remittance. 25% Deposit required on all C.O.D. orders.

GREYLOCK ELECTRONICS SUPPLY CO. Dept. C-6
115 Liberty Street New York 6, N. Y.

NEW CONDENSER TESTER
Finds Intermittent Condensers Instantly
NET
Pres-probe's sliding tip with variable resistance prevents condenser heating. Tests with power on. Requires no adjustment. Stops guesswork. Saves time. Convenient probe size (7 1/4" long). Satisfaction guaranteed.
795 Postpaid U.S.A.
See Your Dist. or Order Direct
PRES-PROBE CO.
4034 N. Sixth St., Milwaukee 12, Wis.

TV "FIX-IT" BOOKS A BOON?

Dear Editor:
I read with great interest "Fix It Yourself" in the March RADIO-ELECTRONICS. While this is a remote area for television I have found some of these fix-it-yourself booklets on our newsstands and heard their radio commercials.

I have been a service technician since crystal-set days, and I do not agree with Mr. Leslie. I am all for the fix-it-yourself books, and would like to see them sell several million. *If the readers of these books do exactly as instructed I am sure service technicians will be working day and night taking care of their calls.*

One of my customers is a doctor. I tried in vain to get him last week and found he had been operating for 7 hours and was two days behind in his calls. I can just see him at home after such a day, at about 11 pm, prying the back off his television set, and going over his little book trying to find the trouble.

No, Mr. Leslie, I don't think we need worry about these books putting us out of work; in fact I think they are doing us a big favor. I remember the customer's son who was handy with a screwdriver and tried to fix the family radio. He tightened up all the screws. That was very profitable for me and I'm looking forward to more like that in television.

All this time in the service field I've been reading your fine magazine, and can truthfully say it has gone a long way in making me a successful radio technician.

FRANCIS D. BUCHANAN

Keokuk, Iowa

(Thanks for a fine letter, Mr. Buchanan, but note that the article did not suggest that business would be lost on account of the books; it objected to the implications of dishonesty and incompetence in the books and their advertising.—Editor)

FAVORS SMALL-TOWN AM

Dear Editor:
I have noticed many letters complaining of "too much this" or "too little that", and I, too, find some articles of no interest to me at a particular moment. But as I study and broaden my understanding of electronics these articles soon find a place in my interests.

Along with Mr. Hawbaker, I advocate more AM broadcast stations. Theoretically, maybe, the band is crowded, but from a practical viewpoint it is wide open. Here in Linton, Indiana, with a good receiver, and when conditions are right, I can get only about 10 stations, all over 75 miles away, and half of them go off the air at 6 pm. We can "detect" 3 FM stations here, but only 1 is listenable.

Therefore I go along with Mr. Hawbaker in demanding more local low-power AM stations, which would be assets to community business and a public service, as well as providing good entertainment.

LOU S. BITTON

Linton, Indiana

Compare! PROVE EMC SUPERIORITY!

MODEL 205
tube tester
• Tests all tubes including Noval and sub-miniature
• Completely flexible lever type switching arrangement • Tests all tubes from .75 volts to 117 filament volts by standard emission test • Tests all cold cathode, magic eye, voltage regulator and ballast tubes • Has pilot light indicator • Line voltage control compensates for line variations between 105 and 135 volts
• Checks for shorts and leakages • Three-color hammer-tone panel.
MODEL 205C—
Sloping Counter Case—illustrated . \$46.50
MODEL 205P—
With hand-rubbed oak carrying case . \$47.50

MODEL 204
tube-battery-ohm capacity tester
Tests all tubes including Noval and sub-miniature • Tests all batteries under rated load • Emission testing method gives easy, direct readings • Tests resistance to 4 megohms • Tests condensers from .01 to 1 mfd • Uses four-position lever type switches • Checks condenser leakage.
MODEL 204—
Portable oak case, removable cover . \$55.90

MODEL 206
Mutual conductance tube tester
• Checks mutual conductance on calibrated microhmo scale
• Checks tubes for gas content • Detects both shorted and open elements
• Tests all tubes from .75v to 117 filament volts
• Tests all local, octal and miniature tubes • Checks individual sections of multi-purpose tubes. Built-in roll chart. Uses lever type switches.
MODEL 206— Sloping Counter Case . \$79.50
MODEL 206P—
With hand-rubbed oak carrying case . \$83.50
Write Dept. RE-6 for FREE Catalog

EMC Electronic Measurements Corp.
280 Lafayette St., New York 12, N. Y.
Export Dept. 363 W. 42nd St., N. Y. C.

TELEVISION

Big demand for graduates
B.S. DEGREE IN 27 MONTHS in radio including TV engineering—VHF, UHF, AM and FM. Students use over \$100,000 worth of equipment including 2 large commercial type transmitters in new TV lab. Intense specialized course includes strong basis in mathematics, science and advanced design in radio and TV.
Hundreds of young men each year are earning engineering degrees in this recognized institution. Start any quarter. Many earn a major part of expenses in this industrial center. Low tuition. Competent instruction. Thorough, intense, practical program.
Also B.S. DEGREE IN 27 MO. in Aeronautical, Chemical, Civil, Electrical and Mechanical Engineering. G.I. Gov't approved. Enter June, Sept., Dec., March. Free catalog. **ENROLL NOW!**
INDIANA TECHNICAL COLLEGE
1762 E. Washington Blvd., Fort Wayne 2, Indiana

NATIONAL EMERGENCY
If you have any scrap iron, steel, copper, bronze, aluminum, lead, zinc or other metal, turn it over to cooperating scrap-collecting agencies. The defense effort needs it more than you do.

AN AID FOR TECHNICIANS

Dear Editor:

Almost every day you can pick up a magazine or a newspaper and read a derogatory article on the ethics and honesty of radio and television service dealers. These smears have been greatly accelerated recently due to the tremendous growth of television, but they are by no means a new development. *Reader's Digest* initiated the first of these attacks more than ten years ago and press at the consumer level at frequent intervals since has kept the service dealers constantly in the public's "doghouse."

The opinion has developed that no one has tried to help the service dealers. Nothing could be farther from the truth.

In 1946 the Receiving Tube Division of the Raytheon Manufacturing Company instituted the RAYTHEON Bonded Electronic Technician Program—a program developed to help service dealers re-establish themselves in the good graces of the public. Raytheon distributors screened the service dealers in their areas, and those with modern and sufficient test equipment, sound financial background, and adequate manpower were selected for bonding consideration. Once these dealers qualified they were bonded with American Mutual Liability Insurance Company, one of the nation's leading surety companies, presented with a registered bond certificate and were pledged to observe an eight-point Code of Ethics designed to protect them and the consumer.

The eight points of the Code are:

1. Guarantee all radio and television repair work for 90 days from date performed and replacement parts 90 days from date installed.
2. Use only parts of recognized quality in such repair work.
3. Charge no more than established prices for parts installed in such repair work.
4. Test customers' tubes as accurately and reliably as possible.
5. Keep charges for labor in such repair work at a fair and reasonable level.
6. Perform only such repair work as is necessary or authorized.
7. Maintain and use service equipment essential to good repair work and reliable tube checking.
8. Maintain in such repair work the high quality service indicated by the experience required of all bonded electronic technicians.

Thousands of service dealers who are operating under the preceding Code of Ethics are enjoying excellent relationships with their customers and are doing much to regain the confidence of consumers in radio-TV service shops.

Incidentally, the bonded program does not cost the dealers a penny—the entire cost of the bond being paid by Raytheon.

The Raytheon bonded program was instituted because we believe the public has been misinformed about the majority of service dealers. We feel that anything that can be done to help

RADIO-ELECTRONICS

TWIN-TRAX* TAPE RECORDER



FIRST PRIZE

*Trade Mark Reg.

You, too, can own a Twin-Trax* Recorder, discriminatingly chosen for the greatest and most historic recording project of our time. As a Twin-Trax* owner, you'll be in good company—with thousands of government agencies, broadcast stations, schools, critical music lovers and others who have also made Twin-Trax* their "official and exclusive" recorder.

Official Magnetic Recorder of 1952 OLYMPICS

Selected in International Competition by the Olympic Purchasing Commission

Because of their quality, dependability and exceptional value, Twin-Trax* Recorders were selected exclusively by the Olympic Purchasing Commission for all on-the-scene recording and subsequent rebroadcasting of this year's Olympic Games by sportscasters and commentators of every nation.

Yes, engineers of Finland's Olympic Purchasing Commission circled the globe while visiting every manufacturer of tape recorders and testing their products, to select the tape recorder that would not only guarantee perfect recording, but give them maximum value for their money.

Write today for Catalog #5324, containing complete specifications and direct factory prices.

AMPLIFIER CORP. of AMERICA • 398-10 Broadway • New York 13, N.Y.

LOOK WHAT WE'LL PAY FOR THIS EQUIPMENT:

We Need	We'll Pay Up to:
ATC or T-47 type ART-13.....	\$250.00
BC-312 & BV-318	70.00
BU-221 & BU/ARN-7	45.00
TS-251	175.00
FL-30 or F-21/ARA-9 Audio Filters.....	6.00 ea.
Plus TS-147, TS-148, RTA-1B, MG-149 or parts.	

What have you?
V & H RADIO & ELECTRONICS SUPPLY CO.
 2033 W. Venice Blvd., Los Angeles 6, Calif.
 Telephone: REpublic 3-1127

STAN-BURN S-P-A-R-K-E

* ANTENNAE SPECIALS *

* CIRCLE X Limited quantities	\$2.98 each	1-11 12 or more
* DOUBLE V 3/4"	\$2.98	\$2.20
* DOUBLE V 1/2" Dowel	3.95	2.95
* 10 Element Conical 3/4"	3.55	2.55
* Folded Hi Straight Low Quick Rig 1/2" elements	4.25	3.25
* WINDOW CONICALS	4.95	3.75
* 5 FOOT SWEGGED79	.69
* 10 FOOT PLAIN	1.39	1.29
TV WIRE		
* 55 Mil. 300 OHM	\$14.95	M Ft.
* 72 OHM COAXIAL	45.00	M Ft.

* CATHODE RAY TUBE SPECIALS *

* 10BP4 Zetka	\$14.95	17BP4A Federal	\$23.00
* 10BP4 N.U.	19.95	17BP4A DuMont	28.00
* 10BP4A N.U.	19.95	19AP4 Sheldon	29.95
* 12LP4 Zetka	18.95	19AP4A GE	39.95
* 12LP4A Thomas	19.95	19BP4A Thomas	39.95
* 16AP4 Zetka	26.00	20CP4A DuMont	41.00
* 16AP4A G.E.	38.00	20CP4A Sheldon	37.00
* 16DP4A Thomas	28.80	21EP4A DuMont	42.95
* 16GP4A Rauland	33.00	24AP4A Sheldon	63.00
* 16GP4A Zetka	26.00	24AP4A GE	76.00
* 16JP4A Thomas	28.80	Single ion traps35
* 16BP4A GE & NU	26.00	Double ion traps59
* 16TP4A DuMont	28.00		

* CHASSIS 830 REGAL with Cascade Tuner

* 211 T3 FLAT BACK (Similar to RCA)

* OPEN FACE CABINET

* TRANSFORMERS *

* RCA type for 16" to 24" X032

* G.E. Type for 16" to 24" X045

* These are very special prices while they last!

* DEFLECTION YOKES *

* Cosine Ferrite Todd Yoke 70"

* SPECIALS *

* 4 Prong Vibrators, each

* Lots of 12 or more

* Standard TV Tuners

* 12" Heavy Slug Speaker

* AUDIO DEVICES and TAPE IN STOCK *

* Audio Plastic Red Oxide Plastic tape—

* Hair hour spool

* One hour spool

* WIRE RECORDERS IN STOCK *

* Model 9T3C—2 speed Tape Recorder

* NET

* Model RC2-HEF Amplifier

* Model RC10—AM-FM Tuner

* Model C5—Williamson Amplifier

* WILCOX GAY—Model 2A10

* CASCODE Guaranteed Tuners (with tubes) Special, while they last

* AUTHORIZED DISTRIBUTORS for: General Electric, Kenrad, Tung-Sol, National Union, Jewel, De Wald, Regal, Automatic and Setchel Carlson.

* We carry a complete line of popular makes of radio and TV tubes, at 50% discount. Also many other special purpose and transmitting types, and all electronic parts and equipment at lowest prices.

* Send us a list of your requirements for prompt quotations.

* Terms: 20% with order, balance C.O.D. All prices FOB, New York Warehouse, Minimum order \$5.00

* Write for our latest price list to Dept. RE-6

STAN-BURN RADIO and ELECTRONICS CO.

(C.B.S. THEATRE BLDG.)
 1697 BROADWAY • NEW YORK 19, N.Y.



Transformer Catalog and TV Replacement Guide

Haldorson's new one-source catalog has the components you need, well classified for easy use.

This highly active line has been super-charged with 114 new items. Special attention is given to TV replacements. A self-contained guide section tells you where they are used.

Here's extra value, too. Haldorson prices actually have been reduced, but Haldorson quality is even better than ever.

Ask for a copy at your distributor, or write direct.

The HALLDORSON COMPANY
 4500 N. Ravenswood Ave, Dept E-6
 Chicago, 40, ILL.

Haldorson

QUALITY Transformers SINCE 1913

SOUNDTRONICS SPECIALS

- 3 SECTION SPIRAL INDUCTIVE TUNER Rance 52 to 218 MC
3 SECTION N 3.95
4 SECTION N 4.95

- TOP BRAND 557 CERAMIC TRIMMERS 15-65 mmfd. or 1.5 to 7 mmfd. 15c ea.
CENT. STYLE 823 AN TRIMMERS 20-125 mmfd. 34c

- TUBULAR TYPE TRIMMERS 5-5 mmfd. 9c

- TOP BRAND BUTTON MICA Type CB 500 mmfd. 9c type 5A 2000 mmfd. 14c

- MUTER CERAMIC CONDENSERS 15, 22, 33, 56, 75, 82, 180, 220 mmfd. 5c ea. \$4.50 per C.

- NEW STANDARD BRAND RESISTORS 1/2 W 2.5c 1 W 3.9c 2 W 4.9c No Min. Order Req. Quantity Discounts

- TOP BRAND .1 mfd. 1000 W. V. D. C. 6c ea. 5 for 25c

- HAIR FELT FOR SOUND WORK 12" x 24" x 1/2" 12c ea.

SPECIAL ASSORTMENTS

- 50 new pop. type 1/2, 1 & 2W code resistors Your Choice \$1.49 ea.
50 small pop. type ceramic cond. All voltages and cap.
50 postage stamp mica cond.

ARC-5 RECEIVER

IF strip—6.9 meg IF. Contains the following circuits: mixer, 1st IF amp, 2nd IF amp, det., AVC, squealch neut., 1st AF & Squealch amp, 2nd A.F. complete wired IF strip, less tubes & output trans. 2.49

Terms—25% w/order, balance C.O.D.

SOUNDTRONICS LABS.

632 Arch St., Phila. 6, Pa. MA-7-2775

!! CABINETS! CABINETS !!

Sturdy wood slide-rule dial oppig. Type "A" Ivory, Inside: 10 1/4 x 6 3/4 x 5 1/2" Dial: 13 3/4" \$1.49
Type "B" Mahog. Inside: 10 1/4 x 6 3/4 x 5 1/2" Dial: 11 1/2 x 10 1/4 2.49
Type "C" Mahog. Inside: 14 1/4 x 8 3/4 x 4 1/2" sq. Dial: 13 3/4 1.95
Type "D"—MIDGET CABINET & CLASSIS. Pol. room. Inside: 8 1/2 x 4 x 4 1/2. V. punched 4 min. dial chassis, wot. 1.49
Type "E"—Red marbled; by, milled plastic. 1.49
Includes on front. Inside: 8 1/2 x 5 3/4

Leotone HARDWARE TREAD URE FULL LB of No. Screws, Washers, Nuts, etc.—69c 3 lbs \$1.98

Radio-TV Builders Library... DRIFT Bar, Topoles... Rosette Screws... Experimental Tubes... Fil. tested kit of 40 assid. revg. tubes... Bakelite Panels... Ornamental Metal Grille... G.E. Plate Relay (CR2791-B109P36)... W-10B Field Wire... 6 Volt Hi-Frequency Buzzer... HARDWARE SPECIAL!!! MACHINE SCREWS!!!

BARGAIN ASSORTMENTS... RADIO PARTS KIT... WIRE SWITCHES, CONDENSERS, SOCKETS... 3" PM Socks... Speaker Cone Kit... Fidelity Crystal Mike... F-8147 High Imped. Loss case... FACTORY SPEAKER REPAIRS SINCE 1927!

LEOTONE RADIO CORP. 67 Day Street New York 7, N. Y. Please mention RADIO-ELECTRONICS when writing advertisers

correct this unfortunate situation is more than worth the effort.

Very truly yours, RAYTHEON MANUFACTURING COMPANY Receiving Tube Division E.I. Montague Sales Promotion Manager Newton, Mass.

A COMPUTER ENTHUSIAST

Dear Editor: I have read Edmund Berkeley's articles on computers and related subjects with great interest (Oct. '50—Oct. '51—Editor) I have constructed for my own edification and amaze ment a small digital computer which I call "Dadac".

It is capable of handling 10 binary digits and at present is able to add and subtract. It has over 80 relays, 30 rectifiers, and quite a few switches. A multiplying circuit is just about complete and will be able to handle two binary-digit numbers and retain a 20-digit answer.



First home-built electronic computer?

I am going to incorporate a teletype printer so that answers may be typed out directly in decimal notation. This has been one of the most interesting projects I have ever started and I hope you keep on giving us more interesting and informative articles on computers and Boolean algebra.

ROBERT C. DAY

Monrovia, California

CORRECTIONS

In the article "Using Blanking Time", on page 117 of the April issue, the last paragraph should be changed to read "The answer is .7835 seconds of picture per second."

The author, Mr. William C. Stoeker, and Mr. George P. Steiner, have called attention to an error in the article "A Practical Multitester", in the March issue. On page 45 the formula for the unknown resistance should read:

R = R_o / I - R_o

(where I is the meter current in milliamperes).

In "Put Those Crystals to Work", in the April issue, WWV's modulating frequencies should read "440 or 600 cycles". —end—

LIQUIDATION SALE

OUR TUBE STOCK IS TOO BIG WE MUST REDUCE INVENTORY AT ONCE, REGARDLESS OF COST

STANDARD BRAND TUBES (Manufacturers of these tubes refuse to permit mention of their names because tubes are far below FAIR TRADE.) Individually Boxed and Guaranteed

TYPICAL VALUES Nearly 300 types

39/44 29¢ 6AV6 59¢ 1B3 99¢

Table of tube types and prices including: 0Z4 .59, 1A3 .89, 1A5 .87, 1A6 .49, 1A7 .98, 1B3 .99, 1B4 .69, 1B5 .69, 1C6 .69, 1C7 .69, 1D5 .49, 1F4 .49, 1F5 .49, 1F6 .49, 1F7 .49, 1G4 .74, 1G6 .74, 1H4 .39, 1H5 .89, 1H6 .49, 1H7 .74, 1L4 .74, 1LC5 .12, 1LC6 .12, 1LD5 .12, 1LH4 .12, 1LN5 .12, 1N5 .87, 1R4 .74, 1R5 .82, 1S4 .74, 1S5 .79, 1T4 .83, 1U4 .69, 1U5 .78, 1V .75, 1V2 .69, 1X2A .94, 2A3 .49, 2A4 .84, 2A5 .84, 2A6 .49, 2A7 .49, 3A4 .89, 3A5 .49, 3B7 .69, 3D6 .69, 3Q4 .89, 3Q5 .99, 3S4 .83, 3V4 .89, 5Y4 1.73, 5U4 .63, 5V4 .99, 5W4 .83, 5X4 .89, 5Y3 .47, 5Y4 .89, 5Z3 .89, 6A3 1.59, 6A6 .91, 6A8 .86, 6A87 1.04, 6A87 1.12, 6AF6 .98, 6AG5 .79, 6AG7 1.51, 6AH6 1.29, 6AK5 1.49, 6AL5 .68, 6AQ5 .72, 6AQ6 .96, 6AQ7 1.29, 6AR5 .67, 6AS5 .86, 6AT6 .68, 6AU5 1.21, 6AU6 .76, 6AV6 .59, 6AX5 .99, 6B4 1.39, 6B7 .96, 6B8 .84, 6BA6 .69, 6BA7 .99, 6BC5 .86, 6BC7 1.17, 6BE6 .79, 6BF6 .86, 6BG6 1.76, 6BH6 .86, 6BJ6 .76, 6BK7 1.15, 6BN6 .99, 6BQ6 1.29, 6BQ7 1.15, 6C4 .69, 6C5 .69, 6C6 .79, 6C8 .96, 6CB6 .81, 6CD8 2.39, 6D4 2.69, 6D6 .89, 6D8 1.29, 6F5 .88, 6F6 .88, 6F8 1.39, 6G6 1.29, 6H6 .76, 6J5 .79, 6J7 .86, 6Z4 .84, 6K7 .84, 6L7 1.04, 6M7 1.19, 6N7 1.11, 6Q7 1.19, 6R7 .99, 6S7 .89, 6T7 1.04, 6U7 1.19, 6V7 .99, 6W7 .89, 6X7 .86, 6Y7 .89, 6Z7 .89, 6Z8 .89, 6Z9 1.59, 6Z10 .76, 6Z11 .65, 6Z12 .79, 6Z13 .65, 6Z14 .65, 6Z15 .65, 6Z16 .65, 6Z17 .65, 6Z18 .65, 6Z19 .65, 6Z20 .65, 6Z21 .65, 6Z22 .65, 6Z23 .65, 6Z24 .65, 6Z25 .65, 6Z26 .65, 6Z27 .65, 6Z28 .65, 6Z29 .65, 6Z30 .65, 6Z31 .65, 6Z32 .65, 6Z33 .65, 6Z34 .65, 6Z35 .65, 6Z36 .65, 6Z37 .65, 6Z38 .65, 6Z39 .65, 6Z40 .65, 6Z41 .65, 6Z42 .65, 6Z43 .65, 6Z44 .65, 6Z45 .65, 6Z46 .65, 6Z47 .65, 6Z48 .65, 6Z49 .65, 6Z50 .65, 6Z51 .65, 6Z52 .65, 6Z53 .65, 6Z54 .65, 6Z55 .65, 6Z56 .65, 6Z57 .65, 6Z58 .65, 6Z59 .65, 6Z60 .65, 6Z61 .65, 6Z62 .65, 6Z63 .65, 6Z64 .65, 6Z65 .65, 6Z66 .65, 6Z67 .65, 6Z68 .65, 6Z69 .65, 6Z70 .65, 6Z71 .65, 6Z72 .65, 6Z73 .65, 6Z74 .65, 6Z75 .65, 6Z76 .65, 6Z77 .65, 6Z78 .65, 6Z79 .65, 6Z80 .65, 6Z81 .65, 6Z82 .65, 6Z83 .65, 6Z84 .65, 6Z85 .65, 6Z86 .65, 6Z87 .65, 6Z88 .65, 6Z89 .65, 6Z90 .65, 6Z91 .65, 6Z92 .65, 6Z93 .65, 6Z94 .65, 6Z95 .65, 6Z96 .65, 6Z97 .65, 6Z98 .65, 6Z99 .65, 6Z100 .65

FREE—NEW CATALOG JUST OFF THE PRESS STEVE-EL ELECTRONICS CORP. 61 READE STREET NEW YORK 7, N. Y. Dept. E-6

COMPLETE TRAINING FOR BETTER RADIO-TV SERVICE JOBS



ONLY \$12

for the complete 2-volume course

3 MONTHS TO PAY

Let these two great new Ghirardi training books teach you to handle all types of AM, FM and TV service jobs by approved professional methods—and watch your efficiency and earnings soar!

Completely modern, profusely illustrated and written so you can easily understand every word, these books pave the way to fast, accurate service on any type of home radio-TV electronic equipment ever made. Each book is brand new. Each contains the latest data on the latest methods and equipment—NOT a re-hash of old-out-of-date material. Each is co-authored by A. A. Ghirardi whose famous RADIO PHYSICS COURSE and MODERN RADIO SERVICE were, for 20 years, more widely used for military, school and home study training than any other books of their type!

THE NEW Ghirardi RADIO-TV SERVICE LIBRARY

Almost 1500 pages and over 800 clear illustrations show step-by-step how to handle every phase of modern trouble-shooting and servicing.

1—Radio and Television Receiver TROUBLESHOOTING & REPAIR

A complete guide to profitable professional methods. For the novice, it is a comprehensive training course. For the experienced serviceman, it is a quick way to "brush up" on specific jobs, to develop improved techniques or to find fast answers to puzzling service problems. Includes invaluable "step-by-step" service charts. 820 pages, 117 illus., price \$6.75 separately.

2—Radio and Television Receiver CIRCUITRY AND OPERATION

This 660-page volume is the ideal guide for servicemen who realize it pays to know what really makes modern radio-TV receivers "tick" and why. Gives a complete understanding of basic circuits and circuit variations; how to recognize them at a glance; how to eliminate guesswork and useless testing. 417 illus. Price separately \$6.

If broken into lesson form and sent to you as a "course", you'd regard these two great books as a bargain at \$50 or more! Together, they form a complete modern servicing library to help you work faster and more profitably. Completely indexed so you can look up needed facts in a jiffy.

Under this new offer, you save 75¢ on the price of the two books—and have the privilege of paying in easy installments while you use them! No lessons to wait for.

New low price . . . easy terms 10-DAY EXAMINATION PRIVILEGE

Dept. RE-62, Rinehart Books, Inc., Technical Division, 232 Madison Ave., New York 16, N. Y.

Send me GHIRARDI'S NEW 2-VOL. SERVICE LIBRARY. I enclose \$3 as my first installment and will send you \$3 a month for three months until the total price of only \$12.00 plus a few cents postage is paid. It is understood I may read the books for 10 days. Then, if not satisfactory, I will return them postage paid and you agree to refund my \$3 and cancel the remaining installments. (Books shipped postpaid if full remittance accompanies order. Same return privilege.)

Name _____

Address _____

City, Zone, State _____

Employer's Name & Address _____

OUTSIDE U.S.A.—\$13.00 cash only. Same 10-day return privilege with money refunded.

RADIO SCHOOL DIRECTORY

Unlimited Opportunities in RADIO ENGINEERING

DEGREE IN 27 MONTHS

Complete Radio Engineering course including Telev., U. H. F. and F. M. Bachelor of Science Degree also in Mech., Civil, Elect., Chem., and Aero. Eng.; Bus. Adm., Acct. Extensive campus, modern buildings, well equipped labs. Low cost. Prep courses. Personalized, practical instruction. Founded 1884. Placement service. Growing shortage of engineers. Prepare now for unlimited opportunities ahead. Enter September, January, March, June. Write for catalog



TRI-STATE COLLEGE

2462 College Ave. ANGOLA, IND.

ATTENTION...

A NEW department of the DON MARTIN SCHOOL OF RADIO AND TELEVISION ARTS AND SCIENCES . . . for instruction and training in—TELEVISION—incorporating:

Production: Writing, Directing, Producing, Acting, Staging, Lighting.

Engineering: Transmission, Receiving, Camera and Studio, Operation, Theory of Video, Pickup and Reproduction.

Approved for veterans.

THE DON MARTIN SCHOOL OF RADIO AND TELEVISION ARTS AND SCIENCES

1655 No. Cherokee, Hollywood 28, Calif. HU. 23281.

LEARN TELEVISION

ELECTRONICS and RADIO
Engineering Laboratory and Classroom Training. Day and Evening Classes.
Write for illustrated Catalog

ELECTRONICS INSTITUTE, Inc.

21 HENRY, DETROIT 1, MICH.

TELEVISION-RADIO ELECTRONICS

Training in all branches television, radio and electronics. FCC exam. preparation. Write for free catalog.

COMMERCIAL RADIO INSTITUTE

(Founded 1920)

38 W. Biddle St., Baltimore 1, Md.
Approved by Maryland State Board of Education

RADIO and TELEVISION ELECTRONICS

in all Technical Phases
New Classes (Day & Evening)
Start 1st of Dec., Mar., June, Sept.
FREE PLACEMENT SERVICE for GRADUATES
For Free Catalog write Dept. RC-52

RCA INSTITUTES, INC.
A Service of Radio Corporation of America
350 West 4th St., New York 14, N. Y.

RADIO ENGINEERING IN 27 MONTHS DEGREE IN 27 MONTHS

Intensive, specialized course including strong basis in mathematics and electrical engineering, advanced radio theory and design, television. Modern lab. Low tuition. Self-help opportunities. Also B.S. degree in 27 months in Aeronautical, Chemical, Civil, Electrical, and Mechanical Engineering. G. I. Gov't approved. Enter September, December, March, June. Catalog

INDIANA TECHNICAL COLLEGE

156 E. Washington Blvd., Fort Wayne 2, Indiana

AUTOMATIC M-90 AUTO RADIO



- Six Tube Superheterodyne • Three Gang Condenser • Powerful, Long-Distance Reception • Fits All Cars, Easy Installation
 - Mounting Brackets Included
 - 6 Tube model M90 *\$34.97
 - 5 Tube Model A-15..... \$28.76
- *Above price includes Federal Excise Tax

Approx. shipping weight either radio (11) eleven pounds

MAIL US YOUR ORDERS

All orders filled within 24 hours.
Standard Brand tubes 50% off list

Bill Sutton's Wholesale Electronics
Fifth at Commerce Fort Worth, Texas

LOVE THAT QUICK-WEDGE!
I use it instead of a conventional screwdriver!

Quick-Wedge **SCREW-HOLDING SCREWDRIVER**
unconditionally guaranteed

ASK FOR IT AT YOUR DEALER
KEDMAN CO. • 233 S. 5th WEST • SALT LAKE CITY, UTAH

MUSICAL ENGINEERING, by Harry F. Olson. Published by McGraw-Hill Book Co., New York, N. Y. 6 x 9 inches, 369 pages. Price \$6.50.

It is unfortunate that many sound technicians, home recordists, and hi-fi enthusiasts know so little of the theory of music. Understanding music could add to the enjoyment of those who listen and could improve the technical results of those who record, pick up, or amplify music. This is one of the truly rare books on the subject which teach it clearly and completely. It is written for engineers, musicians, and music lovers. No previous knowledge of music, mathematics or engineering is required.

There are nine chapters. The first three show the nature of sound, music theory, scales, chords, and terminology. The next three deal with characteristics of vibrating systems and resonators. They give interesting descriptions of various stringed, percussion, and wind musical instruments. The last three chapters describe the properties of music and sound-reproducing systems. Human hearing and vocal mechanisms are illustrated. Loudness, volume, and timbre are explained. Diagrams and charts show optimum placement of musicians and audience for recording and broadcasting music. Acoustics is discussed at length. Microphones, speakers, sound-film, tape, discs, and hearing aids are treated briefly.—*IQ*

WHY YOU SHOULD NOT TRY TO FIX YOUR OWN TV, by John D. Burke. Published by the John D. Burke Co., 88-14 168th St., Jamaica 32, N. Y. 5½ x 9 inches, 44 pages. Price 50c.

Latest of the fifty-cent books says "Don't Do It!" More than one TV technician, reading the fix-it books, has seen places where the owner would get in wrong if he attempted to put the instructions in practice. Burke points these out in capital letters. Some chapter heads are: "Very Few Bad Tubes Are Cold; No Kidding, You Could Get Killed; Why Be Ignorant?; You Can Easily RUIN Your Picture Tube; Some Examples of Amateur Tinkering."

The book is written in the individualistic and racy style of the author's articles in this magazine ("Don't Touch Those Screws!; Formula for TV Success"). It would be an excellent text for every TV owner—if he could be persuaded to read it.—*FS*

ALL ABOUT TELEVISION, by John Derby. Published by Popular Mechanics Press, Chicago, Illinois. 6 x 9½ inches, 171 pages. Price \$3.00

This book is written especially for the person who knows little or nothing about television. It describes how TV works and gives hints for making it work when it doesn't. It tells how to choose a set, erect an antenna, adjust focus and the ion trap, replace tubes, and make other simple repairs. Jobs of this type are within the capabilities of many careful laymen who have had no experience with electronics.

JUNE, 1952

Practical, Popular-priced Books on
RADIO•AUDIO•SERVICING

At last—a practical book on basic radio principles!

BASIC RADIO COURSE—No. 44. By John T. Frye. 176 Pages, 120 illustrations. Durable hard cloth cover. \$2.25.

RADIO-ELECTRONICS' popular technician-writer, John T. Frye, takes the mystery away from learning theory! A 25-year veteran technician himself, he talks your language when he tells you just why resistors, capacitors, tubes and other components act as they do in a radio. His style makes each of the 26 chapters as easy to read as a novel. But when you've finished, you realize he's made every basic rule stand out clearer than you ever thought possible. Covers theory from Ohm's Law to advanced servicing techniques. Order your copy today!

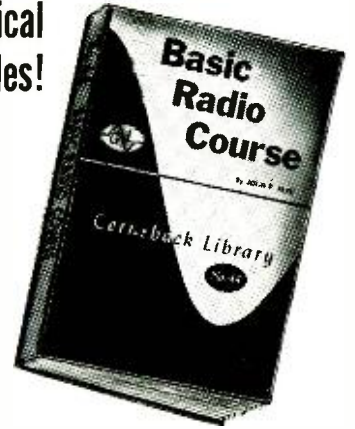

TWO TOP-FLIGHT \$1.00 BOOKS



MODEL CONTROL BY RADIO—No. 43. By Edward L. Safford, Jr., 112 pages. An authority in the field of radio control gives you the first complete book on the subject. For beginner and expert. Tells you what radio control is, how it works and how to construct not only component parts but a complete system as well. Illustrations explain each step.

HIGH-FIDELITY TECHNIQUES—No. 42. By James R. Langham, 112 pages. You've never seen a technical book like it! Just as he'd talk to you across the work bench, RADIO-ELECTRONICS' popular audio writer tells you how to design your own equipment and how to get top performance from it. Takes the double talk out of high-fidelity work.

THREE IMPORTANT 75¢ BOOKS

PUBLIC-ADDRESS GUIDE—No. 41. 80 pages. This handy book shows the service technician the way to extra income in big-paying PA work. Covers installation, maintenance and construction.

THE CATHODE-RAY OSCILLOSCOPE—No. 40. 112 pages. A "must" for servicing TV, FM and AM receivers and in amateur operation! Tells in simple, but technically sound language, how the scope works and how to use it.

PRACTICAL DISC RECORDING—No. 39. 96 pages. Tells you how to make good disc recordings. Covers every phase, theory as well as technique. A full chapter is devoted to each component.



5 POPULAR 64-PAGE BOOKS — 50¢ EACH

HANDY KINKS AND SHORT CUTS—No. 29. A treasury of time savers! Antennas, power supplies, test equipment, phonographs, amplifiers. Easy reference, illustrated.

UNUSUAL PATENTED CIRCUITS—No. 30. A gold mine of important hook-ups. Control circuits, detectors, amplifiers, power supplies, foreign circuits.

RADIO QUESTIONS & ANSWERS—No. 31. Answers the tough ones on circuit diagrams,

amplifiers, receivers, transmitters, meters and test equipment.

ADVANCED SERVICE TECHNIQUE—No. 32. A "must" for the advanced service technician! Covers specialized problems of servicing not usually found in ordinary textbooks.

AMPLIFIER BUILDER'S GUIDE—No. 33. For the designer and builder of audio equipment. Covers a variety of amplifiers with power outputs from 8 to 30 watts.

THE GERNSBACK LIBRARY

SEE YOUR DISTRIBUTOR OR MAIL THIS COUPON TODAY

RADCRAFT PUBLICATIONS, INC. Enclosed is \$..... for which please send 25 West Broadway, New York 7, N. Y. me postpaid, the books checked below.

- 29 30 31 32 33
 39 40 41 42 43 44

Name.....

Street.....

City..... Zone..... State.....

TAB That's A Buy!

STORAGE BATTERIES

36 Volt WILLARD Mini-BRAND. New! 5 oz. Designed For portable Equip. Models: 53084-10-12 \$98.40
 6 Volt 40AH WILLARD ER40-G \$6.98
 2V 20AH Willard Plus Vibrator..... 2.39
 6V 6AH Willard N70-BR214..... 1.98
 Battery Acid. (REPAIR KIT) \$9c; 3 lbs. 93c
 Hydrometer 1.06 to 1.24 Sp. Grav. 1.98

END EQUIPMENT BUYS

1-108 Range Calibrator, Metal Case..... 29.98
 1-198 Sig. Gen. Good Cond. Less Tubes..... 14.95
 SC8595 HF, Gen. Good Cond. Less Tubes..... 3.98
 BC906 Freq. Mtr. Excellent Cond. Less Tubes..... 29.95
 1-122A Sig. Gen. 115V 50 CY..... 149.50
 BC221 Sig. Gen. Exc. Cond..... 125.00
 SC8524 1-Css/XTals Tubes..... 69.95

BLOWERS

40 CFM 28 vacd. \$5.98 250 CFM 28 vacd. \$9.95
 250 CFM with 28 to 115 vac Trans. 11.95
 175 CFM 220 vac. 11.98 40 CFM 24 vac Bl. 1000 6.90
 70 CFM 115V 400 Cycle..... 6.95

SELENIUM RECTIFIERS

Current (Cont.)	18 14 volts	26 18 volts	36 28 volts	130 100 volts
1 amp	2.20		2.10	10.50
2 amps			3.50	13.00
2.5 amps				
4 amps	3.75		6.75	25.00
5 amps			7.95	
10 amps	6.75	9.98	12.00	45.00
12 amps	8.50	16.20	16.00	52.50
20 amps	13.25			
24 amps	16.25			
30 amps	18.50	24.30	31.00	
40 amps	25.50		45.00	

CT Rectifiers 100 amp 100-10V \$44.95
 80 Amp 100-18V \$29.95 No Amp. 300-30V \$53.95
 Full Wave Selen Rect. & Trans. with Ageing Tabs. in Kit form. All 115V 60cy inputs.
 up to 16VDC at 12 amps..... \$23.98
 up to 28VDC at 12 amps..... 31.98
 up to 28VDC at 48 amps..... 149.50
 up to *20VDC at 6 amps..... 12.98

RECTIFIER TRANSFORMERS

18.8-10.2-20.4-21.4 volts/12 amp 2kVins \$14.98
 31-32-31-36 volts/12 amp 2kVins..... 16.49
 18-12-9-CT-9-12-18 volts/12 amp..... 16.75
 18-12-9-CT-9-12-18 volts/12 amp..... 16.75
 18-12-9-CT-9-12-18 volts/24 amp..... \$35.75

INFRA-RED SNOOPSCOPE

Image-Converter Tube Hi-Sensitivity simplified design 2" dia. Wilhelmite screen Resolution up to 350 lines/in. Complete data & tube, each..... \$49.98; 2 for \$94.49

ELECTROLYTIC CONDENSERS SPECIALS!

50 mf/350Vdc FP..... 3 for 98c
 30-15-10mf/250Vdc..... 3 for 98c
 40-20mf/250-25Vdc..... 2 for 98c
 40-2x20mf/50-25Vdc FP..... 3 for 98c
 10-2X 20mf/40-25Vdc..... 3 for 98c
 4mf/450Vdc "Type-Dry"..... 2 for 98c
 6000mf/15vac. 3P2C1AL..... \$1.98

SOUND-POWERED PHONES

NAVY MIKE Push to Talk \$1.25
 Complete Navy Unit—Cushioned Head-sets. Chest Box, Mike, Cable & Wpf Plug. Adjustable Units. Tested. Used. Each Unit \$5.49. Pair \$9.98
 RCA Head & Chest Set. Sound Pwr. no Batteries Needed. Ideal for TV. Antenna Installation. New..... \$15.95
 P-20 Hevers w/Band & Cord. 24K ohms..... \$4.98
 HS-15, 2 Hevers/Cord w/PL54 loss HL Band..... 96c

UHF ANTENNA

TV CONICAL ANTENNA. Sturdy. Prefab Const. Versatile. 72, 150 or 300 ohm Match. Incl. 8 elements & 100 ft. Copper Twine Cross Bar & Hardware..... \$8.49
DOUBLE STACKED Conical array. 16 elements. ALL HARDWARE, 2 Cross bars, 100 ft. Twine..... \$12.98
 ANT AN130B, 33' Whip..... \$1.98
 ANT AN131A, 11 ft. 8 sect..... \$3.98

NEW TV COMPONENTS

CRP3 Vert. Integrator Netwk. 3 Res./3Cndrs. only 3 connection. 29c
 Disc Ceramic Dual .004mf/600V 6 for \$1.00
 H/V Horiz & Defl. Output Transformers Sim RCA 211T. \$1.98
 ERLE HV Cond. 5000mf/15KV..... 7.45
 JEFFERS Cond. 300mf/20KV..... 84c
 ION Trap Permalloy Type..... 79c
 TWINE TV 300ohm Line 100 ft. \$2.49; 1000 ft. \$19.95
WE STOCK TV TUBES. COMPLETE YOUR INVENTORY AT GREAT SAVINGS TELL US YOUR NEEDS. WE WILL QUOTE "TAB" LOW PRICES.

TRANSFORMERS 115V 60CY INPUT

2500V 4 CRT 6.3V/.6A 2.5V/1.75A \$7.98
 1320V 4 3.75VCT 110MA 5V/3A 8.4V
 3-25A 6.3V/2.75A H810 HVins. \$9.98
 1000VCT 45MA 7.95VCT 80MA & 360Vct/55MA 3x5V/3A 6.3VCT 1A 6.3Vct/3A Csd HVins Can be used 2X Rating. (after theon Hpersil core)..... \$4.98
 1000VCT 200MA 18V .55A 6.3V/3.5A 5V/6A \$6.98
 900V/35MA 2x2.5V/2A Xelent 1800V dblr two 2x2 Fil. wdgds H810 HVins..... \$3.49
 750VCT 200MA 6.3V/3A 5V/4A..... \$5.95
 800VCT 400MA Tapped 350VCT 6.3V/3A 2.5V/3A Isolation Wdg 115V/450MA..... \$3.25
 700VCT 120MA 2x6.3V/3A 6.3V/1A..... \$2.98
 500VCT 60MA 6.3V/4A H810..... \$2.98
 450VCT 200MA 6.3V/3A 5V/3A..... \$3.95

FILAMENT TRANSFORMERS

6.3VCT 1A \$1.98; 6.3VCT .6A \$1.98
 2.5V 2 AMP .79; 7.5VCT 12A 15Kvins. \$10.98
 24V 1.25A \$1.98; 2.5VCT 5A \$1.98
 2.5VCT 10A \$1.98; 3.5V; 2X12V 2A \$3.89
 5V 2A 6.3V 3A \$2.25; 6V 6AMP \$2.95

SELENIUM POWER SUPPLY

0 to 12VDC/2 Amp Variable DC supply. Increased and completely built-inmp. 115V 60 cy. Complete LAB supply. Filament DC. Rating. Heavy charging, motor railroad, includes voltage or speed control and center of reversing sw. Ideal for two "HO" locomotives. "TAB" Special \$10.95 2 for \$20.00

SELL US YOUR TUBES AND EQUIPMENT WE STOCK LARGE VARIETY OF COMPONENTS TELL US YOUR NEEDS

SOLDERING IRON GUN

SENSATIONAL VALUE. Lightweight. Sensational value. Lifetime alloy tip—will not corrode. Tip is flat. "TAB" Special..... \$7.49 2 for \$14.49

WRITE FOR TABFORM

Prices Subject to Change. Dept. 6RE, 6 Church Street New York 6, N. Y., U. S. A. Cor. Church & Liberty Sts. Room 200, Phone Rector 2-6245



ADVERTISING INDEX

Adelman, Nat	80
Allied Radio Corp.	113
Almo Radio Co.	113
American Phenolic Corp.	68
Amperite Company, Inc.	193
Amplifier Corporation of America	73, 108
Arkay Radio Kits, Inc.	70
Astron Corporation	102
Aude Publishers	93
Barry Electronics Corp.	112
Bell Telephone Labs.	22
Bendix Radio Division	103
Blondier-Tongue Labs.	83
Bradley Associates	97
Brook Electronics, Inc.	97
Brooks Radio & Television Corp.	101
Burke, John D.	100
Candler System Co.	82
Capitol Radio Engineering Institute	7
Channel Master Corp.	91
Clarasat Manufacturing Co., Inc.	91
Cleveland Institute of Radio Electronics	11
Communications Equipment Co.	100
Cornell-Dubilier Electric Corp.	70, 64
Cornish Wire Co., Inc.	72, 104
Coyne Electrical & TV Radio School	90
Crest Labs., Inc.	106
Davis Electronics	9
DeForest's Training, Inc.	9
Delco Radio	59
Electronics Beam Corp.	113
Electronic Instrument Co., Inc.	24
Electronic Measurements Corp.	107
Federal Telephone & Radio Corp.	20
Feiler Engineering Co.	100, 103
G & G Radio	103
General Industries Co.	76
General Test Equipment	73
Gonset Company	69
Greylock Electronic Supply Co.	107
Halderson Company	108
Heath Company	84, 85, 86, 87, 88, 89, 93
Hickok Electrical Instrument Co.	58
Hytron Radio & Electronics Corp.	15
Indiana Technical College	107
Instrulograph Company	77
International Resistance Co.	74, 75
Jackson Electrical Instrument Co.	60
Jones & Laughlin Steel Corp.	17
Kay-Townes Antenna Co.	104
Kedman Company	110
Klein Industries Corp., Manuel	79
La Pointe Plascomold Corp.	20
Leetone Radio Corp.	109
Macmillan Company	78
Mallory & Co., Inc., P. R.	Inside Back Cover
McGraw-Hill Book Co.	113
Merit Coil & Transformer Corp.	8
Merit Label Co.	73
Miles Reproducer Co., Inc.	103
Milwaukee School of Engineering	96
Mosley Electronics	99
Nassau Company	105
National Electronics of Cleveland	106
National Radio Institute	3
National Schools	5
New England Television Corp.	72
Oxford Electric Corp.	62
Opportunity Adlets	83
Perfection Electric Co.	82
Phico Corporation	14
Plastoid Corporation	21
Precision Apparatus Co., Inc.	64
Pres-Probe Co.	107
Progressive Electronics Co.	103
RCA Institutes, Inc.	19
RCA Victor Division (Radio Corporation of America)	Inside Front Cover, Back Cover, 12
Radelet Manufacturing Co.	83
Radiart Corporation	55, 102
Radio City Products	93
Radio Dealers Supply	66
Ray Manufacturing Co.	92
Raytheon Manufacturing Co.	6
Regency Div. (I.D.E.A., Inc.)	82
Relay Sales	114
Rider, John F. Publisher, Inc.	95
Rinehart Books, Inc.	102, 110
Rose Company	109
Sammik Co., Inc., Howard W.	18, 100
Sangamo Electric Co.	23
Sannett, Bob	71
Schott Company, Walter L.	105
Simpson Electric Co.	69, 77, 99, 101
Soundtronics Labs., Inc.	103
Sarasberry Academy of Radio	53
Stan-Burn Radio & Electronics Corp.	108
Steve-EI Electronics Corp.	109
Sun Radio of Washington, D. C.	97
Superior Instruments Co.	57
Sutton's Wholesale Electronics, Bill	110
Sylvania Electric Products	112
Tab	112
Tallen Company, Inc.	106
Tech-Master Products	90
Technological Developments	70
Tel-A-Ray Enterprises, Inc.	80
Telematic Industries, Inc.	80
Telephone Engineering Co.	70
Telesound Corporation	67
Transvision, Inc.	80, 81
Triad Transformer Mfg. Co.	92
Trio Manufacturing Co.	61
V&H Radio Electronics Supply Co.	108
Vee-D-X	9
Weller Electric Corp.	10
Wholesale Radio Parts Co., Inc.	102
Z-Lab Company	71

Radio-Electronics does not assume responsibility for any errors appearing in above index.

SELENIUM RECTIFIERS

Full-Wave Bridge Types
 All our Rectifiers are new & Guaranteed one year. We manufacture special types of rectifiers and rectifier supplies to your specs. **FAST DELIVERY AND LOW PRICES** on Small and Large Quantities. We stock over 100,000 Selenium Plates for overnight rectifier service. **Write—Phone—Wire!**

Current (Continuous)	18 14 Volts	26 18 Volts	36 28 Volts	54 42 Volts	130 100 Volts
1 Amp.			\$2.10		\$8.95
2 Amps.	2.20		3.60	6.50	10.50
2 1/2 Amps.					13.00
4 Amps.	3.75		6.75	8.75	32.00
5 Amps.			8.00	13.00	45.00
10 Amps.	6.75		12.00	20.00	52.50
12 Amps.	8.50		16.00	36.00	90.00
20 Amps.	13.25		24.00	39.50	98.00
24 Amps.	16.00		31.00		
30 Amps.	18.50		45.00		
36 Amps.	25.50				

New, Selenium Rectifier Transformers
 PRI. 115 V. 60 cycles In 4 Amps..... \$ 8.75
 SEC. 0 12 18 24 and 30 1 1/2 Amps..... 18.75
 * Made to our specs for continuous heavy duty use.
 • 115V. PRI-36V. 50 amp second XFMR \$39.95
 • 115V. PRI-5V. @ 190 Amp. SEC. \$59.95
 • 115 230 V. 60 cy. PRI. SEC. 1.5. 30.5. 33.5. and 36.5V @ 4 AMPS. Herm. Sealed @ \$7.95.

NEW! Exclusive with Barry. UNIVERSAL RECTIFIER

The new Directron Universal Selenium Rectifier for the first time permits a single stack to work in a variety of voltages as a half-wave rectifier, full-wave center-tap, or full-wave bridge rectifier merely by proper connections to the contacts. These rectifiers are a must for labs and occasional users of Selenium Rectifiers. Full book-up information. Designed for AC input voltages up to 20 volts RMS. Order in the following sizes:
 2 Amps..... \$3.75
 5 Amps..... 7.50
 10 Amis..... 12.15
 12 Amps..... 14.25

New Listing Every Month TUBES

Standard R.M.A. Warranty. We endeavor to give you low, low prices, consistent with quality merchandise and service.
 Here is only a partial listing of our large stocks. You may order popular types not listed at approx. same savings.

0A2	98 6BC565 12H675
0B2	1.10 6BD686 12AT785
0Z460 6BE650 12AU759
1A7GT	1.00 6BG6-G	1.20 12AV655
1B3GT83 6BH680 12BA670
1AE4	1.10 6BK7	1.40 12BA790
1L467 6BL7-GT	1.35 12BD6	1.25
1N2178 6BY-5	1.10 12BE670
1N21-B	3.45 6C465 12C675
1N23	1.35 6CB685 12D570
1N23-A	2.45 6CD6-G	1.75 12D685
1N23-B	3.95 6E6-M95 12SH797
1N3464 6F798 12SJ775
1N34-A88 6F8-G98 12SK775
1N5489 6G6-G95 12TL775
1R585 6J5-GT55 12V687
1V465 6J659 12X775
1X2A90 6J795 12SR7-M75
2B775 6K6-GT79 25A5	1.25
2E24	3.95 6K7-M70 25B06-GT98
2E26	3.19 6L6	1.75 25L6-GT65
2E30	2.19 6L798 25Z680
3A485 6R880 35B540
3D6 129950 6S7-M98 35C540
3Q455 6SA770 35L675
3Q5 GT-G	1.00 6SCT7	1.35 35Z5-GT55
35490 6SD795 50C550
5FP7	1.85 6SF786 50L6-GT55
5V4G59 6SF585 8060
5V4G	1.05 6SG768 21169
5X4G85 6SH770 304-TL	8.50
5Y3GT49 6SJ7-GT75 304-TH	8.50
5Z375 6SJ7-M80 717-A98
6AB475 6SK7-GT65 807	1.59
6AB798 6SL7-GT70 GE872-A	3.50
6AC798 6SN7-GT65 12B0	3.95
6AG570 6T895 160374
6AG7	1.50 6U4-GT60 1616	1.40
6AH6	1.50 6V6-GT60 1624	1.40
6AJ5	1.65 6W4-GT60 1625	1.40
6AK570 6X445 162640
6AK6	1.20 6X5-GT45 162930
6AL555 6Y6-GT95 163175
6AN5	2.75 7A675 2050	1.47
6AP670 7A875 5608-A	3.95
6AR575 7C595 5654	2.50
6AT670 7C795 591075
6AU655 7H780 9001	1.35
6AV655 12A665 900439
6BB65 12C885 900639



136 Liberty Street, N.Y. 6, N.Y. Rector 2-2563
 Terms: 25% with order, balance C.O.D.—Send a few cents for postage—All merchandise guaranteed. F.O.B. N.Y.C. *Please, min. order \$2!

NOW! BECOME EXPERT AT RADIO-TELEVISION IN 4 EASY STEPS!



Complete Self-Training Course in RADIO and TV by Famous Experts—Takes You BY SIMPLE STEPS From Basic Theory to Problems of Repair, Installation, Color TV, etc.

NOW you can do ANY Radio-TV installation, service, or repair job like an expert; operate field-testing equipment; understand problems of TV, FM-AM transmission, etc. Step into a good-paying job—or start your own service business. Train yourself AT HOME . . . IN SPARE TIME . . . with the McGraw-Hill Basic Course in Radio and TV.

2296 Pages—1611 Illustrations

The men who wrote this complete 4-volume course are among the outstanding radio and TV instructors in America today. Every detail is clearly explained in over TWO THOUSAND PAGES of step-by-step instruction and over SIXTEEN HUNDRED "how-to-do-it" illustrations, cross-section diagrams, etc. The review questions and answers "nail down" everything you learn. At-a-glance "trouble-shooting" charts show how to diagnose instantly any radio or TV breakdown . . . and how to repair it expertly and quickly.

The course will pay for itself many times over. It can qualify a beginner for FCC's 1st-Class License test; gives an experienced technician more confidence and skill.

SEND NO MONEY

Mail coupon below to examine complete four-volume course FREE for 10 days. No obligation. Or you may examine individual books FREE for 10 days by checking the proper boxes in coupon.

PARTIAL CONTENTS

ESSENTIALS OF RADIO.
800 pages, 433 illus.
Circuit Analysis • Vacuum Tubes • Circuits • Detector • Amplifier • Tube Oscillator • Power Supply • Transmitting, Receiving • etc.

ELEMENTS OF RADIO SERVICING.
475 pages, 375 illus.
Multimeters • AC Power Supply • Speakers • Antennas • Auto Radios • Push-Pull Output Stage

BASIC TELEVISION.
592 pages, 415 illus.
Scanning • Synchronization • Video Signal • Brightness Control • DC Reinsertion • Picture • FM Alignment • Picture Tubes • VHF and UHF transmission • Reception

TELEVISION SERVICING.
429 pages, 388 illus.
Antennas • Transmission Lines • Test-pattern and Picture Analysis • Localizing Reception Troubles • Interference Remedies • Deflection Circuits . . . AND MUCH MORE!

FREE 10-DAY TRIAL COUPON

McGRAW-HILL BOOK CO., Inc., Dept. RE-6-52
327 West 41st St., New York 18, N. Y.

Send me for 10 day free examination the Basic Course in Radio and TV, 4 Vols. (Regular retail price is \$26.00; Special Course Price only \$21.95 in easy installments.) If not satisfied with Course, I will return it, pay nothing. Otherwise, I'll send \$1.95 plus delivery then and only \$4.00 in monthly installments.

If you wish to examine any of these books individually, check below the ones you wish us to send you for 10 Days' FREE EXAMINATION:

Essentials of Radio, \$6.75
 Elements of Radio Servicing, \$5.25
 Basic Television, \$7.50
 Television Servicing, \$6.50

For any book I keep, I'll send \$2.00 plus delivery in 10 days, balance in easy monthly installments.

Name

Address

City

Zone

State

Position

Company

WE PAY FOR DELIVERY if you send first payment of \$1.95 when ordering Course or full price when ordering individual books (prices above). Same return privilege.

There is also information on more delicate, complicated (and even dangerous) repairs such as tuning the oscillator, removing the kinescope and replacing high-voltage components.

Theory is given from a very elementary and popular viewpoint. It covers transmitters as well as receivers, projection and color TV.

TV TERMS SIMPLY EXPLAINED, by H. G. Cisin, 200 Clinton St., Brooklyn 2, N. Y. 8½ x 10½ inches, 24 pages. Price \$1.00.

An elementary compilation of TV terms and their meanings, including definitions of terms used in TV transmission as well as reception.

Also shown are various defective picture patterns and the descriptive term which applies to each of them. Probable circuit defects are listed with the faulty patterns. Some of the defects are not too completely captioned; the circuit troubles to which they are attributed might easily cause other effects which are not shown.

INTRODUCTION TO ELECTRONIC CIRCUITS, by R. Feinberg. Published by Longmans, Green & Co., New York, N. Y. 5½ x 8½ inches, 163 pages. Price \$3.50.

This is a fairly rigorous textbook based on a course for students at University of Manchester (England). It is concise and clear, but requires mathematical skill. Equations, curves, and diagrams appear frequently. Each chapter gives numerical problems (with answers) and lists experiments for the reader.

The first two chapters are titled "Thermionic Vacuum Tubes." They describe the construction and use of tubes, including magnetron and cathode-ray types. Special type tubes are discussed in the last two chapters. These include phototubes, mercury-pool, and cold cathode tubes. The last four chapters discuss amplification, tube nonlinearity, and oscillators.—IQ

TELEVISION SERVICING, by Matthew Mandl. Published by The Macmillan Co., New York, N. Y. 6 x 9 inches, 421 pages. Price \$5.50.

This volume teaches modern circuit theory and indicates practical methods for trouble-shooting. A separate chapter describes each basic section of a receiver. Among them are sweeps, antennas, power supplies, mixers, sync circuits. More advanced material appears toward the end of the book. This includes projection TV, u.h.f., test equipment, and color TV.

Explanations are accompanied by simplified diagrams. The reader need not wade through a complicated diagram while the author tells the function of a certain tube or network. Waveforms are drawn at critical points so the reader may compare normal conditions with those he encounters. A very helpful and time-saving feature is the 12-page trouble index. It lists trouble symptoms and probable causes, together with the particular chapter and section which discusses the problem.

You will want to keep this book near your soldering iron, multimeter, and scope.—IQ —end—



Mfrs. of
PICTURE TUBES
and
Electronic Equipment

Sold only thru Radio Parts Jobbers

17" Rectangular C.R.T. net \$21.95
With Glass Allowance

20" Rectangular C.R.T. net \$29.95
With Glass Allowance
Prices include tax

EIGHTEEN MONTHS GUARANTEE!

**"EBCO" Dual-Purpose
CHECKER-REACTIVATOR**

for TV Picture Tubes

A Money Maker
For Servicemen:

Check picture tubes for shorts, cathode emission, leakage, etc., without removing tube from TV set. Also PUT NEW LIFE into weak tubes with the REACTIVATING power of this instrument. Lightweight, portable; 110V-60 cycles. Factory-guaranteed.



Model 10
net \$19.95

ASK YOUR JOBBER.

Dynamic Analyzer

for TV Picture Tubes

NEW EBCO Dynamic Analyzer makes your Vacuum Tube Voltmeter the finest CRT Tester. It's the ONLY instrument that performs all vital dynamic tests: checks all socket voltages; checks emission of tube; gives related emission; checks open elements, shorted elements, leakage. It's your FREE Service Engineer's Manual for CRT Testing, with each instrument.

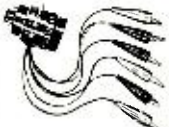

\$7.95
Net

2-SET CONNECTORS

Two-set Connector for TV Net \$2.95
Four-set Conn., operates 3 or 4 sets from 1 antenna Net \$4.95

ASK YOUR JOBBER!

ELECTRONIC BEAM CORP.



923 Old Nepperhan Ave.
YONKERS, N. Y.
Phone: YOnkers 3-3514

3-SPEED CHANGER
By WEBSTER-CHICAGO



Now
22.95

Plays 10, 7, and 12 inch records at speeds of 33 1/3, 78, or 45 R. P. M. This fine Webster has special arm with a feather-light touch to give extra long record life. The pick-up arm comes to rest position after records have played. Plays standard as well as micro-grooves. This chassis normally lists at \$47.50. Write for yours—while they last.

10% Cash With Orders

ALMO RADIO CO.
509 ARCH ST. & 6205 MARKET ST.
Philadelphia, Pa.
6th & ORANGE STS. • Wilmington, Del.
4401 VENTNOR AVE. • Atlantic City, N. J.
1133 HADDON AVE. • Camden, N. J.

Over a Million RELAYS!

This list represents only a small part of more than a million relays in our stock — one of the world's largest. All relays are standard make, brand new in original packing, and fully guaranteed by Relay Sales. Send us your relay requirements. We can make immediate delivery at substantial savings in cost to you.

IMMEDIATE DELIVERY!

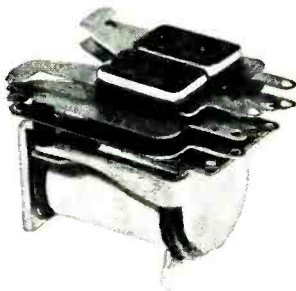
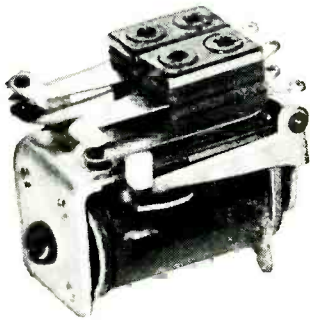
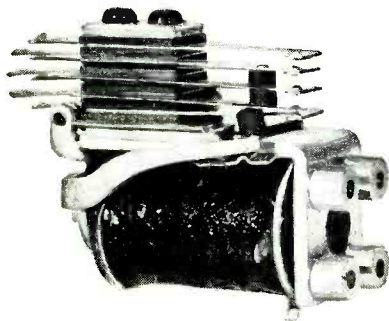

Midget Relays						
STK. NO.	VOLTAGE	OHMAGE	CONTACTS	MFG. & NO.	UNIT PRICE	
R-416	4 VDC.	9	1C @ 1.5 AMP.	ADVANCE 16035	\$1.65	
R-378	6 VDC.	100	1A @ 1.5 AMP.	ADVANCE 16015	1.50	
R-850	12 VDC.	450	1A @ 1.5 AMP.	ADVANCE 1601	1.50	
R-379	19/27 VDC.	250	2A @ 1.5 AMP.	ADVANCE 1605	1.65	
R-694	24 VDC.	300	1A @ 5 AMP.	ADVANCE 1601A	1.50	
R-935	28 VDC.	1000	1C @ 1.5 AMP.	ADVANCE 1603S	1.65	
R-572	24 VDC.	256	1C	AIRCRAFT RADIO CORP.	1.25	
R-857	24 VDC.	260	1 MAKE BEFORE MAKE	AIRCRAFT RADIO CORP. 9453	1.75	
R-912	4/5 VDC.	20	3A-1C CERAMIC	ALLIED TKX50	1.45	
R-291	6 VDC.	5	1A	ALLIED .73A71	1.25	
R-921	6.7 VDC.	18	1A Dbl. Brk. @ 10 amp.	ALLIED CRX-11	1.45	
R-738	12 VDC.	60	3A	ALLIED TX3A	1.20	
R-922	12 VDC.	75	1A Dbl. Brk. @ 10 amp.	ALLIED CRX-13	1.45	
R-144	12 VDC.	228	1A	ALLIED D-283486	1.45	
R-696	24 VDC.	230	1A @ 8 AMP.	ALLIED 55837	2.00	
R-145	18/24 VDC.	250	2A CERAMIC	ALLIED 7252	1.45	
R-723	24 VDC.	280	1C	ALLIED 7251	1.50	
R-298	21 VDC.	300	1A	ALLIED CB-5	1.25	
R-296	21 VDC.	300	1A	ALLIED CA-5	1.25	
R-586	21 VDC.	300	1A & 1C	ALLIED 73A-69	1.25	
R-142	24 VDC.	400	2C	ALLIED 73A50	1.50	
R-785	24 VDC.	200	2C @ 10 AMPS.	AUTO. ELECT. ZH-37169-1	2.00	
R-375	24 VDC.	200	2A heavy duty	AUTO. ELECT. H-87063-1	1.75	
R-373	12/20 VDC.	225	1A split	AUTO. ELECT. SQA	2.50	
R-370	12 VDC.	75	1C	AUTO. ELECT. MANKATO R-25	2.30	
R-607	24 VAC.	INT.	1A	AUTO. ELECT. MANKATO R-45-D	1.20	
R-606	24 VAC.	INT.	1A & 1B	AUTO. ELECT. MANKATO R-45-F	1.20	
R-605	24 VAC.	INT.	3A	AUTO. ELECT. MANKATO R-45-G	1.20	
R-374	24 VDC.	300	2A heavy duty	BETTS & BETTS RAC-15AS	1.75	
R-728	6 VDC.	30	1A	CLARE A-26690	1.25	
R-149	6/8 VDC.	45	1B	CLARE A-20545	1.50	
R-732	12 VDC.	120	1A	CLARE A-25454	1.45	
R-281	12 VDC.	126	2A	CLARE A-13415	1.25	
R-347	18/24 VDC.	300	1A	CLARE A-19469	1.10	
R-376	24 VDC.	300	1A	CLARE K	1.25	
R-818	18/24 VDC.	300	1B	CLARE A-8058	1.30	
R-133	24 VDC.	300	NONE	CLARE A-20388	.75	
R-348	18/24 VDC.	300	2A	CLARE A-16734	1.15	
R-138	24 VDC.	300	4A	CLARE A-16280	1.45	
R-349	18/24 VDC.	300	1C	CLARE B-16947	1.25	
R-377	24 VDC.	300	1C	CLARE B-22441	1.45	
R-132	24 VDC.	300	2C	CLARE	1.50	
R-731	24 VDC.	300	2C	CLARE A-16265	1.55	
R-492	24 VDC.	300	4C 1A	CLARE	1.95	
R-626	24 VDC.	400	1A @ 5 AMPS.	CLARE A-22717	1.55	
R-786	60 VDC.	1300	2C	CLARE A-12408	2.00	
R-415	60/85 VDC.	1800	2A	CLARE K	1.95	
R-371	2 VDC.	30	1C Ceramic	COOK 418	1.75	
R-755	24 VDC.	300	1A	COOK 55340	1.45	
R-150	6 VDC.	30	1A	E-Z ELECTRIC	1.50	
R-893	14 VDC.	150	1A, 1C	G. E. 55526	2.50	
R-895	14 VDC.	150	2A, 1B, 1C	G. E. 55531	2.50	
R-896	24 VDC.	260	2A	G. E. 55589	2.50	
R-959	24 VDC.	747	2C	GUARDIAN 36761	1.50	
R-693	2/6 VDC.	125	1C @ 3 AMP.	LEACH P-501424	1.20	
R-947	12/24 VDC.	320	1C @ 3 AMP.	LEACH P-3	1.25	
R-692	6/24 VDC.	1280	1C @ 3 AMP.	LEACH P-3	1.35	
R-856	18/24 VDC.	300	1B	PAUL HENRY 1010	1.45	
R-913	6 VDC.	20	3A, 1C CERAMIC	PRICE BROS.	1.45	
R-915	12 VDC.	70	1A Dbl. Brk. @ 10 amp.	PRICE BROS.	2.00	
R-148	12 VDC.	100	2C & 1B	PRICE BROS.	1.85	
R-222	12 VDC.	100	2A	POTT. & BRUM.	1.00	
R-834	6 VDC.	20	3A, 1C	RBM	1.45	

OTHER RELAY TYPES IN STOCK

- Keying Relays
- Rotary Relays
- Contactors
- telephone Relays
- Voltage Regulators
- Differential Relays
- Sealed Relays
- Special Relays

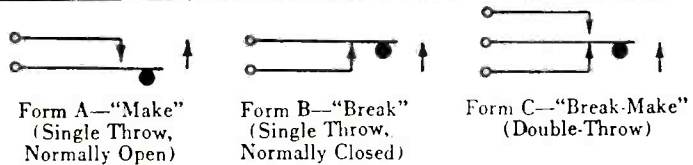

Manufacturers and Distributors:
Write for the new Relay Sales Catalog.

Telephone
Seeley 8-4146

833 W. CHICAGO AVE., DEPT. 10, CHICAGO 22, ILL.

The "Fittingest" thing you ever saw...



MALLORY MIDGETROL®

Dual Concentric Volume Controls

FIT 'EM FAST... FIT 'EM EASY

- In just five steps that take less than five minutes, you assemble a dual control that gives you the precise resistance values you need.
- Directions are short, easy to follow and you need no special tools... no soldering.
- Front and rear sections are factory-assembled and inspected.
- Instant AC switch attachment without control disassembly.

MAKE YOUR CUSTOMERS HAPPY

- Longer lasting resistance elements even in extremes of temperature and humidity.
- Better and more accurate taper curves resulting from precision processing methods.
- No pigtail connections to break—thanks to Mallory's exclusive sliding contact that gives EXTRA quiet operation.
- Minimum wobble with Mallory exclusive two-point shaft suspension.

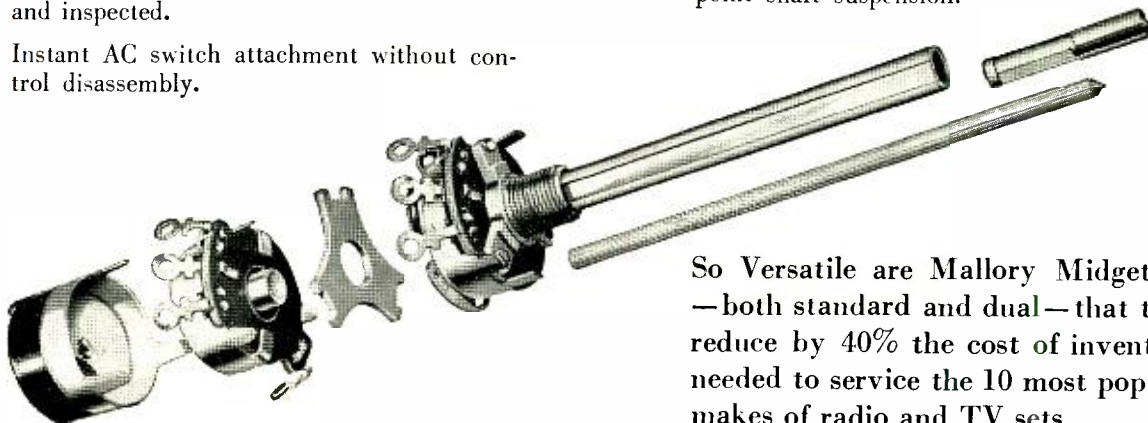

So Versatile are Mallory Midgetrols—both standard and dual—that they reduce by 40% the cost of inventory needed to service the 10 most popular makes of radio and TV sets.

**Make Sure!
Make it Mallory!**

You can build more than 10,000 different combinations with Mallory Midgetrols and do it fast... easily. Each dual control you build duplicates exactly the control it replaces. The Mallory Midgetrol Line, in addition to dual concentrics, includes round shaft, standard controls with the advantages of stable, two-point shaft suspension, instant AC switch attachment. Ready adaptability to split-knurl and flatted type knobs.

P. R. MALLORY & CO. Inc.
MALLORY

CAPACITORS • CONTROLS • VIBRATORS • SWITCHES • RESISTORS
• RECTIFIERS • VIBRAPACK* POWER SUPPLIES • FILTERS

APPROVED PRECISION PRODUCTS

P. R. MALLORY & CO., Inc., INDIANAPOLIS 6, INDIANA

Get out Front

with RCA's new
Sales and Servicing aids

and watch
your business grow!

NEVER BEFORE has RCA made available to you such a varied and colorful assortment of Radio-TV Sales and Servicing Aids to help you build your business—the most comprehensive and useful promotions in the industry. You'll find all the basic business builders . . . from traffic-stopping illuminated "Service" signs and displays to colorful mailing pieces and souvenir gift items, to build your local reputation as "TV-Radio Service Headquarters."

In addition, RCA offers you top-flight technical publications such as the famous "Pic-O-Guides," the "Triple Pindex" with tube base diagrams, "RCA Kinescopes" . . . and the new, authoritative book on "TV Servicing" . . . to make your job easier and more profitable.

For the whole exciting story, ask your RCA Tube Distributor *today* for your free copy of the colorful brochure "In Focus for '52," that describes and illustrates 33 dynamic Sales and Servicing Aids to help you cash in on the fast-growing TV-Radio service business.

RCA TUBES
BRING OUT
THE BEST...
IN ANY
SET!



ILLUMINATED FLASHING
WINDOW DISPLAY



"TELEVISION SERVICE
CAMPAIGN KIT"



EDGE-LIGHTED
"LUCITE" CLOCK-SIGN



INDOOR ILLUMINATED
"FIREGLOW" SIGN

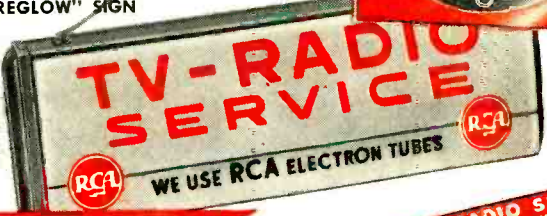

Get this Free Brochure Today from your local RCA Tube Distributor. Read all about RCA's plans to promote your business *right now*.



"REPEAT SERVICE"
LABELS



RADIO CORPORATION of AMERICA
ELECTRON TUBES
HARRISON, N. J.