

RADIO — ELECTRONICS

AUGUST 1952

LATEST IN TELEVISION • SERVICING • AUDIO

HUGO GERNSBACK, Editor



**AUDIO DEMONSTRATION SETUP
HAS 400,000 COMBINATIONS**
See page 4

30¢

U. S. and
CANADA

**In this issue: A New Audio Distortion Meter •
Home Trials—and Tribulations • “Long-Lines” TV Booster**



You're a Radio Man...we're a Radio Company...
...so let's make money together

HERE'S HOW!

We've been telling millions of radio listeners and television viewers that you, the Radio Service-Dealer are best qualified to sell and install RCA Radio Batteries. You can capitalize on this national advertising coverage right in your own neighborhood by stocking and promoting fast-selling RCA Radio Batteries.

We help you advertise for repeat sales on the RCA Radio Battery carton itself. Volume-type RCA Batteries carry a printed message directing the portable radio owner back to *you* for replacements. And a special space is provided below this message for you to imprint your own name and address with a personalized stamp which you may obtain from your RCA Battery Distributor. You can make more money selling RCA Batteries because customers come back to *you* for battery replacements.

We create new, *ready-made* markets for *you*. The revolutionary new RCA VS236 and VS216 Batteries make possible the design of personal portables having a "Balanced Life" battery complement which will provide 10 times longer playing time without battery change than previ-

ously possible. The new RCA Victor Super "Personal" radio was designed especially for these new battery types. Here's a whole new battery replacement business open to you when you sell RCA Radio Batteries.

For the whole exciting profit-building story, call your RCA Battery Distributor *today*. Let's get started selling RCA Batteries together . . . *right now*.



Revolutionary New RCA Radio Batteries Provide 10 Times Longer Playing Time Without Battery Change in New RCA Victor Super "Personal"



RADIO CORPORATION of AMERICA
RADIO BATTERIES **HARRISON, N. J.**

You Practice COMMUNICATIONS

I send you parts to build this transmitter

As part of my Communications Course you build this low power broadcasting transmitter, learn how to put a station "on the air," perform procedures demanded of Broadcast Station operators, make many tests.



This is just part of the equipment my students build. You keep all parts I send.

You Practice Radio SERVICING

on this modern radio you build with parts I send

As part of my Servicing Course, I send you the speaker, tubes, chassis, transformer, loop antenna, EVERYTHING you need to build this modern, powerful Radio Receiver! I also send parts to build many other Radio circuits. You use equipment for practical experience and to earn EXTRA money in spare time.

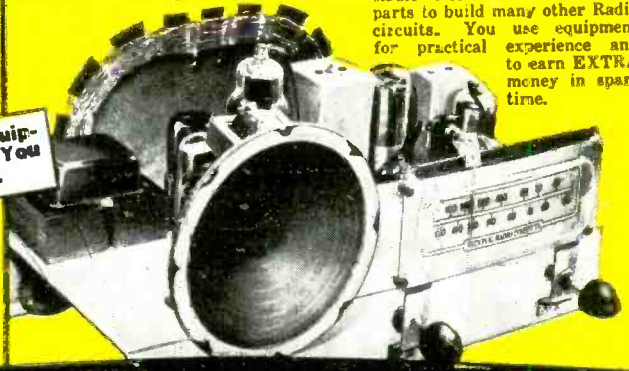

BE A RADIO-TELEVISION TECHNICIAN

NOW! Advanced Television Practice

New, special TV kits furnished to build high-definition SCOPE... RF OSCILLATOR with flyback power supply complete TV set... many other units. You see pulse, trapezoidal, saw-tooth wave forms. Get valuable PRACTICAL EXPERIENCE locating and correcting for facts, pictures and prices!

Learn Servicing or Communications Practice at Home in Spare Time



Do you want good pay, a job with a bright future and security? Would you like to have a profitable shop or store of your own? If so, find out how you can realize your ambition in the fast growing, prosperous RADIO-TELEVISION industry. Even without Television, the industry is bigger than ever before. 90 million home and auto Radios, 3100 Broadcasting Stations, expanding use of Aviation and Police Radio, Micro-wave Relay, Two-way Radio for buses, taxis, etc., are making opportunities for Servicing and Communications Technicians and FCC-Licensed Operators.

Television is TODAY'S Good Job Maker

In 1950, over 5,000,000 TV sets sold. By 1954, 25,000,000 TV sets estimated. Over 100 TV Stations now operating. Authorities predict 1,000 TV Stations. This means more jobs, good pay for qualified men all over the United States and Canada.

Many Make \$10 Extra a Week in Spare Time

Keep your job while training. Hundreds of successful RADIO-TELEVISION TECHNICIANS I trained had no previous experience, some only a grammar school education. Learn Radio-Television principles from illustrated lessons. Get PRACTICAL EXPERIENCE—build valuable multitester—experiment with circuits common to Radio and Television. Keep all equipment. Many students make \$5, \$10 extra a week fixing neighbors' Radios in spare time. SPECIAL BOOKLETS start teaching you the day you enroll.

Send Now For 2 Books FREE—Mail Coupon

Send now for my FREE DOUBLE OFFER. You get actual Servicing lesson to show you how you learn at home. Also my 64-page book, "How to Be a Success in Radio-Television." Read what my graduates are doing, earning; see equipment you practice with at home. Send coupon in envelope or paste on postal. J. E. SMITH, President, Dept. 2HP, National Radio Institute, Washington 25, D. C. Over 39th Year.

I TRAINED THESE MEN

"I have been operating my own Servicing business. In two years I did \$14,000 worth of business; net profit \$6,860. Have one full time employe, an NRI student."—PHILLIP G. BEGAN, Louisville, Ky.

"Four years ago, I was a bookkeeper, with a hand-to-mouth salary. Now I am a Radio Engineer with a key station of the American Broadcasting Company network."—NORMAN H. WARD, Ridgely Park, New Jersey.

"When halfway through the NRI course, I made \$5 to \$8 a week fixing sets in my spare time. Am now selling and installing Televis on sets and antennas."—E. F. STREITBERGER, New Britain, O.

"My first job was operator with KDLR, obtained for me by your Graduate Service Dept. I am now Chief Engineer of Police Radio Station WOOL. I never hesitate to endorse NRI."—T. E. MORTON, Mason, Ohio.



EXTRA PAY IN ARMY, NAVY, AIR FORCE



Knowing Radio, TV, Electronics can help you get extra rank, extra prestige, more interesting duty at pay up to several times a private's base pay. You are also prepared for good Radio-TV jobs upon leaving service. Mail Coupon TODAY.

Have Your Own Business

Many NRI trained men start their own Radio-Television sales and service business without capital. Let me show you how you, too, can be your own boss, have a good income from your own shop. Send coupon for FREE book now!

Tested Way to Better Pay

Good for Both—FREE

MR. J. E. SMITH, President, Dept. 2HP National Radio Institute, Washington 25, D. C.

Mail me Sample Lesson and 64-page Book about How to Win Success in Radio-Television. Both FREE. (No Salesman will call. Please write plainly.)

Name..... Age.....
Address.....
City..... Zone..... State.....

Approved for training under G. I. Bill

The ABCs of SERVICING

Be a Success in RADIO-TELEVISION

RADIO - ELECTRONICS

Formerly RADIO-CRAFT • Incorporating SHORT WAVE CRAFT • TELEVISION NEWS • RADIO & TELEVISION*

Hugo Gernsback
Editor-in-Chief

M. Harvey Gernsback
Editorial Director

Fred Shunaman
Managing Editor

Robert F. Scott
W2PWC, Technical Editor

I. Queen
Editorial Associate

Angie Pascale
Production Manager

Wm. Lyon McLaughlin
Tech. Illustration Director

Sol Ehrlich
Art Director

Lee Robinson
General Manager

John J. Lamson
Sales Manager

G. Aliquo
Circulation Manager

Robert Fallath
Promotion Manager

ON THE COVER
Model Claudia Laymon compares the quality of two Auditioner-controlled musical selections. Battery of speakers is part of the demonstration room described in the article on page 36.
Color original courtesy Allied Radio Corporation

CONTENTS

AUGUST 1952

Editorial (Page 21)			
Electronic Brains	by Hugo Gernsback	21	
Television (Pages 22-31)			
Home Trials and Tribulations	by John T. Fry	22	
TV DX Reports		24	
"Long Lines" TV Booster	by James Boyett	25	
The Last Word on Conversion, Part I	by M. Harvey Gernsback	26	
Short Circuits	by Robert F. Scott	28	
TV Service Clinic	Conducted by Matthew Mandl	30	
Servicing—Test Instruments (Pages 32-34)			
Tube Tester for Industrial Replacements	by David Allen	32	
Handy Substitution Box	by Harold Pallatz	33	
Why the Small Shop Will Stick	by John Burke	34	
Electronics (Page 35)			
Inexpensive Electrostatic Precipitation	by Edwin N. Kaufman	35	
Audio (Pages 36-46)			
Auditioner (Cover Feature)		36	
Tape Recording, Part I	by I. Queen	38	
Novel French Speaker	by P. Hemardinquer	41	
Phase Shift Distortion Meter	by Robert L. Libbey	42	
Electronics & Music, Part XXVI	by Richard H. Dorf	44	
Construction (Pages 47-48)			
Voltage Regulation	by R. D. Horwitz	47	
Long Period Radio Timer	by H. A. Vasques	48	
New Design (Pages 50-54)			
Electronic Recorder	by Ralph W. Hallows	50	
New Tubes		54	
Departments			
Radio Month ..	8	New Patents ..	66
Radio Business ..	14	Try This One ..	69
With the Technician ...	58	Radio-Electronic Circuits	72
New Devices ..	62	Question Box ..	76
		Technotes	79
		Miscellany	82
		People	84
		Communications ..	85
		Book Reviews ..	88



MEMBER Audit Bureau of Circulations

RADIO-ELECTRONICS

Published monthly by Radcraft Publications, Inc., at Erie Ave., F to G Streets, Philadelphia 32, Pa.

Vol. XXIII, No. 11

EXECUTIVE, EDITORIAL and ADVERTISING OFFICES: 25 West Broadway, New York 7, N. Y. Telephone REctor 2-8630. Hugo Gernsback, President; M. Harvey Gernsback, Vice-President; G. Aliquo, Secretary.

SUBSCRIPTIONS: Address correspondence to Radio-Electronics, Subscription Dept., Erie Avenue, F to G Sts., Philadelphia 32, Pa., or 25 West Broadway, New York 7, N. Y. When ordering a change please furnish an address stencil impression from a recent wrapper. Allow one month for change of address.

SUBSCRIPTION RATES: In U. S. and Canada, in U. S. possessions, Mexico, South and Central American countries, \$3.50 for one year; \$6.00 for two years; \$8.00 for three years; single copies 30¢. All other foreign countries \$4.50 a year, \$8.00 for two years; \$11.00 for three years. Entered as second class matter September 27, 1948 at the post office at Philadelphia, Pa., under the Act of March 3, 1879. Copyright 1952 by Radcraft Publications, Inc. Text and illustrations must not be reproduced without permission of copyright owners.

BRANCH ADVERTISING OFFICES: Chicago: 100 E. Ohio St., Tel. SUPERior 7-1796. Los Angeles: Ralph W. Harker, 1127 Wilshire Blvd., Tel. MADison 6-1271. San Francisco: Ralph W. Harker, 582 Market St., Tel. GARfield 1-2381. FOREIGN AGENTS: Great Britain: Atlas Publishing and Distributing Co., Ltd., London E.C.4. Australia: McGill's Agency, Melbourne. France: Brentano's, Paris 2e. Holland: Trilectron, Heemstede. Greece: International Book & News Agency, Athens. So. Africa: Central News Agency, Ltd., Johannesburg. Capetown; Durban. Natal. Universal Book Agency, Johannesburg. Middle East: Steimatzky Middle East Agency, Jerusalem. India: Broadway News Centre, Dadar, Bombay-214. K. L. Kannappa Mudaliar, Madras 2. Pakistan: Paradise Book Stall, Karachi 3.

POSTMASTER: If undeliverable send form 3578 to: RADIO-ELECTRONICS, 25 West Broadway, New York 7, N. Y. *Trademark registered U.S. Patent Office.

RADIO-ELECTRONICS

TRAIN for Security! Good-Paying Jobs! MAKE THE MONEY YOU'VE ALWAYS DREAMED OF!



LEARN RADIO -TELEVISION

AND ELECTRONICS BY EASY SHOP METHOD TRAINING AT HOME!

You get all the parts—even tubes!— for this modern Superheterodyne Receiver. You learn to build it step by step. And you keep it! Get all the facts. Mail coupon now.

Let **NATIONAL SCHOOLS**—a resident-training school for nearly 50 years—train you at home for today's unlimited opportunities in Radio-Television-Electronics. National Schools is one of the largest schools of its kind. It is located in Los Angeles—the center of Radio and TV world! It has four large buildings of modern shops and labs. Its faculty is considered tops in the business.



You learn from lessons prepared by experienced instructors and engineers. Men who are successful Radio and Television technicians. Men who have trained 1000's of men like YOU!



FREE BOOK TELLS YOU HOW!

Page after page—in color—tells you everything you want to know. Mail the coupon. Get this valuable book today. And if you hurry—YOU GET A FREE SAMPLE LESSON, TOO! Shows how easy National Schools Home Training is. Mail the coupon today.

You Train At Home—In Your Spare Time

National Schools Shop Method Home Training gives you basic and advanced instruction in all phases of Radio-TV-Electronics. And remember—your training is based on resident school training principles. You learn fast from hundreds of diagrams and pictures. All instructions are written by experienced technicians who work in Radio and TV every day. All instructions have been developed and tested in National Schools' own labs and studios, which are equipped with the latest RCA equipment. No wonder this National Schools course is so up-to-date, practical, interesting. And so easy to learn! And no wonder it is held in such high regard by leaders of American industry! Approved for eligible Veterans.

We Teach You How To Make Welcome Extra Money—While You Learn!

Many National Schools students—men like you—make plenty of extra dollars each week in spare time! Fixing neighbors' radios, appliances and other ways we teach you. You start learning and earning from the day you enroll. From the very first lesson!

WE SEND YOU LOTS OF PARTS LIKE THIS!

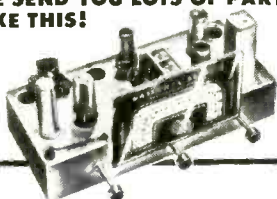

With National Schools Shop Method Home Training, you get basic principles and plenty of practical training. You learn by doing. No wonder you learn so fast! We send you many parts—all of professional, modern quality. You do lots of practical experiments. You advance day by day, step by step. Until you can even build the modern Superheterodyne Receiver you see above—plus other important testing units. The free book tells you all about it. The free sample lesson shows how easy the training is. Use the coupon. Send today—without fail!

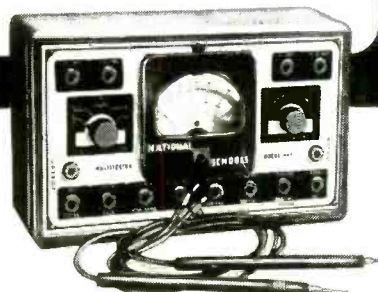

Only National Schools Gives You This Professional Multi-Tester!

You get this amazing, new testing instrument—factory-made and tested—complete—ready to use! Simple to operate. Accurate and dependable. An instrument every Radio-TV man needs. Light enough to carry around—so you can use it at home or on service calls. You'll be proud to own this valuable equipment.

Here are only a Few of the Good-Paying Jobs You Can Choose

Radio Station Engineer, District Service Manager, Aircraft Radio Inspector, Own Your Own Repair Shop, Inspector Technician, Service Specialist, Special Government Jobs, Complete TV Service, Sound Truck Operator. Many more!

National Schools graduates have secure, good-paying jobs like these! So don't wait—mail the coupon today. Now—while you're thinking about it!

Attention! Men Going into Service Soon!

National Schools' course quickly prepares you for many important jobs in the Armed Services. With National Schools Training you have an opportunity to get into special service classifications—with higher pay and grade—immediately!

FREE SERVICE FOR GRADUATES

National Schools uses its great influence and prestige to help you find your place in the field of your choice. Don't put it off! Start yourself toward a skilled trade! Get the big pay you've always wanted!

Today's Shortage of Trained Technicians Creates Chance of a Lifetime For You!

Think of it! With guided missiles, radar, and other electronic devices so important to national defense! With big, new developments in TV. With over 90,000,000 home and auto radios, over 12,000,000 TV sets. With more than 3100 radio stations...over 100 TV stations—and more building every day...yes, imagine the great opportunity you have today! YOU are wanted in Radio-Television-Electronics! America's fastest-growing field. High-pay jobs—the kind you've always wanted—are waiting for YOU!

Job Security! Big Money! For YOU! in Today's Expanding Industries!

Trained Radio and Television technicians really make important money these days. Thousands of National Schools graduates—men just like you—are earning good money all over the country. Why not you? And—National Schools graduates get the personal satisfaction of being highly-skilled technicians. Men people respect. Men who enjoy their work—rather than having to drag along in just any old job.

National Schools Has Trained 1000's of Successful Men! Why Not YOU?

In almost every state—and many foreign countries—National Schools graduates are filling big jobs with famous companies. Or running their own successful businesses. What are YOU waiting for? National Schools training is complete training. So when you graduate you can take advantage of today's big opportunities in Radio-Television-Electronics—fast.

DON'T PUT IT OFF! GET THE BIG SALARY YOU HAVE ALWAYS WANTED!

NATIONAL SCHOOLS

LOS ANGELES 37, CALIFORNIA • ESTABLISHED 1905
In Canada: 193 E. Hastings St., Vancouver, B. C.

MAIL THIS COUPON TODAY—WITHOUT FAIL!

NATIONAL SCHOOLS, Dept. RG-82
4000 South Figueroa Street
Los Angeles 37, California

Mail in envelope or paste on penny post card.

Mail me FREE the book mentioned in this ad. Also a free sample lesson. I understand no salesman will call on me.

NAME _____ AGE _____

ADDRESS _____

CITY _____ ZONE _____ STATE _____

Check here if you were released from the Service less than 4 years ago.

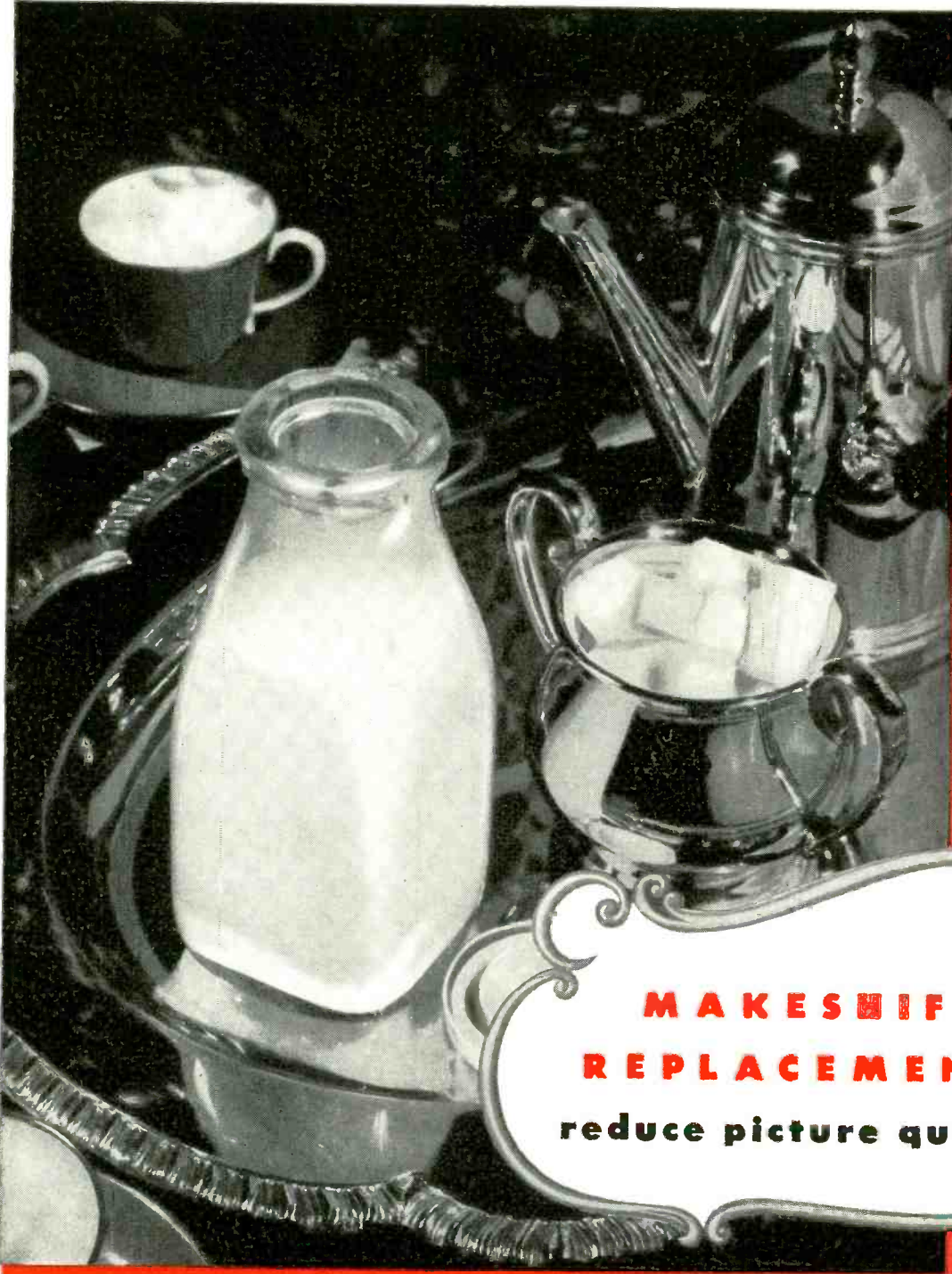

**MAKEShift
REPLACEMENTS
reduce picture quality**

Right
for
Sight



Replacements with
Raytheon Television Tubes
assure picture quality



Excellence in Electronics

RECEIVING AND PICTURE TUBES • RELIABLE SUBMINIATURE AND MINIATURE TUBES • GERMANIUM DIODES AND TRANSISTORS • RADIAC TUBES • MICROWAVE TUBES

New model Raytheon Picture Tubes with Cornea Inhibitor give constant picture clarity whatever the weather.

RAYTHEON MANUFACTURING COMPANY

Receiving Tube Division

Newton, Mass., Chicago, Ill., Atlanta, Ga., Los Angeles, Calif.

RADIO-ELECTRONICS

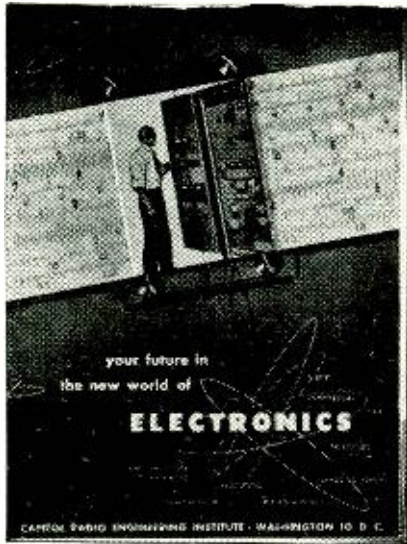

RADIO-TV- ELECTRONICS

*Will these fast-growing industries
leave you behind...
or skyrocket you up with them?*

← Send for this free CREI booklet today... and find out!

When you find success in your chosen field, you may look back on one small incident that changed the course of your career. It may be a conversation you had. It may be the day your father bought you a radio kit, or the day you applied for a job just when somebody was needed. It may well be (as it has for thousands) the day you took two minutes to request the free CREI booklet called "Your Future in the New World of Electronics."

When you read this fact-packed booklet, you will get a complete picture of the electronics industry: where it is going, and what you can do to rise with it. For here is a field expanding so rapidly that the most optimistic experts fall short in their predictions.

Consider the 108 TV stations now operating, and the 2,073 more made possible by the recent FCC "un-freeze." Consider the 17,000,000 TV sets and 100,000,000 radios now in operation. Consider the gigantic defense orders for electronic equipment and installations.

Consider the thousands of radio-equipped fire and police departments; the radio-equipped railroads; the hundreds of cities with 2-way radio service for cars and cabs; the wide-ranging field of aviation communications—radio-controlled aircraft, navigation-and-traffic control, airport stations.

Consider the maritime world with its radar and navigation aids, fathometers, ship-to-shore and ship-to-ship communications. Think of electronic heating, Fax and ultra-Fax, electronic medicine, electric computers, and all the industrial applications of electronic know-how.

Then think of the unlimited number of positions to be filled—in development, research design, production, testing and inspection, manufacture, broadcasting, telecasting, and servicing. Luck won't get you a job. Contracts won't. Knowledge *will*. You will have knowledge if you prepare now—if you are alert enough and ambitious enough to obtain that knowledge—if you take two minutes to send for "Your Future in the New World of Electronics" and then follow the plan it describes.

This helpful book shows you how CREI-Home Study leads the way to greater earnings through the inviting opportunities described above. However, being an accredited technical school, CREI does not promise you a "short-cut." You must translate your willingness to learn into salable technical

CREI Resident Instruction (day or night) is offered in Washington, D. C. Here work is done with the latest equipment, in ideal surroundings, under close personal supervision. New classes start once a month. For a CREI Residence School catalog, check the last line of the coupon below.

knowledge—via *study*. CREI knows what it means to grow along with a booming industry. This year CREI is celebrating its 25th Anniversary, having started in 1927 in the early days of radio-electronics. Since then CREI has provided thousands of professional radiomen with technical educations. During World War II, CREI trained thousands for the Armed Services. Leading firms use CREI courses for group training in electronics at company expense; among them are United Air Lines, Canadian Broadcasting Corporation, Trans-Canada Airlines, Sears Roebuck & Co., Bendix Products Division, All-American Cables and Radio, Inc., and RCA-Victor Division and Mochlett Laboratories.

CREI courses are prepared by recognized experts, in a practical, easily-understood manner. You get up-to-date study materials; your work is under the personal supervision of a CREI Staff Instructor. You choose your own hours of study *at home*. Upon completion you join the many CREI graduates who have found their diplomas keys-to-success in Radio, TV and Electronics, CREI alumni hold many top positions.

At your service is the CREI Placement Bureau which finds positions for students and graduates and now has many more requests for personnel than can be filled. Talk to men in the field and check up on CREI's high standing in electronics instruction. Determine for yourself right now that your earnings are going to rise with your knowledge—and that you will rise *with* this booming industry. All this CREI offers you, provided you sincerely want to learn. Fill out the coupon and mail it today. We'll promptly send you your free copy of "Your Future in the New World of Electronics." The rest—your future—is up to you.

MAIL COUPON FOR FREE BOOKLET

CAPITOL RADIO ENGINEERING INSTITUTE

Dept. 148D, 3224 16th St., N.W., Washington 10, D. C.

Send booklet "Your Future in the New World of Electronics" and course outline.

CHECK TV, FM & Advanced AM Servicing Aeronautical Radio Engineering
FIELD OF Practical Television Engineering
GREATEST Broadcast Radio Engineering (AM, FM, TV)
INTEREST Practical Radio Engineering

Name.....

Street.....

City..... Zone..... State.....

If residence school in Wash., D. C. preferred, check here

MERIT

tv full-line*

components give universal coverage

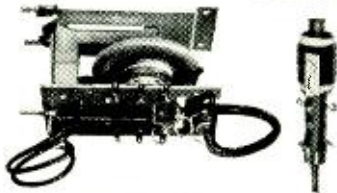

**NEW IMPROVED HVO-7
FOR GREATER COVERAGE**
Tapped AFC Winding. Covers Admiral Chassis 21-24 Series.

MWC-1 UNIVERSAL WIDTH COIL
(3-27 MH) A Tapped Secondary For AGC or AFC.

IF-RF COILS
Only complete line of TV replacements.



"COSINE" YOKES
Complete with leads & network.

MATCHED FOR DIRECT DRIVE

MDF-30 HVO-8



**A-3080 Vert. Mtg.
A-3081 Horiz. Mtg.
Autotformer**



KIT NO. 1000
MATCHED SET FOR SPEEDY
PROFITABLE SERVICE!

**MERIT . . . HQ for PRACTICAL TV
Service Aids**

MERIT'S 1952 Catalog No. 5211 with new
MERIT IF-RF Coils.

Other MERIT service aids:

TV Repl Guide No. 404, 3500 models &
chassis.

Cross Ref Data, IF-RF Coils, Form No. 14.
See your Jobber or write: Merit Coil and
Transformer Corp., 4425 Clark Street,
Chicago 40.



These three MERIT extras help
you:
Exclusive: Tapemarked with
specs and hook-up data.
Full technical data packed with
every item.
Listed in Howard Sams Photo-
facts.



*Merit is meeting the TV im-
provement, replacement and con-
version demand with a line as
complete as our advance in-
formation warrants!

POOR MAN'S HI-FI system is prom-
ised in a speaker developed by Dr.
Jordan J. Baruch and Henry C. Lang
of the Massachusetts Institute of Tech-
nology Acoustics Laboratory. Four mod-
ified 5-inch speakers in a one-half cub-
ic foot enclosure give sound output
flat within 3 db from 40 to 11,000 cycles.
Only two watts audio power is used,
with an *acoustical* output of one-half
watt.

The speaker cabinet is like a cubical
box with one-foot inside dimensions cut
diagonally across top and bottom. Four
speakers are mounted on the diagonal
face. Fifteen 15/32-inch holes are
drilled in the top. These take the place
of the ports in bass-reflex types of
speakers. Mounted in a corner with the
holes up (or down, if the speaker is
mounted near the ceiling), these holes
are said to produce an acoustic mirror
effect in conjunction with the walls,
doubling the virtual size of the enclos-
ure.

The speaker, for all its apparent sim-
plicity, is no job for the home con-



Courtesy Ultrasonic Corporation

The speaker fits neatly in a corner.

structor, its developers warn. Its secret
is careful measurement and engineer-
ing, with each part carefully selected
and modified for its function. Speakers
of a different type might call for match-
ing changes in the size and pattern of
the holes or the volume of the cabinet.
Several manufacturers were said to be
planning to manufacture the unit in
quantity at a price which would pro-
vide moderate high-fidelity within the
reach of an "instructorial salary."

The device was first described and
demonstrated at the May 22 meeting of
the Radio Club of America in New
York City.

WWV'S STANDARD FREQUENCY

services now include simultaneous
round-the-clock transmissions on 2.5, 5,
10, 15, 20, and 25 mc. Carrier frequen-
cies have an accuracy of 1 part in 50
million (.02 cycle per megacycle). Am-
plitude modulation of 440 cycles and 600
cycles is used for alternate 4-minute
periods. These are separated by 1-min-
ute time announcements in which each
second is marked by a 1-kc pulse. Warn-
ings of propagation disturbances and
predictions of transmitting conditions
in the North Atlantic area are sent in
code twice every hour. WWVH (Ha-
waii) provides a similar service on 5,
10, and 15 mc only.

TV SET OWNERS believe in their
service technicians. This was discovered
in a poll conducted recently by leading
pollster Elmo Roper, under the sponsor-
ship of RCA Victor and the RCA Serv-
ice Company. An overwhelming major-
ity (86%) of all television set owners
who have had their sets serviced have
a high opinion of the quality of the
work done. A large majority also con-
sider the TV service technician to be
courteous, prompt in responding to
calls, and fair in his charges.

"Recently published articles have re-
flected on the honesty and competence of
television servicemen by charging that
the TV public was being gouged," said
E. C. Cahill, president of the RCA Serv-
ice Company. "While we knew from ex-
perience that these reports were based
on isolated instances and did not re-
flect the true character of the serv-
ice industry, we were disturbed by the
unfair and misleading impressions they
were creating among the public. So we
commissioned Mr. Roper to get the full
facts from the people who were best
able to judge—the TV set owners."

The Roper survey polled 5,000 fam-
ilies, representing an accurate cross-
section of adults in television areas
throughout the country. The findings
are based on the replies received from
over 90% of the television homes in the
sample. The survey is believed to be the
first scientific, impartial, nationwide
sampling ever made to determine the
true public attitude toward the techni-
cians who install and maintain the na-
tion's 17 million TV receivers. While
other surveys have been conducted on
this subject, they have been confined to
local areas.

"The findings have fully substanti-
ated our confidence in the ability and in-
tegrity of television technicians," Mr.
Cahill stated.

"For example, when the set owners
who had had service calls were asked to
evaluate the work done, only 7% ex-
pressed dissatisfaction. A sizeable ma-
jority, 68%, replied the work was
'really good,' while 18% described it as
'fairly good.'" (7% did not reply.)

When asked if the technician who
called to service or repair a set was
pleasant and courteous, only a fraction
of 1% gave a negative reply. Almost 9
out of 10 of these respondents, 88%,
said he was "pleasant and courteous."
Another 6% considered the techni-
cian's manner "satisfactory." (6% did
not reply.)

The public maintains a similar high
opinion of the promptness of service
technicians, the survey reveals. Three
out of four said they thought the work
had been done in a reasonable length
of time. Only one out of five felt he had
had to wait too long. Even on the deli-
cate matter of price, the TV set owners
had a high opinion of their service
technicians. In spite of the articles
which have appeared purporting to "ex-
pose" television technicians for over-
charging their customers, two out of
three customers described the service
charges as "entirely reasonable." Only
one out of ten considered their service
bills "too high."

RADIO-ELECTRONICS

Now IN YOUR OWN HOME Learn

TELEVISION RADIO

the Amazingly Effective
D.T.I. WAY

—with the aid of **BOTH**
HOME EQUIPMENT
and **HOME MOVIES**

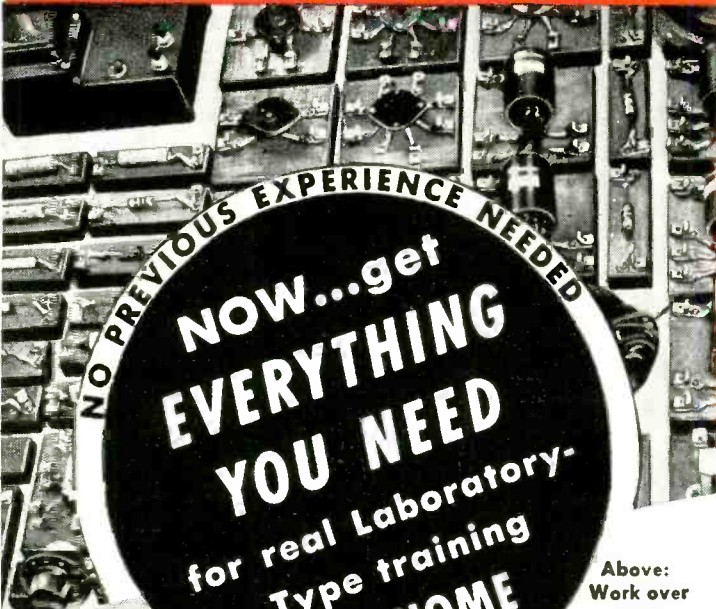

NO PREVIOUS EXPERIENCE NEEDED

**NOW...get
EVERYTHING
YOU NEED**
for real Laboratory-
Type training
AT HOME

Above:
Work over
300
fascinating
experiments
with this
equipment

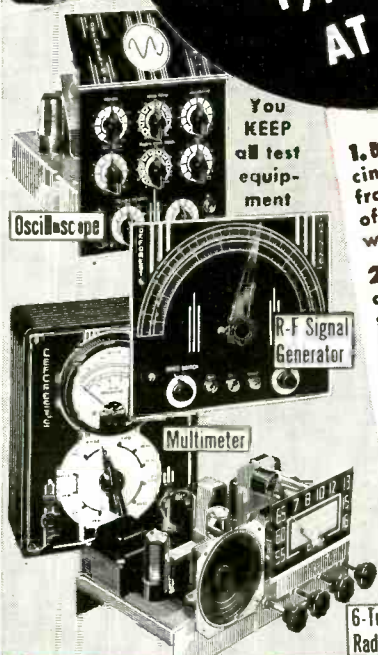

You
KEEP
all test
equip-
ment

Oscilloscope

R-F Signal
Generator

Multimeter

**1. Build over 300 fasci-
nating experiments
from 16 BIG SHIPMENTS
of Electronic-Radio parts
which you KEEP.**

**2. Build valuable commer-
cial-type test equipment—as
shown to the left—which you
KEEP. This includes a quality
OSCILLOSCOPE—a must for
Television work.**

**3. Use a 16 mm. movie projector
and new series of Hollywood pro-
duced instructive movies—a wonder-
ful aid to help you grasp important
fundamentals faster...easier...better.**

**4. Enjoy well-illustrated, easy-to-read
lessons with handy FOLD-OUT diagrams.**

**5. Get an honest-to-goodness EMPLOY-
MENT SERVICE to help you get a good job
after graduating—or assistance in starting
your OWN SALES AND SERVICE BUSINESS.
Mail coupon today for the complete details.**

What will mailing the coupon below do for YOU? Just this! You'll find out about one of today's most remarkable... practical ways to prepare to get into America's amazing billion dollar opportunity field of TELEVISION-RADIO-ELECTRONICS. You'll see how to get into fascinating work that pays well... that offers one of America's most promising futures... that enables you to start your own business almost "on a shoe string," if you prefer this to a job opportunity.

And above all, you'll get some GOOD NEWS especially welcomed by men anxious to earn REAL MONEY in this thrilling field. For you'll see that NOW you can get the kind of practical, laboratory-type training so desirable for making real progress in Television-Radio-Electronics... and WITHOUT LEAVING HOME.

You'll see that DeForest's Training, Inc. sends everything needed to set up your own HOME LABORATORY. You get and keep the same type of basic electronic equipment used in our modern Chicago Training Laboratories. You get home training that includes the knowledge and experience gained from training thousands of students first hand in Chicago. And to top it all, you use DTI's amazingly effective and exclusive home training aid—INSTRUCTIVE MOVIES. But why not get the complete story? Mail coupon today for information-packed literature.

MODERN LABORATORIES

If you prefer, get all your preparation in our new Chicago Training Laboratories—one of the finest of its kind. Ample instructors, modern equipment. Write for details!

MILITARY SERVICE!

If you're subject to military service, the information we have for you should prove very helpful. Mail coupon today.

Get **BOTH** of these colorful,
information-packed folders
FREE

**89 WAYS
TO
EARN
MONEY
IN TELEVISION**

**YOU GET
ALL 6**

*Mail Coupon
Today*



New "black"
RECTANGULAR
TUBE

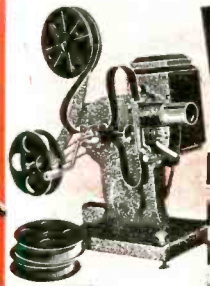

DeFOREST'S TRAINING, INC., DEPT. RE-8-1
2533 N. Ashland Avenue, Chicago 14, Ill.

I would like valuable, information-packed folders showing how I may get started toward a good job or my own business in Television-Radio-Electronics.

Name..... Age.....
Street..... Apt.....
City..... Zone..... State.....

DeFOREST'S TRAINING, INC.
AFFILIATED WITH
De Vry Technical Institute
CHICAGO 14, ILLINOIS

Famous Guns

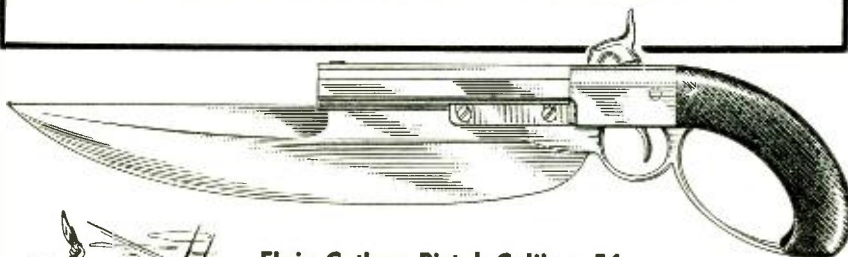

Elgin Cutlass-Pistol, Caliber .54, 1837 Model, made by C. B. Allen. Invented by George Elgin of New York, this formidable arm was intended to take the place of the cutlass and pistol commonly used by naval boarding parties. One of several variations of this weapon is the shorter Bowie-Knife Pistol.

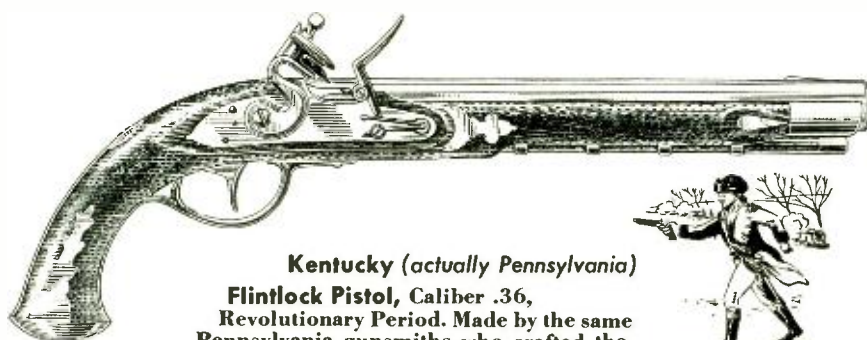

Kentucky (actually Pennsylvania) Flintlock Pistol, Caliber .36, Revolutionary Period. Made by the same Pennsylvania gunsmiths who crafted the famous "Kentucky" rifles, these full-stocked pistols actually were rifles-in-miniature. Every "Kentucky" pistol is unique; the same gunsmith never made two alike.



Instant-heating Weller Soldering Gun for light or heavy work. Dual heat greatly increases tip life. Switch instantly to high or low heat as job requires. Pre-focused spotlights end "blind soldering". Exclusive tip-fastening arrangement assures full, constant heat. Shatter-proof plastic housing. Perfect balance. Low-cost, replaceable tips. Pays for itself in a few months. See at your Distributor or write for Bulletin direct.

Get **SOLDERING TIPS**, new Weller Handy Guide to faster, easier soldering. 20 pages fully illustrated. Price 10c at your Distributor, or order direct.

Weller BETTER FROM GRIP TO TIP!

SOLDERING GUNS 828 Packer Street, Easton, Pa.

The Finest Soldering Tool for the Finest Craftsmen

TRANSIT RADIO'S LEGALITY was upheld by the U. S. Supreme Court in a 7 to 1 decision. While supporting the majority opinion permitting broadcasts to public transit vehicles, Justice Black expressed the belief that broadcasts of news, speeches, or propaganda would violate the First Amendment. Opponents of transit radio plan to continue their fight by seeking Congressional legislation.

BINAURAL BROADCASTING, utilizing AM and FM outlets for simultaneous transmission of separate sound pickups, was demonstrated late in May by KOMO-AM-FM, Seattle, and WGN-WGNB, Chicago. Dual receivers, audio channels, and speaker systems are reported to have reproduced the programs with phenomenal realism.

TV IN VENEZUELA will be operating by November. A government-run 10-kw RCA transmitter in Caracas, the capital, will furnish non-commercial cultural and educational programs.

EMPORIUM SECTION OF THE IRE will hold its 13th annual Summer Seminar at Emporium, Pennsylvania, Friday and Saturday, August 15th and 16th. Four papers on late television developments will be presented. Two will be given Friday evening after the opening cocktail party and banquet, and the others the following morning. The Seminar will close with a picnic Saturday afternoon. Information regarding reservations, transportation and tickets can be obtained from Francis T. Quigley, General Engineering Department, Sylvania Electric Products, Inc., Emporium, Penna.

NEW LIGHT on northern lights was cast by Harvard astronomer Dr. Donald Menzel at a recent meeting of the American Physical Society. Clouds of ionized particles erupted from the sun are normally deflected by the earth's magnetic field. Strong concentrations, reinforced by cosmic debris, break through the field at its weakest point—just below the North Pole—and produce dazzling auroral displays when they collide with dust particles in our upper atmosphere.

CANADA'S FIRST TV STATIONS were expected to start transmissions in July. According to Fergus Mutrie of the Canadian Broadcasting Corporation, Montreal (channel 2) is to send test patterns and International League baseball games intermittently from July 25 until the station's formal opening early in September. Toronto (channel 9) will start about the same time.

A microwave relay link to Buffalo, New York, will enable Toronto to carry U. S. network programs. An extension of the link to Ottawa and Montreal, now under construction, is scheduled for completion early next year.

Both stations will have 5-kw transmitters with multibay antennas, giving an effective radiated power of 26 kw. American standards will be used.

Program policy is still undecided, but will probably divide time equally among Canadian commercial, U. S. commercial, and local sustaining programs.

—end—

Want To Double Your Pay?

Edward H. Guilford
Executive Vice President



How To Pass FCC COMMERCIAL RADIO OPERATOR LICENSE EXAMINATIONS

MONEY MAKING FCC LICENSE INFORMATION

TELEVISION ENGINEERING
included in our Training and coaching

GET THIS AMAZING NEW BOOKLET FREE!

TELLS HOW —

HERE IS YOUR GUARANTEE

If you fail to pass your Commercial License exam after completing our course, we guarantee to continue your training without additional cost of any kind, until you successfully obtain your Commercial license, provided you first sit for this examination within 90 days after completing your course.

WE GUARANTEE TO TRAIN AND COACH YOU AT HOME IN SPARE TIME UNTIL YOU GET YOUR FCC LICENSE

TELLS HOW —

Our Amazingly Effective JOB-FINDING SERVICE

Helps CIRE Students Get Better Jobs

Here are a few recent examples of Job-Finding results:

If you have had any practical experience—Amateur, Army, Navy, radio repair, or experimenting.

TELLS HOW — Employers make **JOB OFFERS Like These to Our Graduates Every Month!**

Letter from Chief Engineer, Broadcast Station, North Carolina. "Need men with radiotelephone 1st class licenses, no experience necessary. Will learn more than at average station for we are equipped with Diesel Electric power, transmitting and studio equipment."

Telegram from Chief Engineer, Broadcast Station, Wyoming. "Please send latest list available first class operators. Have November 10th opening for two combo men."

Letter from Chief Engineer, Broadcast Station, Texas. "Please send list of latest licensed graduates."

These are just a few examples of the job offers that come to our office periodically. Some licensed radioman filled each of these jobs . . . if might have been you!

HERE'S PROOF FCC LICENSES ARE OFTEN SECURED IN A FEW HOURS OF STUDY WITH OUR COACHING AT HOME IN SPARE TIME

Name and Address	License	Lessons
Lee Worthy 2210 1/2 Wilshire St., Bakersfield, Calif.	2nd Phone	16
Clifford E. Vogt Box 1016, Danla, Fla.	1st Phone	20
Francis X. Foersch 38 Beucier Pl., Bergenfield, N. J.	1st Phone	38
S/Sgt. Ben H. Davis 317 North Roosevelt, Lebanon, Ill.	1st Phone	28
Albert Schoell 110 West 11th St., Escondido, Calif.	2nd Phone	23

CLEVELAND INSTITUTE OF RADIO ELECTRONICS
Carl E. Smith, E. E., Consulting Engineer, President
Desk RE-44, 4900 Euclid Bldg., Cleveland 3, Ohio

- GETS CIVIL SERVICE JOB**
"Thanks to your course I obtained my 2nd phone license, and am now employed by Civil Service at Great Lakes Naval Training Station as an Equipment Specialist."
Kenneth R. Leiser, Fair Oaks, Md. Del., McHenry, Ill.
- GETS STATE POLICE JOB**
"I have obtained my 1st class ticket (thanks to your school) and since receiving same I have held good jobs at all times. I am now Chief Radio Operator with the Kentucky State Police."
Edwin P. Healy, 264 E. 3rd St., London, Ky.
- GETS BROADCAST JOB**
"I wish to thank your Job-Finding Service for the help in securing for me the position of transmitter operator here at WCAE, in Pittsburgh."
Walter Koschik, 1442 Ridge Ave., N. Braddock, Pa.
- GETS AIRLINES JOB**
"Due to your Job-Finding Service, I have been getting many offers from all over the country, and I have taken a job with Capital Airlines in Chicago, as a Radio Mechanic."
Harry Clare, 4537 S. Drexel Blvd., Chicago, Ill.

OURS IS THE ONLY HOME STUDY COURSE WHICH SUPPLIES FCC-TYPE EXAMINATIONS WITH ALL LESSONS AND FINAL TESTS.

Your FCC Ticket is recognized in all radio fields as proof of your technical ability.



MAIL COUPON NOW

CLEVELAND INSTITUTE OF RADIO ELECTRONICS
Desk RE-44—4900 Euclid Bldg.
Cleveland 3, Ohio
(Address to Desk No. to avoid delay.)

I want to know how I can get my FCC ticket in a minimum of time. Send me your FREE booklet, "How to Pass FCC License Examinations" (does not cover exams for Amateur License), as well as a sample FCC-type exam and the amazing new booklet, "Money-Making FCC License Information."

Tell me about your Television Engineering Course.

Name

Address

City.....Zone.....State.....

Paste on penny postcard or send air mail.

PHILCO

Test Equipment for Measurements you can rely on



GET it right the *first* time with precision-built Philco Test Equipment. Save time, avoid guessing, build your reputation for dependable, thorough service work. Choose Philco instruments, tested and approved in the famous Philco Engineering Laboratories, for reliable performance and long-life accuracy.

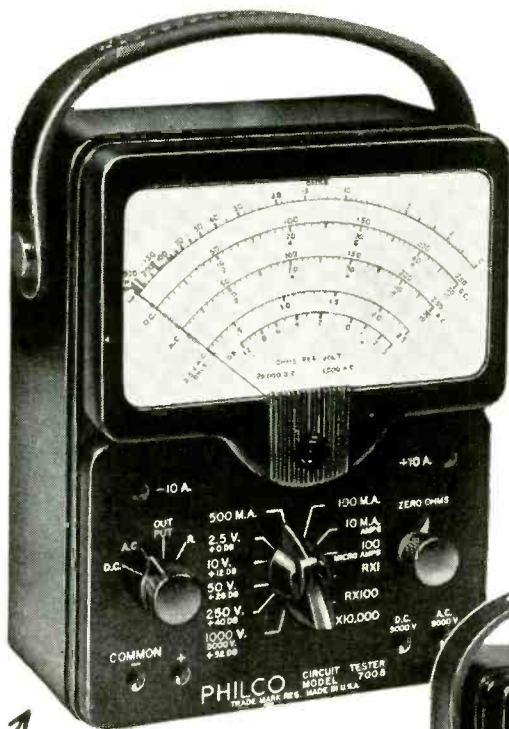

Philco Circuit Tester

Model 7005 Dimensions—5 $\frac{3}{8}$ " wide x 7 $\frac{1}{8}$ " deep x 3 $\frac{1}{2}$ " high.

Battery—Dry cell—"A" size.

Voltage Ranges DC—(20,000 ohms per volt) 2.5, 10, 50, 250, 1000, 5000 Volts.

Voltage Ranges AC—(1000 ohms per volt) 2.5, 10, 50, 250, 1000, 5000 Volts.

A.F. Output—2.5, 10, 50, 250, 1000.

Volume Level— -12 to +55 db (5 steps).

Resistance—RX1—12 ohms center—2000 Full Scale. RX100—1200 ohms center—200,000 Full Scale. RX10,000—120,000 ohms center—20 Megs. Full Scale.

Current—100 Microamperes; 10, 100, 500 Milliampere; 10 Amperes.

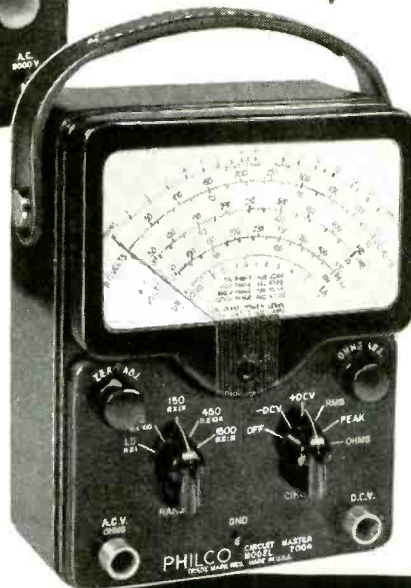

Philco Circuit Master

Model 7004 Dimensions—5 $\frac{3}{8}$ " wide x 7 $\frac{1}{8}$ " deep x 3 $\frac{1}{2}$ " high.

Operating Voltage—105-125 Volts; 60 cycles.

Basic Circuit—Balanced difference amplifier. Miniature double triode.

Voltage Ranges (DC)—1.5, 15, 150, 450, 1500 Volts.

Voltage Ranges (AC)—1.5, 15, 150, 450, 1500 Volts. 1.5, 15, 150 Volts. AC—RMS and peak—compensated to same frequency response.

Circuit Switch Positions—Off + DC Volts, —DC Volts, RMS Volts, Peak Volts, Ohms.

Ohms Ranges—Full scale, 100 times center. RX1—10 ohm center, RX100—100 ohm center. RX1000—10,000 ohm center. RX10,000—100,000 ohm center. RX1 Meg.—10 Megohm center.

Decibels— -20 to +65 on AC Peak. Reference level 1 Milliwatt, 600 ohms—zero level.

Internal Resistance—AC Volts (RMS and Peak), 5 Megohms. DC Volts, 10 Megohms.

External Adjustments—Zero adjust and ohms adjust.

For Information and Prices—Call Your
PHILCO DISTRIBUTOR

Fast . . . easy replacement for any set



MALLORY MIDGETROL®

Dual Concentric Volume Controls

DO THE JOB WITH SMALL STOCKS

- You can match 10,000 combinations of resistance values, taps and tapers with a minimum inventory of Mallory Dual Concentrics.
- Assembly involves just five simple steps. Takes less than five minutes. You need no special tools . . . do no soldering.
- Front and rear sections are factory-assembled and inspected.
- Instant AC switch attachment without control disassembly.

PERFORMANCE THAT PAYS OFF

- Longer-lasting resistance elements even in extremes of temperature and humidity.
- Better and more accurate taper curves resulting from precision processing methods.
- No pigtail connections to break—thanks to Mallory's exclusive sliding contact that gives EXTRA quiet operation.
- Minimum wobble with Mallory exclusive two-point shaft suspension.

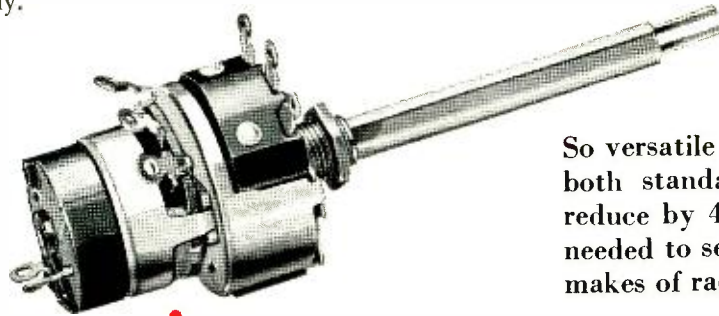

So versatile are Mallory Midgetrols—both standard and dual—that they reduce by 40% the cost of inventory needed to service the 10 most popular makes of radio and TV sets.

**Make Sure!
Make it Mallory!**

Shown here is the Mallory Dual Concentric Midgetrol with a wire wound front section, available for such uses as TV focus controls. The Mallory Midgetrol line, in addition to dual concentrics, includes round shaft, standard controls with the advantages of stable, two-point shaft suspension, instant AC switch attachment, ready adaptability to split-knurl and flatted type knobs.

MALLORY

CAPACITORS • CONTROLS • VIBRATORS • SWITCHES • RESISTORS
• RECTIFIERS • VIBRAPACK® POWER SUPPLIES • FILTERS

APPROVED PRECISION PRODUCTS

P. R. MALLORY & CO., Inc., INDIANAPOLIS 6, INDIANA

INDISPENSABLE!
PHOTOFACT BOOKS



Photofact Television Course. Covers TV principles, operation and practice. 216 pages; profusely illustrated; 8 1/2 x 11". Order **TV-1**.....Only **\$3.00**

Television Antennas. New 2nd edition. Describes all TV antenna types; tells how to select, install, solve troubles. Saves time; helps you earn more. 200 pages; illustrated. Order **TAG-1**.....Only **\$2.00**

Television Tube Location Guide. Volume 2. Accurate diagrams show position and function of all tubes in hundreds of TV sets; helps you diagnose trouble without removing chassis. 224 pages; pocket-size. Order **TGL-2**. Only **\$2.00**

Television Tube Location Guide. Vol. 1. Over 200 pages of TV receiver tube position diagrams on hundreds of models. Order **TGL-1**.....Only **\$1.50**

Making Money in TV Servicing. Tested proved methods of operating a profitable TV service business. Covers all important phases. Authoritative, valuable guide to success. Over 130 pages. Order **MM-1**.....Only **\$1.25**

Servicing TV in the Customer's Home. Shows how to diagnose trouble using capacitor probe and VTVM. Short-cut methods help save time, earn more on outside service calls. Order **TC-1**.....Only **\$1.50**

1949-1950 Record Changer Manual. Vol. 3. Covers 44 models made in 1949, including multi-speed changers and wire and tape recorders. Original data based on actual analysis of equipment. 286 pages; 8 1/2 x 11"; paper-bound. Order **CM-3**.....Only **\$3.00**

1948-1949 Changer Manual. Vol. 2. Covers 45 models made in 1948-49. Paper bound. Order **CM-2**. Only **\$4.95**

1947-1948 Changer Manual. Vol. 1. Covers 40 post-war models up to 1948. Order **CM-1**.....Only **\$3.95**

Recording & Reproduction of Sound. 2nd Edition. New, completely revised and vastly enlarged edition of the outstanding original volume. The most authoritative treatment of all phases of recording and amplification ever written. Over 800 pages. 6 x 9". Order **RR-2**.....Only **\$7.95**



Audio Amplifiers. Vol. 3. Clear, uniform, accurate data on 50 important audio amplifiers, plus full coverage of 22 FM and AM tuners, produced during 1950. 362 pages, 8 1/2 x 11". Order **AA-3**.....Only **\$3.95**

Audio Amplifiers. Vol. 2. A complete analysis of 104 well-known audio amplifiers and 12 tuners made 1949-50. 368 pages, 8 1/2 x 11". Order **AA-2**.....Only **\$3.95**

Audio Amplifiers. Vol. 1. 102 amplifiers and FM tuners made through 1948. 352 p. Order **AA-1**.....Only **\$3.95**

Auto Radio Manual. Complete service data on more than 100 post-war auto radio models. Covers over 24 mfrs. 350 pages, 8 1/2 x 11". Order **AR-1**.....Only **\$4.95**

Communications Receiver Manual. Complete analysis of 50 popular communications models. 246 pages, 8 1/2 x 11". Order **CR-1**.....Only **\$3.00**

Radio Receiver Tube Placement Guide. Accurate diagrams show where to replace each tube in 5500 radio models; covering 1938-1947 receivers. 192 pages, pocket-size. Order **TP-1**.....Only **\$1.25**

Dial Cord Stringing Guide. Vol. 2. Covers receivers made from 1947 through 1949. Shows you the one right way to string a dial cord in thousands of models. Pocket-size. Order **DC-2**.....Only **\$1.00**

Dial Cord Guide. Vol. 1. Covers sets produced 1938 through 1946. Order **DC-1**.....Only **\$1.00**

Order from your Parts Jobber or write direct to
HOWARD W. SAMS & CO., INC., 2201 E. 46th St., Indianapolis 5, Indiana
HOWARD W. SAMS & CO., INC.



BAROMETER of the PARTS INDUSTRY

During June, 50 of the leading 400 manufacturers of Radio-Television-Electronic parts and equipment made changes in their lines. Actually there was a decrease in "change activity" as compared to May. In price revisions by the number of manufacturers and products affected, the following summary illustrates the comparative trend for the months of May and June:

	No. of Manufacturers		No. of Products	
	May	June	May	June
Increased prices	13	10	885	67
Decreased prices	25	16	392	315

For a summary of the most active product categories, see the following table:

Products Group	Increased Prices		Decreased Prices		New Products		Discontinued Products	
	No. of Mfrs.	No. of Products	No. of Mfrs.	No. of Products	No. of Mfrs.	No. of Products	No. of Mfrs.	No. of Products
Antennas & Access.	2	6	4	56**	10	190*	5	75*
Capacitors	0	0**	0	0	1	5**	0	0**
Controls & Resistors	0	0	0	0**	2	19**	0	0**
Sound & Audio	1	1	3	118*	10	60*	4	8**
Test Equipment	3	22*	0	0**	3	12**	2	5*
Transformers	0	0	1	1*	1	6**	1	1*
Tubes	4	38**	8	140**	5	30**	3	20**
Wire, Cable, Connectors	0	0**	0	0**	0	0**	0	0

* Increase over May
** Decrease from May

Comment: For the first time in 5 months tube prices seem to be leveling off. The antenna and accessory manufacturers, on the other hand, have become increasingly active which might possibly be due to the expected opening of new TV areas.

This data is prepared by the staff of United Catalog Publishers, Inc., 110 Lafayette Street, New York, publishers of RADIO'S MASTER, the Official Buying Guide of the Parts Industry.

General Electric Tube Department, Schenectady, N. Y., is conducting a nation-wide service-promotion contest for radio and TV service technicians from June 15 to August 15. The contest is aimed at bringing in more summer servicing business based on preventive maintenance. Three 1952 Dodge panel trucks are the top prizes. Entrants will be judged on the planning, originality, and results brought in by their campaigns. Judges will be Mort Farr, president of NARDA; George Wedemeyer, president of NEDA; John Rider; Howard Sams; and John T. Thompson, G-E replacement-tube sales manager.

Entry blanks and promotional material are available from G-E tube distributors.

Merchandising and Promotion

National Union Radio Corp., Orange, N. J., is offering a 17-piece, all-purpose tool kit especially designed for TV and radio service work. The kit comes in a heavy plastic roll which may be worn as an apron or hung on the wall. National

Union is giving the kit free, through its distributors, with the purchase of 250 tubes.

Grayburne Corp., New York City, is supplying its distributors with a newly-designed counter-display stand. The



stand holds three of the company's fastest selling products—Ferri-Loopsticks, Vari-Loopsticks and the TV-IF Signal Booster. The stand is available with the purchase of a combination of three cartons of any of the products mentioned.

Allen B. Du Mont Laboratories is emphasizing improvement in television reception rather than mere replacement in the new promotional campaign on its TV picture tubes. Around the slogan,

RADIO-ELECTRONICS





You can double your fall service business with this

NEW SYLVANIA CAMPAIGN

Two gorgeous movie stars, Ann Blyth and June Havoc, feature their personal endorsements of your service in this brand new Sylvania advertising campaign for service dealers. On life-like window displays and streamers, they recommend you just the way they will in the big Sylvania ads in *Collier's*, *Life*, *Look*, and *The Saturday Evening Post*, which will appear this Fall.

In addition, the Sylvania Campaign offers you four sets of personalized mailings imprinted

with your name, address and phone number. All of the mailing pieces have stamps already attached. You pay **NO POSTAGE!** Radio spot announcements, and reminder stickers for your customers' sets round out this sure business-attracting kit!

And all you pay is **just 2 cents per prospect per month** for the mailers. All the rest is absolutely **FREE . . . even the postage on the mailers!** Call your Sylvania Distributor today, or mail the coupon below.



SYLVANIA



RADIO TUBES; TELEVISION PICTURE TUBES; ELECTRONIC PRODUCTS; ELECTRONIC TEST EQUIPMENT; FLUORESCENT TUBES, FIXTURES, SIGN TUBING, WIRING DEVICES; LIGHT BULBS; PHOTOLAMPS; TELEVISION SETS

Sylvania Electric Products Inc.
Dept. R-2708, Emporium, Penna.

Please send me full details on Sylvania's big Fall Campaign for Radio-TV Service Dealers.

Name _____

Street _____

City _____ Zone _____ State _____

"A new Du Mont television picture tube is more than a replacement . . . it is a definite improvement." The program will be backed by vigorous advertising and sales-promotion efforts.

New Plants and Expansions

The New Haven Clock & Watch Co., New Haven, Conn., completed negotiations for the acquisition of Condenser Products Co., Chicago, manufacturer of capacitors, power supplies, and pulse-forming networks. Condenser Products will operate as a division of New Haven Clock. S. M. Levenberg, former president of Condenser Products, will be in charge of administration in Chicago. Other key personnel, including James

Claxton, production manager, Stephen Meskan, chief engineer, and Jack Powers, sales manager, will continue their association with the company.

General Electric is constructing a multimillion-dollar transformer manufacturing plant in Rome, Ga. It is expected to be completed some time in 1953.

Speer Carbon Co., St. Marys, Pa., and its subsidiaries, Jeffers Electronics, Inc., Du Bois, Pa., International Graphite & Electrode Corp., Niagara Falls, N. Y., and Speer Resistor Corp., St. Marys, Pa., have consolidated into one company with headquarters in St. Marys, Pa. The subsidiaries will henceforth operate as divisions of Speer Carbon.

Jersey Specialty Co., Little Falls, N. J., is rapidly completing construction of its new plant in Mountainview, N. J. The company's operations include the manufacture of television lead-in wire and wire spooling operations.

Allied Electric Products and its Sheldon Electric Division, Irvington, N. J., moved its West Coast branch office and warehouse to larger quarters in Los Angeles to improve its facilities for serving manufacturers and distributors in that area.

Krylon, Inc. is now occupying a new two-story plant in Philadelphia which provides an additional 18,000 square feet of space. A new research laboratory will be set up to provide for product expansion.

Workshop Associates, Needham Heights, Mass., completed a new antenna-pattern measuring range on the site of its new laboratory in Natick, Mass.

Ajax Condenser Co., Chicago, opened a new factory on the West Coast which will be operated by the company's newly formed California affiliate, Ajax Condenser Corp., North Hollywood.

Hytron Radio & Electronics Co. moved its executive and sales offices to its new plant in Danvers, Mass.

Raytheon Manufacturing Co. opened a new Receiving Tube Division branch plant in Brockton, Mass., for the assembly of subminiature electronic tubes. A staff of 200 will be employed. The new Brockton operation reports to O. P. Susmeyan, manager of the Newton and Quincy receiving-tube plants. Raytheon also established an International Division to meet its expanding foreign business. Ray C. Ellis, formerly vice-president in charge of the Equipment Sales Divisions, now heads the new division.

Approved Electronics, New York City manufacturer of test equipment, moved to new, larger quarters at 928 Broadway.

Business Briefs

. . . P. R. Mallory & Co., Inc., Indianapolis, is augmenting its program for providing replacement information to service technicians by listings in Howard W. Sams' *Photofacts*.

. . . The 1952 Western Electronic Show and Convention will be held in the Municipal Auditorium, Long Beach, Calif., August 27 to 29, sponsored by the West Coast Electronic Manufacturers Association, with the Institute of Radio Engineers acting as convention hosts. About 175 exhibitors are expected to display at the show.

. . . Capitol Radio Engineering Institute, Washington, D. C., is celebrating its 25th anniversary this year. The celebration was opened in June with a banquet in the Mayflower Hotel in Washington, D. C.

. . . Littelfuse, Inc., Des Plaines, Ill., celebrated its 25 years in the industry with a buffet-bar party in Chicago. E. V. Sundt, Littelfuse president, T. N. Blake, executive vice-president, and Jack D. Hughes, vice-president in charge of sales, were presented with silver cufflinks in honor of the occasion.

—end—

RADIO-ELECTRONICS

TINY-TRIM and TERRIFIC

THE TURNER 80



This is the new Turner 80 — a crystal microphone so tiny it hides in the palm of your hand, yet so strikingly designed it is the very picture of scintillating symmetry. Weighs less than five ounces, yet its high output and unusually fine response characteristics make it a natural for announcing and mobile public address systems, for home recording, dictating machines, amateur communications, portable recorders and dozens of other applications. Finished in beautiful satin chrome. Level: Approximately 58 db below 1 volt/dyne/sq. c.m. Response: 80 — 7000 c. p. s. 7 foot attached single conductor shielded cable.

List Price.....\$15.95



THE TURNER COMPANY 933 17th St., N. E. Cedar Rapids, Iowa

IN CANADA:
Canadian Marconi Co., Ltd. Toronto, Ont., and Branches
EXPORT:
Ad. Auriema, Inc. 89 Broad Street, New York 4



Crystals licensed under patents of the Brush Development Company

always in stock at
ALLIED!

HICKOK Precision
TEST
INSTRUMENTS

Model 533AP Tube Tester

Dynamic Mutual Conductance portable tester for radio and TV technicians. Reads in micromhos—tests tubes under simulated operating conditions. Tests all type tubes including miniature and subminiature. Accurately detects weak, borderline tubes; checks for gas. Carrying case has detachable cover. For 110-130 volts, 50-60 cycle AC. Size, 16 3/4 x 18 3/4 x 7 1/2". Shpg. wt., 33 lbs. **84-187. Net. \$168.00**

Model 533AC. As above, but in counter-type blue enameled steel case. Size, 17 1/2 x 18 1/2 x 6". Shpg. wt., 32 lbs. **84-186. Net. \$168.00**

Model 539A. Lab model; measures mutual conductance in micromhos; vernier adjustment. Durable leatherette case. For 110-130 volts, 50-60 cycle AC. Size, 16 3/4 x 18 3/4 x 7 1/2". Shpg. wt., 39 lbs. **84-180. Net. \$271.50**

Model No. 600A Tube Tester

Dynamic Mutual Conductance tester for highly accurate radio servicing, and for lab and industrial applications. Tests for gas content; reads in micromhos; applies separate voltage to each element; easily detects weak tubes. Triple-scale meter has ranges of 0-3000-6000-15,000 micromhos and REPLACE—?—GOOD. Replaces roll chart gives setup data at a glance. Leatherette-covered case. Size, 16 3/4 x 7 1/2 x 11 3/4". For 110-130 volts, 50-60 cycles AC. Shpg. wt., 21 lbs. **84-185. Net. \$155.00**

Model 605. As above, but has built-in VOM. A compact, low-cost portable tube and set tester. Shpg. wt., 27 lbs. **84-189. Net. \$167.60**

Cathode Ray Tube Tester Adapter. For use with tube testers above; permits checking of all present TV picture tubes without removing tube from set. Shpg. wt., 1 lb. **84-184. Net. \$9.90**

Model No. 680 VHF-UHF Marker Generator

A new RF signal and UHF TV front ends. Provides crystal calibrated markers from 53-89 mc and 174-217 mc on fundamentals and from 522-651 mc and 696-868 mc on harmonics. A magic eye insures accurate calibration. Choice of 3 calibrating crystals is provided by front panel switch (a 2.5 mc crystal is supplied). RF output, .15 v. Portable steel case, 11 1/2 x 9 x 6". For 110-130 v., 50-60 cycle AC. With tubes. Shpg. wt., 18 lbs. **84-188. Net. \$129.50**

Model 650 Videometer

A specialized signal generator for quickly localizing any TV trouble. Fundamental output on all 12 channels. Can be externally video modulated on all channels. Crystal-controlled circuit generates 60-900-15,750 cycle and 315 kc video pulses—produces horizontal and vertical bar patterns individually, or together; also dot pattern. Pulses also available externally; metered in peak-to-peak. Has 1 to 100,000 microvolt calibrated attenuator. Has video amplifier with 180° phase control, for use as substitution amplifier. Sawtooth outputs for substitution in TV set. Reads AC line voltage. Blue Hammertex case, 13 x 16 x 7". With test leads, output cable, and instructions. For 105-125 volts, 50-60 cycles. Shpg. wt., 40 lbs. **84-183. Net. \$310.90**

180° phase control, for use as substitution amplifier. Sawtooth outputs for substitution in TV set. Reads AC line voltage. Blue Hammertex case, 13 x 16 x 7". With test leads, output cable, and instructions. For 105-125 volts, 50-60 cycles. Shpg. wt., 40 lbs. **84-183. Net. \$310.90**

All HICKOK instruments are available on ALLIED'S Easy Terms: Only 15% Down, 12 Full Months to Pay

Model 610A TV Alignment Generator

For complete visual alignment of TV receivers—only a scope is required. Covers 10-250 mc with 0-15 mc variable sweep width, for alignment of RF on all 12 channels, alignment of sound and video IF's, and alignment of traps. Provides both pip oscillator markers and absorption markers, directly calibrated from 20-48 mc. Output multiplier is 5-stage type, with vernier control. Attenuator accuracy, 5%. Panel jack takes separate calibrating crystals (not supplied) for local channels. Also provides horizontal sweep voltage (phasing control). Standby switch. In blue Hammertex steel case, 14 x 16 1/2 x 7". Less crystals. For 105-125 v., 50-60 cycles. Shpg. wt., 35 lbs. **84-139. Net. \$219.00**

Model 630. TV voltage calibrator. Permits exact peak-to-peak voltage measurements—regardless of waveform. Size, 11 1/2 x 8 3/4 x 6". For 110-120 volts, 50-60 cycles. Vt., 15 lbs. **84-175. Net. \$87.50**

Model 292X Microvolt Signal Generator. Covers 125 kc to 110 mc and 150-220 mc, on fundamentals, with 1.0% accuracy. Size, 14 x 16 1/2 x 7". With cables and 1000 kc crystal. For 105-125 v., 50-60 cy. AC. Shpg. wt., 36 lbs. **84-145. Net. \$266.00**

New Model 670 5" Oscilloscope

For the service technician. Direct-coupled, P-P amplifiers for vertical and horizontal deflection provide perfect square wave response on low frequency signals. Vertical amplifier has useable response beyond 2 mc. Horizontal amplifier response from 0 to 100 kc. Sensitivity: vertical amplifier, 10 millivolts rms per inch; horizontal amplifier, 70 millivolts rms per inch. Input impedance: vertical amplifier, 2.2 meg and 30 mmf; horizontal amplifier, 1 meg and 35 mmf. Recurrent linear sweep from 3 to 50,000 cps and fixed sweeps at 30 and 7,875 cps. Def-modulator for viewing modulation on RF signals. Line phasing control. Internal 60 cycle or external Z-axis modulation. Hammertex blue case, 12 3/4 x 9 1/2 x 18". Complete with 5UP1 CRT, tubes and instructions. For 105-125 volts, 50-70 cycles AC. Shpg. wt., 35 lbs. **84-160. Net. \$199.98**

Model 640 5" Oscilloscope. Professional quality. Response: 0-4.5 mc (down only 3 db). Vertical—10 mv/inch (low sens. pos. 25 mv/inch); horizontal—50 mv/inch full gain, 20 v/inch direct. Size: 14 x 11 1/2 x 19". For 105-125 v., 60 cycles. Shpg. wt., 45 lbs. **84-179. Net. \$355.00**

Model 34 Probe. For above scopes; extends RF range to 500 mc. Shpg. wt., 1 1/2 lbs. **84-138. Net. \$9.80**

Model 209A Electronic VOM

Lab-size instrument. Zero-center scale for fast discriminator alignment. Measures AC rms and peak-to-peak volts directly from 30 cycles to 300 megacycles. 42 ranges: AC-DC volts, 0-3-12-30-120-300-1200; DC current, 0-3-12-30-120-300-1200 ma; resistance, .1 ohm to 10,000 megs in 8 ranges; capacity, 0-10,000 mmf and 0-1000 mfd (7 ranges); inductance, 50 mh to 100 henries; db, -20 to -25 in 3 ranges; AC peak-to-peak volts, 0-3-12-30-120-300. Input impedances: DC, 12 megs; AC, 12 megs and 6 mmf. 9" meter has easy-to-read scales. Separate jack for 1200 volt AC range. Case is blue Hammertex; 16 1/2 x 13 1/4 x 7". With tubes, high-frequency probe, leads. For 105-125 v., 60 cycle AC. Wt., 25 lbs. **84-136. Net. \$132.50**

Model PR30A Probe. High voltage DC probe for use with above. Extends range to 30,000 volts DC. With 4-foot cable and connector. Shpg. wt., 1 1/2 lbs. **84-149. Net. \$11.90**

Model 450 VOM. Lightweight, portable general-purpose VOM; 5" meter; high sensitivity; 20,000 ohms/volt on DC; 5000 ohms/volt on AC. Only 8 3/4 x 5 3/4 x 2 1/2". Shpg. wt., 4 lbs. **84-182. Net. \$46.50**

Model 215 VTVM. A professional unit of high accuracy. Reads RMS and peak-to-peak AC volts (7 ranges each), and DC volts: 0-1.5, 3-12-30-120-300-1200. 5" meter. 8 3/4 x 5 3/4 x 4 1/2". Shpg. wt., 8 lbs. **84-181. Net. \$67.50**

FREE 212-PAGE 1952 BUYING GUIDE

Send today for ALLIED's authoritative, complete catalog, listing the world's largest stocks of tubes, parts, test instruments, audio equipment, industrial components—everything in electronics at lowest prices. Look to ALLIED for speedy delivery, expert personnel help and complete satisfaction. Get your FREE catalog now.



ALLIED RADIO

ALLIED RADIO CORP., Dept. 2-H-2
833 W. Jackson Blvd., Chicago 7, Illinois

Send FREE 1952 ALLIED Catalog
 Please ship the following HICKOK instruments:

.....\$.....enclosed

Name.....

Address.....

City.....Zone.....State.....

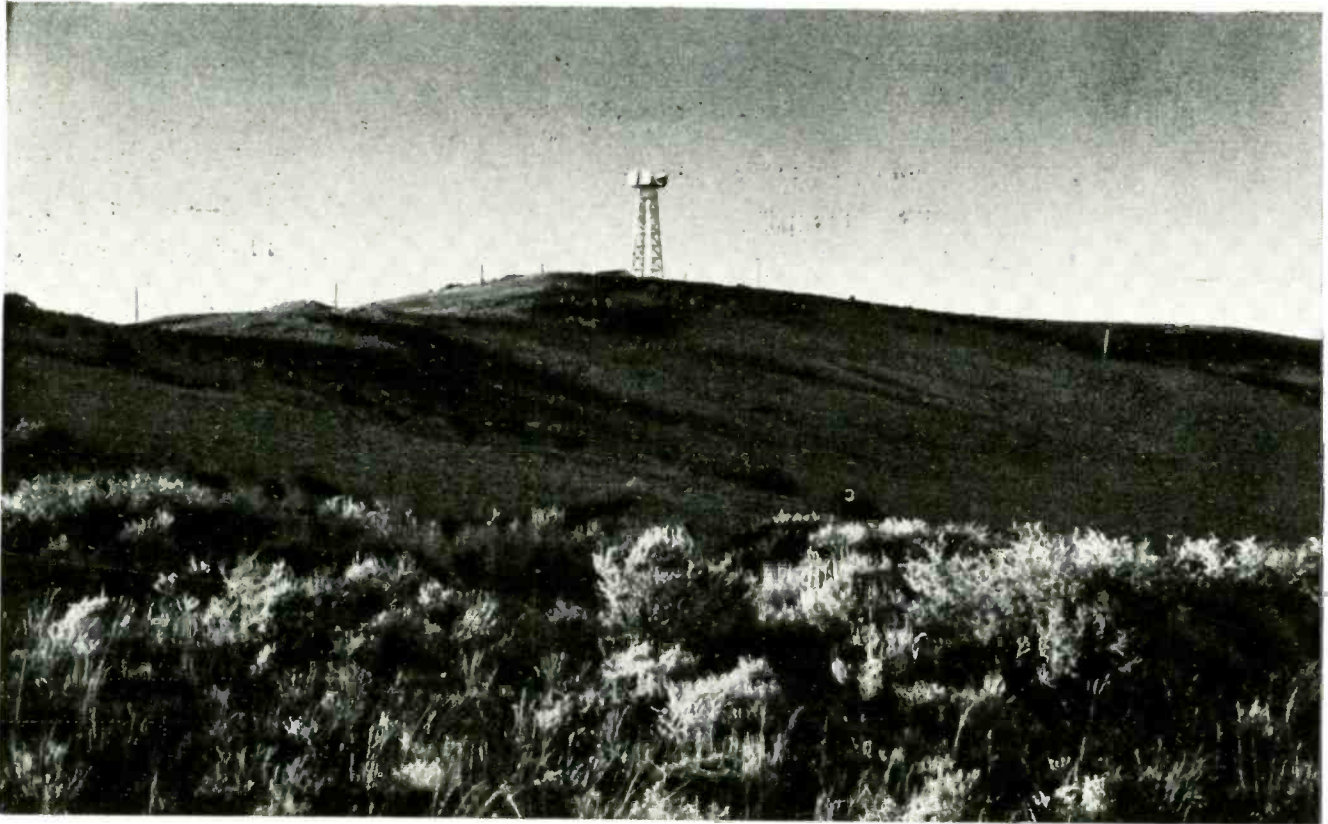

Radio-relay station at Evanston, Wyoming

a **W**atcher for lonesome places

Many of the Bell System's 107 radio stations connecting New York and San Francisco by microwave radio-relay stand on hills and mountains far from towns. Day after day, the apparatus does its duty; no man need be there to watch it. But when trouble threatens, an alarm system developed by Bell Telephone Laboratories alerts a testman in a town perhaps a hundred miles away.

A bell rings. The testman sends a signal which asks what is wrong. A pattern of lights gives the answer—a power interruption, an overheated tube, a blown fuse, a drop in pressure of the dry air which

keeps moisture out of the waveguide. At intervals the testman puts the system through its paces to be sure it is on guard.

Sometimes the testman can correct a trouble condition through remote control, or the station may cure itself—for example, by switching in an emergency power supply. Sometimes the trouble can await the next visit of a maintenance man—sometimes he is dispatched at once.

This is one of the newest examples of the way Bell Laboratories adds value to your telephone system by reducing maintenance costs and increasing reliability.



Alarm-receiving bay in town. Lights on a chart report on 42 separate conditions affecting service. Telephone is to communicate with maintenance crews. Eleven alarm centers across the country cover all 107 radio-relay stations. Stations too far off the beaten trail for wire connections signal by very high frequency radio.



BELL TELEPHONE LABORATORIES

IMPROVING TELEPHONE SERVICE FOR AMERICA PROVIDES CAREERS FOR CREATIVE MEN IN SCIENTIFIC AND TECHNICAL FIELDS.

RADIO-ELECTRONICS

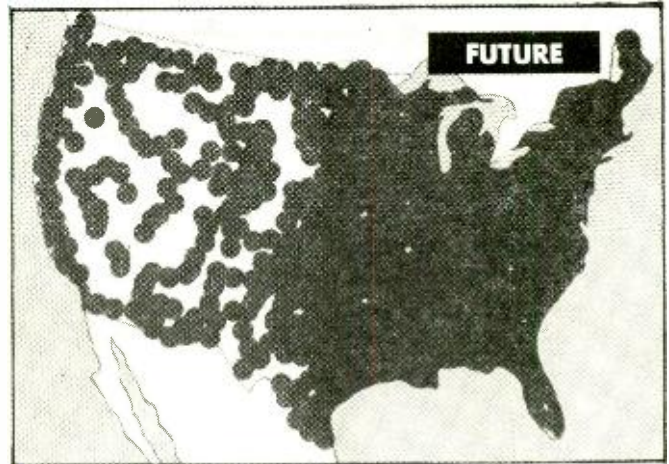
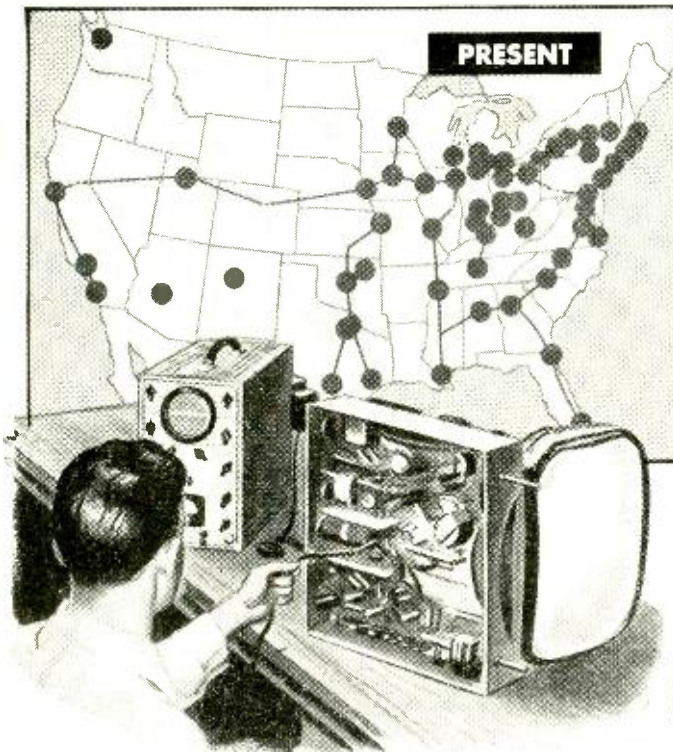

FUTURE—How new TV stations are expected to cover the nation.
PRESENT—Chart shows extent of current coverage.

Cash in on this Great Opportunity

... for good-pay jobs in TV SERVICING

YES, thousands of opportunities are going begging right now for good-pay jobs in TV Servicing.

The lifting of the "freeze" on new television stations clears the way for the expansion of the industry for 2,053 new stations, in 1,291 communities in the United States, its territories and possessions. There are only 108 stations telecasting now.

This is your golden opportunity to get all set for a good job that can mean employment security and a bright future for years to come. It's a great opportunity that can lead you, as a trained and experienced TV Serviceman, into establishing a profitable business of your own.

Big shortage of TV Technicians creates opportunities—NOW

Industry experts have estimated over 130,000 experienced TV technicians will be needed for the installation, trouble-shooting and repairing of television receivers in use by 1955. There are fewer than 50,000 fully trained TV service technicians available today. What an opportunity this creates for you!

Here are some of the good-pay jobs you can

choose—installation and trouble-shooting of TV receivers in homes . . . bench technician in radio-TV service shops . . . inspector, tester, repairman, field serviceman for TV receiver manufacturers, distributors and dealers . . . testing and servicing with electronic instrument manufacturers and companies with military contracts for electronic equipment . . . civilian serviceman with U. S. Military Bases . . . your own TV service shop—and many more.

RCA Institutes home study course trains you in your spare time

If you are associated with the radio-electronics industry, with no experience in TV servicing, the addition of the RCA Institutes Home Study Course in TV Servicing to your present experience will quickly qualify you to step out and grasp the good jobs now open in television.

The RCA Institutes course gives you a sound knowledge of television fundamentals . . . intensive practical instruction on the proper maintenance and servicing of TV receiver circuits . . . teaches you the "short cuts" on TV installation and trouble-shooting. Learn TV servicing (based on actual experience of hundreds of skilled technicians) from RCA engi-

neers and experienced instructors—pioneers and leaders in radio, television and electronic developments.

RCA Institutes home study course planned to your needs

You keep your present job. In your spare time, you study at home. You learn "How-to-do-it" techniques with "How-it-works" information in easy-to-study lessons prepared in ten units. Cost of RCA Home Study Course in Television Servicing has been cut to a minimum—as a service to the industry. You pay for the course on a "pay-as-you-learn" unit lesson basis. You receive an RCA Institutes certificate upon completion of the course. The RCA Institutes Home Study Course in Television Servicing is approved by leading servicemen's associations.

Don't pass up this lifetime opportunity for financial security and a bright future in TV.

SEND FOR FREE BOOKLET

Mail the coupon—today. Get complete information on the RCA INSTITUTES Home Study Course in Television Servicing. Booklet gives you a general outline of the course by units. See how this practical home study course trains you quickly, easily. Mail coupon in envelope or paste on postal card.

RCA Institutes conducts a resident school in New York City offering day and evening courses in Radio and TV Servicing, Radio Code and Radio Operating, Radio Broadcasting, Advanced Technology. Write for free catalog on resident courses.



RCA INSTITUTES, INC.
 A SERVICE OF RADIO CORPORATION OF AMERICA
 350 WEST FOURTH STREET, NEW YORK 14, N. Y.

AUGUST, 1952

MAIL COUPON NOW!

RCA INSTITUTES, INC., Home Study Department RE-852
 350 West Fourth Street, New York 14, N. Y.

Without obligation on my part, please send me copy of booklet "RCA INSTITUTES Home Study Course in TELEVISION SERVICING." (No salesman will call.)

Name _____ (please Print)

Address _____

City _____ Zone _____ State _____



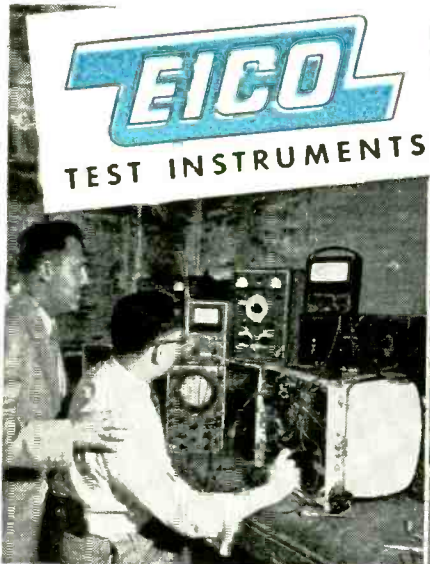

In the CBS-Columbia design laboratories, Al Goldberg takes some important readings with the EICO Model 221 Vacuum Tube Voltmeter and Model 555 Multimeter, as Harry R. Ashley looks on.



Mr. Al Goldberg, Assistant Chief Engineer of CBS-Columbia, and Harry R. Ashley, President of EICO, inspecting the use of the EICO Model 221 Vacuum Tube Voltmeter and Model HVP 1 High Voltage Probe at the Sweep Frequency Troubleshooting Position on the CBS-Columbia Television production lines.

CBS-Columbia Inc.
HIGH STANDARDS OF
TELEVISION PRODUCTION QUALITY



NEW
221K VTVM KIT \$25.95
WIRED \$49.95



HIGH VOLTAGE
PROBE \$6.95

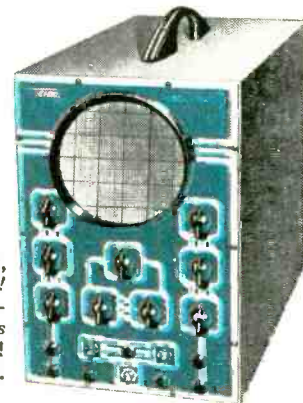

NEW 425K 5" PUSH-PULL
SCOPE KIT \$44.95 WIRED \$79.95

KITS
WIRED INSTRUMENTS



NEW 565K MULTIMETER
KIT \$24.95 WIRED \$29.95
20,000 ohms/volt



320K SIG.
GEN. KIT \$19.95. WIRED \$29.95

NEW 322K SIG. GEN.
KIT \$23.95. WIRED \$34.95

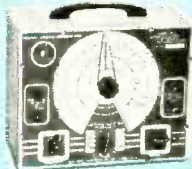

NEW 950K R-C BRIDGE &
R-C COMP. KIT \$19.95
WIRED \$29.95



NEW 1040K BATTERY ELIM.
KIT \$25.95. WIRED \$34.95



511K VOM
KIT \$14.95
WIRED
\$17.95



NEW 536K MULTI-
METER KIT \$12.90
WIRED \$14.90
1000 ohms/volt



NEW 1171K RES.
DECADE BOX KIT
\$15.95
WIRED \$24.95

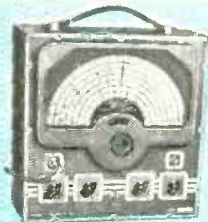

NEW 315K DELUXE SIG.
GEN. KIT \$39.95
WIRED \$59.95



145K SIG.
TRACER KIT
\$19.95
WIRED
\$28.95



NEW 625K
TUBE TESTER KIT \$34.95
WIRED \$49.95
NEW CRA CR ADJUSTER
for above \$4.50

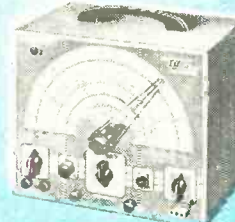

360K SWEEP GEN. KIT \$34.95
WIRED \$49.95

*For Laboratory Precision at Lowest Cost—
the Leaders Look to EICO!*

WHY does CBS-Columbia, Inc., another one of America's leading TV manufacturers, use EICO Test Instruments on both its production lines and in its design laboratories?

BECAUSE — like Emerson, Tele-King, Tele-Tone, Majestic, and many another famous TV manufacturer coast to coast, CBS-Columbia knows that . . .

*Only EICO Test Equipment delivers
All 10 EICOnomical Features!*

1. Laboratory Precision
2. Lowest Cost
3. Lifetime Dependability
4. Speedy Operation
5. Rugged Construction
6. Quality Components
7. Latest Engineering
8. Super-Simplified Assembly and Use Instructions
9. Laboratory-Styled Appearance
10. Exclusive EICO Make-Good Guarantee



New 377K Sine & Square Wave
AUDIO GEN. KIT \$31.95 WIRED \$49.95

Before You buy any higher-priced equipment, look at the EICO line — in *Wired and Kit form!* Each EICO product is jam-packed with unbelievable value. Compare, see EICO instruments today—in stock at your local jobber—and SAVE! Write NOW for FREE newest Catalog 8-C.

**FOLLOW THE LEADERS
. . . INSIST ON EICO!**

© 1951, Electronic Instrument Co., Inc. Prices 5% higher on West Coast. Due to unstable conditions, prices and specifications are subject to change without notice.



ELECTRONIC INSTRUMENT CO., Inc.
84 WITHERS STREET, BROOKLYN 11, N. Y.

ELECTRONIC BRAINS

. . . . *An electronic computer boom is now in the making.*

By HUGO GERNSBACK

SCIENTISTS are pretty well agreed now that most animal brain functions are partly electric, many wholly electric. It is known that the human brain has the equivalent of over ten billion neurons (nerve-cells), many of which act very much like vacuum tubes, or, to be more up-to-date, transistors. The human brain has the facility of storing many millions of impressions fed to it from the outside world. When required, these stored impressions act upon or solve various problems.

Some exceptional human beings have what are called computing brains. They can solve, in a few seconds, complicated mathematical problems merely by exercising certain not-too-well-understood functions in the brain.

Electronic computers as we know them today can duplicate many functions of the human or animal brain. Frequently electronic brains can do all this much faster and better and without chance of error.

No wonder then that the best electronic engineering minds have been busy for many years devising better and more efficient electronic computers. These machines started out originally as highly complex and cumbersome devices, and now are becoming even more complex, but are also constantly shrinking in size.

With the advent of the transistor, compact electronic desk computers of the highest order will be a reality in the not very distant future. Not all electronic computers and calculating machines are alike. They differ in various respects, depending upon the work they are called upon to do.

The vast quantity of intricate calculating done nowadays by humans takes a terrific amount of mind power and man-work hours. This valuable power will in the future be released and used for other more productive work. The reason is that one good computer can easily do the work of dozens of accountants in a fraction of the time it takes humans to do the same chore. Indeed in many instances the ratio is 1000 to 1, increasing in favor of the computers as they become more efficient.

How closely the human brain is now imitated is best illustrated by a recent invention of Dr. Howard Aiken, head of Harvard Computing Laboratory. He developed the new *Static Magnetic Memory*—a rapid storage device. The brain of the nation's most ambitious computer, the fabulous new Mark IV, now nearing completion, has 40,000 such Static Magnetic Memory Units.

No wonder then that one of the biggest branches of the electronic industry is now electronic computers. More and more firms are engaged in building these calculators for various purposes. It is quite certain that electronic computers will be one of the biggest, if not the biggest, division of electronic manufacturing in the foreseeable future. This estimate was recently made by Dr. Simon Ramo, chief of research of Hughes Aircraft Corporation, at the fifth annual convention of the Federated Financial Analysts Society in San Francisco.

At the present time, as is only natural, military establishments have first call on electronic computers, because of the importance of the military uses of these devices. In modern war, electronic computers are priceless. They literally spell the difference between victory and defeat. All guided missiles, whether modern cannon or long-distance guided rockets or planes, must be directed by elec-

tronic computers. Even in World War II, the German robot long-distance V1 and V2 rockets were shot down with almost perfect regularity by electronic computing devices attached to anti-aircraft guns in England.

This, however, is only the beginning. The future general, before he goes into a battle, will have the possible results forecast by an electronic computer in such a manner that he will know for a certainty—given certain vital factors—if he can win or not.

There are today hundreds of special military electronic computer uses, and it may be safely stated that if and when World War III comes, it will be fought—and won—chiefly with military electronic computers.

On a more peaceful side, according to General David Sarnoff, chairman of the board of the Radio Corporation of America, "the nation's business operations will be revolutionized within a reasonably near future." In a recent talk, Sarnoff said: "These modern electronic robots promise to revolutionize and simplify the clerical operations of insurance companies, banks, tax bureaus, stock exchanges, and business in general. A single electronic computer can do the combined accounting of receivables, payables, purchases and stock controls."

He continued, "With some nine million persons—or 16% of the working population—engaged in clerical activities, present business systems are too slow and costly. The men responsible for making major decisions all too often find out that they must shape tomorrow's policy on the basis of statistics which are weeks or months out of date. It is now feasible to combine the automatic devices which have been developed for radio-television to form a complete electronic accounting system for even the largest business organization."

It was recently predicted by government scientists that new and simplified electronic computers will soon make their appearance for practical business uses, such as inventorying, accounting, market research, sales, mailing lists, and such business calculations as payroll amortization, prorating, various statistics, quality control, and other records.

Electronic computers will not only be used for future business systems, but for many other endeavors, chiefly for scientific and research purposes, which were the first to use the electronic computers in the past. They can also be used for such unusual purposes as sports. College football has already begun to use electronic computers. An eastern university has used electronic brains in analyzing opponents' plays. The best scientist of the university uses the usual punch-card system and electronic computers to plot in advance a coming game. It is also a fact that in the past several seasons the electronically-guided team remained undefeated!

From this it seems reasonable to deduce that organized baseball will use computers to give the team the right answers well in advance. Other sports, such as tennis, and horse racing, are in the same class.

Right here the thoughtful non-electronic mind may well calculate what is going to happen if the opposing team also uses electronic computers. For the answer we need no electronic computer—almost certainly *the better team will win.*

Mobility makes
money when customers
can try—then buy

HOME TRIALS AND

If you were to ask ten television dealers selling sets fifty miles or more from a TV transmitter what was the biggest headache in their business, at least seven of them would probably answer without hesitation: "Home demonstrations!"

The sales manager of Marocco's Music Mart, Logansport, Indiana, points out that putting a piece of equipment into a potential customer's home "on trial" has always been a time-and-money-consuming gamble on the part of any dealer; but the problem is greatly aggravated when the merchandise is a TV set, carrying a microscopic margin of profit in the first place, and so far from a transmitter that the built-in antenna of the set is entirely useless.

Yet the ultra-fringe dealer is practically forced into this practice. Most stores are located in downtown areas where the noise level completely swamps the anemic television signal. Moreover, in many cases there isn't room enough to put up an elaborate antenna array that will catch enough signal to override the noise. Even if this can be done, it will not guarantee on-the-spot sales.

"If I've got to put up an antenna tower like the one you're using here," the customer is likely to tell you, "I'll just wait until we have a closer transmitter. In the first place, I couldn't afford to put up something like that; and in the second place, my wife would never stand for anything that big being put up at our home."

It does no good to explain that in a quiet residential area a much simpler antenna installation can bring in even better reception. The customer is willing to be shown this, but you cannot tell him. He knows from what he has read and heard that TV signal strength varies widely—and often unpredictably—from one receiving location to another, even when these points are comparatively close together. The fact that a dealer can get a fair picture in his store by using a skyscraper antenna with at-the-antenna boosters and special lead-in does not convince the customer that reception at his own home using ordinary equipment will compare favorably with this "souped-up" installation—and you can hardly blame him!

A dealer who flatly refuses to make home demonstrations simply invites suspicion that the sets he sells are in-

ferior and that he is afraid to have them compared with competitors' sets in the customer's home. "If the sets are as good as he says they are, why is he afraid to demonstrate them?" the customer wonders; and you may rest assured that the dealer's competitors will make capital of his refusing to put his sets in on trial. So, whether he wants to or not, the fringe-area television dealer is practically forced into making home demonstrations.

Demonstration antennas

The worst feature of making the demonstration is the antenna problem. If the reception is to be of selling quality, the antenna must be good, and it must be up in the air high enough to pull in a strong signal. At the same time, since the sale is problematical, the whole antenna installation must be temporary: no permanent anchors can be screwed into the customer's house, and not too much time or money can be expended in erecting the trial antenna.

The portable antenna-tower mounted on some sort of trailer has proved to be one of the best answers to this problem. Views of a modern, commercially-built example are shown. Fig. 1 shows the telescoping aluminum tower extended to its full height of 80 feet. In Fig. 2 it is in its folded position for transport. The antenna can be raised and lowered at will with this equipment for determining the best height for reception—information that will be very useful when and if a permanent antenna is put up later. Another feature is that this crank-up tower can be used as a telescoping ginpole, requiring only two men to raise permanent towers up to 100 feet in height.

Mobile show rooms

The owner of Booth's Radio & Appliance Company, Bakersfield, Calif., has worked out a much more elaborate setup. He uses a specially-constructed tubular antenna mast that can be hydraulically extended to a height of 80 feet, mounted permanently on a truck that also contains boosters, signal-strength measuring equipment, a television receiver, and comfortable accommodations for viewers. When a customer wants to know what kind of television reception he can expect if he buys a set, the truck is simply parked in front of his door, the antenna is pumped up to any desired height, and he can sit there

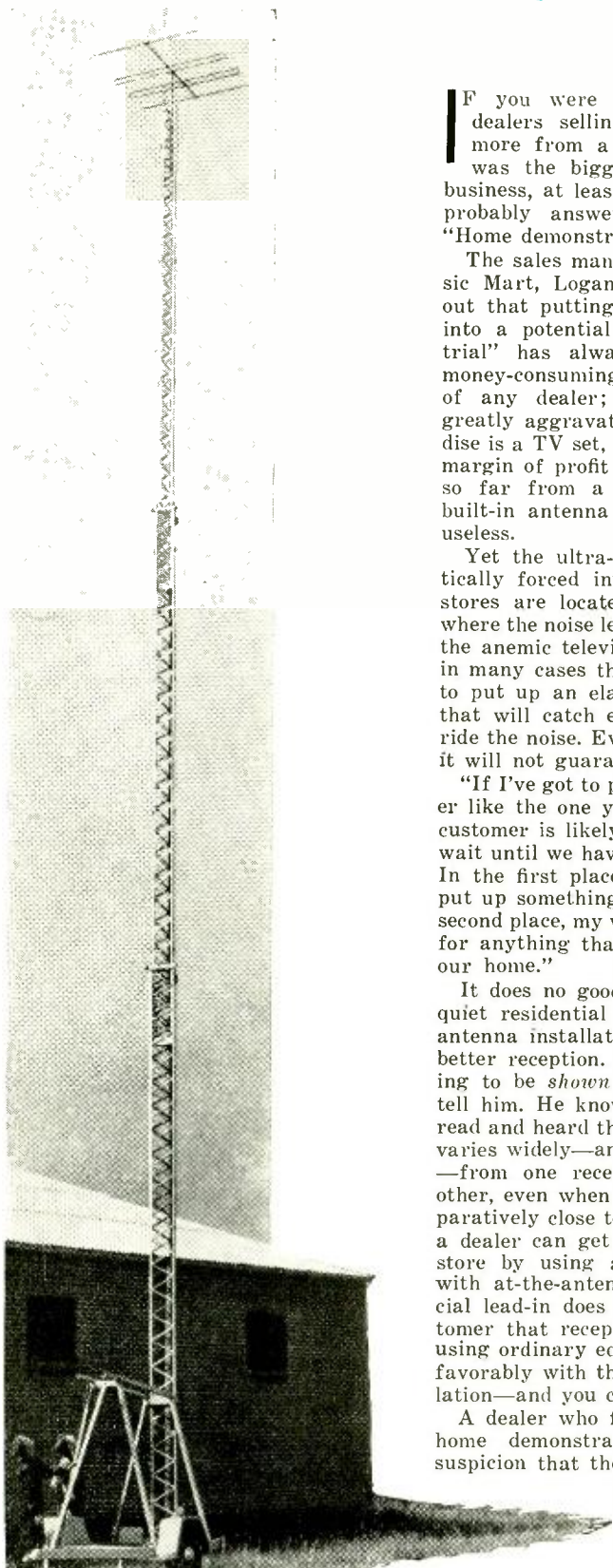

TRIBULATIONS

By JOHN T. FRYE

in the truck and see exactly how the set performs. This method of home demonstration has several advantages: One man can make the entire demonstration. Nothing in the customer's home needs to be disturbed. The set is in the dealer's possession at all times, and is out of the shop for only a few hours. No compromise between a good antenna and an inadequate temporary antenna installation need be made. The only catch—and of course there is one—is that the owner of this mobile demonstrator has some six thousand dollars tied up in it!

The Home Furniture Company of Zanesville, Ohio, has gone this even one better. A huge trailer has been expensively equipped with rugs, fluorescent lamps, and fine furniture to simulate a living room and provide a flattering setting for the TV sets displayed. These are demonstrated in action with the aid of a telescoping antenna mounted on the trailer roof. The on-the-hoof value of this perambulating living room is figured at seventeen thousand dollars; but it should be pointed out that in addition to being used for home demonstrations, this equipment is also valuable for mass demonstrations at fairs, carnivals, and conventions.

Not many fringe-area dealers want to invest that much money in home-demonstration equipment, especially now that the freeze has been lifted and new stations will soon start the fringe areas shrinking; but the illustrations show to what lengths some dealers have gone to let potential customers see what kind of reception they can expect before they buy. Certainly

those dealers considered home demonstrations very important.

Home-trial headaches

There is one kind of customer in the fringe area who solves the antenna problem for himself. He installs his own antenna—or has an independent outfit put it up for him—he buys a booster, and then he feels free to try out various makes of television receivers to his heart's content and for as long as he wishes without apparently feeling the slightest obligation to the dealers who sell these sets! After all, he put up his own antenna, didn't he?

Some dealers encourage him in this matter of installing his own antenna, for they feel that if he goes that far he is almost certain to end up buying a television set from someone. At the same time, this does away with the expense and trouble of erecting a temporary antenna. Other dealers, though, are not pleased with the arrangement. They dislike seeing the profit of the antenna installation going to someone else. On top of that, they usually have a pet antenna and booster that seem to give the best results with the sets they handle, and they prefer to sell a complete installation rather than just the set alone.

If the customer is determined to put up his own antenna, there is not much anyone can do about it. When he does, he usually wants to try out two or more sets at the same time so that he can compare them on the same program. Since the strength of the TV signal in an ultra-fringe area can vary greatly

from minute to minute, this makes good sense (though exasperating to the dealer).

However, it does bring up several new problems. For one thing, it is not practical to operate two sets from the same antenna with the puny signal found in a fringe area. Couplers that permit such operation without mismatch necessarily introduce some loss, and ordinarily you have no signal to spare. Moreover, it is quite possible to connect two TV sets to the same booster with certain critical lengths of lead-in so that on the same station one set will receive much more signal than the other. This state of affairs is an open invitation to electronic skulduggery when one dealer is asked to connect up his set with a competitor's set.

If the sets must be connected simultaneously to the same booster, the leads from the booster to the sets should be of identical length. A better arrangement is to use a single lead from the booster with one of those glorified clothes-pin connectors on the end so that it can be quickly connected first to one set and then to the other. Be sure to explain to the customer that the set actuating the booster through its automatic switch must be left turned on all the time these quick comparisons are being made, even though the picture is being watched on the other set. I know a case in which failure to do this simple thing lost a sale.

One thing that makes the average dealer take a dim view of home demonstrations is the fact that after a TV set has weathered about a half dozen of these home trials it can no longer be offered as new merchandise. Be as careful as you will, hauling a heavy TV set around is almost certain to result in some marks and scratches. To my surprise, most dealers report that customers take reasonably good care of the sets while they are in on trial; but sets in the home are bound to receive some damage, especially if there are small children. Then there was the case told me by a dealer who, when he went to pick up his demonstrator set, found the speaker grille cloth badly frayed.

Fig. 1 (opposite)—Collapsible 80-foot mast finds best antenna height at customer's site, doubles as derrick for raising permanent tower. Fig. 2 (right)—The aluminum test tower in transport position—ready to roll to another customer-home demonstration.



"Oh yes," the lady of the house said when this was called to her attention; "I meant to tell you about that. It was the cutest thing! When the weatherman draws on his glass-covered map, his chalk squeaks; and Agnes—that's our cat—thinks there's a mouse in the speaker and tries to get it. You would just die to see her!"

1 Demonstration = 1 Sale

Ralph Todd of Todd's Home Appliance Store in Logansport, Indiana, who has been outstandingly successful in selling fringe-area installations told me that he considered home demonstrations as a challenge and an opportunity rather than a nuisance. I quizzed him closely about his methods, and his answers went like this:

"First, we never take a set out until it has operated satisfactorily in the store for at least three consecutive hours. Before we put a set in on trial, the antenna must be adequate for the location; and this goes if the customer has put up his own antenna or if we use one of our antenna-trailers. When it is delivered either I or my technician goes along with it and sees that it gives top performance in the home.

That means the picture size is adjusted so that it will stay beyond the mask during the drop in line voltage we have during the early evening hours. A too-small picture will be noticed much more quickly than one that is a trifle too large. Ion trap, focus, hold, and a.g.c. controls are carefully reset at the customer's home, even though they were in perfect adjustment when the set left the store.

Considerable time is devoted to showing someone in the home how to operate the set. When possible, these instructions are given to the most interested party, the one who will make the decision about buying the set; but there are times, say when an elderly person is the potential purchaser, when a younger member of the household can be more easily taught to run it. In any event, the person is first shown how to tune the set, adjust the contrast and brilliance, operate the hold controls, etc. Then the set is deliberately thrown out of tune and sync, and the person is asked to bring it back into adjustment. This is repeated about three times to make sure he or she has the hang of it. Mimeographed instructions, using the same steps and phraseology, are left with the set.

While I am giving these instructions, I try to show the customer how to recognize a good picture when he sees one. I show him how 'the size of the snow'—often talked about by laymen—is just a function of the contrast setting. He is taught to look for fine detail, especially in the small vertical elements of the picture. I show him that a really good picture still looks good at reasonably close range, while to a bad picture 'distance lends enchantment.' The ability of a picture to remain steady under ignition interference is stressed. In short, I want him to be able to do an intelligent job of compar-

ing when he stacks my set up against a competitor's."

Lend or Lease?

The final problem of home demonstrations is how long to leave the set in on trial. All dealers with whom I talked agreed there should be a clear understanding that it would not be left indefinitely, but they did not agree on what limit should be set. One left the set in for a flat three days. Another did not pick up the set until there had been at least one night of good reception. Still another said he had no definite limit, but he kept the customer aware of the passing of time by frequent callbacks while the set was on trial.

He pointed out that these calls, if they were made—as they should be—by a TV technician, served several other useful purposes: First, they allowed the technician to spot and correct any minor trouble that might develop with the set; second, they provided insurance that competitors did not foul up the installation in any way detrimental to the dealer's set; and third, they gave the customer the comforting assurance that the dealer had trained personnel on hand to take care of any future trouble. A commission on sales was given the technician to interest him in making these evening calls.

Still another approach to the home demonstration headache is the practice of charging for this trial. For example, Ken's Radio of Jackson, Michigan, charges a flat five dollars for each set put in on trial, with the understanding that if the set is purchased, the money is applied to the purchase price. He claims this discourages the grafters, and cuts down the number of home demonstrations, but increases the number of sales. Certainly it neatly shifts the expense of making the demonstration from the dealer to the customer. At the same time there is serious doubt that this method will enjoy any great popularity under the dog-eat-dog competition of large urban areas. American people have been accustomed too long to free trials of everything from toothpaste to automobiles to take kindly to the idea of paying for their sampling—no matter how unfair to the dealer this well-rooted practice may be.

But the purpose of this article was not to advocate any one way of meeting the problem. Instead, it was hoped that by presenting a cross-section of what many dealers think and do about home demonstrations, the reader would be stimulated to do some thinking of his own on the subject. If it has done that, we can write: "Mission Accomplished."

The writer would like to express his deep appreciation to all the dealers and service technicians who contributed their ideas in preparing this article; and he especially wants to thank the management and service departments of Todd's Home Appliance Store and Marocco's Music Mart—both of Logansport, Indiana—for their invaluable assistance.

—end—

TV DX REPORTS

August will be bad news for the TV dx enthusiast. This month will mark the end of the major TV dx period of 1952. The dx season averages just about three months, taking the country as a whole, but the starting and ending dates shift from one year to the next by as much as two weeks. This year's dx was very late in getting under way, so it is reasonable to assume that it will carry over farther into August than usual.

The last major opening of the year will probably occur around July 25 to 28, but there will be scattered dx during the first two weeks of August, with the possibility of fairly good conditions as late as August 10 to 12. It is doubtful if there will be any sporadic-E skip dx after the 15th, though there is a good possibility of major auroral disturbances later in the month. Past experience has shown that July and August auroral activity is often accompanied by dx that closely resembles sporadic-E skip in character. In fact, many propagation authorities now consider them to be variations of one phenomenon.

August marks the turning point for the better in tropospheric propagation. Over much of the country there is a shift in the weather toward fall late in the month, and with this change come the year's best opportunities for observing tropospheric phenomena on the frequencies above 30 mc.

The daily weather maps printed in many newspapers will give the best clues as to when weather effects will show in TV reception. Look for pronounced high-pressure areas, especially the slow-moving variety. Tropospheric propagation will be at a peak when these pass across your part of the country, usually being associated with calm, stable, local weather. A slowly increasing overcast is a good sign. If you have a barometer, watch for steady periods of above 30 reading, or a very slow fall in pressure after a spell of fair weather.

The effect of stable inversions of late summer is most marked on the high channels. Particularly along coastal areas, in the Mississippi and other large river valleys, and around the Great Lakes, the bending of v.h.f. waves may be very marked at this season, producing strong steady signals for many hours at a time. Amateurs have communicated on the 144-mc band over distances as great as 1,200 miles on at least one occasion under such conditions, and 500 miles or more is quite common. Although the amateur works with much weaker signals than are capable of producing a satisfactory TV picture, the TV dx enthusiast should not overlook the possibility of reception up to several hundred miles by this medium, especially on the high-frequency channels.

—end—

LONG LINES TV BOOSTER

An
Efficient
Single-channel
Job

By JAMES BOYETT

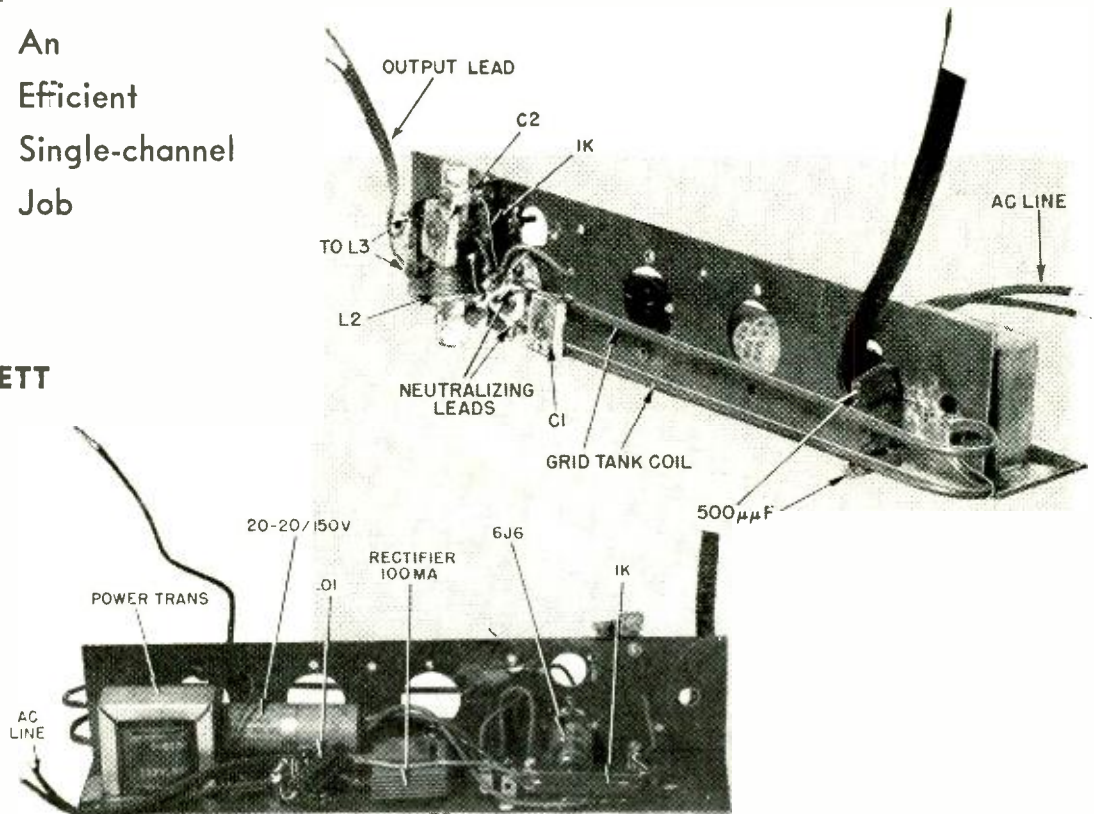

HERE'S a novel, easily-built booster for a single low-band TV channel. It uses a 6J6 as a neutralized push-pull amplifier, and gives excellent reception from a station 120 miles away.

The circuit, shown in Fig. 1, borrows a trick from v.h.f.-transmitter practice by using a folded-line grid tank made of $\frac{1}{8}$ -inch brass or copper tubing. A 22-inch length of tubing is bent into a hairpin 10½ inches long and $\frac{3}{4}$ inch wide on the outside. The closed end is folded over and grounded at the center as shown in the upper photo L2, the plate coil, consists of 13 turns of No. 20 plastic-insulated wire close-wound on a $\frac{1}{4}$ -inch polystyrene rod. Make a tap at the exact center for the plate-voltage connection. L3, the output link, is two turns of the same wire wound in the same direction over the center of L2. The 1,000-ohm loading resistor should be soldered directly across the ends of L2.

C1 and C2 are 2–8- μ f mica trimmers. C1 is soldered across the grid line about 1 inch from the open end. This can also be seen in the upper photograph.

The neutralizing leads are 2-inch lengths of insulated wire from the 6J6 plate pins inserted in the opposite open ends of the grid tank.

Plate voltage for the 6J6 is supplied by a 100-ma selenium rectifier and an R-C filter. Heater voltage may be taken from the TV receiver, or from a small 6-volt transformer (see photo). If the TV receiver is the transformerless type, or if any part of the antenna system

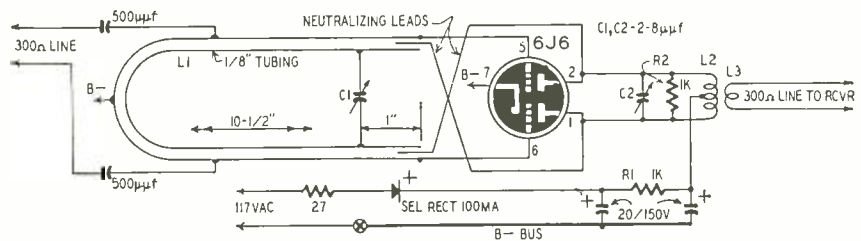

Fig. 1—The schematic. Amateur "long-lines" technique is used to get high-Q circuits.

is grounded, take the following precautions to prevent shocks or short circuits: Isolate the B minus lead from the booster chassis and connect it directly to the B minus line of the TV receiver; use a *single line-cord* lead from the rectifier input to one side of the booster line plug.

To neutralize the 6J6, connect the booster output link to the TV-receiver antenna terminals and set the receiver to the desired channel. Short out the booster antenna terminals. With both units turned on, slide both neutralizing leads in or out of the grid tank in equal steps until the rushing sound (oscillation) from the speaker just disappears. With the station tuned in and the grid and plate tanks tuned for maximum gain, readjust the neutralizing leads for possible improvement.

The best points for connecting the 500- μ f antenna-blocking capacitors to the grid tank should be found in the same way.

Although this booster was designed for a single low-band channel, you can prune L1 and L2 and use it for FM,

150–170-mc emergency, or high-band TV signals. The grid tank can be tuned to a higher frequency by snipping short lengths from the open ends and turning C1 through its range to peak the signal. If you don't notice an increase in signal strength, clip about one-quarter inch more from the ends and repeat the process until you can peak the signal with C1 in the center of its range.

L2 is comparatively broad because of the loading effect produced by R2. However, it may be necessary to remove a few turns from this winding so the output circuit resonates in the center of the desired frequency range. Of course, if you have a v.h.f. grid-dip meter, you simply prune the coils until the meter indicates resonance at the desired frequency.

Materials for booster

Resistors: 1—1,000 ohms, 1 watt; 1—1,000 ohms, $\frac{1}{2}$ watt, 1—27 ohms, $\frac{1}{2}$ watt.
Capacitors: (Ceramic or mica) 2—500 μ f. (Electrolytic) 2—20 μ f, 150 volts. (Variable) 2—2.8 μ f trimmers.
Miscellaneous: 1—6J6; 1—100-ma selenium rectifier; 22 inches $\frac{1}{8}$ -inch brass tubing; 1—7-pin miniature socket; polystyrene rod; chassis; s.p.s.t. toggle switch; wire, solder, terminals, hardware.

—end—

the last word on

CONVERSION

Including problem discussions
and pointers which do not often
appear in a conversion article

By M. HARVEY GERNSBACK

Editorial Director

PART I

THE LAST word on the important subject of television conversions has not been said. Far from it. Suppose, for instance, you make a big-tube conversion and find there isn't enough high voltage. What then? Or maybe there's not enough width—or height. Or the linearity or focus is poor. Or the horizontal output tube droops after a few days. If you don't know the answers to all these everyday conversion problems, stick around. You'll find some of them here.

To show how conversion problems can be licked, let's take the case of an RCA 8T244 (KCS28 chassis) which we converted recently.

The conversion was to a low-voltage electrostatic-focus tube, the 17TP4. The original set delivered 8.5 kv to the 53-degree 10BP4, so a new yoke and horizontal output transformer were needed. We selected a new ferrite-core output transformer, the RCA 231T1. This transformer has a number of interesting features. It is a *universal* job designed for both replacement and conversion work and will properly match a variety of output tubes to yokes with horizontal coil inductances ranging from 8 to 30 mh. This covers just about all types of yokes for tubes with 50- to 66-degree deflection angles. A 7-tap secondary provides this matching flexibility.

An extra primary tap provides the proper match for all horizontal output tubes. Thus in sets with d.c. supply voltages of from 250 to 300, using a 6BQ6-GT or 6AU5-GT, the plate connection goes to tap 2. If the receiver has a d.c. supply voltage of 300 to 350 and uses tubes such as the 6BG6-G, plate connection goes to tap 3. Maximum high-voltage output is 15 kv.

Because of its flexibility, the transformer can be used in straight replacement work in 10-inch (53-degree) tube sets, in 21-inch (66-degree) tube sets, or anything in between.

Before starting on any conversion

job, make sure the receiver is in top operating condition. If the set is operating properly beforehand, you will know that any troubles after conversion are due to the conversion itself. Make sure that the low d.c. supply voltages are at normal values, and that the vertical and horizontal sweep systems function normally (good interlace, sufficient height and width, normal linearity, hold controls locking in at the center of their range). Replace all weak tubes in these circuits and give the set a final operating check. Don't start the conversion until all these things have been done.

Why is all this necessary? Conversion means higher sawtooth voltages, higher boost voltages. The higher sawtooth voltages can stray around the chassis, causing interlace difficulties. The higher boost voltages (if they are applied to the horizontal oscillator or discharge tubes) change operating conditions and may cause the oscillator to shift frequency. The same trouble can occur in

the vertical oscillator circuit. If the v. and h. hold controls are checked before conversion and serviced so that they lock at the center of their range, a considerable frequency change would have to occur before the picture could not be locked in by adjustment of the hold controls. Suppose, however, that the hold controls were *not* checked before conversion. If one of them locked near one end of its range, a small frequency change resulting from the conversion could throw the lock setting outside the range of the control. The technician's reaction to this trouble would be, "What did I do wrong?" He would waste time checking for wiring errors that weren't there. So check before conversion!

In making this conversion a number of small parts were removed in addition to the old yoke and flyback transformer. The focus control R191 and the 330-ohm resistor R190 in series with it were eliminated. The focus coil L115 was shorted out in the chassis and removed,

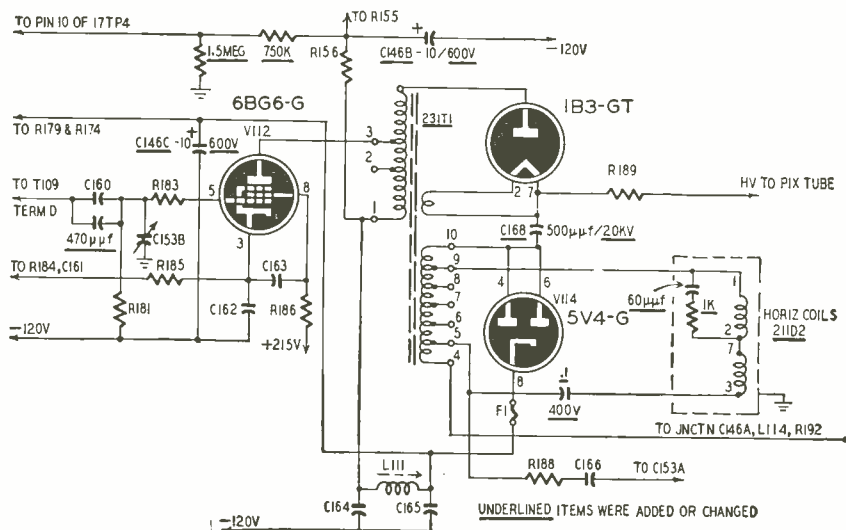
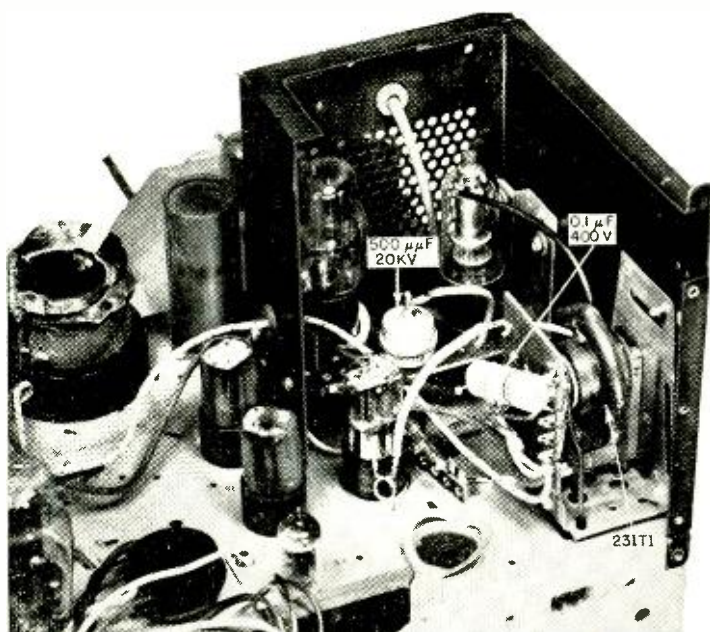

Fig. 1—Conversion of an RCA 8T244, using the 231T1 universal transformer.

RADIO-ELECTRONICS



Mounting details of the replacement transformer.

since it is not required for the 17TP4. The width control L110 was also removed, as was R187, the 3.3-ohm filament resistor for the 1B3-GT.

The method of mounting the new flyback transformer is shown in the photograph. Follow the usual precautions against corona and arcing in wiring the high-voltage circuits. Keep all high-voltage leads at least an inch from other wires and the chassis. Length and placement of the lead from the top of the primary winding to the plate cap of the 1B3-GT are particularly critical. Keep it as short as possible and make sure that it is far away from the walls of the high-voltage cage or from other wiring, to keep stray capacitance to ground at a low value. Too much capacitance between this lead and ground will reduce high voltage and affect horizontal linearity. Incidentally, the 231-T1 transformer comes with 4 plate lead clips (2 small and 2 large) to fit the plate caps of all popular h.v. rectifiers and horizontal output tubes. The 2 large ones are used in this case.

The circuit changes for converting the 9T244 are shown in Fig. 1. The underlined items in this figure indicate either an added part or one whose value or voltage rating has been changed.

Few changes were needed in the horizontal circuit other than those having to do with the new flyback transformer. A 470- μ f capacitor was shunted across the coupling capacitor C160 to increase the drive voltage to the 6BG6-G grid, for more high voltage and width.

A word about drive. In any horizontal output amplifier circuit a certain amount of sawtooth voltage is needed to drive the horizontal output tube at maximum efficiency. If the horizontal oscillator or discharge tube can't supply sufficient voltage, the output tube will run at lowered efficiency, drawing an excessive amount of cathode current and shortening its life. The high-voltage output will be low and picture width insufficient.

An easy way to tell if the output tube is getting enough driving voltage is by the raster's appearance. Adjust the drive control for maximum. Then adjust the linearity coil through its range to see if you can produce a vertical white overdrive line near the center of the raster (Fig. 2). Back off the drive control until the overdrive line just disappears. This is the optimum drive point. If it is not possible to produce the overdrive line, the sawtooth driving voltage is not high enough. To increase it, increase the size of the coupling capacitor feeding the output-tube grid. (Be careful. Too large a capacitor may shift the oscillator frequency.) Another way to increase drive is to *decrease* the size of the plate-load resistor of the oscillator or discharge tube. A third method is to increase the plate voltage on these tubes by feeding their plate-load resistors from the boosted B plus supply through an R-C decoupling network.

If the drive voltage is sufficient to overdrive, but width and high voltage are insufficient, increase the output-tube screen voltage by reducing the resistance of its screen-dropping resistor. When doing this be careful not to exceed the tube's maximum allowable screen dissipation in watts (the product of screen-to-cathode voltage and screen current in ma). You may find that with increased screen voltage you can no longer overdrive the output tube. The remedy is to increase the output of the horizontal oscillator or discharge tube, using the methods indicated above. Then readjust the drive control to overdrive, then back off just enough to eliminate the overdrive condition. If width and high voltage are still insufficient, decrease the output-tube screen resistor until the desired results are obtained.

Fortunately in the 8T244, the only change necessary was the addition of the 470- μ f capacitor mentioned above. In a low line-voltage area it might be necessary also to reduce the 6BG6-G

screen resistor R186 to get enough width, or the screen resistor could be reduced to 5,000 ohms and a 2,500-ohm rheostat installed in series with it to act as a width control.

C168, the 500- μ f high-voltage filter capacitor, was replaced with one having a 20-kv rating. In a circuit of this kind, where C168 is returned to the damper tube plate, it is important not to eliminate the 1-meg filter resistor R189. It isolates the damper-tube plate circuit from the 100 to 500- μ f capacitance which exists between the anode of the C-R tube and ground. If this capacitance was directly across the damper-tube winding it would greatly increase retrace time and cause foldover difficulties and loss of high voltage.

The only other horizontal circuit changes were to replace the 10- μ f capacitors C146B and C with 600-volt rating units, and to eliminate the d.c. flow through the new yoke by placing a 0.1- μ f, 400-volt capacitor in series with it. Eliminating the d.c. tends to give a cleaner raster with fewer ripples. The new yoke is an RCA 211D2, an anastigmatic edge-to-edge focus unit. It differs from the older 211D1 only in that the connecting leads and damping resistors are already installed. (But the neutralizing 60- μ f capacitor and 1,000-ohm resistor which connect across part of the yoke's horizontal windings are supplied in an envelope since they must be connected to different yoke terminals in some applications. With an isolated-secondary flyback transformer such as the 231T1, they connect as shown in Fig. 1.)

The horizontal a.f.c. phasing feedback network R188-C166—which formerly connected to the damper tube plate—was moved down to a point of much lower output on the secondary of the flyback transformer. With the increased



Fig. 2—How the overdrive line looks.

sweep voltages resulting from the conversion, the original connection gives far too much voltage for proper a.f.c. operation. This causes the horizontal oscillator either to operate off frequency (a torn picture results), or merely slightly out of phase (result—foldover appears on the left side of the raster. This looks like foldover due to wrong retrace time, but the cause is different).

In the second part of this story next month we'll discuss the vertical circuit changes and the things that can cause poor linearity, foldover, not enough (or too much) width, blooming and some other points.

(to be continued)

short circuits

Some of the more unusual applications of familiar tubes and selenium rectifiers in modern TV set design

By ROBERT F. SCOTT

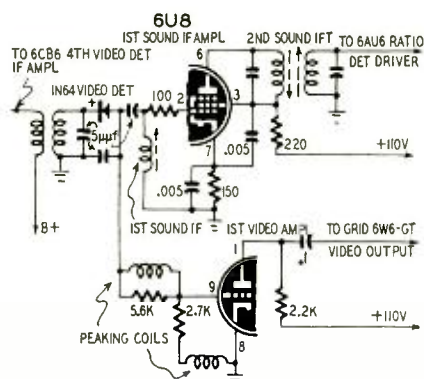
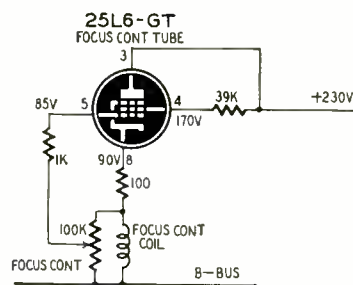

Fig. 1 (above)—Sound and video takeoffs with a 6U8. Fig. 2 (right)—A 25L6 as a focus control in recent G-E television receivers.



LAST month we talked about the use of conventional receiving tubes in unconventional applications in TV receivers. Along these lines, two more circuits warrant discussion.

The 6U8 is a comparatively new high-frequency miniature triode-pentode, best known as an oscillator and mixer in TV, short-wave, and FM receivers. When used in the front-end of a receiver, the 6U8 does not arouse unusual interest because circuitwise it resembles the 6K8 in broadcast sets and the 6AG5-6C4 or 6AG5- $\frac{1}{2}$ 6J6 combination in TV sets. But when it is used elsewhere in TV circuits, it stands out like a blot of ink on the wife's new lace tablecloth. Stromberg-Carlson engineers have put this tube to work in the video amplifier and sound i.f. of their 421 series. The circuit is shown in Fig. 1.

The germanium-diode video detector is direct-coupled to the triode section of the 6U8. Typical operating conditions for this triode are: Plate voltage 150, plate current 18 ma, amplification factor 40, transconductance 8500 μ mhos, and plate resistance 5,000 ohms.

The pentode first sound i.f. amplifier is coupled to the video detector through a 5- μ f capacitor. This section of the 6U8 is similar to the 6AU6.

25L6-GT focus control tube

Generally, whenever we see a 25L6-GT nestled in its socket on a TV chassis, we can safely assume that it is in the audio output circuit and can disregard it if the symptoms indicate trouble in the sync or video circuits, or replace it if the trouble is definitely in the audio output stage. If you don't have a diagram or table of tube functions for the G-E 16K1 or 16K2, don't let the 25L6 mislead you. It is *not* in the audio output stage. It is the focus-control tube

and its circuit is shown in Fig. 2.

In this application, the plate-cathode resistance of the 25L6 is used as a variable resistance in series with the coil of the EM-PM type focusing unit. Varying the 100,000-ohm focus control varies the bias on the grid of the tube and controls the flow of current through the tube and focus coil in series. We can see that a weak or gassy 25L6 can seriously affect the current through the focus coil and make it impossible to focus the picture properly. Although poor focusing can be caused by a bad picture tube, open or shorted focus coil, or weak magnet in the PM section of the focusing assembly, it is only reasonable to check the tube first, as it is easier to get at and simpler to check than the other components.

Selenium rectifiers

We are familiar with selenium rectifiers in the low-voltage power supplies of a.c.-d.c. receivers and transformerless TV sets, but in other applications their use and operation are not always evident from the circuit or manufacturer's data. One example is the Setchell-Carlson model 151. A selenium rectifier supplies d.c. to the screen of the horizontal output tube by rectifying a part of the 15,750-cycle voltage developed across the secondary of the flyback transformer. This novel application is shown in Fig. 3.

There is an excellent reason for using the rectifier in this manner. When the horizontal output stage is operating with normal drive and plate and screen voltages, the heat dissipated in the plate and screen is close to the maxi-

mum ratings set by the tube manufacturer. In the absence of drive to the output stage, plate current and dissipation increase and the tube may be damaged within a few seconds. During the period the tube is without drive, excessive plate current may cause the primary of the flyback transformer to open up or catch fire.

Many sets have fuses to protect the transformer primary, but if the fuse is the wrong size or has too long a delay before blowing, the tube and transformer can still be damaged. Some TV sets have an extra-large cathode-biasing resistor to provide safety bias if excitation fails. The use of a high cathode bias reduces the actual plate voltage, limits the horizontal deflection power and reduces the high voltage.

In the circuit of Fig. 3, the positive spike of the 15,750-cycle horizontal sawtooth is rectified to produce approximately 140 volts at 25 ma for the 6BQ6 screen grid. In the absence of grid drive, there is no a.c. voltage to be rectified so the d.c. screen voltage is supplied through the 1-megohm resistor from the 280-volt d.c. line. The voltage on the screen is now so low that plate current is reduced to the point where the plate dissipation rating cannot be exceeded and the primary winding of the transformer cannot burn out.

Bendix centering circuit

Some late-model Bendix TV sets use a selenium rectifier as a centering aid rather than as an auxiliary source of B voltage. The Bendix circuit used in

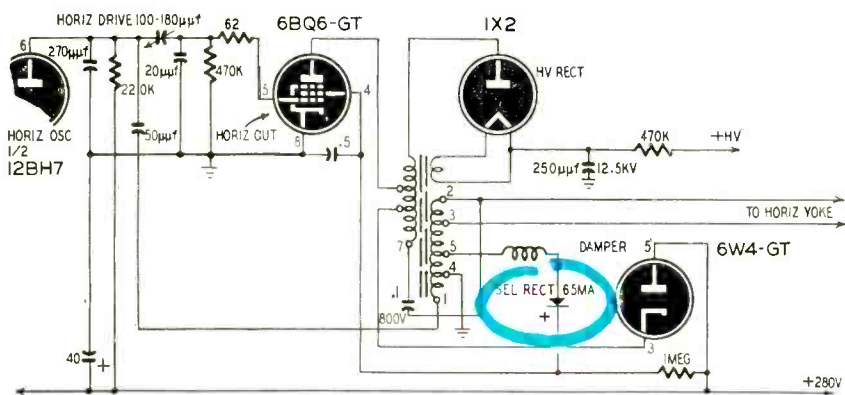

Fig. 3—Screen voltage for the 6BQ6-GT is supplied by the selenium rectifier from the sweep output. Drive failure cuts off the screen voltage, protects the 6BQ6.

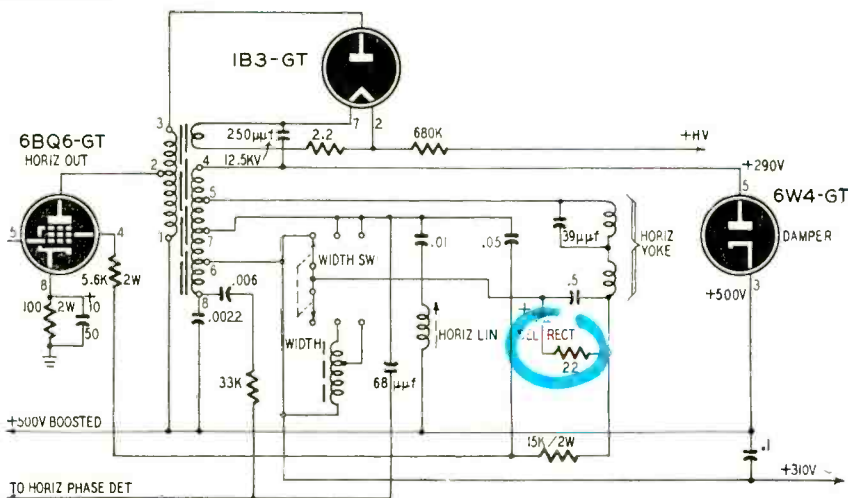

Fig. 4—Automatic bucking bias from the selenium rectifier keeps raster centered.

TV receiver models C172 and C2000 is shown directly above in Fig. 4.

Since boosted B plus voltage from the damper tube is used in the horizontal deflection circuit, the horizontal deflection coils are above ground. The direct current flowing from top to bottom through the horizontal yoke windings causes the picture to be displaced to the right. To compensate for this, the selenium rectifier is connected to B plus to supply a bucking current which flows through the coils in the opposite direction. This allows the picture to be centered with the normal centering device.

Radio Craftsmen power supply

Fig. 5-a shows the low-voltage power supply circuit in the Radio Craftsmen RC-201 receivers. This circuit uses four selenium rectifiers and a 300-volt center-tapped 275-ma transformer to deliver 130, 150, 300, and 320 volts to the various sections of the set. This arrangement replaces the twin 5U4-G's and voltage dividers used in many other makes and models of TV sets. With this circuit, any minor change in current drain on one B plus line will not affect the voltages on the others as it will with many voltage dividers.

Fig. 5-b shows the basic circuit of the 150-volt supply with V1 and V2 sub-

stituted for selenium rectifiers SR1 and SR2. This is a conventional full-wave rectifier with the plate and cathode connections reversed and the positive potential taken from the center-tap on the transformer.

In Fig. 5-c, tubes have again been substituted for the selenium rectifiers. This is a full-wave bridge circuit. The center-tap of the transformer is not needed in a full-wave bridge.

When the top of the secondary winding is positive with respect to the bottom, V2 conducts and current flows through it to ground, up through the load, and then back to the transformer through V3. Current cannot flow through V1 or V4 because their cathodes are more positive than their plates. When the a.c. voltage reverses, the bottom of the secondary is positive. V1 conducts and passes current to the load. The current returns to the transformer through V4.

Fig. 6 is the full-wave voltage-doubler circuit used in the low-voltage power supply of the RCA KCS66 and similar chassis. When the voltage across the secondary of the transformer makes the anode of SR2 positive, this element conducts and a positive charge accumulates on the positive plate of C2. SR1 does not conduct, because its cath-

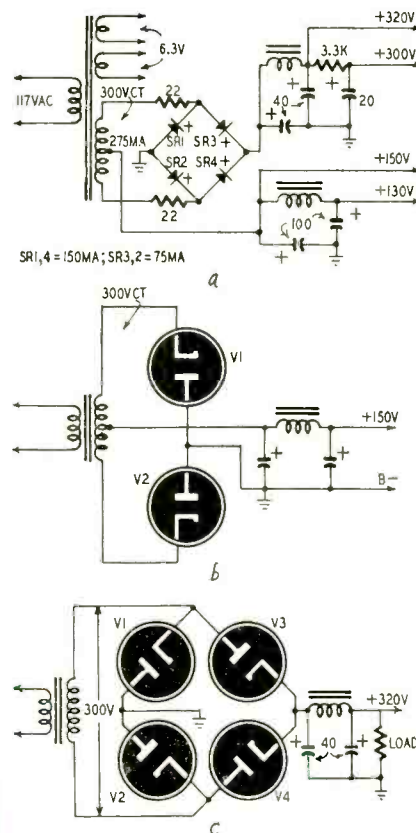

Fig. 5—Radio Craftsmen full-wave bridge power supply with equivalent vacuum-tube rectifier circuits.

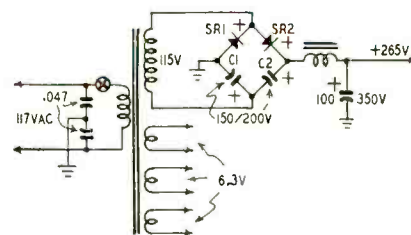

Fig. 6—Full-wave voltage doubler rectifier in RCA KCS66-series chassis.

ode is more positive than its plate. When the polarity of the a.c. voltage changes on the following half-cycle the cathode of SR1 is negative with respect to its anode. This element conducts and places a negative charge on the negative plate of C1. Each capacitor charges to the peak voltage developed across the transformer. Since C1 and C2 are in series, the charges on them are in series, and the total voltage across them is twice the peak across the transformer. When these capacitors are delivering power to the load, the voltage drops slightly to a value determined by the magnitude of the load current and the values of C1 and C2. With this circuit, the voltage drops to approximately 265 under load.

—end—

TV SERVICE CLINIC

Conducted by
MATTHEW MANDL

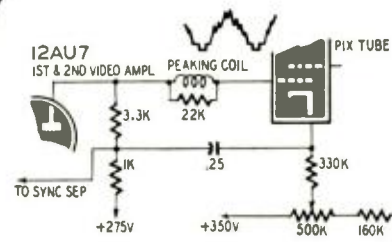

Fig. 1—Direct video coupling.

READERS often ask about brilliancy-control troubles in receivers using direct coupling between the last video amplifier and the picture tube. When direct coupling is used, no d.c. restoration is necessary and the grid circuit of the picture tube is simplified. Troubles occur, however, because B plus voltages exist at both the grid and cathode. Defects can include insufficient or excessive brilliancy, inoperative brilliancy control, poor contrast, and unstable sync.

With direct coupling the video signal may be fed to either the grid or cathode of the picture tube. Fig. 1 shows a typical grid feed used in Olympic and many other receivers. With plate voltage directly on the grid, the cathode must be at a higher d.c. voltage so the grid will be negative with respect to the cathode. The brilliancy control permits varying the voltage on the cathode to change the relative grid bias and control the beam current.

It is important that the d.c. supply voltages at both grid and cathode remain stable. If changes occur in voltage or in the values of series resistors, the balance of potentials between grid and cathode may be upset. A decrease in cathode voltage or an increase in the voltage at the grid will lower the bias and make the picture excessively bright. The control is then unable to decrease brilliancy sufficiently for good viewing.

If changes in resistance values increase cathode voltage or decrease the grid voltage, insufficient brilliancy will result.

The same is true in circuits where the signal is fed to the cathode. Fig. 2 shows a circuit used by Stewart-Warner. Here the functions have been transposed and the brilliancy control is now in the grid circuit. With the signal applied to the cathode, positive variations are equivalent to negative changes in the grid circuit in their effect on the electron beam.

When brilliancy-control troubles occur, a v.t.v.m. can be used to measure the relative potentials between grid and cathode. Regardless of the feed method used, the grid should be negative with respect to the cathode. When

the brilliancy control is varied throughout its range, the v.t.v.m. should show a change in negative bias sufficient to cut off the beam or release a sufficient amount of electrons for good brightness. The potentials from grid to chassis and cathode to chassis should also be checked and compared with the values given in the service notes.

The values of the various dropping resistors also should be checked. The same holds true for the brilliancy control. This should be tested for continuity through each of the three potentiometer terminals.

If all components and voltages conform to the service notes, the second-anode potential and the accelerating-grid voltage should be checked. It is also essential that the ion-tray magnet be placed properly on the neck of the tube for maximum brilliancy. A weak ion-tray magnet can also contribute to poor brilliancy. Only after all other possibilities have been exhausted should the picture tube be suspected of being gassy or otherwise defective.

Intermittent width in Admiral

I am having considerable trouble servicing an Admiral 24E1 receiver. This set has insufficient width, noisy sound, and intermittent picture. I removed the chassis from the cabinet and checked all tubes and voltages. Upon trying the receiver it played all right and I returned it to the customer. Upon installation in the cabinet there was again an intermittent picture, and all the other troubles encountered previously. What could cause this trouble? L. B., Trenton, New Jersey.

You are undoubtedly running into a trouble which existed in the early production of this receiver, and the following is the manufacturer's recommendation for correction:

In early production models the chassis is mounted on a board with 1/4-inch bolts. The mounting bolt near the horizontal width control may short-circuit the control, resulting in insufficient width, horizontal nonlinearity, and loss of picture brightness, or no raster at all.

To correct this, pull the mounting board four or five inches out of the cabinet, remove the bolt, and put four or five washers under the bolt head. Late production sets use a shorter bolt.

When installing the chassis do not use a sharp-pointed tool for locating this mounting hole, as the width-control winding might be damaged.

Horizontal sync in Westinghouse

On a Westinghouse model 627K16 receiver, the picture loses horizontal sync after the set is on from one-half hour to two hours. I have replaced the tubes in the horizontal sweep circuits and also checked the values of parts. This chassis does not have the 6AL5 type of horizontal phase detector. What could cause this condition? F. R., Ridgewood, N. Y.

Several different horizontal control circuits were used in these models, and from your description the receiver you are working on uses the single-6C4 phase-detector circuit.

The fact that horizontal sync is lost only after an hour or two of operation indicates that some component is intermittent and changing its characteristics after warm-up. As you have already changed tubes, check the resistors and capacitors in the phase-detector circuit as well as in the horizontal oscillator.

Also make sure the changes you have made according to the manufacturer's supplements include the following:

If R446 is 15,000 ohms, change to 18,000 ohms.
Change R436 to 270,000 ohms.
Insert a 220,000-ohm resistor in parallel with R434 (pin 7, grid circuit of horizontal multivibrator).
Insert a 120- μ fd capacitor in parallel with C422. (In some chassis using a 12BN7 as the horizontal multivibrator not containing above changes, a 1.5- μ fd capacitor is connected between pins 6 and 7 to improve performance.)

Keystoned picture

In a Techmaster 630 type receiver, the picture has a keystoned appearance, with the right side of the picture having less height than the left side. What could cause this trouble? L. R., Groveland, Florida.

This is usually caused by shorted turns in the vertical deflection coil (or a shorted resistor across one section of the vertical coil).

The particular coil section involved can be identified from the nature of the keystoned picture. As shown in Fig. 3, the vertical coil sections are on either side of the picture tube neck. For downward vertical sweep the coils must be positioned as shown. When one coil section shorts, the remaining coil section must perform the entire vertical sweep by itself. The beam is influenced less as

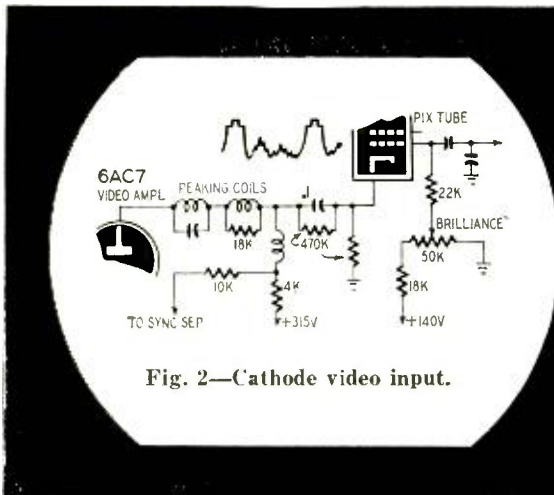

Fig. 2—Cathode video input.

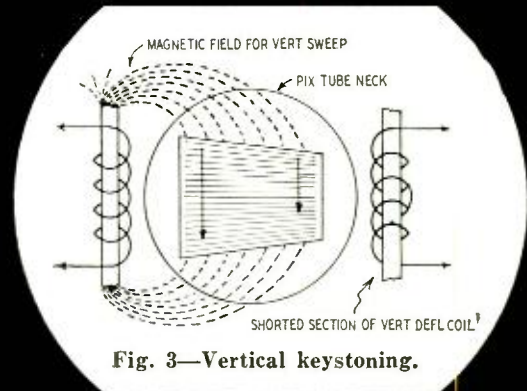

Fig. 3—Vertical keystone.

the horizontal sweep pulls it away from the field of the single coil, and the latter is unable to sweep the beam fully at extreme horizontal deflection. The narrowed section shows on which side of the deflection yoke the shorted coil section is located.

Open-wire line match

In the installation of an open-wire transmission line, I find that the line crimps in making a loop to allow for rotor operation. Could I use 300-ohm ribbon line from the stacking bars of the antenna down to and just below the motor, and from here attach the open-wire line? Will this cause a mismatch? M. M., Grove City, Pa.

If you are using 300-ohm open-wire line, you can attach any length of 300-ohm ribbon line to it without worrying about a mismatch. The open-wire line has much lower losses than the 300-ohm ribbon type. As you are going to use only a short length of ribbon line from the stacking bars to a place right below the motor, you should have virtually no loss.

This procedure is sometimes followed at the receiver end, whenever it is difficult to bring the open-wire line into the house without a large opening. Open-wire line is run to the entry point and 300-ohm ribbon line is then used. If too much 300-ohm ribbon line is used, you will defeat the purpose of using the low-loss open-wire line.

Even with 400-ohm open-wire line, good results will be obtained, although the losses will increase because of the mismatch. If the signal strength is fairly high, the loss will be hardly noticeable.

Flyback transformer match

In a conversion, I have on hand an RCA 204T2 vertical output transformer, a 211T5 horizontal output for voltage doubling, a 206D1 deflection yoke, and a 470-ohm focus coil. In view of the fact that the 211T5 is listed as a 53-degree component, and the 206D1 has a 70-degree angle, with the combination given will I obtain proper sweep and deflection for a 17BP4A tube? Also, could I substitute the Merit MDF-70 cosine yoke for the 206D1 in the

same circuit? W. V., New Orleans, La.

The 211T5 horizontal output transformer has a rating of 50 to 57 degrees deflection at 13.5 kv. This may work with the 206D1, depending on the efficiency of the drive circuit of the receiver. For the 206D1, however, the RCA 218T1 would be a better match. The latter is rated at 14 kv for deflection angles from 66 to 70 degrees.

The Merit MDF-70 cosine yoke has the same characteristics as the 206D1 except for a slight difference in vertical-winding inductance. You can use the Merit instead of the 206D1 and get better edge-to-edge focus. The very slight vertical mismatch should produce no noticeable difference in height, but there may be a slight pincushion effect characteristic of practically all cosine-wound yokes.

Vertical defects (Philco)

In a Philco receiver model 52T2252 I am having difficulty in getting good vertical linearity. The height is also insufficient. Besides this, there are trailing smears on the screen for large circles or letters. None of the controls seems to clear up this trouble. The receiver was only installed a few weeks ago. What could cause these troubles? J. W. L., Wayne, W. Va.

Normally, the vertical linearity control should correct compression at the bottom and elongation at the top. If it does not, check the coupling capacitor to the grid of the vertical output tube. A leaky one will cause the symptoms you describe. Adjustment of linearity and height should then be made with a test pattern. Horizontal width and linearity may also require correction.

On some of these sets this condition can be cured by adjustments to the yoke, and the following information is supplied by the manufacturer:

Remove the deflection yoke from the housing; then remove the metal band around the yoke. Apply pressure to both sides of the ferrite metal pieces around the yoke so that the ends of the pieces are as close together as possible. Apply two layers of plastic tape to hold the pieces in this position. Replace metal band and reinsert the yoke. Another cause of poor linearity and insufficient height may be a defective width-coil core. These sometimes change permeability with temperature. This affects boost voltage which, in turn affects vertical output-tube plate voltage. If this is the case, a new width coil and core must be installed.

Trailing smears indicate poor low-frequency response in the picture-amplifier system. This might be caused by improper video-i.f. alignment or defects in the video amplifier, particularly open decoupling capacitors in the resistive networks feeding plate voltages to the tubes. Check these first before testing, tracking, or alignment. Overloading on strong local signals may also produce a smearing effect in the picture. This may call for using attenuator pads in the antenna input circuit.

High-voltage resistor troubles

In a Magnavox CT244 there is repeated failure of a 1.5-megohm high-voltage resistor (R225) connected to the cap of one of the 1B3GT tubes. The failure results in loss of focus with accompanying jitter. I have tried different types of resistors, but each gave me trouble. Would two 750,000-ohm resistors in series help, or what do you advise? R. C., Brooklyn, N. Y.

You could use two 750,000-ohm resistors in series, each having the same wattage rating as the original 1.5-megohm resistor. This will divide up the load as you surmised, but it would be well to check several items in the receiver first to see whether or not the high-voltage system is being overloaded.

Check your drive control setting to make sure the drive is not excessive. Reduce the drive to the point where left-hand stretch and center compression disappear. If width is inadequate, readjust the width control. In this receiver there is a "width compensating switch" which changes the screen voltage of the horizontal output tube to compensate for various line voltages and tube aging. Improper setting of this switch can cause excessive width and high voltage, shortening the life of the high-voltage tubes and overheating parts (including the 1.5-megohm resistor). In No. 1 position it compensates for low line voltage (105 volts). No. 2 position is for 117 volts with a weak horizontal amplifier tube. No. 3 is for 117 volts with good tubes. No. 4 is for high line voltage (125 volts).

—end—

This

Practical

TUBE TESTER FOR INDUSTRIAL REPLACEMENTS

Can Check

Up to

10 Tubes

At One Time

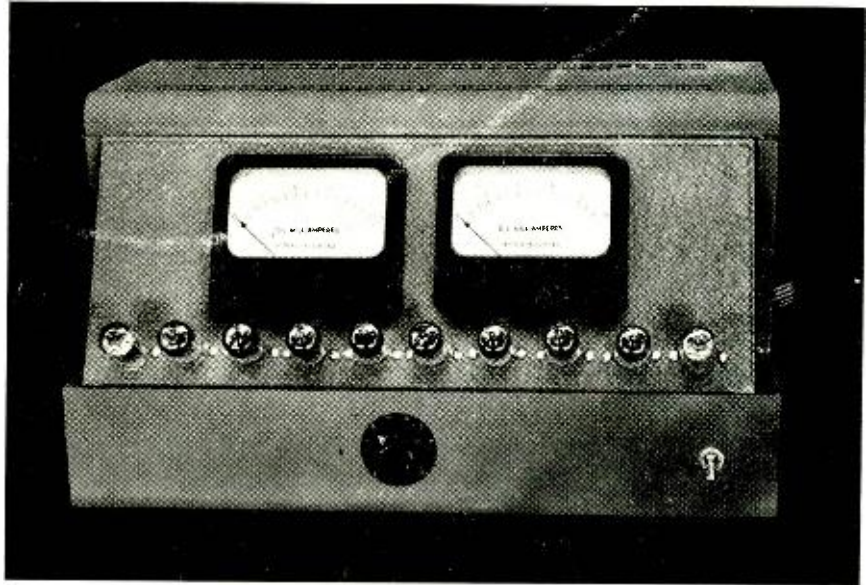

The multiple checker, with a bank of ten tubes inserted ready for checking.

By **DAVID ALLEN**

EXPERIENCE in testing large numbers of new tubes shows that approximately one out of every hundred is defective. Testing batches of new tubes, or periodic checking of tubes in service is a tiring, disagreeable chore.

In testing dual triodes several controls must be reset on the tube checker for each triode section. This is a serious inconvenience when anywhere from 20 to 500 tubes must be checked. So much time is wasted just waiting for the tubes to warm up, and in switching between sections, that the simple emission tester shown in Fig. 1 was a logical contrivance. It checks both sections of a dual triode simultaneously. Up to 10 tubes can be plugged in at one time and tested in quick succession with the rotary switch. (This control is a Centralab type 1423. Equivalents may be used.) It is used mainly for 12AU7's, but other twin-triode types can be checked by adjusting the bias with the panel control.

A good 12AU7 with matched sections is first selected with a conventional tube checker. It is then placed in the multiple checker and the bias is ad-

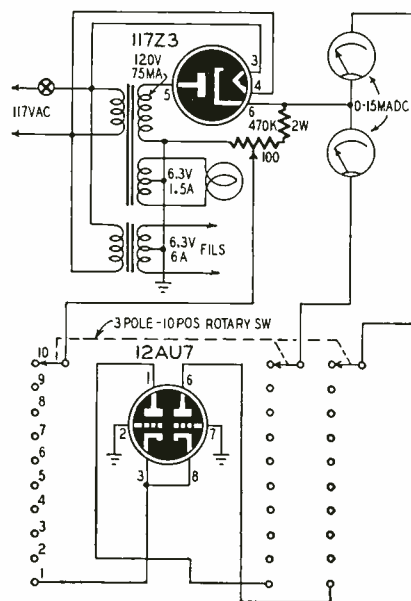

Fig. 1—Circuit of the checker, showing only one of the sockets wired in. Connections to the other numbered switch positions (2, 3, 4, etc.) are identical.

justed for 10 ma on each meter. This is the rated plate current for each triode. The plate currents of other 12AU7's can then be read as percentages of the standard—for example, 8 ma = 80%, 5 ma = 50%. I generally discard tubes that read below 7 ma (70%), or whose sections differ by more than 1.5 ma (15%). In testing other types, adjust the bias to give rated plate current for the reference tube.

The filament transformer shown in Fig. 1 has a secondary rating of 6 amperes, which is more than enough to supply 10 12AU7's. A 6AX5-GT rectifier with plates connected in parallel may be used in place of the 117Z3, by operating its heater from the 6.3-volt winding of the power transformer (a Thordarson T-22R12 or equivalent).

Parts for tube tester

Resistors: 1—470,000 ohms, 2 watts; 1—100-ohm wire-wound potentiometer.
Transformers: 1 Thordarson T22R12 (or equivalent); 1 Stancor P4089 (or equivalent).
Miscellaneous: 2—0-15-d.c. milliammeters; 1—3-pole, 10-circuit selector switch; 1—s.p.s.t. toggle switch; 1—7-pin miniature socket; 10—9-pin miniature sockets; 1—117Z3 tube; 1—No. 44 or No. 47 pilot lamp; 1 pilot-light socket; 1 cabinet (Bud CA1753 or equivalent); chassis; wire; solder; hardware.

—end—

HANDY SUBSTITUTION BOX

identifies
unlabelled or
damaged
parts—supplies
equivalent
values



By HAROLD PALLATZ

THE construction of a substitution box will provide the service man with a most useful tool. The values of burned-out resistors or unmarked capacitors may be determined quickly by simply inserting the box in the circuit and selecting the values that result in best operation.

To cover a wide range and yet keep the unit compact in size, a switching system was decided upon. Two 6-position, 2-gang selector switches select any desired resistor, capacitor, or inductor. These units also may be connected up in combinations to form wavetraps and R-C networks.

The possibility of requiring odd resistance values in certain circuits is met by the dual potentiometer included in the unit. One section covers a range between 0 and 20,000 ohms, while the other section goes to 350,000 ohms. The selector switch determines which section is used.

A small variable capacitor also has been included, which permits an easy determination of trimmer values. The capacitor should be of the straight-line capacitance type for ease of calibration. When combined with the various inductance values in this unit, this capacitor makes a handy adjustable wavetrapp or tuned circuit. The resonant frequency may be quickly determined

by reference to charts or by use of the formula:

$$f = \frac{159,200}{\sqrt{LC}}$$

L in μ h
C in μ uf
F in Kc

All component values should be checked on a bridge if possible. In any case it would be wise to obtain resistors of 5% accuracy or better. One-watt carbon resistors can be used, although wire-wound 2-watt units are recommended. Paper and mica units are used for the capacitor decade. The inductance decade uses r.f. chokes for the smaller values. The 1-henry and 10-henry coils are standard filter chokes.

Construction

The instrument is housed in a standard metal cabinet. All parts should be mounted on the removable front panel.

Two rows of jacks are arranged for short leads and low resistance. When wiring in the inductors leave as much room as possible between coils. This will reduce coupling and prevent resonant dips.

If carbon resistors are used, solder fast, as heat may cause a change in value.

Measure the values of the dual potentiometer at different shaft positions and mark them on the panel. Do the same with the variable capacitor (after the unit has been completely wired), but if the necessary instruments are not available, refer to the manufacturer's literature for capacitance curves. In this case be sure to add about 7 μ f to the figures given to allow for wiring capacitance.

—end—

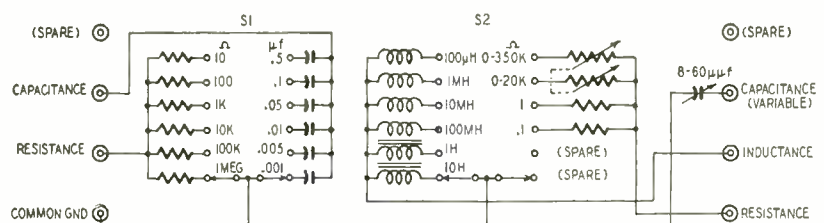

Circuit of the substitution box. Use switches with low-resistance contacts.

WHY THE SMALL SHOP WILL STICK



By JOHN D. BURKE

CAN well understand why anyone should pose the question: "Can the one-man shop survive in television?" It is a problem.

One could also ask: "Can the big television shop survive?" Many have gone smash, others are groggy. The small shop can survive in television.

I shall try to set down the positive features in today's somewhat chaotic repair field—features which help the small man. Also, I shall try to point out the pitfalls to avoid (most can be anticipated, though sometimes one is taken by surprise).

At a time when among doctors there is a great tendency to specialize, there is still a great field for the general practitioner.

That is what we are in television—general practitioners.

We fix them all. Yet, if the repairman is able to stabilize his clientele to some extent, so that he has a basic number of sets to take care of, he will know those sets—those particular chassis. Then the new sets can be taken in stride, the new tubes stocked as needed, the new diagrams obtained and looked over.

The question of big shop *vs.* small shop can be put in another way.

It can be compared with the situation in transportation, as between bus, street-car, and subway service on one hand, compared to taxicab service on the other. The big job is done by the mass transportation facilities. But there is still plenty of room for the taxicabs. They do all sorts of special jobs and people are willing to pay extra for that service.

Now—we little fellows in TV cannot charge anything like the difference between subway fare and cab fare—proportionately—for our services. But, since we can give extra services, we can reap an extra reward here and there.

We work the late shift

Where fast service, available on the instant, is needed, the small man can survive. An example is public places, such as bars, where fast service is essential. I have a number of bars that call me regularly. I never sought such business; it came through recommendations.

To survive, the one-man television shop must operate in the evenings and even do some work on Sundays.

Part of the annoyance people feel about the way the big shops operate is because service is offered only during the day, on week-days.

One might argue that the policy protects the workers in the industry from

longer hours and further exploitation.

True, in a sense. But I feel that the main idea of the service contractors is to save money—and allow the one-year contract to run its course without having to make too many calls. If the service contractors would meet union requirements for men to work evenings and week-ends, more people would renew their contracts.



That is their problem. We "independents," self-employed, work all sorts of hours. However, our working day usually doesn't start till around noon, so we really don't have it so bad.

But we can go broke

The records show that a big percentage of small businesses of all kinds fail within their first year of existence.

It has been thought by some that the same rule would apply to the small radio-TV repair shop. In my opinion this is not the case. Failure is quite possible, but not so likely as in other lines of business.

Every day, in our local newspaper,

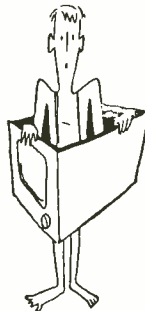

there are about a dozen ads offering TV service. In today's paper five of these ads offer service on the basis of \$1 per call, plus parts. Some of the five add statements which would indicate that: (1) All the work is done in the

customers' homes. (2) All work is guaranteed. (3) Only such parts as are needed are put in.

I can only wonder at these ads! Why—if they actually are doing such remarkable services for people, at such low prices—is it necessary for them to advertise day after day?

If these \$1 concerns really did what they imply, they would be flooded with work, and, rather than advertising for business, they would have ads apologizing for their inability to answer all the calls.

The point—at this moment in TV repair history—is that the small shop operates under a considerable strain, created precisely by those fools (or crooks) among us who advertise service at the impossible figure of \$1 per call.

These ads are a new development. Where it will end, I do not know. Even a year ago I was able to tell people individually that they could call on me at odd hours, and even on Sundays, for service at the rate of \$4 plus parts. This news they welcomed.

Now—they have only to open their paper and read that so-and-so is ready to rush them a repairman, available 24 hours a day, for \$1 plus parts.

I feel that all established, self-respecting repair shops, large and small, are suffering from this definitely unfair, and definitely unethical, manner of doing business.

We can stick—and make money!

How then is the small shop to survive?

As before, by basing itself on:

A small clientele.

A limited territory.

Mutual confidence between customer and repairman.



No wild promises. Instead, a thorough effort to explain the causes of TV breakdowns, and make understood our inability to predict what failure will be next, or when.

Charges based on time spent, but

RADIO-ELECTRONICS

limited to a reasonable figure (without actually losing money, of course).

An effort to save the customer expense (Such as on picture tubes).

Fast service. Limited distance of call; fast methods of trouble-shooting; a good stock of tubes and parts; substitution or revision of circuits where necessary. Work done in homes where practical and sensible.

No sales. The repairman loses more than he gains by engaging in TV sales. (???)—Editor)

Repair of radios (all kinds) and phonographs. (This is one of the weakest spots in the position of the big TV shops.) Customers appreciate the service; you will double your income.

Accessibility of the shop for the customer. Many will bring their sets directly to the shop.

No service contracts. All work by the job.

Open workbenches. Let customers see us suffering over their chassis. The more sweat they see, the more they will appreciate us.

Refuse some jobs. Do not take jobs where the customers show inability to realize what TV repair entails. Let them take their arguments elsewhere.

Limited overhead. Low rent; little advertising.

Careful explanation of: (1) What the set needs to play at all. (2) What the set needs to play properly.

And a real effort to have the customer decide which he wants—the minimum or the maximum. But—do not let him imagine that the maximum repair job is, in any sense, an overhaul. Don't get out on a limb—don't get "married" to a set simply by selling a customer a \$20 repair job!

Watch out for the "dogs" among TV sets. If a set should not be repaired—say so! They may love the set, but in the long run they will appreciate your truthfulness.

Be patient—be philosophical. No matter what you do, you are bound to be misunderstood by some people; blamed when sets break down again; bound to be thought a "robber" by some; bound to suffer from the public's inability to comprehend television, and also from their misconceptions fostered by all sorts of interests, such as the publishers of some of the "dollar books" offered to set users, or the ads screaming "fantastic trade-in allowances" with no down payments on "new, super-powered sets."

Concentrate on doing the best job of repair you can, on treating people as well as you can—and work for recognition and success.

—end—

INEXPENSIVE ELECTROSTATIC PRECIPITATORS

By EDWIN N. KAUFMAN

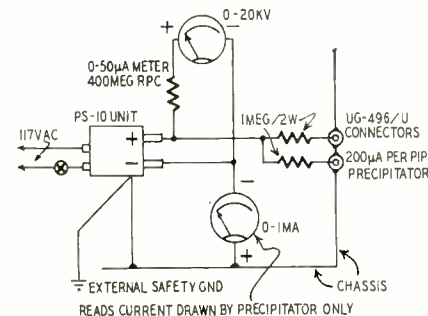

Fig. 1—Power supply for two precipitators, using commercial high-voltage unit.

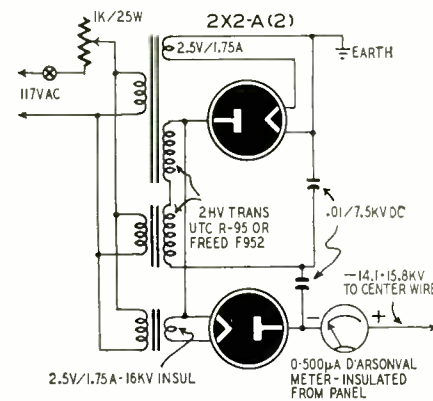

Fig. 2—A full-wave doubler high-voltage supply built from commercial parts.

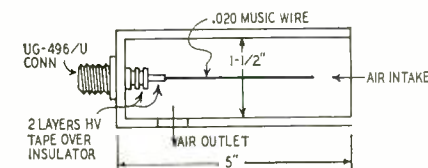

Fig. 3—Details of the precipitator unit.

SMALL electrostatic precipitators are used in many laboratories today for experiments in air filtering, materials finishing, and collecting radioactive particles. Commercial power supplies for small units cost between \$350 and \$750. Two types are in common use: a spark-coil-rectifier unit and a transformer-rectifier unit. Voltages range from 10,000 to 30,000 at currents up to 1 milliampere.

It is possible to build a precipitator power supply for much less than these figures. A unit that will deliver 10,000 volts at 2 ma, or 12,000 volts at 500 µa can be assembled for about \$100. This is shown in Fig. 1. The power unit is a Condenser Products Company PS-10 "Hi-Volt" supply. The voltmeter is merely a convenience, since the milliammeter shows the actual precipitation current. If used, the voltmeter must be

mounted on high-voltage standoff insulators, or on an insulating panel with several inches clearance from any grounded metal objects.

The 1-megohm resistors limit the current in case of accidental body contact or short circuit. Use dummy plug as cover for unused terminal.

Type UG-496 U receptacles and UG-59A/U plugs have been used successfully at this voltage. The UG-496/U must have several layers of plastic high-voltage tape wrapped around the insulating portion of the receptacle.

All connections must be made before the voltage is turned on. These voltages will kill you if contacted.

The PS-10 Hi-Volt unit has the advantages of compactness and reduced shock hazard, as all components including tubes are contained in a hermetically sealed case. The entire supply must be replaced in the event of a breakdown anywhere in the circuit. The unit delivers 200 µa at each terminal.

Assembled power supply

Fig. 2 shows a high-voltage supply that can be constructed from standard commercial parts. The circuit is a full-wave voltage doubler using two 2.5–2.8-kv transformers. The Freed transformer delivers 2.5 kv a.c. and develops 14.1 kv. The U.T.C. unit supplies 2.8 kv. a.c. and develops 15.8 kv. A separate filament transformer with at least 16,000-volt insulation must be used for the negative rectifier. This transformer must also be mounted on stand-off insulators to prevent arc-over to any grounded part of the circuit. The 1,000-ohm resistor controls output voltage and current.

(Two 1B3's can be used instead of the 2X2A's for greater safety in case of accidental contact. Two separate 1.25-volt filament transformers will be required. The transformer for the negative rectifier will need the same insulation as for the 2X2A.—Editor)

Precipitator construction

The precipitator unit shown in Fig. 3 is a 5-inch length of 1½-inch inside diameter dural tubing. The inside of the tube is polished to make it easy to remove the collected particles. The center electrode is .020-inch diameter stainless steel wire, with the open end folded over to prevent arcing or heavy corona discharge from the tip.

The center wire is usually negative, but the polarity may be reversed to suit the application. I have not found much difference with either polarity for cigarette smoke collection.

—end—

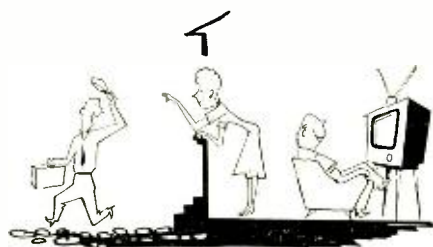

AUDITIONEER

A switching system
that simplifies
and speeds up
the selection of
electronic musical
equipment

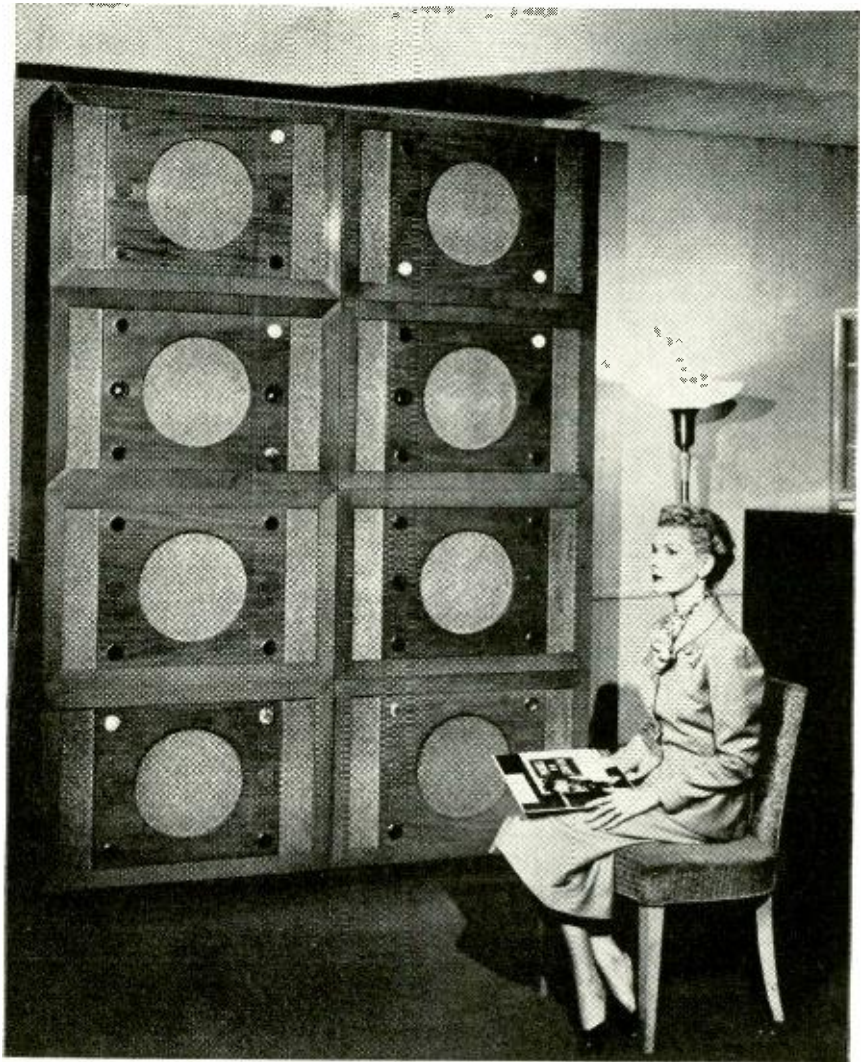

This battery of speakers is part of the equipment controlled by the Auditioner.

THE MAN who wants to buy an audio system is likely to come into the demonstration room with no definite idea of what components he wants. He may ask to hear a "good speaker" or an amplifier with "high-fidelity response." He may have no idea of whether he can get the most faithful rendition of Bach or Beethoven through a Jensen or Electro-Voice speaker; whether "Carmen" or the "Bolero" will sound better when reproduced by Pickering or G-E pickup arms and cartridges. He may not know whether his musical taste will be satisfied with a moderately priced system

or whether his ears demand the output of a high-priced one.

Many of the large suppliers who stock a wide variety of audio units also have facilities for demonstration. Sales personnel simply find out approximately what the customer wishes to spend for his equipment, and then discover his tastes with the famous *AB Test*.

The customer simply listens to part of a selection with one pickup, amplifier, microphone, or other component, and in the middle of the selection is rapidly switched over to another pickup, amplifier, or whatever component may

have been on test. The identity of the components is withheld—the customer only knows that he is listening (for example) to "speaker A" or "speaker B". Thus any preconceived ideas about any brand name have no effect. Comparison is made strictly on the basis of what the listener hears and the actual performance of the components as they are switched rapidly in and out of the playing system. The rapid change-over also makes the most minute differences in quality stand out clearly—differences which in all probability would not be uncovered by other testing methods.

The AB test, by eliminating the time

RADIO-ELECTRONICS

lag in switching from one combination of units to another, as well as neutralizing the effects of any previous ideas about the performance of given units, has become the accepted method of comparing high-fidelity equipment in the modern audio salesroom.

But if there is a time lag in switching from one combination of units to another the advantages of side-by-side performance testing are lost and the demonstration does not provide a true listening test. Every time amplifiers, tuners, or speakers are to be switched for comparison, connections have to be made and unmade.

The Auditioner

The perfect solution would be a switching system which would connect *any* combination of audio apparatus instantaneously. One such successful solution of the demonstration problem appears on our cover. The engineers of Allied Radio Corporation (Chicago) who designed it, call it the "Auditioner". Pushing a button on its control panel switches a component in or out of the system instantaneously. And a fantastic number of different music-system combinations can be made with it.

Speakers or other components can be switched in and out for comparison in a fraction of a second, as many times as the listener wishes. Often just a few minutes of side-by-side comparison enables him to make a decision which may have been delayed for days or weeks just because of the apparent similarity of two units in which he was interested. The *speed* of the change-over is a tremendous help in making such decisions. There is no time lag to dim the listener's impressions or confuse his judgment.

The Auditioner is fundamentally a console carrying a sufficient array of switches to connect into an audio system any one of the more than 60 separate components installed in the demonstration room. Numbers of these are arrayed on the shelves of the cabinet seen in the picture—others are installed in cabinets in various parts of the room. The number of components varies, but at the time the photo was taken it was possible to take your choice of any combination of 9 pickups, 3 changers, 8 preamps, 12 tuners, 15 amplifiers, 26 speakers, and 4 tape recorders. Some of these cannot be combined at the same time, of course—one would not use a pickup and a tuner in the same combination—but the total number of possible combinations is over 400,000! Allied engineers calculate that it would take a listener over three years to hear every separate combination available by pushing Auditioner buttons (one combination a minute, 8 hours a day, 5 days a week).

The sloping panel of the Auditioner has seven vertical rows of push-buttons. Each of the first three rows handles a different type of component—pickups, preamps, or tuners. Two of the remaining rows handle amplifiers and the other two rows control speakers.

To set up a program, a button is pressed to select a pickup or tuner as a source of program material. By pressing another button, its output is channeled to the desired amplifier. Another push-button feeds the amplifier output to any one of a large selection of speakers. A master volume control at the Auditioner adjusts the audio-output level. This control is in the speaker section and is in addition to the individual volume controls on the amplifiers.

In addition to the switching system, the Auditioner has its own phonograph system, with five pickup arms on two turntables. An interesting application of the AB testing technique is the placing of two pickup arms in the same groove on the same record. The output of each pickup is fed to the amplifier and speaker in turn, while the turntable rotates. This provides an unbeatable aural comparison. When the listener hears the two pickups virtually side by side, with practically no time lag between, he can easily tell which unit is—to him—the better one.

The demonstration room

A high-fidelity demonstration room must be designed to have typical home acoustics rather than those of a professional sound studio, so the customer will have no letdown when he puts the equipment to work in his home. Every effort has been made to cloak the Au-

ditioneer, with its complex switching mechanism and circuits, in the pleasing garb of tasteful modern home furnishings.

The console itself is a specially-designed steel cabinet with sloping control panel and "sunken garden" turntable area. The finish closely resembles natural bleached mahogany. Comfortable divans and attractively-styled drapes highlight the decor of Allied's high-fidelity studio, and though many conventional pieces of furniture are replaced with loudspeaker cabinets, the listener can feel he is sitting in an ordinary living room. Isolated from street noises and other disturbances, a demonstration of high-fidelity audio equipment becomes a leisurely period of musical relaxation.

The many mail-order customers, who cannot select audio components in person, are also served by the Auditioner. As a typical example, a Maine or New Mexico audiophile may ask Allied to help him select a music system for about \$500. He may specify that he definitely wants the Browning HJ-20A FM-AM tuner and matching amplifier, but has several alternates in mind for the speaker, record player, and other accessories. The consultant handling this request will usually base his recommendations for a well-matched music system on a listening test—or on prior tests—with the Auditioner.

—end—

MASS PRODUCTION OF RADAR UNITS



U.S. jet-fighter guns find targets automatically with these small radar units. Highly successful in Korea, and mass-produced on these high-speed General Electric assembly lines, they are now standard equipment for all U.S. air arms.

TAPE RECORDING

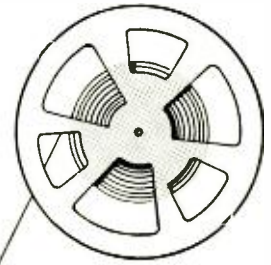
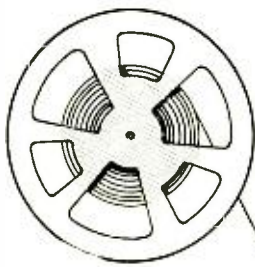

By I. QUEEN

First in a series on this swiftly-growing field for electronic technicians — principles and circuitry highlighted by analysis of new commercial units

PART I

THE *New York Times*,* marking the 75th anniversary of Edison's phonograph, noted the current "revolution . . . in the science of capturing and reproducing sound." Thus does *The Times* refer to tape recording, the new art which has already found many important applications. Tape has become the most popular medium for storing sound or other information. It is now widely used in entertainment, business, educational, and professional fields.

Tape has many advantages over other recording media. Among them are:

1. High fidelity.
2. Erasability.
3. Long play.
4. Indefinite life.
5. Editing flexibility.
6. Ease of operation.

A good tape recording is free from background noise, hiss, scratch or hum. Normally the l.f. response remains flat down to about 70 cycles. Professional equipment provides flat response down to 50 cycles. The h.f. limit varies with tape speed (given in inches per second):

I.P.S.	Kc
1.88	3.0
3.75	5.0
7.5	7.5
15.0	15.0

Speeds slower than 3.75 i.p.s. are suitable for speech only. At 7.5 i.p.s., speech and music can be reproduced with good quality. Broadcast quality is obtained at a speed of 15 i.p.s. Fig. 1 shows the frequency response of three professional recorders.

Because of its excellent fidelity, tape is often used by professional recorders to make an original or master track. This original may be edited, cut, or erased as desired (provided it is a single-track recording). Then the final track is re-recorded onto disc, film, or another tape. This saves considerable cost in film and processing during motion picture retakes and rehearsals. The double recording causes no appreciable distortion.

A versatile medium

Tape has little competition in the field of temporary recordings (office dictation, sales talks, audio tests, rehearsals). When a recording is no longer needed, it is simply erased and the tape is ready to be used again. Erasure is automatic. All previous sound is removed during the process of recording a new one.

Tape accommodates a maximum amount of sound in minimum space. A 7-inch reel of tape holds 1,200 feet. With dual tracks (one on each edge of the tape) and a speed of 7.5 i.p.s., a solid hour of recording is available. Professional type machines can hold extra-large reels with up to 9 hours of track. (A schedule of playing times is

given in Table I, which appears below.)

Tape recorders are readily adapted to special requirements. Battery-operated machines are made by the Amplifier Corporation of America, Stancil-Hoffman, Miles, and others. The Ampli-

Reel Size (Ins.)	Tape Length (Ft.)	Tape Speed (i. p. s.)			
		1.88	3.75	7.5	15
5	600	2	1	0.5	0.25
7	1,200	4	2	1	0.5
10.5	2,500	9	4.5	2.25	1
14	5,000	18	9	4.5	2.25

Running times are approximate

fier Corp. also sells a "synchronized sound" model for use with any automatic slide projector. Fairchild model 126 is designed to keep a tape track in exact synchronism with a motion picture film. Recently, a thin magnetic strip has been adapted to be put on movie film instead of the optical track. Thus it is possible to change the track easily if and when desired.

Continuous-tape machines are available for advertising campaigns, repeated public announcements, and similar purposes. Some have automatic switching. At the end of one track, the machine reverses itself and plays the other. Other machines (such as Ekotape model 114 and Ampro model 731) provide for a magazine which holds a

*April 10, 1952



Ekotape and Stencil-Hoffman portables—General Industries tape-phono unit

closed loop of tape. The loop runs continuously until the machine is shut off.

Tape itself is very rugged and can run many hundreds of times without deterioration or loss of fidelity. If accidentally broken, the ends are easily spliced together.

Recorder applications

Educational institutions and workshop groups have been quick to see the value of tape recorders. Some use the machines to record educational or entertainment programs for subsequent broadcast or reproduction.

Cornell University operates a Tape Recording Center with a library of hundreds of subjects. Educational and scientific topics, speeches, and special events are included. This Center is prepared to record on tape any desired topic supplied to it. At present the service is free but limited to schools and other interested groups in New York State. The Berkeley Opera Workshop (Berkeley, California, Adult Evening School) uses tape to record rehearsals and actual performances. This helps the members improve their efforts.

Many broadcast stations use tape to record lengthy transcriptions, delayed programs, and commercial "spots" for advertisers and clients. Lawyers and doctors are using tape to record testimony and consultations. More and more business offices are using tape recorders for dictation.

Good recorders are now moderately

priced and within the reach of most homes. They are a source of much fun and entertainment as well as education at social gatherings. Here are some of the uses to which they are put:

1. Recording children's voices.
2. Accompaniment for home movies.
3. Recording radio programs.
4. Code practice for amateurs.
5. Greetings for mailing to friends.

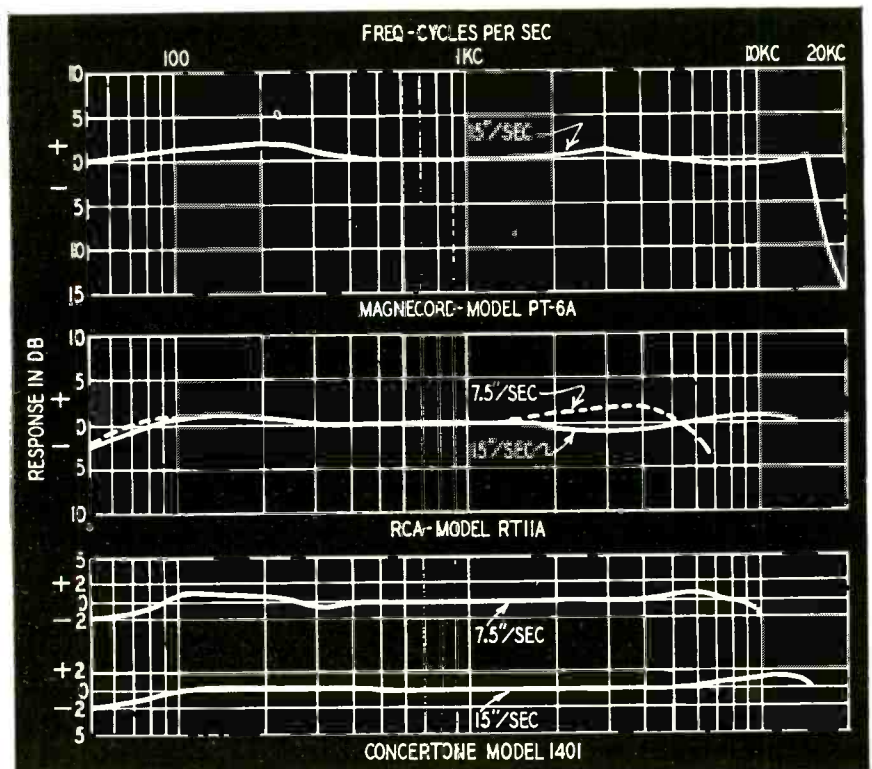

Fig. 1—Frequency-response curves of three broadcast-type tape recorders.

- 6. Weddings, birthdays, party events.
- 7. School, church, and club plays.

Recorder circuits

A tape recorder consists of two major portions, (1) the electronic cir-

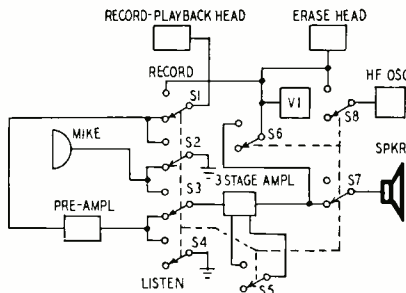

Fig. 2—Recording playback switching.

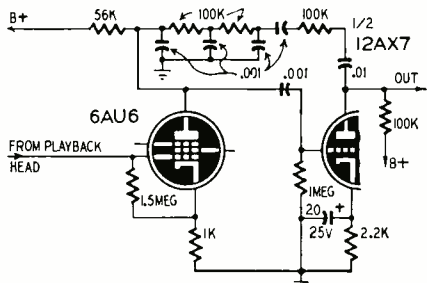

Fig. 3—Feedback-type high-low booster.

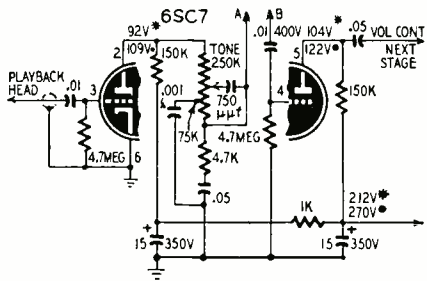

Fig. 4—Input switching and h.f. boost.

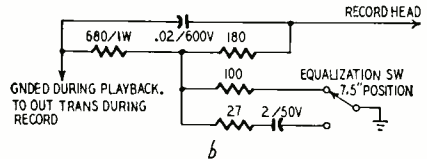

Fig. 4—Input switching and h.f. boost.

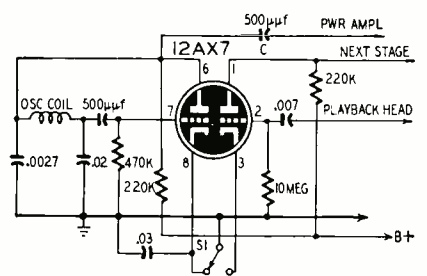

Fig. 5—Typical erase-oscillator circuit.

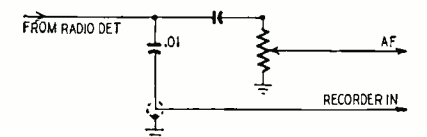

Fig. 6—Suggested radio-record hook-up.

cuits which include the recording, play, and erase heads, amplifier and equalizer, and power supply; (2) the tape transport or mechanism.

A tape amplifier differs from a conventional amplifier in two important ways. A tape circuit requires a special—often elaborate—switching arrangement. Also, considerable equalization is required in a tape amplifier. Both bass and treble boost must be used, because of the inherent characteristics of the tape itself. Professional-type recorders (such as Concertone) use separate record and playback amplifiers. The treble boost is incorporated in the record amplifier, the bass boost in the playback amplifier. This arrangement attenuates hiss and other noise. Inexpensive recorders use a single amplifier and a less efficient equalizer.

A typical switching arrangement is shown in Fig. 2. The switches are usually ganged. They are shown in the "listen" position. S1 connects the playback head to the preamplifier input. Note that the same head is used for both playback and recording. S2 grounds out the microphone. The tape signal passes through S3 and S7 to the main amplifier and speaker. The volume indicator (VI) and h.f. oscillator are in the circuit only during "record." When recording, the ultrasonic voltage feeds the erase head and also mixes with the a.f. signal at the record head.

S4 grounds the preamplifier during recording while the sound source is connected to the main amplifier through S3. Usually the speaker is disconnected during recording to avoid feedback howl. This is done by S7. The tape travels through the two heads (or the combination head) "erase" and "record-playback." S8 disconnects the ultrasonic signal in the "listen" position.

S5 cuts out the tone control during recording. It also controls equalization, which must be changed when tape speed is changed (if the recorder includes more than one speed). Therefore S5 may be part of the motor speed control.

The more expensive recorders include some method for monitoring, usually through headphones.

Fig. 3 is one type of equalization circuit. This network is recommended for use with model 250 General Industries recorder, which does not include its own amplifier. The R-C network couples the plates of the two tubes as shown, when the instrument is switched to "playback." The network attenuates both highs and lows, so only the middle register is fed back to the first tube. This degeneration provides *boost* for both bass and treble as required.

Boost at h.f. alone is sometimes obtained by using only low capacitance across an amplifier cathode resistor. Fig. 4-a shows the excellent equalization system of Webcor model 210 (Webster-Chicago). The first triode is a bass-boost preamplifier for playback. The mike feeds directly to the second triode. Fig. 4-b shows the treble boost circuit for recording.

A tape erasing oscillator generates a frequency near 30 or 40 kc. The more expensive-type recorders are designed for push-pull output which gives less noise and better efficiency. Ultrasonic erasure is considered superior, but some less expensive recorders rely on PM erasure. In the latter method, a permanent magnet is mounted near the tape just ahead of the recording head. As the tape moves past, it encounters magnetic polarity changes and is demagnetized. Of course, the magnet must be drawn well away from the tape path during playback or rewind.

Manufacturers have shown considerable ingenuity in simplifying their circuits to reduce costs, yet maintain efficiency. Some circuits use the same tube as power amplifier during playback and as oscillator during recording. One model (the Ampro 731, Fig. 5) uses a duo-triode tube for two different functions. One triode is a Colpitts oscillator during recording. The other triode pre-amplifies during playback. S1 opens the cathode of the triode not being used.

Less-expensive machines use a neon lamp instead of an "eye" indicator or meter to indicate the level of modulation input. The lamp is small and requires no power supply, yet is well adapted for this application. The recording level is correct when the lamp flashes only occasionally during peaks. When an eye is used, it should close only during occasional peaks.

Many recorders are provided with output jacks to connect an external high-fidelity speaker instead of the recorder speaker when desired. In a small portable instrument, there is no space for a speaker larger than about 8, or perhaps 5 x 7 inches.

The number of inputs is sometimes an important consideration. The simpler machines have only one input jack or terminal, for a high-impedance source such as a crystal microphone. Other recorders have separate inputs for mike, radio, and phono.

Recordings may be made from a radio receiver as shown in Fig. 6. This eliminates the receiver amplifier and uses the recorder amplifier and volume control. A short shielded lead should be used between the radio and the recorder. If this method is not convenient, the recorder may be connected across the radio-speaker voice coil. No shielded lead is needed, but the speaker level may have to be kept very low.

Frequency-checking a tape recorder is much like making a frequency run on an amplifier. An a.f. generator with calibrated output is required. A known signal of a few millivolts is applied to the input terminals and recordings are made at 100, 1,000, and 5,000 cycles, or higher frequencies if desired. The same input signal is used in each case. Then the tape is played back with an a.c. voltmeter measuring the output across the speaker voice coil.

Wow is best tested by listening to a tape recorded at a single high frequency.

(to be continued)

NOVEL

FRENCH SPEAKER

By P. HEMARDINQUER



Apartment model of the unique sound mixer with low-frequency chamber and aperture.



Large sound mixer baffle (Pathe type) used in French film-theatre sound systems.

A SPEAKER mounted on a flat baffle transmits the middle range and part of the bass satisfactorily, but the higher notes are radiated in a narrow beam, so that the sound quality depends on the position of the listener.

For bass notes, reflection and refraction become very complex as the baffle dimensions approach the length of the sound waves.

Numerous acoustic systems have been devised in the attempt to distribute the high notes over an angle of 60 to 80 degrees, and to improve reproduction of the low notes with folded horns and resonant chambers. Another solution, recently developed in France, uses a conch-shell-shaped element, which in form is part of an ellipsoid of revolution. (See photos.) An ordinary cone-type speaker is placed in one of the foci of the ellipsoid. Middle and higher-range sound waves from this point are collected at the other focus of the system, which becomes a virtual point of origin for the sound waves, diffusing them at a wide angle (Fig. 1). The special shape of the reflector concentrates the sound energy at one point

in space, giving the subjective impression that the point is itself emitting the sound.

Bass notes are reinforced by a resonant chamber in the lower part of the equipment, with a carefully-calculated opening for the back-wave, following the principle of the reflex baffle.

The complex baffle form is made of plaster. The surface is glazed to provide a reflecting surface for the higher frequencies. The interior of the resonant chamber is given a rough sound-absorbing finish.

The new baffle reduces intermodulation distortion and improves the efficiency of the speaker. See Fig. 2. In spite of the fact that only one speaker is used, there is a lifelike effect of depth, of a diffused source.

The concentration of sound toward the listener, with reduced transmission into neighboring spaces, will be especially appreciated in apartments.

An acoustic device of this nature must be used with a high-quality loud speaker and a well-designed amplifier with precise control of the high and low ends of the spectrum.

—end—

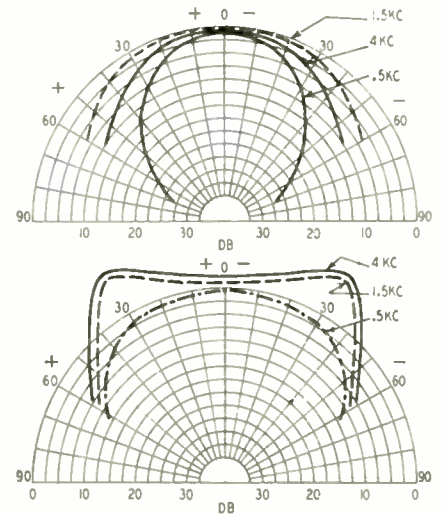

Fig. 1—Relative directivity of 10-inch speaker mounted in a 3-foot flat baffle and in the new ellipsoidal sound mixer.

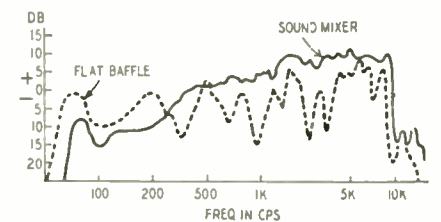

Fig. 2—Improvement in musical quality when sound mixer replaces flat baffle.

By ROBERT L. LIBBEY

PHASE SHIFT

DISTORTION METER

makes accurate "must" measurements on audio amplifiers easy and inexpensive

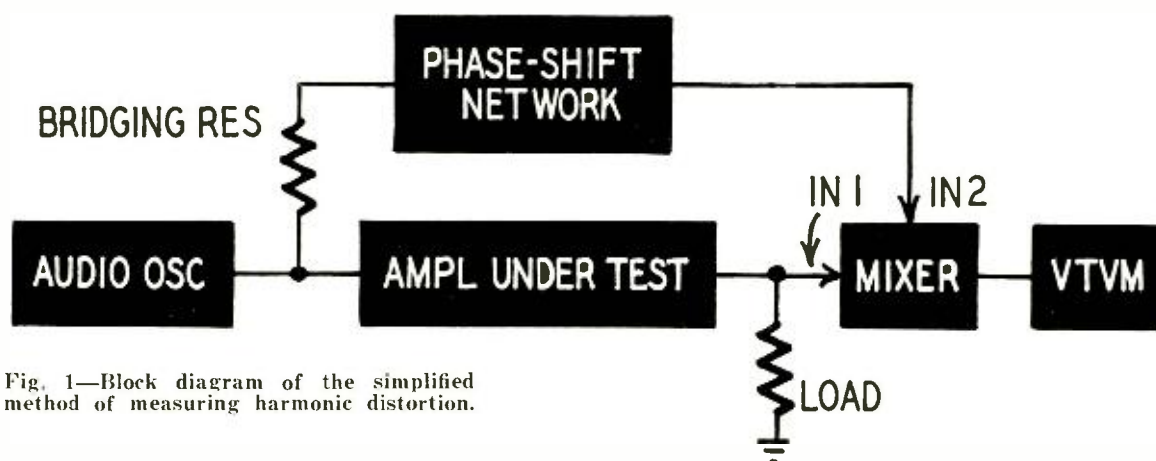

Fig. 1—Block diagram of the simplified method of measuring harmonic distortion.

THE measurement of harmonic and intermodulation distortion is an important step in determining the quality of an audio amplifier. In the broadcast industry, distortion meters are a *must* by FCC rule. Serious audio enthusiasts and technicians who build and service audio equipment are turning to the distortion meter for specific and accurate checks on amplifier performance.

The first distortion meter was a milliammeter in the plate circuit of an amplifier tube. Theoretically, there should be no fluctuation in the *average* plate current of a class A amplifier. At times, however, the meter needle will kick up or down from its steady-state value. Kicks of more than 10 percent of the steady-state reading indicate unsymmetrical amplification, with resulting distortion.¹ The plate-current distortion meter indicates only that distortion is present; the remedy is still a problem.

The principle of modern distortion-measuring technique is simple. A signal from an audio oscillator is applied to the amplifier under test. The output of the amplifier is fed to the distortion meter.² This output contains the fundamental frequency of the oscillator, plus

any harmonic distortion (multiple or submultiple frequencies) introduced by the amplifier. The output voltage is adjusted to a reference mark on the v.t.v.m. associated with the distortion-measuring equipment. This is called the "calibrate" step. Next, the fundamental frequency is eliminated, leaving only the harmonics. The combined amplitude of these harmonics is then read directly on the v.t.v.m. as a percentage of the total output.

The heart of the distortion meter is the means used to eliminate the fundamental frequency and leave all the harmonics for measurement. One method uses a bridge circuit. The bridge is highly effective, but requires costly precision components and very careful balancing adjustments. Another method is by means of a T or bridged-T filter network. This also requires balancing, and a switching arrangement for each frequency band, since a given set of high-Q filter components are effective only over very narrow frequency limits.³

A new approach

With the basic principles of these two commonly-used distortion meters in mind, we will outline the theory and construction of a different type of instrument. This new distortion meter

was developed in the electronics laboratory of the University of Wyoming. The new meter is inexpensive, easy to operate, and accurate within 2 percent. It can be used with inexpensive audio oscillators with no sacrifice in accuracy.

The new circuit eliminates the fundamental by *phase cancellation*. If we impress two sine waves of equal frequency on the same circuit, a number of results may be obtained. If the two waves are *in phase* (in the same position in their respective cycles at any given time), they will add, and the measured voltage will be the sum of the two individual amplitudes. If the waves are exactly opposite in polarity (180° *out of phase*), the larger will cancel the smaller, and if they are of equal amplitude, they will cancel each other completely.

No doubt you have jumped ahead of us in your thinking, and see the basic principle involved: *If the output of an amplifier containing a fundamental and harmonics is mixed with the correct amount of fundamental shifted exactly 180° , the resultant will contain only the harmonics.*

Fig. 1 shows the principle in block-diagram form. The oscillator output is applied to the amplifier. A phase-shift network is "bridged" across the oscillator output. (A *bridging connection* should not be confused with a *bridge circuit*. "Bridging" is a term used in telephone and broadcast work to de-

¹Ghirardi's *Radio Physics Course*, 3rd edition, pages 509 to 514, gives a fine review of distortion due to nonlinear amplification.

²In measurements of this type, perfect impedance matching between all components is imperative to prevent reflections that affect the accuracy. See any text on sound, sound recording, or communications.

³Both methods of eliminating the fundamental are discussed in Terman's *Radio Engineer's Handbook*, 1st edition, page 944.

scribe a high-impedance connection across a low-impedance circuit. Program monitors, volume indicators, and other testing devices are bridged across standard 600-ohm lines through high series resistances to reduce loading effects and provide a high degree of isolation. The v.t.v.m. is the most common example of a bridging device.—*Editor*)

The impedance match between oscillator and amplifier is not affected by the bridging connection, but the amplitude of the signal going to the phase-shift network is small. The amplifier output is fed to a suitable resistance load, and the load voltage is applied to one input of the mixer. The output of the phase-shift network is fed to the other mixer input.

Amplifier phase relations

In an ideal vacuum-tube voltage amplifier stage with a resistive load, the grid and plate voltages are exactly 180° out of phase. This relationship is not true in practical circuits. Tube and stray capacitances, coupling transformers, capacitors, and reactors upset the perfect resistive condition. In a multistage amplifier, we may have different phase shifts in each stage. The shift-per-stage will also change as the frequency changes. In any case the shift-per-stage cannot vary more than 90° from the 180° ideal. Thus an amplifier with an even number of stages would have an ideal phase shift of 360°, a minimum shift of 180°, and a maximum shift of 540°. An odd number of stages would have an ideal shift of 180°, a minimum shift of 90°, and a maximum shift of 270°.

The phase-shift network in this instrument has two functions: (1) It provides a fixed shift of 180° to compensate for an odd or even number of amplifier stages; (2) it can be also varied over a range of approximately ±90° to make up for practical amplifier conditions.

(For a detailed explanation of the effects of phase relationships in amplifiers, see the series of articles "Audio Feedback Design," by George Fletcher Cooper, in the October, 1950, to November, 1951, issues of RADIO-ELECTRONICS.—*Editor*)

The distortion-meter circuit

The basic phase-shift circuit of the instrument is shown in Fig. 2. This circuit has been borrowed from industrial electronic equipment.⁴ Reversing-switch S gives a fixed shift of 180°. Smaller shifts are obtained by varying R.

Fig. 3 is the complete circuit. T1 is a line-to-push-pull-*grids* or plate-to-push-pull-*grids* type, with the highest possible step-up ratio. It need not be a high-fidelity type, but the secondary center-tap must be accurately balanced. Resistor R should match the input impedance of T1. R2 and R3 are equal

bridging resistors. Their value is not critical and may be from 10,000 to 100,000 ohms. Higher values improve isolation but reduce the voltage to the transformer.

R1 should be about 50,000 ohms. C1 may be from 0.01 μf to 0.1 μf. Its value depends on the characteristics of T1, and can be found with the help of an audio oscillator and a scope. Set the oscillator to 1,000 cycles and connect it to the network input terminals, and to one of the scope inputs (either vertical or horizontal). Connect the other scope input to X1, and shut off the internal sweep. Select C1 so that by varying R1 the scope pattern changes from a diagonal line to an ellipse, and then to a circle.

A 6N7 mixer is shown in the diagram, but any twin-triode type (6SL7, 6SN7, 12AT7, or 12AU7) may be used. R4 and R5 may be 500,000-ohm volume controls, or a T pad may be substituted for R5 if a calibrated attenuator is preferred.

The mixer is operated as a cathode follower. There is no voltage gain, but the stage has no measurable distortion. X1 and X2 are test jacks for oscilloscope checks. The 6SJ7 is a conventional resistance-coupled amplifier, except that the cathode resistor is double the usual value because of the direct-coupled input. X3 is the terminal for the v.t.v.m.

Testing and operation

After a complete continuity and voltage check, connect a v.t.v.m. to X3, and short out both mixer inputs. Any reading on the meter indicates hum or noise in the instrument, which must be tracked down and eliminated.

When the unit is in perfect working order, connect an audio oscillator to the OSCILLATOR INPUT terminals and check the controlling effect of R4 on the output. At least 1 volt output should be obtained through the phase-shift circuit. Next, check the amplifier input section of the mixer in the same way.

Actual harmonic distortion measurements are carried out in the following way:

1. Connect the audio oscillator to the input of the amplifier under test, and bridge the phase-shift circuit across the input as shown in Fig. 1. Adjust R4 for full-scale reading on the highest possible range of the v.t.v.m. plugged into X3.

2. Disconnect the bridging circuit from the input to the amplifier and short out the bridging input terminals. Connect the amplifier load resistor to the AMPLIFIER INPUT of the mixer, and adjust R5 for the same full-scale reading as in step 1.
3. Restore the bridging connection

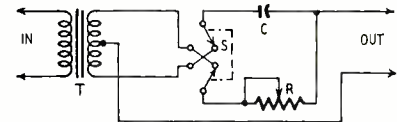

Fig. 2—Fundamental phase-shift circuit used for harmonic distortion measurements on audio-frequency equipment.

across the input to the amplifier and adjust R1 for minimum output. If the v.t.v.m. pointer goes off scale, reverse S and adjust R1 again for minimum output voltage.

4. Repeat steps 1, 2, and 3 for absolute minimum reading. The final reading is the harmonic distortion in volts. For maximum accuracy, the v.t.v.m. may be switched to a lower range only after steps 1, 2, and 3 have been completed.

The final voltage measurement may be converted to a percentage by the formula:

$$\% \text{ Distortion} = \frac{100 E_{m,1n}}{E_{max}}$$

Distortion in the audio oscillator itself will not affect the accuracy of the measurements, since the original signal is completely canceled in the mixer if the final balancing adjustments are made with care.

If T1 is an inexpensive type, the frequency range of the instrument may be limited. Several different capacitance values for C1, connected to a selector switch, will improve the response.

The new distortion meter will give professional results with simple and inexpensive equipment. With the kit-type audio oscillators and v.t.v.m.'s now available, you can build a measuring set that any service technician or audio enthusiast will be proud to own.

Materials for measuring set.

Resistors: 1—510,000 ohms; 2—100,000 ohms; 10,000 ohms; 1—2,200 ohms; 1—1,000 ohms; R, R₂, R₃: R₂ (see text) 1/2 watt; 2—500,000-ohm potentiometers.
 Capacitors: (Paper) 1—0.25 μf, 1—0.1 μf, 1—0.05 μf, 400 volts; C1 (see text). (Electrolytic) 1—20 μf, 25 volts, 1—8 μf, 150 volts.
 Miscellaneous: 1—6N7 tube; 1—6SJ7 tube; 1 push-pull input transformer (see text); 2 octal sockets; chassis, connectors, terminals, solder, hardware; power supply—100 volts d.c. at approximately 20 ma; 6.3 volts a.c. or d.c. at 1.1 amp; 1 d.p.d.t. switch.

—end—

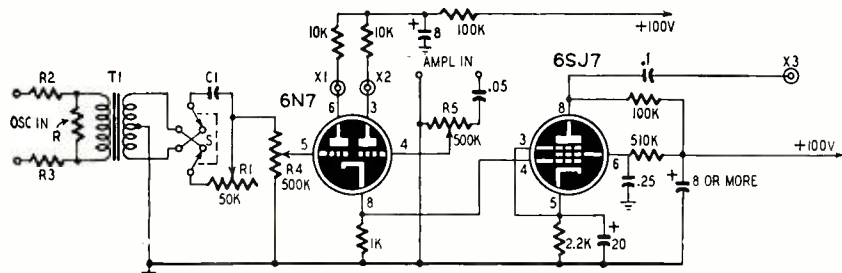

Fig. 3—Schematic of the complete distortion measuring instrument. Characteristics of lettered parts are given in the text. Any similar tube types may be used.

⁴The Westinghouse Industrial Electronics Reference Book explains the operation of this circuit in complete detail. It is available at most large public libraries.

ELECTRONICS and MUSIC

Part XXVI – More on the Minshall organ



By RICHARD H. DORF

Fig. 1—The Minshall Model E two-manual electronic organ. The speaker is installed in a separate enclosure.

THE tone-color filters or "stops" of the Minshall electronic organ are among its most interesting features. Vacuum tubes are used as tuned-circuit electronic filters without inductors. The tone resources of various Minshall models differ. Model E shown in Fig. 1 has 16 stops, 5 couplers, and vibrato.

Fig. 2 shows how the GREAT manual stops operate. This circuit, the SWELL manual circuit (Fig. 3), and the controls—couplers and vibrato—are mounted on a tablet board, each switch controlled by a standard organ-stop tablet. Twenty-four of these tablets may be seen above the swell manual in Fig. 1.

In Fig. 2 the three GREAT manual signal busses, 4-, 8-, and 16-foot, represent keyed tones with octave separation. Unlike the Baldwin organ, the Minshall does not provide separate sets of filters for each of these registers, but uses a single set of filters on each manual, with provision for coupling any or all of the registers to them. The Minshall system is less expensive.

The first requirement is a method of selecting the registers which are to speak. This is done by grounding the bus or busses which are *not* to be heard. Each switch in Fig. 2 operates schematically when the straight arm is pressed downward at the end opposite the terminal. All switches are shown in normal (unoperated) position.

The 4-foot bus is normally grounded by the GREAT SUPER switch through a normally-closed contact of the FULL ORGAN switch. The same is true of the

GREAT SUB switch, which grounds the 16-foot bus. The 8-foot bus is normally *ungrounded*, and the GREAT UNISON OFF switch must be operated out of its normal position to silence the 8-foot tone. The terms *super*, *unison*, and *sub* have been adopted by Minshall rather than 4-, 8-, and 16-foot.

The three busses are connected through 470,000-ohm resistors R1, R2, and R3, to a common point, thence through 100,000-ohm resistor R7 to the amplifier input lead. The 470,000-ohm resistors are for isolation purposes so that grounding a bus through the *super*, *unison*, or *sub* switch will not affect the other busses.

The tone filters are of the shunt type. They are connected between the junction of each set of 470,000-ohm resistors and the corresponding 100,000-ohm resistor.

The *string* filter is connected to the junction of R7, and R1, R2, and R3. This filter is electronic rather than electric and is unique in electronic musical instruments. There are two such filters in the GREAT-manual portion of the tone-coloring system; they employ the two triode sections of a single 12AX7. The tube is connected as an amplifier with a reactive feedback network from plate to grid. The feedback reactance is a multiple R-C combination in the form of a low-pass filter. The first portion of the filter is the tube plate resistance in series and the .0047- μ f capacitor in shunt. The second section is the right-hand 47,000-ohm resistor and the .0027- μ f capacitor.

Since the feedback phase changes with frequency, the effective voltage at the grid for a constant input voltage signal also varies with frequency. Over a certain band of frequencies the phase of the feedback signal at the grid is in the same quadrant as the input voltage and reinforces it. At one frequency in this band the reinforcement is maximum and the voltage at the grid reaches a peak. When this happens the filter circuit has minimum shunting effect on the signal line to the amplifier and a response peak is produced.

In another band of frequencies the phase of the amplified signal fed back to the grid is in the opposing quadrant and tends to reduce the grid voltage. At one frequency the opposition is maximum and a trough is produced in the response of the bus-to-amplifier signal.

The electronic filter acts like a resonant circuit which has a peak at one frequency (and may therefore be considered a parallel-tuned circuit), and a dip at another (at which it may be considered a series-resonant circuit). These analogies are relative, of course, and are correct here because the entire circuit shunts the signal line. The parallel-resonant frequency of the GREAT STRING filter is approximately 4,000 cycles; its series resonance takes place at about 500 cycles. The Q of the electronic filters used in the Minshall runs between about 3 and 6. Greater Q's are attainable, but it is not desirable to peak the response too sharply in analogizing musical formants. The "reso-

nant" filters give formant characteristics to the tone colors.

The STRING filter is controlled by the switch shown in the lower grid circuit. The switch is normally closed, shorting the grid and the first signal path to ground. Resistors R1, R2, R3, and R7 in the signal network prevent this short from grounding the amplifier input or any of the signal busses.

The shunt for the other filters of the GREAT manual is connected in the other signal path, at the junction of R8 and R4, R5, and R6. In addition to a second electronic filter, this group also has R-C components which modify the shape of the signal transmission curve.

allowing the generated tone to go to the amplifier. The size of R9 controls the level of the signal, since it is effectively the output leg of a voltage divider.

When the flute stop is required and the FLUTE switch opened, the bus network is shunted to ground through R10 and C1. This low-pass filter attenuates the high frequencies rapidly, making the output lose much of its harmonic content. When the DULCIANA switch is opened two things happen. The impedance to ground of the shunt is raised by the addition of the 12,000 ohms of R11, and the upper electronic filter is brought into play. The peak of

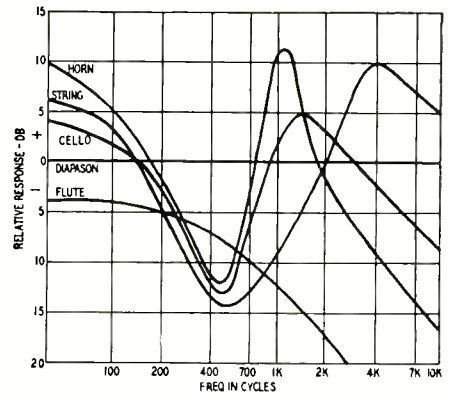

Fig. 3—Frequency response curves produced by the electronic filters in simulating characteristic instrument tones.

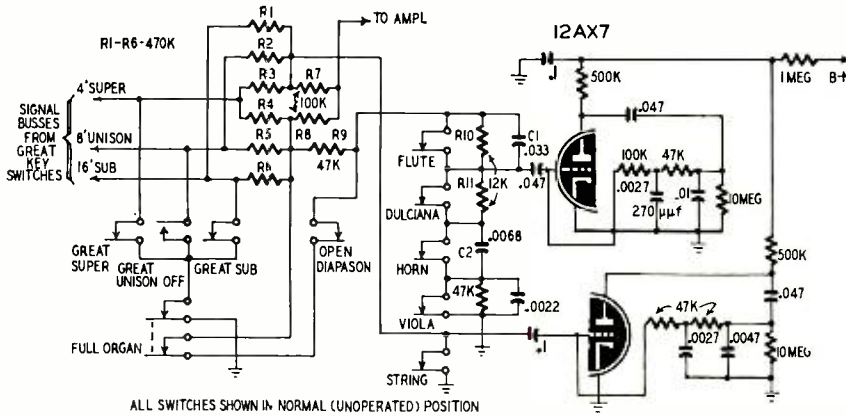

Fig. 2—Tone-color control circuits of the Minshall GREAT manual. The 12AX7 feedback amplifiers are electronic resonant filters across the signal line.

These components are all in series and a normally-closed switch shunts each element.

The OPEN DIAPASON stop does not use a filter; it is simply the generated waveform, a sawtooth with a fairly large flyback time. The OPEN DIAPASON switch is normally closed; with all the other switches closed (except the STRING switch, which does not matter for this purpose), the junction of R8 and R4, R5, and R6 is shorted to ground, so that no signal passes through the bus network to the amplifier. When the OPEN DIAPASON stop is required, the switch is opened. This places the 47,000-ohm resistor R9 between the network and ground, removing the short and

this filter is about 1,100 cycles and the trough 450 cycles. To this response is added the treble attenuation of the flute filter, though in reduced quantity. Opening the HORN switch connects C2 in series with the shunt, increasing the bass response. Opening the VIOLA switch further alters the curve in the same manner.

These descriptions of the filter action are only qualitative, since it is the overall shape of the curve which matters. A more exact story is told by the curves of Fig. 3, which show actual frequency characteristics of the signal path with various R-C and electronic filters connected across the amplifier-input circuit by the keyboard stops.

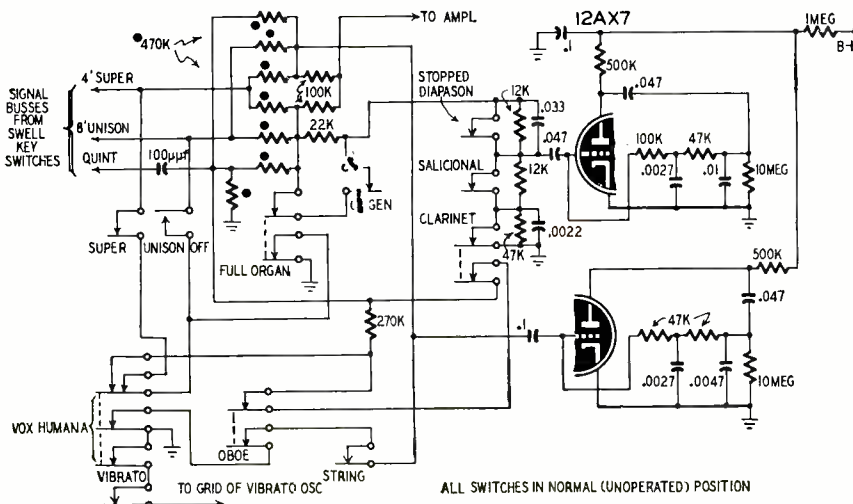

Fig. 4—The SWELL manual stop circuits add more tone qualities and a vibrato.

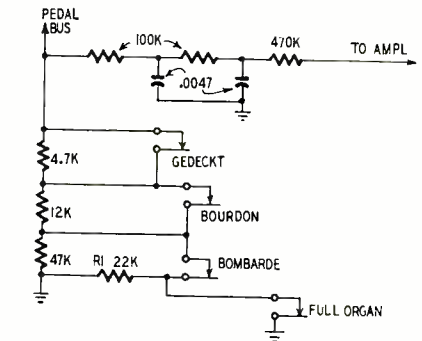

Fig. 5—Pedal stop switches change volume in fixed steps, have no effect on tone. Filter removes harsh quality.

The swell filters

The SWELL filter system, diagrammed in Fig. 4, operates basically in the same way as the GREAT filters, even using many of the same circuit components, but the switching is more complex. In the SWELL the three busses include 4- and 8-foot but not 16-foot tones. Instead there is the quint bus, containing tone one octave and a musical fifth above the 8-foot tone (approximately the third harmonic). As in the GREAT, there are a SUPER switch and a UNISON OFF switch. The SUPER switch leads through sections of the VOX HUMANA switch and both go through the FULL ORGAN switch. (The latter is the same switch in both diagrams, different sections of it being shown in Figs. 2 and 3.) Thus, when the VOX and FULL ORGAN are not in use, the 8- and 4-foot tones may be shorted out, but operating the VOX automatically turns on the SUPER and pulling FULL ORGAN makes both main busses speak.

The string filter is similar to that in the GREAT. The return end of the STRING switch is not returned directly to ground, but is grounded through sections of the OBOE and VOX HUMANA switches so that when these stops are drawn the string tone sounds. The main shunt filter is fed from the lower of the two signal paths, this time through a 22,000-ohm resistor. When the GEIGEN switch is opened, the signal is shunted by the main filter in series with the 22,000-ohm resistor; if STOPPED DIAPASON, SALICIONAL, and CLARINET switches are closed, the tone heard is attenuated

sawtooth 4- and 8-foot tone plus QUINT. The same is true if the FULL ORGAN switch is opened.

The STOPPED DIAPASON, SALICIONAL, and CLARINET stops operate in the same way as the similarly-placed circuits in the GREAT. In addition, when CLARINET tone is desired, a second section on its switch removes the ground which is placed on the *quint* bus through sections of the OBOE, VOX, and FULL ORGAN switches. Then the *quint* tone is attenuated only by the 270,000-ohm resistor shunting it to ground through the VOX and FULL ORGAN switches.

tion at the top removes the ground short from the *quint* bus, allowing the *quint* to come forth at full strength (a lower level than the other two busses due to the permanent filter just mentioned). This section also sounds the 4-foot bus by removing its ground. The center section removes the short from the *string* filter, adding it to the combination. The lower section adds vibrato by ungrounding the line through the VIBRATO switch to the vibrato oscillator.

When the FULL ORGAN switch is used, it causes *geigen* tone (raw sawtooth) to sound, and also removes the ground

low-pass filter to remove most of the harshness of the sawtooth tone and give a more or less flutelike quality.

When all *pedal* tabs are in normal position (up) the bus is shorted to ground. When the FULL ORGAN tab is pressed (the contacts shown in Fig. 5 are part of the entire FULL ORGAN switch already shown in Figs. 2 and 3), the bus is grounded through R1. With *full organ* not in use and the GEDECKT tab down, the shunt is 4,700 ohms. The BOURDON tab adds 12,000 ohms in series, raising the level, and the BOMBARDE tab adds 47,000 ohms for maximum level.

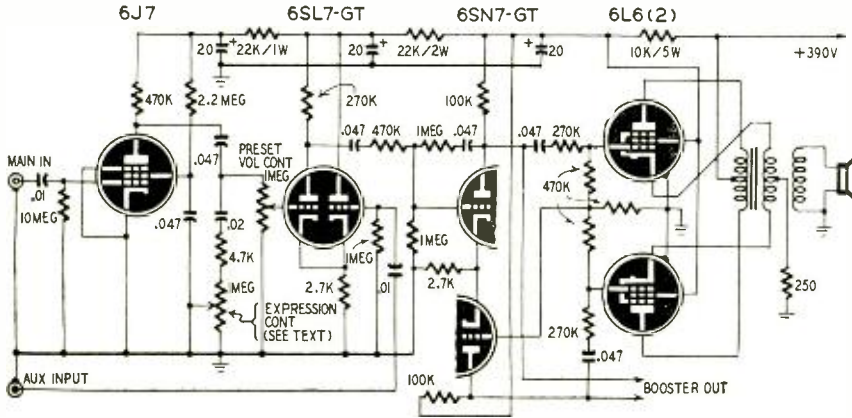

Fig. 6—Main amplifier. The output transformer has a tertiary cathode-feedback winding.

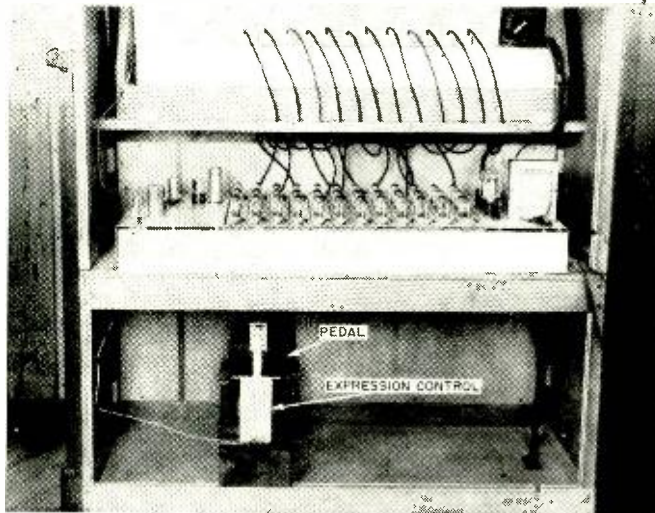

Fig. 7—Rear view of the Minshall organ showing the expression - control foot-pedal linkage.

When the OBOE switch opens, the short across the *string* filter opens and the *string* characteristic is heard. Added to that, the *quint* bus is unshorted, just as with the CLARINET switch, and is shunted to ground only by the resistor.

The *quint* bus does not provide the ordinary sawtooth wave present on the other busses. At the *quint* input to the filter assembly this line has a series 100-μf capacitor and a shunt 470,000-ohm resistor. As a result, the *quint* signal is attenuated about 3 db per octave below 6,500 cycles and has practically no fundamental. The waveshape more nearly resembles sharp pulses than sawtooth waves. This has a "buzzy" quality which sharpens any tone to which it is added.

The VOX HUMANA switch, when opened, does several things. The double sec-

tion from the UNISON OFF switch and the grounds going through the VOX switch from the 4-foot and *quint* busses, so that all three busses sound at full level. Slight amounts of the desired characteristics can be added to the FULL ORGAN by using the desired stops in addition to the FULL ORGAN.

The pedal filters

The principal purpose of the pedal clavier in ordinary organ playing (as distinguished from concert work) is to provide foundation bass. Pedal stops are rarely elaborate and this idea has been followed in the Minshall.

Fig. 5 is a diagram of the pedal control system. Three stops are provided. They do not alter the tone quality but simply change the volume level. The output of the *pedal* bus from the pedal key switches passes through an R-C



Fig. 8—Inside the expression control. Sliding bar contacts fixed resistors. Attenuates volume in 60 small steps.

The amplifier

The amplifier used in the model H (single-manual spinet) and Model J (dual-manual with built-in speaker) is diagrammed in Fig. 6. This is a conventional circuit with some novel features. The EXPRESSION pedal operates a step-type variable resistor which shunts the input to the second stage through a fixed 4,700-ohm resistor and a .02-μf capacitor. The fixed resistor prevents the pedal from reducing the level to zero. The .02-μf capacitor is a rudimentary "loudness control", raising the bass relatively as the volume decreases.

The *expression control* assembly can be seen linked to the pedal in Fig. 7. Fig. 8 is a close-up of the control with cover removed. It contains 60 contact bars embedded in plastic, each connected to a pair of resistors which make up the attenuation steps. The actuating bar is grounded and a spring contact on it rides the contact bars as it is moved by its link to the SWELL pedal.

Returning to Fig. 6, the first-triode grid of the 6SL7-GT has a standard potentiometer which is preset at installation for a maximum volume suited to the room and the organist's taste. The second triode is an auxiliary input amplifier provided for future addition of an electronic chime system.

Output from the plates of the 6SN7-GT phase inverter is fed to a BOOSTER OUTPUT connector as well as to the grids of the 6L6 final stage. This permits signals to be fed to a separate tone cabinet for sound reinforcement, or it may be used in a radio station for connection through a suitable transformer to the station's audio system.

(to be continued)

VOLTAGE REGULATION

These circuits will deliver constant d.c. voltage under large line and load changes

By R. D. HORWITZ

SERVICE technicians, radio amateurs, and electronics experimenters meet many circuit situations calling for highly stable d.c. power supplies. Variations in B plus voltages will affect the accuracy of a signal generator, the stability of even a crystal-controlled oscillator, and the gain of an amplifier. In receivers with high-Q tuned circuits, changes in supply voltages may affect the selectivity. This is especially true in TV receivers, where the settings of the contrast, brightness, and volume controls, the horizontal drive and the other sweep adjustments, and normal aging of the tubes cause large variations in the total current drawn from the power supply.

Gas-filled regulator tubes will maintain constant voltage where only a few milliamperes are required, and their use is generally limited to a single critical tube or circuit. Fortunately, an electric regulator that will deliver constant voltage to the full load from almost any type of power supply can be built at low cost.

The basic regulator circuit is shown in Fig. 1. The input to the regulator (from the rectifier-filter) must be greater than the required output voltage. V1 acts as a series resistor. The voltage drop across V1 is controlled by the voltage on its grid. The purpose of the complete regulator circuit is to vary this voltage drop automatically, to maintain the output voltage constant at any predetermined level.

V2 is a d.c. amplifier, with its cathode held at a fixed positive voltage by the gas-filled regulator tube V3. The grid of V2 is set at a slightly less positive voltage than its cathode by the potentiometer across the output. The net bias on V2 is the voltage difference between its grid and cathode. The plate of V2 is connected directly to the grid of V1.

If the load voltage decreases for any reason, a proportional decrease occurs at the grid of V2. The voltage at the plate of V2 (and the grid of V1) becomes more positive, reducing the voltage drop in V1, and raising the output voltage to its original value. If the load

voltage increases, the grid of V1 becomes more negative, and a greater drop takes place across the tube. The action is practically instantaneous, as there are no coupling capacitors or inductors to introduce any time delay. Any change in load voltage is automatically counteracted by a change in the drop across V1.

V1 must carry the full load current. A high-plate-current triode, such as the 2A3 or 6AS7-G, or a triode-connected 6L6 or 6Y6-G, is required. V2 should have the highest possible voltage gain. A single 6AH6 or 6AC7 pentode is suitable, or a high-mu twin-triode, a 12AT7 or 6SL7, may be used as a two-stage amplifier.

An important element in the circuit is the gas tube which provides a constant reference bias for V2. The VR series, or 0A2, 0B2, and 5651 types are standard for this application. A neon lamp without an internal limiting resistor also may be used.

Complete regulator circuits are shown in Fig. 2 and Fig. 3. The first will supply 90 ma (the maximum capacity of the 6Y6-G) at any voltage between 150 and 250. Additional 6Y6's may be connected in parallel for heavier load currents. The 0.1- μ f capacitor improves filtering by feeding any a.c. ripple back through the regulator for cancellation.

Fig. 3 is a heavy-duty regulator capable of supplying 225 ma at 250 volts. The 6SL7 is a two-stage d.c. amplifier. Its high gain improves regulation by responding to even the smallest changes in load voltage.

In addition to its value as a source of unvarying d.c., the voltage regulator has another great advantage. Because it has practically zero internal impedance, it is an almost perfect bypass to ground for any a.c. in the supply circuits of the equipment with which it is used. Motorboating and oscillation, especially in high-gain multistage circuits, are eliminated without the need for elaborate decoupling networks.

Materials for 90-ma regulator

Resistors: 1—10,000 ohms, 1—8,200 ohms, 2 watts; 1—1 megohm, 1—82,000 ohms, 1—39,000 ohms, 1—

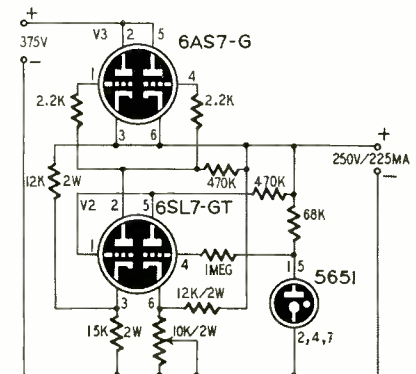
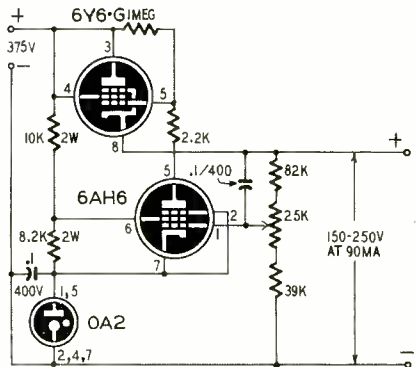
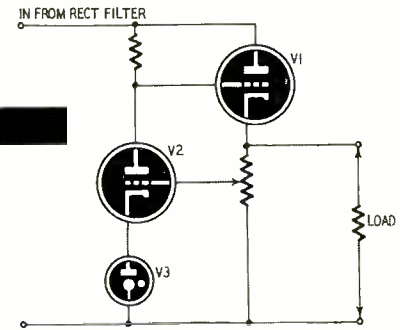

Fig. 1 (top)—The basic electronic regulator circuit uses amplified negative feedback to hold load voltage constant.

Fig. 2 (center)—Complete regulator for loads up to 90 ma, with adjustable output. Note input voltage required from filter. Use separate heater winding or transformer for 6Y6 to prevent heater-cathode insulation breakdown.

Fig. 3 (bottom)—A heavy-duty regulator unit, with 2-stage triode feedback amplifier and high-stability reference tube. Give all components—especially the 6AS7-G—plenty of ventilation.

2,200 ohms, 1/2 watt; 1—25,000-ohm potentiometer. Capacitors: (Paper) 2—0.1 μ f, 600 volts.

Miscellaneous: 1—6Y6-G, 1—6AH6, 1—0A2; 1 octal socket, 2—7-pin miniature sockets; chassis, connectors, wire, solder, hardware.

Materials for 225-ma regulator

Resistors: 1—15,000 ohms, 2—12,000 ohms, 2 watts; 1—1 megohm, 2—470,000 ohms, 1—68,000 ohms, 2—2,200 ohms, 1/2 watt; 1—10,000-ohm, 2-watt potentiometer.

Miscellaneous: 1—6AS7-G, 1—6SL7-GT, 1—5651; 2 octal sockets, 1—7-pin miniature socket; chassis, connectors, wire, solder, hardware.

—end—

LONG-PERIOD RADIO TIMER

By H. A. VASQUES

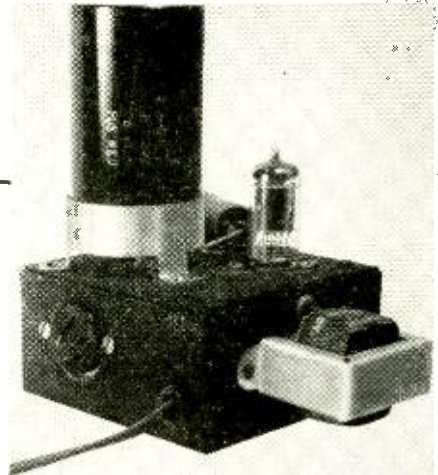
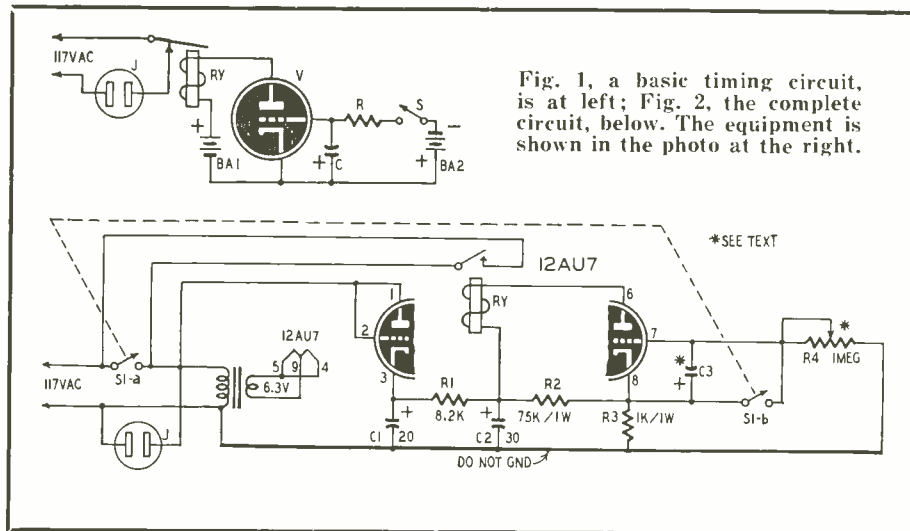

THIS timer was prompted by my habit of falling asleep while listening to the radio and letting it run all night. Although many mechanical timers are on the market, I decided to build an all-electronic model from the spare-parts box.

With the radio plugged into the timer outlet, it plays continually until the timing cycle is started. The flick of a switch starts the timing cycle and after a predetermined interval the relay opens and radio and timer both are turned off automatically.

Timing principle

The basic circuit of the timer is shown in Fig. 1. V is a 6J5 or any equivalent medium-mu triode. RY is a plate-circuit relay with normally-open s.p.s.t. contacts. J is an ordinary power-outlet receptacle.

As long as switch S is open, V has no grid bias and draws enough plate current to energize RY. The relay contacts close and apply power to receptacle J. When S is closed, capacitor C charges gradually through R, developing an increasing negative voltage at the grid. Plate current falls as the grid becomes more negative, and eventually becomes too small to energize the relay. The contacts open and remove power from the receptacle J.

The time required to release the relay depends on the values of C and R.

Intervals of one-half hour or more are possible with large values.

The timer circuit

The circuit of a complete timer is shown in Fig. 2. The 12AU7 is used as a combination line-voltage rectifier and control tube. C1, R1, and C2 form the power-supply filter, with R2 and R3 as a voltage divider across the output. RY is a 2,500-ohm relay with normally-open contacts (Potter and Brumfield type LM-1, Staco type T40F, or equivalent). S1-a and S1-b are the two sections of a d.p.s.t. toggle switch. J is the power receptacle for the controlled radio or other device.

Closing the switch applies power through S1-a to J; to the heater and rectifier section of the 12AU7; and shorts the grid and cathode of the control triode through S1-b. About 12 volts is developed across R3 by the control-tube plate current and the bleeder current through R2. RY is energized by the plate current and the contacts close.

The timing interval is started by opening S1. Power is still applied to the circuit through the closed relay contacts. With S1-b open, C3 is connected in series with the 1-megohm potentiometer across R3. The capacitor charges slowly, developing a negative potential at the grid end.

The plate current falls as the negative grid voltage increases, until it

drops low enough to release the magnetic pull of the relay and open the contacts. This automatically disconnects J and the timer itself from the power line.

The correct setting of R4 must be found by experiment, since the exact value of charging resistance depends not only on the desired time interval, but on the characteristics of C3, the control triode, the relay, and the supply voltage. In the original model a timing interval of 25 minutes was obtained when resistor R4 was set at approximately 350,000 ohms.

Construction

The unit was built on a 4 x 5 x 2-inch chassis. The layout is not critical. C3 may be made up of several lower-capacitance units in parallel, if a 4,000- μ f capacitor is not available. R2 and R3 must be adjusted so the voltage across R3 is never greater than the rated working voltage of C3. Less than 4,000 μ f may be used by increasing the resistance of R4.

Materials for timer

Resistors: 1—75,000 ohms, 1—8,200 ohms, 1—1,000 ohms, 1 watt; 1—1-megohm potentiometer.
Capacitors: (Electrolytic) 1—20 μ f, 1—30 μ f, 150 volts; 1—4,000 μ f, 15 volts (see text).
Miscellaneous: 1—12AU7 tube; 1—2,500-ohm s.p.s.t. relay, normally-open contacts (see text); 1—6.3-volt filament transformer; 1 d.p.s.t. toggle switch; 1—9-pin miniature socket; 1 power receptacle; chassis; terminals, wire, solder, hardware.

—end—



Learn RADIO TELEVISION

**-New Package Unit Plan- PAY AS YOU LEARN
NO MONTHLY PAYMENT CONTRACT TO SIGN!**

**I Send You
18 BIG
KITS
OF RADIO-
TELEVISION
EQUIPMENT**

**TRAIN IN 10 MONTHS OR LESS
At Home in Your Spare Hours**

Now . . . be ready for Radio-Television's big pay opportunities in a few short MONTHS! Frank L. Sprayberry's completely new "Package" training unit plan prepares you in just 10 MONTHS . . . or even less! Equally important, there is NO monthly payment contract to sign . . . thus NO RISK to you! This is America's finest, most complete, practical training—gets you ready to handle any practical job in the booming Radio-Television industry. In just 10 months you may start your own profitable Radio-Television shop . . . or accept a good paying job in this fascinating expanding field at work you've always wanted to do. Mr. Sprayberry has trained hundreds of successful Radio-Television technicians—and stands ready to train you in less than one year, even if you have no previous experience. You learn by DOING . . . actually working with your hands with equipment of special design to illustrate basic theory instead of relying on books alone.

VALUABLE EQUIPMENT INCLUDED WITH TRAINING

The new Sprayberry "package" plan includes many big kits of genuine, professional Radio-Television equipment. While training you actually perform over 300 demonstrations, experiments and construction projects. In addition, you build a powerful 6-tube standard and short wave radio set, a multi-range test meter, a signal generator, signal tracer, many other projects. All equipment is yours to keep . . . you have practically everything you need to set up your own service shop. The interesting Sprayberry book-bound lessons and other training materials . . . all are yours to keep.

EARN EXTRA MONEY WHILE YOU LEARN!

All your 10 months of training is AT YOUR HOME in spare hours. Keep on with your present job and income while learning . . . and earn EXTRA CASH in addition. With each training "package" unit, you receive extra plans and ideas for spare time Radio-Television jobs. Many students pay for their entire training this way. You get priceless practical experience and earn generous service fees from grateful customers. Just one more reason why the Sprayberry new 10 MONTH-OR-LESS training plan is the best Radio-Television training in America today. If you expect to be in the armed forces later, there is no better preparation than good Radio-Television training.

FREE 3 BIG RADIO-TELEVISION BOOKS

I want you to have ALL the facts about my new 10-MONTH Radio-Television Training—without cost! Act now! Rush the coupon for my three big Radio-Television books: "How to Make Money in Radio-Television," PLUS my new illustrated Television Bulletin PLUS an actual sample Sprayberry Lesson—all FREE with my compliments. No obligation and no salesman will call on you. Send the coupon in an envelope or paste on back of post card. I will rush all three books at once!

SPRAYBERRY ACADEMY OF RADIO
Dept. 20-M, 111 N. Canal St., Chicago 6, Ill.

**APPROVED
FOR VETERANS
UNDER THE
G.I. BILL**

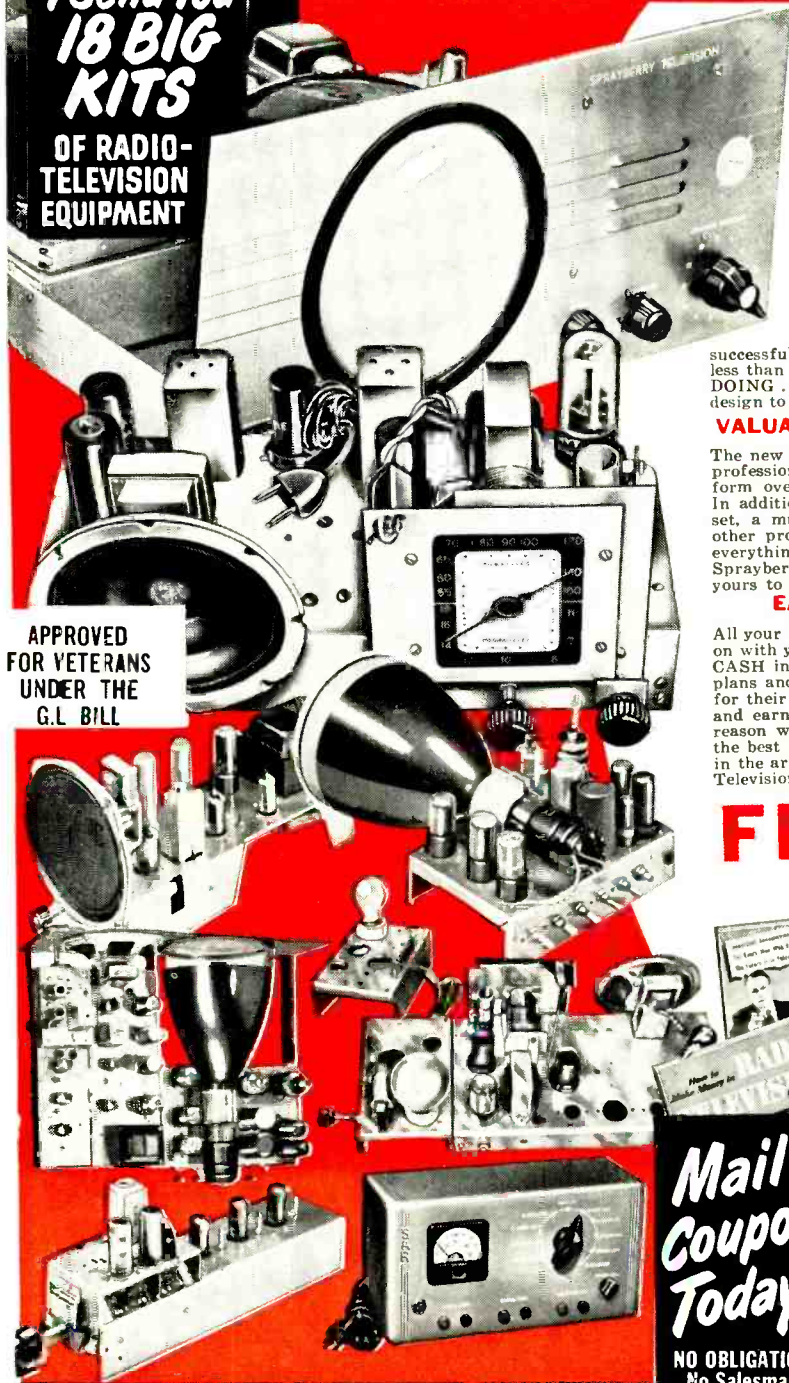

**IF YOU ARE
EXPERIENCED IN RADIO**

Men already in Radio who seek a short intensive 100% TELEVISION Training with FULL EQUIPMENT INCLUDED are invited to check and mail the coupon at the right.

**Mail
Coupon
Today!**

**NO OBLIGATION
No Salesman
Will Call**

SPRAYBERRY ACADEMY OF RADIO, Dept. 20-M
111 North Canal St., Chicago 6, Ill.

Please rush to me all information on your 10-MONTH Radio-Television Training Plan. I understand this does not obligate me and that no salesman will call upon me.

Name.....Age.....

Address.....

City.....Zone.....State.....

Please check Below About Your Experience

Are You Experienced? No Experience

WE GREW UP WITH THEM

Ever since radio was in "knee pants," Supreme has been providing aids to help electronic technicians use their training and experience more efficiently and profitably. We know that in television today, as it was with the TRF's and neutrodynes of yesteryear, they must have high quality, dependable test equipment to save time and keep up with this progressive electronic industry. We also know that service technicians do not want Supreme to sacrifice quality by substituting unproven materials in place of those temporarily under control due to our nation's mobilization program. They will, as they have in other emergencies, give us extra time, if needed, to deliver a product that is "Supreme By Comparison" in every respect.

Supreme's mission in our defense program, just as it was during World War II, is to help the technicians in our armed forces locate that faulty part or maladjustment quickly by supplying them with well designed and reliable testing equipment. For a quarter century Supreme has been a major contributor to the efficiency of the electronic technician—we grew up with them. By continuous research, development, improvement, and production of equipment for maintenance of electronic devices—plus our close contact with the electronic technician—knowing the job he has to do—what it could mean if he fails—leads us to accept new challenges with confidence and pride. Supreme's "know-how," gained both in peace and war, is one of this nation's assets in times like these.

Our 25th Year

SUPREME

Testing Instruments

"SUPREME BY COMPARISON"

TUBE TESTERS • SIGNAL GENERATORS
PANEL METERS • MULTI-METERS
OSCILLOSCOPES

Supreme, Inc., Greenwood 1, Mississippi



Photographs courtesy *Wireless World*
A Servograph assembly. Action is reversed by merely uncrossing the vane drive belt.

ELECTRONIC RECORDER

By RALPH W. HALLOWS

A new electronic data recorder called the Servograph has been developed by the Fielden Company of Manchester, England. It provides continuous ink records of any measurements that can be made with pointer-type instruments.

The meter pointer is replaced by an aluminum vane. Another vane is added, insulated from the first and free to move independently over the scale. If the free vane is set at a given position, any movement of the meter vane will vary the capacitance between them.

The vanes are connected to an electronic capacitance relay which controls the direction of a reversible motor. The free vane is driven by the motor; at a predetermined vane spacing the motor is idle; if the meter vane moves, the motor starts instantly and moves the free vane in the correct direction to restore the original spacing. This is the servo principle.

A stylus linked to the motor shaft records all movements on a calibrated chart driven by clockwork or a synchronous motor. Meter variations are thus recorded continuously over any desired period of time.

The motor circuit

Fig. 1 is the basic circuit of the Servograph motor unit. A two-winding motor moves the free vane and the recording stylus. Winding X receives voltage continuously from the 6-volt winding of the power transformer, but the motor cannot start until a voltage approximately 90 degrees out of phase with X is applied to winding Y. The direction in which the motor turns depends on whether the voltage across Y leads or lags the voltage across X.

The required leading and lagging phase shifts are provided by L1 and C1 respectively. These receive a.c. *alternately*—in the same phase as winding

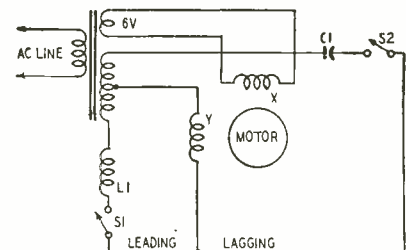
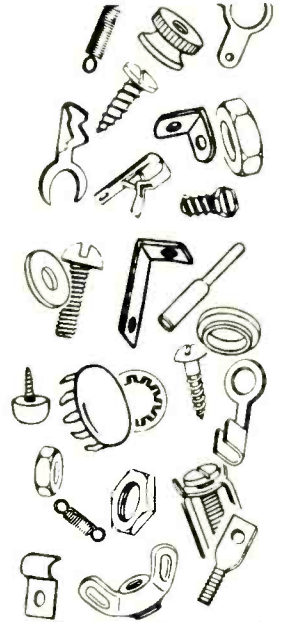

Fig. 1—The basic motor-control circuit.

RADIO-ELECTRONICS

**Select your hardware
in these new, handy, plastic,
re-usable containers**



New WALSCO 50 LINE



It's the smart way to buy hardware...it's the convenient way to store hardware...it's the economical way to use hardware. The new WALSCO 50 LINE is attractively packaged in transparent, plastic containers. The part number, the contents, and its uses are all plainly visible on each container, making it easy for you to select your hardware in a jiffy. The new 50 LINE eliminates the waste of small, loose hardware items being misplaced... keeps your busy work bench free from congestion. Now, all your hardware items can be neatly stacked in sturdy, re-usable containers. Available at your jobber. Select all your hardware from the new, self-service 50 LINE display.

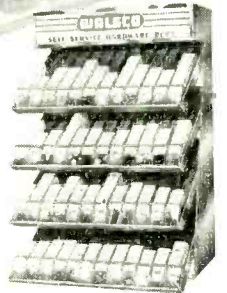

Walsco quality earned its reputation



Walter L. Schott Co.
3225 Exposition Place
Los Angeles 18, Calif.
Branch: Chicago 6, Ill.

In Canada
Atlas Radio Corp., Ltd.
Toronto, Canada

NOW! BECOME EXPERT AT RADIO-TELEVISION IN 4 EASY STEPS!

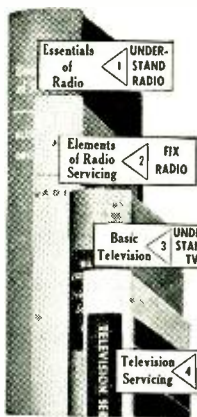

Complete Self-Training Library in RADIO and TV by Famous Experts—Takes You BY SIMPLE STEPS From Basic Theory to Problems of Repair, Installation, Color TV, etc.

NOW you can do ANY Radio-TV installation, service, or repair job like an expert; operate field-testing equipment; understand problems of TV, FM-AM transmission, etc. Step into a good-paying job—or start your own service business. Train yourself AT HOME . . . IN SPARE TIME . . . with the McGraw-Hill Radio and Television Servicing Library.

2296 Pages—1611 Illustrations

The men who wrote this complete 4-volume Library are among the outstanding radio and TV instructors in America today. Every detail is clearly explained in over TWO THOUSAND PAGES of step-by-step instruction and over SIXTEEN HUNDRED "how-to-do-it" illustrations, cross-section diagrams, etc. The review questions and answers "nail down" everything you learn. At-a-glance "trouble-shooting" charts show how to diagnose instantly any radio or TV breakdown and how to repair it expertly and quickly.

The Library will pay for itself many times over. It gives all you need to know for FM and TV in the FCC's 1st-class license exam; gives an experienced technician more confidence and skill.

SEND NO MONEY

Mail coupon below to examine complete four-volume Library FREE for 10 days. No obligation. Or you may examine individual books FREE for 10 days by checking the proper boxes in coupon.

PARTIAL CONTENTS
ESSENTIALS OF RADIO.
 600 pages, 433 illus.
 Circuit Analysis • Vacuum Tubes • Circuits: Detector • Amplifier • Tube Oscillator • Power Supply • Transmitting, Receiving, etc.
ELEMENTS OF RADIO SERVICING.
 475 pages, 375 illus.
 Multimeters • AC Power Supply • Speakers • Antennas • Auto Radios • Push-Pull Output Stage
BASIC TELEVISION.
 592 pages, 415 illus.
 Scanning • Synchronizing • Video Signal • Brightness Control • DC Reinsertion • Picture • FM Alignment • Picture Tubes • VHF and UHF transmission • Reception
TELEVISION SERVICING.
 429 pages, 388 illus.
 Antennas • Transmission Lines • Test-pattern and Picture Analysis • Localizing Reception Troubles • Interference Remedies • Deflection Circuits
AND MUCH MORE!

FREE 10-DAY TRIAL COUPON

McGraw-Hill Book Co., Inc., Dept. RE-8-52
 327 West 41st St., New York 18, N. Y.

Send me for 10 day free examination the Radio and TV Servicing Library, 4 Vols. (Regular retail price is \$26.00; Special Course Price only \$21.95 in easy installments.) If not satisfied with Course, I will return it, pay nothing. Otherwise, I'll send \$1.95 plus delivery then and only \$4.00 in monthly installments.

If you wish to examine any of these books individually, check below the ones you wish us to send you for 10 Days' FREE EXAMINATION:

<input type="checkbox"/> Essentials of Radio, \$6.75	<input type="checkbox"/> Elements of Radio Servicing, \$5.25
<input type="checkbox"/> Basic Television, \$7.50	<input type="checkbox"/> Television Servicing, \$6.50

For any book I keep, I'll send \$2.00 plus delivery in 10 days, balance in easy monthly installments.

Name.....

Address.....

City..... Zone..... State.....

Position.....

RE-8-52

Company.....
 WE PAY FOR DELIVERY if you send first payment of \$1.95 when ordering Library or full price when ordering individual books (prices above). Same return privilege.

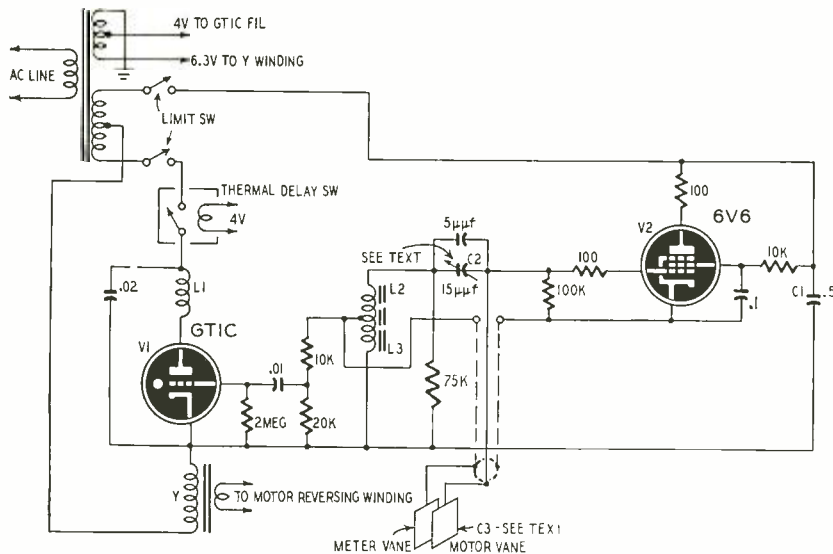

Fig. 2—The complete Servograph circuit, as used in the electronic data recorder.

X—from opposite ends of the center-tapped winding on the power transformer. If S1 and S2 are closed winding Y will receive alternate leading and lagging pulses from L1 and C1 at the line frequency. These tend to rotate the motor in opposite directions and no movement results. If S1 is opened, Y receives only lagging pulses, and turns clockwise; if only S2 is opened, the motor turns in the opposite direction.

The complete relay circuit

In the complete circuit (Fig. 2) V1 and V2 act as the switches. Each tube conducts on alternate half-cycles from the line. V1 is a thyratron adjusted to draw twice as much plate current as V2. With both tubes conducting alternately Y, the primary of a transformer for the reversing winding of the motor, receives more voltage during the half-cycles from L1-V1, and the motor turns counterclockwise. If V1 is cut off, Y receives pulses only from the V2-C1 circuit and the motor turns clockwise.

In addition to acting as a switch, V2 is also part of the oscillator circuit L2-C2-C3. C3 is the capacitance between the meter vane and the motor-driven vane. C2 is adjusted to equal C3 at the desired reference position on the

meter scale. Under these conditions equal and opposite voltages from the ends of L2 are applied to the V2 grid and the circuit cannot oscillate. If the meter pointer moves, C3 decreases, more voltage reaches the grid through C2, and oscillation starts. Enough voltage is induced in L3 to develop cutoff bias for V1 through the .01-µf capacitor and 2-megohm grid leak.

In the nonoscillating condition, with both branches conducting, the motor turns counterclockwise until stopped by the left-hand limit switch, or until C1 decreases enough to start oscillation and reverse the motor. The right-hand limit switch prevents overswing in the clockwise direction.

Polar diagrams of antenna directivity that take about one-half hour to make by older methods, have been drawn automatically in 15 seconds with the Servograph. The antenna feeds a crystal diode detector whose output is indicated on a sensitive microammeter. Synchronized motors rotate the antenna and a recorder chart with polar co-ordinates. Variations in signal strength from a test transmitter as the antenna rotates are drawn directly on the chart by the Servograph stylus.

—end—

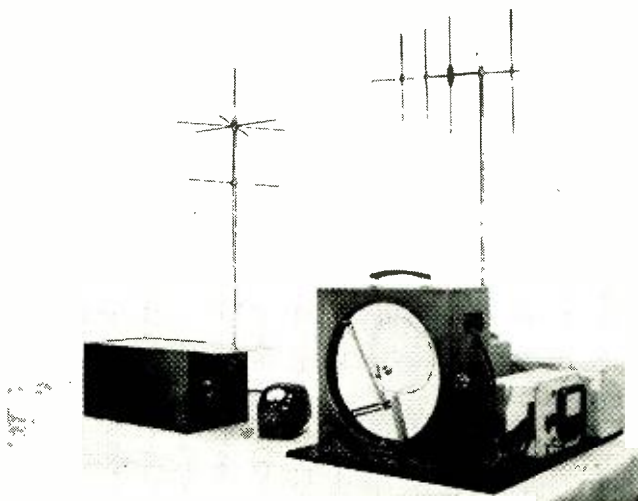

Typical Servograph setup for plotting antenna directivity patterns automatically in 15 seconds.

A Guiding Beacon For
Quality Electronic Parts

Your Local
RADIART
Distributor

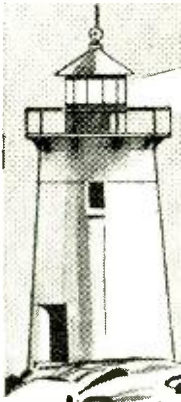

RADIART Sales Offices Across The Nation

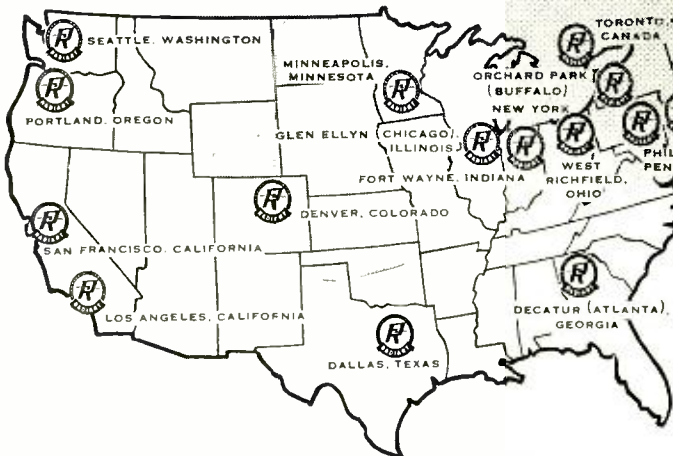

These Are The Cities With RADIART Distributors
In Alabama, Florida, Georgia, Mississippi, North
Carolina, South Carolina and Tennessee

Alabama

- BIRMINGHAM
- DOTHAN
- GLADSDEN
- MOBILE
- MONTGOMERY
- TUSCALOOSA

Florida

- FORT LAUDERDALE
- JACKSONVILLE
- LAKELAND
- MIAMI
- ORLANDO
- PANAMA CITY
- PENSACOLA
- SARASOTA
- ST. PETERSBURG
- TALLAHASSEE
- TAMPA
- WEST PALM BEACH

Georgia

- ALBANY
- ATLANTA
- AUGUSTA
- COLUMBUS
- MACON
- SAVANNAH

Mississippi

- GREENVILLE
- JACKSON
- MERIDIAN

North Carolina

- ASHEVILLE
- BURLINGTON
- CHARLOTTE
- DURHAM
- FAYETTEVILLE
- GOLDSBORO

- GREENSBORO
- SALISBURY
- WINSTON SALEM
- WILMINGTON
- WASHINGTON

South Carolina

- CHARLESTON
- COLUMBIA
- FLORENCE
- GREENVILLE
- SPARTANBURG

Tennessee

- CHATTANOOGA
- JACKSON
- KINGSPORT
- KNOXVILLE
- MEMPHIS
- NASHVILLE

BUY OF THE MONTH



The RADIART TV TWINS are the two best friends any TV set ever had! They are the RADIART BOOSTER and the RADIART CDR ROTOR! A perfect team in working together to get the most out of any TV set...they are also designed when combined to appear as a single unit—a welcome piece of furniture in any home.

FOR NAME OF YOUR NEAREST RADIART DISTRIBUTOR
USE COUPON BELOW

RADIART SALES CO. 212 Mimosa Drive, Decatur, Georgia

.....Please send names of the Radiart Distributors in my area stocking the following Radiart products in which I am interested: Tele-Rotors, Vibrators, TV and FM Antennas, "Spee-Dee" Chimney Mounts, Lightning Arresters, Auto Aerials, Power Supplies

.....Please have a Radiart Distributor call on me.

Name.....

Address.....

City..... State.....



THE RADIART CORPORATION CLEVELAND 2, OHIO

VIBRATORS • AUTO AERIALS • TV ANTENNAS • ROTATORS • POWER SUPPLIES



C-D's Blue Cubs

the cub paper tubular with bear strength

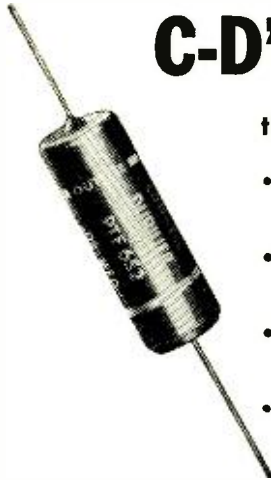

- 50% extra margin of reserve... Makes allowance for changes in original characteristics of set since it left factory.
- The only paper tubular designed and built specifically for service replacement. Sold only through authorized C-D jobbers.
- *Vikane impregnated*... Another C-D exclusive! One of the outstanding insulating impregnants known to science.
- Write for Catalog #200C. Cornell-Dubilier Elec. Corp., So. Plainfield, N.J. Your local Classified Phone Directory lists your nearest C-D jobber.



CONSISTENTLY DEPENDABLE
CORNELL-DUBILIER
CAPACITORS

PLANTS IN SO. PLAINFIELD, N. J. • NEW BEDFORD, WORCESTER AND CAMBRIDGE, MASS. • PROVIDENCE, R. I.
INDIANAPOLIS, IND. • FURQUAY SPRINGS, N. C. • SUBSIDIARY, RADIART CORP., CLEVELAND, OHIO



Most of the tubes announced this month are high-stability, shock-resistant versions of familiar types, intended for military and industrial equipment. Practically the entire production of these types is going to the defense program.

In this category G-E has developed a series of ruggedized tubes which are direct replacements for existing standard types. These include: the GL-6072, equivalent to the 12AY7 except for an increase in heater current to 350 ma; the GL-6135, identical to the 6C4W except for heater current of 175 ma; the GL-6136, equivalent to the 6AU6; the GL-6137, interchangeable with the 6SK7; and the GL-6201, a direct replacement for the 12AT7.

Sylvania is producing the 6111 and 6112 subminiature twin triodes, whose characteristics were given in last month's RADIO-ELECTRONICS.

Receiving and TV types

The Sylvania 6AN4 is a miniature triode for use as a grounded-grid r.f. amplifier or mixer in u.h.f.-v.h.f. TV receivers. It features high transconductance, shielding between plate and cathode leads, and double pin connections to grid and plate. The 6AN4 will give a gain of 10 db, a bandwidth of 10 mc, and a noise figure of 15 db at 900 mc. Cascaded 6AN4's may be used for improved oscillator-antenna isolation and increased r.f. gain.

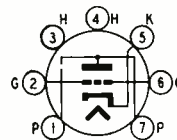

6AN4

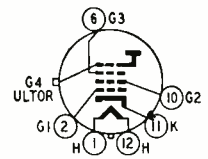

10SP4

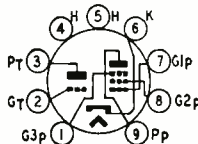

19X8

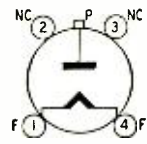

8013-A

RCA has announced the 19X8, a triode-pentode converter with 150-ma heater for transformerless AM-FM-TV receivers. The triode section is used as the oscillator, and the pentode sec-

RADIO-ELECTRONICS

BE YOUR OWN BOSS!



MAKE MORE MONEY
\$1.00 VALUE
25c
40,000 WORDS IN TEXT
NO ADS ALL "MEAT!"
Money Back Guarantee

NATIONAL PLANS COMPANY
1966R BROADWAY, NEW YORK 23, N. Y.

RADIO ENGINEERING DEGREE IN 27 MONTHS

Intensive, specialized course including strong basis in mathematics and electrical engineering, advanced radio theory and design, television, Modern lab. Low tuition. Self-help opportunities. Also B.S. degree in 27 months in Aeronautical, Chemical, Civil, Electrical, and Mechanical Engineering. G.I. Gov't approved. Enter September, December, March, June. Catalog.

INDIANA TECHNICAL COLLEGE
158 E. Washington Blvd., Fort Wayne 2, Indiana

RADIO-ELECTRONICS is paying good rates on acceptance for original and unusual articles on phonograph, television, FM and AM servicing, as well as articles on industrial electronic equipment and applications. Good constructional stories on receivers or other pieces of electronic equipment can also be used. Send for a copy of our Authors' Guide. Address:

THE EDITOR
RADIO-ELECTRONICS
25 West Broadway New York 7, N. Y.

COMMON SENSE about easy tv servicing

Make your servicing job easier
than you ever thought possible

Complete Servicing Facts Method Proved Outstanding Success

Tens of thousands of service technicians throughout the country have learned this key to fast, easy, profitable servicing: They *insist* on having the complete servicing facts for every receiver they repair! They know that by having the complete story... and only by having the complete story... can they spot trouble quickly and do an easy, permanent servicing job.

Here's an example: On Philco models 52-P-1810, 52-P-1812, 52-P-1840, 52-P-1842, 52-P-1844, 52-P-1882, 52-P-2110, 52-P-2142, codes 122 and 123, the manufacturer released 32 pages (8-1/2 x 11") of official service data. (That is what we published in Rider TV Manual Vol. 9 and in Rider TV Tek-File Pack 22.)

These models were made in a variety of production runs: using three different chassis... each with its own schematic. These chassis are identical in many respects... but the vital differences can make servicing a real headache. For instance, three types of power transformers are used. Each has different electrical constants—and a different part number. In the C2 deflection chassis, the power transformer has one high voltage winding of 635 volts, center-tapped, and four low voltage windings: one 5 volts, two 6.8 volts and one 6.4 volts. In the CP1 deflection chassis, the power transformer has one high voltage winding of 635 volts, center tapped, but only three low voltage windings: one 5 volts, one 6.8 volts and one 6.4 volts. In the F2 chassis, the power transformer has one high voltage winding of 675 volts, center-tapped, and four low voltage windings: one 5 volts, two 6.8 volts and one 6.4 volts.

Suppose you were the service technician faced with one of these receivers. A single schematic showing just *one* of these chassis and *one* of these power transformers certainly would not be coverage for all production runs. If you were lucky, the single schematic might happen to match the receiver you had before you. But—and it's a very big but—you might also be unlucky and be faced with a receiver not described by the schematic! This is only one example in thousands of why you need *complete*, factory-prepared and factory-issued data for every set you service.

Here is how you can get this vital information. Insist on Rider Servicing Data. For 22 years Rider Servicing Data has been the *only* publishing source for the complete servicing facts: Exactly as issued by the manufacturer who made the set. Unabridged facts... everything is here to make your diagnosis and repair EASY. You get page after page of troubleshooting test patterns... large, easy-to-follow *complete* schematics... circuit explanations... stage by stage alignment curves... clear, enlarged chassis views... all circuit changes... and much, much more. For example: Rider tv servicing data has shown 'scope waveforms in tv receivers ever since the first tv receiver was made!

To meet your individual needs, Rider Servicing Data comes in two forms... both with these important, new features:

Manufacturers' Trouble Cures

These 3" x 5" standard index cards called Rider Handies contain vital manufacturer-issued permanent trouble cures plus production changes. Each Handy is identified with a manufacturer and a receiver model. With Rider Handies you save countless hours of diagnosis and repair time... because Handies contain the data you *must* have to make *permanent repairs* on many manufacturers' models. (Rider Handies information appears in Rider TV Tek-File packs, and Rider TV Manuals beginning with Vol. 9.)

Guaranteed Replacement Parts Listings

Beginning with Rider T.V. Manual 10 and Rider T.V. Tek-File Pack 57, replacement parts listings are included. All the replacement parts listed in Rider tv servicing data meet the physical and electrical performance ratings of the original equipment!

Rider T.V. Manuals Vols. 1 to 9 (covering more than 4,200 models)



Each contains full data for manufacturers' receivers produced during a certain period. (The latest, T. V. 9, recently published, covers October 1951 through February 1952.) Each manual has over 2,000 (8-1/2" x 11") pages in permanent binder, with an index covering the contents of all manuals. Rider manuals are perfect for shop use and permanent reference. Price—\$24 each.

Rider T.V. Tek-Files (Packs now cover 2,200 models)

A typical T.V. Tek-File pack is shown below. In Rider Tek-File packs you buy complete Rider servicing data for whatever receivers you want... when you want it. You buy according to your needs with the assurance of getting the *complete servicing facts* for every repair. Notice that each pack consists of handy, standard file folders for easy use. Only \$2 each pack.

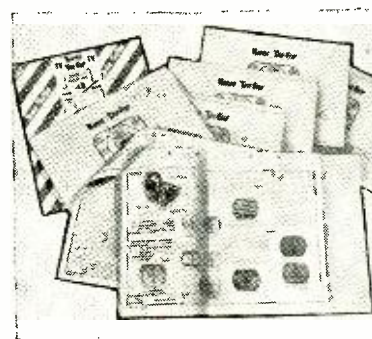

FREE Rider T.V. Tek-File indexes covering the contents of all published packs are at your jobber's. If he doesn't have them, write us.

DON'T BE SWITCHED!

Rider Tek-File is DEFINITELY NOT the same as any other publisher's service. If your jobber doesn't carry them, DON'T BE SWITCHED. Write us direct... we'll sell you. (Please include your jobber's name.)

TRY A PACK

Prove to yourself that Rider Tek-File makes tv servicing easy. Buy one pack for the next receiver you service. If you don't agree it's better than anything you ever used, return the pack to us within seven days... we'll send you a full refund.

Rider Radio Manuals, Vols. 1 to 22. Contain complete, factory-issued, official AM, FM radio servicing data... plus auto radios, record changers, tuners and recorders.

OUT SOON!

Rider RADIO Tek-Files! Same style as T.V. Tek-Files. Now, get your complete radio servicing data this easy economical package way. Ask your jobber.

John F. Rider Publisher, Inc., 480 Canal St., New York 13, New York. West Coast Office: 4216-20 W. Jefferson Blvd., Los Angeles, California.

"Services & Tests Auto Radios Best"

SAY RADIO MANUFACTURERS*



Leading Manufacturers Say . . .

"It's the only one to withstand continuous high overloads, so we specify the Model "B" for servicing." Exclusive application of selenium rectifiers, aided by conduction cooling, doubles rectifier power rating, dissipates over 3 times the heat with lowest cost per ampere output. 1 to 20 amperes continuous duty with peak instantaneous rating of 35 amperes. Operates 2 auto radios with push-button solenoids simultaneously. Net \$49.80.

Other Uses . . . Operates many low power 2-way mobile radios, phone circuits, relays, instruments, low voltage devices. Battery charging and electroplating.

*Names on request.

Low Cost Model "BJ" POWER SUPPLY
6 Volts DC, 1 to 12.5 Amps. Net \$37.50



Converts Battery Radios to All-Electric

Plug into AC outlet. Hum-free reception from any 1½ volt 4-6 tube battery radio. Uses less than ¼ the power of cheapest AC radio. Fits battery space. Guaranteed 3 years.

Many Others Available



FREE BULLETIN
ON BATTERY ELIMINATORS

See Your Distributor or Write to
ELECTRO PRODUCTS LABORATORIES
4501-Rb Ravenswood Ave. Chicago 40, Illinois
In Canada: Atlas Radio Corp., Ltd., Toronto

tion as the mixer. The mixer section may be triode-connected for lower noise level where the receiver does not have an r.f. stage. The 19X8 has the following ratings for typical operation: triode section (250-mc oscillator): plate

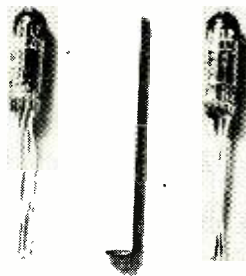

The 6111 and 6112 described last month.

voltage, 150; grid resistor, 2,700 ohms; plate current, 13 ma; grid current, 3.6 ma; power output (approximately), 0.5 watt. Pentode section (as pentode mixer): plate voltage, 150; grid 3, connected to cathode at socket; grid 2 voltage, 150; grid 1 supply voltage, minus 3.5; grid 1 circuit resistance, 120,000 ohms; conversion transconductance, 2,100 μ mhos; plate current, 6.2 ma; grid 2 current 1.8 ma; grid 1 current, 2 μ a. Except for heater voltage and current ratings, the 19X8 is identical to the 6X8.

RCA has also released the 10SP4, a high-resolution picture tube for monitor service in studio equipment, theater-television systems, and industrial TV installations. The 10SP4 utilizes 50-



The five new ruggedized G-E tubes.

degree magnetic deflection and electrostatic focus. A special electron-lens structure maintains constant focus under variations in line voltage and brightness adjustment. The Filterglas face-plate is relatively flat, and the metallized screen improves brightness and requires no ion-trap magnet. Typical design-range ratings of the 10SP4

at the maximum ultor voltage of 14,000 are: ultor current, 100 μ a, grid 3 (focus) voltage, 1,640 to 2,225; grid 2 voltage, 200; grid 1 voltage for visual



Sylvania 6AN4.

USE PHOTOFAC

the world's best Radio and TV Service Data . . .



WE'LL PROVE YOU'LL SAVE TIME and EARN MORE WITH PHOTOFAC

FREE Service Technicians: We'll send you any Photofact Folder listed in the "PF INDEX and Technical Digest." If you haven't an Index, get a free copy from your local Photofact distributor or write for it today. To obtain Free Folder, be sure to state Photofact Set and Folder Number as shown in the Index.

NOW—learn for yourself how PHOTOFAC makes your Radio and TV work quicker, easier, more profitable! Just get and use an actual PHOTOFAC Folder. Discover why over 35,000 successful service technicians count on this invaluable data daily. No other service gives you PHOTOFAC'S completeness, accuracy, uniformity and lowest cost. PHOTOFAC is the only Radio-TV service data prepared from laboratory analysis on the actual equipment. Get your FREE Folder now. Examine, use, compare. See why you can't afford to be without PHOTOFAC!

NOTE: Our FREE Folder offer is limited to Service Technicians only. Attach coupon below to your letterhead and mention your jobber's name. Experimenters and others may obtain the Photofact Folder by remitting amount shown below.

HOWARD W. SAMS & CO., INC.

HOWARD W. SAMS & CO., INC.
2201 E. 46th St., Indianapolis 5, Ind.

I am a Service Technician. Send me Free Folder No. which appears in Photofact Set No. (as listed in the PF Index).

I am an Experimenter. Enclosed \$ Send me Folder No. which appears in Photofact Set No. (TV—\$1.00. AM/FM—50c. Record Changer or Communication Receiver—75c)

Name

Address

City Zone State

EASY PAY PLAN!

PAY AS YOU EARN! Ask your distributor about this amazing plan. Only \$18.39 puts the entire profit-boosting Photofact library in your shop now!

RADELCO

LIGHTNING ARRESTOR

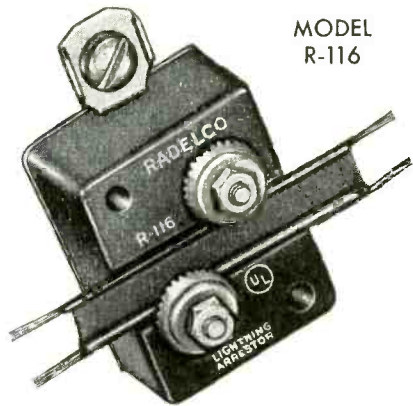

MODEL R-116

IT'S THE LOWEST PRICE UNDERWRITERS' LISTED ARRESTOR ON THE MARKET

ORDER FROM YOUR NEAREST PARTS JOBBER

LIST PRICE **90¢**

FASTER STURDIER
Lower Installed Cost

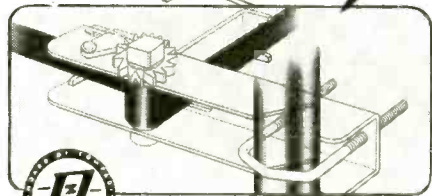

SPEE-DEE CHIMNEY MOUNT

Model AK 85 The fastest-installed chimney mount ever devised for TV antennas! Rugged in design—simple to install. Simply thread strapping through ratchet, around chimney and back through ratchet—wind up ratchet tight—and the job's done! Heavy gauge, zinc-plated steel with large "U" bolt for up to 1 3/4" O.D. mast and full length galvanized steel strapping.

THE RADIART CORPORATION
CLEVELAND 13, OHIO

AUGUST, 1952



The 10SP4 is a 10-inch monitor tube.

extinction of the standard 6 x 8-inch rectangular raster, minus 18 to minus 48.

Industrial and special tubes

Taylor Tubes, Inc., has announced production of the 8013-A high-voltage rectifier. For operation in air, the

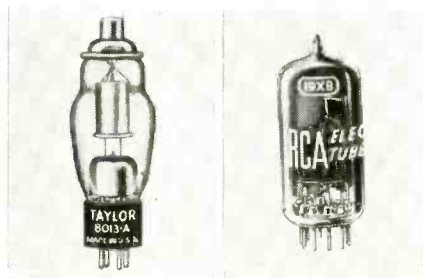

The Taylor 8013-A and RCA 19X8 tubes.

8013-A has a peak rating of 40,000 volts inverse or forward, and an average current of 20 ma. In oil-immersed operation the rated peak voltage is 55,000, and the average current, 30 ma. Instantaneous peak current is 450 ma. The thoriated-tungsten filament requires 5 amperes at 2.5 volts.

The 8013-A has a Nonex glass bulb and an oil-resistant silicone base. Its life expectancy is more than 5,000 hours at the ratings given above.

A number of new tubes have been announced and will be described in next month's issue. Possibly the most interesting of them is RCA's new 27-inch metal-shell kinescope, planned for high-quality 1953 receivers.

—end—

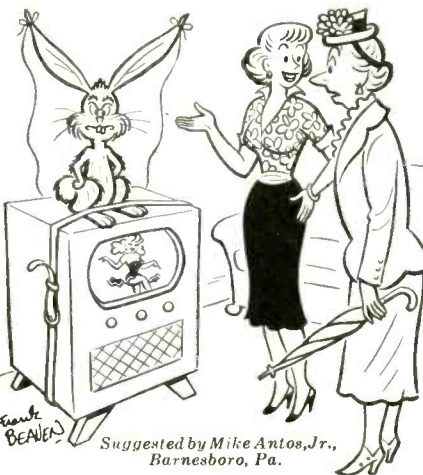

"Why buy a 'Rabbit-Ear' antenna when we have a rabbit of our own!"

"PACKAGED ENGINEERING"
at Its Best!
For the TV Technician

The B-T MIXER-AMPLIFIER SYSTEM

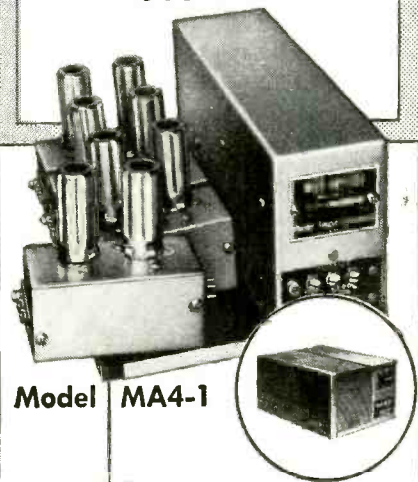

Model MA4-1

For All VHF and UHF Multi-Antenna Problems

Designed for the Service Technician to enable him to plan and make any installation . . . whether a single receiver or a complete 2000-set Master Antenna System . . . at lower cost, and without outside engineering.

The B-T MA4-1 is a wide-band, all-channel TV signal mixer for feeding 5 antennas to 1 TV receiver or distribution system. One input is broad-band for signals requiring no pre-amplification, and the remaining 4 accommodate separate plug-in strip assemblies. All terminals have 75 and 300 ohm connections. Several units may be ganged to serve any number of antennas.

B-T PLUG-IN STRIPS

Channel Strip CS-1 is a 2-tube (6AB4-6CB6), single channel, highly selective amplifier with a gain of at least 17 db., one strip for each TV channel.

The UHF Converter, UC-1 is designed for lowering UHF signals to existing TV frequencies, permitting UHF reception on present TV receivers.

Eliminates all need for rotators, separate boosters, converters, and other costly projects.

Once connected the MA4-1 performs without further attention . . . no switching . . . no adjustments.

LIST PRICES:

Model MA4-1 (less plug-in strips) **\$52.50**
Channel Strip CS-1 (specify channel) **19.50**
UHF Converters UC-1 to be announced
Standard RTMA Warranties Apply.



For the Complete 'Packaged Engineering' story, ask about B-T Signal Amplifiers and B-T Distribution Amplifiers at your local Distributor, or write to Service Department, F

BLONDER-TONGUE LABS. inc.
Mount Vernon 1, New York

You'll Always Find What You Need In The...

CD Skyhawk TV ANTENNA LINE

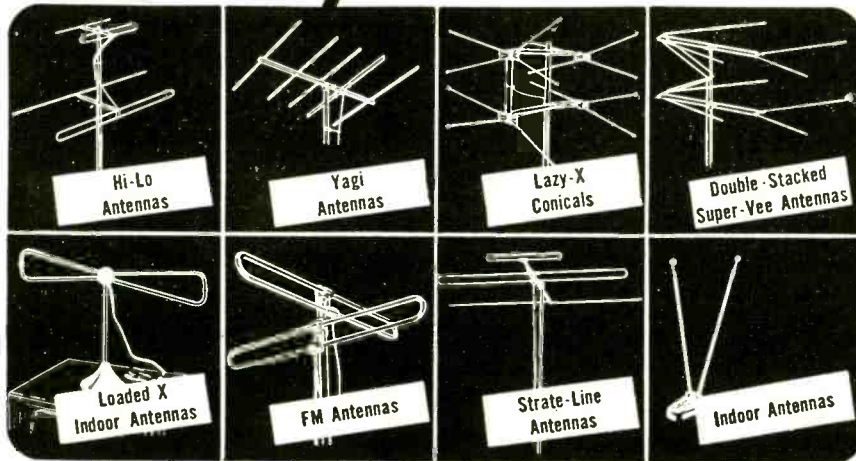

and you'll find excellence in performance and quality, too!

When you, as a serviceman intent on really serving his customers, choose CORNELL-DUBILIER SKYHAWK TV ANTENNAS, you save time, trouble and money. These are facts. C-D makes an antenna for every requirement and these SKYHAWK antennas have a reputation for top quality and excellent performance—which adds up to customer satisfaction. Why hesitate? — Choose CORNELL-DUBILIER SKYHAWK TV ANTENNAS.

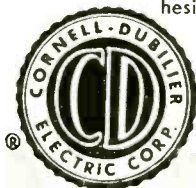

CONSISTENTLY DEPENDABLE
CORNELL-DUBILIER
SOUTH PLAINFIELD, NEW JERSEY



- ROTATORS
- CAPACITORS
- ANTENNAS
- CONVERTERS
- VIBRATORS

APPEALS TO COLLEAGUES

The Television Installation Service Association (TISA) of Chicago, has recently appealed to service associations in other cities to police local service complaints and weed out undesirables in their own areas. The recent success of TISA in closing up several firms which advertised three-dollar service calls (which were stated to have cost the average customer between \$15 and \$25 per call) was cited as an instance of what a vigorous and determined TV service association can do.

LUZERNE IN DRIVE

The Luzerne County (Pennsylvania) Radio Servicemen's Association was reported to be carrying on an extensive membership drive. The *FRSAP News Letter*, source of the information, stated that they expect to increase their membership of 115 considerably. New members are coming in and old members' interest is increasing as a result of the unfreeze, and information is being gathered on the problems that will arise in a virgin television area.

Plans for the annual outing to be held at Lily Lake this month were rapidly being worked into shape. The entertainment committee was also busy on the annual theater production with which the association raises money.

LACKAWANNA HOLDS PARTY

The annual charter night party of the Lackawanna County (Pennsylvania) Radio Technicians Association was held May 22 at the Dietrick Hotel in Scranton. John McGoldrick was toastmaster and Attorney Daniel Jenkins was principal speaker. Mr. McGoldrick gave a brief history of the association, and discussed the coming impact of u.h.f. television. Mr. Jenkins discussed the workings of the Pennsylvania Public Utilities Commission.

More than 80 members, wives, and friends attended the affair, as well as a number of guests from the neighboring Luzerne County association.

AKRON IS ACTIVE

The Akron Radio Technicians Association is now reorganizing with the idea of doubling the membership of the eight-year-old organization.

The membership includes *Qualified* members, who have had three years of technical experience and are now actively employed, and *Associate* members, which includes those with less than three years experience, radio amateurs, or others whose connection with electronics qualifies them for admission.

Activities include group hospitalization and medical insurance; a training program which will open the possibility of introducing an *Apprentice* grade of membership; work towards stabilizing the wage situation among service shop employees, thus reducing too-frequent job changing; and plans to meet the problem posed by the wildcat \$1.00-per-call operator.

Officers for 1952 are Walter Dickerson, president; John Mintz, vice-president; and Joseph Vegh, secretary-treasurer.

RADIO-ELECTRONICS

FREE

Write today for "How to Service T.V. Receivers" with the HICKOK VIDEO GENERATOR.
Hickok Electrical Instrument Co.
10814 Dupont Ave., Cleveland, Ohio

ON-THE-SPOT BATTERY RECORDER

WALKIE-RECORDJALL 8 lb. miniature BATTERY RECORDER-PLAYBACK Continuous, permanent, accurate, indexed recording at only 5¢ per hr. Instantaneous, permanent playback. Picks up sound up to 60 ft. Records conversations, lectures, dictation, 2-way phone & sales talks; while walking, riding or flying. Records in closed briefcase with "hidden mike"! Write for details.

MILES REPRODUCER CO., INC.
812 BROADWAY Dept. RE-8 NEW YORK 3, N. Y.

Every RADIOMAN can use these SERVICE HINTS!

Valuable Manual Yours—FREE Write today—no obligation
FEILER ENGINEERING CO. Dept. 8RC2-1
8026 N. Monticello Ave., Skokie, Ill. (Suburb of Chicago)

Every page of "How to Simplify Radio Repairs" is packed with on-the-bench, practical ideas.

PEN-OSCIL-LITE

Extremely convenient test oscillator for all radio servicing; alignment • Small as a pen • Self powered • Range from 700 cycles audio to over 600 megacycles u.h.f. • Output from zero to 125 v. • Low in cost • Used by Signal Corps • Write for information.

GENERAL TEST EQUIPMENT
38 Argyle Ave. Buffalo 9, N. Y.





THE LITTLE INDIAN SAYS.

you know you're right
when you service with



SANGAMO
"Twist-Tab" Replacement
Capacitors

Sangamo Type PL  Dry Electrolytics
are used  as original equipment by
all major TV set manufacturers 

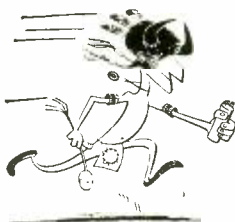

Here's "good medicine" for ailing TV sets (and servicemen's headaches, too)! Sangamo "Twist-Tab" (Type PL) Electrolytics are *exact* replacements

—they assure long life and dependable performance at 85° C. and under conditions of high surge voltages and extreme ripple currents often found in TV applications.

"Twist-Tabs" are compact, light in weight and easy to mount. They are used by leading TV manufacturers . . . and they are available from the largest listing of capacities and voltages available in the industry.

Ask your distributor for a copy of the Sangamo TV Replacement Catalog. It's easy to use and helps you choose the *right* replacement every time.

Those who know

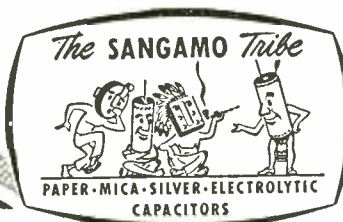

...choose Sangamo

SANGAMO ELECTRIC COMPANY
MARION, ILLINOIS

SC52-8

IN CANADA: SANGAMO COMPANY LIMITED, LEASIDE, ONTARIO

AUGUST, 1952

Tel-a-Ray's Swing-Over Tower is the easiest, quickest way to good reception

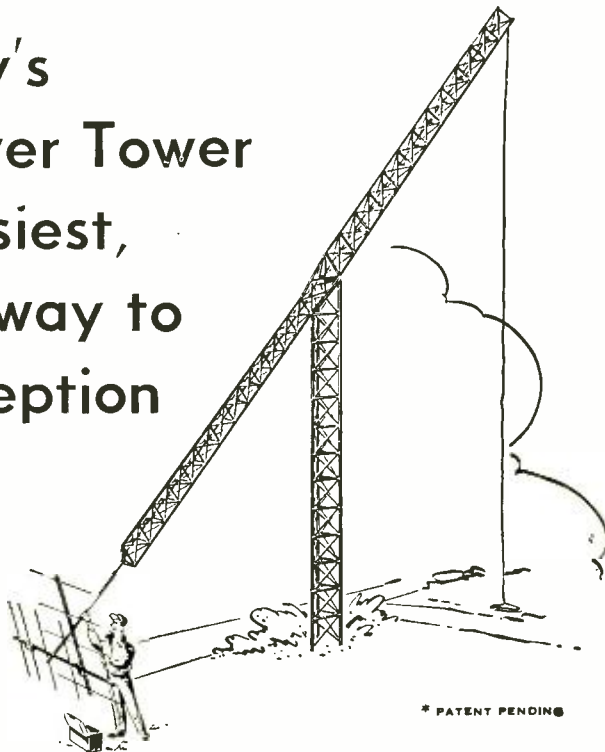

Other Tel-a-Ray products that will bring you the best TV possible: The Model T and TD antennas, the Butterfly, the All-Purpose antenna and the Pre-Amplifier. Get the story of good reception—call or write today.

Tel-a-Ray
ENTERPRISES, INCORPORATED
 SOX 3320
HENDERSON, KENTUCKY

TRADE MARK



NEW! Transformer Catalog and TV Replacement Guide

Halldorson's new one-source catalog has the components you need, well classified for easy use.

This highly active line has been super-charged with 114 new items. Special attention is given to TV replacements. A self-contained guide section tells you where they are used.

Here's extra value, too. Halldorson prices actually have been reduced, but Halldorson quality is even better than ever.

Ask for a copy at your distributor, or write direct.

The HALLDORSON COMPANY
 4500 N. Ravenswood Ave, Dept RE-8
 Chicago, 40, ILL.

Halldorson
 QUALITY Transformers SINCE 1918

TUBES Today's Best Buys

Top Quality at Terrific Savings
RTMA Guaranteed

1A7GT	\$.79	6B4	1.50	7G7	1.30
1B3	.85	6BA6	.55	7H7	.70
1L4	.60	6BC5	.50	7N7	.90
1L6	.60	6BE6	.49	7QZ	.89
1LN5	.95	6BF5	.65	7V7	.95
1N23B	3.50	6BF6	.70	7W7	1.25
1N34	.69	6BG6G	1.48	12A76	.40
1R5	.60	6BH6	.75	12A77	.80
1S4	.85	6B16	.65	12A16	.55
IS5	.80	6B86	.94	12A17	.75
IT4	.85	6C4	.60	12A17	.95
IU4	.60	6CB6	.65	12A17	.75
IU5	.50	6CD6G	1.93	12BA6	.48
IX2A	.85	6E5	1.05	12BA7	.80
2D21	1.40	6H6M	.70	12BE6	.55
2X2	.60	6J5M	.65	12J5GT	.50
3A4	.75	6J6	.73	12SA7GT	.70
3A5	1.25	6K6	.65	12SF5M	.65
3Q4	.55	6K7	.70	12S17	.60
3V4	.62	6L6GA	1.05	12SK7	.65
3S4	.90	6N7G	.95	12SQ7	.70
5U4G	.55	6S4	.51	12SN7GT	.75
5V4	.95	6S7M	.85	12SR7	.65
5Y3GT	.39	6SA7GT	.70	14B6	.95
5Z3	.85	6SC7	1.10	19T8	.86
6A7	1.00	6SH7	.65	25AV5	.95
6AB4	.65	6SJ7	.70	25L6GT	.60
6AB5/6N5	1.25	6SK7GT	.53	25W4	.80
6AC7	.95	6SL7GT	.65	35L6GT	.47
6AG5	.65	6SN7GT	.65	35W4	.53
6AG7	1.40	6SQ7GT	.65	35Z5GT	.49
6AH6	1.40	6T8	.86	41	.85
6AJ5	1.45	6V0GT	.60	50B5	.53
6AK5	.95	6W4GT	.40	50C5	1.05
6AK6	1.20	6X4	.45	50L6GT	.53
6AL5	.54	6X5	.45	59	1.50
6AQ5	.65	6Y6	.85	75	.85
6AS5	.75	7AD7	1.25	89Y	.75
6AT6	.45	7C5	.70	9001	1.25
6AU6	.95	7C7	.85	50C5	1.05
6AV6	.50	7E7	1.30	9003	1.25
6AX5GT	.85	7F7	.95	9006	.35

Minimum Order \$15.00

IMMEDIATE DELIVERY!
 Write for quotations, many other types available. 20% deposit with order, balance C.O.D. All tubes subject to prior sale. Prices subject to change without notice.

WRITE, WIRE, CALL—TODAY!
 We Buy Anything in Electronics—
 large or small quantities!

Nat Adelman
 168 Washington St. New York 6, N. Y.
 CO. 7-6091

DO THEIR OWN RESEARCH

Dell Davis, vice-president and director of public relations of the Glendale (Calif.) Society of Radio and Television Technicians, reports progress from that association. They now have a group doing research on horizontal output transformers, he states, and have already come up with useful information on their characteristics, interchange adaptability, use in conversions, action under different loading conditions, and horizontal retrace time.

The information gained by the research group is demonstrated at meetings, and the association is developing a technique of using color slides with accompanying tape-recorded explanation, which it hopes will make the information available to neighboring associations.

NEWS FROM B. C.

The Okanagan (British Columbia) Chapter with its president, Bert Thornburn, was host to the B. C. Provincial Council for the May 24 meeting at Kelowna, B. C., with representatives from Victoria, Vancouver, Fraser Valley, and Okanagan Chapters.

The meeting was attended by Dominion Radio-Electronic Technicians Association (R.E.T.A.) executives Wilf Munton, president, and Jim Baird, secretary-treasurer. A large number of members turned out.

The highlights of the meeting included the B. C. Bulletin's editor, Tom Grant, in an exhortation requesting better co-operation in getting material for the paper.

Bookkeeping procedure took a lot of batting around with secretary-treasurer Sam Beyer getting a decision handed down to the effect that chapters' dues assessments are to be paid annually in advance at the beginning of the year.

Wilf Munton read a letter from the R.T.M.A. (Canada), who are planning a series of tape-recorded lectures for R.E.T.A. across Canada, and also a home-study TV course.

Election of officers made Sam Beyer the chairman for the next year and Bill Filtress secretary-treasurer.

SAN DIEGO ORGANIZES

The San Diego County (California) Electronic Association announces that it has received its charter. With a membership of over one hundred, it aims to establish, promote, and maintain the highest standard of ethics in the business practices and service of its members, and to function as a public service.

Frederick Palmer was elected president of the new Association, with Upton Hildebrand vice-president; C. J. Mahoney, treasurer; and William E. Stout, secretary. Directors are: John R. Dorsen, John Miner, George N. Corcoronis, Sonny Kahn and Tom C. Crawford.

As its first step in developing qualified technicians, the Association is formulating a standard training plan for all members. They will be tested and classified by the San Diego Vocational School, which functions as a public agency training for industry.

—end—

102 BILLION

FREE SALES BOOSTS A YEAR FOR YOU!



NEW
CBS-HYTRON
BRAND
gives you:

Acceptance



1,973,326,000 times a week! 102,612,952,000 times a year! The magic letters "CBS" are seen and heard on radio and TV station breaks. Impact is terrific. An average of 13 sales impressions weekly for every man, woman and child in the country. Every one of your customers knows CBS. Knows he can depend upon CBS. Consumer acceptance of your CBS-Hytron brand grows hourly.

Engineering



As a division of the Columbia Broadcasting System, Inc., CBS-Hytron commands tremendous engineering resources for you. Because CBS embraces the field of electronic entertainment: Radio broadcasting. TV broadcasting. Radio, television, and phonograph sets. Records. Electronic research laboratories. And CBS-Hytron tubes.

Leadership



For example, CBS-Hytron originated: the GT tube . . . the subminiature tube . . . the rectangular picture tube . . . specialized, low-cost TV receiving tubes. CBS-Hytron's new picture-tube and miniature-tube plants are the most modern in the world. Such aggressive leadership guarantees you the newest and best in tubes.

YOU CAN'T BUY BETTER

Demand the CBS-Hytron brand. You get the finest electron tubes that progressive engineering skill and craftsmanship can make. You get the brand known and respected by every one of your customers. You get the brand they see and hear the most . . . CBS-Hytron.



MAIN OFFICE: SALEM, MASSACHUSETTS

Our Lowest Price Ever For this Great New 1952 Model 630-DX CHASSIS

FREE Channel Strips for UHF in locales where UHF is transmitted this year!

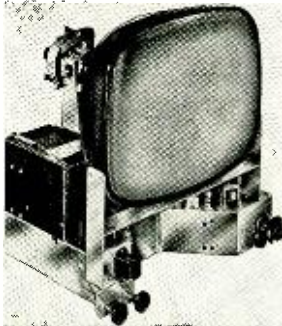

ADVANCED DESIGN INCLUDES NEW CASCODE TUNER—30 TUBES—FOR 16" to 24" PICTURE TUBE

Save Many Dollars for this. The Finest Chassis Available At Any Price. For long range and best reception up to 200 miles without a booster, this new, advanced 630-DX Chassis gives 3-times normal reception. Special extra-high-gain standard coil tuner gives greater sensitivity, top performance on any channel; aligned & tested for 5 hours; molded condensers; 4 microvolts sensitivity; FM sound system; horizontal & linear lock and is directly adaptable for color and UHF. Don't wait for color or UHF—Buy now and use this same chassis.

\$139.50 (incl. Fed. Tax, less CRT) *Can't be beat for Quality—Can't be beat for Price!* RMA Guaranteed—Factory Wired, ready to play. Complete with 12" speaker, hardware and knobs.

UNIVERSAL MOUNTING BRACKETS \$5.95
FREE: New Trouble Shooting book with every chassis!

New Reduced Prices TV PICTURE TUBES

Full Year Guarantee—Non-glare—Black Face—Brand New—Standard Brands—Sealed Cartons

10BP4 Round Glass \$19.95	16KP4 Rect. Glass \$24.95
12LP4 Round Glass 22.95	17BP4 Rect. Glass 23.95
14BP4 Rect. Glass 23.95	19AP4 Round Metal 33.95
16AP4 Round Metal 36.95	20CP4 Rect. Glass 34.95
16GP4 Round Metal 28.95	21EP4 Rect. Cyl. face 36.95
16HP4 Round Glass 32.95	24AP4 Round Metal 63.95

Never Before have we been able to sell these tubes at such low prices—order now while supply lasts!

Table model cabinets for these chassis. Model 100: Original list: \$79.95. Now! **\$38.50**
Model 200 Console: Original list: **\$45.50**
\$99.95. Now! **\$45.50**
Blonde finish, add \$10.
300 OHM LEAD-IN Heavy duty—Best quality
100 ft. hank. \$1.95
1,000 ft. spool. \$17.95
NOW! Write for FREE Catalog including new complete line of tubes, parts, accessories for radio & TV, plus test instruments.

MINIMUM ORDER: \$5.00, 25% deposit with order, balance C.O.D. Include postage with order. All merchandise subject to prior sale, F.O.B. New York City. Prices subject to change without notice.

The ROSE Company

100 Park Place, Dept. E-8, New York 7, N. Y., COrtlandt 7-6195

IT'S A SHAME to throw away that beautiful old Console . . . replace the obsolete radio with a modern, easily-installed

ESPEY AM / FM CHASSIS and your console is "right-up-to-date"

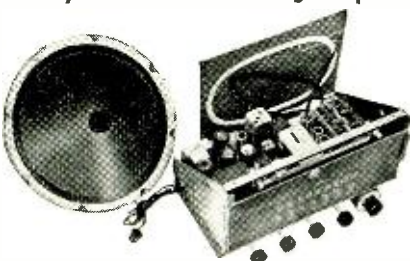

It is not necessary to spend a large sum of money to modernize your old radio or to become a "High Fidelity" enthusiast. ESPEY chassis provide the Highest Quality at moderate prices.

Fully licensed under RCA and Hazeltine patents. The photo shows the Espey Model 511-C, supplied ready to play. Equipped with tubes, antenna, speaker, and all necessary hardware for mounting.

NEW FEATURES—Improved Frequency modulation circuit, drift compensated • 12 tubes plus rectifier, and pre-amplifier 12A7 tube • 4 dual purpose tubes • High quality AM-FM reception • Push-pull beam power audio output 10 watts • Switch for easy changing to crystal or variable reluctance pick-ups • Multi-tap audio output transformer supplying 3.2—8—500 ohms.

Makers of fine radios since 1928.

ESPEY MANUFACTURING COMPANY, INC.
528 EAST 72nd STREET, NEW YORK 21, N. Y.

Write Dept. RE-8 for literature and complete specifications on Model 511-C and others.

SUBMINIATURE TRANSFORMERS

Crest Laboratories, Inc., Whitehall Bldg., Far Rockaway, N. Y., is producing a new line of sub-miniature transformers for transistor applications. The units are available in the micro-miniature size (1/8 inch diameter and 5/8 inch high). They are hermetically sealed and are available with glass bead headers or military-type ceramic feed-through terminals. The transformers are also available in 3/4 x 3/4 x 1 1/8-inch military-type cases.

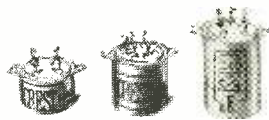

INDOOR TV ANTENNA

Telrex, Inc., Asbury Park, N. J., is manufacturing the new Bat Wing indoor antenna for TV and FM reception. The unit does not require tuning, pruning, or other adjustments. The polished aluminum elements are mounted on a tip-proof base.



FLYBACK TRANSFORMER

Ram Electronics Sales Co., South Buckhout St., Irvington-on-Hudson, N. Y., has added the new model X069 high efficiency ferrite-core horizontal-output and flyback transformer to its line of TV receiver components. The unit, designed as a direct replacement for the ferrite-core units used in the newest G-E and Stromberg-Carlson sets, has

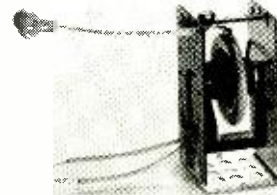

wide replacement application in sets employing the latest circuits. The X069 features low retrace time, good regulation, and improved anticorona construction. It delivers 16-17.5 kv for 19-21-inch TV picture tubes. The X70F14 14-mh cosine deflection yoke is the matching unit for the transformer.

TWO-SET TV COUPLER

Mosley Electronics, 2125 Lockland Road, Overland, Mo., has introduced the Dual-Match, a new coupling unit designed to permit two TV sets to be operated simultaneously from a single



antenna without interacting or interfering with each other. The unit is compact and mounts on the back of the set or baseboard. Connections to standard 300-ohm ribbon lines are made without solder.

SPEAKER ENCLOSURES

Jensen Mfg. Co., 6601 S. Laramie Ave., Chicago, Ill., recently demonstrated two new back-loading folded-horn speaker cabinets and a new three-way reproducer system. The three cabinets feature a long, folded Hypoex-formula horn which loads the back of the speaker for low distortion and good bass response. The horn is within the cabinet with mouth sections at sides

to permit effective operation with the cabinet against the wall and full corner effect with the cabinet placed in a corner.

The new Tri-trex three-way reproducer system consists of the cabinet described above, and three speakers. A Jensen RP-302 tweeter and A-402 network handle signals from 4,000 cycles to the limits of audibility. A RP-201 speaker unit handles frequencies from 600-4,000 cycles. A model A-61 network feeds signals in the 600-4,000-cycle range to the RP-201 and signals below 600 cycles to the P15-LL 15-inch woofer. The cabinet is 38 3/4 inches high, 25 1/2 inches wide, and 18 3/4 inches deep.

The model BL-151 cabinet is designed for 15-inch speakers and the BL-121 for 12-inch speakers. The three cabinets are available in mahogany and in blonde Korina finishes.

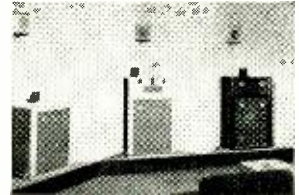

SINE-SQUARE-WAVE GENERATOR

Electronic Instrument Co., Inc., 84 Withers St., Brooklyn 11, N. Y., has added the model 377 sine and square-wave audio generator to its line of kit and factory-wired test instruments. The model 377 generates sine waves from 20 to 200,000 cycles in four individually



calibrated ranges. Square-wave coverage is from 60 to 10,000 cycles with 5% overshoot at 10 kc. The unit uses an improved Wien-bridge circuit with variable-capacitor tuning. Response is flat within 1.5 db from 60 cycles to 150 kc. Output is continuously variable with a maximum of 10 volts across the 1,000-ohm rated load. Distortion is only 1% of rated output and hum level is less than 0.4% of rated output.

The unit is housed in an 11 1/8 x 7 1/8 x 7 3/8-inch steel case with a three-color etched panel. The 377-K (kit) is supplied with complete construction and operating instructions.

TV LIGHTNING ARRESTERS

The LaPointe Plascormold Corp., Windsor Locks, Conn., has added several new models to the VEE-DX line of lightning arresters. The RW-200 S and RW-204-S feature straps and gripping prongs for nonslip mounting on all size masts and pipes. Their electrical characteristics are similar to those of the standard RW-200 and RW-204 arresters. Model RW-310 open-wire arrester has brass connecting blocks and Prona-tooth washers that provide positive connections and assure accurate wire spacing. This model is similar to the heavy-duty RW-300. Models RW-210 and RW-214 are modifications of the RW-200 and RW-204 with a single wood screw for mounting on wood surfaces. All the arresters are UL-approved.



BUY TEST EQUIPMENT ON THIS RADICALLY NEW TIME PAYMENT PLAN

NO INTEREST!! - NO CARRYING CHARGES!!

USE CONVENIENT TIME PAYMENT ORDER BLANK BELOW

Superior's New JUNIOR SUPER-METER

MOST COMPLETE AND COMPACT MULTI-SERVICE INSTRUMENT EVER DESIGNED

Measures:
 * Voltage * Current * Resistance
 * Capacity * Reactance * Inductance
 * Decibels

Specifications: D.C. Volts: 0-7.5/75/150/750/1500 Volts. A.C. Volts: 0-15/150/300/1500/3000 Volts. Resistance: 0-10,000/100,000 ohms. 0-10 Megohms. D.C. Current: 0-7.5/75 Ma. 0-7.5 amps. Capacity: .001 Mfd.—2 Mfd.—1 Mfd.—20 Mfd Electrolytic Leakage: Reads quality of electrolytics at 150 Volt test potential. Decibels: -10 Db to +18 Db. -10 Db to +38 Db. +38 Db. to +58 Db. Reactance: 15 ohms—25 K ohms 15 K ohms—2.5 Megohms. Inductance: 5 Henry—50 Henries 30 Henries—10 K Henries Plus Good-Bad scale for checking the quality of electrolytic condensers.



Handsome round cornered molded bakelite case 3 1/2" x 5 7/8" x 2 1/4" complete with all test leads and instructions

\$21.40 NET

Superior's New TUBE TESTER Model TV-11



• Uses the new self-cleaning Lever Action Switches for individual element testing. Because all elements are numbered according to pin number in the RMA base numbering system, the user can instantly identify which element is under test. Tubes having tapped filaments and tubes with filaments terminating in more than one pin are truly tested with the Model TV-11 as any of the pins may be placed in the neutral position when necessary. • Uses no combination type sockets. Instead individual sockets are used for each type of tube. Thus it is impossible to damage a tube by inserting it in the wrong socket. • Free-moving built-in roll chart provides complete data for all tubes. • Phono jack on front panel for plugging in either phones or external amplifier detects microphonic tubes or noise due to faulty elements and loose external connections.

Operates on 105-130 Volt 60 Cycles A.C. Hand-rubbed oak cabinet complete with portable cover **\$47.50** NET

Superior's New Model 670-A SUPER-METER

A combination volt-ohm milliammeter plus capacity reactance inductance and decibel measurements

SPECIFICATIONS:
 D.C. VOLTS: 0 to 7.5 15 75 150 750 1500 7500 Volts
 A.C. VOLTS: 0 to 15 30 150 300 1500 3000 Volts
 OUTPUT VOLTS: 0 to 15 30 150 300 1500 3000 Volts
 D.C. CURRENT: 0 to 1.5 15 150 Ma. 0 to 1.5 15 Amperes
 RESISTANCE: 0 to 1,000 100,000 Ohms 0 to 10 Megohms
 CAPACITY: .001 to 1 Mfd. 1 to 50 Mfd. (Qual. by test for electrolytic)
 REACTANCE: 50 to 2,500 Ohms 2,500 Ohms to 2.5 Megohms
 INDUCTANCE: .15 to 7 Henries 7 to 7,000 Henrys
 DECIBELS: -6 to +18 +11 to +38 +33 to +58



Comes housed in rugged, crackle-finished steel cabinet complete with test leads and operating instructions. Size 6 1/2" x 9 1/2" x 4 1/2"

\$28.40 NET

ADDED FEATURE
 The Model 670-A includes a special GOOD-BAD scale for checking the quality of electrolytic condensers at a test potential of 150 Volts

Superior's New TV BAR GENERATOR

THROWS AN ACTUAL BAR PATTERN ON ANY TV RECEIVER SCREEN!!

Two Simple Steps

1. Connect Bar Generator to Antenna Post of any TV Receiver.
2. Plug Line Cord into A. C. Outlet and Throw Switch.

RESULT: A stable never-shifting vertical or horizontal pattern projected on the screen of the TV receiver under test.



Power Supply: 105-125 Volt 60 Cycles. Power Consumption: 20 Watts. Channels: 2-5 on panel. 7-13 by harmonics. Horizontal lines: 4 to 12 (Variable). Vertical lines: 12 (Fixed). Vertical sweep output: 60 Cycles. Horizontal sweep output: 15,750 Cycles.

TV Bar Generator comes complete with shielded leads and detailed operating instructions. Only **\$39.95** NET

New Model 200-AM and FM SIGNAL GENERATOR

Provides complete coverage for A.M.-F.M. and TV alignment

RF Frequency Ranges: 100 Kilocycles to 150 Megacycles. Modulating Frequency: 100 Cycles. May be used for modulating the RF signal. Also available separately. Attenuation: The constant impedance attenuator is isolated from the oscillating circuit by the buffer tube. Output impedance of this model is only 50 ohms. This low impedance reduces losses in the output cable. Oscillatory circuit: Hartley oscillator with cathode follower buffer tube. Frequency stability is assured by modulating the buffer tube. Accuracy: Use of high Q permeability tuned coils adjusted against 1/10th of 1% standards assures an accuracy of 1% on all ranges from 100 Kilocycles to 10 Megacycles and an accuracy of 2% on the higher frequencies.



Tubes used: One 954 as oscillator; one 954 as modulated buffer amplifier; T-2 as modulator; 7193 as rectifier.

The Model 200 comes complete with output cable and operating instructions

\$21.85 NET

NEW TIME PAYMENT PLAN ORDER BLANK

MOSS ELECTRONIC DISTRIBUTING CO., INC. Dept. B-30, 38 Murray Street, New York 7, N. Y.

Please send me the units checked below. I am enclosing the down payment with order and agree to pay the monthly balance as shown. It is understood there will be no carrying, interest or any other charges, provided I send my monthly payments when due. It is further understood that should I fail to make payment when due, the full unpaid balance shall become immediately due and payable.

- JUNIOR SUPER METER Total Price \$21.40 \$5.40 down payment. Balance \$4.00 monthly for 4 months.
 - MODEL TV-11 Total Price \$47.50 \$11.50 down payment. Balance \$6.00 monthly for 6 months.
 - MODEL 670-A Total Price \$28.40 \$7.40 down payment. Balance \$3.50 monthly for 6 months.
 - TELEVISION BAR GENERATOR Total Price \$39.95 \$9.95 down payment. Balance \$5.00 monthly for 6 months.
 - MODEL 200 Total Price \$21.85 \$5.85 down payment. Balance \$4.00 monthly for 4 months.
- I enclose \$_____ as down payment.
 Ship C.O.D. for the down payment.

Signature _____

Name _____

Address _____

City _____ Zone _____ State _____



can you
call the
close ones?

Much like the umpire—you can call them, if you can see them—so in television it's the "picture quality" that determines whether or not you can see them.

Be sure the TV set is "picture powered" with an Amphenol In-line Antenna—one of the first TV antennas created and still the best broadbanded type providing uniform gain and signal strength across the entire range of VHF channels.

Call the close ones with Amphenol.

AMERICAN PHENOLIC CORPORATION
1830 SO. 54TH AVE. • CHICAGO 50, ILLINOIS

AMPHENOL



Dealers, Installers, and Owners of TV sets will all be interested in this free book. Write Department 13A.

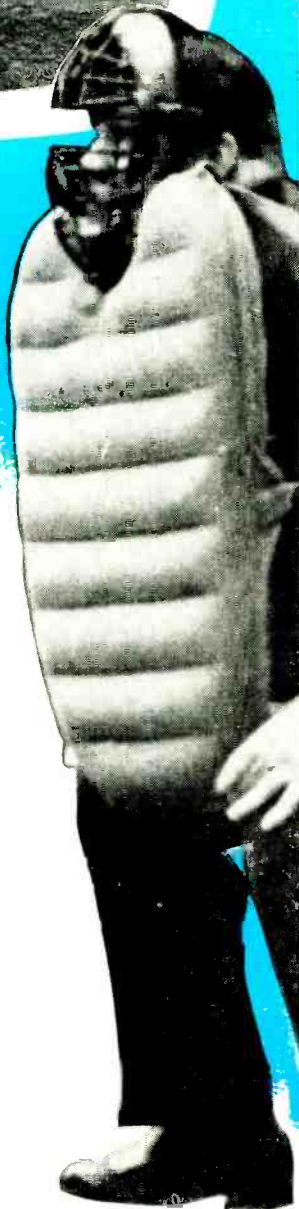

New Devices

NEW TUBE TESTER

Electronic Measurements Corp., 280 Lafayette St., New York, N. Y., has announced the addition of a new mutual-conductance tube tester to the EMC line of electrical testing equipment. Model 206 is designed to give microhmo readings for all amplifier tubes. It also tests cold-cathode, electron-ray, voltage-regulator, and bal-

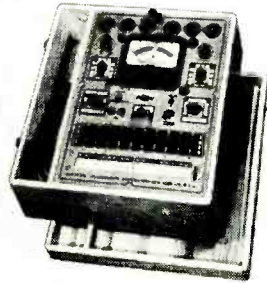

last tubes. Flexible lever switching allows all present and future tubes to be tested regardless of location of elements on tube base. Individual sockets for each tube-base type eliminate possible errors. This instrument is available in stationary or portable oak cases.

TV TEST EQUIPMENT RACK

The Tube Department of RCA Victor, Harrison, N. J., has announced a four-section test-equipment rack designed for the WR-39C television calibrator, the WR-59B sweep generator, WO-56A oscilloscope, and WV-87A Master Volt-

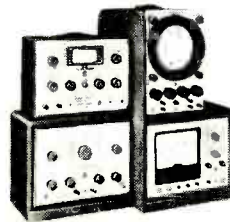

Ohmyst. The double-tiered wood rack is finished to harmonize with the line of test instruments. It saves space on the workbench and consolidates major TV test instruments in one location, saving time and steps for the service technician.

MODEL 650 VTVM

Triplett Electrical Instrument Co., Bluffton, Ohio, is distributing the new model 650 v.t.v.m. Peak-to-peak or r.m.s. a.c. and r.f. voltages from 20 cycles to over 110 mc. are measured with one probe. A.c. voltages are read on six different dial scales with r.m.s.

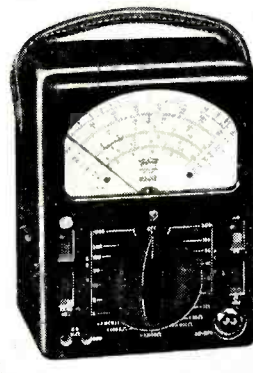

ranges of 1, 5, 10, 50, 100, and 500. A special control permits zeroing the meter for a.c. voltages under varying line conditions.

D.c. voltages are metered in ranges of 1, 5, 10, 50, 100, 500, and 1,000 with 11 megohms input impedance. A zero center is provided for discriminator alignment.

ANTENNA LINE CLIP

General Cement Mfg. Co., 919 Taylor Ave., Rockford, Ill., has just introduced a new three-way TV antenna line clip

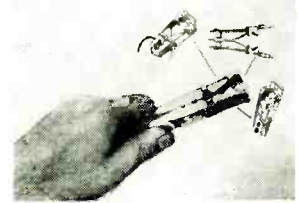

which is easily attached to the antenna lead-in without solder. In addition to clipping onto the terminals at the back of any receiver straight on, this clip can be hooked up sideways where space is tight, and it can also be quickly connected to the RCA plug-in type terminals.

RECORDER AMPLIFIER

TapeMaster, Inc., 13 West Hubbard St., Chicago 10, Ill., is now distributing the new TapeMaster model SA-13 power amplifier and speaker as a companion unit to the PT-125 tape recorder. Together, they form a complete tape recorder and playback



assembly. The amplifier delivers 8 watts peak. Total distortion is less than 1% at 5 watts output. Frequency response is within 1 db from 30 to 15,000 cycles. Damping factor is 10. The unit has a 7 1/2 x 9 1/2 x 18 1/2-inch portable carrying case designed for good baffling.

PAPER CAPACITORS

Astron Corp., 255 Grant Ave., East Newark, N. J., announces the availability of the new type AQ capacitors. These are subminiature paper units designed for good capacitance sta-



bility over a temperature range of -65° to +125° C. Extended-foil, non-inductive type construction is employed in the AQ capacitors to insure low resonance losses. The units are available in a variety of hermetically-sealed tubular cases and construction types.

NEW RIBBON LINE

Belden Mfg. Co., 4647 W. Van Buren St., Chicago 44, Ill., is the manufacturer of the new *Weldohm* 300-ohm ribbon-type TV lead-in wire. The cable is designed to resist conductor breakage caused by wind whipping and severe flexing. The conductors are made of 20 gauge, 7 x 28 copper-clad steel with brown polyethylene insulation.

TV ANTENNA TOWER

Rohn Electronic Supply Co., 2108 Main St., Peoria, Ill., manufactures a line of antenna towers designed to withstand winds up to 80 miles per hour when set in a 3-foot concrete base. The tower is a three-cornered arrangement with 1-inch tubular steel legs. Since the tower is grounded, damage from lightning is negligible.

All specifications given on these pages are from manufacturers' data.

RADIO-ELECTRONICS

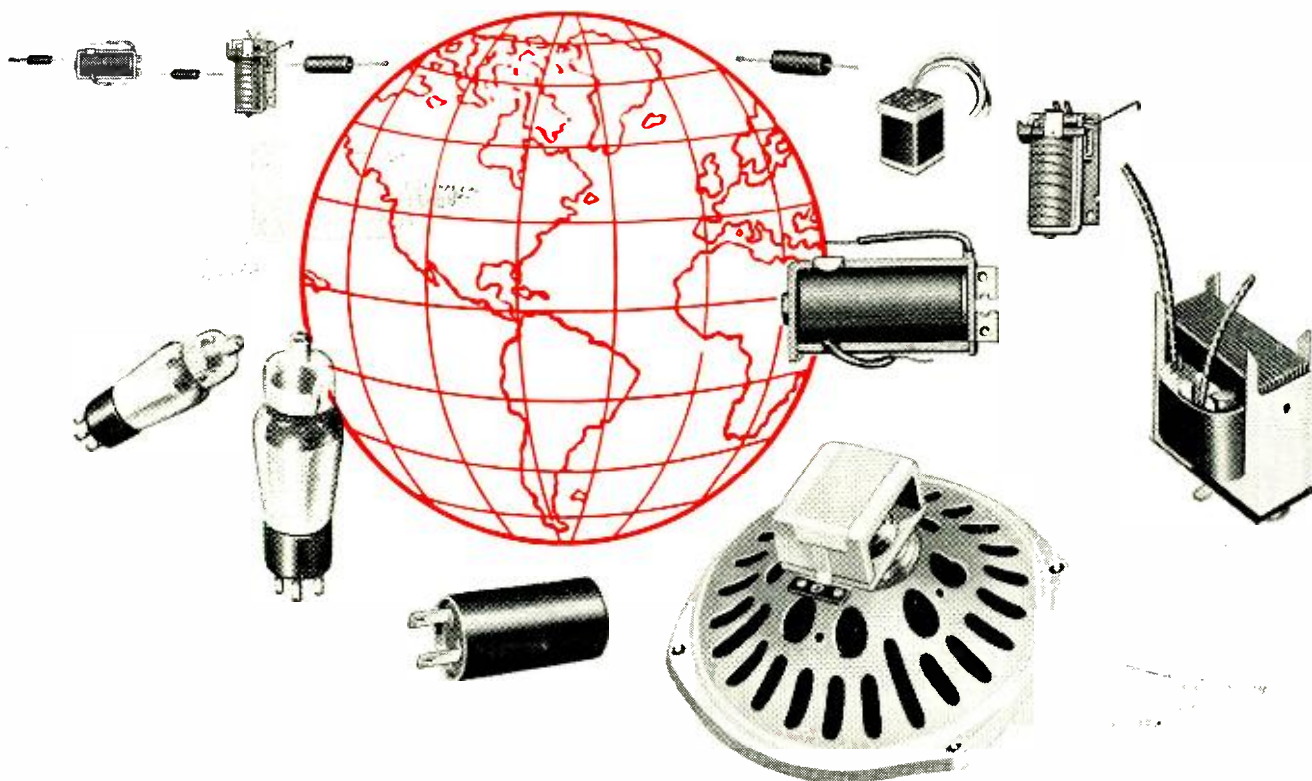

Have a Look at some of the

World's Finest Radio Parts!

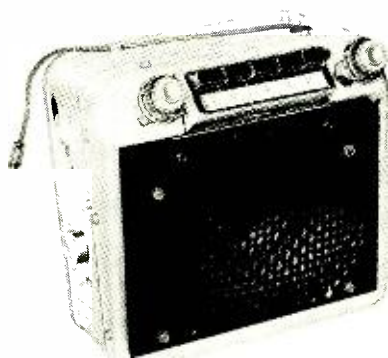

Ordinary radio parts? Not at all! You see, these automobile radio parts—like thousands of others bearing the Delco Radio name—are of uniform high quality.

More than half of all radio-equipped cars are equipped with Delco Radios—*seven million* in all. Think of the volume-building opportunity for you!

THINGS TO REMEMBER ABOUT DELCO RADIO SERVICE PARTS

1. Offer largest market for original-equipment replacement parts.
2. Made in the world's largest factory devoted exclusively to automobile radios.
3. Designed by one of the largest and most forward-looking engineering groups devoted exclusively to automotive radio.

DELCO RADIO PARTS

A GENERAL MOTORS PRODUCT



UNITED
SERVICE
MOTOR

A UNITED MOTORS LINE

DISTRIBUTED BY WHOLESALERS EVERYWHERE

DELCO RADIO

DIVISION OF GENERAL MOTORS CORPORATION
KOKOMO, INDIANA

IT'S NEW **10-POUND PORTABLE BATTERY-OPERATED TAPE RECORDER**



MAGNEMITE®

Write today for Magnemite® literature

4 models priced from \$225

Model 610-B

8½ in. D.
5½ in. H.
11½ in. W.

NEW DRY BATTERIES
Inexpensive flashlight-type cells that last 100 hours.

NEW SPRING MOTOR
Governor-controlled motor runs 15 minutes per winding.

NEW TAPE PLAYBACK
Playback and monitoring thru earphones or ext. amplifier.

NEW SENSITIVITY
Crystal-clear recordings up to 100 feet from microphone.

AMPLIFIER CORP. of AMERICA
398 Broadway New York 13, N. Y.

SELECTIVE SQUELCH

Patent No. 2,590,310

George D. Hanchett, Jr., Millburn, N. J.
(Assigned to Radio Corp. of America)

In a police radio network, headquarters must contact various cars from time to time. Sometimes a general call must be picked up by all cars. At other times, the call concerns only one car or a certain group of cars. This patent discloses a selective control system which alerts the desired

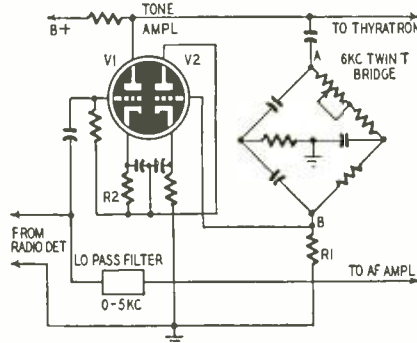

cars. A distinctive h.f. signal is assigned to each car. The tones, superimposed on the carrier, are chosen to be above the audio pass-band so they cannot be heard. Normally all receivers are blocked. When the assigned tone is picked up, the corresponding receiver begins to operate.

The radio detector delivers all control tones as well as the audio message. The control tones are filtered out so only the audio feeds the audio amplifier. However, as mentioned above, this amplifier is normally squelched and the set is quiet. It is up to the control tone to operate it. The control circuit is shown in the diagram.

Detector output is fed to the tone amplifier which consists of V1 and V2 in series. This amplifier cannot function if either triode is blocked. Assume a positive signal is applied to V1. Then its plate goes negative. Part of this negative voltage appears across R1 and is delivered to V2. It blocks the triode. Now let a negative signal appear at V1. A positive drop occurs across R1.

V2 conducts fully, but this produces such a large bias across R2 that V1 is blocked. There is only one way to get any output from the tone amplifier. This is by eliminating the degenerative voltage across R1.

Many of us know how a twin-T works. All frequencies will be transmitted through the twin-T except that to which the bridge is tuned. Input signals may be fed in between A and ground. The output will appear between B and ground. Therefore, at the tuned frequency there will be no degeneration across R1. Since the twin-T is tuned to the assigned signal tone, V1 has output only while this particular tone is being transmitted.

When V1 output is available, it triggers a thyatron. This gas tube completes the cathode circuit of the a.f. tube and permits it to operate.

COLD CATHODE FLIP-FLOP

Patent No. 2,593,375

Charles R. Williams, Hawthorne, and Glenn E. Hagen, Lawndale, Calif.
(Assigned to Northrop Aircraft, Inc., Hawthorne, Calif.)

This flip-flop circuit requires a special gas-filled tube with two cathodes and a single anode. Pulses applied to the anode trigger the cathodes alternately. A single output pulse is available (at either cathode) for every pair of pulses across the input. Since the tube has no filament, power requirements are low.

A discharge is normally present between the anode A and one of the cathodes, K1 or K2. At a given time, assume that K1 is the conducting cathode. Current then flows from ground to K1 and from the anode into battery A. It charges C2 to a potential greater than that of the constant voltage supply.

The generator sends out negative pulses. These can flow through X1 and C1 to the tube anode, to interrupt the tube discharge. When this occurs, the anode voltage begins to rise to the terminal voltage BA. When the potential between A and K2 is large enough, a discharge occurs between these elements. The tube does not fire between A and K1 (instead) due to the positive charge on C2.

The next negative pulse again interrupts the tube discharge. By this time C2 has been dis-

PARTS LISTS

Bills of material for most of the pieces of equipment described in RADIO-ELECTRONICS construction articles are on hand at all radio parts jobbers and distributors who sell the magazine. See your dealer for a complete parts list of any of this apparatus you wish to construct.

LEARN Practical RADIO AT HOME



COMPLETE ONLY . . .

\$19⁹⁵

BUILD 15 RADIOS

ABSOLUTELY NO PREVIOUS TRAINING NEEDED
EXCELLENT BACKGROUND FOR TELEVISION

10-DAY MONEY-BACK GUARANTEE

WHAT THE 1952 PROGRESSIVE RADIO "EDU-KIT" OFFERS YOU:

This is a practical home radio course. You learn theory, construction, operation, trouble shooting, code. You build RECEIVERS, TRANSMITTERS, AMPLIFIERS, CODE OSCILLATOR, SIGNAL TRACER.

You start with a simple radio circuit, and gradually advance to more complex circuits. No previous background is required. No instructor is needed. All parts and instructions are included and every single step is clearly explained.

All parts are guaranteed, individually packaged, identified, and explained. There is nothing extra to buy. You receive all parts, tools and instructions at once. You keep everything; there is absolutely nothing you return to us.

You can easily pay for the kit in a short time by repairing radios. Use the tester and signal tracer for servicing. The signal tracer alone is worth more than the price of the entire kit.

USED BY RADIO SCHOOLS AND GOVERNMENT AGENCIES!

The Progressive Radio "Edu-Kit" includes tubes, paper condensers, mica condensers, electrolytic condensers, variable condensers, selenium rectifiers, chassis, hardware, tie strips, tube sockets, solder, wire, soldering iron, tubing, coils, instruction book, radio tester, etc.; in brief, everything you need in a practical radio course.

Send for further information and receive FREE Radio & TV Trouble Shooting Guide. Or order direct from this ad and receive FREE Code Oscillator Key (Value \$2.95) in addition to Radio & TV Trouble Shooting Guide.

Postage prepaid on Cash orders—C.O.D. orders accepted in U.S.A.

PROGRESSIVE ELECTRONICS CO.

497 UNION AVE. -- DEPT. RE-62 -- BROOKLYN, NEW YORK

FREE RADIO TESTER & SOLDERING IRON

GET A WELL-PAYING JOB



GO INTO A PROFITABLE BUSINESS AND PLAN FOR A FUTURE



charged. K1 now has a lower potential than K2. Thus K1 becomes the conducting cathode. Thus the cathodes conduct alternately.

When either cathode fires, there is an instantaneous drop in the potential between it and the anode. Also, a high current surge flows between this cathode and the anode. While K2 conducts, a

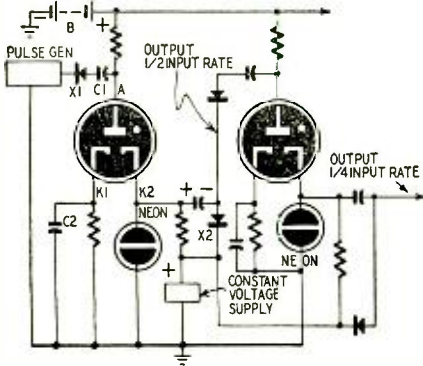

large current flows through the constant voltage supply and its limiting resistor. The neon lamp is triggered, thus indicating the binary count. This lamp is extinguished when K1 conducts.

At the moment K2 begins to conduct, a sharp positive pulse appears across the neon lamp. It biases rectifier X2 to full conduction and charges the capacitor with the polarity shown. As a result, a negative pulse is available for transfer to the next tube. The output of the second stage has a pulse rate one-fourth that of the input generator.

X1 prevents negative pulses from passing from the tube anode back into the pulse generator.

DIRECT-COUPLED AMPLIFIER

Patent No. 2,590,104

Howard L. King, Vancouver, Wash.

(Assigned to United States of America as represented by the Secretary of the Interior)

This amplifier handles signal voltages from d.c. up to about 10,000 cycles with negligible phase shift. It has high input impedance and can feed loads as small as 1 ohm. Distortion is very low. The input may be balanced or single-ended.

For single-ended input, SW is closed. Plate and cathode resistors of V3 and V4 are all equal. These tubes feed a bridge network composed of V5, V6, V7, and V8. With no signal and P1 correctly set, the voltage across the load will be zero.

Assume that the input signal is positive at A and negative at B. Current through V3 will decrease while the V4 current will rise. Grids of V5 and V8 will go more negative, while the grids of V7 and V6 will be driven more positive. These simultaneous changes unbalance the bridge, and a voltage appears across the load.

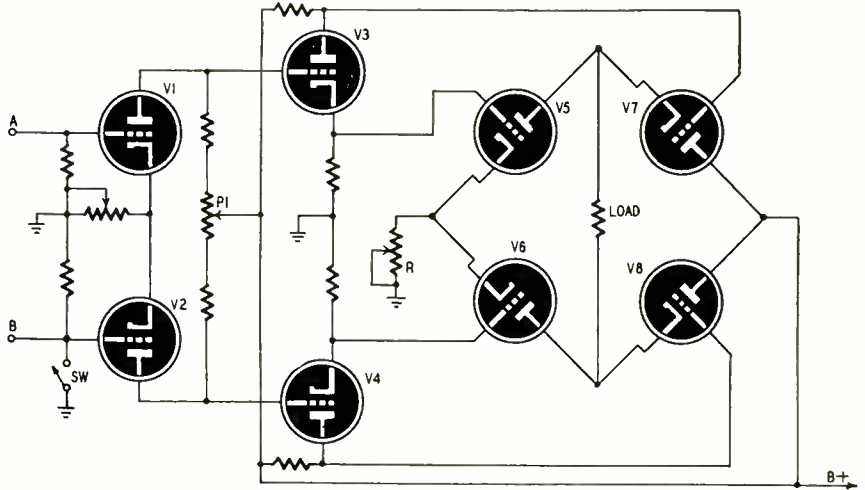

TeleSound CUSTOM-BUILT TV CABINETS

DIRECT FROM MANUFACTURER TO YOU—COMPARE PRICE and QUALITY!



H:25", D:21 1/2", W:25" Wgt: 50 Lbs.
TABLE MODEL 500 **\$42.00**



As above, for 24" Picture Tube
H:31", D:24", W:27" Wgt: 60 lbs. **\$55.80**

H:40 1/4", D:22 1/2", W:25 1/4" Wgt:60 lbs.
CONSOLE MODEL 200 **\$45.50**

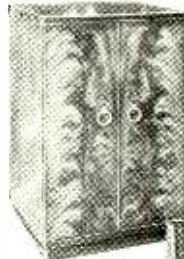

H:40 1/2", D:24", W:25" Wgt: 100 lbs
CONSOLE MODEL 800 **\$82.50**



CREDENZA MODEL 1200
H: 35", D: 23", W: 40",
Shpg. Wt. approx 100 lbs.
For 17", 20", 21" Picture Tube, includes record-changer compartment. TV only, for 24" and 27" This cabinet also available for TV only (17" to 24" CRT) side mount, 34" Wide. **\$105**



Be price conscious! TELESOUND Wholesale Prices enable you to sell more, make a BETTER PROFIT for yourself!

ALL PRICES TAX INCLUDED

Famous SUPER DeLUXE 630 CHASSIS

—YOUR CHOICE—
REGAL
or
VIDEO



TERRIFICALLY LOW PRICED!
\$139.50

- 30 tubes—for 16" to 24" Picture Tubes
- High Efficiency High Voltage Circuit
- Keyed AGC
- Automatic brightness control
- Special extra high gain Cascode Standard Coil Tuner
- Directly adaptable for UHF.
- 12" Quality Sneaker
- Factory wired, aligned, tested.
- Complete, ready to play, including knobs and hardware
- Less CRT

Techmaster C-30 Chassis, Ccomplete with Tubes & Speaker, Less CRT. **\$149.50** **FREE OFFER!** Schematic Diagram and complete 24 page service manual FREE with any of these chassis!

Please include 25% deposit with orders, balance C.O.D. All shipments F.O.B., NYC "Designers & Manufacturers of Custom TV and Radio Furniture"



421 West 28th Street
New York 1, N.Y.
Phone: WI 7-0719

TV PICTURE TUBES

Sheldon Blue Label One Year Guarantee Dumont—6 Mos. Guarantee

12 1/2" Black or White	\$20.50	19" Round (Blk)	\$33.50
14" Glass Rect. (Blk)	\$20.50	20" Rectangular (Blk)	\$35.50
16" Glass Round (Blk)	\$30.50	21" Rectangular (Blk)	\$39.50
16" Glass Rect. (Blk)	\$30.50	24" Metal	\$69.50
17" Rectangular (Blk)	\$29.50	27" Rectangular	Wholesale Price on Request

SPECIAL COMBINATION OFFERS!

SAVE MONEY! Order the cabinet of your choice from the TeleSound models illustrated, in combination with the famous 630 TV Chassis. (Regal or Video), 12" speaker, and your choice of picture tube. If Techmaster C-30 chassis desired, add \$10.00 to combination price. Check these sensationally low prices:

CABINET STYLE	COMBINED WITH Super 630 chassis, 12" speaker, and			
	17" CRT	20" CRT	21" CRT	24" CRT
500	\$205.75	\$211.60	\$215.50	\$258.20
200	209.15	215.00	218.90
800	245.10	251.05	254.95
1000	245.10	251.05	254.95	284.20
1200*	291.50	297.35	301.25

*Record Changer not included.



*Lic. A.A.K. Pats. 2,422,458; 2,282,292, others pending

Look for these patented* bright red Electronic Channel Separators that incorporate a printed circuit for the first time in any antenna.

REVOLUTIONARY

ALL-CHANNEL



WITH PATENTED* BUILT-IN

Channel Separators

Here it is—the antenna that is taking the TV industry by storm. With its sensational Electronic Channel Separators employing a printed circuit for the first time in antenna history, the Q-TEE is fast replacing other types of all-channel antennas. With its powerful performance, clean-cut silhouette, light weight, and pre-assembled construction, the Q-TEE incorporates everything the finest all-channel antenna should have. Available in three series for every reception need — Q-TEE Single Bay — for primary areas; Q-TEE Double — two-bay array for near-fringe areas; Q-TEE Quad—four-bay stacked array for fringe areas.

VEE-D-X

makers of the world's most powerful TV antenna systems

THE LaPOINTE-PLASCOMOLD CORP. Rockville, Connecticut

RE8

Gentlemen:

- Send complete Q-TEE literature
- Send copy of new Vee-D-X catalog

Name
 Street
 City Zone.....State.....

R should be adjusted to avoid overdriving the tubes in the last stage. Because of the balanced operation no a.c. appears across this resistor and there is no degenerative feedback.

In the balanced condition there is no d.c. through the load. This makes it possible to apply the circuit to electromagnetic or iron-core inductance loads without loss of inductance due to partial or complete core saturation. A loud-speaker voice coil might be connected directly as a load, eliminating the output transformer. The B supply voltage would have to be twice the normal value, as the output tubes are in series for d.c. V7 and V8 might require a separate heater supply insulated for the high voltage to ground.

FREQUENCY MEASUREMENT

Patent No. 2,592,235

Alfred F. Bischoff, Ballston Spa, N. Y. (Assigned to General Electric Co.)

This r.f. meter can measure a changing frequency as well as one that remains constant. A motor-driven variable capacitor tunes a resonant circuit over the desired frequency band. The interval between the start of each sweep and the instant of resonance determines the frequency of an incoming signal. A directly-calibrated meter is used.

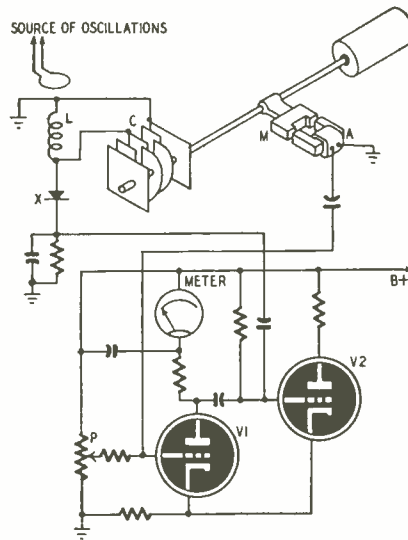

L-C is a variable tank whose capacitor C is swept by a motor. The same motor also moves magnet M past the poles of armature A. C has a straight-line frequency characteristic during its forward sweep from minimum to maximum capacitance. Preferably, the remainder of the sweep (return from maximum back to minimum) should be accomplished within a relatively small angle of rotation. Triodes V1, V2 form a multivibrator. Normally V2 conducts and V1 is blocked. This condition is set up by adjusting P. As in any multivibrator, only one of the triodes conducts at any given time.

At the start of each forward sweep of C, the magnet M moves past A as shown. This induces one complete a.c. cycle in the armature coil. The coil of armature A is polarized to induce a negative half-cycle first. This voltage, applied to the grid of V1 has no effect since this triode is already blocked. The positive half-cycle which follows unblocks the triode and cuts off V2. The plate current meter now starts to indicate. At some later instant, L-C tunes to the signal and a positive pulse is transmitted through rectifier X. This unblocks V2 and cuts off V1, ending the flow through the meter. The average reading on this meter depends upon the interval during which V1 conducts. In turn, this depends upon the signal frequency.

For a higher frequency, resonance occurs at lower capacitance of C, that is, shortly after the start of its forward sweep. Therefore V1 conducts for a relatively short time and the meter reads low. The reading will be higher on a lower frequency. For convenience the meter is calibrated from known signals.

—end—

OPPORTUNITY AD-LETS

Rates—35¢ per word (including name, address and initials). Minimum ad 10 words. Cash must accompany all ads except those placed by accredited agencies. Discount for 6 issues, 10%, for 12 issues, 20%. Misleading or objectionable ads not accepted. Copy for October issue must reach us before August 21, 1952.

Radio-Electronics, 25 W. Broadway, New York 7, N. Y.

WANTED: AN/TRC-1 EQUIPMENTS, T14 TRANSMITTERS, R19 RECEIVERS, TS32 TEST OSCILLATORS. Any condition or quantity. Box 752-2, Radio-Electronics, 25 West Broadway, New York 7, N. Y.

SPEAKERS REPAIRED! at wholesale prices. Guaranteed workmanship. Fast service. Amprite Speakers Service, 70 Vesey St., New York 7, N. Y.

WANTED: ARMY WALKIE-TALKIES. STATE PRICE, conditions and model number. Andy Andros, 249 North 48, Lincoln, Nebraska.

TV AND FM ANTENNAS, YAGI, CONICAL, BOW-TIE Mounts, accessories. Lowest prices. Wholesale Supply Co., Lunenburg 2, Mass.

WE REPAIR, CONVERT, SELL, ALL TYPES OF electrical instruments, tube checkers and analyzers. Hazleton Instrument Co. (Electric Meter Laboratory), 128 Liberty Street, New York, N. Y. Telephone—BARclay 7-4239.

WANTED: AN/APR-4, other "APR", "TS-", "IE-", ARC-1, ARC-3, ART-13, BC-348, etc. Microwave Equipment, everything Surplus, Special tubes, Test Manuals, Lab Quality Equipment, Meters, Fast Action, Fair Treatment, Top Dollar! Littell, Parhills Box 26, Dayton 9, Ohio.

FIVE ELEMENTS TV YAGI BEAMS, ALUMINUM TUBING, ETC. Write for prices. Willard Radcliff, Fostoria, Ohio.

FREE INFORMATION, HOW TO REPAIR RADIOS, Slate's Radio Service, Corsicana, Texas.

ACCURATE COMPONENT TESTER—New Measuring Bridge Design—Booklet: Complete "build yourself" plans. (Precision measurements: resistances, inductances, capacitances). Guaranteed. Only \$1.00. Technological Developments, 475H Fifth, N. Y. 19, N. Y.

TELEVISION TOWERS DIRECT FROM FACTORY write Youngstown Steel Towers Co., Youngstown 8, Ohio.

ENJOY 3 COLOR TELEVISION SCREEN. SEND \$1. State Screen Size. Zingo Products, Dept. K, Johnstown, New York.

WANT REPRINTS?

Offset reproductions of any of the fine articles appearing in RADIO-ELECTRONICS supplied! Excellent work, low cost! Orders for reprints accepted in any quantities over 100. Write for an estimate.

PASSANTINO PRINTING CO.

250 West 49th St. New York 19, N. Y.



EVERY

RADIOMAN

Can Use These

SERVICE HINTS!

Valuable Manual Yours—FREE!

Every page of "How to Simplify Radio Repairs" is packed with on-the-bench, practical ideas. Contains photos, charts, diagrams—no fluff, no vague theory. In plain, every-day language it gives you priceless suggestions—new servicing ideas. You'll use and benefit from the experience of experts. Partial list of contents: How to Locate Trouble; How to Service Amplifiers; How to Test for Distortion; How to Test Audio Circuits; How to Test Speakers; How to Find Faults in Oscillators; How to Test Radio Parts—and it's all yours—FREE! No obligation.



SEND COUPON OR GOVERNMENT POSTCARD FOR YOUR FREE COPY TODAY!

FEILER ENGINEERING CO., Dept. BR2 8026 N. Monticello Ave., Skokie, Ill. (Suburb of Chicago)

Please Rush my FREE copy of "How to Simplify Radio Repairs."

Name
 Address
 City Zone.....State.....

LOW LINE VOLTAGE

Many common complaints on three-way portable sets are due to low line voltage. Generally the converter tube refuses to oscillate at reduced plate and filament voltages. This trouble is easily cured by either of two methods:

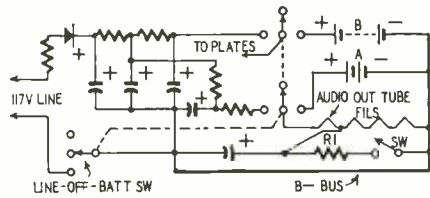

Fig. 1—Filament-voltage booster circuit.

In Fig. 1, a s.p.s.t. switch is connected between the resistor from the power-amplifier filament and ground (R1). This switch is opened when the line voltage drops, increasing the filament current of the tubes by the amount of the power-amplifier plate current.

Where the line voltage fluctuates over wide ranges the circuit of Fig. 2 is recommended. This circuit will sup-

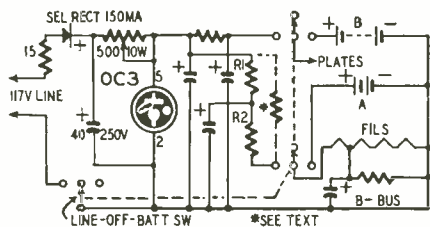

Fig. 2—Regulating tube supply voltages.

ply 105 to 107 volts d.c. to the receiver at all times. The 500-ohm series resistor is adjusted for a current of 30 ma through the regulator tube at the highest line voltage. It may be necessary to shunt the filament-dropping resistors R1 and R2 to supply the required current under the new conditions.

Fig. 1 will also compensate for low-voltage from filament batteries.—*L. H. Trent.*

NOISE IN TV TUNERS

The front ends of the RCA KRK-2 tuners used in early 630-type TV sets are supported by brackets which have a fiber bushing fitted snugly around the tuning control shaft. When the fiber wears, it often permits enough play in the shaft to cause erratic operation and noisy tuning. This is often the cause for unnecessary tuner replacement. The

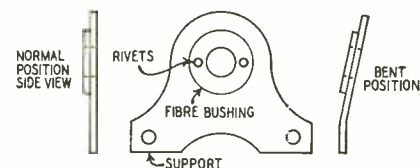

trouble can be cleared up by bending the support either in or out so it fits more snugly on the shaft. You may have to raise the shaft a few thousandths of an inch. If so, enlarge the screw holes used to bolt the bracket to the chassis, then tighten the screws while holding the support in the best position.—*Hyman Herman.*

AUGUST, 1952

Cut TV trouble-shooting time with this NEW Gernsback Library Book



128 pages
58 illustrations

Compiled from the experiences of practicing service technicians and the servicing notes of manufacturers by the editors of RADIO-ELECTRONICS

Only \$1.50

TELEVISION TECHNICAL NOTES was specially planned to save you time, money and effort in tracking down the hard-to-find troubles that crop up in TV sets. A collection of 607 actual case histories of persistent and frequent troubles found in models made by 27 manufacturers, it is probably the most valuable practical work book on television ever written! You can save yourself hours of time-consuming routine trouble-shooting by learning from manufacturers' own tips and from the hard-won experience of technicians like yourself who have run into the same bugs. For the amazing low price of only \$1.50, TELEVISION TECHNICAL NOTES gives you a priceless collection of servicing data which is bound to help you save time and show up in increased profits. Check this list of helpful features from TELEVISION TECHNICAL NOTES—then order your copy today.

Just a few of the troubles TELEVISION TECHNICAL NOTES will help you solve!

Adjacent channel interference • Horizontal jitter • Excessive picture height • Horizontal tearing or bending • Veiling • Sync buzz • Vertical foldover • Horizontal sync instability • Vertical bars in picture • Hum • Poor contrast • Insufficient width • Increasing sensitivity in weak-signal areas • Curvature at top of picture • Horizontal wiggle • Vertical roll in fringe areas • Poor vertical linearity • Vertical white bars in picture • Arcing in vertical output stage • Microphonics • Horizontal pulling • Horizontal oscillator radiation • Elimination of retrace lines • Audio buzz • Horizontal foldover • Improving

vertical sync stability • Intermittent picture tubes • Arcing • Ineffective o.g.c. • No vertical sweep • Blooming picture • Noise in picture • Loss of vertical and horizontal sync • Insufficient vertical size • No control of horizontal sync • Left-hand bulge • Unstable horizontal sync • Vertical jitter • Blacking on strong signals • Corner-cutting of picture • Improper focus • Intermittent decrease in horizontal scan • White bar at bottom of picture • Black bars at left side of picture • Horizontal drift • Vertical roll • Hula effect • Neck shadow • Intermittent horizontal tear-out • Critical contrast • Horizontal sweep sing.

Other popular GERNSBACK LIBRARY BOOKS you'll find helpful

Radio Tube Fundamentals • No. 45—\$1.00
Basic Radio Course • No. 44—\$2.25
Model Control by Radio • No. 43—\$1.00
High-Fidelity Techniques • No. 42—\$1.00
Public-Address Guide • No. 41—75¢
The Cathode-Ray Oscilloscope • No. 40—75¢

Practical Disc Recording • No. 39—75¢
Amplifier Builder's Guide • No. 33—50¢
Advanced Service Technique • No. 32—50¢
Radio Questions & Answers • No. 31—50¢
Unusual Patented Circuits • No. 30—50¢
Handy Kinks and Short Cuts • No. 29—50¢

SEE YOUR DISTRIBUTOR OR MAIL THIS COUPON TODAY

RADCRAFT PUBLICATIONS, INC.
25 West Broadway, New York 7, N. Y.

Enclosed is \$..... for which please send me, postpaid, the books checked below:

- 46—Television Technotes
 45 44 43 42 41 40
 39 33 32 31 30 29

Name.....
(Please print clearly)

Street.....

City..... Zone..... State..... 72

Don't worry about CHANNEL CHANGES

AMAZING ALL CHANNEL Reception
Replace Those Old TV Antennas

- 360° Electronically Switched Beam
 - No Motors
 - No Roof Orientation
 - No Electric Power
 - No Ghosts
- Flick of Switch Clears Picture Instantly

with the Famous **Rocket DIRECTRONIC**

MOTORLESS TV ANTENNA

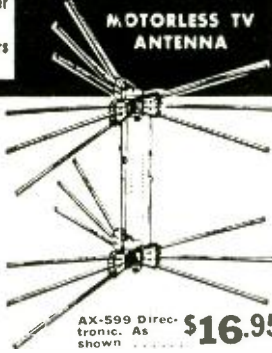

The Directronic 18-element 360° antenna is the finest for ultra-fringe or metropolitan reception. The Hi-PAC molded insulator is a material of extreme tensile strength not affected by weather or temperature, either mechanically or electrically. Included in the AX-599 "Service Men's Array" are 18 hi-tensile aluminum alloy elements. Universal U Clamps for masts to 1 1/2". Directronic Beam Selector 75 feet of Tri-X Cable. AX-59 Directronic, 6-element Single.....\$10.35

SENSATIONAL INDOOR ANTENNA

Indoor Directronic for use on ceilings, attics, closets. 360° coverage. Finest reception on all channels. No ghosts. Clearer, sharper pictures. Hidden insulation. Steadier focusing. Strongest signal. Minimum noise or interference. Beam selector switch for best picture on every channel. Kit contains three tape elements with insulator, mounting fasteners for use if needed. Directronic Beam Selector Switch, 25 feet Tri-X Cable, and Twin-X Cable Extension. Only \$5.95 complete. Model II-303

Rocket YAGI

5 ELEMENT TV ANTENNA
Excellent Pictures in Fringe Areas

HIGH GAIN. Clearer, sharper, steadier pictures in Fringe Areas. Minimum interference from ghosts and noise due to a directive pattern. Five elements include one folded dipole, three directors, and one reflector. Supplied lock mast. MATCHES 300 OHMS IMPEDANCE. Molded insulator provides additional strength. Exclusive design mast clamp prevents antenna turning or canting under any conditions. STURDY, TROUBLE-FREE CONSTRUCTION. No return calls. No broken elements. Stands the test of severest weather. Elements of extra heavy aluminum-clamped top and bottom. QUICK RIG. Completely pre-assembled. Just swing elements into line and tighten wing nuts. Simple . . . quick . . . easy. Available for any channel, high or low band.

Channels 2 or 3.....\$7.95 each
Channels 4, 5, or 6.....\$6.95 each
Channels 7 to 13.....\$3.95 each

EACH CHANNEL requires a DIFFERENT Yagi. When ordering specify exact channel number desired.

OTHER ANTENNA BARGAINS

ALL CHANNEL CONICALS.....\$3.75
Single Bay.....\$3.35
Stacked Array with Tie Rods.....\$7.40

ALL CHANNEL INLINE.....\$3.75
ALL CHANNEL FOLDED DIPOLE.....\$3.95
ALL CHANNEL DOUBLE VEE.....\$3.75

LOWEST PRICES ON TV ACCESSORIES

Mast Steel (Ductile) 5' Crimped 1 1/2" O.D.....\$1.05
Mast Steel (Ductile) 10' 1 1/2" O.D.....1.95
Mast Steel (Zinc Plated) 10' 1 1/2" O.D.....1.59
Mast Connectors for 1 1/2" O.D. Mast—10".....1.49
Chimney Mount Complete with Straps.....1.19
Peak Roof Saddle (will take up to 1 1/2" O.D.).....1.49
Lightning Arrestor—TV......69
Galvanized Guy Wire—6 strand ±20.....3/4c ft.
Galvanized Guy Wire—11 strand ±20.....1 1/2c ft.
Aluminum Guy Wire—300 ft. Reel.....4.95
Tri-X 3 Conductor Lead-In......4c ft.
300 ohm Twin Lead ±55 mil Stranded 1500' Reel.....\$8.50
300 ohm Open Line Twin Lead—500' Reel.....22.50
300 ohm Low Loss Twin Lead 100 mil Stranded......4c ft.
Mast Stand-off Insulators—3".....8.50 C
Stand-off Screw Insulators—3".....2.75 C
Stand-off Screw Insulators—7".....2.50 C

Rocket Products sold only by mail by National Electronics. Prices Subject to Change Without Notice. ALL PRICES F.O.B. CLEVELAND, OHIO. Do not remit more than complete purchase price. Pay shipping charges on receipt of goods. 25¢ deposit on C.O.D. orders, please. Money-back guarantee.

INSTALLATION PROBLEMS BOTHERING YOU Write for FREE helb. No obligation.

FREE Catalog of Bargains

TV antennas, accessories at lowest prices. Tells about our best service, free installation help, send name, address now.

National Electronics
OF CLEVELAND
THE HOUSE OF TV VALUES

208 Zelco Building Cleveland 3, Ohio

HANDY TEST PROBE

Much of my daily work in an electronic laboratory is with test leads and probes for making circuit measurements. For this work, I have made several probes like the one shown in the drawing.

We remove approximately 3/4 inch of insulation from one end of a 10-inch piece of No. 8 rubber-covered wire and then hammer and file the end to the shape shown. The other end of the lead is soldered to a brass jack designed to fit standard phone tips and the assembly is fitted snugly into a countersunk hole drilled through a 3/8-inch hard fiber or plastic rod.

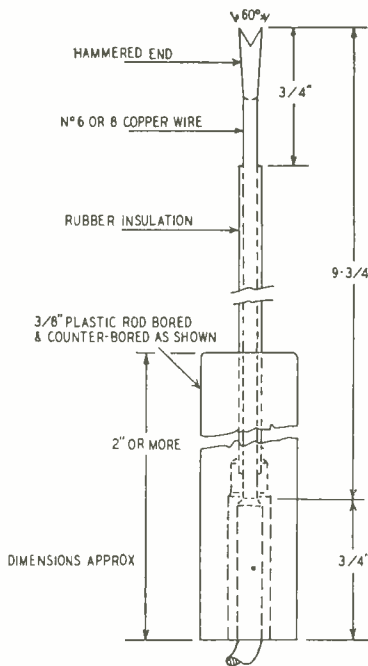

The fish-tail end of the probe straddles circuit leads like a rider on a horse so it does not require a special effort to prevent it from slipping off. The wire end of the probe can be bent as desired to reach into crowded spots on the chassis.—Wm. Oburger.

(A standard tip jack can be used as a substitute for the brass jack described by the author. This eliminates a lot of time-consuming metal work.—Editor

SODA STRAW SERVICING AID

I find that a soda straw is a good substitute for a syringe or injector for squirting carbon tet into tuners and volume controls. Place one end of the straw into the bottle of carbon tet and put your finger over the other end. The liquid will be held in the straw until you release it by removing your finger.—Jack J. Rothstein

IMPROVISED SLIDERS

When you have heavy equipment that requires a lot of moving around on the service bench, get four metal bottle caps from gallon jugs and slip them under the rubber feet of the equipment. The metal caps make good temporary casters.—B. W. Welz.

AMPERITE

Studio Microphones
at P.A. Prices

Ideal for
BROADCASTING
RECORDING
PUBLIC ADDRESS

"The ultimate in microphone quality," says Evan Rushing, sound engineer of the Hotel New Yorker.

- Shout right into the new Amperite Microphone—or stand 2 feet away—reproduction is always perfect.
- Not affected by any climatic conditions.
- Guaranteed to withstand severe "knocking around."



Models
RBLG—200 ohms
RBHG—Hi-imp.
List \$42.00



"Kontak" Mikes
Model SKH, list \$12.00
Model KKH, list \$18.00

Special Offer: Write for Special Introductory Offer, and 4-page illustrated folder.

AMPERITE Company, Inc.

561 BROADWAY • NEW YORK 12, N. Y.
Canada: Atlas Radio Corp., Ltd., 560 King St. W., Toronto

SPECIAL CLOSEOUT



WILCOX-GAY
"RECORDIO"

List — \$149.95

NOW \$69.95

Cash in on this closeout! Wilcox-Gay Recordio Model 1B10. Brand new. Factory sealed cartons. Two hours recording on 5 inch reel tape. Records from mike or phono. Plug-in for extra speaker. Has self-contained turntable—high fidelity crystal mike. Automatic stop and erasing. Weight 21 pounds. Supply limited. Order yours today.

10% cash with order

ALMO RADIO CO.

509 ARCH ST. & 6205 MARKET ST.
Philadelphia, Pa.
6th & ORANGE STS. • Wilmington, Del.
4401 VENTNOR AVE. • Atlantic City, N. J.
1133 HADDON AVE. • Camden, N. J.
219 Highland Ave. • Salisbury, Md.

\$3.00 FOR CARTOON IDEAS

RADIO-ELECTRONICS prints several radio cartoons every month. Readers are invited to contribute humorous radio ideas which can be used in cartoon form. It is not necessary that you draw a sketch, unless you wish.

Address
RADIO-CARTOONS,
RADIO-ELECTRONICS
25 West Broadway, New York 7, N. Y.

MEASURING VOICE COILS

In high-fidelity sound systems and high-power PA installations, speakers must be correctly matched to the output of the amplifier for maximum output and minimum distortion. Sometimes we are reluctant to use a speaker because we do not know its voice-coil impedance.

By using the method recommended in the *Philco Serviceman*, anyone having a scope and audio oscillator can quickly and easily measure the impedance of a speaker voice coil. The setup of equipment is shown in the diagram below.

Connect a 5-ohm resistor across the vertical input terminals of the scope and connect the a.f. oscillator and a calibrated attenuator or variable resistor in parallel across the horizontal input terminals. Set the calibrated variable resistor to 5 ohms and the oscillator to 400 cycles. Adjust the

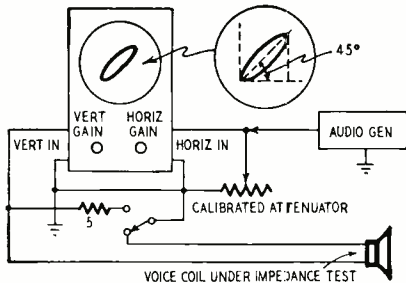

scope gain controls so the trace is a 45-degree line forming the hypotenuse of an equilateral triangle having its legs parallel to the X and Y axes of the screen. Do not touch the scope controls after you have obtained this trace.

Disconnect the 5-ohm resistor and replace it with the speaker voice coil. Adjust the variable resistor for a 45-degree line identical to the one obtained in the initial adjustment. The voice-coil impedance will be equal to the reading on the dial of the calibrated resistor.

If you don't have an attenuator calibrated in resistance, substitute a 20-ohm potentiometer and use an accurate ohmmeter to make the initial setting at 5 ohms and to measure its resistance at the final setting.

EMERGENCY POWER SUPPLY

I use a surplus DM-33-A dynamotor and a 6-volt storage battery to operate small a.c.-d.c. receivers in my car and in rural areas where power lines are not available. The low-voltage leads of the DM-33-A, a 28-volt dynamotor used on the modulator of the SCR-274-N command sets, are connected to the storage battery; the high-voltage leads are fitted with a receptacle for the receiver line cord. The output voltage is about 90 volts, enough to give good results with most small receivers. This method will not work with three-way portables having tube filaments connected in series for line operation since they usually require more than 90 volts input to operate.—*Ross L. Merryheue.*

—end—

#630 SUPER DELUXE 31-TUBE TV CHASSIS

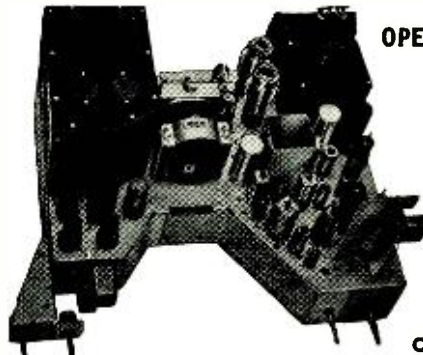

NATIONALLY KNOWN MFR.

Licensed under RCA patents

OPERATES ALL 16" TO 24" PICTURE TUBES

Engineered in strict adherence to the genuine RCA #630, plus added features ★ ★ ★ ★

NOTHING BETTER AT ANY PRICE!

- Standard Cascode Turret Tuner for DX
- Cosine 70° Deflec. Yoke for Definition
- Original 630 Synch. Chain for Stability
- 16.5 KV for Clarity and Brilliance
- Fast Action Pulse Keyed AGC
- Large Concert-tone 12" PM Speaker

COMPLETE READY TO PLAY \$167.97 with all tubes, hardware, knobs, etc. (less C.R. Tube)

FINEST STANDARD GUARANTEED PICTURE TUBES

Most desirable 4 sizes — Choice of Dumont or Sheldon with one full year guarantee.

17" \$29.63 RECT.

20" \$39.74 RECT.

21" \$44.68 RECT.

24" \$69.49 ROUND

Brooks LIFE-SIZE Edition

=630 TV KIT BUILDER - SET OF INSTRUCTIONS Compiled and Edited by...MORRIS BROOKS

Everything at a glance—LIFE SIZE

INDISPENSABLE—for building, converting, modernizing or even trouble shooting ANY #630 TV RECEIVER.

Popular priced at only \$2.49 Postpaid

#630 SUPER DELUXE 31-TUBE TV KIT

OPERATES ALL 16" TO 24" PICTURE TUBES

COMPLETE SET OF PARTS, FOR SAME CHASSIS AS PICTURED ABOVE

Complete with all tubes and the new LIFE-SIZE TV builder's instructions (less CRT and wire) \$119.44

#630 TV BASIC PARTS KIT

Totals over \$100 if purchased separately at list prices

- PUNCHED & DRILLED CHASSIS PAN
- BRACKET & SHIELD KIT (18 items)
- VIDEO & I.F. KIT (19 items)
- POWER TRANSFORMER #201T6
- VERTICAL OUTPUT TRANSFORMER
- VERTICAL BLOCKING TRANSFORMER
- FLYBACK TRANS. #211T3 or #211T5
- FOCUS COIL, #202D1 or #202D2
- DEFLECTION YOKE, 60° or 70°

ALL FOR ONLY \$39.49 Incl. the LIFE-SIZE TV builder's instructions

Hottest TV Package for "One Buck"

- Hints for Better Performance on your 630TV.
- 630TV Schematic Diagram with Modifications.
- Illustrated Television Conversion Manual.
- Pulse Keyed Type AGC Circuit Diagram.
- RMA Handy Resistor and Mica Code Charts.

ALL FOR ONLY \$1.00 POSTPAID

#630 STANDARD 29-TUBE TV KIT

COMPLETE SET OF PARTS for the FAMOUS ORIGINAL RCA #630 29-TUBE 10" to 12 1/2" CHASSIS

Complete with all tubes and the new LIFE-SIZE TV builder's instructions (less CRT and wire) \$99.99

Modernize Your #630 TV Set With a New

STANDARD CASCODE TUNER

For better all around performance

Complete with tubes, and step-by-step instruction. \$22.49

#630 TV PARTS ... TOP QUALITY ... LOW PRICES

RCA FRONT END TUNER, compl. w./tubes...	\$22.49	PUNCHED CHASSIS PAN, cadmium plated	\$4.87
STANDARD CASCODE TUNER, w./tubes...	22.49	630KIT, screws, nuts, rivets, washers...	1.69
ESUTCHEON PLATE, for either tuner...	.69	12" PM SPEAKER, heavy alnico #5 magnet	6.94
COMPLETE SET OF KNOBS, incl. decals...	1.34	TV WIRE & SOLDER KIT, for any Set...	1.49
COMPLETE SET OF KNOBS, gold inc., decals	2.49		
POWER TRANSFORMER, 295ma., 201T6...	9.97	# 630 PARTS-COMPLETE SETS	
VERTICAL OUTPUT TRANS. 208T2...	2.69	VIDEO AND I.F. KIT, 19 items...	\$7.84
VERTICAL BLOCKING TRANS. 208T2...	1.32	AGC KIT, complete with instructions...	4.59
HORIZONTAL OUTPUT TRANS. 211T3...	2.98	VARIABLE CONTROL KIT, 9 controls...	5.83
HORIZONTAL OUTPUT TRANS. 211T5...	3.98	CARBON RESISTOR KIT, 107 resistors...	6.98
FOCUS COIL, 470 ohms, 202D2...	3.42	WIREWOUND RESISTOR KIT, 4 resistors...	2.31
DEFLECTION YOKE, Cosine 70°, 206D1...	3.98	BRACKET AND SHIELD KIT, 18 items...	8.63
HORIZONTAL DISCRIM. TRANS. 208T8...	1.49	ELECTROLYTIC CONDENSER KIT, 6 cond.	7.37
FILTER CHOKE, 62 ohms...	1.47	TUBULAR CONDENSER KIT, 37 condensers	4.28
WIDTH CONTROL COIL, keyed AGC...	.79	CERAMIC CONDENSER KIT, 28 condensers	3.37
ION TRAP BEAM BENDER, (single) 203D1...	.79	MICA CONDENSER KIT, 11 condensers...	1.38
AUDIO OUTPUT TRANSFORMER (6K6)...	.69		

BROOKS RADIO & TV CORP. 84 Vesey St., Dept. A, New York 7, N. Y.

SO IMPORTANT— it was
Featured in Special Article
in
The New York Times
Jan. 28, 1952
FREE copy
of article on request

**UNIT REACTIVATES
TV PICTURE TUBES**

Small Electronic Device Tests
Sets at Home and May Add
Year or More of Use

By T. K. KENNEDY Jr.

A small electronic device that can be applied to home television receivers to test and reactivate the picture tube without removing the tube from the set, resulting in renewed brightness in many and considerably longer useful life, has been placed on the market for the first time by a New York manufacturer.

In some cases, it was said, the picture tube may be made almost as good as new and given as much as a year's useful life before replacement is necessary. The instrument is small and compact. It weighs three pounds as large as the average lunch box, costs little and is simple to operate. Picture tubes have always been a major expense item in a TV set. The average receiver has about 10 picture tubes. All of them are subject to wear and tear. The average receiver has about 10 picture tubes. All of them are subject to wear and tear. The average receiver has about 10 picture tubes. All of them are subject to wear and tear.

The almost insupportable urgency for such an instrument, which also soon may be produced in kit form for home assembly, is apparent. Eight to ten million TV picture tubes, Transvision engineers estimate, have now been in use for three to four years or more and "probably are in need of test and reactivation to renew their brightness." Unfortunately, loss of brightness, it was pointed out, seldom can be detected short of comparing the old tubes with new ones in lately produced sets. Furthermore, picture tubes in their original cartons in stores may have lost some of their brightness which has been described as "kind of aging process" to which all large cathode-ray tubes and similar devices are subject. Such tubes, in the current sizes marketed today, cost from \$25 to \$65. New picture tubes can be tested and reactivated without removing them from their cartons, and tubes in TV sets without removing the tube from the receivers. It is done by attaching a standard picture tube socket to the new instrument, by turning a switch on the



**TRANSVISION CR TUBE
TESTER - REACTIVATOR**

performs 2 vital functions:

- Tests Picture Tubes
- Renews Brightness of Dim Picture Tubes

It's a **TESTER**:

Without removing picture tube from set, you apply this precise instrument to:—

- Measure Cathode emission
- Locate shorts between elements
- Locate high resistance shorts or leakage as high as 3 megohms

It's a **REACTIVATOR**

for dim CR Picture Tubes

Revives dim TV Picture Tubes, without removal of tubes from sets. Reactivation works on tubes with low light output, if there's no mechanical break in tube. 110 V—60 cycles. Weighs only 3 lbs. One or two applications pays for instrument.

SATISFACTION GUARANTEED or money refunded if you return the instrument in 10 days in good condition.

\$19.95
NET

RUSH THIS COUPON—
TRANSVISION, INC.

DEPT. RE8 NEW ROCHELLE, N. Y.

() Send me CR Tube Tester-Reactivator(s).

() Enclosed find \$ deposit. Balance C.O.D.

() Enclosed find \$ in full. Send prepaid.

Name _____

Address _____

City _____ State _____

SQUARE WAVE OUTPUT FROM ANY AUDIO OSCILLATOR

Square-wave generators are continually being adapted for new applications. They are used in electronic switches, timing devices, and for audio and video testing. A generator which develops square waves from a sine-wave source for testing audio amplifiers and allied equipment is described in *Photo-fact Index and Technical Digest*.

In the circuit shown, an audio sine wave between 100 and 10,000 cycles is applied to the input terminal. After amplification in the first section of the 6SN7-GT, the signal is passed to the second half of the tube, which operates as a cathode follower transformer-coupling the amplified signal to the 6AL5 bias rectifier. This tube develops a d.c. signal voltage which drives the 6SJ7 grid beyond cutoff to produce a square wave in the plate circuit.

The maximum square-wave output, 75 volts at 100 cycles and 71 volts at 1 kc, is sufficient to check a single stage in a conventional amplifier. A 4-volt sine wave on pin 1 of the 6SN7-GT de-

velops maximum output at 100 cycles. At 1 kc, 3.4 volts is required to develop the rated output.

The transformer is an interstage audio unit having a step-up turns ratio of 2.6 to 1. The unit which was used has a primary resistance of 1,120 ohms, which provides just enough bias to limit the cathode-follower plate current to 10 ma. If the d.c. resistance of the primary is less than 1,100 ohms, make up the resistance by connecting a suitable resistor in series with the grounded side of the primary and bypass the resistor with a 10- μ f, 25-volt capacitor. The 27,000-ohm resistor across the secondary reduces spurious pips and traces on the waveform by damping out shock oscillations in the transformer. The correct value may have to be determined experimentally for each transformer.

The generator draws approximately 40 ma from a 275-volt source. The supply should be well filtered to prevent hum from affecting the waveform at low frequencies.

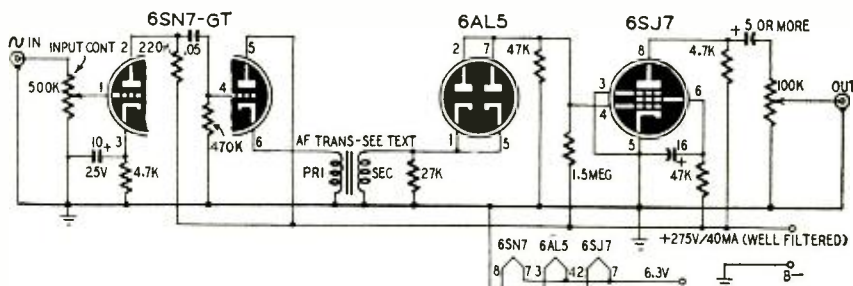

POWER SUPPLY HAS AUTOMATIC REGULATION

A regulated power supply which delivers B voltages and currents at levels usually encountered in average receivers and amplifiers is a useful instrument in a radio-TV service shop or electronic laboratory. A supply of this type which also includes a 300-volt regulated bias supply and a 1-kv negative source for C-R tubes is a much more valuable instrument because of its versatility. Such a supply is incorporated in a TV test instrument described in *TSF Pour Tous* (Paris, France).

The circuit, with minor variations, is

shown in the diagram. It delivers 300 volts regulated at current drains up to 200 ma, 300 volts negative bias at up to approximately 18 ma, and 1,000 volts with negligible load. The 5V4 or 5Z3 is a full-wave rectifier. The 6L6's and 6J7 regulate the voltage delivered by this rectifier. The bias supply uses a single 6X5 half-wave rectifier supplied from one side of the high-voltage winding on the power transformer. Voltage is regulated at 300 volts by the series-connected OD3's. The 10,000-ohm series resistor may have to be varied

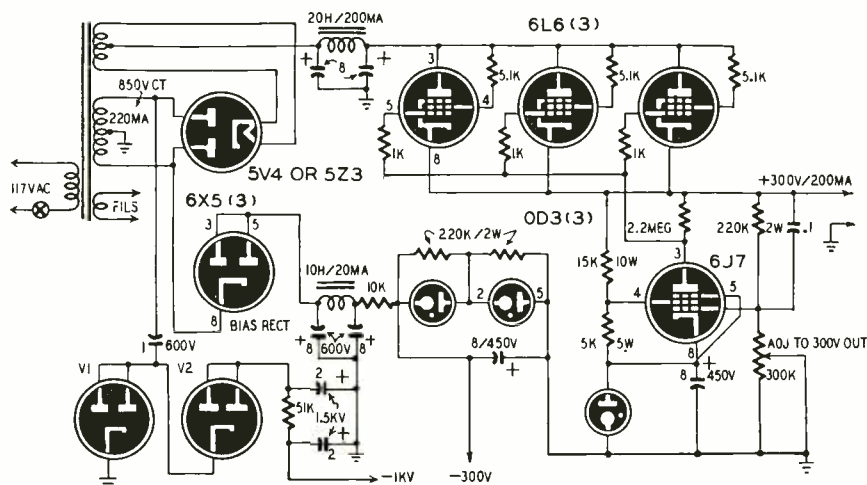

slightly so the two 0D3's draw 10-12 ma.

One thousand volts negative is developed by a half-wave voltage doubler circuit connected to the opposite end of the high-voltage secondary. With light loading, the voltage developed on the input filter capacitor is approximately twice the peak voltage across one-half the high-voltage secondary.

The power transformer should have several 6.3-volt filament windings. One is rated at 5 amps or more for external circuits and the heater of V1. Two 600-ma windings are for the bias rectifier and V2. The winding for the latter tube should be insulated for 2 kv or more. Two additional windings rated at 3 amps and 300 ma are for the 6L6's and 6J7, respectively.

MINIATURE AUDIO AMPLIFIER

The schematic shows the circuit of a compact audio amplifier which is designed for listeners who would like to play their FM tuners through something better than the audio system of the average radio receiver. The unit has good volume and fidelity. It drives a 15-inch speaker with clean tones and no discernible hum, even at low volume levels.

Good low-frequency response is assured by the large coupling and decoupling capacitors, inverse feedback from plate to grid of the output stage, and the equalizer in the input circuit.

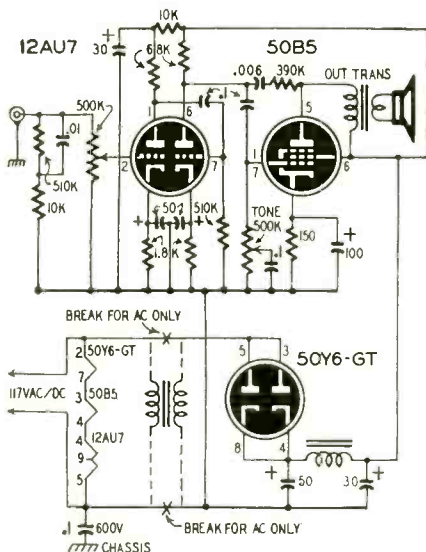

The amplifier can be constructed on a chassis approximately 5½ inches square. For the filter choke, we used the primary of a small surplus head-phone transformer. A small a.c.-d.c. type filter choke can be used if you make the chassis larger.—Paul J. Aschert

(This amplifier is designed to operate from a.c. or d.c. lines. If you plan to use it on a.c. only, it is advisable to install a half-wave power transformer to isolate it from the power line. Break the connections at the points indicated and connect the transformer as shown by the dashed lines.—Editor)

TV DIRECT FROM THIS GREAT FACTORY TO YOU
BRINGS YOU
Finest Quality at Lowest Prices



TRANSVISION
TV KITS, WIRED CHASSIS, and SETS
CABINETS, COMPONENTS, INSTRUMENTS, and ACCESSORIES
NEW LOW PRICES
on top quality TV Picture Tubes.

• FREE—VALUABLE PREMIUMS:

With every Transvision tube you buy, you get a Merchandise Premium Coupon of real value. Write for list today.

• TRADE-IN ALLOWANCE on old tubes: Make from \$2.50 to \$5.00 glass allowance on each "dud."

• FULL 2 YR GUARANTEE:

Only Transvision gives you a Guarantee for 24 months.

COMPARE: Get the full details on the Transvision tube deal today.

FREE BOOKLET: "INSIDE CRT, or What You Should Know about Picture Tubes". Written by CRT experts, illustrated. It will MAKE MONEY FOR YOU. WRITE FOR IT.



New... TRANSVISION Picture Tube PRICES

Tube Type	Cost WITH GLASS allowance	Cost WITHOUT GLASS allowance
10BP4	\$13.80	\$13.80
12Y6 Glass (any type)	13.45	15.75
12Y6 Metal (any type)	13.35	15.25
14RP4	16.50	18.25
16" Metal (any type)	19.90	23.20
16" Round or Rect. (any type)	18.90	22.25
17BP4	18.90	22.25
19" Metal or Glass (any type)	23.95	28.95
20CP4	23.95	31.95



SPECIAL!



REMOTE CONTROL TV CHASSIS

Here's the finest buy in Remote Control TV. Unit is all-electronic; no troublesome mechanical parts. Gives complete operating control of set. Plus—the latest Transvision A-4 Wired TV Chassis; completely aligned; ready to plug in. Has AFC and AGC. Top quality reception, even in fringe areas. 17" A-4 TV Chassis, remote control, and CRT...net \$199
20" A-4 TV Chassis, remote control, and CRT...net 219
With Du Mont Tuner and FM radio, add... 10

BEAUTIFUL TV CONSOLES

Ideal for Custom-Building or Conversion. Factory prices start from \$49. Send for Cabinet Catalog now.

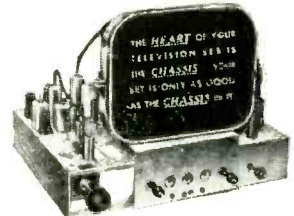

FIELD STRENGTH METER AT NEW LOW PRICE

Improve TV installations; save half the work with the Transvision Field Strength Meter. Especially good for fringe areas—measures field strength as low as 10 microvolts. **\$59 net**
Model FSM-1, complete with tubes...



U. H. F. ADAPTERS

will be available for all Transvision Sets and Kits.
Write for Factory Agent Plan

MULTI-SET CONNECTORS

feed up to 5 TV Sets from 1 Antenna
Prices: Multi-Set Conn. for 2 sets... \$4.95 list*
For 3 or 4 sets... 7.95 list*
*Dealers, write for discounts

FREE: EXTRA INCOME EVERY MONTH from hints in "TV and Electronics Notes." Request sample copy, plate and mailing for FREE subscription. Monthly issues are gold mines of info on New Products, Sales, Service, Conversion, etc. **WRITE DEPT. RE8 TODAY!**

TRANSVISION, INC. NEW ROCHELLE, N. Y.

**GOING OVER BIG—NEW
DAVIS SUPER-VISION**

**ALL-CHANNEL ANTENNA
FOR FRINGE AREA or DX**
with ELECTRONIC DIPOLE SEPARATORS

**"THE ONLY TV ANTENNA SOLD WITH A
MONEY-BACK GUARANTEE"**

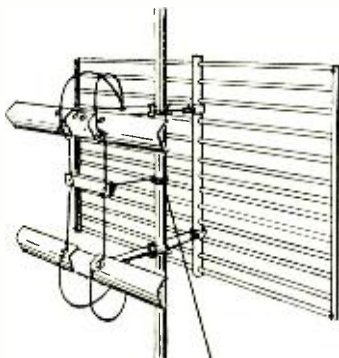

10 OUTSTANDING FEATURES:

1. EXCELLENT FOR FRINGE AREA and DX RECEIVING—and broad band receiving with high gain on all channels—2 through 13.
2. CLEARER PICTURES UP TO 125 MILES OR MORE—from the station.
3. GHOST PROBLEMS REDUCED or eliminated due to excellent pattern.
4. PROVIDES 10 DB OR MORE GAIN ON HIGH CHANNELS where gain is needed most.
5. EXCELLENT FRONT TO BACK RATIO on all channels. Eliminates co-channel interference.
6. MINIMIZES INTERFERENCE: Airplane Flutter—Diathermy and Ignition—F.M.—Neon Signs—X-Ray—Industrial—Etc.
7. ELIMINATES DOUBLE STACKED ARRAYS, and out-performs 2 bay yagis on low band and 4 bay yagis on high channels.
8. ONLY ONE TRANSMISSION LINE NECESSARY.
9. NO WORRY OVER POSSIBLE CHANNEL CHANGES on either high or low channels.
10. CAN BE TIPPED WITHOUT TILTING MAST to take advantage of horizontal wave lengths.

AT YOUR JOBBERS, OR WRITE TO:

DAVIS ELECTRONICS 1-14
4313 West Magnolia Blvd., Burbank, California

SIRS: RUSH INFORMATION TO ME AS CHECKED BELOW:

Send Free Technical Data on new SUPER-VISION ANTENNA.

Send Name and Address of NEAREST JOBBER.

Name _____
Street _____
City _____ State _____

EASY TO LEARN CODE

It is easy to learn or increase speed with an Instructograph Code Teacher. Affords the quickest and most practical method yet developed. For beginners or advanced students. Available rates for beginner's alphabet to typical messages on all subjects. Speed range 5 to 40 WPM. Always ready—no QRM.



ENDORSED BY THOUSANDS!

The Instructograph Code Teacher literally takes the place of an operator-instructor and enables anyone to learn and master code without further assistance. Thousands of successful operators have "acquired the code" with the Instructograph System. Write today for convenient rental and purchase plans.

INSTRUCTOGRAPH COMPANY

4701 Sheridan Rd., Dept. RC, Chicago 40, Ill.

FOR AUDIO AND I.F. CIRCUITS

This simple signal tracer has two tuned channels for tracing signals and aligning broadcast receiver i.f.'s, and an input circuit for tracing and probing in audio circuits. The tuned stages consist of two 6SK7 amplifiers with 175- and 456-kc i.f. transformers in their plate circuits. The secondary of either transformer can be switched to the detector diodes of the 6SQ7 detector and first a.f. amplifier.

After aligning the tracer's transformers with an accurate signal gener-

ator, it can be used to trace a signal from the mixer plate to the second detector in receivers using 175- or 456-kc i.f.'s. Smaller receivers can be aligned without using a signal generator. Switch the tracer to the proper i.f. and connect its input to the i.f. output of the set. Adjust the set's i.f. trimmers for maximum output from the tracer's speaker. Plug a shielded lead into the audio jack for audio-signal tracing.—B. W. Welz

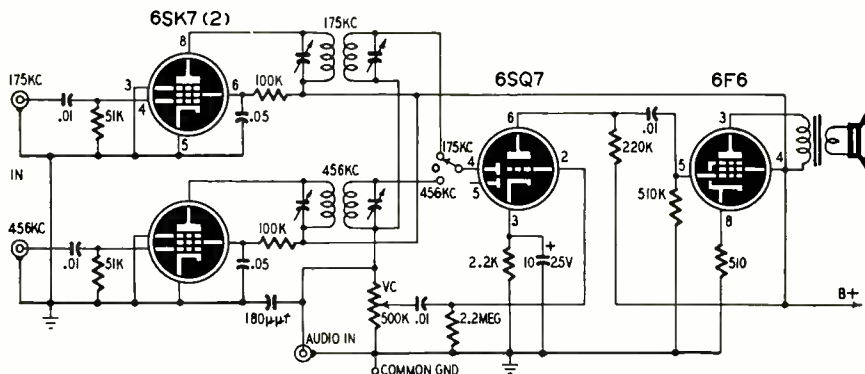

PORTABLE G-M COUNTER

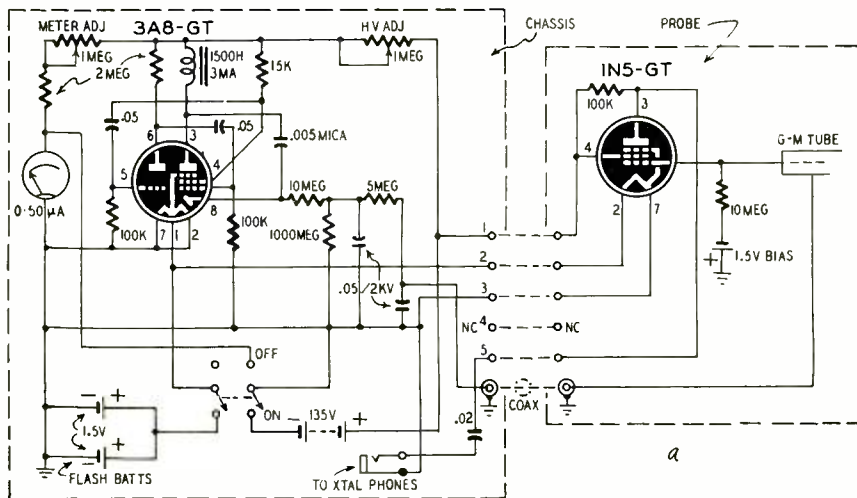

A supersensitive G-M counter, designed especially for detecting contamination where beta and gamma activity is near background level is described in bulletin MDDC 1502, published by the United States Atomic Energy Commission and sold for ten cents per copy by the U. S. Government Printing Office, Washington, D. C.

The instrument, called the "Clinton Walkie-Talkie," consists of a 9 3/16 x 7 x 3 7/8 inch case to house the batteries and a multivibrator-type high-voltage supply, and a probe housing a Eck and Krebs G-M tube and IN5-GT amplifier tube. The circuit is shown at a.

The triode and the screen-grid section of the pentode in the 3A8-GT form a symmetrical flip-flop multivibrator with a frequency of about 100 cycles. Each time the pentode section is cut off a positive pulse of several thousand volts appears across the 1,500-henry choke. This is rectified by the diode section

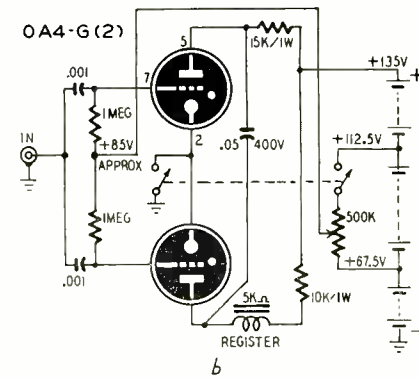

and filtered to give about 1,500 v.d.c. The scale-of-two counter shown at b may be used as an indicator in place of crystal headphones. The register is a 5,000-ohm unit made by Cyclotron Specialties Co. of Moraga, California.

VOLTAGE DIVIDER DESIGN

The design of a divider for a v.t.v.m. is not difficult but it may become confusing unless a system is followed.

A	B	C
VOLT RANGE		DIVIDER
5	10 MEG	
10	5 MEG	5 MEG
50	1 MEG	4 MEG
100	500K	500K
500	100K	400K
1000	50K	50K
		50K

First list the desired voltage ranges in column A, starting with the lowest range. Next fill out column B, writing down the total divider resistance at the top. Under this are numbers which are inversely proportional to the corresponding voltage ranges. For example, if the next range is 5 times as large, the corresponding column B number is $\frac{1}{5}$ the preceding one.

When the first two columns are finished, start column C. The numbers in this column are the differences between consecutive numbers in column B. When column C is finished it gives the individual divider resistances in megohms from the hot terminal to ground.—I. Q.

MEASURING INDUCTANCE

If you use this circuit arrangement for measuring the inductance of audio-frequency chokes and transformers, you need no longer pass up a good-looking surplus choke or transformer just because its value isn't given.

Connect the circuit up like this: The input is connected to a source of approximately 6 volts at 60 cycles

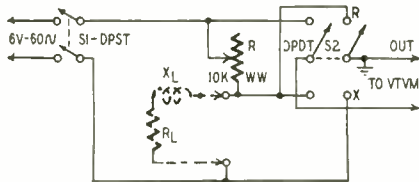

through S1. This voltage appears across resistor R and the unknown inductance in series. The 10-volt range of an a.c. v.t.v.m. is connected across the output terminals. S2 is then flipped rapidly back and forth while R is adjusted until the meter reading does not change as the switch is thrown between the two positions. The voltage drops across R and the coil are equal so the impedance of the coil equals R.

Open S1, switch the meter to the ohms range, and record the resistance readings with S2 in the R and X positions. The inductance of the coil is now calculated from the formula

$$X_L \text{ (in henries)} = \frac{R^2 - R_c^2}{377}$$

where R is the resistance of the resistor and R_c is the resistance of the coil.

You can measure the capacitance of large paper and mica capacitors by using the same setup. In this case, the resistance of the capacitor will be very high and can be ignored. The capacitance in microfarads equals 1,000,000 divided by 377R.—Paul S. Lederer

—end—

outsells all others combined

MODEL 260 VOLT-OHM-MILLIAMMETER

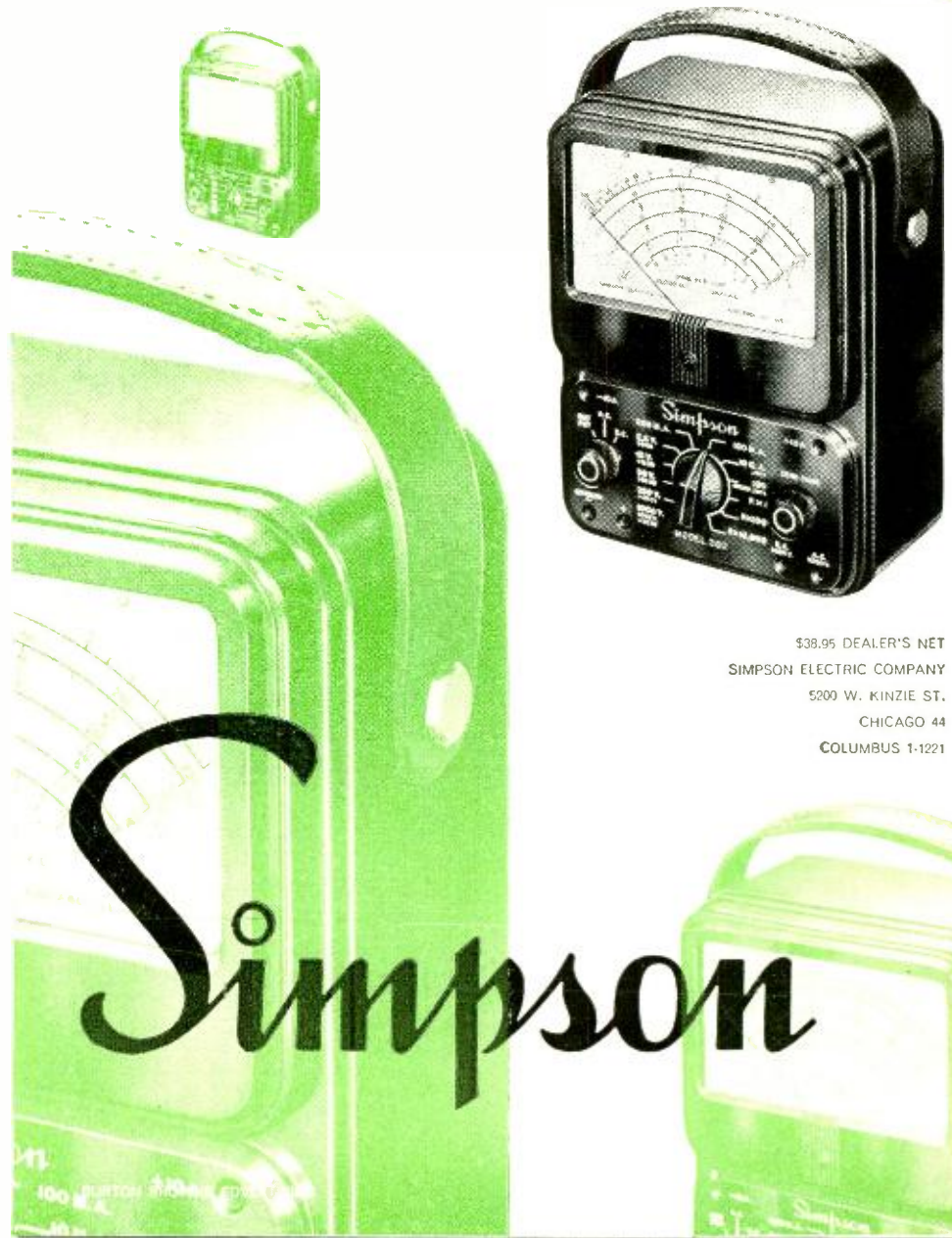

\$38.95 DEALER'S NET
SIMPSON ELECTRIC COMPANY
5200 W. KINZIE ST.
CHICAGO 44
COLUMBUS 1-1221

So You Want To Be A Writer!

That idea you may have for writing a technical book is absolutely no good unless you do something about it. If you're dying to reveal all you know about TV; if you feel the world is wasted without your words on servicing, or if you nurture a secret ambition to out-theorize all the books on TV theory, then start your writing career by writing to us. Just send us a letter outlining your ideas. Our reply will contain a copy of our author's guide and details of royalty payments.

Book Dept.
RADCRAFT PUBLICATIONS, INC.

25 West Broadway
New York 7, N. Y.

*class-B audio stage that I have.—
E. W. S., New York, N. Y.*

A. The circuit shows the r.f. stages and power supply. You can wind your own coils or use commercial plug-in units. L1 and L2 consist of approximately 30 turns of No. 22 enameled wire spaced to 1½ inch on a 1½-inch form. L3 is 30 turns of No. 14 wire, 2½ inches in diameter and 3½ inches long with a tap at the center. L4 is 1-5 turns of No. 14 wire wound around the center of L3. The exact number of turns depends on the impedance of the antenna transmission line.

With 1,250 volts on the plate of the 811, the plate current should not exceed 140 ma. Assuming that the stage is about 75% efficient, the r.f. power output will be approximately 132 watts.

V.H.F. INDUCTOR DATA

? *I need winding data for a series of coils for tuned circuits in the range of 30 to 300 mc. Can you supply winding data? How can I be sure that the coils and capacitors are tuned to the desired frequency?—A. C. F., Greensboro, N. C.*

A. You have not specified the value or range of the capacitors you plan to use with the inductors. For 30 mc and above, slug-tuned coils are often ideal for receivers, signal generators, and low-power transmitter stages since you can vary the inductance over a fairly wide range to compensate for stray inductance and capacitance. In some cases, you will be able to tune to the desired frequency by using the variable inductance and tube and wiring capacitance.

There are several commercial coils which can be used to cover frequencies in the 30-300-mc range. Cambridge Thermionic Corporation's LS-3 type 30-mc coils cover a range of approximately 15 to 50 mc and 27 to 90 mc depending on the position of the slug when tuned with a 10-100-µf capacitor. The 50-mc coil tunes from 48 to 144 and 60-190 mc with a 10-100-µf tuning capacitor. AR-2 and AR-5 coils made by The National Company cover from 75 to 220 mc and 37 to 110 mc respectively when used with 10-100-µf capacitors. The J. W. Miller Company has a set of antenna, r.f., and oscillator coils for use in receivers in the 110-235-mc range.

The simplest method of tuning a coil to the desired frequency with a given capacitance is to use a grid-dip meter which covers the desired range. If you don't have one and the frequency you want to reach is within the tuning range of your TV, FM, or v.h.f. receiver, you can connect the tuned circuit as an antenna trap. Insert the coil and capacitor combination in series with the antenna lead if the circuit is parallel-tuned, or across the antenna terminals of the set if the circuit is series-tuned. Adjust the inductance and capacitance for minimum signal pickup.

Coils for frequencies above about 225 mc are very critical. You can start with a simple hairpin loop or a 1 or 2-turn coil and vary its size until you get the inductance you need.

MODEL 480 GENESCOPE

Simpson

RECOMMENDED

by service managers of leading manufacturers:

- | | |
|-----------------------|----------------------|
| <i>don anderson</i> | <i>hoffman</i> |
| <i>frank smolek</i> | <i>zenith</i> |
| <i>floyd makstein</i> | <i>emerson</i> |
| <i>norm cooper</i> | <i>hallicrafters</i> |
| <i>max schinke</i> | <i>admiral</i> |
| <i>tim alexander</i> | <i>motorola</i> |

\$395 dealer's net

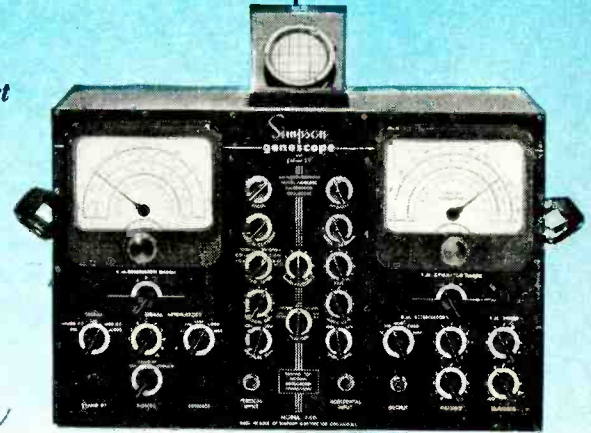

Simpson

SIMPSON ELECTRIC COMPANY, 5200 W. KINZIE ST., CHICAGO 44, COLUMBUS 1-1221

BURTON BROWNE ADVERTISING

NEW! MOSLEY WALL-THRU



For TV, FM and Amateur Transmission Line

- Fits Any Wall Up To 13" Thick!
- Completely Weather-Proof!
- For Standard Flat 300 Ohm Line or RG-59/U Co-ax Cable!
- MOSLEY Lead-In Socket Can Be Mounted Direct To Inside Plate!
- Precision Molded Polystyrene End Plates!
- Easily, Quickly Installed!

Cat. No. 625
List Price \$1.95

Cat. No. 625-PK WALL-THRU, complete with MOSLEY Universal TV Lead-In Socket and Plug.
List Price \$3.00

MOSLEY ELECTRONICS

2125 Lackland Road Overland, Missouri

Standard Brands
Individually Boxed
TUBES
PRICES SLASHED

0Z4	.45	6BD6	.45	12AU6	.46	50B5	.47	6AG7	.84	6L6G	.81
1T4	.55	6E6	.46	12BA6	.43	50C5	.48	6AH6	.75	6S4	.42
1T5	.64	6BG6G	1.49	12BE6	.48	50L6GT	.50	6A57G	2.88	6SC7	.48
1X2A	.63	6BC6GT	.90	12BH7	.63	183GT	.63	6AX5GT	.40	6SF5	.51
3Q5GT	.63	6CE6	.53	12SA7GT	.50	1N5GT	.55	6B4G	.95	6SH7	.59
5U4G	.40	6J5GT	.40	12SJ7GT	.47	1R5	.54	6BA7	.65	6SJ7	.47
5Y3G	.28	6J6	.63	12SK7GT	.50	1S4	.53	6BF5	.55	6SL7GT	.65
6AG5	.53	6K6GT	.39	12SN7GT	.55	1S5	.45	6BM6	.60	6SR7	.38
6AK5	.95	6SA7	.45	12SQ7GT	.45	1U4	.55	6BJ6	.50	6SS7	.48
6AL5	.40	6SN7GT	.52	19BG6G	1.39	1U5	.45	6BN6	.81	6T8	.75
6AQ5	.46	6SQ7GT	.45	25AV5GT	.83	3A5	1.06	6C4	.39	12AU7	.52
6AR5	.35	6V6GT	.51	25BQ6GT	.90	3O4	.60	6C5	.51	12SG7	.52
6AS5	.48	6W4GT	.49	25L6GT	.47	3S4	.57	6CD6G	1.55	19T8	.75
6AT6	.36	6W6GT	.50	35B5	.47	3V4	.58	6D6	.65	25Z6GT	.41
6AU6	.41	6Y4	.35	35C5	.47	5T4	1.08	6E5	.66	117N7GT	1.09
6AV5GT	.87	6X5GT	.35	35L6GT	.47	5V4G	.73	6F5	.48	117P7GT	1.09
6AY6	.36	12AL5	.48	35W4	.31	6AB4	.46	6F6GT	.48	117Z3	.42
69A6	.43	12AT6	.40	35Z5GT	.30	6AC7	.80	6H6	.49	17BP4	19.50
6BC5	.53									20CP4	24.50

Many other types equally low priced—Include all your tube needs with your order.

One of the largest stocks in the country
 Terms: DEDUCT 2% when enclosing full payment with order; C.O.D.'s, 25% with order;
 Min. Order: \$25.00; F.O.B. New York City.
 All Merchandise subject to prior sale.

TeleVision Materials Corp.
 120 LIBERTY ST., NEW YORK 6, N.Y. • COrtlandt 7-4307

Over 43,000 Technicians Have Learned
**HOW TO GET THE MOST OUT
 OF BASIC TEST EQUIPMENT**
 Why Not You, Too?

SERVICING by SIGNAL SUBSTITUTION
 A BEST SELLER FOR OVER 9 YEARS! (NEW, UP-TO-DATE, 12TH EDITION)

The Simple, Modern, Dynamic Speed Approach To Receiver Adjustment and Alignment Problems, AM-FM-TV.

- Nothing complex to learn
- Universal—non-obsolete
- No extra equipment to purchase
- Employs Only Basic Test Equipment

Ask for "S.S.S." at your local Radio Parts Jobber or order direct from factory.

PRECISION APPARATUS COMPANY, INC. • 92-27 Horace Harding Blvd., Elmhurst 4, N. Y.

only 40¢

100 pages. Invaluable information that will help you re-double the value of your basic test equipment.



PICKERING EQUALIZER PREAMP

? I have a Pickering model 120M cartridge in a Webster record changer. I find that I must use a preamplifier and equalizer when using this cartridge with the audio system of my radio. Please prepare a diagram of a simple circuit for this purpose, using a miniature tube if possible.—F. R., Columbia. S. C.

A. The circuit of the Pickering model 125H preamplifier-equalizer is shown in the diagram. You can substitute a 12AX7 for the 6SL7-GT used in the

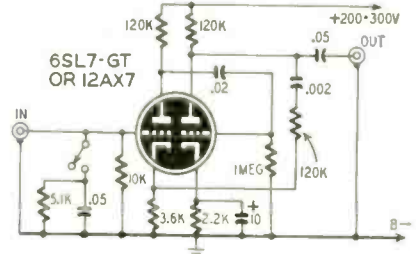

original model. The response of this circuit is approximately flat from 500 to 20,000 cycles with a rise of 6 db per octave below 500 cycles with the switch open. Closing the switch causes the highs to roll off at the rate of 20 db per octave above about 4,000 cycles.

High-grade resistors and capacitors minimize circuit noise. Use wire-wound resistors for the plate loads (120,000 ohms) and for the 3,600-ohm cathode resistor. Use shielding and a compact layout to reduce hum pickup. Noise and hum level of various tubes vary over comparatively wide levels. Hand-pick the tube for low noise and hum.

Pickering also makes a similar preamplifier with built-in power supply (model 230H); and the 132E record compensator, with six h.f.-rolloff curves. (The plate resistors may be made up of two 56,000-ohm (or 51,000-ohm) resistors in series, as higher ohmages are available only in expensive high-wattage ratings.—Editor)

—end—



Regency



Largest Selling Booster

LOOK TO
FRETLINE
REG. U.S. PAT. OFF.
FOR LEADERSHIP

IN OPEN WIRE TRANSMISSION LINE

- 1/10 the loss
- Lifetime Installation
- Clearer Pictures
- New low Price

FRETCO
 INCORPORATED
 1041 Forbes St. • Pittsburgh 19, Pa.

Operate 2 sets from 1 Antenna
 with the
TELEMATIC
ADD-A-SET
 TV Receiver Coupler

SAVE
 money! labor!
 materials!

- Highest efficiency transformers used.
- Operates in fringe areas.
- High pass filter action.
- No inter-set coupling.
- Eliminates soldering, screw terminal.
- Compact, mounts inside cabinet.

Sold by leading Jobbers Everywhere
 Send for FREE booklet on TV INTERFERENCE

TELEMATIC
ONE JORALEMON ST. BROOKLYN 2, N. Y.

AUGUST, 1952

RE: INTERMITTENT GHOSTS

In the "Television Service Clinic" of the March, 1952, issue, a reader inquired as to the cause of intermittent ghosts in the Techmaster 630 type receiver. I had this trouble in my Techmaster 630 and traced it to an intermittent plate-coupling capacitor between the first and second video i.f. amplifiers. This trouble can be caused by leaky or intermittent coupling capacitor anywhere in the video i.f. strip. I suggest that he get some high-quality 270- μ f capacitors and replace those now in the set.—*E. F. Scheer*

(We received several phone calls from readers who advised us that the condition was probably caused by intermittent coupling capacitors. It seems that this trouble is common to many 630-type sets.—*Editor*)

UNUSUAL SERVICING TROUBLE

An RCA model 87K1 that came in for repairs exhibited every sign of a defective volume control. Moving the control knob even a short distance caused a terrific scratching sound and the volume would shift erratically from high to low. I doubt that any service technician would have hesitated to order a new volume control. That's what I did. But, I first decided to check the tubes. Two, the 6P5 and the 6H6 a.v.c. tube, were a bit weak. We replaced them and then turned on the set to note the performance. When the set came on it played like new; volume was high, tone quality was excellent. Not a sign of scratchiness was evident in the volume control. It was as silent as a tomb over the entire length of travel; not a trace of noise could be heard from it.

More than a little puzzled by the error in my original diagnosis, I replaced the old tubes and tried the volume control again. Sure enough, there it was—the scratching was just as bad as ever! We never found out why two weak tubes could cause a condition with all the symptoms of a defective volume control, but we do know that replacement of the volume control was completely unnecessary.—*Joseph Amorose*

1950 SPARTON SETS

Late in 1950, the shortage of resistors made it necessary to use resistors which were improperly color-coded. These units meet all specifications except color identification markings and were inspected at the factory to insure proper resistance. Therefore, if it is necessary to replace a resistor in one of these sets, please refer to the schematic diagram for the correct resistance value.—*Sparton Service Bulletin*

SERVICING TV SETS

When servicing a TV set, be sure to check the 5U4-G rectifier socket before turning the set on end or on its side to get at the under side of the chassis. Pins 1 and 4 must be in the vertical plane or the filament is likely to sag and short to the plate, thus causing the tube to blow out. I had the sad experience of blowing a couple of new tubes before I realized the source of the trouble.—*Paul Trinkle*

here's transformer news!

TRIAD
 TRIAD TRANSFORMER MANUFACTURING COMPANY
 1205 ANGLETON AVE., CALIFORNIA, U.S.A. CATALOG TR-52

TRIAD
CATALOG TR-52
 featuring:

- "HS" (hermetically sealed) transformers to MIL-T-27 specifications
- High quality Audio transformers
- 400-cycle Power transformers
- "TRIJET" Miniature transformers
- Toroids
- General Purpose transformers for television and radio replacement
- Geophysical transformers
- Amplifier Kits

Write for Catalog TR-52 today
 or pick up your copy at
BOOTH 1201
WESTERN ELECTRONIC
SHOW & CONVENTION
 Long Beach, California
 August 27-28-29

TRIAD
 TRANSFORMER MFG. CO.

Plant, General Offices: 4055 Redwood Ave.
 Venice Area, Los Angeles, Calif.
 Address correspondence to: Box 17813
 Los Angeles 34, Calif.

ARCING IN OLYMPIC TV SETS

Unusually high humidity and heat may cause arcing and corona discharge on the underside of the 1B3-GT socket assembly. This condition may be corrected by the following procedure:

1. Procure ceramic insulator kit. (Part number SB51-13)
2. Remove screws holding high-voltage cage to chassis; remove tube clip leads and high-voltage clip lead. It is unnecessary to unsolder any leads.
3. Turn cage over. Remove two screws holding bakelite plate to side of cage and mount two ceramic insulators to plate. Fasten two spade bolts to opposite ends of ceramic stand-offs and mount assembly to end of cage

in approximately the same former position.

4. Solder the tube-socket retainer ring to the nearest corona button. Reassemble cage to chassis.
5. Check rubber cover on high-voltage capacitor and on second-anode lead for dust and moisture. Dress leads carefully.

Olympic Television Service Bulletin

ADMIRAL 30A1 TV CHASSIS

Hum or black bars across the picture can be caused by a faulty input filter capacitor in the B supply feeding the video and sweep circuits. This capacitor, connected to the 5U4 side of the 2-henry filter choke, should be replaced with a 40- μ f, 450-volt unit.—*Wilbur J. Hantz*

DU MONT RA-103 TELESETS

Separation of sound and picture, accompanied by a strong hum on either side of the sound center frequency, has been the complaint on several of these sets. In each case the trouble was traced to a shorted .0068- μ f screen bypass in the first 6AG5 picture i.f. amplifier. Replacing this capacitor clears up the trouble.—*A. D. Marikle*

CHECKING AUTO-RADIO FUSES

Visual inspection of auto radio fuses will not always tell you if they are bad, because some of them blow out at one end instead of in the center. Test the fuse with a low-range ohmmeter because just a few ohms of resistance in the fuse will allow a good vibrator to operate but will not supply proper heater voltages.—*Peter J. Foradas*

SERVICING 3-WAY SETS

Many of us tend to underestimate the value of a variable-voltage line transformer when servicing three-way portables. One of these sets was brought in because it had stopped playing while being operated on the power line. It didn't play in the shop until we replaced the 1R5 oscillator tube. We returned the set to its owner after allowing it to play normally for a few hours. The next day, the set was returned with the same complaint. It had stopped playing during the day and had been left turned on and plugged into the line. It started to play again in the middle of the night and woke up the whole family.

Plugging the set into the output of a variable-voltage line transformer, we found that it would not start to operate until the line voltage reached 120 and would cut out again when the voltage dropped to about 115.

The trouble was cleared up by substituting a 75-ma selenium rectifier for the 50-ma unit in the set. Apparently the original did not pass enough current at normal line voltages, although its forward and backward resistances checked o.k. on an ohmmeter.—*Walter Stern*

MOTOROLA AUTO RADIOS

Replacing the cloth cover of the speaker grill with a well-grounded copper screen often eliminates ignition noise and similar interference which may enter the set through the speaker opening. This practice is equally useful in other models having the speaker mounted in the receiver cabinet.—*O. C. Vidden*

SERVICING TV INTERMITTENTS

Many compactly-built TV receivers develop intermittents only after the set has heated up during several hours of operation. The intermittents seldom appear when the set is removed for servicing because the added ventilation prevents the temperature from rising to the point where intermittents begin.

Mr. Richard Wiseman, of Tomaso's Inc., 7115 West Grand Avenue, Chicago, Ill., has found a practical solution to the problem. He simply uses a home

RADIO-ELECTRONICS

the BIG 10

fabulous
10 element
Yagi

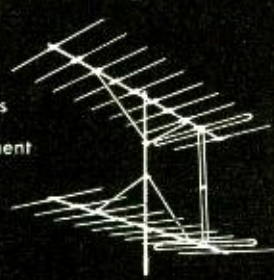

- The highest gain Yagi in TV history: 12 DB single, 14½ DB stacked (78% stacking gain).
- "Boom Braced" (low band) to prevent picture flicker.

600 Series
5 element
Yagi

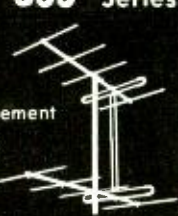

- Highest gain of any 5 element Yagi: over 9 DB single, 12 DB stacked.
- Full 100% stacking gain!

do
you
get
these

Major Benefits

in your present TV installations?

1. Adjustable impedance eliminates mismatch to 300 ohm line in single and stacked arrays.
2. Wider spaced elements, on longer cross-arms, for still higher gain.
3. Up to 100% additional gain in stacking.
4. And you don't pay for stacking bars!

4

major benefits are provided by Channel Master Z-Match Yagis which are essential to better, more profitable fringe installations. No other Yagi gives you any of them! However, in the Z-Match Yagi, you get all 4 features — at no extra cost.

Write for new catalog

List Prices

Ch.	600	BIG 10
7-13	7.65	13.89
2-3	17.65	31.94
4-5	16.67	28.47
6	16.67	25.69



CHANNEL MASTER CORP.

ELLENVILLE, N. Y.



Finest Hobby of All
AMATEUR RADIO
 It's Easy to Begin With This
NOVICE TRANSMITTER & POWER SUPPLY KIT
 A Real Value For The Beginner!
\$29.40

- Easy To Operate!
- Easy To Assemble!

POWER INPUT 25 WATTS
2 BAND OPERATION

Features: Untuned Pierce type crystal oscillator. Oscillates freely with any type crystal. Tuned output amplifier with pi type tuning system. Works with simple single wire antenna. No meters required for tuning and loading. Complete with tubes standard key and foolproof pictorial wiring diagrams. Operates on 3.7 Mc to 3.75 Mc and 26.96 Mc to 27.23 Mc. Order Philmore Model NT 200. Complete, less crystals.

Address Orders to Dept. RE-8
 Write For FREE FYI Bulletin

WHOLESALE RADIO PARTS CO., Inc.
 311 W. Baltimore St.
BALTIMORE 1, MD.

220-110 V AC STEP-DOWNS

WATTS	PRICE
250	\$5.95
300	7.49
500	10.95
1000	19.95
1500	24.95

Universal POWER XFMRs

Vibrator Input: 6/12/24/110 VDC.
 AC Input: 115/200 VAC.
 60-800 Cy.
 Output: 230-0-230 V, 40 MA.
 6-3 V, 1.8 A.
 While they last... \$1.49

INVERTERS

115V DC-115 VAC INVERTERS
 Rated 300W Int and 350W Contin.
 All Brand New, Famous Mfr. \$75.00

RU/GF COIL SETS

SINGLE BAND RCVR UNITS

Band	Frequency	Price: each
A	430-600KC	\$1.50
C	545-850KC	
D	850-1330KC	
E	1330-2040KC	
F	2040-3000KC	
G	3000-4525KC	
H	4000-6000KC	
M	5200-7700KC	
N	6000-9050KC	
K	9050-13,375KC	

LOW BAND
 400-600 KC } Price: \$2.25 each
 540-830 KC }
 195-290 KC }
 540-830 KC }
 HIGH BAND
 6000-9050 KC }
 5200-7700 KC }
 290-435 KC }
 540-830 KC }

HEADSETS

Headset, 300 ohms imp., using R-30 elements. Same as HS-30 but plush velvet ear cushions are more comfy. Kill all background noise. With 6 in. cord and PL-54 plug. Supplied in kit form with headband, 2-R-30 elements, 6 rubber inserts (4 extras). Assembled in 5 min. Roll Your Own... \$2.49

XMTR. COIL SETS

2000-2500 KC	\$1.75 ea.
3000-3675 KC	
3675-4525 KC	
6000-7350 KC	
7350-9050 KC	

RU/GU ACCESS.
 Remote tuning box type CW23012 \$1.75 ea.
 Xmtr. control box, CW-23097 \$1.79 ea.

RADAR TRAINER-15C

Bench set designed for training personnel in use of ASB radars, or any sets using "B" presentation. Write for info.

SENTINEL 421 AND 423

Symptoms: No high voltage, horizontal oscillator not working, and 50-150 volts positive on the grid of the control section of the 6SN7 horizontal oscillator tube. This is caused by a shorted or leaky coupling capacitor between the horizontal output transformer secondary and the 6AL5 phase-detector tube. The condition can be cleared up by replacing the capacitor. It is advisable to check the diode load resistor and the plate resistor of the reactance tube.—Arthur D. Marikle

COMMUNICATIONS EQUIPMENT CO.
 131 Liberty St. Dept. C-8 New York City 7, N. Y.

hair dryer to blow a stream of warm air on the suspected parts, thus simulating an in-the-cabinet condition.—S. L. Chentok

60-CYCLE DISTORTION IN TV SETS

A strong 60-cycle signal in video or horizontal-sweep circuits may cause a heavy horizontal bar across the sides of the raster, or both. This trouble is easily identified and simple to localize. A trouble which is often deceptive and difficult to diagnose occurs when just a small amount of 60-cycle voltage finds its way into the video or sweep circuits. The result is a slight distortion or interference pattern in the picture. During some programs, the distortion is motionless and is likely to pass unnoticed. On others, it may move vertically and be very annoying to viewers.

The interference pattern is stationary when its frequency and that of the set's vertical oscillator are exactly the same, as is the case when the TV sync generator is locked in with the 60-cycle power source supplying the TV set. Thus the interference is usually motionless on local programs. However, when the local station broadcasts programs originating at a distant point, as is the case with many network programs, the frequencies of the vertical oscillator and the interference will be slightly different and the distortion will drift vertically.

Whenever you receive a complaint of distortion or interference of this type, be sure to check the set on a network program and examine the picture carefully for a faint horizontal bar and slight bending at the sides of the raster. The sources of this trouble are the same as when the interference is much more severe but it may be more difficult to localize. The hum may be caused by heater-to-cathode leakage in the picture tube, d.c. restorer, video amplifier, video detector, picture i.f., or tuner stages. It can usually be tracked down with a scope, with an r.f. detector probe added for the stages ahead of the video detector. It may also be due to insufficient filtering in the B supply circuits to these stages, or to capacitive or inductive coupling between signal and heater leads. A speaker field coil can cause similar troubles, and occasionally the antenna lead-in wires may pick up strong 60-cycle fields from power lines or machinery.—Robert C. Ramsey

Symptoms: No high voltage, horizontal oscillator not working, and 50-150 volts positive on the grid of the control section of the 6SN7 horizontal oscillator tube. This is caused by a shorted or leaky coupling capacitor between the horizontal output transformer secondary and the 6AL5 phase-detector tube. The condition can be cleared up by replacing the capacitor. It is advisable to check the diode load resistor and the plate resistor of the reactance tube.—Arthur D. Marikle

Compare!
PROVE EMC SUPERIORITY!

Model 104
 (20,000 ohms per volt meter)
 • 4 1/2" SQUARE METER (50 micro-amperes-Alnico magnet)
 • Includes carrying strap
 5 DC Voltage Ranges at 20,000 ohms volt to 3,000 V.
 5 AC Voltage Ranges to 3,000 V.
 3 Resistance Ranges to 20 megs.
 Also 3 AC & DC Current Ranges at 5 DB Ranges **\$26.95**

Model 102
 (1000 ohms per volt meter)
 • 3" SQUARE METER
 • 3 AC CURRENT RANGES (0-30/150/600 ma.)
 • Same zero adjustment for both resistance ranges (0-1000 ohms, 0-1 meg-ohms)
 5 DC & 5 AC Voltage Ranges to 3,000 Volts
 Also 4 DC Current Ranges **\$14.90**

Model 103
 (1000 ohms per volt meter)
 • 4 1/2" SQUARE METER
 • 3 AC CURRENT RANGES (0-30/150/600 ma.)
 • Same zero adjustment for both resistance ranges (0-1000 ohms, 0-1 meg-ohms)
 Same Ranges as Model 102.
 Also 5 DB Ranges **\$18.75**

Model 103-S with plastic carrying strap **\$19.25**

All of the above have molded bakelite cases.
 Write Dept. RE-8 for Free Complete Catalog of these and other instruments.
 See them at your Jobbers —

Electronic Measurements Corp.
 280 Lafayette St., New York 12, N. Y.
 Export Dept., 303 W 42nd St., N. Y. C.

NEW CONDENSER TESTER

Finds Intermittent Condensers Instantly

NET **795** Postpaid U.S.A.

Pres-probe's sliding tip with variable resistance prevents condenser heating. Tests with power on. Requires no adjustment. Stops guesswork. Saves time. Convenient probe size (7/8" long). Satisfaction guaranteed.

See Your Dist. or Order Direct
PRES-PROBE CO.
 4034 N. Sixth St., Milwaukee 12, Wisc.

At your RMS Jobber



CVA-500 end-fired array — excellent reception in the fringe. Rugged — up fast, stays fast.



The little man



SP-6J Triode Tube Boosters — new beauty . . . excellent performance in semi-fringe and fringe. U/L approved.

is always there

SP-6 Pentode Tube Booster with external gain control ideal in the extreme fringe. U/L approved.



with everything



HG-450 Hi-Gain open transmission line is Copperweld . . . far stronger!

you need for

LA-3 lightning arrester — static discharge eliminator for twin lead or open line. Mounts flat or to mast. U/L approved.



TV installation



STYLE 8 and 10 element yagis . . . real uniquely steel-braced.



ask him for RMS products
RMS, New York 60, N. Y.

THE FUND REACHES \$9,654.76

HELP - FREDDIE-WALK FUND



It is with great pleasure that we acknowledge the continued response to the Help-Freddie-Walk Fund, contributions to which are still coming in from far and wide. Inaugurated over two years ago, the fund was started in an attempt to supply some of the thousands of dollars that will be needed in the fight to aid Freddie Thomason, little son of Herschel Thomason, radio technician of Magnolia, Arkansas. For four-year-old Freddie was born without arms and legs, and all his life he will be dependent upon mechanical appliances.

But already he is mastering the rudiments of walking by artificial means. As his father wrote recently: "Freddie received his new legs and he can practically walk on them. He can pick them up one at a time, but still has to master the forward motion. The legs are about three inches longer, and make him look like a very grown-up boy. Our hopes for him are very high now, and we know that he will be walking more than ever before long."

The faith and encouragement of his parents are mirrored in the many letters we here at RADIO-ELECTRONICS receive each month. Typical of the personal interest our readers take in Freddie are the following excerpts:

From Jacob Shapiro, Brooklyn, N.Y.: "I like the way Freddie smiles in your latest issue. Here is my check." And from Juli, New York City, we get the following comments: "I derive a great deal of pleasure helping Freddie walk. Having made contributions in the past, I feel it my duty to write this letter.

With prices high and salaries at a standstill, it's difficult to make large donations. Many times I wanted to send a little something, but every time I felt I could spare a little more next week. Many readers must feel the same way. So kindly accept my modest donation. I hope the many who have helped Freddie in the past will do so again and again."

We should like to point out to Juli, and any others who have been afraid that their donations might be too small to be of any importance, that NO donation is too small for our sincere appreciation and acknowledgment. Every little bit helps!

We should also like to make special note of a donation of \$34.10 sent in by Dixon J. Helmick, E.T.1, in the name of the E-T Gang on the U.S.S. Boxer. Many thanks to our servicemen who take time from their varied duties to contribute to this worthy cause.

Please send your contributions, large or small, from time to time. *Make all checks, money orders, etc., payable to Herschel Thomason.* Address letters to:
HELP-FREDDIE-WALK FUND
c/o RADIO-ELECTRONICS Magazine
25 West Broadway
New York 7, N.Y.

The Book that takes Drudgery out of Mathematics

Only \$1. postpaid

SOLVES EVERYDAY PROBLEMS HELPS YOU GET AHEAD IN LIFE



How many times have you lost money because of a mistake in figuring? Do you know how to figure quickly and correctly? Can you figure discounts, interest rates, taxes and all the other calculations you meet up with in your daily life?

Are you having trouble qualifying for Civil Service Exams or Armed Services Promotions, because you're not up on mathematics?

ILLUSTRATED

Here is the book that gives you a good background in mathematics; that takes all the irritation and drudgery out of it. You don't need to be scared of mathematics, because here's the subject explained without frills, without useless computations. Here's the book for men in radio jobs; for business men; technicians and craftsmen, explaining and answering everyday mathematic problems in easy-to-understand words and illustrations.

A BOON TO EVERY RADIOMAN

The Radio Technician will find information on the following: Ohm's Law—Resistance—Reactance—Capacities—Inductances.

The valuable tables are multiplication and division table. Squares; Square Roots; Cubes and Cubic Roots Tables. Areas of Circles Table. Common Fractions reduced to Decimal Table. Factors and Prime Numbers Table. Table of Multiples.

Yes, it's the key to a simple understanding of mathematics. It's a real home-study course in mathematics for the man who's alert to its importance in the world today.

ELEMENTARY MATHEMATICS

• EASY — SIMPLIFIED — PRACTICAL •

CONTENTS OF BOOK

- CHAPTER I.** Arithmetic—Addition—Subtraction—Multiplication—Division.
- CHAPTER II.** Factoring and Cancellation—Fractions—Decimals—Percentage—Ratio—and Proportion.
- CHAPTER III.** The Metric System.
- CHAPTER IV.** How to Measure Surfaces and Capacity (Geometry).
- CHAPTER V.** Powers and Involution—Roots and Evolution.
- CHAPTER VI.** Mathematics for the Manual and Technical Craftsman—Thermometer conversions—Graphs or Curve Plotting—Logarithms—Use of the Slide Rule.
- CHAPTER VII.** Special Mathematics for the Radio Technician.
- CHAPTER VIII.** Commercial Calculations—Interests—Discounts—Short Cut Arithmetic.
- CHAPTER IX.** Weights and Measures—Useful Tables.

ONLY \$1. POSTPAID

STAMPS, CASH OR MONEY ORDER ACCEPTED

Send Today for Your Copy of This Indispensable Book. It Can Be Carried Readily in Your Pocket. (Size 6 x 9 in.)

TECHNIFAX, 100 East Ohio St. Chicago 11, Ill.

Enclosed find \$1.00 for which send me **ELEMENTARY MATHEMATICS** prepaid.

Name _____

Address _____

City & State _____

RE-8-52

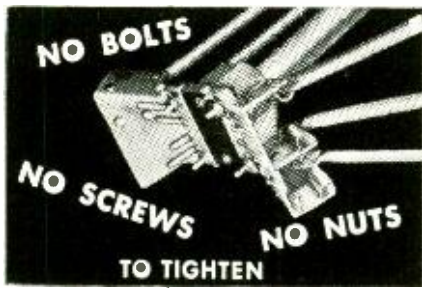

The New "PR" **ROCKETENNA**

SERIES OF COMPLETELY PRE-ASSEMBLED

CONICAL ANTENNAS

"QUICK-AS-A-WINK" CONSTRUCTION

- Amazingly powerful signal reception on all channels.
- All-aluminum construction.
- Lifetime factory warranty.
- Sold thru selected, legitimate distributors only.

Write for New Complete Catalog E-1



TV PRODUCTS COMPANY
152 SANDFORD ST.
BKLYN. 5, N. Y.

RADIOS TELEVISION TEST INSTRUMENTS
AC/DC Operation
Write for FREE Catalog
ARKAY—Radio Kits, Inc.
120 Cedar St., New York 4, N. Y.

WANTED
BD110 Telephane Switchboards, BD100 Telegraph Switchboards, BD90 Power Boards, EE101 V-F Rings, BE72 Cabinets, FM19 Frames, RA43, RE630, KS5988, RA87, RA37, RA91 Rectifiers, BD101 Test Boards, SB6 Switchboards, Type CF1A, CF3A, CF2B Carrier Equipments. Any condition and quantity.
Box 752-1 Radio Electronics
25 W. Broadway, New York 7, N.Y.

From the earliest days of Radio . . . to the present era of Television . . .
CORNISH WIRES
"Made by Engineers for Engineers"
CORNISH WIRE CO., Inc. — 50 Church St., N. Y. C. 7

CODE SENDING RECEIVING SPEED
Be a "key" man. Learn how to send and receive messages in code by telegraph and radio. Commerce needs thousands of men for jobs. Good pay, adventure, interesting work. Learn at home quickly through famous Candler System. Qualify for Amateur or Commercial License. Write for FREE BOOK
CANDLER SYSTEM CO.
Dept. 3-1, Box 928, Denver 1, COLO., U.S.A.

FAMILY CIRCLE CONTRIBUTIONS
Balance as of May 19, 1952 \$ 551.50
Mary Westerlind, Brooklyn, N. Y. 2.00
\$ 553.50

RADIO-ELECTRONICS CONTRIBUTIONS
Balance as of May 19, 1952 \$9,026.16
Anonymous, Boston, Mass. 1.00
Anonymous, Albuquerque, New Mex. 1.00
Anonymous, Kew Garden Hills, N. Y. 2.00
A Reader, Chicago, Ill. 1.00
C.R. Buchanan, W4JBV, Disputanta, Va. 3.00
E. J. Cazeman, Shreveport, La. 5.00
John L. Cooper, Petal, Miss. 1.00
C. J. Dempsey, Euclid, Ohio 3.00
From the ET Gang on the U.S.S. Boxer 34.10
Juli, New York, N. Y. 1.00
William P. Oieffenbach, c/o Postmaster, San Francisco, Cal. 10.00
Lt. Wille J. Rivers, Shaw AFB, S. C. 5.00
Jacob Shapiro, Brooklyn, N. Y. 4.00
Mr. & Mrs. F. Walsh, Castleton-on-Hudson, N. Y. 1.00
T. J. Welch, Brooklyn, N. Y. 3.00

RADIO-ELECTRONICS CONTRIBUTIONS Received to June 19, 1952, \$9,101.26
FAMILY CIRCLE CONTRIBUTIONS 553.50
TOTAL CONTRIBUTIONS to June 19, 1952, \$9,654.76

Radio Thirty-Five Years Ago
In Gernsback Publications

HUGO GERNSBACK Founder

Modern Electrics	1908
Wireless Association of America	1908
Electrical Experimenter	1913
Radio News	1919
Science & Invention	1920
Television	1927
Radio-Craft	1929
Short-Wave Craft	1930
Television News	1931

Some of the larger libraries still have copies of ELECTRICAL EXPERIMENTER on file for interested readers.

AUGUST, 1918
ELECTRICAL EXPERIMENTER
The Magnetic Storm, by H. Gernsback
The Phenomena of Electrical Conduction in Gases, by Rogers D. Rusk, M.A.
Memorizing The Code, by Harold A. Bauman
New "Glass Slate" For Teaching Hook-Ups.
An Improved Condenser Scale.
A Different Rotary Switch.
The Design and Use of the Wave-Meter, by Morton W. Sterns
—end—



"Glad to see you—couldn't keep my husband from tinkering with it any more."

RCP is **FIRST** again with this . . .
"DO-ALL"
TV Set and Tube Tester
(Includes VT Voltmeter and Reactivator)

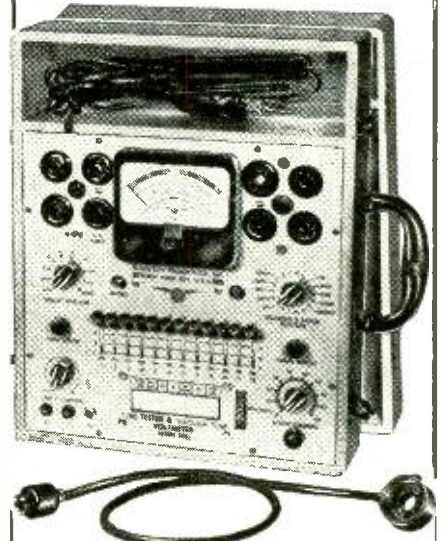

MODEL 808
TV-RADIO-GR TUBE
TESTER and TV VOLTMETER

All in One Unit:

- A TUBE TESTER
- A CATHODE RAY TUBE TESTER
- A CATHODE RAY TUBE REACTIVATOR
- A VACUUM TUBE VOLTMETER (AC-DC)
- AN OHMMETER

Housed in handsome hand-rubbed oak carrying case with test leads, isolation probe, batteries, etc. Size 12 1/2" x 12 3/4" x 4 3/4", weight 12 1/2 lbs.

MODEL 808—complete, ready to operate \$99.95 NET

High Voltage Multiplier Probe for Model 808 Extends Range of VTVM to 30,000 volts. \$8.95 NET

MODEL No. HVMP-1 Write for our latest RCP catalog to Dept. RE-8

RADIO CITY PRODUCTS CO., INC.
152 West 25th Street, New York 1, N. Y.

* **WANTED** WE NEED YOUR SURPLUS ELECTRONIC EQUIPMENT *
* **WE PAY TOP \$\$\$ FOR:** *
* RADIO RECEIVERS * CLAMPS *
* TRANSMITTERS * PLUGS *
* ARC-1 * CORDS *
* ARC-3 * RELAYS *
* ART-13 * TELEPHONE *
* CONTROL BOXES * MATERIALS *
* INDICATORS *
* AN CONNECTORS * **WE BUY ANYTHING!!** *
* **Write, Wire Today!** *
* Tell us what you have *
* **TALLEN COMPANY, INC.** *
* Dept. RE, 159 Carlton Ave. *
* Brooklyn 5, New York *

MONEY-SAVER KITS!

Kit No. 1—Basic 1 tube training kit. Simple to construct complete with all parts one tube and headset diagrams and instructions included. Use 1-354 tube and a 67½ volt Battery. Price \$3.95—less Battery.

Kit No. 2—2 tube Amplifier Kit complete with 50L6, 35Z5, and 4" PM to convert Kit No. 1 to a 3 tube set for loudspeaker operation. \$4.95

Kit No. 3—A low-priced 6 TUBE KIT designed for high sensitivity, excellent selectivity and good tone quality. Uses 25L6, 25Z6, 6SQ7, 6SA7, 6SK7, 6SK7 in an easily constructed circuit. The 6 Tube Kit is shipped with all parts, including punched chassis, resistors, condensers, coil, sockets, PM Speaker, hardware, etc.

And at a closeout price of only **\$6.95** less tubes and cabinet

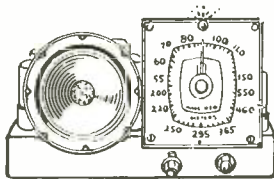

Extra for matched set of six tubes for kit **\$3.25**

5 TUBE AC-DC SUPERHET KIT

Kit No. 4—Five Tube superheterodyne kit, A.C.-D.C. contains all components required to construct this latest design, highly sensitive superheterodyne broadcast receiver complete with black bakelite cabinet (excludes wire and solder) Price \$7.95

Extra for a kit of 5 tubes (12AT6, 12BA6, 12BE6, 35WA, 50C5). Price \$3.25.

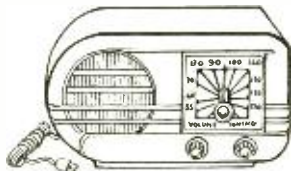

Electronic Code Practice Oscillator & Blinker Kit

AC/DC or Battery Operated!

Kit No. 5—One of the most practical Code Practice Oscillators ever designed, yet one of the simplest to build and operate.

Can be used with any number of headphones. Adjustable Pitch Control—Any type of headphone can be used.

No warmup time—ready to operate instantly Simple and safe to operate

Operates anywhere—with AC or DC power, or from a 90 volt Miniature Battery

Learn Blinker Code with flashing light

Blinker can be used as signaling device

International Morse Code included

Kit each **\$195** Assembled **\$295**

THREE TUBE PHONO AMPLIFIER

An assembled unit ready for installation using tone and volume control and six feet of rubber cord **\$2.95**

(Not including Tubes)

With Complete Set of Tubes **\$3.95**

PHONO OSCILLATOR

Wireless phono oscillator transmits recording for crystal pick-ups or voice from carbon mike through radio without wires. Can also be used as an intercom by using P.M. speaker as mike. Price (excluding tubes) **\$2.95**

With Complete Set of Tubes **\$3.95**

Satisfaction guaranteed on all merchandise All prices subject to change without notice.

Write for FREE Catalog.

RADIO DEALERS SUPPLY CO.

154 Greenwich St. New York 6, N. Y.

Eugene J. Fleisch, who had been chief specification engineer of STANDARD TRANSFORMER CORP., Chicago, was promoted to the position of assistant to the general sales manager, according to an announcement by Jerome J. Kahn, Stancor president. He will assist Gilbert C. Knoblock, general sales manager, in sales and distribution.

Frank B. Powers was elected vice-president in charge of manufacturing at a meeting of the Board of Directors of P. R. MALLORY & Co., Indianapolis. He came to the company from Federal Telephone and Radio where he had been vice-president in charge of operations and a member of the Board of Directors.

Charles Castle was named sales manager of the Distributor Division of WEBSTER-CHICAGO CORP. Charles Dwyer, former service manager, succeeds Castle as assistant sales manager of the Distributor Division. Both men have been with the company since 1948.

Samuel B. Williams was promoted to assistant to the president of SYLVANIA ELECTRIC PRODUCTS. He had been director of public relations since 1949.

T. M. Douglas was elected a vice-president and director of FEDERAL TELEPHONE AND RADIO CORP., Clifton-Passaic, N. J., affiliate of International Telephone & Telegraph Corp. At the same time, S. J. Powers, manager of Federal's Selenium-Intelin Division, was elected a vice-president. Douglas, who had been works manager, will now serve as general works manager.

Victor Mucher, president of CLAROSTAT MFG. CO., Dover, N. H., and AUSTIN C. LESCARBOURA, head of the Croton-on-Hudson, N. Y., advertising agency which services the Clarostat account, were awarded gold wrist watches and testimonial scrolls honoring their quarter century of service to the company.

... George W. Henyan resigned as chief of the components branch of the Electronics Division of the NATIONAL PRODUCTION AUTHORITY. He returned to General Electric as assistant to the general manager of the Tube Department. Robert O. Bullard, who had been manager of manufacturing for industrial and transmitting tubes, advanced to Henyan's former position as manager of industrial and transmitting tubes.

... Joseph J. Kearney, A. K. Mallard, and Ted Martin, Jr., former field sales representatives for the RCA TUBE DEPARTMENT, were promoted to be district managers of the East Central, Southwestern, and Northeastern districts, respectively.

... Albert Saunders and C. Pat Walder were appointed district managers for ALLIANCE MANUFACTURING CO., Alliance, Ohio, in the first of a series of decentralization moves by the company. Saunders will be responsible for all field men east of Altoona, Pa., and Walder will handle the new western district. Both have been with the company for three years.

—end—

FREE

32 PAGE BOOK

HOW TO... SERVICE TELEVISION

Completely illustrates advanced TV servicing techniques with the latest HICKOK Universal Video Generator.

Free — Send for your copy today.

THE HICKOK ELECTRICAL INSTRUMENT CO.
10531 Dupont Ave. • Cleveland 8, Ohio

Polio Printers

FOR 1952

DON'T get chilled nor bathe too long in cold water.

DON'T become fatigued from overwork or play.

DON'T mix with new groups.

DON'T take children out of camp or playground where there is good health supervision.

Recommended by

THE NATIONAL FOUNDATION
FOR INFANTILE PARALYSIS
RADIO-ELECTRONICS

DUTCH CRAFTSMANSHIP

Dear Editor:

In the four years I have been reading RADIO-ELECTRONICS I have seen only a few articles from Dutch sources. Perhaps you will be interested in this photograph of my home-made TV-Radio-Phonograph combination. The TV set has a 12-inch picture tube, with a 250-kc r.f. high-voltage supply. There is only one channel in Holland at the present time, transmitting a 625-line

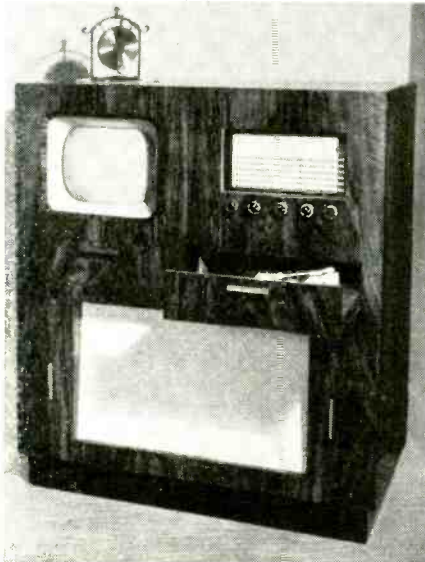

Mr. de Graaf's homebuilt combination. picture, with 50-cycle interlace (25 frames per second). The channel is 7 mc wide, with picture carrier on 62.25 mc, and FM sound on 67.75 mc.

The broadcast receiver covers six bands, and has a high-fidelity, 10-watt, push-pull amplifier with dual tone controls, also used for TV programs.

The phonograph has only two speeds—78 and 33 1/3, since "45's" are not used in Holland—and a special lightweight pickup.

I am happy to tell you that I hope to come to the United States this year, and expect to make my permanent residence in the State of Utah.

P. de GRAAF

Utrecht, Holland

KARLOFF'S KEEPERS?

Dear Editor:

In regard to Mr. Richardson's letter—"Conversions Dangerous?"—in the March issue of RADIO-ELECTRONICS, I get the impression that we TV-Radio technicians are being referred to as "parts replacers". I concede that parts must be replaced, but the technician must have the knowledge and ingenuity to find out *which part* to replace. The design engineer, like Frankenstein, has created a monster, and we technicians have to turn it loose and keep it on the right path.

As to the reference to garagemen—the auto mechanic is a skilled technician in his own right, but in a full day's work he does not use as much knowledge as it takes to do *one* TV repair job.

EUGENE RHODES

Kansas City, Mo.

AUGUST, 1952

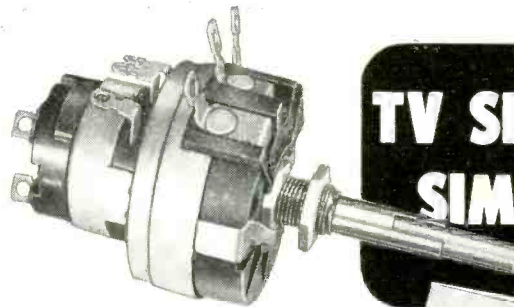

TV SERVICING SIMPLIFIED

Use this big Clarostat TV Control Replacement Manual! Almost 3000 control listings of all the popular TV set models and chassis. You can spot the correct replacement for any wornout or defective TV control.

Best of all, your Clarostat jobber has that right replacement in stock. No delay. And it fits — electrically and mechanically — without fussing or cussing. Stays put, too, for a profitable job.

GET THAT TV CONTROL REPLACEMENT MANUAL NOW!

Supply is running out. Send your dollar bill and start saving time, trouble, money, in TV servicing. Or get your copy from your Clarostat jobber.



Controls and Resistors

CLAROSTAT MFG. CO., INC. • DOVER, NEW HAMPSHIRE

IN CANADA: CANADIAN MARCONI CO. LTD., MONTREAL, P.Q., AND BRANCHES

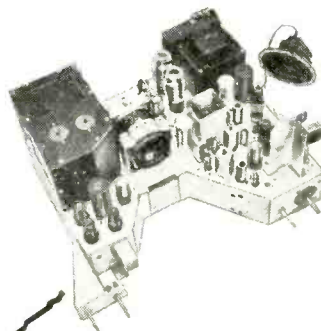

HERE IS THE BIGGEST BARGAIN YOU EVER SAW!

World's finest 630 DX chassis

New CASCADE tuner assures best reception in fringe areas without a booster. Handles all Cathode Ray tubes from 16" to 24". Improved 30 tube super-quality TV receiver (including 3 rectifiers) mfd. under license by RCA. Complete Less Picture Tube

\$138.50

\$127.50

With Hi-Gain standard coil tuner and R.C.A. Hi-Fi 12" Speaker, complete with knobs and hardware. Complete with Fed. Taxes Paid. Less Cathode Ray Tube.....

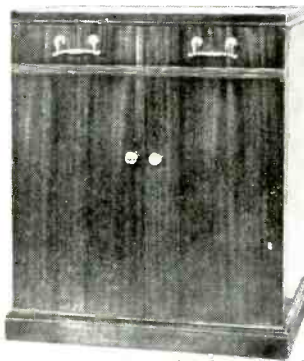

All Mahogany CABINET

Most beautiful console made. Solid 3/4" mahogany wood including panels. Measures 31" W. X 24" D. X 39" H. E-equipped with 20" mask

\$95.00

20CP4A Pic. Tube. \$32.00 (Not a rebuilt)

Guaranteed one year.

Special Offer!

Chassis, Picture Tube and Cabinet.

\$239.50

(with 630DX chassis) **\$249.50**

Send for latest catalog

STANDARD BRAND TUBES

Individually Boxed and Guaranteed (Manufact. of tubes refuses permission to mention name because tubes are FAIR BELOW FAIR TRADE)

1A7	.89	6BH6	.86	12AT6	.65
1B3	.89	6BK7	1.15	12AU7	.86
1H5	.71	6BQ6	1.24	12AV7	1.19
1N5	.74	6BQ7	1.15	12AX7	.99
1S5	.79	6C4	.54	12BA6	.69
1T4	.79	6CB6	.71	12BH7	.77
1U5	.78	6CD6	2.39	12BK7	.84
30A	.94	6E5	.54	12SQ7	.68
305	.89	6F6	.94	14A7	.84
3V4	.89	6K6	.66	14B6	.94
5U4	.63	6K7	.74	25BQ6	1.29
5Y3	.97	6SA7	.64	25L6	.64
6AC7	.47	6SH7	.74	25W4	.78
6AG5	.94	6SL7	.74	35L6	.67
6AH6	.79	6SK7	.64	35W4	.52
6AK5	1.29	6SN7	.74	50A5	.96
6AL5	.68	6SQ7	.64	50B5	.79
6AQ5	.59	6T3	.74	50L6	.64
6AU6	.68	6V6GT	.93	117Z3	.64
6AT6	.69	6W4	.64		
6B0D	.68	6X5	.62		
6BA6	.69	7C5	.74		
6BC5	.74	7E7	.74		
6BE6	.79	7K7	1.09		
6BG6	1.76	7N7	.84		

Also partial listing only. Send for complete list.

STEVE-EL ELECTRONICS CORP.

VISIT OUR NEW STORE

Dept. E-8

61 Reade St., New York 7, N. Y. COrrlandt 7-0086

Become an Electrical Engineer



MAJOR IN ELECTRONICS



- B. S. Degree in 36 Months
- Radio-Television Technician Certificate in 18 Months

By 1954 there will be at least two positions for every engineering and technician graduate. This College offers a tested plan that permits you to enter these vast employment opportunities at an early date. First — you save a valuable year through optional year-round study. Second — you can receive advanced credit for prior training gained in the armed forces, other schools or field experience.

Enter Both Radio and Television Through This Plan

12 months or one-third of the B. S. degree course (Electronics major) — also brings you the Radio Technician's certificate. An added 6-month course qualifies you for the Radio-TV Technician's Certificate. Recent developments open unlimited opportunities for TV technicians and engineers.

The Proven "UNIT CHASSIS SYSTEM"



of teaching was developed here. It "breaks down" the TV set by stages. You learn every component of all types and makes — and are prepared for future design changes, including the advent of color.

General Preparatory Course

Exclusive 3-month course is tailor-made to help young men fulfill academic deficiencies and meet engineering admission requirements. Terms open October, January, April, July Over 48,000 former students from all states and 23 overseas countries. Faculty of trained specialists. Modern laboratories and equipment. Nonprofit technical institute and college in its 49th year.

MILWAUKEE

SCHOOL OF ENGINEERING

FREE — Write for "Occupational Guidance Bulletin," "Your Career" booklet, and catalog.

Milwaukee School of Engineering
Dept. RE 852, 1025 N. Milwaukee
Milwaukee, Wisconsin

Without obligation send Catalog for Electrical Engineering, B. S. Degree, major in Electronics; Power; "Your Career"; Occupational Guidance Bulletin on: Radio-TV; Electrical Power; Welding; Heating, Refrigeration Air Conditioning Mechanical Engineering, B.S. Degree; Preparatory.

Name.....Age.....

Address.....

City.....Zone.....State.....

If veteran, indicate date of discharge.....

RADIO SCHOOL DIRECTORY

Unlimited Opportunities in RADIO ENGINEERING

DEGREE IN 27 MONTHS

Complete Radio Engineering course including Telev., U. H. F. and F. M. Bachelor of Science Degree also in Mech., Civil, Elect., Chem., and Aero. Eng.; Bus. Adm., Acct. Extensive campus, modern buildings, well equipped labs. Low cost. Prep courses. Personalized, practical instruction. Founded 1884. Placement service. Growing shortage of engineers. Prepare now for unlimited opportunities ahead. Enter September, January, March, June. Write for catalog.



TRI-STATE COLLEGE

2482 College Ave. ANGOLA, IND.

TELEVISION

Big demand for graduates

B.S. DEGREE IN 27 MONTHS in radio including TV engineering—VHF, UHF, AM and FM. Students use over \$100,000 worth of equipment including 2 large commercial type transmitters in new TV lab. Intense specialized course includes strong basis in mathematics, science and advanced design in radio and TV.

Hundreds of young men each year are earning engineering degrees in this recognized institution. Start any quarter. Many earn a major part of expenses in this industrial center. Low tuition. Competent instruction. Thorough, intense, practical program.

Also B.S. DEGREE IN 27 MO. in Aeronautical, Chemical, Civil, Electrical and Mechanical Engineering, G.I. Gov't approved. Enter Sept., Dec., March, June. Free catalog. ENROLL NOW

INDIANA TECHNICAL COLLEGE

1782 E. Washington Blvd., Fort Wayne 2, Indiana

FOR THE FIRST TIME!

For several years you've read about the Don Martin School now—for the first time—we are prepared to offer a course by mail. You can obtain your first class radio telephone operator's license from this special course. Operators are desperately needed now by radio and TV stations as well as the aircraft industry. Secure your future.

Be certain that your training is of the best, enjoy the school recognized by the profession. Write today for full information.

THE DON MARTIN SCHOOL OF RADIO AND TELEVISION ARTS AND SCIENCES
Correspondence Section
1655 No. Cherokee, Hollywood 28, Calif. HU. 2-3281.

YOU GET 2

ABSOLUTELY THE GREATEST CABINET BUY IN YEARS



Size 5 3/4" x 5" x 3 1/4"

No C.O.D. Send check or money order.

MANUEL KLEIN CO.

94-R CHAMBERS ST., NEW YORK 7, N. Y.

101 uses for this sturdy handsome black plastic cabinet. Can be used for TV boosters, remote control units, meters, etc.

A GENUINE BARGAIN YOU CAN'T AFFORD TO MISS.

2 For \$3 only

Postpaid anywhere in the United States

RADIO & TELEVISION
... **TRANSMITTERS**
LAB. WORK EVERY DAY
LEARN BY EXPERIENCE

REHRIG SCHOOL
11-13 S. GAY ST.
BALTIMORE 2, MD.
Lex. 3195

BE A RADIO ENGINEER!

You can enter this unoverlooked, interesting field. Defense expansion, new developments in electronics demand trained technicians. Study all phases radio & electronics theory and practice: TV; FM; broadcasting; servicing; aviation, marine, police radio. 18-month course equal in radio content to 4 yrs. college, H.S. or equivalent required. Begin Jan., March, June, Sept. Campus life. Catalog.

VALPARAISO TECHNICAL INSTITUTE
Dept. C Valparaiso, Ind.

RADIO and TELEVISION ELECTRONICS

in all Technical Phases
New Classes (Day & Evening)
Start 1st of Dec., Mar., June, Sept.
FREE PLACEMENT SERVICE
for GRADUATES

For Free Catalog write Dept. RC-52
RCA INSTITUTES, INC.
A Service of Radio Corporation of America
350 West 4th St., New York 14, N. Y.

LEARN TELEVISION

ELECTRONICS and RADIO
Engineering Laboratory and Classroom
Training. Day and Evening Classes.

Write for illustrated Catalog

ELECTRONICS INSTITUTE, Inc.
21 HENRY, DETROIT 1, MICH.

TELEVISION-RADIO ELECTRONICS

Training in all branches television, radio and electronics. PUC exam, preparation. Write for free catalog.

COMMERCIAL RADIO INSTITUTE
(Founded 1920)
38 W. Biddle St., Baltimore 1, Md.
Approved by Maryland State Board of Education

You can't beat

Radio-Electronics

for complete coverage of

RADIO, TELEVISION and AUDIO

JAM ON AM

Dear Editor:

Your June issue contained a letter from L. S. Bitton asking "Why not more AM broadcast stations?" He says "Theoretically the band is crowded—but not practically." I think any competent radio engineer will assure him that the band is crowded to the gunwales, no matter how you look at it. The stations that he says "go off the air at 6 pm" do so from sheer necessity because of this extreme crowding.

My point is: FM is the obvious and perfect answer, hence my sincere bewilderment at why anyone should even consider adding more units to the AM band. FM can—and does—do everything that AM ever has, at less cost, less technical trouble, and with greater clarity. Its only disadvantage is a temporary lack of receivers, which will be corrected automatically by the very lack of AM service which Mr. Bitton decries. Except for long-distance clear channels AM is dead—it just hasn't fallen off its feet yet.

MARK T. MCKEE, JR.
WMLN, Mt. Clemens, Michigan

(The admitted lack of FM receivers is, of course, just the point that those who agree with Mr. Bitton consider decisive. Even though FM stations are erected in small communities, they ask, who will receive them? But this lack of FM receivers can be remedied, whereas no amount of rationalization can increase the available spectrum space on the already badly overcrowded high-frequency end of the present broadcast band.—Editor)

FOR TV DX HOUNDS

Dear Editor:

I have been reading the article "TV Pattern For The Future" in the May issue of RADIO-ELECTRONICS. The changes made or suggested for stations in New York, Connecticut, and Rhode Island make very good sense to me.

I worked on Mt. Washington, New Hampshire, at an elevation of 6,288 feet. We were 145 miles from the nearest TV stations in Boston, yet there was never a day when we could not receive them clearly. However, there was generally co-channel interference on channel 4 from WRGB in Schenectady, N. Y. We were also able to get the low-channel New York City stations, but with co-channel interference on 5 between WABD and WSyr-TV (Syracuse, N. Y.).

In the fall of 1949 a smoke layer from forest fires in Canada gave us a chance to log about 20 high- and low-channel stations, including every station in New York City and Philadelphia.

Our best dx was Jacksonville, Florida, on channel 2, although we were never able to get anything from Delaware, Maryland, or Washington, D. C.

If anyone is interested in conducting tests on Mt. Washington, I suggest they get in touch with Mr. Wallace E. Howell, Director, Mt. Washington Observatory, 2 Divinity Avenue, Cambridge, Mass.

NORMAN TURNER

Cerro de Pasco, Peru

—end—

don't throw it away...
weak picture tubes can be saved!

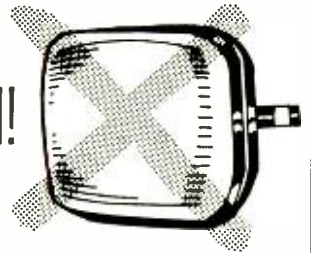

use a

Picture Tube
REJUVENATOR

- ✓ Simple Plug-in Unit
- ✓ Permanent Hook-up
- ✓ No Exposed Wires
- ✓ Usable on All Size Tubes
- ✓ Automatically Operated
- ✓ Only \$2.79 Dealer Net

Model "C"



Available at Local Jobbers

LABORATORIES, INC.

Whitehall Building

Far Rockaway, New York

- 60 Cycle Synchronous Motor . . . 110V. Part of Watt-Hour Meter movement. Loaded with precision-matched gears, worms, etc. . . . \$1.95
- 4 Gang Variable Condenser . . . 250mmf. per sect. . . . 1.29
- 1/4" shaft. 7 1/2"x3 1/4"x2 3/4" 8/1.00
- 50-200MMF Dual Mica Trimmers 25c

- 12 SCE 50 ft./1.29 100 ft./1.98
- 32 P.E. 12 oz. spool98
- 30 P.E. 400 ft. spool98
- MAGNET WIRE 29c
- 4 Volt Fil. Transformer, .4 amps. 3 1/4"x2 1/2"x2" 1.95
- RG-544/U Co-Ax Cable, 58' 1.00 ft./ .89
- 1/4" Sponge Rubber, 3" wide, 15 ft. roll98
- 120W-100 Ohm Slider Resistor . . . wire-wound 79
- 120W-10K Ohm Fixed Resistor . . . wire-wound 98
- Phone Scratch Filter . . . eliminates needle hiss 98

- !! SPEAKER SPECIALS !!
- 4" DYNAMIC (Oxford)—2500 ohm field \$1.29
 - 12" Dynamic . . . Heavy duty Rola, 2000 ohm field. With push-pull output xmr. 3.95
 - Speaker Replacement Cones . . . 4" to 12" incl. free-edge. Less voice coils. Kit 12 asstd. 1.98
 - Speaker Repair Kit . . . A professional assortment of: Rings, Spiders, V.C. forms, chamois, Bar, Felt, Cement, Shim Kit & INSTRUCTIONS 2.49
 - !! BOTH !! "CONE & REPAIR KITS" for ONEY 3.95

- Rheostats: 50W-32 . . . \$1.69 50W-17 . . . \$1.29
- 110V AC Electromagnet . . . O.D. 1 1/8" . . . 800 ohm coil, 6 oz. pull. Cont. duty98
- DPDT Rotary Power Switch 10A, 125V, w/knob; off pos.98
- Tube Cartons . . . plain white. Prices per 100: M14 1 1/2" sq. x 2 3/4" . . . \$1.20 GT (1 1/2" sq. x 3 1/4") . . . \$1.45; Med. (1 1/2" sq. x 4 1/2") . . . \$1.65; Large (2" sq. x 5") . . . \$1.98; Extra Large (2 1/2" sq. x 6 1/2") . . . 3.95
- 78 RPM Hand-Wound Phono Motor (G.I.) . . Adjust. gov. control. With plate & crank. NEW Flyer 4.95
- 33 1/3 RPM Flyer Phono Motor (G.I.) . . . 110V AC, adjust. gov. control. With mtg. plate; less T.T. 4.95

Portable Radio-Amplifier Cabinet . . . Ideal for Test, Medical or Indust. Eqp. Walnut finish steel; hinged front panel. 14"x8"x8" \$2.49

- BARAINS IN KITS!! SAVE WITH THE NEW "JUMBO RADIO PARTS KIT" FULL LBS. OF: WIRE, COILS, RESISTORS, CONTROLS, SWITCHES, SOCKETS, CONDENSERS, ETC., ETC. \$3.95
- ROTARY SELECTOR SWITCHES . . . incl. multi-deck. Kit of 6 asstd. 1.75
 - W.W. Resistors . . . 5W to 20W. Kit of 12 asstd. 49
 - Water Sockets . . . 4 to 8 pin. Kit of 12 asstd. 49
 - Mica Padders & Trimmers . . . Kit of 15 asstd. 69
 - Carbon Resistors . . . 1/2 to 2W, 100 asstd. 95
 - Knobs . . . screw & spring types. 25 asstd. 98
 - "Alnico Magnets" . . . Powerful Bar, Block, "U", Rod, etc. Kit of 10 asstd. 1.98
- (WRITE FOR LATEST "ALNICO" SUPPLEMENT)

"FACTORY SPEAKER REPAIRS SINCE 1927"
Min. order \$3.00, 20% deposit req. on all C.O.D.'s. Full remittance with foreign orders. Please add sufficient postage—excess refunded.

LEOTONE RADIO CORP.
67 Bay Street
New York 7, N. Y.

LEARN
Television-Radio Electricity
REFRIGERATION-ELECTRONICS
IN THE GREAT SHOPS OF **COYNE**

TRAIN QUICKLY! OLDEST, BEST EQUIPPED SCHOOL OF ITS KIND in U.S.
Draft Age and Older Men..

Come to the Great Shops of Coyne in Chicago. Get practical training in TELEVISION-RADIO or ELECTRICITY—vital in Defense Program. Prepare now for a better job or better service rating.

START NOW—PAY LATER
You can finance most of your tuition, pay for it later in easy monthly payments. Special plan for men of Draft Age. Part time employment service available.

FREE BOOK Clip coupon for Big Free Illustrated Book. Indicate below, course that interests you. No salesman will call. Act NOW.

COYNE [SCHOOL]
B. W. Cooke, President
A TECHNICAL TRADE INSTITUTE CHARTERED NOT FOR PROFIT
Established 1899
500 S. Paulina, Chicago

ELECTRICITY ★ TELEVISION
RADIO ★ REFRIGERATION ★ ELECTRONICS

B. W. COOKE, Pres.
COYNE School
500 S. Paulina St., Chicago 12, Ill. Dept. C2-81H

Send FREE BOOK and full details on:

TELEVISION-RADIO ELECTRICITY

NAME

ADDRESS

CITY STATE

ENGINEERS



Make this your home for important work under ideal conditions

- TV Receiver Design Eng.
- Test & Inspection Eng.
- Electronics Eng.
- Field Engineers
- Lab Technicians

TO WORK ON:

Radar, G. C. A., Mobile Radio, Auto Radio, Airborne Communication & Navigation Equipment, Television, Antennas, Microwave Equipment, Servo Mechanisms, Guided Missiles and Test Equipment.

YOU BENEFIT

from high wages, a modern, air-conditioned plant, paid vacations and holidays, group insurance and a good chance for advancement. Housing immediately available in the beautiful suburban and country areas that surround the Bendix plant.

Write Wire, Phone Mr. E. O. Cole, Dept. 5

Bendix Radio

DIVISION OF BENDIX AVIATION CORP.
BALTIMORE-4, MD.
Makers of the World's Finest Electronic Equipment

PROVE to yourself in 7 DAYS that you can PASS FCC RADIO EXAMS for AMATEUR and COMMERCIAL easily, quickly—or NO COST!

Only 15 Minutes A Day With This Amazing New "Hear and See How" Low Cost Home Study Method For Passing Amateur Code and Theory Exams and Commercial Code Exams. From \$7.95 With this method you ACTUALLY SEND and RECEIVE messages as you practice. You learn code and theory immediately from records and books, at your own convenience. Valuable sturdy Hand Key and High Frequency Buzzer Included FREE for practicing. Typical practice FCC code and theory exams included. FREE consultation privileges. Hundreds have received their licenses with these courses.

Write today for FREE information.

AMERICAN ELECTRONICS CO., Dept. RE-8
1451 Wilkins Avenue, New York 59, N.Y.—Tel. Dayton 9-4815

ELECTRONICS FOR COMMUNICATION ENGINEERS, by John McGraw and Vin. Zeluff. Published by McGraw-Hill Book Co., Inc., New York, N.Y. 8 1/4 x 10 3/4 inches, 610 pages. Price \$10.00.

This is a compilation of selected articles which have appeared in *Electronics Magazine* during the past 5 years. They have been edited and condensed. Seldom have such a wide variety of subjects and such solid information been published in one book. A total of 252 articles are presented.

There are 16 chapters, with such representative headings as: amplifiers, microwaves, filters, measurements, electronic music, oscillators, components. A list of contents names the various articles, gives page number and original publication date. The index lists by author as well as by subject matter. This makes it easy to locate any desired article.

This book is a good cross-section of recent electronic research, design and instrumentation. Many articles are practical in nature. Schematics, operating data and charts appear often. We find information on such practical topics as cathode followers, gated-beam circuits, sweep oscillators, voltmeters, transistors, thermistors, TV tuners and generators, a. f. filters, and others.

—IQ

RADIO AND TELEVISION RECEIVER TROUBLESHOOTING AND REPAIR, by Alfred A. Ghirardi and J. Richard Johnson. Published by Rinehart Books, Inc., New York, N.Y. 6 x 9 inches, 822 pages. Price \$6.75.

This volume is written for the practical man. Theory is given where needed, but attention is focused on proved methods for locating and correcting defects. It is well suited for radio beginners who know the basic principles of electricity.

The first half of the book (11 chapters) describes receiver components and their most common faults. Clues are given for locating noise, hum, and distortion, as well as that most-dreaded trouble, intermittent operation. Sepa-

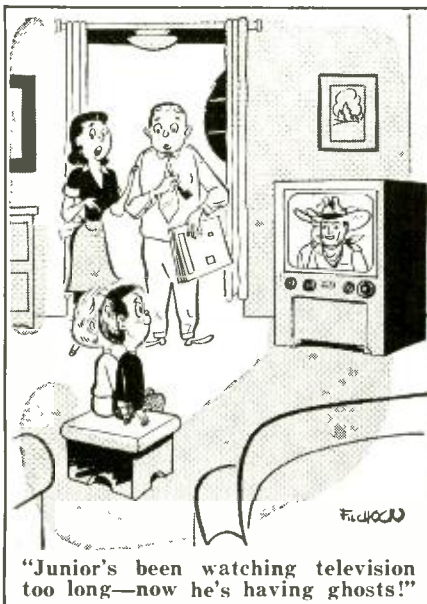

"Junior's been watching television too long—now he's having ghosts!"

STAN-BURN SPARKS

ANTENNAE SPECIALS

- CIRCLE X Limited quantities . . . \$2.98 each
- DOUBLE V 3/8" \$2.98 \$2.20
- DOUBLE V 3/8" Dowel 3.48 2.48
- DOUBLE V 1/2" Dowel 3.95 2.95
- 10 Element Conical 3/8" 3.55 2.55
- Folded Hi. Straight Low Quick
- Rig 1/2" elements 4.25 3.25
- WINDOW CONICALS 4.95 3.75
- MASTS
- 5 FOOT SWEDGED79 .69
- 10 FOOT PLAIN 1.39 1.29
- TV WIRE
- 55 MIL. 300 OHM \$14.95 M Ft.
- 72 OHM COAXIAL 48.00 M Ft.

CATHODE RAY TUBE SPECIALS

- 10BP4 Zetka . . . \$14.95 Federal. \$23.00
- 10BP4 N.U. . . . 19.95 17BP4A DuMont. 26.00
- 10BP4A N.U. . . . 19.95 19AP4 Sheldon. 29.95
- 12LP4 Zetka . . . 18.95 19AP4A GE. . . 39.95
- 12LP4A Thomas. 19.95 19P4A Thomas. 39.95
- 16AP4 Zetka . . . 26.00 20CP4A DuMont. 39.95
- 16AP4A G.E. . . . 38.00 20CP4A Sheldon. 37.00
- 16P4A Thomas. 28.80 21EP4A DuMont. 42.95
- 16GP4A Rauland. 33.00 24AP4A Sheldon. 63.00
- 16GP4 Zetka . . . 26.00 24AP4A GE. . . 76.00
- 16P4A Thomas. 28.80 21EP4A DuMont. 42.95
- 16RP4A GE & NU 26.00 Double ion traps. .59
- 16TP4A DuMont. 26.00
- CHASSIS 630 REGAL with Cascode Tuner. \$139.50
- 211 T3-FLY BACK (Similar to RCA) 2.98
- OPEN FACE CABINET 39.00

TRANSFORMERS

- RCA type for 16" to 24" X032 \$3.85
- G.E. Type for 16" to 24" X045 3.85

DEFLECTION YOKES

- Cosine Ferrite Todd Yoke 70" \$4.20

SPECIALS

- 4 Prong Vibrators, each \$1.29
- Lots of 12 or more 1.19
- Standard TV Tuners 18.95
- 12" Heavy Slug Speaker Special 4.98

AUDIO DEVICES and SCOTCH TAPE IN STOCK

- Audio Plastic Ixal Oxide Plastic tape—
- Half hour spool \$2.30
- One hour spool 3.30

WIRE RECORDERS IN STOCK

- WILCOX GAY—Model 2A10 \$89.97
- PENTON—Model 973C—2 spd. Tape Recorder . . . 134.50
- RADIO—Model RC2-HIF Amplifier 42.99
- CRAFTS—Model RC10—AM-FM Tuner 130.84
- MEN—Model C3—Williamson Amplifier 99.45
- CASCODE Guaranteed Tuners (with tubes) \$21.95
- Special, while they last.
- AUTHORIZED DISTRIBUTORS for:** General Electric, Kenrad, Tung-Sol, National Union, Jewel, DeWald, Regal, Automatic and Setchel Carlson.
- We carry a complete line of popular makes of radio and TV tubes, at 50% discount. Also many other special purpose and transmitting types, and all electronic parts and equipment at lowest prices.
- Send us list of your requirements for prompt quotations.
- Terms: 20% with order. Balance COD All prices FOB New York Warehouse. Minimum order \$5.00
- Write for our latest price list to Dept. RE-8

STAN-BURN RADIO and ELECTRONICS CO.
(C.A.S. THEATRE BLDG.)
1697 BROADWAY • NEW YORK 19, N.Y.

AUTOMATIC M-90 AUTO RADIO



- Six Tube Superheterodyne • Three Gang Condenser • Powerful, Long-Distance Reception • Fits All Cars, Easy Installation
- Mounting Brackets Included
- 6 Tube model M90 \$34.97
- 5 Tube Model A-15 \$28.76
- Above price includes Federal Excise Tax
- Approx. shipping weight either radio (11) eleven pounds

MAIL US YOUR ORDERS

All orders filled within 24 hours.
Standard Brand tubes 50% off list

Bill Sutton's Wholesale Electronics
Fifth at Commerce Fort Worth, Texas

When Writing Advertisers Please Mention Radio-Electronics

DEDICATED TO YOU!



This great new **EICO**
FACTORY... these **NEWEST**
EICO INSTRUMENTS...

YOU made them possible with your
CONFIDENCE in EICO. We pledge to strive
with all our power, product-wise and
service-wise, to continue to merit your
trust in us.

Harry R. Ashley
President



6 NEW V-O-M KITS and Instruments

FOR LABORATORY PRECISION AT LOWEST COST

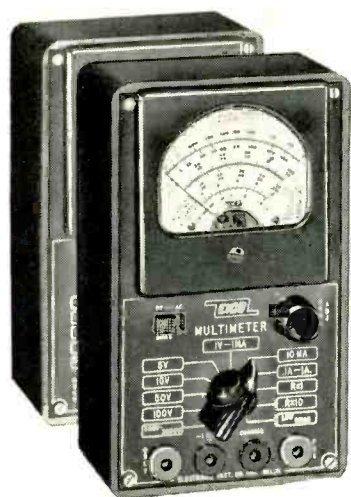

EICO New Model 536 —
1000 Ohms/Volt Multimeter
Wired \$14.90. KIT \$12.90.

- 31 full scale ranges!
- DC/AC Volts: Zero to 1, 5, 10, 50, 100, 500, 5000
- DC/AC Current: 0-1 ma, 10 ma; 0.1 A, 1 Amp.
- Ohms: 0-500, 100K, 1 meg.
- 6 DB Ranges: -20 to +69.
- Large 3" 400 ua meter movement.
- High-impact Bakelite case. 6¼ x 3¼ x 2".

EICO New Model 526 1000 Ohms/Volt Multi-
meter KIT \$13.90. Wired \$16.90. As above, with 1%
precision resistors.



EICO New Model 566 1000 Ohms/Volt Multimeter KIT
\$14.90. Wired \$18.95. Ranges: same as Model 536 (left), plus
7 output voltages. Large 4½" 400 ua meter movement.

EICO New Model 556 1000 Ohms/Volt Multimeter KIT
\$16.90. Wired \$23.50. Ranges: same as Model 536 (left), plus
7 output voltages. Large 4½" 400 ua meter movement and 1%
precision resistors.

Compare these value-crammed EICO V-O-Ms with
any others at any price—at your local jobber—and
SAVE! Write NOW for FREE newest Catalog 8CA

EICO New Model 565
20,000 Ohms/Volt Multimeter KIT \$24.95.
Wired \$29.95.

- 31 full scale ranges!
- DC/AC/Output Volts: 0-2.5, 10, 50, 250, 1000, 5000.
- DC Current: 0-100 ua; 10, 100, 500 ma; 10 Amp.
- Ohms: 0-2000, 200K, 20 meg.
- 5 DB Ranges: -12 to +55.
- Large 4½" 50 ua meter movement.
- High-impact Bakelite case. 6¼ x 5¼ x 3".

EICO New Model 555 20,000 Ohms/
Volt Multimeter KIT \$29.95. Wired
\$34.95. As above, with 1% precision res-
istors.

ONLY **EICO** GIVES YOU ALL
10 **EICO** NOMICAL FEATURES

- Laboratory Precision • Lowest Cost • Life-time Dependability • Speedy Operation
- Rugged Construction • Quality Components • Latest Engineering • Super-Simplified Assembly & Use Instructions • Laboratory-Styled Appearance • Exclusive EICO Make-Good Guarantee.



Prices slightly higher on West Coast. Due to unstable conditions, prices and specifications are subject to change without notice.

ELECTRONIC INSTRUMENT CO., Inc. 84 Withers Street, Brooklyn 11, New York

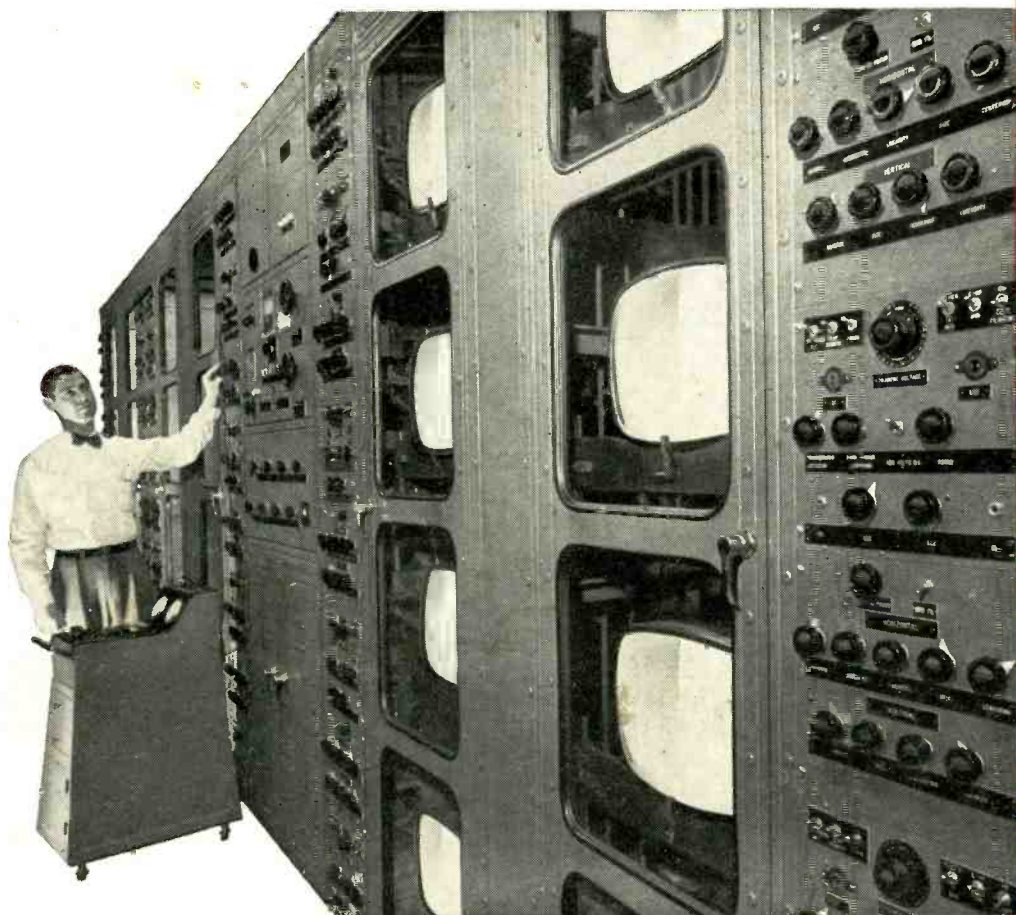

Specialized racks like these are used to life-test RCA Kinescopes.

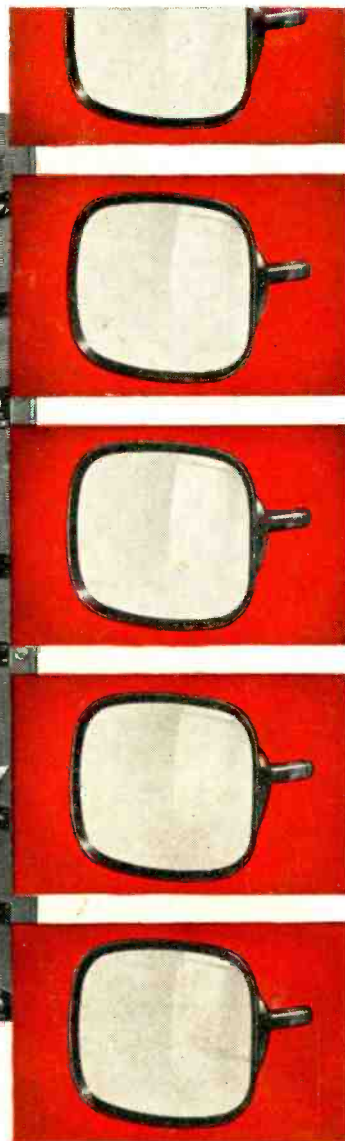

The Million-Dollar Test Equipment

... that pays off in better picture tubes

AT RCA's picture tube plants, constant vigilance over quality is maintained with specialized test equipment valued at well over one million dollars. This huge investment is one reason why RCA picture tubes are the best you and your customers can use.

In one phase of the quality-control program, random samples of picture tubes are taken directly from the pro-

duction lines and subjected to rigorous life tests in racks such as those shown. Any deviation from prescribed quality standards is promptly noted and corrected at the source. In addition, a portion of these samples is given an extended life test equivalent to *years* of actual service in the home.

RCA's constant vigilance at all stages of manufacture is your assur-

ance that only top-quality RCA Kinescopes leave the factory. In this way, RCA closely guards its own reputation . . . and yours as well.

With RCA Receiving Tubes, as well as RCA Kinescopes, TOP-QUALITY CONTROL makes the difference.



RADIO CORPORATION of AMERICA
ELECTRON TUBES

HARRISON, N. J.

TMKS. ®