

Antennas for Color TV

65

MASTER

HUGO GERNSBACK, Editor-in-chief

APR.

50c

Radio-Electronics

TELEVISION • SERVICING • HIGH-FIDELITY

~ 1 P 76

GERNSBACK PUBLICATION

**Hypersensitive
Light-Operated
Relay**

**New Life for
Old Auto Radios**

P. 39

TO AC

MANO = LIST - P 58

**Industrial
Electronics
For TV Men**

MABINE
P 56



**EASY-TO BUILD
Transistor Ignition**

See page 40

THOMAS VERESPILE 3-66
31 DATURA AVE
MILFORD CONN

TRIPPLET

EXTRA QUALITY IS HIDDEN*

MODEL 630 V-O-M PRICE † \$49.50

Standard Of The Industry

USES UNLIMITED:

- Field Engineers
- Application Engineers
- Electrical, Radio, TV, and Appliance Servicemen
- Electrical Contractors
- Factory Maintenance Men
- Industrial Electronic Maintenance Technicians
- Home Owners, Hobbyists

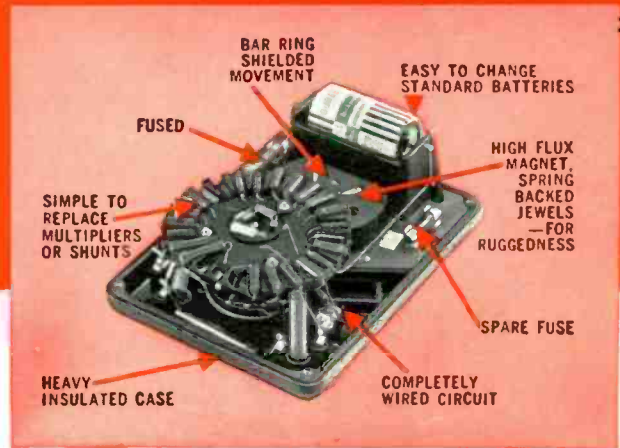
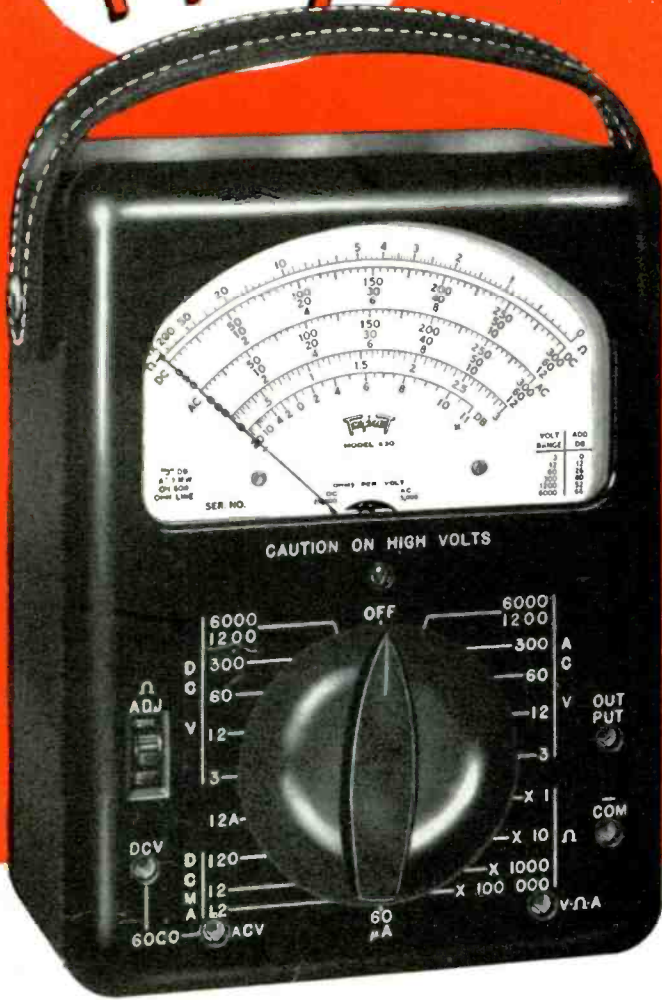

FACTS MAKE FEATURES:

- 1** Popular streamlined tester with long meter scales arranged for easy reading. Fuse protected.
- 2** Single control knob selects any of 32 ranges—less chance of incorrect settings and burnouts.
- 3** Four resistance ranges—from .1 ohm reads direct; 4½ ohm center scale; high 100 megohms.

Attention to detail makes the Triplet Model 630 V-O-M a lifetime investment. It has an outstanding ohm scale; four ranges—low readings .1 ohm, high 100 megs. Fuse affords extra protection to the resistors in the ohmmeter circuit, especially the X1 setting, should too high a voltage be applied. Accuracy 3% DC to 1200V. Heavy molded case for high impact, fully insulated

†630A same as 630 plus 1½% accuracy and mirror scale only \$59.50

TRIPPLET ELECTRICAL INSTRUMENT COMPANY, BLUFFTON, OHIO

RANGES

DC VOLTS	0-3-12-60-300-1,200-6,000 at 20,000 ohms per volt.
AC VOLTS	0-3-12-60-300-1,200-6,000 at 5,000 ohms per volt.
OHMS	0-1,000-10,000.
MEGOHMS	0-1-100.
DC MICRO-AMPERES	0-60 at 250 millivolts.
DC MILLI-AMPERES	0-1.2-12-120 at 250 millivolts.
DC AMPERES	0-12.

DB: -20 to +77 (600 ohm line at 1 MW).

OUTPUT VOLTS: 0-3-12-60-300-1,200; jack with condenser in series with AC ranges.

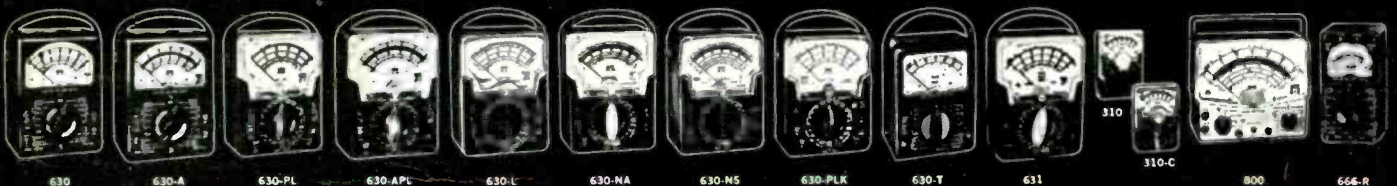

THE WORLD'S MOST COMPLETE LINE OF V-O-M'S. AVAILABLE FROM YOUR TRIPPLET DISTRIBUTOR'S STOCK

LOOK!

A New Electronics Slide Rule with Instruction Course

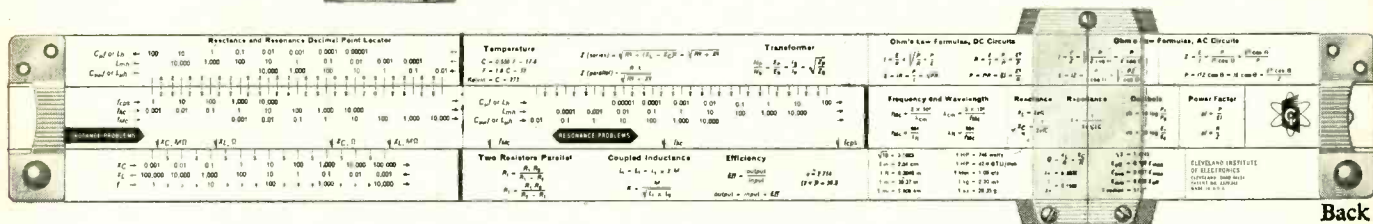
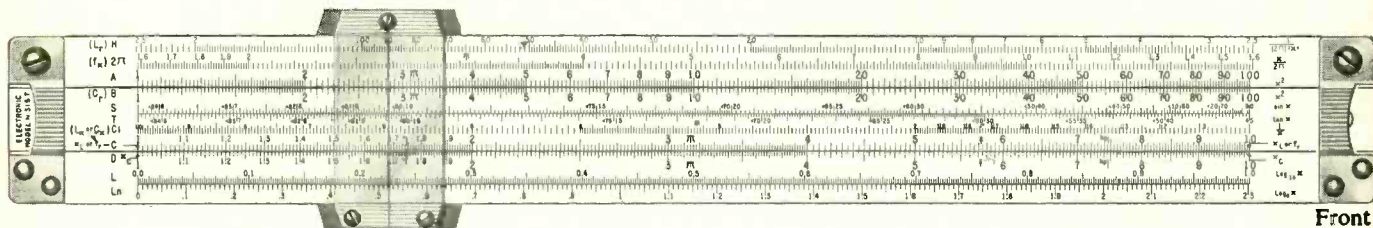

Here's the first truly professional slide rule designed especially for electronic engineers, technicians and students. No longer must you struggle along with a general purpose slide rule . . . this new CIE Electronics Slide Rule* will enable you to solve electronic problems quickly . . . accurately. It's an all-metal 10" measuring instrument that can be used for conventional computation, too.

This patented Electronics Slide Rule is made to our rigid specifications by Pickett Inc. . . . has special scales for solving reactance and resonance problems . . . locates decimal points . . . has widely used electronics formulas and conversion factors on the back of the rule for instant reference.

A four lesson AUTO-PROGRAMMED Instruction Course comes with each rule . . . includes clear diagrams and step-by-step explanations to make learning fast, easy. Several hundred practice problems deal with widely occurring situations in electronics . . . teaches many short cuts . . . lists the best settings for solving complex problems. Slide rule, instruction course and handsome top-grain leather carrying case . . . all yours for just \$14.95. Cleveland Institute of Electronics, Dept. RE-109, 1776 E. 17th St., Cleveland, Ohio 44114.

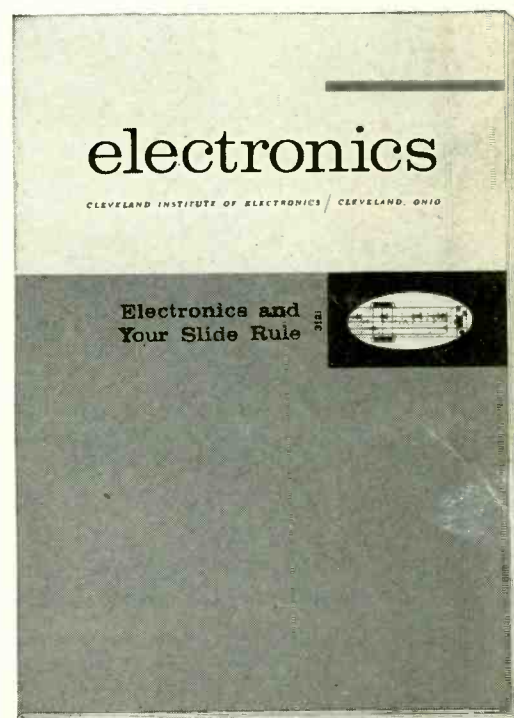

SATISFACTION Warranty

The Electronics Slide Rule with Instruction Course is available only from Cleveland Institute of Electronics, and is covered by CIE's exclusive "Satisfaction Warranty." Order it now . . . use it for ten full days. Then, if you're not completely satisfied, CIE will refund full payment. *U.S. Patent Number 3,120,342.

SEND COUPON TODAY

to: Cleveland Institute of Electronics

1776 East 17th St., Dept. RE-109 • Cleveland, Ohio 44114

Please send me your Electronics Slide Rule with Instruction Course and top-grain leather carrying case. I am enclosing \$14.95.

Please send descriptive brochure only . . . without obligation.

Name _____ (Please Print)

Address _____ County _____

City _____ State _____ Zip _____

A leader in electronics training . . . since 1934

Radio-Electronics

APRIL 1965 VOL. XXXVI No. 4

Over 55 Years of Electronic Publishing

GUEST EDITORIAL

- 33 The Future of CB Royden Freeland

ELECTRONICS

- 46 Basic Industrial Electronics for TV Men Jack Darr
Some very familiar circuits used in slightly less familiar ways
- 52 Hypersensitive Photoelectric Relay Lawrence Shaw
Two-transistor circuit has dozens of uses
- 56 More on the Boat's Electronics Elbert Robberson
Pre-season work almost every boat needs

GENERAL

- 24 Service Clinic Jack Darr
Odd Vertical Troubles
- 40 Single-Transistor Ignition System Vern E. Baker
Improves acceleration and extends point life
- 60 What's Your EQ? E. D. Clark

TELEVISION

- 19 Glossary of Color Terms Ed Bukstein
- 34 Antennas for Color TV Lon Cantor
What you should know about selecting and installing
- 54 Three-Dimensional Television Mohammed Ulysses Fips
Long-awaited advance in video technique

RADIO

- 39 New Life for Old Auto Radios Alex F. Burr
They make very respectable built-in AM sets
- 42 Pep Up Your Old FM Set Donald E. Phillips
Booster for older tuners builds right on set's own chassis
- 58 Japanese Transistor Radio and Tape Recorder Guide
Who has service information

TEST INSTRUMENTS

- 44 Time-Mark Generator for Your Scope Clifton W. Roberts
Make your scope a really accurate frequency meter
- 49 The Small World Peter E. Sutheim
Ten oft-ignored shop "right hands"
- 67 Equipment Report: Monterey ME-109 and American Electronic Laboratories 250
Square-wave maker; semiconductor circuit tester

AUDIO-HIGH FIDELITY-STEREO

- 36 What's Improved in Loudspeakers? Victor Brociner
A glimpse at recent developments in "sound transduction"
- 61 Equipment Report: Sonotone CM-1050WR and Acoustic Research AR-4
Wide-range low-impedance ceramic microphone; acoustic suspension speaker system

THE DEPARTMENTS

92 Correction
16 Correspondence
95 New Books
84 New Literature
93 New Patents

76 New Products
71 New Semiconductors & Tubes
6 News Briefs
89 Noteworthy Circuits

86 Technicians' News
73 Technotes
90 Try This One
88 50 Years Ago



Member,
Institute of High Fidelity
Radio-Electronics
Is Indexed In
Applied Science
& Technology Index
(Formerly
Industrial Arts Index)

HUGO GERNSBACK, editor-in-chief and publisher. M. HARVEY GERNSBACK, editor. Fred Shunaman, managing editor. Robert F. Scott, W2PWG, technical editor. Peter E. Sutheim, associate editor. Jack Darr, service editor. I. Queen, editorial associate. John J. Lamson, eastern sales manager. Wm. Lyon McLaughlin, technical illustration director.

GERNSBACK PUBLICATIONS, INC., 154 W. 14 St., N.Y. 10011. AL 5-7755. Board Chairman Hugo Gernsback. President M. Harvey Gernsback. Secy. G. Alliquo, Treas. Charles A. Raible

Choose Your Tailor-Made Course in N.T.S. "PROJECT METHOD" ELECTRONICS!

Now! N.T.S. — one of America's oldest leading home-study and resident technical schools — offers you **GREATER CAREER OPPORTUNITIES IN ELECTRONICS**. N.T.S. "Project Method" home training lessons are shop-tested in the Resident School in Los Angeles. You work on practical job projects, learn to use shop manuals and schematics. Your N.T.S. training is individual. You proceed at your own pace. The Schools' practical methods, plus more than 60 years of experience, have helped thousands of students all over the world to successful careers. Prepare now for a secure future in one of 8 N.T.S. Electronics Courses designed to fit your own particular needs.



Work on the electronic "brains" of industry — computers, data processing and other automation equipment. Become a TV-Radio Technician, an electronics field engineer, or succeed in your own business.

CHOOSE YOUR FIELD — INSURE YOUR FUTURE!

- 1 ELECTRONICS-TV-RADIO-SERVICING & COMMUNICATIONS** A basic course thoroughly covering fundamentals of electronics, radio, TV servicing and communications.
- 2 MASTER COURSE IN ELECTRONICS-TV-RADIO, PLUS ADVANCED TV & INDUSTRIAL ELECTRONICS** This course covers everything included in Course No. 1 plus Automation and every phase of the Electronics industry.
- 3 FCC LICENSE** Preparation for this government license essential for interesting jobs in radar, radio, television, communications, guided missiles, many others. Upon completion of this course, if you do not pass the FCC exam for a 1st Class Commercial Radiotelephone License your tuition will be refunded.
- 4 RADIO SERVICING (AM-FM-Transistors)** Train for radio sales and service with dealer or distributor.
- 5 TELEVISION SERVICING (Including Color)** Covers installation, adjustment, repair and servicing of black and white and color television... prepares you for your own sales and service business.
- 6 STEREO, HI-FI AND SOUND SYSTEMS** A growing field. Prepares you to build, install and service modern sound equipment for home or industry.
- 7 BASIC ELECTRONICS** Gives you the fundamentals you must know to build on for a future Electronics career. Also offers an excellent background for Salesmen, Purchasing Agents, and others in Electronics.
- 8 ELECTRONICS MATH** Simple, easy-to-follow instructions in the specialized math you need in many electronics jobs.

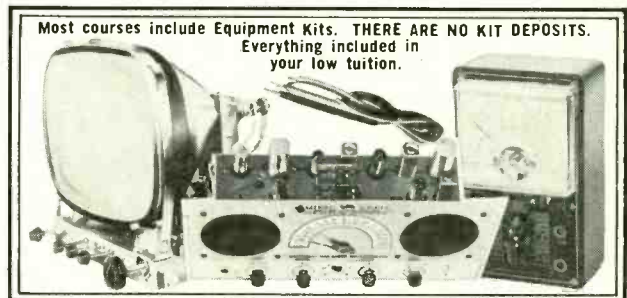

CLASSROOM TRAINING AT LOS ANGELES

You can take classroom training in our famous Resident School at Los Angeles in Sunny Southern California. N.T.S. is the oldest and largest school of its kind. Associate in Science Degree also offered in our Resident Program. Check Resident School box in coupon for full details.

HIGH SCHOOL AT HOME

Learn easily. New modern method. National also offers accredited high school programs for men and women. Take only subjects you need. Study at your own pace. Latest approved textbooks—yours to keep—everything included at one low tuition. Check High School box in coupon for information.



MAIL COUPON TODAY FOR FREE BOOK AND SAMPLE LESSON

In Field of Your Choice. You enroll by Mail — and Save Money. No Salesmen: This means lower tuition for you. Accredited Member N.H.S.C.



NATIONAL TECHNICAL SCHOOLS

4000 S. Figueroa St., Los Angeles, California 90037

Please Rush **FREE** Electronics "Opportunity Book" and actual sample lesson on course checked below:

- Electronics-TV-Radio Servicing & Communications
- Master Course in Electronics-TV-RADIO Advanced TV & Industrial Electronics
- FCC License
- Radio Servicing (AM-FM-Transistors)
- Television Servicing (Including Color)
- Stereo, Hi-Fi and Sound Systems
- Basic Electronics Electronics Math

Dept. 206-45

Name _____ Age _____

Address _____

City _____ State _____ Zip _____

- Check here if interested **ONLY** in Classroom Training at L.A.
- Check here for High School Department Catalog only.



4000 S. Figueroa St., Los Angeles, California 90037

NEWS BRIEFS

TWO LASERS LOCKED IN PHASE BY BELL LABS SCIENTISTS

Using techniques resembling those of afc in ordinary electronic circuits, two Bell Labs scientists have locked two lasers together in phase for the first time. This may make it possible to combine several low-power lasers in parallel to produce one high-power beam. It will also make possible detection refinements that can halve required transmitted power in experimental light communications systems, and will enable scientists to study the interactions of light waves from separate sources.

As seen in the drawing, laser beams were combined by a half-silvered mirror, which sent part of the combined beam to a screen and part to a photomultiplier. The output current from the photomultiplier is proportional to the instantaneous power of the combined light waves striking the photomultiplier surface. The current increases when the two light waves interfere constructively, and decreases when they interfere destructively. Thus, the value of the instantaneous current depends upon the



Inventor Louis Enloe examines the interference rings produced by two laser beams being transmitted at exactly the same frequency and with a constant phase difference.

phase difference between the two laser beams.

The voltage produced by the current is fed back through a dc amplifier (not shown) and a low-pass filter to a piezoelectric transducer which supports one of the mirrors for the resonator of the "receiving" laser (the one at the left end in the drawing). The varying voltage applied to the transducer changes the resonator length and thus the frequency of the laser. This forces the "receiving" laser to track the frequency and phase of the transmitting laser.

FIRST "CHROMATRON" SETS TO COME FROM JAPAN

Akio Morita, executive vice president of Sony Corp., announced that Sony is placing a nonshadow-mask 19-inch Chromatron color television receiver on the market in Japan. The first sets will be available some time in April or May, and they may be exported to the United States somewhat later, said Mr. Morita.

He also hinted at the possibility of selling Chromatron tubes, instead of completed receivers, to American or European receiver manufacturers.

PAY TV NOT THE ANSWER FOR PARTICULAR PATRONS

A "massive study" of pay-TV subscribers indicates that the problems of free TV still exist in the un-free type. The survey, published in part in the Jan. 30 *Business Week*, covered interviews with subscribers in Etobicoke (Ont.), Hartford, Los Angeles and San Francisco.

The average pay-TV family, it was found, watches no more than two pay shows per week, spends less than \$2 weekly, and is more interested in good movies and sports than theater and con-

certs. Those families which cancelled pay-TV, the report went on, were the heavier patrons of cultural events. They expressed themselves as being as disappointed in pay-TV as in its free counterpart.

JOHN HAYS HAMMOND JR. DIES

John Hays Hammond Jr., inventor of early remote radio-control apparatus and numerous other devices and techniques, died Feb. 12. His inventions included radio transmission systems, hi-fi amplifiers and other audio equipment, and even a teaching machine. He was 76 years old.

He sent an experimental yacht from Gloucester, Mass., to Boston and back by radio control as early as 1914, and continued his remote control work through radio-guided torpedoes in World War I to remote-controlled boats and planes for carrying instruments into the radioactive areas surrounding the Bikini atomic bomb tests in 1946.

He was active till at least as late as 1961, when he worked with the Navy to develop a station capable of transmitting to any point on the earth.

N.Y. ATTORNEY GENERAL WANTS TV SERVICE LICENSING

The Attorney General of New York State proposes that television service technicians be licensed on the basis of moral character, technical training and experience in the field.

To fight what he calls the "tinkering fringe element" among the thousands of competent technicians, Attorney General Louis J. Lefkowitz is recommending a bill in the New York State Legislature "to protect the qualified and honest TV repairman . . . and to weed out the incompetents and gyp repairmen."

Qualifications will include good moral character, technical training and experience. The bill was prefiled in the legislature by Senator Thomas Laverne (R) of Monroe County and Assemblyman John M. Burns (R) of New York.

SUNSPOT MINIMUM PAST

The sunspot cycle which began in 1954 and reached a record peak in March 1958 was declared definitely over, and the number of sunspots on the upgrade, about the beginning of the year. The actual number of sunspots was 15 for December and 18 for

continued on page 8

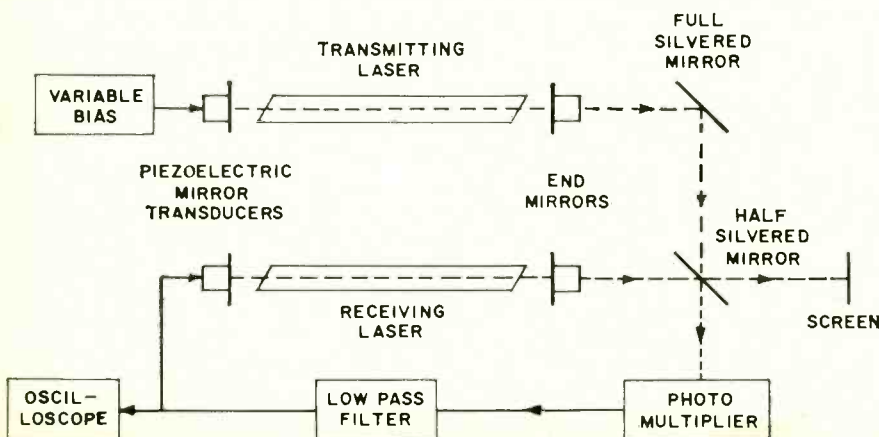



**50,000 MEN HAVE
FOLLOWED OUR ADVICE..
HOW ABOUT YOU?**

Profit and Grow as a DeVry-Trained Electronics Technician

"FOR REAL MONEY, A SOLID FUTURE AND EXCITING WORK, GET INTO THIS GREAT INDUSTRY!" — that's the kind of advice we've given ever since DeVry Tech started more than three decades ago. And our advice still holds true, for today's electronics industry is a multi-billion-dollar field, growing fast, calling for more and more trained men, offering some of the greatest opportunities in its history.

There is an air of excitement about electronics, whether you are in radio and television, space and missile electronics, communications, computer work, your own service business, or other branch of the field. Thousands of men much like yourself, men with ambition to be somebody — have learned electronics the DeVry way, either at home or in day or evening classes at one of our well-equipped resident schools. You, too, may keep your present job while preparing for a better one; make extra money in spare time while you learn. And . . . you don't need previous technical experience or advanced education to get started.

When you graduate, our efficient Employment Service will help you get started toward a good job, a promotion or a business of your own. Get the full story — no obligation! All you have to do is fill out the coupon and send it in.

MODERN TRAINING AIDS

"Programmed" texts
. . . visual aid training
movies . . . actual
equipment to build.
DeVry's programs are
designed with progress
in mind.

2,200 RESIDENT STUDENTS

DeVry Tech now has
2,200 resident students
attending day and
evening classes.

5,000 FIRMS HAVE EMPLOYED DeVRY GRADUATES

Our men are "wanted"
in many industries.
There must be a reason!

DeVry Technical Institute

Chicago • Toronto

FREE!



Get two valuable
booklets telling about
today's opportunities
in electronics.

MAIL THIS COUPON TODAY!

DeVRY TECHNICAL INSTITUTE

4141 Belmont Ave., Chicago, Ill. 60641, Dept. RE-4-V

Please give me your two free booklets, "Pocket Guide to Real Earnings" and "Electronics in Space Travel"; also include details on how to prepare for a career in Electronics. I am interested in the following opportunity fields (check one or more):

- | | |
|--|---|
| <input type="checkbox"/> Space & Missile Electronics | <input type="checkbox"/> Communications |
| <input type="checkbox"/> Television & Radio | <input type="checkbox"/> Computers |
| <input type="checkbox"/> Microwaves | <input type="checkbox"/> Industrial Electronics |
| <input type="checkbox"/> Automation Electronics | <input type="checkbox"/> Broadcasting |
| <input type="checkbox"/> Radar | <input type="checkbox"/> Electronic Control |

NAME _____ AGE _____

ADDRESS _____ APT. _____

CITY _____ ZONE _____ STATE _____

Check here if you are under 16 years of age.

Canadian residents: Write DeVry Tech of Canada, Ltd.

2097 970 Lawrence Avenue West, Toronto 19, Ontario

COMPLETE TUNER OVERHAUL

ALL MAKES—ONE PRICE

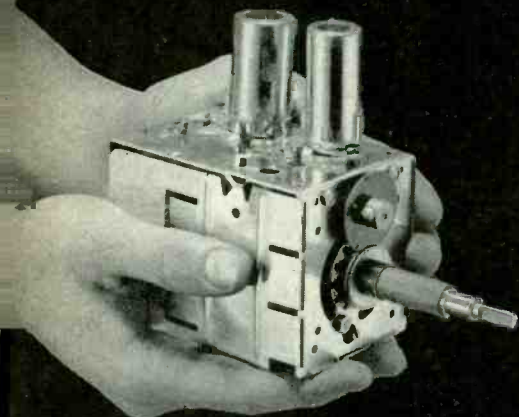

9.95

ALL LABOR AND PARTS (EXCEPT TUBES & TRANSISTORS)*



VHF



UHF



COLOR



U-V



COLOR TUNERS



TRANSISTOR

Guaranteed Color Alignment—No Addit. Charge

Simply send us the defective tuner complete; include tubes, shield cover and any damaged parts with model number and complaint. Your tuner will be expertly overhauled and returned promptly, performance restored, aligned to original standards and warranted for 90 days.

UV combination tuner must be single chassis type; dismantle tandem UHF and VHF tuners and send in the defective unit only.

Exact Replacements are available for tuners unfit for overhaul. As low as \$12.95 exchange. (Replacements are new or rebuilt.)

Pioneers in TV Tuner Overhauling

CASTLE TV TUNER SERVICE, INC.

MAIN PLANT: 5715 N. Western Ave., Chicago 45, Illinois
 EAST: 41-96 Vernon Blvd., Long Island City 1, N.Y.
 CANADA: 136 Main Street, Toronto 13, Ontario

*Major Parts are additional in Canada

NEWS BRIEFS continued

January (as compared with 3 in June and 4 in September, 1964).

Some students fear that—if experience with past cycles is a guide—the next sunspot maximum (expected in late 1968) will be considerably lower than the past two, with a consequent lowering of the highest frequencies useful for communication.

The exact bottom of the cycle—which is determined by an averaging process to exclude the effects of extraordinarily large or small numbers of sunspots in a given month—had not been determined at the beginning of the year. Professor Waldemeier of the Zurich Observatory reported it provisionally as occurring in October. American workers in the field, including J. H. Nelson of RCA Communications (who predicted an early sunspot minimum over a year ago) believe that the cycle may have bottomed as early as June.

EPITAXIAL TRANSISTOR PATENT AWARDED BELL SCIENTISTS

A patent on the method of making the epitaxial transistor and other improved semiconductor devices has been awarded to J. J. Kleimack, H. H. Loar and H. C. Theuerer of the Bell Telephone Laboratories. This important step in transistor fabrication was first announced by Bell Labs in 1960, and is now used to make a majority of transistors.

The heart of the epitaxial process is the vapor deposition and epitaxial growth of a very thin layer of a material, such as silicon, on a carefully prepared, single-crystal wafer of the same semiconductor that has been doped to have a lower resistivity. (The term

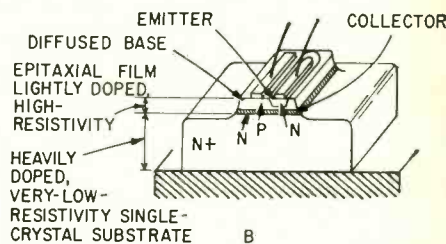
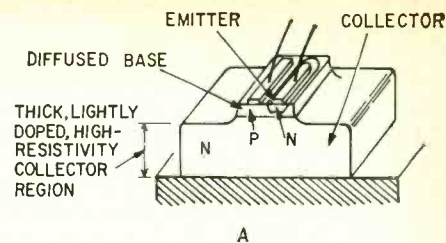

How the epitaxial differs from an ordinary transistor. In (A), a diffused-base transistor, the collector region's high resistivity and large size (necessary for mechanical strength) increase collector resistance and, through increased charge storage, switching time. In (B), high resistivity of the collector section has been confined to a very narrow epitaxial film, grown on and supported by a heavily doped, low-resistivity substrate, giving the same mechanical strength with much lower series resistance and switching time.

epitaxial means the layer grows with the same crystal structure orientation as the wafer.) After the layer is deposited, standard diffused transistor techniques are used to fabricate the emitter and base zones of the transistor within the grown layer. Since the thickness and resistivity of the grown layer can be easily controlled, the characteristics of the transistor or other device can be tailored as desired.

FM DUPLICATION TO END

Beginning Aug. 13, 1965, at least 50% of the program content of the FM affiliates of AM/FM stations in cities of over 100,000 population must be different from the AM programs. Many stations have simply duplicated AM programs on the FM station, thus making it, in effect, little more than a translator of the AM outlet.

HOME VIDEO TAPE RECORDER ANNOUNCED BY SONY CORP.

Sony is putting on the market in Japan a practical home video tape recorder, the model 2000. It uses a 1/2-inch tape moving at only 7 1/2 inches per second. The price will be about 200,000 yen (\$550, US).

The Sony Videocorder has a rotary two-head scanner and is capable of recording and playing back black-and-white television signals and sound.

continued on page 14

Advertising Representatives:

EAST John J. Lamson Eastern Sales Manager Radio-Electronics 154 West 14th Street New York, N.Y. 10011 (212) Algonquin 5-7755	MIDWEST P. H. Dempers Co. 740 North Rush Street Chicago, Illinois 60611 (312) Michigan 2-4245
---	--

SOUTHEAST

Neff Associates 15 Castle Harbor Isle Ft. Lauderdale, Fla. 33308 (305) Logan 6-5656	J. Sidney Crane, Assoc. 22 Eighth St., N.E. Atlanta, Ga. 30309 (404) Trinity 2-6720
---	--

TEXAS/ARKANSAS

Media Sales Co. 2600 Douglas Avenue, Irving, Texas 57060. (214) BLackburn 5-6573

WEST COAST/OKLAHOMA

Husted-Coughlin, Inc. 1830 W. 8th Street Los Angeles, Calif. 90057 (213) 389-3132	Husted-Coughlin, Inc. 444 Market Street San Francisco, Calif. 94111 (415) GARfield 1-0151
---	---

UNITED KINGDOM

Publishing & Distributing Co., Ltd., Mitre House, 177 Regent St., London W.1, England

Subscription Service: Postmasters: Address form 3579 and correspondence to Radio-Electronics, Subscriber Service, 154 West 14th Street, New York, N. Y. 10011. Subscribers: When requesting a change of address, please furnish an address label from a recent issue. Allow one month for change of address.

do

LIVE BETTER ELECTRONICALLY with LAFAYETTE RADIO ELECTRONICS

HI-FI AND CB EQUIPMENT Headquarters



NEW! LAFAYETTE 70-WATT COMPLETE AM-FM STEREO RECEIVER

Just Add Speakers and Enjoy FM, FM Stereo and High-Quality AM Reception

- A powerful 70-Watt Amplifier plus Complete Preamplifier Control Facilities plus a Standard AM Tuner plus a sensitive FM Tuner plus an FM Stereo Tuner—all on One Compact chassis
- Amazing FM "Stereo Search" Circuit Signals Presence of Stereo Broadcasts
- Tuned Nuvistor "Front End" provides Greater Sensitivity, Lower Noise
- Bar-Type Tuning Indicator for AM and FM
- Variable AFC Control
- Imported



TAKES REELS UP TO 7"

‡ adaptable to stereo playback

DYNAMIC MICROPHONE

THE WIDELY ACCLAIMED LAFAYETTE RK-137A TAPE RECORDER

FEATURING **4**-TRACK STEREO PLAYBACK‡
4-TRACK MONAURAL RECORD PLAYBACK

With Electronic Track Selector Switch, VU Recording Level Meter and Pause Switch For Instant Editing

Includes Lightweight carrying case, dynamic microphone, output cable, 7 inch empty tape reel.

- Two Speeds—3¾ & 7½ ips
- Pause Lever Provides Instant Stop for Editing
- Record—Erase Safety Switch
- Fast, Rugged Shift Lever Control
- Extension Speaker Jack
- High Impedance Monitoring Jack
- VU Meter Recording Level Indicator
- Electronic Track Selector Switch
- Specially Designed Heavy-Duty 6x4" PM Speaker
- Separate Erase and Record Heads
- Imported

Model HB-500
139⁵⁰
99-3027WX



Small . . . Quiet . . . Powerful!

NEW! LAFAYETTE SOLID-STATE DUAL CONVERSION 5-WATT CB TRANSCEIVER

With Authentic Mechanical Filter

- ✓ Only 3" high—fits easily in any car
- ✓ Special multi-stage noise limiting circuit ends problem of mobile noise
- ✓ The same output as the most powerful tube unit yet uses only 1/50th of the battery power

The Perfect Unit For Mobile!

- 12 Crystal Transmit and Receive Positions
- 23 Channel Tunable Receiver With Spotting Switch
- 3-Stage Transmitter Rated For Full Legal Power
- Dual Conversion Receiver with 5/10 μV Sensitivity
- Multi-Stage Automatic Noise Limiting Circuit
- Rugged Silicon Mesa Transistors
- Compact—3"Hx11¼"Wx6½"D
- 12V DC Mobile Operation (Negative or Positive ground)
- 117V AC operation when used with Matching Solid-State AC Power Supply (Optional at \$16.95)

Model LR-800
199⁵⁰
99-0005WX



Model RK-137A
89⁵⁰
99-1511WX

Model HB-400
169⁵⁰
99-3001WX

NEW! LAFAYETTE 23-CHANNEL 5-WATT CB TRANSCEIVER

Double Side Band Full Carrier

- ✓ 17-Tube Performance with 13 Tubes
- ✓ Low Noise Nuvistor "Front End"
- ✓ 5 Double-Tuned If Transformers
- ✓ Meets All FCC Requirements

With Advanced "Range-Boost" Circuit

- Frequency Synthesized Circuit Provides 23 Crystal-Controlled Transmit & Receive Channels—No Extra Crystals to Buy
- Continuous One-Control Channel Tuning
- Full 5-Watt Input
- Push-To-Talk Microphone & Electronic Switching
- Dual Conversion Receiver With 3/10 μV Sensitivity
- Delta Tuning Offers "Fine Tuning" of ±2.5Kc on Receive
- Illuminated "S" and RF Output Meter
- Variable Squelch, Variable Noise Limiter, AGC
- Built-in 117V AC & 12V DC Power Supply
- "Vari-Tilt" Mounting Bracket for Easy Mobile Installation
- Plug-in Facilities For Lafayette Selective Call Unit

FREE!

LAFAYETTE RADIO ELECTRONICS

1965 CATALOG NO. 650 516 PAGES!

See The Largest Selection in Our 44-Year History

- Stereo Hi-Fi — Famous Brands plus Lafayettes own Top-Rated Components
- Citizens Band Equipment
- Tape Recorders
- Ham Gear
- Radio's, TV's and Accessories
- P.A. Equipment; Intercoms
- Test Equipment
- Optical Goods
- Auto Accessories
- Musical Instruments

LAFAYETTE RADIO ELECTRONICS
Dept. JD-5 P.O. Box 10
Syosset, L.I., N.Y. 11791

- Send me the FREE 1965 Lafayette Catalog 650 \$..... enclosed; send me.....
(Prices do not include shipping charges).

Name.....
Address.....
City..... State..... Zip.....

You get more for your money from NRI-

America's oldest and largest Electronic, Radio-TV home-study school

Compare if you like. You'll find—as have so many thousands of others—that NRI training can't be beat. From the delivery of your first lessons in the remarkable, new Achievement Kit we send you, to "bite size," easily-read texts and carefully designed training equipment . . . NRI gives you more value.

Shown below is a dramatic, pictorial example of all of the training materials included in just one NRI Course. *Everything* you see pictured below is included in low-cost NRI training. Other major NRI courses are equally complete. Text for text, kit for kit, dollar for dollar—your best home-study buy is NRI.

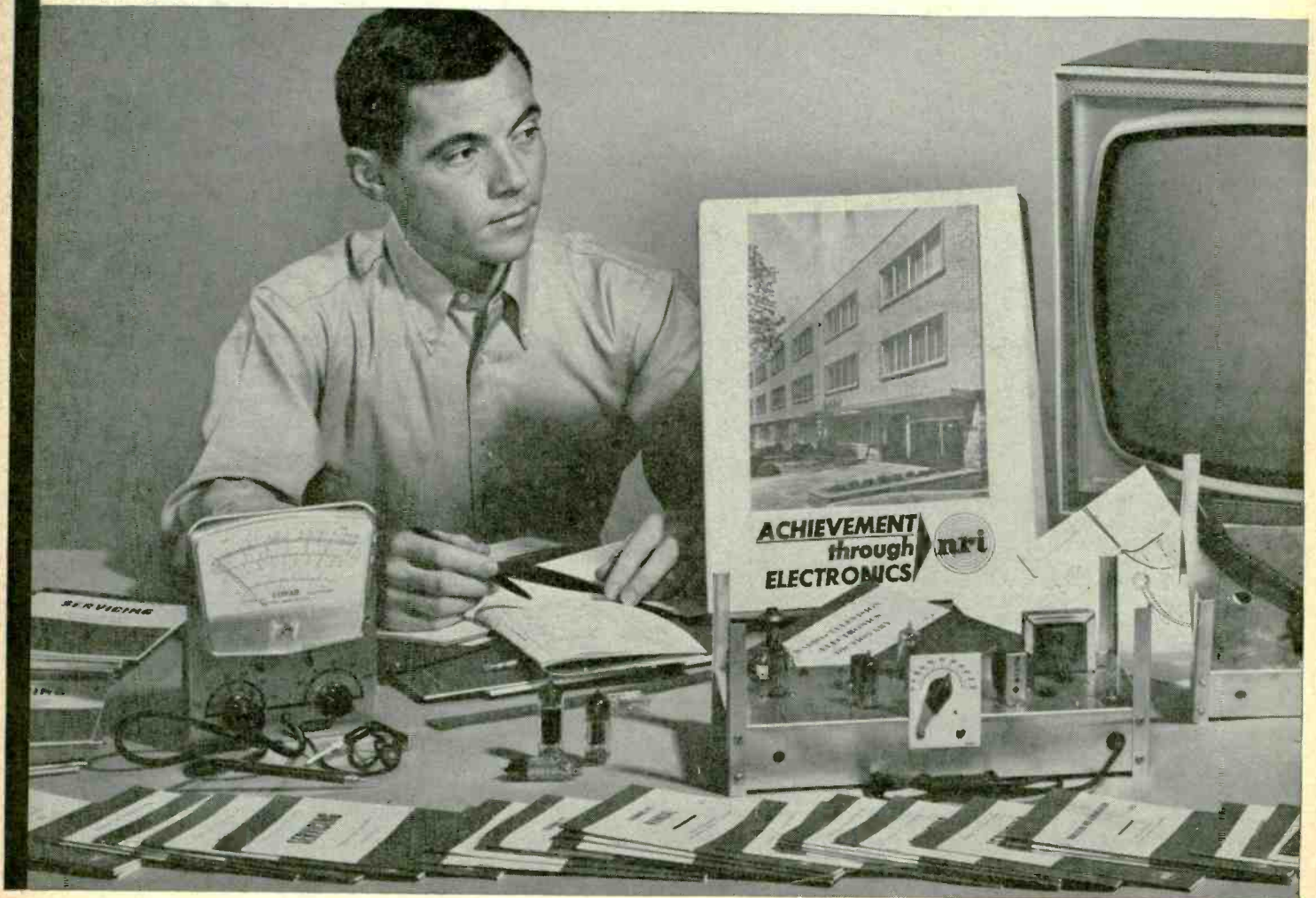

GET A FASTER START WITH NRI'S NEW EXCLUSIVE ACHIEVEMENT KIT

The day we receive your enrollment application we mail out your Achievement Kit. It contains everything you need to make an easy, fast start in the Electronics training of your choice. This attractive, new starter kit is an outstanding, logical way to introduce you to home-study as NRI teaches it . . . an unparalleled example of the value of NRI training . . . training that is backed up by a dedicated staff and the personal attention you should expect of a home-study school. It is your first of a number of special training aids carefully developed by the NRI laboratories to make your adventure into Electronics absorbing, meaningful. What's in the Achievement Kit? Your first group of lesson texts; a rich vinyl desk folder to hold your study material; the industry's most complete Radio-TV Electronics Dictionary; valuable reference texts; lesson answer sheets; pre-addressed envelopes; pencils; pen; engineer's ruler—even postage. No other school has anything like the NRI Achievement Kit.

LEARNING BECOMES AN ABSORBING ADVENTURE WITH NRI TRAINING KITS

Electronics comes alive with NRI training kits. What better way to learn than by doing it? That's why NRI pioneered and perfected the "home lab" technique of learning at home in your spare time. You get your hands on actual parts and use them to build, experiment, explore, discover. NRI invites comparison with training equipment offered by any other school. Begin NOW this exciting program of practical learning. It's the best way to understand the skills of the finest technicians—and make their techniques your own. Whatever your reason for wanting to increase your knowledge of Electronics . . . whatever your field of interest . . . whatever your education . . . there's an NRI instruction plan to fit your needs, at low tuition rates to fit your budget. Get all the facts about NRI training plans, NRI training equipment. Fill in and mail the attached postage-free card today. No salesman will call. NATIONAL RADIO INSTITUTE, Washington, D.C. 20016.

OUR 50th YEAR OF LEADERSHIP

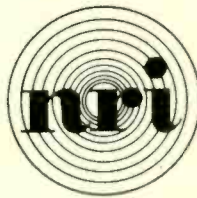

IN ELECTRONICS TRAINING

This is an example of material included in just one NRI course. Other courses are equally complete. But NRI training is more than kits and "bite-size" texts. It's also personal services which have made NRI a 50 year leader in the home-study field. Mail the postage-free card today.

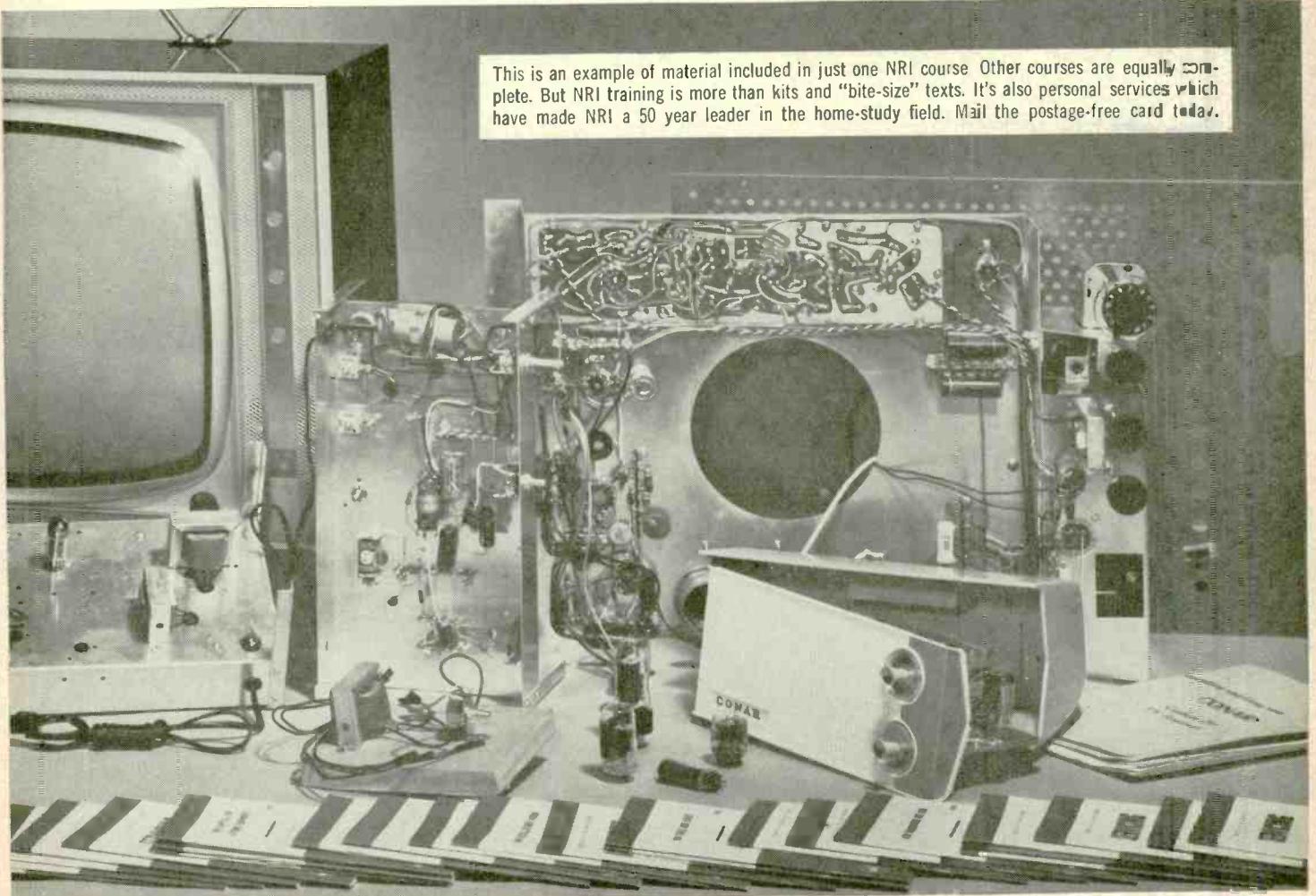

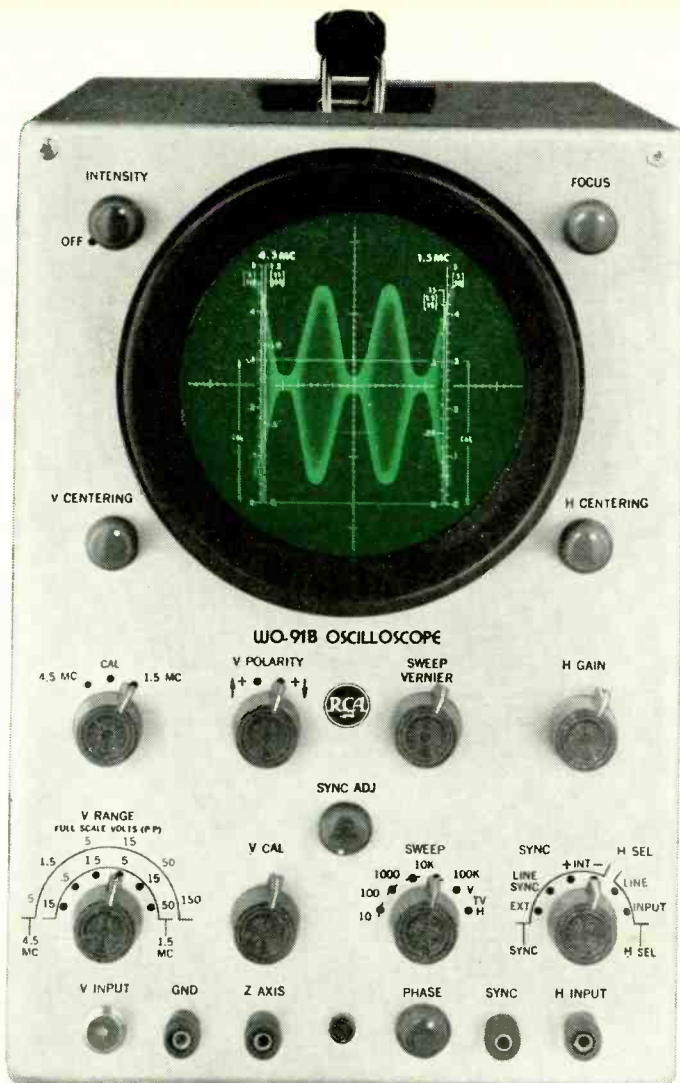

The famous RCA 5-inch scope
NOW WITH MORE FEATURES
TO SIMPLIFY YOUR JOB

Here's the latest model of the famous RCA 5-inch scope: the **NEW WO-91B**

- Provision for connecting signals directly to the vertical deflection plates of the CRT. Permits observation of high frequency RF waveforms, such as trapezoidal and wave-envelope modulation patterns.
- Two-stage sync separator simplifies checking of TV horizontal and vertical sweep synchronization... provides exceptionally solid lock-in action on composite TV signals.
- Choice of wide-band or high-sensitivity, narrow-band display.
- Complete with RCA WG-300B Direct/Low Cap. Probe and Cable.

• Optional at slight extra cost: RCA WG-354A slip-on capacitance-type voltage-divider probe that extends the range of the scope to permit observation of signal pulse amplitudes up to 5000 volts. RCA WG-302A slip-on RF/IF/VF signal tracing probe for RF applications from 100 Kc to 250 Mc.

- WO-91B Scope: **\$249.50***
- WG-354A Probe: **\$ 7.50***
- WG-302A Probe: **\$ 8.50***

Ask to see it at your Authorized
RCA Test Equipment Distributor.

*Optional distributor resale price. All prices subject to change without notice. Prices may be slightly higher in Alaska, Hawaii and the West.

RCA Electronic Components and Devices, Harrison, N. J.



The Most Trusted Name in Electronics

NEWS BRIEFS continued

The weight is 33 lb. It can record up to 63 minutes continuously.

No statement has as yet been made about plans to market the tape recorder in the United States, but it is extremely likely that it will appear here in the near future if the machine is a success in Japan.

CALENDAR OF EVENTS

IEEE International Convention, Mar. 22-25; Coliseum and New York Hilton Hotel, New York, N.Y.

National Electronics Week, Mar. 29-Apr. 4; 1965 Electronic Parts Distributors Show, Mar. 31-Apr. 4; New York Hilton and Americana Hotels, New York, N.Y. (Trade show—not for the public)

Colloque International sur les Techniques des Memoires (International Symposium on Techniques of Memories), Apr. 5-10; Paris, France

International Exhibition of Electronic Components, Apr. 8-13; Parc des Expositions (Fairgrounds), Porte de Versailles, Paris

National Telemetry Conference, Apr. 13-15; Shamrock Hilton Hotel, Houston, Tex.

1965 Electronics & Instrumentation Conference & Exhibit, Apr. 14-15; Cincinnati, Ohio

Symposium on System Theory, Apr. 20-22; Polytechnic Institute of Brooklyn, Brooklyn, N.Y.

19th Annual Frequency Control Symposium, Apr. 20-22; Shelburne Hotel, Atlantic City, N.J.

B & K Instrument Seminars: Apr. 26-30, 203 Jackson Building, 220 Delaware Ave., Buffalo, N.Y.; May 10-14, 1605 Chatham Ave., Charlotte, N.C.; May 17-21, 1845 Temple Dr., Winter Park, Fla.

BRIEF BRIEFS

French scientists of the Haute Province Observatory have bounced a laser beam off the American Explorer 22 satellite and measured its distance from the earth with an accuracy within 26 feet.

The United States Weather Bureau plans a weather data service, in which reports will be transmitted from buoys moored in inaccessible ocean areas to satellites passing over. The satellites will then retransmit the information when they reach spots within range of US meteorological stations. About 300 buoys are planned.

Radio Monte Carlo, now being heard in the United States occasionally on the broadcast band frequency of 1466 kc, is finishing a new 1200-kw long-wave broadcast station on 218 kc, which is to be the world's most powerful broadcast station. **END**

CALL FOR PAPERS

1965 NEC Technical Sessions on Consumer Electronics Oct. 25-27, McCormick Place, Chicago, Illinois. Sponsor: IEEE Audio, Broadcast/Television Receiver and Electron Devices Groups. Deadline for 75-word abstracts: May 3, 1965. Contact: James S. Aagaard, Electrical Engineering Dept., Northwestern University, Evanston, Ill. 60201.

you get **PRODUCT PLUS** *from your Sylvania Distributor*



“Go Places” with your Sylvania Distributor

An invitation to one of America's most famous resorts is waiting for you at your participating Sylvania Distributor's. Complete with excellent accommodations, professional entertainment, boating, dancing and other fun and sun features. Be our guest and show the Mrs. the time of her life.

Your Sylvania Distributor will be awarding week-

end holidays between now and May 31. So now is the best time to stock up for a busy spring and summer with the quality, fast-moving line of tubes. It may take you to your vacation paradise. Ask your participating Sylvania Distributor for details.

Electronic Tube Division, Sylvania Electronic Components Group.

SYLVANIA
 SUBSIDIARY OF
GENERAL TELEPHONE & ELECTRONICS GTE

NEW CAPABILITIES IN: ELECTRONIC TUBES • SEMICONDUCTORS • MICROWAVE DEVICES • SPECIAL COMPONENTS • DISPLAY DEVICES

TUNER REPAIRS

Includes ALL parts (except tubes)...
ALL labor on ALL makes for complete overhaul.

\$9.50



FAST, 24-HOUR SERVICE
with **FULL YEAR WARRANTY**

Sarkes Tarzian, Inc., largest manufacturer of TV and FM tuners, maintains two completely-equipped Service Centers, offering fast, dependable tuner repair service. Tarzian-made tuners received one day will be repaired and shipped out the next. More time may be required on other makes. Every channel checked and realigned per manufacturer's specs. Tarzian offers full, 12-month guarantee against defective workmanship and parts failure due to normal usage. Cost, including all labor and parts (except tubes), is only \$9.50 and \$15 for UV combinations. No additional costs. No hidden charges. You pay shipping. Replacements at low cost are available on tuners beyond practical repair.

Always send TV make, chassis and Model number with faulty tuner. Check with your local distributor for Sarkes Tarzian replacement tuners, parts, or repair service. Or, use the address nearest you for fast factory repair service.

S **SARKES TARZIAN, INC.**
TUNER SERVICE DIVISION

Dept. 200
537 South Walnut St.,
Bloomington, Indiana
Tel: 332-6055

Dept. 200
10654 Magnolia Blvd.,
North Hollywood, Calif.
Tel: 769-2720

MANUFACTURERS OF TUNERS, SEMICONDUCTORS,
AIR TRIMMERS, FM RADIOS, AM-FM RADIOS,
AUDIO TAPE and BROADCAST EQUIPMENT

Correspondence

S-- FEB P. 30

WE DIDN'T MEAN TO IMPLY . . .

Dear Editor:

May I congratulate Mr. Peter Sutheim and his article on "anonymous" loudspeakers.

I feel that you have definitely done the industry a service by reporting our obvious weaknesses, but I would like to point out that the use of the JBL registered corporate name is not allowed unless permission is obtained in advance.

Our name is used in the lead area of the article with some anonymous loudspeakers, and in the body of the article it was never pointed out that JBL is a manufacturer of long and outstanding quality in the industry.

T. J. JENNINGS

Director of Marketing

JBL International
Los Angeles, Calif.

QUESTIONS "ANONYMOUS" TESTS

Dear Editor:

The tweeter control should have been set at 9 o'clock, not at 12 o'clock (midposition) as it was for the tests. This would have lowered the 1-kc to 8-kc peak. From your charted response at 100 cycles, compared to that of the other speakers, the XAM-1D would appear to be a fabulous value at \$29.89. (5-year guarantee.)

For a fair comparison the AR-4 should be tested in the same room with the same equipment and the resulting curve published. (AR-4 sells for \$57.)

Assume you say "anonymous" referring to speakers enclosed. Are you positive of origin of speakers in name-brand advertised systems?

The RCA LC-1A, most common broadcast monitor, doesn't use inductance. Neither do we, in our crossovers. Using mass of cone [to effect crossover] just as legitimate as using bale of wire.

All other things equal, lowering cone resonance in same enclosure results in lower system resonance. XAM-1D's on sale at time your article appeared contained new model woofer and tweeter. Cone resonance [of woofer] was 30 cycles, is now 25 cycles in current product.

HAROLD WEINBERG

Audio Buyer, E. J. Korvette
New York, N. Y.

The author replies:

What we objected to was passing off low-price (and low-performance) speakers in company with high-quality, name-brand tuners, amplifiers and record players, causing the purchaser to believe that the speaker was of the same high quality, thus possibly destroying his confidence even in the reputable equipment he purchases, and damaging the reputation of the high-fidelity industry as a whole.

That the speakers may be worth the price paid for them is beside the point. They are inserted in the package deal to keep the price down and persuade the buyer that he is getting a bargain. The fact that, as one of the three makers stated, "those speakers are really worth only about \$12 each in package deals", makes the point beautifully. Even if you got them free they would be a waste.

PETER E. SUTHEIM

A MANUFACTURER COMMENTS

Dear Editor:

As one of the principal manufacturers of high-fidelity speakers in the industry, I read [Mr. Sutheim's] article with far more than casual interest.

There is no question that a great deal of the no-name merchandise being sold is shockingly inferior; some is so bad that its sale borders on fraud, in our opinion. But there is another class of private-label merchandise to which none of those epithets is applicable. Indeed, Electro-Voice and some of our most respected competitors are manufacturing private-label speakers and systems for certain dealers.

The principal objective of these private-label customers of ours is not to take advantage of the consumer, but to develop a line of proprietary products not readily discounted by competition. Generally, they seek, not to undersell someone with cheap merchandise, but to find a unique product they alone will sell. When we make such a product, we give it the same attention we give a standard Electro-Voice product.

I know from personal contact that E. J. Korvette's has made a genuine effort to have the XAM represent good value to its customers. Our specific criticism of XAM products is not so much the individual speaker systems, which frequently represent very fine value for the money, but rather Korvette's insistence on combining them with electronics that in our opinion calls for higher-priced speaker systems of better quality. There is nothing to say that a \$20 XAM speaker might not be excellent value for \$20.

Most of the manufacturers of downright dishonest merchandise have gone out of business, and those who persist will follow them. The consumer seems to be quite adept at seeking out

FULL COLOR TV COVERAGE IN PHOTOFACT[®]

gives you up-to-the-minute servicing know-how!

COLOR TV COVERAGE AVAILABLE IN PHOTOFACT THROUGH FEBRUARY 1965.*

Photofact Set	Brand	Photofact Set	Brand
252	RCA Victor	640	RCA Victor
259	Westinghouse	643	Andrea
262	Arvin	644	Westinghouse
265	Stromberg-Carlson	650	DuMont
283	Motorola	653	Magnavox
293	CBS-Columbia	655	Silvertone
299	Spartan	658	Sylvania
300	RCA Victor	660	Bradford
305	Hoffman	663	Zenith
314	RCA Victor	665	Curtis Mathes
320	Sentinel	670	Coronado
323	Magnavox	673	RCA Victor
324	Airline	678	General Electric
327	Capehart	680	Airline
344	Sentinel	683	Philco
346	Philco	685	Packard-Bell
353	RCA Victor	688	Zenith
357	Westinghouse	690	Westinghouse
358	RCA Victor	693	Sylvania
371	Motorola	695	Motorola
378	Raytheon	698	Philco
382	Truetone	700	Airline
383	Admiral	703	Admiral
385	Hoffman	705	Zenith
386	Packard-Bell	708	Magnavox
388	Silvertone	710	Magnavox
399	RCA Victor	713	Silvertone
412	Emerson	715	Setchell-Carlson
433	RCA Victor	716	Truetone
437	Westinghouse	717	Penncrest
459	RCA Victor	719	Emerson
495	Admiral	721	Motorola
517	RCA Victor	722	Zenith
540	Admiral	724	DuMont
546	Packard-Bell	726	Coronado
565	General Electric	727	Muntz
576	DuMont	729	General Electric
584	Silvertone	731	Olympic
588	Magnavox	732	Electrohome
592	Emerson	734	Andrea
596	Olympic	736	RCA Victor
599	Zenith	737	Catalina
614	Packard-Bell	739	Motorola
626	Sylvania	741	AMC
627	Delmonico		

* An average of 3 Color TV chassis now covered monthly in current PHOTOFACT

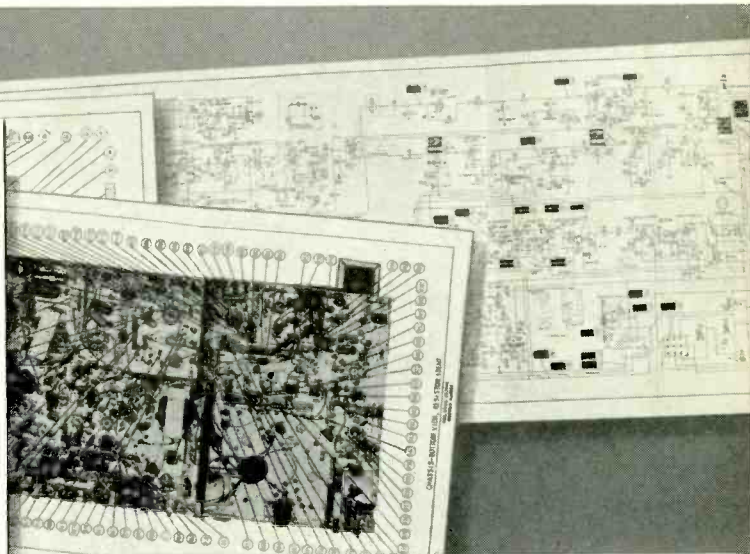

HAVE EVERYTHING YOU NEED TO PERFORM EXPERT PROFITABLE COLOR TV SERVICING!

- Famous SAMS "Standard Notation" Detailed Schematics
- Chassis View Photos
- Disassembly Instructions
- Set-up Adjustments
- Full Alignment Data
- Resistance Charts
- Tuner Schematics
- Block Diagrams
- Waveform Diagrams
- Tube Placement Charts
- Complete Parts Lists

Plus dozens of other invaluable PHOTOFACT features

FOR THE COLOR TV COVERAGE YOU NEED, check your latest PHOTOFACT Master Index—the issue dated February, 1965 includes a special section listing all Color TV makes and models now covered in PHOTOFACT—so you can instantly locate the Color TV PHOTOFACT Folder you want. See your Sams Distributor—he stocks all PHOTOFACT Sets to fill your requirements immediately.

NOW MORE THAN EVER—A PHOTOFACT LIBRARY AND SUBSCRIPTION PAYS OFF!

FREE

Deluxe new 4-drawer File Cabinet (full-drawer suspension) worth \$55—now available with your purchase of a PHOTOFACT LIBRARY consisting of 200 Sets (plus a selection of valuable Free extras!)

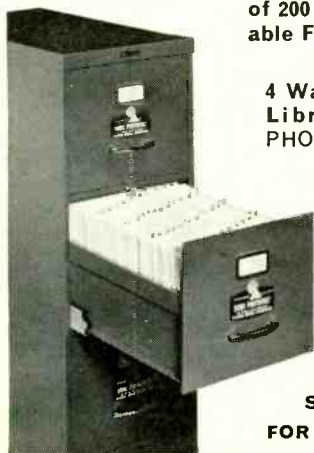

4 Ways to Select Your PHOTOFACT Library: 1. Complete your present PHOTOFACT Library. 2. Order a "Starter" Library—200 Sets (Nos. 401-600—coverage from 1958 to 1963—only \$12.66 per month). 3. Order by brand name and year—see handy selection chart at your Distributor. 4. Order a complete PHOTOFACT Library—get FREE file cabinets, plus a selection of valuable books and Electronics Courses.

SEE YOUR SAMS DISTRIBUTOR FOR FULL DETAILS, OR MAIL COUPON

OWN A PHOTOFACT LIBRARY THE EASY-BUY WAY

Only \$10 down • 30 months to pay • No interest or carrying charges • Prepaid transportation • Add-on privilege of a year's advance subscription to current PHOTOFACT on the same Easy-Buy contract • Save 30c per Set—special \$1.95 price applies on Easy-Buy (instead of the regular \$2.25 price).

HOWARD W. SAMS & CO., INC.

Howard W. Sams & Co., Inc. Dept. REF-4
4300 W. 62nd St., Indianapolis, Ind. 46206

- Send FREE Photofact Cumulative Index.
 Send full details on Easy-Buy Plan.

My Distributor is: _____

Shop Name _____

Attn. _____

Address _____

City _____ State _____ Zip _____

short, short story
about a great new mobile cb antenna:

Capacity-matched
to car body for
excellent, low
VSWR.

Fine-tuning
adjustment

brand new loading
techniques for
more effective
center loading

rugged, professional-
type 2½" stainless
steel shock spring

the
beauty of
this baby
is its
18" length!

At last—a high-performance mobile CB antenna you can mount on your roof where it belongs, without making your car look like a space satellite!



M-130
"Mighty Mite"
¾" snap-in mount—
no soldering

M-131
"Maggie Mite"
Gutter clip mount—
hang it anywhere



M-130
"Mighty Mite"
18" Mobile CB antenna

the antenna  specialists co.

12435 Euclid Ave., Cleveland, Ohio 44106

A division of A/S Industries, Inc.

Export Div.:
64-14 Woodside Ave.,
Woodside 77, N.Y.

"stripes of quality" 

23
TRAM

Citizen's Band
TRANSCEIVERS
Mobile & Base

TRAM ELECTRONICS
INCORPORATED

P. O. BOX 187, WINNISQUAM, N. H.

ENGINEERED FOR TOP PERFORMANCE
MANUFACTURED FOR QUALITY
GUARANTEED FOR RELIABILITY

BEFORE YOU BUY—CHECK THE SPECS... WRITE TO:

GOING TO THE N.E.W. SHOW? SEE US AT BOOTH N-25

quality goods and distinguishing them from dishonest value. At Electro-Voice we test a great deal of competitive merchandise, and we find that many so-called reputable manufacturers overstate the facts to a degree that would put them in precisely the same category as some of the anonymous speaker manufacturers referred to in the article.

LAWRENCE LEKASHMAN
Vice President, Sales

Electro-Voice, Inc.
Buchanan, Mich.

A READER COMMENTS

Dear Editor:

I have never felt that I had to write to a magazine as much as I do today. First, I want to express my appreciation of your article on "anonymous" speakers.

The article was long overdue and supports my idea that selling this kind of equipment is doing a disservice to the entire component market. As Larry LeKashman of Electro-Voice recently said, "What do we in the component field have to offer that is different from the so-called package system?—versatility, value for the dollar, excellent sound."

With these prepicked systems including the "anonymous" speakers, the versatility is gone because the system is prepackaged, the value is gone, and the sound, ugh!

To combat my New York competition, I have put together my own "garbage" system (with the R & A speaker, which is not bad for the price), but I do not offer it as a quality system. I use it to sell against. A customer walks in to discuss a system, and asks about the one he saw advertised in the *New York Times* by one well known perpetrator of this junk. I tell him that if he wants junk, I've got it. I call my system the Mark I. I then show him the difference between the \$70-a-pair Mark I and an inexpensive name-brand speaker. I am happy to say I have never had to sell a Mark I. I hope I never will. But if I do, be assured that I will mark in pencil the speaker phasing and impedance, and state that it is "garbage".

BOB BONOFF

Greenwich Radio/Television Co.
Greenwich, Conn.

END

The electronics industry will come in for a share of President Johnson's antipoverty project for training unskilled and idle youths. Two centers will operate: at Federal Electric in Paramus, N.J., in cooperation with Rutgers University, and at Tongue Point Naval Station in Oregon, to be operated by the University of Oregon and the Philco Corp.

Glossary of Color Terms

By ED BUKSTEIN

Final section. The first two appeared in the January and February issues.

phase detector: A circuit that compares the burst signal and the local 3.58-mc oscillator of the receiver. If they differ in frequency or phase, the phase detector produces a correction voltage, which is applied to a reactance tube to correct the phase or frequency of the local oscillator.

phosphor-dot screen: A glass plate containing small dotlike deposits of phosphor. The dots are deposited in groups of three, each containing a red-, a blue- and a green-light-emitting dot. The three electron beams of the color picture tube are so adjusted that one strikes only red dots, another strikes only green, and the third strikes only blue.

phosphor trio: A group of three phosphor dots (red, blue and green). For each such group there is one hole in the aperture plate through which the three electron beams can pass. The intensity of the three beams can be varied independently so that any or all of the three colors can be combined in various proportions to produce other colors.

primary colors: Colors which can be combined in various proportions to produce a wide range of other colors, but which cannot themselves be produced by mixing other primaries. Red, green and blue are the primaries in color TV. (See **additive primaries**.)

purity: The condition in a color picture tube when the electron beam from the red gun strikes only red phosphor dots, the blue beam strikes only blue dots, and the green gun only green dots.

purity magnet: A magnet mounted on the neck of the picture tube and used to direct the electron beams for good purity. (See **purity**.)

Q demodulator: A demodulator circuit whose inputs are the chrominance signal and the signal from the local 3.58-mc oscillator after it has been shifted 90°. This phase shift is necessary so that the local signal will be an accurate representation of the Q subcarrier that was suppressed at the transmitter. Output of the Q demodulator is a color video signal representing colors in the televised scene. (See **I demodulator**.)

Q signal: A color information signal produced at the transmitter by combining portions of the outputs of the red, green and blue cameras. This Q signal is then converted to sidebands of a 3.58-mc subcarrier (the subcarrier modulated by the Q signal is 90° out of phase with the subcarrier modulated by the I signal). At the receiver, the sidebands are reconverted to color video signals. (See **I demodulator**.)

rainbow generator: A test instrument whose output, applied to a color TV receiver, produces a continuous spectrum of colors across the screen.

reactance tube: The tube that controls the frequency and phase of the 3.58-mc oscillator in the receiver. Responding to correction voltage supplied by a phase detector, the reactance tube adjusts the phase and frequency of the oscillator. (See **apc**.)

red gun: The electron gun whose beam, when properly adjusted, strikes only red phosphor dots in the color picture tube.

red video voltage: The signal voltage that controls the grid of the red gun in a three-gun picture tube. This signal is a reproduction of the output from the red camera at the transmitter.

ringing circuit: In some color receivers, the 3.58-mc oscillator operates continuously. In others, the burst signal is used to shock-excite a quartz crystal. Because of its high Q, the crystal continues to vibrate (ring) until the next color burst arrives.

R - Y signal: A color-difference signal representing the difference between the brightness signal (Y) and the output of the red camera. In the receiver, the brightness signal can be added to the R - Y signal to produce $R - Y + Y = R$. This R signal controls the red gun of the picture tube.

saturation: The extent to which a color is undiluted by white. High-saturation colors are deep and brilliant; low-saturation colors are soft and pale. Red and pink, for example, are the same hue at different levels of saturation. Deep red contains very little white and is therefore highly saturated. Pink contains a considerable amount of white and is therefore low in saturation.

continued on page 22

ASSEMBLE YOUR OWN ALL-TRANSISTOR *Schober* ELECTRONIC ORGAN



3 NEW MODELS
Recital \$1500
Console II \$850
Spinet \$550

This is the all-new, all-transistor Schober

Recital Model... the most versatile electronic organ available today. Its 32 voices (plus amazing "Library of Stops"), 6 couplers and 5 pitch registers delight professional musicians... make learning easy for beginners. Comparable to ready-built organs selling from \$5000 to \$6000.

The pride and satisfaction of building one of these most pipe-like of electronic organs can now be yours... starting for as low as \$550. The Schober Spinet, only 39 1/4 inches wide, fits into the smallest living room. The new, all-transistor Schober Console II is the aristocrat of "home-size" organs... with two full 61-note manuals, 17 pedals, 22 stops and coupler, 3 pitch registers and authentic theatre voicing.

AND YOU SAVE 50% OR MORE BECAUSE YOU'RE BUYING DIRECTLY FROM THE MANUFACTURER AND PAYING ONLY FOR THE PARTS, NOT COSTLY LABOR.

It's easy to assemble a Schober Organ. No special skills or experience needed. No technical or musical knowledge either. Everything you need is furnished, including the know-how. You supply only simple hand tools and the time.

You can buy the organ section by section... so you needn't spend the whole amount at once.

You can begin playing in an hour, even if you've never played before—with the ingenious Pointer System, available from Schober.

Thousands of men and women—teenagers, too—have already assembled Schober Organs. We're proud to say that many who could afford to buy any organ have chosen Schober because they preferred it musically.

Send for our free Schober Booklet, describing in detail the exciting Schober Organs and optional accessories; it includes a free 7-inch "sampler" record so you can hear before you buy.

THE Schober Organ CORPORATION

43 West 61st Street, New York, N.Y. 10023

Also available in Canada, Australia, Hong Kong, Mexico, Puerto Rico, and the United Kingdom

THE SCHOBER ORGAN CORP., Dept. RE-36
43 West 61st Street, New York, N.Y. 10023

- Please send me FREE Schober Booklet and free 7-inch "sampler" record.
- Enclosed find \$2.00 for 10-inch quality LP record of Schober Organ music. (\$2.00 refunded with purchase of first kit.)

Name _____

Address _____

City _____ State _____ Zip No. _____



247 WAYS TO MAKE MORE

From now on, color-TV work is going to bring in a bigger and bigger part of your income. And RCA has EVERYTHING to make color-TV service MORE PROFITABLE for you.

To save you money and manhours.

To increase your efficiency so you can get more jobs out in the same time.

To eliminate those time-wasting extra phone calls and trips to the distributor.

Take the famous RCA Color-TV Test Jig (large unit at right). It cuts manhours in half on a color house call. With-

out it, when you have to pull a set into the shop, it takes two men. With it, it takes just one (you pull the chassis only—leave the color tube and the cabinet). That means MONEY ... extra money for you.

Take the RCA Color Parts Rack (large unit at left). The rack is FREE when you buy the basic complement of 120 most-needed color service parts. Keeps your color parts neatly organized, all in one place. Simplifies restocking, lets you know what you're short of. No more running out of a vital part just when you need it—which slows down a job.

28

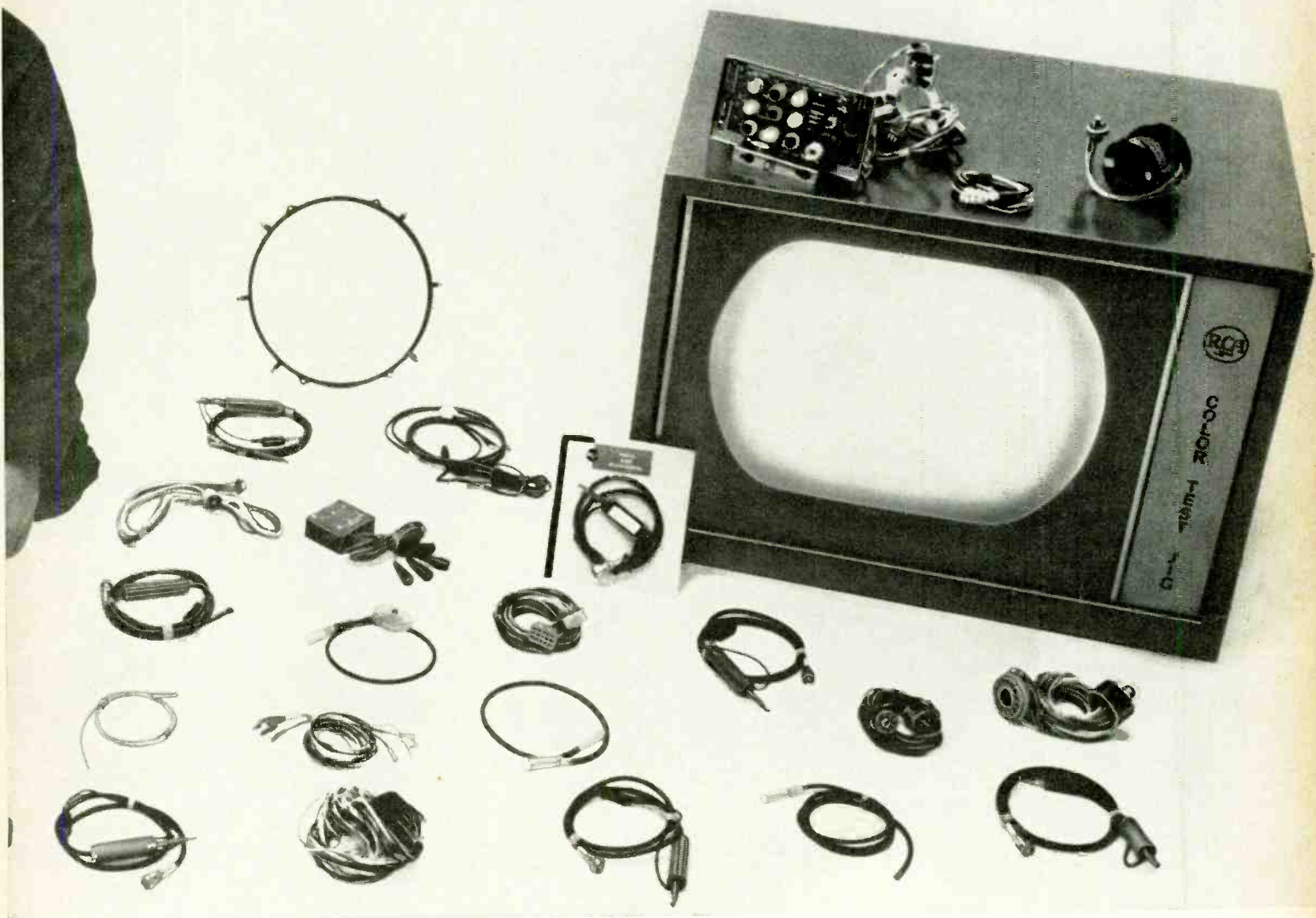

MONEY IN COLOR-TV SERVICE

That means MONEY...extra money for you.

Take the other color service parts arrayed in the photo and listed at right. Degaussing coils, transformers, chokes, yokes, connectors, cables, replacement parts...each with a special function to save you time, to increase the quality and accuracy of your work, to help you cut down on call-backs. That means MONEY...extra money for you!

245 specialized color service parts in all. The Rack and the Jig make it 247. And all of them mean MONEY...extra money for you.

RCA PARTS AND ACCESSORIES, DEPTFORD, N. J.



The Most Trusted Name in Electronics

RCA Parts and Accessories for color-TV service include:

Color Test Jig—to test all RCA color-TV chassis • *Color Parts Rack*—sturdy, well-organized unit containing complement of 120 most-needed color-service parts • *Degaussing coils*—to demagnetize picture tube and chassis • *Special-purpose extension cables*—to extend kinescope socket, deflection yoke, convergence magnet and kinescope high-voltage leads when chassis is removed from cabinet for servicing • *Special alignment probes*—video detector test blocks, IF test blocks, sound detector test blocks, mixer grid matching pad, tuner IF input head • *High-voltage interlock plug*—to by-pass high-voltage shorting switch • Plus sockets, transformers, fixed and variable capacitors, reactors, resistors, diodes, switches, coils...EVERYTHING to save you time and make more money for you in color-TV service.

Have you tried new **QUIG**[®] connectors?

Not just another wire spring connector!
 The 3-in-1 QUIG is brand new and different . . .
 Copperweld wire inner core, a layer of flux, and
 an outer jacket of solder . . . all you need is heat!
Makes one-handed soldering possible!

Once again, Sprague helps the TV-radio service industry by solving two increasingly serious problems . . . parts replacement in those "inaccessible" chassis nooks, such as crowded tube sockets, as well as soldering onto the delicate circuitry of printed wiring boards.

Mechanically sturdy and electrically reliable, the revolutionary QUIG provides fast, expertly-soldered connections as easy as A-B-C!

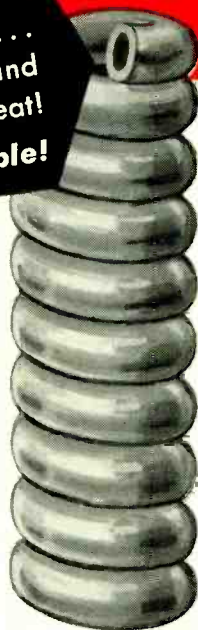

Ten times
actual size

GLOSSARY continued

shadow mask: A thin metal plate mounted slightly behind the phosphor-dot screen of the color picture tube. The shadow mask contains many small openings through which the electron beams bombard the phosphor dots. (See **aperture plate**.)

static convergence: See **dc convergence**.

subcarrier: A signal that is modulated by a lower frequency and then used to modulate a higher frequency. Two subcarriers are employed in color TV, both of the same frequency (3.58 mc) but 90° out of phase. One subcarrier is modulated by the I signal and the other by the Q signal. The sidebands of the modulated subcarriers modulate the picture carrier of the channel.

synchronous detector: A detector circuit, one of whose inputs is a locally generated signal which represents a signal suppressed at the transmitter. (See **I demodulator**.)

white: For color TV, white is a mixture of red, green and blue. In the picture this is produced by exciting all three dots in each phosphor trio. Since the eye cannot distinguish the individual dots, the mixture appears white.

Y signal: A signal containing luminance information (see **brightness signal**).

X and Z demodulation: A system of demodulation in which the two reinserted 3.58-mc subcarrier signals differ by approximately 60° rather than the usual 90°. R - Y, B - Y and G - Y voltages are derived from the demodulated signals, and these control the three guns of the picture tube. An important advantage of this system is that receiver circuitry is simpler than that required with I and Q demodulation. END

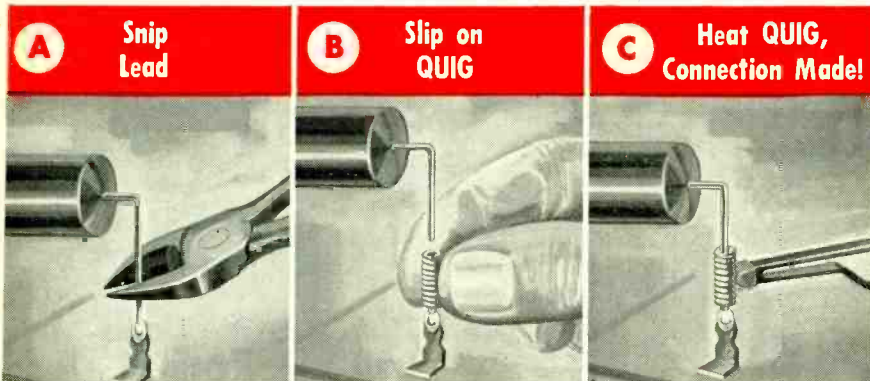

**NOBODY ELSE HAS QUIG CONNECTORS...
 YOU GET 'EM ONLY FROM SPRAGUE PRODUCTS!**

QUIGS are now being packed with Sprague Atom[®] Capacitors at no extra cost to you! Whenever you need tubular electrolytics, insist on pre-packaged Sprague Atoms from your parts distributor and you'll automatically get your QUIG component connectors . . . the biggest boon to the service technician since the soldering gun!



WORLD'S LARGEST MANUFACTURER OF CAPACITORS

65-4105



"You're too late."

RADIO-ELECTRONICS

**INTERNATIONAL
750-HM2
CITIZENS BAND
TRANSCEIVER**



TOTALLY NEW!

International's Executive 750-HM2 transceiver with 24 built-in test circuits, is truly the most versatile transceiver manufactured for Citizens Radio communication. • At the turn of a switch, the test circuits provide a fast and positive check on the operating performance of receiving and transmitting circuits within the set. • This "years ahead" test feature checks the filament, plate and input voltages, transmitter forward and reflected power, modulation, etc. A 24-position switch, located on the transmitter/receiver unit, is used to select individual test circuits. Tune-up and servicing is easy. • The transceiver has a sensitive and selective dual conversion receiver combined with a highly stable and efficient transmitter. The 23-channel crystal controlled transmit and receive frequency selector circuits are housed in the remote console. • Features include a new delayed/expanded AVC, new speech clipper/filter amplifier, new built-in S/meter and transmit meter. Operates on 115 vac, 6 or 12 vdc. The 750-HM2 includes remote console, speaker S/meter, transmitter/receiver unit, push-to-talk microphone, cables, and mounting racks.

REMOTE CONSOLE

TRANS. / REC.

TEST SWITCH POSITION	CHECKS FUNCTION	TEST SWITCH POSITION	CHECKS FUNCTION
A	RF Amplifier Cathode	Trans. P.A. Bias	
B	1st Converter Screen	N	Trans. Osc. Grid
C	2nd Converter Screen	O	Trans. Adder Grid
D	2nd Rec. Osc. Grid	P	Channel Osc. Grid
E	1st IF Amp. Cathode	Q	Power Supply B+ Voltage
F	2nd IF Amp. Cathode	R	Reflected RF Power
G	2nd IF Screen	S	RF Power Output
H	Rec. "S" Meter-Trans. Audio Out	T	Bat. + Volts Neg Gnd.
I	1st Audio Plate	U	Bat. - Volts Pos Gnd.
J	2nd Audio Cathode	V	Fil. Voltage Level
K	Audio P.A. Cathode	W	Percentage of Mod.
L	Buffer Grid	X	Rec. & Trans. Audio Level
M	Rec. Relay Voltage-		

Write today for the name of your nearest International dealer. Trade-in/trade-up to a 750-HM2.



SERVICE CLINIC

By **JACK DARR** Service Editor

Odd Vertical Troubles

Every now and then we run into a TV set with vertical troubles that are "abnormal": they're not caused by typically faulty parts, but by something external—something nearby that is affecting the vertical circuits, and is just too much for the poor set to handle.

One of these is air-conditioner motors on the same power line as the set. They can create pulses on the line and make the picture jitter. The motor, pumping against a high head pressure, creates sharp voltage spikes on the ac line, something like the "glitches" that

plague television transmitter engineers.

In most sets, we can get rid of this effect by adding massive filtering to the B+ line feeding the vertical output and oscillator stage. Fig. 1 shows how. Add an isolating resistor of about 100–180 ohms in series, and a large electrolytic capacitor, from 80 to 100 μf or even more. Use whatever it takes to get the circuit calmed down.

We'll find a very similar effect in some of the lower-priced TV chassis. This isn't from external causes, but simply from insufficient filter capacitance in the original design. Check the B+ line with a scope, and you'll see an odd pattern on the filter output, something like Fig. 2. The peaks of the ripple won't be the same height, and if you watch this pattern for a minute or two, you'll see it "crawling". The high peak walks along the line, making first one peak of the ripple higher, then the other!

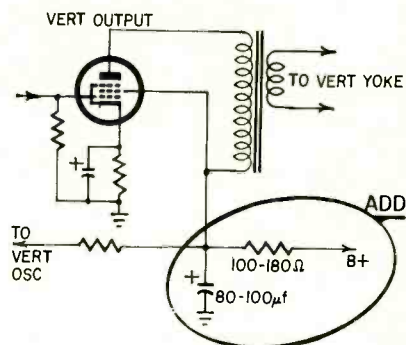

Fig. 1—Add massive filtering to B-plus line to help cure jitters.

That's due to the large pulse of current drawn by the vertical output stage, and the inherently poor regulation of the B+ when too-small filter capacitors are used. This pulse is locked to the vertical scanning frequency. If the TV picture is coming via a network, from out of town, the scanning rate may not be in phase with the local line frequency. The very small difference—usually about 10-12 cycles per minute—is enough to cause trouble when this pulsation gets into the vertical oscillator.

The common symptom of this ailment is a group of scanning lines compressed so that they look like a bright horizontal line, floating up or down the picture. When the "clump" reaches the

This column is for your service problems—TV, radio, audio or general and industrial electronics. We answer all questions individually by mail, free of charge, and the more interesting ones will be printed here.

If you're really stuck, write us. We'll do our best to help you. Don't forget to enclose a stamped, self-addressed envelope. Write: Service Editor, Radio-Electronics, 154 West 14th Street, New York 10011.

AT LAST!
a true
professional
performing
TUBE TESTER
for only
\$29.95
NET

Slightly higher in the West

Model 1100A TUBE TESTER

a new LOW in cost... a new HIGH in value!



TESTS RECEIVING TUBES FOR:

- ✓ Dynamic cathode emission
- ✓ Shorts and leakage
- ✓ Grid leakage and gas

If you're looking for a professional performing tube tester and want to keep the cost way down, the new Model 1100A was designed just for you. MERCURY's vast tube tester experience is behind this unique instrument. It is engineered to operate simply, quickly and accurately... to detect hard-to-find tube defects... to test both old and new tube types—more than any other tester in its price class. Even if you're presently using a tube tester, the Model 1100A is priced so low, is so versatile, and portable, so light you'll want it as an extra tester to keep at your side always, while making service calls.

ADDITIONAL FEATURES

- Checks each section of multi-section tubes separately
- Will detect any short in a tube, even where internal pins are tied or heater is tapped
- Exclusive meter bridge circuit provides accuracy found only in the more expensive tube testers
- Handsome two-tone aluminum panel
- Built-in 7-pin and 9-pin straighteners conveniently located on panel
- Complete easy-to-read tube chart
- Small compact size: 9"x8 1/4"x3 1/4"
- Housed in handsome, sturdy leatherette case

TESTS MORE TUBES THAN ANY OTHER TESTER IN ITS PRICE RANGE

- ✓ Novars and Nuvistors
- ✓ Compactrons and 10-pin types
- ✓ Battery type, Foreign and hi-fi tubes
- ✓ Auto radio hybrid tubes and most industrial types

See your parts distributor or write for complete Mercury catalog

Mercury ELECTRONICS CORPORATION
manufacturers of quality electronic products

111 Roosevelt Avenue, Mineola, New York

See the Mercury Electronics Corp. exhibit—Booths N-403/N-405
New York Hilton—April 2-4—Electronic Parts Show

top or bottom of the raster, it may cause a momentary jitter in the picture.

The cure, again, is massive filtering. Try adding about 100 μf of capacitance to the B+, usually at the filter output,

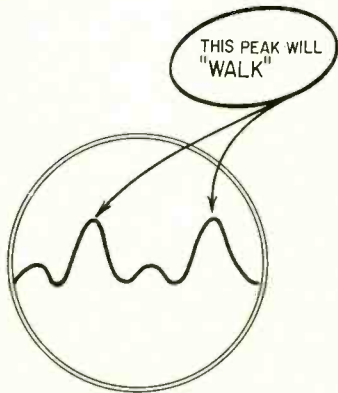

Fig. 2—Look for the unequal peaks on the ripple waveform. One of them will “walk”.

but sometimes at the input. Watch the scope, and add capacitance until the pattern settles down to a nice straight line!

Poor interlace, or pairing of scanning lines, can be helped by adding filter capacitance—usually something like 60–80 μf at the output.

Silicon rectifiers will sometimes cause vertical jittering troubles if the small bypass capacitor across the rectifiers is open or was omitted in the original design. Look for small, sharp peaks in the ripple waveform. If you find them, add about a .05- μf paper bypass capacitor across each rectifier or from the B+ line to ground.

Whenever you find any of these “inexplicable” symptoms, with trouble apparently in the sync circuits, start out by checking the B+ line with a scope for any sign of things that should not be there. The only thing you want there is a nice straight dc line. Anything else means trouble!

Intermittent picture & sound in Zenith TV

The picture and sound both cut in and out on a Zenith 17X22 TV; this happens while the set is warming up, for an hour or so. It began with channel 8 and now it does it on all the others. It doesn't do this every time; sometimes it goes for weeks, playing fine, then starts acting up.—A. P., Portland, Ore.

Since the trouble affects both picture and sound, but not the raster, it's going to be in the tuner or video i.f.—some circuit that handles both signals.

Just for luck, I believe it might be wise to replace the mixer-oscillator tube, if you haven't already done so. The symptoms (starting at the highest channel and working downward) could indicate an intermittent oscillator.

Other than that, your most likely cause of trouble would be an intermittent contact somewhere in the circuits I mentioned. Take both tubes out of the tuner and spray the sockets thoroughly with contact cleaner. Spray tube bases, too. Replace the tubes, working them in and out of the sockets several times. Spray the tuner contacts, turning the channel selector all the time.

TV: Swedish standards

One of my customers has an Admiral TV that he wants to take with him to Sweden. What changes will be necessary?—J.V., East Hampton, N.Y.

Swedish TV operates on the 625-line CCIR system. This has a 15,625-cycle horizontal frequency and 50-cycle vertical—close enough to ours so that most sets will adjust to reach it. They use 7-mc channels, and the video bandwidth is 5 mc. The worst trouble will be the sound i.f.'s. CCIR uses a 5.5-mc spacing between video and sound carriers, compared to our 4.5 mc.

You'll have to replace the sound i.f. transformers. Since 5.5-mc transformers are not readily available in this country, you may have to get them overseas, where 5.5-mc carrier spacing is quite common. (Germany, Belgium and several other countries' TV systems

NOW.. Courier 23

WITH

RANGE BOOST



23 CHANNELS
24 ~~23~~ FEATURES

DUAL CONVERSION • TRANSISTOR POWER SUPPLY

Still **\$189.50**
slightly higher west of Rockies

including all crystals, mounting brackets, power cords and noise-cancelling microphone

Send for details . . .

Name
Address
City State

eci. electronics communications, inc.
dept. RE4, 56 hamilton ave., white plains, n. y.

World famous manufacturers of quality CB & BB equipment including Courier 1M, Courier 23, Courier 12, Courier 30B, Courier 50 FM, Port-A-Lab, Transistorized Power Supply, Linear Amplifier.

“What our business needs is a good UHF VHF amplifier.” “What our business needs is a good UHF-VHF amplifier.” “What our bu..”

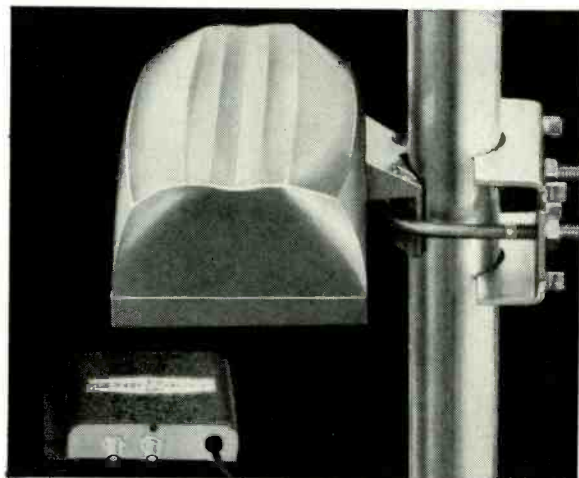

“Say no more.”

“You mean there’s an amplifier that covers all TV channels from 2 to 83?”

“You bet. In fact there are two—the outdoor U/Vamp-2 and the indoor V/U-ALL2.”

“Suppose I live in an area where there’s only VHF?”

“Your motto should be ‘Be Prepared’ because there are a lot of new UHF stations soon to come on the air. These all-channel amplifiers are obsolescence-proof.”

“Anything I should know about the U/Vamp-2?”

“Well, the U/Vamp-2 is compact and easy to install on the antenna mast. Has a remote AC power supply.”

“How about performance?”

“Two transistors give you all the power you need for better reception on VHF and UHF. Also protect against overload. Lists for \$49.95.”

“Supposing I don’t want to put an amplifier up on my antenna mast?”

“Then use the V/U-ALL2. Not as effective as the U/Vamp-2, but you don’t have to climb a ladder . . . and it delivers signals to two TV sets. Only \$42.50 list.”

“Guess I’ll rush down and get one of the new Blonder-Tongue UHF/VHF amplifiers.”

(This message was paid for out of the gross profits of BLONDER-TONGUE, 9 Alling St., Newark 2, N.J.)



use it.) I haven’t had much luck trying to realign our 4.5-mc transformers to 5.5 mc.

The rf channels are close enough in frequency that our sets will reach most of them. For instance, the “Sveriges Radio” station in Stockholm is on their channel E4, which is 62.25 mc video and 67.75 sound—within the fine-tuning range of our channel 3 with a bit of juggling.

They have a license fee of about \$20 US, although they do have a slight “relief”: in areas where the picture is not “reasonably good”, they let you off for only 10 kronor (\$2)!

No bass control

I’ve got an old radio, and the control marked BASS has no effect at all. Parts all seem to be OK. Can you explain this?—A. S., Columbus, Ohio

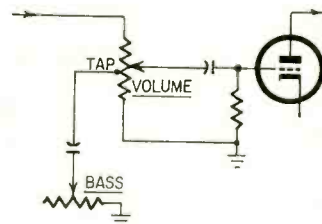

Fig. 3—“Bass” control in some auto radios was tied to tap on volume control.

Yes. This circuit worked only when the volume control was set well below the tap (Fig. 3). It was used on some pretty good brands back in the late 1930’s (It’s related to the loudness-compensated volume controls on many of today’s hi-fi amplifiers.) What I did usually was to rewire them as simple treble-cut controls. That way they had more obvious effect, and my customers were happy. [Bass boost of the kind supplied by this type of control would probably be lost on small speakers anyway.—Editor]

Replacement transistors

I’ve got a transistor radio with no listing on replacement transistors. Is there such a thing as a universal replacement?—J. B., Claremont, N. C.

G-E, Workman, RCA, Semitron and several others are making “sets” of replacement transistors. They have rf, i.f. and audio types, made for general replacement in small radios. Check some of these. You’ll often find such sets advertised in RADIO-ELECTRONICS. Or see your distributor. END

Radio-Electronics Is Your Magazine!

Tell us what you want to see in it. Your suggestions may make it a better magazine for the rest of the readers as well as yourself. Write to the Editor, RADIO-ELECTRONICS, 154 West 14 St., New York, N. Y. 10011.

NEXT MONTH IN Radio-Electronics

All-Transistor FM Multiplex Generator

Now, build a multiplex generator that will perform almost all the checks and tests you can make with the high-cost commercial jobs. Indispensable to the hi-fi service technician or the audio experimenter. Checked out by Leonard Feldman, stereo expert and author.

Soup Up Your TV Tuner

Want to get all those far-out stations? Or get *good* pictures from those you're just getting? Here's the recipe, showing how with a little work you can bring up the marginal stations to the best possible point.

Make A Musical Horn For Your Car

Transistorized! Sounds different from any horn you ever heard! Sounds *six* musical tones. Easy and inexpensive to build, using only one transistor to give plenty of sound. A natural for the experimenter.

Easy-to-Build Stereo Enclosure

Make a pair of excellent-sounding (and good-looking) speaker enclosures for less than \$22. You can put it together without any special tools (although a sander and keyhole saw are helpful) if you can get the lumber sawed at the yard. And you gain a bonus of a shelf to put them on—all from one 4 × 8-foot piece of plywood.

All About The Field-Effect Transistor

Here is a device that combines most of the advantages of the transistor with most of those of the vacuum tube. Yet it is still little used—because it is still little known. This article tells how it works and how to use it in practical circuitry.

You'll find these and many other articles, features and regular departments in next month's RADIO-ELECTRONICS.

MAY ISSUE (on sale April 20)

APRIL, 1965

Recommend the TURNER 500 Cardioid

**DON'T GO WRONG
... GO TURNER**

In your business, your reputation depends on your recommendation. Don't risk either — always recommend the high-performing, trouble-free Turner 500 Cardioid. Most problems in PA or sound applications — extraneous noises, poor acoustics, etc. — can be successfully solved by incorporating Turner 500's into the system. So before you make your next installation, write for the complete Turner catalog. Get details on the Model 500 — list price \$84.00 — and the rest of the Turner line, including the popular and versatile microphones shown below.



MODEL 251

Low cost, high performance paging microphone with Turner's unique lift-to-talk feature. List price \$49.50

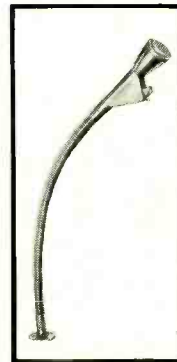

MODEL SR585D

Fixed mounted microphone conveniently mounted on a flexible 16" gooseneck. List price \$40.

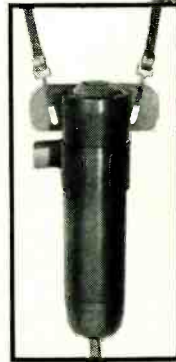

MODEL 58

A natural for any application requiring freedom and mobility ... does double-duty on desk stand. List price \$57.

THE TURNER MICROPHONE COMPANY
933 17th Street N.E.
Cedar Rapids, Iowa

In Canada: Tri-Tel Associates, Ltd., 81 Sheppard Avenue West, Willowdale, Ontario
Export: Ad Auriema Inc., 85 Broad Street, New York 4, N.Y.

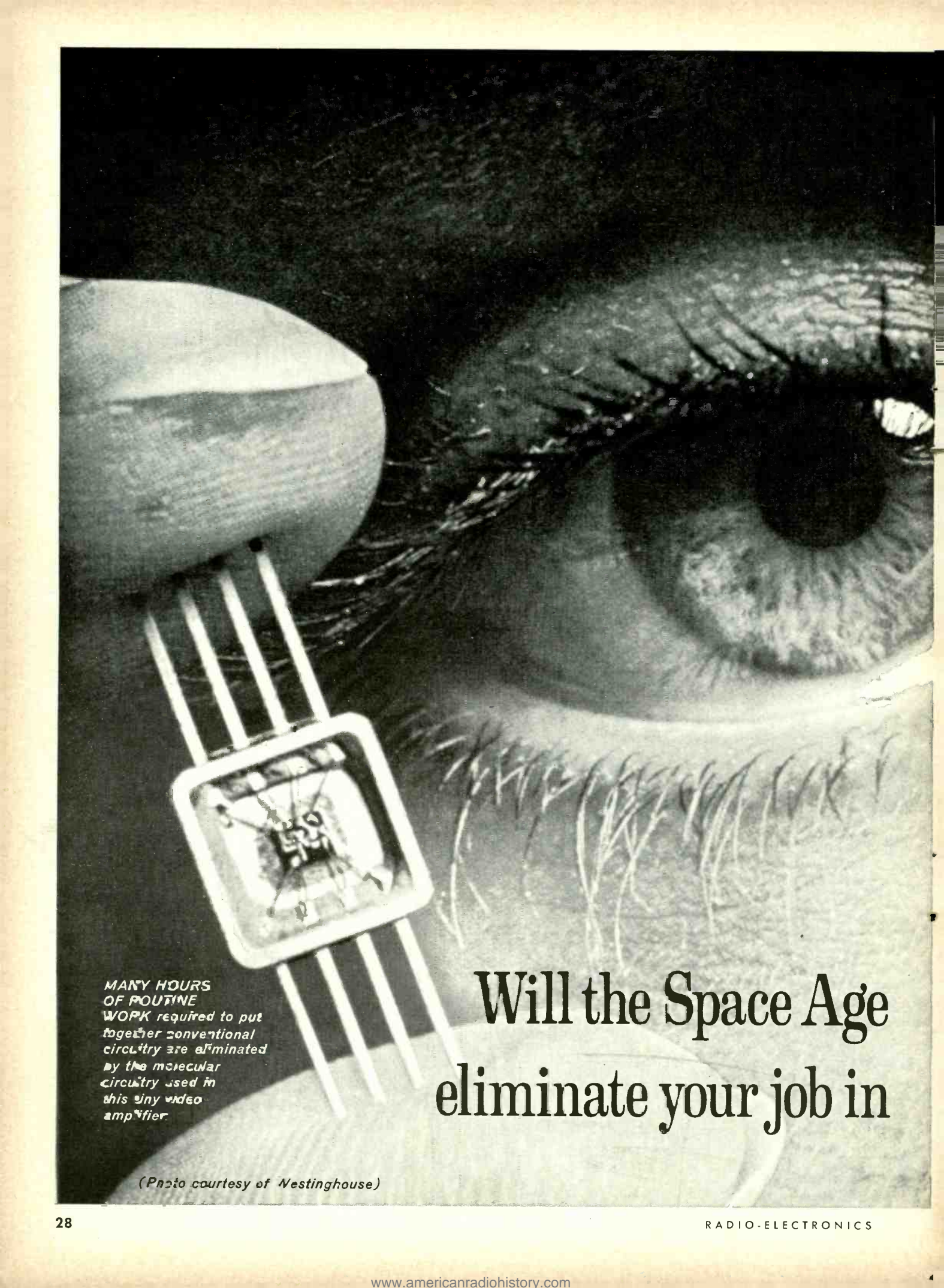

**MANY HOURS
OF ROUTINE
WORK** required to put
together conventional
circuitry are eliminated
by the molecular
circuitry used in
this tiny video
amplifier.

(Photo courtesy of Westinghouse)

Will the Space Age
eliminate your job in

Protect your future through the New CREI Programs in Space Electronics

Will the space age end your career in electronics? Or will it open up new opportunities for you? What happens depends on whether or not you supplement your education in electronics with the new knowledge needed to make you a valuable employee today. The new CREI Programs in Space Electronics offer you the up-to-date knowledge employers want and need.

SPACE DATA SYSTEMS—Includes multi-channel recording, analog to digital conversion systems, data acquisition and processing.

SPACECRAFT TRACKING AND CONTROL—Includes such areas of space technology as orbit calculation and prediction, inertial guidance, electromagnetic wave generation, space surveillance and environment.

AEROSPACE RADAR ENGINEERING—Includes specialized knowledge of surveillance radar, antennas, receivers, components and microwave equipment used in space applications.

■ The first extension programs developed specifically to help men in electronics apply their experience to the space effort.

■ Content developed to meet employment requirements as determined by consulting government and private organizations in the space field. Text material prepared in leading space-oriented organizations.

CREI also offers specialized education in these important areas of electronics: **Automation, Industrial, Nuclear, Servomechanisms, Computers, Radar, Communications, Aeronautical, Navigational and Television.**

You are eligible for these programs if you work in electronics and have a high school education.

FREE BOOK gives full information on CREI programs.



For your copy, mail postpaid card or write: CREI, Dept. 1404-C, 3224 Sixteenth St., N. W., Washington, D. C. 20010

THE CAPITOL RADIO ENGINEERING INSTITUTE
Accredited Member of the National Home Study Council



YOUR JOB IS IN DANGER if you work on the routine level where new automated manufacturing techniques are rapidly replacing men. And your job is in danger if you haven't learned enough about new developments in electronics to be of real value to your employer in the space age.

and Automation Electronics?

Where to use audio attenuators

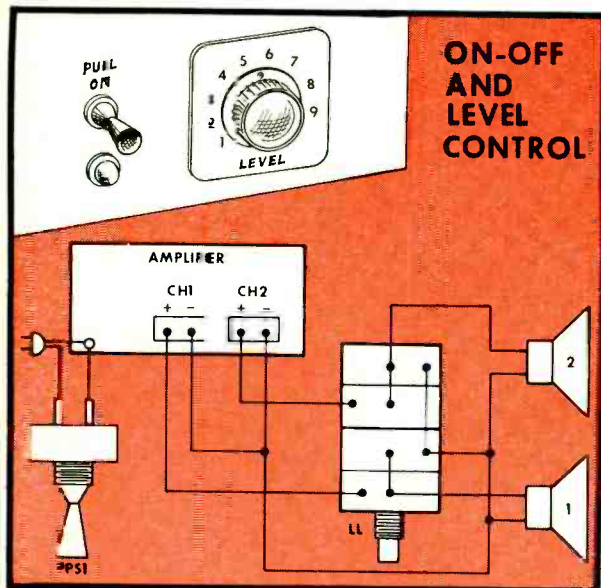

Are volume control "twidgeters" upsetting the careful balance of your hi-fi rig? After you spend an hour or better setting "levels", "contour", "bass", and "treble" does your dear wife come along and goof the whole deal up because everything is too *LOUD*?

Why not maintain your balance, your temper, and your domestic tranquility by installing a simple on-off switch and an audio attenuator. In this way the dear girl can simply turn the music on at one place and control the sound with one knob. The drawing to the left shows a Mallory PPS1 push-pull switch and an LL pad controlling the whole works. It works great and looks fine. If you want to add a "Hands Off" sign on your amplifier, that's up to you.

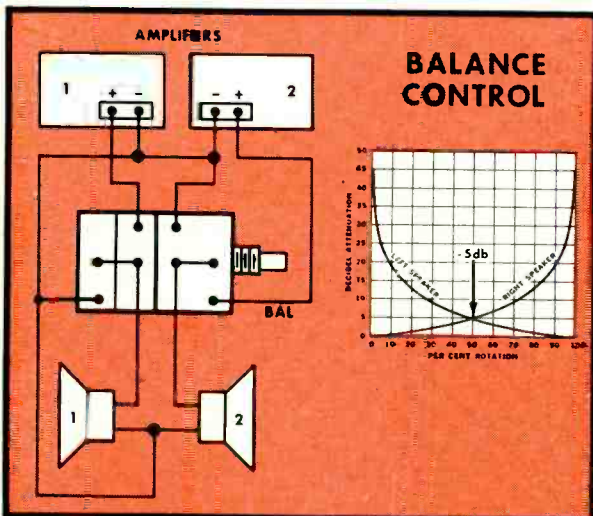

Balance Control. We have a brand new control you'll be interested in (BAL8 and BAL16). It's a true stereo balance control. Consists of two L pads connected back to back so that when one level goes up the other goes down. Dead center loss is a tiny 5 db which you'll never miss. Saves a lot of time and gives marvelous flexibility to your stereo sound system.

Remote Speaker Control. Why not install a set of stereo speakers in your family room or other remote location? Use an LL dual pad to control the level here, too. You can install the LL in one speaker enclosure and eliminate all those extra steps back to the main controls. Or you might want to check out the RR50 control (a dual rheostat) which is the perfect low-cost way to control inexpensive speakers in the basement or on the porch.

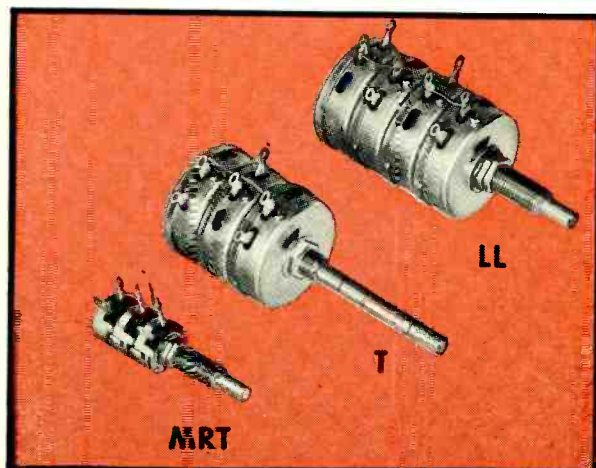

Your Mallory Distributor can help you select an audio attenuator exactly right for the job. Choose from the new miniature MRL, MRT and MRL pads . . . rugged Mallory RL, RT and RR . . . the 15-watt T, L, LL, and BAL pads, or the powerful 50-watt MGL and MGT series. You name it, he has it.

In case you'd like a complete list of Mallory audio controls and other precision electronic components, drop us a line. We'll send you the new 1965 Mallory Catalog. Write to MALLORY DISTRIBUTOR PRODUCTS COMPANY, a division of P. R. Mallory & Co. Inc., P.O. Box 1558, Indianapolis, Indiana 46206.



ROYDEN FREELAND
PRESIDENT OF
INTERNATIONAL CRYSTAL
MANUFACTURING CO., INC.

The Future of CB

Guest editorial by ROYDEN FREELAND

IN 1958, the Federal Communications Commission allocated the 11-meter band for the Citizen Radio Service. No other service has ever grown so fast in numbers of licenses issued. With such heavy use of these 23 frequencies, policing by the Commission has been a major problem. Directives are issued periodically to spell out the intent of the rules that govern the service.

As with all public services in the United States, people seek to use the service as they most enjoy, in this case talking to others. The borderline between hobby and carrying on business of the family and home is thin. Certainly it is only fair to direct the best usage for the greatest number.

The battle rages between limiting channel usage and message content on one hand, and power and antenna height on the other. Overall, the users of Citizen Radio follow the intent of the service, although rules are bent here and there. The commission appears open-minded and willing to attempt to change the rules to allow fair use of these frequencies.

A brief study of the radiated power available, noise levels and receiver requirements reveals some interesting facts.

The Citizen Radio Service is most useful in rural areas and in cities under 50,000 population. A rule of thumb for coverage is a circle of 5 miles radius around the transmitting antenna. Larger areas can be covered, depending on the terrain and noise encountered. We are at present in the

Royden Freeland was born in 1921. He graduated from the University of Oklahoma with an electrical engineering degree. After service as a Signal Corps officer in World War II, he entered industry first as a broadcast engineer, then as an independent consultant and head of a frequency-measuring service for Southwestern radio and TV stations. In 1950, he organized International Crystal Manufacturing Co., Inc., maker of frequency crystals and radio components and subassemblies.

low part of the sunspot cycle and skywave interference is limited. However, in the next few years this will be a factor to consider where 100% communication is desired.

Excellent business communications can be realized in the smaller towns—by taxicabs, plumbers, dry cleaners, markets, etc. The use for family communication must not be overlooked. For the woman traveler the set provides security and comfort. She can ask for assistance without leaving the car. In boating, CB is an additional safety aid when the motor stalls in the middle of the lake. All these are good uses for the Citizen Radio Service and all are within the intent of the FCC rules.

In cities of over 50,000 population, the strict business use of this service becomes more and more difficult in proportion to population. In large cities, business communication requires an area of coverage not possible with 5 watts. The home and safety features can still be utilized within the range limits of the equipment.

Users of these frequencies must consider other limitations. No other service requires so many stations to operate on so few 10-kc channels. Greater requirements are therefore placed on the equipment. Receiver attenuation of 60 db on the adjacent channel can be realized. However, this is only 1,000 times and some interference can still be heard with strong signals. Since 23 channels are available, alternate channels should be used to obtain communication when the primary channel is encountering interference. The interference problem goes hand in hand with channel usage and distance between stations. These adverse conditions will affect all channels in large metropolitan areas, and limit the 100% area to less than 5 miles. Daytime transmissions during the summer months will produce skywave interference from stations 600 to 1,500 miles away. Such signals will reach levels of 10 μv or greater. When communication depends on signals of less than 5 μv to cover a given area, communication will not be possible for the total distance. The area will be reduced from 5 miles to perhaps 1 mile.

Sensitive receivers capable of detecting signals in the 1- μv range are subject to noise interference. Throughout heavy industrial areas, the measured noise level can exceed 15 μv , covering weaker signals. There again the coverage area will be greatly reduced.

Careful selection of the antenna site can somewhat overcome this type of noise at the base-station location. The mobile unit may operate also at a selected site for better coverage.

Interference will vary from time to time; therefore where 50% communication can be tolerated, the coverage area will be increased. Knowledge of the equipment and frequencies being used will enable the user to obtain the greatest coverage possible with the low power available. Knowing the limitations and planning around them will prevent the user from being disappointed in his investment.

Increased use of the Citizen Radio Service in the future will bring about equipment changes to meet the public demand. Construction keyed more to the home and auto decor will allow these radios to blend in with everyday living. Simplicity of operation and maintenance may well make this equipment as common as any other household appliance.

END

Peaked antennas, lumpy response curves and rotted 300-ohm ribbon just won't do for color reception

ANTENNAS FOR COLOR TV

By LON CANTOR*

PUT A GOOD ANTENNA ON A ROTATOR. Connect it to a color TV set and aim it at a station transmitting color. Now rotate the antenna slowly. At one point, you see good color pictures, but there are areas on either side where the color washes out completely. Yet you see good black-and-white pictures.

This little experiment illustrates a point: it's harder to get good color than to get good black-and-white reception.

Why? Fig. 1 shows the frequency spectrum of channel 3. The video and sound carriers are separated by 4.5 mc (4 mc for the video bandwidth and 0.5 mc as a guard band). The color carrier, however, is only 3.58 mc from the video carrier.

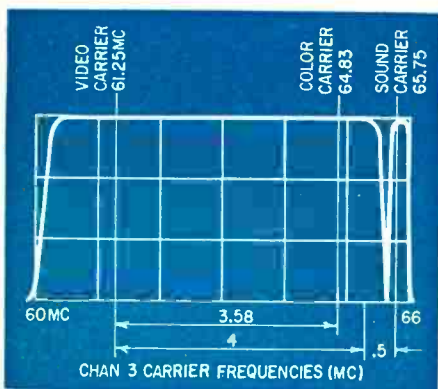

Fig. 1—Channel 3 carrier frequencies.

The color carrier is suppressed to avoid interference. This means that to get good color reception, antenna gain must be higher. Further, the color carrier is phase-modulated, not amplitude-modulated as is the picture carrier. Let's see what this means in terms of receiving antennas.

Fig. 2 shows the response of a very poor TV antenna. This is not an exaggerated curve. It was actually recorded on a nationally sold antenna which will remain nameless. An antenna with this response would work fine for black-and-white. Gain is higher at the video carrier frequency and lower at the sound carrier, but sound requirements are not too stringent anyhow.

The problem is with color TV reception. The color carrier needs all the gain it can get, yet it is far down on the curve.

Phase differences can have a very

unhappy effect on color response. Yellows may get greenish and reds orangish. Very poor phase response can result in no color at all.

Match and mismatch

Another consideration very important to color TV is matching. In a TV installation, the antenna acts as a generator, and the receiver as the load. Most TV receivers and antennas have a nominal characteristic impedance of 300 ohms.

Now, let's suppose you have a mismatch. Of course, the receiver does not absorb all of the antenna signal. What happens to the rest? This is where the trouble comes in. The portion of the signal that is not absorbed is reflected into the transmission line out of phase, to become a standing wave.

Standing waves wreak havoc with color reception. Since phase and time are involved, standing waves cause the same kind of troubles as antennas with poor frequency response—only more so. A badly mismatched antenna installation will often kill color reception completely.

So some antennas used for black-and-white reception are unsuitable for color. "Rabbit ears"—the most widely used indoor antenna—are very badly mismatched. It is possible to get fairly good color reception with rabbit ears under optimum conditions, but the dealer who recommends a pair is asking for trouble.

The most popular outdoor antenna, the conical type, is also very badly mismatched. It is not recommended for color.

In the past, many antennas were adapted to the area in which they were used. Gain was increased for the channels in the area, at the expense of gain

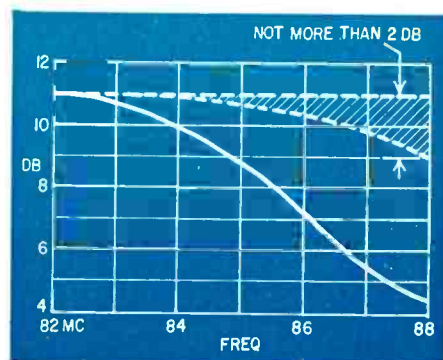

Fig. 2—Response of a poor antenna on channel 6. Shaded area shows where curve must lie for antenna to be suitable for color reception on channel 6.

on unused channels. This method of increasing gain is not practical for color reception, where flat response is more important than gain.

Fig. 3 shows (as a solid line) the overall response of an antenna designed specifically for maximum response on channel 10. Channels 13 and 6 have very uneven response, with 4-db and 6-db variations respectively from one side of the channel to the other. Because of phase shifts, it would be almost impossible to get good color reception on these channels. Yet antennas like this have been used very successfully on black-and-white for many years.

The dashed line in Fig. 3 shows the response of an antenna designed specifically for good color reception. Notice that gain of channel 10 is only about 10.5 db, compared with 13 db on the older type antenna. But flatness has been significantly improved. Gain variations within an individual channel do not exceed 1 db. Generally, color reception capability is considered adequate if gain variations within a particular channel are limited to 2 db.

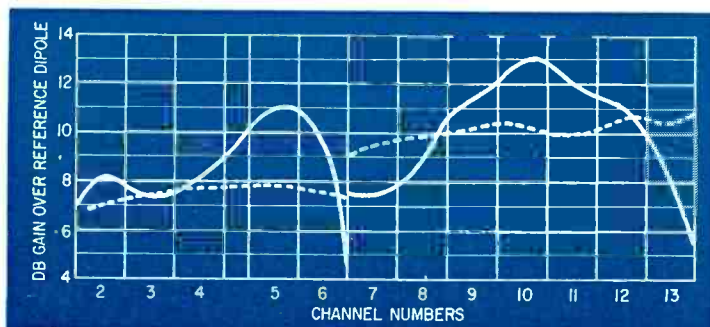

Fig. 3—Solid curve shows response of antenna peaked for maximum gain on channel 10. Dashed line shows much flatter response suitable for color TV.

*Jerrold Electronics Corp., Philadelphia, Pa.



Jerrold

Fig. 4—Set-mounted matching transformer (also a balun) matches 75-ohm coax to 300-ohm set input.

Transmission lines

The antenna and the receiver are not the only units that determine match. Match is most significantly affected by the transmission wire that connects the generator and the load.

Because most TV antennas and receivers have a characteristic impedance of 300 ohms, 300-ohm ribbon lead is the most commonly used transmission wire. However, 300-ohm ribbon has many drawbacks. It is unshielded and balanced, and so is susceptible to external interference. Its impedance is 300 ohms only in free space. In an actual installation, 300-ohm lead must be run close to surfaces, and every surface near the line causes some imbalance. The amount of imbalance depends on the size of the surface, how close it is and how good a conductor it is.

To understand what happens when a transmission line is mismatched, let's

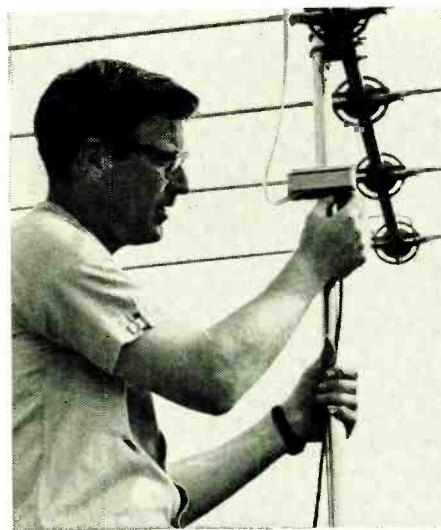

Jerrold

Fig. 5—Mast-mounted balun matches 300-ohm antenna to 75-ohm coax cable.

consider the worst possible case. Suppose it is unterminated. The signal then travels down the line. When it sees no load at the end, it bounces up like a yo-yo, setting up standing waves. Standing waves lead to ghosts in a black-and-white set, but they can kill color.

Almost as important, the attenuation of 300-ohm ribbon lead varies with weather conditions. Attenuation is relatively low when the wire is new and dry. As the wire ages, becomes dirty, or gets wet, attenuation can increase by as much as 6 times. The installation you make today might work fine; but 6 months later, losses may increase to the point where color reception is intolerable. The newer encapsulated 300-ohm transmission lines, such as Belden 8285 and Ampherol 214-271 Marine Core, overcome this problem. However, they are still subject to mismatch caused by stand-offs and proximity to metals.



Winegard

Fig. 6—Newer boom- or mast-mounted preamplifiers come with 75-ohm outputs, to work directly into coaxial cable.

How about coax?

The most commonly used coaxial cable is RG-59/U. Its main advantage is that it is shielded and unbalanced. It won't pick up auto ignition noise or other types of outside interference. Also, it won't pick up TV signals directly—a cause of ghosting in 300-ohm installations. A metal standoff won't affect the match of 75-ohm coax. (You can tape it to the mast and staple it to the wall without affecting its impedance.) Also, RG-59/U is a lot more rugged. It lasts a lot longer and its attenuation doesn't change with age and weather.

Does RG-59/U sound like the answer to a technician's prayer? If so, why hasn't it been used more extensively? Because it too has its drawbacks:

1. It's more expensive (but lasts much longer).
2. It's harder to make connections with, especially if you don't know how.
3. Its attenuation is much greater than that of encapsulated 300-ohm line or ribbon lead, thus cutting the signal and making boosters necessary in all but strong-signal areas. The attenuation increases rapidly with frequency.

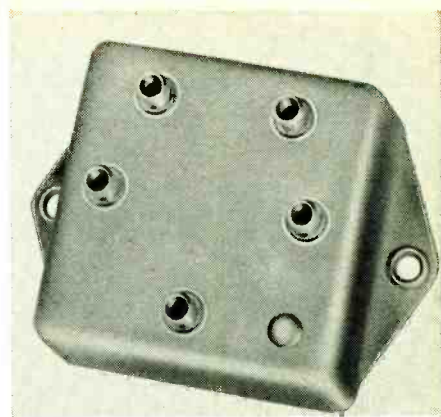

Blonder-Tongue

Fig. 7—Coaxial splitter may be used to feed several TV sets from one cable.

4. Its impedance is 75 ohms and it's an unbalanced line. This means that you need two matching transformers—one at the antenna and one at the set. Fig. 4 shows a 300- to 75-ohm balun (short for *balanced-unbalanced*) used to match set's antenna input to RG-59/U cable. At the other end of the line you use a 75-ohm to 300-ohm balun, as shown in Fig. 5.

Coax is, however, the preferred transmission line in many metropolitan areas, where the noise level is very high and large apartment buildings make runs long. A weak signal with no interference is better than a strong signal drowned in noise.

Boosters

Boosters are even more useful for color than they are for black-and-white. Mast-mount boosters are made with 75-ohm outputs, specifically for color TV (Fig. 6). However, even indoor boosters, whether used with outdoor or indoor TV antennas, can improve color picture quality dramatically.

Multi-set couplers

It's not surprising that most people who own a color TV also own a black-and-white set, so most color installations will have to provide for one or two black-and-white sets also. If this is the case, be sure to use an excellent multi-set coupler. Cheap couplers are poorly matched, and provide inadequate isolation between sets. This, of course, can ruin color pictures. If the TV sets are not too far apart, you can use a quality 300-ohm coupler. Where the lines are long, coaxial cable is once again recommended, and you will need a 75-ohm splitter like that in Fig. 7.

You have probably gathered by now that a good color installation costs money. But a professional job will give you excellent color pictures as well as superior black-and-white reception. What's more, it will last considerably longer.

END

This concluding article tells of some more recent, less widely known approaches to turning electrical waves into sound

What's Improved in Loudspeakers?

By VICTOR BROCIER*

LAST MONTH WE PROMISED DETAILS ON methods designers use to get around the problem of *cone breakup*—what happens when a speaker cone vibrates in several modes at the same time, causing peaks and valleys in the frequency response.

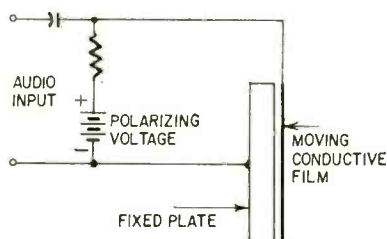

Fig. 1—The basic electrostatic speaker. Most use a push-pull arrangement to reduce distortion.

Consider the elementary electrostatic speaker in Fig. 1. The diaphragm is a thin, flexible sheet of metallized plastic film suspended limply in front of a metal plate. The two metal surfaces constitute the plates of a capacitor. When a varying voltage is applied to these plates, they are attracted and repelled by each other. The plastic film, being lighter, does the moving. Note that it is driven uniformly over its surface. It need not be rigid; it should have no modes of breakup. Although reality departs from this ideal, electrostatic speakers are capable of producing sound of a purity hard to duplicate by other means.

Successful designs are far more elaborate than the elementary unit of Fig. 2. They all require a dc polarizing voltage, which is something of an inconvenience because the speaker system requires a line cord. Also, most amplifiers are not at their best when driving a capacitance (electrostatic speaker) as compared to a resistance (dynamic speaker).

Practical electrostatics are usually flat in shape, or nearly so. Except when used as super-tweeters they tend to be somewhat large as well, since the distance the plates can move is inherently limited. Increased surface is the only other way to radiate appreciable power. The large size and flat surface make the speakers rather directional—increasingly so as the frequency goes up.

*Assistant to the President, H. H. Scott, Inc.

In the last few years, further attempts have been made to build the magnetic counterpart of the electrostatic speaker—a dynamic speaker with uniform, or nearly uniform, drive. The basic idea was used in 1924 in the Blat-haller, described by McLachlan. Modern materials have made a difference. Permanent magnets have replaced the clumsy (but effective) electrodynamic field assemblies of the original speaker. Expanded polystyrene forms the diaphragm in one design (Fig. 2). Performance is similar in smoothness to electrostatics. Efficiency is rather low. The zig-zag aluminum ribbon used as a

voice coil has a very low impedance—less than 0.5 ohm. These speakers are used either in series multiples which approach or equal conventional impedances, or with a matching transformer.

Another approach, originated in Israel (Fig. 3), uses a thin, light, flexible plastic diaphragm with a voice coil applied by "printed-circuit" techniques. This design is more economical to manufacture than the foam-plate type described above. The voice coil operates in the leakage field of the magnets, which is relatively weak, so that efficiency is extremely low. Since the power-handling capability of a speaker

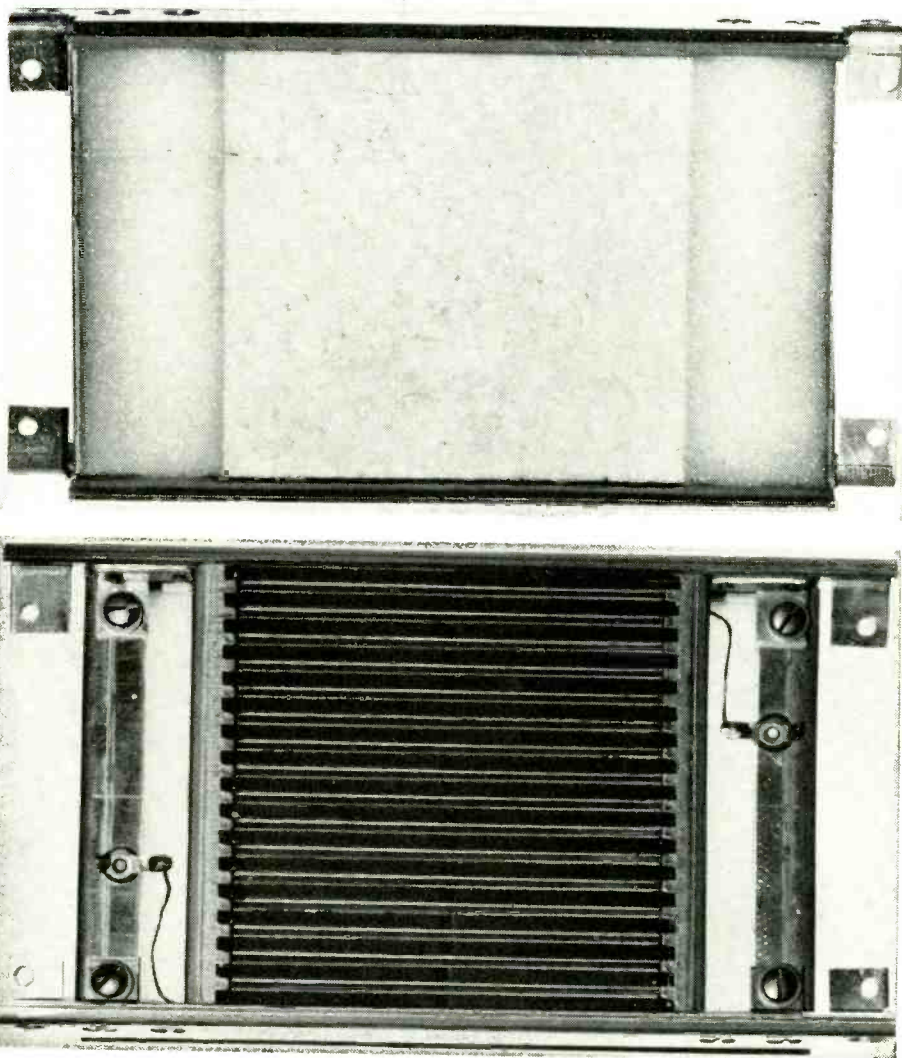
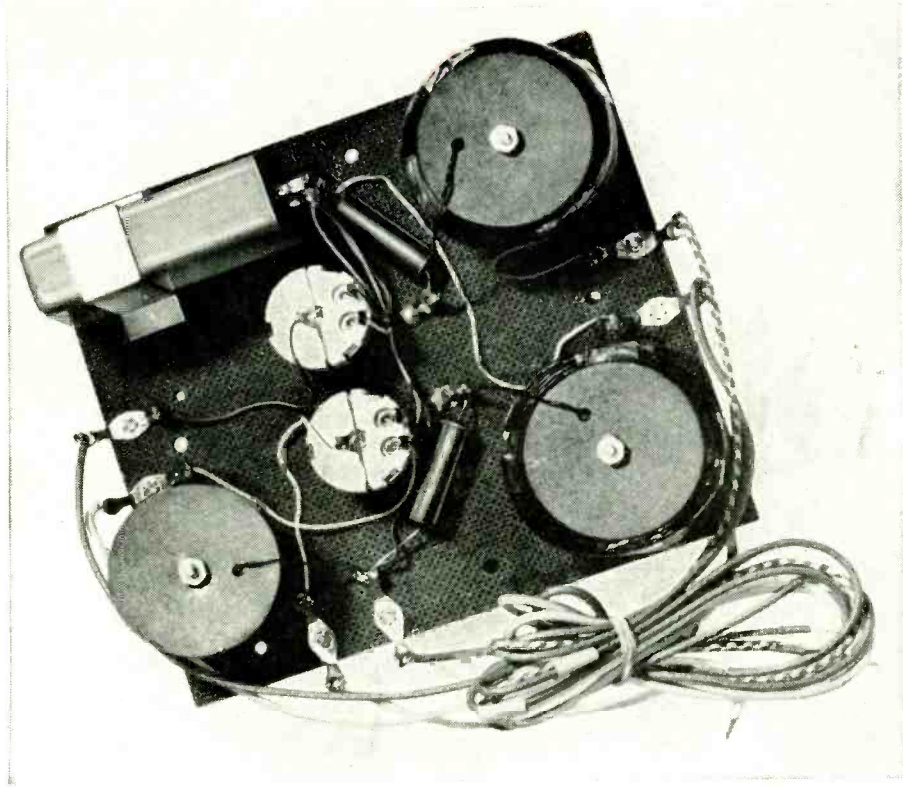

Fig. 2—Front (top) and back views of French Orthophase speaker, with foam-polystyrene diaphragm. Back view shows aluminum ribbon drive "coil".



Complex frequency dividing network in H. H. Scott speaker.

always has limits, we can compensate for low efficiency with increased input power only to a certain point.

Baffleless wood diaphragms

For the sake of decor, a speaker system with a thin silhouette has advantages. Some slim speaker systems use conventional speakers of flattened design. A different design uses a dynamic speaker "motor" to drive a large, lightweight wood diaphragm. (How many readers are old enough to remember the "balsa wood speakers" of the 1920's?)

These large diaphragms cannot be used in a slim enclosure; its stiffening

effect could not be tolerated. They are used right out in the open, like the Rice-Kellogg speakers before the invention of the baffle.

This "doublet" radiation theoretically drops with decreasing frequency at the rate of 6 db per octave above system resonance and at 18 db per octave below that frequency. Above the frequency at which the speaker dimensions become an appreciable fraction of a wavelength, the response is fairly flat, the decreasing power output being compensated by increased directionality as the frequency increases.

Low-frequency power capability is rather limited, even with the relatively large diaphragm area tending to make up for the modest excursion capability. Variations in design include the use of conventional tweeters for the extreme treble, and of multiple flat diaphragms, one in back of the other to form a sort of two- or three-way system. Despite

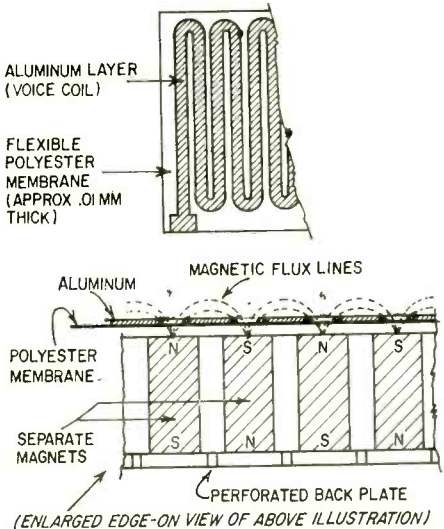

Fig. 3—Details of a flat speaker with an integral drive "coil" bonded to the diaphragm.

their theoretical handicaps, these designs can deliver pleasing sound.

Enclosures

The closed-box infinite baffle (within and outside the "acoustic suspension" category) is extensively used. The vented-box, bass-reflex, ported-cabinet design is also popular. Ducts, multiple ports, resistance-loaded ports and the like are variations, the utility of which depends on the speaker constants and the size of the box. All are capable of excellent performance if properly designed.

The vented enclosure requires more care in coordination with speaker design than the closed box, and, if incorrectly used, can be a real "boom-box". Tuned pipes, multi-compartmented and other complicated designs are out of fashion, presumably because the improvement, if any, is not worth the trouble. Horns are in use, especially in mid-range units and tweeters, and are capable of fine performance. Refinements in design there are; basic advances, no.

Magnetic materials

The energy product—a measure of the strength of a magnet—has been steadily increased. Ceramic magnets have properties that permit designing very flat structures. Since, in general, the amount of flux that can be obtained in a gap of given size is limited by the shape and material of the pole pieces rather than by the magnet itself, there has been little effect on performance. Cost and flexibility of design have been favorably influenced.

Uniformity of impedance

Amplifiers are designed to work into specific load values. If they are mismatched, distortion increases and output power drops. With transistor amplifiers, there is also the hazard of damage to the power transistors. Speaker impedance over the audio-frequency range can vary as much as 40 to 1!

Increasing attention is being paid in speaker design to avoid such extreme

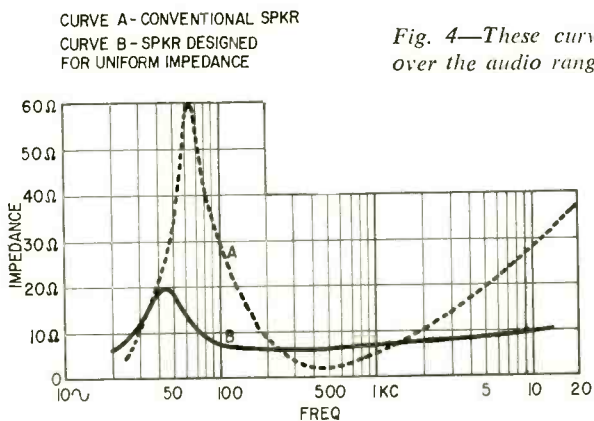

Fig. 4—These curves compare the impedance over the audio range of a conventional speaker (A) and one designed for more uniform impedance (B). The low-frequency peak, which often accounts for "boominess," is suppressed by acoustical or mechanical damping; the high-frequency rise is flattened by a copper cap over the pole piece. A flatter impedance curve reduces amplifier distortion and instability.

variations. In single speakers, impedance variation is reduced by acoustical or mechanical damping at the fundamental resonant frequency. High-frequency impedance rise due to the voice-coil inductance is limited by a copper cap over the pole piece (Fig. 4). In multi-speaker systems, the dividing network (crossover) design has a marked effect on system impedance. The complexity of the network for the H. H. Scott model S2 system, expressly designed for uniform impedance, can be seen in one of the photographs.

Integrated speaker-amplifier systems

Recently, some amplifier-speaker combinations have been integrated into one enclosure. The idea of incorporating an amplifier into a speaker cabinet is, in itself, neither new nor inherently advantageous. One of the first commercial speakers to be marketed in its own cabinet had a built-in tube amplifier. This was in the 1920's. It was a convenient arrangement because it got the bulky amplifier out of the way; more important, it insured that the speaker would be driven by an amplifier of adequate power rating, something that was not generally available in those days.

The modern version uses transistors, of course, and presents an interesting parallel to its ancient predecessor in that the amplifier and speaker can be designed to complement each other. Amplifier frequency response and damping factor can be tailored to produce the best possible overall performance.

There is another advantage, too. Transistor amplifiers, unlike tube amplifiers, are designed for optimum operation into one specific load value; integrated systems guarantee correct loading. The need for a power-line connection for the amplifier is not a serious disadvantage. Since the idling power of a transistor amplifier is small, there is really no reason why it cannot be left on all the time. For the same reason, the amplifiers do not heat up the speaker cabinet. (There is certainly plenty of room for a large heat sink!)

The integrated speaker of the 1920's was a logical development for another reason: the speaker had an electrodynamic field, not a permanent magnet, and this required a dc power supply anyway, so why not power the amplifier as well? This gives rise to an interesting speculation: modern electrostatic speakers require dc supplies; might they not be suitable for integration with a transistor amplifier?

Even though the speaker supply is high-voltage and the amplifier low-volt-

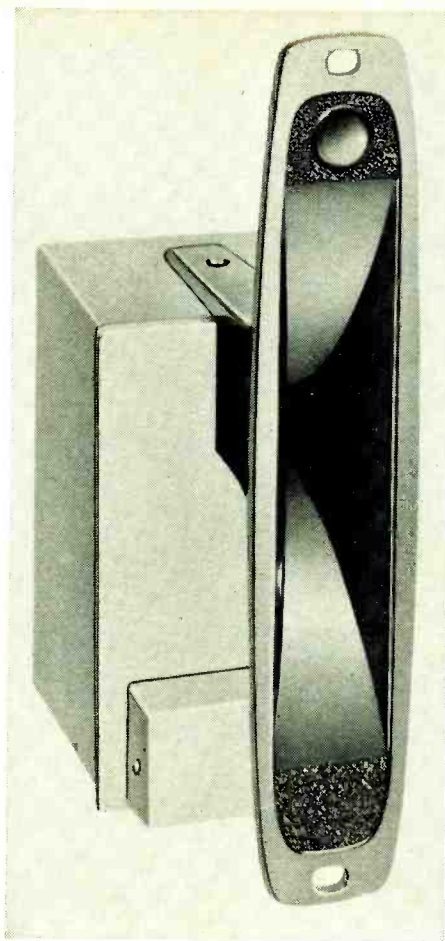

"Ionovac" ion-cloud tweeter.

age, both require a power-line connection. In such a combination, the amplifier can be designed to be especially suitable for the electrostatic speaker load, which is predominantly capacitive, eliminating problems of coupling a "standard" amplifier to an electrostatic speaker.

Motional feedback

Designing a negative feedback loop that includes the speaker, to flatten frequency response and minimize distortion, is an attractive approach. (Fig. 5). Many obstacles must be overcome.

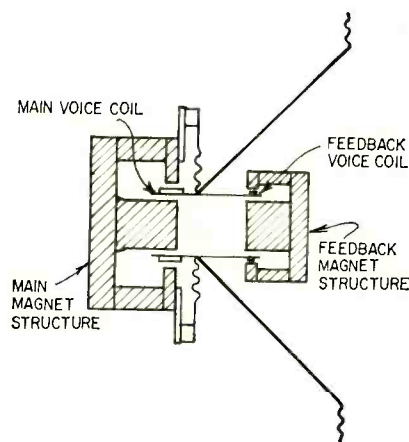

Fig. 5—Speaker with velocity feedback from auxiliary coil and magnet structure.

The principal one is diaphragm breakup in the upper mid-range and high frequencies. What good does it do to achieve ideal motion of the voice coil if the sound pressure generated by the diaphragm is not proportional to it? In the low-frequency range, this problem is not too severe, but neither is it very difficult to get good performance in this region with conventional design. Just as other difficulties have been overcome in the past, perhaps this one will be, too. The outcome may be a speaker of outstanding smoothness, minimal distortion and excellent frequency response. When and if this comes about, the speaker and amplifier will probably form a complementary, integrated system.

Nonmechanical systems

All the speakers discussed so far have involved a mechanical element—the diaphragm—actuated electrically. The diaphragm, in turn, moves the air. Practically all serious problems in speakers involve this mechanical device. The diaphragm is too small or too heavy, it cannot move far enough, it breaks up into modes. Why not eliminate it entirely?

The throttled air-flow speaker uses a voice-coil-operated valve to control the flow of air under pressure generated by a pump. Strictly speaking, this uses a mechanical element, but at least it is not a cone. Such speakers are successful, but only as high-power devices of limited frequency range and rather high distortion—for applications where intelligibility is the objective, rather than high quality. It is really too bad, in a way. If one leaves the valve open, the constant outflow of air under pressure is dc. Imagine a speaker that goes down to zero cycles per second!

A truly nonmechanical system that has been available for some time is the Ionophone, developed in France, and marketed in this country as a tweeter under the name "Ionovac". The moving element is a tiny cloud of ionized air moving in step with an electric field varied by the audio signal. For proper impedance matching of the ion cloud to the air, a horn is used. The tweeter is capable of extremely extended-range reproduction (up to about 100,000 cycles!) and its response curve is very smooth. A line connection is required for the high-frequency power oscillator used in the system. The cost, however, is rather high.

A related principle is used in the corona-wind speaker. This uses the movement of air in the vicinity of an arclike electrical discharge. Experimental models have been demonstrated; sound of a sort is generated. No development work on this device has been announced.

END

¹ Frederick V. Hunt, *Electroacoustics*, p. 80 (Radiola Model 104).

New Life for Old Auto Radios

6-volt radios may no longer be much use in cars,
but can make fine sets for your home

By ALEX F. BURR

SINCE MOST CARS TODAY HAVE 12-VOLT electrical systems, old 6-volt auto radios are cheap and easy to obtain. These sets are sensitive, solidly built, and have surprisingly powerful and wide-range audio. The better receivers offer pushbutton tuning and a tone control. It takes very little effort to convert one of these sets into a good home radio.

All it takes is a cheap transformer and a few other parts. To get 5 amps or so of 6-volt dc is rather expensive. But many of these receivers operate very well with ac on the heaters. Most of them need about 50 ma at 250 volts for plate supply. Thus all you have to do is get a transformer that puts out 250 volts each side of a center tap, and 6 volts ac at about 2 amps.

The conversion itself is simple. Fig. 1 is a diagram that can be used with radios that have a nonsynchronous vibrator. These sets are most common and can be recognized by the presence of a rectifier tube.

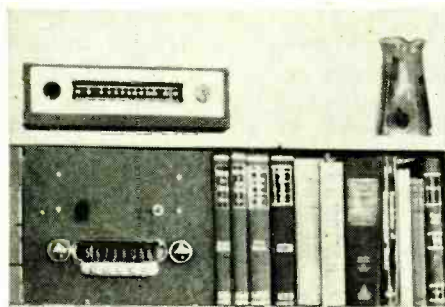

Finished job fits in bookcase. FM tuner stands on top.

Disconnect and, if you like, remove the original vibrator transformer. Ground the center tap of the high-voltage winding of the new transformer and one side of the filament winding. Connect the other side of the filament winding to the original dc input. Connect one of the two remaining high-voltage winding leads to each of the plates of the rectifier tube. Remove the vibrator, and the conversion is complete.

[In a 6-volt auto radio with a nonsynchronous vibrator and a rectifier tube, you can often remove the vibrator and connect the low-voltage winding of a 6-volt filament transformer to half of the original vibrator transformer primary (between center tap and one end). No further changes are necessary. For radios with a single audio out-

put tube, a 4- to 5-ampere transformer should be enough. For radios with push-pull output, a 6- to 7-ampere transformer is advisable. Such transformers seldom cost more than \$5 or \$6 new, and much less on the surplus market.—
Editor]

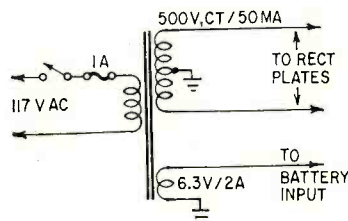
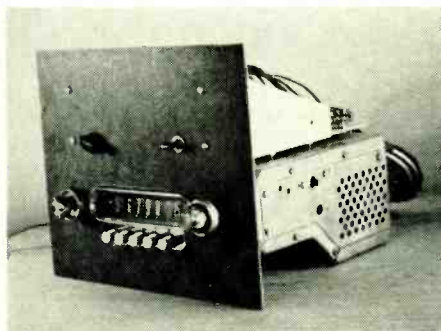

Fig. 1—For radios with simple vibrators. Possible transformers are Stancor PM or PC-8402, Knight 62 G 503 or 61 G 462, or Triad R-6.

If your set has a synchronous vibrator, you will need two 800-piv silicon rectifiers. A set of this type has no rectifier tube. The vibrator itself rectified the current, and since it is not going to be used, you will have to provide the rectifiers. Follow Fig. 2. Pull out the vibrator in this case too.

While the set is on the bench, you might as well increase its usefulness by adding an audio input. Use a jack, an spdt switch and three pieces of shielded wire. Put the jack in any convenient place. Fig. 3 shows the exact arrangement. You can now run your FM tuner or some phonographs through the old auto radio. The quality will be surprisingly good.

Electrically, your set is now completely converted, but since it was designed to mount behind the dash of a car it probably will look a bit odd in the livingroom. A piece of Masonite and a little work will solve this problem. Cut a piece 2 inches wider than the



Converted radio's new panel has an on-off and audio switch (Fig. 3).

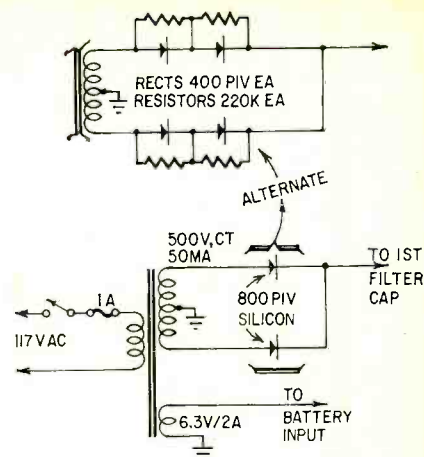

Fig. 2—For radios with self-rectifying (synchronous) vibrators.

auto radio and as high as the space between the shelves of your bookcase. Using the radio as a guide, cut out the panel to accept your radio. This will probably require holes for the volume control and tuning control and a hole cut with a coping saw to fit the dial. Arrange the holes so that the body of the radio will sit on the bookshelf. The panel above the radio can be used to mount the parts used to convert it to ac.

Some auto radios come with their speakers built in. If yours is this type, there is nothing more for you to do. Most sets have the added flexibility of an external speaker. In the converted set shown in the pictures, this speaker was mounted behind the new front panel pointing upward so that the sound diffuses from behind the bookcase and spreads throughout the room. Since auto radios are designed for noisy locations, ample volume is available.

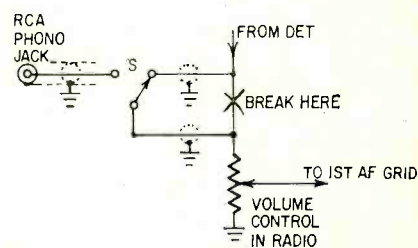
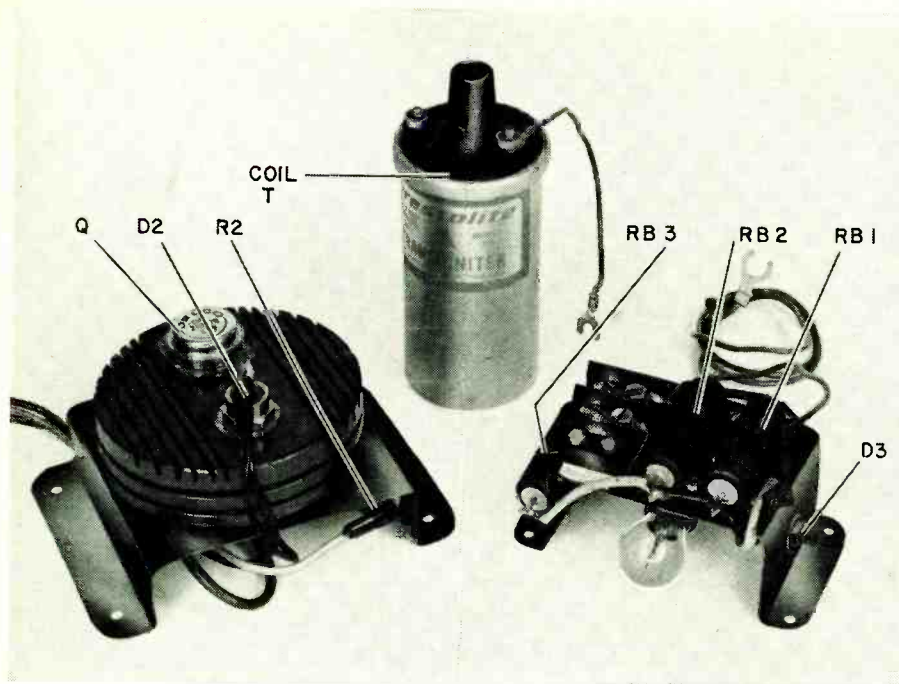

Fig. 3—How to add extra audio input for FM tuner or crystal cartridge.

If you wish to go to some additional trouble, a matching panel can be cut from the same Masonite used for the radio, and the speaker mounted on it. The panel and speaker can then be set in the bookcase beside the radio, or, with a slightly longer speaker cord, mounted in a symmetrical position at the other end of the shelf from the radio.

Now all you have to do is plug 6 feet of wire into the antenna socket, plug the line cord into the wall socket, adjust the antenna trimmer, and sit back and enjoy your radio. END



COVER STORY

SINGLE-TRANSISTOR IGNITION SYSTEM

Unique circuit is built on an old piston head as a heat sink. Easy and cheap to build.

By VERN E. BAKER

A TRANSISTOR IGNITION SYSTEM IS A worth-while project; its cost is soon regained. Points and plugs last several times their normal life. Performance of stock ignition falls off at 4,000 to 5,000 miles after new points and plugs are installed. But with transistor ignition, performance is good even after 30,000 miles. Another advantage is that motor life is extended. Because of better combustion, less raw gasoline is forced into the crankcase, and the oil stays cleaner. This is especially the case on short trips, when the motor is operating cold. There is also a reduction in air pollution.

Building this reliable unit is easy. It uses few parts and works better than any other single-transistor system I tried. Ordinary tools will do the job. You may adapt the heat sink (Figs. 1 and 2) to your favorite circuit or use the one described here.

Voltage drop across the diode D2, (Fig. 3) due to the small current drawn by R1, insures that the base will always have a fraction of a volt bias when the points are open. The circuit switches fast even at high temperature. One of these units, in a 1963 Dodge truck, works fine in 120° desert heat.

The ceramic or mica noninductive

capacitors C1 and C2 handle any abnormal voltage spikes. However, it is not wise to leave any secondary wires open

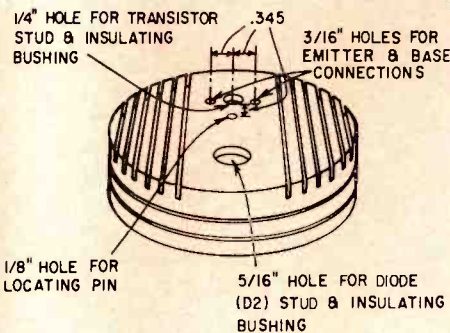

Fig. 1—Top view of sawed-off piston shows saw cuts for air and holes for transistor and diode. Drill holes after finishing operations in Fig. 2.

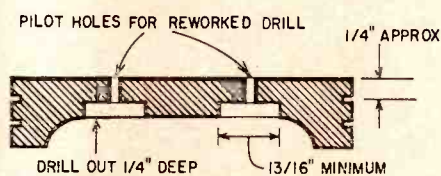

Fig. 2—Cross-section shows enlarged recesses for transistor and diode hardware and connections.

more than 1/4 inch when you test any transistor ignition system.

The coil can be any 400:1 transistor type coil. This unit is for negative ground only (6 or 12 volts).

The solid heat sink is made from an old auto piston. The cavity on the lower side makes an ideal housing for all the parts except the base resistor. The piston I used was from a 1958 Ford. A late Lincoln would be ideal—it is a full 4 inches across. I purchased mine for 15¢ at a motor shop.

Construction begins

First saw off the top of the piston in or below the last ring groove and above the pin hole. Smooth the surface with a file so the back cover will fit tight. Lay out and saw five or six grooves on the top of the piston on each side of the diode and transistor as shown in Fig. 1. A hacksaw with a 24-tooth blade works well, if you start at the edge and work to the center. The fins thus formed, along with the ring grooves, make a good heat sink.

Drill 1/4-inch holes where the diode and transistor will be mounted. (Enlarge them later to proper size for studs and insulators.) The underside of the piston head will have to be milled out so that the mounting hardware can be installed. Though it looks like a job for a machine shop, it can easily be done with a filed-down 7/8- or 1-in. wood bit. File the spurs off the bit. Clamp or nail the piston head to a board, face down. Now, by using an ordinary hand brace, you can cut carefully until the metal is about 1/4 in. thick (see Fig. 2). It takes only a few minutes. Next enlarge one of the holes to 5/16 in. to mount the diode. Then carefully drill the holes for the transistor. Drill four holes to mount the back cover, and two inside the cavity to mount two tie points. I used a 3/32-in. drill and 6-32 tap. Self-tapping screws would work well. The photographs will help you position the holes.

Clean out all the cuttings. The top surface should be finished smooth with fine sandpaper, especially where the diode and transistor mount, to prevent puncturing the mica insulators.

Candy apple red

At this point I was so pleased with my 15¢ heat sink that I masked off the mounting surfaces for the diode and transistor and painted the sink candy-apple red.

Form a piece of heavy aluminum for the back cover, and another for the ballast—resistors and bulb socket. Paint these flat black. Make a bracket to hold the socket for the bulb you choose to use. This bracket is shown in Fig. 4, and has to be insulated from the socket with good heat-resisting material. Var-

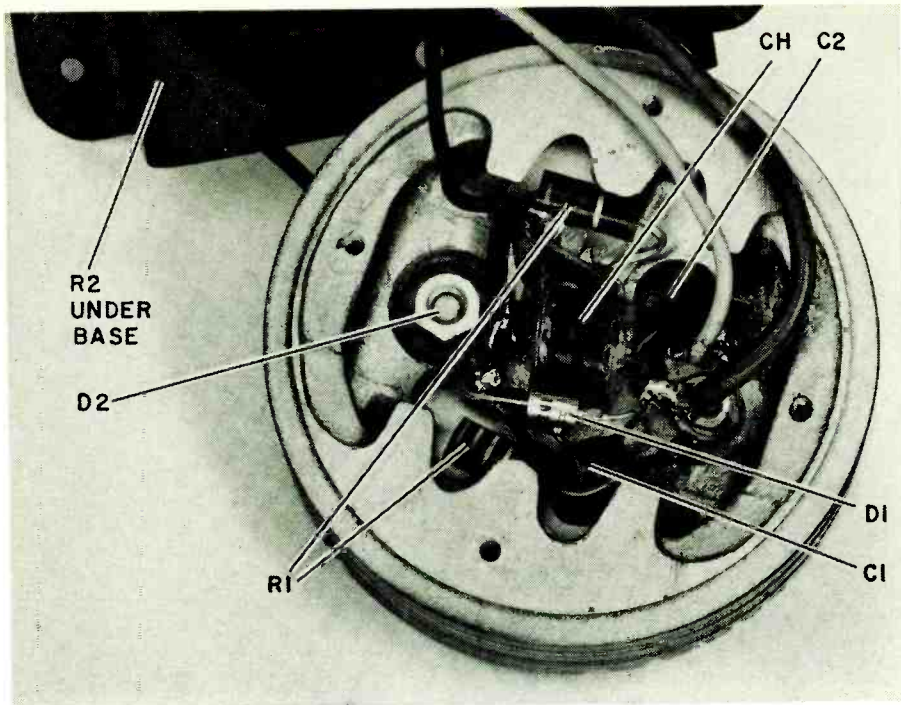

Almost all wiring is inside piston head. Be sure Q and D2 are insulated from head.

nished cambric works well.

The choke coil is made by scramble-winding No. 34 enamel wire on a 1-megohm 1-watt resistor with paper discs glued onto each end to make a coil form. Checking with a phono cartridge scale, wind until you have a total weight of

- C1, C2—75 to 100 pf, 1 kv, noninductive
- CH—choke (see text)
- D1—Zener diode, 68 volts, 1 watt (International Rectifier Corp. Z1130 or Dickson 1N3040, or equivalent)
- D2—silicon diode, 20 to 35 amps, 200 volts (surplus, or RCA 1N1186A, 1N250C, etc.)
- D—see text and Fig. 3.
- Q—2N1970 (Delco, Tung-Sol), or 15-amp, 100-volt equivalent
- R1—620 ohms, 2 watts (or two 1,200-ohm 1 watt in parallel)
- R2—7.5 ohms, 10 watts
- RB1, RB2—2 ohms, 25 watts or 1 ohm, 50 watts (half this for 6-volt systems)
- RB3—2 ohms, 10 watts (optional cold-start circuit)
- S—pushbutton, spst (optional cold-start circuit)
- T—ignition coil, 400:1 ratio (Prestolite 201 or equivalent)
- Bulb—(see text)
- Heat sink, mounting hardware, insulating washers for Q and D2, socket for bulb.

12–14 grams. Total resistance can vary from 30 to 40 ohms. Almost any commercial 3- to 5-mh 125-ma choke of about that resistance will do.

Assemble and solder

If you mount all the parts as in the photos, there is plenty of space. Mount the diode and transistor with the proper insulators and silicone grease (Dow Corning 340). Ream the holes in the heat sink slightly for clearance if necessary.

Two tie points were secured with small sheet-metal screws. Rigid mounting is a must. The base resistor is located on the back cover. It gets a little warm.

Three colors of No. 14 wire are used for the leads. The collector and base-resistor wires are brought out through the back cover. Use a rubber grommet here and seal it to keep moisture out.

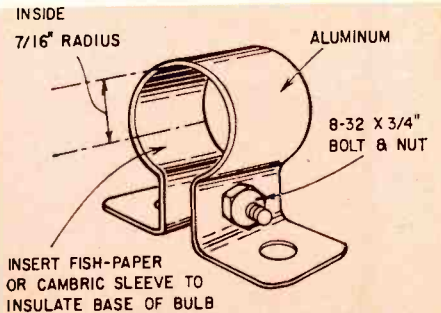

Fig. 4—Details of the holder for bulb ballast. Socket must be insulated from holder.

The ballast (RB) is made up as illustrated. Almost any two 2-ohm 25-watt resistors or one 1-ohm 50-watt will do for the 12-volt system. Half the resistance is needed for 6-volt cars. A No. 1129 21-candlepower bulb gives about 1/4 ohm cold—the correct resistance for 6 or 12 volts. (More on this later in

This system was checked out in a 1962 Ford Galaxie for more than 5 months. I noticed a definite improvement in acceleration in road-testing, especially in the important range between 40–60 mph and 50–75 mph. Top speed increased about 5 mph or more. Gas mileage was not checked, although it was good.

Some trouble developed in the first test series, after the temperature got below 30° in the early morning. The engine was hard to start, although after it had once started, I had no further difficulty. Talks with experts revealed that this was a common complaint, even with some commercial transistor ignitions.

A cold-start circuit was added. The second test series showed definite improvement. With the whole-hearted cooperation of the weatherman, we had temperatures of 2, 4 and 5 degrees at dawn for about 3 weeks! The engine now started with no more than normal delays, and the original excellent running characteristics were retained. After that initial start, no trouble was found, even at these low temperatures.

The Galaxie engine used is the "290" or "regular-gas" version. Its plugs and points had almost 25,000 miles on them, and the car was on the verge of getting an ignition system overhaul. However, to get a "worst-case" test, the original parts were left in. The results were good, and if an engine is cleaned up and tuned up as the author recommends, a very definite improvement should result.

Construction of this unit is rugged, and installation is easy, since only three wires are needed. Check your ignition system to be sure how the original ballast-shortening circuit is hooked up.

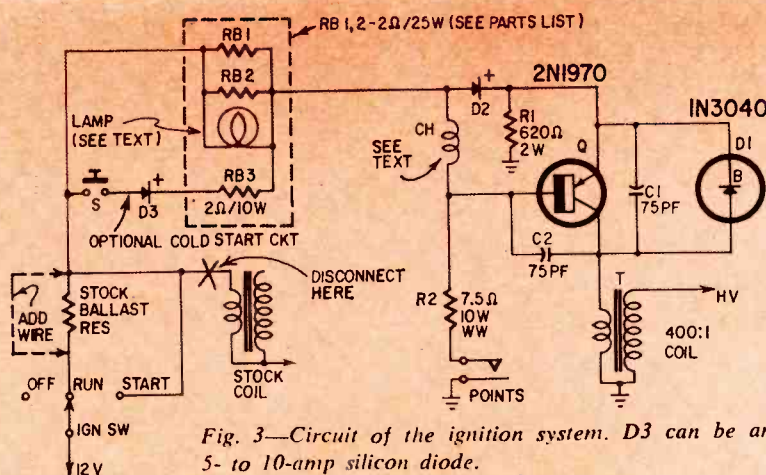

Fig. 3—Circuit of the ignition system. D3 can be any 5- to 10-amp silicon diode.

article.) A cold-start circuit can be added for below-freezing weather.

(Diode D3 (Fig. 3) is not needed if S goes direct to battery. Or, omit S and connect anode of D3 to load side of ignition switch.)

Out with the old, in with the new

The best place to mount the transistor unit is to the left or right of the radiator between the radiator and the grille. Mount the ballast unit under the hood on the firewall. Mount the coil close to the distributor and ground the negative terminal with No. 14 wire. Remove the condenser and bypass the original coil resistor. (Check with your car dealer, if necessary, to locate this resistor.) A No. 14 wire direct to the ignition switch is the best. A mistake could be made on some cars. Wire as in Fig. 3.

You are wired from switch to ballast, from ballast to anode of D2, from collector to coil, coil to ground, and base resistor to distributor points. Insert an ammeter between the transistor unit and the ballast. Remove the center wire from the distributor and ground that end. Don't leave it open.

With the ignition on and points closed, the ballast light will come on. The ammeter should read 9 amps. If it's close, turn the key off and replace the distributor wire. Start the motor and check current again. Should be at least 8 amps.

If the current is too low, change the bulb to a No. 1133. If too high, use a No. 1073. A reading of 8½ amps, motor running, is ideal.

Built-in timing light

The ballast lamp is a good timing indicator. To tune up:

1. Remove and inspect spark plugs. Clean and regap to .040 in. Do not re-install yet.

2. Replace or clean distributor points and set gap at .012 to .015 in.

3. Remove center distributor wire and ground it. Turn ignition switch on and turn motor over until rotor points to No. 1 cylinder. Motor can be turned with fanbelt held tight with one hand, turning fan with other hand. Light on ballast will come on. It should go out 5° to 7° before top dead center. Be sure you have the right cylinder, and do not advance more than 2° over manufacturer's setting. At sea level, set timing at exact specs. Too much advance will do serious damage; maybe burn a hole in a piston.

4. Turn key off. Replace everything. Wipe plugs with silicone grease.

5. Clean or replace air cleaner.

6. Run motor for 15 minutes. Adjust air idle screws slowly to the right until motor starts to stall. Back off ¼ turn. If you have a vacuum gage, adjust for highest reading.

END

Pep Up Your Old FM Set

Single-nuvistor rf stage brings in stations you never heard before.

By DONALD E. PHILLIPS

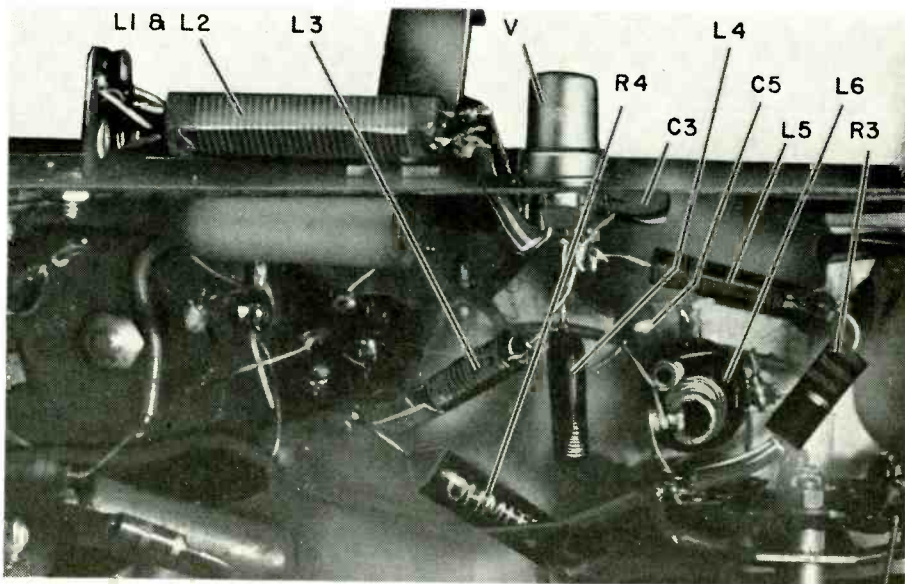

Edge-on view of the nuvistor booster. It fits neatly into most FM tuners. L6 in this photo is the set's original antenna coil.

A NUVISTOR RF STAGE IS EASY TO ADD to older FM sets, which often have good limiting and selectivity, but don't have the useful gain of modern low-noise rf circuits. Improving the sensitivity and noise factor will clear up some of those hard-to-get stations.

The 6CW4 nuvistor fits into a very

small space. No additional tuned circuits are necessary. The circuit has considerable gain and excellent signal-to-noise ratio, and eliminates the inconvenience and expense of an additional booster at the receiver or on the antenna.

The basic circuit is shown in Fig. 1. The 6CW4 is a very-high-transconduct-

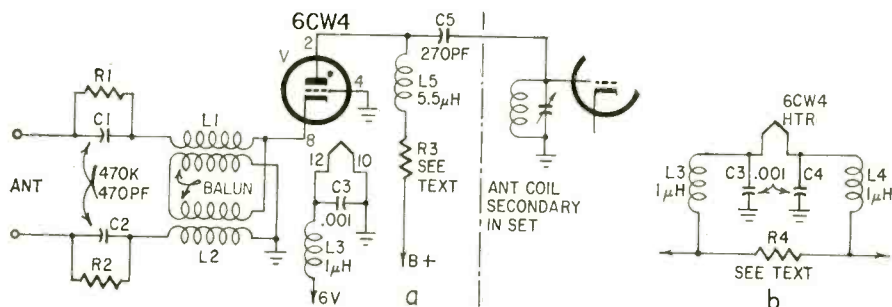

Fig. 1-a—Circuit of the nuvistor rf stage. b—Variation of heater circuit for use in series-string sets.

ance triode, with a low input impedance in the grounded-grid circuit. Balun coils L1 and L2 match the balanced 300-ohm input to the lower input impedance of the cathode. The high impedance of the plate circuit works directly into the first tuned circuit of the receiver.

Either series or parallel heater circuits are satisfactory. In a series circuit, use chokes and bypass capacitors on both heater leads, and a parallel resistor, as in Fig. 1-b. The usual 150-ma series string would require a resistor of about 420 ohms at 7 watts to handle the extra current in case the nuvistor should open or be removed. The heater current of the 6CW4 is 135 ma.

The tube socket should be mounted close to the present antenna coil, with the plate lug, pin 2, pointed toward the coil (Fig. 2). The socket can be installed in a 1/2-inch hole by spreading the mounting clips sideways and soldering to the top of the chassis. The balun coils can be mounted on top of the chassis if necessary, by running the cathode lead (insulated) through a hole in the chassis near the cathode lug, pin 8. Be sure to add isolating networks (R1-C1 and R2-C2) in series with the antenna terminals if the chassis is connected to one side of the power line.

Do not ground the grid lug, pin 4, with a piece of wire! I spent more time trying to eliminate oscillation caused by a 3/4-inch piece of No. 18 wire from grid to ground than on all the rest of the circuit! The way to be sure is to use a 1/2-inch-square piece of thin sheet copper (such as the straps between the picture-tube frame and chassis in many TV sets), shaped as in Fig. 3. Solder all along the bottom edge of the copper to the chassis, making a clean, neat joint. Then bend the grid lug over across the top of this strap and solder it down well. The inductance between grid and ground has to be kept very low.

If one heater lug is to be grounded, use pin 10, and solder it to the same copper strap. The ground returns for the antenna coils and heater bypasses are not as critical, but should be as short and direct as possible, close to the socket.

Plate resistor R3 should be chosen for 70 volts on the plate, with plate current approximately 10 ma. If the B-plus is 250 volts, R3 will be about 18,000 ohms 2 watts. If B-plus is 100 volts, R3

- C1, C2—470 pf disc ceramic. See text
- C3, C4—.001 μ f disc ceramic
- C5—270 pf disc ceramic
- L1, L2—balun coils (Colman 1205 or equivalent)
- L3, L4—rf choke, 1 μ h (Stancor RTC-8515, Miller 4602 or equivalent)
- L5—rf choke, 5.5 μ h (Stancor RTC-8519, Miller 4609 or equivalent)
- R1, R2—470,000 ohms. See text
- R3, R4—see text
- V—6CW4 (RCA)
- Nuivistor socket (Cinch Jones 5NS or equivalent)

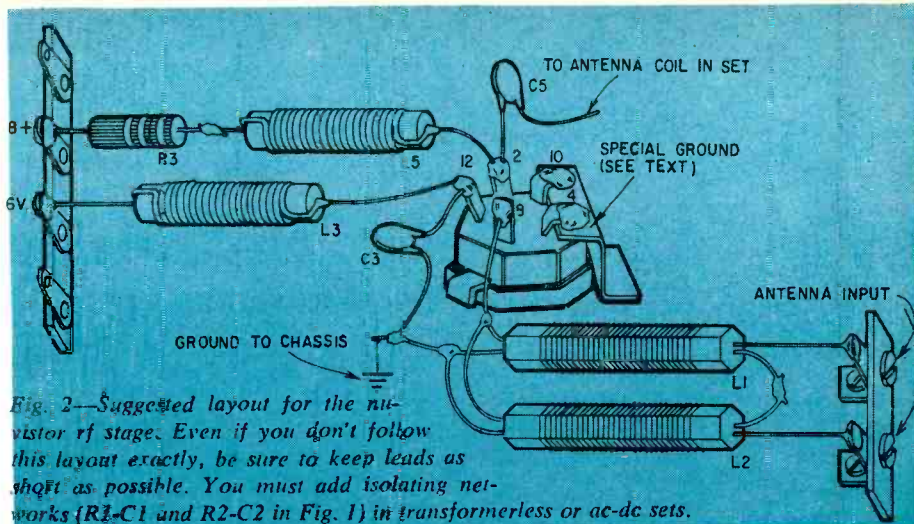

Fig. 2—Suggested layout for the nuvistor rf stage. Even if you don't follow this layout exactly, be sure to keep leads as short as possible. You must add isolating networks (R1-C1 and R2-C2 in Fig. 1) in transformerless or ac-dc sets.

will be 3,300 ohms 1/2 watt, etc. The tube is designed to work with zero bias.

The choke and resistor in series form the rf plate load. I prefer to join them without a terminal lug, to minimize stray capacitance. Keep the leads short, except at the B-plus end, where a terminal lug may be used. The B-plus end of the resistor may be bypassed with an additional .001- μ f capacitor if it helps, but it has not been necessary so far.

Coupling capacitor C5 connects directly to the secondary of the original antenna coil (the winding that is tuned). Remove connections on the primary or taps that were in the antenna input cir-

cuit. This tuned circuit must be parallel-resonant. If it is series-resonant, as in the G-E Musiphonic model 45, reconnect the series trimmer in parallel with the coil.

It is best to align the entire receiver carefully, but be sure at least to peak up the former antenna coil on a weak signal for maximum gain.

Tests of this circuit were made by comparing performance "before and after." Increased gain caused full limiting on much weaker signals than before, reducing noise and distortion, and the signal-to-noise ratio was greatly improved. Naturally, the degree of improvement depends on the design of the original rf circuits. In every case so far, performance was brought up to where a good low-noise booster ahead of the receiver made no improvement, proving that the sensitivity was at the maximum usable level.

The amplifier is most suitable for use with pentode rf stages (6BA6, 6AG5, etc.) or receivers with no rf stage. It will not work with a grounded-grid stage, except as a replacement for that stage. END

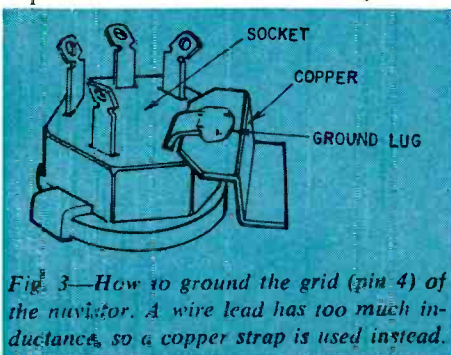
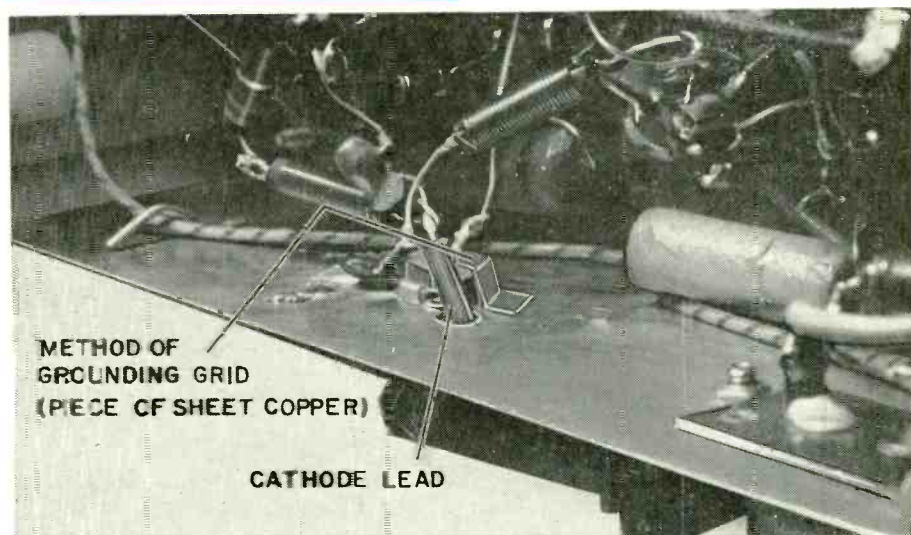

Fig. 3—How to ground the grid (pin 4) of the nuvistor. A wire lead has too much inductance, so a copper strap is used instead.



Another view of the added nuvistor rf stage

Time-Mark Generator for Your Scope

Pocket-size time-and-frequency marker is crystal-controlled

The most important calibration a scope user can make on his instrument is a sweep time calibration. Most applications are frequency or time rather than amplitude measurements. This battery-operated Time-Mark Generator produces 100-kc (10-microsecond) and 1-kc (1 millisecond) pulses on your scope screen. Sweep calibration checks should be made at regular intervals. Low-priced scopes are apt to drift more rapidly than high-performance lab types.

For many general-purpose oscilloscopes, 1 kc is a typical midpoint adjusting frequency. The two markers can be used to calibrate oscilloscope sweep rates from 200 cycles (5 msec) to 1 mc (1 μ sec) per division. (Line frequency can be used for calibrating sweep rates below 200 cycles.)

The sweep control setting determines the number of pulses in the display. Scopes such as those used in TV shops have a typical sweep range from 10 cycles to 500 kc. Sweep rates slower than 200 cycles per division, especially in scopes using 1-cm divisions, may crowd the 1-kc markers, resulting in poor definition. Sweep rates higher than 1 mc per division may place the markers off screen.

By CLIFTON W. ROBERTS

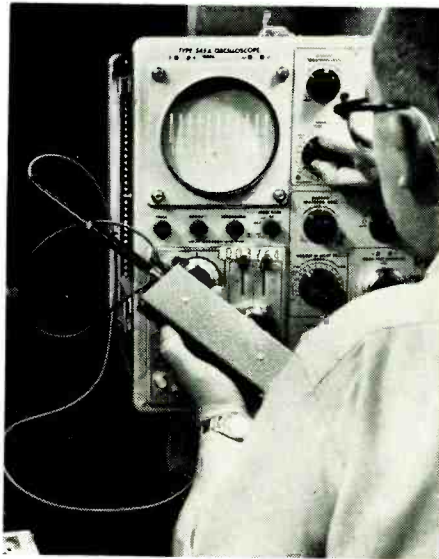

Technician calibrates 10- μ sec sweep on Tektronix 545A with the time-mark generator. Marker's use isn't limited to lab scopes. Where there's time, there's frequency—so you can check accuracy of service type scope sweep, too. Exactly ten 1-millisecond pulses on screen mean that sweep rate is precisely 100 cycles per second.

This generator can also be used for trace-intensity (Z-axis) modulation, as a sweep-triggering source (if your scope has a triggered sweep) and for calibrating other pulse generators.

If your scope has provision for intensity modulation, the markers can be applied to the CRT grid for trace intensification or to the cathode for trace blanking. Intensified or blanked portions will be at marker-frequency intervals. The blanking may not be complete—sometimes just a dimming—depending on the voltage required. The generator output voltage is between 5 and 6. When you use intensity modulation, the signal and the markers must be synchronized.

Using the generator as a sweep-triggering source is practically self-explanatory. The only requirement is that the trigger input of the scope be high-impedance.

In calibrating other generators, the Time-Mark Generator could be used as a secondary standard. Battery power and crystal control give the marker generator greater stability than most generators on TV benches or hobby workshops.

To calibrate a generator with the time marks as standards, the easiest way

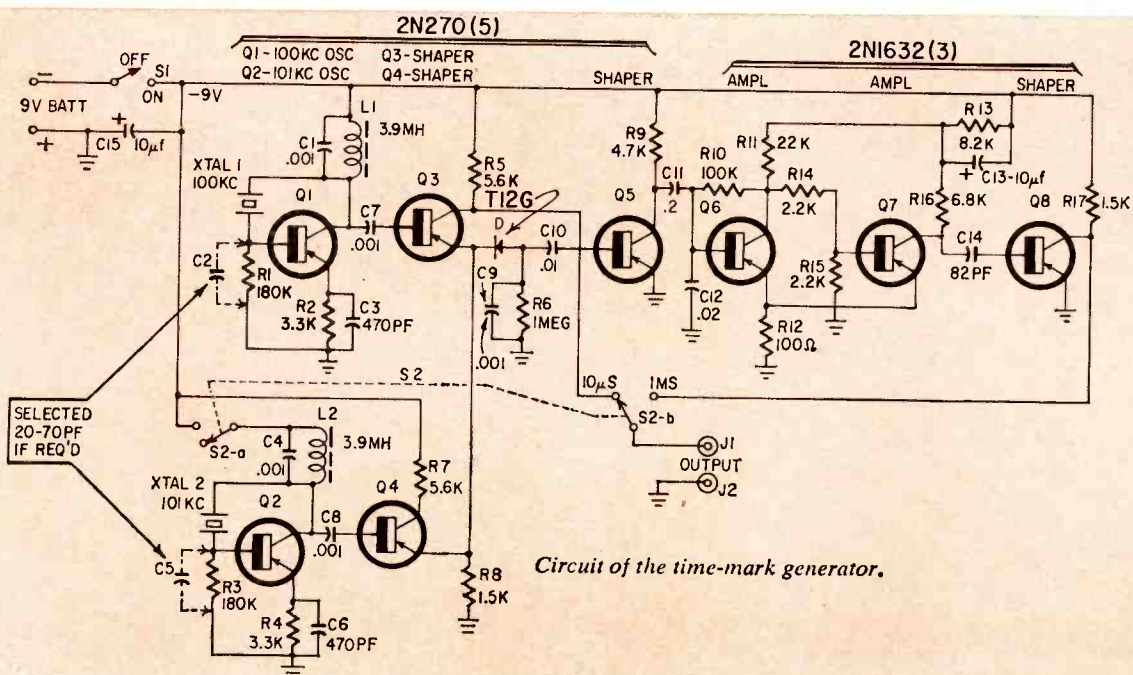

Circuit of the time-mark generator.

is to use a dual-input oscilloscope or electronic switch. Another is to use intensity modulation, and a third way to use the time marks, first to mark points with a crayon on the CRT face or graticule, then to connect the generator to be calibrated and match its pulses to those points.

Markers will drop to 50% amplitude when they "look" into a dc-coupled input impedance of approximately 6,000 ohms for the 100-kc marker and approximately 2,000 ohms for the 1-kc marker. Most dc scopes have input impedances above 100,000 ohms, so that should be no problem. Ac coupling will have little effect on marker amplitude.

Constructing this pocket generator shouldn't present any problems. Placement of parts is important only if you want to keep the unit small. Substitutions should be all right if they have equivalent electrical specifications.

Circuit operation

When switch S2 is in the 10- μ sec position, the 100-kc oscillator (Q1) output is amplified and fed to the output connector. When the slide switch is in the 1-msec position, the 100- and 101-kc oscillator (Q2) outputs are mixed to produce a 1-kc difference which is amplified and reshaped before being fed to the output connector.

Selected capacitors (20 to 70 pf) across R1 and R3 provide fine frequency control. They may be unnecessary. Experiment will tell. They can be variable if you want to take the space.

The 100-kc sine wave at the collector of Q1 is coupled through .001- μ f capacitor C7 to the base of Q3. Q3 acts as a signal amplifier and a signal shaper. When the oscillations drive the base of Q3 negative, it turns on and supplies the output jack with 100-kc pulses. The output amplitude is from 5 to 6 volts.

The 100- and 101-kc oscillations from Q1 and Q2 are fed to the T12G diode mixer tied to the emitters of Q3 and Q4. A .001- μ f capacitor (C9) and a 1-megohm resistor (R6) constitute a

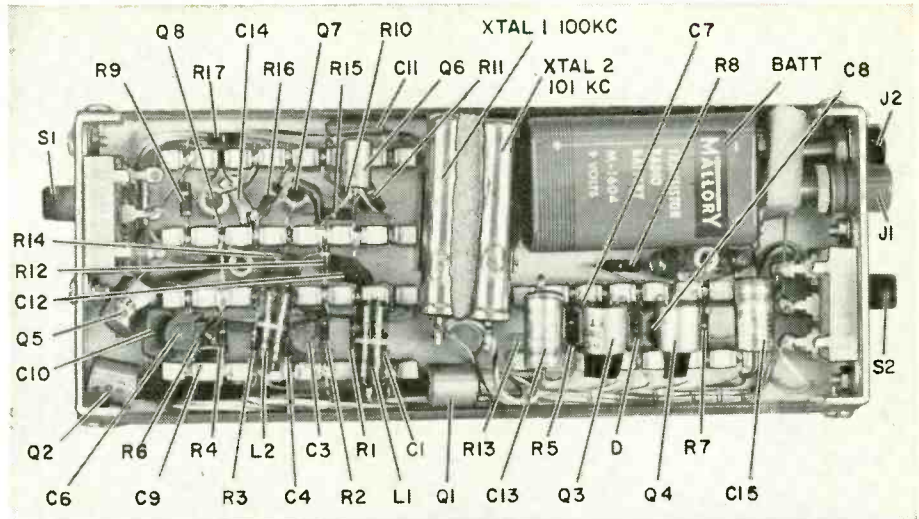

"Nick" type solder-terminal strips make wiring neat and help keep leads short. Author used 1/4-watt resistors to save space, but that's optional.

BATT—9-volt "transistor radio" battery (Mallory M1604, Burgess 2U6, etc.)

C1, C4, C7, C8, C9—.001 μ f, 500 volts
C2, C5—see text
C3, C6—470 pf
C10—.01 μ f
C11—.02 μ f, 25 volts
C12—.02 μ f
C13, C15—10 μ f, 15 volts, electrolytic
C14—82 pf

All capacitors except C13, C15 are ceramic

D—T12G diode (Transitron), or general-purpose type (1N34, etc.)

J1, J2—banana jacks, binding posts, etc.

L1, L2—3.9-mh coils (J. W. Miller No. 4668 or equivalent)

Q1, Q2, Q3, Q4, Q5—2N270 (RCA)

Q6, Q7, Q8—2N1632 (RCA)

R1, R3—180,000 ohms

R2, R4—3,300 ohms

R5, R7—5,600 ohms

R6—1 megohm

R8, R17—1,500 ohms

R9—4,700 ohms

R10—100,000 ohms

R11—22,000 ohms

R12—100 ohms

R13—8,200 ohms

R14, R15—2,200 ohms

R16—6,800 ohms

S1—spsst slide or toggle switch

S2—dpdt slide or toggle switch

XTAL 1—100-kc, 5° X-cut crystal for 32-pf load capacitance

XTAL 2—101-kc crystal, other specs same as XTAL 1

Order 100- and 101-kc crystals from International Crystal Mfg. Co., 18 North Lee, Oklahoma City, Okla. 73102. Specify type no. FX-1, .01% tolerance, and enclose \$8.75 each plus postage (check or money order) with your order. Delivery 10 days after receipt of order.

Metal or plastic case to suit; terminal strips, miscellaneous hardware

filter network that removes unwanted 100- and 101-kc signals after mixing. The 1-kc frequency is then fed to the base of Q5, which acts as a class-C amplifier and shaper. Q5 drives Q6 and Q7, connected as a regenerative amplifier.

The amplifier output is applied to the base of Q8 through an 82-pf capacitor, C14. Q8, like Q3 and Q5, is driven into conduction by the negative portion of the signal at its base. The coupling capacitor, together with the low impedance of the base-to-emitter junction of Q8, differentiates the input signal, producing 5- to 6-volt, fast-rising 1-kc markers on the collector. They are fed to the output jack via S2-b. END

NOW: INSTANT VOLTAGE

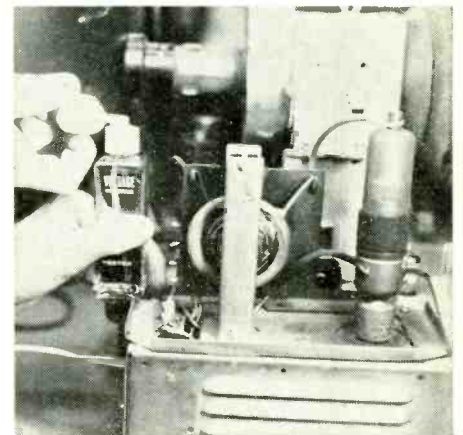

Two Time-Mark Generators and a dual-beam oscilloscope were used to make this picture. One supplied a 10- μ sec pulse (upper trace) and the other the 1-msec wave. The two outputs of a single generator cannot be used at the same time. Sweep for upper beam was 10- μ sec/cm; for lower, 1 msec/cm.

At first glance, seems to be the ideal solution for too-low high-voltage, no? (Look very carefully at the top two words on the bottle: Voltage Concentrate! And the lower word is "Tester.")

Try it, and you'll have one of the most fragrant sets in the neighborhood. The "Voltage Concentrate" in the atomizer bottle is a drugstore perfume sampler.—Jack Darr

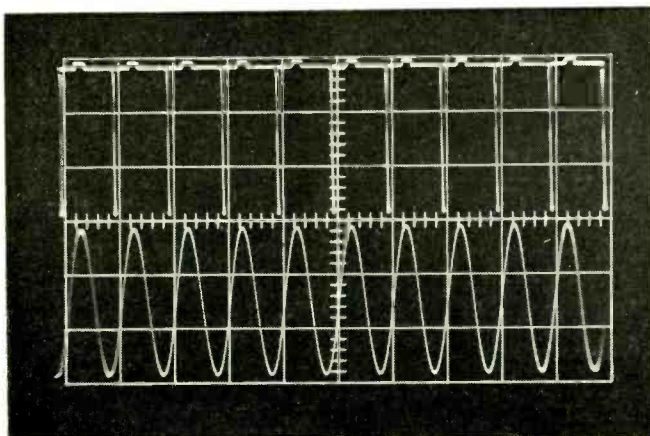

BASIC INDUSTRIAL ELECTRONICS FOR TV MEN

I-E language has some words and pictures of its own.
A quick jog through some things you don't find in TV

By **JACK DARR**
SERVICE EDITOR

A LOT OF TV MEN HAVE WONDERED about trying to get into industrial electronics. What kinds of things are used and how do they work? Well, they're not too much different from TV—simpler in many cases! You'll find applications of such things as photocells, thermostats and pressure switches. Almost everything in this kind of work involves relays, since we have to make and break heavy currents.

In TV design, many circuits are always built almost alike; so you know what is meant when someone says a circuit is "conventional". Industrial electronics uses certain conventions, too, and we have to know what they are if we're going to work with them. The use of relays is one; "fail-safe" operation is another.

What's "fail-safe"? Simply this: the whole process is designed so that if anything at all is not exactly *right*, the machine *stops*. It can't blow up or run wild. This is done by using safety interlocks and monitors to check on all the important factors while the process is going on.

So, the first lesson is this: always check up on interlocks and safety controls. Maybe the trouble is in one of these, and not in the electronics at all! (Although, when you get a call, the op-

Typical electronic programmer control. Photocell relay controls main fuel valve via electronic amplifier.

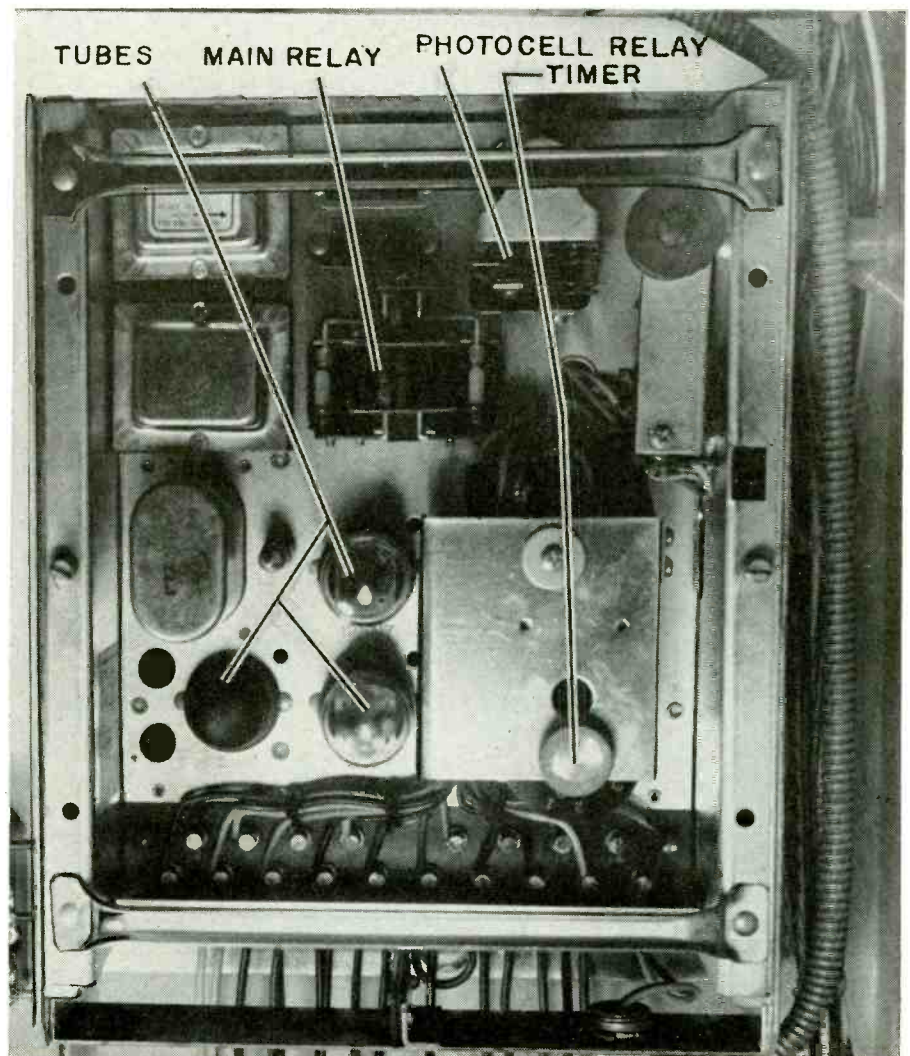

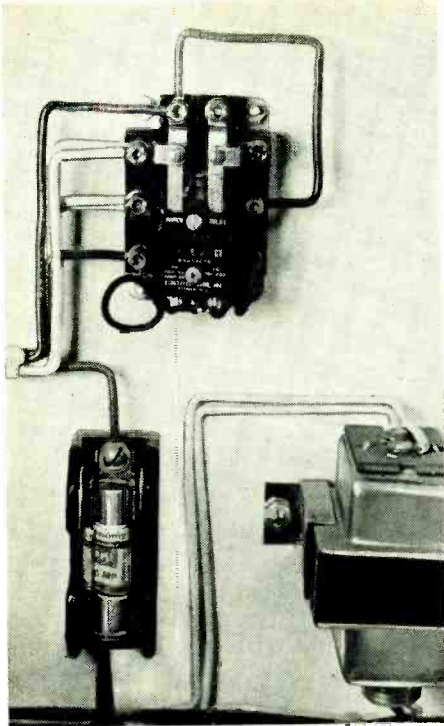

Typical switchbox wiring. At top of photo, medium-sized contactor; at bottom fuse (left) and 24-volt transformer for safety cutoff coils and other control devices. Parts of control equipment often operate at 24 volts ac, other parts at 110 or 220 or other line voltage.

erator always insists that it is in the electronic apparatus!)

A typical unit

Let's look at one typical device, a control unit for a large boiler. Starting this isn't as simple as lighting a cigarette. We have to go through a regular sequence of procedures to be sure it's going to work and not blow us through the ceiling. This is what happens:

A thermostat "calls for heat". A blower motor starts, flushing air through

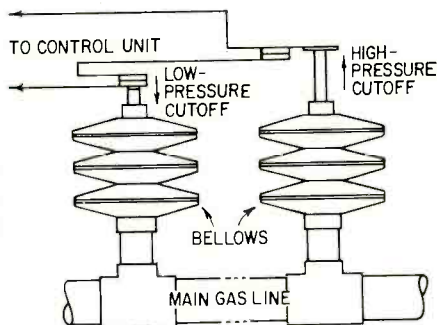

Fig. 1—How high- and low-pressure cutoff switches work. If pressure falls below a preset value, bellows at left collapses, opening switch. If pressure rises too high, bellows at right expands enough to open its contacts. This is just one example of simple electromechanical sensing devices common in industrial electronics.

the firebox to get rid of any unburned gas that might be there. The pilot light, controlled by a solenoid valve, opens and is lit by an electric spark from a special transformer. The main gas valve, also a solenoid, opens and the boiler is lit.

All these processes are electrically controlled and timed by cam switches on a one-rpm timer motor. Opening and closing switches causes valves to open. (If you're thinking this sounds like the timer switch on an automatic washing machine, you're right. It *is*!) However, at each step in the process, the control voltage never goes through the cam contacts *alone*. It is always made to pass through extra contacts on the "safety switches". If any of these are open, indicating that something is out of order, the process stops right there! This is fail-safe operation.

Safety switches

Now, how do we do this? By using special switches, or *sensors*, in each device or circuit. For example, we must have exactly the right gas pressure, not too high or too low. So we use a pair of

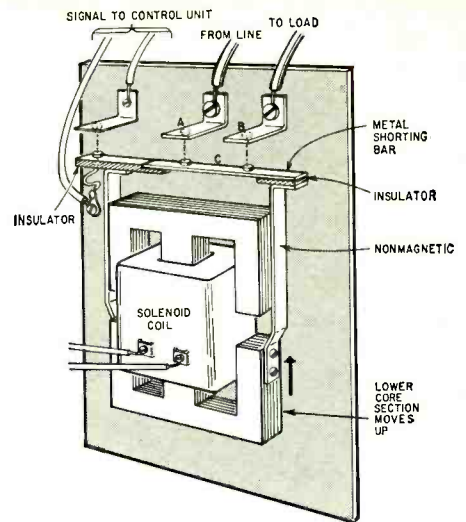
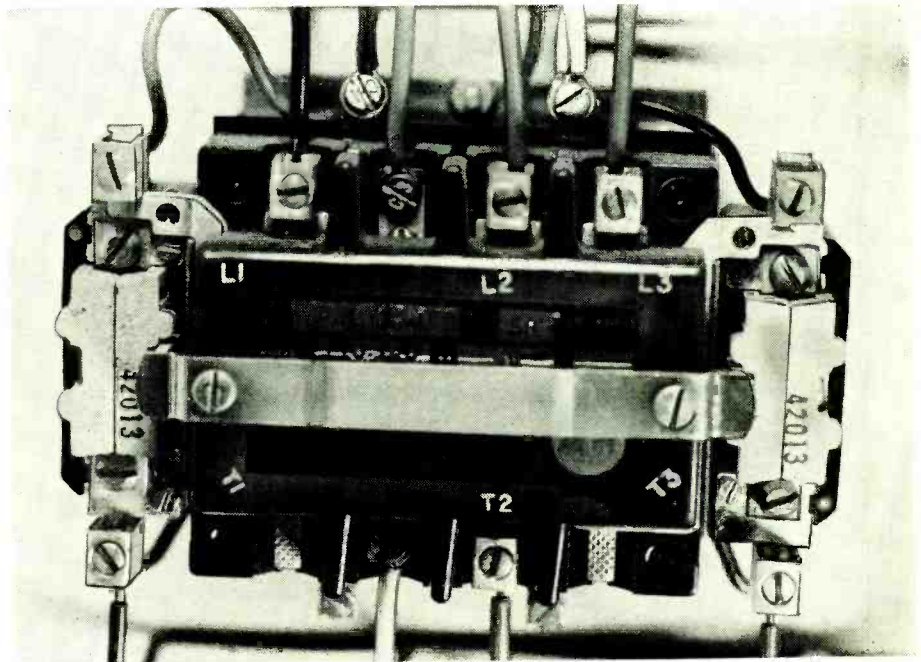

Fig. 2—Contactor = relay (in principle). Main contacts A and B are fixed to eliminate flex leads common in smaller relays; contacts are jumped by bar C when contactor is energized. Small contacts at left are for "signaling" that the contactor has been actuated. Spring (not shown) returns armature and bar C to "open" when coil is de-energized.



Closeup of a contactor. "Signaling" contacts (see Fig. 2) are at either end of assembly.

gadgets like the ones in Fig. 1. The drawing shows how they work. Unless gas pressure is within the preset limits, one of the switches will be open and we can't go on until it is closed.

For heavy-duty motors, such as those used on blowers and, for that matter, on all kinds of heavy-duty electrical apparatus, we use a device like the one in Fig. 2. We'd call it a relay; they (industrial people) usually call it a *contactor*. On the armature, besides the heavy-duty contacts that do the actual work, there is a pair of smaller contacts, closing at the same time. We use these

to signal when the main contacts are closed.

To make this gadget work fail-safe, we simply connect all the contacts on all the sensors in series (Fig. 3). We connect this series into the circuit of the programmer, so that it will break the circuit if any of them is open.

This is usually done by a relay, a more conventional (to us) one this time. This relay starts and stops the programmer motor, or controls the process. In other words, it will be hooked up *somehow* so that it must be *closed* before we can go on with our rat-killin'.

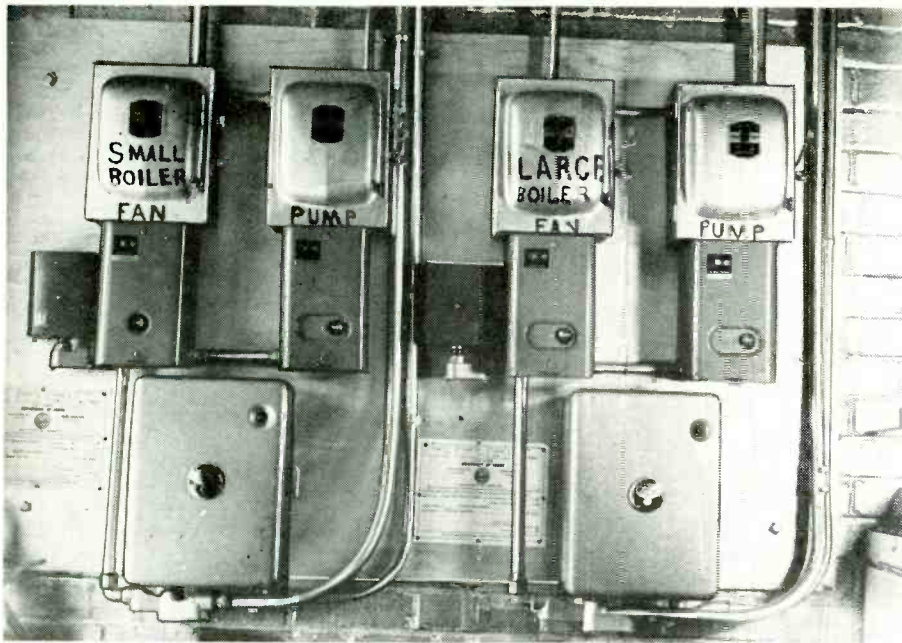

Most main switches aren't marked as plainly as this, but they ought to be! Two large boxes in bottom row contain electronic controls.

So, if we lose gas pressure, water pressure or anything else important, the contacts on the safety device open, the relay drops out and the whole machine stops until we find out what happened and correct it.

Checkout procedures

So there's the first check: look at all the safety interlocks to be sure they're closed. Almost all of these are set up so "optical inspection" will let you see how they are. For example, in the high- and low-gas cutoffs in Fig. 1, the actual switch is a bottle of mercury! You can readily see whether it's tilted enough for the mercury to close the contacts. Some of the large relays use mercury switches themselves, with small auxiliary points for the interlock contacts. It doesn't matter *what* is used; what's important is *how* it's used and "Is it working?"

With a machine you're seeing for the first time, always study blueprints and wiring diagrams carefully before

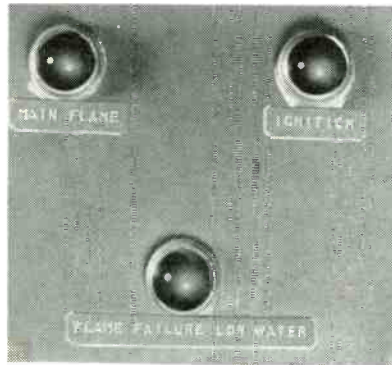

Labeled pilot lights are a great help, but don't expect to find them often!

making any diagnosis at all! In large installations, *these drawings will always be somewhere around.* Check to see exactly *how* they connected the safety interlocks, how many are used and what kind. Don't be ashamed to ask for that data, either; you're not supposed to be a walking encyclopedia of assorted IE machinery!

High-low pressure switches like the ones diagrammed in Fig. 1. Gage between shows gas-line pressure in inches of water.

Unfortunately, you'll find quite a few machines with all the electrical wiring neatly drawn out, numbered and so on, and a nice, blank box in the drawing marked concisely ELECTRONIC CONTROLS! However, this isn't too hard to figure out. For example, in the boiler control we've been talking about, this blank was filled by a very obvious photo-cell and a pair of tubes with a relay in the plate circuit of one of them! By watching the operation of the relay, it was easy to see that this cell was used to close the relay when the *pilot light* lit. Unless the photocell "saw fire", the main gas valve refused to open.

One service call on this rig was due to a defective photocell, three more to bad tubes, and one to someone getting into the terminal box and mixing up the wiring! So, check all possible causes of trouble. In this one, you could check the cell by waving a flashlight back and forth in front of it, after removing it from the boiler door. If the relay clicked in every time the cell saw light, OK; go on and check something else.

Relay contacts, especially in small types exposed to industrial fumes, dust and moisture, cause lots of trouble. Get in the habit of checking and cleaning these contacts every time you work on the machine. A piece of cardboard like a postal card, or a relay burnisher tool (a polished flat blade like a spatula), should be used. *Never* sandpaper or use emery cloth!

The best tool in the IE technician's box is good common sense. (Just like TV work in that respect!) Look to see what the thing isn't doing and find out why by intelligent testing! **END**

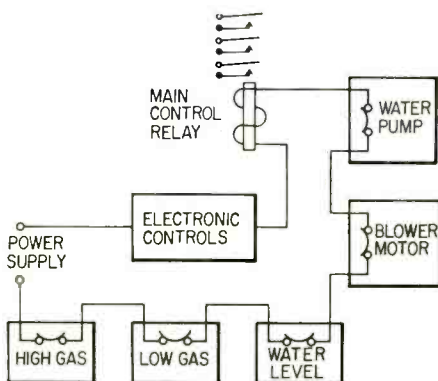
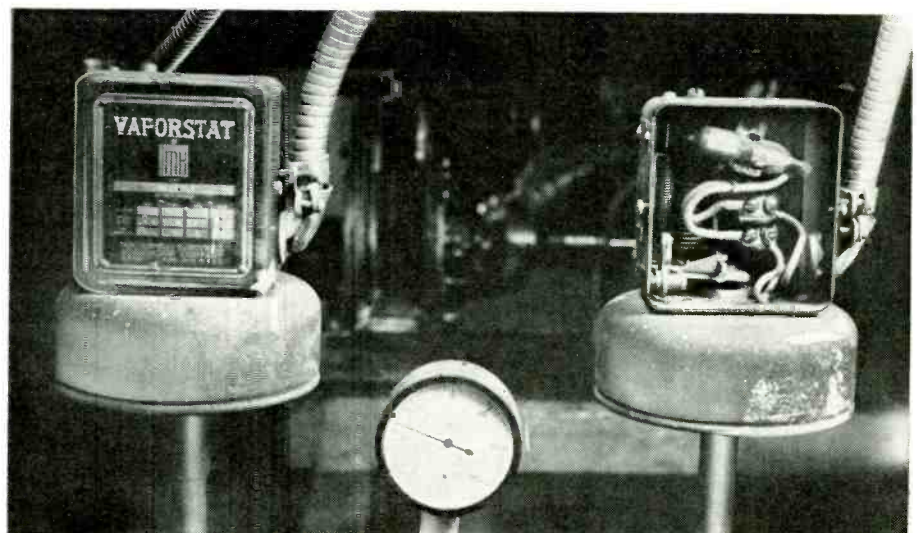

Fig. 3—A simplified circuit (left) shows series interlocks that interrupt operation (or prevent it from starting) if any condition deviates from normal. Similar scheme, for example, keeps subways and some railroad trains from starting until all doors are safely closed and locked.





All photos by P. E. Sutheim

THE SMALL WORLD

By **PETER E. SUTHEIM**
ASSOCIATE EDITOR

HALF HIDDEN BETWEEN THE BIG DISPLAY splashes on catalog and magazine pages is a small world of devices, instruments, accessories—whatever you'd like to call them. Some are fairly well known; others, pretty obscure. All of them can make your work as a service technician or radio-electronic experimenter easier, faster and more enjoyable. Here are ten such items. All are inexpensive, and all do jobs that could otherwise be done only clumsily—with makeshift arrangements.

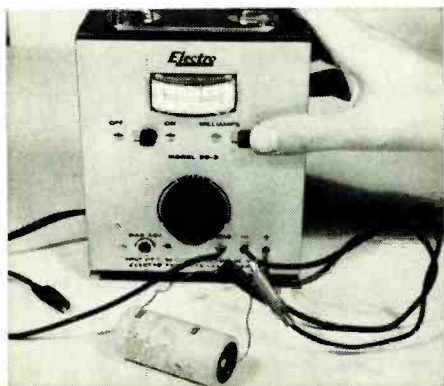

Dc supply for transistors

This is the *Electro EC-3* filtered dc power supply with a continuously variable output of 0–24 volts at up to 100 ma. A switch lets the panel meter show either voltage or current. I found it useful for powering transistor radios, both for servicing and just to prolong battery life. Ripple is less than 0.1% at rated load

so there is no trace of hum. Source impedance is low enough to prevent internal feedback.

Another application for the *EC-3* is forming high-capacitance, low-voltage electrolytics.

The manufacturer suggests charging nickel-cadmium batteries as an application. For higher currents, manufacturer's model *EC-2* supplies 0–16 volts at up to 5 amps, 0.5% ripple at rated load. Good for mobile radios and PA amplifiers, bigger battery charging, light electroplating and etching.

Electro Products Laboratories, Inc., 6125 W. Howard St., Chicago 48, Ill. **EC-3**, \$19.95; **EC-2**, \$39.95.

Audio oscillator

Most experimenters need a clean, reliable audio tone now and then. Good for checking for clipping and other kinds of distortion in audio amplifiers, checking continuity, measuring or just guesstimating gain, signal-tracing, code practice, AM and SSB transmitter adjustment . . .

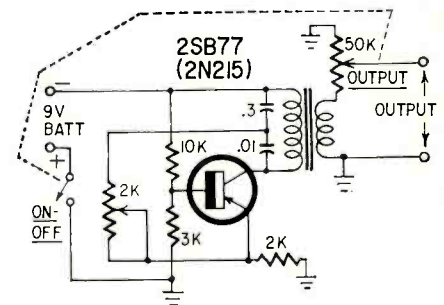

The *Lafayette TE-39* is a self-contained, battery-operated transistor oscillator that generates a fixed, pure sine wave of 1,000 cycles. Stability is excellent and distortion is less than 2%—the equal of many service type audio generators. Level is adjustable from 0 to about 0.5 volt across a medium impedance. A pair of "five-way" binding posts in back are spaced $\frac{3}{4}$ inch for a double banana plug. With a plate-to-line or backward-connected line-to-grid transformer, it will match low-level, low-impedance professional audio equipment inputs (250 to 600 ohms). The direct output impedance is about 10,000 ohms.

Lafayette Radio-Electronics Corp., 111 Jericho Turnpike, Syosset, N. Y. \$4.95.

Low-voltage dc supply

For powering small experimental transistor circuits, it's hard to beat this well filtered power supply. Use it as a bias box, too, for substituting for avc/avc voltages while you align controlled i.f. and rf stages. Ripple is less than 0.1% at full load, which is 200 ma. The *Heath EUW-17* supplies up to 25

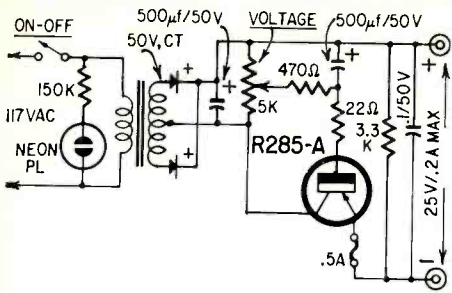

volts at that current, or up to 35 volts with no current drawn. Source resistance is less than 50 ohms, so it makes a good experimental fixed-bias source for audio and linear rf amplifiers. The supply has a transistor "capacitance multi-

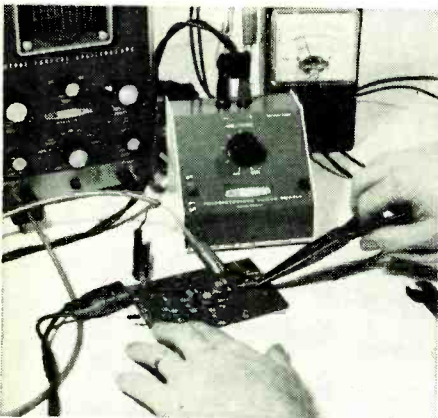

plier" circuit, so that the 500- μ f filter has the effect of about 25,000 μ f. Note that this is *not* a kit; it's part of the Heath Instrumentation Lab series.

Heath Co., Benton Harbor, Mich. \$20.

Grid-dip meter

One of the most useful single instruments ever invented. This model, the *Knight G-30*, has the added attribute of being the least expensive dipper kit on the market. The most obvious application, the one that gave the instrument its name, is finding the resonant frequency of an L-C combination. Couple the dipper to the circuit and tune until the meter pointer dips. Then read the frequency off the dial. Six coils cover the range of 1.5 to 300 mc.

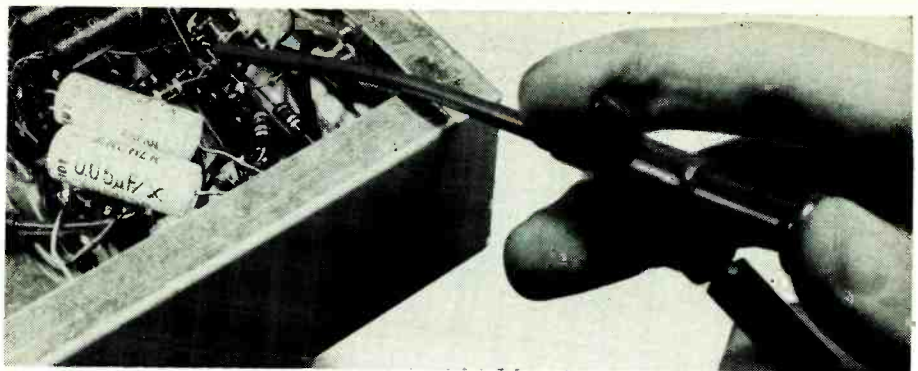
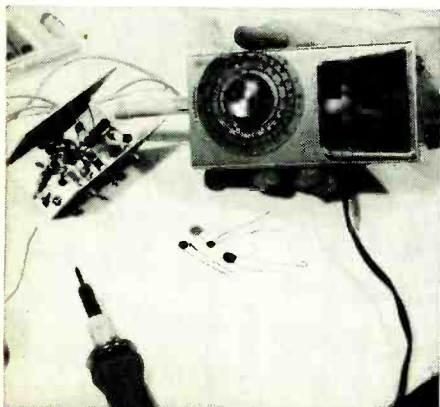

Since the unit can be used either as an oscillator or as a passive, nonoscillating absorption wavemeter, you can check active and inactive resonant circuits. It also makes a signal generator (quite accurate)—wind two turns of hookup wire onto a plastic tube, slip it over the dipper coil, and connect a coax cable with clips to the two-turn link. As an oscillating detector: plug in earphones (jack provided) and listen for a beat note from weak radiations. You can even plug in a *crystal* instead of a coil, and the dipper will oscillate at the crystal's frequency. (The tuning dial has no effect then.)

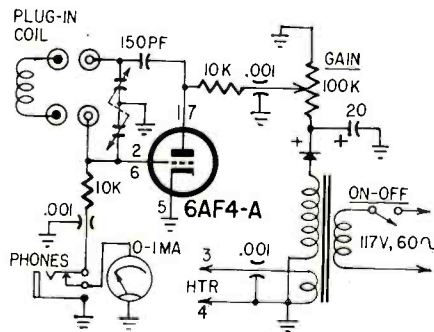

It will tune resonant stubs and antennas; measure Q; check neutralization, harmonics and parasitics; measure capacitance and inductance; check relative field strength; help align receivers, and adjust tracking.

Allied Radio Corp., 100 N. Western Ave., Chicago 80, Ill. \$22.95, kit.

Unusual test probe

This squirt-gun-like tool is actually a highly ingenious clip-on probe. A German product (Hirschmann), the *Kleps 30* is almost as good as growing an extra hand. As you push the plunger, two little grippers emerge from the business end and spread, letting you hook onto a wire or terminal. As you release the plunger, the "forked tongue" retracts into the insulated sleeve under spring tension, as far as whatever you've clipped onto will let it go. After that, the chances of accidentally shorting against an adjacent wire or terminal, all too common with ordinary probes and clips, are practically zero. What's more,

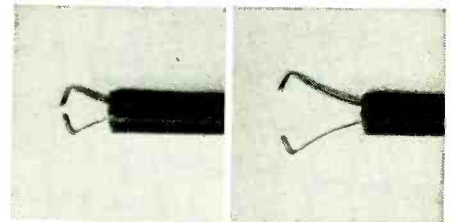

you can bend the probe double, if you like, without affecting its action.

If you want only to touch without clipping on, that's OK too—the hooks protrude just enough when retracted to make contact with a flat surface. A socket near the plunger accepts a standard banana plug or just ordinary heavy test lead. If you want to shield the probe, for low-level audio measurements, say, just slip some ordinary shield braid over the insulating sleeve and ground it to the test lead's shield.

Rye Sound, Inc., Mamaroneck, N.Y. Red or black, \$1.47.

Semiconductor checker

The *Knight Transistor and Diode Checker* also checks selenium and copper-oxide rectifiers. It can select matched pairs of diodes or transistors, select low-noise transistors and give a rough idea of current gain. The kit takes only about an hour to build. Con-

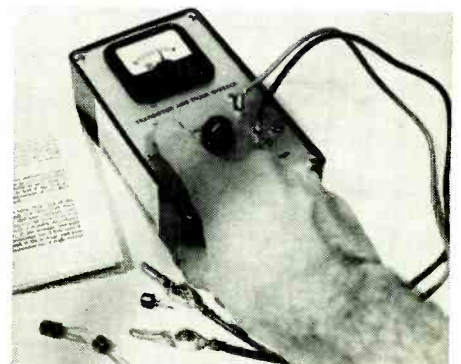

sidering price and time, this instrument seems worth having on the shelf, because it's self-contained and designed especially for the job. Quick and easy to use: small transistors plug in, larger ones and diodes connect via clip leads supplied.

Allied Radio Corp., 100 N. Western Ave., Chicago 80, Ill. \$6.95, kit.

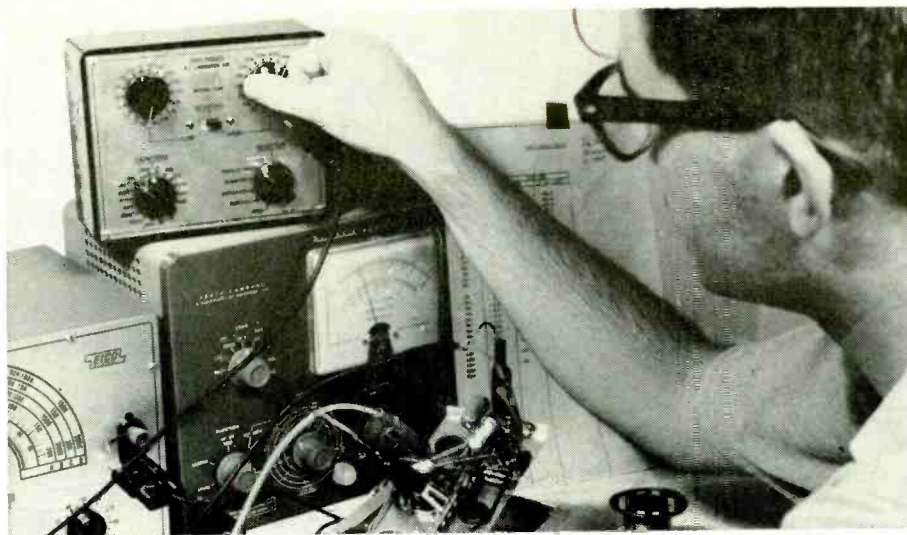

Substitution box

The *Eico 1140 Series-Parallel R-C Combination Box* is useful whenever you want to design or substitute for a network that has a resistor and a capacitor. (Naturally, either type component can be used separately.) One major application is designing tape and phono playback equalization networks for pre-amps (photo above). Other possibilities are feedback networks in tube and transistor amplifiers, R-C integrating and differentiating networks in waveform shapers, pulse formers, TV deflection circuits, function generators or operational amplifiers.

The *1140* gives 18 EIA capacitor values from 100 pf to 0.22 μ f, and 36 EIA resistor values from 15 ohms to 10 megohms (1 watt, 10%). A selector lets you choose open, series R-C, capacitors, resistors, parallel R-C and short, across the terminals.

Electronic Instrument Co., Inc., 131-01 39th Ave., Flushing 54, N. Y. \$14.95, kit.

Signal injector

The *Mosquito* is aptly named: small, light, sharp-pointed and high-pitched, buzzy-toned. In essence, the

Mosquito is a fountain-pen-sized pulse generator with a tiny battery. The pocket clip is the on-off switch. Its harmonic-rich pulses can be used in signal-tracing audio or rf circuitry into the AM broadcast range and above. You can control signal level roughly by holding the probe in different ways: the tighter your grasp and the larger the area of contact with your hand, the more effective the coupling and the stronger the signal.

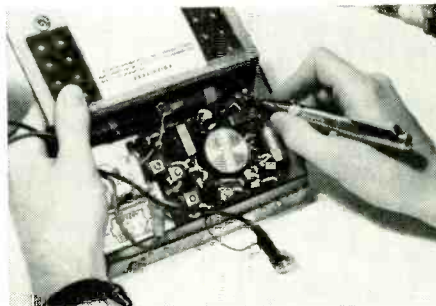

The *Mosquito* couples readily to magnetic or electrostatic devices, so it can be used in checking microphones, tape heads, phono pickups, earphones, etc. Weighs about an ounce.

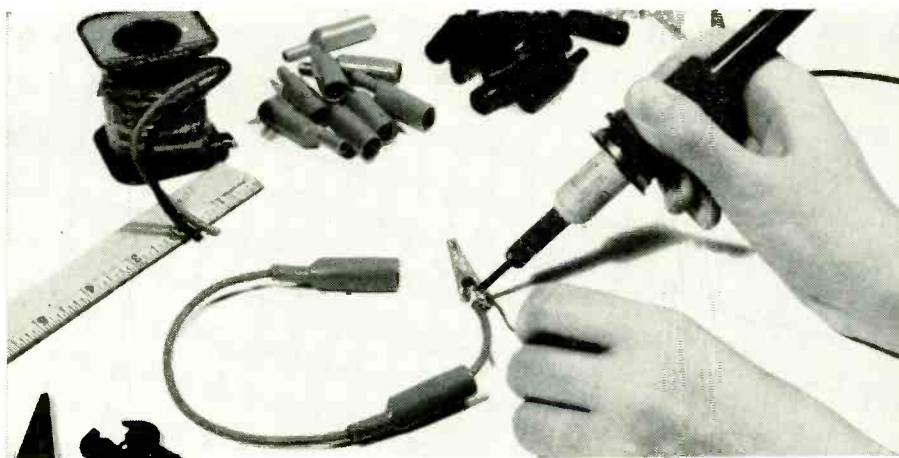

APRIL, 1965

Don Bosco Electronics, Inc., Littell Rd., Hanover, N.J. \$9.95.

Filament and continuity checker

The *Sencore HM119 Handyman* handles most of the little daily shop trivia for which you might otherwise have to fire up some other, larger instrument. It checks tube heaters and filaments (of octals, loctals, 7-, 9- and 10-pin miniatures, nuvistors, compactrons,



novars and picture tubes), and checks fuses and general continuity. Its TV cheater cord has a switch and auxiliary ac outlets. It checks for ac or dc from 60 to 600 volts with a neon lamp. It has 7-, 9- and 10-pin miniature tube pin straighteners, and a trouble light on a long cord for looking into dark corners of a chassis. As the photo shows, the unit is small and all its cords wind around cleats for easy stowing and carrying.

Sencore, Inc., 426 So. Westgate Dr., Addison, Ill. \$9.95.

The simplest test instrument

The lowly clip lead merits an essay all its own. I never have enough. A clip lead is a test instrument all by itself. If you don't believe that, read "Jumping to Conclusions," *RADIO-ELECTRONICS*, June 1962.

Clip leads short, jump, borrow power, lend power, ground, tie, suspend, extend . . . You can build up whole circuits with them.

If you are lazy and extravagant, you can buy clip leads for about 50 cents apiece (H. H. Smith or G-C), but it's cheaper to make your own if you can spare an hour or so with a soldering iron. Clips cost from 7 to 10 cents a piece (approximately, depending on make and type) and much less in lots of 10 or more. Insulators, if you want them, are about a nickel each, red or black. You can buy a 25-foot spool of No. 18 flexible rubber-covered test lead for less than 60 cents. One spool will usually make at least 10 assorted 6-inch, 1-foot and 3-foot leads, so each lead, with clips and insulators, will cost you 30 to 35 cents absolute tops.

You'll want some red and some black. Just remember to slip the insulators on *before* you solder! **END**

HYPERSENSITIVE PHOTOELECTRIC RELAY

Sensitive relay uses minimum number of parts. Reacts to tiny amounts of light—7½-watt lamp at 20 feet. Can be used as burglar alarm.

By LAWRENCE SHAW

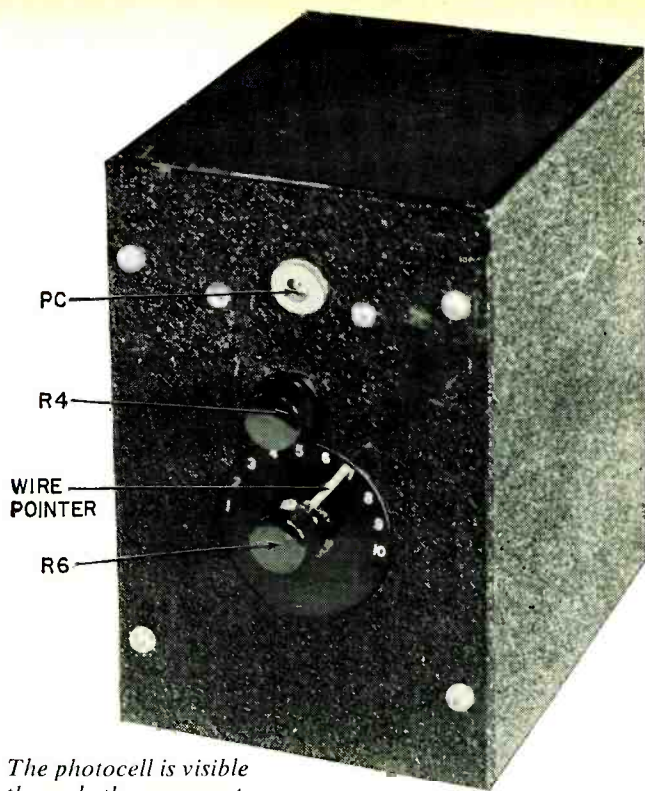

The photocell is visible through the grommet.

SO SENSITIVE IS THIS DEVICE THAT A night light (7½ watts) holds it on at 20–25 feet. Since the presence of a night light is natural, it will not alarm a burglar. But, if he monkeys with it or the unit, he is announced in an appropriate fashion.

Its low power drain makes operation easy on the pocketbook. The current in the standby position is only a couple of milliamperes from a low-voltage transformer. The operating elements are two transistors with an indefinitely long life and they are comparatively rugged.

Should you desire, you can use "black" light. An infrared filter over the light source does the trick. Only a slight red glow is visible.

If used as a counter or for illumination control, low operating power is a primary consideration. Here you save on both the unit and the (more costly

to operate) light source.

The photoelectric cell may be removed from the cabinet and placed where convenient. A two-wire run up to 500 feet will not change operation. The wire need not be heavy—even No. 36 may be used—as the current is a few microamperes. The wiring should be well insulated. Wiring and cell may be painted to blend with the wall if precautions about insulation and covering the front of the cell are observed.

How it works

The active element is a CdSe (cadmium selenide) photoconductive cell. Its window faces out through a rubber grommet on the front of the unit. Its resistance decreases as illumination increases. The dark resistance is in the order of megohms while under strong light it may be only thousands of ohms.

The photocell (Fig. 1) is in V1's base circuit where it controls base and collector current.

V1 is the first half of a two-transistor dc amplifier. Its collector is tied to V2's base. Increased collector current in V1 causes a greater voltage drop in load resistances R6 and 7, thereby driving

V2's base negative. As a result, V2's base and collector currents drop. So the current through the relay decreases as the photocell is illuminated. If the light beam is interrupted, the converse happens—more current passes through the relay coil and it pulls in.

Two voltages are provided by the power supply. One, at about 40 volts, supplies the photocell (PC) through a voltage-dividing potentiometer, R4. The other furnishes collector power to the remainder of the circuit at some 20 volts. In my model, the surge resistor (R1) was placed after the selenium rectifier for wiring convenience. This is acceptable, but it must be ahead of the first filter capacitor. C1 acts as a line filter for any rf disturbances.

R4 (SENSITIVITY) controls the photocell's reaction to light by varying the voltage applied to it and consequently to the base of the first transistor. It, too, may have an escutcheon on the panel for easy resetting.

R6 (LEVEL) sets the current through the relay and controls the amplifier gain. An escutcheon is mounted on the panel for this control.

R5 is a 100,000-ohm safety resistor in series with the power feed to PC and V1's base.

Capacitor C4 prevents triggering the alarm by sudden pulses of induced current from the power line. It prevents relay chatter as a secondary function.

In the schematic (Fig. 1) the relay armature is connected to ground. This means that the relay must be insulated from the chassis since the armature is connected to the relay frame (on the Sigma 4F). If the relay is not insulated, one side of the power line might be connected directly to the chassis (depending on what circuits are switched).

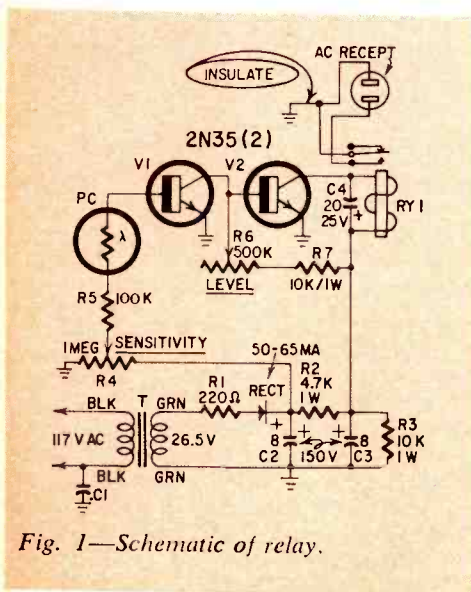

Fig. 1—Schematic of relay.

- R1—220 ohms, ½ watt
- R2—4,700 ohms, 1 watt
- R3—7—10,000 ohms, 1 watt
- R4—pot. 1 megohm
- R5—100,000 ohms, ½ watt
- R6—pot. 500,000 ohms equivalent
- C1—01 μf, 200 volts or higher
- C2—3—8 μf, 150 volts
- C4—20 μf, 25 volts
- V1, 2—2N35
- PC—photocell, Clairex CL-603
- T—primary, 117 volts; secondary, 26.5 volts, 600 ma (Thorcarson 21F27 or equivalent)
- RY1—plate-circuit relay, 5,000-ohm coil, spdt contacts (Sigma 4F or equivalent)
- RECT—50–65 ma, 130 volts, selenium (Amphenol 61-F or equivalent)
- RECEPT—standard ac receptacle
- Case—6 x 5 x 4 inches with chassis on front panel
- Miscellaneous hardware, shoulder washers, terminal strips, grommets, etc.

Construction

Building the unit is easy since nothing is critical. The components may be used as templates. Some comment will clear up doubtful points, however.

A three-lug terminal strip is bolted to the front panel by two 6/32 x 1/2 machine screws and nuts. The photocell and its safety resistor are mounted on the strip. The photocell should be mounted after the other work is done. Drill a 3/8-inch hole for the grommet. Next, solder the second-from-top lug of another terminal strip to the end lug of the first strip (see photo). [Mounting the strip on standoffs will result in a more rugged unit.—*Editor*] The second strip (supported by the first) supports V1 and 2.

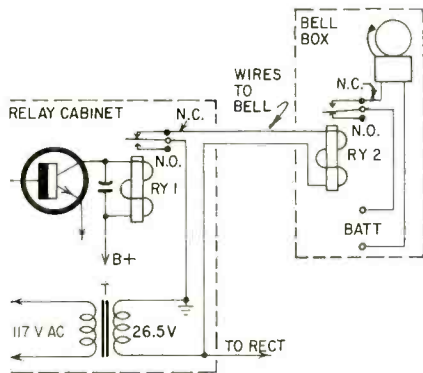

Fig. 2—Cutting the wires, breaking the light beam or a power failure will set off the alarm.

One screw of the transformer also secures a third terminal strip. The filter-capacitor leads should be taped or covered with spaghetti to preclude the possibility of shorts.

The Sigma 4F relay (if used) must be insulated from the chassis. Use two shoulder washers in a 1/4-inch hole secured by a 6/32 machine screw with nuts on both sides. Screw on the relay. Make sure that the screw does not bite into the relay coil. If necessary, add another nut or space the top nut.

Drill and deburr a hole on the chassis near the relay. This is for the relay connections.

The rear panel has a standard female receptacle (for connection to the relay contacts). The hole may be cut with a circular punch or by drilling and filing. A rubber grommet in a 3/8-inch hole permits the power line to feed through the rear panel without danger. Put a knot in the power cord inside the panel—toward the power transformer—to relieve any strain on the cord. In some burglar-alarm and similar services the power line, as well as the relay connections, may be brought to the control unit via BX cable. In this case, drill for BX connectors instead of the receptacle-and-grommet arrangement.

Operation

Bench-test the device prior to final assembly. Leave the relay leads long enough so that the rear panel may be laid on the table.

APRIL, 1965

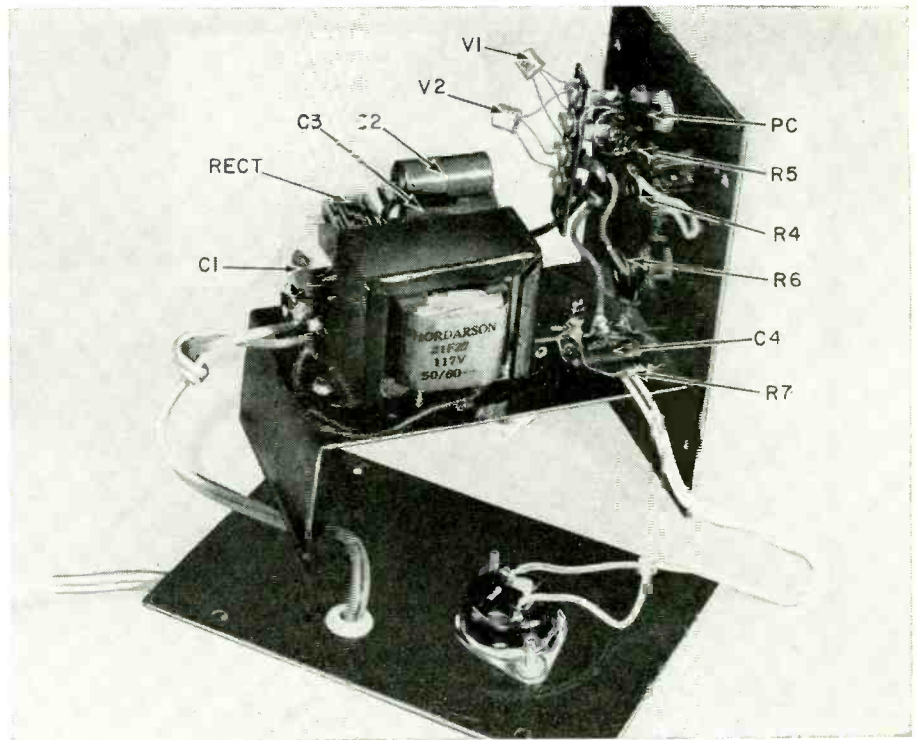

Interior of unit. Transistors are mounted on terminal strip.

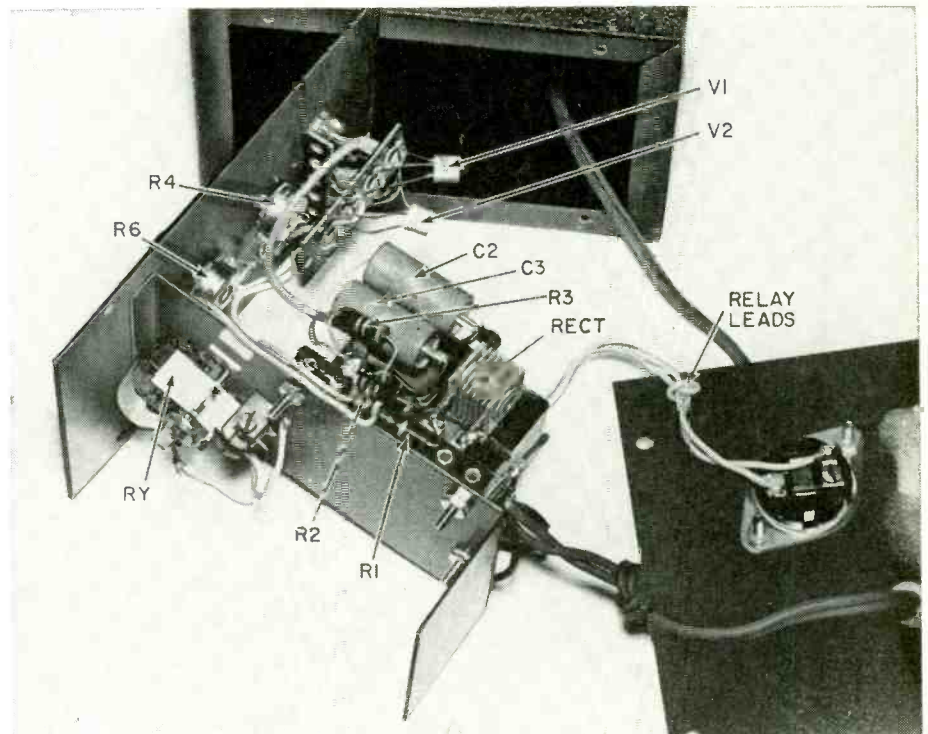

Note relay below chassis. If Sigma 4F is used, it must be insulated from chassis.

Something is needed to indicate when the relay is on or off. A simple way is to use the alarm itself. A flashlight lamp and two cells may also be used.

Shield the test lamp (if used) from the photocell (both rear and front). Use black cloth, cardboard or a box. Set the LEVEL control to about its mid-range (half rotation). Plug in the power cord.

With the cell illuminated as previously indicated (7 1/2-watt bulb at 20 feet), the relay will probably be energized (test light will light or alarm

will ring). Turn up the LEVEL control (clockwise) until the light goes out or the alarm stops. A trifle past this setting is the operating position. Do not increase the setting more than a trifle (about 10° maximum).

A voltmeter will aid in finding the most sensitive spot for the LEVEL set. Connect the voltmeter across the relay coil (use a scale over 30 volts). As the LEVEL control is advanced clockwise, the voltage across the relay will rise. At a certain setting it will drop again. To find the correct setting back off the con-

trol from maximum (rotate the knob counterclockwise). That is, the setting is a trifle less than maximum voltage across the coil.

When this control is set, the SENSITIVITY control may be adjusted for any light values within range of the instrument. Rotating the SENSITIVITY control fully clockwise applies maximum voltage to the photoconductive-cell circuit (with corresponding maximum range). Should you desire, you may use a power supply with a higher input voltage to this circuit. Its limit, according to the manufacturer, is 300 or so volts. In experiments, 200 volts has been used with no adverse effects. Sensitivity is in direct proportion to the applied voltage.

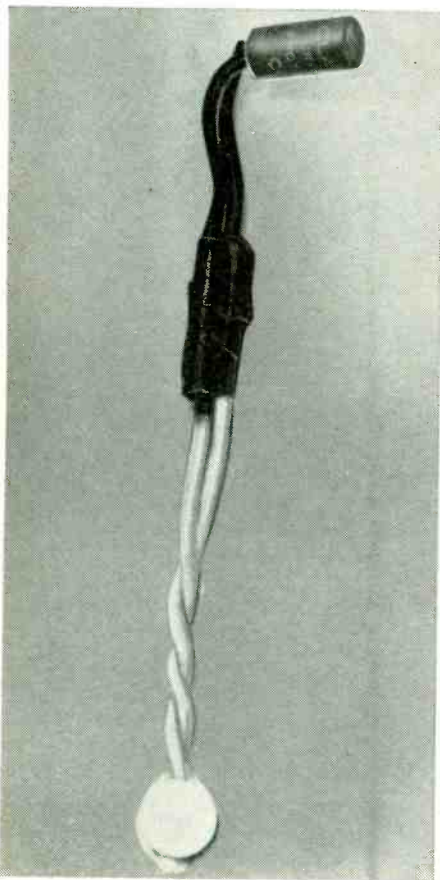

Photocell may be removed from unit proper and placed on doorframe by itself.

Follow the same procedure in installation. Use the settings obtained on the bench check as guides in the original setup. Readjust the controls after about a week of operation since the rectifier and electrolytic capacitors will age.

For burglar-alarm duty, you may try the circuit of Fig. 2. The sensitive relay RY1 is connected to a second (25-volt, ac) relay (RY2) with the transformer (T) furnishing power. The normally closed contacts on RY1 keep RY2 energized. If someone or something should break the light beam, RY1 will pull in, RY2 drops out and the bell will sound. A power failure will result in the same thing.

Notice that, if someone cuts the wires leading to the bell, it will go off. END

THREE-DIMENSIONAL TELEVISION

By MOHAMMED ULYSSES FIPS, IEEE*

FOR A LONG TIME I HAD WANTED TO submit to the big boss my 3DTV, on which I had been working for over a year. Television as it is today is extremely unsatisfactory because at best it shows only a sort of shadow pictures which have no depth, no shading, no relief. Take, for instance, a picture of a baseball in flight; it is most unsatisfactory because you never know where it comes from nor where it is going.

The boss, sitting in his comfortable chair, smoking one of his big 7-inch cigars, listened carefully, and for once he was pleasantness itself. Encouraged by his attitude, I went on:

"Painters know all about three dimensions. For hundreds of years, whether it was Michelangelo, Leonardo da Vinci or Rubens, they were always careful to show shadows in depth in their paintings. They were masters in this art. Later on, other French painters developed *Trompe-l'oeil*. This "fool the eye" sort of painting exaggerated the shading and the depth as well as the relief and often fooled the onlooker completely. All this was common for the painting art.

"When motion pictures finally came, they often failed to make use of the necessary relief and depth. Again we had just a sort of glorified shadow. Some directors tried to correct these faults, motion pictures themselves were never really in three dimensions, except

for a very few where you must wear blue and red eye-glasses to see the picture in depth."

I now showed the big boss my three-dimensional television tube, because I could not bring a complete television set with me to give him a demonstration. I did, however, show him my blue prints of how the three-dimensional tube was built.

The philosophy of my tube is: Instead of a single electron gun, you have two, side by side. You also have two screens, one transparent. The picture of one gun therefore falls on the transparent screen, painting an electronic picture on it. The other gun throws another picture on the front screen. So you have two pictures, the same as you get in your eyes. One picture is superimposed on the other. One shows the necessary shadow; the other another picture which is supplemented by the other shadow, and if you now view the picture from the proper distance, the three-dimensional illusion is perfect. Of course it is necessary to view the picture from a certain point. If you sit too much to the left or to the right, the illusion will be broken and you will see only an imperfect picture.

I have great hopes that the three-dimensional picture will revolutionize television and predict the unquestionable superiority it deserves.

For the last few minutes as I explained the advantages of three-dimen-

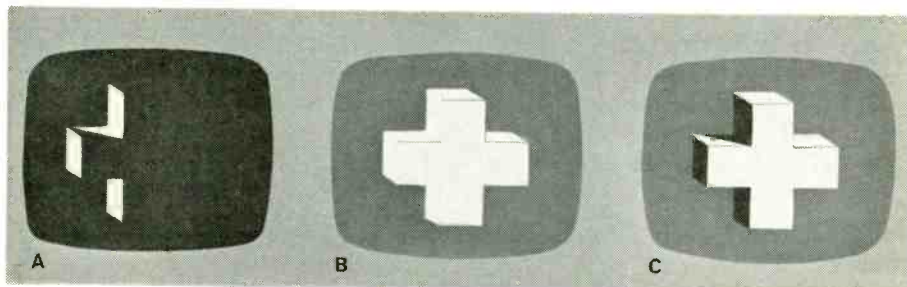

Underlying principle of the 3DTV tube. By separating the image into two portions and projecting each portion (A and B, above) on separate screens displaced in space, an illusion of three-dimensionality is produced (indicated imperfectly at C, above).

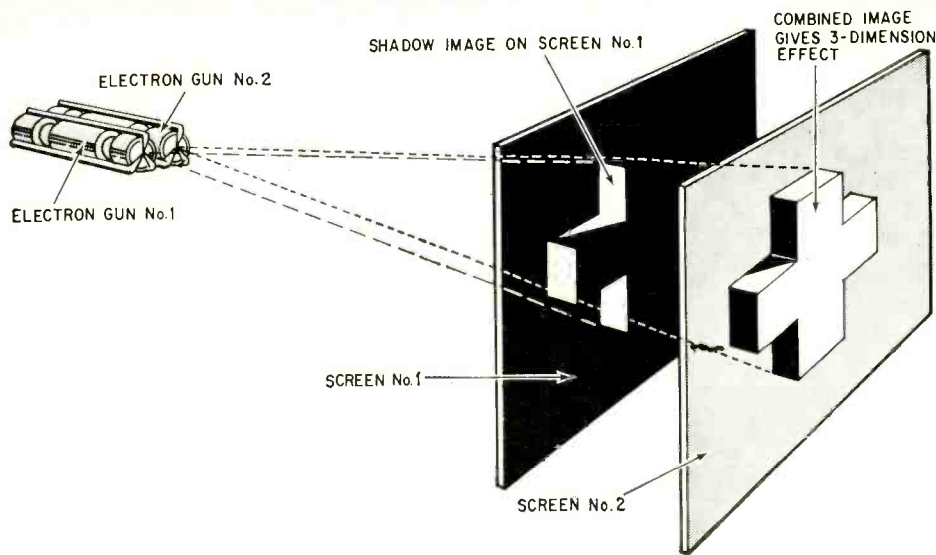

in the future a monster tube, because all the color guns will have to be duplicated if we are to get a good color picture. Six color guns! And all to be lined up precisely! What do you think that will do to the price of a color TV set?

"Motion picture interests have fooled around with three-dimensional pictures for over fifty years and have found that the present product is good enough.

"Three-dimensional pictures—hell, who needs them? I can do without them. Most of the things you talk about were tried by the motion picture interests and discarded, so I am not going to burn my fingers by publishing this videocy."

With that he picked up his leaf calendar from his desk and whacked me over the head, almost breaking my sample tube. Then he took all my blue prints and threw them at me.

Chagrined as I was, I couldn't help noticing the top leaf which had accidentally become detached and was now fluttering down to the floor. Curiously enough, it read

How the two components are actually projected on the two separate screens. The matrix, or mixer, that combines them is of course the eye of the beholder.

sional television, I noticed the boss had become very restless. He started chewing his cigar and was fidgeting with his hands. Finally he exploded and burst out in one of his famous sarcastic diatribes.

"Fips, you are a *dummkopf*—a vidiot! Who needs three-dimensional

pictures? The cost of your three-dimensional tube will be high and it must be a precision instrument if it is to work right or else the illusion will be lost. All this you know from the sample tube you built yourself.

"We are now coming into color television. This means that we will need

APRIL 1.

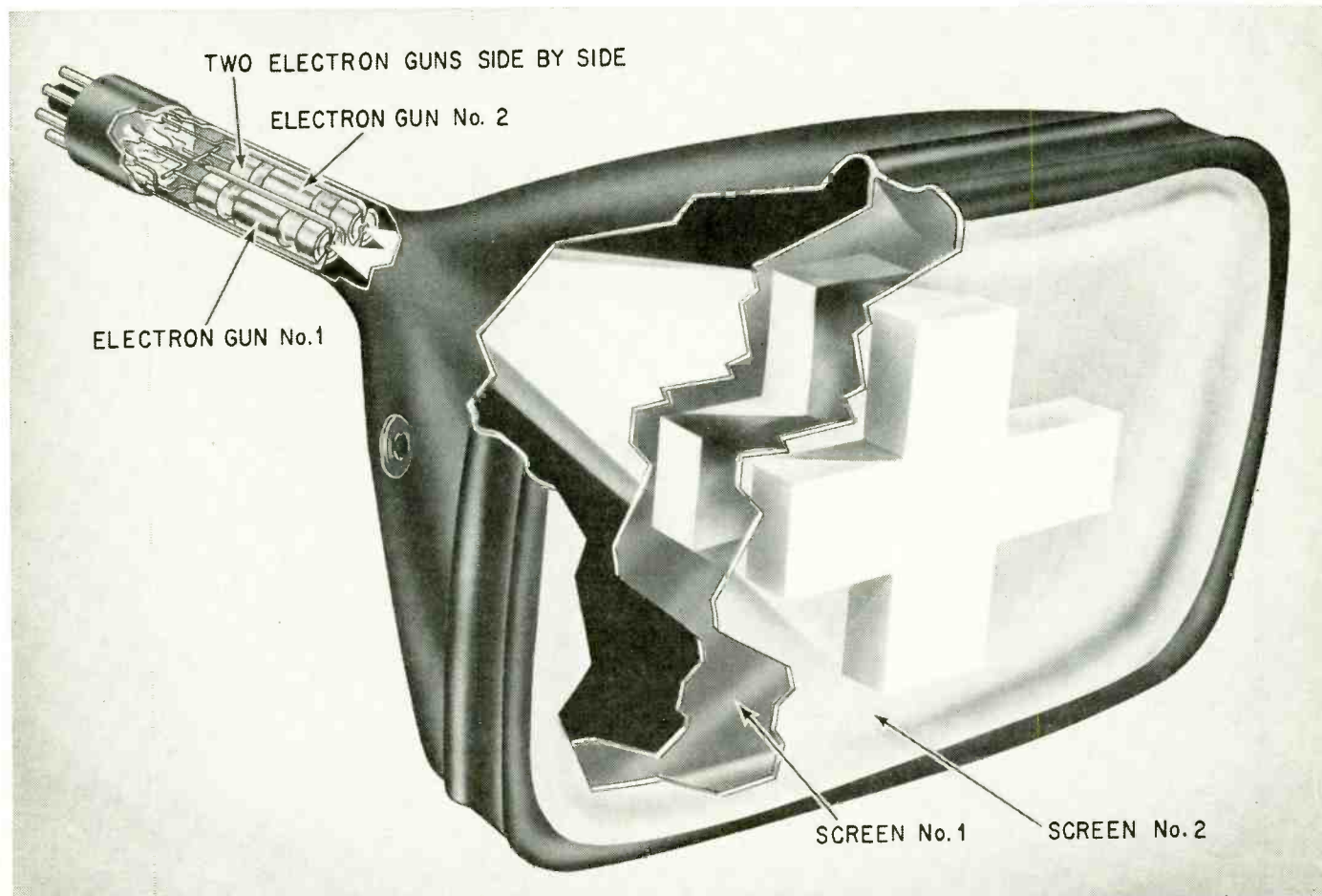

The experimental 3DTV tube is constructed in an envelope closely resembling that of an ordinary black-and-white kinescope, with

provision for the additional phosphor screen and a few minor modifications not important for the purpose of this article.

More on the Boat's Electronics

How to inspect and repair antennas, grounds, echo-sounders and direction finders—before the active boating season starts

By ELBERT ROBBERTSON

IN AN ANTENNA SYSTEM, ANY POWER dissipated as heat in bad solder connections, corroded joints or electrically leaky insulation is power wasted for communications. This means that losses must be kept to an absolute minimum. The approximate radiation resistance of many a boat antenna is on the order of 1 ohm. It is not uncommon to find loss resistance very many times this figure—like 9. Under such circumstances, every \$9 out of \$10 spent for transmitter power is thrown away!

Antenna losses are mostly in bad insulation, low-Q loading coils, poor connections, excessive shunt capacitance (as in base insulators) and an inadequate ground. Wire should be heavy to keep skin-effect losses down. Check the entire circuit from the antenna tip to ground connection for perfect continuity (no series resistance) and perfect insulation (infinite resistance to ground). If insulation checks as little as a million ohms to ground, replace it. Shake the antenna

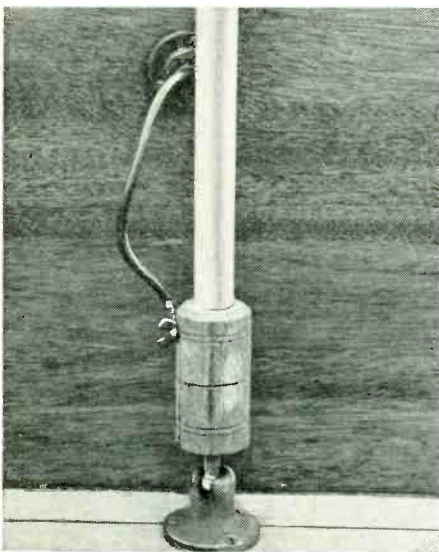

Weathered antenna insulation, cable bushing (or plain hole) for lead-in are sources of loss. Fix or replace them now.

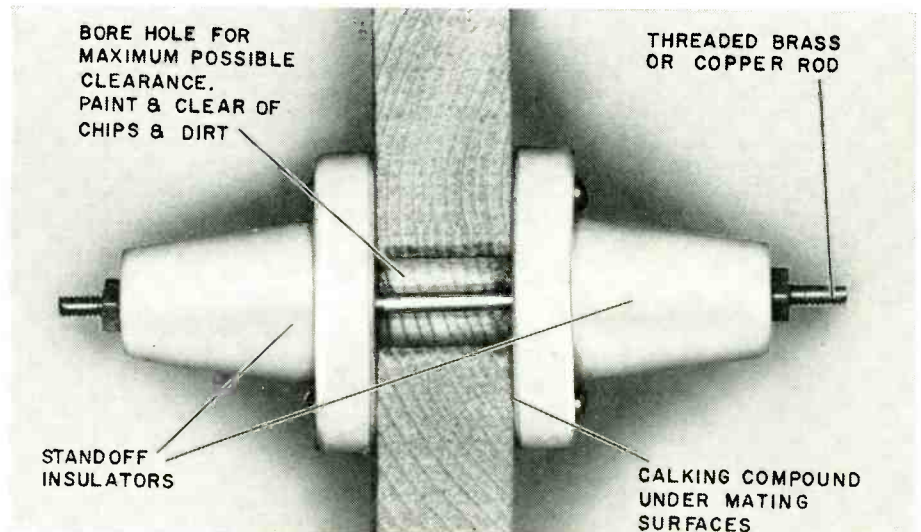

Low-loss lead-in insulator can be improvised from standoffs. Paint inside of hole through wood, use sealing compound under insulators.

to make sure that contacts do not open under mechanical stress.

Sometimes, plain old "ohmic" resistance of the conductors in the antenna circuit causes unnecessary loss. One time I ran into an installation in which the entire lead-in was made of automobile spark-plug cable "because it had high-tension insulation." The only trouble was that its conductor was a very thin wire of stainless steel, with a dc resistance of many ohms and even more resistance at radio frequency. No wonder the owner complained of transmitter trouble!

Many boat lead-ins consist just of an insulated wire run through the cabin side or cockpit bulwark. When the wood is dry and the insulation of the wire is thick and perfect, loss may not be serious. But wet wood (especially wet with salt water) is a good enough conductor to increase ground capacitance at the lead-in point, or to cause leakage resistance. In such installations, install a low-loss lead-in insulator to get the circuit from the antenna into the boat. A

large glazed porcelain through-panel insulator fitted with a rod long enough to accommodate the bulkhead thickness can be used. Another way to get through the wood is to bore an oversize hole and install a large standoff insulator on both sides, with a long threaded rod passing through. Commercial transmitting lead-in insulators are best, but inclined to be bulky and expensive.

You can make a satisfactory substitute by the old ham method of drilling a hole through the centers of a pair of small pyrex bowls, and running a threaded rod through to hold them on opposite sides of the bulkhead. Holes for lead-in insulators should be large enough so nothing touches the antenna conductor. The raw wood should be sealed with paint or white lead to keep water vapor from breathing out of the wood and condensing inside the insulator.

Check the end-to-end resistance of any antenna that has a built-in loading coil. Sometimes the connections between the copper wire of the coil and the usual aluminum antenna tubing corrode or

work loose through "whipping" of the antenna in a sea. And I have seen antennas with loading coils made of many turns of very small wire in a 1-inch diameter coil more than 2 feet long. Although the inductance of such a coil *does* help resonate a short antenna, its resistance is out of all reason. One recent example I checked had a dc resistance of 2 ohms. This kind of loading coil is useless. A loading coil should check *zero* ohms, or the antenna is best tossed overboard in favor of a new one with a high-Q coil.

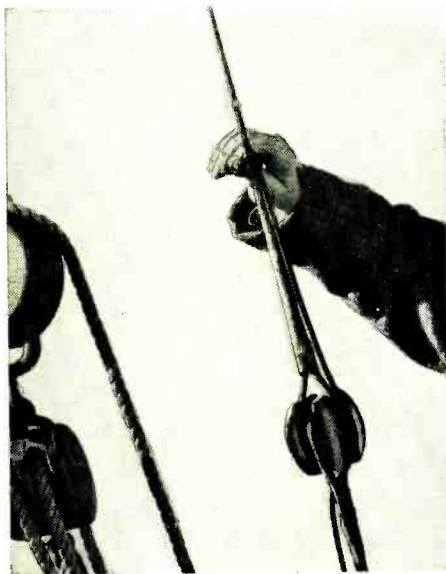

Check all antenna connections, especially where corrosion from dissimilar metals can cause high-resistance contact.

A few telescoping antennas are used. These should be thoroughly cleaned of every trace of corrosion in the joints. Otherwise, you are likely to have mechanical troubles, as well as unwanted resistance in the joints.

Ground

While the boat is out of the water, check the ground plate. Scrape at the fastening screws with the point of a knife. They should be hard and bright with just a thin layer of corrosion. If screw heads are soft, pitted or reddish in color, replace them. When the faulty screw cannot be removed, because of crumbling or breaking, drive others alongside. See that the ground bolt is soldered to the plate, and the nuts and connections in the bilge are tight.

If the boat does not have a ground plate, this is the time to install one. It should increase antenna efficiency, improving transmitter range and reliability.

Copper flashing makes an inexpensive and efficient ground plate. It can be installed anywhere below the waterline, on the hull or sides of the deadwood (or keel). Shape is unimportant, but the

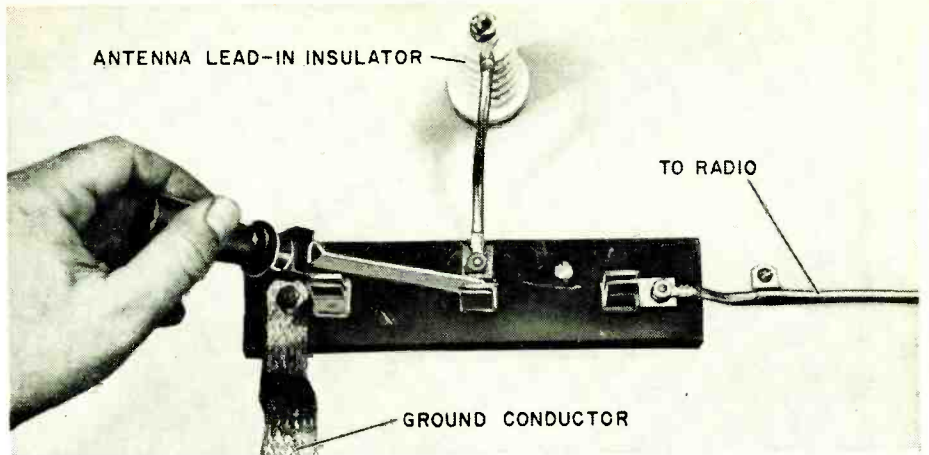

If your boat is not protected already, install grounding switch at base of antenna. Use 60-amp or heavier switch with good insulation.

area should be as great as practical. Fasten the edges at intervals not greater than 1 inch with flat-head Everdur screws. Spot additional screws across the breadth of the plate as close together as necessary to make the copper conform to the hull contour, but no farther apart than 6 inches.

At a location as close under the radiotelephone as possible, install a bronze carriage bolt through the plate and planking into the bilge, securing it inside with a large bronze washer and nuts. Use calking compound under the washer to keep it watertight. If the hull is planked with soft wood, seal an oak pad inside the hull for the washer and nut to bear on. Use a heavy soldering iron or torch (keeping a fire extinguisher handy) to solder the head of the bolt to the copper outside.

Echo sounders

Clean the transducer of marine growth and wash it with solvent. Be careful not to scratch the transducer

housing or face. Special anti-fouling paints are now available that (the manufacturers say) will inhibit the growth of barnacles without affecting transducer operation. Check the fastening nut inside to see that it is tight. If the stem of the transducer is plastic, do not bear down too hard or you may break it. Go over the cable for breaks or flaws in the insulation. Secure the cable against abrasion from vibration or moving objects. Clean cable terminals or plug contacts.

Some sounders use internal batteries. Unless they can be recharged or have extra-long life, it is a good idea to replace them and start the season afresh.

Sounders with rotating or sliding contacts should be inspected for excess friction or possibly corroded connecting surfaces. For example, the lamp voltage in the flashing-light types is transmitted through a rotary contact to the revolving arm. Some of them are keyed by a contactor sliding across a keying block. Follow manufacturer's instructions for

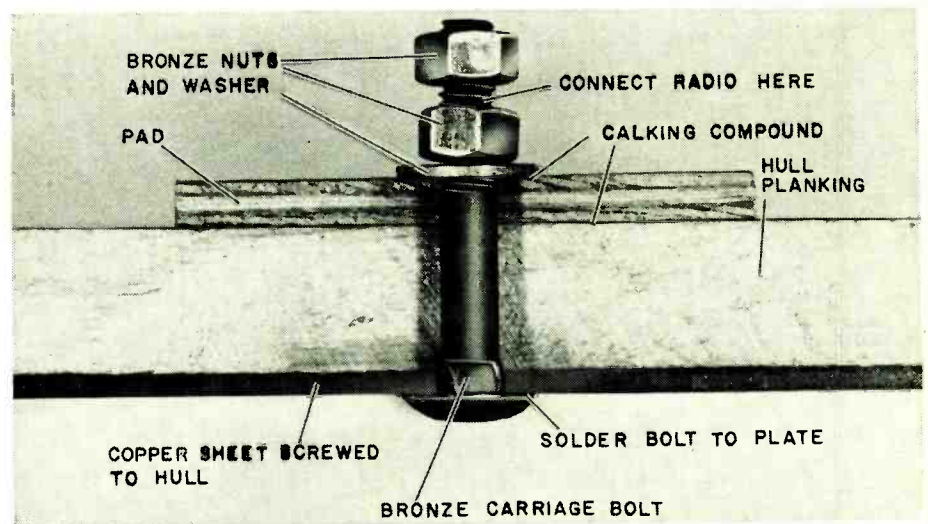

Outside ground plate of large area raises transmitting efficiency. Solder head of bolt to plate, use sealer under wood pad and washer.

cleaning and lubricating. Calibration depends upon the motor speed. Check this with a stroboscope or by comparing the sounder depth reading with a depth measurement made with a lead line.

When the speed is off in dc-motor types, the governor or motor may need repair or replacement. Synchronous ac motors are governed by the frequency of the ac supply. In vibrator types, motor speed can be corrected by replacing the defective vibrator.

Use a plastic cleaner to brighten the transparent dial window; do not use ordinary window polish—it may contain abrasives.

Direction finders

Clean and lubricate the slip rings ("Lubriplate" works well) so there are no squeaks or scratchy sounds when the loop is rotated. With a signal generator, touch up the front-end and i.f. alignment. Install new batteries. Take the set to a location free of nearby metal objects and make sure you get sharp and deep nulls, and that the two nulls on any one station are exactly 180° apart. If they are not, the loop circuit could be out of tune or suffering from current



Paint echo-sounder transducer with special transducer paint to prevent barnacle breeding—like this!

leakage or stray coupling.

On a boat that voyages offshore, Consol and Consolan signals are useful, but they are continuous-wave transmissions that require a bfo for reception. If a DF is not so equipped, you can add a bfo quite simply.

The "quick and dirty" method is to wire a "gimmick" capacitor, made of

two short wires twisted together, from the input to the output of an i.f. amplifier. Use just enough capacitance so the stage goes into oscillation when the sensitivity control is turned on full, making CW audible.

A better system is to construct a small transistor oscillator that will tune over the frequencies around 190 kc. Such an oscillator can run a whole season on a single flashlight battery. It can be set alongside the equipment, and its frequency adjusted for the desired beat signal with the Consolan signal.

A slightly more complicated alternative is to build a bfo into the DF and couple it into the i.f. amplifier. The internal bfo should tune across the intermediate frequency, as is common in communications receivers.

When the time comes for launching, everyone becomes impatient and in a hurry to get under way. Many small jobs that are put off until later never get done. Electronic equipment is just as much safety equipment as the boat's life preservers or fire extinguisher. Take care of it now, before the rush is on, to be sure that everything is working right when the boat takes to the water. **END**

Transistor Radio and Tape Recorder Guide

Where to write for service data and parts for Japanese imports

Troubleshooting and repairing Japanese transistor tape recorders and radios quickly and profitably is often a trying task—particularly for the TV-oriented service technician. Problems are multiplied when the equipment is identified only by an unfamiliar trade name with no information as to the importer or a source of service data and replacement parts. Unfortunately, this category of poorly identified equipment consists of low-cost recorders and radios that make up a large percentage of those Japanese units imported in the U.S.

Here is an alphabetical listing of brand names and labels used on transistor radios and recorders with the names and addresses of corresponding importers. Some importers—particularly those that also handle more expensive units—can supply detailed service data and parts. Some have their own service agencies and require that equipment be sent to them for repairs. Others supply neither parts nor service data and may not even reply to requests for assistance.

Brands not included here are those used on some more expensive small-market sets and recorders, also private labels used by large retail stores and chains whose products are covered in Sams Photofact folders and service manuals. Also omitted are the trade names

used by small importers with limited regional distribution. Many of these sets are well known within limited geographical areas. They can cause headaches when they are carried into other areas. If you have information on trade names and the addresses of service-minded importers with limited distribution, send them to us so that we can keep our guide up to date.

Acme	Manhattan Novelty Co. 263 Canal St., New York
AGS	American General Supply Co. 11 W. 42nd St., New York
Aiwa	Selectron International 4215 W. 45th St., Chicago, Ill.
Alaron	B & B Import Co. 157 Wyoming Ave., Detroit 28, Mich.
Ambassador	Allied Purchasing Co. 401 5th Ave., New York
Amertone	Amerex Trading Co. 444 5th Ave., New York
Angel	Arrow Trading Co. 1133 Broadway, New York
Arrow	Arrow Trading Co. 1133 Broadway, New York
Belcor	Belcor Electronic Corp. 457 Chancellor Ave., Newark, N. J.
Beniida	Marubeni Iida 39 Broadway, New York
Brenell	Fen Tone Corp. 106 5th Ave., New York

Browni	Charles Brown & Co. 1170 Broadway, New York
Candle	Candle Corp. 3408 S. Western Ave., Los Angeles, Calif.
Canton-Son	Canton-Son, Inc. 12 W. 27th St., New York
Capri	Nason Trading Co. 230 5th Ave., New York
Capri	Alfred Toepfer 1 Broadway, New York, N. Y.
Channel Master	Channel Master Ellenville, N. Y.
Claricon	World Mark Electronics 300 S. St. Clair St., Pittsburgh 6, Pa.
Commodore	Commodore Import Corp. 507 Flushing Ave., Brooklyn, N. Y.
Constant	Canton-Son, Inc. 12 W. 27th St., New York
Consul	General Consolidated 87 Dell Gen Ave., Lodi, N. J.
Continental	Continental Merch. Corp. 236 5th Ave., New York
Coronet	Arrow Trading Co., 1133 Broadway, New York
Corvair	Transistor World Corp. 513 W. 24th St., New York
Crest	Alfred Toepfer, 1 Broadway, New York, N. Y.
Crestline	Canton-Son, Inc. 12 W. 27th St., New York
Craig	Craig Panorama 3412 La Cienega Blvd., Los Angeles, Calif.

NOTE: Where no state appears after **New York**, write **New York, N. Y.**

Crown	Crown Radio Corp., 150 5th Ave., New York	Juliette	Topp Imp./Exp. 35 N.E. 17th St., Miami, Fla.
Cipher	Inter Mark Corp., 29 W. 36th St., New York	Kaytone	Kaysons International 6500 Flotilla St., Los Angeles, Calif., and 1123 Broadway, New York, N. Y.
Daltone	Dalamal & Sons, 1185 Broadway, New York	Ken	Ken Electronics, 500 5th Ave., New York
Delmonico	Delmonico International 50-35 56th Rd., Maspeth General Consolidated 87 Dell Gen Ave., Lodi, N. J.	Kensington	Terra International 3 E. 28th St., New York
Delux	Rengo Trading Co. 234 5th Ave., New York	Kent	Kent Overseas Inc. 14 W. 23rd St., New York
Dokorder	Fen Tone Corp., 106 5th Ave., New York	Kowa	Kowa American Inc. 230 5th Ave., New York
Ebner	A. Cohen & Sons, Inc. 27 W. 23rd St., New York	Koyo	Koyo International, 330 Madison Ave., New York
Eldorado	Electra Industries Inc. 1204 Broadway, New York	Lafayette	Lafayette Radio Co. 111 Jericho Tpke., Syosset
Electra	Electro-Brand, Inc. 325 W. Huron St., Chicago, Ill.	LIC	Lucky International, 1155 Broadway, New York
Electro		Little Pal	Manhattan Novelty Co. 263 Canal St., New York
Empire	Empire Trade Distributors, Inc., 1199 Broadway, New York	Lloyd's	Lloyd Trading Co., 1147 S. Hope St., Los Angeles, Calif., and 1261 Broadway, New York
Everplay	Gulton Industries, 212 Durham Ave., Metuchen, N. J.	Mantone	Manhattan Novelty Co., 263 Canal St., New York
Family	Arrow Trading Corp., 1133 Broadway, New York	Marvel	Manhattan Novelty Co., 263 Canal St., New York
Fen-Tone	Fen Tone Corp., 106 5th Ave., New York	Mayfair	Artic Import Co., 1024 W. Randolph St., Chicago, Ill.
Fleetwood	Transworld Industrial Corp. 5404 Hudson Ave., West New York, N. J.	Mel Rose	Federal Aides Corp. 875 Broadway, Brooklyn
Fountain	Harpers International 315 5th Ave., New York	Marvel	Marvel International 11 W. 42nd St., New York
Four Star	Fortune Star Products 1207 Broadway, New York	Mitsubishi	Mitsubishi International 227 Park Ave., New York
Fujitone	Arrow Trading Co., 1133 Broadway, New York	Monarch	Monarch Electronics 7035 Laurel Canyon Blvd., N. Hollywood, Calif.
Fujiya	Fujiya Corp., 45 W. 21st St., New York	Morse	Morse Sewing Machine Co. 115 5th Ave., New York
General	Trans America Imp./Exp. 6479 N. Avondale, Chicago 3, Ill.	Nobility	N.Y. Merchandise Co. 32 W. 23rd St., New York
Golden Shield	Golden Shield Corp. 10 S. Middle Neck Rd. Great Neck, N. Y.	OMGS	North American Foreign Trading 220 5th Ave., New York
Grand Prix	A & S Trading Co., 124 W. 30th St., New York	Onkyo	Sanyo Trading Co. 39 Broadway, New York
Halco	Halen Associates, 125 5th Ave., New York	Orion	Otake Trading Co., 1199 Broadway, New York
Harlie	Harlie Transistor Products 393 Sagamore Ave., Mineola, N. Y.	Pacific	Pacific Import Co. 149 5th Ave., New York
Harpers	Harpers International 315 5th Ave., New York	Panasonic	Matsushita Electric Co. 535 W. 46th St., New York
Hi-Delity	Petely Enterprises, 300 Park Ave. S., New York	Peerless	Peerless Telerad Inc. 15 W. 29th St., New York
Hilton	Tessler Industries Inc. 1 Park Ave., New York	Petite	Sterling Hi Fi Co. 20-20 40th Ave., Long Island City, N. Y.
Hitachi	Hitachi Ltd., 660 5th Ave., New York	Plata	Kaysons International 6500 Flotilla St., Los Angeles, Calif., and 1123 Broadway, New York, N. Y.
Honeytone	Associated Importers 1168 Battery St., San Francisco, Calif.	Raleigh	Kaysons International 6500 Flotilla St., Los Angeles, Calif., and 1123 Broadway, New York, N. Y.
Imperial	Harpers International 315 5th Ave., New York	Realistic	Radio Shack Corp. 730 Commonwealth Ave., Boston, Mass.
Intermark	Inter Mark Corp., 29 W. 36th St., New York	Realtone	Realtone Electronics 34 Exchange Place, Jersey City, N. J.
International	International Amerex Trading Co., 444 5th Ave., New York	Ross	Ross Electronics, 589 E. Illinois St., Chicago, Ill.
Invicta	Toyomenka Inc., 2 Broadway, New York		
ITT	International Tel. & Tel. Co. Dist. Prod. Div. Box 99, Lodi, N. J.		

3 WAYS TO BIGGER



NEEDLE



CARTRIDGE PROFITS!

1. More "look-alike" exact replacement models than any other brand. Over 350 needles, 225 cartridges.
2. Easy-to-use reference material. E-V computer-printed catalogs make proper needle/cartridge selection easy, fast and accurate.
3. Highest standards. Rigid quality control and inspection cuts call-backs, gives full value to every customer.

Stock and sell E-V needles and cartridges for more profits, today! Write for FREE replacement guides!

ELECTRO-VOICE, INC.
Dept. 457E, Buchanan, Michigan 49107

Electro-Voice®
SETTING NEW STANDARDS IN SOUND

new SAMS BOOKS

Servicing With Dip Meters

by John D. Lenk. The dip meter is one of the most valuable of test instruments, with virtually unlimited applications in electronics testing. This handy reference guidebook tells how to use dip meters to measure the resonant frequency of an LC circuit without direct connection to the circuit under test, and with or without current applied. All of the countless applications for dip meters are explained (and illustrated where necessary). The easy-to-follow text tells how dip meters will help align receivers; measure capacitors, inductors, and resonant circuit combinations; check matching of antenna systems; measure impedance and electrical length of transmission lines; check crystal and filter circuits; make measurements of capacitors and coils; and serve as a field-strength meter and SWR meter. This comprehensive book about practical dip meter applications is invaluable to technicians, experimenters, and hobbyists. 128 pages; 5½ x 8½". \$295
Order DML-1, only.

Solid-State Power Supplies & Converters

by Allan Lytel. The advantages of long life and greatly reduced size offered by solid-state devices in power supply design is creating widespread interest. This book is a complete guide to building advanced solid-state power supplies. Describes more than 50 circuits for power supplies, voltage regulators, converters, and inverters. Details the use of power transistors, heat sinks, and silicon rectifiers in circuits for both single- and 3-phase power supplies. Includes full information and parts lists for building each circuit. 112 pages, 5½ x 8½". \$250
Order PSL-1, only.

ABC's of Telemetry

by Alan Andrews. Provides a basic understanding of the fascinating field of telemetry—the use of instruments to measure a condition, transmit the results to a remote station, and there indicate and record the measurement. While telemetry is best-known for its use in space research, it also plays an important role in medicine, oil processing, weather forecasting, oceanography, nuclear research, and industry. Describes both wired and radio-frequency basic systems; covers transducers, various methods of multiplexing the measured information, and the reception and demodulation of the data. Clearly explains processes and terminology—a solid introduction to the subject. 96 pages; 5½ x 8½". \$195
Order ATA-1, only.

DC Instrumentation Amplifiers

by L. George Lawrence. DC amplifiers are the most important link in an instrument control system. Their function is to boost weak low-frequency or DC signals from a data-sensing device to a level permitting their registration by the final recording or control apparatus. Details the basic operating principles, the capabilities, and the limitations of various types of DC amplifiers. Describes typical high-quality circuits to illustrate equipment now in commercial use. Provides a basic introduction to the "heart" of an instrument control system. \$295
128 pages, 5½ x 8½". Order IAL-1, only.



FREE SAMS BOOKLIST

Your valuable guide to over 300 authoritative books covering every area of electronics and allied subjects. Check coupon below.

AUDEL BOOKLIST FREE

Describes over 60 titles on automotive, building trades, electronics/electricity, do-it-yourself and related subjects. Check coupon below.



HOWARD W. SAMS & CO., INC.

Order from your Sams Distributor today, or mail to Howard W. Sams & Co., Inc., Dept. RE-4, 4300 W. 62nd Street, Indianapolis, Ind. 46206

Send me the following books:

DML-1 PSL-1 ATA-1 IAL-1

Send FREE Sams Booklist. \$_____ enclosed

Name _____

Address _____

City _____ State _____ Zip _____

My Distributor is _____

IN CANADA: A. C. Simmonds & Sons, Ltd., Toronto 7

- Satellite Best of Tokyo, 11 W. 42nd St., New York
- Saxony Trans-Aire Electronics 393 Sagamore Ave., Mineola, N. Y.
- Seminole Sans & Streiffe, 8400 Brookfield Ave., Brookfield, Ill.
- Sharp Sharp Electronics, 1270 6th Ave., New York
- Sheraton Brother International 680 5th Ave., New York N.Y. Merchandise Co.
- Skymaster 32 W. 23rd St., New York
- Sony (Radio & TV) Sony Corp. of America 580 5th Ave., New York
- Sony Superscope, Inc. Sun Valley, Calif., and 585 5th Ave., New York, N. Y.
- (Tape recorders) Brother International 680 5th Ave., New York
- Sovereign Summit International 44 Whitehall St., New York
- Spica Summit International 44 Whitehall St., New York
- Standard Standard Radio Corp. 410 E. 62nd St., New York
- Starlite Starlite Electronics 37 W. 23rd St., New York
- Stellar Astra Trading Co. 175 5th Ave., New York
- Summit Summit International 44 Whitehall St., New York
- Sun Glass AV Electronics 240 S. Teilmann, Fresno, Calif.
- Radio
- Tempest Azad International 1133 Broadway, New York
- Ten Sanyo Trading Co. 39 Broadway, New York
- 3-Star Nason Trading Co. 230 5th Ave., New York
- Tiffany Asiatic Import Corp. 1200 Santee St., Los Angeles, Calif.
- TMK Toyomenka Inc. 2 Broadway, New York, N. Y.
- Tokai Tokai Corp., 500th 5th Ave., New York
- Toptone Goshu Trading Co. 50 Broad St., New York
- Toshiba Transistor World Corp. 513 W. 24th St., New York
- Trancel Transistor World Corp. 513 W. 24th St., New York
- Truetone Western Auto Supply Co. 2107 Grand Ave. Kansas City 8, Mo.
- Tussah Tussah Corp., 1412 Broadway, New York
- TWI Transworld Industrial Corp. 5404 Hudson Ave., West New York, N. J.
- Valiant Valiant Importers 156 5th Ave., New York
- Viscount Consolidated Merchandise Corp., 520 W. 34th St., New York
- Vista Craig Panorama 3412 La Cienega Blvd., Los Angeles, Calif.
- Wilco Sanyo Trading Co., 39 Broadway, New York
- Winston Toyomenka Inc. 2 Broadway, New York, N. Y.
- York New York Transistor Co. 150 5th Ave., New York

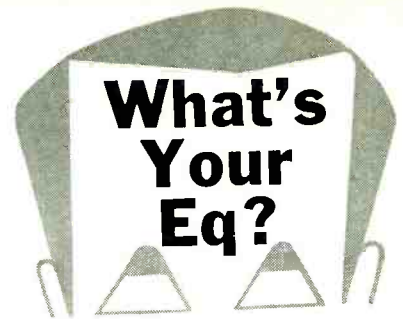

What's Your Eq?

Conducted by E. D. CLARK

Two puzzlers for the students, theoretician and practical man. Simple? Double-check your answers before you say you've solved them. If you have an interesting or unusual puzzle (with an answer) send it to us. We will pay \$10 for each one accepted. We're especially interested in service stinkers or engineering stumbers on actual electronic equipment. We get so many letters we can't answer individual ones, but we'll print the more interesting solutions—ones the original authors never thought of.

Write EQ Editor, Radio-Electronics, 154 West 14th Street, New York, N. Y., 10011.
Answers to this month's puzzle are on page 88.

Gate Circuit

N1 and N2 are neon glow lamps. N1 fires at 75 volts and maintains voltage at 55. N2 fires at 70 volts and main-

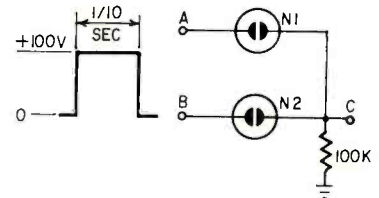

tains voltage at 50. If a square-wave pulse of 100 volts is applied to terminals A and B simultaneously, an output pulse is developed between terminal C and ground. Can you determine the maximum amplitude of the output pulse?—Kendall Collins

What's in the Box?

When the filament transformer is energized, the lamp glows dimly. Shorting the two terminals (marked X) extinguishes the lamp. After the short is removed, the lamp glows dimly again.

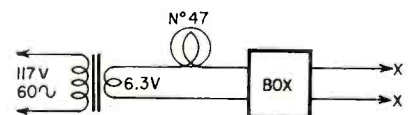

If the circuit is operated by a 6-volt battery, the operation is reversed. The lamp lights only when the terminals are shorted.

The box contains two components, neither of which is a power source, relay, vacuum tube, gas-filled tube or semiconductor. What's in the box?—Thomas G. Dighy

AUDIO EQUIPMENT REPORT

Sonotone CM-1050WR Wide-Range Low-Impedance Ceramic Microphone

LOW IMPEDANCE, LIKE LOW INCOME OR low anything-else, is a relative term. Don't be misled into thinking that this microphone will work into a 600-ohm line direct. But, compared to other piezo-electric devices, which usually require a load resistance of several megohms for flat bass response, this is indeed a low-impedance device. It sounds good when working into 100,000 ohms. At 50,000 ohms, bass is very sharply attenuated, and the microphone takes on a crisp, "telephone" quality.



SPECIFICATIONS

(All specifications are the manufacturer's)

Frequency response: 50 to 10,000 cycles
Sensitivity: -58 db
Recommended impedance: 250,000 ohms (usable to 33,000)
Damping grid: Lanced, louvered metal grid
Price: \$11
Sonotone Corp., Elmsford, N.Y.

The curves show the response of the microphone from 500 cycles down to 50, with load resistances from 3 megohms to 50,000 ohms. You'll note that there's little difference between the responses with 3 megohms and 1 megohm. Even 1/2 megohm still produces reasonable bass—only 3 db down at 70 cycles (better than most bookshelf-size speakers). Most ceramic mikes and pickups roll off much more sharply than that with load resistances of less than 2 or 3 megohms.

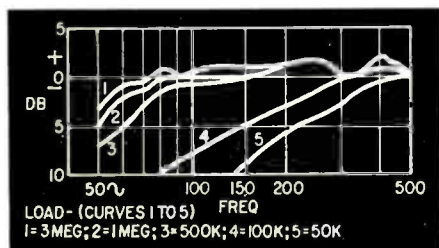

Bass response of Sonotone CM-1050WR with five different load resistances.

What does this mean, for practical applications? First, it makes using ceramic mikes with transistor amplifiers practical. Though an ordinary germanium transistor stage has an input impedance of perhaps only 2,000 ohms, it can, by "bootstrapping", raise its input impedance to 200,000 ohms or more. Certain silicon transistors can do even better. This is still too low for most piezoelectric transducers, but the Sonotone CM-1050 will do quite an acceptable job.

Second, you can use much longer cables with this mike than with most other high-impedance devices. Because the mike itself is an almost purely capacitive source, cable capacitance has little effect on it. I simulated the capacitance of a long cable with a .002- μ f capacitor (roughly equivalent to 100 feet of low-capacitance single-conductor shielded cable). With the microphone "listening to" a 1-kc tone from a speaker, the level dropped only 2 db when the capacitor was connected across the mike's 5-foot cable. At 5 kc, the level dropped 3 db; at 10 kc, 3.5 db.

Another feature of this microphone is its low distortion at high output levels. As a rough check of distortion, I connected the mike to an oscilloscope and placed it near a speaker being fed with a 1-kc tone. I slowly brought up the level of the tone, and hence the sound pressure on the diaphragm of the microphone, to an almost painful level. The sine wave on the scope screen stayed pure—even though the output from the microphone was 0.8 volt!

This is a good little microphone for all sorts of home recording, public-address and ham applications. It looks and feels indestructible—there's nothing to take apart or come loose accidentally. The CM-1050WR has a neat, streamlined shape, easy to hold and inconspicuous.

Acoustic Research AR-4 Acoustic-Suspension Speaker System

ACOUSTIC RESEARCH'S SPEAKERS HAVE always been noted for their relative lack of coloration, and especially for the most commendable characteristic of not seeming to have any bass response until the music calls for it. They have also been notably inefficient, depending on "brute force" for generating acoustic output: a long-throw voice coil and a very-high-compliance ("floppy") cone

continued on page 66

**NEW
WEN**

SOLDERING

all GUN

MODEL 450

**ONE
LIGHTWEIGHT
INSTRUMENT
FOR PRINTED
CIRCUITS**

(25-100 WATT RANGE)

HOME WIRING

(100-200 WATT RANGE)

GUTTERS & PLUMBING

(200-450 WATT RANGE)

**ONLY
\$13.95
INCLUDES
HEAVY DUTY
TIP**

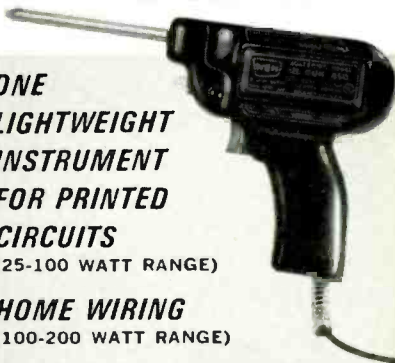

The new Wen "All" Gun does any soldering job you can think of from delicate kit work and printed circuits to appliance repair to heavy jobs formerly requiring an industrial type soldering iron. Because of its perfect balance, the "All" Gun functions with minimum operator fatigue and with great precision. Three separate tips provide the ranges. A "pencil" tip (25-100 watt range) . . . a medium duty tip (100-200 watt range) . . . a heavy duty tip (200-450 watt range). You can change tips in seconds with just 2 set screws. No double triggers or tricky switches . . . a full range of heat-power is automatic with Wen's exclusive ATR. ATR (Automatic Thermal Regulation) is made possible through the use of a high temperature magnetic wire developed for the space age missile program.

Pencil tip, medium tip, flat iron attachment (to remove wood dents, seal plastic bags) and plastic cutter attachment (to cut plastic and tile) are sold separately.

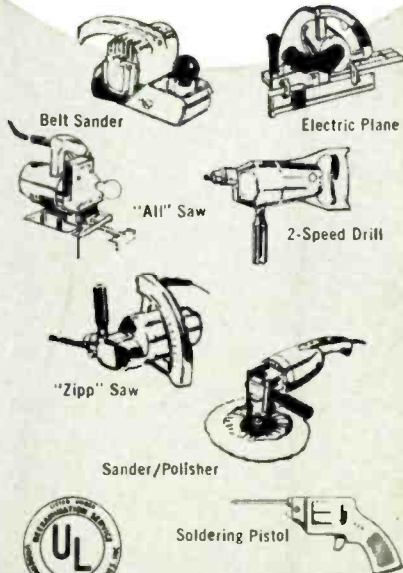

WEN

PRODUCTS, INC.

5810 Northwest Highway
Chicago 31, Illinois

You can earn more money if you have an FCC License

FCC Form 750 A

The United States of America

NUMBER
P1-20-6490

FEDERAL COMMUNICATIONS COMMISSION

RADIO TELEPHONE OPERATOR LICENSE

FIRST CLASS
(General Radiotelephone Certificate)

This certifies that _____ TOMMY WILLIS DUFFY _____

IS A LICENSED RADIO OPERATOR, AUTHORIZED, SUBJECT TO ANY SPECIAL ENDORSEMENT PLACED HEREON, TO OPERATE THE CLASSES OF LICENSED RADIO STATIONS FOR WHICH THIS CLASS OF LICENSE IS VALID UNDER THE ORDERS, RULES AND REGULATIONS OF THE FEDERAL COMMUNICATIONS COMMISSION, ANY STATUTE OF THE UNITED STATES AND ANY TREATY OF WHICH THE UNITED STATES IS A PARTY.

THIS LICENSE IS GRANTED UNDER THE AUTHORITY OF THE COMMUNICATIONS ACT OF 1934 AS AMENDED, AND THE TERMS AND CONDITIONS THEREOF AND OF ALL LEGISLATIVE ACTS, EXECUTIVE ORDERS, AND TREATIES TO WHICH THE UNITED STATES IS SIGNATORY, AND ALL ORDERS, RULES AND REGULATIONS OF THE FEDERAL COMMUNICATIONS COMMISSION, WHICH ARE BINDING UPON RADIO OPERATORS, ARE MADE A PART HEREOF AS THOUGH SPECIFICALLY SET OUT IN FULL HEREIN.

NEITHER THIS LICENSE NOR THE RIGHTS CERTIFIED TO HEREIN SHALL BE ASSIGNED OR OTHERWISE TRANSFERRED TO ANY OTHER PERSON.

PLACE AND DATE OF ISSUANCE: BUFFALO, NEW YORK SEPTEMBER 11, 1963

DATE AND TIME OF EXPIRATION: SEPTEMBER 11, 1968 AT THREE O'CLOCK A. M., EASTERN STANDARD TIME.

SPECIAL ENDORSEMENT: SHIP RADAR ENDORSEMENT - SEPTEMBER 11, 1963 - BUFFALO, NEW YORK

 **SPECIMEN** 
ISSUING OFFICER

Federal Communications Commission

Tommy Willis Duffy (Licensee) *[Signature]* (Issuing Officer) *Ron F. Waples* (Secretary)

NOT VALID UNTIL SIGNED

Employers are paying good money for men holding FCC tickets. Read how to get yours:

When you hold a Commercial License issued by the FCC (Federal Communications Commission) you have written proof that you know and understand basic electronic theory and fundamentals. It's worth plenty . . . particularly to companies on the lookout for qualified electronics technicians. Here's how one of the country's leading office machine manufacturers rates men with FCC Licenses:

"An FCC License is an asset to any man looking to enhance his career in the field of electronics. At our Company, a licensed man is well-rewarded because an FCC License attests to his knowledge of electronics theory . . ."

Thousands of employers will tell you the same thing. Licensed men get the good jobs. They make more money

. . . move ahead faster . . . enjoy exciting, challenging work. What's more, they're needed badly in every field of electronics. Industrial electronics. Radio-TV Broadcasting. Aerospace. Electronics Servicing . . . including mobile and marine radio *plus* CB.

Yes . . . your opportunities are unlimited once you're carrying that FCC Commercial Ticket. AND CLEVELAND INSTITUTE OF ELECTRONICS CAN GET ONE FOR YOU! On the facing page, read how four ambitious men just like you have cashed in on CIE's sure-fire FCC Licensing Program. Read about CIE's exclusive money-back offer. And then send in the postage paid reply card. CIE will quickly send you complete FREE information. You will soon be on *your* way to a Commercial FCC License and the many rewards that go with it!

These CIE men have good jobs

(they have Commercial FCC Licenses)



Matt Stuczynski, Senior Transmitter Operator, Radio Station WBOE. "I give Cleveland Institute credit for my First Class Commercial FCC License. Even though I had only 6 weeks of high school algebra, CIE's AUTO-PROGRAMMING teaching method makes electronics theory and fundamentals easy. After completing the CIE course, I took and passed the 1st Class Exam. I now have a good job in studio operation, transmitting, proof of performance, equipment servicing. Believe me, CIE lives up to its promises!"



Ted Barger, Electronic Technician, Smith Electronics Co. "I've been interested in electronics ever since I started operating my own Ham rig (K8ANF). But now I've turned a hobby into a real interesting career. Cleveland Institute of Electronics prepared me for my Commercial FCC License exam . . . and I passed it on the first try. I'm now designing, building and testing all kinds of electronic equipment . . . do a lot of traveling, too. It's a great job . . . and thanks to CIE and my FCC License, I'm on my way up."



Chuck Hawkins, Chief Radio Technician, Division 12, Ohio Dept./Highways. "Cleveland Institute Training enabled me to pass both the 2nd and 1st Class License Exams on my *first* attempt . . . even though I'd had no other electronics training. (Many of the others who took the exam with me were trying to pass for the eighth or ninth time!) I'm now in charge of Division Communications and we service 119 mobile units and six base stations. It's an interesting, challenging and extremely rewarding job. And incidentally, I got it through CIE's Job Placement Service . . . a free lifetime service for CIE graduates."



Glenn Horning, Local Equipment Supervisor, Western Reserve Telephone Company (subsidiary of Mid-Continent Telephone Company). "There's no doubt about it. I owe my 2nd Class FCC License to Cleveland Institute. Their FCC License Program really teaches you theory and fundamentals and is particularly strong on transistors, mobile radio, troubleshooting and math. Do I use this knowledge? You bet. We're installing more sophisticated electronic gear all the time and what I learned from CIE sure helps. Our Company has 10 other men enrolled with CIE and take my word for it, it's going to help every one of them just like it helped me."

FCC LICENSE WARRANTY

A CIE FCC License Course will quickly prepare you for a Commercial FCC License. If you don't pass the FCC exam . . . on the first try . . . after completing your course, CIE will refund all your tuition. You get an FCC License . . . or your money back!

Two out of three men who took the 1st Class Commercial FCC License exam in 1964, failed.

Nine out of ten CIE-TRAINED men who take this exam, pass . . . the very first try!

And that's why CIE can back their courses with the warranty you see at the left. CIE-trained men know their stuff . . . because CIE AUTO-PROGRAMMED Home Study works!

Get started now. Send postage-paid reply card for free information about a plan that gets you an FCC License or costs you nothing!

CIE **Cleveland Institute of Electronics**
1776 East 17th Street, Dept. RE-3, Cleveland, Ohio 44114

finger-
tip avail-
ability

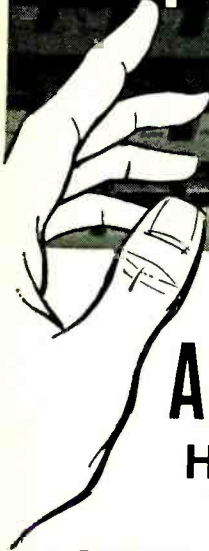

AEROVOX HAS 1212 EXACT REPLACEMENT TWIST PRONG AFH ELECTROLYTICS

Why fool with "jerry-rigged" electrolytics when there's an Aerovox exact replacement to give you the right rating and the right size? Aerovox actually stocks 1212 twist prong AFH electrolytics—this means off-the-shelf availability... not "we'll build it for you if you order it" delivery.

Available in singles, doubles, triples and quads, these popular types are now manufactured in new values for filter bypass applications in color TV as well as radio, black and white TV and amplifier equipment. Many values are now being used for industrial applications.

Aerovox AFH Twist Prong Electrolytics feature ruggedized prongs and mounting terminals, high purity aluminum foil construction, improved moisture resistant seal and 85°C operation. Here is the quality you need to protect your professional reputation.

Go to your Aerovox Distributor for a perfect electrolytic fit—he will deliver exactly what you want in less time than it takes to tell. Ask him for the new Aerovox Servicemen's Catalog #SE-565 or ask us. We'll be happy to send one your way.



**AEROVOX
CORPORATION**

DISTRIBUTOR DIVISION, NEW BEDFORD, MASS.

Technical Leadership—Manufacturing Excellence

AUDIO REPORT continued

suspension, allowing huge excursions that literally pump the air, without the help of any phase-inverting ports or impedance-matching horns.

This job also takes a big cone (or piston, if you will). The original AR (the AR-1) had a 12-inch woofer, and the AR-2 and AR-2a have 10-inch woofers. The bass response of the 2's, while still impressive, is noticeably "less low" than that of the AR-1 (and the AR-3, which has the same 12-inch woofer). What, then, could one expect of an 8-inch woofer?

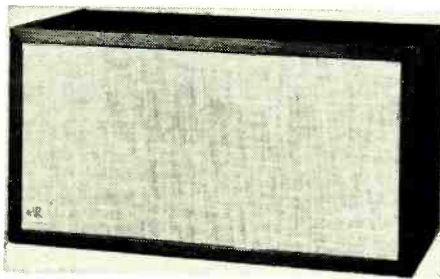

The answer came with the AR-4, which looks like the other AR's but measures only 19 × 10 × 9 inches. It has an 8-inch, long-throw, high-compliance woofer and a 3½-inch cone tweeter, both in an "acoustic-suspension" enclosure—a rigid, airtight box nearly filled with acoustic absorbent.

The distinctive lack of obtrusive coloration that made the speakers famous is still very much evident (though I realize this is a little like speaking of "the presence of a vacuum"). It is most noticeable on string bass, which has a clean "bite" and growl to it that is often obscured in larger systems whose response extends lower.

The AR-4 sounds unmistakably like its older brothers, but the bass is, of course, less substantial. There is no useful output below 50 cycles, and rolloff begins around 70-80 cycles.

Part of the reason for the clean bass is undoubtedly the low harmonic distortion generated by the woofer. I checked the speaker with a microphone and oscilloscope, and distortion became severe only at a high level. Another reason, tied to the first, is the high damping which makes the initial transient sound of the bow "biting" into the string (very different from the sustained tone generated once the bow is moving) stand out clearly.

The same flat, nonresonant quality was apparent on male speech, which quickly shows up any peaks in the range from about 60 or 70 cycles to about 150. Unequalized speech had an almost eerie presence and naturalness.

Mid-range and highs were similarly free of obvious peaks and dips. (A frequency response and distortion plot,

by the way, is available from the company on request.) There is a level control for the tweeter on the back, which comes set at mid-position. After trying it at other settings, I finally left it a few degrees counterclockwise of center. The range is considerable, and would allow a listener to more than compensate for over-live or over-dead acoustics. The quality of the highs is like that of the bass—there "on demand" but never obtrusive. Balance between woofer and tweeter is excellent—there is no clear transition to "tweeter sound" either on a sine-wave glide tone or on music, at normal distances from the speaker.

As usual, the finish (on the oiled-walnut cabinets—I can't vouch for the unfinished pine version) is excellent. A circular recessed panel in back carries the tweeter control and the terminals, marked 1 and 2 for phase reference. The terminals are binding posts with thumb-nuts rather than ordinary slotted-head screws, a rather superfluous but nice touch. (A gift, I gather, to the occasional music lover who has never owned a screwdriver and wouldn't quite know how to use one if he did.) The warranty card, the serial number and detailed instructions for hookup and placement are fastened to the back—a very fine idea. No instruction book to lose, and the instructions almost demand to be read; you can't help looking at them when you go to hook up the speaker. AR's usual 5-year all-expenses-paid warranty applies, incidentally.

It all comes down to how much you want that low, low bass. There isn't a great deal of music down there (sound, yes; music, no), and that extra octave below 50 cycles comes terribly expensive, if it's real. And the AR-4 still sounds pretty respectable on organ music and drum rolls. Its relatively low price (\$57, walnut; \$51, unfinished pine) and outstanding sound will make it real competition for other speakers in its size class.—Peter E. Sutheim END



"That's funny. He looked at your window display and kept on going."

RADIO-ELECTRONICS

test equipment report

The Squaremaker

I'VE ALWAYS BEEN FOND OF SQUARE-wave tests for audio and video amplifiers. You get more information in less time. However, it isn't always easy to get a true *square* waveform. Unless it is really square (or at least rectangular), you lose a good bit of the usefulness. You can't tell whether the trouble is in the generator or in the equipment.

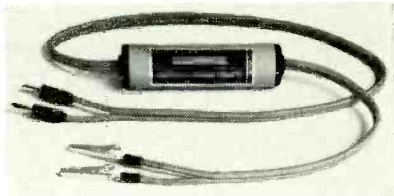

Monterey Electronics has an answer for this, in their transistorized *Squaremaker*, model ME-109. This is a two-stage transistor feedback network, with the operating power actually coming from the input *signal voltage*. It converts a sine-wave input into a very good square wave. Fig. 1 shows input and output superimposed. The proportions are misleading here, since I deliberately increased the vertical gain of the scope to make the square wave show above the sine waves. Actually, since the input sine wave is clipped and shaped to make the square waveform, the output is less than the input: 1 volt rms in gives about 0.25 volt rms

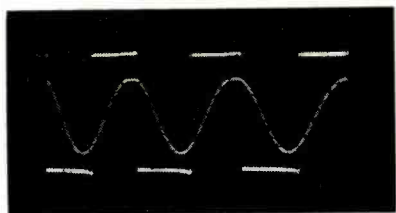

Fig. 1—Sine-wave input and square-wave output of the Squaremaker, superimposed. Fast rise time make transition (vertical portion) invisible.

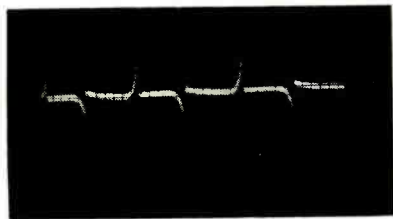

Fig. 2—When a pretty square wave turns into this at the output of whatever you're testing, it's differentiating the square wave something awful! (Of course, maybe it's supposed to.)

out. (And don't remind me about the rms value of a square wave. I know!)

Note the very good rise time on the square waves. The vertical lines are not visible, even on the original scope pattern! The maker claims a 50-nanosecond rise time with an 85-nsec fall time (50×10^{-9} , or .50 microsecond).

There are only a few precautions to observe when you use this instru-

ment. The input signal must not exceed 25 volts rms, and the output terminals should not be connected to any dc voltage, such as a plate circuit, without a blocking capacitor in series. Hook up the Squaremaker to the signal generator and turn the attenuator up gradually. Don't turn the generator output up, then suddenly hook up the Squaremaker. (This is probably to avoid puncturing transistor junctions by the sudden surge.)

The instrument is built into a handy round case, about 1 inch in diameter and 3 inches long, with leads on

continued on page 70



Who'd expect
SUN-GLASSES
from Perma-Power,
the Britener
people?

you get them **FREE** with either
of these **BRITENER PACKS**

When the sun is bright, you're uncomfortable—so Perma-Power gives you sun-glasses. When the TV picture is faded or dull, your customer is uncomfortable—so Perma-Power

gives you Vu-Brite and Tu-Brite. For brighter TV pictures and brighter customer smiles, rely on the Brite line. Install easy to use Perma-Power Briteners.



Air Force type wrap around sun-glasses, stylish for men and women, \$2.95 value—FREE with 10 Vu-Brites, Series or Parallel, at the special \$9.95 price.



Same high quality sun-glasses FREE with 4 Tu-Brites. If the base is right, the boost is right! Only \$8.95.

See your distributor now for both these specials.

PERMA-POWER COMPANY 5740 North Tripp Avenue, Chicago, Ill. 60646
Phone (area 312) 539-7171

13 Heathkit Values... See the other

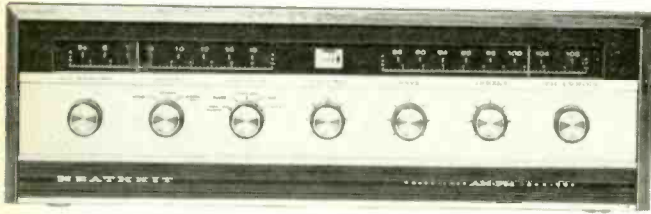

\$195⁰⁰ All-Transistor AM/FM/FM Stereo Receiver, AR-13A

Just add 2 speakers for a complete stereo system! 46 transistor, 17 diode circuit for cool, instant operation, plus the quick, uncompromising beauty of "transistor sound." Compact, yet houses two 20-watt power amplifiers (33 watts each, IHF music power), two preamplifiers, and wide-band AM/FM/FM Stereo. Attractive new "low-silhouette" walnut cabinet styling. 34 lbs.

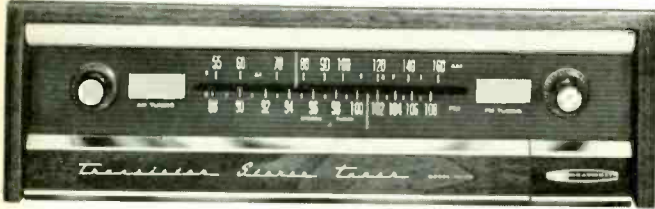

\$129⁹⁵ Deluxe All-Transistor AM/FM/FM Stereo Tuner, AJ-43C

Up to the minute AM, beautifully quiet FM, thrilling, natural FM stereo... all reproduced in the exciting new dimension of "transistor sound." Features 25 transistor, 9-diode circuitry, automatic switching to stereo, AFC, filtered outputs for direct, beat-free stereo recording, and new walnut cabinet styling. 19 lbs.



\$149⁹⁵ Matching Deluxe All-Transistor 70-Watt Stereo Amplifier, AA-21C

Enjoy the quick, unmodified response of each instrument with its characteristic sound realistically reproduced. No compromising! Enjoy 100 watts IHF music power at ± 1 db from 13 to 25,000 cps. Enjoy cool, instant operation from its 26 transistor, 10 diode circuitry. Unusual value. 29 lbs.

Deluxe 21" All-Channel Hi-Fi Color TV, GR-53A... \$399.00

Compares to sets costing up to \$200 more! Only color TV you can build yourself, only color TV you can adjust & maintain yourself with exclusive "built-in service center," only color TV you can install 3 ways... wall, custom cabinet, or either of Heath factory-built cabinets. Tunes all channels, 2 thru 83, to bring you 21" of true-to-life color and black & white pictures, plus hi-fi sound. Features 24,000 volt regulated picture power; deluxe Standard-Kollsman VHF tuner with push-to-tune fine tuning & new transistor UHF tuner; 26 tube, 8-diode circuit. All critical assemblies prebuilt & aligned... goes from parts to picture in just 25 hours. GR-53A, chassis, tubes, VHF & UHF tuners, mount, kit, speaker, 127 lbs... \$399.00 GRA-53-7, deluxe walnut cabinet, 85 lbs... \$115.00 GRA-53-6, economy walnut-finished cabinet, 52 lbs... \$49.00

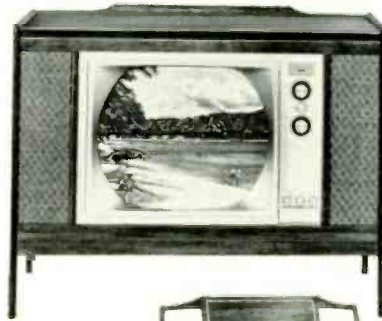

GR-53A
\$399⁰⁰
(less cabinet)

New! Deluxe Heathkit/Thomas "Coronado" All-Transistor Organ, GD-983... \$849.00

No extras to buy! Easy to build & play! Saves up to \$400! Every organ feature you've ever dreamed of... 17 true organ voices; 28-notes of chimes; built-in Leslie, plus 2-unit main speaker systems; 13-note heel & toe pedalboard, C thru C; two full-size 44-note keyboards; attack, sustain & repeat percussion—the only organ with all 3; stereo chorus control for exciting "stereo" effects; reverb; 5-year warranty on transistor tone generators; 75-watt EIA peak music power amplifier; and hand-crafted, hand-rubbed, full-bodied walnut-finished cabinet & matching bench. Hear it yourself!—Send 50c for demonstration record GDA-983-2, 7", 33 1/3 rpm. 242 lbs.



GD-983
\$849⁰⁰

New! Heathkit 4-Band Shortwave Listener's Radio, GR-64... \$39.95

Covers 550 kc to 30 mc in 4 bands to bring you international, ham, weather, marine, Voice of America, and AM broadcasts. Features built-in 5" speaker; lighted bandspread tuning dial, relative signal strength indicator, and 7" slide-rule dial; 4-tube super-het circuit plus 2 rectifiers; simple circuit board construction; "low-boy" cabinet. 13 lbs.

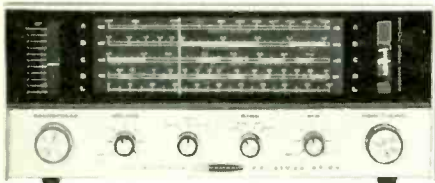

GR-64
\$39⁹⁵

Kit GR-24
\$29⁹⁵



NEW! Deluxe All-Transistor AM Portable, GR-24... \$29.95
6 transistor, 2-diode circuit gives 8 transistor performance. Uses 6 standard flashlight batteries... cuts operating cost to one-tenth of pocket-size portables. RF stage & double-tuned I.F. stage for greater sensitivity & selectivity. Built-in 1/2" dia. rod antenna, 4"x6" speaker, vernier tuning, slide-rule dial, & black simulated leather case. 6 lbs.

237 in your FREE Heathkit® Catalog!



IM-11
\$24⁹⁵

World's Largest Selling Vacuum Tube Voltmeter, IM-11 . . . \$24.95
A versatile performer anywhere in electronics! Boasts single AC/Ohms/DC probe; 7 AC, 7 DC, & 7 Ohms ranges; easy-to-read 4½" 200 UA meter; 1% precision resistors for high accuracy; and an extended low frequency response of ±1 db from 25 cps to 1 mc. Functions include AC volts (RMS), AC volts (peak-to-peak), DC volts, resistance & db measurements. Simple circuit board assembly. 5 lbs. Assembled IMW-11 \$39.95



IM-13
\$32⁹⁵

Deluxe "Service Bench" Vacuum Tube Voltmeter, IM-13 . . . \$32.95
Measures AC volts (RMS), DC volts, resistance & db. Separate 1.5 & 5 volt AC scales for high accuracy; "gimbal" mounting bracket for easy bench, shelf or wall mounting; meter tilts to any angle for best viewing; smoother vernier action zero & ohms adjust controls; large, easy-to-read 6" 200 UA meter; and single AC/Ohms/DC test probe. 7 lbs. Assembled IMW-13 \$49.95



IG-112
\$99⁰⁰

New! Heathkit FM Stereo Generator, IG-112 . . . \$99.00
Produces all signals required for trouble-shooting & alignment of multiplex adapters, FM tuners & receivers. Generates mono FM or composite stereo FM signals. Switch selection of 400 cps, 1000 cps, 5000 cps, 19 kc, 38 kc, plus 65 kc or 67 kc SCA test signals for complete alignment capability. Simple to assemble & use. 10 lbs.



GDP-134
\$34⁹⁵

New! Heathkit/NELI Transistor Ignition Kit, GDP-134 . . . Only \$34.95
Save \$35! Features 4-transistor, zener-diode protected circuitry; built-in conversion plug for switching to conventional ignition. Operates on 6 or 12 v. DC pos. or neg. ground system—installs easily on all cars, foreign & domestic. Completely sealed against moisture, corrosion, etc. Simple to assemble & install . . . all parts included. 7 lbs.



GD-973
\$17⁵⁰

New! Motor Speed Control, GD-973 . . . \$17.50
Reduces power tool speed without loss of operating efficiency. Ideal for use with drills, saws, mixers . . . any power tool with a universal AC-DC motor rating of 10 amperes or less. Prolongs life of drill bits, blades and other attachments. Features Silicon Controlled Rectifier with feedback circuit that slows motor, yet maintains high torque power! Adjustable speed control lets you dial desired motor speed. 3 lbs.



GW-31
\$19⁹⁵ ea.

Low Cost 4-Transistor "Walkie-Talkie," GW-31 . . . \$19.95 ea.
Only \$35 a pair! Operates ¼ mile and more; crystal-controlled transmitter; superregenerative receiver; 75 hour life on 9-volt battery (not included). No license, forms, tests or age limit. Crystals for 1 channel (specify). 2 lbs.



. . . Buy Now—Use This Order Blank . . .

HEATH COMPANY, Dept. 20-4, Benton Harbor, Michigan 49023
In Canada: Daystrom, Ltd., Cooksville, Ontario

Please send FREE 1965 Heathkit Catalog.

SHIP VIA:

- Parcel Post
- Express Collect
- Freight
- 20% Included, C.O.D.
- Best Way

Model	Description	Weight	Price
Name _____ (Please Print)			
Address _____			
City _____	State _____	Zip _____	

All prices & specifications subject to change without notice.

CL-203



Free...

108 colorful pages packed with over 250 Heathkits! Over 250 ways to have fun & save up to 50% by doing the easy assembly yourself! Use coupon opposite & send for your free 1965 Heathkit catalog now!

TEST EQUIPMENT continued

each end. The input leads have banana plugs and the output alligator clips, both color-coded. The output is actually a negative-going rectangular pulse. By putting a blocking capacitor in series, it becomes real "ac". If a positive-going pulse is needed, a diode can be connected from the output side of the capacitor, with its anode to ground.

A maximum output voltage of 35 is available, and the frequency range is from 1 cycle up to 1 mc. Makes it useful for testing amplifiers up to 3 or 4 mc (video amplifier stages). Nominal output impedance of the device is 2,000 ohms.

This kind of apparatus is very handy for all audio tests. See any handbook on audio. The tilt, rounding or other distortion in the output waveform will tell you a lot about the frequency response and phase shift, and what needs correcting: lows, highs, etc. It's also good for checking matching. If you want to know, as I did, whether a certain pair of transformers was properly matched in the use I had for them, check the output, with square-wave input. Fig. 2 shows what I got. Obviously, this is something less than perfect! In fact, the hookup turned out to be a pretty good integrator, but that wasn't what I wanted!

SPECIFICATIONS

(All specifications are the manufacturer's)

Rise time (2,000-ohm load)	50 nanoseconds
Fall time (2,000-ohm load)	85 nanoseconds
Maximum output	35 volts
Maximum rms input	25 volts
Frequency of 5% tilt	15 cycles
Frequency of 5% rounding	500 kc
Overall useful frequency range	1 cycle to 1 mc
Output impedance	2,000 ohms
Output polarity	negative
Overshoot	1%
Symmetry deviation	±5%
Jitter (viewing one cycle)	None observable
Net Price	\$15.95
Shipping weight	10 oz.

Monterey Electronic Products, 651 Cannery Row, Monterey, Calif.

For the best results, check the response of your scope. Feed the square wave to the scope input, and check the response. Even if your scope isn't absolutely perfect, by making a direct comparison between input and output waveforms, you can tell what's wrong with the amplifier.

Any audio signal generator with a reasonably good sine-wave output can be used. Mine is a venerable Heathkit G2. The audio-frequency output of a good rf signal generator can be used. In fact, video amplifiers can be checked by feeding them a low-frequency square wave, say about 40 cycles, and then a high-frequency square wave at about 100 kcs, made from the unmodulated rf output of the signal generator.

In most cases, the direct probe of the scope will work very well. In very high-impedance circuits, use the low-capacitance probe to prevent circuit loading and distortion introduced by the scope and test leads.

This is a most useful instrument, especially at a nominal price, and its uses are limited only by the ingenuity of the technician!—*Jack Darr*

Semiconductor Circuit Tester American Electronic Laboratories Model 250



SEMICONDUCTORS HAVE MADE IT NECESSARY to change the simple circuitry of many familiar test instruments.

The ohmmeter circuit in the conventional vom can "turn on" semiconductor devices. When measuring a resistance element across a semiconductor, it is possible for a change in state to occur within the semiconductor. This shunting effect will change the apparent value of a resistor or indicate leakage in a capacitor where there is none.

American Electronics Laboratories has overcome this problem with its model 250 Semiconductor Circuit Tester.

Instead of vom probes that deliver currents as high as 130 ma and power of approximately 50 mw on the $R \times I$

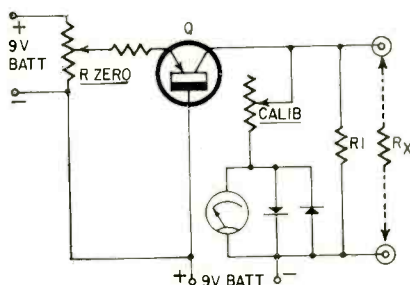

Simplified diagram of AEL 250 resistance-measuring circuit.

scale, the power output of the ohmmeter circuitry is limited to a maximum of 100 microwatts on all resistance ranges.

The basic circuit (see diagram) is a modern variation of the "slide-back ohmmeter" which is popular for measuring low resistances.

The AEL model 250 uses a transistor (Q) to stabilize the current to the test leads. Keeping the current as constant as practical increases the accuracy of the readings and increases the useful life of the 9-volt batteries in the instrument.

The meter measures the voltage across the test leads. To measure resistance, the meter is adjusted to full scale and the test leads are bridged across the component under test.

Current drawn by the external resistance (R_x) is subtracted from that flowing through the meter and resistor R1. Actually the meter is measuring the voltage drop across R1. When an external current path is connected in parallel (through the test leads), the voltage drop across the combined resistance of R1 and R_x is lowered. The change is indicated on the meter in ohms.

Another feature for semiconductor testing is an adaptation of the resistance-measuring circuitry for testing diodes. The model 250 is set for the resistance function but the range switch is set to the diode (extreme clockwise) position. Here the maximum power output to the test leads is increased to 1 mw.

SPECIFICATIONS

(All specifications are the manufacturer's)

Dc voltage:	0-3, 10, 30, 100, 300 and 1,000 volts (±3% of full scale)
AC voltage:	0-10, 30, 100, 300 and 1,000 volts (±5% of full scale)
Dc current:	0-0.1, 1, 10, 100 and 1,000 ma (±3% of full scale)
Resistance:	0-200, 2,000, 20,000, 200,000 ohms, 2 megohms. Accuracy of any reading is within 3° of the arc of the scale.
Price:	\$99.50

American Electronic Laboratories, Inc., PO Box 552, Lansdale, Pa. 19446

If increased power were not made available for diode testing, the diode would not "turn on" and a high resistance would be read in both directions. The front-to-back resistance ratio would be very low—much less than the average 100 to 1.

The rest of the circuitry is just about standard for vom's. Even the diode meter protectors are becoming standard items to protect this most expensive portion of the instrument.

Dc voltages are measured at 20,000 ohms per volt. ac voltages at 5,000, with a frequency response of approximately 20 cycles to 50 kc.

The black, high-impact plastic case has a handgrip molded right into the shape. The slope of the case also allows the vom to be used in a semihorizontal as well as a vertical position.—*Elmer C. Carlson*

END

New Semiconductors and Tubes

SILICON BULLETS

A line of epoxy-molded silicon rectifiers in a "bullet" shape is unusually wide in that it offers either high-current, or high-voltage units in the same size package. And we mean *high!*

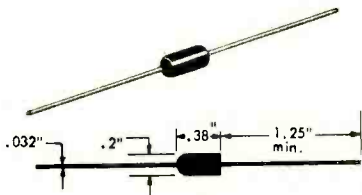

The new rectifiers, from Electronic Devices, Inc., Yonkers, N. Y. are available in four varieties—500, 350, 250 and 200 ma forward current at 50° C—in peak-inverse voltage ratings from 1,000 to 5,000! Not every current rating is available in every voltage rating.

Or, you can get from 50 to 1,000 piv at 1.2 amperes average rectified forward current at 50° C (derate to 0.6 amps at 100° C). One-cycle surge rating is 75 amps; recurrent peak, 12 amps.

This is without heat sinks. The drawing shows how small these rectifiers are.

HIGHER-OUTPUT LIGHT-EMITTING DIODES

Three new gallium arsenide light-emitting diodes, with an infrared output at room temperatures an order of magnitude higher than previous designs, have been announced by General Electric.

The new devices are expected to widen the range of applications for LED's. For example, in computer card

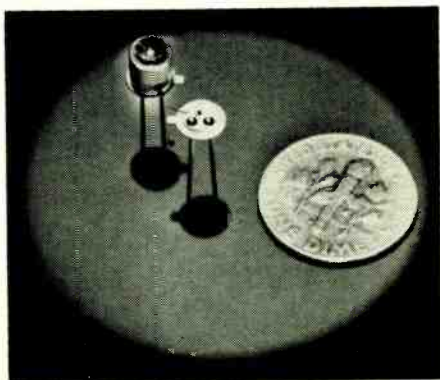

APRIL, 1965

a big improvement on an old favorite ... NEW WINEGARD BOOSTER COUPLER



Model BC-208

*Runs 1 to 4 TV or FM sets
Replaces Model WBC4-X*

ONLY
\$29⁹⁵
LIST

**Boosts Signal ... Cuts snow ...
no picture smear ... no interac-
tion ... 8 DB gain to each out-
put.**

Winegard engineers have taken advantage of the newest ampliframe shielded triode tubes to develop an improved booster-coupler. The new BC-208 uses *two* 6HA5 tubes

for higher gain and less noise. FM gets a boost, too, in this new circuit as it covers the entire FM band 88-108MC. It's a great new product from Winegard for better color, black & white or FM reception. Ask your distributor or write today for spec. sheets. Check the comparison chart against the old Winegard Booster Coupler.

	BC-208	WBC4-X
Number of tubes	2 6HA5	1 6DJ8
Gain to each isolated output	+8db	+5.8db
Gain across FM Band	+7db	+1.2db
Noise Figure, Low Band	3.7db	3.8db
Noise Figure, High Band	5db	5.2db
Isolation between outputs	18db	8db
Signal Input	20 to 350,000 microvolts	20 to 300,000 microvolts
Maximum Signal Output	1,800,000 microvolts	1,500,000 microvolts
ON-OFF Switch	Yes	Yes
Response	Flat = 1/2db per any 6mc channel	Flat = 1/2db per any 6mc channel
No-strip terminals	Yes	Yes
Removable mounting bracket	Yes	No
Module wiring	Yes	No
Number of isolated outputs	4	3



Winegard Co.
ANTENNA SYSTEMS

3013E KIRKWOOD, BURLINGTON, IOWA

NEW EICO

435

ULTRA-COMPACT 3-INCH WIDEBAND SCOPE



A LAB QUALITY OSCILLOSCOPE $\frac{1}{3}$ THE SIZE, $\frac{1}{2}$ THE WEIGHT OF CONVENTIONAL 5-INCH SCOPES. SMALL ENOUGH TO TAKE ALONG ON TV AND INDUSTRIAL SERVICE CALLS. OUTPERFORMS MUCH LARGER AND MORE EXPENSIVE 5-INCH SCOPES.

- FLAT DC TO 4.5 MC/S
- BRIGHT, SHARP TRACE
- TRACE EXPANSION TO SEVERAL TIMES CRT DIAMETER
- FLAT-FACE 3-INCH CRT
- ZENER DIODE CALIBRATOR
- DIRECT-COUPLED PUSH-PULL VERTICAL AMPLIFIER

THE MOST USEFUL SCOPE EVER DESIGNED. KIT \$99.95. WIRED \$149.95.

SEND FOR CATALOG

EICO Electronic Instrument Co. Inc. RE-4
131-01 39th Avenue, Flushing, N.Y. 11352

Send new 1965 catalog featuring more than 230 EICO products

Name _____
Address _____
City _____ Zip _____ State _____

Add 5% in West

readers, cards could now be read by reflective means rather than directly by transmitted light. Other applications include photoelectric security systems, high-speed infrared photography, thickness monitoring of semitransparent material, optically coupled computer elements, which could transmit information quickly without cables. LED's can also be used with light-activated switches to give high-voltage isolation.

One of the new types, the LED-10, has a typical output of 300 μ w for a current of 100 ma. The output is at a wavelength of 9,000 A with a bandwidth of 210 A. Pulsed output at -77° K (liquid nitrogen) reaches 3 watts at 8,450 A.

A major advantage of light-emitting diodes compared to other types of light sources is that they can be modulated with frequencies up to 10 mc and beyond. This means that a substantial amount of information can be carried on the light beam. Other advantages include ruggedness and long life. G-E reports that in 1 year of life-testing there have been no "catastrophic failures" (such as burnout). The light source is uniform over the radiating area.

The model LED-11 is the same as the LED-10 except for a removable lens cap which permits designers to supply their own optics. The LED-9 is a lower-output version of the LED-10.

Prices for the LED-10 and -11 are \$45 each in quantities from 1 to 99. The LED-9 costs \$12, 1 to 99 pieces.

REFERENCE AMPLIFIERS

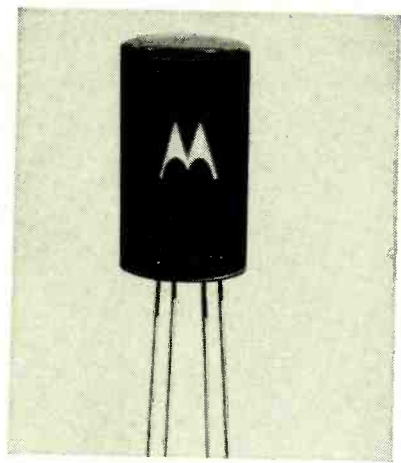

Multi-function semiconductors are becoming almost as common as multi-function tubes (twin triodes, pentagrid converters and such). Not as cheap, though, unfortunately. Anyway, here is a line of *reference amplifiers* from Motorola. The idea (not new) is to combine a Zener diode voltage reference (used in voltage regulators, for instance) with a transistor amplifier stage, direct-coupled to it. Saves one or

TYPICAL APPLICATION IN REGULATED POWER SUPPLY

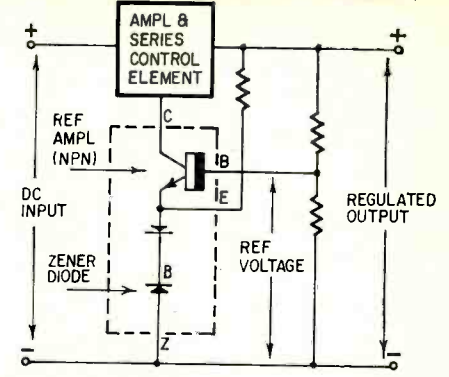

two connections, is somewhat more compact, and, best of all, because the two elements are in the same package, temperature changes affect them both about equally, making temperature compensation less of a problem.

The amplifier-Zener combo can "amplify" the regulating ability of a Zener diode alone, making circuit design more flexible. (Only in the simplest and crudest regulators does the Zener clamp the series regulating transistor directly.)

The reference amplifier units are available with ratings of 6.8, 8, 9.5 or 11 volts, with either n-p-n or p-n-p transistors, three temperature ranges and a variety of reference-voltage-change-with-temperature spec. END

for your convenience

over
600
electronic
parts
distributors

now sell
Radio-Electronics
in the United States
and Canada

TECHNOTES

HARMAN-KARDON 500 TUNER: PERIODIC OSCILLATOR SHIFT

A Harman-Kardon 500 produced a step function amounting to 100% modulation at a rate of approximately 1 per second when viewed on a scope. The tuning meter deviated up and down with this signal. Reception was lost or distorted. This difficulty was present only when tuned to a station and in both NORMAL and AFC modes.

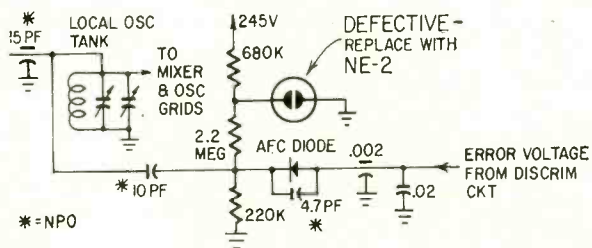

The trouble originated in a neon bulb used to stabilize the polarizing voltage to the voltage-variable diode capacitor for afc. These bulbs would change their discharge mode with a resulting change in voltage drop and shift in local oscillator frequency. The glow could be seen to shift along the electrode in some of these bulbs. Replacement with standard NE-2 has been entirely satisfactory.

Since the front end of this unit was apparently not designed for service, merely clip the hot lead of bulb, leave it in place, and solder in another bulb attaching the ground to the bottom or side of the mixer shield. Rf currents are not involved.

This can be done by removing only the i.f./rf strip cover (two screws and a soldered braid) and soldering from the top of the chassis while holding the component from the bottom. —W. Thornton

SILVERTONE CHASSIS 528.50180, -81, ETC.

Many of these chassis have the same symptom: horizontal frequency drifting and squegging. In most cases, readjusting the horizontal oscillator coil secondary (phasing section)

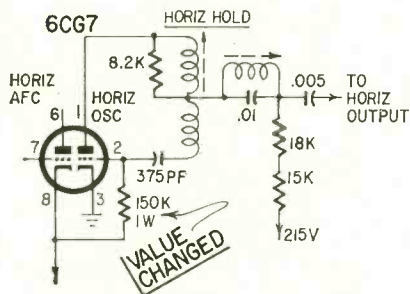

cures the trouble. Recently one set fooled me: after readjustment the oscillator continued to drift. However, it did not

APRIL, 1965

it's here! most advanced
color TV test instrument
ever developed



- OBSOLETE ALL OTHERS
- ELIMINATES ALL GUESSWORK

LECTROTECH V7*

A sensational new color generator with 4 major Lectrotech exclusives . . . plus all of the time-proven standard features . . . in one compact, portable unit. For the first time, you can install and service color TV completely, accurately and faster! Here are the facts:

EXCLUSIVE—COLOR VECTORSCOPE—Until now, available only in \$1500 testers designed for broadcast. Accurately measures color demodulation to check R-Y and B-Y plus all 10 color bars for color phase angles and amplitude. A must for total color and those hard to get skin tones.

EXCLUSIVE—SELF-CALIBRATING — Adjust timing circuit without the use of external test equipment. No need to return unit to a factory for adjustment.

EXCLUSIVE—DIAL-A-LINE — Now, you can adjust horizontal line to any width desired from 1 to 4 lines wide.

EXCLUSIVE—SOLID STATE RELIABILITY — Only two tubes are used in combination with fully transistorized diode-rectifier circuit.

PLUS— the V7 produces all Crosshatch, Dots, Vertical only, Horizontal only and Keyed Rainbow Patterns. RF at channels 3, 4 or 5. Video Output (Pos. and Neg. adjustable) for signal injection trouble-shooting. Red-Blue-Green Gun Killer. All transistor and timer circuits are voltage regulated to operate under wide voltage ranges. Lightweight, compact — only 8¼" x 7½" x 12½". Net. 189.50

*Designed and produced by the men who introduced and developed the modern approach to TV testing — Bill Grossman and Bob Korel.

For the full story on the V7, write for complete catalog or see your distributor.



V6 Complete color bar generator with all the features of the Lectrotech V7 except the Vectorscope. Only 99.50

Distributors: Phone or Wire Collect.



LECTROTECH, INC.

1737 Devon Ave. ■ Chicago, Ill. 60626 ■ Area 312 465-2622

FREE ELECTRONICS CATALOG
Tremendous Bargains (see coupon)

BUILD 20 RADIO

CIRCUITS AT HOME

with the New Progressive

RADIO "EDU-KIT"®

Reg. U.S.
Pat. Off.

All Guaranteed to Work!

PRACTICAL HOME RADIO COURSE only **\$26.95**



TRAINING ELECTRONICS
TECHNICIANS SINCE 1946

NOW INCLUDES

- ★ 12 RECEIVERS
- ★ 3 TRANSMITTERS
- ★ SQ. WAVE GENERATOR
- ★ AMPLIFIER
- ★ SIGNAL TRACER
- ★ SIGNAL INJECTOR
- ★ CODE OSCILLATOR

- ★ No Knowledge of Radio Necessary
- ★ No Additional Parts or Tools needed
- ★ Excellent Background for TV
- ★ School Inquiries Invited
- ★ Attractively Gift Packed

FREE EXTRAS

- SET OF TOOLS ● RADIO & ELECTRONICS TESTER ● ELECTRIC SOLDERING IRON ● TESTER INSTRUCTION MANUAL ● MEMBERSHIP IN RADIO-TV CLUB: CONSULTATION SERVICE ● HI-FI GUIDE ● QUIZZES ● TV BOOK ● FCC AMATEUR LICENSE TRAINING ● RADIO BOOK ● PRINTED CIRCUITRY ● PLIERS-CUTTERS ● ALIGNMENT TOOL ● WRENCH SET ● CERTIFICATE OF MERIT ● VALUABLE DISCOUNT CARD

WHAT THE "EDU-KIT" OFFERS YOU

The "Edu-Kit" offers you an outstanding PRACTICAL HOME RADIO COURSE at a rock-bottom price. Our course is designed to train Radio & Electronics Technicians, making use of the most modern methods of home training. You will learn radio theory, construction, servicing, basic Hi-Fi and TV repairs, code, FCC amateur license requirements.

You will learn how to identify radio symbols, how to read and interpret schematics, how to mount and lay out radio parts, how to wire and solder, how to operate electronic equipment, how to build radios. Today it is no longer necessary to spend hundreds of dollars for a radio course. You will receive a basic education in radio, worth many times the small price you pay, only \$26.95 complete.

THE KIT FOR EVERYONE

The Progressive Radio "Edu-Kit" was specifically prepared for any person who has a desire to learn Radio. The "Edu-Kit" has been used successfully by young and old in all parts of the world, by many Radio Schools and Clubs in this country and abroad. It is used for training and rehabilitation of Armed Forces Personnel and Veterans throughout the world.

The Progressive Radio "Edu-Kit" requires no instructor. All instructions are included. Every step is carefully explained. You cannot make a mistake.

PROGRESSIVE TEACHING METHOD

The Progressive Radio "Edu-Kit" is the foremost educational radio kit in the world, and is universally accepted as the standard in the field of electronics training. The "Edu-Kit" uses the modern educational principle of "Learn by Doing." Therefore, you will construct circuits, perform jobs and conduct experiments to illustrate the principles which you learn.

You begin by examining the various radio parts included in the "Edu-Kit." You then learn the function, theory and wiring of these parts by building a simple radio. With this first set, you will enjoy listening to regular broadcast stations, radio, practice testing and troubleshooting. Then you build a more advanced radio, learn more advanced theory and techniques. Gradually, in a progressive manner, and at your own rate, you will find yourself constructing more advanced multi-tube radio circuits, and doing work like a professional Radio Technician.

Included in the "Edu-Kit" course are 20 Receiver, Transmitter, Code Oscillator, Signal Tracer, Signal Injector, Square Wave Generator and Amplifier circuits. These are not unprofessional "bread board" experiments, but genuine radio circuits, constructed by means of professional wiring and soldering on metal chassis, plus the new method of radio construction known as "Printed Circuitry." These circuits operate on your regular AC or DC house current.

In order to provide a thorough, well-integrated and easily-learned radio course, the "Edu-Kit" includes practical work as well as theory; troubleshooting in addition to construction; training for all, whether your purpose in learning radio be for hobby, business or job; progressively-arranged material, ranging from simple circuits to well-advanced topics in Hi-Fi and TV. Your studies will be further aided by Quiz materials and our well-known FREE Consultation Service.

THE "EDU-KIT" IS COMPLETE

You will receive all parts and instructions necessary to build 20 different radio and electronics circuits, each guaranteed to operate. Our Kits contain tubes, tube sockets, variable electrolytic, mica, ceramic and paper dielectric condensers, resistors, tie strips, coils, hardware, tubing, punched metal chassis, Instruction Manuals, hookup wire, solder, selenium rectifiers, volume controls, switches, knobs, etc.

In addition, you receive Printed Circuit Materials, including Printed Circuit chassis, special tube sockets, hardware and instructions. You also receive a useful set of tools, a professional electric soldering iron, and a self-powered Dynamic Radio & Electronics Tester. The "Edu-Kit" also includes Code Instructions and the Progressive Code Oscillator, in addition to the F.C.C.-type Questions and Answers for Radio Amateur License training. You will also receive lessons for servicing with the Progressive Signal Tracer and the Progressive Signal Injector, and a High Fidelity Guide and Quiz Book. Everything is yours to keep.

J. Statistis, of 25 Poplar Pl., Waterbury, Conn., writes: "I have repaired several sets for my friends, and made money. The "Edu-Kit" paid for itself. I was ready to spend \$240 for a course, but I found your ad and sent for your Kit."

UNCONDITIONAL MONEY-BACK GUARANTEE

The Progressive Radio "Edu-Kit" has been sold to many thousands of individuals, schools and organizations, public and private, throughout the world. It is recognized internationally as the ideal radio course.

By popular demand the Progressive Radio "Edu-Kit" is now available in Spanish as well as English.

It is understood and agreed that should the Progressive Radio "Edu-Kit" be returned to Progressive Radio "Edu-Kit" for any reason whatever, the purchase price will be refunded in full, without quibble or question, and without delay.

The high recognition which Progressive "Edu-Kits" Inc. has earned through its many years of service to the public is due to its unconditional insistence upon the maintenance of perfect engineering, the highest instructional standards, and 100% adherence to its Unconditional Money-Back Guarantee. As a result, we do not have a single dissatisfied customer throughout the entire world.

ORDER FROM AD - RECEIVE FREE BONUS
RADIO & TV PARTS JACKPOT WORTH \$15

- Send "Edu-Kit" Postpaid. I enclose full payment of \$26.95.
- Send "Edu-Kit" C.O.D. I will pay \$26.95 plus postage.
- Rush me FREE ELECTRONICS BARGAIN CATALOG. Include descriptive literature on "Edu-Kit."

Name.....
Address.....

Progressive "EDU-KITS" Inc. 1186 Broadway, Dent. C240G
Hewlett, N. Y.
(ATT: S. GOODMAN, M.S. IN ED., PRES.)

drift as severely, and would stabilize after about an hour.

The bad component in this set turned out to be a resistor in the oscillator circuit (see diagram). It dropped from 150,000 to about 135,000 ohms when heated with a soldering gun. I replaced it with a 2-watt 10% unit and had no more trouble.—Charles B. Randall

DISASSEMBLING PHONO MOTORS

When a phono motor becomes sticky and slow, it must be taken apart. Clean the top and bottom bearings with cleaning fluid. Also clean the armature of sticky oil and grease.

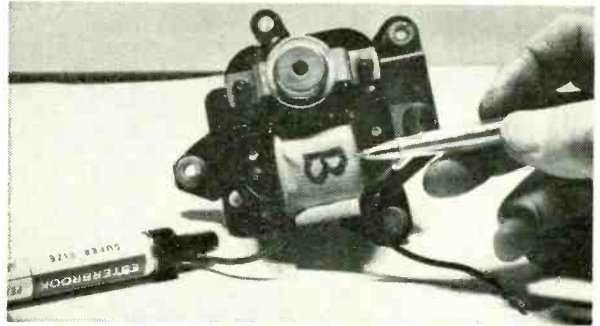

Before taking the motor apart, mark the bottom frame of the field coil with a "B". (Use a marker that will not rub off easily.) If the field-coil assembly were turned over, the motor would run backward. The assembly will go together either way, and you generally will not know the motor is running backward until the turntable is in place.—Homer L. Davidson

MONARCH LATHE MODEL EE, 10-INCH

If the machine will not run faster than 1,200 or 1,500 rpm, see if both large (armature) thyratons (EL-C16J or equivalent) are firing. If one is out, interchange the two 3C23 (or equivalent) thyratons. If the other C16J now fires, one of the 3C23's is defective. Replace the one located below the C16J which is not firing.—R. C. Roetger

RCA CHASSIS KCS 82

Symptoms: Video and sound overloading. Cutting back agc control reduces overload, but not enough. Horizontal pulling near top of picture.

Preliminary Findings: Bridging agc line with 30- μ f filter clears up horizontal pulling but does not reduce over-



"Help. We are marooned on an island located . . ."

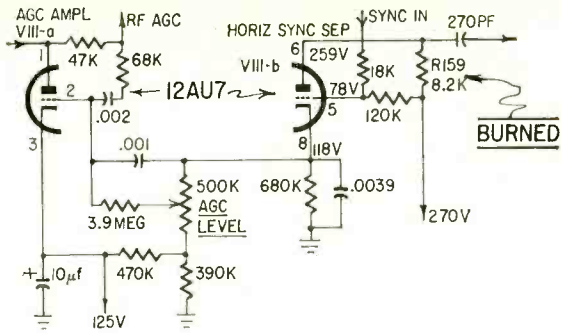

load. Voltages at VIII-b (12AU7) sufficiently off to warrant investigation.

Trouble: Plate resistor (R159) of 12AU7 horizontal sync separator increased in value, upsetting age level and disrupting horizontal sync.

Replace original 1/2-watt resistor with a 2-watt. This reduces chance of a defective 12AU7 again damaging plate resistor.—Charles B. Randall

AGC TROUBLES

Two sets of different makes showed the same trouble. Switch off a station and back to it (or to another station) and the set would overload. On one local it was severe enough to blank the screen for several seconds. On another the picture went negative with loss of sync for several seconds. After the set became normal it would work fine. In these cases, the 18-megohm resistor between B-plus and tuner agc had changed value. Between stations the agc bypass would charge up positive. When the set was tuned to a station, the bypass would have to leak off. Then the agc would charge it negative. Replace the resistor and, for good luck, replace the tuner agc bypass.—W. G. Eslick

END

FOR RADIO-ELECTRONICS SUBSCRIBERS

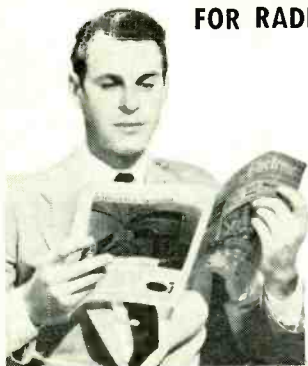

An unusual chance
to introduce a friend
to Radio-Electronics

Some of your friends probably share your interest in electronics—either professionally, as a hobby, or both.

If one such friend is not reading Radio-Electronics now we'll be happy to send him a complimentary copy.

He'll appreciate your thoughtfulness in having a free copy sent to him. And, if he chooses to subscribe after seeing a sample copy, you will add still another mutual bond of interest to your friendship.

RADIO-ELECTRONICS 4-65
154 West 14th St., New York, N.Y. 10011
Without obligation, send a complimentary copy of Radio-Electronics and your special offer.

TO
ADDRESS
CITY STATE ZIP.....
Radio-Electronics Subscriber
(Must be signed to validate offer)

add an fm-stereo service center
with this one new
sencore unit!

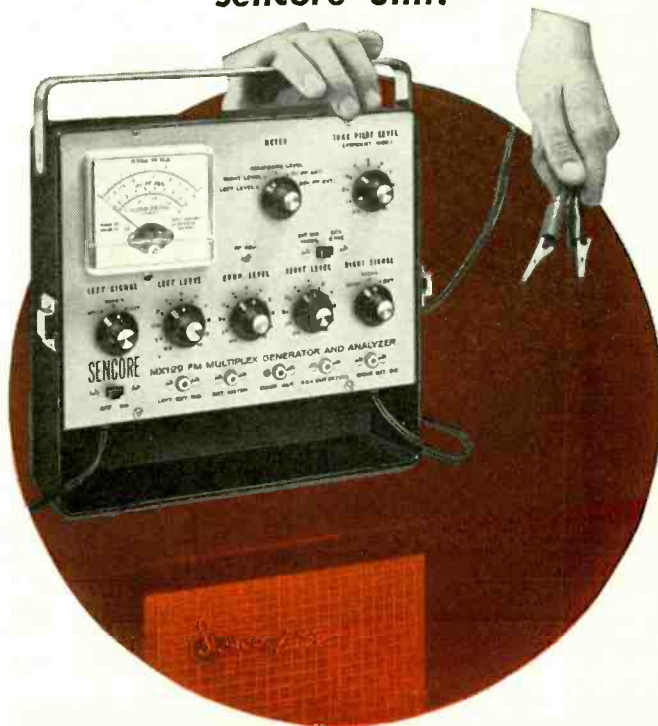

THE SENCORE MX129 FM STEREO MULTIPLEX GENERATOR & ANALYZER

FM-Stereo growth continues to mount and is fast becoming as big a field as Color TV. This means more FM-Stereo service business for you, now and in the future. Is your shop equipped? It can be—completely and economically—with the MX129, the FM-Stereo "Service Center in a Case." The instantly stable, 19-Transistor, crystal controlled MX129 is the most versatile, most portable (only 7½ pounds), most trouble free and efficient multiplex unit on the market—just like having your own FM-Stereo transmitter on your bench or in your truck. Powered by 115 volts AC, it produces all signals for trouble shooting and aligning the stereo section of the FM receiver... can be used to demonstrate stereo FM when no programs are being broadcast. Self-contained meter, calibrated in peak to peak volts and DB, is used to accurately set all MX129 controls and as an external meter to measure channel separator at the FM-Stereo speakers. NO OTHER EQUIPMENT IS REQUIRED. only **\$169⁵⁰**

SIGNALS AVAILABLE FOR ALIGNMENT, TROUBLE SHOOTING AND ANALYZING:

FM-RF carrier with composite multiplex audio signal with 38kc suppressed carrier, 19kc pilot and 67kc SCA signals • Multiplex signal formed by 60 or 1000 cycle internal tones or any external signal
• Full control over left and right channel amplitude (modulation)
• External 67kc SCA signal available for trap adjustment • Composite signals available for signal injection FM detector •

professional quality—that's the difference!

SENCORE
426 SOUTH WESTGATE DRIVE • ADDISON, ILLINOIS

NEW PRODUCTS

ANTENNA ROTATOR, model T-45, has 5-wire circuit unaffected by motor current, cable length or line voltage variations. Finger pressure on control bar at top of *Tenna-Rotor* plastic unit directs antenna through 360°. Handling capacity includes the largest color antennas in winds in excess of 90 miles per hour.—Alliance Mfg. Co., Inc., Alliance, Ohio.

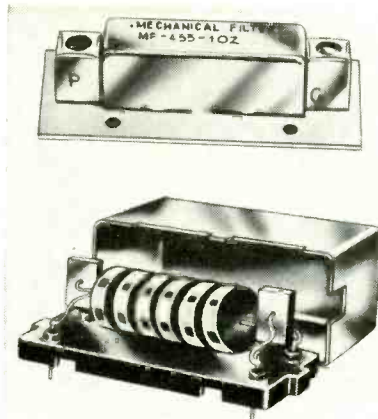
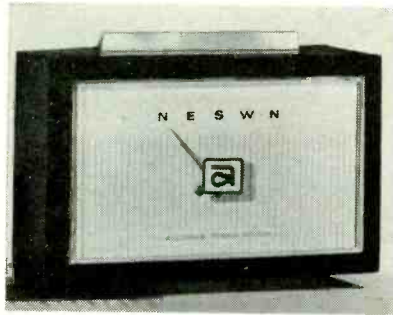

MECHANICAL FILTER, No. 99-0123, for 455-kc i.f. Closely approximates steep-skirted, flat-top bandpass for high selectivity. Bandwidth: 2 kc at 6 db, 7 kc max at 60 db. Connects between mixer and first i.f. in superhet receivers; pas-

sive—requires no power. Input and output impedances, 10,000 ohms. Transmission loss, 1.5 to 3 db. Consists of input transducer, row of six rod-coupled ferro-nickel chromium alloy discs, and output transducer. Mounted with input and output transformers on printed-circuit board. 2 3/4 x 3/4 x 1 1/2 in.—Lafayette Radio Electronics, 111 Jericho Turnpike, Syoset, N. Y. 11791.

AUTOMATIC TURNTABLE, *Mira-cord 18H*, plays individual records, has cueing device which lowers or raises arm in any band or groove. Hysteresis-synchronous motor, heavy balanced turntable



ble platter and transcription arm. Rumble — 55 db; wow and flutter less than 0.1%; stylus force gauge 1 to 5 grams.—Benjamin Electronic Sound Corp., 80 Swalm St., Westbury, N. Y.

Let Detroit **DUAL** TRANSISTORIZE Your Car—At Less Than Half-Price!

AMAZING DUAL-TRANSISTOR **POWERTRON** FEATURES COMPONENTS BY TOP NAMES IN AUTOMOTIVES — OUTPERFORMS ANY OTHER TRANSISTOR IGNITION SYSTEM — AT ANY PRICE!

✓ CHECK YOUR VALUES!

FACTORY-INSTALLED ON THUNDERBIRDS, CONTINENTALS, ETC.; BUT ALSO IN AUTO STORES AT THE RETAIL PRICES SHOWN:

PRESTOLITE Trigniter	\$ 74.50
MOTOROLA Transignition	69.95
GM Delco CT System	125.00
FORD TI System	64.95
MALLORY TI System	79.50
TUNGSOL CD System	99.50

POWERTRON kit, complete, only **\$29.95**

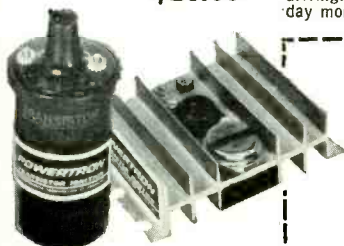

Forget about paying \$90.00 — \$60.00 — \$40.00 to add the pep, power and fuel economy to your engine only a modern transistorized ignition system can deliver! Now... ten major automotive companies contribute the **POWERTRON** dual-transistor ignition you install yourself in 20 minutes — and save more than half!

DETROIT-ENGINEERED. Look at these features of **POWERTRON**... guaranteed to deliver 18,000 volts to the spark plugs when you start your engine — then deliver full voltage at cruising speed. Guaranteed to release **FULL ENGINE POWER** at all rpms... increase gas mileage by 15%, keep plugs and points bright and clean for the life of the car — keep fouled plugs firing — deliver instant starting in coldest weather.

HOW POWERTRON WORKS. The power and performance of any gasoline engine depends on the fire-power at the spark plugs. Low voltage at the plugs means incomplete combustion — great loss of power — a fantastic waste of fuel running out the exhaust pipe — accumulations of power-killing carbon — and a worsening condition every mile you drive. As engineers know, high voltage at the plugs solves the problem... and **POWERTRON** is the answer!

NOW... POWERTRON AT A PRICE YOU CAN AFFORD. Powertronics Corporation of America was formed to distribute the **POWERTRON** do-it-yourself transistor ignition kit. **POWERTRON** is completely waterproof, shockproof. Each factory assembled system is tested under actual operational load and is guaranteed for three full years. Your **POWERTRON** will pay for itself in less than 10,000 miles of driving. Order only with the coupon below on 10-day money-back guarantee!

POWERTRON IS GUARANTEED TO

- Outperform any other transistor ignition system
- Release full engine power at all speeds — increase power and economy performance 10%
- Add 15% extra mpg—actually 2 to 6 extra mpg
- Give you instant starts — always!
- Eliminate engine "tune-ups"
- Keep breaker points perfect over 75,000 miles — spark plugs clean up to 50,000 miles



POWERTRONICS CORP., 387 Park Ave. So., New York 10016

I enclose \$29.95; rush my **POWERTRON** Transistor Ignition System on 10-day money-back guarantee for

Car Make _____ Year _____ Model _____

NAME _____

ADDRESS _____

CITY, STATE, ZIP CODE _____ RE-4



MOTORIZED WINCH UNIT, model 100 Tower Controller for HD series crank-up towers, consists of the winch, a heavy-duty weatherproof motor and gearbox and the *Tower Controller*. Factory-wired, supplied with 25 feet of 2-conductor power cable. Requires 2 connections to a 115-volt 60-cycle source. *Model 200* remote control unit optional. —Rohn Mfg. Co., Peoria, Ill.

TRANSISTORIZED COLOR GENERATOR, CG135 Deluxe, produces RCA standard color bars, cross-hatch, white dots and individual vertical and horizontal bars. Color gun switches on front panel, unmodulated video for chroma-circuit trouble isolation and unmodulated sync pulses keep Zenith receivers in sync

RADIO-ELECTRONICS

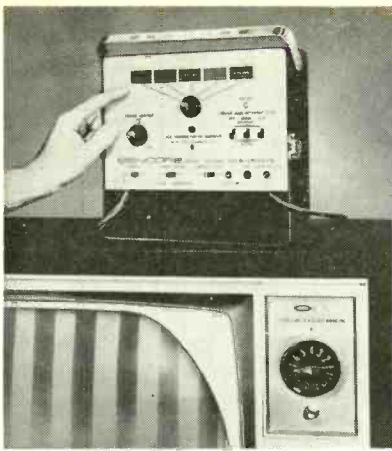

for this test. Lead-piercing clips, CRT adapters optional, crystal-controlled 4.5-mc sound carrier analyzing signal, rf output on channel 4 adjustable to channel 3 or 5. Uses 115 volts ac, takes less than 1 foot of bench space. 8 lb.—Sencore, Inc., 426 Westgate Dr., Addison, Ill. 60101

PLUGS AND CONNECTORS. Molded-On line includes part 15RSP-RE, coil cord to connect guitar to amplifier, shielded phone plug, one end of 15-ft black jacket, shielded coil cable. Other end straight phone plug, retracted length 3 in. Part 3LP-D3J, 3-conductor phone

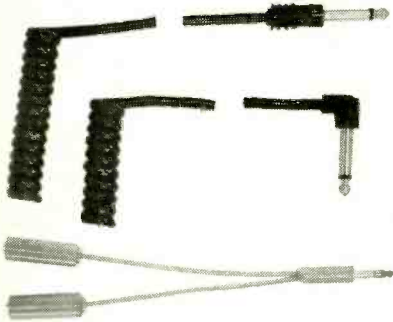

plug one end of two 36-in. lengths of three-conductor cable, other end two 3-conductor phone jacks, to adapt 2 stereo headsets to single amplifier jack.—Barker Products Co., Audio Div. of Component Mfg. Service, Inc., 3 Component Park, West Bridgewater, Mass.

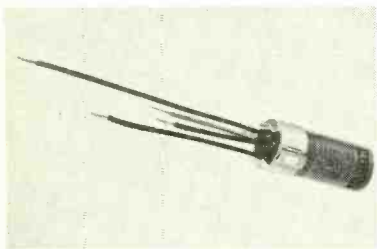

ALUMINUM ELECTROLYTIC CAPACITORS, CVM types, have unique snap-in mounting method—capacitor base has permanently attached metal ring and can be snapped into any metal can electrolytic mounting plate. 1-in. diameter, rated at 3 to 150 working volts dc from -20° to $+65^{\circ}$ C. 5 to 5,000 μ f. Ratings dual or triple section.—Mallory Distributor Products Co., Indianapolis, Ind. 46206

THREE NEW ANTENNA PRE-AMPS. Colortron model AP 220T: 300 ohms in and out, 18 db gain. Colortron model AP275T: 300 ohms in, 75 ohms out, 18 db gain. Super Colortron model AP75T: 300 ohms in, 75 ohms down-lead, 300 or 75 ohms out, 33 db gain. All are twin transistor.—Winegard Co., 3000 Kirkwood, Burlington, Iowa



AUTO RADIO ACCESSORIES. New line of ignition suppressors and condensers. Auto radio suppressors D-201



and D-301 are sealed in molded Bakelite and feature machine-brass metal parts.—Duosonic Corp. of America, 255 Park Ave. So., New York, N. Y. 10010

Non-Commercial Classified Ads

RADIO-ELECTRONICS now has a new Non-Commercial rate of 30¢ per word for individuals. (Our commercial rate remains at 55¢ per word.)

Readers interested in buying or selling personal items or equipment can now do so at little cost.

See the classified section for details and order form.

FOR MOBILE EQUIPMENT
TRANSISTORIZED VIBRATOR ELIMINATOR
VI-TRAN ELIMINATES VIBRATOR HASH
INCREASES EFFICIENCY

Vi-Tran 1: Oscillates as low as 5 volts; for 12 volt operation. VE-194 P (vibrator pin #1 pos.) VE-195 P (vibrator pin #1 neg.) User net: \$5.95.



Vi-Tran 11: For heavy duty equipment, 5 watts up to 25 watts, either 6 or 12 Volts. Commercial, emergency (police, ambulance, fire apparatus, etc.) applications. VE-196 (one model fits all sets). User net: \$9.95.

Ready to install . . . Vi-Trans just plug in. Complete instructions on card. Now at your local parts jobber or dealer. Or write:

TEH I.E.H. Mfg. Co., Inc.
102 Prince St., New York, N.Y. 10012
(212) OR 7-1881 - TWX 212-867-7990
Subsidiary of Industrial Electronic Hardware Corp.

EIGHT INSTRUMENTS IN ONE

- Out-of-Circuit Transistor Analyzer
- Dynamic In-Circuit Transistor & Radio Tester
- Signal Generator
- Signal Tracer • Voltmeter
- Milliammeter
- Battery Tester
- Diode Checker

Transistor Analyzer Model 212
Factory Wired & Tested — \$18.50
Easy-to-Assemble Kit — \$13.50

YOU DON'T NEED A BENCH FULL OF EQUIPMENT TO TEST TRANSISTOR RADIOS! All the facilities you need to check the transistors themselves — and the radios or other circuits in which they are used — have been ingeniously engineered into the compact, 6-inch high case of the Model 212. It's the transistor radio troubleshooter with all the features found only in more expensive units. Find defective transistors and circuit troubles speedily with a single, streamlined instrument instead of an elaborate hook-up.

Features:
Checks all transistor types — high or low power. Checks DC current gain (beta) to 200 in 3 ranges. Checks leakage. Universal test socket accepts different base configurations. Identifies unknown transistors as NPN or PNP.
Dynamic test for all transistors as signal amplifiers (oscillator check), in or out of circuit. Develops test signal for AF, IF, or RF circuits. Signal traces all circuits. Checks condition of diodes. Measures battery or other transistor-circuit power-supply voltages on 12-volt scale. No external power source needed. Measures circuit drain or other DC currents to 80 milliamperes. Supplied with three external leads for in-circuit testing and a pair of test leads for measuring voltage and current. Comes complete with instruction manual and transistor listing.

EMC, 625 Broadway, New York 12, N. Y.

Send me FREE catalog of the complete value-packed EMC line, and name of local distributor.

NAME _____ RE-4

ADDRESS _____

CITY _____ ZONE _____ STATE _____

EMC
ELECTRONIC MEASUREMENTS CORP.
625 Broadway, New York 12, New York
Export: Pan-Mar Corp., 1270 B'way, N.Y. 1

HERE IT IS FROM ENGLAND!

As Beulah Electronics, Ltd.
Promised In Our Previous Advertisements . . .

The Revolutionary
**WESGROVE VIDEO
TAPE RECORDER**

Using Only 1/4" Recording Tape

TRANSISTORIZED
KIT FORM **\$450.**

WIRED BY SPECIAL ORDER ONLY \$650.00

"BEUKIT"

TRANSISTORIZED
TV CAMERA KIT

Complete with Vidicon
(less lens) **\$226.75**

All Prices Above F.O.B. Bayonne, N.J.

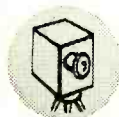

For full
Information
Write to:

P. A. F. ENTERPRISES

32 EAST 22nd STREET
BAYONNE, N.J. 07002



Distributors for Beulah
Electronics, England.
Complete line of Video
Cameras and Lenses



**WORLD'S
FINEST
5-CORE
SOLDER**

**ERSIN
MULTICORE**

**NEW EASY
DISPENSER
PAK ONLY 50¢**

BUY IT AT RADIO-TV PARTS STORES
MULTICORE SALES CORP. PORT WASHINGTON, N.Y.

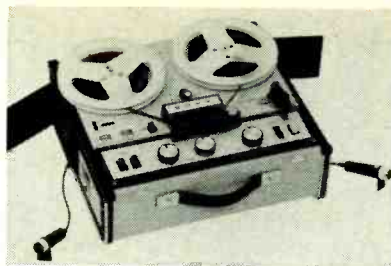

STEREO TAPE RECORDER, Sony model 200-A Stereorecorder, 4-track, stereo and mono. 2 VU meters, separate record buttons for each channel, 7 1/2 and 3 3/4 ips, automatic tape lifters, digital tape counter, instant stop lever. Power: 70 watts, 110-117 volts, 60 cycles. Response: 50-14,000 cycles at 7 1/2 ips. Flutter and wow less than 0.19% at 7 1/2. Signal-to-noise ratio 45 db. 2 mike inputs and 2 high-level inputs for tuners, etc. 26 1/2 lb.—Superscope Inc., 8150 Vineland Ave., Sun Valley, Calif.

SPEAKER SYSTEM, model S-5. Response: 8-ohm impedance ± 5 db from 60-15,000 cycles. 2-way loudspeaker has low-resonance woofer and high-

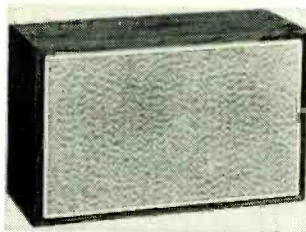

frequency tweeter, crossover network. 10 x 16 x 6 1/2 in., 12 lb.—H. H. Scott, Inc., Dept. P, 111 Powdermill Rd., Maynard, Mass.



SOLDERING GUN, model 450 All, features automatic thermal regulation (ATR) providing heat to the tip 36 times faster than comparable 500-watt soldering iron. Three separate tips: printed circuit (25-100-watt range), home wiring (100-200-watt range), gutters and plumbing (200-450-watt range).—Wen Products, Inc., 5810 Northwest Highway, Chicago, Ill.



TRANSISTOR IGNITION SYSTEM KIT. Kit version of Neli Trans-ignition system. 6- or 12-volt operation, positive or

negative ground, can be installed on domestic or foreign cars. 4-transistor, Zener-diode protected circuit, with built-in conversion plug.—Heath Co., Benton Harbor, Mich.



COAXIAL TV PREAMP, model SPC-132 Super Powermate, replaces Jerrold's model DSA-132, a tube unit. Part SPC is boom-mounted 2-transistor pre-amp; 132 is remote power supply and 3-transistor post amplifier, with single coaxial cable between. Gives 29 db gain on high and 25 db gain on low vhf band. Requires 40 ma at 117 volts ac.—Jerrold Electronics Corp., 15th & Lehigh Ave., Philadelphia 32, Pa.

THREE NEW VOM'S. Pocket-size model 102A (shown) (3 1/2 x 6 1/4 x 2 in.); 800- μ a meter movement has 5 dc voltage ranges: 0-6, -60, -300, -600, -3,000; 5 ac voltage ranges: 0-12, -120, -600, -1,200, -3,000; 4 direct current ranges: 0-6, -30, -130 ma, 0-1.2 amp; 3 alternating current ranges: 0-30, -150, -600 ma; 2 resistance ranges: 0-1,000 ohms, 0-1 meg. In kit form, model 102AK. Model 109A has 40- μ a meter movement, ac-dc voltage ranges same as 102A. Cur-



rent: dc, 0-6, -60, -600 ma; ac: 0-30, -300 ma, -3 amp; resistance: 0-20,000, -200,000, -20 megs; 5 db ranges: -4 to +67 db. 5 1/2 x 6 1/4 x 2 1/2 in. Model 103A same as 109 but with 800- μ a meter.—Electronic Measurements Corp., 625 Broadway, New York, N. Y. 10012

CB CONVERTER, model 10-4, permits tuning all channels from 26.540 to 27.650 mc. Features printed circuit, 3 transistors, rf stage, mixer and crystal-

RADIO-ELECTRONICS



controlled oscillator. Power requirements: 9 volts at 3 ma from self-contained battery. Broadcast-band image rejection better than 80 db. For standard auto and marine radios. 5 x 2 1/4 x 2 1/4 in., 6 oz.—Instrument Devices Corp., PO Box 284, Huntington, N. Y.

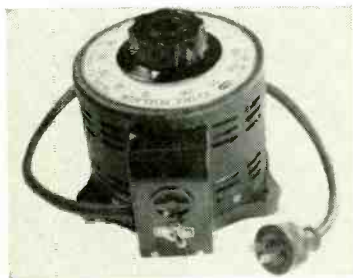

VARIABLE VOLTAGE TRANSFORMER, model T-279, 500-watt, toroidal core design, delivers ac voltage from 0-130 volts. Maximum rating applies over full range of output voltage; negligible voltage drop from no load to full load. Output terminated in standard ac receptacle mounted on side of transformer. Operates on 110-120 volts, 60 cycles.—Olson Electronics, Inc., 260 S. Forge St., Akron, O. 44308

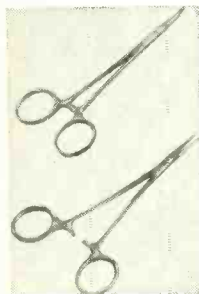

JR. SEIZERS, only 5 in. long, for components retrieval, clamping wires for soldering, serving as heat sinks, etc. Stainless steel, box-joint construction, nonserrated jaws, 2-position snap lock.—Xcelite Inc., Orchard Park, N. Y.

CAPACITOR ANALYST, model 801, tests electrolytic capacitors in-circuit up to 2,000 μ f, using balanced bridge.

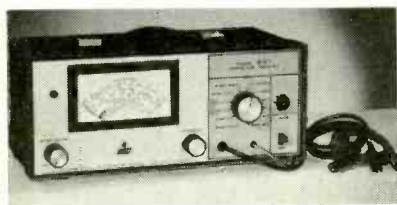

Tests capacitor value accurately within range of 25 pf to 100 μ f. 5 x 8 x 1 1/2 in.—B & K Mfg. Co., Div. of Dynascan Corp., 1801 W. Belle Plaine Ave., Chicago, Ill. 60613

CB MODULE, Sea-B-Mate, converts Pearce-Simpson's Catalina 68-watt marine radiotelephone to a dual-system



marine/CB 2-way radio, with 11 channels (5 marine and 6 CB). 3 1/4 x 6 1/2 x 12 1/2 in.; 3 lb, 11 oz. Push-to-talk mike and crystals.—Pearce-Simpson, Inc., 2295 N.W. 14th St., Miami, Fla. 33125



GUITAR AMPLIFIER, model S-800, has 2 speakers in 6-lb. luggage-type case. All-transistor; bass and mid-range speaker and 3-in. tweeter. Tone and volume controls.—Perma-Power Co., 5740 N. Tripp Ave., Chicago, Ill. 60646

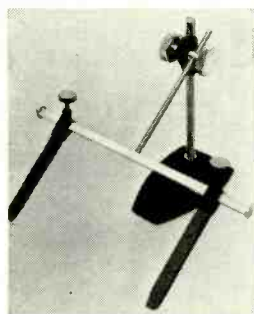

PRINTED-BOARD ASSEMBLY STAND, designed to hold Veroboard or any other printed circuit boards when assembling or soldering components. Spring-loaded bakelite arms allow circuit testing on stand, will accommodate any boards up to 12 1/2 in. long and from 1/32 in. to 1/2 in. thick; mounted on cast-iron base.—Vero Electronics, 48 Allen Blvd., Farmingdale, N. Y.

MINIATURE MONITOR OSCILLOSCOPE, model MS-5 Moniscope for CB and amateur use. 117-volt ac operation. Connect one wire and a shield, and



it is ready for monitoring. 2-in. screen, 7 x 5 x 3 in.—Control Radio Labs, 123 Ave. U, Brooklyn 23, N.Y. END

All specifications from manufacturers data.



World's
Fastest Selling
FM Cordless
Microphone



IMP II

Transmits voice or signal with power and fidelity to any standard FM tuner or radio. Perfect for use where mike cords are inconvenient. For broadcasting, remote tape recording, communicating or hundreds of other applications in schools, churches, theatres, plants, stores, homes and sporting activities, indoors or out. Tunable: 88-108 mc band.

IMP II-221 Transmitter only.... \$39.95
IMP II/M-222 Complete with built-in pin-head microphone \$49.95



See Distributor or write Dept. RE-4

Made in U.S.A.

kinematix, inc.
2040 West Washington Boulevard
Chicago, Ill. 60612 Area 312 • 666-0065

50 easy-to-build Transistor Circuits

Electronic Projects
FOR
students, beginners,
hobbyists

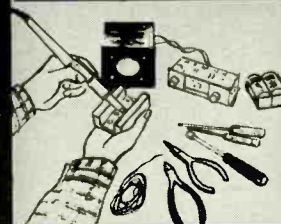

at your
dealer
\$1.95
or mail
coupon

100 pages of exciting transistor projects you can make with easy-to-get inexpensive parts. No technical knowledge needed—just the small tools shown. Tells you HOW TO: solder, recognize electronic parts, read electronic symbols. Clear pictorial and wiring diagrams make instructions easy. You can make: crystal radio, sun-powered radio, electronic megaphone, flashers, intercom, hi-fi tester, appliance tester, tachometer, stereo balance, code transmitter, and 40 other useful devices. A wonderful introduction to electronics. Published by Semitron, the leading professional line of semiconductor.

SEMITRON

Semitronics Corp.
265 Canal St.
N.Y., N.Y. 10013

I enclose \$1.95. Send me your 50-projects handbook postpaid.

Name

Address

City State Zip

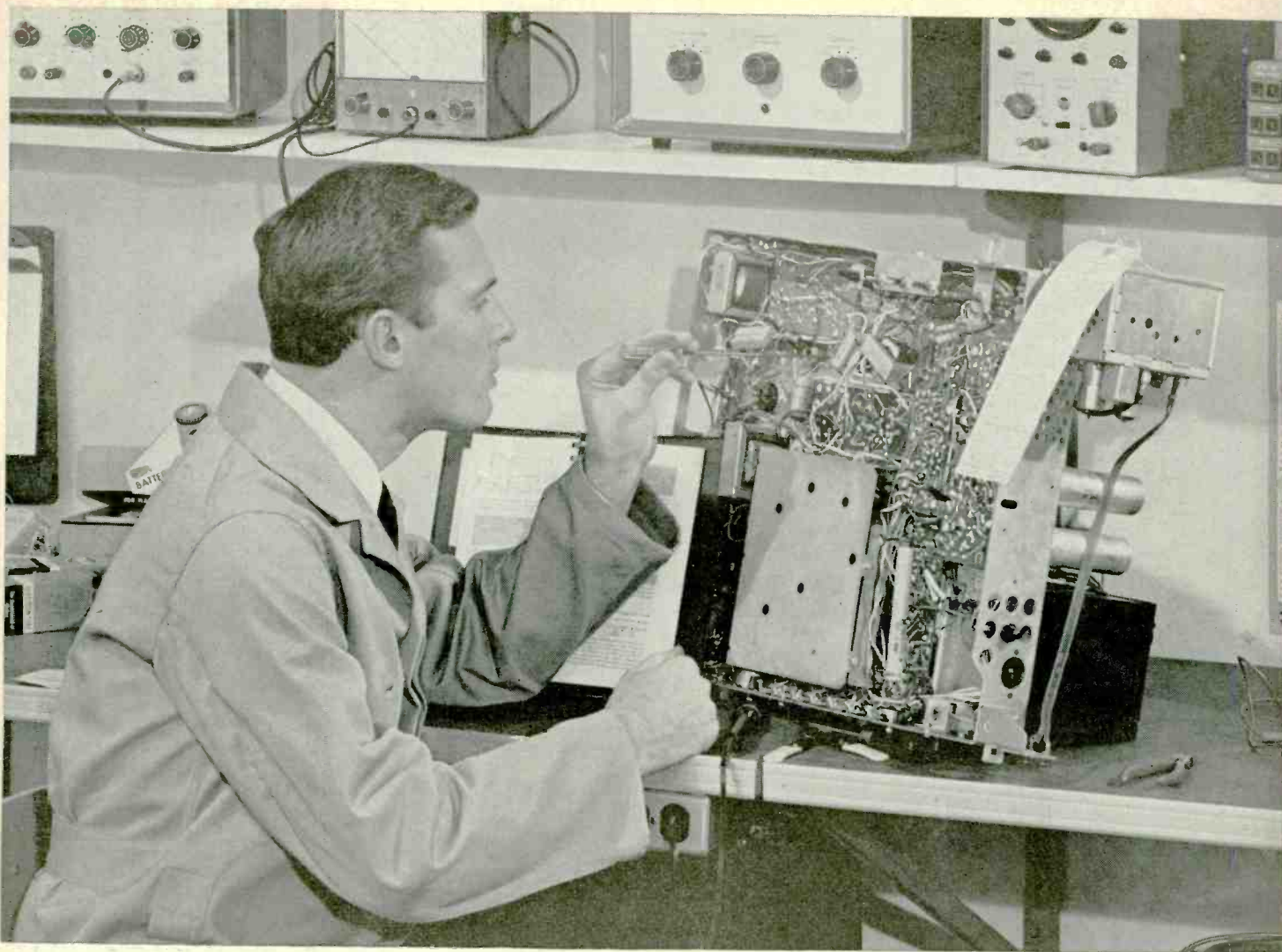

RCA TRAINING **can be the smartest investment you ever made!**

Start building a profitable career in electronics now!

NEW RCA "AUTOTEXT" programmed instruction will help you learn faster and easier!

If you're considering a future in electronics, now is the time to start! A great new teaching aid—"AUTOTEXT" programmed instruction developed by RCA and introduced by RCA Institutes will help you master the fundamentals of electronics almost automatically. Even people who have had trouble with conventional home training methods are finding it easier and more fun to start their training in Electronics Fundamentals the RCA way. Prove

it to yourself as others throughout the country are now doing. An interest or inclination in electronics is what you need. RCA "Autotext" helps you to do the rest. You'll be ready to go on to advanced training sooner than you ever thought possible! The future is unlimited; the jobs are available. The important thing is to get started—now.

Founded in 1909, RCA Institutes is one of the largest technical schools in the United States devoted princi-

pally to electronics. The very name "RCA" means dependability, integrity, and scientific advance. RCA Institutes offers the finest facilities of home training. A Service of the Radio Corporation of America, RCA Institutes gives you the technical instruction you need to plan, build and realize the career you want in today's fastest growing field.

Investigate your future now at RCA Institutes. It can be the smartest investment you ever made.

HOME TRAINING COURSES

RCA Institutes offer this complete selection of Home Training Courses

- Electronic Fundamentals
- Electronic Fundamentals (in Spanish)
- TV Servicing
- Color TV Servicing
- Transistors
- Communications Electronics
- FCC License Preparation
- Mobile Communications
- Automation Electronics
- Automatic Controls
- Industrial Applications
- Nuclear Instrumentation
- Digital Techniques
- Computer Programming
- Drafting

Liberal Tuition Plan. All RCA Institutes Home Study courses are available under a Liberal Tuition Plan. This plan affords you the most economical possible method of home study training. You pay for lessons only as you order them. If, for any reason, you should wish to interrupt your training, you can do so and you will not owe a cent until you resume the course. No other obligations! No installment payments required.

RCA Personal Instruction. With RCA Home Study training you set your own pace in keeping with your own ability, finances and time. RCA Institutes allows you ample time to complete the course. Your lesson assignments are individually graded by technically trained personnel, and helpful comments are added where required. You get theory, experiment, and service practice beginning with the very first lesson. All lessons are profusely illustrated. You get a complete training package throughout the entire course.



You Get Prime Quality Equipment. All kits furnished with the course are complete in every respect, and the equipment is top grade. You keep all the equipment furnished to you for actual use on the job... and you never have to take apart one piece to build another.

CLASSROOM TRAINING IN NEW YORK CITY

No previous training required. You are eligible even if you haven't completed high school.

RCA Institutes Resident School in New York City offers training that will prepare you to work in rewarding positions on research and production projects in fields such as automation, transistors, communications, technical writing, television, computers, and other industrial and advanced electronics applications. If you did not complete high school, RCA will prepare you for such training with courses specially designed to provide the basic math and physics required for a career in electronics. Check classroom training on attached card, and full information will be rushed to you.

Free Placement Service. RCA Institutes graduates are now employed in important jobs at military installations with important companies such as IBM, Bell Telephone Labs, General Electric, RCA, and in radio and TV stations all over the country. Many other graduates have opened their own businesses. A recent New York Resident School class had 93% of the graduates who used the FREE Placement Service accepted by important electronics companies... and had their jobs waiting for them on the day they graduated!



Coeducational Day and Evening Courses. Day and Evening Courses are available at RCA Resident Schools in New York City. You can prepare for a career in electronics while continuing your normal full-time or part-time employment. Regular classes four times each year.

SEND POSTCARD FOR FREE ILLUSTRATED BOOK TODAY!
SPECIFY HOME TRAINING OR CLASSROOM TRAINING.

RCA INSTITUTES, INC. Dept. RE-45 A SERVICE OF RADIO CORPORATION OF AMERICA, 350 WEST 4TH ST., NEW YORK, N.Y. 10014



The Most Trusted Name in Electronics

Experimenters Science Fair Contestants Advanced Constructors

Design and build your own portable Hi-Fi Solid State Amplifier-Speaker with the Moog XP-2 Kit. If you enjoy building electronic equipment from your own designs, then here is a kit concept planned especially for you. The Moog XP-2 Kit contains all electronic components to build an integrated amplifier-loudspeaker with these advanced features:

■ All solid state circuitry with two independent low noise inputs, separate bass and treble controls, and conservatively rated 15 watt output.

■ Genuine JBL speaker for low distortion and high efficiency.

■ Precisely regulated A.C. supply doubles as battery charger.

■ Heavy duty rechargeable battery (optional) allows full-power operation with complete portability.

■ Textbook-style instruction booklet discusses every circuit feature in detail, gives all data necessary to design and build the cabinet, chassis and circuit boards, and suggests circuit additions and modifications.

Order yours today! And be sure to ask for your Free catalog of Moog Electronic Music Equipment.

XP-2 Kit without battery **\$ 89.50**

XP-2 Kit with battery **134.50**

(No C.O.D.'s, please)



R. A. Moog Company
Dept. 3R, Trumansburg, N.Y. 14886

COYNE
TRAINS YOU
IN SPARE TIME
AT HOME

COYNE QUALITY TRAINING AT LOWEST COST

TELEVISION

COLOR TV-RADIO-ELECTRONICS

Coyne—and only Coyne—can give you this modern, TV Home Training. Easy to follow 2150 photos and diagrams covering Radios-TV, Color, UHF, Transistors. We also show you how to start making money while learning, right at home. Get your basic training at home, then make a flash finish with 2 weeks of actual shop work in Chicago under direction of same instructors who guide our resident students.

LOW COST—Easy to Pay

You don't pay for costly "put together" kits. Small monthly payments and low, low cost make it easy for everyone to train. Free employment service for graduates—or we show you how to start your own service business on a "shoestring." Send name today for complete facts and valuable book on Television. No salesman will call. Everything mailed free, postpaid.

Coyne Electronics Institute
Not for Profit
1501 W. Congress Parkway
Dept. 45-H4 CHICAGO 7, ILL.

COYNE ELECTRONICS INSTITUTE, Dept. 45-H4
1501 W. Congress Parkway, Chicago 7, Ill.

Please mail free book and offer of two weeks personal training in Chicago without extra tuition for home study graduates. Explain low monthly payments.

NAME _____ AGE _____
ADDRESS _____
CITY & STATE _____

booklets New Literature catalogs charts

TRANSISTOR IGNITION FLYER, Transistorgram, 4 pages, illustrated, describes transistor ignition kit that can be installed in 20 minutes with ordinary hand tools.—**Powertronics Corp. of America**, 387 Park Ave. So., New York, N.Y. 10016

CAPACITORS CATALOG, Ceralam line. 8 pages of specs on ceramic capacitors MC-70, MC-21, MC-91, MC-51 and MC-61, all of monolithic structure.—**Aerovox Corp., Hi-Q Div.**, Olean, N.Y.

TRANSISTORS CATALOG, No. IND-800, 12 pages with price supplement, of Sprague transistors and Unicircuit networks for computer applications, including flip-flop/counter/shift register, 6-input nor/nand gate, 3-input nor/nand gate, exclusive or circuit.—**Sprague Products Co.**, North Adams, Mass.

CUSTOMER ENGINEERING BULLETINS: CEB 3, "Head Wear, Alignment and Care." CEB 6, "The Vacuum Tube Playback Preamplifier." CEB 7, "Transistorized Playback Preamplifier." CEB 8, "Transistorized Recording Amplifier."—**Nortronics Co., Inc.**, 8101 10th Ave. N., Minneapolis, Minn. 55427

TECHNICAL NEWSLETTER, Vol. 2, No. 1, tells in 8 pages about a new bridge method of sweep-frequency impedance measurement; i.e. how a matched bridge circuit is used to provide an oscilloscope display and measurement of return loss vs. frequency.—**Jerrold Electronics Corp.**, 15th & Lehigh Ave., Philadelphia 32, Pa.

1965 SHORT-FORM CATALOG, pocket-size, 48 pages, photos and specs of voltmeters, scopes, sweep generator, color bar generator, signal and audio generators, tube and transistor testers, decade boxes, transceivers, amplifiers, tape recorders, etc. Most in kit form.—**EICO Electronic Instrument Co., Inc.**, 131-01 39th Ave., Flushing, N.Y. 11352

1965 STOCK CATALOG, No. 145, 178 pages with thumb index for semiconductors, tubes, resistors, capacitors, transformers, connectors, wire, switches, relays, timers, fuses, pilot lights, hardware, test equipment, PA and sound, etc. Illustrations, specs, prices.—**Radio Shack Corp.**, PO Box G, Boston 17, Mass.

TECHNICAL BULLETIN, No. 45, 4 pages, describes 14 x 20-in. transparent plastic templates, to be laid over architectural drawings. They reveal best location and aiming angle for Jensen Calstar Column Speakers.—**Jensen Mfg. Co.**, 6601 S. Laramie Ave., Chicago, Ill. 60638

HIGH-VOLTAGE CAPACITORS BROCHURE, 4 pages of specs on types 20, 25, 26 and 27 paper and combination paper/plastic film dielectrics.—**Aerovox Corp., OEM Div.**, New Bedford, Mass.

JR. SEIZERS BULLETIN, N564, one universal-punched sheet, revision of seizer data sheet to include new 5-in. straight and curved Jr. Seizers.—**Xcelite, Inc.**, Orchard Park, N.Y.

STOCK PANEL METERS, Bulletin No. 2065. Specs and prices in 20-page bulletin for more than 1,300 types of pivot and jewel meters, taut-band units, contactless meter relays, segmental voltmeters, elapsed-time meters; plus shunts, current transformers and multipliers. 3-page glossary of instrument terms.—**Simpson Electric Co.**, 5200 W. Kinzie St., Chicago, Ill. 60644

BOOKLET, "Creativity in Communications," 20 pages with photos of receivers, transmitters, transceivers and accessories for government, commercial, amateur and Citizens band. Also variable capacitors.—**Hammarlund Mfg. Co.**, Mars Hill, N.C.

SCHOOL CATALOG, "You and Camera Repair." This very handsomely illustrated booklet describes in its 76 pages the lesson texts and materials furnished to students and services provided to graduates.—**National Camera Repair School**, Dept. OD, Englewood, Colo. 80110

CATALOG, 448 pages of electronic components and tools from adapters to wrenches with drawings, diagrams, specs.—**For New England, Cramer Electronics, Inc.**, 320 Needham St., Boston, Mass. 02164. **For New York, Electronic Supply Corp.**, 80-02 51st Ave., Elmhurst, N.Y. 11373

CB CATALOG, 16 pages, 2 colors, photos. Block diagrams and specs of transceivers and accessories.—**International Crystal Mfg. Co., Inc.**, 18 N. Lee, Oklahoma City, Okla.

REPRINT of article "New Designs in Shock and Vibration Protection" from June 1964 *Electronic Industries* describes cable isolation installations.—**Aeroflex Laboratories, Inc.**, South Service Rd., Plainview, N.Y. 11803

DATA SHEET, T/J-1, on test jacks. Specs, drawings of 45E with metal body, and 45J with Zytel body.—**Cannon Electric Inc.**, 3208 Humboldt St., Los Angeles, Calif. 90031

TOOL CATALOG, 48 pages, universal-punched: drawings, specs, prices of tweezers, pliers, cutters, optical aids, relay tools, micro-tools, fiber optics, zoom stereo microscopes, encapsulating materials, conductive epoxies, wire strippers, audio detection, gloves, etc.—**Techni-Tool, Inc.**, 1216 Arch St., Philadelphia, Pa. 19107

BOOKLET on Mallory Voltage Reference Standard Cells, 8 pp., loose-leaf punched, photos, diagrams, describing applications, performance features, operating procedures.—Available exclusively from **Don Bosco Electronics, Inc.**, 16 Littell Rd., Hanover, N.J.

CHART, No. PP 102 R8, 6 pages, germanium and silicon power transistor selection chart. Cross-reference guide lists EIA-registered types and manufacturer's nearest equivalent. Illustrated, prices included.—**Motorola Semiconductor Products Inc.**, PO Box 955, Phoenix 1, Ariz.

SEMICONDUCTOR CATALOG for 1965 describes 57 families of semiconductor products in 28 pages with full-color cover, including a new family of microminiature regulators. JEDEC-registered tunnel diodes, silicon controlled rectifiers, solar battery, others.—**Hoffman Electronics Corp., Semiconductor Div.**, Hoffman Electronic Park, El Monte, Calif.

MASTER TV SYSTEM BROCHURE, DS-C-004.3, 16-page, looseleaf-punched booklet describes master and parabolic antennas, amplifiers, converters, sound inserters, filters, traps, matching transformers and mixers, distribution equipment, field-strength meter.—**Jerrold Electronics Corp.**, 15th & Lehigh Ave., Philadelphia 32, Pa.

VIDEOTAPE RECORDER DATA SHEET gives applications, features and specs of model VR-660 and VR-1560 portable Videotape television recorders.—**Ampex Corp.**, 401 Broadway, Redwood City, Calif. 94063

TRANSISTORIZED PHOTOELECTRIC CONTROLS described in brochure *GEA-6822C*, 10 pages, illustrated, with specifications and applications of photoelectric control devices, outputs, optional equipment and sensing heads.—**General Electric Specialty Control Dept.**, Waynesboro, Va.

SENSOR DATA SHEET describes and illustrates the A-2 series of acceleration sensors which record maximum acceleration.—**Sensory Products**, PO Box 143, Cochituate, Mass.

Any or all of these catalogs, bulletins, or periodicals are available to you on request direct to the manufacturers, whose addresses are listed at the end of each item. Use your letterhead—do not use postcards. To facilitate identification, mention the issue and page of RADIO-ELECTRONICS on which the item appears.

UNLESS OTHERWISE STATED, ALL ITEMS ARE GRATIS. ALL LITERATURE OFFERS ARE VOID AFTER SIX MONTHS.

Now you can quickly locate defective capacitors affecting the performance of electronic circuits —and prevent costly call-backs!

CAPACITOR TESTING IN-CIRCUIT/OUT-OF-CIRCUIT IS QUICK AND EASY

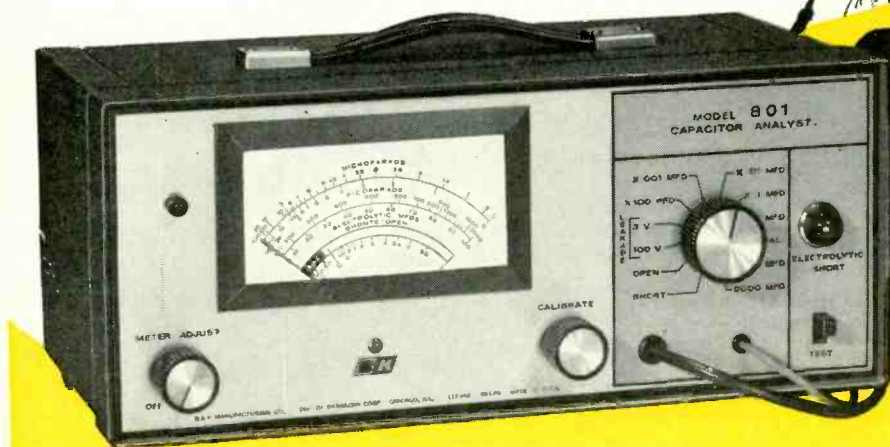

NEW B & K CAPACITOR ANALYST

for TV, Radio, Transistor Radio, Auto Radio, Hi-Fi, and other electronic equipment

Unique new B & K development puts the measurement of capacitors and electrolytics on a practical basis—picks up all defects that will affect performance—turns lost time into profit dollars.

Servicemen are aware that capacitors and electrolytics are second only to receiving tubes in creating the most servicing problems.

The new B & K Capacitor Analyst enables you more easily to measure capacitance and leakage resistance—detect both opens and shorts—both in-circuit and out-of-circuit. In-circuit leakage resistance test can be made on low-voltage circuits such as transistor radios, or on higher voltage circuits. Checks capacitor value from 25 pfd to 100 mfd.

Tests electrolytic capacitors by unique circuit (Pat. Pend.) which determines how well the electrolytic does the job of storing electrical energy and returning it back to the circuit. Detects marginal electrolytics that should be replaced. Also predicts life expectancy of any electrolytic capacitor rated 3 volts or more.

Model 801 Capacitor Analyst is attractive, rugged, and easy to use.

NET, \$99⁹⁵

Ask Your B & K Distributor for Details,
or Write for Bulletin No. 108-E



B & K MANUFACTURING CO.
DIVISION OF DYNASCAN CORPORATION
1801 W. BELLE PLAINE AVE. • CHICAGO, ILL. 60613
Canada: Atlas Radio Corp., 50 Wingold, Toronto 19, Ont.
Export: Empire Exporters, 123 Grand St., New York 13, U.S.A.

technicians' News

TSADV BOYCOTT RULED ILLEGAL

A Federal Trade Commission hearing examiner has ruled that the Television Service Association of Delaware Valley unlawfully boycotted wholesale parts distributors who competed with association members for retail sales in the Delaware Valley.

The 35 members of the TSADV and their officials, Herman Shore and Raymond Fink, were ordered to halt coercion of wholesale distributors to force them to give up their retail business.

[The FTC's charges were listed in detail in "FTC-Delaware Valley Case Arouses Interest," Technicians' News, RADIO-ELECTRONICS, September 1964, p. 92.]

The supposed pressure on the wholesalers consisted of urging selective buy-

ing and of publishing the names of distributors who cooperated by abandoning retail sales.

The FTC pointed out that its decision is not final, but may be appealed, stayed or docketed for review.

WASHINGTON STATE COUNCIL LAUNCHES VOLUNTARY CERTIFICATION

The Washington State Electronics Council has introduced a voluntary certification program for working electronics technicians. Applicants will list their training and experience in electronics, and those qualified will be issued a framed certificate and a wallet card certifying them as Industry Registered and Certified Electronics Specialists.

The program is open to all working technicians on a voluntary basis, regardless of union or association membership.

The state council instituted the program in an effort to begin policing itself, encouraged by law enforcement agencies and Better Business Bureaus. It is felt that if the voluntary arrangement is successful and accepted statewide by technicians, there will be little need for a mandatory license law.

Technicians can qualify in any of several ways. By showing evidence that (1). He has passed an examination in a

state or town that requires licensing. (2). He has passed a journeyman examination in a union with jurisdiction over the trade. (3). He has satisfactorily completed a resident trade-school course in electronics and servicing. (4). He has successfully completed an Apprenticeship Training Program approved by a state or federal department of apprenticeship. (5). His training and experience constitute the equivalent of the above standards. A minimum of 4 years actual working experience in the trade is required.

Persons who fail to meet the requirements will be told where they are weak, and where to go for additional training.

A \$15 application fee covers expenses of administering the program and of some light advertising, aimed at alerting the public to the voluntary self-policing.

GALVESTON TO VOTE: CATV OR NO?

Residents of Galveston, Tex., will be given an opportunity to elect a community antenna TV system or leave things as they are, in a referendum due the second Tuesday in April.

District Judge L. D. Godard has ruled that petitions seeking an election on the CATV system were sufficient reason to call the election. He denied an injunction and other relief sought

"MOVING OUT SALE" PORT OF N. Y. AUTHORITY TAKING OVER 13 BLOCKS FOR TRADE CENTER & WE'RE IN IT!

We must unload 3 BULGING WAREHOUSES . . . at the GREATEST PRICE SLASH in Electronic History!

We will have 2 Places to serve you — Uptown at 2271 Broadway, Downtown still pending — Sale may end soon — HURRY, HURRY, HURRY.

FREE \$1 BUY WITH EVERY 10 YOU ORDER Only applies to "\$1" Buys **FREE GIFT WITH EVERY ORDER**

TV BARGAIN COLUMN		MARKET SCOOP COLUMN	
<input type="checkbox"/> \$50 STARLITE AM-FM RADIO \$12 complete needs adjustments, as is	<input type="checkbox"/> 50 ASSORTED MYLAR CONDENSERS Popular types .001 to .47 . \$1	<input type="checkbox"/> STANDARD TV TUNER 41 mc Complete with Tubes & Schematic . \$5	<input type="checkbox"/> TRANSISTOR RADIO—asst types good, bad, broken, as-is, potluck . \$1
<input type="checkbox"/> \$50 HI-WAVE AM/FM RADIO \$24 12 Transistors. Deluxe quality. sold on a money refund basis—complete	<input type="checkbox"/> 3 AMPHENOL CO-AX CONNECTORS 50-239, PL-239, M-359 or asst . \$1	<input type="checkbox"/> STANDARD TUNER UHF STRIPS 26K, 34K, 43K, 46K, 48K, 51K, 54Q, 56F, K or Q, 58K . . . each \$1	<input type="checkbox"/> TAPE RECORDER—assorted types good, bad, broken, as-is, potluck \$3
<input type="checkbox"/> UNIVERSAL 5" PM SPEAKER \$1 Alnico 5 magnet, quality tone . . .	<input type="checkbox"/> 50—RCA LUCITE RADIO KNOBS popular type w. indicator pointer \$1	<input type="checkbox"/> \$15.00 TELEVISION PARTS "JACKPOT" best buy ever . . . \$1	<input type="checkbox"/> CHAPT ZU DI MITZIA "JACKPOT" double your money back if not completely satisfied \$1
<input type="checkbox"/> UNIVERSAL 4" PM SPEAKER \$1 Alnico 5 magnet, quality tone	<input type="checkbox"/> 100"—MINIATURE ZIP CORD 2 conductor, serves 101 uses . . . \$1	<input type="checkbox"/> 4 — TV ALIGNMENT TOOLS most useful assortment \$1	<input type="checkbox"/> 50—G.E. FLASHLIGHT BULBS #1R-9, 2.7 volts \$1
<input type="checkbox"/> 4 — 50' SPOOLS HOOK-UP WIRE \$1 4 different colors	<input type="checkbox"/> 100—ASST. RADIO KNOBS all selected popular types \$1	<input type="checkbox"/> \$12 TV FLYBACK TRANS 90° for all type TV's incl schematic . \$1	<input type="checkbox"/> 2—G.E. PIECES OF EQUIPMENT stacked with over 200 useful parts \$1
<input type="checkbox"/> 5—I.F. COIL TRANSFORMERS sub-min for Transistor Radios . . \$1	<input type="checkbox"/> 50—RADIO & TV SOCKETS all type 7 pin, 8 pin, 9 pin, etc. \$1	<input type="checkbox"/> 70° FLYBACK TRANSFORMER universal incl schematic diagram \$1	<input type="checkbox"/> G.E. TV POWER TRANSFORMER 250ma, 360/360v, 6.3-9A, 5v-3A . \$4
<input type="checkbox"/> 5 — AUDIO OUTPUT TRANSFORM sub-min for Trans Radios \$1	<input type="checkbox"/> 100—ASST. TERMINAL STRIPS all types, 1-lug to 6-lug \$1	<input type="checkbox"/> 5—TV CHEATER CORDS with both plugs \$1	<input type="checkbox"/> 20 — ASSORTED TUBES Radio, Television and Industrial . . \$1
<input type="checkbox"/> 4—TOGGLE SWITCHES SPST, SPDT, DPST, DPDT \$1	<input type="checkbox"/> 100—ASST. CERAMIC CONDENSERS some in 5% \$1	<input type="checkbox"/> 3—TV VERT OUTPUT TRANS universal 10:1 ratio for all TV's . . \$1	<input type="checkbox"/> ALL AMERICAN TUBE KIT \$2 Top Standard Brand — 12BA6, 12BE6, 12AV6, 50C5, 35W4
<input type="checkbox"/> 15—ASST. ROTARY SWITCHES all popular types \$20 value \$1	<input type="checkbox"/> 100—ASST 1/4 WATT RESISTORS stand. choice ohmages, some in 5% \$1	<input type="checkbox"/> 4—DUMONT VERT OSC TRANS incl schematic for many TV uses \$1	<input type="checkbox"/> 3 — TOP BRAND 35W4 TUBES \$1
<input type="checkbox"/> CLEAN UP THE KITCHEN "JACKPOT" Big Deal only one to a customer \$1	<input type="checkbox"/> 70—ASST 1 WATT RESISTORS stand. choice ohmages, some in 5% \$1	<input type="checkbox"/> 20—ASSORTED TV COILS I.F. video, sound, ratio, etc. . . . \$1	<input type="checkbox"/> 20—INDUSTRIAL TUBES 1626 \$1
<input type="checkbox"/> 100—BRASS FAHNSSTOCK CLIPS popular type & size, plated \$1	<input type="checkbox"/> 35—ASST 2 WATT RESISTORS stand. choice ohmages, some in 5% \$1	<input type="checkbox"/> 40—ASSORTED TV KNOBS all standard types, \$40 value . . \$1	<input type="checkbox"/> 15—DELUXE SLIDE SWITCHES \$1 useful as SPST, SPDT or DTST . .
<input type="checkbox"/> 25—2 TERMINAL PIN JACKS asst types for various uses \$1	<input type="checkbox"/> 50—PRECISION RESISTORS asst. list price \$50 less 98% . . \$1	<input type="checkbox"/> 6 — TV ELECTROLYTIC CONDENSERS Sprague 80-250v . . . \$1	<input type="checkbox"/> BONANZA "JACKPOT" not gold, not oil, but a wealth of Electronic Items—Money-Back-guarantee . . . \$5
<input type="checkbox"/> 1000—ASST. HARDWARE KIT screws, nuts, washers, rivets, etc. \$1	<input type="checkbox"/> 20 — ASS'TED WIREWOUND RESISTORS, 5, 10, 20 watt . . . \$1	<input type="checkbox"/> 7 — ASST TV ELECTROLYTIC CONDENSERS popular selection . \$1	
<input type="checkbox"/> 10—6' ELECTRIC LINE CORDS with plug standard brands \$1	<input type="checkbox"/> 10 SETS — DELUXE PLUGS & JACKS asst. for many purposes \$1	<input type="checkbox"/> 50—ASSORTED TV PEAKING COILS all popular types \$1	
	<input type="checkbox"/> 25 — SYLVANIA HEAT SINKS for Transistors, etc. \$1	<input type="checkbox"/> 20—ASSORTED GRID CAPS for 1B3, 1N2, 6BG6, 6HQ6, etc. . \$1	
	<input type="checkbox"/> 10 — SETS PHONO PLUGS & PIN JACKS RCA type \$1		

BROOKS RADIO & TV CORP., 84 Vesey St., Dept. A, New York 7, N.Y. TELEPHONE COlllandt 7-2359

by Phonoscope, Inc., potential operator of the system, which tried to have the petitions declared invalid. The ruling results from court proceedings last July and August.

Roy Searcy, a director of the Texas Electronics Association, has announced the formation in Galveston of a "Committee for Free TV" to "inform the voters and oppose the granting of a franchise."

CONN. TELSA OPPOSED TO CATV

A banner headline in a recent issue of the Connecticut Television Service Association's bimonthly *News* reads "In the Interest of the public, TELSA of Conn. Stands Opposed to CATV."

The article that follows lists several reasons for the stand. First, the loose, local control (if any) over CATV franchises, as contrasted with the tight control the FCC maintains over ordinary commercial telecasters. This, notes the article, is a paradox, because CATV is no longer a local affair only, but one of national significance and influence.

The article also questions what will happen to subscribers if a CATV system goes broke. Will regulations be established to cover that possibility? Would the state take over? Will subscribers simply go back to individual antennas, if commercial stations are still broadcasting?

Might CATV companies enter the service field also? Or sell TV sets? Rent them?

Further objection to CATV posed by the TELSA writer centers on the probability that CATV might stunt the growth of uhf TV, which the FCC tried hard to promote by requiring that all new sets be able to receive uhf programming. Present CATV uses only vhf channels.

The article also speculates briefly on the possibilities that CATV might begin to accept objectionable advertising and show "censored" movies; that it might favor large population centers and leave sparser, less profitable rural areas without service and that transmissions might be of poor or irregular quality because of a lack of standards and established "practice".

TV REPAIR COMPANY FINED— FOUR PERSONS JAILED

The American Television Corp. of Los Angeles, Calif., was fined \$800 after conviction on charges of false advertising and petty theft in making television set repairs.

Los Angeles Municipal Court Judge Howard E. Crandall also sentenced Fred Sands, president of the firm, to 20 days in jail and fined him \$500. Three employees of the company got 15 days each. END

NEW-EXCITING VEROBOARD BREADBOARD KIT MODEL BK-5

NOW — For the first time you can build circuits for any electronic equipment using **THE SENSATIONAL NEW VEROBOARD** — No more need for chassis, brackets, terminals, tools or wires... Design your component layout directly on **VEROBOARD** and solder... that's it!

This **ALL-NEW VEROBOARD KIT** contains 5 universal wiring boards and spot face cutter with instructions for use.

VEROBOARD is the most advanced method of circuit construction yet developed—Try it once and you'll never want to use anything else. **VEROBOARD** is now being used in leading electronics companies all over the world.

\$5.50

COMPLETE

CLIP AND MAIL COUPON TODAY

To: VERO ELECTRONICS INC.
48 ALLEN BLVD., FARMINGDALE, N. Y.

Please send me your Model BK-5 Kit. I am enclosing \$5.50.

Name _____ (Please Print)
Address _____
City _____ State _____ Zip _____

\$200 SONOTONE HEARING AID \$5

Each HEARING AID is a complete Audio Amplifier and incl. Cabinet, Tubes, Crystal Microphone, Etc.

Top Item for Experimenter. Can be converted to Inter-Coms, Walkie Talkies, Etc.

5"x2 1/2"x1" 1-lb.

Complete incl. Schematic Diagram (less Earphone & Battery) **\$5**



DIAMOND NEEDLES

RONETTE

TO-200 to TO-400
No. 1—Stereo

or All Speed

Also fits—Astatic, Lenco, BSR, Webster, Vaco, Etc.

No. 2 RONETTE BF-40, No. 3 RCA 71A, No. 4 ELECTRO-VOICE 131, No. 5 ELECTRO-VOICE 132, No. 6 G.E. C100, No. 7 G.E. VR11, No. 8 SONOPHONE 2T-S, No. 9 SON 8TA, No. 10 SON 9T.

Your choice... **\$1.19**

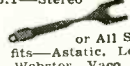

RECORDING TAPE

3" MYLAR 225' \$.29
3" MYLAR 300' .39
3 1/4" MYLAR 600' .66
5" MYLAR 600' .76
7" MYLAR 1200' .99
7" MYLAR 1800' 1.37
7" MYLAR 2400' 2.24

PHONE JACK & PLUG



JACK **\$1**
PLUG **\$1**

TELEPHONE RECORDING DEVICE

For amplifying or recording both sides of a telephone conversation. Records by placing it under telephone. Your choice of underphone type or suction cup type... **\$1**

HOTTEST VALUE EVER

IBM COMPUTER SECTIONS

Each Unit "cost IBM over \$5.00"

6 Units we sell for \$1 are loaded with over 100 valuable parts.

6 for \$1
35 for \$5

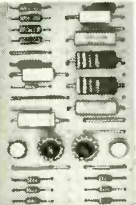

- | | | | |
|--|---|--|--|
| <input type="checkbox"/> 20 — EXPERIMENTER'S COIL \$1
"JACKPOT" assorted for 101 uses | <input type="checkbox"/> 200—BUSS WIRE #20 tinned for hookups, special circuits, etc. \$1 | <input type="checkbox"/> 100—MIXED DEAL "JACKPOT" \$1
Condensers, Resistors, Surprises... | <input type="checkbox"/> STANDARD 1/4W RESISTORS 10% 470, 1500, 3900, 6800, 15k, 100k, 2.2meg, 5meg Your choice... 100 for \$1 |
| <input type="checkbox"/> 10—ASSORTED DIODE CRYSTALS 1N34, 1N48, 1N60, 1N64, 1N82 | <input type="checkbox"/> 100 — ASST. RUBBER & FELT FEET FOR CABINETS best sizes | <input type="checkbox"/> 5—TOP HAT SILICON RECTIFIERS 500ma-300 pIV | <input type="checkbox"/> 3—ASST WEBSTER CARTRIDGES \$ best types, complete with sapphires |
| <input type="checkbox"/> 10—TOP BRAND TRANSISTORS —2N94, 2N404, 2N696, GT-2477 | <input type="checkbox"/> 50 — STRIPS ASSORTED SPAGHETTI handy sizes | <input type="checkbox"/> \$15.00 RADIO PARTS "JACKPOT" handy assortment | <input type="checkbox"/> 20—ITT SELENIUM RECTIFIERS 65ma for Radios, Meters, Chargers, Transistors, Experiments, etc. \$1 |
| <input type="checkbox"/> 250—ASST. SOLDERING LUGS best types mid sizes | <input type="checkbox"/> 100—ASSORTED RUBBER GROMMETS best sizes | <input type="checkbox"/> 50—ASSORTED PRINTED CIRCUIT SOCKETS best types | <input type="checkbox"/> 10—SNAP HOOK & CABLE RIG for boat, car, handy for 101 uses \$1 |
| <input type="checkbox"/> 250—ASST. WOOD SCREWS finest popular selection | <input type="checkbox"/> 50 — ASSORTED TV PEAKING COILS all popular types | <input type="checkbox"/> 25 — INSTRUMENT POINTER KNOBS selected popular types | <input type="checkbox"/> 20 — ADJUSTABLE ANTENNA MAST BAND CLAMPS with STAND-OFFS |
| <input type="checkbox"/> 250 — ASST. SELF TAPPING SCREWS #6, #8, etc. | <input type="checkbox"/> 3—1/2 MEG VOLUME CONTROLS with switch, 3" shaft | <input type="checkbox"/> 20—ASST. PILOT LIGHTS #44, 46, 47, 51, etc. | <input type="checkbox"/> 10—SNAP HOOK & CABLE RIG for boat, car, handy for 101 uses \$1 |
| <input type="checkbox"/> 150—ASST. 6/32 SCREWS and 150 6/32 HEX NUTS | <input type="checkbox"/> 5 — ASST. 4 WATT WIRE-WOUND CONTROLS | <input type="checkbox"/> 10—ASST. DIODE CRYSTALS 5—1N60 and 5—1N64 | <input type="checkbox"/> 20 — ADJUSTABLE ANTENNA MAST BAND CLAMPS with STAND-OFFS |
| <input type="checkbox"/> 150—ASST. 8/32 SCREWS and 150—8/32 HEX NUTS | <input type="checkbox"/> 20—ASSORTED VOLUME CONTROLS less switch | <input type="checkbox"/> 3 — ELECTROLYTIC CONDENSERS 50/30-150v | <input type="checkbox"/> 25'—MICROPHONE CABLE Grey, deluxe, 2 conductor, shielded |
| <input type="checkbox"/> 150—6/32 HEX NUTS and 150—8/32 HEX NUTS | <input type="checkbox"/> 7—ASSORTED VOLUME CONTROLS with switch | <input type="checkbox"/> 10 — ASST. RADIO ELECTROLYTIC CONDENSERS | <input type="checkbox"/> 5—LINE FILTER COILS 110v, to 117v, 2.5mh, dual, many uses \$1 |
| <input type="checkbox"/> 150—ASST. 2/56 SCREWS and 150—2/56 HEX NUTS | <input type="checkbox"/> 15—RADIO OSCILLATOR COILS standard 456kc | <input type="checkbox"/> 50 — ASST. TUBULAR CONDENSERS .001 to .47 to 600v | <input type="checkbox"/> 300—ASST. 1/2 W RESISTORS Top Brand, Short leads, excellent |
| <input type="checkbox"/> 150—ASST. 4/40 SCREWS and 150—4/40 HEX NUTS | <input type="checkbox"/> 3—I.F. COIL TRANSFORMERS 456kc, most popular type | <input type="checkbox"/> 20—GOODALL TUBULAR CONDENSERS .047-600v | <input type="checkbox"/> 100—MOLDED TUBULAR COND. Top brand, short leads, excellent |
| <input type="checkbox"/> 150—ASST. 5/40 SCREWS and 150—5/40 HEX NUTS | <input type="checkbox"/> 10—ASST DUAL CONTROLS for Radio, TV, Hi-Fi, Stereo, etc. | <input type="checkbox"/> 10—ASSORTED SLIDE SWITCHES SPST, SPDT, DPDT, etc. | <input type="checkbox"/> 50—ASSORTED #3AG FUSES Popular assorted ampere ratings \$1 |

IMMEDIATE DELIVERY... Scientific light packing for safe delivery at minimum cost. HANDY WAY TO ORDER: Pencil mark or write amounts wanted in each box, place letter F in box for Free \$1 BUY. Enclose with check or money order, add extra for shipping. Tearsheets will be returned as packing slips in your order, plus lists of new offers.

Name _____ Address _____

Cost of goods _____ Shipping estimated _____ TOTAL _____

Please specify refund on shipping overpayment desired: CHECK POSTAGE STAMPS MERCHANDISE (our choice) with advantage to customer

CAN YOU SAVE MONEY ON PARTS?

Now You Can. Just Write for Edlie's

FREE MONEY-SAVING CATALOGUE

Write to: EDLIE ELECTRONICS INC.
154 Greenwich St. Dept. RE 1,
New York 1, N. Y.

Listed below are just a few of the many

BARGAINS

in our stock

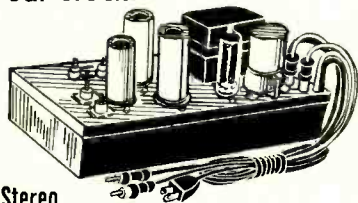

FM Stereo

MULTI-PLEX

ADAPTER

A self powered new unit, completely wired, includes 4 tubes 2-12AU7, 1-6V4/EZ80, & 1-6C4 made with 5 adjustable coils 19KC, 23KC, 38KC, 38KC doubler, and 67KC chassis size 4 1/2" x 9" x 2". Weight 3 1/2# operates from 115 volt, 60 cycle source. Price **\$14.95**

GRUNDIG-MAJESTIC ELECTRONIC SWITCH

Designed for use in multiplex-adapters operates from a 115 volt, 60 cycle source. Housed in a small metal cabinet size 2 3/4" x 3 3/4" x 1 3/4" containing a 28 volt relay, 2500 ohm, DPDT and D.P.S.T., normally closed contacts. AC input rectified to DC by means of an epoxy silicon rectifier and an electrolytic condenser 10 mfd at 250 volts, drop in voltage made by a 470, 10 watt wire wound resistor. Connections are provided to phono input, phono output, multiplex left and multiplex right.

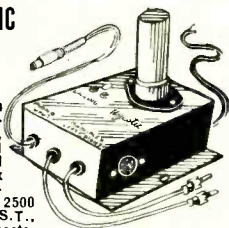

Price **95¢** ea.

TUBE BARGAINS

Laboratory tested & guaranteed for one year.

0A2\$.55	Z22585	5750/6BE6W		
0B255	282A95	45	
0C3	VR10555	307A35	5751/12AX7W	
0D3	VR15055	807 1.25	65
1AE435	811 1.95	5814A/12AU7		
2C5165	829B 4.95	65	
2D2145	832A 3.95	582335	
2E26 1.65	88465	587965	
3B2435	161925	5894/AX9903		
3B24WA65	162535	 6.95	
3B2665	205065	6098/6AR6WA		
3C33 1.45	205165	65	
3D2165	565145	6080 1.45	
3D21WA 1.95	5654/6AK5W		6101/6J6W45	
5R4GY65			6146 1.65	
6AN4/121835	565645	6186/6AG5W		
6AN5WA65	567045	45	
6B845	568865	6201/12AT7W		
6BM8 1.25	568735	65	
6H69T25	5725/6AS645	6293/614665	
6SC745	5726/6AL5W		6384/6098WA		
6SG745			 1.65	
19X865	5727/2D21WA		758165	
26A765			900145	
EM84 1.35	5749/6BA6W		900245	
26Z5WA85					

Terms of sale: Full payment or 20% with order. Minimum order \$2.

This is but a small fraction of the many thousands of electronic components contained in our Winter, 1965 catalog, free for your asking. Write to:

EDLIE ELECTRONICS, INC. Dept. RE-1
(The Electronic Bargain House)
154 Greenwich St., New York 6, N. Y.

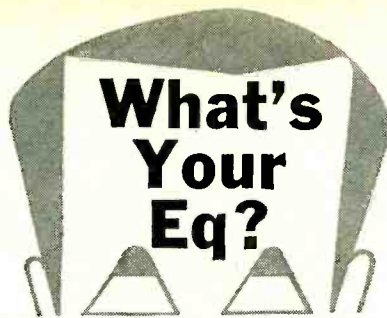

What's Your Eq?

These are the answers. Puzzles on page 60.

Gate Circuit

When the 100-volt input pulse is applied simultaneously to both inputs, the lamp with the lowest firing potential fires and the other lamp remains nonconducting. Since N2 has the lower firing potential (70V), it fires for the duration of the pulse (1/10 second). The maximum amplitude of the output pulse equals the difference between the input voltage and the maintaining voltage of N2—or 50 volts.

What's in the Box?

The box contains a filter choke and capacitor connected as a series-resonant circuit. At resonance (60 cycles), the circuit looks like a resistance equal to the dc resistance of the choke, plus a little extra due to other losses in the

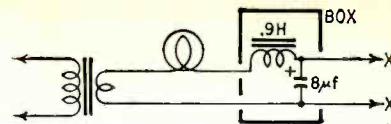

components. When the terminals are shorted, we have a filter choke in series with our lamp. The fairly large X_L (inductive reactance) keeps the lamp dark. (The constants shown on the diagram are approximate; the results of a rough test. Choke resistance was 35 ohms.) Operating with dc input should be self-explanatory.

Alternate Method

Here's an alternate solution method for the "Q" puzzler (July). In the steady state, the resistor can be shorted.

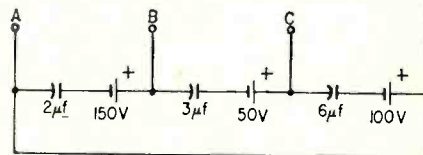

All initial capacitor voltages can be replaced with initial-condition generators and the capacitors replaced with others having zero initial voltage as shown.

The problem is now solved:

$$V_{AB} = \frac{1/2 (300)}{1/2 + 1/3 + 1/6} = 150 = 0 \text{ volts}$$

$$V_{BC} = \frac{1/3 (300)}{1/2 + 1/3 + 1/6} = 50 = 50 \text{ volts}$$

$$V_{CD} = \frac{1/6 (300)}{1/2 + 1/3 + 1/6} = 100 = -50 \text{ volts}$$

Or to agree with the original circuit:

$$V_{C1} = -V_{AB} = 0 \text{ volts}, V_{C2} = -V_{BC} = -50 \text{ volts}, \text{ and } V_{C3} = -V_{CD} = 50 \text{ volts.}$$

—Herbert A. Katz

The original puzzle, which appeared on page 45 of the July issue, read "Three capacitors, each charged initially as shown, are connected in series with a resistor and switch. Determine the steady-state voltage on each capacitor after the switch is thrown."

SILICON RECTIFIER SALE

IMMEDIATE DELIVERY

FULLY GTD NEWEST TYPE

AMERICAN MADE FULLY TESTED

750 MA-SILICON "TOPHAT" DIODES

LOW LEAKAGE FULL LEAD LENGTH

PIV/RMS 50/35 .05 ea.	PIV/RMS 100/70 .07 ea.	PIV/RMS 200/140 .10 ea.	PIV/RMS 300/210 .12 ea.
PIV/RMS 400/280 .14 ea.	PIV/RMS 500/350 .19 ea.	PIV/RMS 600/420 .23 ea.	PIV/RMS 700/490 .27 ea.
PIV/RMS 800/560 .35 ea.	PIV/RMS 900/630 .45 ea.	PIV/RMS 1000/700 .60 ea.	PIV/RMS 1100/770 .75 ea.

ALL TESTS AC & DC & FWD & LOAD

SILICON POWER DIODE STUDS

D.C. AMPS	50 PIV 35 RMS	100 PIV 70 RMS	150 PIV 105 RMS	200 PIV 140 RMS
3	.08 ea.	.12 ea.	.16 ea.	.22 ea.
12	.25	.50	1.25	.75
35	6.55	1.35	2.20	1.40
50	1.50	1.75	2.20	2.60
100	1.60	2.00	2.40	3.00

D.C. AMPS	300 PIV 210 RMS	400 PIV 280 RMS	500 PIV 350 RMS	600 PIV 450 RMS
3	.27 ea.	.29 ea.	.37 ea.	.45 ea.
12	.90	1.30	1.40	1.65
35	2.00	2.35	2.60	3.00
50	3.25	4.00	4.75	6.00
100	3.60	4.50	5.25	7.00

"SCR" SILICON CONTROLLED RECTIFIERS "SCR"

PRV	7 AMP	16 AMP	25 AMP	PRV	7 AMP	16 AMP	25 AMP
25	.30	.50	.85	250	1.75	2.15	2.50
50	.45	.75	1.00	300	2.00	2.40	2.75
100	.80	1.25	1.50	400	2.40	2.75	3.25
150	.90	1.60	2.00	500	3.20	3.40	3.80
200	1.25	1.80	2.25	600	3.40	4.00	4.50

SPECIALS! SPECIALS!

100 Different Precision Resistors
1/2-1-2 watt 1/2%-1% TOL **\$1.50**

2 amp 1000 Piv Silicon Power Rect. .70 ea. **10 for \$6.50**

Filament Transformer Pri-120 v
sec. 6.3 v at 1 amp. **.50 ea.**

Type IN34 DIODE GLASS .07 ea. **100 for \$5**

240 amp 200 Piv sil power rect. **\$7.50 ea.**

Money Back guarantee. \$2.00 min. order. Orders F.O.B. NYC. Include check or money order. Shpg. charges plus. C.O.D. orders 25% down.

Warren Electronic Components

230 Mercer St., N. Y., N. Y. 10012 • OR 3-2620

50 Years Ago

In Gernsback Publications

In April 1915

Electrical Experimenter

100,000-Cycle Alternators
Producing Electric Sleep or Anesthesia

The D.C. Arc for Wireless Telegraphy and Telephony
A Calibrated Spark Gap
Tikker for Undamped Waves

noteworthy

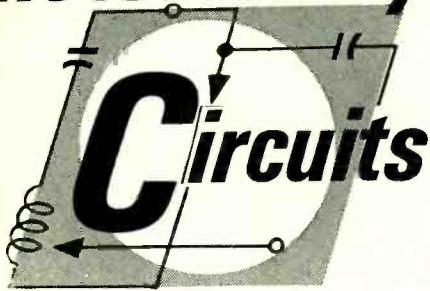

USE TRANSISTOR PORTABLE IN YOUR CAR

I had been using my transistor radio as a car radio. Playing it most of the time used up quite a few batteries. The set uses 6 volts (four penlite cells), so I tapped the 12-volt automobile battery at its 6-volt spot. (If your set requires 9 volts, use the 8- or 10-volt tap.) I brought the battery leads up the dash and terminated them in an earphone-

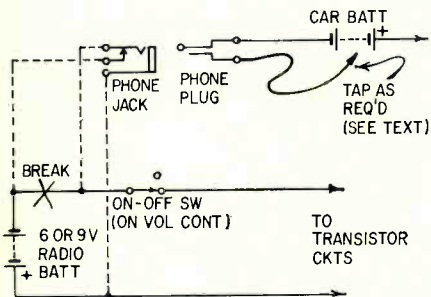

type plug. As I never used the earphones with the radio, I rewired the phone jack as shown in dashed lines. With the plug in the earphone jack, the radio operates off the car battery. Remove the plug and the set runs off its own battery. While operating off the car battery the internal battery is disconnected. Don't forget to solder together two of the wires that were on the normally closed contacts of the earphone jack. The third one (ground) is left loose.—*Don Dudley*

[Watch it! Battery polarity is critical in transistor sets. Be sure that you get it right the first time. Remember that either the tip or the sleeve of the phone plug will be hot and will cause a short circuit if it touches the body of the car. Play safe. Connect a low-current fuse in series with the hot lead.—*Editor*]

VERNIER OUTPUT CONTROL

Have you ever felt the need of a vernier output control on an audio generator, regulated power supply or similar device? If so, here is a simple solution. The original single pot is replaced by a single fixed resistor and two pots as in the diagram.

R1 is a dual pot whose sections have twice the resistance of the original control. R3 has about one-tenth the value of the original pot. R2 may be the original pot or one with a reasonably high value.

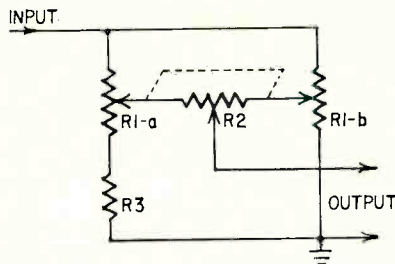

R1 is the coarse control used to set the approximate output level. R2 is the vernier control that varies the output over a range of potential difference established by the setting of R1. Fineness of control can be varied by changing the ratio of R1-a to R3. For that, R3 can be a series of switched resistors or a potentiometer.—*Harry G. Campbell* END

WHEN YOU ORDER MERCHANDISE BY MAIL

Be sure to include your name and address. Type or print if you can—if not, write clearly. Don't send cash! Remit by check or money order. Mention you saw it in *Radio-Electronics*.

Made in U.S.A.



For complete details see your
Distributor or write
Dept. RE-4

kinematix, inc.

2040 W. Washington Blvd.,
Chicago, Illinois 60612
Area Code 312 666-0066

CAR OWNERS SAY...

"Terrific," "Fabulous,"
"Improves radio 100%!"

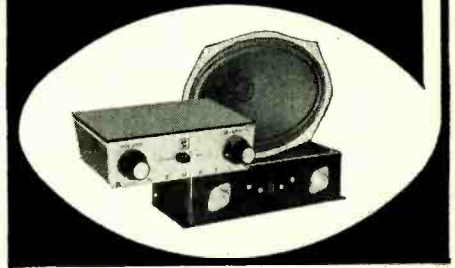

VERBA-MATIX

America's Prestige

REVERBERATION

The only system with

- 4 Transistors • Heavy 7 oz. Ceramic-Magnet Speaker • Complete Control Panel (with Reverb % Control) • No Drilling, No Screws, for easy installation • Fits all Cars, Neg. or Pos. Ground (12 volt) • All Speakers 2 to 40 ohms • No Noise Driving Over Bumps.



March 22-26, 1965

ELECTRICAL-ELECTRONICS

- Exhibit hours (4 days): Monday & Thursday, 9:45 a.m.-9 p.m.; Tuesday & Wednesday, 9:45 a.m.-6 p.m.
- Technical sessions (5 days) 10 a.m.-5 p.m. (Hilton, Tuesday to 10 p.m.)
- 80 subject-organized technical sessions presenting 400 vital "break-through" papers.

Over 1000 Exhibits using 140,000 running feet of display units in N.Y. Coliseum & N.Y. Hilton.

Gala IEEE Banquet on Wednesday, March 24, 1965 at 6:45 p.m. in Grand Ballroom, N.Y. Hilton.

Registration: \$2.00 IEEE Members, \$5.00 Non-members. High School students admitted Thursday afternoon only, \$2.00 if accompanied by an adult (not over 3 per adult).



NEW YORK COLISEUM and the NEW YORK HILTON

Buses every few minutes

send for New FREE
CRYSTAL CATALOG . . . with New
TRANSISTOR OSCILLATOR CIRCUITS

3 PLANTS TO SERVE YOU BETTER
**HERMETICALLY SEALED
 PRECISION GROUND
 CUSTOM-MADE
 NON-OVEN CRYSTALS**

Gold or silver plated, spring mounted, vacuum sealed or inert gas, high freq. stability. 10 milliwatt max. current cap. Meet mil. specs.
 1000KC to 1600KC (Fund. Freq.)

	Prices on Request
1601KC to 2000KC (Fund. Freq.)	\$5.00 ea.
2001KC to 2500KC (Fund. Freq.)	4.00 ea.
2501KC to 5000KC (Fund. Freq.)	3.50 ea.
5001KC to 7000KC (Fund. Freq.)	3.90 ea.
7001KC to 10,000KC (Fund. Freq.)	3.25 ea.
10,001KC to 15,000KC (Fund. Freq.)	3.75 ea.
15MC to 20MC (Fund. Freq.)	5.00 ea.

OVERTONE CRYSTALS

15MC to 30MC Third Overtone	\$3.85 ea.
30MC to 40MC Third Overtone	4.10 ea.
40MC to 65MC Third or Fifth Overtone	4.50 ea.
65MC to 100MC Fifth Overtone	6.00 ea.

DRAKE 2-B Receiver Crystals \$4.00
 (All Channels—Order by Freq.)

OVEN-TYPE CRYSTALS

For Motorola, GE, Gonset, Bendix, etc.
 Add \$2.00 per crystal to above prices
 SUB-MINIATURE PRICES slightly higher

**ORDER FROM CLOSER PLANT
 TEXAS CRYSTALS**

DEPT. RE
 1000 Crystal Drive
 FORT MYERS, FLORIDA
 Phone 813 WE 6-2109



AND
 4117 W. Jefferson Blvd.
 LOS ANGELES, CALIF.
 Phone 213-731-2258

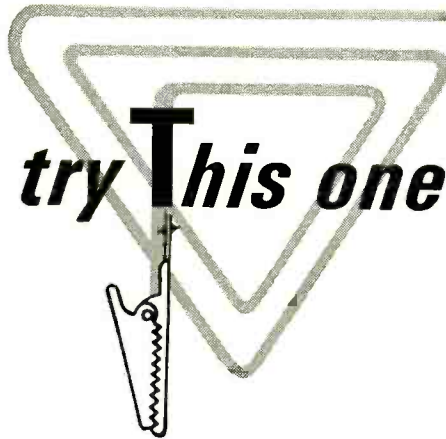

**JEWELER'S LOUPE
 AS SERVICING AID**

Straightening the plates of a variable capacitor when something has pushed them out of alignment is a tedious, time-consuming job.

A 5-power jeweler's loupe, or similar magnifying glass, makes it possible for you to see the alignment of plates clearly when a capacitor is held up against white paper in a well lighted room. You can see where they are touching, and you can see when you have them properly realigned so they will not bend slightly in a few days and touch again—*Jerome Fowler*

**PHOTOCELLS
 FROM SELENIUM RECTIFIERS**

Selenium rectifiers in your junkbox can be used as photocells. Simply take apart a rectifier, separate its plates and carefully remove the enamel with lacquer thinner. It is difficult to solder leads to either surface of these plates, so another means of connection must be used.

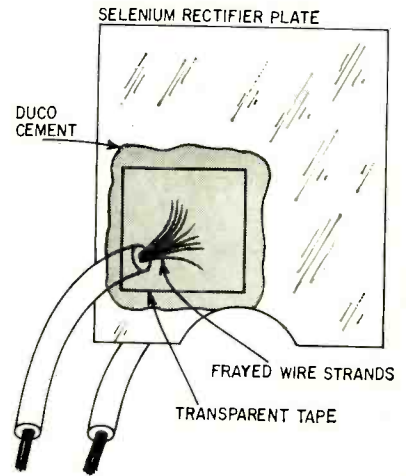

Strip about 1/4 inch of insulation from a piece of small-gage stranded hookup wire. Fan out the strands and use a small square of transparent tape to fasten them firmly in contact with one surface of the cell, as shown. Similarly
continued on page 92

**IF YOU'RE NOT
 GETTING THE
 BEST OUT OF
 YOUR HI-FI
 EQUIPMENT,
 YOU NEED THIS
 NEW BOOK**

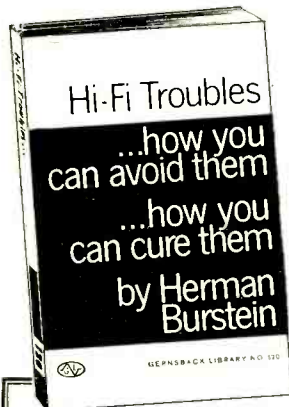

HERMAN BURSTEIN, the author of this new book, is a recognized authority in the high fidelity field. He has written over 100 articles for such leading newspapers and magazines as: *Audio*, *High Fidelity*, *Hi-Fi/Stereo Review*, *Radio-Electronics*, *Electronics World*, *The New York Times*, and *The San Francisco Chronicle*. Some of his books include: *Getting the Most out of Your Tape Recorder*, *Stereo How It Works*, and *Fundamentals of High Fidelity*.

HI-FI TROUBLES

How You Can Avoid Them . . . How You Can Cure Them
 by *Herman Burstein*

Just published! At last, a book which deals directly with the problems you face in maintaining your audio system in peak condition. Tells you how to locate troubles, what to do about them and how to do it—and, just as important: what *not* to do. Saves you valuable time and money—helps you to achieve the best in listening pleasure from your hi-fi equipment.

GERNSBACK LIBRARY, INC.

3-8-RE/465

154 West 14th Street, New York, N. Y. 10011

Please send me *Hi-Fi Troubles*. If I am not completely satisfied, I may return the book within ten days with no obligation. If I decide to keep it, bill me for only \$3.95 plus a few cents for postage and packing.

NAME.....
 (PLEASE PRINT—it prevents errors)

STREET.....

CITY.....STATE.....ZIP CODE.....

SAVE POSTAGE COSTS by enclosing your payment of \$3.95 now—same 10 day return privilege, of course.

**HOW MANY OF THESE PROBLEMS
 INTERFERE WITH YOUR LISTENING PLEASURE?**

- equipment deteriorating
- excessive hum
- noise in switches, tubes, resistors, etc.
- distortion
- bass and treble problems
- special installation problems
- tuner, amplifier, phono, speaker troubles

Invaluable for anyone who wants to know how to buy and maintain hi-fi equipment

160 Pages

139 Illustrations

Paperbound \$3.95

10 DAY FREE EXAMINATION — Money Back Guarantee

SCHOOL DIRECTORY

Get Your First Class Commercial F. C. C. LICENSE QUICKLY!

Career opportunities in *communications electronics* are almost unlimited. Prepare now. Let Grantham train you—by correspondence, or by classroom and laboratory instruction. Get your *first class commercial F.C.C. license* in as little as 3 months, or at a slower pace if you prefer. Then, continue in more-advanced electronics training if you wish. Diploma awarded. Our catalog gives full details.

Learn how our training can prepare you for your F.C.C. license; write or telephone the School at any one of the teaching divisions listed below, and ask for "Catalog 57."

Grantham School of Electronics

1505 N. Western Av., LOS Angeles, Cal. 90027
(Phone: HO 9-7878)

408 Marion Street, Seattle, Wash. 98104
(Phone: MA 2-7227)

3123 Gillham Road, Kansas City, Mo. 64109
(Phone: JE 1-6320)

818-18th St., NW, Washington, D.C. 20006
(Phone: 298-7460)

B.S. degree in 36 months

Small professionally-oriented college. Four-quarter year permits degree completion in three years. Summer attendance optional. *Engineering*: Electrical (electronics or power option), Mechanical, Civil, Chemical, Aeronautical. *Business Administration*: Accounting, General Business, Motor Transport Administration. One-year Drafting and Design Certificate program. Graduate placement outstanding. Founded 1884. Rich heritage. Excellent faculty. Small classes. Well-equipped labs. New library. New residence halls. Attractive 300-acre campus. *Modest costs*. Enter June, Sept., Jan., March. For Catalog and View Book, write Director of Admissions.



TRI-STATE COLLEGE

2445 College Ave., Angola, Indiana

APRIL, 1965

EARN Electronics Engineering DEGREE

You can earn an A.S.E.E. degree at home. College level HOME STUDY courses taught so you can understand them. Continue your education, earn more in the highly paid electronics industry. Missiles, computers, transistors, automation, complete electronics. Over 27,000 graduates now employed. Resident school available at our Chicago campus—Founded 1934. Send for free catalog.

American Institute of Engineering & Technology
1139 West Fullerton Parkway, Chicago 14, Ill.

FREE! NEW CAREER GUIDE TO Success in ELECTRONICS

Automation, Math—Basic or Advanced
Wide choice of new Home Study Programs to prepare you for well paying career or advancement in present job. Choose Service, Broadcasting, Industrial, Automation. We assist you in choosing best program... save time and money. Tuition refund surety. Since 1931. Write today—
CENTRAL TECHNICAL INSTITUTE
Dept. 03045, 1644 Wyandotte St. Kansas City, MO. 64108

Engineering Technician
A.S. Degree—2 Years
Electronics Engineer
B.S. Degree
Evening Courses Available
ELECTRONIC TECHNICAL INSTITUTE
970 W. Manchester Ave., Inglewood, Calif.
4863 El Cajon Blvd., San Diego, Calif.

GET INTO ELECTRONICS

V.T.I. training leads to success as technicians, field engineers, specialists in communications, guided missiles, computers, radar and automation. Basic & advanced courses in theory & laboratory. Electronic Engineering Technology and Electronic Technology curricula both available. Assoc. degree in 29 mos. B.S. also obtainable. G.I. approved. Graduates in all branches of electronics with major companies. Start Sept., Feb., Dorm. campus. High School graduate or equivalent. Catalog.

VALPARAISO TECHNICAL INSTITUTE
Department C, Valparaiso, Indiana



Learn Electronics for your SPACE-AGE EDUCATION at the center of America's aerospace industry

No matter what your aerospace goal, you can get your training at Northrop Tech, in sunny Southern California.

COLLEGE OF ENGINEERING. Get your B.S. degree in engineering in just 36 months by attending classes year round. Most Northrop Tech graduates have a job waiting for them the day they're graduated!

A & P SCHOOL. Practical experience on real aircraft. One-year course prepares you for F. A. A. A&P certificate. **WRITE TODAY FOR CATALOG.**

NORTHROP INSTITUTE OF TECHNOLOGY
1199 W. Arbor Vitae, Inglewood, Calif.



ELECTRONICS

Electronics Engineering Technology
Electrical-Electronics Technician
TV-Radio-Electronics Technician
Combined Electronics Technician
Practical Electrical Maintenance
Specialized Industrial Electronics
Pract. Refrigeration Air Conditioning



Special finance and loan plans. Part time employment service while in school. Free graduate employment service.

Founded 1899

Not-For-Profit

WRITE TODAY FOR CATALOG

COYNE ELECTRONICS INSTITUTE
Dept. 45-N 1501 W. Congress Pkwy., Chicago, Ill. 60607

A JOB or a POSITION?

The difference is **ELECTRONIC MATHEMATICS**

NOW! A NEW WAY TO LEARN—I. H. S. I. WAY. A complete home study course in electronic math to help you get the position you want—**MORE MONEY—MORE RESPECT.**

COURSE PREPARED BY COLLEGE PROFESSORS who have lectured to thousands of men on math and engineering. You learn at home quickly, easily—**AS FAST** as you want.

YOU SIGN NO CONTRACTS Pay only if satisfied—you owe it to yourself to examine the **INDIANA HOME STUDY INSTITUTE COURSE IN ELECTRONIC MATH.** **FREE BONUS**—if you join now, a refresher course in basic arithmetic.

Write for Brochure—No Obligation
THE INDIANA HOME STUDY INSTITUTE
Dept. RE-4, P.O. Box 1189
Panama City, Fla. 32402

when it's time to think of college
you should read this
FREE CAREER BOOKLET
about electronics at

MSOE



**MILWAUKEE MS-237
SCHOOL OF ENGINEERING**

Dept. RE-465, 1025 N. Milwaukee Street
Milwaukee, Wisconsin 53201

Tell me about an engineering career through residence study in:

Electrical fields Mechanical fields

Name..... Age.....

Address.....

City, State.....

The largest stock of obsolete tubes in the USA at the lowest prices—compare

BRAND NEW UNITED'S FIRST QUALITY TUBES DISCOUNTS up to 80% OFF GUARANTEED ONE FULL YEAR! NOT USED! NO PULLS! WHY PAY MORE?

Type	Price	Type	Price	Type	Price	Type	Price	Type	Price	Type	Price	Type	Price	Type	Price	Type	Price	Type	Price	Type	Price
00A		3DK6	.58	6AK5	.90	6CY7	1.22	6J5G	.95	8AU8	.98	12F8	.99	2050	1.25						
UV200	2.00	3DT6	.52	6AK6	.94	6CZ5	1.59	6J5M	1.30	8AW8	.99	12FA6	.97	2050	1.25						
014	.95	3DZ4	1.59	6AL3	1.00	6CZ7	1.95	6J5GT	1.20	8RH8	1.36	12FK6	.83	210V5	1.49						
02	.90	3E7	1.00	6AL5	.45	6D4	1.75	6J6	.72	8R05	.99	12FME	.81	21HR5	1.65						
0A3	.90	3E7	1.00	6AL7	1.95	6D6	2.50	6J7	1.85	8C07	.95	12FQ8	1.19	22B83	1.15						
0B2	1.50	3E8	.95	6AN5	1.95	6D7	1.49	6J8	1.82	8C7	1.25	12FQ8	1.19	22B83	1.15						
0B3	1.20	3F5	.95	6AM8	.76	6D8	1.49	6J9	1.82	8E7	1.39	12FQ8	1.19	22B83	1.15						
0C3	.75	3G5	1.18	6AN4	2.50	6D9	1.05	6K7	1.49	8E8	1.25	12FQ8	1.19	22B83	1.15						
0C3	1.20	3G5	1.18	6AN6	2.45	6D9	1.05	6K8	2.50	8E9	1.25	12FQ8	1.19	22B83	1.15						
0C4	2.75	3H5	1.49	6AN8	1.50	6D9	1.05	6K9	1.30	8E9	1.25	12FQ8	1.19	22B83	1.15						
0G3	1.20	3Q5	1.29	6AQ5	1.52	6D9	1.05	6L8	1.49	8E9	1.25	12FQ8	1.19	22B83	1.15						
0Z4	.95	3M5	1.23	6AQ6	1.05	6D9	1.05	6L9	1.49	8E9	1.25	12FQ8	1.19	22B83	1.15						
1A3	1.49	3Q5	1.29	6AR5	1.03	6D9	1.05	6M8	1.49	8E9	1.25	12FQ8	1.19	22B83	1.15						
1A5	1.45	3Q5	1.29	6AR7	1.03	6D9	1.05	6M9	1.49	8E9	1.25	12FQ8	1.19	22B83	1.15						
1A6	1.49	3Q5	1.29	6AR8	1.03	6D9	1.05	6N8	1.49	8E9	1.25	12FQ8	1.19	22B83	1.15						
1A7	1.95	3V4	.61	6AR8	2.00	6D9	1.05	6N9	1.49	8E9	1.25	12FQ8	1.19	22B83	1.15						
1AB5		4A6	.89	6AR11	1.65	6D9	1.05	6K7G	1.70	8E9	1.25	12FQ8	1.19	22B83	1.15						
1AD4	1.75	4A6	.89	6AR11	1.65	6D9	1.05	6K7G	1.70	8E9	1.25	12FQ8	1.19	22B83	1.15						
1AF4	1.30	4A7	.75	6AS5	1.00	6D9	1.05	6K8	2.50	8E9	1.25	12FQ8	1.19	22B83	1.15						
1AG4	2.20	4B6	.90	6AS7	2.85	6D9	1.05	6K9	1.30	8E9	1.25	12FQ8	1.19	22B83	1.15						
1AH4	1.00	4B6	.90	6AS11	1.95	6D9	1.05	6L8	1.49	8E9	1.25	12FQ8	1.19	22B83	1.15						
1AJ4	1.00	4B8	1.00	6AT6	.45	6D9	1.05	6L9	1.49	8E9	1.25	12FQ8	1.19	22B83	1.15						
1AU3	1.25	4B8	1.00	6AT7	1.49	6D9	1.05	6M8	1.49	8E9	1.25	12FQ8	1.19	22B83	1.15						
1AX2	.95	4B8	1.00	6AU4	.95	6D9	1.05	6M9	1.49	8E9	1.25	12FQ8	1.19	22B83	1.15						
1A2	1.45	4B8	1.00	6AU5	1.60	6D9	1.05	6N8	1.49	8E9	1.25	12FQ8	1.19	22B83	1.15						
1B3	.88	4B8	1.00	6AU7	.54	6D9	1.05	6N9	1.49	8E9	1.25	12FQ8	1.19	22B83	1.15						
1B4	2.00	4B8	1.00	6AU8	.87	6D9	1.05	6O8	1.49	8E9	1.25	12FQ8	1.19	22B83	1.15						
1C5	.98	4B8	1.00	6AU9	.87	6D9	1.05	6O9	1.49	8E9	1.25	12FQ8	1.19	22B83	1.15						
1C6	.98	4B8	1.00	6AV1	1.52	6D9	1.05	6P8	1.49	8E9	1.25	12FQ8	1.19	22B83	1.15						
1D5GP		4C6	.87	6AV5	1.45	6D9	1.05	6P9	1.49	8E9	1.25	12FQ8	1.19	22B83	1.15						
1D	.98	4C6	.87	6AV6	.45	6D9	1.05	6Q8	1.49	8E9	1.25	12FQ8	1.19	22B83	1.15						
1DN5	.53	4C6	.87	6AV7	1.01	6D9	1.05	6Q9	1.49	8E9	1.25	12FQ8	1.19	22B83	1.15						
1ESGP	.98	4C6	.87	6AV8	1.01	6D9	1.05	6R8	1.49	8E9	1.25	12FQ8	1.19	22B83	1.15						
1E7	.98	4C6	.87	6AX3	1.05	6D9	1.05	6R9	1.49	8E9	1.25	12FQ8	1.19	22B83	1.15						
1F4	.98	4C6	.87	6AX4	1.05	6D9	1.05	6S8	1.49	8E9	1.25	12FQ8	1.19	22B83	1.15						
1F5	.98	4C6	.87	6AX5	1.05	6D9	1.05	6S9	1.49	8E9	1.25	12FQ8	1.19	22B83	1.15						
1F6	1.00	4C6	.87	6AX6	1.05	6D9	1.05	6T8	1.49	8E9	1.25	12FQ8	1.19	22B83	1.15						
1G3	.88	4C6	.87	6AX7	1.05	6D9	1.05	6T9	1.49	8E9	1.25	12FQ8	1.19	22B83	1.15						
1G4	1.75	4C6	.87	6AX8	1.24	6D9	1.05	6U8	1.49	8E9	1.25	12FQ8	1.19	22B83	1.15						
1G5	1.25	4C6	.87	6AX9	1.24	6D9	1.05	6U9	1.49	8E9	1.25	12FQ8	1.19	22B83	1.15						
1H4	1.25	4C6	.87	6B2	2.15	6D9	1.05	6V8	1.49	8E9	1.25	12FQ8	1.19	22B83	1.15						
1H6	2.55	4C6	.87	6B3	4.65	6D9	1.05	6V9	1.49	8E9	1.25	12FQ8	1.19	22B83	1.15						
1J3	.88	4C6	.87	6B4	2.75	6D9	1.05	6W8	1.49	8E9	1.25	12FQ8	1.19	22B83	1.15						
1J5	.88	4C6	.87	6B5	2.75	6D9	1.05	6W9	1.49	8E9	1.25	12FQ8	1.19	22B83	1.15						
1J6	.88	4C6	.87	6B6	2.75	6D9	1.05	6X8	1.49	8E9	1.25	12FQ8	1.19	22B83	1.15						
1K3	.88	4C6	.87	6B7	2.75	6D9	1.05	6X9	1.49	8E9	1.25	12FQ8	1.19	22B83	1.15						
1K4	.88	4C6	.87	6B8	2.75	6D9	1.05	6Y8	1.49	8E9	1.25	12FQ8	1.19	22B83	1.15						
1L4	.88	4C6	.87	6B9	2.75	6D9	1.05	6Y9	1.49	8E9	1.25	12FQ8	1.19	22B83	1.15						
1L6	2.35	4C6	.87	6C0	2.75	6D9	1.05	6Z8	1.49	8E9	1.25	12FQ8	1.19	22B83	1.15						
1LA4	1.30	4D6	1.24	6C1	2.75	6D9	1.05	6Z9	1.49	8E9	1.25	12FQ8	1.19	22B83	1.15						
1LA5	2.60	4D6	1.24	6C2	2.75	6D9	1.05	6Z9	1.49	8E9	1.25	12FQ8	1.19	22B83	1.15						
1LA6	1.49	4D6	1.24	6C3	2.75	6D9	1.05	6Z9	1.49	8E9	1.25	12FQ8	1.19	22B83	1.15						
1LB4	1.80	4D6	1.24	6C4	2.75	6D9	1.05	6Z9	1.49	8E9	1.25	12FQ8	1.19	22B83	1.15						
1LC5	1.05	4D6	1.24	6C5	2.75	6D9	1.05	6Z9	1.49	8E9	1.25	12FQ8	1.19	22B83	1.15						
1LC6	1.80	4D6	1.24	6C6	2.75	6D9	1.05	6Z9	1.49	8E9	1.25	12FQ8	1.19	22B83	1.15						
1LD5	1.95	4D6	1.24	6C7	2.75	6D9	1.05	6Z9	1.49	8E9	1.25	12FQ8	1.19	22B83	1.15						
1LE4	1.75	4D6	1.24	6C8	2.75	6D9	1.05	6Z9	1.49	8E9	1.25	12FQ8	1.19	22B83	1.15						
1LGS	1.98	4D6	1.24	6C9	2.75	6D9	1.05	6Z9	1.49	8E9	1.25	12FQ8	1.19	22B83	1.15						
1LH4	1.80	4D6	1.24	6C0	2.75	6D9	1.05	6Z9	1.49	8E9	1.25	12FQ8	1.19	22B83	1.15						
1LNS	1.20	4D6	1.24	6C1	2.75	6D9	1.05	6Z9	1.49	8E9	1.25	12FQ8	1.19	22B83	1.15						
1NS	1.75	4D6	1.24	6C2	2.75	6D9	1.05	6Z9	1.49	8E9	1.25	12FQ8	1.19	22B83	1.15						
1PS	2.00	4D6	1.24	6C3	2.75	6D9	1.05	6Z9	1.49	8E9	1.25	12FQ8	1.19	22B83	1.15						
1Q5	1.95	4D6	1.24	6C4	2.75	6D9	1.05	6Z9	1.49	8E9	1.25	12FQ8	1.19	22B83	1.15						
1R4	.80	4D6	1.24	6C5	2.75	6D9	1.05	6Z9	1.49	8E9	1.25	12FQ8	1.19	22B83	1.15						
1S2A	1.90	4D6	1.24	6C6	2.75	6D9	1.05	6Z9	1.49	8E9	1.25	12FQ8	1.19	22B83	1.15						
1S4	.75	4D6	1.24	6C7	2.75	6D9	1.05	6Z9	1.49	8E9	1.25	12FQ8	1.19	22B83	1.15						
1T4	1.49	4D6	1.24	6C8	2.75	6D9	1.05	6Z9	1.49	8E9	1.25	12FQ8	1.19	22B83	1.15						
1T5	.80	4D6	1.24	6C9	2.75	6D9	1.05	6Z9	1.49	8E9	1.25	12FQ8	1.19	22B83	1.15						
1U5	.87	4D6	1.24	6D0	2.75	6D9	1.05	6Z9	1.49	8E9	1.25	12FQ8	1.19	22B83	1.15						
1V2	1.05	4D6	1.24	6D1	2.75	6D9	1.05	6Z9	1.49	8E9	1.25	12FQ8	1.19	22B83	1.15						
1X2B	.84	4D6	1.24	6D2	2.75	6D9	1.05	6Z9	1.49	8E9	1.25	12FQ8	1.19	22B83	1.15						
1Z2	3.25	4D6	1.24	6D3	2.75	6D9	1.05	6Z9	1.49	8E9	1.25	12FQ8	1.19	22B83	1.15						
2A3	2.50	4D6	1.24	6D4	2.75	6D9	1.05	6Z9	1.49	8E9	1.25	12FQ8	1.19	22B83	1.15						
2A5	1.95	4D6	1.24	6D5	2.75	6D9	1.05	6Z9	1.49	8E9	1.25	12FQ8	1.19	22B83	1.15						
2A6	3.75	4D6	1.24	6D6	2.75	6D9	1.05	6Z9	1.49	8E9	1.25	12FQ8	1.19	22B83	1.15						
2AF4	1.10	4D6	1.24	6D7	2.75	6D9	1.05	6Z9	1.49	8E9	1.25	12FQ8	1.19	22B83	1.15						
2AH2	1.34	4D6	1.24	6D8	2.75	6D9	1.05	6Z9	1.49	8E9	1.25	12FQ8	1.19	22B83	1.15						
2B2	2.70	4D6	1.24	6D9	2.75	6D9	1.05	6Z9	1.49	8E9	1.25	12FQ8	1.19	22B83	1.15						
2B3	2.70	4D6	1.24	6E0	2.75	6D9	1.05	6Z9	1.49	8E9	1.25	12FQ8	1.19	22B83	1.15						
2B7	.95	4D6	1.24	6E1	2.75	6D9	1.05	6Z9	1.49	8E9	1.25	12FQ8	1.19	22B83	1.15						
2B8	.95	4D6	1.24	6E2	2.75	6D9	1.05	6Z9	1.49	8E9	1.25	12FQ8	1.19	22B83	1.15						
2C2	.95	4D6	1.24	6E3	2.75	6D9	1.05	6Z9	1.49	8E9	1.25	12FQ8	1.19	22B83	1.15						
2C4	1.95	4D6	1.24	6E4	2.75	6D9	1.05	6Z9	1.49	8E9	1.25	12FQ8	1.19	22B83	1.15						
2EAS	1.45	4D6	1.24	6E5	2.75	6D9	1.05	6Z9	1.49	8E9	1.25	12FQ8	1.19	22B83	1.15						
2EAS	1.45	4D6	1.24	6E6	2.75	6D9															

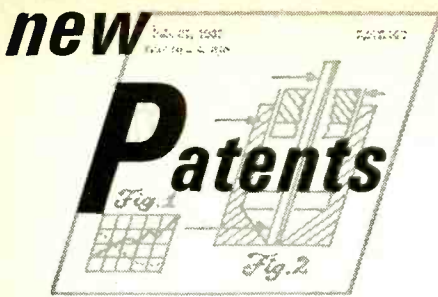

PERMEANCE MEASUREMENT

PATENT No. 3,153,191

Arthur W. Obenschain, Silver Spring, Md. and John E. Nicholson, Washington, D.C. (Assigned to USA as represented by the Secretary of the Navy)

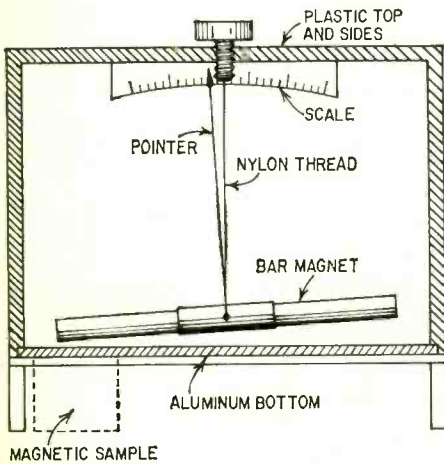

This simple but very sensitive magnetic detector comprises a plastic enclosure with aluminum bottom. A bar magnet, 4 inches long and 1/4 inches in diameter is suspended by a silk or nylon thread.

When magnetic material is placed under the metal base, it attracts the magnet and deflects the pointer. The enclosure prevents movement due to air currents. The metal base damps out any tendency for the magnet to swing or vibrate.



"Your 5U4 was rare, your resistor was well done and your transformer is still cooking."

FLASH-BY-NIGHT

Patent No. 3,139,556

Ray B. Cronkowsky, Bronx, N.Y. (Assigned to Signal-State Corp., Brooklyn, N. Y.)

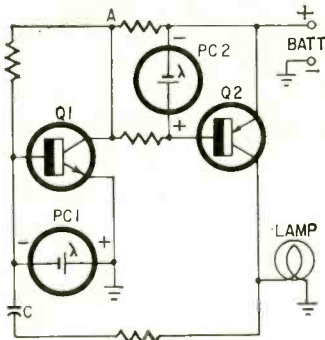

Both transistors are blocked during daytime, because the photocells (PC1, PC2) put reverse bias on them. At night, Q1 can conduct because of the charge on C. Then point A goes negative, and Q2 also conducts. The lamp, now across the battery through Q2, lights up. During conduction, Q2's collector goes positive and discharges C. Now Q1 blocks, and so does Q2. The cycle repeats and the lamp continues to flash during the night.

During daylight, the reverse bias from the photocells not only blocks the transistors, but cuts normal leakage, thus saving battery current.

TESTING EXPLOSIVES

PATENT No. 3,153,757

Marquis W. Bolton, Burbank, Calif. (Assigned to United States of America, as represented by the Secretary of Air Force)

Explosives are often designed to be set off by passing current through a resistive element within the explosive. It is difficult to test such a device.

In this test method, the resistive element is connected across a sensitive galvanometer. Then the meter is rotated to swing its needle. If the element is good, the deflections are quickly damped out. If the element is defective (not continuous) the needle will oscillate.

The current through the resistive element will be safely small (microamps). It is the current generated by the meter windings cutting the magnetic field around them.

SURPLUS VARIABLE TRANSFORMER

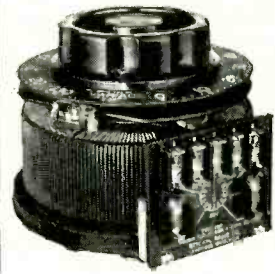

10-amp.

Regular

\$43.00

\$19.95

Postpaid

Adjust-A-Volt type 8159. Brand new as pictured with dial and enclosed housing. Ship. wt. 10 lbs.

\$24.95

Each

Same as above except for panel mount less enclosure and dial.

\$19.95

Postpaid Each

Ganged type of 3 of above for 3-phase service with dial. Postpaid

\$59.95

THE DEPOT HIGHWAY 107 BYPASS MADISON, INDIANA

FREE Catalog OF THE WORLD'S FINEST ELECTRONIC GOV'T SURPLUS BARGAINS



HUNDREDS OF TOP QUALITY

ITEMS — Receivers, Transmitters, Microphones, Inverters, Power Supplies, Meters, Phones, Antennas, Indicators, Filters, Transformers, Amplifiers, Headsets, Converters, Control Boxes, Dynamotors, Test Equipment, Motors, Blowers, Cables, Keys, Chokes, Handsets, Switches, etc. etc. Send for Free Catalog—Dept. R.E.

FAIR RADIO SALES 2133 ELIDA RD. • Box 1105 • LIMA, OHIO

ELECTRONICS

Engineering-Technicians

Bachelor of Science Degree, 30 Months Save Two Years' Time

- Radio-Television Plus Color Technician (12 Months)
- Electronics Engineering Technology (15 Months)
- Electronics Engineering (B.S. Degree)
 - Electrical Engineering (B.S. Degree)
 - Mechanical Engineering (B.S. Degree)
 - Civil Engineering (B.S. Degree)
 - Architecture (B.S. Degree) (36 Months)

Approved for Veterans

DAY AND EVENING CLASSES

Write for Catalog and Registration Application. New Term Starting Soon.

Your Name

Address

City

State

HEALD'S

ENGINEERING COLLEGE

Est. 1863—101 Years

Van Ness at Post, RE

San Francisco, Calif.

Radio-Electronics Market center



"TAB" SILICON 750MA* DIODES Factory Tested
***NEWEST TYPE! LOW LEAKAGE** Gtd.!

Piv/Rms 650/35 .05	Piv/Rms 100/70 .09	Piv/Rms 200/140 .12	Piv/Rms 300/210 .14
Piv/Rms 400/280 .15	Piv/Rms 500/350 .19	Piv/Rms 600/420 .23	Piv/Rms 700/490 .27
Piv/Rms 800/560 .35	Piv/Rms 1000/630 .45	Piv/Rms 1000/700 Query	Piv/Rms 1100/770 Query

ALL TESTS AC & DC & FWD & LOAD!

1700 Piv/1200Rms @ 750Ma \$1.20 @ 10 for \$10 same 1100Piv/770Rms 75c @ .16 for \$11

Silicon Power Diodes Studs & P.F. **

D.C. Amps	50Piv 35Rms	100Piv 70Rms	150Piv 105Rms	200Piv 140Rms
3	.08	.14	.17	.24
12	.30	.55	.70	.85
18**	.20	.30	.50	.75
35	.70	1.00	1.35	1.50
100	3.75	2.05	3.75	3.25
240	3.75	4.75	5.75	8.75

D.C. Amps 300Piv 400Piv 500Piv 600Piv
 210Rms 280Rms 350Rms 420Rms

3	.20	.30	.40	.48
12	1.00	1.50	1.40	1.70
18	1.10	1.50	Query	Query
35	2.15	2.45	2.75	3.30
100	3.75	3.75	5.00	8.00
240	11.70	19.80	27.90	Query

Sil. Pressfit 18A up to 100 Piv 4 for \$1
 Micro or Muwitch CSD 35 Amp/AC-DC . . . 3 for \$1

"TAB" * SCR'S * TRANSISTORS * DIODES!!!
Full Leads Factory Tested & Gtd! U.S.A. Mfg.

PNP/HiPower/15Amp Round TO36 Pckg!
 2N441, 442, 277, 278, DS501 up to
 50 volts VCB0 \$1.25 @ 5 for \$5
 2N278, 443, 174 up to 80V @ 2 for \$5
 PNP Diamond/3A-2N155, 156, 235, 242,
 254, 255, 256, 257, 201, 351 c35 @ .4/\$1
 PNP/Signal up to 350mw TO5 c25 @ .6 for \$1
 NPN/Signal IP, RF, USC, TO5, OV5, c25 @ .6 for \$1
 PNP 2N670/300mw c35 @ .4 for \$1
 PNP 2N671/1watt c50 @ .3 for \$1
 Silicon PNP TO5 & TO18 Pckg. c 25 @ .5 for \$1
 Power Heat Sink Finned 100 \$1 @ .6 for \$5
STABILIZER Diodes Fwd Regulators 1 watt 5 for \$1
 Zener Diodes up to One Watt 6to200v c70 @ 3for \$5
 Zener Diodes Ten Watt 6 to 150v \$1.45 @ .4 for \$5
 Zener Diodes 1watt 5% Tolerance \$1.25 @ .3 for \$3
 Zener Diodes 10watt 5% Tolerance \$2 @ .3 for \$5
 TO36 or TO3 or TO10 Mica Mtg Kit c30 @ .4 for \$1

3000 Piv/2100 Rms @ 200 Ma \$1.80 @ .6 for \$10
 6000 Piv/4200 Rms @ 200 Ma \$4 @ .3 for \$25
 12000 Piv/8400 Rms @ 200 Ma \$10 @ .6 for \$111
 But Chr 6 & 12v up to 5A \$8 @ .2 for \$15
 ZENER AUTO IGNITION 50 to 60v/10 watt. \$1
 2N538, 539, 540 3A/TO10 c50 @ .3 for \$1

"SCR" SILICON CONTROLLED RECTIFIERS:

PRV	7A	16A	25A	PRV	7A	16A	25A
25	.30	.50	.85	250	1.85	2.25	3.60
50	.50	.75	1.00	300	2.00	2.45	2.80
100	.90	1.35	1.60	400	2.50	2.90	3.35
150	1.00	1.65	2.00	500	3.25	3.60	4.00
200	1.30	1.90	2.30	600	3.50	4.35	4.60

Silicon Diodes 3&6 Amp Studs Untested 12 for \$1
 Glass Diodes 1N34/48/60/64 Untested 20 for \$1

"TAB" TERMS: Money Back Guarantee.
 Our 20th year. \$2 Min. order.
 F.O.B. N.Y.C. Add ship. charges
 shown subject to change.

111-JG Liberty St., N. Y. 6, N. Y.
 SEND 25c Phone: Rector 2-6425 for CATALOG

SUB CARRIER DETECTOR

Add programs of commercial music thru your FM tuner. Detector, self-powered, plugs into multiplex output of tuner or easily wired into discriminator and permits reception of famous background music programs now transmitted as hidden programs on the FM broadcast band from coast to coast. Use with ANY FM tuner.

Wired Unit \$75.00
 KIT, with pretuned coils, no alignment necessary \$49.50
 crystal-controlled receivers available

MUSIC ASSOCIATED
 65 Glenwood Road
 Upper Montclair, New Jersey
 phone 744-3387 area code 201

LOW-COST BUSINESS AIDS FOR RADIO-TV SERVICE

Order books, invoice forms, job ticket books, service call books, cash books and statement books for use with your rubber stamp. Customer file systems, book-keeping systems, many others. Write for **FREE 32 PAGE CATALOG** now.

OELRICH PUBLICATIONS
 6556 Higgins Rd., Chicago, Ill. 60656

CONVERT TO COLOR TV

COLORDAPTOR—A simple 10-tube circuit and rotating color wheel converts any size B & W TV to receive compatible color.

COLORDAPTOR—Easily attached to any TV set, does not affect normal operation, often built from parts experimenters have on hand, **BRILLIANT COLOR!**

Complete booklet—gives theory of operation, all construction details, schematic, and sample color filters. **\$195**

Essential Parts Kit—Includes all special parts—coils, delay line, crystal, color filters. Add \$1.00 for sets over 16". **\$19.95**

COLORDAPTOR 1798 Santa Cruz, Menlo Park, Calif.

Rectifiers & Transistors

750 ma Silicon diodes "Epoxy" or "Top Hat"		Silicon Power Diode Studs 3 amps	
PIV	PIV	PIV	PIV
50	5c	600	21c
100	7c	*700	25c
200	10c	*800	32c
400	14c	*900	40c
500	18c	*Top Hat only	200 22c

All Tests
 Full Leads, Tested, Guaranteed, American made

10 Watt Sil. Zener studs, 5v-130v, any voltage \$1.25 ea.
 1 Watt Zener Diode Axial leads 6v-200v 50c ea.
 Sil. diode stud 1500 PIV 300ma 50c ea.
 18 Amp Stud Sil. Rect. 100 PIV 75c ea.
 Hi-Voltage-Silicon epoxy diode, 2 1/2" x 3/8" x 1/2", Hoffman—3000 PIV-200ma. \$1.95 ea.
 Hoffman—6000 PIV-200ma. \$4.50 ea.
 Thermistor, glass bead, 1200 ohms, 600°F, 2/\$1.00
 Sil. Power 2N1724—\$1.50; 2N1936—\$2.00
 20 Watt Germanium (Internal Heat Sink)

2n1038 8 for \$1.00	2n1042 6 for \$1.00
2n1039 6 for \$1.00	2n1043 4 for \$1.00
261040 4 for \$1.00	2n1044 2 for \$1.00
2n1041 2 for \$1.00	2n1045 70c

150 Watt Germanium Hi-Freq Power
 100 Volts, 10 amp. 2n1046 \$1.50 ea.

150 Watt Germanium Power

2n250 2 for \$1.00	2n457 80c
2n456 70c	2n458 90c

HF Sil. 2N702-100mc 40c; 2n703-150mc 60c
 Ger. Switching Transistors 2n 1300 series, assorted, tested, PNP or NPN 10 for \$1.00
 Philco Sil., NPN, 2N2479, new 3 for \$1.00
 Ger Mesa transistor, PNP, 10/\$1.00
 HF Silicon tetrode, 3N35—75c ea.
 Sil. diodes, 1N200 series, assorted, new 15 for \$1.00
 Ger. diodes, glass, new 15 for \$1.00
 Nickel Cadmium Battery 9 1/2" oz. 2 3/4" x 3/4" x 4 1/2", 8 amp-hrs.—\$1.95 ea.

Varicap-voltage variable capacitor—47 pf at 4v., 4:1 new \$1.25 ea.

12 different pots 2-4 W \$1.00
80 assorted 1/4W resistors \$1.00
25 different power resistors to 50W \$1.00

Silicon Controlled Rectifiers

PRV	7	16	PRV	7	16
	amp.	amp.		amp.	amp.
25	.28	.48	200	1.05	1.70
50	.48	.70	300	1.60	2.20
100	.70	1.20	400	2.10	2.70
150	.80	1.50	500	2.80	3.30
			600	3.00	3.90

Money back guarantee, \$2.00 min. order, include postage, Catalogue 25c

ELECTRONIC COMPONENTS CO.
 Box 2902B Baton Rouge, La. 70821

TUCO GUARANTEED SEMI-CONDUCTORS TJCO

NPN "Sylvania"—Germanium, HF, 35 v., TO-5 case 7/\$1.00
 NPN "Transistor"—Silicon, HF, 45-50 v., TO-5 case 4/\$1.00
 2N174 \$1.50, 2N174A \$2.00, 2N1100 2/\$1.00
 \$2.50, 2N307 2/\$1.00
 Stabilizers—SG22—matched pairs each .40
 1N2804b "Motorola" 50M8.825 Zeners. 5.00
 10 watt, TO-3 4.00
 1N3011b "Motorola" 10M150Z5 Zeners. 5.00
 TO watt, stud 150 v. 4.00
 Assorted diodes, all excellent, silicon & germanium 30/\$1.00
 Transistors and silicon controlled switches, TO-18 1.00
 Variable Capacitor—Hammerlund #B128-213, 10 sq. 1 1/2" shaft50
 #49384—Driver transformer, 3/4" x 1 1/2" 8200 to 2500 ohm CT \$3/1.00
 Assorted electrolytics, sub-min, all values 10/\$1.00
 Coil forms, iron & ceramic core, axial, all min. sizes 15/\$1.00
 Porcelain hi-freq. coil ferrite screw, capacitors, 1/4 & 1/2" 6/\$1.00
 Dime size volume controls, 250, 5K, 10K, 100K, 50K ohms 3/\$1.00
 12 pole, 2 pos. rotary switch, HF, sub-min. gold leads75
 Relay 12 volts DC, Potter & Blumfeld, miniature, sensitive 1.50
 Thermistors, sub-min.35
 Insulator kit for TO-36 power transistors25
 Heat sinks for TO-5 case30
 NEW PC board, dual flip-flop hi-freq. 4 transistors & comp. 4/\$1.00
 4 pole DT mom. push button switch, min. Excellent for Intercom50
 Bag of most needed miniature electronic parts—assorted 2.00

Write for Free Catalog. Minimum order \$3.00
TRANSISTORS UNLIMITED COMPANY
 462 Jericho Tpke., Mineola, New York. 516-Pi 7-7221

PARTS
 + SERVICE +
 FOR ALL
GERMAN
 RADIOS-PHONOGRAPHS
 TAPE RECORDERS
EUROTECH SERVICE CO.
 66-44 FOREST AVENUE
 BROOKLYN 27, N.Y. HY 7-1448

FREE CATALOG!
 148 PAGES • NEARLY 4,000 BARGAINS
 OPTICS • SCIENCE • MATH

Completely new 1965 edition. New items, categories, illustrations. 148 new easy-to-read pages packed with nearly 4000 items. Dozens of electrical and electromagnetic parts, accessories. Enormous selection of astronomical Telescopes, Microscopes, Binoculars, Magnifiers, Magnets, Lenses, Prisms. Many war surplus items for hobbyists, experimenters, workshop, factory. Write for catalog "EH".

CLIP AND MAIL COUPON TODAY

EDMUND SCIENTIFIC CO., Barrington, N. J.
 PLEASE SEND ME FREE CATALOG "EH"
 Name _____
 Address _____
 City _____ State _____

new Books

DIODE SELECT-A-SPEC, by Editorial Staff of Tech-Press Publications, Brownsburg, Ind. 46112. 6 x 9 in., 137 pp. Paper, \$2.95.

Contains specifications (working and peak voltages, forward current and voltage, reverse-current, type and use) on 2,000 signal and power diodes of over 50 manufacturers, with more than 25,000 substitutions, listed in order of their suitability. Two additional tables list diodes according to maximum working voltage and maximum forward current.

ABC'S OF COMPUTER PROGRAMMING, by Allan Lytel. Howard W. Sams & Co., Inc., 4300 W. 62 St., Indianapolis 6, Ind. 5 1/2 x 8 1/2 in., 126 pp. Paper, \$1.95

This book presents the fundamentals of digital computer programming. Actual examples show how to handle simple and complex problems.

TELECOMMUNICATION SATELLITES, edited by Kenneth W. Gatland. Prentice-Hall, Inc., Englewood Cliffs, N. J. 5 1/2 x 8 1/2 in., 441 pp. Cloth, \$14.50

Technical information about Echo, Telstar, Syncom and other satellites for relaying TV messages over vast distances. Construction, theoretical problems, results of tests, and future prospects are discussed and analyzed.

INTRODUCTION TO MICROELECTRONICS AND INTEGRATED CIRCUITS, by Allan Lytel. Howard W. Sams & Co., Inc., 4300 W. 62 St., Indianapolis 6, Ind. 5 1/2 x 8 1/2 in., 160 pp. Paper, \$2.95

A reference book for technicians and students. Discusses the design, construction and application of miniaturized components printed circuits and micromodules.

continued on page 97

Don't settle for less!

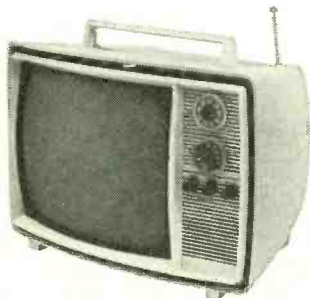

new! semi-kit 19" TV

gives you absolutely

TOP PERFORMANCE

Excellent reception even in poorest reception areas; sharper, brighter pictures. Shipped to you in pretested, easy to assemble modular units. Great for built-ins. Write today for descriptive literature and low direct-to-you price.

For the best in sight and sound
Arkay International, Inc.
2376 Linden Blvd., Brooklyn 8, N.Y.

ADVERTISING INDEX

RADIO-ELECTRONICS does not assume responsibility for any errors which may appear in the index below.

Aerovox Corporation (Distributor Div.)	66
Antenna Specialists Co., The	18
Arkay International, Inc.	95
Blonder-Tongue	26
B & K Manufacturing Co. (Div. of Dynascan Corp.)	85
Brooks Radio & TV Corp.	86, 87
Capitol Radio Engineering Institute, The	28-31
Castle TV Tuner Service, Inc.	8
CLASSIFIED	96, 97
Cleveland Institute of Electronics	3, 62-65
Coyne Electronics Institute (Home Training Div.)	84
Depot, The	93
DeVry Technical Institute	7
ECI Electronics Communications, Inc.	25
Edlie Electronics, Inc.	88
EICO Electronic Instrument Co., Inc.	72
Electronic Measurements Corp. (EMC)	77
Electro-Voice, Inc.	59
Fair Radio Sales	93
Jerrold Electronics	Third Cover
Gernsback Library, Inc.	90
Gregory Electronics Corporation	95
Heald's Engineering College	93
Heath Company	68-69
IEEE Convention and Show	89
I.E.H. Manufacturing Co., Inc. (Subsidiary of Industrial Electronic Hardware Corp.)	77
International Crystal Mfg. Co., Inc.	23
Kinematix, Inc.	79, 89
Lafayette Radio Electronics	9
Lectrotech Inc.	73
Mallory Distributor Products Company (Div. of P. R. Mallory & Co., Inc.)	32
Mercury Electronics Corporation	24
Moog Company, R.A.	84
Multicore Sales Corp.	78
National Radio Institute	10-13
National Technical Schools	5
P.A.F. Enterprises	78
Perma-Power Company	67
Poly Paks	97
Powertronics Corp.	76
Progressive "Edu-Kits" Inc.	74
Radio Shack	98
RCA Electronics Components and Devices Test Equipment	14
Tubes	Fourth Cover
RCA Institutes, Inc.	80-83
RCA Parts and Accessories	20-21
Sams & Co., Inc., Howard W.	17, 60
Sarkes Tarzian, Inc. (Tuner Service Div.)	16
Schober Organ Corp., The	19
Semitronics Corp.	79
Sencore	75
Sprague Products Company	22
Sylvania (Subsidiary of General Telephone & Electronics)	15
Tarzian, Inc. Sarkes (Tuner Service Div.)	16
Texas Crystals (Div. of Whitehall Electronics Corp.)	90
Tram Electronics, Incorporated	18
Triplett Electrical Instrument Company, The	Second Cover
Turner Microphone Company, The	27
United Radio Co.	92
Vero Electronics Inc.	87
Warren Electronic Components	88
Wen Products, Inc.	61
Winegard Co.	71

MARKET CENTER	94
Colordaptor	
Edmund Scientific Co.	
Eurotech Service Co.	
Electronic Components Co.	
Music Associated	
Oelrich Publications	
TAB	
Transistors Unlimited Company	

SCHOOL DIRECTORY	91
American Institute of Engineering & Technology	
Central Technical Institute	
Coyne Electronics Institute (Resident Training Div.)	
Electronic Technical Institute	
Grantham School of Electronics	
Indiana Home Study Institute, The	
The Milwaukee School of Engineering	
Northrop Institute of Technology	
Tri-State College	
Valparaiso Technical Institute	

GREGORY ELECTRONICS Reconditioned FM 2-Way Radio Savings

THIS IS A PARTIAL LIST—
WRITE FOR NEW 1965
E-X-P-A-N-D-E-D CATALOG

SPECIAL PURCHASE

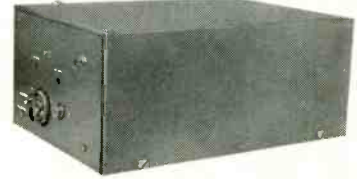

RCA 25-54 MC-CMV2F5
6/12 VOLT 30-WATT
VIBRATOR
POWER SUPPLY

Fully Narrow Banded
(TX + RX)—Complete with
all accessories

\$88.

Same unit tuned to desired
frequency, including
new antenna . . . \$128.

Extra Special Purchase

Reconditioned General Electric

Voice Commander

Personal FM
Transmitter-Receiver
132 to 172 MC, 1 W
9.5" x 5.3" x 1.7"



The General Electric VOICE COMMANDER Personal Transmitter-Receiver is a high performance, completely self-contained two-way FM Radio. Extremely compact and light weight, the VOICE COMMANDER is simple to operate and easily hand carried.

Except for the final stages of the transmitter, the VOICE COMMANDER is completely transistorized. PRICE, including Brand New rechargeable Nickel-Cadmium Battery Pack

\$178

If crystals and tuning is desired, add \$40.00.

We also have the proper chargers for these units, GE Model #4EP27A10, Price: \$18.

If add'l. nickel cadmium batteries are required, \$25. each. Lapel microphones at \$5. or battery pack, power supply bottom housing at \$40.



We Buy Late Model Equipment for Cash
—Write; Wire or Phone!



GREGORY ELECTRONICS CORPORATION

249-A Rt. 46 • Phone 773-7550
Saddle Brook, N.J. • Area Code 201

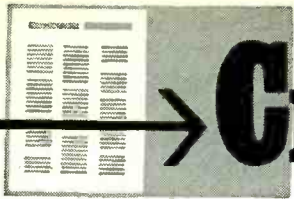

Classified Ads

COMMERCIAL RATE (for firms or individuals offering commercial products or services): 55¢ per word . . . minimum 10 words.
NON-COMMERCIAL RATE (for individuals who want to buy or sell personal items): 30¢ per word . . . no minimum.
 Payment must accompany all ads except those placed by accredited advertising agencies. 10% discount on 12 consecutive insertions, if paid in advance. Misleading or objectionable ads not accepted. Copy for June issue must reach us before April 10th.
WORD COUNT: Include name and address. Name of city (Des Moines) or of state (New York) counts as one word each. Zone or Zip Code numbers not counted. (We reserve the right to omit Zip Code if space does not permit.) Count each abbreviation, initial, single figure or group of figures or letters as a word. Symbols or groups such as 8x10, COD, AC, etc., count as one word. Hyphenated words count as two words. Minor over-wordage will be edited to match advance payment.

General

TV SERVICE ORDER BOOKS for use with your rubber stamp. Duplicate or triplicate. Low cost. Write for **FREE 32 PAGE CATALOG** and Special Rubber Stamp Offer. **OELRICH PUBLICATIONS**, 6556 W. Higgins, Chicago, Ill. 60656.

72 page Illustrated Government Surplus Radio, Gadgets Catalog 20¢. **MESHNA**, Nahant, Mass.

McGEE RADIO COMPANY. Big 1965 176-page catalog sent free. America's best values hi-fi amplifiers-speakers-electronic parts. 1901 McGee Street, Dept. RE, Kansas City, Mo. 64108.

FREE CATALOG of 200 special slide rules and calculating aids. **DYNA-SLIDE**, 600 South Michigan, Chicago, Illinois 60605

HOBBYISTS Electroplating Kit. \$3.95 postpaid. Details. **MINIPLATING**, Box 115, Mansfield, Mass.

Canadians

GIANT SURPLUS BARGAIN PACKED CATALOGS. Electronics, Hi-Fi, Shortwave, Amateur, Citizens Radio, Rush \$1.00 (Refunded). **ETCO**, Box 741, Dept. R. Montreal, Canada.

CANADIANS Have you seen **ELECTRON**, Canada's own Service and Hobby magazine? Subscription \$3.50. **ELECTRON**, Box 796, Montreal, Canada.

TRANSISTOR AND SEMICONDUCTOR SPECIALISTS. Free winter catalogue contains reference data on over 300 types. **J. & J. ELECTRONICS**, Box 1437, Winnipeg, Manitoba.

WANTED

G-R, H-P, L&N, etc. Special tubes, manuals, military electronics. **ENGINEERING ASSOCIATES**, 434 Patterson Road, Dayton 19, Ohio.

QUICK CASH . . . for Electronic EQUIPMENT, COMPONENTS, unused TUBES. Send list now! **BARRY**, 512 Broadway, New York, N. Y. 10012, 212 WALKER 5-7000.

USED TV SETS WANTED—as is any quantity. TR 4 8128 WHOLESALE TV, 282 Columbus Avenue, New York 23, N.Y.

SERVICES

METERS—MULTIMETERS REPAIRED and calibrated. **BIGELOW ELECTRONICS**, Box 71-B, Bluffton, Ohio.

SPEAKER RECONING. Satisfaction Guaranteed. **C & M RECON CO.**, 11 Witherspoon Street, Princeton, New Jersey

TRANSISTORIZED products dealers catalog, \$1. **INTERMARKET**, CPO 1717, Tokyo, Japan.

ALL MAKES OF ELECTRICAL INSTRUMENTS AND TESTING equipment repaired. **HAZELTON INSTRUMENT CO.**, 128 Liberty St., New York, N.Y.

TV TUNERS Rebuilt and Aligned per manufacturer specification. Only \$9.50. Any Make UHF or VHF. We ship COD Ninety day written guarantee. Ship complete with tubes or write for free mailing kit and dealer brochure. **JW ELECTRONICS**, Box 51 D, Bloomington, Ind.

1-Day Service. Transistor Radios, recorders, walkie-talkies. 3.50 covers parts, labor, return postage. Guaranteed. **TRANSISTOR SPECIALISTS**, Box 304 Station A, Owensboro, Ky. 42302

PUBLISH your book! Join our successful authors: publicity advertising promotion, beautiful books. All subjects invited. Send for free manuscript report and detailed booklet. **CARLTON PRESS**, Dept. RDP, 84 Fifth Avenue, New York 11.

Motion Pictures

SPECTACULAR '64 Indianapolis "500" Classic. 188' 8mm Eastman Color including fiery second lap crash \$11.95 postpaid. **SPORTLITE "500" FILMS**, 20-RE North Wacker, Chicago, Illinois 60606

Audio—Hi-fi

Component quotations—tapes Mylar 1800' postpaid \$1.59 each. **BAYLA**, Box 131RE Wantagh, N.Y.

DISCOUNT RECORDS—All labels. Free list. Write **CLIFF HOUSE**, Box 42R12, Utica, N.Y.

WRITE for highest discounts on components, recorders, tapes, from franchised distributors. Send for **FREE** monthly specials. **CARSTON**, 125-R East 88. N.Y.C. 10028.

TAPE RECORDER BARGAINS. Brand new, latest models. \$10.00 above cost. **ARKAY SALES**, 22-05 Riverside Avenue, Medford, Mass. 02155

RENT STEREO TAPES—over 2,500 different—all major labels—free brochure. **STEREO-PARTI**, 1616 Terrace Way, Santa Rosa, Calif.

STEREO TAPES. Save up to 60% (no membership fees). We discount recorders, batteries, accessories, and mail pre-recorded tape prepaid anywhere that United States rates prevail. Free 60 page catalog. **SAXITONE**, 1776 Columbia Road N.W., Washington, D.C. 20009

RECORDS made from your tapes. 45 or 33 rpm. For price list and format send \$1 **BARRIE LABORATORIES**, Box 206, North Wales, Pa.

TOP quality Sarkes Tarzian's Galaxie tensitized Mylar tapes: 1800"—1.56, 2400"—2.59, 3600"—3.69, plus postage. Moneyback guarantee. Free Price list, handbook: "Fun with your tape recorder". **POPE ELECTRONICS**, 1716-RE Northfield, Muncie, Indiana

STEREO TAPE RENTALS for the discriminating listener. Free Catalog. **GOLD COAST TAPE LIBRARY**, Box 2262-Palm Village, Hialeah, Fla.

TAPE recorders, Hi-Fi components, Sleep-learning equipment, Tapes, Unusual values. Free catalog. **DRESSNER**, 1523 Jericho Turnpike, New Hyde Park 5, N.Y.

HI-FI COMPONENTS. Tape Recorders, at guaranteed "WE will not be undersold" prices. 15-day moneyback guarantee. Two-year warranty. NO Catalog. Quotations Free. **HI-FIDELITY CENTER**, 1797 (R) 1st Ave., New York, N.Y. 10028

TAPE-MATES MAKES AVAILABLE TO YOU—all 4 Track stereo tapes—all labels—postpaid to your door—at tremendous savings. For free brochure write **TAPE-MATES CLUB**, 5280-RE, W. Pico Blvd., Los Angeles, Calif. 90019

Introductory opportunity for servicemen, experimenters. New accounts will receive 10% off transistors and parts for month of April. Electronic parts of any project in RE supplied. Send 10¢ for catalog. **BRANDWEIN CO.**, 306 W. 100 St., N.Y.C.

Electronics

FREE! Giant bargain catalog on transistors, diodes, rectifiers, components, valuable parts, equipment. **POLY PAKS**, P. O. Box 942S, Lynnfield, Mass.

15 **DISTANCE** One-tube plans—25¢. "Radio Workbench" Handbook—50¢. Catalog. **LABORATORIES**, 1131-B Valota, Redwood City, California

RESISTORS, newest type metal-film, Copper Circuit Board, Capacitors, Terminal Blocks, Free Catalog. **FARNSWORTH ELECTRONIC COMPONENTS**, 88 Berkeley, Rochester, New York 14607

GOVERNMENT SURPLUS JEEPS—\$62.50. Voltmeters—\$1.05. Transmitters—\$6.18. Oscilloscopes, Walkie-Talkies, Multimeters. Typical Surplus Prices. Exciting Details **FREE**. Write: **ENTERPRISES**, Box 402-F21, Jamaica 30, New York

DIAGRAMS FOR REPAIRING RADIOS \$1.00. Television \$2.50. Give make, model. **DIAGRAM SERVICE**, Box 1151 RE, Manchester, Conn.

TV CAMERAS, transmitters, converters, etc. Lowest factory prices. Catalog 10¢. **VANGUARD**, 190-48-99th Ave., Hollis, N.Y. 11423.

PROFESSIONAL ELECTRONICS PROJECTS—Organs, Timers, Computers, etc.—\$1 up. Catalog 25¢, refundable. **PARKS**, Box 25565, Seattle, Wash. 98125.

CLASSIFIED ADVERTISING ORDER FORM

Please refer to heading at top of classified section for complete data concerning terms, frequency discounts, closing dates, word count, etc.

1	2	3	4	5
6	7	8	9	10
11	12	13	14	15
16	17	18	19	20
21	22	23	24	25
26	27	28	29	30
31	32	33	34	35

No. of Words { @ .30 Non-Commercial Rate } = \$
 { @ .55 Commercial Rate }

Total Enclosed \$

Insert _____ time(s)

Starting with _____ issue

Payment must accompany order unless placed through accredited advertising agency. 45

NAME _____

ADDRESS _____

CITY _____ STATE _____ ZIP _____

SIGNATURE _____

MAIL TO: RADIO-ELECTRONICS, CLASSIFIED AD DEPT., 154 WEST 14TH ST., NEW YORK, N.Y. 10011

SALVAGE CIRCUIT BOARDS packed with dozens of transistors, diodes, miniature transformers, capacitors etc. Assortment "A" \$5.00, "B" \$4.00, "C" \$3.00, all different, postpaid. **ENGINEERING ASSOCIATES**, 434 Patterson Road, Dayton, Ohio 45419.

RADIO & TV TUBES 33¢. Free List. **CORNELL**, 4217-E University, San Diego, Calif. 92105.

BEFORE You Buy Receiving Tubes, Transistors, Diodes, Electronic Components & Accessories... send for Giant Free Zalytron Current Catalog, featuring all STANDARD BRAND TUBES all Brand New Premium Individually Boxed. One Year Guarantee—all at BIGGEST DISCOUNTS in America! We serve professional servicemen, hobbyists, experimenters, engineers, technicians. **WHY PAY MORE? ZALYTRON TUBE CORP.**, 469R Jericho Turnpike, Mineola, N.Y. 11502

TRANSISTOR IGNITION! Coil, ballast 7.95 Free parts lists. **TRANSFIRE** Carlisle 20, Mass. 01741

DIAGRAMS, plus complete service information. Television \$2, Radio, Hi-Fi, etc. \$1. **SERVICAIDE**, Box 3412, Harrisburg, Pa. 17105

SILICON CONTROLLED SWITCHES 3N58-\$1.50; 3N59-\$1.60; 3N60-\$1.75. Glass silicon rectifiers-200 Ma-50PIV-100/\$4.25; 100PIV-100/5.25; 150 PIV 100/7.25; 200PIV-100/9.75. Transistorized power supply-12V DC to 115 V AC 50W-KIT-\$9.95. **ADVANCE ELECTRONICS**, 79A Cortland St., New York, N.Y. 10007

\$100.00 WEEKLY or more selling Banshee TS-30 transistor ignition systems and coils big demand demonstration discount FREE money making brochure. **SLEEP ELECTRONICS COMPANY**, Drawer 178RE, Ellenton, Florida 33532

APPLIANCE-LAMP-parts. Wholesale Catalogue 25¢. **SECO**, 112 South 20th Street, Birmingham, Alabama 35233

RESISTORS. 1/2-watt .04, 1-watt .05, 2-watt .08. **T. J. SOUND STUDIOS**, 139 Pugsley Avenue, Bronx 72, N.Y.

TUBES. Oldest, latest. Lists free. **STEINMETZ**, 7519 Maplewood, Hammond, Indiana 46324

MANUALS for surplus electronics. Stamp for list. **BOOKS**, Box 184, Riverdale, Maryland

UNUSUAL electrical devices. Free catalog. **WELLSCO**, 15845 Simonds, Granada Hills, California

LIKE NEW Hickock 650C: used Jackson TVG-1; Jackson, CRO-1; Extra ray tube; Sylvania 220 Tube tester and new tube adapter. Make offers. **R. CONOVER**, Stone Ridge, New York

EDUCATION/INSTRUCTION

LEARN ELECTRONIC ORGAN SERVICING. New home study course covering all makes electronic organ including transistors. Experimental kits—schematics—trouble-shooting. Accredited NHSC-GI Approved Write for free booklet. **NILES BRYANT SCHOOL**, 3631 Stockton Blvd., Dept. F, Sacramento 20, Calif.

HIGHLY—effective home study review for FCC commercial phone exams. Free literature! **COOK'S SCHOOL OF ELECTRONICS**, Craigmont, Idaho 83523.

FCC LICENSE in 6 weeks. First Class Radio Telephone. Results Guaranteed. **ELKINS RADIO SCHOOL**, 2603E Inwood, Dallas, Tex.

SLEEP LEARNING. Hypnotism! Tapes, records, books, equipment. Details, strange catalog FREE. **RESEARCH ASSOCIATION**, Box 24-RD, Olympia, Wash.

BROADCASTING, Communications Electronics taught quickly—resident classes; correspondence. Free details. Write: Dept. 4, **GRANTHAM SCHOOLS**, 1505 N. Western, Hollywood, Calif. 90027

LEARN WHILE ASLEEP. 92% effective. Build dynamic personality. Improve health. Motivate success. Details free. **A.S.R. FOUNDATION**, Box 70721RE, Henry Clay Sta., Lexington, Ky.

Business Opportunities

PIANO Tuning learned quickly at home. Tremendous field! Musical knowledge unnecessary. Information free. **EMPIRE SCHOOL OF PIANO TUNING**, Dep't. RE Box 327, Shenandoah Station, Miami, Florida 33145. (Founded 1935.)

BUSINESS AIDS

JUST STARTING IN TV SERVICE? Write for FREE 32 PAGE CATALOG of Service Order books, invoices, job tickets, phone message books, statements and file systems. **OELRICH PUBLICATIONS**, 6556 W. Higgins, Chicago, Ill. 60656.

1,000 Business Cards, "Raised Letters" \$3.95 postpaid. Samples. **ROUTH RE12**, 2633 Randleman, Greensboro, N.C. 27406.

BOOKS

continued from page 95

CONCISE DICTIONARY OF ATOMICS, by Alfred del Vecchio. *Philosophical Library, Inc.*, 15 E. 40 St., New York, N.Y. 10016. 5 1/2 x 8 1/2 in., 262 pp. Cloth, \$6.

An apparently complete dictionary of the new terms that have come into use since the atom was first split in 1939, and the common-language words (can, coffin, etc.) that have special meanings in the world of nuclear physics. Definitions are clear.

EARLY ELECTRICAL COMMUNICATION, by E. A. Marland. *Abelard-Schuman Publishers*, 6 W. 57 St., New York, N.Y. 10019. 5 1/2 x 9 in., 220 pp. Cloth, \$6.

A history of the telegraph, starting with the earliest proposals for signaling over wires. Americans will be surprised to find that S. F. B. Morse is given only a dozen pages, beginning on page 129. The last chapter of the book describes the invention of the telephone.

ADVANCED SERVICING TECHNIQUES (Vol. 1), by Paul B. Zbar and Peter W. Orne. *John F. Rider Publisher, Inc.*, 116 W. 14 St., New York, N.Y. 10011. 8 1/2 x 11 in., 298 pp. Cloth, \$8.25

Breaks the set down into sections with a chapter for each, giving special attention to color. Has chapters on test equipment, printed circuit servicing and transistor TV servicing. **END**

DOUBLE BONUS

\$25

PLUS
CHOOSE
ANY
\$1.00
ITEM
FREE

WORTH OF
 TRANSISTORS
 RECTIFIERS
 RESISTORS
 CONDENSERS
 DIODES ETC.

Add 25¢ for handling

BOTH FREE WITH ANY \$10 ORDER

SILICON POWER RECTIFIERS					
D.C. AMPS	50 PIV 35 RMS	100 PIV 70 RMS	150 PIV 105 RMS	200 PIV 140 RMS	
7	.25	.35	.49	.59	
16	.45	.65	.75	.90	
25	.75	.85	.95	1.10	
30	1.60	1.90	2.30	2.80	
D.C. AMPS	300 PIV 210 RMS	400 PIV 280 RMS	500 PIV 350 RMS	600 PIV 450 RMS	
7	.79	.95	1.05	1.29	
16	1.10	1.35	1.50	1.70	
25	1.20	1.50	1.70	1.90	
30	3.50	4.20	5.25	7.00	

WORLD'S MOST POPULAR \$1 PARTS PAKS

- 4 TRANSISTOR TRANSFORMERS, asst. worth \$25 \$1
- 40 WORLD'S SMALLEST RESIST., 50¢ too. 1/10W \$1
- 60 CERAMIC CONDENSERS, discs, 1µf to .05µf \$1
- 40 PRECISION RESISTORS, asst. 1%, 1/2, 1, 2W \$1
- 10 ELECTROLYTICS, FP & tubulars, to 500µf \$1
- 30 SPRAGUE MYLAR condensers, asst. val., volts \$1
- 75 ASST. HALF WATT RESISTORS, 50¢ too \$1
- 35 TWO WATERS, resistors, 50¢ too. A-B too \$1
- 40 DISC CONDENSERS, to .01 to 1KV, mylars too \$1
- 10 RCA PHONO PLUG 'n' JACK SETS, tun-amps \$1
- 60 HI-Q RESISTORS, 1/2, 1, 2W to 1 meg. 50¢ too \$1

FACTORY TESTED SEMI-KON-DUCTORS

- 6-1AMP 400V epoxy rectifiers, made by Sylvania \$1
- 3-2N255 TRANSISTORS, or equals, TO3 cases \$1
- 6-2N408 RCA OUTPUT TRANSISTORS, pnp, TO18 \$1
- 1-2N1613 3W NPN SIL. 120 me, by "Rheem" \$1
- 1 20W SILICON MESA, 2N1648, 2N424 equals, nnp, \$1
- 5-2N107 TRANSISTORS, pnp, audio, by "G.E." \$1
- 3 CBS 35W PWR TRANSISTRS. 2N1434, pnp, stud. \$1
- 3-20 WATERS. 2N1038/42, w/sink by TEXAS \$1
- 3-2N341 NPN SIL. ONE WATT, by Transiltron \$1
- 10 PNP SWITCHING TRANSISTORS, TO5 cases \$1
- 4-2N43 OUTPUT TRANSISTORS, by GE, pnp, TO5 \$1
- 4-2N170 TRANSISTORS, by GE, rf, npns \$1
- 10 NPN SWITCHING transistors, like 2N388, etc. \$1
- 5 ONE WATT ZENERS, 6V, gold axial by Transiltron \$1
- 4 CK721 TRANSISTORS, in new atom. cases, pnp \$1
- 10 "PIN HEAD" TRANSISTORS, rf, if, pnp \$1
- 2 500MC, 2N964, epitaxial, mesa, pnp, TO18 cases \$1
- 3-300MC TRANSISTORS, 2N1264, by Sylvania \$1
- 4 TRANSISTORS, 2N35, by Sylvania, nnp, TO22 \$1
- 2-25AMP SILICON RECT., (1) 50V, (1) 100V \$1
- 2 TRANSISTORS, 2N497, 2N498, made by Rheem \$1

NEW TRANSITRON SCRS SILICON CONTROLLED RECTIFIERS

PRV	7 AMP	16 AMP	25 AMP	PRV	7 AMP	16 AMP	25 AMP
25	.50	.85	1.20	250	2.30	2.65	3.10
50	.85	1.20	1.40	300	2.60	3.00	3.40
100	1.35	1.80	2.20	400	2.90	3.25	3.75
150	1.60	2.10	2.55				
200	1.75	2.40	2.90				

FULLY TESTED

1 Amp-SILICON "TOPHAT" DIODES

LOW LEAKAGE FULL LEAD LENGTH

PIV/RMS	FIV/RMS	FIV/RMS	PIV/RMS
50/35	100/70	200/140	300/210
.05 ea.	.09 ea.	.12 ea.	.16 ea.
PIV/RMS	PIV/RMS	PIV/RMS	PIV/RMS
400/280	500/350	600/420	700/490
.20 ea.	.24 ea.	.32 ea.	.40 ea.
PIV/RMS	PIV/RMS	PIV/RMS	
800/560	900/630	1000/700	
.48 ea.	.55 ea.	.70 ea.	

- MAGNETIC SWITCH burglar alarms, with magnets \$1
- FILAMENT TRANSFORMERS 115 v. to 6.3 v. 3-A. \$1
- 25 'CERAFIL' WORLD'S SMALLEST COND., to .05 µf \$1
- 10 VOLUME CONTROLS to 1 meg. switch too \$1
- 3 INFRA-RED PHOTO DETECTORS, long leads \$1
- 30 'CORNING' LOW NOISE RESIST'S, 1/2, 1, 2W \$1
- \$25 RELAY SURPRISE, assorted SUBMINIATURE \$1
- 50 COILS & CHOKES, rf, if, osc, peaking, etc. \$1
- \$25 RADIO 'n' TV SURPRISE, wide variety \$1
- 10 TRANSISTOR ELECTROLYTICS, 10 to 100µf \$1
- 50 RADIO & TV KNOBS, assorted colors, styles \$1
- 50 MICA CAPACITORS, to .01µf, silvers too \$1
- 30 POWER RESISTORS, to 50W to 24kohms \$1
- 60 TUBE SOCKETS, receptacles, audio, plugs, etc. \$1
- 50 TUBULAR CONDENSERS to .5µf to 1KV \$1
- 10 TRANSISTOR SOCKETS for pnp-npn transistors \$1

<h4 style="text-align: center;">TRANSITRON Planar Controlled Switch</h4> <table style="width: 100%; border-collapse: collapse;"> <thead> <tr> <th>PRV</th> <th>NET</th> <th>Sale</th> </tr> </thead> <tbody> <tr> <td>15</td> <td>9.00</td> <td>.98</td> </tr> <tr> <td>30</td> <td>11.25</td> <td>1.21</td> </tr> <tr> <td>60</td> <td>14.70</td> <td>1.37</td> </tr> <tr> <td>100</td> <td>21.60</td> <td>1.60</td> </tr> <tr> <td>150</td> <td>32.00</td> <td>2.22</td> </tr> <tr> <td>200</td> <td>36.00</td> <td>2.40</td> </tr> <tr> <td>300</td> <td>41.25</td> <td>2.75</td> </tr> </tbody> </table>	PRV	NET	Sale	15	9.00	.98	30	11.25	1.21	60	14.70	1.37	100	21.60	1.60	150	32.00	2.22	200	36.00	2.40	300	41.25	2.75	<h4 style="text-align: center;">10 WATT ZENERS</h4> <table style="width: 100%; border-collapse: collapse;"> <thead> <tr> <th>5V</th> <th>6V</th> <th>12V</th> <th>14V</th> <th>20V</th> <th>24V</th> <th>42V</th> <th>45V</th> <th>60V</th> </tr> </thead> <tbody> <tr> <td>Each</td> <td>1.00</td> <td></td> <td></td> <td></td> <td></td> <td></td> <td></td> <td></td> </tr> <tr> <td></td> <td></td> <td></td> <td></td> <td></td> <td></td> <td></td> <td></td> <td></td> </tr> <tr> <td></td> <td></td> <td></td> <td></td> <td></td> <td></td> <td></td> <td></td> <td></td> </tr> <tr> <td></td> <td></td> <td></td> <td></td> <td></td> <td></td> <td></td> <td></td> <td></td> </tr> <tr> <td></td> <td></td> <td></td> <td></td> <td></td> <td></td> <td></td> <td></td> <td></td> </tr> <tr> <td></td> <td></td> <td></td> <td></td> <td></td> <td></td> <td></td> <td></td> <td></td> </tr> <tr> <td></td> <td></td> <td></td> <td></td> <td></td> <td></td> <td></td> <td></td> <td></td> </tr> <tr> <td></td> <td></td> <td></td> <td></td> <td></td> <td></td> <td></td> <td></td> <td></td> </tr> <tr> <td></td> <td></td> <td></td> <td></td> <td></td> <td></td> <td></td> <td></td> <td></td> </tr> </tbody> </table>	5V	6V	12V	14V	20V	24V	42V	45V	60V	Each	1.00																																																																															
PRV	NET	Sale																																																																																																																	
15	9.00	.98																																																																																																																	
30	11.25	1.21																																																																																																																	
60	14.70	1.37																																																																																																																	
100	21.60	1.60																																																																																																																	
150	32.00	2.22																																																																																																																	
200	36.00	2.40																																																																																																																	
300	41.25	2.75																																																																																																																	
5V	6V	12V	14V	20V	24V	42V	45V	60V																																																																																																											
Each	1.00																																																																																																																		

<h4 style="text-align: center;">3-TRANSISTOR AMPLIFIER</h4> <ul style="list-style-type: none"> • Only 3"x2"x3/4" • Printed circuit • Wired, subminiature <h2 style="text-align: center; font-weight: bold;">\$139</h2>	<h4 style="text-align: center;">GERMANIUM DIODE 100 FOR Sale \$1</h4>
---	---

<h4 style="text-align: center;">PARTS BY THE POUND</h4> <p style="text-align: center;">500-1000 pcs ONE POUND DISCS 48¢</p>	<h4 style="text-align: center;">TRANSISTORS 100 for \$2.95</h4> <p style="text-align: center;">Power, Audio, RF, untested</p>
--	---

- 3-2N329A NPN TRANSISTORS, by Rheem \$1
- 5-300MC TRANSISTORS, 2N247, by Sylvania \$1
- 10-WATT ZENER STUD ANY VOLTAGE 3V to 200 \$1
- 2-2N718 NPN SILICON PLANARS, by Fairchild \$1
- 10 2-AMP RECTIFIERS, 50 to 400V, studs \$1
- 1 3N35 TETRODE, 150mc transistor, silicon pnp \$1
- HOFFMAN SATELITE SILICON SUN CELL, 3/8x1" \$1
- 4 2N219 TRANSISTORS, mixer-conv, by Sylvania \$1
- 15 PNP & NPN SWITCHING transistors, by TEXAS \$1
- 30 TRANSISTORS, rf, if, TO5 cases, untested \$1
- 25 TOP HAT RECTIFIERS, silicon, 1 untested \$1
- 25 GERMANIUM DIODES, silicon, too, untested \$1
- 10 1000ML CERAMIC RECTIFIERS 50 - 400 PIV \$1
- 25 SEMI-KON-DUCTORS, rect, diodes, transistors \$1
- 15 NPN TRANSISTORS, rf, if, audio, sw, untested \$1
- 15 PNP TRANSISTORS, rf, if, audio, sw, untested \$1
- 10 CK722 TRANSISTORS, pnp, made by Raytheon \$1
- 10 MICRO DIODE STABILISERS. EPOXY silicon \$1
- 4-1AMP 700V TOP HAT RECTIFIERS, SILICON \$1
- 4 1N429 ZENER REFERENCES by Transiltron 6V, \$1
- 2 2N706 500MW, 300MC NPN PLANAR, TO18 \$1
- 15 TRANSISTORS, osc-ifs-driver-p-p, by Rheem \$1
- 4. 2N333 NPN SILICON TRANSISTORS, Sylvania \$1

10¢ GIANT SPRING CATALOG ON:

Zeners Rectifiers Transistors SCRs

POLY PAKS

TERMS: send check, money order, include postage-avg. wt. per pak 1 lb. Rated, net 30 days. CODS 25% down.

P.O. BOX 942R
50. LYNNFIELD, MASS.
"PAK-KING" of the world

NEW from RADIO SHACK

AN INTERCOMMUNICATIONS BREAKTHROUGH!

REALISTIC SELECTaCOM

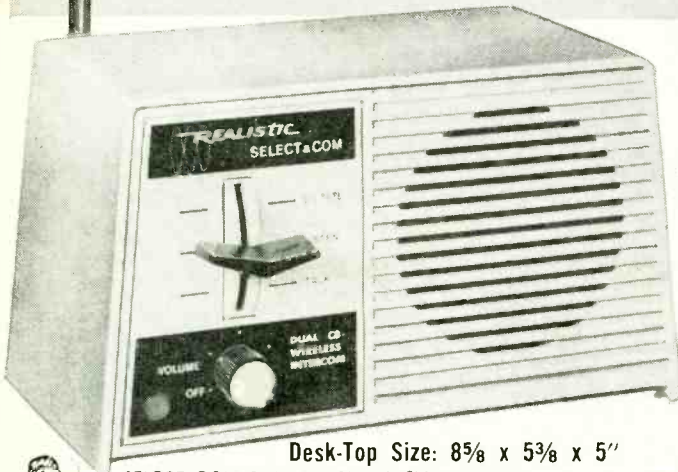

Desk-Top Size: 8 $\frac{5}{8}$ x 5 $\frac{3}{8}$ x 5"

SELECTaCOM Order No. 21-1160; Ship. wt. 6 lbs.



and it's **ONLY...**

49⁹⁵

PAIR
\$99.50

YES! You Can Buy "ON TIME"

AT ALL

48

**RADIO SHACK
STORES**
Coast to Coast

CALIFORNIA
BAKERSFIELD — 1308 19th St.
DOWNEY — Stonewood Shop. Ctr.
LA MESA — Grossmont Shop. Ctr.
LONG BEACH — 127 W. 7th St.
LONG BEACH — 3976 Atlantic Ave.
SAN LEANDRO — Bay Fair Shop. Ctr.

CONNECTICUT
NEW HAVEN — 92 York St.
MANCHESTER — Manchester Shop. Parkade

STAMFORD — 28 High Ridge Rd.
WEST HARTFORD — 39 So. Main St.

ILLINOIS
CHICAGO — Evergreen Plaza at 95th St.

MASSACHUSETTS
BOSTON — 167 Washington St.
BOSTON — 594 Washington St.
BOSTON — 110 Federal St.
BRAINTREE — South Shore Plaza
BROOKLINE — 730 Commonwealth Ave.
CAMBRIDGE — Fresh Pond Shop. Ctr.
FRAMINGHAM — Shoppers' World
LOWELL — Central Shop. Plaza
SAUGUS — N. E. Shop. Ctr.
SPRINGFIELD — 1182 Main St.
WORCESTER — Lincoln Plaza

MAINE
PORTLAND — Pine Tree Shop. Ctr.

MINNESOTA
ST. PAUL — 16 E. 6th St.

NEW HAMPSHIRE
MANCHESTER — 1247 Elm St.

NEW MEXICO
ALBUQUERQUE — 6315 Lomas, N. E.

NEW YORK
NEW YORK — 1128 Ave. of the Americas
SYRACUSE — 3057 Erie Blvd. East

OKLAHOMA
OKLAHOMA CITY — Mayfair Shop. Ctr.
TULSA — 317 South Detroit St.

OHIO
CINCINNATI — 852 Swifton Ctr.

PENNSYLVANIA
PHILADELPHIA — 2327 G Cottman Ave.
PHILADELPHIA — 1128 Walnut St.

RHODE ISLAND
CRANSTON — 1301 Reservoir Ave.
EAST PROVIDENCE — Shoppers' Town

TEXAS
DALLAS — 1601 Main St.
DALLAS — Medallion Center
DALLAS — 125 Wynnewood Village
FORT WORTH — 1515 So. Univ. Dr.
FORT WORTH — 900 East Berry St.
FORT WORTH — 3524 East Denton Highway
HOUSTON — 2315 Travis St.
HOUSTON — 322 Northline Mall
HOUSTON — 4759 Bissonette
SAN ANTONIO — Wonderland Ctr.
WACO — 1016 Austin Ave.

VIRGINIA
ARLINGTON — Washington-Lee Shop. Ctr.

WASHINGTON
SEATTLE — 2028 Third Ave.

it's a true
100mw
wireless
intercom!

it's a true
dual CB
100mw/3W
transceiver

House current is NOT used to transmit! SELECTaCOM transmits the wireless CB way, with rock-stable crystal control on quiet Ch. 5. Users do not have to be on same AC line. No license; no mike needed. Truly unique.

IDEAL FOR HOME, OFFICE, LAB, GARAGE, WAREHOUSE, SCHOOL!

Each 'Realistic' SELECTaCOM is a "master"—use it with any number of similar units; also receive Ch. 5 signals from mobile or walkie-talkie CB sets! Office styled front and rear in high-impact beige case. The only NEW intercom in 15 years!

A PRODUCT OF RADIO SHACK RESEARCH. A BARGAIN PRICE.

Be the first in your neighborhood or business to own the world's first "CB intercom". Useful, versatile, thrifty—a "telephone" for space-age communications. Order by mail or buy it at your nearest RADIO SHACK store.

SELECTaCOM is the only DUAL CB transceiver we've ever seen—low power switch (100mw) plus built-in telescoping antenna give you NO LICENSE operation. Flip to high power, plug in external antenna for 3-watt operation on quiet Ch. 5.

THE ONLY DESK-TOP CB ON THE MARKET, AND IT'S "HOT"

No external mike required, yet modulation is sensational in arm's length "intercom" operation! Operate on no-license 100mw until your 3W license arrives. Transmit to and receive any mobile walkie-talkie working Ch. 5. Crystals replaceable!

WHO EVER HEARD OF CB AT A PRICE BELOW \$50 ? ?

True! The 'Realistic' SELECTaCOM is priced below "closeouts". Sold only by RADIO SHACK stores coast to coast. External antenna only \$9.95, order no. 21-901

INTRODUCTORY SPECIAL! We will fill your SELECTaCOM order for 50c a unit (postage & handling) — anywhere in the U.S.A.

Send Free Radio Shack Bargain Catalog

MAIL
TO STORE
NEAREST
YOU

Name _____
Street _____
City _____ State _____ Zip _____

INTRODUCING **Jerrold COLORAXIAL™ Program** **COAX IS A MUST FOR COLOR TV**



← **THIS**
NOT
THIS →



Commercial installations have proved that coaxial downlead is *essential* for predictable, consistently good color TV pictures. Coax loss doesn't increase in wet weather, while twinlead loss goes up as much as six times. Coaxial cable can be run anyplace, even next to metal, without mismatch. Coax doesn't deteriorate with age. It won't pick up ignition noises or other interferences. In a word, for satisfactory color reception, even in "ideal" reception areas, your customers need coax.

And now, new Jerrold COLORAXIAL antennas

and kits give you a perfect home-installation package for every color-reception need. With COLORAXIAL, you can offer the whole system, from coaxial antenna to indoor matching transformer, or adapt an existing 300-ohm antenna for coax operation. Listed below are all the COLORAXIAL components packaged individually and in kits, for easy, low-cost conversion. Ask your Jerrold distributor for COLORAXIAL brochure, or write *Jerrold Electronics, Distributor Sales Division, Philadelphia, Pa. 19132.*

CAX-16 • COLORAXIAL COLORGUARD

COLORAXIAL Antenna for metropolitan and suburban reception areas. Prematched to 75-ohm coaxial cable; complete with fitting. No outdoor matching transformer required—only an indoor Model T378. List \$11.95

K-CAX-16 • COLORAXIAL Antenna Kit. Everything you need for complete installation—a CAX-16 Antenna, antenna tri-mount with 5-ft mast, 50 feet of coax cable with fittings, and T378 indoor matching transformer. List \$29.95



COLORAXIAL PARALOGS

PAX-40 • COLORAXIAL Antenna for difficult suburban areas. Prematched to 75-ohm coaxial cable; complete with fitting. No outdoor matching transformer required—only an indoor Model T378 needed. List \$22.95

PAX-60 • COLORAXIAL Antenna for suburban to semi-fringe areas. Prematched to 75-ohm coaxial cable; complete with fitting. No outdoor matching transformer required—only an indoor Model T378 needed. List \$32.95

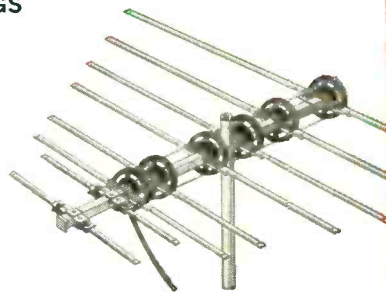

CAT-2 • COLORAXIAL MATCHING TRANSFORMER KIT

One TO-374A mast-mounting matching transformer for any 300-ohm antenna, and one T378 set-mounting matching transformer, complete with bracket and mounting strap. List \$8.20

COLORAXIAL matching transformers are also available individually: TO-374A, list \$4.95; T378, list \$3.25

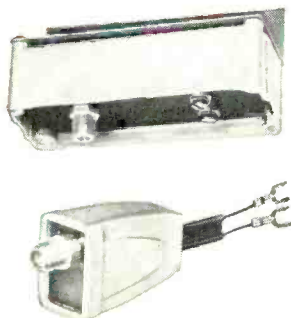

COLORAXIAL CABLE

CAB-50 • 50 feet of sweep-tested RG-59/U 75-ohm coaxial cable complete with F-59A fittings attached, plus weatherboot. List \$9.50

CAB-75 • 75 feet of sweep-tested RG-59/U 75-ohm coaxial cable complete with F-59A fittings attached, plus weatherboot. List \$11.50



A subsidiary of The Jerrold Corporation

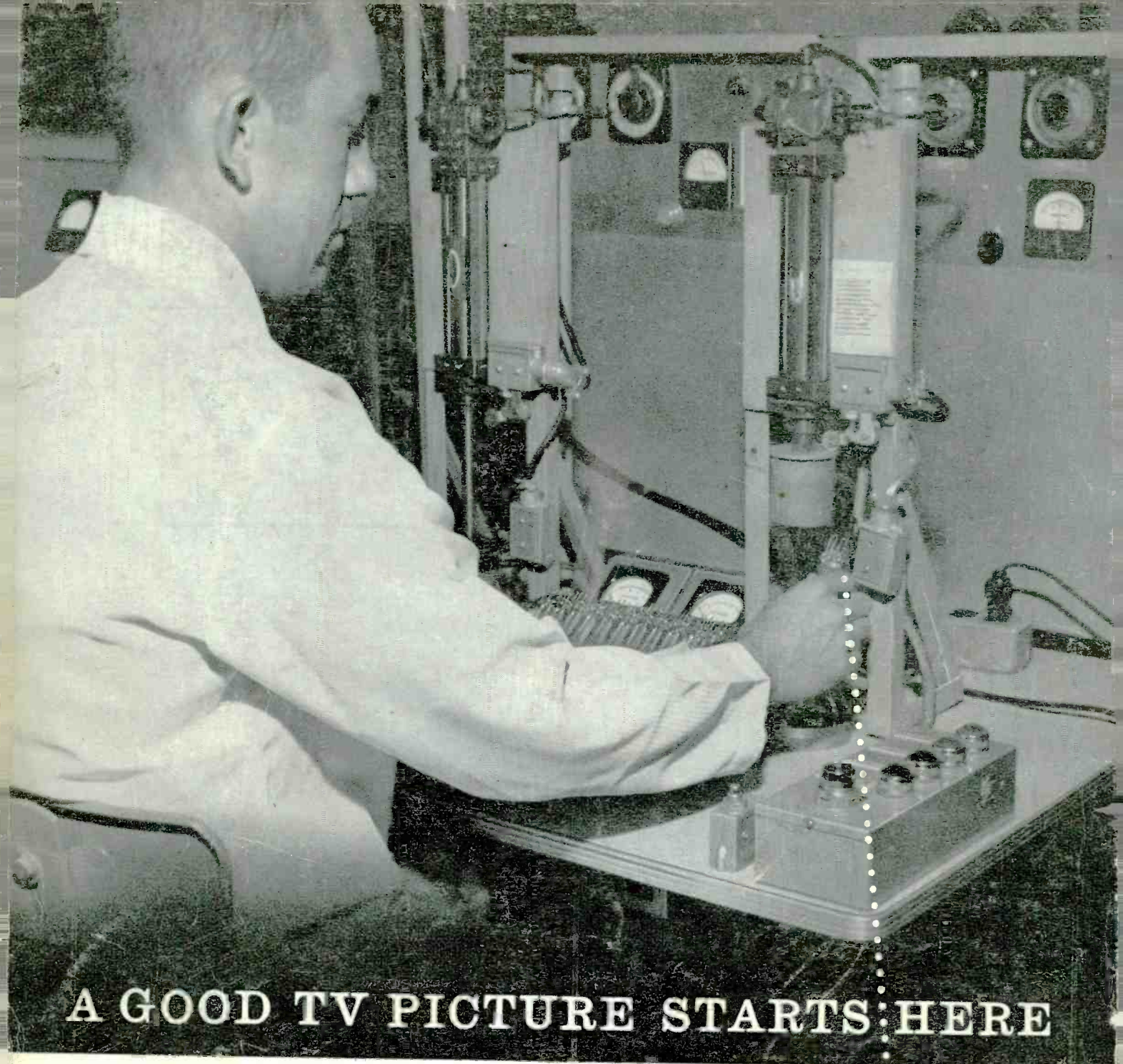

A GOOD TV PICTURE STARTS HERE

It Depends on a Leakproof Stem Seal

The slightest leakage of air weakens the high vacuum of a TV picture tube...resulting in a costly callback and a dissatisfied customer for you. This is why RCA takes extra precautions to maintain the vacuum in Silverama picture tubes.

Potential trouble spots are the glass-to-metal lead-wire seals in the electron-gun stem assembly (below). At RCA, stem assemblies are batch tested for leakage in a supersensitive leak detector *before* they go into electron guns.

So sensitive is this detector that it can pinpoint a leak that would not affect tube performance for years...a leak so tiny that no other inspection method could hope to find it.

Yet the slightest sign of a leak is cause for rejection of a stem. This extra precaution is one more example of the care that goes into every phase of Silverama manufacture...and one more reason why RCA Silverama should be your first choice in replacement picture tubes.

Silverama is made with an all-new electron gun, finest parts and materials, and a glass envelope that has been thoroughly cleaned and inspected prior to re-use.

RCA ELECTRONIC COMPONENTS AND DEVICES, HARRISON, N. J.

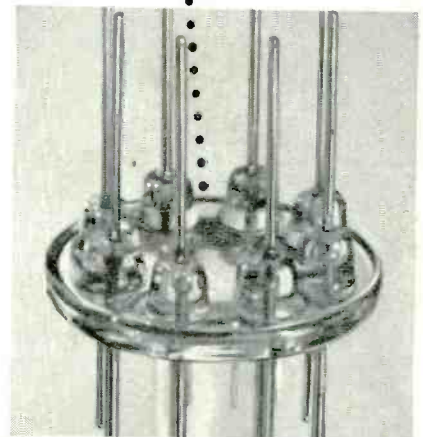

Stem assemblies are tested on a special high-vacuum leak detector. Detector is a helium mass-spectrometer, detecting passage of helium "tracer" gas through any of the glass-to-metal seals. A stem assembly passing this rigorous test is ready to become a vital part of an RCA Silverama® Picture Tube.



The Most Trusted Name in Electronics