

Electronics World

FEBRUARY, 1966
50 CENTS

SUPERSENSITIVE COMMUNICATIONS SYSTEMS
VIDEO TAPE RECORDER FOR HOME USE
NON-DESTRUCTIVE TESTING
AMPLIFICATION USING
SWITCHING TECHNIQUES

SCR

PRICE BREAKTHROUGH
OPENS NEW MARKETS

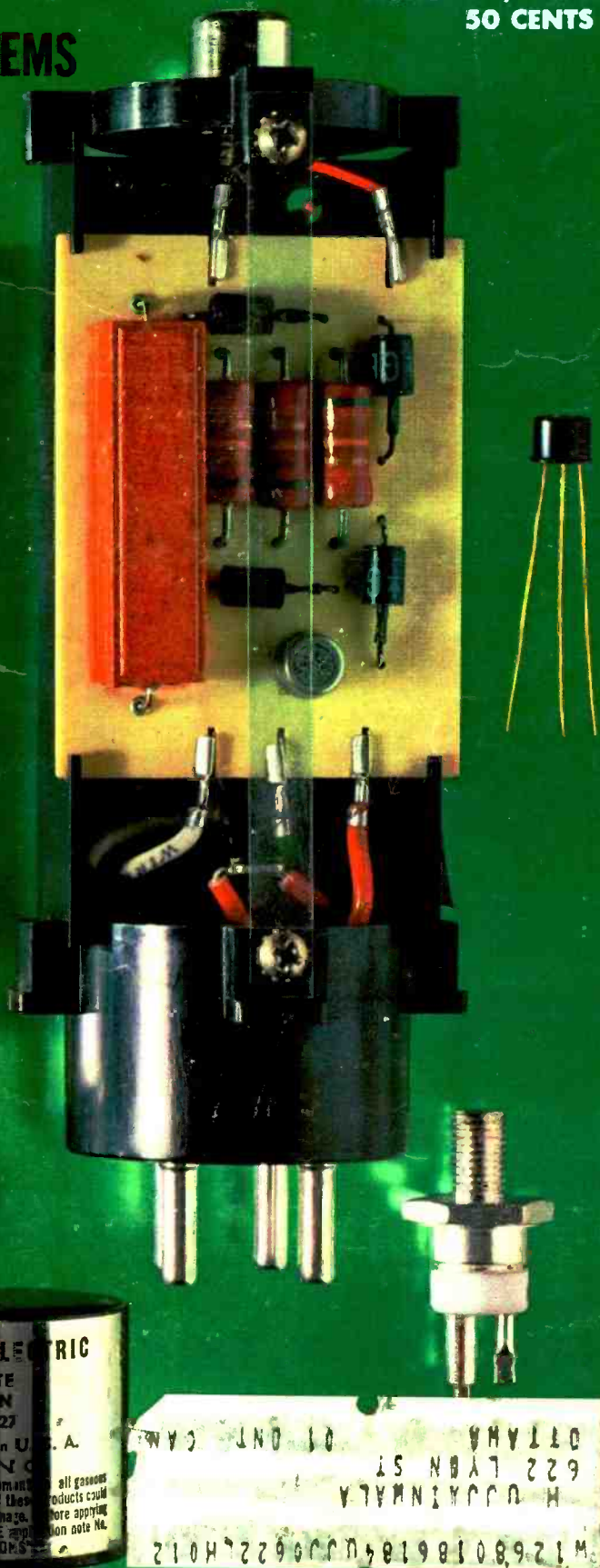

50 years of leadership for Radio-Television



BUILD, EXPERIMENT, EXPLORE, DISCOVER WITH NRI SPECIAL TRAINING EQUIPMENT

Begin now an exciting adventure. Learn by doing with custom-designed training equipment that gives you on-the-job experience as you train at home. "Stock" or "standard" equipment has never been good enough for NRI. The kits you receive are designed exclusively for experience, for bringing to life the things you read about in programmed "bite size" texts. It's the necessary "third dimension" in NRI's training method.

These Men Trained for Success with NRI—YOU CAN, TOO



"I want to thank NRI for making it all possible," says Robert L. L'Heureux of Needham, Mass., who sought our job consultant's advice in making job applications and is now an Assistant Field Engineer in the DATAmatic Div. of Minneapolis-Honeywell, working on data processing systems.

His own full-time Radio-TV Servicing Shop has brought steadily rising income to Harlin C. Robertson of Oroville, Calif. In addition to employing a full-time technician, two NRI men work for him part-time. He remarks about NRI training, "I think it's tops."



Even before finishing his NRI training, Thomas F. Favaloro, Shelburne, N.Y., obtained a position with Technical Appliance Corp. Now he is foreman in charge of government and communications divisions. He writes, "As far as I am concerned, NRI training is responsible for my whole future."

"I can recommend the NRI course to anyone who has a desire to get ahead," says Gerald L. Roberts, of Champaign, Ill., whose Communications training helped him become an Electronic Technician at the Coordinated Science Laboratory, U. of Illinois, working on Naval research projects.



NATIONAL RADIO INSTITUTE
Oldest and largest school of its kind



1
2
3
4
5
6
7
8
9
10

Choose From NRI'S Specialized Instruction Plans

Television-Radio Servicing

Learn to fix black-and-white and color sets, AM-FM radios, stereo hi-fi, etc. A profitable field for part or full-time business of your own.

Industrial-Military Electronics

Learn Principles, Practices, Maintenance of Electronics equipment. Covers computers, servos, telemetry, multiplexing, other subjects.

Complete Communications*

A comprehensive program for careers in broadcasting or mobile, marine, aviation communications. Learn to operate, maintain transmitting equipment. Prepares for FCC License.

FCC License*

Prepares you quickly for First Class License exams. Every communications station must have licensed operators. Also valuable for Service Technicians.

Math for Electronics

A short-course of carefully prepared texts going from basic arithmetic to graphs and electronic formulas. Quick, complete, low in cost.

Basic Electronics

Abbreviated, 26-lesson course covering Automation-Electronics, TV Radio language, components, principles. Ideal for salesmen, hobbyists, others.

Electronics for Automation

For the man with a knowledge of basic electronics who wants to prepare for a career in process control, ultrasonics, telemetering and remote control, electromechanical measurement, others.

Aviation Communications*

For the man who wants a career in and around planes. Covers direction finders, ranges, markers, loran, shoran, radar, landing system transmitters. Prepares for FCC License.

Marine Communications*

Learn to operate, repair transmitters, direction finders, depth indicators, radar, other Electronic equipment used on commercial and pleasure boats. A growing, profitable field. Prepares for your FCC License.

Mobile Communications*

Learn to install, operate, maintain mobile equipment and associated base stations as used by police, fire departments, taxi companies, etc. Prepares for FCC License.

*NOTE: You must pass your FCC license exams (Communications Courses) or NRI refunds in full the tuition you have paid.

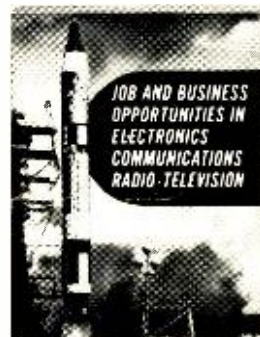

SEND FOR NEW NRI CATALOG

Read the story of NRI's half-century of pioneering and leadership in training men at home for Electronics. Read about the NRI "3-Dimensional" method that speeds your progress. Read about NRI's exclusive Achievement Kit, sent to you the day you enroll. See the fascinating equipment that brings to life things you read about in "bite size" texts. Mail postage-free form today.

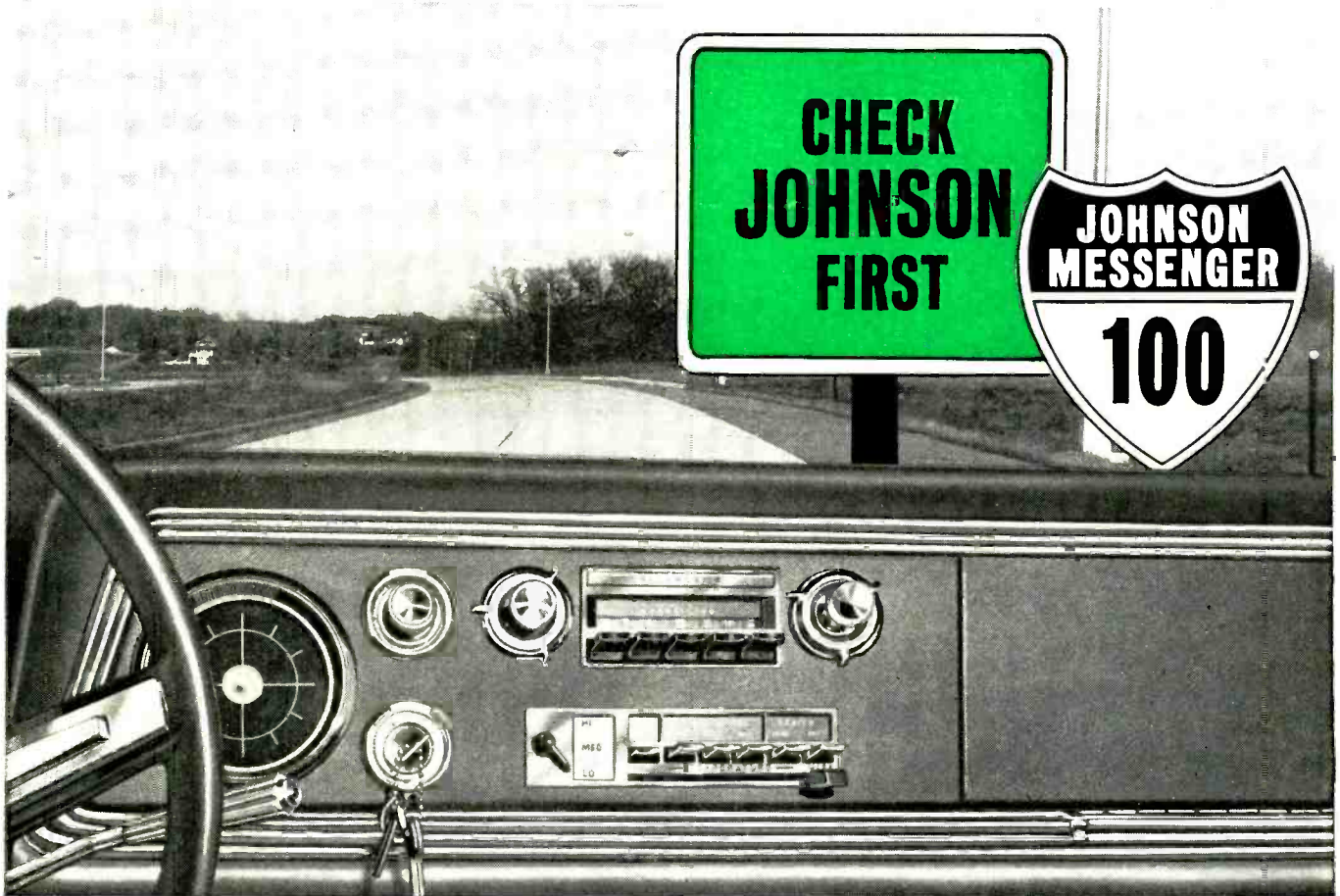

MESSENGER "100"

new! Low cost—all solid-state CITIZENS RADIO TRANSCEIVER

Check the performance features — then take a look at the price tag! You won't find a CB unit on the market that gives you as much value and reliability for your two-way radio dollar. The same highly competent engineering team that designed the famous Messenger III now brings you this low cost, compact, 5 channel transceiver for Mobile, Base or Portable field use! Delivers maximum power from legal input. High performance noise limiting for "whisper quiet" operation. Adjustable "squelch" control. Receiver is both sensitive and selective — unique speech compression circuit prevents overmodulation and delivers a crisp, clean signal without adjacent channel "splatter" . . . boosts average transmitted power for maximum readability at extended ranges.

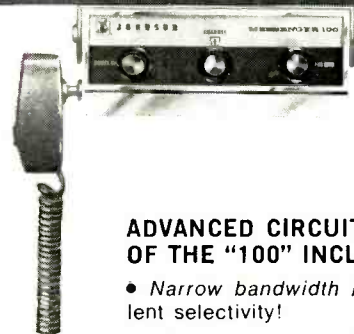

ADVANCED CIRCUITRY FEATURES OF THE "100" INCLUDE:

- *Narrow bandwidth receiver* for excellent selectivity!
- *High receiver sensitivity* for maximum range!
- *Unique speech compression circuit* which prevents overmodulation and helps deliver a clean, crisp signal without adjacent channel "splatter"! *Three types of usage* from one unit — Mobile, Base or Portable.



CALL OR WRITE TODAY
for complete information!



E. F. JOHNSON COMPANY

1106 10th Ave. S.W. • Waseca, Minn. 56093

\$129⁹⁵
NET
(Mobile Unit)



new
8290
Shielded Permohm*
 Shown Actual Size



82 Channel TV lead-in

for the strongest, cleanest picture signal and best color... ever!

- Provides 82 channel color reception
- Less installation time and cost
- Eliminates transmission line pick-up of noise and ghost signals
- No expensive matching transformers required
- Can be installed anywhere

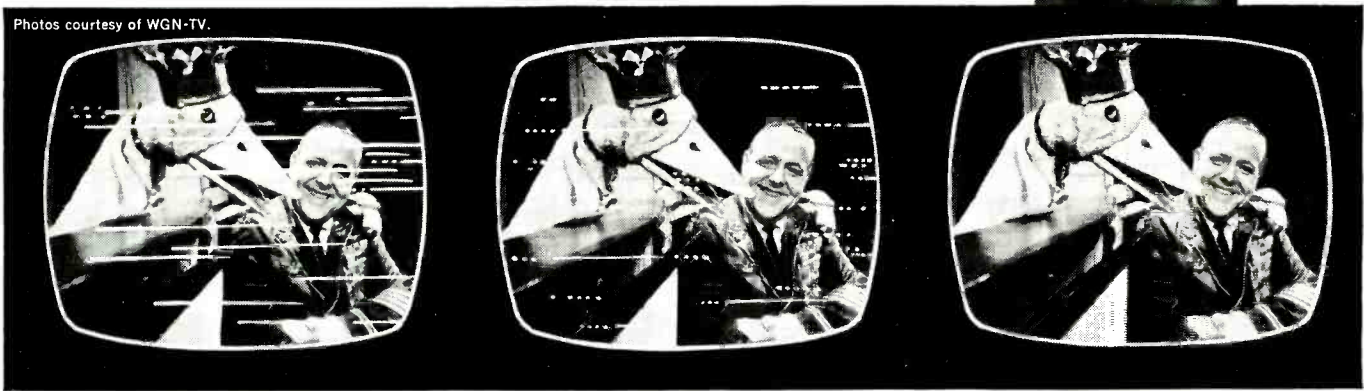

Photos courtesy of WGN-TV.



Unshielded twin-lead
 Severe picture disturbance due to ignition noise.



Coaxial Cable
 Ignition noise minimized—but not eliminated.



*** Shielded Permohm**
 Eliminates automobile ignition noise.

■ New 8290 Shielded Permohm TV Lead-in combines the strong signal strength of twin-lead with the clean signal protection of shielded cable. Because it is a balanced line for 300 Ohm TV antennas and receivers, *costly matching transformers and connectors are eliminated.*

8290 is specifically designed for superior color reception on all 82 channels. The twin-lead is encapsulated in low-loss cellular polyethylene insulation, Beldfoil** shielded against all outside disturbances, and protected with a weatherproof

*Belden Trademark—Reg. U.S. Pat. Off.

jacket. A drain wire is provided for grounding the shield to the chassis. The need for stand-offs, twisting or routing of lead-in is eliminated. 8290 can be taped directly to a mast or tower, routed through metal pipe, buried underground, or even installed in rain filled gutters to reduce installation time and cost.

Ask your distributor about 8290 Shielded Permohm TV Lead-in cable, today! Or, write P. O. Box 5070-A for complete information.

**Belden U.S. Patent 2,782,251 and patent pending

8-9-5

BELDEN MANUFACTURING COMPANY



P. O. Box 5070-A • Chicago, Illinois 60680



THIS MONTH'S COVER shows a grouping of G-E SCR's and SCR circuits. The large assembly at the right is a solid-state replacement for a thyatron gaseous tube. The assembly is complete with tube socket and plate cap. At the bottom center, in an octal-socket housing, is another "solid-state thyatron." The circuit assembly at the bottom left is an SCR speed control unit for portable handtools, such as drills or saber saws. The small semiconductors in the background are fairly low-power devices except for the SCR at the bottom right. This unit will handle 55 amps at up to 1200 volts despite its small size. For details, see page 23. (Photograph: Bruce Pendleton)



Publisher
PHILLIP T. HEFFERNAN

Editor
WM. A. STOCKLIN

Technical Editor
MILTON S. SNITZER

Associate Editors
LESLIE SOLOMON
P. B. HOEFER

Assistant Editor
MARSHA JACOBS

Contributing Editors
WALTER H. BUCHSBAUM
Prof. ARTHUR H. SEIDMAN

Art Editor
RICHARD KELLY

Art and Drafting Dept.
J. A. GOLANEK

Advertising Sales Manager
LAWRENCE SPORN

Advertising Service Manager
ARDYS C. MORAN

February, 1966

Electronics World

FEBRUARY 1966

VOL. 75, No. 2

CONTENTS

- 23** The SCR Revolution *J. E. Mungenast*
- 27** Straight-Wire Inductance Graph *Donald W. Moffat*
- 28** Recent Developments in Electronics
- 30** Amplification Using Switching Techniques *Donald E. Lancaster*
- 33** Non-Destructive Testing (Part 1) *John R. Collins*
- 37** Nanosecond Pulses: Techniques & Applications *Donald E. Lancaster*
- 40** Line-Operated Transistor TV Sets: Emerson *Walter H. Buchsbaum*
- 41** Supersensitive Communications Systems *Jim Kyle*
- 45** Designing an All-Channel TV Antenna *Paul E. Mayes*
- 49** Video Tape Recorder for Home Use *Eugene Leman*
- 61** Why 50-Ohm Coax?
- 66** Correcting Color Signal Distortion
- 75** Square-Wave Generator *Marvin J. Moss*
- 78** RC Waveshaping *Walter B. Ross*
- 79** One-Transistor Muter for FM Receivers *James A. Palmer*
- 80** Transit-Time Semiconductors
- 83** Improving the Low-Frequency Multivibrator
- 84** Oscilloscope Preamplifier *E. Norbert Smith*

6 For the Record (Editorial)
Transistor Replacement Problems

16 EW Lab Tested
Scott 348 Stereo Receiver

54 Keeping Up with New Components *John Frye*

62 Test Equipment Product Report
Blonder-Tongue Model 4122 Sweep Generator
B&K Model 1245 Color Generator
Grand Transformers "Insta-Test" Dielectric Strength Tester

MONTHLY FEATURES

- 4** Coming Next Month
- 68** Book Reviews
- 12** Letters from Our Readers
- 87** New Products & Literature

Electronics World: Published monthly by Ziff-Davis Publishing Company at 307 North Michigan Ave., Chicago, Ill. 60601. One year subscription \$5.00. Second Class Postage paid at Chicago, Ill. and at additional mailing offices. Subscription service: Fortland Place, Boulder, Colo. 80311. Copyright © 1965 by Ziff-Davis Publishing Company. All rights reserved.

**Buy the BEST!
Buy in KIT form!**



MARK® TEN

SRC CAPACITIVE DISCHARGE
IGNITION SYSTEM

ONLY \$29⁹⁵ PPD.!

Why settle for less in motor vehicle ignition systems when you can buy the very BEST from Delta, the originators, the leaders in capacitive discharge (SCR) systems. Delta pioneered this electronic marvel. Thousands have installed this remarkable electronic system. Now YOU can purchase at low, LOW cost, and in easy-to-build kit form, the king of them all, the DELTAKIT. Low price due simply to high production levels at no sacrifice in peerless Delta quality.

**Operate Any Motor
Vehicle More Efficiently**

Compare these proven benefits:

- ▲ Up to 20% Increase in Gasoline Mileage
- ▲ Installs in Only 10 Minutes on any Car or Boat
- ▲ Spark Plugs Last 3 to 10 Times Longer
- ▲ Instant Starts in all Weather
- ▲ Dramatic Increase in Acceleration and General Performance
- ▲ Promotes More Complete Combustion

Literature and complete technical information sent by return mail.

BETTER YET — ORDER TODAY!



DELTA PRODUCTS, INC.

P.O. Box 1147 F • Grand Junction, Colo.
Enclosed is \$_____. Ship prepaid.
 Ship C.O.D.

Please send:
 Mark Tens (Assembled) @ \$44.95
 Mark Tens (Delta Kit) @ \$29.95
SPECIFY — Positive Negative
 6 or 12 Volt

Car Year _____ Make _____
Name _____
Address _____
City/State _____ Zip _____

CIRCLE NO. 119 ON READER SERVICE CARD

COMING NEXT MONTH



Special Feature Article:

General Electric's unique 11-inch color portable is analyzed in some detail in a featured article by Walter H. Buchsbaum. A new and different color tube with a new convergence technique is the heart of this "Porta-Color" television set.

ORBITING ASTRONOMICAL OBSERVATORY

Probably the most complex satellite to be built to date, the OAO uses the latest electronic techniques to enable scientists to see the universe without atmospheric interference. Donald A. Imgram, Project Engineer at Grumman, discusses this unique device in depth.

USING LOW-COST INTEGRATED CIRCUITS

Since Fairchild has several epoxy micrologic integrated circuits on the market, Donald E. Lancaster discusses techniques and circuitry to be employed to take advantage of these circuits' best features.

SUBSTITUTING FET'S FOR TUBES IN HI-FI AMPLIFIERS

A discussion of the steps taken in converting low-level stages of a power amplifier to use field-effect transistors. Com-

parative measurements show superior performance from such FET units.

NEW U.H.F. TV ANTENNA DESIGN

An impedance-controlled, end-fire dipole which may be connected to a v.h.f. antenna without a u.h.f./v.h.f. coupler is described in this article by Harold Harris of Channel Master. With this design only a single download is needed.

NON-DESTRUCTIVE TESTING

Part 2 of a two-part series, John R. Collins covers ultrasonics and Hall-effect devices used for such testing.

METER-RELAY DEVICES

Widely used in industry for indicating small changes in voltage and current and for operating control circuits when preset values have been reached, these devices get a thorough discussion in this basic article.

All these and many more interesting and informative articles will be yours in the MARCH issue of **ELECTRONICS WORLD**... on sale February 17th.

ZIFF-DAVIS PUBLISHING COMPANY

William B. Ziff
Chairman of the Board (1946-1953)

William Ziff
President

W. Bradford Briggs
Executive Vice President

Hershel B. Sarbin
Vice President and General Manager

Philip Sine
Financial Vice President

Walter S. Mills, Jr.
Vice President, Circulation

Stanley R. Greenfield
Vice President, Marketing

Phillip T. Heffernan
Vice President

Frank Pomerantz
Vice President, Creative Services

Arthur W. Butzow
Vice President, Production

Editorial and Executive Offices
(212 OREGON 9-7200)
One Park Avenue, New York, N.Y. 10016

NEW YORK OFFICE (212 OREGON 9-7200)
James J. Sullivan
Joseph E. Halloran

MIDWESTERN OFFICE (312 726-0892)
307 North Michigan Avenue, Chicago, Ill. 60601
Midwestern Advertising Manager, Royce Richard

WESTERN OFFICE (213 CRESTVIEW 4-0265)
9025 Wilshire Boulevard, Beverly Hills, Cal. 90211
Western Advertising Manager, Bud Dean

JAPAN
James Yagi, c/o Sekihara,
1, Sakamachi, Shinjuku-ku, Tokyo, Japan

CIRCULATION OFFICE
Portland Place, Boulder, Colorado, 80311



Member
Audit Bureau of
Circulations

Radio & TV News • Radio News • Radio-Electronic Engineering Trademarks Reg. U.S. Pat. Off.
SUBSCRIPTION SERVICE: All subscription correspondence should be addressed to Electronics World, Circulation Dept., Portland Place, Boulder, Colorado 80311. Please allow at least six weeks for change of address. Include your old address as well as new—enclosing if possible an address label from a recent issue.

EDITORIAL CONTRIBUTIONS must be accompanied by return postage and will be handled with reasonable care; however publisher assumes no responsibility for return or safety of art work, photographs, or manuscripts.

ELECTRONICS WORLD (February, 1966, Vol. 75, No. 2) is published monthly by Ziff-Davis Publishing Company at 307 North Michigan Avenue, Chicago, Ill. 60601. (Ziff-Davis also publishes Skiing, Flying, Business/Commercial Aviation, Popular Boating, Car and Driver, Popular Photography, HiFi/Stereo Review, Popular Electronics, Modern Bride, Skiing Trade News and Skiing Area News.) One year subscription rate for U.S., U.S. Possessions and Canada, \$5.00; all other Foreign, \$6.00. (Schedule for payment in Foreign currencies may be found elsewhere in this issue.) Second class postage paid at Chicago, Illinois and at additional mailing offices. Authorized as second class mail by the Post Office Department, Ottawa, Canada and for payment of postage in cash.

ELECTRONICS WORLD

FINCO

COLOR-VE-LOG ANTENNAS

FOR UHF, VHF, FM RECEPTION

ALL-BAND UHF-VHF-FM ANTENNA

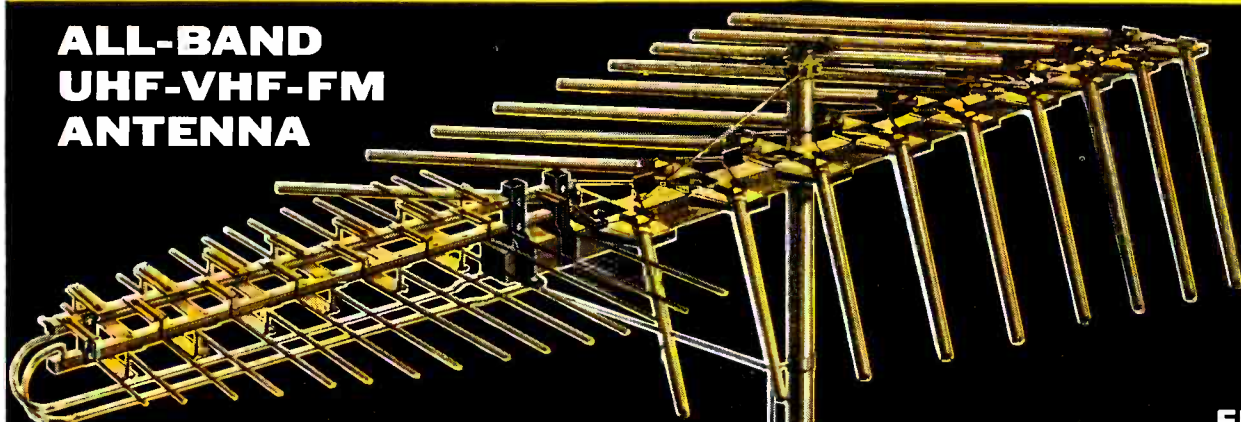

FINCO
Model UVF-24
\$59.95 list

The one antenna that does the work of 3! Gives startlingly clear black and white pictures and beautiful color on both UHF and VHF television channels — plus the finest in stereophonic and monophonic sound reproduction.

FINCO Model UVF-18 — \$42.50 list
FINCO Model UVF-16 — \$30.50 list
FINCO Model UVF-10 — \$18.50 list

SWEPT-ELEMENT VHF-FM ANTENNA

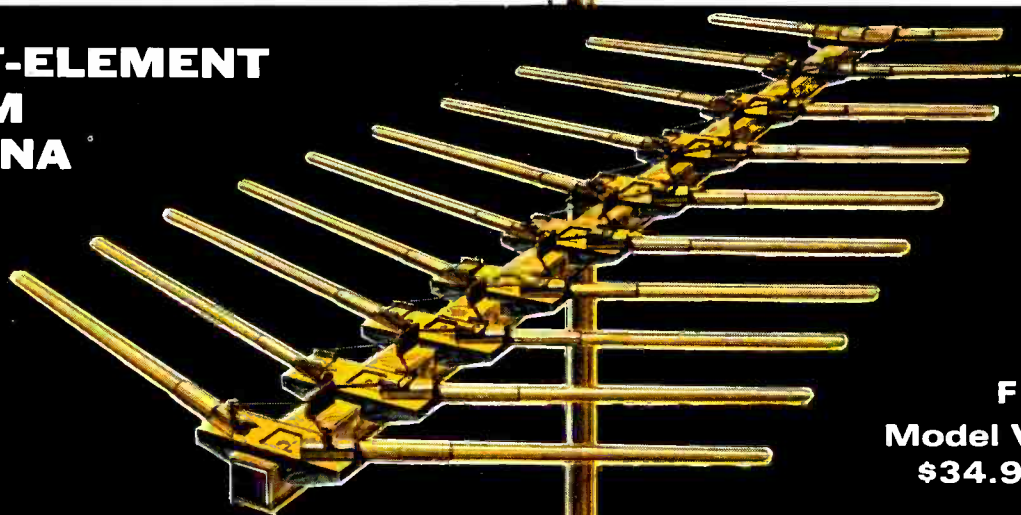

FINCO
Model VL-10
\$34.95 list

FINCO's Color-Ve-Log challenges all competition! Its swept-element design assures the finest in brilliant color and sharply defined black and white television reception — as well as superb FM monaural and stereo quality.

FINCO Model VL-18 — \$54.50 list
FINCO Model VL-15 — \$46.95 list
FINCO Model VL-7 — \$23.95 list
FINCO Model VL-5 — \$16.95 list

Featuring FINCO's exclusive Gold Corodizing

FINCO COLOR-VE-LOG

Prices and specifications subject to change without notice

THE FINNEY COMPANY • 34 W. Interstate Street • Bedford, Ohio

Write for beautiful color brochures Number 20-322, and 20-307, Dept. 410.

NEW

PACE

I

SOLID STATE CB RADIO

only \$129⁰⁰



more talk power
per dollar

3.5 watt output. This new solid state 6-channel mobile CB transceiver delivers the most talk power you can get from a 5-watt transmitter—3.5 watts at 100% modulation.

Outstanding mobile performance—Unique double conversion receiver, with noise limiting, provides excellent reception of even weak, distant signals.

All silicon transistor design, plus lifetime guaranteed glass-fiber circuit boards, combine to offer unmatched reliability, minimum current drain, and smallest possible size.

Write for *Bulletin Pace I*, and the name of your nearest Pace dealer.

From the makers of the famous PACE 5000

PACE

COMMUNICATIONS CORP.
24049 Frampton Ave., Harbor City, Calif. 90710
Telephone (213) 325-8444



For the record

WM. A. STOCKLIN, EDITOR

TRANSISTOR REPLACEMENT PROBLEMS

THE era of the vacuum tube is gradually passing behind us. In its stead we now have solid-state components. The change was inevitable, and just as progress is impossible without change, so is change without problems. Design engineers, technicians, and manufacturers have been confronted with their own problems over the past few years. Now, with most of them solved, solid-state products are flowing off production lines by the thousands. Most efforts had been directed toward military, industrial, and commercial products, but since the beginning of this year we have all seen many more new types of consumer items that are designed around solid-state components. Almost all hi-fi systems now use solid-state components and many transistorized TV portables, CB, and ham equipment are being marketed.

Although theoretically transistors are supposed to last forever, they may be damaged by excessive heat, improper hook-up, or by the failure of some related component. Hence it is safe to assume that the consumer may be faced with the need for replacement some day.

It is obvious, when reviewing the schematic diagrams and parts lists of most consumer products, that many transistors are special devices available only from the manufacturer. This is a serious problem not only in increasing the cost of an item but in causing serious delays in servicing and maintenance.

Rest assured, though, that with few exceptions manufacturers themselves dislike the situation. To supply items for replacement is never a profitable enterprise for equipment manufacturers.

We are all familiar with tube replacement where one simply had to select a tube type from any manufacturer and get practically identical performance. Transistors, however, even with the same type number, may differ widely in performance.

It is common knowledge that semiconductor manufacturers, when producing a specific type of transistor, will obtain as many as half a dozen differently designated transistors with different characteristics from one run. Even after selection, each type has a wide range of limits.

This presents further problems to end users. In one particular case, *H. H. Scott* for example may order as many as 20,000 2N2926 transistors. They, in turn, test each one and segregate them into five groups; each is then color-coded with a dot signifying a different *beta*. Almost all transistors designed for high-quality or critical applications go through similar selection processes by the end user. *Fisher Radio* does the same thing and so do the TV manufacturers such as *Zenith*, *Motorola*, *Emerson*, etc. In view

of this, it should be apparent that any direct replacement for such transistors must inevitably come from the manufacturer and not from the customary electronics parts dealer. This is extremely unfortunate for the consumer, the radio-TV service technician, and certainly for the parts dealer.

There are no obvious solutions at this point that seem promising. Companies like *Scott*, *Fisher*, *Zenith*, *Admiral*, *G-E*, and others have service centers across the country, each of which is completely stocked with special components that are therefore readily available at reasonable cost.

The independent TV service technician is certainly in trouble. He must, as soon as possible, set up liaison with the manufacturers so that there will be no delay in obtaining special components. He must work out his cost problem so bulk purchases at certain points will prove more economical. He must, under all circumstances, provide service within a reasonable time and at comparable cost. Otherwise, he will gradually give way to the captive service groups. Certainly, simple substitutions for portable transistor radio sets are in order since quality is the least important factor. But when one wants to get the utmost performance from any hi-fi system or TV set, haphazard replacement should not be considered. The technician can't make a hit-and-miss substitution, though no doubt many will. A recent test group of transistors were replaced at random and a variation of as much as 20 db in gain was encountered.

Why then don't semiconductor manufacturers produce transistors with tighter limits? The answer is quite simple if one takes a look at any of the present industrial parts dealers' catalogues. We have more different types of solid-state components at the present time, in the short history of the industry, than we ever had over all the years of the vacuum tube. To ask for further selection would seem out of the question.

A solution that might have some merit would be for EIA to standardize on a specific *beta* test unit which could be used by every service organization in the country. If this were done, each manufacturer could indicate on his schematic diagram or parts list a standard transistor type number along with the specific gain requirements. Service technicians could then select as required.

We should all ask ourselves if the service industry is going in a direction similar to that of the white goods field. It might be. Certainly refrigerators, washing machines, dryers, etc. are made mostly of specialized components. Will it go further in that direction when we reach the integrated-circuit period? At the moment, it seems that these will definitely be extremely specialized components. ▲

YOU GET PRODUCT PLUS FROM YOUR SYLVANIA DISTRIBUTOR.

He'll put you in TV Guide

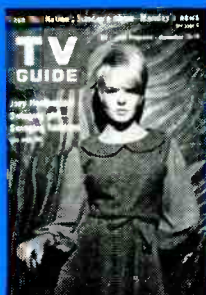

To give you a jump on color set repairs, your Sylvania distributor will put your name, your town, your phone number in *TV Guide*. Four ads will run this year exclusively for Independent Service Dealers carrying Sylvania's picture tubes and receiving tubes.

The plug for you will be run in localized, full-color double-page ads. Customers learn that you're the "right TV serviceman" for color set repairs. For all TV repairs.

And because you're Independent, they learn you give unbiased opinions on TV replacement parts. Sylvania knows that, more often than not, you recommend Sylvania tubes.

See your Independent Sylvania distributor. He'll tell you how Sylvania ads, featuring *you*, can make you your area's "right TV serviceman" for color sets. He'll tell you how to get into up to 4 *TV Guide* ads.

Sylvania Electronic Tube Division, Electronic Components Group, Seneca Falls, N. Y. 13148.

SYLVANIA
SUBSIDIARY OF
GENERAL TELEPHONE & ELECTRONICS **GTE**

RCA HOME TRAINING CAN PREPARE YOU FOR THE BIGGEST CAREER OPPORTUNITIES IN HISTORY! NEW 'CAREER PROGRAMS' POINT THE WAY!

Electronics Jobs Expanding Every Day; Trained Technicians in Demand; RCA Institutes "Space Age" Methods make learning faster, easier!

Government reports have indicated the increasing demands for manpower in the electronics fields.* New developments in modern technology, automation, the growth of new areas of work, such as atomic energy, earth satellites and other space programs, and data systems analysis and processing are changing the occupational picture daily. To help meet this need, RCA Institutes offers a wide variety of Home Training Courses, all geared to a profitable, exciting electronics career in the shortest possible time.

New Career Programs right on target

RCA Institutes new "Career Programs" are complete units that train you for the specific job you want. And each of them starts with the amazing "AUTOTEXT" Programmed Instruction Method—the new scientific way to learn. RCA "AUTOTEXT" helps even those who have had trouble with ordinary home training methods in the past. Learn faster and easier than ever before!

Valuable Equipment Included

With each RCA Institutes Career Program, you receive valuable equipment to keep and use on the job. You'll get the new Programmed Electronics Breadboard which provides limitless

laboratory type experimentation, from which you construct a working signal generator and a superheterodyne AM Receiver. And as a special bonus, you get valuable Multimeter and Oscilloscope Kits—all at no additional cost!

Liberal Tuition Plan Ideal for Today's Budgets

RCA Institutes offers you this most economical way to learn. You pay for lessons only as you order them. No long term contracts. You can stop your training at any time and you will not owe one cent! Compare this with any other home training plan!

Choose from these Job-Directed Programs.

- TELEVISION SERVICING
- FCC LICENSE PREPARATION
- AUTOMATION ELECTRONICS
- AUTOMATIC CONTROLS
- DIGITAL TECHNIQUES
- TELECOMMUNICATIONS
- INDUSTRIAL ELECTRONICS
- NUCLEAR INSTRUMENTATION
- SOLID STATE ELECTRONICS
- ELECTRONICS DRAFTING
- plus a wide variety of separate courses from Electronics Fundamentals to Computer Programming.

technicians!

CLASSROOM TRAINING ALSO AVAILABLE

You may also learn electronics at one of the most modern laboratory and classroom electronics schools in the country—RCA Institutes Resident School in New York City. Day and Evening Courses start four times a year—and courses are planned so as not to interfere with your job or social life. No previous technical training needed for admission. You are eligible even if you haven't completed high school.

SEND NOW FOR NEW VALUABLE FREE CAREER BOOK—YOURS WITHOUT COST OR OBLIGATION. SEND POSTAGE PAID CARD TODAY. CHECK HOME TRAINING OR CLASSROOM TRAINING.

Free Placement Service For all Students

Recently, RCA Institutes Free Placement Service has placed 9 out of 10 Resident School graduates in jobs before or shortly after graduation! And, many of these jobs are with top companies—like IBM, Bell Telephone Labs, General Electric, RCA, and radio and TV stations throughout the country. This service is now available to Home Study students as well.

RCA INSTITUTES, Inc. Dept. EW-26
350 West 4th St., New York, N. Y. 10014

A Service of Radio Corporation of America



The Most Trusted Name in Electronics

*"Scientists, Engineers, and Technicians in the 1960's" U.S. Dept. of Labor Bureau of Labor Statistics, 1964.

CONAR ELECTRONIC KITS

Your copy
is waiting...

The do-it-yourselfer's newest catalog

Here's your new catalog of quality electronic kits and assembled equipment... your shopping guide for TV set kits, transistor radios, voltmeters, scopes, tube testers, ham gear, PA systems, and a host of other carefully engineered products. Every item in the Conar catalog is backed by a no-loopholes, money-back guarantee. It's not the biggest catalog, but once you shop its pages you'll agree it's among the best. For years of pleasurable performance, for fun and pride in assembly, mail the coupon. Discover why Conar, a division of National Radio Institute, is just about the fastest growing name in the kit and equipment business.

CONAR

MAIL NOW!

CONAR BB6C
3939 Wisconsin Avenue, Washington, D.C. 20016
Please send me your new catalog.

Name _____

Address _____

City _____

State _____ Z-Code _____

CIRCLE NO. 121 ON READER SERVICE CARD

LETTERS FROM OUR READERS



NUMERICAL CONTROL SYSTEMS

To the Editors:

I am employed as a maintenance technician for three numerical control systems for metalworking equipment (Bendix "Dynapoint" 42, Cintamatic 220, and Pratt & Whitney 1000). I would like to hear from others in the same field regarding preventive maintenance and troubleshooting techniques. I would be happy to exchange ideas and suggestions along these lines, as I have not to date encountered any literature on this subject outside of trade publications, which merely discuss specifications.

The above-mentioned controls are solid-state digital types employing binary logic. The machine tools involved are respectively: Moore measuring, Cincinnati drill, and P & W jig bore. I think such an exchange would be mutually beneficial, especially if anyone has had as many problems as I have had with some of this equipment.

ROBERT MCGLYNN
2039 Gull Road
Kalamazoo, Mich. 49001

BATTERY ELECTRODES

To the Editors:

Please explain why the negative electrode is labeled the "anode" and the positive electrode the "cathode" in your article "Carbon-Zinc Batteries" in the October, 1965 issue.

My impression, and that of everyone to whom I have spoken, has been that the cathode was identified with the negative pole—as in cathode rays (electrons which are negatively charged particles), or the cathode of a vacuum tube which, again, is negative in operation, or the negative electrode in a plating tank which is always called the cathode. Again, the anode of a vacuum tube or an x-ray tube is always connected to the positive side of the voltage source.

DR. IRVING D. EHRENFELD
Bronx, N.Y.

The designations employed were quite correct and are in keeping with industry standards. If you consider, for example, that the battery is a source of power and that the electron flow within

the battery is from the positive carbon rod or carbon lining (Fig. 1 in the article) to the negative zinc vanes or container and thence to the external load, then the terminology makes sense.

Incidentally, some dictionaries are not too helpful with regard to the proper use of the terms "anode" and "cathode." The Webster's Third New International Dictionary (Unabridged) is quite accurate, however, in defining an "anode" as "1. The electrode at which electrons leave a device to enter the external circuit—opposed to cathode. 2a. the positive terminal of an electrolytic cell. b. the negative terminal of a primary cell or of a storage battery that is delivering current. c. the electron-collecting electrode of an electron tube: plate."

—Editors

FIXED CAPACITOR ISSUE

To the Editors:

I am a subscriber to ELECTRONICS WORLD, and I am particularly interested in your recent issue featuring fixed capacitors. Frankly, my interest is so great that I have become accustomed to carrying the issue about with me in the front seat of my car for frequent business reference.

Thank you for an increasingly comprehensive and absorbing magazine.

BRYAN GEYER, Regional Sales Mgr.
General Instrument Corp.
Semiconductor Products Group
Redwood City, Calif.

Thanks to Reader Geyer and to others we have heard from complimenting us on the various special components issues we have been running. We intend to continue this approach with other important components that are used in the electronics field. The slant of these articles will enable our readers to make an intelligent selection of the particular component they require for their application.—Editors

"KNIGHT-KIT" OSCILLOSCOPE

To the Editors:

Your report on the new "Knight-Kit" Model KG-635 (November, 1965) makes the instrument sound pretty good. However, the write-up was too indefinite as to the size of the scope, which you



FREE!

Offer extended through April 1, 1966

Get a Color-TV TEST Picture Tube with every RCA WR-64B Color Bar/Dot/Crosshatch Generator you buy

Yes! You read right!

From now through April 1, 1966—with every purchase of an RCA WR-64B Color Bar Generator—you get a FREE color-TV TEST picture tube for use in your color-TV test jig. This is a 21-inch 70° round color-TV TEST picture tube, electrically guaranteed six months from first installation date. These tubes will have minor mechanical (not electrical) defects... they're not quite good enough to go into a new TV set but perfectly adequate for testing purposes.

How to get your FREE Color Test Tube

Simply buy an RCA WR-64B Color Bar Generator—THE essential color-TV test instrument—between now and April 1, 1966. Fill out your warranty registration card and attach the red identification label on the WR-64B carton. Send them to RCA, Test Equip-

ment Headquarters, Bldg. 17-2, Harrison, N.J. We send you the tube (either from Lancaster, Pa. or Marion, Ind.) freight charges collect. To allow for postal delay, we will honor cards received up until April 15th.

Don't miss out on this never-before offer. You've got to have a color-bar generator anyway—so be sure you buy it now—at the regular price—while you can get a FREE color test tube.

\$189.50*

Optional distributor resale price, subject to change without notice. Price may be higher in Alaska, Hawaii and the West.



RCA WR-64B Color Bar/Dot/Crosshatch Generator

RCA ELECTRONIC COMPONENTS AND DEVICES, HARRISON, NEW JERSEY



The Most Trusted Name in Electronics

Is Hallicrafters' new solid-state,
23-channel (they all work),
S-metered, loud-hailer-
circuited, model CB-14 . . .
the ultimate CB transceiver?



See your dealer or
send for complete specifications,
and judge for yourself.
We're prejudiced.



hallicrafters

5th & Kostner Aves., Chicago, Illinois 60624
Export: International Division

Available in Canada through Gould Sales Co.

"Quality through Craftsmanship"

CIRCLE NO. 110 ON READER SERVICE CARD

*Back Issues
Available*

Use this coupon to
order back issues
of **ELECTRONICS WORLD**

We have a limited supply of back issues that can be ordered on a first-come, first-served basis. Just fill in the coupon below, enclose your remittance in the amount of 65¢ each and mail.

ZIFF-DAVIS SERVICE DIVISION
Dept. BCEW, 589 Broadway
New York 12, New York

Please send the following back issues of **ELECTRONICS WORLD**. I am enclosing _____ to cover the cost of the magazine, shipping and handling.

Month _____ Year _____

Month _____ Year _____

Month _____ Year _____

Name _____

Address _____

City _____ Zone _____ State _____

No charge or C.O.D. orders please. EW

said was "smaller than the usual 5-inch bench scope." I wonder if the unit will fit on some shelves I have directly above my test bench.

M. E. DUNN
Houston, Tex.

For Reader Dunn's information, as well as for several other readers who requested the size of this scope, its dimensions are 11 7/8" high by 7" wide by 15 7/8" deep.—Editors

TUNNEL DIODE SWEEP TRIGGER

To the Editors:

Your article "Tunnel Diode Sweep Trigger" (November, 1965 issue) looks like an excellent addition to the transistor sweep circuit that I constructed from your January, 1965 issue. This latter circuit, incidentally, works very well except for low-frequency instability. Perhaps this new front end will cure this problem.

In looking over this latest circuit and the parts list, is the value given for R2 correct? Can R2 (500 ohms) in series with R3 (820,000 ohms) change the bias on Q1 very much?

GORDON S. FEITLER
Phoenix, Ariz.

The pot in question should have been a 500,000-ohm unit. We are sorry that our printer left out the three zeros.

—Editors

TUBE-TESTER CHARTS

To the Editors:

Please inform your readers that Precision tube-tester charts are now available from Coletronics Service, Inc., 1744 Rockaway Avenue, Hewlett, L. I., New York 11557.

I am sure that you have had many requests for this information.

LARRY'S ELECTRONIC SERVICE
Brooklyn, N.Y.

LOW-NOISE SIGNAL BOOSTER

To the Editors:

In the article "Low-Noise TV and FM Signal Booster" (November, 1965 issue), I would like to question the connecting of the silicon rectifiers D1 and D2 in Fig. 1 on p. 30. I have used a similar voltage-doubler as a detector in many AM sets and have always polarized the diodes cathode to anode, rather than cathode to cathode as shown in the article.

EUGENE M. FUNK
Richmond Hill, N.Y.

Reader Funk is correct. Diode D2 in the circuit diagram shown should be reversed for proper voltage-doubler operation. The anode side of the diode should go to the junction of C13 and D1, with the cathode going to ground. In addition, the polarity of C13 should be reversed.—Editors ▲



Why We Make the Model 211 Available Now

Although there are many stereo test records on the market today, most critical checks on existing test records have to be made with expensive test equipment.

Realizing this, HiFi STEREO REVIEW decided to produce a record that allows you to check your stereo rig, accurately and completely, **just by listening!** A record that would be precise enough for technicians to use in the laboratory—and versatile enough for you to use in your home.

The result: the HiFi STEREO REVIEW Model 211 Stereo Test Record!

Stereo Checks That Can Be Made With the Model 211

- ✓ Frequency response—a direct check of eighteen sections of the frequency spectrum, from 20 to 20,000 cps.
- ✓ Pickup tracking — the most sensitive tests ever available on disc for checking cartridge, stylus, and tone arm.
- ✓ Hum and rumble—foolproof tests that help you evaluate the actual audible levels of rumble and hum in your system.
- ✓ Flutter—a test to check whether your turntable's flutter is low, moderate, or high.
- ✓ Channel balance — two white-noise signals that allow you to match your system's stereo channels for level and tonal characteristics.
- ✓ Separation—an ingenious means of checking the stereo separation at seven different parts of the musical spectrum—from mid-bass to high treble.

ALSO:

- ✓ Stereo Spread
- ✓ Speaker Phasing
- ✓ Channel Identification

PLUS SUPER FIDELITY MUSIC!

The non-test side of this record consists of music recorded directly on the master disc, without going through the usual tape process. It's a superb demonstration of flawless recording technique. A demonstration that will amaze and entertain you and your friends.

NOW...GET THE FINEST STEREO TEST RECORD ever produced for just...\$4.98

Featuring Tests Never Before Available Outside Of The Laboratory

UNIQUE FEATURES OF HiFi/STEREO REVIEW'S MODEL 211 STEREO TEST RECORD

- Warble tones to minimize the distorting effects of room acoustics when making frequency-response checks.

Warble tones used are recorded to the same level within ± 1 db from 40 to 20,000 cps, and within ± 3 db to 20 cps. For the first time you can measure the frequency response of a system without an anechoic chamber. The frequency limits of each warble are within 5% accuracy.

- White-noise signals to allow the stereo channels to be matched in level and in tonal characteristics.
- Four specially designed tests to check distortion in stereo cartridges.
- Open-air recording of moving snare drums to minimize reverberation when checking stereo spread.

All Tests Can Be Made By Ear

HiFi/STEREO REVIEW's Model 211 Stereo Test Record will give you immediate answers to all of the questions you have about your stereo system. It's the most complete test record of its kind—contains the widest range of check-points ever included on one test disc! And you need no expensive test equipment. All checks can be made by ear!

Note to professionals: The Model 211 can be used as a highly efficient design and measurement tool. Recorded levels, frequencies, etc. have been controlled to very close tolerances—affording accurate numerical evaluation when used with test instruments.

DON'T MISS OUT—ORDER NOW

The Model 211 Stereo Test Record is a disc that has set the new standard for stereo test recording. There is an overwhelming demand for this record and orders will be filled by ELECTRONICS WORLD promptly upon receipt. At the low price of \$4.98, this is a value you won't want to miss. Make sure you fill in and mail the coupon together with your check (\$4.98 per record) today.

FILL IN AND MAIL TODAY!

Stereo Test Record
ELECTRONICS WORLD—Dept. SD
One Park Ave., New York 16, N.Y.

Please send me _____ test records at \$4.98 each. My check (or money order) for \$_____ is enclosed. I understand that you will pay the postage. (Orders from outside the U.S.A. add 50c to partially defray postage and handling costs.)

Name _____
(Please Print)

Address _____

City _____ Zone _____ State _____

SORRY—No charges or C.O.D. orders!

EW-26

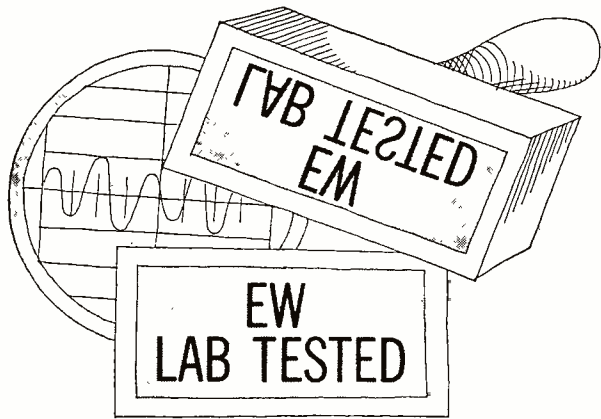

HI-FI PRODUCT REPORT

TESTED BY HIRSCH-HOUCK LABS

Scott 348 Stereo Receiver

Scott 348 Stereo Receiver

For copy of manufacturer's brochure, circle No. 31 on Reader Service Card.

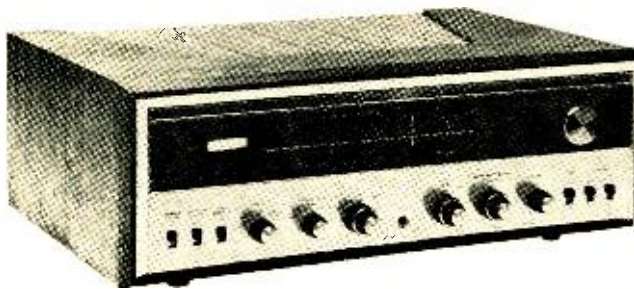

MOST integrated stereo receivers have relatively low-powered audio systems, as well as FM tuners which often lack the sophistication and extreme sensitivity of higher priced separate tuners. This is consistent with their being designed for a broad market which desires good sound with a minimum of complication and cost.

The hi-fi enthusiast who does not wish to compromise the performance of any part of his system or who feels the need for a high-powered amplifier or a tuner with fringe-area sensitivity often hesitates to buy an integrated receiver, despite its obvious convenience.

The new Scott Model 348, at the top of the company's line in price and performance, serves as clear proof that a receiver on one chassis can hold its own in critical comparison with practically any grouping of separate components at, or even well above, its price.

The salient specifications of the re-

ceiver are: 1.9- μ v. IHF usable FM sensitivity; 35-db stereo separation; 4-db capture ratio; 50- to 15,000-cps FM-frequency response ± 1 db; 30 watts per channel continuous output at 0.8% distortion; and 20- to 20,000-cps power bandwidth. There are many other specifications (Scott is one of the few manufacturers who supplies a complete list of specifications with each product), but these are the major ones.

The Model 348 is styled attractively, with a pale gold brushed aluminum panel and a softly lighted slide-rule dial. It has an illuminated tuning meter, which reads maximum at the correct tuning point, and an FM-stereo indicator light. The input switch has positions for tape head, magnetic phono cartridge

(with a three-position sensitivity switch on the rear of the unit for matching the phono level to that of the tuner), FM, FM with sub-channel filter, and a high-level external input. A three-head tape recorder may be connected for monitoring while recording through the receiver, and the "Tape Monitor" switch on the panel connects the recorder playback preamplifiers to the receiver audio system for playing recorded tapes.

A seven-position selector switch, similar to that used on other Scott amplifiers, has settings for mono, stereo, reversed-channel stereo, and playing either left or right channel through both speakers. In addition, there are two balance positions for playing the mixed channels through only one speaker at a time. Used with the balance control, these are very effective in balancing a complete system, including the speakers.

The tone controls have slip clutches for independent adjustment of the two channels, or they may be operated together. The loudness control has a compensated frequency response for low-level listening, boosting the low and high frequencies as volume is reduced. This can be disabled if one desires. Concentric with the balance control is an FM-muting control.

(Continued on page 65)

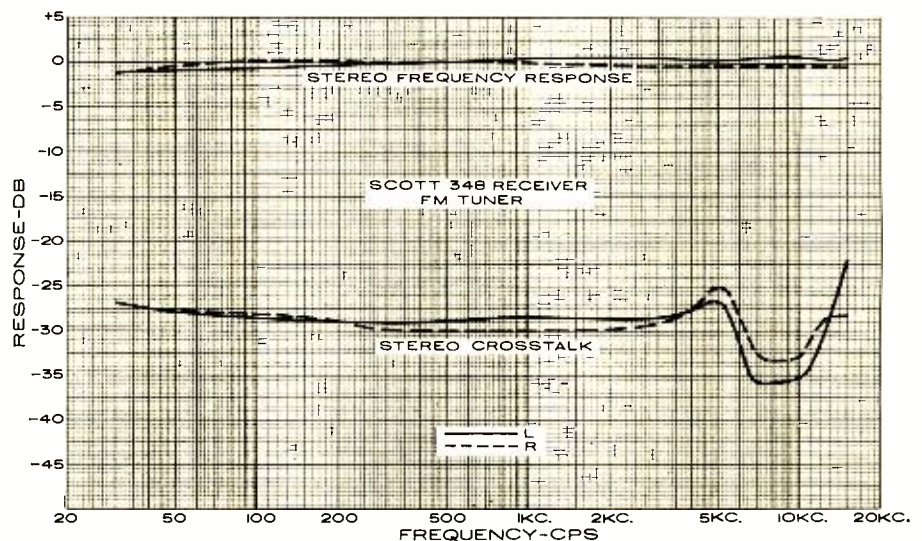
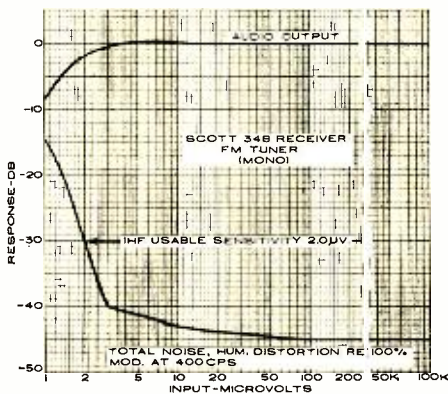

Crime does pay!

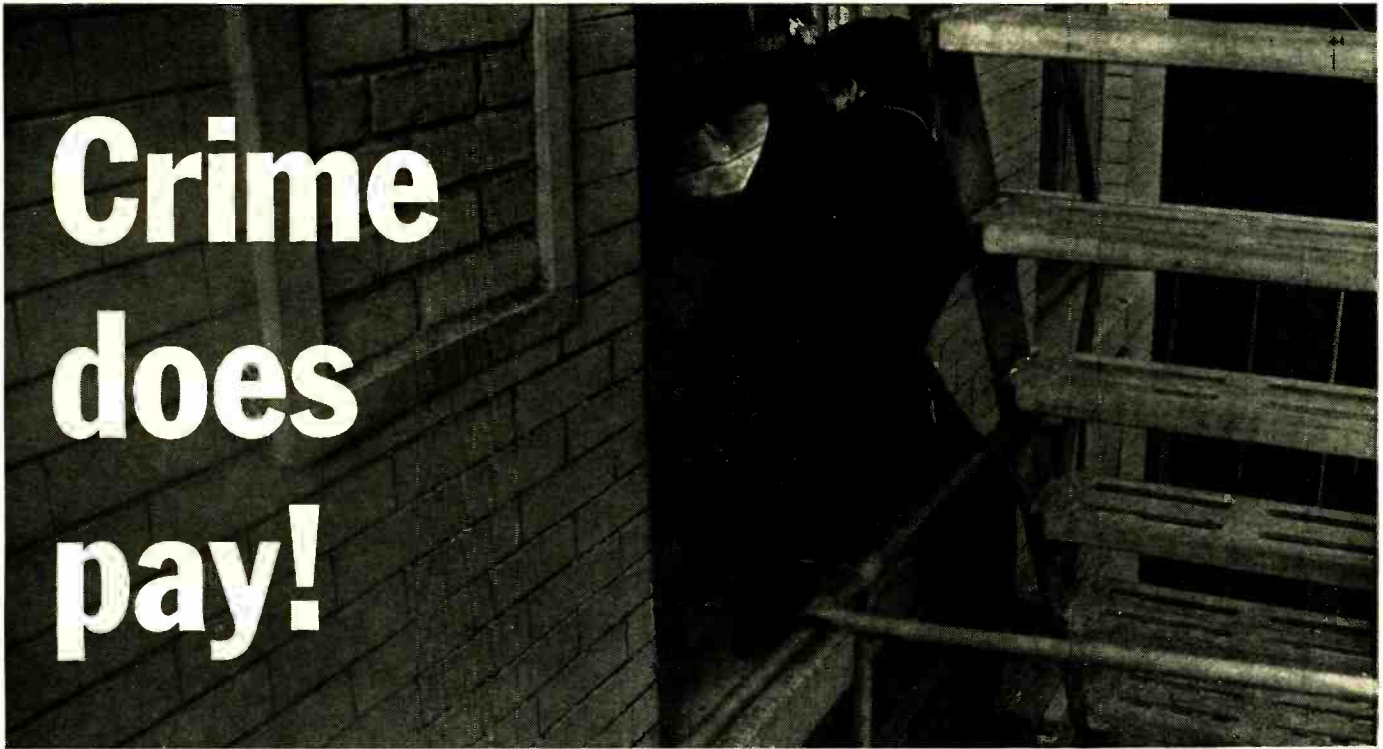

Every 40 seconds a burglary takes place in the United States.

TECHNICAL INFORMATION

The RADAR SENTRY ALARM is a complete U.H.F. Doppler Radar System which saturates the entire protected area with invisible r.f. microwaves. It provides complete wall to wall—floor to ceiling protection for an area of up to 5,000 square feet. Without human movement in the protected area, the microwave signal remains stable. Any human movement (operation is unaffected by rodents and small animals) in the area causes the doppler signal to change frequency approximately 2 to 4 cps. An ultra-stable low frequency detector senses this small frequency change, amplifies it and triggers the police type siren—which is heard up to a half mile away.

In addition, the RADAR SENTRY ALARM's protection can be extended to other areas with the use of the following optional accessories:

- remote detectors for extending coverage to over 10,000 sq. ft.
- rate of rise fire detector U.L. approved for 2,500 sq. ft. of coverage each (no limit on the number of remote detectors that can be used)
- hold-up alarm
- central station or police station transmitter and receiver (used with a leased telephone line)
- relay unit for activating house lights
- battery operated horn or bell which sounds in the event of: powerline failure; equipment malfunction or tampering

At that rate, it's a multi-million dollar a year business...for burglars.

And an even better business opportunity for you.

Why? Because burglary can be stopped...with an effective alarm system.

In fact, police and insurance officials have proved that an alarm system reduces, and in many cases, eliminates losses—even helps police apprehend the criminal.

Here's where you come in.

Only a small percentage of the more than 100 million buildings—stores, offices, factories, schools, churches and homes are protected by an effective alarm system.

That means virtually every home, every business is a prospect. You can sell them!

And you don't have to be a super-salesman to sell the best protection available—a Radar Sentry Alarm unit. All you have to do is demonstrate it...it sells itself.

A glance at the technical information shows why.

It's the most unique and effective alarm system ever invented.

And here's the proof.

In the past six years, thousands of RADAR SENTRY ALARM units have been sold in the Detroit, Michigan area alone—sold by men like yourself on a part-time and full-time basis.

Here are just a few customers who are protected by RADAR SENTRY ALARMS:

U.S. Government
U.S. Air Force
Detroit Board of Education
Hundreds of Churches,
Banks, Businesses and
Homes.

Everyone is a prospect.

So take advantage of your profession. Put your technical knowledge and experience to work for you in a totally new area—an area that will make money for you!

Don't wait!

Let us prove that crime does pay.

Become a distributor.

Write now for free details.

RADAR SENTRY ALARM



Mail to: RADAR DEVICES MANUFACTURING CORP.
22003 Harper Ave., St. Clair Shores, Michigan 48080



Please tell me how I can have a business of my own distributing Radar Sentry Alarm Systems. I understand there is no obligation.

Name _____ EW-2

Address _____

City _____ State & Code _____

“He’s a good worker.
I’d promote him
right now
if he had
more
education
in electronics.”



NOW! TWO NEW PROGRAMS!

- Industrial Electronics for Automation
- Computer Processing Systems

Could they be talking about you?

You'll miss a lot of opportunities if you try to get along in the electronics industry without an advanced education. Many doors will be closed to you, and no amount of hard work will open them.

But you can build a rewarding career if you supplement your experience with specialized knowledge of one of the key areas of electronics. As a specialist, you will enjoy security, excellent pay, and the kind of future you want for yourself and your family.

Going back to school isn't easy for a man with a full-time job and family obligations. But CREI Home Study Programs make it possible for you to get the additional education you need without attending classes. You study at home, at your own pace, on your own schedule. You study with the assurance that what you learn can be applied to the job immediately.

CREI Programs cover all important areas of electronics including communications, servomechanisms, even spacecraft tracking and control. You're sure to find a program that fits your career objectives.

You're eligible for a CREI Program if you work in electronics and have a high school education. Our FREE book gives complete information. For your copy, airmail postpaid card or write: CREI, Dept. 1102-D, 3224 Sixteenth Street, N.W., Washington, D.C. 20010.



Founded 1927
CREI
Accredited Member
of The National Home Study Council

The ideal base/mobile combination for CB radio

FOR BASE STATIONS where 117 V 60 cycle AC current is available...



The Low-Cost RCA Mark VIII and Mark NINE

- 9 crystal-controlled transmit and receive channels.
- Tunable receiver for reception of 23 C-B channels; dial marked in both channel numbers and frequency.
- Exceptionally good voice reproduction.
- Highly selective superheterodyne receiver with one RF and two IF amplifier stages.
- Electronic switching—no relay noise or chatter.
- Illuminated "working channel" feature.
- Light and compact—only 3¾ inches high, weighs only 9 pounds with mike.
- Improved Automatic Noise Limiter.

Plus these EXTRA features in the Mark NINE

- Combination "S" Meter and relative RF Output Meter (indicates the relative strength of incoming signal) and Relative RF Output Meter (indicates relative strength of signal being transmitted).
- Spotting Switch. Permits precise manual tuning of receiver without use of receiver crystals.
- External Speaker Jack. Lets you connect an external speaker to set, so that incoming calls can be heard in remote locations.

Mark VIII: \$99.95*

Mark NINE: \$114.50*

FOR MOBILE UNITS where low power consumption is important...

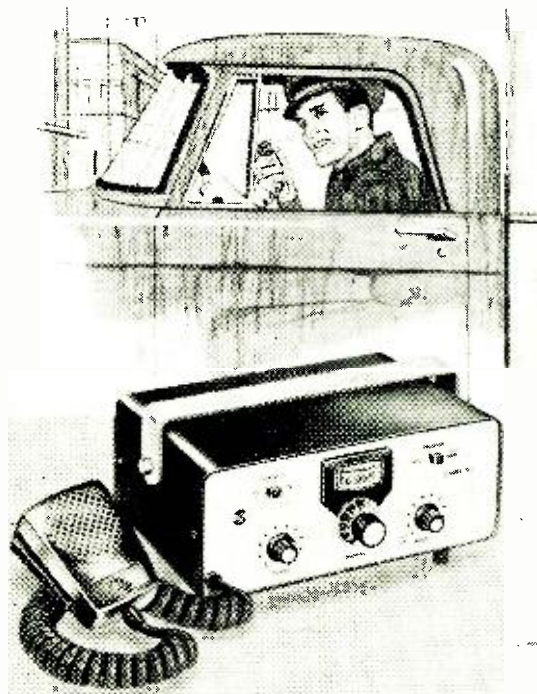

The all-solid-state MARK 10

- All silicon transistors assure low power consumption, dependable communications at temperatures from -23° to +130° F.
- Compact, lightweight. Fits easily under dash of any car or truck. Only 3¾" high, 5¾" deep, 8½" wide. Weighs less than 4½ pounds.
- 12 crystal-controlled transmit and receive channels with illuminated channel selector.
- Combination "S" Meter and relative RF Output Meter.
- Operates from 12-volts DC power source (positive or negative ground).
- Crystal-controlled double conversion, superheterodyne receiver provides frequency accuracies greater than 0.004%.
- Separate AGC amplifier eliminates blasting and overloading, minimizes fading.
- Six-stage IF bandpass filter for maximum selectivity without ringing.
- Low-distortion, series-type noise limiter with automatic threshold adjustment.
- Receiver power regulated for maximum stability.
- Acoustically designed cabinet with audio characteristics shaped for maximum intelligibility.
- External speaker jack (de-activates internal speaker).

Mark 10: \$189.95*

*Optional distributor resale price.

See them at your Authorized
RCA CB Radio Distributor.
Look for stores
displaying this symbol.



RCA ELECTRONIC COMPONENTS AND DEVICES, HARRISON, N. J.

The Most Trusted Name in Electronics

THE SCR REVOLUTION

By J. E. MUNGENAST
Semiconductor Products Dept.
General Electric Co.

A drastic price decline has opened up many new applications for this semiconductor switching device. By the end of this year, SCR's may represent a \$40 million market. This article shows a large number of basic static switching and control circuits.

IN 1957 electronics took a giant step into the broad world of electric control. In that year, the first practical silicon controlled rectifier was fabricated by Gordon Hall of *General Electric*. This was the first semiconductor that could economically switch kilowatts. The SCR has since grown into a wide family of devices with a potential \$40 million market by the end of 1966. Let's examine why it has grown so swiftly and what opportunities it offers to the electronics industry as a whole.

The SCR's and their close relative the bidirectional a.c. switches (known variously as Triacs, symmetrical switches, or five-layer switches) are logical extensions of the solid-state rectifier and transistor family. Fig. 1 shows these four basic devices along with some of their characteristics and applications. When the SCR and its thyatron gas-tube counterpart is compared with the transistor and its receiving-tube counterpart, we see that the prime difference is not only the power-handling capability but also the fact that the SCR

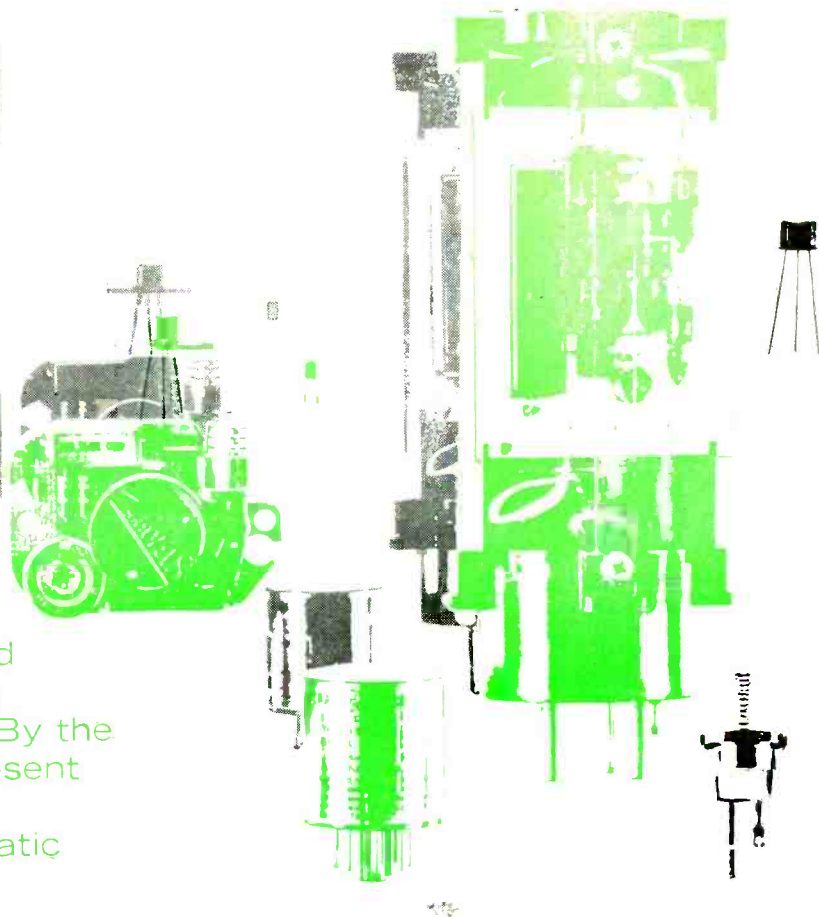
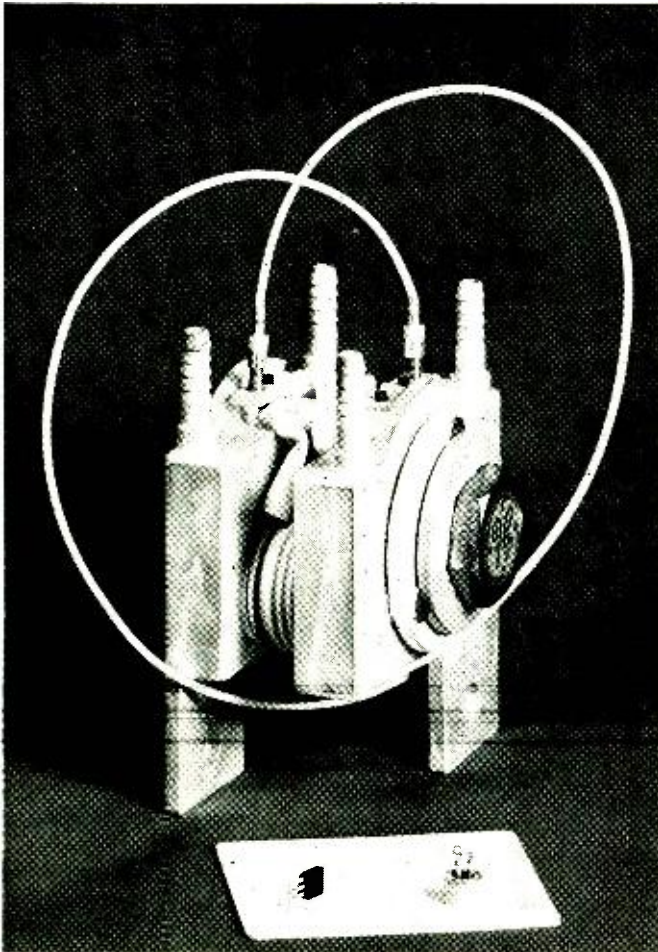

Fig. 1. Four basic semiconductor devices along with their main characteristics and their applications.

NAME OF DEVICE	CIRCUIT SYMBOL	JUNCTION SCHEMATIC	ELECTRICAL CHARACTERISTICS	MAXIMUM RATINGS	MAJOR APPLICATIONS	ANALOGOUS TO
DIODE OR RECTIFIER			<p>ANODE I $V_{anode (-)}$ $V_{anode (+)}$</p> <p>CONDUCTS EASILY IN ONE DIRECTION, BLOCKS IN THE OTHER</p>	500 AMPS, 500 VOLTS OR MORE	RECTIFICATION BLOCKING DETECTING STEERING	CHECK VALVE, DIODE TUBE OR GAS DIODE
TRANSISTOR			<p>I_c I_{b5} I_{b4} I_{b3} I_{b2} I_{b1} O $V_{collector (+)}$</p> <p>CONSTANT COLLECTOR CURRENT FOR GIVEN BASE DRIVE</p>	200 VOLTS, 60 WATTS	AMPLIFICATION SWITCHING OSCILLATION	TRIODE OR PENTODE TUBE
SILICON CONTROLLED RECTIFIER (SCR)			<p>ANODE I $V_{anode (-)}$ $V_{anode (+)}$</p> <p>WITH (+) ANODE VOLTAGE, SCR CAN BE TRIGGERED BY I_g REMAINING IN CONDUCTION UNTIL ANODE I IS REDUCED TO ZERO</p>	300 AMPS, 1300 VOLTS OR MORE	POWER SWITCHING PHASE CONTROL INVERTING CHOPPING	GAS THYRATRON OR IGNITION
TRIAC			<p>I $V_{anode 2 (-)}$ $V_{anode 2 (+)}$</p> <p>OPERATES SIMILAR TO SCR EXCEPT CAN BE TRIGGERED INTO CONDUCTION IN EITHER DIRECTION BY (+) OR (-) GATE SIGNAL</p>	10 AMPS, 400 VOLTS	A.C. SWITCHING PHASE CONTROL RELAY REPLACEMENT	TWO SCR'S IN INVERSE PARALLEL



Three members of the SCR family showing the very wide range of currents and voltages. The large assembly is a water-cooled a.c. switch that will handle up to 1200 amps at 1800 volts peak. The small unit at the left is the new, inexpensive plastic-encapsulated SCR with a current rating of 2 amps at 200 volts peak. The small unit at the right is a bi-directional switch (Triac) with a 10-amp, 400-volt peak rating. Additional SCR's are shown in the cover photograph.

works in the switching mode only. This is the key to its power-handling capability—but it can cause some inconvenience on direct-current circuits, as we will see later. The second valuable SCR attribute is its extraordinary sensitivity. Again, like the thyatron, it offers a degree of power amplification that makes possible inexpensive, simple control circuitry triggered by a number of sensors, such as photocells and thermistors.

Thus, the SCR will play an important role in automotive applications, as for example in electronic ignition systems or in electric windshield wiper controls. It will be used in the appliance field for varying the speed of motors and for varying the brightness of lamps. It will be found in the toy/hobby market where its sensitivity will make possible unique control schemes such as for model trains.

The cover photograph, as well as the one in this article, show some members of the SCR family. Note the wide range of size and operating characteristics. Also note par-

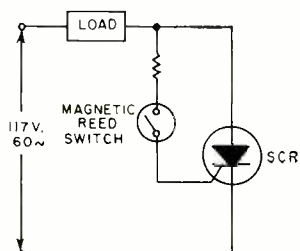
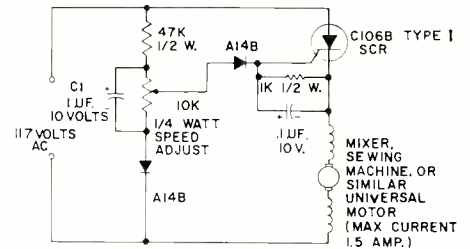

Fig. 2. Simple static-switch circuit.

Fig. 3. A popular variable speed control circuit using SCR.



ticularly the tiny new plastic-encapsulated SCR. This device has an instantaneous power gain of over one million, yet it costs only 35 to 50 cents in large quantities. Like most semiconductors, the SCR has been characterized by a precipitous price decline. The first units in 1957 cost about \$325 each. Today a comparable unit costs less than \$2.00.

The SCR is in itself of little use; auxiliary circuitry is necessary to accomplish the desired function. The main circuits that form the basis for many of the thousands of SCR applications of today and tomorrow are discussed below.

The Static Switch

Fig. 2 shows the simplest form of the half-wave static switch using a magnetic reed switch for energizing the gate circuit of an SCR. Note that the SCR fires, or latches into conduction, whenever gate current is allowed to flow through the reed switch. This can be actuated either by a permanent magnet, making a proximity switch, or by passing current through an electromagnet coil. The wide range of uses includes simple explosion-proof switches (there is no arcing mechanism and no fumes are entrapped, as the semiconductor and reed switch are mounted in a plastic block), relay replacement where highly repetitive operations are needed, and sensitive relay replacement where an SCR amplifier in

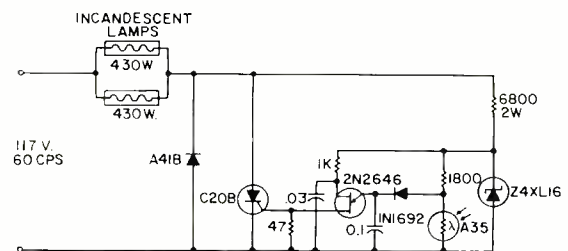

Fig. 4. High-gain limited-range light control circuit with unijunction transistor. For applications in which control of the load below the half-power point is not required, a rectifier can supply a half cycle uncontrolled, and an SCR can provide regulation by phase control during the other half cycle.

conjunction with a rugged, inexpensive power relay does a more reliable, economic job than a delicate sensitive relay.

Phase Control

But the most promising family of applications for the SCR's involves phase control, whereby the load is switched on and off at certain times in the applied a.c. cycle, thereby metering the power to the load. The basic principles of operation have been described many times in past issues of this publication, so they will not be repeated here. Fig. 3 shows one of the most popular circuits, the series motor speed control.

For many years, tool and appliance manufacturers have sought a way not only to adjust the speed of the series motor but, more important, to furnish governor action that would maintain the necessary torque, even at the low-speed settings. This is accomplished in the circuit shown in Fig. 3. Essentially the SCR performs three functions here: first as an on-off switch, second as the means for voltage reduction, and third as the sensing mechanism making feedback control possible. The counter-e.m.f. of the rotor gives us a tachometer indication of speed which is compared with the desired setting of the speed-adjust potentiometer. Any differential

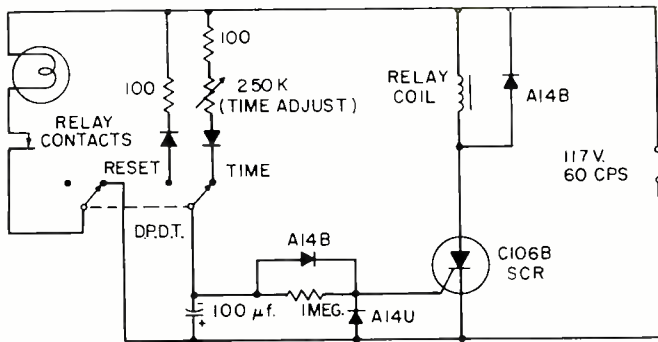

NOTE: ALL RESISTORS 1/2 WATT

Fig. 5. Time-delay relay circuit for enlarger, patio light, or garage light. Circuit can be used to turn off lights after an interval of up to about 1 minute. The SCR supplies enough current to energize a low-cost relay coil. The SCR is triggered by only a few microamps of current from the RC network.

then varies the phase angle to maintain the necessary speed. Thus, both the sensitivity and the power-handling capability of the SCR are essential.

Other phase-control circuits use the unijunction transistor as a sensitive preamplifier. The circuit shown in Fig. 4 has a control gain of over 10 million and can be constructed with less than \$16 worth of parts even in relatively small quantities. Sensors such as cadmium-sulphide photocells, thermistors, and silicon strain gages can all be used, making possible functions that were economically unfeasible just a few years ago.

A variation of phase control is shown in Fig. 5. This is a time-delay relay for photographic enlargers, garage lights, etc. Since phase control is a form of time delay, it is only necessary to extend the RC time constant to time out intervals of approximately one minute or so.

Full-Wave A.C. Phase Control

As useful as the above circuits are, a simple, economical method of controlling alternating current was needed. Previously, a.c. control required two SCR's plus a number of auxiliary components to control both halves of the sine-wave cycle. Recently, the bi-lateral switch emerged. A most useful version is the gate-triggered unit known as the Triac.

Fig. 6 shows a comparison of the SCR method with the Triac method to accomplish phase control. Not only is the Triac much simpler but it also includes protection from line-voltage transients that can otherwise harm semiconductor circuitry. The circuit is suitable for the speed control of small a.c. motors of the shaded-pole and permanent-magnet split-capacitance types. This control is not suitable for a.c. motors with starting mechanisms, such as split-phase, split-capacitance, or synchronous motors. However, when used with a motor properly designed for the control, variable speed of furnace blowers, circulating pumps, and air-conditioning blowers will bring a new level of comfort to the household of the future. Such a system replaces the manual potentiometer with a special thermistor located in the furnace bonnet. With a variable speed control the blower idles continuously, eliminating the stratified air layers, with speed increased only when the thermostat calls for more heat and bonnet temperature rises.

SCR lighting controls were among the earliest applications

Fig. 6. Full-wave control circuits using SCR's and Triacs.

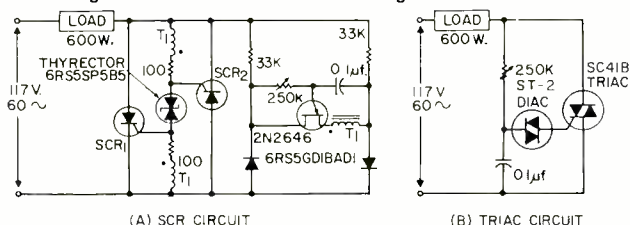

of phase controls to be used in the home and in industry. Hundreds of thousands of 600-watt SCR dimmers are now used for control and dimming of ceiling fixtures. The larger table- and floor-lamp market can now be served with the more compact Triac devices in circuits similar to that shown in Fig. 6B. Indeed, an entire low-power dimmer circuit can be readily built into a standard lamp socket.

The Inverter-Chopper Control

The basic circuit shown in Fig. 7 essentially changes the state of electric power, functioning in reverse, as it were, from the familiar transformer-rectifier power supply. The latter takes 60-cps, 117-volt a.c., for example, and converts it into 12 volts d.c. The inverter takes the 12-volt d.c. from an automobile battery, for example, and converts it to 117-volt, 60-cps a.c. by means of electronic switching, enabling the voltage to be stepped up by means of the transformer.

While this job has been accomplished for years by both the automotive breaker points of an ignition system and the older vibrator power supplies, the availability of higher

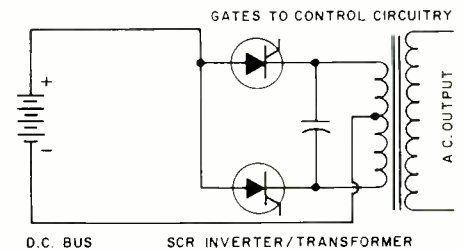
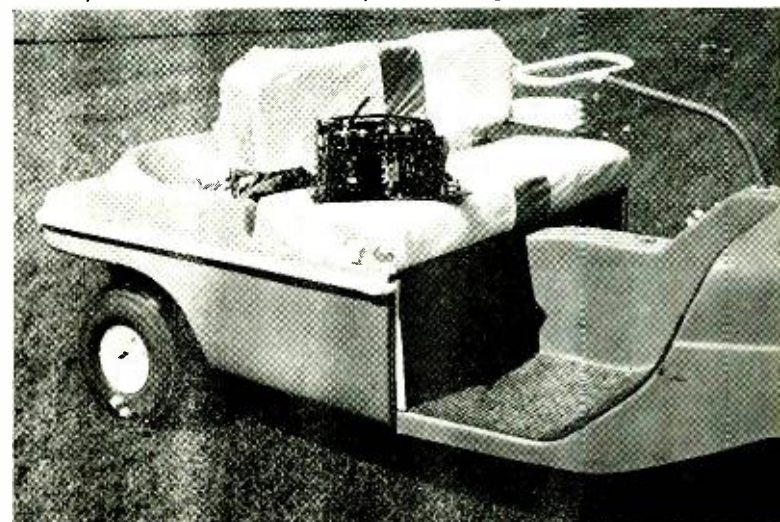

Fig. 7. Inverter circuit changes d.c. to higher voltage a.c.

power, more efficient solid-state switches in recent years has greatly increased the market. The wide variety of uses, such as operation of fluorescent lamps from low-voltage d.c. standby power supplies for telephone communications systems and computers, and operation of satellite electronic equipment from very low voltage fuel cells, are all based on the use of the inverter. By employing SCR's rather than simple power transistors in the inverter, control circuits may be incorporated into the gate circuits to adjust output.

But an even more interesting use is the conversion of 60-cps power to higher frequencies. This is done by rectifying the 60-cps line and using the resultant d.c. to power an inverter whose output is at some higher frequency. This technique is used to increase the synchronous speed of induction motors or to reduce the size of inductive or capacitive elements in power supplies or filters. The use of higher frequencies is also important when fluorescent lights are

This golf cart employs SCR's for speed control. The entire electronic package with the throttle rod coming out of the top of it has been removed and placed on the golf-cart seat.



A POINT would not be considered properly grounded if there were 100 ohms between that point and the ground plane. But this type of problem can easily occur because a straight piece of AWG #30 wire 6 inches long has 200 nanohenrys (0.2 μ hy.) of self-inductance. At only 80 megacycles, 200 nanohenrys means that this short piece of wire has close to 100 ohms inductive reactance.

The accompanying curves give the self-inductance of a straight wire according to the formula: $L = 1 (2 \log_e 4l/d - 3/2) 10^{-9}$ where L is the self-inductance in microhenrys,

l is the length of the wire in centimeters, and d is the diameter of the wire in centimeters.

This equation is valid for non-magnetic wires such as copper and aluminum; permeability must be taken into account with magnetic material.

(Editor's Note: Although the most useful portion of this graph is at the left-hand side where short wire lengths are considered, it is informative to see how the inductance changes for various wire sizes when much longer lengths are considered.) ▲

STRAIGHT-WIRE INDUCTANCE GRAPH

By DONALD W. MOFFAT

Design chart permits rapid determination of amount of inductance in various lengths of common hook-up wire.

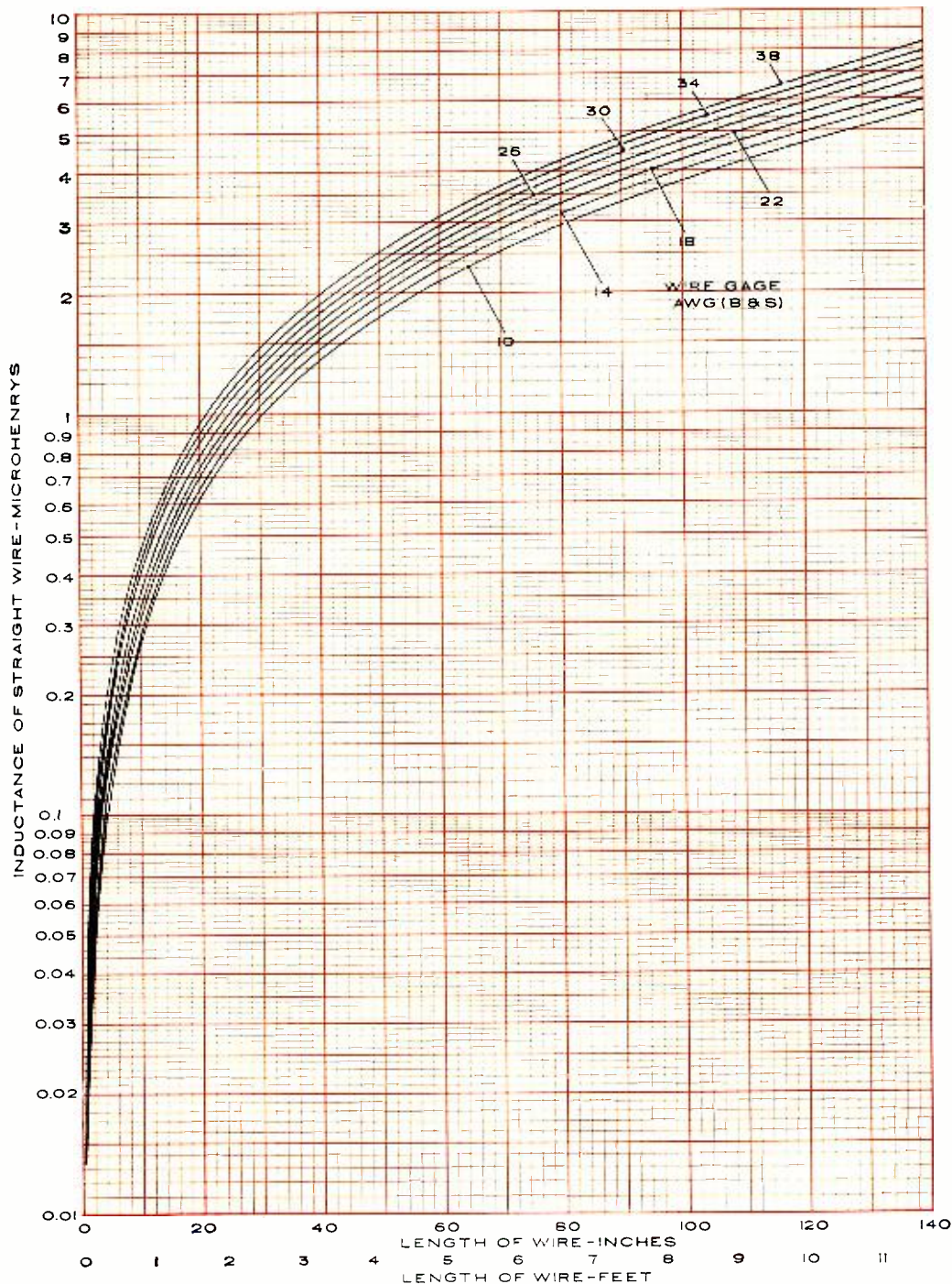

RECENT DEVELOPMENTS IN ELECTRONICS



Ultrasonic Production-Line Tester. (Top left) The use of ultrasonics is increasing in the field of non-destructive testing. The unit shown is an ultrasonic image-conversion system that is designed for production-line testing and inspection. A metal piece to be inspected is placed in a table-top water tank which transmits ultrasonic waves from a generator to a quartz crystal transducer. The waves, passing through the sample, are absorbed in proportion to the density of the material. An image-converter tube continuously scans the transducer and transmits an amplified electrical signal to be displayed on a cathode-ray tube. The new system, developed by James Electronics, Inc., can be used to detect cracks, non-bonds, voids, fractures, or flaws either on the surface of the metal piece being checked or deep within the material. Castings and extrusions can also be examined for porosity, granular structure, and homogeneity. It is also possible to examine non-metals, like plastics or rubber.



Triggered Vacuum-Gap Protector. (Center) The recent giant power failure in the Northeast has focused attention on newer and better protective devices to prevent future blackouts. This protector is a developmental model of a triggered vacuum-gap device that can protect utility power lines and complex electronic equipment from sudden power surges. The surge causes a trigger to create a small arc. The heat from the arc releases a small amount of hydrogen from the surrounding electrodes. The gas is immediately ionized causing the vacuum gap to become conducting with the formation of a metal vapor arc. When the surge has passed, the metal vapor condenses and the path across the vacuum gap becomes an insulator again. Advantages of the new protector, invented by G-E scientists, are the very high operating speed and the very wide range of operating voltage. The breaker is said to operate within a microsecond, or about 1000 times faster than conventional breakers. It might function over a voltage range of from 500 v. to 30,000 v., while a conventional protective device might be effective only over a range of several hundred volts. The bank of capacitors in the background of the photo is used to supply high currents for laboratory experiments.

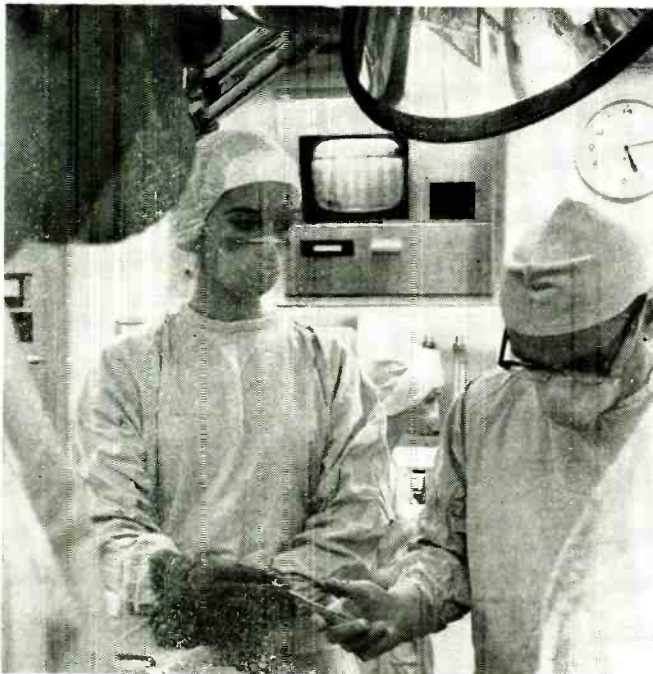

Electronic Surgical Monitoring System. (Bottom left) The video screen mounted on the operating room wall at St. Mary's Hospital in Rochester, Minn. displays a continuous flow of information on a patient's physiological condition during neurosurgery. The system alerts physicians to sudden changes so that remedial action can be taken quickly. The information is also stored for later computer analysis. Displayed on the 14-in. screen are such life-sustaining indicators as heart and respiratory rates, arterial pressure, and body temperature. Automatic readings of electrocardiograms and electroencephalograms are also supplied by the system on a 5-in. oscilloscope screen located near the patient. Monitor was developed by Mayo Clinic and IBM.

Computer-Produced Trumpet Sounds. (Top right) Trumpet-like sounds indistinguishable from the sounds of the trumpet itself have been synthesized through a computer at Bell Labs. It is believed to be the first time the sound of any musical instrument has been generated with such fidelity by a computer. Brass timbre has proved particularly difficult to reproduce in the past. In listening to the computer-generated tone, 20 persons, several of whom were professional musicians, were unable to tell the difference between the computer trumpet and the real one. In the study, trumpet tones were recorded on tape in an anechoic room. Each tone was converted into digital form and fed into a computer which analyzed frequencies and amplitudes of the various components. The computer then produced similar spectra which led to the generation of numbers that were converted into electrical signals. These were then reproduced by a loudspeaker.

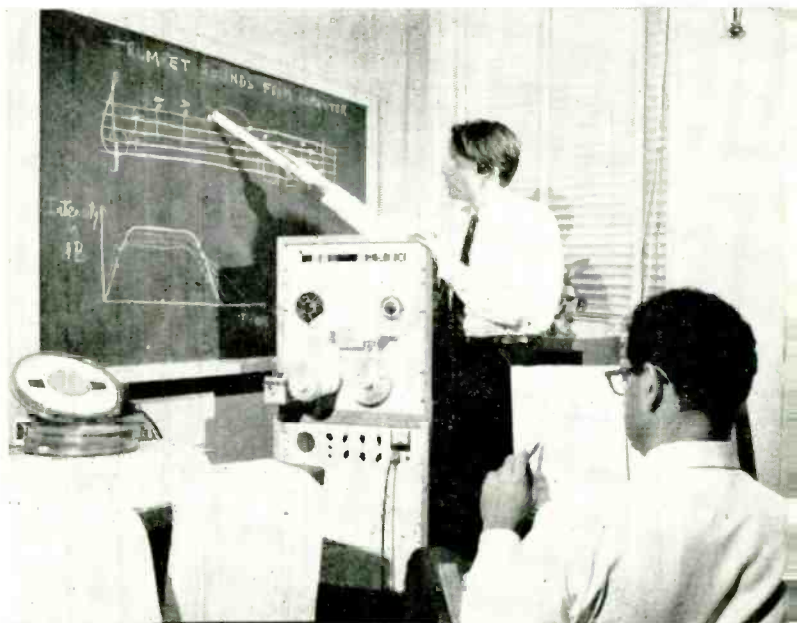

Airborne-Maintenance Computer. (Center) A new, integrated-circuit, digital airborne computer and recording system is being flight-tested on an Eastern 727 jet. The system will check many elements at least once every second, record the data, and provide information immediately for the cockpit crew for improved flight management. At the end of the flight, ground-maintenance personnel will find ready detailed data isolating potential or actual faults. The system will ultimately measure up to 296 different parameters. The photo shows a member of the crew inserting flight number, date, time, aircraft weight into the system.

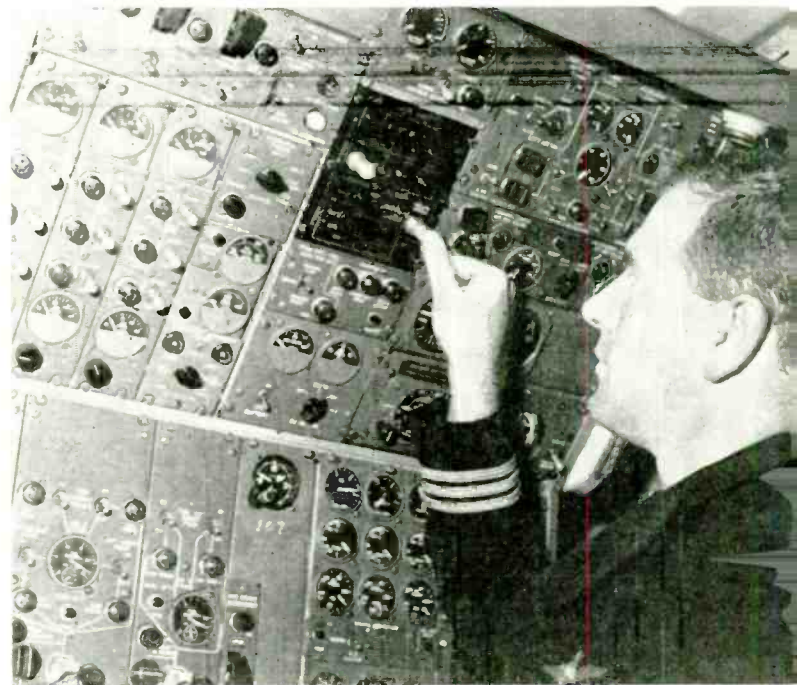

Continuity Tester. (Below left) This is the display board of a giant continuity tester at Honeywell's new \$10 million plant at Fort Washington, Penna. The device checks as many as 2600 connections of card files on which printed-circuit boards are mounted. The new plant is said to be the world's largest for the production of the "tools of automation." The facility employs closed-circuit TV monitors linked to cameras at key exits, audio detectors that flash an alarm at any unusual noise, and an intercom that parallels the audio system for fire, theft protection.

CCTV Office Monitor. (Below right) Telephone operators at the Bethlehem Steel Corp. use this CCTV office-monitoring system to route calls to sales personnel. Three Sylvania TV cameras are installed to allow the operators to view the sales area from the switchboard to determine which salesmen are at their desks to receive incoming calls. If a salesman is not available, calls can be routed to other personnel or a light can be actuated at the phone of the individual being called to indicate that there is a message waiting at the switchboard. The system should help provide the company's customers with better service.

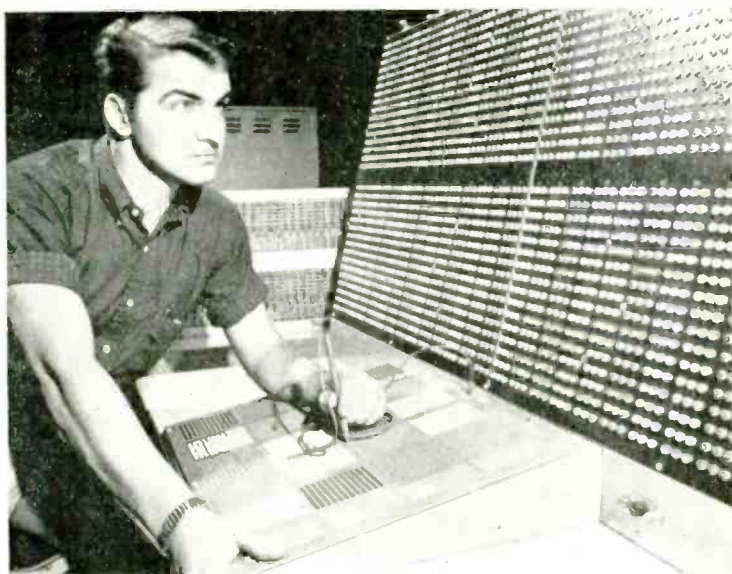

This "class-D" switching mode technique will permit solid-state circuits to exceed power capabilities of tubes without heatsinking at nearly 100% efficiency. Useful for audio, r.f., and control applications.

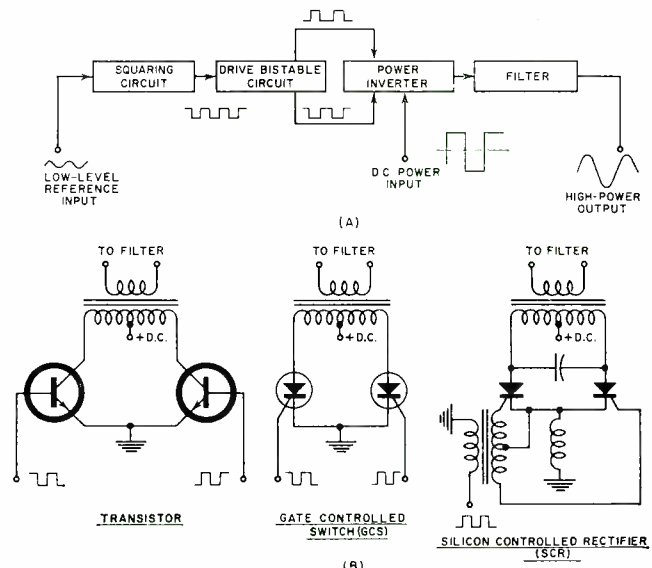

Fig. 1. (A) Constant-amplitude, single-frequency system. (B) Various semiconductors can be used in inverter stage.

AMPLIFICATION USING SWITCHING TECHNIQUES

By DONALD E. LANCASTER

THERE is a new way to amplify signals. It violates every one of the rules of conventional class-A, B, or C amplifiers in that it allows linear amplification of any signal at practically 100% efficiency. This new concept may drastically alter every electronic system from hi-fi amplifiers to complex military systems. It will allow integrated circuits to deliver substantial power to a load without the need for heatsinking. It will allow solid-state systems to meet and exceed the very high power capabilities still the sacred preserve of the vacuum tube. As an example, one unit now available on the market is an r.f. power amplifier that delivers over a kilowatt of output with an efficiency of over 95%.

Other ramifications of the technique, which has been called "class-D amplification," are almost hard to believe. All of the normal amplifier concepts are totally absent. Frequency response may be made essentially flat from d.c. to some precisely specified upper cut-off frequency, with the phase behaving just as well. Linearity of the semiconductors employed is no problem at all. There is no worry over non-linearity or crossover distortion, no problems with drive matching and balance. In fact, silicon controlled rectifiers (SCR's) or gate controlled switches (GCS's) can be used instead of the more familiar transistor. Use of these higher voltage devices as output semiconductors allows simple, direct-line-operated power supplies, eliminating the bulky power transformer and expensive high-current filter elements. In addition, the gain of an SCR or GCS is very much higher than ordinary transistors due to the regener-

ative turn-on mechanism. With these regenerative devices, fewer stages of amplification are needed in order to attain a given level of power output.

Basic Principles

The key to class-D operation is quite simple: *All of the amplifying stages in the system are run switching mode, that is, they are always either completely "on" (saturated) or completely "off"*. In neither of these states does the switching device consume any significant supply power, hence the possibility of near 100% efficiency.

There are two basic types of class-D systems, those that produce only a single-frequency (not necessarily fixed) constant-amplitude output; and those that handle any amplitude and frequency input signals over a wide range while providing linear amplification.

Let us consider the simpler system first. Fig. 1 shows a basic class-D system of the constant-amplitude type. The input signal consists of a sine-wave reference frequency at a very low level. Typical would be the output from a crystal frequency standard or a reference oscillator. This input signal is squared up to produce a square wave at the reference frequency. The reference signal, in turn, drives a bistable circuit that produces two high-level square-wave outputs. One is in phase with the input signal, while the second forms the complement, or the 180° phase-shifted replica of the input.

These two drive signals are used to drive a push-pull transformer-coupled output stage. This stage is nothing but

a driven high-power inverter. First one semiconductor, then the other, is turned "on," the opposite semiconductor turning "off" as its mate turns "on." The alternating current flow will induce a square wave in the transformer secondary. This square wave will be a very high power signal of precisely the same frequency and phase as the input reference.

Any square wave consists of a fundamental sine wave and series of diminishing odd harmonics. If a low-pass filter is introduced between a square wave and its load, only the fundamental frequency component, an ordinary pure sine wave, will be passed provided the cut-off frequency of the filter is above the fundamental and below the third harmonic. All of the square-wave input power will appear as a sine wave at the output, since the higher order harmonics will be looking into a very high impedance at the input to the filter.

Note that this system is *not* a resonant one and that it will easily pass a wide band of frequencies, as long as the fundamental frequency is below the cut-off of the filter and the third harmonic is above the cut-off point. Using sharp filters, a 2:1 frequency spread of input signals may be accommodated. This is a most important advantage over the normal class-C system. Another important advantage is the ratio of peak-to-average current in the output semiconductors. The peak-to-average ratio is only 2 in the class-D system, while it can approach several thousand in class-C operation. Because the semiconductors do not have to handle brief, extremely high current pulses, higher actual efficiencies may be realized.

Since the output works well over a band of frequencies, the system will handle frequency-modulated signals, carrier-shift industrial communications, swept radar waveforms, and other wide bandwidth signals. As the output power will be a constant determined only by the load resistance and the supply voltage employed, the class-D system is also an effective amplitude limiter, for no variation in the strength of the input signals will appear at the output of the particular circuit that is illustrated.

Applications of Fixed-Amplitude Systems

Fig. 2 shows the output stage of the previously mentioned r.f. carrier generator, intended for prime c.w. power output in the 10 to 500 kc. range. This all-solid-state system puts out 1200 watts of carrier with an over-all efficiency of 95% and with all spurious outputs attenuated by 50 decibels. Similar vacuum-tube systems at best attain an efficiency of less than 70%, considering all losses.

Motor controls are another application of a single-frequency, constant-output class-D amplifier. By using class-D techniques, it is possible to precisely vary or hold fixed the speed of any a.c. motor. Since the speed of an a.c.-only motor is a function of frequency and not the applied voltage, all the normal control schemes (e.g., autotransformers, rheostats, conventional SCR controls) will not effect control and can, in certain instances, damage the motor. A class-D system varies the applied frequency to the motor, allowing precise control of synchronous, induction, or hysteresis motors.

Fig. 3 shows a typical scheme. Here a low-power control sine wave of the desired frequency is clipped into a square wave and used to drive a power inverter. The inverter output, in turn, powers the motor. A filter is not normally required since the motor's inductance effectively filters the higher order harmonics of the square wave. The values shown provide a 200-watt, 400-cps power source.

This technique is useful in three major ways. It may be used to maintain a constant motor speed in light of a varying or unpredictable supply frequency. This problem often crops up in aircraft systems, where the supply frequency can often be far too unstable for such constant-speed drives as are used in tape-recording systems and precision servos.

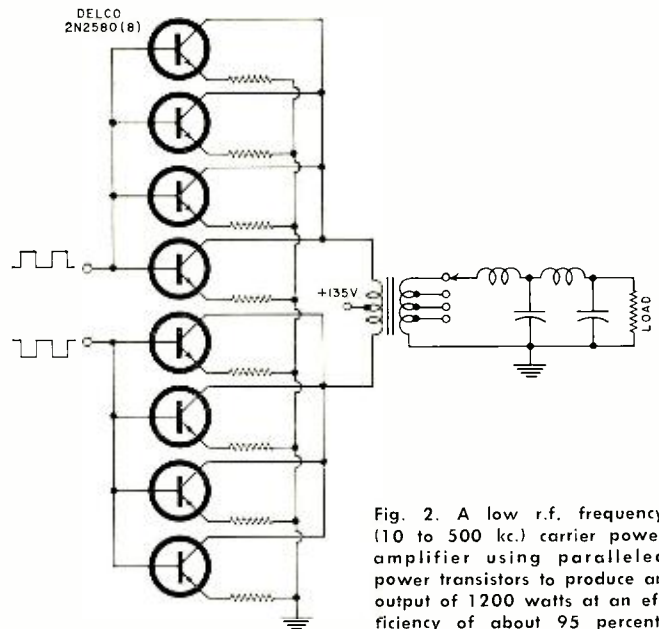

Fig. 2. A low r.f. frequency (10 to 500 kc.) carrier power amplifier using paralleled power transistors to produce an output of 1200 watts at an efficiency of about 95 percent.

Usually a tuning fork or a synchronized reference signal is used for the low-level drive.

Alternately, we may purposely wish to change the speed of a motor, perhaps to control a fan, an industrial drive, or a drill press or a table saw in the home shop. A small variable frequency audio oscillator forms the reference that is amplified to provide the motor power. Feedback may be easily used to maintain any desired set speed of an induction motor using this technique.

All the power inverters operate from a d.c. source. Usually, the available 60- or 400-cps power is rectified and filtered to provide the necessary motor power. The fact that the inverter is, in reality, d.c.-powered allows a.c.-only motors to be run from a d.c. source. Such a.c.-only motors are generally much lower in cost than d.c. designs and much more maintenance-free since they have no brushes or commutators that require attention. Further, there is no brush wear, brush noise, or any danger of sparking, and most important of all, there is no radio-frequency interference generated by an a.c. induction motor.

Linear Class-D Systems

The linear class-D amplifier must not only amplify a single frequency to some specified power level, but it has to simultaneously handle many frequencies and amplitudes,

Fig. 3. This circuit allows precise speed control of a.c. motor.

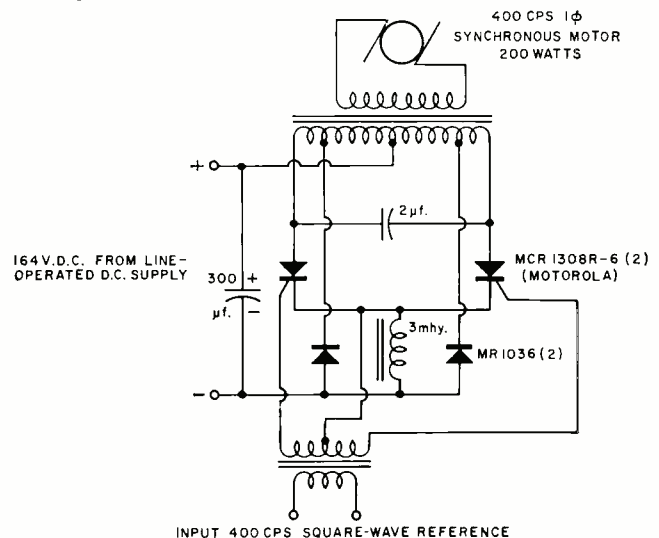

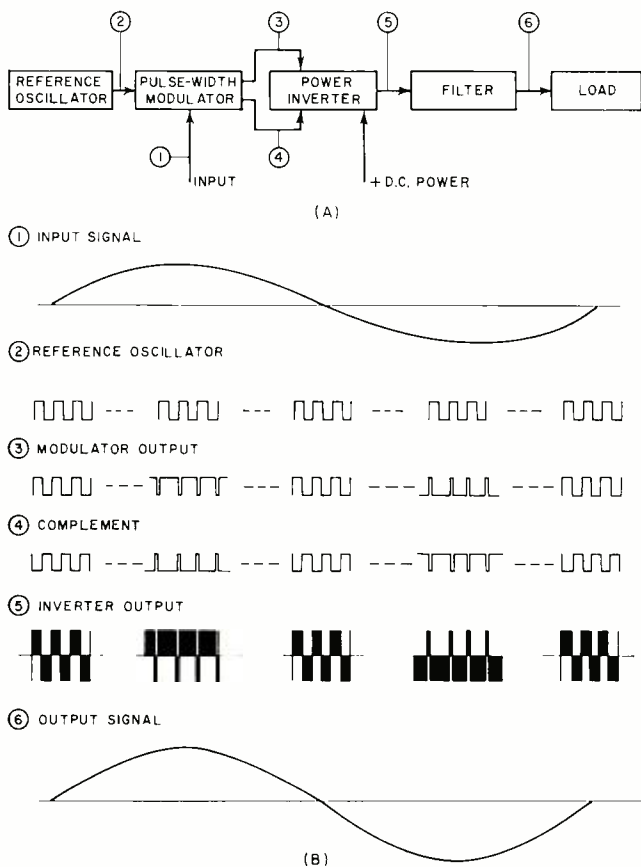
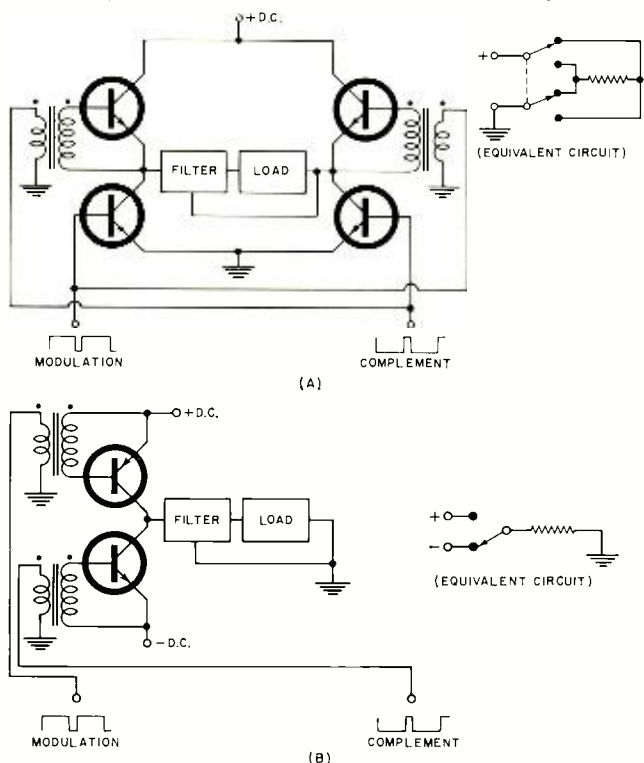

Fig. 4. Block diagram and waveforms for linear class-D circuit.

providing an output that linearly follows the input signals. Square-wave "off-on" techniques are again used, except that in the linear systems, the frequency of the square waves is much higher than the signals to be amplified. The input signals are used to *pulse-width modulate* the square-wave reference. This is done in such a way that the ratio of "on" time to "off" time is a linear function of the input

Fig. 5. Two typical linear class-D power output stages.



signal, but the period (the sum of the "off" time and the "on" time) is a constant, independent of the signal.

Some typical waveforms are shown in Fig. 4. Here the input signal is a sine wave but, in reality, any waveform works as well. This input sine wave modulates the square-wave reference. At the positive peaks of the input sine wave, the reference output is "on" very much more than it is "off," and at the negative signal peaks, the reference output is "off" very much more than it is "on." For in-between signal levels, the ratio of "on" time to "off" time is a precise function of the signal amplitude. At the "zeroes" of the sine wave, the output is a symmetrical square wave with equal "on" and "off" times.

The output of this circuit, together with a complementary signal is used to drive a power inverter. Typical output stages are shown in Fig. 5; these are a full-wave bridge circuit for single-ended supplies and a two-semiconductor switching type that requires dual supply voltages. The load waveforms are the same in either case and appear as the bottom two waveforms of Fig. 4B. At the input to the filter, the current flows for equal times to the right and the left, and the output power, averaged over an entire period is precisely zero in the case of no input signal or the zero of an input signal. With positive signal inputs, the current flows to the left (through the filter and load) for a longer time each cycle than to the right. The average value, over a cycle, results in a positive output to the load. Similarly, with a negative signal input, the current flows to the right for a longer time each cycle than to the left, resulting in a negative output to the load averaged over each cycle.

The averaging (or integrating) is done by a low-pass filter that responds only to the average energy in each cycle. This is done by choosing the cut-off frequency of the low-pass filter well below the reference frequency but far enough above the input signal frequencies so that they are not attenuated. The net effect of the filter is to produce an output voltage that faithfully follows the input signal, amplified many times at very high efficiency.

The frequency response of this technique varies from d.c. to half the sampling or reference frequency. No matter how slowly the input signal is varying, the output of the inverter is always the same reference frequency, pulse-width modulated to form a "lopsided" rectangular wave in proportion to the input. The d.c. amplification takes place when there is no change from cycle to cycle in the "width" of the modulation signal.

The upper frequency limit is precisely one-half the sampling frequency. This is dictated by a fundamental theorem of sampling mathematics that states that at least two samples per cycle of any signal must be taken to fully characterize that signal. Frequencies above half the sampling frequency appear as noise at the output; it is thus desirable to sharply low-pass-filter the input at a frequency somewhat less than half the reference frequency.

Practical Limitations

There are several practical limitations to class-D systems, some of which have precluded the use of these techniques with vacuum tubes and earlier solid-state devices. This is why such a relatively obvious technique is only today feasible.

The semiconductor switches must be fast and efficient. Considerable power is dissipated during the switching interval. For high efficiency, the total switching time must be very small compared to the reference frequency period. For ordinary SCR's, the upper limit is around 20 kc. for the reference, resulting in a 10-kc. maximum signal bandwidth. Premium SCR's will work to 100 kc., while the somewhat faster GCS's and four-layer diodes are useful to 200 kc. with a resultant d.c. to 100 kc. signal bandwidth. Transistors may be used as high as 600 mc., but at reduced power levels, lower gains, and usually lower supply

(Continued on page 82)

NON-DESTRUCTIVE TESTING

In this first part of a two-part series, magnetic, liquid-penetrant, x-ray, fluoroscope-TV, gamma-ray, and neutron radiographic methods of non-destructive testing are covered.

By JOHN R. COLLINS

IN an era such as the present, when human lives, months of work, and millions of dollars may be lost because of an imperfection in an extremely complex mechanism, it is impossible to overstress the vital importance of quality control and inspection apparatus to assure that every piece of material and each component going into an end product is flawless.

In earlier times it was often possible to compensate for small defects simply by increasing the size of the elements—by doubling the calculated thickness of a metal part to prevent its breaking, or by increasing the metal in a transformer core to avoid overheating. However, the weight-conscious aerospace industry cannot tolerate such stratagems and demands parts trimmed to bare essentials. Economics in other fields also dictates a sparse use of materials coupled with a higher level of reliability.

Traditionally, products were checked by destructive testing—that is, by subjecting samples to rugged treatment until breakdown occurred. However, such testing provides only inferential evidence that the untested devices will perform as well. Also, many modern devices are too costly to ruin by destructive testing.

In view of these considerations, it is not surprising that much effort is devoted to devising systems of non-destructive testing. NDT, as such methods are abbreviated, involves not only flaw detection but also quality control and the measurement of mechanical, physical, chemical, and metallurgical properties, and variations in those factors. It is applied to materials, components, and systems, not only during manufacture but also for maintenance purposes.

Energy in practically all forms is used for NDT, and an exhaustive list of methods would be difficult to compile. However, most NDT techniques can be classified under one of the following categories: visual inspection, including magnetic-particle methods and liquid penetrants; x-ray and neutron radiography; ultrasonics; eddy-current methods, including Hall-effect devices; and infrared and thermal methods.

Helping the Eye

The original and fundamental instrument for NDT is, of course, the human eye. Nevertheless, its limitations are obvious. The eye can inspect only the surfaces of objects; it usually cannot detect impurities and metallurgical differences that may be important; and it is relatively slow and subject

to fatigue. Even with the aid of a microscope, the eye is unable to detect surface flaws that are too small to reflect light.

For locating surface defects in ferromagnetic metals, and even those slightly below the surface, the eye is greatly aided by the use of magnetic-particle testing techniques. The theory is quite simple. An intense magnetic field is set up in the part to be inspected. If the piece contains surface cracks or flaws close to the surface, some of the magnetic flux will be crowded out from the surface at the point of the discontinuity. If the piece is then dusted or coated with a fine iron powder, the powder will adhere at the location of the flaw, showing the precise size and shape of the flaw. The particles are usually colored to contrast with the test piece.

To work properly, the magnetic field must be perpendicular to the flaw, not parallel with it, so that the flux will have to

Fig. 1. (A) Longitudinal magnetization will detect crosswise flaws. (B) Circular magnetization reveals longitudinal ones.

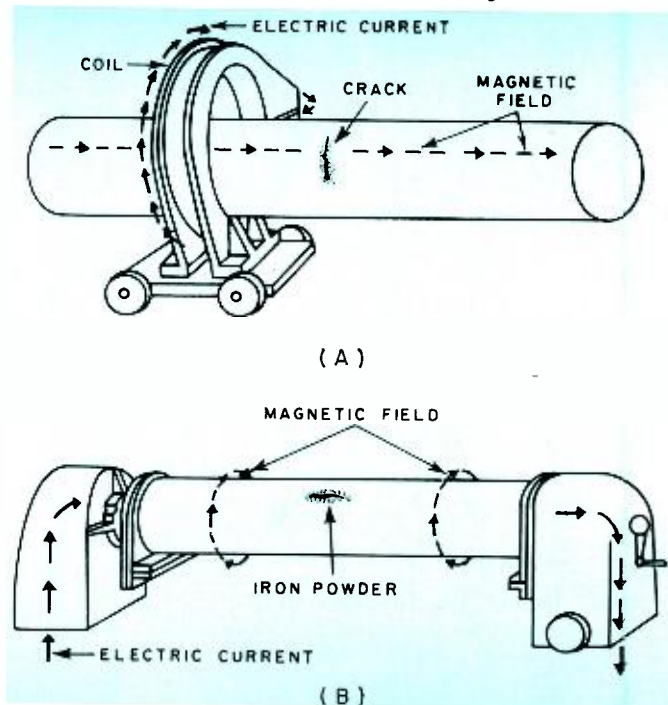

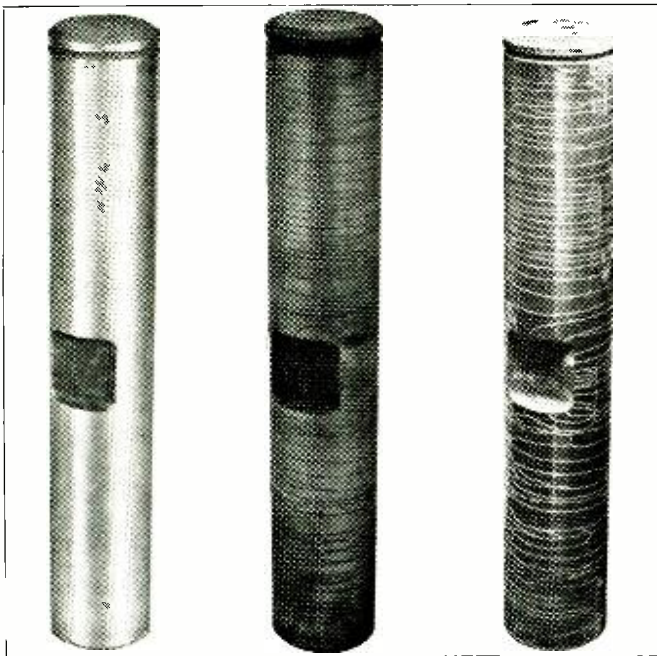

Fig. 2. Apparently perfect king pin (left) is revealed by magnetic-particle testing to have dangerous cracks (center). The same cracks are even more apparent when outlined by fluorescent particles under an ultraviolet light beam (right).

jump the gap. A crack or other flaw extending in the same direction as the magnetic field will not usually force flux outside the test piece. If the direction of flaws cannot be predicted, it is necessary either to rotate the piece in the magnetic field or to provide a field that sweeps the piece in different directions.

Various solutions have been found, and the method selected usually depends on the size and shape of the piece to be inspected. Where relatively small pieces are involved, they can be rotated in a coil which provides the needed field. Coils may also be used in the case of rods and tubing to detect

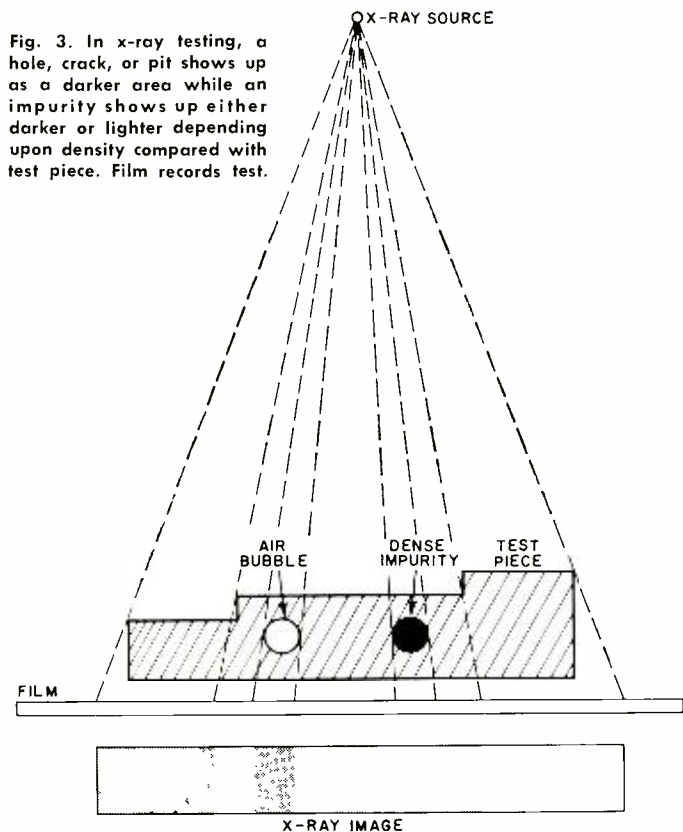

Fig. 3. In x-ray testing, a hole, crack, or pit shows up as a darker area while an impurity shows up either darker or lighter depending upon density compared with test piece. Film records test.

transverse flaws, as in Fig. 1A. The magnetic field in this instance will be directed lengthwise in the parts. When this field cuts across a crack, it will attract and hold the iron powder.

A second method, called circular magnetization, involves passing electric current lengthwise through the test part itself, as in Fig. 1B. This sets up a magnetic field around and within the part at right angles to the direction of the current. It is suitable, therefore, for locating longitudinal defects, as shown.

Finally, there is the so-called "swinging field," or multi-directional magnetization. Electrical contacts are made at a number of points on the test piece, and current flow is such as to produce magnetic fields in several directions. In this way, defects over the entire surface may be detected simultaneously. The method is most commonly used for large castings, forgings, welded assemblies, and pressure vessels.

Either a.c. or d.c. may be used to provide the magnetic field. However, because of the tendency of a.c. to travel on the surface (skin effect), d.c. is generally used when below-surface flaws are of interest.

Dry magnetic particles can be applied by hand from a shaker or automatically by means of a blower. The dry

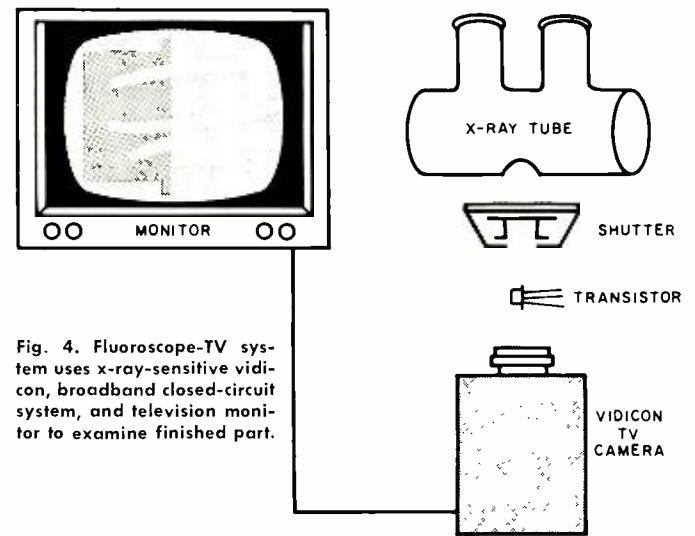

Fig. 4. Fluoroscope-TV system uses x-ray-sensitive vidicon, broadband closed-circuit system, and television monitor to examine finished part.

method is generally used for inspection of welds, large forgings and castings, and other parts having extremely rough surfaces—also, for location of subsurface defects. However, wet methods, in which the powder is mixed in a water or oil suspension, are usually more effective. They are used for inspection both in manufacture and for maintenance.

The wet method is universally used for applying a special kind of particle product called "Magnaglo," made by *Magnaflux Corporation*, which becomes fluorescent when exposed to ultraviolet light. When parts are inspected by this method in a darkened area, the smallest cracks become readily apparent, even those only a few millionths of an inch wide.

The value of magnetic-particle inspection methods is illustrated by Fig. 2, which shows a king pin for a truck front axle which appears, at left, to be perfectly sound. However, magnetic-particle inspection reveals, at center, that it is webbed with cracks caused by excessive heat during grinding. At right, the same king pin and the same cracks are shown glowing under ultraviolet light after treatment with "Magnaglo."

One of the largest installations for fluorescent-particle testing is operated in an Indiana plant of *Youngstown Sheet and Tube Company*. Billets up to eight inches in cross-section and 40 feet in length are dropped into a long trough in a room illuminated only by ultraviolet light. Metal plates make contact with each of the ends, and a low-voltage, high-amperage current passes through the billets. The surfaces

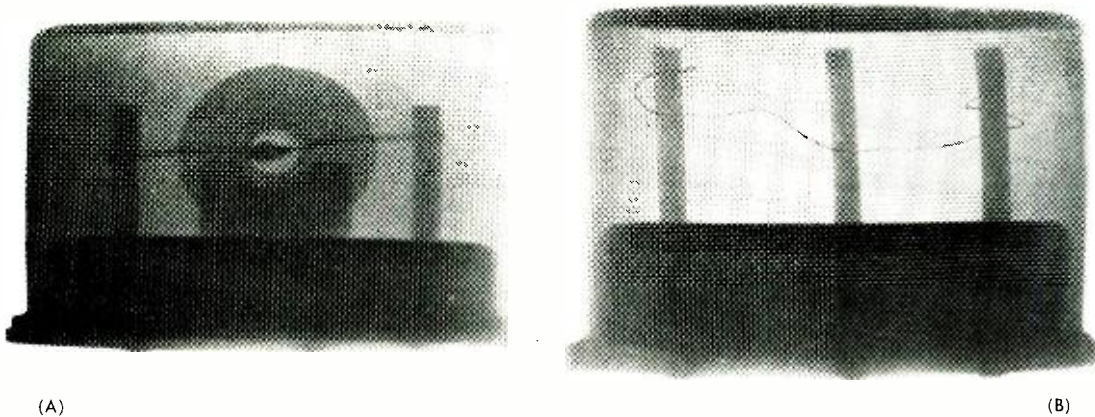

Fig. 5. (A) Fluoroscopic image of a good transistor. (B) A gold wire, .0007-in. diameter, is clearly visible through its metal container.

of the billets are then flooded with a solution containing magnetized fluorescent particles. The particles build up in seams, cracks, pits and other surface defects. These glow with a yellow light in the ultraviolet radiation and are marked by an inspector as the billets are rotated by a chain-sling mechanism. Units excessively marked are removed.

Liquid Penetrants

Non-magnetic metals may be inspected for surface flaws by treatment with a fluorescent penetrant solution that is absorbed into small cracks by capillary action. In practice, the entire part is coated with the penetrant and is then thoroughly rinsed and dried. Penetrant on the surface is thus washed away, leaving only the penetrant in the defects. A developer which works like a blotter is next applied. It draws the penetrant back to the surface, where it glows brilliantly under ultraviolet light.

A somewhat similar test is used for non-metallic materials, such as porcelain, ceramics, and glass-to-metal seals. The part to be inspected is first dipped or sprayed with a water-base penetrant which is an electrical conductor and which enters any surface cracks that may be present. The part is then dried with a cloth or hot air.

The next step involves applying a special powder, a form of calcium carbonate, by means of a spray gun. Each particle is positively charged as it passes through the gun nozzle. The particles adhere electrostatically to any pores, cracks, or scratches. Cracks less than a quarter-wavelength of light (about four millionths of an inch) do not reflect light but can be located through the buildup of particles. The powder may be selected to provide color contrast with the test article.

In the case of a metal coated with glass or ceramic, electrostatically charged particles can be used to locate flaws directly, without first applying a conducting penetrant. This is possible because electrons from the metal base are attracted to the positively charged powder and tend to leak through the cracks in the coating making the flaws visible.

X-Ray Methods

The methods described above are useful only for surface or near-surface inspection. Where deep penetration is needed, x-rays provide a most valuable inspection tool. X-rays are a form of radiant energy similar to light. Because of their extremely short wavelength, however, they can penetrate materials that would absorb or reflect light. The ability of an x-ray to penetrate is related to its wavelength. So-called "soft" x-rays (about ten angstrom units) have difficulty in even escaping from the x-ray tube. Very "hard" x-rays, with wavelengths a small fraction of one angstrom unit, can penetrate many inches of steel.

The theory of x-ray radiography is shown in Fig. 3. X-rays are focussed on the test piece and, in a homogeneous material, are absorbed in direct proportion to its thickness. A hole or bubble shows up as a darker area because less material is in the path. The same is true of a crack or pit. A piece of

extraneous matter may show up either darker or lighter, depending on its density as compared with that of the test piece.

The finest radiography can be performed through the use of film in the conventional manner. However, film techniques are slower than fluoroscopic methods, and the latter have been much improved in recent years. A fluoroscopic TV system, made by *Picker X-Ray Corporation*, is shown in Fig. 4. The beam from the x-ray tube passes through the object to be inspected and falls on an x-ray sensitive vidicon TV camera tube. The image from the camera is conveyed to a television screen over a high-resolution system having a 20-mc. bandpass. Resolution is better than 500 mesh, permitting the detection of a break in a filament only 0.0005 inch in diameter. Since the inspector may be some distance from the x-ray source, the problem of adequate shielding is simplified.

The system can instantly locate hidden structural defects in such components as transistors, diodes, and potted assemblies and is useful for the inspection of printed circuits, thin-section welds, precision light-alloy castings, and similar objects. It has the advantage over film x-rays in that the inspection piece can be maneuvered and viewed from various angles. Image brightness and contrast are adjustable, image polarity is reversible (black-and-white portions interchanged) for improved display, and the image can be magnified up to 30 times for detailed scrutiny. Photographs can be made from the television screen with a still camera when a permanent record is desired (Figs. 5A and 5B).

The use of x-rays for NDT is by no means confined to the examination of small parts. *Picker* designed a system

Fig. 6. Fluoroscopic-TV inspection systems have also been developed for rapid inspection of large diameter steel pipe.

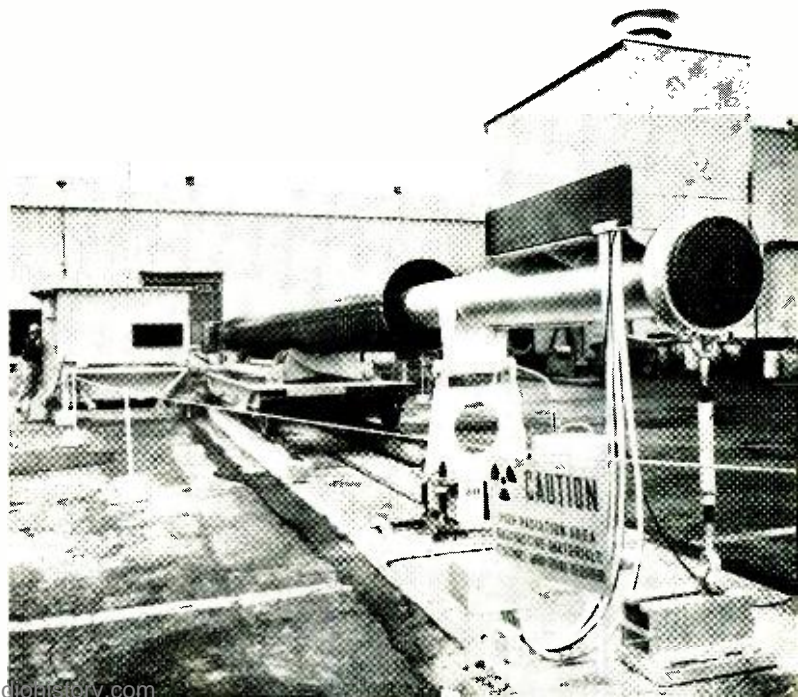



Fig. 7. Portable gamma-ray thickness gage checks pipe walls.

(Fig. 6) for the production inspection of steel pipe sections up to 36 inches in diameter and 40 feet long. Through the use of an image tube and TV system, an inspector seated in a remote, radiation-shielded, air-conditioned cabin can inspect steel pipe as it comes off the fusion-welding line and rumbles by on a railway carriage at speeds up to 40 feet per minute.

X-ray apparatus also provides an effective method of screening out chips of heavy metals mingled with lighter metals which look the same to the eye. For example, molybdenum and tungsten chips are often found mixed with aluminum-vanadium chips, an alloying compound for titanium. The presence of either of those metals in a finished aircraft part would be cause for its rejection.

An inspection system has been devised whereby the metal chips are carried on a conveyor belt between an x-ray tube and an image tube. Heavy metals, such as tungsten and molybdenum, are less transparent to x-rays and appear as dark chips on the screen. Thus, when an inspector sees a dark chip, he stops the belt and removes the chip.

Gamma-Ray Equipment

Gamma rays are very similar to x-rays except that they are produced by radioactive materials, such as cobalt 60 and cesium 137. Since they radiate continuously, care is necessary at all times to prevent personnel exposure. Since their strength is constant, their radiation cannot be adjusted for a particular job, as can conventional x-rays. However, these difficulties are offset by the fact that no power supply is needed and portable equipment is readily designed.

A portable thickness gage, developed by *Black, Sivalls & Bryson, Inc.* for non-destructive measuring of vessels and piping associated with refinery, chemical plant, and power plant operations, is shown in use in Fig. 7. Through periodic

inspection of such equipment, it is possible to assess the amount of metal remaining in pipe walls and thus predict the corrosion or erosion rates and life expectancy without expensive shutdowns or dangerous blowouts.

The details of the instrument are shown in Fig. 8. The radiation source is housed in a tungsten shield, with a window to beam gamma rays directly at the sensing tube in the handle. As the rays pass through the pipe, they are diminished in proportion to the thickness of the material. The detector senses the radiation intensity and produces electrical pulses at a proportional rate. These pulses are amplified and integrated to produce direct current. The reading of the microammeter is indicative of wall thickness. The instrument is calibrated by using it with pipe of known thickness.

Radioactive isotopes are used to inspect the fill level of containers in a system developed by *Industrial Nuclear Corporation*. Cans which may contain beer, soup, cola, juice, milk, etc., are carried on a continuous belt past a source of radiation which is located at a level near the top of the can. If cans are filled to a suitable level, the radiation is absorbed and does not exit from the opposite side. If a can is under-filled, however, radiation passes all the way through and strikes a Geiger-Muller detector tube. A signal is thus developed which triggers an air blast or pneumatic hammer to knock the improperly filled container off the belt. Cans can be inspected at the rate of 1000 per minute by this method.

Neutron Radiography

Elements absorb x-rays in direct proportion to their atomic numbers; hence, absorption is greatest for heavy elements such as iron, gold, and lead and is very slight for plastics and the lighter metals. In contrast, the absorption of neutrons by elements appears to be unrelated to their atomic number. For example, hydrogen, boron, cadmium, and gadolinium absorb neutrons heavily, while lead and aluminum are relatively transparent to a neutron beam.

Although not yet well-developed, neutron radiography is a promising field for exploration. For the examination of such products as plastics, which have a high hydrogen content, it permits good contrast, impossible to obtain with x-rays. It also permits examination of large slabs of some heavy materials which would absorb x-rays but which are more transparent to neutrons.

Both the production and detection of neutrons present difficult problems. The most prolific source of neutrons is a nuclear reactor. Otherwise, they can be produced by bombarding a lithium target with protons or a beryllium target with deuterons.

Since neutrons have little effect on photographic film, indirect methods must be used to obtain an image. In one system, a fluorescent screen is covered with a thin layer of boron or lithium. When either of those substances is bombarded with neutrons, it emits alpha particles, which causes the screen to fluoresce. The light thus produced is recorded on film. In a second method, a thin layer of cadmium emits gamma rays under neutron bombardment, and gamma rays can be recorded directly on film.

Gamma radiation, which is generally present in the neutron source, tends to obscure images formed by either of the above procedures. To overcome that difficulty, a transfer method has been devised in which a thin screen of gold or indium is placed beneath the test object. Both gold and indium become radioactive when exposed to neutron bombardment, so an invisible image is formed on the screen in which areas are more or less radioactive, depending on the degree of neutron absorption by the test object.

After the neutron source has been removed, the radioactive screen thus formed is placed in contact with photographic film, and an image is formed by radioactive decay radiation. Although the method is slow, the results thus obtained are not obscured by gamma radiation.

(Concluded Next Month)

Fig. 8. Details of the portable thickness gage of Fig. 7.

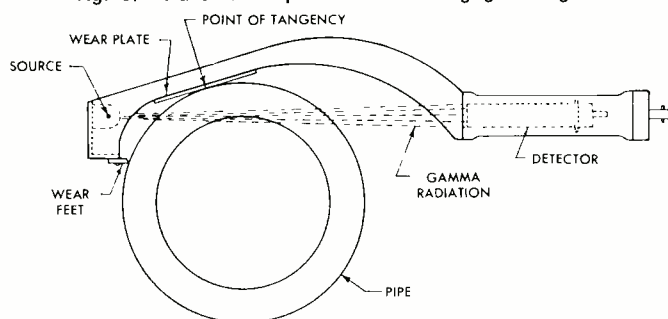

NANOSECOND PULSES: *techniques & applications*

By DONALD E. LANCASTER

Some important uses for these ultra-short pulses are in the fields of electro-optics, measurements, and circuit analysis.

A NANOSECOND (10^{-9} second) is but the briefest instant—one billionth of a second or the time it takes light to travel a mere 11.8 inches. In fact, there are more nanoseconds in a second than there are seconds in thirty years. The techniques for electronically generating nanosecond-wide pulses are as bizarre as the pulses are short. One method purposely exceeds the breakdown rating of a transistor. A second method uses special diodes whose recovery times are made quite long. For a third, the spark gap is removed from a dusty shelf, polished up a bit with modern techniques, and given an important and presently unbeatable place in state-of-the-art electronics.

The resulting pulses have now opened up many important new electronic applications, particularly in electro-optics, measurements, and circuit analysis. Other important areas are in the fields of radar and microwave studies, transmission-line testing, and for use as electronic shutters.

Applications

An injection diode laser consists of a *p-n* semiconductor junction that emits coherent light when it is pulsed with a short, high-current impulse. Operation often takes place at supercool temperatures with emission normally being in the near-infrared region. Nanosecond techniques are called upon to provide the required power pulses. These lasers are of value in film-exposure tests, high-frequency communications, and optical-response testing.

Light modulators usually consist of a capacitor with a transparent dielectric of KDP or some similar material. As the applied voltage is varied, the plane of polarization of the cell changes. By combining one of these with a polarizing filter, an electrically variable diaphragm results in which the brightness (actually the attenuation) of the transmitted light is a function of the applied voltage. If an electro-optic modulator is powered by a nanosecond pulse, a shutter open for one nanosecond results. This is of tremendous importance in high-speed photography.

Typical modulator units are called "Pockels cells." These have a capacitance of around 1000 picofarads and require several hundred volts to operate properly. To charge a 1000-pf. capacitor to 100 volts in 0.1 nanosecond requires 1000 amperes of current. This is why there is such a demand for extremely high-current nanosecond pulses. Actually, the modulator itself dissipates very little power and only requires the extreme currents to charge or discharge its own capacitance during the turn-on and turn-off transitions.

Other forms of electro-optic modulators are beginning to demand more and more from the nanosecond sources. Typical applications are extreme bandwidth communications links using c.w. lasers and other similar laboratory devices.

There are some rather elaborate mathematical proofs that can demonstrate that the response of any linear network to any arbitrary input signal can be exactly determined if the *impulse response* is known. An impulse is defined as a pulse of zero width, infinite amplitude, and unity area. Obviously, these do not exist in the real world, but for many applications, the nanosecond pulses form an excellent approximation. By pulsing a network with a nanosecond pulse, its impulsive response may be measured. Then, by using a mathematic technique called "convolution," the response of the network to an arbitrary input may be precisely determined. This is a very important new circuit-analysis tool.

A less elegant and more practical application of impulsive testing is *time-domain reflectometry*. It is important in v.h.f. and microwave work, particularly for measuring and evaluating transmission lines and other distributed networks. As an example, an unknown transmission line could be connected to a generator that produces a step input with a nanosecond rise time and the other end of the cable could be terminated in a known impedance. The voltage at the input to the cable is then monitored by a sampling oscilloscope. The time it will take the first reflection to return will equal twice the electrical length of the cable. The amplitude and polarity of the return will indicate the characteristic impedance of the cable, and the rate the returns diminish tells the attenuation of the cable. Any noise will indicate cable faults and discontinuities; the time delay between discontinuities and the input will show the exact location of the fault.

If 100-picosecond (100×10^{-12} sec.) risetimes are available, discontinuities only 1.18" apart can be resolved and separately evaluated. Large-scale models may be used to resolve smaller prototype distances.

The nanosecond pulses are now finding their way into radar. In a normal pulse radar, a one-nanosecond pulse could, in theory, give a one-foot resolution at close range. This should prove important in applications such as highway safety radars, and measuring devices for high temperature, fast moving, radioactive, or otherwise untouchable objects.

Another new application is harmonic generation. Nanosecond pulses invariably have a very high harmonic content. By filtering the desired harmonic, any multiple of an input frequency may be obtained. With this technique, frequency mul-

tiplication of very high orders is possible. The efficiency is the same as it would be with conventional varactor multipliers, but far fewer stages are normally required. Similar techniques may be utilized to generate test pulses that are only a few cycles long at microwave frequencies.

Conventional Techniques

All the conventional techniques for generating short, high-power pulses are pretty much device-limited to pulses longer than ten nanoseconds. The gas-tube modulator is often used for radar work, but, at best, ionization times of 10 to 40 nanoseconds are available, and the tube simply will not turn on in one nanosecond. Vacuum tubes, in turn, are limited by their poor "on" impedance, their stray capacitances, and their inability to provide a low impedance for negative-going input signals. Some u.h.f. lighthouse and pencil-triode tubes are useful for amplifying nanosecond pulses already generated, but they are largely incapable of generating these pulses by themselves.

Conventional solid-state devices are also limited by present-day technology. The best of power transistors require 20 to 50 nanoseconds to switch any large amounts of power. Lower level logic circuitry can work with 10-nanosecond risetimes but only with limited power capability. Unsaturated logic techniques using u.h.f. transistors now break the nanosecond barrier, but only at very low power levels and supply voltages. The same is true of tunnel diode pulse circuits.

We can arbitrarily draw a line somewhere around 5 nanoseconds. Slower risetimes and wider pulses are obtained by conventional techniques. Faster or narrow pulses require the use of special nanosecond techniques.

Avalanche Transistors

The avalanche turn-on of a transistor is extremely fast and not current dependent. Efficient, powerful nanosecond pulses are easily generated in this manner. Fig. 1A shows the characteristics of a typical diffused silicon transistor. Notice the difference between the breakdown voltages for the zero base-current curve as compared with the other curves. The circuit in Fig. 1B uses this difference to advantage. The circuit is biased to point "A" on the curve of Fig. 1A by the high-voltage collector supply and resistor R_1 . R_1 also charges C_1 to the same voltage as point "A" after the power is applied.

If the base of Q_1 is now pulsed with any reasonably fast waveform, the transistor goes into avalanche conduction and assumes a very low impedance state. (The mechanism is the same as in the four-layer diode or SCR.) As long as C_1 can supply current through the transistor to the load R_L , the transistor remains in the "on" state. When C_1 is nearly discharged, the transistor turns "off," e.g. returns to a non-conducting state. R_1 is always made large enough so that it cannot hold the transistor avalanched and after turn-off R_1 recharges C_1 slowly, rebiasing the transistor to point "A" to await a new input trigger pulse.

The avalanche current forms an output pulse across R_L . Typical risetimes of one nanosecond are easily achieved. The pulse width is determined by the value of C_1 and R_L . During the avalanche time, the transistor dissipation is extremely high, but the long duty cycle between pulses averages out the

total dissipation to a value within the transistor's rating.

If a flat-topped output pulse is needed, the capacitor may be replaced by an open-circuited transmission line. This is shown in Fig. 1C. The transmission line will provide a constant avalanche current for a time equal to its electrical length. This is around 1.6 nanoseconds per foot for most coax. Now the output is a rectangular pulse equal to the electrical length of the cable and has a steep rise, a flat top, and an abrupt fall time.

Most diffused silicon transistors can operate in avalanche mode. The 2N706 is an inexpensive transistor that will produce a one nanosecond rise and fall time with 20 volts of output into a 50-ohm load, giving a peak pulse power of 8 watts. To stay within the 300-milliwatt rating of the device, a duty cycle of 24:1 or less must be adhered to. In the interest of safety margins, 100:1 is a more realistic figure. If the pulse width is 10 nanoseconds (as would be the case with a six-foot length of coax used as a delay cable), the maximum permissible repetition rate would be once each microsecond, or one megacycle. The width of the pulse is determined by the delay or width cable, and can range from 1 to 500 nanoseconds. "Trombone" adjustable-length transmission lines can give continuous adjustment of pulse width.

Special avalanche transistors which have been optimized for avalanche operation are also available. Cost ranges from \$10 to \$40 each. Using these special transistors, 500-watt, 2-nanosecond-wide pulses can be easily produced across very low impedance loads.

It is very important to keep the leads extremely short on all nanosecond circuits as the lead inductance can interfere seriously with the fast risetimes. Because of this, strip-line and other v.h.f. techniques are generally used for this type of circuit.

The avalanche technique is presently limited to risetimes of 1 nanosecond or more and pulse powers of less than half a kilowatt, but it has advantages of moderately low cost and simplicity combined with low jitter and high repetition rate.

Step-Recovery Diodes

A new class of diodes makes possible the fastest pulses and waveforms available today, but is currently limited to pulses less than 30 volts in amplitude and pulse powers well under 100 watts. Pulse widths as short as 50 picoseconds ($\frac{1}{20}$ nanosecond) are obtainable using these devices.

Any semiconductor diode has a storage time based on the finite mobilities of carriers in the semiconductor material. If the forward bias on a diode is suddenly reversed, the diode will continue conducting for a storage (reverse recovery) time determined by the diode itself and the amount of forward current that was present before the turn-off. In normal high-speed diodes, it is highly desirable to reduce the storage time to as low a value as possible. In a step-recovery diode, the opposite is the case. The storage time is made quite long, but the diode is designed so that *the diode ceases conduction very abruptly at the end of the storage time*, producing a turn-off waveform that is extremely steep. This abrupt cessation is called the *transition time*. Presently available diodes have transition times as short as 50 picoseconds.

Fig. 2A shows the important differences between an ordi-

Fig. 1. (A) Avalanche biasing. (B) C_1 produces fast-rising current pulse. (C) Transmission line produces rectangular pulse.

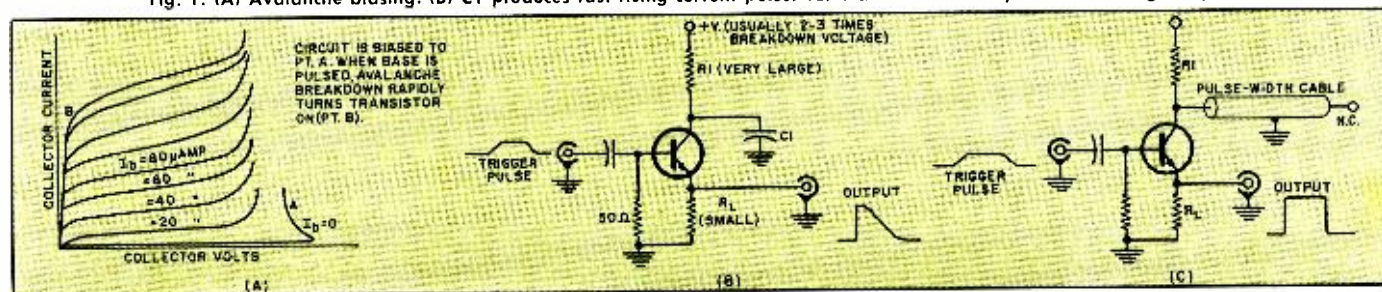

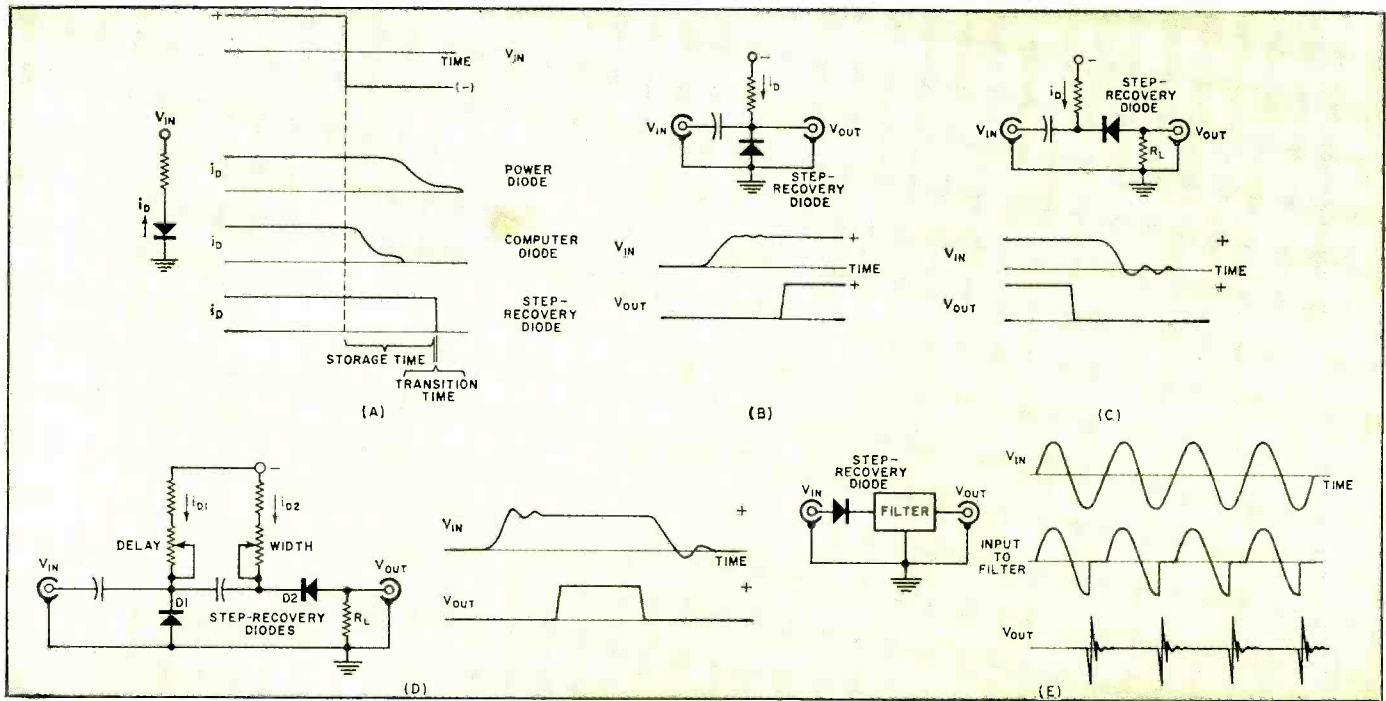

Fig. 2. (A) Recovery-time plots show difference between step-recovery and ordinary diodes. (B) Leading-edge sharpening. (C) Trailing-edge sharpening. (D) Rectangular-pulse generation. (E) High-frequency pulse-train generation.

nary and a step-recovery diode as the two are abruptly reverse-biased, while Fig. 2B shows how a step-recovery diode may be used to steepen the front of a waveform having a poor risetime. In the absence of an input, the diode is normally conducting some forward current, and since it is shunting the output, no input signal will appear at the output.

An input with a risetime of a few nanoseconds (usually generated by conventional transistor circuitry) attempts to turn off the diode, producing a step waveform at the output with a risetime of less than a nanosecond.

Varying the forward current of the diode will, in turn, vary the storage time anywhere from 1 to 500 nanoseconds. The risetime of the input waveform is immaterial as long as the step-recovery diode is adjusted to have a storage time long enough to allow the input to assume a stable value.

Fig. 2C shows the opposite circuit. Here a step-recovery diode in series with the output is used to steepen the end of a waveform with a poor fall time. Again the diode is normally conducting heavily, but the input signal now appears simultaneously at the output and tries to stop conduction through the step-recovery diode. The diode continues conducting for the storage time and abruptly ceases conduction, this time removing the input signal from the output terminals.

Where rectangular pulses are desired, Figs. 2B and 2C may be combined, as in Fig. 2D. Here the first step-recovery diode steepens the risetime and the second steepens the fall time, leaving a rectangular pulse carved out of the middle of the input waveform. Varying the current through the first diode varies the *time delay* between the input pulse and the start of the output pulse. The current through the second diode controls the *width* of the pulse.

Fig. 2E shows yet another technique. Here a high-frequency sine wave is fed to a step-recovery diode that has a storage time of one-fourth the period of the input wave. The diode produces an abrupt turn-off midway in each negative half cycle. An output filter is added which passes only the steep transition and rejects the fundamental sine wave and the d.c. component. This produces a train of output pulses with extremely fast risetimes and a very high repetition rate. Repetition rates of 100 megacycles are possible, combined with 50 to 100 picosecond risetimes.

These components are somewhat expensive, ranging from

a low of \$15 to a high of several hundred dollars for the more exotic types. Strip-line and other low-inductance pill packages that minimize the amount of circuit inductance as much as possible are now readily available.

Spark-Gap Nanopulser

The spark gap may seem a crude electronic component, but carefully designed models can produce waveforms with nanosecond risetimes and peak currents of *several thousand amperes*, combined with peak voltages of several kilowatts. The price paid for such extreme power is a very low duty cycle. Normally, only a few pulses per second are possible. Further, there is quite a bit of pulse-to-pulse jitter, and synchronization requires an input that already

(Continued on page 64)

Fig. 3. (A) Spark-gap circuit (B) waveforms, (C) configuration.

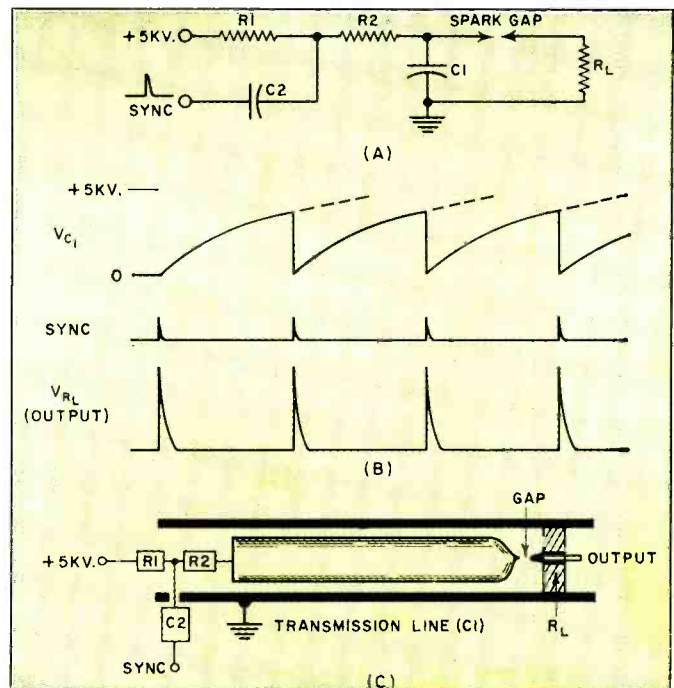

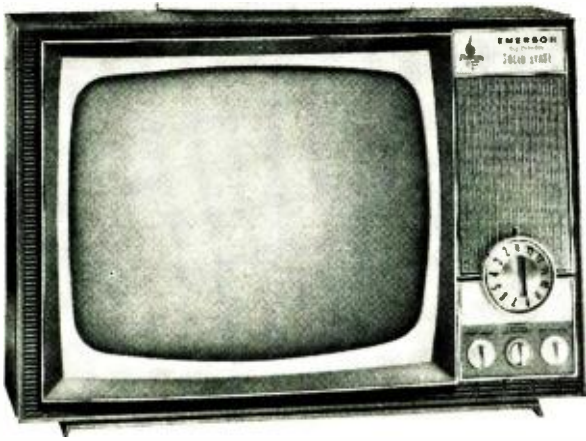

Fig. 1. The Emerson 11-inch, line-operated transistor TV uses 22 transistors, a gate-controlled switch horizontal output stage, and a 1X2B vacuum rectifier, the only tube in the set.

Line-Operated Transistor TV Sets: Emerson

By WALTER H. BUCHSBAUM

Third of a series of articles covering line-operated, large-screen transistor TV sets. This article covers the Emerson 11-inch model.

THE Emerson Model 11PO4A is a transistorized TV set operated from the a.c. power line and features a low heater power 11-inch picture tube. As illustrated in Fig. 1, the speaker and the controls are on the front of the set and a single concentric control serves both u.h.f. and v.h.f. channel selection.

This receiver uses 18 transistors in the chassis circuitry, one in the u.h.f. tuner, and three in the v.h.f. tuner. A special gate-controlled switch is used as horizontal-output stage, and a 1X2B vacuum tube is the high-voltage rectifier. The gate-controlled switch, a device generally used in industrial and military electronics, provides a highly efficient and unusual horizontal output stage.

An unusual arrangement is the local-distance switch on the antenna terminals which connects a simple resistor attenuator into the v.h.f. tuner input to reduce the level of strong signals. Three stages of i.f. are used, and to provide maximum a.g.c. control, a novel arrangement is employed in the first two stages. As shown in Fig. 2, the a.g.c. voltage, normally approximately 3 volts, is applied to the base of the first i.f. amplifier, Q1. As signal strength increases, the a.g.c. bias voltage decreases, providing more forward current for the first stage. As the a.g.c. voltage on the base of Q1 is reduced, more current can pass through the emitter and collector of Q1. This increases the voltage drop across emitter resistor R1. R2 applies a portion of this increased voltage to the emitter of Q2 through R3. Since the base of Q2 is held at a fixed bias voltage due to R4 and R5, the effect of the increase in emitter voltage means that the current through Q2 decreases. The result of forward a.g.c. action on Q1 is then a reverse a.g.c. action in Q2. By using the combination of forward and reverse a.g.c. action on two successive stages, the bandwidth can be held constant over relatively large ranges of a.g.c. voltages. Fig. 2 also shows single-tuned coils in the collector of each of the i.f. stages with a tap to provide neutralization by feed-

Fig. 2. First and second i.f. stages showing application of a.g.c.

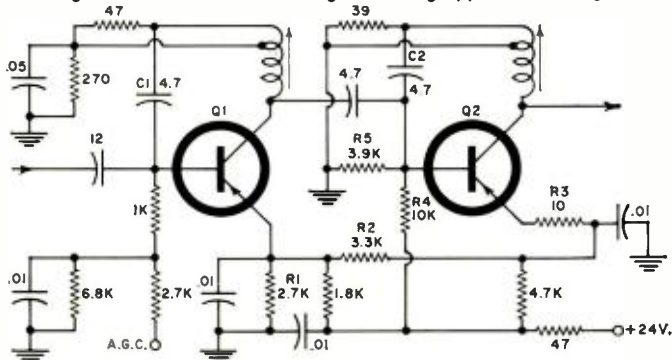

back through the small-valued capacitors C1 and C2.

Following the third i.f. stage is a conventional video detector and a single-stage video amplifier. The video amplifier collector is returned, through suitable resistors, to the +160-volt bus. This is the boost voltage obtained from a tap on the flyback transformer and is rectified and filtered separately. The actual video signal amplitude applied at the picture tube is only 35 volts peak-to-peak, but the d.c. level of +160 volts is required to provide sufficient range of brightness and contrast. The grid of the picture tube is at -6 volts with a vertical blanking pulse superimposed.

This set uses a conventional class-A transistor audio system with a double-diode discriminator of the circuit type found in vacuum-tube receivers. D.c. coupling between the driver and output amplifier permits low-current operation between the +24 and -35 volt power-supply buses.

The horizontal sweep section uses a phase-detection type of a.f.c. and a Hartley-type oscillator. The horizontal oscillator itself is controlled by a transistor stage, connected almost exactly like the well-known reactance tube. This stage receives the filtered error voltage from the phase detector on its

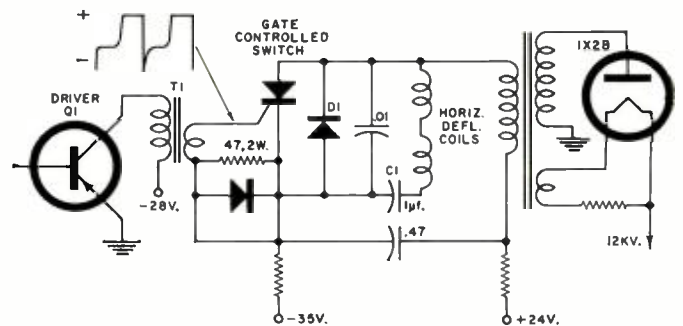

Fig. 3. Horizontal-output stage uses a gate-controlled switch.

base, has a capacitor connected from collector to base, and is slanted as a "tuning capacitor" across the horizontal oscillator coil. A pickup loop on the horizontal oscillator coil feeds the signal to the horizontal driver which is transformer-coupled to the gate-controlled switch.

As illustrated in Fig. 3, a positive pulse coupled from T1 to the gate element turns the gate-controlled switch on. This device operates like a grid-controlled thyatron tube, except that here the current can be shut off by a negative pulse on the gate element. When a positive pulse is coupled by T1 onto the gate of the switch, current starts to flow through the horizontal deflection coils, charging C1. The inductance of the horizontal deflection coils determines the rise time of this current, and for this reason, unlike most transistor sets, the coils are connected in

(Continued on page 74)

Design trends in space-age receivers using phase-lock techniques that are setting new records for sensitivity.

Supersensitive Communications Systems

By JIM KYLE

BORN of the space age because weight limitations in satellites precluded high-power radio equipment, a new family of communications systems is setting new records for range-to-power efficiency. Where conventional systems begin to reach their "noise-floor" limits at received-signal levels in the neighborhood of -130 to -180 dbm (decibels below one milliwatt), the new group is still providing solid copy when received-signal levels drop below -200 dbm. This 20- to 70-db improvement is the equivalent of raising transmitter power from 100 to 10 million times.

The new systems are known by several names. Most are being used by space scientists, the military, and amateur radio operators, in that order. Commercial application of them remains in the future. Despite the multiplicity of names, however, the basic principles underlying all of them are similar.

The key to performance is simply that the systems are planned as *systems* rather than as isolated subsystems. This means that the receiver operator has at least *some* previous knowledge of the nature of the transmitted signal. With this knowledge, the receiving portion of the system need only detect the *changes* in the signal which carry the desired intelligence. The concept is rooted in information theory; it is similar in theory (though not in practice) to the principle of pulse-code modulation.

Actual types of modulation employed in these systems may be conventional AM, conventional FM, or combinations of AM and FM by using subcarrier techniques. The received signal may be recovered by loudspeakers or ear-phones if the information is audio (such as speech), may be pen-recorded, or may be fed to data-processing equipment, all depending upon the system's purpose and requirements.

The systems achieve their increased sensitivity by reducing *noise* bandwidth of the receivers while retaining a larger *information* bandwidth. The reduction of noise bandwidth means that at any specified input signal level, the signal-to-noise ratio will be greater. This seemingly impossible splitting of bandwidth properties is accomplished by a phase-lock loop, which operates as follows.

Basic Phase-Lock System

This basic circuit is known by many names, and these names are usually applied to the complete system using it. Some engineers call it a *synchronous detector*, others know it as a *tracking filter*, and still others refer to it as a *linear detector*. Throughout the remainder of this discussion it will be referred to simply as "phase lock."

The phase-lock circuit is shown in block diagram form in Fig. 1. It employs two phase detectors, a voltage-controlled oscillator, a narrow-band filter, and a 90° r.f. phase-shift network.

The phase detector is a device for comparing two input signals of the same frequency but with unknown relative

phase. The output of the device is a d.c. voltage of variable polarity. If the two input signals are precisely 90° separated in phase, output of the phase detector will be zero. If the two inputs are in phase, phase-detector output will be maximum at one polarity. If the inputs are 180° out of phase, output will be maximum but of opposite polarity. The curve of output voltage *vs* phase difference is identical with the familiar discriminator curve of an FM receiver (which is, incidentally, a phase detector in which the second input signal is derived from the first by transformer design).

In the region near 90° phase difference, output is linear with changes of phase.

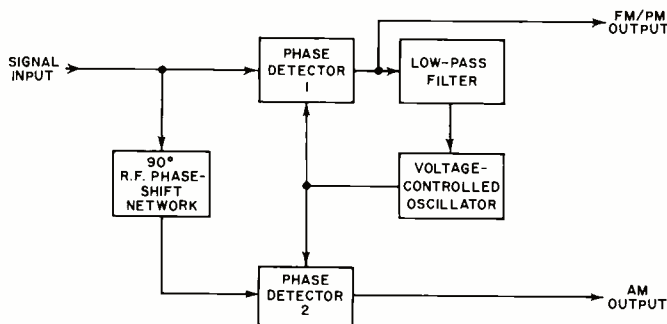
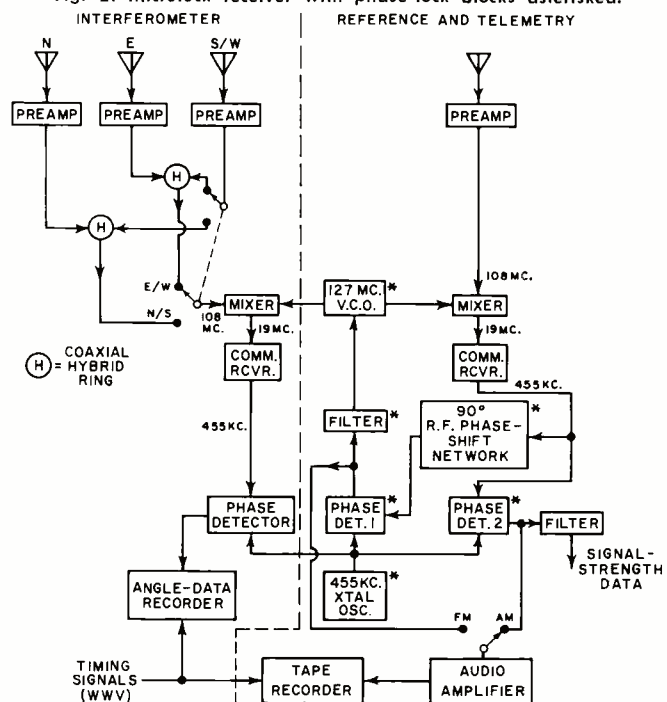

Fig. 1. Basic phase-lock circuit which limits noise bandwidth.

Fig. 2. Microlock receiver with phase-lock blocks asterisked.



The phase-lock circuit applies the amplified input signal (containing amplified noise also) to a phase detector as one of its inputs, and applies the output of the voltage-controlled oscillator (v.c.o.) to the other input. Output of the phase detector is passed through a low-pass filter with narrow passband (very low cut-off frequency) and returned to the control input of the v.c.o. to complete a feedback loop.

To examine operation of this portion of the circuit, assume that a signal is being received and that the v.c.o. is adjusted to approximately the same frequency as the signal.

If the v.c.o. and signal are not at precisely the same frequency, the term "relative phase" applied to them has no meaning. However, examined cycle by cycle, the apparent phase difference between the two signals will vary slowly.

This apparent phase difference will produce an output from the phase detector. The output is filtered to remove all noise and signal information and is applied to the v.c.o. to vary its frequency. If tuning is near enough to correct, and if the various polarities involved are correct (a design consideration; assume that they are), the control voltage applied to the v.c.o. will change its frequency in such a way as to pull it into exact correspondence with the signal frequency.

At this point, the term "relative phase" can again be employed. If the relative phase between v.c.o. output and the signal is anything other than 90° , control voltage will still be produced by the phase detector and applied to the v.c.o. This correction process alters phase of the v.c.o. until the relative phase of the oscillator is exactly 90° removed from the signal. At this time, the oscillator is "phase-locked" to the signal, and any change of signal phase with information will be reflected as a corresponding control voltage from the phase detector.

For PM or FM reception, the phase-lock circuit is complete at this point. The information-carrying changes of signal appear at the phase-detector output but cannot pass through the low-pass filter; they may be tapped off at the filter input for use as needed.

The 90° phase-shift network and the second phase de-

tor shown in Fig. 1 allow reception of AM signals, since the basic phase detector is not linear with respect to the amplitude of incoming signals.

The v.c.o. output voltage is locked, as just described, to a 90° phase relationship with the signal. The signal, after passing through the 90° phase-shift network, is at the same (or exactly opposite) phase as the v.c.o. when it reaches the second phase detector.

When a phase detector is operated with both input signals either in phase or 180° out of phase, the output voltage amplitude is at a maximum. As the amplitude of either input signal varies, the output will be proportional to the amplitude of the *weaker* input signal. This is always the "signal" input, by design. Thus, the output voltage from the second phase detector reproduces the modulation envelope of the input signal that is applied to the circuit.

Signals Plus Noise

Mathematically, the output of the second phase detector is the product of the v.c.o. signal and the information-carrying input signal. This is written $(S + N)S'$. S denotes the input signal itself, N denotes its accompanying noise, and S' denotes the v.c.o. signal. This output, when expanded, becomes $SS' + NS'$. The conventional detector normally used in radio communications multiplies the input signal by itself, which is written $(S + N)^2$, and expands to $S^2 + 2SN + N^2$. When the signal is much larger than the noise, both expressions reduce to approximately S^2 . However, when the signal is equal to or less than the noise, absence of the N^2 term from the phase-detector output is significant.

Discussion so far has considered only a coherent input signal having a definite frequency and phase to illustrate the functioning of the circuit. In practical use at -200 dbm input levels, the actual input signal will consist of a coherent component (the desired signal from the transmitting end of the system) and an equally large if not larger non-coherent or random component consisting of noise from miscellaneous sources.

To examine operation under these conditions, first assume that the input signal is completely non-coherent. Under such a condition, output of the first phase detector would be zero unless an instantaneous component of the non-coherent signal corresponds in amplitude and polarity to some portion of the signal for which the system is designed. When this occurs, phase-detector output will be the same as it would have been had the design signal been present.

Since the correspondence of these instantaneous components occurs at a totally random rate, the output of the phase detector will also be random—which is a definition of electrical noise.

Only those components of this "noise" output from the phase detector which are able to get through the low-pass filter will be able to have any effect upon the v.c.o. Thus, the filter establishes the *noise* bandwidth of the system. However, all such components will be present at either the FM/PM or the AM output terminals so that *information* bandwidth is not limited by the phase-lock circuit.

When the input signal consists of a mixture of both coherent and non-coherent components, the phase detector will respond to the coherent component but will have no response to the non-coherent elements. The only effect of the non-coherent elements will be in those cases in which they instantaneously override and cancel the coherent portion of the signal.

Even this effect is minimized by the filter, however, since any output from the phase detector due to a coherent input will be summed over a period of time, while any output due to noise will not pass through the filter.

Thus, the filter in the phase-lock circuit retains the advantage of narrow bandwidth insofar as noise is concerned without requiring impractically narrow bandwidths in other

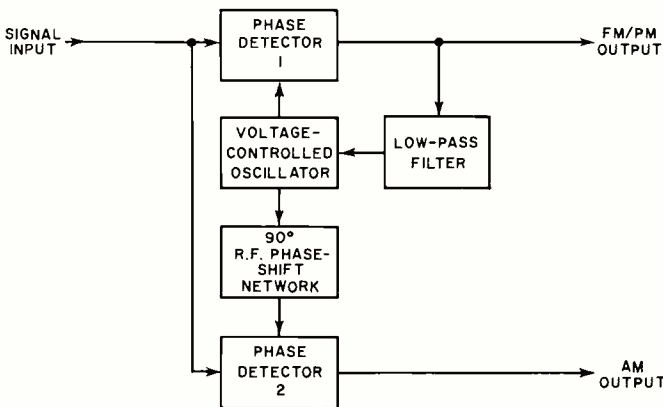
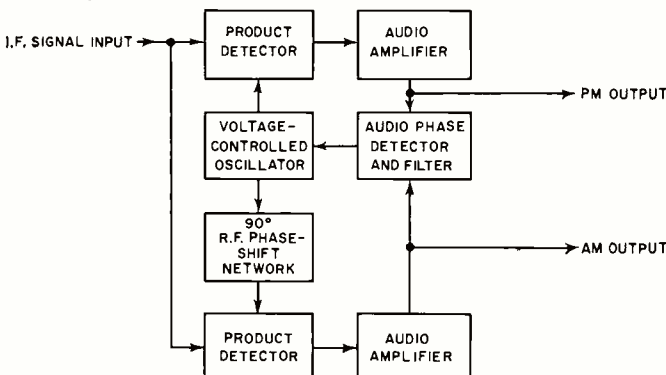

Fig. 3. Alternate arrangement with in-phase signal input.

Fig. 4. Phase-lock circuit used for "universal" detector.



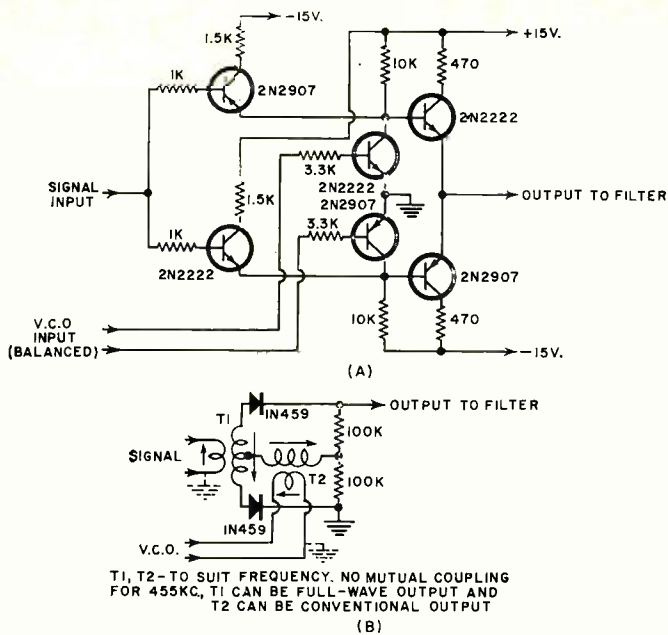

Fig. 8. Some suitable phase detectors used in phase-lock circuits.

acteristics are also important. The difference between AM and PM is nothing more nor less than a 90° shift in phase of carrier frequency with sideband phase held constant.

The artificial carriers applied to the two product detectors are separated in phase by 90°. One of these two carriers will be closer in phase to the original suppressed carrier than will the other. Even if they are exactly 45° away from original phase when frequency lock is achieved, drift effects will move them from this balance point rapidly.

When, through chance, the carriers reach a point at which one is exactly in phase with the original suppressed carrier, the other will be exactly 90° separated.

Thus, the sidebands and artificial carrier supplied to one of the product detectors will meet the original conditions for amplitude modulation, while those supplied to the other will meet the specifications for phase modulation instead—and this phase modulation will have a constant envelope amplitude.

However, a product detector responds to changes in envelope amplitude only. When the amplitude becomes con-

stant, as with the PM channel, detector output drops to zero.

When this occurs, input to the phase detector from that channel will be zero, and with one input removed the phase detector's output will also be zero. This removes control voltage, stopping all change of v.c.o. frequency.

As soon as phase of the v.c.o. output attempts to change (due to heating or other physical causes), output is obtained from the PM channel and applied to the phase detector. Phase-detector output then returns the v.c.o. to the proper phase relationship and keeps it there.

The phase-lock portion of the synchronous detector locks the v.c.o. 90° away from the phase of the suppressed carrier. Thus, the product detector which receives its artificial carrier direct from the v.c.o. is the PM channel, and that which receives its carrier through the phase-shift network is the AM channel. Webb and Costas designate the channels as Q and I, respectively, for "quadrature" and "in-phase."

The circuit works equally well in the presence of a carrier so it can be used as a detector for either DSB or conventional AM signals. If the v.c.o. is stable enough, it can also be used for reception of SSB transmissions.

If the input signal is phase- or frequency-modulated with a modulation index of less than 1.0, the circuit of Fig. 4 will also detect it. In this case, audio output is taken from the Q or PM channel rather than from the I or AM channel. Thus, this relatively simple circuit can be employed as a "universal" detector for communications receivers.

The schematic diagram of the circuit appears in Fig. 5. As originally published, a number of additional components were included to reject heterodyne interference from signals appearing in only one sideband.

To make maximum use of the capabilities of these new systems, the transmitters must be designed to the system approach also. In particular, transmitter frequency stability should be such that the phase-lock circuit is not required to track the input signal over a wide range.

One new approach to this involves circuitry similar to that used in the phase-lock receiver. It is shown in block diagram form in Fig. 6.

Here a v.c.o. is the primary frequency control for the transmitter and drives the remaining transmitter stages in the conventional manner. A portion of the v.c.o. output is applied, through a buffer amplifier, to a crystal discriminator.

The crystal discriminator sets frequency stability of the transmitter. It performs the same function as a phase detector, except that a quartz crystal replaces the second input signal. The circuit of a typical crystal discriminator is shown in Fig. 7, with the response of the discriminator.

Typical separation between f_s and f_p in a crystal discriminator is less than 500 cps. When the output of the v.c.o. is at the exact midpoint between f_s and f_p , output of the discriminator is zero. Any variation of v.c.o. frequency results in a voltage output from the discriminator. This output is filtered and applied to a variable-capacitance diode in the v.c.o. to restore the frequency to the midpoint.

Modulation frequencies are also applied to the variable-capacitance diode. Thus, the modulation frequency may cause instantaneous deviations of output frequency up to ±300 kc., but the locking loop including the crystal discriminator holds the mean center frequency of the transmitter output constant. Typical figures show a mean-center-frequency stability for an S-band transmitter of 0.001%.

Though the phase-lock approach has not yet found use in commercial equipment, its performance is well proven, and readers with experimental inclinations should have no difficulty in applying the technique. Fig. 8 shows schematic diagrams of a pair of phase detectors, applicable to any of the phase-lock variations described here. V.c.o. circuits are shown in Fig. 9. Ordinary RC filters are perfectly adequate for the filtering required, and Fig. 10 shows 90° r.f. phase-shift networks.

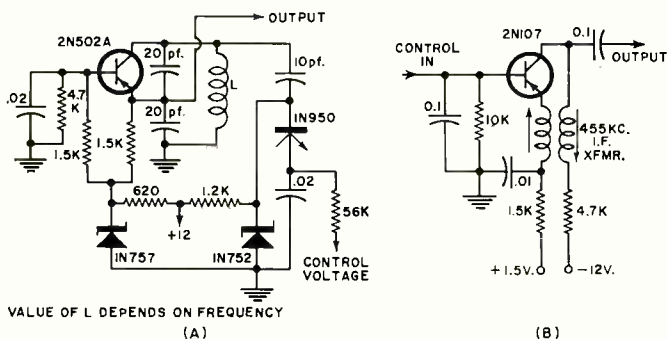

Fig. 9. Voltage-controlled oscillators using (A) voltage variable capacitance diode, (B) variable collector capacitance of transistor.

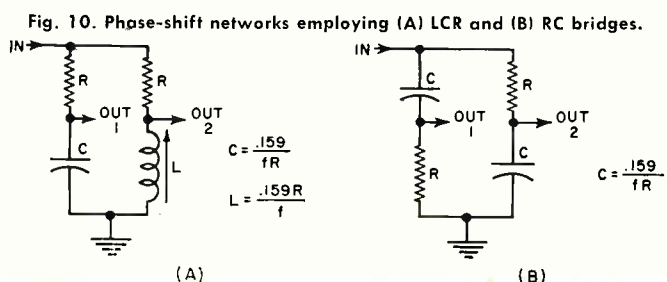
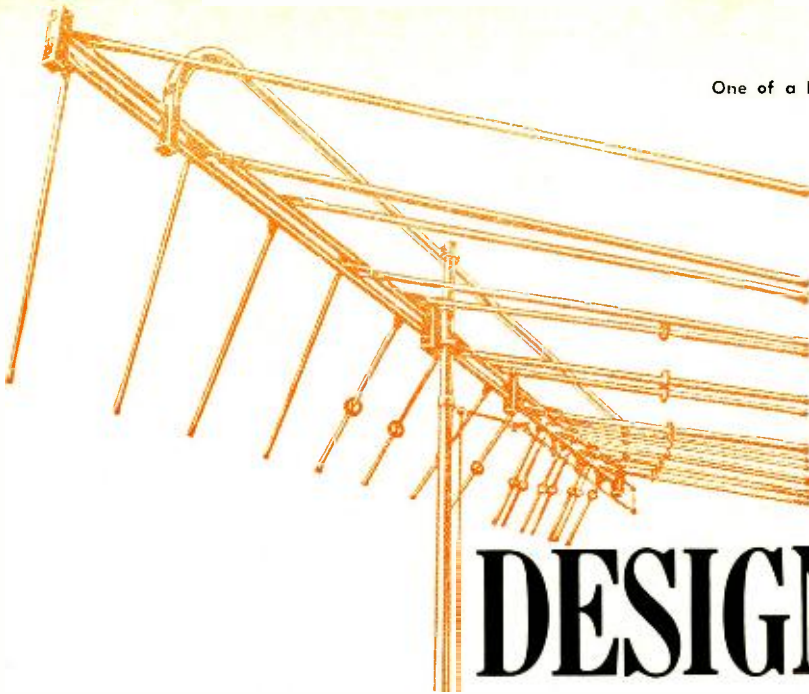

Fig. 10. Phase-shift networks employing (A) LCR and (B) RC bridges.



DESIGNING an all-channel TV antenna

By PAUL E. MAYES
Technical Consultant
JFD Research & Development Laboratories

Evolution of the design of an antenna that will cover both v.h.f. and u.h.f. TV channels and that employs but a single download.

THE emergence of u.h.f. television broadcasting brought about by Federal legislation has presented antenna designers with a new challenge. The advantages of an all-channel (v.h.f. plus u.h.f.) antenna in areas with inter-mixed telecasting are apparent. Only one lead-in need be run from antenna to set. Installation time is reduced since it is not necessary to mount separate v.h.f. and u.h.f. antennas. The possibility of scattering from one antenna affecting the performance of the other is eliminated. Although separate v.h.f. and u.h.f. input terminals are still present on most sets now available, single-input sets will be the inevitable result of improved tuner design. For multiple-input sets, efficient signal splitters can be used at the receiver to provide separate v.h.f. and u.h.f. signals (also to drive an FM tuner).

Broadband Antenna Arrays

One of the first problems encountered in attempting to design an all-channel (2-83) antenna is that of frequency response. Although variable frequency testing and the resulting ratings of audio components are familiar to most, similar data showing antenna performance may be new to many. The problem can be illustrated by considering the input impedance *versus* wavelength characteristics of a simple linear dipole as shown in Fig. 1.

The horizontal scale shows the ratio of dipole length (l) to wavelength (λ). The vertical scale on the upper graph is the resistive part of the impedance; on the lower graph, the reactive part. Note that only near the resonances of the dipoles which occur approximately at $l/\lambda = (2n+1)/2$ ($n=0,1,2$, etc.) is the impedance almost totally resistive and at the same time small enough to be easily matched to the resistive characteristic impedance of a common low-loss transmission line. The frequency band over which the reactance can be maintained at low values is dependent upon the cross-section of the dipole. However, even for very "fat" dipoles as indicated by small values of the length-to-diameter ratio, l/d , the variation in input impedance may not be tolerable. The relative bandwidth is often defined as the difference between the fre-

quencies at which the reactance is equal to the resistance at resonance divided by the geometric mean of these frequencies. The curves of Fig. 1 correspond to a length-to-diameter ratio of 100. The relative bandwidth at the first resonance is approximately 0.18. For $l/d=300$, the bandwidth is 0.15.

Fig. 1. (A) Resistive and (B) reactive components of the input impedance of a center-fed linear dipole antenna element.

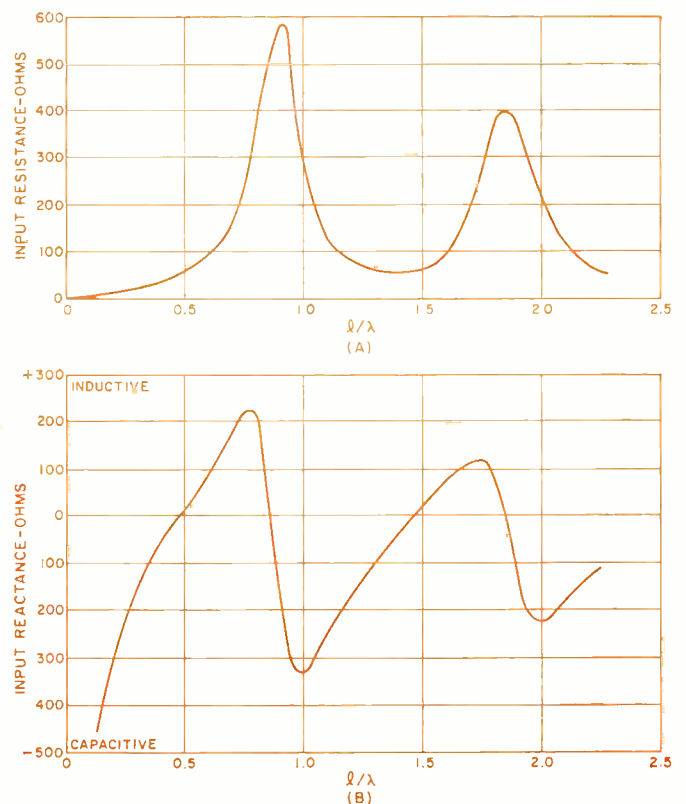

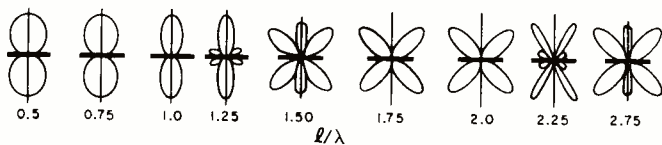

Fig. 2. Radiation patterns of linear dipoles (center-driven to produce in-phase currents in both halves of the element) having various lengths and with l/d ratio greater than 100. Antennas are indicated by the dark horizontal lines shown.

Not only does the impedance of a single dipole change considerably with frequency but the radiation pattern as well. Fig. 2 shows some graphs of relative response of linear centered dipoles to signals arriving from various directions around the antenna. As long as the dipole length is less than one-half wavelength, the pattern is a characteristic figure-of-eight and does not change much with frequency. However, as the l/λ ratio continues to increase, the pattern shape becomes multi-lobed and changes rather rapidly as frequency changes. These pattern variations are generally undesirable since the usual requirement for maximum signal reception is to have large response in a single direction and minimum response from all other directions.

The problems of maintaining a resistive impedance and unidirectional pattern over extremely wide frequency bands have been subjects of extensive research. Considerable progress in this area has been made at the Antenna Laboratory of the University of Illinois since 1954. One of the most useful designs to come out of this work is the "log-periodic" dipole array which was developed by D. E. Isbell in 1959. A schematic diagram of this antenna is shown in Fig. 3. The antenna is composed of a number of linear dipoles which are all connected to a common transmission-line feeder. The distinguishing feature of this array is the fact that the dipoles are all cut to different lengths with the length gradually diminishing from one end of the feeder to the other.

Note that the spacings between dipoles likewise decrease from a largest value at the longest dipoles to a smaller value at the shortest dipoles. When properly controlled, this tapering of dipole lengths and spacings is capable of minimizing variations in input impedance and radiation pattern over extremely wide bandwidths. The theoretically ideal situation is for the ratio of lengths of any two adjacent dipoles to be constant throughout the array and for the ratio of spacings between adjacent pairs of dipoles to be given by the same constant. As in most practical situations, some departures from

the ideal are permissible before the antenna performance is seriously affected but, generally speaking, the closer the practical design to the theoretical ideal, the smaller the performance variations with frequency.

The operation of the log-periodic dipole array is similar to that of a stagger-tuned amplifier in that the dipoles are resonant at various frequencies (depending upon the length) and yet the overlapping responses of the multiplicity of elements produces a total effect which changes little with frequency. The resonant frequencies of the several dipoles in a typical log-periodic dipole array are shown in Fig. 3. Conventional linear dipoles for the v.h.f. band are constructed from 3/8-inch diameter aluminum tubing with maximum lengths of approximately 111 inches. Thus the largest l/d ratio encountered in these antennas is approximately 300. Hence, a single dipole which is resonant at 69 mc. in the middle of the low v.h.f. TV band will have a bandwidth of $0.15 \times 69 \approx 10$ mc. This is adequate to cover only two channels and even that at a reduced performance on the band edges (64 and 74 mc.) where only 80 percent of the received power would be delivered to a load which is ideal at resonance.

The manner in which the interconnection of several dipoles of different length can overcome the problem of impedance variation can best be understood by considering the antenna to be operating as a transmitter. A basic result of antenna theory states that the input impedance and radiation patterns of an antenna are the same for transmitting and receiving. In the transmitting case, a generator is connected to the feedpoint as shown in Fig. 3. Let us suppose that the frequency of the generator is such that $l_1/\lambda = 0.5$ where l_1 is the length of the longest dipole. The dipoles near the feedpoint will have considerably smaller values of l/λ and Fig. 1 shows the input impedance of these dipoles to be primarily a high reactance. Little energy will be transferred to these dipoles from the feedline. However, as the wave traveling along the feeder encounters longer dipoles, more and more energy will be transferred. One secret of a successful log-periodic design is to insure that most of the energy is coupled into the dipoles before reaching the end of the feeder. The termination at the last dipole, Z_L , can be important in this regard, particularly for an antenna containing only a few dipoles. It is preferable to use a reactive load across the longest dipole since any resistive component will absorb power and reduce the antenna gain. This load may take the form of an open- or shorted-stub, sometimes in conjunction with a small capacitor.

The several dipoles which absorb the greater power from the feeder are often called the "active region." Consideration will be given in the next section to the manner in which the currents in these dipoles can be made to radiate a highly directive beam. But now consider what happens when the frequency is changed. In particular when the next shorter dipole corresponds to $l/\lambda = 0.5$, the active region has simply moved up the feeder by one dipole spacing. The input impedance at the front of the active region is the same as before and the feeder plus shorter dipoles between the active region and the feedpoint all have the same or approximately the same wavelength dimensions as before. Hence the input impedance at this higher frequency will be the same as at the lowest frequency. Since the dimensions of the active region are the same in wavelengths, the radiation pattern produced is also unchanged.

Although the above considerations of scaling indicate that the performance characteristics of the antenna will repeat at any two frequencies related by the scale factor for adjacent dipoles, there is no guarantee that the performance will remain constant between these frequencies. This must be accomplished by proper choice of scale factor, depending upon the bandwidth of the individual dipoles in the array. For dipoles with l/d in the range from 300 down, scale factors as low as 0.9 have proved satisfactory. When scale factor and dipole bandwidth are properly related, then the active region

Fig. 3. Log-periodic dipole array for low-band v.h.f. TV.

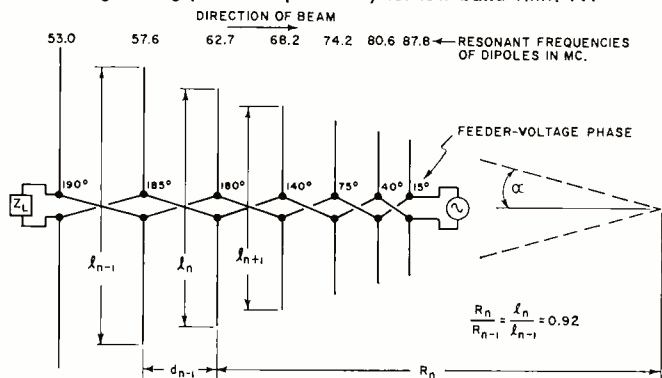

ELEMENT	LENGTH (in.)	ELEMENT	SPACING (in.)
l_1	111	d_1	18.0
l_2	102	d_2	16.6
l_3	94	d_3	15.2
l_4	86	d_4	14.0
l_5	79	d_5	12.9
l_6	73	d_6	11.8
l_7	67		

moves smoothly from dipole to dipole as frequency changes and variations in antenna performance over an extremely wide frequency band are very small.

Achieving Unidirectional Patterns

Although a smoothly moving active region is very important in achieving frequency-independent performance, there are other important considerations as well. The single-lobe radiation pattern which has a high ratio of front-to-back response requires that several dipoles be interconnected in the proper manner. Consider the transmitting case once again. The generator connected to the input terminals of the antenna launches a traveling wave on the feeder. The voltage on the feeder undergoes a phase delay as an observer moves away from the feedpoint. The phase shift between dipoles is increased above the value obtained on an unloaded feeder because of the additional capacitive reactance which the short dipoles present across the line. Thus, although the spacing between dipoles in the active region usually corresponds to less than 60 electrical degrees, the feeder voltage phase shift is more nearly 90 degrees.

For determining the pattern of the array, it is the dipole currents which are of prime importance. The transposition of feeder conductors between adjacent dipoles introduces an additional 180 degrees of phase shift between dipoles as compared to using a straight feeder. The combination of these effects is to produce a phase delay in the dipole currents which is toward the feedpoint of the array rather than away from it. As a result, the direction of maximum radiation (as a transmitting antenna) and maximum response (as a receiving antenna) is along the axis of the array in the direction of the feedpoint. This phenomenon is often called "backfire" radiation to distinguish it from the more conventional "end-fire" antennas, such as multiple-element yagis. Yagis have maximum response off the end which is farthest removed from the feedpoint.

The manner in which the "backfire" phasing of the dipoles is achieved is illustrated in Fig. 4 by the arrows labeled "feeder voltage phasors" and "dipole current phasors." The data shown in Fig. 3 for feeder voltage phases is for a frequency near the center of the low v.h.f. TV band so that the active region is located at the intermediate-length dipoles. The feeder voltage phases at the dipoles are characteristic of a wave traveling away from the generator, *i.e.*, phase increasing toward the left. This is shown in Fig. 4A by the rotation of the phasors in a counterclockwise direction.

Due to the transposition of the feeder between adjacent dipoles, the dipole currents in alternate dipoles have a phase which is advanced (or retarded) by approximately 180 degrees. Reversing the direction of alternate phasors, as shown in Fig. 4B, the direction of phase progression in the dipole currents is opposite to that of the feeder voltage. An important feature of backfire phasing is that the radiation is directed away from the longer dipoles and the result is a high front-to-back ratio. To preserve the high front-to-back ratio it is necessary to observe a minimum feeder length of approximately one-third to one-half the maximum wavelength. Minimum front-to-back size for a backfire antenna with a good front-to-back ratio at channel 2 is, therefore, about 60 inches.

Multiband Operation

Although the combination of tapered dipole lengths and spacings plus backfire phasing is ideal for continuous coverage of an extremely wide band, the frequency allocations for television do not call for this type of operation. In fact, for an all-channel antenna, it is necessary to cover three separate frequency bands, 54-88, 174-216, and 470-890 mc. There are several approaches to adapting the above principles for this type of intermittent coverage, however, and we shall consider briefly the advantages and disadvantages of some of them.

Of course, it would be possible to build a log-periodic di-

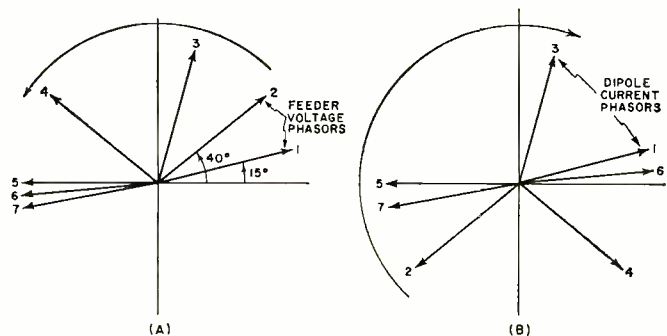

Fig. 4. Feeder voltage and dipole current phasors illustrating the effect of transposition of the feeder that is used.

pole array which would cover the entire band from 54 to 890 mc. even though this represents a frequency span of over 16 to 1. The disadvantage to this approach is that many dipoles would be required and the total length of the feeder would be rather large even for achieving moderate antenna gain. It was demonstrated early in the work on log-periodic dipole antennas that the dipoles which were resonant at frequencies somewhat removed from the bands which were to be covered could be removed from the antenna without adversely affecting the performance in these bands. While it is true that this will eliminate several dipoles and thereby shorten the required feeder, as shown in Fig. 5, the gain remains relatively constant for all frequencies in the desired bands. This may produce satisfactory reception in some locations, but generally the properties of wave propagation with increasing frequency make it desirable to have larger gain on the upper frequency bands.

The dipole impedance characteristics shown in Fig. 1 suggest a way in which each dipole on the antenna can be made to operate effectively at more than one frequency. Since the formation of the active region is primarily dependent upon the impedance properties of the dipoles, it is reasonable to expect that an active region could be formed in the vicinity of dipoles which are three-half-wavelengths long. As a matter of fact, even higher-order resonances which occur at other odd integer multiples of a half-wavelength could be used for this purpose. In order to achieve an active region which

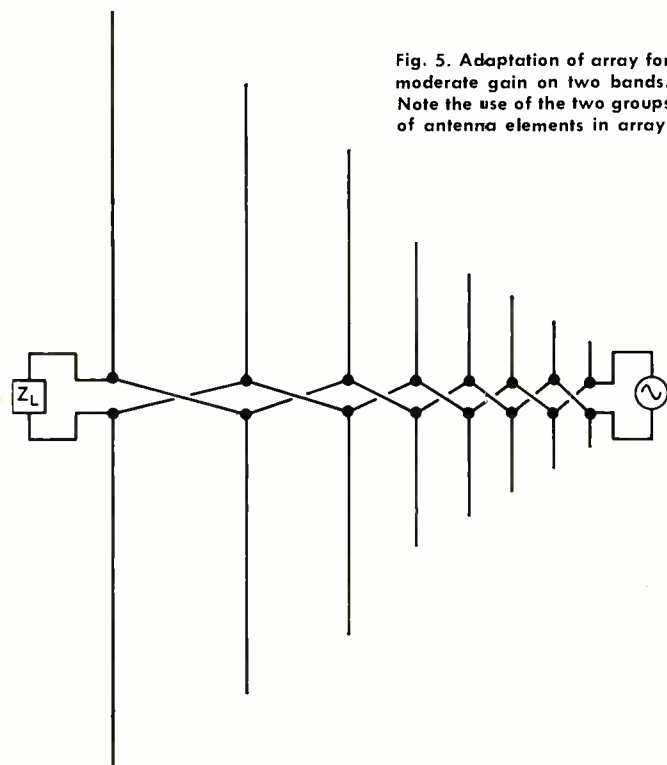

Fig. 5. Adaptation of array for moderate gain on two bands. Note the use of the two groups of antenna elements in array.

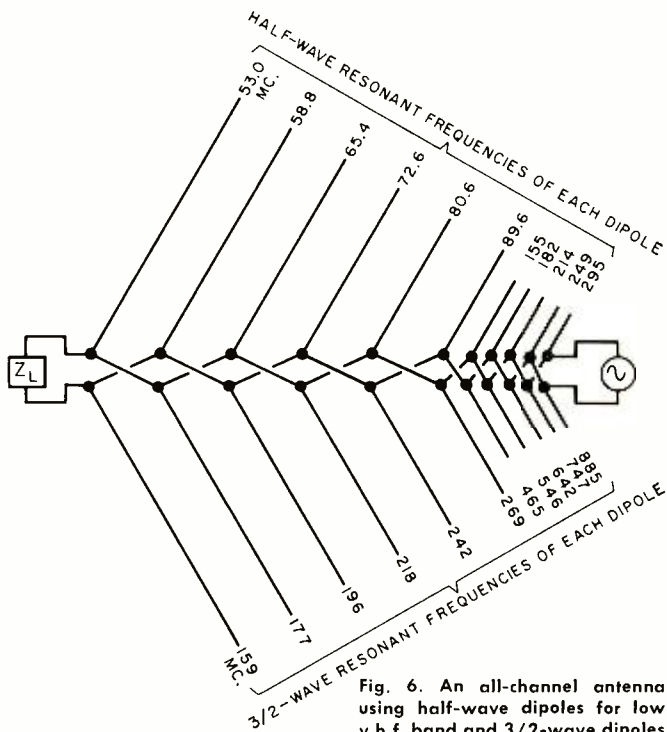

Fig. 6. An all-channel antenna using half-wave dipoles for low v.h.f. band and 3/2-wave dipoles for high v.h.f. and u.h.f. bands.

moved smoothly with frequency, only an appropriate adjustment in the spacing between dipoles was required; the higher the order of the resonances, the closer the spacing.

Inspection of the patterns of Fig. 2 reveals another problem with operating in the higher-order resonances. Note that the pattern of a linear dipole which is three-half-wavelengths long has six distinct lobes rather than two. Considering the transmitting case once again, it is easy to see that the power radiated in the side lobes is wasted. The side lobes can be greatly reduced by shaping the dipole. The simplest configuration is a V-dipole made by tilting the dipole halves toward one another. The combination of V-dipoles in a driven array with backfire phasing can be made to have no observable side lobes and a front-to-back ratio greater than 20 decibels. Since the dipole is larger in wavelength when used at the

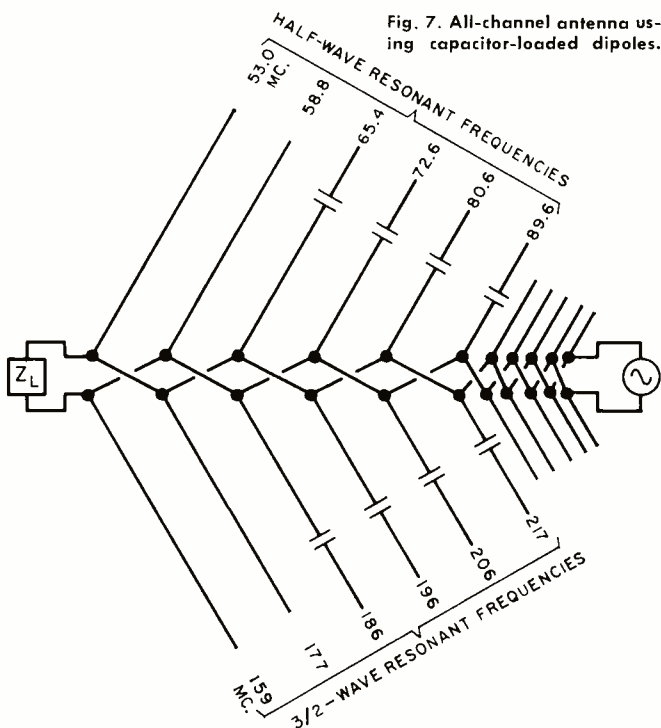

Fig. 7. All-channel antenna using capacitor-loaded dipoles.

higher resonances, the beams produced are much narrower, resulting in the increased gain which is desired in the higher frequency bands.

Fig. 6 shows one way in which the higher modes can be utilized in an all-channel antenna. In this example 3/2-wave dipoles are used throughout the high v.h.f. and u.h.f. bands. Since the maximum theoretical bandwidth of a 3/2-wave antenna is 3 to 1, further modification of the dipoles is required. The desired result is achieved through the reactance-loading discussed in the following section.

Reactance-loaded Dipoles

Consideration of the resonances of the dipoles shown in Fig. 6 suggests a way in which performance of the antenna might be improved, especially in the high v.h.f. band. Note that the 3/2-wave resonances of several of the dipoles fall at frequencies outside the 174-216-mc. band. Hence, although these dipoles are required on the antenna to adequately cover the 54-88 mc. band, they are not contributing effectively toward achieving the higher gain which is desired in the upper v.h.f. band.

In order to force more of the dipoles to resonate within the 174-216-mc. band, a way is needed to cause the ratio of first to second resonance frequencies to depart from the customary value of 3. Recent research has shown that proper placement of a lumped reactance along the dipole arms can be made to produce the desired shift. When a capacitor is inserted in the dipole, the frequency variation in the reactance produces a different effect at the second resonance than at the first. Ratios as low as 2 have been achieved in this way. The antenna shown in Fig. 7 illustrates how more of the capacitance-loaded dipoles can be made to resonate in the higher v.h.f. band. The more

(Continued on page 60)

Fig. 8. An all-channel, 15-element antenna using capacitor-loaded dipoles. Capacitance and load values were determined empirically for best performance during original design work.

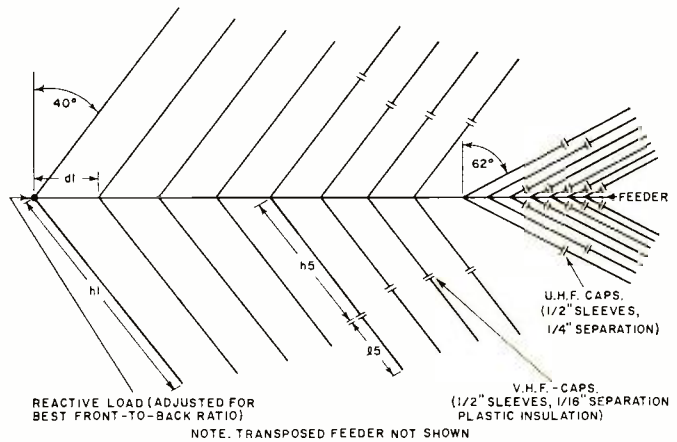

ELEMENT LENGTH (in.)	ELEMENT LENGTH (in.)	ELEMENT SPACING (in.)
h_1	l_5	d_1
55.4	15.3	14.92
h_2	l_6	d_2
52.0	18.56	13.98
h_3	l_7	d_3
48.5	18.75	13.09
h_4	l_8	d_4
45.6	18.95	12.16
h_5	l_9	d_5
34.6	27.37	11.48
h_6	l_{10}	d_6
26.6	23.5	10.74
h_7	l_{11}	d_7
23.6	43.0	10.07
h_8	l_{12}	d_8
21.2	39.65	10.9
h_9	l_{13}	d_9
26.8	36.63	5.47
h_{10}	l_{14}	d_{10}
26.1	34.1	5.07
h_{11}	l_{15}	d_{11}
4.25	31.91	4.7
h_{12}		d_{12}
4.25		4.36
h_{13}		d_{13}
4.25		4.05
h_{14}		d_{14}
4.25		3.75
h_{15}		
4.25		

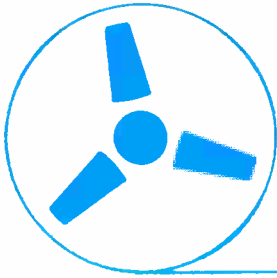

VIDEO TAPE RECORDER FOR HOME USE

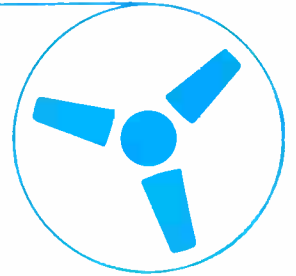

By EUGENE LEMAN/Memorex Corp.

Design of a longitudinal-track recorder constructed by author which produces useful pictures at 72 ips with a frequency response to about 1.5 megacycles.

Editor's Note: Because of the special tape transport, tape heads, and other special parts required, this recorder is not intended to be home-built by the average experimenter unless these parts are available to the builder. The article is useful, however, in showing circuitry and design techniques required for such a unit.

DURING the past few years various companies have announced and demonstrated home video tape recorders. Many of these recorders utilize the inherently simple method of linear or longitudinal-track recording. In this method, the recorded track is put on the tape along the same line as the tape travel rather than at some angle with respect to the length of the tape.

A slant-track or helical-scan recorder will usually offer superior performance by using rotating heads, which allow an increase in tape-to-head speed while still maintaining low (7½ ips, for example) tape speeds. This high writing speed (typically 600 ips) allows the use of an FM carrier system

which can substantially increase the signal-to-noise ratio and the low-frequency response.

The signal system of such a rotating-head recorder consists of the FM modulator and record-head driver, and on playback, a preamp equalizer, head switcher, limiter, and FM detector must be used.

On record as well as on playback it is necessary to servo the head drum. The times of head switching on record have to coincide with the vertical sync, while on playback the rotating head has to follow the recorded track to very close tolerances. This tracking is usually achieved by recording a control track on one edge of the tape, the remainder being used for the video signal. Tape widths of 1 inch are most commonly used for this type of recording.

The linear or longitudinal-track recorder is far less elaborate and is capable of providing reasonable performance with the only major disadvantage being the high tape speed. However, tape efficiency can be improved by reducing the track width, allowing a number of video tracks to be recorded.

The author was quite intrigued by these recorders. Since

Top view of the instrumentation tape transport employed.

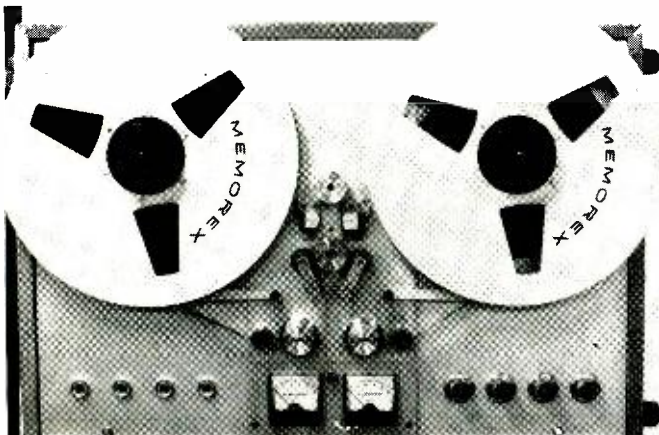

Close-up view of the closed-loop tape drive system used.



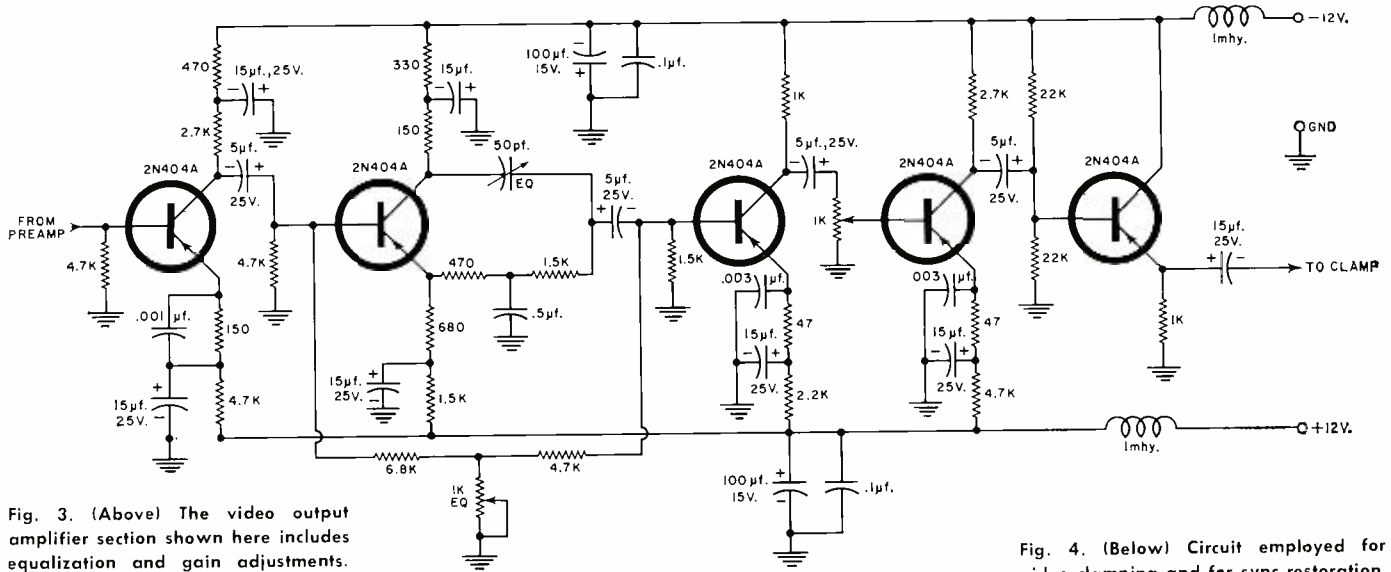

Fig. 3. (Above) The video output amplifier section shown here includes equalization and gain adjustments.

incoming video signal from a TV receiver or camera is amplified by transistor 2N404 (Fig. 1). Transistor 2N1141A drives the video record head after further amplification. A crystal-controlled 7-mc. oscillator and amplifier provides the r.f. bias. The 50-pf. trimmer in the bias output stage is used to re-tune the record head to the 7-mc. frequency, improving its biasing efficiency.

Monitoring of record and bias current can be done across the 10-ohm resistor connected in series with the record head. With the presently used head, the record current is approximately 10 ma. peak-to-peak and the bias current approximately 100 ma. peak-to-peak. Since only one power supply is used, it is necessary to carefully decouple all sections to avoid record signal pickup in the playback chain.

The specially designed low-noise preamp (Fig. 2) limits the recorder noise to that produced by the tape. The preamp gain is on the order of 35 db and the equivalent noise over its 2-mc. bandwidth is on the order of 5 µV. Since no emitter-follower is used, no more than a few inches of low-capacity coax should be used for the connection to the video output amplifier. The two 8-volt zener diodes provide excellent reduction of the 120-cps power-supply component.

The preamplified video signal enters the video output amplifier (Fig. 3), is amplified, and fed to the equalizer stage.

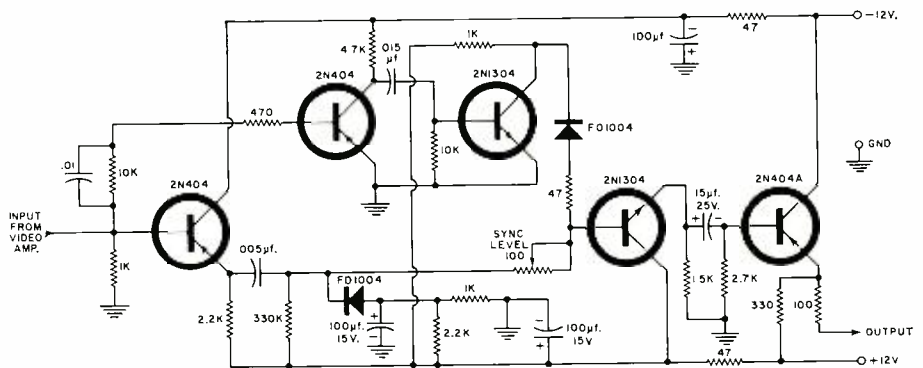
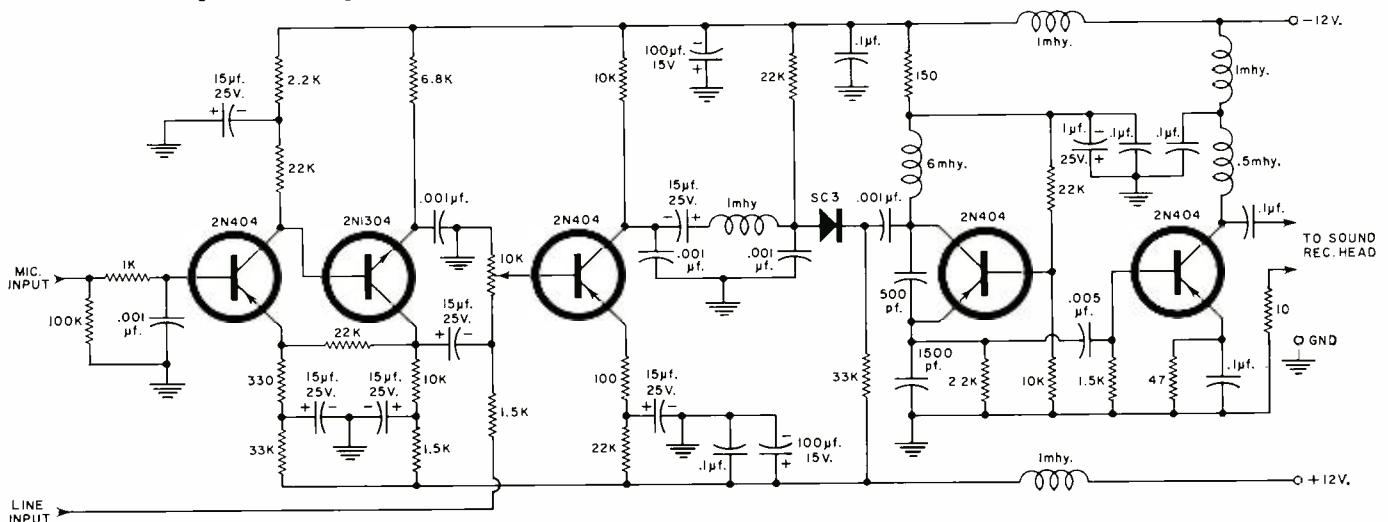

Fig. 4. (Below) Circuit employed for video clamping and for sync restoration.

The equalizer stage integrates the video signal to compensate for the 6 db-per-octave increase in signal amplitude of the playback head. At frequencies above approximately 300 kc., the playback signal begins to fall off and has to be boosted to provide a flat response. The boost signal is taken off at the collector to provide proper phase relationship with the integrated signal. After equalization, the signal is further amplified and finally applied to the keyed clamp through an emitter-follower.

Low-frequency transistors (2N404A's) are used in the video output amplifier and in the clamp. Together with the emitter peaking employed, they give a flat response to 1.5 mc. with the response falling off rapidly at about 2 mc. Initially, high-frequency transistors were used, but special low-

Fig. 5. Circuit diagram of mike preamp, modulated voltage-controlled oscillator, and sound-head driver stage.



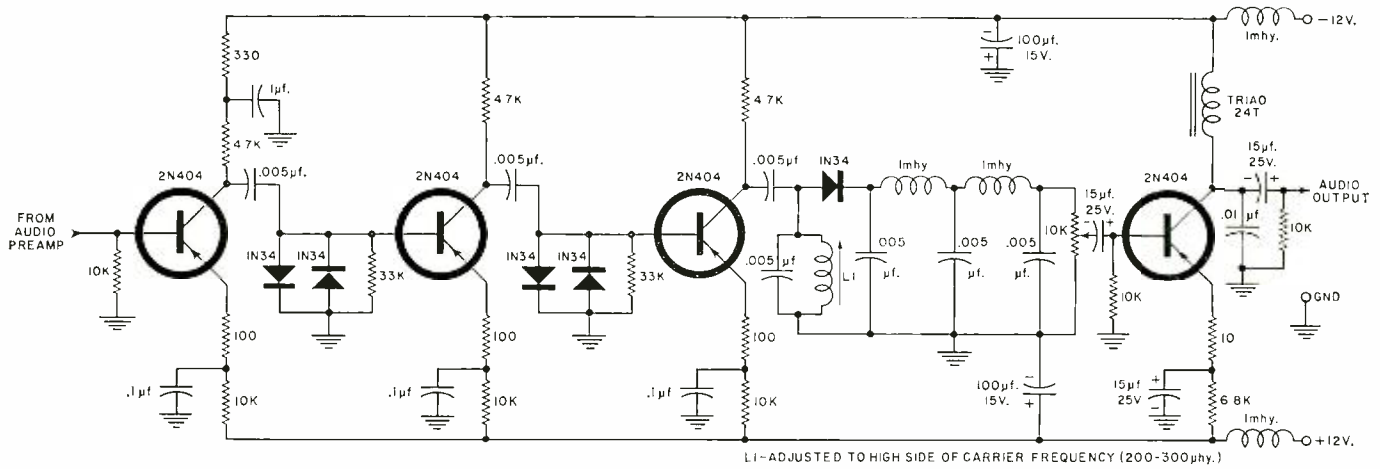

Fig. 6. A two-stage audio limiter is followed by a slope detector, low-pass filter, and audio output amplifier.

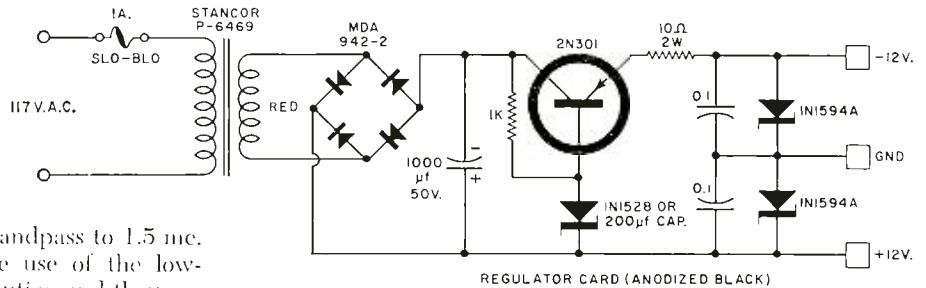

Fig. 7. (Right) Power supply is well-regulated and very low in ripple.

pass filters had to be used to restrict the bandpass to 1.5 mc. to keep high-frequency noise down. The use of the low-frequency transistors provides an easier solution and they are also less expensive.

The clamp (Fig. 4) provides a significant improvement in the reproduced picture. It is designed so that the old sync pulse is removed and replaced by the keying pulse. Its presence is especially noticeable in pictures with high contrast. In addition, a more stable sync stability is provided with the average TV set. In some cases, it may also help to reduce the horizontal sync detector time constant.

Audio Circuit

A magnetic tape system operating at 72 ips has serious difficulties reproducing frequencies below 1 kc. with any reasonable signal-to-noise ratio. Therefore, a carrier system was used for the separate sound track. FM was chosen because of its simplicity and since it allows the signal to be recorded at saturation without the use of bias.

A simple voltage-controlled oscillator employing variable-capacitance diode SC3 (Fig. 5) is used and it operates at approximately 150 kc. with a swing of ± 30 kc. Modulation frequency is limited to approximately 8 kc. The oscillator output is then fed to the record-head driver whose circuit values are chosen to provide tape saturation.

A three-stage audio preamplifier raises the microphone level to operate the voltage-controlled oscillator. A second input is provided for line or other high-level audio signals.

The same type head preamplifier is used for the audio as

was used for the video channel (refer back to Fig. 2). Its output feeds a two-stage limiter and a simple slope detector to recover the audio (Fig. 6). After conversion to AM, the signal is rectified and separated from the carrier by a low-pass filter. A one-stage audio amplifier raises the level to over 1 volt, sufficiently high to drive an audio output amplifier.

The power supply (Fig. 7) is straightforward. Ripple is reduced by an emitter-follower and regulation and further ripple reduction is obtained with two 12-volt, 3-watt zener diodes. The 120-cps component remaining is on the order of 10 μ v. at the power-supply output terminals.

Tape Heads

Very recently some experimental two-track, $\frac{1}{4}$ -inch record and playback heads, made by *Nortronics*, have been tried with promising results. These heads are fairly readily available. The record head gap is 100 μ m., while that of the playback head is on the order of 30 μ m. It is necessary, however, to reduce the bias frequency to 4 mc. in order to get enough bias sensitivity.

In the initial stages of the project, some instrumentation-type heads were borrowed. After the project was well underway and good quality pictures were reproduced, it was decided to get some idea of the problems involved in precision head building. A used *Ampex* 350 playback head was taken apart piece by piece and (Continued on page 67)

In both waveform photos, the upper trace is the output of the video amplifier, lower trace is output of clamp. Note restoration of d.c. level and sync pulses. Waveforms at left are at horizontal rate, those at right are at vertical rate.

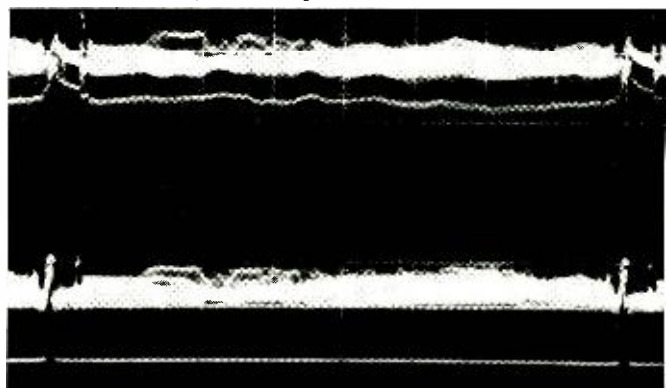
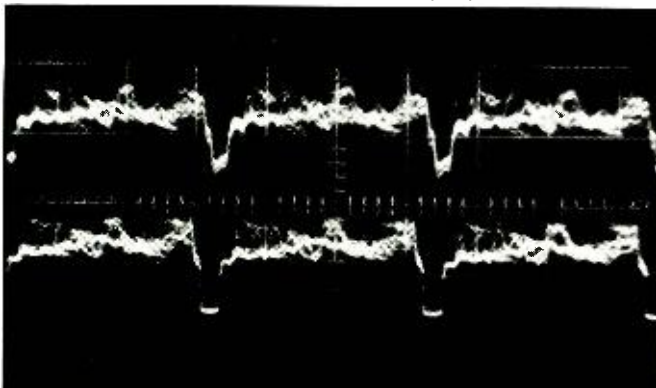

A PUBLISHING FIRST

... THE ONLY COMPLETE GUIDE FOR SERVICEMEN AND HOBBYISTS TO EVERY MAJOR PHASE OF CONSUMER ELECTRONICS SERVICING!



For the progressive serviceman who wants to find out how to service better and faster . . . how to expand his business by handling a wider variety of electronics equipment —

For the "do-it-yourself" hobbyist who wants to save hundreds of dollars by installing and repairing his own equipment —

The 1966 ELECTRONICS INSTALLATION & SERVICING HANDBOOK has arrived! The only comprehensive and authoritative guide to every major phase of consumer electronics servicing. There's nothing like it anywhere!

A handy, on-the-bench reference volume containing 128 pages—over 150 illustrations, charts and tables—on how to spot, analyze and correct trouble . . . quickly, efficiently and economically!

Complete, in-depth coverage of: the fundamentals of servicing • servicing b/w & color TV • AM-FM household radios • stereo/hifi • CB equipment • intercoms and PA systems • antennas • transistorized ignition systems.

Hundreds of money-saving techniques and shortcuts. Every up-to-date method and procedure. All in easy-to-understand language for the novice...yet thorough enough to answer the professional's most complex question!

You'd have to purchase several expensive manuals to equal this kind of incisive, all-inclusive coverage. But now you get it all in the 1966 ELECTRONICS INSTALLATION & SERVICING HANDBOOK. A small investment that will pay for itself many times over with just one practical application. **only \$1.25**

GET THE EXQUISITE
LEATHERFLEX BOUND EDITION
for just \$3 POSTPAID!

The 1966 ELECTRONICS INSTALLATION & SERVICING HANDBOOK is also available in an attractive, gold-embossed, Leatherflex-bound edition — a superb addition to your library of permanent reference books. This deluxe volume will be mailed to your home, postpaid, for just \$3.00, when you check the appropriate box on the order form.



--- FILL IN, CLIP & MAIL THIS FORM TODAY! ---

Ziff-Davis Service Division • Dept. IS
589 Broadway • New York, N.Y. 10012

YES! Send me a copy of the 1966 ELECTRONICS INSTALLATION & SERVICING HANDBOOK, as checked below:

\$1.25 enclosed, plus 15¢ for shipping and handling. Send me the regular edition. (\$1.50 for orders outside the U.S.A.)

\$3.00 enclosed. Send me the DeLuxe Leatherflex-bound edition, postpaid. (\$3.75 for orders outside the U.S.A.) Allow three additional weeks for delivery.

name _____ please print _____ EW-26

address _____

city _____ state _____ zip code _____

--- PAYMENT MUST BE ENCLOSED WITH ORDER ---



JOHN FRYE

Becoming familiar with the latest semiconductor devices should be standard operating procedure for the technician.

KEEPING UP WITH NEW COMPONENTS

BUSINESS at Mac's Service Shop was becalmed in the February doldrums. Pocketbooks were still suffering from the Christmas trauma, and taxpaying time had begun to loom darkly on the horizon: so customers were having only essential service work done. Mac and Barney had cleaned and re-arranged the entire shop; they had checked and recalibrated all their test equipment; but now they were entirely caught up. Mac sat on a stool, chin in hand, trying to think how he could keep his restless red-headed assistant gainfully employed—or just employed.

Suddenly he slid off the stool and took three bright-red display cards from a cabinet and placed them, together with a thick, paper-bound manual, on the bench in front of Barney.

"What are those nasty-looking things?" the latter asked, peering suspiciously at the various small components contained in formed pockets of the clear plastic covers of the cards.

"They are Experimenter's Kits put out by RCA last fall. That large card contains five diode rectifiers, an *n-p-n* silicon transistor, a *p-n-p* germanium transistor, and a heat-sink-mounted silicon controlled rectifier. As explained in the manual, these constitute the major items used in the construction of the basic universal motor-speed control and lamp-dimmer unit. The other two cards contain add-on kits to be used with the basic unit. A photocell in the light-sensor kit permits conversion of the basic unit into a light-activated switch. Three thermistors of different ranges and special solder for mounting them contained in the heat-sensor kit allow changes in temperature to control devices plugged into the basic unit.

"The manual explains in great detail how fourteen different control devices can be built from these three kits, but it does much more than that. It goes into the theory of diodes, transistors, and silicon controlled rectifiers in a thorough manner: it describes simple circuitry for testing every component furnished with the kit and for testing sub-assemblies of the basic unit; and it shows normal scope traces to be found at various points in the silicon controlled rectifier circuit with various levels of the controlling signal. The construction of a two-transistor regenerative 'triggered switch' is given and the action explained. I particularly like the manual because the actual construction information is simple and yet detailed enough so that almost anyone can build and use the devices; nevertheless, the theory of operation is not 'watered down' below the technician level. When you finish constructing, testing, and understanding the devices described, you'll know a lot more about the practical use of silicon controlled rectifiers, photocells, and thermistors than you do now."

"You mean you intend for me to build up these gadgets?"

"Right. Most of them can be put to good use right here in the shop. The motor-speed control will work fine with our electric drills. The light dimmer, light-activated switch, and electronic flasher can all be used to create crowd-stopping displays in the front window. The electronic overload switch is just the ticket to monitor power drawn by a cooking inter-

mittent TV set and to cut it off when something fails and the power consumption rises above the normal level. And one of the thermistors can be placed in a critical cabinet area or fastened directly to a component so that the set will be automatically switched off if the temperature rises above a preset value. But you don't need to limit yourself to the devices described in the RCA manual," Mac concluded, taking another manual from the cabinet and handing it to Barney.

"Gee, how lucky can a guy be?" Barney asked sarcastically.

"That's the 'Silicon Controlled Rectifier Hobby Manual' put out by G-E," Mac explained, ignoring Barney's sarcasm. "It contains construction information on several other interesting SCR devices you can build and try out during your spare time here in the shop. I'll be especially interested in seeing you check out various suggestions in the manual for getting rid of radio interference created by the abrupt turning on of the controlled rectifier during each cycle or half-cycle. Also, you will find that thyrectors are used across the line to suppress transients that might damage the rectifiers, that light-activated switches are described, and that unijunction transistors are used. Experimenting with the apparatus described will give us an opportunity to observe the behavior of all three devices. And some of the equipment in this manual employs zener diodes. While we both know how zener diodes work and encounter them more and more frequently in the transistorized equipment we service, it won't hurt either of us to play around with them in experimental equipment where we can observe and measure their voltage-limiting action under deliberately induced extreme conditions."

"I think I'm beginning to see what you're driving at," Barney mused. "You're not primarily interested in using the devices you want me to build. What you really want is for me to obtain some first-hand experimental knowledge of various types of semiconductors and related members of the 'istor' family that will be of use to me in the servicing of home and industrial equipment."

"Precisely!" Mac applauded. "We both know there's a big difference between learning about a new component from reading about it and from actually working with it. Back in the early days of servicing a technician was invariably an experimenter, too. When he wasn't working on a customer's receiver, he was building his own and trying to improve its performance. Every time a new tube or a new circuit or a design for a new antenna came out, he was quick to try it out; and a great deal of what he learned from this experimenting was of great practical value to him in his service work."

"But nowadays things are different. Very few present-day service technicians do any experimenting or any construction worthy of the name. We excuse ourselves by saying we're too busy to 'fool around' with new components and that we can learn all we need to know about them when we encounter them in new equipment. That's a little like a doctor's claiming he can learn all he needs to know about new diseases by

treating them in patients who bring these diseases to him. He can learn, all right, but it's likely to be rough on the patient and very time-consuming.

"Just as a doctor learns about the human body thoroughly by dissection and keeps himself abreast of new techniques by sitting in on new operations, so the technician should keep himself thoroughly informed on the capabilities, weaknesses, and peculiarities of new electronic components used in equipment he intends to service by experimenting with these new components as soon as they are made available at reasonable prices—before they are incorporated into new electronic equipment for home and industry.

"Many manufacturers are aware of this, and they are doing what they can to help the technician by bringing out kits and manuals such as those on the bench. Leaflets describing the parameters of new semiconductor devices and showing possible applications of these devices can be obtained free of charge from practically any manufacturer as soon as the devices are introduced. The technician who obtains a leaflet and one of the devices and experiments with it will be in a position to approach a piece of equipment using one of the devices with complete confidence. He knows what it is supposed to do, and he is familiar with any peculiarities or weaknesses it may have. He will be prepared to decide quickly whether a defect in that particular component is causing the trouble with the equipment or not."

"You're making sense," Barney admitted. "I know for a fact that when I'm working on a piece of equipment containing an unfamiliar component, I'm always haunted by the possibility the trouble may lie in that little puzzler I'm not prepared to test."

"I know what you mean. And we have to face up to the fact that more and more of these exotic devices are being used in ordinary home and factory equipment every day," Mac continued. "Controlled rectifiers have become cheap enough to be built into many drills, mixers, jig-saws, movie projectors, lamps, etc., and I think we've just scratched the surface of the possible uses for this versatile semiconductor. Our audio oscillator uses a thermistor in series with a capacitor across the load resistor of one of the amplifiers to hold the output nearly constant regardless of the frequency. And you know how often thermistors are used in liquid-level controls and temperature-monitoring devices in industry. Voltage-variable capacitors are used to vary the b.f.o. of communications receivers and to provide *delta* tuning of the receiver circuits of several ham and CB transceivers. They are also used to provide frequency sweeping of signal generators and in a.f.c. circuits. Photocells are almost as common as flashlight bulbs. They do everything from opening huge garage doors to adjusting the iris opening of even small and inexpensive cameras for the proper exposure."

"You needn't beat the subject to death. I get the picture," Barney interrupted. "You furnish the jazzy electronic components and the spec sheets, and I'll certainly whip them up into circuits and put them through their paces. I really enjoy building and experimenting. What's more, I'll even let you look over my shoulder while I'm doing it so that I won't be the only hep guy in the shop. But now, if you don't mind, I'd like to get started putting this motor control and lamp dimmer together."

Mac nodded agreement, and Barney, humming "Getting to Know You" slightly off-key, started to work. ▲

CB OPERATOR SENTENCED

ON November 15, 1965, Richard P. Greenside of the Mattapan (Boston) area was sentenced to one year in jail for transmitting obscene, indecent, and profane language over a class-D CB station. Similar enforcement efforts are presently being conducted by nationwide FCC monitoring stations. ▲

February, 1966

Live Better Electronically With

LAFAYETTE RADIO ELECTRONICS FREE!



512
Pages

1966
Catalog
660

Now BETTER THAN EVER

Featuring Everything in Electronics for

• HOME • INDUSTRY • LABORATORY

from the

"World's Hi-Fi & Electronics Center"

Stereo Hi-Fi • Citizens
Band • Ham Gear •
Tape Recorders • Test
Equipment • TV and
Radio Tubes and Parts •
Cameras • Auto Acces-
sories • Musical Instru-
ments • Tools • Books



CRITERION 1000B
4-TRACK STEREO
RECORDER IN
TEAK CABINET



"PRO-50" COMPACT SOLID
STATE COMPONENT STEREO
MUSIC SYSTEM

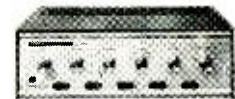

50-WATT SOLID STATE
STEREO AMPLIFIER
MODEL LA-248

Mail the Coupon Today for Your
FREE 1966 Lafayette Catalog 660

LAFAYETTE Radio ELECTRONICS

Dept. RB-6, P.O. Box 10

Syosset, L.I., N.Y. 11791

Send me the Free 1966 Lafayette Catalog 660

Name

Address

City

State Zip

(Please Give Your Zip Code No.)

CIRCLE NO. 105 ON READER SERVICE CARD

How To Have Fun While You Save . . . Something For Everyone . . . In This Vast Heathkit Selection!

Kit GR-43
\$159⁹⁵

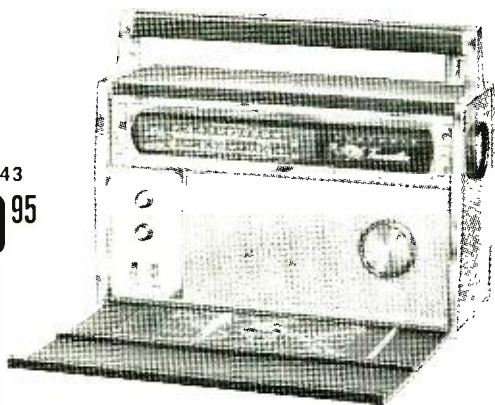

New Heathkit 10-Band Transistor Portable!

10 bands tune Longwave, Standard Broadcast, FM and 2-22.5 mc Shortwave. 16 transistors, 6 diodes, and 44 factory assembled and pretuned circuits. Two separate AM & FM tuners and IF strips. FM tuner & IF strip are same components used in deluxe Heathkit FM stereo gear. 2 built-in antennas. Battery saver switch cuts current drain up to 35%. Rotating tuning dial. Dial light. 4 simple controls for tuning, volume, tone, AFC and band switching. 4" x 6" PM speaker. Earphone & built-in jack. Optional 117 v. AC converter/battery charger available @ \$6.95. Time zone map & "listener's guide." Man size: 13½" W x 5¼" D x 10½" H. 17 lbs.

Kit GW-14
\$89⁹⁵

Assembled GWW-14
\$124⁹⁵

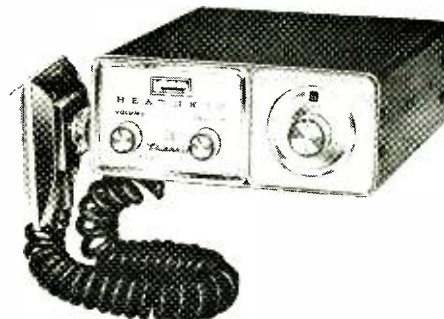

New 23-Channel, 5-Watt, Transistor CB Transceiver!

Your best 23-channel CB buy—bar none! Compare! 23 crystal-controlled transmit & receive channels for the utmost reliability . . . at lowest cost. All-transistor circuit for instant operation, low battery drain . . . only .75 A transmit, .12 A receive. Compact . . . 3" H x 7" W x 10½" D . . . ideal for car, boat, and 12 v. neg. gnd. mobile use. ½ uv sensitivity for 10 db signal plus noise-to-noise ratio. Includes "S" meter, adjustable squelch, automatic noise limiter, built-in speaker, ceramic PFI mike, gimbal mounting bracket, aluminum cabinet with die-cast chrome-plated front panel. 8 lbs. Kit GWA-14-1, optional power supply for AC operation, 5 lbs. . . \$14.95. GWA-14-2, complete 23 channel crystal package (46 CB crystals)—\$135.70 value . . . only \$79.95

Can You Match A Color With A Color, And A Letter With Another Letter? That's All It Takes To Make Music On This NEW Heathkit®/Thomas COLOR-GLO Organ!

Play complete songs in *minutes* instead of months! Color-Glo key lights show you the correct notes and chords . . . you and every member of your family can play melody, harmony and bass notes *instantly*. Just match up the colors with your left hand, the letters with your right hand . . . and you play complete songs . . . even if you've never played an organ before! And when you're finished, just flip a switch and the Color-Glo keys disappear, leaving a beautiful spinet organ console. Other features include 10 true organ voices; variable repeat percussion; 13-note heel and toe bass pedals; 2 overhanging 37-note keyboards; 50-watt EIA peak music power amplifier; 12" speaker; vibrato . . . all genuine Thomas factory-fabricated parts! Plug-in tone generators, the heart of the organ, warranted for 5 years. Fully transistorized. Handcrafted walnut cabinet. 153 lbs. GDA-232-1, matching walnut bench, 18 lbs. . . . \$24.95

Kit GD-325
\$349⁹⁵
(less bench)

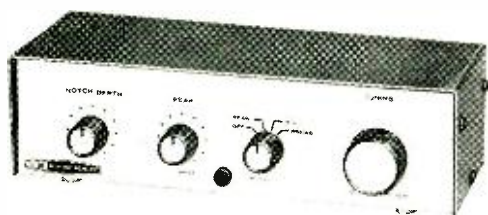

New Heathkit "Q" Multiplier

Ideal for use with SWL & Ham receivers with IF circuits from 450 to 460 kc such as the matching low cost Heathkit GR-64 shortwave radio (\$37.95). Creates extra sharp selectivity through an efficient "Q" of 4000, and provides a notch for adjacent signal attenuation. Includes built-in power supply. Attractive "low boy" charcoal cabinet with gray front panel. 3 lbs.

Kit GD-125
\$14⁹⁵



Kit HD-10
\$39⁹⁵

New Heathkit Solid-State Electronic Keyer

All solid-state circuitry. Speed range—15 to 60 words per minute. Solid-state switching—no relays to stick or clatter. Adaptable to either right or left handed operators. Convertible to semi-automatic operation. Variable dot-space ratio. Self-completing dashes. Sealed switches on paddle—no exposed contacts to clean or adjust. Built-in paddle—"feel" is adjustable to your fist during assembly. "Hold" switch for transmitter tuning. Transformer-operated power supply isolates keyer from line power. Fused for protection. 6 lbs.

... Build A Heathkit®!

Now Choose From 2 Heathkit® Transistor Stereo Receivers!

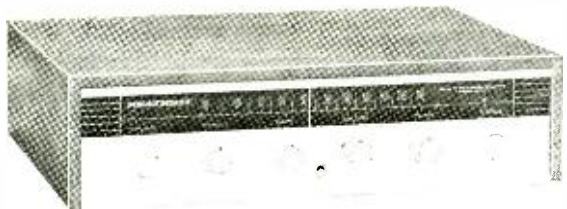

**New 30-Watt Transistor FM Stereo Receiver . . .
Less Than \$100!**

Features 31 transistors, 11 diodes for cool, natural transistor sound; 20 watts RMS, 30 watts IHF music power @ ±1 db, 15 to 60,000 cps; wideband FM/FM stereo tuner plus two preamplifiers & two power amplifiers; front panel stereo headphone jack; compact 3 7/8" H x 15 1/4" W x 12" D size. Assembles in 20 hours or less. Custom mount it in a wall, or optional Heath cabinets (walnut \$9.95, beige metal \$3.95) 16 lbs.

Kit AR-14
\$99⁹⁵
(less cabinet)

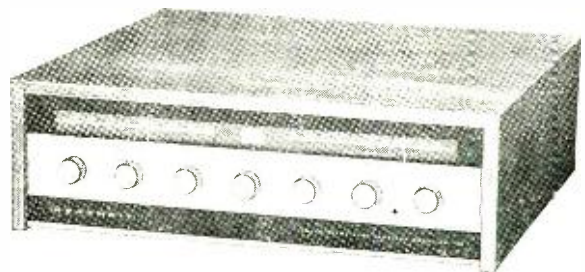

66-Watt Transistor AM/FM Stereo Receiver

Just add 2 speakers for a complete stereo system. Boasts AM/FM/FM Stereo tuning; 46-transistor, 17-diode circuit for cool, instant operation and natural transistor sound; 66 watts IHF music power (40 watts RMS) at ±1 db from 15 to 30,000 cps; automatic switching to stereo; preassembled & aligned "front-end" & AM-FM IF strip; walnut cab. 35 lbs.

Kit AR-13A
Now Only
\$184⁰⁰

Best Hi-Fi News Of '66 . . . New Low-Cost Transistor Stereo Twins!



New Transistor FM/FM Stereo Tuner

Heath's easiest to build stereo/hi-fi kit . . . takes only 4 to 6 hours! 14 transistor, 5 diode circuit for cool instant operation, transparent transistor sound. Phase control assures best stereo performance. 3 transistor "front-end" plus 4-stage IF section. Filtered outputs for direct stereo recording. Automatic stereo indicator light. Preassembled & aligned "front-end." Install in a wall or either Heath cabinet (walnut \$7.95, beige metal \$3.50). 6 lbs.

Kit AJ-14
\$49⁹⁵
(less cabinet)

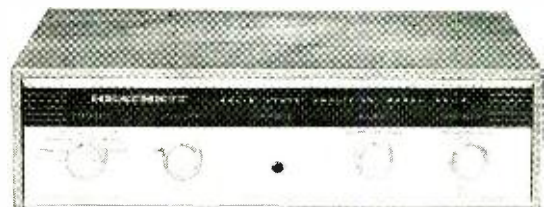

Matching 30-Watt Transistor Stereo Amplifier

Assembles in 10 hours or less! 17 transistors, 6 diodes. 20 watts RMS, 30 watts IHF music power @ ±1 db, 15 to 60,000 cps. No audio transformers . . . assures minimum phase shift, extended response, lower distortion. Solid-state power supply plus electronic filter for regulation within 10%. Accommodates phono, tuner, auxiliary . . . 4, 8, 16 ohm speaker impedances. Lighted panel. Installs in wall, or Heath cabinets (walnut \$7.95, metal \$3.50). 10 lbs.

Kit AA-14
\$59⁹⁵
(less cabinet)

FREE 1966 CATALOG!



108 pages . . . many in full color . . . describe these and over 250 easy-to-build Heathkits. Save up to 50%. Mail coupon or write Heath Company, Benton Harbor, Michigan 49022 for your FREE copy.

Buy Now—Use This Order Blank

Heath Company, Dept. 15-2
Benton Harbor, Michigan 49022



Please send FREE Heathkit Catalog

Model	Description	Weight	Price

Name _____ (Please Print)

Address _____

City _____ State _____ Zip _____

SHIP VIA:
 Parcel Post Express Collect Freight 20% Included, C.O.D. Best Way
 Prices & Specifications subject to change without notice. CL-236

WHATEVER YOUR COMMUNICATIONS YOU NEED
Frequency Controlling
TEXAS CRYSTALS
Unconditionally Guaranteed

Whether on land, sea or air, your radio communications will be more dependable with **TEXAS CRYSTALS** . . . made with the same precision, care and quality as those supplied to numerous space projects. And, you'll appreciate the attractive prices. Send for descriptive catalog today.

If your dealer can't supply your **TEXAS CRYSTALS** needs, send his name with your order to our plant nearest you.

TEXAS CRYSTALS
A Division of Whitehall Electronics Corp.

1000 Crystal Drive 4117 W. Jefferson Blvd.
Fort Myers, Florida Los Angeles, California
Phone 813 WE 6-2109 Phone 213 731-2258

CIRCLE NO. 92 ON READER SERVICE CARD

**Get Your First Class Commercial
F.C.C. LICENSE
and earn your
A.S.E.E. DEGREE**

Move up. Increase your salary and prestige. How? By acquiring the knowledge and skill that industry needs and pays for!

The unique A.S.E.E. degree program available at Grantham School of Electronics teaches you what industry wants you to know for *advanced* employment. And you can complete three-fourths of this program while at home on your present job. Only one semester must be completed in residence.

Get the facts from our free catalog. Then, with our assistance, get the knowledge. Your F.C.C. license, your A.S.E.E. degree, and higher-paid employment follow naturally. Ask for *Catalog 66*.

Grantham School of Electronics

1505 N. Western Av., Hollywood, Cal. 90027
(Phone: HO 9-7878)
408 Marian Street, Seattle, Wash. 98104
(Phone: MA 2-7227)
818-18th St., NW, Washington, D.C. 20006
(Phone: 298-7460)

All-Channel TV Antenna

(Continued from page 48)

active dipoles, the greater the gain. An additional benefit of the capacitor is to cause the resonances to occur at longer dipole lengths. Greater length produces greater gain.

Reactance loading can be used to achieve yet another result. The directivity of 5/2-wave dipoles is greater than 3/2-wave and that of 7/2-wave greater than 5/2-wave, etc. Hence it would be desirable to use these longer dipoles to cover u.h.f. frequencies. Since the wavelength is so much shorter at u.h.f., operating in even these higher resonances does not require an inordinately long dipole. However, the tilt of the dipoles for the higher modes must be increased to maintain low side lobes. A section of dipoles which operates on the higher modes for u.h.f. is easily added to the front of a section designed to operate in no higher than 3/2-wave resonance at v.h.f. and can, in fact, be integrated to enhance the v.h.f. performance.

To achieve this, however, an adaptation of the linear dipoles is required. Ordinarily the longer u.h.f. dipoles would resonate at frequencies in or near the v.h.f. band. This would prevent the less-sharply ve'e'd dipoles from receiving any energy from the generator (considering the transmitting case). It is possible to effectively disconnect the larger dipoles from the feeder at v.h.f. frequencies by once again inserting a capacitor in the dipole. The capacitor (formed merely by a break in the element) is designed to have sufficiently high reactance to decouple the sections of the dipole at v.h.f. frequencies and yet low enough reactance to couple at u.h.f. frequencies. The outboard portion resonates above the upper end of one of the v.h.f. bands and therefore will enhance the v.h.f. gain in the manner of a conventional parasitic element. Fig. 8 shows an antenna which makes use of these latter modifications, along with

radiation patterns (Fig. 9) which have been measured in each one of the three bands. The reduction in beamwidth illustrates the increased directivity and gain which is achieved by operating in the higher modes.

Installation of All-Channel Antennas

Although the use of a well-designed, all-channel antenna will alleviate the difficulties often encountered in a multiple antenna installation, there are still several precautions which should be observed to insure realization of the full performance potential of the antenna. Experience with v.h.f. installation is no guarantee of equal performance on u.h.f. since the higher frequencies behave quite differently. The first rule of a good u.h.f. installation is to use best quality, low-loss lead-in. This is essential for u.h.f. but will also increase the v.h.f. signal level at the set. Encapsulated lead-in is recommended for general use. Low-loss stand-offs which hold the lead-in away from any metal are best for u.h.f. In those cases where electrical interference is a problem, a low-loss *shielded* twin-lead should be used.

If amplification is required on an all-channel antenna, be sure to use an all-channel amplifier. The u.h.f. signals are generally attenuated severely by a v.h.f. amplifier and *vice versa*. If only u.h.f. or only v.h.f. amplification is desired, the amplifier can be used on the output of the signal splitter.

The narrow patterns of the all-channel antennas require careful orientation of the antenna toward the station. If stations are located in more than one direction, a good quality continuous-turning rotator is a wise investment.

With the rapid growth of u.h.f. and color television with their more stringent performance requirements, most antenna installations which are more than three years old are probably not adequate. The new all-channel antennas provide a good answer to the question of how to improve the reception of today's television programming. ▲

Fig. 9. Horizontal directivity patterns of fifteen-element antenna.

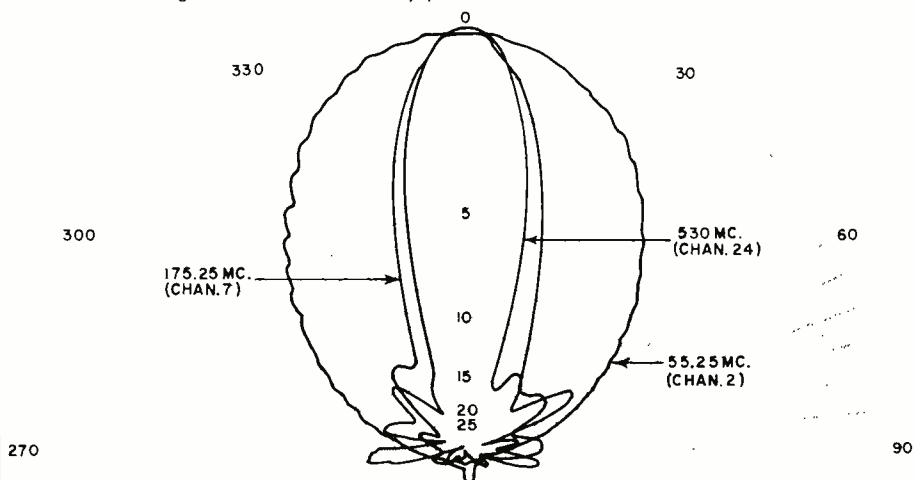

WHY 50-OHM COAX?

STANDARD coaxial line impedance for r.f. power transmission in the U.S. is almost exclusively 50 ohms. Why this value was chosen is given in a paper presented by *Bird Electronic Corp.*

Different impedance values are optimum for different parameters. Maximum power-carrying capability occurs at a diameter ratio of 1.65 corresponding to 30-ohms impedance. Optimum diameter ratio for voltage breakdown is 2.7 corresponding to 60-ohms impedance (incidentally, the standard impedance in many European countries).

Power carrying capacity on breakdown ignores current density which is high at low impedances such as 30 ohms. Attenuation due to conductor losses alone is almost 50% higher at that impedance than at the minimum attenuation impedance of 77 ohms (diameter ratio 3.6). This ratio, however, is limited to only one half maximum power of a 30-ohm line.

In the early days, microwave power was hard to come by and lines could not be taxed to capacity. Therefore low attenuation was the overriding factor leading to the selection of 77 (or 75) ohms as a standard. This resulted in hardware of certain fixed dimensions. When low-loss dielectric materials made the flexible line practical, the line dimensions remained unchanged to permit mating with existing equipment.

The dielectric constant of polyethylene is 2.3. Impedance of a 77-ohm air line is reduced to 51 ohms when filled with polyethylene. Fifty-one ohms is still in use today though the standard for precision is 50 ohms. ▲

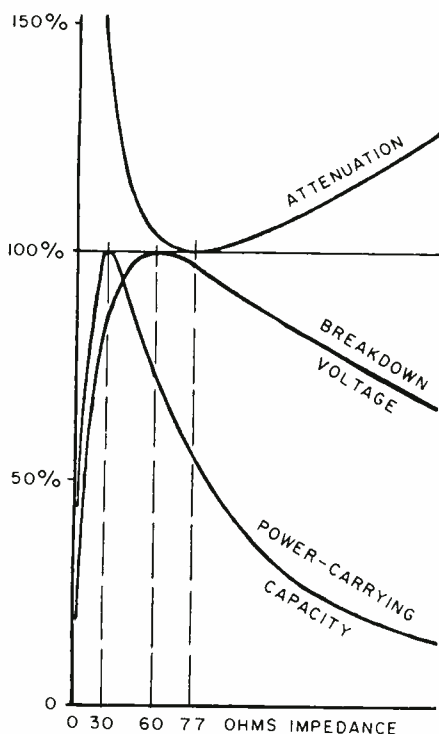

Features never before offered on a stereo headset

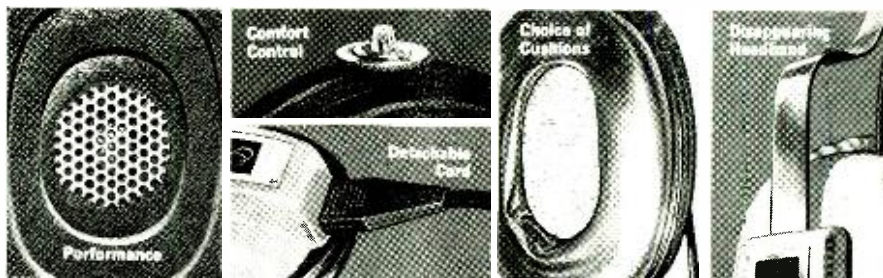

are standard on the new Telex professional quality...

Serenata



A TELEX FIRST—Comfort Control... knob adjusts ear-cup pressure for best sound and comfort.

A TELEX FIRST—Electronic Tone Control... controls tone according to preference and program.

A TELEX FIRST—Disappearing Headband... no bulky exposed adjustment parts. Smooth, clean design, completely adjustable.

A TELEX FIRST—Detachable Cord... New convenience. Stores neatly. Add adapter cords for a variety of connections.

A TELEX FIRST—Choice of Cushions... Liquid-filled are standard, foam cushions optional.

A TELEX FIRST—Choice of Impedance... Either 8 or 600 ohms. Use for tape editing or monitoring.

A TELEX FIRST—Performance... New all dynamic sound reproducers set a new standard in stereo response. One minute's listening will convince you.

Listen-test Telex Stereo phones and You'll Accept Nothing Less. Ask your dealer to demonstrate the *Serenata* (\$59.95) or write for full information. See also the three other great Telex stereo headsets. One will match your exact preference—*Adjustatone* (\$15.95), ST-10 (\$24.95), ST-20 \$29.95.



Products of Sound Research

TELEX

DEPARTMENT 29B, 3054 EXCELSIOR BLVD., MINNEAPOLIS, MINNESOTA
CIRCLE NO. 85 ON READER SERVICE CARD

NIMS

NATIONWIDE IMPROVED

MAIL SERVICE—

A PROGRAM
FOR REDUCING POSTAL COSTS

AND IMPROVING SERVICE
MAIL EARLY IN THE DAY

IT'S THE BETTER WAY!

LETTERS READY? — MAIL THEM EARLY!

TEST EQUIPMENT

PRODUCT REPORT

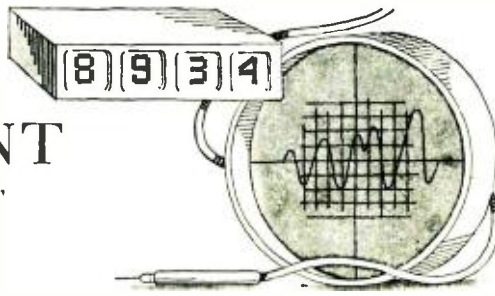

Blonder-Tongue Model 4122 Sweep Generator

For copy of manufacturer's brochure, circle No. 32 on Reader Service Card.



THE Model 4122 u.h.f./v.h.f. sweep generator, a recent addition to the Blonder-Tongue "Lab-Line" of r.f. and video test equipment, is a versatile solid-state instrument intended for use in design, testing, and maintenance of wide- and narrow-band u.h.f. and v.h.f. equipment. Covering the 20- to 240-mc. and 470- to 890-mc. bands in two continuously tuned ranges, it can be used to measure v.s.w.r. (return loss), amplifier gain and bandpass, and frequency linearity of attenuators, or it can be employed as a signal source for amplifier, converter, and TV tuner alignment. The unit features an exceptionally wide sweep with continuously adjustable center frequency and sweep width. Automatic level control (a.l.c.) is also pro-

vided to assure constant output over the entire sweep width.

The u.h.f. sweep signal is generated by a specially designed wide-band Colpitts oscillator with a tuned circuit employing a varactor element, whose capacitance varies with the voltage applied across it. A 60-cps waveform of variable amplitude is applied across the varactor, creating a periodic change of capacitance. This produces the desired repetitive sweep. This signal is then amplified and leveled by a detector-feedback network, fed through a step-type attenuator, and brought out at a front-panel jack. The a.l.c. network, in addition to providing leveling within ± 0.5 db, also acts as a continuous fine-gain control, adding approximately 10 db to the 50 db of step-type attenuation furnished by the output attenuator switches. This provides an extremely convenient method for setting exact output levels to match a mark on the scope face.

The v.h.f. sweep is generated by heterodyning a reduced-width u.h.f. sweep against a fixed 900-mc. oscillator. The filters shown in the block diagram minimize any spurious signals which might otherwise result. As with u.h.f., the v.h.f. signal is then amplified, leveled, and passed through the output

attenuator before application to the front-panel jack. With v.h.f. there is also an additional consideration. When a fixed 900-mc. signal beats with an 880-mc. signal, the result is 20 mc., and when the 900-mc. signal beats with a signal of 660 mc., the result is 240 mc. This would mean that the apparent direction of sweep is reversed by the heterodyne method and that the v.h.f. dial should actually have its lowest frequency at the maximum clockwise position. For convenience, this problem is eliminated by having the v.h.f./u.h.f. switch act as a phase-reversing switch (in addition to activating and connecting the fixed 900-mc. oscillator in the v.h.f. mode) so that the "Center Frequency" dial reads from left to right on both ranges.

One of the unique features of the generator is its *sinusoidal* sweep. In contrast to the usual linear sweep, which requires a saw-tooth oscillator, the sinusoidal waveform eliminates the need for direct connection between generator and oscilloscope, thus increasing the unit's flexibility. While the unit's horizontal output jack may be utilized on the laboratory bench, it is quite impractical to employ such connections when making summation sweeps of large distribution systems. With the sine-wave horizontal signal, all that is required is a fairly stable source of 60 cps a.c., such as a power line. Any necessary phasing adjustments can then be made with the phase control of a line-synced oscilloscope or by using a filament transformer with an external, variable phase-shifting network. Besides simplifying system check-out, this feature makes the 4122 ideal for feeding a production test line as well as a series of technicians' benches.

Two methods of marker injection are provided by the generator. The front-panel "Marker In" jack inserts the marker signal directly into the r.f. line where it beats with the output signal, producing a "birdie." However, this method limits the size (and therefore the visibility) of the birdie, since a high-amplitude marker signal may produce overload in the unit under test, thus distorting test results. The other method, which eliminates these difficulties, is marker post-injection. A 10-mv. sweep signal is available for this purpose at the rear-panel "Marker Out" jack. This signal is then fed to the marker generator where it beats with the marker signal, producing an audio output each time the sweep frequency approaches the vicinity of the marker. The detected r.f. signal is looped through the marker generator, where the audio is mixed with it to be fed to the scope vertical input. Since this method bypasses the device under test, "birdies" of virtually any size may be used, thus greatly improving

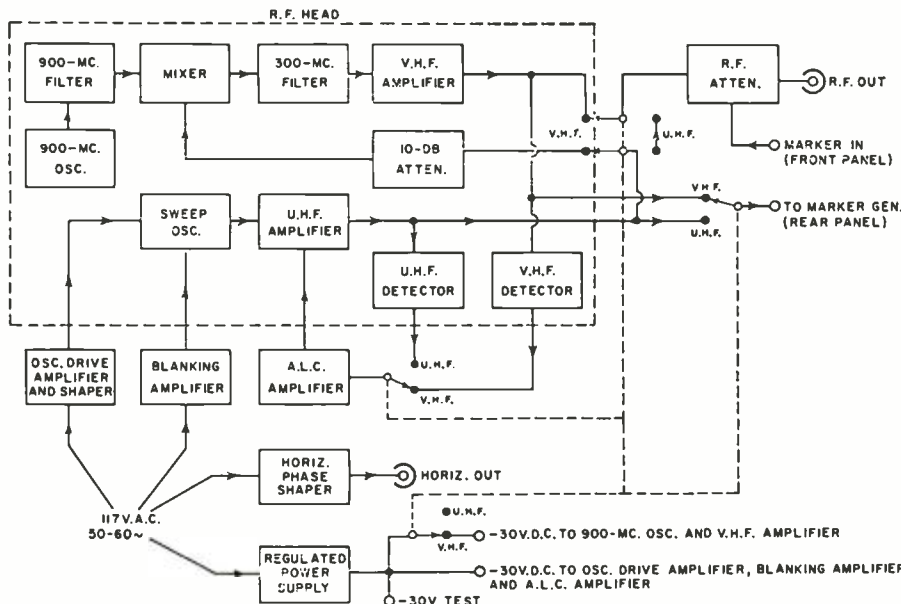

marker visibility during bandpass measurements.

Model 4122 is housed in a rugged, heavy-gauge, wrinkle-finish cabinet

which may be positioned so that the panel is vertical or horizontal. There is no heat problem: the unit readily lends itself to stacking. Price is \$595. ▲

B & K Model 1245 Color Generator

For copy of manufacturer's brochure, circle No. 33 on Reader Service Card.

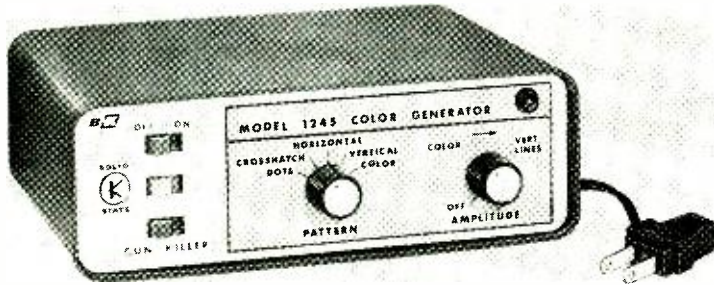

THE B & K Model 1245 all-solid-state color generator duplicates the waveforms transmitted by a color-TV station. The station-quality waveforms include a well-defined back porch on the horizontal sync pulse for accurately setting the color killer, almost eliminating the need to adjust brightness, contrast, and fine tuning. This makes it easier to converge the color tube. Complete blanking of all video information during the sync periods produces a scan free of retrace lines and enables easier sync-circuit testing. This portable, transistorized generator provides a crystal-controlled, keyed, rainbow color-bar display along with dot, crosshatch, and horizontal and vertical line patterns, as well as gun-killer controls that will work with any picture tube. A unique horizontal line generator develops a pulse of less than .25 microsecond duration. This high-

speed pulse becomes an extremely sharp dot for accurate convergence.

Output is at r.f. with more than 5000 μv . of signal on channel 3, 4, or 5. The 1245 utilizes the "offset-subcarrier" principle to generate the color bars. See the block diagram of the complete generator below.

Hue-control adjustment, or tint control, is made on the receiver so that the color bars appear with the proper hues. The eighth bar is cyan and it can be used in adjusting the hue. Incorrect adjustment to one side will cause the eighth bar to be predominantly blue; to the other side, to be predominantly green.

Color sync "lockability" of the receiver is checked by using the chroma control. The 100% setting of the color amplitude control represents normal color sync-burst amplitude. Color sync lock action

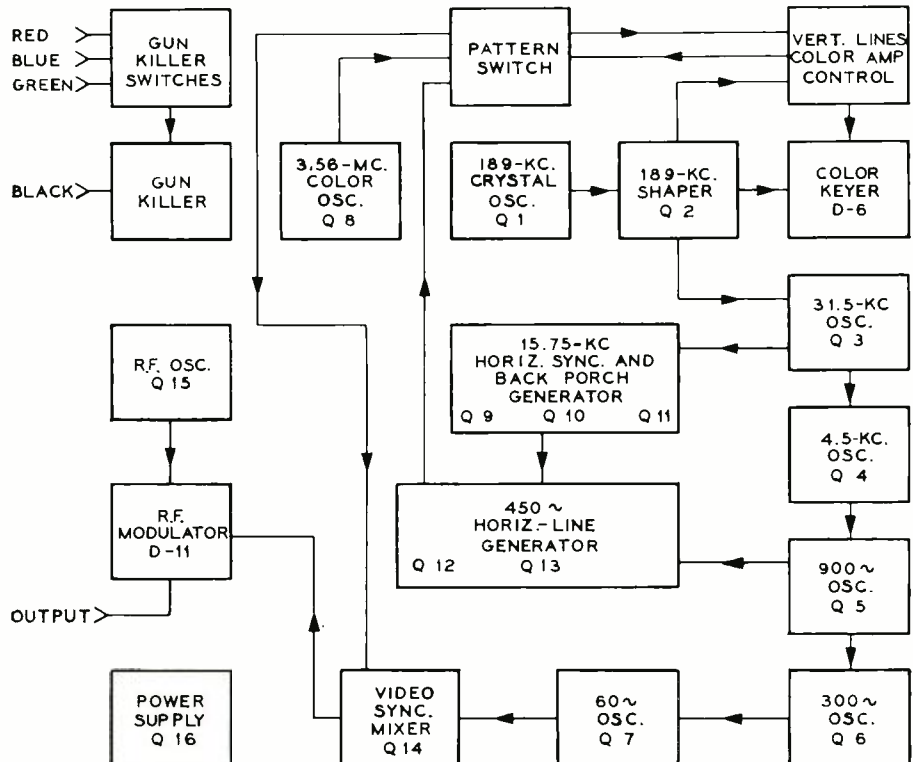

send just  and I will send you this special Test Equipment issue of PF REPORTER

David R. Ham

There's no better way to acquaint you with the invaluable, practical help PF REPORTER offers you month-after-month in your electronics work, than to start your subscription with a copy of the special March 1966 Test Equipment issue for just one cent!

We'll enter your subscription with March, and send you the next 11 big issues for only \$2.49—regular subscription rate is \$5.00 per year—so you save ONE-HALF!

To see what we mean about the practical value of PF REPORTER, here are just some of the features in the Test Equipment issue:

Inside View of Color Test Equipment • Test Equipment for FM-Stereo • Square-Wave Tests for Hi-Fi • Test Equipment for UHF-TV • Repairing Automotive Test Equipment • Meter Repair for Steady Hands • Converting Scopes to Triggered Sweep • Guide to Test-Lead Adapters • Servicing Mobile Radio with a Scope • Understanding Color-Bar Generators • Checking Color TV with B/W Equipment • Notes on Latest Test Equipment—AND MUCH MORE!

A single issue of PF REPORTER can bring you information and help worth many times our special low introductory subscription price. And here's your solid guarantee: Subscribe to PF REPORTER today. If you aren't completely satisfied it's the best magazine in the electronics servicing field, just let us know and we'll refund the unexpired portion of your subscription immediately.

SPECIAL HALF-PRICE PF REPORTER INTRODUCTORY SUBSCRIPTION OFFER!

PF REPORTER, Dept. EWR-2
Box 68003, Indianapolis, Ind. 46268

Okay—here's my penny—start my subscription with your Special Test Equipment issue, and bill me for \$2.49 for a full one-year term (regular rate is \$5 per year).

\$2.50 enclosed Bill me

Name _____

Firm _____

Address _____

City _____ State _____ Zip _____

Enjoy the "music-only" programs now available on the FM broadcast band from coast to coast.

- NO COMMERCIALS •
- NO INTERRUPTIONS •



It's easy! Just plug Music Associated's Sub Carrier Detector into multiplex jack of your FM tuner or easily wire into discriminator. Tune through your FM dial and hear programs of continuous commercial-free music you are now missing. The Detector, self-powered and with electronic mute for quieting between selections, permits reception of popular background music programs no longer sent by wire but transmitted as hidden programs on the FM broadcast band from coast to coast. Use with any FM tuner. Size: 5½" x 6". Shipping weight approx. 7 lbs.

KIT \$49.50

(with pre-tuned coils, no alignment necessary)

WIRED \$75.00

COVER \$4.95 EXTRA

Write to

MUSIC ASSOCIATED

65 Glenwood Road, Upper Montclair, New Jersey
Phone: (201)-744-3387

CIRCLE NO. 100 ON READER SERVICE CARD

"Hot-Shot" is Here

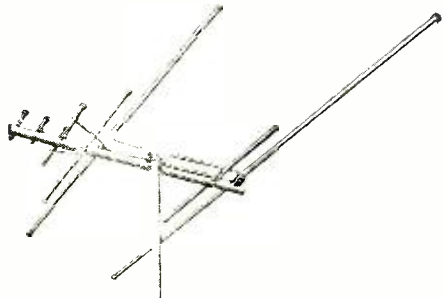

Winegard's new all-band (UHF, VHF, FM) antenna that sells for less than the most popular indoor models

- Hot-Shot Gives Your Customers Beautiful Ghost-Free Outdoor Performance On All Bands
- Hot-Shot Delivers Life-Like Color, Brilliant Black and White, Full-Tone FM Sound
- Hot-Shot Will Boost Your All-Band Antenna Sales and Profits

"Hot-Shot" is the all new, sensibly priced, high performance, all-band antenna designed specifically for metropolitan and suburban installations. It not only gives your customers the superior performance of an outdoor antenna, but also lets them receive all the broadcast bands (UHF, VHF, and FM). For about one dollar less than indoor antennas, you can deliver all the performance and versatility of "Hot-Shot". Installs easily on roof or in attic . . . you work with just one download. Only \$8.80 list. Ask your distributor or write for Fact-Finder #241 today.

Winegard Co. ANTENNA SYSTEMS

3000 Kirkwood • Burlington, Iowa

CIRCLE NO. 89 ON READER SERVICE CARD

64

is checked by turning the chroma control slowly counterclockwise. The color should become pale and finally disappear. Since some receivers are equipped with an automatic chroma-control circuit, the rate of fading will depend upon the model under test. Most receivers will hold color sync just before the color disappears, as evidenced by diagonal running of the colors. Both of these conditions indicate normal operation of the color sync circuits. If, however, a slight reduction of the chroma amplitude causes the color to fall out of lock, it indicates that the color synchronization ability of the receiver may be inadequate.

The ten bars of color in the pattern can be checked to see that they "fit" in the proper position. The colors should not lap over the blank spaces between the bars. Improper fit may be caused by incorrect delay in the video amplifier or by incorrect alignment of the band-pass amplifier. Normal receiver overscan may hide some of the bars of the pattern. These can be seen by reducing the raster width. Overscan adjustment of the set can be checked and adjusted by using the crosshatch pattern. Service notes for color receivers usually specify a recommended amount of overscan at the left and right and a different amount of overscan at the top and bottom. The recommended overscan varies in different receiver models. Because the Model 1245 provides a fixed number of 10 vertical and 14 horizontal lines, it is easy to judge the amount of overscan. The crosshatch pattern also permits accurate checks of the horizontal and vertical linearity in both black-and-white and color receivers. Convergence adjustments are made using dots, crosshatch, or vertical or horizontal lines.

This color generator measures only 2¾" x 8½" x 8¾", weighs only 3 pounds, and sells for \$134.95. ▲

Grand Transformers "Insta-Test" Dielectric Strength Tester

For copy of manufacturer's brochure, circle No. 151 on Reader Service Card.

PATTERNED after a prototype model that has been used in quality control for nearly ten years, a dielectric breakdown checker called the "Insta-Test" dielectric strength tester is being marketed by *Grand Transformers, Inc.* The unit gives both an audio and visual response to a breakdown of windings used in coils, motors, transformers, etc. Six test a.c. voltages may be selected, ranging from 750 volts to 3000 volts. The unit operates from the a.c. line with fused protection.

Two high-voltage probes permit a quick check across any winding. At the potential breakdown point, a buzzer will



sound and a red "leakage" lamp will light up if the part or circuit is defective. A check is made by increasing the applied voltage in steps until breakdown occurs.

Safety features of the unit include a grounded line cord, fused primary circuit, molded high-voltage lead plugs, and safety test prods—all to reduce shock hazard.

The tester gives breakdown tests to UL, CSA, and NEMA standards, which are usually at twice the operating voltage plus 1000 volts.

The unit is available from the manufacturer at just under \$75. ▲

Nanosecond Pulses (Continued from page 39)

has a steep wavefront and a large amplitude. Nevertheless, no other technique today can approach the extreme power pulses obtained in nanosecond times but the spark gap.

Fig. 3 shows the details. The circuit is essentially a relaxation oscillation. Resistors R_1 and R_2 charge capacitor C_1 from a high-voltage source until the charge on C_1 reaches the arc-over potential of the spark gap. The holding voltage of an arc is substantially less than the arc-over potential, and C_1 will thus discharge itself into the load. When the charge on C_1 is finally too low to sustain the arc, the conduction abruptly ceases and R_1 and R_2 once again start slowly charging C_1 for a new cycle.

The pulser may be synchronized by a trigger pulse that arrives just before discharge would normally occur. By a careful design, the inductance of the discharge circuit is held to an absolute minimum, permitting extreme risetimes and currents. To insure proper waveforms, the load resistance must be very low. By plating and the use of controlled atmosphere, the effects of burning, aging, and oxidation may be minimized.

A rectangular pulse is produced by using a transmission line instead of a capacitor, just as in Fig. 1C. This time, the transmission line must have an extremely low impedance and is designed as an integral part of the gap itself. ▲

EW Lab Tested
(Continued from page 16)

In our lab tests, the FM sensitivity of the receiver was 2.0 μv ., confirming the manufacturer's rating within the normal measurement accuracy of our equipment. This is unquestionably one of the most sensitive tuners we have tested. Furthermore, its high sensitivity is really usable, since it will deliver virtually noise-free, undistorted reception with only 3- μv . input due to its steep limiting characteristics. The capture ratio was 3.4 db.

The frequency response of the tuner was within ± 1 db from 30 to 15,000 cps. The stereo separation was unusually uniform, averaging nearly 30 db over the entire audio range. It actually improved at high frequencies (unlike many tuners), reaching 35 db between 7000 and 10,000 cps. (Editor's Note: When this same receiver was checked later in the manufacturer's lab, it was found to have somewhat greater separation at the mid-frequencies but a little less at the very high frequencies. This was probably due to differences in the test setups used in the two labs.)

The audio amplifiers also met their specifications handily. The frequency response was down 2 db at 20 cps (the result of a designed roll-off below that frequency) and down 1 db at 20,000 cps. RIAA phono equalization was ± 1.5 db from 30 to 15,000 cps. The NAB tape-head equalization was down slightly at low frequencies, by 2 db at 75 cps and 7.5 db at 30 cps, but was within ± 0.5 db from 100 to 15,000 cps.

The power output at 2% distortion with both channels driven was 40 watts (sine wave) per channel over practically the entire audio range. It fell off insignificantly to 39 watts at 20 and 20,000 cps. Obviously, the power bandwidth of the Model 348 extends well beyond the rated 20 to 20,000 cps. We checked the distortion with both channels delivering 30 watts and found it to be less than 0.3% at 1000 cps. The IM distortion was about 0.5% up to several watts, rising at 30 watts power output to 1.1% on one channel and 0.7% on the other.

Although these measurements unquestionably establish the receiver as an outstanding performer, its true mettle can only be appreciated under actual use conditions. For one thing, the FM tuning is completely non-critical. Many tuners can deliver minimum distortion only at one critical point in their tuning, not necessarily that indicated by their tuning indicators. Not so the 348—it is difficult to tune in a station so that it is not received with minimum distortion.

The loudness compensation is moderate in its action and therefore pleasant to use. The filters are gentle, removing little program (or noise). This is of minor importance with reasonably modern records. As any good solid-state receiver should be (but not all are), the receiver is totally free from hum or noise at any usable setting of the controls.

As for power, the unit has more than enough for any home environment, even with low-efficiency speakers. For most users, there is little that could be done to improve this fine receiver. Its price of \$479.95 may seem high, but not when compared to the cost of comparable separate components. The basically cool-running and reliable solid-state design (although the FM "front end" does use four nuvistor tubes) should insure a long and trouble-free life for the receiver. ▲

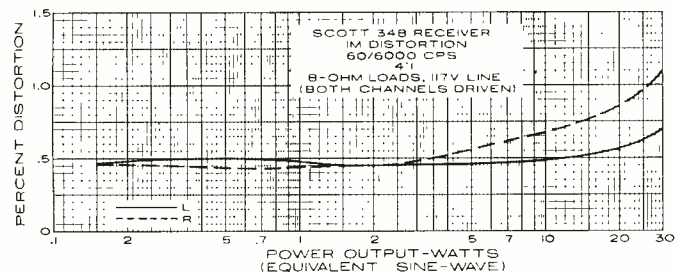

Now you can solder
tuners, planes,
pre-amps and trains
with the finesse
of a production-
line pro



New
MARKSMAN
PENCIL
Soldering Iron

Featherweight precision tool has stainless steel long-reach barrel with replaceable tip. Handle remains cool. Tip runs up to 750°F. Complete with cord. Model SP-23. **\$2⁹⁸** list
Also available in kit with two extra soldering tips, handy soldering aid and supply of solder. Model SP-23K. **\$4⁴⁴** list

WELLER ELECTRIC CORP., Easton, Pa.

WORLD LEADER IN SOLDERING TECHNOLOGY

CIRCLE NO. 90 ON READER SERVICE CARD



**ARE YOU CASHING-IN
ON THE PROFITABLE
2-WAY RADIO SERVICE BUSINESS?**

- ★ Motorola will train you for this rewarding, elite profession
- ★ Send for our FREE EVALUATION EXAM. Prove to yourself that you are ready to learn FM 2-way radio servicing.

Opportunities in 2-way radio servicing are virtually unlimited. ■ Just one of the hundreds of successful Motorola Service Stations writes, "we would be pleased to interview any graduate of your school that has received some training in 2-way radio maintenance. We are an established firm, 10 years old, with a promise of expansion governed by our ability to obtain competent technicians." ■ Get all the facts today. There is no obligation and no salesman will call.



MOTOROLA TRAINING INSTITUTE

4545 West Augusta Blvd. • Chicago 51, Illinois • Dept. AEF607

- Send me FREE entrance exam.
- Send full details on Home Study Course on FM 2-way Radio Servicing
- Send me details on how you can help me prepare for an FCC License.

Name _____ Occupation _____

Address _____

City _____ Zone _____ State _____

CIRCLE NO. 102 ON READER SERVICE CARD

SELLING THAT RECORDER? BUYING A RECEIVER?



ELECTRONICS WORLD runs a Hot Line into the 197,524 electronics professionals who buy the magazine each month. And, for only 40¢ a word, a personal classified ad will help you make your connection.

ELECTRONICS WORLD has the largest audience of its kind in the world, and this creates an ideal market place for you. Actually, when you get together with your co-professionals, you may find that many are near neighbors. Yet your mutual needs may be met only through the medium of our classified columns.

Take advantage of our special personal rate of 40¢ a word (including name and address)

NO MINIMUM REQUIRED

a saving of 30¢ a word from our commercial rate of 70¢.

A small investment can bring quick results, and complete data is printed in the Classified Advertising Section. Write your ad and mail it today, with your payment to:

HAL CYMES

Classified Advertising Manager
ELECTRONICS WORLD

One Park Ave., N. Y., N. Y. 10016

APRIL ISSUE CLOSES FEB. 1st.

CORRECTING COLOR SIGNAL DISTORTION

One of the major drawbacks of the NTSC color system is that variations in signal gain and phase produce wrong colors. British engineers have a novel solution for this.

IN the NTSC system of color TV, the luminance information is conveyed as amplitude modulation while the chromatic information is carried as both phase and amplitude modulation of a subcarrier. Color saturation determines the subcarrier amplitude while color hue controls the subcarrier phase relative to the color reference burst carried on the horizontal sync pulse back porch.

When such a signal is carried long distances, via microwave links for example, there exists the possibility that the composite color signal can be distorted in phase, amplitude, or both. Such distortions, called differential phase or differential gain distortion, can produce the wrong colors on the receiver screen. This problem can also exist within the color receiver itself.

This has been the major reason why certain European countries have objected to the use of the NTSC color-TV system in Europe.

According to engineers of the British Post Office Research Station and the BBC Designs Dept., a new circuit has been developed that minimizes the effects of phase and amplitude distortion.

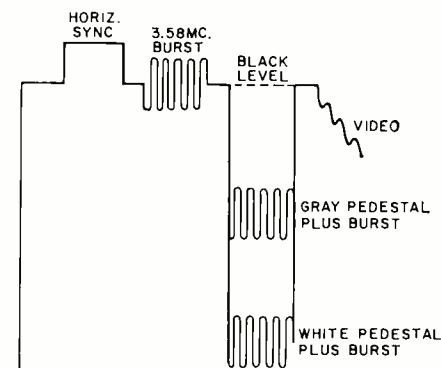

Fig. 1. Suggested locations for added bursts at gray and white video levels.

As shown in Fig. 1, the circuit involves the transmission of five cycles of the subcarrier frequency (3.58+ mc. in the U.S.), added to a pedestal following the horizontal sync signal, whose amplitude varies between peak white and gray (50% amplitude)—two lines at peak white and two lines at gray. Both pilot burst and pedestal are suppressed during the equalizing and vertical pulse periods. This signal can be added to the NTSC signal without reduction in the active line period and does not interfere with sync, color burst, or black reference signals in the waveform.

Operation of the circuit is shown in

Fig. 2. The incoming video color signal is first referenced to the black level, in order to correctly establish black, white, and gray points.

The differential phase detectors shown in Fig. 2 compare the phase of the black level color burst with the phase of the burst on the white and gray pedestals, while the differential gain de-

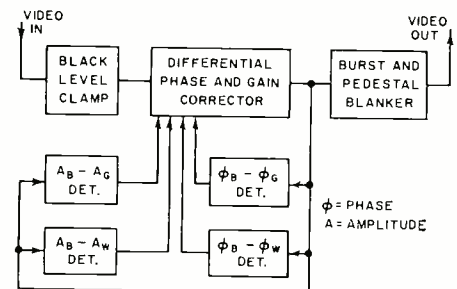

Fig. 2. Phase and amplitude detectors provide correction signals for video.

tectors compare the respective amplitudes. An output signal is developed at each detector proportional to the amount of difference that exists between the amplitude and phase of the color burst at the black level and the amplitude and phase of the bursts existing at both the white and gray pedestals. These signals are passed to the corrector.

The corrector provides variable differential phase and gain characteristics whose values can be controlled by the level of the four input control signals from the detectors.

The corrector consists of an arrangement of hybrid transformers and voltage-sensitive resistors, so arranged that as the value of the resistors change with the applied control currents, the corrector circuit introduces the appropriate amount of phase and amplitude difference, in the opposite sense, so as to correct the video signal passing through.

The burst and pedestal blanker removes the extra bursts and pedestal signals from the video thus preserving the NTSC configuration.

This equipment was recently used in a 4500-km. transmission link between London and Moscow and over numerous very long distance monochrome links within the Soviet Union. Apart from a reduction in the over-all signal-to-noise ratio, the corrected NTSC color signals were reported to show very little degradation in quality. ▲

REFERENCE

1. MacDiarmid, I. F. & Shelley, I. J.: "Correcting Colour Signal Distortion," *Wireless World*, March 1965.

Video Tape Recorder

(Continued from page 52)

then reassembled to give a track width of approximately 40 mils. The playback head was wound with 80 turns of #45 wire per leg while only 12 turns are wound on each record-head leg.

The core pieces were then epoxied into the head frame and lapped in several stages to give a uniform gap surface. The smallest abrasive size was 1U and kerosene was used to provide lubrication during lapping. The final lap consisted of a few strokes on a clean piece of writing paper.

The record head gaps were set around 150 μ m, and the playback head gaps were made approximately 20 μ m. Chromium dioxide was evaporated onto the lapped surfaces in a small lab-type vacuum chamber.

Some of the home-made heads did not work efficiently enough to provide proper bias and record field with the transistor record unit. A tube-type record unit provided higher currents so that these heads could be used.

In all, several record and playback heads were built and good results obtained after some initial failures.

Final settings of bias and high-frequency equalization are determined by the particular heads used. A simple method for getting flat response consists of recording a 200-kc. sine wave and adjusting the bias for maximum output. After that a 200-kc. square wave is recorded and the equalization trimmer and potentiometer (refer back to Fig. 3) are set for best pulse shape, limiting overshoot to 15%.

The 72-ips tape speed is about the lowest possible, while still maintaining better than 1-mc. resolution. An increase in tape speed to 100 or 120 ips would improve performance or may be necessary in case inferior or homemade heads are to be used. The good signal-to-noise ratio and resolution can, to a large extent, be attributed to the instrumentation grade (*Memorex 62J*) tape that was used. The use of good tape is a must; ordinary audio tape will not only give poor electrical performance, but can very drastically limit head life.

Initial plans called for experimentation with color, but because of a lack of time, these experiments were not carried out. Use of a ring counter would allow the sequential recording and playing back of separate red, green, and blue signals of a color transmission.

The author would like to thank his employer, *The Memorex Corporation*, for allowing him to use their machine shop and laboratory equipment. Further, the author appreciates the assistance of Alt Case and John Klein in various phases of construction. ▲

EARN BIG MONEY IN MOBILE-RADIO MAINTENANCE

GET INTO THIS RAPIDLY GROWING FIELD WITH 2nd CLASS TICKET AND

LAMPKIN MOBILE-SERVICE METERS!

LAMPKIN 105-B MICROMETER FREQUENCY METER

Measures all mobile-transmitter center frequencies, 100 KC to 175 MC. Heterodyne-type, with internal crystal standard. Pinpoint signal generator for receiver alignment. Ideal for Citizens Band, Business Radio, Marine, Aviation and other services. Lowest cost per channel. Ample accuracy for all services, except split-channels above 50 MC.* Weight 8 lbs., price \$295.00.

LAMPKIN 205-A FM MODULATION METER

Measures true, instantaneous peak swing due to modulation on FM transmitters, 25 MC to 500 MC, continuous. Easy to operate, direct readout on 0-12.5, 0-25 PKC meter. Portable, just a 2-finger load. \$290.00. Quad-Scale version with 0-1.25/0-2.5 PKC added for selective calling, \$340.00.

FREE BOOKLET!

Send for "HOW TO MAKE MONEY IN MOBILE-RADIO MAINTENANCE".

MAIL COUPON TODAY!

LAMPKIN LABORATORIES, INC.
MFM Division, Bradenton, Florida 33505

At no obligation to me, please send free booklet and information on Lompkin meters.

Name _____

Address _____

City _____ State _____ Zip _____

CIRCLE NO. 104 ON READER SERVICE CARD

NOW! Solve Electronics Problems fast with New Patented Slide Rule.



That's right! This amazing new Electronics Slide Rule will save you time the very first day you use it. It's a patented, all-metal 10" rule that features special scales for solving reactance, resonance, inductance and circuitry problems . . . an exclusive "fast-finder" decimal point locator . . . widely-used formulas and conversion factors for instant reference. And there's all the standard scales you need to do multiplication, division, square roots, logs, etc.

Best of all, the CIE Electronics Slide Rule comes complete with an Instruction Course

of four **AUTO-PROGRAMMED** lessons. You'll quickly learn how to whip through tough problems in a jiffy while others plod along the old-fashioned "pad and pencil" way.

Electronics Slide Rule, Instruction Course, and handsome, top-grain leather carrying case . . . a \$50 value for less than \$20. Send coupon for FREE illustrated booklet describing this Electronics Slide Rule and Instruction Course and FREE Pocket Electronics Data Guide. Cleveland Institute of Electronics, 1776 E. 17th St., Dept. EW-118, Cleveland, Ohio 44114.

*TRADEMARK

GET BOTH FREE!

ELECTRONICS SLIDE RULE

Send coupon today →

Cleveland Institute of Electronics

1776 E. 17th St., Dept. EW-118, Cleveland, Ohio 44114

Send FREE Electronics Slide Rule Booklet. Special Bonus: Mail promptly and get FREE Pocket Electronics Data Guide too!

NAME _____ (Please Print)

ADDRESS _____ COUNTY _____

CITY _____ STATE _____ ZIP _____

A leader in Electronics Training... since 1934

BOOK REVIEWS

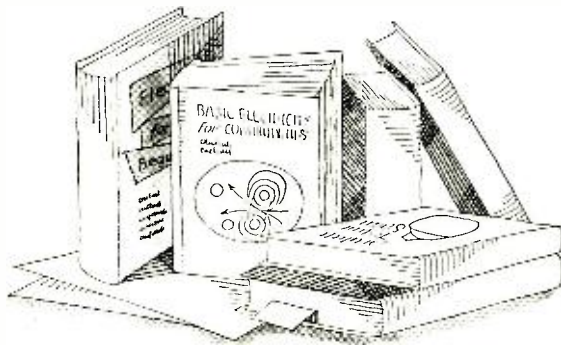

"INTRODUCTION TO ELECTRONICS" prepared by Bureau of Naval Personnel. Published by *Dover Publications, Inc.*, New York. 140 pages. Price \$1.00. Soft cover.

This is another of the basic training manuals supplied by the U.S. Armed Forces to their personnel and made available to the general public by *Dover*. As mentioned in connection with reviews of earlier volumes, these books represent one of the best electronics book "buys" on the market.

This volume was prepared specifically for naval trainees whose duties require an elementary yet general knowledge of the fundamentals of electronics. Because this book is directed to the beginner, anyone wishing to make a start in electronics couldn't go far wrong if he masters this material first. The text covers power supplies, electron tubes, amplifiers, electron tube oscillators, transistors, servo systems, radio, radar, and sonar. An appendix supplies the common abbreviations and letter symbols used throughout the book.

The book is illustrated with charts, wiring and circuit diagrams, photographs, line drawings, and cross-sectional views to amplify the text.

"BEST WAYS TO USE YOUR VOM AND VTVM" edited and published by *Allied Radio Corporation*, Chicago. 91 pages. Price \$0.50. Soft cover.

This handy little book goes well beyond the instruction manuals that come with v.o.m.'s and v.t.v.m.'s by suggesting a wide range of applications for these indispensable test instruments. There are six chapters devoted to applications in testing components, checking hi-fi equipment, servicing receivers, working on CB and ham gear, and troubleshooting a wide variety of miscellaneous equipment. A separate and valuable chapter covers maintenance and troubleshooting of the instruments themselves.

The text is well illustrated by line drawings, partial schematics, and photographs of representative commercial units.

"RCA SILICON CONTROLLED RECTIFIER EXPERIMENTER'S MANUAL" compiled and published by Electronic Components and Devices, *RCA*, Harrison, New

Jersey. 80 pages. Price \$0.95. Soft cover.

This handy manual presents a large number of practical and interesting control circuits which experimenters, who may not be too familiar with solid-state circuits and components, can build.

The manual is lavishly illustrated with schematic diagrams, detailed chassis layouts, and photos of wired chassis and active circuit elements. In addition, the book contains material on semiconductor theory, general construction details, and descriptions and operation details for 14 control circuits; timers, battery chargers, light-operated switches, heat-control circuits, a lamp dimmer, and overload and synchronous switches. Review questions are included in case the manual is to be used for instruction purposes.

"INDUSTRIAL ELECTRONIC CIRCUITS AND APPLICATIONS" by R. Ralph Benedict & Nathan Weiner. Published by *Prentice-Hall, Inc.*, Englewood Cliffs, N.J. 514 pages. Price \$14.60.

This is a completely revised edition of "Introduction of Industrial Electronics" which Prof. Benedict published some years ago. This new volume includes new material as well as updated and revised material from the earlier edition.

This comprehensive volume includes a treatment of vacuum tubes and transistors while an entire section is devoted to electronic motor control and regulation. Throughout the book emphasis is placed on industrial applications. Practical problems are discussed in conjunction with theoretical principles. The general approach to the subject is analytical and quantitative, yet no previous knowledge of calculus is required of the reader.

The text contains hundreds of illustrations and each chapter has a number of "exercises" for self-testing or classroom assignment. Three appendices include much of the supplementary information required of the user.

"POWER SUPPLY HANDBOOK" by Paul Birman. Published by *Kepeco, Inc.*, Flushing, N.Y. 11352. 160 pages. Price \$3.75. Soft cover.

This volume covers the subject of regulated d.c. supplies in considerable

detail with special emphasis on the programming concept and its application to complex systems and control problems.

Written by a *Kepeco* applications' engineer, the material is based on the "most-often-asked" questions by designers and others involved in power-supply specification and application.

Illustrated by circuit diagrams, block diagrams, and photographs, this volume will be a handy reference work for any engineer's shelf. Covered are: regulated power supply, the bridge regulator, operational analysis and symbology, short-circuit protection and current regulation, controlling power dissipations, measuring performance, power-supply interconnections, extension of the regulating loop, and a.c. characteristics of d.c. supplies.

"TRANSISTOR CIRCUIT ANALYSIS AND DESIGN" by John J. Comins. Published by *Prentice-Hall, Inc.*, Englewood Cliffs, N.J. 456 pages. Price \$14.00.

Here is a basic book for technicians and design engineers covering the principles of circuit analysis and the application of these principles to the design of circuits with specific performance attributes. Algebra and basic electrical circuit theory are all that is prerequisite.

The book is divided into four main sections covering an introduction to semiconductor physics and its relation to junction behavior in diodes and transistors; concentrated coverage of transistors from the device viewpoint; the analysis and design of transistor circuits; and finally a series of lab experiments and an appendix of semiconductor specification sheets.

"GRAPHICAL CALCULATORS AND THEIR DESIGN" by Norman Crowhurst. Published by *Hayden Book Company, Inc.*, New York. 93 pages. Price \$5.95.

This is a practical and comprehensive guidebook to the techniques of using graphical calculators—slide rules, graphical charts, and nomograms—and practical tips on selecting, designing, and constructing such calculators for specific applications when "ready made" ones are not available.

The volume is well illustrated and is designed to be of special interest to engineers, technical writers, scientists, and educators. The author's style is lucid and concise, packing a maximum amount of information in a relatively few pages.

"BASIC ELECTRONICS" edited by J. W. Friedman, H. G. Rice & G. McGinty. Published by *Prentice-Hall, Inc.*, Englewood Cliffs, N.J. 534 pages. Price \$13.00.

This is one of *RCA Institute's* "Auto-text" programmed instruction manuals,

FOREIGN CURRENCY RATES
for 1-year subscriptions
outside the U.S.A.,
its Possessions & Canada.

(All prices include postage.)

- Australian pounds: 2/14
- Austrian schillings: 155
- Belgian francs: 300
- Colombian peso: 78
- Danish kroner: 40
- Dutch guilders: 20
- English pounds: 2 3
- Finnish new markka: 20
- French francs: 30
- Greek drachmas: 180
- Hong Kong dollars: 35
- Indian rupees: 29
- Irish pounds: 2/3
- Israeli pounds: 17
- Italian lire: 3,745
- Japanese yen: 2,150
- Lebanese pounds: 18
- Mexican pesos: 75
- New Zealand pounds: 2/3
- Norwegian kroner: 43
- Pakistan rupees: 29
- Philippine peso: 23
- Portuguese escudos: 172
- South African rands: 4.25
- Spanish pesetas: 375
- Swedish kronor: 31
- Swiss francs: 26
- Venezuelan bolivares: 27
- West German marks: 24

Mail order with remittance to:
ELECTRONICS WORLD
Portland Place / Boulder, Colo., U.S.A. / 80311

MOVING?

ATTACH LABEL HERE

If you've recently changed your address or plan to in the near future, be sure to notify us at once. Affix address label showing old address here, and print new address below.

My New Address is:

name _____ please print

address _____

city _____ state _____

zip-code _____ date at new address _____

Notify us of your address change as far in advance as possible—it takes about 2 months for a change to become effective. (Eg. A notice received in May becomes effective with the July issue.)

Mail to: **ELECTRONICS WORLD**
1255 Portland Pl., Boulder, Colo. 80311

February, 1966

addressed to the beginner with no previous knowledge or experience in electronics. The manual provides basic instruction in a.c. and d.c. circuits and includes the principles of resonance and filters. From this the student should then be able to go ahead to further study of electron tube and transistor circuits.

Because of the graded approach, lavish illustrative material, and self-contained reference data, this book is well suited for home study and self instruction. ▲

DIRECT BROADCAST SATELLITE FOR HOME RECEPTION

NASA has requested the electronics industry to submit proposals for a feasibility study of two types of spacecraft, one for the FM band and the other for the short-wave bands, both capable of broadcasting directly to conventional home FM and short-wave sets.

The re-broadcasted signals will originate from earth-based stations.

Potential contractors are expected to have their proposals back to NASA by mid-February, 1966. Following a NASA evaluation, one or more contracts will be awarded for a detailed six-month mission evaluation study.

The result of this study will be used by NASA to help direct its future research and development program and to assess the need for a voice broadcast spacecraft development and flight test program. ▲

TWO-COLOR HOLOGRAM

ATWO-color picture has been produced through a method that requires no lenses but instead "captures" light waves on a photographic plate called a hologram (see the October, 1965 issue of this magazine). Although holograms with black and a single color have been made before, two scientists at the Bell Telephone Labs. have created a two-color (red and blue) picture.

In their experiments, the Bell scientists achieved the two-color pictures by using two different lasers as the source of coherent light required to make the hologram. The red light from a helium-neon laser and the blue light from an argon laser were combined into a single bluish-pink beam.

The beam is split into two parts: one scatters directly from the object or color transparency onto a photographic plate, while the other part is reflected from a mirror to the same plate. The two beams then form interference patterns.

The same two beams are used to project the finished hologram. As lasers of other colors become available, then full-color images may be generated.

Besides their potential for three-dimensional photography, holograms, because of their unusual storage capacity, have potential use in memory systems for data processing. They have also been called promising for x-ray microscopy because of their ability to magnify and because x-rays cannot be lens-focused. ▲

Thinking of college and a space age career in electronics?

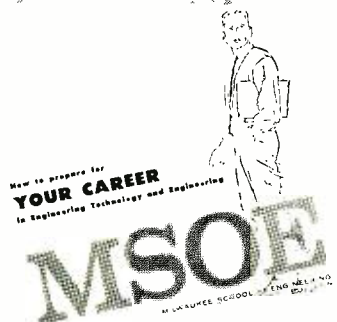

Send for this booklet on **ENGINEERING TECHNOLOGY AND ENGINEERING**

Learn how you can prepare for a dynamic career as an electrical or mechanical engineering technician or engineer in such exciting, growing fields as **avionics, missiles, reliability control, fluid mechanics, data processing, metallurgy, microelectronics, and advanced aerospace research.**

MSOE offers residence study programs leading to these degrees in engineering technology and engineering:

- 2 years—Associate in Applied Science
- 4 years—Bachelor of Science

Also get facts about scholarships and financial aids, job placement and other student services, plus photographs of MSOE technical laboratories and student activities.

For your copy, just mail the coupon — no obligation.

MSOE

Milwaukee School of Engineering
Dept EW-266, 1025 N. Milwaukee St.,
Milwaukee, Wisconsin 53201

Please send the "Your Career" booklet. I'm interested in
 Electrical fields Mechanical fields

Name.....Age.....

Address.....

City.....State.....ZIP.....

CIRCLE NO. 103 ON READER SERVICE CARD



Why Fred got a better job . . .

I laughed when Fred Williams, my old high school buddy and fellow worker, told me he was taking a Cleveland Institute Home Study course in electronics. But when our boss made him Senior Electronic Technician, it made me stop and think. Sure I'm glad Fred got the break . . . but why him . . . and not me? What's he got that I don't. There was only one answer . . . his Cleveland Institute Diploma and his First Class FCC License!

After congratulating Fred on his promotion, I asked him what gives. "I'm going to turn \$15 into \$15,000," he said. "My tuition at Cleveland Institute was only \$15 a month. But, my new job pays me \$15 a week more . . . that's \$780 more a year! In

twenty years . . . even if I don't get another penny increase . . . I will have earned \$15,600 more! It's that simple. I have a plan . . . and it works!"

What a return on his investment! Fred should have been elected most likely to succeed . . . he's on the right track. So am I now. I sent for my three free books a couple of months ago, and I'm well on my way to Fred's level. How about you? Will you be ready like Fred was when opportunity knocks? Take my advice and carefully read the important information on the opposite page. Then check your area of most interest on the postage-free reply card and drop it in the mail *today*. Find out how you can move up in electronics too.

How You Can Succeed In Electronics

... Select Your Future From Five Career Programs

The "right" course for your career

Cleveland Institute offers not one, but five different and up-to-date Electronics Home Study Programs. Look them over. Pick the one that is "right" for you. Then mark your selection on the reply card and send it to us. In a few days you will have complete details . . . without obligation.

1. Electronics Technology

A comprehensive program covering Automation, Communications, Computers, Industrial Controls, Television, Transistors, and preparation for a 1st Class FCC License.



2. First Class FCC License

If you want a 1st Class FCC ticket *quickly*, this streamlined program will do the trick and enable you to maintain and service all types of transmitting equipment.



3. Broadcast Engineering

Here's an excellent studio engineering program which will get you a 1st Class FCC License and teach you all about Program Transmission and Broadcast Transmitters.



4. Electronic Communications

Mobile Radio, Microwave, and 2nd Class FCC preparation are just a few of the topics covered in this "compact" program . . . Carrier Telephony too, if you so desire.

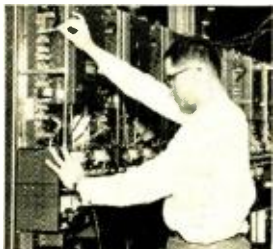

5. Industrial Electronics & Automation

This exciting program includes many important subjects such as Computers, Electronic Heating and Welding, Industrial Controls, Servomechanisms, and Solid State Devices.



An FCC License . . . or your money back!

In addition to providing you with comprehensive training in the area indicated, programs 1, 2, 3, and 4 will prepare you for a Commercial FCC License. In fact, we're so certain of their effectiveness, we make this *exclusive* offer:

The training programs described will prepare you for the FCC License specified. Should you fail to pass the FCC examination after completing the course, we will refund *all* tuition payments. You get an FCC License . . . or your money back!

CIE's **AUTO-PROGRAMMED** lessons help you learn faster and easier

Cleveland Institute uses the new programmed learning approach. Our **AUTO-PROGRAMMED*** lessons present facts and concepts in small, easy-to-understand bits . . . reinforce them with clear explanations and examples. Students learn more thoroughly and faster through this modern, simplified method. You, too, will absorb . . . retain . . . advance *at your own pace*.

*TRADEMARK

NEW
in
1966

Only CIE offers new, up-to-the-minute lessons in all of these subjects:

- Logical Troubleshooting
- Laser Theory and Application
- Microminiaturization
- Single Sideband Techniques
- Pulse Theory and Application
- Boolean Algebra

Free nationwide job placement service . . . for life, for every CIE graduate

Once enrolled with CIE, you will get a bi-monthly listing of the many high-paying interesting jobs available with top companies throughout the country. Many Cleveland Institute students and graduates hold such jobs with leading companies like these: American Airlines, American Telephone and Telegraph, General Electric, General Telephone and Electronics, IBM, Motorola, North American Aviation, New York Central Railroad, Raytheon, RCA and Westinghouse.



Full accreditation . . . your assurance of competence and integrity

Cleveland Institute of Electronics is accredited by the Accrediting Commission of the National Home Study Council. You can be assured of competent electronics training by a staff of skilled electronics instructors.

Your Future In Electronics Is Up To You. Make It A Brighter One. Mail Reply Card Today.

CIE

Cleveland Institute of Electronics

1776 East 17th Street, Dept. EW-11, Cleveland, Ohio 44114

FREE

NEW 1966 GIANT CATALOG

BURSTEIN-APPLEBEE CO. Dept. EW,
 1012-14 McGee St., Kansas City, Mo. 64106

Rush me the FREE 1966 B-A Catalog.

NAME _____

ADDRESS _____

CITY _____ STATE _____

Please be sure to show your Zip No. _____

FOR 38 YEARS THE OUTSTANDING MONEY SAVING BUYING GUIDE FOR:

- Stereo & Hi-Fi Systems and Components
- Tape Recorders
- Electronic Parts, Tubes, Books
- Phonos & Records
- Ham Gear
- Test Instruments and Kits
- Cameras and Film
- Public Address
- Citizens Band
- Transistor & FM-AM Radios.

RUSH COUPON TODAY

CIRCLE NO. 123 ON READER SERVICE CARD

NIMS

NATIONWIDE IMPROVED MAIL SERVICE—

A PROGRAM FOR REDUCING POSTAL COSTS AND IMPROVING SERVICE MAIL EARLY IN THE DAY IT'S THE BETTER WAY!

LETTERS READY?—MAIL THEM EARLY!

Transistor TV Sets (Continued from page 40)

series. The inductance of the horizontal deflection coils is sufficiently high so that only the linear portion of the rise time is used. Before the current waveform flattens out, the gate-controlled switch is turned off by a negative-going pulse through T1 as indicated by the waveform in Fig. 3. D1 is the damping diode which conducts only after the retrace pulse, when its cathode swings negative. The gate-controlled switch is turned on again slightly before the deflection-coil current has dropped to zero to provide a smooth transition of current from the damping diode to the gate-controlled switch. Compared with a number of other transistor TV receivers, this horizontal sweep circuit appears relatively simple and efficient. Because of the operating mode just described, sudden current surges, such as occur when the high voltage is shorted to ground, can damage the gate-controlled switch. When the horizontal oscillator frequency is off for more than a few seconds, such as during alignment or troubleshooting, the gate-controlled switch can also be damaged. For this reason, the Emerson service manual recommends removal of the anode clip of the gate-controlled switch whenever lengthy troubleshooting or alignment is required.

The vertical sweep circuit uses an emitter follower to feed the sync pulses from the integrating network to oscillator. Although oscillator, driver, and output transistors are used, the over-all circuit is equivalent to the two-stage combination oscillator and output amplifier found in most vacuum-tube sets. The output stage drives the deflection coils directly, with B+ returned to ground through a choke. Like most transistor receivers, this model uses a diode for vertical damping, and a portion of the damped pulse is applied to the control grid of the picture tube as vertical blanking signal.

The power supply is a straightforward transformer type, with two full-wave rectifier circuits and their filters providing +24, -18, -28, and -35 volts. The +24-volt supply is filtered by a choke and capacitors; all the others use only RC filtering. Total power required from the line is only 67 watts, and no attempt at regulation is made.

The gate-controlled switch is mounted on its own insulated heat sink adjacent to the flyback transformer, with the horizontal driver transistor insulated against the chassis on the opposite side of the flyback. The vertical output and the audio output stages are also heat-sink-mounted against the chassis, but the vertical driver and the video amplifier have heat-dissipation fins and are mounted right on the printed-circuit board. ▲

SQUARE-WAVE GENERATOR

BY MARVIN J. MOSS

Two-transistor device can be used for rapid appraisal of amplifier frequency response.

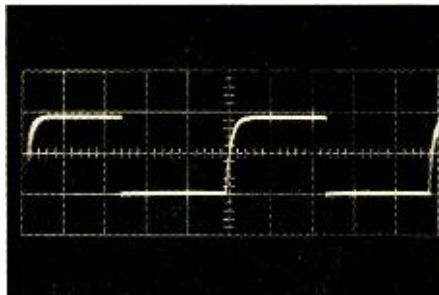
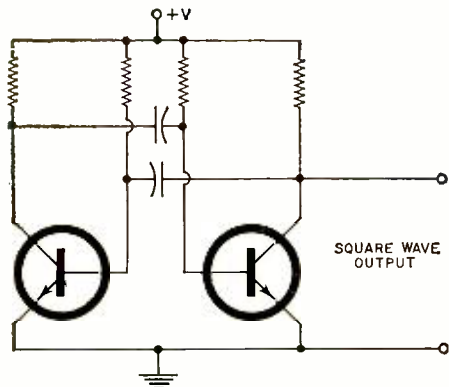

Fig. 1. Basic multivibrator produces square waves with slightly rounded upper corners.

BOTH the low-frequency and high-frequency response characteristics of an audio amplifier can be observed quickly and easily on an oscilloscope. This can be accomplished without the need for expensive equipment or time-consuming measurements through the use of a square-wave generator having 50-cps and 10-kc. outputs.

Several methods of generating square waves are available. For example, a sine wave of sufficient amplitude can be fed into a single-transistor audio amplifier. If saturation occurs during the positive half of the input sine wave and cut-off occurs during the negative half, then the output waveform will look like a square wave. The frequency of the square wave will be the same as the frequency of the sine-wave input. The speed of transition from saturation to cut-off of the amplifier is a function of the gain and frequency response of the amplifier and the magnitude of the input sine wave.

Another method involves the use of a pair of zener diodes arranged in a

back-to-back configuration. A series resistor and the diodes form a clipper whose output magnitude depends upon the zener breakdown voltage. The ratio of the peak-to-peak sine-wave input voltage to the peak-to-peak square-wave output voltage determines the speed of transition from the positive to the negative part and from the negative to the positive part of the square-wave output. The larger the input voltage and the smaller the output voltage, the faster this transition occurs.

One way to eliminate the problem of slow transition is to use a conventional Schmitt trigger circuit. This regenerative circuit has only two stable output-voltage levels, and the transition between them is speeded up by positive feedback in the circuit. In each of the three cases just mentioned, one major drawback exists. This is that the availability of a sine-wave input at the desired square-wave frequency is assumed.

Multivibrator

The symmetrical free-running mul-

tivibrator shown in Fig. 1 will generate the collector waveform illustrated. Note that this waveform looks very much like a square wave except for the rounded upper corner on the positive-going portion. This rounded corner is a result of the current through the collector load resistor charging the cross-coupling capacitor up to the supply voltage. This waveform could be cleaned up by passing it through the Schmitt trigger circuit. However, there is a much simpler solution which involves the addition of only two components.

These components are resistor R_4 and diode D_1 in the square-wave generator shown in Fig. 2. The use of diode

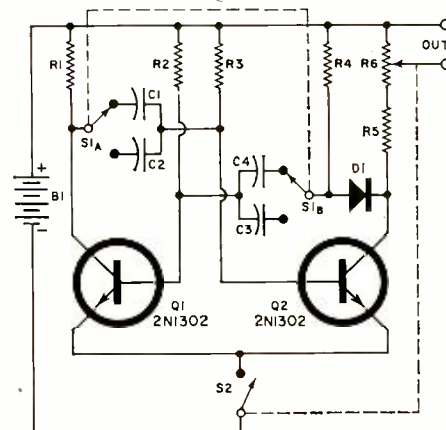

- R_1, R_4, R_5 —4700 ohm, $\frac{1}{2}$ w. res.
 R_2, R_3 —150,000 ohm, $\frac{1}{2}$ w. res.
 R_6 —1000 ohm pot.
 C_1, C_4 —470 pf. disc ceramic capacitor
 C_2, C_3 —.1 μ f., 200 v. capacitor
 D_1 —1N34A
 S_1 —D.p.d.t. switch
 S_2 —S.p.s.t. switch (on R_6)
 B_1 —9 v. battery
 Q_1, Q_2 —2N1302

Fig. 2. Schematic and parts list for the modified square-wave generator discussed.

Fig. 3. Typical amplifier square-wave output patterns. (A) Clean 50 cps. (B) Poor low-frequency response. (C) Extremely poor low-frequency response. (D) Clean 10 kc. (E) Poor high-frequency response. (F) Ringing at the higher frequencies.

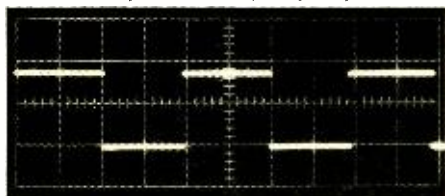

A

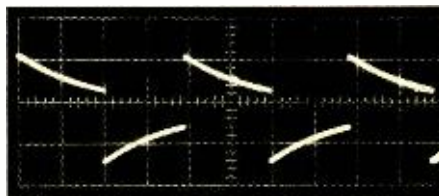

B

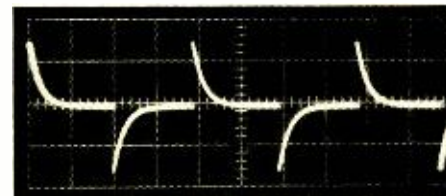

C

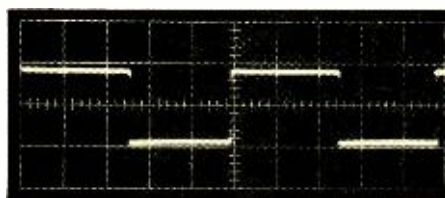

D

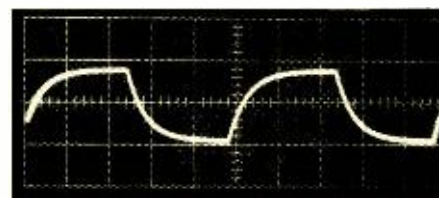

E

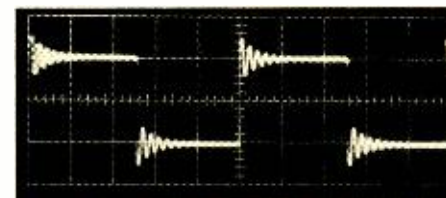

F

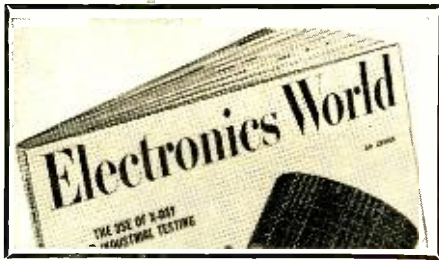

SUBSCRIPTION OFFER SAVING UNDER SINGLE-COPY PRICE

- 3 Years \$12 YOU SAVE \$6
 2 Years \$9 YOU SAVE \$3
 1 Year \$5 YOU SAVE \$1
 New Renewal Extension

**SEND ELECTRONICS WORLD
 REGULARLY EACH MONTH, FOR:**

name _____ please print

address _____

city _____ state _____ zip code _____

- Bonus!**
 Payment enclosed. (We will add 2 EXTRA ISSUES at no extra cost, for each year of your order!)
 Bill me. I'll pass up the bonus. _____ initial _____

Additional postage: Add \$1 per year for Pan-Am and all other foreign countries.

Mail to: ELECTRONICS WORLD

Dept. 0134, Portland Place, Boulder, Colo. 80311

Olson

Fill in coupon for a **FREE** One Year Subscription to **OLSON ELECTRONICS' Fantastic Value Packed Catalog - Unheard of LOW, LOW PRICES on Brand Name Speakers, Changers, Tubes, Tools, Stereo Amps, Tuners, CB, Hi-Fi's, and thousands of other Electronic Values. Credit plan available.**

NAME _____
 ADDRESS _____
 CITY _____ ZONE _____ STATE _____

If you have a friend interested in electronics send his name and address for a **FREE** subscription also.

OLSON ELECTRONICS, INC.

453 S. Forge Street Akron, Ohio 44308

D1 allows the charging current for selected cross-coupling capacitor C3 or C4 to flow through R4. Thus, the waveform at the output across R6 is a high-quality square wave without visible signs of rounded corners.

A small Minibox was used to house all components. Switch S1, used for selecting the output frequency, output level control R6, and a pair of binding posts employed for the output connections are mounted on the front panel. No special wiring precautions are necessary, and the transistors can be either wired in directly to terminal strips or mounted in sockets. It is very important to remember that heat from a soldering iron can damage a diode or transistor. An appropriate heat sink should be used if these components are wired directly onto the terminal strips. The battery can be held in place by a modified 1.5-volt penlight cell holder which has had the end pieces removed. The on-off switch S2 is incorporated into the output control R6.

The generator provides the square-wave output at an impedance of less than 1000 ohms, variable from zero to 1.8 volts peak-to-peak. The 50-cps and 10-kc. waveforms have a rise time of .2 μ sec. and a fall time of .1 μ sec. Current drain from the 9-volt battery is 2 ma.

Almost any type of *n-p-n* transistor will work in this circuit. However, Q1 and Q2 should have a *beta* of at least 30 to ensure saturation. Balanced values of *beta* are not necessary. The 2N1302 is suggested but other types seem to work quite nicely. Should the *p-n-p* type of transistor be available, simply reverse diode D1 and the connections to battery B1. No change in performance should be noted.

It may be desired to have different frequencies available other than 50 cps and 10 kc. If this is the case, switch S1 can be replaced by a two-pole multi-position switch. For example, if 400 cps were needed, 0.0125- μ f. cross-coupling capacitors could be used; for 1000 cps, 0.005- μ f. capacitors could be used. The upper frequency limit depends upon the transistors but 50 kc. does not seem difficult to obtain even with the most inexpensive-type transistors. The output terminals can be replaced by an RCA-type phono jack if conventional audio connecting cables are employed in the circuit.

Using the Generator

It is normally poor practice to operate an amplifier at maximum output for a long period of time. This is especially true with transistor amplifiers where decreased efficiency at higher frequencies may cause severe overheating of the output transistors. Therefore, care should be exercised in the application

of a large input signal, and tests under maximum output conditions should be limited to several seconds. It is recommended that lower power levels be used whenever possible. Lower power levels can be tolerated for several minutes and almost as much information can be gained without any danger to the amplifier.

The operation of this generator is quite simple. Connect the output of the square-wave generator to the high-level (auxiliary or tuner) input of the amplifier. If a separate preamp is used, connect directly to the input of the basic amplifier. Place a suitable resistive load of the proper resistance and capable of dissipating the maximum amplifier power across the output terminals of the amplifier. The oscilloscope should be hooked up across this load resistor. The output control on the generator allows a variation from zero to 1.8 volts peak-to-peak into the amplifier.

Switch to the 50-cps position and adjust the level control and oscilloscope gain controls for a suitable presentation. Avoid overdriving the amplifier. This will be evident when an increase in input amplitude no longer produces a corresponding increase in output as seen on the oscilloscope. The 50-cps input to the amplifier is shown in Fig. 3A. (All waveforms were photographed from a Tektronix Type 543 oscilloscope.) An amplifier which is deficient in low-frequency response will have a 50-cps output similar to that shown in Fig. 3B. The poorer the low-frequency response, the more severe will be the slope or droop of the square wave. An amplifier with an output like Fig. 3C indicates extremely poor low-frequency response. This could be the result of an open coupling capacitor in the amplifier or output transformer-core saturation caused by unbalanced output tubes or transistors.

Switch to the 10-kc. position and once again obtain a suitable presentation on the oscilloscope. The input waveform to the amplifier is shown in Fig. 3D. An amplifier which has poor high-frequency response will produce an output which has rounded corners as shown in Fig. 3E. The poorer the high-frequency response, the more rounding will occur to the corners of the square wave. A response which has a peak at the high end or an unstable condition in the feedback loop in the amplifier can produce ringing and overshoot as shown in Fig. 3F. The ringing frequency and damping will, of course, be a function of the particular amplifier under test.

If the waveform shown in Fig. 3A does not appear on the oscilloscope exactly as shown, it is possible that the oscilloscope may have inadequate low-frequency response. If a d.c.-coupling input position is available on the oscillo-

scope, it should be used. A measurement of the amplifier response can still be made if a comparison is used between input and output waveforms of the amplifier under test.

Alternately, if the waveform shown in Fig. 3D does not appear exactly as illustrated, it may indicate either poor high-frequency response of the oscilloscope or misadjustment of the oscilloscope input compensation network. Very little can be done about the former, whereas a slight readjustment of the input capacitor can correct the latter. In any case, be sure that the oscilloscope is working satisfactorily before starting the tests on the amplifier.

If the frequency is changed to 1000 cps and a locking-type potentiometer is used, this square-wave generator can be used as a 1000-cps, 1-volt reference for calibration and compensation network adjustments of oscilloscopes. Also, this generator can be used as a source of r.f., i.f., and audio for signal tracing in a radio or amplifier because its output is rich in harmonics. ▲

HIGHWAY RADIO

THE traffic department covering the motorway between Hannover and Hamburg of the Federal German Republic has been testing a new radio traffic warning system that alerts motorists to road hazards in their immediate area.

To restrict the area covered by a broadcast, a 40-watt transmitter operating at 70 kc. is fed to an induction loop consisting of a thin cable buried at an average depth of one foot and paralleling both sides of the highway for a distance of about 2 miles.

When a car fitted with a 70-kc. receiver passes through the long narrow induction loop, the transmissions will alert the driver to any possible occurrences that may be present along that particular stretch of road.

As the broadcast is only heard when the vehicle is actually within the loop, many transmitters on the same frequency can be used to cover long stretches of highway.

Pertinent information is recorded on an endless tape recording for continuous broadcast.

According to West German engineers, there are two approaches to receivers. One will consist of a low-price, integral 70-kc. unit using a ferrite antenna that can be mounted on the car, or a 70-kc. adapter for the conventional car radio.

If the system proves feasible, then West German road authorities expect to cover their almost 3000 miles of motorways with almost 800 transmitters and a similar number of induction loops.

It is estimated that nearly 60,000 cars travel along some sections of this network in 12 hours.

The engineers feel that with more than a million new vehicles a year joining the more than 12 million now on the road, the new highway signaling system will prove of great value. ▲

First One-Piece All-Channel Antenna with Individual UHF and VHF Orientation

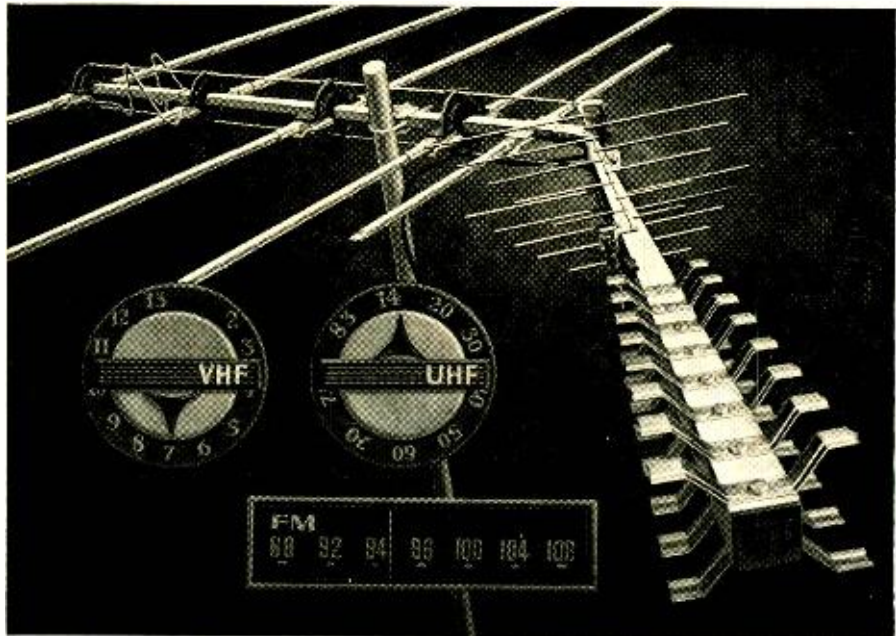

New JERROLD Coloraxial™ *Pathfinder*™

Now you can pull in strong VHF, UHF, and FM signals all from a single antenna, with the assurance that all three bands are properly oriented for best reception.

The new PATHFINDER offers this all-channel versatility *plus* a choice of 75-ohm coaxial or 300-ohm standard outputs. Prices are as low as \$21.95 list.

Note from the illustration that the UHF section is hinged for individual orientation and maximum directivity. You get all the flexibility of separate antennas, without the losses from coupling separate antennas to a common downlead. Rugged square-boom construction and Golden Armor corrosion-resistant finish assure long life. Flat response across all 82 channels, low VSWR, excellent front-to-back ratio make PATHFINDER *the* antenna to answer every TV and FM reception need. Send for complete information.



JERROLD ELECTRONICS CORPORATION
Distributor Sales Division, Dept. EW-2
15th & Lehigh Ave., Philadelphia, Pa. 19132

Please send me complete information on
PATHFINDER all-channel TV and FM antennas.

Name _____
Address _____
City _____ State _____ Zip _____

CIRCLE NO. 107 ON READER SERVICE CARD

PUT **ZIP**
in
your mail

Include
ZIP CODE NUMBERS
IN ALL ADDRESSES

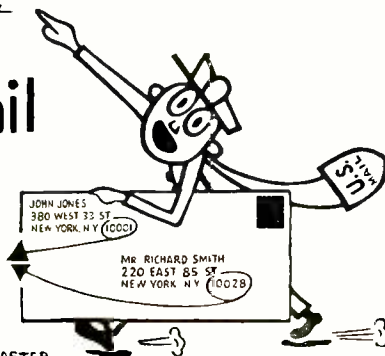

POSTMASTER



GREENLEE CHASSIS PUNCHES

Make accurate, finished holes in 1½ minutes or less in metal, hard rubber and plastics. No tedious sawing or filing—a few turns of the wrench does the job. All standard sizes . . . round, square, key, or "D" shapes for sockets, switches, meters, etc. At your electronic parts dealer. Literature on request.

GREENLEE TOOL CO.
 2027 Columbia Ave., Rockford, Illinois
CIRCLE NO. 112 ON READER SERVICE CARD

VALUABLE books from E. & E.
 great "how-to-build" data in the famous

RADIO HANDBOOK (16th Ed.)
 Tells how to design, build, and operate the latest types of amateur transmitters, receivers, transceivers, and amplifiers. Provides extensive, simplified theory on practically every phase of radio. Broadest coverage; all original data, up-to-date, complete. 816 pages. Order No. 166, only \$9.50

RADIOTELEPHONE LICENSE MANUAL
 Helps you prepare for all commercial radiotelephone operator's license exams. Provides complete study-guide questions and answers in a single volume. Helps you understand fully every subject you need to know to obtain an operator's license. 200 pp. Order No. 030, only \$5.75

LEADING BOOK ON TRANSISTORIZED COMMUNICATIONS EQUIPMENT
TRANSISTOR RADIO HANDBOOK, by Donald L. Stoner, W6TNS, Lester A. Earnshaw, ZL1AAX. Covers a wide range of communication uses for both amateur and commercial applications. Includes audio and speech amplifiers, VHF transmitting and receiving equipment, SSB excitors, and complete SSB transceivers. 180 pages. Order No. 044, only \$5.00

Order from your electronic parts distributor or send coupon below.

EDITORS and ENGINEERS, Ltd.

P.O. Box 68003, New Augusta, Indiana, Dept. EWE-2
 Ship me the following books:
 No. 166 No. 030 No. 044 \$_____encl.

Name _____
 Address _____
 City _____ State _____ Zip _____

CIRCLE NO. 118 ON READER SERVICE CARD
 78

RC WAVESHAPING

By WALTER B. ROSS

Passive components can be used to create various types of complicated waveforms.

MANY different waveforms can be obtained by passing a square-wave pulse through an RC network. A sine wave passing through the same RC network will shift in phase, but will still look like a sine wave.

Two of these circuit configurations are the high-pass RC network called a "differentiation circuit," and the low-pass RC network called an "integrating circuit."

A very important part of these circuits is in the RC time constant that determines what the output will look like. The equation to determine the time constant is $T = R \times C$, where R is the resistance in ohms, C is capacitance in farads, and T is the time in seconds. A more useful form is to have R in ohms, C in microfarads, and T in microseconds.

In an RC network with a d.c. source, it will take a discrete time for the circuit to reach a steady state. For an RC circuit, the time needed to reach steady state is 5T or five time constants. By using the equations in Fig. 1, the voltage and current may be calculated at any unit of time after the switch is turned on.

If the d.c. source (E) is replaced by a periodic square-wave, the output may be found by using the equations in Fig. 1. The equations are general in nature and may be used for both integrating and differentiating circuits.

When the output is the differential of the input, the circuit is called a differentiating network and the output is taken across the resistor. To make sure the circuit differentiates it should follow the equation $e_r = (dc/dt)RC$. This means that the RC time constant should be much smaller than the period of the input square wave. The period is the reciprocal of the frequency. The waveform may be determined mathematically by using the equations in Fig. 2. It should be noted that the first two cycles in the circuit are in the transient state and will change values until the steady state is reached.

If the waveforms are observed on a scope, transient conditions are not seen since the first two cycles are missed.

When the output is the integral of the input, the circuit is called an integrating network and the output is taken across the capacitor. To make sure the circuit integrates, it should follow the equation $e_c = (1/RC) \int e_i dt$. This means the RC time constant must be larger than the period of the input waveform. The equations in Fig. 3 may be used to determine points of interest on the output waveform. The first few cycles are transient, but after that steady-state values are obtained.

The mathematics is not able to trace the waveform exactly as a d.c. level is not carrier through a capacitor. ▲

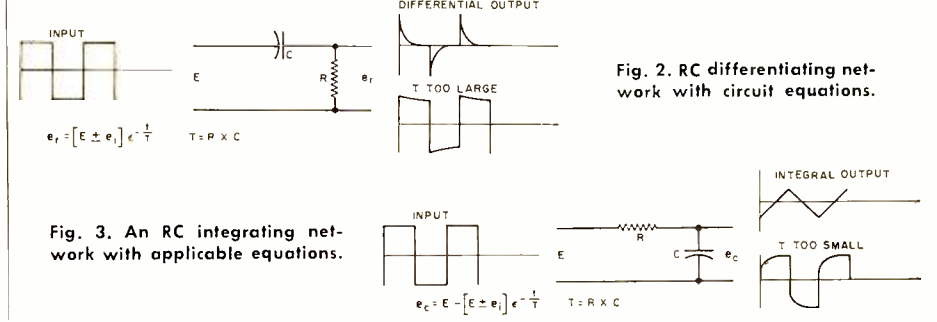
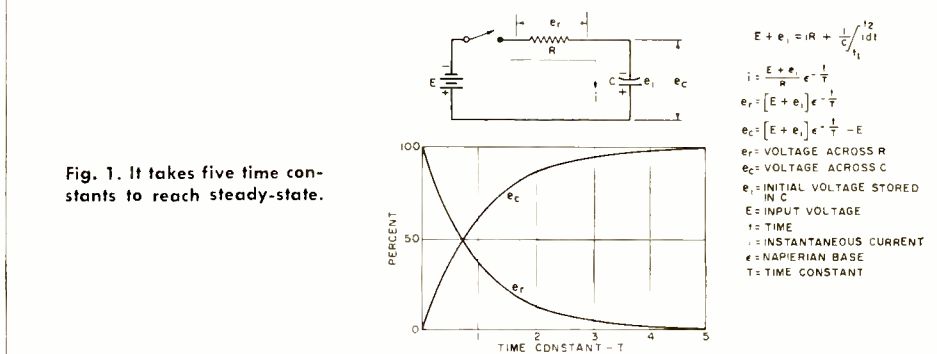

Transit-time Semiconductors

This new family of semiconductors can generate or amplify microwaves at power levels far higher than those of conventional transistors or tunnel diodes.

At the present time, the only practical sources of substantial microwave power are vacuum-tube devices such as special triodes, klystrons, and magnetrons. Devices of this type depend on the emission of electrons from a cathode and require a relatively high voltage power supply for operation. However, such vacuum-tube devices have a somewhat limited life because their cathodes deteriorate with use. Also, they are often physically large and, in some cases, rather bulky.

By using solid-state components such as transistors, tunnel diodes, and varactors, component life can be extended and power requirements reduced. System size can also be reduced considerably. Although solid-state devices are inherently compact and reliable and do not require thermionic cathodes, their biggest disadvantage is the fact that they cannot equal the high power levels achieved by the vacuum-tube devices.

Recently, scientists at the *Bell Telephone Labs.* produced a promising means of extending the solid-state device power capability with the introduction of the so-called "transit-time" semiconductors.

A transit-time semiconductor gets its name from the fact that its operating frequency is determined by the time that it takes electrons to move (transit) through a length of semiconductor material. Typically, this time corresponds to one cycle of oscillation at the operating frequency. By comparison, the time utilized by electric charges in traveling through

the junctions of other solid-state microwave semiconductors—conventional transistors or tunnel diodes—corresponds to a small fraction of a cycle; as a consequence, the volume of semiconductor material in which the microwave energy is being generated is much larger in a transit-time device than in conventional junction devices operating at the same frequency. This enables a transit-time device to operate at much higher voltages and therefore higher power levels because power is proportional to the square of the applied voltage.

The new devices operate as self-excited generators or oscillators; *i.e.*, they generate microwaves directly when the correct amount of d.c. voltage is applied to them. Amplification is achieved from the same device by using an external stabilizing circuit. All the new devices operate at room temperature and require no cooling.

Present-day transit-time devices cannot equal the power-handling capability of a vacuum device that can operate at average powers exceeding one kilowatt. However, transit-time devices are closing the gap and have already produced pulsed microwave power of 205 watts.

Dr. Charles Mosher of *Varian Associates* has predicted that within a few years 10-kw. peak at 1 gc., 1 kw. at S-band, and 100-watts peak in X-band may be available from the bulk gallium arsenide types of transit-time semiconductors to be described.

When used as microwave amplifiers, transit-time devices

Fig. 1. Bulk gallium arsenide diode generates microwaves when d.c. is applied. Frequency is a function of time that charges travel through the material and strength of the electric field.

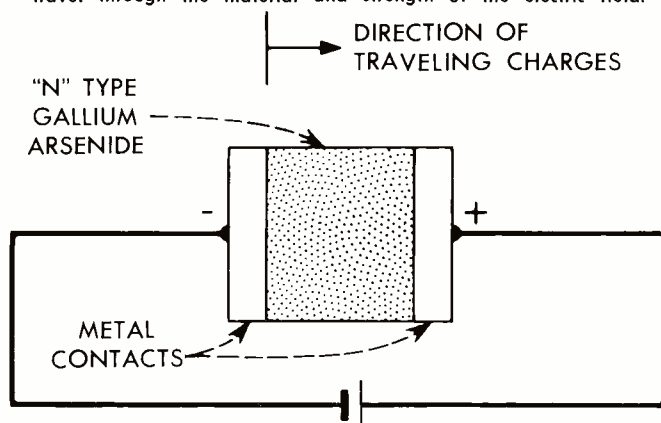
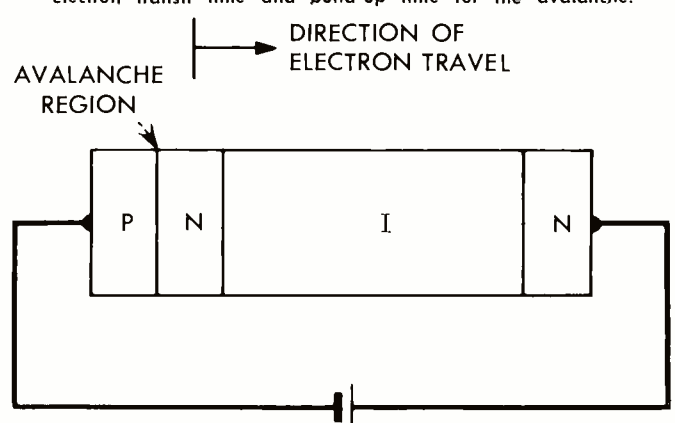
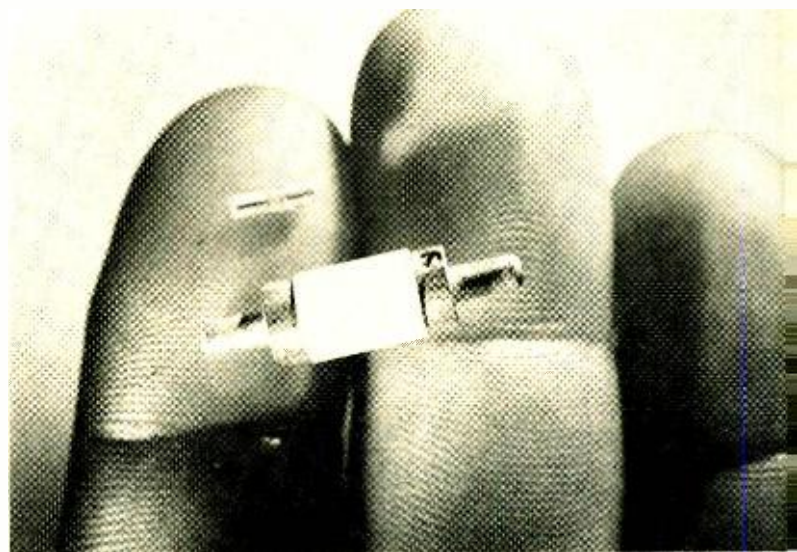

Fig. 2. The Read avalanche diode also generates microwaves when d.c. is applied. The frequency is a function of sum of electron transit time and build-up time for the avalanche.





The large device is a gallium arsenide diode. The other is a silicon avalanche diode. Both can either generate or amplify microwave signals at relatively high power levels.

show promise of providing more power output, or higher frequency operation with a given output power, than transistors or tunnel diodes. They should be useful for high-gain, high-power stages that follow a low-noise preamplifier. However, because their noise output is higher, it is unlikely that these devices will be used in the sensitive, low-noise input stages of a receiver.

Used as oscillators, some of the transit-time devices have exhibited spectral purities better than any other self-excited microwave oscillator. That is, they generate frequencies that are relatively free from random modulation. As an example, bulk gallium arsenide devices have a frequency width narrower than one kc. in the 2-3 gc. range.

The three types of transit-time devices presently being studied are: bulk gallium arsenide diodes, silicon avalanche diodes, and the Read type of avalanche diode.

Bulk Gallium Arsenide

Shown in Fig. 1 is a bulk gallium arsenide device consisting of a piece of *n*-type gallium arsenide to which two metal contacts have been affixed. When a suitable d.c. field is applied across the device, it will oscillate. This phenomenon is called the "Gunn Effect" after J. B. Gunn of IBM who discovered it in 1963 and who later observed that the effect is accompanied by moving "domains" of high electrical resistance. The frequency is a function of the time it takes for the domains to transit through the semiconductor and is controlled by the length of the material along the applied electric field.

Oscillation or amplification is obtained when a wafer of gallium arsenide is subjected to a d.c. field exceeding about 3000 volts per centimeter.

Like other microwave oscillators, the wafers are placed within a tunable microwave cavity. When operating as amplifiers, they are connected to a 50-ohm coaxial transmission line using a circulator to separate the input and output signals.

Outputs exceeding 60 mw. at efficiencies up to 5% to 6% have been generated within the frequency range of 2-3 gc.

Microwave amplification (2-10 gc.) has been achieved with gains of 4-5 db, bandwidths of 600-700 mc., and a noise figure of about 20 db.

Silicon Avalanche Devices

Other types of transit-time devices are made from semiconductors containing a junction that is reverse-biased to produce avalanche breakdown. The avalanche region is

either inside or adjoins a high field "transit" region. Avalanche is a high field discharge caused by internal secondary emission and is not destructive to the junction. One of these avalanche transit-time devices, the Read diode (first proposed by W. T. Read of *Bell Labs.*), is shown in Fig. 2.

Note the voltage arrangement of Fig. 2. When a voltage is applied to a diode as shown, avalanche occurs at the left, producing electrons and holes. The electrons then travel (transit) to the right and the device oscillates at a frequency determined by the sum of the electrons' transit time and the build-up time for the avalanche. The *p-n-i-n* structure shown is nearly a pure semiconductor material such as silicon, doped with impurities to produce an avalanche effect at one end.

Diodes of this type contain consecutively a *p*-region, an *n*-region, an *i* (intrinsic)-region of low-conductivity silicon, and a heavily doped *n*-type substrate.

In the proper circuitry, Read diodes have been made to oscillate at 5.2 gc. with 19-mw. output and efficiencies of approximately 1.5%. The relationship between the Read avalanche diode and the simple *p-n* junction avalanche diode is somewhat complex. In the simple *p-n* diode, the avalanche junction and the transit-time region occupy the same space, while in the Read diode, the avalanche junction is separated from the transit region but is right on the edge of it.

A device like the silicon avalanche junction diode makes use of a simple *p-n* junction and was the first of the avalanche series made to oscillate. In this type, avalanche occurs near the center of the device with electrons traveling to the *n*-side and the holes to the *p*-side.

In the *Bell Labs.* experiments, these devices have been used to generate and amplify microwave signals in the 10-11 gc. range with continuous oscillation generated at 10.5 gc. with an output of 13 mw. and at an efficiency of .5%. Signals in the 10-11 gc. range were amplified with gains of 20 db, bandwidths of 30 mc., and 50-db noise figure.

These devices were also found to have self-sustained parametric effects; *i.e.*, while the devices were generating a particular fundamental frequency they also (depending on the external circuit) generated other frequencies at lower power levels. They are called self-pumped parametric oscillators because their fundamental frequency acts as the pump generating other frequencies.

At present, these devices are still undergoing development and will not be available commercially for some time. ▲

PERMANENT PROTECTION!



Electronics World

Deluxe Magazine Files that hold a full year's copies!

Designed to keep your periodicals orderly and easy to refer to. These durable files guard against soiling, tearing, wear or misplacement of issues. They look, feel like leather and are washable! 23kt. gold lettering and exquisite 2-color binding make them highly-decorative additions to your bookshelves.

Shipped POSTPAID! FULLY GUARANTEED!

Only \$3.50 each—3 for \$10, 6 for \$19

Order several today—for ELECTRONICS WORLD and all your other favorite magazines.

Jesse Jones Box Corp., Dept. EW
Box 5120
Philadelphia 41, Pa.
Please send me:

TITLE	QTY.	BLACK BACKING/MAROON SIDES	MAROON BACKING/BLACK SIDES
Electronics World	_____	<input type="checkbox"/>	<input type="checkbox"/>
_____	_____	(Other publications shipped in colors available.)	
_____	_____		

Total amount enclosed \$ _____

name _____

address _____

city _____ state _____ zip-code _____

----- (Payment Must Accompany Order) -----

GET INTO ELECTRONICS



V.T.I. training leads to success as technicians, field engineers, specialists in communications, guided missiles, computers, radar and automation. Basic & advanced courses in theory & laboratory. Electronic Engineering Technology and Electronic Technology curricula both available. Assoc. degree in 29 mos. B. S. also obtainable. G.I. approved. Graduates in all branches of electronics with major companies. Start February, September. Dorms, campus. High school graduate or equivalent. Write for catalog.

VALPARAISO TECHNICAL INSTITUTE
Dept. RD, Valparaiso, Indiana

353B AM/FM VHF RECEIVER

Covers 26-54 and 88-174 MC in eight calibrated bands. High sensitivity. Completely self-contained, ideal for fire, police, aircraft, amateur, CB, etc. listening. Headphone jack for private listening.



\$64.50

Order today or send for free catalog on full line of converters and receivers for every application.

KUHN ELECTRONICS
CINCINNATI 17, OHIO

LEARN Electronics Engineering AT HOME

Fix TV, design automation systems, learn transistors, complete electronics. College level Home Study courses taught so you can understand them. Earn more in the highly paid electronics industry. Computers, Missiles, theory and practical. Kits furnished. Over 30,000 graduates now employed. Resident classes at our Chicago campus if desired. Founded 1934. Catalog.

American Institute of Engineering & Technology
1141 West Fullerton Parkway Chicago, Ill. 60614

Amplification Using Switching

(Continued from page 32)

voltages. The requirement for a high-level continuous-drive signal when using transistors largely offsets the reduced switching time losses at lower frequencies.

The low losses of class-D allow a substantial increase in the amount of power that can be controlled without the use of heatsinks. As an example, a TO-5 packaged semiconductor can dissipate one watt of heat into a 25°C ambient without any damage. If a class-A linear amplifier is built out of two TO-5 heatsinkless transistors, the maximum dissipation will be two watts, and the most output we could possibly hope for would be one watt, due to the 50% theoretical maximum efficiency of class-A operation. Now, if a class-D amplifier is built out of two TO-5 can SCR's operating at a low reference frequency, each SCR will be able to control 1.5 amperes at 400 volts, or 600 watts. The pair can, in theory, control 1200 watts of load power.

Using conventional techniques, we have built a heatsinkless one-watt amplifier. Using class-D techniques, we have built a 1200-watt amplifier in the same space with the same heatsinking. Naturally, we need a considerably heavier power supply for the kilowatt amplifier.

A second class-D limitation is distortion. Since the input signal effectively disappears shortly after entering a class-D system and does not appear again until the output, all the normal forms of distortion are simply not possible. Unfortunately, there are two new forms of distortion that must be dealt with. One results from the finite switching times and other device limitations, while the second is fundamental intermodulation distortion between the signal and sampling frequencies. The former is a much more severe problem and can be eliminated by better circuits. Typical distortion figures run from 1 to 20%. For high-fidelity applications, the distortion can be substantially reduced by using a reference frequency much higher than the highest signal frequency of interest. For low-distortion 20-kc. response using today's circuits and techniques, a reference frequency of 150 to 200 kc. would be required. This frequency is well above the audio range so that the usual r.f. techniques must be employed in the audio amplifier. Added to this is the complexity of an accurate, distortion-free pulse-modulation circuit.

The constant-amplitude systems have one or two additional limitations. Should the drive disappear in these simpler systems, very high fault currents would shortly damage either the output inverter or the power supply. Some form of drive failure protection, or at least very fast-

acting circuit breakers must be provided with this type of design. There is also a limit to the range attainable when controlling the speed of an a.c. motor due to the motor's impedance changing with frequency. At frequencies much lower than the design frequency, the motor draws heavy current. At frequencies well above the design frequency, the motor's impedance is so high that very little current flows, and no mechanical power reaches the shaft. Because of this, the class-D controls are effective only over a 2:1 or, at best, a 3:1 speed range.

Applications

The applications for such devices are quite numerous. High-gain, high-power integrated circuits are practical using this technique, allowing extremely low power consumption of the output stages of transceivers or hand-held units. Battery current would be drawn only on a demand basis, greatly prolonging operating time and allowing smaller batteries to be used.

Home high-fidelity and commercial sound systems will benefit. The high gains, absence of heatsinks, transformerless design, and simplified line-operated supplies should reduce the manufacturing cost. The reduction of size and weight and the greatly reduced supply power requirements will provide important advantages in portable public address equipment, especially mobile systems.

We have already seen how the fixed-amplitude systems may be used for r.f. carrier generation, either FM or c.w., for commercial broadcasting. These same techniques are useful for ultrasonic power generation and sonic testing. Similar principles allow precise speed control and direct current operation of any a.c. motor.

The linear class-D amplifiers will allow high power amplitude-modulation signals for commercial AM broadcasting stations, radar and identification devices, and other high-power r.f. applications. They are also ideal for superpower audio amplifiers, 1-kilowatt plus units, for sirens, plant-wide communications systems, outdoor chimes, and environmental shock testing.

Perhaps in the near future we will see a good many commercial products introduced to the market that make use of this powerful new amplification technique.

(Editor's Note: This article is not intended to describe a construction project. We have no further information on any of the circuits described, parts values, or parts availability. Construction details on circuits of this type for audio use have been published. However, those that we have examined are quite complex and do not yet have the fidelity of performance required for hi-fi applications.) ▲

IMPROVING THE LOW-FREQUENCY MULTIVIBRATOR

Splitting the collector load of a low-frequency transistor multivibrator permits the use of much smaller coupling capacitors, improves operation.

IN the well-known simple multivibrator shown in (A), a difficulty arises at low frequencies due to the physical size of capacitors $C1$ and $C2$. There is also a limit to the maximum value of $R1$ and $R2$ since during the conducting period of each transistor, these resistors must pass sufficient current to keep the appropriate transistor fully conducting and the loop gain above unity during the changeover period.

In the improved circuit (B), the base resistors $R1$ and $R2$ are returned to taps on the collector loads. These resistors ($R1$ and $R2$) must be reduced slightly from their previous maximum value so that $R1 + R3$, and $R2 + R4$ do not exceed this value. When $Q1$ is cut off, the base conditions for $Q2$ are similar to those of the previous circuit. Since $Q2$ is now bottomed, the potential to which $R2$ is returned is now much smaller than in the original circuit; thus, the current recharging $C2$ is much less, and for a

given recurrence rate, $C2$ may be correspondingly reduced in value. Similarly, for the other half cycle, $C1$ may be correspondingly smaller than in the original circuit. The reduction in size of $C1$ and $C2$ increases as the ratios ($R3/R5$) and ($R4/R6$) increase. These ratios are limited by the need to pass sufficient current through base resistors $R1$ and $R2$ to enable the loop gain to reach unity and initiate the changeover. Also, if this ratio is too great, some instability of operating frequency may occur. In practice, reductions of up to 20:1 for $C1$ and $C2$ may be obtained.

Since capacitors $C1$ and $C2$ have been reduced in value, the rate of rise in collector potential when a transistor cuts off will be increased. The time constant of this rise is approximately ($R3 + R5$) $C1$, or ($R4 + R6$) $C2$. As this product may be reduced by up to 20:1, a considerable improvement in waveform may be obtained.

The output waveform may be further improved by using an emitter-follower to supply capacitors $C1$ and $C2$ and any loads, as is commonly done with the multivibrator shown in (A). Any of the triggering methods normally used with the first multivibrator may be used with the improved multivibrator.

If potentiometers are used to replace $R3$, $R5$ and $R4$, $R6$ of circuit (B) or $R3$, $R5$ of circuit (D), and the base leads are connected to the contact arm, then it is possible to make the multivibrator frequency variable.

The advantages of the improved circuit are now obtained at the lower frequencies while still retaining stability at the higher frequencies.

In the typical monostable multivibrator shown at (C), the time constant consisting of $R1$ and $C1$, and $Q1$ collector load resistor $R3$, may be modified to include $R5$ as shown in (D). This circuit will now have the same advantages as the previously discussed one.

The information contained in this article was abstracted from the British Broadcasting Company's Engineering Monograph 55. ▲

HERE IT IS! THE 1966 EDITION OF THE FLYING ANNUAL!

10 reasons why it's the most valuable aviation yearbook ever compiled!

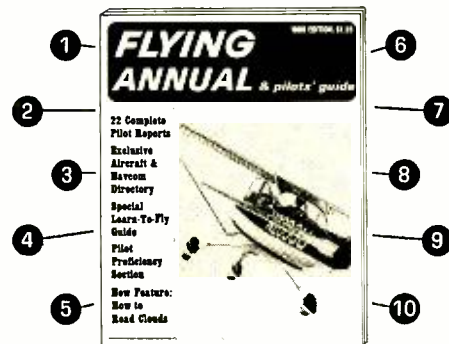

1. Enlarged aircraft directory! Point-by-point comparisons of every domestic airplane and helicopter in production. Also used planes, conversions and gliders.
2. How to buy a used airplane! Points to look for and look out for... with handy tear-out checklist.
3. 23 Pilot Reports! New and used aircraft from the two-place sport trainers to the latest business jets.
4. Navcom Directory! The latest in navcom equipment—including transponders, radar and DME, complete with prices.
5. Proficiency Section! Valuable tips to help you sharpen your flying skills.
6. Clouds! A pictorial cloud guide to help you judge the weather from the ground... and in flight.
7. '66 Bookshelf! Descriptions of new books on civil historical, and military aviation, plus flight instruction and reference books.
8. Learn to Fly Section! Where to go, what to pay, what the lessons will include.
9. Careers in aviation for you! What the airlines and commercial operators require in experience and education—and what they'll pay!
10. '66 Forecast! What's coming in airplanes and equipment for 1966.



DELUXE LEATHERFLEX-BOUND EDITION ... just \$3.00 Prepaid

A handsome and permanent edition that belongs in every airman's library! Great way to preserve this valuable "collector's item" for constant use all during 1966. (Check appropriate box on coupon.)

FILL IN AND MAIL THIS COUPON TODAY!

Ziff-Davis Service Division / Dept. FA
589 Broadway, New York, N.Y. 10012

Roger! Send my copy of the 1966 FLYING ANNUAL right away!

\$1.25 plus 15¢ for shipping and handling (25¢ outside U.S.A.) is enclosed. Send me the regular edition.

\$3.00 enclosed. Send me the Deluxe Leatherflex-Bound edition, postpaid. (Allow two extra weeks for delivery.)

NAME _____ EW-26

ADDRESS _____

CITY _____ STATE _____ ZIP _____

(Payment must be enclosed with order.)

(A) Simple multivibrator circuit. (B) Improved circuit of simple multivibrator permits small-sized coupling capacitors. (C) Conventional monostable multivibrator. (D) The similar improvement also permits use of smaller capacitors.

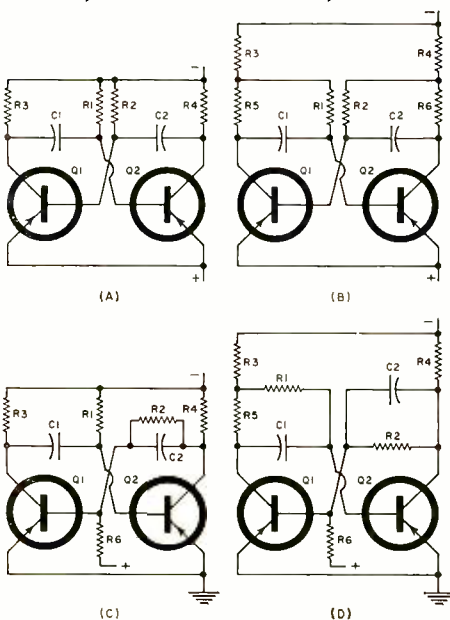

OSCILLOSCOPE PREAMPLIFIER

By E. NORBERT SMITH

This five-transistor broadband amplifier can deliver a 2-volt output signal from a 10-microvolt source.

MANY times, when working with low-level signals, the oscilloscope in use just doesn't have enough gain to bring the signal up to a reasonable size for both viewing and sync. Many vacuum-tube preamplifiers for this purpose have been described; however, they are usually bulky and may introduce hum at the very low signal levels involved.

The transistor preamplifier to be discussed here uses the recently introduced *Texas Instruments* TI415 and TI416, part of the company's low-cost line of plastic encapsulated transistors.

These two transistor types have been incorporated into a five-stage audio preamplifier with a voltage gain of 200,000 and a 3-db frequency response of 5 cps to 100 kc. Included in the circuit are a decade attenuator and a calibration gain control along with a manual gain control. Signals as small as ten microvolts produce two volts peak-to-peak output.

The preamplifier shown in Fig. 1 consists of four cascade voltage amplifier stages followed by an emitter-follower output stage.

In the most sensitive, or 10-microvolt position, the input signal is applied unattenuated to the base of Q1. In the 100-microvolt and 1-mv. position, series resistance is added to decrease the gain and increase the input impedance. In the 10-mv. to 1-volt positions, the series resistance is fixed at 1 megohm, and an additional shunt resistance is added to produce the required attenuation. It should be understood that this is not a precision decade attenuator which is relatively difficult and expensive to build, but it does give excellent results with close-tolerance standard resistor values.

Q1 is a common-emitter voltage amplifier whose emitter resistor (R14) is unbypassed to produce a high input impedance and introduce negative feedback that increases linearity.

Q2 has gain control R17 as its collector load. Using the gain potentiometer as the collector load has the disadvantage of having direct current flowing through it, but it eliminates an electrolytic capacitor and provides slightly more voltage

gain. Fig. 2B shows the alternate arrangement. A small value of emitter bypass is used in the emitters of Q2 and Q4 as a partial bypass to boost high-frequency response. At low frequencies, the capacitive reactance of C3 and C6 is much greater than R18 and R27 so that the stages are essentially unbypassed with reduced gain. At high frequencies, however, the capacitive reactance becomes less than the resistance so that gain at high frequencies is increased.

Q3 has the calibration potentiometer R23 in its emitter, which can be omitted by experimentally substituting a resistor value between 100 and 1100 ohms until the desired gain is obtained.

Q5 is an emitter-follower producing reasonably low output impedance without excessive battery drain.

The preamp is housed in a *Bud* "Minibox" (CU-2104-A) with components mounted on Vectorboard. Transistor sockets are not necessary, although they make substituting for maximum signal-to-noise ratio in the first stage easier. As with any high-gain amplifier, reasonable care should be taken to keep input leads well separated from output leads.

Q3, Q4, and Q5, along with their associated components, are grouped near one end of the board with gain control R17 acting as a shield for Q1 and Q2, the low-level stages. The attenuator switch is mounted near the input end of the board to provide maximum separation from the output stage.

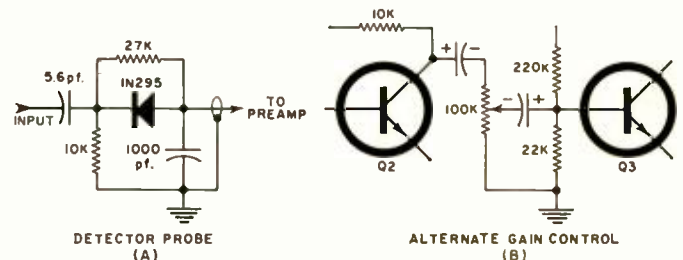
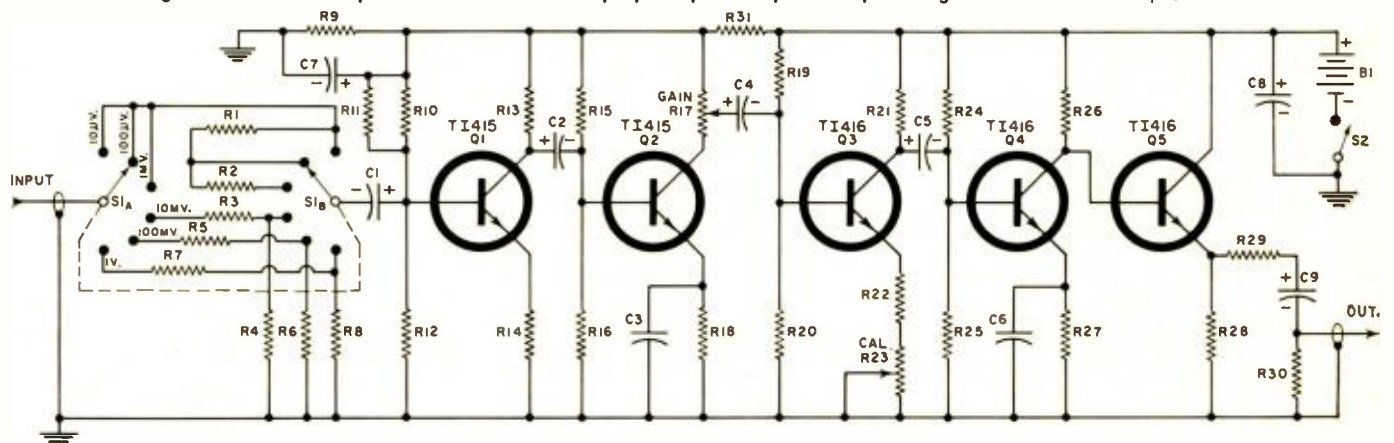

Fig. 2. (A) Detector probe for use with the amplifier. (B) Alternate method of connecting the gain control to the circuit.

Fig. 1. Schematic and parts list for the oscilloscope preamplifier capable of producing 2-v. out from a 10- μ v. source.



R1—91,000 ohm, $\frac{1}{2}$ w. res.
 R2—910,000 ohm, $\frac{1}{2}$ w. res.
 R3, R5, R7, R10—1 megohm, $\frac{1}{2}$ w. res.
 R4, R12, R14, R18—1000 ohm, $\frac{1}{2}$ w. res.
 R6, R22, R27, R29—100 ohm, $\frac{1}{2}$ w. res.
 R8—10 ohm, $\frac{1}{2}$ w. res.
 R9—6800 ohm, $\frac{1}{2}$ w. res.
 R11—150,000 ohm, $\frac{1}{2}$ w. res.
 R13, R16, R24—100,000 ohm, $\frac{1}{2}$ w. res.

R15—260,000 ohm, $\frac{1}{2}$ w. res.
 R17—10,000 ohm pot
 R19—220,000 ohm, $\frac{1}{2}$ w. res.
 R20—22,000 ohm, $\frac{1}{2}$ w. res.
 R21, R25, R30—10,000 ohm, $\frac{1}{2}$ w. res.
 R23—1000 ohm miniature pot
 R26, R28—4700 ohm, $\frac{1}{2}$ w. res.
 R31—2700 ohm, $\frac{1}{2}$ w. res.
 C1—10 μ f., 20 v. elec. capacitor

C2—1 μ f., 10 v. elec. capacitor
 C3—0.001 μ f. disc ceramic capacitor
 C4, C5—15 μ f., 10 v. elec. capacitor
 C6—0.02 μ f. disc ceramic capacitor
 C7, C8, C9—180 μ f., 10 v. elec. capacitor
 S1—D.p. 6-pos. rotary switch
 S2—S.p.s.t. switch B1—9-volt battery
 Q1, Q2—TI415 transistor (Texas Instruments)
 Q3, Q4, Q5—TI416 (Texas Instruments)

**if you
snap with
this...**



**it's a
snap with
this!**

If you own a Polaroid Land camera, or are in the market for one, sign up now for the most important "excursion" of your picture-taking career. An exciting tour through the miraculous world of "instant" pictures.

Your guide is the all-new 1966 edition of POLAROID LAND PHOTOGRAPHY — the only comprehensive and up-to-date handbook on the subject. The one knowledgeable guide that delivers the skill and know-how for the most rewarding Polaroid Land photographs you've ever taken!

Your tour begins the moment you open your copy... with a detailed inspection of every Polaroid Land camera in existence, including the swingin' "Swinger" and the fabulous, new Model 180, plus the complete line of accessories and film... next, a valuable course in photography basics and technique... an important discussion

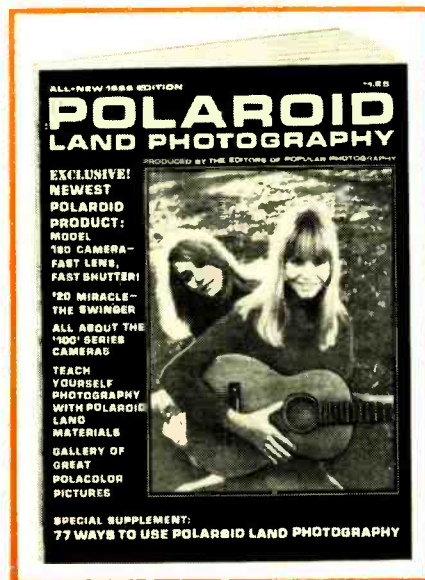

on amazing Polacolor... followed by your discovery of 77 fascinating uses for Polaroid Land photography.

And along the way, you'll wander through gallery after gallery of masterful, enchanting Polaroid Land photographs — including 16 eye-opening pages in glorious color. The kind of photos you will soon be taking!

All in all, 116 fact-and-photo-packed pages of the most extensive, authoritative, important-to-you information available. (Compiled by the editors of POPULAR PHOTOGRAPHY. Need we say more?)

Sign up today. Just clip the coupon below and return it with your remittance. It's a small investment that's guaranteed to bring you big dividends... every time you count to 10 (or sixty).

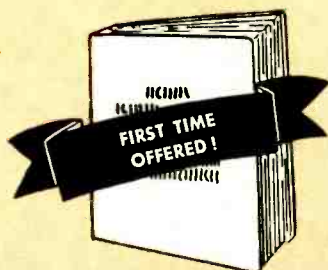

**GET THE
EXQUISITE
LEATHERFLEX-
BOUND EDITION**
for just \$3 POSTPAID!

The 1966 POLAROID LAND PHOTOGRAPHY is now available in an attractive,

gold-embossed, Leatherflex-bound edition—a superb addition to your library of permanent reference books. This deluxe volume will be mailed to your home, postpaid, for just \$3.00, when you check the appropriate box on the order form.

Ziff-Davis Service Division • Dept. PLP
589 Broadway • New York, N.Y. 10012

YES! Send me a copy of the 1966 POLAROID LAND PHOTOGRAPHY, as checked below:

- \$1.25 enclosed, plus 15¢ for shipping and handling. Send me the regular edition. (\$1.50 for orders outside the U.S.A.)
- \$3.00 enclosed. Send me the DeLuxe Leatherflex-bound edition, postpaid. (\$3.75 for orders outside the U.S.A.) Allow three additional weeks for delivery.

name	please print	EW-26
address		
city	state	zip code

PAYMENT MUST BE ENCLOSED WITH ORDER.

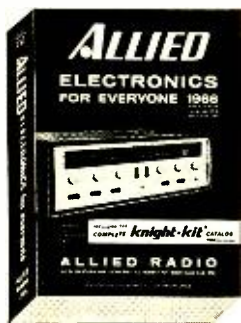

FREE

send for your
MONEY-SAVING
508-page

1966 ALLIED CATALOG

SAVE MOST ON:

- Stereo Hi-Fi
- Tape Recording
- CB 2-Way Radio
- Shortwave & Ham Gear
- Automotive Electronics
- FM-AM & AM Radios
- Portable TV & Phonos
- Test Instruments
- TV Tubes & Antennas
- Power Tools, Hardware
- Parts, Tubes, Transistors

See the world's largest selection of top money-saving buys, including exclusive Knight-Kits and products available only from ALLIED. Get fastest service, easy-pay terms, satisfaction guaranteed or your money back. Send coupon today for your **FREE 1966 ALLIED Catalog**.

EASY TERMS: Use the Allied Credit Fund Plan.

ALLIED RADIO

free catalog

ALLIED RADIO, Dept. 1-B
100 N. Western Ave., Chicago, Ill. 60680

Send **FREE 1966 ALLIED Catalog**.



Name _____

PLEASE PRINT

Address _____

City _____ State _____ Zip _____

CIRCLE NO. 125 ON READER SERVICE CARD

for **PROFITABLE, TIME-SAVING SERVICING**
OF: *Black & White TV* 
Color TV 
AM and FM, Tube or Transistor Home, Portable and Auto Radios 
Communications equipment & Home Appliances 
Hi-Fi Components 

B & K PROFESSIONAL TEST EQUIPMENT

WITH SIGNAL INJECTION AND IN-AND-OUT OF CIRCUIT MEASURING TECHNIQUES

Send today for your free copy of Catalog AP22



DS-602

1801 WEST BELLE PLAINE AVENUE, CHICAGO, ILL. 60613
Telephone: (312) 327-7270 • Cable Address: BANDKCO

CIRCLE NO. 124 ON READER SERVICE CARD

To prevent overcrowding, resistors are mounted on both sides of the board, keeping them close to their respective transistors.

After construction is completed, check for d.c. levels at each collector. The d.c. level will be about 4.5 volts at Q3 and Q4 and the emitter of Q5. About 3 volts should be found at the collectors of Q1 and Q2. Resistor tolerance and transistor differences may cause some variation. If the voltage is low, slightly decrease the value of bias resistance going from the base to the supply by substituting lower value resistors or by shunting the normal resistor with a high-value one for small changes. If the voltage is high, increase the resistance. After all d.c. levels are correct, calibrate the gain with gain control R17 advanced to the full on position. Inject a known level input and adjust the calibration potentiometer R23 (or substitute various resistors) until the output is the desired level.

The unit was primarily designed as a high-gain, low-noise oscilloscope pre-amplifier to observe waveforms and frequency response directly from instruments such as magnetic cartridges, ceramic microphones, and other low-level devices. A detector probe (Fig. 2A) was added for observing low-level r.f. and i.f. signals.

The output stage was designed for use with the high input impedance of an oscilloscope and should not be used to drive loads much lower than 5000 to 10,000 ohms.

To obtain the best signal-to-noise ratio, operate the unit with the gain control set within the first quarter turn or less.

The preamplifier should be connected to the oscilloscope vertical input through a short lead to prevent hum pickup, and a good ground connection should be made between the two units. ▲

NEW 22-INCH COLOR CRT

ZENITH Radio Corporation, in conjunction with its tube manufacturing and research subsidiary, Rauland Corp., and with the Corning Glass Works has announced plans to manufacture a 22-inch rectangular color tube. Production samples of these new tubes are expected in the very near future.

According to a Zenith spokesman, this new size was decided upon in response to requests for a mid-sized tube between the presently available 19- and 25-inch rectangular types.

Sets using the new 22-inch tube will be introduced in the latter half of 1966 and, at present, prices or other details of these new sets are unknown.

The new 22-inch color tube has 228 square inches of picture area, is of the three-gun shadow-mask type, and has a 90-degree deflection angle. It is approximately 19½ inches from front to back, about 2 inches shorter than the 25-inch rectangular type. ▲

THE MOST COMPLETE AND UP-TO-DATE GUIDE TO THE EXCITING WORLD OF SPECIALIZED RADIO COMMUNICATIONS!



ONLY \$1.25

COMMUNICATIONS 1966 HANDBOOK

4 Fact-Packed Sections

- SHORT WAVE LISTENING
- AMATEUR RADIO
- CITIZENS RADIO SERVICE
- BUSINESS RADIO SERVICE

All-new and better than ever, the 1966 Communications Handbook brings you 148 pages of exclusive information on such vital subjects as getting started in SWL—buying equipment and station reporting; establishing your CB station, public service activities; ham license applications procedures, learning the code; typical business radio installations...

PLUS a special nation-wide listing of 250 amateur radio clubs offering code and theory courses and a roster of 400 CB clubs—both lists available nowhere else!

... and much, much more. Everything you need to know about your specialty is covered by a leading authority in the field—from basic instruction for the beginner through the most advanced data and techniques.

Complete with charts, tables and illustrations galore, it's a big, valuable "encyclopedia" of communications information you'll use all year long.

Now Available—A DELUXE LEATHERFLEX-BOUND EDITION FOR JUST \$3 POSTPAID!

Fill in, detach and mail coupon today!

Ziff-Davis Service Division • Dept. CH,
589 Broadway • N.Y., N.Y. 10012

YES! Send me a copy of the 1966 Communications Handbook, as checked below:

\$1.25 enclosed, plus 15¢ for shipping and handling. Send me the regular edition. (\$1.50 for orders outside the U.S.A.)

\$3.00 enclosed. Send me the DeLuxe Leatherflex-bound edition, postpaid. (\$3.75 for orders outside the U.S.A.) Allow three additional weeks for delivery.

NAME _____ EW-26

ADDRESS _____

CITY _____ STATE _____ ZIP CODE _____

Payment must be enclosed with order.

ELECTRONICS WORLD

NEW PRODUCTS & LITERATURE

Additional information on the items covered in this section is available from the manufacturers. Each item is identified by a code number. To obtain further details, fill in coupon on the Reader Service Card.

COMPONENTS • TOOLS • TEST EQUIPMENT • HI-FI • AUDIO • CB • HAM • COMMUNICATIONS

2-AMP SILICON PLANAR UNITS

A new 2-amp silicon planar "n-p-n" power transistor is designed specifically for military, industrial, and commercial applications. It can also be used in consumer products, in power sup-

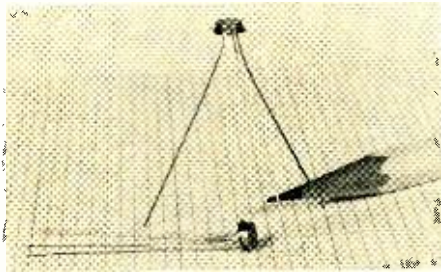

plies for computers, medium-power amplifiers, compact lightweight airborne equipment, and medium-power switching applications.

Features include collector-to-base breakdown voltages from 60 to 180 volts d.c.; collector-to-emitter sustaining voltages from 40 to 120 volts; gains from 50 minimum to 150 maximum; and saturation voltage (collector-to-emitter) of 0.35 volt maximum. Solitron

Circle No. 126 on Reader Service Card

LAMINATED BASE FOR PC'S

A new laminated base for printed circuits, using a patented process, integrates sub-micron size glass fibers with continuous-filament woven glass fabric. The fibers fill and cover irregularities in the fabric. The combination is then impregnated with epoxy resin or thermoplastic FEP to form a pre-preg for lamination with appropriate foils.

The resulting integrated layers of glass fabric, fibers, resin are designed to be extremely thin and still offer very desirable thermal and electrical properties. Absence of pinholes, as well as high thermal and electrical stability, mechanical strength, and a clean etched edge are the characteristics of this proprietary process. Pallflex Products

Circle No. 127 on Reader Service Card

SILICON SWITCHING TRANSISTOR

Fast switching silicon switching transistors with typical f_r values to 1800 mc. are now available as the types 2N3959 and 2N3960.

These silicon annular "n-p-n" units are de-

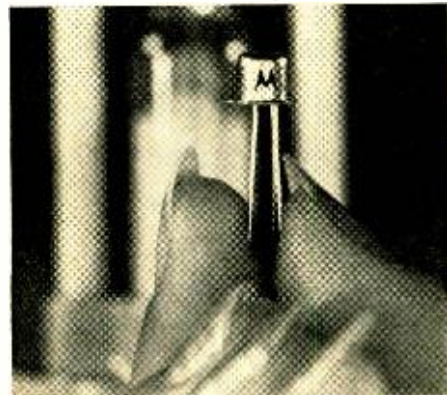

signed for high-speed, non-saturated switching applications. New "narrow base profile" techniques permit base thicknesses on the order of only 0.1 micron in volume production transistors. Collector-base breakdown voltage is 20 volts

minimum while collector-emitter breakdown voltage is 12 volts minimum. Detailed specifications are included in a technical data sheet which is available on request. Motorola Semiconductor

Circle No. 128 on Reader Service Card

TRANSISTOR/DIODE CHECKER

A new transistor/diode checker which has been designed primarily for servicing, field engineering, and production line applications is being marketed as the "Transitest." The instrument can be used to check all types of junction transistors and diodes, including both small-signal and high-power types, as well as germanium and silicon units.

The checker gives positive indication of transistor or diode condition by means of a transistorized electronic audible signal (with a self-contained oscillator circuit), thus avoiding difficult-to-interpret and deceptive meter readings. Battery-operated, it is reliable and safe to use since it cannot damage transistors or diodes even if improperly connected. Workman

Circle No. 1 on Reader Service Card

VIDEOTAPE RECORDER

A new low-cost professional videotape recorder and mobile videotape recording system for closed-circuit use in education, training, and various industrial applications is now available.

The VR-7000 recorder, which weighs 78 pounds in a rugged luggage mounting, records high-quality TV pictures and sound on magnetic tape for immediate playback. The VR-7100 "Video-trainer" combines the new recorder with a television camera, television receiver, and all related equipment necessary for the production and display of videotape programs. It is self-contained

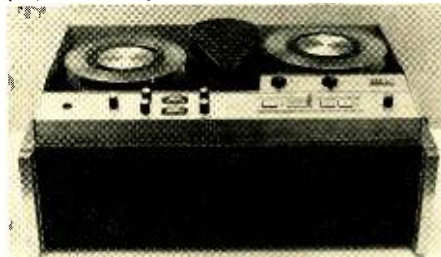

in a heavy-duty, compact mobile console. Full technical specs on either the recorder or the system, or both, are available on request. Ampex

Circle No. 2 on Reader Service Card

PRECISION LEAD BENDING

A new machine producing precision bends in resistor, diode, and other component leads is designed to fill the gap between needle-nose pliers and mass-production bending technologies and is designated the Model 100A "Leadbender."

The new unit is manually operated and produces uniform and accurate lead bends in a variety of configurations. Axial-lead components as large as 1/2" in diameter can be accommodated by the machine without body damage or damage to the leads, while production rates of up to 600 per hour are possible.

Complete technical specifications are available on request. D. Vel Research

Circle No. 129 on Reader Service Card

EXPERIMENTAL DIODE

A new experimental diode which is light-emitting and exhibits strong negative resistances is now being offered for experimental purposes.

The GaAs diode is composed of three layers—a central high-resistivity "p"-type layer flanked by low-resistivity "n"- and "p"-type layers. For moderate overvoltages, the diodes switch from a high-resistance, high-voltage state to a low-resistance, low-voltage state in a few nanoseconds. Infrared light at 9000 angstroms is emitted from the high-resistivity "p" region when the diode is in the low-resistance state. The efficiency of light emission is comparable to that of ordinary gallium arsenide diodes. IBM

Circle No. 130 on Reader Service Card

SUBMINIATURE THERMISTOR PROBE

A tiny glass thermistor probe, measuring only 0.03" in diameter and a little over 1/4" in length, has been announced.

The new "Submini-probe" features extremely fast response time. It consists of a miniature



thermistor bead sealed in the top of the shock-resistant, thin-wall glass tube, with corrosion-resistant platinum-iridium leads.

An extremely short time constant (on the order of 25 msec. in moving water) makes the unit particularly well suited to dynamic temperature measurements in liquids and gases.

The new probes are available in nominal resistances of 500 ohms to 300,000 ohms and can be used at temperatures up to 300°C. Fenwal

Circle No. 131 on Reader Service Card

PENCIL SOLDERING IRON

A new, competitively priced pencil-type soldering iron, the SP-23, is featherweight, 23 watts, and features a narrow, long-reach stainless steel barrel, replaceable nickel-plated copper tip, and comes in a hang-up style vinyl pouch. Weller

Circle No. 3 on Reader Service Card

LINEAR INTEGRATED CIRCUIT LINE

A new family of linear integrated circuits designed specifically for applications in industrial environments is marketed as the Series 72.

This new family of monolithic silicon circuits initially includes the SN723 general-purpose differential amplifier and the SN724 general-purpose operational amplifier. These units are limited-temperature versions of circuits first announced for military applications more than a year ago. Operating temperature range of the SN723 and SN724 is 0° to +70°C. The package for the SN723 is the standard hermetically sealed TO-84 flat pack with 14 lateral leads while the SN724 package is the 10-lead TO-89 flat pack. Texas Instruments

Circle No. 132 on Reader Service Card

ILLUMINATED PUSH-BUTTON SWITCHES

A new line of four basic styles of illuminated push-button switches is being marketed as "Press-Lites." The new units are said to be the smallest available at current ratings at 5 or 15 amps and offer a number of options, s.p.d.t. or d.p.d.t. alternate or momentary action, and accommodate incandescent or neon lamps. Snap action provides high current handling capacity with very low con-

tact bounce. Service life is a minimum of 25,000 operating cycles at rated current load. Keyed non-rotatable caps in four basic styles and matching indicators are also available. Marco-Oak

Circle No. 133 on Reader Service Card

MINIATURE TERMINAL BLOCK

A new miniature 300-v. sectional terminal block has 1/4-in. center-to-center spacing and fea-

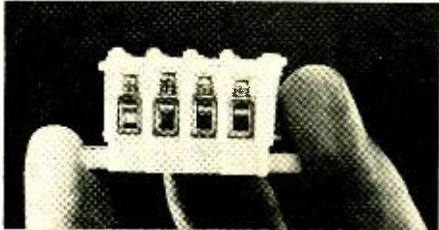

tures captive clamp contacts that eliminate lugging and allows easier wire insertion.

The new block is able to handle wire range to #12 AWG and is rated at 300 volts NEMA General Industrial Control Devices and 600 volts NEMA Limited Power Circuits. A 12-inch length houses 48 contacts. Buchanan Electrical Products

Circle No. 134 on Reader Service Card

THREE-WAY ANTENNA SPLITTER

A high-efficiency signal-divider network for distributing separate v.h.f., u.h.f., and FM signals from a single antenna system is now available as the Model SC80 splitter/combiner.

This ruggedly housed device can conversely serve as an outdoor combiner when separate v.h.f., u.h.f., and FM antennas must be used. It eliminates the confusion of multiple downleads by matching the antennas to a single transmission line. JFD

Circle No. 4 on Reader Service Card

VIBRATION INTRUSION ALARM

An automatic alarm system called "Periguard" detects small vibrations of the ground given off by intruders within 10 feet of the buried detector. Pressure changes are converted to electrical signals which are used to actuate alarms. The system can be made to reject traffic noises, aircraft sonic booms, and even earthquake vibrations. Westinghouse

Circle No. 5 on Reader Service Card

NEW SEMICONDUCTORS

Two new low-cost gate-controlled silicon bi-directional switches designed for either positive or negative gate triggering are now available. The TA2676 can control up to 600 w. at 120 v., 60 cps, while the TA2685 can control up to 1.2 kw. at 240 v., 60 cps.

Two new low-cost 7-amp SCR's are announced. The 40378 is for 120-v. operation and the 40379 for 240-v. operation. Both have peak forward blocking rating of 600 v., peak surge current of 80 amps.

Eight new low-cost 35-ampere SCR's, including four stud-mounted and four press-fit types, designed for 120- and 240-v. operation and controlling up to 8 kw. are also available. Each device can withstand peak surges of 350 amperes and can operate from -40 to +100°C. RCA

Circle No. 135 on Reader Service Card

TUNER CLEANER-LUBE



A new chemical product called "TC-5" has been specially developed for cleaning and lubricating color-TV tuners.

According to the manufacturer, the chemical makeup of the new product is such that it cannot cause frequency drift or detuning with use. Chemtronics

Circle No. 6 on Reader Service Card

PISTON TRIMMER CAPACITORS

Having physical dimensions of .075" diameter $\frac{3}{32}$ " long, the MH-11 precision glass piston trimmer capacitor has a range of .1 to 1.25 pF., "Q" at 1 mc. at maximum rated capacitance of 500 min., "Q" at 250 mc. of 200 min., working voltage of 200 v.d.c., temperature coefficient of 0 ± 50 PPM/°C, and temperature of -55 to +125°C.

The MH-13 is $\frac{3}{8}$ " long x $\frac{1}{8}$ " diameter and has a capacitance from .5 to 3 pF., "Q" at 1 mc. of 300 min., "Q" at 250 mc. of 200 min., temperature coefficient of -300 ± 100 PPM/°C, operating temperature of -55 to +125°C, dielectric strength of 500 v.d.c. at maximum capacitance, and has a working voltage of 250 v.d.c. Roanwell

Circle No. 136 on Reader Service Card

TEMPERATURE TRANSDUCER

A pair of small (less than 1/2-square-inch area and less than 1/4-ounce weight) temperature-to-voltage transducers that are designed specifically to provide a voltage proportional to temperature in the -50° +50°C range have been announced.

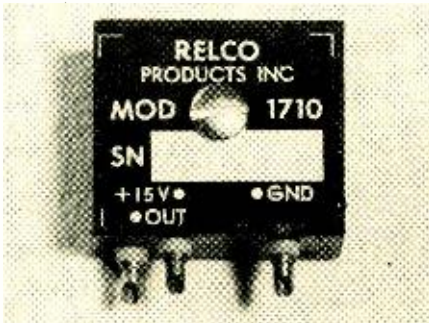

Output is 5 v. at a specified temperature, and accuracy and linearity of more than .5% with sensitivities ranging from 40 to 200 mv. per degree C are achieved through the latest silicon semiconductor technology. Relco Products

Circle No. 137 on Reader Service Card

VARIABLE BANDWIDTH FILTER

This new voltage-controlled variable bandwidth crystal filter can perform the same function as several filters for different bandwidths. For example, a single filter with a center frequency of 100 kc. may have a 3-db bandwidth variable from 5 to 20 kc. D.c. control voltage is from 0 to 10 volts, package size is $4\frac{3}{16}$ " x $1\frac{1}{2}$ " x $3\frac{1}{16}$ ", and the unit is mounted on an octal plug. Reeves-Hoffman

Circle No. 138 on Reader Service Card

AUTOMATIC BATTERY CHARGER

Designed to keep 12-v. batteries always fully charged, the "Taperite 50-192" automatically ad-



justs its charging current to fit the battery condition. When the battery is fully charged, the unit shuts itself off. A switch is provided to rapidly charge batteries when desired. The unit is $3\frac{1}{2}$ " x $6\frac{1}{2}$ " x 4" in its heavy steel, baked enamel case and weighs 8 lbs. Terado

Circle No. 7 on Reader Service Card

TRANSISTOR TESTER

Measurements include transistor h_{FE} in three ranges from 1 to 1100; transistor saturation voltage; reverse-biased junction leakage current in 5

ranges from 11 na. to 110 μ a.; FET g_{m1} in 3 ranges from 10 to 11,000 μ a./v.; FET pinch-off voltage to 10 v. in two ranges; and regulator diode voltage in two ranges to 50 v. In addition, the instrument can derive FET on/off R_{DS} ratio, I_{DSS} , and transistor H_{FE} . Readout is by galvanometer with 3% full-scale accuracy. Applied Electronics

Circle No. 8 on Reader Service Card

HI-FI—AUDIO PRODUCTS

IMPROVED SPEAKER SYSTEM

A newly developed 8-ohm tweeter has been added to the TF-3 bookshelf speaker system, resulting in significantly improved high-frequency performance, according to the manufacturer. With the new tweeter, the system, now designated TF-3A, improves power output above 10,000 cycles as effectively as a 3-db increase in amplifier output at these frequencies.

The 10-inch special woofers cover the range from 25 to 2000 cycles, while two $3\frac{1}{2}$ -inch mid-range units cover 2000 to 10,000 cps. The new tweeter covers the range from 10,000 to 20,000 cycles. Because the system is high efficiency, less than 10 watts per channel will drive the system.

The cabinet measures $13\frac{1}{2}$ " x $23\frac{3}{4}$ " x $11\frac{3}{8}$ " and comes either unfinished or in custom finishes. Speaker components, crossover networks, and all electrical accessories are available in kit form for those wishing to build their own enclosures. Jensen

Circle No. 9 on Reader Service Card

RECEIVER/PAGING AMPLIFIER

A 35-watt AM-FM receiver and paging amplifier, designated as the "MusiCall" Model BC-350 has been put on the market recently. The unit was especially designed to meet the demand for a background music and paging system in areas that require additional power coverage. The sys-



tem is equipped with a priority paging feature which silences the system at the time paging is desired. In addition to AM and FM radio reception, the system can be used with a phono table, tape recorder, or tape deck. Audio output of the push-pull amplifier circuit is rated at 35 watts sine wave input at 1.5% distortion. The manufacturer will supply complete specs on request. Fanon

Circle No. 10 on Reader Service Card

60-WATT STEREO RECEIVER

The Model TK-60 is an all-solid-state, silicon-power transistorized AM-FM stereo receiver which provides a total music power of 60 watts (IHF Standard at 4 ohms) and 50 watts (IHF Standard at 8 ohms). Frequency response is 20-70,000 cps ± 1 db.

Features of the new unit include four-gang tuning capacitor; five i.f. stages with three noise limiters and wide-band ratio detector; automatic, silent mode switching; low and high filter; direct tape monitor system; front-panel stereo headset jack; and power transistor protection circuit. Kenwood

Circle No. 11 on Reader Service Card

ALL-TRANSISTOR STEREO RECEIVER

A stereo receiver that tunes FM, FM-stereo and delivers 30 watts of IHF music power is now available in kit form as the AR-14. It can be assembled in 20 hours or less and can be custom-mounted in a wall or other enclosure.

Features include a 31-transistor, 11-diode circuit for cool, instant operation; a frequency/power response of ± 1 db from 15 to 60,000 cps at full power in both channels; channel separation of 45 db or better; amplifier input sensi-

tivity sufficient for the low output of magnetic cartridges; and filtered tuner outputs for beat-tree stereo recording.

The assembled unit measures 3 $\frac{7}{8}$ " high x 15 $\frac{1}{4}$ "

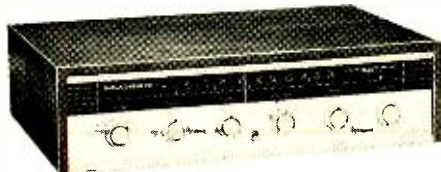

wide x 12" deep. Walnut veneer and beige metal cabinets to house the unit are available. Heath
Circle No. 12 on Reader Service Card

CAR STEREO TAPE SYSTEM

A completely transistorized, four-track stereo cartridge tape system for cars which is small enough to fit into the car's glove compartment is now on the market. The unit measures 7 inches square by 4 inches deep. Music power output is

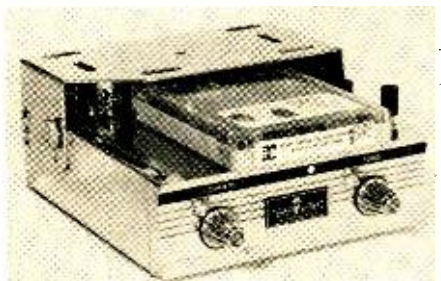

8 watts per channel and tape speed is 3 $\frac{3}{4}$ ips. The system plays magnetic stereo cartridges each of which contain as much as 2 $\frac{1}{2}$ hours of recorded stereo music. Muntz
Circle No. 13 on Reader Service Card

STEREO CABLE TERMINATION

A new cable termination design that offers stereo equipment manufacturers a unique and simplified method for accommodating twin phono plugs is now available as the Types SF-36 and RA-36.

The new termination is a molded plastic cable assembly that houses two phono plugs in one rugged, neat-appearing, moisture- and shock-proof assembly. The plugs are mounted on $\frac{3}{16}$ " centers, have brass nickel-plated tips, and sleeve connections of cadmium-plated brass. The SF-36 is a straight twin-phono-plug housing while the RA-36 is a right-angle housing. Engineering Bulletin E-522 contains full details and is available without charge. Switchcraft

Circle No. 14 on Reader Service Card

BATTERY-OPERATED RECORDER

A battery-operated tape recorder which incorporates a number of automatic features is being marketed as the Model 350. With this unit it is not necessary to change reels to reverse a tape. The user simply pushes a reverse button,



or pre-programs the unit for automatic reverse. It also features built-in voice operation. Remote start and stop may also be accomplished manually with the remote-control dynamic microphone.

The recorder takes standard 5" reels and will record at 1 $\frac{7}{8}$ and 3 $\frac{3}{4}$ ips. It is powered by six "D" size batteries or optional a.c. Battery life is over 10 hours. Concord

Circle No. 15 on Reader Service Card

SOLID-STATE TAPE RECORDER

The "Vista 212," a solid-state two-speed portable tape recorder, incorporates simplified single "F" function controls for play, record, and fast-forward function. It is equipped with automatic level control which makes the unit suitable for large business conferences since the control seeks its own volume level automatically, eliminating the annoyance of having to point the microphone directly at the speaker.

The recorder weighs only 4 $\frac{1}{2}$ pounds with batteries and accepts 85 mm. (3 $\frac{3}{4}$ ") maximum tape reels, records at self-equalization speeds of 3 $\frac{3}{4}$ and 1 $\frac{7}{8}$ ips on an electronically governed capstan drive. Dimensions are 7 $\frac{7}{8}$ " x 9 $\frac{3}{4}$ " x 3 $\frac{1}{8}$ ". Craig Panorama

Circle No. 16 on Reader Service Card

UNDERWATER "INTERCOM"

A unique "undercom" for underwater communications has been developed to permit the diver's voice to be heard clearly and without distortion. Normal speech sounds are carried through the water for 50 feet or more and can be heard by other divers without special receivers or listening equipment.

The transistorized unit, dubbed the "Yack Yack" system, consists of two parts: a face mask including a microphone and a special sound diffuser to eliminate bubble sounds; and a compact, non-corrosive plastic case containing the amplifier circuitry, dry cell battery, and speaker. The microphone assembly fits inside an ordinary diving mask while the speaker case is worn on the weight belt. The complete system weighs only 25 ounces in the water. Raytheon

Circle No. 17 on Reader Service Card

AUTO REVERB SYSTEM

An ultra-compact auto radio reverberation system that measures only 6 $\frac{1}{2}$ inches long is being sold as the "Verba-Mite." The self-contained unit mounts under the dash without drilling or screws.

Hook-up into the car radio system, clearly explained in the easy-to-follow instruction book.

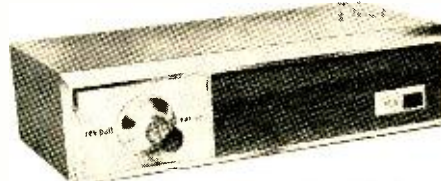

employs tap fittings that eliminate soldering or need for special fittings. Full information, prices, and illustrated literature is available upon request. Kinematix

Circle No. 18 on Reader Service Card

CB-HAM-COMMUNICATIONS

SOLID-STATE CB UNIT

With 12 crystal-controlled channels and an all-silicon transistor complement for dependable operation at high temperatures, the new "Mark 10" CB receiver weighs less than 4 $\frac{1}{2}$ pounds and occupies a space of slightly more than one cubic foot.

Features of the new unit include r.f. power output up to the maximum legal FCC limit of 4 watts; drift-free crystal-controlled channel selection, with frequency accuracies greater than 0.0004%; and high-level modulation (up to 100%) with speech-shaping for maximum intelligibility.

Full technical details are available from the manufacturer, RCA

Circle No. 19 on Reader Service Card

23-CHANNEL CB TRANSCEIVER

A solid-state, 5-watt CB transceiver that is capable of transmitting and receiving on all 23 CB channels is now being offered in both kit and factory-wired versions.

The unit measures 2 $\frac{7}{8}$ " high x 7" wide x 10 $\frac{1}{2}$ " deep, making it suitable for car, boat, or any mobile installation having a 12-volt d.c. negative-ground source. In addition, the new transceiver



can operate fixed with an optional a.c. power supply.

The unit (GW-14) uses 14 transistors and 6 diodes, has provision for 23 crystal-controlled transmit and receive channels, and features a front-panel "S" meter, adjustable squelch control, and an automatic noise limiter. Full specifications are available from the manufacturer. Heath

Circle No. 20 on Reader Service Card

NEW HAM-BAND RECEIVER

The new SX-146 ham receiver employs a single conversion signal path and pre-mixed oscillator



chain to provide high-order frequency stability and freedom from adjacent-channel cross modulation. A 2.1-ke. six-section quartz crystal lattice filter provides maximum selectivity of SSB. The unit also has provisions for plug-in user installation of a 0.5-ke. c.w. crystal filter and a 5-ke. AM crystal filter.

The 9-tube, 3-diode receiver measures 5 $\frac{7}{8}$ " high x 13 $\frac{1}{8}$ " wide x 11" deep. The company will supply complete specifications on the SX-146 on request. Hallcrafters

Circle No. 21 on Reader Service Card

FURNITURE-STYLED HAM CONSOLES

A line of walnut communications consoles and desks to house amateur radio equipment has been recently introduced. Both consoles and desk feature fine furniture styling to permit ham stations to be operated in the living room. When not in use the console looks like a small organ.



Its walnut finish and simple design will go with any decor. Equipment is neatly flushed-mounted in a durable white formica panel for easy operation. The door folds down to provide a roomy, scratch-proof formica work surface. Precision cut-outs are available for most manufacturers' equipment. Design Industries

Circle No. 22 on Reader Service Card

PAGING RECEIVER

A compact paging receiver, the "Pagemaster," is now available. This new receiver is about 50% smaller and 30% lighter than any selective paging receiver currently on the market. It measures 4 7/8" long x 1 7/8" wide x 3/4" deep and weighs 1.5 ounces complete with battery.

Individual decoding plug-in reed assemblies enable receivers to be speedily repaired and reissued with the same code and identification numbers, thus allowing users to stock a minimum of replacement parts. The speaker has been moved to the top of the unit to improve listening conditions in high-noise environments. The long-life mercury battery will provide approximately 1000 hours of service. Bogen

Circle No. 23 on Reader Service Card

MANUFACTURERS' LITERATURE

QUALITY-CONTROL TESTS

Information on the facilities and techniques for manufacturing precision recording and measuring instruments is offered in a new 24-page, fully illustrated brochure (No. 1110).

The booklet describes the "Metrisite" transducer and takes this component through various production stages, accuracy checks, and reliability inspections to its final incorporation into a finished oscillograph. Brush

Circle No. 139 on Reader Service Card

FILTER CATALOGUE

Low- and high-pass filters, band-pass filters, multiplexers, and special filter devices are described and illustrated in a new 80-page, technically oriented filter catalogue (ME-100). Basic technical explanations that enable a systems engineer to precisely characterize the filter to meet his requirements are provided, as well as detailed order forms. American Electronic Laboratories

Circle No. 140 on Reader Service Card

INSTRUMENT CATALOGUE

Voltage references, voltage dividers, precision wirewound resistors, and modular ladder networks are among the products described and illustrated in a new 4-page condensed catalogue.

Complete specifications are given in the catalogue, which is comprised of two bulletins, Nos. 441-A and 441-B. General Resistance

Circle No. 141 on Reader Service Card

TUNNEL DIODES

An 8-page technical report on tunnel-diode measurements has been published. Characteristics of typical microwave tunnel diodes are fully described, as well as application requirements and stability conditions.

Also included is a discussion of the technique of measuring negative resistance, and one section of the report is devoted to cut-off frequency, with a chart supplied for calculation. Sylvania

Circle No. 142 on Reader Service Card

ELECTRONICS BOOKLIST

A full range of current titles on electricity, radio, TV, hi-fi, computer technology, and math for electronics is presented in a new booklist. Included in the brochure are many study courses for home or school, ranging from beginning to engineering levels. Howard W. Sams

Circle No. 24 on Reader Service Card

P. A. CATALOGUE

A full line of amplifiers, boosters, and receivers is presented in a new 8-page catalogue. Featured in the brochure is the "Commander Series" of modular amplifiers and accessories.

When completely opened, the catalogue also doubles as a wall chart, providing quick reference to equipment specifications. Two tables indicate which accessories are used with each amplifier, booster, or receiver. Harman-Kardon

Circle No. 25 on Reader Service Card

TWO-WAY RADIO

Information on the new "Messenger 106" business/industrial hand-held transceiver is offered

in a 4-page brochure. Features and applications of the lightweight, all-transistor unit are covered in the illustrated booklet. E. F. Johnson

Circle No. 26 on Reader Service Card

SWITCH CATALOGUE

Over 90 varieties of switches, including ribbon and mat types, foot-operated devices, safety-edge switches, and chime-mat annunciator kits, are described in a new catalogue (C-3).

Also included are technical and circuit hints, along with applications data, for controls, alarms, and automated equipment. Tapeswitch

Circle No. 143 on Reader Service Card

INDICATOR LIGHTS

Complete technical information on one- and two-terminal subminiature indicator lights for translucent-panel edge lighting is supplied in a new 4-page illustrated catalogue, L-158E.

In addition, the booklet covers light-emitting and incandescent assemblies, as well as non-dimming and dimmer-type indicator lights. Dialight

Circle No. 144 on Reader Service Card

MICROPHONES

A new 16-page illustrated catalogue covering both professional and consumer microphones is now available. Eleven different instruments are described, and each unit is fully covered in terms of engineering specifications, accessories, and performance characteristics. Sony

Circle No. 27 on Reader Service Card

GLASS CAPACITORS

Technical information on two series of glass capacitors for military and industrial applications is contained in a new 4-page catalogue (B-9157).

Specifications for the series CY and CYW capacitors include voltage rating, capacitance tolerance, temperature coefficient, and insulation and moisture resistance. Performance curves are also given. Westinghouse

Circle No. 145 on Reader Service Card

TAPE RECORDERS

Two new tape recorder/reproducers, Models 1020 and 1024, are fully illustrated and described in a 6-page folder. Both all-transistor units feature two permanent split-capacitor reel-drive motors, 8 1/4" reels, two vu meters, and automatic shut-off.

Also included in the brochure is a discussion of the tape-drive system and tape-head construction. Magnecord

Circle No. 28 on Reader Service Card

LOUDSPEAKERS

A complete range of p.a. loudspeakers, including paging and talk-back speakers, directional trumpets, electronic-siren units, and mobile speakers, is offered in a new 10-page illustrated catalogue (No. 565). In addition, the brochure describes a full line of drivers, matching transformers, desk and floor microphone stands, and other accessories. Atlas Sound

Circle No. 29 on Reader Service Card

CAPACITOR BROCHURE

Information on axial-lead and printed-circuit miniature electrolytic capacitors is offered in a new 4-page illustrated catalogue. Specifications, dimensional drawings, and performance curves are supplied. Centralab

Circle No. 146 on Reader Service Card

CCTV CAMERA

A new 2-page illustrated data sheet on the Model CC-323 vidicon camera for closed-circuit TV has been released. Bulletin V-015 supplies information on lighting compensation, output, resolution, applications, and specifications. Ampex

Circle No. 147 on Reader Service Card

TIN-OXIDE RESISTORS

A new 4-page folder describing a line of "C-Style" tin-oxide resistors has been published.

Reference file CE-211 outlines physical and electrical characteristics of the devices and also provides typical performance curves. Corning

Circle No. 148 on Reader Service Card

DELAY-LINE CATALOGUE

A number of entirely new series of electromagnetic delay lines are introduced in the pages of a new 12-page catalogue recently made available. In addition, the booklet incorporates a delay-line selection chart as a specifying aid to engineers. Kappa Networks

Circle No. 149 on Reader Service Card

AUDIO CATALOGUE

Console and bookshelf speakers, stereo headphones, unitary loudspeakers, system kits, components, and accessories are fully illustrated and described in a new 24-page hi-fi products catalogue. A special section on designing speaker enclosures is also provided. Jensen

Circle No. 30 on Reader Service Card

TEST EQUIPMENT

A new 28-page 1966 catalogue covering a wide range of pulse generators, timing units, signal generators, pulse accessories, microwave devices, and other test instruments has been published.

The fully illustrated booklet also contains detailed summaries of core testing and component testing. E-H Research

Circle No. 150 on Reader Service Card

SEMICONDUCTORS

Exact replacements for about 5000 semiconductors are listed in a new 8-page replacement and interchangeability guide. Transistors (both foreign and American types), germanium diodes, silicon power rectifiers, selenium rectifiers, selenium dual diodes, and color-TV rectifier replacements are presented in easy-to-use tabular form.

The booklet is available without charge at the company's dealers. Semitronics

CAPACITOR CATALOGUE

A new 32-page illustrated catalogue covering a wide variety of capacitors and related products is now available. Electrolytic, ceramic, and paper types are carried in detailed listings, along with mica, Mylar, Mylar-paper, and oil-paper capacitors.

Designed for the technician, the booklet also contains a section devoted to capacitor "kits," which are packages incorporating a number of the most popular types of electrolytic, ceramic, and mica devices.

Catalogues are available free of charge at the company's local distributors. Aerovox

PHOTO CREDITS

Page	Credit
16	H. H. Scott, Inc.
23, 24, 25, 26, 28 (center)	General Electric Company
28 (top)	James Electronics, Inc.
28 (bottom), 29 (center)	IBM
29 (top), 80, 81	Bell Telephone Laboratories
29 (bottom left)	Honeywell
29 (bottom right)	Sylvania Electric Products Inc.
33	Magnaflex Corporation
35 (Fig. 6)	Picker X-Ray Corporation
36	Black, Sivalls & Bryson, Inc.
40	Emerson Radio & Phonograph Corp.
45	JFD
49, 50, 52	Memorex Corp.
62	Blonder-Tongue
63	B&K Mfg. Co.
64	Grand Transformers, Inc.

ELECTRONICS MARKET PLACE

COMMERCIAL RATE: For firms or individuals offering commercial products or services. 70¢ per word (including name and address). Minimum order \$7.00. Payment must accompany copy except when ads are placed by accredited advertising agencies. Frequency discount: 5% for 6 months; 10% for 12 months paid in advance. READER RATE: For individuals with a personal item to buy or sell. 40¢ per word (including name and address). No Minimum! Payment must accompany copy. GENERAL INFORMATION: First word in all ads set in bold caps at no extra charge. Additional words may be set in bold caps at 10¢ extra per word. All copy subject to publisher's approval. Closing Date: 1st of the 2nd preceding month (for example, March issue closes January 1st.) Send order and remittance to: Hal Cymes ELECTRONICS WORLD, One Park Avenue, New York, New York 10016

FOR SALE

JUST starting in TV service? Write for free 32 page catalog of service order books, invoices, job tickets, phone message books, statements and file systems. Oelrich Publications, 6556 W. Higgins Rd. Chicago, Ill. 60656.

GOVERNMENT Surplus Receivers, Transmitters, Snooperscopes, Radios, Parts, Picture Catalog 25¢. Meshna, Nahant, Mass. 09108.

INVESTIGATORS, FREE BROCHURE, LATEST SUBMINIATURE ELECTRONIC SURVEILLANCE EQUIPMENT. ACE ELECTRONICS, 11500-J NW 7TH AVE., MIAMI, FLA. 83168.

CANADIANS—Giant Surplus Bargain Packed Catalogs. Electronics. Hi-Fi, Shortwave, Amateur, Citizens Radio. Rush \$1.00 (Refunded). ETCO. Dept. Z, Box 741, Montreal, Canada.

HARD-TO-GET TUBES IN STOCK BRAND NEW—1 YR. GUARANTEE

Type	Price	Type	Price	Type	Price	Type	Price
00A	3.50	6AT8	1.39	6SQ7GT	1.25	12L8	.50
01A	2.75	6AU4	1.19	6SR7	1.42	12Q7	1.50
0D3	.75	6AU5	1.55	6S7M	1.88	12SA7	1.49
1A7	1.05	6AU6	.62	6T8	.15	12SC7	1.89
1A2	.75	6AU8	1.38	6U5	2.35	12SF5	1.30
1B3	.92	6AW8	1.25	6U6	1.12	12SG7	2.23
1H5	2.59	6AX4	.89	6V8GT	.83	12SH7	1.54
1L6	2.60	6AX5	1.05	6W4	.98	12SJ7	1.40
1L4A	1.30	6AX7	1.25	6W6GT	.98	12SK7	1.35
1L6A	1.49	6B4	5.95	6Y6CA	1.22	12SL7	1.28
1L6C	1.05	6B7	2.75	6X5GT	.72	12SL7	1.28
1L6E	1.80	6B8	2.46	6X8A	1.05	12SQ7	1.29
1LDS	1.95	6BA6	.60	6Y6CA	1.22	12V6	1.15
1L3	1.25	6B4B	1.20	6Z4/84	1.22	12V6	1.15
1LH4	2.69	6BE6	.74	7A4	2.25	12W6	1.15
1L5	2.25	6BH6	.89	7AS	1.95	13CF7	1.70
1N5	1.85	6BQ6	1.45	7B5	2.35	13J10	1.83
1P5	2.00	6BK5	1.25	7A7	2.35	14A4	1.45
1R4	.80	6BK7	1.14	7AB	2.75	14A5	1.45
1R5	.99	6BQ6	1.45	7AD7	1.25	14A7	1.85
1S5	.99	6BQ7	1.33	7AF7	2.10	14AF7	1.85
1T5	.80	6BX7	1.75	7AG7	2.85	14B6	1.85
1U4	.99	6C4	.55	7B7	1.95	14F8	1.95
1U5	1.85	6CSM	1.63	7AU7	.83	14C5	1.75
1V	1.85	6CC	2.00	7B4	2.35	14C7	2.19
1V2	.79	6C8G	2.95	7B5	2.35	14E7	1.99
2A3	3.50	6B5	1.15	7C7	1.25	14F7	2.95
2A5	2.50	6CC7	.75	7B7	2.50	14F7	2.95
2A6	4.50	6C8	.95	7B8	2.00	14H7	1.95
2B7	1.95	6CL6	1.15	7C5	1.19	14J7	1.95
2X2A	1.95	6CL8	1.10	7C5	1.19	14J7	1.95
3A3	1.18	6CM7	.94	7C6	2.69	14N7	1.95
3A5	1.10	6C8B	1.42	7AB	2.35	14N7	1.95
3AU6	3.80	6C8	.98	7E5	2.00	14R7	2.35
3B7	2.39	6CWA	1.59	7E6	1.25	14S7	1.95
3BN4	1.05	6CX8	1.42	7F7	2.59	14X7	1.75
3Z6	1.75	6C8	1.15	7F7	2.59	14X7	1.75
3C6	.79	6D4	1.75	7F8	3.00	14Y4	1.75
3D4	1.25	6D6	2.50	7G7	1.99	14Z4	1.00
3D7	.74	6D6	1.95	7G7	1.65	2050	1.25
3Q5	2.00	6DN6	2.54	7H8	1.29	22	1.15
3V4	.85	6DN7	1.21	7J7	2.50	25C5	1.35
4B7	1.30	6D4	1.75	7K7	1.96	25C5	1.35
4B8	1.19	6DQ5	2.75	7L7	1.99	25D6	1.95
4B7Z	1.40	6DQ6	1.39	7N7	2.61	25D6	1.95
4CB6	.75	6E5	1.75	7M7	2.61	25L6	1.95
5A8B	1.30	6F6	1.75	7R7	2.25	25Z5	.77
5AN8	1.35	6F5GT	1.72	7S7	1.79	25Z6	1.50
5AQ5	.76	6F6G	1.95	7T7	1.65	27	1.60
5A58	1.59	6F7	1.95	7W7	1.39	30	1.25
5AT8	1.27	6F8	3.08	7X6	1.35	30	1.25
5A24	1.85	6GJ5	1.75	7X7	2.75	32Z5	1.80
5B07	1.30	6K45	1.39	7Y4	2.35	32Z5	1.80
5BR8	1.25	6K6	.98	7Y7	1.79	33	1.15
5CC8	1.12	6H28	1.85	7Z4	2.25	34	1.45
5U6	.96	6J5G	1.10	8A8	1.39	35A5	2.94
5U8	1.14	6J6A	.67	8BQ5	.99	35L6	.86
5V4	1.24	6J7	.67	8C7	.86	35W4	.35
5W4GT	1.75	6J7GT	.99	8J8	1.31	35Z3	1.54
5X8	1.20	6J7G	1.50	8GN8	1.29	35Z5	.58
5Y3	.59	6K8	2.50	8J8	1.32	37	1.50
6A7	1.40	6K6GT	1.75	8Y8	1.32	37	1.50
6B8M	2.39	6L7M	2.48	9U8	1.05	38	1.10
6B4	.76	6N7M	1.75	10E7	1.14	39/44	1.40
6B7	2.10	6P5	1.25	10G7	1.14	40	1.40
6AC5	1.20	6P5	1.25	12A8	2.95	42	1.98
6AC7	1.75	6S7	1.95	12A7	1.03	46	.95
6AF3	.99	6S8GT	1.50	12A8	2.95	47	3.00
6AC5	1.20	6S7	1.95	12A7	1.03	47	3.00
6AC7	1.95	6S7Y7	2.19	12A8	2.95	49	3.50
6A4	1.19	6S07	1.49	12A7	.87	50A1	1.75
6AK5	1.49	6S7	1.95	12A8	2.95	50A1	1.75
6AL3	.99	6S7	1.95	12B6	.59	50C5	.65
6AL7	1.95	6S7	1.95	12B7	.96	50L6	.85
6AMB	2.49	6S7GT	1.95	12B6	.59	50X6	1.95
6AN8	1.35	6S7GT	1.49	12B7	1.08	50Y6	1.49
6A07	1.37	6S7M	1.72	12B7	1.09	50Y7	1.42
6AR5	.99	6S7	1.95	12C5	.84	53	2.50
6AS5	.82	6S7M	1.38	12K7	2.25	55	2.75
6A57	2.85	6S7GT	1.19	12KM	2.95	56	1.25
6AT6	.58	6S7GT	.89	12L6	1.18	57	1.50

MINIMUM ORDER \$5.00

ADD POSTAGE

SEND FOR COMPLETE TUBE CATALOG

UNITED RADIO CO.

EW-2, P.O. BOX—1000 A4, NEWARK, N.J.
CIRCLE NO. 87 ON READER SERVICE CARD
February, 1966

RESISTORS precision carbon-deposit. Guaranteed 1% accuracy, 1/2 watt 8¢. 1 watt 12¢. 2 watt 15¢. Rock Distributing Co., 902 Corwin Road, Rochester 10, N.Y.

NEW supersensitive transistor locators detect buried gold, silver, coins. Kits, assembled models. \$19.95 up. Free catalog. Relco-A22, Box 10563, Houston 18, Texas.

JAPAN & Hong Kong Electronics Directory. Products, components, supplies. 50 firms—just \$1.00. Ippano Kaisha Ltd., Box 6266, Spokane, Washington 99207.

ELECTRONIC Ignition Kits, Components. Free Diagrams. Anderson Engineering, Epsom, New Hampshire 03239.

WEBBER Labs. Transistorized converter kit \$5.00. Two models using car radio 30-50mc or 100-200Mc. one Mc spread. Easily constructed. Webber, 40 Morris, Lynn, Mass.

ACHTUNG! Das machine is nicht fur Gerfingerpoken und mittengraben. Is easy schnappen der Springenwerk, blowenfusen und poppencorken mit spitzen-sparken. Ist nicht fur gewerken by das Dummkopfen. Das rubbernecken sightseeren kepen hands in das pockets. Relaxen und watch das Blinkenlights. This attractive, brass metal plaque only \$2.00 ea. ppd. Southwest Agents, Dept. E, 8331 Hwy. 80 West, Fort Worth, Texas 76116.

CANADIANS, transistors, all semiconductors and components. Free catalogue contains reference data on 300 transistor types. J.&J. Electronics (Dept. EW), P.O. Box 1437 Winnipeg, Manitoba, Canada.

CONVERT any television to sensitive, big-screen oscilloscope. Only minor changes required. No electronic experience necessary. Illustrated plans, \$2.00. Relco, Box 10563, Houston 18, Texas.

TRANSISTORS—Miniature Electronic Parts. Send for Free Catalog. Electronic Control Design Company, P. O. Box 1432M, Plainfield, N.J.

ELECTRONIC Bargains—Free Catalog, Tubes, Diodes, CRT's Tuner Cleaner, etc. Cornell, 4213-W University, San Diego, Calif. 92105.

TELEVISION Cameras Transistorized also monitors. Spera Electronics, 37-10 33 Street, L.I.C., N.Y.

TRANSISTORIZED Products Importers catalog. \$1.00. Intercontinental. CPO 1717, Tokyo, Japan.

MESHNA'S TRANSISTORIZED CONVERTER KIT \$4.50 Two models—converts car radio to receive 30-50 mc or 100-200 mc (one mc tuning). Meshna, Lynn, Mass. 01901.

SECURITY ELECTRONICS introduces its NEW 1966 line of SURVEILLANCE EQUIPMENT. Improved NEW designs for maximum performance and greater value. FREE DETAILS. Security Electronics-EW, 11 East 43rd St., New York, N.Y. 10017.

R.F. CONVERTERS \$10 up. World's largest selection. Also CCTV cameras, transmitters, etc. Lowest factory prices. Catalog 10¢. Vanguard, 196-23 Jamaica Ave., Hollis, N.Y. 11423.

HOW COMPUTERS WORK. Send \$2.00 for this easy to understand booklet. ELECTRONIC RESEARCH LABORATORY, Box 67, St. Albans Station, New York, N.Y. 11412.

IT'S SUPERCALIFRAGILISTICEXPIALIDOCIOUS. Free information on Kit-of-the-Month Club and new catalog of etched circuit boards and radio books. Many exclusive items. Leader Enterprises, Box 44718KN, Los Angeles, 90044.

SAFEGUARD PRIVACY! New instrument detects electronic "bugs," wire-tapping and snooping devices. Free information. Dee Equipment, Box 7263-7, Houston 8, Texas.

REVERBERATION UNITS (HAMMOND) Free Details, from \$9.95 postpaid. Harvey Organ Electronics, Box 268, Harvey, Ill. 60427.

METERS—Surplus, new, used, panel and portable. Send for list. Hanchett, Box 5577, Riverside, Calif. 92507.

GIANT TESLA COIL—FORTY-INCH SPARKS! Complete plans, photo \$5.00; details 30¢. Huntington Electronics, Inc., Box 9, Huntington Station, Shelton, Conn. 06486.

REMOTE CONTROL DEVICE. Small hand-held ultrasonic Transmitter Controls TV, Lamps, Anything Electrical—Full Plans and Parts Information, \$2.00—Electronic Specialists, Box 9339, Rochester, N.Y. 14604.

FREE—FREE—FREE—FREE—FREE—FREE—FREE Send in for your FREE one year subscription to Olson Electronics' fantastic value packed catalog—unheard of low, low prices on brand name speakers, changers, tubes, tools, stereo amplifiers, tuners, CB and other values. Credit plan available. If you have a friend interested in electronics send his name and address for a FREE subscription also. Olson Electronics, Inc., 454 S. Forge St., Akron, Ohio 44308.

SAMS PHOTOFACTS complete 541 through 731 in three drawer file. Will accept first reasonable offer. Claude Reed, Mt. View Rd., Fishkill, N.Y.

PHOTOGRAPHY—FILM, EQUIPMENT, SERVICES

MEDICAL FILM—Adults only—"Childbirth" one reel, 8mm \$7.50; 16mm \$14.95. International W, Greenvale, Long Island, New York.

SCIENCE Bargains—Request Free Giant Catalog "CJ"—148 pages—Astronomical Telescopes, Microscopes, Lenses, Binoculars, Kits, Parts, War surplus bargains. Edmund Scientific Co., Barrington, New Jersey.

RECTIFIERS & TRANSISTORS

Silicon Diodes					
Amps	50 PIV	100 PIV	150 PIV	200 PIV	200 PIV
.75*	.05	.07		.10	
3	.08	.14	.16	.22	
15	.35	.50	.65	.75	
18**	.26	.45	.60	.70	
35	.60	.80	1.15	1.30	

Amps	300 PIV	400 PIV	500 PIV	600 PIV
.75*	.12	.14	.18	.34
3	.25	.28	.36	.40
15	.90	1.30	1.40	1.65
18**	.85	1.25	1.85	2.50
35	1.90	2.25	2.50	2.90

Amps	700 PIV	800 PIV	900 PIV	1000 PIV
.75*	.25	.32	.40	.55
3	.49	.58	.67	.78
15	1.90	2.30	2.50	2.70
35	3.65	4.40	4.65	4.90

* Top Hat. Enoxy or Flangless ** Press Fit pkg

1100 PIV, 70¢, 1200 PIV, 85¢, .75A (Top Hat, Enoxy or Flangless)

10 Watt Sil. Zener Stud 20%, 12-200V. .95¢ ea. 1 Watt Zener, axial leads 20%, 8-200V

Sil. diode Stud, 1500 piv, 300 ma. 50¢ ea.
Sil. diode, 1500 piv, 50 ma, axial leads. 35¢ ea.
Hoffman S.L. Enoxy diodes 2 1/2x3/8x1/2 200 ma—3000 piv \$1.49 ea., 6000 piv. \$2.49 ea.
Thermistor bead, 900 or 1200 ohms, 600°F.2 \$1.00
SILICON POWER TRANSISTORS, 85W, 2n172A. \$1.50

LIGHT SENSITIVE RESISTOR
75 ohms - 10 meg, 100 volts, 150 mw \$1.75 ea.

Matched diodes, 9V, 25ma, 100 mas. 30¢ pair
Ger. diodes, glass—1N34A, 15/\$1.00—1N99 10/\$1.00

Sil. diodes, 1N200 series, ass't new. 15 for \$1.00
Nickel Cadmium Battery 9 1/2 oz. 8 amp hr. \$1.95
Mercury Batt. 5.4V, 5/8x1. 20¢

Varicap—Voltage Variable Capacitor
27.47, or 100 pf at 4v. 4-1, new \$1.25 ea.

2N1300 series, NPN or PNP. 6 for \$1.00
2N497—60¢; 2N498—80¢; 2N696—50¢;
2N699—70¢; 2N1252—85¢; 2N650—49¢;
2N243—25¢; 2N1149—20¢; 2N117—20¢;
70 amp stud, 50PIV—\$2.50; 100PIV. \$3.50
Sensitivity Amplifier, 7 tubes 5"x4"x3" 1.75

SILICON CONTROLLED RECTIFIERS									
PRV	75A	1A	7A	16A	PRV	75A	1A	7A	16A
25	—	.20	.28	.48	200	.80	.90	1.15	1.70
50	—	.40	.48	.70	300	1.20	1.30	1.80	2.20
100	—	.55	.70	1.20	400	1.70	1.85	2.20	2.70
150	.60	.70	.80	1.50	500	1.95	2.05	3.00	3.30
75A Top Hat, IATO-5, 7A & 16A Stud					600	2.30	2.50	3.20	3.90

Money back guarantee. \$2.00 min. order, include postage. Catalog 10¢.
Electronic Components Co.
Box 2902, Baton Rouge, La. 70821

CIRCLE NO. 116 ON READER SERVICE CARD

BIG CATALOG

World's "BEST BUYS" in GOV'T. SURPLUS Electronic Equipment

CODE EQUIPMENT:

TG-10 Keyer—Code Practice.....Used: \$14.95
 VO-3 Code Oscillator.....Used: 12.95
 MX-333/GG Code Tape Puller.....New: 12.95
 Blank Paper Tape: 3/8" 900 Ft. Rolls 25¢ ea. 30/\$3-60/\$55

HEADSETS:

HS-33 Headset: with chamois cushions.....New: \$ 7.95
 with rubber cushions.....New: 6.95
 HS-23 Headset: with chamois cushions.....New: 6.95
 with rubber cushions.....New: 5.95
 Chamois Cushions only.....1.50
 Rubber Cushions only.....1.00
 HB-7 Headband only, for HS-33/23.....New: 3.00
 ANB-1 Element only, for HS-33.....New: 4.00
 HS-30 Headset—Hearing Aid Type.....Used: .98

HANDETS:

TS-9 Butterfly Switch—Used: \$2.95—Re-Cond: \$ 3.95
 D170312 Sound Powered.....New: 7.95

MICROPHONES:

T-30 Throat Microphone—Used: 3 f/\$1.00 New: \$ 1.00
 T-45 Lip Microphone.....Used—each: .75
 T-17 Microphone—Less Front Cover and Re-Cond: 7.95
 H-18M Microphone Carbon.....Used: \$1.00 New: 1.50
 T-24/M Microphone Carbon.....New: 4.95

OSCILLOSCOPE—Per NOV. '65 Ad:

OS-51 USM-24—Less Front and Back Covers—with Delay Line.....\$59.50
 OS-26 USM-24—Less Front Cover and Less Delay Line.....\$49.50
 OS-26 USM-24—With Front and Back Covers—Less Delay Line.....\$59.50

TELEPHONE EQUIPMENT:

EE-8 Field Telephone—Batt. Oper.....Used: \$12.95
 EE-8B Field Telephone—Sound Powered.....Used: 15.00
 BD-71 Switchboard—6 line.....Used: 9.95
 BD-89 Switchboard—20 Mag. & 40 CB lines Used: 59.50
 BD-95 Switchboard—Cordless.....New: 24.95

BC-221 FREQ. METER—per Aug. 1965 Ad:
New: \$125.00—Used: \$79.50

FOR BIG CATALOG—SEND 25¢ (stamps or coin) and receive 50¢ CREDIT on your order!

Address Dept. EW • Prices F.O.B. Lima, O. • 25% Deposit on C.O.D.'s • Minimum Order \$5.00

FAIR RADIO SALES
2133 ELIDA RD. • Box 1105 • LIMA, OHIO

GET INSTANT MONEY!

We want your surplus, obsolete, or excess inventory equipment, components and parts! Need quotes, teletype, all CRC, PRC, ARC, ARN—all test equip. What have you? WE PAY TOP DOLLARS! We make deals—now! And we pay freight. Tell us what you have—not tomorrow—today!

COLUMBIA ELECTRONICS—DEPT. EW
4365 W. Pico Blvd.
Los Angeles, Cal. 90019

ELECTRONICS ENGINEERING AND INSTRUCTION

FCC LICENSE in six weeks. First class radio telephone. Results guaranteed. Elkins Radio School, 2603C, Inwood, Dallas, Texas.

ELECTRONICS! Associate degree—29 months. Technicians, field engineers, specialists in communications, missiles, computers, radar, automation. Start February, September. Valparaiso Technical Institute, Dept. N, Valparaiso, Indiana.

ELECTRONICS—F.C.C. License Training—correspondence, or resident classes. Free details, Write: Dept. 6, Grantham, 1505 N. Western, Hollywood, Calif. 90027.

REI First Class Radio Telephone License in (5) weeks Guaranteed. Tuition \$295.00. Job placement free. Radio Engineering Institute, 1336 Main Street, Sarasota, Fla.

HIGHLY—effective home study review for FCC commercial phone exams. Free literature! **COOK'S SCHOOL OF ELECTRONICS**, Craigmont, Idaho 83523.

LEARN ELECTRONIC ORGAN SERVICING at home. All Makes including transistors. Experimental kit—trouble-shooting. Accredited NHSC. Free Booklet. **NILES BRYANT SCHOOL**, 3631 Stockton, Dept. A, Sacramento 20, Calif.

ELECTRONIC training. Fundamental and advanced correspondence courses. Free sample lesson. Huntington Institute, Division of Lantec. Box 2244-B, Huntington Park, Calif.

TELEVISION Servicing Course, complete, latest edition. Special, \$3. Satisfaction guaranteed. Supreme Publications, 1760 Balsam, Highland Park, Ill. 60035.

B.Sc. DEGREE (Engineering) or College Entrance by home study. Send \$1 for 1966 prospectus. CIST, Suite 674, 263 Adelaide St. W., Toronto, Canada.

REPAIRS AND SERVICES

TV Tuners Rebuilt and Aligned per manufacturers specification. Only \$9.50. Any Make UHF or VHF. We ship COD Ninety day written guarantee. Ship complete with tubes or write for free mailing kit and dealer brochure. **JW Electronics**. Box 51B. Bloomington, Indiana.

EQUIPMENT

McGEE RADIO COMPANY. Big 1966 Catalog Sent Free. America's Best Values. Hi-Fi-Amplifiers—Speakers—Electronic Parts. Send name, address and zip code number to McGee Radio Company, 1901 McGee Street, Dept. EG, Kansas City, Missouri 64108.

NATION-WIDE



1-YEAR GUARANTEE ON ALL TUBES
Individually boxed
CODE DATED
BRANDED

\$33 per HUNDRED

For all type TUBES

024	6A05	6J6	11CY7
1A7	6A4	6K6	12AD6
1B3	6AU6	6K7	12AF6
1M5	6AV5	6SC7	12AT7
1K3	6AV6	6SF7	12AV6
1L6	6AW8	6SG7	12AX4
1W5	6AX4	6SH7	12AU7
1R5	6BA6	6SJ7	12AX7
1S5	6BC5	6SK7	12BA6
1U4	6BE6	6SL7	12BE6
1X2	6BH6	6SN7	12BH7
2CW4	6BK7	6SQ7	12BY7
2D54	6BL7	6US	12CS
2DV4	6BN6	6U8	12CA5
31Z6	6BQ5	6V6	12L6
3DT6	6BQ6	6W4	12RS
3V4	6BQ7	6W6	12SA7
4BQ7	6C	6X4	12SC7
5AT8	6CB6	7A5	12SK7
5J6	6CD6	7A7	12SQ7
5U4	6CQ7	7B6	12W6
5Y3	6CM7	7B8	18FX6
6A7	6CV5	7C5	18FX6
6AB4	6DA4	7E6	22DE4
6AC7	6DE4	7F7	25L6
6AF4	6DE6	7O7	25Z6
6AG5	6DH6	7Y4	32L7
6AH4	6DQ6	8AW8	50A5
6AL5	6D54	8CC7	50CS
6AM8	6DV4	9AU7	50L6
6AN8	6J5	10E7	117L7
			117Z3

Fresh New Stock of Console Self Service **TUBE CHECKERS** Shell's, U-Test-M's, Mercury's, Colex's! All with 3 or more drawers to hold more than 300 tubes. Latest charts available to test more than 1000 types. Lighted back panel with each machine. Shipped FOB \$29.95 Adapters for Compactron's available for \$12.95

New Stock of Government **SURPLUS TUBES** (While They Last) 6AC5, 6SN7, 6AU6, 6AX4, 6K6 16¢ Each 10 for \$1.50 Nest of 100 \$13.50 May Be Assorted

Self Service 18 Socket Shell **Portable Tube Testers** Latest Charts... Carry Case with Handle! Shipped FOB \$24.95 Compactron Adapter available \$12.95 Extra!

Assorted Knob Specials Bag of 25 for T.V. 99¢ Bag of 35 for Radio 99¢ Sent in attractive Poly-Paks! Postage Paid!

16" Used Console TV's Complete from knobs to back cover! FOB \$14.95 3 for \$40.00! TV's Shipped East of Mississippi Only!

ANY TYPE NOT LISTED MAY ALSO BE ORDERED AT 35¢ each. (\$33 per 100)

PICTURE TUBE SPECIALS
NO DUES REQUIRED
Any 70" 21" \$13.95
110" 21CP4, 21CP4, 21ESP4, 170SP4, 170TP4, 170WP4 \$13.95

COLOR PIX TUBES
21AXP22 \$59.95
Dud required

TERMS: FREE POSTAGE in USA on prepaid orders. Add 50¢ for handling on orders under \$5. Send 25¢ deposit on C.O. orders. Send Approx. postage on Canadian & Foreign orders. Money refunded in 5 days if not completely satisfied. Tubes are new, used or seconds are so marked. Send for complete tube list! This is our current price list and cancels any previous price lists!

NATION WIDE TUBE CO. HU 4-9848
406 HARRISON AVENUE, HARRISON, NEW JERSEY
CIRCLE NO. 99 ON READER SERVICE CARD

GOVERNMENT SURPLUS

JEPS FROM—\$52.50 Typewriters From—\$4.15, Cars From—\$31.50, Walkie-Talkies, Guns, Airplanes, Boats. Typical "As Is" Bid Bargains From Uncle Sam. Tremendous Variety. Exciting Free List. Write: Enterprises, Box 402-B6, Jamaica, N.Y. 11430.

JEPS Typically From \$53.90... Trucks From \$78.40... Boats, Typewriters, Airplanes, Electronics Equipment, Photographic Equipment, used, 100,000 Bargains Direct From Government. Complete Sales Directory and Surplus Catalog \$1.00 (Deductible First \$10.00 Order). Surplus Service, Box 820-K, Holland, Mich. 49424.

CLUBS

COUPON BOOK, special offers from various firms. Latest Membership Benefit of Electronic Experimenters' Club. Dues \$2.00. Further Information FREE. Box 5332S, Inglewood, Calif. 90310.

CLASSIFIED ADVERTISING ORDER FORM

Please refer to heading on first page of this section for complete data concerning terms, frequency discounts, closing dates, etc.

1	2	3	4	5
6	7	8	9	10
11	12	13	14	15
16	17	18	19	20
21	22	23	24	25
26	27	28	29	30
31	32	33	34	35

Words (@ .40 Reader Rate) = \$ _____
(@ .70 Commercial Rate)

Insert _____ time(s) Total Enclosed \$ _____

NAME _____

ADDRESS _____

CITY _____ ZONE _____ STATE _____

SIGNATURE _____

WORD COUNT: Include name and address. Name of city (Des Moines) or of state (New York) counts as one word each. Zone or Zip Code numbers not counted. (Publisher reserves right to omit Zip Code if space does not permit.) Count each abbreviation, initial, single figure or group of figures or letters as a word. Symbols such as 35mm, COD, PO, AC, etc., count as one word. Hyphenated words count as two words. EW-266

WANTED

MILITARY SURPLUS ELECTRONIC EQUIPMENT: ARC-27, ARC-34, ARC-38, ARC-44, ARC-52, ARC-55, ARC-57, ARC-66, ARC-70, ARC-73, ARC-84, ARN-14, ARN-18, RT-220C/ARN-21, ARN-59, APN-22, APN-70, APR-13, APR-14, ARR-41, COLLINS 51X-2 RECEIVER, 17L-7 TRANSMITTER, 51V-3, 51Y-3, 618S-1. **RECEIVERS:** R-388, R-390, R-390A, R-391, 51J-4, RT-66 THRU RT-70/GRC, R-108/GRC, R-109/GRC, AM-65, RT-77/GRC-9, GRC-10, GRC-19, PRC-10A, PRC-25, TRC-1, TRC-7, TRC-24, AN/TCC-7, GMD-1. **TEST EQUIPMENT WITH ARM, SG, PRM, URM, UPM, USM PREFIXES.** **MILITARY ELECTRONIC TECH MANUALS.** **NEW BOXED TRANSMITTER TUBES.** **AIRCRAFT INSTRUMENTS.**

SEND YOUR LISTING! TOP CASH DOLLAR PAID, PLUS SHIPPING! ADVISE CONDITION AND QUANTITY.
WRITE, WIRE, PH. (813) 722-1843.
BILL SLEP, EXPORT DIVISION, W4FHY
SLEP ELECTRONICS CO.
 DRAWER 178, HIGHWAY 301
 ELLENTON, FLORIDA 33532

SAY YOU SAW IT IN

Electronics World

UNUSUAL BARGAINS

... MANY U. S. GOV'T SURPLUS

Brand New, Quick-Charge, Industrial Surplus
NICKEL-CADMIUM BATTERY

Unparalleled Value

For the first time a 6-volt, light-weight nickel-cadmium battery in stainless steel, strap type casing, 4-amp hour capacity. Almost unlimited life—thousands of discharge-charge cycles with minute deterioration—charges fully in approx. 1 hr. with Edmund charger kit. Just a few drops of water per year provide full maintenance.

Hundreds of uses for hobbyists, amateur photographers, campers, model builders, etc. Unequaled for rechargeable lanterns; cycle scooters, and boat lights; portable fluorescent and ultraviolet lights; electronic flash units. Battery requires minimum of electrolyte, is sealed to prevent loss, delivers nearly 100% of output at below freezing temperatures compared to 50% by lead-acid batteries. No corrosive fumes under any stage of recharge. Can't be damaged by accidental charge in reverse (but not recommended). Stud type terminals on top 1 1/8" apart, marked for polarity; 6-32 thread, nuts and lock washers, 6" x 2" x 4", Wt. approx. 2 lbs.

Stock No. 70,776-AK \$15.00 Ppd.
CHARGER KIT FOR 6-VOLT BATTERY. Charges in approx. 1 hr. Shuts off automatically, attaches to Stock No. 70,766 battery case. Includes transformer, ballast resistors, charger circuit board, mounting hardware, 8-ft. cord, plug switch, assembly instructions.
Stock No. 79,807-AK \$8.00 Ppd.
ONE 1.2 VOLT NICKEL-CADMIUM CELL
Stock No. 40,798-AK \$3.95 Ppd.

SPELLBINDING EXPERIMENTS with SILICON SOLAR CELL AND SUN BATTERY!

Experience endless fascination in converting sunlight into electricity to power small motors, amplifiers, etc. ideal for scientific student projects. Plastic case 1 1/2" x 1 1/2" x 3/16". Produces 3 to 45 volts—10-16 milliamps. 24-page Handbook gives full data on 12 pat. experiments.
Stock No. 60-216-AK \$2.25 Postpaid
Selenium PhotoCell. Lower power, lower price than Silicon Cell.
Stock No. 20,411-AK \$1.50 Postpaid

Solar Cell and PhotoCell Handbook. Fascinating 112-page Handbook on Silicon Cell and Selenium projects, demonstrations, etc. Explains photovoltaic theory, performance. Gives infrared and ultra-violet applications. Paper-bound, 6" x 9".
Stock No. 9230-AK \$2.00 Postpaid

Send Check or M.O.—Money-Back Guarantee
EDMUND SCIENTIFIC CO., BARRINGTON, N. J.

SEND FOR NEW 148-PAGE FREE CATALOG—"AK"
 completely new 1966 edition. New items, categories, illustrations, 148 easy-to-read pages packed with nearly 4000 unusual items. Dozens of electrical and electronic parts, accessories. Extensive selection of Astronomical Telescopes, Microscopes, Binoculars, Magnifiers, Magnets, Lenses, Prisms. Many war surplus items: for hobbyists, experimenters, workshop, factory. Write for catalog "AK".

EDMUND SCIENTIFIC CO., BARRINGTON, NEW JERSEY 08037
CIRCLE NO. 117 ON READER SERVICE CARD
 February, 1966

WANTED

QUICKSILVER. Platinum, Silver, Gold. Ores Analyzed. Free Circular. Mercury Terminal, Norwood, Mass.

URGENTLY NEED MILITARY SURPLUS: ARC-27, ARC-34, ARC-38, ARC-44, ARC-52, ARC-55, ARC-73, ARC-84, ARN-14, ARN-18, ARN-21, ARN-59, 51X-2/17L-7, RT-66/GRC THRU 70, RT-77/GRC-9, GRC-19, Test Sets with ARM, UPM, URM, USM, SG Prefixes. Top Dollar Paid. Slep Electronics Company, Drawer 1782D EW, Ellenton, Fla. 33532, Phone (813) 722-1843.

CASH Paid! Sell your surplus electronic tubes. (Want UNUSED, clean Radio/TV Receiving, Transmitting, Special Purpose, Magnetrons, Klystrons, Broadcast Types.) Want military and commercial Lab/Test Equipment. Want commercial Ham Receivers and Transmitters. For a Fair Deal Write: **BARRY Electronics**, 512 Broadway, New York, N.Y. 10012 (WA 5-7000.)

WANTED LABORATORY Test Equipment. Electronicraft, P. O. Box 13, Binghamton, N.Y. 13902.

WANTED: Latest, "RCA" 8 lesson (4 booklets) Color TV Home Study Course (1A1325). Alford N. Lalum, Brinsmade, North Dakota 58320.

TV SETS Wanted! "As is." T.V., 467 Columbus Ave., N.Y., N.Y. TR 3-9400.

TUBES

BEFORE you buy receiving tubes, Transistors, Diodes, Electronic Components and Accessories... send for Giant Free Zalytron Current Catalog, featuring Standard Brand Tubes; RCA, GE, etc.—all Brand new premium quality individually boxed. One year guarantee—all at biggest discounts in America! We serve professional servicemen, hobbyists, experimenters, engineers, technicians. Why pay more? Zalytron Tube Corp., 469-W Jericho Turnpike, Mineola, N.Y. 11502.

TUBES—33¢ each. One year guaranteed. Complete stock. Free list. Cornell, 4215—W University, San Diego, Calif. 92105.

FREE Catalog. Electronic parts, tubes, Wholesale. Thousands of items. Unbeatable prices. Arcturus Electronics ZD, 502-22 St., Union City, N. J. 07087.

TUBES, SEMICONDUCTORS, ELECTRONIC EQUIPMENT & COMPONENTS. Quality merchandise only! Serving engineers, purchasing agents TV/Hifi servicemen and hams for 16 years. Write for catalog or call WA 5-7000, **BARRY ELECTRONICS**, 512 Broadway, New York, N.Y. 10012.

DO-IT-YOURSELF

PROFESSIONAL ELECTRONIC PROJECTS—\$1.00 up. Catalog 25¢, refundable. **PARKS**, Box 25565, Seattle, Wash. 98125.

TAPE AND RECORDERS

RENT Stereo Tapes—over 2,500 Different—all major labels—free brochure. Stereo-Parti, 1616—E. W. Terrace Way, Santa Rosa, California.

BEFORE renting Stereo Tapes, try us. Postpaid both ways—no deposit—immediate delivery. Quality—Dependability—Service—Satisfaction—prevail here. If you've been dissatisfied in the past, your initial order will prove this is no idle boast. Free Catalog. Gold Coast Tape Library, Box 2262, Palm Village Station, Hialeah, Fla. 33012.

TAPE RECORDER SALE. Brand new, latest models, \$10.00 above cost. Arkay Sales, 1028-B Commonwealth Ave., Boston, Mass. 02215.

STEREO TAPES. Save up to 60% (no membership fees, postpaid anywhere USA). Free 60-page catalog. We discount batteries, recorders, tape accessories. Beware of slogans "not undersold," as the discount information you supply our competitor is usually reported to the factory. **SAXITONE**, 1776 Columbia Rd., Washington, D. C. 20009.

HI-FI components, tape recorders, sleep learn equipment, tapes. Unusual Values. Free Catalog. Dressner, 1523 Jericho Turnpike, New Hyde Park 10, N.Y.

TAPE-MATES now offers **ALL TAPES—ALL LABELS** at **TREMENDOUS SAVINGS** plus **FREE Tape-Mates membership.** For **FREE** brochure write **TAPE-MATES**, 5280-EW W. Pico Blvd., Los Angeles 90019.

PATENTS

INVENTIONS: Ideas developed for Cash Royalty sales. Raymond Lee, 130-G West 42nd, N.Y.C. 10036.

AN/APR-4Y FM & AM RECEIVER "FB" FOR SATELLITE TRACKING!



High precision lab instrument, suitable for monitoring and measuring frequency and relative signal strength of signals from 38 to 4000 Mc., in 5 tuning ranges. For 110 volt 60 cycle AC operation, built-in power supply. Original circuit diagram included. Check out perfect. **LIKE NEW \$88.50**

TN-19 TUNING UNIT for above, continuous tuning 975 to 2200 Mc., just right for 1290 Mc. Satellite Frequency and other current Ham activity. Checked out perfect \$69.50
 Other tuning units for above, TN-16, TN-17, TN-18, TN-34 in stock P.U.R.

LORAN R-65/APN-9 RECEIVER & INDICATOR

Used in ships and aircraft. Determines position by radio signals from known xmitters. Accurate to within 1% of distance. Complete with tubes and crystal. **IN LIKE NEW Condition** \$79.50
Used, with all parts, less tubes, crystal and visor **Special \$29.50**

Shock Mount for above \$2.95
 Circuit diagram and connecting plugs available.



LORAN APN-4 FINE QUALITY NAVIGATIONAL EQUIPMENT

Determine exact geographic position of your boat or plane. Indicator and receiver complete with all tubes and crystal. **INDICATOR ID-6B/APN-4, and RECEIVER R-9B/APN-4, complete with tubes. Exc. Used** \$88.50

NEW! APN-4A Receiver-Indicator as above, changed to operate same as APN-4B for improved performance **NEW \$88.50**
Shock Mount for above \$2.95

INVERTER POWER SUPPLY for above APN-4 and APN-9. **INPUT: 24 V DC. OUTPUT: 115 V AC, 800 cycles.** **Like New** \$22.50
 We carry a complete line of replacement parts and accessories for above.

234-258 MC RECEIVER AN/ARR-2
 BRAND NEW! Tune 11. Tunable Receiver with schematic. Only a few at this low price! Complete with tubes. Exc. Used \$10.95

SCR-625 MINE DETECTOR
 Complete portable outfit in original packing, with all accessories. **\$2950**
 Excellent. Used

BC-929 3-Inch Scope, with all tubes, LIKE NEW \$16.50

Conversion instructions, with diagram, for 110 V AC operation \$.65

LM FREQUENCY METER

Crystal calibrated, modulated. Heterodyne, 125 KC to 20,000 Kc. with Calibration book \$79.50

Complete, like new
LM Frequency Meter as above, completely checked out, with tubes and crystal, less calibration book. Exc. Used, clean \$34.50

SCR-274 COMMAND EQUIPMENT

ALL COMPLETE WITH TUBES	Like New	BRAND NEW
BC-453 Receiver	Used	
BC-450 Receiver 3-6 Mc.	\$14.95	\$18.95
BC-454 Receiver 3-6 Mc.	\$15.95	\$24.50
BC-455 Receiver 6-9 Mc.	\$13.95	\$19.50
BC-456 Receiver, 550-1500 Kc. Complete with tubes, Brand New, in original packing		\$48.50
1.5 to 3 MC. Receiver Brand New		\$22.50

110 Volt AC Power Supply for all 274 N and ARC-5 Receivers (complete with metal case, instructions. Factory wired, tested, ready to operate) \$12.50

SPLINED TUNING KNOB for 274-N and ARC-5 RECEIVERS. Fits BC-453, BC-454 and others. Only **49¢**

2.1 to 3 Mc. Transmitter, Brand New \$12.95
BC-458 TRANSMITTER—5.3 to 7 Mc. Complete with all tubes and crystal **\$13.95**

BRAND NEW \$8.95
 Like New

BC-459 TRANSMITTER—7 to 9 Mc. Complete with all tubes and crystal **\$19.50**

Like New \$12.95
BC-696 TRANSMITTER 3-4 Mc Complete with All Tubes & Crystal, Brand New **\$16.95**

Like New \$12.95
BC-456 Modulator **USED 3.45 NEW \$5.95**
 ALL ACCESSORIES AVAILABLE FOR ABOVE

SEND FOR BIG NEW G&G CATALOG

Military & Electronic Surplus—Sensational Bargains!

Include **25¢**

(Refunded with First Order)

Please include 25¢ Deposit with order—Balance C.O.D. or Remittance in Full. 50¢ Handling Charges on all orders under \$5.00. All shipments F.O.B. Our Warehouse, N.Y.C. All Merchandise subject to Prior Sale and Price Change.

G & G RADIO SUPPLY CO.

Telephone: (212) CO 7-4605

77 Leonard St. New York, N.Y. 10013

CIRCLE NO. 114 ON READER SERVICE CARD

GREGORY ELECTRONICS
Reconditioned & Used FM
2-WAY RADIO SAVINGS
 Partial list—Send for New '66 catalog

Lowest Price Ever!
 Reconditioned General Electric
Voice Commander

Personal FM Transmitter-Receiver
 132 to 172 MC, 1 W 9.5"x5.3"x1.7"



PRICE, including Brand New rechargeable Nickel-Cadmium Battery Pack

\$148

If crystals and tuning is desired, add \$40.00.

We also have the proper charges for these units, GE Model #4EP27A10, Price: \$18.

If add'l. nickel cadmium batteries are required, \$25. each. Lapel microphones at \$5. . . or battery pack, power supply bottom housing at \$40.

Free \$5 Lapel Microphone
 WITH EACH VOICE COMMANDER
 Offer for Limited Time Only!

NEW LOW PRICE!



148-172mc
 RCA CMC 60B

6/12v dual dynamotor 60 watt. Fully narrow banded complete

with all accessories, less crystals & antenna. **\$158**

Less Accessories \$128.00. Same unit tuned to desired frequency including new antenna **\$193**



MOTOROLA 30-50mc
 T-51G SERIES

Vibrator Power Supply

6 12v 50-60 watts

Complete with all accessories, less crystals and antenna.

Wide Band **\$208**

Transmitter & Receiver

Fully Narrow Banded **\$238**

(Less accessories, deduct \$30.00)

We Buy Late Model Equipment for Cash
 —Write: Wire or Phone!



GREGORY ELECTRONICS CORPORATION

249 Rt. 46 • Phone 489-9000
 Saddle Brook, N.J. • Area Code 201

CIRCLE NO. 111 ON READER SERVICE CARD

REAL ESTATE

FLORIDA WATER WONDERLAND—Home, cottage, Mobil-sites. Established area. \$590 full price. \$9.00 a month. Swimming, fishing, boating. Write: Lake Weir, Box KE38, Silver Springs, Fla. AD 6-1070 (F-1)

FREE!—ALL NEW SPRING CATALOG Giant 180 pages! Thousands of properties described, pictured—Land, Farms, Homes, Businesses—Waterfront, Recreation, Retirement. Selected Best Buys from The World's Largest. 490 Offices, 35 states Coast to Coast. Mailed **FREE!** STROUT REALTY, 60-ZD East 42nd St., New York, N.Y. 10017.

INVENTIONS WANTED

PATENT Searches including maximum speed, full air-mail report and closest patent copies. \$6.00. Quality searches expertly administered. Complete secrecy guaranteed. Free Invention Protection forms and "Patent Information." Write Dept. 1. Washington Patent Office Search Bureau, 711 14th Street N.W., Washington 5, D.C.

February, 1966

INVENTORS. Outright cash sale or royalties for your inventions. Patented. Unpatented. Active demand from our client manufacturers. Financial assistance available. Write Dept. 48, United States Invention Brokerage, 78 Wall Street, New York 5, N. Y.

IMMEDIATE cash, for Patent Applications, free Patent Searches. Write for details, Universal Patents, 184-Y, Marion, Ohio.

EMPLOYMENT INFORMATION

AUDIO/RF ENGINEER WANTED. Rapidly growing high fidelity manufacturer wants talented circuit designer with experience in audio and RF. Located in New England, firm offers tremendous opportunity. Send resume to: Box 584, **ELECTRONICS WORLD**, One Park Ave., New York, N.Y. 10016.

FOREIGN Employment. Construction. other work projects. Good paying overseas jobs with extras, travel expenses. Write only: Foreign Service Bureau, Dept. D, Bradenton Beach, Florida.

CALIFORNIA EMPLOYMENT. Selected names, addresses of Electronic and Aerospace companies now hiring. Airmail. \$2.00. Jobs, 3105 Mount Vernon, Bakersfield, Calif.

EMPLOYMENT Resumes. Get a better job & earn more! Send only \$2.00 for expert, complete Resume Writing Instructions. J. Ross, 80-34 Kent St., Jamaica 32, N.Y. Dept HF.

BUSINESS OPPORTUNITIES

INVESTIGATE Accidents—Earn \$750 to \$1,400 monthly. Men urgently needed. Car furnished. Business expenses paid. No selling. No college education necessary. Pick own job location. Investigate full time. Or earn \$6.44 hour spare time. Write for Free Literature. No obligation. Universal, CZ-2, 6801 Hillcrest, Dallas, Texas 75205.

SELL CB Equipment—Dealerships available to aggressive people who can sell Citizens Band Radio full or part time. Knox Electronic, Dept. 194, Galesburg, Ill. 61401.

FREE BOOK "990 Successful, Little-Known Businesses." Work Home! Plymouth-945T, Brooklyn, New York 11218.

I MADE \$40,000.00 YEAR by mailorder! Helped others make money! Start with \$10.00—Free proof. Torrey, Box 3566-N, Oklahoma City, Oklahoma 73106.

ARNOLD PALMER OFFERS YOU unequalled opportunity to profit from tremendous popularity of golf and power of Palmer. Highly profitable exclusive Palmer Golf Franchises available. Complete national program. Hefty profits—minimum investment. Write for details. Arnold Palmer Enterprises, Dept. CD, Pleasantville, New Jersey, Tel. 609-646-3500.

MAILORDER LAWS \$2.00. Kelvin Kahn, Attorney, 4504 Pine, Philadelphia, Pa.

EARN extra money selling advertising book matches. Sample kit furnished. Match Corp, Dept. MO-26, Chicago, Ill. 60632.

FREE "Franchise Profit Letter" tells how unique NFR service is helping thousands seeking profitable businesses. Write today. National Franchise Reports, D-528, 333 North Michigan, Chicago 60601.

STAMPS

FREE—Mint British Colonials from Antarctic Territory, Borneo, Brunei, St. Christopher, Nevis, Caymans, Tranganu, Pitcairns. Free with approvals. **VIKING**, Great Neck 50, N.Y.

WOW! 110 All Different Germany 10¢ Commemoratives, Airmails, High Values, Big Catalog, bargain lists plus selections of fine stamps from our approval service, returnable without obligation. Jamestown Stamp, Dept. A26EG, Jamestown, N.Y. 14701.

HYPNOTISM

FREE Hypnotism. Self-Hypnosis, Sleep Learning Catalog! Drawer H400, Ruidoso, New Mexico 88345.

MISCELLANEOUS

WINEMAKERS: Free illustrated catalog of yeasts, equipment. Semplex, Box 7208, Minneapolis, Minn. 55412.

POEMS or new songs wanted. Tin Pan Alley, Inc., 1650 Broadway, New York, N.Y. 10019.

FREE! PLUS CHOOSE ANY \$1.00 ITEM FREE

\$25 WORTH OF TRANSISTORS, RECTIFIERS, RESISTORS, CONDENSERS, DIODES & ETC.

Add 25¢ for handling

BOTH FREE WITH ANY \$10 ORDER

FACTORY TESTED SEMI-KON-DUCTORS

- 10 PNP SWITCHING TRANSISTORS, 2N3404, asst \$1
- 10 NPN SWITCHING TRANSISTORS, 2N338, asst. \$1
- 15 PNP TRANSISTORS, CK722, 2N35, 107 no test \$1
- 15 NPN TRANSISTORS, 2N35, 170, 440, no test \$1
- 30 TRANSISTORS, rf, Audio osc-if's, TO5 no test \$1
- 10 FAMOUS CK722 TRANSISTORS, pop no test \$1
- 5 2N107 TRANS'RS, by GE, pop, pop. audio pak \$1
- 2 40W NPN SILICON MESA 2N1648, 2N1014 \$1
- 4 2N13 TRANSISTORS, mixer-cony, TO22 . . . \$1
- 10 MICRODIODE STABILIZERS, epoxy, silicon . . \$1
- 3 2N706 500MW, 300MC NPN PLANAR, TO16 . \$1
- 3 2N255 POWER TRANSISTOR EQUALS, TO3 cases! 2—500MC, 2N708 NPN Silicon planar TO16 . \$1
- 3 2N711 300MW, 300 MC, PNP MESA, TO1B . \$1

HIGH POWER SALE \$1

PNP 100Watt/15 Amp HPower
 TO36 Case! 2N441, 442, 277,
 278, DS501 up to 50 Volts

- 5 SUN BATTERIES TO 1 1/2" sizes, lite sensitive \$1
- 85 WATT 2N424 PLANAR, silicon, TO-53 npn \$1
- 6 TRANSITRON TRANS'RS, 2N341, no test, npn \$1
- 4 "TEXAS" 20 WATTERS, 2N1038-1042, w/sink \$1
- 4 2N170 TRANSISTORS, by GE, npn for gen'l rf \$1
- 6 TRANSISTOR RADIO SET, osc-if's, driver-pp . \$1
- 25 GERMANIUM & SILICON DIODES, no test . . \$1
- 25 TOP HAT RECTIFIERS, silicon, 750ma, no test \$1
- 3 2-WATT PLANAR TRANS'RS, 2N697, 100mc \$1
- 4 2N35 TRANSISTORS, npn, by Sylvania, TO22 . \$1
- 25 "EPOXY" SILICON RECTIFIERS no test . . . \$1
- 4 ZENER REFERENCES, 1N429, 6-volt, silicon . \$1
- 2 "TINY" 2N1613 2W, 100MC, TO46 case, npn \$1
- 85 WATT 2N1212 PLANAR, drift, 10mc, npn . . \$1
- 4 2N443 OUTPUT TRANSISTORS, by GE, nnp, TO5 \$1
- 4 2N333 NPN SILICON transistors, by GE, TO5 \$1
- 10 2-6AMP RECT's, studs, silicon, 50 to 400V . \$1
- 10 30-MC TRANSISTORS, silicon, TO18, no test \$1

"EPOXY"—3000 piv 200 ma RECTIFIERS . . . 1.00
 "EPOXY"—6000 piv 200 ma RECTIFIERS . . . 2.50
 10-WATT ZENER STUD ANY VOLTAGE 3V to 200.75
 ONE WATT ZENER DIODES, choose from 3V to 200.45
 "EPOXY" 1AMP 1000 PIV RECTIFIERS, axial,45

WORLD'S MOST POPULAR \$1 PARTS PAKS

- 40 WORLD'S SMALLEST COND., to .05mf . . . \$1
- 4 TRANSISTOR TRANSFORMERS, asst. worth \$25 \$1
- 3 TRANSISTOR AUDIO AMP, tiny, wired . . . \$1
- 3 INFRA-RED DETECTORS, with leads \$1
- \$25 SURPRISE PAK: transistors, rect, diodes, etc. \$1
- 40 PRECISION RESISTORS, 1/2, 1, 2W; 1% values \$1
- 30 CORNING "LOW NOISE" resistors, asst. . . \$1
- 60 TUBULAR CONDENSERS, to .5mf, to 1KV, asst \$1
- 40 DISC CONDENSERS, 27mmf to .05mf to 1KV \$1
- 60 TUBE SOCKETS, receptacles, plugs, audio, etc. \$1
- 30 POWER RESISTORS, 5 to 50W, to 24 Kohms. \$1
- 50 MICA CONDENSERS, to .1mf, silvers tool . . \$1
- 10 VOLUME CONTROLS, to 1 meg, switch tool . \$1

CLAIREX CL505 PHOTO CELL \$1.00
 .500" dia. x 1/2" l.

- 10⁶ ELECTROLYTICS, to 500mf, asst FP & tubulars \$1
- 50 RADIO & TV KNOBS, asst'd. colors & styles . \$1
- 10 TRANSISTOR ELECTROLYTICS: 10mf to 500mf \$1
- 50 COILS & CHOKES, if, rf, ant, osc, & more . . \$1
- 35 TWO WATTERS, asst incl: A.B., 5% tool . . \$1
- 75 HALF WATTERS, asst incl: A.B., 5% tool . . \$1
- 60 HI-Q RESISTORS, 1/2, 1, 2W, 1% & 5% values \$1
- 10 PHONO PLUG & JACK SETS, tuners, amps . . \$1
- 30 "YELLOW" MYLAR CONDENSERS, asst val \$1
- 60 CERAMIC CONDENSERS, discs, npo's, to .05 \$1
- 40 "TINY" RESISTORS, 1/10W, 5% tool . . . \$1
- 10 TRANSISTOR SOCKETS for pnp-npn transistors \$1

TRANSITRON

TESTED SILICON CONTROLLED RECTIFIERS

PRV.	7A AMP	16A AMP	25A AMP	PRV.	7 AMP	15 AMP	25 AMP
25	.30	.50	.85	350	1.25	1.85	2.50
50	.45	.75	1.00	400	1.50	2.25	2.75
100	.80	1.00	1.50	400	1.75	2.69	3.25
150	.90	1.30	2.00	500	1.95	3.19	3.80
200	1.15	1.75	2.25	600	2.25	3.50	4.50

GIANT SPRING CATALOG ON: PARTS RECTIFIERS TRANSISTORS SCRS ZENERS

10¢

POLY PAKS

TERMS: Send check, money order. Add postage—avg. wt. per pak 1 lb. Ret'd net 30 days. Deposit 25% deposit.

P.O. BOX 942W
 50, LYNNFIELD, MASS.
 "PAK-KING" of the world

CIRCLE NO. 96 ON READER SERVICE CARD

Don't Buy a 1966 Car!

... unless you've read the 1966 Car and Driver Yearbook. It's got the answer to every automotive question you can think of . . .

- All new road tests of 60 models — economy cars; compact, intermediate and full-size sedans; sports sedans; sports and GT cars; luxury cars.
- A buyer's guide to more than 100 other models, covering virtually every car available in the U.S.A.
- A comprehensive analysis of what's happening in the automobile industry — styling, engineering, safety, prices and predictions.
- Technical specifications of all domestic and imported cars.
- A spectator's guide to racing, with action-packed photos.
- 16 pages of accessories and performance equipment.



8-COLOR ANTIQUE CAR CHART

—ready for framing—printed in Sweden. Regularly \$2.95. Save \$1 by ordering now with 1966 Yearbook—both for just \$3.35!



— Fill in Detach and Mail Coupon Today —

Ziff-Davis Service Division/Dept. CDY
589 Broadway/New York, N.Y. 10012

Send me the Yearbook only. \$1.25 enclosed, plus 15¢ for shipping and handling. (\$1.50 for orders outside the U.S.A.)

Please send me the 1966 Car and Driver Yearbook plus the Antique Car Chart. \$3.35 enclosed. (\$4.00 for orders outside the U.S.A.) Allow three additional weeks for delivery.

print name _____ EW-26

address _____

city _____ state _____ zip code _____

PAYMENT MUST BE ENCLOSED WITH ORDER

ELECTRONICS WORLD FEBRUARY 1966

ADVERTISERS INDEX

READER SERVICE NO.	ADVERTISER	PAGE NO.	READER SERVICE NO.	ADVERTISER	PAGE NO.
125	Allied Radio	86	105	Lafayette Radio Electronics	55
	American Institute of Engineering & Technology	82	104	Lampkin Laboratories, Inc.	67
124	B&K Manufacturing Co.	86	103	Milwaukee School of Engineering	69
88	Belden Manufacturing Company	2	102	Motorola Training Institute	65
123	Burstein-Applebee Co.	74	100	Music Associated	64
	Capitol Radio Engineering Institute, The	18, 19, 20, 21	99	Nation-Wide Tube Co.	92
122	Cleveland Institute of Electronics	67		National Radio Institute	SECOND COVER
	Cleveland Institute of Electronics	70, 71, 72, 73	98	Olson Electronics, Inc.	76
	Columbia Electronics	92	97	P. F. Reporter	63
121	Conar	12	200	Pace Communications Corp.	6
120	Cornell Electronics Co.	94	96	Poly Paks	95
119	Delta Products	4		RCA Electronic Components and Devices	FOURTH COVER
118	Editors and Engineers, Ltd.	78	95	RCA Electronic Components and Devices	13
117	Edmund Scientific Co.	93	94	RCA Electronic Components and Devices	22
116	Electronic Components Co.	91		RCA Institutes, Inc.	8, 9, 10, 11
	Fair Radio Sales	92	84	Radar Devices Manufacturing Corp.	17
115	Finney Company, The	5		Slep Electronics Co.	93
114	G & G Radio Supply Co.	93	93	Sylvania	7
113	Goodheart Co. Inc., R. E.	94		Telex	61
	Grantham School of Electronics	60	92	Texas Crystals	60
112	Greenlee Tool Co.	78			
111	Gregory Electronics Corporation	95			
	Hallicrafters	14			
110	Hallicrafters	14	87	United Radio Co.	91
109	Heath Company	56, 57, 58, 59	91	University Sound	79
	JFD Electronics Corporation	THIRD COVER	86	University Sound	79
108	JFD Electronics Corporation	THIRD COVER		Valparaiso Technical Institute	82
107	Jerrold Electronics Corporation	77		Weller Electric Corp.	65
106	Johnson Company, E. F.	1	89	Winegard Co. Antenna Systems	64
	Kuhn Electronics	82			

CLASSIFIED ADVERTISING 91, 92, 93, 94, 95

america's no. 1

LICENSED UNDER ONE OR MORE OF U.S. PATENTS 2,958,081; 2,985,879; 3,011,168; 3,108,280; 3,150,376; 3,210,767; RE. 25,740 AND ADDITIONAL PATENTS PENDING IN U.S.A. AND CANADA. PRODUCED BY JFD ELECTRONICS CORPORATION UNDER EXCLUSIVE LICENSE FROM THE UNIVERSITY OF ILLINOIS FOUNDATION.

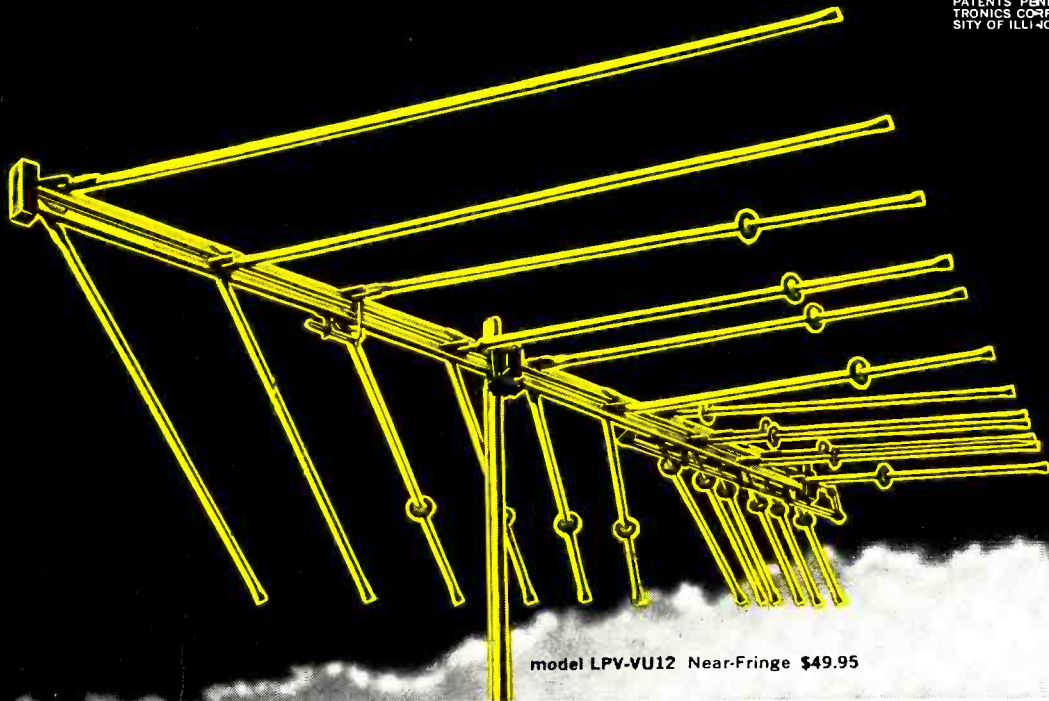

model LPV-VU12 Near-Fringe \$49.95



VHF / UHF / FM ANTENNA!

Because it delivers best 82-channel TV performance—COLOR or black/white—plus FM/Stereo—using only a single downlead!

No other antenna works like the 82-channel JFD LPV-VU Color Log Periodic...

- Only the JFD LPV-VU is designed according to the patented log periodic design of the University of Illinois Antenna Research Laboratories.
- Only the JFD LPV-VU utilizes capacitor-coupled Cap-Electronic dipoles for higher mode operation that achieves higher gain, narrower beamwidths on VHF channels 7 to 13 and UHF channels 14 to 83. (Our competition's copies of the JFD LPV-VU use only fundamental mode which resonate as simple dipoles with consequently limited gain.
- Only the JFD LPV-VU offers true frequency-independent performance that insures brilliant color on any channel.

JFD®

LPV-VU® Color LOG PERIODIC

You bet you can have everything you want in one antenna—VHF, UHF, FM—with a single down-lead, too! Start tearing up JFD 82-channel LPV-VU Color Log Periodics with all the 82-channel TV sets in your area—see the difference in profits and performance. Call your distributor or write for brochure 806.

32 million readers of LIFE will be seeing spectacular JFD LPV Color Log Periodic advertisements all season long. This unprecedented LIFE campaign will be pre-selling JFD LPV antennas for you!

Full-color television commercials will show millions more why the LPV's patented space-log periodic design works best on any channel—color & black/white.

6 GREAT MODELS TO CHOOSE FROM



model LPV-VU18
Far-Fringe
\$69.95



model LPV-VU15
Fringe
\$59.95

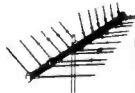

model LPV-VU12
Near-Fringe
\$49.95



model LPV-VU9
Suburban-Fringe
\$39.50



model LPV-VU6
Metro-Suburban
\$27.50



model LPV-VU5
For City Use
\$25.95

JFD ELECTRONICS CORPORATION

15th Avenue at 62nd Street, Brooklyn, N. Y. 11219
JFD Electronics-Southern Inc., Oxford, North Carolina
JFD International, 64-14 Woodside Ave., Woodside 77, N. Y.
JFD Canada, Ltd., Canada

RCA all-new, rare-earth Hi-Lite Color Picture Tubes are being stocked by smart dealers who are ready for the replacement color picture tube business.

why?

Hi-Lite's rare-earth phosphors provide picture brightness unsurpassed in the color TV industry. Natural color reproduction. Great black-and-white pictures, too! **RCA's Hi-Lite Color Picture Tube Line is here. Now! Available in 19-inch and 25-inch rectangulars and 21-inch round tube types.**

What about you? Are you ready for color?

RCA ELECTRONIC COMPONENTS AND DEVICES, HARRISON, N.J.



The Most Trusted Name in Electronics

