

Radio-Electronics

FEB. 50¢

TELEVISION • SERVICING • HIGH FIDELITY

HUGO GERNSBACK, Editor-in-chief

A
GERNSBACK
PUBLICATION

How to be a Go-Go sound man!
(THE DISCOTHEQUES NEED YOU!)

Build a capacitor-discharge ignition

How to keep a service shop open

**Build this super-sensitive
LIGHT METER
for less than \$10!**



TRIPLET

EXTRA QUALITY IS HIDDEN*

MODEL 630 V-O-M PRICE † \$5500

Standard Of The Industry



USES UNLIMITED:

- Field Engineers
- Application Engineers
- Electrical, Radio, TV, and Appliance Servicemen
- Electrical Contractors
- Factory Maintenance Men
- Industrial Electronic Maintenance Technicians
- Home Owners, Hobbyists

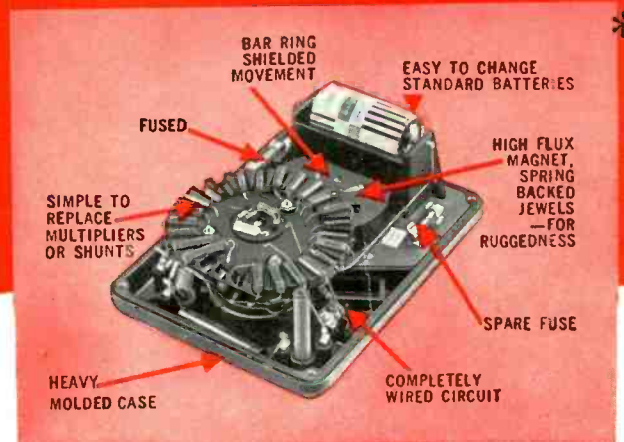

FACTS MAKE FEATURES:

- 1** Popular streamlined tester with long meter scales arranged for easy reading. Fuse protected.
- 2** Single control knob selects any of 32 ranges—less chance of incorrect settings and burnouts.
- 3** Four resistance ranges—from .1 ohm reads direct; 4½ ohm center scale; high 100 megohms.

Attention to detail makes the Triplet Model 630 V-O-M a lifetime investment. It has an outstanding ohm scale; four ranges—low readings .1 ohm, high 100 megs. Fuse affords extra protection to the resistors in the ohmmeter circuit, especially the X1 setting, should too high a voltage be applied. Accuracy 2% DC to 1200V. Heavy molded case.

†630A same as 630 plus 1½% accuracy and mirror scale only \$6500

TRIPLET ELECTRICAL INSTRUMENT COMPANY, BLUFFTON, OHIO
Circle 1 on reader's service card

RANGES

DC VOLTS	0-3-12-60-300-1,200-6,000 at 20,000 ohms per volt.
AC VOLTS	0-3-12-60-300-1,200-6,000 at 5,000 ohms per volt.
OHMS	0-1,000-10,000.
MEG OHMS	0-1-100.
DC MICRO AMPERES	0-60 at 250 millivolts.
DC MILLI-AMPERES	0-1.2-12-120 at 250 millivolts.
DC AMPERES	0-12.

DB: -20 to +77 (600 ohm line at 1 MW).

OUTPUT VOLTS: 0-3-12-60-300-1,200; jack with condenser in series with AC ranges.

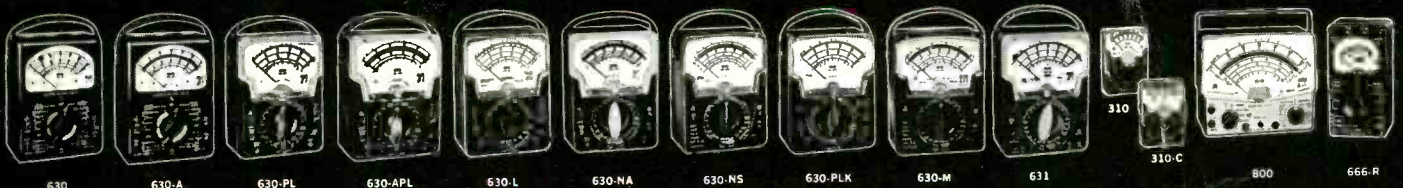

THE WORLD'S MOST COMPLETE LINE OF V-O-M'S. AVAILABLE FROM YOUR TRIPLET DISTRIBUTOR'S STOCK.

COLUMBIA STEREO TAPE CLUB

now offers you

ANY 4 STEREO TAPES

\$5.98

FOR ONLY

Value up to \$33.80 at regular Club prices

if you join the Club now and agree to purchase as few as 5 selections in the next 12 months from the more than 200 to be offered.

FREE if you join now REVOLUTIONARY SELF-THREADING TAKE-UP REEL



Just drop the end of the tape over this reel, start your recorder, and watch it thread itself! Unique Scotch® process automatically threads up tape of any thickness, releases freely on rewind.

COLUMBIA STEREO TAPE CLUB
Terre Haute, Indiana 47808

I accept your special offer and have written in the right the numbers of the 4 tapes I would like to receive for \$5.98, plus a small mailing and handling charge. I will also receive my self-threading reel — FREE!

My main musical interest is (check one):

CLASSICAL

POPULAR

I understand that I may select tapes from any field of music. I agree to purchase five selections from the more than 200 to be offered in the coming 12 months, at the regular Club price plus a small mailing and handling charge. Thereafter, if I decide to continue my membership, I am to receive a 4-track, pre-recorded tape of my choice FREE for every two additional selections I accept.

Print

Name..... First Name Initial Last Name

Address.....

City.....

State..... Zip Code.....

This offer is available only within the continental limits of the U.S.

(fill in numbers below)

48-TA

IF YOU ARE ONE OF THE FORTUNATE PEOPLE who owns 4-track stereo tape playback equipment, you know the thrill of the near-perfect fidelity, the unsurpassed sound of tape. Now you have an exceptional opportunity to build an outstanding collection of superb stereo tapes at great savings through this generous offer now being made by the Columbia Stereo Tape Club!

By joining now you may have ANY FOUR of the magnificently recorded 4-track stereo tapes described here — sold regularly by the Club for up to \$33.80 — for only \$5.98!

TO RECEIVE YOUR 4 PRE-RECORDED STEREO TAPES FOR ONLY \$5.98 — simply fill in and mail the coupon provided above. Be sure to indicate the type of music in which you are mainly interested: Classical or Popular.

HOW THE CLUB OPERATES: Each month the Club's staff of music experts chooses a wide variety of outstanding selections. These selections are described in the entertaining and informative Club Magazine, which you receive free each month.

You may accept the monthly selection for the field of music in which you are primarily interested . . . or take any of the wide variety of other tapes offered . . . or take no tape in any particular month.

Your only membership obligation is to purchase 5 tapes from the more than 200 to be offered in the coming 12 months. Thereafter, you have no further obligation to buy any additional tapes . . . and you may discontinue your membership at any time.

FREE TAPES GIVEN REGULARLY. If you wish to continue as a member after purchasing five tapes you will receive — FREE — a 4-track stereo tape of your choice for every two additional tapes you buy.

The tapes you want are mailed and billed to you at the regular Club price of \$7.95 (occasional Original Cast recordings somewhat higher), plus a small mailing and handling charge.

SEND NO MONEY — Just mail the coupon today to receive your four pre-recorded 4-track stereo tapes—ALL FOUR for only \$5.98!

IMPORTANT NOTE: All tapes offered by the Club must be played on 4-track stereo playback equipment. If your tape recorder does not play 4-track stereo tapes you may be able to convert it simply and economically. See your local service dealer for complete details.

COLUMBIA STEREO TAPE CLUB
Terre Haute, Indiana

<p>DOWN TOWN PETULA CLARK Now That You've Gone In Love • 10 MORE</p>	<p>THE KING FAMILY SHOW! Pass Me By • Stardust Climb Every Mountain 13 MORE</p>	<p>DORIS DAY'S SENTIMENTAL JOURNEY COLUMBIA</p>	<p>BROADWAY BOUQUET The Magnificent Strings of Percy Faith</p>	<p>God Bless America Mormon Tabernacle Choir Ormandy, Phila. Orch.</p>	<p>DAVE BRUBECK QUARTET Angel Eyes Let's Get Away From It All Violets For Your Furs 4 MORE</p>
<p>1780. Also: Baby It's Me, Be Good to Me, Music, etc.</p>	<p>2136. Also: Love At Home, Pass Me By, Amen, Remember, etc.</p>	<p>2153. Serenade In Blue, I'll Never Smile Again, 12 in all</p>	<p>2161. Long Ago, Make Someone Happy, Who Can I Turn To, etc.</p>	<p>2180. America, The Beautiful; American Salute; 9 more</p>	<p>2159. Also: The Night We Called It A Day, etc.</p>
<p>REVERIE Clair De Lune • Pavane Greenleeves • Nocturne • Other Favorites</p>	<p>ROGER WILLIAMS plays THE HITS Dear Heart • Mr. Lonely People 9 more</p>	<p>Elgart au Go Go LES & LARRY ELGART</p>	<p>GOLDFINGER Original Motion Picture Sound Track</p>	<p>WEST SIDE STORY Original Soundtrack Recording</p>	<p>THE VENTURES PLAY TELSTAR THE LONELY BULL 10 MORE</p>
<p>908. Also excerpts from "Swan Lake" and "Peer Gynt" Suite</p>	<p>2077. Also: Willow Weep for Me, French, Try to Remember, etc.</p>	<p>2126. Wing of the Road, Down Town, Meditation 9 more</p>	<p>1704. Featuring the title song sung by Shirley Bassey</p>	<p>1037. "The most adventurous musical ever made."—Life</p>	<p>1008. Also: Green Onions, Red River Rock, Calcutta, etc.</p>
<p>My Name Is Barbra COLUMBIA</p>	<p>Tchaikovsky: NUTCRACKER SUITE Prokofiev: PETER AND THE WOLF Leonard Bernstein N.Y. Philharmonic</p>	<p>TONY'S GREATEST HITS I Let My Heart Go in San Francisco I Wanna Be Around The Good Life 9 MORE</p>	<p>This Is My Country NORMAN TABERNACLE ★ STAR-SPANGLED BANNER ★ AMERICA, THE BEAUTIFUL ★ FINLANDIA • MARSEILLAISE 13 IN ALL</p>	<p>ROBERT GOULET SUMMER SOUNDS plus Summertime • 18 Cut By • 8 more</p>	<p>BOB DYLAN BRINGING IT ALL BACK HOME Featuring SUBTERRANEAN HOMESICK BLUES</p>
<p>2183. Also: Where Is The Wonder, I've Got No S rings, etc.</p>	<p>1070. "Skillfully warmly, richly performed."—High Fidelity</p>	<p>2150. Iap, If I Ruled the World, Who Can I Turn To, etc.</p>	<p>1266. Also: Land of Hope and Glory, This Is My Country, etc.</p>	<p>2154. Also: Old Cape Cod, Mam'selle, If You Love Me, etc.</p>	<p>2007. Also: Gates of Eden, On The Road Again, 11 in all</p>
<p>PETER, PAUL & MARY A Song Will Rise</p>	<p>ORIGINAL MOTION PICTURE SCORE What's New Pussycat? featuring TOM JONES singing the title song</p>	<p>LOVE A FAIR THE RA CONNIFF SINGERS Hi-Low, Hi-Low 10 more</p>	<p>STANDING OVATION JERRY VALE Lum's Back In Town Granada The Song Is You 10 MORE</p>	<p>THE RETURN OF ROGER MILLER (featuring DO-WACKA-DO) SMASH plus KING OF THE ROAD 10 more</p>	<p>BOB BROOKMEYER and friends STAN GETZ • RON CARTER HERBIE HANCOCK GARY BURTON • ELVIN JONES</p>
<p>214. When The Ship Comes In, For Lovin' Me, 10 more</p>	<p>2151. Other artists include Dionne Warwick, Manfred Mann</p>	<p>1983. Also: For All We Know, Just Friends, Mam'selle, etc.</p>	<p>1768. Also: If I Had You, I'm Always Chasing Rainbows, etc.</p>	<p>1892. Also: In The Summertime, There I Go Dreamin', etc.</p>	<p>1713. A lively session abounding in passion and truth</p>

TWIN-PACK Equivalent To Two Selections

KWIKETTE SOLDERING AIDS...

the revolutionary new connectors that make **QUICK** work of parts replacement!

WIRE + FLUX + SOLDER, ALL in One!

The 3-in-1 KWIKETTE is not just another wire spring connector...Copperweld wire inner core, a layer of flux, and an outer jacket of solder... all you need is heat!



Ten times actual size

Once again, Sprague helps the TV-radio service industry by solving difficult servicing problems... parts replacement on printed wiring boards, in "inaccessible" chassis nooks, and on crowded terminal lugs. Mechanically sturdy and electrically reliable, the KWIKETTE provides quick, expert, "one-handed" soldered connections as easy as A-B-C!

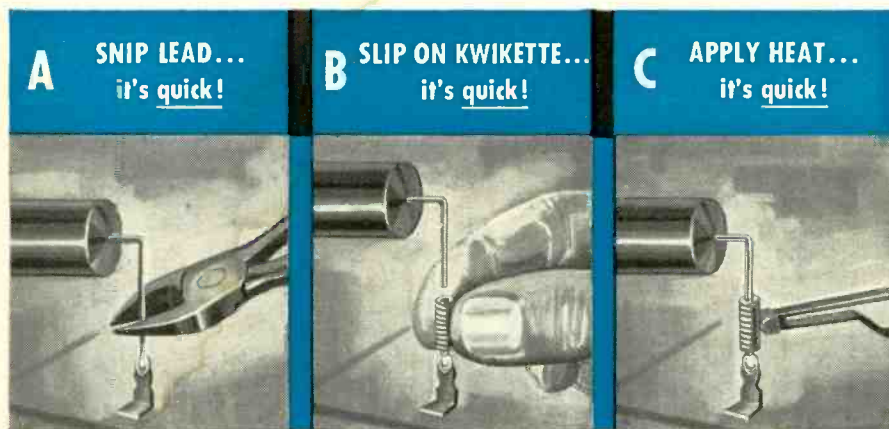

NOBODY ELSE HAS KWIKETTE CONNECTORS... YOU GET 'EM ONLY FROM SPRAGUE PRODUCTS!

KWIKETTES are now being packed with Sprague Atom[®] Capacitors at no extra cost to you! Whenever you need tubular electrolytics, insist on pre-packaged Sprague Atoms from your parts distributor and you'll automatically get your KWIKETTE component connectors... the biggest boon to the service technician since the soldering gun!

* Trademark

SPRAGUE[®]
THE MARK OF RELIABILITY

WORLD'S LARGEST MANUFACTURER OF CAPACITORS

65-0116

Circle 2 on reader's service card

Our cover shows most of the parts you'll need to build the super-sensitive light meter on page 50. (The meter has its mind fixed on 80 μ a, but yours should read zero when it isn't connected to anything.) All parts are available from Lafayette (see parts list), except the knob, which is sold by Alco Electronic Products, 3 Wolcott Ave., Lawrence, Mass.

Color photography and cover design by Harry Schlack

TRY CAPACITOR-DISCHARGE IGNITION

for your car. Costs a little more than conventional or transistor ignition, but worth it! Better firing of fouled plugs, less drain from the battery, no weak or missed sparks from breaker-point bounce. Uses reliable SCR circuit with transistor power inverter.

What you read on PAGE 34 may be the most helpful material you'll read all year!

HOW TO BE A GO-GO SOUND MAN

There's spare-time cash for you in discotheque sound systems! Read how to set up a system—find out what you need, how to charge for your services, what precautions to take, plus pointers from an author who's learned by experience!

Simple, direct and astonishingly easy-to-follow pointers start on PAGE 46.

WHY GLOW LAMPS GLOW

Ionic glow lamps (like neon lamps) are used in computers, electronic organs, color television sets, tape recorders, test instruments, regulated power supplies, and hundreds of other kinds of electronic apparatus. How do they work? Read all about them, and try practical circuits: an electronic siren or chime, computer logic flip-flops, relay triggers.

Turn to PAGE 53 for this lively story on an intriguing phenomenon!

Radio-Electronics

FEBRUARY 1966 VOL. XXXVII No. 2

Over 55 Years of Electronic Publishing

EDITORIAL

- 33** Electromagnetic Interference.....*Fred Shunaman*

ELECTRONICS

- 34** Try a Capacitor-Discharge Ignition System.....*Theodore Gerald*
Far better than ordinary transistor or conventional ignition, author claims

COVER STORY

- 50** Build this Ultra-Sensitive Light Meter.....*Leon A. Wortman*
Simplifies fine-detail photography, measures light levels around home or shop

- 58** "Electronic Key" Unlocks Automatic Garage Doors.....*L. M. Dezettel*
Only your door, that is!

- 66** The Diode with Gain.....*Albert C. W. Saunders*
How the tunnel diode works. Three experimental circuits you can build.

- 94** Special Tricks with Relays.....*Ronald L. Ives*
Relays can do some switching jobs better and cheaper than tubes or transistors

GENERAL

- 22** Service Clinic.....*Jack Darr*
Power Supply Impedance: "Common" Troublemaker

- 53** Why Glow-Lamps Glow.....*Tom Jaski*
... and how they are used in a variety of helpful and interesting circuits

- 61** What's Your EQ?

AUDIO-HIGH FIDELITY-STEREO

- 36** Tuning Electronic Organs.....*Daniel J. Ehrlich*

- 37** Build the Simpli-fier.....*Harold Balyoz*
"Gutless" three-transistor amplifier is a natural for portable stuff

- 46** How to be a Go-Go Sound Man.....*Thomas R. Haskett*
Supply sound for a discothèque in your town

- 69** Equipment Report: KLH Model 18 FM Stereo Tuner

- 92** Transistor Mike Preamp for PA.....*James E. Pugh, Jr.*
Two-mike mixer uses only one transistor

TELEVISION

- 43** Gestalt Service.....*Thomas R. Haskett & Jack Blount*
TV service gets a little boost from the local psychoanalyst

- 49** Scanning Laser Makes TV Pix in Total Darkness

- 56** How to Keep a Service Shop Open.....*Jack Darr*
Keep people from dead-beating down your door

RADIO

- 38** Getting Acquainted with Transistor AGC.....*Lambert C. Huneault*
How gain is controlled by voltage from the detector

- 60** Fast Turn-on for Vacuum-Tube Radios.....*Edward L. Bonin*

TEST INSTRUMENTS

- 40** Get More Out of Your Scope.....*Robert G. Middleton*
You can discover a lot about coils with just your oscilloscope

- 45** Voltage Regulator Stabilizes RF Signal Generators.....*Harold J. Weber*

- 68** Equipment Report: Eico 965 Farad-Ohm Bridge Analyzer

- 78** T. I. Potpourri
Assorted shop ideas

THE DEPARTMENTS

- 61, 101** Corrections
14 Correspondence
103 New Books
90 New Literature

- 85** New Products
76 New Semiconductors & Tubes
4 News Briefs

- 102** Noteworthy Circuits
80 Technotes
97 Try This One
61 50 Years Ago

- 82** Reader's Service Page

HUGO GERNSBACK, *editor-in chief and publisher.* M. HARVEY GERNSBACK, *editor.* Fred Shunaman, *managing editor.* Robert F. Scott, W2PWG, *technical editor.* Peter E. Suthem, *associate editor.* Jack Darr, *service editor.* I. Queen, *editorial associate.* Wm. Lyon McLaughlin, *technical illustration director.*

RADIO-ELECTRONICS, February 1966, Volume XXXVII, No. 2. Published monthly by Gernsback Publications, Inc., at Ferry Street, Concord, N. H. 03302. Second-class postage paid at Concord, N. H. Printed in U.S.A. One-year subscription rate: U. S. and possessions, Canada, \$5. Pan-American countries, \$6. Other countries, \$6.50. Single copies: 50¢. © 1966, by Gernsback Publications, Inc. All rights reserved. POSTMASTERS: Send Form 3579 to 154 W. 14th St., New York 10011.



Member,
Institute of High Fidelity
Radio-Electronics
Is Indexed In
Applied Science
& Technology Index
(Formerly
Industrial Arts Index).

NEWS BRIEFS

1966 IEEE PRESIDENT

Dr. William G. Shepherd, vice president of academic administration of the University of Minnesota, succeeds Dr. Barnard M. Oliver as presi-



dent of the Institute of Electrical and Electronics Engineers for 1966, whose membership is now over 146,000. Dr. Shepherd was at Bell Labs from 1937 until 1947; his principal research activities were concerned with nonlinear microwave circuits and electron tubes, particularly reflex klystrons for radar applications. At Minnesota he helped establish the Physical Electronics Research Laboratories.

One of the vice presidents for 1966 will be Walter K. MacAdams of American Telephone & Telegraph.

CATV IN NYC

New York City has granted franchises to supply New Yorkers with wired television through three community antenna television (CATV) systems. This, the franchises state, will improve subscribers' reception greatly by eliminating interference and distortion caused by New York's tall buildings, bridges and ever-present electrical noise. Installation will cost \$19.50; the monthly rental fee will be \$5. New York is the first large United States city to franchise a CATV system.

RADIO TUBES NOT DONE FOR, SAYS RCA EXECUTIVE

The present strong demand for replacement electron tubes for home-entertainment applications will contin-

ue well into the 1970's, states Harold F. Bersche, RCA Electronic Components & Devices vice president. "The tremendous surge of color television, plus the strong demand for black-and-white sets, will result in close to one billion new receiving-tube sockets created by new TV receivers during the next five years."

SYLVANIA SEEKS MARKETS IN UNIQUE FIELDS

The new Commercial Electronics Division of Sylvania, in Bedford, Mass., is planning to exploit three new electronic markets: educational electronics systems, transportation control systems and hospital communications systems.

E. F. Vigneron, vice-president and general manager, showed a small FM receiver with four pushbuttons, to be used in the Educating system (RADIO-ELECTRONICS, March 1965, p. 6), an educational system in which programs are transmitted from FM stations. During the lessons, questions are asked of the students, who select one of four answers by pressing the appropriate button. If a student hits the correct button he is commended for his choice; if not, he is given an explanation.

The second avenue of expansion is an in-motion freight-car identifica-

tion system called KarTrak. An unmanned trackside scanner reads a band of colored stripes attached to each freight car. The stripes are coded to give the freight-car number and other pertinent information. The device can also be used to keep track of trailer trucks traveling piggyback on railroad cars. The KarTrak scanner can identify rolling stock traveling up to 100 miles per hour.

Neither system is now in actual commercial use. The third, the hospital communications system, is, but the new Sylvania approach is a considerable advance on the present art. It includes such things as hand-held microphone units (to replace the call bell) for calling a nurse, with additional controls for turning room TV or radio off or on, etc. Provision is also made for direct viewing of patients under intensive care, and there are more cheerful aspects, such as TV-intercom with children in the hospital foyer, and TV tours for patients of the hospital's facilities.

HOLOGRAMS NOW IN TWO COLORS

The hologram, that strange type of "picture" produced with the help of a laser and viewable in three dimensions, can now be made in two colors. Two Bell scientists, Keith S. Pennington and Lawrence H. Lin, achieved

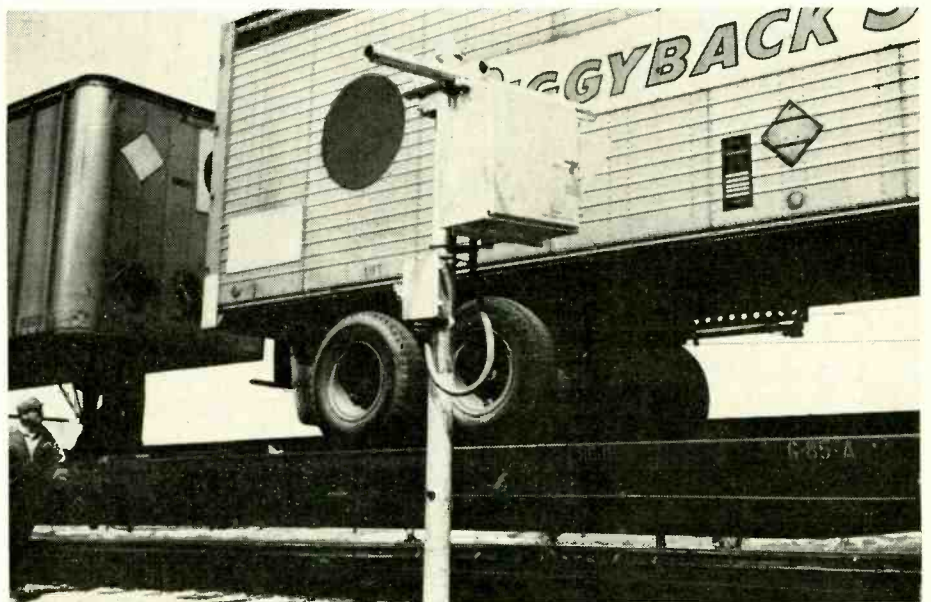

A KarTrak scanner, mounted beside the track in position to identify freightcars or piggyback trailer units. The scanner also provides a strong beam of light to illuminate the identifying strip on the car or trailer.

DEVRY TECH NOT ONLY TRAINS YOU... BUT HELPS YOU GET STARTED AT NO EXTRA COST IN THE **BIG-MONEY FIELD** OF

ELECTRONICS!

✓ PREPARE AT HOME

Whether you want to prepare for a good-paying new job or for advancement in Electronics with your present employer, DeVry Tech offers specialized educational programs designed to meet your needs. You set up your own HOME LABORATORY and work over 300 construction and test procedures to develop on-the-job type skills. You build a quality Transistorized Meter, a 5-inch Oscilloscope and a special Design Console. DeVry also includes modern "programmed" texts, instructive motion pictures, Consultation Service. Effective? Yes!

✓ RESIDENT SCHOOL

If you prefer you may get all of your training in DeVry's U.S. or Canadian resident schools under the close guidance of friendly, experienced instructors. You work with a wide variety of commercial equipment similar to that actually used in industry as you prepare in our laboratories for a technician's job in Communications, Microwaves, Radio-Television, Automation, Radar, Computers, or other branch of Electronics. DeVry even provides part-time job placement service to those who wish to earn extra money while attending day or evening classes.

✓ PLACEMENT SERVICE

Meet W. E. Bartz, who has helped thousands of DeVry men toward exciting, profitable careers in Electronics. When YOU complete your program, he will help you too. As Placement Manager in touch with business and industry across the nation, Bartz knows the employer demand for DeVry-trained men. He has cooperated in placing our graduates with thousands of firms!

Men 18-45, start preparing NOW for this vast opportunity field. Soon you should be ready for DeVry's valuable employment help!



HOME LABORATORY EQUIPMENT — YOURS TO KEEP!



EXPERIENCED INSTRUCTORS



MAIL COUPON TODAY!

No Advanced Education or Previous Technical Experience Needed to Get Started

Your ambition and desire to succeed are more important! DeVry guides you every step of the way toward success.

Free

Send coupon for these two factual booklets NOW!



DEVRY TECHNICAL INSTITUTE

4141 Belmont Avenue • Chicago, Illinois 60641

Accredited Member of National Home Study Council

DEVRY TECHNICAL INSTITUTE

4141 Belmont Avenue, Chicago, Ill., 60641 Dept. RE-2-W

Please give me your two free booklets, "Pocket Guide to Real Earnings," and "Electronics in Space Travel"; also include details on how to prepare for a career in Electronics. I am interested in the following opportunity fields (check one or more):

- | | |
|--|---|
| <input type="checkbox"/> Space & Missile Electronics | <input type="checkbox"/> Communications |
| <input type="checkbox"/> Television and Radio | <input type="checkbox"/> Computers |
| <input type="checkbox"/> Microwaves | <input type="checkbox"/> Broadcasting |
| <input type="checkbox"/> Radar | <input type="checkbox"/> Industrial Electronics |
| <input type="checkbox"/> Automation Electronics | <input type="checkbox"/> Electronic Control |

Name _____ Age _____

Address _____ Apt. _____

City _____ State _____ Zip _____ Code _____

Check here if you are under 16 years of age.

2103 HOME STUDY AND RESIDENT SCHOOL TRAINING AVAILABLE IN CANADA

COMPLETE TUNER OVERHAUL

ALL MAKES - ONE PRICE

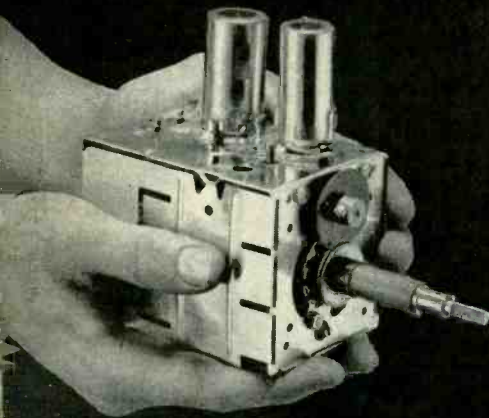

ALL LABOR AND PARTS (EXCEPT TUBES & TRANSISTORS)*

995



VHF



UHF



COLOR



UV



COLOR TUNERS



TRANSISTOR

Guaranteed Color Alignment—No Addit. Charge

Simply send us the defective tuner complete; include tubes, shield cover and any damaged parts with model number and complaint. Your tuner will be expertly overhauled and returned promptly, performance restored, aligned to original standards and warranted for 90 days.

UV combination tuner must be single chassis type; dismantle tandem UHF and VHF tuners and send in the defective unit only.

Exact Replacements are available for tuners unfit for overhaul. As low as \$12.95 exchange. (Replacements are new or rebuilt.)

Pioneers in TV Tuner Overhauling

CASTLE

TV TUNER SERVICE, INC.

MAIN PLANT: 5715 N. Western Ave., Chicago 45, Illinois
 EAST: 41-96 Vernon Blvd., Long Island City 1, N.Y.
 IN CANADA: Castle Television Services, Ltd. . . .
 Nation-wide service

*Major Parts are additional in Canada

the two-color pictures by using two lasers as the source of the coherent light required to make a hologram.

A red light from a helium-neon laser and a blue light from an argon laser were combined into a single beam of bluish-pink. The beam is split into two parts; one part scattered directly from the object or color transparency onto a photographic plate; the other part reflected from a mirror to the same photographic plate. The two beams striking the plate form interference patterns throughout the emulsion.

When the original red and blue beams are directed on the completed hologram, a single two-color image can be seen.

HIGHER-POWER MICROWAVES WITH SIMPLE DEVICES

"Transit-time" devices have been shown by Bell Telephone scientists to be more effective under some conditions than transistors or tunnel diodes for generating and amplifying microwaves. They have already generated as much as 60 mw of continuous power in the 2-11-gHz range.

The simplest of these devices is a piece of n-type gallium arsenide between two metal contacts. This is the Gunn oscillator, described by J. B. Gunn of IBM in 1963. At Bell Labs it has been used to generate continuous microwaves between 2-3 GHz, with more than 60 mw output at efficiencies around 5%.

Two other types of transit-time devices look for all the world like old-time crystal detectors. A small silicon crystal is held between two solid contacts in a small cartridge. One type is the Read avalanche diode, which consists of a p-n junction, an intrinsic area and another n-type area. The length of the intrinsic area governs the tran-

sit time, and therefore the frequency. This type has produced continuous oscillations at about 5 GHz with an output of 20 mw.

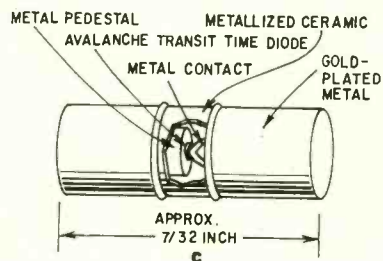
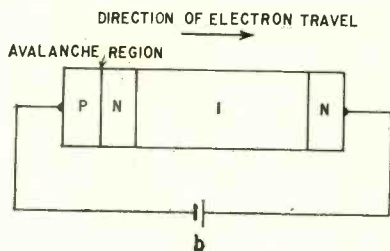
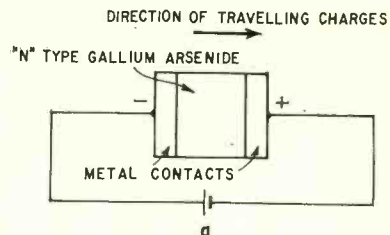

(a) Gunn oscillator (b) Read avalanche diode (c) Simple junction diode (the physical appearance of the simple junction diode and the Read avalanche diode are much the same).

Another form uses a simple p-n junction in a silicon avalanche diode. These have been used as amplifiers at Bell Laboratories for frequencies as high as 10-11 GHz, with a gain of 20 db and a bandwidth of 30 MHz. As generators, their output was as high as 13 mw.

HARMONIC COMPRESSOR MAKES "SPEED HEAR" RECORDINGS

An electronic device recently developed by Bell Labs can make recordings of the human voice that are playable at twice their normal speed, while retaining normal voice pitch. This device, it is believed, would permit blind persons to listen to recorded material at normal persons' silent reading speed, to name one valuable application. (It also might make tape correspondence more practical. While a tape can be made faster than a letter can be typed, the readback speed is

continued on page 12

RADIO-ELECTRONICS is published by Gernsback Publications, Inc.
 Chairman of the Board: Hugo Gernsback
 President: M. Harvey Gernsback
 Vice President-Secretary: G. Aliquo
 Vice President-Treasurer: Charles A. Raible
 Editorial, Advertising, Subscription and Executive offices: 154 West 14th Street, New York 10011.

Subscribers: When requesting change of address please furnish an address label from a recent issue. Allow one month for change of address.

ADVERTISING REPRESENTATIVES: East: John J. Lamson, Eastern Sales Manager, RADIO-ELECTRONICS, 154 West 14th Street, New York 10011, 212 AL 5-7755; Midwest: P. H. Dempers Co., 5555 N. Lincoln Ave., Chicago, Illinois, 60611, 312 561-0220; South Central: Media Representatives, Inc., 7900 Carpenter Freeway, Dallas, Texas 75247, 214 ME 1-4480; West Coast: J. E. Publishers' Representative Co., 8380 Melrose Avenue, Los Angeles, California, 90069, 213-653-5841; 420 Maret Street, San Francisco, California, 94111, 415-981-4527; United Kingdom: Publishing & Distributing Co., Ltd., Mitre House, 177 Regent St., London W.1, England.

◀ Circle 12 on reader's service card

RADIO-ELECTRONICS



NEW DUO-BEAM 10 by hy-gain

Now, with Hy-Gain's Duo-Beam 10, you can add miles of distance to your Citizens Band range...transmit and receive stronger and clearer signals in the area you've been working. And, because the Duo-Beam 10 is ROTATABLE, you can do it with PINPOINT ACCURACY in any of the 360 degrees surrounding your station! The Duo-Beam 10 is a twin-driven 10 element beam that re-forms the 5 watts output power from your transceiver and funnels it in a "ray-like" path close to the ground to deliver you power equivalent to what you'd get from a CB rig with output power as high as 120 watts. That's "Talk Power." The Duo-Beam 10 is rugged, too...all heavy gauge aluminum construction with iridite treated hardware...designed to survive 80 mph winds. Easy to install on rooftop towers, TV towers, or on a 1 5/8" mast...It's guaranteed to outperform any legal antenna for CB. **Model 1110DB \$99.95 Net**

93 Watts TALK POWER...

DUO-BEAM 6—Another new rotatable Duo-Beam by Hy-Gain...twin-driven 6 element model that delivers 93 watts "Talk Power." Guaranteed to outperform any legal CB antenna other than the Duo-Beam 10. **Model 116DB . . . \$69.95 Net**

42 Watts TALK POWER...

DUO-BEAM 4—The smallest of Hy-Gain's new rotatable Duo-Beams...a 4 element model that delivers 42 watts "Talk Power." Guaranteed to outperform any legal CB antenna other than the Duo-Beam 6 or 10. **Model 114DB . . \$39.95 Net**

*Available now from your Hy-Gain Dealer or Distributor
Send for complete descriptive literature—Form No. 13*

HY-GAIN ELECTRONICS CORPORATION
8561 N.E. Highway 6—Lincoln, Nebraska 68501

Circle 4 on reader's service card

You get more for your money from NRI-

America's oldest and largest Electronic, Radio-TV home-study school

Compare if you like. You'll find—as have so many thousands of others—that NRI training can't be beat. From the delivery of your first lessons in the remarkable, new Achievement Kit we send you, to "bite size," easily-read texts and carefully designed training equipment . . . NRI gives you more value.

Shown below is a dramatic, pictorial example of all of the training materials included in just one NRI Course. *Everything* you see pictured below is included in low-cost NRI training. Other major NRI courses are equally complete. Text for text, kit for kit, dollar for dollar—your best home-study buy is NRI.



GET A FASTER START WITH NRI'S NEW EXCLUSIVE ACHIEVEMENT KIT

The day we receive your enrollment application we mail out your Achievement Kit. It contains everything you need to make an easy, fast start in the Electronics training of your choice. This attractive, new starter kit is an outstanding, logical way to introduce you to home-study as NRI teaches it . . . an unparalleled example of the value of NRI training . . . training that is backed up by a dedicated staff and the personal attention you should expect of a home-study school. It is your first of a number of special training aids carefully developed by the NRI laboratories to make your adventure into Electronics absorbing, meaningful. What's in the Achievement Kit? Your first group of lesson texts; a rich vinyl desk folder to hold your study material; the industry's most complete Radio-TV Electronics Dictionary; valuable reference texts; lesson answer sheets; pre-addressed envelopes; pencils; pen; engineer's ruler—even postage. No other school has anything like the NRI Achievement Kit.

LEARNING BECOMES AN ABSORBING ADVENTURE WITH NRI TRAINING KITS

Electronics comes alive with NRI training kits. What better way to learn than by doing it? That's why NRI pioneered and perfected the "home lab" technique of learning at home in your spare time. You get your hands on actual parts and use them to build, experiment, explore, discover. NRI invites comparison with training equipment offered by any other school. Begin NOW this exciting program of practical learning. It's the best way to understand the skills of the finest technicians—and make their techniques your own. Whatever your reason for wanting to increase your knowledge of Electronics . . . whatever your field of interest . . . whatever your education . . . there's an NRI instruction plan to fit your needs, at low tuition rates to fit your budget. Get all the facts about NRI training plans, NRI training equipment. Fill in and mail the attached postage-free card today. No salesman will call. NATIONAL RADIO INSTITUTE, Washington, D.C. 20016.

OUR 50th YEAR OF LEADERSHIP

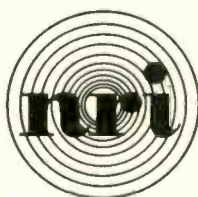

IN ELECTRONICS TRAINING

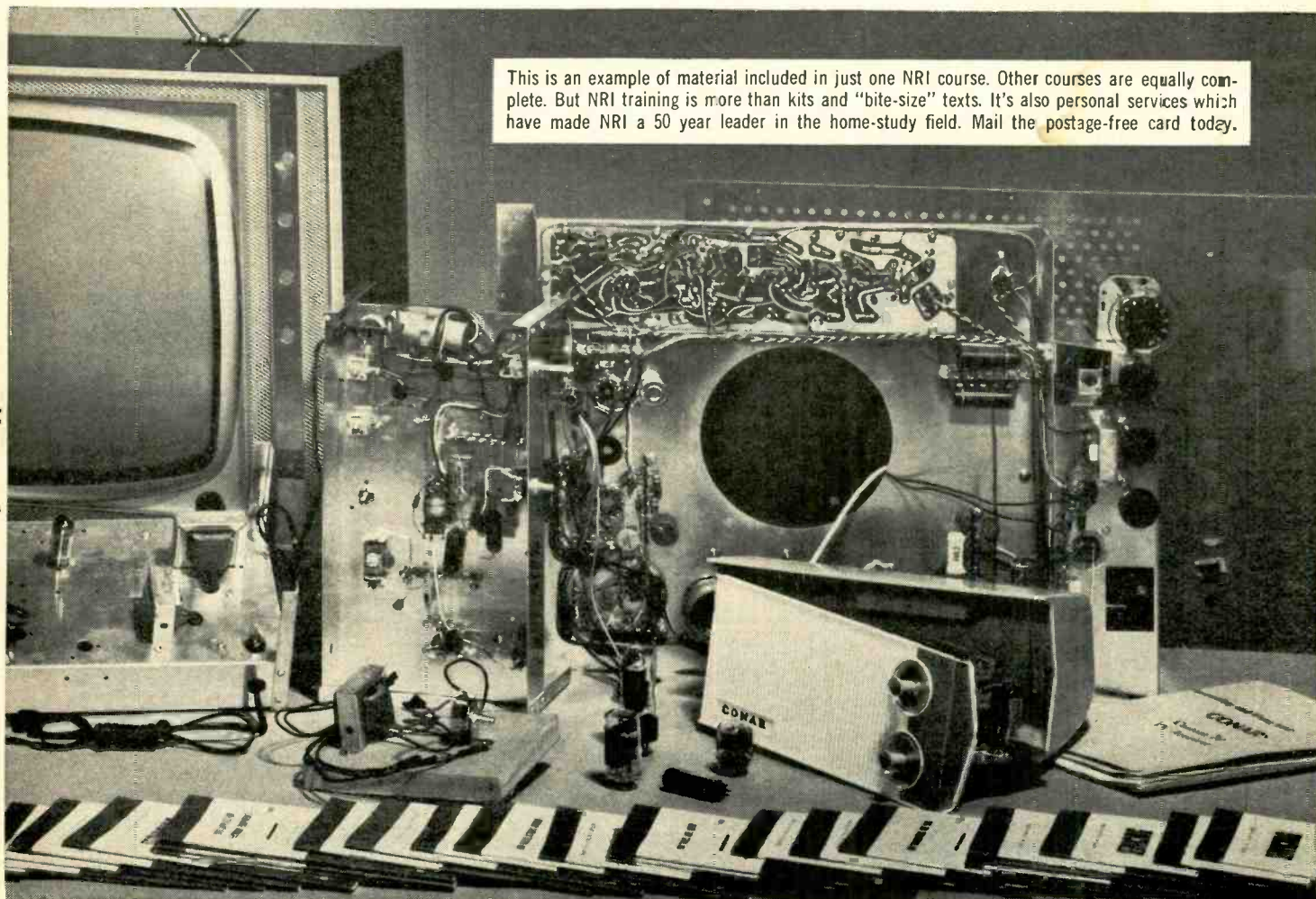

This is an example of material included in just one NRI course. Other courses are equally complete. But NRI training is more than kits and "bite-size" texts. It's also personal services which have made NRI a 50 year leader in the home-study field. Mail the postage-free card today.

Complete TUNER REPAIR

\$9.50



Includes
ALL parts
(except tubes)...
ALL labor on
ALL makes for
complete
overhaul.

**FAST, 24-HOUR SERVICE
with FULL YEAR WARRANTY**

Sarkes Tarzian, Inc., largest manufacturer of TV and FM tuners, offers unexcelled tuner overhaul and factory-supervised repair service.

Tarzian-made tuners received one day will be repaired and shipped out the next. More time may be required on other makes. Every channel checked and realigned per original specs. And, you get a full, 12-month guarantee against defective workmanship and parts failure due to normal usage. Cost, including labor and parts (except tubes) is only \$9.50 and \$15 for UV combinations. Replacements at low cost are available on tuners beyond practical repair.

Always send TV make, chassis and Model number with faulty tuner. Check with your local distributor for Sarkes Tarzian replacement tuners, parts or repair service. Or, use the address nearest you for fast, factory-supervised repair service.

SARKES  TARZIAN

TUNER SERVICE DIVISION

537 S. Walnut St., Bloomington, Ind.
Tel: 812-332-6055

10654 Magnolia Blvd., N. Hollywood, Calif.
Tel: 213-769-2720

TUNER SERVICE  CORPORATION

(Factory-supervised tuner service
authorized by Sarkes Tarzian, Inc.)

547 Tonnele Avenue, Jersey City, N.J.
Tel: 201-792-3730

**Manufacturers of Tuners, Semiconductors,
Air Trimmers, FM Radios, AM-FM Radios,
Audio Tape and Broadcast Equipment**

NEWS BRIEFS continued

very much slower than reading a letter.)

Speech is fed to a bank of 36 bandpass filters which separate it into its various frequency components. The output of the bank of filters is sent through 36 frequency dividers which halve the frequencies in each of the narrow-band components. The halved frequency signals then go to networks that remove any distortion and combine the 36 halved signals into one signal. This is recorded on magnetic tape. The halved frequencies are restored to their original values by doubling the playback speed, which reproduces the original speech at normal pitch but at double the speed.

CB USER SENTENCED TO JAIL

A Massachusetts resident, Richard P. Greenside, has been sentenced to one year in jail for transmission of obscene, indecent and profane language over a Citizens Radio station.

This, states the Boston office of the Federal Communications Commission's Field Engineering Bureau, is the first step in an intensive enforcement campaign to combat the use of improper language by Class-D Citizens Radio stations. Similar enforcement efforts are being conducted by the other Field Engineering Bureau officers in the United States and territories.

CALENDAR OF EVENTS

International Symposium on Information Theory, Jan. 31-Feb. 12; UCLA, Los Angeles, Calif.

International Exhibition of Electronic Components, Feb. 3-8; Porte de Versailles, Paris

International Solid-State Circuits Conference, Feb. 9-11; Univ. of Pa. & Sheraton Hotel, Philadelphia, Pa.

Philadelphia High-Fidelity Music Show of 1966, Feb. 18-20; Benjamin Franklin Hotel, Philadelphia, Pa.

Institute of High Fidelity Paris Show, March 10-15; Paris, France

IEEE International Convention, March 21-25; Coliseum and New York Hilton Hotel, New York, N.Y.

The National Bureau of Standards has let a contract for design of a building at Fort Collins, Colo., for its standard frequency station WWV, now located at Greenbelt, Md. WWV is scheduled to begin transmitting from the new site on July 1, 1966. Improved services will result from the move.

Radio-Electronics Adopts Hertz

RADIO-ELECTRONICS is now using the term *Hertz*—recently adopted officially in the United States—in place of cycles in all references to frequency. This term has been used for many years in other countries. Hz, KHz and MHz, abbreviations for Hertz, kilohertz and megahertz, are replacing cycles, kc and mc in all recently edited material. You may run across the older abbreviations in copy set in type before the change.

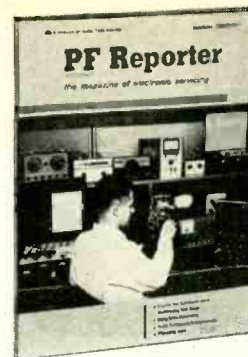

send just  and
I will send you this special
Test Equipment issue of
PF REPORTER

David K. Hamer

There's no better way to acquaint you with the invaluable, practical help PF REPORTER offers you month-after-month in your electronics work, than to start your subscription with a copy of the special March 1966 Test Equipment issue for just one cent!

We'll enter your subscription with March, and send you the next 11 big issues for only \$2.49—regular subscription rate is \$5.00 per year—so you save ONE-HALF!

To see what we mean about the practical value of PF REPORTER, here are just some of the features in the Test Equipment issue:

Inside View of Color Test Equipment • Test Equipment for FM-Stereo • Square-Wave Tests for Hi-Fi • Test Equipment for UHF-TV • Repairing Automotive Test Equipment • Meter Repair for Steady Hands • Converting Scopes to Triggered Sweep • Guide to Test-Lead Adapters • Servicing Mobile Radio with a Scope • Understanding Color-Bar Generators • Checking Color TV with B/W Equipment • Notes on Latest Test Equipment—AND MUCH MORE!

A single issue of PF REPORTER can bring you information and help worth many times our special low introductory subscription price. *And here's your solid guarantee:* Subscribe to PF REPORTER today. If you aren't completely satisfied it's the best magazine in the electronics servicing field, just let us know and we'll refund the unexpired portion of your subscription immediately.

**SPECIAL HALF-PRICE PF REPORTER
INTRODUCTORY SUBSCRIPTION OFFER!**

**PF REPORTER, Dept. RER-2
Box 68003, Indianapolis, Ind. 46268**

Okay—here's my penny—start my subscription with your Special Test Equipment issue, and bill me for \$2.49 for a full one-year term (regular rate is \$5 per year).

\$2.50 enclosed Bill me

Name _____

Firm _____

Address _____

City _____ State _____ Zip _____

Circle 5 on reader's service card

RADIO-ELECTRONICS

NEW from

FINCO

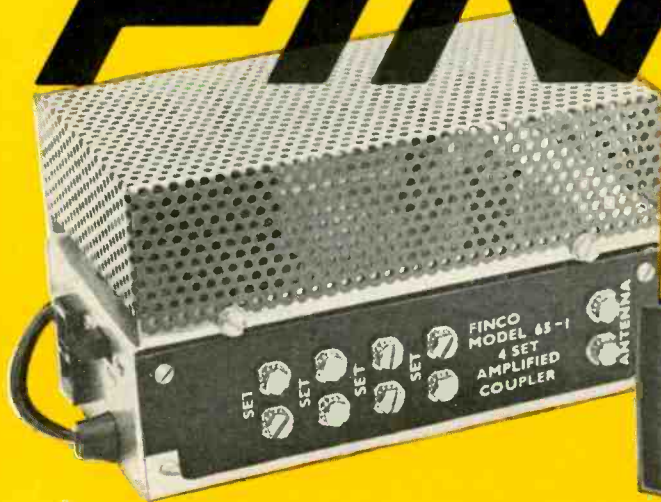

BOOSTER-COUPLER

Model No. 65-1 List \$29.95



UHF CONVERTERS

Model U-Vert 300 List \$39.95

Model U-Vert 200 List \$26.90

Model U-Vert 100 List \$19.95

ALL FINCO PRODUCTS "COLOR"
ARE ENGINEERED FOR

The BOOSTER-COUPLER

"for Deluxe Home and Commercial Use"

Two tube, 4 set VHF-TV or (FM) Distribution Amplifier for home and small commercial distribution systems . . . with low loss splitters (FINCO #3001 or #3003) can feed 16 or more sets, depending on signal level and line length losses. FEATURES:

- On-Off Switch
- AC convenience receptacle
- Ventilated perforated steel cabinet 6 $\frac{5}{16}$ " x 3 $\frac{7}{16}$ " x 3 $\frac{3}{16}$ "
- Metal enclosed to eliminate shock hazard
- Easy access for tube servicing
- Convenient, easy mounting . . . bracket and screws supplied
- UL listed AC cord
- 117 Volts, 60 cycles
- Attractive appearance with rugged commercial construction
- No strip terminals
- Minimum "snow" (very low noise figure)
- 100% test for all electronic characteristics

The CONVERTERS

"That challenge all competition"

FEATURES:

- Drift free fine tuning
- Post conversion signal amplification
- Solid state chassis — shockproof
- Convenient AC outlet on converter
- Exact input-output impedance match
- Lighted dial tuning
- Full color and black-white signal conversion
- High gain — low noise
- Conforms to FCC radiation specifications
- Easy installation — UL approved
- Instant warm-up — Operates at Channel 5 or 6
- A model for every reception area

Write for beautiful color brochures — Numbers 20-338 and 20-377

Atlanta
Fort Worth
Kansas City
Chicago
Cleveland
Detroit

THE FINNEY COMPANY

34 West Interstate Street Bedford, Ohio 44014 Dept. RE

New York
Pittsburgh
San Francisco
Los Angeles
Boston
Albany

Circle 6 on reader's service card

Announcing the new line of world-famous Schober Organ Kits...

ASSEMBLE YOUR OWN ALL-TRANSISTOR SCHOBER ELECTRONIC ORGAN



Designed by organists for organists, the new Schober Recital Organ actually sounds like a fine pipe organ. The newly-invented Schober Library of Stops provides you with an infinite number of extra voices so that you can instantly plug in the exact voices you prefer for a particular kind of music. Thirteen-piston, instantly resettable Combination Action makes the

Recital Organ suitable for the most rigorous church and recital work. The Schober Reverbatape Unit gives you big-auditorium sound even in the smallest living room. An instrument of this caliber would cost you \$5000 to \$6000 in a store. Direct from Schober, in kit form (without optional percussions, pistons, Reverbatape Unit) costs you only \$1500.

All-New, All-Transistor Schober Recital Organ

- 32 voices, 6 couplers delight professional musicians...make learning easy for beginners.
- Standard console, pedals, keyboard correspond exactly to pipe-organ specifications.
- Printed circuit construction and detailed, illustrated instructions make for easy assembly...no previous experience necessary.
- Highly accurate church and theatre pipe tone in 5 pitch registers make every kind of organ music sound "right".
- Optional: Combination Action, Schober Reverbatape Unit, Repetitive Theatre Percussions.

New, All-Transistor Schober Console II

Here's the most luxurious "home-size" organ available today...with the same circuitry and musical design as the impressive Recital Organ. Full 61-note manuals, 17 pedals, 22 stops and coupler, 3 pitch registers, and authentic



theatre voicing leave little to be desired. Musically much larger than ready-made organs selling for \$1800 and more...the Console II, in kit form, costs only \$850.

New Schober Spinnet

The Schober Spinnet is among the very smallest genuine electronic organs; only 39 1/4 inches wide, it will fit into the smallest living room or playroom—even in a mobile home. Yet it has the same big-organ tone and almost the



same variety of voices as the larger Console II. The Schober Spinnet far exceeds the musical specifications of ready-made organs selling for \$1100 and more. In easy-to-assemble kits...only \$550.

Schober Organ Kits are sold in the U.S. only by...

THE *Schober Organ* CORPORATION

43 West 61st Street, New York, N.Y., 10023

Dealers in Canada, Australia, Hong Kong, Mexico, Puerto Rico and the United Kingdom.

SEND FOR FREE SCHOBER BOOKLET

...Describes the exciting Schober Organ and optional accessories in detail; it includes a FREE 7-inch "sampler" record so you can hear before you buy.

Also available:
10-inch high-quality, long playing record... fully illustrates all three models with different kinds of music. Price is refunded with first kit purchase... \$2.00



The Schober Organ Corp., Dept. RE-41
43 West 61st St., New York, N.Y., 10023

Please send me, without cost or obligation, the Schober Organ Booklet and free 7-inch "sampler" record.

Enclosed find \$2.00 for 10-inch quality, LP record of Schober Organ music. (\$2.00 refunded with purchase of first kit.)

Name _____

Address _____

City _____ State _____ Zip No. _____

Circle 7 on reader's service card



RELIABLE TRANSISTOR TACH: ACCUSATION AND DEFENSE

Dear Editor:

Referring to "A Reliable Transistor Tachometer" by Stephen Gross, RADIO-ELECTRONICS, September 1965, Mr. Gross states that total error does not exceed 5%. Total error is equal to the sum of each error, i.e., 14%. (Worst case error from Fig. 2—temperature error at 38°F, 8% supply-voltage error at 5.55 vdc, 6%.) This is without considering meter-movement error. Proper design, using a one-shot multivibrator as a pulse-forming network, would be far superior *without* thermistor compensation.

THOMAS J. BARMORE

San Diego, Calif.

Stephen Gross Replies:

First: Systematic errors of this type are random and must not be added directly. The total error is expressed in the form of a *mean square error*.

For example, if three such random errors are 7%, 5% and 8%, the total error e_T would be

$$e_T = \left[\frac{(7)^2 + (5)^2 + (8)^2}{3} \right]^{1/2} = 6.8\%$$

Second: To discuss the behavior of an instrument as its environment varies from zero to infinity is meaningless. You have to specify limits in which the equipment is to operate. I did this on the temperature curve but did not on the voltage curve since the voltage limits are set primarily by the voltage regulator and battery condition—usually 5.8 volts full load at idle and 6.4 volts no load with engine racing. As far as meter error is concerned, I don't know what type of meter Mr. Barmore has in mind; however, 2% is a fairly common figure. Total error using maximum error shown on the curves, computed by the same method as before, comes to only 3.46%.

Finally the basic design objective in a circuit of this type is to generate a constant-energy pulse independent of variations in circuit operating conditions. A good circuit for that is a blocking oscillator with saturable-core transformer. But the transformer is expensive. And a one-shot (Schmitt trigger or similar) is not necessarily superior. The energy in the output pulse of the one-shot would depend on bias voltage and transistor

Engineered for Professional Quality and savings up to 50%

Whether you want the creative pleasure and thrift of build-it-yourself, or factory-assembled professional quality equipment ready-to-use—you save up to 50% with EICO

no-compromise engineering. Be super-critical. Compare EICO with anybody else. The more critically you judge, the more you'll see for yourself that your best buy is EICO.

EICO

KITS & WIRED

COLOR TV LAB

Three compact portable instruments for shop or home Color TV servicing. Add one more and you're set for FM-MPX stereo.



New Model 380 Solid State NTSC Color Generator generates exact NTSC color signals individually and all required dot-bar patterns. Super-compact, 4 pounds light, instant operation. \$159.95 wired only.

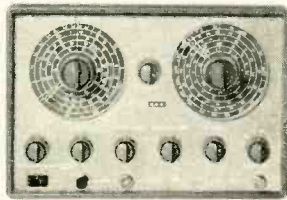

Model 369 Sweep/Marker Generator for easiest, fastest visual alignment of color or B&W TV and FM RF and IF circuits. Five sweep ranges from 3-220mc. Four marker ranges from 2-225mc. Crystal marker oscillator. Post injection of markers. \$89.95 kit, \$139.95 wired.

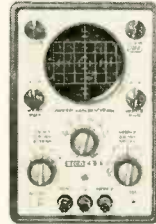

New Model 435 Direct-Coupled Wideband Scope. Top-quality DC-4.5mc scope with 3" flat-face CRT. Zener calibrator: Outperforms 5" scopes three times its size, facilitates on-location color TV and other servicing. \$99.95 kit, \$149.95 wired.



New Model 342 FM Multiplex Signal Generator. Design lab quality. Both composite audio and FM RF outputs. Inputs for stereo audio source for store demonstrations, critical A/B listening tests. \$149.95 wired.



New Model 1030 Regulated Power Supply. Speeds troubleshooting, design work, production line testing, electronics teaching. Variable bias and plate sources regulated to 1/3 of 1%: 0-150V @ 2ma; 0-400V @ up to 150ma. Ripple less than 3mv rms. Unregulated fil. volts of 6.3V & 12.6V, @3A. Switchable, monitoring milliammeter and voltmeter. \$59.95 kit, \$99.95 wired.



New Model 378 Audio Generator. Near-distortionless sine wave generator (<0.1% 20-20,000c) providing fast, convenient switch-selection of frequencies from 1c to 110kc (1c steps 1c-100c, 10c steps 100c-1kc, 100c steps 1kc-10kc, 1kc steps 10kc-110kc), 8-pos. 10db/step output attenuator & fine attenuator. Output meter (4 1/2" 200ua) with 8 voltage ranges & db scale. \$49.95 kit, \$69.95 wired.



New Model 965 FaradOhm Bridge/Analyzer. "Unusually versatile" — Electronics World. 9-range, low-voltage capacitance-resistance bridge safely measures even 1-volt electrolytics. Metered bridge balance, leakage test voltage (6 DC VTVM ranges 1.5-500V), leakage current (11 DC VTAM ranges 0.15ua-15ma). DC VTVM & VTAM externally usable. \$129.95 wired.



Model 460 Wideband Direct-Coupled 5" Oscilloscope. DC-4.5mc for color and B&W TV service and lab use. Push-pull DC vertical amp., bal. or unbal. input. Automatic sync limiter and amp. \$89.95 kit, \$129.50 wired.



Model 232 Peak-to-Peak VTVM. A must for color or B&W TV and industrial use. 7-non-skip ranges on all 4 functions. With Uni-Probe.® \$29.95 kit, \$49.95 wired.



New Model 779 Sentinel 23 CB Transceiver. 23-channel frequency synthesizer provides crystal-controlled transmit and receive on all 23 channels. No additional crystals to buy ever! Features include dual conversion, illuminated S/R/F meter, adjustable squelch and noise limiter, TVI filter, 117VAC and 12VDC transistorized dual power supply. Also serves as 3.5 watt P.A. system. \$169.95 wired.



New Model 3566 All Solid-State Automatic FM MPX Stereo Tuner/Amplifier. "Very satisfactory product, very attractive price" — Audio Magazine. No tubes, not even nuvistors. Delivers 112 watts IHF total to 4 ohms, 75 watts to 8 ohms. Completely pre-wired and pre-aligned RF, IF and MPX circuitry, plus plug-in transistor sockets. \$219.95 kit (optional walnut cabinet \$14.95), \$325.00 wired including walnut cabinet. UL approved.



New Model 753 The one and only SSB/AM/CW Tri-Band Transceiver Kit. "The best ham transceiver buy for 1966" — Radio TV Experimenter Magazine. 200 watts PEP on 80, 40 and 20 meters. Receiver offset tuning, built-in VOX, high level dynamic ALC. Unequaled performance, features and appearance. Sensationally priced at \$179.95 kit, \$299.95 wired.

FREE 1966 CATALOG

EICO Electronic Instrument Co., Inc. RE-2
131-01 39th Ave., Flushing, N.Y. 11352

Send me FREE catalog describing the full EICO line of 200 best buys, and name of nearest dealer. I'm interested in:

- test equipment ham radio
 stereo/hi-fi Citizens Band radio

Name _____

Address _____

City _____ State _____

1945-1965: TWENTY YEARS OF LEADERSHIP IN CREATIVE ELECTRONICS

Circle 8 on reader's service card

FIRST AND ONLY compact Scrulox® screwdriver sets

Increasing use of Scrulox square recess screws in appliances, radios, TV sets, electronic instruments... even the control tower at Cape Kennedy... has created a need. A need for compact, versatile driver sets. Small enough to tuck in a pocket. Complete enough to be practical on shop bench or assembly line.

Now, here they are... from Xcelite, of course.



PS44
COMPACT
CONVERTIBLE SET

Five color coded midget Scrulox drivers—#00 thru #3

One midget nutdriver—1/4" hex

"Piggyback" torque amplifier handle increases reach and driving power

See-thru plastic case doubles as bench stand



99SL
INTERCHANGEABLE
BLADE KIT

Five Scrulox blades—#00 thru #3

Shockproof, breakproof, Service Master handle
Durable, see-thru plastic case



XCELITE, INC., 10 BANK ST., ORCHARD PARK, N. Y.
Circle 9 on reader's service card

characteristics. Collector-emitter saturation voltage will vary with temperature. Tom could be right, however, in that a carefully designed one-shot might have acceptable temperature stability. I discarded the one-shot also in that I wanted a circuit that placed a minimum of constraints on transistor selection. I did not want to limit the builder to a particular type of transistor. My solution was to use a circuit which would accept a wide variety of transistors. An overdriven switch fits this requirement. In a one-shot or in a blocking oscillator I_{CBO} , V_{CEsat} , V_{BEsat} all have to be completely specified. However in a simple switch with a fanout of 1, as in my circuit, almost any transistor you put in the socket will work.

I think it would be an interesting design problem for Tom to work up a one-shot tach and see exactly how much temperature dependency there is. I would be pleased to hear the results, as well as to give him as much assistance as I can. He might also be interested in looking through a copy of Experimental Statistics put out by the NBS. They have an interesting chapter or expression of the Uncertainties of Final Results (Chap. 24).

STEPHEN GROSS

Bell Telephone Labs
Whippany, N. J.

TRIBUTE TO GERNSBACK

Dear Mr. Gernsback:

I wish to congratulate you on your contribution to the electronics industry.

You are responsible to a great degree for electronics as it is today.

As for myself, I cut my eyeteeth on your early articles and writings, and I thank you. Hope you continue. Enclosed please find my subscription for RADIO-ELECTRONICS magazine.

A. JOS. SCHWING

Philadelphia, Pa.

THIS'LL KILL YOU

Dear Editor:

Your December 1965 issue was quite an issue. On pages 10 you break down shock dangers, and on page 34 you have a circuit that is a *shocker*. The fellow who put that circuit in an old set should be made to read the letter on page 10 about 10,000 times. These old sets were insulated from the ac line by the power transformer. He has put the chassis of the set directly to one side of the line, making each metal shaft of each control a shock terminal. Did he tell the customer this?

O. F. PORTH

Hollywood, Pa.

[You're so right, Mr. Porth! We hope Mr. Davis, who wrote about the conversion on page 34 of the December issue, saw to it that the customer

could not touch any metal parts in normal use of the radio. If he did, the radio was probably no more dangerous than the millions of transformerless radios and TV sets in daily use all over the country.

RADIO-ELECTRONICS has always tried hard to steer away from the circuits that are not isolated from the line. We have occasionally redesigned or even rejected construction projects because of shock hazards, and we try to insert reminders about the danger of the ac line every few months. Looks like we slipped up in December, though. Maybe too few of us remember the old knobs with set-screws.—*Editor*]

COLORGAN PASSES WITH FLYING —

Dear Editor:

Re your Colorgan (October 1965, p. 34)—I just built it and it is undoubtedly the best thing that I ever did in the field. It does all you said it would. Not only was it easy to build, but withstood wrong connections to the light display. I used a slightly different version by putting the whole works in a Minibox (using the box as a heat sink for the SCR's) and used Centralab type FI pots. If you don't push the shafts all the way in, you can set the background for the desired level, pull the shafts out and nobody else can change the settings.

As far as operation is concerned, a few observations (all this is with 125 watts per channel): capacitors C3-C5 should be about 1.1 μf to extinguish the bulbs in normal reading light. With the red, perhaps a little more capacitance. Possibly a master control pot of about 100 ohms could be inserted at the input before the regular sensitivity controls so the unit won't lock on at high listening levels.

Also important is the value of the capacitors C9-11. Depending on the type of music that you play most often, the value should range from .04 μf for slow, dreamy music to your choice on fast guitar music.

The Colorgan is an excellent project for the hi-fi addict. And for a lot who aren't—quite a few non-addicts have asked me how much it cost and "Where can I get it?" Sounds like a good bet for Knight-Kit or something Allied to it.

ROBERT BRUNER

Kensington, Md.

END

ADD SOUND TO YOUR HOME MOVIES

Build this simple, inexpensive sound synchronizer for use with any tape recorder—mono or stereo. Add even lip-synchronized dialogue to your own 8- or 16-mm films without special magnetic striping!

March Radio-Electronics

YOU GET PRODUCT PLUS FROM YOUR SYLVANIA DISTRIBUTOR.

He'll put you in TV Guide

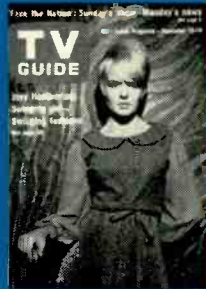

To give you a jump on color set repairs, your Sylvania distributor will put your name, your town, your phone number in *TV Guide*. Four ads will run this year exclusively for Independent Service Dealers carrying Sylvania's picture tubes and receiving tubes.

The plug for you will be run in localized, full-color double-page ads. Customers learn that you're the "right TV serviceman" for color set repairs. For all TV repairs.

And because you're Independent, they learn you give unbiased opinions on TV replacement parts. Sylvania knows that, more often than not, you recommend Sylvania tubes.

See your Independent Sylvania distributor. He'll tell you how Sylvania ads, featuring *you*, can make you your area's "right TV serviceman" for color sets. He'll tell you how to get into up to 4 *TV Guide* ads.

Sylvania Electronic Tube Division, Electronic Components Group, Seneca Falls, N. Y. 13148.

SYLVANIA
SUBSIDIARY OF
GENERAL TELEPHONE & ELECTRONICS **GTE**

Circle 10 on reader's service card

MALE

ELECTRONIC

career opportunities with

Programmers SYSTEMS & APPLICATIONS

Professional programmers with college degrees and 2 or more years of experience on large-scale computers are needed to participate in the specifications and implementa-

MALE HELP WANTED
TECHNICIANS

MAINTENANCE TECHNICIANS

For Commercial Communications Equipment

are immediate openings for technical school graduates with related experience with equivalent training experience. Must have FCC radio telephone license and telecommunications experience. Actual experience in data communications telephone systems and in transmission systems be helpful.

MALE HELP WANTED
ENGINEERS

FIELD ENGINEERS AND TECHNICIANS

Requires minimum of 2 years experience in maintenance of AN/FST-2 equipment.

TEST EQUIPMENT REPAIRMEN

Requires minimum of 2 years experience in maintenance of AN/FST-2 equipment.

LABORATORY TECHNICIAN

High school graduate with good technical ability and high intelligence to train for photoresist application of precision patterns in metal and on glass.

Complete benefit program including profit sharing. An Equal Opportunity Employer.

ELECTRONIC TEST TECHNICIANS

Production testing and troubleshooting of VHF and UHF aviation equipment. Exceptional opportunity for permanent first and second shift positions with AAA standing profit-sharing program. Male and female.

MECHANICAL DRAFTSMEN

Immediate openings for both electrical and mechanical draftsmen. High school graduates with advanced technical schooling in drafting.

ELECTRON TECHNICIA

Permanent positions offering excellent working conditions and new equipment. Air Force Reserve opportunity for

ELECTRONICS TECHNICIAN

With experience in transistor circuitry and electro-mechanical devices wanted as engineering assistant for experimental work in the development of data communications equipment. Excellent technical background and full familiarity with

ELECTRONIC WIRING & SOLDERING

We are seeking to our staff again, and have openings for experienced wiremen and solderers on precision electronic equipment. Ability to read schematics

ELECTRONIC SERVICE TECHNICIAN

Requires minimum of 2 years experience in maintenance of AN/FST-2 equipment.

ELECTRONIC TECHNICIAN MICRO-ELECTRONICS

Set-up, maintenance, and trouble shooting of electronic equipment in testing micro-electronic units and de-programming of test panels from engineering specifications.

DATA REDUCTION TECHNICIANS

Immediate openings LOCAL. Duties involve scanning film records of radar and optical data, plus low speed data sheet, using voice recording and in the selection of data to be processed. Should be familiar with radar and optical data characteristics, operating procedures and signature

TECHNICIANS

FOR ANALOG, DIGITAL AND HYBRID COMPUTERS & CALIBRATION

We offer challenge, advancement potential and the opportunity to contribute to the latest advances in computer technology.

GOOD SALARY
FRINGE BENEFITS

RADAR SYSTEMS

Long term program in radar systems and electronic systems and systems capability and application.

Requires 5 or more years experience in radar system design, analysis and evaluation. Advanced degree preferred. Background in digital processing of radar data, or other related fields. Position of interest in radar and related systems. Visit us today. Salary and benefits based on experience.

ELECTRONIC TECHNICIANS

INSTRUMENTATION TECHNICIANS

Must be experienced in the use of electronic test equipment. Must have a minimum of 2 years experience in the use of electronic test equipment. Must have a minimum of 2 years experience in the use of electronic test equipment.

RESEARCH TECHNICIANS

Excellent opportunity for men ex

WANTED: half a million

RCA HOME TRAINING CAN PREPARE YOU FOR THE BIGGEST CAREER OPPORTUNITIES IN HISTORY! NEW 'CAREER PROGRAMS' POINT THE WAY!

Electronics Jobs Expanding Every Day; Trained Technicians in Demand; RCA Institutes "Space Age" Methods make learning faster, easier!

Government reports have indicated the increasing demands for manpower in the electronics fields.* New developments in modern technology, automation, the growth of new areas of work, such as atomic energy, earth satellites and other space programs, and data systems analysis and processing are changing the occupational picture daily. To help meet this need, RCA Institutes offers a wide variety of Home Training Courses, all geared to a profitable, exciting electronics career in the shortest possible time.

New Career Programs right on target

RCA Institutes new "Career Programs" are complete units that train you for the specific job you want. And each of them starts with the amazing "AUTOTEXT" Programmed Instruction Method—the new scientific way to learn. RCA "AUTOTEXT" helps even those who have had trouble with ordinary home training methods in the past. Learn faster and easier than ever before!

Valuable Equipment Included

With each RCA Institutes Career Program, you receive valuable equipment to keep and use on the job. You'll get the new Programmed Electronics Breadboard which provides limitless

laboratory type experimentation, from which you construct a working signal generator and a superheterodyne AM Receiver. And as a special bonus, you get valuable Multimeter and Oscilloscope Kits—all at no additional cost!

Liberal Tuition Plan Ideal for Today's Budgets

RCA Institutes offers you this most economical way to learn. You pay for lessons only as you order them. No long term contracts. You can stop your training at any time and you will not owe one cent! Compare this with any other home training plan!

Choose from these Job-Directed Programs.

- TELEVISION SERVICING
- FCC LICENSE PREPARATION
- AUTOMATION ELECTRONICS
- AUTOMATIC CONTROLS
- DIGITAL TECHNIQUES
- TELECOMMUNICATIONS
- INDUSTRIAL ELECTRONICS
- NUCLEAR INSTRUMENTATION
- SOLID STATE ELECTRONICS
- ELECTRONICS DRAFTING
- plus a wide variety of separate courses from Electronics Fundamentals to Computer Programming.

technicians!

CLASSROOM TRAINING ALSO AVAILABLE

You may also learn electronics at one of the most modern laboratory and classroom electronics schools in the country—RCA Institutes Resident School in New York City. Day and Evening Courses start four times a year—and courses are planned so as not to interfere with your job or social life. No previous technical training needed for admission. You are eligible even if you haven't completed high school.

SEND NOW FOR NEW VALUABLE FREE CAREER BOOK—YOURS WITHOUT COST OR OBLIGATION. SEND POSTAGE PAID CARD TODAY. CHECK HOME TRAINING OR CLASSROOM TRAINING.

Free Placement Service For all Students

Recently, RCA Institutes Free Placement Service has placed 9 out of 10 Resident School graduates in jobs before or shortly after graduation! And, many of these jobs are with top companies—like IBM, Bell Telephone Labs, General Electric, RCA, and radio and TV stations throughout the country. This service is now available to Home Study students as well.

RCA INSTITUTES, Inc. Dept. RE.26

350 West 4th St., New York, N. Y. 10014

A Service of Radio Corporation of America



The Most Trusted Name in Electronics

*"Scientists, Engineers, and Technicians in the 1960's" U.S. Dept. of Labor Bureau of Labor Statistics, 1964.

Circle 11 on reader's service card

3 WAYS TO BIGGER

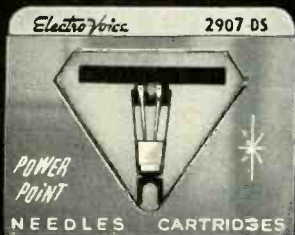

NEEDLE



CARTRIDGE PROFITS!

1. More "look-alike" exact replacement models than any other brand. Over 350 needles, 225 cartridges.

2. Easy-to-use reference material. E-V computer-printed catalogs make proper needle/cartridge selection easy, fast and accurate.

3. Highest standards. Rigid quality control and inspection cuts call-backs, gives full value to every customer.

Stock and sell E-V needles and cartridges for more profits. Pick up your FREE replacement guide at your nearby Electro-Voice distributor today!

ELECTRO-VOICE, INC.

Dept. 267E, Buchanan, Michigan 49107

Electro-Voice
SETTING NEW STANDARDS IN SOUND

SERVICE CLINIC

By JACK DARR Service Editor

Power Supply Impedance: "Common" Trouble-maker

A READER ASKS: "HOW CAN I POWER A transistor stereo amplifier without getting crosstalk, if I use a single power supply?" The answer is simple. *Filtering!* Lots of it! However, several things contribute to the design of a successful power supply, not only for transistor equipment, but for many kinds of electronic equipment, including TV sets.

One is power supply internal impedance. Since it is *common* to all stages supplied by it, you'll get a voltage drop across this impedance proportional to any current drawn from it by them (Fig. 1). Here, we can see that the three currents— I_1 , I_2 and I_3 —all flow through the same impedance Z . So, each current would create a voltage

means, and it turns out that that's exactly the same thing as reducing the power-supply impedance.

Second factor: plenty of capacitance. Why? Because the filter capacitors act as reservoirs. Once they're charged with a certain quantity of electrical energy, some of it can be drawn off without causing a serious voltage drop, if the storage capacitors are big enough. Just like a water reservoir, in fact; you can have full pressure and lots of water even if the pump isn't running all the time, as long as that tank is big enough.

Chokes, transformers, etc., must have the *lowest possible dc resistance*. This ties in with the current rating of

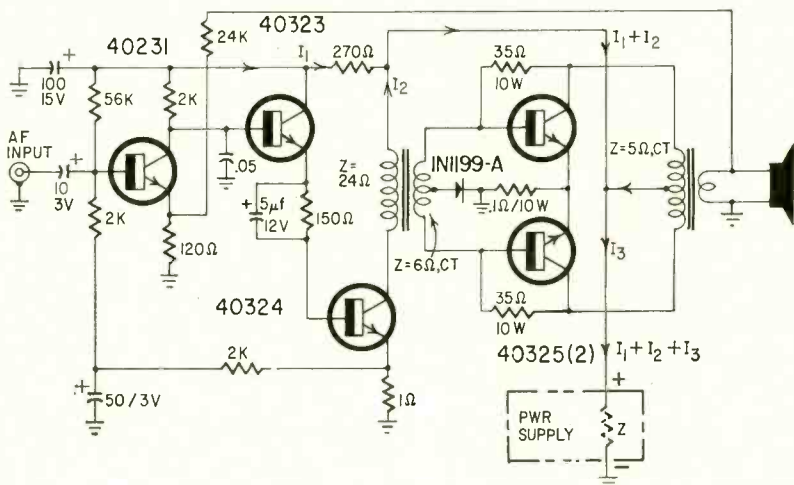

Fig. 1

drop across Z . If Z is too big, we'll get three good-sized voltage drops here, and they'll all "mix" (add) since they're in the same circuit. Depending on what the stages fed from the supply are and do, you may get crosstalk, hum and even oscillation, like howls or motor-boating.

To prevent that, we must keep Z from changing, and from getting too big. This brings us to the first way of doing it: regulation.

When you design a power supply, use a good, big safety factor. If you need 200 ma, pick components that will supply 300 without any strain. Then, any variations will be a smaller percentage of the supply's total capacity, and fluctuations in the supply voltage will be reduced. That's what better regulation

transformer windings; the higher the current rating, the bigger the wire, and the lower the dc resistance of the whole circuit. That's one reason why chokes are more efficient than resistors as filters; there's less dc voltage drop across them for the same impedance to ripple.

A third factor, in using more than one unit on a given power supply, is isolation. Given a reasonably well designed power supply, as in Fig. 2, you can add extra filter circuits as shown, one resistor (or choke) and one capacitor, to give additional isolation between the two circuits. Resistors can be used in low-power tube circuits; in transistor circuits—especially with power transistors—where currents are higher, low-dc-resistance filter chokes are better.

Now, how can you tell when the

LOOK!

A New Electronics Slide Rule with Instruction Course

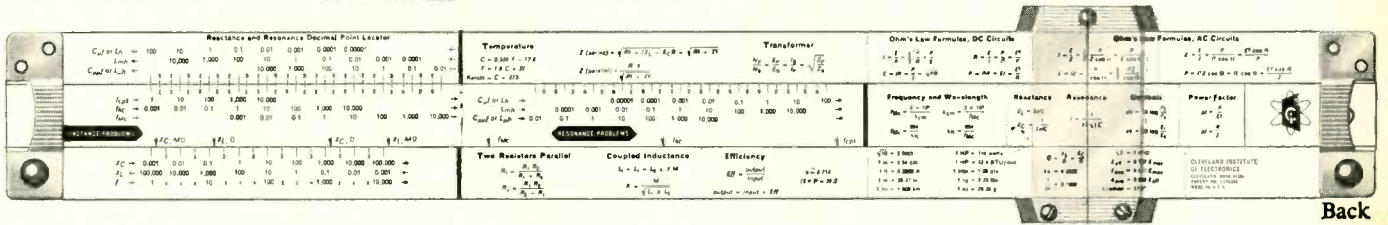
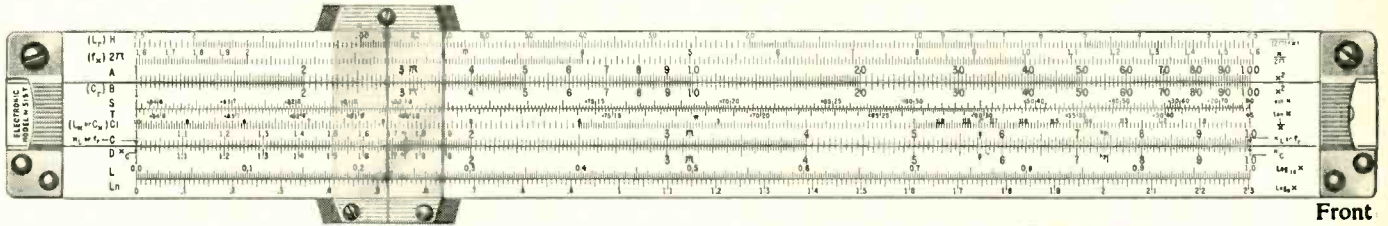

This amazing new "computer in a case" will save you time the very first day. CIE's patented, all-metal 10" electronics slide rule was designed *specifically* for electronic engineers, technicians, students, radio-TV servicemen and hobbyists. It features special scales for solving reactance, resonance, inductance and AC-DC circuitry problems . . . an exclusive "fast-finder" decimal point locator . . . widely-used formulas and conversion factors for instant reference. And there's all the standard scales you need to do multiplication, division, square roots, logs, etc.

Best of all, the CIE Slide Rule comes complete with an Instruction Course of four **AUTO-PROGRAMMED*** lessons. It includes hundreds of illustrations, diagrams and practice problems. You'll learn ingenious short cuts . . . whip through exacting electronics problems quickly and accurately. This course alone is worth far more than the price of the entire package!

Electronics Slide Rule, Instruction Course, *and* handsome, top-grain leather carrying case . . . a \$50 value for less than \$20. Send coupon for **FREE** illustrated booklet and **FREE** Pocket Electronics Data Guide, without obligation. Cleveland Institute of Electronics, 1776 E. 17th St., Dept. RE-119, Cleveland, Ohio 44114.

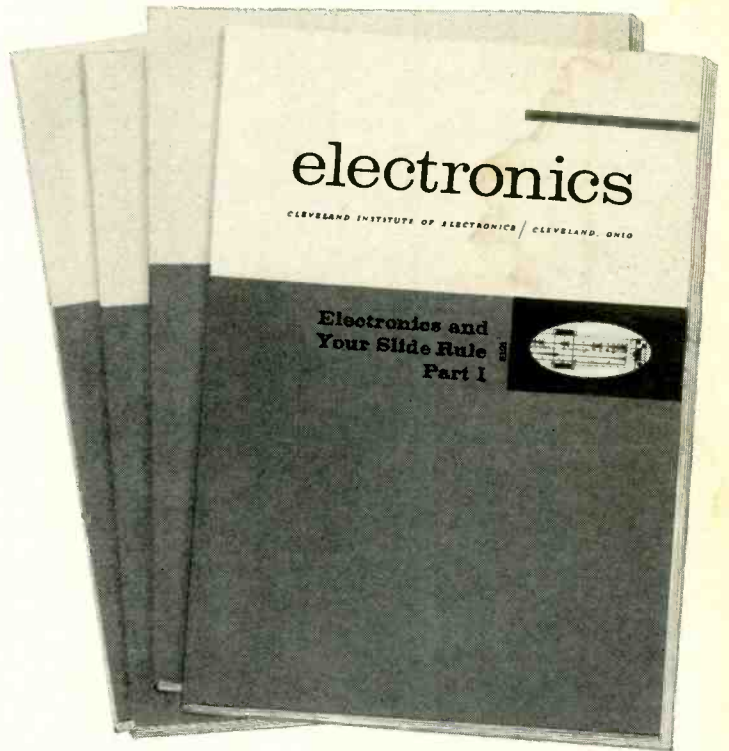

*TRADEMARK

GET BOTH FREE!

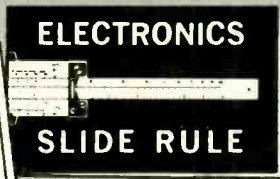

Send coupon today →

Cleveland Institute of Electronics

1776 E. 17th St., Dept. RE-119, Cleveland, Ohio 44114

Please send **FREE** Illustrated Booklet describing your Electronics Slide Rule and Instruction Course.

SPECIAL BONUS! Mail coupon promptly . . . get **FREE** Pocket Electronics Data Guide too!

Name _____ (PLEASE PRINT)
 Address _____ County _____
 City _____ State _____ Zip _____

A leader in Electronics Training . . . since 1934.

Circle 13 on reader's service card

finger-
tip avail-
ability

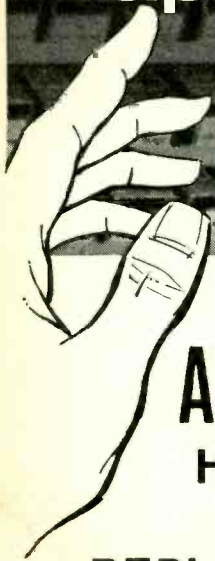

AEROVOX HAS 1212 EXACT REPLACEMENT TWIST PRONG AFH ELECTROLYTICS

Why fool with "jerry-rigged" electrolytics when there's an Aerovox exact replacement to give you the right rating and the right size? Aerovox actually stocks 1212 twist prong AFH electrolytics—this means off-the-shelf availability... not "we'll build it for you if you order it" delivery.

Available in singles, doubles, triples and quads, these popular types are now manufactured in new values for filter bypass applications in color TV as well as radio, black and white TV and amplifier equipment. Many values are now being used for industrial applications.

Aerovox AFH Twist Prong Electrolytics feature ruggedized prongs and mounting terminals, high purity aluminum foil construction, improved moisture resistant seal and 85°C operation. Here is the quality you need to protect your professional reputation.

Go to your Aerovox Distributor for a perfect electrolytic fit—he will deliver exactly what you want in less time than it takes to tell. Ask him for the new Aerovox Service-men's Catalog #SE-565 or ask us. We'll be happy to send one your way.



**AEROVOX
CORPORATION**

DISTRIBUTOR DIVISION, NEW BEDFORD, MASS.

Technical Leadership—Manufacturing Excellence

Circle 14 on reader's service card

trouble is actually in the power supply? Use the scope. Check the B+ lines for any sign of ripple. This is the most simple and reliable test you can make. For crosstalk in stereo equipment, it's easy. Feed a 400-cycle audio signal through one channel, at fairly high level. Now, check the B+ supply lines of the other channel for any sign of the 400-cycle signal! If you find it, you need more filtering. (Generally, mixing in the power supply gets worse at low frequencies.)

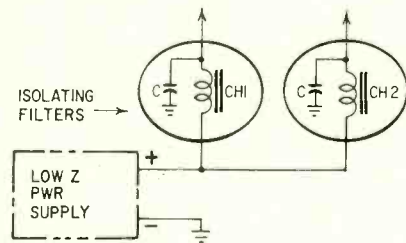

Fig. 2

If you do find ripple or crosstalk on power supply lines, the easiest solution is to add more capacitance. This is admittedly a brute-force method, but it works. Very-high-value capacitors are available now, in very small cases, especially in the low-voltage types used in transistor work. You can easily get three or four thousand microfarads into a single low-voltage power supply; these values are unbelievable to old-timers used to thinking of an 8- μ f capacitor as a big one!

How hot is hot?

How hot can a power transformer get, safely? I've heard several different opinions.—E.F., Hemet, Calif.

This depends on the rating, and on the insulation used on the windings. Some recent plastics can run darn near red hot without damage, but don't try this on the older ones. The old-timers use a pretty good rule of thumb (literally!)—if you can hold your thumb on 'em, they're not too hot. Of course, this depends a lot on how thick the callouses are on your thumb! Another one is "As long as they don't stink, they're OK."

This column is for your service problems—TV, radio, audio or general and industrial electronics. We answer all questions individually by mail, free of charge, and the more interesting ones will be printed here.

If you're really stuck, write us. We'll do our best to help you. Don't forget to enclose a stamped, self-addressed envelope. Write: Service Editor, Radio-Electronics, 154 West 14th Street, New York 10011.

The best assurance that the transformer is within its limits is to measure the actual drain with a wattmeter, and check that against the rating on the label on the chassis!

Picture out of position horizontally

I can't center the picture on a Zenith 19R20U. Test patterns come in at the right of the screen, about 4-5 inches from where they ought to be. I've replaced the yoke and checked everything I can think of!—T.J., Norfolk, Va.

There are always two problems, in such cases. Is the raster off-center, or just the picture? If the raster and picture are off, then you can get it back by resetting the positioning magnets on the back of the yoke. However, if the raster is centered and the picture isn't, then it's something else again!

This comes down to a phase relationship between the horizontal scan and the video signal. Our raster is OK, but our picture elements are getting there a bit late. Check your horizontal phase detector circuitry; this is the most common cause of such troubles.

Brightness problems in G-E CX color TV

In a G-E CX color chassis, the brightness is low when the set is turned on and creeps up to normal after it's been on for about an hour. Sometimes the brightness will drop and the picture will turn very red; turning the brightness control up and down brings it back. What is this?—P. L. D., Providence, R. I.

I'd make some routine check first. Monitor the HV at turn-on, and then after it's been on for a while. Check the HV regulator adjustments, the B+ and the boost, in the same way. If this doesn't show anything, then check the video amplifier tubes for gas or grid emission.

With the dc coupling used in color sets, any trouble like this will affect the brightness. Look out for plate dropping resistors that change value when hot. Test by heating them with a soldering iron and watching for a change in a value.

The red shift can be one of two things: a sudden loss of blue and green, or trouble in the red amplifier that drives it to "full-on." For example, an intermittent leakage in the .01- μ f coupling capacitor of the red amplifier. This would make its grid go positive, driving it to full conduction.

Audio takeoff from transistor radio

I'd like to convert a Sears model 1019 transistor radio into an AM tuner.



FREE!

Offer extended through April 1, 1966

Get a Color-TV TEST Picture Tube with every RCA WR-64B Color Bar/Dot/Crosshatch Generator you buy

Yes! You read right!

From now through April 1, 1966—with every purchase of an RCA WR-64B Color Bar Generator—you get a FREE color-TV TEST picture tube for use in your color-TV test jig. This is a 21-inch 70° round color-TV TEST picture tube, electrically guaranteed six months from first installation date. These tubes will have minor mechanical (not electrical) defects... they're not quite good enough to go into a new TV set but perfectly adequate for testing purposes.

How to get your FREE Color Test Tube

Simply buy an RCA WR-64B Color Bar Generator—*THE* essential color-TV test instrument—between now and April 1, 1966. Fill out your warranty registration card and attach the red identification label on the WR-64B carton. Send them to RCA, Test Equip-

ment Headquarters, Bldg. 17-2, Harrison, N.J. We send you the tube (either from Lancaster, Pa. or Marion, Ind.) freight charges collect. To allow for postal delay, we will honor cards received up until April 15th.

Don't miss out on this never-before offer. You've got to have a color-bar generator anyway—so be sure you buy it now—at the regular price—while you can get a FREE color test tube.

\$189.50*

Optional distributor resale price, subject to change without notice. Price may be higher in Alaska, Hawaii and the West.



RCA WR-64B Color Bar/Dot/Crosshatch Generator

RCA ELECTRONIC COMPONENTS AND DEVICES, HARRISON, NEW JERSEY



The Most Trusted Name in Electronics

Circle 15 on reader's service card

Add to Your Profits in Radio-TV Repairs with PROFESSIONAL APPLIANCE SERVICING

Learn easily, quickly with
NRI's new course

Appliance Servicing is a natural, profitable side-line for Radio-TV Repairmen. The boom in electric appliances means greater profits for you. There are probably hundreds of broken appliances right in your neighborhood.

Free book tells you about profitable opportunities for you to increase your income *fast*.

NRI, the world-famous home study school, now offers a new, *low-cost course* to prepare you quickly for extra profits. Training includes appliance test equipment and covers—

- Small and Large Home Appliances
- Farm and Commercial Equipment
- Small Gasoline Engines

—there is even a special course arrangement to learn air conditioning and refrigeration.

If you are in business for yourself, course costs can be tax deductible.

Send for FREE book describing opportunities and details of course—plus a sample lesson. There's no obligation and no salesman will call. Send coupon below or write:

Appliance Division, Dept. 503-026
National Radio Institute
Washington, D.C. 20016



Send for
**FREE
BOOKS**

Appliance Division, Dept. 503-026
National Radio Institute
Washington, D.C. 20016

Please send Free Book on Professional Appliance Servicing and Sample Lesson.

Name _____

Address _____

City _____ Zone _____

State _____

Accredited Member National
Home Study Council

Where would be the best place to take off the audio?—D. H., Fargo, N.D.

Right after the detector. In fact, you might even reverse the radio-phono switch you already have there and use it (diagram). Use low-capacitance shielded cable to the hi-fi amplifier, and use the crystal phono or auxiliary or tuner input.

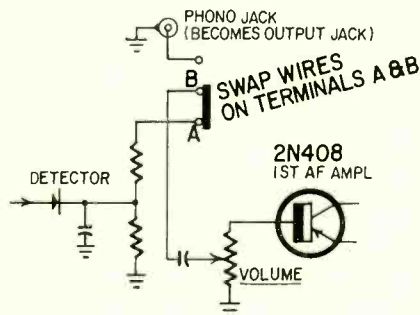

By the way, you can save a lot of current and make your voltage regulation a lot better, if you disconnect the four transistors in the existing audio stages. Since these take almost all the current drawn by the radio, your power supply regulation will be a lot better. (A battery would last a long time.)

Signal generator tracking

I've just finished assembling a low-priced kit signal generator. It works, but won't track properly. If I set a radio to 900 kc, then set the generator to 300 kc, I can't get the right harmonic; I pick it up at 460 kc and then at 440. How do the adjustments work on this thing?—J. T., Millville, N.J.

Whoa! First, let's get these "harmonics" straight! A harmonic is always a whole-number multiple of the fundamental frequency, and always lower in amplitude; this is how we trace them down. For instance, if you set the generator for 300 kc, you'd have a second harmonic at 600, a third at 900, a fourth at 1200, a fifth at 1500 kc, and so on. Remember that.

The best way to check out a signal generator is to get a radio that will cover a wide range of frequencies, like a communications receiver. Start by locating several broadcast stations, and note their frequencies. If you use harmonics of a lower frequency, be sure that you're getting the *right* one! Example: you want to check 300 kc on the generator. Find a station as close to 900 kc as possible, and mark its location on the radio dial. (*Don't* take the radio dial calibration as accurate unless you *know* it is.) Now, set the generator at 300 kc; tune the radio to 600 kc and look for the second harmonic of the generator signal. If it's there, then go on up the dial until you hear the next harmonic: 900 kc. Then go on to 1200 kc and find the fourth harmonic, and so on. On the

900-kc station, you can also check the second harmonic of 450 kc.

If the signal generator dial is quite a way off calibration, you can readjust it. Check the instructions in the book. As a general rule, though, you'll find that you adjust the inductance, either by moving the iron core of a coil or by spreading or squeezing the turns of the coil, at the *low*-frequency end of a band, and adjust the capacitance (trimmers) at the *high* frequency end. In most cases you'll have to go back and forth from one end to the other several times to get the best results.

As to *tracking*—that is, absolute accuracy from one end of a band to the other—don't expect too much from the lower-priced instruments! Tracking is one of the hardest things to achieve in a generator or receiver, and even a few very good instruments have minor tracking errors. In general, if the generator is OK at the high and low ends of the band, and pretty close at the center, it will be fine. If you know the amount of error, you can use the generator just as easily as if it tracked perfectly!

Ohmmeter error in VTVM

I've got a good vtvm, but the ohmmeter is pretty badly off and getting worse. Any idea?—P. R. M., Tulsa, Okla.

Most likely cause, under the circumstances, the ohmmeter batteries. Replace them, and see if this doesn't help out a lot. When the batteries get too low, their voltage drops and their internal resistance rises. This throws the ohmmeter off.

Helpful hint: get a low-tolerance resistor, say one of the numerous 1% resistors available from surplus, and keep it on the bench. Get one that falls about in the center of the most-used range of the ohmmeter. (I use a 1-meg-ohm.) Every so often, pick up this resistor and measure it, just to make sure your meter is still on the nose. You can use one for each range if you want to be fancy, but one seems to be enough. END

1966 BATTERY RECORDER ROUNDUP

See this comprehensive buying guide of better-quality, capstan-driven battery portable tape recorders. Big ones, pocket-size ones, mono and stereo. You'll want to clip this guide and keep it handy. Know how many speeds, what special features, who makes which—all spread out in easy-to-read style.

COMING IN . . .

MARCH RADIO-ELECTRONICS

free

with your purchase of **PHOTOFACT!**

the famous 14-volume **NEW STANDARD ENCYCLOPEDIA!**

*an invaluable
Treasury of Knowledge
for all the family!*

*sells at retail for
\$149.50*

now **FREE**
yours

*with the purchase of a
PHOTOFACT LIBRARY
consisting of 225 Sets
or more—limited time only—
ACT NOW!*

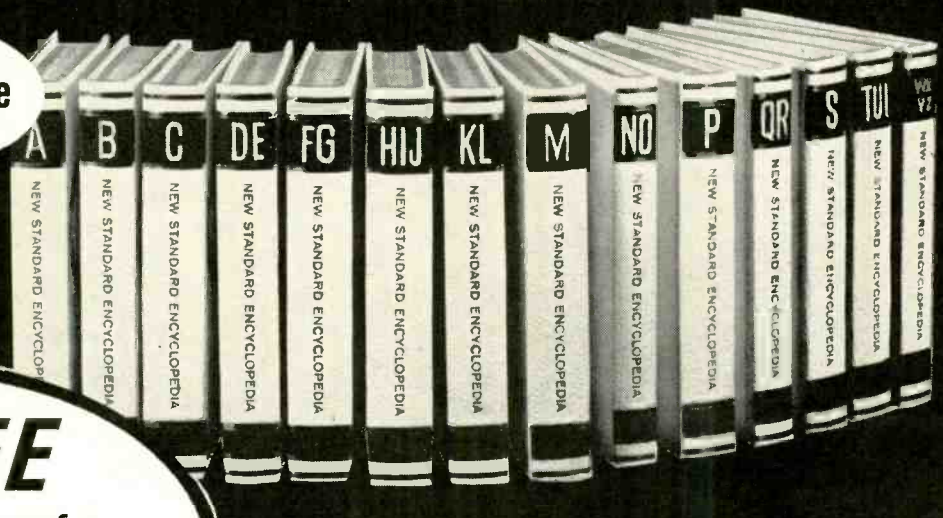

*give your family this wonderful gift—
give your earning power a big boost with
PHOTOFACT—world's finest TV-radio service data*

Now, more than ever, it pays to own a PHOTOFACT Library—the time-saving, troubleshooting partner guaranteed to help you earn more daily. Now, you can start or complete your PHOTOFACT Library the special Easy-Buy way, and get absolutely FREE with your purchase, the famous 14-volume NEW STANDARD ENCYCLOPEDIA. It's a great reference library for all the family—complete, authoritative, indispensable. Retail for \$149.50—yours absolutely FREE with the purchase of a PHOTOFACT Library consisting of 225 Sets or more!

**THERE ARE 4 CONVENIENT WAYS
TO SELECT YOUR PHOTOFACT LIBRARY**

1. Complete your present PHOTOFACT Library.
2. Order a PHOTOFACT "Starter" Library—225 Sets (Sets 451-675—coverage from 1959 to 1964—only \$14.29 per month).
3. Order by brand name and year—see the handy selection chart at your distributor.
4. Order a complete PHOTOFACT Library—and the famous 14-Volume New Standard Encyclopedia is yours FREE!

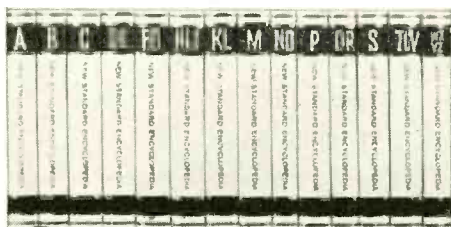

OWN A PHOTOFACT LIBRARY THE EASY-BUY WAY:

- Only \$10 down • 30 months to pay
- No interest or carrying charges • Prepaid transportation
- Add-on privilege of a year's advance subscription to current Photofact data, on the same Easy-Buy contract
- Save 30¢ per Set—special \$1.95 price applies on Easy-Buy (instead of regular \$2.25 price)

THERE'S NEVER BEEN A DEAL TO EQUAL THIS!

**GET THE
DETAILS
NOW**

HOWARD W. SAMS & CO., INC.

Howard W. Sams & Co., Inc., Dept. REF-2
4300 W. 62nd St., Indianapolis, Ind. 46206

Send full information on the PHOTOFACT Library-Encyclopedia Deal, and details of the Easy-Buy Plan

My Distributor is: _____

Shop Name _____

Attn. _____

Address _____

City _____ State _____ Zip _____

**ORDER YOUR PHOTOFACT LIBRARY NOW—
AND GET YOUR FREE STANDARD ENCYCLOPEDIA**

See your Distributor for the full details of the PHOTOFACT-Encyclopedia Deal, or send coupon at right! Also ask about a Standing Order Subscription to current PHOTOFACT and Specialized Service Series (FREE File Cabinets available with Subscriptions). **ACT NOW!**

SEE YOUR DISTRIBUTOR OR SEND COUPON TODAY

Circle 16 on reader's service card

**“Get more
education
or
*get out of
electronics***

...that’s my advice.”

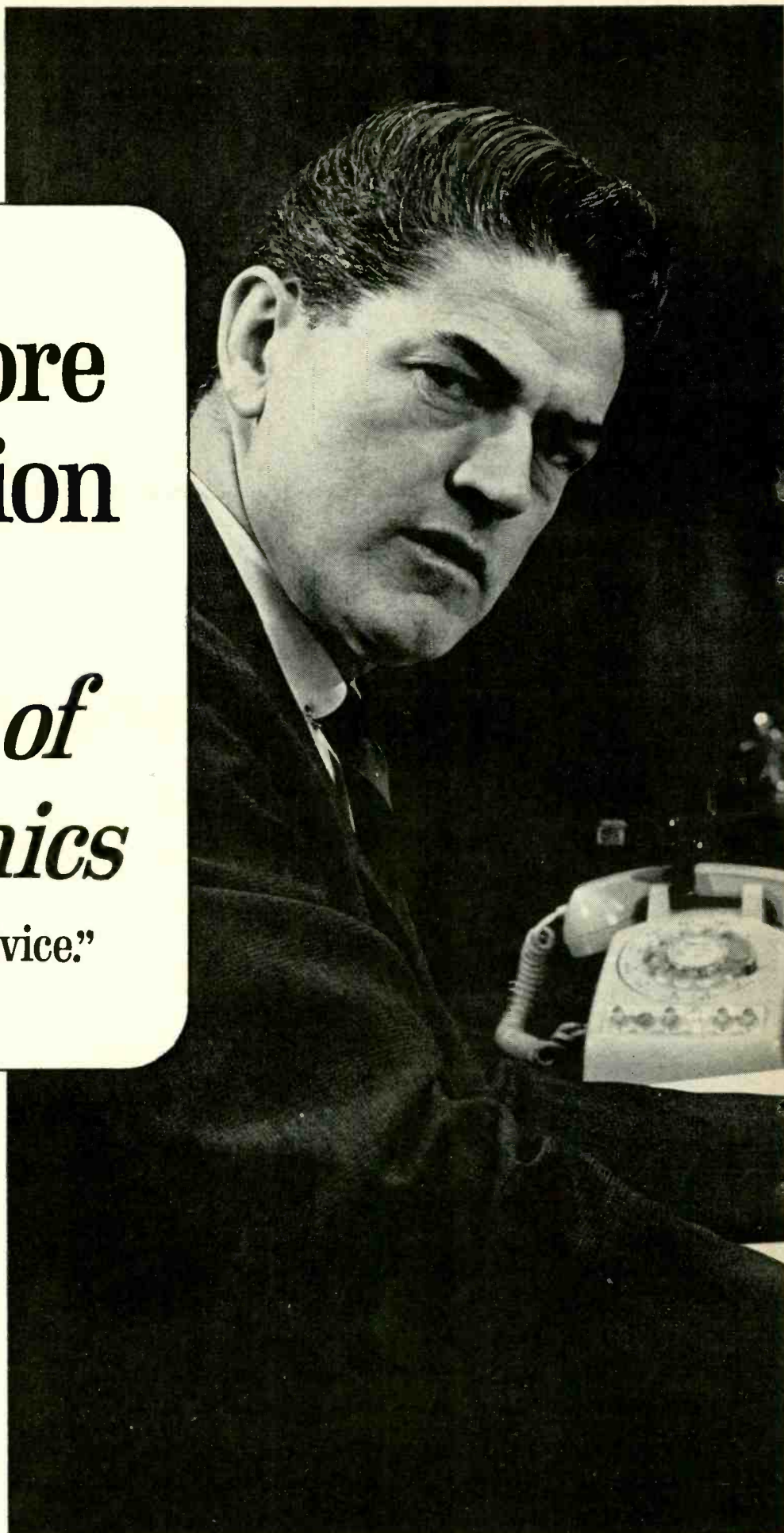



Ask any man who really knows the electronics industry. Opportunities are few for men without advanced technical education. If you stay on that level, you'll never make much money. And you'll be among the first to go in a layoff.

But, if you supplement your experience with more education in electronics, you can become a specialist. You'll enjoy good income and excellent security. You won't have to worry about automation or advances in technology putting you out of a job.

How can you get the additional education you must have to protect your future—and the future of those who depend on you? Going back to school isn't easy for a man with a job and family obligations.

CREI Home Study Programs offer you a practical way to get more education without going back to school. You study at home, at your own pace, on your own schedule. And you study with the assurance that what you learn can be applied on the job immediately to make you worth more money to your employer.

You're eligible for a CREI Program if you work in electronics and have a high school education. Our FREE book gives complete information. For your copy, airmail postpaid card or write: CREI, Dept. 1402-D 3224 Sixteenth Street, N.W., Washington, D.C. 20010



- NOW!**
TWO NEW PROGRAMS!
- Industrial Electronics for Automation
 - Computer Processing Systems

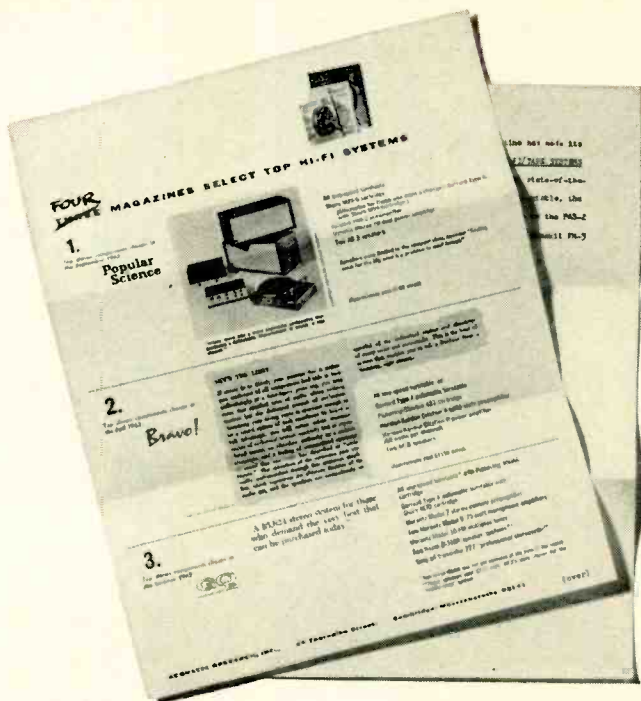

This is a survey (*available for the asking*) of the hi-fi equipment recommendations of four magazines.

These four lists of equipment choices, from stereo cartridge to speakers, were compiled independently by each of four national magazines — *Gentlemen's Quarterly*, a men's clothing magazine for the carriage trade; *Bravo!*, a concert program "wrapper" with a circulation of almost a million; *Popular Science*, the leading high-circulation science magazine; and *Hi-Fi/Tape Systems*, a hi-fi annual.

AR-3 speakers were the top choice of three of the four.

The fourth magazine, *Gentlemen's Quarterly*, chose speakers costing \$770 each for its most expensive stereo system; AR-3's were relegated to the "middle-range" (\$1,273) system.

The AR turntable was the top choice of all four.

The AR turntable is \$78 including arm, oiled walnut base, and transparent dust cover. The AR-3 is \$203 — \$225, depending on finish (other speaker models from \$51). AR's catalog is available on request.

ACOUSTIC RESEARCH, INC., 24 Thorndike Street, Cambridge, Massachusetts 02141

Circle 17 on reader's service card

ELECTROMAGNETIC INTERFERENCE

... *The Future's Greatest Communication Problem* ...

FRED SHUNAMAN, Managing Editor

THE UNITED STATES IS THE ONLY CIVILIZED COUNTRY that cannot legally restrain the manufacturer of equipment that will produce electronic interference. Our FCC can set the amount of radiation a uhf-TV tuner (for example) may produce. But it cannot prevent a manufacturer from making a TV set that produces more radiation. (The little notice you see on the back of the receiver is an indication of *voluntary compliance*. If a manufacturer does not wish to comply, he can construct a set with any radiation level he likes.)

But as soon as the set gets into a customer's hands and is put into operation, the FCC can seize the offending equipment and proceed against the owner, even to the point of levying fines and imprisonment.

This, of course, is nonsense. The place to stop trouble of this kind is at the source, not after a layman has bought in good faith what was sold to him as a perfectly legal piece of equipment. The FCC has requested Congress more than once to pass laws that would give it the power to stop the trouble at the source. Two bills (Senate 1015 and HR 564) that will give the FCC just that power have been introduced. Their way through Congress may be long and hard.

These bills would give the FCC authority to "prescribe the permissible degree of emission of radio-frequency energy of any devices capable of emitting radio frequency by radiation, conduction, or other means, in a great enough degree to harmfully interfere with radio communications." Radio and TV sets, electronic garage-door openers, electronic toys, electronic heaters, diathermy machines and welding equipment are among the things the FCC says can cause dangerous interference.

And interference *can* be dangerous. We have heard of devices (including portable FM receivers and garage-door openers—see p. 58) that interfere with aviation safety and which might cause a plane to crash. Rexford Daniels, president of Interference Consultants, Inc., tells of an electroencephalograph that was sending sane people to institutions because it was picking up signals from a freight elevator in the hospital and creating spurious brain waves. A story is told of a woman dispatcher in a taxicab company whose messages interfered with those used to control a guided missile. Her instructions to a cab driver actuated the destruct circuitry and blew up the missile.

Electromagnetic radiation can endanger human life and safety by interfering with communication. It can also be dangerous to human life and health by its direct biological effects, some understood, others probably yet unknown. We all know that direct exposure to powerful radar signals can have serious physical effects, possibly extending even to the

second generation. We know less about the more selective effects of radiation at certain frequencies, although radio waves at 5 mc have been found to increase the size of tumors, and signals at 700 cycles can anesthetize the brain (RADIO-ELECTRONICS, February 1965). The effect of radio broadcast signals on birds in foggy weather is another thing that is well known, and it has been pointed out that certain signals in the centimeter range can cause ants to line up with their antennae all oriented in the same direction.

Another radiation hazard, a little outside the field of radio communications, was reported recently in New York City. Fourteen children who had been watching steel girders being tested with high-voltage X-rays were rushed to the hospital and examined for radiation effects.

The Army took action against a station in Oakland, Calif., because signals from the station caused sparks in the equipment used to load and unload ammunition. An even more dramatic case was one in which a Navy plane touched off the whole stock of flash bulbs in a photographic store near where it was testing its radar.

This interference is curable. In many cases devices that are likely to produce trouble can be kept out of sensitive areas. In a research laboratory, for example, incandescent lamps can be used instead of fluorescent ones. Such things as radar transmitters can be confined to areas where they are not likely to cause trouble. (Citizens of the Pittsburgh suburb of Oakdale report that an Air Force radar unit in that thickly settled area produces beeps in radios, TV's, hi-fi equipment, electronic organs and public-address systems. These cannot be removed by any method of filtering, apparently.)

The second, possibly most important, remedy is to keep all undesired radio frequency *inside* the equipment. Amateurs have learned that it is quite possible to reduce harmonics of the operating frequency to an imperceptible level, and that direct radiation from the equipment itself can be cured by good shielding. Shielding has now become a science. We have louvres, screens and solid sheets especially designed to control radiation at various frequencies. We even have electromagnetic "weatherstripping" that will insure that the shielded back of a shielded cabinet, for instance, will make a perfect electrical connection when screwed on. (This has often not been the case in many "shielded rooms".)

We are continuing to use more and more power and to extend our signals over a wider range of frequencies at an increasingly greater rate. It is important not only that the FCC have the power to deal with all the known bad effects of electromagnetic radiation, but that we put in a great deal more time and effort searching out still unknown effects. **END**

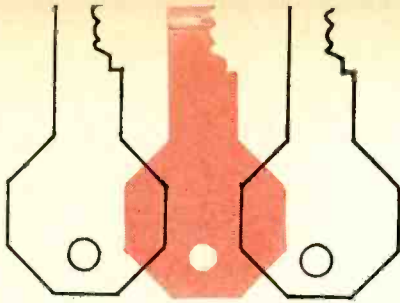

TRY A CAPACITOR-DISCHARGE IGNITION SYSTEM

Now made simpler and more trouble-free with semiconductors, this ultimate form of electronic ignition is for serious drivers

By THEODORE GERALD

THIS UNUSUAL ELECTRONIC AUTO IGNITION system has all the advantages of the more common transistor-switch system, plus several extra features:

1. Better fouled-plug firing.
2. Lower power consumption.
3. No spark deterioration from breaker-point bounce.

The capacitor-discharge ignition system has been known and admired for years. The main reason for its obscurity is that, until recently, only thyatron tubes could do the job of discharging a large capacitor rapidly into a load. The size and heater-current demands of thyratrons chilled most of the enthusiasm for what is really a superior system.

Now, with a variety of inexpensive silicon controlled rectifiers available, the c-d ignition system looks much more attractive.

My system has been in use for nearly a year without a breakdown. The car's breaker points are still used to trigger the SCR, but the trigger circuit is easily adapted to magnetic-pulse or photoelectric triggering.

The advantages of the c-d system stem from the ability of an SCR (or a thyatron) to dump a charge stored in a capacitor into the primary of the ignition coil. The common transistor ignition system switches a current in the coil primary. The secondary voltage hits its peak 90° after the points open. The time required for the voltage to break down the sparkplug gap gives fouling materials a chance to accumulate around the gap and begin leaking away the voltage, causing poor ignition or complete missing. The faster the voltage is applied across the gap, the less chance there is for misfiring. When a capacitor charged to about 300 volts is connected across the coil primary by an SCR, the connection takes about 2 microseconds. The secondary voltage rises very rapidly the instant the SCR is triggered.

If the SCR is triggered by a short pulse each time the breaker points open, it will be shut off again, as soon as the capacitor is discharged, by the momentary reverse voltage generated by the oscillating circuit of the coil primary and

capacitor C6 (diagram).

The schematic shows the main parts of the system: the power supply and the triggered-discharge unit. The whole arrangement draws about 2½ am-

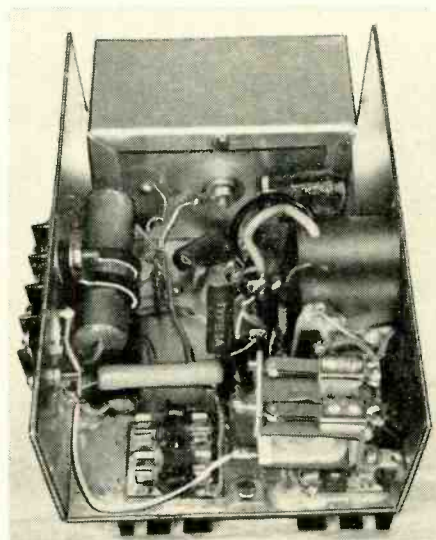

Internal view of single-unit c-d system (power supply and discharge circuit combined).

peres at idling speeds, and the drain increases in proportion to engine speed.

The power supply, a conventional dc-to-dc converter circuit built around the toroid transformer manufacturer's design, is switched by a relay from full-wave to half-wave operation during starting. The relay shifts the ground from the transformer center tap to one end, feeding a 50% higher voltage to the capacitor. This helps, especially in cold weather, when battery resistance rises and oil is thick. The relay has given no trouble.

While the C15D SCR used in this circuit is rated nominally at 400 volts, there is no trouble even when the voltage across it rises to 480, as it may when the engine begins to fire and relieves some of the load on the battery. Under the slow firing rate and at normal temperatures when starting an engine, the SCR takes the voltage without breakdown. The 400-volt rating is for high temperatures and maximum current, which are not likely to occur during starting.

The only load on the power supply, once the capacitor is charged, is bleeder R6. The capacitor charges rapidly at normal engine rpm. Don't omit the fuse

THE SCORE: CONVENTIONAL VS. C-D IGNITION

With an input to the power supply of 14.5 volts, the voltage of the capacitor-discharge system described here is about 330 volts. Applying this to a 1-μf capacitor, the available energy is:

$$\frac{E^2 C}{2} = \frac{(330)^2 \times 10^{-6}}{2} = .0545 \text{ watt-seconds}$$

A typical conventional system with a 6-mh coil inductance and 4½ amperes in the primary has .061 watt-seconds ($I^2 L/2$). Calculations can show that at 6,000 rpm, the energy remaining is less than 40%, or .024 watt-seconds. The approximate minimum energy required for reliable ignition is .03 watt-seconds. So, although the conventional ignition system starts with an excess, it is still slightly deficient at maximum speed.

A capacitor-discharge ignition system's output does not fall off. Why? Again assume a typical coil of 6 mh and a capacitor of 1 μf. The resonant frequency of this combination is about 2,050 cycles, and the time per cycle is 1/2,050 or 488 μsec. The SCR shuts off in a half cycle or 244 μsec after the points close. At 6,000 rpm, the distributor shaft revolves at 3,000 rpm or 50 revs per second. This is 20,000 μsec per revolution, and with an eight-cylinder engine, a spark period of 20,000/8 or 2,500 μsec. If the SCR turns off in 244 μsec, the time available to recharge C6 is (2,500 - 244) or 2,256 μsec. C6 charges rapidly through the ignition-coil primary during just a few cycles of the power supply (1,800 cycles per second, or about 3,600 pulses per second from the full-wave rectifier). The conventional ignition coil has a turns ratio of 80:1 to 100:1. This produces a spark voltage of about 30,000 volts, and voltages greater than this are neither necessary nor advisable.

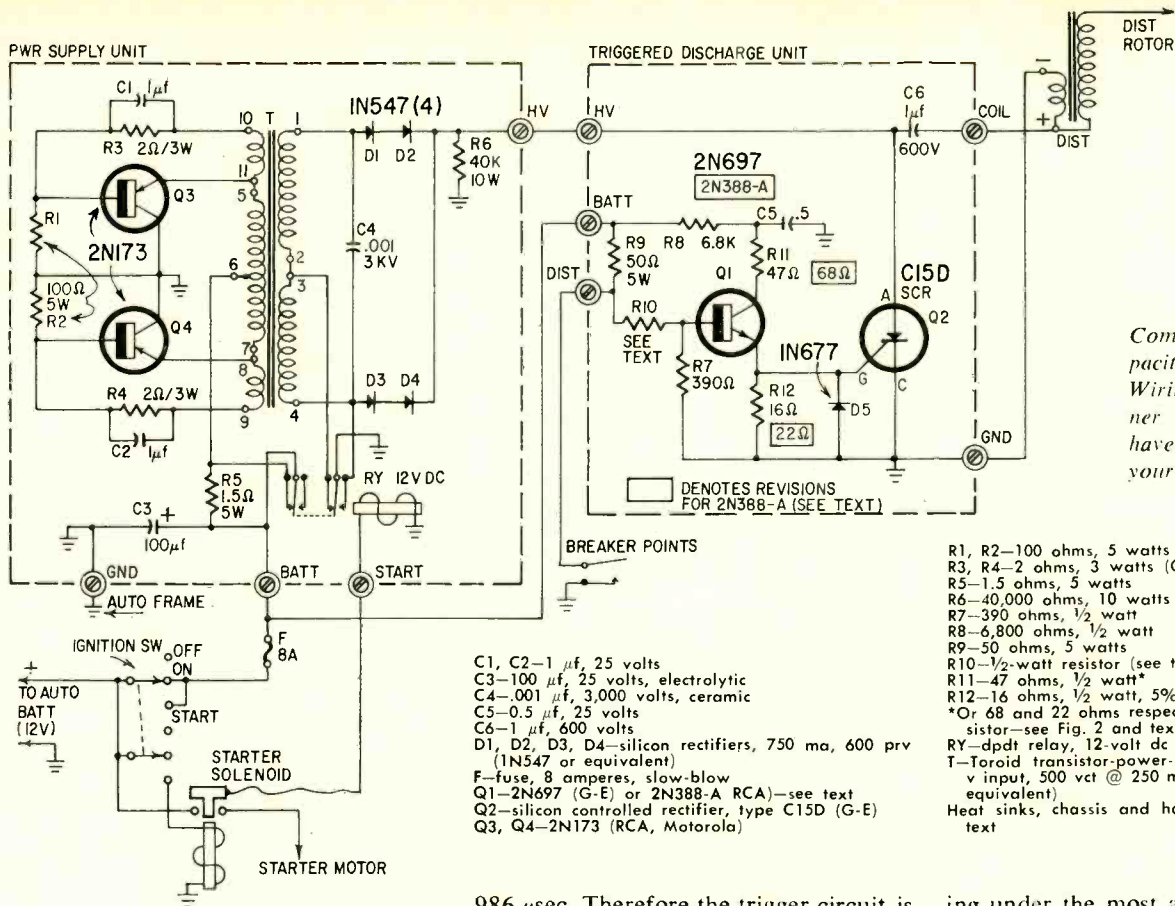

Complete circuit of capacitor-discharge system. Wiring in lower left corner of schematic may have to be altered to suit your car's circuit.

- R1, R2—100 ohms, 5 watts
- R3, R4—2 ohms, 3 watts (Ohmite type 995-3A)
- R5—1.5 ohms, 5 watts
- R6—40,000 ohms, 10 watts
- R7—390 ohms, 1/2 watt
- R8—6,800 ohms, 1/2 watt
- R9—50 ohms, 5 watts
- R10—1/2-watt resistor (see text)
- R11—47 ohms, 1/2 watt*
- R12—16 ohms, 1/2 watt, 5%*
- *Or 68 and 22 ohms respectively for 2N388-A transistor—see Fig. 2 and text
- RY—dpdt relay, 12-volt dc coil
- T—Toroid transistor-power-supply transformer, 12.6 v input, 500 vct @ 250 ma output (Triad TY-83 or equivalent)
- Heat sinks, chassis and hardware as described in text

- C1, C2—1 μ f, 25 volts
- C3—100 μ f, 25 volts, electrolytic
- C4—.001 μ f, 3,000 volts, ceramic
- C5—0.5 μ f, 25 volts
- C6—1 μ f, 600 volts
- D1, D2, D3, D4—silicon rectifiers, 750 ma, 600 prv (IN547 or equivalent)
- F—fuse, 8 amperes, slow-blow
- Q1—2N697 (G-E) or 2N388-A RCA—see text
- Q2—silicon controlled rectifier, type C15D (G-E)
- Q3, Q4—2N173 (RCA, Motorola)

in the supply lead to the power oscillator. A failure of one of the transistors (Q3 or Q4) could damage other components and wiring.

How the triggering works

First consider the circuit of Q1 with the points closed. Q1 is then cut off and the gate of Q2 is grounded through R12. With Q1 cut off, C5 charges to the battery voltage through R8. When the breaker points open, the bias current through R9 and R10 saturates Q1. This discharges C5 through R11, R12 and Q2's gate. The short positive pulse at the gate causes the SCR to discharge C6. After C5 is discharged (time constant about 30 μ sec), Q1 is held saturated by the bias current but the emitter current is limited by R8. The drop across R12 with the breaker points open is about 0.2 volt at normal generator voltages (below 0.25 volts even at the highest generator voltages). This assures that the SCR gate remains below the firing level of any SCR. The potential on C5 is slightly greater than that at the emitter.

When the points close again, Q1 cuts off and C5 begins to charge through R8. It has been determined that C5 must charge to a minimum of approximately 3.7 volts before it is possible to obtain sufficient gate drive to trigger Q2. Assuming a battery voltage of 14.5, 3.7 volts is about 25% of full charge, and C5 reaches this level in about 0.29RC. This is $0.29 \times 6,800 \times 0.5 \times 10^{-6}$ or

986 μ sec. Therefore the trigger circuit is incapable of firing the SCR for 986 μ sec and any point bounce after the initial point closing cannot fire the SCR. As the points remain closed, C5 will continue to charge to a higher voltage till it recovers its firing capability.

R10 should be adjusted to the largest value that will still permit triggering Q2 with a battery voltage of 7 1/2 to 8 but not lower. This minimizes the bias current to keep the voltage drop across R12 low, while assuring reliable trigger-

ing under the most adverse winter conditions. (Low temperatures reduce Q1's beta and increases the gate drive required for Q2.) With Q1 a 2N697 (silicon), R10 is about 1,000 ohms. With the n-p-n germanium type 2N388-A, R10 is about 1,500 ohms.

D5 protects the SCR gate against any high negative surges from the oscillating circuit. The reason for R9 is worth explaining. Keying by the breaker points directly at the base of Q1 was tried first, but triggering was unsatisfactory, with unpredictable misfiring. Breaker points, it is claimed, require a certain minimum current to operate reliably. The circuit with 50 ohms for R9 maintains dependable trigger circuit operation. The tungsten contacts apparently become contaminated quickly at low operating currents, and require a moderate current to keep them clean.

The ignition system may be built as a self-contained unit or as two separate units. I built one as a single unit in an aluminum box chassis 7 x 5 x 3 inches. The triggered-discharge circuit is in another box chassis 4 x 2 x 2 3/4 inches with Q2 mounted on one face so the anode stud faces into the power supply section. C6 also mounts in the power supply section.

Using two separate chassis makes a much smaller triggered-discharge unit that is more convenient to mount near the distributor and ignition coil, where space may be precious. The power supply unit can then be placed anywhere else convenient, with leads connecting the two. Avoid placing the power unit

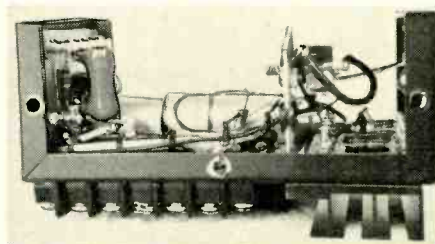
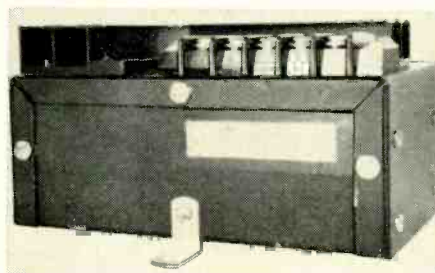

Outside and inside of discharge portion of two-unit arrangement.

inside the passenger compartment, because the 1,800-cycle sound from the converter will probably be annoying.

The power supply for the two-unit arrangement is constructed in a box 6 × 5 × 4 inches with the 4-inch dimension cut down to 2½ inches.

The triggered-discharge unit is constructed in an aluminum Minibox 5¼ × 3 × 2½ inches. The SCR is mounted on the vertical surface of the inner part of a Minibox 2¾ × 2½ × 1½ inches mounted so the 2½-inch dimension is vertical. The heat sink is an Astro Dynamics 2504 (Lafayette Radio catalog No. 30 R 1017) cut into two pieces and mounted on top.

Construction

Keep leads on self-supported components short to avoid breakage from vibration. Clamp, tie or cement larger components. As much as practical, place capacitors in the coolest location. Use good capacitors rated at full voltage to 100 or 125°C. Use silicone grease to mount the power transistors, the heat-sinks to the aluminum chassis, the SCR, and between the SCR chassis and the main chassis. Use good-quality wire and cable it to increase rigidity and prevent breakage under vibration.

Installing the system requires some care. Determine the wiring of the ignition switch, starting solenoid and ignition series resistor. Autos vary in these details; the shop manual for the model is very useful. It would be a good idea too to refer to the article "Troubles in Transistor Ignition System Hookup?" in the

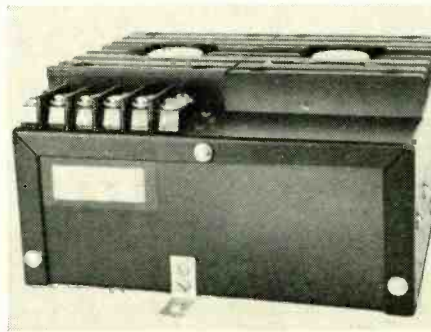
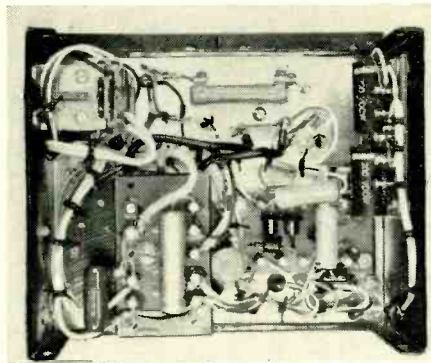

Interior and exterior of power supply for two-unit system.

June 1964 issue of RADIO-ELECTRONICS (page 60).

In the schematic diagram, the START terminal of the system (from RY) can connect to the hot terminal of the starter solenoid or to the ignition-switch terminal. The ignition system BATT terminal must retain battery voltage during normal running and during cranking. The START terminal of the ignition system must be energized only during cranking, whether from the solenoid or from the ignition switch.

Some cars use a series resistor at or near the ignition coil and others use a series resistance wire connected near the ignition-switch contact. The latter will require a tap into the wire on the ignition-switch contact; the new lead is then run through the firewall into the engine compartment. The starting circuit shown is typical of Fords.

The capacitor (condenser) across the points should be removed. The system triggers satisfactorily with the capacitor, but the increased time constant of the Q1 base circuit increases the turn-on time of Q1 and its dissipation.

When installing the power supply unit, choose a cool location in the path of abundant cool moving air but shielded from road splashes. The germanium power transistors, Q3 and Q4, are the most vulnerable to heat. Less concern is necessary for the triggered-discharge unit because Q1 and Q2 are silicon, but C5 and C6 should remain as cool as possible to prolong their life. A little time spent looking for a cool location is an investment in long reliable service. END

TUNING ELECTRONIC ORGANS

QUITE A FEW DEVICES HAVE BEEN DEvised for tuning electronic organs and other instruments, and it is often claimed that a complex instrument cannot be tuned by ear. That is not absolutely true. Professional piano and organ tuners rely on their ears very successfully, but they do not depend on so-called "perfect pitch." They use beat frequencies between two simultaneously sounded tones.

A "scientific" version of this technique uses a standard 440-cycle "A" tuning fork (available at most music stores for about \$2), a microphone, and any kind of oscilloscope. The mike goes to the vertical input of the scope (with an amplifier between if necessary), and the organ's A-440 tone generator to the horizontal input. Set the scope's horizontal selector to EXTERNAL. You will be looking at Lissajous figures. Sound the fork in front of the mike, then adjust the tone generator until you see a 1:1 pattern (circle, ellipse or line). Now you are all set to tune the other organ generators. (Octaves are automatically in tune with most organs, because they come, via dividers, from the same master oscillator.)

The ideal 12-note chromatic scale does not have equal intervals between notes. But since the time of Bach, we have been using the *tempered* scale, in which each note is related to its adjacent semitone. The ratio is 1 to the 12th root of 2. As a result, it turns out that the "perfect fifth" interval between the notes A and E in any octave (ideally 2:3) is not "perfect" but shrunk slightly. The perfect fourth (E to A, 3:4) is stretched slightly. (There are good musical reasons for this, which aren't to the point here.) This stretching and shrinking is highly critical.

The departures from physically perfect intervals can be heard as beats between the tempered and perfect intervals. The beat rates have all been calculated.

The technique, and the beat rates, are set down in detail in W. B. White's book *Piano Tuning and Allied Arts* (Tuners Supply Co., Boston, 1953) and other books.

For example: if the A generator just tuned is connected to the scope in place of the mike, and the D above it (a fourth) is connected to the horizontal terminals, the 3:4 Lissajous pattern should not be quite stationary, but made to rotate about 0.6 time per second by tuning the D slightly higher than 3:4. Consult the tables in the book (or in the Radiotron Designer's Handbook 4th Ed., page 873) for exact figures.—Daniel J. Erlich

HOW WELL DOES IT WORK?

Mr. Gerald's transistor ignition system is installed in his 1960 Ford Falcon with manual transmission. A RADIO-ELECTRONICS editor borrowed the car and spent an hour or so making rally-type runs over the winding, hilly side roads and straight expressways on Long Island's North Shore. Performance was evaluated by retracing the route in 1961 and 1963 Falcons—also with manual transmission.

Every effort was made to duplicate the driving conditions on each run. No attempt was made to check the degree of tune (sparkplugs and distributor points, timing, carburetor, etc.) of any of the three cars.

Acceleration from a start to top speed in second gear appeared to be a little better with the electronic ignition system and top speed was 4-5 miles higher. There was less tendency to lug when climbing hills at slow speeds. Passing acceleration (without down-shifting) was noticeably better with electronic ignition.

Build the Simpli-fier

Just about the simplest source-to-speaker amplifier yet:
three transistors and a potentiometer!

By HAROLD BALYOZ

TAKE THREE TRANSISTORS, A VOLUME control, a speaker, a power switch and one or two flashlight batteries. Hook them up in the circuit of Fig. 1. Connect an input, set the volume and listen!

As you can see from the photographs, construction is simple and layout is completely noncritical! Sockets are used for the two low-level transistors so that various transistors can be tried easily. Generally, changing a transistor requires only a minor change in the gain control setting. However, the circuit is sensitive to the overall gain of each transistor, and can be used to select "hot" transistors for special audio projects!

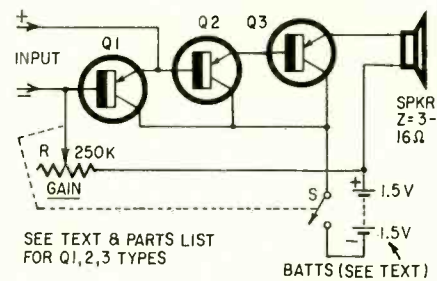

Fig. 1—Circuit of the Simpli-Fier. Try the transistors you have before you buy any!

- Q1, Q2—any small p-n-p audio transistor (2N109, 2N217, 2N408, etc.)
- Q3—p-n-p power transistor (2N255, 2N2869/2N301, etc.)
- R—pot, 250,000 ohms
- S—spst switch mounted on R
- SPKR—any size PM speaker, 3.2 to 16 ohms impedance
- BATT—battery (see text)

A Radio-Electronics editor who tested and listened to the amplifier wrote:
"While not hi-fi, this amplifier gives surprisingly clear output from FM and other sources. Response is good from about 100 to 6,000 cycles. With single-cell power, output is about 10–15 mw. Two cells raise it to 30–40 mw, already sufficient for small-room listening."

The three transistors are direct-coupled and biased "on" by the volume control, which thereby sets the gain of the system. All three transistors must be of the same polarity—all p-n-p or all n-p-n types. The types shown are p-n-p. If n-p-n transistors are used, merely reverse the battery, and, if the input is polarized, reverse the input polarity from that shown in Fig. 1.

The first two transistors can be small, low-current audio types, but the output stage must use a power transistor because all the battery current, except for a few microamperes, flows through it. If the input is to be connected to an audio transformer, use an isolating capacitor in series with the base input lead to the amplifier so the bias can be set properly by the volume control.

If a switch is used on the volume control, wire the control so that maximum resistance is in when the volume control is turned counterclockwise to "off". Use the center lug and the right-hand lug of the volume control as you see it from the back end (the end opposite the shaft).

If the volume-control resistance is lowered too much, the transistors will be overbiased, causing distortion and much wasted current through the output transistor. Always set the volume control to the high-resistance side of the distortion point. With a 5- μ f capacitor in series with the input, you can get excellent gain from a dynamic microphone (or a magnetic earphone used as a microphone).

If you want to make a radio out of the amplifier, connect a ferrite-core antenna, a tuning capacitor and a crystal diode (Fig. 2). No coupling capacitor is needed if the crystal is connected with the polarity shown.

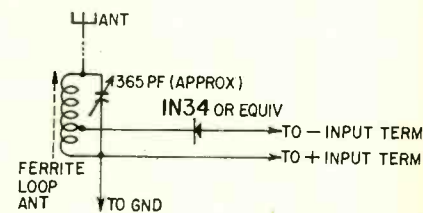
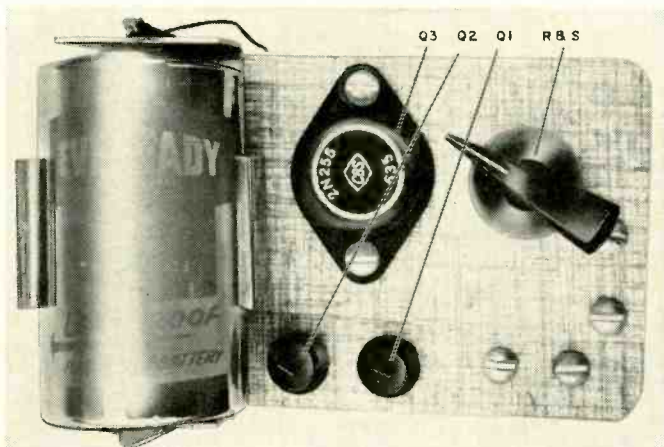

Fig. 2—Tuned circuit plus crystal diode make the Simpli-Fier into a radio.

You can use any speaker, and no output transformer is required. If a 3.2-ohm (4-ohm) speaker is used, maximum undistorted output is about 150 mw. If you use an 8- or 16-ohm speaker, you can use voltages between 6 and 12. However, for a 3.2-ohm speaker, no more than 4.5 volts is recommended.

Two of these little amplifiers would make an ideal low-powered stereo set for portable use. The circuit could also be used as a bridge or other instrument amplifier, as a signal tracer, or with a musical instrument pickup. If the speaker were replaced with a pilot light, it could be used as a visual indicator of a low-level input signal. No doubt you'll come up with a multitude of other uses for this simple little circuit. END



Original Simpli-Fier was built on scrap sheet metal. No shielding is required, because gain and impedances are low.

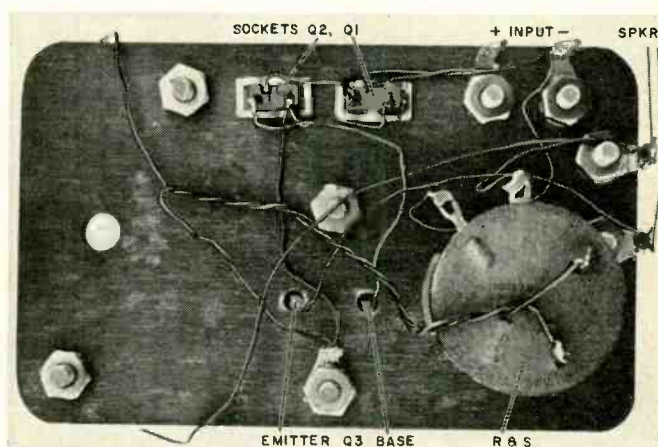

Q3's case is common to its collector, so don't use chassis for connections except negative battery terminal, unless you insulate Q3.

Getting Acquainted with Transistor AGC

It isn't quite the same as tube agc or avc, but certainly no more difficult

By LAMBERT C. HUNEALT

DID YOU EVER TRY TO COMPARE AUTOMATIC GAIN CONTROL (agc) in a transistor radio to avc in a vacuum-tube radio, and end up wondering just *how* agc works in a transistor circuit? If you are not quite happy with your understanding of these circuits, you have plenty of company!

Just as automatic volume control is necessary in vacuum-tube radios, agc is required in transistor radios to provide the second detector with a fairly constant signal strength from widely different antenna input signals on various stations. This reduces the need for resetting the volume control when tuning in different stations. It also reduces fading of distant stations and prevents overloading of the i.f. circuits on very strong signals.

Just as in tube radios, agc must reduce the gain of one or more i.f. amplifier stages, and possibly the r.f. stage, when the receiver is tuned to a strong signal, and allow maximum gain when receiving very weak signals. How is the gain of transistor amplifiers controlled?

Agc circuitry affects transistor biasing; so, first recall that an increase in forward emitter-to-base bias increases collector current, and a decrease in bias decreases collector current.

then functions as a dc amplifier for the agc voltage, resulting in much larger changes in average emitter current than could be produced by feeding the control voltage directly to the emitter itself. This amplified agc action reduces the power required from the detector.

Fig. 1 shows a typical circuit using that principle. The positive control voltage required for p-n-p transistors is thus available at the top of the volume control (R8). It is first filtered by R6 and C6, and then fed back to the i.f. bases.

Note that C6 is large (30 μ f) compared to the equivalent avc filter capacitor in a vacuum-tube radio, usually about .05 or 0.1 μ f. This is due to the low value of filter resistor R6 necessary in such a current-operated circuit. Voltage divider R2-R3 establishes the main forward bias on Q2's and Q3's bases. R1 is a decoupling resistor; C1 and C4 are decoupling capacitors. The forward bias results in a certain amount of emitter current flowing in Q2 and Q3, and this establishes the gain for each i.f. amplifier.

When a strong signal is received, a high-amplitude rectified signal current flows through detector load R8. This produces a relatively high positive dc voltage which is filtered by R6-C6 and then fed back to the i.f.'s. This positive agc bias opposes the negative forward bias and thus reduces emitter current in Q2 and Q3. The gain of both transistors falls off, preventing the strong signal from overloading the i.f. circuit and from producing too loud a volume from the speaker.

When a weaker signal is received, the amount of positive agc fed back to the bases is reduced, allowing more forward bias, more emitter current and more gain, maintaining a fairly constant signal level at the detector.

This agc system is the most popular type in transistor portables, but other methods are occasionally used. In one method, emitter current is controlled by applying agc bias direct to the emitters of the i.f. amplifiers, instead of to the bases. More agc power is needed to control the emitters directly. Since this would load the diode detector too heavily, such circuits customarily use a transistor power detector instead of a germanium diode.

Another system is based on a different characteristic of transistor amplifiers: the gain of an amplifier can be varied by varying its dc collector voltage within certain limits. The higher the voltage, the higher the gain. By inserting a fairly high value of resistance in series with the transistor load, the average dc collector voltage will depend on the average collector current which, in turn, depends on the amount of

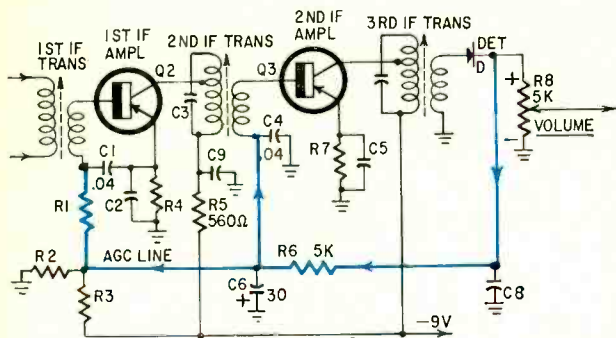

Fig. 1—Because transistor gain varies with emitter current, a control signal that changes emitter current (often via base, to get amplification) can be used to control the gain of an i.f. stage.

The gain of a transistor can be controlled in several ways. The first is based on the fact that the gain of a transistor amplifier is proportional to its emitter current. Therefore the agc system must reduce the emitter current of the controlled stage(s) to decrease gain.

Emitter current can be varied directly by an agc control voltage developed in the detector. Unlike vacuum tubes, which are voltage-operated, transistors are current-operated devices. This means that to control the emitter current of an i.f. amplifier, the controlling stage (the detector) must supply an appreciable amount of current. This compares unfavorably with a vacuum-tube avc circuit, where the detector supplies only a control voltage (no current) to the i.f. amplifiers, no power being required from the detector. To minimize loading on the detector, the power it must supply should be kept small.

Therefore, the i.f. emitter current is usually controlled indirectly. Instead of feeding the emitter directly, agc voltage is fed back to the base of the i.f. amplifier, taking advantage of the amplification of the transistor itself. The transistor

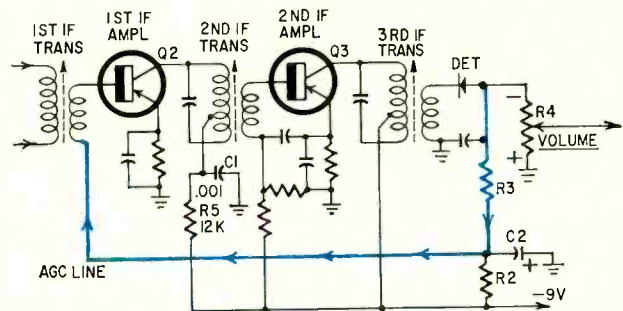

Fig. 2—Gain variation with collector voltage is used in some sets to control stage gain.

emitter-base forward bias. R5, in Fig. 1, does not do this, because it is only a small resistance and is unable to cause appreciable variations in collector voltage. Instead, R5 acts with C9 as a collector-circuit decoupling network. Furthermore, the agc bias fed back from the second detector would have the wrong polarity for such a collector-voltage type of agc system.

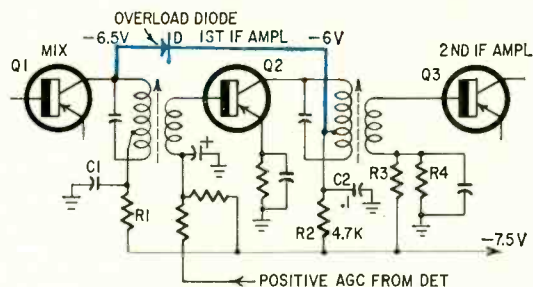

Fig. 3—Overload diode extends range of control of simple agc by damping first i.f. transformer on very strong signals.

A circuit using collector-voltage gain control is shown in Fig. 2. Here, forward bias is provided by the R2-R3-R4 voltage divider across the battery. The R2-R3 junction keeps Q2's base more negative than its emitter. The same junction also carries the agc voltage developed by detector load R4 and filtered by R3-C2.

When a strong signal is received, the agc line becomes more negative, because the diode is reversed in this circuit compared to Fig. 1. This increase in forward bias tends to increase conduction in Q2. The increasing collector current must, however, flow through R5, which is not simply a low-value decoupling resistor in this circuit, but a large resistance (10,000 ohms or more) which is bound to cause a considerable reduction in collector voltage. The drop across this resistor reduces the gain of the i.f. amplifier. When a weaker signal is received, forward bias is reduced, collector current drops, and collector voltage and gain is increased, maintaining a fairly constant signal strength at the detector.

Because both emitter current and collector voltage are varied by this method, you might wonder which more strongly affects the gain of Q2. The rise in emitter current, which

tends to increase gain on a strong signal, or the corresponding drop in collector voltage, which tends to reduce gain?

The secret is in the value of R5. In the collector-voltage agc method, R5 must have sufficient resistance to cause a large enough change in collector voltage to more than offset the change in gain from emitter-current variations. As a matter of fact, a close look at R5's value and the detector diode polarity will tell you which method is used in an unfamiliar circuit.

The circuits of Fig. 1 and Fig. 2, though they have reasonably good agc action, suffer from one shortcoming: on very strong signals there could be some i.f. overloading because of the limited control action possible in such simple agc circuits. To overcome this deficiency and provide a greater range of control, an overload diode is sometimes added to supplement the primary agc. Fig. 3 illustrates such a circuit.

Assume the radio is tuned to a medium-strength signal. A moderate agc voltage (positive) is fed back to Q2's base, allowing sufficient collector current to flow through R2 to keep the collector voltage below -6.5. The collector of Q1, on the other hand, has a fixed voltage of -6.5. (The decoupling resistor R1 drops 1 volt.) Under these conditions diode D is reverse-biased and does not conduct; thus we have normal agc action. When a very strong signal is tuned in, however, a large positive agc voltage is fed back, bucking forward bias and reducing the gain of Q2. In addition, the collector current of Q2 is reduced so much that its collector voltage rises to, say, -7. The overload diode is now forward-biased and conducts, acting as a low resistance in series with the large capacitor C2. This loads the Q1 collector tuned circuit heavily, reducing the amplitude of the signal fed to the i.f. circuits.

You may also encounter other, more sophisticated, agc systems, including separate agc rectifiers or agc amplifier transistors, in some of today's portable radios, but familiarity with the basic principles and circuits will enable you to tackle less common circuits and troubleshoot them systematically. END

REFERENCES

Milton S. Kiver, *Transistors* (3rd ed.), McGraw-Hill Book Co., Inc. Slurzberg and Osterheld, *Essentials of Radio-Electronics* (2nd ed.), McGraw-Hill Book Co., Inc. A Schure, *A Programmed Course in Basic Transistors*, McGraw-Hill Book Co., Inc.

ELECTRONICALLY CONTROLLED WHEELCHAIR IS HEAD-OPERATED

Bruce Lowe, totally paralyzed from the neck down, has been getting around for the last year and a half in an electronically controlled wheelchair, which he sets in motion and steers by wagging his head. The system uses inertial sensors in a plastic helmet. It was designed by Donald Selwyn of ITT (International Telephone & Telegraph Corp.) Federal Laboratories.

The head-control system also permits Mr. Lowe to operate a tape recorder for taking notes in the classes he attends. (He is pursuing a full-time college curriculum.)

To start the wheelchair forward, Mr. Lowe nods forward; to stop, he nods backward, and can coast or brake to a stop as he wishes. Special sequences of nodding operate his tape recorder



and a signal light in the helmet, which indicates to an instructor that he wants to speak. An "enabling circuit" prevents the various devices from being actuated by spurious signals, such as accidental head movements.

The head-movement sensors give eight possible commands to the logic circuits that interpret the motions. Only six are needed to operate the wheelchair, so that leaves two for auxiliary apparatus. One—a direct movement to the left—beeps the horn. The other—a nod to the right—triggers a multichannel transfer switch, which disconnects the control system from the wheelchair motors and connects it instead to a set of additional "appliances" (the tape recorder, signals of different kinds, etc.). Another nod to the right could set up still another set of auxiliary functions, and a final nod to the right would bring the control circuits back to wheelchair operation again.

Use your scope to find out some things about coils that we'll bet you didn't know!

GET MORE OUT OF YOUR SCOPE

By ROBERT G. MIDDLETON

MOST SHOPS HAVE OHMMETERS FOR testing resistors, and bridges with accessory features for testing capacitors, but very few shops have facilities for testing coils—or so they say. Most technicians just measure winding resistance, which is enough to tell whether a coil is open or shorted, and sometimes whether any turns are shorted. Sometimes an experienced technician follows up by making a *ringing test* on a coil. That can tell you practically anything you need to know about the coil.

Every real coil has not only inductance, but also resistance and capacitance. The capacitance is distributed—it occurs between individual turns of wire. Fig. 1 shows this. The inductance is shunted by what we can consider a lumped capacitance, C_D . The coil is in effect a parallel-resonant circuit at some frequency given by the familiar resonant-frequency formula.

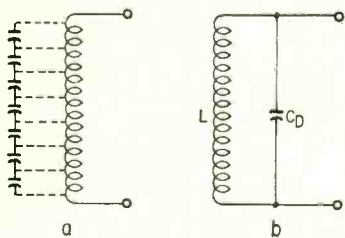
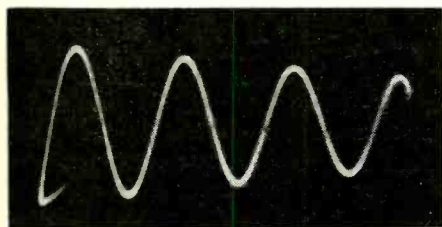
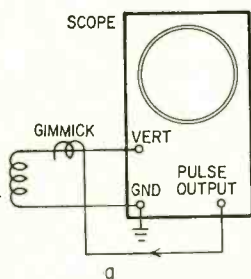

Fig. 1-a—There is a small capacitance between adjacent turns of any coil, but for practical analysis we can “lump” together all the capacitances into one value across the entire coil— C_D , as at b.

Fig. 2-a—Simple ringing test setup.

In Fig. 2-b, a typical damped-wave ringing pattern.



b

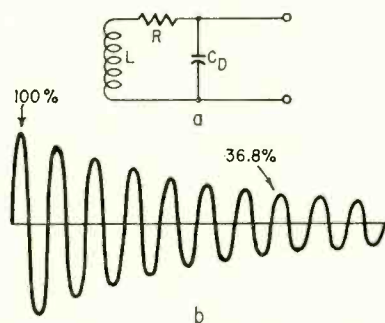

Fig. 3-a—All coils have some resistance, so this is a truer representation of a parallel-resonant circuit. b—Amplitude falls to about 37% in $2L/R$ seconds.

Measuring self-resonant frequency

Let's disregard the resistance for now. The shunt capacitance permits the coil to be shock-excited into oscillation. A preliminary test setup is shown in Fig. 2. Connect a peaking coil (for example) to the scope's vertical input terminals. To shock-excite the coil, loosely couple a pulse voltage to its “hot” lead with a “gimmick”. When you adjust the horizontal deflection rate, you will see a ringing pattern (Fig. 2-b). Some scopes have a test-pulse output terminal. Others can be easily modified by tapping off the blanking circuit.

The scope must have adequate vertical bandwidth for this test. The smaller the coil, the greater must be the scope's bandwidth to display the ringing pattern. Otherwise, the waveform will be “choked out”. You must apply sufficient pulse voltage to get adequate vertical deflection. This depends on the sensitivity of the vertical amplifier. Most ringing tests are made with the vertical gain set to maximum output. If vertical deflection is insufficient, use several turns on the gimmick. Finally, use a sharp pulse. One with slow rise will not ring a small coil satisfactorily.

Suppose you want to measure the ringing frequency (f_0) of the waveform in Fig. 2. If you have a scope with calibrated sweeps, the sweep setting gives this frequency by simple calculation. The sweep setting lets you observe the time of one complete cycle in the ringing waveform, and frequency is the reciprocal of this period:

$$f_0 = 1/T$$

Most shops don't have scopes with

calibrated sweeps, but there's another simple method.

Disconnect the peaking coil and connect a signal generator to the scope. Don't change the deflection rate in the scope. You can change the vertical attenuator setting if you want. Now tune the signal generator to obtain the same number of cycles in the pattern as before. The generator dial then reads the ringing frequency.

Note that the pattern in Fig. 2 has decreasing amplitude. When a coil is shock-excited, it is energized by the test pulse at the left-hand end of the pattern. The initial amplitude is not sustained because of resistance loss. In other words, a more exact equivalent circuit for a coil is as shown in Fig. 3. The self-oscillatory current surges back and forth through R, and undergoes an I^2R loss. Over a time equal to $2L/R$ second(s), the initial amplitude decays to 37%. Thus, the ringing pattern gives the ratio of inductance to resistance.

Most technicians don't analyze ringing patterns, but merely make comparative tests. For example, you might check a width coil by observing its ringing pattern in comparison with a known-good width coil. Note in passing that a coil will *not* ring unless its resistance is less than $2L/C$. Shorted turns effectively *add* resistance to a coil and reduce its inductance; in turn, the ringing waveform dies out faster than for a similar coil without shorted turns. Because shorted turns reduce the coil's inductance, its ringing frequency is higher.

Exact self-resonant frequency

When waveform decay is slow, the familiar resonant-frequency formula is accurate enough for all practical purposes. On the other hand, when the L/R ratio is comparatively small, and the ringing waveform decays rapidly, the exact self-resonant frequency formula should be used:

$$f_0 = \frac{1}{2\pi} \sqrt{\frac{1}{LC} - \frac{R^2}{4L^2}}$$

This exact formula is of interest to technicians in electronic labs, but is not used in ordinary shop work. Note that when R is zero, the exact formula becomes the same as the familiar resonant-frequency formula. This corresponds to the situation in an ordinary

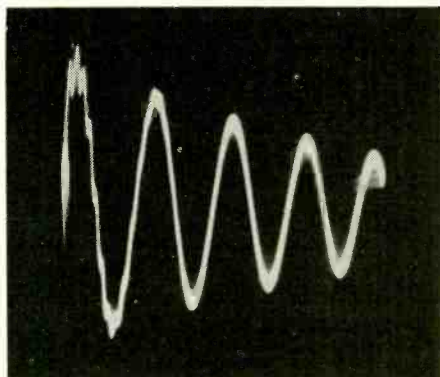
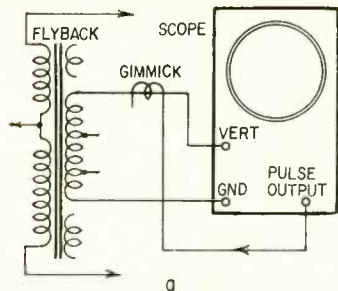

b

Fig. 4-a—Ringing test for flyback transformer. b—Note high-frequency oscillations riding on low-frequency wave.

oscillator circuit, where the tube cancels out the coil resistance.

Transformer ringing tests

A test setup for a ringing checkout of a flyback transformer is shown in Fig. 4. Flyback transformers have more than one winding, and each winding is coupled to the other. Since each winding has a different resonant frequency, it is not surprising to find that a pure damped sine wave may not be displayed on the scope screen. Test results depend considerably on which winding is pulsed. Fig. 4-b shows a high-frequency damped sine wave superimposed on a lower-frequency one. In making comparative tests of transformers, always connect the same winding of each transformer to the scope.

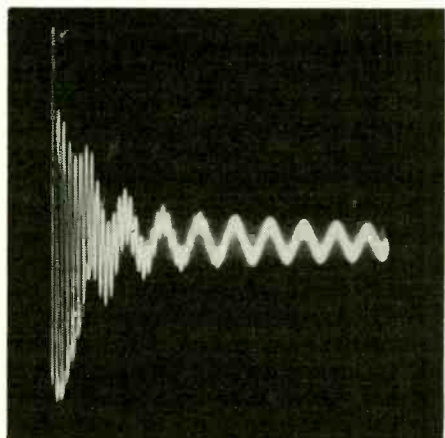

Fig. 5—Mixed transient wave produced by transformer with two or more windings.

Autotransformers can be tested across the complete winding (as in Fig. 4-a) or between an end terminal and the tap. It is necessary only to select the same pair of terminals to compare a known-good transformer with one you suspect to be defective. For the most conclusive results, make a series of comparative tests for all the significant windings. (A filament winding, of course, would be neglected.) A series of tests is desirable because a defect in the high-frequency component of the waveform in Fig. 4-b, for example, is somewhat difficult to observe—it tends to be masked by the high-amplitude lower-frequency wave.

When you test another winding on a flyback transformer, you will expect to see an entirely different ringing waveform, as in Fig. 5.

Now, consider tests on hi-fi audio transformers. Although the transformer has only two windings, you will often observe more than two ringing components in the waveform. These are caused by leakage reactances in the transformer, which cause multiple resonances in the unloaded test condition.

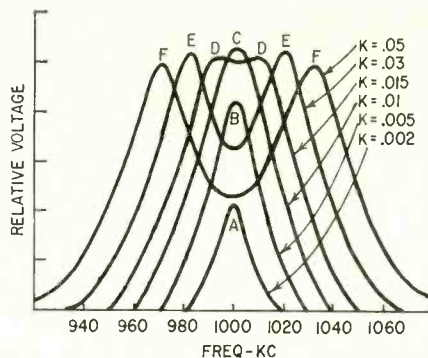

Fig. 6—Two peak frequencies of i.f. transformer show up as coupling gets tighter—curves D, E and F.

Again, it is necessary only that the audio transformer under test display the same complex ringing waveform as a known-good transformer of the same type.

Fundamentals of coupled circuits

The i.f. transformers in radio receivers provide a classic example of two windings resonant to the same nominal frequency. I say "nominal" because each winding has a center frequency which is useful to imagine when you describe simple circuit action. Actually, the nominal resonant frequency is a fiction and, unless you recognize that, ringing tests will be incomprehensible.

First, consider the frequency-response curves for i.f. transformers (Fig. 6). For coupling coefficients greater than 1%, it is clear that the transformer (either primary or secondary) has peak responses at two fre-

quencies. In any case, the nominal resonant frequency in Fig. 7 is 1,000 kc. The coupling coefficient merely refers to the spacing between primary and secondary.

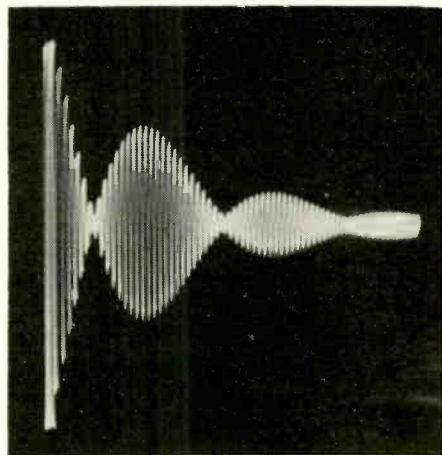
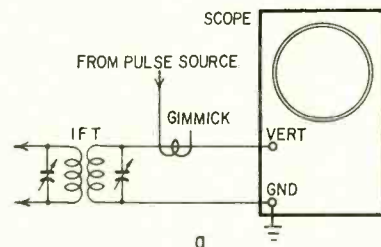

b

Fig. 7-a—Test setup for "ringing out" a transformer. b—Ringing waveform with primary and secondary tuned to same nominal frequency.

In Fig. 6, it appears that for coupling coefficients less than 1%, there is only one peak response. But this only seems to be true. Actually, curves A, B and C also have two peak response frequencies, although they are so close together that they seem to form one peak in a frequency-vs-voltage curve. Note that the peak broadens a little, as we go from A to B to C. This is simply due to the spreading apart of the two masked peak-response frequencies.

In Fig. 7, the transformer has a nominal frequency of 456 kc. Obviously, it does not ring at its nominal frequency. Instead, it rings at two frequencies, and they beat with each other to generate a damped modulated rf waveform. In this case, the windings happen to be coupled quite a bit more than 1%, and the two peak frequencies are considerably different (note the number of cycles between successive zero-beat points).

Recognize that complete zero-beat points occur only when primary and secondary are tuned to the same nominal frequency. This is clearly shown in Fig. 8, where stagger-tuning is present in this same transformer. This is a perhaps unexpected fact. Stated otherwise, we might expect to obtain the same

transient response from a transformer either by overcoupling or by stagger-tuning. However, this is not so, and you can prove it algebraically as well as experimentally.

It follows that, other things being equal, the number of cycles observed between zero-beat points (Fig. 7) depends *only* on the coefficient of coupling. You can easily demonstrate this with an i.f. transformer that has adjustable coupling. As you vary the coupling, the number of cycles between zero beats also varies. Changing the coupling also changes the tuning *very slightly*. To keep other things equal, you may have to touch up the trimmers slightly when you change the coupling. The need for touchup appears simply as an incomplete null at the zero-beat points.

Just why does absolute zero beat occur only when primary and secondary are tuned to exactly the same frequency? Because the secondary is coupled to the primary, just as the primary is coupled to the secondary. This being so, the secondary induces a voltage in the primary, just as the primary induces one in the secondary. If you use external sync and check the primary waveform against the secondary waveform, you will see that the envelope peaks are 90° out of phase from primary to secondary. This is just another way of stating that, when one winding has zero energy, the other winding has maximum energy.

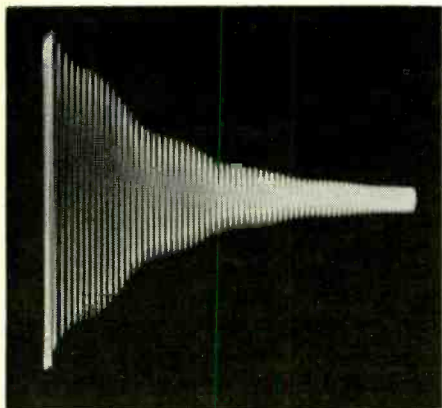

Fig. 8—Stagger-tuning shows up by incomplete zero beats.

Obviously, over the ringing interval, all the energy in the primary is gradually transferred to the secondary, leaving no energy in the primary. But because the coupled system is symmetrical, the secondary then proceeds to transfer its electrical energy gradually back to the primary. This seesaw action continues between the two windings until all the original pulse energy is dissipated as heat in the ac resistances

of the coils. If the coupling is tight, energy transfers back and forth very rap-

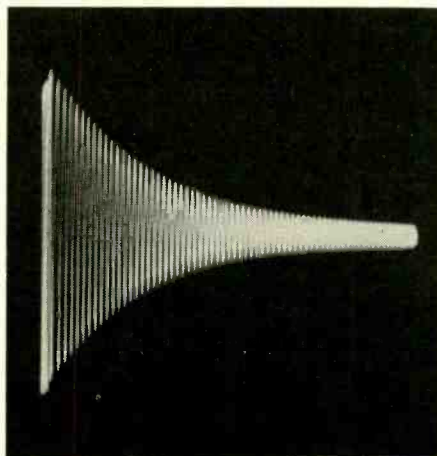

Fig. 9—Loose coupling obscures zero beat.

idly between the windings, and the zero-beat points are close together. If the coupling is loose, energy transfers back and forth slowly between the windings, and the zero-beat points are far apart.

Now suppose that we are "ringing out" an i.f. transformer from a narrow-band receiver. This means that the coupling coefficient will be small. Fig. 9 shows the observed response. Two ringing frequencies are present, but they are so nearly the same that the ringing interval dies out before the zero-beat point appears in the scope pattern. The fact that two frequencies are really present is shown by the lack of smooth peaks in each cycle. Expand the waveform, and you will see a progressive change in peak shape from beginning to end of the ringing interval.

Experimental notes

To ring radio i.f. transformers effectively, you need a sharp and strong

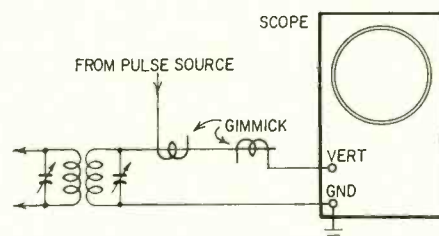

Fig. 10—Extra gimmick (the one on the right) minimizes detuning of transformer by scope's input capacitance.

pulse. This type of pulse may not be provided by ordinary service scopes. However, you can often obtain a suitable pulse by using the horizontal de-

flexion voltages in the scope. Feed the horizontal sawtooth voltage through a small capacitor (about 10 pf) to a test-pulse terminal on the front panel of the scope. This will usually give a good pulse output for ringing i.f. transformers. If the retrace in your scope is too slow, a separate pulse generator is the most practical alternative.

Also note that the simple test set-up shown in Fig. 7 places the scope's input capacitance across the transformer. To compensate for this, you will need to open up the trimmer across the right-hand coil. You may prefer to reduce the effective input capacitance of the scope by using another gimmick, as in Fig. 10. The gimmick reduces the voltage available to the scope, but if you have a strong, sharp pulse source, this is no problem.

So, you see that ringing tests of transformers not only have considerable practical utility, but they also open our eyes to circuit action which we should know. Equations are dreary reading, but scope patterns make learning interesting and easy. END

NO-POWER TRANSISTOR RADIO

I was interested to read the article by Leonard E. Geisler in the September 1964 issue of RADIO-ELECTRONICS.

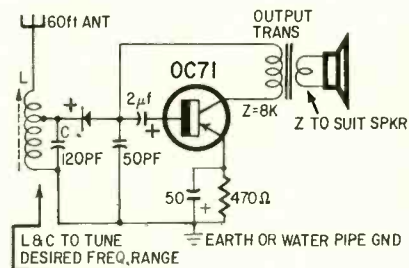

He writes on "How to Get Something for Nothing, Almost." His circuit is not as economical as the one I have been using for some time. The original idea for my self-powered crystal-transistor set came from the April 1955 issue of RADIO-ELECTRONICS. I have substituted an 8-in. permanent-magnet speaker with an 8,000-ohm output transformer. It gives excellent volume in a quiet room when used with a 60-ft outside aerial and a ground.

I have made two other slight modifications to the original circuit and use a slug-tuned coil for tuning. The circuit shown gives greatest volume. A volume control is not necessary.

I have also tried a push-pull version, with two 8-in. speakers, but the output is not as great as from the single-speaker version.—Harry C. Major

Gestalt psychology (ge-shtahlt') [Ger. *Gestalt*, form.] Psychology based on the theory that events do not occur singly or independently but through formed configurations or patterns called *gestalten*, whose properties are not directly derivable from their parts.

GESTALT SERVICE

A little applied psychology goes a long way!

By THOMAS R. HASKETT

Art by JACK BLOUNT

RECENTLY, WHILE INSTALLING AN intercom for Doc Berry, our local head-shrinker, I was introduced to *Gestalt Psychology*. What seemed to fit the service business was his statement, "The whole is often greater than just the sum of its parts." Less than a week later, a color set proved him right.

Outside men were scarce that day, and I was sent out on this callback—a new color set we had installed only a week before. The color was sickening. A singer's dress, green at the beginning of a song, was blue by the end. I tried some new tubes—no help. "Oh, no!" I moaned, "convergence!" Then, swallowing my pride, I borrowed the customer's phone and called the shop. "Fred," I gulped, "I need some help on a color set—it looks like a sick rain-

bow." that tube out of its harness and got a new one in place, the color set bugging me all the while. Fred said nothing, but looked at his watch and walked over to the demo. He turned up the sound and we heard an announcer say: "... program was recorded earlier for presentation at this time." Then a commercial came on, a series of colored slides. I had a funny feeling as I noticed the colors holding rock-steady. A black-and-white program followed.

"OK—I give up," I grumbled. "What's going on?"

"Easy. That station just bought a new video tape recorder, but they haven't got all the bugs out of it yet. Color phase is one. Every tape show they put on looks like your sick rainbow. Now, in about an hour and a half you can get back to that customer's home and set up their TV right. A network program is on then, so you'll know the signal coming in is clean. Any *other* trouble will have to be in their set. And just as a double-check, I'll phone you if it should happen to look bad here."

I guess Fred thought I was nuts when I mumbled something about doing Gestalt servicing now. But I thought about that idea as I touched up a couple of controls back at the customer's house. I showed her how everything was fine during a network show. Then I explained that she could expect some color trouble during local tape programs—at least until the station got their recorder debugged.

The Hair of the Dog

This Gestalt principle, as Doc had called it, kind of dropped from my mind until Friday afternoon. Then Woody, our enterprising salesman, asked me to run out and see what was wrong with a new stereo "package" he'd sold recently. The customer complained that it sounded terrible, and it had left the store only 3 weeks earlier. So I drove out fearing the worst. Woody is no technician, and to make a sale he would slap components together with the zeal of a dog scratching fleas. Sometimes, that meant a dog for *me*.

A pair of carnivorous-looking Great Danes conveyed me into a base-

ment playroom where I met the lady of the house. Mrs. Jones put on a record and I noted that Woody had, for once, done a pretty good job; twin three-way speakers in tuned cabinets, a 40-watt power amplifier, our best preamp and a honey of a three-speed changer.

But the sound—distorted, scratchy and muffled!

I reached for a screwdriver, but the sight of a pile of naked LP's nudged my mind. Suspicious, I plucked the record from the changer and held it up to the light. Whoo—ee! Loaded with dog hair, dust and some fuzzy stuff. Environment? I gazed past a room divider at a laundry tub and a washer/dryer combo. Well, maybe. I checked through the pile of bare LP's, their covers neatly stacked on the shelf below, and every one was as gummed-up as the first. Only one (on



"It looks like a sick rainbow."

how." Briefly I outlined what I'd found.

Back across the phone line came a laugh. Fred was our top-notch benchman, an expert who'd done nothing but fix video for 12 years. "You don't need any help," he chortled. "Turn off the set, tell the customer you'll be back in 2 hours and come back to the shop. I need some help." And he hung up.

Mystified, I did as he said. As I entered the shop, I saw him struggling with a CRT replacement on a big black-and-white job. He had a color demo set running nearby, and *that same shifting color* was beaming from the 21CYP22. "Hey," I yelped, "what is this, a gag? Have you got the same trouble here?"

"That's right. Here, gimme a hand with this picture tube." We wrestled

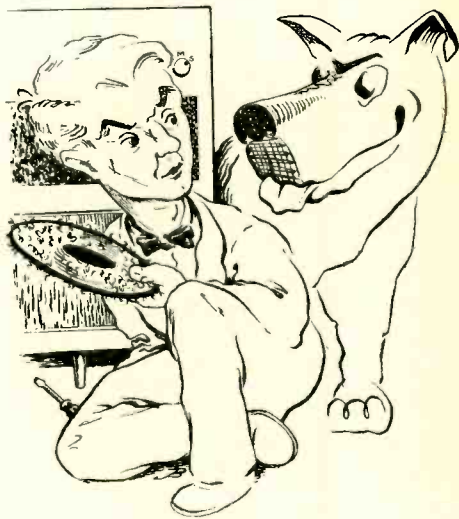

Hi-Fido

the bottom, of course) was still in its cover. I popped it on the turntable.

When Mrs. Jones asked, "What is it?" I hardly knew whether to get mad or laugh. While I cleaned a gob of grime off the stylus, I said, "Just listen." There was a little pause and then a marching band started up full tilt. From the oompah of the tuba to the tinkle of the glockenspiel, every note came through loud and clear. "How's that?" I asked.

She nodded. "Mmm, it sounds all right, I guess. We hardly every play that

one. (No kidding, I thought.) What was wrong?"

I wasn't sure about attempting an explanation of Gestalt service—I was still trying to understand it myself. But at least I could explain its practical application. "Mrs. Jones, there's nothing wrong with your stereo—it's in great shape," I began, looking at the two dog beds and trying to remember how to be tactful. "New owners often overlook one point: This is a piece of fine equipment, as precise as a fine watch. And like a watch, a single hair in the wrong place can clog it up. You wouldn't think of leaving the back of your watch open, would you?"

As she shook her head I could see she was beginning to get the idea. I pulled a wiping cloth from my caddy and picked up one of the hairy records. After she saw the fuzz on the disc I nodded toward the pair of oversize Fidos.

"Oh, you mean we should keep the dogs out of this room?" she asked unhappily.

"Oh no, ma'am. But you see those album folders? They're like the case on your watch. When the records are in the folders they won't pick up the dog hairs so much." I wiped off one of the records and put it on the changer. The sound was pretty good, but not as clear as the marching band. "Playing your records with the fuzz on them cuts scratches in the grooves, scratches that no amount of wiping can remove."

Mrs. Jones was pleased that the trouble hadn't been expensive. Apparently she'd understood more than I gave her credit for; as I was leaving she changed her mind about something.

"Don't you think we really ought to move the dogs' beds to another room so they won't shed around the stereo?"

Well, what're you gonna do? It was a great idea, but I hadn't *dared* to suggest it. First Gestalt psychology, now female psychology—I was really learning to take a wide view.

The Case of the Anemic Pulse

A wide view was what I needed when I got back to the shop and glared at a TV set on my bench. It glared right back, its 21-inch eye stubbornly displaying a perfect picture—in spite of a tag marked "Horizontal tearing." Actually, it had been working OK for 3 hours and on all three channels. I stalled for a while but, when Fred asked how I was coming, I admitted defeat.

"Well, call the customer first and verify the complaint. Maybe the outside man goofed."

I checked with the lady who owned it. ". . . and goes to those funny silver ribbons now and then. Not all the time, though." I asked her when, but she



"It seemed to be a healthy pulse . . ."

couldn't be specific. With the stereo fresh in mind, I wondered what kind of "dog hair" I'd find this time. ". . . now and then . . ." Another "sick rainbow"—in black-and-white? I turned to Fred. "What about the station signal?"

My colleague raised an eyebrow and flipped channels on my nemesis. It still locked in sharply on all three stations. "I don't think the stations are at fault," he said. "Everything's been fine all afternoon. Have you tried changing the line voltage with the Variac?" I hadn't, so I did. No soap.

We got caught in a rush, though, and I ignored the beast until the next day, Saturday. I mention the day be-

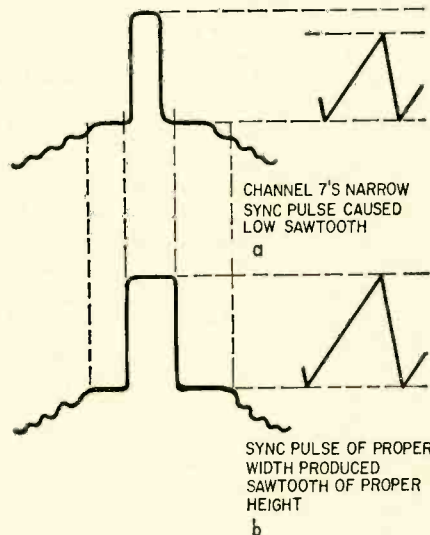

Fig.1

cause we've an outside man who's a sports bug. He came in about 2:30 and switched our problem child over to channel 7, which had a basketball game. She locked in for an instant, then tore. I moved in for the kill. She synced in fine on 4 and 11, but was unstable on 7. As

I reached for my scope probe I noticed Fred flipping another set to 7; his picture held steady. I scoped horizontal sync from video detector to the horizontal afc diodes. It *seemed* to be a healthy pulse, but I wanted to be sure. I went back to the video detector and got the single sync-and-blanking pulse shown in Fig. 1-a. Frank had moved over by my bench and was peering over my shoulder as I switched the set to 11 and then to 4. Fig. 1-b shows what I found: 7's pulse *was* a bit narrower than 4 or 11's.

Before I could crow, Frank was handing me a new afc diode. After I soldered it in place, the temperamental chassis display a beautiful picture on all three channels. I grinned at Frank: "Gestalt service wins again—the sync is still narrow on 7. Thought you said it couldn't be the station signal?"

He chuckled. "I only said 'maybe'—and besides, that was a real dog. I wonder what's wrong with 7? And what's this 'Gestalt service'?"

I told him the idea Doc had given me about psychology and service work while I phoned channel 7's control room. The chief engineer's a friend of mine, and when I reached him I explained our experience and asked him if anything was wrong with his sync. He told me to hold on a minute. After checking his own scope and monitor, he replied: "Our local sync is as wide as everybody else's. But during network programs, as you know, we transmit *their* sync instead of *ours*, and this ball game is coming from another city over a special sports network. They generate their own sync out there in that gym. There's probably a long cable run somewhere that's attenuating horizontal sync. But you must *really* have a touchy set—I can see it on my scope, but it's not giving our monitors any trouble."

I thanked the chief and repeated his remarks to Frank, who said, "I see—touchy set, diode just a hair off, and it took a subnormal pulse to lose sync. Also, that subnormal pulse only came along every now and then—a real toughie." I could feel my head growing, I was grinning from ear to ear, and I wondered if Frank would have the boss give me a raise. Then he deflated me. "Gestalt service, huh? I've been using it for years. And I don't know a word of German!"

Locus Pocus

Jerry, one of our outside men, brought in an old TV one day and put it on my bench. "Here's a puzzler," he said, plugging it in. "I know these people, and it's not their regular set. I promised to try to stop you before you did too much. They only want it for their kids, and don't want to put too much money in it." He fired it up and—you guessed it

—everything was screwy: low height, distorted sound, overloaded video and a very dim raster.

“You done anything?”

“Some new tubes is all—6BQ6, 6S4, 6AX4 and a 6SN7. They picked up the size—for a couple of minutes. When it slowly got smaller and dimmer I brought it in. Couldn’t figure out that video overload either—the agc switch has no effect on it.”

I tried the agc myself; nothing happened. Wheels turned in my skull. Dim raster? Low height? “Jerry, did they buy this set from us?”

“No, I think they got it from relatives,” he said, scratching his crewcut. “Why?”

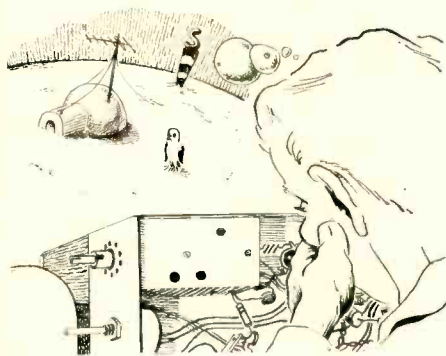

“... from a real fringe area”

“Help me pull the chassis and we’ll check it out.” He did, and I quickly had a new 5U4 in it and was clipping the filters loose. I jumpered in a new set of ‘lytics, plugged in a cheater, and took a look at the agc switch. “Well, lookie here!” I announced gleefully.

“Hey, what’s that, a jumper?”

“Exactly,” I said. “That makes the control a dummy. Somebody didn’t want it to work, so they shorted it out, and the set runs wide open all the time.

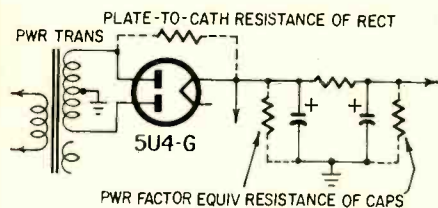

Fig.2

Around here signal levels are high, and no wonder the set’s overloaded.” The CRT bloomed up full size, with lots of brightness, just then. Jerry readjusted the brightness and contrast, then played around with the ion trap, while I snipped the short off the agc switch and put that control in the “local” position.

“How about that,” commented Jer-

ry. “Sound’s fine, video’s clear, plenty of size and plenty of brightness. How’d you figure it?”

To myself I said Gestalt service, but to Jerry I said: “It must have been a change in location. I’ll bet that set came from a fringe area where the line voltage was low, like the signal. They had to drive everything wide open to get a picture. The low voltage? That old 5U4 was almost gone and the demands of your new tubes raised its plate-to-cathode resistance enough to drop the B-plus.” I sketched out Fig. 2 for him. “And under low line voltage those ancient filters barely made it with their leakage. The higher line voltage ran up their power factor and sapped the B-plus even more.”

A too-simple job

Although Fred taught me a lot, once I actually came out ahead of him. One morning I came to work and found him with a little five-tube radio on his bench. Grinning sheepishly, he asked me if I had any ideas about it. “You mean you can’t fix it?” I asked, incredulous.

“I never mess with radio—been doing TV for all these years and nothing else. My wife keeps this thing in the kitchen. It stopped playing a couple of days ago. I put all new tubes in it this morning before you got here, and when it still wouldn’t work I thought I’d give you a crack at it.”

I picked up the little monster and plugged in the line cord. The pilot flared up and the heaters lit, but there was no sound from the speaker. My vtvm showed plenty of B-plus on all plates, so I tried my finger on the 12AT6 grid. No hum—no buzz—no sound. I tried the same on the 50C5; still nothing. It was a long shot, but I got another 50C5 from the shelf and switched output tubes. In a minute music and static came up and the set was working again. Fred was staring silently at the tube I’d pulled out of the socket. Suddenly he took it over to our tube tester and pushed it in. I came over and looked at the meter; the tube wasn’t emitting at all.

“What made you try another output tube?” he asked in a serious tone.

“Call me Dick Tracy,” I replied. “I’m naturally suspicious. When I didn’t find any audio hum I wanted to be real sure that 50C5 was clean. *You yourself* told me ‘The tube companies don’t put warranties on the cartons just to impress people.’ And I’ve run into fresh-from-the-shelf duds before. That, too, is part of this Gestalt service I’m learning.”

Fred’s enthusiasm bounced back. “Good boy,” he said. “I’ve run into that kind of duds too, but I guess I just got careless when I got away from my usual TV. What was it you said? Gestalt service wins again?”

Voltage Regulator Stabilizes RF Signal Generators

INEXPENSIVE RF SIGNAL GENERATORS CAN often be improved noticeably by voltage-regulating the power supply. A sudden shift of 10 volts or so in the ac line voltage, as when an air-conditioner motor starts, can change the output frequency by several kilocycles—just when you’re trimming up a slug-tuned coil.



All the improvement project takes is a gaseous voltage regulator tube and a series resistor. The nominal voltage of the regulator tube should be not too much lower than the voltage the oscillator circuit was designed to work with. The “raw” power supply output must be at least 20% greater than the VR tube operating voltage for stable operation. See table for VR tube characteristics.

REGULATOR TUBES AND VOLTAGES

TYPE	NOMINAL OPERATING VOLTAGE	FOR E _h FROM . . . TO
0A3/VR75	75	95-125 volts
0C2*	75	95-125
0B3/VR90	90	110-130
0C3/VR105	105	125-180
0B2*	105	125-180
0D3/VR150	150	180-220
0A2*	150	180-220

*7-pin miniatures. Others have octal bases.

For E_h voltages of 215 to 240, use two 0B3 in series; 240 to 270, two 0C3 or 0B2; 265 to 300, 0C3 and 0D3, or 0A2 and 0B2, in series. Over 300 volts, two 0D3 or 0A2.

Calculating the value of the dropping resistor is easy. It’s just the power supply voltage (E_h) minus the VR tube operating voltage (E_{VR}), divided by the maximum rated current for the VR tube (.03 or .035 amp for most popular types). As a formula:

$$R = \frac{E_h - E_{VR}}{I_{VR}}$$

For voltages higher than 150, you can simply connect two VR tubes in series. The operating voltage of the series pair is equal to the sum of the voltages of the individual tubes. This won’t usually be necessary, since rf generators usually have low supply voltages, at least for the oscillator portion.—Harold J. Weber

[The formula above applies only when the load current is constant and small compared to the VR tube current. Calculations are more complex when the load current is large or swings over a wide range. For design data, refer to The Radio Amateur’s Handbook or to *Tubes and Circuits*, by Christ (Gernsback Library Book No. 82).—Editor]



Chick in a plate-glass cage—she demonstrates the dances. A small speaker in the cage lets her hear the band.

Cash in on the discotheque fad! Here's how to set up and keep up a go-go club sound system

By THOMAS R. HASKETT

YOU'VE PROBABLY HEARD OF "GO-GO"—PROBABLY IN ASSOCIATION with *discothèque*. This craze is sweeping the country right now—a new style of nightclub, catering mainly to youth (but attracting a lot of people over 30). The Whiskey à Go-Go in Cincinnati is a good example—it has the same name as the Parisian club that originated the technique, and it's where I cut my teeth as a go-go sound man.

The Paris club started as a private club with recorded music as its sole source of entertainment. The recordings were not on a juke box, however, but played on manual turntables. The US style is a little different. Records are used, often played by a radio disc jockey (who publicizes the club on his station). But a live band provides more than half of the evening's music. The main attraction is the go-go girls—sexy young things in skimpy costumes who dance the latest far-out dances in glass cages or booths. They're supposed to be "demonstrating" new dances for the customers; somehow, male customers show considerably more interest than do their girl friends. Oh, by the way, the patrons dance also—there's usually a small dance floor in front of the bandstand, and it's usually jammed.

The keynote for go-go is rock-and-roll or twist music. People dancing the Frug, the Jerk, the Swim, the Freddie, etc., demand lots of sound. It's not unusual for a go-go club to have 200 customers on a good night. Since they dance, talk and sing, it takes a lot of power to push the music out

HOW TO BE A GO-GO SOUND MAN



Mikes get pretty rough handling. Better keep a spare handy.



across the crowd. *But this doesn't mean a lot of wattage in a few booming speakers*—for that only complicates matters. People close to the speakers are blasted out of their seats, while those farther away can't hear much. The solution is to spread the sound. At the Whiskey à Go-Go we used distributed speakers and two 30-watt amplifiers in parallel.

Discotheque-nique

If you come into a new installation, you can specify the exact material to do the job properly. Depending on the club size, you will need from 40 to 150 watts of audio power, and at least four speakers, although it's much better to have a dozen or more. Some places have false ceilings, and you can flush-mount speakers. If the ceiling is concrete, use sealed hi-fi enclosures. *Why ceiling speakers rather than wall-mounted?* You can put the sound sources much closer to the audience that way. You can also control speaker-phasing problems, reverberation and wall flutter, and prevent overload distortion, since you don't have to turn up the volume so much.

Often, though, you will be called in to do over a club that has been using a different mode of entertainment—jazz or ordinary dancing. We had this problem at the Whiskey à Go-Go, where the music changed from jazz to rock-and-roll.

The PA system had been set up merely to augment the live jazz band by filling in dead spots. Our problem with go-go was to cover the entire club area with high-level sound from records and microphone, without blasting the customers at any location.

We changed the system little by little, rewiring something each day and trying it out on the customers at night. First we placed six sealed enclosures (each containing a woofer and a tweeter) over the dance floor and the two main seating areas bordering it. (See the diagram). This gave us direct coverage of the most important areas, where customer density is high every night. The club had been using a number of 6-inch speakers in small baffles (background-music type). They were rather cheap, with small magnets, so wouldn't take much power before breaking up. But we had to use them, so we placed them around the edges of the club to fill in dead spots.

When the club was converted to go-go, cages were built of solid sheets of plate glass. These were three-sided, with an open back facing bandstand drapes (see photos). The go-go girls complained they couldn't hear the records they were dancing to. We then put a 6-inch speaker inside the top of each cage. A third speaker was mounted in the ceiling above the bandstand, mainly to let the musicians hear the singer. (The singer is the only one using the PA, as drums don't need amplification, and the other instruments—guitar, bass, piano or organ—have their own amplifiers and speakers.)

At this point, using a 30-watt amplifier, sound coverage was barely sufficient, but on peak nights something was lacking. Another 30-watt amplifier and a couple of outdoor trumpets just happened to be on hand. We drove the second amplifier from a bridging output on the first, and installed the trumpets in two corners of the room, as far as possible from tables and patrons. These speakers raised the level enough to flood the club with sound, even on peak nights.

One peculiar problem at the Whiskey à Go-Go is the presence of 10 concrete pillars spaced throughout the room. These pillars not only interfere with some customers' view of the bandstand and cage area, but interrupt the flow of sound. This was another reason for distributed speakers.

Discothèque music is often played on a manual turntable. The Whiskey à Go-Go uses two of them. Several disc jockeys work the club on various nights. They brought along a remote broadcast console with two turntables and a mixer amplifier. These allow them to program continuous music with a running commentary. We reworked the unit to make it compatible with our equipment by adding a 600-ohm to 600-ohm isolation transformer at the mixer amplifier output. We fed that to the auxiliary input of the No. 1 PA amplifier.

What about servicing?

The live-music portion of a go-go club is simply this: The musicians use electronic instruments—amplified guitar, bass, piano (or organ)—so that the only thing you need PA for is the singer. He (or she) will try to be heard above the roar of the instruments. (At the Whiskey à Go-Go the instruments have a total audio power of 150 watts.) He will clutch the mike tightly against his lips and yell at the top of his lungs. Naturally, he overloads the first stage in the pre-amp, and his voice is distorted. You'll have a minor problem with some singers—you'll have to educate them to use the mike. If they *must* yell, they have to hold the mike back a little. A dynamic omnidirectional is probably best because it's least expensive. You won't often have trouble with feedback, considering how loud the singers are. But musicians will be dropping mikes, yanking on the plugs, stepping on the cable, and every now and then you'll have a bad mike.

It's best to have at least two mikes, even if only one is used, just to have a spare handy at all times. You probably

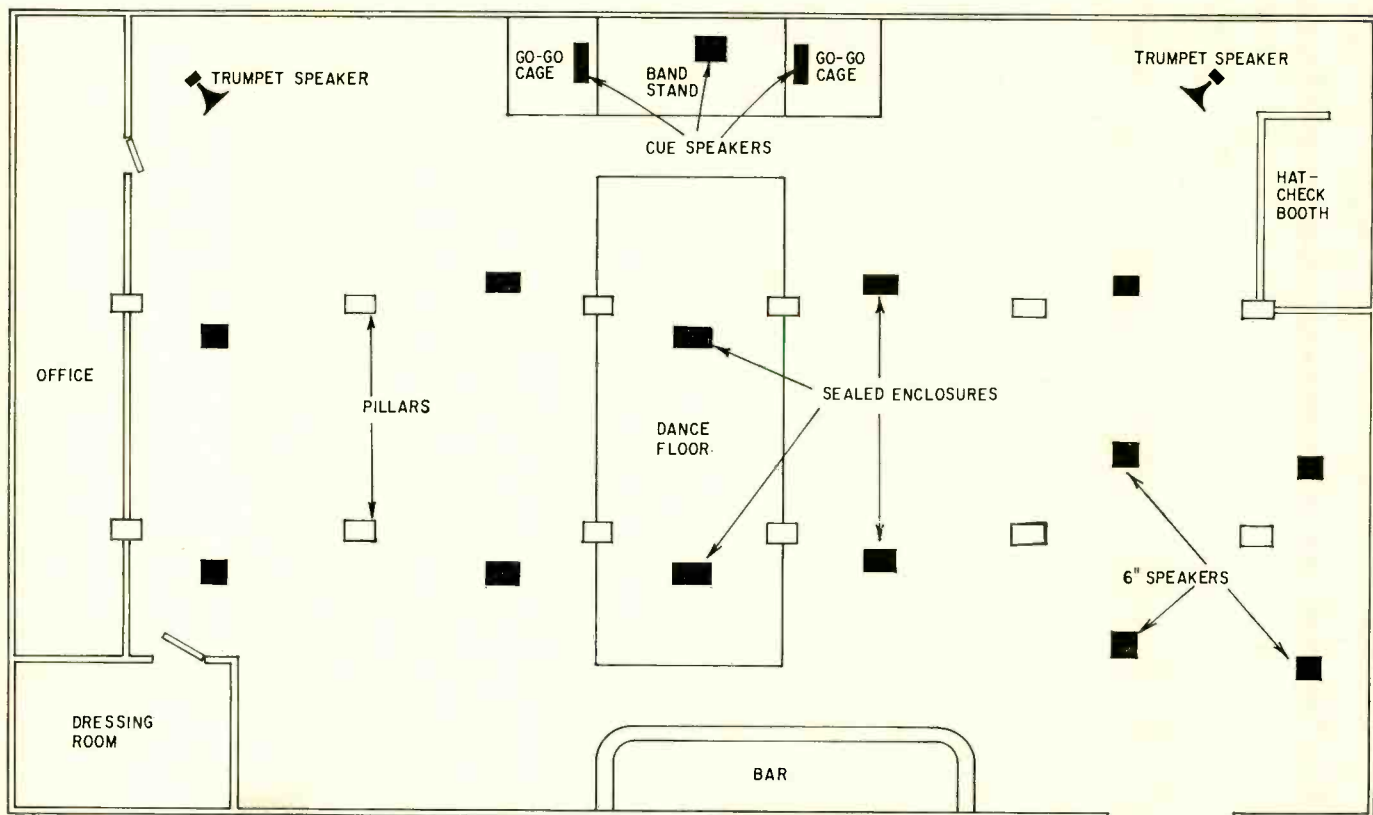

This is how the author set up the basement of a downtown Cincinnati hotel for discothèque sound. The key is to use enough speakers to prevent blasting any one area with sound and leaving other areas dead.

won't be able to service your own mikes and will have to send them back to the factory for repair. This takes about two weeks, but you can speed things up by enclosing a \$20 check with the mike. The manufacturer will return the difference or bill you for any additional charge, and he'll service the mike when he gets it and send it back to you in a day or so. Be certain to insure mikes both ways—they have been known to get lost in shipment.

Where an MC or DJ plays records, I recommend inexpensive manual turntables, cheap arms and ceramic cartridges. Use a turnover cartridge, but put an LP stylus on *both* sides. That way each turntable has a spare needle in case somebody chips or breaks one. You will find go-go girls, DJ's, and musicians (not to mention waitresses and sometimes even customers) all play records, so the arms must take a lot of abuse. You can get imported arms and cartridges at \$3 or \$4 a pair. If they are broken in a couple of months you haven't lost much. If the club doesn't use a disc jockey but has the bartender putting a stack of LP's on a changer, I recommend an automatic turntable. Usually, in this arrangement, the changer can be located back of the bar in a protected location, and won't take so much mechanical abuse. Reliability is more important here.

Other things you should know

A popular nightclub gimmick (and go-go is no exception) is to try to attract the street traffic. Depending on the site and local ordinances, you may be asked to install a door



Sealed hi-fi enclosures on the ceiling are the mainstay of the dance-floor sound distribution.

or street speaker. If you are using a 70-volt or 500-ohm constant-voltage system, you can simply add another transformer and speaker, with an L- or T-pad where the bartender can reach it. (City codes often require outdoor speakers to be turned off at some hour of the evening.) If you must work with an existing cheap system, where all speakers are wired at voice-coil impedance, you can use a 10-ohm rear-seat speaker volume control (designed for auto radios). Wire it across the 8-ohm tap on the amplifier. You may lose

a bit of volume, but you'll have more than you need, anyhow.

If you work in these clubs in the morning, when they're closed, what you wear is your business. But if you are on



The band needs a cue speaker so the players can hear the singer.

call for emergencies and you must go in to replace a tube at 10 pm when the place is full of customers, wear a coat and tie. You *might* be able to get away with overalls once or twice, but you'll keep the club owner happy if you dress like everyone else.

Many nightclubs are run on a cash basis—they pay the help in cash every night, and whatever they buy they pay cash for upon delivery. Some clubs will pay you on the spot, while others will send you a check later. *You must deliver a bill for services rendered, and be specific about what you list.* Don't say: "Wired speakers." Say: "Installed 4 speakers and baffles over dance floor. Ran speaker cables to speakers. Phased speakers and set levels, connecting them to PA amplifier No. 1." When you describe what you did in detail, your customer doesn't feel so bad about paying your labor or service charge. Fees run from \$4 to \$10 per hour, depending on what city you're in. *By the way, when you write out a bill, make two carbon copies*—clubs have a way of losing bills. You come back a week later and ask them why they haven't paid the bill and they say, "What bill?" Always carry that extra carbon.

Watch out for free booze! Some club operators will feed you free drinks while you're on the job, in the hopes of cutting the size of your bill. Whether you drink or cut the bill is up to you. I never take a thing until the job is finished, and while I won't turn down an occasional free drink, I don't make a habit of it.

Once you've done a go-go job well, it becomes your prime reference for other jobs. Keep the owner happy and he'll talk about you to his friends. Most club operators see each other regularly, and they will pass on the word. Leave a few business cards at the bar, tape a couple to the backs of amplifiers, and give the musicians a few. Occasionally a patron will hear of you and ask you to fix his stereo. You never know where you'll pick up business.

END

SCANNING LASER MAKES TV PIX IN TOTAL DARKNESS

The laser has entered a new field

A NEW KIND OF TELEVISION CAMERA was demonstrated recently by Perkin-Elmer Corp. to a conference of New York journalists. The camera was pointed toward the audience and the super-bright deep-red laser beam illuminated a very small spot on the back of the room. Horizontal sweep was applied and the spot became a broad, dim beam, making the back wall look like a TV screen when the vertical sweep goes out. But when the vertical sweep was applied, everything disappeared and the room became dark. There was not enough light in the beam to cover the whole wall.

At the same instant, however, the journalists saw themselves on a television set on the stage beside the camera. They were being scanned by a flying-spot laser beam which was being detected by a photocell and used to operate the TV receiver in the manner of an ordinary flying-spot scanner. But the extreme brightness of the laser spot made it possible to produce a much better picture with much less light than with an old-time flying spot.

The laser used in the model was a helium-neon unit with approximately 15 milliwatts output. The beam from the laser was reflected off a folding mirror to the line scanner, which consisted of a 16-sided prism mounted on the shaft of a scanner motor. The speed of the motor is such that the line scan frequency is 15,750 lines per second.

Leaving the line scanner, the beam strikes a 24-sided frame scanner, which deflects it vertically 60 frames per second. The spot is projected to the subject being televised, and the reflected light is picked up by an 11-stage photomultiplier. The amount of light at any given instant depends on the lightness or darkness of the object struck by the spot.

The phototube changes the light signal to an electrical one which is amplified and applied to the video amplifier of a commercial television set. The differences in light intensity from the flying spot are translated into differences in electrical signal and reproduce on the TV screen an excellent likeness of the subject televised.

Photocells placed in the scanning beam synchronize the deflection circuits of the television set with the beam. The two sync amplifiers produce 20-volt pulses which trigger the horizontal and vertical deflection circuits of the television receiver.

END

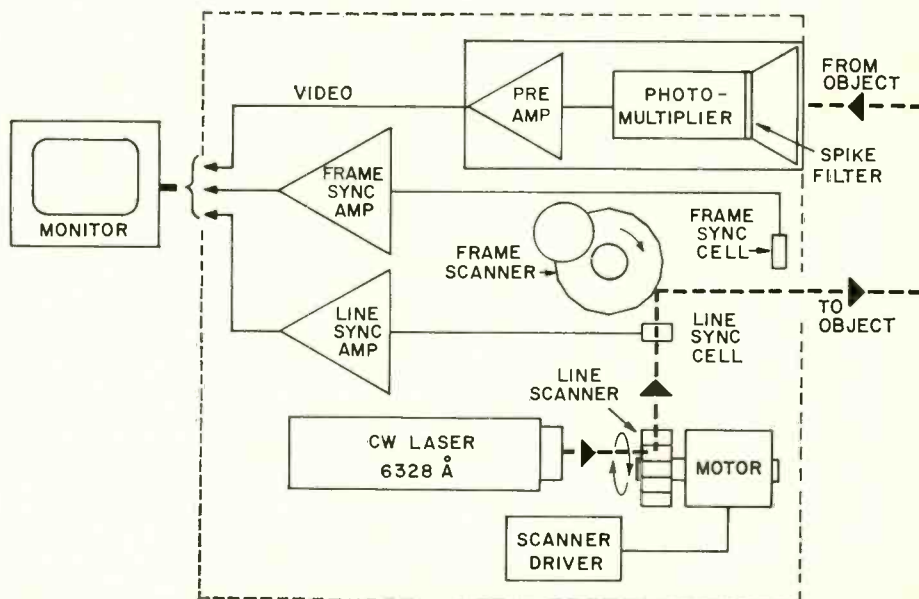



Pushbutton reading switch can be reached easily with the thumb.

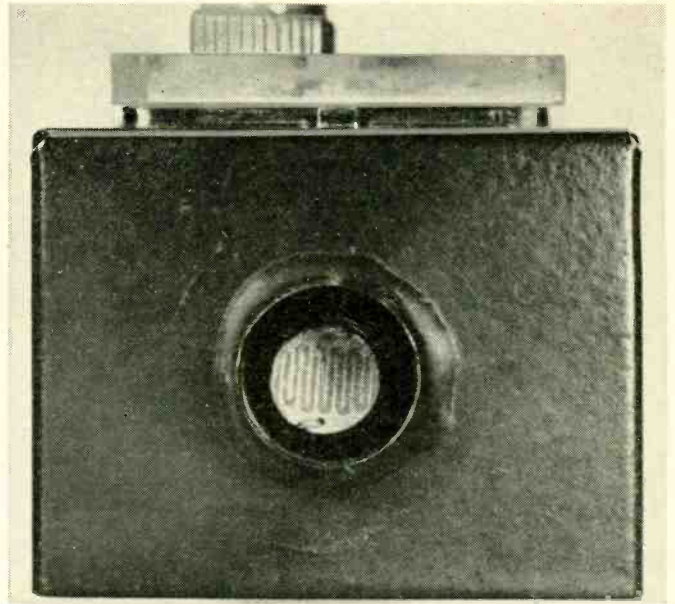

View into "tunnel" shows zig-zag-stripe pattern of CdS photocell.

BUILD THIS ULTRA-SENSITIVE LIGHT METER

By LEON A. WORTMAN

For less than \$10, you can build and calibrate this midjet light meter

COVER STORY

PROFESSIONAL PHOTOGRAPHERS AND SERIOUS amateurs all use *light meters*, which measure either the light that falls on the subject (*incident light*), or the light reflected off the subject (*reflected light*). A dial on the meter gives the correct camera settings for the kind (speed) of film being used.

Every kind of film, color or black-and-white, is assigned an "ASA rating" or "exposure index." These are numbers such as 32, 64, 125, 400 and so on. They are published by the film manufacturer as guides to the light sensitivity of the film for optimum exposure. The higher the number, the "faster" or more sensitive the film.

Many photographers do the type of picture-taking I do in my work as a writer and engineer. The major difference between me and some of them is that I like simple equipment, especially an easy-to-read meter that will accomplish with great reliability exactly what I want to do. There *are* commercial meters that will do what I want, but they are expensive, fragile, and contain many features I have no foreseeable use for.

What kind of photography do I do? I take extreme closeups of small electronic components and equipment (like this light meter). Often, this requires

"exposing for" a miniature component virtually hidden beneath another. The reflected illumination is as small as .02 foot-candle. Most commercial meters show the barest needle deflections under such conditions—hardly reliable. So my solution was to design and construct my own ultrasensitive exposure meter.

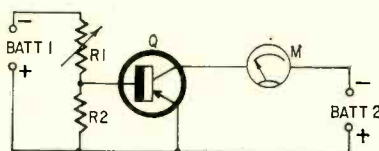

Fig. 1—Basic circuit of the light meter. Meter reading varies as R1 varies.

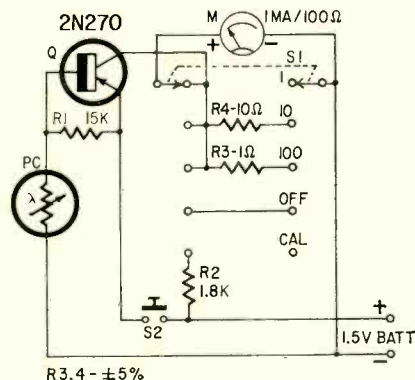

Fig. 2—Complete circuit of light meter.

The basic circuit is shown in Fig. 1. R1 and R2 in series form a voltage divider across battery BATT 1. The base bias current for transistor Q is set by them. If we make R1 variable, the current to the base of Q is variable. As R1 is increased, the current from BATT 2 in the collector-emitter circuit of Q is decreased, and vice versa.

If R1 can be made to vary inversely with light that reaches its surface, the base current and collector current of Q can be made to vary in accordance with that light. The resistance of cadmium sulfide cells varies just that way. In total darkness, their resistance is high, usually megohms, but drops to several hundreds or thousands of ohms in direct sunlight. If we replace R1 in Fig. 1 with a cadmium sulfide photocell, we have an operating circuit for a light meter. The final circuit and parts values are given in Fig. 2.

An RCA type 2N270 transistor was selected for the circuit. It combines high current gain, high collector-current capability at low collector voltage, linear characteristics, relatively low leakage, ruggedness and a price of less than a dollar. Several 2N270's were tried—all performed exactly alike. The two batteries of Fig. 1 have been combined into one. An ordinary penlight cell will power the meter for almost shelf life.

BENCH



TESTED

The Ultra-Sensitive Photometer was compared with two commercial photographic exposure meters and found to agree substantially with them in exposure time for given stop sizes. It had a narrower "field of

vision" than either of the other two, making it especially useful for equipment photography. Sensitivity on the lowest range was remarkable—the unit gave readings in surroundings approaching darkness.

In closeup photography of a small area, only light reflected from that area must be measured. Ambient light or peripheral illumination read by the conventional incident-light meter gives an average reading that can be misleading, causing incorrect exposure of the main subject. The problem of unwanted incident light is solved by enclosing the CdS cell inside a "tunnel" or tube. The dimensions for the tube can easily be computed so that the cell "sees" the same included angle as the lens. Purely for convenience (and it has worked out perfectly) a light "tunnel" was found ready-made right at home: the cap from a lipstick tube. The inside diameter of the cap is $\frac{3}{16}$ inch. The inside depth measures $\frac{5}{8}$ inch. The outside diameter of the cell is $\frac{1}{2}$ inch. Its thickness is $\frac{1}{8}$ inch.

Assembling the cell and tube is simple. Drill a $\frac{1}{4}$ -inch hole at the base of the tunnel to accommodate the two leads from the cell. Paint the tunnel inside and outside with flat black. Put a dab of epoxy cement on the underside of the cell. Pass the leads through the $\frac{1}{4}$ -inch hole in the tunnel, and press the cell securely against the inside of the tunnel's base. Allow the whole thing to stand overnight, to let the epoxy harden and form a firm bond.

The $4 \times 1\frac{5}{8} \times 2\frac{1}{8}$ -inch Minibox is drilled to accept all the parts. For the tunnel-cell assembly, ream a $\frac{5}{8}$ -inch hole slightly to assure a snug fit. Press the tunnel into the hole to half its length. Again apply epoxy to form a secure bond between the Minibox and the tunnel-cell assembly. Allow to stand overnight for hardening. The box and tunnel are spray-painted to give the unit a professional, custom-made look.

A red ballpoint pen can be used to color the area of the meter scale between 0.7 and 0.8 ma. This red zone indicates, when S1 is thrown to CAL, that the battery is adequate for accurate reading. Replace the battery when the needle indicates below the red.

At the OFF position, the meter is directly short-circuited and removed from the transistor and battery circuits. This damps the meter movement to reduce the possibility of damage to it while it is being carried about. The remaining three positions of S1 are the sensitivity

Wiring inside the box is simple and uncluttered. Battery is in other half of box.

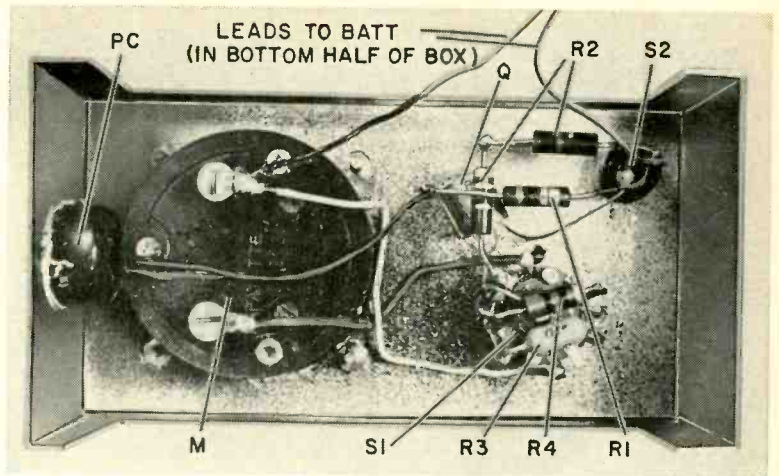

- M—1-ma meter, 100 ohms resistance (Lafayette 99 R 5052)
- Q—2N270 (RCA)
- PC—Cadmium sulfide photocell (Lafayette 99 R 6321)
- R1—15,000 ohms, $\frac{1}{2}$ watt, 10%
- R2—1,800 ohms, $\frac{1}{2}$ watt, 10%
- R3—1 ohm, 5% wirewound (IRC type BWH or equivalent)
- R4—10 ohms, 5% wirewound (IRC type BWH or equivalent)
- S1—Subminiature rotary switch, 2 poles, 5 po-

- sitions (Lafayette 99 R 6164 or equivalent)
- S2—Miniature momentary pushbutton, spst, normally open (Lafayette 99 R 6218 or equivalent)
- BATT—1.5 volt carbon-zinc or mercury battery, penlight size
- Holder for battery
- Two-piece aluminum box, $4 \times 2\frac{1}{8} \times 1\frac{1}{8}$ in.
- Epoxy cement
- Lipstick-tube cap or equivalent for tunnel
- Paint, decals or dry-transfer lettering, knob
- Miscellaneous hardware

settings: 100, 10 and 1. The last position is the most sensitive. In the last three positions, S1 either adds or removes shunts at the meter terminals. It is necessary to depress S2 to complete the circuit when S1 is in the last three settings. This is a precaution against possible damage to the meter from slamming the pointer against the stop.

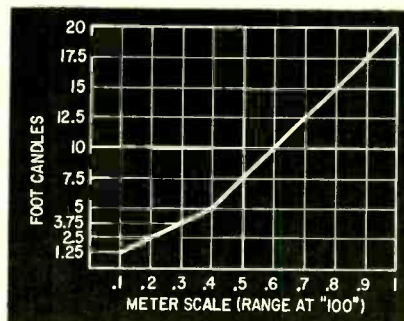

Fig. 3—Scale-reading-to-foot-candles chart.

Calibration is simple, but must be done carefully. The results of the procedure are given in Fig. 3, which relates meter indications to foot-candles. For calibration, a "darkroom" can be constructed from a small carton sprayed flat black inside. A 25-watt light bulb is mounted at one end, inside the box. The light meter and the commercial meter against which it will be calibrated are placed at the other end.

The flat surfaces of the light cells of both meters must be pointed at the center of the bulb's brightest spot. This is easily done by turning on the bulb and rotating the meters for maximum deflection. You will also need a way to vary the light output of the lamp continuously. (A calibrated control is not needed.) I used a variable transformer. This gave smooth, flickerless control from full on to full out.

With the two meters in position in the "darkroom", turn on the variable

EASY-TO-USE CALIBRATION CHART FOR YOUR LIGHT METER

Meter: (100 scale)	0.1	0.2	0.3	0.4	0.5	0.6	0.7	0.8	0.9	1.0	
f: stops	16	1-1/2	3/4+	1/2	2/5	1/4	1/5	1/8	1/8	1/10	16
ASA 125	11	3/4	1/3	1/4	1/5	1/8	1/10	1/15	1/15	1/25	11
	8	1/3	1/5	1/8	1/10	1/15	1/25	1/30	1/30	1/50	8
	5.6	1/5	1/10	1/15	1/25	1/30	1/50	1/60	1/60	1/100	5.6
	4	1/10	1/25	1/30	1/50	1/60	1/100	1/125	1/125	1/200	4
	2.8	1/25	1/50	1/60	1/100	1/125	1/200	1/250	1/250	1/400	2.8
	2	1/50	1/100	1/125	1/200	1/250	1/400	1/500	1/500	1/800	2

(CUT OUT AND PASTE ON BOTTOM OF METER CASE)

Meter range at 10—multiply exposure time by 10 or open aperture 3+ stops.

Meter range at 1—multiply exposure time by 100 or open aperture 6+ stops.

ASA 64—multiply exposure time by 2 or open iris 1 stop.

ASA 400—multiply exposure time by 1/4 or close iris 2 stops.

"+" means "slightly more than"

transformer, depress the READ switch on the meter. Start advancing the variable transformer's knob slowly. Stop where the meter reads exactly full scale. Note down the reading of the comparison meter. (This can be done as a graph, as in Fig. 3, or in a table.) Decrease the output of the variable transformer to begin dimming the lamp. Hold at 0.9 on the newly built meter's scale, and again note down the reading of the comparison meter. Continue this process, holding and reading at each 1/10-milliampere division. If the commercial meter against which you are calibrating does not have a foot-candle scale, this formula will provide a rough scale of foot-candle values:

$$FC = \frac{f^2}{T \times S},$$

where FC is foot-candles, f is aperture or lens stop, T is exposure time in seconds, and S is ASA speed rating.

Before each use of the meter, turn S1 to CAL to assure that the battery is in good condition. Move the switch through OFF to 100. Take a reading by placing the opening of the tunnel close to the subject. Be sure you do not throw a shadow onto the subject. Depress the READ button, read the meter and refer to the calibration table. Instantly, you have lens stops from f:2 to f:16, and corresponding exposure times or shutter speeds related to standard ASA film ratings. If the 100 range doesn't give a high enough reading, switch to 10 or even 1.

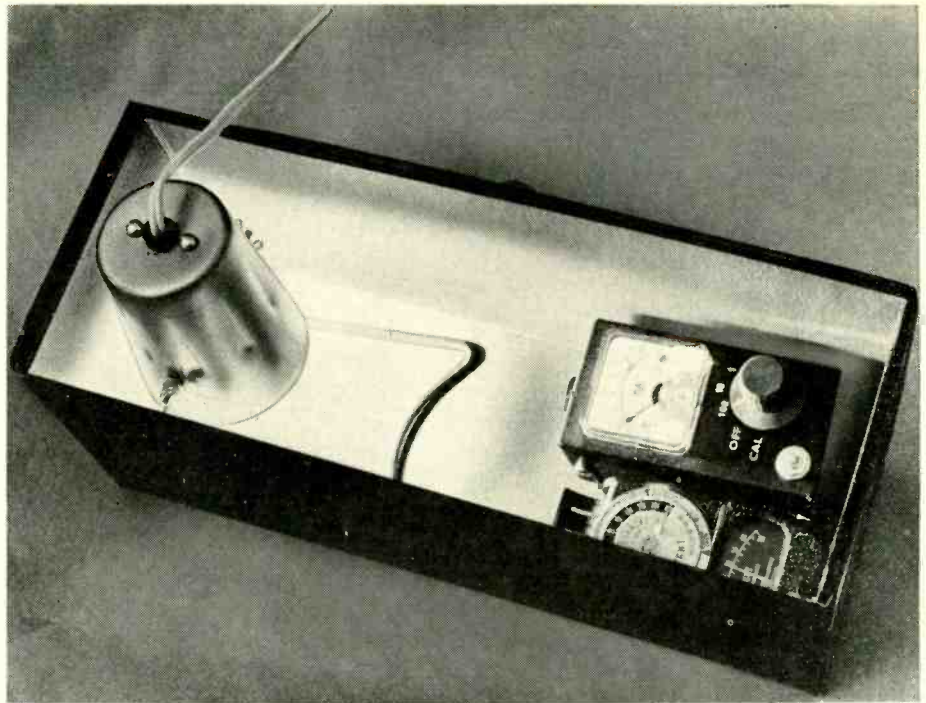

How to arrange meters and light source in "darkroom" for calibration. Text explains the whole operation.

You'll note that the angle of view is so sharp that, if the tunnel is pointed at a sheet of paper with bands of black and white, the meter will swing sharply up and down as you scan that paper with it. In photographing a subject that has such severe contrasts, you can expose for the lightest or for the darkest areas, or use an average value between. The average

gives the best results, unless you want to emphasize an area which may be more (or less) bright than the average.

I have used the meter with great success in photographing night scenes outdoors, indoor scenes by moonlight, and making copies of multicolor documents, electronic equipment and micro-miniature components. END

THE MIXWELL THEORY

OR

DRINKS UNDER THE "COUNTER"



"Every time I pour a drink the channel changes."

An experienced bartender knows how to mix liquor to make up any kind of drink. The customer's taste quickly determines whether it has been mixed well. It is more difficult to measure a bartender's efficiency. For example, Arthur M. Reichenberger of Phoenix, Ariz., believes that some bartenders tend to "overpour" or even "fail to collect for drinks." Accordingly, he has invented a way to check up on the bartender. His device consists of a dispenser to measure the quantity of liquor as it is being poured out of a bottle. It has been assigned patent No. 3,170,597.

The invention is a removable top and spout to be locked in place on a bottle. When the bottle is tilted for pouring, a mercury switch activates a tiny transistor transmitter inside the top. Beeps are generated while liquor flows. The rf signals are picked up on a nearby receiver fitted with a mechanical counter. If the beep count has been correctly calibrated against liquor flow, one can determine exactly how much liquor has left the bottle.

At the end of the day's business, the beep count may be compared with money taken in for drinks. If there is a shortage, it is up to the boss to determine whether his bartender has been careless, wasteful or just over-generous.—I. Queen

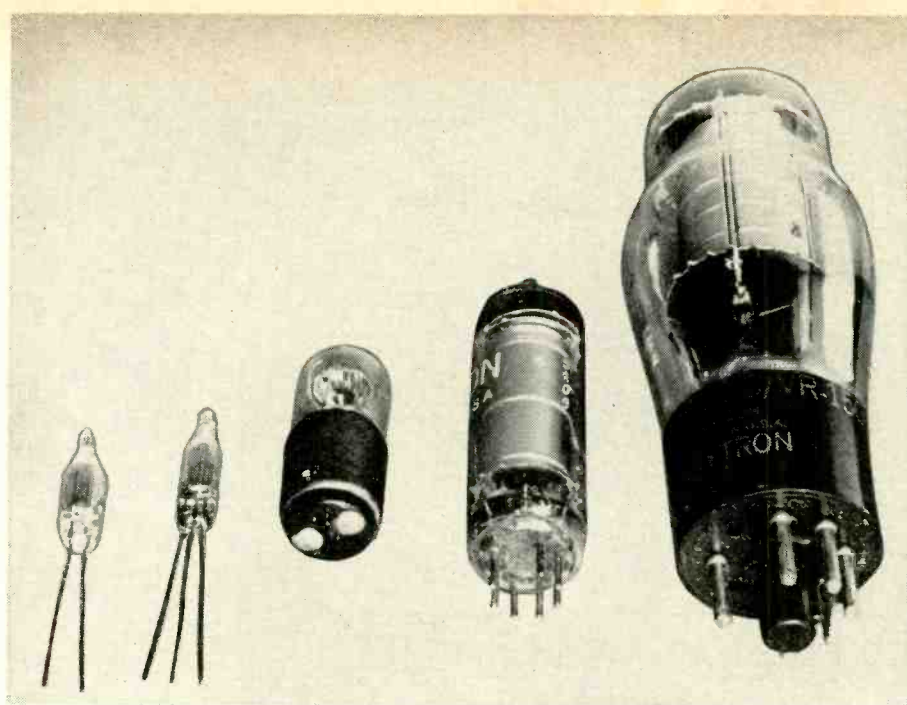

Glow-tube muster. From left: NE-2, NE-77 (three electrodes), NE-48, 0A2 regulator tube, argon-filled, with coated cathode; and VR-150/0D3, older version of regulator tube.

Why Glow-Lamps Glow

The ionization mechanism by which neon and other gas-filled lamps become indicators, regulators, switches, oscillators

By TOM JASKI

ALMOST EVERYONE USES NEON LAMPS—for pilot lights, oscillators, voltage regulators, coupling elements and even as gates, binary counting and logic elements. But who really knows why and how they operate?

A few of the many types of glow lamps are shown in the photos. Some have neon gas, some argon; some have coated electrodes and some uncoated. The lamp in one of the pictures has cathodes shaped like numerals. What are the reasons for the differences will become clear.

To understand glow lamps, we must look back to the very basic nature of matter—atoms. All matter—gas, liquid or solid—consists of atoms. The atom is the smallest part into which we can divide an element without losing the characteristics of that element.

Atoms themselves consist of a nucleus with a positive charge, around which travel electrons in one or more orbits. Some of these orbits are close to the nucleus, some farther out. Many atoms have quite a number of "layers" of electrons. Each layer may contain several electrons traveling in different orbits. (This is a slightly simplified picture of the atom, but it will do for our purposes.)

Electrons are negative charges, and normally in an atom the number of electrons will exactly balance the positive charge of the nucleus. But some

atoms hang together loosely enough so that with a little effort we can remove one of the outer electrons. Then the atom is no longer balanced. It has an excess of positive charge, and we call it a *positive ion*. If an extra electron is forced on an atom, there is an excess of negative charge, and we call this atom a *negative ion*.

Nature has a tendency to balance, and given a chance, the negative ion will soon shed the electron and the positive ion will soon find a free electron to add to its collection, restoring balance.

Electrons are attracted to points where there is a shortage of them—to where there is a positive charge. Obviously negative ions would also be attracted there, while positive ions would tend to be attracted to a negative charge—to a cathode.

To obtain electrons, we must remove them from electrodes. This is easy if the electrode is made of a material with free electrons. All good conductors have free electrons, but nickel gives them up more readily than many other materials.

If we place in a vacuum a pair of nickel electrodes not too far apart and apply a relatively high voltage between them, some electrons are pulled out of the surface of the negative electrode by the attraction of the positive one. Once free from the surface they travel to the anode, the positive electrode. Only a few electrons are needed for a start;

they are replaced right away from the source, the dc supply.

Now if we add some argon or neon gas (both easily ionized) to the vacuum with the electrodes, the electrons traveling to the anode collide with gas atoms, and knock other electrons out of the outer orbits, forming positive ions. Few negative ions will be formed, for the electrons are traveling too fast to be "captured", to take up the empty orbits. The positive ions are attracted to the cathode. There they meet electrons that have just left the cathode and are not yet traveling fast. The ions and electrons combine to form complete atoms again. In the process of recombination visible light is created. Nobody really knows why this happens but we do know that the kinetic energy of the electron is converted in some way.

Some ions reach the cathode before recombining with electrons. These raise the temperature of the cathode, for their kinetic energy is converted to heat. Between anode and cathode are other ions, created by collisions of electrons with gas atoms. The whole tube becomes a current-carrying conductor. If we raise the voltage, we cause more ionization and more current. If we put a series resistor in the circuit, the voltage across this resistor increases with increasing current, so that the tube voltage stays about the same. When the cathode is entirely "covered with glow," we cannot raise the current any further. This is the limit of the tube's capability. To get the tube started, a higher voltage (called the *starting* or *firing* voltage) is needed than to maintain the glow—sometimes 30% or 40% higher. This is shown in the curve of Fig. 1.

The two electrodes in many glow lamps (for example, in the NE-2 neon lamps) are identical. If we apply ac to the tube, each electrode will

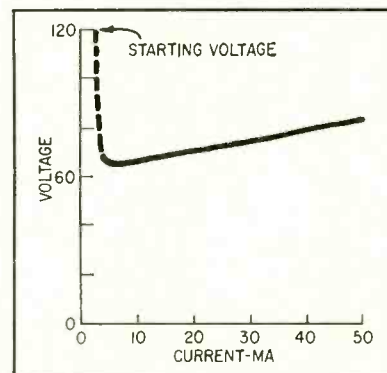

Fig. 1—Voltage-current characteristic of neon glow lamp. When entire cathode glows, no more current can pass.

function alternately as the cathode, and thus each electrode will glow for 1/120 second. To our eyes it appears as though both electrodes are glowing simultaneously. With dc only one electrode glows.

There is also a limit to the maximum voltage that can be applied. If the voltage rises too high, an arc results. The lower the tube's glow voltage, the closer is the arcing voltage to the start-

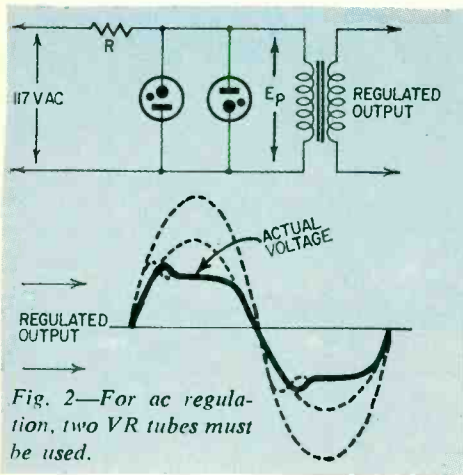
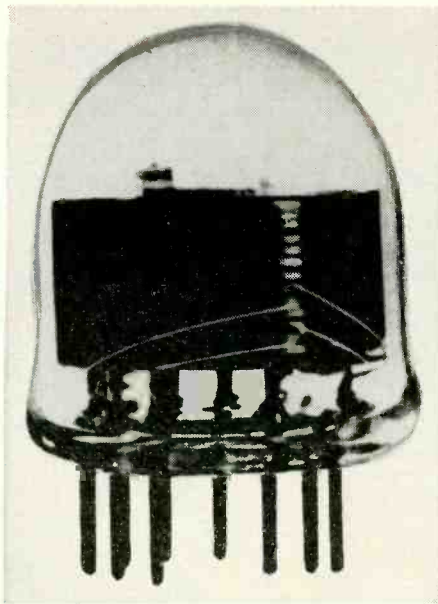

Fig. 2—For ac regulation, two VR tubes must be used.

ing voltage. We can't space the electrodes closer and closer to get a lower-voltage tube, for it would inevitably arc over if the electrodes got too close.

Tubes specially designed for regulator service have a cathode coated with barium oxide, which is capable of releasing quite a number of electrons while cold and with moderate anode voltages. But it also makes it important to use the tube only one way; with reverse connections it will not function well, if at all.

Glow tubes are also used for control. The current through some of them is sufficient to keep a sensitive relay energized. These tubes have an additional starting electrode close to the cathode. With a voltage less than the normal fir-



"Nixie" ten-cathode lamps are used as numeric readouts in computers.

surrounds the cathodes. When a particular numeral-cathode is connected, the tube glows with the shape of that numeral. It is used in visual display of counter or computer readout.

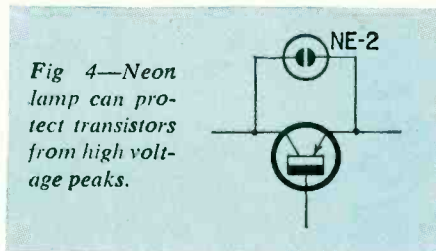

Fig. 4—Neon lamp can protect transistors from high-voltage peaks.

Fig. 2 shows the use of glow tubes for ac regulation. It follows from the one-way action of the tubes that two are needed back to back for ac regulation.

A number of applications of neon tubes were described in the November 1959 issue of RADIO-ELECTRONICS. Several new and interesting circuits have been published since then. Fig. 3 is a novel regulator circuit. The intensity of the glow of the neon lamp changes the resistance of the first LDR (light-dependent resistor). This alters the brightness of the incandescent lamp, which in turn varies the resistance of the second LDR. This second LDR is a shunt across the output. With rising voltage, the neon tube becomes brighter, the incandescent lamp is also brighter and the LDR passes more current. Since there is a dropping resistor, the net result is more voltage drop across it and less voltage across the load. With the proper component values, regulation is very close.

Fig. 4 shows how power transistors can be protected against high-voltage

peaks, as in transistor ignition systems, for example. I've used such a system for 20,000 miles without any Zener diodes in the circuit—just two NE-2's protecting my transistors.

Fig. 5 shows an electronic siren. The 1- μ f capacitor forms a supply with

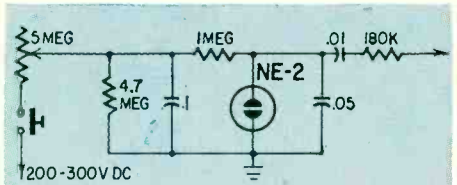

Fig. 5—Electronic siren. When button is pushed, 1- μ f capacitor charges slowly, providing slowly rising voltage for relaxation oscillator.

gradually rising voltage to supply the relaxation oscillator, which is the NE-2 with a .05- μ f capacitor and a 1 megohm series resistor.

Fig. 6 shows a square-wave generator. Its operation is based on the fact that capacitor C can charge in two ways—negatively when V1 is off and positively when V1 is on.

Fig. 7 shows a flipflop circuit published by M. E. Scherer in the October 1962 issue of *Electronics World*. The circuit is reliable, provided the lamps are carefully matched for striking and firing voltages and the pulse rate is no greater than 250 per second. Biquinary counters can be built from these flipflops, in which case the neons serve as indicators at the same time.

Because of the lack of precise control over neon-lamp characteristics, counters made from them are not often successful. Selection is a major problem—many lamps must be available for adequate selection and matching.

[The ordinary glow lamp is designed for non-critical applications such as pilot lamps and must be hand-picked, with rejects running up to 75% when used for such critical applications as photochoppers, memory and logic cir-

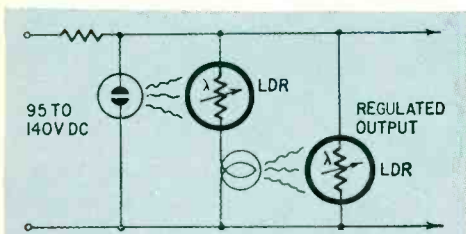

Fig. 3—Ingenious regulator circuit uses neon and LDR's (light-dependent resistors) to produce amplified variations and use them for regulating the supply.

ing voltage, a small positive voltage on the starting electrode starts ionization. These tubes must be used with an ac supply, or some means must be provided to cut off the dc supply, for once started, a tube of this type will continue to glow over a considerable range of voltages.

Another special glow tube is the one in the photo with cathodes in the form of numerals. Each cathode has a lead brought out to a pin. The anode

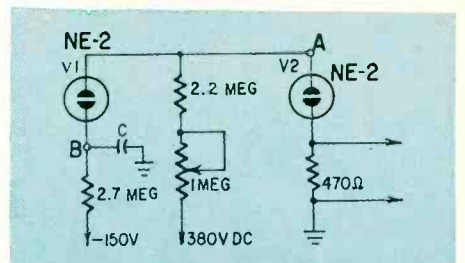

Fig. 6—Square-wave generator. C charges until point B is at -20 volts. Voltage at A then drops from about 60 originally to 40 and V2 extinguishes. Now C charges through V1, its voltage rises and so does the voltage at A (across V2). When voltage on capacitor C gets high enough, V1 extinguishes and V2 fires. This completes one cycle.

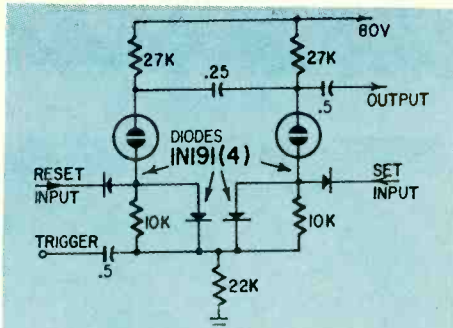

Fig. 7—Flip-flop works because the voltage drop across the "cathode" resistor common to both lamps makes it impossible to maintain both lamps conducting.

cuits, voltage regulators and timers. Signalite, Inc., 1933 Heck Ave., Neptune, N. J. has a line of close-tolerance lamps made especially for close-tolerance uses.—Editor]

Fig. 8 shows how a neon lamp can help create a chime sound. Basically an organ percussion circuit, it can readily be used to create chime sounds for a PA system. Normally the diodes are reverse-biased and the signal from the oscillator does not get through to the amplifier. When the switch is momentarily closed (this can be a relay, a telephone dial or an electronic switch of some sort), the neon lamp flashes and puts some charge into the 4- μ f capacitor. This quickly charges the 1- μ f capacitor, giving a relatively rapid attack, but not a hammerlike sound. While there is sufficient charge on the 1- μ f capacitor, the diodes are forward-biased and the signal from the oscillator goes through to the amplifier. After a short time the signal is again blocked. The time depends on the size of R, here shown as 1 meg. If the oscillator is modulated by another one, a sort of tremolo oscillator, a chimelike sound will be produced. Variations of this circuit (for example, keying the oscillator for various frequencies) can produce chimes of different tones.

The second lamp in the photo is a three-electrode NE-77. The spacing between electrodes is not even. The mid-

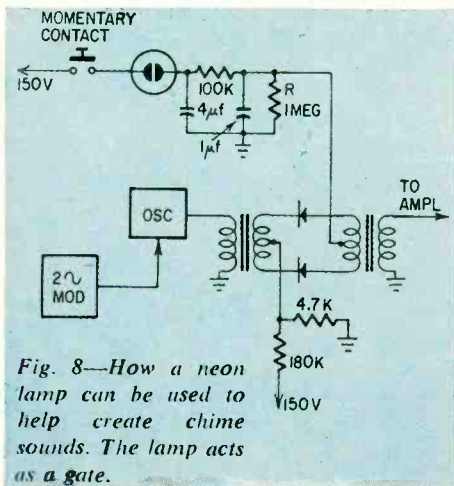

Fig. 8—How a neon lamp can be used to help create chime sounds. The lamp acts as a gate.

dle one is closer to the cathode. Fig. 9 shows how this lamp can be used for control in both ac and dc circuits. The center electrode is used as a trigger electrode and starts ionization. While the lamp is not glowing, it isolates control and controlled circuits somewhat.

A larger cousin of these glow lamps, the thyratron, operates on the same principle. It is either a cold-cathode or hot-cathode glow lamp with a trigger electrode, and sometimes contains mercury vapor or a mixture of hydrogen and argon. Very large currents can be carried by some thyratrons. Still larger, the ignitrons and mercury-arc rectifiers borrow the same principle of ionization, but there arcing is allowed—

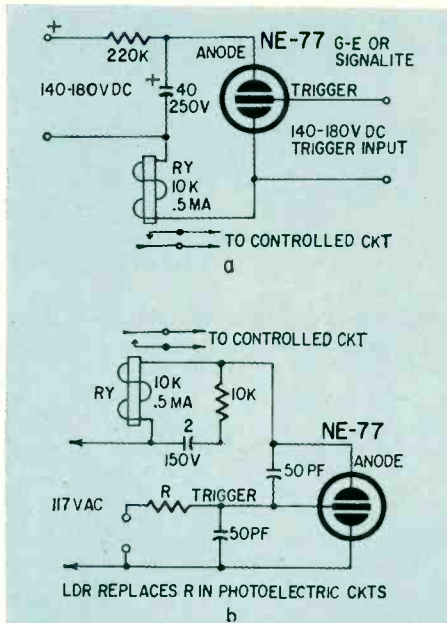

Fig. 9—Control circuits with the NE-77 three-electrode neon lamp: (a) a dc control circuit; (b) an ac control circuit. The 50-pf capacitors function as voltage divider, putting some voltage on trigger electrode so that only small additional control signal fires tube.

in fact forced. This drastically lowers the tube resistance and allows very high current to flow in the desired direction.

Zener diodes have taken jobs over from some of the regulator tubes, especially at lower voltages. and the SCR's (silicon controlled rectifiers) some of the duties of thyratrons, but nothing has yet been found to compete with the inexpensive neons for some tasks, and new applications are showing up all the time. Neon lamps and other glow lamps will be with us for a long time to come.

[Many new and interesting glow-lamp applications are described in *Signalite Application News*, available upon request from Mr. Ed Bauman, Chief Engineer, Signalite, Inc., 1933 Heck Ave., Neptune, N. J.—Editor] END

Buy the BEST!
Buy in KIT form!



MARK TEN
SRC CAPACITIVE DISCHARGE
IGNITION SYSTEM

ONLY \$29.95 PPD.!

Why settle for less in motor vehicle ignition systems when you can buy the very BEST from Delta, the originators, the leaders in capacitive discharge (SCR) systems. Delta pioneered this electronic marvel. Thousands have installed this remarkable electronic system. Now YOU can purchase at low, LOW cost, and in easy-to-build kit form, the king of them all, the DELTAKIT. Low price due simply to high production levels at no sacrifice in peerless Delta quality.

Operate Any Motor Vehicle More Efficiently

Compare these proven benefits:

- ▲ Up to 20% Increase in Gasoline Mileage
- ▲ Installs in Only 10 Minutes on any Car or Boat
- ▲ Spark Plugs Last 3 to 10 Times Longer
- ▲ Instant Starts in all Weather
- ▲ Dramatic Increase in Acceleration and General Performance
- ▲ Promotes More Complete Combustion

Literature and complete technical information sent by return mail.

BETTER YET—ORDER TODAY!

DELTA PRODUCTS, INC.
P.O. Box 1147 F • Grand Junction, Colo.
Enclosed is \$_____. Ship prepaid.
 Ship C.O.D.
Please send:
 Mark Tens (Assembled) @ \$44.95
 Mark Tens (Delta Kit) @ \$29.95
SPECIFY — Positive Negative
 6 or 12 Volt
Car Year _____ Make _____
Name _____
Address _____
City/State _____ Zip _____

DP 6-2

Circle 19 on reader's service card

... the story that asks the question, "Can a Young Ham succeed in the service business on guts, know-how and enthusiasm alone?"

How to Keep a Service Shop Open

By JACK DARR SERVICE EDITOR

THE SHOP DOOR BURST OPEN, AND A khaki-clad figure dashed in, whooping. The Old-Timer jumped, burned his finger, and growled, "Con-found it! Didn't the Army teach you *any* manners at all?" The Ex-Young Ham paid no attention, but kept on jumping up and down howling, "Weeeee! Waaa-hooo!"

"All right, all right!" grumbled the Old-Timer to his current Young Ham. "Git his other arm, there. There's only one thing to do—apply restoratives before he tears up the place! A cuppa Plunkett's coffee oughta settle him down. Come on, you!" and they rushed the XYH out the back door. He and the current Young Ham had trouble holding the exuberant youth down, but they managed to get him into the drugstore and settled in a booth.

Blowing his coffee, the Old-Timer asked, "Now, what's all th' runnin' and screamin' about?"

"Ohhh, boy!" babbled the XYH. "All set! Dandy building! Good location! Test equipment all set up! My *Own Shop!* Eeeeee-yah!" and he gave his version of a Rebel yell.

"Free coffee and doughnuts for the Grand Opening?" The Old-Timer grinned. "We'll be there early and often." The Young Ham nodded.

"Plenty of parking space! Fine neighborhood! Boy, I can't wait to open up!" burbled the XYH, gulping his coffee.

"Hey, Bill! Y'got a coupla double-strength tranquilizers left? Slip 'em in his coffee, so I can make sense out of what he's sayin,' willya?" The pharmacist leaned over the prescription case and laughed. He knew this gang from long ago.

"Blow hard, boy. Finish that up, and then come on back over to th' shop. Got something I want to tell you. Saved it up 'til just now, because it's the most important thing of all." The Old-Timer sounded unusually somber.

The XYH got a puzzled look as the older man's unexpected soberness penetrated the clouds of joy.

"Yep, this is it: Lecture Number the Last. From now on, you're on your own. Just like you wanted to be, and I'm for you. Sink or swim, and I want

to tell you something that's absolutely necessary if you're gonna stay afloat! This is the hard part."

Back at the shop, the Old-Timer motioned the XYH to a stool. He sat on the edge of the bench, pushing a couple of intermittent transistor radios out of sight to make room. "Now," he began, "set there, keep your ears open an' your mouth shut and listen. Lemme tell you about the really *hard* part of runnin' your own service shop. Been around a long time, and I've seen a lot of fine young fellers start up on their own, run for about a year, an' *go broke!* I know *why*, too."

The Young Ham found an inconspicuous corner of the shop, and settled down. He knew, when the Old-Timer used that serious tone, that he was good for at least 15 minutes. The Old-Timer dug out his pipe, filled it, and went on.

"All right. Anybody can *open* a service shop. All it takes is a hole in th' wall, a voltmeter and a screwdriver. Takes a smart man to *keep* one open. Do you read me?" The XYH nodded.

"What's the most important thing in bein' a successful TV technician?" asked the Old-Timer.

"Good work? A guarantee? . . ."

"Nope. *Money!*" declared the Old-Timer, very seriously. "That's what you pay your bills with, and what keeps you eatin'. There's no doubt you can *earn* money—you're a darn good technician. But, can you *get* it after you *earn* it? In other words, your credit business.

"I've seen this happen time after time over the past 30 years or so: Young feller opens up a shop, does a big business for a while, then in less than a year, he's closed—gone broke! All the one-man shops that opened up around here—that's what closed 'em: Too much *bad credit* business. They fixed the sets, but they didn't collect for 'em. So, they couldn't pay *their* bills, and they went broke."

"But—but—" protested the XYH. "You don't seem to have much trouble collecting."

"Son," said the Old-Timer, "that's because I went through this stage quite a while before you were born! You'd

be surprised if you knew how close I was to being flat busted, and for exactly that reason, about 30 years ago! I've *made* all those mistakes: that's why I can tell you about 'em!" He relit his pipe, chewed on it for a moment, then laid it down and forgot it, as usual.

"There's a group of people in every town, and in every neighborhood in a city, that are bad credit risks. A lot of 'em are nice folks, but they just don't pay their bills! So, here's what happens. They go to one TV shop, get work done, but won't pay. Well, that takes care of him. So, next time they go to another shop. First thing you know, they've made the rounds of every shop in town. They ain't organized or anything like that, but you could almost call 'em a club—the 'Joyriders' Club! They'll take you for a ride if you don't watch out!"

"I kinda remember hearing you use that expression," said the XYH, thoughtfully. "I remember some of 'em coming around here. In fact, I used to feel that you were pretty rough. Almost felt sorry for 'em!"

"Well, don't!" said the Old-Timer. "They don't deserve it. They'll take you for a ride, but remember this—they are the ones that are having the fun, not you! All right, so what happens when a brand-new TV shop opens up in a neighborhood? Here comes the Joyriders' Club with their TV sets under their arms! They can't get credit at the other shops, so they hop right on the new boy. He hasn't heard about 'em yet!"

The XYH's brown face took on a serious look. "You're right. I see what you mean."

"Good!" said the Old-Timer. "Just remember it. You remember when Tom opened the shop just around the corner from here? I tried to tell him then, but he wouldn't listen. They'd swarmed on him, and he had his whole shop full of TV's! Boy, he thought he was really doing business! Instead, they were giving *him* the business! Why, I recognized more'n half the sets in there. Some of 'em still had our stickers. Tried to warn him about collecting for 'em, but he wouldn't listen. How long did he last? You were here then."

"About a year, I think," said the XYH. "By golly, you're right. I can remember him coming over here and crying on your shoulder about how bad his collections were!"

"That's exactly what I mean," said the Old-Timer, looking for his pipe. "That's a perfect case history. So, there's only one thing to do: *COLLECT!* When they start that 'I'll pay you Saturday sure' business, look 'em right in the eye and say, 'Fine. The set will be right here when you come in!'"

"But what if I've hauled it all the way out to their house?" asked the XYH.

"By golly, haul it back!"

"But what if there's nobody home?"

"Same thing. Come back when there is. It's more trouble, but you're not takin' chances. Besides, it's never a good idea to go bargin' around in someone else's house when the owner ain't there."

"All right, how about this?" asked the XYH. "Suppose the man isn't home, and his wife hasn't got any money in the house? What do you do then?"

"This," answered the Old-Timer, tossing him a pad of job tickets. "Dang it all, you've filled out enough of *them* to recognize 'em."

"Oh, yeah," said the XYH, picking them up. "These are the ones with the promissory note form on the back of the first sheet."

"Right!" declared the Old-Timer with emphasis. "Never leave a set at a house without gettin' somebody to sign that form. No kids, either: the man or his wife. Any time they won't, just pick the set up and lug it back to the shop! No honest customer will object to signing a form like that, if he intends to pay you anyhow. It's no more than signing the bill, which, by the way, is pretty dern worthless as a legal form in most states! Now, if you have that signed, you have a legal claim on that TV set, and you can pick it up for non-payment of the bill without any formality at all! And, since most joyriders are scared to death of legal forms, they'll pay you, or else refuse to sign. If they do, just pick it up and take off! You *can* take it back to the shop and sell it for the charges, after a certain time. Better have a sign posted, like 'All sets left over 30 days will be sold for charges' so it'll be legal."

"If that's true, why don't you sell some of those junk sets in the back room?" asked the Young Ham from his corner.

"Keepin' 'em for parts!" The Old-Timer grinned. "Lotta old clunkers couldn't be repaired otherwise."

The XYH laughed, remembering what the "back room" looked like. The Old-Timer meanwhile had found his pipe again, lit it for the fifth time, and

got ready to go on again.

"One more thing. When you start, don't let that *first guy* get to you! If you're kind but firm, and collect from him, the rest'll be easier. Let one of 'em get away with it, and the rest of 'em will come down on you like a flock of vultures! Let 'em know you're not going to put up with any hanky-panky in the credit department and they'll have a lot more respect for you."

The XYH thought for a moment, then asked, "But what if they get mad?"

"Let 'em!" said the Old-Timer.

"But they might not come back!"

"Son," said the Old-Timer patient-

time you get a chance. They've been working in that side of town for a long time. Ask 'em if they'll give you their lists of bad accounts. Here—" the Old-Timer handed him a typed list of names—"here's mine. I wrote it up the other day to give you. Check it against theirs. You may be surprised at how many names are on all of the lists!"

"Stick the list up behind the counter where no one else can see it, and watch out. If one of these guys comes in, or calls, get the cash before you give up the set! You can do it; you're legally entitled to hold that set until the repair bill is paid. All they can do is cuss, and



The whole moral of this story is contained in this one sign!

ly, "do you fix TV sets for fun? I know, you do enjoy fixin' 'em—we all do, or we wouldn't be in this exasperatin' business. But, by golly, you've gotta make *something* out of it! What good does it do to put in all that time and parts in a set if you don't get *paid* for it? Any time you got money to throw away, come over here and throw it at me, y'hear? What if a guy like that *doesn't* come back? You're money ahead!"

"Now, after you've worked over there for a while, you'll know a lot of the good ones. Frankly, you know that a *very* big percentage of our customers are honest, reliable folks that pay their bills. If they weren't, we'd *all* starve. But, you gotta watch the bad ones. One bad job costs you the profit on four or five good ones, and you're not going to come out that way! You're going to lose *some* money on credit; that's the nature of things and we can't do anything about it. But you can sure hold your losses down to a minimum if you'll use a little common sense."

"Talk to Pete and ol' Bill, first

you'll get plenty of that. Just set there and smile politely at 'em."

He handed the XYH the book of job tickets. "Here. These'll get you started right. You can get 'em at any distributor's for about two cents apiece. Hey, just a minute. C'mere." and he went into the front room of the shop.

Reaching up on the wall behind the check-in counter, he took down a large sign. Handing it to the XYH, he said, "Put that up where it's the first thing they see when they come in the door! And *you* read it first thing every morning, too."

The sign had only three words on it, in bright red ten-inch letters:

ALL WORK CASH!

The XYH looked at the faded place on the wall where the sign had hung. "That was here when I first came. Been there a long time, hasn't it?"

"Yep." The Old-Timer grinned. "And *so have I!* And that's why, too. I read it every morning, and remembered it all through the day. Believe me, friend, that's *the only way you can do it!*" END

“Electronic Key” Unlocks Automatic Garage Doors

New transmitter-receiver design makes system unresponsive to false signals—deliberate or accidental

By L. M. DEZETTEL

IN SOME HOUSING DEVELOPMENTS where there are a great many radio-controlled garage doors, now and then you'll find a kid on a bike indulging in his favorite leisure-time sport. He'll be whistling into the mike of a portable CB transceiver, trying to find the right tone to open somebody's garage door.

Unfortunately that isn't the only sort of interference that will send garage doors rumbling up their tracks. Diathermy equipment, auto ignition and a few more mysterious sources have helped wreck the peace of automatic-garage-door owners. Some ingenious and sophisticated engineering has been brought to bear on the problem. We'll look at it in a moment, but first a little history.

The first popular commercial radio-controlled garage-door openers used 27.255 mc, which later became channel 23 of the Citizens band. At that time the security required was only to prevent the door from being lifted by voice-modulated rf carriers of 10-meter amateur transmitters, or by man-made sources like auto ignition radiation and diathermy equipment. The radio-control transmitters were vacuum-tube, crystal-

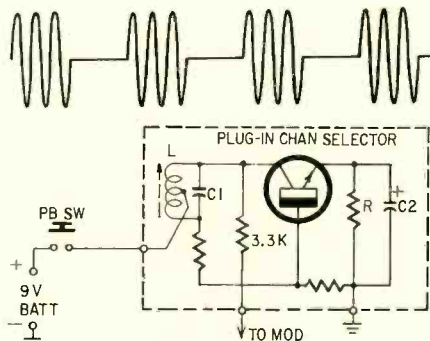

Fig. 1—Pulsed audio comes from oscillator stage in transmitter. Audio blocking oscillator turns itself on and off at a regular rate when switch is closed.

controlled oscillators, modulated by an audio tone. The receivers were trf types, with intentionally low sensitivity (compared to communication receivers), and each responded to only the audio tone from its companion transmitter. Twelve tones were available, so neighbors could operate their own garage doors without interference from, or interfering with, others nearby.

That system was very effective against transmitted speech and any kind of noise. But along came the deluge of Citizens band operation, with off-frequency beat notes between carriers. A few, but enough, such beat notes coincided with the tone channel and persisted long enough to trigger the receiver. Something had to be done.

Some equipment manufacturers went higher in frequency. Some went lower. The region from 200 to 300 mc was relatively empty. Self-excited tube oscillators were easy to design, using hairpin inductances. Superregenerative detectors gave high sensitivity. But new difficulties are now appearing at these high frequencies: the region between 230 and 290 mc is used for aircraft homing systems. And 243 mc is an emergency frequency for the military. The superregenerative detector in the receiver radiates rf at the frequency to which it is tuned and can interfere with these services. On the West Coast, where these frequencies are in more active use, a number of owners of garage-door radio-control equipment were forced to revert to hauling their garage doors up and down by hand. The FAA is investigating the problem, and the FCC is asking to be allowed to control the problem where it starts: at the manufacturers (see editorial, page 33).

At the other end of the spectrum is equipment operating between 150 and 230 kc. These systems suffered from inability to operate reliably beyond a very short range. Elaborate coding devices were required to prevent false triggering from man-made and natural radio-interference sources.

The case for 27 mc

Perma-Power Co., a major manufacturer of garage-door openers, felt that the 27-mc band had many advantages. The FCC had authorized those frequencies for radio control and had promulgated rules under which practical, well-performing equipment could be produced for operation without license.

Six frequencies between 26.97 and 27.27 mc are designated for class-C radio control: channel 23 and five other regularly assigned remote-control CB channels. These six channels, with 12 pulsed audio frequencies between 600 and 7,500 cycles, give 72 combinations—enough for any number of neighbors to have radio-controlled garage doors.

How does pulsed audio work?

The rf is a crystal-controlled carrier at one of the radio-control frequencies in the 27-mc band. The modulation on the carrier is switched on and off at a low audio rate to give the tone bursts or pulses (Fig. 1). The ability of the receiver to discriminate in favor of these transmitted tone pulses and against all other signals is the real secret of success of the system. The engineers at Perma-Power developed a very clever, yet simple, transmitter to produce the tone pulses. Only four transistors are used in the transmitter, all except one in a very conventional way. The audio tone-burst generator oscillates at two frequencies: an audio tone predetermined by a precisely tuned L-C parallel-resonant circuit (L and C1), and at a low audio rate. The low audio or burst rate (about 30 cycles) has a square wave envelope, and is produced by on-off, or “squegging” action of the tone oscillator. Normally the emitter of a transistor oscillator is biased to keep the stage stable and prevent thermal runaway. By making the biasing resistor and bypass capacitor (R and C2) values high, the transistor goes into a self-quenching oscillation with steep rise and decay time. During the “on” time, it also oscillates at the frequency determined by the L-C network. During the “off” time, of course, no current flows and the rf carrier is turned off. Thus, the carrier is keyed on and off and modulated at an audio rate.

The receiver

Ten transistors and one diode are used in a superhet circuit that includes an rf stage. Tuned circuits in the antenna and rf stage reduce response to

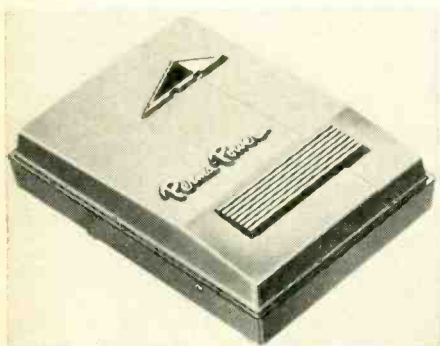

Transmitter of the Perma-Power system.

images by 40 db. Six i.f. tuned circuits are cascaded for sharp selectivity. The conversion oscillator is crystal-controlled. Beyond that is a detector and af amplifier, the output of which is the audio tone from the transmitter and any noise and interfering signals that may have gotten through the i.f. passband.

Only the decoding part of the receiver circuit is shown in Fig. 2. Security against false signals is set up here. It is here that the control signal is decoded and made to operate the relay that actuates the motor.

Major signal security begins with the plug-in channel selector (Fig. 2). A tuned audio circuit passes only one of the twelve available tone channels—the one being transmitted by the user. Heterodyne beat notes from nearby CB equipment which happen to be at the same frequency will also be passed by the channel selector; that's taken care of later. Fig. 2-a is the idealized waveform at point A in Fig. 2.

The waveshape at point A represents an audio tone modulated by a low-frequency square wave (about 30 cycles). Transistors Q1 and Q2 amplify and limit the output from the tone filter. Diode D1 detects the tone bursts and produces the waveshape at B in Fig. 2. R1 and C1 are a low-pass filter which reduces the amplitude of the detected square wave as the frequency is increased. C2 and R2 are a differentiator network which operates on the leading edge of the square wave. The purpose of this network is to pass pulses whose width does not depend on the duty cycle of the square wave except for very short or very long duty cycles. The positive portion of the constant-width pulse will turn on transistor Q3 for a finite time determined by the positive width of the waveshape at C.

Transistor Q3 now transfers a fixed charge into capacitor C4 via R3 (D in Fig. 2). The time constant of C4 and R3 is such that many pulses are necessary to charge C4 to 3 or 4 volts (point E). In addition, the many pulses must come in rapid succession or the voltage across C4 is bled off between pulses by R4. Capacitor C3 further reduces the gain of transistor Q3 at the higher pulse-repetition rates (45 cycles and higher).

Transistors Q4 and Q5 form a complementary dc amplifier which is biased beyond cutoff by R6 and R7. When C4 is charged sufficiently by the pulsing action of Q3 to exceed the threshold level of Q4, both Q4 and Q5 conduct. Turn-on of Q5 is speeded by regeneration through R5. Q5 is a relay driver.

Security is provided by the low-frequency bandpass of Q3. Steady tones have no effect because of the blocking action of C2. The combined characteristics of capacitors C1 and C2 and resistors R1 and R2 maximize the re-

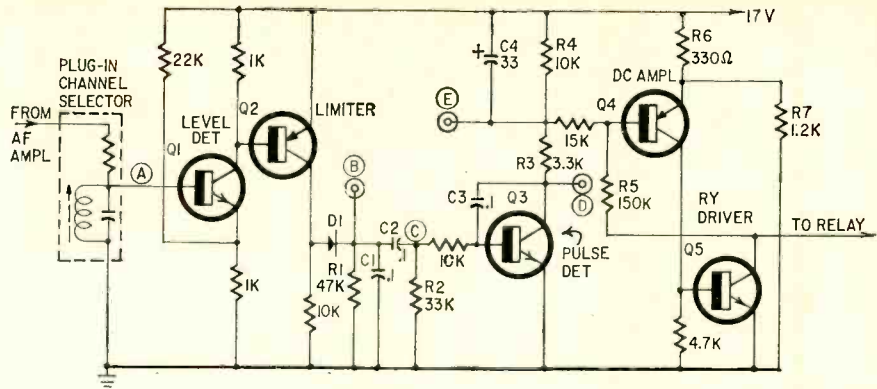
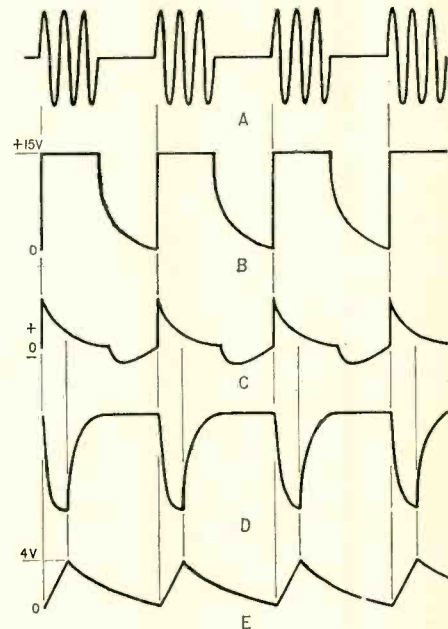

Fig. 2—"Lock" of receiver. Demodulated signal ("key") must meet a series of sharply defined characteristics before it can actuate relay. Waveforms are keyed by letters to appropriate points in circuit.

sponse of the circuit to duty cycles of between 20% and 80%. This results in maximum immunity to short-duration disturbances like ignition, lightning, sparking, etc., and to steady tones broken up by such noises.

Only a signal meeting five requirements simultaneously could reach the control stages and trip the garage-door relay. It would need to have the right carrier frequency to get by the high selectivity of the receiver. The sub-carrier would have to be within 5% of the right audio tone to get through the audio filter. The tone bursts would have to be at the proper pulse frequency and also be within the 20% to 80% on-to-off time limits to develop the control dc, and the signal must be on about 1/4 second. The signal from the transmitter has all these components, but no other signal can possibly have them all, except by intent.

Atmospheric and man-made static (ignition noise, etc.) are a series of spikes, mostly random. Only a very small amount of spike energy can get by



the audio filter. That which does may be of high level, but the spikes are leveled by the limiter stage. Those that remain are too far apart ever to develop the staircase charge on C4.

Two CB stations operating slightly off frequency could beat together and produce a tone equal to the audio frequency to which the filter is tuned. But when the level detector demodulates this signal, nothing is left but straight dc, which will never get past C2.

Now, you say, what about a combination of beat frequency and noise spike? This could break up the beat note into tone bursts. But with the short duration of noise spikes, there is no chance that the off time of the beat note would exceed 20% recurrently, so such noise cannot trigger the relay.

So the pulse-tone detection system has maximum noise and interference immunity because it is a signal enabling circuit: each of five characteristic parts of the transmitted signal must meet the conditions set up in the circuit, just as notches in a key must match corresponding elements in a lock. Only the signal from the transmitter has the necessary qualities to get through all check points.

END

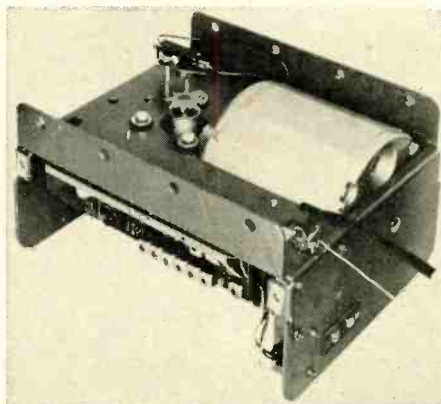

Receiver mounts with garage-door motor (note i.f. cans visible just under mounting flange). It draws only 3.5 watts.

Fast Turn-On for Vacuum-Tube Radios

Put "transistor speed" into your old ac-dc-battery tube sets

By EDWARD L. BONIN*

TRANSISTOR RADIOS HAVE SPOILED US with their instant playing. We get annoyed with our old tube radios—which are still too good to junk—because we have to wait 15 or 20 seconds for them to warm up.

Wish you could change that? You can—very easily. By keeping the heaters of the tubes half-hot all the time, and arranging the power supply to provide B-plus the moment you turn the set on, you can cut warmup to a second or less. And extend the life of tubes and pilot lamp, too! These simple, inexpensive alterations will work with almost any transformerless tube radio that operates from the power line.

Ac/dc/battery circuit

This type of radio has been rather completely replaced by the transistor portable, but large numbers of them are still around. It operates on 117 volts ac or dc or on internal batteries. It can be identified by the tubes, such as 1L4, 1R5, 1S5, 1T4, 1U5, 3S4, 3V4. This type starts slowly on ac or dc line operation when

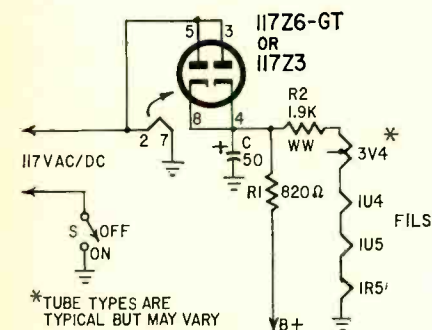

Fig. 1—Power supply of typical "three-way" set with 117-volt tube rectifier (battery power connections are not shown).

it also has a tube with a 117-volt heater such as the 117Z3 or 117Z6-GT. When the radio can be operated from batteries, it warms up in just over a second. Since the 117-volt tube is the rectifier, an easy solution is to replace it with a semiconductor rectifier. Because the semiconductor rectifier operates instantly, the warm-up time of the radio is just that of the other tube filaments.

*Texas Instruments, Dallas, Tex.

The power supply circuit is like that in Fig. 1. (Circuits for internal battery operation have been omitted for clarity.) The heater of the 117-rectifier is not part of the other filament circuit, so the tube can be eliminated when the semiconductor rectifier is added. The other tubes obtain filament current from the dc supply through current-limiting resistor R2.

After replacing the rectifier tube with a semiconductor rectifier and series resistor (R3), we have the circuit of Fig. 2. R3 does two jobs: it limits the current that charges filter capacitor C

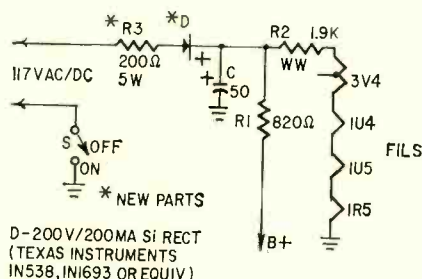

Fig. 2—Circuit of Fig. 1 after conversion to silicon rectifier. Warmup time is now 1 or 2 seconds.

when the set is first turned on and also lowers the power supply voltage to about the same value as with the rectifier tube. I put the diode and resistor in an old tube base that plugs into the original rectifier socket, so that no changes were needed in the main wiring. (Seven-pin miniature plugs are available for replacing 117Z3 rectifiers.) Connect the rectifier with the polarity shown in Fig. 2 to prevent damage to the filter capacitor.

Ac/dc circuit

This type of radio contains tubes like 12BE6, 12AT6, 12BA6, 12SA7, 12SK7, 12SQ7, 35C5, 35W4, 35Z5-GT, 50C5, 50L6-GT. These tubes have slow-heating heaters, so we need to apply the technique of heating the filaments when the radio is off.

A typical rectifier and heater circuit for this type of radio is shown in Fig. 3. For fast turn-on, change this circuit to that shown in Fig. 4 if the radio is to be operated from ac only. For ac and dc operation, the circuit changes are a bit more complex and will be described later.

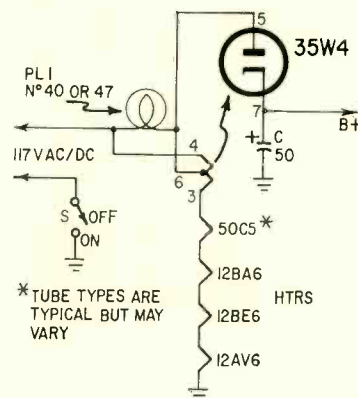

Fig. 3—Typical ac-dc power supply.

In Fig. 4, the 35W4 rectifier is no longer used to supply the tube plates. In its place are resistor R5 and semiconductor rectifier D1. These new parts develop B+ instantly. Also the current that charges C when the radio is turned on no longer goes through pilot lamp PL1, which lengthens the lamp's life. The 35W4 stays on as a heater-circuit ballast. That way, no changes are needed in the heater and pilot-lamp circuits.

R6 and D2 supply a small current to the heaters when the radio is off. Because of the rectifying action of D2, the heater current when the on-off switch is open flows during only half of each ac cycle. The current that can flow through D1 to charge the filter capacitor must also be half-cycle. But the way D1 and

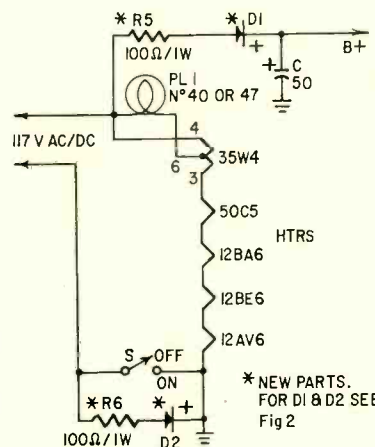

Fig. 4—Circuit of Fig. 3 after conversion to silicon rectifiers for B-plus and "preheating" (ac operation only). Tube rectifier must be retained as pilot-lamp and heater-circuit ballast.

D2 are connected in the circuit, they cannot conduct on the same half-cycle; they must alternate. Because D2 passes current around S only while D1 cannot conduct, B+ is not developed when the switch is open, and the radio cannot operate.

When the switch is closed, R6 and D2 are shorted. This gives the heaters full rated current and allows B+ to be developed. The radio operates immediately.

The polarity of D1 must be as shown in Fig. 4 to avoid damage to C. There will be no damage if D2 is connected the wrong way; the radio will simply continue to play at low volume when turned off.

To operate from both ac and dc, the circuit in Fig. 5 may be used. Note that a different type of on-off switch is required. In all previous circuits, the original switch was used. The on-off switch is usually attached to the volume control. In some cases a dpst switch which exactly mates with the original volume control is available, but more often the entire control will have to be replaced with one fitted with a dpst switch.

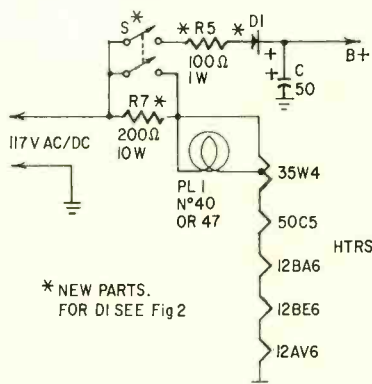

Fig. 5—Conversion for ac-dc type set used on dc. Note two-pole switch.

In the circuits in which current is allowed to flow through the filaments or heaters when the radio is off, the values for the resistors which limit this current (R6 and R7) are chosen only small enough to give fast turn-on. This way, the (rms) heater current is well below ratings (about 50%), and the effect on the tube electron-emission lifetime should be insignificant. The current surge into the filaments when the radio is first turned on will be much less than it was originally, which will increase tube life.

In one small radio, reducing R6 to 75 ohms, which increased the filament current, reduced oscillator warm-up drift, cutting the time during which the volume slowly increased on the weak stations to less than 2 seconds. Usually this drift is not objectionable. END

WHAT'S YOUR EQ?

Conducted by E. D. CLARK

How Wide?

Find the bandwidth (Δf) of the tank circuit in the diagram.—William Uhlenhoff

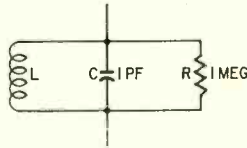

Series-Parallel Circuit

From the information given on this series-parallel circuit, can you de-

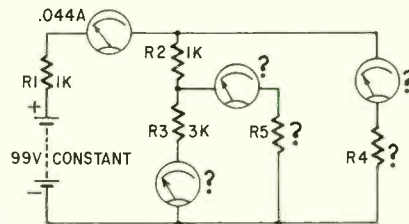

termine the values of R4 and R5, also the current flow through R3, R4 and R5? Disregard the meters' internal resistance.—Chester A. Kelley

Two Lamps

Two lamps and a spst switch are mounted in this black box. With the switch in one position, one lamp is on. In the other position, the other lamp is on; both lamps are not on at the same

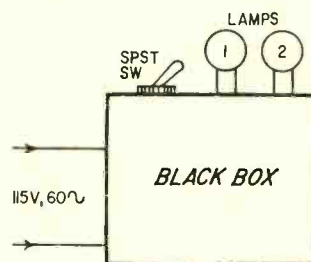

time. Power is supplied to the box from a 115-volt 60-cycle source. No relays or transistors are involved.

What's the circuitry in the box? —R. A. Reiss

CORRECTION

The value of C2 (1.0 μf) did not appear in the parts list for the Semi-Sweeper (September 1965, page 37) possibly because of a damaged printing plate.

Three puzzlers for the students, theoretician and practical man. Simple? Double-check your answers before you say you've solved them. If you have an interesting or unusual puzzle (with an answer) send it to us. We will pay \$10 for each one accepted. We're especially interested in service stinkers or engineering stumpers on actual electronic equipment. We get so many letters we can't answer individual ones, but we'll print the more interesting solutions—ones the original authors never thought of.
Write EQ Editor, Radio-Electronics, 154 West 14th Street, New York, N. Y. 10011.
Answers to this month's puzzles are on page 101.

50 Years Ago

In Gernsback Publications
In February, 1916
Electrical Experimenter

Army Pursues Bandits with Wireless
Latest de Forest Radio Apparatus
Dubilier Musical Tone Radio System
Constructing a Collins Radiophone
Arc
A Silicon "Tikker"



The lively sound of the Mustang!
The more-than-you-pay-for performance of University's newest and liveliest line of Mustang speakers. New slim line profile permits easy installation. Read the full story of the Mustang in University's newest catalog. You'll also receive our Guide To Component Stereo High Fidelity. They're Free! Write today.

UNIVERSITY
Desk B69S, Box 1056
Oklahoma City, Okla.

Name _____
Address _____
City _____
State _____ Zip _____

Circle 18 on reader's service card

You can earn more money if you have an FCC License

FCC Form 788 A

The United States of America

NUMBER
P1-20-6490

FEDERAL COMMUNICATIONS COMMISSION

RADIO TELEPHONE OPERATOR LICENSE

FIRST CLASS
(General Radiotelephone Certificate)

This certifies that TOMMY WILLIS DUFFY

IS A LICENSED RADIO OPERATOR, AUTHORIZED, SUBJECT TO ANY SPECIAL ENDORSEMENT PLACED HEREON, TO OPERATE THE CLASSES OF LICENSED RADIO STATIONS FOR WHICH THIS CLASS OF LICENSE IS VALID UNDER THE ORDERS, RULES AND REGULATIONS OF THE FEDERAL COMMUNICATIONS COMMISSION, ANY STATUTE OF THE UNITED STATES AND ANY TREATY TO WHICH THE UNITED STATES IS A PARTY.

THIS LICENSE IS GRANTED UNDER THE AUTHORITY OF THE COMMUNICATIONS ACT OF 1934 AS AMENDED AND THE TERMS AND CONDITIONS THEREOF AND OF ALL LEGISLATIVE ACTS, EXECUTIVE ORDERS, AND TREATIES TO WHICH THE UNITED STATES IS SIGNATORY, AND ALL ORDERS, RULES AND REGULATIONS OF THE FEDERAL COMMUNICATIONS COMMISSION, WHICH ARE BINDING UPON RADIO OPERATORS, ARE MADE A PART HEREOF AS THOUGH SPECIFICALLY SET OUT IN FULL HEREIN.

NEITHER THIS LICENSE NOR THE RIGHTS CERTIFIED TO HEREIN SHALL BE ASSIGNED OR OTHERWISE TRANSFERRED TO ANY OTHER PERSON.

PLACE AND DATE OF ISSUANCE: BUFFALO, NEW YORK - SEPTEMBER 11, 1963

DATE AND TIME OF EXPIRATION: SEPTEMBER 11, 1968 AT THREE O'CLOCK A. M., EASTERN STANDARD TIME.

SPECIAL ENDORSEMENT: SHIP RADAR ENDORSEMENT - SEPTEMBER 11, 1963 - BUFFALO, NEW YORK

 *[Signature]*
ISSUING OFFICER

Federal Communications Commission

[Signature] (Licensee) *[Signature]* (Issuing Officer) *[Signature]* (Secretary)

NOT VALID UNTIL SIGNED

Employers are paying good money for men holding FCC tickets. Read how to get yours:

When you hold a Commercial License issued by the FCC (Federal Communications Commission) you have written proof that you know and understand basic electronic theory and fundamentals. It's worth plenty... particularly to companies on the lookout for qualified electronics technicians. Here's how one of the country's leading office machine manufacturers rates men with FCC Licenses:

"An FCC License is an asset to any man looking to enhance his career in the field of electronics. At our Company, a licensed man is well-rewarded because an FCC License attests to his knowledge of electronics theory..."

Thousands of employers will tell you the same thing. Licensed men get the good jobs. They make more money... move ahead faster... enjoy exciting, challenging work. What's more, they're needed badly in every field of electronics. Industrial electronics. Radio-TV Broadcasting. Aerospace. Electronics Servicing... including mobile and marine radio plus CB.

Yes... your opportunities are unlimited once you're carrying that

FCC Commercial Ticket. AND CLEVELAND INSTITUTE OF ELECTRONICS CAN GET ONE FOR YOU! On the facing page, read how four ambitious men just like you have cashed in on CIE's sure-fire FCC Licensing Program. Read about CIE's exclusive money-back offer. And then send in the postage paid reply card. CIE will quickly send you complete FREE information. You will soon be on your way to a Commercial FCC License and the many rewards that go with it!

NEW
in
1966

Only CIE offers new, up-to-the-minute lessons in all of these subjects:

- Logical Troubleshooting
- Laser Theory and Application
- Microminiaturization
- Single Sideband Techniques
- Pulse Theory and Application
- Boolean Algebra

These CIE men have good jobs

(they have Commercial FCC Licenses)



Matt Stuczynski, Senior Transmitter Operator, Radio Station WBOE. "I give Cleveland Institute credit for my First Class Commercial FCC License. Even though I had only 6 weeks of high school algebra, CIE's AUTO-PROGRAMMING teaching method makes electronics theory and fundamentals easy. After completing the CIE course, I took and passed the 1st Class Exam. I now have a good job in studio operation, transmitting, proof of performance, equipment servicing. Believe me, CIE lives up to its promises!"



Ted Barger, Electronic Technician, Smith Electronics Co. "I've been interested in electronics ever since I started operating my own Ham rig (K8ANF). But now I've turned a hobby into a real interesting career. Cleveland Institute of Electronics prepared me for my Commercial FCC License exam . . . and I passed it on the first try. I'm now designing, building and testing all kinds of electronic equipment . . . do a lot of traveling, too. It's a great job . . . and thanks to CIE and my FCC License, I'm on my way up."



Chuck Hawkins, Chief Radio Technician, Division 12, Ohio Dept./Highways. "Cleveland Institute Training enabled me to pass both the 2nd and 1st Class License Exams on my *first* attempt . . . even though I'd had no other electronics training. (Many of the others who took the exam with me were trying to pass for the eighth or ninth time!) I'm now in charge of Division Communications and we service 119 mobile units and six base stations. It's an interesting, challenging and extremely rewarding job. And incidentally, I got it through CIE's Job Placement Service . . . a free lifetime service for CIE graduates."



Glenn Horning, Local Equipment Supervisor, Western Reserve Telephone Company (subsidiary of Mid-Continent Telephone Company). "There's no doubt about it. I owe my 2nd Class FCC License to Cleveland Institute. Their FCC License Program really teaches you theory and fundamentals and is particularly strong on transistors, mobile radio, troubleshooting and math. Do I use this knowledge? You bet. We're installing more sophisticated electronic gear all the time and what I learned from CIE sure helps. Our Company has 10 other men enrolled with CIE and take my word for it, it's going to help every one of them just like it helped me."

FCC LICENSE WARRANTY

A CIE FCC License Course will quickly prepare you for a Commercial FCC License. If you don't pass the FCC exam . . . on the first try . . . after completing your course, CIE will refund all your tuition. You get an FCC License . . . or your money back!

Two out of three men who took the 1st Class Commercial FCC License exam in 1964, failed.

Nine out of ten CIE-TRAINED men who take this exam, pass . . . the very first try!

And that's why CIE can back their courses with the warranty you see at the left. CIE-trained men know their stuff . . . because CIE AUTO-PROGRAMMED Home Study works!

Get started now. Send postage-paid reply card for free information about a plan that gets you an FCC License *or costs you nothing!*

CIE

Cleveland Institute of Electronics

1776 East 17th Street, Dept. RE-13, Cleveland, Ohio 44114

FEBRUARY, 1966

THE DIODE WITH GAIN

By ALBERT C. W. SAUNDERS

Get experimental insight into the marvelous tunnel diode. It oscillates, amplifies, flips and flops at thousands of millions of cycles per second

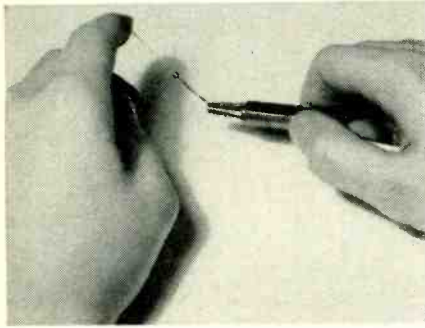

THE TUNNEL DIODE—POSSIBLY THE most exciting developments to come out of electronics laboratories during the last decade—still puzzles many newcomers to electronics. How often have you heard the question, "But how can a diode oscillate?" If you have been brought up on tubes and transistors, the idea of a diode with gain is strange. To find out how this tiny two-element device can amplify, oscillate and switch, let's start by building what is probably the simplest possible sine-wave oscillator, and then go on to some explanations of how and why it works.

The tunnel-diode oscillator in Fig. 1 is an inexpensive project. Simply by changing the tuned circuit, you can get frequencies from 400 cycles to hundreds of megacycles. A large capacitance-to-inductance ratio provides a good sine-wave output. The tuned circuit in this project is a 50- μ h peaking coil (used in TV) and a .01- μ f capacitor.

Potentiometer R may be replaced by a 120-ohm resistor. I used the potentiometer to adjust the operating bias, which should be at the center of the negative-resistance slope (Fig. 2).

The tunnel diode is a single p-n

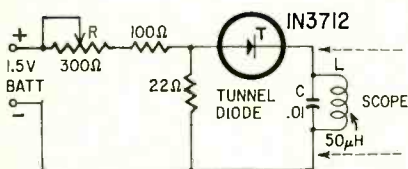

Fig. 1—Inexpensive "starter" circuit. General Electric type 1N3712 tunnel diode costs only \$3.30. This circuit will work at practically any frequency out to a few hundred megacycles with proper choice of L and C. Keep tank heavy on the C; L should be comparatively small, for stability; and its resistance must be 20 ohms or less.

junction. The essential difference between the tunnel diode and the conventional diode is the high conductivity of the p- and n-materials used in its construction. Tunnel-diode conductivity is more than 1,000 times that of conventional diodes. This is due to a greater concentration of impurities (doping) applied to the crystals while forming. The result is a very narrow junction (depletion layer) between the p- and n-electrodes. The narrow junction permits the electrons to "tunnel" through the potential barrier at a relatively low bias voltage (less than 50 mv for germanium). In conventional diodes the electrons lack the energy to penetrate, or overcome, the potential barrier at such a low applied potential. With a narrow junction, a relatively small bias can develop a field strong enough to cause valence electrons to escape across the barrier at a velocity close to the speed of light.

A forward or reverse bias of less than 50 mv applied to the diode will cause the valence electrons of the semiconductor atoms near the junction to tunnel in either direction, depending on the polarity of the bias. If the forward bias is increased to more than 50 mv, the free electrons in the n-region will acquire more energy than the valence electrons in the p-region, causing the tunnel current to decrease (Fig. 4).

A decrease in current with an increase in voltage indicates a negative resistance characteristic. However, a further increase of forward bias, above 300 mv (for germanium), will energize the free electrons and holes sufficiently to overcome the potential barrier. At this point, the tunnel diode becomes just a conventional diode (Fig. 2).

The negative resistance of the tunnel diode at a low forward bias makes it an ideal device for oscillators. In an oscillator, it acts like any other device with gain—to replenish the tank circuit losses, thereby sustaining oscillations.

Biasing

When a bias of 0.125 volt is applied to the diode, tunnel current of about 0.5 ma flows. To apply this small voltage from a 1.5-volt battery requires a series resistance of 3,000 ohms. However, the resistance of the diode is -100 ohms, therefore the total series resistance is 2,900 ohms. This would obviously cancel the negative resistance of the tunnel diode. To avoid this, the bias

voltage should be developed across a resistance less than the negative resistance of the diode. For example, if the bias resistance is 20 ohms (22 and 220 ohms in parallel), the combined resistance will be -80 ohms (Fig. 3).

To study how the diode operates, let us assume that a tuned circuit has no heat-producing resistance and that its oscillating current produces a magnetic field that returns all its energy to the circuit when it collapses. This would be an ideal condition: one shock pulse would cause the tuned circuit to oscillate forever—a form of perpetual motion. That is not possible. But all tuned circuits contain heat-producing resistance (positive resistance). When shock-

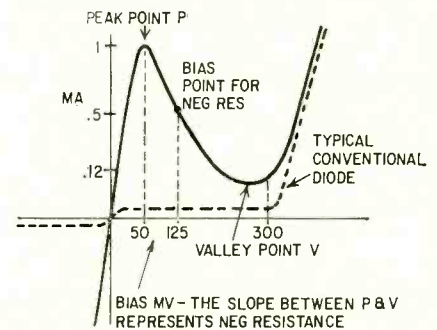

Fig. 2—Typical tunnel-diode characteristic. Diode conducts with either polarity, but negative-resistance slope appears only in forward conduction.

excited, they produce a damped wave in which each succeeding cycle diminishes in amplitude. Additional energy must be supplied to keep the circuit oscillating. For instance, in a vacuum-tube oscillator, some energy is fed back from the output to the input and returned to the output, amplified. This compensates for the resistance losses. A similar feedback system is used in a transistor oscillator. In both cases a third element is used—the control grid of the vacuum tube or the base of the transistor.

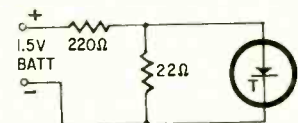

Fig. 3—Basic tunnel-diode biasing divider.

The tunnel diode has no third electrode as such, but uses a quantum-mechanical tunneling of energy through the diode junction. For example, while the tuned circuit (tank) is oscillating, its alternating voltage aids and opposes the dc bias across the diode; hence, the diode bias increases and decreases in unison with the frequency of the tuned

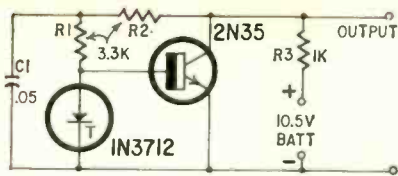

Fig. 4—Astable multivibrator made with tunnel diode and transistor.

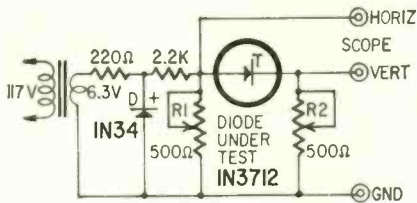

Fig. 5—Tunnel diode curve tracer. Its operation is described in the text.

circuit. When the diode bias decreases, it supplies additional current because of its negative resistance characteristic.

For amplification, the tunnel-diode circuit must be stabilized with an external circuit that has a positive resistance equal to the negative resistance of the diode. When this condition is satisfied, the circuit becomes a tunnel-diode amplifier. For oscillation, the external circuit resistance (positive) must be less than the negative resistance of the diode.

Free-running multivibrator

A multivibrator that uses a tunnel diode with an n-p-n transistor is illustrated in Fig. 4. When power is applied, capacitor C1 begins to charge through R2 and R3 and develops a bias voltage across the tunnel diode. Note that C1 is connected across R1 and the tunnel diode.

As soon as the capacitor voltage rises above zero, a current flows through the tunnel diode and R1. When this current reaches the peak-point value (Fig. 2), the diode switches from a high-current, low-voltage state (low impedance) to a low-current, high-voltage state (high impedance). This occurs along the negative resistance region of the curve.

The switch from low to high impedance diverts diode current flow through the emitter-base junction of the transistor and causes the transistor to conduct. Simultaneously, the capacitor discharges through the transistor and R2. During the discharge, the voltage across the tunnel diode decreases and the diode returns to its low-impedance state. This diverts the emitter-base current, the transistor is cut off, and the capacitor starts to charge again. The cycle is repeated. Note that it is the charge and discharge of C1 that causes the tunnel diode to turn the transistor on and off. The repetition rate of the square-

wave output depends on the time constants of the charge and discharge paths of the capacitor.

Tunnel-diode curve tracer

Testing a conventional semiconductor diode with an ohmmeter to determine its forward and reverse resistance ratio is simple and useful. But the ohmmeter test must not be applied to the tunnel diode: First, the tunnel diode conducts almost equally in both directions, so the test serves no purpose. Second, you could damage the diode permanently, especially in a low-resistance (high-current) range.

Despite the bi-directional characteristic of the tunnel diode, it does have that negative resistance characteristic in one direction. A test circuit can be devised, which, used with an oscilloscope, provides an excellent display of applied bias vs diode current for observation and quantitative analysis. The circuit in Fig. 5 is inexpensive and works well.

To supply the tunnel-diode bias, 6.3 volts from the filament transformer was applied to a half-wave rectifier, causing the output across R1 to swing

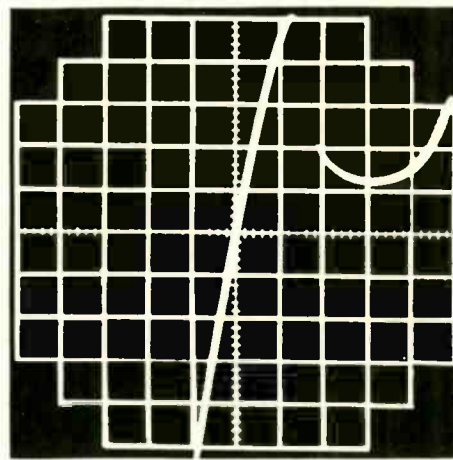
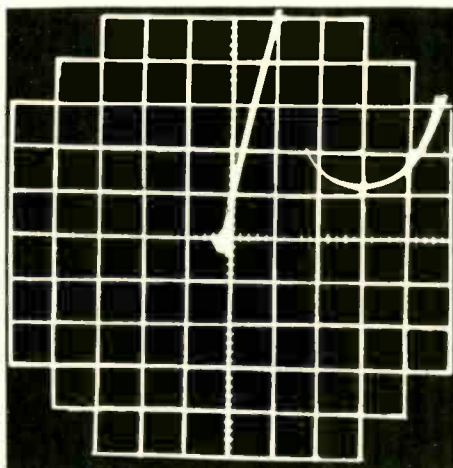

Fig. 6-a—Oscillogram of tunnel-diode curve made with curve tracer with pulsating half-wave dc; b—curve made with raw ac.

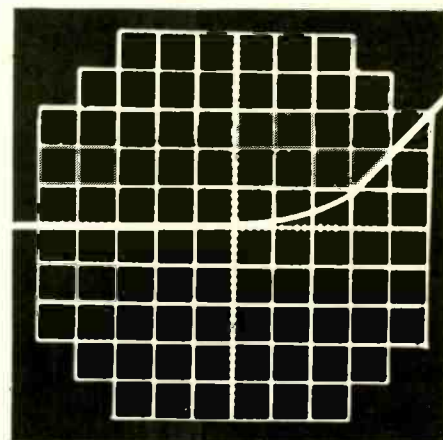
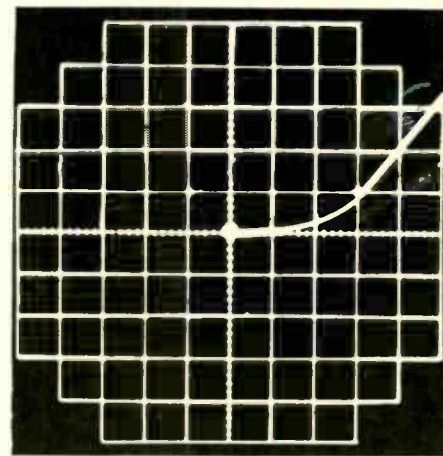

Fig. 7—Conventional diode characteristics made on curve tracer with half-wave dc (a) and raw ac (b).

from zero to approximately 900 mv rms. This is applied to the horizontal input of the scope and represents the voltage axis. The current through the diode develops a voltage across R2 which is applied to the vertical input of the scope to represent the current axis. As the applied bias voltage (horizontal axis) sweeps from zero to maximum (positive peak), the diode current (vertical axis) rises to peak current, falls to valley current and then rises again. The region between peak and valley current represents the negative-resistance region, an excursion from low diode impedance to high impedance. It is this property that makes the tunnel diode useful as an oscillator, amplifier, multivibrator and switch.

Fig. 6-a shows the curve when the ac bias is rectified. (The positioning controls were adjusted so that the curve began at the intersection of X and Y axes.) Fig. 6-b shows the curve displayed when the rectifier D was removed. Note the effect of the negative half-cycle. This illustrated the bi-directional characteristic of the tunnel diode.

Figs. 7-a and -b show the curve displayed when the tunnel diode was replaced by a conventional diode, with and without rectifier D. END

new SAMS BOOKS

Transistor Ignition Systems Handbook NEWLY REVISED UPDATED EDITION



by Brice Ward. Many automotive dreams have become realities during the past decade; few equal the benefits afforded by the new, compact, efficient electronic ignition systems. This completely updated handbook provides the fullest understanding of transistor and capacitive discharge ignition systems, including breakerless units. Explains theory of operation and the practical details of installation, troubleshooting, and maintenance. Manufacturers and model specifications are listed in the appendix. This important book is of special value to anyone in automotive electronics, as well as hobbyists and experimenters. 176 pages. 5½ x 8½". Order IGS-2, only..... \$2.95

ABC's of Modern Radio NEWLY REVISED

by Walter G. Salm. A remarkable book written so clearly anyone can easily understand its explanation of the basic principles of radio transmission and reception. Simplified block diagrams take you along the entire path of the radio wave, from its origin at the broadcast station, to its reception in the home. Elements of an a-m radio are clearly analyzed to fully explain the operation of the entire receiver. Also covers f-m and stereo broadcasting. 128 pages; 5½ x 8½". Order ARS-2, only..... \$1.95

Digital Computers in Automation

by Allan Lytel. The information provided in this book is important to persons in every phase of industry. Provides a complete, clear introduction to the computer and explains the basic methods used to program the computer to control a variety of industrial tasks. Describes the decision-making ability which sets computer-controlled production apart from other automated systems. Shows why the application of computers for the operation of a complete manufacturing complex requires new techniques and devices, and a thorough understanding of both computer and manufacturing processes. Describes numerous applications of process-control computers in steelmaking, chemical processing, food-handling, and warehousing operations. 224 pages; 5½ x 8½". Order DCA-1, only..... \$4.50

LATEST COLOR-TV BESTSELLERS!

Color-TV Servicing Guide



by Robert G. Middleton. This great new book on color-TV troubleshooting follows the same picture-tube-and-trouble-symptom format made famous in the best-selling *TV Servicing Guide*, now used by more than 100,000 servicemen. Shows how to apply fast troubleshooting procedures, based on an analysis of trouble symptoms. Includes many full-color picture tube photos illustrating various operating

troubles, accompanied by clear, concise explanations of probable causes and diagnosing procedures. Takes you through each section of the color-TV receiver, describing the symptoms for various types of troubles. A final chapter explains in detail how to test and service color-bar generators. If you service color-TV, this book is a gold-mine of help. 112 pages. 8½ x 11". Order SGC-1, only..... \$3.95

OTHER SAMS COLOR-TV SERVICING BOOKS

Color TV Training Manual (new 2nd Edition), by Oliphant & Ray. Order TVC-2, only..... \$5.95
Color TV Servicing Made Easy, by Wayne Lemons and Carl Babeoke. Order CSL-1, only..... \$2.95
Know Your Color-TV Test Equipment, by Robert G. Middleton. Order KOC-1, only..... \$2.50

HOWARD W. SAMS & CO., INC.

Order from your Sams Distributor today, or mail to Howard W. Sams & Co., Inc., Dept. RE-2, 4300 W. 62nd Street, Indianapolis, Ind. 46206

Send me the following books:

- IGS-2 DCA-1 TVC-2 KOC-1
 ARS-2 SGC-1 CSL-1

Send FREE Sams Booklist. \$_____ enclosed

Name _____

Address _____

City _____ State _____ Zip _____

My Distributor is _____

Circle 20 on reader's service card

EQUIPMENT REPORT

Eico 965 Farad-Ohm Bridge Analyzer

Circle 21 on reader's service card

WHILE SERVICE TECHNICIANS AND EXPERIMENTERS rely mainly on an ohmmeter for measuring resistance, engineers for more than half a century have preferred a bridge, because of its higher accuracy and extremely wide range. Furthermore, a bridge can also be used for measuring and comparing inductances and capacitors. The new Eico model 965 Farad-Ohm bridge-analyzer combines a resistance-capacitance bridge with a vtvm for measuring voltage. It will also measure current from 3 nanoamperes to 15 ma.



In the schematic, when the unknown resistance (R_x) has the same value as the known standard resistor (R_s), and the bridge balance potentiometer (R_b) is set to its mid-resistance position, the voltage at the null indicator (meter, in this case) is zero. The bridge is then balanced. When R_x and R_s have different values, R_b must be set so that its dividing ratio is the same as the ratio of $R_x:R_s$ in order to get a null. The value of the resistance can be calculated, or read from the dial of R_b if it is calibrated in ohms.

Known and unknown inductances and capacitors may also be compared in the same manner, but always with an

ac bridge supply. The resolution of a bridge is limited by the null indicator. In the Eico 965, a high-gain amplifier and detector drive an ultra-sensitive dc vtvm, which makes for an unusually sensitive null detector.

The bridge voltage is very low, only 0.45 volt (60 cycles), making it possible to check devices that might be damaged by a higher voltage. The ac error voltage from the bridge is fed to the grid of V1, a pentode amplifier with its own automatic gain control. The output signal is rectified by diodes D1 and D2 to produce a negative bias voltage which increases as the signal voltage rises. Hence, V1's gain is maximum when the error voltage is smallest.

The signal at the plate of V1 is also fed to a detector (diode D3) which rectifies the signal and applies positive dc voltage to the grid of V2-a through R16, the bridge null sensitivity control.

When the error voltage is zero (null condition), and R2 and R3 are correctly adjusted, the meter indicates zero. Even a very minute error voltage will cause the meter to indicate other than zero because of the high gain of V1 and the vtvm.

The vtvm circuit resembles that used in most dc vtvm's, except here we have a two-stage balanced dc amplifier driving the meter.

The vtvm is so sensitive that it is possible to measure current as low as 3 nanoamperes (3 billionths of an ampere, or .003 microampere) at the first division of the 0-50 meter scale, on the most sensitive range of the 11-range vtvm—vacuum-tube ammeter (0-0.15 μ a). Higher current values from 5 to 150 nanoamperes (na) can be read directly on the 0-150 meter scale.

Capacitance is measured by using an internal or external capacitor standard in the bridge. To measure inductance, an external inductance standard is required.

The instrument can measure capacitance from 5 pf to 5,000 μ i and resistance from 0.5 ohm to 100,000 megohms. Using it as a comparator, the ratio of the inductance standard can be multiplied by .025 to 50. As a dc vtvm, six full-scale ranges from 1.5 to 500 volts are available with 10-megohm in-

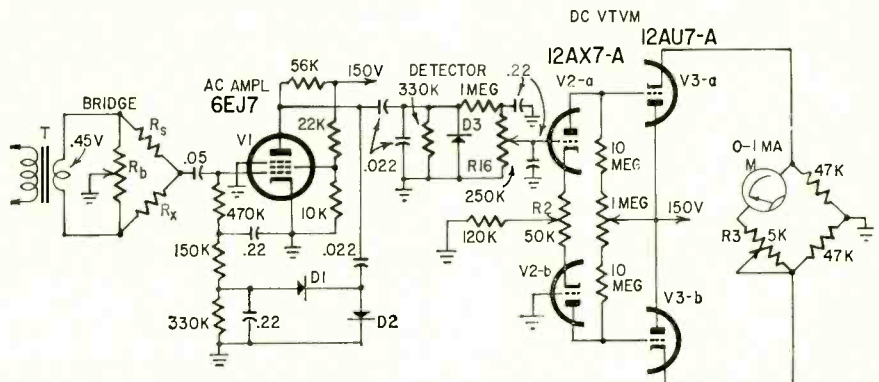

put impedance. Full-scale vtam ranges run from 150 na to 15 ma with a 75-mv maximum voltage drop across the terminals.

So what can be done with an instrument with such fascinating numbers? Besides the obvious, it is possible to measure the quiescent current of low-leakage transistors, the leakage resistance or shunt capacitance of coaxial cable, the inductance of home-made coils, and on and on. It can also be used to measure extremely low light levels by using a light-sensitive resistor as the unknown resistance, or a thermistor for measuring temperatures or observing subtle changes in temperature. By using an external rf detector, it can be used as a very sensitive field-strength meter.

As a comparator, it can be used as an incoming-parts inspection or classification device. Its ultimate usefulness depends only on your imagination. Its true significance is the combining of a bridge with an ultra-sensitive vtvm and its ability to measure extremely low current. These things have been done before with separate instruments; there is nothing particularly new about the circuits. It is their combination and application that are new.—*Leo G. Sands*
Price: \$129.95 (wired only)

KLH Model Eighteen FM Stereo Tuner

Circle 22 on reader's service card

MINIATURIZATION WAS ONE OF THE KEY advantages claimed for transistors when they were first introduced. Thanks to transistors, we now have receivers the size of older integrated amps, and amplifiers built into record-changer bases. But until now, tuners have shrunk little.



The KLH model Eighteen tuner breaks that barrier. Because transistors generate so little heat, they need less ventilation: the chassis can be closed at the top as well as the bottom, and circuit boards can be suspended from the upper chassis shield, double-decked to save space. KLH has done just that, gaining increased shielding in the process. The i.f. strip and the front end are further shielded by additional enclosures.

KLH claims that the newly designed i.f. transformers will not shift out of alignment in use or during shipment. All tuning adjustments for the i.f. strip, front end and multiplex section are

NO COMPETITORS

Nobody else but **EMC** designs in so much value



Tube Tester Model 213

Compact, light-weight portability. Use it on the bench or in the field.

Full-view meter gives direct, clear-cut quality indications.

Three heavy-duty controls for quick set-up of all tests. Check a fistful of tubes in the time it often takes to test one.

12 slide switches for individual selection of tube pins provides versatility in testing, prevents obsolescence.

Full complement of sturdy sockets accepts compactron (12-pin), nuvistor, novar, 10-pin, 9-pin, octal, loctal, and miniature tubes.

Precise programming. Only one socket per tube-base configuration prevents accidental plug-in.

THE MODEL 213 saves you time, energy, money ■ Checks for shorts, leakage, intermittents, and quality ■ Tests all tube types including magic eye, regulator, and hi-fi tubes ■ Checks each section of multi-purpose tubes separately ■ Gives long, trouble-free life through heavy-duty components, including permanently etched panel ■ Keeps you up to date with FREE, periodic listings on new tubes as they come out ■ Your best dollar value in a tube tester. Available in high-impact bakelite case with strap: \$28.90 wired; \$18.90 in kit form. Wood carrying case (illustrated) slightly higher.

EMC

ELECTRONIC MEASUREMENTS CORPORATION
625 Broadway, New York 12, New York
Export: Pan-Mar Corp., 1270 B'way, N. Y. 1, N. Y.

EMC, 625 Broadway, New York 12, N. Y.
Rush me FREE catalog describing all EMC value-loaded test instruments and name of local distributor.

NAME _____
ADDRESS _____
CITY _____ ZONE _____ STATE _____

RE-2



Your new copy is waiting

FREE! For fun and pride in assembly, for long years of pleasure and performance, for new adventures in creative electronics mail the coupon below and get Conar's brand new catalog of quality do-it-yourself and assembled kits and equipment. Read about items from TV set kits to transistor radios . . . from VTVM's to scopes . . . from tube testers to tools. And every item in the Conar catalog is backed by a no-nonsense, no-loopholes, money-back guarantee! See for yourself why Conar, a division of National Radio Institute, is just about the fastest growing entry in the quality kit and equipment business.

CONAR

MAIL THIS COUPON NOW

CONAR 3939 Wisconsin Ave., Washington 16, D.C. BC6C
Please send me your new catalog.
Name _____
Address _____
City _____ State _____ Z-Code _____

Circle 23 on reader's service card

ATTENTION! CB OPERATORS

save on citizens radio equipment

Discontinued Models From International Radio Exchange

Select that extra transceiver for mobile or base installation, or equip a new station. Our stock includes International types as well as other makes.

*Write Today for A
Complete List of
Equipment in Stock*



RADIO EXCHANGE
18 NO. LEE, OKLA. CITY, OKLA. 73102
Division Of International Crystal Mfg. Co.
Dealing In Used Citizens
Radio Equipment



Circle 24 on reader's service card

immediately accessible once the outer wood case is off, without further disassembly.

Despite its small size (the front panel measures only 9 x 4¼ inches, and the unit occupies a volume of less than 1/10 cubic foot) the KLH controls are well spaced and easy to operate. These include not only the usual tuning dial (a planetary vernier type), on-off volume control and mono-stereo switch, but an SCA filter as well, to cut out interference from background music (SCA) broadcasts. Tuning is pinpointed by a zero-center tuning meter. A small neon light behind the panel glows when a stereo signal is picked up.

The center-of-channel tuning meter and stereo indicator light are sometimes blocked from view by the operator's hand on the tuning knob, but left-handed owners will find this no problem.

There is no pilot light. That could be troublesome in a vacuum-tube tuner. But because transistors run so cool, the electrical shocks of turning the set on and off are more likely to cause failure than would continuous operation, and the power consumption is very small. So the lack of a pilot light is of little consequence.

The tuner has two sets of outputs: one volume-controlled pair at 25,000 ohms output impedance and another, fixed-level pair, at 10,000 ohms. Both pairs may be used simultaneously. Thus you can tape from the fixed-level outputs, independent of the volume setting, and adjust the tuner's volume control for optimum listening level. Cables up to 10 feet long may be used with the volume-controlled outputs, and up to 25 feet with the fixed-level outputs.

The manufacturer claims that the antenna supplied (a 37-inch length of stranded wire with a spade lug at one end) "will be adequate even in many fringe areas." Not too surprisingly, there was little difference in performance with the short wire and with no antenna whatsoever—but this performance was surprisingly good. In my New York location, the Eighteen picked up nearly as many stations with no antenna as it did with the twin-lead dipole supplied. My tube tuner, without antenna, would not do quite as well.

Although transistor tuners have a reputation for overload on strong signals, producing cross-modulation distortion, the KLH displayed no such distortion, even among New York City's powerful transmitters. Interchannel noise was low, and the sound quality was tops—virtually identical to that of my tube tuner, which cost about half again as much.

Considering appearance, size, performance and price (\$129.95), the KLH is one of the most attractive units now available.—*Ivan B. Berger* END

INNOVATION
INNOVATION
INNOVATION
INNOVATION



In Electrical Electronics Engineering

- 80 Technical sessions, 300 papers — all at the New York Hilton
- 4 floors of exhibits — all at the New York Coliseum. Four days only — Monday-Thursday
- Gala IEEE Banquet—Wednesday, 7:15 p.m., New York Hilton Grand Ballroom — \$15.00
- Free shuttle busses between the Hilton and the Coliseum — every few minutes
- Registration — Members \$2.00 — Non-members \$5.00. Ladies \$1.00. Good for all days — Technical Sessions and Exhibits. In and out privileges.

EXHIBITS (4 days only)

Monday through Thursday
11:30 a.m. - 9:30 p.m.

NEW YORK COLISEUM

TECHNICAL SESSIONS

Monday through Friday

NEW YORK HILTON

MARCH 21-25, 1966

Students (over 14) accompanied by adult will be admitted to Exhibits Thursday only. \$2.00. (Not more than 3 per adult)



IEEE EXHIBITION



Let servicing expert Leonard Lane tell you his radio servicing secrets!

Get these two great books . . . a \$9.90 value

only **99¢**

by joining the **Electronics Book Club** today!

RADIO SERVICING MADE EASY—by Leonard C. Lane.

Here is a wonderfully helpful set of two handbooks written by an expert with years of practical servicing experience. He tells you everything you want and need to know about radio servicing today. Nothing is left out. You get down-to-earth facts and techniques you can use at once, including many tricks-of-the-trade never put in print before. Just a few of the eye-opening things you'll discover: **Working With Transistors/Getting started.** What is a reference point? Approaching the transistor. Pairs of diodes. **Testing Transistors and Printed Circuits/Checking transistors.** In-circuit transistor testing. **Troubles.** Measurements. Replacing resistors and capacitors. **Servicing Transistor Radios/Batteries.** Stage-by-stage analysis. **Typical circuits.** **Servicing Auto Radios/Installation and removal.** Servicing. Using signal generator. **AM Receivers/Frequency range.** Ac-dc power supplies. **Troubleshooting. FM Receivers/AM-FM Tuners/Communications Receivers/Tuning troubles.** Receiver analysis. **Noise limiters.** **Marine receivers/Marine frequencies.** Receiver circuitry. **Checking the direction finder.** Rf amplifier stage. **Mobile Radio.** Plus many other subjects.

Here is an extraordinary offer to introduce you to Gernsback Library's famous Electronics Book Club, specially designed to help you increase your know-how and earning power.

WHY SHOULD YOU JOIN!

Whatever your interest in electronics—radio and TV servicing, audio and hi-fi, industrial electronics, communications, electronics as a hobby—you'll find that the Electronics Book Club will help you get the job you want, keep it, improve it, or make your leisure hours more enjoyable. By broadening your knowledge and skills, you'll build your income and electronics enjoyment as well.

WHAT BOOKS ARE OFFERED?

From Gernsback Library and other leading publishers come the country's most respected books in the field of electronics. All are deluxe, hard-covered books of permanent value, offered at considerable cash savings to members, regardless of higher retail prices.

TYPICAL CLUB SELECTIONS:

Servicing AGC Circuits
Reg. \$6.00—Club price \$4.95
(You save \$1.05)

Probes For Test Instruments
Reg. \$4.60—Club price \$3.35
(You save \$1.25)

Diode Reference Book
Reg. \$6.25—Club price \$4.95
(You save \$1.30)

TV Sweep Oscillators
Reg. \$6.00—Club price \$4.95
(You save \$1.05)

Color TV Repair
Reg. \$4.60—Club price \$3.25
(You save \$1.35)

Handbook of Electronic Tables
Reg. \$4.95—Club price \$3.50
(You save \$1.45)

Elements of Electron Physics
Reg. \$5.65—Club price \$4.45
(You save \$1.20)

Transistor Reference Book
Reg. \$6.00—Club price \$4.50
(You save \$1.50)

Audio Design Handbook
Reg. \$5.00—Club price \$3.75
(You save \$1.25)

Electronics Data Handbook
Reg. \$4.60—Club price \$3.25
(You save \$1.35)

Mandl's Television Servicing
Reg. \$8.95—Club price \$7.95
(You save \$1.00)

Electrical Appliance Service Manual
Reg. \$6.75—Club price \$5.75
(You save \$1.00)

Basic Math Course for Electronics
Reg. \$6.45—Club price \$5.15
(You save \$1.30)

The V.T.V.M.
Reg. \$4.60—Club price \$3.35
(You save \$1.25)

Basic Transistor Course
Reg. \$5.75—Club price \$4.50
(You save \$1.25)

Industrial Electronics Made Easy
Reg. \$5.95—Club price \$4.35
(You save \$1.35)

Horizontal Sweep Servicing Handbook
Reg. \$5.75—Club price \$4.50
(You save \$1.25)

The Oscilloscope
Reg. \$5.20—Club price \$3.95
(You save \$1.25)

HOW THE CLUB WORKS

The Electronics Book Club will send you, every other month, the News Bulletin describing a new book on a vital area of electronics. As a member, *you alone* decide whether you want a particular book or not. You get 2 books now for 99¢ and need take only 4 more within a year, from a wide selection to be offered. And the Club *saves you money* on the books you take, regardless of higher retail prices.

HOW TO JOIN

Simply mail the coupon today. You will be sent your two-handbook set—RADIO SERVICING MADE EASY, which regularly sells for \$9.90. We will bill you 99¢ (plus a few cents postage). If you are not pleased with the set, send the books back within 10 days and membership will be cancelled. Otherwise, you will enjoy all these benefits:

- ★ Get two books immediately for 99¢
- ★ Free 10-day examination privilege.
- ★ Continuous cash savings.
- ★ Free charts given with many books.
- ★ You alone decide which books you want. Books are returnable.
- ★ Club books are practical working tools, written by experts.

Gernsback Library, Inc., Electronics Book Club, Dept. RE26
154 West 14th Street, New York, N.Y. 10011

Please enroll me in the Electronics Book Club and send me the TWO-HANDBOOK SET: RADIO SERVICING MADE EASY. Bill me only 99¢ plus shipping. If not pleased, I may return both books in 10 days and this membership will be cancelled.

As a member, I need only accept as few as 4 additional books a year—and may resign any time after purchasing them. All books will be described to me in advance, every other month, in the Club Bulletin, and a convenient form will always be provided for my use if I do not wish to receive a forthcoming book. You will bill me the special Club price for each book I take (plus a few cents postage)—regardless of higher retail prices.

Name
(please print)

Address

City State Zip Code

SAVE! Enclose your 99¢ now with this coupon and we will pay postage. Same return guarantee privilege.

How To Have Fun While You Save . . .

Something For Everyone . . . In This Vast Heathkit Selection!

Kit GR-43
\$159⁹⁵

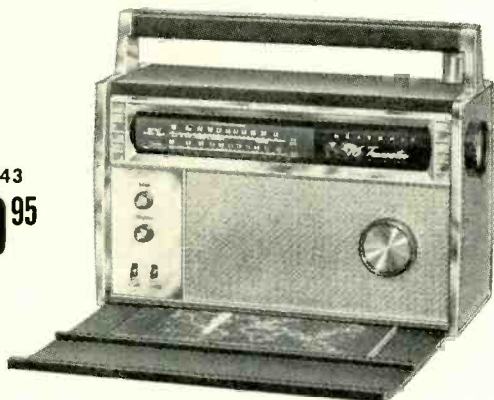

New Heathkit 10-Band Transistor Portable!

10 bands tune Longwave, Standard Broadcast, FM and 2-22.5 mc Shortwave. 16 transistors, 6 diodes, and 44 factory assembled and pretuned circuits. Two separate AM & FM tuners and IF strips. FM tuner & IF strip are same components used in deluxe Heathkit FM stereo gear. 2 built-in antennas. Battery saver switch cuts current drain up to 35%. Rotating tuning dial. Dial light. 4 simple controls for tuning, volume, tone, AFC and band switching. 4" x 6" PM speaker. Earphone & built-in jack. Optional 117 v. AC converter/battery charger available @ \$6.95. Time zone map & "listener's guide." Man size: 13½" W x 5½" D x 10%" H. 17 lbs.

Kit GW-14
\$89⁹⁵

Assembled GWW-14
\$124⁹⁵

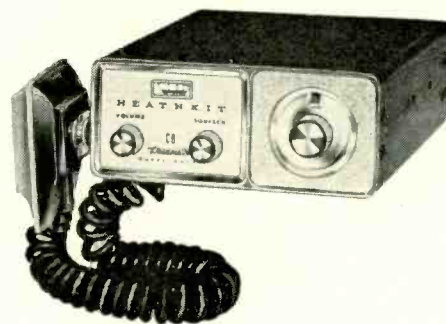

New 23-Channel, 5-Watt, Transistor CB Transceiver!

Your best 23-channel CB buy—bar none! Compare! 23 crystal-controlled transmit & receive channels for the utmost reliability . . . at lowest cost. All-transistor circuit for instant operation, low battery drain . . . only .75 A transmit, .12 A receive. Compact . . . 3" H x 7" W x 10½" D . . . ideal for car, boat, and 12 v. neg. gnd. mobile use. ½ uv sensitivity for 10 db signal plus noise-to-noise ratio. Includes "S" meter, adjustable squelch, automatic noise limiter, built-in speaker, ceramic PTT mike, gimbal mounting bracket, aluminum cabinet with die-cast chrome-plated front panel. 8 lbs. Kit GWA-14-1, optional power supply for AC operation, 5 lbs. . . \$14.95. GWA-14-2, complete 23 channel crystal package (46 CB crystals)—\$135.70 value . . . only \$79.95

Can You Match A Color With A Color, And A Letter With Another Letter? That's All It Takes To Make Music On This NEW Heathkit®/Thomas COLOR-GLO Organ!

Play complete songs in *minutes* instead of months! Color-Glo key lights show you the correct notes and chords . . . you and every member of your family can play melody, harmony and bass notes *instantly*. Just match up the colors with your left hand, the letters with your right hand . . . and you play complete songs . . . even if you've never played an organ before! And when you're finished, just flip a switch and the Color-Glo keys disappear, leaving a beautiful spinet organ console. Other features include 10 true organ voices; variable repeat percussion; 13-note heel and toe bass pedals; 2 overhanging 37-note keyboards; 50-watt EIA peak music power amplifier; 12" speaker; vibrato . . . all genuine Thomas factory-fabricated parts! Plug-in tone generators, the heart of the organ, warranted for 5 years. Fully transistorized. Handcrafted walnut cabinet. 153 lbs. GDA-232-1, matching walnut bench, 18 lbs. . . . \$24.95

Kit GD-325
\$349⁹⁵
(less bench)



New Heathkit "Q" Multiplier

Ideal for use with SWL & Ham receivers with IF circuits from 450 to 460 kc such as the matching low cost Heathkit GR-64 shortwave radio (\$37.95). Creates extra sharp selectivity through an efficient "Q" of 4000, and provides a notch for adjacent signal attenuation. Includes built-in power supply. Attractive "low boy" charcoal cabinet with gray front panel. 3 lbs.

Kit GD-125
\$14⁹⁵



Kit HD-10
\$39⁹⁵

New Heathkit Solid-State Electronic Keyer

All solid-state circuitry. Speed range—15 to 60 words per minute. Solid-state switching—no relays to stick or clatter. Adaptable to either right or left handed operators. Convertible to semi-automatic operation. Variable dot-space ratio. Self-completing dashes. Sealed switches on paddle—no exposed contacts to clean or adjust. Built-in paddle—"feel" is adjustable to your fist during assembly. "Hold" switch for transmitter tuning. Transformer-operated power supply isolates keyer from line power. Fused for protection. 6 lbs.

... Build A Heathkit®!

Now Choose From 2 Heathkit® Transistor Stereo Receivers!

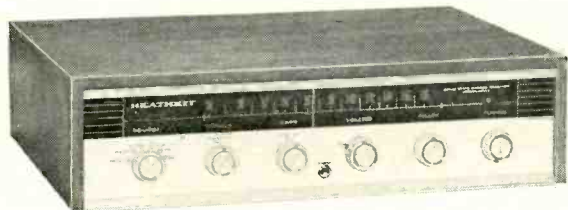

**New 30-Watt Transistor FM Stereo Receiver . . .
Less Than \$100!**

Features 31 transistors, 11 diodes for cool, natural transistor sound; 20 watts RMS, 30 watts IHF music power @ ±1 db, 15 to 60,000 cps; wideband FM/FM stereo tuner plus two preamplifiers & two power amplifiers; front panel stereo headphone jack; compact 3 7/8" H x 15 1/4" W x 12" D size. Assembles in 20 hours or less. Custom mount it in a wall, or optional Heath cabinets (walnut \$9.95, beige metal \$3.95) 16 lbs.

Kit AR-14
\$99⁹⁵
(less cabinet)



66-Watt Transistor AM/FM Stereo Receiver

Just add 2 speakers for a complete stereo system. Boasts AM/FM/FM Stereo tuning; 46-transistor, 17-diode circuit for cool, instant operation and natural transistor sound; 66 watts IHF music power (40 watts RMS) at ±1 db from 15 to 30,000 cps; automatic switching to stereo; preassembled & aligned "front-end" & AM-FM IF strip; walnut cab. 35 lbs.

Kit AR-13A
Now Only
\$184⁰⁰

Best Hi-Fi News Of '66 . . . New Low-Cost Transistor Stereo Twins!



New Transistor FM/FM Stereo Tuner

Heath's easiest to build stereo/hi-fi kit . . . takes only 4 to 6 hours! 14 transistor, 5 diode circuit for cool instant operation, transparent transistor sound. Phase control assures best stereo performance. 3 transistor "front-end" plus 4-stage IF section. Filtered outputs for direct stereo recording. Automatic stereo indicator light. Preassembled & aligned "front-end." Install in a wall or either Heath cabinet (walnut \$7.95, beige metal \$3.50). 6 lbs.

Kit AJ-14
\$49⁹⁵
(less cabinet)

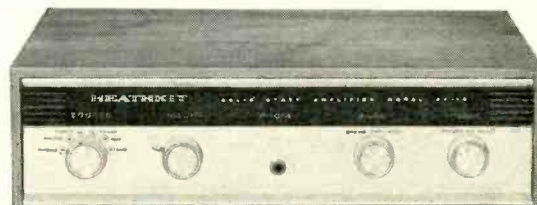

Matching 30-Watt Transistor Stereo Amplifier

Assembles in 10 hours or less! 17 transistors, 6 diodes, 20 watts RMS, 30 watts IHF music power @ ±1 db, 15 to 60,000 cps. No audio transformers . . . assures minimum phase shift, extended response, lower distortion. Solid-state power supply plus electronic filter for regulation within 10%. Accommodates phono, tuner, auxiliary . . . 4, 8, 16 ohm speaker impedances. Lighted panel. Installs in wall, or Heath cabinets (walnut \$7.95, metal \$3.50). 10 lbs.

Kit AA-14
\$59⁹⁵
(less cabinet)

FREE 1966 CATALOG!



108 pages . . . many in full color . . . describe these and over 250 easy-to-build Heathkits. Save up to 50%. Mail coupon or write Heath Company, Benton Harbor, Michigan 49022 for your FREE copy.

Buy Now—Use This Order Blank

Heath Company, Dept. 20-2
Benton Harbor, Michigan 49022



Please send FREE Heathkit Catalog

Model	Description	Weight	Price

Name _____ (Please Print)

Address _____

City _____ State _____ Zip _____

SHIP VIA:
 Parcel Post Express Collect Freight 20% Included, C.O.D. Best Way
 Prices & Specifications subject to change without notice. CL-236



SPECIAL HI-FI TAPE RECORDING ISSUE

coming next month in RADIO-ELECTRONICS:

A goldmine of unbiased reports on tape recorders and test equipment . . . things to build . . . servicing dope . . . new products . . . an editorial about a job not being done . . . new ideas in hi-fi and tape recording.

- 24 Ways to Use Your Tape Recorder:** Put your recorder to work at home, in business, in school and at the service shop. These hints will save you time, worries and money—and put some fun in your life, too!
- 1966 Battery Tape Recorder Roundup:** The most extensive collection anywhere of solid facts on all sizes, shapes and price ranges of battery-operated tape recorders. Clip it and take it with you when you shop!
- Build-Your-Own Stereo Headset Amplifier:** Compact and convenient, this battery-powered, all-transistor flea-power amplifier is great for private listening. Works with any stereo phones, any conventional high-quality magnetic phono pickup.
- The IHF Amplifier Standard Grows Up:** Since 1959 the target of disparaging remarks among engineers and technicians, the new 1965 standard redefines the controversial "music power" and prescribes new, tightened instrument specs and procedures for today's higher-quality stereo equipment.
- Add Sound to Your Home Movies:** Polish those vacation films by adding professional quality sound tracks with your tape recorder! Build a simple synchronizer to keep sound and pictures together—works with any recorder (stereo or mono), any projector.

all in March Radio-Electronics

on sale February 17 at newsstands and parts distributors!

NEW SEMI- CONDUCTORS AND TUBES

8637 IS PTTS-RATED

A new transmitting-tube rating called PTTS—push-to-talk service—has emerged as a result of the recent stress on keeping messages as short as possible. Amperex has announced the first of a series of new rf power tubes rated on the PTTS basis, the 8637.

PTTS is based on an operating cycle of 1 minute on and 4 minutes off. Amperex engineers felt, apparently, that users were paying for greater power reserve than they ever needed, since high-power tubes were used whose ratings far exceeded the long-term demands.

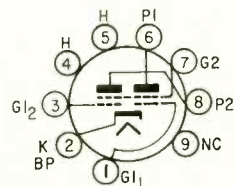

BP= BEAM-FORMING PLATES

8637

The 8637 is a radiation-cooled twin-beam tetrode designed for use as an rf power amplifier, oscillator or frequency multiplier in mobile or base-station equipment to 200 mc. It will deliver 72 watts under PTTS service, and costs less than half the price of a tube with a similar rating under CCS (continuous commercial service) or ICAS (intermittent-commercial/amateur service).

Key feature of the new tube is an anode material with extremely high thermal inertia. The plates take quite a while to heat up to maximum rated temperature.

The 8637 can deliver 72 watts at 175 mc from less than 3 watts drive. Its maximum total plate dissipation is 45 watts. It has 9-pin magnoval ("novar") base.

"BLASTOFF" PHOTOMULTIPLIER

A new photomultiplier tube built entirely of ceramics and metals is sturdy enough to take the tremendous forces created when space vehicles blast off and land "in interplanetary operations" (quoted from the RCA release)!

Question: if this is a photomultiplier, and it uses no glass, how does the light get in? Answer: through an *aluminum oxide* (alumina) window 2 inches in diameter. The nonglass window also offers improved optical characteristics—its refractive index is higher than that of glass, which permits more efficient



optical coupling to the sensitive element.

The tube will be used to detect minute amounts of radiation on the moon, on Mars or on more distant planets. It costs about \$2,000.

VARIABLE SEMICON CAPACITORS

For people who appreciate the many advantages of tuning with a variable resistor instead of a variable capacitor or coil, Motorola has announced a new line of voltage-variable-capacitance diodes, aimed at amateur and hobby applications. These VVC's will even track, in case you need a "ganged diode" setup, as you might in a multi-stage tuned amplifier or in the front end

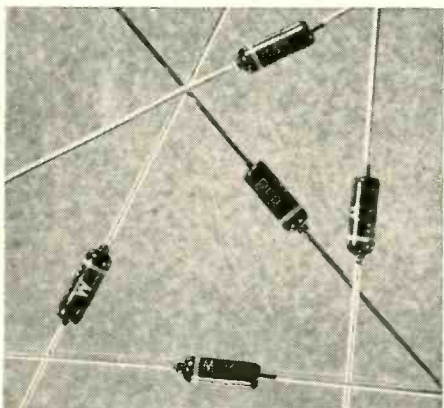

of a receiver. Their voltage-vs-capacitance curves are guaranteed to fall within certain limits.

Dubbed MV830, MV831, etc., through MV840, the VVC's have nominal capacitances of 15, 18, 22 pf, etc. (standard EIA values) up to 100 pf. Tuning ratio is 2:1 or better. Q is 35 for the 15-pf diode, 15 for the 100-pf diode; other diodes have Q's that fall between those limits. The given capacitance range is over a voltage swing of 4 to 25 volts. Reverse breakdown voltage is 30; leakage at 25 volts reverse bias is 0.2 μ a. Maximum dissipation at 25°C is 400 mw.

One-apiece price for any of the MV830-line VVC's is \$3.05.

"What our business needs is a good UHF VHF amplifier." "What our business needs is a good UHF-VHF amplifier." "What our bu.."

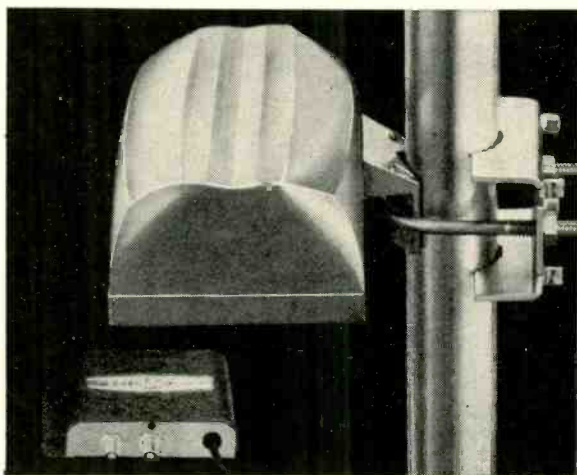

"Say no more."

"You mean there's an amplifier that covers all TV channels from 2 to 83?"

"You bet. In fact there are two—the outdoor U/Vamp-2 and the indoor V/U-ALL2."

"Suppose I live in an area where there's only VHF?"

"Your motto should be 'Be Prepared' because there are a lot of new UHF stations soon to come on the air. These all-channel amplifiers are obsolescence-proof."

"Anything I should know about the U/Vamp-2?"

"Well, the U/Vamp-2 is compact and easy to install on the antenna mast. Has a remote AC power supply."

"How about performance?"

"Two transistors give you all the power you need for better reception on VHF and UHF. Also protect against overload. Lists for \$49.95."

"Supposing I don't want to put an amplifier up on my antenna mast?"

"Then use the V/U-ALL2. Not as effective as the U/Vamp-2, but you don't have to climb a ladder... and it delivers signals to two TV sets. Only \$42.50 list."

"Guess I'll rush down and get one of the new Blonder-Tongue UHF/VHF amplifiers."

(This message was paid for out of the gross profits of BLONDER-TONGUE, 9 Alling St., Newark 2, N.J.)

Circle 26 on reader's service card



T.I. POTPOURRI

Shop and Service Hints on Test Instruments

By JACK DARR

Sermon:

When we test, *what* are we testing? The operation of electronic circuits. What kind? Simple ones—the operating voltages on a vacuum tube or transistor, a tuned transformer, a diode rectifier, the voltage drop across a re-

sistor, the ability of a capacitor to block dc and pass ac. The simple dc continuity of a circuit. That's all.

All fundamentals—building blocks. The kind of stuff we got in radio school. Why do we have so much trouble then? Because we make things hard for ourselves. We too often look for some-

thing very difficult instead of looking for something easy. No matter what the actual trouble is, it'll boil down to one of the very simple things named above. The trick is to narrow the symptoms down to a particular circuit, then decide what basically simple malfunction in that circuit is making trouble.

CONVERTING OLD CRT TESTERS FOR LOW-G2 TUBES

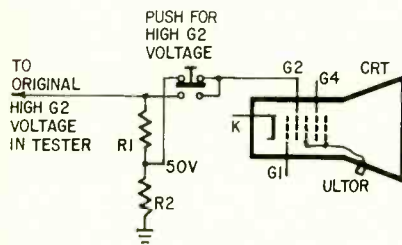

Several older CRT testers can be converted to test the new "low-G2" tubes safely. What we have to do is cut down the original 200 volts or so that is applied to G2 in the original circuit: the low-G2 tubes get only 50 volts.

So, find where G2 is connected to B+, and add a spdt pushbutton switch

and a voltage divider (diagram). Hook it up so that the button must be *pushed* to apply the higher voltage to the tube, that way you'll be safe and won't accidentally hit a low-G2 tube with too much voltage.

Choose the divider resistors according to the supply voltage and the current drain of the CRT's G2.

TRY A WATTMETER FOR DIAGNOSIS

A wattmeter will give you more useful information about what's going on in all ac-powered equipment than almost any other meter.

Why? Because it tells you what's taking place in the power supply, the source of most of our troubles. Just plug the instrument or the appliance into the wattmeter and check the wattage against that shown on the label. Any overload will show up immediately. (After a while you won't have to check the the label: you will learn typical drains for each kind of set.)

To be precise, of course, we ought to have the line voltage set at 117 volts ac, the design center. Use a variable-voltage transformer to set this first. An isolation transformer is also handy for ac-dc equipment; it can be hooked up with a variable transformer.

A wattmeter can make a lot of specialized tests, too. For example, if you want to know whether a power

transformer's shorted internally, take off all load and hook it up to the watt-

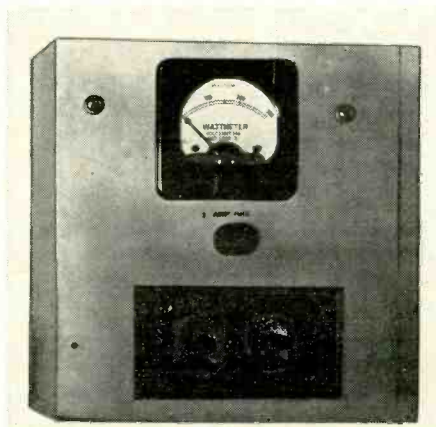

meter. A good transformer will show only about 2 watts or even less (losses

in the core). If you get as much as 10 watts with no load, throw it out.

After finishing a set, once it seems to be working fine, plug it in and read the drain. If the label says 70 watts and you read 80, don't stop. You've still got trouble! This test can actually spot a leaky coupling capacitor in an audio amplifier, because of the increased drain in the output stage.

You can get a wattmeter like the one in the photo, and mount it on a panel. The isolation transformer or variable-voltage transformer can be mounted there, or in the bench, as you prefer. Be sure to include a quick-acting fuse to match the full-scale reading of your meter. You can also get portable versions of this instrument, and they come in handy on house calls.

Handy tests: plug in an ac/dc radio, turn it on. If the wattmeter does not deflect immediately, disconnect the radio and find the dead tube, open

switch or broken line cord. You've got *one* of them! Another one: after putting the back on a TV set when you get through with it, plug it into the

wattmeter and turn it on. If you don't get a deflection on the meter, take the back off again. You missed the interlock socket! A wattmeter also catches

those embarrassing open TV line cords that you didn't find because you used a cheaper cord while working on the set!

CURING (AND PREVENTING) CORRODED MULTIMETERS

Trouble in your vom? Won't read on the higher voltage ranges? Hmm. Maybe you're as lazy as the slob who owns the vom in the photo below and let the ohmmeter batteries go dead and stay in there too long!

For your information, that wide white line across the top of the circuit board is *not* one of the regular conductors! It's a conductor, all right, because it's a long stripe of gook out of the bat-

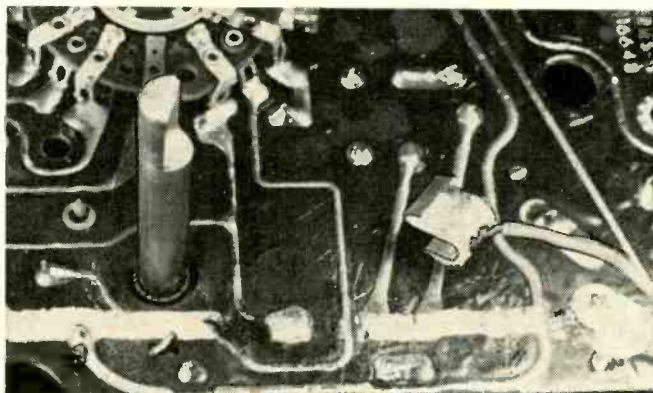
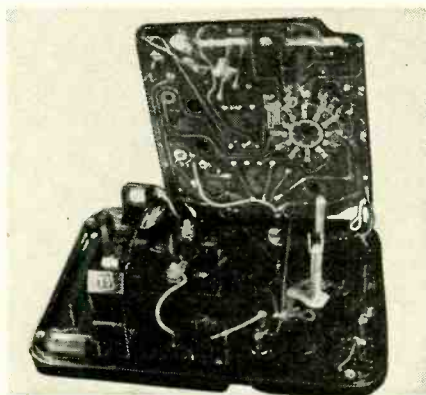

teries, but it's not supposed to be there!

The photo above shows what happens. When high voltage is applied, it arcs over. In this case, it took out a good-sized piece of one of the nearby "wires", but fortunately didn't get into the meter movement.

Cure: Clean the printed-circuit board very well. Replace any missing bits of foil with small pieces of hookup wire. Check the instrument out to be sure

it's working, and, finally, finish with at least three coats of clear acrylic spray (Krylon, etc.) over the side of the board under the batteries. Corona dope would do, of course, but the clear plastic lets you see the board.

Be very careful not to get any of the insulating spray into the switch contacts! Cover them with masking tape or something similar when you spray the board.

REPAIRING SWITCHES IN TEST EQUIPMENT

A flash of blue light and a small cloud of smoke from inside some of our pet test equipment is discouraging,

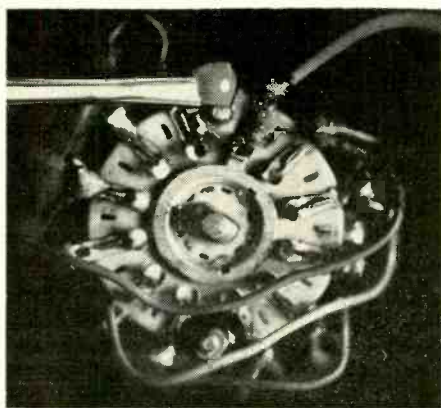

boost voltage went wild, flashed to the grounded bolt that holds the switch together, and even generated enough heat to crack the ceramic body of the switch. Looked pretty bad.

I cleaned all the carbon off the ceramic, where the flashover had made a conductive path, and straightened the contact itself. Then, I stuck the broken piece, which held the contact, back on with epoxy. An overnight rest, and it was fine.

For safety's sake, I took off the tiny nut and washer that had held the switch together. Another dab of epoxy cement holds it together very nicely. The distance between the hot switch terminal and the grounded bolt is now greater, and by rounding up the blob of epoxy on the end of the bolt, we got extra insulation. The switch is still working beautifully.

In photo at right, more drastic measures are called for. Here we had a similar breakdown, but this time it got the switch contact—which completely disappeared! Since this deck had only six contacts, I was able to get a replacement deck from the parts

house. Taking the switch apart, I moved the more "populous" rear deck to the front, installed the dpdt deck

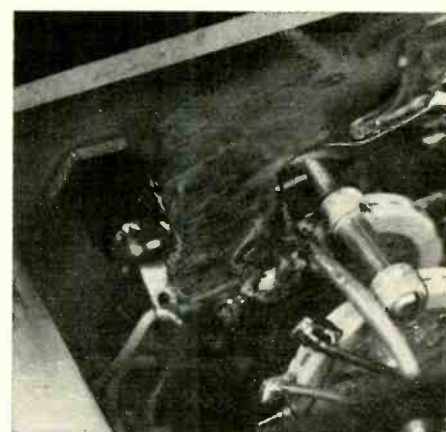

on the back, wired it up and that was all. If things are really bad, you can often get complete replacement switches, even more intricate than this, and do the job yourself. END

but not necessarily fatal. Repairs can often be made with a little patience and a couple of tubes of epoxy cement.

Photo above shows a switch in my favorite sweep-circuit analyzer. The

Now you can solder
tuners, planes,
pre-amps and trains
with the finesse
of a production-
line pro



New
MARKSMAN
PENCIL
Soldering Iron

Featherweight precision tool has stainless steel long-reach barrel with replaceable tip. Handle remains cool. Tip runs up to 750°F. Complete with cord. Model SP-23. **\$2⁹⁸** list

Also available in kit with two extra soldering tips, handy soldering aid and supply of solder. Model SP-23K. **\$4⁴⁴** list

WELLER ELECTRIC CORP., Easton, Pa.

WORLD LEADER IN SOLDERING TECHNOLOGY
Circle 27 on reader's service card

Sonar CITIZENS BAND
2 WAY RADIO

completely Solid State Design

Power packed and dependable performer that will amaze you with its performance and sound quality. Compact, hand held 2 way radio, transistorized for long life use. Delivers a sharp clear signal over a long range. Fully crystal controlled for precise operation. 100% modulation, automatic noise limiter, adjustable squelch, self contained rechargeable nickel cadmium batteries plus provisions for external antenna, mike and earphone. Take it anywhere...play everywhere. 12VDC. (2 lbs.) Compatible with all systems.

**FOR CONSTRUCTION,
WAREHOUSE,
FARMS & BUSINESS**
Perfect for Portable
and Mobile use



14 TRANSISTORS
2 CHANNELS
2 WATTS **\$139⁹⁵**

SONAR RADIO CORPORATION 448
73 Wortman Ave., Brooklyn 7, N. Y.
Please send me complete information on "T-2"

Name.....
Address.....
City..... Zone..... State.....

PRICE INCLUDES:

- 1 pair of crystals
- nickel cadmium batteries
- 110 VAC charger
- leather case
- earphone

Circle 28 on reader's service card

TECHNOTES

RCA COLOR REMOTE-CONTROL TROUBLE

On a RCA color chassis CTC10-CF, the remote control would not turn on the set, nor could you turn on the switch manually. The gear assembly seemed to bind and lock in place. By rocking the on-off control back and forth you could finally get the set turned on. It is very easy to strip the plastic gears that way, or break the on-off control assembly.

This particular set jammed on us twice, and, since the customer had spent over a thousand dollars for it, the chassis was pulled to see what the trouble was. The clutch assembly on the bottom solenoid would stick inside the solenoid and would not spring out, to release the starting gear. With the help of some Contact Shield (an aerosol contact lubricant and cleaner) and resetting the solenoid, this set is still working.

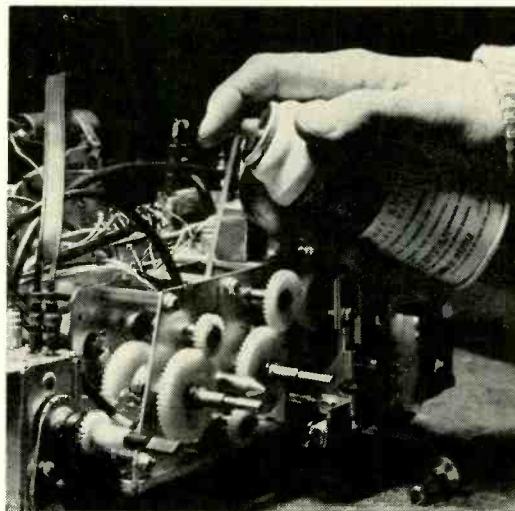

Another color set had the same trouble but a little oil didn't do the trick. The assembly was taken apart and the plunger pulled from the solenoid. There were no rough edges on the gears or teeth and the clutch assembly seemed to move in and out of the solenoid. It was found, after trial and error, that pulling the spring about 1/8 inch apart gave it enough tension to throw out the plunger. Do not pull the spring too far apart as too much tension will prevent the solenoid from pulling the plunger into position.—Homer L. Davidson

AMPRO 730 TAPE RECORDER

The complaint was intermittent squeals and motorboating. Making a recording while the trouble was temporarily not there, we ended up with severe distortion when playing back the tape. A prerecorded tape sounded OK.

The instability was still there even with the 6AU6 grid shorted to chassis. Pulling the 12AX7 amplifier and bias oscillator did not help. A scope check revealed that the trouble was occurring in a hidden feedback loop somewhere between the 6AU6 second audio amplifier and the 6AQ5 power amplifier.

Bridging electrolytic capacitors across the B-plus decoupling network feeding the plate of the 6AU6 and across the cathode bypass capacitors for the 6AU6 and 6AQ5 did no good. All other components checked out okay. Capacitor C2-c, a 10-μf 15-volt section of the four-section electrolytic, was disconnected and a single 10-μf electrolytic wired tem-

porarily in its place. All traces of instability disappeared.

I touched the scope probe to the disconnected 10- μ f section. There was the same waveform as across capacitor C2-d, connected across the 220-ohm cathode resistor of the 6AQ5. The two sections of the electrolytic capacitor were interacting with each other. The four-section capacitor was replaced with a new one.

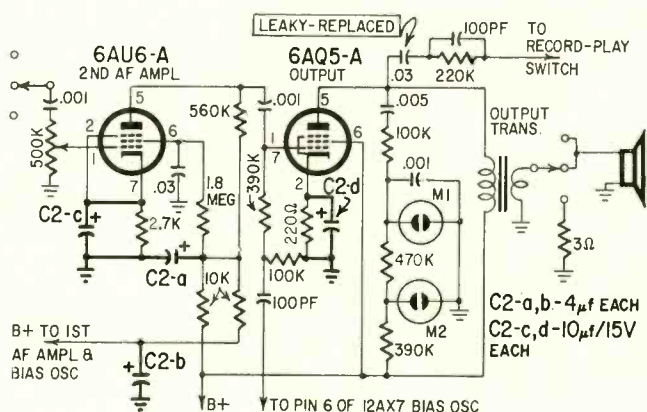

The distortion problem was next. Checking all coupling capacitors, we ended up with the .03- μ f capacitor connected from the 6AQ5 plate to the R-C network feeding the record head. It was leaky.—George P. Oberto

DS-501 FAILURES

The DS-501 transistor used for audio output in many Delco auto radios has a maximum power rating of 60 watts. Its nominal power dissipation in this use is less than 12 watts. It *should* have an extremely long life. However, failure rate has been high.

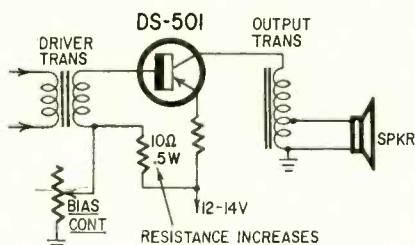

The circuit of the DS-501 stage is much the same for all GM cars. The high rate of failure results from the 10-ohm $\frac{1}{2}$ -watt resistor increasing in value. A 1-watt (preferably wire-wound) resistor (IRC type BW) is an ideal replacement. In some instances the resistance increase is not permanent and occurs only after the set operates a while; at other times the increase is permanent and can be measured with an ohmmeter. Replace the resistor as a preventive, before a DS-501 has failed. It should be done if the original transistor has to be replaced.—Allan F. Kinckiner

TUBES OSCILLATE IN EICO 667 CHECKER

Oscillation of tubes during merit test causes a high reading on one section of a dual tube and a low reading on the other. In my unit, this happened with 6J6's and 6X8's.

A small capacitor (200 to 300 pf) connected between plate and cathode of the offending section will prevent the trouble. I connected the capacitor from pin 2 to pin 7 on the 7-pin socket for the 6J6, and from pin 3 to pin 6 on the 9-pin socket for the 6X8. This establishes normal readings for these types and does not affect others.—Charles Andrews

END

at last...
instant color patterns
at your finger tips...
zero warm-up time



THE ALL NEW SENCORE CG135 DELUXE TRANSISTORIZED COLOR GENERATOR

The big push is on in Color TV. Equip yourself now with the new, solid state Sencore CG135 and cash in on the zooming volume of new service business as Color-TV booms! Instant, service-ready RCA standard color bars, cross-hatch, white dots and individual vertical and horizontal bars enable you to set up or trouble-shoot more Color TV sets per day; earn top money in this fast growing service field. It's an analyzer too: Color gun interruptors, unmodulated video for chroma circuit trouble isolation and unmodulated sync pulses to keep Zenith receivers in sync for this test, make color trouble shooting a snap. Sturdy all-steel construction for rugged, heavy duty in the field or shop. Another Best Buy in profit-building service instruments from Sencore at

\$149⁹⁵

COMPARE THESE FEATURES: SEE WHY THE CG135 IS IN A CLASS BY ITSELF

- Solid state construction employs high priced GE "Unijunctions" to develop six "jump out proof counters" that guarantee stable patterns at all times with no warm-up
- Standard RCA licensed patterns as shown on schematics throughout the industry
- Handy universal color gun interruptors on front panel
- Lead piercing clips insure non-obsolescence
- CRT adaptors optional
- Crystal-Controlled 4.5mc Sound Carrier Analyzing Signal to insure correct setting of fine tuning control
- RF output on Channel 4 adjustable to Channel 3 or 5 from front of generator when Channel 4 is being used
- No batteries to run down; uses 115 V AC
- Less than one foot square, weighs only 8 lbs.

professional quality — that's the difference!

SENCORE

426 SOUTH WESTGATE DRIVE • ADDISON, ILLINOIS

Circle 29 on reader's service card

The following free advertising material is available through

RADIO-ELECTRONICS READER'S SERVICE

- ACOUSTIC RESEARCH INC.** (Pg. 32) Circle 17
Survey of the hi-fi equipment recommendations of four magazines.
- AEROVOX CORP.** (Pg. 24) Circle 14
Aerovox Servicemen's Catalog SE-565.
- ALLIED RADIO CORP.** (Pg. 90) Circle 113
Catalog.
- BLONDER-TONGUE** (Pg. 77) Circle 26
Information on UHF/VHF amplifiers.
- BROOKS RADIO & TV CORP.** (Pg. 98-99) Circle 124
Catalog sheets and price lists of tubes and parts.
- BURSTEIN-APPLEBEE CO.** (Pg. 86) Circle 107
Catalog.
- CASTLE TV TUNER SERVICE, INC.** (Pg. 6) Circle 12
Information on complete tuner overhaul by mail.
- CLEVELAND INSTITUTE OF ELECTRONICS** (Pg. 23) Circle 13
Electronics slide rule booklet and data guide.
- CONAR INSTRUMENTS** (Pg. 69) Circle 23
Catalog on kits.
- CORNELL ELECTRONICS CO.** (Pg. 106) Circle 133
Catalog and price list of tubes and parts.
- COYNE ELECTRONICS INSTITUTE** (Pg. 93) Circle 119
Booklet on TV home training.
- COYNE ELECTRONICS INSTITUTE** (Pg. 103) Circle 130
Booklet: "Your Opportunities in Electronics".
- DELTA PRODUCTS, INC.** (Pg. 55) Circle 19
Literature and complete technical information on Mark Ten SCR capacitive discharge ignition system.
- DEVRY TECHNICAL INSTITUTE** (Pg. 5) Circle 3
Booklets "Pocket Guide to Real Earnings" and "Electronics in Space Travel".
- EICO ELECTRONIC INSTRUMENT CO.** (Pg. 15) Circle 8
Catalog.
- ELECTRONIC CHEMICAL CORP.** (Pg. 88) Circle 110
Information on no-noise aerosol service chemicals.
- ELECTRONIC COMPONENTS CO.** (Pg. 104) Circle 131
Information on rectifiers & transistors.
- FINNEY CO.** (Pg. 13) Circle 6
Brochures on booster-coupler and UHF converters.
- GRANTHAM SCHOOL OF ELECTRONICS** (Pg. 103) Circle 129
Catalog.
- HALLICRAFTERS CO.** (Pg. 89) Circle 111
Specifications on "Legionnaire" short-wave and broadcast receiver.
- HEALD'S ENGINEERING COLLEGE** (Pg. 101) Circle 126
Catalog and registration application.
- HEATH COMPANY** (Pg. 72-75) Circle 25
Catalog.
- HY-GAIN ELECTRONICS CORP.** (Pg. 7) Circle 4
Descriptive literature on CB antennas.
- INTERNATIONAL CRYSTAL MFG. CO.** (Pg. 108) Circle 135
Information on International Model MO Transceiver for Citizens Radio Service.
- INTERNATIONAL RADIO EXCHANGE** (Pg. 70) Circle 24
List of CB equipment in stock.
- JERROLD ELECTRONICS CORP.** (Pg. 87) Circle 108
Information on Pathfinder all-channel TV and FM antennas.
- LAFAYETTE RADIO ELECTRONICS** (Pg. 93) Circle 118
Catalog.
- LECTROTECH, INC.** (Pg. 88) Circle 109
Information on picture tube analyzer.
- MALLORY DISTRIBUTOR PRODUCTS CO.** (Third Cover) Circle 136
Information on wet-slug tantalum capacitors.
- MULTICORE SALES CORP.** (Pg. 102) Circle 127
Information on Ersin Multicore 5-core solder.
- MUSIC ASSOCIATED** (Pg. 99) Circle 123
Information on Music Associated's Sub Carrier Detector for "music only" programs on FM Broadcast Band.
- OLSON ELECTRONICS, INC.** (Pg. 101) Circle 125
Catalog.
- OXFORD TRANSDUCER CO.** (Pg. 85) Circle 106
Catalog of "speakers for every purpose".
- POLY PAKS INC.** (Pg. 107) Circle 134
Catalog of semiconductors.
- QUIETROLE CO.** (Pg. 91) Circle 114
Information on TV and radio lubricant & cleaner.
- RCA INSTITUTES** (Pg. 18-21) Circle 11
Brochure on home study and classroom study.
- RCA TEST INSTRUMENTS** (Pg. 25) Circle 15
Information on RCA WR-64B color bar/dot/crosshatch generator.
- R.F.S. INDUSTRIES, INC.** (Pg. 90) Circle 112
Information on Balfour Princess automatic/manual turntable systems.
- RYE SOUND CORPORATION** (Pg. 97) Circle 121
Information on the Kleps 30 Test Prober.
- SAMS, HOWARD W., CO. INC.** (Pg. 12) Circle 5
Information on subscriptions to PF Reporter.
- SAMS, HOWARD W., CO. INC.** (Pg. 27) Circle 16
Information on Photofact Library-Encyclopedia deal.
- SAMS, HOWARD W., CO. INC.** (Pg. 68) Circle 20
Booklist.
- SCHOBER ORGAN CORP.** (Pg. 14) Circle 7
Booklet and 7" sampler record.
- SENCORE** (Pg. 81) Circle 29
Information on CG135 transistorized color generator.
- SONAR RADIO CORPORATION** (Pg. 80) Circle 28
Information on "T-2", Citizens Band 2-way radio.

- SONOTONE CORP.** (Pg. 92) Circle 116
Catalog on Ceramikes microphones.
- SPRAGUE ELECTRIC CO.** (Pg. 2) Circle 2
Information on Sprague Atom Capacitors and Kwikette component connectors.
- SYLVANIA ELECTRIC CO.** (Pg. 17) Circle 10
Information on how independent service dealers can get listings in TV Guide.
- TRIPLETT ELECTRICAL INSTRUMENT** (Second Cover) Circle 1
Information on complete line of v-o-m's.
- UNITED RADIO CO.** (Pg. 105) Circle 132
Catalog.
- UNIVERSITY SOUND** (Pg. 61) Circle 18
Catalog and guide to component stereo high fidelity.
- UNIVERSITY SOUND** (Pg. 91) Circle 115
Booklet: "Microphones '66".
- WARREN ELECTRONIC COMPONENTS** (Pg. 102) Circle 128
Information on silicon rectifier sale.
- WELLER ELECTRIC CORP.** (Pg. 80) Circle 27
Information on Marksman Pencil Soldering Iron.
- WINDSOR ELECTRONICS, INC.** (Pg. 97) Circle 122
Booklet entitled "The Open Door to TV Profits".
- WINEGARD CO.** (Pg. 92) Circle 117
Fact-finder #242 with information on Chroma-Tel antenna.
- XCELITE, INC.** (Pg. 16) Circle 9
Information on the compact scruloc screwdriver sets.

Here's how you can get manufacturers' literature fast:

1. Tear out the post card on the facing page. Clearly print or type your name and address.
2. Circle the number on the card that corresponds to the number appearing at the bottom of the New Products, New Literature or Equipment Report listing in which you are interested. For literature on products advertised in this issue circle the number on the card that corresponds to the number appearing at the bottom of the advertisement in which you are interested, or use the convenient checking list in the column at the left.
3. Mail the card to us (no postage required in U. S. A.)

Note: If the postcard has already been detached from your copy of RADIO-ELECTRONICS, use the coupon on this page instead. Enclose the coupon in an envelope and address it to: RADIO-ELECTRONICS READER'S SERVICE, P. O. Box 7365, Philadelphia, Pa. 19101. (Use this address only for Reader's Service requests.)

RADIO-ELECTRONICS READER'S SERVICE

P.O. Box 7365, Philadelphia, Pa. 19101

The numbers I have circled below indicate the material I would like to receive:

1	2	3	4	5	6	7	8	9	10	11	12	13	14	15
16	17	18	19	20	21	22	23	24	25	26	27	28	29	30
31	32	33	34	35	36	37	38	39	40	41	42	43	44	45
46	47	48	49	50	51	52	53	54	55	56	57	58	59	60
61	62	63	64	65	66	67	68	69	70	71	72	73	74	75
76	77	78	79	80	81	82	83	84	85	86	87	88	89	90
91	92	93	94	95	96	97	98	99	100	101	102	103	104	105
106	107	108	109	110	111	112	113	114	115	116	117	118	119	120
121	122	123	124	125	126	127	128	129	130	131	132	133	134	135
136	137	138	139	140	141	142	143	144	145	146	147	148	149	150

VOID AFTER MARCH 31, 1966

Name _____

Address _____

City _____ State _____

2-66 Zip Code _____

NEW PRODUCTS

More information on new products is available free from the manufacturers of items identified by a Reader's Service number. Turn to the Reader's Service Card facing page 82 and circle the numbers of the new products on which you would like further information. Detach and mail the postage-paid card.

Hz = Hertz = cycles per second; KHz = kilocycles; MHz = megacycles

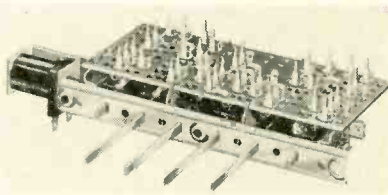

PRINTED CIRCUIT LUGS available on *type 130* and *131* pushbutton switches. For standard insertion, lug length ranges from $\frac{1}{4}$ to 1 inch from switch stator to printed circuit board. Increments of $\frac{1}{16}$ in. available within this range. Silver-plated brass.—Oak Mfg. Co.

Circle 46 on reader's service card

AC POWER SUPPLY, *Master Model*, can be plugged into firm's 23'er (23-channel) and 55S (5-channel) transceivers to adapt them for base-station operation. Has heavy-duty transformer, silicon rectifier with 3 silicon transistors and Zener diode reference. Electronic regula-

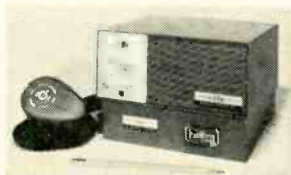

tion offers 13.8 vdc ± 0.2 vdc with input voltage variation from 105 to 125 vac. Added feature is calibrated S-meter for measuring signal strength. 3 potentiometer adjustments for voltage adjust, S-meter zero adjustment and sensitivity adjust.—Squires-Sanders, Inc.

Circle 47 on reader's service card

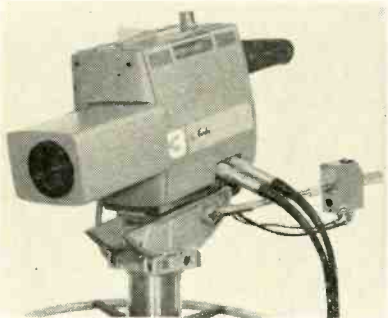

COLOR TELEVISION CAMERA, *Plumbicon PC-60*. Scanning: EIA, 525 lines, 60 fields per second or CCIR 625 lines, 50 fields per second. 10 to 1 zoom lens, servo-controlled. Camera cable compensation adjustable in 6 equal steps up to 1,000 ft. Inputs: horizontal drive, vertical drive, composite blanking; all 0.75 to

4.5 volts peak-to-peak across 75 ohms. External video signal to viewfinder 1 volt noncomposite across 75 ohms. Video outputs R, G, B and 1, 2, 3; 0.7 volt noncomposite, nominal across 75 ohms for external use; video 4, 5: 0.7 volt noncomposite, nominal, across 75 ohms for picture monitor and waveform monitor, respectively. Horizontal resolution 80-100% modulation at 400 TV lines in center in Y channel, properly registered. Scanning linearity within 0.5% in a circle having diameter equal to picture height, within 1% elsewhere. 19 $\frac{1}{2}$ x 14 x 35 in. (with lens), 35 lb.—Norelco Studio Equipment

Circle 48 on reader's service card

CB TRANSCEIVER, the *XL-100*, delivers 95 db+ adjacent-channel rejection. Power output to antenna 3.5 watts minimum. 95% to 100% average speaking-level modulation capability. Harmonic suppression and spurious emissions at least 80 db down. Draws 6 amps at 12.6 volts, ac power consumption 80 watts at 117 volts. Sensitivity: 0.3- μ v input modu-



lated 30% at 1,000 Hz provides at least 1 watt of audio output. Signal-to-noise ratio: input for 10-db signal plus noise-to-noise ratio 0.18 μ v; input for 6-db signal plus noise-to-noise ratio 0.1 μ v. Selectivity: 4 KHz minimum at 6 db; 20 KHz maximum at 95 db. Spurious responses better than 75 db down. Automatic series-gate noise limiter operates on noise peaks. 8 $\frac{1}{2}$ x 8 $\frac{1}{2}$ x 4 $\frac{1}{2}$ in., 5 lb.—Tram Electronics, Inc.

Circle 49 on reader's service card

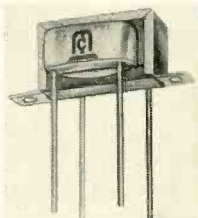

DC-TO-DC CONVERTER TRANSFORMER, *P/N M8072*, converts low to high voltage for applications such as Geiger counters, infrared detectors, flasher tubes, mobile radio equipment. Deliv-



Commercial Sound Speaker Source...



You never compromise with fidelity or quality when you specify Oxford on all your speaker needs.



That's because Oxford electronic and sound engineers know that specialized applications require specialized developments. Oxford doesn't produce just horn or cone types. Oxford studies the application and the problem, develops specific units for specific needs. You're never stuck with trying to pour a bushel basket into a pint measure. Paging and talk-back horns, outdoor hi-fi systems, P.A. systems and other commercial sound installations all find the perfect speaker for the system at Oxford.



Match your skills with the Oxford line of speakers that bring out the best in every sound installation. Write for the Oxford catalog of "speakers for every purpose" today!

OXFORD TRANSDUCER COMPANY
A Division of
Oxford Electric Corporation
3911 S. Michigan Ave.
Chicago, Ill. 60653

Circle 106 on reader's service card

ers 500 v at 500 ma. Used with 3-vdc input applied to typical converter circuit realizes 70% efficiency. Higher voltages obtainable with doubler circuits. 1 $\frac{3}{4}$ x 1 $\frac{3}{16}$ x 2 $\frac{7}{32}$ in., exclusive of mounting feet.—Microtran Co., Inc., P.O. Box 236, Valley Stream, N.Y. 11582

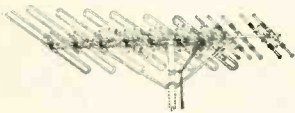

VHF ANTENNA, model AA-116, 37 elements. Full picture power up to 175 miles from station. High front-to-back ratio for clean high-gain signal. Gold

anodized elements. Overall length 145 in. Color-approved for use on all vhf channels.—Olson Electronics, Inc.

Circle 51 on reader's service card

82-CHANNEL ANTENNAS, the Pathfinder series. Hinged so uhf and vhf

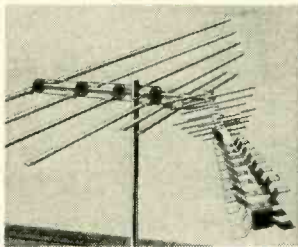

sections can be aimed in different directions. Available with outputs for both 300-ohm ribbon and 75-ohm coaxial cable. Cascaded-periodic design for flat, uniform response. At TV set end, uhf and vhf signals are split by special frequency-sensitive coupler. Five 300-ohm models (PAB-30, PAB-45, PAB-50, PAB-70, PAB-90) and 5 coaxial output models. (PXB-30, PXB-45, PXB-50—shown, PXB-70 and PXB-90).—Jerrold Electronics Corp.

Circle 52 on reader's service card



CB RADIO, the Mark 10, solid-state, 12 crystal-controlled channels, all-silicon transistor complement operates from -23°F to +130°F. Requires 12-volt dc power supply, positive or negative ground. Regulated power supply with Zener diode for receiver section. 6-stage i.f. bandpass filter. Rf power outputs up to maximum FCC limit of 4 watts. Automatic noise limiter, push-to-talk mike with coiled cord, mobile mounting bracket. 3 $\frac{3}{4}$ x 5 $\frac{3}{4}$ x 8 $\frac{1}{2}$ in., less than 4 $\frac{1}{2}$ lb.—RCA Electronic Components and Devices

Circle 53 on reader's service card



INTERCOM, No. 99-4570, 10-station, transistor, permits up to 5 private simultaneous conversations. Indicator light circuit and/or aural signal. Will communicate to 1,000 feet. Operates on batteries or optional ac power supply. 10 lb.—Lafayette Radio Electronics Corp.

Circle 54 on reader's service card

BUSINESS-BAND TRANSCEIVER, model BB-30. Range: 27-36 MHz. Modulation: 6A-3, controlled carrier. FCC



type-accepted. Power supply: self-contained 12.6 vdc, 115 vac. Power drain: 5 amps at 12.6 v, 70 watts at 115 vac. 9 tubes including compactrons and Nu-vistors give 14 tube functions, 8 silicon diodes plus germanium meter diode for

FREE

NEW 1966 GIANT CATALOG

1966 ANNUAL CATALOG NO. 961
RADIO • TV • ELECTRONICS
 INDEX PAGE 226... PHONE BAltimore 1-1165

BURSTEIN-APPLEBEE CO. 1012-14 McGee St., Kansas City, Mo. 64106

100's OF BARGAINS NOT IN ANY OTHER CATALOG

100's of new items listed for first time

EVERYTHING IN HI-FI AND STEREO

SAVE UP TO 50% ON CHOICE KITS

Satisfaction GUARANTEED or your money back!

SAVE ON CAMERAS FILM & PHOTO EQUIPMENT

TUBES PARTS ETC. AT LOWEST PRICES

TOP VALUES IN POWER & HAND TOOLS

NO MONEY DOWN PLUS REVOLVING CHARGE ACCOUNT

100's of pages packed with savings

FOR 38 YEARS THE OUTSTANDING **MONEY SAVING**

BUYING GUIDE FOR:

- Stereo & Hi-Fi Systems and Components
- Tape Recorders
- Electronic Parts, Tubes, Books
- Phonos & Records
- Ham Gear
- Test Instruments and Kits
- Cameras and Film
- Public Address
- Citizens Band
- Transistor & FM-AM Radios.

RUSH COUPON TODAY

BURSTEIN-APPLEBEE CO. Dept. RE, 1012-14 McGee St., Kansas City, Mo. 64106

Rush me the FREE 1966 B-A Catalog.

NAME _____

ADDRESS _____

CITY _____ STATE _____

Please be sure to show your Zip No. _____

Circle 107 on reader's service card

4 extra tube functions. Controls: volume/on-off, squelch, tone, bull horn/radio switches. 8½ x 11 x 4½ in., 15 lb.—General Radiotelephone Co.

Circle 55 on reader's service card

H.E.L.P. TRANSCIEVER, the *Mark I*, designed for the Highway Emergency Locating Plan. Transmitting: crystal-controlled oscillator. Receiving: superhet with rf amplifier, squelch control and noise limiter. 12 transistors, 1 diode. Frequency tolerance ±.005%. 27-MHz Citizens band. I.f., 455 KHz 200 mw maximum input power to final stage. 180 mw audio output power. 54 in. antenna; 2½-in. PM dynamic speaker. 8 penlight batteries (12 volts). 8½ x 3½ x 2 in. 2.2 lb.—AV-COMM Div., Ajax Floor Products Corp.

Circle 56 on reader's service card



CITIZENS BAND TRANSCIEVER, *Pace 11*, 12 channels. 5 watts input delivers 3.5 watts to antenna at 100% modulation. Double-conversion superhet circuit with narrow-band, shaped audio response, single-crystal tolerance of .0033%. Noise limiter; squelch with rear- and front-panel sensitivity adjustments. Silicon transistors, temperature range -30°F to +185°F. Vinyl-coated aluminum case, 7 x 2½ x 8½ in. Standard 12-volt dc, positive or negative power. Ceramic mike and set of channel-11 crystals supplied.—Pace Communications Corp.

Circle 57 on reader's service card

VHF FM RECEIVER, model *KG-221* (152-174 MHz) or model *KG-220* (30-50 MHz). Bandwidth: 100 KHz at 6 db down. Sensitivity 10 µv at ±5-KHz deviation. 1-watt audio output to built-in speaker or external speaker/headphones. 3 x 5-in oval PM speaker. Variable tran-

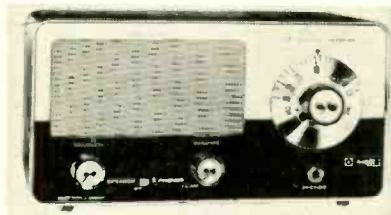

sistorized squelch opens for signals as small as 5 µv. I.f. 10.7 MHz, 2 i.f. amplification stages. 5 tubes and 1 transistor; silicon diode rectifier in power supply circuitry. Antenna impedance matches 50 to 75 ohms. 30 watts nominal power consumption. 5½ x 11½ x 5½ in.—Allied Radio Corp.

Circle 58 on reader's service card

ELECTRONIC KEYSER KIT, *HD-10*, has solid-state switching and sealed



contacts on built-in paddle. Optional transmitting speed ranges of 10-20 or 15-60 words per minute. Each dash is 3 dot

BIG CATALOG

World's "BEST BUYS" in GOV'T. SURPLUS Electronic Equipment

FULL OF TOP QUALITY ITEMS—

Transmitters, Receivers, Power Supplies, Inverters, Microphones, Filters, Meters, Cable, Keyers, Phones, Antennas, Chokes, Dynamotors, Blowers, Switches, Test Equipment, Headsets, Amplifiers, etc., etc. SEND 25¢ (stamps or coin) for CATALOG and receive 50¢ CREDIT on your order. Address Dept. RE.

FAIR RADIO SALES

P. O. Box 1105 · LIMA, OHIO · 45802

First One-Piece All-Channel Antenna with Individual UHF and VHF Orientation

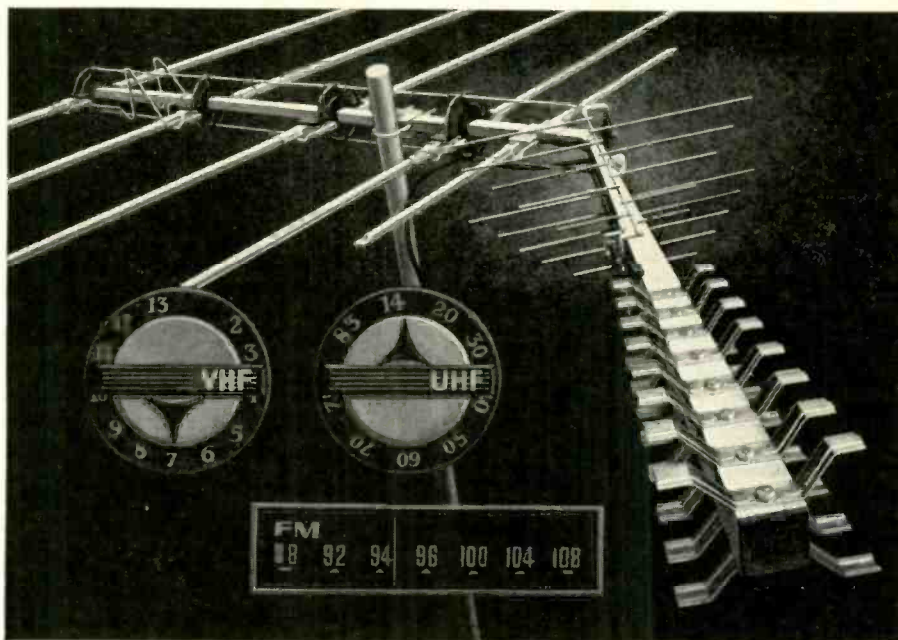

New JERROLD Coloraxial™ Pathfinder™

Take advantage of the growing UHF and FM stereo markets by selling the antenna to answer every home reception need from metropolitan to deep-fringe areas... Jerrold's new Coloraxial PATHFINDER.

Look at the advanced design of the PATHFINDER (Series PAB and PXB): a cascaded periodic VHF section plus a radically new UHF section hinged for individual orientation and maximum directivity. Here's all the flexibility of separate antennas, without the splitter losses from coupling separate antennas to a common download.

Both 75-ohm Coloraxial and 300-ohm standard outputs for every taste and budget. Prices as low as \$21.95. Rugged square-boom construction and Golden Armor corrosion-resistant finish assure long life. Flat response across all 82 channels, low VSWR, excellent front-to-back ratio make PATHFINDER a natural for quick sales and satisfied customers. Send coupon for complete information.

JERROLD ELECTRONICS CORPORATION
Distributor Sales Division, Dept. RE-Z
15th & Lehigh Ave., Philadelphia, Pa. 19132
Please send me complete information on
PATHFINDER all-channel TV and FM antennas.

Name _____
Company _____
Address _____
City _____ State _____ Zip _____

JERROLD

Circle 108 on reader's service card

tests all color tubes

the way tube manufacturers do!



ONE YEAR WARRANTY

LECTROTECH CRT-100 picture tube analyzer

No other brand has all these features. Tests each color gun to a standard set of test conditions. With variable G-2 voltage, each grid is normalized to a reference cut-off voltage. Line voltage adjustment (to insure all tube voltages are correct regardless of line voltage). Tests all black and white and all color tubes for leakage, shorts and emissions. Rejuvenates and removes shorts on both color and black and white tubes for increased brightness. Continuously variable G-2 voltage for all tubes, present and future, including new 15 inch color tubes.

Made in U.S.A. Only **8950**



See your distributor or write Dept. RE-2

LECTROTECH, INC.

1221 W. Devon Ave., Chicago, Illinois 60626

Circle 109 on reader's service card

Every No-Noise Aerosol Product

Guaranteed

Non-Flammable

Non-Toxic and

Won't Affect Plastics

"NO NOISE"

Insist On This Trusted
NAME BRAND
Avoid Risky "Private Labels"

"No Noise" PRODUCTS ARE
PERFECT FOR COLOR TV

- Volume Control & Contact Restorer
- Tuner-Tonic with Perma-Film
- EC-44 For Electrical Contacts

FREE 5" plastic extender push-button assembly for pin-point application with all No-Noise products.

ELECTRONIC CHEMICAL CORP.
813 Communipaw Avenue, Jersey City 4, N. J.

Circle 110 on reader's service card

spaces in duration; each character separated by equal dot spaces. Side-tone generator and speaker with adjustable volume for off-the-air practice and monitoring on-the-air transmissions. Keys any line to ground with maximum current limit of 35 ma and maximum open-circuit voltage of -105. Can be used with grid block keying transmitters such as Heath-kit SB series or DX-60A. Ac line-operated (117 vac, 50-60 Hz) and provision for battery operation.—Heath Co.

Circle 59 on reader's service card



DYNA-JET TUBE TESTER, model 606, tests for shorts, grid emission (100-megohm-sensitive circuit) leakage, gas, cathode emission under simulated load conditions. Phosphor bronze socket contacts. Each section of multisection tubes is checked. Leatherette carrying case.—B & K Mfg. Corp.

Circle 60 on reader's service card

OSCILLOSCOPE, model S-16-A *Craftscope*, portable. 5-in. CRT. Wide-band response dc to 7.0 MHz, calibrated sensitivity 100 mv/cm with high sensitivity of 2.5 mv/cm. Features signal inver-

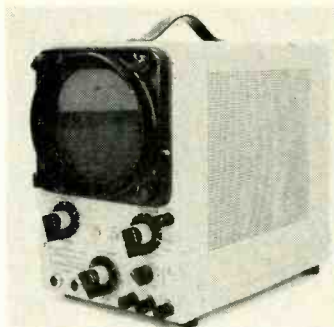

sion, trace expansion, built-in calibration, edge lighting, direct-reading vertical scales. 65 watts, 12 x 7 x 10 in., shipping weight 21 lb.—Schaevitz M.C.D.

Circle 61 on reader's service card



AMATEUR RECEIVER, the SX-146, uses single conversion circuit. 2.1 kHz, 6-section quartz-crystal lattice filter, plug-in provisions for 0.5-KHz CW crystal filter and 5-KHz AM crystal filter. Sensitivity: less than 1 μ v for 10 db signal-to-noise in AM (30% modulation); less than $\frac{1}{2}$ μ v for 20 db in SSB/CW. Less than 500 Hz drift first hour after warmup, less than 100 after. I.f. and spurious rejection better than 50 db. 9 tubes, 3 diodes. 5% x 13% x 11 in.—Hallcrafters Co.

Circle 62 on reader's service card

PA AMPLIFIER, PA-645, stock No. 44-0130WX. 45 watts rms output. Response: 30-20,000 Hz ± 2 db. Inputs: 1 microphone, 2 auxiliary. Controls: 2 microphone, auxiliary fader, bass, treble, master gain, anti-feedback, on-off. Out-



puts: 4, 8, 16 ohms; 25 and 70.7 volts. Power consumption 110 watts at 120 volts, 50-60 Hz ac. 15% x 10% x 5 1/16 in., 30 lb. Amphenol 75 MCIF connector and phone plug.—Lafayette Radio Electronics Corp.

Circle 63 on reader's service card



POWER TOOL, *Micro Miniature Workshop*, cuts, grinds, sands, polishes, burnishes, cleans, carves, saws, drills and engraves. Included with tool are sanding discs, bristle brushes, cutoff discs, mandrel, grinding stones, buff, file and drills.

Circle 64 on reader's service card

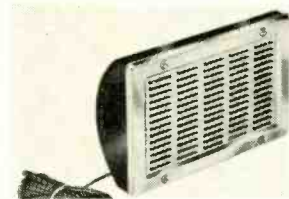

AUXILIARY SPEAKER for communications equipment. Voice coil ($\frac{1}{4}$ -in. diameter) handles up to 6 watts. Chrome grille. Speaker rated at 8 ohms. 7 1/2 x 5 x 2 1/2 in. Self-tapping sheet-metal screws for easy mounting.—Oxford Transducer Co.

Circle 65 on reader's service card

SOCKET WRENCH, the *Seeing Eye Sock-O-Matic*, will do work of 4 wrenches without adjustment. Concentric, spring-loaded hexagons in socket

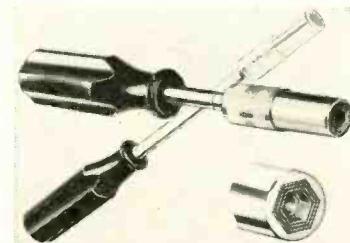

adapt to size of nut as you push wrench on; will fit nuts in 1/4- to 3/16-in. range. 5 models have same multi-hex socket. Shown: standard 7 1/2-in. and *Slim-Jim* 10-in. models.—Meredith Separator Co.

Circle 66 on reader's service card

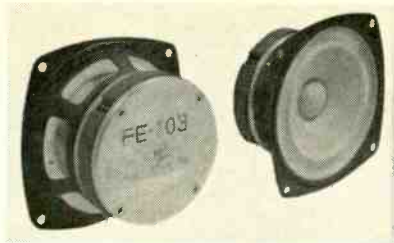

4-INCH HIGH-COMPLIANCE SPEAKER, model S-732. Cone suspended from metal frame by flexible cloth ring. Ceramic magnet develops over 10,000 gauss. Response: 35 to 16,000 Hz. Impedance 8 ohms. Power capacity 15-watt IHE. Recommended cabinet size 8 $\frac{1}{4}$ x 8 x 6 $\frac{1}{8}$ in.—Olson Electronics, Inc.

Circle 67 on reader's service card

DESK-TOP REMOTE-CONTROL CONSOLE for FM 2-way radio systems. In-bound and out-bound compression amplifier compensates for outgoing voice levels of different office dispatchers; gives anti-blast protection of incoming calls. Voltage regulation keeps console steady in surges of as much as 20% in 117-volt ac power lines. Silicon transistors. Optional intercom can provide communication console-to-console, console-to-base and base-to-console.—General Electric Communications Dept.

Circle 68 on reader's service card

UNIVERSAL SOCKET, type 9005, holds most standard encapsulated operational amplifiers of 1 $\frac{1}{8}$ x 1 $\frac{1}{8}$ -in. size, hav-

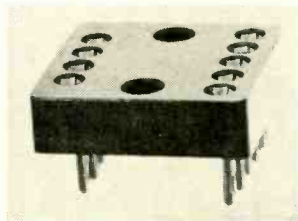

ing 7 or 9 leads on 0.2-in. grid spacing. Will accommodate leads diameters from .028 in. to .042. Designed for mounting on PC board or metal chassis.—Data Device Corp.

Circle 69 on reader's service card



VANE-SWITCHED OSCILLATOR (VSO) is basically a transducer that transforms mechanical movement into electrical signal. Unit consists of oscillator and diode rectifier connected to separate coupling winding of the oscillator for isolated dc output. Whenever metal passes through gap between the coil windings, oscillation stops and dc output drops to zero. Switched dc output can be used to drive a Schmitt trigger, Amperex pulse shaper or similar circuitry. Temperature range -20°C to +85°C. No moving parts, encapsulated in epoxy resin. Supply voltage 6 or 12 vdc. Current consumption 12 ma.—Amperex Electronic Corp., Digital Products Dept.

Circle 70 on reader's service card

MOLDED CAPACITORS, types MC52 and MC62, have radial leads, will

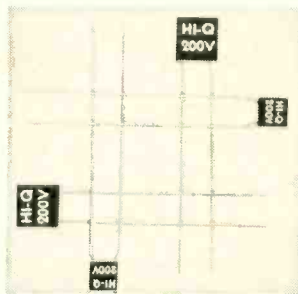

operate without derating at 200 vdc from -55°C to +150°C.—Aerovox Corp.

Circle 71 on reader's service card



TWO NEW NUTDRIVER SETS, color-coded. Set No. 77: 7 solid-shaft nut-

Now—tune short wave as easily as AM!

...with hallicrafters' new
S-200 "Legionnaire"
foreign broadcast (plus U.S.) receiver

300		900		1000	
VOA	NETHERLAND	SWITZERLAND	SOVIET	BERLIN	HAVANA
EGYPT	PORTUGAL	6.1	BBC	SKELTON	
BERLINS	ALGIERS	WARSAW	VATICAN	MEXICO	
9.6	CANADA	MOSCOW	CARACAS	9.7	
JUELICH	SKELTON	SHEPPARTON	VATICAN		
11.8	SOVIA	CO	BBC		
BUCHAREST			BBC		
MOSCOW	SKELTON	SWEDEN	MEXICO		
2	ANKARA	15.3	CANADA	BIO	
LYNDMURST			ATHENS		
50					

Hallicrafters new "S-P-R-E-A-D TUNING" lets you zero in with local-station ease and precision from all over the globe!

- Four super-spread short wave bands plus U.S. standard broadcast.
- Logging scale for instant re-tuning of any station.
- All new, sensitive super-heterodyne circuitry.
- Jack for headphone.

ONLY \$5995

write for complete specifications



hallicrafters

Available in Canada through Gould Sales Co.

5th & Kostner Aves., Chicago, Illinois 60624
Export: International Division

"Quality through Craftsmanship"

Circle 111 on reader's service card



**AS BRITISH AS
BIG BEN**

BALFOUR
Princess
**automatic/manual
turntable systems**

Only the British could create Big Ben, a marvel of lasting precision. And only Balfour can give you such fine hi-fi quality at low cost! Priced at \$37.50 & \$47.50. See Your Dealer

- Featuring • Built-in Stylus Brush
• Automatic Tone Arm Lock
• Low Wow and Flutter

RFS INDUSTRIES, INC.
102 Harbor Road, Port Washington, N.Y. 11050

Circle 112 on reader's service card

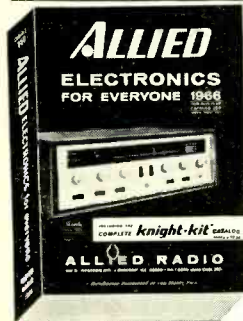

FREE

send for your
MONEY-SAVING
508-page

1966 ALLIED CATALOG

SAVE MOST ON:

- Stereo Hi-Fi
- Tape Recording
- CB 2-Way Radio
- Shortwave & Ham Gear
- Automotive Electronics
- FM-AM & AM Radios
- Portable TV & Phonos
- Test Instruments
- TV Tubes & Antennas
- Power Tools, Hardware
- Parts, Tubes, Transistors

See the world's largest selection of top money-saving buys, including exclusive Knight-Kits and products available only from ALLIED. Get fastest service, easy-pay terms, satisfaction guaranteed or your money back. Send coupon today for your FREE 1966 ALLIED Catalog.

EASY TERMS: Use the Allied Credit Fund Plan.

ALLIED RADIO

**free
catalog**

ALLIED RADIO, Dept. 2-B
100 N. Western Ave., Chicago, Ill. 60680

Send FREE 1966 ALLIED Catalog.

Name _____

PLEASE PRINT

Address _____

City _____ State _____ Zip _____

Circle 113 on reader's service card

drivers with hex openings from $\frac{3}{16}$ through $\frac{1}{2}$ in. Set No. HS6-18: 10 hollow-shaft nutdrivers, (illustrated) hex openings from $\frac{3}{16}$ through $\frac{1}{4}$ in. Pebble-grain plastic cases.—Xcelite Inc.

Circle 72 on reader's service card

RADIO-INTERCOM SYSTEM, model 8408. Intercom circuits: 45-ohm balanced line system; power input 16 vac, 6 watts; hum and noise level -50 db. Radio: AM 540-1,600 KHz; 2-gang variable

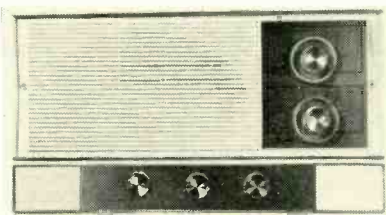

capacitor; 7 tuned circuits AM; 11 tuned circuits FM; 4-in. 45-ohm PM speaker; 9 transistors, 9 diodes. Remote station 4-in. 45-ohm speaker; wiring, 3 pairs, color-coded. Master control 16 x 14 $\frac{1}{2}$ x 4 $\frac{1}{2}$ in.—FASCO Industries, Inc.

Circle 73 on reader's service card

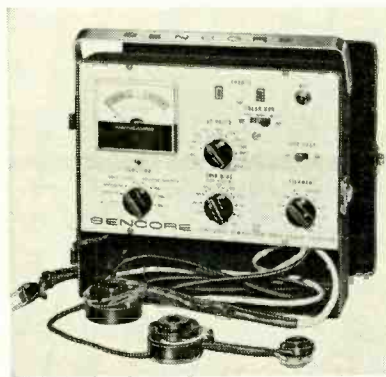

CRT CHECKER AND REJUVENATOR, model CR128A, updated, improved version of CR128. Has variable G2 control replacing old 3-position G2 switch. All sockets mounted on two permanently attached cables including rectangular color-tube socket for such tubes as 15-, 19-, 23-, 25-inch. Uses Sencore automatic controlled rejuvenation to rejuvenate picture tubes without danger of damage. Taut-band meter. All-steel construction. Checks for emission shorts, leakage between elements, gas, tube life. 10 x 9 x 3 $\frac{1}{2}$ in., 10 lb.—Sencore, Inc.

Circle 74 on reader's service card

Write direct to the manufacturers for information on the item listed below:



AEROSOL-CANNED AIR. Pure dry air in a 12-oz aerosol can for removing microscopic dust from instruments, precision equipment. Supplies 15 minutes of pressurized air. 6-in. extension spray nozzle. Free sample to letterhead requesters.—Miller-Stephenson Chemical Co. END

**NEW
LITERATURE**

All booklets, catalogs, charts, data sheets and other literature listed here are free for the asking with a Reader's Service number. Turn to the Reader's Service Card facing page 82 and circle the number of items you want. Then detach and mail the card. No postage required!

4-PAGE REPORT, Bulletin 6.104.10. Understanding Acoustic Enclosure Systems, describes 3 common types of acoustic enclosures, discusses acoustic properties of anechoic, reverberant and quiet rooms. Photo and figs.—Industrial Acoustics Co., Inc.

Circle 75 on reader's service card

1966 CONDENSED CATALOG, 27 pages, looseleaf-punched, 3-page foldout of device outline dimensions. Specs, photos of semiconductor line.—Motorola Semiconductor Products Inc.

Circle 76 on reader's service card

CATALOG, No. 65, 60 pages, universal punched. Many new additions in i.f. transformer and rf choke lines. Also Mil spec molded chokes, industrial coils, special windings.—J. W. Miller Co.

Circle 77 on reader's service card

PHOTOCELL FORUM, Vol. 1, No. 2. Photocells Reduce Refractometer Package Size, discusses the application of a new dual-element photocell.—Clairax Corp.

Circle 78 on reader's service card

TECHNICAL BULLETIN, No. BA-125, 4 pages, universal-punched, gives photos, curves, characteristics of firm's line of sealed nickel-cadmium battery cells.—Battery Div., Senotone Corp.

Circle 79 on reader's service card

BUILD-YOUR-OWN SPEAKER SYSTEM, Catalog 165-L. 24 pages, photos and specs of speakers, enclosures and complete systems, including stereo headphones. Tables for enclosure size, duct length.—Jensen Mfg. Div./Muter Co.

Circle 80 on reader's service card

PUBLIC-ADDRESS CATALOG on Commander Series of modular amplifiers and accessories for commercial sound installations. 8-page catalog which opens out as a wall chart. **POWER-COM Guide** tells how talk-back and intercom may be integrated into any PA installation.—Harman-Kardon, Inc.

Circle 81 on reader's service card

MICROPHONE CATALOG, 16 pages. Full specs, drawings, curves on 11 condenser and dynamic mikes. Stereophonic mike (two-in-one); F-75 Telemicrophone, which picks up sounds from as far as 150 ft; the CR-5 wireless mike; others.—Sony Superscope

Circle 82 on reader's service card

SILICON RECTIFIER SELECTION GUIDE shows maximum reverse-voltage and current/temperature derating curves, plus case dimensions of rectifier line from 1 to 1,000 amps.—Motorola Semiconductor Products Inc.

Circle 83 on reader's service card

SERVICEMEN'S CATALOG, No. SE-565. 32 pages, looseleaf-punched, drawings, of capacitors, resistors, filters, test gear. Includes several capacitor kits: bi-electric Mylar, tubular Mylar, twist-prong electrolytic types.—Aerovox

Circle 84 on reader's service card

TEST EQUIPMENT CATALOG, Lab-Line series, designed specifically for cable distribution

industry: uhf/vhf sweep generators, uhf/vhf field-strength meters, rf switchers, delay lines, 50-75-ohm matchpads, fixed attenuators, uhf connectors, etc. 8 punched pages.—Blonder-Tongue Labs, Inc.
 Circle 85 on reader's service card

THERMISTOR MANUAL, EMC-5, 22 pages, looseleaf-punched, discusses uses of bead, glass-probe, rod and washer thermistors. With resistance, temperature curves and tables; voltage/current curves.—Fenwal Electronics, Inc.
 Circle 86 on reader's service card

CATALOG, 34th Anniversary Harvest of Values, 36 pages of electronic components and equipment, from slide rules to TV cameras.—Olson Electronics, Inc.
 Circle 87 on reader's service card

SCIENCE, OPTICS, MATH CATALOG, No. 661, Fascinating collection of hobby and school items, including such new ones as: eyeglass wearers' kit, underwater ant farm, magnet variety kit, nickel-cadmium battery, selsyns, transducer kits, fun chest, moiré patterns. 148 pages, fully illustrated.—Edmund Scientific Co.
 Circle 88 on reader's service card

1966 STEREO CONSOLE GUIDE, At Home with Stereo, shows new line of consoles in room settings designed by 4 well-known interior designers, with articles by the designers on the role of music in the home.—H. H. Scott, Inc.
 Circle 89 on reader's service card

SINGLE CONTROLS REPLACEMENT CHART, plastic-laminated, universal-punched, identifies control resistances and tapers, shaft lengths, all types of flats and knurls in Fastatch II system.—Centralab
 Circle 90 on reader's service card

TECHNICAL REPRINT, "Operational Amplifiers—Principles of Operation and Analysis of Errors" from *Electromechanical Design Components & Systems*, Theory and characteristics of operational amplifiers, sources of static and dynamic errors. Gives criteria for closed-loop stability and limitations on bandwidth and loop gain; factors contributing to offset drift and effects of finite impedance.—Analog Devices, Inc.
 Circle 91 on reader's service card

Write direct to the manufacturers for information on the items listed below:

APPLICATION NOTE, No. 70, 12 pages, on precision dc voltage measurements. 5 applications with figures: (1) standard cell comparisons, (2) precision 0-1-volt source, (3) precision 1-1,000-volt source, (4) certifying precision dc standard, (5) calibrating the HP 735A to 1 volt ± 2 ppm.—Hewlett-Packard Co., PO Box 30, Loveland, Colo.

SEMICONDUCTOR REPLACEMENT/INTERCHANGEABILITY GUIDE lists replacements for about 5,000 semiconductors: transistors, diodes, silicon rectifiers, selenium rectifiers, selenium dual diodes, TV color rectifiers. Free at Semitron dealer or 25¢ for postage to Semitronics Corp., 265 Canal St., New York, N. Y. 10013



Just what we've all been waiting for.
 Stereo static!

FEBRUARY, 1966

there's
EXTRA PROFIT in NOISECTOMIES*



QUIETROLE

IS HARMLESS TO PLASTICS

Harmless to metal... non-conductive, non-inflammatory and non-corrosive. Zero effect on capacity and resistance.

* a simple quick operation performed by Doctors of Electronics with the aid of Quietrole to cure scratchy, noisy tuners and controls of TV and radio. Fast set recovery with no ill side-effects assured. Saves time... makes money for servicemen.

At Your Distributor... Ask for Quietrole by Name.



manufactured by
QUIETROLE CO.
 Spartanburg, South Carolina

Circle 114 on reader's service card

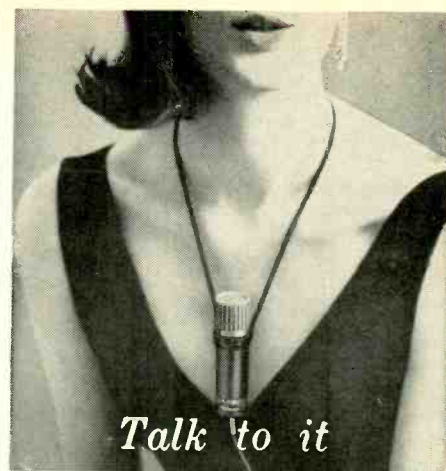

Talk to it

... right into your tape recorder — then play it back and listen to the lively sound of your own voice — so natural, no one can tell the difference. University's new revolutionary Attaché is the smallest cardioid dynamic microphone ever made. Priced right too! Free! "Microphones '66" — a book every owner of a tape recorder should have.

UNIVERSITY SOUND
 A DIVISION OF THE UNIVERSITY, INC.
 Dept. B69M, Box 1056
 Oklahoma City, Okla. 73101

Name _____
 Address _____
 City _____
 State _____ Zip _____

Circle 115 on reader's service card

Now save hours of design time with GERNSBACK LIBRARY'S new

ELECTRONIC DESIGN CHARTS

By Norman H. Crowhurst

A comprehensive collection of nomographs in one convenient book. Simplifies design procedures. Saves hours of time and effort on computations. Helps solve virtually every electronic design problem quickly. Eliminates uncertainty and mistakes. Large, accurate, clear charts on 8½ x 11 page size. Lies flat or stands up.

- 59 CHARTS
- 128 PAGES
- FULL EXPLANATION
- EASY-TO-READ TEXT

Permanently cloth-bound **\$5.95**

Money-back guarantee within 10 days if not completely satisfied with book

GERNSBACK LIBRARY, Inc., Dept. 266
 266 West 14th Street, New York, N. Y. 10011

Enclosed is \$_____. Please send _____ copy(ies) of *Electronic Design Charts* @ \$5.95.

Name _____
 Street _____
 City _____ State _____ Zip Code _____

BOOKS PURCHASED FOR PROFESSIONAL PURPOSES ARE TAX DEDUCTIBLE

Solid-state CB mate

The best way to ring up more 10-2s with the new solid-state transceivers is by using one of the new low-impedance Sonotone Ceramikes®. They are designed specifically for all-transistor transceivers. Transmission is loud and clear, and Ceramikes are built to take abuse. Get the low-impedance "CM-3050" or the "CM-3050M" with Magnetic Mount, today. Also Models "CM-30" and "CM-30M" for tube transceivers. Prices start at \$15.75. Write for Free catalog SAH-7.



SONOTONE
audio products

Sonotone Corp., Electronic Applications Div., Elmsford, N. Y.

Circle 116 on reader's service card

Meet Winegard Chroma-Tel

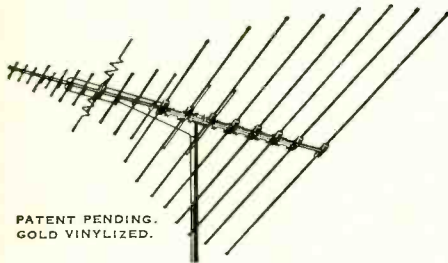

PATENT PENDING.
GOLD VINYLIZED.

First 1/2 size all-band (UHF, VHF, FM) antenna with full size power

- Delivers Brilliant Color, Beautiful Black and White, Full-Tone FM Sound
- Brings in All the UHF, VHF and FM Stations in Your Area

Now there's an All-Band (UHF, VHF, FM) antenna that is actually half the size of most other all-band antennas. It eliminates half the bulk, half the wind loading, half the storage space, half the truck space and half the weight of ordinary all-band antennas... without sacrificing one bit of performance! Features Winegard's new Chroma-Lens Director System and impedance correlators.

Compare size, cost and performance... you'll choose Winegard Chroma-Tel every time. Ask your distributor or write for Fact-Finder #242 today.

3 Models from \$17.50 list.

Winegard Co. ANTENNA SYSTEMS
3000 Kirkwood • Burlington, Iowa

Circle 117 on reader's service card

TRANSISTOR MIKE PREAMP FOR PA

Single-transistor mixer-amplifier handles
two low-impedance mikes with low noise and no hum

By JAMES E. PUGH, Jr.

WHEN YOU ADD A MICROPHONE TO A PA system, or to a remote pickup, its output is often lower than required for the main amplifier. A small, single-stage transistor preamplifier like this one is fine for many such jobs. A dual input circuit handles two microphones with ease, there is enough gain for a wide range of uses, the noise level is very low, hum is nonexistent, and the tiny battery drain reduces operating costs to practically nothing.

A center-tapped input transformer (T1) accommodates the two low-impedance (150-ohm) microphones. The levels of the two inputs are controlled individually by R1 and R2. Conventional controls used here will do, but T-pads can replace them if it is necessary to maintain constant impedance over the full range of control settings.

The amplifier uses an inexpensive low-noise, high-gain transistor connected in a conventional common-emitter circuit. While nothing is very critical, check that the collector current of Q1 is in the

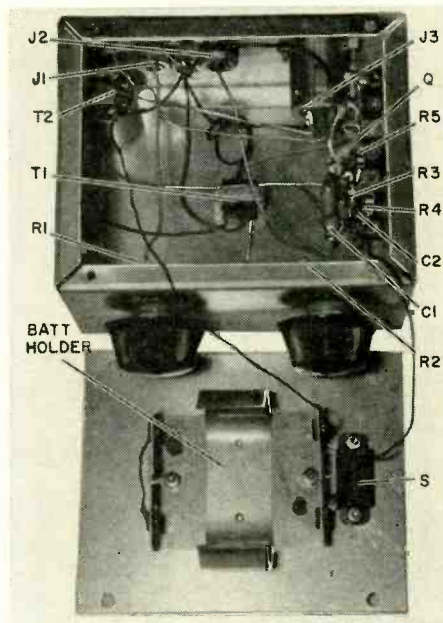

Author's model uses Amphenol screw-on connectors for mike inputs, and Cannon XLR-3-13 for output to amplifier.

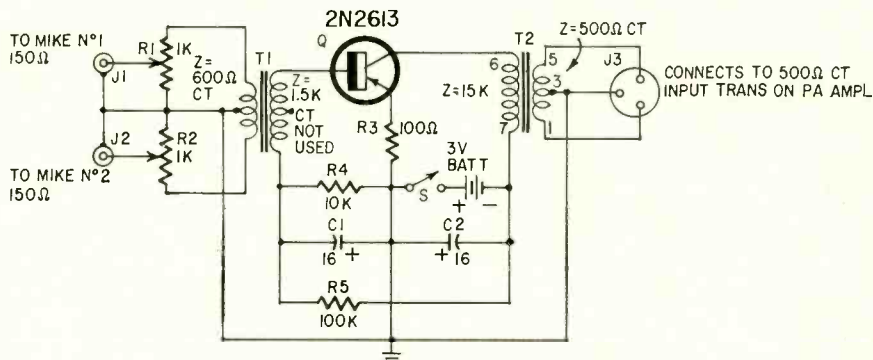

Circuit uses low-noise 2N2613, found in many commercial hi-fi amplifiers' preamp stages.

BATT—3-volt battery (see text)
C1, C2—16- μ f, 6-volt electrolytic
J1, J2—Shielded input jacks to suit
J3—Shielded output jack to suit
Q—2N2613 (RCA) or equivalent
R1, R2—1,000-ohm potentiometer, log taper
R3—100 ohms, 1/2-watt
R4—10,000 ohms
R5—100,000 ohms (see text)

S—spst switch
T1—600 ohms ct to 1,500 ohms
(UTC SSO-20 or equivalent—see text)
T2—15,000 ohms to 500 ohms ct (UTC O-9 or
equivalent—see text)
Metal case
Battery holder
Knobs for controls
Miscellaneous hardware

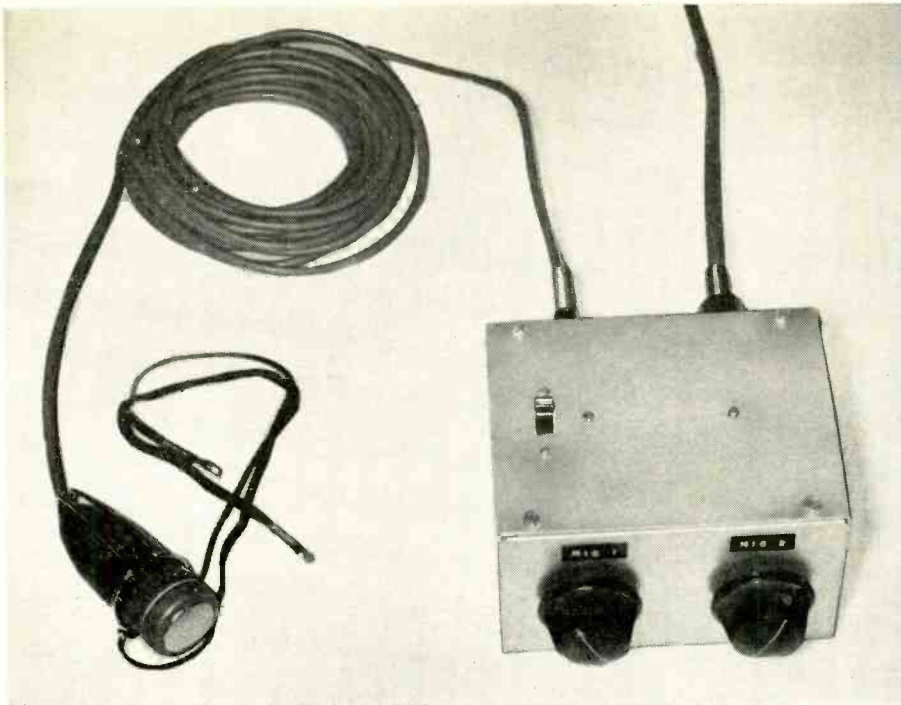

Mixer/preamp is small and light enough for any temporary PA job. Fidelity is as good as the transformers are.

region of 0.4 to 0.6 ma. This gives the lowest noise figure. Increase R5 to reduce the current and make R5 smaller to bring it up.

Two ordinary flashlight cells power the preamp. At this low current, they last a long time. If you want to hold the output level and the noise figure constant throughout the useful life of the battery, use a 2.7-volt mercury battery instead of dry cells.

A transformer with a different input impedance for other microphones, or with additional windings or taps, can be used if your needs are different. The output unit, T2, provides several impedance taps for a wide range of applications in audio work, but it too can be changed. If any substitutions are made, keep the secondary impedance of T1 and the primary impedance of T2 approximately as shown. Change the primary of T1 and the secondary of T2 to the values needed to match your mike and amplifier. Keep in mind that the impedance on either side of the center tap will be one quarter of the total end-to-end impedance.

Construction can be in any form that suits your needs, but build all circuit elements in a metal enclosure. Connect all grounds to a common point inside the case, and, if the PA amplifier has a ground bus, connect the preamp's ground point to it through a third wire in the cable between J3 and the PA amplifier's input jack. The case of the preamp can then be connected to the main amplifier chassis through the cable shield if there is any hum pickup.

[With the center-tapped transformer primary shown, two identical mikes connected with the same polarity will be 180° out of phase, and if both are situated to pick up sound from the same source (as, for instance, two mikes on a table for recording a conference), there may be partial cancellation at some positions of the mixer knobs. If you anticipate having such a setup frequently, reverse the phase of one of the microphones by transposing the two "hot" leads (leave the shield alone). Mark the reverse-phased mike to identify it, in case you wish to use it sometime with other mikes and conventional mixing equipment. With two different mikes, you may have to experiment.—Editor] END

BUILD A STEREO HEADSET AMPLIFIER

Compact, versatile battery-powered amplifier is ideal for private listening through high-quality stereo phones. Works direct from any stereo pickup cartridge—and it can drive a tube or transistor stereo power amplifier, too.

Coming in March
RADIO-ELECTRONICS special
1966 Hi-Fi/Tape Recording Issue

Live Better Electronically With
LAFAYETTE
RADIO ELECTRONICS
FREE!



512
Pages
1966
Catalog
660

Featuring Everything in Electronics for
• HOME • INDUSTRY • LABORATORY
 from the
"World's Hi-Fi & Electronics Center"

Mail the Coupon Today for Your
FREE 1966 Lafayette Catalog 660
LAFAYETTE Radio ELECTRONICS
 Dept. JB-6, P.O. Box 10
 Syosset, L.I., N.Y. 11791

Send me the Free 1966 Lafayette Catalog 660 **JB-6**

Name _____

Address _____

City _____

State _____ Zip _____
 (Please Give Your Zip Code No.)

Circle 118 on reader's service card

COYNE
TRAINS YOU
IN SPARE TIME
AT HOME

COYNE
QUALITY
TRAINING
AT LOWEST
COST

TELEVISION
COLOR TV-
RADIO-ELECTRONICS

Coyne—and only Coyne—can give you this modern, TV Home Training. Easy to follow 2150 photos and diagrams covering Ra-dios-TV, Color, UHF, Transistors. We also show you how to start making money while learning, right at home. Get your basic training at home, then make a flash finish with 2 weeks of actual shop work in Chicago under direction of same instructors who guide our resident students.

LOW COST—Easy to Pay
 You don't pay for costly "put together" kits. Small monthly payments and low, low cost make it easy for everyone to train. Free employment service for graduates—or we show you how to start your own service business on a "shoestring." Send name today for complete facts and valuable book on Television. No salesman will call. Everything mailed free, postpaid.

Coyne
Electronics Institute
 Not for Profit
 1501 W. Congress Parkway
 Dept. 26-H5 CHICAGO 7, ILL.

FREE
of Extra Charge
to Graduates
TWO WEEKS
Shop Training in Chicago
 No increase in home training cost, but the day you graduate you will be entitled to two full weeks of personal instruction on actual projects in the great Shop-Labs of Coyne in Chicago—without one cent of extra tuition whatsoever.

FREE Just Send Name
 No charge. No obligation. No salesman will bother you. Just send name for free copy of big 21 page book on quickest, lowest cost way to train for top pay job or business of your own... Mail coupon today.

COYNE ELECTRONICS INSTITUTE, Dept. 26-H5
1501 W. Congress Parkway, Chicago 7, Ill.
 Please mail free book and offer of two weeks personal training in Chicago without extra tuition for home study graduates. Explain low monthly payments.

NAME _____ AGE _____

ADDRESS _____

CITY & STATE _____

Circle 119 on reader's service card

Ordinary relays can flip, flop, switch, oscillate, pull in or drop out slower or faster than normal with the help of a few extra parts. Find out how to do these . . .

Special Tricks with Relays

By RONALD L. IVES

MOST ELECTRONIC WORKERS REGARD A relay as a primitive form of remote-controlled switch, with which a load of several hundred watts can be turned on and off at a considerable distance, with only a few watts. That (in very general terms) is the most common function of a relay, and most relays are made for that kind of job.

But a look at a telephony or computer manual immediately shows that relays are used for many other purposes. At slow speeds (roughly above .05 sec), relays can do many jobs that vacuum tubes and transistors do at higher speeds and frequencies. *In a surprising number of cases, complicated and costly electronic circuits are used to do things that actually can be done better and cheaper by relays!*

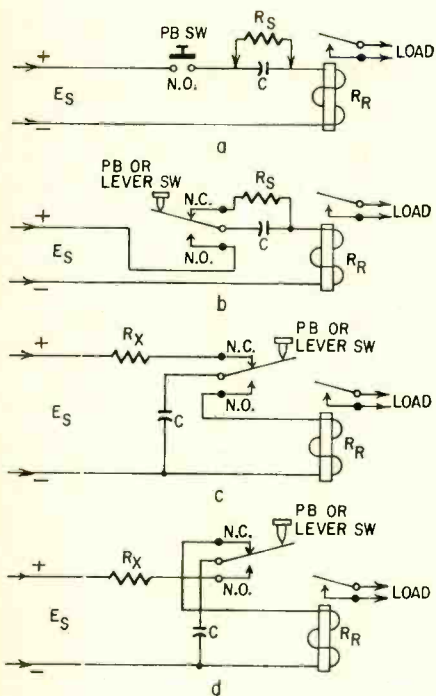

Fig. 1—Four "momentary" circuits: relay holds in only for a certain time, regardless of how long circuit is closed.

All the circuits here (and these are just a few of the thousands possible) have been used extensively in the industry. All, within their limits, are consistent performers and often need no servicing other than routine cleaning.

Momentary operation

In a wide variety of control circuits, the controlled circuit should be closed (or open) for a short fixed time no matter how much longer the control switch is closed. For this purpose, the *relay limiter* is ideal. Four conventional limiter circuits are shown in Fig. 1. All depend for their operation on the rate of charge of a capacitor through a resistance (the relay coil).

When the switch is closed in Fig. 1-a, current flowing into the empty capacitor energizes the relay coil and magnetic circuit, pulling down the armature. As the charge on the capacitor gradually increases, the voltage across the coil decreases. When the voltage across the coil falls to the dropout value of the relay, the armature releases, and nothing more happens, no matter how long the circuit remains closed.

The time the armature is pulled in is closely approximated by:

$$(1) \quad T = 2.303 R_r C \times \log_{10} \frac{E_s}{E_d}$$

in which: T = time in seconds, R_r = relay resistance in megohms, C = capacitance in microfarads, E_s = supply voltage and E_d = dropout voltage of the relay.

Since the ratio of E_s/E_d for many low-power commercial relays is approximately 3, and the common log of 3 is approximately 0.478, we may simplify our computations, in many instances, by using the formula

$$(2) \quad T = R_r C$$

with the symbols the same as before.

With the circuit in Fig. 1-a, the time lapse between operations must be very long, so that the charge on the capacitor can leak away. This could be several days with high-grade capacitors. We can speed up by shunting the capacitor with a resistor, R_x , of a relatively high value (10 or more times R_r). This still introduces a considerable delay between operations—usually 10 or more times the duration of the contact closure. For more rapid recycling, use the circuit shown in Fig. 1-b.

Here, the control switch is single-pole double-throw. When it is depressed, the action is as just described. When the switch is released, resistor R_x is shunted across the capacitor, discharging it and

readying the system for the next operation. Charge-dumping resistor R_x can be small (an ohm or two), and is used only to limit the discharge current through the switch.

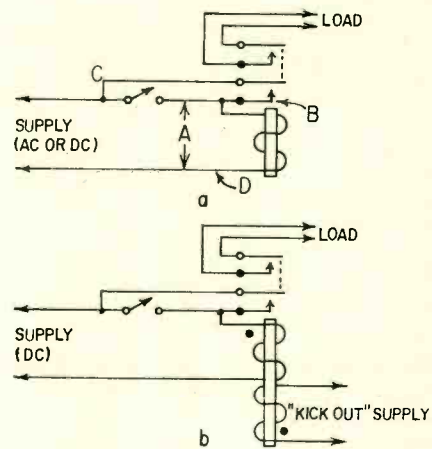

Fig. 2—Two latching, or self-holding, circuits. Circuit b requires a special relay.

Equally useful is the *shunt limiter*, one form of which is shown in Fig. 1-c. Here, the capacitor charges from the line through a small resistor, R_x , which limits inflow current. When the switch is pressed, the charged capacitor is shunted across the relay coil, and the stored charge operates the relay until the voltage across the capacitor falls to the dropout value of the relay. As this point, the relay contacts open, and no further relay action takes place no matter how long the switch remains depressed. Time of contact closure is shown by formulas (1) and (2).

A similar circuit, which actuates the relay only when the switch has been depressed and released, is shown in Fig. 1-d. This circuit is particularly useful in systems incorporating indirect-action stepping switches, where the contacting arm is not stopped until the driving circuit is interrupted.

Self-holding circuit

The circuit of a relay which closes and remains closed when the actuating switch is closed only momentarily is shown in Fig. 2-a. Here, when the relay armature pulls down, one set of contacts shorts the actuating switch, maintaining the relay current indefinitely.

The armature can be released by shorting the coil at point A (not recommended) or by opening the circuit at point B, C or D. An elegant release method, with a dual-winding relay, is diagrammed in Fig. 2-b. Here, an auxiliary coil produces a field in the magnetic circuit of the relay which exactly counteracts that produced by the main coil. When this "kickout" coil is energized, there is no magnetic field to hold the armature down, and it releases.

The same coil configuration can be used to produce an "either but not both" logic circuit, minus the self-holding feature.

Relay oscillator

When connected so that it alternately charges and discharges a capacitor, a dc relay can be made to oscillate, from about 20 cycles per second to 1 cycle every 5 minutes. Circuit of a series relay oscillator is shown in Fig. 3-a. Here, when the switch is closed, the charging current of the capacitor energizes the relay coil, pulling the armature down. As the capacitor charges, the charging current decreases, eventually falling to such a value that the voltage across the relay coil reaches the drop-out point. The armature then releases, the capacitor discharges rapidly through resistor R_z , and another cycle starts.

Time for a single cycle is closely approximated by formula (1). R_z prevents welding of the relay contacts during the discharge phase of the cycle, which is very short. Its value should be as low as the contact rating permits—if the contacts are rated at 5 amperes, R_z should be $\frac{1}{5}$ ohm per supply volt.

The circuit of a shunt relay oscillator is shown in Fig. 3-b. When the switch is closed, capacitor C (shunted by the relay resistance) charges up to the pull-in voltage of the relay. The relay armature then pulls down, and the capacitor discharges through the relay until the voltage across the coil falls to the drop-out value. Then the relay armature releases, and another cycle starts.

Time for a single cycle is closely approximated by

$$(3) \quad T = 2.303 R_r C \times \log_{10} \frac{E_p}{E_d}$$

in which E_p is the pull-in voltage of the relay, and all other symbols have been defined before. Note that the shunt oscillator operates through the range $E_p - E_d$, whereas the series oscillator uses the voltage range $E_p - E_d$. So, for a given set of components, the series oscillator will give a slightly longer period. It is, however, quite sensitive to changes in the value of R_z . Numerous long-continued experiments show that, while both oscillators work well, the shunt relay oscillator is very slightly more dependable, and more consistent, than the series oscillator.

Relay accelerators

We often need a relay that will respond somewhat faster than its rating in a conventional circuit. Numerous people have discovered in the last three-quarters of a century that a relay can be speeded up by overvolting it. And most of these same people later discovered—to their dismay—an overvolted relay doesn't last long.

To secure the advantages of overvolting without most of its disadvantages, a system of time-limited overvolting of relays was worked out during WW II. The basic circuit is shown in Fig. 4-a. The supply voltage is somewhat higher than the rated operating voltage of the relay. When the switch is open, the capacitor charges to full supply voltage. Closing the switch applies this high voltage to the relay, which operates rapidly. As the charge on the capacitor is reduced, the voltage across the relay terminals falls, due to the drop across R_m , to a value sometimes called the "holding voltage," somewhere between the pull-in voltage (E_p) and the drop-out voltage (E_d).

A relay will operate without immediate damage, using this method, with supply voltages of up to 10 times the relay rating. This shortens the response time of the relay by a factor of about 6, and the life of the relay by about the same factor.

Even higher voltages, producing even higher response speeds, are possible, but at the risk of dished relay armatures, peened-over pole pieces and burned coils.

Another relay accelerator, which requires only a resistor and a higher-than-rated supply voltage, takes advantage of the fundamental properties of an electromagnet for its operation. The time of operation of any relay can be indicated by the simplified relation

$$(4) \quad T \sim \frac{L}{R} + M,$$

in which L is an inductive term, R is a resistive term and M is a mechanical term.

All other factors remaining the same, the operating time can be reduced if we reduce L, increase R or reduce M. Because L and M are commonly built into the relay and variable only with great difficulty, we can accelerate the relay most simply by working with R. The circuit of this relay accelerator is shown in Fig. 4-b.

As used, the supply voltage is above the relay rating, and the series resistor is so chosen that the steady-state current through the coil is the rated current. Between turn-on and armature pull-down, current flow through the relay coil is less than normal, due to the inductance of the coil. With the accelerator

circuit, voltage across the relay coil is then higher than normal when current through the coil (and therefore the drop across the series resistor) is less than normal. This produces a self-limiting overvolting during the turn-on lag only, and thereby shortens this lag.

With small industrial relays, quadrupling the supply voltage, in this circuit, roughly triples the response speed of the relay. Still higher voltages can further increase speed, but most of these relays have an upper limit of about 80 cycles per second, due to mechanical factors, which cannot be exceeded by any ordinary electrical means.

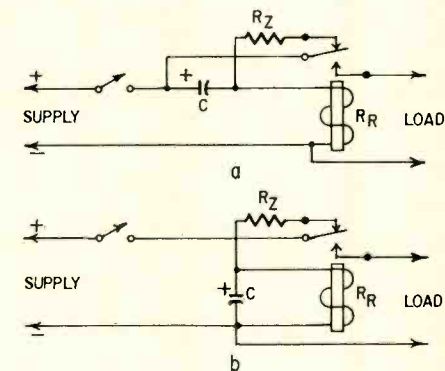

Fig. 3—Two relay oscillators: series capacitor, a, and shunt capacitor, b.

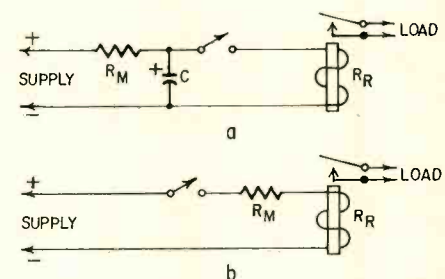

Fig. 4—Relay accelerators speed pull-in. Circuit a applies short-time overvoltage to coil from capacitor C. Circuit b uses inductance of coil to give initial higher-than-normal voltage.

Relay retarder

Slow-acting relays are commercially available in a wide variety. They are retarded by using copper slugs on the pole pieces for lags of up to about 1 second, and by dashpot mechanisms for longer delays. Thermal time-delay relays, with lags of from a few seconds to a few minutes, are made commercially by Amperite and Edison.

A very satisfactory slow-response relay can also be made with a standard relay and a resistance-capacitance circuit. An elementary form is shown in Fig. 5-a. Note the similarity to the relay accelerator of Fig. 4-a.

Supply voltage is normally above the relay rating, and series resistor R_m is so chosen that the steady-state voltage

across the coil is the rated voltage.

When the switch is closed, current is applied to the relay and capacitor in shunt, through series resistor R_m . Initially, the charging current of capacitor C is high, producing a voltage drop in R_m , so that voltage across the relay is below the pull-in value. As the capacitor charges, its inflow current falls, and the voltage drop across R_m also falls. After a time determined by the capacitance of C , the resistance of R_m and the relay coil resistance, voltage across the capacitor rises to the value at which the armature pulls in. Delays of more than 1 minute can be secured by proper choice of relay, capacitor and series resistor.

In its simplest form (Fig. 5-a), the relay retarder is both a slow-operate and a slow-release device. When the switch is opened, the charge on capacitor C leaks away through relay resistance R_r , keeping the relay armature down for a time indicated by formula (1).

The basic relay retarder can be converted into a slow-operate, quick-release device by an auxiliary relay contact, as in Fig. 5-b. Here, during the delay, when the switch is on and before the relay armature pulls down, the capacitor is connected by the normally closed contacts. This produces the delay. When the relay armature pulls down, the capacitor is disconnected and discharged through "dumper" resistor, R_n , whose value is small compared to R_r . When the switch is opened, the relay armature releases immediately, and the capacitor, discharged, is restored to the circuit and ready for the next operation.

With inexpensive and dependable

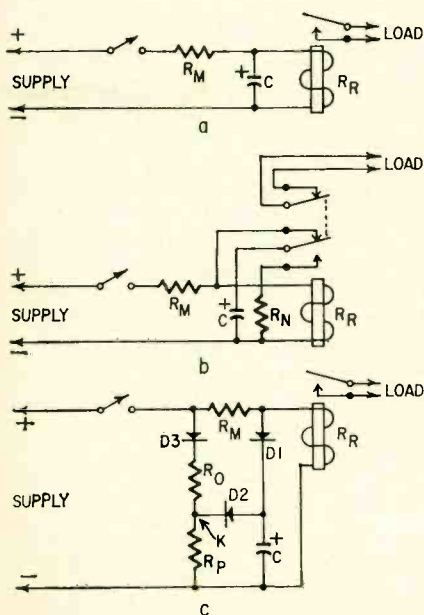
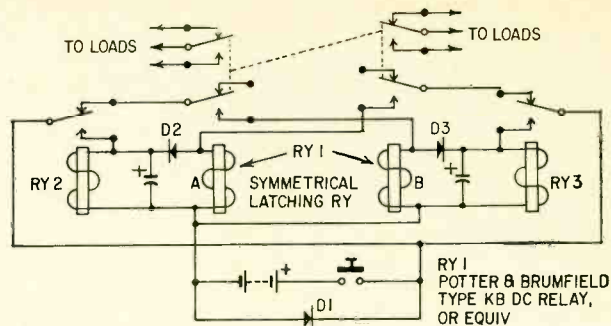

Fig. 5—Relay retarders. In a, slow operate, slow release; b and c, slow operate, quick release.

Fig. 6—A relay flip-flop, for very slow counting, from one count per day to one per minute.



silicon and germanium rectifiers, we can eliminate the auxiliary relay contact and construct a slow-operate, quick-release relay circuit as in Fig. 5-c. Resistors R_o and R_p are chosen so that the voltage between point K and ground (system negative) equals the steady-state voltage across the relay coil. With this arrangement, current cannot flow through $D1$ and $D2$ to ground when the switch is closed, for there is no potential difference across the rectifiers when the switch is closed.

With this circuit, when the switch is closed, current flows through R_m and $D1$ to capacitor C . This charges slowly until its voltage equals the pull-in voltage of the relay, which then operates. When the switch is opened, the relay armature is released immediately. Point K is no longer held above ground by current through $D3$ and R_o , so $D2$ conducts, and C discharges through $D2$ and R_p , readying the circuit for the next operation. $D3$ is necessary to block a sneak circuit to the relay coil through $D2$, R_o and R_m .

Relay scale-of-2

For very slow operations, such as in many types of meteorological and climatological instruments, and for handling relatively large powers at medium speeds, vacuum-tube and solid-state flip-flop scales of 2 leave much to be desired, particularly when power economy is important.

For such applications, a relay flip-flop has been developed, admirably suited for operating speeds from 1 per day to 1 per minute. Circuit of one form of the relay flip-flop is shown in Fig. 6.

Assume that the A armature of the electro-mechanical symmetrical latching relay (RY1) is down and locked in position, and that the switch is open. Closing the switch energizes coil B of RY1 and the coil RY3, and charges the capacitor shunted across RY3's coil. (The circuit from the switch is through the upper contact of RY2 and the lower contact of RY1, A.) The armature of coil B (RY1) pulls down, releasing the armature of coil A. This latches armature B in its down position, and removes the voltage feed to coil B. At the same time, the armature of RY3 has pulled down, connecting it in a self-

maintaining mode, with slow release provided by the shunt capacitor. This assures that, after armature B of RY1 has pulled down, no further switching action will take place until the switch has been opened and again closed. When the switch has been released, and a very short time allowed for discharging the capacitor shunted across the active auxiliary relay (here RY3), armature B is locked in down position, and all other armatures are up. A second closing of the switch repeats the process in mirror-reversed order, restoring the circuit to the initial conditions.

Rectifier $D1$ is a spark absorber, which reduces flyback voltages to a negligible value, preventing much contact sparking and radio interference. Rectifiers $D2$ and $D3$ isolate the capacitors across the auxiliary relays from the main relay (RY1) coils, so that much smaller capacitors can be used. As the main relay coils are rather low-resistance, whereas the auxiliary relay coils are comparatively high, this leads to a great saving in capacitor bulk. These same rectifiers also lead to a considerable power saving, as the active coil of the main relay (RY1) draws current only during the instant of switching, no matter how long the switch remains closed.

By omitting the normally open (lower) contact of each auxiliary relay, this circuit becomes an astable multivibrator, whose half-cycle period is indicated by formula (1). With high-resistance auxiliary relays and large electrolytic capacitors across them, cycle durations of more than 5 minutes are possible.

Relays can also be used for a number of logic functions. One of the first large computers was a relay integrator developed by Bell Telephone Laboratories more than a generation ago. END

Radio-Electronics Is Your Magazine!

Tell us what you want to see in it. Your suggestions may make it a better magazine for the rest of the readers as well as yourself. Write to the Editor, RADIO-ELECTRONICS, 154 West 14th St., New York, N. Y. 10011.

TRY THIS ONE

HEATHKIT IT-12 MODIFICATIONS

Although this signal-tracer is very useful as is, a few simple changes makes it even more worthwhile.

1. Use standard mike connectors for the probe input. This will make the unit more portable and allow easier testing of microphones, etc.
2. Construct an induction pickup probe. This will allow rf pickup in critical circuits where the probe would detune the stage. The drawing below explains itself.

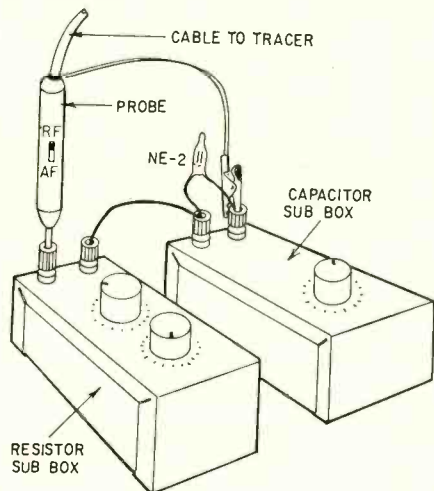
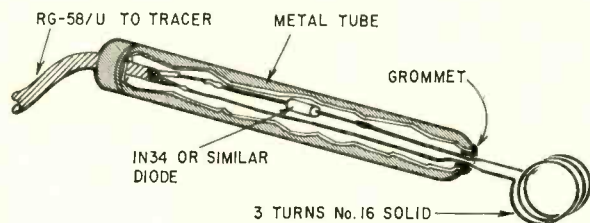

3. Often, a variable audio generator is needed just when one isn't available. Use your resistor and capacitor substitution boxes and a neon bulb as shown above for good results. Set the probe switch to AUDIO and the tracer's switch to NOISE. Tap output from the speaker posts.

4. To prevent the eye tube from being pushed back and shorting to the cabinet, put a layer of wide adhesive tape on the point where it would touch.—Alan Glaser

FLASH-WELD GROUND RIVETS TO CHASSIS

Ground connections in some chassis are made by fastening hollow rivets to the chassis and frame. Wires are inserted and soldered to the rivet. Trouble often develops because of poor contact between rivet and chassis.

While this can be cured by soldering the rivet securely to the chassis, a quicker repair is to discharge a capacitor bank of 400-500 μ f, 450 volts from chassis to each suspected ground rivet. Also 150-volt capacitors will do the job if charging voltage is lower.—H. Josephs

MORE GAIN FROM TABLE SETS

Small table radios that use 50B5 or 50C5 output stages can be made considerably more sensitive by changing the

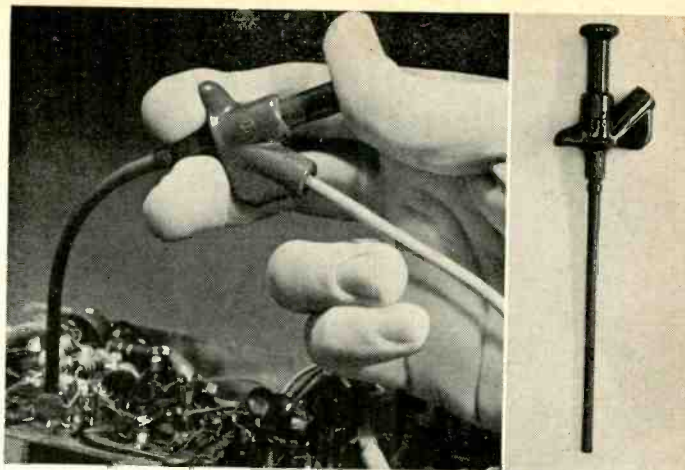

Clever Kleps 30

Push the plunger. A spring-steel forked tongue spreads out. Like this  Hang it onto a wire or terminal, let go the plunger, and Kleps 30 holds tight. Bend it, pull it, let it carry dc, sine waves, pulses to 5,000 volts peak. Not a chance of a short. The other end takes a banana plug or a bare wire test lead. Slip on a bit of shield braid to make a shielded probe. What more could you want in a test probe?



Available through your local distributor, or write to: **\$1.47**

RYE SOUND CORPORATION
121 Spencer Place, Mamaroneck, N.Y.

Circle 121 on reader's service card

Me...? Rebuild Color Tubes???

Why Not!

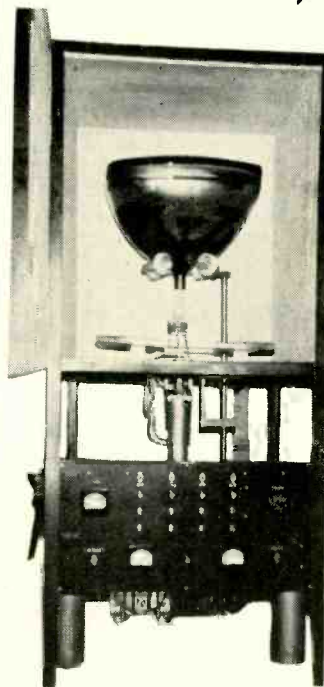

Windsor Equipment
Handles Color & Bonded-Face As Well As Black-and-White Tubes.

So What?

Rebuilding with Windsor is a **QUALITY PROCESS . . . and PROFITABLE !!!**

Rebuild Color Tubes for a Cost of \$11.75 each . . . You sell them for???

Windsor Equipment pays for itself in a few months.

Financing Available
Free Training at our Plant

Write for our Booklet "The Open Door to TV Profits"

WINDSOR ELECTRONICS, INC.

Equipment Division
999 N. Main St., Glen Ellyn, Illinois

Circle 122 on reader's service card

FIELD ENGINEERS & TECHNICIANS

STATESIDE AND OVERSEAS

Philco's TechRep Division has provided technical support to government and industry for over twenty-four years. The Division continues to offer a variety of employment opportunities and a modern, liberal, benefits program. The following categories are typical of current needs:

- DIGITAL COMPUTERS / DATA PROCESSING
- HEAVY GROUND RADAR
- TELEMETRY & INSTRUMENTATION
- GROUND COMMUNICATIONS
- SHIPBOARD RADAR
- SHIPBOARD COMMUNICATIONS
- SONAR
- PRECISION TEST EQUIPMENT CALIBRATION
- POWER PRODUCTION—DIESEL/STEAM
- GROUND SUPPORT EQUIPMENT
- TECHNICAL WRITERS; TRAINEE TO SENIOR LEVEL

To investigate these opportunities please rush resume in confidence to:

PHILCO TECHREP DIVISION

A SUBSIDIARY OF *Ford Motor Company*

P. O. Box 10, Dept. 804-G, FORT WASHINGTON, PENNA. 19034

An Equal Opportunity Employer

output tube to a 50EH5, which requires only 3 volts peak audio drive against the 50C5's and 50B5's 8 volts.

The only change required is to replace the usual 150- or 180-ohm cathode resistor with a 68-ohm resistor. To replace the 50B5, the resistor must be changed *and* the socket rewired for the different base connections.

Once the resistor is changed, the old tube types must not be used; the lower bias resistance will cause too much plate current to flow.

Of course this change applies as well to small phonographs or intercoms. And a 35B5 or 35C5 can be replaced by a 35EH5.

Hum may be more audible with the more sensitive tube. If so, use larger filter capacitors.—*Harold J. Weber*

NYLON GLOVES PREVENT SAFETY-GLASS SMEARS

When replacing the safety glass on a television set after a cleaning, wear nylon gloves. Then skin oil won't contaminate the clean glass no matter how much you handle the viewing surfaces. Those smudges that always seem to appear on the inside of the glass just after the last screw on the decorative trim is tightened will no longer be there, and you won't have to "edge handle" the glass as if you're performing a balancing act.

You can get white nylon gloves from an industrial supplier who deals with factories having "clean rooms" or vacuum systems. If you're a domesticated male, you may be able to prevail upon your wife to give up an old pair of her dress gloves which will serve the purpose nicely after a thorough washing to remove any oils trapped in their fibers. Keep your gloves in a plastic bag when you store them in your tool box, to avoid soiling them.—*George R. Wisner*

"MOVING OUT SALE" PORT OF N. Y. AUTHORITY TAKING OVER 13 BLOCKS FOR TRADE CENTER & WE'RE IN IT!

We must unload 3 BULGING WAREHOUSES . . . at the GREATEST PRICE SLASH in Electronic History!

We will have 2 Places to serve you — Uptown at 2271 Broadway, Downtown still pending — Sale may end soon — HURRY, HURRY, HURRY.

FREE \$1 BUY WITH EVERY 10 YOU ORDER Only applies to "\$1" Buys FREE GIFT WITH EVERY ORDER

- 1000—ASST. HARDWARE KIT \$1
screws, nuts, washers, rivets, etc.
- 250—ASST. SOLDERING LUGS \$1
best types and sizes
- 250—ASST. WOOD SCREWS \$1
most popular selection
- 250 — ASST. SELF TAPPING SCREWS #6, #8, etc. \$1
- 150—ASST. 6/32 SCREWS and 150 6/32 HEX NUTS \$1
- 150—ASST. 8/32 SCREWS and 150—8/32 HEX NUTS \$1
- 150—6/32 HEX NUTS and 150—8/32 HEX NUTS \$1
- 150—ASST. 2/56 SCREWS and 150—2/56 HEX NUTS \$1
- 150—ASST. 4/40 SCREWS and 150—4/40 HEX NUTS \$1
- 150—ASST. 5/40 SCREWS and 150—5/40 HEX NUTS \$1
- 500—ASSORTED RIVETS \$1
most useful selected sizes
- 500—ASSORTED WASHERS \$1
most useful selected sizes
- 100 — ASST. RUBBER & FELT FEET FOR CABINETS \$1
best sizes
- BONANZA "JACKPOT" not gold, not oil, but a wealth of Electronic Items—Money-Back-guarantee \$5
- 100'—MINIATURE ZIP CORD \$1
2 conductor, serves 101 uses
- 10 SETS — DELUXE PLUGS & JACKS \$1
asst. for many purposes
- 10 — SETS PHONO PLUGS & PIN JACKS \$1
RCA type
- 10 — SURE-GRIP ALLIGATOR CLIPS \$1
2" plated
- 4—50' SPOOLS HOOK-UP WIRE \$1
4 different colors
- 200'—BUSS WIRE #20 tinned for hookups, special circuits, etc. \$1
- 100 — STRIPS ASSORTED SPAGHETTI \$1
handy sizes
- 100—ASSORTED RUBBER GROMMETS \$1
best sizes
- 50—ASSORTED PRINTED CIRCUIT SOCKETS \$1
best types
- 20—ASSORTED VOLUME CONTROLS \$1
less switch
- 7—ASSORTED VOLUME CONTROLS \$1
with switch
- 15—RADIO OSCILLATOR COILS \$1
standard 450ke
- 20—ASST. PILOT LIGHTS \$1
#44, 46, 47, 51, etc.

TV BARGAIN COLUMN

- 3—MALLORY 80-450v ELECTROLYTIC CONDENSERS (sparkling new) top item for TV and amplifiers \$1
- RCA 110° FLYBACK TRANSF. \$3
for all type TV's incl schematic
- 90° FLYBACK TRANSFORMER \$1
for all type TV's incl schematic
- 90° TV DEFLECTION YOKE \$1
for all type TV's incl schematic
- 70° FLYBACK TRANSFORMER \$1
for all type TV's incl schematic
- 70° TV DEFLECTION YOKE \$1
for all type TV's incl schematic
- 4 — TV ALIGNMENT TOOLS \$1
most useful assortment
- 20—ASSORTED TV COILS \$1
I.F. video, sound, ratio, etc.
- 40—ASSORTED TV KNOBS \$1
all standard types, \$20 value
- 20—ASSORTED GRID CAPS \$1
for 1B3, 1X2, 6BG6, 6BQ6, etc.
- 100 — ASSORTED TV PEAKING COILS \$1
all popular types
- \$15.00 TELEVISION PARTS \$1
"JACKPOT" best buy ever

MARKET SCOOP COLUMN

- AU-15 BSR RECORD CHANGER \$11
complete with dual sapphire arm
Brand new — 110 volts, 50 cycles
- 1—LB SPOOL ROSIN-CORE SOLDER \$1
40/60 top quality
- 2—G.E. PIECES OF EQUIPMENT \$1
stacked with over 200 useful parts
- \$14 QUAM 12" PM SPEAKER \$5
Top quality, 10oz ceramic mag.
- TRANSISTOR RADIO \$1.50
asst type good, bad, broken, as-is, potluck
- TAPE RECORDER \$4
assorted types good, bad, broken, as-is, potluck
- \$50 STARLITE AM-FM RADIO \$12
complete needs slight adjustment
- 10—ASSORTED DIODE CRYSTALS \$1
1N34, 1N48, 1N60, 1N64, 1N82
- 10—TOP BRAND TRANSISTORS \$1
NPN & PNP 2N404, 2N414, etc.
- 10 — ASST. RADIO ELECTROLYTIC CONDENSERS \$1
- 7 — ASST. TV ELECTROLYTIC CONDENSERS \$1
popular selection

IMMEDIATE DELIVERY . . . Scientific light packing for safe delivery at minimum cost. **HANDY WAY TO ORDER:** Pencil mark or write amounts wanted in each box, place letter F in box for Free \$1 BUY. Enclose with check or money order, add extra for shipping. Tearsheets will be returned as packing slips in your order, plus lists of new offers.

Name

Address

Cost of goods

Shipping estimated

TOTAL

Please specify refund on shipping overpayment desired: CHECK POSTAGE STAMPS MERCHANDISE (our choice) with advantage to customer

QUICK GO/NO-GO TESTS FOR SCR'S

Silicon controlled rectifiers can be checked in a rough way just as quickly as transistors. All you need is your ohmmeter. You will have to find out which lead goes to the positive side of the battery on ohms ranges. In the Simpson 260, it's the red lead, but that's not true for all meters. (See "Transistors and your Ohmmeter," November 1963, RADIO-ELECTRONICS, page 80).

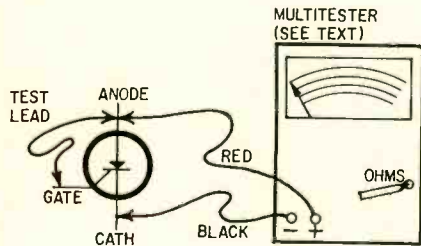

Connect the meter leads with proper polarity to the cathode and anode of the SCR you want to test (see the drawing). The meter should read a very high resistance—several megohms. A low or zero reading indicates a shorted SCR.

Now connect a test lead momentarily from anode to gate. The meter reading should drop to a very low value. If the SCR has a low holding cur-

rent, the reading may remain low even after you remove the test lead, and until you disconnect the SCR. In other devices, the reading will be low only while the gate is biased on. Either situation can be all right, as long as by resetting the SCR (disconnecting the test lead or the whole ohmmeter) you can get the high-resistance reading again.

Touch the test lead only momentarily to the gate terminal to avoid any chance of damaging the gate-to-cathode junction.

This is only a quick way to check an SCR suspected of being defective. To measure specific characteristics, a more complex setup is needed.—Paul Galluzzi END

24 WAYS TO PUT YOUR RECORDER TO WORK

Your tape recorder is too valuable to bury in the back closet under a heap of old clothes! Put it to work for you in dozens of ways at home, at school, in business or in the shop and ham shack!

COMING IN . . .
MARCH RADIO-ELECTRONICS

Enjoy the "music-only" programs now available on the FM broadcast band from coast to coast.

- NO COMMERCIALS •
- NO INTERRUPTIONS •



It's easy! Just plug Music Associated's Sub Carrier Detector into multiplex jack of your FM tuner or easily wire into discriminator. Tune through your FM dial and hear programs of continuous commercial-free music you are now missing. The Detector, self-powered and with electronic mute for quieting between selections, permits reception of popular background music programs no longer sent by wire but transmitted as hidden programs on the FM broadcast band from coast to coast. Use with any FM tuner. Size: 5 1/2" x 6". Shipping weight approx. 7 lbs.

KIT \$49.50

(with pre-tuned coils, no alignment necessary)

WIRED \$75.00

(Covers extra \$4.95 ea.)

Write to:

MUSIC ASSOCIATED

65 Glenwood Road, Upper Montclair, N. J.
Phone: (201)-744-3387

Circle 123 on reader's service card

SARKES TARZIAN TV TUNER 41mc

Latest Compact Model—good for all 41 mc TV's.
BRAND NEW—MONEY BACK GUARANTEE



Best TUNER "SARKES TARZIAN" ever made—last word for stability, definition & smoothness of operation. An opportunity—to improve and bring your TV Receiver up-to-date.

COMPLETE with Tubes & Schematic **\$7.95**

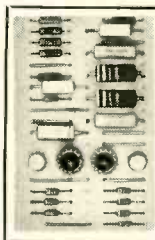

IBM COMPUTER SECTIONS

8 assorted Units we sell for \$1 are loaded with over 150 valuable parts.

Incl.—Transistors
Condensers, Resistors,
Heat Sinks, Diodes, Etc.

8 for \$1
100 for \$10

HIGHWAVE AM-FM PORTABLE RADIO



Elegance in Ebony & Chrome

14 Transistors—A Powerhouse of Quality Reception with AFC Operates on four "C" Cells

22" Telescoping FM Antenna & Personal Listening Attachment

Money refund—if not better than any Known Brand selling for even twice the price 8"x5 1/4"x2 1/4"—4 lbs

COMPLETE **\$19.50**

- | | | | |
|---|--|---|--|
| <input type="checkbox"/> 50—ASSORTED MYLAR CONDENSERS popular selected types . . . \$1 | <input type="checkbox"/> UNIVERSAL 4" PM SPEAKER Alnico 5 magnet, quality tone . . . 69¢ | <input type="checkbox"/> 100—ASST. CERAMIC CONDENSERS some in 5% . . . \$1 | <input type="checkbox"/> \$15.00 RADIO PARTS "JACKPOT" handy assortment . . . \$1 |
| <input type="checkbox"/> 4—SHOCKPROOF SCREWDRIVERS best sizes incl Phillips . . . \$1 | <input type="checkbox"/> UNIV. 3" x 5" PM SPEAKER Best type for Radios, TV, Etc. . . 75¢ | <input type="checkbox"/> 100—ASST. MICA CONDENSERS some in 5% . . . \$1 | <input type="checkbox"/> 20—ITT SELENIUM RECTIFIERS 65ma for Radios, Meters, Chargers, Transistors, Experiments, etc. . . \$1 |
| <input type="checkbox"/> 4—TRANSISTOR RADIO EARPIECES wired complete with plug . . . \$1 | <input type="checkbox"/> UNIVERSAL 4" PM TWEETER SPEAKER for FM, Hi-Fi, etc. . . 69¢ | <input type="checkbox"/> 100—ASST 1/4 WATT RESISTORS stand. choice ohmages, some in 5% . . . \$1 | <input type="checkbox"/> 20—ASSORTED TUBES Radio, Television and Industrial . . . \$1 |
| <input type="checkbox"/> 20—EXPERIMENTER'S COIL "JACKPOT" assorted for 101 uses . . . \$1 | <input type="checkbox"/> UNIV. 2" PM SPEAKER for Radios, Extra Speakers, Etc. . . 36¢ | <input type="checkbox"/> 100—ASST 1/2 WATT RESISTORS stand. choice ohmages, some in 5% . . . \$1 | <input type="checkbox"/> 50—WHITE TUBE CARTONS asst. for all 4 important sizes . . . \$1 |
| <input type="checkbox"/> 50—G.E. FLASHLIGHT BULBS #PR-9, 2.7 volts . . . \$1 | <input type="checkbox"/> 10—SPEAKER PLUG SETS deluxe type, 2 conductor, wired . . . \$1 | <input type="checkbox"/> 70—ASST 1 WATT RESISTORS stand. choice ohmages, some in 5% . . . \$1 | <input type="checkbox"/> ALL AMERICAN TUBE KIT Top Standard Brand — 12BA6, 12BE6, 12AV6, 50C5, 35W4 . . . \$2 |
| <input type="checkbox"/> 10—ASSORTED SLIDE SWITCHES SPST, SPDT, DPDT, etc. . . \$1 | <input type="checkbox"/> 300—ASST. 1/2 W RESISTORS Top Brand, Short leads, excellent . . . \$1 | <input type="checkbox"/> 35—ASST 2 WATT RESISTORS stand. choice ohmages, some in 5% . . . \$1 | <input type="checkbox"/> 3—TOP BRAND 35W4 TUBES \$1 |
| <input type="checkbox"/> CHAPT ZU DI MITZIA "JACKPOT" double your money back if not completely satisfied . . . \$1 | <input type="checkbox"/> 100—MOLDED TUBULAR COND. Top brand, short leads, excellent . . . \$1 | <input type="checkbox"/> 50—PRECISION RESISTORS asst. list-price \$50 less 98% . . . \$1 | <input type="checkbox"/> 5—RCA 1U4 TUBES brand new boxed, also serves as a 1T4 . . . \$1 |
| <input type="checkbox"/> RONETTE SAPPHIRE CARTRIDGE dual flipover type—value \$5 . . . \$1 | <input type="checkbox"/> 50—ASSORTED #3AG FUSES Popular assorted ampere ratings . . . \$1 | <input type="checkbox"/> 20—ASST'ED WIREWOUND RESISTORS, 5, 10, 20 watt . . . \$1 | <input type="checkbox"/> 25—SYLVANIA HEAT SINKS for Transistors, etc. . . \$1 |
| <input type="checkbox"/> RONETTE STEREO CARTRIDGE latest dual sapphire flipover type . . . \$2 | <input type="checkbox"/> 5—I.F. COIL TRANSFORMERS sub-min for Transistor Radios . . . \$1 | <input type="checkbox"/> 100—ASST. TERMINAL STRIPS all types, 1-lug to 8-lug . . . \$1 | <input type="checkbox"/> 100—BRASS FAHNSTOCK CLIPS popular type & size, plated . . . \$1 |
| <input type="checkbox"/> 3—SAPPHIRE STYLUS NEEDLES Ronette type for most cartridges . . . \$1 | <input type="checkbox"/> 5—AUDIO OUTPUT TRANSFORM sub-min for Trans Radios . . . \$1 | <input type="checkbox"/> 25—INSTRUMENT POINTER KNOBS selected popular types . . . \$1 | <input type="checkbox"/> 3—ELECTROLYTIC CONDENSERS 50/30-150v . . . \$1 |
| <input type="checkbox"/> 3—STANDARD SAPPHIRE NEEDLES for all thumb-screw cartridges . . . \$1 | <input type="checkbox"/> 4—TOGGLE SWITCHES SPST, SPDT, DPST, DPDT . . . \$1 | <input type="checkbox"/> 50—ASST. RADIO KNOBS all selected popular types . . . \$1 | <input type="checkbox"/> 6—TV ELECTROLYTIC CONDENSERS Sprague 80-175v . . . \$1 |
| <input type="checkbox"/> 50—BALL POINT PENS Retractable, assorted colors . . . \$1 | <input type="checkbox"/> 15—ASST. ROTARY SWITCHES all popular types \$20 value . . . \$1 | <input type="checkbox"/> 5—PNP TRANSISTORS general purpose, TO-5 case . . . \$1 | <input type="checkbox"/> 2—POWER TRANSISTORS No. 1 Replace 2N155, 2N176, 2N301, etc. . . \$1 |
| <input type="checkbox"/> 20—STANDARD TUBULAR CONDENSERS .047-600v . . . \$1 | <input type="checkbox"/> 50—RADIO & TV SOCKETS all type 7 pin, 8 pin, 9 pin, etc. . . \$1 | <input type="checkbox"/> 5—NPN TRANSISTORS general purpose, TO-5 case . . . \$1 | <input type="checkbox"/> 50—ASST. TUBULAR CONDENSERS .001 to .47 to 600v . . . \$1 |
| | <input type="checkbox"/> CLEAN UP THE KITCHEN "JACKPOT" Big Deal only one to a customer . . . \$1 | <input type="checkbox"/> 50—RCA LUCITE RADIO KNOBS popular type w. indicator pointer . . . \$1 | <input type="checkbox"/> 100—MIXED DEAL "JACKPOT" Condensers, Resistors, Sprites . . . \$1 |

CANADIANS: Ordering is easy . . . we do the paperwork . . . try a small order

BROOKS RADIO & TV CORP., 84 Vesey St., Dept. A, New York 7, N.Y. TELEPHONE: COrtlandt 7-2359

Circle 124 on reader's service card



Take your toughest electronics problems to the Gernsback Book Rack at your parts distributor —for instant answers!

When you need immediate answers to thorny electronics problems, go directly to the Gernsback Library Book Rack at your favorite electronics parts distributor. This unique information center will automatically give you accurate answers to every imaginable electronics problem you may face. You'll find answers on radio and TV servicing, transistors, hobby projects, test instruments, audio, hi-fi, stereo, tape recording, communications, industrial electronics, to name just a few areas. Each book is written by an expert and designed to give you practical assistance in the field you desire. So check the Gernsback Rack at your parts distributor when you have a question. You'll increase your know-how and get more fun out of electronics as well.

Service AGC Circuits

By Harry E. Thomas. This practical how-to-do-it manual first shows you everything that can go wrong with AGC circuits and then goes on to reveal all you need to know to correct the trouble. Enables you to locate breakdowns quickly, in AGC circuits, and then make your repairs rapidly and intelligently. Specific service approaches are plainly spelled out so you can use them immediately. Special emphasis is placed on TV troubleshooting, giving you the devices and techniques used in modern circuitry. Easy-to-read explanations, helpful illustrations, readily understood charts give you the information you need to start servicing AGC circuits as soon as you've read the book. 204 pages, softbound, available through parts jobbers only.

Order #126 \$3.95

Color TV Repair

By 10 Servicing Experts. Top technicians like David R. Anderson, Ed Bukstein, Jack Darr, Homer L. Davidson, Art Margolis, Robert Middleton and Warren Roy have created here, an important tool for the profit-minded service technician. Tells you clearly and concisely just what can go wrong in color TV receivers and how to fix them. First each trouble symptom is described in detail, then a perfect solution is provided for the problem. Book covers color circuits, ABC's of color TV servicing, antennas and boosters, replacing the color picture tube, how to pinpoint the defective color section fast, servicing the chroma circuits, unexpected causes of TV color failure, troubleshooting with a color bar generator, color servicing tips, plus a glossary of color TV terms. In addition, the volume is crammed with photos and schematics. 160 pages, softbound.

Order #123 \$2.95

TV Sweep Oscillators

By Harry E. Thomas. A giant reference and practical working tool for every service technician and engineer who wants to know what can go wrong with sweep oscillators and how to repair them. Covers relaxation oscillators, pulse techniques, transistorized oscillators, failure analysis, sawtooth generators, synchronization, sweep oscillator servicing, AFC in horizontal circuits, multivibrators and blocking oscillators. Completely illustrated. 226 pages, softbound, available at parts jobbers only.

Order #119 \$3.95

Horizontal Sweep Servicing Handbook

By Jack Darr. Gives you fast, simple methods of locating and repairing troubles in the sweep sys-

tem. Shows you lots of practical shortcuts developed on the bench for the rapid isolation of trouble. Written by an expert in the field and packed with schematics to help you do a better job. 224 pages, softbound.

Order #115 \$4.10

The Handbook of Electronic Tables

By Martin Clifford. Here is an effective new approach to solving electronics problems. You don't have to make mathematical computations, or carry a slide rule or memorize any formulas whatsoever. Every answer you will ever need is worked out for you in 160 fact-packed pages of accurate electronic tables. Simply take the figures of your electronics problems and turn to the appropriate table. Then move your finger across the table and read the answer, instantly. You'll find these tables are easy to use, offer a wide choice of solutions and provide a high degree of accuracy. Softbound.

Order #125 \$2.95

Electronics Data Handbook

By Martin Clifford. Gives you the most-needed formulas and data in electronics. Tells exactly which formula to use to solve a problem. Provides an easier formula if there is one. Shows what substitutions, if any, can be made in formulas. 160 pages, softbound.

Order #118 \$2.95

Hi-Fi Troubles

By Herman Burstein. High fidelity is complex and sophisticated and the more complex it is, the more apt it is to develop troubles. This book tells you how to maintain your audio system to keep it in peak condition for peak performance. It shows you why you have troubles, how to locate them, how to fix them. Most important, it shows you what *not* to do. *Hi-Fi Troubles* saves both time and money and helps solve problems like these: excessive hum; deteriorating equipment; noise in switches, tubes, resistors, etc.; distortion; bass and treble problems; installation; problems faced by kit builders; stereo and tape completely illustrated, softbound.

Order #120 \$3.95

Probes for Test Instruments

By Bruno Zucconi and Martin Clifford. A probe is a link. It is a device you connect between a test instrument like a scope or v.t.v.m. and a radio or TV set being repaired. The finest scope or v.t.v.m. is limited by the kind of probe you use, and by how much you know about putting probes to work for you. Now comes this valuable handbook showing you in clear detail exactly what probe to use for a particular job. Covers

crystal-demodulator probes, voltage-doubler probes, balanced probes, low-capacitance probes, high-voltage probes, isolation probes, direct probes, specialized probes, vacuum-tube and semiconductor probes. 224 pages, softbound. Newly Revised.

Order #54 \$2.50

The Oscilloscope

By George Zwick. Enables technicians to become masters of the scope. Incorporates newest uses and techniques. Covers waveforms, the cathode-ray tube, sweep systems, typical oscilloscopes, alignment, oscilloscope techniques, tests and measurements, experiments using the oscilloscope. The book is fully illustrated. 224 pages, softbound.

Order #108 \$3.65

The V.T.V.M.

By Rhys Samuel. Get the most out of this electronic workhorse. Explains V.T.V.M. circuits and how and why they work. Gives many new time-saving uses. Eleven important chapters tell all: instrument characteristics, how the V.T.V.M. works, meter scales, probes and cables, using the V.T.V.M., TV troubleshooting, AM-FM alignment and repair, servicing audio amplifiers, the V.T.V.M. in the ham shack, miscellaneous applications, troubleshooting the V.T.V.M. 224 pages, completely illustrated, softbound.

Order #57 \$2.50

How to Get the Most out of your VOM

By Tom Jaski. Get more mileage out of this versatile instrument. A complete analysis including theory and practical usage, plus important chapters on construction. 224 pages, illustrated, softbound.

Order #85 \$2.90

Order from your Parts Distributor or Mail to:
Gernsback Library, Inc., Dept. RE 26
154 West 14th Street, N.Y., N.Y. 10011

Please send the following books.

I enclose \$

- | | |
|---------------------------------------|---------------------------------------|
| <input type="checkbox"/> 123 (\$2.95) | <input type="checkbox"/> 54 (\$2.50) |
| <input type="checkbox"/> 115 (\$4.10) | <input type="checkbox"/> 108 (\$3.65) |
| <input type="checkbox"/> 125 (\$2.95) | <input type="checkbox"/> 57 (\$2.50) |
| <input type="checkbox"/> 118 (\$2.95) | <input type="checkbox"/> 85 (\$2.90) |
| <input type="checkbox"/> 120 (\$3.95) | |

Prices 10% higher in Canada.

Name

Address

City State Zip

My Distributor is

Get these books at your parts distributor or mail ➤

WHAT'S YOUR EQ?

These are the answers. Puzzles are on page 61.

How Wide?

At first this appears impossible since no value is given for L. However, there is a solution.

(1) $\Delta f = f_r/Q$ where $f_r = 1/2\pi \sqrt{LC}$ and $Q = R/X_L = R/2\pi f_r L$

Substituting for Q in equation (1):

(2) $\Delta f =$

$$\frac{f_r}{R/2\pi f_r L} = \frac{2\pi f_r^2 L}{R}$$

Substituting for f_r in equation (2):

$$\Delta f = \frac{2\pi L/4\pi^2 LC}{R} = \frac{1}{2\pi RC}$$

Substituting given values of R and C:

$$\Delta f = 159 \text{ kc.}$$

Series Parallel Circuit

By determining the voltage at point A (55 volts), R1 can be eliminated. The remaining total resistance must be 1,250 ohms (55/.044). If we make the value of R4 and the combi-

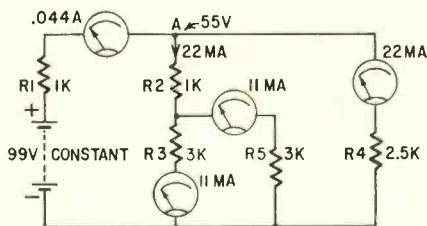

nation of R2, R3 and R5 both equal to 2,500 ohms, they equal 1,250 ohms when paralleled. To make the combination equal to 2,500 ohms, R5 must be 3,000 ohms. (3,000 paralleled with 3,000 equals 1,500. This in series with 1,000 equals 2,500.)

There is .022 amp current through R2 and R4. This current is divided equally (.011 amp) between R3 and R5.

Two Lamps

With the switch open, current flows through Lamp 1 on negative half-cycles (Lamp 2 being shorted by D2); no current flows when the ac goes positive. With switch closed, Lamp 1 is shorted

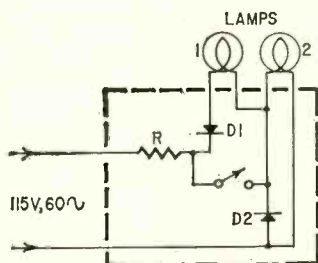

and current flows through Lamp 2 on positive half-cycles. When the ac is neg-

ative, the current is "bypassed" through D2.

The resistor prevents excessive current when D2 is directly across the supply. END

CORRECTION 400Hz TRANSFORMERS

There is a drafting error in the transformer wiring diagram on page 92 of the December issue. The bottom of the line indicating 300 volts should end at the bottom lead of the lower of the two series-connected high-voltage secondaries instead of at the outside lead of the lower 6-volt winding. This error was spotted and reported by sharp-eyed Robert B. St. Almond of El Paso, Tex.

Note well that all similar secondaries must be connected in *series-aiding*. Connect one pair of windings and check for correct polarity before connecting the next pair. Avoid chances of a shock or short circuit by using spaghetti tubing to insulate all lugs and leads not being checked. Be sure that the meter is set to the correct range. If in doubt, use the highest ac range. Clip an insulated test lead to *one* of the two leads to be metered. Turn on the power and *then* touch the other test prod to the remaining lead. Keep your free hand in your pocket! See "Watch Out for Transients" in the April 1963 issue.—*Editor*

Olson

FREE

Fill in coupon for a FREE One Year Subscription to OLSON ELECTRONICS' Fantastic Value Packed Catalog—Unheard of LOW, LOW PRICES on Brand Name Speakers, Changers, Tubes, Tools, Stereo Amps, Tuners, CB, Hi-Fi's, and thousands of other Electronic Values. Credit plan available.

NAME _____
ADDRESS _____
CITY _____ ZONE _____ STATE _____

If you have a friend interested in electronics send his name and address for a FREE subscription also.

OLSON ELECTRONICS, INC.

455 S. Forge Street Akron, Ohio 44308

Circle 125 on reader's service card

Please include your ZIP code No. when renewing your Radio-Electronics subscription.

ELECTRONICS

Engineering-Technicians

Bachelor of Science Degree, 30 Months
Save Two Years' Time

- Radio-Television Plus Color Technician (12 Months)
- Electronics Engineering Technology (15 Months)
- Electronics Engineering (B.S. Degree)
 - Electrical Engineering (B.S. Degree)
 - Mechanical Engineering (B.S. Degree)
 - Civil Engineering (B.S. Degree)
 - Architecture (B.S. Degree)

Electronic Technicians, Radio TV Technicians is at an all time high. Heald Graduates are in demand for Preferred High Paying Salaries. Train now for a lucrative satisfying lifetime career.

Approved for Veterans

DAY AND EVENING CLASSES

Write for Catalog and Registration Application.
New Term Starting Soon.

HEALD'S

ENGINEERING COLLEGE

Est. 1863—103 Years
Van Ness at Post, RE
San Francisco, Calif.

Your Name _____
Address _____
City _____
State _____

Circle 126 on reader's service card

NOTEWORTHY CIRCUITS

REVERSING DC MOTORS

It is sometimes necessary to be able to reverse the rotation of small dc motors. If the motor has a permanent-magnet field, it is only necessary to reverse the polarity of applied voltage.

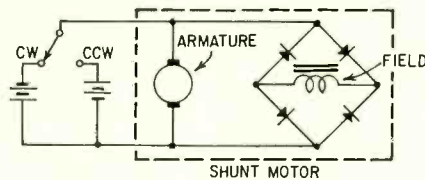

However, if the motor has a wound field, you must reverse the field connections with respect to the armature to reverse the motor. The circuits shown cause the current through the field winding to be in one direction regardless of the polarity of applied voltage, thus the direction of rotation is determined by the polarity of applied voltage and switching is simplified.

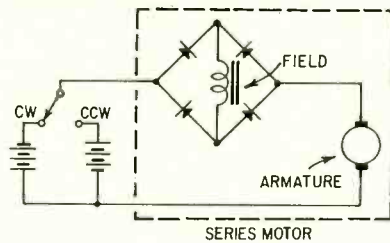

The field winding is connected to the output of a full-wave bridge rectifier to maintain the current through it in one direction at all times. For small motors (6 to 24 volts) the 1N538-1N540 series diodes have been used. The diodes may be mounted within or on the motor and become an integral part of it.

Two batteries are shown in each illustration. You can use one battery with a polarity-reversing switch.—Richard L. Koelker

BUILD A HANDY CURRENT TESTER

Ever wish you had a wattmeter to measure the power requirement of a piece of electronic gear? Several companies make nice plug-in wattmeters, but they cost about \$100.

Most of the appliances and electronic instruments we use do not have a very poor power factor, so the product of volts and amps is not too far from true watts. If you know your line voltage is in the neighborhood of 120, you

need only an ammeter. (Most of us have a vom which will measure ac volts if we need to be more accurate.)

You could buy a bona fide ac ammeter and supply it with a cord and an outlet all properly mounted in a suitable box. But you probably have an old dc milliammeter, taken out of some surplus gear, lying around in the junkbox. I happened to have a defunct rf ammeter with the thermocouple burned out. The dc movement was still in good shape and somewhere in the neighborhood of 0-1 ma. With addition of a 39-cent diode, a 1/2-ohm resistor, an old pot, a few connectors and a suitable box, I came up with a perfectly usable little instrument.

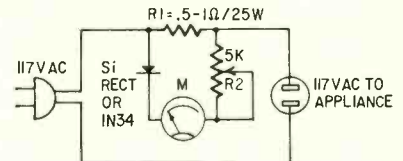

The diagram shows the circuit. Resistor R1 in my case was two pieces of No. 22 nichrome 1 foot long twisted together and then wound around a pencil and spaced. Any 1-ohm resistor that will stand the maximum current you expect will work equally well. I used 1/2-ohm because it was enough to give a 0-2.5-amp scale on the low-reading scale. The pot was 5,000 ohms but less than half of it is used for any scale.

For calibration, try to get a laboratory meter as a standard of comparison. With the pot nearly shorted out I got a 2.5-amp scale. With a little more resistance I got a 5-amp scale and with a little more I got a 10-amp scale. The setting of the pot was carefully marked for each of these scales. If you have a blank scale on the meter you can calibrate direct. I used the existing scale and drew three graphs of current vs scale reading for the three ranges.—R. E. Baird, W7CSD

MUSIC POWER REDEFINED

The chairman of the influential Standards Committee of the Institute of High Fidelity tells how the tricky and controversial "music power" concept has been redefined. A whole new set of standards has been developed for today's stereo amplifiers.

COMING IN . . .

MARCH RADIO-ELECTRONICS

WORLD'S FINEST 5-CORE SOLDER

ERSIN MULTICORE

NEW EASY DISPENSER PAK ONLY 69¢

BUY IT AT RADIO-TV PARTS STORES

MULTICORE SALES CORP. WESTBURY, N.Y. 11591

Circle 127 on reader's service card

SILICON RECTIFIER SALE

IMMEDIATE DELIVERY
FULLY GTD AMERICAN MADE
NEWEST TYPE FULLY TESTED

750 MA-SILICON "TOPHAT" DIODES
LOW LEAKAGE FULL LEAD LENGTH

PIV/RMS 50/35 .05 ea.	PIV/RMS 100/70 .07 ea.	PIV/RMS 200/140 .10 ea.	PIV/RMS 300/210 .12 ea.
PIV/RMS 400/280 .14 ea.	PIV/RMS 500/350 .19 ea.	PIV/RMS 600/420 .23 ea.	PIV/RMS 700/490 .27 ea.
PIV/RMS 800/560 .35 ea.	PIV/RMS 900/630 .45 ea.	PIV/RMS 1000/700 .60 ea.	PIV/RMS 1100/770 .75 ea.

ALL TESTS AC & DC & FWD & LOAD

SILICON POWER DIODE STUDS			
D.C. AMPS	50 PIV 35 RMS	100 PIV 70 RMS	200 PIV 140 RMS
3	.08 ea.	.12 ea.	.16 ea.
12	.25	.50	.65
25	.65	.90	1.25
50	1.50	1.75	2.20
100	1.60	2.00	2.40

D.C. AMPS	300 PIV 210 RMS	400 PIV 280 RMS	500 PIV 350 RMS	600 PIV 450 RMS
3	.27 ea.	.29 ea.	.37 ea.	.45 ea.
12	.90	1.20	1.40	1.65
25	2.00	2.35	2.60	3.00
50	3.25	4.00	4.75	6.00
100	3.60	4.50	5.25	7.00

"SCR" SILICON CONTROLLED RECTIFIERS "SCR"					
PRV	7 AMP	16 AMP	25 AMP	7 AMP	16 AMP
25	.50	.75	1.00	250	1.75
50	.60	.90	1.25	300	2.00
100	.80	1.25	1.50	400	2.40
150	.90	1.60	2.00	500	3.20
200	1.25	1.80	2.25	600	3.40

SPECIALS! SPECIALS!

100 Different Precision Resistors
1/2-1-2 Watt 1/2%-1% TOL \$1.25

2 amp 1000 Piv Silicon Power Rect. .70 ea.
10 for \$6.50

TEXAS INSTRUMENT—POWER TRANSISTOR—85
WATT—DIFFUSED NPN, SILICON MESA
TYPE 2N424 FACTORY NEW \$1.50 EA

Computer Grade Condenser 15,500 MFD
15 VDC American Mfg. .75 ea.

Type 1N34 DIODE GLASS .07 ea 100 for \$5

Money Back guarantee. \$2.00 min. order. Orders
F.O.B. NYC. Include check or money order. Shpg.
charges plus. C.O.D. orders 25% down.

Warren Electronic Components

230 Mercer St., N. Y., N. Y. 10012 • OR 3-2620

Circle 128 on reader's service card

SCHOOL DIRECTORY

Get Your First Class Commercial

F.C.C. LICENSE
and earn your
A.S.E.E. DEGREE

Move up. Increase your salary and prestige. How? By acquiring the knowledge and skill that industry needs and pays for!

The unique A.S.E.E. degree program available at Grantham School of Electronics teaches you what industry wants you to know for advanced employment. And you can complete three-fourths of this program while at home on your present job. Only one semester must be completed in residence.

Get the facts from our free catalog. Then, with our assistance, get the knowledge. Your F.C.C. license, your A.S.E.E. degree, and higher-paid employment follow naturally. Ask for *catalog 64*.

Grantham School of Electronics

1505 N. Western Ave., Hollywood, Cal. 90027
(Phone: HO 9-7878)

408 Marion Street, Seattle, Wash. 98104
(Phone: MA 2-7227)

818-18th St., NW, Washington, D.C. 20006
(Phone: 298-7460)

Circle 129 on reader's service card

A JOB or a POSITION ?

The difference is **ELECTRONIC MATHEMATICS**

NOW! A NEW WAY TO LEARN—I. H. S. I. WAY. A complete home study course in electronic math to help you get the position you want—**MORE MONEY—MORE RESPECT.**

COURSE PREPARED BY COLLEGE PROFESSORS

who have lectured to thousands of men on math and engineering. You learn at home quickly, easily—**AS FAST** as you want.

YOU SIGN NO CONTRACTS

Pay only if satisfied—you owe it to yourself to examine the **INDIANA HOME STUDY INSTITUTE COURSE IN ELECTRONIC MATH.**

FREE BONUS—if you join now, a refresher course in basic arithmetic.
Write for Brochure—No Obligation
THE INDIANA HOME STUDY INSTITUTE
Dept. RE-2, P.O. Box 1189
Panama City, Fla. 32402

GET INTO ELECTRONICS

V.T.I. training leads to success as technicians, field engineers, specialists in communications, guided missiles, computers, radar and automation. Basic & advanced courses in theory & laboratory. Electronic Engineering Technology and Electronic Technology curricula both available. Assoc. degree in 29 mos. B.S. also obtainable. G.I. approved. Graduates in all branches of electronics with major companies. Start Feb., Sept. Dorms, campus. High school graduate or equivalent. Catalog.

VALPARAISO TECHNICAL INSTITUTE
Department C, Valparaiso, Indiana



LEARN Electronics Engineering AT HOME

Fix TV, design automation systems, learn translators, complete electronics. College level Home Study courses taught so you can understand them. Earn more in the highly paid electronic industry. Computers, Missiles, theory and practical. Kits furnished. Over 30,000 graduates now employed. Resident classes at our Chicago campus if desired. Founded 1934. Catalog.

AMERICAN INSTITUTE OF ENGINEERING AND TECHNOLOGY
1139 W. Fullerton Pky., Chicago, Ill. 60614

Learn Electronics for your SPACE-AGE EDUCATION at the center of America's aerospace industry

No matter what your aerospace goal, you can get your training at Northrop Tech. in sunny Southern California.

COLLEGE OF ENGINEERING.

Get your B.S. degree in engineering in just 36 months by attending classes year round. Most Northrop Tech graduates have a job waiting for them the day they're graduated!

A & P SCHOOL. Practical experience on real aircraft. One-year course prepares you for F. A. A. A & P certificate. **WRITE TODAY FOR CATALOG.**

NORTHROP INSTITUTE OF TECHNOLOGY

1199 W. Arbor Vitae, Inglewood, Calif.

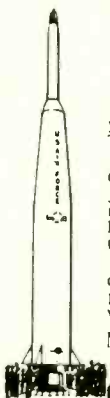

ENGINEERING DEGREES

Associate—Bachelor
Electronics—Mechanical
earned by

HOME STUDY

Resident Classes Also
Available if Desired
Specify course preferred



PACIFIC INTERNATIONAL COLLEGE OF ARTS & SCIENCES

Primarily a correspondence school
Chartered 1935

5507M Santa Monica Blvd. Hollywood, Calif., 90038

LEARN

ELECTRONICS

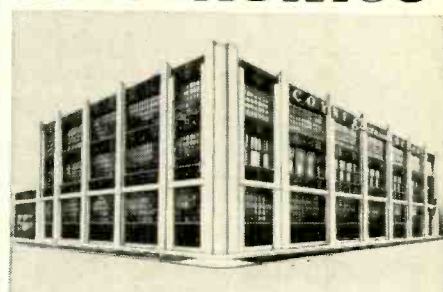

FOUNDED 1899

NOT-FOR-PROFIT

COYNE ELECTRONICS INSTITUTE

Electronics Engineering Technology	—	Degree (2 Yrs.)
Electrical-Electronics Technician	—	Diploma (40 Wks.)
TV-Radio-Electronics Technician	—	Diploma (40 Wks.)
Combined Electronics Technician	—	Diploma (80 Wks.)
Practical Electrical Maintenance	—	Diploma (32 Wks.)
Practical Refrigeration Air Conditioning and Appliance Repair	—	Diploma (24 Wks.)
Specialized Industrial Electronics	—	Diploma (16 Wks.)
Introduction to Electricity-Electronics	—	Certificate (8 Wks.)
FCC First Class Radiotelephone	—	Certificate (100 Hrs.)

Special finance plans. Part time employment service while in school. Also Free graduate employment service.



Use this coupon to get our **FREE BOOK "YOUR OPPORTUNITIES IN ELECTRONICS"**

COYNE ELECTRONICS INSTITUTE, Dept. of Electronics 26-N
1501 W. Congress Parkway, Chicago, Illinois 60607

Name _____ Age _____
Address _____ Phone _____
City _____ Zone _____ State _____
Unlike most other schools, we do not employ salesmen

Circle 130 on reader's service card

start your career here

Tri-State graduates hold important engineering and business administration posts throughout the U. S. Tri-State is a small professionally-oriented college in the beautiful lake section of NE Indiana. Excellent faculty... well-equipped labs... new library and residence halls... 300-acre campus... small classes... rich tradition. Modest costs. Four-quarter year permits degree in three years. One-year Drafting-Design Certificate program. For Catalog, write Director Admissions indicating career interest. Graduate placement outstanding!



TRI-STATE COLLEGE

2426 College Avenue, Angola, Indiana

NEW BOOKS

PRINCIPLES OF MICROWAVE CIRCUITS, edited by C. G. Montgomery, R. H. Dicke and E. M. Purcell. Dover Publications, Inc., 180 Varick St., New York 14, N.Y. 5 1/2 x 8 1/2 in., 486 pp. Paper, \$2.25

Based on the familiar MIT "Radiation Laboratory Series". Written and edited by many authorities, it interprets waveguides in terms of network theory.

TRANSISTOR CIRCUITS, Second Edition, by K. W. Cattermole. Gordon and Breach, Science Publishers, Inc., 150 Fifth Ave., New York 11, N.Y. 5 1/2 x 8 1/2 in., 470 pp. Cloth, \$14.50

A study of transistors and their cir-

cuits, written for circuit designers. Emphasizes amplification, feedback and switching.

ENERGY, ELECTRICITY AND ELECTRONICS, 4 vols., by Rex Miller, Fred W. Culpepper, Jr. McKnight & McKnight Publishing Co., Bloomington, Ill. 61702. Fundamental text: 8 x 10 1/2 in., 235 pp., cloth, \$5.20. Applied Activities: 7 x 10 1/4 in., 103 pp., cloth, \$4. Laboratory Manual: 7 1/2 x 10 in., 152 pp., paper, \$1.80. Professional Edition: 9 x 8 in., 235 pp., cloth, \$6.

A set of four books. The text deals with electricity and electronic theory in a fundamental way. It is accompanied by a

laboratory manual and an Applied Activities book, actually a collection of 26 simple construction projects. A Professional Edition contains the text, plus marginal teaching aids for the instructor.

GRAPHICAL TECHNIQUES FOR ENGINEERING COMPUTATIONS, by Walter Herbert Burrows. Chemical Publishing Co., Inc., 212 5th Ave., New York, N.Y. 10010. 6 x 9 1/2 in., 435 pp. Cloth, \$15

Covers the field of nomography in standard fashion, but in addition contains two chapters on "Calculating with Graph Papers" and "Calculating with Graphs" which may present methods not known to (or overlooked by) most readers. **END**

MARKET CENTER

BLACK/WHITE OR COLOR

THE ONLY SAFE NON-DRIFT TV TUNER CLEANERS AVAILABLE AT ALL DISTRIBUTORS

CHEMTRONICS

BROOKLYN, N. Y. 11236



The time to sell is when you have a customer. And the place to sell is where you have some 157,000 customers—the classified pages of RADIO-ELECTRONICS

FREE CATALOG!

148 PAGES • NEARLY 4,000 BARGAINS

OPTICS • SCIENCE • MATH



Completely new 1986 edition. New items, categories, illustrations. 148 easy-to-read pages packed with nearly 4000 unusual items. Dozens of electrical and electromagnetic parts, accessories. Enormous selection of Astronomical Telescopes, Microscopes, Binoculars, Magnifiers, Magnets, Lenses, Prisms. Many war surplus items, for hobbyists, experimenters, workshop, factory. Write for catalog "EH".

CLIP AND MAIL COUPON TODAY

EDMUND SCIENTIFIC CO., Barrington, N. J.
PLEASE SEND ME FREE CATALOG "EH"

Name

Address

City

State

Rectifiers & Transistors					
SILICON DIODES					
Amps	50 PIV	100 PIV	150 PIV	200 PIV	
.75°	.05	.07	.16	.10	
3	.08	.14	.16	.22	
15	.35	.50	.65	.75	
18°	.26	.45	.60	.70	
35	.60	.80	1.15	1.30	
Amps	300 PIV	400 PIV	500 PIV	600 PIV	
.75°	.12	.14	.18	.21	
3	.25	.28	.35	.40	
15	.90	1.30	1.40	1.65	
18°	.85	1.25	1.85	2.50	
35	1.90	2.25	2.50	2.90	
Amps	700 PIV	800 PIV	900 PIV	1000 PIV	
.75°	.25	.32	.40	.55	
3	.49	.58	.67	.78	
15	1.90	2.30	2.50	2.70	
35	3.65	4.40	4.65	4.90	

* Top Hat, Epoxy or Flangless °° Press Fit pkg.

1100 PIV, .70 1200 PIV, .85 (75A TH Epoxy, Flangless) .95¢ ea.
 10 Watt Sil. Zener Stud 12-200 v, 20% .50¢ ea.
 1 Watt Zener diode, axial leads 8-200v, 20% .50¢ ea.
 Sil. diode, 1500 PIV, 50ma, axial leads .35¢ ea.
 Hoffman Hi-Voltage Sil. Epoxy Diode, 2 1/2 x 3/8 x 1/2 6000 PIV \$3.49
 200 ma. 3000 PIV \$1.49 ea.
 Thermistor, bead, 900 or 1200 ohms, 600°F, 2/\$1.00
 150 w GER POWER, T0-5

2N456A 70¢ 2N457A 80¢
 2N458A 90¢ 2N511B \$1.50
 2N3075 300 mc, 150 mw, 2 ma, 40 volt Germanium 75¢
 Silicon Power Transistors, 85 w, 2N1724 \$1.50
 Philco Sil., NPN, 2N2479, new 3 for \$1.00
 HF Silicon, 2N702, 100 mc 40¢; 2N703-150 mc .60¢

Light Sensitive Resistor
 75 ohms—10 meg, 100 volts, 150mw \$1.75 ea.

Matched diodes—9v, 25 ma, 100 mcs .30¢ pair
 Sil. diodes, 1N200 series, asst'd., new .15 for \$1.00
 Ger. diodes, glass—1N34A, 15/\$1.00 1N99, 10/\$1.00
 Nickel-Cadmium Battery, 9 1/2 oz., 8 amp-hr. \$1.95

Varicap-Voltage Variable Capacitor
 27, 47, or 100 pf, 4v, 4:1, new \$1.25 ea.

Silicon Controlled Rectifiers

PRV	.75A	1A	7A	16A	PRV	.75A	1A	7A	16A
25	—	.20	.28	.48	200	.80	.90	1.15	1.70
50	—	.40	.48	.70	300	1.20	1.30	1.80	2.20
100	—	.55	.70	1.20	400	1.70	1.85	2.20	2.70
150	.60	.70	.80	1.50	500	1.95	2.05	3.00	3.30
	.75A Tophat—1A T0.5—7A				600	2.30	2.50	3.20	3.90

& 16A Stud
 Money back guarantee. \$2.00 min order, include postage. Catalog 10¢.

Electronic Components Co.
 Box 2902B Baton Rouge, La. 70821

Circle 131 on reader's service card

CLASSIFIED COMMERCIAL RATE (for firms or individuals offering commercial products or services): 60¢ per word . . . minimum 10 words.
 NON-COMMERCIAL RATE (for individuals who want to buy or sell personal items): 30¢ per word . . . no minimum.
 Payment must accompany all ads except those placed by accredited advertising agencies. 10% discount on 12 consecutive insertions, if paid in advance. Misleading or objectionable ads not accepted. Copy for April issue must reach us before February 10th.
 WORD COUNT: Include name and address. Name of city (Des Moines) or state (New York) counts as one word each. Zone or Zip Code numbers not counted. (We reserve the right to omit Zip Code if space does not permit.) Count each abbreviation, initial, single figure or group of figures or letters as a word. Symbols or groups such as 8-10, COD, AC, etc., count as one word. Hyphenated words count as two words. Minor over-wordage will be edited to match advance payment.

ADVERTISING INDEX

RADIO-ELECTRONICS does not assume responsibility for any errors which may appear in the index below.

Acoustic Research, Inc.	32
Aerovox Corporation (Distributor Div.)	24
Allied Radio Corp.	90
Blonder-Tongue	77
Brooks Radio & TV Corp.	98-99
Burstein-Applebee Co.	86
Capitol Radio Engineering Institute, The	28-31
Castle TV Tuner Service, Inc.	6
CLASSIFIED	104-107
Cleveland Institute of Electronics	23, 62-65
Columbia Stereo Tape Club	1
Conar (Div. of National Radio Institute)	69
Cornell Electronics Co.	106
Coyne Electronics Institute	93
DeVry Technical Institute	5
Delta Products, Inc.	55
EICO Electronic Instrument Co., Inc.	15
Electro-Voice, Inc.	22
Electronic Chemical Corp.	88
Electronic Measurement Corp. (EMC)	69
Fair Radio Sales	87
Finney Co.	13
Gernsback Library, Inc.	71, 91, 100
Hallcrafters	89
Heald's Engineering College	101
Heath Company	72-75
Hi-Gain Electronics Corporation	7
I.E.E.	70
International Crystal Mfg. Co., Inc.	70, 108
Jerrold Electronics Corporation (Distributor Sales Division)	87
Lafayette Radio Electronics	93
Lectrotech Inc.	88
Mallory Distributor Products Company (Div. of P.R. Mallory & Co., Inc.)	Third Cover
Multicore Sales Corp.	102
Music Associated	99
National Radio Institute	8-F1, 26
Olson Electronics, Inc.	101
Oxford Transducer Company (A Division of Oxford Electric Corporation)	85
Philco (Techrep Div.)	98
Poly Paks	107
Quietrol Co.	91
RCA Electronic Components and Devices Test Equipment	25
Tubes	Fourth Cover
RCA Institutes, Inc.	18-21
RFS Industries Inc.	90
Rye Sound Corporation	97
Sams & Co., Inc., Howard W.	12, 27, 68
Sarkes Tarzian, Inc. (Tuner Service Div.)	12
Schober Organ Corp., The	14
Score	81
Sonar Radio Corporation	80
SonoTone Corp.	
(Electronic Applications Div.)	92
Sprague Products Company	2
Sylvania (Subsidiary of General Telephone & Electronics)	17
Tarzian, Inc. Sarkes (Tuner Service Div.)	12
Triplet Electrical Instrument Company, The	Second Cover
United Radio Co.	105
University Sound (Div. of LTV Ling Altec, Inc.)	61, 91
Warren Electronic Components	102
Weller Electric Co.	80
Windsor Electronics, Inc.	97
Winegard Co.	92
Xcelite, Inc.	16
MARKET CENTER	104-107
Chemtronics	
Edmund Scientific Co.	
Electronic Components Co.	
TAB	
SCHOOL DIRECTORY	103
American Institute of Engineering & Technology	
Coyne Electronics Institute	
Gratham School of Electronics	
Indiana Home Study Institute, The	
Northrop College of Science & Engineering	
Pacific International College	
Tri-State College	
Valparaiso Technical Institute	

GENERAL

TV SERVICE ORDER BOOKS for use with your rubber stamp. Duplicate or triplicate. Low cost. Write for FREE 32 PAGE CATALOG and Special Rubber Stamp Offer. OELRICH PUBLICATIONS, 6556 W. Higgins, Chicago, Ill. 60656.

SAFEGUARD PRIVACY! New instrument detects electronic "bugs", wire-tapping and snooping devices. Free information. DEE EQUIPMENT, Box 7263-E8, Houston 8, Texas.

CONVERT ANY TELEVISION to sensitive Big-Screen Oscilloscope. Only minor changes required. No electronic experience necessary. Illustrated plans \$2.00. RELCO-A25, Box 10563, Houston 18, Texas.

ENGRAVED BADGE—call letters or name \$1.49—both \$1.89, engraved key chain—deduct \$6.00. ARNAT, 1864 Jerome, Bronx, New York 10453.

LOSING Hair? Balding? Dandruff? Free copy-righted booklet. DR. SHIFFER LABORATORIES, 529 Euclid Arcade, Cleveland, Ohio 44115.

GIANT TESLA COIL—FORTY-INCCH SPARKS! Complete plans, photo \$5.00. Details 30c. HUNTINGTON ELECTRONICS, INC., Box 9 Huntington Station, Shelton, Conn., 06486.

WOW! 110 ALL Different Germany 10¢ Commemorative, Airmails, High Values, Big catalog, bargain lists plus selections of fine stamps from our approval service, returnable without obligation. JAMESTOWN STAMP, Dept. A26RE, Jamestown, N.Y. 14701.

FREE! 25 Egypt, 10¢ handling, Approvals, BELLET R-E, Hazel Park, Michigan 48030.

VALUABLE UNITED STATES STAMPS—Only 10¢! Scarce genuine centennial postage stamp, picturing first USA (issued in 1847!); Collection all-different United States—Ancient 19th Century, \$1.00 stamp, etc; Collection beautiful commemoratives: American Revolution, Wild West, 1393 Columbian, many others. PLUS Collector's Guide; other fine stamps from our approval service returnable without obligation; Complete new profusely illustrated USA Catalog. Send only 10¢! H. E. HARRIS, Dept. C-35, Boston, Mass. 02117.

PRINTING PRESSES. Type, Supplies. Lists 5¢. TIJRNBAUGH SERVICE, Mechanicsburg, Pa.

WANTED

QUICK CASH... for Electronic EQUIPMENT, COMPONENTS, unused TUBES. Send list now! BARRY, 512 Broadway, New York, N.Y. 10012, 212 WALKER 5.7000.

CASH, SONY TRANSISTOR TV's etc. swapped for G-R, H-P, L&N etc. equipment, special tubes, manuals, military electronics. ENGINEERING ASSOCIATES, 428 Patterson Road, Dayton, Ohio 454-19.

SERVICES

METERS—MULTIMETERS REPAIRED and calibrated. BIGELOW ELECTRONICS, Box 71-B, Bluffton, Ohio.

TRANSISTORIZED products dealers catalog, \$1. INTERMARKET, CPO 1717, Tokyo, Japan.

AUDIO - HI-FI

RENT STEREO TAPES—over 2,500 different—all major labels—free brochure. STEREO-PARTI, 161E Terrace Way, Santa Rosa, Calif.

WRITE for highest discounts on components, recorders, tapes, from franchised distributors. Send for FREE monthly specials. CARSTON, 168E-R Second Ave. N.Y.C. 10028

PRICES LOWERED—NO MORE FEDERAL TAX—SAVE \$\$ The largest stock of obsolete tubes in the USA at the lowest prices—COMPARE

BRAND NEW UNITED'S FIRST QUALITY TUBES

80% OFF

GUARANTEED ONE FULL YEAR! NOT USED! NO PULLS! WHY PAY MORE?

Table with columns: Type, Price, Type, Price, Type, Price, Type, Price, Type, Price, Type, Price, Type, Price. Lists various vacuum tube types and their prices.

SEND FOR COMPLETE PARTS CATALOG WITHOUT COST TERMS: Minimum order \$5.00 exclusive of postage. Remit full price plus postage. No C.O.D. The above list does not reflect our entire stock as we have one of the largest selections of SPECIAL PURPOSE, BROADCAST & TV TUBES in the U.S. Write for quotation.

UNITED RADIO CO. ESTABLISHED 1920 BOX 1000R, Dept. RE-2 NEWARK, N.J.

SEND FOR COMPLETE PARTS CATALOG ABOVE PRICES SUBJECT TO CHANGE WITHOUT NOTICE

-THIS AD CANCELS ALL PREVIOUS QUOTATIONS BY MAIL OR ANY OTHER ADVERTISING MEDIUM-

Circle 132 on reader's service card

MARKET CENTER

LOW LOW QUOTES Dyna, Garrard, AR, Eico
...HIFI, Roslyn, Pa. 19001.

STEREO REVERBERATORS for experimental application—\$7.—Mono—\$5.—CAL'S, Box 2, Bearborn, Michigan.

BUSINESS AIDS

JUST STARTING IN TV SERVICE? Write for FREE 32 PAGE CATALOG of Service Order books, invoices, job tickets, phone message books, statements and file systems. OELRICH PUBLICATIONS, 6556 W. Higgins, Chicago, Ill. 60656. New Hyde Park 5, N.Y.

1,000 Business Cards, "Raised Letters" \$3.95 postpaid. Samples. ROUTH RE12, 2633 Randleman, Greensboro, N. C. 27406.

BUSINESS OPPORTUNITIES

New scientific transistor instrument detects buried coins, treasures. Will detect gold, silver, copper, iron, etc. \$19.95 up. Free catalog. RELCO-A-25, Box 10563, Houston 18, Texas.

ELECTRONICS

BARGAINS in Canadian Electronic equipment and surplus. Send \$1.00 for giant catalogs. ETCO, Dept. R, 520 Fifth Avenue, New York 36, N.Y.

FREE CATALOG of 200 special slide rules and calculating aids. DYNA-SLIDE, 600 South Michigan, Chicago, Illinois 60605

PROFESSIONAL ELECTRONICS PROJECTS — Organs. Timers. Computers. etc.—\$1 up. Catalog 25¢. PARKS, Box 25565, Seattle, Wash. 98125.

Silicon Power Diodes		Studs & P.F.	
D. C. Amps	Piv/Rms	200Piv 140RMS	300Piv 210RMS
12	35	.50	.75
18**	20	.30	.75
25	65	.85	1.10
150	2.50	2.90	3.50
240	3.75	4.75	7.75

D. C. Amps	400Piv 280Rms	500Piv 350Rms	600Piv 420Rms	750Piv 525Rms
12	1.10	1.30	1.55	1.75
18	1.50	2.00	2.70	3.40
25	2.25	2.50	2.90	3.50
150	5.40	6.50	7.50	12.00

5U4 Silicon Tube Rep. \$2 @, 6 for \$10
5R4 Silicon Tube Rep. \$5 @, 2 for \$9

"TAB", SILICON 1-AMP* DIODES
*NEWEST TYPE! LOW LEAKAGE Gtd.1

Piv/Rms	100/70	100/140	300/210
50/35	.10	.12	.15
400/280	.20	.25	.35
Piv/Rms	900/630	1000/700	1200/840
50/40	.50	.55	.60

*ALL TESTS AC & DC & FWD & LOAD!

1700 Piv/1200Rms @ 750Ma \$1.20 @. 10 for \$10
same 1100Piv/770Rms 75c @, 16 for \$11

"TAB" TERMS: Money Back Guarantee. Our 21st year. \$2 Min. order prepaid 48 states U.S.A.
111-GF Liberty St., N. Y. 6, N. Y.
SEND 25¢ Phone: Rector 2-6245 for CATALOG

HI-FI COMPONENTS, Tape Recorders, at guaranteed "WE will not be undersold" prices. 15-day moneyback guarantee. Two-year warranty. NO Catalog. Quotations Free. HI-FIDELITY CENTER, 239R East 149th St., N.Y., N.Y. 10451.

TAPE RECORDER SALE. Brand new, latest models, \$10.00 above cost. ARKAY SALES, 1028-E Commonwealth Ave., Boston, Mass. 02215.

HI-FIDELITY COMPONENTS, Ham Marine and Communication equipment at considerable savings. If you want to save money write us for our low prices on all your needs. AIREX RADIO CORP., 85 (RE) Cortlandt St., N.Y., N.Y. 10007

STEREO TAPES. Save up to 60% (no membership fees, postpaid anywhere USA). Free 60-page catalog. We discount batteries, recorders, tape accessories. Beware of slogans "not undersold," as the discount information you supply our competitor is usually reported to the factory. SAXITONE, 1776 Columbia Road, Washington, D. C. 20009

RENT STEREO RECORD ALBUMS—latest hit albums, trial offer, write: DISCO-TAPE, P.O. Box #5202, Sta. #4, No. Hollywood, Calif. 91604.

HI-FI Equipment at largest discount. Catalog. MENDOTA FURNITURE CO., Mendota, Minnesota.

NEON AC/DC ELECTRIC TESTER FOR HOME AUTO SHOP

Special! 59¢

6AG5 6SN7
6AU6 6J6 6S4
6AQ5 6K6 6W4

Special! 25¢ per tube (No Limit) from this list.

Prestige & Success are yours as an ELECTRONIC EXPERT

FOR CORNELL CUSTOMERS ONLY by special arrangement with the publisher, these amazing bargains are available.

COMPLETE RADIO SERVICING AND BASIC ELECTRONICS COURSE ONLY \$3.00 (4-10 - 16 in-hand order)

NEW PRACTICAL TV TRAINING COURSE ONLY \$3.50 (8-10 - 16 in-hand order)

Both above courses \$6.00

NEW! EASY TO USE! RADIO-TV/TUBE TESTER TEST AND REPAIR TV & RADIO SETS APPLIANCES 2.89 plus 30¢ shipping

CORNELL TUBES

1 YR. GUARANTEED

Mutual Conductance Lab-tested, Individually Based. Branded and Code Data Tubes are new, or used and so marked

33¢ PER TUBE

100 TUBES OR MORE: 30¢ PER TUBE

TUBE CARTONS

HIGH GLOSS CLAY COATED RED & BLACK WITH BUILT IN DIAGONAL PARTITIONS

FOR TUBE SIZE	PRICE PER 10 CARTONS (Shipping)	PRICE PER 100 CARTONS (Shipping)
MIN 6AU6	29	2.99
GT 6SN7	39	3.49
LG 6Y 6W4	50	5.29
G 6U4C	89	7.99

TUBE SUBSTITUTES \$1.25

ABC TV \$100 GET AHEAD OF THE FIELD

PICTURE EXPANDER INCREASES LOW KEY OUTPUT FROM ORIGINAL CIRCUIT COMPENSATES FOR LOW VOLTAGE SUPPLY 99¢

TERMS: Add 3c per tube shipping. Orders under \$5.00 add 3c per tube shipping plus 50c handling. Canadian orders add approximate postage. Send 25¢ deposit on C.O.D. orders. No C.O.D. orders under \$5.00 or to Canada. No 24 hr. free offer on personal check orders 5-DAY MONEY BACK OFFER!

21 PICTURE TUBES 1395¢ 1st. Class. Aluminized Pay Dub Deposit COB or Send Quot with Order

all purpose ELECTRONIC CLEANER 89¢ plus 20¢ shipping

SILICON RECTIFIERS 69¢ PAIR 750 MA 400 P.V.

DIODES/RECTIFIERS 39¢ per pack plus shipping

SENSATIONAL KIT VALUE!

SOLDERING GUN 2.99 plus 30¢ shipping

ELECTRONIC SOLDER 29¢

Circle 133 on reader's service card

TRANSISTOR ignition kits, components. Free diagrams. ANDERSON ENGINEERING, Epsom, N.H. 03239

RADIO & TV TUBES 33¢ each. One year guaranteed. Plus many unusual electronic bargains. Free catalog. CORNELL, 4217-E University, San Diego, California 92105

TUBES. "Oldies", latest. Lists free. STEINMETZ, 7519 Maplewood, Hammond, Indiana, 46324.

FREE Catalog. Electronic parts, tubes. Wholesale. Thousands of items. Unbeatable prices. ARCTURUS ELECTRONICS RE, 502-22 St., Union City, N. J. 07087

McGEE RADIO COMPANY. Big 1966 catalog sent free. America's best values, Hi-Fi amplifiers, speakers, electronic parts. Send name, address and zip code number to McGEE RADIO COMPANY, 1901 McGee Street, Dept. RE, Kansas City, Missouri 64108

GOVERNMENT SURPLUS Jeeps from—\$52.50, Voltmeters from—\$1.05, Transmitters from—\$6.18, Oscilloscopes, Walkie-Talkies, Multimeters. Typical "As Is" Bid Bargains from Uncle Sam. Tremendous variety. Exciting free list. Write: ENTERPRISES, Box 402-F6, Jamaica, New York 11430.

It's SUPERCALIFRAGILISTICEXPIALIDOCIOS. Free: Information on Kit-of-the-Month Club, Catalog of Etched Circuits and Radio Books. Exclusive items. LEADER ENTERPRISES, Box 44718KR, Los Angeles, 90044

JAPAN & HONG KONG Electronics Directory. Products, components, supplies. 50 firms—just \$1.00. IPPANO KAISHA LTD., Box 6266, Spokane, Washington 99207.

TV CAMERAS, transmitters, converters, etc. Lowest factory prices. Catalog 10¢. VANGUARD, 196-23 Jamaica Ave., Hollis, N.Y. 11423.

300 Page Chemical Apparatus Catalog \$2.00 LABORATORY MATERIALS, 1322 Hydepark, Chicago 60615.

72 page illustrated Government Surplus Radio, Gadgets Catalog 20¢. MESHNA, Nahant, Mass.

EXPERIMENTERS, builders giant catalog—25¢, refundable. LABORATORIES, 993-B, Redwood City, California 94064.

METERS—Surplus, new, used, panel and portable. Send for list. HANCHETT, Box 5577, Riverside, California 92507.

TV TRADES wanted "as is" Hi Prices paid. TV WHOLESALE OUTLET CORP., 427 Columbus Avenue, N.Y., N.Y.

FREE LIST Servicing books. THOMAS GARBER, 104 Ashley Street, Korn Krest, Wilkes-Barre, Pa. 18702.

ZIP

stands for the Post Office Department's new Zoning Improvement Plan. When renewing your RADIO-ELECTRONICS subscription, or sending us a change of address, please let us know what your ZIP Code is. We'll add it to your address mailing plate ... and you'll get speedier delivery

service from the Post Office.
By the way,
when writing
to us, address:



RADIO-ELECTRONICS,
154 West 14 St.,
New York, N. Y.
10011

MESHNA CONVERTER KITS convert car radio to short-wave receiver for police and fire. 30-50 mc kit \$5.00, 100-200mc kit \$5.00. MESHNA, Lynn, Mass. 01904.

BEFORE You Buy Receiving Tubes, Transistors, Diodes, Electronic Components & Accessories ... send for Giant Free Zalytron Current Catalog, featuring all STANDARD BRAND TUBES all Brand New Premium Individually Boxed, One Year Guarantee—all at BIGGEST DISCOUNTS in America! We serve professional servicemen, hobbyists, experimenters, engineers, technicians. WHY PAY MORE? ZALYTRON TUBE CORP., 469R Jericho Turnpike, Mineola, N.Y. 11502

TV CAMERA KITS, including printed circuit models. \$16.95 up! Send 10¢ for catalog. ATV RESEARCH, Box 396, South Sioux City, Nebr. 68776.

EICO USED EQUIPMENT FOR SALE—Excellent condition. Delux Peak to Peak VTVM #249, Dynamic Conductance Tube & Transistor Tester #666, Adaptor, Generator & Market #368, Audio Generator #377, Comparator #950B. Other Equipment for Sale—Dwell Angle & Tachometer Model AT 162, Signal Generator LSG 10—Lafayette, C.R. Bridge & Signal Tracer Superior Inst. Co., Model 76, P.O. Box 91, Mt. Marion, Uister Co., New York, Phone # Cherry 6-6746. Area code 914.

EDUCATION/INSTRUCTION

LEARN ELECTRONIC ORGAN SERVICING. New home study course covering all makes electronic organ including transistors. Experimental kits—schematics—trouble-shooting. Accredited NHSC-GI Approved. Write for free booklet. NILES BRYANT SCHOOL, 3631 Stockton Blvd., Dept. F, Sacramento 20, Calif.

HIGHLY—effective home study review for FCC commercial phone exams. Free literature! COOK'S SCHOOL OF ELECTRONICS, Craigmont, Idaho 83523.

FCC LICENSE in 6 weeks. First Class Radio Telephone. Results Guaranteed. ELKINS RADIO SCHOOL, 2603E Inwood, Dallas, Tex.

SLEEP LEARNING. Hypnotism! Tapes, records, books, equipment. Details, strange catalog FREE. RESEARCH ASSOCIATION, Box 24-RD, Olympia, Wash.

BROADCASTING, Communications Electronics taught quickly—resident classes; correspondence. Free details. Write: Dept. 4, GRANTHAM SCHOOLS, 1505 N. Western, Hollywood, Calif. 90027

COUPON BOOK, Special offers from various firms, to Members of Electronic Experimenters' Club. Dues \$2.00 or write for further particulars. Box 5332-U, Inglewood, Calif. 90310

TELEVISION Servicing Course, complete, latest edition. Special, \$3. Satisfaction guaranteed. SUPREME PUBLICATIONS, 1760 Balsam, Highland Park, Illinois 60035.

NEW CONCEPT in Electronic Training Aids for schools, for information write ELECTRO-SCHEMATIC, 4708 Alabama Street, El Paso, Texas 79930.

FCC License training through tape recorded instruction. Bob Johnson, AUDIO-VISUAL LICENSE PREPARATION, 1201 Ninth Manhattan Beach, Calif.

B.Sc. DEGREE (Engineering) or College Entrance by home study. Send \$1 for 1966 prospectus. CIST, Suite 655, 263 Adelaide Street W., Toronto, Canada.

TELEVISION TROUBLESHOOTER answers all your service problems. Waste no time on book theory. Spot faults in minutes. Used by "pros" in repairing all makes and models. Write, specifying black & white, or color. NATIONAL TECHNICAL RESEARCH LABS. 6410 S. Western Ave., Whittier, California.

FREE! PLUS CHOOSE ANY \$100 ITEM FREE

\$25 WORTH OF TRANSISTORS, RECTIFIERS, RESISTORS, CONDENSERS, DIODES, ETC.

Both FREE WITH ANY \$10 ORDER

FACTORY TESTED **SEMI-KON-DUCTORS**

- 10 PNP SWITCHING TRANSISTORS, 2N3404, asst \$1
- 10 NPN SWITCHING TRANSISTORS, 2N338, asst. \$1
- 15 PNP TRANSISTORS, CK722, 2N35, 107 no test \$1
- 15 NPN TRANSISTORS, 2N35, 170, 440, no test \$1
- 30 TRANSISTORS, rf, lf, audio osc-ifs, TO5 no test \$1
- 10 FAMOUS CK722 TRANSISTORS, pnp no test \$1
- 5 2N107 TRANSISTRS, by GE, pnp, pop, audio pak \$1
- 2 40W NPN SILICON MESA 2N1648, 2N1048 \$1
- 4 2N213 TRANSISTORS, mixer-conv, TO22 ... \$1
- 10 MICRODIODE STABILATORS, epoxy, silicon ... \$1
- 3 2N706 500MW, 300MC NPN PLANAR, TO16 ... \$1
- 3 2N255 POWER TRANSISTOR EQUALS, TO3 case \$1
- 2—500MC, 2N708 NPN Silicon planar TO46 ... \$1
- 3 2N711 300MW, 300 MC, PNP MESA, TO18 ... \$1

HIGH POWER SALE \$1

PNP 100Watt/15 Amp HiPower TO36 Case! 2N441, 442, 277, 278. DS501 up to 50 Volts

- 5 SUN BATTERIES TO 1 1/2" sizes, lite sensitive \$1
- 85 WATT 2N424 PLANAR, silicon, TO-53 1 pnp \$1
- 6 TRANSISTOR TRANSISTRS, 2N341, no test, pnp \$1
- 4 "TEXAS" 20 WATTERS, 2N1038-1042, w/sink \$1
- 4 2N170 TRANSISTORS, by GE, pnp for gen'l rf \$1
- 6 TRANSISTOR RADIO SET, osc-ifs, driver-pnp ... \$1
- 25 GERMANIUM & SILICON DIODES, no test ... \$1
- 25 TOP HAT RECTIFIERS, silicon, 750ma, no test \$1
- 3 2-WATT PLANAR TRANSISTRS, 2N697, 100mc \$1
- 4 2N35 TRANSISTORS, pnp, by Sylvania, TO22 ... \$1
- 25 "EPOXY" SILICON RECTIFIERS no test ... \$1
- 4 ZENER REFERENCES, 1N429, 6-volt, silicon ... \$1
- 2 "TINY" 2N1613 2W, 100MC, TO46 case, pnp \$1
- 85 WATT 2N1212 PLANAR, drift, 10mc, pnp ... \$1
- 4 2N43 OUTPUT TRANSISTORS, by GE, pnp, TO5 \$1
- 4 2N333 NPN SILICON transistors, by GE, TO5 \$1
- 10 2-6Amp RECT's, studs, silicon, 50 to 400V ... \$1
- 10 30-MC TRANSISTORS, silicon, TO18, no test \$1

"EPOXY"—3000 piv 200 ma RECTIFIERS, ... 1.00
 "EPOXY"—6000 piv 200 ma RECTIFIERS ... 2.50
 10-WATT ZENER STUD ANY VOLTAGE 3V to 200.75
 ONE WATT ZENER DIODES, choose from 3V to 200.45
 "EPOXY" 1AMP 1000 PIV RECTIFIERS, axial, ... 45

WORLD'S MOST POPULAR **\$1 PARTS PAKS**

- 40 WORLD'S SMALLEST COND., to .05mf ... \$1
- 4 TRANSISTOR TRANSFORMERS, asst. worth \$25 \$1
- 3 TRANSISTOR AUDIO AMP, tiny, wired ... \$1
- 3 INFRA-RED DETECTORS, with leads ... \$1
- 25 SURPRISE PAK: transistors, rect, diodes, etc. \$1
- 40 PRECISION RESISTORS, 1/2, 1, 2W; 1% values \$1
- 30 CORNING "LOW NOISE" resistors, asst. ... \$1
- 60 TUBULAR CONDENSERS, to .5mf, to 1KV, asst \$1
- 40 DISC CONDENSERS, 27mmf to .05mf to 1KV \$1
- 60 TUBE SOCKETS, receptacles, plugs, audio, etc. \$1
- 30 POWER RESISTORS, 5 to 50W, to 24 Kohms. \$1
- 50 MICA CONDENSERS, to .1mf, silvers too! ... \$1
- 10 VOLUME CONTROLS, to 1 meg, switch too! ... \$1

CLAIREX CL505 PHOTO CELL \$1.00
 .500" dia. x 1/4" L.

- 10° ELECTROLYTICS, to 500mf, asst.FP & tubular \$1
- 50 RADIO & TV KNOBS, asst.d. colors & styles ... \$1
- 10 TRANSISTOR ELECTROLYTICS: 10mf to 500mf \$1
- 50 COILS & CHOKES, if, rf, ant. osc, & more ... \$1
- 35 TWO WATTERS, asst incl: A.B., 5% too! ... \$1
- 75 HALF WATTERS, asst incl: A.B., 5% too! ... \$1
- 60 HI-Q RESISTORS, 1/2, 1, 2W, 1% & 5% values \$1
- 10 PHONO PLUG & JACK SETS, tuners, amps ... \$1
- 30 "YELLOW" MYLAR CONDENSERS, asst'd val \$1
- 60 CERAMIC CONDENSERS, discs, npo's, to .05 \$1
- 40 "TINY" RESISTORS, 1/10W, 5% too! ... \$1
- 10 TRANSISTOR SOCKETS for pnp-npn transistors \$1

TRANSITRON

TESTED SILICON CONTROLLED RECTIFIERS

	7A	16A	25A	7	15	25	
PRV AMP	AMP	AMP	AMP	AMP	AMP	AMP	
25	.30	.50	.85	250	1.25	1.95	2.50
50	.45	.75	1.00	300	1.50	2.25	2.75
100	.80	1.00	1.50	400	1.75	2.60	3.25
150	.90	1.50	2.00	500	1.95	3.19	3.80
200	1.15	1.75	2.25	600	2.25	3.50	4.50

GIANT SPRING CATALOG ONLY PARTS PAKS
 TERMS: Send check, money order.
 Add postage—avg. wt. per pak 1 lb. Rate net 30 days. COD 25% deposit.
POLY PAKS
 P.O. BOX 942R
 50 LYNNFIELD, MASS.
 "PAK-KING" of the world



SMALL PACKAGE

BIG PUNCH!

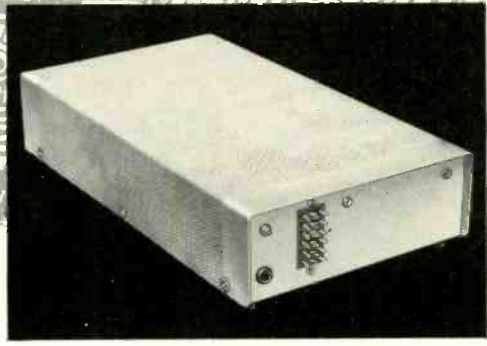
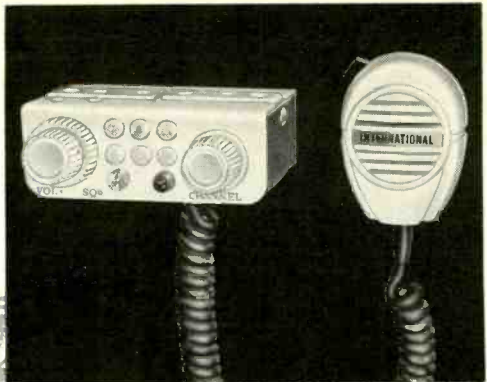

**INTERNATIONAL Model MO TRANSCEIVER
For CITIZENS RADIO SERVICE**

- New Compact Size
- New Solid-State Crystal Switching Circuit
- New Photo-Control Volume Circuit
- New Remote Control With Matching Microphone

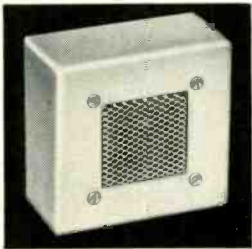

The International Model MO Citizens Radio transceiver, custom designed for mobile installation, provides instant push-to-talk crystal controlled operation on any 6 channels with full 5 watts power input. The new compact control head provides complete remote controlled operation. All circuits are dc using solid-state crystal switching. The operating channel is indicated by an illuminated button on the control head. Tubes and silicon transistors are combined to provide a rugged trouble-free circuit.

The complete transceiver includes: a remote control head (about the size of a cigarette package), matching white microphone, new compact transmitting / receiving unit which may be conveniently installed in the trunk, and a matching white speaker which mounts under the dash. Operates from 12 vdc negative ground power source. Other power input units are available on special order.

See the "all new" International Model MO at your dealer today.

FCC Citizens Radio license required. All use must conform with Part 95, FCC Rules and Regulations.



CRYSTAL MFG. CO., INC.
18 NO. LEE • OKLA. CITY, OKLA. 73102

Circle 135 on reader's service card

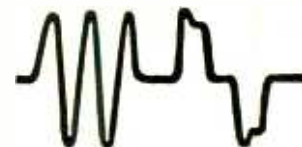

What you should know about wet-slug tantalum capacitors

COMPARATIVE SIZES TANTALUM CAPACITORS

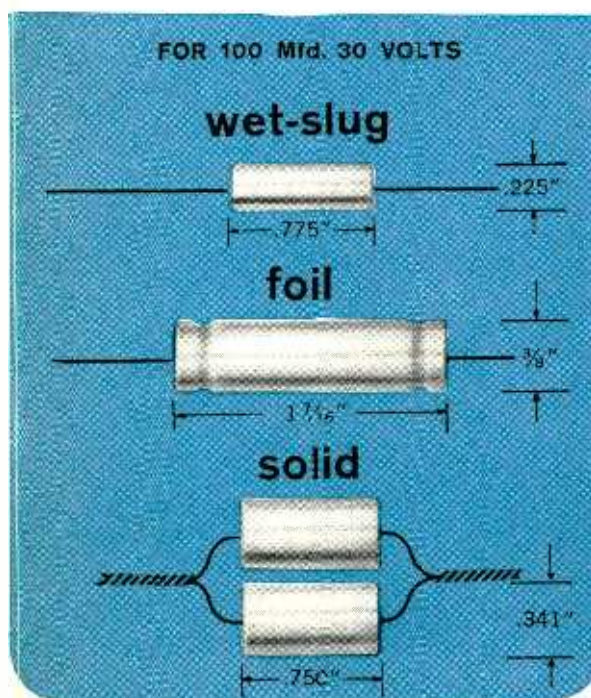
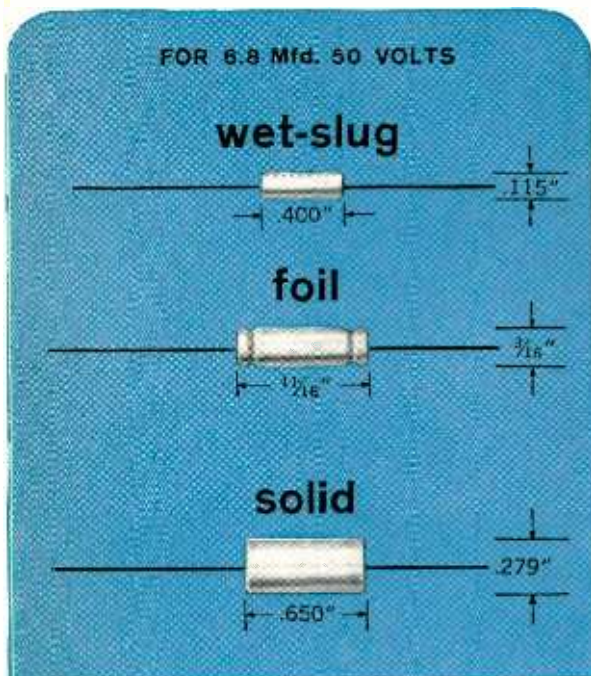

When you're bread-boarding a piece of high-reliability equipment, you'll probably consider tantalum capacitors. They'll do things that you can't do with aluminum electrolytics. Run at higher temperatures—up to 200°C. Put a lot of rating in minimum size. And most of all, operate with extreme reliability under extreme environmental conditions.

There are three basic types of tantalum capacitors—wet-slug, foil, and solid electrolyte. How do you know which kind to use? Here are some facts about wet-slug types which are worth knowing. And we at Mallory aren't prejudiced, because we make *all* tantalum types—the widest line in the industry, in fact.

Wet-slug tantalum capacitors are smallest; rating for rating, about 20% the size of solid electrolyte types. The newest Mallory wet-slug models, the MTP for instance, has up to 170,000 mfd-volts per cubic inch—almost 5 times what you can get in a solid electrolyte counterpart.

DC leakage of the wet-slug models is as low as 10% that of comparable solid types. This can be important in an RC timing circuit, where you need to maintain charge on a capacitor.

In the language of reliability engineers, wet-slug capacitors are inherently free from catastrophic failure. Pin-point failures of the dielectric film are self-healing, because there's wet electrolyte present to permit re-forming when voltage is applied. When a solid electrolyte capacitor fails, it's gone for good (or for bad).

If you need voltage ratings over 100 WVDC, you can get them only in foil or wet-slug models—the latter going all the way to 630 volts. Solid tantalum ratings in standard types go up to 100 volts.

How good is the case seal on wet-slug capacitors? Good enough to pass the toughest MIL tests, including those for the Minuteman II project which are about as tough as they come.

What about cost? All tantalum capacitors are relatively expensive, and solids usually are lowest in price. *But* when you need fairly high capacitance, wet-slug types often turn out to be the best buy!

A Mallory Industrial Distributor near you can supply all Mallory wet-slug, foil and solid tantalum capacitors, including many MIL types. Mallory Distributor Products Company, a division of P. R. Mallory & Co. Inc., Indianapolis, Indiana 46206.



Circle 136 on reader's service card

RCA rare-earth Hi-Lite

Color TV Picture Tubes

for every smart
customer who wants
a superior color picture

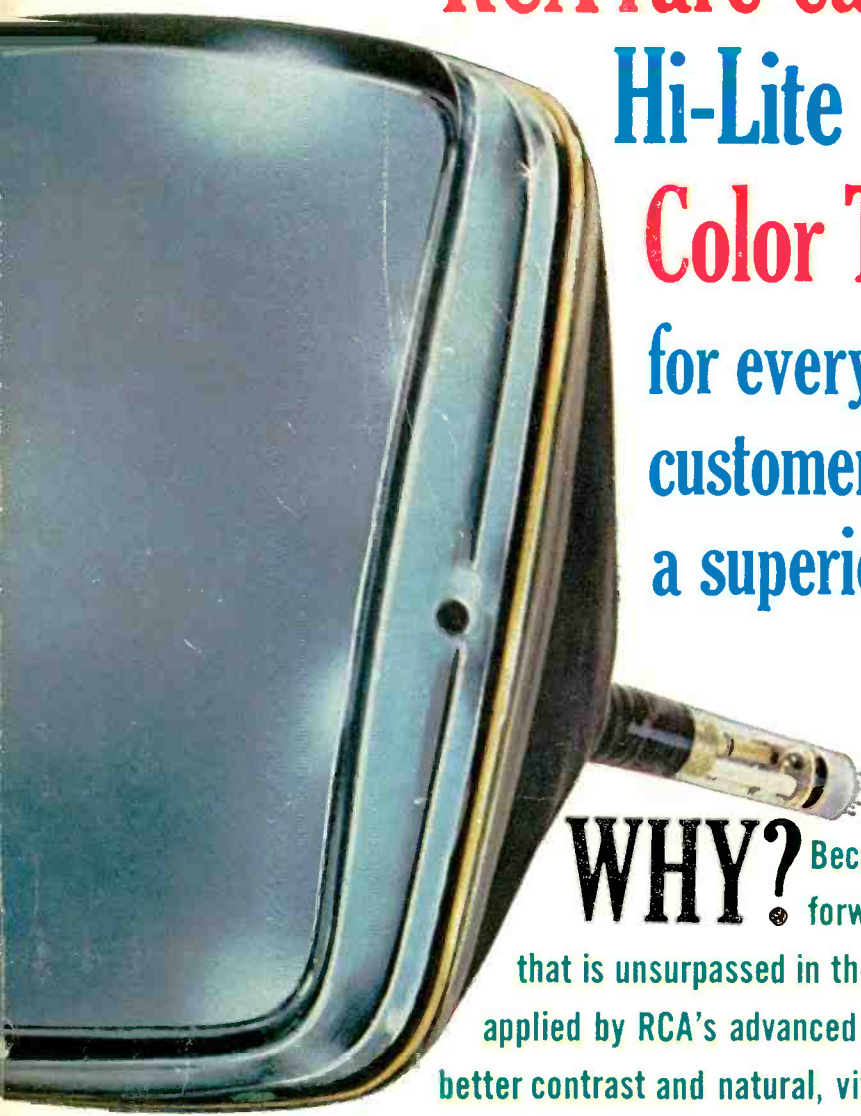

WHY?

Because RCA's Hi-Lite line represents a big step forward in color picture brightness—brightness that is unsurpassed in the color TV industry. Rare-earth phosphors applied by RCA's advanced screening methods create brighter reds, better contrast and natural, vivid colors . . . Everything the smart customer wants. Are you ready to service your smart customers? Keep posted. See your RCA Distributor today.

RCA ELECTRONIC COMPONENTS AND DEVICES, HARRISON, N.J.



The Most Trusted Name in Electronics

