

60c ■ SEPT. 1970

Radio-^{IND}Electronics®

FOR MEN WITH IDEAS IN ELECTRONICS

COLOR TV ANTENNAS

How to get top performance
Installer's **GUIDEBOOK**



BUILD

Driver's stay-awake alarm
Electronic music synthesizer

X 67-68
ROTOR
B/T-PM-1

~ 1P 80

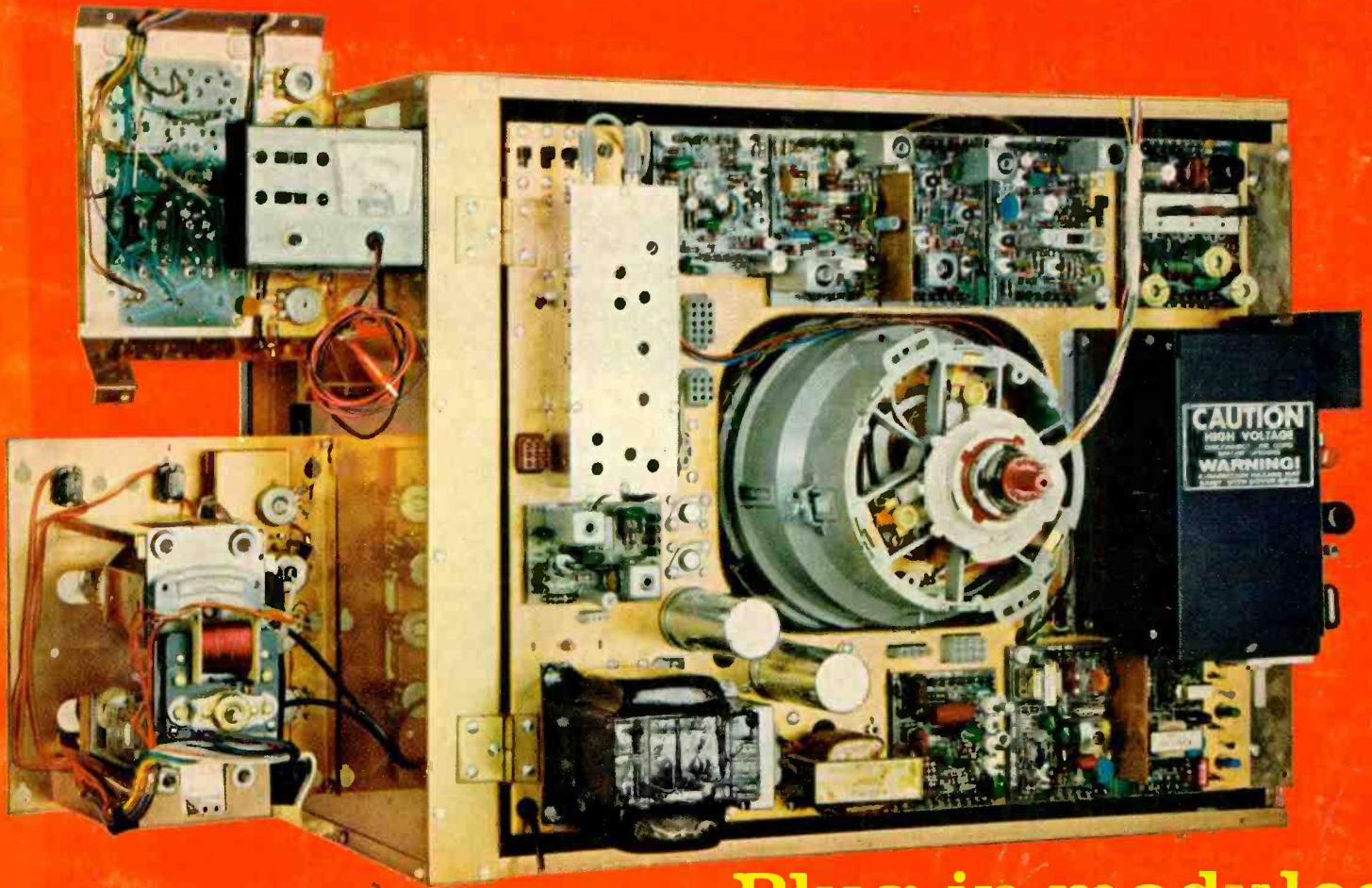

**Plug-in modules
in new solid-state color-tv kit**

Dazzle your friends with lightworks.

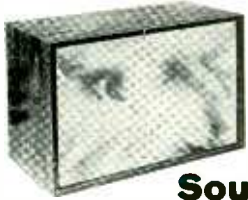

Sound n' Color®

The new dimension to music pleasure. EICO All Electronic Solid-State Audio-Color Organs transform sound waves into moving synchronized color images. Connect easily to speaker leads of hi-fi or radio. From \$29.95.



Translators

The electronics you need to create audio-stimulated light displays to your own imagination. Actuates: Light Display Units, Strobe Lites, any lamp configuration (Xmas trees, patio lights, etc.). From \$24.95 kit, \$39.95 wired.



Strobe Lites

High-intensity bursts of white light from Xenon tube flash in cadence with each beat of audio. From \$24.95 kit, \$39.95 wired.

Build the Stereo Kits praised by experts.

All amplifier power ratings according to IHF standards. Cortina® designed and manufactured in U.S.A. and guaranteed by EICO.

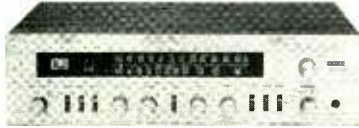

70-Watt AM/FM Stereo Receiver including cabinet. Cortina 3770, \$189.95 kit, \$279.95 wired.

70-Watt FM Stereo Receiver including cabinet. Cortina 3570, \$169.95 kit, \$259.95 wired.



150-Watt Silicon Solid-State Stereo Amplifier, including cabinet. For the audio perfectionist. Cortina 3150, \$149.95 kit, \$225 wired.

70-Watt Silicon Solid-State Stereo Amplifier, including cabinet. Cortina 3070, \$99.95 kit, \$139.95 wired.



FM Stereo Tuner including cabinet. Cortina 3200, \$99.95 kit, \$139.95 wired.



EC-1100
FM WIRELESS MIKE \$9.95

Build for fun and use with Eicocraft® jiffy project kits.

The newest excitement in kits. 100% solid-state and professional. Expandable, interconnectable. Excellent as introductions to electronics. No technical experience needed. Finest parts, pre-drilled etched printed circuit boards, step-by-step instructions. 36 kits to select from, \$2.50 to \$9.95. Just released: EC-2600 "Super Snoop" \$8.95; EC-2700 Police & Fire Converter



(lo band) \$7.95; EC-2800 Aircraft Converter \$7.95; EC-2900 Police & Fire Converter (hi band) \$7.95; EC-3100 2-Station Intercom (with cases) \$10.95; EC-3200 "Do-It-Yourself" PC Etching Kit \$4.95; EC-2300 Audio Preamplifier \$8.95; EC-2400 Bullhorn \$8.95; EC-2500 Fuzzbox \$8.95.



EC-1900 TREASURE FINDER \$9.95

Shape up your own car/boat with EICO Engine Analyzer

For all 6V/12V systems; 4, 6, 8-cyl. engines. Now you can keep your car or boat engine in tip-top shape with this solid-state, portable, self-powered universal engine analyzer.

Completely tests your total ignition/electrical system. Complete with comprehensive Tune-up & Trouble-shooting Manual. EICO 888, \$49.95 kit, \$69.95 wired.



The first and only solid-state test equipment guaranteed for 5 years.

Only EICO brings you laboratory precision and long life at lowest cost.

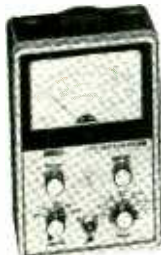

EICO 240 Solid-State FET-TVOM \$59.95 kit; \$79.95 wired



EICO 379 Solid-State Sine/Square Wave Generator \$69.95 kit, \$94.50 wired



EICO 242 Solid-State Deluxe FET-TVOM \$69.95 kit, \$94.50 wired

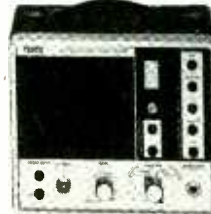

EICO 150 Solid-State Signal Tracer \$49.95 kit, \$69.95 wired

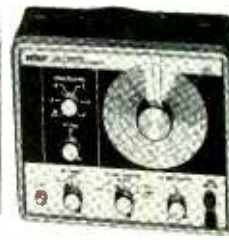

EICO 330 Solid-State RF Signal Generator \$59.95 kit, \$84.50 wired

You save up to 50% with EICO Kits. Since 1945, Best Buys in Electronics. Over 3 Million EICO Instruments Now in Use.

FREE 1970 CATALOG

Send me FREE catalog describing the full EICO line of 200 best buys, and name of nearest dealer.



EICO Electronic Instrument Co., Inc.
283 Malta Street, Brooklyn, N.Y. 11207
Available In Canada

Name _____

Address _____

City _____

State _____

Zip _____

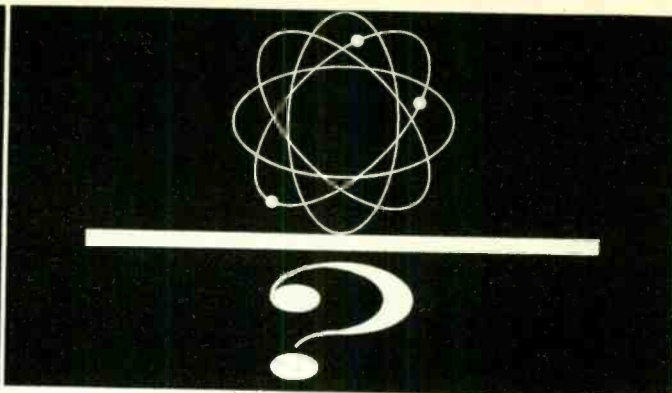
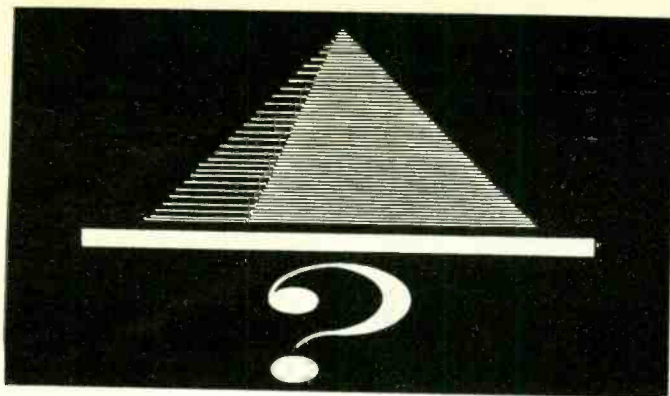

WHAT IS THE COMMON DENOMINATOR OF AN ANCIENT EGYPTIAN PYRAMID AND A MODERN ELECTRONICS CAREER?

A STRONG FOUNDATION!

The ancient pyramids were built on strong foundations and thus have endured extensive changes in their environment. How about your *electronics career*? Is it built on the solid foundation of knowledge and understanding? Can the foundation under your electronics career endure the rapid changes now occurring in the electronics industry?

GRANTHAM'S strong-foundation educational program in electronics engineering is designed especially for the *working technician*. This program, offered mostly by home-study, leads to non-obsolete skills—to skills based on reasoning—and leads to the DEGREE of Associate in Science in Electronics Engineering (the ASEE Degree).

This *accredited* degree program consists of four "correspondence semesters" of 100 lessons each, a *total* of 400 lessons. All except the last ten of these lessons are completed entirely by correspondence. However, after you have completed Lesson 390 you must then attend a two-week *Graduation Seminar* at the School. It is during this attendance that you complete Lessons 391 thru 400 and receive your ASEE Degree.

Earn Your FCC License Along the Way

You have heard and read, over and over again, about how important an FCC license is to your success in electronics. It is true that an FCC license is important—sometimes essential—but it's not enough! Without further education, you can't make it to the top. Get your FCC license without fail, and then *continue* your electronics education to earn your degree. It makes good sense to prepare for your FCC license with the School that includes the FCC license preparation as an incidental part of your degree program.

In the Grantham ASEE Degree program, FCC-license and radar-endorsement preparation are *integrated into the first two semesters* for the benefit of those students who have never obtained such a license.

GRANTHAM SCHOOL OF ENGINEERING

"the college that comes to you"

1505 N. Western Av, Hollywood, CA 90027

Accreditation and G.I. Bill Approval

Grantham School of Engineering is *accredited* by the Accrediting Commission of the National Home Study, is *approved* under the G.I. Bill, and is *authorized* under the laws of the State of California to grant academic degrees.

A Three-Step Program For Success

It's your move, and the move you make today can shape your future. Begin now with a step in the right direction—Step #1—and then follow through with Steps #2 and #3.

Step #1 is a simple request for full information on the Grantham Associate Degree Program in Electronics. You take this step by filling out and mailing the coupon shown below. We'll send full information by return *mail*. No salesman will call.

Step #2 is earning your FCC first class radiotelephone LICENSE and radar endorsement. You complete this step in the first two semesters of the Grantham educational program.

Step #3 is earning your ASEE DEGREE. This degree is conferred when you have earned credit for all four semesters of the Grantham curriculum.

● Mail the coupon below for our free Bulletin ●

Grantham School of Engineering RE-9-70
1505 N. Western Ave., Hollywood, Calif. 90027

Gentlemen:

Please mail me your free Bulletin which explains how the Grantham educational program can prepare me for my FCC license and Associate Degree in Electronics Engineering. I understand no salesman or counselor will call.

Name _____

Address _____

City _____ State _____ Zip _____

I have been in electronics for _____ years.

Circle 2 on reader service card

< Circle 1 on reader service card

PIEZOELECTRICITY RUNS HEART PACEMAKER



MURRAY HILL, N.J.—Piezoelectric discs in an experimental heart pacemaker developed at Bell Labs convert energy produced in the heart into electricity to power

the unit. The batteryless heartpacer, which could eliminate periodic battery changes for thousands of people, has not been tested on humans.

A plastic tube wrapped with electrode wires is inserted through a vein into the right ventricle. A small, water-filled balloon at the end of the tube contracts with each heart beat. Water squeezed up the tube mechanically strains the discs, and the electricity generated is stored in a capacitor to run the pacemaker.

Should the heart stop beating, the unit has a sufficient energy reserve to restimulate the heart into action.

INSTANT HOLOGRAMS ON THIN METAL FILM

PRINCETON, N.J.—A "branding iron" technique of evaporating thin metal film from a glass surface is being studied by RCA to make instant holograms.

The new technique eliminates chemical development and the massive, low-vibration tables needed for conventional holograms. Light from a pulsed ruby laser is split into two beams, one going directly to the metal film and the other going first to the object to be holographed and then to the metal film.

At points where the two beams interfere constructively (add their powers), laser light evaporates the metal. Where the two beams cancel each other nothing happens.

The metal-film hologram can be read out immediately by shining a continuous-wave laser beam through it. Non-destructive industrial testing is a likely use for the technique.

Also, some 300 million bits of permanent information could be stored on a 4¼ x 16-inch holographic card. A standard magnetic memory card that size holds about 2 million bits. The new holograms are free of "grain noise" that limits the storage capacity of photographic holograms.



LUNAR LANDSCAPE? This crater-like pit may look like an astronaut's view of the moon, but it's actually microscopic pitting on the normally smooth surface of a telephone electrical switch contact. The pit, about 0.003-inch wide, was snapped at Bell Labs to study telephone switching apparatus.

NEW 'GLASS' MAGNETS

CORNING, N.Y.—Glass impregnated with a lead-bismuth combination becomes an excellent, low-cost superconductor. This new superconductive material, developed at Corning Glass Works, is about 35% metal. Like the more expensive niobium-titanium alloys, the glass superconductor can produce up to 125,000 gauss at 4.2°K.

These high magnetic fields, generated by the superconductive electric current, quench the superconducting ability of materials.

Flexible tapes and fibers of the new glass material can be wound into magnets.

RCA SHOWS COLOR TV CAMERA FOR SPACE



Brilliant lamp equals sun's intensity, but cannot harm tube.

NEW YORK—Two color TV cameras that may be used on future lunar missions have been delivered to NASA by RCA under a \$196,500 contract.

The space agency will decide whether the RCA cameras or Westinghouse-developed versions (or both) will be used in space. Westinghouse color cameras have

been used on all Apollo missions to date.

Both versions have a color wheel spinning behind the lens for field sequential scanning and both use SEC (secondary electron conduction) image tubes for low-light sensitivity.

RCA is using its new silicon intensifier tube (SIT) which has the ability to greatly boost low light levels and cannot be damaged when pointed at the sun. An IC array of some 400,000 silicon diodes forms the imaging surface of the space camera SIT. Details in the same scene of very bright and very dark objects are possible with the SIT.

The 10-lb RCA camera requires 13 watts, will operate at ±250°F and has an automatic light control system. Its resolution is more than 300 TV lines.

DIGITAL FM READOUT MODELS DEMONSTRATED

H. H. Scott showed a prototype hi-fi receiver at the N.Y. Consumer Electronics Show with Nixie tube digital readout. Other manufacturers also demonstrated digital readout models.

Scott's unit employs a

phased-locked loop, eliminating the need for complex counters. Holding a button or inserting a punched card tunes the unit.

(N & T continued on page 12)

NEXT MONTH

Build a low-cost FM multiplex generator.

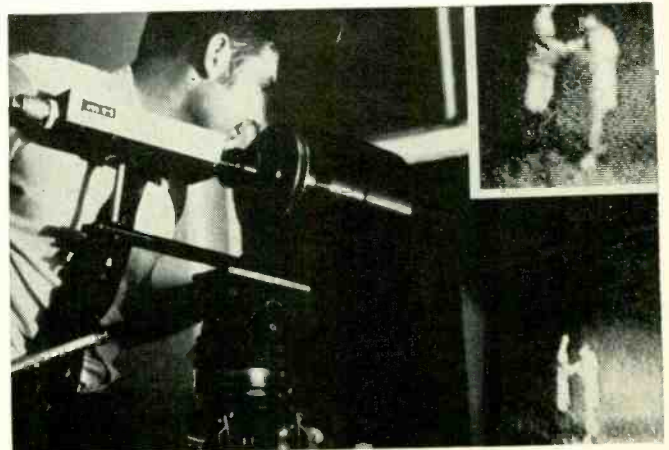

See-in-the-dark TV camera knives through darkness and rain in New York's Central Park to capture the images of two simulated narcotics pushers (see inset) making a transaction. The telephoto shot at 400 yards is possible because of the sensitivity of the image tube to infrared-illuminated scenes. The tube, called the Tivicon by Texas Instruments, costs \$750, and has 750 rows of 1,000 photochemically formed light-sensitive diodes. Another Tivicon camera, mounted on a telescope, was used to transmit network TV pictures during the March 7 solar eclipse. Applications for the tube range from hospital ward surveillance to industrial security.

Radio-Electronics

September 1970 • Over 60 Years of Electronics Publishing

TELEVISION

In The Shop	26	Jack Darr
Color TV Antennas—Get Top Performance <i>An expert tells how to use them</i>	33	Carey Shelledy
Heathkit's New Solid-State Color TV <i>Modular approach for the '70s</i>	37	Larry Steckler
R-E Reference Manual <i>How to install TV antennas</i>	54	James A. Gupton Jr.
Uhf TV Antennas <i>A look at their operation</i>	60	Warren Roy
Service Clinic	72	Jack Darr

BUILD ONE OF THESE

Technician's Equipment Cart	41	Peter Sutheim
Autotransformer Package <i>0-135 volts ac at your fingertips</i>	42	James Squires
Pulsed-Light Darkroom Timer	44	Frank H. Tooker
Digisyntone Music Synthesizer	47	Fred Maynard
<i>'Computerized' keyboard you can build</i>		
Wake-up Alarm For Your Car <i>Steering wheel antenna is a life saver</i>	52	R. M. Marston
Build A Ham VFO	69	
Build: Multipurpose IC Digital Clock <i>Part 2—More construction details</i>	97	Leo Walker

GENERAL ELECTRONICS

Looking Ahead	4	David Lachenbruch
<i>Current happenings with future overtones</i>		
Editorial	6	
<i>Hugo Gernsback Scholarship Award to Home Study Students</i>		
Blueprint to Progress	45	L. L. Farkas
<i>Jobs in electronics for your future</i>		
Etchless Circuits	59	Byron G. Wels
<i>How to paint on circuit patterns</i>		
Technical Topics	67	Robert F. Scott
<i>An antenna rotator and bridge</i>		
Brains of Automation	94	John W. Dietrich
<i>Controlling machines with tape</i>		
Equipment Report	88	Chester H. Lawrence
<i>Bell PA amplifier</i>		

DEPARTMENTS

CB Troubleshooter's Casebook	70	New & Timely	2	New Tubes & Semiconductors	91
Coming Next Month	92	New Literature	86	Noteworthy Circuits	93
Correspondence	16	New Products	80	Try This One	102



Dozing at the wheel can be fatal. Build this wake-up alarm for your car and stay alert on the road. . . . see page 52



Installing TV antennas doesn't have to be difficult if you know the right steps. To find out how it's done see page 55

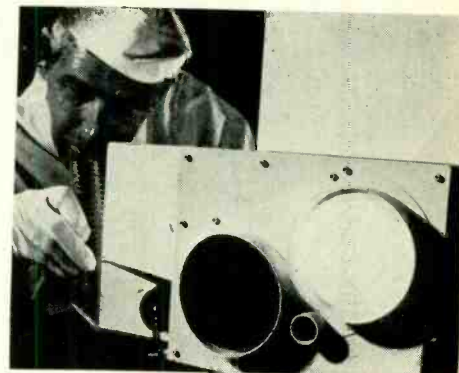

Electronic careers can take a lot of paths with a technician's background. Here are some of the fields open to you see page 45

RADIO-ELECTRONICS, SEPT. 1970, Vol. 41, No. 9
 Published monthly by Gernsback Publications, Inc., at Ferry St., Concord, N. H. 03302
 Editorial, Advertising, and Executive offices: 200 Park Ave. S., New York, N.Y. 10003. Subscription Service: Boulder, Colo. 80302.
 Second-class postage paid at Concord, N. H. Printed in U.S.A. One-year subscription rate: U.S. and possessions, Canada, \$6.
 Pan-American countries, \$7. Other countries, \$7.50. Single copies 60¢. © 1970 by Gernsback Publications, Inc. All rights reserved.
 POSTMASTER: Notices of undelivered copies (Form 3579) to Boulder, Colo. 80302.



Radio-Electronics is indexed in
*Applied Science & Technology
 Index (formerly Industrial
 Arts Index)*

LOOKING AHEAD

Volume 41 Number 9

RADIO-ELECTRONICS

September 1970

by **DAVID LACHENBRUCH**
CONTRIBUTING EDITOR

Home videoplayer standards?

The question of standards for home color VTR's and videoplayers comes into sharp focus with the introduction of still another system scheduled for early production. You can add Avco Cartrivision to Sony's Videocassette player, CBS's EVR, RCA's SelectaVision and Philips' VCR (for Video Cassette Recorder)—making five systems, none compatible with any other.

The Cartrivision system received its public premiere at this summer's Consumer Electronics Show in New York and is scheduled to be marketed early next year by both Avco and Admiral, which is a Cartrivision licensee. The initial offering will be a combination recorder, player and 19-inch color set, to sell in the \$800-\$900 price range. An optional monochrome camera will cost \$199, and a deck will be made available later at \$400-\$500 for use with existing color sets.

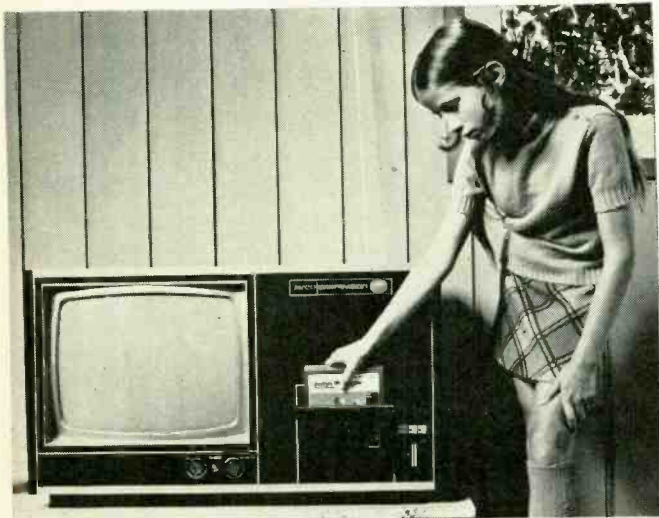

Cartrivision system used with 19-inch color set

Cartrivision uses cassette-type cartridges about the size of a large book, with half-inch tape, moving at 3.8 ips. Three video heads revolve at 12,000 rpm, scanning every third field. Blank cartridges will sell for various prices, from about \$10 for 15 minutes to \$25 for two hours.

Motion pictures, for which rights have already been obtained, will be available on a sale or rental basis. Rental cartridges will provide one-time viewing only—they can't be rewind, except by the dealer.

The Cartrivision system is designed, according to its sponsors, to "give the consumer a picture about as good as he can get off the air." Based on our viewing of a prototype, we'd say it does just that. It doesn't match the picture quality of the CBS or Sony players, in our opinion. (We haven't yet seen the Philips player, and the RCA system has yet to be shown in a pre-production prototype.)

Quad sound is 'commercial'

The Consumer Electronics Show proved that four-channel stereo is here, or nearly here, as a commercial product. Almost two dozen exhibitors showed tape systems featuring quadraphonics or quadrasonics, or whatever you want to call it. Four-channel amplifiers are becoming avail-

able from such firms as Scott and Fisher, and four-channel open-reel tape decks are now almost commonplace.

In the eight-track cartridge format, RCA will provide both players and tapes, and Motorola will have players. Telex demonstrated an eight-track recorder-player which will both record and play back four-channel stereo. Ampex demonstrated a four-channel stereo cassette system.

Philips, the proprietor of the cassette concept, has endorsed four-channel stereo and promises both hardware and software for a compatible two- and four-channel system this year—but at press time it hadn't revealed the system.

Cassette as hi-fi

At least three manufacturers will soon be offering "Dolby" cassette decks which feature a noise-reduction system designed to eliminate the annoying surface hiss from cassettes when played through a good sound system. The decks will be marketed by Advent, Harmon-Kardon and Vivitar, and probably others. They're designed to record and play back with a special electronic circuit which cancels unwanted noise.

Three recorded tape labels will provide program material which has been "Dolbyized" for no-noise playback through Dolby recorders—Ampex, London and British Decca. A Dolby tape may be played through a non-Dolby recorder with no noticeable loss in quality.

Another development aimed at improving the cassette as a hi-fi medium is the availability of tapes using chromium dioxide as the coating material. (Du Pont, which developed the coating, uses the trademark Crolyn.) The first two companies to announce chromium dioxide cassettes are BASF and Advent. The new coating is more sensitive at higher frequencies, provides greater dynamic range with less surface noise. For playback, the bias of the recorder must be changed—and no cassette recorders with a special chromium dioxide bias switch are yet available (Concord has announced a tape recorder—reel-to-reel and 8-track cartridge that does). This condition is expected to be remedied soon.

Throwaway circuits

RCA has unveiled its own approach to repair of solid-state color sets. Its new 18-inch color set with a 110-degree-deflection picture tube (more than four inches slimmer than

(continued on page 14)

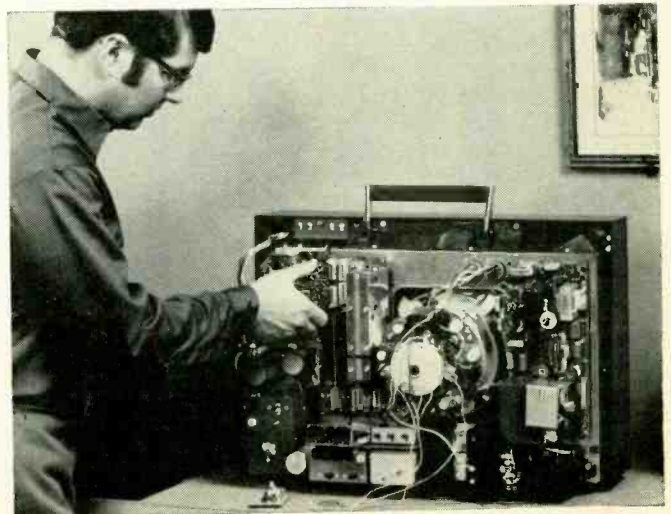

Module approach on solid-state 18-inch RCA set.

RADIO-ELECTRONICS

If you can't come to the world's newest, largest and most exciting electronics department store, we'll mail the store to you!



Exclusive!
Knight-Kit and Science-Fair Kits
 Exciting build-your-own kits made to our own exacting standards. Stereo, CB, automotive, ham radio, science, hobby, test equipment, photography and more!



Exclusive!
Battery-A-Month Club
 Join the Allied Radio Shack Club and receive a powerful battery every month for a full year—FREE!



Exclusive!
Realistic Lifetime Tubes
 Never worry about buying another tube. We guarantee ours will last as long as your set—or we replace it FREE!



ALLIED RADIO SHACK
 DIVISION OF TANDY CORP.
CATALOG 1971
 AT 300 PRICE #11
50th
 ANNIVERSARY EDITION

Is this the last stereo receiver we'll ever design?
 Model 88 Stereo Receiver \$499⁹⁵



Exclusive!
Quality Audio Products at Factory-Direct Savings
Allied TD-1099. 3-Head Stereo Tape Deck. New one-piece head makes tape threading a snap. Price includes walnut-grain vinyl covered case. Spectacular value! **\$179.95**
Realistic STA-120 Wideband AM, FET-FM Stereo Receiver. 140 Watts, 8 Ohms. With walnut case. Outstanding value! **\$269.95**

World's finest selection of famous-name electronic brands—enjoy the convenience of shopping from one book!



McDONALD, FISHER, GE, MOTOROLA, PANASONIC, KENWOOD, HARMAN KARDON, AMPEX, JFD, TELEX, KROSS, SCOTT, BARZILAY, SHERWOOD, VIKING, WHARFEDALE, DUNGEO INC., ROBERTS, JENSEN, PICKERING, EMPIRE, GARRARD, BENJAMIN MIRACORD, GAMBER/JOHNSON, ELECTRO VOICE.

1971 Allied Radio Shack Catalog!
 Thousands of electronic values!
 Allied Radio and Radio Shack have joined forces to form the largest electronics distributing company in the world! This new 460-page catalog offers you the best of both companies: famous-name brands, new products you'll find nowhere else (including some items you didn't even think were invented yet), and special money-saving prices that only the *combined buying power* of these two great companies could offer!

World's Largest Electronic Department Stores. Over 800 stores in 48 states. See your phone book for store nearest you.

MAIL THIS COUPON TO ADDRESS BELOW
 ... or bring it to an Allied Radio Shack store for your new 1971 catalog!



ALLIED RADIO SHACK 100 N. Western Ave., Chicago, Ill. 60680
 Yes! I want your big new 1971 catalog. I enclose \$1 for mailing and handling (refundable with my first purchase of \$1 or more). 603

NAME _____
 First Middle Last

ADDRESS _____
 Street or Route and Box No.

CITY _____ STATE _____ ZIP _____

I enclose check money order cash

THE HUGO GERNSBACK AWARD

RADIO-ELECTRONICS firmly believes technical training to be the backbone of any successful career in electronics. And now, we're backing that belief with \$1000 each year.

RADIO-ELECTRONICS has established the annual Hugo Gernsback Award, to be made to deserving students at leading electronics home-study schools, to be used towards furthering their education in electronics. Each year, a grant of \$125 will be made to 8 deserving students. The first awards will be made by the end of this year. The award is in memory of Hugo Gernsback, electronics pioneer, inventor, publisher, and founder of RADIO-ELECTRONICS who contributed so much to the field, and who, if alive today, would be expending his efforts toward development of the technological skills of our nation's youth.

Each school will select one of its students for the scholarship award and notify us. Names of the winning students will be published annually in RADIO-ELECTRONICS.

If you would like the names of the home-study schools through which the first Hugo Gernsback Awards will be made, write to: Hugo Gernsback Awards, c/o RADIO-ELECTRONICS Magazine, 200 Park Avenue South, New York, New York 10003.

Hugo Gernsback

1884-1967



HUGO GERNSBACK, Editor-in-Chief of RADIO-ELECTRONICS, writer, publisher, educator, inventor and prophet, was born in Luxembourg, August 16, 1884. Gernsback received an electrical engineering education at the Technikum in Bingen, Germany. He came to the United States in 1904 to exploit an invention—an improved dry battery. A year later he started the *Electro Importing Co.*, the world's first radio supply house.

In 1906 Gernsback founded *Modern Electrics*, the first of a long series of radio and technical magazines. He sold it in 1912, and after a series of combinations, it became one of the ancestors of today's *Popular Science*. He immediately started a larger magazine, the *Electrical Experimenter* (which became *Science and Invention* in 1921). In 1919 he established a purely radio magazine, *Radio Amateur News*. It became *Radio News* in 1920.

When *Radio News* passed into other hands, Gernsback founded a new magazine, *Radio-Craft* (now RADIO-ELECTRONICS). It first appeared on the stands in July, 1929. Other magazines were *Television* (1929) and *Television News* (1932-33).

As inventor, Gernsback obtained numerous patents, including one on the compression-type capacitor (the principle used in trimmers) and the use of bone conduction as an aid to hearing.

In 1928, his radio station, WRNY in New York City, was the first to broadcast television on a regular schedule. The miniature pictures were not considered entertainment quality even in that day, but were faithfully received by more than 2,000 amateur viewers.

Radio-Electronics

HUGO GERNSBACK (1884-1967)
founder

M. HARVEY GERNSBACK,
editor and publisher

LARRY STECKLER, *managing editor*

Robert F. Scott, W2PWC
senior technical editor

John R. Free, *associate editor*

Jack Darr, *service editor*

I. Queen, *editorial associate*

Matthew Mandl, *contributing editor*

David Lachenbruch, *contributing editor*

Joan Washington, *editorial assistant*

Vincent P. Cienia, *production manager*

Barbara Rosefelt, *production assistant*

H. Matysko, *circulation*

Cover by Harry Schlack

RADIO-ELECTRONICS is published by Gernsback Publications, Inc. 200 Park Ave. South New York, N.Y. 10003 (212) 777-6400

President: M. Harvey Gernsback
Secretary: Bertina Baer

ADVERTISING SALES

EAST
Stanley Levitan, Eastern Sales Mgr. N.Y.C. (212) 777-6400

MIDWEST/Texas/Arkansas/Okla.

Ralph Bergen, 6319 N. Central Ave. Chicago, Ill. 60646 (312) 792-3646

PACIFIC COAST/Mountain States
J. E. Publishers Representative Co., 8560 Sunset Blvd., Suite 601 Los Angeles, Calif. 90069 (213) 659-3810
420 Market St. San Francisco, Calif. 94111, (415) 981-4527

SOUTHEAST
E. Lucian Neff Associates
25 Castle Harbor Isle
Fort Lauderdale, Florida 33308 (305) 566-5656

SUBSCRIPTION SERVICE: Send all subscription orders and correspondence to RADIO-ELECTRONICS, Subscription Department, Boulder, Colo. 80302.

MOVING? For change of address, allow six weeks, furnishing both the old and new addresses and if possible attaching label from a recent issue below. Otherwise please print clearly your name and address exactly as it appears on your label.

ATTACH LABEL HERE

name (please print)

address

city state zip code

Mail to: RADIO-ELECTRONICS
SUBSCRIPTION DEPT., BOULDER, COLO. 80302

RADIO-ELECTRONICS

Why get caught with your pants down because of false shorts? The new B & K Model 607 Dyna-Jet is the first reasonably priced tube tester to give you nothing but positive short indications in every tube you'll ever test.

Why? Because 10 lockout buttons let you create any combination of live pin connections you want. How? By locking out the pin connections you *don't* want.

It's so easy to use too. A shape-coded chart does practically all the thinking for you. And the B & K multiple socket design means you need only 3 or 4 settings to complete a quality check.

Consider all the advantages:

- Exclusive multiple-pin lockout switches mean *all* tubes now can be tested for shorts. You never get false short indications regardless of pin connections. Reset button clears all lockouts.

- Tube testing speed doubled by (1) exclusive shape-coded symbols that match controls to chart, and (2) minimum number of settings—maximum of 4, and sometimes only 3.
- Checks tubes the accurate way—under simulated load conditions.
- Exclusive grid leakage and gas tests.
- Simplified heater voltage setting.
- Power 'ON' indicator.
- Superior load and plate voltage capability.
- Attractive, attache-type case for professional appearance.

Ask your distributor about the new solid state Model 607 Dyna-Jet from B & K. It's the most modern portable tube tester yet. And you'll never be left in the cold with false shorts. And that's the naked truth!

Put an end to false shorts that leave you naked

...with the new 607 portable tube tester from B&K

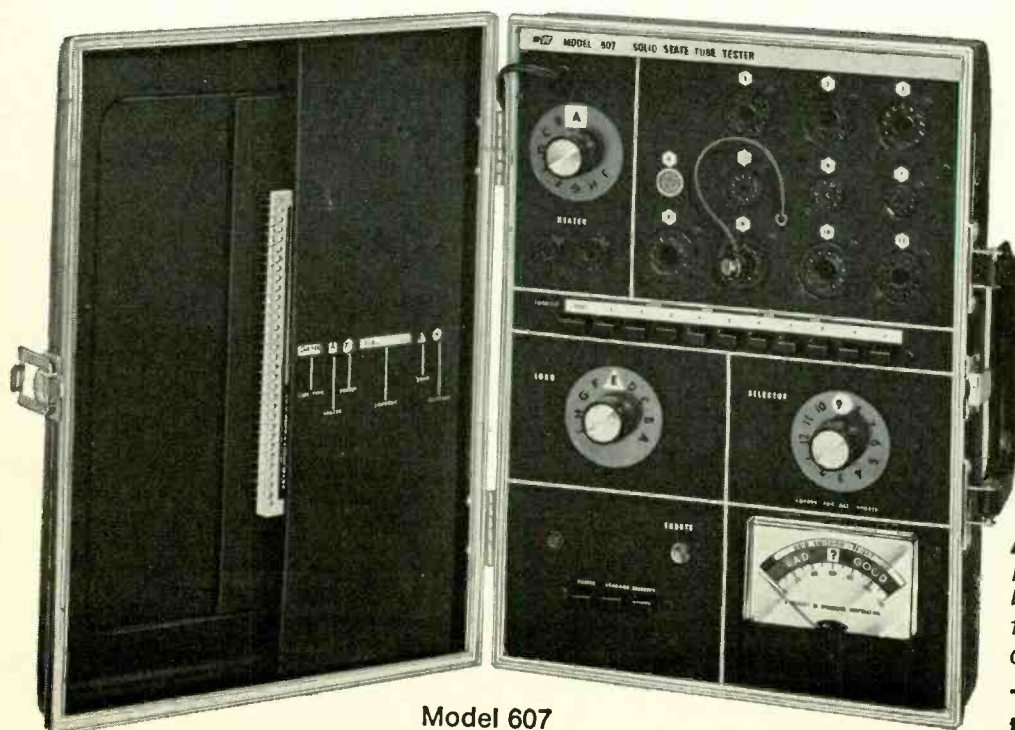

Model 607
Dyna-Jet \$114.95



Product of
DYNASCAN CORPORATION
1801 W. Belle Plaine
Chicago, Illinois 60613

The professional
test equipment.

NRI "hands-on" training in TV-Radio, Electronics can give you as much as 2 years of on-the-job experience.

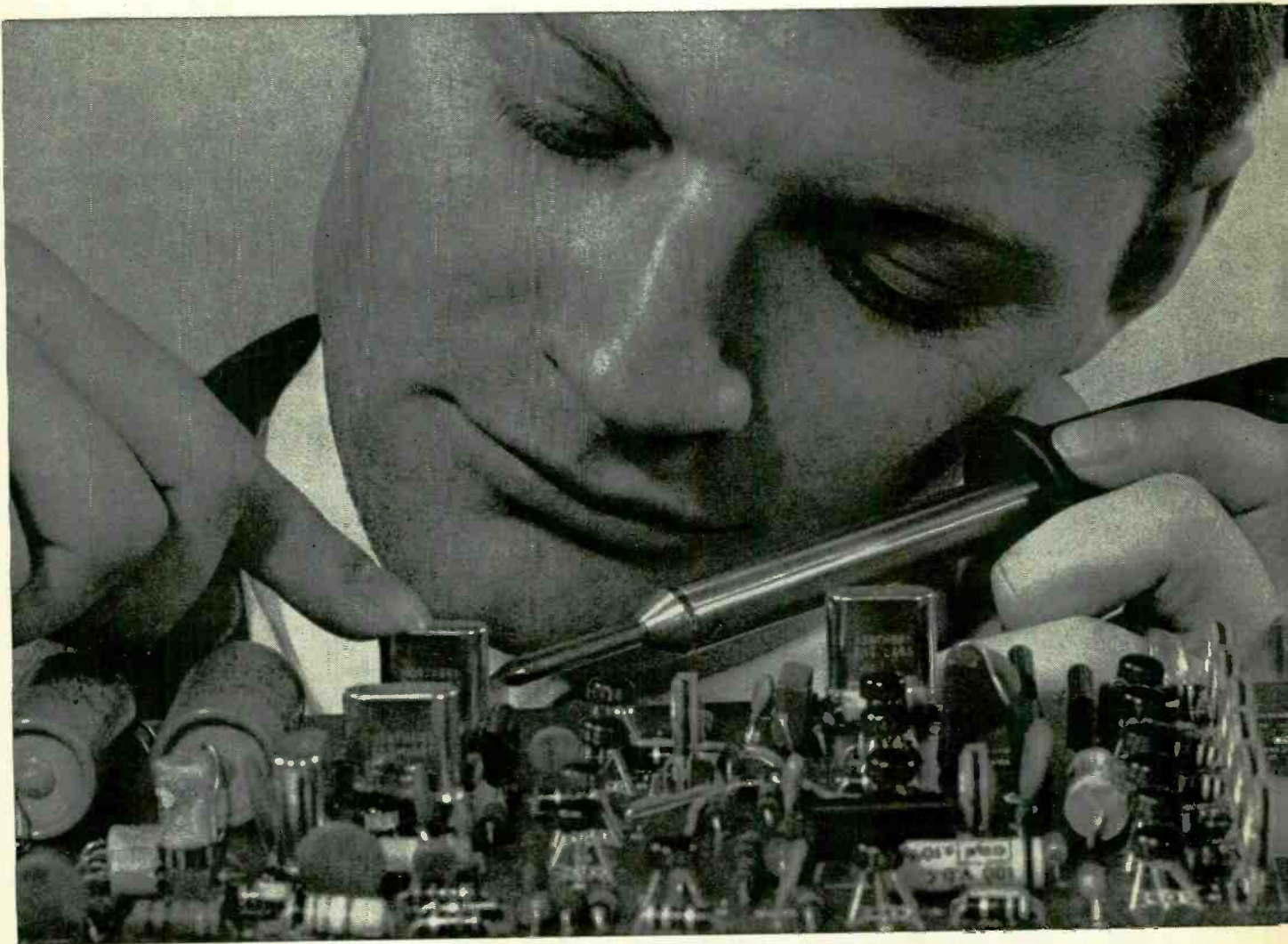

EARN YOUR FCC LICENSE – OR YOUR MONEY BACK

NRI Communications training programs will qualify you for a First Class Commercial Radiotelephone License issued by the FCC. If you fail to pass the FCC examinations for this license after successfully completing an NRI Communications course we will, on request, refund in full the tuition you have paid. This agreement is valid for the period of your active student membership and *for six months* after completion of your training. No school offers a more liberal FCC License agreement.

Experience is still your best teacher



NRI Achievement Kit is educator-acclaimed and the original "starter" kit in home study training. Imitated but never duplicated, this kit is designed and personalized for you and your training objective. It has one purpose — to get you started quickly and easily.

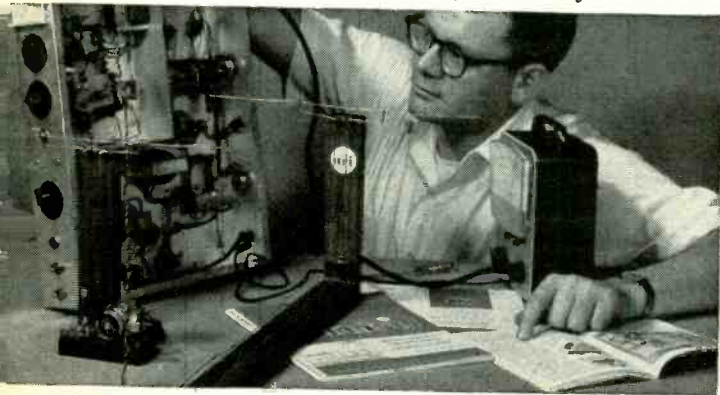

"Bite-Size" Texts average an easily-digested 40 pages of well-illustrated, scientifically prepared subject matter in the course of your choice. Questions in each book are carefully hand-graded and returned to you with helpful instructional notes. You get unlimited personal help from the day you enroll.

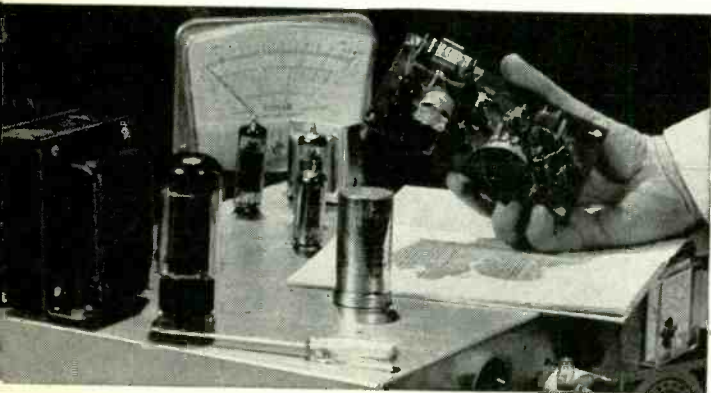

Designed-For-Learning Equipment

Like this phone-cw transmitter (Kit #7 in the Communications course) is engineered from chassis up to demonstrate principles you must know. NRI does not use modified hobby kits for training, but the finest parts money can buy, professionally and educationally applied.

...here's how you get it with unique NRI training at home

Ask any teacher, job counselor, engineer, technician or prospective employer about the need for practical application of theory in Electronics. He'll tell you Electronics is as much a "hands-on" profession as dentistry or chemistry. That's how you learn at home with NRI. You prove the theory you read in "bite-size" texts, by actual experimentation with the type of solid-state, transistor and tube circuits you'll find on the job today — *not* hardware or hobby kits. You introduce circuit defects, analyze results, discover quickly the kind of trouble-shooting and design techniques that will make you employable in Electronics.

Train with the leader—NRI

NRI lab equipment is designed from chassis up for effective, fascinating training — not for entertainment. The fact that end results are usable, quality products is a bonus. In Communications, for example, you build and analyze, stage by stage, your own 25-watt phone/cw transmitter. It's suitable for use on the 80-meter amateur band, if you have an interest in ham radio. In TV-Radio Servicing your practical training gives you your choice of monochrome or color TV sets. All training equipment is included in the low tuition — you pay nothing extra. Discover for yourself the ease, excitement and *value* of NRI training. Mail postage-free card today for new NRI Catalog . . . or use the coupon below. No obligation. No salesman will call on you. NATIONAL RADIO INSTITUTE, Washington, D.C. 20016.

APPROVED UNDER NEW GI BILL

If you have served since January 31, 1955, or are in service now, check GI line on postage-free card or in coupon.

MAIL THIS COUPON IF CARD IS GONE



NATIONAL RADIO INSTITUTE

Washington, D.C. 20016

3-070

Please send me your new NRI Catalog. I understand no salesman will call and there is no obligation.

Name _____ Age _____

Address _____

City _____ State _____ Zip _____

Check for facts on new GI Bill

ACCREDITED MEMBER NATIONAL HOME STUDY COUNCIL

(Continued from page 2)

DIANA IN THE SHOP



LINDEN, N. J.—Ask 17-year-old Diana Ildefonso what she's doing in such a strange line of work—for a girl anyway—and she replies with, "What's Josephine doing as a plumber?"

Miss. Ildefonso is a cute, earnest, hardworking TV repairwoman. Her career in electronics started when she had to leave high school to help pay her grandmother's medical bills and help sup-

port her mother and five sisters.

Trapped in a factory job, she eventually found her way to the Job Corps and began training as a piecemeal assembler. "I didn't want to just put things together," she says, "I wanted to know why things went together and how they worked." An instructor took the time to teach her elementary electronics principles.

An employment office then directed her to a Magnavox home entertainment center in Linden, and Diana began working on TV's, radio's, hi-fi and other products while simultaneously taking a home study course in TV repair.

She's the first to admit she's got a lot to learn, but thinks she's learning fast. "I only holler for help when I'm really stuck," she says.

Diana expects to make house repair calls when she finishes her training, but wor-

ries what homeowners will think when a girl arrives at the door carrying a case of tubes and repair tools. "I'm going to be asked to prove myself," she says, "and that's hard work for me when someone is watching every move I make." She thinks people somehow trust men more in her line of work, but is out to prove the disbelievers wrong.

She has a lot of pride in her work and a sense of accomplishment. "I like this repair work because you're being paid because you know something, not because you did something," she says. "There's always something new coming up . . . like a TV cassette, you know. Put a cartridge in a set and watch a show."

In August, Diana started at a Magnavox service training school for instruction on remote control functions, solid-state TV and radio and cabinet repair. She also hopes to broaden her knowledge by starting college at night.

"I want material things, but education comes first. The other things will follow," she says.

COMPUTER ALARM FOR TRUCK DRIVERS

A device designed to reduce the ever growing rate of truck accidents in the U. S. will be a special-order option on Ford trucks. According to a recent *Business Week* article, in 1969 over 3 million truck accidents caused 12,000 fatalities.

Incorporating an IC memory, the device sounds a buzzer when a driver starts to doze at the wheel. During the first few minutes of high-speed driving, the small wheel adjustments made by the driver are counted. If the wheel reversal rate drops 50% below a safety limit, the memory circuit activates an alarm circuit. [See R-E's alarm, page 53.]

(N & T continued on page 14)

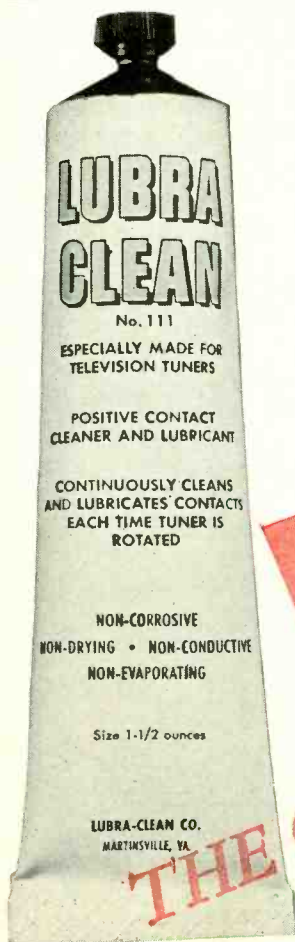

LUBRA CLEAN

... A T.V. TUNER CLEANER THAT REALLY WORKS!

MADE ESPECIALLY FOR TELEVISION TUNERS

Finally, a tuner cleaner that really works. Apply LUBRA CLEAN and let it do the work for you. Physical cleaning and polishing contacts is no longer necessary. Simply apply—and LUBRA CLEAN continues to polish and lubricate tuner contacts for months after all other cleaners and lubricants have failed. Sold at leading dealers and distributors for \$2.98 per tube.



LUBRA CLEAN COMPANY

P. O. BOX 926 - MARTINSVILLE, VA. 24112 - PHONE (703) 638-1211

Circle 5 on reader service card

Circle 6 on Reader Service Card →

HEARD THE LATEST?



A-24

- 4-track, 2-channel stereo
- All-silicon transistor pre-amps
- Pause control
- Digital counter
- Dual VU meter
- Fast winding
- Automatic stop at end of tape
- 0.2% wow and flutter (RMS)
- Frequency response: 40 to 12,000 HZ
- S/N ratio: 45 dB or more
- Crosstalk: 40 dB between adjacent tracks at 100 Hz
- Microphone optional

This is what happens when a big name thinks small. It's the TEAC A-24, and it's making cassette history. This deck is powered by a unique hysteresis synchronous outer rotor motor for compact convenience, powerhouse performance. And it comes complete with all the craftsmanship it takes to make a TEAC.

More exclusive features: a special end-of-tape sensing circuit which not only stops the cassette, but completely disengages the mechanism – releasing pushbuttons, pinch roller and idlers – to avoid “flats” and deformation of critical drive components. Two specially-designed heads for outstanding frequency response. Just about the lowest wow and flutter that ever came out of a cassette.

Of course, no sound system is really complete without cassette capability. So if it's time to round out your equipment, it's time to sound out our A-24.



TEAC

TEAC Corporation of America • 2000 Colorado Avenue • Santa Monica, California 90404

UNEXCELLED! THE UVM ANTENNA

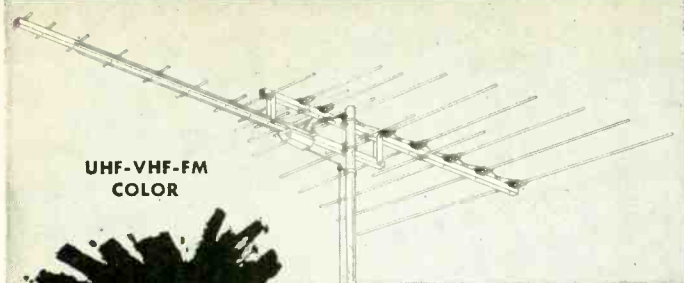

UHF-VHF-FM
COLOR

**COMPLETELY
NEW!**

**Combination
UHF-VHF-FM Antennas**

for superior performance.

Tuned and engineered featuring a LOG PERIODIC VHF section incorporating a PATENTED MAGNETIC WAVE design for UHF. Discriminate between desired signal and unwanted noise. An absence of minor lobes and extremely high front to back ratio are characteristics of these antennas. Mechanical features include all new fittings and special alloy aluminum tubing for added strength. Six models available.

Write or phone for complete information.

S & A ELECTRONICS, INC.

210 W. Florence St. Phone (419) 693-0528 Toledo, Ohio 43605

Circle 7 on reader service card



*It's yours
FREE
for the
asking!*



BA
**GIANT 260 PAGE
1971
RADIO-TV
ELECTRONICS
CATALOG**

YOUR BUYING GUIDE FOR EVERYTHING IN ELECTRONICS!

Write to:

**BURSTEIN-APPLEBEE CO.,
DEPT. RE-9, 3199 MERCIER ST.,
KANSAS CITY, MO. 64111**

Name _____

Address _____

City _____

State _____ Zip Code _____

Circle 8 on reader service card

LOOKING AHEAD

(continued from page 4)

conventional receivers of the same picture size) uses 11 plug-in modules for about 75% of its circuitry.

Eight of the modules are relatively conventional printed-circuit boards. The other three—the video drive circuits—are plastic-encapsulated, on ceramic substrates, combining thick-film technology and some discrete components. When trouble develops, the service technician merely throws away the faulty ceramic circuit and plugs in a new one. Cost of these circuits: Probably about three dollars each.

RCA plans gradually to replace the remaining discrete modules with ceramic ones. And they'll be direct replacements, inserted in the field when repairs are necessary. The modules are designed to be standard, and eventually fit a large number of sets. All modules will be pre-aligned and pre-adjusted, with no adjustments required on the chassis.

The 18-inch set is all solid-state and sells for something under \$450. In addition to the three video drive modules, the others are: Two for the chroma circuit, power supply, horizontal oscillator, video sync, sound, vertical and combination i.f. and a.f.c.

Labor warranties universal

At least in the color TV field, almost every manufacturer now includes some "free" labor in his warranty. This quiet revolution in the television manufacturing field quickly followed RCA's move to include one year's labor (at prevailing retail prices, at a service dealer of the customer's choice) in the warranties for all its solid-state color sets. Motorola quickly followed with a one-year labor policy (at Motorola authorized service dealers) on its '71 color sets.

Virtually all other domestic and foreign manufacturers now include at least 90 days' complete service in their warranties. And RCA says the response to its one-year policy has been so strong that it feels the others will have to follow.

FCC revises tuner rules

Responding to the objections of TV set makers, the FCC has eased its requirements for the changeover to "comparable" ease of tuning for uhf and vhf.

It adopted the recommendations of manufacturers that July 1, 1974 be established as the date for the complete switch to tuning parity—through either detent (click-type) or electronic varactor tuners.

But the FCC established an interim timetable. By July 1, 1971, 10% of each manufacturer's models must have comparable tuning facilities. One year later, the required percentage will rise to 40%, and on July 1, 1973, the tuners must have equal tuning ease in 70% of the models. **R-E**

New & Timely

(continued from page 12)



Dial-a-program system being installed at Cape Cod, Mass. uses this special color TV or conventional sets with convertors. A multipair cable carries a 5-10-MHz "super video" band of vhf/uhf signals. Users can feed signal to source for two-way communication.



Panasonic's new time-announcing, experimental FM/AM clock radio uses two rotating magnetic disk sheets (hours, minutes) to "tell" time when switch is operated **R-E**

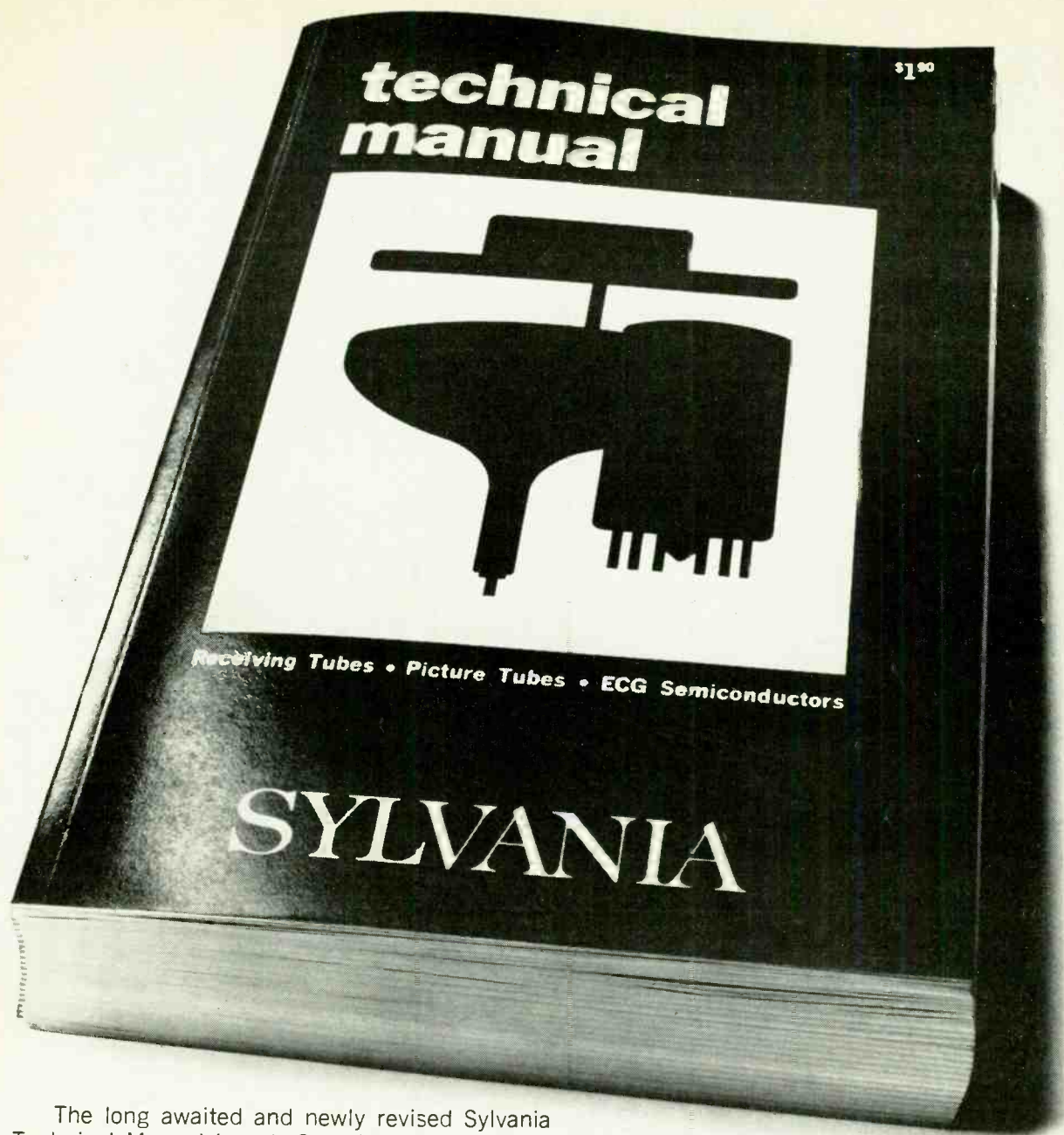

The long awaited and newly revised Sylvania Technical Manual is out. Complete and unexpurgated. The fantasy of every Independent Service Technician. Written anonymously by an agile team of Sylvania engineers. 32,000 components described in breathtaking detail. Including thousands of unretouched diagrams and illustrations. Discover the unspeakable thrill of new color TV Tubes, listed as never before. The ecstasy of 28,000 ECG Semiconductors.

From exotic Deflection Oscillators to a lurid account of Transistors and Rectifiers.

This book has what you want. Components for the man who knows what to do with them.

The 14th Edition of the Sylvania Technical Manual is not available in any bookstore. Your Sylvania Distributor is discreet. Speak to him.

SYLVANIA
GENERAL TELEPHONE & ELECTRONICS

“Electrifying”

NOW - CHECK ALL TRANSISTORS IN OR OUT OF CIRCUIT ...

Flick function switch to left to check all regular transistors.

Flick function switch to right to check any FET.



... plus the new FIELD EFFECT TRANSISTORS too!

You won't be stopped when you run into the new FETs that are wired into the latest hi-fi, newest TV receivers and nearly every other new device coming on the market. For the very first time, you can check them all, in or out of circuit. The TF151 works every time using tried and proven signal injection techniques. New, improved tests on special RF transistors and the latest high power transistors, mean that the TF151 is the only up-to-date transistor tester on the market. A new, exclusive setup book in rear compartment guides you to every test for over 12,000 transistors and FETs. The book is not needed for general service troubleshooting. Regular transistors are checked for beta gain and Icbo leakage. FETs are checked for transconductance and Igss leakage. **only \$129⁵⁰**

NEW SENCORE TF17 compact in and out of circuit transistor FET tester. Same as TF151 except in new Sencore Handi case and with 4-1/2" meter. . . \$109.50

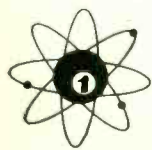

SENCORE

NO. 1 MANUFACTURER OF ELECTRONIC MAINTENANCE EQUIPMENT

426 SOUTH WESTGATE DRIVE, ADDISON, ILLINOIS 60101

Circle 10 on reader service card



DIFFERENT DWELL READINGS

Regarding the article "Tune up your car with a VOM", by Louis E. Frenzel Jr. (April, 1970). This was an excellent article of considerable practical value. However, I have experienced a problem with the use of my dwell-adapted vom as described in the article.

The dwell angle readings on my Catalina V8 indicates 30° correctly; however, when I compare with both an inexpensive Sears dwell meter and a RAC Dwell/Tach meter, I only get a reading of 23°.

My adapted vom is a FET solid-state Heathkit model IM-17 (20,000 ohms/volt sensitivity). I used a diode with 3,800 ohms forward resistance and 1.3 megohms reverse resistance. After observing correct polarity, I zeroed the needle on my R × 10K range. My meter scale is linear with equal divisions to a maximum reading of 10. My math shows that a 30° dwell equals 6.66 on this scale for a V8.

When I set my distributor dwell at 30° with the comparison meters, then my adapted vom will read only 5.0 (or 23° dwell). The reverse is naturally true also; (i.e., when my vom reads 6.66 (30°) the comparison meters read 23°).

My only conclusion is that since my car operates better when the dwell is set to 30° by my newly adapted vom than it did with the Sears dwell meter, and since my meter is a more accurate instrument, that my adapted meter is correct and the comparison dwell meters are in error.

Why such a wide variance in dwell readings? A 7° difference, in my mind, is more than insignificant.

JOHN S. GARDNER
Alexandria, Va.

Frankly, your problem has me stumped. I've given it quite a bit of consideration but I can't really come up with what I feel is a satisfactory answer. Nevertheless, let me tell you what I have found out, then you can take it from there.

If you will recall, the article specifies the use of a vom. While a vvm or FET meter like yours can be used, the formulas given in the article are

(continued on page 22)

"Here's the 'BEST TIME' You'll Ever Have!"



**This \$15.00
ELECTRIC
DIGITAL
CLOCK**

FREE

**when you buy the "FASTEST-MOVING"
MOTOROLA HEP REPLACEMENT-SEMICONDUCTORS**

TERRIFIC VALUE!

Regular Price of
Semiconductors \$51.40
CLOCK Price 15.00
Total Price \$66.40
Special Sale Price .. 49.95
YOU SAVE \$16.45



This big, handsome SETH THOMAS "Speed Read" Electric Digital Clock is yours absolutely FREE when you buy only 10 each of the 5 most frequently used HEP Semiconductors (HEP 170, HEP 254, HEP 53, HEP 54 & HEP 55). Ask your HEP Supplier for the HFM-5 "Dealer Deal" — and buy at a saving — plus you get the Electric Digital Clock Free, including the latest Motorola HEP Cross Reference Guide!

get HEP with

MOTOROLA Semiconductor Products Inc.

5005 E. McDowell Rd., Phoenix, Arizona 85008

How to become a “Non-Degree Engineer”

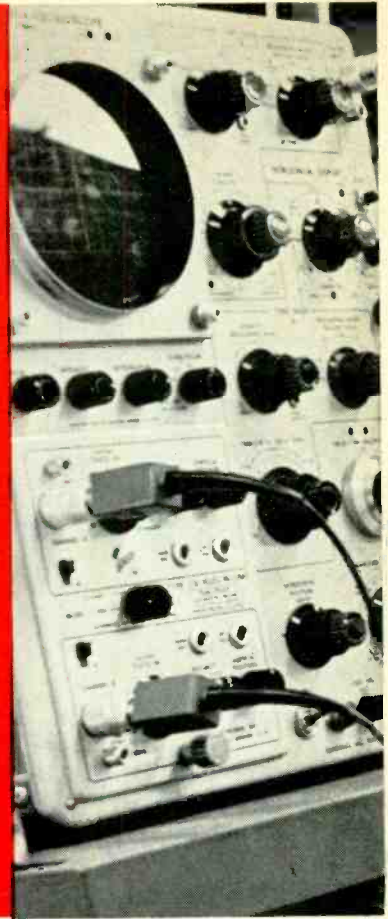

In today's electronics boom the demand for men with technical education is far greater than the supply of graduate engineers. Thousands of real engineering jobs are being filled by men without engineering degrees—provided they are thoroughly trained in basic electronic theory and modern application. The pay is good, the future is bright... and the training can now be acquired at home—on your own time.

THE ELECTRONICS BOOM has created a new breed of professional man—the non-degree engineer. Depending on the branch of electronics he's in, he may “ride herd” over a flock of computers, run a powerful TV transmitter, supervise a service or maintenance department, or work side by side with distinguished scientists on a new discovery.

But you do need to know more than soldering connections, testing circuits and replacing components. You need to really know the fundamentals of electronics.

How can you pick up this necessary knowledge? Many of today's non-degree engineers learned their electronics at home. In fact, some authorities feel that a home study course is the *best* way. *Popular Electronics* said:

“By its very nature, home study develops your ability to analyze and extract information as well as to strengthen your sense of responsibility and initiative.”

Cleveland Method Makes It Easy

If you do decide to advance your career through home study, it's best to pick a school that *specializes* in the home study method. Electronics is complicated enough without trying to learn it from texts and lessons that were designed for the classroom instead of the home.

Cleveland Institute of Electronics concentrates on home study exclusively. Over the last 30 years it has developed tech-

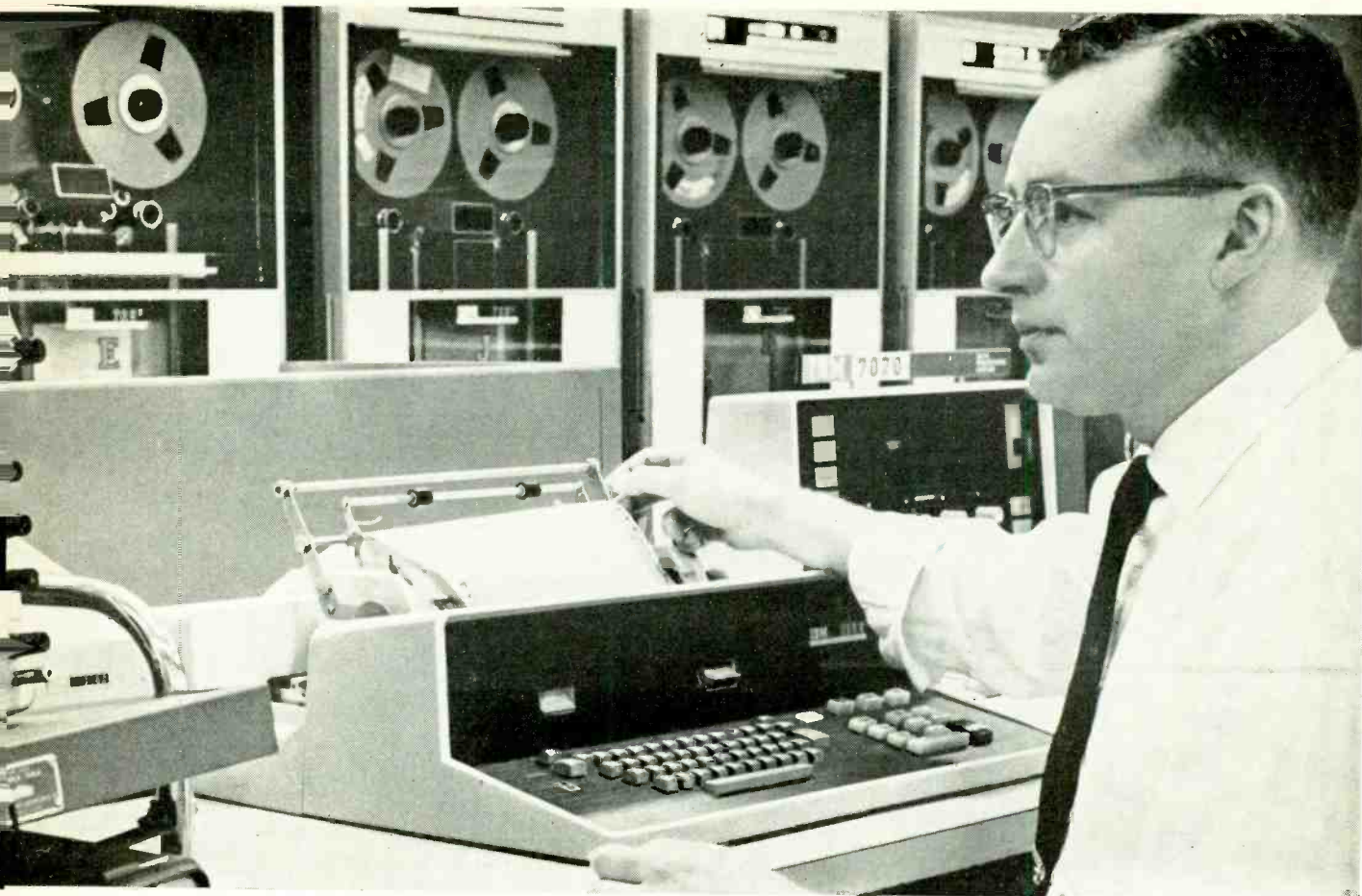

niques that make learning at home easy, even if you once had trouble studying. Your instructor gives the lessons and questions you send in his undivided personal attention—it's like being the only student in his "class." He not only grades your work, he analyzes it. And he mails back his corrections and comments the same day he gets your lessons, so you read his notations while everything is still fresh in your mind.

Students who have taken other courses often comment on how much more they learn from CIE. Says Mark E. Newland of Santa Maria, Calif.:

"Of 11 different correspondence courses I've taken, CIE's was the best prepared, most interesting, and easiest to understand. I passed my 1st Class FCC exam after completing my course, and have increased my earnings by \$120 a month."

Always Up-to-Date

Because of rapid developments in electronics, CIE courses are constantly being revised. This year's courses include up-to-the-minute lessons in Microminiaturization, Laser Theory and Application, Suppressed Carrier Modulation, Single Sideband Techniques, Logical Troubleshooting, Boolean Algebra, Pulse Theory, Timebase Generators...and many more.

CIE Assures You an FCC License

The Cleveland method of training is so successful that better than 9 out of 10 CIE

graduates who take the FCC exam pass it. This is despite the fact that, among non-CIE men, 2 out of every 3 who take the exam fail! That's why CIE can promise in writing to refund your tuition in full if you complete one of its FCC courses and fail to pass the licensing exam.

This Book Can Help You

Thousands who are advancing their electronics careers started by reading our famous book, "How To Succeed in Electronics." It tells of many non-degree engineering jobs and other electronics careers open to men with the proper training. And it tells which courses of study best prepare you for the work you want.

If you would like to cash in on the electronics boom, let us send you this 44-page book free.

Just fill out and mail the attached post-paid card. Or, if the card is missing, mail the coupon at right.

NEW COLLEGE-LEVEL CAREER COURSE FOR MEN WITH PRIOR EXPERIENCE IN ELECTRONICS

ELECTRONICS ENGINEERING... covers steady-state and transient network theory, solid state physics and circuitry, pulse techniques, computer logic and mathematics through calculus. A college-level course for men already working in Electronics.

CIE
**Cleveland Institute
of Electronics**
1776 East 17th Street
Cleveland, Ohio 44114

Please send me without cost or obligation:

Your 44-page book "How To Succeed in Electronics" describing the job opportunities in Electronics today, and how your courses can prepare me for them.

Your book on "How To Get A Commercial FCC License."

I am especially interested in:

- Electronics Technology
- Broadcast Engineering
- First Class FCC License
- Electronic Communications
- Industrial Electronics
- Electronics Engineering

Name _____ (PLEASE PRINT)

City _____

Address _____

State _____

Zip _____ Age _____

ENROLL UNDER NEW G.I. BILL. All CIE courses are available under the new G.I. Bill. If you served on active duty since January 31, 1955, or are in service now, check box on card or in this coupon for G. I. bill information.

RE-82

Circle 12 on reader service card

The does-it-all turntable at a do-it-yourself price.



It's the BSR McDonald 310/X, and it's the best buy in automatic turntables. Anywhere.

This is no "little brother" turntable, either. It's got a full-size platter, cue and pause control, low mass tone arm system and a visible stylus pressure indicator.

And because it's a famous BSR Total Turntable, it comes complete with a tinted dust cover, custom molded base and a Shure

BSR
McDONALD

M-75 magnetic cartridge—all factory-installed and balanced and included in the low price.

The BSR McDonald 310/X. It's perfect for people who want the best, no matter how little it costs.

Send for free full color catalog on all our automatic turntables. BSR (USA) Ltd., Blauvelt, N.Y. 10913

Circle 13 on reader service card

CORRESPONDENCE

(continued from page 16)

not correct for these units. They apply only to the vom. The reason for this is the difference between the way the ohms scales operate. In the vom, zero ohms appears at the far right hand extreme of the meter scale. In the FET meter, zero ohms is at the left hand extreme of the meter scale. When using the ohmmeter for dwell indication as mentioned in the article, maximum dwell (45°) is up the scale on the vom and down scale on the FET vom like your Heath IM-17. To get the correct value on the 0-10-volt scale, you subtract the figure you calculated (6.66) from full scale or $10 - 6.66 = 3.34$. On your meter 30° of dwell corresponds to 3.34 volts.

This could be your problem. You can try resetting your dwell and check the results. However, the fact that your Catalina runs so well at the 6.66 setting leads me to believe that something else is wrong. The readings of the RAC and Sears dwell meters almost confirms it.

The RAC dwell meter may be inaccurate. I've used several of these units and in checking them against a calibrated unit, I've experienced errors of 15-20%. My personal unit is off by 10%, still too much to be useful. I'd suspect your RAC unit if both the Sears and RAC meter had not given the same result. You are correct. Seven degrees is a lot to be off.

All I can suggest is to give it another try using the new setting I mentioned. Be sure the ohmmeter is properly zeroed with the diode before you begin. Try another diode and another ohms range (not $R \times 10K$). Just to be sure. If you have a vom, try it too.

LOUIS E. FRENZEL, JR.
Silver Spring, Md.

AVIONICS PROGRAM

We were pleased to see the article in your June issue entitled "Careers in Aviation Electronics" by Len Buckwalter.

As a supplement, we would like to announce that Ferris State College will commence a 2-year course in Avionics starting this fall.

ALAN A. DAVID, Head
Electrical & Electronics Department
School of Technical and Applied Arts
Ferris State College, Mich. **R-E**

NEXT MONTH

4-channel stereo is the hot new kind of sound. Do you know where it is today and what systems are in use? See the October issue of Radio-Electronics for full details.

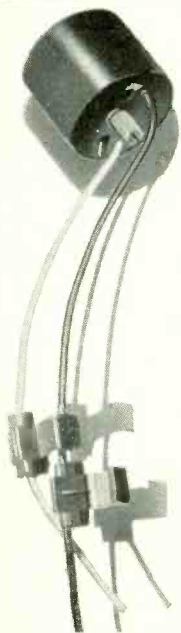

MODEL

B-150

\$800 Suggested List Price

When one gun fades
restore color balance
with a Perma-Power
single-brite
COLOR GUN CONTROL



Here's a unique new product that lets you restore color picture balance when a single gun weakens. You just adjust the bias between the G1 and G2 grid leads of the weakened gun, permitting color intensity variation as needed for a balanced picture. Installation is easy . . . just two simple connections, no soldering. Now available at your parts distributor.

CHAMBERLAIN MANUFACTURING CORPORATION
845 Larch Avenue • Elmhurst, Illinois 60126 • Phone: (312) 279-3600

Circle 14 on reader service card

not all
cardioid microphones
are alike . . .



the

SHURE UNISPHERE® I

TRUE CARDIOID UNIDIRECTIONAL DYNAMIC
MICROPHONE SOLVES ALL THESE
COMMON MICROPHONE PROBLEMS!

PROBLEMS CAUSED BY INEFFICIENT REJECTION OF UNWANTED SOUNDS BY THE MICROPHONE

SITUATION	PROBLEM	CAUSES	SOLUTION
<p>REFLECTIONS</p>	Feedback occurs where a so-called "cardioid" microphone is used and the speakers are placed to the rear of the microphone. A common occurrence in churches, auditoriums, and meeting rooms.	Sound bounces off hard surfaces on the walls, floor and ceiling, in and around the audience area and the microphone used is not effective in rejecting these sounds at all frequencies, and in all planes about its axis.	The Unisphere rejects sound at the rear with uniformity at all frequencies. Sounds bouncing off floors or other surfaces are uniformly rejected.
<p>COLUMN LOUDSPEAKERS</p>	Unexplained feedback. Column loudspeakers are used to distribute sound more evenly to the audience in churches and auditoriums.	Feedback occurs when rear and side sound lobes of column speakers coincide with rear and side lobes of so-called "cardioid" microphones.	The Unisphere solves the problem because it has no rear or side lobes. Thus it rejects the side and rear lobes of the sound column speakers.
<p>REVERBERANT BOOM!</p>	A disturbing, echoing effect of low frequency sound often found in churches, large auditoriums, and arenas.	Low frequency reverberation and boominess occur when microphone fails to retain unidirectional characteristics at low frequencies.	The Unisphere maintains a uniform pattern of sound rejection at all frequencies, even as low as 70 Hz. The response has a controlled roll-off of the low end—low frequency reverberation diminishes effect of boomy hall.

PROBLEMS CAUSED BY THE MICROPHONE'S INEFFECTIVENESS IN PICKING UP THE DESIRED SOUND

<p>GROUP COVERAGE WITH ONE MICROPHONE</p>	A single microphone does not provide uniform coverage of a group. This is commonly experienced with choral groups, quartettes, instrumental combos, and speaker panels.	The particular "cardioid" microphone used lacks a uniform pickup pattern, so that persons in different positions within the general pickup area of the microphone are heard with varying tonal quality and volume.	The Unisphere affords uniform pickup of the group with a resulting consistency in volume and sound quality among the members of the group.
<p>USING MULTIPLE MICROPHONES</p>	Variation in the pickup level and tonal quality exists throughout the broad area to be covered. This may occur in stage pickup of musical and dramatic productions, panels and audience participation events.	The pickup pattern of the microphones used is too narrow, causing "holes" and "hot spots." The off-axis frequency response of the microphones also varies.	The Unisphere permits smoothness in pickup as true cardioid pattern gives broad coverage with uniformity throughout coverage area. Eliminates "holes," "hot spots," and variations in sound quality, simplifies blending many microphones.
<p>DISTANT PICKUP</p>	Too much background noise or feedback results when working with microphone at desired distance from sound source.	Long-range microphones are less directional with lower frequencies. Lobes or hot spots allow background noise or feedback.	Use the Unisphere to gain relatively long range with effective rejection of sound at all frequencies at the rear of the microphone.

SHURE BROTHERS, INC., 222 HARTREY AVE., EVANSTON, ILL. 60204

Circle 15 on reader service card

New Heathkit® Solid-State

Design and performance features add up to one-of-a-kind superiority.

Over five years were spent in research and development to achieve the notably superior performance, improved convenience features, and ease of service now embodied in the new GR-270 and GR-370. They are premium quality receivers in the truest sense, and, we believe, the finest color TV's on today's market. Here's why ...

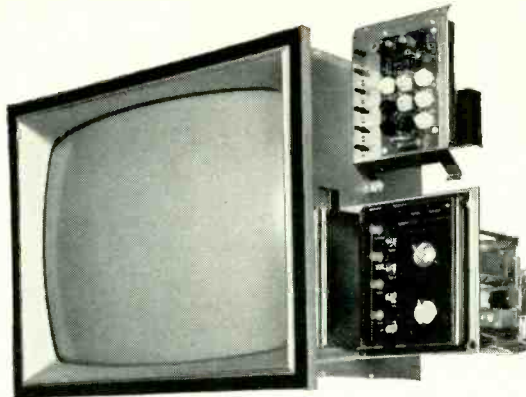

Compare these features:

- Modular plug-in circuit board construction.
- MOSFET VHF tuner and 3-stage IF.
- Adjustable video peaking.
- Sound instantly, picture in seconds.
- Built-in Automatic Fine Tuning.
- Pushbutton channel advance.
- Tilt-out convergence and secondary controls.
- Hi-fi sound outputs — for amplifier.
- Virtually total self-service capability with built-in volt-ohm meter, dot generator, and comprehensive manual.
- Premium quality bonded-face etched glass picture tubes.
- Choice of 295" or 227" picture tube sizes.

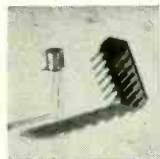

Exclusive solid-state circuitry design ... total of 45 transistors, 55 diodes, 2 silicon controlled rectifiers; 4 advanced Integrated Circuits containing another 46 transistors and 21 diodes; plus 2 tubes (picture and high voltage rectifier) combine to deliver performance and reliability unmatched by conventional tube sets.



Exclusive design solid-state VHF tuner uses an MOS Field Effect Transistor for greater sensitivity, lower noise, and lower cross-modulation ... gives you sharply superior color reception, especially under marginal conditions. Gold/Nioborium contacts give better electrical connections and longer wear. Memory fine tuning,

standard. Solid-state UHF tuner uses hot-carrier diode design for increased sensitivity.



3-stage solid-state IF has higher gain for better overall picture quality. Emitter-follower output prevents spurious signal radiation, and the entire factory-aligned assembly is completely shielded to prevent external interference.

Automatic Fine Tuning — standard on both sets. Just push a button and the assembled and aligned AFT module tunes in perfect picture and sound automatically ... eliminates manual fine-tuning. Automatic between-channel defeat switch prevents tuner from locking in on stray signals between channels. AFT can be disabled for manual tuning.

VHF power tuning ... scan through all VHF and one preselected UHF channel at the push of a button.

Built-in automatic degaussing keeps colors pure. Manual degaussing coil can be left plugged into the chassis and turned on from the front panel ... especially useful for degaussing after the set is moved some distance.

Automatic chroma control eliminates color variations under different signal conditions.

Adjustable noise limiting and gated AGC keeps pulse-type interference to a minimum, maintains signal strength at constant level.

High resolution circuitry improves picture clarity and new adjustable video peaking lets you select the degree of sharpness and apparent resolution you desire.

"Instant-On". A push of the power switch on the front panel brings your new solid-state set to life in seconds. Picture tube filaments are kept heated for instant operation, and extended tube life. "Instant-On" circuit can be defeated for normal on-off operation.

Premium quality color picture tubes. Both the 227 sq. in. GR-270 and 295 sq. in. GR-370 use the new brighter bonded-face, etched glass picture tubes for crisper, sharper, more natural color. And the new RCA HiLite Matrix tube is a low cost option for the GR-370. See below.

Adjustable tone control lets you choose the sound you prefer ... from deep, rich bass to clean, pronounced highs.



Hi-fi output permits playing the audio from the set through your stereo or hi-fi for truly lifelike reproduction. Another Heath exclusive.

Designed to be owner serviced. The new Heath solid-state color TV's are the only sets on the market that can be serviced by the owner. You actually can diagnose, trouble-shoot and maintain your own set.

Built-in dot generator and tilt-out convergence panel let you do the periodic dynamic convergence adjustments required of all color TV's for peak performance. Virtually eliminate technician service calls.



Snap-out glass epoxy circuit boards with transistor sockets add strength and durability and permit fast, easy troubleshooting and transistor replacement. Makes each circuit a module.



Built-in Volt-Ohm Meter and comprehensive manual let you check circuits for proper operation and make necessary adjustments. The manual guides you every step in using this built-in capability. Absolutely no knowledge of electronics is required.

Easy, enjoyable assembly ... the Heathkit way. The seven-section manual breaks every assembly down into simple step-by-step instructions. With Heath's famous fold-out pictorials and simple, straightforward design of the sets themselves, anyone can successfully complete the assembly.

Heathkit Solid-State Modular Color TV represents a significant step into the future ... with color receiver design and performance features unmatched by any commercially available set at any price! Compare the specifications. Then order yours today.

Kit GR-270, all parts including chassis, 227" picture tube, face mask, UHF & VHF tuners, AFT & 6x9" speaker, 114 lbs. **\$489.95***

Kit GR-370, all parts including chassis, 295" picture tube, face mask, UHF & VHF tuners, AFT & 6x9" speaker, 127 lbs. **\$559.95***

Kit GR-370MX, complete GR-370 with RCA matrix picture tube, 127 lbs. **\$569.75***

GR-270 AND GR-370 SPECIFICATIONS — PICTURE TUBE SIZE: GR-370 Approximate Viewing Area: 295 Sq. In. GR-270 Approximate Viewing Area: 227 Sq. In. **DEFLECTION:** Magnetic, 90 degrees. **FOCUS:** Electrostatic. **CONVERGENCE:** Magnetic. **ANTENNA INPUT IMPEDANCE:** VHF 300 ohm balanced or 75 ohm unbalanced. UHF: 300 ohm balanced. **TUNING RANGE:** VHF TV channels 2 through 13. UHF TV channels 14 through 83. **PICTURE IF CARRIER:** 45.75 MHz. **SOUND IF CARRIER:** 41.25 MHz. **COLOR IF SUBCARRIER:** 42.17 MHz. **SOUND IF FREQUENCY:** 4.5 MHz. **VIDEO IF BANDWIDTH:** 3.58 MHz. **HI-FI OUTPUT:** Output impedance — 1 k ohm. Frequency response — ±1 dB 30 Hz to 10 kHz. Harmonic distortion — less than 1% at 1 kHz. Output voltage — 0.3 V rms nominal. **AUDIO OUTPUT:** Output impedance — 4 ohm or 8 ohm. Output power — 2 watts. **POWER REQUIREMENTS:** 110 to 130 volts AC, 60 Hz, 240 watts. **NET WEIGHT:** GR-370, 114 lbs.; GR-270, 101 lbs.

24

Modular Color Television!

Exclusive Modular Design... Circuit Boards snap in and out in seconds for easy assembly, simple servicing

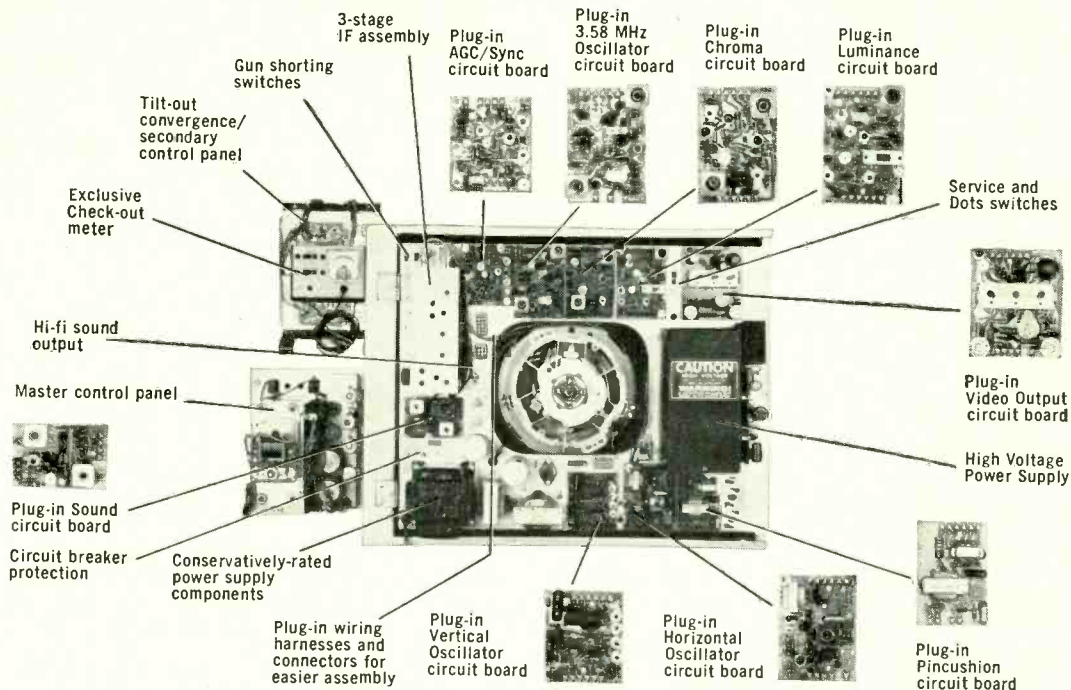

New Expedited 48-Hour No-Charge Warranty Service Plan for Solid-State TV Modules! Special service facilities have been established at the factory and all Heathkit Electronic Centers to expedite service and return of Solid-State TV circuit modules within two working days. During the 90-day warranty period, TV modules will be serviced or replaced with no charge for labor or parts. After the initial 90-day warranty period expires, TV modules will be serviced or replaced at a fixed charge of \$5.00 per module for labor and parts for a period of two years from date of original kit purchase.



Add extra convenience and versatility to your new GR-270 or GR-370 Solid-State Color TV with this new ultrasonic remote control kit. Lets you turn the set on and off, adjust volume, change VHF channels and adjust color and tint from the comfort of your chair. Assembles and installs complete in just a few hours and the built-in meter on the receiver makes final adjustment a matter of minutes.
Kit GRA-70-6, 6 lbs. \$64.95*

Choose One Of These Handsome, Factory Assembled Cabinets

3 models in 295 sq. in.

Luxurious Mediterranean Cabinet... factory assembled of fine furniture grade hardwoods and finished in a flawless Mediterranean pecan. Stately bronze trim handle. 30-1/32" H x 47" W x 17 3/4" D. Assembled GRA-304-23, 85 lbs. \$129.95*



Deluxe Early American Cabinet... factory assembled of a special combination of hardwoods & veneers and finished in classic Salem Maple. 29-21/32" H x 37 1/4" W x 19 3/4" D. Assembled GRA-303-23, 67 lbs. \$114.95*

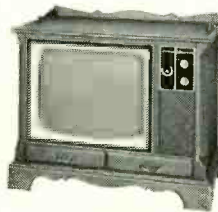

Contemporary Walnut Cabinet... factory assembled of fine veneers & solids with an oil-rubbed walnut finish. 29-17/32" H x 35-13/16" W x 19 7/8" D. Assembled GRA-301-23, 56 lbs. \$74.95*

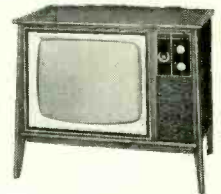

3 models in 227 sq. in.

Exciting Mediterranean Cabinet... assembled using fine furniture techniques and finished in stylish Mediterranean pecan. Accented with stately bronze handle. 27-31/32" H x 41 7/8" W x 19-9/16" D. Assembled GRA-202-20, 70 lbs. \$114.95*



Contemporary Walnut Cabinet and Base Combination. Handsome walnut finished cabinet sits on a matching walnut base. Cabinet dimensions 20-31/32" H x 31-7/16" W x 18 5/8" D. Base dimensions 7 3/4" H x 27 3/4" W x 18 5/8" D. Assembled GRA-203-20 Cabinet, 45 lbs. \$49.95* GRS-203-6 above cab. w/ matching base, 58 lbs. \$59.95*

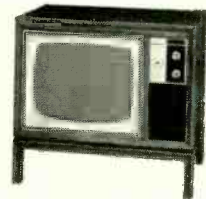

Handy Roll-Around Cart and Cabinet Combination. Features the GRA-203-20 walnut cabinet plus a walnut-trimmed wheeled cart with storage shelf. Assembled GRA-203-20 Cabinet, 45 lbs. \$49.95* GRA-204-20 Roll-Around Cart, 18 lbs. \$19.95* GRS-203-5, Cart & Cabinet Combo, 58 lbs. \$59.95*

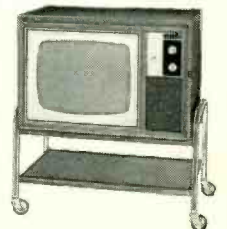

NEW FREE 1971 CATALOG!

Now with more kits, more color. Fully describes these along with over 300 kits for stereo/hi-fi, color TV, electronic organs, guitar amplifiers, amateur radio, marine, educational, CB, home & hobby. Mail coupon or write Heath Company, Benton Harbor, Michigan 49022.

HEATH COMPANY, Dept. 20-9
Benton Harbor, Michigan 49022



a Schlumberger company

Enclosed is \$ _____, plus shipping.

Please send model (s) _____

Please send FREE Heathkit Catalog.

Please send Credit Application.

Name _____

Address _____

City _____

State _____

Zip _____

*Mail order prices; F.O.B. factory. Prices & specifications subject to change without notice. CL-387

Circle 16 on reader service card

ARROW AUTOMATIC STAPLE GUNS

CUT WIRE & CABLE INSTALLATION COSTS

... without cutting into insulation!

SAFE! Grooved Guide positions wire for proper staple envelopment! Grooved Driving Blade stops staple at right depth of penetration to prevent cutting into wire or cable insulation!

No. T-18—Fits wires up to 3/16" in diameter.

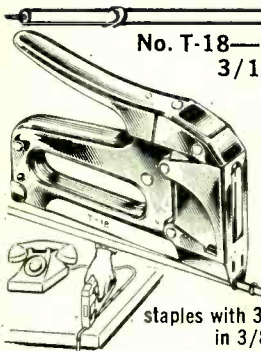

BELL, TELEPHONE, THERMOSTAT, INTERCOM, BURGLAR ALARM and other low voltage wiring.

Uses T-18 staples with 3/16" round crown in 3/8" leg length only.

No. T-25—Fits wires up to 1/4" in diameter.

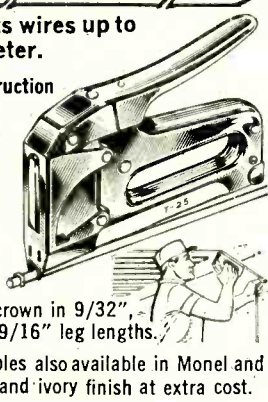

Same basic construction and fastens same wires as No. T-18.

Also used for **RADIANT HEAT WIRE**

Uses T-25 staples with 1/4" round crown in 9/32", 3/8", 7/16" and 9/16" leg lengths.

T-18 and T-25 staples also available in Monel and with beige, brown and ivory finish at extra cost.

No. T-75—Fits wires and cables up to 1/2" in diameter.

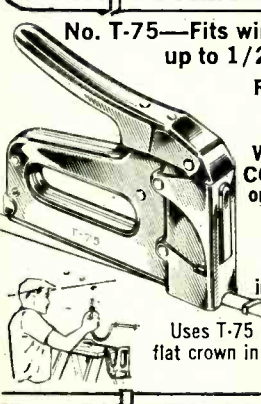

RADIANT HEAT CABLE, UF CABLE, WIRE CONDUIT COPPER TUBING or any non-metallic sheathed cable.

Also used as **DRIVE RINGS** in stringing wires.

Uses T-75 staples with 1/2" flat crown in 9/16", 5/8" and 7/8" leg lengths.

Arrow Automatic Staple Guns save 70% in time and effort on every type of wire or cable fastening job. Arrow staples are specially designed with divergent-pointed legs for easier driving and rosin-coated for greater holding power! All-steel construction and high-carbon hardened steel working parts are your assurance of maximum long-life service and trouble-free performance.

Ask your Electrical Supply Dealer or write for further details.

ARROW FASTENER COMPANY, INC.
Saddle Brook, New Jersey 07663
"Pioneers and Pacesetters
For Almost A Half Century"
Circle 17 on reader service card

In the Shop . . . With Jack

By **JACK DARR**
SERVICE EDITOR

WE GET A LOT OF MAIL ASKING, "HOW can I change the speakers on my transistor amplifier to _____ ohm types?" We answer, quite truthfully, "With great difficulty." In the good old days, tube output circuits were very forgiving. You could do almost anything you wanted to (except operating high-powered amplifiers with the speaker circuit completely open!) without getting into anything worse than mild distortion.

Solid-state stuff, though, isn't so good natured. Mismatch the speakers just a little too much one way or the other, and you're in trouble deep. You're usually out the cost of an expensive output transistor pair, too. The worst thing is that this happens so fast.

You should know exactly what you're doing, and take extreme care when fiddling around with new speakers, etc. The best way is to get back to the original output load impedance. By combining speakers in series and parallel you can generally do this without too much trouble. This is very important in the higher-power stereo systems, musical instrument amplifiers and all heavy-duty solid-state stuff. The tiny stereo am-

a, b show typical circuits.

The two-transistor circuits come in two types: the stacked, which uses the same transistors, and the "complementary-symmetry," (Fig. c), which looks

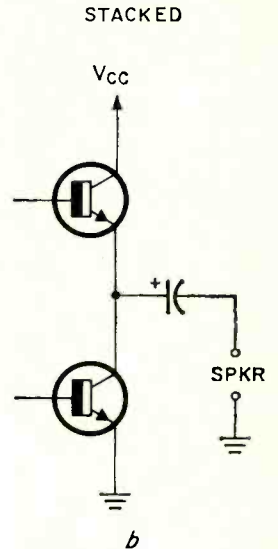

TRANSFORMER - COUPLED

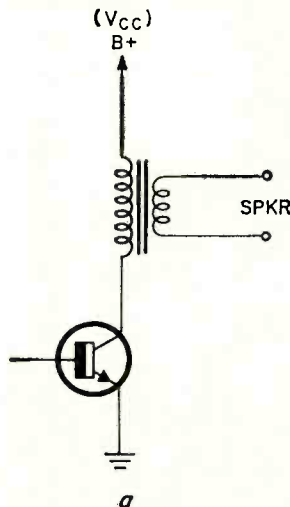

plifiers aren't so critical, usually because their power supplies aren't heavy enough to blow the output transistors! They're self-protecting.

The most common output circuit in use today is the two-transistor, class-AB or class-B output, transformerless, capacitor-coupled, and the single-transistor, class-A transformer coupled. The last is used in a lot of car radios, portables, etc., and the first is found in most high-power designs because of its simplicity, efficiency and economy. Figures

exactly like the stacked circuit, but uses different types of transistors. However, both stacked and complementary-symmetry react in the same way to incorrect load impedances, and that's all we're interested in now.

Let's take the easy one first, the transformer-coupled class-A stage. Assuming that this is designed to work into, say, an 8-ohm speaker, what would be the result of changing to a speaker of a different impedance? The answer is that it depends on *how far* you go from the rated impedance.

Class-A stages are designed to draw a certain amount of current at rest, or no signal. With the right load impedance, this will cause a certain voltage to develop across the transistor. As you can see in the Figs., the load is in series with the collector circuit. This voltage will be well within the breakdown rating of the transistor. Reduce the load impedance, and the current does not change too much. So, the voltage across the transistor actually falls slightly.

However, if we increase the load impedance, the voltage across the transistor actually goes up. Increase it far enough, and the voltage will rise above the collector-emitter breakdown voltage of the transistor and POW! The transistor is destroyed by an increase in *voltage*.

If you simply must make a change in the speakers in this type of circuit,

(continued on page 72)
Circle 9 on reader service card →

THE CALECTRO SUPERMARKET

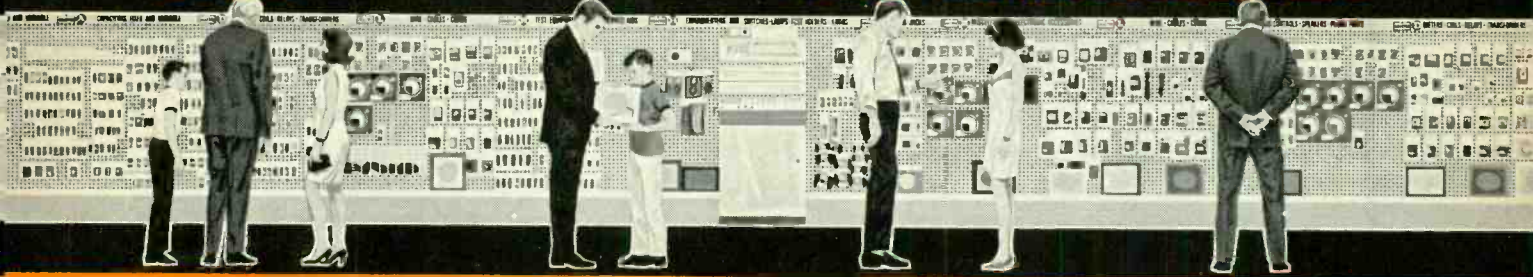

EVERYTHING IN ELECTRONICS!



VARIABLE BALANCE STEREO HEAD PHONE

Unique "Sound Level" control on each earpiece permits adjustment. Frequency range: 20 to 20,000 + cps. 6½' cord with stereo plug. Impedance 4 to 16 ohms.
Cat. No. Q4-132 \$17.95 Net

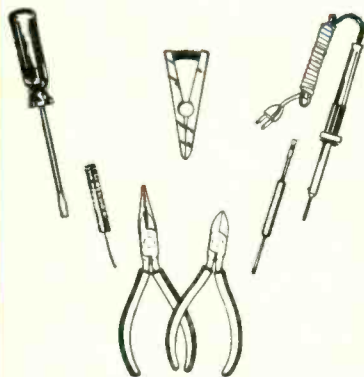

HOBBYIST'S SOLDERING AND TOOL KIT

Diagonals, long nose pliers, soldering iron and solder, solder aid tool, heat-sink, and screwdriver. An ideal gift item.
Cat. No. H3-378 \$7.95 Net.



TAPE RECORDER MICROPHONE

Outstanding performance on music and speech for the price. Low impedance matches late model solid state recorders. Removable desk stand; 4½' cord with dual plugs that fit most models. Freq. Response: 100-8k Hz. Output: — 77 dB. Impedance: 200 ohms
Cat. No. Q4-146 \$4.95 Net

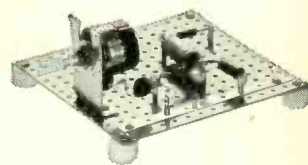

EXPERIMENTER'S CIRCUIT BOARD KIT

Contains a 3¾" x 4" perforated board, 15 terminals (No. J4-636) and 4 mounting feet w/screws. Build small circuits, hobby and science projects, etc.
Cat. No. J4-660 \$.98 Net

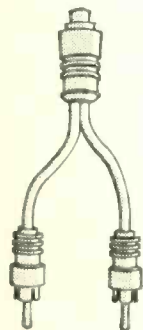

AUDIO ADAPTORS

"Y" Audio Adaptor has a phono pin jack on one end and dual phono pin plugs on the other.
Cat. No. Q4-288 \$.99 Net



TWO STATION WIRELESS INTERCOM

Just plug into any electrical outlet. Completely portable. Expand system anytime with additional units. Two unit system complete in display pack.
Cat. No. N4-110 \$34.95 Net

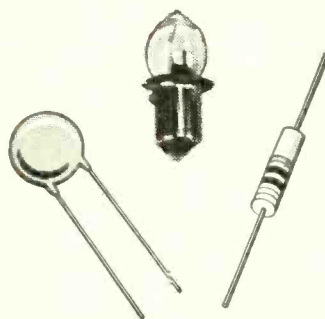

MINIATURE LAMPS

Type PR2 • 2.5 vdt • 0.50 amp • Cat. No. E2-430 • 2kg. of 2 \$.29 Net
Type PR3 • 3.6 vdt • 0.50 amp • Cat. No. E2-431 • 2kg. of 2 \$.29 Net

STANDARD 1000 VOLT CAPACITOR
High quality, compact and reliable.

RESISTORS

Attractively packaged 2 per pack, showing values, color codes and formulas.



THE "GC CALECTRO HOBBYIST HANDBOOK"

The "GC Calectro Hobbyist Handbook" is available at your nearest Calectro Electronic Supermarket. One is located near you. WRITE TODAY and we'll rush you the name and address of your nearest Calectro Supermarket.



CALECTRO

G-C ELECTRONICS
A DIVISION OF
HYDROMETALS, INC.



400 SO. WYMAN ST. ROCKFORD, ILLINOIS 61101

www.americanradiohistory.com

10 Reasons why RCA Home Training is your best investment for a rewarding career in electronics:

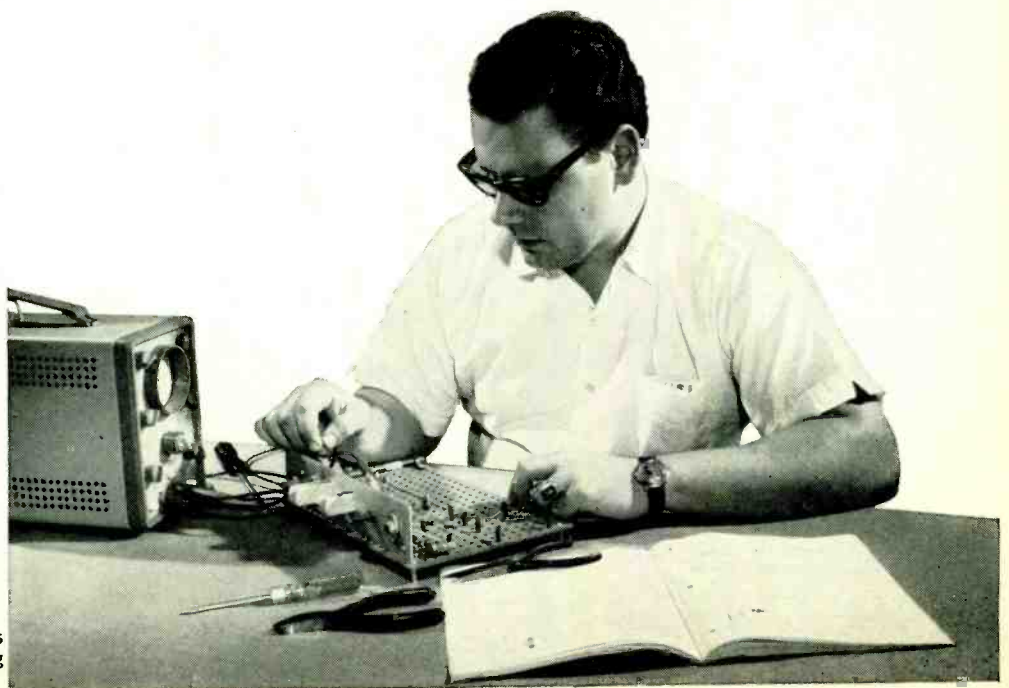

Performing transistor experiments on programmed breadboard—using oscilloscope.

1 LEADER IN ELECTRONICS TRAINING

When you think of electronics, you immediately think of RCA... a name that stands for dependability, integrity and pioneering scientific advances. For over a half century, RCA Institutes, Inc., a service of Radio Corporation of America, has been a leader in technical training.

2 RCA AUTOTEXT TEACHES ELECTRONICS FASTER, EASIER, ALMOST AUTOMATICALLY

Beginner or refresher, AUTOTEXT, RCA Institutes' own method of programmed Home Training will help you learn electronics more quickly and with less effort, even if you've had trouble with conventional learning methods in the past.

3 THOUSANDS OF WELL PAID JOBS ARE NOW OPEN TO MEN SKILLED IN ELECTRONICS

RCA Institutes is doing something positive to help men with an interest in electronics to qualify for rewarding jobs in this fascinating field. Every year, literally thousands of high paying jobs in electronics go unfilled just because not enough men take the opportunity to train themselves for these openings.

4 WIDE CHOICE OF CAREER PROGRAMS

Start today on the electronics career of your choice. On the attached card is a list of "Career Programs", each of which starts with the amazing AUTOTEXT method of programmed instruction. Look the list over, pick the one best suited to you and check it off on the card.

5 SPECIALIZED ADVANCED TRAINING

For those already working in electronics or with previous training, RCA Institutes offers advanced courses. You can start on a higher level without wasting time on work you already know.

6 PERSONAL SUPERVISION THROUGHOUT

All during your program of home study, your training is supervised by RCA Institutes experts who become personally involved in your efforts and help you over any "rough spots" that may develop.

7 VARIETY OF KITS YOURS TO KEEP

To give practical application to your studies, a variety of valuable RCA Institutes engineered kits are included in your program. Each kit is complete in itself. You never have to take apart one piece to build another. At no extra cost, they're yours to keep and use on the job.

8 FROM RCA INSTITUTES TRANSISTORIZED TV KIT, VALUABLE OSCILLOSCOPE

Those enrolled in RCA's television course or program receive complete transistorized TV Kit. All students receive a valuable oscilloscope—both at no extra cost and only from RCA Institutes.

9 CONVENIENT PAYMENT PLANS

RCA Institutes offers a unique tuition plan that lets you progress at your own pace. You only pay for lessons as you order them. You don't sign a contract obligating you to continue the course. There's no large down-payment to lose if you decide not to continue.

However, if you desire, RCA Institutes also offers a convenient monthly payment plan.

10 RCA INSTITUTES GRADUATES GET TOP RECOGNITION

Thousands of graduates of RCA Institutes are now working for leaders in the electronics field; many others have their own profitable businesses. This record is proof of the high quality of RCA Institutes' training.

CLASSROOM TRAINING ALSO AVAILABLE

If you prefer, you can attend classes at RCA Institutes Resident School, one of the largest of its kind in New York City. Coeducational classroom and laboratory training, day and evening sessions, start four times a year. Simply check "Classroom Training" on the attached card for full information.

JOB PLACEMENT SERVICE, TOO!

Companies like IBM, Bell Telephone Labs, GE, RCA, Xerox, Honeywell, Grumman, Westinghouse, and major Radio and TV Networks have regularly employed graduates through RCA Institutes' own placement service.

SEND ATTACHED POSTAGE PAID CARD TODAY! FREE DESCRIPTIVE BOOK YOURS WITHOUT OBLIGATION! NO SALESMAN WILL CALL!

All RCA Institutes courses and programs are approved for veterans under the New G.I. Bill.

RCA INSTITUTES, DEPT. 758-009-0
320 West 31st Street,
New York, N.Y. 10001

Accredited Member National Home Study Council

RCA

Construction of Multimeter.

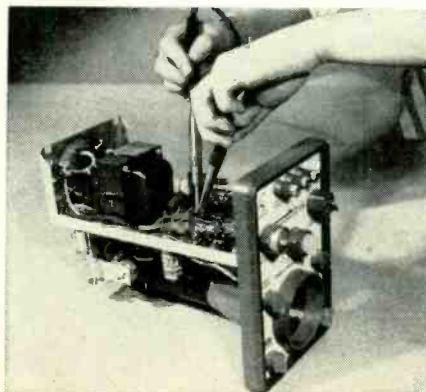
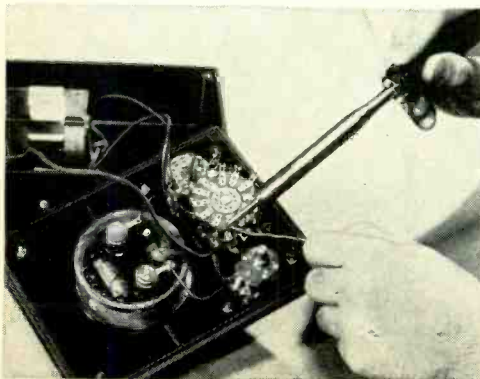

Construction of Oscilloscope.

Temperature experiment with transistors.

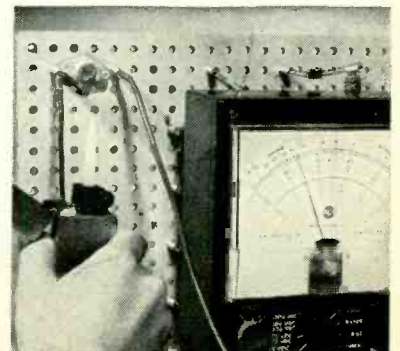

12110 1002

STRONGEST! LIGHTEST! LOWEST IN COST!

Nobody in the antenna rotator business ever put it all together before.



That's why nobody ever built an Antenna Rotator like **BLONDER-TONGUE'S** **PRISM-MATIC PM-1** before.

ALL
SOLID
STATE

Not only stronger, lighter, and lowest in cost of all automatic solid-state antenna rotators, but the easiest to install as well because PRISM-MATIC is better engineered! 4-wire leads instead of the usual 5 save up to 30% in labor and cost, and . . . PRISM-MATIC is goof-proof! It won't burn out or short circuit even in case of faulty installation. The hardware is all pre-assembled — saves you time and money! Here's more:

PRISM-MATIC Is Strong!

In off-center load tests, PRISM-MATIC didn't break at 1300 foot-pounds. Strongest competitive make broke at 1100 foot-pounds. Rugged, high-tensile aluminum (just like that used in jet aircraft) houses the unit in one piece — no other antenna rotor is as strong as PRISM-MATIC, or as light! It weighs only 4.6 pounds!

PRISM-MATIC Is More Reliable!

It's a rock-steady unit that's perfectly synchronized from the moment it's hooked up — and will remain accurate unaffected by wind, ice, snow, variations in line voltage, or age. If it does need repair, it remains in perfect sync and need not be dis-assembled. Replacement of motor and gear train is possible on the mast.

PRISM-MATIC Costs You Less . . .

and earns you more! It's the lowest cost solid-state automatic antenna rotator on the market.

PRISM-MATIC'S Control Unit Is A Beauty!

Decorator-styled, with an elegant, low profile. The illuminated dial and sleek lines bring to mind a glowing "jewel" box — yet, it's made of sturdy hi-impact styrene plastic.

Contact your local **BLONDER-TONGUE** representative today, or write or call:



BLONDER-TONGUE

One Jake Brown Road,
Old Bridge, New Jersey 08857
(201) 679-4010

Circle 18 on reader service card

COLOR TV ANTENNAS

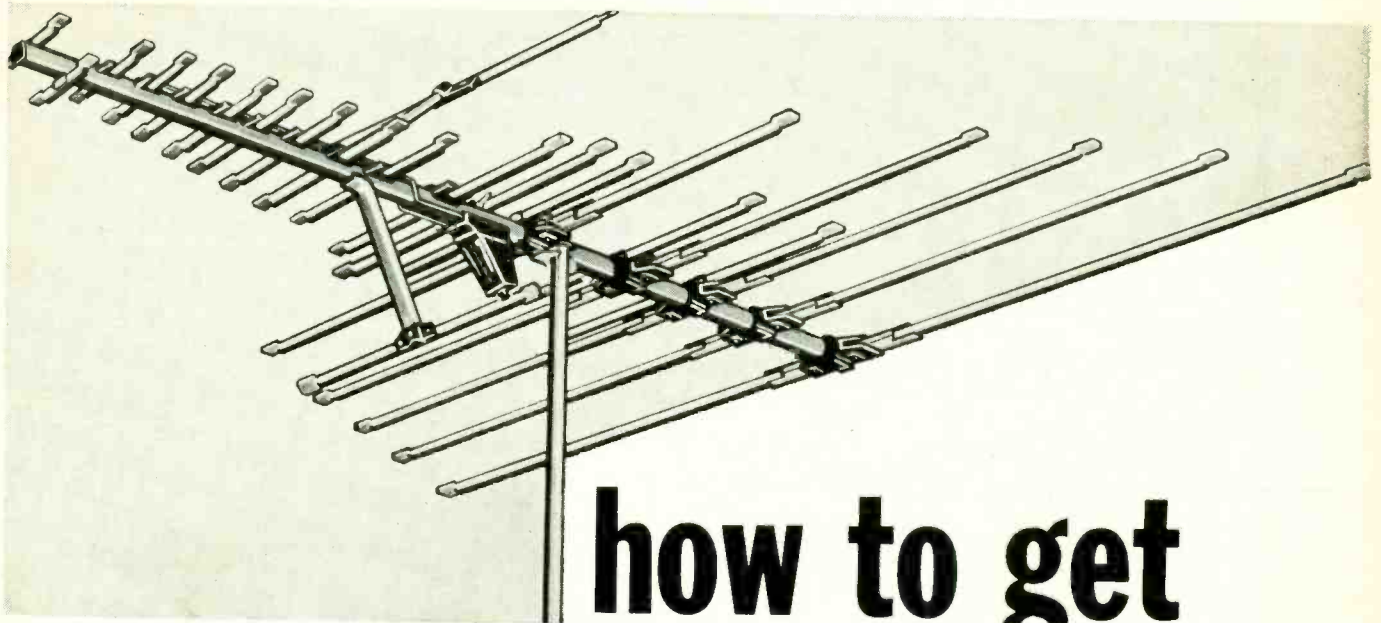

COMBINATION OF ANTENNA for fringe area reception both vhf and uhf color TV signals.

how to get TOP performance

Here's inside expert dope on how to make your antenna installations deliver the absolute maximum. Must reading before you install another antenna.

by CAREY SHELLÉDY*

IF YOU AGREE THAT IT MAKES GOOD sense to have the sharpest, clearest pictures possible on a television receiver, then this article is must reading. Each year, the percentage of TV set owners who insist on clean reception seems to be growing. Color TV has played an important part in this demand for picture perfection. Picture quality that may be acceptable on black and white frequently is unacceptable in color.

Fortunately for the set owner, as well as the installer, manufacturers of television reception aids have come up with a number of products to eliminate poor reception. Some of these items, such as preamplifiers, are much improved over those available just a few years ago. Others are new to the reception improvement scene. Frequently, a simple, inexpensive device makes the difference between poor picture quality and excellent picture quality.

Selecting the best antenna

The first consideration is: What

*Antenna Design Engineer, Winegard Co.

channels do you want to receive? This determines whether you use a vhf only, uhf only, or a combination vhf-uhf-FM antenna. (Fig. 1 shows vhf and uhf frequency distribution.) If long distance FM is desired, it is best to use a separate FM antenna.

In strong FM signal areas, FM can cause interference problems on vhf channels unless the antenna selected offers you the choice of eliminating FM reception. Here again, a separate FM antenna is needed. At least one manufacturer designs its antennas so that the FM band is *not* covered unless the installer shorts certain elements at indicated "break-off" points.

Next: Where are the stations to be received? Are they all in one general direction or do the signals come from two or more different directions?

If the stations are located in different directions, you have the option of adding a rotating device to the antenna so it may be turned, or, two or more antennas may be permanently mounted and coupled, each pointing toward the stations to be received. This latter (multiple antenna) method is required when two or more sets are connected to the same antenna system are tuned to different channels in different directions.

How big should the antenna be? This can usually be determined by antennas currently being used successfully in the area. What about price? This depends on how much you are willing to spend, the performance of the antenna and the quality of construction desired. Price is usually a good indication of performance. A manufacturer obviously cannot set a

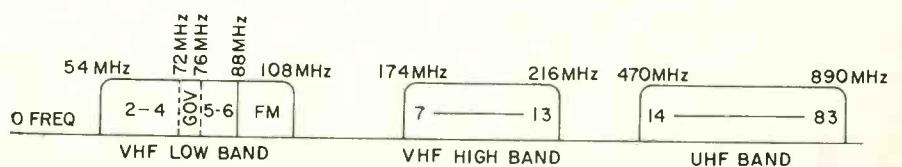

FREQUENCY BREAKDOWN of the TV portion of the vhf and uhf frequency spectrum.

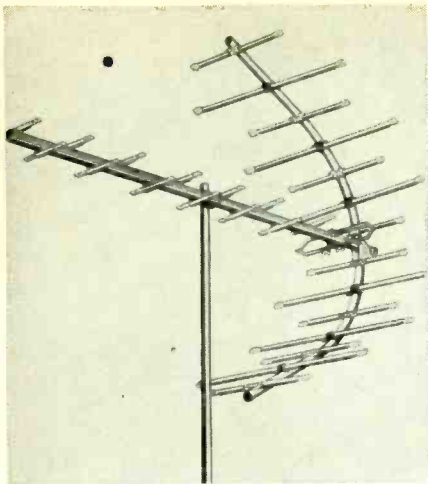

FRINGE AREA UHF RECEPTION is what this unusual-appearing antenna is designed for. It should be used in conjunction with a separate vhf antenna for all-channel coverage. Antenna consists of a basic dipole with directors and a parabolic reflector to eliminate any signal pickup from the rear of the antenna and enhance its directivity.

price of \$75 on an antenna that doesn't perform as well as his \$50 model.

What about performance? What should you look for? First is the gain characteristic of the antenna or the amount of signal it picks up on each channel. The weaker the signal available, the more you will want to pick up, and the larger the antenna you will need. Then consider the polar directional pattern of the antenna. A "good" polar pattern (Fig. 2) means the antenna rejects multiple reception

paths from the sides and back which cause ghosting and, in some cases, loss of signal.

Another important consideration in the electronic design of an antenna is linear response. Ideally, the response is flat across both each 6-MHz channel and across the entire band of frequencies being received (see Fig. 3). There should be no "suckouts" or dips in the response curve. Here the installer must rely on the manufacturer for accurate specifications because of the specialized equipment required for checking antenna response.

Next comes the vswr (voltage standing wave ratio) of the antenna. This term is also known as "match," and represents a measure of the amount of mismatch between the load terminating the transmission line and the characteristic impedance of the line. While the industry standard is expressed as a ratio of 2:1, most manufacturers strive for 1.5:1 or better. According to industry specifications, if you were using 300-ohm twinlead, the load resistance at the antenna terminals could range from 150 ohms to 600 ohms and still be within the 2:1 ratio. The closer the vswr comes to a perfect (or 1:1) match, the more signal the antenna transfers to the transmission line.

Here is an example of high vswr. If you connected 75-ohm coaxial cable directly to the downlead terminals of a 300-ohm antenna, you would have a 4:1 mismatch. Such a mismatch would result in signal loss and could also show up as ghosting. The weaker the signal area, the more im-

portant it is to have a low vswr.

One should certainly take a look at the quality of construction of the antenna. This can be done visually by a simple side-by-side inspection of two or more models. The stronger the antenna, of course, the longer it will last and the more value you get for your money. Insist, for instance, on knowing whether the color of the antenna is the result of a weather protective process such as anodizing, or a simple dye coating which offers little or no corrosion protection.

Finally, all things being equal, take a look at the antenna hardware, ease of installation, convenience of downlead connection and the availability of complementary amplifiers, traps, etc.

Antenna installation

The most frequent cause of antenna malfunction, by far, is improper installation. A lot of time, money and frustration can be eliminated if the installer takes the time to read the manufacturer's instruction sheet—*before*—not after installation.

After the instructions are thoroughly understood, you must select the best location and height for the antenna. If you know that signal strength on one or more channels is weak, it is advantageous to "probe" both vertically and horizontally for the most uniform wavefront. Here is one method for doing this.

Connect a temporary transmission line from the antenna to either a TV or a field-strength meter set for the weakest channel. Raise and lower the antenna at various locations on the roof until the best picture or strongest signal is obtained. Then check the other channels to see if they are satisfactory. Sometimes as little as 12-inch change in location of the antenna will make the difference between a satisfactory and an unsatisfactory picture. At the same time, the receiving end of the antenna should be oriented to determine exactly what direction it should point for best results.

A word of caution! Under no circumstances, let an antenna or mast touch power lines. This can be fatal. In addition, the antenna should not point directly toward metal objects and should not be mounted on a tin roof if avoidable. When two or more antennas are mounted on the same mast, they should be kept as far apart from each other as possible to avoid interaction. A uhf antenna, however, could be mounted as little as 15 inches above an all-channel vhf antenna.

75-ohm coax vs 300-ohm twinlead

While either of the two principal

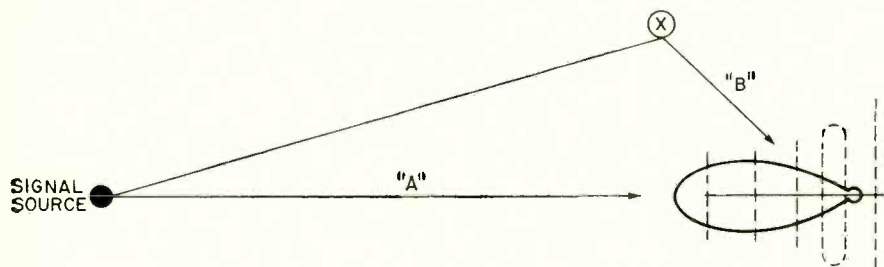

DIRECTIONAL ANTENNA reduces chance of pickup of reflected signals that would otherwise appear as ghosts on the screen of your color set.

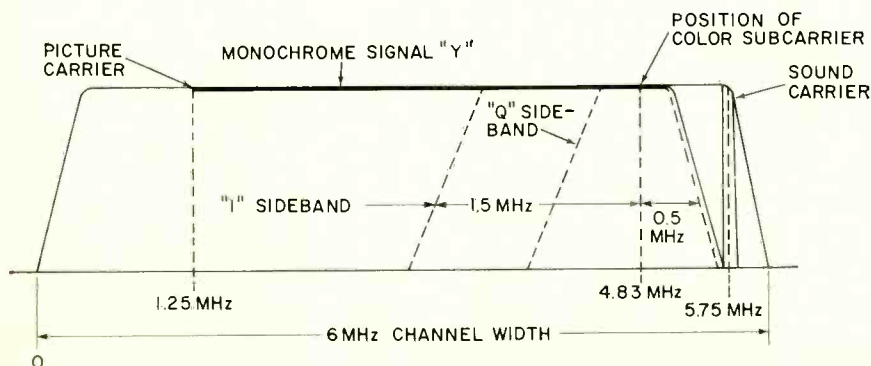

HOW THE 6-MH CHANNEL width of the standard TV channel is used. Note that if the antenna won't deliver full bandwidth you may lose color information.

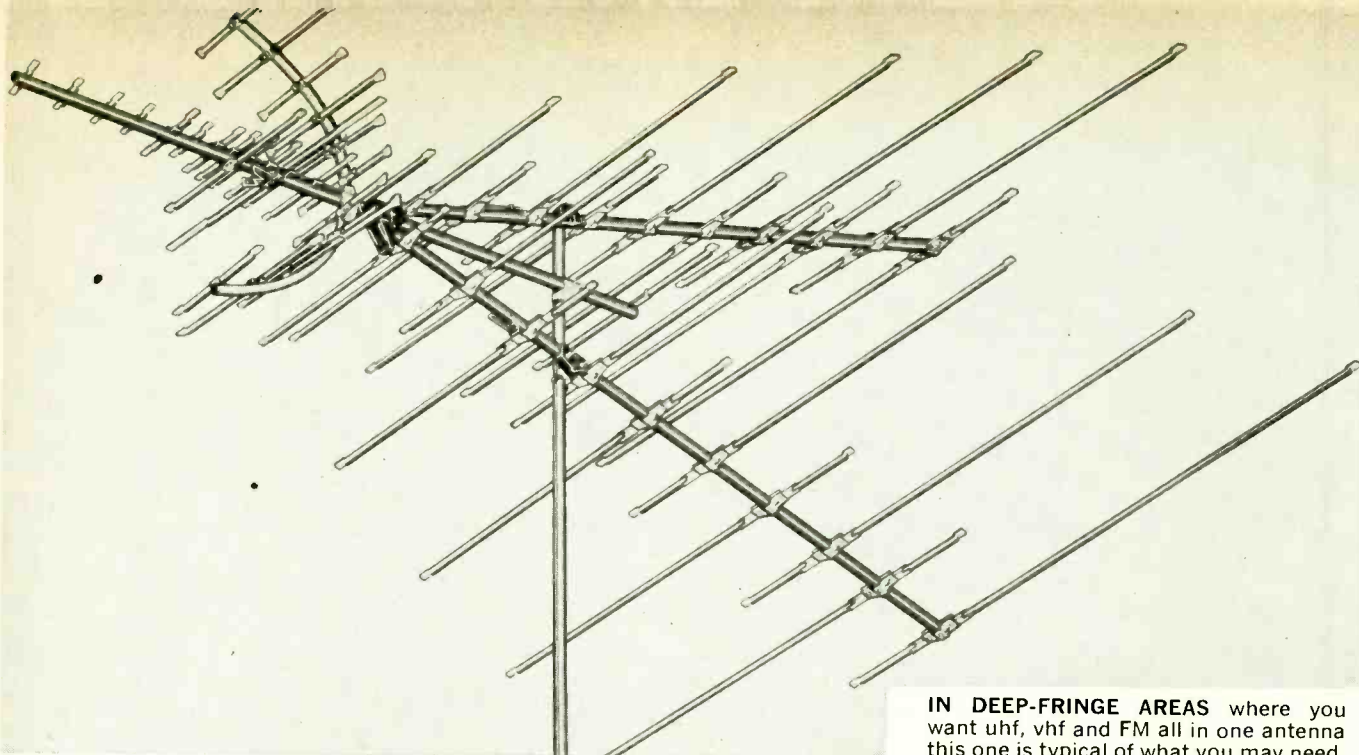

transmission lines will deliver acceptable signals when properly installed (Fig. 4), it is wise to consider both types before deciding which to use. Here are some facts you should know.

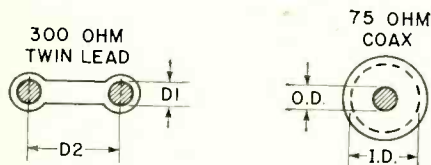

ENDWISE VIEW OF TWINLEAD (left) and coax (right). Major differences are impedances and shielding. See text for more data.

Coaxial cable—Costs two to three times more per foot than twinlead, but requires no standoffs. It can be taped to the antenna mast, can touch metal surfaces and can be run through conduit without adversely affecting the signal. It has higher signal loss per foot (Table 1) and this can be detrimental in weak signal areas, especially on the high-band channels. It has longer life when exposed to the weather. It requires special connectors and preparation. Because it is shielded, it is less likely to pick up noise and reflected signals which adversely affect picture quality. It may be run horizontally and excess length may be coiled up without problems.

Twinlead—This ribbon-type wire has lower signal loss than coaxial cable and costs less. In extremely weak signal areas it may be preferred to cable unless the cable signals are amplified. Twinlead should generally be replaced every few years. It should not be run in long horizontal lengths (it acts as an antenna); it should be kept at least 6 inches away from metal objects and excess twinlead should not be coiled up behind a TV set.

While this article will not detail

the various types of systems that can be used for operating two or more TV sets, *the amount of signal received is of prime importance.* If signal strength on all channels is sufficient, a simple two- or four-way non-amplified coupler may be used. In weaker signal areas, a preamplifier, booster-coupler or distribution amplifier is required to produce good quality reception at each TV receiver.

When to use an antenna preamp

In a weak signal situation, no matter how many sets are to be operated, the installer should consider a preamplifier mounted on or near the antenna. As opposed to post-amplification (such as a booster-coupler or distribution amplifier), a preamplifier increases signal strength *before* pickup of interference by the transmission line. Signal-to-noise ratio is far better and the result is more interference-free, snow-free pictures. Keep in mind that wherever an amplifying device is placed, it can only amplify the amount and quality of signal put into it. It cannot create signal by itself.

What about traps and filters?

A number of devices once used primarily for large master antenna systems are now commonly used to solve home TV reception problems.

Let's take the example of a small town location where TV signals are received from distant cities, but there is a local FM station. Because the FM frequencies are adjacent to the TV low band, interference usually shows up in the TV picture—especially on channel 6. Adding an inexpensive, broadband FM trap between the download and TV set terminals will usually solve this problem. Another type of broadband trap is a high-pass filter. This device

IN DEEP-FRINGE AREAS where you want uhf, vhf and FM all in one antenna this one is typical of what you may need.

blocks frequencies below channel 2 to trap out interferences caused by Citizens band radio, ham radio, diathermy machines, auto ignition, etc.

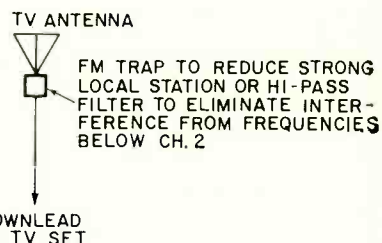

TRAPS AND FILTERS should be used to minimize interference.

Another type of trap, which is more selective, is the narrowband trap. It can be fixed-tuned (usually at the factory) to reject signals of a single frequency. Then there is a tunable trap which may be adjusted by the installer to sharply block a signal in a given frequency range.

For maximum signal rejection, a trap or filter should be mounted as close as possible to the antenna download terminals. In actual practice, however, traps or filters are commonly placed inside a home or building because of convenience.

Troubleshooting antenna installations

When there is a reception problem, too often we find people assuming it is the fault of the antenna—and just as common, the fault of the TV receiver. So analyze the problem carefully before climbing to the roof. Is the set functioning properly? One way to find out quickly is to try another set (a small portable will do) and connect it to the antenna download. Is the picture grainy? Check the fine tuning

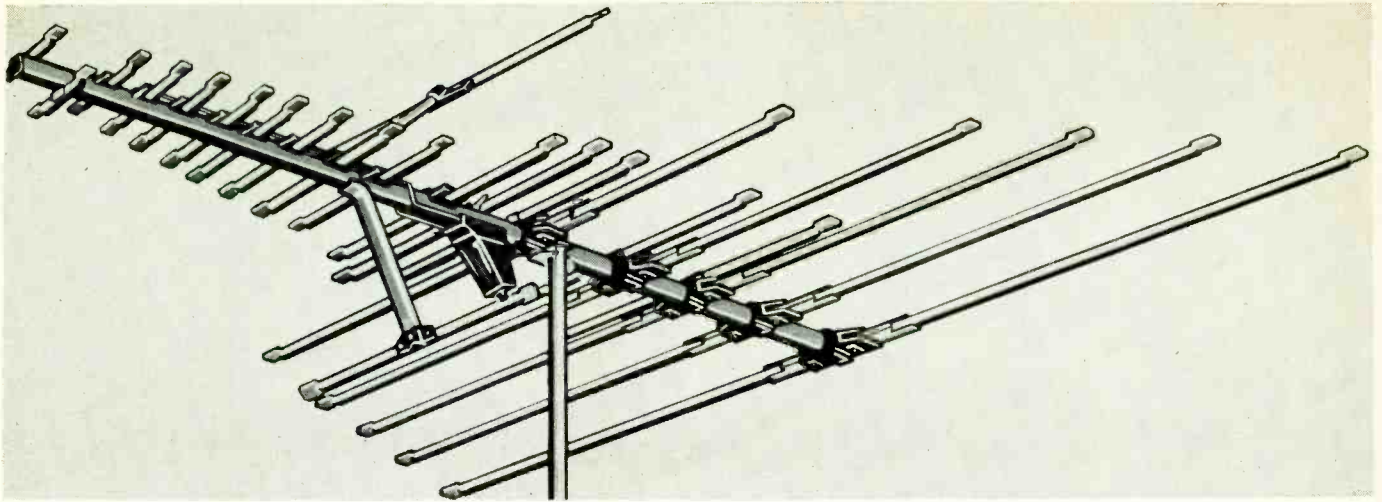

control. These and a number of other problems can be corrected at the set.

But let's say that the set seems ok and the problem persists. Then take a look at the antenna installation. Are all transmission-line connections tight? Is there a break or short in the line? If you are using 300-ohm twinlead to the set, clasp your hand tightly around the twinlead. Move your hand along the line behind the set while looking at the weakest channel. The purpose is to check for "standing waves."

If the picture is the same or poorer while moving your hand along the line, then *no* detrimental standing waves are present. If, however, the

picture improves, standing waves *are* present. This condition can be corrected by clipping one or two inches at a time from the end of the line. Reconnect the line to the set terminals and run the hand test again. Continue this procedure until no change occurs in picture quality when you run your hand along the line.

Cross modulation, a fairly common problem, is occurring when you see two different channels impressed one over the other. Sometimes the set goes out of sync and the picture rolls. Check the agc control, because this condition indicates signal overload. A trap or attenuator will usually solve this problem. When a preamp is

mounted at the antenna, it may be necessary to install a trap ahead of it. Bending or distortion of the picture also indicates signal overload. Once again, check the receiver's agc.

Finally, keep up to date on the product literature put out by the various manufacturers. The descriptions explain to you what items solve just what problems.

In the last analysis, don't expect miracles from an antenna alone. It cannot create signal. It takes what it receives and delivers it to your set. The quality of the pictures you actually get depend a great deal on whether or not you make proper use of available reception aids. **R-E**

CHANNEL	TABLE I AVERAGE ATTENUATION PER 100'									
	300-OHM FLAT TWINLEAD	300-OHM TUBULAR FOAM TWINLEAD	300-OHM FOAM OVAL TWINLEAD	300-OHM SHIELDED TWINLEAD	75-OHM RG-59/U SOLID DIELECTRIC	75-OHM RG-59/U FOAM COPPER BRAID	75-OHM DIELECTRIC FOIL	75-OHM DIELECTRIC FOIL	75-OHM RG-11/U SOLID DIELECTRIC	75-OHM RG-11/U FOAM DIELECTRIC
Channel 2	.75dB	.72dB	.95dB	1.66dB	2.47dB	2.20dB	2.20dB	1.57dB	1.43dB	1.05dB
Channel 3	.79dB	.76dB	1.05dB	1.75dB	2.62dB	2.30dB	2.31dB	1.65dB	1.51dB	1.10dB
Channel 4	.86dB	.82dB	1.09dB	1.87dB	2.74dB	2.40dB	2.44dB	1.75dB	1.60dB	1.18dB
Channel 5	.93dB	.89dB	1.18dB	2.00dB	2.95dB	2.57dB	2.60dB	1.87dB	1.73dB	1.27dB
Channel 6 FM 108MHz	.98dB	.94dB	1.23dB	2.10dB	3.07dB	2.67dB	2.70dB	1.95dB	1.80dB	1.32dB
	1.15dB	1.10dB	1.46dB	2.40dB	3.70dB	3.20dB	3.10dB	2.35dB	2.20dB	1.62dB
Channel 7	1.60dB	1.52dB	2.00dB	3.15dB	4.55dB	3.86dB	4.00dB	2.89dB	2.78dB	2.04dB
Channel 8	1.63dB	1.54dB	2.04dB	3.22dB	4.64dB	3.94dB	4.06dB	2.95dB	2.84dB	2.08dB
Channel 9	1.66dB	1.58dB	2.08dB	3.28dB	4.73dB	4.01dB	4.11dB	3.00dB	2.90dB	2.12dB
Channel 10	1.69dB	1.61dB	2.12dB	3.34dB	4.82dB	4.08dB	4.17dB	3.05dB	2.95dB	2.16dB
Channel 11	1.72dB	1.63dB	2.16dB	3.39dB	4.90dB	4.14dB	4.23dB	3.10dB	3.00dB	2.20dB
Channel 12	1.75dB	1.67dB	2.20dB	3.44dB	4.98dB	4.20dB	4.29dB	3.15dB	3.05dB	2.23dB
Channel 13	1.78dB	1.70dB	2.24dB	3.49dB	5.05dB	4.25dB	4.35dB	3.19dB	3.10dB	2.26dB
Channel 14	2.98dB	2.82dB	3.60dB	5.40dB	7.75dB	6.35dB	6.50dB	4.86dB	4.92dB	3.60dB
Channel 20	3.17dB	3.00dB	3.93dB	5.72dB	8.15dB	6.53dB	6.74dB	5.11dB	5.20dB	3.78dB
Channel 25	3.32dB	3.14dB	4.10dB	5.93dB	8.48dB	6.71dB	6.97dB	5.29dB	5.40dB	3.92dB
Channel 30	3.45dB	3.27dB	4.27dB	6.13dB	8.72dB	6.89dB	7.19dB	5.45dB	5.60dB	4.05dB
Channel 35	3.58dB	3.39dB	4.42dB	6.33dB	8.96dB	7.07dB	7.41dB	5.60dB	5.78dB	4.17dB
Channel 40	3.70dB	3.50dB	4.57dB	6.53dB	9.20dB	7.24dB	7.62dB	5.75dB	5.95dB	4.29dB
Channel 45	3.80dB	3.60dB	4.70dB	6.71dB	9.42dB	7.41dB	7.82dB	5.89dB	6.12dB	4.40dB
Channel 50	3.90dB	3.71dB	4.83dB	6.87dB	9.62dB	7.58dB	8.00dB	6.02dB	6.27dB	4.50dB
Channel 55	4.00dB	3.80dB	4.95dB	7.02dB	9.82dB	7.75dB	8.18dB	6.15dB	6.42dB	4.60dB
Channel 60	4.10dB	3.90dB	5.07dB	7.16dB	10.02dB	7.92dB	8.35dB	6.27dB	6.56dB	4.70dB
Channel 65	4.19dB	4.00dB	5.19dB	7.29dB	10.20dB	8.09dB	8.52dB	6.39dB	6.70dB	4.80dB
Channel 70	4.28dB	4.09dB	5.30dB	7.42dB	10.35dB	8.26dB	8.68dB	6.50dB	6.83dB	4.90dB
Channel 75	4.37dB	4.18dB	5.40dB	7.55dB	10.50dB	8.43dB	8.84dB	6.60dB	6.96dB	4.99dB
Channel 80	4.46dB	4.26dB	5.50dB	7.67dB	10.65dB	8.60dB	9.00dB	6.70dB	7.09dB	5.08dB

NEW MODULAR COLOR TV SET

10 plug-in boards,
4 IC's, 44 transistors,
49 diodes, 2 SCR's, and
2 tubes go together
to make this a most unusual
color TV. Build it
for yourself

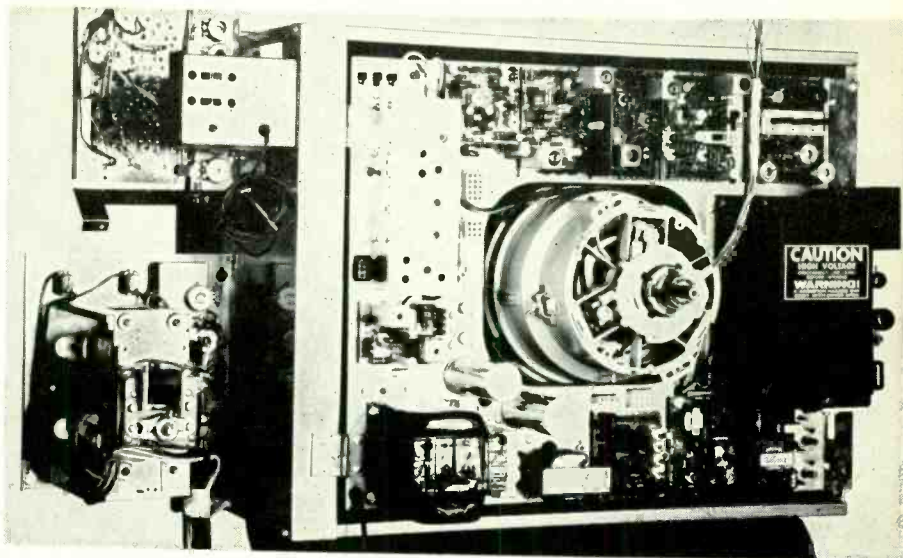

IS A SOLID-STATE KIT

I'VE BUILT HEATHKITS BEFORE—MANY OF THEM—including two earlier color TV receivers. But this time, Heathkit has outdone all their earlier versions in presenting their models GR-270 and GR-370 solid-state plug-in-module color TV.

Except for screen size, the two sets are identical. I built the large-screen version, the GR-370 with a 295-square-inch, 23-inch diagonal screen.

The set arrived in three huge boxes—the electronics, the CRT, and the cabinet. After unpacking the main package and putting aside the boxes containing cabinet and CRT I located the manual inside the top carton flap. That was my first surprise, for there wasn't just a single manual, there were eight separate manuals—Book 1 contains the introduction and assembly details for the circuit boards; Book 2 the details of the chassis assembly; Book 3, the front-panel assembly, Book 4, adjustments and operation; Book 5, troubleshooting and data. Then there was a manual on picture tube and shield assembly and another on cabinet installation. To top it off there was a manual on how to assemble the "Troubleshooter", a miniature volt-ohm-meter that goes inside the color set cabinet and becomes a permanent built-in test instrument.

Actually the set went together a lot faster than the size of the manuals portended. All the circuit boards (10 of them) went together in 9 hours and 35 minutes. Chassis assembly required another 10 hours and 45 minutes. The front panel required about 3 hours and 20 minutes, while picture-tube and shield assembly ran an additional 2 hours and 5 minutes. Total assembly time—25 hours and 45 minutes. Add on a couple of additional hours for checkout and convergence, and total time from start of construction to finished set in

the cabinet, aligned, converged and picture on the screen was just under 30 hours—29:50 to be exact.

I started off with Book 1 and the 9 plug-in circuit boards you assemble yourself. There is a tenth plug-in section, the horizontal sweep circuit, but it comes already assembled. The 9 plug-in boards you do build include the audio, luminance, video output, chroma, color oscillator, agc-sync, vertical oscillator, horizontal oscillator, and pincushion circuits.

These boards are all relatively small and go together rapidly. The video output board took the longest, 1 hour 40 minutes; and the vertical oscillator was the fastest, a mere 35 minutes. All steps are clearly and fully detailed. In some places two full pages of the manual are used to illustrate and insure proper installation of a single transistor.

The only difference between assembling these boards and other Heathkit circuit boards is attaching the plug-in connectors. But clear instructions and a special alignment block, make this easy.

There is a tenth circuit board to assemble, the convergence board. It is not a plug-in assembly but mounts on the convergence bracket. Plug-in cables connect it to the chassis assembly.

After all the circuit boards are assembled, they are put aside and you turn to Book 2 for chassis assembly. Mechanical parts assembly comes first. Grommets, terminal strips, transformers, shields, sockets, switches, controls, electrolytic capacitors, power transistors and sockets are mounted next. The pre-assembled i.f. strip and aft module complete the mechanical assembly. Next the circuit board plugs are inserted. These later connect the plug-in circuit boards to the chassis and interconnect receiver circuitry. Fi-

START

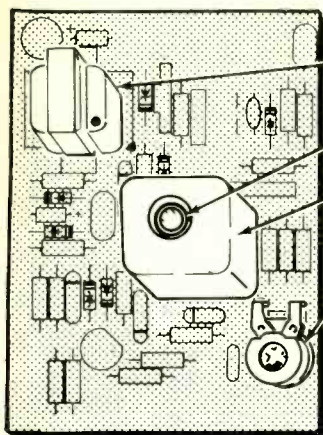

- After each of the following parts are installed, solder its lugs to the foil.
- () Horizontal driver transformer (#51-154). Position the corner with the dot as shown.
 - () Horizontal oscillator coil (#40-1001).
 - () Shield. NOTE: The hole in the shield will not be centered over the coil.
 - () 25 k Ω control (#10-300).

PROCEED TO PICTORIAL 8-6

WHEN WIRING PRINTED CIRCUIT BOARDS, this is typical of the instructions you are provided with. Follow them slowly and carefully for complete success in building your receiver.

nally, the horizontal output assembly, also pre-assembled, is mounted on the chassis.

To complete the chassis it must be wired. Here Heathkit has provided special 2-color diagrams to show how it's done. A sample illustration is on page 38. Note how individual steps are numbered. Also note how each time a connection is to be soldered, the number of leads to be soldered and their location is carefully detailed.

Several preassembled wiring harnesses help simplify the wiring task and reduce the possibilities of error. However, I must thank the doublecheck of how many wires to solder for keeping me from making a number of minor errors, and I soon found that I had the chassis completely assembled.

There were some minor problems when three slide switches were a bit different from the illustrations, and when I mistook two miniature tantalum electrolytic capacitors for silicon diodes. But these were soon resolved and construction continued steadily.

FRONT VIEW OF CHASSIS after mechanical parts mounting is completed. The printed-circuit sockets (plugs) have been mounted on the chassis, but the plug-in boards won't be snapped into position until later.

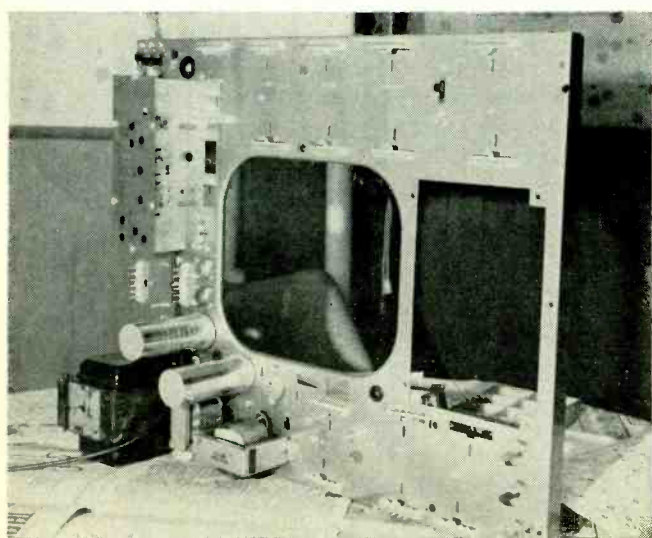

Once the chassis was fully wired (this includes assembling the low-voltage power supply), the boards which were assembled earlier were snapped into the chassis. Each circuit board is identified. The position where it mounts on the chassis is also identified, so there is little excuse for plugging a board into the wrong position.

The remainder of the assembly went smoothly and it wasn't long before the entire set was together. Now came the most interesting and different part of the whole procedure. Before applying power to the chassis, you follow a series of step-by-step checks to make sure the set is properly wired. Wherever you get an improper reading the instructions detail exactly what action to take. It isn't long before you have all the circuitry checked and are ready to turn on the power.

Sure enough with the power on, the set worked and all that was still needed to complete the job was static and dynamic convergence. Following the manual carefully this task was rapidly completed. Now all that was left was to sit back and watch the screen. Color was great; rich and deep. Picture detail appeared excellent, as you can see in the off-the-air photo on page 40. There was a little noise in the picture, but this is standard here and is no fault of the set.

Now let's take a look at the technical side of the GR-370 and GR-270. These two solid-state receivers feature 10 plug-in boards; and a preassembled i.f. strip, aft module, and horizontal output circuit. The set uses a regulated power supply and has 4 integrated circuits, 44 transistors, 49 diodes, 2 SCR's, and 2 tubes (HV rectifier and CRT). All transistors are in sockets and can be easily removed and replaced if necessary. The "Troubleshooter" which accompanies the receiver is a diode-protected 50 μ A, 20,000-ohms-per-volt meter with ranges from 5 to 500 volts and from 100 ohms to 200,000 ohms. There is a built-in transistor-diode dot generator on the luminance circuit board. If an enthusiastic experimenter really wants to make a study of transistor color TV and is prepared to take the time for

UNDER THE CHASSIS after mechanical parts have been mounted. A lot of wiring must still be done. Fortunately, most of it consists of wiring in cable harnesses and assembling the power supply.

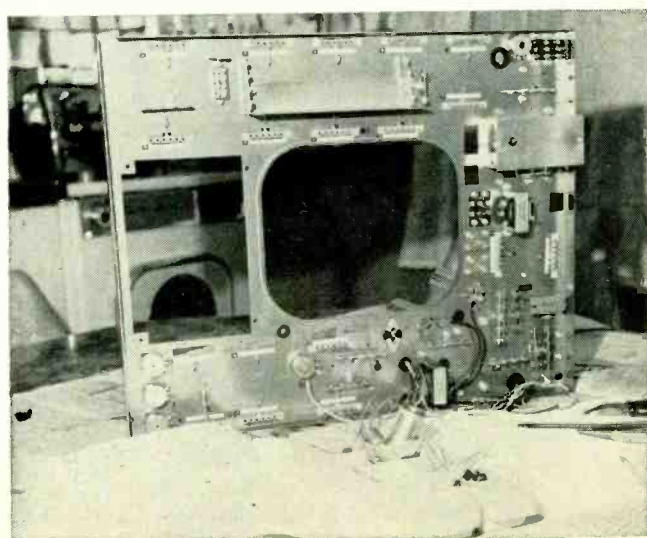

careful construction and few hours of serious reading, the detailed procedures and information are in the Heath manuals.

Circuit description

The uhf continuous tuner has a conventional transistor oscillator with diode mixer and varactor aft control. The vhf turret tuner has an FET rf amplifier, transistor oscillator and mixer and is also varactor aft controlled. The aft itself is made up of two halves of an IC, center-coupled by a double-tuned primary-secondary discriminator transformer. It keeps the uhf and vhf tuners on frequency when the response at the collector of the 3rd video i.f. varies above or below 45.75 MHz.

The three i.f. stages are all common-emitter npn amplifiers with RC and LC coupling, having a 41.25-MHz sound carrier and 47.25-MHz adjacent-sound-carrier traps before the first i.f., and another 41.25-MHz and 4.5-MHz series trap just before and closely following the video detector diode respectively. There's also a SOUND REJECT potentiometer control.

The audio amplifier, discriminator and driver are part of a single IC. It is internally shielded and has 3 Zeners and four transistors for positive voltage regulation, there are also three sets of buffered differential amplifiers. The output is from emitter-follower stages and there are takeoffs for driving an in-set speaker or input for a high-fidelity amplifier.

Luminance circuit components consist of a pair of luminance amplifiers with signal passing through the DOTS-NORMAL switch and the NORMAL-RASTER-SERVICE switch to the final luminance emitter-follower on the video output board.

The video output board uses an IC to translate to an IC chroma demodulator and the usual three power red, green, blue amplifiers that matrix chroma R-Y, B-Y, and G-Y demodulated information with the luminance fine detail. All three CRT cathode drive controls are in the emitters of the RGB amplifiers. Luminance

CHASSIS WIRING COMPLETE, circuit boards are plugged in to complete the assembly. The tuner and convergence panels must still be assembled and joined to the receiver. Note the circuit boards in the foreground. All are small individual circuits. See text for details.

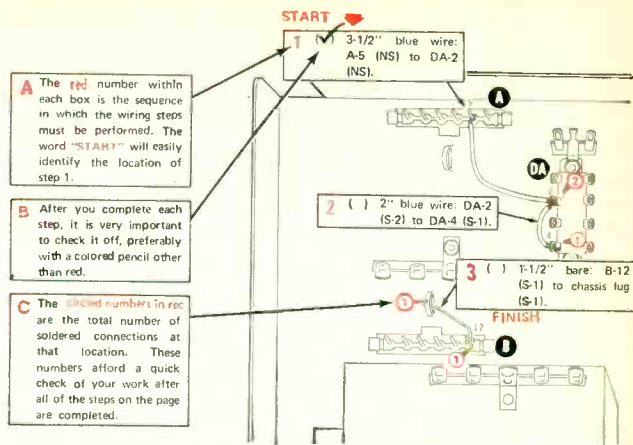
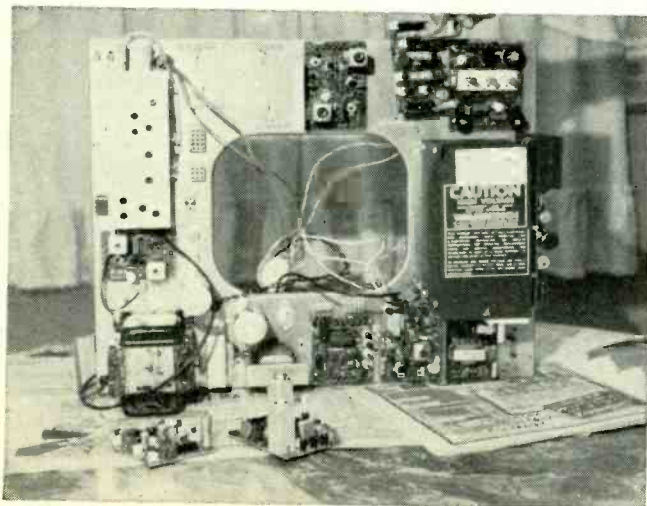

TWO-COLOR WIRING DIAGRAMS simplify wiring steps. Doublecheck the leads at a terminal before soldering to reduce possibility of wiring errors.

is dc coupled from the video detector and from the IC through to the CRT cathodes to insure good definition and color mix.

The chroma board takes composite video from the emitter-follower on the i.f. circuit board and processes it through a tuned (RLC) input to the 1st and 2nd color amplifiers and the bandpass amplifier, and then to the IC on the video output circuit board. The blanker transistor on the luminance board cuts off the bandpass amplifier and the color killer back biases the bandpass amplifier when there is no color. When there is color, varying amounts of dc are generated by the burst, and the automatic chroma control amplifier develops more positive voltage, turning the color-killer off, and permitting the bandpass amplifier to conduct. At the same time, the color amplifiers are controlled through the acc voltage on the base of the 1st color amplifier.

The color oscillator circuit board picks up the burst signal from the 2nd color amplifier and the burst amplifier passes this 8-cycle sinewave at the horizontal sync rate of 63.5- μ sec and amplifies it negatively and positively through center-tapped burst transformer.

COMPLETED WIRED CHASSIS looks crammed and difficult. But a preassembled horizontal sweep-high voltage section and cut-to-length cable harnesses speed wiring time. The set turns out to be relatively easy to assemble, despite its complexity.

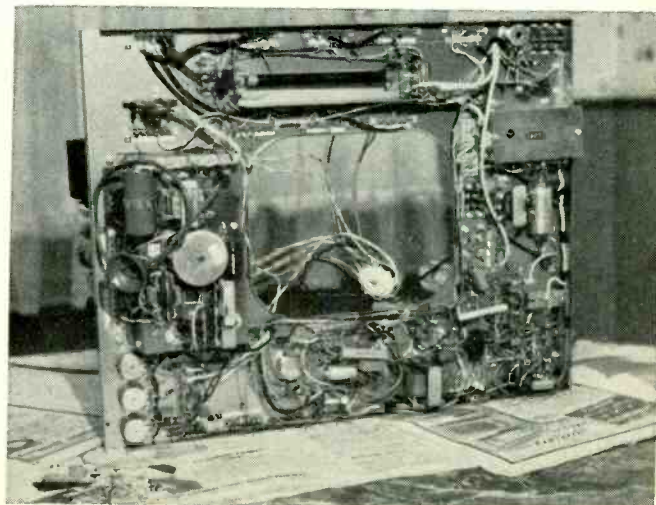

Have you ever had the hair-graying experience of trying to find room on your bench for just one more test instrument? Or worse, of picking up a vtvm to make room for a grid-dipper and suddenly finding all three of the vtvm's leads tangled around the other junk on the bench, dragging it along behind? Crash? Crash!

Suggestion: build an equipment cart, like this one. Engineering labs and service shops use them to great advantage, and so can you. You can make this one in an evening, if you're willing to forego a paint job, and it will cost you not more than \$3.50, exclusive of finishing touches and accessories.

The drawing and photos should tell you all you want to know. Within reasonable proportions, you can make the cart as high, low, broad or narrow as you wish. You may want to reduce the tilt of the top shelf, depending on your height and whether you stand or sit when you work.

Along the back of the slanted top shelf runs a piece of 1-inch aluminum angle stock, which serves mainly to keep instruments from sliding off the back of the shelf. But another advantage is that the aluminum strip can be grounded to a conduit box or water pipe to serve as a common ground for all the equipment on the cart.

For power, I use a receptacle strip (Tap-a-Line, or similar). Plan for as many ac outlets as you think you'll ever use, then double the number. If you're squeamish, wire in a 10- or 15-amp fuse in a socket on the back of the cart. In any case, provide some sort of multiple outlet so that you can power all the instruments on the cart and yet have only one power cord running to a bench or wall outlet. Make it a good, heavy one, by the way.

If you care to go that far, install a heavy-duty master switch and a pilot light. When you're through for one day, you can just hit the switch and be sure everything on the cart is turned off.

Larger casters, or 3-inch rubber-tired wheels, would help the cart over bumps and cables on the floor. Smaller casters, though, are quite enough for normal floors.

One more idea (which I haven't got around to trying yet) is to install more or less permanently a couple of variable regulated power supplies—one for tubes and one for transistors, say. Bring the outputs to five-way binding posts on strips near the top of the cart. This way, you can conveniently run cables from the cart to the bench, to whatever you want to power.

R-E

BUILD

an equipment cart

Get more space on your crowded test bench and put heavy, bulky equipment on wheels for portability

by PETER SUTHEIM

CONSTRUCTION is easy with drawing. Include ac outlets and other accessories to fit needs. Photos show audio test gear.

EXPLODED VIEW

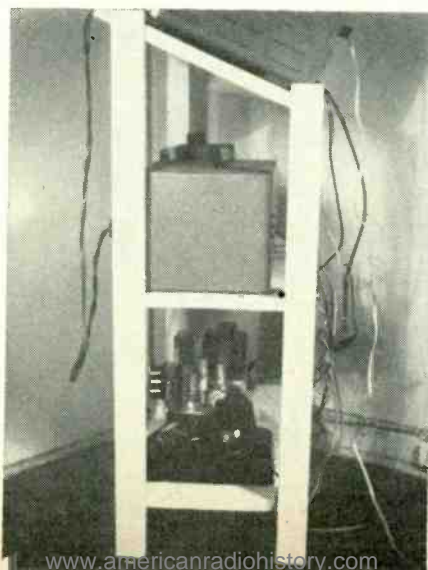
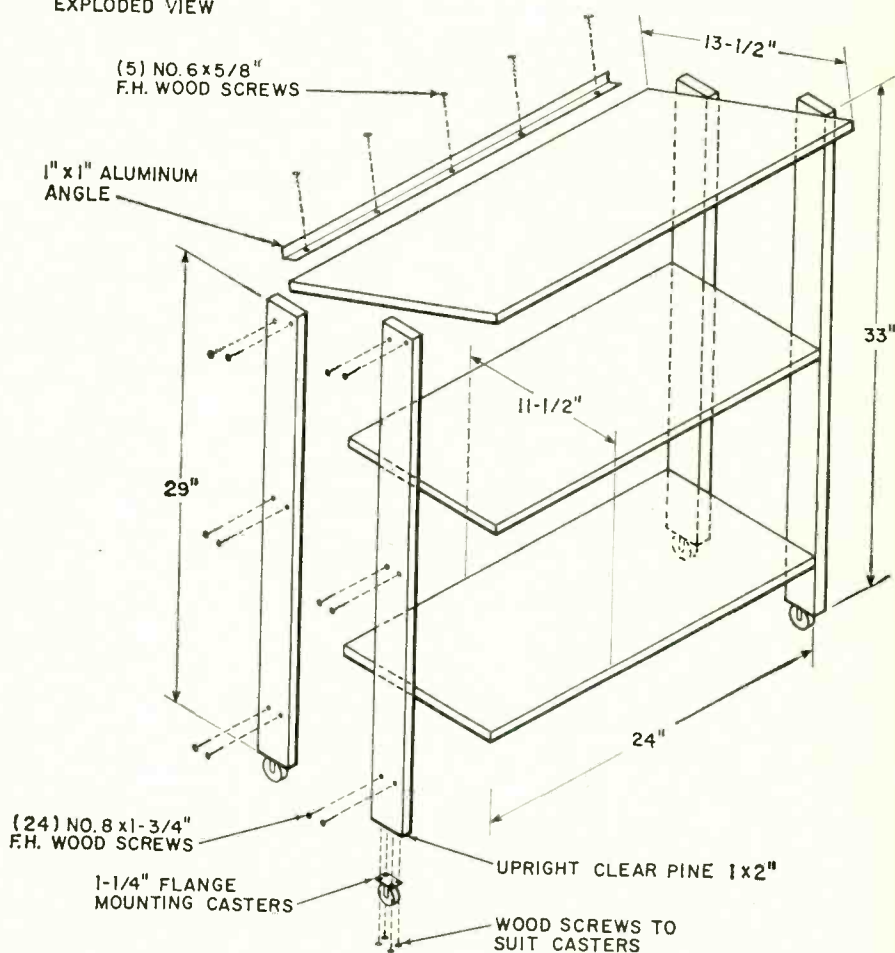

BUILD

The Autotransformer Package

Custom-made unit delivers a smooth variable ac voltage with a range from 0 Vac to 130 Vac at up to 600 watts

by JAMES ROBERT SQUIRES

THE CASUAL ELECTRONICS NOVICE AS well as the serious experimenter and service technician can find more and more uses for the autotransformer. It provides a safe, convenient method of smoothly varying alternating voltage to your test circuit without the complicated SCR controls.

You can have smooth control from 0 Vac to 135 Vac at up to 600 watts from a 5-amp Variac autotransformer. Unlike electronic controllers, it is, within its range, almost indestructible, absorbing large overloads for short periods without seriously altering its characteristics. Drill speed, light dimming and radio and TV troubleshooting are but a few of the functions of this versatile work horse.

The autotransformer in our house became an important member of the family one Sunday when, as it usually happens during an interesting football game, the rectifier tube in our cranky old TV started to go. Not wanting to miss any of the game during a mad dash to replace the tube, we brought in the autotransformer and plugged the TV into it. I turned it up high enough to stop the picture flipping and enjoyed the rest of the game. I don't recommend this for extended periods of TV operation, but we did see the rest of the game uninterrupted.

As with any electrical appliance, the autotransformer must be mounted in a well-insulated box for safety. While you are packaging your autotransformer, there are other convenient items that can be added for future tests you may want to perform. The remote feature lets you switch the unit ON or OFF and use a voltage, previously set, at a remote position. An additional feature of the remote relay lets you supply power to the autotransformer service jacks from a distant location.

How to make yours

The autotransformer shown is the larger 600-watt size needed to handle the heavier loads encountered in my shop. Not all available autotransformers have all the taps shown here. But you can use the same cir-

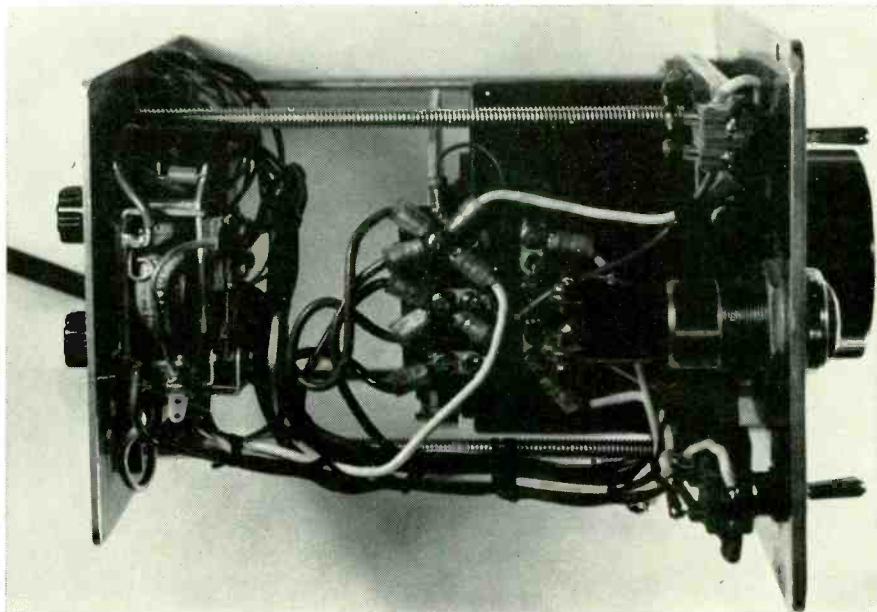

TOP INSIDE VIEW of autotransformer package shows threaded rods that are used to support the rear panel. Remote relay RY1 is mounted on this panel. Transformer used by the author (see below) has fixed-voltage tapoffs, but other units may not.

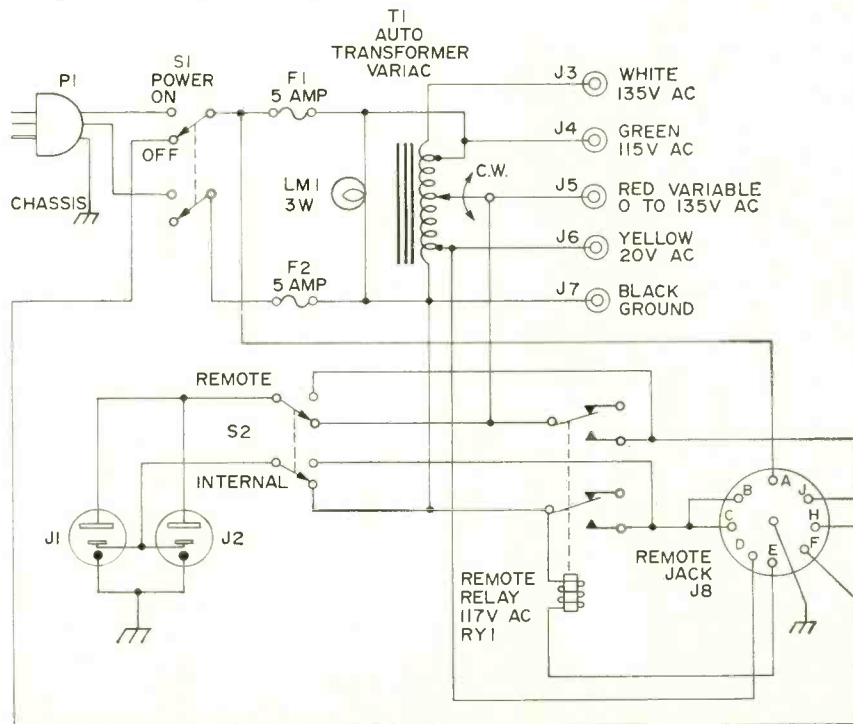

PARTS LIST

- | | |
|--|---|
| T1—See text | LM1—3W, 117V ac lamp |
| RY1—dpdt, 117V ac, n.o. relay | S1, S2—dpdt toggle switch |
| J1, J2—duplex three-wire wall receptacle | MISC—fuse holder, 8 x 6 1/2 x 8-inch chassis (Portacab or equiv.), three-wire power cord with plug, 10-position barrier-type terminal block |
| J3-J7—binding post (five colors) | |
| J8—9-pin socket (Amphenol) | |
| F1, F2—5A, 3AG fuse | |

cuit and simply restrict the output jacks to the taps you do have. Construction notes apply to all sizes of units. All components including the autotransformer are hung from the front panel and weigh about 10 pounds. A Bud Portacab, modified for this purpose, was used as the chassis with the exception of the $\frac{1}{4}$ " front panel supplied with the cabinet. To support the autotransformer, it was replaced with a piece of $\frac{5}{8}$ " panel. Use the original panel as a template for cutting the replacement. Mount a smaller panel either to the front panel for the smaller autotransformers or to the transformer itself for the larger units. Cut a stock piece of threaded steel rod, from the hardware store, into four $7\frac{1}{4}$ " pieces to

mount the rear panel. Relay, fuses and other components are mounted to the rear panel before it is assembled to the main panel. I used a standard household type ac receptacle because of the durability and safety built into these units. There are other types available if you feel that filing the odd shaped holes to size is too difficult. Part of the rear opening of the Portacab must be cut away to accommodate the fuses and service jacks. A "nibbling" tool is handy for this operation.

Wiring the unit

A standard ac line cord terminates at a 10-terminal Cinch-Jones barrier strip. The remote cable and the relay also are wired to the strip. A good place to start is with the line

cord wiring. The remote jack is easier to wire on the bench before mounting it to the rear panel. Use 10-inch long wires, color-coded one to nine.

During rear panel wiring, I found it best to not mount the panel on the four threaded studs. Instead I hung it on them for wire length measurement. Remember, you may want to service your unit later, so it is a good idea to cut the wires long enough to let you slip the rear panel off its studs and out of the way. Check to be sure that no small pieces of wire have shorted terminals. At line voltages this could be a dangerous as well as an expensive oversight. Don't lace the wiring until you have tested the circuits—there may be some last minute changes.

Test before using

All wiring and components used in the autotransformer package are rated at a minimum of 3 amps at 125 Vac. Any appliance that uses 120 Vac is potentially lethal, so be extremely cautious at all times. Plug the unit into the ac line without the fuses and measure the voltage between the white jack high tap, and the black jack on the front panel.

If it is zero, install the fuses and turn the unit on. The pilot light will light and you should read approximately 135 Vac at the white jack. There should be 115 Vac at the green jack and 20 Vac at the yellow jack (all are measured in reference to the black ground jack). These values, within a few volts, serve as a check for proper autotransformer wiring. Any deviations beyond a few volts, indicate that there is a wiring error and the unit should be turned off and the fault located.

Next, place the voltmeter between the variable red and black jacks. Verify that the ac voltage increases smoothly in a clockwise direction as you rotate the knob from zero to maximum. If so, then check to see that it varies the same at the rear panel service receptacles. With nothing plugged into the remote jack, throw the INTERNAL-REMOTE switch to REMOTE. There should be no power at the service receptacles. Turn the unit off and insert an insulated short between A and E on the remote jack. With the unit on, there should be variable ac at the service receptacles in either position of the INTERNAL-REMOTE switch. In the REMOTE position, measure the ac voltage between B,C and J,H. The variable ac should also appear here.

With the POWER switch off, there should be continuity between pins A and F on the remote jack. This is nec-



COLOR-CODED TERMINALS on the front panel provide easy access to the fixed and variable voltages available.



REAR PANEL VIEW shows duplex receptacles, remote jack J8 and fuses. Remote control can be safety feature.

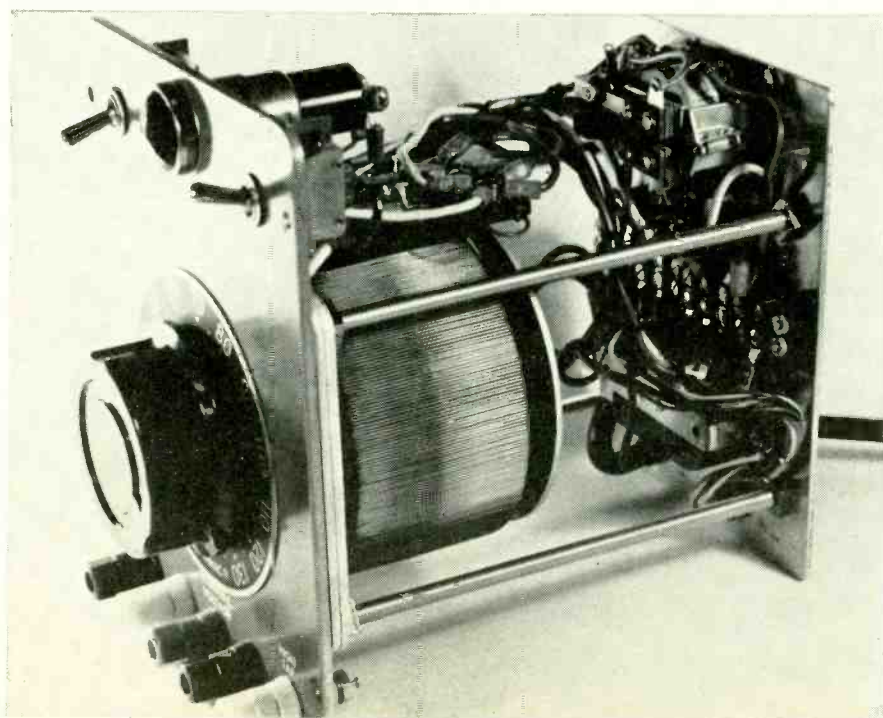

NEAT WIRING and insulated wire lugs protect against shorts.

Autotransformer Package *continued*

essary to determine the power switch position at a remote point. Never apply power in the reverse direction, that is from the remote location, to the unit service receptacles through B,C and J,H when either of two things happen. One—if you measure an ac voltage between A and E (remote relay not energized) and/or two—when you measure continuity between pins A and F at the remote point. This would indicate that, although there is no ac voltage (tested in one above), the switch is on and there is the possibility that there will be ac voltage. The remote relay can be energized either from the unit by shorting pins A and

E or by applying ac voltage between pins B,C and E.

There are times when you want to perform an experiment yet don't want to be around for your own safety when the switch is thrown. The remote feature lets you move away from where it is happening and in addition lets it happen at a smaller voltage if that's its bag. I put this in so that the youngsters will groove all that I have been scratching.

Whether it's running a drill motor slowly to drill through ceramics or driving a variable voltage power supply, the autotransformer will provide a lifetime of useful service. **R-E**

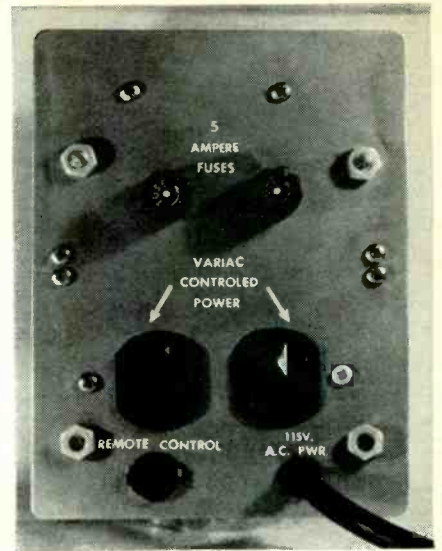

PLUG-IN, variable 0-135 Vac power.

PULSED-LIGHT DARKROOM TIMER

by **FRANK H. TOOKER**

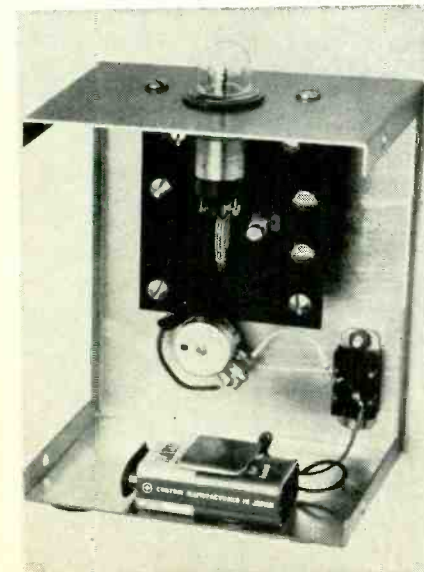
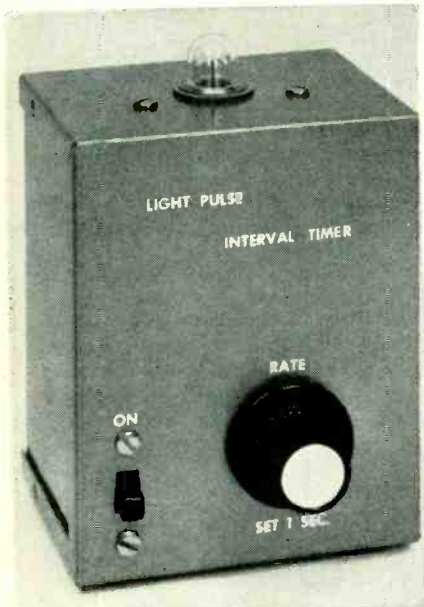

THIS CIRCUIT USES AN INEXPENSIVE unijunction transistor (UJT) to produce pulses of light from the NE-51 neon lamp at 1-second intervals. Repetition rate is determined by the setting of potentiometer R2.

When the unit is switched on, the capacitor charges through R1 and R2. When the voltage across the capacitor reaches the peak-point emitter voltage of the UJT, the transistor fires, discharging the capacitor and producing

a strong pulse of current through the transformer primary. The voltage developed across the primary as a result of this current pulse is stepped up in the secondary, reaching a value sufficient to flash the neon lamp.

Following discharge of the capacitor, conduction ceases and the cycle repeats. One pulse per second is best for timing the exposure of enlargements and other short-term photographic manipulations. **R-E**

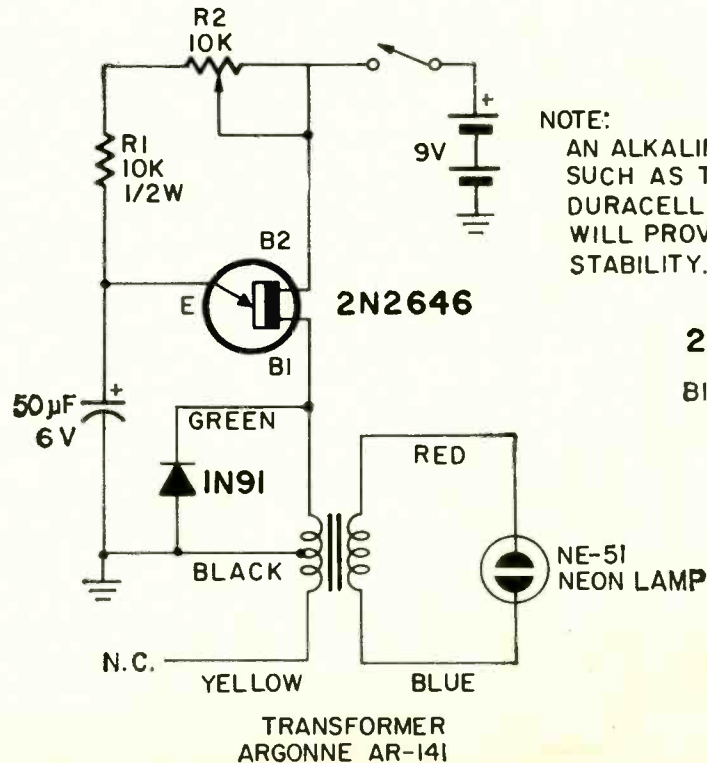

CAREERS in ELECTRONICS

blueprint to your future

*All kinds of jobs are open to electronic technicians.
See what they are and what special training is required*

by L. L. FARKAS*

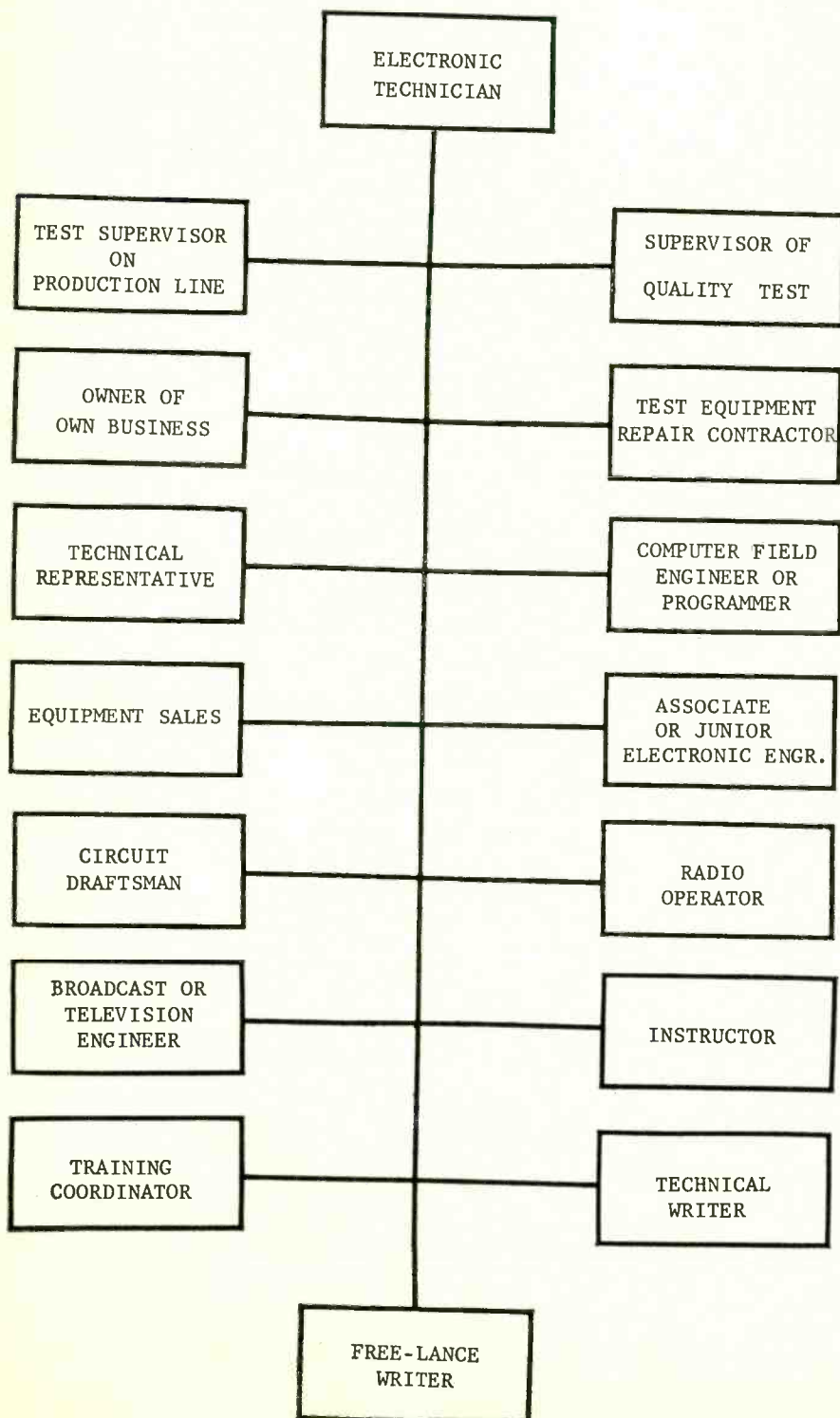

THE OTHER DAY A FRIEND OF MINE SAID, "Here I've been an electronic technician for 5 years. I'm a good technician, but where do I go from here? How can I move up into a salary job?" That set me thinking about the problem. Where can an electronic technician progress to? And what action must he take to do it?

Actually there's no reason why an electronic technician must feel he's reached a dead end, that he must spend the rest of his life working at an hourly job. There are any number of related areas into which he can progress. All that is needed is a little initiative and effort.

Some major areas that offer opportunities are shown on the chart. Together with a discussion of the experience and education the technician will require to obtain a job in any of these areas, it constitutes a blueprint to progress.

Let's start with the first position, bearing in mind the order is not sequential. You don't progress from one position to the next. Rather, each job area is a different channel you may choose based upon your inclination, experience and education.

Production test supervisor

The experienced electronic technician who has been working on a production line for a number of years is in an excellent position to move into a line or test supervisor's job. But it takes a little bit more than test experience. The test supervisor must have these qualifications:

- He must be able to plan the work of his people.
- He must be capable of finding alternate acceptable ways of solving problems that stump his men and can stop production.
- He must command the respect of his men.
- He must be able to communicate, not only with his men, but also with his supervisor.

To obtain these qualifications he should take an introductory course in management. This will provide him with examples of supervisory problems and actions. It will help him understand his point of view must change from that of an employee to that of a supervisor who has a responsibility both to his men and

*Martin Marietta Corp., Vandenberg Operations

to his company.

Many firms offer such a course as part of an evening education program. It can also be obtained at a junior or full-time college, a business school, or through correspondence. Other helpful courses are those on effective writing and public speaking. An organization such as Toastmasters can provide excellent practice in speechmaking.

All this might sound like a long-term program, but actually these courses can be completed within a year. Naturally, completing them will not automatically transform a technician into a supervisor. First there has to be an opening or opportunity. But it helps to be ready when that chance comes along.

Quality test supervisor

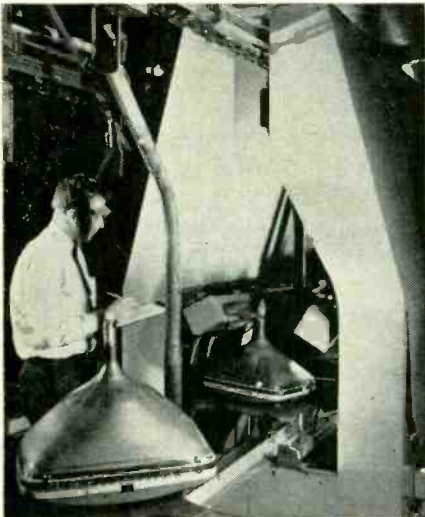

Photo Courtesy RCA Institutes

A good electronic technician can also perform well as a quality supervisor of testers assigned either to monitor test operations conducted by production technicians or, in plants where the quality department actually does the production testing, as a supervisor of quality testers. Having done the work himself, he knows the areas where a technician may short-cut procedures, and he knows the problem spots, so that he can instruct his quality inspectors or testers on what to look for. This applies to both in-plant and field operations.

In addition to the requirements indicated for the test supervisor, the supervisor working in quality should have read and be aware of the quality requirements affecting the equipment his personnel is checking. In fact, a good course in quality control is invaluable, not only for doing the job well, but also as a background for future advancement in the quality department. Such a course is often available in adult education programs set up for local industries.

Business owner

A competent electronic technician can often establish his own radio and television repair shop, but this type of operation, like the establishment of any small business, is fraught with danger. Not only must the technician know the various techniques of radio and television repairs, but he must also invest a

sizable sum in test equipment, shop rental—even advertising. Such an investment requires a knowledge of business methods that can normally be obtained in a course on business management. Only by preparing to control his business operation and finances will the technician be successful.

One area in which the electronic technician can fare well is the installation of hi-fi systems. Many shops, offices, apartments and individuals want professional installations of audio equipment. Once it is installed, people often contract for periodic maintenance. If this work is tied in with the sale of high-quality record players, tape recorders, stereo tuners, amplifiers and loudspeakers, a technician has the basis for a profitable business.

Another inviting field is in radio communications. The sale, installation and servicing of ship-to-shore, aircraft transmitters and receivers, direction finders, fathometers and other special electronic instruments can provide both interesting and profitable employment.

Test equipment repair

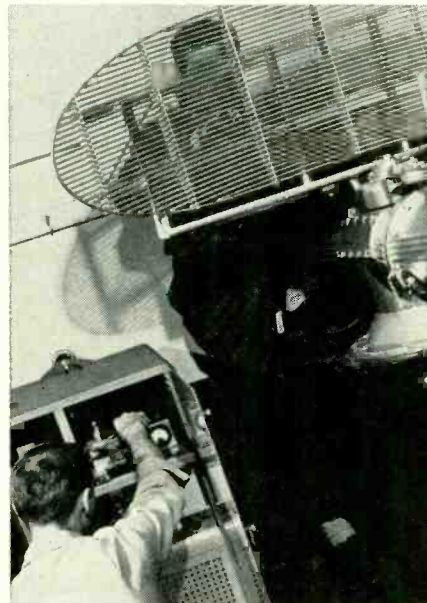

Photo Courtesy RCA Institutes

Whenever an electronic company is working away from its home plant, especially at a remote installation, it will encounter the need to repair and calibrate its test equipment. Since this is a specialized field, it must either have a test equipment technician available or subcontract the work. As many companies prefer to have someone else do this type of work for them, a test equipment repair service can be profitable.

The first requirement for this type of work is a detailed knowledge of test equipment. Experience in repairing oscilloscopes, signal generators, all kinds of meters and other types of electrical and electronic measuring instruments is a must. A great deal of information on the maintenance, repair and calibration of test equipment can be obtained from manufacturers.

Calibration is another area where experience is necessary. This is the pro-

cess of comparing a piece of test equipment against a known standard, and then making the necessary adjustments or drawing up correction charts to indicate deviations from the standard. Unfortunately the cost of standards is high. Usually they must be kept in a controlled atmosphere, so the average small business man cannot afford to set himself up to handle calibration. However, he can make arrangements for calibrations with one of the testing laboratories located throughout the country.

Technical representative



Photo Courtesy RCA Institutes

Perhaps one of the easiest fields in which a good electronic technician can progress into a good salary bracket is that of technical representative. Most electronic companies have field men with a dual function: they represent the company at customer sites or plants, and act as technical consultants in the operation, maintenance and repair of the company's equipment.

There are several ways to move into this field. The electronic technician who has become proficient in the operation and testing of particular equipment or a system can request a transfer into the service department of his company as a technical field representative. This is a salaried job, often with paid traveling expenses, in which he may be located at a specific vendor's plant; he may cover a number of plants in a specific geographical area, or he may be assigned to a field operation either in the U.S. or overseas.

Besides knowledge of the equipment with which he is working, the field representative should be able to meet and talk to people, for he will often be called upon to discuss plans or problems with various officials. He may also have to teach the operation and maintenance of his equipment to operators and technicians, either civilian or military. And as he may be far away from his home office, he should be able to write clearly in order to communicate his findings, by reports, to his company.

Courses that qualify a technician for work as a field representative include effective speaking and writing, business management and languages. When he knows the country to which he will be assigned, and has sufficient time, it will also help to take a course in the history and customs of the land. This will not only make it easier for him to work with foreign officials and workers, but will make his stay in the country immeasurably more enjoyable.

(continued next month)

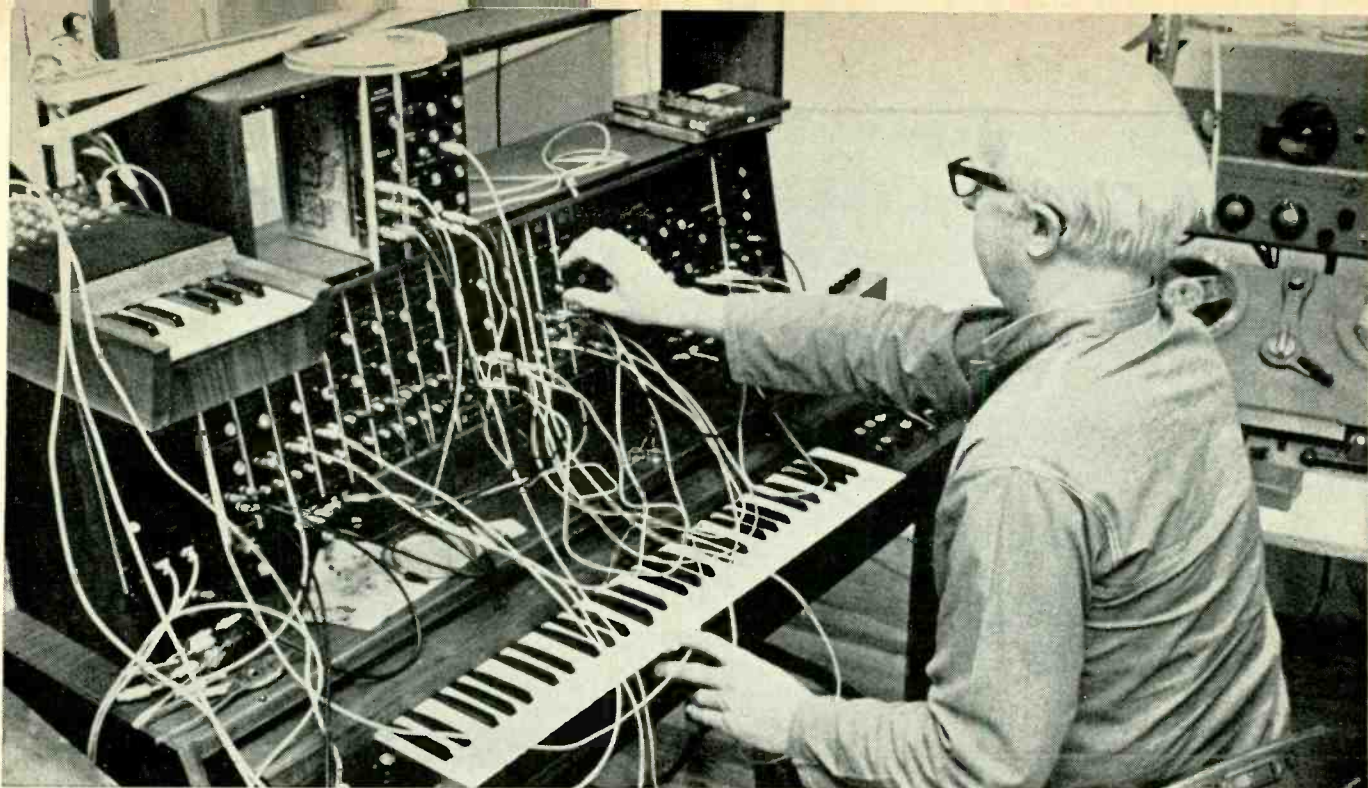

THREE LIONS PHOTO

Build DIGISYNTONE—new music synthesizer

Digital synthesis of musical tones. Unique instrument works through digital operations with musical 'numbers'

by F. B. MAYNARD

THE DIGISYNTONE IS A RADICALLY NEW approach to a build-it-yourself music synthesizer. Basically, the Digisyntone system is a special-purpose IC digital computer. It reduces the musical scale to numbers, and generates tonal effects by digital operations with these numbers.

The Digisyntone system gives you a wide range of voices, whose quality can be controlled by mixing pure and accurate harmonics. Digisyntone is the only electronic musical instrument you can build that never needs tuning—it's automatically tuned when you build it.

The basic project uses 21 IC's, and costs from \$75 to more than \$100.

Although Digisyntone has a standard organ keyboard, it is monatonic. That is, it will play only one note at a time, and hence is strictly a solo instrument like the trumpet, clarinet, saxophone, etc. Pure harmonic mixing results in many tonal effects—the instrument's major musical capability.

Numerical musical relations

There are several basic numerical relations in music. Octaves are related by a factor of 2. For any note, middle C, for example, there are other C's above 2X, 4X, 8X, etc. the middle C frequency, and some below 1/2, 1/4, etc. the frequency. Hence, a simple way of generating octaves is multiplying or dividing exactly by 2.

The musical scale has 12 notes in

FIG. 1—BLOCK DIAGRAM of the system. The three main sections, oscillator/counter, logic control and filters are detailed for wiring in Figs. 2, 3 & 4.

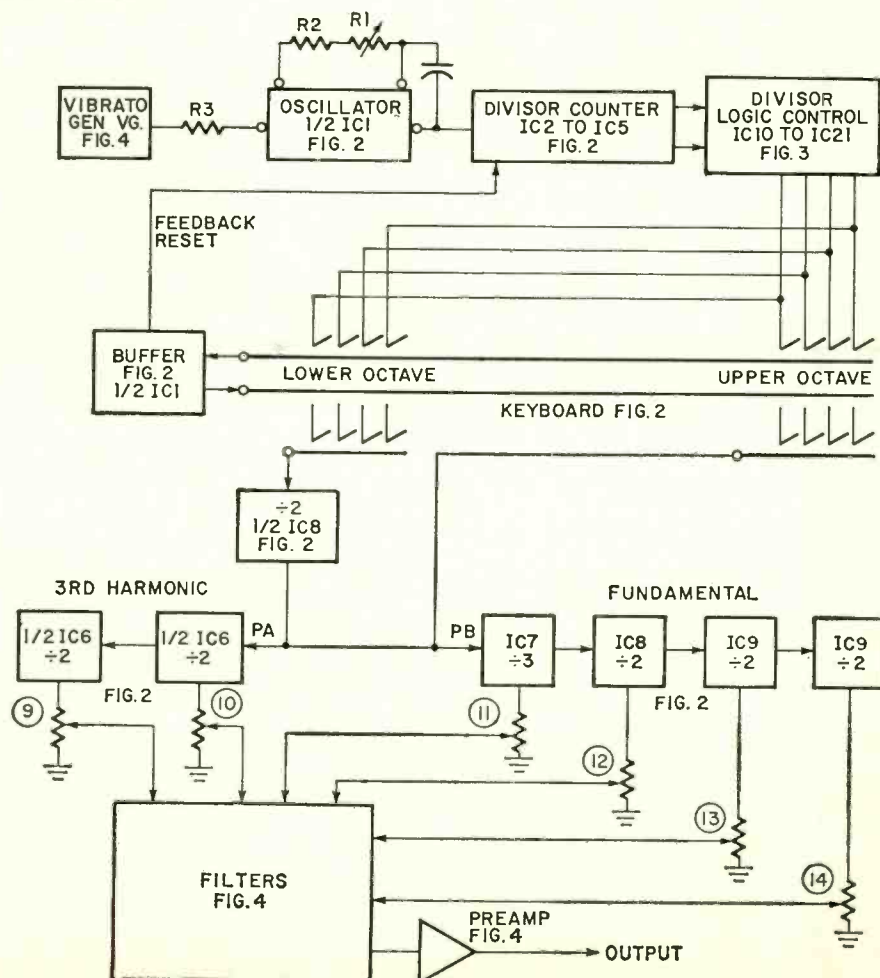

each octave. The frequency relation here between any one note and its neighbor is a $12\sqrt{2}$ factor. That is, the frequency of C#, and this applies to any C# in the scale, is the frequency of any $C12\sqrt{2}$. The numerical value of $12\sqrt{2}$ is irrational: like π , it never comes out even. A close value is 1.0595. The series of numbers listed in Fig. 3 have this relationship. Other series of numbers could be used, but they would be no better, if as good as these. The derived intervals are not perfect, but are very close. The worst case error is less than 5% of a semitone.

A third numerical relation concerns harmonics. By definition, a second harmonic is $2\times$ the frequency of any starting or fundamental frequency, or simply a frequency 1 octave above the fundamental. The fourth harmonic is $4\times$ the fundamental, or 2 octaves above, and so on with the even harmonics.

A third harmonic is $3\times$ the fundamental, and octaves of this give the

sixth, twelfth, twenty-fourth, etc. The fifth harmonic is of course $5\times$, and this gives the octaves as $10\times$, $20\times$, $40\times$, etc. harmonics.

Much more could be written about the theory of musical tones but, for this project, the above is quite adequate.

The basic digital system

Using electronic circuits, it is much easier to divide frequencies than to multiply them. With integrated circuits, a frequency can easily be divided by any positive whole number, and this is the basis for the digital music system to be described. Fig. 1 shows the basic system in functional block form.

The oscillator operates at a relatively high frequency. The precise frequency can be controlled with R1, and the frequency can be modulated with a vibrato signal through R3.

The oscillator drives a divisor counter which is in turn controlled by a logic control or decoder and keyboard

switches. The logic controller controls a feedback to the counter and the combination divides the oscillator frequency by any one of 12 whole numbers. These numbers, listed in Fig. 3, have ratios close to $12\sqrt{2}$.

Hence the output from the logic control feedback circuit will present the factors of a musical scale which is independent of actual frequency. This output is now split into two paths. Path PA is divided by 2 twice, providing two octaves of the third harmonic. Path PB is divided by 3 and by 2 three times. This provides four octaves of the fundamental. (Note that since the path PB is divided by 3, the frequencies will be lower by this factor than from path A; i.e., A is a third harmonic of B.)

The six outputs are routed to attenuator controls and into a system of filters which change the output waveforms from square to sinusoidal. Four bypass switches are provided to pass the square waves for bright-tone effects.

FIG. 2—OSCILLATOR IC1's OUTPUT drives divisor counter IC2-IC5, whose outputs go to the logic control (Fig. 3). Via the keyboard, the control divides the oscillator frequency by one of 12 numbers to provide harmonics and fundamentals.

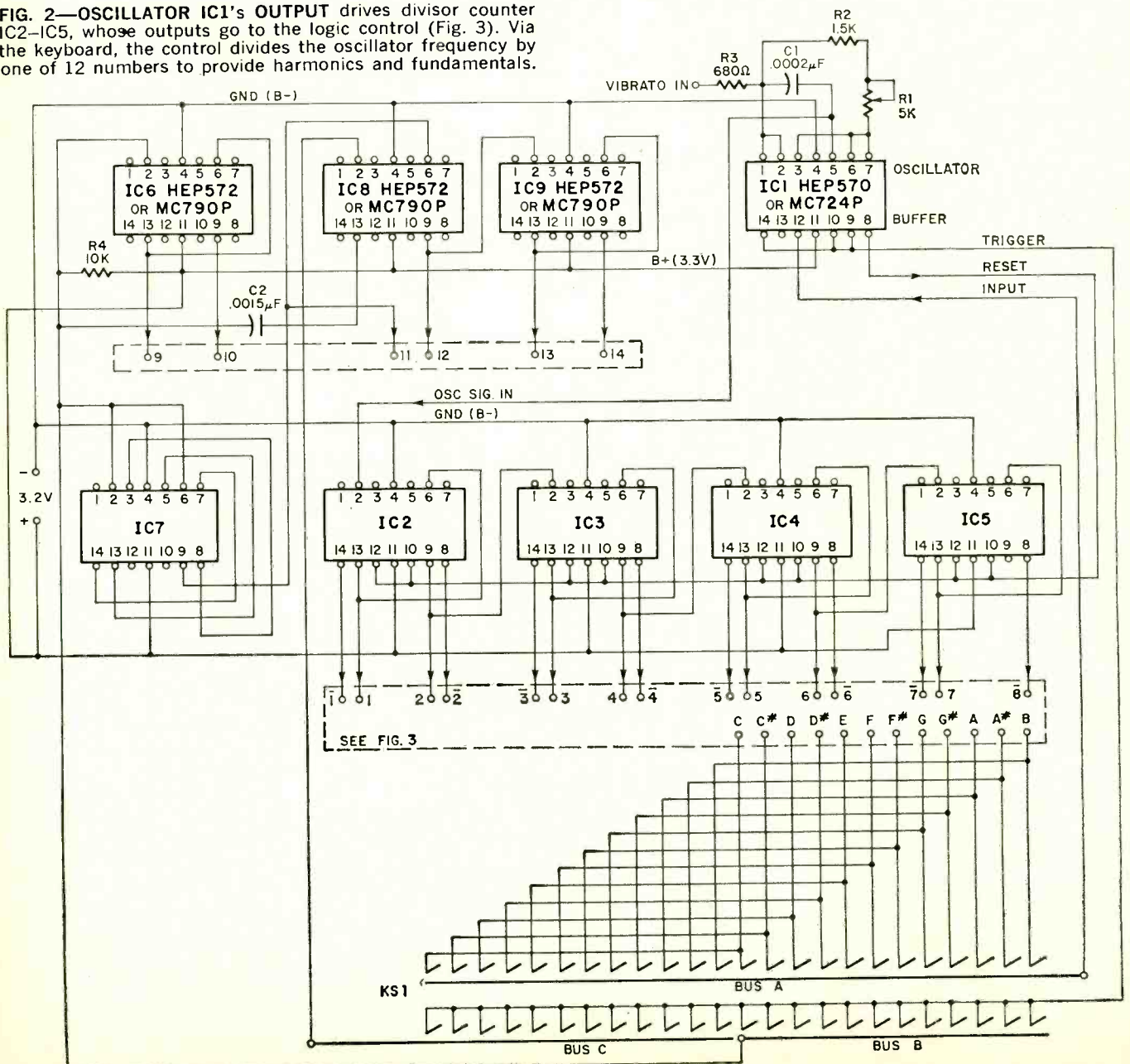

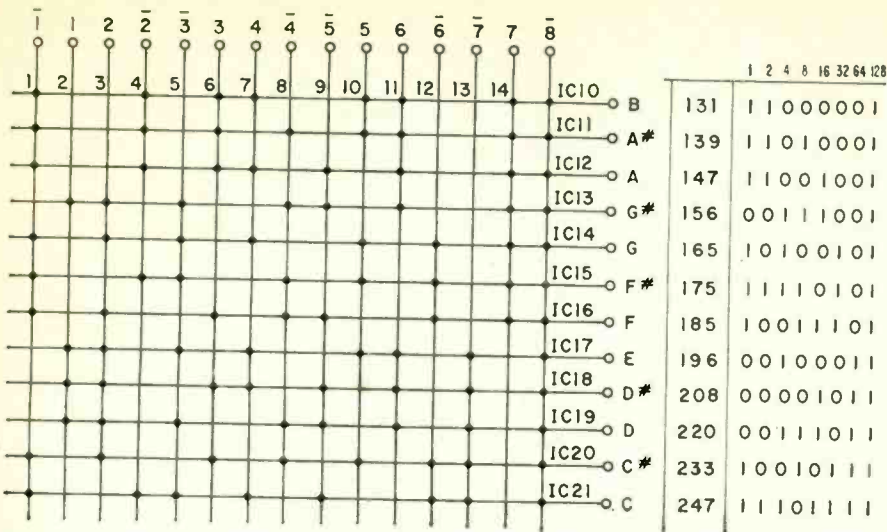

- ### PARTS LIST
- Capacitors**
 C1—200 pF
 C2—.0015 μF
 C3—100-μF, 3V electrolytic
 C4-C6—.01 μF
 C7-C9—.033 μF
 C10-C12—.01 μF
 C13-C15—.025 μF
 C16—2 μF, 10V
 C17, C18—1 μF, 10V
 C19, C20—10 μF, 10V
 C21—1 μF, 200V
 C22—2,000-μF, 6V electrolytic
 C23—5,000-μF, 6V electrolytic
- All resistors 1/2W, 10% unless noted**
 R1, R18-R234, R51—5,000-ohm linear potentiometers
 R2—1,500 ohms
 R3—680 ohms
 R4, R41-R44—10,000 ohms
 R5-R16—620 ohms
 R17—33 ohms, 1W
 R24-R36—13,000 ohms
 R37-R40—390,000 ohms
 R45—6,800 ohms
 R46-R48—47,000 ohms
 R49—1,200 ohms
 R50—68,000 ohms
 R52—20,000 ohms
 R53—200 ohms
 R54—13,000 ohms
 R55—5 ohms, 10W
 R56—100 ohms, 2W
 R57—120 ohms, 2W
- Semiconductors**
 D1—3.6V, 1W Zener diode (HEP 102 or equiv)
 Q1, Q2—MPS2926 or HEP50 transistor
 Q3—npn power transistor (HEP 247 or equiv)
 RECT 1—full-wave bridge rectifier (HEP 175 or equiv)
 IC1, IC10-IC21—Quad 2-input gates (MC724P or HEP570)
 IC2-IC9—Dual JK flip-flop (MC790P or HEP-572)
- Other parts**
 T1—6.3V, 2A filament transformer
 S1-S5—spst switch
 S1—spst toggle or slide switch
 S2 through S5—spdt toggle or slide switch
 Keyboard (see text)
 Pattern G vector board
 T-28 push-in terminals
 Miscellaneous wire and hardware

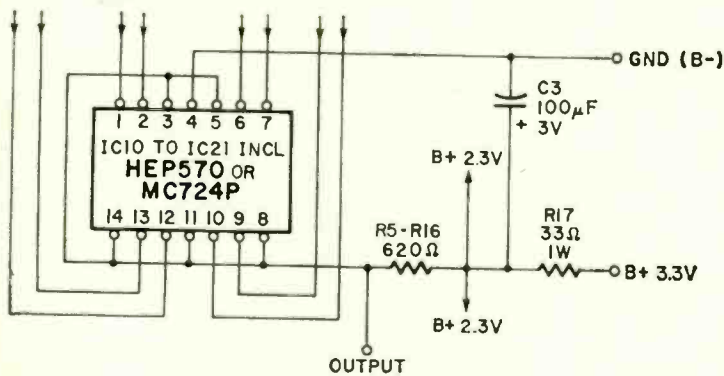

FIG. 3—DECODER LOGIC section uses 12 IC's connected as eight-input NOR gates as shown in the lower drawing. Dots on the horizontal lines indicate where the NOR gate inputs should be connected to the divisor counter (IC's 2-5). Outputs to the switches are the scale notes (vertical column).

OUTPUTS FROM FIG. 2

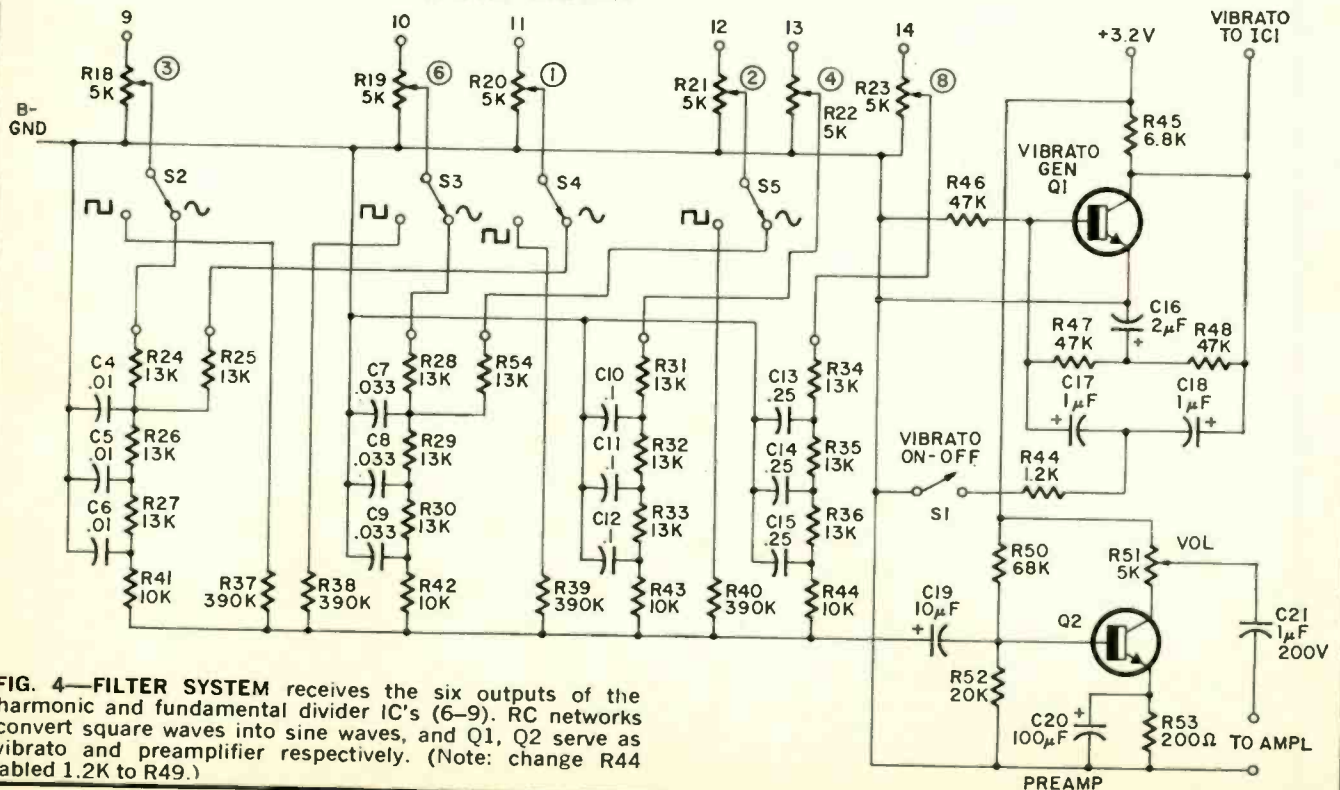

FIG. 4—FILTER SYSTEM receives the six outputs of the harmonic and fundamental divider IC's (6-9). RC networks convert square waves into sine waves, and Q1, Q2 serve as vibrato and preamplifier respectively. (Note: change R44 labeled 1.2K to R49.)

Circuit details are shown in Fig. 2, 3 and 4. Figs. 2 and 3 consist almost entirely of integrated circuits. Two integrated circuits are called for: the MC724P quad 2-input gate, and the MC790P dual JK flip-flop. Also suitable is the HEP 570 quad 2-input gate, and the HEP 572 dual JK flip-flop.

In Fig. 2, IC1 is the oscillator, with C1 and R1 and R2. This simple RC oscillator can be set up to run at any frequency to about 4 MHz. In this case, its frequency range, variable with R1, is about 1.2–2.5 MHz. IC1 also provides a single-input, two-output buffer.

The oscillator output drives the input (pin 2 of IC2) of the divisor counter, an eight-stage binary counter (IC2 to IC5). There are two binaries in each IC. These are cascaded to count straight binary. Each binary has two outputs: Q outputs, pins 13 and 9 (for the two flip-flops in each package), and \bar{Q} (not Q), pins 14 and 8. These outputs, except for pin 9 in IC5, go to the decoder logic (IC10–IC21). These outputs are designated in Figs. 2 and 3 as 1, $\bar{1}$, 2, $\bar{2}$, etc. from the flip-flops down the cascaded chain.

The decoder logic control is shown in Fig. 3. This shows the flip-flop inputs across the top of the figure, and horizontal lines indicating connections to the logic control IC inputs.

This decoder logic system consists of 12 MC724P gates connected as eight-input NOR gates. One of these IC's is detailed in Fig. 3. Pins 3, 5, 8, 11 and 14 are connected to a common-output circuit with external load resistors R5 to R16. The load resistors go to a 2.3V B+ source obtained by decoupling from the main 3.3V source through R17 and C3. When the final circuit tests are made, if there are any conditions under which operation appears fuzzy, they can often be corrected by adjusting this voltage. Making R17 smaller raises the voltage, and vice versa.

The input pins are 1,2,6,7,9,10,12 and 13. These are all the same, and any input can be connected to any flip-flop output. These connections are shown as dots on the 12 horizontal lines which represent the inputs and outputs of the 12 IC gates. IC10–IC21. The IC outputs are labeled to notes of the scale, B, A#, A, G#, etc., indicating the key switches to which they are connected. The column of divisor numbers indicates the set of numbers which closely approximate the ratios of $12\sqrt{2}$. The logic connections (inputs to the gates) are derived from the equivalent binary numbers shown to the right in Fig. 3. For convenience, these binary numbers are shown backward from conventional—the least significant digits are to the left.

These NOR gates function as follows. IC10, for example, divides by the number 131, and connections are made such that when there are 1's in the binary numbers, the \bar{Q} , or $\bar{1}$, $\bar{2}$, etc. flip-flop outputs are connected to gate inputs; where there are 0's, the Q outputs are connected. During its cycle of 256 counts, when and only when the counter has accumulated 131 counts, all the flip-

flop outputs to IC10 will be 0's, and this is the only time when IC10 can produce an output.

The logic control system is shown in Fig. 2 as the lower dashed-line box, with flip-flop inputs $\bar{1}$, 1, 2, $\bar{2}$, etc. and the gate outputs.

Gate outputs B, A#, A, etc. are switched by key-switch contacts on keyboard KS1. This has two key-switch contact sets (that is, two make contacts) and buses on each key. The upper contacts are wired with all B keys, all A# keys, etc. on common circuits, making 12 key-switch inputs from the 12 gate outputs.

When a key is pressed, the output is transferred to bus A which goes to IC1 input pin 12. Part of IC1 serves as the oscillator already described, as well as the buffer function. The buffer has two outputs. The reset output (pin 8) goes to pins 10 and 12 of counter binaries IC2–IC5. This completes the feedback loop, causing a reset of the counter to zero at the number of counts designated in Fig. 3 for any key pressed.

The trigger output from the buffer (pins 9, 10, 14 of IC1) goes to the second set of key switches on the keyboard. This set is split into buses B and C, each 1 octave long. When a key in the upper octave is pressed, the trigger from IC1 is transferred to bus B. This connects to pin 2 input of IC6 and pins 2 and 6 inputs of IC7. The input frequency for these will be the same as the trigger frequency, or the oscillator frequency divided by the divisor number for that key.

When a lower octave key is pressed, the trigger goes to bus C, and to the pin 2 input of IC8. The pin 13 output of the first flip-flop in IC8 is coupled through C2 to the same inputs connected to bus A. This operation divides the trigger frequency by 2, lowering it by 1 octave whenever a lower octave note is played. If the manual or keyboard used has 3 octaves of keys, a third trigger bus under the lower octave routes the signal to a divide-by-4 (two cascaded binaries) or one MC790 connected in cascade, and the output of this is connected through a 0.0015- μ F capacitor to the bus B input line. This lowers the trigger frequency 2 octaves. This connection (not shown in Fig. 2) is sketched in Fig. 5.

IC6 divides its input frequency by 2 and again by 2, providing two third-harmonic outputs, 9 and 10. IC7 divides

this same output by 3 (note the special feedback connections on IC7). The pin 9 output from IC7 goes to the pin 6 input of IC8 and output 11. The output of IC8 pin 9 divides by 2 on output 12, and IC9 divides by 2 twice more, providing outputs 13 and 14.

These six outputs go to Fig. 4. Attenuator pots R18–R23 insure that any

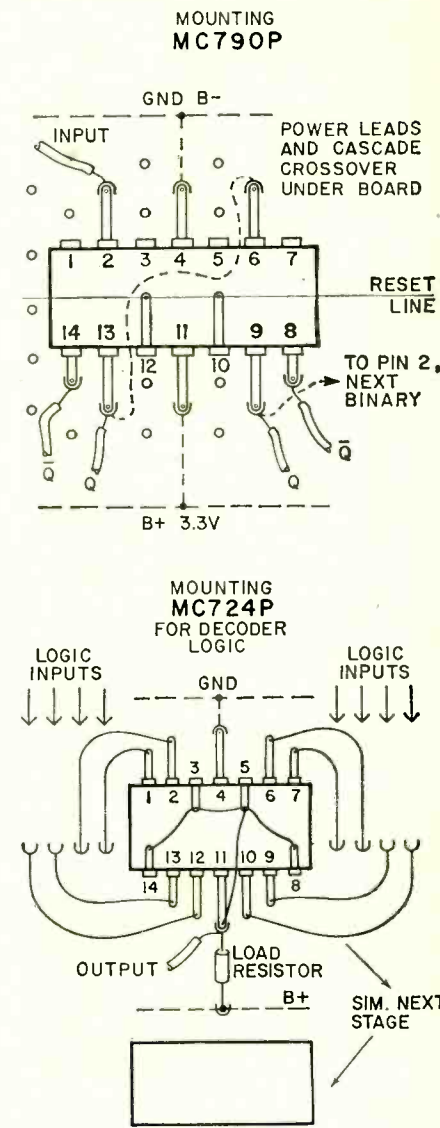
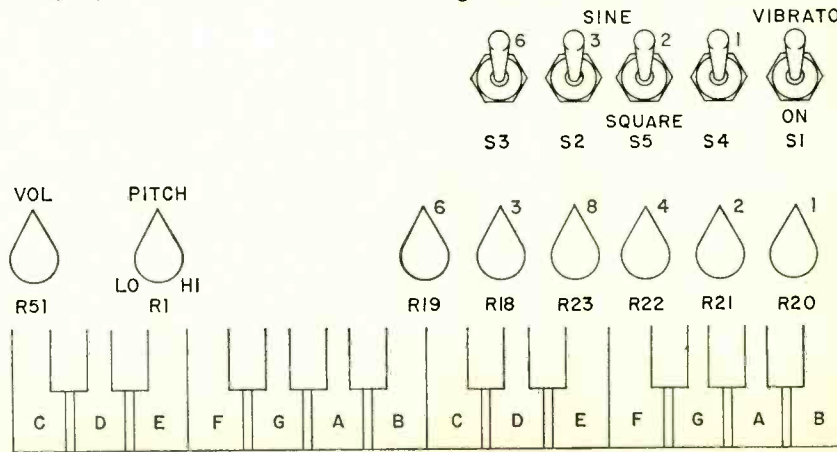

FIG. 5—IC MOUNTING technique will insure a neat and functional layout. FIG. 6—KEYBOARD and control arrangement suitable for the Digisynthone.



of these outputs, in any combination, can be gated from zero to maximum into the filter system of Fig. 4. Note 1K pots are called for, but any values between 1K and 10K are suitable here.

The filters are four low-pass RC networks which convert the square waves from the IC circuits into sine waves. These are desirable for the best harmonic mixing effects. Some square waves are also desirable, and two each of the fundamentals and harmonics are bypassed through switches S2 to S5. The filter and square-wave outputs are collected on a common line into a pre-amplifier with volume control Q2, and patched into any medium- or high-gain external amplifier through C21, which should be a 200-volt or more paper or Mylar unit for safety in patching into vacuum-tube amplifiers.

Transistor Q1 provides a 6-Hz twin-T oscillator for vibrato. This output goes to resistor R4 on the main oscillator, IC1. In the event the vibrato is

too deep, R4 can be made larger, and vice versa. The vibrato is stopped by opening switch S1.

Construction

Despite its complexity the Digisynthone is surprisingly easy to build, thanks to the integrated circuits. Make sure all connections are correctly and securely made, and that no shorts occur from stray bits of solder and incorrectly oriented connecting wires.

There are several good ways of mounting IC's including the use of sockets, which, however, are expensive. The best way is probably on etched circuit boards. The mounting used for the prototype is on pattern G Vector board with T-28 push-in terminals. The IC's are mounted upside down and the power and in and out leads are made either directly from the terminals or to extended leads to terminals. Fig. 5 shows enlarged views of typical mountings for both the MC724P gates and the MC790P flip-flops. A suggested switch and control arrangement is shown in Fig. 6.

The circuit requires a supply voltage of 3.3 to 3.7 volts at about 180 mA. A suitable power supply to furnish this regulated voltage is simple to construct and is shown in Fig. 7.

The mounting of the assembled circuits, keyboard and controls is not critical. It is probably advisable to mount the oscillator, or at least control pot R1, in a shield, since it has a frequency in the radio broadcast range. Also, keeping the interconnecting leads as short as possible will reduce tendencies for crosstalk.

Using the Digisynthone

The several controls which govern the musical capability are described here. Refer to Fig. 6 for a pictorial layout of these controls. The instrument pitch is under PITCH control R1. Since the system automatically delivers a cor-

rect musical scale independent of pitch, the pitch can be adjusted to tune to any conditions. A point can be found where the middle A key, for example, will tune to 440 Hz, in which case the entire instrument is in normal tune to the standard scale. R1 can also tune to any other frequency. This provides, among other things, a key-shift feature in which the player may play on the keyboard, for example, in a simple key such as C, but obtain sound in any other key. This capability should be a welcome feature to the many "favorite key" musicians. This same control (R1) permits dynamic sliding or gliding tone effects. Try a Hawaiian melody using R1 to swoop the tone upward or downward in real Island style.

Other special effects

The VOL knob is simply a volume control which can be manipulated as a dynamic swell or loudness control for special effects. The four harmonic mixer controls (1, 2, 4 and 8) provide the fundamental, and 3, 6 controls the third-harmonic system. When off, to the left, these controls do not permit any signal admittance to the output system. In the full clockwise position, all the signal is injected. These controls may be adjusted of course to any level in between. Many combinations are possible with these six controls, and most of them will sound distinctive.

The harmonic mixing will be most effective on the sine filters (S2-S5 up). Other tonal effects can be obtained with square waves (S2-S5 down). The vibrato is turned on or off with S1.

It has been said that the instrument is monatonic; i.e., only one note is played at one time. Note that if two keys are played at once, except for octaves, nothing sounds. Inherent in the digital tone system, this characteristic may be used to provide interesting chopped-tone effects by playing on a key and rapidly keying another to chop the tone.

A note on keyboards

A suitable keyboard for the Digisynthone is the one thing a builder cannot readily buy over the counter. There are a number of possibilities for salvaged keyboards from a piano, toy piano, accordion or reed organ. Most any of these can be fitted with key switches to provide a suitable playing medium.

The best bet, however, is a commercial organ keyboard. These can be obtained from 3 to 5 octaves, with dual key switches and buses, for approximately one dollar per note, from Pratt Read & Co., Inc. Ivoryton, Conn. 06442. You should specify "3 octave, 37 note, manual with two key buses per note, no resistors," and ask for quotations.

This keyboard has a high C, which will be dead in the system shown. But this can be doubled or connected in parallel with the next lower C key. It will sound an octave low, but this is a fairly common way of handling an end note in some organs. This is shown in the diagram of Fig. 8.

R-E

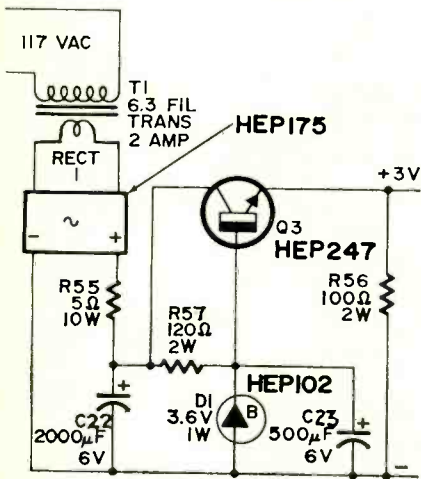
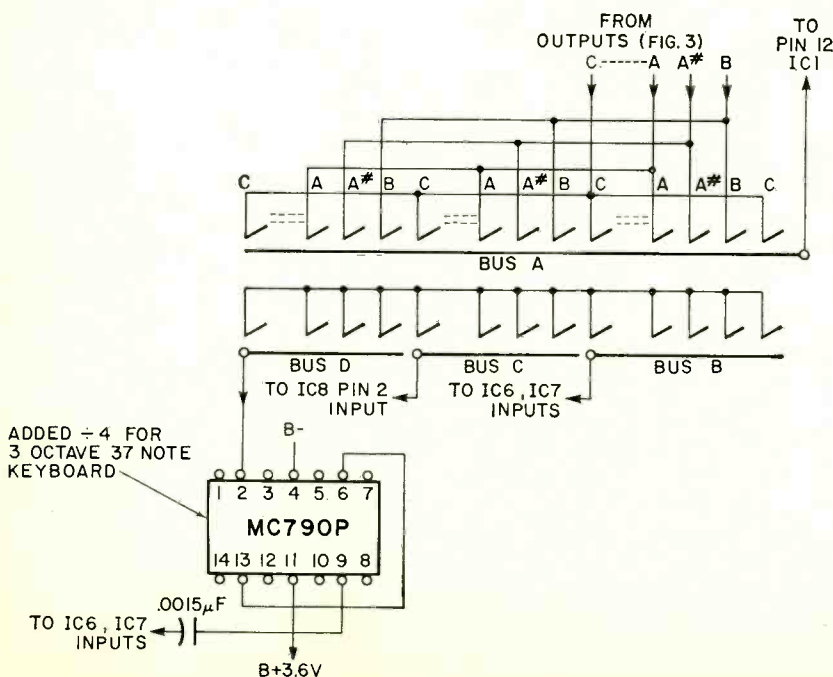
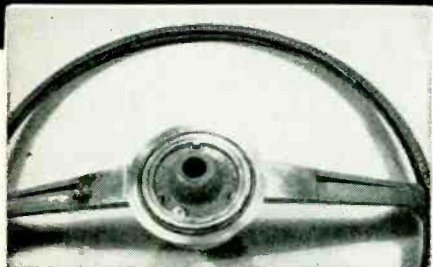

FIG. 7—POWER SUPPLY for the synthesizer provides well-regulated 3 volts. FIG. 8—HIGH C wiring for suggested keyboard will play an octave low.





ANTENNA for the touch-sensitive circuit is carefully fixed to rear of steering wheel.

For your car

Stay-awake alarm

by R. M. MARSTON

Proximity antenna added to your steering wheel can be a life saver. Car horn alerts you if your grip slackens

HERE IS A LIFE-SAVING ALARM THAT AUTOMATICALLY OPERATES your car horn if you relax too much while driving. Should you start to fall asleep at the wheel, it instantly brings you back to full alertness. The anti-sleep alarm is especially valuable on long night drives.

The operating principle of the alarm is quite simple (see Fig. 1). A metallic antenna is bonded to the rim of the steering wheel and coupled to a touch-sensitive, relay-driving electronic switch via a slip ring and pickup brush. The relay contacts are wired across the horn switch, and the unit is operational only when the ignition is turned on and S1 is closed.

Suppose that S1 is closed. When the car is driven normally, the driver has a firm grip on the steering wheel and the antenna. Under this condition, the touch-sensitive electronic switch keeps the relay and car horn off. When the driver starts to relax (prior to falling asleep), his grip on the steering wheel and the antenna inevitably slackens; the touch-sensitive electronic switch senses the relaxation of grip, and responds by automatically driving RY1 on.

The circuit design is such that the horn operates only when *both* hands relax simultaneously; thus one hand can be safely removed from the steering wheel to operate light switches, etc., without inadvertently triggering the alarm.

The electronic part of the circuit can be constructed easily. Construction and fitting of the pickup brush assembly and slip ring, however, may present some mechanical problems, and you should be competent to tackle them.

The full circuit of the relay-driving, touch-switch part of the unit is in Fig. 2. Transistor Q1 is wired as a simple Colpitts oscillator, its gain adjustable with R4. The antenna is coupled to Q1's tuned circuit via C5. The output of this oscillator, which operates at about 300 kHz, is made available at a low impedance level across R5 from emitter follower Q2.

This low-impedance signal is rectified and filtered by the D2-D3-R7-C7 network to produce a positive bias that is fed to Q3's base through R8. Transistors Q3 and Q4 are wired as common-emitter amplifiers. The collector current of Q3 is fed into Q4's base via R9, and Q4 drives relay RY1.

When the unit is in use, R4 is adjusted so that the oscillations of Q1 are barely sustained when the antenna is not externally loaded. Consequently, when the antenna is held firmly under normal driving conditions, the driver's grip adds enough capacitive loading to Q1's tuned circuit to stop oscillation. With no output available at Q2's emitter, bias is not developed on Q3's base, at Q3-Q4, and the relay and the car horn is off.

When the driver's grip on the antenna is sufficiently relaxed or removed, the extra antenna loading falls to such a low value that Q1 starts to oscillate normally. The ac signal developed at Q2's emitter is rectified and filtered by D2-D3-R7-C7, driving Q3-Q4 on and energizing RY1. The car horn, operated through the relay contacts, alerts the driver.

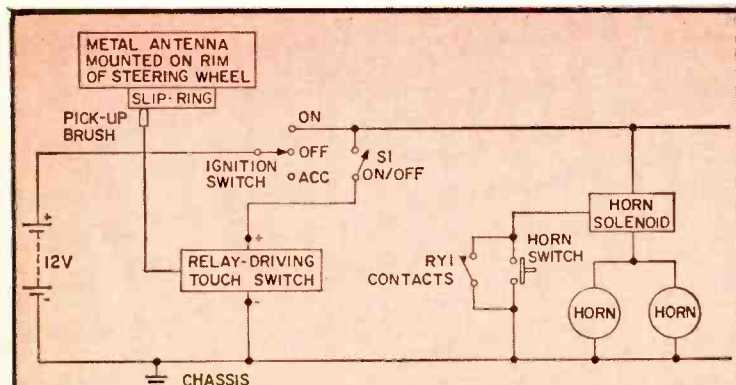
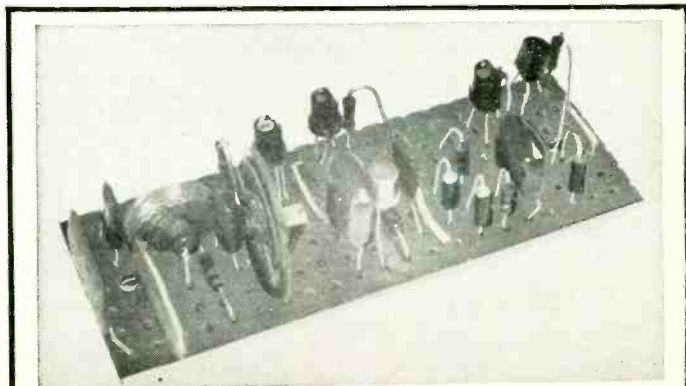

FIG. 1—BASIC WIRING SETUP for anti-sleep alarm. This is a negative ground. The positive-ground wiring is the same, except the polarities on the relay-driving switch are reversed.



ALARM CIRCUIT COMPONENTS, except for horn relay RY1, can be mounted on a 1 1/8 x 3 1/4-inch Veroboard. To prevent shorts, install the board in a shock-mounted plastic case.

Although this circuit has been described as a "touch-sensitive" switch, it's actually a proximity detector that works on a capacitive loading principle. Operation is not

dependent on a resistive contact between the driver's hands and the antenna, but on the capacitive loading caused by effectively connecting him between the antenna and "ground" (the car body). For correct operation, one side of the alarm power supply must be wired to the car chassis. The driver's body, of course, is effectively grounded capacitively by its sheer mass. To insure that the circuit sensitivity is unaffected by battery voltage variations, the supply to Q1 is stabilized by Zener diode D1.

Construction and use

The relay-driving, touch-switch part of the unit is built—less the relay—on a 3/4 x 1/8-inch piece of Veroboard panel with 0.15-inch hole spacing. Fig. 3 shows full construction details of the circuit.

When construction is complete, give the unit a functional test. Solder a 6-inch piece of insulated wire in antenna hole 1a, and strip 1/4-inch of its free end. Wire the relay in place, adjust R4's wiper to ground (B-) and connect the supply leads across a 12-volt battery. Relay RY1 should be off under this condition.

Carefully adjust R4 until the relay just turns on. Now place one hand across the B+ or B- terminal of the battery, and grip the bare end of the antenna wire with the other hand. The relay should turn off under this condition; it should turn on again when the hand is removed from the antenna wire. By carefully adjusting R4, it should be possible to set the unit so RY1 goes off only when the antenna is gripped very firmly, lightly, or barely touched, as required.

The true proximity-detecting nature of the unit can be demonstrated at this stage by connecting the antenna to a metal plate with a surface area of several square inches. By adjusting R4, it should be possible to set the unit so that the relay is normally on, but goes off if one hand is merely placed within an inch or two of the metal plate—with the other hand on one of the battery terminals.

Once the touch switch has been tested it is ready for installation in the vehicle. The antenna assembly can now be made up, together with the slip ring and pickup brush. The idea here is to bond a thin copper-strip "antenna" to the inside rear of the steering wheel rim.

In such a position the antenna is contacted by the hands only when the steering wheel is gripped firmly. One end of this antenna is connected electrically to a brass slip ring mounted on the steering wheel boss near the steering column. A spring-loaded copper pickup brush and metal holder are then mounted on the steering column cowling, so that the copper brush is in contact with the brass slip ring. The metal pickup brush holder is wired to the antenna lead of the Veroboard circuit. A conducive path exists between the steering-wheel antenna and the antenna lead of the Veroboard circuit in all positions of the steering wheel. The steering wheel and steering-column cowling must, of course, be of nonconductive material.

Construction of the antenna and pickup assembly is rather difficult and time-consuming. (The prototype took over 20 hours to complete.) Fig. 4 shows the construction method used for the prototype. Details may be varied to suit individual vehicles. Here is the general procedure for making the assembly:

- (1) Remove the steering wheel from the vehicle.
- (2) Thoroughly clean the steering wheel, and use sandpaper to remove all paint from the inside rear of the rim.
- (3) Make up a slip ring from heavy brass sheet, as shown in Fig. 4-d, and bend back the two (or more) tabs so they fit the shape of the steering wheel spokes. Bolt a solder lug to one of the lugs.
- (4) Bond the slip ring in place on the steering wheel boss, as shown in Figs. 4-a and b, using a contact adhesive

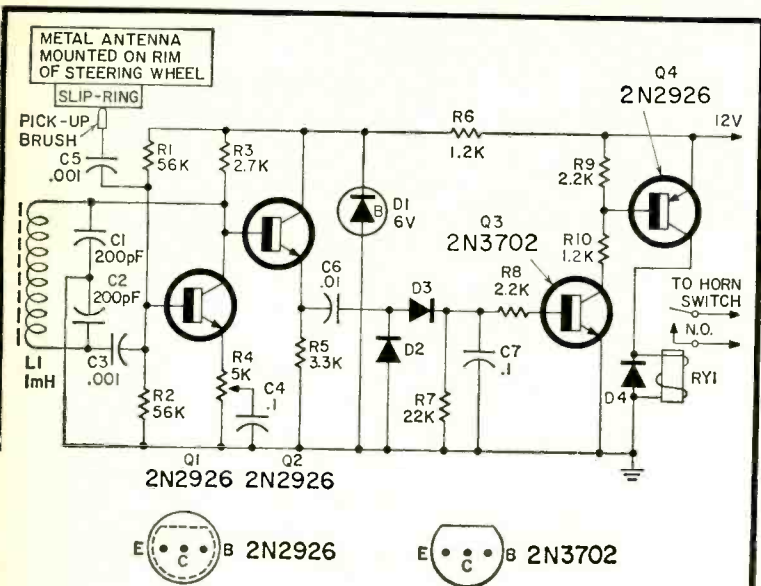

PARTS LIST

- C1, C2—200-pF capacitor (silver mica)
- C3, C5 .001- μ F capacitor (Mylar)
- C4, C7—0.1- μ F capacitor (Mylar)
- C6—.01- μ F capacitor (Mylar)

All resistors 1/4W

- R1, R2—56,000 ohms
- R3—2700 ohms
- R4—5000-ohm trimmer potentiometer
- R5—3300 ohms
- R6, R10—1200 ohms
- R7—22,000 ohms
- R8, R9—2200 ohms

Semiconductors

- Q1—Q3—2N2926 (GE)
- Q4—2N3702 (TI)
- D1—6-volt Zener diode
- D2—D3—germanium diode (general purpose)
- D4—silicon diode (general purpose)

Other parts

- L1—1-mH, rf choke on ferrite form
- RY1—12-volt N.O. relay (coil greater than 120 ohms)

S1—spst switch

- MISC—Vero board, hookup wire, CIR-KIT (available from Olson Electronics, 260 S. Forge St., Akron, Ohio 44308. Kit KB-189, \$4.99 ppd plus postage)

FIG. 2—CAPACITIVE coupling from driver holding antenna keeps Q1 from oscillating and prevents RY1 from completing circuit to horns.

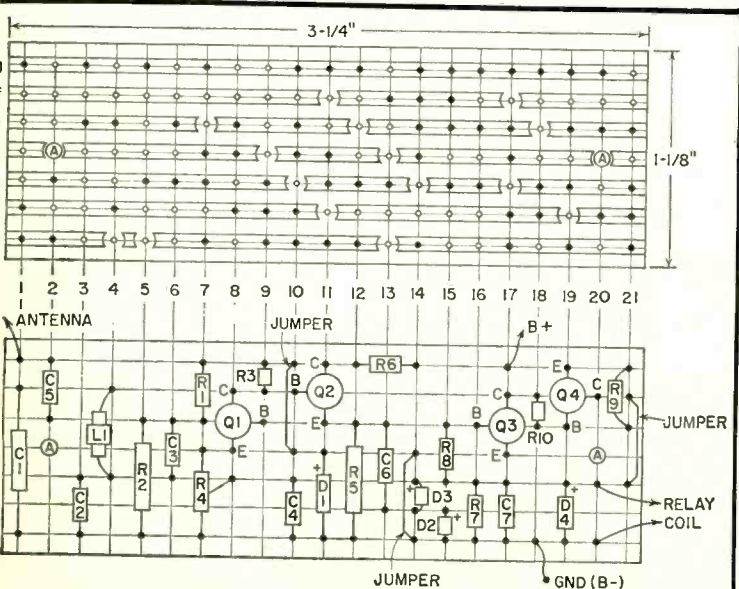

FIG. 3—COPPER SLIDE of Veroboard layout is on top. The letter-number code shows you where to place components.

between the steering wheel spokes and the rear of the slip-ring lugs.

(5) Mold "plastic metal," epoxy resin or a similar "filler" material between the slip ring and the steering wheel boss, and carefully file and sandpaper the material so the ring blends smoothly into the shape of the boss.

(6) The antenna can now be prepared, using a 5-foot length of 1/8-inch-wide CIR-KIT (see parts list) or a similar product. This is a fine copper strip approximately 0.002-inch thick with a powerful contact adhesive bonded to one side. The adhesive is normally covered with a protective backing paper.

Remove the backing paper from one end of the strip and solder the end to the solder lug on the brass slip ring. Run the strip along one spoke, then around the inside rear of the steering wheel rim as shown in Fig. 4-a. In this position the strip will be contacted by the hands only when the wheel is gripped reasonably firmly. As the strip is run into place, remove the backing paper and firmly bond the strip to the wheel. Burnish the copper with the smooth shank of a drill or similar object so all kinks are removed. Finally, remove all rough edges from the strip with fine sandpaper.

(7) At this stage, the antenna stands slightly above the surface of the steering wheel rim, and might be damaged by continuous rough handling. To overcome this, paint over the area of the antenna with cellulose filler (used in repairing scratches in car paint). When this is dry, rub the surface down with fine "wet-and-dry" sandpaper so the antenna blends smoothly with the rim surface.

(8) Next, spray-paint the entire wheel and rim in its original shade. When dry, carefully remove the paint from the antenna and the face of the slip ring and finish off with "wet-and-dry" paper.

(9) Polish the face of the slip ring, coat it with silicone grease, and then fit the steering wheel back in the vehicle.

(10) Now make up the copper pickup brush and brass holder, as shown in Fig. 4-c. The brush is made from a soldering iron tip, and has its free end carefully rounded and smoothed. The holder is made from a brass rod, drilled out to take the brush and a spring. The spring should give at least 3/8-inch free movement to the brush.

(11) Finally, make up a metal clamp and use it to fix the holder to the steering-column cowling. Position the assembly so the brush is in contact with the face of the slip ring. Secure a solder lug behind the clamp so a lead can be soldered from the lug to the Veroboard panel. Check that the steering wheel moves freely and without undue friction. This completes the construction of the antenna and pickup assembly. Now the complete unit can now be wired and tested.

Connect the Veroboard supply leads to the car bat-

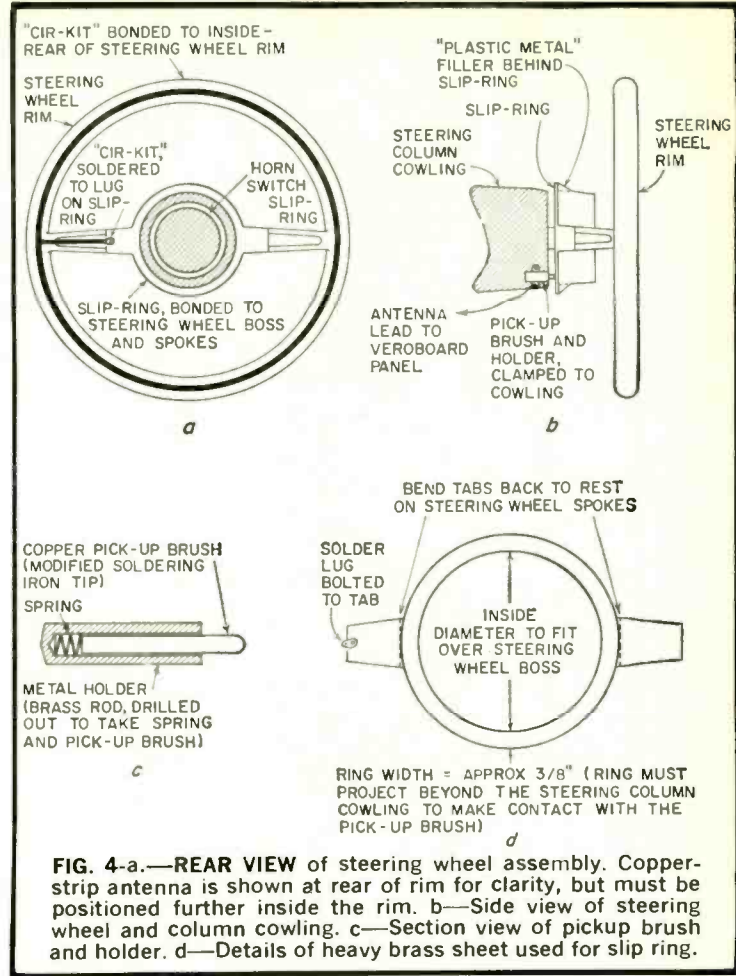

FIG. 4-a.—REAR VIEW of steering wheel assembly. Copper-strip antenna is shown at rear of rim for clarity, but must be positioned further inside the rim. b—Side view of steering wheel and column cowling. c—Section view of pickup brush and holder. d—Details of heavy brass sheet used for slip ring.

tery via S1 and the ignition switch, as shown in Fig. 1. Connect a lead from hole 1a in the Veroboard to the pickup brush holder. Temporarily wire a lamp in series with the relay contacts, and connect across the car battery so the lamp goes on when the relay closes.

Now close S1, turn on the ignition and adjust R4 so RY1 just turns on and the lamp operates. Grasp the steering wheel firmly, to insure the lamp goes off, and goes on again when the grip is relaxed. Readjust R4 if necessary.

Finally, give the car a test run and make sure operation is stable when the steering wheel is turned back and forth. Operation will probably be slightly erratic until the car has been driven for several miles. The pickup brush and slip ring must become "bedded in." Once stable operation is achieved, the temporary indicator lamp can be removed and the relay contacts wired across the car horn switch (Fig. 1). The system is then ready for use. **R-E**

COLOR TV ANTENNA INSTALLER'S GUIDE

This month Section II of your Radio-Electronics Reference Manual continues to grow. We present the first part of an article on TV antenna installation. We feel it will be a valuable addition to your permanent store of valuable reference material.

If you wish you can purchase a special hardcover binder to keep your Reference Manual pages together. It has a dark blue fabric cover and is gold-stamped Radio-Electronics Reference Manual. The cost is \$1.00 postpaid. Order from N. Estrada, 17 Slate Lane, Central Islip, L. I., N. Y. 11722.

ANTENNA INSTALLER'S GUIDEBOOK

by JAMES A. GUPTON, JR.

Installing an outside TV antenna generally insures a marked improvement in picture quality plus a wider selection of stations and programs. Rabbit-ear antenna problems—airplane flutter, poor color, picture fade when someone enters the room—will usually vanish. Those annoying ghost images can often be eliminated by using a rotating outside antenna.

Select your antenna carefully. Talk with neighbors about their reception of distant stations, visit local TV dealers or call TV stations to learn the best antenna for your area. Don't try for a reception range greater than 100 miles. Look over your house to determine how and where to mount the antenna and the potential hazards to avoid.

Survey the antenna site

- Are there any electrical wires running over the house or within 20 feet of the side of the house? You should never work with an antenna when wires are within 20 feet of the mounting site or within 20 feet of total mast length to wires.
 - What kind of roof does the house have? Composition shingle roof is O.K., but stay off slate or tile roofs—particularly if there is a slope of 15° or more.
 - How high is the roof? The average man can safely work on a single-story roof or a two-story roof providing there is a single-story porch or section of the house.
 - Does the chimney run up the outside wall or exit only at the ridge of the roof? For multi-story, high-pitched roofs the only safe mount would be an outside chimney or eave mount.
- The examination will show potential mounting sites such as the chimney, center of roof with base mount and guying, or the side of an eave. In some cases it might be necessary to use a base mount on a low section with a tall mast to clear the second story and roof.
- Having determined mounting requirements and estimating the distance from the antenna to TV set you are ready to purchase the necessary material.
- The many varieties of homes and mast height requirements makes it virtually impossible to prepare an antenna kit complete with every

Assembling the antenna

The antenna shown is a deep-fringe combination vhf and uhf unit. The vhf section should be assembled "upside down" since the antenna elements will bend out of shape with mishandling during assembly. The supports and mast section can be attached without

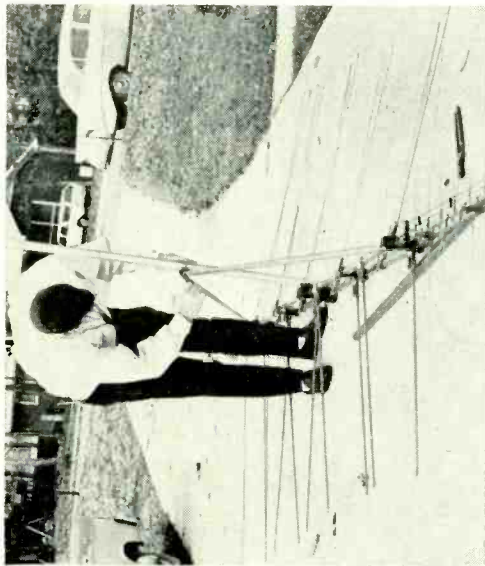

When practical assemble the antenna at ground level. This avoids the problem of keeping your balance on a slanted roof top. Always assemble upside down, as shown, to prevent the chance of antenna elements getting bent during assembly.

moving the antenna, and you can even attach the rotor with the antenna in this position.

Now you are ready to assemble the rotator unit. Most rotators are shipped from the factory with control head and rotor both in the North position. All rotators require a multi-wire cable, and each wire must be attached to the proper rotor-control head terminal. To keep the wires identified, cut and strip them in a pattern. Just attach the white wire to terminal 1 and the remaining terminals will be under the appropriate wire.

Next the rotor is attached to the mast. With many rotors, the mast is held in position by a plate which mounts onto studs that are a part of the rotor housing. Two small U bolts and a metal bar hold the antenna mast in the rotor housing. The mast mount for the antenna mast contains a small molded pin that must fit into the hole in the rotor housing to prevent unwanted antenna rotation.

Although most rotors will safely handle antennas on as much as 5 feet of mast, the best performance and longer motor life is obtained with mast sections no more than 2 feet long.

needed item. Therefore, here are a few items you will have to purchase separately: 1. Mast sections for mounting antenna and rotor. 2. TV transmission line, rotor cable and guy wire. 3. Antenna rotor and control box. 4. Mounting hardware, guy hardware and insulated stand-off's. 5. Installation accessories such as feedthroughs, wall plates, lightning arrestors, ground rods and No. 8 ground wire.

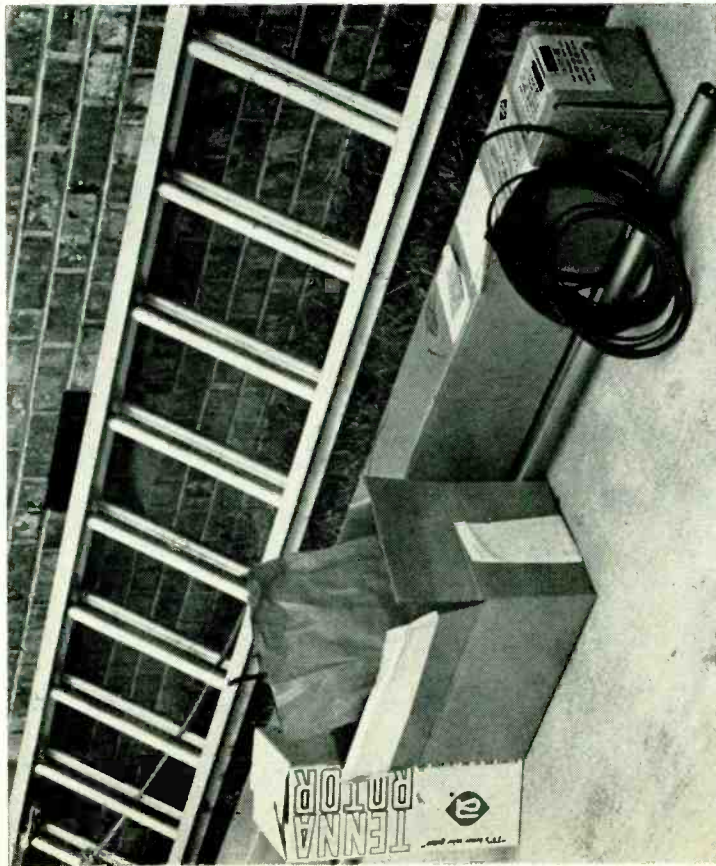

Ready to go—Line up all the materials and tools you expect to use for the antenna installation. Then, when you need something, you'll know exactly where it is. Don't forget the little things, like standoffs.

Long mast sections ordered by mail may have shipping costs that exceed the cost of the mast. A good substitute for mast sections is electrical EMT conduit. The 1-inch I.D. tubing is under the 1¼-inch maximum outside diameter for most rotor units and each section is 10 feet long. The only disadvantage lies in the need for a coupler to join two sections together.

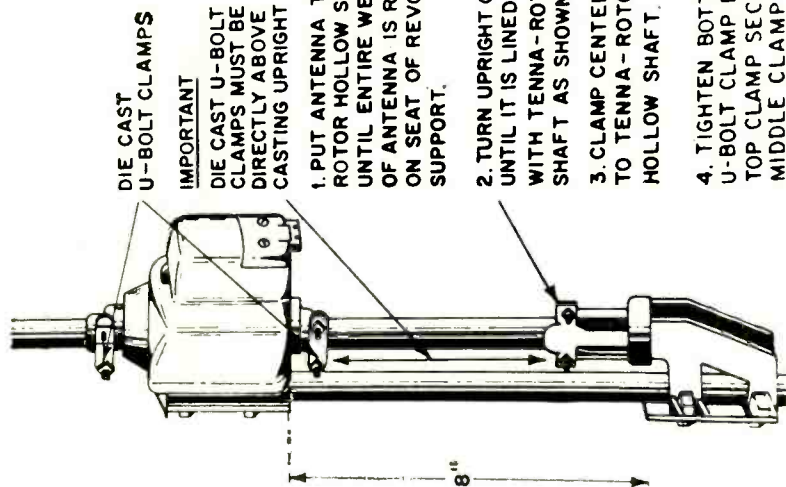

DIE CAST U-BOLT CLAMPS

IMPORTANT

DIE CAST U-BOLT CLAMPS MUST BE DIRECTLY ABOVE CASTING UPRIGHT

1. PUT ANTENNA THRU ROTOR HOLLOW SHAFT UNTIL ENTIRE WEIGHT OF ANTENNA IS RESTING ON SEAT OF REVOLVING SUPPORT.

2. TURN UPRIGHT CASTING UNTIL IT IS LINED UP WITH TENNA-ROTOR SHAFT AS SHOWN.

3. CLAMP CENTER POST TO TENNA-ROTOR HOLLOW SHAFT.

4. TIGHTEN BOTTOM U-BOLT CLAMP FIRST - TOP CLAMP SECOND & MIDDLE CLAMP LAST

Closeup look at proper assembly of a rotor. Note the locations of bolts holding the rotor to the mast, and make sure you provide adequate space to permit the rotor to turn freely. The thrust bearing is an accessory and not standard. (Courtesy Alliance.)

Three ways to mount antennas

Now you are ready to install the house mount. There are three basic mounts: the chimney mount, eave mount and the guyed mount. Since the chimney mount is the most often used, let's begin with this one.

The chimney mount consists of two brackets with mast clamps, two eye bolts attached to steel or stainless steel bands, and the necessary nuts and bolts to hold everything together. It is customary to attach the top mount just under the chimney crown, or the overhanging portion of the chimney top. For straight chimneys with no overhang, mount the bracket about 6 inches from the top of the chimney. The second mount will be placed 3 to 4 feet below the top mount. The taller the mast, the greater the mount spacing.

Running the antenna transmission line will be easier if the mounts

are placed on the outside (away from the house) portion of the chimney. Check the steel bands to make sure they have no kinks in them, then tighten them.

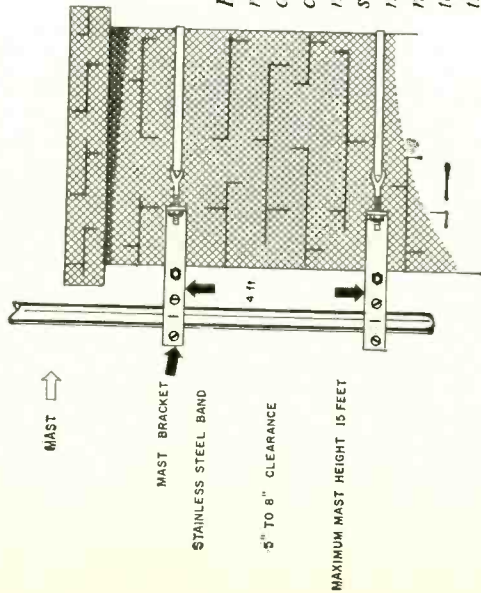

Here's the right way to mount an antenna to a chimney. Before using a chimney for an antenna mount, however, make sure it is solid. We've seen more than one old chimney crumble when the technician tightened up the mounting straps.

There should be no movement of the mounts when the antenna mast is finally positioned and tightened.

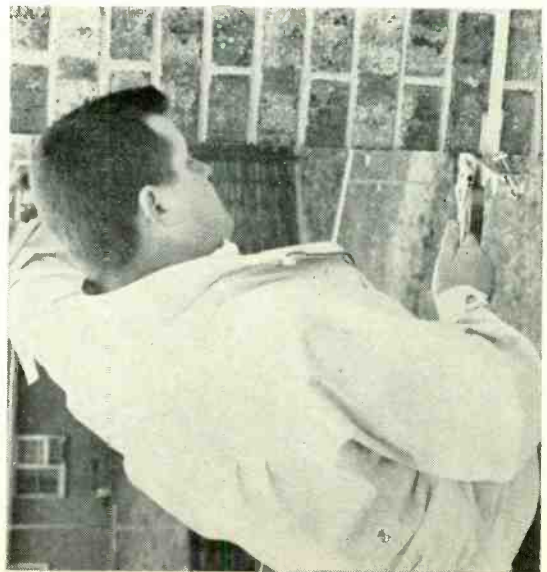

Check the straps and make sure they are straight and tight. The security of the entire antenna installation depends on this basic step.

machine screws with large washers on the inside between wood and nut.

Brick wall requires drilling into the brick with star drill or Carboly electric drill bit and attaching the mount with lead anchor bolts or Rawl Plugs. Never drill into mortar joints for mounting the bracket. When the lead anchor or Rawl Plug expands—the mortar will crumble and the attachment will have little or no support.

The eave mount requires the same 3 to 4 feet separation of brackets for firm support of the mast as did the chimney mount; therefore it is generally necessary to place the antenna on the eave mount from a ladder. Again, the antenna is pointed North and final tightening of the mast clamps is made.

Guyed mounts for height

For maximum fringe area reception, the height of the antenna becomes important. Masts of 20, 30, 50, even 100 feet are not uncommon for deep fringe reception. The height of the mast sections makes guying mandatory; here wind velocities play havoc with guy wires.

Let's begin this installation with the antenna and rotor already assembled on the mast. The procedure is identical to the chimney mount instructions and need not be repeated. The installation starts

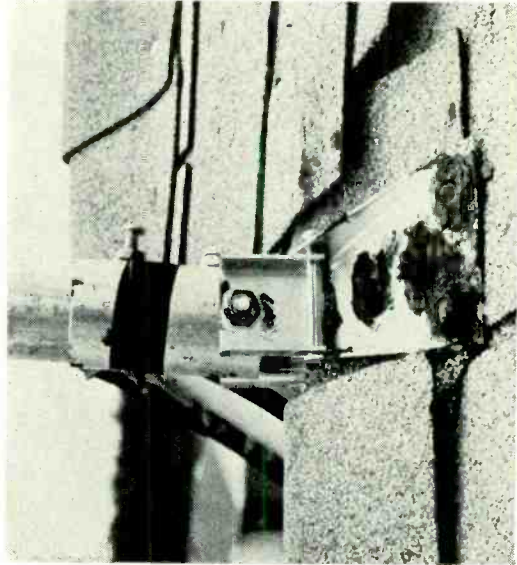

Antenna base mount is most readily positioned on the peak of the roof. When using this type mount, keep the bottom of the mast off the roof or you can cause a water leak. Carefully seal all screw holes—silicone rubber is excellent for this purpose.

with the mounting of the antenna base mount. While the base mount may be positioned on any part of the roof, it will look better if the

For chimney mounts don't use more than 15 feet of mast without guying. This limitation more or less restricts the mast to 10 feet from mount to rotor and 1 to 2 feet from rotor to antenna. Before leaving the roof to get the antenna be sure to loosely assemble the mast clamps on the chimney mount; just run the nuts several turns on the bolts and let the clamp hang.

Antenna eave mounting

The eave mounting method is used when there is no chimney and roof guying is not desired. Here again, the eave mount limits the total overall length of mast to no more than 15 feet. Like chimney mounts, longer mast sections will require guying.

The basic eave mount is nothing more than steel brackets with mast clamps bolted or screwed onto the building's wall. The size of the eave bracket depends on the amount of roof overhang. It must support the mast and clear the roof. Use a bracket that has a bottom angle brace to prevent sagging of the mount with the antenna and motor weight.

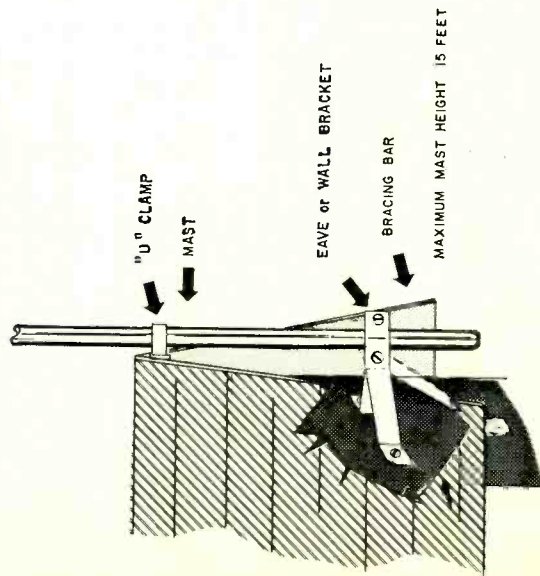

Eave mounting is used when there is no chimney suitable for antenna mounting. The sketch shows the proper installation technique. Note the restriction on maximum mast height.

To attach the brackets to wooden walls, use either lag bolts or wood screws screwed to vertical studs for maximum holding. For clapboard mounting, drill holes through the board and attach the bracket with

antenna is in the center of the roof. The slope of the roof may present a minor problem, however. I use a saddle mount designed to fit over the ridge of the roof. The mounting plates adjust for any slope angle.

The base mount is fastened to the roof with wood screws or lag bolts. Apply tar liberally over, under and around every screw to prevent water leakage. Next comes the mounting of the guy wire eyebolts. I generally place one eye-bolt at the end of the house just below the roof ridge. The remaining eyebolts are located at each side of the rooftop to maintain 120° spacing. I use 6-inch woodscrew-type eyebolts and run the bolt in until no thread is visible.

Properly guyed mast requires that the installer adjust the guy wires to eliminate all bows in the mast. This will give the installation maximum strength. Don't skimp on the quality and size of the guy wire either. These installations are costly.

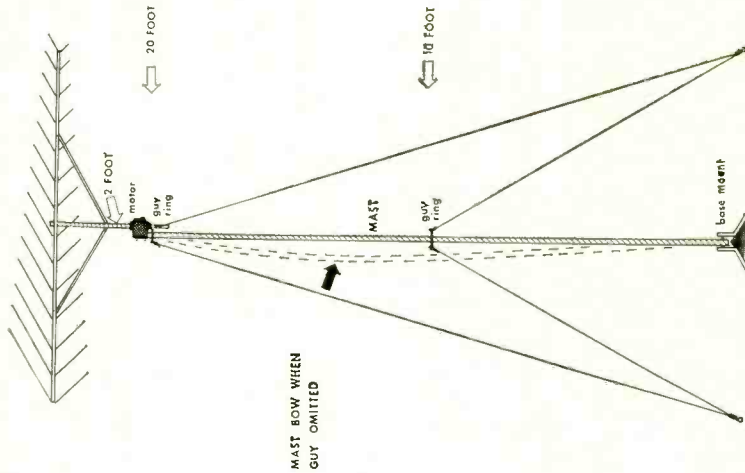

The two basic guy wire types are galvanized standard iron wire and copperweld solid wire. For very high wind areas, use the No. 12 copperweld guy wire. Both copperweld and galvanized wire readily form tight (to be continued)

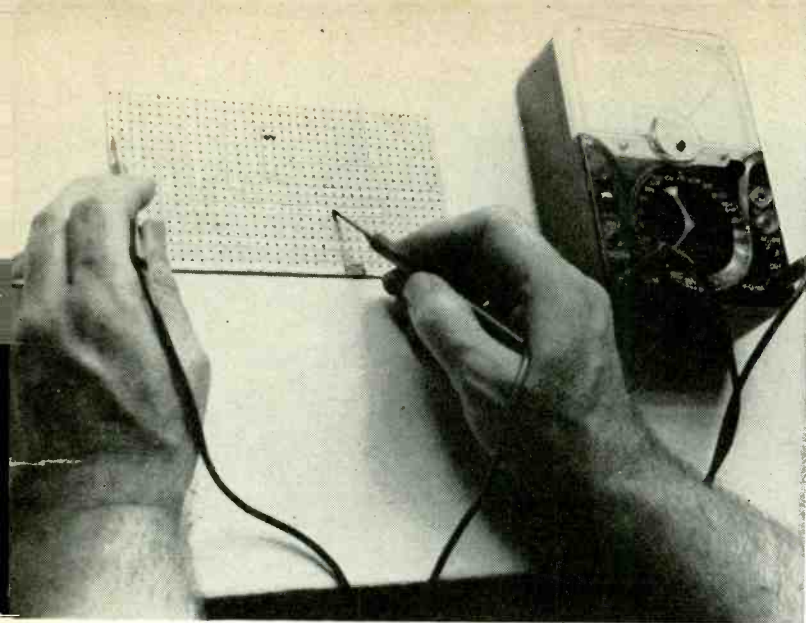

How To Make Etchless Circuits

by BYRON G. WELS

Try painting your circuit patterns on perf board to eliminate complex, messy etching

YOU'VE HAD THE PROBLEM YOURSELF. You see an interesting project in a magazine, read the details, but find the author has blithely skimmed over the matter of etching the circuit—as if it were something you did every day.

To build the project, you find you first have to photograph the circuit pattern shown, obtain expensive photosensitive circuit boards, expose the board to the negative you just made in an enlarger for 5 minutes (or get an enlarged negative) and then take the time to develop and wash the board.

Then you immerse the board in an etchant, which must be poured into a glass tray because the stuff attacks metal or plastic. If everything went all right, the etchant will eat away the copper. Now you must dispose of the etchant without ruining your plumbing, wash the board and drill holes in the proper places to connect components.

If you have patience, you can skip the photographic part by first painting the board with acid-resisting inks, then etching and using turpentine to wash away surplus ink.

A solution to the problem comes in the form of perforated circuit boards with no copper on them. You can get these in different sizes and with various hole patterns and sizes.

Spread masking tape over the entire board, overlapping each strip slightly. Press it down with your fingers so you can see indentations where the holes are. Use a razor blade and steel rule to mark off the circuit pattern shown in the magazine. Remove the excess tape so you leave exposed board where the circuit pattern calls for foil.

Now you have a choice. You're going to *paint* the conductive strips on the board. You can use either silver conductive paint or copper conductive

OHMMETER test of painted strip will show good conductivity.

PAINT goes on quickly, drying in one-half hour.

FINISHED pattern looks like this (middle) with tape off.

SOLDERLESS connections are made with a paint dab (bottom).

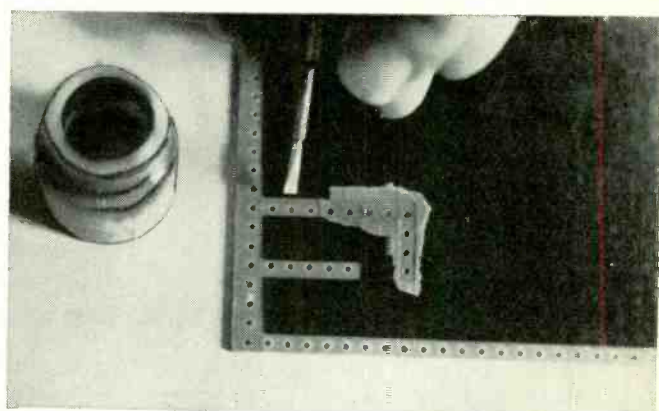

paint (used for printed circuit repair). The copper paint is a lot less expensive.

Shake the bottle well to distribute the solids, then paint the board layout pattern. The paint goes on easily. I used two coats, not because I had to, but because I like to play it safe. Allow about one-half hour drying time between coats. A half hour after the second coat is dry, you can peel away the rest of the tape. Put an ohmmeter across the board, just to prove to yourself that it really works.

Unfortunately, you can't solder this stuff, but don't start laughing yet. There are two ways to go.

If you *insist* on soldering all the way, insert "flea clips" in the appropriate holes, and put a dab of conductive paint between the clip and circuit board. Another little dab on the other side will help seal the clips in place. The clips can be soldered.

But a nicer way to handle the problem is to bend the leads of your components, slip them into the holes, and connect with a dab of paint between the component lead and the circuit you've painted on the board. When the paint is dry clip off the excess lead length.

Where wire leads are needed, run the wire in one hole, bend it up and

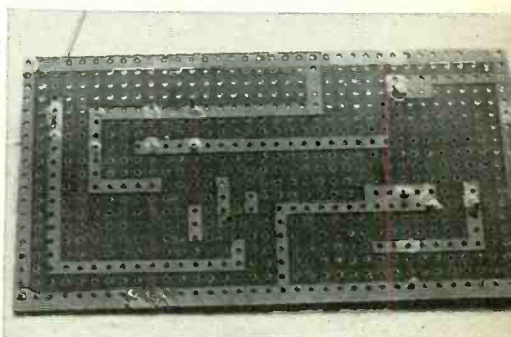
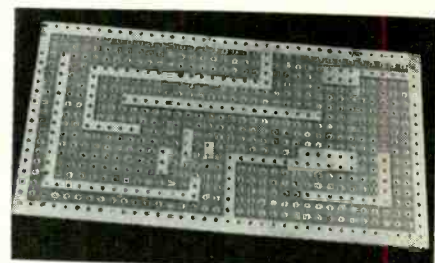

lock it in another hole in the same circuit area. Add a dab of the paint to keep it in place. Stranded wire is more flexible than solid and less likely to chip the paint away.

There's a useful side benefit, too: No more cold solder joints to worry about! And don't overlook the fact that since no heat is applied, delicate components such as diodes and transistors cannot be destroyed. **R-E**

UHF TV ANTENNAS-

RECEIVING UHF TELEVISION SIGNALS ON channels 14 to 80 (470-890 MHz) presents problems similar to those for vhf reception (channels 2 to 13; 54-216 MHz). As for vhf, in the more difficult fringe areas, or areas where reflections or interference are severe, special antennas must be used.

One prime method of classifying antennas, is to compare gain. Low-gain antennas are adequate in high signal-strength areas—reasonably close to the transmitter. High-gain antennas are a must in weak-signal fringe areas.

Directivity is another important antenna characteristic and it is often used to identify different antenna types. Directivity can vary from the low-gain omnidirectional antenna, which by definition receives from all directions, to the special highly-directional antenna, which has an extremely narrow angle of reception, from only one direction, and can easily discriminate against unwanted signals.

Directivity can be detailed as either horizontal or vertical. Horizontal directivity is extremely useful for reducing reflections. Vertical directivity is useful for eliminating effects of signal cancellation caused by reflections from the ground or other objects located above or below the path between the receiving antenna and the transmitter. For example, flutter caused by a passing airplane can be greatly reduced by using an antenna with high vertical directivity.

Bandwidth is another characteristic often used to classify antennas. Bandwidth is the capability of an antenna to receive signals over a wide range of frequencies. Since the uhf spectrum covers 69 channels, the bandwidth requirements of a uhf antenna are quite different from those of vhf antennas.

It is possible to pick up uhf signals with an existing vhf antenna. Unfortunately, many vhf antennas do not work very well at uhf. However, they can be used in medium- and high-signal-strength areas which are free from re-

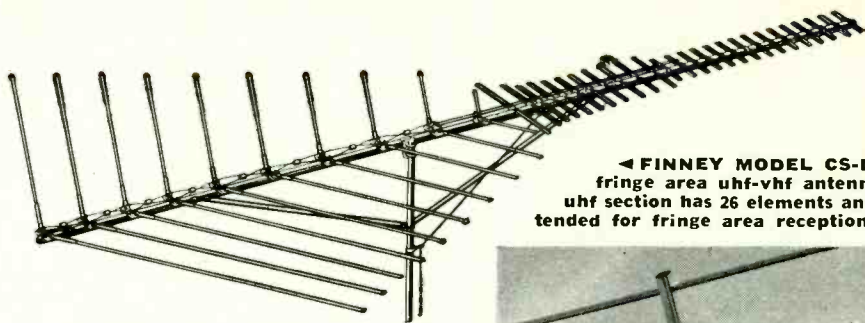

APERTURE REFLECTOR UHF ANTENNA is RCA Model 7B141. This is actually a corner reflector. Antenna is 28" wide, 38" high.

flexion problems. The problem is that the gain of vhf antennas used for uhf reception is low. Also they have poor directivity patterns as shown below. Therefore, it is usually necessary to use a uhf antenna for good reception of uhf stations. Now let's look at some typical kinds of uhf antennas.

The simplest uhf antenna is the fan dipole. It consists of two metal triangles. Both dipoles are set in the same plane and the transmission line is attached to each apex.

Gain varies from a low of about 1.3 dB at 500 MHz to 3 dB at 700 MHz to about 3.9 dB at 900 MHz. (This gain specification, as all others in this article, are referenced to a half-wave dipole.) Directivity is like most dipoles, the same in front as in back, with side lobes almost completely missing. Bandwidth is excellent.

This simple dipole can be stacked vertically. When this is done and the dipoles are properly phased, gain is increased to 4.5 dB at 500 MHz, 5.5 dB at 700 MHz and 7.5 dB at 900 MHz. Stack four fan dipoles and get 7 dB at 500 MHz, 8 dB at 700 MHz and 9.5 dB at 900 MHz.

Although rarely seen today, the rhombic antenna can be used successfully for uhf reception. In this application, the rhombic is designed for unidirectional operation and are termi-

◀ **FINNEY MODEL CS-D3** is a fringe area uhf-vhf antenna. The uhf section has 26 elements and is intended for fringe area reception.

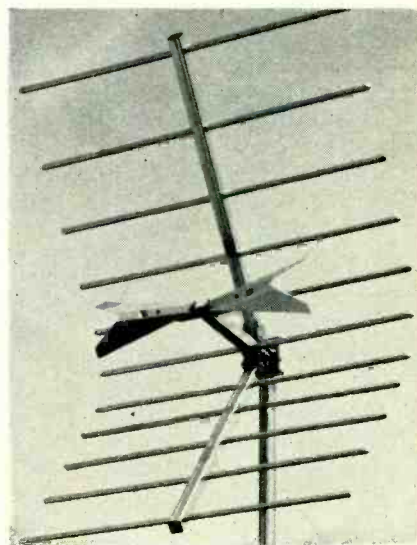

FREQUENCY 600 MC

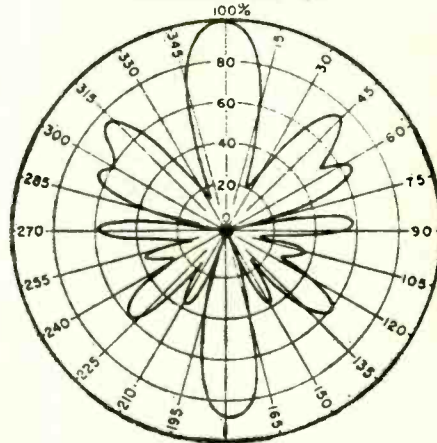

POLAR PATTERNS OF VHF ANTENNA (below) being used at uhf shows that these antennas are not effective and a specially-designed unit is a must. **STACKED-V ANTENNA** produces polar patterns shown at right. (Patterns courtesy RCA).

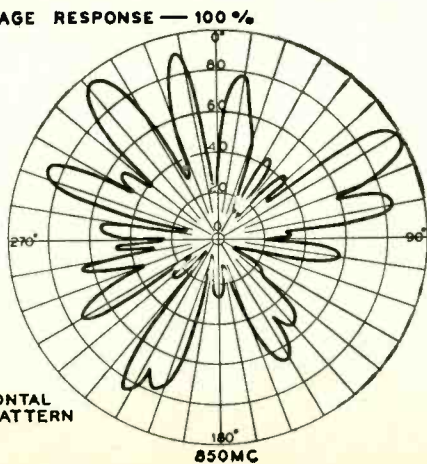
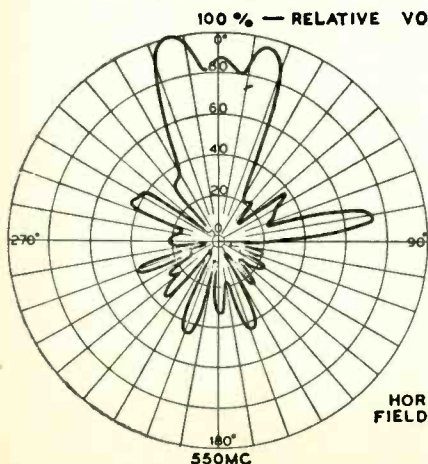

FREQUENCY 900 MC

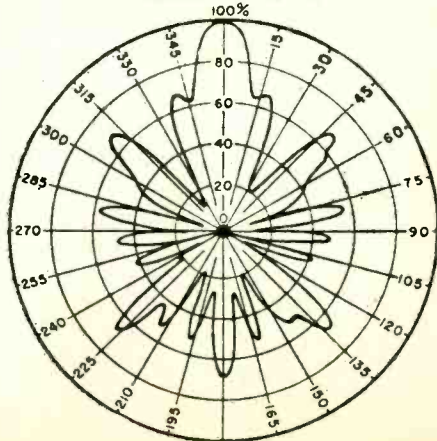

ready for your rooftop

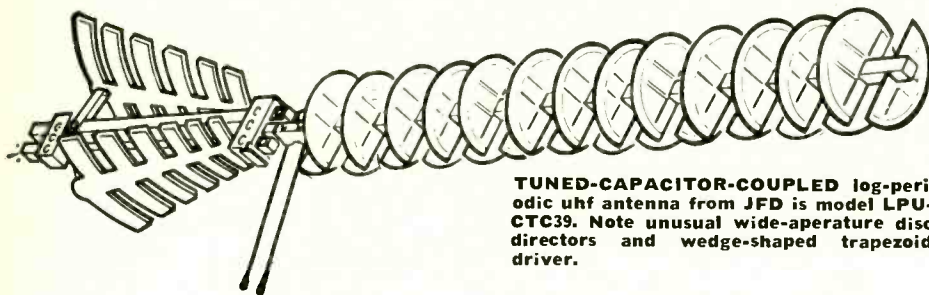

TUNED-CAPACITOR-COUPLED log-periodic uhf antenna from JFD is model LPU-CTC39. Note unusual wide-aperture disc directors and wedge-shaped trapezoid driver.

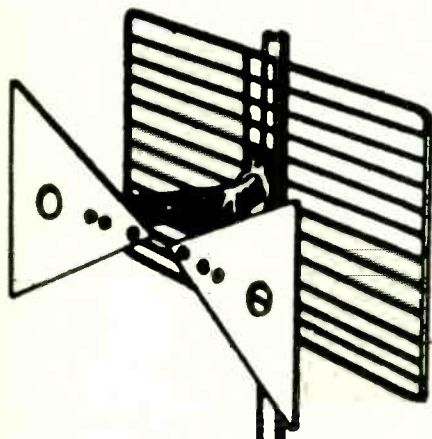

DELUXE UHF BOWTIE has sheet reflector. Suggested for reception up to 30 miles from station. Compact unit mounts almost anywhere. It's GC Electronics' model 32-8965.

nated with a suitable resistor. Gain is high—6 dB at 500 MHz, 9.8 dB at 700 MHz and 11 dB at 900 MHz.

Directivity is also very good. The major forward lobe is quite narrow horizontally, decreasing in width with increasing frequency. While there are some minor side and back lobes. These should not give any trouble except in severe cases of reflections or multi-path reception.

The rhombic is a broad-band antenna that has higher gain toward the high-frequency end of the band, which is very desirable for uhf TV reception.

The stacked-V antenna which is merely two V-type antennas arranged one above the other makes an efficient uhf antenna. Its gain is relatively high and climbs with frequency. Starting with 5.5 dB at 500 MHz, 8 dB at 700 MHz and 10.5 dB at 900 MHz. It is useful in medium and weak signal areas. As its gain increases with frequency it helps overcome both propagation and transmission line losses which increase with frequency.

Directivity patterns of this antenna

STANDARD UHF TRIANGULAR DIPOLE produces the polar patterns you see on the left. Because there is no reflector, front and back patterns are almost identical. IN A CORNER REFLECTOR, ANTENNA SPACING (see below) has a definite effect on the antenna characteristics. (Patterns courtesy RCA.)

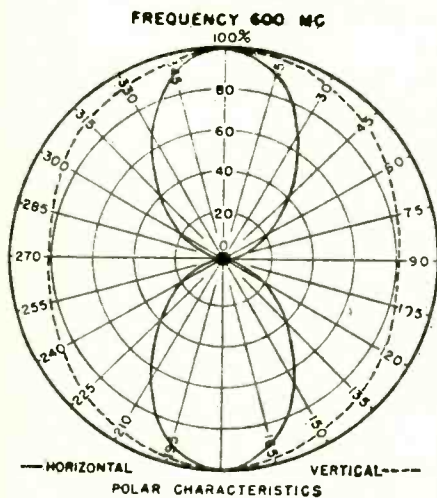

EFFECT OF ANTENNA SPACING

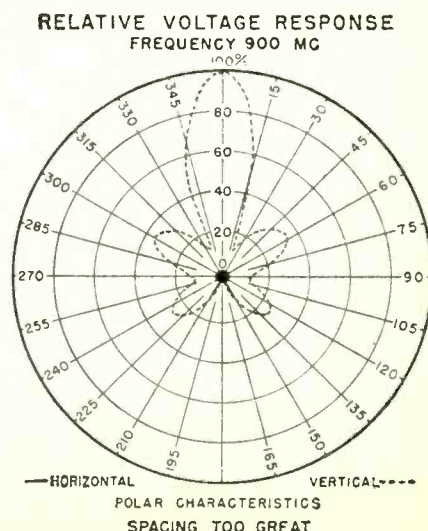
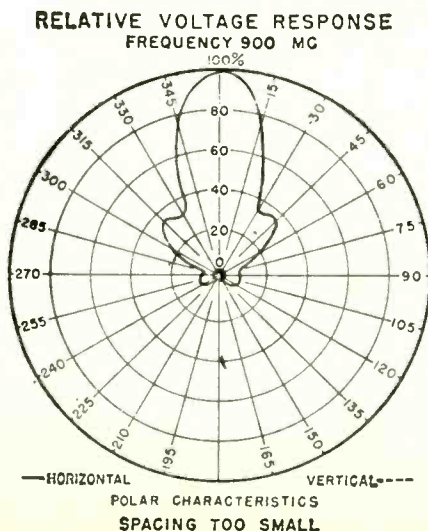
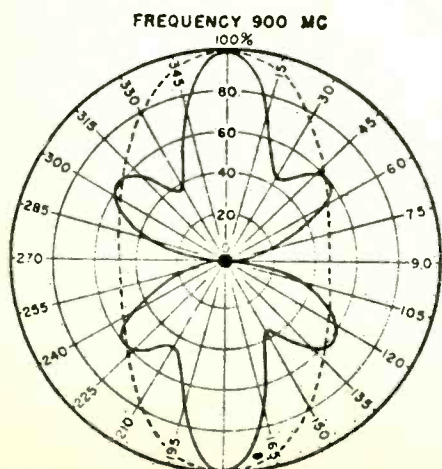

indicate one narrow major lobe, plus multiple secondary lobes. This is adequate in areas that are reasonably free from reflections. Bandwidth is excellent for covering the entire uhf band.

Sheet-reflector antennas consist of one or more dipoles arranged in front of a large metallic sheet. This type of antenna has been used for many years in radar and microwave transmission. These antennas can take many different shapes, but the most common are dipoles in front of a flat sheet, co-linear dipoles at the focus of a parabolic sheet, and fan dipoles in front of a corner reflector.

The ideal sheet reflector is, of course, a solid sheet of metal. However, this is not very practical, and instead, a multiple number of rods or a wire mesh is used to reduce wind resistance, ice loading, and weight. This is fine from an electrical viewpoint, as long as the openings in the metal are only a small fraction of a wavelength.

Since the corner reflector is one of the more compact and efficient sheet reflectors types it is the only one discussed here. The gain of this antenna is excellent—7 dB at 500 MHz, 11 dB at 700 MHz and 13 dB at 900 MHz.

Its directivity is also outstanding. The almost complete absence of unwanted lobes reduces reflection and multi-path troubles to a minimum.

The bandwidth of a corner reflector is normally considered to be relatively narrow. However, the combination of a proper size reflector and carefully designed dipole results in a unit that covers the entire uhf band.

Flat sheet reflectors with fan dipoles are narrow-band units and useful when only a portion of the uhf band must be received. In these instances

FREQUENCY 600 MC

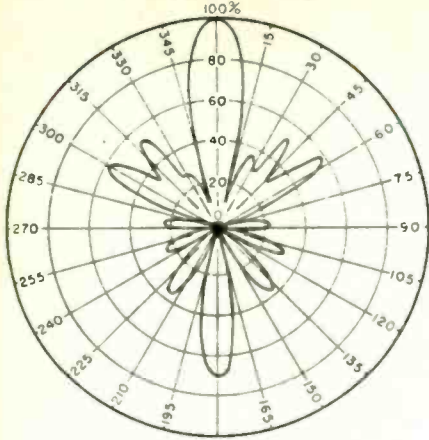

FREQUENCY 900 MC

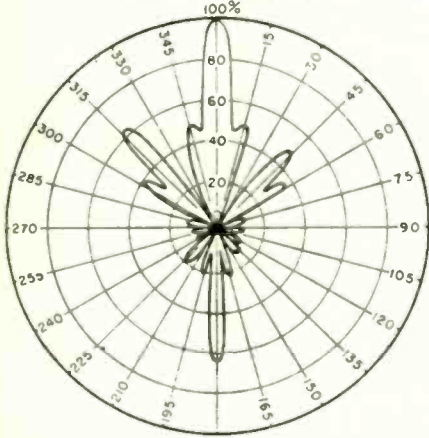

FREQUENCY 630 MC

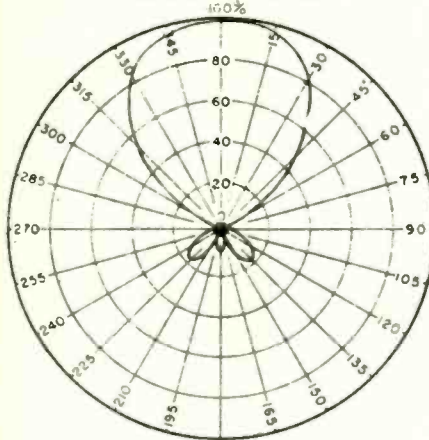

FREQUENCY 900 MC

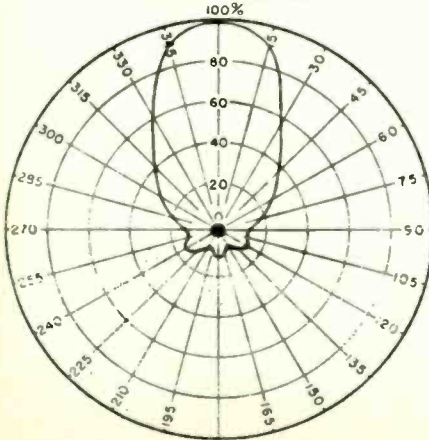

make sure you get the right antenna for the stations you want to receive.

Yagi antennas are a familiar type of high-gain narrow-bandwidth arrays. They are just as useful for uhf reception as they are for vhf. These antennas produce more gain for their size and weight than any other type of antenna. The mechanical construction of a Yagi built for uhf is very critical. A six-element uhf Yagi can deliver 10 dB gain at 540 MHz, yet is so narrow band that gain drops sharply to 3 db at 500 and 580 MHz. If greater gain is needed, stack two or more of these antennas.

Directivity of the Yagi is excellent for eliminating reflections and other unwanted signals.

Transmission lines are an important part of the antenna system. Best antenna performance can be obtained only by selecting and installing the proper antenna lead-in. The chart shows four antenna lead-in types. Because of the greater loss in the flat ribbon type line under adverse weather conditions, types 2, 3, and 4 work best. See the article on page 33 for a more complete description of lead-in problems and selection.

Selecting the uhf antenna that is best for you makes the difference between getting pictures on your TV

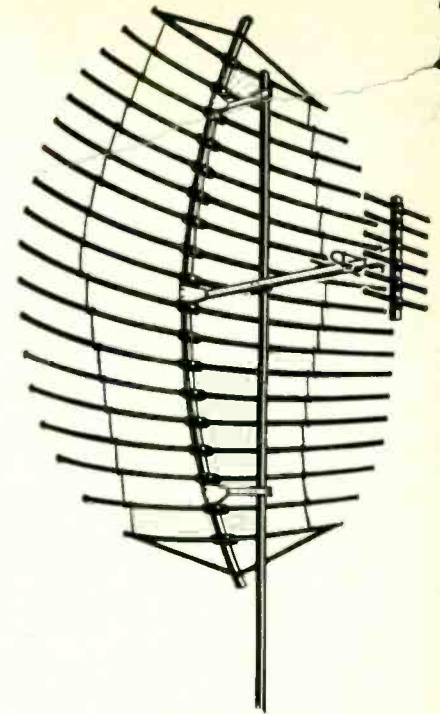

IT'S NOT A RADAR ANTENNA. It is a fringe-area parabolic unit made for uhf reception. This sheet-reflector type antenna is made by Finney.

LOSS—dB/100 FEET

TYPE	100 MHz		500 MHz		1,000 MHz	
	Dry	Wet	Dry	Wet	Dry	Wet
1 Standard 300-ohm flat line	1.2	7.3	3.2	20.0	5.0	30.0
2 Tubular 300-ohm line	1.1	2.5	3.0	6.8	4.6	10.0
3 RG-59/U coax	3.7	—	9.6	—	14.5	—
4 RG-11/U coax	1.9	—	5.2	—	7.8	—

screen and getting sharp, clear, detailed pictures on that same screen. So choose carefully **R-E**

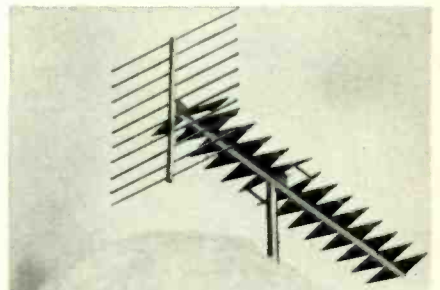
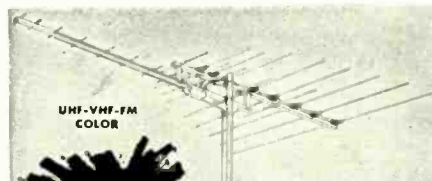

RHOMBIC ANTENNA FOR UHF produces the polar patterns at the top left. **AT BOTTOM LEFT** are polar patterns of corner reflectors for uhf. **BELOW ARE TYPICAL PATTERNS** for a 6-element uhf Yagi. **PHOTO ABOVE LEFT** shows an S&A Electronics combination vhf-uhf antenna. **ABOVE RIGHT** is photo of Channel-Master fringe uhf antenna. (Patterns courtesy RCA.)

YAGI ANTENNA POLAR CHARACTERISTICS

RELATIVE VOLTAGE RESPONSE
FREQUENCY 540 MC

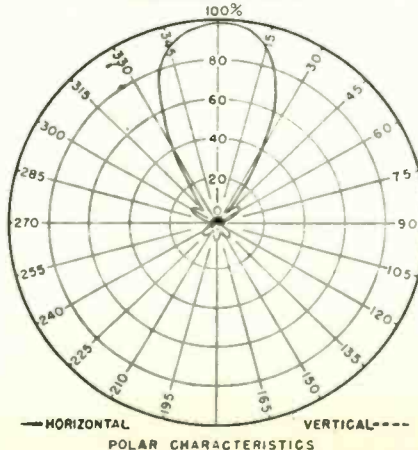

RELATIVE VOLTAGE RESPONSE
FREQUENCY 540 MC

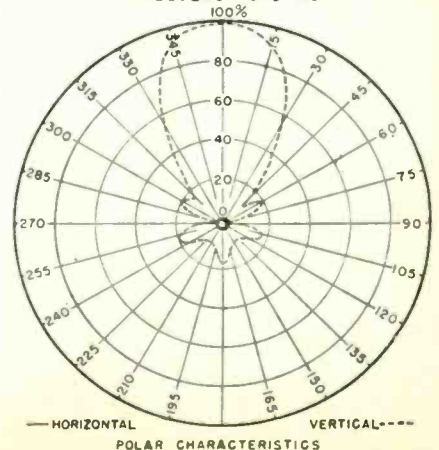

Newest SAMS Books

Hi-Fi Stereo Servicing Guide

by ROBERT G. MIDDLETON. A complete guide to effective hi-fi and stereo servicing. Provides the basis for a full understanding of hi-fi tuner and amplifier circuitry and procedures for servicing this type of equipment. The proper use of audio test and measurement equipment and the basic principles of acoustics are also given. Covers all hi-fi components (except record players and tape recorders). Order 20785, only... \$3.95

ABC's of Avionics

by LEX PARRISH. Provides a basic understanding of avionics—the electronic equipment used to insure the safety of crew and passengers. The type of equipment and the techniques employed in private aircraft operations are featured. Discusses requirements for basic communications, navigation aids, instrument flight aids, weather guidance, and flight control safety devices. Order 20764, only... \$3.50

Mobile-Radio Systems Planning

by LEO G. SANDS. Here is practical, basic information about various types of mobile-radio systems, how they work, their capabilities and limitations, system requirements, licenses, channels, band and frequency selection, transmitter-receiver selection, antenna systems, and accessories. Includes an invaluable system-requirements form for planning a mobile-radio system. Order 20780, only... \$4.50

Transistor-TV Servicing Made Easy

by JACK DARR. This practical guide will help you become skilled in the special techniques of transistor-TV servicing. Covers tools and equipment required; transistors and transistor-servicing techniques; power supplies; horizontal and vertical sweep circuits; video i-f and output circuits; agc and sync-separator problems; tuners; audio circuits; and selecting replacement transistors. Order 20776, only... \$4.95

Security Electronics

by JOHN E. CUNNINGHAM. Explains the operating principles of modern electronic devices and systems used to provide security against crime. Describes intrusion alarms and intrusion-detection devices. Includes chapters on the detection of hidden metal objects, announcement of detected intrusions, bug-ging, debugging, and speech-scrambling systems, and future developments. Order 20767, only... \$4.50

How to Hear, Police, Fire, and Aircraft Radio

by LEN BUCKWALTER. After World War II, police, fire, and aircraft radio moved to the less crowded vhf bands, and the "police band", which was found in many older radios, was silenced. Few listeners had receivers capable of covering the vhf band, because they were relatively expensive. With the advent of solid-state circuitry, a wide variety of relatively low-cost monitoring equipment is available. This book is a guide to the selection and use of vhf radio. Order 20781, only... \$3.50

101 Questions and Answers About Transistor Circuits

by LEO G. SANDS. Answers the most commonly asked questions about transistor circuitry. Explains transistor nomenclature, biasing, the three basic circuit configurations, input and output impedances, current and voltage gain, and other basic considerations. Covers power supplies and circuits; af circuits; rf circuits, and oscillators. Order 20782, only... \$3.50

1-2-3-4 Servicing Automobile Stereo

by FOREST H. BELT. This book first applies the ingenious "1-2-3-4" repair method to both mechanical and electrical equipment. It then proceeds to cover the electronic and mechanical principles of automobile stereo, fm multiplex and tape cartridge systems. Finally, the book shows how to apply the method to auto stereo systems. Order 20737, only... \$3.95

North American Radio-TV Station Guide, 6th Edition

by VANE A. JONES. Lists all radio and TV stations in the U.S., Canada, Mexico, and the West Indies. Includes operating a-m, fm, and television stations, as well as those that are about to start operating, or are temporarily off the air. Separate listings arranged by geographical location, frequency (or channel), and call letters make this guide the most useful one available. Order 20779, only... \$2.95



Aviation Electronics, 2nd Edition

by KEITH W. BOSE. This practical handbook for aircraft owners, pilots, technicians, and engineers explains the design, operation, and maintenance of aviation electronics equipment. Covers automatic direction-finders, distance-measuring equipment, omnirange, ATC transponders and weather radar, communications and instrument-landing systems, and related devices and systems used in aviation today. Order 20743, only... \$9.95

Questions & Answers on Short-Wave Listening

by H. CHARLES WOODRUFF. A helpful guide to the interesting world of listening afforded by short-wave receivers. Questions and answers cover international short-wave broadcasting, frequencies, and services; how short-wave is transmitted; how short-wave is received; and how short-wave receivers are constructed and operated. Order 20783, only... \$3.50

1-2-3-4 Servicing Transistor Color TV

by FOREST H. BELT. The "1-2-3-4 Method" is a simple, logical, step-by-step process that helps do the service job the right way and the easy way. In this book, the fundamentals of transistor color TV are covered, followed by a detailed explanation of how to apply the method for quick troubleshooting and easy repairs. Order 20777, only... \$4.95

HOWARD W. SAMS & CO., INC.

Order from your Electronic Parts Distributor, or mail to Howard W. Sams & Co., Inc., Dept. RE-090
4300 W. 62nd St., Indianapolis, Ind. 46268

Send books checked at right. \$_____ enclosed

Send FREE 1970 Sams Book Catalog

Name _____

PLEASE PRINT

Address _____

City _____

State _____

Zip _____

- | | |
|--------------------------------|--------------------------------|
| <input type="checkbox"/> 20785 | <input type="checkbox"/> 20777 |
| <input type="checkbox"/> 20764 | <input type="checkbox"/> 20767 |
| <input type="checkbox"/> 20780 | <input type="checkbox"/> 20781 |
| <input type="checkbox"/> 20776 | <input type="checkbox"/> 20782 |
| <input type="checkbox"/> 20743 | <input type="checkbox"/> 20737 |
| <input type="checkbox"/> 20783 | <input type="checkbox"/> 20779 |

Circle 22 on reader service card

IN THE SHOP

(continued from page 26)

always go down to a lower impedance. You should never go up, and never operate the unit without a speaker load connected across the output transformer secondary. In fact, this one doesn't care if the secondary is shorted. This is the reason they used those "shorting speaker jacks" on transistor car radios. When the speaker plug was pulled, the jack auto-

COMPLEMENTARY - SYMMETRY

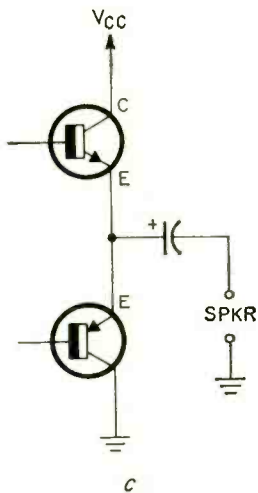

matically shorted the output secondary.

In the far more common class-AB/B, capacitor-coupled circuit of Fig. 8, each transistor amplifies half the signal cycle. Half the supply voltage will

appear across the output load (the speaker voice coil through the coupling capacitor). This voltage will stay about the same, no matter what the load impedance is—as long as it isn't zero ohms.

But! The peak current through the conducting transistor won't stay the same. Let's suppose that we have an amplifier designed for a 30-watt output into an 8-ohm load. We would have a certain value of current at full rated output. Now, if we change the load to a 4-ohm speaker, what happens to this current? Since the voltage stays about the same, the current will double! So will the power output.

Let's plug in some figures. Let $I = 2$ amps and Z (speaker impedance) = 8 ohms. By I^2R , we get $2^2 \times 8 = 32$ watts. (This is a very good conservatively rated amplifier!) Now, let's halve Z to 4 ohms and see what happens. Current (I) will double, and we get $4^2 = 16 \times 4 = 64$ watts. Now our poor little 30-watt amplifier is trying to keep up with a load of 64 watts. And it'll do it, too, right up to the second the output transistors melt. (I believe this generally takes about 200 msecst!)

We can see this type of output stage has characteristics that are exactly opposite to those of the transformer-coupled class A. With these, the higher the load resistance, the better off you are. Power output will decline with increasing resistance, of course. These can tolerate an open circuit with equanimity, but will not tolerate a short. **R-E**

Service Clinic

by **JACK DARR**
SERVICE EDITOR

This column is for your service problems—TV, radio, audio or general and industrial electronics. We answer all questions individually by mail, free of charge, and the more interesting ones will be printed here.

If you're really stuck, write us. We'll do our best to help you. Don't forget to enclose a stamped, self-addressed envelope. Write: Service Editor, Radio-Electronics, 200 Park Ave. South, New York 10003.

High-Frequency Oscillation, Vertical White Bar On Screen

After this Delmonico 8PV-47U portable has been on for about 10 minutes, a high-frequency oscillation starts and a 1-inch vertical white bar shows up in the middle of the screen. Scope waveforms give no indication as to where this is.—D. S., San Antonio, Tex.

This should be some sort of "transition defect." Something that affects the drive waveform or the point

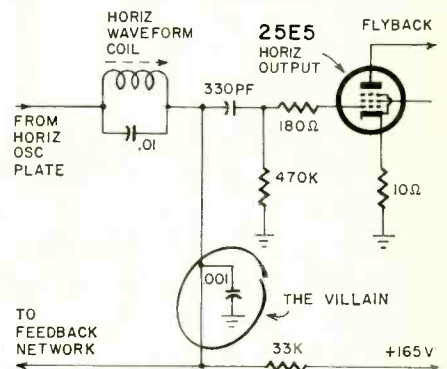

where the damper tube takes over the sweep from the horizontal output tube; something like the "drive lines" we used to see in older sets.

Check the 330-pF coupling capacitor or the saw-forming network components. [the reader found the 0.001 μ F bad.]

Thermal Runaway In Transistor TV

A Crown CTV-12 transistor TV has been used on dry batteries for about 8 months. Then, when the customer used it on ac, it played for 2 hours before the vertical sweep collapsed. The 2SB178 and 2SD178 transistors and a couple of resistors blew out.

(continued on page 78)

Make the wiggly test.

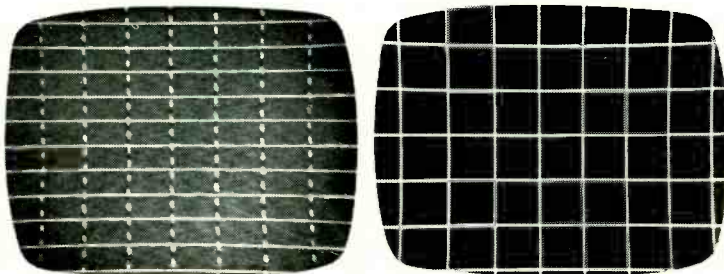

On the left, a pattern* produced by an ordinary color bar generator. On the right, the equivalent pattern* produced by Leader's LCG-388. Perfectly stable, the instant you turn the power on.

Flip the switch, and you can select from 15 patterns. Including the single dot, single cross, single horizontal and single vertical.

The magic is in Leader's binary counters and gates. Nobody else has them, and what a difference they make.

\$149.00, and you can make the wiggly test at your distributor's. For the one nearest you, just drop a line or call.

*As photographed.

Seeing is believing.

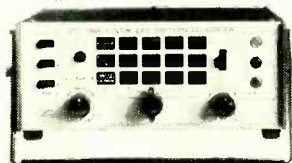

LEADER INSTRUMENTS CORP.

37-27 27th Street, Long Island City, N. Y. 11101/(212) 729-7411

Circle 20 on reader service card

Untie your money

With "QT." The Quick Turnover Inventory System from RCA.

How much money do you have tied up in old, unsold replacement parts? If you have more than your share of them, then it could be plenty.

RCA can change all that with a new Quick Turnover Inventory System—"QT" for short. It represents years of studying inventory control.

Now you can have an inventory of the fastest moving RCA parts, selected by RCA's computers. You'll have the parts you need when you need them. You'll know when the supply is running low. And, if any parts are dropped from the "top-mover" list, simply return them through your "QT" distributor.

Talk to your RCA Parts Distributor about putting in a "QT" Inventory System. The sooner you untie your money the sooner you'll be counting it.

RCA Parts and Accessories

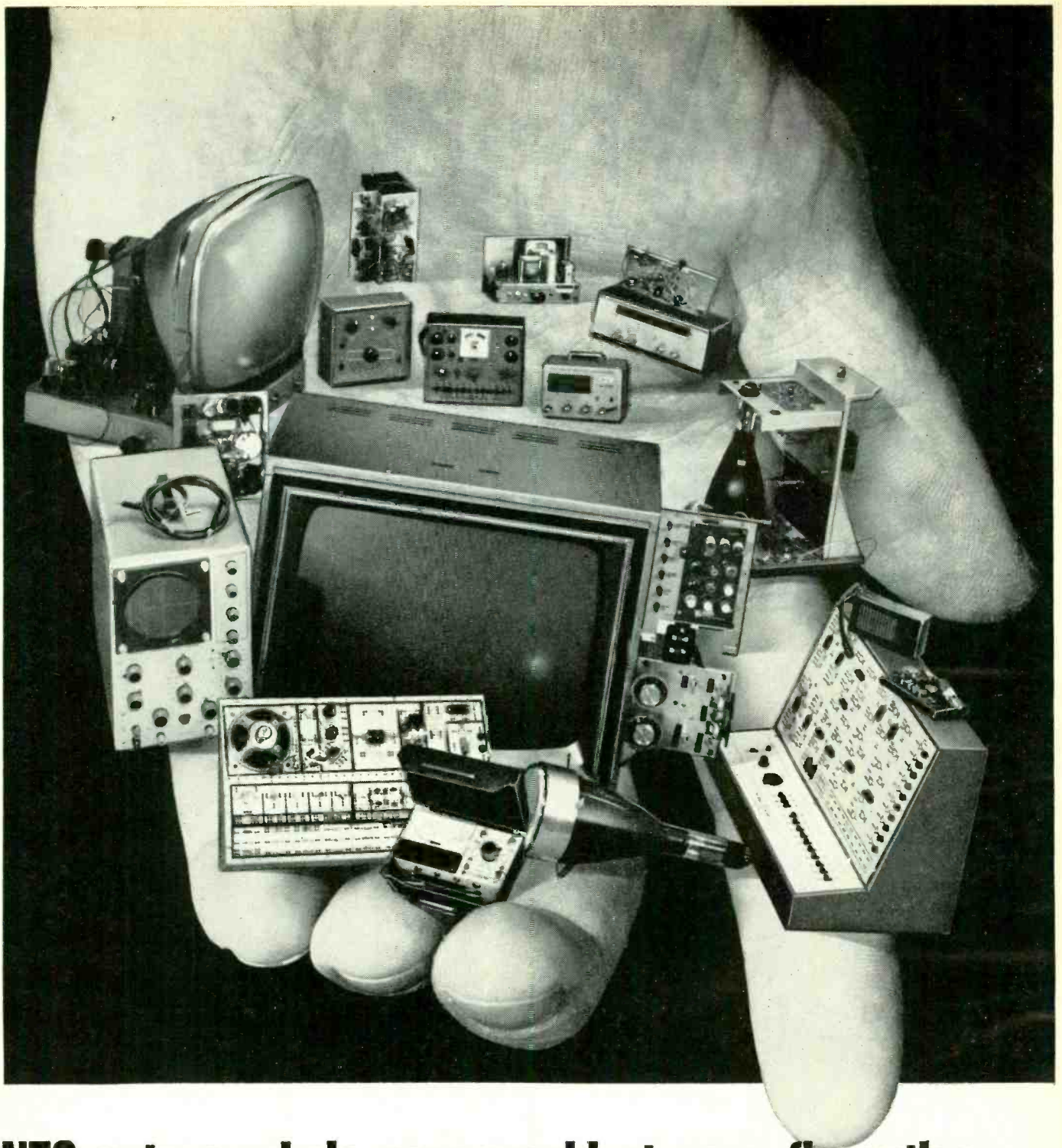

NTS puts a whole new world at your fingertips.

NTS home training can put a whole new way of life in the palm of your hand. A new, exciting job, a much bigger income is now easily within your reach.

NTS training is something special. We provide all the kits you need for the most effective training. National Technical Schools sends kits with every course, and teaches you to build and test a

wide range of professional equipment — the same kind of equipment you'll actually use on the job. That's the NTS "Project Method" — training that's practical and in-depth. You learn everything from fundamentals to the latest innovations. From beginning to end, NTS makes it fascinating and fun to learn this way. And all you need is a little

spare time and an interest in electronics.

Each year, men are moving into important new jobs, or their own businesses, straight out of NTS electronics training. NTS is what's happening to men everywhere. Check the coupon. Take hold of the career you want most. Do it now. No obligation. No salesman will call.

We pack your electronics course with kits to make your training fast. You'll enjoy every minute of it.

NTS COLOR TV SERVICING

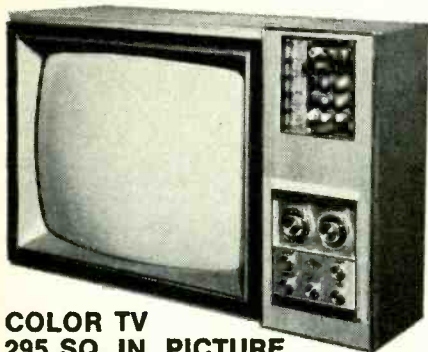

COLOR TV
295 SQ. IN. PICTURE

NTS training provides an easy way to become a professional home-entertainment service technician. You receive a big screen Color TV with many unique features. The unit even includes self servicing equipment that permits you to make all normal test operations. No additional test equipment is needed for adjusting your set. In addition you get an AM-SW radio, Solid-State radio, Field-Effect Transistor Volt-Ohmmeter, and Electronic Tube Tester. You learn about Electronic principles and trouble shooting, hi-fi, multiplex systems, stereo, and color TV servicing.

NTS COMPUTER ELECTRONICS

This is the future. And it's happening now. The number of computers will increase many times in the next few years.

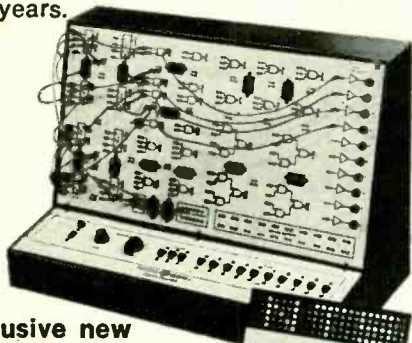

Exclusive new Compu-Trainer®

If card is missing check coupon and mail for free color catalog and sample lesson. Now.

National Technical Schools

4000 S. Figueroa St., Los Angeles, Calif. 90037
Please rush Free Color Catalog and Sample Lesson, plus information on course checked below. No obligation. No salesman will call.



NTS offers a solid grounding in computer operation, wiring, data processing and programming. One of the 10 important kits included is our exclusive Compu-Trainer®. It's a fully operational computer logic trainer — loaded with integrated circuits — the first ever offered in home study. It introduces you quickly to how, what, when and why of computers . . . from theory to practical servicing techniques. This unit is capable of performing 50,000 operations per second.

NTS ELECTRONICS COMMUNICATIONS

Choose from two exciting courses to get into the big-paying fields of transmitting and receiving equipment: (1) The FCC License Course. (2) The Master Course in Electronic Communications (more comprehensive, with Citizens' Band Two-Way-Radio). Either Communications program qualifies you for your FCC First Class Commercial Radio-Telephone License — *NTS assures you will pass this FCC exam within six months after successfully completing your course or your tuition is refunded.* Kits include an Amateur-Phone 6 Meter VHF Transceiver — NTS exclusive, 6 transistor Solid-State Radio, Volt-Ohmmeter (fully transistorized).



5 Watt AM Transmitter/Receiver

NTS AUTOMATION/ INDUSTRIAL ELECTRONICS

Let NTS put you into the age of electronic controls. Systems Automation is rapidly becoming the emphasis of modern industry. Your NTS training in automation electronics includes equipment like a 5" wide band Oscilloscope. You also get the new NTS Electronics Lab. It's an exclusive NTS experimental laboratory — a complete workshop that simplifies learning about solid-state, miniature and integrated circuits.

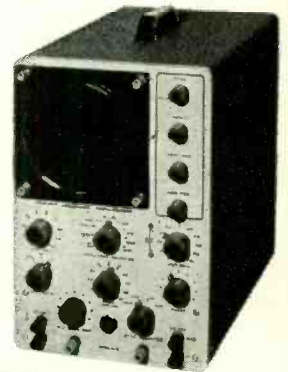

5" Oscilloscope

CLASSROOM TRAINING AT LOS ANGELES

You can take classroom training at Los Angeles in sunny Southern California. NTS occupies a city block with over a million dollars in facilities devoted exclusively to technical training. Check box in coupon.

NATIONAL TECHNICAL SCHOOLS

WORLD-WIDE TRAINING SINCE 1905

4000 South Figueroa Street
Los Angeles, Calif. 90037, U.S.A.

APPROVED FOR VETERANS

Accredited Member: National Association of Trade and Technical Schools; National Home Study Council.

- Master Course in Color TV Servicing
- Color TV Servicing
- Master Course in TV & Radio Servicing
- Practical TV & Radio Servicing
- Master Course in Electronic Comm.
- FCC License Course
- Master Course in Electronics Tech.
- Industrial and Automation Electronics
- Computer Electronics
- Basic Electronics

Name _____ Age _____

Address _____

City _____ State _____ Zip _____

- Check if interested in Veteran Training under new G.I. Bill
- Check if interested only in Classroom Training at Los Angeles

206-090

SERVICE CLINIC (cont'd. from pg. 72)

I've replaced these and checked everything I can think of. Played for about 3 hours then collapsed again. The 2SD178 went out this time. After replacing this, it plays, but the transistors heat up and their collector voltages start up after a while!

Can't figure this out. What's causing them to blow on ac?—J. B., Washington, D.C.

From the symptoms it sounds like a thermal runaway. You have probably got some trouble in the voltage regulator circuitry which is letting these transistors get too much dc voltage. Check this by running the ac line voltage up and down from about 105 to 120 volts. The dc voltage from the voltage regulator should hold at almost exactly 12 volts. If it won't, check the regulator transistors.

We have had quite a bit of trouble with these transistors in other applications: stereos, etc. Try using an RCA SK-3010 for the 2SD178 and an SK-3004 for the 2SB178. Be very sure the heat-sinks are tight and well insulated. Use silicone grease between heat-sinks and transistor cases.

Hot diode in GE TC chassis

The series diode in a GE TC chassis keeps getting hot and going

out. I've checked everything in the boost circuit, but no shorts. The 12-volt regulated supply OK, regulator works, and so on, but this diode wants to blow. No light on screen. I'm lost!—S. G., Syracuse, N.Y.

This "series diode" in the TC chassis is actually used as a voltage doubler, with that big 200- μ F elec-

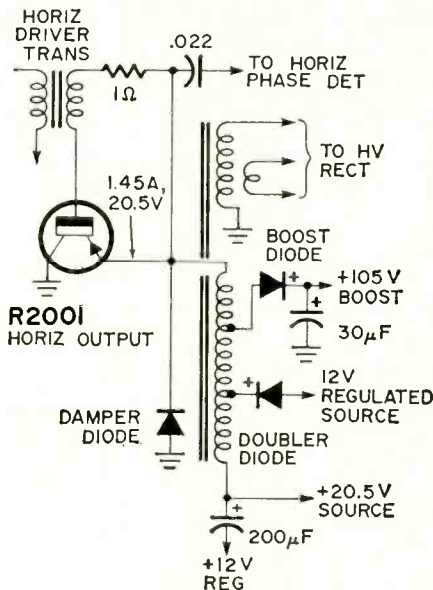

trolytic. You come out with about 20.5 volts for the horizontal output transistor emitter supply. All of the horizontal output current flows

through this diode.

Since the horizontal output transistor is the main load on this circuit, its collector current should be checked. If the thing is leaky, this will raise the current through the doubler diode, and blow it in time. This is given in some schematics as 1,450 mA (1.45 amps.) but in the ones I have worked on, it reads considerably less, with a full sweep, good high voltage, etc.

Be sure to use at least a 1-amp diode for this doubler. By the way, if you must replace the R2001 horizontal output transistor, you won't find it listed. The GE number is ET15X26, and an RCA SK-3035 will replace it nicely.

Also, check the width of the drive pulse signal on the base of this transistor. It should be 180 volts p-p, and very narrow. If the ON pulse is too wide, the transistor will conduct for too long and overheat. **R-E**

COMING NEXT MONTH

- Are you getting the best sound possible from your hi-fi gear? In R-E's special October hi-fi issue, Peter Sutheim tells you how to get the most from your system.
- Time to switch to 4-channel sound? Find out the latest on the new "surround sound" next month.

Your caddy is the only caddy our tubes fit.

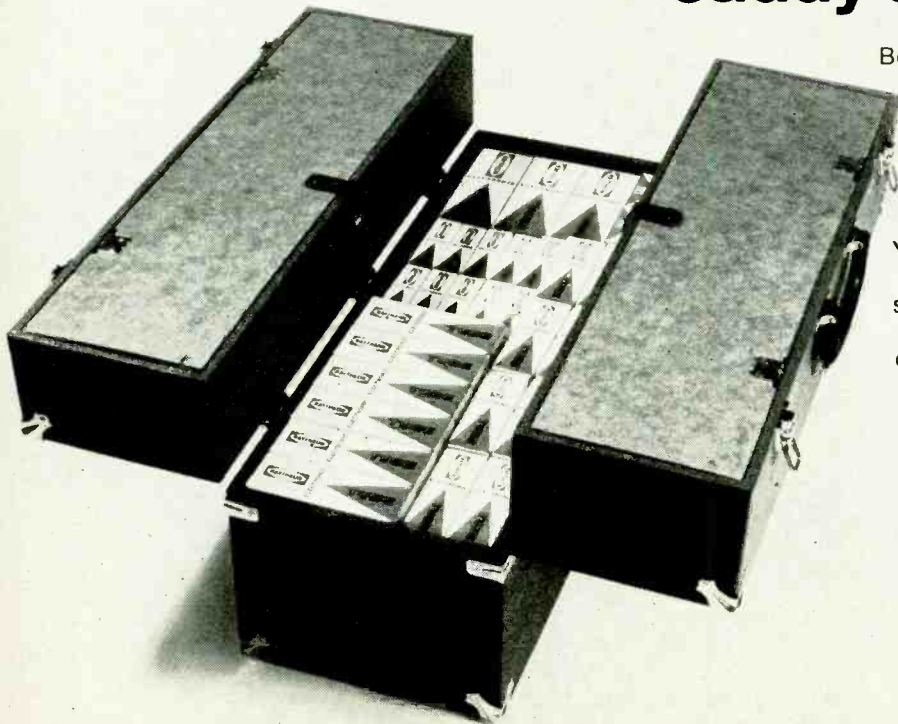

Because we market our tubes only through you—the independent serviceman.

We don't have service trucks or retail outlets. Our tube caddies are available only to you.

You see, we're independent too—the largest independent tube supplier in the business. We have to cooperate with you—not compete. Because we depend on you just as you depend on us.





79

Stereo You Can Feel

It begins even before you've heard a note from the new Sony TA-1144 Stereo Amplifier and ST-5100 FM Stereo/FM-AM Tuner. Pleasure.

The switches flick firmly. The pushbuttons push back just enough before locking in smartly. Continuous controls (like tuning, volume, balance), feel almost viscous-damped. Your fingers are guided to function swiftly, effortlessly. You've experienced a feeling of quality that is a hint to the performance you'll enjoy once you turn on these Sony components.

Take the ST-5100. The combination of two tuning meters, a 2.6uV IHF sensitivity, and 1.5dB capture ratio zero in on your first station. FM stereo you can feel.

Now the TA-1144 Stereo Amplifier. More stereo you can feel. Rich (the TA-1144 puts out 50 watts IHF per channel into 8 ohms, both channels operating). Clean (less than 0.03% IM, 0.05% harmonic, at 1 watt). And just the way you like it (thanks to those subtly-detented bass and treble sliders on each channel).

So now you're wondering, of course, about the prices. Jus; \$219.50* each; \$439* the pair. You'll hardly feel that at all.

Sony Corporation of America, 47-47 Van Dam St., Long Island City, N.Y. 11101.

*Suggested List



**NEW SONY®
AMPLIFIER AND TUNER**

NEW PRODUCTS

More information on new products is available from the manufacturers of items identified by a Reader Service number. Use the Reader Service Card on page 103 and circle the numbers of the new products on which you would like further information. Detach and mail the postage-paid card.

PLASTIC DRY TRANSFER, JotDraft, improves printed circuit drafting methods. Patterns are printed on transparent polyethylene strips for precise positioning. Plastic overcoat insures no distortion or

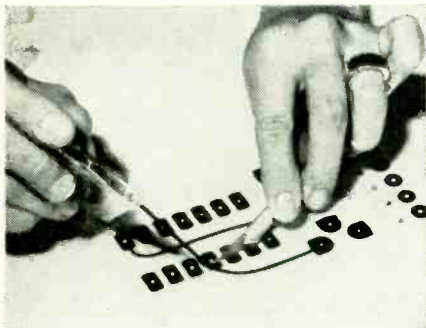

abrasions. Transfers with the use of ballpoint pen or burnisher. Incorporated in a line of 128 printed circuit pad arrays and component outlines.—**Datak Corp.**, 85 Highland Ave., Passaic, N.J. 07005

Circle 31 on reader service card

PULSE GENERATOR ADAPTER, Model APG-100, Converts sine/square wave generator to high speed generator. By attaching the output of wave generator to the input of the pulse generator adapter, achieve fast rise and fall times,

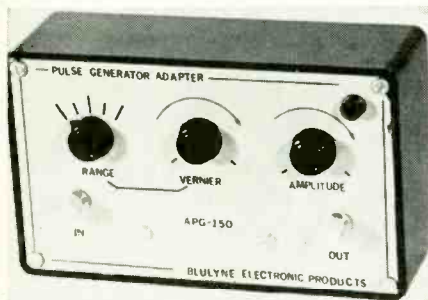

variable pulse width, aptitude, and frequency. Calibrates scope at high freq. (50 Mhz rise time), controls chopper circuits, frequency range 1 Hz to 10 MHz. \$39.95.—**Blulyne Electronic Corp.** 3 Sand Springs Rd., Williamstown, Mass. 01267

Circle 32 on reader service card

WIRELESS SPEAKER ADAPTER Model 65, when hooked up to speaker from stereo, TV, tape recorder, etc. will broadcast sound to any radio within 100 feet. Automatic volume control prevents distortion and eliminates need for adjustment on equipment, adapter is attached to, for monitoring CB, amateur radio, PA systems, etc. that have varying

audio volumes. Enables listening to TV programs through radio, eliminates turning volume up to leave the room. Needs just the two wires that clip to the equip-

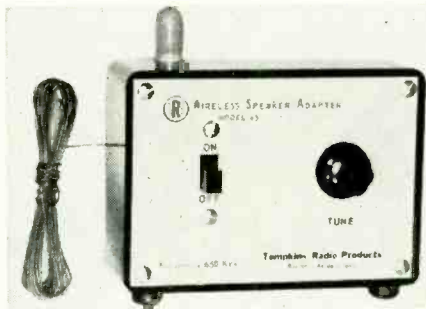

ment speaker, terminals or earphone jack. Output tunes from 640 to 660 kHz. Complete with 9-volt transistor battery. \$19.95.—**Herbert Salch and Co.** Woodsboro, Texas 78393

Circle 33 on reader service card



NO-ARC INSULATING SPRAY, in 8 oz. aerosol can. Leaves a tough, thick smooth, protective red coating that can withstand 30,000 volts. Recommended for "potting" components, waterproofing, and insulating circuit boards and exposed wiring. Stops arcing and corona shorts. \$2.79 per can—**Chemtronics Inc.** 1260 Ralph Ave., Bklyn., N.Y. 11236

Circle 34 on reader service card

STEREO AMPLIFIER, Citation 12. Assembled on single, heavy-duty etched circuit board that plugs into special non-corrosive type connectors mounted on the chassis. Two separate power supplies, one for each channel. Frequency



response: from below 1 Hz to above 100,000 Hz at normal listening level. Power bandwidth; flat from 5 Hz to 35 kHz. Power output 120W-60 per channel. Distortion at all frequencies from 20-20,000 Hz, at full rated power, unmeasurable. Factory-wired, \$295.00. Kit, \$225.00. **Harmon-Kardon, Inc.**, 55 Ames Ct., Plainview, N. Y. 11803

Circle 35 on reader service card

FM-VHF MONITOR, Model COP-50HL. Has 6 high band frequencies (150 MHz to 175 MHz) 6 low (25 MHz to 50 MHz). 117 Vac and 12 Vdc



operation. Rf peaking control, noise immunity circuit, tone control switch. Measures 8" x 7 1/2" x 2 1/2". \$139.95.—**Courier Communications**, 100 Hoffman Place, Hillside, N.J. 07205

Circle 36 on reader service card

STEREO HEADPHONE SET, Model 10R200. High sensitivity, delivers over 100 dB of sound with 10mW input. Frequency response from below 50 to be-



yond 16,000 Hz. 6 1/2-foot cable, foam ear pads, standard stereo plug. \$19.95. **RCA Parts and Accessories**, 2000 Clements Bridge Road, Deptford, N.J. 08096

Circle 37 on reader service card

ALL-CHANNEL TV ANTENNA, Model VU-937. 300-ohm, narrow-

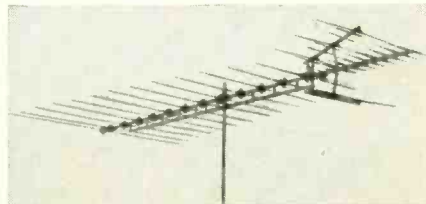

beamwidth unit focuses on main signal lobe only. Boom length-196", turning radius-116", weighs 17 lbs. 13 driven

don't miss this opportunity

If You Have What It Takes to Qualify for Training in Electronics We'll Not Only Train You...

We'll Help You Finance Training and Help Place You In the Job You Want!

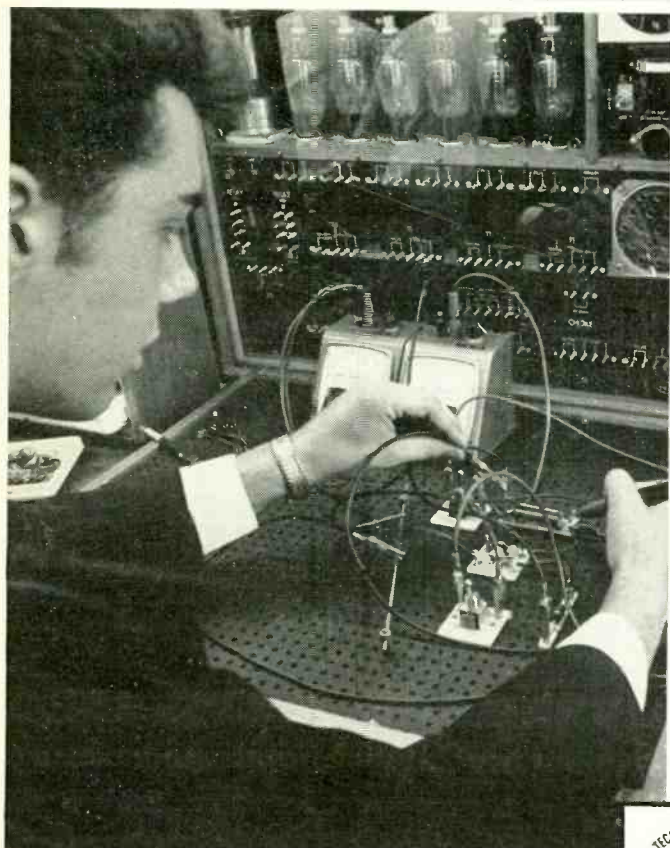
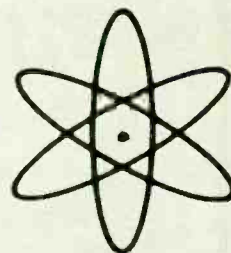

Just a few short years ago, who could have imagined electronic marvels like the micro-miniaturized printed circuit, no larger than the head of a pin . . . battery-powered heartbeat regulators . . . computers that make split-second calculations it would take the human brain years to duplicate! This is the amazing world of technology.

The demand for trained Electronics Specialists and Draftsmen is increasing every year! These are well-paid, prestige positions with practically unlimited opportunities for advancement. In 12 months or less, United Technical Institute can prepare you to take your place in this dynamic, expanding field. You can study right at home, in your spare time and at your own pace — or attend a UTI resident school near you.

Because UTI is an eligible institution under the Federally Insured Student Loan Program, you may attend the Institute on a government-guaranteed educational loan. And after you finish your training, we can help you find your first position!

Accredited Member of National Association of Trade and Technical Schools. Approved for Veteran Training.

Get the facts now! Just clip the coupon and send today for a **FREE**, fact-filled book describing the exciting opportunities in electronics, and how you can qualify for them. We'll rush your book by return mail so you can read it and decide for yourself. No obligation, of course. But don't delay — clip the coupon for your free book today! →



United Technical Institute

division of Career Academy

125 W. Wells St. Milwaukee, Wis. 53203 Dept. 07N215204

Please rush me your free 28 page booklet
with all the details on your Electronics course

Name _____ Age _____
(Please print)

Address _____

City _____ State _____ Zip _____

Phone _____

I am interested in: Classroom Study Home Study Facts on GI Bill

Circle 61 on reader service card

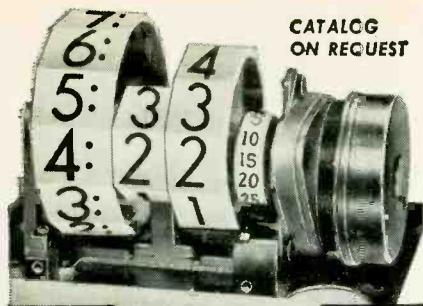

CATALOGG
ON REQUEST



CLOCK MOVEMENTS

DIGITS RESETTABLE INDIVIDUALLY

Available in 50, 60 cy., all voltages, AC. UL approved motor, cord. One Year Guarantee.

#130...12-HOUR #131...24-HOUR

#75
Tymeter
Elapsed
Time
Digital
Computer



Made in U.S.A.

Complete Line: Delay, Interval
and Cycle Timers, Digital Computers

PENNWOOD NUMECHRON CO.
TYMETER ELECTRONICS

7249 FRANKSTOWN AVE., PITTSBURGH, PA. 15208

Circle 62 on reader service card

The sure way to ELIMINATE CALLBACKS



Only Injecto-All's new **BLUE LUBE** foam spray contains Oxidant — an anti-oxidation chemical that cleans contacts, keeps them permanently clean and prevents callbacks. Eliminates picture streaking and intermittents with one application.



INJECTORALL
ELECTRONICS CORPORATION

Great Neck, N.Y. 11024

In Canada:
CANADIAN GENERAL ELECTRIC LTD.
Ontario

Circle 63 on reader service card

vhf elements, uhf/vhf signal separator included.—Jerrold Electronics, 401 Walnut St. Phila. Penn. 19105.

Circle 38 on reader service card

PROFESSIONAL TOOL ASSORTMENTS offer popular sizes of fixed handle screwdrivers and color-coded nutdrivers in 5, 6, and 7 piece assortments. Include round and square blade

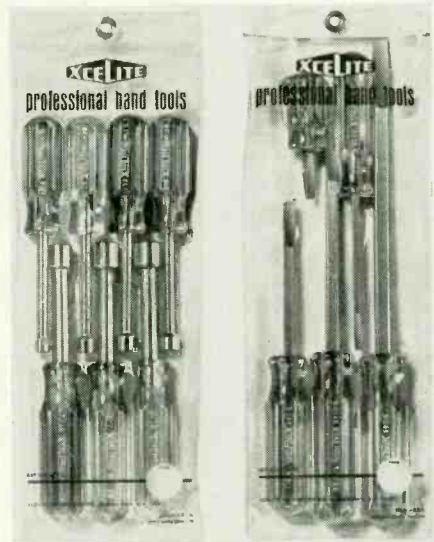

screwdrivers for slotted screws, Phillips type screwdrivers, hollow shaft nutdrivers, and nutdrivers with 1 1/4" clearance hole depth. In plastic cases to save space and keep tools in order. Xcelite Inc., Orchard Park, N. Y. 14127.

Circle 39 on reader service card

STEREO HEADPHONES, model PH-173, soft, vinyl-covered, air-filled cushions seal tightly around ears. Lightweight and fully adjustable. Includes 20'



of cable with 3/4" 3-circuit phone plug attached. Response: 15 to 25,000 Hz. Impedance: 4 to 16 ohms. \$24.98. Olson Electronics, Inc., Akron, Ohio.

Circle 40 on reader service card

COMPONENT CHANGER, Model CA442, Four-speed accessory changer designed to use with the G-E T2010 radio and other component systems. Is jam resistant with flipover stylus with diamond and synthetic sapphire tip, and automatic shut-off with repeat play option and 45-rpm spindle adapter. Com-



plete with dust cover. \$59.95.—General Electric, Audio Products Dept. Decatur, Ill.

Circle 41 on reader service card

DIGITAL TEST PROBE permits hand-free testing of DTL, TTL, and other logic systems. Indicator lights visible from both sides; green light indicates 0 level from 0-0.6 V, red light at

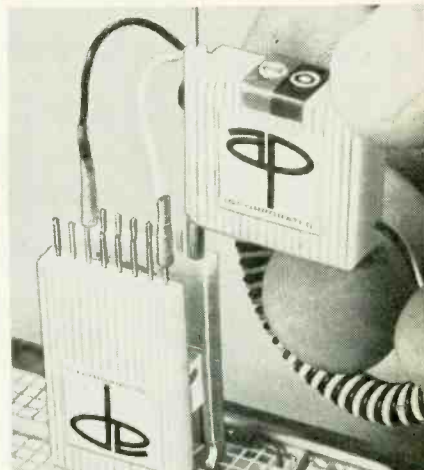

1 level at 2.4 V. Guaranteed dead band 1.0-2.0 V. Indicates pulses of 30 ms, rates of 30 pps. Max current 60 mA at 5 V Vcc. No batteries needed. \$35—AP Inc. Painesville, Ohio

Circle 42 on reader service card

HIGH VOLTAGE PROBE, HVP-5 has built-in voltmeter. Measures up to 30kV. Barrier sections isolate the high-voltage tip from the handle and meter sections. \$19.95—EICO Electronic Instruments Co. 283 Malta St., Bklyn, N. Y. 11207



Circle 43 on reader service card

ELECTRONIC BONGO KIT Model KG-391 plays through your amplifier. Use like real bongo drums. High and low bongo heads have sustain and vol-



THE GREAT ANTENNA DEBATE



The current heated debate over the greatness of our Color Crossfire versus our Color Vector was not our intent when we engineered them. We merely wanted to see that you have more than one way to provide outstanding color and black and white reception.

That's why we didn't stop with the Color Crossfire...the antenna that pushed the fringe farther back than anyone ever thought possible. We went ahead with the Color Vector for extra-

ordinary performance from a compact. And we build them both so you're not going to be called for repairs after every windstorm or smog inversion.

But since both sides stand firm for the finest color and black and white TV reception there is, and the debate rages on, may we say:

Gentlemen, please don't fight! There are still plenty of roofs left in this country for two great antennas...

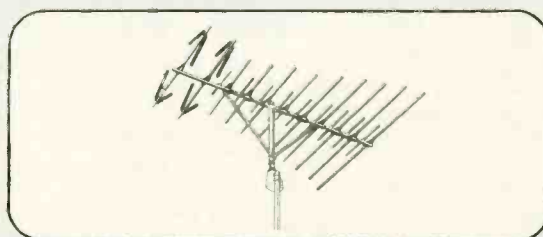
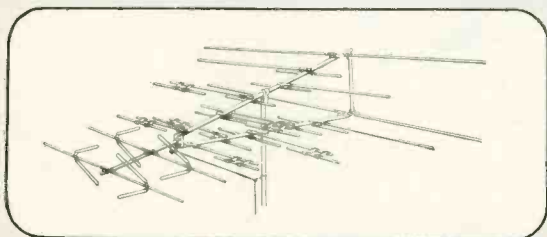

The **COLOR VECTOR** or the **COLOR CROSSFIRE** from

CHANNEL MASTER

DIVISION OF AVNET, INC. ELLENVILLE, N.Y. 12428

ume controls, plus on-off switch. 9 V battery. Includes wood base and instructions. Allied Radio Corp. 100 N. West-ern Ave., Chicago, Ill.

Circle 44 on reader service card

UNIDIRECTIONAL MICROPHONE
Model 588, "ball-type", has cardioid pickup pattern, built-in wind filter, locking on-off switch, 20 ft detachable cable and swivel adapter. Cartridge is shock-



mounted. Frequency response; 80-13,000 Hz. Available in high & low impedance versions. \$60.—Shure Bros. 222 Hartrey Ave., Evanston, Ill.

Circle 45 on reader service card

"SPECTRE" R/C RACE CAR KIT
Model GD-101. 1/8" scale body is 19 3/4" long. White plastic. Reaches 200 mph. Engine mount uses .15 to .23 Cu. in. R/C engine. Gear train has 5.5:1 ratio. Includes body, chassis, wheels, tires, 4-oz. fuel tank, tubing, clutch, gears, axles,

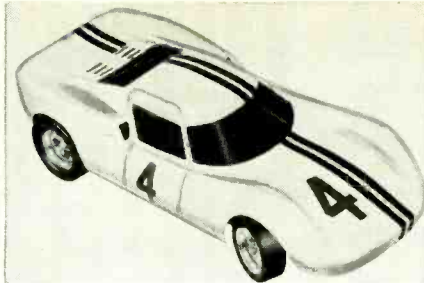

all hardware. \$49.95.—Heath Co. Benton Harbor, Mich.

Circle 46 on reader service card

REPLACEMENT CARTRIDGES,
BSR McDonald, Full line of single-boxed cartridges with sapphire or dia-

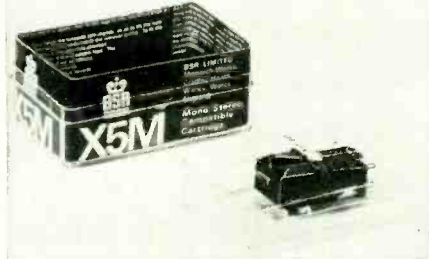

mond/sapphire stylii. Line includes 12 different cartridges, covering crystal or ceramic requirements—BSR (USA) Ltd. Route 303, Blauvelt, New York.

Circle 47 on reader service card

DIGITAL DESIGN PROGRAM, DDP-1.
Course in semiconductor theory and logic circuits includes lesson notebook, 14 programmed self-tests and printed circuit

board. Kit and PC board has switches, lamps, diodes, resistors, capacitors and transistors (batteries not included), \$99.50. Course is designed to teach solid-state fundamentals by combining theory with practical experiments. Center for Technical Development, Box 103, Louis-ville, Ohio 44641.

Circle 48 on reader service card

AUTO RADIO ACCESSORIES,
No. 49-906, includes all basic items to



eliminate most of engine, generator, sparkplug, ignition, and wheel-bearing noise and static. GC Electronics, Rock-ford, Ill.

Circle 49 on reader service card

YOUR BEST BUYS AND VALUE

FREE \$1 BUY WITH EVERY 10 YOU ORDER Only applies to "\$1" Buys **FREE GIFT WITH EVERY ORDER**

- | | | | |
|--|--|---|--|
| <ul style="list-style-type: none"> <input type="checkbox"/> 300 — ASST. 1/2 W RESISTORS Top Brand. Short Leads. Excellent Selection \$1 <input type="checkbox"/> 100—ASST 1/4 WATT RESISTORS stand. choice ohmages, some in 5% \$1 <input type="checkbox"/> 100—ASST 1/2 WATT RESISTORS stand. choice ohmages, some in 5% \$1 <input type="checkbox"/> 70 — ASST 1 WATT RESISTORS stand. choice ohmages, some in 5% \$1 <input type="checkbox"/> 35 — ASST 2 WATT RESISTORS stand. choice ohmages, some in 5% \$1 <input type="checkbox"/> 50 — PRECISION RESISTORS asst. list-price \$50 less 98% \$1 <input type="checkbox"/> 20 — ASSORTED WIREWOUND RESISTORS, 5, 10, 20 watt \$1 <input type="checkbox"/> 5 — TOGGLE SWITCHES SPST, SPDT, DPST, DPDT \$1 <input type="checkbox"/> 10—ASSORTED SLIDE SWITCHES SPST, SPDT, DPDT, etc. \$1 <input type="checkbox"/> TRANSISTOR RADIO asst. type good, bad, broken, as-is, potluck \$1.50 <input type="checkbox"/> TAPE RECORDER—assorted types good, bad, broken, as-is, potluck... \$4 <input type="checkbox"/> \$20 — SHURE M7D DIAMOND NEEDLE exact replacement \$3 <input type="checkbox"/> SHURE M44 SERIES DIAMOND NEEDLE exact Replacement \$4.69 <input type="checkbox"/> PICKERING V-15 DIAMOND NEEDLE Exact replacement \$4.69 <input type="checkbox"/> COLOR POWER TRANSFORMER Good for most sets 20R150 \$6.95 List Price—\$36.75 \$6.95 <input type="checkbox"/> 6 — TRANSISTOR RADIO EAR-PIECES wires complete with plug \$1 <input type="checkbox"/> 100' — FINEST NYLON DIAL CORD best size, .028 gauge \$1 <input type="checkbox"/> 10 — SETS PHONO PLUGS & PIN JACKS RCA type \$1 | <ul style="list-style-type: none"> <input type="checkbox"/> TV TUNER — asst. all new standard makes. Less tubes \$1 <input type="checkbox"/> TV TUNERS asst. all new standard makes, including Tubes \$3 <input type="checkbox"/> WESTINGHOUSE STANDARD TUNER #470V1221101 — (3GK5-6JCS) Tubes) \$4 <input type="checkbox"/> G.E. STANDARD TUNER Model # (ET-86x292) (ET-86x293) \$6.95 <input type="checkbox"/> UHF TUNER — TRANSISTOR TYPE Used in all TV Sets \$3.95 <input type="checkbox"/> 50 — ASSORTED PRINTED CIR- CUIT SOCKETS best types \$1 <input type="checkbox"/> 2 — COLORBURST QUARTZ- CRYSTAL REPLACEMENT For most Color TV Sets. 3579.545 KC \$1.49 <input type="checkbox"/> 50 — ASST. DISC CERAMIC CONDENSERS popular numbers .. \$1 <input type="checkbox"/> 10 — ASST. RADIO ELECTRO- LYTIC CONDENSERS \$1 <input type="checkbox"/> 50 — ASST. TUBULAR CON- DENERS .001 to .47 to 600v .. \$1 <input type="checkbox"/> 20 — STANDAD TUBULAR CONDENSERS .047-600v \$1 <input type="checkbox"/> 3-1/2 MEG VOLUME CONTROLS with switch, 3" shaft \$1 <input type="checkbox"/> BONANZA "JACKPOT" not gold, not oil, but a wealth of Electronic Items—Money-Back-guarantee ... \$5 <input type="checkbox"/> ASTATIC #13T STEREO CAR- TRIDGE plug in. power point. ... \$3.78 <input type="checkbox"/> RONETTE STEREO CARTRIDGE latest dual sapphire flipover type ... \$2 | <ul style="list-style-type: none"> <input type="checkbox"/> 12—MINIATURE ELECTROLYTIC CONDENSERS For Transistor & miniature work \$1 <input type="checkbox"/> 10 — MINIATURE 456KC IF TRANSFORMERS Exceptional value —PC—1/4" x 1/8" \$1 <input type="checkbox"/> HEAVY DUTY COLOR FOCUS RECTIFIER 14,000 PIV @ 1 ma .. \$1 <input type="checkbox"/> 50 — OIL IMPREGNATED TUBULAR CAPACITORS Por- celain, Axial Leads—Most popular values \$3.25 <input type="checkbox"/> COLOR-TV RECTIFIER — Used in most color sets—6500 kv 3 for \$1.95 <input type="checkbox"/> 15 — ASST. ROTARY SWITCHES all popular types \$20 value \$1 <input type="checkbox"/> 15 — G.E. #NE-2 TUBES Neon Glow Lamp for 101 uses... \$1 <input type="checkbox"/> 150' — BUSS WIRE #20 tinned for hookups, special circuits, etc. \$1 <input type="checkbox"/> 50 — .0033 DISC CERAMIC CAPACITORS C.R.L. \$1 <input type="checkbox"/> 3—ELECTROLYTIC CONDENSERS most popular number 50/30—150v \$1 <input type="checkbox"/> 7 — TV ELECTROLYTIC CON- DENERS desirable types \$1 <input type="checkbox"/> 5 — 6' LINE CORDS #18 Stranded Copper Wire \$1 <input type="checkbox"/> MOTOROLA PWR TRANSFORM 110v, CT 150/150v. 6.8v \$1 <input type="checkbox"/> 25 — #130 WESTINGHOUSE PI- LOT BULBS 5000 hours... Same as #47 \$1 <input type="checkbox"/> 25—WESTINGHOUSE PILOT BULBS Your choice of #241, #154, #PR-23 \$1 <input type="checkbox"/> 3—ELECTROLYTIC CONDENSERS C.D. 500 mfd—200 volts \$1 | <p>KNOB SPECIAL</p> <ul style="list-style-type: none"> <input type="checkbox"/> 100 — ASSORTED RADIO KNOBS All standard types \$1 <input type="checkbox"/> \$20 value \$1 <input type="checkbox"/> 50 — TV KNOBS — POPULAR TYPES For most sets \$1 <input type="checkbox"/> 25 — VERTICAL LINEARITY KNOBS Long shank Front mount miniature assortment \$1 <input type="checkbox"/> 30 — VERTICAL LINEARITY KNOBS Side mount Standard sizes \$1 <input type="checkbox"/> 25—KNURLED RADIO KNOBS Hard to get Best selection \$1 <input type="checkbox"/> 25 ASSORTED CLOCK-RADIO KNOBS Best assortment, Most popular types \$1 <p>ANY 6 KITS FOR \$5</p> <p>STEREO HEADPHONES</p> <ul style="list-style-type: none"> <input type="checkbox"/> Hi-Fi Quality Complete with Stereo plug \$5.95 <input type="checkbox"/> 50 — TUBE CARTONS (colored) assorted sizes for Popular Tubes .. \$1 <input type="checkbox"/> 4 — 36" Hi-Fi CABLES RCA Molded Phone plug at one end stripped and tinned leads on other end \$1 <input type="checkbox"/> 3' JUMPER CABLES Male RCA Type Plug on Both Ends, 2 For \$1.19 \$1 <input type="checkbox"/> 50 — ASST. TERMINAL STRIPS all types, 1-lug to 6-lug \$1 <input type="checkbox"/> 2—G.E. PIECES OF EQUIPMENT stacked with over 200 useful parts \$1 <input type="checkbox"/> MOTOROLA HEP KIT—INTE- GRATED CIRCUITS INCLUDES —One J-K flip flop, One Dual Buffer, One 4-input Gate, Two Dual 2-Input Gates. All Five \$3.95 |
|--|--|---|--|

IMMEDIATE DELIVERY . . . Scientific light packing for safe delivery at minimum cost. HANDY WAY TO ORDER: Pencil mark or write amounts wanted in each box, place letter F in box for Free \$1 BUY. Enclose with check or money order, add extra for shipping. Tearsheets will be returned as packing slips in your order, plus lists of new offers. Minimum Order \$3.00

Please specify refund on shipping overpayment desired: CHECK POSTAGE STAMPS MERCHANDISE (our choice) with advantage to customer

BROOKS RADIO & TV CORP., 487 Columbus Ave., New York, N. Y. 10024 212-874 5600 TELEPHONE

SOLDER BLOTTER, *Bonus Wik* (10 ft.) for desoldering large connections. *Micro-Wik* for desoldering smaller (20 ft.). For fast removal of solder, use with 35-W iron. Hand spools prevent burning. \$1.80 and \$3.50 respectively—Easy Electronics Co. P.O. Box M-33, Fremont, Calif. 94537.

Circle 50 on reader service card

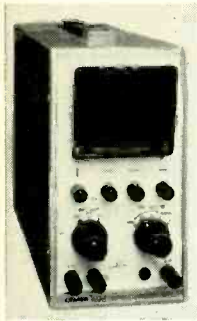

3-INCH SCOPE, *Model LBO-31M*, has 4" wide chassis. Bandwidth 1MHz; Vertical sensitivity 80 mV p-p/cm at 1 kHz, response 3 dB, 3 Hz to 1 MHz. Horiz. sensitivity 2.5 V p-p/cm. Sweep frequency 10 Hz to 100 kHz \$99. Leader Instruments, 24-20 Jackson Ave., Long Island City, N.Y. 11101

Circle 51 on reader service card

TUNER REBUILDING SERVICE for uhf or vhf TV tuners. \$8.50 each. Guaranteed for 90 days. Uhf/vhf combinations, \$15.00 each. Major parts at dealers' net. Atlantic Tuner Service, P.O. Box 895, Boynton Beach, Fla. 33435.

Circle 52 on reader service card

TO-5 EXTRACTOR, *Model #6983*, as-

sures quick, safe removal of TO-5 cans. Spring-loaded device fits over can and locks by lever action. When solder is melted, semiconductor automatically

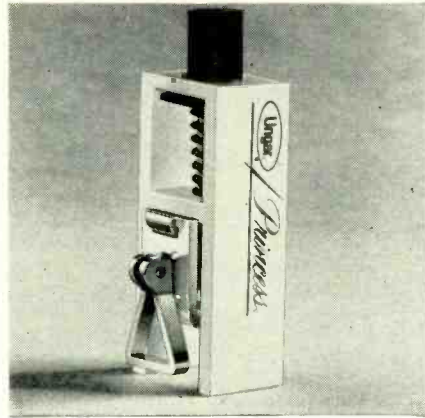

pops off board. Metal clamps act as a heat sink.—Ungar, Division of Eldon Ind., Inc. 233 E. Manville St. Compton, Calif. 90220.

Circle 53 on reader service card

Write direct to the manufacturers for information on items listed below:

SUB-CARRIER DEMODULATOR, *SCA-3B*, enables you to enjoy background music transmitted on 68 kHz subcarrier on many FM stations. 4 x 2 1/2 x 1 3/4". Adjustable muting. Simple plug-in connections to FM tuner/amplifier. (Will supply hook-up information to those without multiplex output jack). Operates on 6-12 V dc. With 2 shielded

cables, 36", \$44.95. 117V ac power supply, *PS-9*, \$4.95. For custom in-

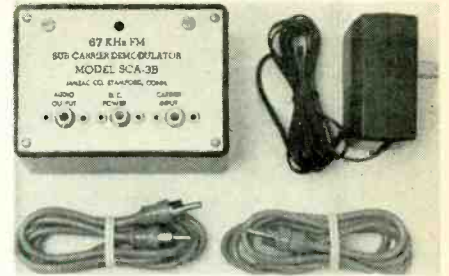

stallations: wired *SCA-3* pc card with instructions, \$39.95. *JanZac Co.*, P.O. Box 177, Stamford, Conn. 06904.

STEREO CASSETTE TAPE DECK, *Model LP-1*, convertible to play and record simultaneously 4-track stereo to be released on prerecorded cassettes. Has foolproof interlocking controls, 4-

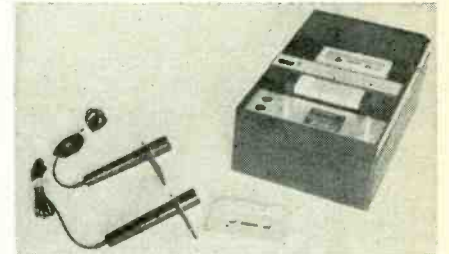

pole synchronous motor, 3-digit counter, dual VU meters with separate input level controls and all interconnecting cables. \$99.95 basic. Walnut base, \$10. Converter pack, \$49.95. *Lumistor Products*, Inc. R-E

SHANNON MYLAR RECORDING TAPE

2 1/2" - 225' .. \$.17	7" - 2400' .. \$1.79
3" - 225' .. .17	7" - 3600' .. 2.95
3" - 300' .. .29	CASSETTE 60 minutes .89
3 1/4" - 600' .. .58	CASSETTE 90 minutes 1.54
5" - 600' .. .62	CASSETTE 120 minutes 1.97
5" - 900' .. .80	
5" - 1200' .. .97	2 1/2" TAPE REEL04
5" - 1800' .. 1.49	3" TAPE REEL05
7" - 1200' .. .77	3 1/4" TAPE REEL06
7" - 1800' .. 1.12	5" TAPE REEL12
	7" TAPE REEL14

CANADIANS: Ordering is easy - we do the paperwork - try a small order

WESTINGHOUSE ALL TRANSISTOR HOME/OFFICE MESSAGE CENTER

Leaves messages for other for replay... Built in speaker/microphone for talk-into convenience... Records up to 3 minutes of messages... Illuminated signal shows when a message is waiting. Control adjusts playback volume without affecting recording volume... Capstan Drive; BRAND NEW SOLD AS IS \$7.95

IBM COMPUTER SECTIONS

8 assorted Units we sell for \$1 are loaded with over 150 valuable parts.

Incl. - Transistors, Condensers, Resistors, Heat Sinks, Diodes, Etc.

8 for \$1
100 for \$10

RCA 110° FLYBACK TRANSFORMER



We scooped the Market Latest type - standard for all 110° TV's
RCA's design of large Coil produces 18KV - assuring adequate width Incl Schematic Diagram application for any TV
List price \$13.90
Your price .. \$3
10% off in lots of 3

- 110° TV DEFLECTION YOKE for all type TV's incl schematic \$3
- "COMBINATION SPECIAL" RCA 110° FLYBACK plus 110° DEFLECTION YOKE \$5
- 90° FLYBACK TRANSFORMER for all type TV's incl schematic \$2
- 90° TV DEFLECTION YOKE for all type TV's incl schematic \$2
- 70° FLYBACK TRANSFORMER for all type TV's incl schematic \$2
- 70° TV DEFLECTION YOKE for all type TV's incl schematic \$2
- 2 - TV CIRCUIT BREAKERS \$1.19 Rated 4-2 TO 5.0 AMPS, etc.
- 70° COLOR YOKE \$10.95 For all round color CRT's
- 90° COLOR YOKE For all Rectangular 19 to 25" Color CRT's \$10.95

MARKET SCOOP COLUMN

- 12" UNIVERSAL SPEAKER. Top Quality... Large Magnet \$4
- 10" PHILCO SPEAKER \$2.69 Top Quality... Large Magnet
- 8" UNIVERSAL SPEAKER - \$2.49 Large Magnet—Special Buy
- UTAH 8"—HEAVY DUTY 10 OZ. SPEAKER Ceramic Type—\$3.69 8 Ohm.
- 6"—ECONOMY SPEAKER Top quality 2.15 Mag. \$2.94
- 5" UNIVERSAL TWEETER \$1.29 1 Oz. Magnet
- UNIVERSAL 5 1/2" PM SPEAKER \$1 Alnico 5 magnet, quality tone
- UNIVERSAL 4" PM SPEAKER \$1 With 50L6 Output Transformer
- 2 1/2" x 4" SPEAKER \$69 Special Buy
- 3 1/2" - ROUND SPEAKER \$59 Special Buy
- 25 - 3900-OHM-7w RESISTOR \$1 10% Corning glass
- 20 - .47-600V CONDENSERS \$1 White Ceramic C.D.-American
- TV TWIN LEAD-IN 300 ohm 500' - \$7 100' - \$1.50 50' - \$1
- CO-AX CABLE RG59U grey or black 250' - \$9 100' - \$3.69 50' - \$2
- 5 - I.F. COIL TRANSFORMERS \$1 sub-min for Transistor Radios
- 5 - AUDIO OUTPUT TRANS- \$1 FORM Sub-min for Trans Radios

- 4 - TV ALIGNMENT TOOLS \$1 most useful assortment #1
- 4 - TV ALIGNMENT TOOLS \$1.49 For Color TV #2
- 6 - TV COLOR ALIGNMENT TOOLS \$2.79 Most popular type
- 5 - PNP TRANSISTOR \$1 general purpose, TO-5 case
- 5 - NPN TRANSISTORS \$1 general purpose, TO-5 case
- UNIVERSAL TV ANTENNA \$1.98 Back of set mounting 5 section rods
- 50 - ASSORTED TRANSISTORS \$1 big factory scoop—solid as-is
- 0 TO 200 MICRO AMP MINIA-TURE METER 1 1/2 x 1 1/2" Wt. 3 Oz. Excellent 8 meter \$1
- 10 - STANDARD TRANSISTORS \$1 NPN & PNP 2N404, 2N414, etc.
- 10 - ASSORTED DIODE CRYSTALS \$1 1N34, 1N48, 1N60, 1N64, etc.
- 3 - TOP BRAND SILICON RECTIFIERS 1 amp, 1000 PIV \$1
- 20 - ASST. PILOT LIGHTS \$1 #44, 46, 47, 51, etc.
- 50 - ASSORTED #3AG FUSES \$1 popular ampere ratings
- 4-50' HANKS HOOK-UP WIRE \$1 assorted colors
- 100'-SPOOL SPEAKER WIRE \$1.50 2 cond, mini zip, clear, 101 uses
- 10 - ASST. RADIO & TV TUBES \$1 Every Tube a good number
- UNIVERSAL MICROPHONE \$2 regular/remote/single & dual plug
- CRYSTAL LAPEL MICROPHONE \$59 high impedance, 200-6000 cps

- WESTINGHOUSE FM TUNER #476-V-006H01 (12D78 Tube) \$2.99
- WESTINGHOUSE FM TUNER #476-V-015D01 Transistor \$3.99
- 300 - ASSORTED HEX NUTS \$1 2/56, 4/40, 5/40, 6/32, 8/32
- 250 - ASST. SOLDERING LUGS \$1 best types and sizes
- 250 - ASST. WOOD SCREWS \$1 finest popular selection
- 250 - ASST. SELF TAPPING SCREWS #6, #8, etc. \$1
- 150 - ASST. 6/32 SCREWS and 150 6/32 HEX NUTS \$1
- 150 - ASST. 8/32 SCREWS and 150-8/32 HEX NUTS \$1
- 150 - ASST. 2/56 SCREWS and 150-2/56 HEX NUTS \$1
- 150 - ASST. 4/40 SCREWS and 150-4/40 HEX NUTS \$1
- 150 - ASST. 5/40 SCREWS and 150-5/40 HEX NUTS \$1
- 500 - ASSORTED RIVETS \$1 most useful selected sizes
- 500 - ASSORTED WASHERS \$1 most useful selected sizes
- 100 - ASST. RUBBER BUMPERS for cabinet bottoms & other uses \$1
- 100 - ASSORTED RUBBER GROM-METS best sizes \$1

**DON'T SETTLE FOR
A HIT AND MISS
IGNITION SYSTEM**



**Install a
JUDSON
ELECTRONIC MAGNETO**

It offers the combined advantages of both the standard transistorized and capacitive discharge systems in one simplified patented circuit. Provides better performance, a smoother running engine and keeps your car in tune. Installed in twenty minutes.

Write Today for Literature

JUDSON
RESEARCH & MFG. CO
CONSHOHOCKEN, PA. 19428

Circle 66 on reader service card

**Build this pipelike
Schober Recital Organ
for only
\$1850!**



*Includes finished walnut console. (Only \$1446 if you build your own console.) Amplifier, speaker system, optional accessories extra.

You couldn't touch an organ like this in a store for less than \$4,000—and there never has been an electronic instrument with this vast variety of genuine pipe-organ voices that you can add to and change any time you like! If you've dreamed of the sound of a large pipe organ in your own home, if you're looking for an organ for your church, you'll be more thrilled and happy with a Schober Recital Organ than you could possibly imagine—kit or no kit.

You can learn to play it—and a full-size, full-facility instrument is easier to learn on than any cut-down "home" model. And you can build it, from Schober kits, world famous for ease of assembly without the slightest knowledge of electronics or music, for design and parts quality from the ground up, and—above all—for the highest praise from musicians everywhere.

Send right now for the full-color Schober catalog, containing specifications of all five Schober Organ models, beginning at \$499.50. No charge, no obligation. If you like music, you owe yourself a Schober Organ!

The Schober Organ Corp., Dept. RE-82
43 West 61st Street, New York, N.Y. 10023

- Please send me Schober Organ Catalog and free 7-inch "sample" record.
- Enclosed please find \$1.00 for 12-inch L.P. record of Schober Organ music.

NAME _____

ADDRESS _____

CITY _____ STATE _____ ZIP _____

Circle 67 on reader service card

NEW LITERATURE

All booklets, catalogs, charts, data sheets and other literature listed here with a Reader's Service number are free for the asking. Turn to the Reader Service Card facing page 102 and circle the numbers of the items you want. Then detach and mail the card. No postage required!

COILS CATALOG #1, Includes i.f. transformers, and components, wave traps, high-pass filters, ferrite antennas, adjustable antenna, rf, oscillator, and width coils, video peaking, and wide-range tapped coils. Filament and hash chokes phenolic, iron and ferrite core chokes. Also has manufacturer's replacement cross reference, and general and electrical equivalent cross references. —Littelfuse, 800 E. Northwest Highway, Des Plaines, Ill. 60016.

Circle 54 on reader service card

TEST EQUIPMENT CATALOG contains the manufacturer's complete line of vectorscopes, color-bar generators, oscilloscopes, picture-tube analyzer, in-circuit transistor analyzer, transistor TV sweep-circuit analyzer, CB analyzer and frequency meter, power supplies, Lectrocell and Metergard. Write Lectrotech Inc., 4929 N. Kedzie Ave., Chicago, Ill. 60625

Circle 55 on reader service card

CATALOG. Hustler Antennas. Includes CB, high- and low-band vhf, beam antennas, base station, mobile, helmet antennas, mounts, springs, cables, and other accessories.—New Tronics Corp., 15800 Commerce Park Drive, Brook Park, Ohio, 44142.

Circle 56 on reader service card

Write direct to the manufacturers for information on items listed below:

RADIO COMMUNICATION ACCESSORIES covering both base and mobile equipment are detailed with performance data, specs and photos in *Brochure IC 3404*, 26 pages. Parts and components listed are for direct replacements or can be added to existing equipment for greater communications capability for radio system.—Motorola Communications & Electronics Inc., 1301 East Algonquin Rd., Schaumburg, Ill. 60172 **R-E**

NEW BOOKS

TRANSISTOR TV SERVICING MADE EASY, by Jack Darr. Howard W. Sams & Co., 4300 W. 62nd St., Indianapolis, Ind. 46206. 160 pp., 5½" x 8½". Soft cover. \$4.95.

Darr at his best. He tells you how the various solid-state circuits work and then gives you step-by-step servicing instructions. After devoting the first two chapters to transistor TV servicing equipment and techniques, Jack devotes the remaining eight chapters to such sections of the TV set as the tuner, dc power supply, sweep circuits, sync, agc, etc.

You don't have to be in the servicing game to profit from this book. It is nice easy reading that will get you squared away on the hows and whys of transistor TV. There is only one flaw, Jack didn't cover solid-state color sets. But, I'll bet that he is saving that material for another book.—RFS

LIGHT AND SOUND FOR ENGINEERS by R.C. Stanley. Hart Publishing Co., 510 Sixth Ave., N.Y. 9¼ x 6½ in., 344 pp. Hardcover, \$12.

Intended for the engineering student. Contents include: reflection and refraction at plane surfaces; reflection and refraction at spherical surfaces; thick lenses; aberrations of mirrors and lenses; optical instruments; prisms, spectra and color; illumination and photometry; interference; diffraction; polarization; waves and vibrations; velocity of sound; transverse vibrations; forced vibrations and resonance; intensity of sound; acoustics of buildings; ultrasonics.

LINEAR SYSTEMS ANALYSIS, compiled by Lewis, Reynolds, Bergseth and Alexandro. McGraw-Hill Book Co., 330 W. 42d St., New York, N.Y. 10036. 9¼ x 6½ in., 489 pp. Hardcover, \$16.95

Introductory text in a continuing education series for engineers. Emphasis is on general concepts applicable to all branches of engineering rather than to particular specialties. Basic physical principles are stressed. Solutions to selected problems included.

FIVE COLOR TV SERVICE MANUALS. Tab Books, Blue Ridge Summit, Pa. 17214. 160 pp. except as noted below, 8½" x 11". \$4.95 paperbound, \$7.95 soft leatherette.

These books *Magnavox Color TV Service Manual*, by Stan Prentiss; *Motorola Color TV Service Manual*, by Forrest Belt; *Philco Color TV Service Manual*, by Robert L. Goodman; *RCA Color TV Service Manual (176 pp.)*, by Carl Babcock and *Zenith Color TV Service Manual*, by Robert L. Goodman) contain all the essential data needed to repair all, or all of the most recent, color TV sets of the makes listed.

Working with the manufacturers, the authors have taken their service data, training manuals, modification notices, case histories and other information and blended this material, in some instances, with their own personal experiences with the chassis covered, to come up with a very valuable series of easy-to-read and use service manuals for the TV service technician.

ELECTROMAGNETIC AND ACOUSTIC SCATTERING BY SIMPLE SHAPES, Edited by J. J. Bowman, T. B. A. Senior and P. L. E. Uslenghi. North-Holland Publishing Co., Wiley Science Div., John Wiley & Sons, Inc., 605 Third Avenue, New York, N.Y. 9¼ x 7 in., 728 pp. Hardcover, \$37.95

Study of the scattering properties of acoustically soft and hard bodies and of perfect conductors, presented for 15 geometrically simple shapes, which serve as a basis for synthesizing the radiation and scattering properties of more complex configurations.

PRINCIPLES OF PULSE CODE MODULATION, by K. W. Cattermole. American Elsevier Publishing Co., Inc., 52 Vanderbilt Ave., New York, N.Y. 10017. 5¼ x 8¾ in., 442 pp. Hardcover, \$17.50











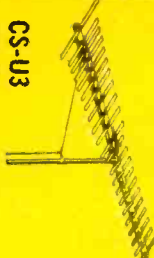
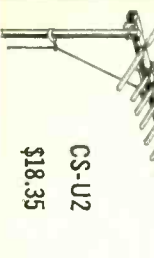
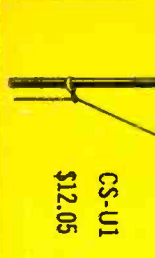
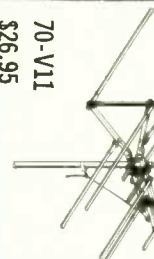

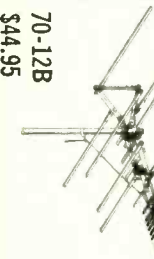

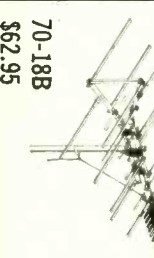

Definitive account of the conveyance of analogue information in digital form. Offers physical explanation and links with the general theory of signal representation. Calculus background necessary. **R-E**

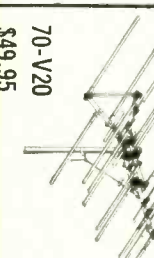
FINCO 70 SERIES

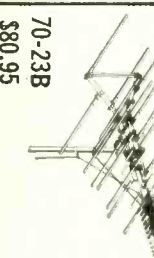
COLOR SPECTRUM TV ANTENNAS

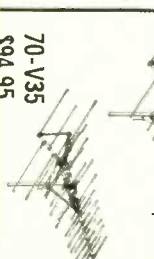
NO VHF VHF STRONG VHF MODERATE VHF WEAK VHF VERY WEAK

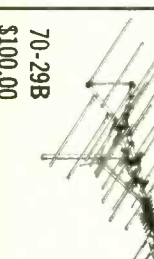
All Prices Subject to Change

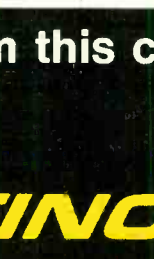
UHF VERY WEAK	UHF WEAK	UHF STRONG	NO UHF
 <p>CS-U3 \$26.40</p>	 <p>CS-U2 \$18.35</p>	 <p>CS-U1 \$12.05</p>	 <p>70-V11 \$26.95</p>
 <p>70-188B \$62.95</p>	 <p>70-12B \$44.95</p>	 <p>70-12A \$39.95</p>	 <p>70-V17 \$39.95</p>
 <p>70-188A \$62.95</p>	 <p>70-188B \$62.95</p>	 <p>70-18A \$56.95</p>	 <p>70-V14 \$34.95</p>
 <p>70-23B \$80.95</p>	 <p>70-23B \$80.95</p>	 <p>70-23A \$73.95</p>	 <p>70-V20 \$49.95</p>
 <p>70-29B \$100.00</p>	 <p>70-29B \$100.00</p>	 <p>70-23A \$73.95</p>	 <p>70-V28 \$74.95</p>

NOTE: Each model above is also available with 75 ohm coaxial cable and compact behind-the-set balun-splitter to match antenna system to proper set terminals.

Select the antenna for your area from this chart
**The set choice is yours...
 the antenna choice is FINCO**

Send for free Catalog 20-556

NAME _____

ADDRESS _____

CITY _____ STATE _____ ZIP _____



THE FINNEY COMPANY
 34 West Interstate St., Dept. RE-9
 Bedford, Ohio 44146

Who Needs a Tuner Wash?

Use

QUIETROLE Mark II Spray Pack

The product that cleans and lubricates better than any product you can buy and has been used for more years than any product of its kind.

The Choice of "Better Servicemen" Everywhere



manufactured by

QUIETROLE COMPANY
Spartanburg, South Carolina

Circle 69 on reader service card

STILL ANOTHER COMPUTER BOARD SPECIAL

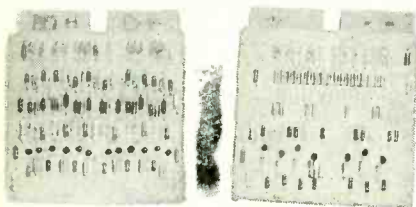

Stock No. 9094

Honeywell Boards 5½" x 6". Loaded with late no. transistors, diodes, resistors and capacitors. 2 different boards \$1.00.

Stock No. B9082

Honeywell Computer boards, 4½"x12". Transistors, diodes, zeners, capacitors, precision resistors, heat sink, trimmers etc. 3 Different boards \$1.00.

Stock No. B9093

Honeywell Power Board contains 4 2N1137B 80 watt PNP power transistors, 8 Top Hat diodes, 8 precision resistors and 4 IN642 diodes \$1.25 ea.

Stock No. B2040

Sangamo or Pyramid 4¼" x 1¾"
4000 MFD 50V 50 .. 5/2.00

Stock No. B2039

Pyramid 4¼" x 3" 6000 MFD 75V
..... 75 .. 3/2.00

Lots of other items—send for free flier; all merchandise fully guaranteed. Please include postage; excess will be refunded.

DELTA ELECTRONICS CO.
BOX 1, LYNN, MASSACHUSETTS 01903

Circle 70 on reader service card

EQUIPMENT REPORT

Bell PA MOD-90 Public Address Amplifier

For manufacturer's literature, circle No. 90 on Reader Service Card.

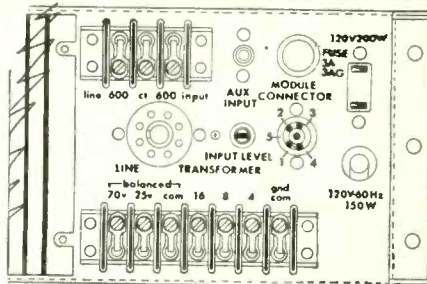

THE MOD-90 IS ONE OF A NEW SERIES of extremely versatile public-address amplifiers. To start off, the unit is a normal solid-state amplifier as you can see from the specifications below. What makes it different is the list of 12 plug-in modules that can be used with amplifier to customize it to the user's requirements.

There are four microphone preamps—one for high-impedance mikes; one for low-impedance mikes; one for high-impedance mikes, but with a paging precedence functions; and one for low-impedance mikes with a paging precedence function.

There are three program modules—a high-gain preamp for phono, tape player or tuner; a unit to match balanced 600-ohm signals such as wired background music or telephone paging; and a preamp for 600-ohm line signal sources permitting telephone PBX paging.

Other plug-in's include a tone-generator that produces a siren tone to permit using the sound system as an alarm. There's also a remote volume control that can be used to regulate preamp levels.

Two output modules complete the lineup. They include a low-impedance (unbalanced) unit for selected specific inputs to be tape recorded or fed to a slave amplifier. The other output module provides a balanced 600-ohm output for selected specific inputs for telephone line feeding for remote broadcasting or transmitting over long lines to a slave amplifier.

The amplifier can accept any combination of one to eight plug-ins which permit easy and rapid modifications without any need for soldering.

The basic MOD-90 described here is a 90-watt amplifier that has low-noise FET's (field-effect transistors in the front-end and four feedback loops for stable operation.

The output circuit incorporates

an automatic sensor circuit that protects the output transistors against overloads and short circuits. A front-panel indicator lamps lights when the circuit is activated. It resets automatically when the fault is corrected.

—Chester H. Lawrence

SPECIFICATIONS

POWER OUTPUT: 90 watts at 5% distortion

REGULATION: 1 dB at 1000 Hz. Better than 3 dB overall.

HUM & NOISE: 90 dB below rated output

GAIN: 130 dB (mic) 90 dB (aux)

INPUT SENSITIVITY: 1 mV (mic), 100 mV (aux)

FREQUENCY RESPONSE: 20 to 20,000, Hz ± 1 dB

TONE CONTROLS: Bass 16 dB boost, 7.5 dB cut, at 50 Hz. Treble 12 dB boost, 15 dB cut at 10,000 Hz.

INPUTS: Aux (Hi Imp. High Level) Bal. 600-ohm with 32B263 transformer. 1-Hi Imp Mic 1-Aux

OUTPUT IMPEDANCES: 4, 8, 16, 10 (Bal. 25 V) 80, (Bal. 70 V) ohms

POWER RESPONSE: 50 to 20,000 Hz 60 W at less than 2% distortion

TRANSISTORS: 20 Transistors (5 FETS) 7 Diodes

POWER CONSUMPTION: 150W 120V, 60 Hz

DIMENSIONS: 7¾"h, 16¼"w, 10¼"d.

WEIGHT: 25 lbs.

Circle 71 on reader service card →

FREE!

Mail
This
Card
Today

LAFAYETTE 1971 Catalog 710 Our 50th Year

Your Complete Buying Guide
to Everything in Electronics

50th
LRE
anniversary



**BETTER THAN
EVER
468
Pages**

- ★ Radios
- ★ Cassette Recorders
- ★ Stereo Hi-Fi
- ★ Citizens Band
- ★ Tape Recorders
- ★ Phonographs
- ★ Cameras and More

Use LAFAYETTE'S Budget Plan

Do A Friend A Favor
Give Him This Card To Send For His

FREE LAFAYETTE CATALOG

STORE LOCATIONS

38 Convenient Store Locations in nine states:

NEW YORK	CONNECTICUT	VIRGINIA
NEW JERSEY	PENNSYLVANIA	MARYLAND
MASSACHUSETTS	OHIO	GEORGIA

Associate Stores From Coast-To-Coast. Visit the Lafayette store nearest you for fast personalized service. Watch For New Grand Openings.

LAFAYETTE Radio ELECTRONICS

Dept. 07090 P.O. Box 10
Syosset, L.I., N.Y. 11791

Please Send the FREE 1971 LAFAYETTE CATALOG 710

Name _____

Address _____

City _____ State _____ Zip _____

Mail
The Coupon
Today for
your FREE
1971
LAFAYETTE
CATALOG
710

MAIL THIS CARD
TODAY FOR YOUR

FREE!

1971 LAFAYETTE
CATALOG 710



Dept. 07090

Name _____

Address _____

City _____

State _____

Zip _____

(Please Give Your Zip Code No.)

MAIL THIS CARD
TODAY FOR YOUR

FREE!

1971 LAFAYETTE
CATALOG 710



Dept. 07090

Name _____

Address _____

City _____

State _____ Zip _____



Mail This Card Today

Shop At the
"World's Hi-Fi &
Electronics Center"
For Widest Selection,
Low Prices

Serving The Public
Since 1921

468
Pages



LAFAYETTE
RADIO ELECTRONICS
P.O. BOX 10
SYOSSET, L.I., N.Y. 11791

PLACE
STAMP
HERE

Your
Complete
Electronic
Buying Guide

FREE!

Stereo Hi-Fi • Citizens Band • Ham Gear • Tape Recorders • Test
Equipment • TV and Radio • Phonographs, Accessories • Intercoms
and PA • Closed Circuit TV • Tubes and Parts • Cameras • Auto
Accessories • Musical Instruments • Tools • Books



Award Winning LR-1500TA
IC Solid State Receiver



Profile 80 AM/FM Receiver
Plus 8 Track-Player



Citizens
Band

Dyna Com
Super Series
Walkie-Talkies



Micro 12

Solid State
2-Way Radio
For Home and Car



Criterion
Speaker Systems



Solid State
Stereo Cassette
Recorders, Decks
& Players



Musical Instruments
and Accessories

LAFAYETTE
RADIO ELECTRONICS
P.O. BOX 10
SYOSSET, L.I., N.Y. 11791

PLACE
STAMP
HERE

Free!
Mail The
Card Today

Do A Friend A Favor . . .
Have a friend interested in hi-fi or electronics? Send us his
name and address and we will send him his own personal
copy of the 1971 Lafayette Catalog 710.

NEW TUBES AND SEMICONDUCTORS

NEW PNP RF POWER TRANSISTORS

Transistors MM4020 through MM4023 have been added to Motorola's line of pnp rf power devices to increase the power range from 0.5 to 40 watts at 175 MHz. The devices feature balanced emitter construction for maximum safe operating area, isothermal design for flat power output versus temperature and low-lead inductance stripline packaging.

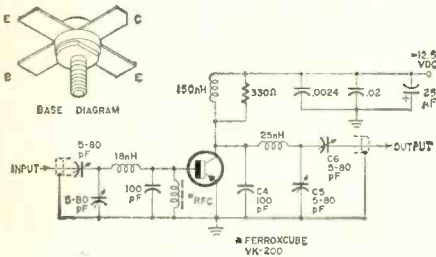

They are designed for 12.5-volt vhf large-signal amplifier application as in military, amateur and industrial transmitters operating at frequencies up to 250 MHz. Using balanced-emitter construction with thin-film nichrome wires in series with each of the multiple emitters, power is distributed evenly throughout the chip to prevent "hot emitters" so the unit stands up

under high swr conditions that may occur in a mistuned rf system.

The isothermal design insures an even generation and flow of heat in and from the chip so that the "power slump" usually encountered in an rf power device operating near its maximum frequency is nearly absent. In the MM4020 series, the power output drops less than 10% as stud temperature increases from 25°C to 100°C. Output power of the MM4020, -21, -22, -23 devices are 3.5, 15, 25 and 40 watts, respectively. Minimum power gains are 11.5 dB, 7 dB, 5.5 dB and 4.5 dB. The diagram shows the 175-MHz test circuit with values shown for the MM4022 and MM4023. In lots of 100 to 999, the MM4020 through MM4023 are \$6.20, \$15.00, \$23.00 and \$38.00, respectively.

14 NEW TV CAMERA TUBES

Amperex has expanded its line of Plumbicon TV camera tubes to include 14 new types for miniature portable TV cameras, replacements for existing vidicon types, and others for such specialized functions as image-intensification and medical, industrial and educational CCTV applications.

The line now includes nine 30-mm diameter tubes. Employing magnetic focus and deflection are the 55875, XQ1020, XQ1023, XQ1025, 7XQ and 7XQ/ACT. The 3XQ has electrostatic focus and magnetic deflection and the 15XQ is an all-elec-

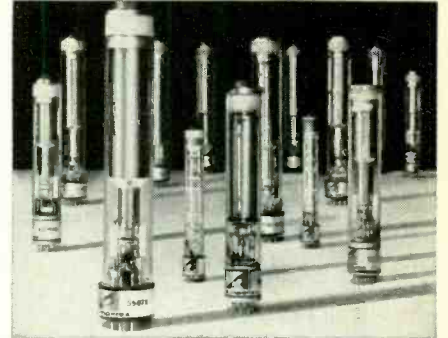

trostatic tube. Four 1-inch diameter Plumicons are the 16XQ/XQ1070, a replacement for most vidicon cameras, the 19XQ "anti-comet-tail" version of the 16XQ/XQ1070, the 30XQ, a fiber-optics faceplate version of the 16XQ, and the 31XQ, a ruggedized 16XQ. The 5/8-inch diameter 12XQ and 21XQ roundout the line.

Write Electro-Optical Devices Div., Amperex Electronic Corp., Slatersville, R.I. 02876 **R-E**

Famous DeltAlert Anti-Theft System Adds High-Intensity Sound To Light!



When you have an intrusion detection system that already cuts theft potential 95% by automatically switching on lights, why add sound? Environmental Variance, EV is another way of saying that numerous individual and business premises are subject to varying levels of background noise, including cars, trucks, trains and industrial activity... as well as varying levels of outside people-traffic. This is why DeltAlert's new audio capability is the answer to Environmental Variance, and why it's your answer to total intrusion detection.

Horn sound is high-intensity, and the horn itself can be located away from the sensing unit. There is a ten second delay to allow authorized entry and access to the horn's on/off switch.

Order your DeltAlert system, complete with horn. You'll see how DeltAlert's variable sensitivity control and adjustable timing provides the most advanced sentry system on the market. Completely monitor and blanket areas fifteen to thirty feet. Easy to connect. No rewiring necessary.

DeltAlert, complete unit, ready to use.....Only **\$69⁹⁵** ppd.
DeltaHorn, Complete with built-in delay.....Only **\$24⁹⁵** ppd.

SPECIFICATIONS:

Ultrasonic Frequency: 35 KHZ Δ
 Area Coverage: 15-30 feet (depending on shape of area) Δ
 Controls: On-Off Switch; Built in Timer;
 Variable Sensitivity Control Δ Output: 110-130V at 5 Amp. Δ Power Requirements: 110-130, 60 HzAC Δ Dimensions: 10 3/4" W x 3 1/4" H x 3 1/4" D Δ Complete with 110-130V Drop Cord Δ Walnut designer finish.
 Unit and all parts manufactured in U.S.A.



DELTA PRODUCTS, INC.

P. O. Box 1147 RE/Grand Junction, Colo. 81501

Please send me literature immediately.

Enclosed is \$ _____ Ship ppd. Ship C.O.D.

Please send ___ DeltAlert(s) @ 69.95 ppd.

Please send ___ DeltHorn(s) @ 24.95 ppd.

Name _____

Address _____

City/State _____ Zip _____

DP 70-9

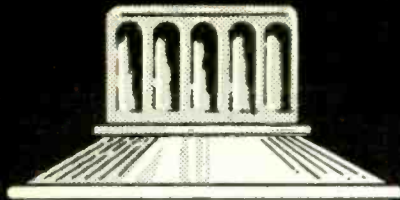

More and More Technicians Say:
 "We've tried cheaper
 substitutes . . . now
**WE'RE BACK TO
 DEPENDABLE, RELIABLE**

"NOISE"

World's No. 1 TRUSTED NAME BRAND

- VOLUME CONTROL & CONTACT RESTORER
- TUNER-TONIC with PERMA-FILM
- EC-44 FOR ELECTRICAL CONTACTS
- TAPE-RECO HEAD CLEANER
- FRIGID-AIR CIRCUIT COOLER

All Guaranteed Non-Flammable,
 No Carbon Tet, Non-Toxic, Non-
 Drift Tuner Cleaner And Guarant-
 eed Not To Affect Plastics.

*The Only Brand Perfect For
 Color TV and Black & White*

FREE extender assembly for pin-
 point application supplied with
 ALL NO-NOISE PRODUCTS.

Electronic Chemical Corp.

813 Communipaw Ave. / Jersey City, N. J. 07304

Circle 73 on reader service card

FOR THE FINEST
 RECEPTION AVAILABLE

**NEW SUPER "T"
 VHF-FM-COLOR TARGET
 ANTENNA SERIES**

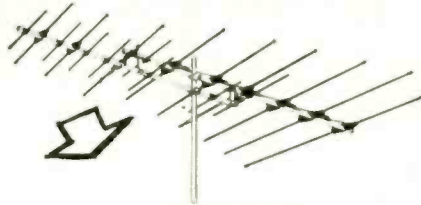

**ELIMINATE THE NEED
 FOR TWO ANTENNAS.**

The best features of Log-Periodic
 and Yagi type arrays are combined
 for outstanding performance in
 Super Target Antennas. New,
 tougher aluminum alloy used for all
 elements. Rugged square boom con-
 struction. Unique construction fea-
 tures reduce installation time.

S & A ELECTRONICS INC.

210 W. Florence Street • Toledo, Ohio 43605

Circle 74 on reader service card

**COMING
 NEXT
 MONTH**

OCTOBER 1970

- High-fidelity stereo is on tap

This month and here are some special articles for you

- Four-Channel Stereo—Progress Report

Up-to-the-minute report on the latest happenings in this newest kind of sound

- Get The Best Out Of Your Stereo System

Easy-to-do checks and procedures that will help you get that little bit extra out of your stereo system.

- Build An FM Multiplex Generator

You need this instrument to tune up FM stereo receivers. This one is small, portable and all solid-state.

PLUS:

R-E Reference Manual
 How To Putter With The
 PUT
 Jack Darr's Service Clinic

RADIO-ELECTRONICS

Clever Kleps

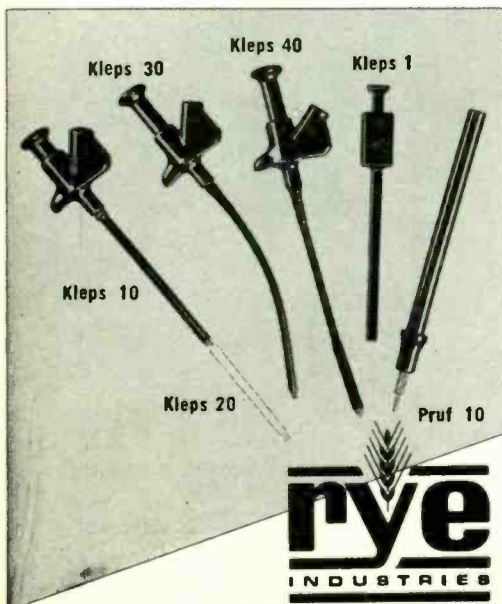

Test probes designed by your needs—
 Push to seize, push to release (all Kleps spring loaded).

Kleps 10. Boathook type clamp grips wires, lugs, terminals. Accepts banana plug or bare wire lead. 4¾" long. **\$1.19**

Kleps 20. Same, but 7" long. **\$1.39**

Kleps 30. Completely flexible. Forked-tongue gripper. Accepts banana plug or bare lead. 6" long. **\$1.47**

Kleps 40. Completely flexible. 3-segment automatic collet firmly grips wire ends, PC-board terminals, connector pins. Accepts banana plug or plain wire. 6¾" long. **\$2.39**

Kleps 1. Economy Kleps for light line work (not lab quality). Meshing claws. 4½" long. **\$.99**

Pruf 10. Versatile test prod. Solder connection. Molded phenolic. Doubles as scribing tool. "Bunch" pin fits banana jack. Phone tip. 5½" long. **\$.79**

All in red or black — specify.
 For additional information, write for our complete catalog of — test probes, plugs, sockets, connectors, earphones, headsets, and miniature components.
Available through your local distributor, or write to:
RYE INDUSTRIES, INC.
 128 Spencer Place, Mamaroneck, N.Y. 10543



Circle 84 on reader service card

www.americanradiohistory.com

NOTEWORTHY CIRCUIT

COMBINATION TIME LOCK

I have always been intrigued by various types of electric locks. Most are multi-switch types that may require stepping relays, time-delay circuits and other circuit configurations for operation. This time-controlled combination lock, devised by Mr. J. F. C. Johnson and described in *Wireless World*, appears to be highly reliable while requiring relatively few parts.

Fig. 1 is the basic circuit. It consists of three switches connected in series with the control relay and

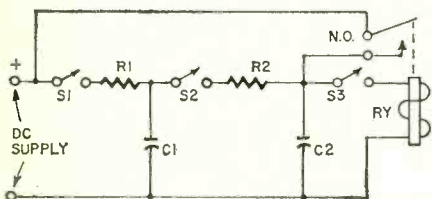

Fig. 1

power through supply two RC time-constant networks. When S1 is closed, C1 charges to supply potential in a period $t = R_1C_1$. Opening S1 and closing S2 causes the charge on C1 to divide C1 and C2; and in time R_2C_2 reaches a voltage determined by the comparative values of C1 and C2. Opening S2 and closing S3 causes C2 to discharge through the relay so it pulls in and is kept energized through its contacts. Auxiliary contacts (normally open) supply voltage to the lock solenoid so the door can be opened. The door is locked again by opening S3.

The supply voltage and R-C time constants are chosen so C1 must be charged and discharged into C2 several times before enough voltage is built up across C2 is high enough to operate the relay.

Fig. 2 is the time-controlled lock. S1, S2 and S3 have been replaced by S1-a, S1-b and S1-c, separate wafers on a 3-pole 12-position rotary switch with stop removed to permit 360° rotation. Capacitors C2 and C3 correspond to C1 and C2 in Fig. 1. Shunt resistors have been added to provide discharge paths for C2 and C3. The series and shunt resistors allow only about 4 seconds in each step in the switching sequence. Switching too fast will not permit the capacitors to reach the required charge level. Remaining too long in one position lets the charge drain off.

The table shows the combination

TABLE

Steps	Combination	Circuit action
1	R-3, 4 sec	C1 charges
2	L-4, 4 sec	C1 discharges into C2
3	R-3, 2 sec	C1 charges
4	L-4, 2 sec	C1 discharges into C2
5	R-2, 4 sec	C1 shorted, C2 discharges into C3
6-10	Repeat steps 1-5	Same as steps 1-5
11	L-5	C3 discharges through relay. Relay operates

used by the author along with circuit operation during each step. In the combination, the letters R and L indicate clockwise and counterclockwise rotation to the particular switch position. You can make your own combination. Note that the switch is wired so turning the switch in the wrong direction will discharge one or more capacitors prematurely so the lock cannot be opened.

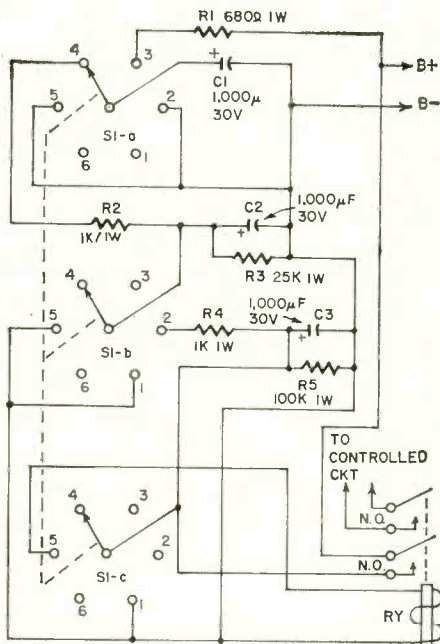

Fig. 2

When, in the 11th step, C3 discharges through the relay, the relay locks in through its normally open contacts and position 5 of S1-c and remains energized until the switch is moved off 5. The power supply voltage, about 1.5 times the minimum relay operating voltage, may be from batteries or a transformer and rectifier. The author recommended taking the dc supply leads to two screws so an external supply can be used if the power fails.—RFS

R-E

There's no substitute
for SUCCESS...



JAMES WONG—Research Engineer
Heald Engineering College Graduate

or IN-CLASS INSTRUCTION!

In electronics, it's the training that makes the difference. Employers require well-trained men and the first thing checked is where you gained your knowledge.

HEALD GRADUATES have many job offers with starting salaries often in excess of \$10,000 per year. AND advancement is rapid.

GET STARTED NOW. Be a

DRAFTSMAN—12 months
TECHNICIAN—15 months
ENGINEER (B.S. Deg.)—36 months
ARCHITECT (B.S. Deg.)—42 months

YOU are eligible for HEALD ENGINEERING COLLEGE if you have a high school education or the equivalent.

Increased income starts with success—success starts with your move to Heald. Send now for FREE brochures with more information on Heald in San Francisco and your future in Engineering.

FREE LIFETIME PLACEMENT SERVICE
VETERAN APPROVED



WRITE TODAY FOR DETAILS

HEALD Engineering College

1215 Van Ness Ave., San Francisco, California 94109

Please send me information about:

- ARCHITECTURE
- ENGINEERING: Civil Electrical
- Electronic Mechanical
- TECHNOLOGY: Electronic Engineering Technician (FCC)
- Radio-Television Technician (FCC)
- DRAFTING: Mechanical Electrical
- Structural

I am interested in Day Evening courses
Also send an application.

NAME _____ AGE _____

ADDRESS _____

CITY _____

STATE _____

ZIP _____ PHONE _____

Circle 75 on reader service card

"INSERT TOOL NUMBER 4 AND MAKE a 0.025-inch cut 4 inches to the right on the horizontal axis."

If a machinist does this it's manual control. If an electronic circuit does the job, it's numerical control, the latest thing in automation. An earlier article on this subject (February, 1969) showed how 8-channel tape is perforated to carry commands.

The photoelectric tape reader scans eight channels, issuing a pulse for each hole. The presence of a hole results in a "true" signal, and the absence of a hole produces a "not-true" signal to logic circuits. (A logic circuit monitors two or more signals to decide if and when a given condition is "true" or "not true.")

The tape reader EL and CH channels (shown in Fig. 4) each have a single purpose only: as detailed earlier, they serve as an end-of-block code and parity check for an odd number of holes, respectively. The other six channels carry all the alpha-



TAPE-CONTROLLED WIRING MACHINE cut errors, rapidly finishing complex panels. Fig. 1 (right) shows single-stage NOT elements that invert incoming data. Fig. 2-a—An electrical AND gate. b—A 4-legged AND gate and its symbol.

BRAINS OF AUTOMATION

by JOHN W. DIETRICH

Logic circuits and tape-controlled machines

bet and numerals. Fig. 1 shows those six channels with six NOT circuits. A NOT circuit is a single-stage amplifier that provides 180° phase inversion. Each NOT stage inverts the incoming data so that "true" becomes "not true" and vice versa.

Assume that "true" or "high" means +10 volts and "not true" or "low" is zero volts. When input X is true, output X is +10 volts, and output \bar{X} (not X) is zero. When input X is not true, output X is zero, and output \bar{X} is +10 volts. The 12 output lines provide all the logic conditions needed to identify tape-coded numerals and alphabet.

One common logic element is the AND gate shown in Fig. 2. Figure 2-a shows an electrical AND gate. Note that switches 1 and 2 and 3 and 4 must close before the "true" lamp can light.

Therefore, an AND gate is a coincidence detector. Figure 2-b shows a 4-legged electronic AND gate, with one example of the symbols for it.

All four inputs to Fig. 2-b must be high (+10 volts) before a high appears at the output. If one or more input legs are low (zero volts), the output is also low. When the

cathode is low the small forward resistance of a diode acts as a shunt from output to zero volts. Legs 1 and 2 and 3 and 4 must be true (high) before the output can go high to indicate true. The high back resistance of each diode appears when the cathode is switched to a high.

Two AND gates connected to tape reader data lines to detect letters x and z are shown in Fig. 3. Refer to Fig. 4 for the EIA tape perforation codes. Note that letter x in Fig. 3 has holes in the 1, 2, 4, and 0 channels, and NO holes in the 8 and X channels. The CH hole provides parity check only and is not needed to decode the letter. If the CH hole is missing, an even number of holes remains. That stops the tape reader.

The upper gate of Fig. 3 is connected to data lines 1, 2, 4, $\bar{8}$, 0 and \bar{X} . When those data lines go high the output of the "x" gate goes high. That condition occurs only when the letter x is in the reader. No other letter has the same combination of tape holes.

Notice the "z" gate in Fig. 3. This is connected to data lines 1, $\bar{2}$, $\bar{4}$, 8, 0, and \bar{X} . Check the tape perforations agree with that data. The

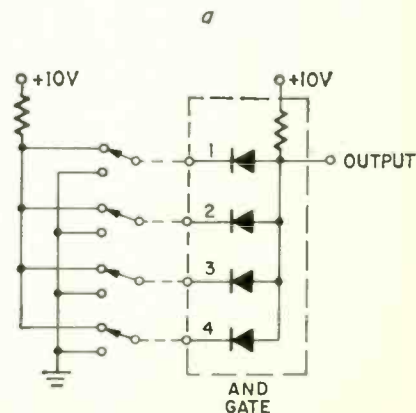
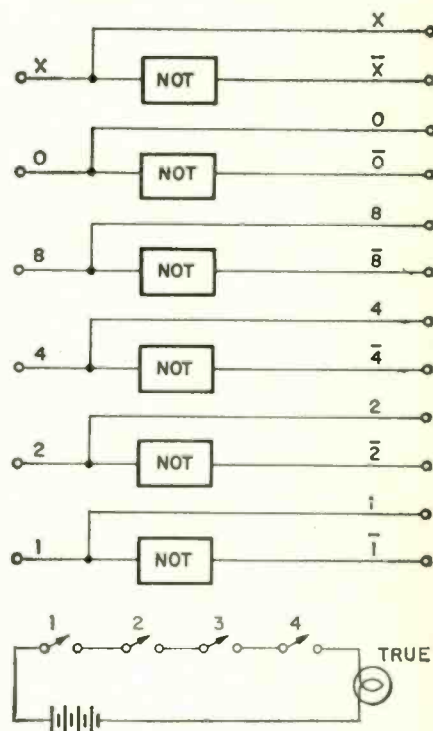

LET YOUR EARS DO THE WALKING

1970 HIGH FIDELITY MUSIC SHOWS

NEW YORK HIGH FIDELITY SHOW AT WESTBURY

Island Inn Motel, September 18-20

BOSTON HIGH FIDELITY SHOW AT NEWTON

The Marriott Motor Lodge, October 30-November 1

Show Admissions: \$1.00. Children under 12,
free when accompanied by an adult.

What you can cover in one day at the 1970 High Fidelity Music Shows, would take you a month of Saturdays if you had to run from store to store.

Because under one roof, you'll be able to listen to and compare 60 rooms of the newest innovations from the world's most important manufacturers of stereo hi-fi equipment—including all the tape configurations (reel to reel, cassette, cartridge) and the amazing 4-channel stereo. And to make sure you get the most from the Shows, there'll be plenty of experts around to help you understand all

the new equipment as well as guide you to what will be best for your room and your budget.

Along with the exhibitions and demonstrations will be daily seminars to help everyone—from the sternest audiophile to the beginner—learn what stereo high fidelity equipment is all about.

There's also plenty of free parking, so you can drive over to where your ears will do the walking.

And save the rest of your time for staying at home and listening.

SPECIAL EVENT — "THE MARVEL OF SOUND"

An exciting, entertaining 30 minute live spectacular!



INSTITUTE OF HIGH FIDELITY, 516 FIFTH AVENUE, NEW YORK, N.Y. 10036

Circle 76 on reader service card

PULSE GENERATOR ADAPTER

APG-100
(not illustrated)
APG-150



Now convert your sine/square wave generator to a high-speed lab quality pulse generator. No longer do you need to be limited with the standard test generator. Now BLULYNE makes it possible for you to have a laboratory variable pulse generator at less than one quarter the cost of a separate unit. Merely attach the output of your present sine/square wave generator to the input of the BLULYNE pulse generator adapter and you have fast rise and fall times, as well as variable pulse width, variable pulse amplitude, and variable frequency.

- calibrate your scope at high frequencies (50 Mhz rise time).
- No need to buy a complete expensive generator.
- Perfect for the designer, experimenter, engineer, technician.
- Perfect for circuits requiring fast rise times.
- Use to control chopper circuits.
- Many more valuable uses.

Specifications:

- Frequency range — 1 Hz to 10 Mhz.
- Rise time — less than 20 nsec. (nanoseconds)
- Fall time — less than 20 nsec. (nanoseconds)
- Pulse width (variable)
- 100 nsec. to 500 msec. (50% duty max)
- Pulse amplitude
- (APG-100) 0.6v - 6.0v (unterminated)
- (APG-150) 0.6v - 10.0v (unterminated)
- Input Impedance — 5000 ohms
- Output Impedance
- (APG-100) 110 ohms
- (APG-150) 50 ohms
- Connectors
- (APG-100) phono jacks
- (APG-150) BNC

Price
(APG-100) not illustrated \$39.95
(APG-150) \$49.95

Write for illustrated literature for this and other BLULYNE products.

Blulyne Electronic Corporation
Dept. R, 3 Sand Springs Road,
Williamstown, Mass. 01267

Circle 77 on reader service card

"z" gate output goes high only when z is in the reader.

The same principle is used to detect any other letter by connecting a six-leg AND gate to the proper lines. Select the proper data lines for any desired letter by noting the perforation code of Fig. 4.

Numerals are detected in 8-4-2-1 code directly from tape and need no gates. Decoding of numbers depends only on one or more numeral channels going high. When the 8 and 1 channels go high, a 9 is read. When 4, 2 and 1 go high, a 7 is read.

Numeral reading is controlled by another logic circuit which recognizes numerals only and is blind to all other data. This permits numerals to be read directly from data lines when no other character appears on tape. For example, the numeral recognition gate prevents "a g" from being read as a 7.

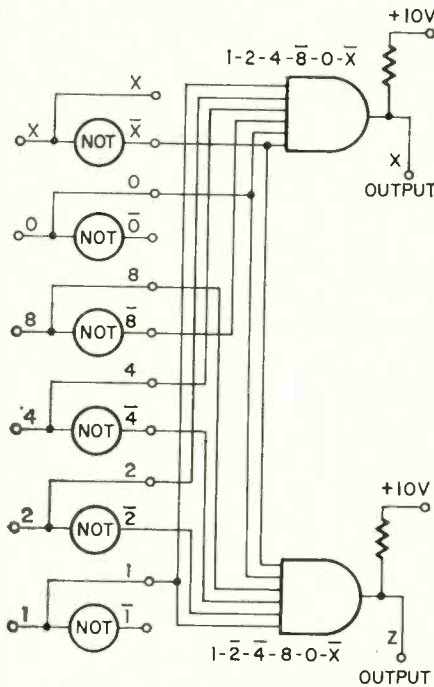

FIG. 3—LETTER DECODING for x and z.

Fig. 5 shows another logic element. Figure 5-a shows an OR gate made up with electrical switches. Note that any one switch (or all) causes the "true" lamp to light. The lamp lights when switch 1 or 2 or 3 or 4 is closed.

Figure 5-b shows an electronic OR gate and two forms of symbols for it. Note that when any one diode connects to a high (+10 volts), the output terminal voltage approaches +10 volts. A high through input 1 or 2 or 3 or 4 causes a high at the output terminal.

Each diode is forward biased at all times, and diode low forward resistance is in effect, when a true signal appears. Each diode clamps the

E.I.A. STANDARD CODING

FOR

1 INCH WIDE, EIGHT TRACK TAPE

TAPE PUNCH	8 7 6 5 4 • 3 2 1							
	EL	X	O	CH	B	4	2	1
0								
1								
2								
3								
4								
5								
6								
7								
8								
9								
a								
b								
c								
d								
e								
f								
g								
h								
i								
j								
k								
l								
m								
n								
o								
p								
q								
r								
s								
t								
u								
v								
w								
x								
y								
z								
.								
(PERIOD)								
(COMMA)								
/								
+ (PLUS)								
- (MINUS)								
SPACE								
DELETE								
CARR. RET OR END OF BLOCK								
BACK SPACE								
TAB								
END OF RECORD								
LEADER								
BLANK TYPE								
UPPER CASE								
LOWER CASE								

FIG. 4 (ABOVE)—PUNCHED TAPE coding. Fig. 5-a—Electrical switch OR gate. b—Electronic OR gate and gate symbols.

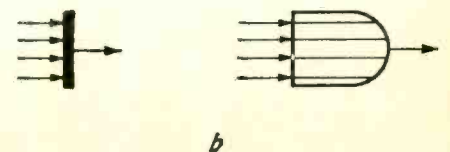
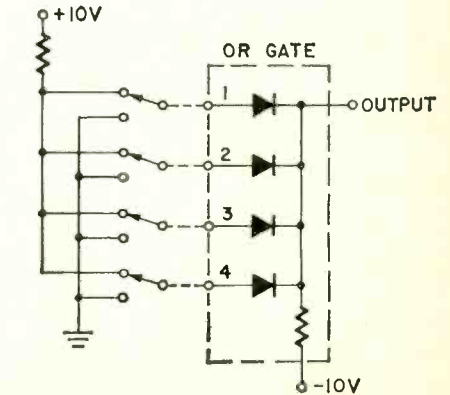
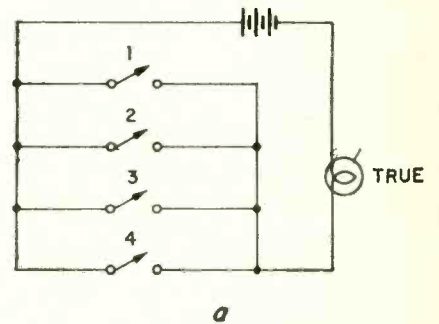

Olson

ELECTRONICS

FREE

Catalog

Fill in coupon for a FREE One Year Subscription to OLSON ELECTRONICS Fantastic Value Packed Catalog — Unheard of LOW, LOW PRICES on Brand Name Speakers, Changers, Tubes, Tools, Stereo Amps, Tuners, CB, Hi-Fi's, and thousands of other Electronic Values. Credit plan available.

NAME _____

ADDRESS _____

CITY _____ STATE _____

GIVE ZIP CODE _____

If you have a friend interested in electronics send his name and address for a FREE subscription also.

OLSON ELECTRONICS
Dept. LI 260 S. Forge Street
Akron, Ohio 44308

Circle 78 on reader service card

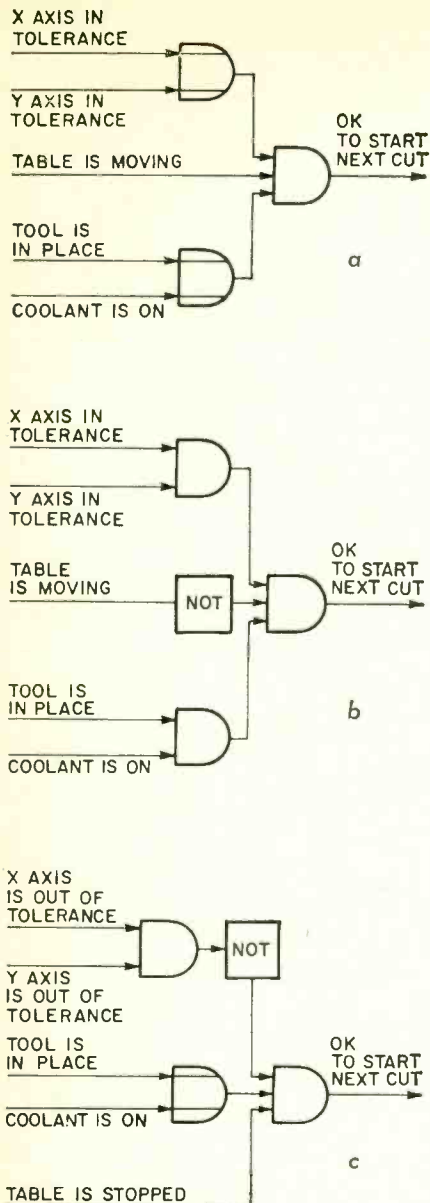

FIG. 6—TEST YOUR KNOWLEDGE. See question in text and select part a, b or c.

output level to the input voltage. When all anodes are low, the output is low. If any input goes high (+10 volts), the output also goes high.

The OR gate forms a junction for two or more circuits without interaction between them. For example, the four legs of Fig. 5-b may monitor four dimension tolerance points on a machine. If any one dimension goes out of tolerance, a switch closes and the OR gate output goes high to stop the machine.

Fig. 6 shows three logic circuits for an exercise. Select the one logic circuit which says "Start next cut when tool is in position, with coolant on and table stopped, if both x and y axes are in tolerance." When you have selected an answer, see the correct selection below. **R-E**

The correct answer is Fig. 6-b.

MULTIPURPOSE IC DIGITAL CLOCK

by LEO WALKER

Part II

Last month we presented the main section of this article, including all printed-circuit patterns and schematics. We did not have room to include all of the text. The following paragraphs contain added data on the optional circuitry.

Fig. 7 shows the ten-minute timer circuit. When pin 8 of QA in the minutes falls to zero at the end of the "9" count, pin 10 goes high enabling the tone generator to drive the output circuit. Pin 8 output of the decade counter QA in seconds section goes high causing the flip-flop to reset. This means that the tone will be on for 8 seconds since pin 8 of QA goes high on the count of 8 and remains high through the count of 9.

Approximately eight hours of assembly time is required to complete this circuit. It's a project that you enjoy everyday because it's always on. It's different from the run of the mill clock. It also shows how far technology has advanced since the cuckoo clock.

Fig. 6 is the schematic for a 100-kHz time base generator for use in applications where power line frequency is subject to change such as when emergency power is used. Of course this leads to another problem and that is memory for the clock while the power is being switched over. A 3.9-volt battery supply floats across the ac supply. The circuit uses a 100-kHz crystal oscillator. The output of the oscillator is divided by 1,000 in three minimum hardware divide-by-10 stages. The ÷6 stage in the clock's main generator is converted to a divide by 10. The 620-ohm resistor tied to pin 6 and 3.9 volts, is removed.

In cases where accuracy is a must and a receiver capable of receiving signals from WWVB on 60-kHz is available, the 1 pps signal can drive the clock.

For operation as a stop watch a spdt switch inserted directly at the input to the ÷60 (seconds) circuit is set to 60 pps.

The START-STOP switch is operated to connect pin 13 of the reset flip-flop to 3.9V through R8, a 620-ohm resistor. This stops the time base from triggering the input of the clock. When the START-STOP switch is set so that pin 9 of the reset flip-flop is connected to 3.9 volts, the clock now runs at a full 60 pps rate.

The minute section of the clock now reads seconds and the hours section now reads minutes. If the 12 hour version of the clock is used, a total time of 13 minutes can be measured; with a 24 hour unit, 24 minutes.

To stop the clock, the START-STOP switch is set so that pin 13 now has 3.9 volts on it. The clock can be set to zero, 00:00:00 by operating the momentary switch. The momentary switch applies 3.9 volts to the reset terminals of all the counters in the clock.

(continued on page 66)

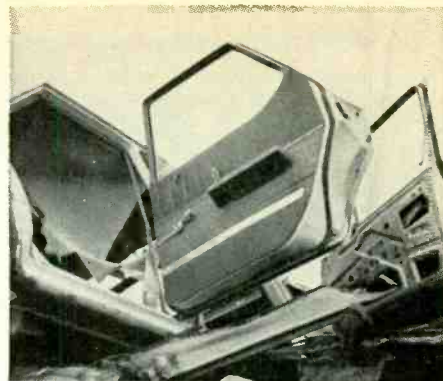

Let's hear it for the drunks.

It's not the drink that kills, it's the drunk, the problem drinker, the abusive drinker, the drunk driver. This year he'll be involved in the killing of at least 25,000 people. He'll be involved in at least 800,000 highway crashes. After all the drunk driver has done for us, what can we do for him? If he's sick, let's help him. But first we've got to get him off the road.

Do something. Write the National Safety Council, Dept. A, 425 N. Michigan Ave., Chicago, Illinois 60611. And your voice will be heard.

Scream Bloody Murder.



EDI

THOUSANDS OF BARGAINS—TOP VALUES IN Electronic Parts

Transistors, Modules, Speakers, Stereo, Hi-Fi, Photo Cells and thousands of other Electronic Parts. Send for **FREE** Catalog

ELECTRONIC DISTRIBUTORS INC.
Dept. TA-2, 4900 Elston
Chicago, Ill. 60630

RUSH CATALOG

Name _____

Address _____

City _____ State _____ Zip Code _____

Circle 80 on reader service card

MARKET CENTER

ELECTRONICS

RELAYS, military surplus, vacuum sealed. Coil 15V (min) minimum. Contacts SPDT 5000 V. \$5.50 each Ppd. **SEYMOUR TASH**, 4709 de la Peltrie, Montreal, Canada.

TRANSISTORIZED DC power supply. Build your own 5-40 volts, 1-3 amps, excellent regulation. Plans \$2.00 **NERONE ELECTRONICS**, Dept. 102, Box 238, New Baltimore, Michigan 48047

USED Tektronix, Hewlett-Packard, RCA Electronic Test Equipment. Used Industrial Motors, Timers, Controls. Free list. **ASSOCIATES**, Box 2421, Allentown, Pa. 18001

BUILD: Transformers, inductors yourself. Save. Free estimates and information. **MAGNETIC CIRCUITS**. 386 Deborah Ct. Dept. B, Upland, Calif. 91786

TUBES, sale to 95% off. All brands guaranteed. Servicemen, Hobbyists. Free list. **J. KNIGHT TV**, 612 Gaines Ave., Hot Springs, Ark. 71901

CONVERT any television to sensitive big-screen oscilloscope. Only minor changes required. No electronic experience necessary. Illustrated plans \$2.00. **RELCO-A25**, Box 10563, Houston, Texas 77018

RECEIVING & Industrial Tubes, Transistors. All Brands—Biggest Discounts. Technicians, Hobbyists, Experimenters—Request **FREE** Giant Catalog and **SAVE!** **ZALYTRON**, 469 Jericho Turnpike, Mineola, N.Y. 11501

TUBES—Lowest prices. Foreign-American. Obsolete, receiving, special purpose, transmitting tubes. Send for tube, parts catalog. **UNITED RADIO COMPANY**, 56-R Ferry St., Newark, N.J. 07105

DISCHARGE Ignition, Photoflash. Free catalog parts, kits. **TRANSPARK**, Carlisle, Mass. 01741

ULTRA-SENSITIVE and Powerful Metal Detectors—Join the many who are finding buried coins, minerals, relics and artifacts. Don't buy till you see our free catalog of new models. Write **JETCO**. Box 132-RE, Huntsville, Texas 77340

RADIO and TV Tubes 33¢ each. One year guaranteed. Plus many unusual electronic bargains. Free Catalog. **CORNELL** 4217-E University, San Diego, California 92105

B & K, sensor test equipment, discount prices. Free catalog and price sheet. **FORDHAM RADIO**, 265 East 149th Street, Bronx, NY 10451

COLOR Organ Kits \$3.25 to \$7.50. Power Supplies \$2.75. Catalog. **MURPHY**, 204 Roslyn Ave., Carle Place, N.Y. 11514

AUDIO — HI-FI

STEREO TAPE TRANSPORT—7" reel—2 speeds—pause control—made for famous manufacturer—50 to 15,000 Hz—with rec/play and erase heads. Without case. Send M.O. or check for \$19.50 to **STEREO CENTER**, 218 Columbia St., Utica, N.Y. 13502. \$2.50 for prepaid shipping and insurance.

CLASSIFIED COMMERCIAL RATE (for firms or individuals offering commercial products or services). 70¢ per word . . . minimum 10 words.

NON-COMMERCIAL RATE (for individuals who want to buy or sell personal items) 30¢ per word . . . no minimum.

FIRST WORD and **NAME** set in bold caps at no extra charge. Additional bold face at 10¢ per word. Payment must accompany all ads except those placed by accredited advertising agencies. 10% discount on 12 consecutive insertions, if paid in advance. Misleading or objectionable ads not accepted. Copy for November issue must reach us before Sept. 5.

CLASSIFIED ADVERTISING ORDER FORM

1	2	3	4	5
6	7	8	9	10
11	12	13	14	15
16	17	18	19	20
21	22	23	24	25
26	27	28	29	30
31	32	33	34	35

No. of Words { @ .30 Non-Commercial Rates } = \$ _____
 { @ .70 Commercial Rate } = \$ _____
 No. of Words in bold caps @ .10 = \$ _____

Total Enclosed \$ _____

Insert _____ time(s)

Starting with _____ issue

Payment must accompany order unless placed through accredited advertising agency 28

NAME _____

ADDRESS _____

CITY _____ STATE _____ ZIP _____

SIGNATURE _____

MAIL TO: RADIO-ELECTRONICS, CLASSIFIED AD DEPT., 200 PARK AVE. SOUTH, NEW YORK, N.Y. 10003

ADVERTISING INDEX

RADIO-ELECTRONICS does not assume responsibility for any errors which may appear in the index below.

READER SERVICE CARD NO.	PAGE
17 Allied Radio Corp.	5
Arrow Fastener Co., Inc.	26
4 B & K (Division of Dynascan Corp.) ..	7
18 Blonder-Tongue Laboratories, Inc.	32
77 Blulyne Electronic Corp.	96
65 Brooks Radio & TV Corp.	84-5
13 BSR USA Ltd.	22
8 Burstein-Applebee Co.	14
82 Castle TV Tuner Service	Cover III
64 Channel Master	83
12 Cleveland Institute of Electronics	18-21
81 Compusad, Inc.	102
CREI, Home Study Division of McGraw-Hill Book Co.	63-66
70 Delta Electronics Co.	88
72 Delta Products, Inc.	91
73 Electronic Chemical Corp.	92
80 Electronic Distributors, Inc.	97
1 EICO, Electronic Instruments Co., Inc.	Cover II
EMC, Electronic Measurement Corp.	70
68 Finney Co.	87
9 G-C Electronics	27
2 Grantham School of Electronics	1
75 Heald Engineering College	93
16 Heath Co.	24-5
63 Injectorall Electronics Corp.	82
76 Institute of High Fidelity	95
83 International Crystal Mfg. Co.	Cover IV
66 Judson Research & Mfg. Co.	86
71 Lafayette Radio Electronics	89-90
20 Leader Instrument Corp.	72
5 Lubra Clean Co.	12
11 Motorola Semiconductor Products Inc.	17
National Radio Institute	8-11
National Technical Schools	74-77
78 Olson Electronics, Inc.	96
62 Pennwood Numechron Co.	82
14 Perma-Power	22
69 Quietrole Co.	88
21 Raytheon Co.	78
RCA Institutes	28-31
RCA Parts & Accessories	73
84 Rye Industries, Inc.	92
7 S & A Electronics	14
74 S & A Electronics	92
22 Sams & Co., Howard W.	71
67 Schober Organ Co.	86
10 Sencore	16
15 Shure Bros., Inc.	23
19 Sony Corp. of America	79
Sylvania	15
6 TEAC Corp. of America	13
61 United Technical Institute, Division of Career Academy	81
MARKET CENTER	98-101
Bele Electronics	
Edmund Scientific Co.	
88 Karg Laboratories, Inc.	
Lakeside Industries	
Monogram Publishing Co.	
Music Associated	
87 Park Electronic Products	
86 Polypaks	
89 Solid State Sales Surplus Center	
SCHOOL DIRECTORY	102
Tri-State College	
Valparaiso Technical Institute	

SCHOOL DIRECTORY

GET INTO ELECTRONICS

V.T.I. training leads to success as technicians, field engineers, specialists in communications, guided missiles, computers, radar and automation. Basic & advanced courses in theory & laboratory. Electronic Engineering Technology & Electronic Technology curricula both available. Associate degree in 20 mos. B.S. also obtainable. G.I. approved. Graduates in all branches of electronics with major companies. Start Sept. Feb. Dorms, campus. High school graduate or equivalent. Catalog.

VALPARAISO TECHNICAL INSTITUTE
Dept. C, Valparaiso, Indiana 46383



distinguished graduates

hold important engineering and management posts throughout U.S. Professionally-oriented college with outstanding placement record. Four-quarter year permits degree in three years. Dedicated faculty. Modern labs. Small classes. 400-acre campus. Accredited. Approved for vets. Moderate total costs. Enter Jan., March, June, Sept. For Catalog, write Director of Admissions, indicating career preference.



TRI-STATE COLLEGE
2490 College Avenue, Angola, Indiana 46703



AMAZING NEW ELECTRONIC COMPUTER NOW AVAILABLE FOR PERSONAL USE... AT AN UNPRECEDENTED LOW PRICE!

For family fun or individual instruction, there's nothing quite like the all-new, all solid-state **COMPULOGICAL TUTOR!** Anyone from 8 to 80 can enjoy it while quickly learning digital logic and all other aspects of computer operation. No prior math required. In 20 minutes time, you'll be solving intricate problems just like computer professionals. You'll be entertained and enlightened as you proceed to learn binary numbers, fundamentals of Boolean algebra, logic-building blocks and symbols, truth tables, computer circuits, error-detecting logic, storage, programming and many other fascinating computer operations. It adds, subtracts, multiplies and divides... in millionths of a second. Shows how to apply computer to practical problems of accounting, economics and finance. Perfect for home, school and office. Master assembly board equipped with appropriate inputs and outputs, plus all circuits, controls and transistorized logic blocks (modules) required to work hundreds of problems. Big instruction manual simply presents basic computer concepts, with all problems and experiments clearly diagrammed and explained. Desk-size, portable, uses standard flashlight cells (not provided). Order for yourself, your family, and for gifts to youngsters, students, business executives, others. It's new... different... unique! Only \$69.95 postpaid and fully guaranteed. Free full-color brochure.



COMPUSAD, INC.
16 Wetmore St. - P.O. Box 10
New York Mills, N.Y. 13417

Use coupon below

Please send at once _____ Compulogical Tutor(s) at \$69.95, postpaid, with the understanding that if I am not more than satisfied in every way, I may return the Tutor(s) for a full refund.

- Full remittance enclosed; send postpaid. (Please Add Sales Tax Where Applicable)
- \$10 deposit enclosed; send C.O.D. for balance plus postage and fees.
- Send free color brochure at no obligation.

NAME _____
ADDRESS _____
CITY _____ STATE _____ ZIP _____

Circle 81 on reader service card

TRY THIS ONE

PULLING GROUND RODS IS EASY

A friend asked me to help relocate his CB antenna. It was a quarter-wave vertical working against a ground plane consisting of around thirty radials. Each radial terminated in a driven 6-foot copper-plated ground rod. He wanted to salvage as many of the radials and rods as possible but didn't want to have to dig them out.

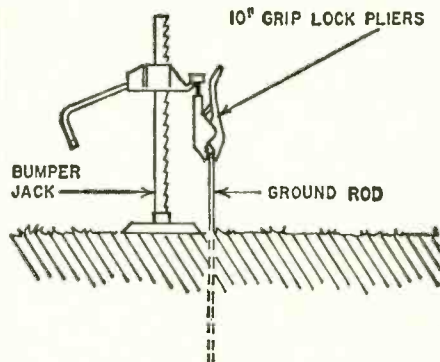

The radials were buried less than an inch deep so all I had to do was grab the exposed end and pull. Pulling the rods looked like quite a problem. I clamped a pair of locking-type pliers on one of the rods but couldn't lift or even twist it. I was stumped until I tried an automobile bumper jack as a lift. I slipped the lip of the jack under the head of the plier's adjusting screw (see diagram) and jacked the rods out without any effort.—*H. O. Maxwell*

COAX AND ROTARY BEAM ANTENNAS

Coax-fed rotary-beam TV, ham and CB antennas are generally plagued by breakage of the coax internal conductor in the flexible section of line running from the antenna to a point below the rotator. This breakage—generally in cold weather—is caused by constant flexing by the rotator and high winter winds.

To simplify replacing the broken section, make up the transmission line in two sections. Terminate the main section and the flexible section from the antenna with PL-259 (Amphenol 83-1SP or equal) male connectors at a point just below the rotator. Join the two sections with a PL-258 (Amphenol 83-1J or equal) coaxial junction. Tape and waterproof the connection. Incidentally, the junction between the two sections of cable is a good spot to insert a swr bridge when tuning up the antenna.—*Richard Mollentine, WAOKKC*

DRY CELL CONNECTIONS

Dry cells are often soldered into

place with flexible leads. This eliminates the problem of intermittents due to the riveted terminals of battery holders. But it also presents a new problem, the intermittent battery.

Most cells have a pressure plate at the bottom, or negative terminal. Many also have steel shells which make a solid contact to the zinc casing. There are no problems with these. But the imports, with cardboard cases and a pressure plate, give lots of grief.

The solution is simple. A single good hard whack on the bottom with a small ball-peen hammer will establish contact between the zinc shell and the pressure plate. More than one blow with the hammer should be avoided since this would distribute the pressure over a greater area and reduce it at any one point.

Before soldering the lead on, scrape the terminals and tin them quickly. A good hot iron will get the job done quicker and reduce heating effects in the cell.—*Roy A. McCarthy, K6EAW*

A UNIQUE HOT-TUBE PULLER

A universal coupling from a discarded bathroom shower hose makes a fine tube puller. The rubber coupling

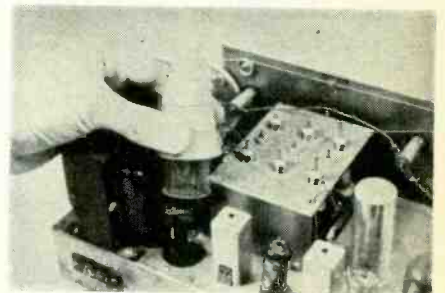

adjusts to almost any size tube and it will prevent any nasty finger burns.—*Robert E. Kelland*

TRANSISTOR REMOVAL

The compact construction of much of our modern solid-state electronic gear often makes it difficult to remove transistors or other components for testing or replacement. More often than not, the part we want to get at is practically buried among other parts on the circuit board. There isn't even "finger" room for grasping and removing the desired part.

I have solved this problem by using a standard size alligator clip with the teeth filed off. Just slip the clip over the component until the jaws grip solidly or slide under it. This provides a handle for pulling the part out as its leads are unsoldered.—*Geo. D. Philpott*

R-E



Castle, the pioneer of television tuner overhauling, offers the following services to solve ALL your television tuner problems.

● **OVERHAUL SERVICE** — All makes and models.
(1960, or later)

- VHF or UHF tuner \$9.95
- UHF-VHF combination (one piece chassis) \$9.95
- TRANSISTOR tuner \$9.95
- COLOR tuner \$9.95
(Guaranteed color alignment . . . no additional charge)

Overhaul includes parts, except tubes and transistors.

Simply send us the defective tuner complete; include tubes, shield cover and any damaged parts with model number and complaint. Your tuner will be expertly overhauled and returned promptly, performance restored, aligned to original standards and warranted for 90 days.

UV combination tuner must be single chassis type; dismantle tandem UHF and VHF tuners and send in the defective unit only.

And remember—for over a decade Castle has been the leader in this specialized field . . . your assurance of the best in TV tuner overhauling.

Remove all accessories . . . or dismantling charge will apply.

● **CUSTOM REPLACEMENTS**

Exact replacements are available for tuners that our inspection reveals are unfit for overhaul. As low as \$12.95 exchange. (Replacements are new or rebuilt.)

● **UNIVERSAL REPLACEMENTS**

Prefer to do it yourself?

Castle universal replacement tuners are available with the following specifications.

STOCK No.	HEATERS	SHAFT		I.F. OUTPUT		PRICE
		Min.*	Max.*	Snd.	Pic.	
CR6P	Parallel 6.3v	1¾"	3"	41.25	45.75	8.95
CR7S	Series 600mA	1¾"	3"	41.25	45.75	9.50
CR9S	Series 450mA	1¾"	3"	41.25	45.75	9.50
CR6XL	Parallel 6.3v	2½"	12"	41.25	45.75	10.45
CR7XL	Series 600mA	2½"	12"	41.25	45.75	11.00
CR9XL	Series 450mA	2½"	12"	41.25	45.75	11.00

*Selector shaft length measured from tuner front apron to extreme tip of shaft.

These Castle replacement tuners are all equipped with memory fine tuning, UHF position with plug input for UHF tuner, rear shaft extension and switch for remote control motor drive . . . they come complete with hardware and component kit to adapt for use in thousands of popular TV receivers.

Order universal replacements out of Main Plant (Chicago) only.



CASTLE TV TUNER SERVICE, INC.

MAIN PLANT: 5715 N. Western Ave., Chicago, Illinois 60645

* EAST: 130-01 89th Rd., Jamaica, N.Y. 11418

Circle 82 on reader service card

“Operation SURVEY”



International
Microwave Oven
Test Lamp

International, in cooperation with the Department of Health, Education and Welfare, is conducting "Operation Survey" on all International Microwave Ovens in use, to advise owners of current safe specifications.

We have contacted all known registered oven owners by mail and have sent them a free simple test lamp with instructions to check their ovens for excessive power leakage.

If you are the owner of an International Microwave Oven and have not received one of our free test lamps advise us of the fol-

lowing: (1) oven serial number (2) where purchased (3) date of purchase.

Causes of Power Leakage

All International Ovens are checked and adjusted for safe leakage levels before leaving the factory. Therefore, when an oven develops power leaks beyond a safe limit, something has to change within the oven adjustment. The most likely area is the door seal. International type seals have been cycle tested the equivalent of 10 years operation with only a small increase in power leakage.

Shipping damage is generally the cause of a change. Normal handling **will not** damage the seal. Usually the damage is obvious where the oven has been dropped.

During use a coating of grease or food particles on the door seal can provide sufficient gap in the fit of the seal to increase the power leakage. Merely keep the seal and the face of the oven cavity wiped clean with a damp cloth and no leakage should occur from this cause.

To obtain additional information address your inquiry to

INTERNATIONAL CRYSTAL MFG. CO., Inc., 10 North Lee,
Oklahoma City, Okla. 73102, **ATTENTION: OPERATION SURVEY.**



CRYSTAL MFG. CO., INC.
10 NO. LEE • OKLA. CITY, OKLA. 73102

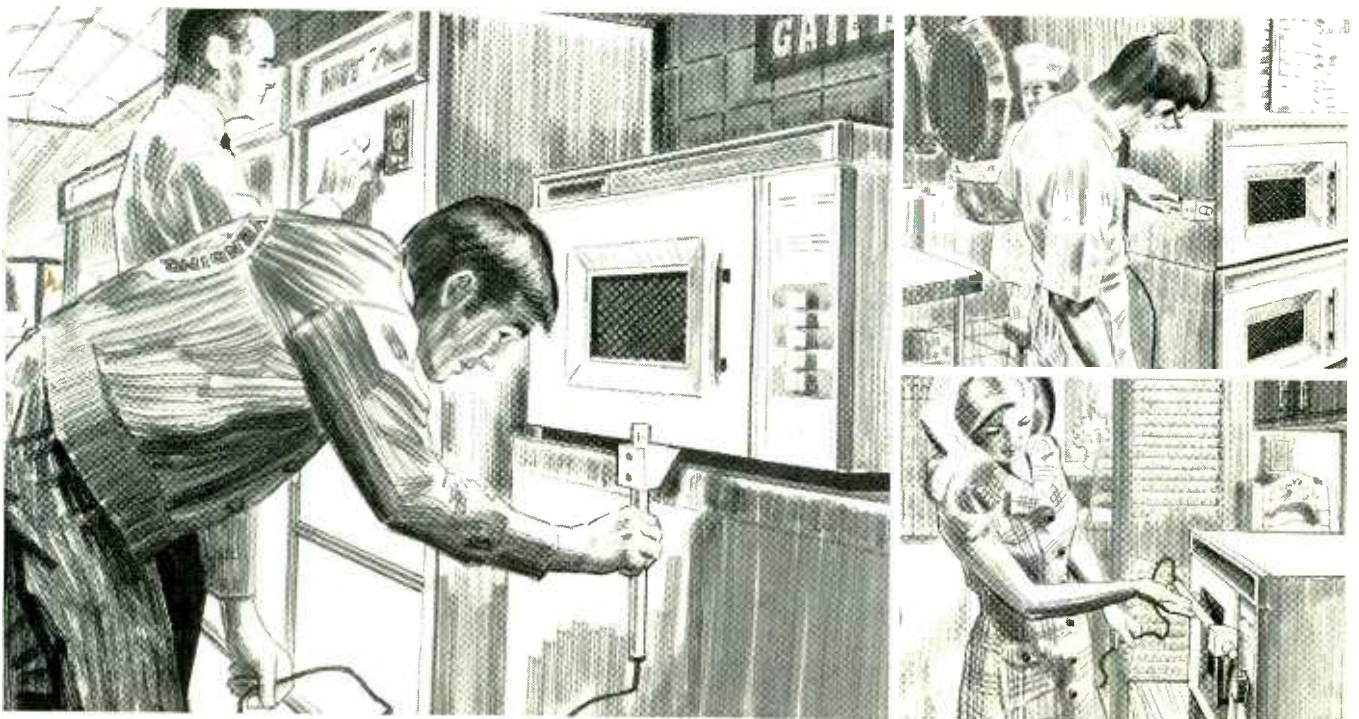

Circle 83 on reader service card