

48783 Radio

ISDN: THE TELEPHONE NETWORK OF TOMORROW

OCTOBER 1988

Electronics

TECHNOLOGY - VIDEO - STEREO - COMPUTERS - SERVICE

DON'T DRIVE DRUNK!

Build our electronic blood-alcohol monitor

A GERNSBACH PUBLICATION

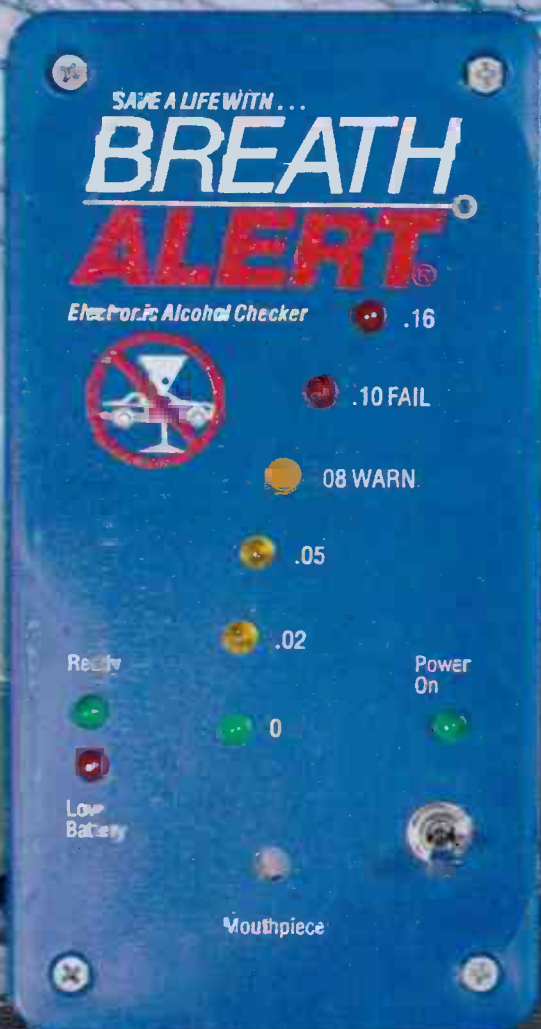

25

IN CANADA \$2.75



BUILD A DIGITAL PHONE LOCK
ELECTRONIC THERMOMETER PROJECT
DIFFERENTIAL DISTORTION TESTS
★ COMPUTER DIGEST ★ HARDWARE HACKER

Fluke. First Family of DMMs.



When accuracy, performance and value are important, professionals the world over look to Fluke — the first family of DMMs.

Reliable Fluke-quality 3½- or 4½-digit DMMs fit every need — from design engineering to industrial troubleshooting.

There's the low-cost 70 Series — the most DMM you can get for the money. The high-energy protected 20 Series — built to survive the toughest jobs. The reliable 8020B Series — made to withstand the rigors of the field service environment. The precise 8060A Series — the most powerful and complete test and measurement system available in a handheld package. And, of course, the versatile Bench/Portables that carry on the Fluke tradition for precision and durability in lab-quality bench instruments.

Fluke comes in first again with the world's largest selection of quality accessories to help extend the capabilities of your DMM even further.

There's no need to look anywhere else. Uncompromising Fluke design and leading edge technology are the reasons why attempts at imitation will never fool the millions of professionals that accept nothing less than a Fluke.

For your nearest distributor or more information, call toll-free 1-800-44-FLUKE, ext. 33.

FROM THE WORLD LEADER
IN DIGITAL MULTIMETERS.



Fluke's newest 3½-digit bench meter, the 37, offers 0.1% basic dc accuracy, analog/digital display, fused 10A range, MIN/MAX recording, Touch Hold, and internal storage compartment.

FLUKE®

John Fluke Mfg. Co., Inc. P.O. Box C9090, M/S 250C, Everett, WA 98206, Sales: (206) 356-5400, Other: (206) 347-6100.
© Copyright 1988 John Fluke Mfg. Co., Inc. All rights reserved. Ad No. 0821-F70

CIRCLE 121 ON FREE INFORMATION CARD

ON THE COVER

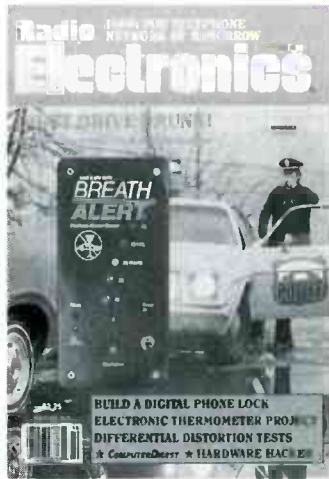

It isn't easy to judge when you've had too much to drink—or to convince someone else that he's in no condition to get behind the wheel of a car. The Breath-Alert offers a friendly, yet definitive, measurement of a person's blood-alcohol concentration by analyzing his exhaled breath. The convincing test is done by simply blowing into a straw. The Breath-Alert's different-colored LED's indicate increasingly dangerous levels of alcohol in the bloodstream, and when the legal limit is reached a buzzer sounds also. To learn how to build this life-saving and educational device, see page 51.

COMING NEXT MONTH

THE NOVEMBER ISSUE IS ON SALE OCTOBER 4

THE FUTURE OF FAX

A pair of articles examine the history of facsimile, and how it works.

COPING WITH COILS

The easy way to pick the proper inductor, and how to make your own.

DIGITAL PHONE LOCK

Finishing up construction, and adapting the unit for pulse lines.

COMPUTER DIGEST

The new EIA-232 standard replaces the RS-232.

As a service to readers, RADIO-ELECTRONICS publishes available plans or information relating to newsworthy products, techniques and scientific and technological developments. Because of possible variances in the quality and condition of materials and workmanship used by readers, RADIO-ELECTRONICS disclaims any responsibility for the safe and proper functioning of reader-built projects based upon or from plans or information published in this magazine.

Since some of the equipment and circuitry described in RADIO-ELECTRONICS may relate to or be covered by U.S. patents, RADIO-ELECTRONICS disclaims any liability for the infringement of such patents by the making, using, or selling of any such equipment or circuitry, and suggests that anyone interested in such projects consult a patent attorney.

RADIO-ELECTRONICS, (ISSN 0033-7862) September 1988. Published monthly by Gernsback Publications, Inc., 500-B Bi-County Boulevard, Farmingdale, NY 11735 Second-Class Postage paid at Farmingdale, NY and additional mailing offices. Second-Class mail registration No. 9242 authorized at Toronto, Canada. One-year subscription rate U.S.A. and possessions \$17.97, Canada \$23.97, all other countries \$26.97. All subscription orders payable in U.S.A. funds only, via international postal money order or check drawn on a U.S.A. bank. Single copies \$2.25. © 1988 by Gernsback Publications, Inc. All rights reserved. Printed in U.S.A.

POSTMASTER: Please send address changes to RADIO-ELECTRONICS, Subscription Dept., Box 55115, Boulder, CO 80321-5115.

A stamped self-addressed envelope must accompany all submitted manuscripts and/or artwork or photographs if their return is desired should they be rejected. We disclaim any responsibility for the loss or damage of manuscripts and/or artwork or photographs while in our possession or otherwise.

Radio Electronics

Hugo Gernsback (1884-1967) founder
M. Harvey Gernsback,
editor-in-chief, emeritus

Larry Steckler, EHF, CET,
editor-in-chief and publisher

EDITORIAL DEPARTMENT

Art Kleiman, editorial director

Brian C. Fenton, editor

Carl Laron, WB2SLR,
editorial associate

Marc Spiwak, associate editor

Jonathan A. Gordon,
assistant technical editor

Teri Scaduto, assistant editor

Jeffrey K. Holtzman,
computer editor

Robert A. Young, assistant editor

Byron G. Wels, editorial associate

Jack Darr, CET, service editor

Robert F. Scott,
semiconductor editor

Herb Friedman,
communications editor

Robert Grossblatt, circuits editor

Larry Klein, audio editor

David Lachenbruch,
contributing editor

Don Lancaster,
contributing editor

Richard D. Fitch,
contributing editor

Kathy Campbell, editorial assistant

Andre Duzant, technical illustrator

Injae Lee, assistant illustrator

PRODUCTION DEPARTMENT

Ruby M. Yee, production director

Robert A. W. Lowndes,
editorial production

Karen Tucker, advertising production

Marcella Amoroso, production traffic

CIRCULATION DEPARTMENT

Jacqueline P. Cheeseboro,
circulation director

Wendy Alanko,
circulation analyst

Theresa Lombardo,
circulation assistant

Nancy Estrada, manager,
R-E Bookstore

Typography by Mates Graphics

Cover photo by Herb Friedman

Background photo by

Alfred T. Campbell

© FPG International

Radio-Electronics is indexed in
Applied Science & Technology Index
and *Readers Guide to Periodical Literature*.

Microfilm & Microfiche editions are
available. Contact circulation depart-
ment for details.

Advertising Sales Offices listed
on page 122.



Intermittents. We Hear You.

Introducing The Heavy-Duty DMM With An Audible Readout That Lets You Keep Both Eyes On The Job.

Intelligent design and solid construction make the new HD 150 Series the best DMMs in their class.

They're the latest in a distinguished line that began when Beckman Industrial pioneered heavy-duty DMMs with their distinctive yellow color. Many competitors have since imitated that color. As for imitating their performance, no one comes close.

The HD 150 Series attains new levels of excellence with a range of advanced features. They're waterproof. Drop proof.

Auto-ranging. Slim-styled for one-hand comfort and convenience. With auto-off to prolong battery life. Plus 2 fuses, PTC resistor and MOV for unsurpassed overload protection.

Audible readout. A "sound" reason to go with the HD 150 Series. With this unique feature on the HD 153, you measure parameters by listening to a continuous variable tone. As the parameter you measure rises or falls, the tone's frequency increases or decreases, accordingly. Use it for volts, amps, or ohms. It's ideal for peaking and nulling, too.

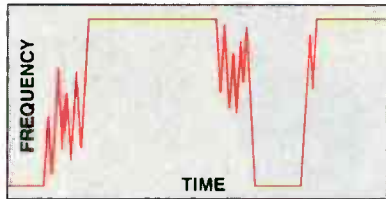

Intermittent alert. A key application of audible readout. The HD 153 pinpoints intermittents by emitting a "crackling" sound when they're detected. The response sounds in about 1 msec—far faster than the information appears on any DMM display.

Logic function.

The HD 153 detects TTL or CMOS logic pulses using standard test leads.

Easy to use.

The HD 150 Series lets you read the LCD even at wide angles. With the large rotary dial you select functions with one-handed (right or left) convenience. Auto-ranging speeds you to the right range. A tilt-stand and Skyhook let you set or hang the DMM almost anywhere.



Built tough to work hard. The HD 150 Series DMMs are so tightly sealed against water and grime that they're *guaranteed for five years* against contamination. And, because they're built so tough, they're guaranteed for two years against *any* damage (except abuse). Crashes, overloads, moisture, dust... you name it. The HD 150 Series can handle it all!

Listening is believing. For a hands-on demo, see your distributor now. Learn why the HD 150 Series is the soundest DMM value you'll see. Or hear.

Key Specifications

	HD 151	HD 152	HD 153
Auto-ranging	✓	✓	✓
Range Lock		✓	✓
Audible readout			✓
Tilt Stand and Skyhook™	Optional	Optional	Included
Logic pulse detector			✓
DC voltage accuracy	0.7%	0.5%	0.25%
10A range		✓	✓
Suggested list price	\$149.00	\$169.00	\$199.00



Beckman Industrial™

Beckman Industrial Corporation
Instrumentation Products Division
A Subsidiary of Emerson Electric Company
3883 Ruffin Road, San Diego, California 92123-1898
(619) 495-3200 • FAX: (619) 268-0172 • TLX: 249031

*In Service
Instruments,
We're The One.*

© 1988 Beckman Industrial Corporation
Specifications subject to change without notice.
Valox is a registered trademark of General Electric Corporation.

WHAT'S NEWS

500 million operations per second with new silicon software



GE SCIENTIST DR. RICHARD I. HARTLEY examines the layout of an IC designed with the aid of PARSIFAL.

Scientists from the GE Research and Design Center (Schenectady, NY) described an advanced "silicon compiler," intended for the design of algorithm-specific IC's for high-speed digital-signal processing, at the recent 25th Design Automation Conference at Anaheim, CA. Speeds in the order of 500 million operations per second are possible with IC's that are compiled with the new software, called PARSIFAL.

The greater operating speed of integrated circuits that are compiled with PARSIFAL is a result of that computer-aided design tool's ability to create IC's that can add, multiply, and perform other operations on "words" up to 16 bits wide. Earlier compilers could han-

dle only one-bit words. Computational throughput is thus remarkably improved.

A fantastic decrease in design time is also possible by using PARSIFAL. One example is a 60,000-transistor IC that was successfully developed for a medical application. It can execute 10 million computations per second. Once the mathematical equations describing the IC's functional requirements had been finalized, it took a designer only one day—using PARSIFAL—to generate an initial layout. That feat could have taken up to five person-years with older design methods. The complete design/optimization cycle involved ten iterations of the IC, and took two weeks.

Electronic "artificial nose" detects dangerous gases

Scientists at Sandia National Laboratories, in Albuquerque, NM, have developed an "artificial nose" that can sniff out several hazardous gases. Concentrations of only a few parts per million can be detected.

The sensor—which has no moving parts, is about the size of a pencil eraser, and operates on a few nanoamps—consists of an array of six tiny diodes. Their active part is a thin layer of catalytic metal, less than 2,000 angstroms thick. Different combinations of palladium and a second metal—typically gold or silver—are placed on individual diodes during manufacturing to tailor their sensitivity to specific gases.

At room temperature, the sensor detects three types of hydrogen gas, and other gas compounds such as hydrogen sulfide and formic acid. At temperatures between 100°C and 200°C, it responds more quickly and detects some gases that cause no response at room temperature.

Various industrial and home applications are seen for the safety/warning device. Particularly in the petrochemical industry, it might be used to indicate accumulations of noxious or explosive gases.

New ceramic superconductor works up to 120° Kelvin

A new ceramic compound that maintains its superconductivity at up to 120°K (–243°F) is reported by researchers at Sandia National Laboratories, Albuquerque, NM. The new superconductor is composed of thallium, barium, calcium, copper, and oxygen. It is capable of carrying currents in its superconductive state that are as high as those carried by the yttrium/barium/copper-oxide type, which is superconductive only to 90° Kelvin.

R-E



JDR INSTRUMENTS

Complete customer satisfaction... superior service... friendly, knowledgeable personnel... quality merchandise... providing the best values in leading edge technology.

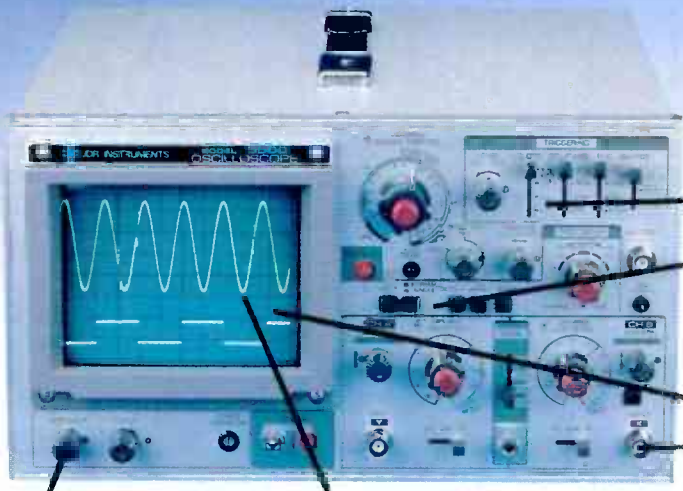

35 MHZ OSCILLOSCOPE

A remarkable value

\$499⁹⁵

Wide bandwidth and exceptional 1mV/DIV sensitivity make the Model 3500 a powerful diagnostic tool for engineers or technicians at a remarkable price. Delayed triggering allows any portion of a waveform to be isolated and expanded for closer inspection. Variable Holdoff allows stable viewing of complex waveforms.

TV SYNC FILTER

DELAYED AND SINGLE SWEEP MODES

EXCEPTIONALLY BRIGHT 5" CRT

X-Y OPERATION

Z AXIS INTENSITY MODULATION

FAST 10NS RISE TIME

DMM-300

\$79.95

3.5 DIGIT DMM/MULTITESTER

This full function 3.5 digit DMM offers highly accurate performance and a host of added features like audible continuity, capacitance, transistor, temperature, and conductance to help you do the job—fast. Temperature probe, test leads and battery included.

- Basic DC accuracy: plus/minus 0.25%
- DC voltage: 200mV–1000V, 5 ranges
- AC voltage: 200mV–750V, 5 ranges
- Resistance: 200 ohms–20M ohms, 6 ranges
- Capacitance: 2000pF–20 μ F, 3 ranges
- Transistor Tester: 0°–2000°F
- Conductance: 200ns
- Fully overload protected
- Input impedance: 10M ohm

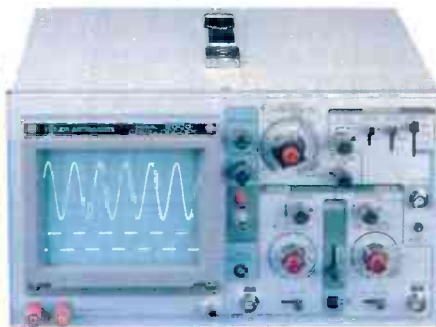

MODEL 2000

\$389.95

20 MHZ DUAL TRACE OSCILLOSCOPE

Model 2000 makes frequency calculation and phase measurement quick and easy. The component tester aids in fast troubleshooting. Service technicians appreciate the TV Sync circuits for viewing TV-V and TV-H and accurate synchronization of the video signal, Blanking, VITS, and V/H sync pulses.

- Exceptionally bright 5" CRT
- Built-in component tester
- TV Sync filter
- X-Y operation \pm 110/220 volts

DMM-100

\$29.95

3.5 DIGIT POCKET SIZE DMM

Perfect for the field service technician. Shirt pocket size without compromising features or accuracy. Large, easy to read 1/2" LCD display. Fully overload protected for safety. 2000 hour battery life with standard 9v cell. Probes and battery included.

- Basic DC accuracy: plus/minus 0.5%
- DC voltage: 2V–1000V, 4 ranges
- AC voltage: 200V–750V, 2 ranges
- Resistance: 2k ohms–2M ohms, 4 ranges
- DC current: 2mA–2A, 4 ranges
- Input impedance: 10M ohm
- Fully overload protected
- Approx. 5" x 3" x 1". Under 7 ozs.



DMM-200

\$49.95

3.5 DIGIT FULL FUNCTION DMM

Get highly accurate performance at a very affordable price. Rugged construction, 20 amp current capability and 22 ranges make it a perfect choice for serious field or bench work. Low battery indicator and tilt-stand. Probes and 2000 hour battery included.

- Basic DC accuracy: plus or minus 0.25%
- DC voltage: 200mV–1000V, 5 ranges
- AC voltage: 200mV–750V, 5 ranges
- Resistance: 200 ohms–20M ohms, 6 ranges
- AC/DC current: 200 μ A–20A, 6 ranges
- Input impedance: 10M ohm
- Fully overload protected
- Approx. 7" x 3 1/2" x 1 1/2". Wt. 11 ozs.



DPM-1000

\$54.95

3.5 DIGIT PROBE TYPE DMM

Custom 80 pin LSI chip provides accuracy and reliability in such a compact size. Autoranging, audible continuity and data hold feature help you pinpoint the problem quickly. Case and batteries included.

- Basic DC accuracy: plus/minus 1%
- DC voltage: 2V–500V, autoranging
- AC voltage: 2V–500V, autoranging
- Resistance: 2k ohms–2M ohms, autoranging
- Fully overload protected
- Input impedance: 11M ohm
- Approx 6 1/2" x 1" x 3/4". Under 3 ozs.

- ★ 2 YEAR REPLACEMENT WARRANTY
- ★ 30 DAY MONEY BACK GUARANTEE
- ★ TOLL FREE TECHNICAL SUPPORT
- ★ NEXT DAY AIR SHIP AVAILABLE

COPYRIGHT 1987 JDR MICRODEVICES



JDR INSTRUMENTS, 110 KNOWLES DRIVE, LOS GATOS, CA 95030
RETAIL STORE: 1256 SOUTH BASCOM AVE, SAN JOSE, CA (408) 947-8881

ORDER TOLL FREE 800-538-5000

CIRCLE 59 ON FREE INFORMATION CARD

www.americanradiohistory.com

VIDEO NEWS



DAVID LACHENBRUCH,
CONTRIBUTING EDITOR

● **HDTV Battle in high gear.** Broadcasters, cable-TV operators, and equipment manufacturers are actively lobbying the FCC and Congress for their own approaches to high-definition TV. There's no unanimity on the subject, but there seems to be some agreement that cable or direct satellite broadcasting may be the first to introduce HDTV in the United States. Broadcasters are urging the FCC not to reallocate some UHF channels to other spectrum users, but to save them instead for added frequencies which probably will be needed for HDTV.

The networks and some other broadcasters have shown support for the ACTV system (Advanced Compatible TV), under development by the David Sarnoff Research Center, NBC, and Thomson Consumer Electronics (RCA- and GE-brand TV sets), which is designed to achieve HDTV in two steps. ACTV I would provide a compatible widescreen picture with improved definition in the bandwidth of a current TV channel. ACTV II would use a second channel to supply augmentation signals to realize true high definition at a future date.

Several other compatible systems are under development. Philips' HDS-NA (High Definition System for North America) would maintain existing channels but add "augmentation" material for additional definition and wide-screen extensions, along with digital audio, on one-half of an additional channel—thus one standard 6-MHz channel could provide augmentation for two standard NTSC channels. Other compatible systems are being developed, including systems by William Glenn of the New York Institute of Technology, and by the Del Ray Group, which would get a compatible HDTV picture into a single channel. As news continues to spread here about Japanese plans for satellite broadcasting of a non-compatible HDTV signal, agitation for quick action to develop a standard and get moving in the U.S. accelerates.

● **Airvision.** You take your seat in the airliner and instead of listening to music or reading a magazine, you flip the switch in the armrest to the TV news, a choice of several movies, language

instruction, or a live picture of the plane's takeoff—and watch the small bright color screen embedded in the back of the seat in front of you (or in the between-seats console if you're traveling first class). You might even choose to play an exciting video game or two to while away your travel time.

How far in the future is all of that? Would you believe this year? Philips of the Netherlands and Warner Brothers pictures say the first aircraft equipped with Airvision will take off some time in 1988. The viewing screens initially will be three-inch active-matrix back-lighted LCD's; at least five VHS videocassette players in the aircraft will be used as signal sources, with other sources possible. They're proposing the system not only for aircraft, but for buses, taxicabs, trains, ships, and other modes of transportation. And a competing system, called ACES (Airborne Cabin services and Entertainment System), with four-inch flat color CRT's has been developed by Sony and Sundstrand Data Control.

● **Bigger tubes coming.** The larger-size direct-view picture tubes have been decreed a winner. So far, they're all made in Japan—everything larger than 17 inches in diagonal measurement, that is. But their success on the American market means that they'll soon be made here, too. The new Matsushita picture-tube plant, scheduled to start production next spring in Troy, Ohio, will specialize in larger sizes and be designed to produce 27- and 31-inch tubes. Toshiba-Westinghouse Electronics, currently producing 19- and 20-inch tubes in Horseheads, New York, is being expanded to turn out 30- and 32-inch sizes. Mitsubishi's plant in Canada is exploring production of larger tubes as is Thomson Consumer Electronics, which makes RCA and GE tubes in two American locations. Other plants looking into the larger sizes are Philips and Zenith. The biggest tube size in general use is the 35-inch, currently made only by Mitsubishi in Japan. So far, there are no plans to produce that size in America, although there is some conjecture that Matsushita's new plant may turn out 36-inch giants later. **R-E**

HITACHI SCOPES AT DISCOUNT PRICES!

\$100 Price Reduction



V-212
NOW \$379
was \$475
List \$560

Plus 'Free' 9600 Function Generator

All Hitachi scopes include two 50 MHz probes and have a 3 year warranty on parts and labor



40MHz **V-425** List 995
CRT readout **\$835**



60MHz **V-660** List 1,195
Delayed sweep **\$949**



100MHz **V-1060** List 1,595
Delayed sweep **\$1,285**

	List	Our Price	Save
V-223 20MHz D.T. 2mV Sens. Delayed Sweep	770	695	75
V-422 40MHz D.T. 1mV Sens. DC offset	875	695	180
V-423 40MHz D.T. 1mV Sens. Delayed Sweep DC offset	955	795	160
V-1065 100MHz D.T. 2mV Sens. Delayed Sweep	1,895	1,575	320
V-1100 100MHz Q.T. 1mV Sens. Curser meas. DVM counter	2,295	1,995	300
V-1150 150MHz Q.T. 1mV Sens. Curser meas. DVM counter	3,100	2,565	535

ELENCO PRODUCTS AT DISCOUNT PRICES!

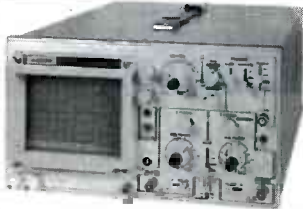

\$349
MO-1251

- 6" CRT
- Built in component tester
- TV Sync
- Much More

20MHz Dual Trace Oscilloscope

Scope Probes

P-1 65MHz, 1x, 10x **\$19.95**
P-2 100MHz, 1x, 10x **\$23.95**
with 5 accessories
10 Meg ohms input impedance
Fits all scopes with
BNC connector
TL-3 BNC to Minigrabber **\$3.49**

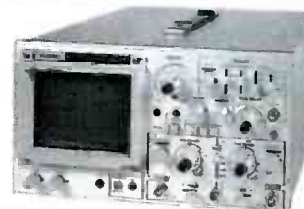

\$498
MO-1252

- High Luminance 6" CRT
- 1mV Sensitivity
- 6KV Acceleration Voltage
- 10ns Rise Time
- X-Y Operation • Z Axis
- Delayed Triggering Sweep
- Much More

35MHz Dual Trace Oscilloscope

Top quality scopes at a very reasonable price. Contains all desired features. Two 1x, 10x probes, diagrams and manual.



True RMS 4 1/2
Digit Multimeter
\$135 M-7000

.05% DC Accuracy
.1% Resistance
with Freq. Counter
& Deluxe Case



10MHz Oscilloscope
S-3000
\$239

10MHz DC or AC
Triggered Sweep
Calibrated Vert & Hor
Reads Volts & Freq



Decade Blox
9610 or 9620
\$14.95

#9610 Resistor Blox
47 ohm to 1M & 100K pot
#9620 Capacitor Blox
47pf to 10MFD



Low Cost
Multimeter
M-1600
\$25

3 1/2 Digit LCD
1% DC Accuracy
10A Scale
Auto zero/polarity



Digital LCR Meter
LC-1800
\$138

Measures
Coils (1uH-200H)
Caps (.1pf-200uf)
Resistors
(.1 ohm-20M ohms)



Breadboard

9436
Shown

9430 1,100 pins \$15
9434 2,170 pins \$25
9436 2,860 pins \$35



Multimeter with
Capacitance and
Transistor Tester
\$55 CM-1500A

Reads Volts, Ohms
Current, Capacitors,
Transistors and
Diodes w/case



Digital Capacitance Meter
CM-1550
\$58.95

9 Ranges
.1pf-20,000ufd
.5% basic accuracy
Zero control
w/case



Analog Multimeter
M-1100
\$19.95

19 ranges
High Accuracy
10A reading
Mirrored scale
KIT 17.50



3 1/2 Digit Meter
Auto and
Manual Ranging
28 Functions
Fully Protected

M-1180 .7% Ac \$36.95
M-1181 .1% Ac \$42.95
M-1182 .25% Ac \$39.95



Function Generator Blox
#9600
\$24.95

Provides sine, tri, squ wave
From 1Hz to 1MHz
AM or FM capability

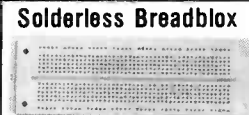

Solderless Breadboard
#9550
\$7.50

550 tie pts
including 2 power
bus lines



IC Test Clips
16 pin \$5.95
20 pin \$8.25
24 pin \$10.75
28 pin \$11.75
40 pin \$18.50

All are gold plated to
assure trouble free contact



Temperature Probe
M-110CF
\$29.95

Semiconductor
type
Range
-58F-302F
Fits most digital multimeters



50MHz Logic Probe
LP-700
\$23

Logic Pulsar LP-600 \$23

Digital 3 Amp Power Supply



XP-750
\$175

0-40V @ 1.5A
0-2V @ 3A

XP-650 with Analog Meters \$129.50

Regulated P.S. Breadboard

\$99.95 XK-400

- Fully regulated
- Short circuit protection
- 3550 test points
- 3 power supplies

• 5V @ 2A, 12V @ .3A, -12V @ .3A

GF-8016 Function Generator with Freq. Counter



\$239

- Sine, Square, Triangle
- Pulse, Ramp, .2 to 2MHz
- Frequency .1 thru 10MHz

GF-8015 without Freq. Meter \$179

Digital Triple Power Supply



XP-765
\$239

0-20V @ 1A
0-20V @ 1A
5V @ 5A

Fully Regulated, Short Circuit Protected with
2 Limit Cont. 3 Separate Supplies

XP-660 with Analog Meters \$169.50

Quad Power Supply



XP-580
\$59.95

2-20V @ 2A
12V @ 1A
5V @ 3A
-5V @ .4A

Fully regulated and
short circuit protected

XP-575 without meters \$44.95

Four-Function Frequency Counters



F-1000 \$259
1.2GH

F-100 \$179
120MH

Frequency, Period, Totalize, Self Check with High-Stabilized Crystal Oven Oscillator, 8 Digit LED Display

WE WILL NOT
BE UNDERSOLD!



C & S SALES INC.
1245 Rosewood, Deerfield, IL 60015
Add 5% for Postage (\$10 Max) IL Res., 7% Tax

(800) 292-7711
(312) 541-0710

15 Day Money Back Guarantee
2 Year Warranty

ASK FOR FREE CATALOG

CIRCLE 109 ON FREE INFORMATION CARD

Train for the Fastest Growing Job Skill in America

Only NRI teaches you to service all computers as you build your own fully IBM compatible microcomputer

With more and more new applications being developed for every facet of business, education, and personal computer use, the demand for trained computer service technicians surges forward. The Department of Labor ranks computer service high on its list of top growth fields, with accelerated demand creating more than 30,000 *new* jobs in the next 10 years.

Total systems training

No computer stands alone. . . it's part of a total system. And if you want to learn to service and repair computers, you have to understand computer

systems. Only NRI includes a powerful computer system as part of your training, centered around the new, fully IBM PC compatible Sanyo 880 Series computer.

You start with the step-by-step assembly of the highly rated Sanyo 880 computer. You build and test the "intelligent" keyboard, install the power supply and 5¼" floppy disk drive, and interface the high-resolution monitor. But that's not all. You go on to install a powerful 20 megabyte hard disk drive—to-day's most-wanted computer peripheral, now included as part of your hands-on training.

It's confidence-building, real-world experience that includes training in programming, circuit design, and peripheral maintenance.

No experience necessary— NRI builds it in

Even if you've never had any previous training in electronics, you can succeed with NRI training. You'll start with the basics, then rapidly build on them to master such concepts as digital logic, microprocessor design, and computer memory. You'll build and test advanced electronic circuits using the exclusive NRI Discovery Lab[®],

Learn Computer Servicing Skills with NRI's "Hands-On" Training . . .



Using NRI's unique Action Audio Cassette, you are talked through the operation and practical application of your hand-held digital multimeter—the basic, indispensable tool for the computer specialist.



You'll set up and perform electronics experiments and demonstrations using your NRI Discovery Lab. You'll even interface the lab with your computer to "see" keyboard-generated data.



After you build this digital logic probe, you'll explore the operation of the Sanyo detached "intelligent" keyboard and its dedicated microprocessor.

NEW!
20 Meg
Hard Disk
Included!

Your NRI total systems training includes all this: NRI Discovery Lab to design and modify circuits • Four-function digital multimeter with walk-you-through instruction on audio tape • Digital logic probe for visual examination of keyboard circuits • Sanyo 880 Series computer with "intelligent" keyboard and 360K, 5 1/4" floppy disk drive • 20 meg hard disk drive you install internally • High-resolution monochrome monitor • 8K ROM, 256K RAM • Bundled software • Reference manuals, schematics, and bite-sized lessons.

professional digital multimeter, and logic probe. Like your computer, they're all yours to keep as part of your training. You even get some of the most popular software, including WordStar, CalcStar, GW Basic and MS DOS.

Send for 100-page free catalog

Send the post-paid reply card today for NRI's 100-page, full-

color catalog, with all the facts about at-home computer training. Read detailed descriptions of each lesson, each experiment you perform. See each piece of hands-on equipment you'll work with and keep. And check out NRI training in other high-tech fields such as Robotics, Data Communications, TV/Audio/Video Servicing, and more.

If the card has been used, write to NRI Schools, 3939 Wisconsin Ave., N.W., Washington, D.C. 20016.

NRI SCHOOLS

McGraw-Hill Continuing Education Center
3939 Wisconsin Avenue, NW
Washington, DC 20016



We'll Give You Tomorrow.

IBM is a Registered Trademark of International Business Machine Corporation.

as You Build Your Own Sanyo 880 Computer System.



The power supply is assembled in the main unit of the computer. You check out keyboard connections and circuits with the digital multimeter included for training and field use.

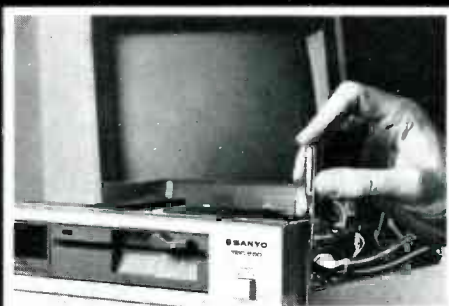

Next, you install the 5 1/4" floppy disk drive, learning disk drive operation and adjustment. Later, you increase your data storage capacity dramatically by installing a 20 meg hard disk drive.



Using the monitor, you focus on machine language programming, an indispensable troubleshooting tool for the technician. You continue by learning BASIC language programming.

ASK R-E

WRITE TO:

ASK R-E
Radio-Electronics
500-B Bi-County Blvd.
Farmingdale, NY 11735

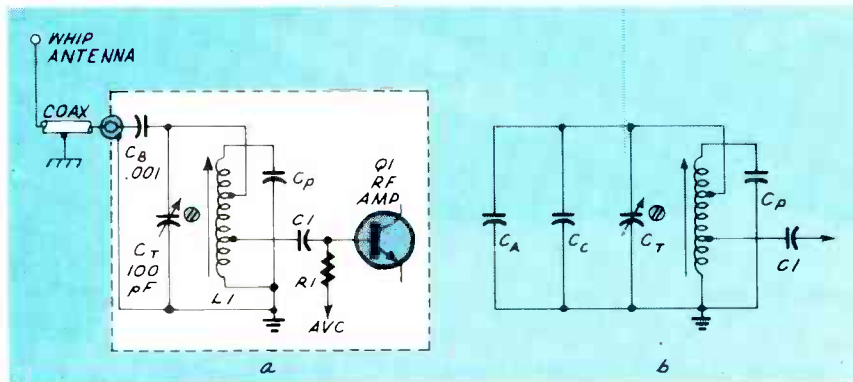

FIG. 1

AUTO RADIO FOR AM DX

I enjoyed the articles on converting old car radios for home use in the May and June, 1987 issues. We are moving onto five acres of rural land in central Florida, and wish to consistently receive the high-power AM-broadcast stations in the vicinity of Cleveland, Ohio. I would like to use a converted car radio for that purpose. I assume that a long-wire antenna will be appropriate. Please show me how to connect it to the low-impedance cable input of an auto radio.—T.J.W., Lake Buena Vista, FL.

There are several variations on the antenna input circuit of a car radio. A typical circuit is shown in Fig. 1-a and the equivalent circuit in Fig. 1-b. The antenna connects to a high-impedance point on the antenna coil through a short length of shielded cable and blocking capacitor C_B . The shielded cable, or coax, is not a matching device. It simply shields the antenna lead-in wire against electrical interference coming from under the hood or dashboard.

Capacitor C_A is the capacitance

between the antenna and the body of the car, and C_C is the capacitance of the shielded cable. Trimmer capacitor C_T peaks the antenna-input circuit at the high-frequency end of the band. The blocking capacitor is not shown because it is effectively in series with C_T and can be ignored.

I, too, am in the Southlands, but not as far south as you are. Much of my late-night radio fare comes from WWWE (1100 kHz) in Cleveland, WCKY (1530 kHz) in Cincinnati, and WOWO (1190 kHz) in Ft. Wayne, Indiana. I have several old auto radios in the junkbox so I thought I'd see how a long-wire compares with a fully extended car-radio antenna. After several weeks and a half dozen different sets, I concluded that a long-wire does not have any advantages, or that the disadvantages outweigh the advantages. Some radios are overloaded by the stronger signal provided by the long-wire antenna, resulting in distortion, birdies, and whistles. If the radio can cope with the stronger signal, you will encounter co-channel interference as the anten-

na pulls in stations from Cuba, the West Indies, and South America.

All things considered, I'd settle for a car-radio antenna mounted on top of the set and a connection to a good outside ground. Just connect the antenna to the set's antenna terminal. Tune in WWWE or the stations that you want, turn the volume control wide open, and use an insulated alignment tool to adjust for maximum output.

TOUCH-SENSITIVE LAMP

There is a new line of table lamps that use some form of touch-sensitive switch for control. Touch the metal frame of the lamp and the lamp comes on low, the second and third touches switch the lamp to medium and then to full brightness. The next touch turns the lamp off. Do you know of a circuit that I can use to accomplish that feat?—J.S., Jamaica, NY.

LSI Computer Systems, Inc., 1235 Walt Whitman Road, Melville, NY 11747 has a line of touch-sensitive light dimmer/switch IC's that can be used in the type of lamp you asked about. One of those light dimmers, the LS7237, was covered in the "State of Solid State" column in the May 1985 issue.

Details on the workings of those LSI devices were also given in that column. The light-dimmer/switch IC's will cost nearly \$10.00 when you order only one from the manufacturer—approximately \$3.50 for the device plus \$5.00 for postage and handling.

Instead of constructing your own touch-sensitive lamp, and possibly developing a dangerous shock hazard, we suggest that you

NEW

OPTOELECTRONICS INC.

FREQUENCY COUNTERS TO 2.4 GHz

POCKET SIZE
SIZE: 4" H x 3.5" W x 1" D
MADE IN USA

#TA-100S

8 LED DIGITS • 2 GATE TIMES
ALUMINUM CABINET
INTERNAL NI-CAD BATTERIES INCLUDED
AC ADAPTER/CHARGER INCLUDED

EXCELLENT SENSITIVITY & ACCURACY

AC-DC • PORTABLE OPERATION



Small enough to fit into a shirt pocket, our new 1.3 GHz and 2.4 GHz, 8 digit frequency counters are not toys! They can actually out perform units many times their size and price! Included are rechargeable Ni-Cad batteries installed inside the unit for hours of portable, cordless operation. The batteries are easily recharged using the AC adapter/charger supplied with the unit.

The excellent sensitivity of the 1300H/A makes it ideal for use with the telescoping RF pick-up antenna; accurately and easily measure transmit frequencies from handheld, fixed, or mobile radios such as: Police, firefighters, Ham, taxi, car telephone, aircraft, marine, etc. May be used for counter surveillance, locating hidden "bug" transmitters. Use with grid dip oscillator when designing and tuning antennas. May be used with a probe for measuring clock frequencies in computers, various digital circuitry or oscillators. Can be built into transmitters, signal generators and other devices to accurately monitor frequency.

The size, price and performance of these new instruments make them indispensable for technicians, engineers, schools, Hams, CBers, electronic hobbyists, short wave listeners, law enforcement personnel and many others.

STOCK NO:

- #1300H/A Model 1300H/A 1-1300 MHz counter with preamp, sensitivity, < 1mV, 27MHz to 450MHz includes Ni-Cad batteries and AC adapter **\$169.95**
- #2400H Model 2400H 10-2400 MHz microwave counter includes Ni-Cad batteries and AC adapter **\$299.95**
- #CCA Model CCA counter/counter, for debugging, ultra sensitive, < 50 micro volts at 150MHz | 1-600 MHz with adjustable threshold, RF indicator LED. Includes Ni-Cad batteries and AC adapter **\$299.95**

ACCESSORIES:

- #TA-100S Telescoping RF pick-up antenna with BNC connector **\$12.00**
- #P-100 Probe, direct connection 50 ohm, BNC connector **\$20.00**
- #CC-12 Carrying case, gray vinyl with zipper opening. Will hold a counter and #TA-1000S antenna. **\$10.00**



FLA (305) 771-2050

ORDER FACTORY DIRECT
1-800-327-5912



AVAILABLE NOW!



OPTOELECTRONICS INC.

5821 N.E. 14th Avenue
Ft. Lauderdale, Florida 33334

Orders to US and Canada add 5% of total (\$2 min, \$10 max)
Florida residents add 6% sales tax. COD fee \$2.
Foreign orders add 15%

CIRCLE 194 ON FREE INFORMATION CARD

www.americanradiohistory.com

shop around for a "Touch and Glow" light-control module that converts any table lamp into a "touch-on" lamp. You simply unscrew the bulb, screw in the Touch and Glow module and then screw the bulb into the module's socket. Touch the metal base of the lamp for on-off control and three brightness levels. The Touch and Glow module is UL-listed and is almost completely encased in porcelain, or a similar ceramic, so it reduces the possibility of a shock.

The Touch and Glow module is available in the housewares department of several large department stores and is on display in home-improvement and building-supply stores for around \$11.00. It is often on sale for much less. If you can't find the Touch and Glow control in your area, write to Bright Image, Inc., PO Box 507, Techny, Illinois, for information on availability.

Nursery departments of discount stores often carry several

touch-sensitive lamps. The control device that is mounted in the lamp's base is a ceramic cube with four leads for connections to the AC line and the lamp. It appears that the module can be easily removed and incorporated in a lamp of your choice. The nursery lamps are about \$10.00.

SHORTWAVE CONVERTERS

I really enjoyed the article "New Life for Old Car Radios" in the May and June 1987 issues. In the June issue you showed a converter circuit for receiving WWV (5 MHz), and the 49- and 31-meter shortwave broadcast bands on the AM band of car radios.

I'd like to convert the AIR band (about 110-134 MHz) down to the standard AM broadcast band. Can you show me how to replace the G2 input of the 40673 mixer with a suitable oscillator circuit, and will the antenna and output circuits still work properly?—J.O.M., West Springfield, MA.

What you want to do cannot be done using a single frequency-control crystal. You'd need a separate crystal for each 1-MHz sector of the AIR band.

A crystal-controlled converter worked into an AM broadcast radio cannot cover more than about 1 MHz of the band you want to receive. When we feed the output of a crystal-controlled converter into the input of a tunable receiver, we have, in effect, a double superhet, or double-conversion receiver. In that case, the tunable radio can be considered as the IF amplifier for the down-converted output of the converter mixer. The intermediate frequency, F_{IF} , is equal to F_{SIG} (the signal frequency) $\pm F_{OSC}$ (the oscillator frequency). We are using a 550- to 1650-kHz receiver as the tunable IF in a down-conversion scheme in which the incoming high-frequency signal is converted to a lower frequency for processing. The lower frequency, F_{IF} , is equal to $F_{SIG} - F_{OSC}$. The band of incoming signals cannot be any wider than the tuning range of the receiver, or approximately 1000 kHz (550 to 1650 kHz).

When a converter is used to receive the 49- and 31-meter bands (5900 to 6200 kHz and 9200 to 9700

Up to 50% Savings on Probes



Model SP100
Switchable 1X-10X \$ **43.**

Performance
Guaranteed

TEST PROBES, INC. **TPI**

9178 Brown Deer Road
San Diego, CA 92121

Call toll free for information
and free catalog:

1-800-368-5719
1-800-643-8382 in CA

ORDER FROM THESE DISTRIBUTORS

Or Phone Toll Free for the Distributor Nearest You



1-800-535-9593
1-800-462-9520 LA

contact east **Metermaster**

1-800-225-5370
(508) 682-2000 MA

1-800-962-8128
(213) 685-4340 CA

Specialized
PRODUCTS COMPANY

1-800-527-5018
(214) 550-1923 TX



1-800-363-6592 Canada
1-800-363-7601 QUE



(617) 879-7650



JENSEN TOOLS INC.

(602) 968-6231

BCS ELECTRONICS LIMITED

(416) 661-5585

ALLIED ELECTRONICS INC.

A SUBSIDIARY OF HALL MARK ELECTRONICS CORP.
1-800-433-5700, (817) 336-5401 TX

WESTCON INC.

(503) 283-0132 OR, (206) 223-1133 WA

CIRCLE 123 ON FREE INFORMATION CARD

kHz, respectively), the 49-meter band is tuned in between 950 and 1200 kHz on the broadcast-band dial; 31 meters comes in between 700 and 1200 kHz.

Now look at the AIR band; it's 24-MHz wide. To cram 24 MHz into the 1 MHz of the broadcast band, you'd have to divide it into twenty four 1-MHz segments. To cover 110 to 134 MHz in one tuning range, you would need a tunable converter with a variable oscillator, and pick some point on the broadcast receiver, say 1500 kHz, as a fixed first IF. For further information on that type of converter, consult current and back editions of *The Radio Amateur's Handbook*, and the *Radio Handbook*, along with back issues of QST, CQ, and Ham Radio magazines.

"RED STAR" 6L6's

I've been servicing electronic equipment for more than ten years, in an area famous for its recording studios and patriotism. I have maintained both vintage and modern amplifiers owned by my clients. Recently I was retubing a guitar amplifier when I noticed that just below the 6L6-GC type number, a small star and the letters "USSR." Perhaps I've been a bit brainwashed, but I'm worried about the quality of tubes made by the Russians. I'm also wondering how my clients would react if they knew that I'd installed tubes that were made in "The Evil Empire" in their 30-year old Fender amplifier. Will I get in any kind of trouble with the authorities if one of the studios reports that I've been using tubes that were made in the USSR?—G.O.P., Sheffield, AL.

We don't believe that the 6L6's were made in the USSR. Instead, we have a hunch that those tubes were made for use in Russian electronic equipment and are from World War II surplus stock.

During the war, the Russians were, of course, our allies. Supplies we sent to Russia ranged from food and fuel up to and including Liberty ships (freighters), with all the equipment carrying Russian markings so that Russian crews could operate them with little or no additional training. The 6L6's were probably used in shipboard PA systems or in the audio stages of radio transmitters. R-E

Philips ECG's Master Guide gives you all the replacement semiconductor information you'll ever need.



For speed, accuracy and ease-of-use, nothing beats the Philips ECG® Master Guide!

- Contains technical data for 4000 Philips ECG semiconductors that replace over 240,000 industry part numbers
- Contains the most accurate cross-references available.
- New edition has 13,000 additional cross-references and 230 new devices

All this, all in one book. Contact your Philips ECG distributor or call 1-800-225-8326. It just might be the smartest call you make all week.

The Smart Choice.

PhilipsECG

A North American Philips Company

CIRCLE 186 ON FREE INFORMATION CARD

ECG® DM-76 Auto-Ranging Digital Multimeter: The smart choice for value!

ECG DM-76 Multimeter is accurate, priced right and packed full of features. Here's what you get:

- Auto or manual range selection
- 0.5% basic accuracy
- 3½ digit LCD with range indicator
- Data hold
- 20 megohm full scale
- Transistor hFE
- Diode V_F
- Audible continuity test

Accuracy! Value! All the features you need! Contact your ECG products distributor or call 1-800-225-8326. It just might be the smartest call you make all week.



The Smart Choice.

PhilipsECG

A North American Philips Company

CIRCLE 250 ON FREE INFORMATION CARD

Keep equipment in top shape with Philips ECG's top of the line Audio/Video products.

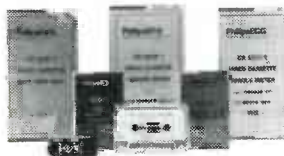

The best performance from any piece of equipment. The line-up that delivers it looks like this:

- To measure and adjust frequency response of audio tape decks, the AR20 frequency response cassette
- To accurately adjust audio tape running speed and record/playback head alignment, the AR30 speed and adjustment cassette
- To observe tape travel path in the VCR, the Video tape path view cassette
- To measure torque in play or fast forward/rewind modes, the Video torque meter cassettes

Contact your Philips ECG distributor or call 1-800-225-8326. It just might be the smartest call you make all week.

The Smart Choice.

PhilipsECG

A North American Philips Company

CIRCLE 68 ON FREE INFORMATION CARD

LETTERS

IN-CIRCUIT IC TESTER

Those of you who built the IC tester we featured on last month's cover may have found the check-out and final-assembly instructions a bit confusing. To clarify the procedure, we have reprinted on page 106 revised, unambiguous instructions.

TV FREQUENCY STANDARD UPDATE

I'd like to share some updated information about my article, "TV Frequency Standard" (*Radio-Electronics*, April 1988.) Regarding James Brodsky's informative letter about frame synchronizers in the July 1988 issue, I have noticed that the non-network affiliate stations will use their own master-sync frequency, but often switch to network sync when carrying network programming.

Other readers using the project noticed the same phenomenon. Generally speaking, however, the network-affiliate stations are using network sync. The project's 1-MHz output is usually within ± 2 Hz under any circumstances, due to the FCC-imposed tolerance of ± 10 Hz of 3579545.454 Hz. (Most stations I measured hold within 5 Hz.)

I don't have professional knowledge of broadcasting equipment, so I can only relate my personal observations while using this project. I'm sure that the output frequency is accurate enough for most uses without considering the broadcast source.

Anyone having difficulty locating a source for the MV834 can use the MV209—available from Active Electronics (237 Hymus Blvd., Montreal, Quebec, Canada H9R

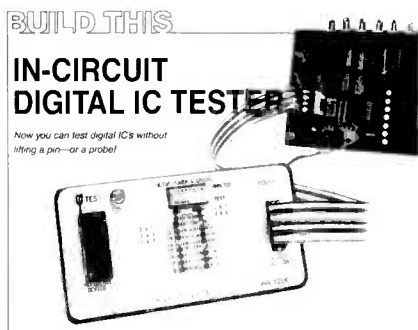

5O7, 514-694-7710)—as a substitute. Some of the general-replacement devices for the MV843 fail to work well in the circuit.

The jumpers shown in Fig. 2 of the article go to the following points on the circuit board at T-S, L-M, H-G, and U-V. The ground wire to front panel is soldered to U-V. The value specified for C8 is 33 pF. That is an average value; it can vary from 22–47 pF for the tuning of some crystals. With some brands of 4069's there is a tendency for the output at pin 8 IC1-d to have high-frequency oscillations riding on the sine wave. That can cause a slight instability in the project's output. To control high-frequency gain, add a .01 μ F capacitor between pin 8 and ground. I have found that the value of C8 must be between 40 pF and 150 pF for various brands of 4046's; select the value needed to allow proper tracking at 1 MHz.

Connect a jumper from pin 9 of IC8 to ground and see that the output at pin 4 is about 900 kHz. If it is not, adjust the value of C8. Next, connect a jumper from pin 9 to +12V and check for 1.1 MHz. Adjust the value of R5 to correct.

Adjusting the VCO for operation over a narrow range limits any phase-lock jitter in the output. A

4011 can be substituted for the 4001 in the Parts List. Almost any switching transistor can be substituted for the 2N3643.

The user will need to experiment with the placement of the antenna near the TV. Use only enough coupling to give a clean square wave at pin 3 of IC1, the 555. Ferrite rods can vary in characteristics quite a bit; a good way to compensate for that is to wind the coil on a paper tube and slide the rod in to find the resonate peak. A substitute antenna can also be fashioned from old television horizontal-circuit coils with a selected resonating capacitor.

A properly operating project gives very stable 3.58- and 1-MHz outputs. Use a coupling capacitor or a 10:1 probe between the project and your frequency counter. A direct coupling into some counters causes instability. A grounded metal enclosure—to minimize radio interference—is a good choice for the project.

I will contract with those wanting assembled, ready-to-use units for \$220.00 each. The style of the enclosure will vary from that shown in my article, but it will be custom-built to the same quality as my working model. I also have the assembled antenna coils, less cable and enclosure, for \$12.00 each. LUTHER STROUD
P.O. Box 1951
Fort Worth, TX 76101

ATARI DEFENDED

As a long-time Atari-computer user, at first I was looked down upon and joked about because I had a "toy" computer. I quickly learned that my Atari 800 with 16K of RAM was vastly superior to almost any other computer on the



market. (I do use an IBM at work. While I'm not a great fan of IBM's, I realize that *all* computers can do a lot of wonderful things when put together with the right software and peripherals.)

I became an Atari fan early on, and paid my dues waiting for decent software and hardware add-ons. Those eventually came, and my computer was gradually upgraded to the maximum of 48K RAM, with a couple of drives and a decent printer. I was happy and paid no attention to those jokes at all.

A few years ago, I upgraded to the 520ST, with no regrets. I have another vastly superior computer in the Atari 520ST.

I can understand your lack of enthusiasm for the machine as a result of your surveys—but I don't think you should operate on surveys alone. From your reply to Carl Kona in *Radio-Electronics'* July 1988 "Letters" column, it looks as though you might not even know what an Atari 520ST is.

In brief, it is a 16-bit, 512K of RAM computer that can be expanded to

4 megs. (512K of RAM will run most available software.) It has double- or single-sided 3.5-inch disk drives, and even a hard-disk drive is available. Its RGB color monitor has 2 screen resolutions (320 × 200 pixels and 640 × 200 pixels); or a black-and-white monitor with a screen resolution 640 × 400 pixels can be used. With its RS-232 port and a parallel-printer port, you can equip the 520ST with any RS-232 modem, and add just about any printer. It also has MIDI input and output ports. Although it doesn't have expansion slots like the IBM, you get just about everything you need in the stock machine. If needed, expansion is possible in a variety of ways.

Just because it is cheaper than most other computers doesn't mean it is an inferior product. This is not a case of "You get what you pay for." The Atari 520ST is a serious computer that is used by a lot of serious people, including European Space Agency, Rockwell Systems, General Dynamics Fort Worth, NASA Ames Research Cen-

ter, and Yale University. Polaroid Holography Lab in Cambridge uses it because of its outstanding graphics. Several well-known recording artists—Dave Mason, B.B. King, Mick Fleetwood, and the Pointer Sisters, to name a few—use the Atari 520ST because of its outstanding MIDI capabilities.

As for compatibility to IBM's and MAC's, there are some penalties on speed, depending on the software package. However, as you stated, there is no "truly seamless, bug-free hybrid." I personally don't use those compatible products, because there is so much high-quality Atari software already available.

As for desktop publishing, I don't know if Atari can run *PageMaker* or *Ventura Publisher*—and I really don't care. It can run *Publishing Partner*, *Fleet Street Publisher*, and *Timeworks Desktop Publisher ST*, which are all excellent packages. I print a newsletter for my department at work using a drawing program—*Easy Draw* by Migraph, that has many

Blister, Boxed or Bulk packed. With all the benefits of 3M.

Your Electronic Specialty Products distributor has a wide selection of 3M Electrical, Electronic and Telecommunications products in quantities from one to 1,000.

Sometimes you need less than industrial quantities. But you still demand quality. We've got all kinds of products for test and measurement, interconnection, static control, circuit-building and prototyping and more.

For maintenance and repair professionals, professional engineers, technicians, hobbyists, students and educators. Get a wide

selection of products with the 3M quality you expect, in the quantities you need. From single packages to bulk packs.

For the name of your nearest Electronic Specialty Products distributor, call toll free 800-321-9668 or (216) 354-2101 in Ohio.

**Electronic Specialty Products,
3M Electronic Products Division**

9325 Progress Parkway
Mentor, OH 44060

We've Packaged Our Solutions.

CIRCLE 76 ON FREE INFORMATION CARD

3M

Worldwide Sponsor
1988 Olympic Games





REASONS FOR SELECTING CIE

- Approved for educational benefits under the G.I. Bill for Veterans and other eligible persons.
- CIE provides printed job resumes, letters of recommendation, and lifetime Employment Service for all graduates at no extra charge.
- State-of-the-Art laboratory equipment is yours to keep and it comes assembled, ready for hands-on-experiments.
- Only CIE offers an Associate Degree program based on actual study time used. The faster you complete your degree, the less your overall tuition.
- Upon graduation, CIE offers you free preparation to pass the Certified Electronics Technician Exam.

CIE

CLEVELAND INSTITUTE OF ELECTRONICS 1776 East 17th Street • Cleveland Ohio 44114
PHONE TOLL FREE 1-800-321-2155 / In Ohio 1-800-523-9109

LEARNING...

THE KEY TO SUCCESS

A CAREER IN ELECTRONICS STARTS WITH CIE.

For the last few years, the electronics field and related industries have been growing at an incredible pace. And today, a career in electronics offers more opportunities and greater rewards than ever before.

Just ask any of the many graduates of the Cleveland Institute of Electronics who have landed high-paying positions with aerospace, computer, medical and communications firms. They'll tell you success didn't come easy... but that CIE made it all worthwhile.

SPECIALIZED TRAINING CIE isn't just another be-everything-to-everybody correspondence school. We're accredited by the National Home Study Council. And with more than 1100 graduates each year, we're the largest independent home study school specializing *exclusively* in electronics. CIE has been training career-minded students like yourself for over 50 years and we know the business inside and out.



Some courses feature the CIE Microprocessor Training Laboratory, an integral part of computers. You'll gain all the practical experience needed to work with state-of-the-art equipment of today and tomorrow.

PRACTICAL TRAINING CIE students learn by doing, using sophisticated electronic learning tools that we've designed and developed. One such tool, our 4K RAM Microprocessor Training Laboratory, teaches programming, interfacing and lets you work with a broad range of computers in a way that working with a single, stock computer simply can't.

We combine that valuable hands-on training with our unique Auto Programmed® lessons, designed to teach you step-by-step and principle-by-principle. The result is practical training... the kind of experience you can put to work in the marketplace.

PERSONALIZED TRAINING While some of our students have a working knowledge of electronics others are just getting started. That's why we have 10 career course levels from Basic to Advanced. They let you start where you want. Learn at your own pace. And learn as much as you like. You can even earn an Associate in Applied Science Degree in Electronics. And when you need help, our trained professionals are on hand to assist you by phone or mail.

Learning electronics isn't easy, but getting started is. For a CIE catalog and enrollment information, just mail the coupon below. Or call toll-free 1-800-321-2155. In Ohio, call 1-800-523-9109.

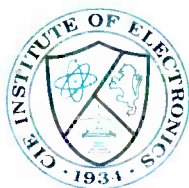

Accredited by the Accrediting Commission of the National Home Study Council, Washington, D.C.

CIRCLE 60 ON FREE INFORMATION CARD



YES! I want to get started. Send me my CIE school catalog including details about the Associate Degree program.

Print Name _____

Address _____ Apt. _____

City _____ State _____ Zip _____

Age _____ Area Code/Phone No. _____ / _____

Check box for G.I. Bulletin on Educational Benefits

Veteran Active Duty

MAIL TODAY!

CIE CLEVELAND INSTITUTE OF ELECTRONICS
1776 East 17th Street, Cleveland, Ohio 44114

ARE-98

desktop publishing features built-in—and a 24-pin printer.

Concerning piracy in the Atari community, I admit that it is a problem. However, most computer families face the same problem. IBM probably has the most software pirates, but it isn't as noticeable because of the enormous base of IBM computers and clones. Piracy is a serious problem for everyone involved in the computer industry.

I'm glad you are still fascinated

by the Atari. I offer a challenge to you. Go out and get an Atari system and see for yourself. Take it apart to see what makes it tick—it's easy. Then put it back together—it will still work. Check out what software is available, and put it through its paces.

True, it's not an IBM, but it's not supposed to be. It's an entirely different system, and an entirely different environment. There is another world out there, besides MS-DOS and CP/M. The ST's oper-

ating system is probably the easiest to learn.

ComputerDigest runs quite a few articles using Commodore computers. It would be nice if you would include Atari in some of those articles, and see what the reaction would be. After all, Jack Tramiel switched. I do enjoy the PT-68K series; I've learned a lot about the 68000 reading those articles. I do not plan on building one, as I have a 68000-based computer in the Atari 520ST.

All I can say to Mr. Kona is, "Hang in there!". Join an Atari computer club. (They are not all pirates.) Subscribe to an Atari-specific magazine. Invest in a modem; the telecommunications end of computing seems to have taken the Atari more seriously than any other. Lastly, enjoy your "toy."

DAVE ROMAN
Redwood City, CA

CORRECTION

In "Editor's Workbench," in the July 1988 issue of *ComputerDigest*, there was a review of the *OS/2 Programmer's Guide*, by Ed Iacobucci. It is an excellent tutorial and reference, and I highly recommend it. However, Ed Iacobucci is the OS/2 design-team leader at IBM—not at Microsoft, as was stated in the column.

DONALD R. BLAKE
Apalachin, NY

RADIATION SCARE

Good grief! You should be ashamed—a respected technical magazine like **Radio-Electronics** should not use scare tactics by placing Chernobyl and Three Mile Island side-by-side in the same sentence. ("Build This Radiation Monitor," **Radio-Electronics**, June 1988.) That is the sort of yellow journalism used by the *National Enquirer*.

The amount of radiation released at Three Mile Island was no more than any Denver resident receives in a year. Chernobyl was a meltdown without a containment building.

ALEX THOMAS
San Antonio, TX

The article clearly states, side-by-side in one sentence, that the Chernobyl nuclear plant "exploded" and the Three Mile Island

POMONA leads the way to reliable SMT test.

Surface-mount technology is the wave of the future, and POMONA is riding the crest, with the broadest line of products designed to test surface-mount devices. Our ever-expanding selection includes PLCC test clips (patent pending), SOIC test clips, SMD Grabber™ test clip and other single-point test devices. All built to POMONA's high quality standards.



For your FREE 1988 General Catalog, circle reader service number printed below

POMONA
ITT Pomona Electronics

CIRCLE 101 ON FREE INFORMATION CARD

plant "almost had a meltdown." Scary, yes. Scare tactics? We don't think so. There is legitimate cause for concern about radiation levels in the atmosphere, whether or not one lives near an accident site. And, judging from the feedback we've had on that article, **Radio-Electronics** readers are among the most concerned.—Editor.

TRANSMITTER HUNTING

In "Ask R-E" in the July 1988 issue of **Radio-Electronics**, G.P.R. of Salt Lake City asked about transmitter-locator systems. You suggested that he consult back issues of ham magazines for information on direction finding and hidden transmitter hunts.

While that is a good suggestion, unfortunately there is a limited amount of information in the ham journals, since transmitter hunting is somewhat of a specialty of ham radio.

I have written a book, *Transmitter Hunting: Radio Direction Finding Simplified*, that is a comprehensive source of information about direction-finding techniques for almost all of the radio spectrum. The book is available from the publisher, TAB Books, Blue Ridge Summit, PA 17294, (book #2701), or directly from Kaleido-Concepts, P. O. Box 3655, Fullerton, CA 92634 (714-447-3000). JOSEPH MOEL
Fullerton, CA

PENDULUM PROBLEMS

I have never written to a magazine before, but I can hold my pen no longer. As a horologist of many years, I must protest the advice given to J.D.G. in "Ask R-E" (**Radio-Electronics**, June 1988). Your "simple answer" will cause him nothing but frustration and grief.

A pendulum has a resonant frequency that is determined mostly by the length of the pendulum. Trying to drive the pendulum with pulses from the circuits shown will cause the pendulum to get out of phase with the pulse generator and stop. No matter how carefully the pulse generator is adjusted, the pendulum will eventually get out of phase, because the pendulum changes length with temperature changes.

J.D.G. would be much better off

with a circuit that "senses" the position of the pendulum and gives it a magnetic "kick" at the same point during each swing. That could be accomplished with a small bar magnet, a sensing coil, a "kick coil," and some simple trigger circuit. (That is probably the original design of his clock.)

He will still have a clock that is tied to the variations effecting pendulums—but at least it will run, and he can adjust the timing by changing the length of the pen-

dulum.

ALAN LOWE

USNAS, FPO NY

USEFUL NETWORK THEOREMS

For a free, 7-page listing of up-to-date network theorems (the latest Thevenin-Norton and associated theorems, etc.) send a 45-cent stamped envelope to Sercolab, Box 767, E. Dennis, MA 02641.

DR. HARRY E. STOCKMAN
East Dennis, MA

SEEK PROFESSIONAL HELP Servicing electronic equipment isn't always easy, especially if you're doing it in the field. At Chemtronics we can help with over 200 specially engineered products for the maintenance, repair and production of high technology equipment. Call today for our latest problem solving catalog.

Chemtronics
Keeping pace with advanced technology

Chemtronics Inc. 681 Old Willets Path, Great Neck, NY 11788 516-882-3322 Telex 968567

EQUIPMENT REPORTS

LATTICE SEMICONDUCTOR GAL39V18 GAL DEVELOPMENT KIT

Use your PC to configure programmable logic devices
CIRCLE 45 ON FREE INFORMATION CARD



THERE IS NO QUESTION THAT PROGRAMMABLE logic devices are becoming more popular among designers. Even some of the construction projects we present in

Radio-Electronics—including the REACTS system and the in-circuit IC tester we presented last month—use PLD's.

You can expect to see PLD's be-

come even more popular because they can help reduce the size and cost of a given design, improve its reliability, and even simplify the design process by giving the designer the ability to implement the exact logic functions required. User-programmable logic devices can also dramatically decrease the time required to take a given design to market. But there's another reason: The design and production of PLD's are becoming easier—and less expensive. A case in point is the *GAL39V18 Design Development Kit* from Lattice Semiconductor Corp. (P.O. Box 2500, Portland, Oregon 97208).

Lattice's development kit is de-

GUARANTEED PERFORMANCE!!

METERS
FLUKE

- 73 3 1/2" digit, DMM \$67
- 75 3 1/2" digit, DMM 99.
- 77 3 1/2" digit, DMM 128.
- 8060A 4 1/2" digit-true RMS 323.
- 8062A 4 1/2" digit-true RMS 260.
- 37 Bench portable DMM 217.
- 8010A Bench portable true RMS 255.
- 8012A Bench portable true RMS 318.
- 8050A Bench portable true RMS 349.

- FULL LINE AVAIL
BECKMAN
Beckman Industrial
- DM15B 3 1/2" digit, 26 ranges, beeper \$51.98
 - DM25L 3 1/2" digit, 29 ranges, logic probe, cap measure 94.50
 - DM850 4 1/2" digit, frequency counter, data hold 207.83
 - Tech300 Diode Test 113.00
 - Tech330 True RMS, Diode Test 206.00
 - DM73 Probe-Auto-ranging, beeper, data hold 55.00
 - CC6 Clamp-on meters (measure up to 600 amps) 68.18
 - DM10 3 1/2" digit 38.

SCOPES
HITACHI *3 Years Manufacturers Warranty parts & labor*

- Special**
- V-212 20 MHZ dual trace scope \$385.
 - V-222 20 MHZ dual trace scope 550.
 - V-423 40 MHZ dual trace, delayed sweep scope 795.
 - V-660 60 MHZ dual trace scope
 - V-665 60 MHZ dual trace/cursor readout scope
 - V-1060 100 MHZ dual trace scope
 - V-1065 100 MHZ/cursor readout scope
 - V-6020 20 MHZ digital storage scope

- Beckman**
- 9020 20 MHZ dual trace scope, component tester, delay sweep 520.
- B&K**
- 2120 20 MHZ dual trace scope \$455.

POWER SUPPLIES
Viz

- WP-702A Dual 0-20VDC (r 0-200MA, dual meter) \$190.
 - WP-703A Single 0-20VDC (r 0-500MA, single meter) 146.
 - WP-704A Single 0-40VDC (r 0-250MA, single meter) 146.
 - WP-705A Single 0-50VDC (r 0-2A, digital meter) 349.
 - WP-706A Single 0-25VDC (r 0-4A, digital meter) 370.
 - WP-707A Dual 0-25VDC (r 0-2A, digital meter) 465.
 - WP-31A Isolation transformer 1.5KVA, 3 fixed 350VA outputs 223.78
- B&K**
- 1610 Power supply 0-30VDC, 0-1A \$147.
 - 1630 Power supply 0-30VDC, 0-3A 228.80
 - 3011 Function generator 0.2 HZ - 2MHZ 217.

IC TESTER
B&K

- 560 Programmable IC tester \$2970.
- 541 Component tester 354.
- 550 T.T.L. IC comparator 364.
- 552 CMOS I.C. comparator 364.

SOLDERING SUPPLIES
Ungar

- UTC 100 Temperature controlled soldering system \$67
- 4024 De-soldering service station 414.
- 9000 Temperature controlled soldering station 208.
- 6970 HD Heat gun (gives 1000 watts) 72.
- 1095 Heat gun (gives 1000 watts) 35.
- 1100 Soldering gun 100/140 watts 20.

WELLER

- WTCPR Control output soldering station \$119.
 - 8200 All purpose soldering gun 21.
 - D550 28.58
- Kester solder and multicore solder available CALL!*



"I GUARANTEE YOUR SATISFACTION!"
For 43 years professionals have counted on **KELVIN**, for the lowest prices and immediate delivery, from our huge inventory. Count on **KELVIN!**
Lisa S. Hadar
Executive V.P., C.P.A.

WE CARRY—
Panavise, Xcelite Tools, Vaco Tools, X-Acto, Kester Solder, Sellstrom Safety Equipment

- Electronic Parts
- Electrical Parts
- Large Selection of State of the Art Educational Kits.

Not Responsible For Typographical Errors.

Tool Kits Our Specialty — Call

KELVIN **FREE CATALOG** **1-800-645-9212**

ELECTRONICS 7 FAIRCHILD AVE., PLAINVIEW, N.Y. 11803 (516)349-7620 FAX:516-349-7830

CIRCLE 201 ON FREE INFORMATION CARD

www.americanradiohistory.com

DAMARK

INTERNATIONAL, INC.

MUST LIQUIDATE AT FAR BELOW DEALER COST!

PUBLIC NOTICE:
Due to a variety of reasons, (overproductions, discontinued lines, Etc. .) manufacturers & distributors get **STUCK** with inventories that must be liquidated. **DAMARK** walks in, lays down cash, and takes the entire inventory. This is how we can offer you products at **BELOW DEALER COST!** Just **LOOK** at the values below and order today - **QUANTITIES ARE LIMITED!**

XEROX/DIABLO DAISY WHEEL PRINTER

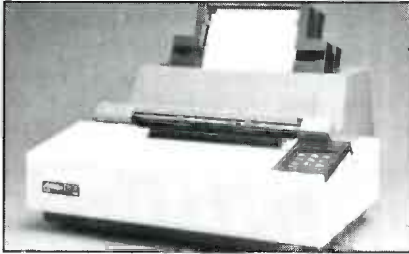

FREE CABLE!

Enjoy the ease and speed of printing with this Xerox/Diablo 630 ECS/API Daisy Wheel Printer. Prints both graphics and letter quality text without changing Daisy Wheel!

- API (All Purpose Interface) works with most personal or business computers on the market including:
- Serial: RS232-C, 110-300-1200-2400 baud.
- Parallel: Centronics, 8-bit.
- Includes: IBM Interface cable, Ribbon, Manual, & Plastic print wheel.
- ECS (Extended Character Set) supports 96 & up to 192 extended character set print wheels.
- 40 characters per second with plastic print wheels.
- Paper width: 16.53" max. if using friction feed; 15.25" max. if using forms tractor (not included)
- Graphics, HyPlot Vector Plotting, Word Processing.
- **90-Day Warranty!**

Manufacturer's Suggested Retail
\$1995.00

DAMARK PRICE:
\$398

Order No. B-835-102103
Insured Ship/Hand: \$26.00

GENERAL ELECTRIC PORTABLE CELLULAR TELEPHONE

NEVER BE WITHOUT A PHONE! Take this portable cellular phone anywhere! To the golf course, on your boat, in your car, or even in your back yard. **COMES READY TO DIAL!! No Assembly! No Phone Number Set-up! No Hassle!**



- Stores 10 preset numbers.
- Portable - requires **NO** installation. Just plugs into your cigarette lighter or power pack (included).
- Extremely light weight - Made in U.S.A.
- Can be moved from vehicle to vehicle in seconds.
- Programmable Lock - prevents unauthorized use of phone.
- Backlight which illuminates keypad for ease of visibility.
- Comes with preassigned phone number
- Comes complete with 12 volt DC charger, battery pack with case and belt, antenna & mount, carrying case w/ shoulder strap.
- **Full 3 Year Parts & Labor Warranty!**
- **FACTORY NEW! FACTORY PERFECT!**

Manufacturer's Suggested Retail
\$1,695.00

DAMARK PRICE:
\$899

Order No. B-835-105460
Insured Ship/Hand: \$15.00

CASIO LIQUID CRYSTAL COLOR TV

ACTION! COLOR! EXCITEMENT! All in the palm of your hand! The latest in electronics provides the best possible signal reception. Perfect for sporting events, picnics, traveling, & almost anywhere!



- **One-Touch Auto Tuning** - One touch and the unit automatically searches for & locks in on the nearest receivable station.
- **Built-In Backlight** - for brighter pictures night or day.
- Screen size: 2 inches.
- Dim: 1-1/4"H x 3-3/10"W x 5-1/8"D.
- Uses 4 "AA" bat. (included).
- Soft case. • Model #: TV-400.
- **Full Factory Warranty!**

Manufacturer's Suggested Retail
\$229.95

DAMARK PRICE:

\$149

Order No. B-835-106948
Insured Ship/Hand: \$5.00

GUSDORF AUDIO & VIDEO CABINETS

Create your own home entertainment center with these **Deluxe, Genuine Oak Audio and Video Cabinets!** Makes a perfect pair! This is **TRUELY** a beautiful combination.

AUDIO CABINET



Deluxe Video Cabinet Features:

- New Weathered Oak finish featuring genuine hardwood solids.
- Accommodates 19" 27" Color TV, VCR & accessories.
- Tempered safety glass doors with magnetic catches
- Adjustable interior shelves
- Easy to assemble.
- Dim: 19"H x 29"W x 17"D.

Deluxe Lift-Top Audio Cabinet Features:

- Genuine Oak solids highlight a handsome Weathered Oak finish.
- Magnetically-secured tempered safety glass doors.
- Four adjustable interior shelves.
- Easy to assemble.
- Dim: 42.75"H x 21.25"W x 17"D.

VIDEO CABINET



AUDIO CABINET Manufacturer's Suggested Retail
\$219.95

DAMARK PRICE:

\$89

Order No. B-835-105289
Insured Ship/Hand: \$19.00

VIDEO CABINET Manufacturer's Suggested Retail
\$139.95

DAMARK PRICE:

\$59

Order No. B-835-105271
Insured Ship/Hand: \$14.50

COMPLETE SET Manufacturer's Suggested Retail
\$359.90

DAMARK PRICE:

\$139

Order No. B-835-105569
Insured Ship/Hand: \$29.00

FOR FASTEST SERVICE CALL TOLL FREE 1-800-832-5555



NAME _____
ADDRESS _____
CITY _____ ST _____ ZIP _____
PHONE _____

Check/Money Order VISA
 MasterCard Discover CARD NO. _____ EXP. DATE _____

Send To: **DAMARK INTERNATIONAL, INC., 6707 Shingle Creek Parkway, Minneapolis, MN 55430**

PRODUCT	ITEM NO.	QTY.	PRICE	S/H/I	TOTAL
XEROX/DIABLO Printer	B-835-102103		\$398	\$26.00	
GE Cellular Phone	B-835-105460		\$899	\$15.00	
CASIO 2" Color TV	B-835-106948		\$149	\$5.00	
GUSDORF Audio Cabinet	B-835-105289		\$89	\$19.00	
GUSDORF Video Cabinet	B-835-105271		\$59	\$14.50	
GUSDORF Complete Set	B-835-105569		\$139	\$29.00	

CORPORATE OFFICE (612) 560-5415
DELIVERY TO 48 U.S. CONTINENTAL STATES ONLY

SUB TOTAL
in MN add 6% Sales Tax
Total S/H/I
TOTAL

OCTOBER 1988

signed to work exclusively with their GAL or Generic Array Logic devices, which are fabricated using E²CMOS (Electrically Erasable CMOS) technology. E²CMOS offers high-speed operation (at least as fast as any other TTL-compatible PLD) with the inherent low power consumption of CMOS devices. Since the devices are easily erasable, they are ideal for prototyping and developing, and they can be fully tested.

Like PAL (Programmable Array Logic) devices, GAL's contain a programmable AND plane and a fixed OR array. That configuration offers high performance and the most efficient architecture for most logic functions. GAL devices are capable of emulating PAL architectures, and they can drop right into any PAL socket.

However, unlike PAL devices, each GAL output can be individually set to active-high, or active-low, with either synchronous or asynchronous configurations. That's because GAL's feature programmable *output logic macrocells* instead of a fixed output

structure. That extra flexibility over fixed-architecture PAL's is extremely important to the designer.

Using the kit

The GAL39V18 development kit, which lists for \$795, includes everything that an engineer needs to design and program GAL devices: a GAL programmer, programmer-control software, a high-level compiler, samples of 20- and 24-pin GAL devices, and handbooks. The programmer, Programmable Logic Technologies' (Longmont, CO) *LogicLab* is controlled via the RS-232 port of a PC-compatible computer; no internal card is required, and hookup is very easy.

The programmer contains no switches, and its operation is controlled completely via the serial port. While the programmer conceivably could be controlled by any computer with a serial port, software is available only for PC/XT/AT's and compatibles.

The development software includes the high-level *LC-9000* GAL compiler (also from Programmable Logic Technologies). That com-

piler doesn't offer such advanced design features as equation minimization, truth-table syntax, or schematic capture entry but, to say the least, it's a far cry from the early 1970's when each of the 3000 or so individual fuse locations in the programmable devices had to be programmed by hand. The LC-9000 compiler is RAM resident and is very fast. The editor supplied with the compiler can be replaced easily with the editor of your choice.

Also included in the design package is *FastMap*, which is the software that controls the programmer through the computer's serial port. *Fast-map* includes an assembler that allows you to input standard Boolean equations, and upload the resulting file into the programmer, and then to the device. While *Fastmap* is not very sophisticated software, it lets you get started programming GAL devices immediately.

If you or your company has ever considered using programmable logic, Lattice's GAL Design Development kit may be the entry-way you've been waiting for. R-E



Cut Your Video Servicing Time By 54%

With the Market Proven VA62 Universal Video Analyzing System.

Today's VCRs, TVs, and MTS Stereo TVs require a proven method to quickly isolate the defective component. New technology has made simple problem solving a time-consuming and expensive procedure.

A survey of over 1500 Video Analyzer owners has shown that the VA62's unique signal substitution method has reduced their video servicing time by an average of 54%, and increased their servicing profits.

You can join the successful service centers that have cut their video servicing time and increased their profits with the VA62 Universal Video Analyzing System. Call for a brochure on the VA62. Call **1-800-843-3338**, and increase your profits. In Canada Call **1-800-851-8866**.

SENCORE

3200 Sencore Drive, Sioux Falls, SD 57107

100% American Made

CIRCLE 199 ON FREE INFORMATION CARD

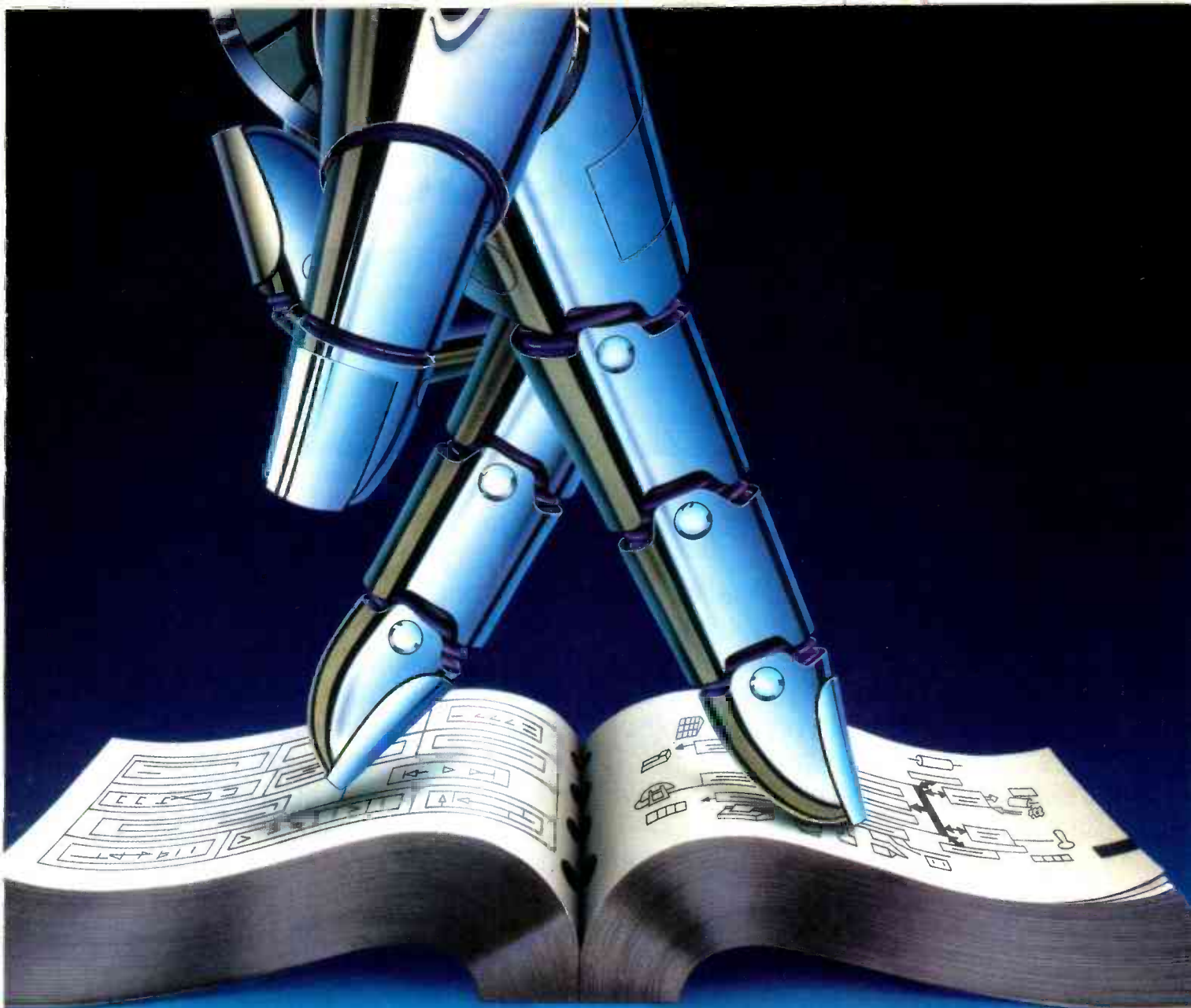

Now you can put your fingers on 214,000 replacement semiconductors.

Finding the precise, quality solid state replacement device is as easy as opening one book, the SK Solid State Replacement Guide.

Inside you'll find listings for making over 214,000 solid state replacements using some 2,900 quality-built SK and KH types. From transistors and thyristors to integrated circuits and microprocessors. All cross-referenced so you can replace original parts of all makes quickly and easily.

When you need a solid state replacement part for servicing a VCR, TV, audio component or personal computer, this is one book your fingers will turn to automatically.

To get your SK Guide (SKG202E), see your local SK Distributor. Or write: Sales Promotion Services, Thomson Consumer Electronics, Inc., Distributor and Special Products, 2000 Clements Bridge Road, Deptford, NJ 08096-2088.

SK Replacement
Solid State

Digital scopes with a

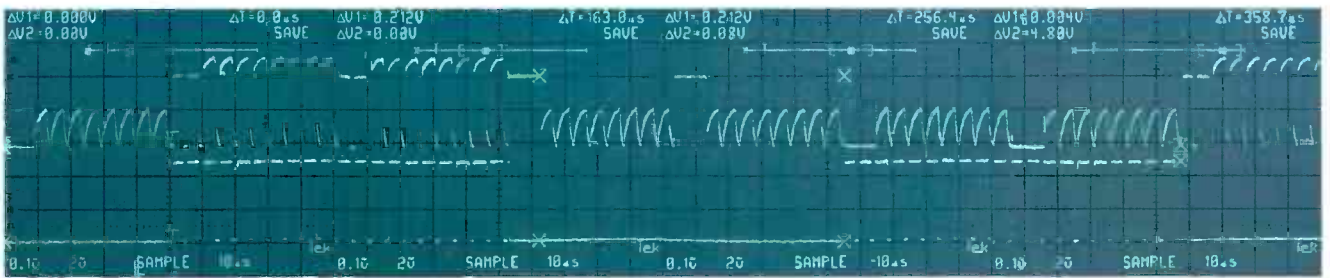

Give up real-time capability for storage? Not with Tek!

That's because analog capability is integral to low-cost Tek digital storage oscilloscopes. So you need only one instrument to make all your measurements efficiently. With no trade-offs.

It's another Tek advantage: analog and digital in one familiar, affordable package.

Select either mode at the push of a button.

With digital storage you can capture events which are difficult if not impossible to see on conventional scopes. Pre and post trigger events. Fast transients.

Single-shot events.
Elusive glitches.
Low-speed phenomena.

Four screen photos spliced end to end illustrate the benefit of full four-screen capture using the 2230's 4K record length.

Any waveform can be viewed for as long as you like. Or stored in 4K of memory for later analysis or comparison to other waveforms. And if there's a question about a digital measurement, just push a button for real-time display analysis.



real-time advantage.

The affordable portables.

These are the world's best-selling digital storage oscilloscopes. And with the new 50 MHz Tek 2210 joining the family, there's now an even better selection—in bandwidth, performance and price.

Select for advanced features such as 100 ns glitch capture at any sweep speed, CRT readout, measurement cursors, multiple acquisition modes and hardcopy output, plus optional GPIB or RS-232C interfaces and software.

These scopes are perfect for first-time digital users. And seasoned operators will appreciate even more their versatility, convenience and value. All backed

Features	2230	2221	2220	2210
Bandwidth	100 MHz	60 MHz	60 MHz	50 MHz
Max. Sampling Speed	20 MS/s	20 MS/s	20 MS/s	20 MS/s
Vertical Resolution	8-12 bits	8-10 bits	8 bits	8 bits
Record Length	4K	4K	4K	4K
Glitch Capture	100 ns	100 ns	100 ns	No
CRT Readout/ Cursors	Yes	Yes	No	No
GPIB/RS-232-C Options	Yes	Yes	Yes	No
Warranty	3-years on labor and parts including CRT			
Price	\$4995	\$3995	\$2995	\$2395



Each scope offers a range of capabilities you'd expect to find only in much more expensive instruments.



by Tek quality and a 3-year warranty. Discover the potential. Let Tek show you what you're missing... without making you give up analog to see it. That's the real-time advantage of Tek digital storage.

For easy ordering or more information call Tek Direct:

1-800-426-2200

VISA, MasterCard

Tektronix®

COMMITTED TO EXCELLENCE

CIRCLE 92 ON FREE INFORMATION CARD

NEW PRODUCTS



CIRCLE 10 ON FREE INFORMATION CARD

ELECTRONIC STILL CAMERA. Casio's *VS-101* is a personal electronic still camera that can both record and play back images on a standard TV set. Unlike traditional cameras, the *VS-101* requires no photographic film or chemical processing for development and printing. Instead, it records to, and plays back from, special magnetic disks—"video floppies"—for immediate viewing of photographs.

The *VS-101* features a high picture-quality MOS-image sensor, resulting in an advanced electronic camera that integrates both recording and playback functions within a single unit. Photographs can be viewed immediately after they are shot, via a simple, direct

connection to a TV or video monitor.

The compact unit weighs only 2.1 pounds, and has a high-resolution automatic-exposure system with lock function. It can operate at a high speed—up to five frames per second.

The still camera has a wireless-remote controller featuring such functions as forward, reverse, and direct-track access for playback of any frame. Up to fifty frames for recording/playback are possible on a single floppy disk, and the built-in erase function permits multiple reuse of disks.

The suggested retail price for the *VS-101* is \$1,499.00.—**Casio, Inc.**, 570 Mt. Pleasant Ave., P. O. Box 7000, Dover, NJ 07801.

be amplitude-modulated by an internal 1-kHz source or externally modulated by any audio-frequency source.

The *Model 2005* features output attenuation to 40 dB, variable am-

plitude modulation from 0–100 percent, auxiliary output for the internal 1-kHz audio source, and separate outputs for the RF connection and an external frequency counter. Output frequency is adjusted by an anti-backlash vernier dial. Dial calibration is accurate to within 3 percent.

The *Model 2005* can be used for many RF-alignment, tracking, and maintenance applications for consumer-electronics products, communications receivers, and industrial-control systems. With its straightforward design, it is also well-suited to the many possible educational applications.



CIRCLE 11 ON FREE INFORMATION CARD

The suggested retail price for the *Model 2005* RF signal generator is \$195.00.—**B&K Precision**, Mextec International Corp., 6470 West Cortland St., Chicago, IL 60635.

DIAL TORQUE GAUGE. The *TQ-1800* dial torque gauge, for use on U-Matic cartridge machines, is designed to evaluate the clutch- and brake-torque performance for optimum tape handling. It replaces the use of a dummy reel and spring scale, as previously suggested in factory-service manuals. It was that cumbersome dummy-reel test procedure that sent Tentel Corp. searching for a better method for critical torque checks.

The *TQ-1800* system involves the use of a motorized torque driver,

specially designed to simulate the tape-pulling speed of a U-Matic—9.5 cm per second. When it is used in conjunction with the *TQ-1800* dial torque gauge, accurate torque measurements can be made, either clockwise or counter-clockwise, directly on the supply or take-up spindle.



CIRCLE 12 ON FREE INFORMATION CARD

No machine disassembly is required—unlike in the dummy-reel method—saving both time and effort, while a high degree of accuracy and reliability in torque measurement is maintained.

The price of the *TQ-1800*, including the 1800 gm/cm torque gauge, motorized torque driver, rechargeable battery, recharger, foam-lined carrying case, and manual, is \$295.00.—**Tentel Corp.**, 1506 Dell Avenue, Campbell, CA 95008.

LOGIC TROUBLESHOOTING KIT.

OK Industries' *LK-680* kit combines three logic troubleshooting instruments into a single kit. It includes the *LC-160* multi-pin IC logic monitor, a 20-MHz logic probe (model *PRB-20*), and a probe-tip adapter with micro-hook (model *PRB-MHT*). The kit also contains a guide to digital-logic troubleshooting, an operating manual, and power cords. The kit is packaged in a rugged carrying case.

All the instruments in the *LK-680* are circuit-powered, for use in the field as well as in the laboratory. The multi-pin IC logic monitor



CIRCLE 13 ON FREE INFORMATION CARD

adapts to IC's with up to 16 pins. It indicates Hi, Lo, Pulse, or clock conditions. The *LC-160* also has unique IC leg-extension pins for easy individual leg probing of components mounted on a PC board. The slim-profile *PRB-20* has separate Hi, Lo, and Pulse LED's, and under/over voltage LED's.

The list price for the *LK-680* logic troubleshooting kit is \$179.00.—**OK Industries Inc.**, 4 Executive Plaza, Yonkers, NY 10701; 1-800-523-0667.

CLEANING PADS AND SWABS. Chemtronics' premoistened cleaners combine precision solvents and disposable applicators in sealed-foil packets. The self-contained products eliminate the need to carry containers of liquids, or to dispense solvents, in the field. The pads and swabs are saturated with measured amounts of high-purity cleaning agents that have been ultra-filtered to 0.2 microns. They are sealed in individual foil packets.

Special INSTRUMENT SALE!

Joseph Electronics' 40th Anniversary Specials!



Model 2120 Oscilloscope
 DC to 20 MHz. Dual Trace, 6" CRT, 1mv Sensitivity.
 Reg. \$520 **\$379.40**
 40TH ANNIVERSARY PRICE

Model 2125 Oscilloscope
 Same great features as 2120, except with delayed sweep
 Reg. \$620 **\$519.40**
 40TH ANNIVERSARY PRICE

Model 1541A Oscilloscope DC to 40 MHz, Dual Trace, 6" CRT 1mv Sensitivity
 Reg. \$845 **\$739.40**
 40TH ANNIVERSARY PRICE

Model 2160 Oscilloscope DC-60MHz, Dual trace, delay sweep, 6" CRT, 1mv. sensitivity
 Reg. \$995 **\$839.40**
 40TH ANNIVERSARY PRICE

Model 2520 Digital Storage 20MHz, Dual Trace, 2mv Sens.
 Reg. \$1990 **\$1795.40**
 40TH ANNIVERSARY PRICE

Model 2521 Digital Storage 20MHz, Dual Trace CRT Readout, Cursors, RS232 Interface
 Reg. \$3050 **\$2745.40**
 40TH ANNIVERSARY PRICE

Model 1249 NTSC/RGB Color Bar Generator. Composite Video Output, RF Output
 Reg. \$499 **\$419.40**
 40TH ANNIVERSARY PRICE

Model 2009 MTS TV Stereo Generator Ideal for Stereo TV, Receivers, VCR's and Stereo Adapter Service
 Reg. \$499 **\$419.40**
 40TH ANNIVERSARY PRICE

Model 2830 3 1/2 DIGIT LED BENCH Multimeter. 5 DCV Accuracy, ALL 33 Ranges and Functions are Push Button Selectable
 Reg. \$243 **\$209.40**
 40TH ANNIVERSARY PRICE

Model 1045 Telephone Product Tester. Provides Basic Operation Tests for Corded and Cordless Telephones, Answering Machines and Automatic Dialers
 Reg. \$495 **\$415.40**
 40TH ANNIVERSARY PRICE

Model 1803 Frequency Counter 100 MHz, 8 digit display, zero blanking AC or Battery
 Reg. \$199 **\$169.40**
 40TH ANNIVERSARY PRICE

Model 2005 RF Signal Generator 100 KHz to 150 MHz, in 6 fundamental bands and 450 MHz in harmonics
 Reg. \$195 **\$165.40**
 40TH ANNIVERSARY PRICE

Model 3011 Function Generator 2 MHz, 4 digit display, TTL & CMOS pulse outputs
 Reg. \$239 **\$199.40**
 40TH ANNIVERSARY PRICE

Model 1630 DC Power Supply 0-30V, 0-3A, high-low current range. Low ripple
 Reg. \$251 **\$209.40**
 40TH ANNIVERSARY PRICE

Model 1601 DC Power Supply isolated 0-50V, 0-2A in ranges, fully automatic shutdown, Adj. current limit
 Reg. \$463 **\$389.40**
 40TH ANNIVERSARY PRICE

Model 1650 Triple Output Power Supply two 0-25 VDC @ 5A and 5VDC @ 5A, fully automatic shutdown
 Reg. \$489 **\$409.40**
 40TH ANNIVERSARY PRICE

Model 1653 AC Power Supply variable isolated 0-150 VAC @ 2A, built-in isolation transformer
 Reg. \$200 **\$169.40**
 40TH ANNIVERSARY PRICE

NEW! Model 388-HD Hand-held 3 1/2 Digit LCD TEST BENCH

41 voltage ranges, frequency counter, capacitance meter, logic probe, transistor and diode tester. All packed into a drop-resistant case. **SPECIAL PRICE!**

Reg. \$139 **\$119.40**



We are celebrating our 40th Anniversary by offering you huge savings on B&K Test Equipment.

Send for FREE 480 page "Industrial Products Catalog." I understand it is FREE with any order or if requested on company letterhead. (Otherwise, \$4.95 to cover catalog and shipping costs.)

ORDER TOLL FREE
1-800-323-5925
 IN ILLINOIS
312-297-4200
FAX: 312-297-6923

Joseph ELECTRONICS



JOSEPH ELECTRONICS, INC. Dept. R
 8830 N. Milwaukee Ave., Niles, IL 60648

Rush merchandise per attached order. I understand rated accounts are shipped open account; otherwise send per credit card.

Include \$5.00 per item for shipping and handling.

Visa Master Card Discover
 Check Money Order Rush Catalog

Card No. _____ Exp. Date _____

Name _____

Company _____

Street Address _____

City _____ State _____ Zip _____

IL Res. 7% Tax

OCTOBER 1988

With Just One Probe Hookup You Can Confidently Analyze Any Waveform To 100 MHz, 10 Times Faster, 10 Times More Accurately, Absolutely Error Free, Guaranteed Or Your Money Back . . .

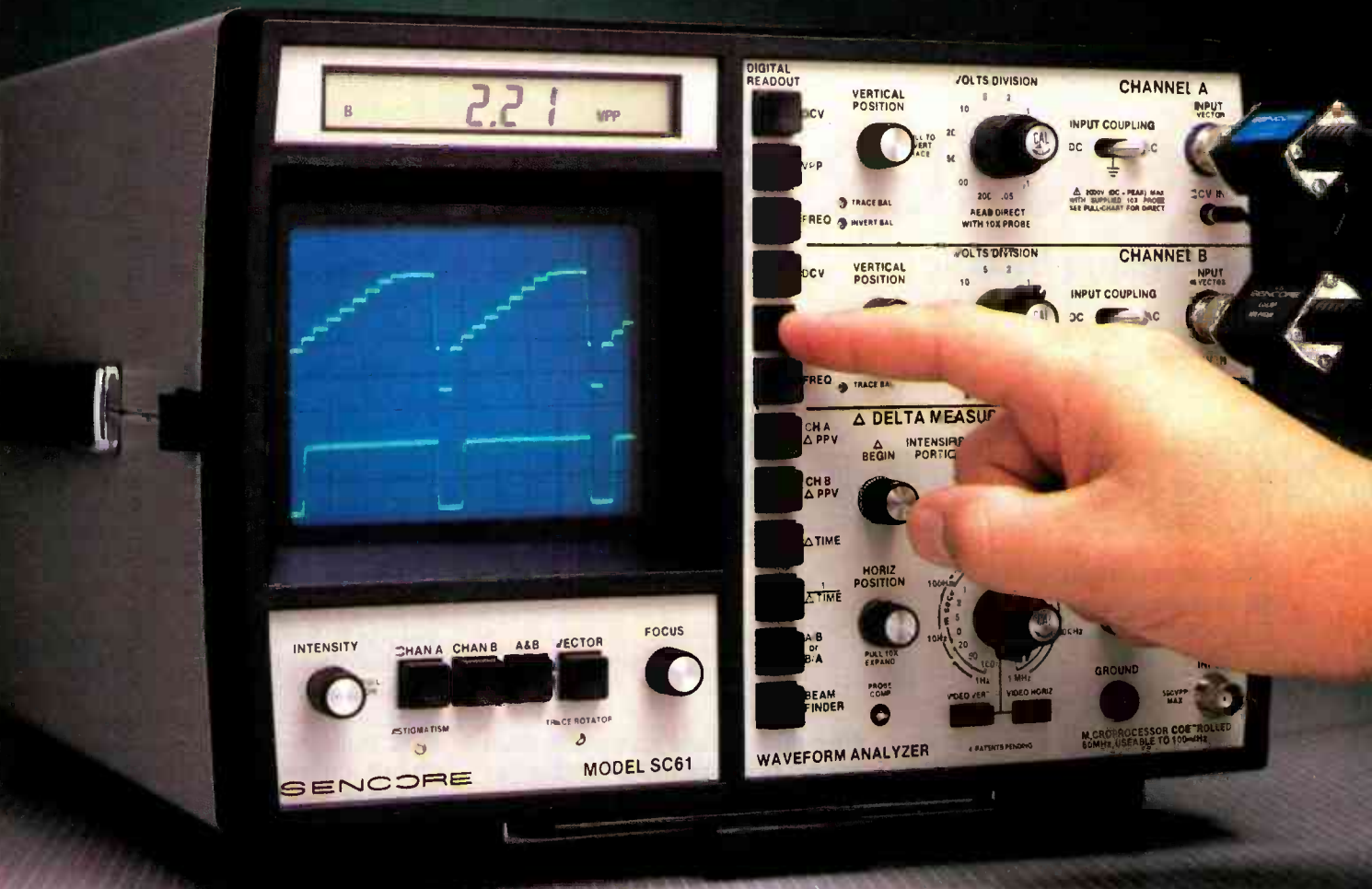

Promises of increased productivity from other oscilloscopes fade fast when compared to the speed and accuracy of the SC61. Eliminate the confusing menus, cursors and complexity of regular oscilloscopes at the push of a button. Here's what the SC61 does for you:

Analyze Waveforms Easily

- Accurate Waveform Display - 60 MHz Bandwidth (usable To 100 MHz) To Test The Latest Digital Circuits.
- Rock-Solid Sync - ECL Logic Circuits And Differential Amplifiers Give Fiddle Free Operation.
- Four Times The Measuring Range - Measure From 5 mV To 2000 Volts (3000 Volts Protection) For Expanded Signal Handling.

Autotracking™ Digital Readings Analyze The Whole Signal

- Autoranging DC Volts Through Single Probe, Even With AC Coupled.
- Automatic Peak-To-Peak Volts - Even If Variable Control Is "Out Of Cal".
- Automatic Frequency Measurements Without Sensitivity Adjustment Or Range Switching.

CIRCLE 198 ON FREE INFORMATION CARD

Digital Delta Tests Analyze Any Part Of The Signal.

- Delta Peak-To-Peak Volts - Peak-To-Peak Volts Of Any Part Of The Signal.
- Delta Time For Any Time Reading - Including Delay Between Traces
- 1/Delta Time - Frequency Of Part Of The Signal - Finds Sources Of Interference Or Ringing.

Frequency Ratio Test - Tests Multiplier And Divider Circuits

Easy To Use - Human Engineered Controls And Virtually No Graticule Counting Or Calculations

The SC61 is designed to give you the measurements you need fast. We make one claim:

"Try the SC61 on your bench for 30 days. If it doesn't cut your present scope time in half, send it back for a complete refund, no questions asked."

Try the SC61 for 30 days, and discover true troubleshooting speed.

Call 1-800-843-3338
In Canada Call 1-800-851-8866

SENCORE

COMMUNICATIONS CORNER

Multiplexing by color.



HERB FRIEDMAN,
COMMUNICATIONS EDITOR

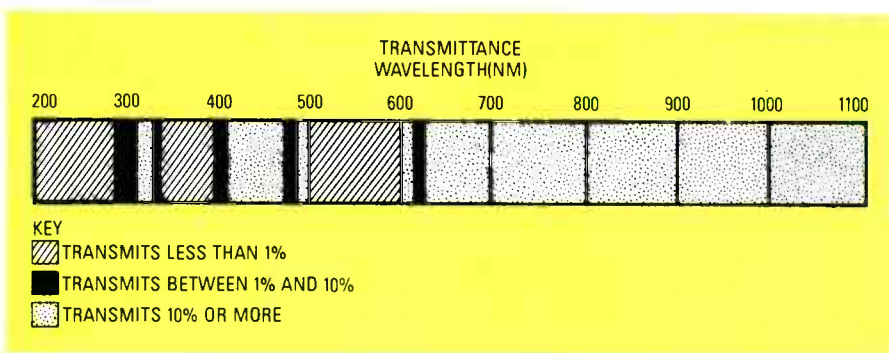

FIG. 1

STRICTLY TO BE POLITE AND TO MAKE small talk over dinner, I asked a representative of the biggest of the "Big Eight" accounting firms what he thought would be the key to business success in the immediate future. Bracing myself for at least 10 minutes worth of capitalization, amortization, depreciation and arbitrage, I must admit I was dumbfounded when he answered "fiber-optic communications." For the next hour or so I sat absolutely mesmerized as he described how

fiber-optic based communication networks will be in the forefront of business management.

At the conclusion of our talk—actually his lecture—he took out the by-now classic photograph of two cables, one a thin fiber optic rated for 225,000 conversations, the other a wire bundle as thick as an elephant's leg rated for under 50,000 conversations. Pointing at the fiber optic he said "It's not enough for tomorrow. Simply to handle business communications

we must be able to increase the capacity of networked fiber cable. We must be able to carry more on less."

Admittedly fascinated, I asked why he, a management consultant, carried around a photograph of wire cables. He replied that he looked at it whenever he came across a compelling naysayer who did not believe that fiber communications was the key to business. He said that had he lived in Edison's time, he would have carried a light bulb to look at when merchants claimed that their bookkeepers needed nothing more than a stand-up desk and a candle.

Multiplexing color

As we have mentioned in previous columns, there are several ways by which we increase the communications-carrying capacity of fiber-optic cables: the primary ones being multiplexed digital encoding and faster transmission rates. Obviously, there are limits

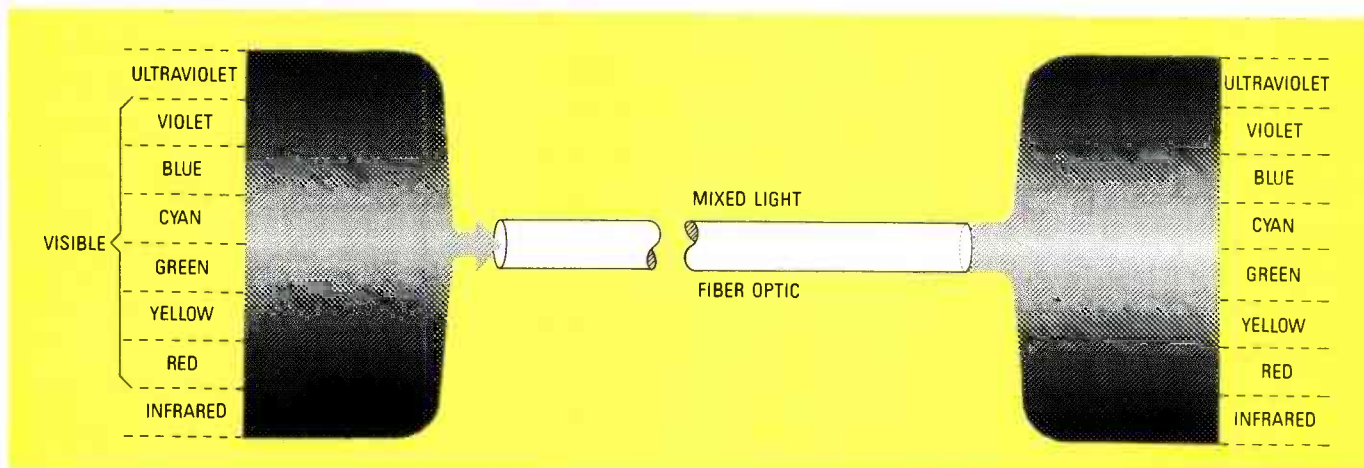
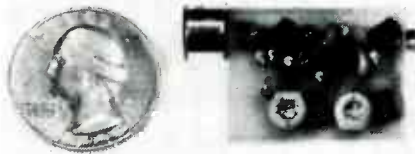

FIG. 2

Radio Electronics mini-ADS



SIMPLY SNAP THE WAT-50 MINIATURE FM TRANSMITTER on top of a 9v battery and hear every sound in an entire house up to 1 mile away! Adjustable from 70-130 MHZ. Use with any FM radio. Complete kit **\$29.95 + \$1.50 S + H**. Free shipping on 2 or more! COD add \$4. Call or send VISA, MC, MO. **DECO INDUSTRIES, Box 607, Bedford Hills, NY 10507. (914) 232-3878.**

CIRCLE 127 ON FREE INFORMATION CARD



RADAR SPEED SYSTEMS. Professional units for clocking speeds in baseball, car & boat racing, etc., starting at **\$269** used, **\$350** reconditioned. Moving and stationary units available with dual displays. All units are road tested and have 30-day warranties. Catalog **\$1**. Complete line of TV accessories. New Panasonic multi-line key business telephone systems from **\$675**. **AIS SATELLITE, INC., 106 N. 7th St./P, Perkasio, PA 18944. 215-453-1400.**

CIRCLE 190 ON FREE INFORMATION CARD

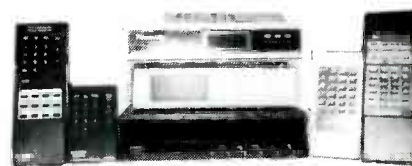

PANASONIC CABLE CONVERTERS, Wholesale and Retail. Scientific Atlanta and Pioneer Cable Converters in stock. Panasonic model 140N 68 channel converter **\$79.95**, Panasonic Amplified Video Control Switch Model VCS-1 **\$59.95**. Scientific Atlanta Brand new Model #8528 550MHZ 80 Channels Converter **\$89.95**. Video Corrector (MACRO, COPYGUARD, DIGITAL) ENHANCER **\$89.95**. We ship to Puerto Rico, Caribbean countries, & So. Amer. Write or call **BLUE STAR IND., 4712 AVE. N, Dept 105, Brooklyn, NY 11234. Phone (718) 258-9495.**

CIRCLE 85 ON FREE INFORMATION CARD

CALL NOW AND RESERVE YOUR SPACE

- 6 x rate \$890.00 per each insertion.
- Fast reader service cycle.
- Short lead time for the placement of ads.
- We typeset and layout the ad at no additional charge.

Call **516-293-3000** to reserve space. Ask for Arline Fishman. Limited number of pages available. Mail materials to: mini-ADS, RADIO-ELECTRONICS, 500-B Bi-County Blvd., Farmingdale, NY 11735.

ANALOG ACQUISITION UNIT



ANALOG ACQUISITION UNIT. CONNECT analog signals from experiments and circuits directly to your computer. Works with IBM, APPLE, TANDY or any computer with a serial port. 4 channels, 8 bit resolution. Up to 4 samples per second. Returns value in HEX or Decimal. **\$129.95** Check, Visa or Mastercard accepted. **GTC INDUSTRIES, PO BOX 2493, NAPERVILLE, IL. 60566 (312) 369-9815**

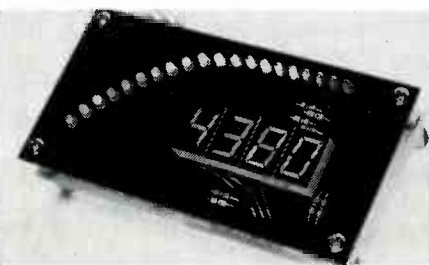

THE DIGITAL TACHOMETER MONITORS engine speed with a fast, easy to read bar/graph along with an accurate digital readout. The Digital Speedometer's dual display delivers vehicle speed with a 3-digit readout and a rapid-read analog display. Adjustable redline on both units. Complete kits only **\$75.00 ea.** Assembled & tested **\$99.95 ea.** Add 4% S/H. 90 day warranty. Contact: **DAKOTA DIGITAL, 11301 Kuhle Drive, Sioux Falls, SD 57107. (605) 332-6513.** Visa/MC accepted. Dealer inquiries welcome.

CIRCLE 191 ON FREE INFORMATION CARD

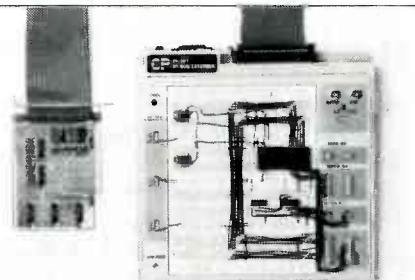

PC-601 XT BUS EXTENDER BREADBOARD LAB connects to any IBM PC compatible computer and extends all PC electrical bus connections out to the PC-601 for easy circuit prototype connection, testing and trouble-shooting. Includes large 3060 tie-point breadboard, $\pm 5V$ and $\pm 12Vdc$ AC line powered power supplies. Includes buffer card, 2' ribbon cable & 1-Year warranty. Price: **\$369.95** **CHENESKO PRODUCTS, 21 Maple St., Centereach, NY 11720. 516-736-7977, Fax: 516-732-4650**

CIRCLE 189 ON FREE INFORMATION CARD



ZENITH SSAVI UHF INPUT FROM \$199, ch. 3 input **\$229**, reconditioned. UHF SSAVI handbook **\$6.50** ppd. Used Sylvania 4040s **\$169**. New N-12-VS **\$99**, ch 2 or 3. MLD-1200s ch 2 or 3. Converters, amplifiers & accessories. Satellite systems. Professional used radar guns from **\$275**. New Panasonic multi-line business telephone systems from **\$675**. Catalog **\$1**. **AIS SATELLITE, INC., 106 N. 7th St./O, Perkasio, PA 18944. 215-453-1400.**

CIRCLE 81 ON FREE INFORMATION CARD

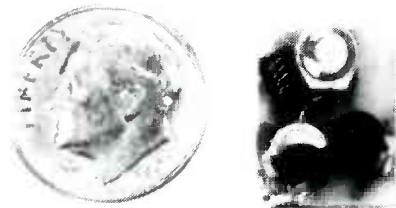

THE MODEL WTT-20 IS ONLY THE SIZE OF A DIME, yet transmits both sides of a telephone conversation to any FM radio with crystal clarity. Telephone line powered - never needs a battery! Up to $\frac{1}{4}$ mile range. Adjustable from 70-130 MHZ. Complete kit **\$29.95 + \$1.50 S + H**. Free Shipping on 2 or more! COD add \$4. Call or send VISA, MC, MO. **DECO INDUSTRIES, Box 607, Bedford Hills, NY 10507. (914) 232-3878.**

CIRCLE 127 ON FREE INFORMATION CARD

COMMUNICATIONS CORNER

continued from page 36

within the restraints of present technology as to how much multiplexing can be done, and how fast data can be transmitted. But to those two elements, we can now add a third, that of *color*.

Simply for the sake of illustration, using figures we all can understand, assume that an infrared transmitter and receiver in a fiber-optic system can digitally multiplex two distinct data streams at 9800 baud. (Admittedly, those are nonsense figures in the world of fiber optics, but they allow a newcomer to fiber optics, assuming some personal-computer experience, to visualize the situation.) A data stream might represent computer data, digitized TV pictures or telephone conversations, FAX, or any combination.

Next, imagine that into the same cable we feed two more data streams at 9800 baud, only this time ultraviolet light is used. Both

light signals travel together at the same time, yet neither interferes with the other.

Lots of room

Although the eye is only sensitive to the visible light frequencies between 400 nm (violet) and 700 nm (red), the practical wavelength of the light spectrum ranges from infrared to ultraviolet: 200–1100 nm, a range of 5.5:1. It doesn't take much imagination to realize that a 5.5:1 frequency range can carry a lot of anything—radio, TV, data, etc. All we need do is have some way to keep visible and near-visible signals from interfering with each other.

In fiber optics, separation is easy to do, once we know how it's done. One way, not immediately practical, is to have LED drivers that cover the light spectrum. Unfortunately, we simply don't have more than a handful of LED colors available at the present time. A similar method uses lasers, and although we still have the problem of limited colors, their phase co-

herence simplifies things at the receiving end. As shown in Fig. 1, a simple commercially-available color filter could be used to separate lasers at the receiver, thereby allowing us to use a white-light detector for each of the colors.

Figure 1 is the transmission characteristics of a common type Wratten color filter; available at any decent photographic-equipment dealer. As you can see, there are two distinct bands, at approximately 320 and 439 nm, that have more than 10% transmission. The filter can easily separate two distinct color-coded beams. By the way, the filter's *greater than 10%* transmission range from 620–1100 nm is part of the problem when using red signal-sources. Virtually no conventional filter attenuates the visible and near-visible red frequencies.

Imagine for a moment what the possibilities would be if we were to use a pencil-thin fiber cable into which we could multiplex specific narrowband colors. The transmission scheme would be similar to the one shown in Fig. 2. Each input color to the cable would originate in a laser (so we have a narrow bandwidth to start with), and the colors would be received through narrowband optical filters. As you can see, each color, even when mixed with the others, would serve as an individual communications path. Notice that the visible and near visible reds have been combined. That is only because we presently have no cost-effective system for precise separation of the reds. Of course, when cost is no object, anything is possible.

Keeping it simple

In future columns we'll get into multiplexing by color blending at the transmitter, and by color splitting at the receiver. For example, a conventional color star shows us that a yellow light could be received as individual red and green components, while its complements would be magenta and cyan. A little juggling of transmitter and receiver filters could give us at least five optic channels from a single color. How come five? Because complementary colors give us neutral densities—another way to separate fiber-optic data. R-E

Crystek Crystals

QUARTZ CRYSTALS FOR

Industrial Equipment/Instrumentation

- Micro-processor control
- Computers/Modems
- Test/Measurement
- Medical



General Communications

- Channel element Service (VHF/UHF)
- Land Mobile 2-way
- Marine
- Aircraft
- Telemetry
- Monitors/Scanners/Pagers



Amateurs/2-Meter/General Coverage CB/Hobbles/Experimenter

FOR OPTIMUM STABILITY AND RELIABILITY IN FREQUENCY MANAGEMENT



The Pulse of Dependable Communications

Crystek Crystals offers their new 16 page **FREE** catalog of crystals and oscillators. Offering state of the art crystal components manufactured by the latest automated technology. Custom designed or "off the shelf." Crystek meets the need, worldwide. Write or call today!

CRYTEK CORPORATION

DIVISION OF WHITEHALL CORPORATION

2351/2371 Crystal Drive • Ft. Myers, FL 33907
P.O. Box 06135 • Ft. Myers, FL 33906-6135

TOLL FREE 1-800-237-3061

PH 813-936-2109/TWX 510-951-7448/FAX 813-939-4226

TOLL FREE IN THE U.S.A. EXCEPT FLORIDA, ALASKA, HAWAII

CIRCLE 191 ON FREE INFORMATION CARD

SHORTWAVE RADIO



STANLEY LEINWOLL,
CONTRIBUTING EDITOR

General conditions and more on fundamentals.

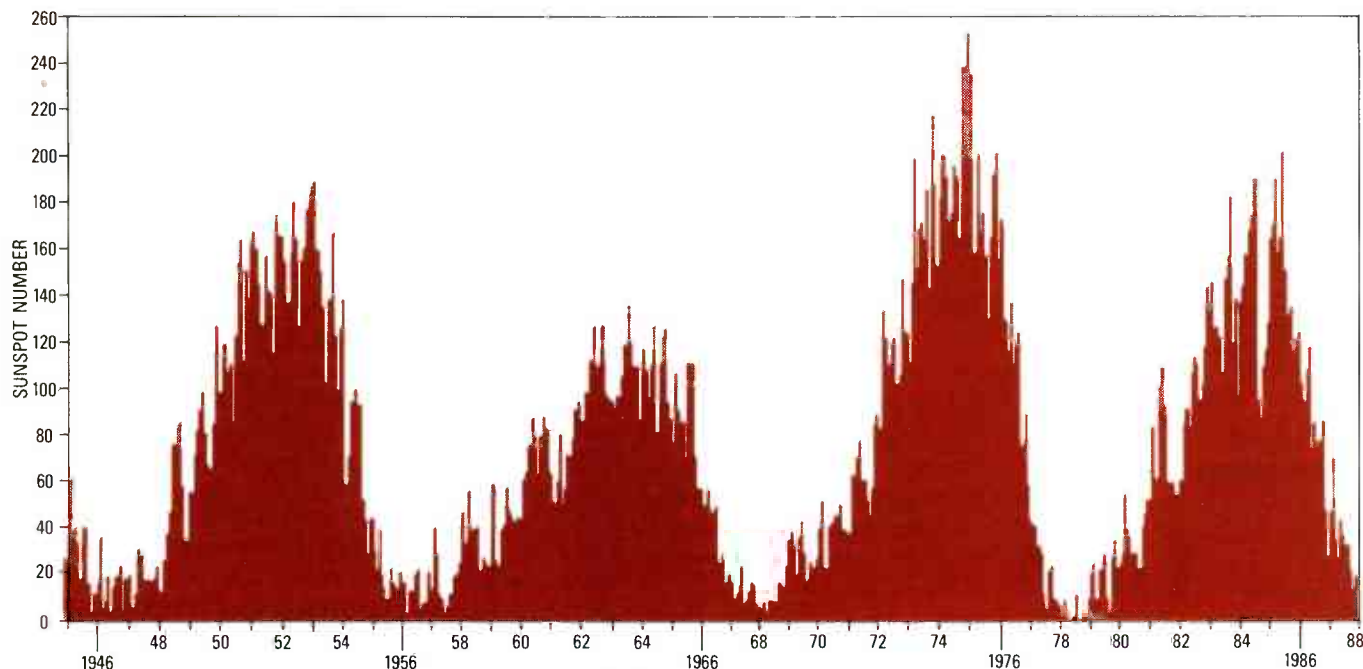

FIG. 1

AS EARTH CONTINUES TO MOVE CLOSER to the sun, the ionosphere becomes more highly ionized during the daylight hours, and the higher frequencies propagate better. At the same time, seasonal decreases in sporadic-E activity will reduce the number of short-skip openings in the higher bands. As a result, there will be fewer TV-DX openings, and short skip on 10 and 11 meters will decrease as well. However, long-distance openings on the higher frequencies will probably increase.

The best daytime DX will be observed in the 10- through 19-meter bands. At night, the range of frequencies from 49 to 19 meters will be good for DX, and on southerly circuits, from Latin America and

Africa, 16 meters will also frequently be good.

During the equinox months, daylengths in the northern and southern hemispheres are about equal. As a result, propagation over long circuits is better than at any other time of the year. Therefore, reception from Australia, New Zealand and southeast Asia will be at their best during that period. Also, seasonal decreases in noise levels will result in improved broadcast-band DX.

Chit-chat

After approximately forty years of operation, the Voice Of America (VOA) will be discontinuing short-wave broadcasting from its Munich, Germany transmitter

site early next year. The VOA recently concluded an agreement with the Federal Republic of Germany under which it will rent four 500-kilowatt transmitters at Wertachtal, the German supersite near Munich. The 100-kilowatt transmitters at Munich will be turned over to Bavarian radio. VOA will continue its medium-wave operation from Munich pending the availability of an alternate site.

Now we are going to continue where we left off on our discussion on the fundamentals of short-wave-radio propagation.

Sunspots

If diurnal, seasonal, and geographic variations were the only
continued on page 84

Your Career in **ELECTRONICS** or **COMPUTERS**

Add prestige and earning power to your technical career by earning your Associate or Bachelor's Degree in electronics or computers—through independent home study.

No commuting to class. Study at your own pace, while continuing on your present job. Learn from easy-to-understand lessons, with help from your Grantham instructors when you need it.

Grantham College of Engineering is a specialized institution catering to adults who are employed in electronics and allied fields such as computers. These fields are so enormous that opportunity for advancement is always present. Promotions and natural turn-over make desirable positions available to those who are prepared to move up!

Put Professional Knowledge and a
COLLEGE DEGREE
in your Technical Career through
HOME STUDY

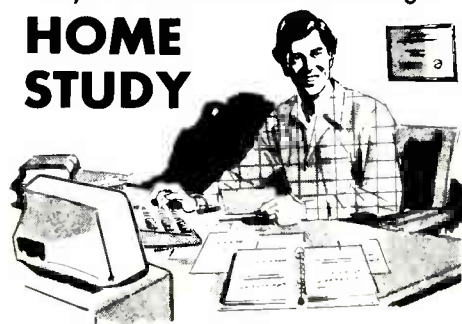

Accredited by the
Accrediting Commission of the National Home Study Council

Grantham College of Engineering
10570 Humbolt Street
Los Alamitos, California 90720

Write for our free catalog
(see coupon below) or phone
(213) 493-4423 (no collect calls)
and ask for our "degree catalog."

Grantham offers two B.S. degree programs — one with major emphasis in **ELECTRONICS** and the other with major emphasis in **COMPUTERS**. Either program can be completed by correspondence (also known as "distance education.") An A.S. degree is awarded along the way in each B.S. program, but the B.S. program is not complete without the A.S. part. Our catalog gives complete details.

Now in Our
38th Year

Grantham College of Engineering
P.O. Box 539, Los Alamitos, CA 90720

Please mail me your free catalog which explains your distance-education degree programs.

NAME _____

ADDRESS _____

CITY _____

STATE _____

ZIP _____

R-10-88

Grantham College of Engineering

has conferred on

John Doe

the degree of

Associate in Science in Engineering Technology
with major emphasis in **Computers**

Grantham College of Engineering

has conferred on

John Doe

the degree of

Bachelor of Science in Engineering Technology
with major emphasis in **Computers**

In witness thereof, this diploma duly signed has been issued by the College Administration upon recommendation of the Faculty, at the College in

Grantham College of Engineering

has conferred on

John Doe

the degree of

Associate in Science in Engineering Technology
with major emphasis in **Electronics**

Grantham College of Engineering

has conferred on

John Doe

the degree of

Bachelor of Science in Engineering Technology
with major emphasis in **Electronics**

In witness thereof, this diploma duly signed has been issued by the College Administration upon recommendation of the Faculty, at the College in Los Alamitos, California, on this day of March 1, 1987.

D. J. Grantham President
H. L. Denny Dean



ISDN

The Telephone of Tomorrow

ISDN promises to bring the world into a new Age of Information by integrating all our current—and future—communications technologies into a single, worldwide network.

ERIC E. SUMMER*

ABOUT A CENTURY AGO—IN 1887, TO BE EXACT—a young man named Ludovic Zamenhof presented to the world his invention that would end war and international strife. To be sure, the same claim had already been made for the machine gun, and would later be made on behalf of the dirigible, the submarine, the airplane, and nuclear weapons. But Zamenhof's idea was different. The need, as he saw it, was for freer communication among the peoples of the globe, and his invention was a totally new language called "Lingvo Internacia."

In writing about his brainchild, Zamenhof used the *nom de plume* "Doktoro Esperanto" (Dr. Hopeful-One), and the language has come to be called *Esperanto*.

Esperanto has plenty going for it.

*Vice President of Operations Planning, AT&T Bell Laboratories

It's simple, rational, and easy to learn and spell—at least for those familiar with the existing European languages. The reader won't need to be told the meaning of "Lingvo Internacia," for example. And Esperanto has attracted a considerable following. Although it is estimated that as many as 8,000,000 people speak Esperanto, including many Japanese and Chinese, that is only a small percentage of the world's billions.

Today, however, there is a significant new hope for international communication—one that is not strictly linguistic, but technological. For we can now do with machines what Zamenhof could not do with people. We can build them with an innate capability for intercommunication. And we can provide the necessary channels to interconnect different types of equipment.

No one would dare claim that this new technology will end war. But there is little doubt that, should a hotline one day be called upon to avert a global military cataclysm, the messages will be carried over a system that uses the new standard.

An international standard

The exciting new sun on the communications horizon is called the *Integrated Services Digital Network* or ISDN. It's the result of a dozen years of effort by communications experts in all the major nations, working together under the aegis of a United Nations agency, the International Telegraph and Telephone Consultative Committee, usually known as CCITT.

The extraordinary potential of ISDN is rooted in technology, both old and new, and in the concept of

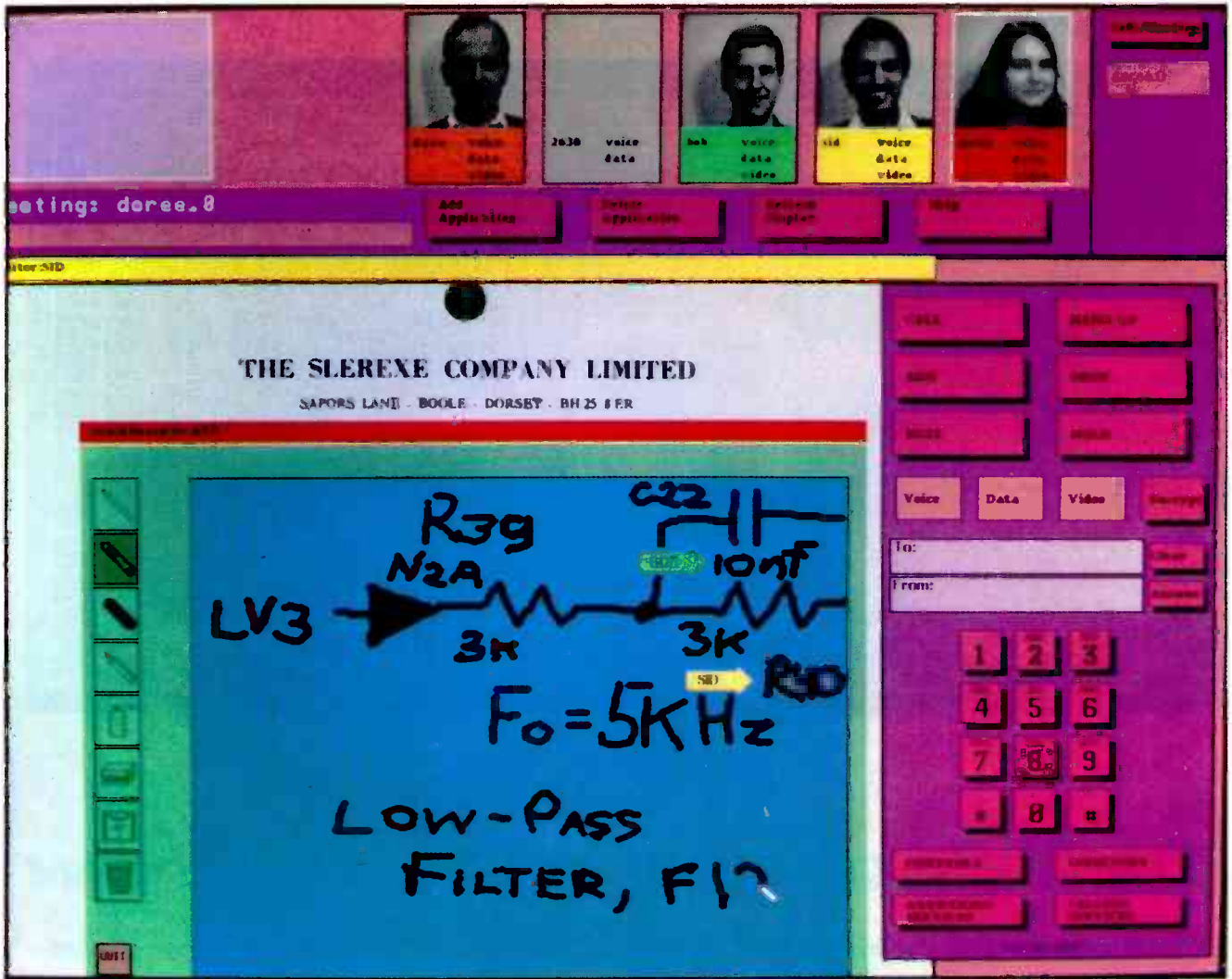

DISTANCE WILL BE NO OBSTACLE at a working meeting transformed into a computer conference by ISDN. Participants will be able to write on a computer-generated blackboard—that will appear on each video-display terminal—as they converse. The colored cursors will indicate who is doing the writing. Participants will also be able to see each other via electronic portraits arrayed across the top of the screen. Although such an exchange will require the rapid movement of a great deal of information, ISDN connections have the capabilities to make such meetings routine.

standardization. An ISDN computer in the phone company's switching office enables ordinary telephone lines to simultaneously carry voice, computer data, and facsimile messages—or any combination of those. ISDN will also have the capacity to carry an infinite number of other services, including video images, remote data retrieval, and alarm systems. The number of services depends solely upon the telecommunications devices connected to it—from an individual's home computer and simple telephone to the complex communications demands of large corporations—giving users tremendous control and flexibility over their own networks. An all-digital network, ISDN offers increased clarity, accuracy, and speed.

Like an electrical system, in which a common outlet is used for virtually every device, ISDN eliminates the need for separate networks and special equipment like modems to send computer or fax messages—and makes it possible to talk on the phone about those messages as they are being sent. Millions of miles of ordinary telephone lines—the physical foundation of that single network—are already up and running. Finally, because ISDN comprises a set of internationally accepted standards, compatibility of equipment is ensured.

ISDN is the product of two converging streams of development: One development stream flowed among users; the other has occurred in R&D

laboratories.

At one time, for example, a business firm was considered very up-to-date if it used computers. Today, however, competitive pressures require that same firm to also connect its computers with those of customers, prospects, suppliers, consultants, and so on. And technological developments now permit new levels of sophistication, both within the machines that need to communicate and in the channels of communication available to them.

The first stream made ISDN necessary; the second made it possible.

Like the elephant examined by the three blind sages, the nature of ISDN seems to vary according to the observer. To one person, for example, ISDN means a compatible computer that can talk—with reliability and security—to computers at other locations, even if they are built by different makers. To another person, ISDN refers to a communications sys-

tem that can carry any existing or expected form of encoded signal, be it voice, data, or image. To yet another, it is a network that permits distributed processing of information and shared use of data bases, producing—in effect—computers of unprecedented size and power.

ISDN is all of those things and yet none of them. ISDN is an international networking standard that will provide increased bandwidth for simultaneous, integrated access to voice, data, and signalling information over existing wiring. ISDN is a set of guidelines, or *standards*, that any designer should use in developing equipment, so it will function effectively within an evolving, worldwide information network.

An important agent in establishing those standards is the *Institute of Electrical and Electronic Engineers (IEEE)*, the largest professional organization in the world. Its Standards Board helped determine rates of transmission for data, packet formats, and so on. The IEEE has played a major role in ISDN progress.

A precious resource

For over a century, telephone companies here and abroad have been patiently and inexorably tying the peoples of the world together with an ordinary copper pair of wires—the ubiquitous “twisted pair.” Those two conductors thread their way from the heights of modern office buildings to the depths of the most-remote valleys, linking isolated farmhouses to vast government bureaucracies.

The very existence of that almost universal linkage is a resource of unequalled dimensions. It is a multi-billion-dollar infrastructure that would be difficult to duplicate or replace in any reasonable time frame.

Equally important, the latest electronics technologies have given the twisted pair enormous untapped reserves of bandwidth, or information-carrying capacity. Using such a powerful circuit solely to carry today’s few-thousand-Hertz telephone calls ignores most of that potential capacity.

ISDN’s creators knew that they could, and should, build the new standards around the twisted pair. They saw that, through creative engineering, they could avoid the need for the high-capacity coaxial cable now used in local interconnection of computers

and other data-handling machines. Among other things, ISDN could protect the world’s enormous investment in twisted-pair construction.

In the ISDN scheme of things, a single twisted pair becomes the local link for all types of communications. Furthermore, ISDN exploits the bandwidth of the twisted pair to the hilt. If, for instance, one party to a telephone conversation wishes to send some data to be displayed on a screen in front of the other party, ISDN techniques will enable both voice and data to travel over that one pair of conductors. In the future, fiber-optic technology will provide even greater bandwidth for data and video services. (The bulk of telecommunications use is still for voice conversation. But the data side is increasing by some 30% a year, and may equal voice in traffic volume by the early 1990’s.)

What to expect from ISDN

Today’s information worker is often barricaded behind a mass of high-tech hardware that apparently just grew in place as the worker’s communication needs increased. Snaking around, under, and behind it all is a mass of unwieldy, bulky cables. More often than not, the various items are not particularly compatible. There’s a telephone, but data from the computer can’t be sent over it—at least, not without some complex juggling. There’s a printer, but data from the telephone can’t be printed on it. And, if a move is required, weeks of advance planning are necessary, and considerable expense is incurred. Sometimes the worker must also acquire a new telephone number, with substantial inconvenience to himself and to his business associates.

ISDN is simplifying all of that. Standards for compatibility of new equipment are being made available to all manufacturers. Existing equipment will be made compatible through special interface devices. Bulky bundles of wire and coaxial cable will become things of the past—replaced by the slender, nearly invisible, traditional-telephone pair. A new control technology, called “out-of-band signalling,” will give users and their equipment extensive power over network switching.

No less important, ISDN is a prerequisite to the effective use of modern long-distance technologies, such

as fiber-optic circuits. ISDN, with its all-digital encoding, distributed processing, and out-of-band signalling, supplies the means to put the tremendous capacity of such facilities to use.

The beneficial fallout from ISDN will not be restricted to owners of huge mainframes or those who send out daily reams of fax transmissions. Thanks to out-of-band signalling, even home telephones will acquire new capabilities. Call Waiting, for instance, which now involves distracting clicks and maneuvers with the handset hook, will become easy and non-intrusive in the ISDN communications environment.

Other services, often mentioned by consumers as “blue-sky” hopes, become economically feasible through ISDN. For example, hi-fidelity telephones, that reproduce a 20–20,000-Hz frequency range at the flip of a switch, would allow a “Shop-at-Home” service for consumers who want to sample part of a stereo record or compact disc before buying it. Electronic mail for everyone, via a fax channel woven into the present home-telephone connection, becomes more practical. Other possible services include remote document retrieval—so that a person at home can search for desired documents stored at distant offices, libraries, or agencies, and then view those same documents on a high-resolution TV screen—and conference calls over PC’s, including video presentation of photos, maps, and the like, for on-line discussion of family happenings, travel, and entertainment events.

What say the experts?

Not long ago, in a major study to help determine how ISDN’s tremendous information-handling capacity would be put to work, the AT&T Network Systems Group polled a large group of business-telecommunications managers. Those experts answered that their most pressing needs were to cut costs and increase revenues, to evolve their telecommunications equipment gracefully as technology evolves, and to gain more control over their communications systems.

In particular, those managers asked for:

- An end to the high cost of moving people and their communications equipment from one office to another.
- Easy access to features without the

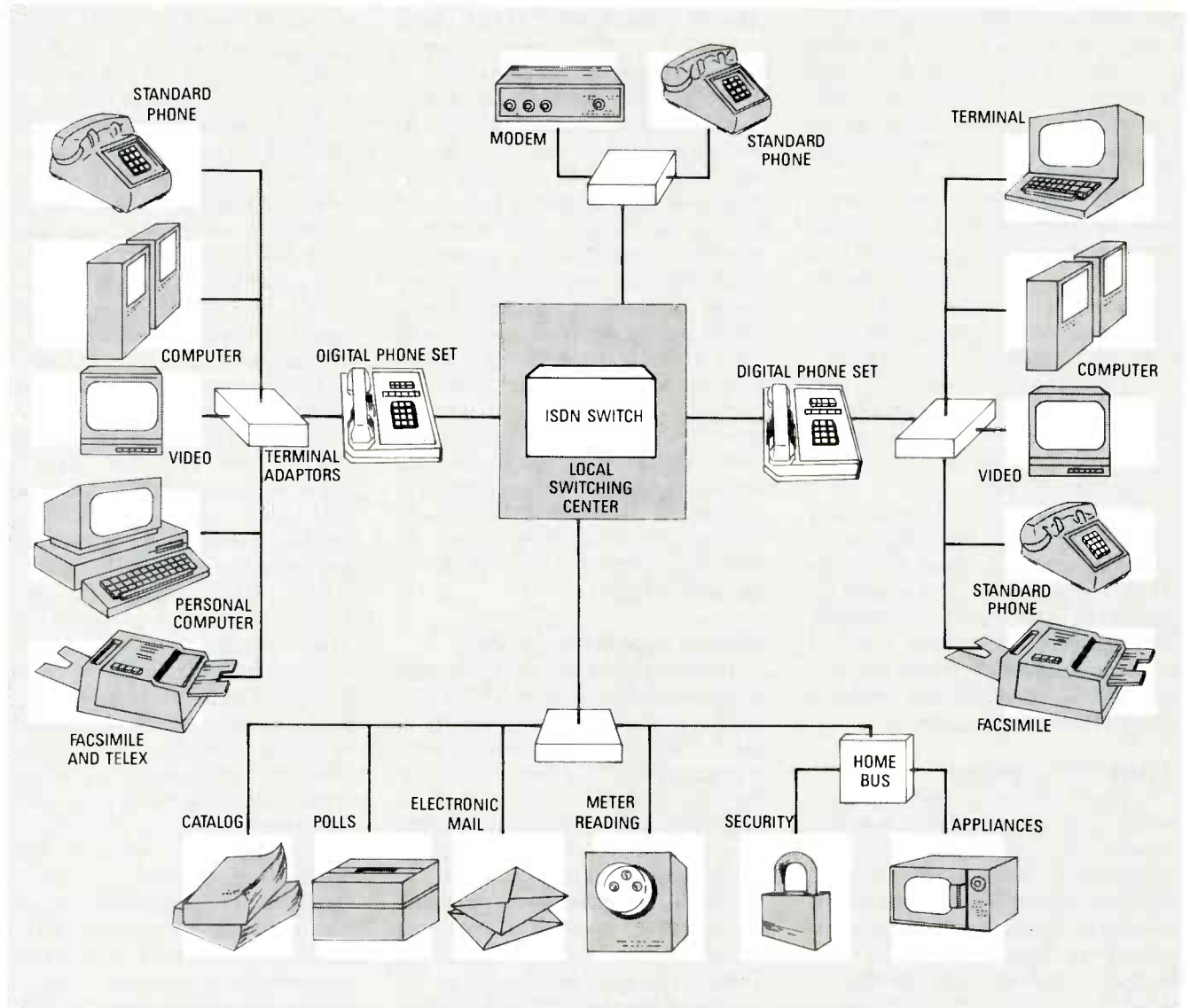

FROM AN OFFICE EQUIPPED WITH ISDN, voice, data, and video can be sent to similarly equipped offices and homes. ISDN voice and data transmissions can also be received on standard telephones and computer modems. Terminal adaptors provide translation between analog and digital data, ensuring compatibility of all the disparate components used. Possible future applications include catalog shopping, polls, electronic mail, meter reading, and remote control of household systems through a home bus.

need to know—or worry—about central-office equipment changes.

- Services that are available when customers want them, and that work and keep working.
- Fewer pieces of communications equipment, such as modems, terminals, and telephone sets.
- Elimination of the two-line desk one-line for voice and one for data—and an end to expensive cable webs entangling secretarial stations, communications centers, and data-processing rooms.
- The ability of a business-telecommunications staff to decide—and to control—who gets which telecommunications services and features.

- The ability of users to control services and features—such as Call Forwarding—by just pressing a few buttons at their stations.
- The ability of business-telecommunications managers to control network resources—such as lines, features, configurations, and data networking—and to control the cost of those resources.

True, many of those benefits are already available in some areas, and with some equipment. But only ISDN, with its universal interconnection and complete software control, makes them available wherever there are, or will be, any kind of networked-communications service,

from a standard telephone to the most-elaborate data-processing web.

That is so because ISDN is not a “tool built for a task.” Rather, it is a *set of standards* that defines any and all imaginable task-oriented electronic tools can be combined into networks that are more effective and powerful than any single tool can be.

A hundred years ago, for instance, a sufficiently wealthy person might have been able to afford a private-telephone system between his home and his office. He might even have been able to afford extending it to each of several plants and to several key business associates. But, despite that heavy investment, he could not enjoy the full value of the telephone until it could, at will, be connected to any other telephone throughout the largest possible area.

Paradoxically, by becoming more

powerful and more valuable, that telephone system simultaneously became affordable even to people of moderate means.

Similarly, most sizable businesses now make extensive use of computers and other data-handling machines; many even have interconnections between some or all of their computers at various locations. But their entire data-processing function is strait-jacketed as long as it cannot interact with other data-processing systems—across town, or around the globe—as the need arises.

Those needs, present and future, stimulated the effort which led to ISDN.

The philosophy of it all

Fundamental to ISDN are two concepts: *distributed processing* and *out-of-band signaling*. Let's look at each of them separately.

Distributed processing allows equipment at one location to make use of data and data-processing capabilities at many other locations. (Security measures are, of course, provided to prevent unauthorized use.) For example, let's say you will be traveling from San Francisco to London in two weeks, and wish to make theater reservations for one evening during your stay. Clearly, it would be impractical for travel agents worldwide to store and continually update information about London theaters. However, with a fully ISDN-compatible network of computers and communications channels, your San Francisco travel agent might examine data bases at a variety of London theaters to learn what is playing and what seats are available. Once you have made your selection, that theater's data base can be informed, and those seats set aside for your arrival. Obviously, that is similar to systems now used by airlines. But its use for reservations of all kinds, everywhere, is contingent upon truly international standards of equipment and communication.

Out-of-band signaling occurring on the "D" channel means that the channels carrying user messages are separated from channels carrying signals for controlling the network. That permits greater efficiency, security, and "transparency" of communication than in most of today's systems, where inter-machine signals follow the same channels as user messages.

Out-of-band signaling puts message-routing control in the hands of the customer rather than in the hands of the communications provider.

Some recently developed telephone capabilities—such as Calling Party Identification, Call Forwarding, and Distinctive Ringing—usually can only be put to full use if both parties are hooked to one exchange. With out-of-band signaling—a technique originated by AT&T—the required control information flashes from exchange to exchange on a separate channel, and the user is undisturbed by (in fact, unaware of) the many steps involved in making it all happen. The user also need not be concerned about where the required



AT&T'S 5ESS SYSTEM, USING THE MOST advanced local digital switch, meets today's needs, and can expand to meet tomorrow's demands—including ISDN's three operating modes. The system's 5ESS switching module is shown above, including a test circuit that monitors communication with other modules over light-wave links.

telephone numbers or the instructions for network and equipment manipulation are stored.

Another vital aspect of ISDN has been making certain that those powerful capabilities are not limited just to traditional "telephone" apparatus, but are also available to all types of information-handling equipment, regardless of who owns it, who makes it, or where it is installed. Thus, the benefits of ISDN are available to ordinary-voice telephone, computers, video, facsimile, and so on.

Basic structure

In ISDN, all information is digi-

tally encoded before transmission. That applies even to those data—such as voice and video—that were originally analog. With an all-digital network, voices will be transmitted at the same speed with improved sound quality, and data will move about seven times faster.

That analog-to-digital translation is just one of the many functions of an IC called *UNITE*, which AT&T developed specifically for ISDN. Current and future equipment can, of course, be designed for ISDN compatibility at the outset. But *terminal adapters* will smooth the transition by allowing existing equipment to reap ISDN's benefits.

The basic ISDN-operating scheme, or *interface*, involves two kinds of channels. One carries the user's message (the in-band, or "B" for Bearer, channel). There are two "B" channels. The other type of channel—the out-of-band, or "D" for Data, channel—carries primarily network-signaling or control information.

Two such interfaces, or classes of service, differing mainly in their carrying capacity, are currently defined. The *Basic Rate Interface* consists of two 64-kb/s (kilobits per second) Bearer channels and one 16-kb/s Data channel. The higher-capacity *Primary Rate Interface* consists of 23 64-kb/s Bearer channels and one 64-kb/s Data channel. In Europe, the *Primary Rate Interface* has 30 64-kb/s "B" channels with two "D" channels.

Essentially, the Data channel is for signaling and switching between various pieces of network equipment. However, since it will probably not be fully occupied with signaling, some user information may travel on it as well, increasing overall system capacity.

In ISDN, user information, once digitized, travels in one of three ways:

- *Circuit Switching* is the familiar method, analogous to the way two telephones have been hooked up since the early 1900's. Once connected, the two—or more—pieces of equipment are kept connected as long as the parties desire.
- Using *Packet Switching*, a "packet" or single batch of information is assembled and tagged with an "address." It is then put onto the "D" channel of the ISDN network and, like some futuristic robotic train, is automatically switched from "track"

Electronics Engineers & Designers!

Take 3 books for only \$1.95

(Values to \$161.85)

SHARPEN YOUR SKILLS—With Quality, Affordable Professional Books

ENGINEERING MATH

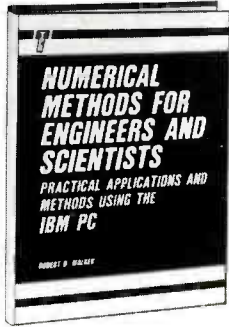

2697 Regular \$19.95
Ready-to-run math programs & subroutines for scientists and engineers. 304 pp.

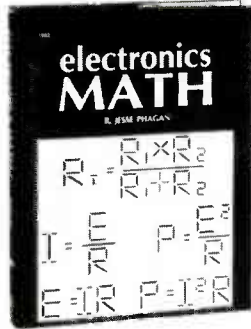

1962 Regular \$22.95
247 illustrations, a practical reference to basic electronics math usage. 256 pp.

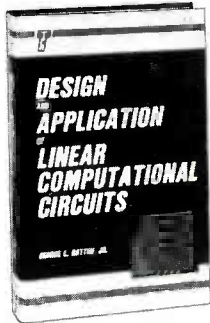

2727 Regular \$24.95
Perform complex calculations with simple analog circuits. 200 pp.

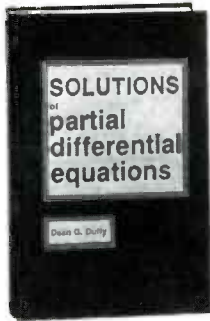

2612 Regular \$25.95
102 illustrations, step-by-step methods for solving real-world partial and differential equations. 560 pp.

STATE-OF-THE-ART

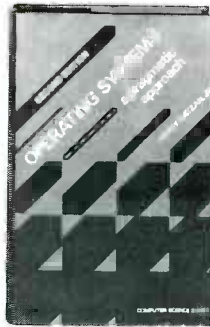

9808 Regular \$34.95
For both micro and main frame users, second edition of the all-time best selling guide. 449 pp.



2931 Regular \$39.95
330 illustrations, a one-volume reference to satellite design and application. 448 pp. Counts as two.

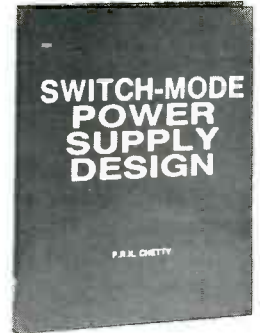

2631 Regular \$22.95
196 illustrations, a practical sourcebook complete with applications examples. 192 pp.

COMPUTER SOFTWARE

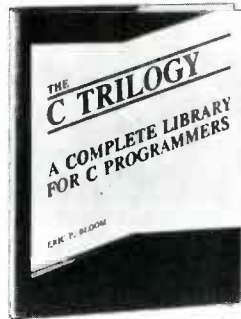

2890 Regular \$32.95
A 1-volume language primer, reference manual and subroutine function library. 588 pp. Counts as two.

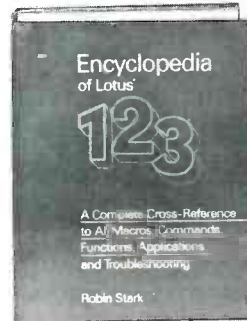

2891 Regular \$29.95
183 illustrations, a newly-published, reference guide. 496 pp.

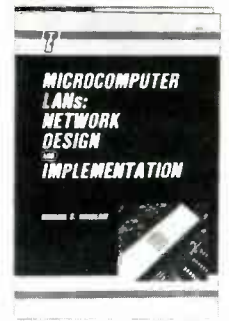

2888 Regular \$26.95
How computer networks work, how to make them work for you. 340 pp.

GENERAL SCIENCE

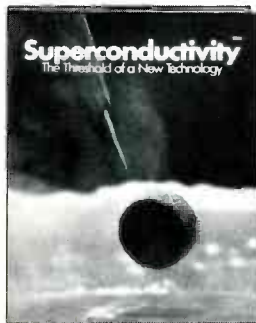

3022 Regular \$18.95
The impact of this new technology—the discoveries, the applications and the future. 66 illustrations. 160 pp.

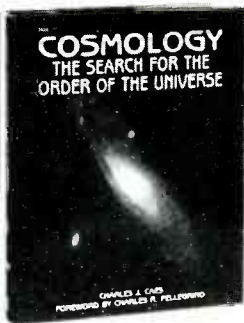

2626 Regular \$16.95
A fascinating book about man's oldest question—the search for understanding of cosmic order. 192 pp.

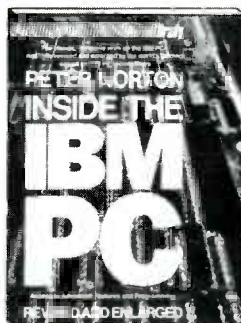

9762P Regular \$21.95
The classic, definitive work on the IBM PC—fully revised and enlarged. 387 pp.

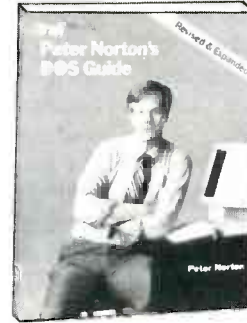

9766P Regular \$19.95
Make your IBM PC work for you with Norton's practical and informative guide. 362 pp.

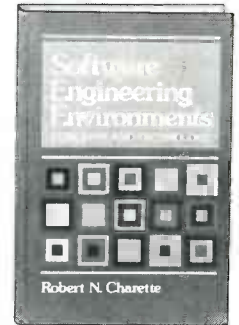

9821 Regular \$38.95
An authoritative and provocative look at the state of today's software engineering. 340 pp. Counts as two.

ELECTRONIC CIRCUITS

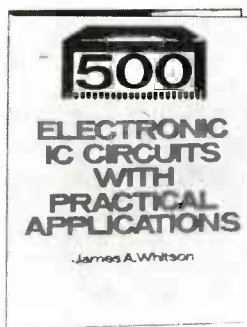

2920 Regular \$28.95
600 diagrams, schematics, and tables showing IC circuits. 352 pp.

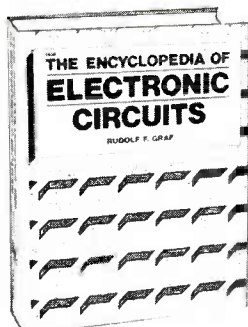

1938 Regular \$60.00
Over 1,300 useful and versatile electronic circuit designs. 768 pp. *Counts as two.*

ELECTRONIC COMPONENTS

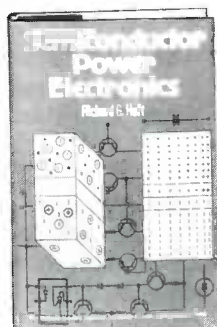

9820 Regular \$46.95
Covers transistor and thyristor circuits for power electronics systems. 324 pp.

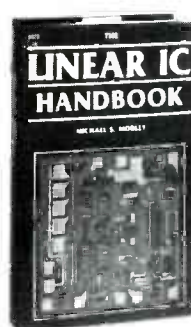

2672 Regular \$49.50
Linear integrated circuits—specifications, prices & data. 614 pp. *Counts as two.*



2957 Regular \$39.95
192 illustrations of electronic display devices. 416 pp. *Counts as two.*

REFERENCE



9785 Regular \$79.95

9785 All about systems, components devices, and software by 50 experts and authorities. 874 pp.

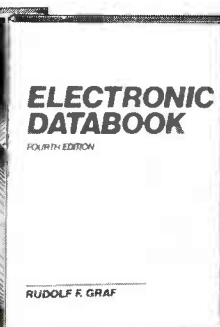

2958 Regular \$34.95

2958 "A rich fund of reliable, easy-to-use data..."—*Engineering Societies Library*, 560 pp. *Counts as two.*

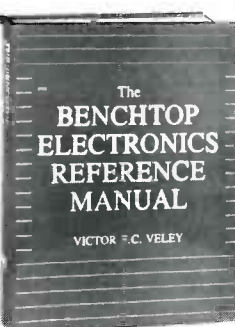

2785 Regular \$34.95

2785 Easy-to-use reference to 160 electronic principles: ac/dc, solid-state, oscillators, amplifiers and radio communications. 620 pp. *Counts as two.*

OTHER TITLES

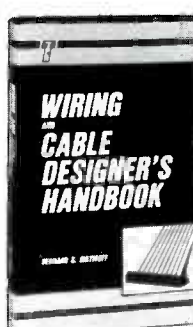

2720 Regular \$32.50

2720 State-of-the-art design techniques and manufacturing methods. 250 illustrations. 304 pp.

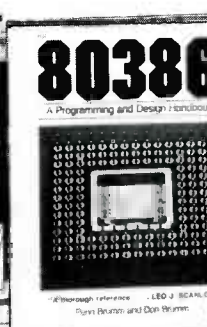

2937 Regular \$29.95

2937 80386 architecture, assembly language programming as well as multi-tasking and multiprocessing. 150 illustrations. 448 pp.

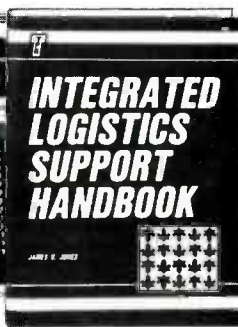

2921 Regular \$42.95

2921 Vital information on the use of ILS disciplines for military and consumer goods production applications, 406 pp. *Counts as two.*

© EE & DBC Blue Ridge Summit, PA 17294-0860

How the Club Works

YOUR BENEFITS: You get 3 books for \$1.95 plus shipping & handling when you join. You keep on saving with discounts up to 50% as a member.

YOUR PROFESSIONAL BOOKSTORE BY MAIL: Every 3-4 weeks, you will receive the EE&D Book Club News describing the Main Selection and Alternates, as well as bonus offers and special sales, with hundreds of titles to choose from.

AUTOMATIC ORDER: If you want the Main selection, do nothing and it will be sent to you automatically. If you prefer another selection, or no selection at all, simply indicate your choice on the reply form provided. As a member, you agree to purchase at least 3 books within the next 2 years and may resign at any time thereafter.

BONUS BOOKS: Starting immediately you will be eligible for our Bonus Book Plan with savings of up to 80% off publishers' prices.

IRONCLAD NO-RISK GUARANTEE: If not satisfied with your books, return them within 10 days without obligation!

EXCEPTIONAL QUALITY: All books are quality publishers' editions especially selected by our Editorial Board.

All books are hardcover unless number is followed by a "P" for paperback. (Publishers' Prices shown)

SEND NO MONEY NOW!

INTRODUCTORY 10-DAY FREE EXAMINATION

ELECTRONICS ENGINEERS & DESIGNERS BOOK CLUB

Blue Ridge Summit, PA 17294-0860

YES! Please accept my membership in the *Electronics Engineers & Designers Book Club*® and send me the volumes I have listed below, billing me only \$1.95 plus shipping and handling charges. I understand that the books are sent on a 10-Day Free Examination basis. If dissatisfied in any way, I may return the books within 10 days and incur no further obligation. Otherwise, I agree to pay the enclosed invoice promptly and to receive regular club bulletins as described in "How the Club Works." To complete my membership obligation I need only purchase 3 additional books at regular members prices during the next 2 years, and may resign at any time thereafter.

(write 2 or 3 title numbers of your choice above)

NAME

ADDRESS

CITY STATE / ZIP

SIGNATURE

Valid for new members only. Foreign applicants will receive special ordering instructions. Canada must remit in U.S. funds. This order is subject to acceptance by the *Electronics Engineers & Designers Book Club*®.

DRE-1088

ELECTRONICS ENGINEERS & DESIGNERS BOOK CLUB®

to "track," steered by the appended address, until it reaches its destination. ISDN signal and control information is transmitted over the "D" channel in that packetized form. Between network tasks, the "D" channel can also be used to carry packetized user information. Converting a particular transmission into packetized form is another job handled by the terminal adapter, further easing the transition to ISDN.

● In the *Virtual-Circuit* mode an "information pipeline," of any desired carrying capacity, is maintained for the exclusive use of the subscribing party, in the manner of the traditional private line used by broadcasting networks and the like. Because of its very-sophisticated information-handling capabilities, the ISDN network need not actually tie the virtual circuit to a particular conductor or path, but can use whatever channels are open at any time. The only requirement is that the prescribed data capacity between the two endpoints is preserved.

Thus, as Ian Ross, president of AT&T Bell Laboratories says, "ISDN will enable users to merge their own internal-data systems seamlessly with the worldwide public networks. On the other hand, if users prefer to take their destinies into their own hands, software will allow them to configure portions of these networks into what are virtually private networks, suited to their individual tastes and needs."

Some hardware

The guiding principle of ISDN is to wring every last drop of communications out of existing and future transmission facilities. So, although the world's stock of data-transmission pathways is growing constantly, with more of everything from the buried line reaching a new suburban development to new fiber-optic light cables, the real ISDN action is elsewhere. It's happening at the *nodes*—the junctions, terminals, and interchange points where information is put on, and taken off, those lines.

We've already spoken of the terminal adapter that will help bridge the transition to ISDN. It will translate the output of existing electronic equipment into ISDN format, so the information can be transmitted to the desired point. There, if non-ISDN equipment is also in use, a second terminal adapter will re-convert the

information to a suitable form. Of course, the companies involved in setting ISDN standards are cooperating fully with other manufacturers, helping them design and test their new products for future ISDN compatibility.

Very significant, too, is the *5ESS* switch, the latest generation of the *Electronic Switching System*. Twenty million communications lines are already terminated on the thousands of *5ESS*-switch offices now in service, and AT&T Network Systems has ensured that it is capable of handling ISDN signals. The *5ESS* switch can be used either as a central office switch or on the premises of a large communications user. Upgrading any *5ESS* to support any of ISDN's three modes requires only the addition of the latest enhanced software.

ISDN case histories

Probably the nearest approach yet to "total ISDN" has been made by the McDonald's restaurant corporation, working with Illinois Bell and AT&T. By the time you read this, McDonald's new headquarters building, specifically wired for ISDN, will be open. McDonald's expects to eventually extend the new technology to include all of its 68 offices and 9,400 restaurants in 45 countries.

According to Bonnie Kos, McDonald's Vice President of Facilities and Systems, ISDN improves the work and productivity of data-processing employees, who can now simultaneously converse and transmit data over the same connection. At the same time, the cost of building wiring and of wiring changes is lowered, because of its simple, twisted-pair wiring. Ultimately, ISDN will permit the consolidation of most of the 20 networks McDonald's previously needed to perform the same tasks. "ISDN is the first product that...will help us manage our business internationally," says Ms. Kos.

There are over 20 ISDN applications in service around the United States, with more being added each month. The ISDN service at American Transtech, in Jacksonville, FL, has been in service since last November. American Transtech, one of the nation's largest telemarketing companies, handles over a million telephone calls and financial transactions per day. Among the distinctive features of American Transtech's

ISDN installation are its nationwide operation and that, due to its great volume, it uses the high-capacity primary rate interface.

As AT&T Planning Supervisor George Gawrys says, "We've shown how effective ISDN can be in a large universe. We've proven the viability of such features as Automatic Number Forwarding, Call-by-Call Service Selection, and Multi-Media Conferencing—not across the street, but across the nation. This is no longer a trial...it's the same equipment that will be sold to other customers as soon as the tariff is approved by the FCC."

Also putting ISDN to work is Intel, of Santa Clara, CA. At first, they viewed their participation as a learning experience, valuable for them because they are a major manufacturer of communications IC's. But gradually, the advantages became so apparent that Intel decided to link all of its offices digitally, and to consider telecommuting for its personnel. One Intel employee currently spends four days a week at home in Phoenix, AZ, making use of an IBM mainframe in Santa Clara. At the same time, others in his family are using the identical pair of wires for making local telephone calls!

Other firms presently testing ISDN include Chevron Corp.'s Chevron Information Technology Co.; and United Technologies Corp.'s Pratt & Whitney Division., with 200 ISDN lines, soon to be expanded to 3,000.

So—What is ISDN, really?

First, ISDN is an international push to get every last bit of communications capacity out of the vast network that has been laid down for the past hundred years.

Second, it represents an all-out effort to upgrade business and home communications, with all the convenience, capability, and economy that the current, and foreseeable, state-of-the-art technologies permit.

Third, ISDN is a set of standards. The fact is that there are now multiple sources of equipment. All equipment, however, must be able to intercommunicate if it is to achieve its full potential. ISDN provides universal standards for interconnection that will make such communication possible.

So, after a hundred years, Ludovic Zamenhof's dream may finally be on the verge of realization. **R-E**

BUILD THIS

BREATH ALERT ALCOHOL TESTER

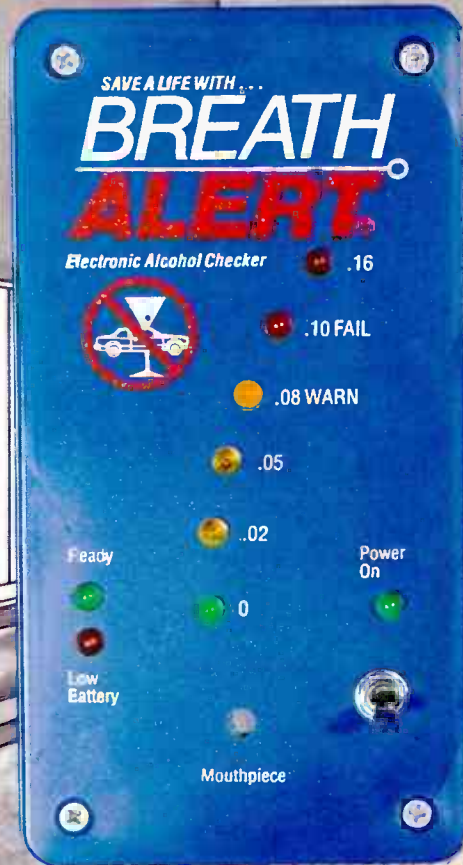

JOHN DILALO

THE BREATH ALERT IS AN ELECTRONIC INSTRUMENT designed to test the concentration of alcohol in a person's blood stream (known as BAC or Blood-Alcohol Concentration), by analyzing his or her exhaled breath. In doing that, the instrument might ultimately save lives, because it can convince people that it doesn't take much alcohol to fail the tests that are given by law-enforcement officers.

Alcohol detection

There are many ways to test for alcohol, such as a color change in a chemical reaction, an optical-interference test, an infrared absorption

test, or heat generation from a catalytic reaction on a hot platinum wire. However, those methods all suffer from the difficulties in handling, maintenance, high cost, and limited life expectancy—certainly not good for a home-built device. Therefore, a simple and inexpensive sensor was required. The semiconductor sensor contained inside the Breath Alert was used because of its high stability, reliability, immunity to shock and vibration, and low cost.

The sensor has a semiconductor material mounted on a ceramic tube, on which gold electrodes are printed (see Fig. 1). The sensor is mounted in

a resin body, protected by a double layer of 100-mesh-per-inch stainless-steel screening. When the sensor is heated to its normal operating temperature, oxygen (which has a tendency to "steal" electrons) is absorbed into the semiconductor's surface. As a result, a depletion layer develops between the surface and the bulk of the sensor, increasing the overall resistance of the sensor.

When alcohol is absorbed by the sensor's surface, it reacts with the oxygen that has already been absorbed. The sensor's resistance then decreases in proportion to the level of alcohol concentration. A graph show-

*It doesn't take
as much alcohol as you think
to seriously
impair your driving skills.*

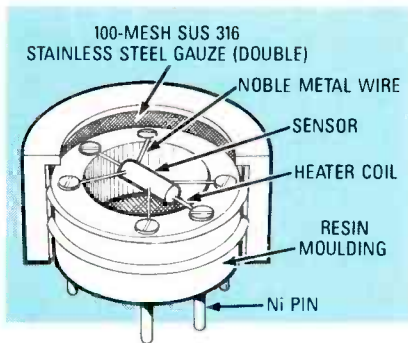

FIG. 1—UNDER NORMAL conditions, this sensor has a very high resistance. When alcohol comes in contact with the sensor, its resistance decreases in proportion to the alcohol concentration.

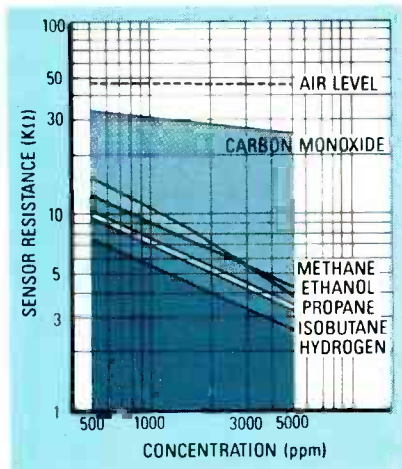

FIG. 2—THIS CHART SHOWS how the sensor's resistance changes according to the concentration of various elements that come in contact with it.

ing the sensor's resistance, in relation to the concentration of various elements that come in contact with its surface, is shown in Fig. 2.

Circuitry

A block diagram of the Breath Alert's circuitry can be seen in Fig. 3, and the complete schematic is shown in Fig. 4. When power is applied to the circuit, the heater coil in the sensor is energized by the 5-volt output of IC5, a 7805 voltage regulator. The entire circuit goes through a sample reading, and then after a warm-up period, the circuit automatically resets to a 0-alcohol level and the ready light comes on. Figure 5 shows a timing chart for the Breath Alert from the moment that power is applied.

Breathing into the sensor with alcohol on your breath will lower the sensor's resistance; consequently, the input voltage to the detector circuit, will change. The detector circuit consists of a quad op-amp, IC2 and its

associated circuitry. All sections of the detector circuit are calibrated via R3 and R4, and the inputs to each section are controlled by the voltage-divider network R21–23. As each section is triggered, the outputs go low

and the sample-and-hold circuitry, made up of IC3 and IC4, will latch onto the highest input value and drive the appropriate LED. The different colored LED's represent the following alcohol levels:

PARTS LIST

All resistors are ¼-watt, 5%, unless otherwise noted.

- R1—25,000 ohms, trimmer potentiometer
- R2—2000 ohms, trimmer potentiometer
- R3, R4—5000 ohms, trimmer potentiometer
- R5–R7, R11–R13—220 ohms
- R8–R10—120 ohms
- R14, R18—10,000 ohms
- R15, R23—1000 ohms
- R16—880 ohms
- R17—4700 ohms
- R19—1300 ohms
- R20—390 ohms
- R21, R22—430 ohms

Capacitors

- C1—10µF, 16 volts, electrolytic

Semiconductors

- IC1, IC2—LM324 quad op-amp
- IC3, IC4—74LS00 quad 2-input NAND gate
- IC5—7805 5-volt regulator
- D1—1N4001 diode
- LED2, LED4, LED10—Green light-emitting diode
- LED3, LED5, LED6—Red light-emitting diode
- LED7—Amber light-emitting diode
- LED8, LED9—Yellow light-emitting diode
- D1—1N4001

SEN1—Nemoto resistive semiconductor alcohol sensor

Other components

- BZ1—Piezo buzzer
- S1—SPST on/off switch

Miscellaneous: Plastic drinking straws, PC board, jumper wire, 5K calibration potentiometer, 2 4-pack AA battery holders, 1 case, 1 phono plug and jack, etc.

Note: The following items are available from Breath Alert MFG. Co., 130 Rockland Street, Hanover, MA 02339 (617) 837-0609. Breath Alert sensor: \$16.95. PC board and sensor: \$27.95. Complete set of parts without case or battery holders: \$44.95. Deluxe kit containing all parts including screen-printed case and battery holders: \$59.95. Charger kit including jack and power-pack adapter: \$7.95. Pre-assembled and calibrated Breath Alert, including Ni-Cd batteries and charger: \$99.95. Quantity discounts available. Allow 2-4 weeks delivery by UPS ground. Add \$4.00 shipping, and \$3.75 for C.O.D., Massachusetts residents must add 5% sales tax. MasterCard and Visa only, call (800) 334-0854, extension 609.

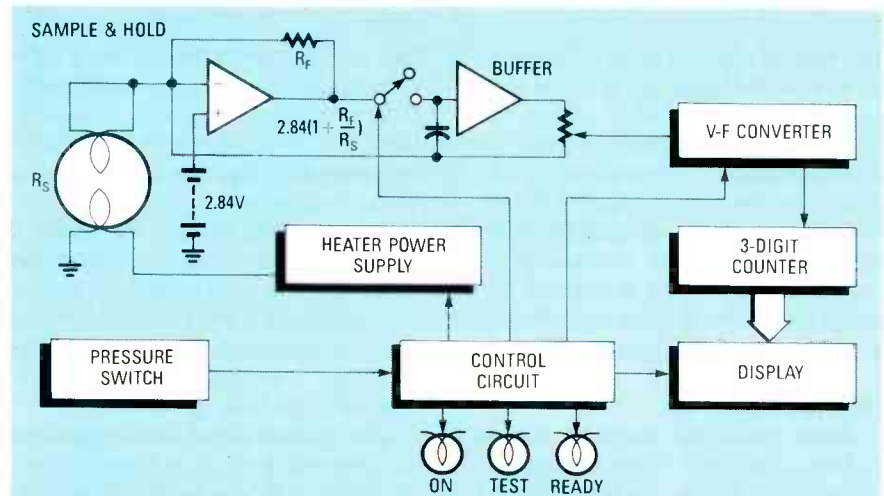

FIG. 3—BLOCK DIAGRAM SHOWS a simplified representation of what's inside the Breath Alert.

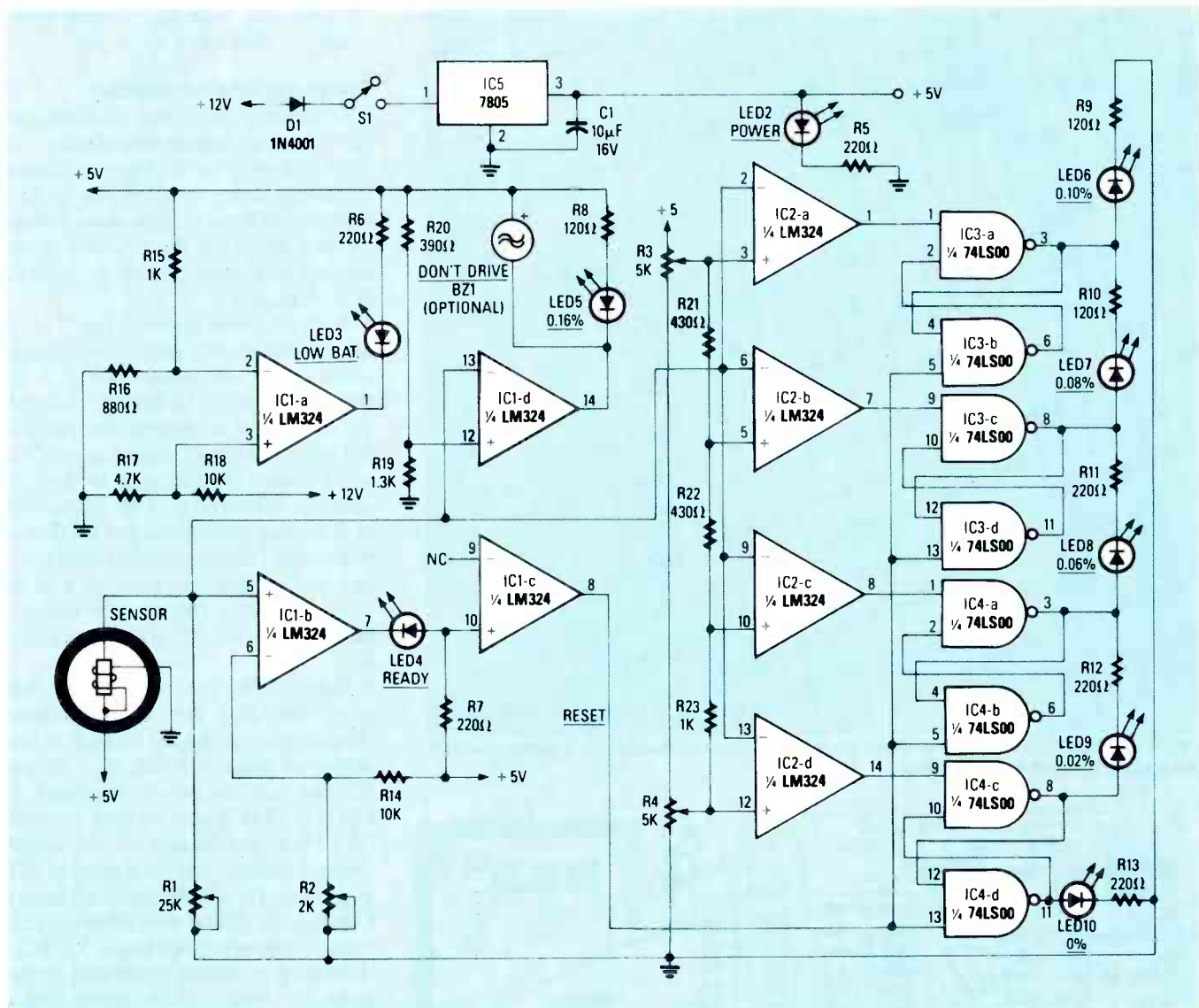

FIG. 4—THE COMPLETE SCHEMATIC for the Breath Alert. The circuit requires the regulated 5 volts from the 7805 regulator.

- 1 green—pass
- 2 yellow—pass (but alcohol present) 0.02%
- 3 yellow—pass (but alcohol present) 0.05%
- 4 amber—warning (danger zone) 0.08%
- 5 red—fail (over legal limit) 0.1%
- 6 red—fail (way over limit) 0.16%

If the level of alcohol is above the legal limit, or 0.16%, part of another quad op-amp, IC1-d, will turn on both the optional buzzer and LED5. That is an indication of a high level of alcohol present in your blood, and you definitely should not drive.

After a test is taken, the sensor takes a few seconds to ready itself for another test. When the sensor is ready, its input to IC1-b (adjusted via R2 to a threshold of 0.5 volt) causes LED4 (ready) to come on. That, in

turn, causes IC1-c to reset the rest of the circuitry. The last section of IC1 is biased via R15 and R16, and used to indicate a low-battery condition (when the battery voltage drops below 6.8 volts), which could result in an inaccurate breath test.

Construction

Be sure to follow the directions carefully, so you won't have to re-do anything later on. A PC board is available either separately, or in kits containing various parts, from the source listed in the Parts List. Start the assembly by installing all of the fixed resistors, and follow Fig. 6 for the correct placement of all components. Then install potentiometers R1–R4.

Now install all of the IC's while observing proper polarity. Be sure to solder all pins carefully and do not

overheat the IC's or the PC board. Also install the 7805 voltage regulator, IC5, making certain to bend it down and solder its tab to the PC board to provide for heat-sinking (see Fig. 7). Next install D1, a 1N4001 diode; capacitor C1; the sensor, SEN1, leaving about 3/8-inch clearance underneath it; S1; BZ1, observing its polarity; and a 1-inch piece of insulated wire for the jumper (J).

The circuit contains 9 LED's. Find a plastic straw about 1/8-inch in diameter, and cut 9 pieces exactly 1/2-inch long; then slip them over the leads of the LED's so that they will all be exactly the same height off the board. Observe polarity when installing the LED's. Also, make sure that all LED's are uniform in height before soldering. The Parts List indicates the correct colors for the LED's, and the

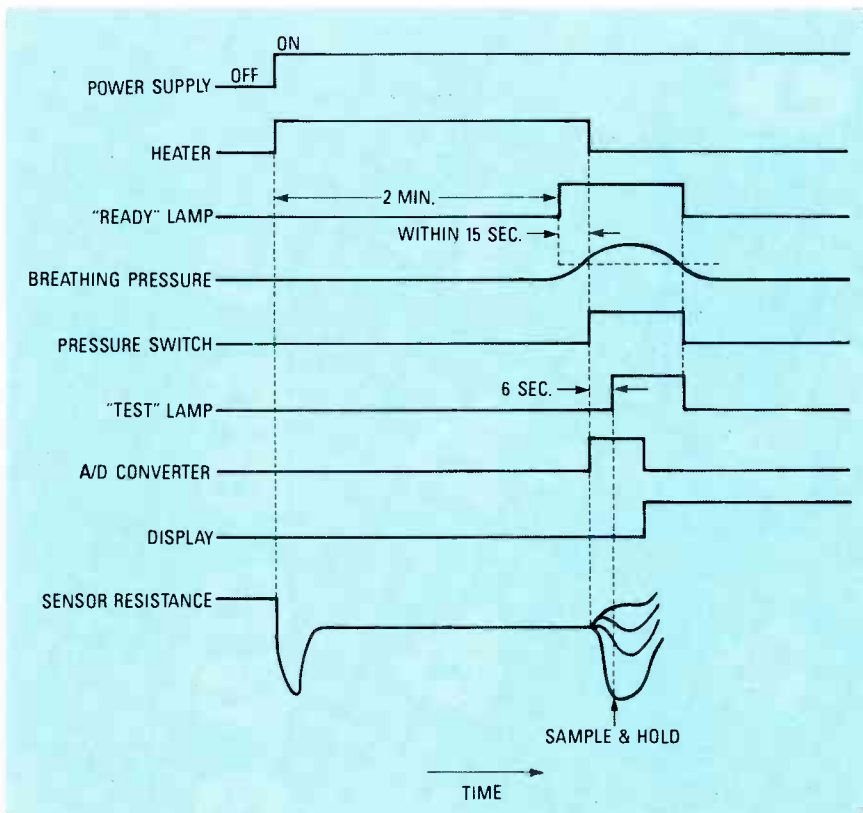

FIG. 5—A TIMING CHART shows the order in which various functions are performed from the instant the unit is powered up.

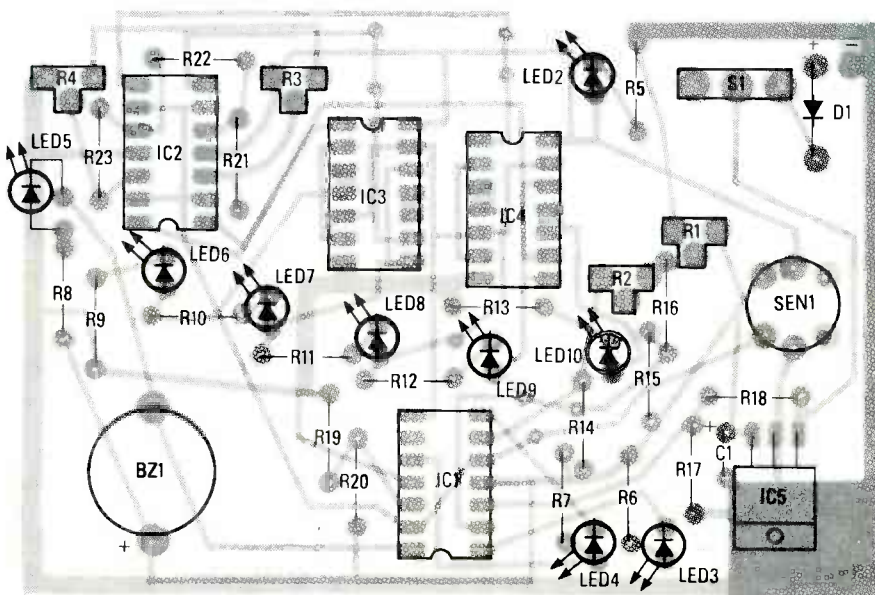

FIG. 6—PARTS-PLACEMENT DIAGRAM. You can make your own PC board, or you can buy one from the source mentioned elsewhere in this article. Pay careful attention to the height of the LED's.

Parts-Placement diagram shows you where they go.

The next thing you have to do is to connect the power source to the PC board. The unit requires 8 AA pen-light batteries, or else you can use rechargeable Ni-Cd's which require the optional AC charger/adaptor. You have to follow the wiring instructions

shown in Fig. 8, depending upon what kind of batteries you're using. You'll need two 4-pack AA battery holders for throwaway cells and, if you are going to use rechargeable cells, you need a 117/18-volt AC power pack, 8 rechargeable AA cells, a phone jack, a 100-ohm resistor, and a 1N4001 diode as shown. All parts

are available from the source mentioned in the Parts List.

Checkout and calibration

In order to check and calibrate the unit, there are certain instruments and tools that you'll need. Those include a soldering iron, small screwdriver, voltmeter, 5K calibration potentiometer and wire (see Fig. 9), and some drinkable alcohol, such as vodka, beer, rum, etc.

With no power applied, you'll have to tack-solder the potentiometer assembly that was shown in Fig. 9 to various points on the circuit. Connect the black wire to ground (the bottom left corner of the PC board near IC5), and connect the red wire to the left side (toward the edge of the PC board) of R20. Set potentiometers R1-R4 at mid-range (arrows should be straight up), and connect the positive lead of your voltmeter (be sure to set the meter on a 5-volt DC scale) to pin 5 of IC1.

Turn on the power using S1; the power-on LED and several others should light up. Adjust R1 so that the voltmeter reads 0.5-volt DC. Adjust R2 just past the on/off threshold of LED4 (LED4 should be lit at 0.5-volt DC). Now turn the unit off and install a 6-inch jumper wire from pin 8 of IC1 to ground. (It will be removed later.) Connect the yellow wire from the calibration potentiometer to pin 5 of IC1. (Leave the voltmeter connected to the same pin while you're doing that.) Now, by adjusting the calibration potentiometer, you should be able to get a voltage reading from 0- to 5-volts DC. Also, LED5-LED9 should light individually at some point from 2 volts to 5 volts.

Set the calibration potentiometer to get a reading of 0.5-volt DC; LED's 2, 4, and 10 should all be lit. Adjust the calibration potentiometer to read 0.7-volt DC. At this point LED4 should not be lit. If it is, turn R2 counterclockwise (just a hair) until LED4 turns off (LED4 should be on at 0.5 volt or lower, and off at 0.7 volts and up). Adjust the calibration potentiometer for a reading of 1.75-volts DC; LED4 and LED10 should be off and LED9 should be on. Now adjust R4 until only LED9 is lit.

Adjust the calibration potentiometer for a reading of 2.5-volts DC; LED9 should go off and LED8 turn on. Now adjust R3 so that only LED8

continued on page 70

Electronic Thermometer

MARC SPIWAK, ASSOCIATE EDITOR

QUITE OFTEN, THE BEST KIND OF PROJECT to build is just a neat little gadget that you don't necessarily need, but one that will give you something to do without costing you an arm and a leg. That way, you don't have to rush the project in order to meet some deadline. And if you should run into any problems while trying to get your project to work, you won't be ready to kill your friends and family—and believe it or not, the fourth-most leading cause of death in this country is due to crazed electronics hobbyists who have wasted hundreds of dollars and hours on a dead-end project.

The project we are presenting, however, is one that you'll want to build. It is an electronic thermometer that displays a temperature range of 40 degrees Fahrenheit (or about 23 degrees Celsius) on a 16-LED bar-type display. It's easy to build, very inexpensive, and it is a great desktop-novelty item when it's finished. It's also so small that, with a little customizing, it can be made to fit, along with two small 6-volt batteries, inside a very small project case.

Circuitry

As you can see from the schematic in Fig. 1, the heart of the electronic thermometer is IC1, a Siemens UAA170. That IC is really just a 16-LED driver. Depending on the level of the input voltage to pin 11, and how $V_{REF(min)}$ and $V_{REF(max)}$ (pins 12 and 13) are biased, one of the 16 LED's is illuminated.

The temperature-sensing ability of the circuit is made possible by R10, an NTC (Negative Temperature Coefficient) thermistor. (A thermistor is a temperature-dependent resistor, and NTC means that as the temperature increases, the resistance decreases; PTC means that as the temperature increases, the resistance also increases.) As the ambient temperature increases, the thermistor's resistance, and consequently the input voltage to pin 11, decreases. The 16 LED's on the prototype display from about 50 to



Here's something that you don't really need—but you'll probably want to build one, anyway!

90 degrees Fahrenheit, but you can calibrate the center temperature (the middle LED) via potentiometer R12.

The circuit also includes an LDR (Light-Dependent Resistor), R11, that adjusts the display's brightness according to how much light is in the room. The LDR's resistance in bright light is about 350 ohms, and in total darkness its resistance approaches 200,000 ohms. When the prototype was tested, the photoresistor did its job too well. The display's brightness varied greatly between a very pleasant level and an excessively bright one. Thus, the light-dependent resistor was covered with a piece of tape so that the display will maintain the same low (pleasant) level of brightness and the

batteries won't have to work so hard. However, because the LDR is in parallel with an 18K resistor (R1), the combined total resistance of those two components will never be more than 18K. Therefore, another alternative is to leave the LDR out of the circuit completely.

Components

The electronic thermometer can be built using parts that you gather individually, or purchased as a complete kit for \$17.54 from the source listed in the Parts List. The kit includes the PC board and all components except a power supply, ON/OFF switch, and a case. While buying the kit is probably the easiest and cheapest way to build the project, you can also make your own PC board from the pattern in the PC-Service section of this magazine. You may even be able to get away with point-to-point wiring since it's such a simple circuit. Then, if you're lucky, your junkbox may contain all the parts you need except the IC.

The ON/OFF switch that was used in the prototype is a momentary push-button-type switch. A momentary switch was used because LED's are very power-hungry, and if the device were left on, the batteries wouldn't last very long. However, if you decide to build or buy a 12-volt DC power supply, or use a much larger battery pack, then it won't hurt a bit to leave the unit on all the time.

Construction

Begin building the project by installing all of the resistors on whatever PC board you're using, as shown in Fig. 2. Then, install the potentiometer R12, the thermistor R10, the light-dependent resistor R11, the IC socket, and lastly the LED's. Be sure to be very careful when spreading the leads of the LED's, because too much force will crack the LED in half. The kit includes 15 LED's of the same color, and one of a different color. You should install that single LED on the right-hand side of the board (above

R12 in the LED16 position) to indicate the maximum temperature on the display. (If you don't buy the kit, it's entirely up to you as far as the colors of the LED's are concerned.) Now just press IC1 into its socket.

After the board is completely assembled, you'll need some wire, an ON/OFF switch, and whatever you are using as a power supply. The prototype uses two 6-volt photo batteries (Eveready type A544 or equivalent)

taped together, with the positive side of one connected to the negative side of the other. They are held in place inside the case with a piece of double-sided tape. Depending on what size case you're planning to install the board in, cut and solder appropriate lengths of wire to the + and - terminals on the PC board. Then install S1 in series with the positive supply line and connect the leads to the batteries. (Depending on what type of switch you use, and how it's supposed to mount to the project case, you may have to install it in the case first, and then solder it in the circuit.)

Test and calibrate

By now you've probably already pressed the button to see if your thermometer is working—if not, do it now. At least one LED, or two right next to each other, should light up. (If nothing happens, check your soldering and the placement of the components—there can't be too much wrong with a circuit this simple!)

Once you are sure that your thermometer is working, you have to let it sit for about a half an hour. That's so the board can cool down to room temperature after all the soldering and handling. Try to let the board cool in a room that's at about 70 degrees—you'll have to get an ordinary thermometer, or look at your home thermostat's reading.

After the board's temperature has settled to about 70 degrees, adjust R12 so that the center LED (or one or two LED's higher or lower, depending on the exact room temperature) is illuminated. Now you should take a sheet of paper and draw 16 circles representing the 16 LED's on your display, and write a 70 next to the appropriate circle.

Place both the electronic thermometer and a regular thermometer inside a refrigerator for about ten minutes, and then remove them both. The temperature inside the refrigerator should be lower than 50 degrees, so the far-left LED should light up when the button is pressed. As soon as the next LED begins to light, check the temperature on the regular thermometer, and record it next to the appropriate circle on the sheet of paper. Then you can estimate what temperature the first LED should indicate. As the temperature continues to rise, keep on recording the readings until both thermometers once again

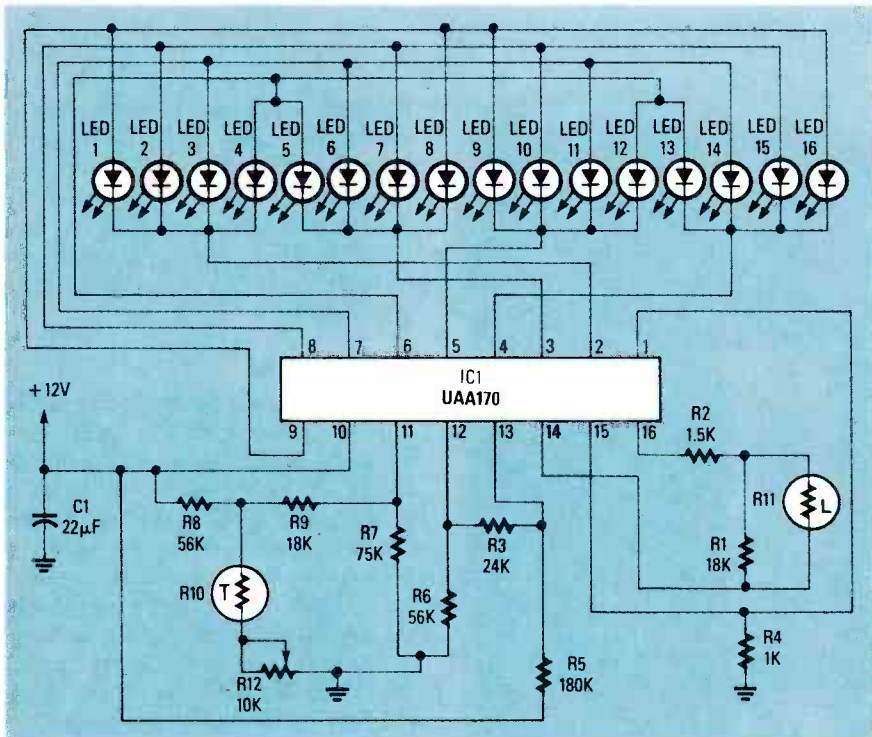

FIG. 1—THE SCHEMATIC FOR the electronic thermometer. It can be built from a kit or from separately purchased pieces on a PC board or perforated construction board.

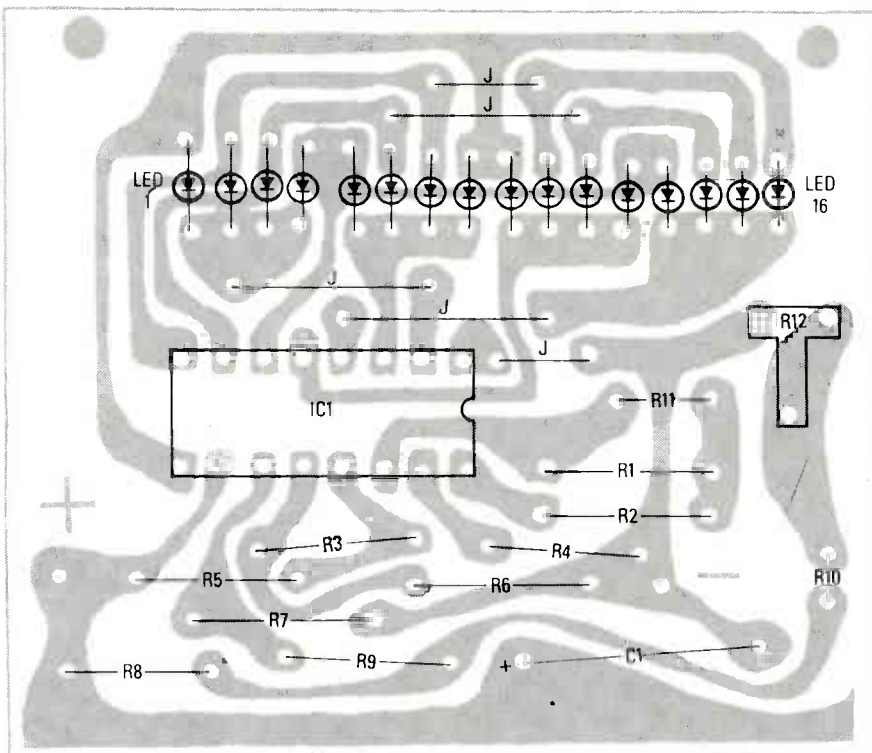

FIG. 2—PARTS-PLACEMENT DIAGRAM. Follow this when soldering the parts on the board supplied with the kit, or the one you can make from the pattern in PC Service.

level off at 70 degrees. (Try not to handle the board while you're doing that). If you are in doubt as to whether or not both thermometers are warming up at the same rate, you will have to do the calibrating by allowing both thermometers to level off in environments having different temperatures. Then you will have to approximate the temperatures in between.

Now you have to work near a warm lamp, or some other source of heat, and continue recording the readings until you reach the far-right LED. (It should be about 90 degrees when that LED lights.) Now you have a sheet of paper that represents the entire display on your thermometer. You should now check it out by placing both thermometers in different environments to make sure that they both display approximately the same temperature. At this time you can approximate the readings you've made in nice even increments, to allow for neat labeling later on.

Final assembly

Now you are ready to put the board in some kind of project case. In order to fit it inside Radio Shack's small project case (number 270220), the PC board's edges had to be filed down, as

All resistors are 1/4-watt, 5%.

R1, R9—18,000 ohms
 R2—1500 ohms
 R3—24,000 ohms
 R4—1000 ohms
 R5—180,000 ohms
 R6, R8—56,000 ohms
 R7—75,000 ohms
 R10—20,000 ohms, NTC thermistor
 R11—350–200,000 ohms, light-dependent resistor
 R12—10,000 ohms, PC-mounting type potentiometer

Capacitors

C1—22 μ F, 15 volts, electrolytic

Semiconductors

IC1—UAA170 or equivalent
 LED's 1–16—rectangular LED's

Miscellaneous

1 16-pin IC socket, plastic case, clear plastic, wire, solder, screws, tape, momentary switch, etc.

Note: A kit containing all parts except a power supply, a momentary pushbutton, and a project case, is available for \$17.54 from all TSM distributors. You can contact the TSM headquarters, at 2065 Boston Post Road, Larchmont, NY 10538, for the TSM distributor nearest you.

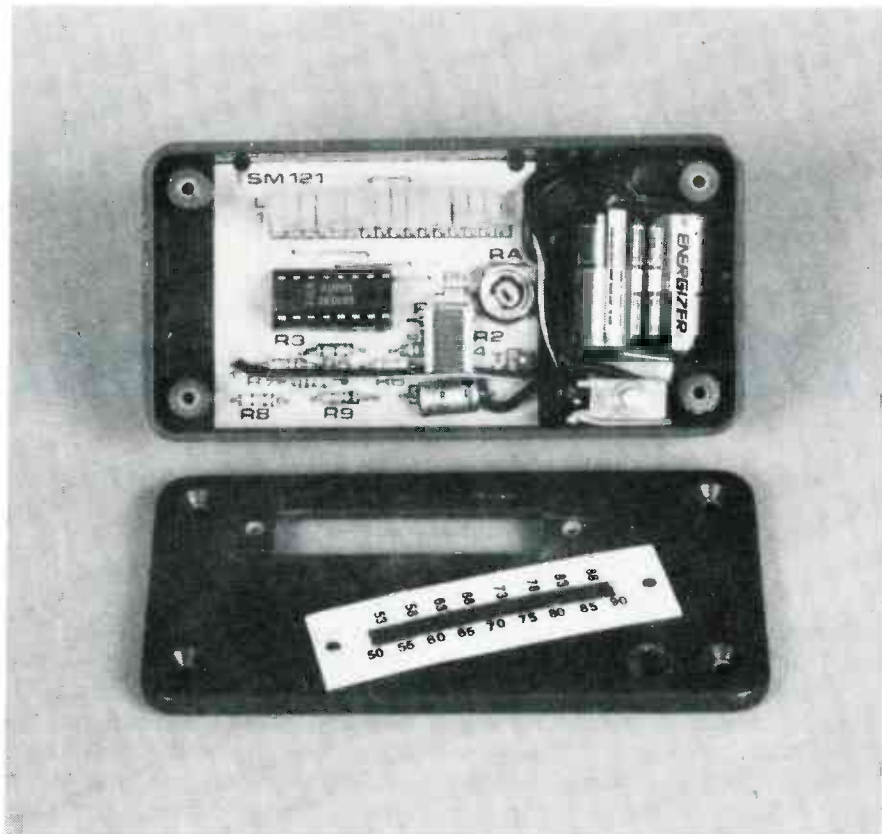

FIG. 3—THE BOARD FITS inside the case as shown. Holes are cut in the cover, and a lens is made using any kind of flexible clear plastic, which is then screwed in place.

well as cutting away the plastic ribs inside the project case. (You can use a larger case if you like.) Then, the cover has to have a hole drilled in it for the switch, and a rectangular slot cut in it so that the faces of the LED's can come through (see Fig. 3). Make sure that the faces of the LED's are flush with the surface of the cover—you might have to put a piece of foam rubber or other kind of non-conductive material underneath the board in order to get them to the right height.

The lens for the display was made from two identical pieces of clear plastic cut from the box that the kit came in. However, any clear plastic, perhaps from bubble-type packaging, may be used. The plastic is cut large enough so that it can fully cover the slot in the case's cover, and also overlap enough to have room to screw it in place (see Fig. 3). Tape both pieces of plastic in place on the case cover, drill a small hole on each side, put a small screw in each hole, and then remove the screws and the tape.

Now take a piece of electrical tape, and cut a strip that is slightly narrower than the faces of the LED's, and the exact length of them (about 4 cm).

Stick the tape down in the exact center of one piece of plastic, and make sure that the edges are firmly pressed down. At a distance of at least a foot, spray the plastic, tape-side up, with some spray paint (whatever color you like), until you can no longer see through it. Wait until the paint is completely dry, and then pull the tape off.

Now you have a lens that covers the rough edges of the slot in the cover of the case, yet still allows the LED's to be seen. Some rub-on lettering was used on the side *without* the paint to indicate the temperature scale on the display, as well as to add a professional appearance to the device. The temperature range on the prototype was divided into 5-degree increments, and the labeling was evenly spaced along the 4-cm display. The finishing touch is the second piece of plastic used to protect the lettering from being scratched off. The two pieces of plastic are then screwed back in place, and the case is then closed up.

The unit is now ready to be placed in the location of your choice. There it will silently wait, ready at all times, to give you an instant yet accurate temperature reading at the touch of a button.

R-E



Digital Telephone Lock

Here's an electronic combination lock that prevents unauthorized use of a telephone.

STEVE SOKOLOWSKI

UNAUTHORIZED TELEPHONE CALLS CAN ROB you blind. With your home telephone, you may think that you have control over the amount of the monthly bill, but in reality, you don't. If you have a business telephone system, it is very difficult to police the incoming and outgoing calls of employees.

Unauthorized telephone costs are usually discovered only if or when the phone company sends you an itemized bill that shows the number of local and long distance calls that were made. But while itemization gives you proof that the calls were made, it doesn't tell you who made them.

The only way to prevent unauthorized use of a home or business telephone is to remove the ability to make the calls by removing all phones from the premises, or by adding a security system in the form of an "invisible" electronic lock; one that can only be "opened" by a special user-programmed four-digit code that is entered through a *Touch-Tone* telephone's normal keypad.

The Tele-Guard

Just such a telephone security device is our electronic combination lock, which for simplicity throughout this article we'll call a *Tele-Guard*. The easy-to-build *Tele-Guard*, which can be installed into practically any single-line *Touch-Tone* telephone system, protects your telephone line from unauthorized use by actually disconnecting the telephone from the line until a four-digit code is entered. The code causes a small relay inside the *Tele-Guard* to close and connect the telephone to the outside line.

At this time, you may ask if the unlocking code must be entered if a telephone call is being received. The answer is *No!* *Tele-Guard* automatically by-passes its electronic lock so that the phone can both ring and be answered without entering any code—as if the *Tele-Guard* didn't exist. When the conversation has been terminated, *Tele-Guard* automatically arms the locking device.

Extra protection

If you know how many digits are required to unlock the device, most keypad-operated security devices can eventually be "broken" by entering every possible combination from dial pad; a procedure that can take hours but one that will eventually prove successful. But not with the *Tele-Guard*, because it automatically resets the decoder circuit every time an incorrect digit is entered into the system. That means that even if the first two digits of the code are guessed correctly by luck, if the third digit is incorrect *Tele-Guard* senses the error and resets the complete circuit. It wipes out all memory of the first two correctly entered digits, thereby requiring that the first two digits be entered correctly again, followed by correct third and fourth digits. That kind of design provides high security *Touch-Tone* telephones.

DTMF is the key

Touch-Tone telephone pads use a special kind of signalling called DTMF, which stands for *Dual Tone Multi Frequency*. In plain terms, it means that each of the 12 keypad but-

tons on a standard telephone produces a very distinct two-tone output.

Although the standard telephone has 12 buttons, as shown in Fig. 1 the complete DTMF keypad has 16 buttons: the conventional 0-9, *, #, and A-D. The A-D buttons are used for special communications equipment and are not used, or found, on conventional telephones.

Each button on a *Touch-Tone* keypad produces a dual-tone output whose frequencies are determined by the row and column the button is in. For example, the number-5 button is in the 1336-Hz column and 770-Hz row; therefore, pressing the number-5 button produces a dual-tone output consisting of 1336 Hz and 770 Hz.

DTMF signalling was developed by Bell Laboratories. When first in-

		DTMF FREQUENCY ASSIGNMENTS			
		COLUMN			
		1209	1336	1477	1633
ROW	697	1	2	3	A
	770	4	5	6	B
	852	7	8	9	C
	941	*	0	#	D

(FREQUENCIES IN Hz)

FIG. 1—THE STANDARD DTMF KEYPAD provides 16 individual dual-tone frequency codes. However, the buttons labeled A-D are not used on conventional telephones. Each code consists of a row and column tone.

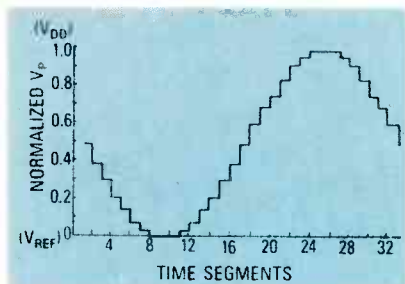

FIG. 2—THE OUTPUT VOLTAGE OF AN ELECTRONIC KEYPAD is a digitally synthesized stairstep waveform that approximates a pure sine wave. Modern DTMF receivers respond to the staircase as well as to a sine wave.

roduced, the keypad that generated the frequencies used a transistor oscillator whose output frequencies depended on relatively large tapped inductors (coils). Today, DTMF keypads use crystal-controlled IC's that generate the synthesized stairstep waveform shown in Fig. 2; a crude approximation of the pure sine-wave signal that was produced by the older, transistor/coil oscillator-type tone dials. Although the synthesized wave-

form is only an approximation of a sine-wave signal, its staircase waveform can be recognized by DTMF receiving equipment, such as Tel-tone's *M-957-01* receiver IC. (Tel-tone, Inc., P. O. Box 657, 10801-120th Ave. N.E., Kirkland, WA 98033).

The DTMF receiver

The *M-957-01* receiver IC is an extremely complicated device. Older DTMF receivers required large and bulky audio filters. The *M-957-01* incorporates all the needed filtering within its 22-pin plastic body. It determines if the signal is just noise, a speech pattern, or a dialing signal that is within $\pm 2\%$ of the DTMF bandwidth of 697–1633 Hz.

The receiver IC processes the conventional DTMF *Touch-Tone* frequencies to provide a 4-bit binary output, and a STROBE output that goes high when a valid DTMF code is received. The strobe signal is used by the Tele-Guard when converting the binary signal to decimal output.

How it works

Figure 3 is a block diagram of the Tele-Guard. Notice that the telephone is normally powered by the Talk Battery, which is actually a +12-volt power source within the Tele-Guard. Entering the correct code on the phone's keypad eventually causes relay RY1 to pull in. Relay poles P1 and P2, which are part of RY1, switch the telephone through the Off-Hook Detector directly to the Central Office Telephone Line, which then provides the power for the telephone instrument. In that way, the telephone line is isolated from power sources within the Tele-Guard. As you'll see shortly, opto-couplers insure that there can be no direct connection between the Tele-Guard's power supply and the telephone line.

The Talk Battery's 12 volts and the 6-volt source for the Tele-Guard circuits are provided by the power supply shown in Fig. 4.

As shown in Fig. 5, the Tele-Guard's internal combination lock is in a reset state when the device is in its

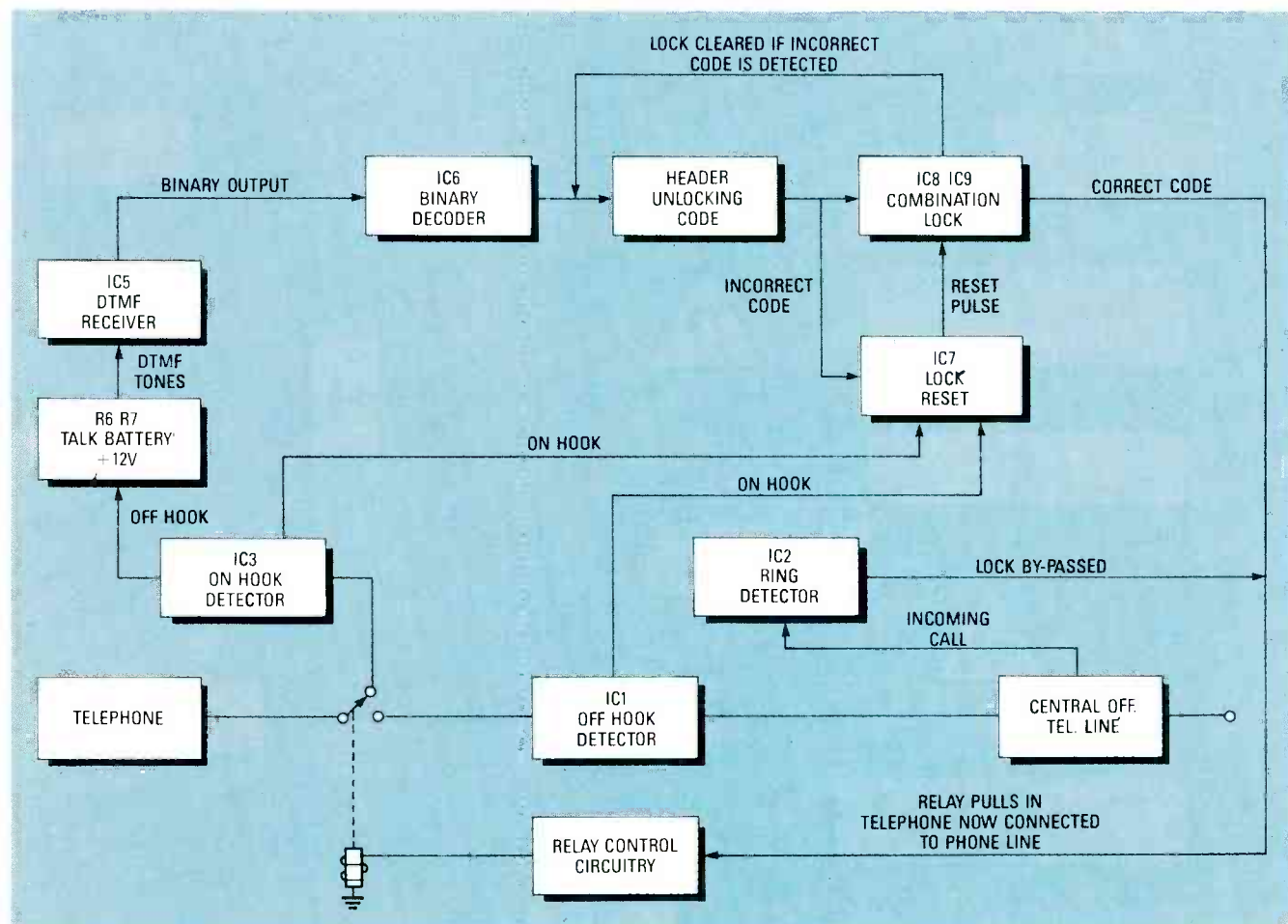

FIG. 3—THE BLOCK DIAGRAM OF THE TELE-GUARD. To provide total isolation between the device and the telephone line, the telephone's power source is switched from an internal power supply—the Talk Battery—to the normal telephone-line voltage.

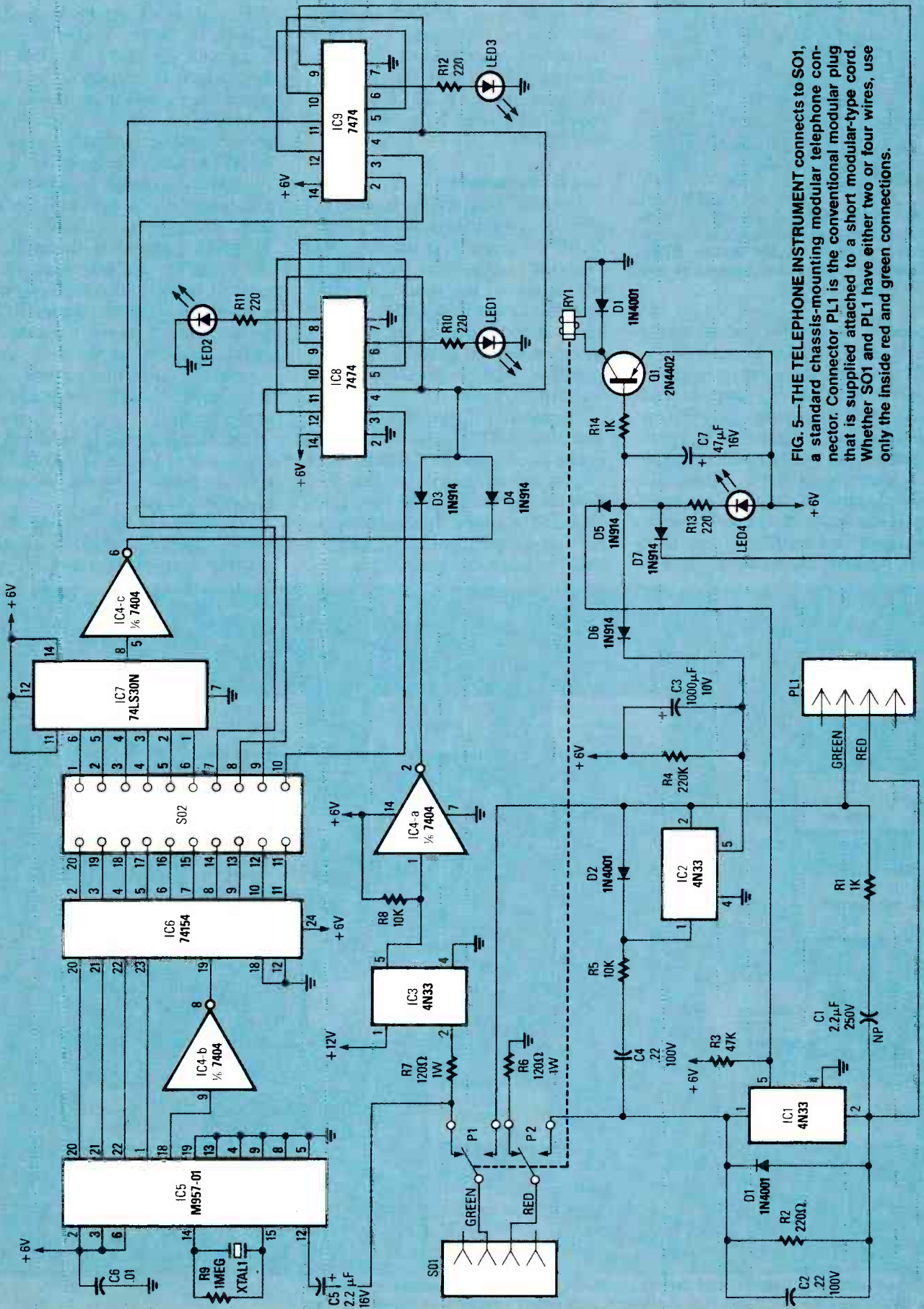

FIG. 5—THE TELEPHONE INSTRUMENT connects to S01, a standard chassis-mounting modular telephone connector. Connector PL1 is the conventional modular plug that is supplied attached to a short modular-type cord. Whether S01 and PL1 have either two or four wires, use only the inside red and green connections.

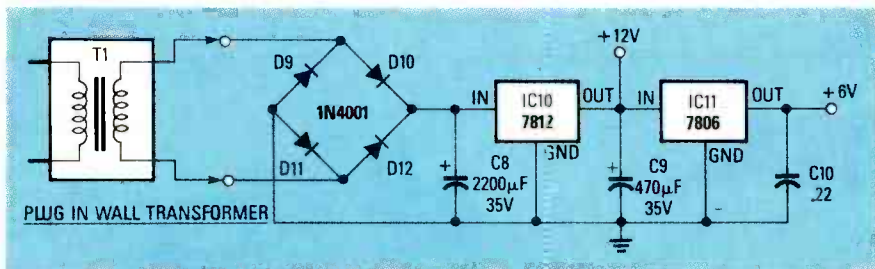

FIG. 4—THE POWER SUPPLY does not include a resident power transformer. Transformer T1 is actually a plug-in wall transformer whose output wires are soldered to terminals on the Tele-Guard's PC board.

normal standby condition. When the telephone handset is lifted from its cradle, the internal transistor of the opto-isolator Off Hook Detector (IC3) conducts and brings pin 5 of that IC low. The low is applied to inverter IC4-a (pin 1), which changes the low to a high. The high is applied to switching diode D3, which "blocks" the high; therefore, pins 4 and 10 of both IC8 and IC9 (D-type flip-flops) are floating. The floating pins allow the IC's to change state from high to low when a valid unlocking code is present; but more on those two IC's a little later.

For the proper operation of the Tele-Guard, we must apply a *Talk Battery*—in this instance +12 volts DC—to the telephone that's to be secured. (The telephone is connected to the Tele-Guard via modular-socket SO1.) The Talk Battery is applied to modular-connector SO1 through IC3 and R6.

The telephone's "talking pair," the red and green wires, connect through contacts P1 and P2, which are part of relay RY1. The resting position of P1 connects the telephone to the Talk

Battery through R7. The telephone's electrical path to ground is provided by P2 and R6.

Making a call

To show how the system works, let's assume that the No. 8 button is being pressed, thereby applying an 852-/1336-Hz DTMF signal to pin 12 of IC5, the DTMF Receiver.

As shown in Table 1, IC5 converts the 852-/1336-Hz signal into its hex-output-format binary equivalent of 1000. In addition to the binary output, IC5 also produces a STROBE high for as long as the No. 8 keypad button is pressed. (Pin 18 goes low when the No. 8 button is released.)

Both the binary and strobe outputs are applied to IC6, a 4-to-16 decoder/demultiplexer. With the DTMF binary output applied to pins 20–23 of IC6, and if pin 19 is held low, the decimal equivalent of the input will appear at IC6's output pins—Nos. 2–11. In this instance, pin 9 of IC6, which corresponds to an input binary code for the number 8, will go low—all other output pins remain high.

Inverter IC4-b is used to invert the

high STROBE coming from IC5 into a low STROBE for IC6 because pin 9 of IC6 requires a low in order to pass the binary equivalent of its input.

The unlocking code

The section that actually senses the unlocking code is SO2, a header socket that is jumpered to correspond to the unlocking code. We will cover the programming next month.

The unlocking sequence is determined by IC8 and IC9, two dual D-type edge-triggered flip-flops wired as a sequential pass-on. The sequential pass-on is a series of four independently clocked, cascaded D-type flip-flops. The unlocking pulse, which is available at pin 9 of IC9, will go low—thereby causing RY1 to switch the secured telephone to the telephone line—only if unlocking-digit 1 is followed by digit 2, then by digit 3, then finally by digit 4. Each unlocking digit will provide a low from IC6 through SO2 to its corresponding pin on IC8 and IC9.

A low must be applied to pins 4 and 10 of both IC8 and IC9 in order for both to flip-flop. The low can be applied from On-Hook Detector IC3, or from IC7, which functions as a Mis-Dialed-Digit Reset.

Pin 9 of IC9 goes low when the correct four-digit unlocking code is entered. The low is applied to the base of Q1 through diode D7, turning both transistor Q1 and LED4 on, thereby energizing relay RY1.

Contact P1, which is controlled by RY1, connects the telephone set to the telephone line through modular plug PL1, thereby providing dial tone and normal operation. Also, when P1 toggles to the telephone line it opens pin 2 of IC3, which forces the output of IC4-a low. That in turn forces pins 4 and 10 of IC8 and IC9 low, which resets their flip-flops to standby.

When the telephone connects to the line it also energizes On-Hook-Detector IC1, causing pin 5 of IC1 to go low. The low is applied to Q1 through D5, which keeps RY1 energized during a normal telephone conversation.

Next month

Next month we'll cover how a telephone connection is maintained, how incoming calls are answered, how the header is programmed with a user-selected code, and, of course, the construction details for *Touch-Tone* and pulse-dialed phones.

R-E

TABLE 1—DTMF TO BINARY DECODING

Signal	Low-Frequency Component (Hz)	High-Frequency Component (Hz)	Hex Output Format
			3210
1	697	1209	0001
2	697	1336	0010
3	697	1477	0011
4	770	1209	0100
5	770	1336	0101
6	770	1477	0110
7	852	1209	0111
8	852	1336	1000
9	852	1477	1001
0	941	1336	1010
*	941	1209	1011
#	941	1477	1100

BUILD THIS

DIFFERENTIAL AUDIO- DISTORTION ANALYZER



This device tells you why an amplifier that passes all conventional tests with flying colors can still sound bad.

HERB FRIEDMAN

THE GREAT LEGENDARY PLUMBER, Stilson Hammerknock, (yes, *plumber*, as in “Get someone to fix the pipe!”) used to tell customers that “If the rate of evaporation exceeds the rate of drip, your pipe isn’t leaking.” The audio-testing corollary to Stilson’s rate-of-evaporation theory is that “If you can’t hear any distortion there *is* no distortion, regardless of what the instruments show.” On the other hand, it also means that the listener might hear an irritating, annoying distortion, even if the distortion can’t be measured by conventional test equipment.

David Hafler, one of the pioneers of high fidelity, developed the first truly low-cost high-performance FM-ster-
eo tuner and the highly respected *Dynaco* amplifiers. Hafler observed that conventional audio-amplifier distortion tests do not indicate all possible distortions because the measurements are made under static conditions: a specified input and output, a resistive load, etc. He believes that amplifiers should also be evaluated by a listening test that compares an amplifier’s output signal to the input signal under *dynamic* conditions—meaning, a *program* signal source and a speaker load.

The Hafler test—one that differentially compares an amplifier’s input

and output signals—was discussed in Larry Klein’s “Audio Update” column in the September 1988 issue of **Radio-Electronics**. This month, we’ll show you how to build a switching device so you can make your own Hafler-type distortion tests.

There are many reasons why there is a continuing debate over amplifier-distortion tests: what test parameters to use, what the parameters represent, and what the results actually mean. A goodly number of test and measurement specialists claim, and have proven, that by using the same set of parameters they can come up with valid tests that prove an amplifier is either good or bad. How the amplifier actually *sounds* is something else; it might have no relationship to the test results.

Amplifiers behave differently to a dynamic signal and load than they do to a resistive load and a fixed or pulsed input signal. Actually, it’s the resistive load that’s the major problem because it does not truly represent the loudspeaker; that is the reason why Amplifier A might sound terrific with Speaker X yet sound rotten with Speaker Z, while Speaker X sounds so-so with Amplifier B, and an absolute disaster with Amplifier C.

The reason for disparities in performance when an amplifier drives a

speaker is due to the fact that a speaker’s impedance is not resistive; it is a reactance that varies with the signal frequency. It would be very nice if we could assume that amplifiers are not sensitive to the load, a condition that some manufacturers imply when they claim their amplifier has a “zero-output impedance.” But the truth is that amplifiers are load-sensitive, and speaker systems are somewhat sensitive to the output impedance of the driving amplifier. Again, that is why amplifier A sounds good with Speaker X, but Speaker X sounds rotten with Amplifier C.

Another problem is the kind of distortion being measured, which is why many audiophiles and sound purists still argue that even when the amplifier is deliberately driven into distortion, tubed amplifiers always sound better than solid-state amplifiers. In other words, a tubed-amplifier’s distortion is less displeasing to listen to than the distortion from a solid-state amplifier. Let’s look at why that might be so.

Assume that we have tubed Amplifier A, which—under the exact same signal, power, and operating conditions as solid-state Amplifier X—is producing 3% THD (Total Harmonic Distortion). Solid-state amplifier X is producing under 0.5% THD. Yet,

without knowing the measured distortion, listeners claim that tubed Amplifier A sounds cleaner. How come?

Harmonically related

The reason why the higher-distortion tubed amplifier sounds better is that it has even-order distortion: second, fourth, etc. Tubed amplifiers, even when driven well into distortion, produce primarily even harmonics, which are musically (harmonically) related. For example, the second harmonic of 440 Hz (the musical note A₄) is 880 Hz; still A (A₅), but an octave higher. The fourth harmonic is 1760 Hz, again A (A₆), but two octaves higher. Because the distortion is primarily even-order, even the intermodulation products are harmonically related. If the user can't hear the input-signal source, the output signal—even though distorted—can sound good, acceptable, or, at worst, still pleasing to the ear.

On the other hand, a solid-state amplifier's distortion products are odd-order: third, fifth, etc. Now the third harmonic of 440 Hz is 1320 Hz, which falls somewhere between the notes E (E₆) and F (F₆). The fifth harmonic of 440 Hz is 2200 Hz, which falls between C (C₇) and D (D₇). As you can see, the distortion products are not harmonically related. For the same reason, the intermodulation products are all over the musical scale. Because harmonic relationship is absent, it's possible for a solid-state amplifier having measurably low distortion to have an edgy, annoying sound.

Not heard at all

It is to avoid discussions about which distortion is caused by what, and what it all means, that Hafler takes the position that no distortion of any kind is tolerable under dynamic conditions, and that the best way to determine whether distortion of any kind exists—even distortions not yet quantified because there's no way to measure them—is to listen to the distortion itself by differential comparison of an amplifier's input and output signals. That can be done by connecting a monitor speaker across the input and output. Because the output signal is in phase with the input signal, nothing will be heard from the

monitor speaker if the amplifier is free of distortion.

However, if the amplifier introduces any kind of distortion—amplitude, frequency, phase, ringing, whatever—there will be no cancellation of the output distortion because there is no corresponding input signal. And *something*—some kind of sound—will be heard in the monitor speaker. As yet, there is no way to quantify what's heard, so the rule of thumb is: "The less you hear, the less the distortion."

Obviously, one cannot connect a monitor speaker from a voltage-sensitive amplifier input to the amplifier's power output; but, as shown in September's "Audio Update," Hafler gets around the problem by using a power amplifier as the signal source. That way, the monitor speaker can be differentially connected from the speaker output of the signal-source amplifier to the speaker output of the amplifier being tested.

Because a stereo amplifier has two independent channels, the signal source can be one channel, while the amplifier being tested can be the second channel. The only restrictions on the Hafler-type test setup are that both amplifiers must have a grounded output terminal, and the amplifier being tested must not invert the phase of the signal from the input to the output.

Because a power amplifier might have a relatively high distortion, it is logical to question how it can function as a signal source for distortion tests. The fact is that the amount of distortion in the signal source makes no difference; the signal source can be 100% distortion because the Hafler test is concerned only with distortion that is *added* to the signal source. Regardless of the input signal's distor-

PARTS LIST

R1-R4—10,000 ohms, ½ watt, 10%
 R5—220 ohms, ½ watt, 10%
 R6—1000-ohm potentiometer
 J1-J8—5-way binding post
 J9—phono jack
 S1—4P3T rotary switch, see text
 Misc.—cabinet, wire, hardware.

tion, if the output of the amplifier being tested is an exact reproduction of the input signal then nothing will be heard from the monitor speaker.

A Hafler tester

A device for making the Hafler distortion test is shown in Fig. 1 and Fig. 2. It is an experimenter's version—in that it uses readily available parts—of the commercial *Excelinear* unit developed by the David Hafler Co.

Almost anything can be used as a cabinet. The circuit can even be assembled on a piece of wood. Jacks J1-J8 can be anything that will hold a wire, but the 5-way binding posts shown on the prototype are suggested. If each pair of jacks is spaced on ¾-inch mounting centers, you will be able to easily connect wires and cables that are terminated with conventional dual banana-plugs.

Function-switch S1 is a 3P3T (triple-pole, triple-throw) switch, which is somewhat unusual and is not likely to be found in local stores. The switch used in the prototype was a conventional 4P3T type, with one pole left unused. Be very careful when making connections to the switch. Although it looks easy enough from Fig. 1, the contact-jumpers can be confusing, and you might end up with the connections reversed on two of the three sections.

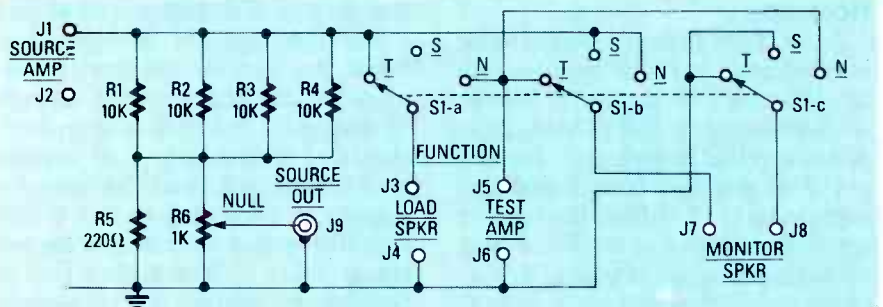

FIG. 1—THE CIRCUIT LOOKS SIMPLE ENOUGH, but take extreme care when wiring S1 because it's easy to get the wiring reversed on two of the three sections.

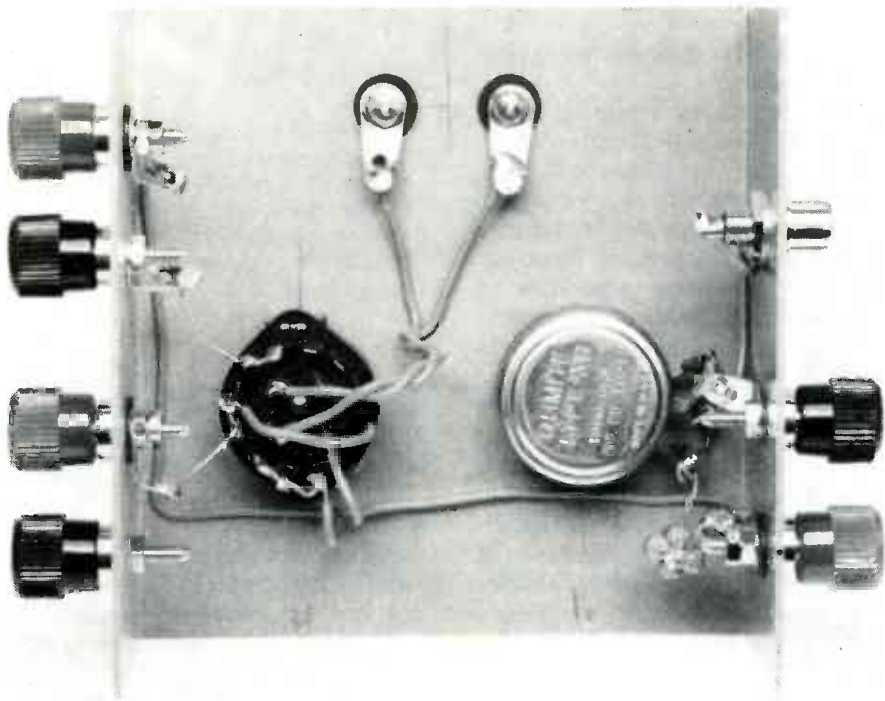

FIG. 2—THE PROTOTYPE TESTER is built in a small metal enclosure. To prevent shorting of uninsulated wires, position the parts so the wiring is as direct as possible between the jacks, the switch, and the null control.

Resistors R1–R4 equal a 2500-ohm, 2-watt resistor. A 2200-ohm, 2-watt resistor is used in the commercial version of the tester. Unfortunately, 2-watt resistors aren't the easiest parts to come by. Because there is no practical difference between 2200 and 2500 ohms, by using four parallel-connected ½-watt resistors, we attain the necessary 2-watt rating with easy-to-get parts.

Theoretically, R5 could be eliminated if R6 was a 200- or a 250-ohm potentiometer, but your chances of finding a 200/250-ohm carbon potentiometer are almost non-existent. The R5/R6 arrangement shown in Fig. 1 allows the use of a 1000-ohm potentiometer—a value that's often available locally.

Hook-up

Jacks J1 and J2 are connected to the output terminals of the signal-source amplifier. Jack J3, the *source output*, connects to the auxiliary (AUX) input of the amplifier being tested. The output of the amplifier being tested connects to jacks J5 and J6. The monitor speaker—which should be of high quality, such as one of your hi-fidelity stereo speakers—connects to jacks J7 and J8.

The load speaker, which connects

to jacks J3 and J4, should be the speaker that is usually driven by the amplifier being tested. As stated earlier, an amplifier's characteristics can be determined by its load, so you want your amplifier to be working into its usual speaker. But there is a problem in that: You will not be able to hear the weak differential sounds in the monitor speaker if the load speaker is pounding away. So locate the load speaker a long way from the test site—preferably in a closet.

Making the test

Just so you understand what's going on, refer to Fig. 1 as we walk through the functions of switch S1. We will refer to the amplifier being tested as the *test* amplifier.

When S1 is set to the T (TEST) position the source amplifier is connected to the load speaker through S1-a, while the monitor speaker is connected to the test amplifier through S1-b and S1-c. When S1 is set to the S (SOURCE) position, the load speaker is disconnected, and the monitor speaker is connected to the source amplifier so that you can hear the test signal. When S1 is set to the N (NULL) position, the load speaker is switched in as the load for the amplifier being tested, and the monitor speaker is

connected differentially to the outputs of both the source and the test amplifiers.

After all connections are made, set null-control R6 to *off* (full counterclockwise), set S1 to the S position (monitor speaker to the source amplifier), connect J3 to the test amplifier's AUX input, and set the test amplifier's volume control almost full open. Using any signal source—disc, tape, radio, even interstation noise—advance the volume of the source amplifier until the sound in the monitor speaker is the maximum volume you usually use.

Then set S1 to the N position (monitor speaker differentially connected to both amplifiers) and advance R6. The sound in the monitor speaker will increase and then start to decrease (null). Very carefully, adjust R6 around the null for the *minimum* sound from the monitor speaker. Anything heard in the speaker will be distortion of some kind: amplitude, frequency, or “only heaven knows.” A really good amplifier should produce a bare pipsqueak of sound, usually caused by slight variations in the amplifier's frequency response.

The nulling should also result in equalized gain in the test amplifier. In other words, the sound level of the test amplifier should be the same as that of the source—a perfect condition for an A-B listening test.

Taking care not to disturb R6, rock switch S1 between the T and S positions, which will switch the monitor speaker between amplifiers. (It will also switch the load speaker between amplifiers to keep both of them loaded at all times.) If the test amplifier truly has low distortion, there should be no discernible difference in sound quality as you switch the monitor speaker between the source and test amplifiers.

You may find that the device has uses that you hadn't thought of. Now you can quickly settle an argument with your friend as to whose stereo has less distortion or better sound reproduction. One thing though—if you have an amplifier that you've held in high regard for many years because of its excellent sound quality and precision craftsmanship, then it's probably not such a good idea for you to perform the Hafler distortion test. You may come to an upsetting conclusion that your unit doesn't sound as good as you thought. **R-E**

Build **REACTS:** THE RADIO-ELECTRONICS ADVANCED CONTROL SYSTEM

This month we discuss wireless home automation.

LAST TIME WE BUILT THE OCTAL I/O module and covered a few of its applications. With the relay option, the octal I/O module provides eight outputs that can control up to 6-amps AC at 120 or 240 volts. While that module is excellent for controlling local devices (those near the system), controlling devices that are located further away from the system requires routing high-voltage wiring from the system to the device. We solve that problem this month when we build an X-10-compatible interface module.

This new module will allow you to send control signals through the AC wiring in your house, so you can automatically turn lights, lamps, and appliances on and off from a central location.

For those of you who are unfamiliar with the X-10 system, it is a means of home control; appliances, lights, etc. The system includes a controller module that plugs into an outlet in your home. The controller module then communicates (through the AC wiring in your home) with accessory modules that are plugged into other outlets in the home. The system can then be programmed to control appliances that are plugged into those accessory modules.

The REACTS X-10 module takes the place of the original X-10 controller module so that the REACTS system can now communicate with the X-10 accessory modules. In addition,



JIM BYBEE

the module also contains eight LED's and eight toggle switches that can be assigned to one of the REACTS system's 256 I/O port addresses. The switches are for user-input, and the LED's are for indicating certain status information about the system; whether an X-10 module is on or off, whether one of the octal I/O's relays is closed or open, etc.

The REACTS module is connected to X-10's PL513 Power-Line Interface module using a four-conductor telephone cable with RJ14 plugs at both ends. You simply plug the PL513 into the nearest wall outlet, then plug one end of the telephone cable into the PL513 and the other end into an RJ14 jack (SO3) that is located on the back of the REACTS module (see Fig. 1).

There are two types of X-10 remote-outlet modules that are used to connect a lamp or appliance to the X-10 system. The first type is plugged into

a wall outlet, and the appliance or lamp is then plugged into the module. The other type of X-10 remote-outlet module replaces the entire wall outlet, and the appliance or lamp is then plugged into that. To adapt an overhead light to work with the X-10 system, the wall switch that controls the light is replaced with an X-10 switch module. (Note that the X-10 modules come with several different power ratings, and that the amount of current drawn by the light or appliance being controlled must be considered when purchasing a module.)

After installing the modules, you must then set them to their own, unique address.

Each X-10 remote module has two addressing dials. One dial (called the house-code dial) is labeled A through P, while the other dial (called the unit-code dial) is labeled 1 through 16. There are 16 unit-code addresses for each house-code address. That is, 16 of the X-10 modules can be set to the same house-code address, with the unit-code address providing the distinction between the modules.

REACTS and the X-10

The X-10 enhances the REACTS control system by simplifying the remote control of on/off devices, meaning that no routing of conductors is required. By using REACTS with the X-10 modules, a basic home-control system, complete with decision-making capabilities, can easily be installed in an already-existing home. Indeed, installing the hardware needed to automate a home could

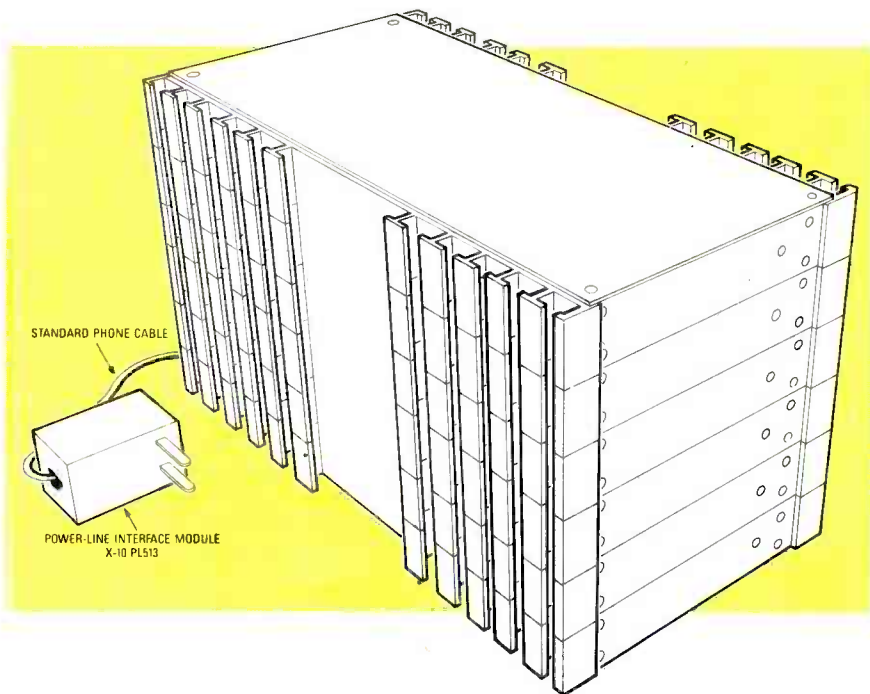

FIG. 1—THE X-10 PL513 POWERLINE INTERFACE module has an adapter that plugs directly into the wall and communicates with its corresponding receiver modules right through you home's AC wiring.

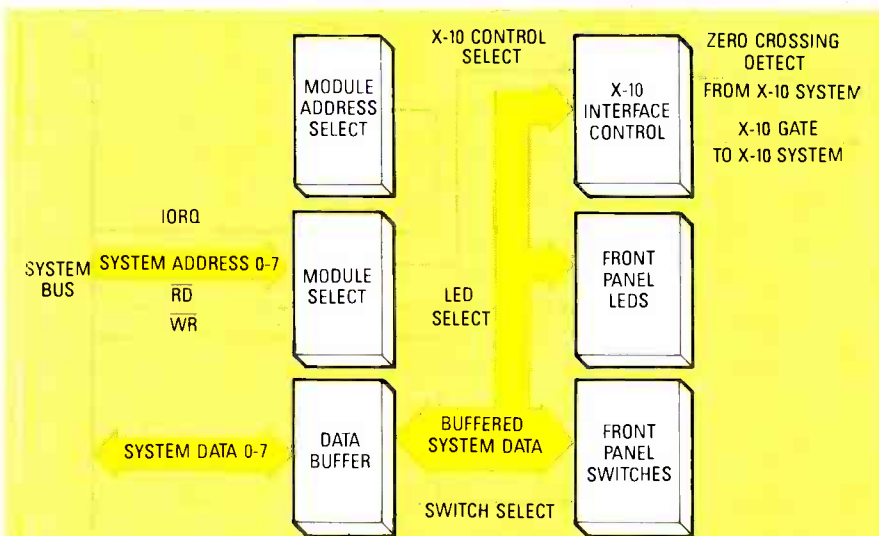

FIG. 2—THE BLOCK DIAGRAM OF THE X-10 MODULE. It uses the same type of I/O-port addressing as does other REACTS modules.

conceivably be done in one day or less. As you think of new uses for the X-10 interface, you need only purchase the required X-10 modules, and write the software (which may be the addition of only a few program lines or a short subroutine).

The X-10 interface module can communicate with up to 256 of the X-10's remote modules and can provide on/off control as well as light dimming and brightening. But while the X-10 system greatly expands the REACTS system's capabilities, it does not provide any type of feedback

to the central unit, in this case, the REACTS system.

Feedback is needed in such applications as controlling your home's climate, sensing the opening and closing of windows or doors, or switching lights on and off as darkness falls or as dawn arrives. It's also needed to verify that a command is carried out. However, the eight-bit input portion of the REACTS octal I/O module is one means of adding feedback, and in future articles we will be discussing additional feedback and monitoring techniques.

Applications

The X-10 kit that is available from the source listed in the Parts List comes with an X-10 interface software driver. Using that driver, writing application programs for the X-10 system is easy. The driver operates in one of two modes. In the first mode you simply assign the string variable X-10\$ to a string which contains the module's house code, its key code (or unit code), and the type of function to be performed (on, off, brighten, dim,

PARTS LIST

All resistors are 1/4-watt, 5%, unless otherwise noted.

R1, R4—10,000 ohms × 9, SIP resistor pack

R2—10,000 ohms

R3—470 ohms × 9, SIP resistor pack

Capacitors

C1—C12—0.47 μF, 25 volts, ceramic disc

C13—47 μF, 10 volts, electrolytic

Semiconductors

IC1, IC11—74HC573 tri-state octal D-type latch

IC2—74HC245 tri-state octal transceiver

IC3, IC4—74HC161 synchronous binary counter

IC5—IC7—74HC163 synchronous binary counter

IC8, IC9—Programmable Array Logic IC's (custom parts)

IC10—74HC14 inverting Schmitt trigger

IC12—74HC688 8-bit magnitude comparator

LED1—LED8—Green right angle PC-mount LED

Other components

1 14-pin IC socket

5 16-pin IC sockets

5 20-pin IC sockets

1 40-pin IC socket

S1—S8—SPST toggle switch

S9—6-segment DIP switch

SO1, SO2—60-pin male and female bus-connector set

SO3—RJ14 6-pin telephone jack

Miscellaneous: PC board, hardware, solder, etc.

Note: The following items are available from DataBlocks, Inc, 579 Snowhill Road, Glenwood, GA 30428, or call (800) 652-1336; in Georgia call (912) 568-7101. A kit containing all parts and a PC board: \$159.00. A PC board is available for \$39.00, and the two PAL's (IC5 and IC6) are \$69.00. Please add \$5.00 shipping for any order that is less than \$37.00, and \$10.00 for any order that is more than \$37.00.

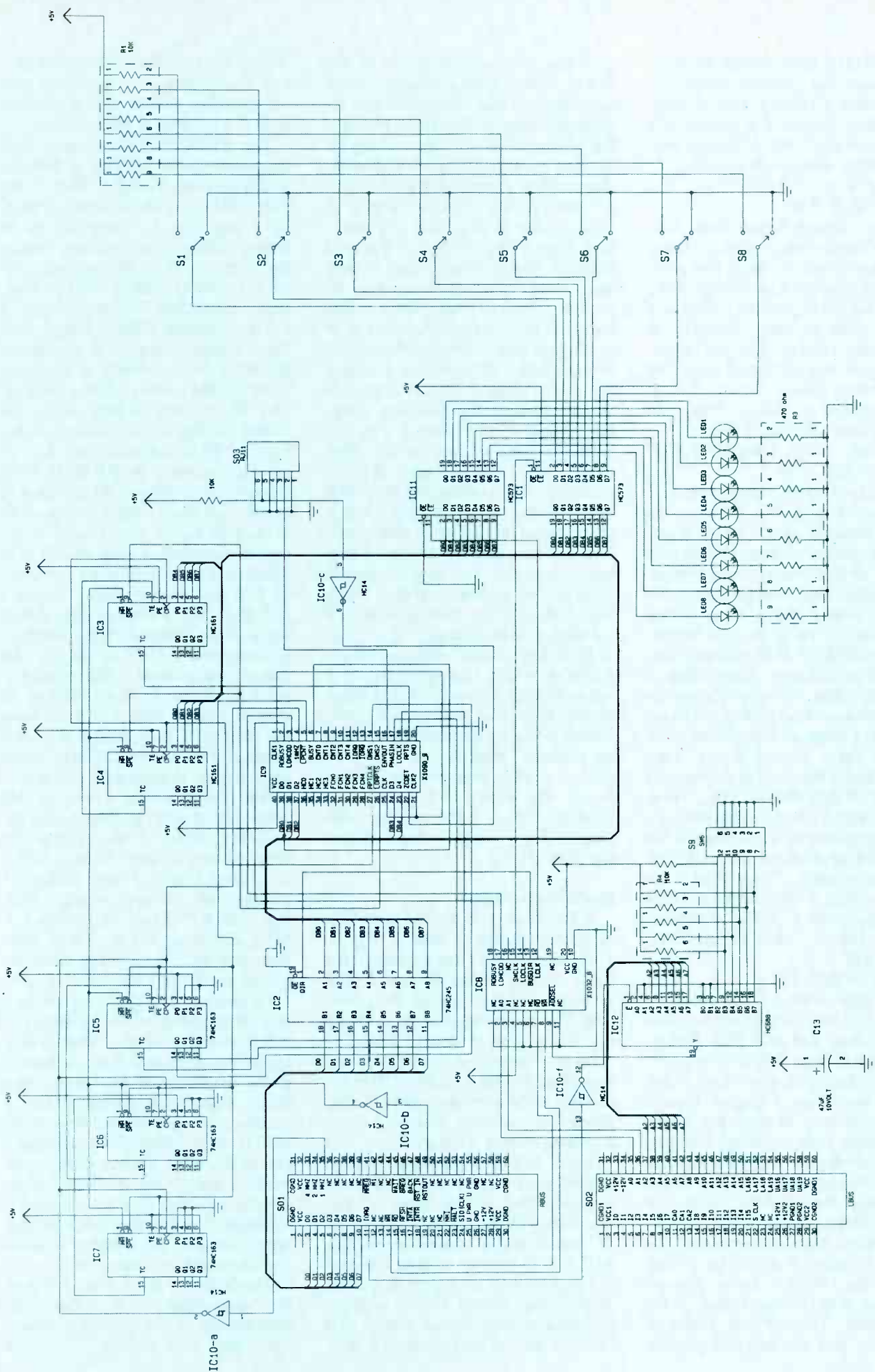

FIG. 3—COMPLETE SCHEMATIC FOR THE X-10 MODULE. The switches can be programmed so that they can manually control things that are connected to the REACTS system. The LEDs can be programmed to indicate the status of various system functions.

all on, all off). You then call the X-10 driver using the GOSUB statement. For example, if a light were connected to a module addressed at house-code A and key-code 2, the following program extract would turn it on:

```
10 X-10$ = "A,2,ON"
20 GOSUB X-10
```

In the case where you were dimming or brightening a light or lamp, the last portion of the string (the function code), would contain the word DIM or BRIGHT, and the percentage of full bright or dim you desire in parenthesis. For example, the following program extract would cause the light connected to the module at house-address A and key-code 2 to burn between full bright and off:

```
10 X-10$ = "A,2,BRIGHT(50)"
20 GOSUB X-10
```

In the X-10 driver's second mode, a configuration table is used to assign user-identifiable strings to particular remote modules' addresses along with the type of function to be performed. Constructing the configuration table is performed using a menu-driven configuration program that comes with the REACTS X-10 interface software. As an example, the address of the module that controlled the master bedroom's overhead light could be assigned to a string along with the function to turn the light on. One possibility for the name of the string is "MASTER BEDROOM ON." However, the string's name is limited only by the programmer's imagination. In the actual application program, the string, as in mode 1, is assigned to the string variable X-10\$ and the driver is called using the GOSUB statement:

```
10 X-10$ = "MASTER BEDROOM ON"
20 GOSUB X-10
```

One application for the octal I/O module that we discussed in previous articles (June and July 1988 **Radio-Electronics**) used REACTS to provide an electronic door lock. One method was to use a keypad, located at the front door, to enter the proper combination code to unlock the solenoid deadbolt. One problem with that is seeing the keypad in the dark. If the switch that controlled the porch light were replaced with an X-10 module, that problem could be remedied. The door-lock software would be written so that the first key to be pressed would cause the system to turn on the porch light. The software could be written so that the first key pressed

does not necessarily have to be the first number of the combination—that way, pressing any key would turn on the light. After the first key is pressed, the system could then start looking for the first number of the combination. (It would be good to put a time limit on how long the light stayed on.)

Using the X-10 system, the door-lock keypad can now perform a dual function. Besides being used to lock and unlock the door, it can also be used to selectively turn lights inside the house on or off when arriving at or leaving the home. The software would be written so that pressing a certain key would place the system in either the light mode or the door-lock mode. For example, the asterisk (*) key could be used to initiate the light mode, while the pounds (#) key could be used to initiate the door-lock mode. In the control program, a flag would be set or reset when either the * or # key were pressed. When the next key is pressed, the program would input the key number and then check the mode flag to determine which subroutine to branch to.

Three keys would be pressed to turn a light on or off. First, pressing the * key would put the system in the lights mode. Next, the key which corresponds to the appropriate light would be pressed. Finally, the last key pressed would either turn the light on or off. The number-1 key could be used to turn a light on, and the number-2 key could be used to turn the light off.

Module operation

A block diagram for the REACTS X-10 module can be seen in Fig. 2. The control signals that are sent to the X-10 modules must be sent at the zero-crossing point of the AC power line. The control signals are made up of combinations of binary 1's and 0's. A binary 1 is represented by the presence of a 120-kHz signal for 120 milliseconds at the zero crossing of the AC power line, and the absence of that signal represents a binary 0.

The X-10 PL513 interface outputs a square wave to the REACTS X-10 module. That square wave is synchronous with the zero-crossing of the AC power, and it is used by the REACTS X-10 module to gate the control signals onto the power line at the proper time. The PL513, in addition to providing the square wave, also provides the 120-kHz signal. The RE-

ACTS X-10 module only has to provide the square-wave signal (to gate the 120-kHz signal onto the power line) if a binary 1 is being output.

The REACTS X-10 module uses the same type of I/O-port addressing as did previous modules. That is, the 74HC688 magnitude comparator, IC12 (see Fig. 3), compares the A inputs which come from the system bus with the B inputs that are connected to X-10 module's I/O-port addressing switches. When the system's I/O ReQuest line (IORQ) is high, and the A inputs match the B inputs, the REACTS X-10 module is selected. Note that the system-address lines A0 and A1 are not connected to the 74HC688, but are instead connected to IC8. While address lines A2-A7 are used to select the REACTS X-10 module, lines A0 and A1 are used to enable functions within the module.

One of those functions is, of course, interfacing with the PL513. That function is performed primarily by IC5 and the five binary counters IC3-IC7. The incoming zero-detect square wave from the PL513 interface is connected to IC9 at pin 22. As already mentioned, that signal enables the REACTS X-10 interface to send the gate signal to the PL513 from pin 16 of IC9. The gate signal is used to place the PL513's 120-kHz signal onto the AC powerline at the appropriate time; that is, when the AC power is at 0 volts. Besides gating the 120-kHz signal at the appropriate time, the signal must also be gated for the correct length of time, which is 1 millisecond. Binary counters IC5, IC6, and IC7 divide the system's 1-MHz clock signal by 1000, thus providing the 1-ms window that is required for the 120-kHz gate signal.

Outputting a control signal to a module requires the transmission of two thirteen-bit words. Additionally, except for bright and dim commands, those words must be transmitted twice. As for the bright and dim commands, a command must be sent for each level of brightness or dimness. On the REACTS X-10 module, counters IC3 and IC4 are used to count the number of times that a command is transmitted. When they reach the pre-specified count, the counters will halt the command transmissions.

That's all we have room for now. But next month we'll continue discussing the X-10 module's operation—then we'll build it. **R-E**

PC SERVICE

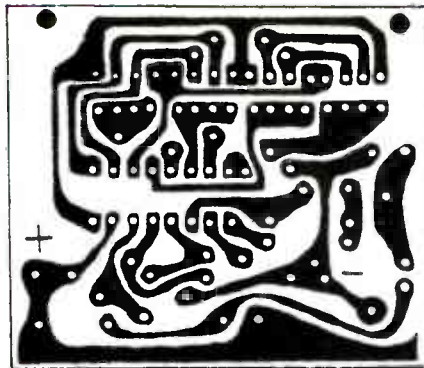

← 2 3/16 INCHES →

THIS IS THE PATTERN for the electronic thermometer.

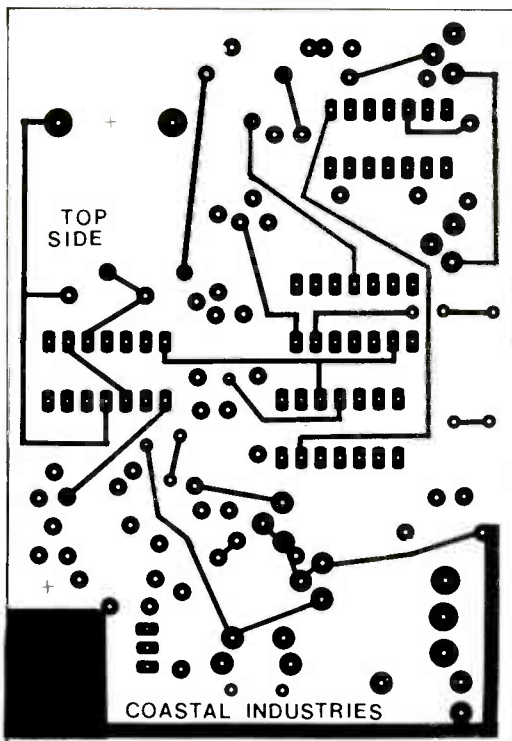

← 2 5/8 →

THIS IS THE COMPONENT side of the Breath Alert alcohol checker.

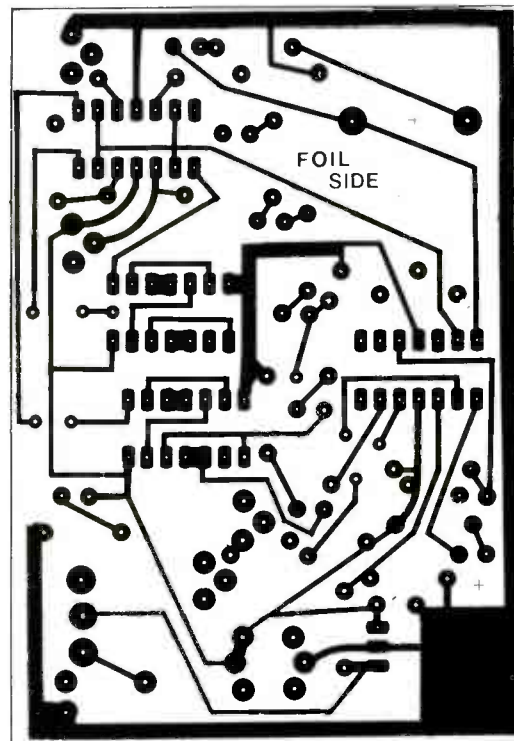

← 2 5/8 →

THE SOLDER SIDE of the Breath Alert alcohol checker is shown here.

BREATH ALERT

continued from page 54

is lit. Adjust the calibration potentiometer to 3-volts DC; LED7 should light. Adjust the calibration potentiometer to 3.5-volts DC; LED6 should light. Adjust the calibration potentiometer to 4.1-volts DC; LED5 should light and BZ1 should buzz. Turn the power off and remove the jumper wire from pin 8 of IC1 and also remove the calibration potentiometer and its connecting wires. The unit is now calibrated to within 0.15% accuracy. If you desire more accuracy, contact the

kit supplier.

To double-check the unit's operation you can light the individual LED's by jumping the following points of the circuit to ground:

- LED3—IC1 pin 1
- LED4—IC1 pin 7
- LED5 and BZ1—IC1 pin 14
- LED6—IC3 pin 1
- LED7—IC3 pin 9
- LED8—IC4 pin 1
- LED9—IC4 pin 9
- LED10—IC4 pin 13

Now you are ready to install the board inside the case, along with the battery holders and the recharging jack, if you're using one. The board

can be held to the cover with either some silicon glue or hot-melt glue. Just be sure to allow for future access to the calibration potentiometers. Hot-melt glue also works well for holding down the battery holders, or else some double-sided tape will work.

Operation

It is important that certain precautions be taken in order to get an accurate test. Most important is that you do not smoke or drink within 15 minutes before a test. An accurate test of your blood-alcohol concentration must be given only after your body has had time to absorb all the alcohol that you've consumed, and that time can vary from one person to another.

Several LED's may come on when you turn the unit on and the alcohol sensor goes through a brief warm-up period. When it's ready, three indicator LED's will light up: power-on, the 0%-alcohol indicator, and the ready light. The unit uses plastic drinking straws as mouthpieces, and a clean one should be used every time. Insert the straw into the mouthpiece hole and steadily blow into it for about 8 seconds. If there is any alcohol present, the ready light will go out and your BAC will be indicated on the display. An automatic reset will occur when sensor is ready for the next test. If the low-battery indicator lights up, the test will be inaccurate, so the batteries must either be replaced or recharged depending on the type that you use.

It is now time to test the unit (in the safety of your own home) using that vodka, beer, rum, etc., we mentioned before. By the way, you may find that testing the unit is even more fun than building it!

R-E

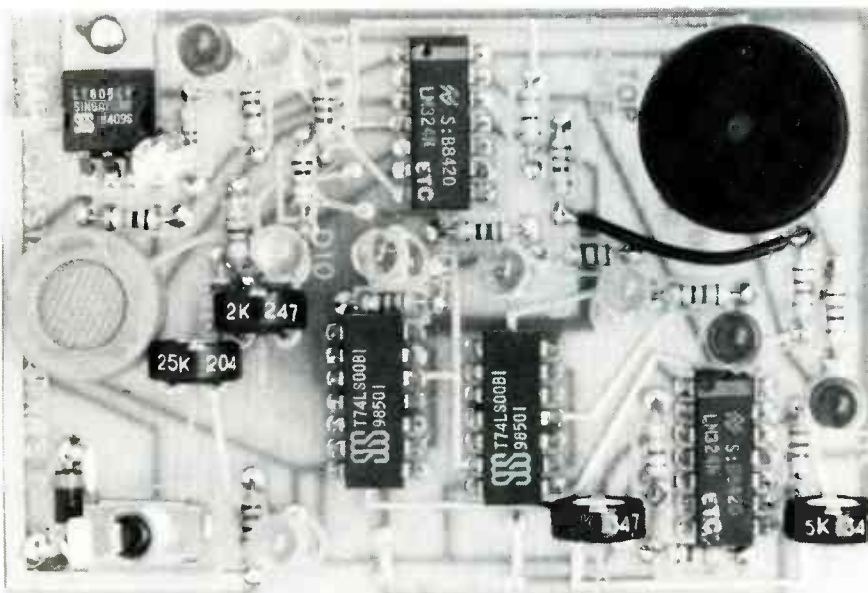

FIG. 7—THE COMPLETED BOARD should look like this when it's finished. Leave about a 3/8-inch space underneath the sensor for the air to flow out.

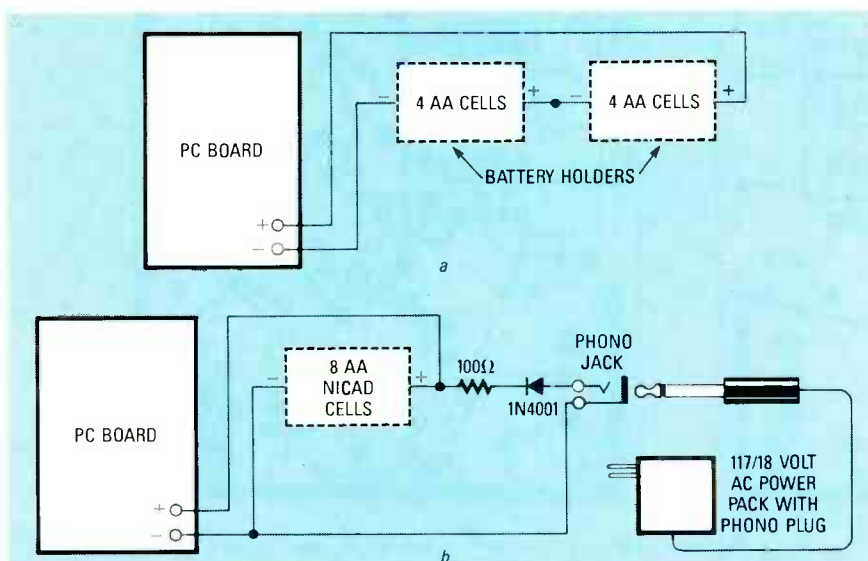

FIG. 8—REGULAR BATTERIES can be used, eliminating the need for the battery charger (a); however, if the unit is used often, it is a good idea to use rechargeable cells (b).



Worst case of parental discretion I've ever seen!

HARDWARE HACKER

Patents and patenting
The LAN of the eighties
Hacking the handicapped
A new pressure transducer
Pressure measurement basics

DON LANCASTER

Patents and patenting and more!

SEVERAL HELPLINE CALLERS HAVE ASKED just how you can go about accurately measuring the cryogenic temperatures involved with superconductor experiments. Ordinary thermometers won't work.

A plain old silicon diode can be used, provided that you can find one with a package that can handle those liquid-nitrogen temperatures without cracking. Since the forward drop of a silicon diode at a constant current is a measurable function of temperature, you can read the voltage across the diode with a digital voltmeter to get the temperature.

Some special silicon cryogenic temperature sensors are now also readily available. One source is *Omega*. Those folks also have an outstanding collection of free catalogs and data books on such things as sensors for temperature, pressure, humidity, pH, strain, and conductivity, as well as for tech books and software.

But note that most of Omega's products are premium ones that command premium prices.

Several of the other sources of low-temperature sensors advertise regularly in the *Measurements and Control* trade journal. That magazine is a great source for sensor and transducer information.

As per usual, this is your column and you can get tech help and off-the-wall networking per the "Need Help?" box. Please also note the *names and numbers* sidebar, that shows where you can go for more information on many of the sources mentioned.

Let's start off with a look-at....

Patents and patenting

I've received several calls and letters this week that drive home the expensive, energy-wasting, and time-consuming misconceptions that many hackers now have over patents and patenting. We'll start off with the one-word bottom line involving any patents for hardware hackers—**don't!** Don't even think about it.

Ever.

Three different helpline callers apparently are in the process of getting patents on three ideas that each have a century of totally obvious prior art involved with them. They are all also readily available as off-the-shelf products. One is a capacitance microphone, the second is an electrolytic level, and the third is a fluorescent lamp.

If a Las Vegas casino manager had the gross effrontery to offer the same odds that the patent office does, he would be run out of town on a rail. Your state lottery is probably a far better investment than a patent.

Fact: Not one single patent in one hundred will ever show any positive cash flow.

Fact: Not one single patent in one thousand is "solid" enough

that it cannot be invalidated or severely reduced in value through a diligent enough search for prior art in obscure enough places.

Fact: A patent does not in any way prevent others from stealing your ideas. All it does is give you the right to sue someone. Once patented, anyone anywhere in the world can get a copy of your idea simply by reading the patent.

Fact: In patent litigation cases, the side with the most resources almost invariably wins. Even with a totally bulletproof patent, the legal process can be made so time-consuming and so costly that the winner loses, and vice versa.

The conventional wisdom goes something like this: First, get an idea. Second, patent it. Third, sell the idea to a large company. Well, each one of those three concepts is "patently" absurd.

I would like to be able to report to you that ideas are still worth a dime a dozen, but those glory days are long gone. Today, ideas are worth less than a dime a bale in ten-bale lots. It is only when an idea is both converted into a form that people can use and in fact are actually and aggressively using it, that the idea gains any value.

Many hackers seeking patents do not bother to search through the literature, especially all the trade journals, to find out ahead of time what the competition is, which of the products already exist, and what the demand is in their area. Some will even ignore all of the fundamental physical laws and the other fundamental constraints that lie behind their ideas.

NEED HELP?

Phone or write your **Hardware Hacker** questions directly to:

Don Lancaster
Synergetics
Box 809
Thatcher, AZ 85552
(602) 428-4073

Most larger companies are not in the least interested in new products and ideas. It is far simpler for them to "steal the plans" and go with an established product. They feel that the pioneers are the ones with all the arrows in their backs. As an obvious example, not one of the traditional dino computer firms even entered the personal-computer market until long after it was thoroughly proven.

And then they did so with some highly conservative and "me too" products. Even at that, many of them failed miserably.

Further, many larger companies will positively refuse to ever look at any submitted patent or idea, since it opens them up to all sorts of "You stole my idea!" litigation hassles, and might compromise in-house research that's already in progress.

So, by all means, continue all of your hacking, and do continue your experimenting and developing of ideas and products. But, for most hackers most of the time, I personally just cannot see any

One pound per square inch (psi) is also equal to 6.895 kiloPascals, 68.947 millibars, 70.307 grams per square centimeter, 51.715 millimeters of mercury, 2.307 feet of water, or 27.673 inches of water.

A column of air one inch square and equal in height to the earth's atmosphere will exhibit a sea level pressure of 14.696 psi.

If 7.5 gallons of water are placed in a box one foot square by one foot high, the box will weigh 62.4 pounds and will exhibit a base pressure of 62.4 pounds per square foot.

A column of air 1000 feet high at terrestrial altitudes exhibits a pressure of roughly 0.5 psi.

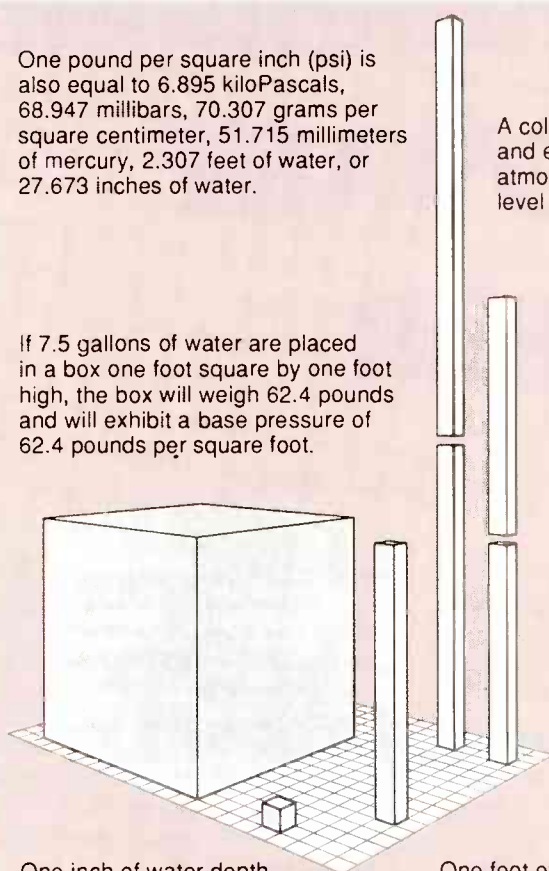

One inch of water depth will exhibit a pressure of 0.0361 psi.

One foot of water depth will exhibit a pressure of 0.434 psi.

FIG. 1—HERE ARE SOME OF the fundamentals behind pressure measurement.

NEW FROM DON LANCASTER

HANDS-ON BOOKS

Ask the Guru Reprints	24.50
CMOS Cookbook	16.50
TTL Cookbook	16.50
Active Filter Cookbook	15.50
Micro Cookbook vol I or II	16.50
Enhancing your Apple v. I or II	15.50
Applewriter Cookbook	19.50
Apple Assembly Cookbook	21.50
Incredible Secret Money Machine	9.50
PostScript Cookbook (Adobe)	16.50
PostScript Ref. Man. (Adobe)	22.50
PostScript Prog. Man (Adobe)	22.50

UNLOCKED SOFTWARE

Absolute Reset IIe & IIc	19.50
Applewriter/Laserwriter Utilities	49.50
PostScript Show & Tell (IIe/Mac/PC)	39.50
Intro to Postscript VHS Video	39.50
PostScript Perspective Draw	39.50
PostScript Printed Circuits	39.50
PostScript Technical Illustrations	39.50
Postscript BBS stuff	19.50
Apple Ram Card Disassembly Script	24.50
Enhance I or II Companion Disk	19.50
Applewriter CB or Assy CB Disk	24.50

FREE VOICE HELPLINE

VISA/MC

SYNERGETICS

Box 809-RE
Thatcher, AZ 85552
(602) 428-4073

CIRCLE 83 ON FREE INFORMATION CARD

(relative)

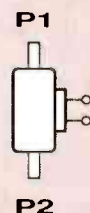

P2

a RELATIVE pressure transducer measures the pressure difference between inputs P1 and P2. Most solid-state sensors start out as relative transducers.

(absolute)

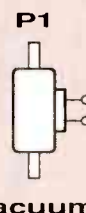

vacuum

an ABSOLUTE pressure transducer measures the pressure difference between input P1 and a good vacuum reference. A mercury barometer is an absolute transducer.

(gauge)

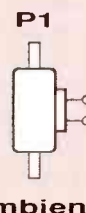

ambient

a GAUGE pressure transducer measures the pressure difference between input P1 and the ambient, or room, air pressure. A water pump gauge is an example.

FIG. 2—THERE ARE THREE FUNDAMENTALLY different types of pressure sensors. Most of the new solid-state transducers start out as relative devices.

point whatsoever in seeking out the time, dollar, and psychic-energy sinks that the patent process represents today.

Measuring pressure

The single-quantity price of solid-state pressure transducers has now dropped to under \$9, opening a whole new world of hacker opportunities. Besides the traditional suppliers of Motorola and Micro-Switch, new outfits that in-

clude SenSym, IC Sensors, and Nova-Sensor are now offering lots of high-volume and low-cost pressure-sensing products.

Before we look into a typical low-cost sensor and its uses, let's review some of the fundamentals.

Pressure is force per unit area, and is often measured in pounds per square inch (PSI) or in similar units. Figure 1 shows us some important pressure relationships.

If you take a box that is one foot

Discover—Explore—Experience
Today's Electronics With ...

McGraw-Hill's Contemporary Electronics Series

Now you can meet the challenges of today's electronics quickly and easily. This professional level learning series is as innovative as the circuitry it explains and as fascinating as the experiments you build and explore! And it's for anyone who has an interest in electronics... from the hobbyist to the professional.

Thousands Have Already Experienced the Excitement!

Today's high-tech world demands an entirely new and innovative approach to understanding electronics. That's why McGraw-Hill has developed this unique "hands-on" learning method that brings to life the dynamics of the new electronics. It's a unique combination of interactive materials that gets you involved as you build and experiment with today's latest electronic circuitry.

Just how well this innovative learning approach meets the challenge of the new electronics is confirmed by those who have already completed the Series... "You have put me right into the middle of an extraordinary learning experience. With each lab exercise I have gained a new understanding of the intricacies of today's electronics." Or... "For me, the Series was just the answer. I felt confident within my specialty, but my grasp of other areas of electronics was slipping away. Your Series helped me upgrade my knowledge of the latest electronics concepts." Or this from a company director of training... "We manufacture sophisticated electronic products, with a lot of people in sales, assembly and purchasing. McGraw-Hill has answered a real need in helping our employees see the total picture. They now communicate with customers and each other more effectively."

Your Involvement in the New Electronics Begins Immediately.

You master one subject at a time with 15 McGraw-Hill *Concept Modules*, sent to you one

every 4 to 6 weeks. You waste no time on extraneous materials or outdated history. It's an entertaining, lively, nontraditional approach to the most modern of subject matter.

Your very first module takes you right to the heart of basic circuit concepts and gets you ready to use integrated circuits to build a digital oscillator. Then, you'll verify the operation of different electronic circuits using a light emitting diode (LED).

And each successive module brings you up to speed quickly, clarifying the latest advances in today's electronics... from digital logic and micro-processors to data communications, robotics, lasers, fiber optics, and more.

Unique Combination of Interactive Instruction Materials Makes Learning Easy.

Laboratory experiments, vividly illustrated text and interactive cassette tapes all blend together to give you a clear, simplified understanding of contemporary electronics.

With each module, you receive a McGraw-Hill *Action-Audio Cassette* that brings to life the facts and makes you feel as if you're participating in a lively dialogue with experts.

Your ability to quickly make this knowledge your own is further aided by strikingly *illustrated* texts that use diagrams, explanations, illustrations, and schematics to drive home and rein-

force the meaning of each important point. Carefully indexed binders conveniently house all this material, as well as the instructions that will guide you through your "hands-on" lab experiments.

Throughout your Series, *laboratory experiments* reinforce every significant concept. With this essential "hands-on" experience using actual electronic components, you master principles that apply all the way up to tomorrow's VLSI (Very Large Scale Integrated) circuitry.

Discover, Explore, Experience for Yourself—15-Day Trial.

In all ways, the Contemporary Electronics Series is an exciting learning experience that offers you the quickest and least expensive method available to master today's electronics... and the only one with "hands-on" experience.

To order your first module for a 15-day

trial examination, simply complete the card and send today! If the card is missing, write to us for ordering information.



McGraw-Hill
Continuing
Education Center

3939 Wisconsin Avenue, NW
Washington, DC 20016

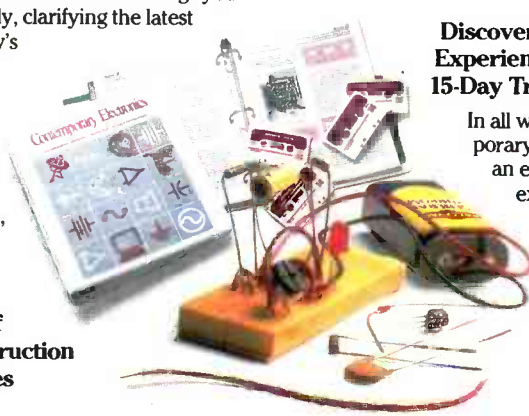

With your first module, you'll build this solderless breadboarding system. As you add additional boards, you create increasingly complex circuits easily and quickly, bringing today's electronics concepts to life.

square by one foot high and fill it with water, it will weigh 62.4 pounds and will thus exhibit a total pressure on its bottom of 62.4 pounds per square foot. It will take a tad under 7.5 gallons of water to do that.

Now, since there are 144 square inches per square foot, the pres-

NAMES AND NUMBERS

Computer Shopper

Box F
Titusville, FL 32781
(305) 269-3211

Exel

2150 Commerce Dr.
San Jose, CA 95131
(408) 432-0500

Fomeboards

2211 N. Elston Avenue
Chicago, IL 60614
(312) 278-9200

Hygenic Manufacturing

1245 Home Avenue
Akron, OH 44310
(216) 633-8460

Measurement & Control

2994 W. Liberty Avenue
Pittsburgh, PA 15216
(412) 343-9666

Micro Switch

11 West Spring Street
Freeport, IL 61032
(815) 235-6600

Monolithic Memories

2175 Mission College Blvd.
Santa Clara, CA 95054
(408) 970-9700

Motorola

PO Box 20912
Phoenix, AZ 85036
(602) 244-6900

Nova Sensor

1055 Mission Court
Fremont, CA 94539
(415) 490-9100

Omega

One Omega Drive
Stamford, CT 06907
(203) 359-7874

R & D Electronics

1202H Pine Island Road
Cape Coral, FL 33909
(813) 772-1441

Siemens Components

19000 Homestead Road
Cupertino, CA 95014
(408) 257-7910

SenSym

1255 Reamwood Avenue
Sunnyvale, CA 94089
(408) 744-1500

Xilinx

2069 Hamilton Avenue
San Jose, CA 95125
(408) 559-7778

TECHNICAL RESOURCES FOR THE HANDICAPPED

Apple Special Education

20525 Mariani Avenue 36-M
Cupertino, CA 95014
(408) 996-1010

Children's Computer Group

2095 Rose Street
Berkeley, CA 94709
(415) 841-3224

Children's Resource Center

1056 E 19th Avenue
Denver, CO 80218
(303) 861-6633

Closing the Gap Inc.

PO Box 68
Henderson, MN 56044
(612) 248-3294

Communication Resources

3201 Marshall Road
Kettering, OH 45429
(513) 298-0803

Computer Access Center

2425 16th Street Room 23
Santa Monica, CA 90405
(213) 450-8827

Computer CITE

215 East New Hampshire
Orlando, FL 32084
(305) 299-5000

Disabled Children's Group

1146 South Third Street
Louisville, KY 40203
(502) 584-1239

Disabled Technical Center

5759 Hedgehaven Court
Las Vegas, NV 89120
(702) 382-3358

Handi-Ham System

3915 Golden Valley Road
Golden Valley, MN 55422
(612) 588-0811

National Braille Press

88 Saint Stephen Street
Boston, MA 02115
(617) 266-6160

Pacer Center

4826 Chicago Ave South
Minneapolis, MN 55417
(612) 827-2966

SpecialLink

2512 Canterbury Avenue
Cincinnati, OH 45212
(513) 531-9233

Special Technology Center

West Jackson Elementary School
PO Box 3683
Jackson, TN 38303

(901) 424-9089

Special Technology Center

535 Race St, Suite 220
San Jose, CA 95126
(408) 288-5010

SuperGroup Evaluation

4129 Beaujolais
Kenner, LA 70065
(504) 561-8713

Technical Access Center

183 Lake Avenue
Newton, MA 02159
(617) 969-4279

Technical Assistance

1950 West Roosevelt Road
Chicago, IL 60608
(312) 421-3373

Technology Resources

3023 Canterbury
Salina, KS 67401
(913) 827-0301

Trace Development Center

1500 Highland Avenue
Madison, WI 53705
(608) 262-6966

sure per square inch is equal to 62.4/144, or 0.434 PSI. If your city water tower is full and it is a hundred feet high, it will give you 43.4 PSI of static line pressure.

Lower pressures, such as those associated with air conditioning and blowers, are sometimes measured in *inches of water*. An inch of water is 1/12th of a foot of water, and equal to 0.0361 PSI.

Turning to air instead of water, if you take a column of air that is one square inch in cross section, and equal to the entire atmosphere in height, it will exhibit a pressure at sea level of 14.696 PSI. While the pressure-vs-altitude curve is non-linear, you will get a pressure drop of roughly 0.5 PSI per thousand feet of elevation on the ground.

A terrestrial altimeter with a one-foot resolution would have to be able to resolve 0.0005 PSI. Digitally, that would take a minimum of 12 bits of resolution, and, more realistically, from 14 to 16 bits.

Atmospheric pressure will also vary with the weather. *Barometers* are pressure transducers that have been optimized for weather-prediction use.

As Fig. 2 shows us, there are three fundamentally different ways of measuring pressure. A *relative* pressure measurement will measure the difference in pressure between the two liquid or air inputs. Nearly all of today's solid-state pressure transducers start out by measuring relative pressure.

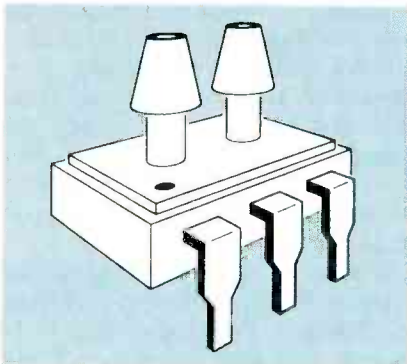

FIG. 3—THE NOVA SENSOR NPS-030-D1 is a 5-PSI \$9 relative pressure transducer that is packaged in a plastic 6-pin mini-DIP.

into an absolute one by evacuating and sealing one input side.

Gauge pressure gets measured against the *ambient*, or atmospheric pressure, that happens to exist here and now. The pressure gauge on a water system measures, of all things, gauge pressure. A relative transducer is converted into a gauge transducer by leaving one of its inputs open to ambient.

Two of the traditional pressure transducers are the *Bourdon gauge* and the *aneroid barometer*. A Bourdon gauge is built by seal-

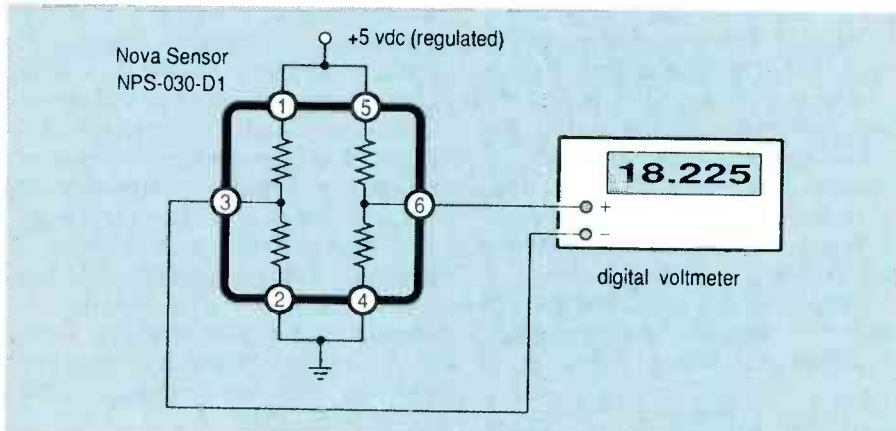

FIG. 4—THIS SIMPLE CIRCUIT WILL get you started experimenting with the new solid-state pressure transducers. The sensor shown is rated at a relative 0-5 PSI.

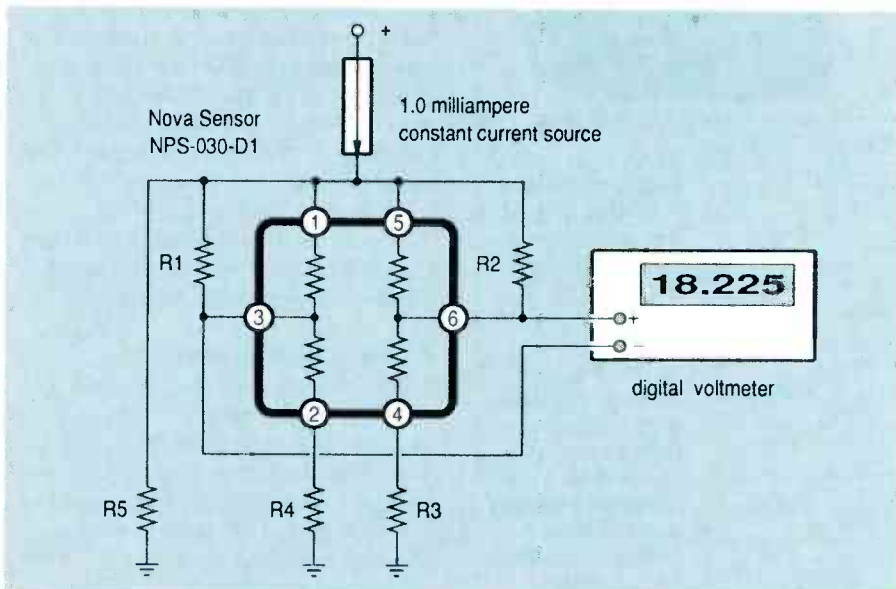

FIG. 5—EXTRA RESISTORS CAN BE provided for temperature compensation and for span adjustments. The correct values are specified for each individual pressure sensor.

Absolute pressure measurements are made by comparing one pressure input against a nearly perfect vacuum, or some other precision reference. A relative pressure transducer is converted

ing a pipe end and spiraling it. As the pressure increases or decreases, the spiral will tighten or loosen, moving the sealed end of the pipe. Those New Year's Eve party favors work on the same principle.

NEW SUPER LONG PLAY TAPE RECORDERS

12 Hour Model — \$105.00*
USES D-120 TAPE

Modified Panasonic Slimline, high quality, AC-DC Recorders provide 6 continuous hours of quality recording & playback on each side of cassette for a total of 12 hours.

Built-in features include:
• Voice level control, • Digital counter, etc. TDK DC 120 Cassette Furnished.

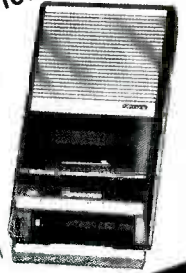

PHONE RECORDING ADAPTER

Records calls automatically. All Solid state connects to your telephone jack and tape recorder. Starts recording when phone is lifted. Stops when you hang up. \$24.50*
FCC APPROVED



VOX VOICE ACTIVATED CONTROL SWITCH

Solid state. Self contained. Adjustable sensitivity. Voices or other sounds automatically activate and control recorder. Uses either recorder or remote mike. \$24.95*
FCC APPROVED



*Add for ship & hdg. Phone Adapter & Vox \$1.50 ea. Recorders \$4.00 ea. Cal. Res. add tax. Mail order, VISA, M/C, COD's OK. Money Back Guarantee. Qty. disc. avail.. Dealer inquiries invited, Free data.
AMC SALES INC. Dept. 9335 Lubec St., Box 928, Downey, CA 90241 Phone (213) 869-8519

CIRCLE 108 ON FREE INFORMATION CARD

Get A Complete Course In

ELECTRONIC ENGINEERING

8 volumes, over 2000 pages, including all necessary math and physics. 29 examinations to help you gauge your personal progress. A truly great learning experience.

Prepare now to take advantage of the growing demand for people able to work at the engineering level.

Ask for our brochure giving complete details of content. Use your free information card number, or write us directly. \$99.95, Postage Included. Satisfaction guaranteed or money refunded.



Banner Technical Books, Inc.
1203 Grant Ave.
Rockford, IL 61103

CIRCLE 183 ON FREE INFORMATION CARD

RELY ON JAN FOR 3-WAY HELP:

1. **TECHNICALLY CORRECT CRYSTALS TO YOUR SPECS.**
2. **QUICK TURNAROUND WITH HUGE INVENTORY, PROMPT SERVICE, AND OUR EMERGENCY ORDER PLAN.**
3. **LOW PRICES.**

QUARTZ CRYSTALS FOR
TWO-WAY — INDUSTRY
MARINE — AMATEURS
SCANNERS — CBs
MICROPROCESSORS



FOR FREE CATALOG,
CALL OR WRITE:
JAN CRYSTALS
P.O. BOX 06017
FORT MYERS, FL 33906
(813) 936-2397

SINCE
1965



TOLL-FREE: 1-800-237-3063

IN FLORIDA: 1-800-226-XTAL
FAX ORDERS: 1-813-936-3750

CIRCLE 104 ON FREE INFORMATION CARD

Be an FCC LICENSED ELECTRONIC TECHNICIAN!



Learn at home in spare time.
No previous experience needed!

No costly School. No commuting to class. The Original Home-Study course prepares you for the "FCC Commercial Radio-telephone License". This valuable license is your "ticket" to thousands of exciting jobs in Communications. Radio-TV. Microwave. Computers. Radar. Avionics and more! You don't need a college degree to qualify, but you do need an FCC License.

No Need to Quit Your Job or Go To School

This proven course is easy, fast and low cost! **GUARANTEED PASS** — You get your FCC License or money refunded. **Send for FREE facts now. MAIL COUPON TODAY!**

COMMAND PRODUCTIONS

FCC LICENSE TRAINING, Dept. 90
P.O. Box 2824, San Francisco, CA 94126
Please rush FREE details immediately!

NAME _____
ADDRESS _____
CITY _____ STATE _____ ZIP _____

An aneroid barometer consists of a sealed bellows with one fixed end. Should the external pressure change, the bellows will expand or contract, moving its other end.

Both of those have some serious shortcomings. Since each one is a mechanical system, you get *stiction* that prevents very small motions, and *hysteresis* where you do not return to the exact same position each time. The linearity is also not all that great, especially for large changes.

Most of those new solid-state transducers consist of a thin silicon diaphragm that has a strain-gauge resistor bridge placed upon it. One pressure port accesses each side of the diaphragm. As the relative pressure changes, the diaphragm flexes, thus changing the resistance values and giving you a resistance change that can produce an output voltage that is in turn proportional to the pressure difference.

Output levels are typically 100 millivolts full scale, so some amplification and other signal con-

ditioning is usually needed for real-world uses. Besides that, various temperature and offset compensation schemes also will usually need to be used. As we saw last month, the latest of the new A/D converters are now able to directly accept an unconditioned transducer signal as an input.

Silicon is an extremely linear material that is easily and precisely machined. The linearity, hysteresis, and stiction of the silicon pressure transducers are often ridiculously better than the earlier mechanical systems. Since all of the structures involved are now insanely smaller, the final frequency response is also greatly improved.

So, what can you now do with a cheap pressure transducer? Some obvious applications are altimeters, barometers, pressure gauges, air regulators, liquid-level sensors, air-conditioning and ventilation systems, fluidics, microphones, stream gauges, blood-pressure monitors, intrusion alarms, automotive emission controls, acoustic sensors, speaker enclosures, flowmeters, and weighing scales.

But, why don't you tell me instead? For this month's contest, just dream up an off-the-wall use for a cheap pressure transducer. A paper design will be just fine. We'll have the usual *Incredible Secret Money Machine* prizes, including an all-expense paid (FOB Thatcher, AZ) *tinaja quest* for two for the very best entry of all.

As per usual, send your entries directly to me, and not to the Radio-Electronics editorial offices.

A new pressure sensor

The *Nova Sensor* people recently had a factory-direct, \$9 in singles sale on their NPS-030-D1 and other sensors. Figure 3 shows us that jewel, which is packaged in a 6-pin mini-DIP with two pipes out the top. The range is 0-5 PSI.

Figure 4 shows you a simple test circuit, which is a plain old resistive Wheatstone Bridge. All you need is a 5-volt regulated supply and a digital voltmeter. As you blow or suck into a hose connected to one of the pipes, the pressure should change by twenty millivolts or so, corresponding to a 1-PSI pressure difference. Full-

DIGITAL VIDEO STABILIZER ELIMINATES ALL VIDEO COPY PROTECTIONS



While watching rental movies, you will notice annoying periodic color darkening, color shift, unwanted lines, flashing or jagged edges. This is caused by the copy protection jamming signals embedded in the video tape, such as Macrovision copy protection. Digital Video Stabilizer: RXII completely eliminates all copy protections and jamming signals and brings you crystal clear pictures.

FEATURES:

- Easy to use and a snap to install
- State-of-the-art integrated circuit technology
- 100% automatic - no need for any troublesome adjustments
- Compatible to all types of VCRs and TVs
- The best and most exciting Video Stabilizer in the market
- Light weight (8 ounces) and Compact (1x3.5x5")
- Beautiful deluxe gift box
- Uses a standard 9 Volt battery which will last 1-2 years.

WARNING :
SCO Electronics and RXII dealers do not encourage people to use the Digital Video Stabilizer to duplicate rental movies or copyrighted video tapes. RXII is intended to stabilize and restore crystal clear picture quality for private home use only.

(Dealers Welcome)

To Order: \$49 ea. + \$3 for FAST UPS SHIPPING
1-800-445-9285 or 516-694-1240
Visa, M/C, COD M-F: 9-6 (battery not included)
SCO ELECTRONICS INC.
Dept. C11 62 Marine St. Farmingdale NY 11735
Unconditional 30 days Money Back Guarantee

CIRCLE 204 ON FREE INFORMATION CARD

scale sensitivity should be around a hundred millivolts.

If you can get a hold of a high-precision DVM that can resolve to tens of microvolts, pinch off a very short hose connected to one of the pipes, and see if you can't get a 10-microvolt change for each foot you raise or lower the sensor.

In a real-world application, it will be very tricky indeed to get better than a 50-foot altimeter accuracy. But please let me know if you can do that, for I know some cave mappers that sure would like to get their hands on an affordable and rugged one-foot altimeter.

Some of the altimetry problems that are involved appear in the *SenSym* data book.

By the way, several low-cost rubber hoses in hacker lengths are available from *Hygienic*. Be sure to have the actual data sheet and application notes on hand when using any pressure transducer.

Each transducer is measured at the factory and is provided with a list of compensation resistors that are needed for the best temperature performance. Figure 5 shows us how they are used. It is up to you to provide those resistors yourself. Usually, either R1 or R2 will be a short circuit, and either R3 or R4 will be an open, so a maximum of three compensating resistors are normally needed.

The LAN of the eighties

There sure is plenty of interest these days in LAN's, or Local Area Networks. Many of them are poorly performing, insanely expensive, or grossly limiting in one way or another. But one LAN is clearly head and shoulders above all of the others. So much so, that I like to call it the *LAN of the eighties*.

The LAN of the eighties is a simple token ring loop. It requires only one single wire between your stations. The wire need not be shielded or a twisted pair, and even *bare wire* has been used in several of the many tens of thousands of installations in use today.

The LAN loop can be ten or more miles long. While only a few dozen servers is the normal, many hundreds can be installed. In turn, each server node normally is able

continued on page 83

FREE Heathkit[®] CATALOG



Featuring superior quality electronic products in kit and assembled form. Innovative home products, test instruments, self-study electronics courses. Challenging and educational kits for first-time as well as seasoned builders. Quality ready-to-use electronic products for homeowners, sports enthusiasts and professionals. All from Heath Company, a leader in the changing electronics market.

Send NOW for your **FREE** Heathkit Catalog.

Send to:

Heath Company, Dept. 020-702
Benton Harbor, Michigan 49022

108 full-color pages packed with the latest in high quality electronic products

Name _____

Address _____

City _____

State _____ Zip _____

Heathkit[®]
Heath
Company

A subsidiary of Zenith Electronics Corporation

CL-792

CIRCLE 86 ON FREE INFORMATION CARD

DOES YOUR DIGITAL CAPACITANCE METER DO THIS?

FULL 4 DIGIT 0.5 INCH LCD DISPLAY COMPLETELY AUTORANGING WITH 10 RANGE MANUAL CAPABILITY

AND THIS
RANGE OF 0.0 pF TO 1 FARAD (999.9 mF)
0.5% BASIC ACCURACY UP TO 100 uF

AND THIS
READS DIELECTRIC ABSORPTION

AND THIS
EXTENDED PSEUDO 5 DIGIT
RESOLUTION ON SOME RANGES ONLY

AND THIS
ABILITY TO ZERO LARGE CAPACITANCE
VALUES UP TO 99.99 uF

AND THIS
CALCULATES TRUE CAPACITANCE
IF CAPACITOR IS LEAKY

AND THIS
DIODE CLAMP AND FUSED
PROTECTED INPUT.
DISCHARGE RESISTOR IN OFF
POSITION AT TERMINAL INPUTS.
POWERED BY 9V BATTERY

**ONE YEAR PARTS &
LABOUR WARRANTY**

FOR ONLY THIS



AND THIS
IDENTIFIES TRANSISTORS (NPN, PNP)
AND THEIR LEADS (E, B, C, ETC.)

AND THIS
TESTS ZENER DIODES AND RECTIFIERS
UP TO 20V ZENER WITH AC ADAPTOR,
ZENER VOLTAGE WITH 9V BATTERY
DEPENDS ON ITS CONDITION

AND THIS
AUTOMATICALLY CALCULATES LENGTHS
OF CABLES IN FEET, METRES, MILES,
KILOMETRES (THEORETICAL RANGE
OF 9,999 MILES)

AND THIS
ABILITY TO SORT CAPACITORS IN
MANY DIFFERENT MODES

AND THIS
ABILITY TO READ LEAKY CAPACITANCE
(INSULATION RESISTANCE OR CURRENT)

AND THIS
CALCULATES TIME CONSTANTS WITH
USER DEFINED RESISTANCE VALUES

AND THIS
HOLD FUNCTION FREEZES DISPLAY

SHIPPING INSTRUCTIONS:

All units shipped out F.O.B. Buffalo NY via United Parcel Service (except Hawaii & Alaska) unless otherwise indicated (in which case shipments will be F.O.B. Canada)

\$189.95

MODEL
MC300 Approx. Size
7" x 4" x 1 1/2"
DAETRON

a division of Bergeron Technologies Inc.
935 THE QUEENSWAY, BOX 641
TORONTO, ONTARIO M8Z 5Y9
CANADA (416) 676-1600

PLEASE SEND ME		U.S. FUNDS
(QUANTITY) MC300(S) @	\$189.95	\$ _____
CARRYING CASE	\$ 16.95	\$ _____
AC ADAPTOR	\$ 9.95	\$ _____
SHIPPING AND HANDLING @ \$.50 PER INSTRUMENT		\$ _____
[] CHECK [] MONEY ORDER		\$ _____
[] VISA [] MASTERCARD	TOTAL	\$ _____
[] CARD NO _____	SIGNATURE _____	
EXPIRY DATE _____	TELEPHONE _____	
NAME _____		
ADDRESS _____		
CITY _____ STATE _____	ZIP CODE _____	

DEALER ENQUIRIES INVITED

CIRCLE 187 ON FREE INFORMATION CARD

OCTOBER 1988

AUDIO UPDATE

The audio answerman returns



LARRY KLEIN,
AUDIO EDITOR

ABOUT A YEAR AGO I DEVOTED A COLUMN to a half dozen or so common hi-fi questions (*Radio-Electronics*, August 1987). My hope was that I would be lending some aid and comfort to both the novice and the technically beleaguered audiophile. Reader reaction was positive enough that I'm about to do it again with a new batch of old stand-bys from my files. I encourage my readers to write to me with their questions and concerns. When possible and appropriate, I'll provide answers in these pages. Let me hear from you.

Speaker impedance

Q. These days most manufacturers rate their speaker system impedance at 4 or 8 ohms, but I remember when systems of 16 ohms and even higher were not uncommon. What are the technical reasons for the range of speaker-impedance ratings?

A. I submitted that question to a half-dozen speaker manufacturers, and it evoked a surprising variety of responses. A couple of the replies took a historical approach, stating that 16-ohm speakers were technically best suited for tube amplifiers, that 4 ohms represented the most appropriate load for the early germanium-output transistors (which could handle high currents but not high voltages), and that 8 ohms is a reasonable choice today since it enables the user to parallel two systems without risking potential overload of the amplifier.

The EIA (*Electronic Industry*



Association) Amplifier Standard specifies 8 ohms as the primary standard load with which manufacturers rate their amplifier's output capabilities. Nevertheless, a few speaker manufacturers are producing systems rated at 6 ohms as a logical and neat compromise between the opposing dangers of running out of current (low impedance) or running out of voltage (high impedance). The improved protection circuits and current capabilities found in today's amplifiers makes it possible for them to handle paralleled pairs of 6-ohm speakers.

Several engineers remarked on the nonstandard ways that speaker impedance is rated in manufacturer's literature. Among the various rating methods (each of which would provide different numbers)

are: (1) DC resistance only, (2) minimum impedance in the audible range—which usually occurs in an octave or so above the bass resonance, (3) impedance at some specified frequency, and (4) average impedance. Methods (1) and (2) yield the lowest numbers and are therefore the most conservative. In any case, I know of no official standard way of specifying impedance, so any particular manufacturer's rating depends simply on what he chooses to regard as "nominal."

...and why it varies

Q. Is there an electrical or physical reason why a speaker's impedance varies with frequency?

A. Both. Since the voice coil of a speaker, like any other wire coil, has inductance, its impedance rises with frequency. The impedance of a speaker system usually starts to rise (unless the designer has taken certain steps to prevent it) somewhere around 400 Hz.

There is another rise—to perhaps five times the rated impedance—at the woofer's in-box resonant frequency. When a woofer cone is in motion, the voice-coil movement in the magnetic gap generates a counter-electromotive force, or "back voltage." Because the back voltage is in opposition to the signal voltage, the effect of "motional impedance" is identical to that caused by an increase in electrical voice-coil impedance. (If the speaker voice coil is physically prevented from moving, there is no counter-EMF generated, and no rise in impedance.) Keep in mind that impedance fluctuations at certain frequencies are not synonymous with variations in the power output.

FCC, Part 15

Q. Every FM receiver or tuner I've ever seen has a label of some sort stating that the product "Conforms to FCC Regulations, Part 15." What exactly are the FCC regulations governing stereo receivers?

A. The FCC regulation in question deals with a diversity of products—including pocket radios, computers, TV sets, and stereo receivers—and establishes limits on the amount of radio-frequency energy that they are permitted to radiate. In FM tuners, the spurious radiation comes about because virtually all of today's tuners use the superheterodyne design configuration. Briefly, the "superhet" circuit has a "local oscillator" whose purpose is to interact (beat) with the incoming signal to provide an intermediate frequency of 10.7 MHz. Since any oscillator operating at radio frequencies is likely to radiate unless preventive steps are taken, the FCC has established maximum external radiation limits to prevent interference with nearby equipment.

In order to market a receiver or tuner in the United States, a manufacturer must provide measurements to the FCC proving that their product does not ex-

New Scanner by AOR

**100 Channels
800 MHz**

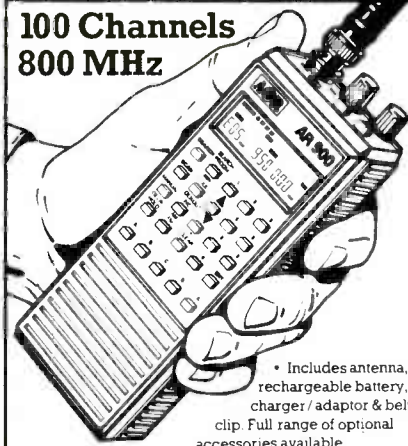

- Includes antenna, rechargeable battery, charger / adaptor & belt clip. Full range of optional accessories available.

- Covers 27-54 MHz, 108-174 MHz, 406-512 MHz, and 800-950 MHz.
- 5 Scan Banks and 5 Search Banks.
- 25 Day Satisfaction Guarantee, Full Refund if not Satisfied.
- No Frequencies cut out.
- Size: 2" x 5 3/4" x 1 1/2" wt: 12 oz.

AR900

Total Price, Freight Prepaid
(Express Shipping Optional)

\$299.00



COMMUNICATIONS

10707 E. 106th St. Indpls., IN 46256

Toll Free 800-445-7717

Visa and MasterCard
(COD slightly higher)

In Indiana 317-849-2570 Collect FAX (317) 849-8794

CIRCLE 182 ON FREE INFORMATION CARD

**ATTENTION!
ELECTRONICS
TECHNICIANS**



**EARN YOUR
B.S.E.E.
DEGREE**

THROUGH HOME STUDY

Our New and Highly Effective Advanced-Placement Program for experienced Electronic Technicians grants credit for previous Schooling and Professional Experience, and can greatly reduce the time required to complete Program and reach graduation. No residence schooling required for qualified Electronic Technicians. Through this Special Program you can pull all of the loose ends of your electronics background together and earn your B.S.E.E. Degree. Upgrade your status and pay to the Engineering Level. Advance Rapidly! Many finish in 12 months or less. Students and graduates in all 50 States and throughout the World. Established Over 40 Years! Write for free Descriptive Literature.

**COOK'S INSTITUTE
OF ELECTRONICS ENGINEERING**



4251 CYPRESS DRIVE
JACKSON, MISSISSIPPI 39212

CIRCLE 58 ON FREE INFORMATION CARD



One tree can make
3,000,000 matches.



One match can burn
3,000,000 trees.



NEW

DO IT YOURSELF

NOW, you can easily make yourself your PCB.
Using CIF photo positive boards epoxy 1 side or 2 sides, thickness 1/16"
5 years guarantee.
Made in France.
Very simple Process!



Photo positive boards
1 or 2 sides

Regular copper clad boards
1 or 2 sides

Standard sizes (inches)	
3 x 5	
4 x 6	
6 x 6	
6 x 9	
6 x 10	
12 x 12	
11 x 14	
12 x 18	

We can supply any size on your request.
Military specifications MIL. P. 13949 F — UL 94 VO

TSM

GENERAL DISTRIBUTOR
PROSPECT ELECTRONICS
PO BOX 9144 ALLENTOWN, PA 18105
TEL.: (215) 770-9029
RETAILERS WELCOME!

CIRCLE 200 ON FREE INFORMATION CARD

ceed the legal RF radiation limit. Those measurements are taken at a receiver's antenna terminals and at its AC line cord, since unwanted signals can be transmitted through the AC power line.

Carbon fiber components

Q. As a tennis buff, I've gotten used to seeing "carbon fiber" and "graphite" featured in advertisements for high-priced rackets. Now carbon fiber seems to be

cropping up in audio products such as speaker cones. What exactly is carbon fiber, and what does that material do for audio performance?

A. As you are probably aware, there are those who also consider audio a "high-price racket," so there is a remote connection. In any event, there are several different types of carbon fiber, but the one used in both tennis rackets and audio products are

made of separate, very fine strands of pure crystalline carbon in an epoxy-resin binder. That fiber-and-resin "composite," as it is called, has several properties that make it very attractive to product designers. It is, among other things, very rigid, low in mass relative to its volume, inherently well damped, and nonresonant.

In making speaker cones, carbon fiber is added to the "slurry" (a liquid mixture of wood pulp, water, and heaven only knows what else) from which the cones are molded. As part of the cone material, the carbon fibers help stiffen the cone and damp out internal resonances and vibration transmission. Carbon fiber has also been used in tone arms and phono-cartridge head shells. In each case, the advantages sought from its use derive from the material's low relative mass, high strength, and high internal damping.

FM hiss

Q. I usually hear hiss when my FM tuner is receiving a stereo broadcast. Since there is no hiss when I switch to mono, I assume that the noise is generated by my tuner's multiplex circuit. Would a noise-reduction unit connected between my tuner and my amplifier help?

A. It might, but that's not the way to handle your problem. First of all, the hiss is *not* generated by the multiplex circuits in your tuner. Because of the way the FM-stereo broadcast system works, a stereo signal is effectively 23 dB weaker at your tuner than an equivalent mono signal. That being the case, I suspect that the stereo broadcasts reaching your tuner are simply too weak.

I suggest that you (1) check your tuner's sensitivity specifications to determine whether they are adequate for your location; (2) determine whether your tuner lives up to its specifications—it may need overhaul or alignment; and (3) determine whether your antenna is oriented properly and is adequate for your tuner *and* location. In any case, it makes more sense to attack your problem with a better tuner or antenna system than with a noise-reduction unit. **R-E**

★ CABLE TV SPECIALS ★

CONVERTERS

	JRX-3 DIC—36 Channel Corded Remote	\$129.95
	RCA 58-3 58 channel set top with Jerrold Decode	\$99.95
	SB-3 — 'The Real Thing'	\$109.95
	SB-3-Taiwan Copy	\$89.95
	DRZ-3D1C—68 Channel Wireless with Decoder	\$199.95
ZENITH:	Z-TAC Cable Add-On	\$169.95
VIEW STAR:	MXC 2001—65 Channel Wireless— with Parental Lockout	\$89.95
	MXC 2001 A-B—Same as above with A-B Switch	\$109.95
	MXC 2501—65 Channel Wireless with Volume	\$119.95
	Universal V7472—72 Channel Wireless Remote MTS Stereo Converter-Full Feature Decoder Compatible	\$129.95

MISCELLANEOUS

OAK:	ECONO-3V Mini-Code	\$89.95
	ECONO-3V Mini-Code Vari-Sync	\$89.95
	ECONO-3V Mini-Code Vari-Sync Plus Auto On-Off	\$119.95
OAK:	Sine-wave Anti-Jammer Kit	\$39.95
JERROLD:	400 & 450 Handheld Transmitters	\$29.95
HAMLIN:	MLD-1200 Channels 2 or 3	\$99.95
NEW ITEMS:	Scientific Atlanta SA-3	\$129.95
GENERAL		
INSTRUMENTS:	VCU Amplified Video Switch Signal Amplifier	\$59.95

ALL UNITS GUARANTEED. QUANTITY PRICES AVAILABLE.

UNITED ELECTRONIC SUPPLY

P.O. BOX 1206 • ELGIN, ILLINOIS 60121 • 312-697-0600

HARDWARE HACKER

continued from page 79

to handle as many as several hundred users.

With the LAN of the eighties, each node uses a unique ID in a collision avoidance, token passing protocol. The node first checks to see if other traffic is present. If not, its own uniquely coded packet gets transmitted. Each packet is then repeated several times for the best possible error correction.

Each LAN node is also sophisticated enough that it continuously measures the network's signal-to-noise ratio. Should any communications problems develop, then an alternate signalling route is automatically selected.

Each node is extremely rugged and requires little maintenance. The nodes use zero electrical input power, by substituting an incredibly ingenious kinetic-energy-based transfer mechanism.

Along with your LAN of the eighties, a streaming tape drive using quite low-cost media is normally used to continuously and permanently record any and all traffic. Thus any message can be replayed at any time.

On the LAN of the eighties, operator training is extremely fast and ridiculously simple. Even a user in a very high-stress environment can master the entire LAN workings in approximately five seconds, since the entire system is hardware-based.

The LAN of the eighties has been thoroughly tested and debugged. So much so, that the total number of user hours to date ridiculously exceeds that of all of the other LAN networking schemes combined.

Yes, this network is so good that it's clearly the LAN of the eighties.

The **eighteen** eighties!

I am, of course, talking about the *Gamewell* fire-alarm telegraph system, otherwise known as that old mangy red box scunging away on the pole down the street. Patented over a century ago.

Deja Vu, anyone?

Hacking the handicapped

The personal computer has been the great equalizer for the handicapped, and we sure get lots of help-line calls on that topic. So this month, we've included a list of many of the organizations and resources involving special education, therapy, and whatever.

Both *Apple* and *Tandy* do have excellent special-education contacts and resources available, as do many ham-radio clubs.

New tech info

Field-programmable gate arrays and complex logic modules are starting to drop in price. They go far beyond your usual EPROM or PLA chips, and literally let you build your own custom IC's.

Three good resources to get you started are the *Exel Data Book*, that *Xilinx Programmable Gate Array Design Handbook*, and the *Monolithic Memories LCA Applications Handbook*.

R & D Electronics is a surplus outfit with some interesting products and excellent prices. Those in-

REGULATED LINEAR POWER SUPPLY



Computer Grade
+ 5VDC @ 3 Amps
+ 12VDC @ 6 Amps
- 5VDC @ 0.5 Amps
Bench Style/Great for Hobbyists

\$24 ea.

MAGNAVOX AMBER PC MONITOR

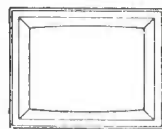

• 12" Tube
• TTL Level Digital VIDEO
• 20 MHz Bandwidth

\$55



Plug in WALL TRANSFORMER

Quantity Pricing Available

• 9.5 VDC @ 1 Amp *3.00
• 19 VAC @ 300 MA *1.50
• 25.4 VAC @ 300 Amp *1.95
• 14 VDC @ 200 MA *1.00

ASTEC POWER SUPPLY

MODEL #AA12690

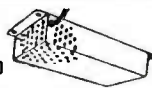

INPUT \$19.95 OUTPUT
1.15V 3.0 Amp + 5V 10 Amp
230V 1.5V Amp + 12V 2.5 Amp
50/60 HZ + 12V 5 Amp UN REG.
113 WATT. MAX. - 12V 0.25 Amp



HEAVY DUTY MOTOR

Heavy-duty reversible dual shaft 12 volt P.M. DC Motor. Ideal for Robots & Tools, etc.

\$2.95 ea.



COMMODORE 64 CARTRIDGES

• Dragons Den • Simon Basic
• Viduzzles • ABC Voice • Easycalc

\$1.50 ea.

TOY MOTORS

6 to 12 VDC

50¢ ea.



PATCH CORDS

3 Ft. dual RCA color coded, stereo cords



50¢ ea.



PLUG-IN POWER WALL SUPPLY

Triple Output
+ 5VDC @ .75 Amps
+ 12VDC @ .12 Amps
- 12VDC @ .12 Amps

2.99 ea.



COMMODORE KEYBOARD

C16 4 Plugs

\$2.95 ea.

FANS

115V - 3" & 4" *6.00
24V - 3" & 4" *6.00
220V - 3" & 4" *5.00



TERMS: Minimum order \$10.00
N.J. residents 6% sales tax added.
Please call for shipping charges.

GEI

GIANT ELECTRONICS INC.

19 Freeman St., Newark, New Jersey 07105

Toll Free: **800/645-9060**

201/344-5700

Fax # 201/344-3282

CIRCLE 203 ON FREE INFORMATION CARD

clude microwave amplifiers at \$2.50 each and step-pers for \$4.95. Ask for catalog #100.

We sure get a lot of requests for blue light-emitting diodes. It turns out that there are some fundamental physical laws that make blue LED's rather tricky to build.

So, yes, you can now run out and buy a blue LED. And the price is only a mere several hundred times higher than a green one. But if you really and truly want a blue LED for colorimetry, or instrument calibration, or whatever, Seimens will be happy to sell you their LBD5410. Its peak wavelength is 480 nanometers with a 6-mcd brightness.

If you are into most any sort of modelmaking, exhibit, or display activities, be sure to investigate the Fomebords people. Start with their *Pumping Foam* catalog that lists all types of interesting and mind-blowing materials.

Turning to my own products, if you want to create and sell your own hacker products or ideas, be sure to check out all the tested and workable insider stuff that's in my underground bestselling *Incredible Secret Money Machine* book.

As I've mentioned a time or two before, I've got a sister column to this one over in *Computer Shopper* that's heavily into desktop publishing, PostScript programming, Apple computing, tinaja questing, and various off-the-wall topics. A sampler of most of the previous columns are available as my *Ask the Guru* reprints. Included is lots of top-secret stuff.

And our *Hardware Hacker* reprints should shortly be available. Write or call for information. **R-E**

R-E Engineering Admart

Rates: Ads are 2 1/4" x 2 7/8". One insertion \$900. Six insertions \$875. each. Twelve insertions \$845. each. Closing date same as regular rate card. Send order with remittance to **Engineering Admart**, Radio Electronics Magazine, 500-B Bi-County Blvd., Farmingdale, NY 11735. Direct telephone inquiries to Arline Fishman, area code-516-293-3000. **Only 100% Engineering ads are accepted for this Admart.**

NO WAITING FOR COMPLETE, LOW PRICED, CHIP COMPONENT KITS

CC-1 Capacitor Kit contains 365 pieces, 5 ea. of every 10% value from 1pF to .33µF. CR-1 Resistor Kit contains 1540 pieces; 10 ea. of every 5% value from 10Ω to 10 megΩ. Sizes are 0805 and 1206. Each kit is ONLY \$49.95 and available for Immediate One Day Delivery!

Order by toll-free phone, FAX, or mail. We accept VISA, MC, AMEX, COD orders, or company PO's with approved credit. Call for free detailed brochure.



COMMUNICATIONS SPECIALISTS, INC.
426 West Taft Avenue • Orange, CA 92665-4296
Local (714) 596-3021 • FAX (714) 974-3420
Entire U.S.A. 1-800-854-0547

CIRCLE 176 ON FREE INFORMATION CARD

FCC LICENSE PREPARATION

The FCC has revised and updated the commercial license exam. The **NEW EXAM** covers updated marine and aviation rules and regulations, transistor and digital circuitry. **THE GENERAL RADIOTELEPHONE OPERATOR LICENSE - STUDY GUIDE** contains the necessary preparation for **ONLY \$25.00.**

WPT PUBLICATIONS
979 Young Street, Suite A
Woodburn, Oregon 97071
Phone (503) 981-6122

CIRCLE 181 ON FREE INFORMATION CARD

MIDI Projects

MIDI PROJECTS



BP182—MIDI interfacing enables any so equipped instruments, regardless of the manufacturer, to be easily connected together and used as a system with easy computer control of these music systems. Combine a computer and some MIDI instruments and you can have what is virtually a programmable orchestra. To get your copy send **\$6.95 plus \$1.25 for shipping** in the U.S. to **Electronic Technology Today Inc., P.O. Box 240, Massapequa Park, NY 11762-0240.**

SHORTWAVE RADIO

continued from page 39

factors affecting ionospheric behavior, then forecasting short-wave radio conditions would be simple. On any given day of the year, at any point on Earth, conditions would be about the same as they were on the corresponding day of the year before.

However, that is not the case, as conditions vary from year to year, and sometimes dramatically. The fact is that in addition to the regular variations, there is also a cyclical variation in the ionosphere which is approximately 10.7 years in duration. Caused by sunspots, that variation is the most influential factor affecting the ionosphere.

Sunspots have been observed with the naked eye for thousands of years. However, it was not until the discovery of the telescope, by Galileo in 1610, that recordkeeping of sunspot activity began. EMCredit for the discovery of the sunspot cycle goes to a German, Henrick Schwabe, a pharmacist by profession, and an amateur astronomer by avocation. Early in the nineteenth century he began a systematic study of sunspots. Painstakingly recording his observations on every day that he could see the sun, Schwabe gradually accumulated a great mass of data

over a period of some twenty years. By studying the results, he observed that the number of spots varied in a cyclical manner, being high some years, and low others.

In 1843 Schwabe published his findings, concluding that sunspot activity was cyclical in nature, varying from minimum to maximum and back to minimum again every eleven years or so.

Sunspots and their effect

Although scientists do not know precisely what causes sunspots, it is currently believed that they are generated by powerful magnetic fields deep within the sun. Those fields, which possess enormous quantities of energy, cause a turbulent, whirlpool-like motion of the gases within the sun. They eventually work their way to the sun's surface, carrying with them rapidly moving atomic particles, as well as radiation, principally in the form of ultra-violet light. Accordingly, sunspots are always associated with magnetic fields.

Sunspots generally appear in groups, and range in size from several hundred miles in diameter to as much as 80,000 miles across—a distance large enough to contain ten planets the size of Earth laid next to one another.

Sunspots and sunspot groups can be short-lived, lasting only a day or so, or they can exist for many months, remaining visible

on numerous successive solar rotations. It is for that reason, that radio storms that are associated with a particular sunspot group sometimes recur at 27-day intervals, coinciding with the rotation of the sun.

Sunspots and the ionosphere

Because ultra-violet radiation from the sun influences the condition of the ionosphere, and since sunspots are a primary source of ultra-violet radiation, it is clear that during years of high sunspot activity, the ionosphere will behave differently than during years of minimum activity. That situation is manifest primarily by the ability of the ionosphere to return higher frequencies to Earth during years of high sunspot activity than during minimum-activity years.

Inasmuch as relatively high sunspot numbers have been observed over the past several months, there has been a marked improvement in the amateur 10-meter band, the 11-meter citizens band, and in the 15-, 17-, 21-, and 26-MHz short-wave broadcasting bands.

Figure 1 shows how monthly mean sunspot numbers have varied from January 1945 to the end of 1987. It can be seen that a new sunspot cycle began in September 1986. How high will it go? What will be the impact on radio conditions?

Next time we will attempt to answer those questions.

R-E

A NEW KIND OF MAGAZINE FOR ELECTRONICS PROFESSIONALS

'386 POWER AT A '286 PRICE

Intel's 386XS

Page 86



BUILD A SYNERGY CARD

To improve your brain power

Page 90

BUILD A BIOFEEDBACK MONITOR

Learn to control your brain waves

Page 95

EDITOR'S WORK- BENCH

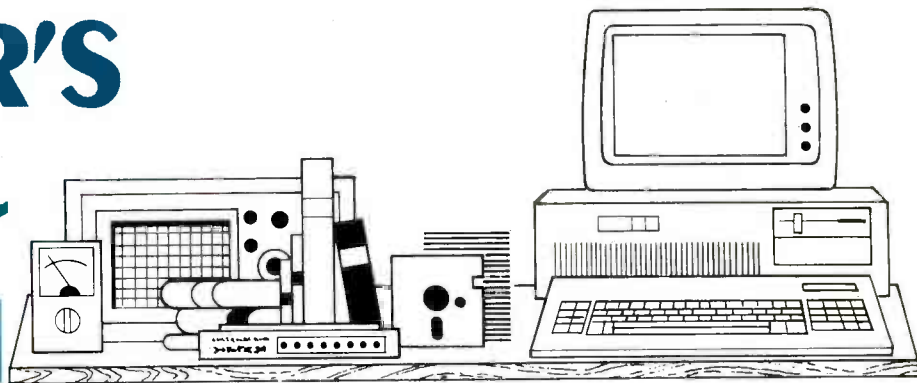

New chips, bus, and DOS; memory woes

Microprocessors are not normally exciting. After all, they're just dumb lumps of silicon, metal, and plastic.

But when a device is introduced that promises to overturn an already exciting industry, well, that's exciting.

The device, if you haven't already guessed, is Intel's 386SX. Long known in trade publications as the P9, the 386SX was formally introduced in mid-June. What's the big deal? The 386SX will allow manufacturers to build AT-priced personal computers that will run 386 software. That makes it the 386 for the rest of us.

To see the significance of the 386SX, you must understand PC history; here's a brief review. In 1981 IBM introduced the PC. Its operating system (DOS 1.0) was little more than a clone of CP/M, and the CPU it was built around (the 8088) has dominated software development ever since. The key features of the 8088 are an 8-bit data bus, 16-bit internal data paths and registers, and a 1-megabyte address space. The 8088 is really a down-scaled version of the 8086, which has a 16-bit data bus, but the two micro's are otherwise identical.

The AT was introduced in 1984; it uses a more powerful CPU, the 80286. The key features of the 80286 are a 16-bit data bus, 16-bit internal data paths and registers, a 16-megabyte address space, and a new mode of operation, called protected mode, that makes it easy (relatively speaking) to implement a multi-tasking/multi-user operating system. The problem was that DOS was unable to tap the advanced features of that IC, and it took IBM and Microsoft until April of 1987 to develop an appropriate operating sys-



tem: What we now know as OS/2. Of course, OS/2 has yet to achieve widespread acceptance.

Meanwhile, Intel was hard at work developing a new microprocessor that corrected the faults of the '286. The 80386 was introduced in 1985. With its 32-bit data and address buses, 32-bit registers, 16-MHz speed, built-in memory management, and a new mode of operation that allows a clean way of running multiple DOS sessions simultaneously, it represented a quantum leap over the 80286.

Since 1985, 20- and 25-MHz versions of the IC have been introduced, and every major manufacturer has introduced one or more PC's based on the 80386.

The funny thing is that speed is not the most exciting aspect of the 80386; it's the memory management and virtual mode that make budget-restrained users drool with envy.

We can't go into the technical details here (watch for in-depth coverage shortly), but here's an idea of what those features can let you do.

The 80386's paging mechanism allows you to map 4K blocks of memory anywhere in the 80386's 4-gigabyte (2^{32}) address space. So suppose you have a 512K motherboard and several megabytes of extended memory (memory located above the first megabyte). With appropriate software, you can re-map 128K of that extended memory down and have what appears to be a complete 640K machine. The point is that that happens at a level that DOS never knows about.

Further, with appropriate software, you can also emulate expanded memory using standard extended memory. The advantage is that plain extended memory boards can be built cheaper than expanded (or combination) boards. And some combination boards allow only a portion of the total memory to be used as expanded memory in a regular 80286 PC. On a '386, however, you could set the board up to be used just as extended memory, and let the '386 handle the rest.

You can also map memory into the "holes" in the upper address space (between DOS and the video adapter(s), and between the video adapter(s) and the 1-megabyte limit), and run programs there. For example, you could load your mouse driver, PRINT.COM, and a command-line editor there—or SideKick—or some other program. In that way, you can have your cake (RAM-resident programs) and eat it too (have about 600K of free memory for running programs. (A program called 386^{MAX} does all those things and more.)

That ability to fine-tune memory usage is what excites hackers and power users, and makes those of us on a budget lust for 386 power. And we haven't even talked about the virtual-8086 mode yet.

Like the 80286, the 80386 can operate in both real and protected modes. However, within protected mode is another mode that, in combination with the memory-paging mechanism discussed above, allows appropriate software to run several "virtual" 8086 machines simultaneously. It's as if you had several 8088 CPU's in one box, all sharing one keyboard and screen.

DESQview, OmniView, Windows/386, and VM/386 all use virtual mode and memory paging to let you create several virtual machines. VM/386, in fact, carries the concept so far that each "machine" may have its own CONFIG.SYS and AUTOEXEC.BAT files!

So what's the problem?

The problem is simply that 80386-based systems are expensive—often \$2000 or more above the price of a comparable AT-class machine. So a 386 system has been little more than a wish-list item for most of us.

The 386SX is going to help change that. It is to the 80386 what the 8088 is to the

8086: functionally equivalent, but with a narrower data bus—in this case, 16 bits. (Also, the address bus is only 24 bits wide, limiting memory to 16 megabytes.) Functionally equivalent means that virtual mode and memory paging work just the same on the 386SX as on its big brother. The initial version of the IC run at 16 MHz; it's expected that a machine based on it will cost \$700 to \$1000 less than a full 80386-based system.

Users after the utmost in speed will spurn the 386SX, because the "narrow" 16-bit data bus (which in reality is twice the width of the bus the vast majority of us use now) will allow half the throughput (more or less) of a full 32-bit bus.

For the rest of us, we who need flexibility more than speed, the 386SX is our ticket to the software of the future—whether it be OS/2, Windows/386, DESQview, OmniView, VM/386, or something we've yet to see.

386SX systems

Compaq, as you might expect, was the first to release a 386SX-based system. A stripped-down version (no hard disk or monitor) lists for about \$3800. Meanwhile, NEC, NCR, and AST have announced that they will be releasing 386SX systems soon, and you can bet that every systems manufacturer with any market savvy will jump on the bandwagon soon. Let's hope that greed will be held in check, (i.e., retail prices kept down) so that the maximum number of users will be able to afford the new 386SX-based technology.

New chips

Meanwhile, Intel is not resting on its laurels. Even though 25-MHz versions of the 80386 are still scarce, versions of the IC that run at 33 and 40 MHz are expected to ship in 1989, as are samples of the next generation: the 80486. That behemoth is expected to run very fast, and to include virtual '286 and virtual '386 modes. What could we do with multiple virtual 80386 machines? Let's see, there's DOS, Unix, OS/2, ...

Memory woes

A financial analyst who has just returned from the Far East (Japan, Korea, and Taiwan) says that, contrary to some speculation, we haven't seen the worst of the memory crunch yet. He expects things to continue as they have been for at least another year—and possibly two!

You may be surprised to know that it's not just the U.S. manufacturers who are suffering from the shortage; so are the Far Eastern manufacturers. In fact, just as some American manufacturers are claiming that the Japanese are getting preferential treatment from the major chip vendors, so are the Far Eastern countries

claiming that the U.S. is getting preferential treatment!

New DOS

Version 4.0 of DOS has been rumored for months, but it appears that the new operating system will be released this summer. It is expected to allow hard disk partitions greater than 32 megabytes, and to include extensive on-line help, a built-in file manager, and a graphic (i.e., Macintosh-style) user interface, most of which resides in extended memory on AT-class machines, leaving most of the "lower 640" free for applications.

Also, version 1.1 of OS/2 is due out in early fall. Version 1.0 has a text-based user interface; version 1.1 has a graphics-based interface called the Presentation Manager that is similar to Microsoft Windows. Presentation Manager requires more memory than version 1.0, so it will be interesting to see how development of new applications for PM proceeds.

New bus

AST got into the systems business less than two years ago, but the company is taking the industry by storm. First came the Premium/286, which includes a pair of special expansion slots called FastSlots into each of which a special memory card may be inserted; the card allows 10-MHz 0-wait state access to memory on the card. (Normal AT memory is accessed at 6 or 8 MHz with 1 wait state.) The company has also designed an 80386-based accelerator card for the FastSlot.

Next came the Premium/386, which includes a special high-speed memory slot of its own, and a new extension to the standard bus that allows intelligent expansion cards to access the bus (and memory on it) without help from the CPU. In that way, an intelligent disk controller, graphics coprocessor, network adapter or other device could operate much more efficiently.

In addition, AST's newest line of low-cost workstations contains special adapter bus modules for proprietary video controller cards. Use of the adapter module saves use of a regular slot.

Obviously, then, AST has quite a bit of experience designing computer buses. However, AST itself, Compaq, Zenith, Tandy, and nearly every other vendor of 80386-based machines has incompatible bus extensions to handle the 32-bit address bus of the 80386. Now AST is forming an industry coalition that will try to arrive at an alternative to, on the one hand, IBM's proprietary MCA bus (introduced with the PS/2 line in spring of 1987), and, on the other, the increasing number of non-standard extensions to the standard AT bus.

We applaud the company's efforts, and hope that they are successful. If

they're not, we'll pay the price, because without standards, third-party vendors won't know which systems to design for, so they won't design for any (or only the most popular), so there will be no price competition. Then we'll be forced to buy expansion products only from the original manufacturers, who will be able to charge whatever they want. Because AST sells both boards and systems, they stand to gain either way—shrewd.

In any case, it's in our best interests that someone creates a standard, and somehow convinces, cajoles, or coerces other manufacturers into adhering to it.



Screen Extender

WordStar has been our word processor of choice ever since CP/M days when it ran on a Z80 and a serial terminal. Even though other programs have surpassed it in popularity and sales, it is estimated that 28% of all users still use the venerable product. And many other products (SideKick, Turbo Pascal, dBASE, Quick BASIC) use the WordStar command set. Version 5.0 of WordStar is due out any day; meanwhile, Stairway Software has an inexpensive (about \$60) utility that allows anyone with a graphics video adapter (Hercules, C/GA, EGA, or VGA) to see more than an 80 × 25 matrix of characters.

Screen Extender does its magic by running the adapter in graphics mode, and by painting each character bit by bit. Depending on the adapter, you can get as many as 58 lines of 180 characters, although your eyes probably will not thank you for operating in that mode for very long.

Even so, some of the intermediate modes do allow you to see more of your file on-screen without straining your eyes. On a Hercules Monochrome Graphics Card Plus, we found either 34 or 43 lines of 80 or 90 characters viewable for extended periods of time. All WordStar commands work as expected, whatever the current dimensions of your screen.

It's easy to find the mode most suitable for your graphics adapters (and eyesight),

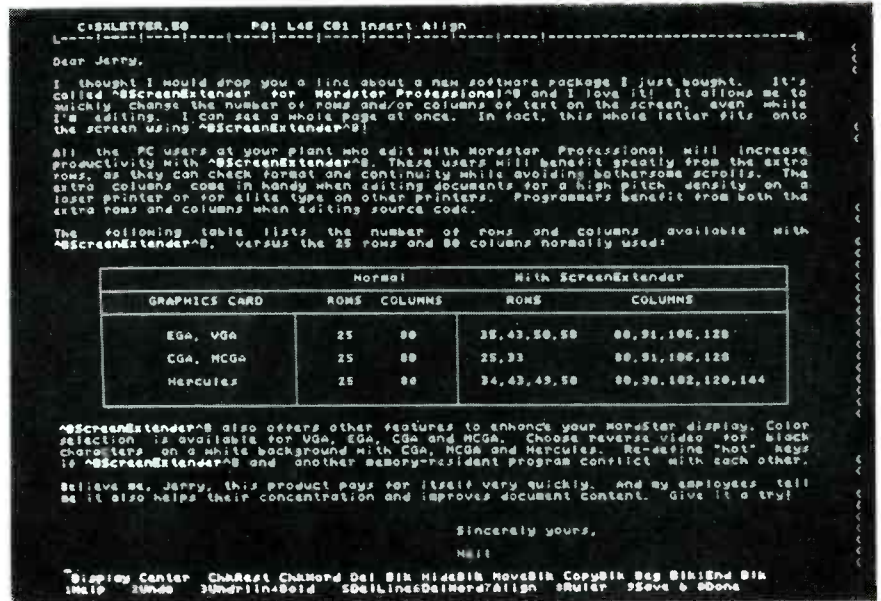

FIG. 2

because you can press Alt-M at any time to bring up a menu that allows you to set the horizontal and vertical dimensions (independently), screen colors, etc. You can change dimensions at any time, even while editing a file, and you can switch to the default 80 × 25 mode at any time by pressing Alt-S. When you find a setup you want to stick with, you can save it, and the program will come up in that configuration next time you use it. And the hot keys are definable.

Because the program operates in graphics mode, you expect some sort of slow-down. Surprisingly, it's not bad. (We tested the program on an IBM PC XT with a Microsoft Mach 20, an 8-MHz accelerator card.)

You load Screen Extender before WordStar; it occupies about 64K of memory. We found one bug: WordStar's undelete command did not function properly with Screen Extender installed. However, the company should have that ironed out long before you read this.

As shown in Fig. 2, a sample screen-displayed letter supplied with ScreenExtender illustrates and explains some of the salient features. For example, the chart shows the possible combinations of rows and columns available from the various graphics cards, while the sample letter itself discusses reverse video displays and the avoidance of conflicts with other memory-resident programs. Also, while you can't see it from our black and white reproduction, the sample letter shows some of the highlighting possibilities available from a color monitor, which includes reverse video—black characters on a white background.

Screen Extender is a neat product; if you want to see more text on-screen, you need it. The company is investigating

adapting Screen Extender to other word processors.

Dr. Shrink

We aren't normally tempted by "entertainment" software, but this time curiosity overwhelmed us. According to the company's literature, "With Dr. Shrink you can learn more about a person in 10 minutes than many people will find out in a lifetime. . . . Dr. Shrink will reveal any person's deepest, innermost secrets, hidden loves and hates, and private libidinal fantasies."

To evaluate someone, the program presents you with a series of about 50 descriptive adjectives (moody, emotional, brilliant, etc.) You must rate the applicability of each to the person you're evaluating on a scale of 1 to 4. Dr. Shrink then tabulates your responses, and prepares a textual report that purports to tell you how to understand that person and manipulate him or her to achieve your ends.

The report first rates your subject on a scale of 1 to 10 on the following characteristics: drive, reliability, sociability, cleverness, emotionality, and aggressiveness. Then it displays several paragraphs of information on the following topics: the subject's "public" image, the subject's "private" image, deepest emotions (loves and hates), sex fantasies, how to make friends with the person, and how to influence the person.

Is it serious? Does it work? It's certainly better than astrology; some of the reports have an astounding ring of truth, and, true or not, they're fun to read. Here's a sample on how to make friends: "To make friends with X, accept her worrisome ways.

Don't pressure her to be something that she is not or to do that which she is afraid of. She'll be miserable and as a result, you will be too. Be sympathetic to her seemingly endless ruminations. Understand that even though such things seem trivial, they are of paramount importance to her. Provide the security in her life that she requires by being there to listen when she needs a shoulder to lean on."

At \$50, Dr. Shrink may seem a bit expensive. But if it gives you an idea for dealing with that nagging mother-in-law (or boss), it'll be money well spent.

PC-File +

Database managers are plentiful these days. Indeed, the problem is not so much finding a good one, as choosing among many good ones. One that caught our eye recently is a new release of a shareware product that has slowly evolved over the years into an easy to use yet highly capable product. PC-File + is no competition for dBASE III Plus or Oracle, but for small- and medium-size jobs, you don't need all the power provided by the big packages. In addition, setting up and manipulating a database with PC-File + is so easy that you can literally save hours and hours of time.

Overview

A PC-File + database can have 70 fields per record, and 65,533 records per database. Maximum field length is 200 characters, except the last field in a database (called a "superfield") can have about 1.5K characters. The total length of a record cannot exceed 3000 characters, which would allow a total size of close to 200 million characters. The program requires 384K of RAM, two floppy disks (or one and a hard disk), and is not copy protected.

There are a number of features that make PC-File + easy to use. First is its 200 context-sensitive help screens, each of which provides a brief summary of current options. You can call up a help screen at any time by pressing Alt-H, or enter a "teaching mode" (by pressing Alt-T) in which the help screens pop up automatically depending on what you're doing. If the help window obscures valuable screen information, you can simply move it using the cursor keys. That's a nice touch.

Creating data input screens is simple; you simply "paint" your field names and lengths on the screen where you want them to appear. Or if you don't want to do that, you can simply tell PC-File + field names and lengths, and the program will do it for you.

In a similar manner, you can obtain

PRODUCTS DISCUSSED

- 386^{MAX}, Qualitas, 8314 Thoreau Drive, Bethesda, MD 20817-3164. (301) 469-8848.
- DESQview, Quarterdeck Office Systems, 150 Pico Blvd., Santa Monica, CA 90405. (213) 392-9701.
- OmniView, SunnyHill Software, P.O. Box 33711, Seattle, WA 98133-3711. (206) 367-0630.
- Windows/386, Microsoft Corporation, 16011 N.E. 36th Way, Box 97017, Redmond, WA 98073-9717. (206) 882-8080.
- AST Research, 2121 Alton Avenue, Irvine, CA 92714. (714) 863-1333.
- Intel Corporation, 3065 Bowers Avenue, Santa Clara, CA 95051. (408) 765-8030.
- Screen Extender, Stairway Software, 700 Harris Street, Suite 204, Charlottesville, VA 22901. (800) STAIRWAY, (804) 977-7770.
- Dr Shrink, Neuralytic Systems, 66 Bovey Road, Suite 325, San Mateo, CA 94402. (415) 573-9001
- PC-File +, Buttonware, Inc., P.O. Box 5786, Bellevue, WA 98006. (800) 528-8866.

printed reports in one of several default formats, or you can define your own highly customized report. You can define as many report formats for each database as you wish. Reports can include calculated fields, time and date information, sub-totals and totals, headers and footers, information from other files, etc.

You can set up complex Boolean search equations to select just the data you want—e.g., everybody from the state of California whose balance is greater than \$100 and is more than 90 days past due. You can also display and print bar graphs, pie charts, line and scatter charts. (Hercules, CGA, and EGA video adapters are supported.)

Like searching, sorting is quite powerful. You can sort on as many as ten fields simultaneously, in ascending order, descending order, or both. Unusual features include the ability to sort numbers in scientific-notation format, to sort roman numerals, to perform a Soundex sort (wherein fields that sound alike will be sorted next to one another), and more.

A separate program (PC-Label) that is part of the package allows you to print mailing labels from a PC-File + database, comma-delimited form, and others.

Other small but useful features include password protection, a pop-up calculator, keyboard macros, and support for a math coprocessor, if one is present. (If not, a co-processor can be easily added; it simply snaps in.) The program can be customized via an ASCII profile file read at startup or at any time later. Different sets of keyboard macros can be loaded at any time.

The real world

Ease of use is not determined solely by a program's internal features, but also in how it interacts with the outside world. Here again, PC-File + is outstanding. You can convert files to and from many different formats, including dBASE, 1-2-3, WordStar, and several others. So, for example, if you've been keeping a mailing list in a WordStar MailMerge file, you can easily import it into PC-File + to obtain the advantages of a real database. On the other hand, if your needs outgrow PC-File + 's capabilities, you can export it to dBASE.

For custom applications, you may want to access a PC-File + database yourself. Doing so is easy, even for inexperienced programmers, because the manual provides example programs in several languages (BASIC, Pascal, C).

All that power costs under \$70, about 10% of what dBASE III Plus costs. That's for a registered copy with a bound, typeset copy of the manual. Evaluation copies of PC-File + are also available on BBSes nationwide (including ours—call (516) 293-2283 at 300/1200 baud, 8 data bits, 1 stop bit, no parity), the Source, and CompuServe. If you download the program and decide you like it, please don't forget to register, because registration ensures that you will be notified of updates and associated software when available. 

Try the

**Radio
Electronics**

**bulletin board
system**

**(RE-BBS)
516-293-2283**

**The more you use it the more
useful it becomes.**

**We support 300 and 1200 baud
operation.**

**Parameters: 8N1 (8 data bits, no
parity, 1 stop bit) or 7E1 (7 data
bits, even parity, 1 stop bit).**

**Add yourself to our user files to
increase your access.**

**Communicate with other R-E
readers.**

**Leave your comments on R-E with
the SYSOP.**

**RE-BBS
516-293-2283**

PART II

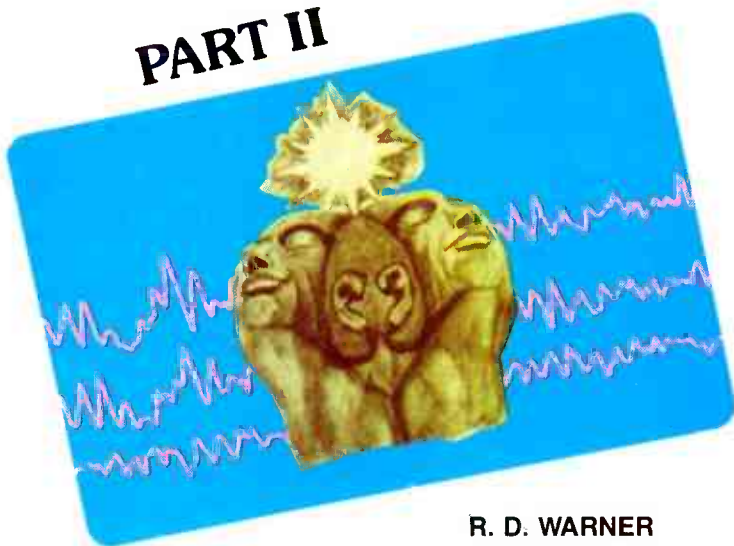

R. D. WARNER

BUILD A SYNERGY CARD FOR YOUR PC

This month let's build the Synergy Card.

Last month we discussed the concepts of hemisphere synchronization (HS) and frequency-following responses (FFR) in the brain. Those terms refer to a technology that uses audio signals to influence brain function. This time we'll show you how to build an expansion card for IBM PC's and compatibles. The Synergy Card can generate sound effects and musical notes, as well as HS signals. In addition, the card has a number of digital I/O lines that can interface your PC to bio-monitoring equipment. With those capabilities, the Synergy Card may be used for research into the affects of sound waves on psychological states.

Circuit overview

First let's look at the block diagram shown in Fig. 1. The address decoder (IC1-IC3) determines where in the micro-

TABLE 1: Memory MAP

Address	Device	Port
D000:FFF8	PPI 0	Port A - PSG 0
D000:FFF9	PPI 0	Port B - PSG 1
D000:FFFA	PPI 0	Port C - PSG 0,1 Ontl
D000:FFFB	PPI 0	Control Register
D000:FFFC	PPI 1	Port A -IO
D000:FFFD	PPI 1	Port B - PSG 2
D000:FFFE	PPI 1	Port C - IO, PSG 2 Cntl
D000:FFFF	PPI 1	Control Register

processor's address space the Synergy Card will respond. The card is built around two standard parallel ports; the ports consist of two 8255's (IC5 and IC6), each of which has three bi-directional 8-bit ports. The 8255 is commonly used in PC's and compatibles.

The 8255's drive three Programmable Sound Generators (PSG's, IC7-IC9), which we introduced last time. One bit of IC6 also drives an output relay, which may be used to control the motor of an external cassette recorder. The remaining I/O lines of IC5 are available at J2 for external use. The analog outputs of the PSG's drive a stereo amplifier, and the 48 digital outputs available from the three IC's are not used at all by the Synergy Card. Those outputs aren't brought to a connector on the PC board; but instead, for experimental purposes, we soldered a ribbon cable to the appropriate pins on the foil side of the PC board.

Unusually, the Synergy Card's I/O ports are not decoded in the CPU's I/O address space, but in main memory where programs run and data is stored. This is known as memory-mapped I/O, a technique usually reserved for "6" family processors (68000, 6502, etc.) Memory-mapped I/O is used because Intel supplies few machine-language instructions for manipulating I/O ports, but many for manipulating main memory. The memory instructions could be simulated using the simple I/O instructions, but speed requirements preclude such simulation.

As shown in Table 1, the Synergy Card's I/O ports are mapped to the eight memory addresses ranging from

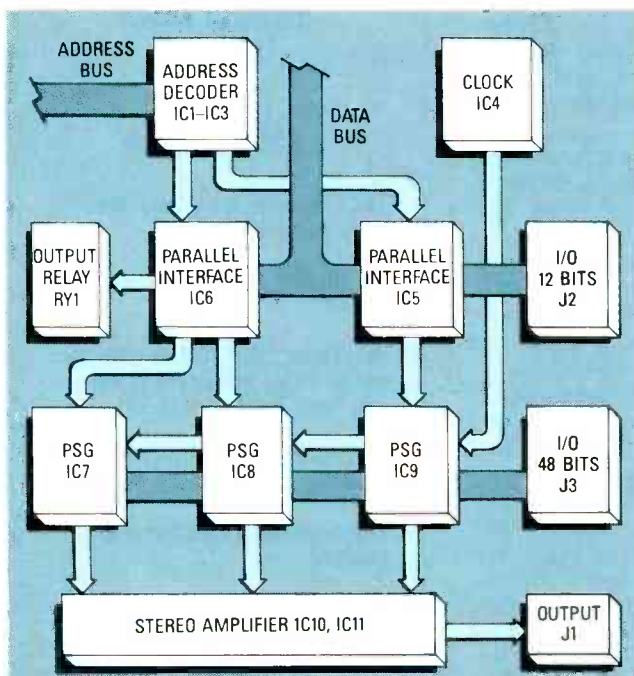

FIG. 1—HEMISPHERE-SYNCHRONIZATION SIGNALS, sound effects, and multi-part music may be synthesized with the inexpensive circuit outlined here.

D000:FFF8 to D000:FFFF. Address lines 5–7 are not decoded, so the circuit actually responds to addresses in the range D000:FF18 through D000:FFFF. In binary this appears:

1101 1111 1111 XXX1 1000 to
1101 1111 1111 XXX1 1111.

Because A5–A7 are not decoded, each register appears every eight locations (18, 20, 28, etc.). However, our software always addresses the F8–FF offsets. Also, because the Synergy Card is memory-mapped, make sure that no other card (especially EMS cards and network adapters) installed in your PC uses memory in the D000 segment. Otherwise the resulting address contention may well crash your machine.

Each of the Programmable Peripheral Interfaces (PPI's, IC5 and IC6) has 4 registers: one each for the three ports (A, B, C), and a control register for setting operating mode, so that's why eight addresses are required.

The complete schematic is shown in Fig. 2; let's discuss the address decoder first. As shown, IC1 and IC2 enable IC3 when an address in the range specified above is accessed. Assuming IC3's B and C (A3 and A4) inputs are high, the $\overline{y6}$ or $\overline{y7}$ output goes low, depending on the state of the A (A2) input. When A2 is high, IC5 is selected; when A2 is low, IC6 is selected. The low-order address lines (A0 and A1) then address the desired register in the selected 8255.

The 8255 has many modes of operation; the desired mode is set by placing highs on A0 and A1, and then writing a value to the control register. (Consult Intel's *Microsystem Components Handbook*, Volume II, for more information on the 8255.) In our software, the PPI's are programmed in Mode 0, so all pins function as outputs. To use any of the I/O pins available at J2 as inputs, you'll have to program a different mode. We'll discuss programming in detail next month.

In Mode 0, a value written to one of the 8255's ports (A, B, or C) will be latched on the corresponding output pins,

TABLE 2: PSG Control Registers

BDIR	BC2	BC1	Name	Description
0	0	0	NACT	Inactive
0	0	1	ADAR	Latch register address
0	1	0	IAB	Inactive, data lines high-Z
0	1	1	DTB	Read from PSG
1	0	0	BAR	Latch register address
1	0	1	DW	Inactive
1	1	0	DWS	Write to PSG
1	1	1	INTAK	Latch register address

TABLE 3: PSG Register functions

Registers	Function
R0–R5	Program tone periods
R6	Program noise period
R7	Enable noise and/or tone on selected channel
R8–R10	Select fixed or envelope-variable amplitude
R11–R13	Envelope period and shape
R14	I/O Port A
R15	I/O Port B

PARTS LIST

All resistors are 1/4-watt, 5% unless otherwise noted.

R1–R3—1000 Ohms
R4, R5—500 Ohms
R6, R7—68,000 Ohms
R8, R9—15,000 Ohms
R10, R11—10 Ohms
R12, R13—10,000 Ohms Trimmer Potentiometer
R14, R15—27,000 Ohms

Capacitors

C1, C2—330 pF, mica
C3, C4—2.2 μ F, 15 volts, tantalum
C5, C6—0.01 μ F, ceramic disc
C7, C8—10 μ F, 15 volts, tantalum
C9, C10—0.1 μ F, 15 volts, tantalum
C11, C12—0.047 μ F, ceramic disc
C13—22 μ F, 15 volts, tantalum
C14–C18—0.1 μ F, 15 volts, tantalum
C19, C20—220 μ F, axial, 15 volts, electrolytic

Semiconductors

IC1—74LS30N, 8-input NAND gate
IC2—74LS10P, triple 3-input NAND gate
IC3—74LS138, 3-to-8 decoder
IC4—1.8432-MHz, clock
IC5, IC6—8255A-5, programmable peripheral interface
IC7–IC9—AY-3-8910A, programmable sound generator
IC10, IC11—LM386N-1, audio amplifier
Q1—2N3904, NPN transistor

Other components

J1—9-pin "D" connector, PC mount
J2—15-pin "D" connector, PC mount
RY1—5-volt SPST reed relay (Radio Shack)

Miscellaneous

Metalized hood for 9- and 15-pin connectors.
Shielded plugs and cables for stereo hookup.
3/32" plug for cassette remote jack.

Note: The following are available from Perceptual Research Ventures, P.O. Box 20151, Missoula, MT 59801: Etched, drilled, tin-plated, and silk-screened PC board (PR-10), \$36.00; assembled, tested, and coated card (PR-48), \$319.95; custom cabling (PR-8), \$28.95; Sleep Lab software, compiled, runs card as a background task, leaving CPU free for other work, (PR-100), \$25. Unfortunately, due to FCC regulations, the assembled and tested unit may be sold only to qualified research institutions. All orders add \$5 for postage and handling.

where an attached PSG can then read the signal at its more leisurely pace. Port C of each PPI may be divided into two independent four-bit ports, and that is done here, for purposes of driving the control lines of the PSG's.

Each PSG has three control lines (BDIR, BC1, and BC2) that tell it what to do. Table 2 shows the actions that result from driving those lines in various combinations. Basically, the IC has four states: Inactive (000), Latch Register Address (111), Read Register (011), and Write Register (110). In the inactive state, the IC's data lines are in a high-impedance state.

To understand the other states, recall from the block diagram of the IC shown in Fig. 1 last time that the PSG has 16 registers that control operation. To access one of those registers, first its address must be latched by placing that address on the PSG's D0–D7 inputs, and then forcing the three control lines high (i.e., entering the Latch state). Then

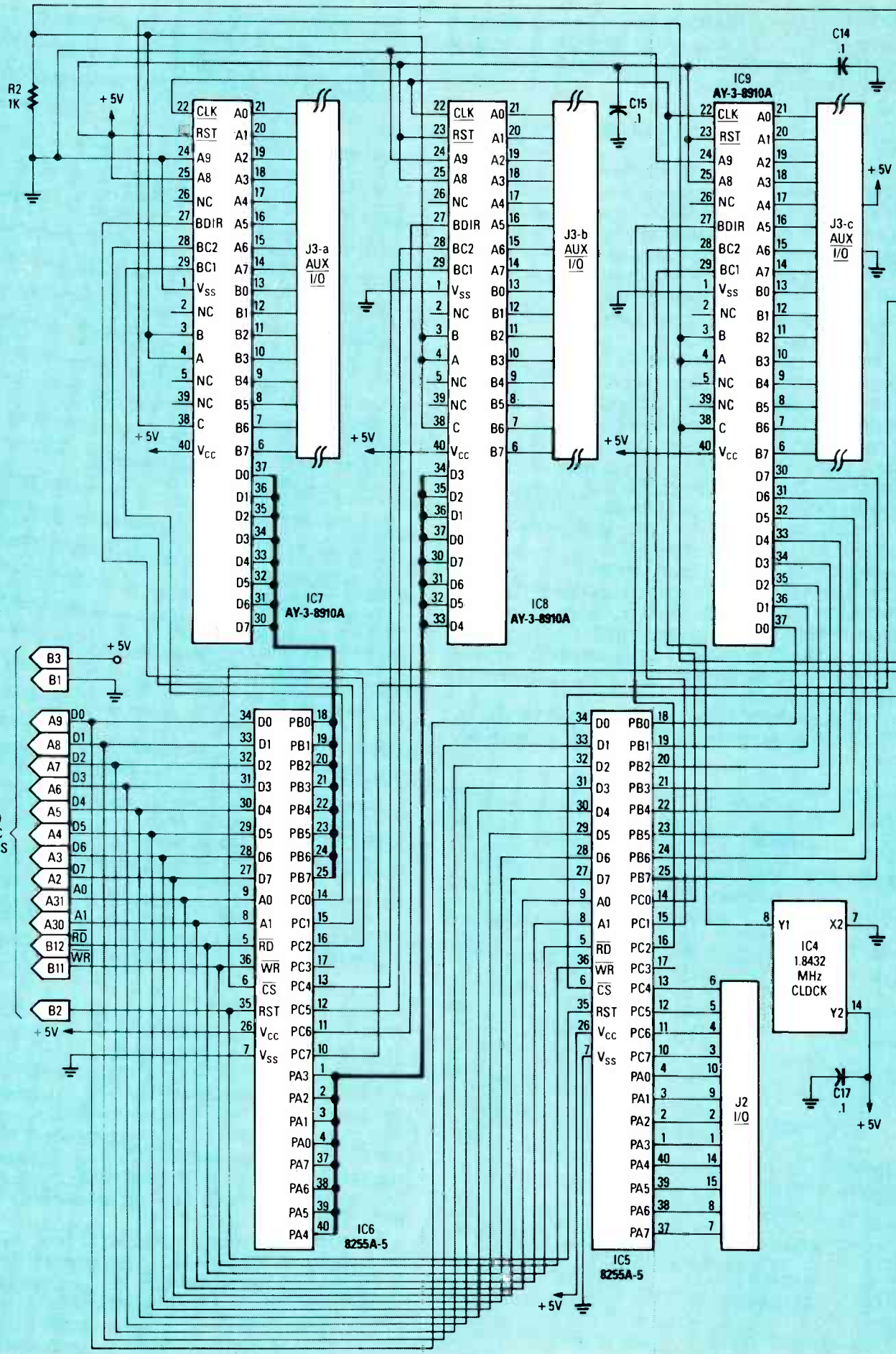

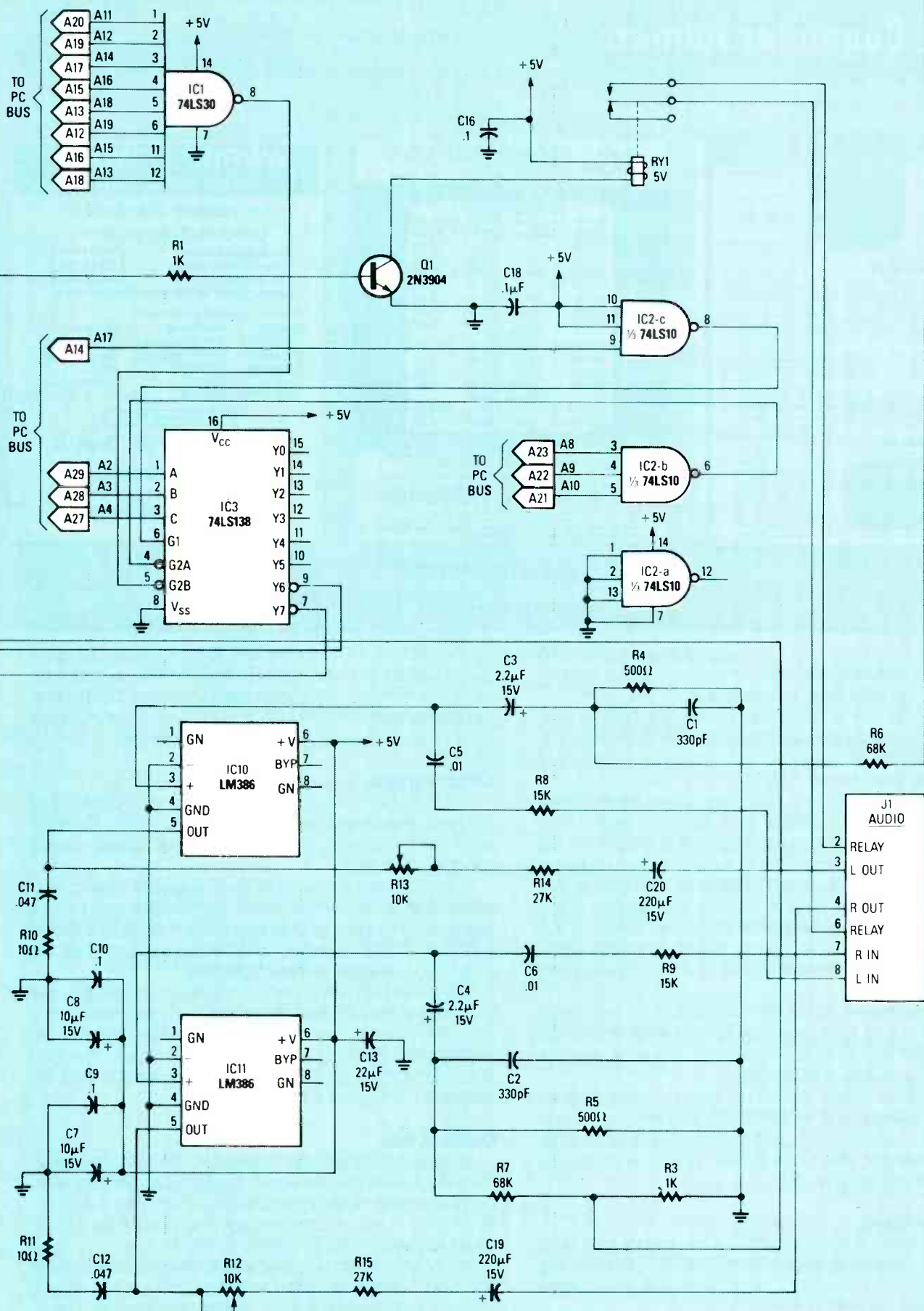

FIG. 2—COMPLETE SCHEMATIC DIAGRAM of the HS generator. The 8255's (IC5 and IC6) are memory-mapped, not I/O-mapped; they control the three programmable sound generators (IC7-IC9).

R-E Computer Admart

Rates: Ads are 2 1/4" x 2 7/8". One insertion \$900. Six insertions \$875. each. Twelve insertions \$845. each. Closing date same as regular rate card. Send order with remittance to Computer Admart, Radio Electronics Magazine, 500-B 3i-County Blvd., Farmingdale, NY 11735. Direct telephone inquiries to Arline Fishman, area code-516-293-3000. Only 100% Computer ads are accepted for this Admart.

DIGITAL VOICE CARD (DVC)
for IBM PC, XT, AT and compatibles

PC SPEAKOUT
The DIGITAL VOICE CARD from Computer Age Ltd. provides a complete solution for your voice message management.

- Store voice data on PC memory at 2K or 4K bytes per second.
- Store up to 170 minutes on hard disk, 300 seconds on floppy.
- Digitize voice at 32K bits per second, 10 bits AD/DA.
- Interrupt and DMA support allows concurrent operation with your normal programs.
- Include software drivers for BASIC, C, PASCAL, and DBASE.
- Include Record and Play Demo, Message Reminder programs. Ready to use.

APPLICATIIONS YOU CAN USE:

- Voice alarm and reminder for busy executives
- Telephone message store and forward.
- Send your voice mails on a floppy or through a modem.
- Speech analysis and voice synthesis
- Voice message management in store, factory, office and hospital.
- Computerized security and monitoring system.
- Sales, exhibit presentation.

DIGITAL VOICE CARD (DVC) \$95.00
MICROPHONE (MIC) \$12.00
3" SPEAKER (SPK) \$3.00

Standalone Digital Voice Recorder (DVR) \$89.00 We accept Visa, MasterCard, COD cash. To Order Call Toll-free U.S.

1-800-263-7487

Computer Age Ltd.
P.O. Box 730
Nobleton, Ontario, L0G 1N0
(416) 859-0370

CIRCLE 196 ON FREE INFORMATION CARD

ICs PROMPT DELIVERY!!!
SAME DAY SHIPPING (USUALLY)
QUANTITY ONE PRICES SHOWN for JULY 12, 1988

OUTSIDE OKLAHOMA: NO SALES TAX!

DYNAMIC RAM		
SIMM	1048Kx9	100 ns \$550.00
1Mbit	1048Kx1	100 ns 37.50
41256	256Kx1	60 ns 14.25
41256	256Kx1	80 ns 13.95
41256	256Kx1	100 ns 13.50
51258	* 256Kx1	100 ns 13.50
41256	256Kx1	120 ns 12.95
41256	256Kx1	150 ns 11.50
41264	+ 64Kx4	120 ns 16.95
EPROM		
27C1000	128Kx8	200 ns \$37.50
27C512	64Kx8	200 ns 13.95
27256	32Kx8	250 ns 7.25
27128	16Kx8	250 ns 6.60
STATIC RAM		
43256L-10	32Kx8	100 ns \$18.50
6264P-12	8Kx8	120 ns 13.75

SAT DELIVERY INCLUDED ON FED-EX ORDERS RECEIVED BY: Th: 9A-3P, Su: 9A-3P, Fr: P: 1 \$16.25 1.8

MasterCard/VISA or UPS CASH COD
Factory New, Prime Parts, JPL
MICROPROCESSORS UNLIMITED, INC.
24,000 S. Peoria Ave., (918) 267-4961
BEGGS, OK 74421
No minimum order. Please note that prices are subject to change. Shipping & insurance extra, & up to \$1 for packing materials. Orders received by 6 PM CST can usually be delivered the next morning, via Federal Express Standard Air or \$6.00, or guaranteed next-day priority One or \$10.25!

OPEN 6 1/2 DAYS, 7:30 AM-10 PM. SHIP VIA FED-EX ON SAT.
WE EXPORT ONLY TO CANADA, GUAM, PUERTO RICO & VIRGIN ISLANDS

CIRCLE 61 ON FREE INFORMATION CARD

WORDFORWORD
PROFESSIONAL

The Industry Standard in document conversion.

- Two way conversions
- Preserves all formatting
- Fast and menu-driven
- Special "Smart" ASCII retains page formatting

\$149.00

Supports conversions between:

WordStar	WordPerfect	MultiMate
PFS: WRITE	PFS: First Choice	PFS: Pro Write
OfficeWriter	IBM Writing Asst.	Microsoft Word
Volkswriter	DCA/RFT	ASCII
XyWrite	EBCDIC	"Smart" ASCII
DisplayWrite	Navy DIF	

LAN Version \$299

Call 800-624-6107, Dept. R

MASTERSOFT, INC.
4621 N. 16th ST.
PHOENIX, AZ 85016

CIRCLE 197 ON FREE INFORMATION CARD

the desired read or write may be performed by placing the correct signals on the control lines and either reading or writing the data lines, as desired.

As for what the registers themselves do, Table 3 indicates briefly the functional groupings. For more information, consult the *Microelectronics Data Catalog* published by General Instrument.

The control lines of the PSG's are driven by the three least-significant bits (LSB's) of each nibble of each C port of the two 8255's. The lower nibble of IC6 (pins 14-16) controls IC7, the upper nibble of IC6 (pins 13-11) controls IC8, and the lower nibble of IC5 (pins 14-16) controls IC9. The "extra" (upper) nibble in IC5 may be used for I/O; it appears at J2. The unused bit in the upper nibble of IC6 drives transistor Q1, which in turn controls the relay (RY1). The unused bit in the lower nibble of IC6 is not used and is not connected.

The A and B ports of the PPI's drive the PSG's in a similar manner. Port B of IC6 drives IC7; Port A of IC6 drives IC8, and Port B of IC5 drives IC9. Port A of IC5 may be used for I/O, and is available through J2.

Counting the sixteen bits of I/O that are available from each PSG (making a subtotal of 48), and the twelve bits from Ports A and C of IC5, that makes a grand total of 60. All bits from the PSG's, along with power and ground signals, are available at J3.

Analog outputs

Looking at the output of the PSG's, five voices are mixed (A, B, and C from IC8, and A and B from IC7) to drive the left channel, and four (A, B, and C from IC9, and C from IC7) to drive the right channel.

Each channel has its own LM386 audio amplifier; IC11

for the right, and IC10 for the left. Also, external high-level audio signals may be mixed with the PSG outputs by applying them to the appropriate inputs of J1. The two trimmer potentiometers (R12 and R13) control the output level of each channel. Set each to mid-range.

Other circuits

The relay (RY1) may be activated by driving Port C7 of IC6 high. That turns Q1 on, which then activates the reed relay. The PPI cannot source or sink enough current to drive the relay directly.

The PSG's have a maximum clock speed of 2-MHz, and rather than try to divide down the motherboard clock signal, we included an onboard clock module. It delivers a TTL-compatible signal at 1.8432-MHz, and can drive the three PSG's directly without buffering.

The power-up (and reset) sequence is as follows. The RESET lines of the PPI's are connected to the motherboard's RESET line. When a reset occurs, the PPI control registers are cleared, and all ports are configured as inputs. The RESET lines of the PSG's are simply tied high; those IC's must be properly configured through software.

Construction

An etched, drilled, and plated PC board is available from the source mentioned in the Parts List. You can also build your own board using the foil patterns we'll show in PC Service. Another option would be to wire the circuit on a prototype card designed for the PC bus.

The only problem is, is that you're going to have to wait until next month to actually build the Synergy card. At that time we will give you the foil pattern and the Parts Placement, and discuss the necessary software. **▶◀**

BUILD A BIOFEEDBACK MONITOR

JIM BARBARELLO



Feeling tense? Then let your computer calm you down.

Although most persons think of the IBM PC primarily as a business computer that grinds its way from 9 to 5 through spreadsheets, databases, and documents, it can also be made to serve other, quite-different roles. One such application is as a computer-assisted biofeedback monitor.

Biofeedback is the process of monitoring a biological function that indicates your level of tenseness, and then feeding back that information to you in real time. By allowing you to see what happens when you try to relax, biofeedback lets you discover the techniques that work best for you. You can then practice those techniques to gain more control over daily tension and stress.

One biological function that indicates tenseness is your galvanic skin response, usually called simply GSR, which in non-medical terms simply means the resistance of your skin. As you become more tense, your rate of perspiration increases, thereby lowering the resistance of your skin. As you become less tense—as you “calm down”—the perspiration rate slows and your skin’s resistance increases. A variation from your normal or average GSR is therefore an accurate biofeedback indicator of how tense or calm you are at a given instant in time. If you then use a computer to store a record of how tense or calm you were over a period of time, the same computer can provide you with a listing or a graphic display of the effectiveness of your efforts at reaching mental nirvana.

Measuring GSR

The easiest, and certainly the most simple way to measure GSR would be with an analog resistance-measuring device such as an ohmmeter. Unfortunately, analog measurements are not well-suited to digital computers. There is, however, a surprisingly simple alternative. By using a circuit that generates a digital pulse whose duration is proportional to a resistance, we can use a computer to measure the length of the pulse and then interpolate the pulse-length into a resistance value. That approach forms the basis for a biofeedback monitor for IBM PC-type computers. The monitor’s schematic is shown in Fig. 1.

Integrated circuit IC1 is a 555 timer that is configured as a simple pulse generator. The width of its output pulse is

the product of capacitance C1, resistance R1, and the skin resistance present between probes A and B. Since C1 and R1 are constant, any change in the pulse width is the direct result of a change in the resistance between probes A and B. Now all we need to do is to trigger IC1 to force its output, output pin 3, high, and measure the period of time until the output on pin 3 goes low (returns to ground—the end of the pulse).

The printer port

It may seem strange, but the computer’s LPT1 parallel-printer port is the ideal way of interconnecting the biofeedback monitor to the computer. The PC’s printer port has a number of input and output lines that are normally used to do things like initialize the printer and check for a busy status. Connector PL1 attaches to the PC’s printer port. Pin 16 of the connector, the *INIT* line, connects to IC1’s trigger input, pin 2. Sending out a short *INIT* pulse from the computer triggers IC1 and causes IC1’s output, pin 3, to go high. Pin 3 goes low at the end of the pulse.

Pin 11 of PL1 is the computer’s *busy* line. If we have the computer check for a low on pin 11, it will know when IC1’s pulse has ended.

The common ground between the computer and the biofeedback monitor is through PL1 pin 20. Switch S1 applies power to the circuit through series-connected

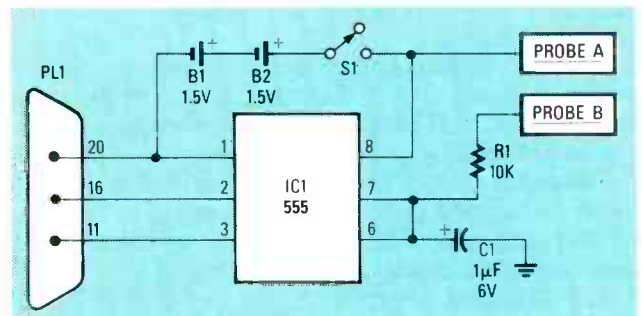

FIG. 1—THE PROBES ARE ACTUALLY FOIL STRIPS cemented to the top of the plastic case that houses the circuit. Because absolute stability is needed, batteries B1 and B2 should be secured by a holder, rather than be simply soldered into the circuit.

batteries B1 and B2. The batteries provide only 3 volts, so the output of IC1 will also be about 3 volts instead of the more usual 5 volts. Although 3 volts is much less than 5 volts, it is high enough to be sensed by the computer's printer port.

The software

The simplicity of the hardware is made possible by the fact that the software does most of the work in creating a screen display of your GSR. Let's look at some of the more important aspects of the program, called *PCBIO*, that is shown in Listing 1 and available on the REBBS (516-293-2283).

Line 30 looks to see if a printer port is installed and determines its address. Line 50 uses that information to set the addresses for the trigger input (T) and output (G) to the circuit. Line 190 begins the process of initialization. Since each person's GSR is different, the program takes five initial samples and averages them to determine a mid-range value (Y in line 220). Line 220 also calculates an increment value (INC) used to determine the range from full calm to full tense. Those range values are stored in array L in line 230.

The actual monitoring process begins in line 250. A call to the subroutine at line 320 gets a sample from the hardware as a count stored in variable X. Lines 280 and 290 determine where the tenseness indicator should be and places it there. The monitoring session ends when either full calm is reached ($L > 92$ in line 280) or when you press the esc key during monitoring ($C = 27$ in line 260).

The subroutine at line 320 interfaces with the hardware. Line 330 generates a short negative-going pulse to trigger IC1. Line 340 begins counting the time by incrementing variable X and checks to see if IC1's output has returned to zero ($INP(G) = 127$). When it does, line 350 checks to see if another sample should be taken ($Z < XF$). Variable XF is a scaling factor used to ensure that the count returned in variable X will always be above 100 (lower counts make the gauge displayed on the screen respond too quickly, and are distracting during the monitoring session). The commands `LOCATE 1,60:PRINT X;` in line 350 display the actual count number just past the title on the screen display. The number may be removed.

Construction

The circuit can be assembled on a small scrap of perforated wiring board, which is installed along with a battery holder in a Radio Shack 270-220, or similar, plastic case. Simply pass the components' leads through the appropriate holes and solder them together on the underside of the board.

Glue the battery holder into the case, as close as possible to one end. If you'd like to secure the circuit board, it, too, can be glued to the case with a drop of silicon rubber (RTV) adhesive or caulk.

The probes are simply two aluminum foil strips glued to the cover of the case; they are connected to the circuit by wires that run inside the case. Cut two strips of ordinary household aluminum foil to a size of $2 \times \frac{3}{4}$ -inch. Apply a drop of white glue to the dull side of the foil. Then, as shown in Fig. 2, place the foil (glue side down) on the cover of the case, smoothing out the foil and removing any excess glue that squeezes out with a damp cloth. Let the glue dry for at least one hour and then drill

LISTING 1

```

1 REM##      PC Biofeedback Monitor Program
2 REM##      NAME: PCBIO
3 REM##      c 1987, JJ Barbarello, Manalapan, NJ 07726
4 REM##      V870911
10 CLEAR:DEFINT G,X;G=0:X=0:DEFSTR A,B:A=CHR$(232):B=SPACE$(2)
20 COLOR 0,6,6:CLS:KEY OFF:WIDTH 80:DIM L(22)
30 DEF SEG=64:PA=PEEK(B)+256*(PEEK(9))
40 IF PA=0 THEN COLOR 7,0,0:CLS:GOTO 430
50 A=CHR$(232):B=SPACE$(2):G=PA+1:L=13:T=PA+2:LOCATE 1,23,0
60 PRINT STRING$(5,16);" P.C. BIOFEEDBACK MONITOR ";STRING$(5,17)
70 LOCATE 2,37:PRINT CHR$(201);STRING$(5,205);CHR$(187)
80 FOR I=3 TO 22:LOCATE 1,37:PRINT CHR$(204);B;A;B;CHR$(185):NEXT I
90 LOCATE 23,37:PRINT CHR$(200);STRING$(5,205);CHR$(188)
100 LOCATE 3,31:PRINT" TENSE ";CHR$(206)
110 LOCATE 13,29:PRINT" AVERAGE ";CHR$(206)
120 LOCATE 22,32:PRINT" CALM ";CHR$(206):PLAY "L64"
130 FOR I=3 TO 22:LOCATE 1,40:PRINT " P#="N"+STR$(60-I*2):PLAY P#;NEXT I
140 FOR I=22 TO 13 STEP -1:LOCATE 1,40:PRINT A:P#="N"+STR$(60-I*2)
150 PLAY P#:LOCATE 1,40:PRINT " ";NEXT I:LOCATE 13,40:PRINT A
160 LOCATE 24,22,1:PRINT" Press <ENTER> to begin, or <ESC> to end...";
170 AA=INPUT$(1):C=ASC(AA):IF C=27 THEN 400 ELSE IF C>13 THEN 170
180 LOCATE 24,22,0:PRINT SPACE$(42);
190 LOCATE 24,34:PRINT" INITIALIZING...";Y=0:PLAY"L64":XF=1
200 GOSUB 320:IF X<100 THEN XF=XF+1:PLAY "L64";N32=Y:GOTO 200
210 FOR I=1 TO 5:GOSUB 320:PLAY "L64";N34=Y=Y+X:NEXT I
220 Y=Y/5:INC=Y/100:LOCATE 24,28:PRINT" Press <ESC> to End Trial.";
230 PLAY"L32":LOW=Y-10*INC:FOR I=3 TO 22:L(I)=LOW+(I-2)*INC:NEXT I
240 REM## MONITORING
250 P#="N"+STR$(60-(L*2)):PLAY P#:IF X=0 THEN 360
260 AA=INKEY$:IF AA<>" " THEN C=ASC(AA):IF C=27 THEN 370
270 GOSUB 320
280 IF X>L THEN LOCATE L,40:PRINT " ":L=L+1:IF L>22 THEN 370 ELSE LOCATE L,40:PRINT A
290 IF X<L THEN L=L-1:IF L<3 THEN L=3 ELSE LOCATE L+1,40:PRINT " ":LOCATE L,40:PRINT A
300 GOTO 250
310 REM## SAMPLING SUBROUTINE
320 X=0:Z=0
330 OUT T,0:OUT T,4
340 X=X+1:IF (INP(G) AND 12B)=0 THEN 340
350 Z=Z+1:IF Z<XF THEN 330 ELSE LOCATE 1,60:PRINT X;:RETURN
360 REM## TRIAL END
370 LOCATE 13,8,1
380 PRINT" TRIAL COMPLETED. Press <ENTER> to try again, or <ESC> to end...";
390 AA=INPUT$(1):C=ASC(AA):IF C=13 THEN CLS:GOTO 50 ELSE IF C>27 THEN 390
400 COLOR 7,0,0:CLS:LOCATE 10,28,1:PRINT" MONITORING SESSION OVER"
410 LOCATE 13,1:END
420 REM## CAN'T FIND STANDARD PRINTER PORT
430 LOCATE 10,27,1 PRINT" PRINTER PORT 1 NOT AVAILABLE":PRINT:PRINT:END

```

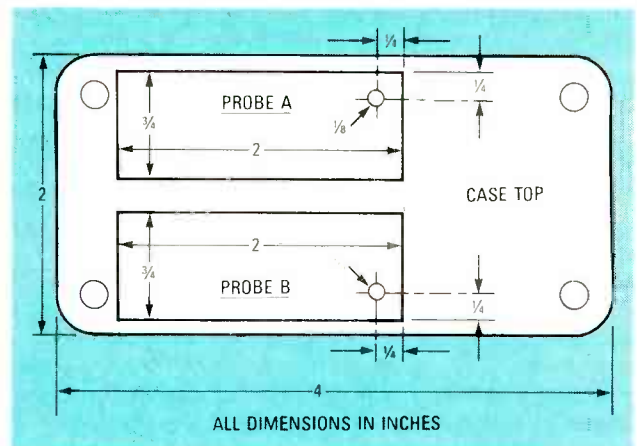

FIG. 2—IT'S NOT ALL THAT CRITICAL, but this kind of installation for the foil strips on the cover of the specified case will prove the most convenient for all sizes of hands and fingers.

two $\frac{1}{8}$ -inch diameter holes at the locations shown in Fig. 2. Place two 4-40 $\times \frac{1}{4}$ -inch machine screws through the holes and loosely screw a 4-40 nut onto each screw. Wrap the bare end of either of the wires from the circuit board

around either of the screws and tighten the nut. Repeat the procedure for the remaining wire and screw. Figure 3 shows how the prototype was assembled.

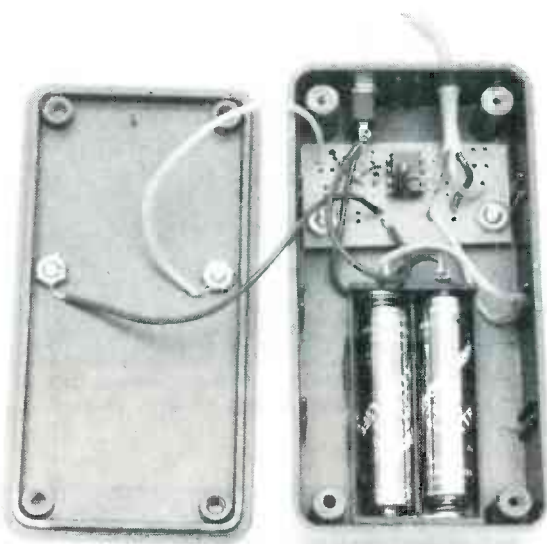

FIG. 3—THE COMPLETED PROTOTYPE. Notice how the wires to the foil strips simply connect to the screws that pass through the cover.

PARTS LIST

- IC1—555 timer
- R1—10,000 ohms, ¼-watt, 10% resistor
- C1—1 µF, 6-volt, Tantalum capacitor
- B1, B2—1.5 volt, AAA battery
- PL1—25 pin D-connector
- S1—SPST switch
- Miscellaneous—Plastic case, battery holder, perforated wiring board, wire, solder, machine screws, etc.

Note: A compiled, enhanced version of the *PCBIO* program is available on 5¼-inch diskette from JJ Barbarello, RD #3, Box 241 H, Tennent Road, Manalapan, NJ 07726. Price of \$7 includes postage and handling. NJ residents must add appropriate sales tax. If known, indicate the type of computer and its clock speed.

Using the monitor

Connect PL1 to your computer's parallel printer port, apply power to the monitor by closing S1, then load BASIC and the PCBIO program in your computer. When you run the program, the computer will create the screen shown in Fig. 4. In the center is a tenseness gauge resembling a thermometer. The top of the gauge is maximum tenseness, the bottom of the gauge is maximum calm, and the center of the gauge (where you begin) is average. The message on the bottom of the screen asks you to press ENTER to begin monitoring, or ESC to end the session.

The room you're in should be comfortable (about 70°F). Sit in a chair that provides good support and loosen any tight clothing. Place the biofeedback monitor next to you on a table or stand that can support the unit and your forearm. Make sure your fingers are free of oil or excess perspiration. Rest your forearm on the stand in front of the unit, place your first (index) finger on one probe and your second (middle) finger on the other probe. It is

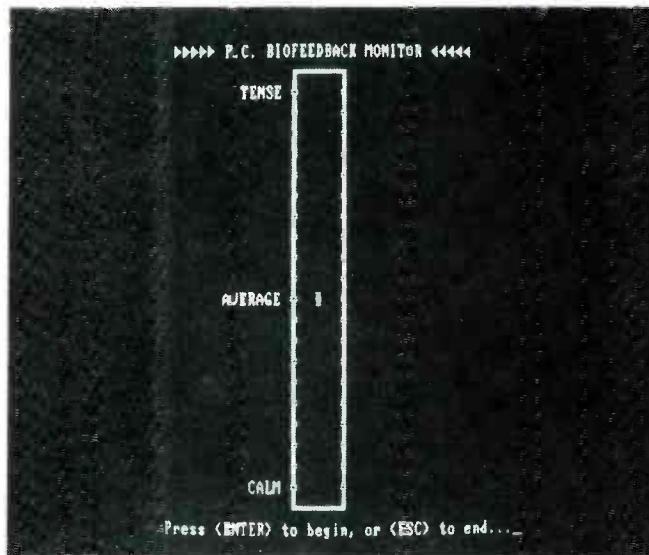

FIG. 4—THE OPENING SCREEN shows a thermometer-type device that ranges from calm to tense.

very important that you do not move your fingers or change the pressure on the probes during the monitoring session, as that will change the resistance between the probes and give a false reading.

Press the ENTER key with your free hand. The message on the bottom of the screen will change to "INITIALIZING" and you will hear a series of beeps as the system measures your initial level of tenseness. After a short time, the message on the bottom of the screen will change to "Press C to End Trial"; you are now monitoring your changing level of tenseness. That's indicated by the moving cursor in the middle of the gauge, and a beep with a changing tone. As you become more tense, the beeps frequency and the indicator ascend, as shown in Fig. 5. When you calm down, the beep's frequency and the indicator descend, as shown in Fig. 6. The session will end when you either press the esc key or reach maximum calm (nirvana?). The message "TRIAL COMPLETED. Press Enter to try again, or Escape to end" will appear in the middle of the screen. When you end the session, the

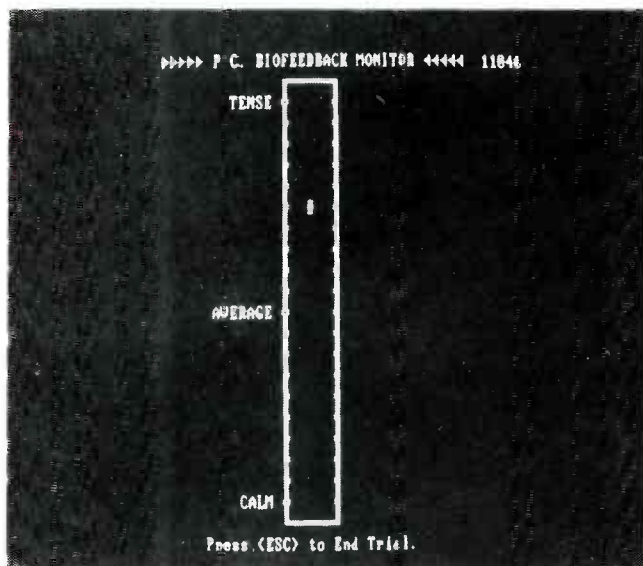

FIG. 5—IF YOU'RE TENSE, the indicator will slide up the thermometer and tone from the computer's speaker will rise in pitch.



FIG. 6—THE CALMER YOU GET the lower the indicator's position, and the lower the tone heard from the speaker.

screen will clear except for the message "MONITORING SESSION OVER."

To test the unit, begin monitoring. Press down hard with your two fingers to simulate increased perspiration (tension). The indicator should begin to rise. Release the pressure and note that the indicator begins to fall. Press esc to end the trial. When you are sure that the unit is working properly, you can begin actual monitoring.

You should now try to concentrate on different images or thoughts and note the results on the gauge. At first it may seem that trying to calm down actually increases tension. That is normal because the untrained mind tends to race through both conscious and unconscious thoughts. Through practice you will learn how to focus on the images and thoughts that actually decrease tension—disregarding everything else, and use them to assist you in your calming process.

Tweaking

The software monitoring subroutine is sensitive to the speed of your computer. The program listing contains the factor "IF X <100" in line 200 to adjust it for use on a standard 4.77-MHz computer. Computers operating at 8 MHz, or AT systems, will respond more quickly and produce a higher count for the same amount of time and seem to be racing along. To compensate for racing, simply change the "100" in line 200 to a higher number (try 300 as a starting value), and adjust it until you are comfortable with the speed).

Enhanced software

The program may have some difficulty with some versions of BASIC on floppy-disk-only systems. If that is the case, you will notice the indicator move very slowly when you initially run the program (normally the indicator zips down the gauge and then back up to "AVERAGE"). If you experience the problem, a compiled version of the program is available from the source given in the parts list. It is an executable program that runs in DOS and, thus, does not require the use of BASIC. The compiled program has also been enhanced to include storage and analysis of results: both lists and graphic plots. Figure 7 shows a

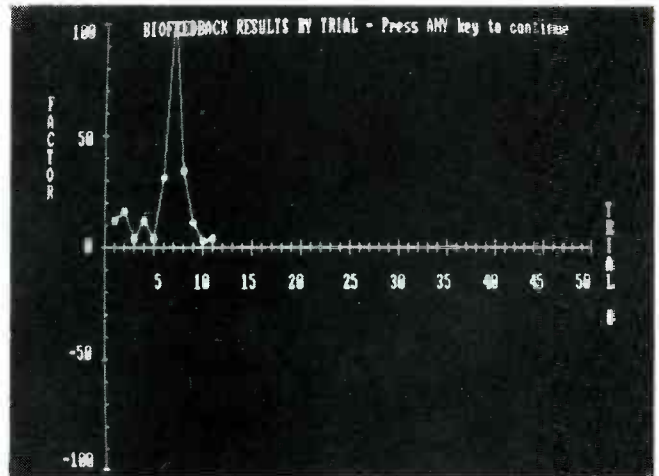

FIG. 7—THE COMPILED SOFTWARE will store and then graphically plot the results of a biofeedback session. This is the standard display.

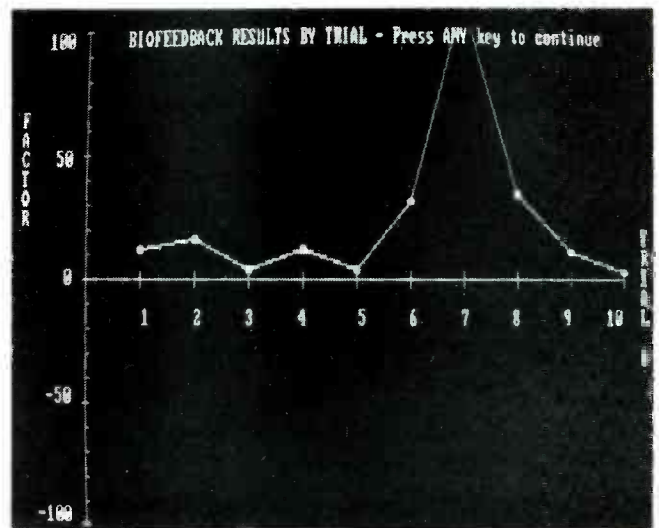

FIG. 8—FOR A MORE PRECISE EXAMINATION of your session, the plot can be expanded.

standard plot display of a monitoring session. Figure 8 shows the same session using the program's expanded plot feature.

Closing thoughts

The biofeedback monitor is basically just a self-learning type of device, that also happens to be a lot of fun. It is not meant to take the place of any necessary medical treatment or equipment. However, with practice, the device can help you learn how to reduce everyday stress and tension. Sooner or later you'll find that you do have the ability to mentally calm and relax yourself. It's just a matter of finding the technique that's right for you.

Another interesting point is that GSR is one measure that is used by polygraphs (lie-detector) to determine whether or not someone is lying. For that reason, the device can be used as a rudimentary "lie detector" for general entertainment at parties and gatherings. We're sure that you'll find many other interesting uses for the biofeedback monitor—perhaps you can even modify it so that you can monitor other bodily functions. If you do, why don't you drop us a note and let us know about." ♦♦♦

DRAWING BOARD



ROBERT GROSSBLATT,
CIRCUITS EDITOR

More on multiplexing

SOME TIME HAS GONE BY SINCE WE LEFT our discussion of display multiplexing. There was a bit of side-tracking so that we could answer in detail the copy-protection quiz, but now we're back on course. The last thing we talked about was why it was a good idea to consider multiplexing LED's when you have a bunch of them in your circuit. If you remember, the answer was

desire. That last one is usually a function of the current-limiting resistor in series with the LED.

Multiplexing a display makes a lot of sense. You can cut the current requirements, the amount of resistors needed, and, if you plan on making a PC board, you'll find that the trace complexity is usually reduced as well. Now, we all know that there's no way you can get

number of LED's you'll be using—the more LED's, the higher the frequency you'll need. We've already seen that the lowest frequency you can get away with is 24 Hz (the repetition rate used by projectors in a movie theater). If, for instance, you were dealing with a 10-LED display, you would want to make sure that each LED was turned on at least once every 24th of a second. Since there are ten LED's in the display, you would need a minimum frequency of 10×24 or 240 Hz.

All you really need for a clock signal is a square wave that swings as close to the supply rails as possible. The circuit in Fig. 2 is suitable because it doesn't use a lot of components. And there's a good chance that your main circuit (whatever it may be) will have a few unused inverters left over that you can then use for your oscillator. And we all remember Grossblatt's fourth rule: Don't waste silicon. Using all available gates makes for a much slicker circuit, and I wouldn't be surprised if there was some sort of ecological benefit as well.

The oscillator in Fig. 2 produces a nice square wave and, since we're using CMOS parts, the high output is going to be within whispering distance of +V. What makes it ideal for our purposes is that we will have control over both the frequency and the duty cycle of the output.

Let's take a closer look at that circuit. The duty cycle is controlled by the combination of R3, D1, and D2. When the output of IC1-a is high, D2 only allows the

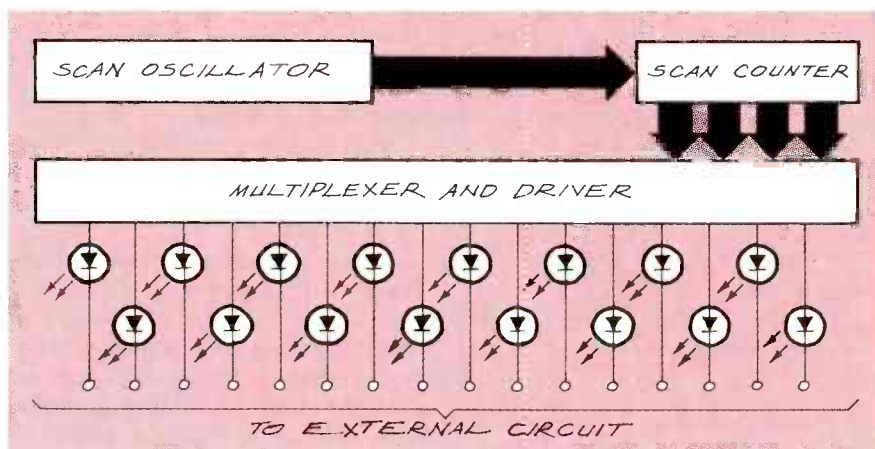

FIG. 1

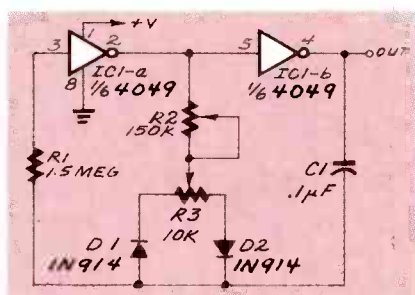

FIG. 2

power. A sixteen-LED display can draw anything from 160 mA to half an amp, depending on the LED's being used and the brightness you

something for nothing—you do need extra circuitry in order to multiplex a display.

Or do you?

Figure 1 is the basic block diagram of a multiplexed display. The details depend on the circuit you're putting together but the basic idea is common to all displays. Let's talk about those things one at a time.

The clock can be anything that oscillates fast enough to drive a flicker-free display. The minimum frequency depends on the

Macrovision ...

now you see it, now you don't.

Remove copy-protection from video cassettes.



- Digital Filter Type, removes only Macrovision pulses
- No adjustments, crystal controlled
- Compatible with all VCR's, uses automatic vertical blanking level

Macro-Scrubber — We stock the exact parts, PC board, and AC adaptor for an article on Building a Macro-Scrubber appearing in *Radio-Electronics* December 1987 issue.

JMAK-1 Parts Package \$19.00

Includes all the original resistors, capacitors, diodes, transistors, integrated circuits, and crystal.

JMAK-2 PC Board \$9.95

Original etched and drilled silk-screened PC board used in article

JMAK-3 AC Adaptor \$7.95

Original (14 to 18 volt DC @ 285 ma) AC adaptor used in article.

Free reprint of article on building a Macro-Scrubber with any purchase above. Add \$2.50 shipping & handling; \$4.50 Canadian orders. Note: Unauthorized duplication of copyrighted material is illegal. Use Macro-Scrubber for viewing only.

72-CHANNEL CABLE CONVERTER WITH INFRA-RED REMOTE CONTROL

MC-702 CONVERTER \$79.95



Add \$3.50 shipping & handling \$9.50 Canadian orders.

- 72-channel capability
- Wireless, Infra-Red remote control
- Channel output 2 or 3 switchable
- Microprocessor controlled PLL operation
- Skip channel memory eliminates unused channels
- Parental control for all channels
- Last channel recall
- Fine tune memory
- UL listed/FCC approved
- Simple installation with any TV
- Includes battery and 3 foot coax cable

CABLEMASTER Cable/VCR Timer \$19.95

- Record multiple premium play channels
 - Turns cable box on and off
 - Selects channel for unattended recording
 - Thousands sold nationally for \$99.95
- Add \$3.50 shipping & handling \$4.50 Canadian orders

ORDER TOLL FREE ANYTIME
1-800-227-8529
 Ask for **FREE Color Catalog**

Inside MA: 617-695-8699
 VISA, MASTERCARD, or C.O.D.



J & W ELECTRONICS, INC.

P.O. BOX 800 • MANSFIELD, MA 02048

©Copyright 1988 by J&W Electronics Inc.

CIRCLE 65 ON FREE INFORMATION CARD

right hand-side of potentiometer R3 to be in the circuit and, when IC1-a's output is low, D1 puts the left side of R3 in the circuit. That gives us separate control of the positive and negative charging of the timing capacitor, C1. By rotating R3 one way or the other we can vary the duty cycle from narrow negative going pulses, through 50/50, to narrow positive pulses.

The frequency of that type of oscillator is basically set by the combination of R2 and C1. The values shown for the components will give us nearly a ten-to-one frequency range—from about 40–400 Hz. You'll find that the control gets sensitive when you get near the low end of R2, but you can take care of that problem by using a log-tapered potentiometer for R2 rather than a linear-tapered one (R3 should always be linear). If the circuit tends to stop working when you set R2 to zero, put a 10K resistor in series with R2.

If you want to change the circuit's frequency range you can vary either C1 or R2, because the frequency is set by: $f = 1/(2.1)(R2)(C1)$. Just make sure that R1 is at least ten times greater than the sum of R2 and R3, and that C1 is more than 0.001 μ F.

Although every multiplexing circuit needs a clock, the amount of additional circuitry besides the clock depends on the kind of display you're going to use. Single LED's can be handled differently than seven-segment displays. The two remaining blocks in Fig. 1 (the scan counter and the multiplexer/driver) can be combined into one by using an IC that has both the counter and drivers in one package. We'll show you how to do that next month. **R-E**

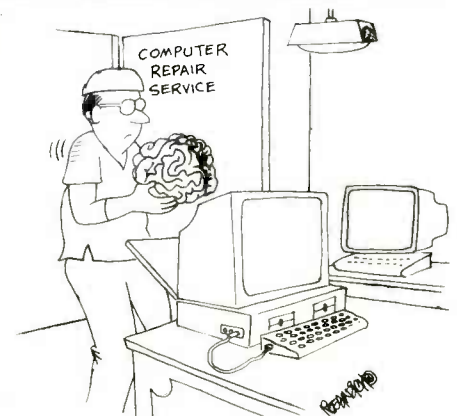

MARKET CENTER

SATELLITE TV

CABLE TV Secrets—the outlaw publication of the cable companies tried to ban. HBO, Movie Channel, Showtime, descramblers, converters, etc. Supplier's list included \$8.95. **CABLE FACTS**, Box 711-R, Pataskala, OH 43062.

SATELLITE TV receiver kits! Instruction manual, boards, semiconductor parts! 59" LNA's! LNB's! Ku-Band LNB's! Catalog \$1.00: **XANDI ELECTRONICS**, Box 25647, Dept. 21KK, Tempe, AZ 85282.

DESCRAMBLERS for movies, networks, \$175 up. Visa, MC accepted. Catalog \$4 **SKYWATCH**, 238 Davenport Road, Toronto, Ontario, Canada, M5R-1J6.

VIDEOCYpher II descrambling manual, schematics, video and audio DES, cloning, muskateering, EPROM codes. (HBO, Cinemax, Showtime, adult channels.) \$13.95, \$2 postage. **CABLETRONICS**, Box 30502R, Bethesda, MD 20814.

Cable TV Converters Why Pay A High Monthly Fee?

Jerrold Products include "New Jerrold Tri-Mode," SB-3, Hamlin, Oak VN-12, M-35-B, Zenith, Magnavox, Scientific Atlanta, and more. (Quantity discounts) 60 day warranty. For fast service C.O.D. orders accepted. Send SASE (60 cents postage) or call for info (312) 658-5320. **MIDWEST ELECTRONICS, INC.**, 5143-R W. Diversey, Chicago, IL 60639. MC/Visa orders accepted. No Illinois orders accepted. Mon.-Fri. 8 A.M.-5 P.M. CST

FREE catalog systems, Upgrades, Houston, Uniden, Chaparral, etc. **Save, \$\$\$\$ SKYVISION**, 2009 Collegeway, Fergus Falls, MN 56537, (218) 739-5231.

SATELLITE TV systems, descramblers, programming, VCR's, TV's, CB's, telephones, at discount prices. **ELMIRA ELECTRONICS**, 8343 M-32, Elmira, MI 49730. (616) 546-3362.

CABLE descrambler liquidation. Major makes and models available. Industry pricing! (Example: Hamlin combo's, \$44 each...minimum 10 orders). **DEALERS ONLY!** Call **WEST COAST ELECTRONICS**, (818) 989-0890.

SATELLITE T.V. systems, upgrades, featuring: Uniden, Chaparral, Tee-Comm, Toshiba, LNA's, LNB's, feeds, dishes. Best prices! Catalog \$1.00 (refundable). **CASCADE ELECTRONICS**, P.O. Box 414, Dundee, IL 60118.

Pay TV and Satellite Descrambling Vol. 2 "Scrambling News"

Vol. 2 is even better than vol. 1. \$12.95 Vol. 1 \$14.95 Experiments with Videocipher Cloning, musketeering \$14.95 Cable TV Security design \$12.95 MDS MDS Handbook Microwave hacking \$9.95 Build Satellite Systems Under \$500. \$12.95 Any 3 \$27 or 6/\$40 Scrambling News. Monthly \$24.95/yr New 2 IAC and VC series. Sample \$3 (refundable). New enlarged Fall product catalog \$1.

Shojiki Electronics Corp., 1327A Niagara St., Niagara Falls, NY 14303 CODs 716-284-2163

NEURAL NETWORKS

AMAZING circuits simulate thought & sensory processing. Plans \$25. Brochure \$2 purchase deductible. Author **MSEE. LP WEBER**, Box 621, Dept. RE-1002, Allenwood, NJ 08720.

FOR SALE

TUBES, new, unused. Send self-addressed, stamped envelope for list. **FALA ELECTRONICS**, Box 1376-2, Milwaukee, WI 53201.

PHOTOFACT folders, under #1400 \$3.00. Others \$5.00. Postpaid. **LOEB**, 414 Chestnut Lane, East Meadow, NY 11554.

TRANSISTORS-tubes: MRF421 \$24.00, MRF454 \$14.50, MRF455-MRF477 \$11.75, MRF492 \$16.00, SRF2072 \$12.75, SRF3800 \$17.50, 2SC2290 \$16.75, 2SC2879 \$22.00, 6LF6, 6LQ6, 6JS6, 8950, etc-call. New **Ranger AR3500** all mode 10 Meter transceiver \$319.00. Quantity discounts! Best prices on hard-to-find parts, antennas, mics, power supplies, & equipment! Catalog \$1.00 (refundable), or free with order. **RFPC**, Box 700, San Marcos, CA 92069. For information or same day shipment—call (619) 744-0728. Visa/MC/C.O.D.

CB RADIO OWNERS!

We specialize in a wide variety of technical information, parts and services for CB radios. 10-Meter and FM conversion kits, repair books, plans, high-performance accessories. Over 12 years of satisfied customers! Catalog \$2.

CBC INTERNATIONAL
P.O. BOX 31500RE, PHOENIX, AZ 85046

LASERS, components and accessories. Free catalog, **M.J. NEAL COMPANY**, 6672 Mallard Court, Orient, OH 43146.

PICTURE flyer lists quality surplus electronics at low prices. Since 1970. Send for the last 3 issues. **STAR-TRONICS**, Box 683, McMinnville, OR 97128.

SATELLITE & cable equipment. We have those hard-to-find units ready to go. Tired of junk that doesn't work properly? Try our 10 day satisfaction guarantee & 90 day warranty (wholesale only). **HI TECH ELECTRONICS**, PO Box 42423, Detroit, MI 48242, (313) 722-9381.

TUBES, name brands, new, 80% off list. **KIRBY**, 298 West Carmel Drive, Carmel, IN 46032.

IS it true... jeeps for \$44 through the government? Call for facts! 1-(312) 742-1142, ext. 4673.



Quality Microwave TV Antennas

Multi-Channel 1.9 to 2.7 GHz, 40dB Gain
30-Channel System complete \$149.95
12-Channel System complete \$104.95
2-Channel System complete \$79.95

Phillips-Tech Electronics
P.O. Box 8533 • Scottsdale, AZ 85262
(602) 947-7700 (\$3.00 Credit all phone orders!)

LIFETIME WARRANTY

MasterCard • Visa • C.O.D.'s QUANTITY Pricing

ATTENTION, are you looking for surplus test equipment volt meters oscilloscope, etc. **J.B. ELECTRONICS**, 9518 W. Grand, Franklin Park, IL 60131, (312) 451-1750.

RESTRICTED technical information: Electronic surveillance, schematics, locksmithing, covert sciences, hacking, etc. **Huge selection. Free brochures.** **MENTOR-Z**, Drawer 1549, Asbury Park, NJ 07712.

FREE power supply, connectors (\$8.95 value) with TV project assortment #103 (February 1984 article) contains **PCB, Toko coils, transistors, (BF085), IC's, diodes**. article reprint. \$25.00. Five/\$112.50. Shipping \$2.00. **MC/VISA, COD accepted. JIM RHODES, INC.**, PO Box 3421, Bristol, TN 37625.

COMMODORE-Amiga chips, diagnostics, parts or low cost repair. Send for complete catalog. (dealer pricing available). **VISA/MC. KASARA, INC.**, 31 Murray Hill Drive, Spring Valley, NY 10977, 1-(800) 248-2983 or (914) 356-3131.

TUBES. "Oldest," "latest." Parts and schematics. SASE for list. **STEINMETZ**, 7519 Maplewood Ave., R.E. Hammond, IN 46324.

TESLA coils—Kirlian electrophotography—plasma bulbs...Free 1988 science plan catalog! **SCIENTIFIC**, Box 1054HRH, Duvall, WA 98019.

GREAT buys! Surplus prices, ICs, linears, transformers, PS, stepping motors, vacuum pump, phototransistor, meters, Isase, **FERTIK'S**, 5400 Ella, Phila., PA 19120.

TWO-Way-Radio, PC computers, Uniden service. General Radiotelephone licensed technician. Catalog-**RAYS**, 2025 Moline, Ft. Worth, TX 76117 (817) 831-7717.

AIDS? Yes we have! Cable aids to help you. Zenith, Jerrold, Scientific Atlanta, Oak, Hamlins, much more. No Michigan sales! **HOTRONICS**, (313) 675-5834.

Multi-Channel Microwave T.V. Receivers



1.9-2.7 GHz Parabolic Dish 40+ dB Gain
LIFETIME WARRANTY
Complete System \$99.95 (Shipping Incl.)
Replacement Components
& Expert Repairs Available

K & S ELECTRONICS Call now for same
P.O. BOX 34522 day shipping!
PHOENIX, AZ 85067 (602) 230-0640

VISA/MC/COD

\$2 CREDIT ON PHONE ORDERS

CABLE TV converters. Remotes, accessories—free catalog—ARIZONA VIDEO, 3661 N. Campbell, #310-A, Tucson, AZ 85719. (602) 323-3330.

TUBES 59¢. Year guarantee. Free catalog. Tube checker \$8.95. **CORNELL**, 4215 University, San Diego, CA 92105.

FAIR prices SB-3, SX3, SA3, TRI-BI, MLD-1200-3. Some Oak, any notch filters. Small dealer only. No Michigan sales (313) 979-8356.

OLD radio TV schematics. Send \$3.00, make, model. **RADIO MAPS**, P.O. Box 791, Union City, CA 94587.

FREE CATALOG

FAMOUS "FIRESTIK" BRAND CB ANTENNAS AND ACCESSORIES. QUALITY PRODUCTS FOR THE SERIOUS CB'er. SINCE 1962

FIRESTIK ANTENNA COMPANY
2614 EAST ADAMS
PHOENIX, ARIZONA 85034

MONITOR room and/or telephone conversation. Range inquest. \$88.00. Catalog, \$3.00. **LISTEN**, 603 Elgin, Muskogee, OK 74401. 1-(800) 633-8277.

CRYSTAL oscillators, any frequency from 1-1000 MHz, low prices for industrial applications. **M.S.I.** P.O. Box 429 Kiron, Israel FAX: 972-3-911000 Att: 2025.

SOLAR electric systems. Discount prices. **SUN POWER-TEXAS**, Dept. 01C, P.O.B. 2788A Freeport, TX 77541. 1-(409) 233-8350.

USED technical books: electronics, mechanics, mathematics, physics; military manuals, magazines, catalogs, handbooks etc. \$1.00 for 10 page list: **SOFTWARE**, 1515 Sashabaw, Ortonville, MI 48462.

THE funniest 3 page article ever written in electronics. "The Vom That Never Was." Guaranteed to make you laugh your buns off! Plus free product invention update. Send \$2.50. **SPITFIRE ELECTRONICS**, 409 Curry, Royal Oak, MI 48067.

LOW prices ICs, semiconductors, capacitors, switches. **SASE SANTECH**, 11 Revere Place, Tappan, NY 10983. (914) 359-1130 FAX: (914) 365-0243.

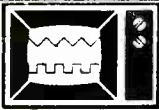

FINALLY!

An interesting and worthwhile project. This **EASY-TO-BUILD** circuit lets you use any regular TV set as a simple **OSCILLOSCOPE**. Build for less than \$10. **NO MODIFICATIONS TO TV!** Single or dual trace. Send for **FREE CATALOG** of other plans and kits.

DETAILED PLANS: \$4.95

TV-SCOPE

PENN RESEARCH,
Box 3543
Williamsport, PA 17701

BUILD this five-digit panel meter and square-wave generator including an ohms, capacitance and frequency meter. Detailed instructions \$2.50. **BAG-NALL ELECTRONICS**, 179 May, Fairfield, CT 06430.

CATALOG: Hobby/broadcasting/HAM/CB: Cable TV, transmitters, amplifiers, bugging devices, computers, more! **PANAXIS**, Box 130-F10 Paradise, CA 95967

KITS*parts*plans. We have hard to find parts! Variable tuning capacitors, tuning coils, crystal headphones, germanium diodes, shortwave, crystal, CB radio kits (no soldering). Very inexpensive. Send large SASE for catalog. **YEARY COMMUNICATIONS**, 12922 Harbor #800R, Garden Grove, CA 92640.

CRYSTAL radio sets, plans, parts, kits, catalog \$1.00. **MIDCO**, 660 North Dixie Highway, Hollywood, FL 33020.

PRINTED circuit boards etched & drilled. Free delivery. **K & F ELECTRONICS, INC.**, 33041 Groesbeck, Fraser, MI 48026. (313) 294-8720.

VIDEOCIPHER II Manuals. Volume 1—hardware, Volume 2—software. Either \$29.95 both \$49.95! CODs—1-(602) 782-2316. Catalog—\$3.00. **TELECODE**, Box 6426, Yuma, AZ 85364-0840.

DESCRAMBLING, new secret manual. Build your own descramblers for cable and subscription TV. Instructions, schematics, for SSAVI, gated sync, sinewave. (HBO, Cinemax, Showtime, etc.) \$8.95, \$2 postage. **CABLETRONICS**, Box 30502R, Bethesda, MD 20814.

DETECTION—surveillance, debugging, kits, plans. Latest high-tech catalog \$2.00. **DETECTION SYSTEMS**, 2515 E. Thomas, 16-864F, Phoenix, AZ 85016.

REMOTE CONTROL KEYCHAIN



Complete w/mini-transmitter and +5 vdc RF receiver. Fully assembled including plans to build your own auto alarm and extend the range.

\$19.95 Check, Visa or M/C 30 days return

VISITECT INC. (415) 872-0128
PO BOX 5442, SO. SAN FRAN., CA 94080

PROJECTION TV...Convert your TV to project 7 foot picture... Easy!...Results comparable to \$2,500 projectors... **Plans and 8" lens \$24.95**... Professional systems available... Illustrated catalog free. **MACROCOMA**, 15GB Main Street, Washington Crossing, PA 18977...Credit card orders 24HRS. (215) 736-3979.

TOP quality imported, domestic kits, surplus, discount electronics, computers, components. Free catalog. **TEKTRASONIX**, 1120 Avenue of the Americas, 1/11 Suite 4038, New York, NY 10036.

"**CB Trick of the Trade book**" learn CB repair tricks and tuning tricks. Send \$19.95 to **CECILINE MAN**, CB P.O. Box 37, Clarksville, AR 72830.

ELECTRONIC kits, devices, testers, components, plans, bugs—software. Catalog \$1.00. **ELECTRONICS**, 1222 Highland, Berwyn, IL 60402.

SURVEILLANCE electronics, debugging, kits. Latest high-tech. Catalog \$2.00. **TECHNOLOGY SERVICES**, 829 Ginette Street, Gretna, LA 70056.

VOICE scrambling system (Jan. 88 issue) for radios, phones, pocket sized. Complete kit \$29.95, \$54.95/pair. Board alone \$8.00, instructions \$2.50. **WAVELINK LABORATORIES**, Box 199, Trumbull, CT 06611.

FREE kit catalog. Home, auto, industrial kits. **BAL- LCO, INC.**, 148S. Clayton, Lawrenceville, GA 30245. (404) 979-5900.

CABLE-TV



BONANZA!

ITEM	1 UNIT	10 OR MORE
HAMLIN MCC 3000 36 CORDED REMOTE CONVERTER (Ch. 3 only)	29 00	18 00
PANASONIC WIRELESS CONVERTER (our best buy)	98 00	79 00
MOVIE TIME VR7200A (manual fine tune)	88 00	69 00
JERROLD 400 COMBO	169 00	119 00
JERROLD 400 HAND REMOTE CONTROL	29 00	18 00
JERROLD 450 COMBO	199 00	139 00
JERROLD 450 HAND REMOTE CONTROL	29 00	18 00
JERROLD SB-ADD-ON	99 00	63 00
JERROLD SB-ADD-ON WITH TRIMODE	109 00	75 00
M-35 B COMBO UNIT (Ch. 3 output only)	99 00	70 00
M-35 B COMBO UNIT WITH VARISYNC	109 00	75 00
MINICODE (N-12)	99 00	62 00
MINICODE (N-12) WITH VARISYNC	109 00	65 00
MINICODE VARISYNC WITH AUTO ON-OFF	145 00	105 00
ECONOCODE (minicode substitute)	69 00	42 00
ECONOCODE WITH VARISYNC	79 00	46 00
MLD-1200-3 (Ch. 3 output)	99 00	62 00
MLD-1200-2 (Ch. 2 output)	99 00	62 00
ZENITH SSAVI CABLE READY	175 00	125 00
INTERFERENCE FILTERS (Ch. 3 only)	24 00	14 00
EAGLE PD-3 DESCRAMBLER (Ch. 3 output only)	119 00	65 00
SCIENTIFIC ATLANTA ADD-ON REPLACEMENT DESCRAMBLER	119 00	85 00

*CALL FOR AVAILABILITY

Quantity	Item	Output Channel	Price Each	TOTAL PRICE
			SUBTOTAL	
			Shipping Add \$3.00 per unit	
			COD & Credit Cards — Add 5%	
			TOTAL	

California Penal Code #593-D forbids us from shipping any cable descrambling unit to anyone residing in the state of California.
Prices subject to change without notice.

PLEASE PRINT

Name _____
 Address _____ City _____
 State _____ Zip _____ Phone Number () _____
 Cashier's Check Money Order COD Visa Mastercard
 Acct # _____ Exp. Date _____
 Signature _____

FOR OUR RECORDS:

DECLARATION OF AUTHORIZED USE — I, the undersigned, do hereby declare under penalty of perjury that all products purchased, now and in the future, will only be used on cable TV systems with proper authorization from local officials or cable company officials in accordance with all applicable federal and state laws. **FEDERAL AND VARIOUS STATE LAWS PROVIDE FOR SUBSTANTIAL CRIMINAL AND CIVIL PENALTIES FOR UNAUTHORIZED USE.**

Dated: _____ Signed: _____

Pacific Cable Company, Inc.

7325½ RESEDA BLVD., DEPT. #R-10 • RESEDA, CA 91335
 (818) 716-5914 • No Collect Calls • (818) 716-5140

IMPORTANT: WHEN CALLING FOR INFORMATION
 Please have the make and model # of the equipment used in your area. Thank You

© Copyright 1987 PACIFIC CABLE CO., INC.

OCTOBER 1988

CABLE T.V. "BOXES"

**Converters—Descramblers
Remote Controls—Accessories**

- ★ Guaranteed Best Prices ★
- ★ 1 Year Warranty—C.O.D.'s ★
- ★ Immediate Shipping ★
- ★ FREE CATALOG ★

Call or Write
TRANS-WORLD CABLE CO.
12062 Southwest 117th Court, Suite 126
Miami, Florida 33186
800-442-9333

The **DECODER**. Satellite and cable descrambling newsletter. News-schematics-modifications-reviews. \$24.00/year. Sample-\$3.00. **TELECODE**, Box 6426, Yuma, AZ 85364-0840.

MICRO-link FM stereo audio transmitter. One chip does it all! Transmit your CD/VCR/Walkman in stereo to any FM radio. Free schematic and info. Send a self addressed/stamped envelope to: **DJ INC.**, 217 E. 85th St., Suite 108, New York, NY 10028.

EDUCATION & INSTRUCTION

F.C.C. Commercial General Radiotelephone license. Electronics home study. Fast, inexpensive! "Free" details. **COMMAND**, D-176, Box 2223, San Francisco, CA 94126.

ENGINEERING software for IBM-PC. CompDes...circuit design. CompMath...math tutor. CompView...digital signal analysis. \$49 each. (614) 491-0832. **BSOFT SOFTWARE**, 444 Colton Road, Columbus, OH 43207.

HOW to rewind power transformers to your specs. \$7.95. **BROSS ELECTRONICS**, 350 Tremont Suite. D-51, Dept. R-9, Murfreesboro, TN 37130.

SAVE/make \$1000's high technology insider secrets catalog \$2.00 exotic parts. **LEEWARE**, Box 5636, Greensboro, NC 27435.

MASTER new skills fast through our short specialized home study courses. Condensed and highly effective! Passport to success! 50 choices! Diploma! **CIEE-12**, Box 20345, Jackson, MS 39209.

MAGIC! Four illustrated lessons plus inside information shows you how. We provide almost 50 tricks including equipment for four professional effects. You get a binder to keep the materials in, and a one-year membership in the International Society of Performing Magicians with a plastic membership card that has your name gold-embossed. You get a one-year subscription to our quarterly newsletter, "IT'S MAGIC!" Order now! \$29.95 for each course + \$3.50 postage and handling. (New York residents add applicable state and local sales tax.) **The Magic Course**, 500-B BiCounty Boulevard, Farmingdale, NY 11735, or telephone (516) 293-3751 and ask for Nancy Estrada.

BIG PROFITS

ELECTRONIC ASSEMBLY BUSINESS

Start home spare time. Investment knowledge or experience unnecessary. **BIG DEMAND** assembling electronic devices. Sales handled by professionals. Unusual business opportunity.

FREE: Complete illustrated literature
BARTA, RE-O Box 248
Wainut Creek Calif 94597

BUSINESS OPPORTUNITIES

EARN thousands with your own part time electronics business. I do. Free proof, information. **INDUSTRY**, Box 531, Bronx, NY 10461-0531.

Big Profits!

LEARN VCR CLEANING-REPAIR. Prior Experience UNNECESSARY. Need only small hand tools & average mechanical abilities. **BIG DEMAND** performing VCR cleaning and repairs. **REAL EXAMPLES** of VCR malfunctions and their solutions. Photos and illustrations. ALSO: Information on starting your own business.

Free information. Write:
Vicjo VCR Repair
23010 Lake Forest Dr. #155
Laguna Hills, CA 92653
(714) 768-1925

EASY, lucrative. One man CRT rebuilding machinery. Free info: (815) 459-0666 **CRT**, 1909 Louise, Crystalake, IL 60014.

PROJECTION TV. Make \$\$\$'s assembling projectors...easy...results comparable to \$2,500 projectors...Plans, 8' lens & dealers information \$22.50...Professional systems available... Illustrated catalog free. **MACROCOMA 15GBX Main Street**, Washington Crossing, PA 18977. Creditcard orders 24hrs. (215) 736-2880.

YOUR own radio station! AM, FM, TV, cable. Licensed/unlicensed. **BROADCASTING**, Box 130-F10, Paradise, CA 95967.

EARN \$1000's or more easily, simply. Quick results. Send \$9 plus \$1 for **S&H**: Box 14008, Seattle, WA 98104 for information packet.

PC board/circuit design, prototyping, and manufacture. orcad/futurenet/schema, netlists routed. **Plotting services**; schema hiwire, smartwork, **EE DESIGNER**, supported call (609) 586-4469.

CAR-STEREO EQUIPMENT

BOOM boom subwoofer systems, electronic crossovers, audio power amplifiers, radio cassettes, CB's etc. Wholesale prices, catalog, information. **BOOM BOOM ELECTRONICS**, 2905 Las Vegas Blvd. North, #53RE, North Las Vegas, NV 89030. (702) 399-3139.

CALL FOR FREE CATALOG

TEXT TO SPEECH BOARD!

PC/XT COMPATIBLE. MAKE YOUR COMPUTER TALK!

A VERY POWERFUL AND AMAZING SPEECH CARD. USES THE NEW GENERAL INSTRUMENTS SPO256-AL2 SPEECH CHIP AND THE CTS256A-AL2 TEXT TO SPEECH CONVERTER.

THIS BOARD USES ONE SLOT ON THE MOTHERBOARD AND REQUIRES A COM SERIAL PORT. BOARD MAY ALSO BE USED IN A STAND ALONE ENVIRONMENT WITH ALMOST ANY COMPUTER THAT HAS A RS232 SERIAL PORT. FEATURES ON BOARD AUDIO AMP OR MAY BE USED WITH EXTERNAL AMPS.

DEMONSTRATION SOFTWARE AND A LIBRARY BUILDING PROGRAM ARE INCLUDED ON A 5 1/4" INCH PC/XT DISKETTE. FULL DOCUMENTATION AND SCHEMATICS ARE ALSO INCLUDED.



NEW!

PRICE CUT!

\$69.95
ASSEMBLED & TESTED

NEW! IC TESTER! \$149.00

SIMILAR TO BELOW EPROM PROGRAMMER. PLUGS IN TO YOUR PC OR XT. TESTS ALMOST ALL 14, 16, AND 20 PIN 74XX SERIES. INCLUDES STANDARD POWER, "S" AND "LS" DEVICES. ALSO TESTS CD4000 SERIES CMOS. SOFTWARE INCLUDED CAN EVEN DETERMINE PART NUMBERS OF MOST UNMARKED AND HOUSE NUMBERED DEVICES WITH SIMPLE MOD. THIS UNIT CAN ALSO TEST 6.4K AND 256K DRAMS! WITH MANUAL AND SOFTWARE. \$149. PERFECT FOR SCHOOLS.

PC/XT EPROM PROGRAMMER \$169



ASK ABOUT OUR NEW PAL PROGRAMMER!

* LATEST DESIGN * PROGRAMS UP TO 4 DEVICES AT ONE TIME * FEATURES EASY TO USE MENU DRIVEN SOFTWARE THAT RUNS UNDER PC OR MS-DOS. * USES AN INTELLIGENT PROGRAMMING ALGORITHM FOR SUPER FAST (8X) EPROM BURNING. * THIS PLUG-IN BOARD ATTACHES TO AN EXTERNAL MINI CHASSIS CONTAINING 4 TEXTUO Z.I.F. SOCKETS. * NO PERSONALITY MODULES REQUIRED * AUTOMATIC VPP SELECTION: 12.5V, 21V, OR 25V. * EPROM DATA CAN ALSO BE LOADED FROM OR SAVED TO A DISKETTE. * PROGRAMMING SOFTWARE SUPPORTS: 2716, 2732, 2732A, 2764, 2764A, 27128, 27128A, 27256, 27256A, 27512, AND 27512A. * ASSEMBLED AND TESTED, BURNED. IN WITH MANUAL. \$169 WITH SOFTWARE.

JUST RECEIVED. SAME AS ABOVE PROGRAMMER, BUT PROGRAMS 8 UNITS AT ONE TIME - \$299.

Digital Research Computers

P.O. BOX 381450 • DUNCANVILLE, TX 75138 • (214) 225-2309

TERMS: Add \$3.00 postage. We pay balance. Orders under \$15 add 75c handling. No C.O.D. We accept Visa and MasterCard. Texas Res. add 6-1/4% Tax. Foreign orders (except Canada) add 20% P & H. Orders over \$50 add 85c for insurance.

JUST SIMPLY SAID

"When you're looking for a company that provides service and up-to-date technical advances, call us. That's what we're here for."

800-85-AMCOM

CABLE EQUIPMENT

NEW! Super SSAVI ADD-ON
ELIMINATES LINE 20 FALSE FLASHING
AUTOMATICALLY HANDLES NORMAL &
INVERTED VIDEO. NO SWITCHES.
FULLY AUTOMATIC
\$219.00

Standard SSAVI ADD-ON
CH #3 IN CH #3 OUT
1 YEAR WARRANTY

VHF TUNER **\$159.00**
NO BLOCK CONVERTER
BETTER VIDEO QUALITY
6 UNITS \$135.00 12 UNITS \$115.00
24 UNITS \$ 95.00 96 UNITS \$ CALL

INTERFERENCE FILTERS **\$15.00**

CHANNEL #2, 3, 5, 6, 8, 9, 14, 17, 22 ONLY

BI-STATE TRIMODE ADD-ON
\$119.00

TV TUNER VARACTORS

VHF/MID/UHF MITSUMI **\$25.00**

LINEAR		CMOS		OTHER	RARE IC CHIP
LM318 .80	ML1310 1.00	CD4002 .70	CD4027 .35	CD4520	CAMERA SYNC CHIP
LM339 .80	MC1390 .75	CD4011 .15	CD4040 .35	CD4526	SUPPLIES ALL SYNC
LM324 .25	MC1390 1.25	CD4012 .25	CD4047 .55	7400	AND COLOR INFO
LF353 .50	CA1308 4.00	CD4013 .25	DD4053 .50	74LS04	
LM309 1.25	MC1468 .75	CD4015 .25	CD4068 .28	74LS04	
LM393 .40	LM1498 .75	CD4018 .25	CD4069 .20	74LS74	
LM555 .35	LM1888 1.00	CD4017 .35	CD4071 .20	74LS123	
LM565 .75	TL082 .75	CD4019 .40	CD4081 .25	74C096	
LM562 .75	TL084 1.25	CD4024 .40	CD4082 .20	MM5321 \$8.50	

DEALERS WANTED!! GREAT QUANTITY PRICES



AMCOM

P. O. Box 68391
Virginia Beach, VA 23455

804-456-5505 (TECHNICAL)

800-852-6266 (ORDERS ONLY)

UPS DAILY

COD ACCEPTED

MINIMUM ORDER \$15.00

PRICES SUBJECT TO CHANGE WITHOUT NOTICE

NO INSTATE SALES

ALL SALES SUBJECT TO THE TERMS OF OUR 90 DAY LIMITED WARRANTY. FREE COPY UPON REQUEST.

RADIO-ELECTRONICS

WANTED

INVENTORS! AIM wants—ideas, inventions, new products, improvements on existing products. We present ideas to manufacturers. **Confidentiality guaranteed.** Call toll free in U.S. and Canada 1-(800) 225-5800.

INVENTIONS, ideas, technology wanted! Industry presentation/national exposition. 1-(800) 288-IDEA. **ISC-RAD**, 903 Liberty, Pittsburgh, PA 15222.

INVENTORS

INVENTORS Can you patent and profit from your idea? Call **AMERICAN INVENTORS CORPORATION** for free information. Over a decade of service. 1-(800) 338-5656. In Massachusetts or Canada call (413) 568-3753.

CABLE TV CONVERTERS

CABLE TV converters. Scientific Atlanta, Jerrold, Oak, Zenith, Hamlin. Many others. "New" Video Hopper "The Copy Killer." Visa, M/C & Amex. 1-(800) 826-7623. **B&B INC.**, P.O. Box 21-327, St. Paul, MN 55121.

PRINTED CIRCUIT BOARDS AND ARTWORK LAYOUTS

LOW prices single, double sided boards. No minimum charge. **CAD artwork** at discounted prices. (704) 464-1164; **PCBAL**, RT-3, Box 662-H, Conover, NC 28613.

PRIVACY PROTECTION

ELECTRONIC surveillance manual, manual plus catalog \$15. Credited towards purchase. **RWB ELECTRONICS**, Box 922, Bronxville, NY 10708.

DESCRAMBLER MODULE

LATEST technology alternative to Jerrold SB-3 or Radio-Electronics Feb. 1984 project. Featuring electronic tuning, AGC, auto-on/off, AD/DC power, mini-size, A&T, and more. For literature—**SOUTH-TECH DISTRIBUTING**, (813) 527-2190.

CABLE-TV AT IT'S BEST

SCIENTIFIC Atlanta models 8500—8550 remote included...\$240.00. **SB-3's**...\$74.00. **TRI-BI's**...\$95.00. **SA-3's**...\$99.00. **Zenith (Z-Tac)** descramblers...\$169.00. **N-12 (Vari-sync)**...\$89.00. **M-35 B (Vari-sync)**...\$99.00. **Hamlin MLD-1290's**...\$89.00. **80-Channel converters**...\$95.00. **Dealer discount** on (5) units. Call—**N.A.S. INTERNATIONAL**, (213) 631-3552. **Fax:** (213) 925-3542.

MASTERCARD AND VISA are now accepted for payment of your advertising. Simply complete the form on the first page of the Market Center and we will bill.

THIS IS AN EXPANDED TYPE AD. Notice how it stands out on this page. To get your ad set in this type style mark your classified ad order, "Expanded-type ad," and calculate your cost at \$4.30 per word.

THIS IS A BOLDFACE EXPANDED AD with a tint background. If you like this format, request it. Your cost is \$6.25 per word.

SPECIAL PURCHASE CCD IMAGING SYSTEM

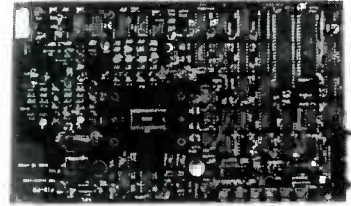

Uses a 4096-element line imaging chip. Part of a high-resolution FAX system. Removed from unused machines. Supplied with some documentation. (Sorry, no information on computer interfacing is available.)

The board has the CCD imaging chip and all the required electronics for operation. Video image information available as raw and processed serial binary data. Many possible uses in machine vision, robotics, or high resolution slow scan TV astronomy, etc.

CCD Image Board \$69.95

Also available:

Complete Document Scanner Mechanism.....\$125.00
(Call for more information.)

Call or write for our **FREE 112 pg.** catalog today.

C and H 2176 E. Colorado Bl.
Pasadena, CA 91107
sales co.

1-800-325-9465

CIRCLE 195 ON FREE INFORMATION CARD

PIONEER



10" WOOFER

Heavy duty paper cone with 20 oz. magnet. 60 watts RMS, 90 watts max. Response: 35-3500 Hz. 1 1/2" v.c.

#290-083 \$1880 (1-3) ~~\$1690~~ (4-up)

SPEAKERS AND COMPONENTS

PIONEER

MOTOROLA

MOTOROLA

3 1/2" PIEZO TWEETER

Super horn tweeter. Mig. #KSN1005A. 3K-30KHz.

#270-010 \$530 (1-9) ~~\$450~~ (10-up)

MIG ELECTRONICS

EMPIRE



12" POLY WOOFER

Super duty, 40 oz. magnet. Polypropylene cone. 100 watts RMS, 145 watts max. 4-8 ohm compatible (6 ohm). 2" voice coil.

#290-125 \$3680 (1-3) ~~\$3450~~ (4-up)

THRUSTER by EMINENCE



15" WOOFER

56 oz. magnet. 2 1/2" voice coil. 150 watts RMS, 200 watts max. Paper cone with poly foam roll edge. 4 ohm.

#290-180 \$4350 (1-3) ~~\$3980~~ (4-up)

Made in U.S.A.



8" WOOFER

Ribbed paper cone with poly foam roll edge. 20 oz. magnet. 4 ohm. 50 watts RMS, 75 watts max. 1 1/2" v.c.

#290-053 \$2150 (1-3) ~~\$1995~~ (4-up)

WOODGRAIN GRILL CLOTH

Authentic woodgrain print design cloth. 36" x 60"

#260-340 \$595 Per Yard

12" 3-WAY, 100 WATT SYSTEM

Pioneer design engineers carefully evaluated the performance characteristics of this speaker system to ensure the best full range frequency response.

System Includes: (1) #290-125 poly woofer, (1) #280-045 heavy duty 5/4" midrange, (1) #270-035 4" soft dome tweeter, (1) #260-210 3-way 100 watt crossover, (2) #260-255 50 watt L-pads, (1) #260-300 terminal, and (1) #260-340 woodgrain grill cloth. Recommended cabinet volume: 3.1 cu ft.

#12-100

Save Over \$1000

\$7395 each

PIONEER

HORN TWEETER

Exponential horn design. Mylar dome. 3 1/2" x 3 1/2". 1800 20,000Hz response. 35 watts RMS, 50 watts max.

#270-050 \$650 (1-9) ~~\$590~~ (10-up)

150 WATT 3-WAY CROSSOVER

12 dB/octave 3-way cross-over network. 800-5000Hz. Automatic resetting over-power protection.

#260-212 \$2180 each

Parts Express
International Inc.

340 E. First St., Dayton, OH 45402
Local 1-513-222-0173
FAX 1-513-461-3391

CALL
TOLL FREE
1-800-338-0531

* 15 day money back guarantee. * \$10.00 minimum order. * We accept Mastercard, Visa, Discover, and C.O.D. orders. * 24 hour shipping. * Shipping charge = UPS chart rate (\$2.50 minimum charge). * Hours: 8:30 am - 6:00 pm EST, Monday - Friday. * Mail order customers, please call for shipping estimate on orders exceeding 5 lbs.



FREE CATALOG

CIRCLE 56 ON FREE INFORMATION CARD

www.americanradiohistory.com

Active gives you more...

- SELECTION
- SERVICE
- QUALITY
- VALUE

WELLER 2 PIECE SOLDERING STATION

94⁰⁰



- * Two piece design for flexibility
 - * Self-feeding water reservoir keeps sponge damp
 - * Excellent temperature regulation
 - * Pencil stand can be right or left side mounted
 - * Storage for up to 6 tips
- ACT#86444

IC MASTER... the source for all info on chips!

109⁰⁰

1988 version...
3 volumes



- * Lists over 100,000 devices
 - * Alternate source listing with over 98,000 substitutions
 - * An indispensable design aid
 - * 2 Updates included to keep you current
- ACT#27051

TEXAS INSTRUMENT DATA BOOKS

32⁰⁰

Set of 3 vol



- * **TTL DATA BOOK VOL I**
Product guide for all TTL-336pp
ACT#27629
- * **TTL DATA BOOK VOL II**
Detailed specs for LS, S and TTL-1400pps
ACT#27630
- * **ALS/AS LOGIC DATA BOOK VOL III**
Detailed specs for ALS and AS logic-1100pps
ACT#27631

QUALITY ANTI-STATIC DESOLDERING TOOL

9⁴⁰



- * Light weight anodized aluminum
 - * Self-cleaning, non-clogging, anti-static tip
 - * Maximum suction with less than 2" stroke
 - * Simple, one-hand operation
- ACT#57095

QUALITY VENTILATION... no hot air!

20⁰⁰



- * Designed for continuous duty
 - * Standard 2-13/16" mounting centers
 - * 30 Cubic Feet/Minute Capacity
 - * Draws only 7 watts at 115VAC
 - * Ultra-quiet
- ACT#52001

830 POINT QUALITY BREADBOARD BY WISHER

7⁹⁰



- * Clearly numbered coordinates
 - * High-impact plastic with quality spring clips
 - * 2 distribution strips (100 points each)
 - * 1 terminal strip with 630 points
 - * Highest quality construction
- ACT#69051

QUALITY MULTICORE SIZE 10 (22 GA) SOLDER

3⁸⁰



- * 60/40 Alloy with Ersin flux
 - * Five core design eliminates flux "voids"
 - * Quicker soldering with less heat
 - * 130 feet per roll
- ACT#96005

QUALITY TSM KITS... a great introduction to electronics

TSM Kits, available at ACTIVE offer both the newcomer and the experienced electronic hobbyist a selection that spans the full spectrum of electronics. From power supplies to high power audio amplifiers - clocks to alarms - intercoms - test equipment and more. Contact your closest ACTIVE store or call our mailorder division for more information. QUALITY TSM kits from ACTIVE!

THE ACTIVE DIFFERENCE... QUALITY!

There are many mailorder companies to choose from - all trying to be competitive with their pricing, but pricing only tells a very small part of the story. All components and accessories sold by ACTIVE are of the highest industrial quality. No surplus... no seconds... no pulls. ACTIVE is a proud affiliate of FUTURE Electronics (the 8th largest electronic components distributor in North America). As such, ACTIVE has over one hundred million dollars of prime, first grade inventory. Our stores (20 now and more opening every month) have over 10,000 items IN STOCK... FOR IMMEDIATE DELIVERY.

FUTURE Electronics is a franchised distributor for over 200 of the best known names in electronics. And since we have been supplying industrial, institutional, O.E.M.'s and service personnel for over 20 years, we know how to do it right. Remember, all ACTIVE parts are first grade, industrial quality, are supplied to us solely by FUTURE Electronics and as such are totally suitable for use in any project or repair. And, you can count on that. Judge us by the companies we keep...

ALPHA SAMS CHEMTRONICS H.H. SMITH WELLER STANCOR BECKMAN TAB
XCELITE TPI DAETRON TSM EDUKIT VACO UNGAR SCORPIO
OK WISHER GC HITACHI MUELLER AND MORE.

Semiconductors and integrated circuits... in stock for immediate delivery.

PART #	ACT #	PRICE	PART #	ACT #	PRICE	PART #	ACT #	PRICE
SN7400 SERIES			CMOS			PROMS		
SN7400N	05500	3/1 14	401BPC	08340	4/1 25	32X8-OC-16PC	71016	1 50
SN7402N	05506	3/1 14	401BPC	08355	3/1 45	32X8-TS-16PC	71017	1 50
SN7404N	05510	3/1 14	40158PC	08370	2/1 20	256X4-OC-16PC	71018	3 60
SN7406N	05516	2/1 03	40168PC	08375	3/1 35	256X4-TS-16PC	71094	3 60
SN7407N	05518	2/1 03	40178PC	08380	2/1 03	256X8-OC-20PC	71005	5 45
SN7408N	05520	3/1 14	40208PC	08405	10 5 60	256X8-TS-20PC	71019	5 10
SN7414N	05526	2/1 03	40238PC	08420	4/1 03	512X4-TS-16PC	71038	2 83
SN7416N	05528	2/1 03	40248PC	08425	2/1 03	1024X4-TS-16PC	71027	4 85
SN7417N	05530	2/1 03	40268PC	08435	1 36	2048X4-TS-16PC	71038	3 92
MORE IN STOCK - CALL			MORE IN STOCK - CALL			MORE IN STOCK - CALL		
SN74ALS SERIES			SN74ALS SERIES			PALS		
SN74ALS02N	06407	3/1 25	SN74ALS02N	05776	4/1 58	PAL16RA4CN	03002	3 99
SN74ALS03AN	06410	3/1 25	SN74ALS04N	05780	4/1 58	PAL16LB4CN	03001	3 99
SN74ALS05AN	06416	3/1 25	SN74ALS08N	05786	4/1 58	6500 SERIES		
SN74ALS20N	06437	3/1 25	SN74ALS14AN	05802	2/1 25	6502APC	12002	6 08
SN74ALS21AN	06440	3/1 25	SN74ALS20N	05806	4/1 58	6502CPK	12009	6 66
SN74ALS30AN	06452	3/1 25	SN74ALS30N	05818	4/1 58	6502ZAP	12006	5 08
SN74ALS32N	06455	3/1 25	SN74ALS32N	05820	4/1 49	6502ZPC	12005	4 86
SN74ALS133N	06468	2/1 03	SN74ALS47N	05834	2/1 58	MORE IN STOCK - CALL		
SN74ALS138N	06494	2/1 64	MORE IN STOCK - CALL			6800 SERIES		
SN74ALS244AN	06499	1 58	MORE IN STOCK - CALL			6802BPC	12060	3 08
MORE IN STOCK - CALL			MORE IN STOCK - CALL			6802IPC	12017	1 95
MORE IN STOCK - CALL			MORE IN STOCK - CALL			MORE IN STOCK - CALL		
SN74AS SERIES			SN74HC SERIES			8000 SERIES		
SN74AS04N	05306	2/1 03	SN74HC02N	16105	3/1 25	8008APC	12023	6 25
SN74AS05N	05309	3/1 36	SN74HC04N	16110	3/1 03	8155APC	12026	5 08
SN74AS08N	05308	2/1 03	SN74HC08N	16115	3/1 03	82051APC	12079	5 08
SN74AS10N	05306	2/1 03	SN74HC14N	16101	2/1 03	82052APC	12034	5 08
SN74AS20N	05310	2/1 03	SN74HC22N	16140	3/1 03	82053APC	12034	5 08
SN74AS32N	05312	2/1 03	SN74HC32N	16145	3/1 03	8255APC	12086	4 58
SN74AS08N	05335	1 03	SN74HC123N	16259	2/1 56	MORE IN STOCK - CALL		
MORE IN STOCK - CALL			MORE IN STOCK - CALL			7800 SERIES		
MORE IN STOCK - CALL			MORE IN STOCK - CALL			7804APC-PS		
SN74AS SERIES			SN74HC SERIES			7805APC-PS		
SN74AS00N	05100	2/1 47	SN74HC02N	16237	2/1 03	7806APC-PS	14003	2 75
SN74AS02N	05101	2/1 47	SN74HC04N	16234	2/1 03	7808APC-PS	14008	2 58
SN74AS04N	05102	2/1 47	SN74HC08N	16301	1 25	7809APC-PS	14011	4 58
SN74AS27N	05108	2/1 47	SN74HC14N	16302	1 03	MORE IN STOCK - CALL		
SN74AS30N	05109	2/1 47	SN74HC22N	16319	1 25	TRIACS		
SN74AS244N	05126	3 08	SN74HC373N	16319	1 03	T28	10001	2 40
SN74AS257N	05127	1 75	MORE IN STOCK - CALL			T148	10013	1 97
MORE IN STOCK - CALL			MORE IN STOCK - CALL			T1215	10070	2 47
SN74F SERIES			OPTO			T1410	10007	3 08
SN74F00N	05044	3/1 36	4N25	13086	2/1 03	T12060	29088	1 75
SN74F02N	05046	3/1 36	4N26	13067	2/1 03	T1216D	29090	2 08
SN74F12N	05222	1 05	4N33	13181	2/1 03	T12226D	29095	2 08
SN74F13N	05224	1 64	4N35	13187	2/1 03	T12226E	29096	1 99
SN74F14N	05226	1 64	4N36	13198	2/1 18	MORE IN STOCK - CALL		
SN74F138N	05228	1 03	4N37	13190	2/1 03	DIODES		
SN74F139N	05230	1 03	6N136	13225	2 86	1N914BR	01160	25/1 03
MORE IN STOCK - CALL			6N139	13226	2 64	1N4001TR	01411	25/1 03
MORE IN STOCK - CALL			10L74	13086	2 25	1N4002	01412	25/1 03
MORE IN STOCK - CALL			LD271	13287	3/1 36	1N4003TR	01413	25/1 03
LINEAR			MORE IN STOCK - CALL			1N4004TR	01414	20/1 03
AM26LS31PC	54012	1 58	TRANSISTORS			MORE IN STOCK - CALL		
AM26LS32PC	54035	1 97	2N2222A	02185	3/1 58	ZENER DIODES		
TL064DN	54041	1 81	2N2906	02188	1 03	1N4734TR	01094	5/1 03
TL071CP	54042	2/1 05	2N2907A	02191	2/1 03	1N4735TR	01095	5/1 03
TL074DN	54044	1 47	2N2907A	02193	3/1 58	1N4736ATR	01301	5/1 03
TL081CP	54142	2/1 05	2N3055	02194	2/2 08	MORE IN STOCK - CALL		
TL082CP	54046	2/1 36	2N3055	02195	1 58			
TL0272CP	54437	1 05	2N3440	02196	2/2 19			
3081C	06132	2/1 03	2N3771	02153	2 36			
3111C	06103	3/1 14	MORE IN STOCK - CALL					
3181C	06014	1 14						
MORE IN STOCK - CALL								

PARTIAL LISTING ONLY

ACTIVE HAS THOUSANDS OF DIFFERENT SEMI-CONDUCTORS AND INTEGRATED CIRCUITS AVAILABLE FOR OFF-THE-SHELF DELIVERY. IF THE TYPE YOU REQUIRE IS NOT LISTED, PLEASE CALL FOR PRICING.

ORDERING FROM ACTIVE IS EASY...

By Phone

Our trained telephone order personnel are ready to take your order from 8:00AM to 6:00PM (Eastern). Orders are processed within 24 hours. Please have your credit card (Visa, MasterCard or American Express) handy when you call. 1-800-ACTIVE 4

By Mail

Simply list the items you would like to order-total your order and add 4.00 (UPS Ground) or 7.00 (UPS Blue) shipping/handling (Massachusetts residents please add state sales tax) and send it, with a cashier's check or money order to cover the total amount to: **Active Mailorder Center, 133 Flanders Road, Westborough, Mass. 01581**

In our Stores
Westborough, MA
Mt. Laurel, NJ

Woburn, MA
Seattle, WA
Chicago, IL

Long Island, NY
Santa Clara, CA
Detroit, MI

In Canada:
Quebec, QC
Toronto, ON (3)
Edmonton, AB

Montreal, QC (2)
Winnipeg, MB

Ottawa, ON
Calgary, AB
Vancouver, BC

Please call TOLL-FREE or use the Reader Service Card for a FREE copy of our NEW, 1989, 240 PAGE CATALOG

Active



TOLL FREE ORDER NUMBER 1-800-ACTIVE 4

CIRCLE 188 ON FREE INFORMATION CARD

SEND FOR
FREE
1988 CATALOG...
56 PAGES

★ QUALITY PARTS ★ DISCOUNT PRICES ★ FAST SHIPPING

ALL ELECTRONICS CORP.

WE STOCK OVER
4,000 ITEMS...
CALL OR WRITE FOR OUR
FREE
CATALOG OF PARTS!

RESISTORS • CAPACITORS • DIODES • CABLES •
BRIDGE RECTIFIERS • CHOKE COILS • CRYSTALS •
CRIMP CONNECTORS • LAMPS • HEAT SINKS • MO-
TORS • SUB MINIATURE D CONNECTORS • TRANSIS-
TORS • I.C.'S • PROTO BOARDS • POTENTIOMETERS •
POWER SUPPLIES • JACKS • PLUGS • SWITCHES •
PERF BOARDS • FANS • FUSES • SHRINK TUBING • TIE
WRAPS • TOOLS • KEYPADS • VIDEO ACCESSORIES •
RELAYS • S.C.R.'S • TRANSFORMERS • TELEPHONE
ACCESSORIES • RIBBON CABLE • CIRCUIT
BREAKERS • VOLTAGE REGULATORS •
AND MANY OTHER ITEMS...

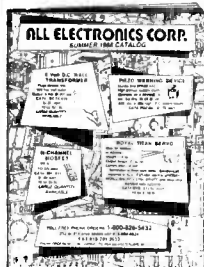

TRANSISTORS

CAT#	TYPE	CASE	PRICE
PN2222	NPN	TO-92	5 for .75
2N2904	PNP	TO-5	3 for \$1.00
2N2906	PNP	TO-18	3 for \$1.00
PN2907	PNP	TO-92	5 for .75
PN3055	NPN	TO-3	\$1.00 each
PN3569	NPN	TO-92	5 for .50
2N3904	NPN	TO-92	5 for .75
2N3906	PNP	TO-92	5 for .75
2N4400	NPN	TO-92	5 for .75
2N4402	PNP	TO-92	5 for .75
2N5400	PNP	TO-92	4 for \$1.00
2N5880	PNP	TO-3	\$2.00 each
2N5882	NPN	TO-3	\$2.00 each
MJ2955	NPN	TO-3	1.50 each
MJE2955T	PNP	TO-220	.75 each
MJE3055T	NPN	TO-220	.75 each
TIP30	NPN	TO-220	.75 each
TIP31	NPN	TO-220	.75 each
TIP32	PNP	TO-220	.75 each
TIP41	NPN	TO-220	.75 each
TIP42	PNP	TO-220	.75 each
TIP121	NPN	TO-220	.75 each
TIP126	PNP	TO-220	.75 each

10 AMP SOLID STATE RELAYS



ELECTROL# S2181
CONTROL:
Rated 5.5 to 10 Vdc
(will operate on 3-32 Vdc)
LOAD:
10 Amp @ 240 Vac
2 1/4" X 1 3/4" X 7/8"
CAT# SSRLY-10B
\$9.50 each
QUANTITY DISCOUNT!
10 for \$85.00
25 for \$175.00
50 for \$300.00
100 for \$500.00

SWITCHES

MINIATURE TOGGLE SWITCHES
all rated 5 Amps

S.P.D.T. (on-on)
Solder lug terminals.
CAT# MTS-4
\$1.00 each
10 for \$9.00



S.P.D.T. (on-on)
Non threaded bushing.
P.C. mount.
CAT# MTS-40PC
75¢ each
10 for \$7.00



D.P.D.T. (on-on)
Solder lug terminals.
CAT# MTS-8
\$2.00 each
10 for \$19.00



PIEZO WARNING DEVICE

Murata Erie #
PKB8-4A0
High pitched
audible alarm.
Operates on



3 - 20 Vdc @ 20 ma. 1" high
X 7/8" dia. P.C. board mount.
CAT# PBZ-84 \$1.75 each

SOUND ACTIVATED BOARD

Designed to react to high pitched sounds. Each
board contains many useful parts
including a condenser mike.
Operates on 6 Vdc.
Instructions included.
CAT# SAB \$2.50 each



24 VOLT D.C. SOLENOID

Intermittent duty cycle. 240 ohm coil.
Mounting flange is 1 1/8" wide.
Solenoid body 1 1/2" X 1/2" X 1/2".



CAT# SOL-34 \$1.00 each • 10 for \$8.50
100 for \$75.00 Large Quantity Available

SOUND & VIDEO MODULATOR

Ti# UM1381-1.
Designed for use
with T.I. comput-
ers. Can be used
with video cam-
eras, games, or
other audio/
video sources.
Built in A/B
switch enables
user to switch
from T.V. antenna without dis-
connection. Operates on chan-
nel 3 or 4. Requires 12 Vdc.
Hook up diagram included
CAT# AVMOD \$5.00 each



GRAB BAGS \$1.00 EACH

50 ASSORTED
DISC CAPS.
Cut leads. Many
common values,
some are 500 volts.
CAT# GRABDC

ASSORTED
1/4 WATT
RESISTORS
Approximately 200
pieces of assorted
values, some
cut leads.
CAT# GRES

ASSORTED
PARTS
Strips of 100 assorted
parts. Each strip
contains an assortment
of resistors, capacitors,
diodes, coils,
etc. 100 pieces.
CAT# GRABTR

15 VALUES OF
ELECTROLYTICS
Assortment contains
15 values of 1 mfd and
up. Some cut leads.
CAT# GRABCP

N-CHANNEL MOSFET

IRF-511
TO-220 case
CAT# IRF 511
\$1.00 each
10 for \$9.00
**LARGE QUANTITY
AVAILABLE...**

MINI PUSH BUTTON

S. P. S. T. momentary.
Push to make. 1/4"
threaded bushing.
Red button.
CAT# MPB-1
35¢ each • 10 for \$3.25



ITT PUSH BUTTON

ITT MDPL series. 3/4" X 1/2"
gray rectangular key cap.
S.P.S.T. N.O. Push to close.
RATED:
0.1 amp
switching,
0.25 amp
carry current. P.C. mount
CAT# PB-8 65¢ each
10 for \$6.00 • 100 for \$50.00



HALL EFFECT SWITCH

MICROSWITCH #4BE3
Slanted keyboard
switch with hall
effect sensor.
Snaps into 5/8"
square chassis
hole. Hall effect
sensor slides easily from
switch and can be used in
other applications.
CAT# HESW 4 for \$1.00
10 for \$2.00
100 for \$15.00

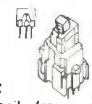

FLASHING L.E.D. KIT

Two L.E.D.'S
flash in
unison when
a 9 volt
battery is
attached.
Requires easy assembly,
you solder the parts to
the circuit board.
CAT# LEDKIT
\$1.50 each



XENON TUBE



1" long flashtube prepped
with 3 1/2" red and black
leads. Ideal for electronic
flash or strobe projects.
CAT# FLT-3 2 for \$1.00

NEW! STROBE KIT

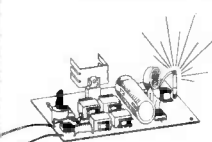

Variable rate strobe kit, flash-
es between 60 to 120 times
per minute. Will operate on
either 6 or 12 Vdc depending
upon how you wire the circuit.
Comes complete with P.C.
board and instructions for
easy assembly.
CAT# STROBE-1 \$7.50 each

NICKEL-CAD (RECHARGEABLE) BATTERIES

SPECIAL

AAA SIZE
Panasonic # P-18AAA
1.2 volt @ 180 mAh
CAT# NCB-AAAX
\$1.50 each
10 for \$13.50
100 for \$125.00
LARGE QUANTITIES



AA SIZE \$2.00 each
1.25 Volts 500 mAh
CAT# NCB-AA

AA SIZE \$2.20 each
WITH SOLDER TABS
CAT# NCB-SAA

C SIZE \$4.25 each
1.2 Volts 1200 mAh
CAT# NCB-C

D SIZE \$4.50 each
1.2 Volts 1200 mAh
CAT# NCB-D

WALL TRANSFORMERS

ALL PLUG
DIRECTLY
INTO
120 VAC
OUTLET



6 Vdc @ 200 ma. \$2.25
CAT# DCTX-620
6 Vdc @ 750 ma. \$3.50
CAT# DCTX-675
9 Vdc @ 250 ma. \$2.50
CAT# DCTX-925
12 Vac @ 930 ma. \$3.50
CAT# ACTX-1293
18 Vac @ 1 Amp. \$3.50
CAT# ACTX-1885

PROTO BOARD



Large enough to
design most
experimental circuits.
This proto board
measures
6 3/4" X 2 1/2".
Contains main board
and two power buss
strips.
CAT# PB-101
\$9.00 each

WATER TIGHT ENCLOSURE

ROSE# 02081905
Molded fiberglass enclosure
with neoprene gasket.
2" X 3" X 7 1/2". Light blue.
CAT# WP-905 \$7.50 each



FULL WAVE BRIDGE RECTIFIERS

10 AMP 200 P.I.V.

5/8" SQUARE
CAT# FWB-1020
\$1.00 each • 10 for \$9.00

25 AMP RATING

1 1/8" SQUARE
metal epoxy filled case
200 P.I.V. \$2.50 each
CAT# FWB-252
400 P.I.V. \$3.00 each
CAT# FWB-254
600 P.I.V. \$3.50 each
CAT# FWB-256



MAIL ORDERS TO:
ALL ELECTRONICS
P.O. BOX 567
VAN NUYS, CA 91408

TWX-5101010163
(ALL ELECTRONIC)

OUTSIDE THE U.S.A.
SEND \$1.50 POSTAGE
FOR A CATALOG!!

STORES:

LOS ANGELES
905 S. VERMONT AVE.
LOS ANGELES, CA 90006
(213)380-8000

TOLL FREE 800-826-5432

INFO: (818)904-0524
FAX: (818)781-2653
MINIMUM ORDER \$10.00
QUANTITIES LIMITED

CALIF. ADD SALES TAX
USA: \$3.00 SHIPPING
FOREIGN ORDERS
INCLUDE SUFFICIENT
SHIPPING.



NO C.O.D.

VAN NUYS
6228 SEPULVEDA BLVD.
VAN NUYS, CA 91411
(818)997-1806

LIGHT EMITTING DIODES (L.E.D.)

STANDARD JUMBO LED
DIFFUSED
T 1-3/4 size
RED 10 for \$1.50
CAT# LED-1 100 for \$13.00
1000 for \$110.00

FLASHING LED
with built in
flashing circuit.
operates on 5 volts...
RED \$1.00 each
CAT# LED-4 10 for \$9.50
GREEN \$1.00 each
CAT# LED-4G 10 for \$9.50

LED HOLDER
Two piece holder.
CAT# HLED
10 for 65¢

CLIPLITE LED
HOLDER
Makes a L.E.D. look
like a fancy indicator.
Fits T 1-3/4 size LED.

GREEN 10 for \$2.00
CAT# LED-2 100 for \$17.00
1000 for \$150.00

YELLOW 10 for \$2.00
CAT# LED-3 100 for \$17.00
1000 for \$150.00

BI-POLAR LED
Lights RED one
direction, GREEN the
other. Two leads.
CAT# LED-6 2 for \$1.70

CLEAR CAT# HLDCL-C
RED CAT# HLDCL-R
GREEN CAT# HLDCL-G
YELLOW CAT# HLDCL-Y

CATALOG OR INFORMATION: (213) 888-8988
IN CAL: 1-800-521-MARK
TOLL FREE 1-800-423-3483 FOR
ORDERS PAID BY    **ONLY**

MARK V ELECTRONICS INC.
 8019, E. SLAUSON AVE.
 MONTEBELLO CA90640
 FAX: (213) 888-6868

SHOWROOM HOURS: (PACIFIC TIME)
MON.—FRI. 9:30 to 5:30 SAT. closed
3rd ANNIVERSARY

8 Digit 1GHz Multifunctional Counter FC-1000A



A versatile laboratory bench digital counter with FIVE FUNCTION performance. FREQUENCY PERIOD UNIT TOTALIZED DATA HOLD SELF CHECK. The period function makes the instrument outstanding for video tape recorder service applications. 0.5" Bright LED display assure easy readability of values. High stabilized dual crystal oscillators are used to assure the accuracy in measurement. Durable aluminum casing with a fancy looking panel. Comes complete with test lead and owners manual.

FEATURES:
 Frequency range 10Hz - 1GHz GUARANTEED 5Hz - 1GHz typically
 Input sensitivity 10Hz - 100MHz (10mV 20mV)
 Period range 0.5 to 100s
 Unit counting capacity 99999999
 Accuracy ±1.000% (100Hz base accuracy)
 Hold function - Hold the last input signal (0Hz - 8 digit)
 Power source 117V AC -10% 50/60Hz
 Dimensions 9.50" (W) x 7.87" (D) x 3" (H)
 *SSM WITH TESTED & CAL

LAB QUALITY AT A BREAKTHROUGH PRICE!
 \$192.00

FREE CATALOG

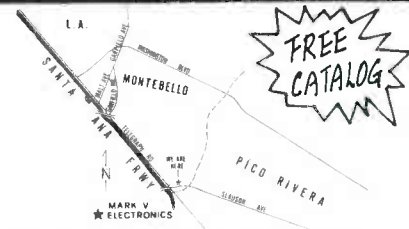

NOTE: THE BUILDING IS BESIDES SHELL GASOLINE STATION

TERMS: \$10 min order or \$20 min charge card order. Check, money order or phone order accepted. We ship UPS Ground. Add 10% of total order (min \$2.5) for shipping outside USA and 20% (min \$5.00) a Transit Insurance add 5% of total (outside USA only). CA residents add sales tax. All merchandise subject to prior sale or price reduction. Changes without notice. Any goods proved to be defective MUST BE RETURNED IN ORIGINAL FORM WITH A COPY OF YOUR INVOICE WITHIN 30 DAYS FOR REPLACEMENT.

150MC Digital SM-100 Frequency Counter



Frequency Range 10Hz - 150MHz
 Event Counter 0 to 99999999 counts (8 Digit)
 Input sensitivity 1kHz range 10Hz - 10MHz, 40mVrms
 1MHz range 1MHz - 150MHz, 40mVrms

Response time 0.2 second
 Hold Function - Hold the last input signal
 Power Supply - DCGV Battery or DCGV Adaptor
 Dimensions 9.7" x 6.11" x 2.34"

Assembled with tested \$99.00

FREE AC ADAPTOR AVAILABLE UNTIL STOCKS LAST!

SURROUND SOUND PROCESSOR SM-333



This processor employs the most updated IC at its heart. It is also equipped with a "DNR" DYNAMIC NOISE REDUCTION SYSTEM. IC made by NATIONAL SEMICONDUCTOR to partially filter out the annoying noise that is commonly found on tapes or CD disk in addition. There is a LOW NOISE OF-AMPS, and all in one board design, no other external connections connect to the main board.

SPECIFICATIONS:
 Frequency Response: 20Hz-20KHz (± 5dB) Total Harmonic Distortion: 0.05% 20Hz-20KHz (front channel), < 0.25% (surround channel). Input Voltage: 0.1V-3.5V. Output Voltage: 0.1V-3.5V (front channel), 0.5V Max. (surround channel). Delay Time: 5ms-50ms. Input Impedance: 47K Ohms Power: AC 110V 60Hz. Dimensions: 4.316" (W) x 4.131" (H) x 2.176" (D).
 KIT/ASSM WITH TESTED \$72.93

Enjoy Surround Sound with our SM-333

ELECTRIC MUSICAL INSTRUMENT EK-38



NEW for 1989

THIS PROGRAMMABLE KEYBOARD IS DESIGNED FOR BOTH FUN AND LEARNING. THIS INSTRUMENT WILL AUTOMATICALLY PRODUCE FIFTEEN FAMILIAR TUNES FOR INSTANT PLEASURE OR YOU CAN PLAY OTHER TUNES FROM RANDOM NOTES OF YOUR OWN.

SPECIFICATION:
 • 25 KEYS • MELODY STORAGE PLUS AUTO PLAY • ONE-KEY PLAY LETS THE BEGINNER ENJOY MELODY PLAY WITH EASE • 15 SONGS PRESET FOR DEMONSTRATION TUNE • BUILD-IN SPEAKER • VOLUME CONTROL • BATTERY OPERATED (4 AA-SIZE DRY CELLS) • DIMENSION (W X D X H) 15" x 4.7" x 1.4" • WEIGHT 0.8 LB • EXTERNAL DC JACK

ONLY \$22.00

120W VERSATILE STEREO POWER BOOSTER TA-302



MATCH WITH OUR SURROUND SOUND PROCESSOR

• QTL full transistorize and low distortion of SEPP circuit design, high output power and sound fidelity.
 • With high and low input impedance for selection, so it can match with all preamplifiers, low power of portable sound equipment, and all types of stereo recorder deck to use. It can boost "walkman" type of radio and tape player, too.
 • With 10 band colour LED power meter, output power can be easily defined. TA-302 is a versatile amplifier for both visual and listening enjoyment.

60Wx2 P.M.P.O.
 KIT/ASSM WITH TESTED \$50.70

PROFESSIONAL COLOR LIGHT CONTROLLER SM-328



FEATURES:
 1. FOUR GROUPS OF INDEPENDENT OUTPUT SYSTEM 1000W/CH. MAX. 4680V (100-117V). 2. PROFESSIONAL COLOR CONTROL SYSTEM (KEY-BOARD TYPE). 3. INDEPENDENT INPUT SIGNAL ADJUSTMENT. 4. FOUR GROUPS OF INDEPENDENT DIMMER CONTROL. 5. SPEED CONTROL CHASER. 6. AUTOMATIC CHASING CONTROL SYSTEM. 7. FOUR KINDS OF SPECIAL CHASING PROGRAMS. 8. COMBINATION OF PROGRAM AND MUSIC CHASING EFFECT. 9. FORWARD/BACKWARD CHASING CONTROL. SM-328 color light controller is specialized for ballroom, night club disco and advertisement lighting. It consorts with several color control characteristics, which employ professional color control system and keyboard program selection. Therefore, it is capable of producing lighting effects by using chasing program and fluctuating music signal. There are two kinds of lighting effects. The first type is controlled by "music" signal. In order to adjust the brightness of four groups of lightings, each music signal will be separated into high, medium low A, and low B frequency range. Furthermore, each group of lightings is incorporated with an independent signal adjustment. The second kind is composed of electrical circuits and this is the main part for creating a special lighting effect. It has four chasing programme.

Dimensions: 14.516" x 8.1516" x 3.316"
 Ass. with tested \$150.00

300W HQ HI-FI POWER AMPLIFIER (MONO) TA-3600



QUASI-COMPLEMENTARY SYMMETRY WITH PARALLEL HIGH OUTPUT TRANSISTORS

SPECIFICATIONS:
 *POWER OUTPUT: 300W (RMS) INTO 8 OHMS - 2450W (P.M.P.O.) INTO 8 OHMS
 540W (MUSIC POWER) INTO 8 OHMS
 *LOAD IMPEDANCE: 4 OHMS OR 8 OHMS
 *FREQUENCY RESPONSE: 10Hz-200,000Hz
 *TOTAL HARMONIC DISTORTION LESS THAN 0.05%
 *INPUT SENSITIVITY AND IMPEDANCE AT 1KHz: 1V-1.4V 47K OHMS
 *SUPPLY VOLTAGE: DC ±75V OR AC 53V x 2.8A
 KIT/ASSM WITH TESTED \$86/110
 X'FORMER \$38.00

Build up your supreme Power Amp

INFRARED REMOTE CONTROL UNIT TY-41 MKV



It has two modes of operation: "Continuous" and "on/off". It is suitable for many kinds of electrical and electronic appliances whose power consumption is within 300W. Such as light control, garage door opener, TV on/off, burglar alarm and many others.

KIT. \$20
 ASSM. WITH TESTED \$35

Special Offer!

COLOR LIGHT CONTROLLER TY-23B



As a result of the advanced technology, this unit can control various colorful spot lights or bulbs. The visual effect of which is most suitable in places like party, disco, electronic game centre and also in lightings for advertisements. Total output power is 300W (1000W/CH) which can control 30 pieces of 100W or 600 pieces of 50W color light bulbs.

FEATURES:
 1. "Music" mode: Audio signal is divided into high, middle and low frequency to drive 3 groups of lights. It has independent controller for sensitivity.
 2. "Chasing" mode: Electronic circuit automatically controls 3 groups of color lights in sequential ON and OFF, also it has a speed controller and shaft program. Chasing Mode on the P.C Board Kit. \$150

STATE OF ARTS HQ FET ST. PRE-AMP TA-377A



This Pre-amplifier employs 18 pairs of HIGH QUALITY N channel and P channel FET and 1% metal film resistor to form a state of arts full complementary symmetric mirror circuit.

• It uses "CM" RIAA EQ preamplifier to minimize TIM distortion and to obtain high-fidelity.
 • The power supply is based on by pass coupling DC stabilizer which uses class A design to obtain low internal impedance at high frequency and to greatly reduce transient distortion.
 • Professional relay delay circuit prevents noise which may occur during power on and off.
 • All FETs were tested and paired in the factory so no problem is likely to occurred during building.
 • It can be directly connected to any power amplifier. The best partner is TA-477 120W MOS FET power amplifier & TA-3600.

KIT/ASS WITH TESTED \$59.95/75
 METAL CABINET \$20.10

TERMS \$10 min order or \$20 min charge card order. Check, money order or phone order accepted. We ship UPS Ground. Add 10% of total order (min \$2.5) for shipping outside USA and 20% (min \$5.00) a Transit Insurance add 5% of total (outside USA only). CA residents add sales tax. All merchandise subject to prior sale or price reduction. Changes without notice. Any goods proved to be defective MUST BE RETURNED IN ORIGINAL FORM WITH A COPY OF YOUR INVOICE WITHIN 30 DAYS FOR REPLACEMENT.

0-15V 2A REGULATED DC POWER SUPPLY TR-100A



Kit \$59.50
 Ass. with tested \$69.50

• Output voltage is adjustable from 0-15V DC, two current limit range are available for selection: 200mA or 2A.
 • An elaborated protection system is specially designed, a "BB" sound and an sparking light will appear when the output is overloaded.
 • High-stability and reliability is resulted by employing high quality voltage regulated IC.
 • King-size meter makes the reading of voltage and current more clearly and accurately.
 • A refined case, meter and all accessory are enclosed for both kit and assembled form. It is most suitable for professional or amateur use.

TALKING CLOCK *Clocks that really tell time!*



SPECIAL VALUE

No. 8501 No. 8504

1. Talk push button for voice announcement of time.
 2. Read out twelve hour system display for hour, minute, second by color flash, AM & PM.
 3. Display three display modes of time, alarm time & quiet.
 4. Alarm: on / off switch with thirty seconds voice alarm.
 5. Sleep: reminder voice alarm of thirty seconds after 4 minutes of first vocal alarm.
 6. Volume: two level of voice output.
 7. Language available: English.

PARROT 8501 \$18.64
 MYNAB 8504 \$17.75

NOT A KIT

ELECTRONIC ECHO AND REVERBERATION AMPLIFIER TA-2400A



RECORDS W/ ECHO EFFECT YOURSELF!

Kit/Ass. with tested \$93.30/\$116.80

STEREO SIMULATOR TA-3000



UPGRADE YOUR TV & VCR

You can gain a Stereo TV from today!
 This simulator is special design of using the most advance able manufactured "S" it produced a superior analog stereo effect since the "S" is equalized 60 pcs of LOW NOISE FET & TRANSISTOR. The simulator can even help you to promote color reception from a normal one to a special one with a Hi-Fi STEREO function. Our simulator is also applicable to any other mono sources in coming it to ANY DIGITAL IC. Undoubtedly it is the most advanced equipment for every family while it should contribute to your listening pleasure.

Ass. with tested \$43.38

FREE CATALOG

120W MOSFET POWER AMPLIFIER TA-477



SUBJECT A PROFESSIONAL AMP BY YOURSELF

This amplifier consists of three super low TIM differential stages, and Hitachi 2SJ49/25K 134 match pair "MOSFET" as output component whose frequency response and transient response is superior to the other power transistor. Therefore this amplifier has high-fidelity and superior analytic power over the entire Audio Spectrum. It is suitable for reproducing classic and modern music. Heavy Duty Heat Sink with 28 radial fins is included!

Kit \$68.00
 Metal Cabinet/X'Former (Optional) \$33.00/24.00

YAMATO 4001 3 1/2 DIGITAL MULTIMETER



Special offer for our 3rd Anniversary

THE YAMATO 4001 is a 3 1/2 DIGIT COMPACT DIGITAL MULTIMETER, it employs FET type LCD, with large figures. IT'S ADVANTAGES: High accuracy in measuring. High impedance assures min. measuring error. One rotary switch allows fast & convenient operation. 26 measurement range enable wider application. Over-input indication & low battery life appears on display. LSI-circuit use provides high reliability and durability. Measurement possible even under strong magnetic field. Measures ONLY 6 3/4" x 3 3/4" x 1"

FREE CATALOG

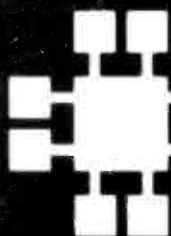

JDR Microdevices®

Complete customer satisfaction... superior service... friendly, knowledgeable personnel
quality merchandise... providing the best values in leading edge technology.

STATIC RAMS

2112	256x4	(450ns)	2.99
2114	1024x4	(450ns)	.99
2114L-2	1024x4	(200ns)(LOW POWER)	1.49
TMM2016-100	2048x8	(100ns)	1.95
HM6116-4	2048x8	(200ns)(CMOS)	3.29
HM6116-3	2048x8	(150ns)(CMOS)	3.95
HM6116LP-4	2048x8	(200ns)(CMOS)(LP)	4.29
HM6116LP-3	2048x8	(150ns)(CMOS)(LP)	4.95
HM6264LP-15	8192x8	(150ns)(CMOS)(LP)	6.49
HM6264LP-12	8192x8	(120ns)(CMOS)(LP)	6.99
HM43256LP-15	32768x8	(150ns)(CMOS)(LP)	12.95
HM43256LP-12	32768x8	(120ns)(CMOS)(LP)	14.95
HM43256LP-10	32768x8	(100ns)(CMOS)(LP)	19.95

DYNAMIC RAMS

4116-250	16384x1	(250ns)	.49
4116-200	16384x1	(200ns)	.89
4116-150	16384x1	(150ns)	.99
4116-120	16384x1	(120ns)	1.49
MK4332	32768x1	(200ns)	6.95
4164-150	65536x1	(120ns)	3.19
4164-120	65536x1	(100ns)	1.95
MCM6665	65536x1	(200ns)	1.95
TMS4164	65536x1	(150ns)	1.95
4164-REFRESH	65536x1	(150ns)(PIN 1 REFRESH)	2.95
TMS4416	16384x4	(150ns)	3.75
41128-150	131072x1	(150ns)	5.95
TMS4464-15	65536x4	(150ns)	7.95
41256-150	262144x1	(150ns)	12.45
41256-120	262144x1	(120ns)	12.95
41256-100	262144x1	(100ns)	13.45
HM51258-100	262144x1	(100ns)(CMOS)	6.95
1 MB-120	1048576x1	(120ns)	34.95
1 MB-100	1048576x1	(100ns)	37.95

EPROMS

2738	1024x8	(450ns)(25V)	4.95
2716	2048x8	(450ns)(25V)	3.49
2716-1	2048x8	(350ns)(25V)	3.95
TMS2532	4096x8	(450ns)(25V)	5.95
2732	4096x8	(450ns)(25V)	3.95
2732A	4096x8	(250ns)(21V)	3.95
2732A-2	4096x8	(200ns)(21V)	4.25
27C64	8192x8	(250ns)(12.5V CMOS)	4.95
2764	8192x8	(450ns)(12.5V)	3.49
2764-250	8192x8	(250ns)(12.5V)	3.69
2764-200	8192x8	(200ns)(12.5V)	4.25
MCM68766	8192x8	(350ns)(21V)(24 PIN)	15.95
27128	16384x8	(250ns)(12.5V)	4.25
27C256	32768x8	(250ns)(12.5V CMOS)	7.95
27256	32768x8	(250ns)(12.5V)	5.95
27512	65536x8	(250ns)(12.5V)	11.95
27C512	65536x8	(250ns)(12.5V CMOS)	12.95

*V_P = Program Voltage

MEMORY PRICES SUBJECT TO CHANGE DUE TO MARKET CONDITIONS. PLEASE CALL TO CONFIRM PRICES.

HIGH-TECH SPOTLIGHT 1 MB EPROMS

■ 128K x 8 ORGANIZATION ■ 200 NS
■ CMOS DESIGN FOR LOW POWER

\$34.95

8031	3.95	8203	14.95	8255-5	1.59
8035	1.49	8205	3.29	8259-5	1.95
8039	2.95	8212	1.49	8259-5	2.29
8052AH BASIC	34.95	8216	1.49	8272	2.25
8080	2.49	8224	2.25	8272	4.39
8085	1.95	8228	2.25	8274	4.95
8086	6.49	8237	3.95	8275	16.95
8088	5.95	8237-5	4.75	8279	2.49
8088-2	8.48	8243	1.95	8279-5	2.95
8155-2	2.49	8250	6.95	8282	3.95
8155-2	3.95	8251	1.29	8283	3.95
8741	9.95	8251A	1.69	8284	2.25
8748	7.95	8253	1.59	8286	3.95
8749	9.95	8253-5	1.95	8287	3.95
8755	14.95	8255	1.49	8288	4.95

8087	5 MHz	\$99.95
8087-2	8 MHz	\$159.95
8087-1	10 MHz	\$229.95
80287	6 MHz	\$179.95
80287-8	8 MHz	\$249.95
80287-10	10 MHz	\$309.95
80387-16	16 MHz	\$499.95
80387-20	20 MHz	\$799.95

MATH COPROCESSORS

intel®

74L500

74L500	16	74LS112	29	74LS241	69
74L501	18	74LS122	45	74LS242	69
74L502	17	74LS123	49	74LS243	69
74L503	18	74LS124	2.75	74LS244	69
74L504	16	74LS125	39	74LS245	79
74L505	18	74LS126	39	74LS251	49
74L506	18	74LS132	39	74LS253	49
74L509	18	74LS133	49	74LS257	39
74L510	16	74LS136	39	74LS258	49
74L511	22	74LS138	39	74LS259	1.29
74L512	22	74LS139	39	74LS260	49
74L513	26	74LS145	99	74LS266	39
74L514	39	74LS147	99	74LS273	79
74L515	26	74LS148	99	74LS279	79
74L520	17	74LS151	39	74LS280	1.98
74L521	22	74LS153	39	74LS283	59
74L522	22	74LS154	1.49	74LS290	89
74L527	23	74LS155	59	74LS293	89
74LS28	26	74LS156	49	74LS299	1.49
74L530	17	74LS157	35	74LS322	3.95
74L532	18	74LS158	29	74LS323	2.49
74L533	28	74LS160	29	74LS365	39
74L538	26	74LS161	39	74LS367	39
74L542	39	74LS163	39	74LS373	79
74L547	75	74LS164	49	74LS374	79
74L548	85	74LS165	65	74LS375	95
74L551	17	74LS166	95	74LS377	79
74L573	29	74LS169	95	74LS390	1.19
74L574	24	74LS173	49	74LS393	79
74L575	29	74LS174	39	74LS541	1.49
74L576	29	74LS175	39	74LS624	1.95
74L583	49	74LS191	49	74LS640	99
74L585	49	74LS192	69	74LS645	99
74L586	22	74LS193	69	74LS670	89
74L590	39	74LS194	69	74LS682	3.20
74L592	39	74LS195	69	74LS688	2.40
74L593	39	74LS196	59	74LS783	22.95
74L595	49	74LS197	59	74LS2521	2.80
74LS107	34	74LS221	59	26LS31	1.95
74LS109	36	74LS240	69	26LS32	1.95

7400	19	TL071	69	LM567	79
7402	19	TL072	1.09	NE570	2.95
7404	19	TL074	1.95	NE592	95
7406	29	TL082	99	LM723	49
7407	29	TL084	1.49	LM733	98
7408	24	LM301	.34	LM741	29
7410	19	LM309K	1.25	LM747	69
7411	25	LM311	.59	MC1330	1.69
7414	49	LM311H	.89	MC1350	1.19
7416	25	LM317K	3.49	LM1458	95
7417	25	LM317T	.69	LM1488	.49
7420	19	LM318	1.49	LM1489	.49
7430	19	LM319	1.25	LM1496	.85
7432	29	LM320	see 7900	LM19203	.79
7438	29	LM323K	3.49	XR2206	3.95
7442	49	LM324	.34	XR2211	2.95
7445	69	LM331	3.95	LM1917	1.95
7447	89	LM334	1.19	CA3046	85
7448	34	LM335	1.79	CA3146	1.29
7474	33	LM336	1.75	MC3373	1.95
7475	45	LM338K	4.49	MC3470	1.99
7476	35	LM339	.59	MC3480	8.95
7483	50	LM340	see 7800	MC3487	2.95
7484	59	LF353	.59	LF353	1.49
7486	35	LF356	.99	LM3911	2.25
7489	2.15	LF357	.99	LM3909	.98
7490	39	LM358	.59	LM3914	1.89
7493	35	LM380	.89	MC4024	3.49
7497	29	LM383	1.95	LM383	1.95
74121	29	LM386	.89	RC4136	1.25
74123	49	LM393	.45	RC4558	65
74125	45	LM394H	5.95	LM13600	1.49
74150	1.35	TL494	4.20	75107	1.49
74151	35	TL497	3.25	75109	1.49
74153	35	NE555	.29	75150	1.95
74154	1.49	NE556	.49	75154	1.95
74157	55	NE568	.79	75188	1.25
74159	1.65	NE568A	1.95	75189	1.25
74161	61	NE568	1.95	75451	1.95
74164	85	LM566	1.49	75452	3.99
74166	1.00	NE590	2.50	75477	1.29
74175	89				
74367	65				

LM567	.79
NE570	2.95
LM723	49
LM733	98
LM741	29
LM747	69
MC1330	1.69
MC1350	1.19
LM1458	95
LM1488	.49
LM1489	.49
LM1496	.85
LM19203	.79
XR2206	3.95
XR2211	2.95
LM1917	1.95
CA3046	85
CA3146	1.29
MC3373	1.95
MC3470	1.99
MC3480	8.95
MC3487	2.95
LF353	1.49
LM3911	2.25
LM3909	.98
LM3914	1.89
MC4024	3.49
LM383	1.95
RC4136	1.25
RC4558	65
LM13600	1.49
75107	1.49
75109	1.49
75150	1.95
75154	1.95
75188	1.25
75189	1.25
75451	1.95
75452	3.99
75477	1.29
H: TO-5 CAN, K: TO-3, T TO-220	

6502	2.25
65C02 (CMOS)	7.95
6520	1.65
6522	2.95
6526	13.95
6532	5.95
6545	2.95
6551	2.95

Z80-CPU	1.25
Z80A-CPU	1.29
Z80A-CTC	1.69
Z80A-DART	5.95
Z80A-DMA	5.95
Z80A-PIO	1.89
Z80A-SIO 0	5.95
Z80A-SIO 1	5.95
Z80A-SIO 2	5.95

1771	4.95
1791	9.95
1793	9.95
1795	12.95
1797	12.95
1799	19.95
2793	19.95
2797	29.95
4339	4.39
UPD765	4.39
MB8876	12.95
MB8877	12.95
1691	6.95
2143	6.95
9216	6.29

V20-5 MHz	8.95
V20-8 MHz	10.95
V20-10 MHz	12.95
V30-8 MHz	13.95

16L8	\$2.95
16R8	\$2.95
16R6	\$2.95
16R4	\$2.95

6800	1.95
6802	2.95
6803	3.95
6809	2.95
6809E	2.95
6810	1.95
6820	2.95
6821	1.25
6824	3.95
6843	4.95
6844	6.95
6845	2.75
6847	4.75
6850	1.95
6883	22.95

MM58167	9.95
MM58174	9.95
MSM5832	2.95

AY5-1013	3.95
AY3-1015	4.95
TR1602	3.95
2651	4.95
IM6402	3.95
IM6403	9.95
INS8250	6.95
NS16450	10.95

ADC0804	2.99
ADC0809	3.85
DAC0800	3.29
DAC0808	1.95
DAC1022	5.95
MC1408L8	1.95
8T28	1.29
8T97	.59
DP8304	2.2

CAPACITORS TANTALUM

1.0µf	15V	.12	1.0µf	35V	.45
6.8	15V	.42	2.2	35V	.19
10	15V	.45	4.7	35V	.39
22	15V	.99	10	35V	.69
DISC					
10µf	50V	.05	001µf	50V	.05
22	50V	.05	005	50V	.05
33	50V	.05	.01	50V	.07
47	50V	.05	.05	50V	.07
100	50V	.05	.1	12V	.10
220	50V	.05	.1	50V	.12

MONOLITHIC

0.1µf	50V	.14	1µf	50V	.18
047µf	50V	.15	47µf	50V	.25

ELECTROLYTIC

RADIAL		AXIAL			
1µf	25V	14	1µf	50V	14
4.7	50V	11	10	50V	16
10	50V	11	22	16V	14
47	35V	13	47	50V	19
100	16V	15	100	35V	19
220	35V	20	470	50V	29
470	25V	30	1000	16V	29
2200	16V	70	2200	16V	70
4700	25V	1.45	4700	16V	1.25

VOLTAGE REGULATORS

7805T	49	7812K	1.39
7808T	49	7905K	1.39
7812T	49	7912K	1.19
7815T	49	78L05	.19
7905T	59	78L12	.19
7908T	59	79L05	.39
7912T	59	79L12	1.19
7915T	59	LM323K	4.79
7805K	1.59	LM338K	6.35

DISCRETE

1N751	.15	4N28	.69
1N4148 25	1.99	4N33	.89
1N4004 10	1.99	4N37	1.19
1N5402	25	MCT-2	59
2N2222	25	MCT-6	1.29
2N2222	10	TIL-111	.99
2N2907	25	2N3906	10
2N3055	79	2N4401	25
2N3904	10	2N4403	25
4N26	69	2N6045	1.75
4N27	69	TIP31	.49

SOLDER STATION

UL APPROVED
ADJUSTABLE HEAT SETTING
WITH TIP TEMPERATURE
READOUT
REPLACEMENT TIPS
AVAILABLE \$2.95
\$49.95



WIREWRAP PROTOTYPE CARDS

FR-4 EPOXY GLASS LAMINATE WITH GOLD PLATED EDGE-CARD FINGERS
SILK SCREENED LEGENDS, MOUNTING BRACKETS INCLUDED



FOR PS/2

JDR-PR32 32 BIT PROTOTYPE CARD 69.95
JDR-PR16 16 BIT CARD WITH I/O DECODING LAYOUT 49.95
PARTS KIT FOR JDR-PR16 ABOVE 15.95
JDR-PR16V 16 BIT CARD FOR VIDEO APPLICATIONS 39.95

FOR AT

JDR-PR10 16 BIT CARD WITH I/O DECODING LAYOUT 34.95
JDR-PR10PK PARTS KIT FOR JDR-PR10 ABOVE 12.95

FOR XT

IBM-PR1 WITH +5V AND GROUND PLANE 27.95
IBM-PR2 AS ABOVE WITH I/O DECODING LAYOUT 29.95

BYPASS CAPACITORS

0.1 µf	CERAMIC DISC	100	\$5.00
0.1 µf	MONOLITHIC	100	\$10.00
1 µf	CERAMIC DISC	100	\$6.50
1 µf	MONOLITHIC	100	\$12.50

RESISTOR NETWORKS

SIP	10 PIN	9 RESISTOR	.69
SIP	8 PIN	7 RESISTOR	.59
DIP	16 PIN	8 RESISTOR	1.09
DIP	16 PIN	15 RESISTOR	1.09
DIP	14 PIN	7 RESISTOR	.99
DIP	14 PIN	13 RESISTOR	.99

SHORTING
BLOCKS
\$1.00



EXTENDER CARDS

FOR PROTOTYPE DEBUGGING AND TROUBLESHOOTING



EXT-8088 FOR XT SYSTEM 29.95
EXT-80286 FOR AT SYSTEM 39.95
EXT-16 MICROCHANNEL 16-BIT 69.95
EXT-32 MICROCHANNEL 32-BIT 99.95

"SNAPABLE" HEADERS

CAN BE SNAPPED APART TO
MAKE ANY SIZE HEADER,
ALL WITH .1" CENTERS

1x40	STRAIGHT LEAD	.99
1x40	RIGHT ANGLE LEAD	.49
2x40	2 STRAIGHT LEADS	2.49
2x40	2 RIGHT ANGLE LEADS	2.99



WHY THOUSANDS CHOOSE JDR

- ★ QUALITY MERCHANDISE
- ★ COMPETITIVE PRICES
- ★ MOST ORDERS SHIPPED IN 24 HOURS
- ★ FRIENDLY, KNOWLEDGEABLE STAFF
- ★ 30-DAY MONEY BACK GUARANTEE
- ★ TOLL FREE TECHNICAL SUPPORT
- ★ EXCELLENT CUSTOMER SERVICE

CALL FOR VOLUME QUOTES

SOLDERLESS BREADBOARDS

WBU-D	100 TIE PTS.	2.95	WBU-204	1660 TIE PTS.	24.95
WBU-T	630 TIE PTS.	6.95	WBU-206	2390 TIE PTS.	29.95
WBU-204-3	1360 TIE PTS.	17.95	WBU-208	3220 TIE PTS.	39.95

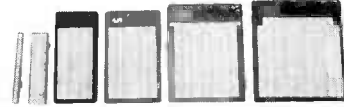

IDC CONNECTORS/RIBBON CABLE

DESCRIPTION	ORDER BY	CONTACTS					
		10	20	26	34	40	50
SOLDER HEADER	IDHxxS	.82	1.29	1.38	2.20	2.58	3.24
RIGHT ANGLE SOLDER HEADER	IDHxxSR	.85	1.35	1.76	2.31	2.72	3.39
WIREWRAP HEADER	IDHxxW	1.86	2.98	3.34	4.50	5.28	6.63
RIGHT ANGLE WIREWRAP HEADER	IDHxxWR	2.05	3.28	4.22	4.45	4.80	7.30
RIBBON HEADER SOCKET	IDSxx	.63	.89	.95	1.29	1.49	1.69
RIBBON HEADER	IDMxx	---	5.50	6.25	7.00	7.50	8.50
RIBBON EDGE CARD	IDExx	.85	1.25	1.35	1.75	2.05	2.45
10' GREY RIBBON CABLE	RCxx	1.60	3.20	4.30	5.40	6.40	7.50

FOR ORDERING INSTRUCTIONS, SEE D-SUBMINIATURE CONNECTORS BELOW

3 VOLT
LITHIUM BATTERY
\$1.95
HOLDER \$1.49



SPECTRONICS CORPORATION EPROM ERASERS

Model	Timer	Chip Capacity	Intensity (µW/cm²)	Unit Cost
PE 140	NO	9	8,000	\$89
PE 140T	YES	9	8,000	\$139
PE 240T	YES	12	9,600	\$189



D-SUBMINIATURE CONNECTORS

DESCRIPTION	ORDER BY	CONTACTS						
		9	15	19	25	37	50	
SOLDER CUP	MALE	DBxxP	.45	.59	.69	.69	1.35	1.85
	FEMALE	DBxxS	.49	.69	.75	.75	1.39	2.29
RIGHT ANGLE PC SOLDER	MALE	DBxxPR	.49	.69	---	.79	2.27	---
	FEMALE	DBxxSR	.55	.75	---	.85	2.49	---
WIREWRAP	MALE	DBxxPWW	1.69	2.56	---	3.89	5.60	---
	FEMALE	DBxxSWW	2.76	4.27	---	6.84	9.95	---
IDC RIBBON CABLE	MALE	IDBxxP	1.39	1.99	---	2.25	4.25	---
	FEMALE	IDBxxS	1.45	2.05	---	2.35	4.49	---
HOODS	METAL	MHOODxx	1.05	1.15	1.25	1.25	---	---
	GREY	HOODxx	.39	.39	---	.39	.69	.75

ORDERING INSTRUCTIONS:
INSERT THE NUMBER OF CONTACTS IN THE POSITION MARKED 'xx' OF THE ORDER BY PART NUMBER LISTED
EXAMPLE: A 15 PIN RIGHT ANGLE MALE PC SOLDER WOULD BE DB15PR

MOUNTING HARDWARE 59¢

RS-232 BREAKOUT BOX

FOR TROUBLESHOOTING
SERIAL COMMUNICATIONS

- OPEN/CLOSE INDIVIDUAL CIRCUITS
- 20 JUMPERS CROSS-CONNECT ANY TWO CIRCUITS
- 10 LEDS SHOW CIRCUIT ACTIVITY
- GENDER-BO \$34.95



GENDER CHANGERS

FOR 25 PIN D-SUBMINIATURE
CONNECTORS

GENDER-FF	FEMALE-MALE	7.95
GENDER-MM	MALE-MALE	7.95
GENDER-MF	MALE-FEMALE	7.95
GENDER-NM	NULL MODEM	8.95
GENDER-JB	JUMPER BOX	8.95
GENDER-MT	MINISTER	14.95

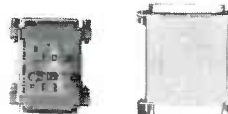

DATARASE

- ERASES 2 EPROMS IN 10 MINUTES
- VERY COMPACT, NO DRAWER
- THIN METAL SHUTTER PREVENTS UV LIGHT FROM ESCAPING

\$34.95



JOYSTICK

- SET X-Y AXIS FOR AUTO CENTER OR FREE MOVEMENT
- FIRE BUTTON FOR USE WITH GAME SOFTWARE
- ADAPTOR CABLE FOR IBM, APPLE II

\$19.95



JDR MICRODEVICES, 110 KNOWLES DRIVE, LOS GATOS, CA 95030
LOCAL (408) 866-6200 FAX (408) 378-8927 TELEX 171-110



RETAIL STORE: 1256 SOUTH BASCOM AVE., SAN JOSE, CA (408) 947-8881
HOURS: M-F 10-7 SAT. 9-5 SUN. 12-4



ORDER TOLL FREE 800-538-5000

COPYRIGHT 1988 JDR MICRODEVICES

CONTINENTAL U.S. AND CANADA

CIRCLE 177 ON FREE INFORMATION CARD

www.americanradiohistory.com

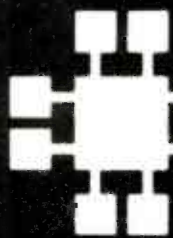

JDR Microdevices®

Complete customer satisfaction... superior service... friendly, knowledgeable personnel
quality merchandise... providing the best values in leading edge technology.

PROMETHEUS 2400 BAUD MODEM

\$129⁹⁵

NEW LOW PRICE!

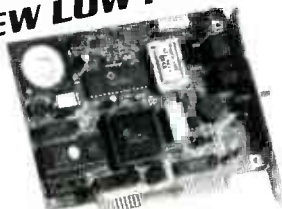

IT'S TIME TO TRADE UP NOW THAT JDR BREAKS THE PRICE BARRIER ON 2400 BAUD MODEMS

- AUTO DIAL ANSWER
- SELF TEST ON POWER-UP
- TOUCHTONE OR PULSE DIALING
- HAYES & BELL SYSTEMS COMPATIBLE
- FULL OR HALF DUPLEX
- MIRROR II COMMUNICATIONS SOFTWARE INCLUDED

MCT-241

MCT-121 1200 BAUD 1/2 CARD

\$ 69.95

EXTERNAL MODEMS

MCT-12E 1200 BAUD
MCT-24E 2400 BAUD

\$ 99.95
\$169.95

COMPUTER CASES

ATTRACTIVE, STURDY STEEL CASES FIT THE POPULAR SIZED MOTHERBOARDS AND INCLUDE SPEAKERS, FACEPLATES, EXPANSION SLOTS, FRONT PANEL KEYLOCKS, LED INDICATORS AND ALL NECESSARY HARDWARE.



XT STYLE FLIP-TOP
XT STYLE SLIDE-TOP
AT STYLE SLIDE-TOP
JR. AT STYLE FLIP-TOP

\$34.95
\$39.95
\$89.95
\$149.95

■ INCLUDES 150 WATT POWER SUPPLY

POWER SUPPLIES

FOR IBM XT COMPATIBLE \$59.95

- UL APP. 135 WATTS
- +5V 15A. +12V 4.2A
- -5V .5A. 12V .5A

PS-135

PS-150 150W MODEL \$69.95

FOR IBM AT COMPATIBLE \$89.95

- 200 WATTS
- +5V 22A. +12V 8A
- -5V .5A. 12V .5A

PS-200

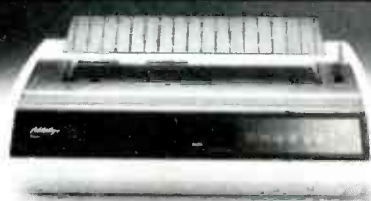

DIABLO PRINTER \$279⁹⁵

- LETTER QUALITY AT 20 CPS, 132 COLS
- 10, 12, 15 PITCH & PROPORTIONAL SPACING
- SERIAL & PARALLEL INTERFACE
- AUTO PAPER LOAD, FRICTION FEED
- FULL XEROX WARRANTY



CENTRONICS LASER \$1195 PRINTER

NEAR TYPESET QUALITY
AFFORDABLE AT LAST

- 8 PAGES PER MINUTE ■ 300 DPI RESOLUTION!
- 1 YEAR WARRANTY ■ CHOICE OF EMULATION BOARDS

MULTI-PRINTER EMULATION BOARD:

EPSON FX-80 EMULATION—NOTHING ELSE REQUIRED
IBM PC GRAPHICS, PROPRINTER & DIABLO 630
EMULATION REQUIRES ADDITIONAL FONT CARD

HP LJ+ EMULATION BOARD:

HP LASERJET EMULATION—3 RESIDENT FONTS &
2 PITCHES ADDITIONAL FONT CARD AVAILABLE

1.5MB RAM CARD

\$139.95

EXTRA FONT CARDS

\$199.95

TONER CARTRIDGES

\$59.95

PFS FIRST PUBLISHER

\$99.95

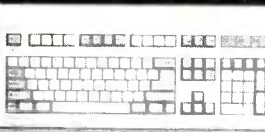

IBM COMPATIBLE KEYBOARDS

FULL ONE YEAR WARRANTY

IBM ENHANCED STYLE LAYOUT

\$79.95

- AUTOSENSE FOR XT OR AT COMPATIBLES
- LED INDICATORS ■ AUTO REPEAT FEATURE
- SEPARATE CURSOR PAD

MCT-5339

IBM AT STYLE LAYOUT

\$59.95

- SOFTWARE AUTOSENSE FOR XT OR AT COMPATIBLES
- LED INDICATORS ■ AUTO REPEAT FEATURE

MCT-5060

MAXI-SWITCH KEYBOARDS

\$84.95

ENHANCED STYLE LAYOUT

- STANDARD ENHANCED KEYBOARD LAYOUT
- TACTILE FEEDBACK
- LIGHTED NUM, CAPS, AND SCROLL LOCK
- NUMERIC & CURSOR KEYPADS. 12 "F" KEYS

MAX-5339

MAX-5060 MAXI-SWITCH, AT STYLE

\$64.95

VGA COMPATIBLE PACKAGE

\$649⁰⁰

MONITOR & CARD TOGETHER

- 800 X 560
MAXIMUM
RESOLUTION
- 640 X 480
IN 16 COLORS
- 320 X 200
IN 256 COLORS
- IBM STYLE
ANALOG MONITOR
- FULLY VGA, EGA,
CGA, HERCULES &
MONOCHROME
COMPATIBLE



NEC MULTISYNC

\$599.95

- ORIGINAL CGA EGA VGA COMPATIBLE MONITOR
- AUTO FREQUENCY ADJUSTMENT
- RESOLUTION AS HIGH AS 800 X 560

CASPER EGA

\$399.95

- 15 75 21 85 KHz SCANNING FREQUENCIES
- 640 X 200 350 RESOLUTION ■ 31 MM DOT PITCH
- 14" BLACK MATRIX SCREEN ■ 16 COLORS

CASPER RGB

\$279.95

- COLOR GREEN AMBER SWITCH ■ 39MM DOT PITCH
- 640 X 240 RESOLUTION ■ 14" NON-GLARE SCREEN
- RGB IBM COMPATIBLE ■ CABLE INCLUDED

SAKATA

MONOCHROME

\$69.95

- IBM COMPATIBLE TTL INPUT
- 12" NON-GLARE SCREEN
- CABLE FOR IBM PC INCLUDED

SAMSUNG MONOCHROME MONITOR

\$129.95

MONITOR STANDS

MODEL MS-100

\$12.95

- TILTS AND SWIVELS
- STURDY PLASTIC CONSTRUCTION

MODEL MS-200

\$39.95

- TILTS AND SWIVELS ■ BUILT-IN SURGE SUPPRESSOR
- INDEPENDENTLY CONTROLS UP TO 5 AC OUTLETS

LOGITECH MOUSE \$79⁹⁵



PC MAGAZINE'S EDITORS CHOICE
ALL MODELS HAVE SERIAL SUPPORT (COM1 COM2), 230
D P I RESOLUTION, LOTUS 1-2-3 SHELL SELF-INSTALLING
SOFTWARE AND POINT EDITOR.

SERIAL MOUSE W/PC PAINTBRUSH

\$99.95

BUS MOUSE W/PC PAINTBRUSH

\$99.95

BUS MOUSE W/PC PAINTBRUSH/CAD

\$149.95

3.5" FLOPPY DISK DRIVE \$149⁹⁵



1.44 MB 3 1/2" DRIVE

- ULTRA HIGH DENSITY
- ALSO WORKS WITH 720K DISKS

FDD-1.44 x BLACK FACEPLATE

\$149.95

FDD-1.44 x BEIGE FACEPLATE

\$149.95

720K 3 1/2" FLOPPY DRIVE

\$129.95

FDD-3.5 x (FORXT)

FDD-3.5 x (FORAT)

Seagate

NEW!
FAST 40MB DRIVE
\$529⁰⁰

THE NEW ST-251-1 DRIVE IS 30% FASTER WITH AN AVERAGE ACCESS TIME OF 28 MS. EASY TO INSTALL HALF-HEIGHT DRIVE.

ST-251-1
WITH MCT-HDC CONTROLLER \$569.00
WITH MCT-ATFH CONTROLLER \$639.00

1/2 HEIGHT DRIVES

20 MB, 65 MS, ST-225 \$225.00
WITH MCT-HDC CONTROLLER \$269.00
WITH MCT-ATFH CONTROLLER \$339.00

30 MB RLL, 65 MS, ST-238 \$249.00
WITH MCT-RLL CONTROLLER \$299.00
WITH MCT-ATFH-RLL CONTROLLER \$389.00

40 MB, 40 MS, ST-251 \$429.00
WITH MCT-HDC CONTROLLER \$469.00
WITH MCT-ATFH CONTROLLER \$539.00

60 MB RLL, 40 MS, ST-277 \$499.00
WITH MCT-RLL CONTROLLER \$549.00
WITH MCT-ATFH CONTROLLER \$639.00

FULL HEIGHT DRIVES

30 MB, 40 MS, ST-4038 \$559.00
80 MB, 28 MS, ST-4096 \$895.00

INTERFACE CARDS FROM MODULAR CIRCUIT TECHNOLOGY DISPLAY ADAPTORS

MONOCHROME GRAPHICS CARD \$59.95
TRUE HERCULES COMPATIBILITY. SUPPORTS LOTUS 123
PARALLEL PRINTER PORT CONFIGURES AS CPT1 OR LPT2
USES VLSI CHIPS TO ENSURE RELIABILITY
MCT-MGP

ENHANCED GRAPHICS ADAPTOR \$149.95
100% IBM COMPATIBLE. PASSES IBM EGA DIAGNOSTICS
256K OF VIDEO RAM ALLOWS 640 X 350 IN 16 OF 64 COLORS
COMPATIBLE WITH COLOR AND MONOCHROME ADAPTORS
MCT-EGA

COLOR GRAPHICS ADAPTOR \$49.95
COMPATIBLE WITH IBM GRAPHICS STANDARDS
SUPPORTS RGB COLOR & COMPOSITE MONOCHROME
640 320 X 200 RESOLUTION. LIGHT PEN INTERFACE
MCT-CG

MULTIFUNCTION CARDS

MONOGRAPHICS MULTI I/O \$119.75
TOTAL SYSTEM CONTROL FROM A SINGLE SLOT!
CTRL 2 FLOPPY S. SERIAL. PARALLEL. GAME PORT. CLOCK CAL.
RUN COLOR GRAPHICS SOFTWARE ON A MONOCHROME MONITOR
MCT-MGMIO

MULTI I/O FLOPPY CONTROLLER \$79.95
A PERFECT COMPANION FOR OUR MOTHERBOARDS
SUPPORTS UP TO 2 360K FLOPPIES. 720K WITH DOS 3.2
SERIAL. PARALLEL. GAME PORT. CLOCK CALENDAR
MCT-MIO
MIO-SERIAL—2ND SERIAL PORT \$15.95

MULTI I/O CARD \$59.95
USE WITH MCT-FH FOR A MINIMUM OF SLOTS USED
SERIAL PORT. CLOCK CALENDAR WITH BATTERY BACK UP
PARALLEL PRINTER PORT ADDRESSABLE AS LPT1 OR LPT2
MCT-IO

AT MULTIFUNCTION CARD \$139.95
ADDS UP TO 3 MB OF RAM TO YOUR AT
USER EXPANDABLE TO 1.5 MB OR 3 MB WITH OPTIONAL PIGGYBACK BOARD (0 K INSTALLED)
INCLUDES SERIAL AND PARALLEL PORT
MCT-ATMF-MC PIGGYBACK BOARD \$29.95
ATMF SERIAL-2ND SERIAL PORT \$24.95

AT MULTI I/O CARD \$59.95
USE WITH MCT-ATFH FOR MINIMUM OF SLOTS USED
SERIAL. PARALLEL AND GAME PORTS
USES 16450 SERIAL SUPPORT CHIPS FOR HIGH SPEED OPS
MCT-ATIO
ATIO-SERIAL—2ND SERIAL PORT \$24.95

MEMORY CARDS

576K RAM CARD \$59.95
A CONTIGUOUS MEMORY SOLUTION IN A SHORT SLOT
USER SELECTABLE CONFIGURATION UP TO 576K
USES 64K 2 256K RAM CHIPS (ZERO K INSTALLED)
MCT-RAM

EXPANDED MEMORY CARD \$129.95
2 MB OF LOTUS INTEL MICROSOFT COMPATIBLE MEMORY FOR AN XT
CONFORMS TO LOTUS INTEL EMS
USER EXPANDABLE TO 2 MB
CAN BE USED AS EXPANDED OR CONVENTIONAL MEMORY RAMDISK AND SPOOLER
MCT-EMS
MCT-ATEMS AT COMPATIBLE VERSION \$139.95

DRIVE CONTROLLERS

FLOPPY DISK CONTROLLER \$29.95
QUALITY DESIGN FOR SINGLE SLOT CONTROL OF 4 FLOPPY S
INTERFACES UP TO 4 FDD S TO AN IBM PC OR COMPATIBLE
SUPPORTS BOTH DS DD AND DS QD WITH DOS 3.2
MCT-FDC

1.2 MB FLOPPY CONTROLLER \$69.95
ADD VERSATILITY AND CAPACITY TO YOUR XT
SUPPORTS 2 DRIVES. BOTH MAY BE 360K OR 1.2 MB
ALLOWS DATA TO FLOW FREELY FROM XT S TO AT S
MCT-FDC-1.2

FLOPPY/HARD CONTROLLER \$139.95
XT SYSTEM STARVED FOR SLOTS? THIS CARD FREES ONE UP
INTERFACES UP TO 2 FDD S & 2 HDD S. CABLING FOR 2 FDD 1 HDD
SUPPORTS BOTH DS DD & DS QD WITH DOS 3.2
MCT-FH

ATIFH CONTROLLER \$149.95
FLOPPY HARD DISK CONTROL IN A TRUE AT DESIGN
SUPPORTS UP TO 2 360K 720K 1.2MB FDD S AS WELL AS 2 HDD S USING STANDARD CONTROL TABLES
MCT-ATFH

RLL DISK CONTROLLER \$199.95
IMPROVE SPEED AND STORAGE OF YOUR AT COMPATIBLE
SUPPORTS UP TO 2 RLL HARD DISCS AND 2 FLOPPY DRIVES
SUPPORTS 360 720 1.2 MB FLOPPIES IN 5 25" & 3 5"
MCT-ATFH-RLL

INBOARD 386/PC \$895.00

UPGRADE YOUR XT TO A 386 FOR LESS THAN \$1000
16 MHZ PROCESSOR REPLACES 8088
1 MB INSTALLED
EXPAND TO 3MB WITH PIGGYBACK CARD
5 YR WARRANTY

INBOARD 386/AT \$1199.95
ABOVE BOARD PS 286 \$399.95
ABOVE BOARD 286 \$369.95

TEAC DISK DRIVE

360K 5 1/4" DRIVE
RELIABLE DIRECT DRIVE MOTOR
DOUBLE-SIDED/DOUBLE-DENSITY FD-55B

\$99⁹⁵

1/2 HEIGHT FLOPPY DISK DRIVES

5 1/4" TEAC FD-55G DS/HD 1.2M \$129.95
5 1/4" FUJITSU M2551A DS/DD 360K \$89.95
5 1/4" FUJITSU M2553K DS/HD 1.2M \$119.95
5 1/4" DS/DD 360K \$69.95
5 1/4" DS/HD 1.2M \$109.95
3 1/2" MITSUBISHI DS/DD (AT OR XT) \$129.95

ARCHIVE XL TAPE BACK-UP \$369⁹⁵

BACK UP 40 MB IN 40 MINUTES!
EASY-TO-USE MENU DRIVEN SOFTWARE
USES STANDARD QIC DATA FORMAT
FULL & INCREMENTAL BACK-UP
PARTIAL & FULL RESTORE

AR 5240 XT — FOR XT S & AT S
AR 5540 AT — AT S ONLY 2X FASTER
TAPE NOT INCLUDED
TAPE CARTRIDGE—40 MB \$24.95

20MB HARD DISK ON A CARD \$349

SAVES SPACE AND REDUCES POWER CONSUMPTION
IDEAL FOR PC S WITH FULL HEIGHT FLOPPIES
LEAVES ROOM FOR A HALF LENGTH CARD IN ADJACENT SLOT



JUST A NOTE TO LET YOU KNOW THAT MY SALESPERSON, HELEN MORSE, AT YOUR COMPANY HAS BEEN VERY HELPFUL AND COURTEOUS. THIS IS A PLEASANT CHANGE FROM MOST TELEPHONE SALESPEOPLE I DEAL WITH. PLEASE PASS MY THANKS TO HELEN. I PLAN ON DOING FREQUENT BUSINESS WITH JDR AS MY NEW COMPANY, ODEM INC, GETS GOING, AND HELEN'S ATTITUDE AND HELPFULNESS ARE A MAJOR REASON WHY I LIKE DOING BUSINESS WITH YOU.

R.C.K. BENSELEM, PA

BARGAIN HUNTER'S CORNER
720K FLOPPY DISK DRIVE BY MITSUBISHI
5 1/4" HALF-HEIGHT
96 T.P.I.
100% IBM COMPATIBLE
DOUBLE-SIDED/QUAD DENSITY
ONLY \$69⁹⁵
SPECIAL ENDS 8/31/88

intel



JDR MICRODEVICES, 110 KNOWLES DRIVE, LOS GATOS, CA 95030
LOCAL (408) 866-6200 FAX (408) 378-8927 TELEX 171-110

ORDER TOLL FREE 800-538-5000

COPYRIGHT 1988 JDR MICRODEVICES



CONTINENTAL U.S. AND CANADA

CIRCLE 170 ON FREE INFORMATION CARD
www.americanradiohistory.com

BUILD YOUR OWN SYSTEM

OVER 20,000 JDR SYSTEMS HAVE ALREADY BEEN BUILT. EASY TO ASSEMBLE IN JUST 2 HOURS WITH A SCREWDRIVER. SAVE MONEY AND LEARN ABOUT YOUR COMPUTER AT THE SAME TIME.

12 MHZ AT COMPATIBLE
\$1101⁷⁰

- 12 MHZ BABY AT MOTHERBOARD
- 256K RAM MEMORY
- MINI-AT CASE W/POWER SUPPLY
- AT STYLE KEYBOARD
- 1.2 MB FLOPPY DRIVE
- FLOPPY/HARD DRIVE CONTROLLER
- MONOCHROME MONITOR
- GRAPHICS ADAPTOR

10 MHZ XT COMPATIBLE
\$656⁵⁰

- INCLUDES SERIAL PORT, 2 PARALLEL PORTS, CLOCK/CALENDAR AND GAME ADAPTOR. RUNS COLOR GRAPHICS ON A MONOCHROME MONITOR
- MOTHERBOARD
- 256K RAM MEMORY
- 135 WATT POWER SUPPLY
- FLIP-TOP CASE
- AT STYLE KEYBOARD
- 360K FLOPPY DRIVE
- MONOGRAPHICS I/O CARD
- MONOCHROME MONITOR

16 MHZ 1 MB 386
\$2298⁶⁵

- MYLEX 386 MOTHERBOARD
- 1 MB RAM ON BOARD
- 200 WATT POWER SUPPLY
- AT STYLE CASE
- ENHANCED AT STYLE KEYBOARD
- 1.2 MB FLOPPY DRIVE
- AT FLOPPY HARD CONTROLLER
- MONOCHROME MONITOR
- MONOGRAPHICS CARD

VIDEO INSTRUCTIONS
\$4⁹⁵
WITH KIT PURCHASE
IT'S A JDR EXCLUSIVE!
EASY TO FOLLOW
20 MINUTE VHS TAPE SHOWS YOU STEP-BY-STEP HOW TO BUILD AN XT COMPATIBLE SYSTEM.
WITHOUT KIT
\$19.95



MOTHERBOARDS

TURBO 4.77/8 MHZ \$99.95 **12 MHZ MINI 80286 \$399.95**

- 4.77 OR 8 MHZ OPERATION WITH 8088-2 & OPTIONAL 8087-2 CO-PROCESSOR
- FRONT PANEL LED SPEED INDICATOR AND RESET SWITCH SET SUPPORTED
- CHOICE OF NORMAL TURBO MODE OR SOFTWARE SELECT PROCESSOR SPEED

MCT-TURBO
MCT-XTMB STANDARD MOTHERBOARD \$87.95

- 6 MHZ, 10 MHZ (0.1 WAIT STATE), 12 MHZ (1 WAIT STATE)
- USES ZYMO'S ASIC'S FOR LESS CHIPS. GREATER RELIABILITY
- SUPPORTS 256K-1024K MEMORY
- RE-CHARGEABLE HIGH CAPACITY NI-CAD BATTERY
- 6 16-BIT SLOTS, 2 8-BIT SLOTS
- MOUNTS IN STANDARD XT CASE

MCT-BATMB-12
MCT-BATMB 6/10 MHZ MINI 80286 BOARD \$389.95

80286 6/8 MHZ \$379.95 **16 MHZ MYLEX 386 \$1649.00**

- 8 SLOT (2 EIGHT BIT, 6 SIXTEEN BIT) AT MOTHERBOARD
- HARDWARE SELECTION OF 6 OR 8 MHZ
- 1 WAIT STATE
- KEYLOCK SUPPORTED, RESET SWITCH, FRONT PANEL LED INDICATOR
- SOCKETS FOR 1 MB OF RAM AND 80287
- BATTERY BACKED CLOCK

MCT-ATMB

- 1 MB RAM ON BOARD
- 8 SLOTS, 2 8-BIT, 6 16-BIT
- SUPPORTS 80287 MATH CO-PROCESSOR
- SUPPORTS 80387 W/ADAPTOR
- 64 KB CACHE FOR NEAR 0 WAIT STATE
- USES AMI BIOS

MCT-386 MB
MCT-386 MB-4 4 MB MEMORY INSTALLED \$2649.00
MCT-386 MB-MCB MATH CO-PROCESSOR ADAPTOR BOARD \$149.00

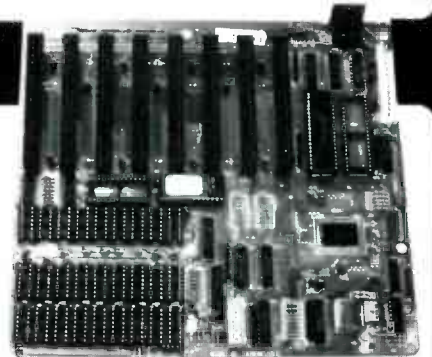

10 MHZ SINGLE CHIP XT
\$129⁹⁵

- SINGLE CHIP USES LESS POWER, IMPROVES RELIABILITY
- KEY SELECTABLE SPEED, 4.77 MHZ OR 10 MHZ
- 2-3 TIMES FASTER THAN A STANDARD
- RESET SWITCH, KEYLOCK AND SPEED/POWER INDICATORS SUPPORTED

MCT-TURBO-10

DEVELOPMENT TOOLS

EPROM PROGRAMMER
\$129⁹⁵

- PROGRAMS 27XX & 27XXX EPROMS UP TO 27512
- SUPPORTS VARIOUS PROGRAMMING FORMATS AND VOLTAGES
- SPLIT OR COMBINE CONTENTS OF SEVERAL EPROMS OF DIFFERENT SIZES
- READ, WRITE, COPY, ERASE CHECK AND VERIFY
- SOFTWARE FOR HEX AND INTEL HEX FORMATS

MCT-EPROM
MCT-EPROM-4 4 GANG PROGRAMMER \$189.00
MCT-EPROM-10 10 GANG PROGRAMMER \$299.95
MCT-PAL PAL PROGRAMMER \$269.95
MCT-MP PROCESSOR PROG. \$199.95



4096 EPROMS



- **1 YEAR WARRANTY ON MCT PRODUCTS**
- **30 DAY MONEY BACK GUARANTEE**
- **TOLL-FREE TECHNICAL SUPPORT**
- **NEXT DAY AIR SHIP AVAILABLE**

JDR Microdevices®

JDR MICRODEVICES, 110 KNOWLES DRIVE, LOS GATOS, CA 95030
LOCAL (408) 866-6200 FAX (408) 378-8927 TELEX 171-110



ORDER TOLL FREE 800-538-5000

COPYRIGHT 1988 JDR MICRODEVICES

CONTINENTAL U.S. AND CANADA

CIRCLE 180 ON FREE INFORMATION CARD
www.americanradiohistory.com

Radio Shack Parts Place™

EXCLUSIVE VALUES AT THE SHACK® NEAR YOU

"Hotline" Service for Rare Parts

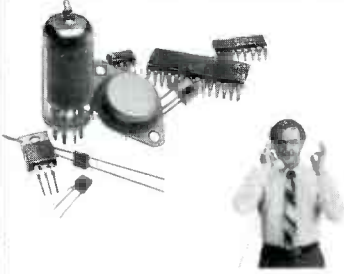

If the part you need is not in our regular stock, we'll check our substitution guide and special order it for you. Over 200,000 substitutions available, including ICs, microprocessors and support chips, tubes, crystals, phono cartridges, transistors, hybrid modules, and Sams Photo-facts. The order will be sent to your local Radio Shack in about a week. No minimum and no shipping charges!

Enhanced-Novice Exam "Prep" Kit

Everything You Need to Quickly And Painlessly Prepare for The New FCC Exam

Take advantage of the new enhanced Novice privileges on Amateur radio! This package quickly prepares you for the voice-class license. You get two audio cassettes for self-paced Morse code learning plus practice exam questions and answers to help you get ready for the test. #62-2402 19.95



Voice Synthesis Pair—23%-30% Off

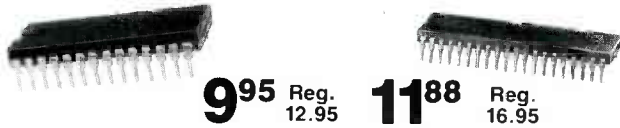

9⁹⁵ Reg. 12.95 **11⁸⁸** Reg. 16.95

SPO256-AL2 Speech Synthesizer IC. Cut 23%. Built-in program makes it easy to interface with most computers. Requires 3.12 MHz crystal. With data and circuit examples. 28-pin DIP. #276-1784 Sale 9.95

CTS256-AL2 Text-to-Speech IC. 30% Off. Preprogrammed to translate ASCII characters into control data for synthesizer chip (above) for RS-232 hookup. Requires 10 MHz crystal. 40-pin DIP. #276-1786 Sale 11.88

Advanced ICs—Slashed 21% to 43%



3⁹⁹ Reg. 6.95 **7⁸⁸** Reg. 9.95

TLC548 8-Bit A/D Converter IC. 43% Off. Complete data acquisition system in one IC. High-speed data transfer with few external components. Single 5VDC supply, internal clock. #276-1796 Sale 3.99

AY-3-8910A Sound Generator IC. Cut 21%. Use with a computer to provide a spectacular variety and range of sounds! Three independent analog outputs. Single 5 VDC supply. 40-pin DIP. With data. #276-1787 Sale 7.88

Computer Helpers

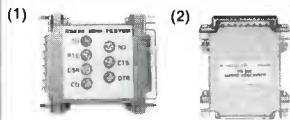

- (1) **RS-232 Tester.** LEDs indicate status of TD, RTS, DSR, CD, RD, CTS, DTR lines. #276-1401 . . . 14.95
- (2) **RS-232 Spike Protector.** Stops transients dead in their tracks. #276-1402 16.95

Builder Bargains

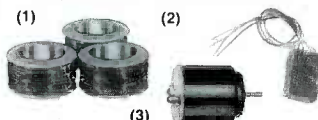

- (1) **Magnet Wire.** Three-spool set—22, 26, 30 gauge. #278-1345 . . . 4.79
- (2) **1:1 Audio Transformer.** #273-1374 3.49
- (3) **1.5-3 VDC Motor.** #273-223 89¢

Parts-Pourri



- (1) **Fuse Holder Clips.** #270-739 . . . 2/99¢
- (2) **8-"AA" Bat. Holder.** #270-387 . . . 1.29
- (3) **4-"AA" Battery Holder.** #270-383 . . . 99¢
- (4) **2-"AA" Battery Holder.** #270-382 . . . 99¢
- (3) **9-Volt Battery Clips.** #270-325 . . . 5/99¢
- (4) **Thermal Fuse.** 139° C. #270-1320 . . . 1.19
- Thermal Fuse.** 226° C. #270-1321 . . . 1.19

Sight 'n Sound

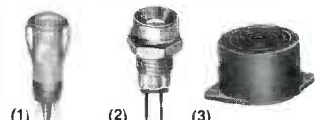

- (1) **Super-Bright Panel LED.** Brilliant 500 mcd ruby light. #276-088 1.79
- (2) **LEDs in Chrome Holders.**
Red LED. #276-068 1.89
Green LED. #276-069 1.89
- (3) **Melodic IC Chime.** #273-071 . . . 8.69

4000-Series CMOS

Low As **99¢**

With Specs



Description	Type	Cat. No.	Each
Quad NOR GATE	4001	276-2401	.99
Quad NAND Gate	4011	276-2411	.99
Dual Type-D Flip Flop	4013	276-2413	1.19
Hex Inverter	4049	276-2449	1.19
Decade Counter/Divider	4017	276-2417	1.49

Hard-to-Find Parts



- (1) **335 pF Variable Cap.** Two-section, PC-mount. #272-1337 4.95
- (2) **6-50 pF Trimmer Caps.** #272-1340 2/1.59
- (3) **TV Colorburst Crystal.** 3.579545 MHz. #272-1310 1.69

Irresistibles

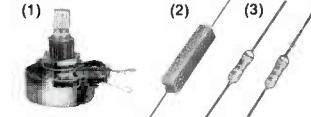

- (1) **25-Ohm, 5W Rheostat.** #271-265, 2.99 #271-120 1.39
- (2) **8-Ohm, 20W Resistor.** #271-120 1.39
- (3) **Metal-Oxide Resistors.**
10 Ohms. #271-151 Pkg. 2/29¢
100 Ohms. #271-152 Pkg. 2/29¢
1000 Ohms. #271-153 Pkg. 2/29¢

Relays & Switches

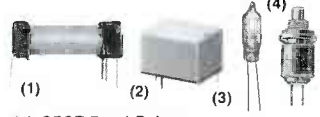

- (1) **SPST Reed Relays.** Contacts: 1A, 125VAC.

Coil	Cat. No.	Each
5VDC, 20 mA, 250 Ω	275-232	1.89
12VDC, 11 mA, 1050 Ω	275-233	1.89
- (2) **Mini SPDT Relay.** #275-248 . . . 2.99
- (3) **Mercury Switch.** #275-027 . . . 1.29
- (4) **Momentary Switch.** #275-1571 . . . 2/2.39

Builders Bargain Corner

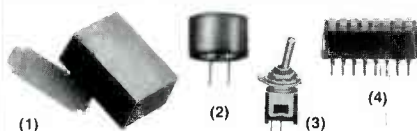

- (1) **Box With PCB.** 2 1/8 x 3 5/16 x 1 3/8" #270-283 3.99
- As Above.** 2 3/4 x 4 3/16 x 1 1/4" #270-284 4.99
- (2) **Electret Mike Element.** PC mount. #270-090 . . . 1.49
- (3) **Mini SPST Toggle Switch.** #275-645 1.99
- (4) **8-Position DIP Switch.** #275-1301 1.79

Solderless Breadboard

Popular Choice Of "Pros" and Students



The 2 1/4 x 6 1/2" universal board is mounted on a 4 x 7" "stay-put" steel base. Accepts DIPs, discrete components and up to 22-gauge wire. Has 640 plug-in tie points and three binding posts for external power. #276-169 19.95

Pocket Autoranging DVM

24⁹⁵

- Autopolarity
- Diode-Checker



A lot of meter in a little package! "Beep" continuity, low-battery indicator. Measures to 400 volts AC/DC, resistance to 2 megohms 4 1/2 x 2 1/8 x 5/16". With batteries, miniprobes and folding case. #22-171 24.95

Over 1000 items in stock: Binding Posts, Books, Breadboards, Buzzers, Capacitors, Chokes, Clips, Coax, Connectors, Fuses, Hardware, ICs, Jacks, Knobs, Lamps, Multitesters, PC Boards, Plugs, Rectifiers, Resistors, Switches, Tools, Transformers, Wire, Zeners, More!

Prices apply at participating Radio Shack stores and dealers

Radio Shack®
The Technology Store™
A DIVISION OF TANDY CORPORATION

Worldwide • Since 1974

• QUALITY COMPONENTS • COMPETITIVE PRICING • PROMPT DELIVERY

MEMBER

MMC

MICROCOMPUTER
MARKETING COUNCIL
of the Direct Marketing Association, Inc.

JAMECO SOLDERLESS BREADBOARD SOCKETS

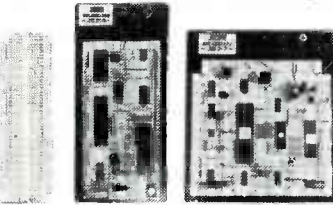

Part No.	Dim. L" x W"	Contact Points	Binding Posts	Price
JE20	6 1/2 x 3/4	200	0	\$ 2.29
JE21	3 1/4 x 2 1/8	400	0	\$ 4.49
JE22	6 1/2 x 1 3/8	630	0	\$ 5.95
JE23	6 1/2 x 2 1/8	830	0	\$ 7.49
JE24	6 1/2 x 3 1/8	1,360	2	\$14.95
JE25	6 1/2 x 4 1/8	1,660	3	\$22.95
JE26	6 1/2 x 5 1/8	2,390	4	\$27.95
JE27	7 1/4 x 7 1/2	3,220	4	\$37.95

COMPUTER PERIPHERALS

Jameco IBM PC/XT/AT Compatible Motherboards



Award BIOS ROMs included

JE1001

JE1001	4.77/8MHz (PC/XT)	\$ 99.95
JE1002	4.77/10MHz (PC/XT)	\$119.95
JE1007	6/8/10/12MHz (AT)	\$349.95

Jameco Computer Power Protection



JE1190	Power Base	\$29.95
JE1191	6-Outlet Power Strip	\$11.95

Jameco IBM PC/XT/AT Compatible Keyboards

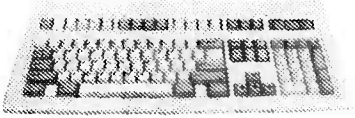

JE1016 Pictured

JE1015	Standard AT layout (XT/AT)	\$59.95
JE1016	Enhanced layout (XT/AT)	\$79.95

Jameco Extended 80-Column Card for Apple IIe



80 Col / 64K RAM • Doubles amount of data your Apple IIe can display as well as its memory capacity • Ideal for word processing • Complete with instructions

JE864 \$39.95

ADD12 (Disk Drive II, II+, IIe) \$99.95

DATA BOOKS

400041	NSC Linear Data Book-Vol. I (88)	\$14.95
400042	NSC Linear Data Book-Vol. II (88)	\$ 9.95
400043	NSC Linear Data Book-Vol. III (88)	\$ 9.95
210830	Intel Memory Handbook (88)	\$17.95
230843	Intel Microsystem Hndbk. Set (88)	\$24.95

IBM AT COMPATIBLE KIT Mini-286 6/8/10/12MHz Kit

JE1007	Baby AT Motherboard (Zero-K RAM — includes Award BIOS ROMs)	\$349.95
JE1015	XT/AT Style Keyboard	\$ 59.95
JE1017	Baby AT Flip-Top Case	\$ 69.95
JE1022	5 1/4" Hi-Density Disk Drive	\$109.95
JE1032	200 Watt Power Supply	\$ 89.95
JE1043	360K/720K/1.2M Floppy Controller Card	\$ 49.95
JE1065	Input/Output Card	\$59.95

Regular List \$789.65

SAVE \$99.70!

JE1059 \$519.95
EGA Monitor and Card not included)

JE2009* IBM AT Compatible Kit. \$689.95

JE286M JE2009 Technical Manual. \$29.95
*RAM not included — Minimum RAM configuration 512K (18 Chips 41256-120, see left)

IBM COMPATIBLE DISPLAY MONITORS

12" Amber Monochrome — TTL Input, High Resolution (PC/XT/AT)
AMBER. \$99.95

14" RGB Color — CGA Compatible Amber/Green/Color Switchable, 640 x 200 Resolution (PC/XT/AT)
TTX1410. \$279.95



14" EGA Color — EGA/CGA Compat., 720 x 350 Max. Resolution (PC/XT/AT)
TE5154. \$399.95

14" EGA Monitor and EGA Card — EGA compatible, 720 x 350 Max. Resolution — displays up to 16 colors (PC/XT/AT)
JE1059. \$519.95

14" Multiscan Color — VGA/PGC/EGA compatible, 800 x 600 Max Resolution (PC/XT/AT)
CTX1435. \$549.95

IBM PC/XT/AT COMPATIBLE CARDS

Graphic Display Cards



JE1050

JE1050	Mono Graphics Card w/Printer Port (PC/XT/AT)	\$59.95
JE1052	Color Graphics Card w/Printer Port (PC/XT/AT)	\$49.95
JE1055	EGA Card with 256K Video RAM (PC/XT/AT)	\$169.95
JE1071	Multi I/O with Drive Controller and Mono Graphics (PC/XT)	\$119.95

Multifunction, I/O and Expansion Cards

JE1060	I/O Card with Serial, Game, Parallel Printer Port and Real Time Clock (PC/XT)	\$59.95
JE1061	RS232 Serial Half Card (PC/XT/AT)	\$29.95
JE1065	I/O Card with Serial, Game and Parallel Printer Port (AT)	\$59.95
JE1078	Expand to 384K (zero-K on-board) Multifunc. w/Serial, Game, Parallel Printer Port & Real Time Clock (PC/XT)	\$69.95
JE1081	2MB of expanded or extended memory (zero-K on-board) (AT)	\$119.95
JE1082	3MB of expanded or extended memory, parallel printer port, serial port and game port (zero-K on-board) (AT)	\$169.95

Floppy and Hard Disk Controller Cards

JE1040	360KB F oppy Disk Drive Controller Card (PC/XT)	\$29.95
JE1041	20/40MB Hard Disk Controller Card (PC/XT)	\$79.95
JE1043	360K/720K/1.2MB Floppy Disk Cont. Card (PC/XT/AT)	\$49.95
JE1045	360K/720K/1.2MB Floppy/Hard Disk Controller Card (AT)	\$149.95

COMPUTER PERIPHERALS



Seagate 20,30 40 and 60MB Half Height Hard Disk Drives
ST225XT (Pictured)

ST225	20MB Drive only (PC/XT/AT)	\$224.95
ST225XT	20MB w/Controller (PC/XT)	\$269.95
ST225AT	20MB w/Controller (AT)	\$339.95
ST238	30MB Drive only (PC/XT/AT)	\$249.95
ST238XT	30MB w/Controller (PC/XT)	\$299.95
ST238AT	30MB w/Controller (AT)	\$389.95
ST251	40MB Drive only (PC/XT/AT)	\$429.95
ST251XT	40MB w/Cont. Card (PC/XT)	\$469.95
ST251AT	40MB w/Controller Card (AT)	\$539.95
ST277	60MB Drive only (PC/XT/AT)	\$499.95
ST277XT	60MB w/Controller (PC/XT)	\$549.95
ST277AT	60MB w/Controller Card (AT)	\$639.95

40MB Tape Back-Up for IBM PC/XT/AT

XR4	40MB Tape Back-Up	\$369.95
TB40	40MB Tape Cartridge	\$24.95



Jameco 5.25" PC/XT/AT Compatible Disk Drives

JE1022 (Pictured)

JE1020	360K Black Bzl. (PC/XT/AT)	\$ 89.95
JE1021	360K Beige Bzl. (PC/XT/AT)	\$ 89.95
JE1022	1.2MB Beige Bzl. (PC/XT/AT)	\$109.95

3.5" PC/XT/AT Compatible Disk Drives

352KU	3.5" 720KB (Bezels and Installation Kit incl.) (PC/XT/AT)	\$129.95
MF355B	3.5" 1.44MB (Bezels and Installation Kit Incl.) (PC/XT/AT)	\$149.95

Datronics

2400/1200/300 Modems



NEW, Pocket Version!

- Hayes command compatible
- Bell 103/212A compatible
- Auto-dial/auto-answer
- FCC approved
- 1-year warranty
- Includes MaxiMite Communication Software (except 1200P)

1200P	1200/300 Baud Packet Modem	\$109.95
1200H	1200/300 Baud Internal Modem	\$ 69.95
2400S	2400/1200/300 Internal Modem	\$139.95
1200C	1200/300 Baud External Modem	\$119.95
2400E	2400/1200/300 External Modem	\$179.95

TEST EQUIPMENT

Digital Multimeters



Kingdom KD302:

- Pocket size in handy carry case
- 3 1/2 Digit LCD
- Auto or manual ranging
- Audible continuity tester
- Tests AC/DC voltage, Resistance, Continuity
- One Year Warranty
- Size: 4 1/4" L x 2 1/2" W x 1 1/2" H

KD302 ..\$79.95

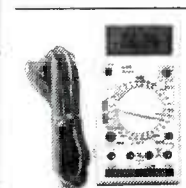

Metex M4650:

- Handheld, high accuracy
- 4 1/2 Digit LCD
- Manual ranging with Overload Protection
- Audible continuity tester
- Tests AC/DC Voltage, Resistance, Continuity
- One Year Warranty
- Size: 7 1/4" L x 3 1/2" W x 1 1/2" H

M4650 ..\$89.95

U.S. Funds Only
Shipping: Add 5% plus \$1.50 Insurance
(May vary according to weight)

California Residents:
Add 6%, 6 1/2% or 7%
Sales Tax

©1988 Jameco Electronics 10/88



\$20 Minimum Order
IBM is a registered trademark of International Business Machines

Mail Order Electronics • Worldwide
Jameco
ELECTRONICS



Data Sheets — 50¢ each
Prices Subject to Change

Send \$2.00 Postage for a
FREE 1988 CATALOG

FAX Numbers: 415-592-2503
or 415-595-2664

Telex: 176043

1355 Shoreway Rd., Belmont, CA 94002 • 24 HR. ORDER HOTLINE 415-592-8097 • All Other Inquiries (7am-5pm PST) 415-592-8121

The answers to all those puzzling questions on electronic parts — are at MCM Electronics!

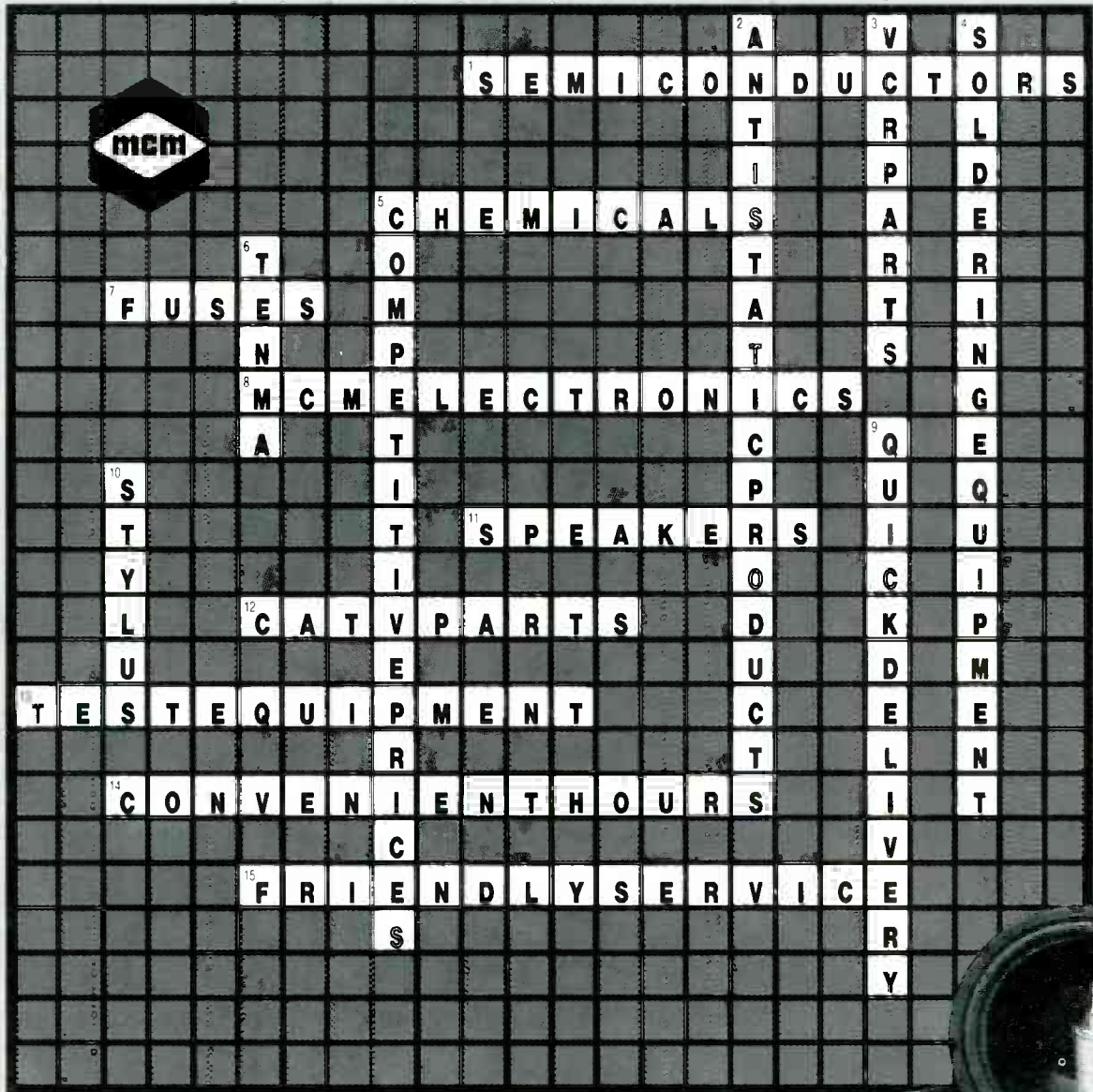

ACROSS

1. Diodes, transistors and ICs
5. Cleaners, lubricants and more
7. Inexpensive circuit protection
8. Your source for quality electronic parts!
11. EV, Pyle, Pioneer
12. Cable TV accessories
13. Tenma, B&K, Leader, Hameg
14. 7 a.m. to 8 p.m. Mon-Fri. and 9 a.m. to 5 p.m. Saturday (EST)
15. Knowledgeable sales people

DOWN

2. ESD protection
3. Video Cassette Recorder sub-assemblies
4. Technician tools for making connections
5. Another reason to buy from MCM!
6. High quality test equipment at competitive prices
9. 90% of all orders shipped in 24 hours
10. High fidelity needle

CALL TOLL FREE 1-800-543-4330
IN OHIO, 1-800-762-4315
IN ALASKA AND HAWAII, 1-800-858-1849



MCM ELECTRONICS

858 E. CONGRESS PARK DR.
 CENTERVILLE, OH 45459-4072

A PREMIER Company



©MCM Electronics. 1988.

Source No. RE-49

CIRCLE 87 ON FREE INFORMATION CARD

www.americanradiohistory.com

INTEGRATED CIRCUITS

7400 TTL

Part	Price	74500 TTL	Part	Price
7400	1.00	7400	1.00	
7401	1.00	7401	1.00	
7402	1.00	7402	1.00	
7403	1.00	7403	1.00	
7404	1.00	7404	1.00	
7405	1.00	7405	1.00	
7406	1.00	7406	1.00	
7407	1.00	7407	1.00	
7408	1.00	7408	1.00	
7409	1.00	7409	1.00	
7410	1.00	7410	1.00	
7411	1.00	7411	1.00	
7412	1.00	7412	1.00	
7413	1.00	7413	1.00	
7414	1.00	7414	1.00	
7415	1.00	7415	1.00	
7416	1.00	7416	1.00	
7417	1.00	7417	1.00	
7418	1.00	7418	1.00	
7419	1.00	7419	1.00	
7420	1.00	7420	1.00	
7421	1.00	7421	1.00	
7422	1.00	7422	1.00	
7423	1.00	7423	1.00	
7424	1.00	7424	1.00	
7425	1.00	7425	1.00	
7426	1.00	7426	1.00	
7427	1.00	7427	1.00	
7428	1.00	7428	1.00	
7429	1.00	7429	1.00	
7430	1.00	7430	1.00	
7431	1.00	7431	1.00	
7432	1.00	7432	1.00	
7433	1.00	7433	1.00	
7434	1.00	7434	1.00	
7435	1.00	7435	1.00	
7436	1.00	7436	1.00	
7437	1.00	7437	1.00	
7438	1.00	7438	1.00	
7439	1.00	7439	1.00	
7440	1.00	7440	1.00	
7441	1.00	7441	1.00	
7442	1.00	7442	1.00	
7443	1.00	7443	1.00	
7444	1.00	7444	1.00	
7445	1.00	7445	1.00	
7446	1.00	7446	1.00	
7447	1.00	7447	1.00	
7448	1.00	7448	1.00	
7449	1.00	7449	1.00	
7450	1.00	7450	1.00	

1% METAL FILM RESISTORS

Available in 1/4 Watt

Value	Part No.	Price
10	27	1.00
15	33	1.00
20	40	1.00
25	47	1.00
30	54	1.00
35	61	1.00
40	68	1.00
45	75	1.00
50	82	1.00
55	89	1.00
60	96	1.00
65	103	1.00
70	110	1.00
75	117	1.00
80	124	1.00
85	131	1.00
90	138	1.00
95	145	1.00
100	152	1.00

5% WIREWOUND RESISTORS

Available in 1/2 Watt

Value	Part No.	Price
10	150	1.00
15	155	1.00
20	160	1.00
25	165	1.00
30	170	1.00
35	175	1.00
40	180	1.00
45	185	1.00
50	190	1.00
55	195	1.00
60	200	1.00
65	205	1.00
70	210	1.00
75	215	1.00
80	220	1.00
85	225	1.00
90	230	1.00
95	235	1.00
100	240	1.00

DISC CAPACITORS

Available in 1/2 Watt

Value	Part No.	Price
10	250	1.00
15	255	1.00
20	260	1.00
25	265	1.00
30	270	1.00
35	275	1.00
40	280	1.00
45	285	1.00
50	290	1.00
55	295	1.00
60	300	1.00
65	305	1.00
70	310	1.00
75	315	1.00
80	320	1.00
85	325	1.00
90	330	1.00
95	335	1.00
100	340	1.00

7400 CMOS

Part	Price	7400 CMOS	Part	Price
7400	1.00	7400	1.00	
7401	1.00	7401	1.00	
7402	1.00	7402	1.00	
7403	1.00	7403	1.00	
7404	1.00	7404	1.00	
7405	1.00	7405	1.00	
7406	1.00	7406	1.00	
7407	1.00	7407	1.00	
7408	1.00	7408	1.00	
7409	1.00	7409	1.00	
7410	1.00	7410	1.00	
7411	1.00	7411	1.00	
7412	1.00	7412	1.00	
7413	1.00	7413	1.00	
7414	1.00	7414	1.00	
7415	1.00	7415	1.00	
7416	1.00	7416	1.00	
7417	1.00	7417	1.00	
7418	1.00	7418	1.00	
7419	1.00	7419	1.00	
7420	1.00	7420	1.00	
7421	1.00	7421	1.00	
7422	1.00	7422	1.00	
7423	1.00	7423	1.00	
7424	1.00	7424	1.00	
7425	1.00	7425	1.00	
7426	1.00	7426	1.00	
7427	1.00	7427	1.00	
7428	1.00	7428	1.00	
7429	1.00	7429	1.00	
7430	1.00	7430	1.00	
7431	1.00	7431	1.00	
7432	1.00	7432	1.00	
7433	1.00	7433	1.00	
7434	1.00	7434	1.00	
7435	1.00	7435	1.00	
7436	1.00	7436	1.00	
7437	1.00	7437	1.00	
7438	1.00	7438	1.00	
7439	1.00	7439	1.00	
7440	1.00	7440	1.00	
7441	1.00	7441	1.00	
7442	1.00	7442	1.00	
7443	1.00	7443	1.00	
7444	1.00	7444	1.00	
7445	1.00	7445	1.00	
7446	1.00	7446	1.00	
7447	1.00	7447	1.00	
7448	1.00	7448	1.00	
7449	1.00	7449	1.00	
7450	1.00	7450	1.00	

1% METAL FILM RESISTORS

Available in 1/4 Watt

Value	Part No.	Price
10	27	1.00
15	33	1.00
20	40	1.00
25	47	1.00
30	54	1.00
35	61	1.00
40	68	1.00
45	75	1.00
50	82	1.00
55	89	1.00
60	96	1.00
65	103	1.00
70	110	1.00
75	117	1.00
80	124	1.00
85	131	1.00
90	138	1.00
95	145	1.00
100	152	1.00

5% WIREWOUND RESISTORS

Available in 1/2 Watt

Value	Part No.	Price
10	150	1.00
15	155	1.00
20	160	1.00
25	165	1.00
30	170	1.00
35	175	1.00
40	180	1.00
45	185	1.00
50	190	1.00
55	195	1.00
60	200	1.00
65	205	1.00
70	210	1.00
75	215	1.00
80	220	1.00
85	225	1.00
90	230	1.00
95	235	1.00
100	240	1.00

DISC CAPACITORS

Available in 1/2 Watt

Value	Part No.	Price
10	250	1.00
15	255	1.00
20	260	1.00
25	265	1.00
30	270	1.00
35	275	1.00
40	280	1.00
45	285	1.00
50	290	1.00
55	295	1.00
60	300	1.00
65	305	1.00
70	310	1.00
75	315	1.00
80	320	1.00
85	325	1.00
90	330	1.00
95	335	1.00
100	340	1.00

7400 CMOS

Part	Price	7400 CMOS	Part	Price
7400	1.00	7400	1.00	
7401	1.00	7401	1.00	
7402	1.00	7402	1.00	
7403	1.00	7403	1.00	
7404	1.00	7404	1.00	
7405	1.00	7405	1.00	
7406	1.00	7406	1.00	
7407	1.00	7407	1.00	
7408	1.00	7408	1.00	
7409	1.00	7409	1.00	
7410	1.00	7410	1.00	
7411	1.00	7411	1.00	
7412	1.00	7412	1.00	
7413	1.00	7413	1.00	
7414	1.00	7414	1.00	
7415	1.00	7415	1.00	
7416	1.00	7416	1.00	
7417	1.00	7417	1.00	
7418	1.00	7418	1.00	
7419	1.00	7419	1.00	
7420	1.00	7420	1.00	
7421	1.00	7421	1.00	
7422	1.00	7422	1.00	
7423	1.00	7423	1.00	
7424	1.00	7424	1.00	
7425	1.00	7425	1.00	
7426	1.00	7426	1.00	
7427	1.00	7427	1.00	
7428	1.00	7428	1.00	
7429	1.00	7429	1.00	
7430	1.00	7430	1.00	
7431	1.00	7431	1.00	
7432	1.00	7432	1.00	
7433	1.00	7433	1.00	
7434	1.00	7434	1.00	
7435	1.00	7435	1.00	
7436	1.00	7436	1.00	
7437	1.00	7437	1.00	
7438	1.00	7438	1.00	
7439	1.00	7439	1.00	
7440	1.00	7440	1.00	
7441	1.00	7441	1.00	
7442	1.00	7442	1.00	
7443	1.00	7443	1.00	
7444	1.00	7444	1.00	
7445	1.00	7445	1.00	
7446	1.00	7446	1.00	
7447	1.00	7447	1.00	
7448	1.00	7448	1.00	
7449	1.00	7449	1.00	
7450	1.00	7450	1.00	

1% METAL FILM RESISTORS

Available in 1/4 Watt

Value	Part No.	Price
10	27	1.00
15	33	1.00
20	40	1.00
25	47	1.00
30	54	1.00
35	61	1.00
40	68	1.00
45	75	1.00
50	82	1.00
55	89	1.00
60	96	1.00
65	103	1.00
70	110	1.00
75	117	1.00
80	124	1.00
85	131	1.00
90	138	1.00
95	145	1.00
100	152	1.00

5% WIREWOUND RESISTORS

Available in 1/2 Watt

Value	Part No.	Price
10	150	1.00
15	155	1.00
20	160	1.00
25	165	1.00
30	170	1.00
35	175	1.00
40		

What's New at AMERICAN DESIGN COMPONENTS?

We warehouse 60,000 items at American Design Components—expensive, often hard-to-find components for sale at a fraction of their original cost!

You'll find every part you need—either brand new or removed from equipment (RFE) in excellent condition. But quantities are limited. Order from this ad, or visit our retail showroom and find exactly what you need from the thousands of items on display.

OPEN MON.—SAT., 9–5

THERE'S NO RISK!

With our 90-day warranty, any purchase can be returned for any reason for full credit or refund.

COMMODORE COMPUTERS...



★ ★ ★ ★
PLUS 4 — (Cust. Returns — Tested Good!)
Built-in software incl.: a word processor, spread sheet, graphics, & a filing system. Comes complete w/power supply & instruction manual.
Item #19202 \$49.95
VIC 20 — (Cust. Returns — As Is!)
No guarantee. (Power supply not incl.)
Item #18770 \$29.95

COMMODORE 8050 Dual Disk Drive Unit...



The 8050 uses 2 full-height, 100 TPI single-sided disk drives, ea. w/storage cap. of 533,248 bytes. Ea. 8050 diskette has 77 tracks & is read/write compatible w/the 8250 disk drive. Complete w/built-in power supply. Power req.: 115VAC/60Hz. (manuals incl.)
Dim.: 13 3/4" W x 13 3/4" D x 6" H.
Item #19313 New — \$89.95

ADAM COMPUTER



(Less Printer)
No wiring necessary (just plugs together). Incl: hook-up diagram; Keyboard, 1 cassette digital data drive, 2 game controllers, power supply & 1 cassette. Capable of running CP/M, has built-in word processor.
Item #7410 Complete — \$99.00

ACCESSORIES...

COLECOVISION to ADAM EXPANSION KIT
Just plugs into your ColecoVision. W/printer power supply & data drive (both incl.) you will have a working Adam computer. Adam keyboard, 1 Smart Basic cassette & hook-up diagram also incl.
Item #9918 \$59.50
DATA DRIVE — Item #6641... \$19.95
PRINTER POWER SUPPLY — Item #6642... \$14.95
ASCII KEYBOARD — Item #6643... \$19.95
CONTROLLERS (Set of 4) — Item #7013... \$9.95 RFE
ADAM CASSETTES — Incl. Smart Basic, Buck Rogers & blank cassette. Item #7786
Baker's Dozen — \$19.95
DISK DRIVE POWER SUPPLY — Item #14603... \$14.95
ADAM DAISY PRINT WHEEL — Item #13305... \$3.95

5 1/4" FULL-HEIGHT HARD DISK DRIVES

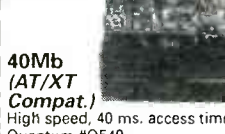

40Mb (AT/XT Compat.)
High speed, 40 ms. access time. Quantum #Q540
Item #17765 New — \$379.00
10Mb (ST412 Compat.)
Major manufacturers — Get them while they last!
Item #17199 \$99.00 ea.

5 1/4" FULL-HEIGHT DISK DRIVE (IBM® Compat.)



48 TPI, 40 Track, Double Side/Double Density
Tandon #TM100-2 or equiv.
Item #7928 \$79.00 New
2 for \$150.00 New

3 1/2" MICROFLOPPY DISK DRIVE



1 Mb (unformatted), 135 TPI, 3 ms. access time. Power requirements: +12, +5 volts. Removed from operational computers — TESTED — LIKE NEW!
Mfr — NEC, model FD1035
Item #17171 \$79.00 ea.
2 for \$150.00

EXTERNAL DISK DRIVE CHASSIS

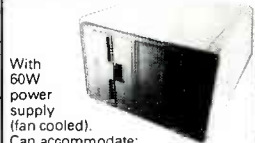

With 60W power supply (fan cooled). Can accommodate: 2 full-ht. drives our item #7928
2 floppy drives... #1904
1 hard drive & 1 floppy... #13250
Input: 115/230V, 50/60 Hz.
Orig. for Burroughs computer.
Dim.: 11" W x 8" H x 12" deep
Item #14541 \$59.50

HIGH POWER SWITCHING POWER SUPPLY



DC Output: +5V @ 18A
-5V @ 2.5A
+12V @ 2.5A
Input: 115/230VAC, 50/60Hz.
Dim: 13" L x 4 1/2" W x 1 1/2" H
Mfr — Sola #39-139
Item #17210 New — \$29.95

COMPUTER GRADE POWER SUPPLY



Other uses—runs CB & car radios. Comes ready to plug in!
DC Output: -5V @ .5 amp.
+5V @ 3 amp.
+12V @ 6 amp.
Input: 115V/60Hz. Dimensions: 9 1/2" W x 3 3/4" H. (Rubber fit. incl.)
Item #9501 New — \$24.95

HIGH-RESOLUTION TTL MONITORS... (Open Frame)



9" — High Resolution
12VDC Green phosphor. Schematic included.
Motorola #MD2003-190
Item #17198 New — \$14.95

12" — High Resolution

12VDC, green phosphor. Sub-assemblies, CRT, board & transformer included. Comes w/hook-up diagram.
Item #6811 New — \$19.95

15" Data Display/Monitor Kit

Alphanumeric & graphics display. Green phosphor. Input power req. 24VDC. Bandwidth: 22–72KHz. Consists of 2 sub-assemblies (monitor & board). Hook-up diagram included.
Wells Gardner #15V7025.
Item #16171 New — \$24.95

115 CFM MUFFIN® FANS



115VAC, 60Hz., 21W., 28A., 3100 RPM, 5-blade model, aluminum housing. Can be mounted for blowing or exhaust.
Dimen: 4 1/16" sq. x 1 1/2" deep
NEW — Mfr: IMC
Item #1864 \$9.95
USED — Mfr: Centaur/Howard
Item #5345 \$5.95

12/24VDC MUFFIN® TYPE FAN 55/100CFM



1" THIN:
5 plastic blades with feathered edges. 8W. Can be mounted for blowing or exhaust. Aluminum housing. Brushless, ball-bearing type. Mfr: — Centaur, #CUDC24K4-601
Item #8541 New — \$19.95

27 CFM MINI FANS



50/60Hz., 12W. Low noise level fans. Can be mounted for blowing or exhaust.
1" Thin — Contains 9 plastic blades. Dimensions: 3 1/8" sq. x 1" deep.
Mfr — Toshiba #U9201B
Item #10960 \$7.95 RFE
1" Standard — Contains 7 metal blades. Mfr — Rotron #SU2A1
Item #5970 \$7.95 New

VOICE-ACTIVATED SWITCH

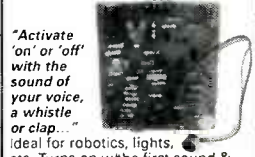

"Activate on" or "off" with the sound of your voice, a whistle or clap... Ideal for robotics, lights, etc. Turns on w/the first sound & off w/the second. Solid-state units w/adjust. sens. control & pick-up microphone attached to PC board.
Dim.: 2 3/4" x 3 1/8" x 1 1/8". VOX input: 6–9VDC; can be used w/any standard battery. Item #16440.
3 switches / \$9.95

We carry a full line of Computer & Game Equipment and Accessories; Electronic Components; Modules; Integrated Circuits & Semiconductors! Please Call or Write with Your Requirements!

ADAM COMPUTER



(Less Printer)
No wiring necessary (just plugs together). Incl: hook-up diagram; Keyboard, 1 cassette digital data drive, 2 game controllers, power supply & 1 cassette. Capable of running CP/M, has built-in word processor.
Item #7410 Complete — \$99.00

ACCESSORIES...

COLECOVISION to ADAM EXPANSION KIT
Just plugs into your ColecoVision. W/printer power supply & data drive (both incl.) you will have a working Adam computer. Adam keyboard, 1 Smart Basic cassette & hook-up diagram also incl.
Item #9918 \$59.50
DATA DRIVE — Item #6641... \$19.95
PRINTER POWER SUPPLY — Item #6642... \$14.95
ASCII KEYBOARD — Item #6643... \$19.95
CONTROLLERS (Set of 4) — Item #7013... \$9.95 RFE
ADAM CASSETTES — Incl. Smart Basic, Buck Rogers & blank cassette. Item #7786
Baker's Dozen — \$19.95
DISK DRIVE POWER SUPPLY — Item #14603... \$14.95
ADAM DAISY PRINT WHEEL — Item #13305... \$3.95

HIGH-RESOLUTION INSTRUMENTATION TAPE



1/2" tape on 14" reels; 9200/reel. Wide band, highly conductive tape, w/magnetic oxide surface (makes it ultrasmooth for chart-wave recording). Orig. used in govt' & other critical instrument applications. Standard hub size.
Mfr — Scotch/Ampex #890/892
Item #17656 \$8.95 ea.
2 for \$16.00

RECORDING TAPE 7 1/2" Reel, 2400 ft.

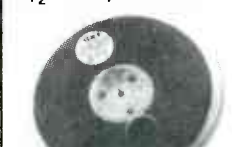

1/4 Mil. Bulk erased. Major mfrs.: Ampex, Scotch, etc. Item #6711.
15 reels for \$9.95

MECHANICAL KEYBOARDS...



48-KEY — Timex Z81/1000
Item #6712 New — \$5.95
75-KEY — Timex or Adam
For computer upgrade—
Item #7429 New — \$5.95
66-KEY — Commodore C-16
Item #9394 New — \$5.95

GELL CELL/LEAD ACID BATTERIES...



Rechargeable. Used for solar energy storage, alarm systems, model boats, planes, cars, trains...
6V @ 2.5AH
Dim: 4" W x 2 5/8" H x 1 1/2" D. Mfr — Gates
Item #9306 \$3.95
6V @ 4.0AH
Dim: 4" H x 2 5/8" W x 1 1/4" D.
Major manufacturers.
Item #15757 \$7.95
6V @ 9.5AH
Dim: 5 1/2" H x 4 1/8" W x 2 5/8" D.
Mfr — Elpower
Item #7039 \$14.95

COLECOVISION Accessories...

EXPANSION MODULE #2
Play arcade quality driving & racing games on your ColecoVision. Incl. Turbo cartridge.
Item #13146 New — \$39.95

ROLLER CONTROLLER

Gives full 360° game control. Hi-speed action of an arcade. Can be used w/the Adam. Incl. Slither cartridge.
Item #13147 New — \$39.95

SUPER ACTION CONTROLLER SET

Gives you indiv. control of 4+ on-screen players. Includes Baseball cartridge.
Item #13148 New — \$39.95

COPPER-CLAD PRINTED CIRCUIT BOARD (Double-Sided)

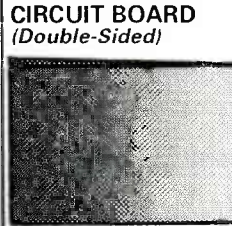

Glass coated, epoxy laminated. 1 oz. Double sided, .022" thick. Dimensions: 24" L x 18.5" H
Item #13606
3 sheets / \$9.95

COMPUTER/GAME ADAPTERS...

Commodore 64

DC Output: 5VDC @ 7.5W and 9VAC @ 6.7VA
Input: 117VAC, 50/60Hz.
Commodore #310157-02 (black)
Item #19315
New — \$14.95

ColecoVision

DC Output: +5VDC @ 9A
-5VDC @ .1A
+12VDC @ .3A
Input: 120VAC/60Hz., .25A
Coleco #55416 (black)
Item #1882 New — \$4.95



Commodore C16

DC Output: 9.5V @ 1A.
Input: 115VAC., 50/60Hz.
Commodore #251539-01/02 (black)
Item #9393 New — \$4.95

"The First Source" — for electromechanical & electronic equipment and components — AMERICAN DESIGN COMPONENTS!

EGA COLOR MONITORS... 25 KHz

Operates ideally w/the ATI Wonder Card (avail. fr. American Design for \$199.00). Perfect for text, CAD & other graphics applications. Scanning freq. to 25KHz. Std. Hi-Res.: 800 x 560, 752 x 410. Input: 110/220V, 50/60Hz, 75W. Mtd. in metal chassis. (Hook-up diagram incl.) Mfr — Hitachi #CD1215DTL.



TESTED — LIKE NEW!
12" — Item #18059 **\$179.00**
14" — Item #18599 **\$189.00**

ANTI-GLARE SCREENS...

Glare & reflection filters that improve speed, accuracy, & operator comfort...



IBM PC Monochrome.....Item #19215
IBM PC Color.....Item #19216
AT&T Monochrome.....Item #19223
APPLE Macintosh.....Item #19225
COMPAQ Portable.....Item #19226
New — \$8.95 ea.; 2 for \$15.00

PC 8300 HOME COMPUTER

Advanced version of the Timex 1000
42-key mech. keyboard;
2K RAM;
Reverse video;
Z80A, 6.5MHz processor; ROM
8K BASIC. Graphics cap.-sound/music, TV or monitor. Joystick input.
115VAC, AC adapt., TV & cass. cables. Runs tapes for Sinclair/Timex 1000-ZX85.
Mfr : Power 3000. In orig. boxes.
Item #10336 New — \$29.95
★ 16K RAMPACK Upgrade
Item #10337 New — \$9.95

3-Way Hi-Fi MINI SPEAKER SYSTEM...

★ 30-50 Watts, 8 Ohm, 50-20,000 Hz.
★ Cabinet finish: heavy-duty aluminum — Black.
★ Dimensions: 7"H x 5"W x 4"D deep.
★ Ideal for use where space is limited. Comes with hang-on mounting brackets. Model #SB-100
★ Item #19314.....Special Price! **\$69.00/Pair—New**

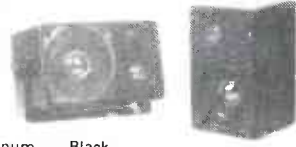

ANALOG to DIGITAL CONVERTER

Binary output: 12 bit. Conversion time: 8ms. Linearity: 8ms; 2 1/2" lbs. Parallel & series outputs; i/r term ref. Mfr — Datal #ADC-HZ-12E GC
Item #7052 (RFE—Testea Good!)
Originally **\$130.00**
Special — **\$39.95**

PROTOTYPING DEVICE w/EPROM INTERFACE — (Z8603)

Complete microcomputer...
2Kb ROM; 128 bytes RAM; 32 I/O lines; up to 62Kb addressable extern. space ea.; 144 byte reg. file; 124 G.P. reg.; 4 I/C port reg.; 16 status & contr. reg.; Full duplex UART; 2 program, 8-bit counter/timers On-chip oscill. accepts crystal or extern. clock drive; 1.5V power supply. TTL compat.
Item #18515 **\$24.95**

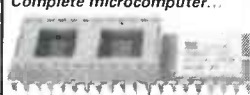

INTEGRATED CIRCUITS...

— STATIC RAMS —

2114.....1024 x 4 (450ns).....\$.99	HM6116LP-3.....2048 x 8 (150ns).....\$11.00
2148-55.....3.49	HM6116LP-4.....2048 x 8 (200ns).....10.00
2149.....1024 x 4 (45ns).....2.49	6147P.....2.95
2167S-45.....3.95	6147P-6.....4.50
2102L-2.....1.90	6514.....3.40

— MICROPROCESSORS —

8086-i.....\$5.80	68008-8.....\$ 9.95	68020RC16.....\$199.00
8088.....5.50	68000P-10.....13.50	68881RC12.....145.00
765.....3.75	68000P-16.....20.00	R80286-6.....55.00

— DYNAMIC RAMS —

4116-200.....16,384 x 1 (200ns).....\$.59	TMS4416.....16,384 x 4 (150ns).....\$12.00
4116-250.....16,384 x 1 (250ns)......49	4.464-150.....65,536 x 4 (150ns).....15.00
4164-150.....65,536 x 1 (150ns).....1.25	8118.....16,384 x 1 (120ns)......49
TMS4164.....65,536 x 1 (150ns).....2.25	41256-150.....262,144 x 1 (150ns).....15.00

— EPROMS —

2708.....1024 x 8 (450ns).....\$ 4.95	2764-250.....8192 x 8 (250ns).....\$ 3.55
2716.....2048 x 8 (450ns).....3.49	MCM68766.....8192 x 8 (350ns).....15.95
TMS2532.....4096 x 8 (450ns).....5.95	27128A-25.....16,384 x 8 (250ns).....5.00
2732.....4096 x 8 (450ns).....3.95	27128-250.....16,384 x 8 (250ns).....4.25
2732A-25.....4096 x 8 (250ns).....3.95	27C256.....32,768 x 8 (250ns).....7.95
27C64.....8192 x 8 (250ns).....4.95	27512.....65,536 x 8 (250ns).....11.55
2764.....8192 x 8 (450ns).....2.95	27C128-26.....7.00
2764A-25.....8192 x 8 (250ns).....3.55	

— LINEAR —

LH0002CN.....\$5.35	TL497ACN.....\$1.97	7818K.....\$1.21
LM10CLH.....2.65	NE555V......26	7824K.....1.21
LM0070-OH.....3.55	7805T......62	7805T......44
TL071CP......63	LM556N......53	7812T......44
TL072CP......71	NE558N.....1.07	7815T......44
LM301N......32	NE564N.....1.75	7818T......44
LM307N......41	LM565N......90	7824T......44
LM310N.....1.16	LM566CN.....1.25	78540.....1.75
LM311N......41	LM567V......80	7905K.....1.21
LM317K.....2.65	NE570N.....2.24	7906K.....1.21
LM317L......62	NE571N.....1.75	7912K.....1.21
LM317MP......80	NE592N......80	7915K.....1.21
LM317T......90	LM749CN......53	7918K.....1.21
LM318N.....1.07	DS8T28N.....1.57	7924K.....1.21
LM319N.....1.07	LM1456V.....1.75	7905T......53
LM324N......35	LM1458N......44	7912T......53
LM334Z.....1.07	LM1488N......65	7915T......53
LM336Z......98	LM1496N......90	7918T......53
LM337MP.....1.03	LM1899N.....1.43	7924T......53
LM339T.....1.34	ULN2003A......90	79L12AC......53
LM338K.....3.55	DS26LS32CN.....1.34	79L15AC......53
LM339N......44	DS26LS32CN.....1.34	LF13201N.....2.33
LF347N......90	LM2901N......53	LM13600N.....1.07
LM348N.....62	LM2903N......53	LM1889.....1.85
LM350K.....3.55	LM2907N.....1.75	75107N......90
LF353N......53	LM2917N.....1.39	75108N......90
LF356N......80	LM2917-14N.....1.34	75110A.....1.34
LM358N......44	LM2931CT.....1.07	75115.....1.07
LM380N.....80	MC346P......90	75123N.....1.34
LM380N-8......98	MC346E.....1.34	75124N.....1.34
LM381N.....1.16	MC3487.....1.34	75138N.....2.65
LM383T.....1.34	SG3524.....1.75	75154N.....1.25
LM385Z.....1.70	LM3900N......53	75450N......53
LM386N-4......80	LM3914N.....1.75	75451CN......44
LM389N......90	RC4136N......80	75452CN......44
LM393N......41	RC415NB......90	75453CN......44
LM398N.....2.15	RC4193NBIDE.....1.62	75464N......53
LF411CN.....71	7805T......21	75472......90
TL494CN.....1.75	7812K.....1.21	75492N......51
TL496CP.....1.34	7819K.....1.21	76477.....3.55

TIMEX-SINCLAIR... 2040 PRINTER

32-column — compatible with any of the Timex-Sinclair computers, as well as our PC8300 Ccomputer. Uses standard 4 1/2" thermal paper.
Item #15851 New — \$39.95

SMART WATCH DS1216

DS1216 is a 28-pin, 6"-wide dip socket w/built-in CMOS watch function. Non-volatile RAM controller & lithium energy source. Accepts either 24-pin 2K x 8 or 28-pin 8K x 8 CMOS static RAM. Communication w/Smart Watch function is established by pattern recognition on a serial bit stream of 64 bits on D.O. Mfr — Dallas Semiconductor
Item #15939 New — \$29.95

PUMPS — COMPRESSORS — FANS — BLOWERS — MOTORS — POTENTIOMETERS — COUNTERS — TIMERS — RELAYS — VOLTAGE REGULATORS — POWER SUPPLIES — OPTICS — BATTERIES

CRYSTALS... \$1.75 ea.

(Microprocessor HC-18U)

Mhz.	Item No.	Mhz.	Item No.
1.8432.....	7915	10.738635.....	1953
3.579545.....	12361	12.0.....	7920
3.6864.....	13501	14.31818.....	7359
4.0.....	7045	16.0.....	13425
4.32.....	13041	18.0.....	13617
4.9152.....	13666	18.432.....	13227
5.0.....	13043	19.6608.....	12112
5.0688.....	6786	20.0.....	12360
6.0.....	12362	24.0.....	18005
6.144.....	13226	32.768.....	13911
7.3728.....	13502	48.0.....	7389
8.0.....	1957	64.0.....	17238
10.0.....	17727	122.666.....	7037

MAGNIFYING LAMP

Multi-position, 30", completely adjustable swing arm with 3-way metal C-clamp. Has 4" diopter magnifying lens, w/ruler. Porcelain lamp socket & on/off switch; uses up to a 60W bulb. Color: beige. UL listed.
Item #13136 New — \$24.95

STEPPING MOTORS for ROBOTICS...

Precision steppers with increments from 1 to 7.5°. Speeds up to 5,000 steps.

Item No.	Step Angle	DC Voltage	Torque oz/in.	Type	Mfr. & Part No.	Dimensions	Fig.	Price
5275	1.8°	1.8	72	PM 20	Superior MO61-FF-6201B	2" x 2 1/4" dia. x 2 1/4" H	1	\$19.95 ea. 2 for \$37.50
7630	1.8°	3.0	200	PM	Superior MO92-FT-402	2" x 2 1/4" dia. x 2 1/4" H	1	\$34.50 ea. 2 for \$59.50
16410	1.8°	12.0	700*	PM	Applied Motion 4017-839	1 1/2" sq. x 1 1/4" D	2	\$9.95 ea. 2 for \$14.95
16406	3.6°	12.0	700*	PM	Applied Motion 4017-838	1 1/2" sq. x 1 1/4" D	2	\$9.95 ea. 2 for \$14.95
7014	7.5°	12.0	900*	PM	Mitsubishi 5S51-25DAYA	2 1/8" sq. x 1" D	3	\$10.95 ea. 2 for \$19.95

*Grams per Cm.

AMERICAN DESIGN COMPONENTS, 62 JOSEPH STREET, MOONACHIE, N.J. 07074

IC SOCKETS... Low Profile

No. of Pins	IHM #	Price
8.....	13518	\$.11
14.....	7350	.12
16.....	7354	.13
18.....	13694	.15
20.....	7353	.18
22.....	16875	.19
24.....	1230	.20
28.....	12865	.22
40.....	7351	.30
64.....	16169	.175

AMERICAN DESIGN COMPONENTS, 62 JOSEPH STREET, MOONACHIE, N.J. 07074

YES! Please send me the following items—

Item No.	How Many?	Description	Price	Total

Total Shipping & handling: we ship UPS unless otherwise specified. Add \$3 plus 10% of total. Canadian: \$3 plus P.O. cost. Charge only. Sales Tax (N.J. residents only, please add 6% of total)

ORDER TOTAL

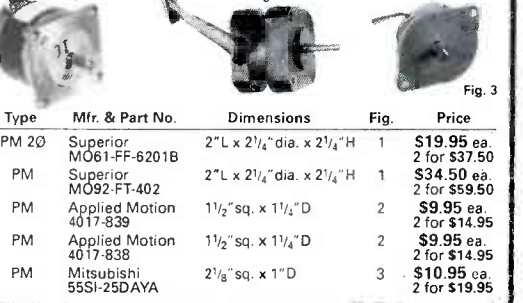

68-Pin Leaderless Chip Carrier Socket

Fits: 80186, 80188, 80286 ICs and more!
Item #18283 **\$5.75 ea.**; 2 for **\$10.00**

FREE! Fall Supplement with every order!

For all phone orders, call TOLL FREE 800-524-0809. In New Jersey call (201) 939-2710.

AMAZING SCIENTIFIC & ELECTRONIC PRODUCTS

PLANS—Build Yourself—All Parts Available In Stock

- LC7—BURNING CUTTING CO₂ LASER \$ 20.00
- RUB4—PORTABLE LASER RAY PISTOL 20.00
- TOC1—3 SEPARATE TESLA COIL PLANS TO 1.5 MEV 20.00
- IOG1—ION RAY GUN 10.00
- GRA1—GRAVITY GENERATOR 10.00
- EML1—ELECTRO MAGNET COIL GUN/LAUNCHER 6.00

KITS

- MFT3K—FM VOICE TRANSMITTER 3 MI RANGE 49.50
- VWPM7—TELEPHONE TRANSMITTER 3 MI RANGE 39.50
- BTC3K—250,00 VOLT 10-14" SPARK TESLA COIL 199.50
- LHC2K—SIMULATED MULTICOLOR LASER 39.50
- BLS1K—100,000 WATT BLASTER OFFENSE DEVICE 69.50
- ITM1K—100,000 VOLT 20" AFFECTIVE RANGE INTIMIDATOR 69.50
- PSP4K—TIME VARIANT SHOCK WAVE PISTOL 59.50
- PTG1K—SPECTACULAR PLASMA TORNADO GENERATOR 149.50
- MVIK SEE IN DARK KIT 199.50

ASSEMBLED

- PTW1K—SPECIAL EFFECT VISUAL PLASMA GENERATOR FOR GLOBES/NEON TUBING ETC. \$59.50
- BTC10—50,000 VOLT—WORLD'S SMALLEST TESLA COIL 49.50
- LGU40—1MW HeNe VISIBLE RED LASER GUN 249.50
- TAT30 AUTO TELEPHONE RECORDING DEVICE 24.50
- CPY10—SEE IN TOTAL DARKNESS IR VIEWER 349.50
- LIST10—SNOOPER PHONE INFINITY TRANSMITTER 169.50
- IPG70—INVISIBLE PAIN FIELD GENERATOR—MULTI MODE 74.50

• CATALOG CONTAINING DESCRIPTIONS OF ABOVE PLUS HUNDREDS MORE AVAILABLE FOR \$1.00 OR USE OUR PHONE FOR "ORDERS ONLY" 603-673-4730.

PLEASE INCLUDE \$3.00 PH ON ALL KITS AND PRODUCTS PLANS ARE POSTAGE PAID. SEND CHECK, MO., VISA, MC IN US FUNDS.

INFORMATION UNLIMITED
P.O. BOX 716 DEPT. RE. AMHERST, NH 03031

CONSOLIDATED ELECTRONICS

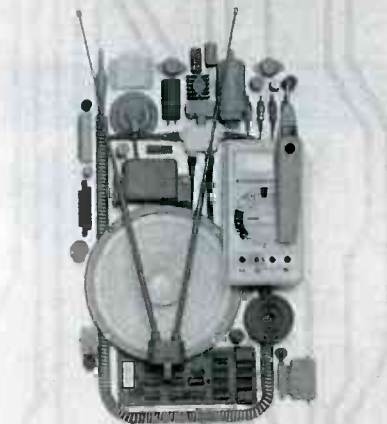

CONSUMER & INDUSTRIAL ELECTRONICS CATALOG • 17TH EDITION

THE ULTIMATE ELECTRONICS CATALOG.

Order your 260 page catalogue packed with over 10,000 money saving electronic parts and equipment. Send \$3.00 check or money order, or call 1-800-543-3568 today and use your Mastercard or Visa

Consolidated Electronics, Incorporated
705 Watervliet Ave., Dayton, Ohio 45420-2599

NAME _____
ADDRESS _____
CITY _____
STATE _____ ZIP _____

CIRCLE 185 ON FREE INFORMATION CARD

ADVERTISING INDEX

RADIO-ELECTRONICS does not assume any responsibility for errors that may appear in the index below.

Free Information Number Page

81, 190	A.I.S. Satellite	37
108	AMC Sales	77
—	AMCOM	104
182	Ace Communications	81
188	Active Electronics	107
107	All Electronics	108
—	Amazing Devices	122
106	American Design Components	120
76	Associated Electronics/3M	17
—	Atlantic Cable Distribution	34
183	Banner Technical Books	78
98	Beckman Industrial	3
85	Blue Star Industries	37
109	C & S Sales	7
195	C&H Sales	105
185	CEI	122
60	CIE	18
54	Chemtronics	23
189	Chenesko Products	37
—	Command Productions	78
176	Communications Specialists	84
196	Computer Age Ltd	94
58	Cook's Institute	81
191	Crystek	38
187	Daetron	79
184	Dakota Digital	37
—	Damark International	25
127	Deco Industries	37
82	Digi-Key	119
—	Digital Research Computers	104
—	Electronics Book Club	46
121	Fluke Manufacturing	CV2
—	Fordham Radio	CV4
203	GEI	83
—	GTC Industries	37
—	Grantham College of Engineering	40
86	Health	79
65	J & W	100
59	JDR Instruments	5
113, 177	JDR Microdevices	110, 111
178, 179	JDR Microdevices	112, 113
180	JDR Microdevices	114
114	Jameco	116
104	Jan Crystals	77
—	Joseph Electronics	33
201	Kelvin	24
87	MCM Electronics	118
53	MD Electronics	106
93	Mark V. Electronics	109
197	Mastersoft	94
—	McGraw Hill Cont. Education Series	75
63	Micro-Mart	106

61	Microprocessors Unltd.	94
—	NRI	8
194	Optoelectronics	13
—	Pacific Cable	103
56	Parts Express	105
68, 186	Philips ECG	15
250	Philips ECG	15
101	Pomona Electronics	22
—	RCA D&SP, (Thomson Consumer Elec.)	27
78	Radio Shack	115
204	SCO Electronics	78
198, 199	Scenore	26, 35
74	Solid State Sales	102
—	Star Circuits	34
83	Synergetics	72
73	T S M	CV3
200	TSM	81
92	Tektronix	28
123	Test Probes	14
193	United Electronic Supply	82
181	WPT Publications	84
66	W.S. Jenks	34

Gernsback Publications, Inc.
500-B Bi-County Blvd.
Farmingdale, NY 11735
(516) 293-3000
President: Larry Steckler
Vice President: Cathy Steckler

For Advertising ONLY
516-293-3000

Larry Steckler
publisher
Arline Fishman
advertising director
Shelli Weinman
advertising associate
Lisa Strassman
credit manager
Christina Estrada
advertising assistant

SALES OFFICES

EAST/SOUTHEAST
Stanley Levitan
Eastern Sales Manager
Radio-Electronics
259-23 57th Avenue
Little Neck, NY 11362
718-428-6037, 516-293-3000

MIDWEST/Texas/Arkansas/Okla.
Ralph Bergen
Midwest Sales Manager
Radio-Electronics
540 Frontage Road—Suite 339
Northfield, IL 60093
312-446-1444

PACIFIC COAST/ Mountain States
Marvin Green
Pacific Sales Manager
Radio-Electronics
5430 Van Nuys Blvd. Suite 316
Van Nuys, CA 91401
1-818-986-2001

T S M

HEADQUARTER - TSM IN AMERICA INC. 2085 BOSTON POST ROAD LARCHMONT N.Y. 10638
 GENERAL DISTRIBUTOR
 PROSPECT ELECTRONICS
 PO BOX 9144 ALLENTOWN, PA 18106
 TEL: (215) 770 - 9029



TSM 5A \$26.30
 AUDIO POWER MODULE 70W PEAK POWER
 35W RMS, INPUT SENSITIVITY 47K/800mV
 OUTPUT 4Ω/8Ω, POWER SUPPLY 39V D.C.
 2.5A



TSM 9 \$14.00
 AUDIO PREAMPLIFIER FOR GUITAR, INPUT
 SENSITIVITY 47K/5mV, OUTPUT LEVEL
 47K/1.5V, VOLUME CONTROL VARIABLE
 POWER SUPPLY 25V D.C./0.1A

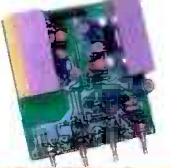

TSM 34 \$9.19
 STEREO RIAA PREAMPLIFIER, INPUT
 SENSITIVITY 47K/3mV, OUTPUT 700mV,
 POWER SUPPLY 12V D.C./0.1A

TSM 35 \$9.19
 MICROPHONE STEREO PREAMPLIFIER,
 INPUT SENSITIVITY 5mV/200Ω OR MORE,
 OUTPUT 700mV, POWER SUPPLY 12V D.C.
 /0.1A

TSM 67 \$38.74
 STEREO AMPLIFIER 2x40W PEAK POWER
 SENSITIVITY INPUT 47K/300mV, OUTPUT
 2.5/8Ω, VOLUME, BALANCE, BASS,
 TREBLE, CONTROLS POWER SUPPLY
 12V D.C. 3/4 A.

TSM 44 \$18.88
 AUDIO POWER MODULE, 50W PEAK POWER
 25W RMS, INPUT SENSITIVITY 800mV/47K
 OUTPUT IMPEDANCE 4/8Ω POWER SUPPLY
 40V D.C./2A

TSM 11 \$15.50
 AUDIO AMPLIFIER 30W PEAK POWER, 15W
 RMS, INPUT SENSITIVITY 47K/150mV, 2.5
 TO 8Ω OUTPUT, COMPLETE WITH VOLUME,
 BASS, TREBLE CONTROL, POWER SUPPLY
 12/16V D.C. /2A

TSM 5B \$33.70
 AUDIO POWER MODULE 90W PEAK POWER
 45W RMS, INPUT SENSITIVITY 47K/800mV
 OUTPUT 4Ω/8Ω, POWER SUPPLY 39V D.C./3A

TSM 18 \$12.97
 AUDIO AMPLIFIER 15W PEAK POWER, 7.5W
 RMS, INPUT SENSITIVITY 47K/150mV, 2.5
 TO 8Ω OUTPUT, COMPLETE WITH VOLUME
 BASS, TREBLE CONTROL, POWER SUPPLY
 12/16V D.C. /1.5A

TSM 19 \$52.05
 AUDIO 2x40W PEAK POWER, 120W RMS
 SENSITIVITY 47K/0.8 V OUTPUT 4 Ω,
 THD 0.3%, RESPONSE 15 Hz - 100 KHz.
 POWER SUPPLY 79V MAX. HEAT-
 SINKS NOT INCLUDED WITH THE KIT.

TSM 66 \$16.50
 AUDIO POWER MODULE 40W PEAK POWER
 20W RMS, INPUT SENSITIVITY 47K/300mV
 OUTPUT 2.5/8Ω POWER SUPPLY 12V D.C./2A

TSM 68 \$22.66
 STEREO AMPLIFIER 2 X 20W
 INPUT 47K/300mV, OUTPUT 2.5/8Ω SUP-
 PLIED WITH HEAT SINK AND BALANCE,
 VOLUME, BASS, TREBLE, POWER SUPPLY
 12V D.C./2.5A

TSM 155/1 \$46.30
 STEREO AMP. 2 X 50W
 PEAK, INPUT SENSITIVITY 47K/300mV
 OUTPUT 4/8Ω SUPPLIED WITH HEAT SINK
 AND BALANCE, VOLUME, BASS, TREBLE
 CONTROLS, POWER SUPPLY 40V D.C./2A-3A

TSM 118 \$62.31
 320W PEAK POWER AMPLIFIER MODULE,
 8Ω OUTPUT IMPEDANCE INPUT 47K/800mV
 FREQUENCY RESPONSE 15HZ TO 60KHZ,
 POWER SUPPLY 2 X 40V D.C./6A
 HEAT SINKS NOT INCLUDED IN THE KIT.

TSM 89 \$30.38
 AUDIO BOOSTER STEREO 2 X 40W FOR
 CAR RADIO, OUTPUT 2.5Ω POWER SUPPLY
 12/16V D.C./4A.

TSM 102 \$22.50
 18 LED OUTPUT POWER LEVEL METER,
 POWERED BY THE MODULATION.

TSM 128 \$20.31
 2 X 6 LED OUTPUT LEVEL METER, STEREO
 2 X 50W, POWER SUPPLY 15/20V D.C.

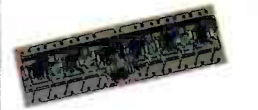

TSM 122 \$13.96
 ALL-BAND FM/YHF/UHF ANTENNA, 20dB
 AMPLIFIER, POWER SUPPLY 8/12V D.C./
 0.15A

TSM 31 s \$14.77
 FM STEREO DECODER, POWER SUPPLY
 12V D.C. / 0.1A

TSM 62 \$13.00
 CAR ANTENNA PREAMPLIFIER MW/LW/FM,
 POWER SUPPLY 12/16V D.C./0.1A

TSM 335 \$15.65
 PHYSIOLOGIC TONE CONTROL, STEREO,
 INPUT IMPEDANCE 150mV/160K, OUTPUT
 LEVEL 800mV, POWER SUPPLY 25V D.C.

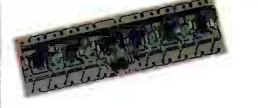

TSM 146 \$33.99
 STEREO 2X5 BANDS EQUALIZER, SUPPLIED
 WITH 10 POTENTIOMETERS, FREQUENCY
 RESPONSE 50HZ TO 15 KHZ, POWER SUPPLY
 2 X 12V D.C./0.2A

TSM 147 \$18.88
 MONO 5 BANDS EQUALIZER, SUPPLIED WITH
 5 POTENTIOMETERS, FREQUENCY RESPONSE
 50 HZ TO 15KHZ, POWER SUPPLY 2 X 12V
 D.C./0.15A.



TSM 61 \$25.48
 FM RECEIVER, OUTPUT 1 WATT 4/8Ω,
 POWER SUPPLY 12/16V D.C. /0.2A.

TSM 158 \$27.42
 FM RECEIVER, OUTPUT 20 WATTS/8Ω
 POWER SUPPLY 12/16V D.C. /2A.

TSM 211 \$10.00
 MEDIUM WAVE RECEIVER, 1 W, 0.5 W RMS
 AUDIO POWER, POWER SUPPLY
 9-12V D.C./0.1 A

TSM 205 \$35.40
 FM RECEIVER, HEADPHONE STEREO OUTPUT
 POWER SUPPLY 9/12V D.C./0.1A

ELECTRONICS KITS

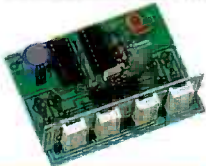

TSM 201 \$26.77
 DIGITAL CLOCK, 5/16" READ OUT, POWER
 SUPPLY 12V D.C./0.2A WITH HOUR AND
 MINUTE SETTING CONTROLS

TSM 157 \$40.00
 DIGITAL CLOCK AND UP TO 24 MN
 1/100 S. CHRONOMETER, COUNT-DOWN
 CAPABILITY FOR THE CLOCK,
 POWER SUPPLY 12V D.C. OR A.C.

TSM 177 \$33.20
 DIGITAL VOLTMETERS 0 V TO 999 V D.C.,
 POWER SUPPLY 12V D.C./0.5A

TSM 206 \$10.15
 METRONOME, POWER SUPPLY 9 - 12V D.C.

TSM 210 \$10.50
 FULLY RANDOMISED ELECTRONIC DICE,
 POWER SUPPLY 9 - 12V D.C./0.1A

TSM 54 \$13.85
 FM TRANSMITTER, POWER SUPPLY 9V
 D.C. / 0.5A

TSM 150 \$82.50
 HOME PROGRAMMER, 4 DEVICES CONTROL
 20 PROGRAMS, OPERATION WITH RELAYS
 POWER SUPPLY 12V D.C./0.8A

TSM 130 \$25.77
 24 TUNE DOOR CHIME, OUTPUT 3/4 WATTS
 POWER SUPPLY 12V D.C./1A.

TSM 123 \$46.15
 SOUND CONDITIONER, OUTPUT LEVEL 800mV
 TO BE CONNECTED TO AMPLIFIER AUXILIARY
 INPUT, POWER SUPPLY 12V D.C.

TSM 78 UNIVERSAL ALARM FOR
 HOME AND CAR, DELAYED EXIT TIME, AD-
 JUSTABLE SOUND ALARM, TALKER PROOF,
 OPERATION WITH CONTACT SWITCHES.
 POWER SUPPLY 12V D.C./0.15A \$33.23

TSM 121 \$17.54
 16 LED DISPLAY THERMOMETER, POWER
 SUPPLY 15/16V D.C./0.15A

TSM 105 \$15.15
 ELECTRONIC ALARM SIREN, 8Ω IMPEDAN-
 CE, 10 WATTS RATING, POWER SUPPLY
 12V D.C., HORN SPEAKER NOT INCLUDED.

TSM 85 \$22.52
 TIME DELAY SYSTEM FROM 1 SEC TO 15
 MINUTES. POWER SUPPLY 12V D.C.

TSM 69 \$15.93
 TELEPHONE AMPLIFIER WITH INDUCTIVE
 PICK-UP AND SPEAKER, ADJUSTABLE
 VOLUME, POWER SUPPLY 9/12V D.C./0.1A

TSM 168 \$12.92
 MOSQUITO REPELLER, POWER SOURCE
 9V D.C.

TSM 88 \$38.77
 FUNCTION GENERATOR, FREQUENCY RANGE
 8HZ TO 200KHZ, PROVIDING SINE/Triangle
 /SQUARE SAW TOOTH WAVE FORMS, PO-
 WER SUPPLY 12V D.C./0.3A

TSM 58 \$19.94
 TWO-STATION INTERCOM WITH SPEAKER
 VOLUME CONTROL, POWER SOURCE 9/12V
 D.C. / 0.4A

TSM 160 \$16.62
 STEREO SIMULATOR, POWER SUPPLY 12V
 D.C./0.1A.

TSM 196 \$19.71
 7 INPUT MIXER STEREO PREAMPLIFIER OR
 14 INPUT MONO WITHOUT ATTENUATION,
 INPUT 47K/100 TO 700mV, OUTPUT 47K/
 100 TO 750mV, POWER SUPPLY 24V D.C.
 /0.1A

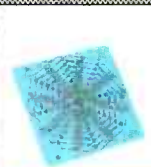

TSM 99 \$130.00
 VEGAS KIT - FESTIVE LIGHT DISPLAY (LED)
 POWER SUPPLY 12V D.C. / 2.5A
 64 LEDS, AS MANY AS 800 PROGRAMS



TSM 212 \$17.50
 LOW OPERATING VOLTAGE
 SPOT TSM 220 AND TSM 221 COMPATIBLE
 CONTROLLED BY A MICROPHONE
 POWER SUPPLY 12V/1A, OUTPUT 0.5A,
 MODULATOR, SAFE 3-CHANNEL LIGHT

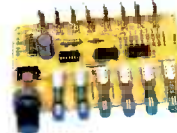

TSM 214 \$29.50
 8-CHANNEL CATERPILAR, SAFE LOW
 VOLTAGE OPERATION USING TSM 220
 AND 221 SPOT, 9V D.C./0.5 A

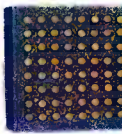

TSM 220 \$25.30
 64 LED'S SPOT FOR SAFE LIGHT MODUL-
 ATION, SUPPLIED WITH BOX.

TSM 213 \$16.20
 SAFE LOW VOLTAGE 2-WAY CATERPILAR
 RANDOMLY FLASHING AND WINKING, TSM
 220 AND TSM 221 SPOT COMPATIBLE,
 POWER SUPPLY 12V/0.5A

TSM 221 \$17.20
 25 LED'S SPOT FOR SAFE LIGHT MODUL-
 ATION SUPPLIED WITH BOX.



TSM 2 V2 \$22.20
 VARIABLE SOLID STATE REGULATED PO-
 WER SUPPLY 8V TO 38V/2A
 TRANSFORMER IS NOT INCLUDED WITH THE
 KIT.

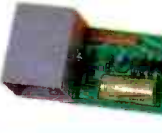

TSM 116 V5 \$11.50
 REGULATED POWER SUPPLY 5V D.C.
 POWER TRANSFORMER NOT INCLUDED WITH
 THE KIT.

TSM 116 V12 \$11.50
 REGULATED POWER SUPPLY 12V D.C.
 POWER TRANSFORMER IS NOT INCLUDED
 WITH THE KIT.

TSM 163 \$12.92
 POWER SUPPLIES 5, 7.5, 9, 12V/1A.
 POWER TRANSFORMER NOT INCLUDED
 WITH THE KIT.

TSM 2 V4 \$25.85
 VARIABLE SOLID STATE REGULATED PO-
 WER SUPPLY 3V TO 14V/5A TRANSFORMER
 NOT INCLUDED IN THE KIT.

ACTIVE DISTRIBUTORS IN CANADA

ALBERTA, CALGARY T2A 5N1
 NBR 2-3220 5 TH AVE N.E.
 TEL:(403) 235-5300
 FAX:(403)248-0750

ALBERTA, EDMONTON T6H 4J8
 5312 CALGARY TRAIL
 TEL:(403) 438-5888
 FAX:(403) 434-0812

B.C. VANCOUVER V5R 5J7
 3070 KINGSWAY
 TEL:(604) 408-3321

MANITOBA, WINNIPEG R3H 0H8
 106 KING EDWARD ST E
 TEL:(204) 786 3075

ONTARIO, MISSISSAUGA L4W 4M1
 MATHESON CENTRE
 NBR 2-1350 MATHESON BLVD
 TEL:(416) 238-8825

ONTARIO, DOWNSVIEW M3J 1Z3
 TORONTO DOWNSVIEW
 86 ST REGIE CRN
 TEL:(416) 630-0400
 FAX:(416) 638-2936

ONTARIO, TORONTO M5C 1M3
 TORONTO DOWNTOWN
 100 LOMBARD ST
 TEL:(514) 367-2911

ONTARIO OTTAWA K1Z 6A6
 1023 MERIVAL ROAD
 TEL:(613) 728-7900

QUEBEC, MONTREAL-WEST H4P 1N1
 5651 FERRIER ST
 TEL:(514) 731-7441

QUEBEC, MONTREAL EAST H1S 1A9
 5080 METROPOLITAIN BLVD E.
 TEL:(514) 256-7538

QUEBEC, STE-FOY G1N 4K8
 1990 BOUL CHAREST 0
 TEL:(418) 682-5776
 FAX:(418) 682-8303

ACTIVE IN U.S.A

MASS, BOSTON WESTBORO 01581
 133 FLANDERS ROAD
 TEL:(617) 366-8899
 FAX:(617)366-1195

WA, BELLEVUE SEATTLE 98005
 13107 NORTHP WAY
 20 TH ST N.E.
 TEL:(206) 881-8191

C.A. SANTA CLARA
 2010 DUANE AV
 SANTA-CLARA 95054 C.A
 TEL:408 727 45 50

N.J. MOUNT LAUREL
 107 GAITHER DR
 MOUNT LAUREL NJ 0854
 TEL: 609 273 21 00

AUTO SOUND SYSTEM
 1269 EAST MAIN STREET
 EL CAJON CA 92021
 TEL:(619) 442-70-22

CC ELECTROWARD
 716 W ST GEORGE AVE
 LINDEN NJ
 TEL:(201)925-83-33

50W RADIO
 2001 HARBOR BLVD
 COSTA-MESA CA 92627

ELECTRO CITY
 801 EAST BROADWAY
 TUCSON ARIZONA 85719

ELECTRONIC OUTLET
 2816 FONDREN
 HOUSTON TEX - 77063

ELECTRONIC WAREHOUSE
 2691 MAIN ST
 RIVERSIDE CA92501
 TEL:(714)686-61-86

KELVIN ELECTRONICS
 7 FAIRCHILD AVE.
 PLAINVILLE N.Y 11803
 TEL:(516)349-7820
 FAX:(516)349-7830

NUTRON COMPUTER ELECTRONICS
 821 E ROOSEVELT RD LOMBARD
 IL. 60148
 TEL:(312)891-89-00

MACS ELECTRONIC
 191 SOUTH E STREET
 SAN BERNARDINO CA 92401
 TEL:(714)884-31-87

ORVAC ELECTRONIC
 1645 EAST ORANETHORPE
 ROLLERTON
 CA 92631 5294
 TEL:(714)871-12-20

CALIFORNIA
 REPRESENTATIVE OFFICE
 MIKE ROTH LAYNS INC.
 1277 SOUTH LYON STREET N#606
 SANTA ANA CA 92705

RF ELECTRONICS
 1164 So. Harbor Blvd.
 Fullerton, CA 92632
 Tel: (714) 447-1133

TREYK ELECTRIC
 9014 NORTH 23 AVENUE PHOENIX
 ARIZONA 85021
 TEL:(602)371-08-60

WELCOME
 DISTRIBUTORS - RETAILERS
 WRITE FOR AN INTERESTING PROPOSAL

Fordham measures up

Quality • Price • Delivery

Mini-Meters with Maxi-Specs



SCOPE 3 1/2 Digit LCD Meter

- 0.5% Accuracy • DC Voltage • AC Voltage • DC Current • Resistance • Diode Test • Battery Life 300 Hrs. • Overload Protection: DC 500V, AC 350V, ohms 250V DC/AC.

Model DVM-630
Our Price **\$2995**

Zippered carrying case
CC-30 \$4.50

NEW!

SCOPE 3 1/2 Digit, LCD 8 Function with Transistor Tester

- 0.5% Accuracy • Audible continuity and diode test • 10 Amp measurement • Resistance • DC/AC Voltage.

Model DVM-632
Reg. \$60.00
Our Price **\$4495**

Zippered carrying case
CC-30 \$4.50

SCOPE 3 1/2 Digit LCD with Autoranging

- 0.5% Accuracy • Auto/Manual range selection • DC Voltage • AC Voltage • AC Current • DC Current • Resistance.

Model DVM-631
Our Price **\$4995**

Special

Deluxe carrying case
CA-92 \$9.95

SCOPE Hand-Held Digital Multimeters

- Overload protection • Auto-decimal LCD readout • Polarity Indication • 300 hr. 9V battery life • Low battery indicator.

- 8 Function, 37 ranges including Transistor and Capacitance measurements

Model DVM-636
Our Price **\$6750**



- 11 Function, 38 ranges including Logic Level Detector, Audible and Visual Continuity, Capacitance and Conductance measurements

Model DVM-638
Our Price **\$8750**



CA-92 Deluxe Padded Case for DVM meters. \$9.95
TL-216 Transistor and Capacitance Test Leads \$9.90



NEW!

SCOPE Frequency Counters
• 8-digit LED • Compact • lightweight • High performance • Automatic range and Hold function • High stability in reference oscillator.

Special
Model FC-7011
100 MHz Our Price **\$14995**

Model FC-7051
550 MHz Our Price **\$19995**



FORDHAM Frequency Counter

- 10 Hz - 150 MHz Range • 7-digit LED display • VHF/HF selection • Gate time 1 sec., 5 sec. • ±1 count accuracy.

Model FC-150
Our Price **\$13990**



NEW FORDHAM Function Generator

- 0.5 Hz - 500 KHz in 6 ranges • Sine, square & triangle wave forms • VCA and VCF inputs • Accuracy ±5% of full scale.

Model FG-202
Our Price **\$14990**



FORDHAM Signal Tracer/Injector

- Easy to operate • VU meter • Two LED mode indicators • 1 KHz test tone • 8 ohm speaker • Test leads.

Model SE-610
Our Price **\$11990**



FORDHAM LCR Bridge Meter

- Fully transistorized • 1 KHz signal generator • Measures resistance • Inductance • High mechanical and electrical stability • Battery operated.

Model LC-340
Our Price **\$14995**



SCOPE Digital Capacitance Meter

- Digital LCD display • LSI-circuit • High accuracy: 100 ppm 0.5% • Broad test range • Fast sampling time • Capacitor discharge protection • Compact, lightweight design • One-hand operation.

Model DCM-602
Our Price **\$5995**

Telephone Orders Now! EVERYDAY INCLUDING SATURDAY
Mon. - Fri. 8 a.m. - 6:30 p.m. EST. Sat. & Sun. 9 a.m. - 3 p.m. EST

ASK FOR FREE CATALOG. Money orders, checks accepted. C.O.D.'s require 25% deposit



Fordham

260 Motor Parkway, Hauppauge, NY 11788

Toll Free **800-645-9518**

In NY State 800-832-1446

Service & Shipping Charge Schedule Continental U.S.A.

FOR ORDERS	ADD
\$25-50	\$4.50
\$51-100	\$5.50
\$101-200	\$7.00
\$201-300	\$8.00
\$301-400	\$9.00
\$401-500	\$10.00
\$501-750	\$12.50
\$751-1000	\$15.00
\$1001-1250	\$17.50
\$1251-1500	\$20.00
\$1501-2000	\$25.00
\$2001 and up	\$30.00