

THREE GREAT PROJECTS YOU CAN BUILD FOR YOUR CAR

APRIL 1993

Electronics

Radio Combined with
Electronics[®]

NOW

[®]

BUILD A REMOTE CAR STARTER

The ultimate convenience add-on for your car!



UPDATE YOUR DASHBOARD

With good-looking, smart electronic gauges



GREAT SOUNDS IN YOUR CAR

Build an audio signal processor



BUILD A SINGLE-CHIP DVM

It provides 4 1/2-digit resolution

FIELD-EFFECT TRANSISTORS

Learn how JFET's work and how you can use them

***** CAR-RT SORT ** CR11
450992TDM0077W099 04 P97

MAY 96
RE

B THOMPSON
77 WALTHAM ST
MAYNARD MA 01754-2427



\$3.50 U.S.
\$3.95 CAN

A
GERNSBACK
PUBLICATION

Top Choices.

Fluke meters are your top choice for accuracy, reliability, and performance. They offer

more combinations of features and functions than any other meters on the

Fluke 97
ScopeMeter®

market. Features like true-rms measurements, high resolution,

Smoothing™ and Peak Hold. Or simultaneous scope and meter

functions in one portable package. Whichever Fluke meter

you choose you can count

on benchtop accuracy,

test lab versatility, and

handheld convenience.

Plus, Fluke keeps you

covered with a full line of quality

accessories, strong customer support,

and product warranties that measure up

to any in the industry. When it's up to you to get the job done, look to

Fluke for the choices you need to get it done right. See your

Fluke distributor, or call 1-800-87-FLUKE

8060A

for a catalog and the name of the

distributor nearest you.



Fluke 87

Fluke 79

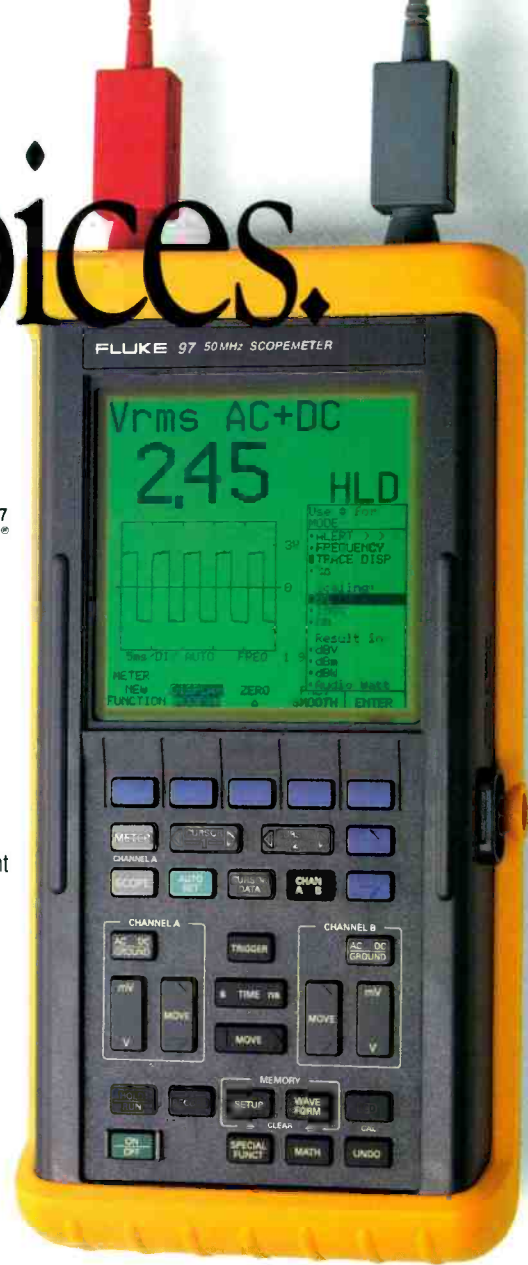

FLUKE 79 FLUKE 87 8060A FLUKE 97

The Fluke meters listed above feature diode test, auto and manual range, continuity, and frequency measurements.

	FLUKE 79	FLUKE 87	8060A	FLUKE 97
Lo-Rms measurements	True-rms	True-rms	True-rms	True-rms ac or dc & ac
Capacitance measurements	Capacitance measurements	Resistance measurements to 300 MΩ	Resistance measurements to 300 MΩ	Scope, Meter or simultaneous meter and scope display
Smoothing™	Duty Cycle measurements	High impedance DC voltage function	High impedance DC voltage function	Dual Trace 50 MHz bandwidth
4000 count display	20,000 count high resolution display	20,000 count display	20,000 count display	40 nanosecond glitch capture
Basic accuracy 0.3%	Offset/Relative reference	Offset/Relative reference	Offset/Relative reference	Store waveforms and setups
	1 millisecond Peak Hold	dB measurements	dB measurements	dBm, dBV, dB Relative and Audio Watt calculations
	Basic accuracy 0.1%	Basic accuracy 0.04%	Basic accuracy 0.04%	Basic accuracy 0.5%

John Fluke Mfg. Co., Inc.
P. O. Box 9090, Everett, WA 98206
For more information call:
(416) 890-7600 from Canada
(206) 356-5500 from other countries

©Copyright 1992 John Fluke Mfg. Co. Inc. All rights reserved.
Ad No. 00282

FLUKE®
CIRCLE 121 ON FREE INFORMATION CARD

BUILD THIS

- 37 BUILD THE AFG II**
The Acoustic Field Generator II will turn your car into a mobile listening room!
Tod T. Templin
- 45 BUILD THE SMARTGAGE**
Get precise readouts of your car's water temperature, oil pressure and battery voltage.
N.J. & R.E. Tuthill
- 59 SINGLE CHIP DMM**
Build this inexpensive alternative to a store-bought 4½-digit volt meter.
Anthony J. Caristi
- 71 REMOTE CAR STARTER**
Start your car from the comfort of your house!
Martin Fournier

TECHNOLOGY

- 64 JUNCTION FIELD-EFFECT TRANSISTORS**
Learn how to bias JFET's and use them in a variety of practical circuits.
Ray Marston
- 82 APRIL 6: ELECTRONICS TECHNICIANS DAY**
If you've been thinking about becoming a CET, now's your chance!
Larry Steckler, EHF/CET

DEPARTMENTS

- 6 VIDEO NEWS**
What's new in this fast-changing field.
David Lachenbruch
- 18 DRAWING BOARD**
Finding a way to detect lines 24 and 247.
Robert Grossblatt
- 75 HARDWARE HACKER**
Using cubic splines, and more.
Don Lancaster
- 85 AUDIO UPDATE**
The Audio Answerman returns.
Larry Klein
- 95 COMPUTER CONNECTIONS**
Microsoft and Intel take on the world.
Jeff Holtzman

AND MORE

- 108 Advertising Sales Offices**
- 108 Advertising Index**
- 102 Buyer's Mart**
- 2 14 Letters**
- 34 New Lit**
- 24 New Products**
- 8 Q&A**
- 4 What's News**

Electronics NOW®

Hugo Gernsback (1884-1967) founder

Larry Steckler, EHF, CET,
editor-in-chief and publisher

EDITORIAL DEPARTMENT

Brian C. Fenton, editor
Marc Splwak, associate editor
Neil Sclater, associate editor
Teri Scaduto, assistant editor
Jeffrey K. Holtzman
computer editor
Robert Grossblatt, circuits editor
Larry Klein, audio editor
David Lachenbruch
contributing editor
Don Lancaster
contributing editor
Kathy Terenzi, editorial assistant

ART DEPARTMENT

Andre Duzant, art director
Injae Lee, illustrator
Russell C. Truelson, illustrator

PRODUCTION DEPARTMENT

Ruby M. Yee, production director
Karen S. Brown
advertising production
Marcella Amoroso
production assistant
Lisa Rachowitz
editorial production

CIRCULATION DEPARTMENT

Jacqueline P. Cheeseboro
circulation director
Wendy Alanko
circulation analyst
Theresa Lombardo
circulation assistant
Michele Torrillo
reprint bookstore

Typography by Mates Graphics
Cover photo by Diversified Photo Services.

Electronics Now is indexed in *Applied Science & Technology Index*, and *Readers Guide to Periodical Literature*, *Academic Abstracts*, and *Magazine Article Summaries*. Microfilm & microfiche editions are available. Contact circulation department for details.

Advertising Sales Offices listed on page 102.

Electronics Now Executive and Administrative Offices
1-516-293-3000.

Subscriber Customer Service:
1-800-288-0652.

Order Entry for New Subscribers:
1-800-999-7139.



Audit Bureau
of Circulations
Member



SURFACE MOUNT MIXERS

...with a difference



actual size

up to 1900MHz from **\$6²⁵**

Now available, a large variety of tiny, ultra-rel high performance mixers to handle your applications from extra wideband, high isolation, low two-tone third-order IM, to very low +3dBm LO power.

Mini-Circuits' new LRMS-series Ultra-Rel™ mixers are offered with a difference...unprecedented reliability. Units are manufactured with Ultra-Rel diodes, all-welded construction, metal stubs to all connections, and to 4.5 sigma performance repeatability. Each Ultra-Rel™ LRMS mixer can withstand strenuous shock and vibration, will perform over a -55° to +100°C range, and is guaranteed for five years.

Aim for 4.5 sigma repeatability in your product designs by specifying Mini-Circuits' Ultra-Rel™ LRMS mixers, available for immediate delivery in tape-and-reel format (500 units, 16mm width) at prices from \$6.25.

**ULTRA-REL™
MIXERS**
5-YR. GUARANTEE *

with extra long life due to unique HP monolithic diode construction, 300°C high temp. storage, 1000 cycles thermal shock, vibration, acceleration, and mechanical shock exceeding MIL requirements.

finding new ways...
setting higher standards

Mini-Circuits

P.O. Box 350166, Brooklyn, New York 11235-0003 (718) 934-4500 Fax (718) 332-4661 Telexes: 6852844 or 620156

CIRCLE 182 ON FREE INFORMATION CARD

www.americanradiohistory.com

SPECIFICATIONS: all spec limits are 4.5 σ from mean

Model	Freq. Range LO. RF	(MHz) IF	LO Level (dBm)	Conv. Loss Mean (\bar{X}) mid-band (dB)	L-R Isol. Mean (\bar{X}) mid-band (dB)	Price \$ (1-9)
LRMS-2L	800-1000	DC-200	+3	6.6	24	6.95
LRMS-1	0.5-500	DC-500	+7	6.4	45	6.25
LRMS-1W	2.0-750	DC-750	+7	5.8	45	6.75
LRMS-2	5-1000	DC-1000	+7	6.8	38	6.95
LRMS-2D	5-1000	DC-1000	+7	6.8	40	7.25
LRMS-2U	10-1000	10-1000	+7	6.5	46	11.45
LRMS-5	5-1500	DC-1000	+7	6.0	41	13.95
LRMS-11A	1400-1900	40-500	+7	7.0	25	16.95
LRMS-1LH	2.0-500	DC-500	+10	5.8	47	7.95
LRMS-2LH	5-1000	DC-1000	+10	6.6	40	8.95
LRMS-5LH	10-1500	DC-900	+10	5.4	38	14.95
LRMS-1MH	2.0-500	DC-500	+13	5.7	44	8.95
LRMS-2MH	5-1000	DC-1000	+13	6.6	44	9.95
LRMS-5MH	10-1500	DC-900	+13	5.8	46	15.95
LRMS-1H	2.0-500	DC-500	+17	6.3	44	10.95
LRMS-2H	5-1000	DC-900	+17	7.2	36	11.95
LRMS-2UH	10-1000	10-750	+17	7.1	38	14.45
LRMS-5H	10-1500	DC-900	+17	7.2	45	17.95

Designers Kit, KH-3

available only \$59.95 includes: 8 mixers, 2 each of LRMS-1, LRMS-2, LRMS-2U, LRMS-11A. 740 page RF/IF DESIGNER'S HANDBOOK Contains application notes using mixers as electronic attenuators, frequency doublers, switches, and bi-phase modulators.

WE ACCEPT AMERICAN EXPRESS AND VISA

WHAT'S NEWS

A review of the latest happenings in electronics.

Sending voice and video over the airwaves

A microwave radio transmission system has been granted approval by the Federal Communications Commission (FCC) to operate in the 28-GHz band. An alternative to cable TV, it makes use of a band that was once considered to be too high a frequency for effective TV transmission.

The Cellular Vision system, financed by the Suite 12 Group (Freehold, NJ), was invented by Bernard Bossard. Microcells transmit high-quality video signals at radio frequencies that are much higher than the UHF or VHF signals assigned to satellite TV transmission. The TV signals are received by a 4.5-inch-square, flat antenna that can be mounted either inside or outside a customer's house.

According to the system's inventor, the elimination of cables, which require costly installation and maintenance, permit Cellular Vision to be offered at a lower price than cable TV. Bossard claims that the system will improve TV the same way that FM improved radio.

Microwaves at 28 GHz can carry more information than longer-wave transmissions, and they can be bounced off buildings. The major drawback to microwave transmission is seen as its limited range—only a few miles from the transmitter. The proposed solution to that problem is the division of large geographical regions into smaller cells, each of which has its own microwave transmitter.

To eliminate mutual interference and ghosting, microwave transmissions from adjacent transmitters will be polarized as "vertical" or "horizontal" signals that can be distinguished by a customer's antenna.

The short 28-GHz wavelength permits the use of the small receiving antennas. Their size contrasts with the three-foot or greater diame-

ters of the parabolic "dish" antennas that now receive TV transmissions directly from satellites. With only slight modification, a Cellular Vision microwave receiving antenna can be converted so it will transmit signals back to the base antenna. This would give Cellular Vision interactive capability.

The service was approved by the FCC in December 1992 for operation in the Brighton Beach section of Brooklyn, NY. At present, 49 channels of TV programming are being offered for less than \$30 a month. The FCC also voted unanimously to seek public opinion on its plan to permit voice and video transmissions in the 28-GHz band. Licenses would be granted to two operators in each of 489 regions across the country. A 1000-MHz block of spectrum would be assigned to each operator.

The new technology puts TV cable companies and telephone operating companies in close competition. It permits cable companies to provide telecommunications services, and local telephone operating companies to provide such services as video teleconferencing and movies on demand.

Unmanned police vehicle

An unmanned ground vehicle was tested by a police department in the



THE HARE can enter hazardous situations without endangering human lives.

simulated apprehension of an armed suspect who was holding hostages. The telecheric machine (rather than a robot) was under human control at all times. It would have permitted police to carry out a hazardous negotiation without exposing themselves to possible hostile gunfire.

Built by Westinghouse Electric Corporation's Huntsville (Alabama) Engineering Center, the vehicle, called the Hazard Avoidance Reconnaissance Extender, or HARE, was tested in the training exercise by Huntsville, AL police.

The Huntsville police department's Special Response Team and Hostage Negotiation Team, equipped with the HARE, put the vehicle to work in the realistic test. "Shots" had been fired on the fourth floor of a Huntsville bank building, and one man seized an unknown number of hostages. A police unit entered the building and set up a command post at the opposite end of the floor on which the hostages were being held.

The "suspect" was persuaded to accept a portable phone delivered to him by HARE. The suspect did not know that HARE also contained three on-board video cameras that were filming his actions. Video of the suspect and the hostages was transmitted back to the police, permitting them to appraise the situation. That information, transmitted from HARE over a four-hour period, helped police to "rescue" the hostages and apprehend their captor without exposing themselves to possible gunfire.

Westinghouse plans to build and ship the first six production HARE's in the second half of 1993. The company asserts that HARE's can also be used by bomb squads to remove suspicious objects or known bombs for safe disposal. It is also seen as being useful in rescue work and fire fighting. Ω

The DMM our customers designed.

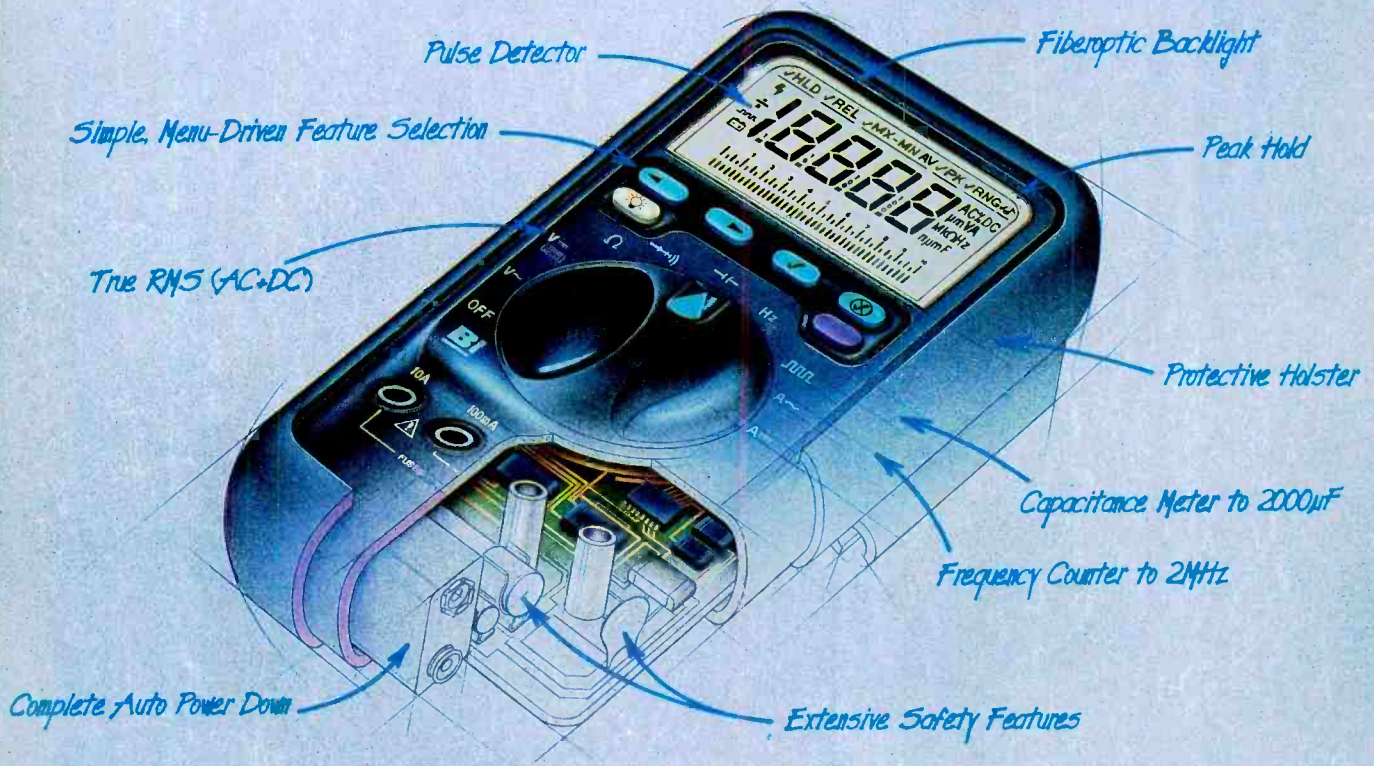

Before we built the new generation Beckman Industrial Series 2000 DMMs, we asked people like you what you *really* want.

You want more. More test and measurement capabilities. More troubleshooting features. All in an affordable hand-held DMM. The Series 2000 features the widest range Frequency Counter in any professional DMM, a full-range Capacitance Meter, True RMS measurements, Intermittent Detection, 50ns Pulse Detection, and Peak Measurement capabilities. Plus, the Series 2000 is the only meter to offer autoranging Min/Max recording and relative modes.

You want a DMM that's easier to use. The Series 2000's display is 25% larger, with bigger digits and backlighting for easier reading, even in the worst light. Plus the fast 4 digit display provides the high resolution needed for adjusting power supplies and generators down to 1mV. And only the Series 2000 features a menuing system for fast, simple feature access.



Made in the USA

The Beckman Industrial Series 2000, priced from \$209 to \$279 offers you the best performance for your dollar. Look again at these features:

- 4 Digit, 10,000 Count Resolution
- Basic Accuracy to 0.1%
- True RMS, AC or AC on DC
- 0.01Ω Resolution
- Automatic Reading Hold
- 1ms Peak Hold
- Fully Autoranging Relative and Min Max Modes
- Intermittent Detector
- UL1244, IEC1010 Design
- Three Year Warranty

The Series 2000 offers the most solutions for your everyday test and measurement needs. The only DMMs designed by the people who use them. You.

For more information on these new DMMs call (outside CA) 1-800-854-2708 or (inside CA) 1-800-227-9781.

WAVETEK INSTRUMENTS DIVISION
9045 Balboa Ave., San Diego, CA 92123
USA (619)279-2200 • UK (384)442394 • FRANCE (1) 4302 7606 • GERMANY (089) 960 94 90

*BI (formerly Beckman Industrial Instrumentation Products Division) is now a part of Wavetek Corporation.

CIRCLE 5 ON OUR FREE INFORMATION CARD
www.americanradiohistory.com

WAVETEK

VIDEO NEWS

What's new in the fast-changing video industry.

DAVID LACHENBRUCH

● **Widescreens are here.** The new TV sets with 16:9 ratio screens have now been introduced and are slowly finding their way to the marketplace. They will not be available in any large numbers, and their high prices sharply limit their appeal for the time being, although manufacturers say price tags could come down fairly rapidly in larger-scale production. The first models are being aimed at movie buffs who like to see films on TV in the same proportions in which they were filmed. The laserdisc owner is being singled out because so many laserdiscs are available in the letterbox format. Suggested list prices for the sets run from about \$5,000 and up, although actual selling prices are expected to range about \$500 below list price.

CinemaScreen, billed as "the television set made for movies," is being offered under the RCA and ProScan brands as a console and table model, respectively. Both are electronically identical and have 34-inch widescreen picture tubes. (This tube is made in Italy, where it's known as a 36-inch tube because of a different way of measuring it.) These sets have two tuners for picture-in-picture (and picture out of picture, which puts the secondary picture to one side of a standard 4:3 ratio image). Among their many features are the capability of displaying two standard TV pictures side by side on a split screen (67% of each picture is displayed). Those sets are currently being offered in some stores at a \$4,999 list price, and will gradually be made available nationwide.

Also scheduled to become available this month is the first widescreen projection TV set from Panasonic—a 50-inch CinemaVision set (the industry seems to be running out of "cinema" trade names), also with two tuners and picture in and out of picture (known in the trade as PIP and POP). Like

the RCA tube-type set, the Panasonic projector carries a \$4,999 list price. It will be followed in September by a 58-inch version, designed for custom home-theater installation, at \$5,999.

Philips' 16:9 TV set, like the RCA, has a 34-inch direct-view tube and is scheduled to be on the market by midyear at a \$5,995 suggested list price. Philips calls its set "HDTV-ready" because it has an RGB input, which can accommodate a future HDTV decoder. Philips concedes the resolution isn't up to high-definition standards, but says that at the distance consumers currently view TV's, the resolution will be as good as on any HDTV set.

Another widescreen projection set, this one 55 inches, is promised for next month by JVC, at a suggested list price of \$4,995. Like the other sets, it can display standard 4:3 pictures either in the proper ratio or stretched out to fit the wide screen. To eliminate distortion where the action occurs, JVC has varied the formula somewhat. When a standard picture is stretched to fit the screen, the central part of the picture is unprocessed, while the left and right edges of the picture are stretched. Sharp also promises a widescreen set later this year, using either a 34- or a 30-inch tube, but it has given no details.

The widescreen set is considered by its proponents as an interim product to ease the transition from the current NTSC image to the HDTV widescreen system, due to be selected this year and in use possibly in 1995. But some manufacturers—including Zenith, Sony, Toshiba and Hitachi—say they'll sit out widescreen because of the lack of availability of wide program material and the confusion which could be caused by introducing non-HDTV widescreen sets. It's expected that the widescreen TV could be the trend-setter among the Hollywood cognoscenti and, in

effect, replace the much more expensive movie screening rooms.

● **Largest TV picture tube.** If you've got \$4,999 burning a hole in your pocket and don't want a widescreen set, perhaps you'll be tempted by Mitsubishi's latest—a TV set in the standard proportions with a picture tube measuring 40-inches in diagonal measurement. Mitsubishi was the first to introduce the 35-inch tube set at about the same price as it's asking for its 40-incher. Today, 35-inch sets are carrying list prices as low as \$1,400 and less. Although the set isn't much bulkier than a 35-inch, you'd better make sure your floor is well reinforced—the set weighs about 266 pounds (still is less than a widescreen set).

● **Snap that video.** In this age of combinations, someone had to come up with a combination TV and Polaroid camera. A company called VideoSnap Inc. has been demonstrating just such a device, and promises to deliver it within a year. In addition, that system includes what is probably the world's smallest projection TV set—with a five-inch screen. The VideoSnap set is a wedge-shaped apparatus with a 0.7-inch LCD as its picture source. It can tune to TV stations or can be hooked up to a camcorder or VCR for capturing those rare moments as stills. The TV or video picture can be viewed on the five-inch rear projection screen, and a still picture of any frame can be made by pushing a button on the remote control. A slot below the screen yields a standard Polaroid Spectra print. The VideoSnap people estimate that the system could list for about \$499.

The VideoSnap system is claimed to be compatible with NTSC, PAL, and SECAM TV standards. Although the product isn't currently available, it's scheduled to be manufactured and marketed by Phonex, of Midvale, Utah. □

Some Breadboards Cost Less Than PROTO-BOARD® Brand . . . They Should

PROTO-BOARD
BRAND
UNCONDITIONAL LIFE-TIME GUARANTEE

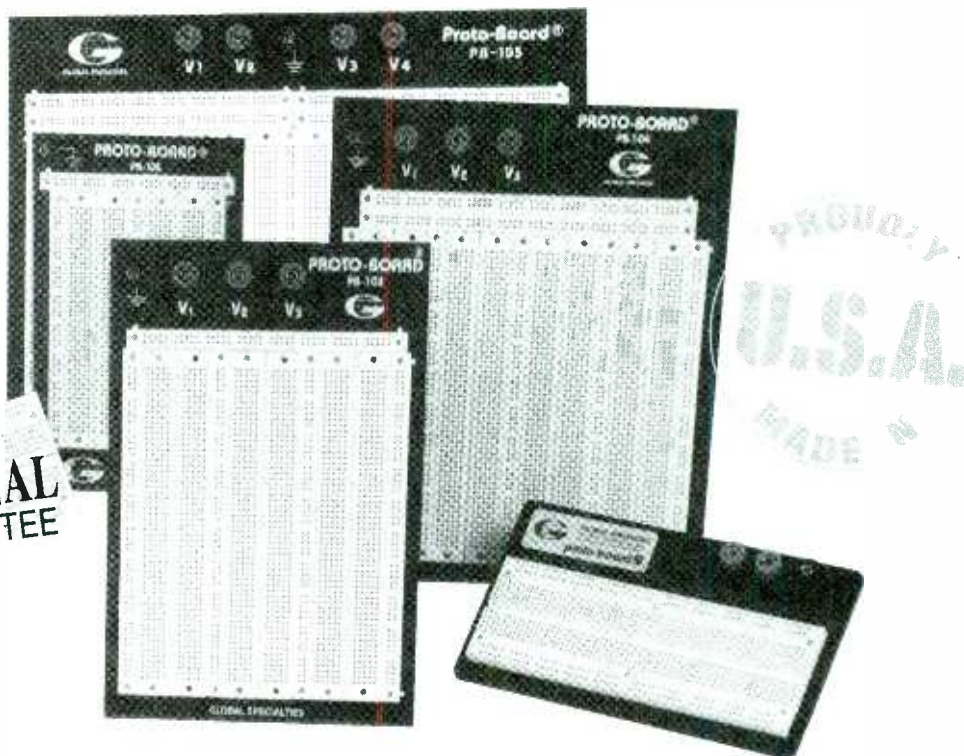

At Global Specialties® we make only one kind of breadboard, the very best, PROTO-BOARD® brand. American made and guaranteed for life.

Sure, save a few dollars today... buy cheap... but remember, you only get what you pay for! Is it really worth it??? Ask yourself... Do they perform like PROTO-BOARD® brand?

How can we guarantee PROTO-BOARD® brand breadboard for life unconditionally? Because we control every step right in our New Haven factory, and because we are obsessed with quality.

That's why we mold our own plastic and stamp our own precision contacts. We even designed our own machine to assemble each breadboard to exacting standards. Assuring every PROTO-BOARD® brand is built to perfection when it leaves our USA factory... backed by our unconditional "Life-Time" guarantee.

The others arrive from Taiwan, with good reason, they are made cheaper!

So next time you consider a cheaper breadboard, think twice. You'll need to, because even after you have worn out your second imported breadboard our PROTO-BOARD® brand would still be going strong.

PROTO-BOARD® brand. The breadboard you only buy once. Now which one really costs less?

PROTO-BOARD® brand breadboards and the complete Global® line of test instruments are in stock at fine electronic distributors everywhere.



**Can't Wait! Call Toll-Free
1-800-572-1028**

GLOBAL SPECIALTIES®

CIRCLE 190 ON FREE INFORMATION CARD
www.americanradiohistory.com

GLOBAL SPECIALTIES®
70 Fulton Terrace, New Haven, CT 06512
© 1993 Global Specialties®
All Global Specialties® breadboarding products are made in New Haven, CT. A031

an
Interplex Industries
company

Q & A

Write to Q & A, Electronics Now, 500-B Bi-County Blvd., Farmingdale, NY 11735

ELIMINATING LOCKUP

I've been using my 286-based PC clone for years without any problems and, since I'm a programmer, I spend a lot more time thinking about software than I do thinking about hardware. When I'm writing software, my computer locks up all the time as bugs show up in the program. Is it better to turn the PC off and then turn it back on or is it better to press the reset button on the front of the case? I want to keep this computer for a while yet, so which method will cause the least damage? Better yet, is there some way to keep it from locking up altogether?—F. Gish, Wind, IN

Computer lockup is common when you're developing software, so the first thing I'd tell you to do is to run your prototype code in some kind of programming shell so you can regain control of the computer when your code crashes. Of course, the best thing you could do is to write the program correctly in the first place so the computer never locks up at all.

Seriously, it's much better to use the reset button than it is to turn the computer off and on. Some of the worst enemies of the PC, or any electronic contraption for that matter, are the surges and peaks that appear as power is applied. Computers, especially the faster ones, generate lots of heat as they run, but that's a normal operating characteristic, and the IC's are designed to handle that. Power surges are much more of a problem because they are, by nature, unpredictable, and can cause a lot of damage.

Pressing the reset button on the case of the computer will, most of the time, be equivalent to turning the power off and on. I say "most of the time" because there are circumstances under which a lockout can be cleared only by disconnecting

the power. This can only happen on AT-class computers, and has to do with how the CMOS memory is accessed by the BIOS.

As a programmer, the reset button on the front of your computer is your best friend. It's interesting that IBM, all the way through its PS2 series, never provided a reset button. Since providing one meant adding only a capacitor, resistor, button, and some wire, I've never understood why they left one out. Considering IBM's falling share in the market they created, and what's happening to the value of their stock, I'd guess that the absence of a reset button is the least of its problems.

BULB DRIVER

I'm building some circuits that must control a few 12-volt light bulbs, and I am having a hard time getting the logic gates to turn the bulbs on and off. The logic is correct, but the bulbs need more current than can be supplied by the circuit. I can't use relays in the design because of the environment in which the circuit has to operate. Do you have any ideas?—J. Linz, Margate, FL

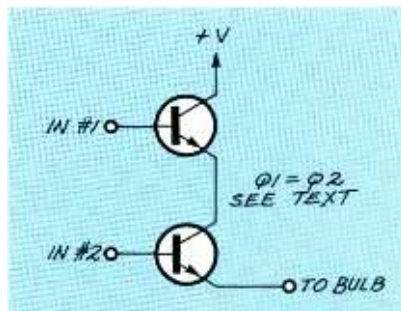

FIG. 1—YOU CAN BUILD ANY GATE with discreet transistors. Here's an AND gate made from two transistors.

You haven't described the details of the environment, but I'm having a difficult time understanding one that could be so harsh that relays can't be used. You can get relays that will

work under even the most severe conditions. Come to think of it though, I've never seen relays that are guaranteed to work on Neptune, so maybe that's what you have in mind.

You're using TTL in your design, so a perfect answer to your problem is to have the TTL output control a transistor configured as a switch, and let the transistor provide current to the bulbs. You didn't tell me how much current each bulb needs but, regardless of the number, this is a good way to go. The two things to avoid if you are to use this approach is that the base-emitter current needed to turn on the transistor can be supplied by the gate you're using, and that the transistor you're using can safely supply the amount of current for the bulb.

Those considerations, by the way, are exactly the same ones you'd have to work out if you were using relays. The base-emitter current of the transistor is equivalent to the coil current of the relay, and the collector current is similar to the switch current. Pay attention to these numbers, they're important.

A more interesting way to carry out the design would be to get rid of the TTL logic completely, and completely replace the smallest number of gates in your design with transistors. You can build any gate with discreet transistors and, if you did that, all your current problems would solve themselves (excuse the pun). To give you an idea how this is done, take a look at Fig. 1. The schematic shows how to make an AND gate from two transistors.

Any logic gate can be built this way. If you're not sure how to set up the transistors for a particular gate, all you have to do is study the gate schematics in any good data book. This might seem like a strange way to solve your problem but, depending on the requirements dictated by the environment, it might be the best way to take care of things.

Start a money-making career in video/audio servicing!

Only NRI gets you started fast with real-world training designed around state-of-the-art equipment you keep!

NRI's newly expanded training covers all the latest advances in home entertainment electronics, then takes you inside today's high-tech equipment as you learn to troubleshoot, diagnose, and service the complete home entertainment system included in your course: 13" color TV, programmable VCR, and integrated audio rack system. Only NRI makes it so easy to start a new career, earn part-time income, even start a video/audio servicing business of your own!

Billions of dollars of video/audio equipment means big opportunity for you

There's never been a better time to get involved in home entertainment electronics. Experts predict that consumers of video/audio equipment will spend over \$26 billion by 1995 as product manufacturers race to fill the demand for increasingly sophisticated technology.

This explosive acceleration of new product innovation means new opportunities for you in video/audio servicing. And NRI prepares you to take advantage of those opportunities by giving you the skills to troubleshoot and service a full range of TV, video, and audio equipment.

The most advanced, most complete video/audio training ever offered!

You start with lessons that give you a strong foundation in electronics fundamentals, mastering the basic circuits and components at the heart of today's video/audio equipment.

Then you build on that foundation as you explore the high technology of digital controls, CDs and digital audio tape players, advanced TV systems, cable TV, VCRs and camcorders, even microprocessors.

Best of all, you're prepared for the technology of today and tomorrow with hands-on training designed to give you invaluable practical experience.

Hands-on training with this incredible array of home entertainment equipment gives you the skills you need for success.



State-of-the-art equipment included in your training makes theory come to life

Only NRI gives you so much real-world equipment ... all yours to train with and keep! Get hands-on experience as you work with a complete, high-tech home entertainment system: a 13" color TV with remote, a programmable VCR, and an integrated remote-controlled audio system including AM/FM tuner, 100 watt amplifier, CD player, dual cassette player, turntable, speakers, and audio rack cabinet.

Theory comes to life as you learn to perform component-level diagnosis and service on advanced technology audio equipment ... conduct in-set demonstrations of TV circuits and components ... and discover first-hand how to maintain and service today's commercial VCRs.

Plus, NRI custom-produced videos

show you in close-up detail how to test, troubleshoot, and service TVs and VCRs like a pro.

No experience necessary ... NRI builds it in

You need no previous experience in electronics to succeed with NRI. Step by step, you accumulate the knowledge and practical experience that will make you uniquely qualified for today's opportunities in home entertainment electronics.

You learn at your own pace and on your own time. And all throughout your training, you have the full support of your personal NRI instructor and the entire NRI technical staff.

FREE catalog tells more

If the coupon is missing, write to NRI Schools, McGraw-Hill Continuing Education Center, 4401 Connecticut Avenue, NW, Washington, DC 20008.

SEND TODAY FOR FREE NRI CATALOG

NRI Schools

McGraw-Hill Continuing Education Center
4401 Connecticut Avenue, NW, Washington, DC 20008

For Career Opportunities approved under G1 Bill
 check for details



Check one FREE catalog only

- | | |
|--|--|
| <input type="checkbox"/> TV/Video/Audio Servicing | <input type="checkbox"/> Desktop Publishing & Design |
| <input type="checkbox"/> Microcomputer Servicing | <input type="checkbox"/> Electronic Music Technology |
| <input type="checkbox"/> Computer Programming | <input type="checkbox"/> Home Inspection |
| <input type="checkbox"/> Telecommunications | <input type="checkbox"/> Automotive Servicing |
| <input type="checkbox"/> PC Applications Specialist | <input type="checkbox"/> Basic Electronics |
| <input type="checkbox"/> Programming in C++ with Windows | <input type="checkbox"/> Bookkeeping & Accounting |

Name _____ (Please print) _____ Age _____

Address _____

City _____ State _____ Zip _____

3-0493

April 1993, Electronics Now

SCHEMATIC DRAWING

I design a lot of PC boards at home and working out the patterns is a really time-consuming procedure. There are a lot of routing programs on the market now and I was wondering if they would make my work any easier. Some of the software is pretty reasonably priced, but before I buy any of them, I'd like to be sure that they would really help me out. I don't expect you to recommend any one in particular, but is there any general rule?—
D. Tunn, Boston, MA

The two major points to consider when you're thinking about getting an autorouter are the complexity of the boards you generally make, and whether you actually make the boards yourself. How you answer those questions will tell you whether it's worth your while to make the investment in hardware and software.

As a board gets more and more complex, the number of needed layers increases. If you regularly de-

sign double-sided boards, you're really in a quandary because autorouting software will undoubtedly generate a board with more vias than a hand-routed design. The algorithms used by autorouters, no matter how good they are, just can't measure up to human experience.

I have a board that I use to test autorouters, and the results are always the same. None of the autorouting packages produce a board that's as easy to manufacture as the one I design by hand. And the more restrictions you give to the autorouter (single-sided boards, single traces through IC pins, minimize vias, etc.), the less chance you have of getting a complete route from the software.

Most autorouters will give you a list of the connections that it couldn't complete, and it then becomes your job to find a way to make them. Every time I've done this, it's been necessary to throw away large quantities of successful routes and redo large sections of the PC board. Sometimes this

takes more time than it would have taken to do the whole job by hand. Autorouters just don't think the way we do, and they don't seem to have the ability to look at the whole board in the middle of the job and decide to start all over again.

If you manufacture your own boards at home, an autorouter will give you a foil pattern that's murder to produce. Boards that are designed for commercial production have the luxury of multiple layers, blind vias, and extremely thin trace widths. This is performance that, even after making lots of boards, I've never been able to match successfully on my kitchen table.

The best test for an autorouter is to ask it to generate a foil pattern with the same restrictions you have when you do a pattern by hand. Look at the results and make your decision based on how you plan to manufacture the board. For what it's worth, I route boards both by hand and with an autorouter at times. Which way I'll do it depends on the budget for the job. □

AMAZING * ELECTRONIC PRODUCTS and KITS

Remember those Martian Space Ships in HG Wells War of the Worlds?



MYSTERY Levitating Device

Objects float on air and move to the touch. Defies gravity! Amazing gift, conversation piece, magic trick or great scientific project.

ANT1K Easy-Ass'y Kit/Plans \$19.50



3 MILE FM Wireless Microphone!

Crystal clear, ultra-sensitive pickup transmits voices, sounds to any FM radio. For security, monitoring children, invalids. Be the local DJ!

MVP1 Plans \$7.00
MVP1K Kit/Plans \$39.50

3 MILE Telephone Transmitter!



Automatically transmits 2 sides of phone conversation to any FM radio. Tunable, easy-assembly PC board. Operates only when phone is in use.

VWPM7 Plans \$7.00
VWPMK7 Kit/Plans \$39.50

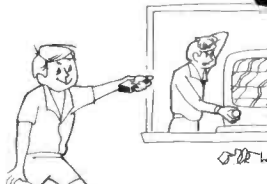

TV & FM Joker/Jammer

Pocket size device lets you remotely disrupt TV or radio reception. Great gag! Discretion required. Easy-build electronic kit. EJK1KM \$19.50

100,000 V - 20' Range Intimidation Device!

Electronic module, may be enclosed for handheld, portable, or fixed uses. ITM2 Plans (creditable to kit) \$10.00
ITM2K Kit & Plans \$49.50

READY-TO-USE, AUTOMATIC Phone Recording System

Complete with extended play tape recorder & line interface switch. Automatically records both sides of conversation. Check Local Laws on Proper Use! Ready-to-Use System. TAP20X System \$149.50

Laser Pen

Pen sized laser, great for movies, drive-ins, pointer. Ready to use, with batt's. LAPN1 Laser Pen . \$149.50

Pocket Laser Kit

3mw or 5mw kits, with solid state 670nm diode. Caution, Class IIIa item. VRL3KM 3mw Laser Kit . . . \$99.50
VRL5KM 5mw Laser Kit . . \$119.50

MORE Laser Kits!

LAS1KM 1mw Laser, 632nm, HeNe Easy to Build Kit \$69.50
LAS4KM 3mw Version, Kit . \$99.50

LAT05 Low Cost HeNe Laser Tube! .5mw Tube & Plans . . only \$24.50
Other parts available separately.
Great Low Budget Science Project!

Shocker Force Field Vehicle Electrifier

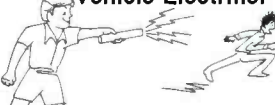

Make hand shock balls, shock wands electrify objects, charge capacitors. Great pay back for those wise guys! SHK1KM Easy-Assembly Kit \$24.50

CATALOG!

with many more items!

FREE with order, or send \$1 P&H

Master Electronics for Just \$2.88 per Experiment



Gain vital, practical skills for today's high-tech world. With Demax, you learn by doing, not memorizing and repeating. Experts know that you learn more, understand better with our hands-on method, plus you definitely have more fun.

Order our 3 course package, *Mastering the Digital Multimeter, Direct Current, and Alternating Current*, and get a special 2 hour video, showing set-up and results for all 104 experiments. Package also includes deluxe digital multimeter, learning module w/self-store case, 3 kits of parts, and 3 clearly written, well illustrated books w/simple, step-by-step instructions for just \$299+\$10S&H (less meter save \$50). Act today: take command of basic electronics!

Items also sold separately. Call for prices.

Demax Corporation

PO Box 946, Benton Harbor, MI 49022
VISA/MC orders, 1-800-79DEMEX

THE SURVIVAL KIT

FREE GIFT

See your participating Chemtronics distributor for an order form for your free SURVIVAL KIT gift (pictured here).

For information, Call 1-800-645-5244

(Available while supplies last.)



THE RIGHT PRODUCTS FOR THE LONG RUN

What to use for Electronics Service and Repair:

CFC FREE ELECTRO-WASH® 2000

Clean and degrease circuit boards and components

- Flush PC boards safely, without CFC's*

FREEZ-IT® 2000

Locate defective components

- Fast freeze with no CFC's*

CFC FREE FLUX-OFF® 2000

Removes flux safely and effectively

- Contains no CFC's* • Dries fast

CONTACT CLEAN® 2000

Cleans switches, pots and relays

- Maximum reliability • Reduced ODP*

ULTRAJET® 2000

Remove dust and dry dirt

- Ultra-filtered • Contains no CFC's*

CHEM-WIN® LITE

Desolder components with the industry standard desoldering braid

- Meets MIL-F-14256E.

Chemtronics®

CIRCLE 54 ON FREE INFORMATION CARD

Product labels contain full environmental impact data and ozone depletion potential (ODP).

* For the name of your stocking Chemtronics distributor, call 1-800-645-5244

www.americanradiohistory.com

LETTERS

Write to Letters, Electronics Now, 500-B Bi-County Blvd., Farmingdale, NY 11735

MISSING TABLES

Our February 1993 issue featured Part 2 of "Crystal Oscillators." Unfortunately, eight tables that were supposed to accompany the article never made it to print. The missing tables appear on page 94. We apologize for any inconveniences we may have caused you.—Editor

PHOTO CD/CD-I VERSUS VIS

I think that Jeff Holtzman did his readers, Philips, and Kodak a disservice in his December *Computer Connections*.

While he admonishes Kodak to "work with Tandy to ensure that VIS can play Photo-CD discs," he fails to mention that Kodak and Philips collaborated on the development of Photo-CD or that Philips (and probably other) CD-I players are already Photo-CD players, too. When I purchased my CD-I player a year ago, it included a coupon for a free Photo-CD demo disc, and I recently received a certificate good for a free Photo-CD with my own film.

Mr. Holtzman also fails to mention that the Philips CD-I player is also a top-notch audio CD player. It has some features not found on the average CD-DA player, such as the ability to create and store "Favorite Tracks Selections" lists in non-volatile memory. Those lists can be recalled at any time to play only selected tracks in a selected order, allowing you to, in effect, "customize" discs.

While the initial cost of a CD-I player might seem high at first (\$599 "street" price here), when you consider that you are also getting a Photo-CD player and an audio CD player, the cost-per-function is very reasonable. Although the Philips CD-I player is the only one currently available in the U.S., I hope we will soon see other manufacturers join in, perhaps with a single player that will handle all CD formats including video formats.

Mr. Holtzman also leaves the impression that the available CD-I titles are limited in number and scope, which is not true. *CD Marketplace 1992*, an industry publication from Knowledge Industry Publications Inc., lists 92 titles published worldwide, and 29 more in production. It also lists more than 80 publishers, producers, and developers of CD-I software, including most of those that Mr. Holtzman lists as potential VIS developers. The current CD-I catalog includes a wide variety of titles, including such standards as Sargon Chess, Battle Ship, Backgammon, and Tetris. Others are ABC Sports Golf (and soon baseball), and adventure games such as Defender of the Crown and Escape from Cybercity. One can obtain "Jukebox" discs that include video lyrics and trivia, a large selection of children's educational works including Sesame Street, Richard Scarry, and Aesop's Fables. Adult educational selections include a tour of the Smithsonian, Time-Life's 35-mm Photography, and both classical and jazz guitar lessons. In the past several weeks, I was notified that Philips released 20 new titles, with more promised before Christmas (1992).

The article also mentions that Tandy's immense retail network will ensure broad availability of its VIS system. Within 10 minutes of my home there are at least six retailers, including Sears, Montgomery Ward, and Service Merchandise, that sell CD-I players and software. That is hardly what I would consider limited availability. Moreover, it exposes CD-I to a much wider audience than the typical Radio Shack Store ever will.

Philips, Sony, and others developed CD-I with the expectation that it would become an international standard (for example, the same CD-I disc can be played on both American NTSC and European PAL format players). I think it's unfor-

fortunate for all of us that Tandy has chosen to develop its own unique format rather than adopt the emerging CD-I standard. I'm afraid that this will only result in another VHS/Betamax-style battle for supremacy that will hurt the consumer in the long run.

Rather than wait for Tandy, Mr. Holtzman should consider hooking a CD-I player to his home-entertainment center to see what he's been missing for the last year. He might not have to "throw it away" as soon as he thinks.

MIKE MAGNUS
Des Plaines, IL

SIMPLER AUTOMATIC POWER CONTROLLER

I have been a subscriber to *Radio-Electronics/Electronics Now* for more years than I can remember, and look forward to each month's issue.

I enjoyed David Sweeney's article, "Automatic Power Controller," in the November 1992 issue. It provided me with new insights on a controller application I have planned.

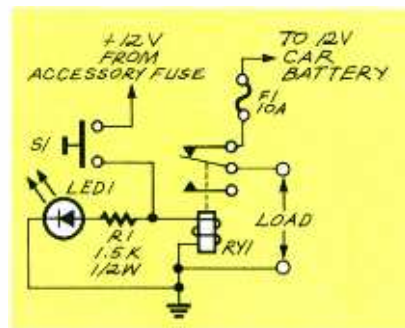

FIG. 1

However, Mr. Sweeney's approach seemed to be a bit of overkill for the task at hand. Figure 1 shows a cheaper, and simpler circuit that performs the same function: operating a remote relay while providing a dashboard indication that the relay has been switched.

By using a push-on/push-off

FROM A TO Z IN 1 SECOND FLAT

THE FASTEST, EASIEST CROSS-REFERENCING OF
ORIGINAL DEVICES TO NTE REPLACEMENT PARTS!

NEW UPGRADE!
QUICKCross™ 3.0

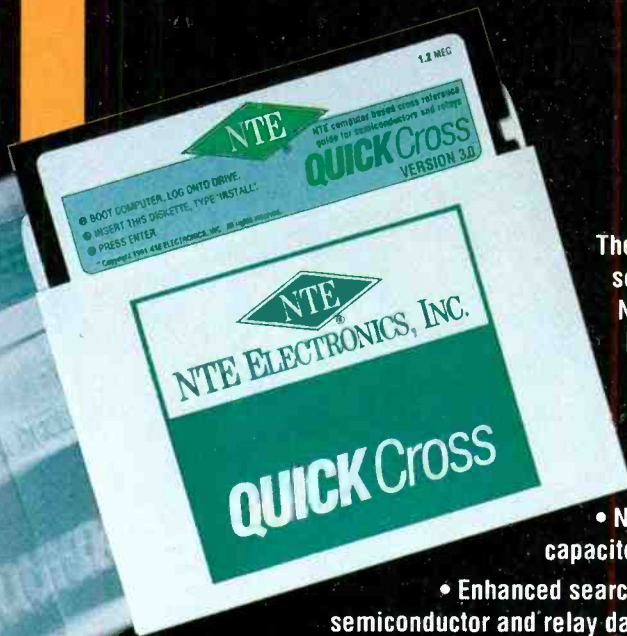

The industry's first PC-based software cross-reference to NTE's highly successful line of semiconductors and relays is better than ever!

"QUICKCross 3.0" now offers:

- New resistor & capacitor selector guides
- Enhanced search capability into semiconductor and relay databases
- On-screen information and literature guide

Just type in any of a quarter of a million industry device numbers – U.S., Japanese, and European – and you'll get the ideal replacement from over 4,000 NTE devices in about one second!

"QUICKCross 3.0" 5 1/4" and 3 1/2" floppy diskette MS-DDS versions are available direct from NTE or through your local NTE distributor. For your nearest one, call NTE toll-free 1-800-631-1250 (including Canada) or (201) 748-5089. FAX: (201) 748-6224.



NTE ELECTRONICS, INC.

A WORLDWIDE REPUTATION FOR QUALITY, SERVICE AND VALUE

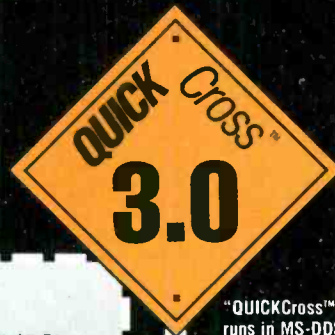

YES, PLEASE SEND ME THE FOLLOWING NUMBER OF COPIES OF "QUICKCross™ 3.0" SOFTWARE ON FLOPPY DISKETTES

___ 5 1/4" (1.2M) \$5.00 ea. ___ 3 1/2" (720K) \$6.00 ea. ___ 5 1/4" (360K) \$7.50 ea.

Prices include shipping and handling. Enclosed please find my check or money order for \$ _____ (U.S. funds only.)

Name _____ Company _____

Address _____

City _____ State _____ Zip _____

Attach this coupon to your letterhead and mail to:
NTE, 44 Farrand St., Bloomfield, NJ 07003

EN4/93

"QUICKCross™ 3.0" software runs in MS-DDS on any IBM PC or compatible with 640K of RAM, a small hard drive, and 5 1/4" or a 3 1/2" floppy drive. NTE's database occupies only 2.5 Mbytes of hard disk space when loaded. It is a public domain release. MS-DOS is a registered trademark of Microsoft Corporation. IBM is a registered trademark of International Business Machines.

CIRCLE 71 ON FREE INFORMATION CARD

www.americanradiohistory.com

switch for S1, one can eliminate the IC circuitry. For example, the switch has a built-in, replaceable 12-volt indicator lamp. That option has an even smaller footprint on the dashboard. (Using that port would eliminate the automatic power-off feature of the circuit presented, however.)

WILLIAM E. BAKER
Independence, MO

"FREEDOM," NOT THEFT

Does placing a tin cup on the sidewalk while I recite *Hamlet* to passers-by create an enforceable claim against one who stops to listen? Mr. Mihok's "implicit" contract (*Letters, Electronics Now* December 1992) exists only in his imagination. Furthermore, removing three newspapers from a coin-operated vending box when only one

was paid for, deprives a news dealer of the opportunity to sell those other two papers. However, tuning in to a signal that I have not paid for deprives the cable company only of the opportunity to sell services to me. The fundamental difference between finite newspapers and infinitely divisible signal renders Mr. Mihok's argument void.

The reality is, passive reception is no more subject to restriction than eavesdropping. Legislation has attempted to intervene, but as Bruno Leoni has instructed us, legislation is not law. Real law is like language: It is universally accepted, and it does not pander to the majority or to the cable-industry's special-interest group.

The socialist in Mr. Mihok would have the police force us to pay him for his *Hamlet*. In a free society, he will need a job making real products that people want to buy, rather than tinkering with something he enjoys while plotting ways for the government to make it worth his while.

JACK DENNON
Warrenton, OR

Electronics Workbench®

The electronics lab in a computer™

"...you can do 10 times as many experiments with Electronics Workbench than you'd get done with the real stuff."

- Jerry Pournelle, Ph.D., Byte Magazine

Building and testing circuits is fast and easy with *Electronics Workbench*. Just click-and-drag with a mouse to add parts, run wires, and adjust instruments. The traces on the simulated instruments are the same as you'd get on real equipment.

DOS Professional Version - \$299
DOS Personal Plus Version - \$199
Macintosh Version - \$199

Prices are in US dollars. Shipping \$15. Offer valid in the USA and Canada only. Macintosh and DOS Personal Plus versions are in monochrome only. All trademarks are the property of their respective owners.

Includes two independent modules:

- **Analog Module** with passive and active components including transistors, diodes, and op-amps; a function generator, an oscilloscope, a multimeter, and a Bode plotter.
- **Digital Module** with gates, flip-flops, adders, a word generator, a logic analyzer, and a unique logic converter and simplifier.

Call (416) 361-0333

Fax: (416) 368-5799

Interactive Image Technologies Ltd.

908 Niagara Falls Boulevard
North Tonawanda, NY 14120-2060

700 King St. W., Ste 815
Toronto, Ontario Canada
M5V 2Y6



FREE DEMO
Call or fax for your copy

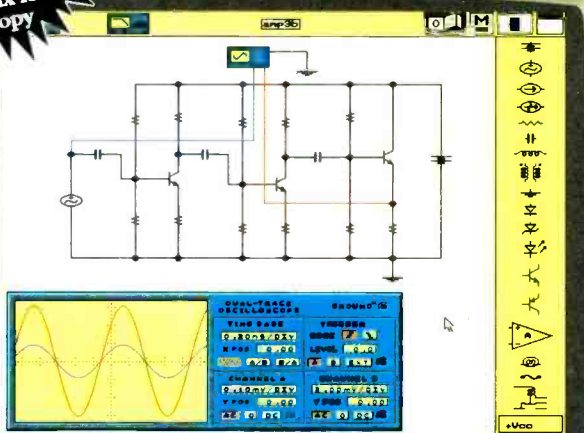

DOS and Macintosh versions available

CURRENT-FLOW CONTROVERSY

I am writing to comment on Don Lancaster's *Hardware Hacker* (*Electronics Now*, December 1992) regarding current flow.

His "bottom line," that any textbook teaching electron current theory is ripping you off and will lead to confusion later on, oversimplifies the field of electronics. When I went to school, both theories were taught side-by-side, each with its application. Conventional current, also known as the Franklin Theory (after Ben) or Flow of Positive Charges, is fine for motors, transformers, and power electrical apparatus, and is used by electrical engineers, electricians, automotive technicians, and others identified in Mr. Lancaster's article.

Conventional current theory simply does not explain the operation of vacuum tubes. They are still as CRT's (monitors or television picture tubes). Here electron-flow theory provides a better explanation of tube operation, and conveys the actual makeup of electricity, re-

Continued on page 87

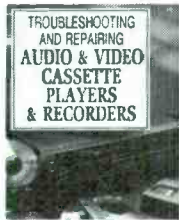

3795 \$29.95



3672P \$18.95
Softcover



4143 \$22.95



3475P \$18.95
Softcover



2790P \$15.95
Softcover

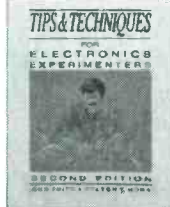

3145P \$12.95
Softcover

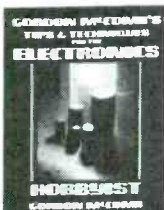

3485 \$27.95



3671P \$18.95
Softcover



2613P \$18.95
Softcover

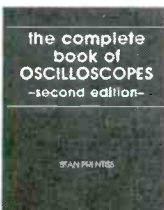

3825 \$26.95

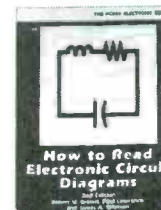

2880P \$14.95
Softcover



3804P \$19.95
Softcover

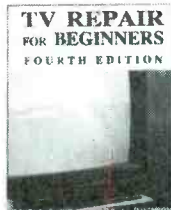

3627 \$29.95



1367P \$29.95
Softcover



2883P \$18.95
Softcover

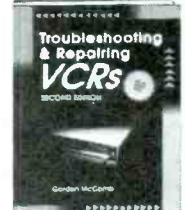

3777-XX \$32.95
Counts as 2

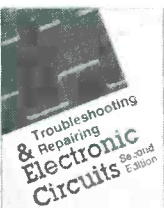

3258P \$19.95
Softcover

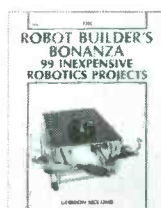

2800P \$17.95
Softcover



3886 \$22.95

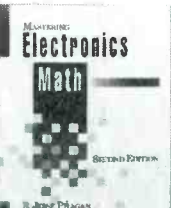

3589 \$27.95

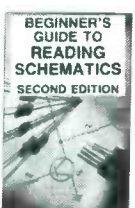

3632P \$10.95
Softcover



3669 \$27.95

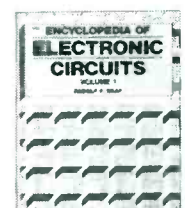

1938-XXX \$60.00
Counts as 3

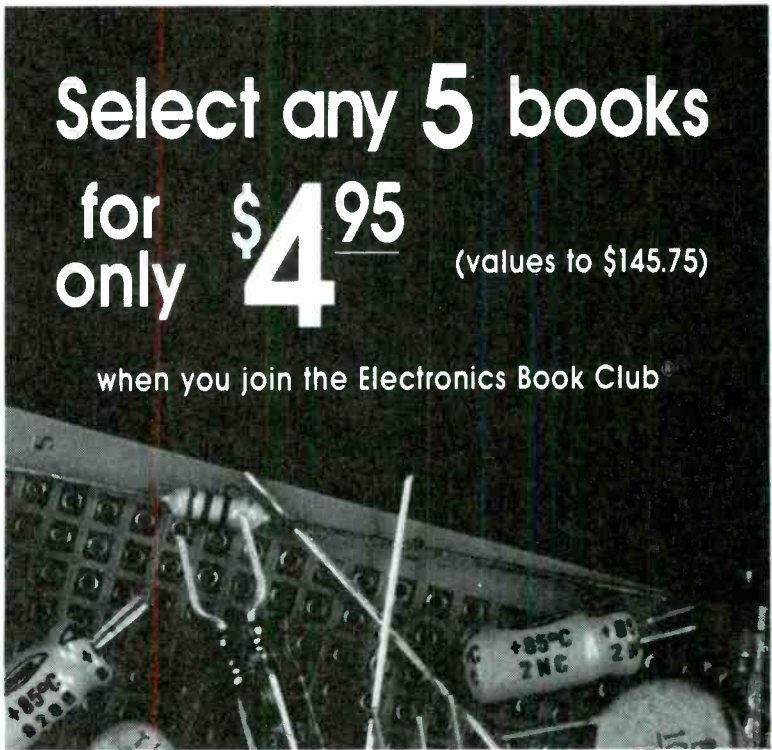

Select any 5 books for only \$4.95

(values to \$145.75)

when you join the Electronics Book Club®

If coupon is missing, write to: Electronics Book Club, Blue Ridge Summit, PA 17294-0810

As a member of the Electronics Book Club . . .

. . . you'll enjoy receiving Club bulletins every 3-4 weeks containing exciting offers on the latest books in the field at savings of up to 50% off of regular publishers' prices. If you want the Main Selection do nothing and it will be shipped automatically. If you want another book, or no book at all, simply return the reply form to us by the date specified. You'll have at least 10 days to decide. And you'll be eligible for **FREE** books through our **NEW Bonus Book Program**. Your only obligation is to purchase 3 more books during the next 12 months, after which you may cancel your membership at any time. (Publishers' Prices shown)

If you select a book that counts as 2 choices, write the book number in one box and XX in the next. If you select a Counts as 3 choice, write the book number in one box and XXX in the next 2 boxes. A shipping/handling charge and sales tax will be added to all orders. All books are hardcover unless otherwise noted. © 1993 EBC

Your most complete and comprehensive source for the finest electronics books.

Electronics Book Club®

Blue Ridge Summit, PA 17294-0810

YES! Please send me the books listed below, billing me for just \$4.95 plus shipping/handling & tax. Enroll me as a member of the **Electronics Book Club** according to the terms outlined in this ad. If not satisfied, I may return the books within 10 days without obligation and have my membership cancelled.

--	--	--	--

If you select a book that counts as 2 choices, write the book number in one box and XX in the next. If you select a Counts as 3 choice, write the book number in one box and XXX in the next 2 boxes.

Name _____

Address _____

City/State _____

Zip _____ Phone _____

Valid for new members only, subject to acceptance by EBC. Canada *must* remit in U.S. funds drawn on U.S. banks. Applicants outside the U.S. and Canada will receive special ordering instructions. All books are hardcover unless otherwise noted. Publishers' prices shown. A shipping/handling charge & sales tax will be added to all orders. RPIE493

DRAWING BOARD

Here's how to make sure your SSAVI descrambler uses the correct sync.

ROBERT GROSSBLATT

No matter how carefully you plan things and how explicitly you set your goals, projects always take on a life of their own. It's very hard to decide officially that a job is finished. The more time you put in, the more difficult it is to stop putting time in. Project goals just seem to grow as the project develops.

There are only a few things to take care of in finishing the design of a basic SSAVI descrambler. We need a detector to let us know when lines 24 and 257 show up because they mark the points where we use our manufactured sync and where we switch to the transmitted sync, respectively. As we discussed last month, this subcircuit is no big deal because it just involves a counter that will keep track of the horizontal line numbers and some decoding circuitry that will signal the arrival of the two lines we're interested in.

You can use any counter you want, and the 4040 we used earlier is as good as any one of them. The tricky part of the design is that the decimal 257 is 100000001 in binary code. That means we need a counter/decoder that can handle nine lines. The 4040 can output the correct count, but the decoder must be able to "watch" nine lines. That's not a problem if you're using discrete logic gates to do the decoding because you can have as many input legs as you want. If you're using an EPROM, it's obvious that the extra available address lines for the input have to be tied to either power or ground.

Somewhere out there in designland, there's a combination of gates that will decode the two numbers (24 and 257), but finding it is pretty tedious and, to make matters worse, there's not a lot to be learned from doing it. I haven't given it a lot of thought, but it can probably be

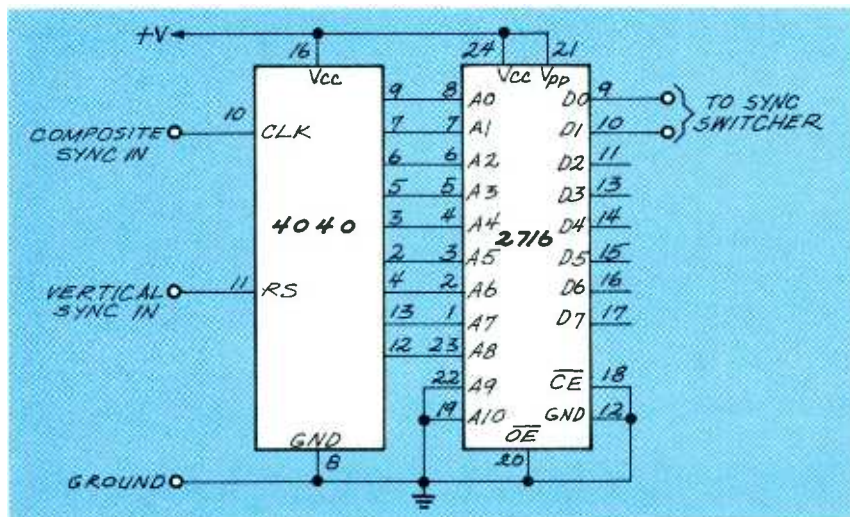

FIG. 1—THE EPROM WILL DECODE two input addresses (24 and 257) with only one or two data lines.

TABLE 1—EPROM CHARACTER GENERATOR CHART

Line Number	Input EPROM Address	Programmed Output Data								Hex Data Byte
		D 7	D 6	D 5	D 4	D 3	D 2	D 1	D 0	
1	000	0	0	0	0	0	0	0	1	1
2	001	0	0	0	0	0	0	0	1	1
3	002	0	0	0	0	0	0	0	1	1
4	003	0	0	0	0	0	0	0	1	1
5	004	0	0	0	0	0	0	0	1	1
6	005	0	0	0	0	0	0	0	1	1
.
.
24	017	0	0	0	0	0	0	1	0	2
25	018	0	0	0	0	0	0	1	0	2
26	019	0	0	0	0	0	0	1	0	2
27	01A	0	0	0	0	0	0	1	0	2
28	01B	0	0	0	0	0	0	1	0	2
29	01C	0	0	0	0	0	0	1	0	2
.
.
257	080	0	0	0	0	0	0	0	1	1
258	081	0	0	0	0	0	0	0	1	1
259	082	0	0	0	0	0	0	0	1	1
260	083	0	0	0	0	0	0	0	1	1
261	084	0	0	0	0	0	0	0	1	1
262	085	0	0	0	0	0	0	0	1	1

This EPROM can also be used to decode line 20 (see text) by programming one of the data lines high when line 20 (address 0Fh in the EPROM) is reached.

done with a handful of gates. I'll leave the rest of this as an exercise for some of you out there. If some-

one works it out, drop me a note and I'll pass it along.

Continued on page 84

Graduate as a Fully Trained Electronics Professional!

If you want to learn about electronics, and earn a good income with that knowledge, then CIE is the best educational value you can receive.

CIE's reputation as the world leader in home study electronics is based solely on the success of our graduates. And we've earned our reputation with an unconditional commitment to provide our students with the very best electronics training.

Just ask any of the 150,000-plus graduates of the Cleveland Institute of Electronics who are working in high-paying positions with aerospace, computer, medical, automotive and communications firms throughout the world.

They'll tell you success didn't come easy...but it did come...thanks to their CIE training. And today, a career in electronics offers more rewards than ever before.

CIE'S COMMITTED TO BEING THE BEST...IN ONE AREA...ELECTRONICS.

CIE isn't another be-everything-to-everyone school. CIE teaches only one subject and we believe we're the best at what we do. Also, CIE is accredited by the National Home Study Council. And with more than 1,000 graduates each year, we're the

largest home study school specializing exclusively in electronics. CIE has been training career-minded students like yourself for nearly sixty years and we're the best at our subject....ELECTRONICS...BECAUSE IT'S THE ONLY SUBJECT WE TEACH!

CIE PROVIDES A LEARNING METHOD SO GOOD IT'S PATENTED.

CIE's AUTO-PROGRAMMED® lessons are a proven learning method for building valuable electronics career skills. Each lesson is designed to take you step-by-step and principle-by-principle. And while all of CIE lessons are designed for independent study, CIE's instructors are personally available to assist you with just a toll free call. The result is practical training... the kind of experience you can put to work in today's marketplace.

LEARN BY DOING...WITH STATE-OF-THE-ART EQUIPMENT AND TRAINING.

CIE pioneered the first Electronics Laboratory Course and the first Microprocessor Course. Today, no other home study school can match CIE's state-of-the-art equipment and

training. And all your laboratory equipment, books and lessons are included in your tuition. It's all yours to use while you study and for on-the-job after you graduate.

PERSONALIZED TRAINING...TO MATCH YOUR BACKGROUND.

While some of our students have a working knowledge of electronics others are just starting out. That's why CIE has developed twelve career courses and an A.A.S. Degree program to choose from. So even if you're not sure which electronics career is best for you, CIE can get you started with core lessons applicable to all areas in electronics. And every CIE Course earns credit towards the completion of your Associate in Applied Science Degree. So you can work toward your degree in stages or as fast as you wish. In fact, CIE is the only school that actually rewards you for fast study, which can save you money.

SEND FOR YOUR CIE COURSE CATALOG AND WE'LL SEND YOU A FREE 24-PAGE CIE ELECTRONIC SYMBOLS HANDBOOK.



electronics

FREE!

SEND FOR YOUR CIE HOME STUDY COURSE CATALOG AND RECEIVE A FREE 24 PAGE CIE ELECTRONIC SYMBOLS HANDBOOK!

Includes hundreds of the most frequently used electronic symbols. Published exclusively by CIE for our students and alumni. Yours free when you request a CIE Course Catalog.

YES! I want to get started. Send me my CIE course catalog including details about the Associate Degree Program. (For your convenience, CIE will have a representative contact you - there is no obligation.)

AE49

Please print clearly

Name _____

Address _____

City _____ State _____

Zip _____ Age _____

Phone No. (____) _____

Check box for G.I. Bill Benefits

Veteran Active Duty



1776 East 17th Street
Cleveland, Ohio 44114

A School of Thousands.
A Class of One. Since 1934.

April 1993, Electronics Now

NEW PRODUCTS

Use the Free Information Card for more details on these products.

PROFESSIONAL-GRADE DIGITAL MULTIMETERS.

Beckman Industrial has introduced two new four-digit DMM's, Models 2020 and 2030. Both offer true RMS, AC, and AC plus DC measurement, a "fault finder," a 2-MHz frequency counter, and a 50-nanosecond pulse detector. Capacitance values to 2000 μ F can be measured. The "fault finder" locates intermittent shorts, bad contacts, and broken wires.

Both DMM's have backlit LCD analog and digital displays. Minimum, maximum and average readings can be recorded in the autoranging mode. Probe hold captures the last stable reading, beeps acknowledgement, and retains the reading on the display. Peak hold captures noise and events as fast as a millisecond. Both positive and negative peaks can be measured. The pulse-detection function detects CMOS and TTL logic pulses as short as 50 nanoseconds. With 0.01-ohms resolution on the resistance range, motor windings and relay coils can be measured.

An overload alert warns



CIRCLE 16 ON FREE INFORMATION CARD

the user of excessive input currents and voltages with a tone, and an incorrect input warning alerts the user when a lead is in the current jack but current is not being measured.

Both meters have AC and DC voltage ranges of 100 millivolts, 1 volt, 10 volts, 100 volts, and 1000 volts. The basic DC ac-

curacy of the 2020 is given as 0.25%; for the 2030, it is 0.1%. A holster, strap, and tilt stand is included.

The Model 2020 DMM is priced at \$249 and Model 2030 DMM is priced at \$279.—**Beckman Industrial Corporation**, 3883 Ruffin Road, San Diego, CA 92123-1898; phone: 619-495-3200.

power supply. An included signal generator produces sine, square, and triangle waves with frequencies from 200 Hz to 200 kHz. A speaker, and 1- and 100-Kohm potentiometers are included. All outputs are short-circuit protected.

The *TA102 Circuit Designer* is priced at \$149.95.—**JPC International, Inc.**, P.O. Box 55, Agoura Hills, CA 91301; Phone: 818-707-1514; Fax: 818-707-7327.

PERMANENT REPLACEMENT CMOS BATTERY BACKUP.

Clover Point is offering its *C-LIFE!* permanent replacement battery for CMOS memories. It is said to have a useful life in excess of ten years. *C-LIFE!* contains a nickel-cadmium (Ni-Cd) power pack and a charging circuit that was designed to match the characteristics of Ni-Cd cells.



CIRCLE 18 ON FREE INFORMATION CARD

CIRCUIT DESIGNER. A solderless "breadboard" for designing, prototyping, and testing circuits is now available from *JPC International*. Circuits can be built, modified, expanded, and dismantled on *Circuit Designer TA102* without soldering. Leaded components are inserted into the breadboards, which accept

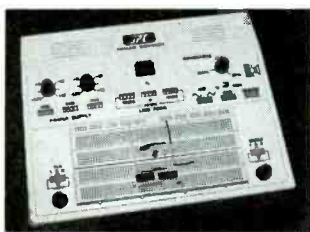

CIRCLE 17 ON FREE INFORMATION CARD

DIP IC's and most active and passive components.

The standard *TA102* has 1380 tie-points, which can accommodate up to 16 14-pin DIP IC's. It is expandable up to 2020 tie-points, to accommodate up to 24 14-pin DIP IC's. *Circuit Designer* includes both +1.25 to +15-volt DC and -1.25 to -15-volt DC variable power supplies, and a center-tapped, 30-volt AC

The Ni-Cd cells are protected against sudden discharge, which could cause cell overheating, and might rupture the cells. *C-LIFE!* obtains its charging current from a disk-drive power-output cable. The nominal output voltage is 4.25 volts. With a CMOS drain of 40 to 50 microamperes, the *C-LIFE!* is said to provide continuous backup

FROM

\$19⁹⁵

Standard



\$199⁹⁵

High Performance

GREAT VALUE!

Standard Features - Models 100, 150, 200 & 400

- AC & DC VOLTAGES ● DC CURRENT ● RESISTANCE
- CONTINUITY TESTER - Buzzer ● DIODE TEST ● 3 1/2 Digit LCD
- LOW BATTERY INDICATOR ● ACCURACY +/- 0.5% RDG

Kelvin Meters backed by a 2 Yr Warranty - Parts & Labor

PRO 400



100 Basic

150 Basic+

200 Advanced

KELVIN PRO 400

BATTERY TEST

TRANSISTOR hFE BATTERY TEST

TRANSISTOR hFE CAPACITANCE

20MHz FREQ COUNTER

KELVIN

990087

100 Basic

\$19⁹⁵

KELVIN

990090

150 Basic+

\$29⁹⁵

KELVIN

990091

200 Advanced

\$39⁹⁵

AC/DC CURRENT

KELVIN

990092

PRO 400

\$69⁹⁵

Protective Cases

For Models 100, 150, 200 \$4.⁹⁵ (990088)

Case For Model Pro 400 \$9.⁹⁵ (990094)



Model 92 PERFORMANCE PLUS

Model 93 DIAGNOSTIC PLUS

Model 95 ENGINE ANALYZER PLUS

Standard Features - Models 92, 93, 94 & 95

- DC/AC VOLTMETERS ● AC/DC CURRENT ● OHM METER
- FREQUENCY COUNTER to 4 MHz ● AUDIBLE CONTINUITY TESTER
- DIODE TESTER ● MAX/MIN AVERAGE MEMORY RECORD
- RELATIVE MODE ● 10A HIGH-ENERGY FUSE PROTECTION
- DATA HOLD ● AUTO SLEEP & AUTO POWER OFF

PERFORMANCE PLUS

Model 92 # 990109

\$99⁹⁵

DIAGNOSTIC PLUS

Model 93 # 990110

\$129⁹⁵

ENGINE ANALYZER PLUS

Model 95 # 990112

\$199⁹⁵

Complete with above **Standard Features** plus WATER RESISTANT (92 & 94 Models only), 2 YEAR WARRANTY, YELLOW HOLSTER, PROBES, BATTERY, FUSE, STAND

Complete with **Standard & Model 92 Features** plus LOGIC PROBE, CAPACITANCE TESTER, TRANSISTOR TESTER, TEMPERATURE TESTER & K-TYPE PROBE, HIGH VOLTAGE WARNING BUZZER

Complete with **Standard & Model 92 Features** plus TEMPERATURE, TACHOMETER & DWELL ANGLE TESTER, DUTY CYCLE, 10 MEGA OHM IMPEDANCE, ANALOG BAR GRAPH, K-TYPE TEMP PROBE, ALLIGATOR CLIP TEST LEADS, INDUCTIVE PICKUP CLIP, 6' TEST LEADS & CARRY CASE

10 HUB DRIVE
MELVILLE, NY
11747

KELVIN

M/C & VISA

(800) 645-9212

Established 1945

(516) 756-1750

(516) 756-1763/FAX

The Ultimate Meter
TRUE RMS - LCR - Hz - dBm



12 INSTRUMENTS IN ONE - DC VOLTMETER, AC VOLTMETER, OHMMETER, AC CURRENT, DC CURRENT, DIODE TESTER, AUDIBLE CONTINUITY TESTER, dBm, FREQ COUNTER, CAPACITANCE METER, INDUCTANCE METER, LOGIC PROBE

0.1% ACCURACY on DC Voltages Water Resistant

10 MEGA OHM IMPEDANCE
RELATIVE MODE / DATA HOLD
MAX/MIN AVERAGE MEMORY RECORD
10A HIGH-ENERGY FUSE PROTECTION
AUTO SLEEP & AUTO POWER OFF with Bypass

\$199⁹⁵ MODEL 94 #990111

COMES COMPLETE WITH YELLOW HOLSTER, PROBES, BATTERY, FUSE, STAND

Freq Counter to 20 MHz

Cases for 90 Series Meters

Regular Padded Zippered ... \$9.⁹⁵ (#990116)

Deluxe Padded Zippered \$14.⁹⁵ (#990115)

This meter is designed in accordance with relevant safety requirements as specified in IEC-348, UL-1244 and VDE-0411.

CIRCLE 186 ON FREE INFORMATION CARD

www.americanradiohistory.com

April 1993, Electronics Now

power for one year. To maintain the CMOS indefinitely, the computer must operate for at least 12 hours within a year.

Clovis Point guarantees its product for the life of your computer—when installed and used according to its instructions. The introductory price of the backup power source is \$25. A "Y" adapter, needed if all your disk power cables are in use, is priced at an additional \$5.—

Clovis Point, 215 Main Street, Rochester, VT 05767; Phone: 802-767-9292.

SPECTRUM PROBE. A new oscilloscope probe can measure RF voltage, field strength, and current being received by or transmitted from electronic equipment. *Smith Design's 255 Spectrum Probe* is intended primarily for detecting and correcting electromagnetic interference (EMI) in equipment such as computers with internal high-frequency generators.

The probe can safely read RF voltage or current (with a simple adapter) on the power line, useful for any manufacturer or builder trying to meet FCC and VDE EMI standards. The probe can estimate the field strength of emissions, and help in efforts to reduce them to obtain FCC compliance.

The probe is said to be able to "see" RF currents and voltages on a PC board without loading the circuit. It will also provide RF "signatures" of the board for further reference, and it can "sniff" out sources of EMI. The 255 can also check the high-frequency sections of infrared and ultrasonic equipment.

The probe has a frequency range of less than 30



CIRCLE 19 ON FREE INFORMATION CARD

kHz up to 2.5 MHz, a minimum dynamic display range of 60dB, and 10 picofarads input loading.

The *255 Spectrum Probe* is priced at \$279.—**Smith Design**, 207 East Prospect, North Wales, PA 19454; Phone: 215-661-9107.

TWO-CHANNEL OSCILLOSCOPE.

A new 20-MHz, dual-channel oscilloscope has been introduced by *Leader Instruments*. The *Model 8020* has twelve ranges from 1 millivolt to 5 volts per division. Vertical accuracy is stated at 3%, and the scope can be calibrated from front-panel controls.

The *Model 8020* offers single-lever selection of NORM-AUTO, X-Y sweep modes, and trigger coupling selections including TV horizontal and vertical sync separators. It has a trigger source switch that includes a VERT setting. Sweep speeds range from 0.5 microseconds to 0.5 seconds per division with a maximum speed of 50 nanoseconds per division with a times ten magnifier. Rear-panel jacks provide



CIRCLE 20 ON FREE INFORMATION CARD

channel 1 output for frequency counters, and Z-axis (intensity) modulation.

The *Model 8020* oscilloscope is priced at \$595.—**Leader Instruments Corporation**, 380 Oser Avenue, Hauppauge, NY 11788; Phone: 516-231-6900 in NY, or 800-645-5104.

HANDHELD LCR BRIDGE.

A new handheld LCR bridge is said to be able to measure inductance from 0.1 microhenry to 2,000 henries, capacitance from 0.1 picofarad to 10,000 microfarads, and resistance from 0.1 ohm to 20 megohms. The *Model 878 LCR Bridge* from *B+K Precision* is intended for field-service or general applications. Basic accuracy of the bridge is stated at 0.7%.



CIRCLE 21 ON FREE INFORMATION CARD

When testing capacitors, the *Model 878* displays capacitance and dissipation factor simultaneously. For inductors, inductance and Q can be read at the same time. The value of a reference part can be stored and then show a plus or minus difference between the reference and the measured value. The LCR bridge can be set to beep when a component is outside the preselected 1%, 5%, or 10% tolerance with respect to the reference value.

A data-hold function freezes any displayed reading. A minimum/maximum/average function keeps track of the running average of readings, and records the highest and lowest values. The microprocessor-based bridge signals when it needs recalibration, and this can be done with a pushbutton switch. The LCD bridge has separate four- and three-digit liquid crystal displays with function annunciators. Other features include auto or manual ranging and battery operation. It can also be powered from the AC-to-DC adapter provided.

The *Model 878* LCD bridge is priced at \$275.—**B+K Precision**, 6470 West Cortland Street, Chicago, IL 60635; Phone: 312-889-9087; Fax: 312-794-9740.

POCKET-SIZED FREQUENCY COUNTER.

Startek's ATH-15 frequency counter is said to be able to count frequencies in the range of 1 MHz to 1.5 GHz. The counter has an eight-digit LED readout (0.3-inch), and a 10-segment red LED bargraph display. The bargraph displays relative signal-strength for signals from less than 1 MHz to more than 4 GHz. The counter's sensitivity is stated as less than 1 millivolt over the range of 1 to 800 MHz, 0.3 millivolt at 150 MHz, and 0.5 millivolt at 450 MHz.

The *ATH-15* has an auto and manual hold switch and indicator. Its indicators include BATTERY CHARGE, COUNT, and HOLD." Auto trigger and hold with AUTO CLEAN DROPOUT are standard. The automatic clean dropout feature prevents the display of erroneous data from a partial reading. A one-shot trigger-and-

Introducing Australia's Leading Electronics Magazine...



Silicon Chip, the most popular hobby electronics magazine south of the equator is written for you; if you are fascinated by building projects, increasing your understanding of theory, fixing consumer electronic products, and keeping up-to-date with world-wide trends within your electronics interests.

Silicon Chip, an Australian publication, is reprinted in the United States offering the best of selected articles suitable for North American readers.

Plan to become a reader of **Silicon Chip.**

SILICON CHIP®

Packaged in a specially prepared format guaranteed to excite the electronics hobbyist with new ideas, novel projects, extraordinary features and down-right good reading.

Inside **Silicon Chip** you will discover how the other side of our world—down under—approaches the same hobby interests as you do, with ramifications that will amaze you.

Detailed construction projects to appear in upcoming issues of Silicon Chip include:

- 4-Channel Guitar Mixer**
- Adjustable 0-45V, 8A Power Supply**
- Interphone Digital Telephone Exchange**
- 1.5V to 9V DC Converter**
- Multi-Sector Home Burglar Alarm**
- 1-Megabyte Printer Buffer**

**Become
A Charter
Subscriber
Today**

Exciting and imaginative Features like:

- Understanding Computer Memory**
- How to Interlink Musical Instruments**
- What's New in Oscilloscopes**

If you are fascinated by electronics, especially the hobby aspects related to construction projects, theory, applications in home and shop, and latest developments, if you are compelled to experiment and "fix-it," then **Silicon Chip** is your kind of magazine.

Silicon Chip is available exclusively by subscription. So take advantage of this great opportunity and start your Charter Subscription today.

SILICON CHIP, 500-B Bi-County Boulevard, Farmingdale, New York 11735 EN493

I'm convinced! Enroll me as a Charter Subscriber. Enter my subscription as designated below.

United States of America		Canada	
<input type="checkbox"/> 12 issues for \$29.95	<input type="checkbox"/> 24 issues for \$49.95	<input type="checkbox"/> 12 issues for \$40.61	<input type="checkbox"/> 24 issues for \$70.57 (Includes postage & G.S.T.)
<input type="checkbox"/> Payment enclosed	<input type="checkbox"/> Please charge my	<input type="checkbox"/> VISA	<input type="checkbox"/> Mastercard

For your convenience, if paying by credit card: To avoid any interruption in service, your subscription will be renewed automatically at 12-issue intervals, at the then prevailing introductory rate, until you advise us to cancel it.

Signature _____ Expiration Date _____

Account No. _____

Offer valid in the U.S.A. and Canada only. No foreign Orders.

Name _____

Address _____

City _____ State _____ Zip _____

All orders payable in U.S.A. funds only. Allow 6-8 weeks for delivery.



CIRCLE 22 ON FREE INFORMATION CARD

hold feature, which will hold the frequency of the first readable signal until manually reset, is offered as an option.

Two ranges each offer three selectable gate times. The *ATH-15* can read an input signal, display the frequency, and automatically switch to hold status in less than 80 milliseconds. The *ATH-15* is powered by rechargeable nickel-cadmium batteries, providing three to five hours of operation. A battery charge indicator and an AC-to-DC adapter/charger are included.

The *Model ATH-15* frequency counter is priced at \$235.—**Startek International Inc.**, 398 NE 38th Street, Ft. Lauderdale, FL 33334; Phone: 305-561-2211 or 800-638-8050 (for orders); Fax: 305-561-9133.

SPECTRUM DISPLAY MONITOR. A spectrum display monitor for panoramic

signal display for VHF scanners and communications receivers such as the ICOM R-7000 has been introduced by Avcom of Virginia. The *SDM-42A* displays all signals present in the receiver's IF on a 5-inch CRT, so the operator can monitor signal activity.

This capability permits the operator to tune quickly to signals as they appear on the spectrum display.



CIRCLE 23 ON FREE INFORMATION CARD

The display monitor makes it easy to locate and tune intermittent signals as well as monitor a particular frequency band.

The *SDM-42A* can monitor a satellite receiver's intermediate frequencies and demodulate single-channel-per-carrier satellite signals (with optional demodulator circuitry). It can also function as a general-purpose spectrum analyzer for specific frequency ranges. With a scanner, the *SDM-42A* can be paired with Avcom's *PSA-65A* spectrum analyzer to form a spectrum monitoring system.

The *SDM-42A* spectrum display monitor costs \$1145.—**Avcom of Virginia, Inc.**, 500 Southlake Blvd., Richmond, VA 23236; Phone: 804-794-2500; Fax: 804-794-8284. Ω

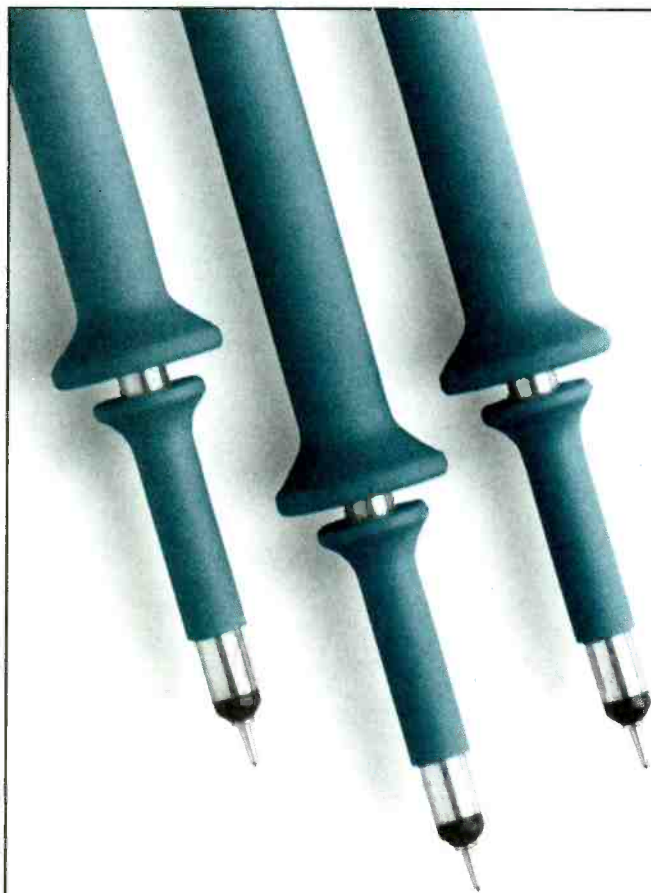

EVEN AT \$39, THE BLUES CAN LAST A LONG, LONG TIME.

Conventional wisdom says if you spend less than forty bucks on a probe, it won't be long until the thrill is gone. But Duraprobes™ start at \$39, live practically forever, and work with almost any scope around, so it won't surprise us if you pick up a whole case.

For the name of your nearest Duraprobe distributor, call us at 1-800-426-2200. After all, some folks were just born to have the blues.

Tektronix

More lessons!

More Services!

A Shocking Offer!

Now you don't have to be enrolled at CIE to receive our introductory Electronic and Electricity Lesson Modules. This program is available for a limited time to non-students for the shockingly low price of only \$99.50.

With CIE's patented AUTO-PROGRAMMED method of learning you will quickly learn and then master the basics of electronics and electricity and then move on to... DC/AC circuit theories, fundamentals of bi-polar junction transistors (BJT), field effect transistors (FET), wiring, diagram and schematic readings, component identification, soldering techniques... and much, much, more. This introductory offer includes the first 39 lessons in CIE's Associate in Applied Science in Electronic Engineering Technology Degree.

Your commitment to CIE ends with your payment, but CIE's commitment to your success just begins when you receive your lessons, exams, binder and equipment. This special introduc-

tory price includes all the benefits and assistance CIE normally extends to its full time students. You'll be entitled to unlimited access to CIE's faculty and staff to assist you in your studies via a toll free 800 number six days a week, 24-hour turnaround on grading your submitted exams, CIE bookstore privileges, a patented learning method, reference library, access to CIE's electronic bulletin board and a free issue of CIE's school newspaper The Electron.

And best of all, when you decide to continue your electronics education in any of CIE's programs you'll receive full academic credit for successful lessons submitted and a \$100.00 Tuition Credit Certificate.

All this knowledge and support will put you on the road to understanding digital electronics, automotive and industrial electronics, microprocessing principals, computer systems, telecommunications and much, much, more.

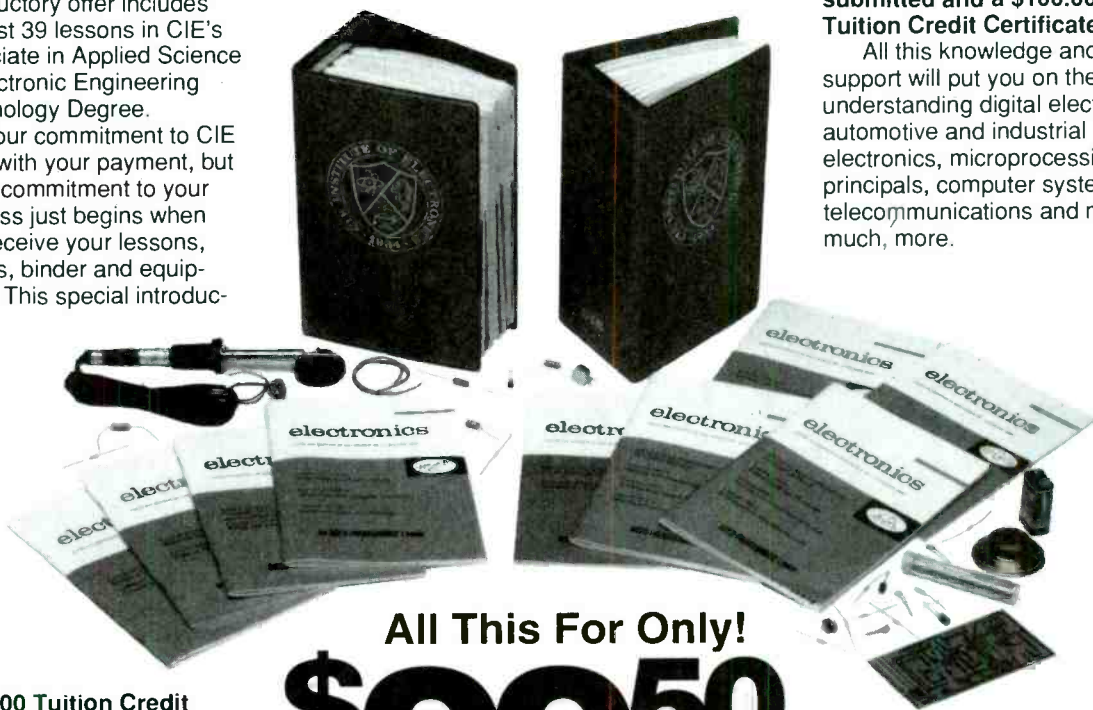

All This For Only!

\$99.50

- \$100.00 Tuition Credit
- Academic Credit
- Free issue of The Electron
- Build your personal burglar alarm
- Toll Free Instructor Assistance
- 24-hour grading
- CIE bookstore privileges

- 39 theory and hands-on training lessons and exams.
- Patented learning method
- CIE electronic bulletin board privileges

Yes! Send me CIE's Introductory Electronic and Electricity Lessons and Equipment. A7320

Name: _____

Street: _____ Apt#: _____

City: _____

State: _____ Zip: _____

Age: _____ Phone: (____) _____

Total Merchandise: _____ \$99.50

Ohio Residents add 7% Sales Tax: _____

California Residents add 6 1/2% Sales Tax: _____

Total This Order: _____

Shipping and Handling Charge: _____ \$5.00

Method of Payment/Amount Enclosed: _____ \$

Personal Check or Money Order

Master Card Visa Discover

Card Expiration Date: _____

Signature: _____



BOOKSTORE
1776 East 17th Street
Cleveland, Ohio 44114



CHARGE BY PHONE!

9 AM to 4:30 PM Eastern Time:
1-800-321-2155 ext. A7320

April 1993, Electronics Now

Get 3 Books for only \$9⁹⁵

Values to \$147.40

when you join the **ELECTRONICS ENGINEERS' BOOK CLUB®**

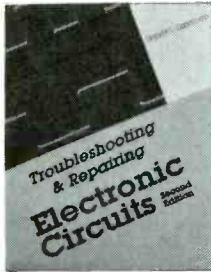

3258P \$19.95
This book offers up-to-date instructions for troubleshooting and repairing all major brands of equipment, with hundreds of diagrams, specs, and schematics. Covers TVs, VCRs, CD players, and much more. 310 pp.

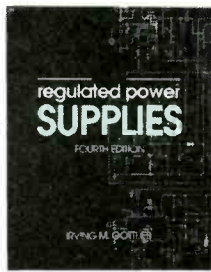

3991 \$39.95
Engineers and technicians will find full coverage of standard power supply sources. Covers new frequency devices including insulated-gate bipolar transistor (IGBT), mos-controlled thyristor (MCT). 464 pp., 365 illus.

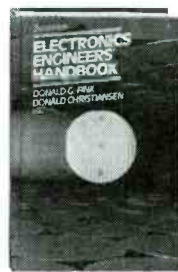

9255-XXX \$105.00
"Outstanding, extensive reference to current technology of electronics. Covers everything from principles to applications."
—Computer Book Review
2,528 pp., 1,800 illus.
Counts as 3

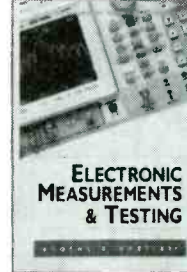

003961 \$39.95
Here's your guide to basic electrical measurements, component measurements, system tests, and performance verification. Most of the methods and procedures you'll find here use available off-the-shelf test equipment. 224 pp., 180 illus.

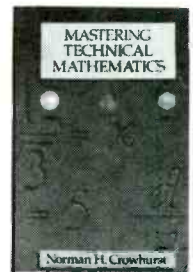

3438 \$39.95
Promotes true understanding by explaining how and why mathematics principles work. Step-by-step instructions and alternative techniques are provided for solving problems in basic arithmetic, algebra, geometry, trigonometry, and calculus. 512 pp., 481 illus.

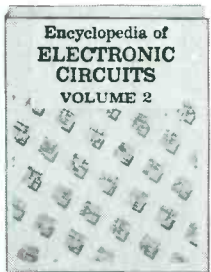

3138-XX \$60.00
A GIANT "Circuit Book" of over 700 of the most widely-used, state-of-the-art electronic and integrated circuits ever compiled in a single source! The perfect sourcebook for all levels of electronics practitioners. 738 pp. Counts as 2

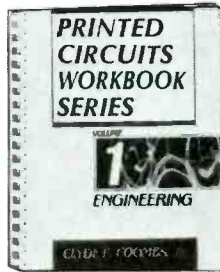

012739-XX \$26.95
From the design, layout, and specification guidelines to material properties, this convenient manual contains authoritative coverage of all aspects of printed circuits engineering. 256 pp., Illus. Softcover
Counts as 2

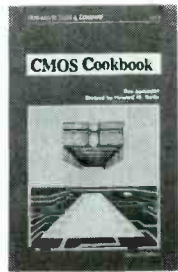

9244P \$18.95
Written in a "cookbook" format, this source offers all the guidance you need to understand and use CMOS devices. It is both a comprehensive, industry-wide reference, and a valuable collection of project ideas. 512 pp., Illus., Softcover

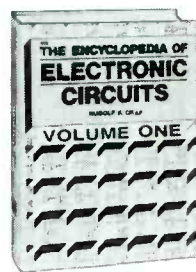

1938-XX \$60.00
For quick-reference and on-the-job use, this sourcebook puts over 1,300 state-of-the-art designs at your fingertips. From A (alarm circuits) to Z (zero crossing detector circuits) this compendium excels in content, scope, and design. 768 pp. Counts as 2

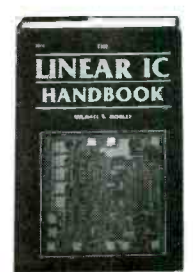

2672 \$49.50
This "one-stop" sourcebook bridges the gap between data books and the designer's search for the right component. Covers how linear ICs are fabricated, how they work, what types are available, and techniques for designing. 624 pp.

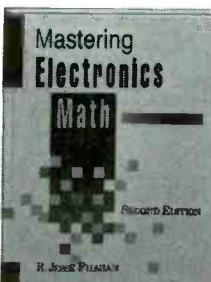

3589 \$27.95
A practical toolbox reference for anyone in the electronics field. Phagan guides you through the practical calculations needed to design and troubleshoot circuits and components. 352 pp., 270 illus.

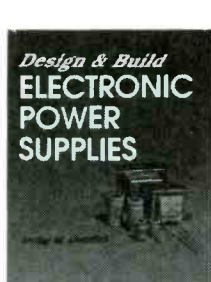

3540 \$26.95
This guide brings you up-to-date on today's most advanced power supply circuits, components, and measurement procedures. Covers switching rates up to 3-MHz and higher as well as the 20-kHz standard. 176 pp.

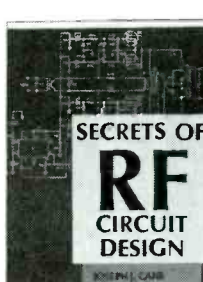

3710 \$32.95
Understand the basics of receiver operation, the proper use and repair components in RF circuits, and principles of radio signal propagation from low frequencies to microwave. 416 pp., 411 illus.

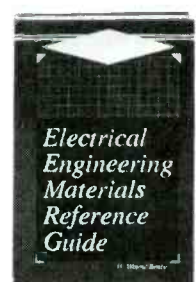

004196 \$47.95
Get concise information on all the major materials used for electrical engineering applications. This guide covers a full spectrum of conductor, magnetic, insulating, and structural materials, and more. 320 pp., Illus.

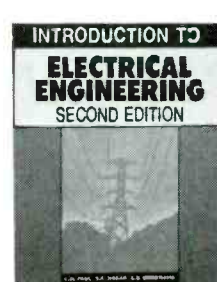

011322-XX \$43.95
Get an inside look at the world of electrical engineering. Basic concepts are covered before moving on to more advanced topics—allowing you to master critical analysis techniques and other basic skills early in the book. 790 pp., illus. Softcover
Counts as 2



053570-XX \$64.95
 This is a "one-stop" guide to the theory and design of communications receivers: short-wave, broadcast, radar, military, broadcast (AM-FM), radar aeronautical, marine, and directions finding. 608 pp., 402 illus. *Counts as 2*

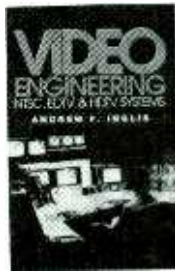

031716 \$49.95
 Get valuable information on the production, recording, editing, transmission, distribution, and display of video signals in this valuable guide. 300 pp., 120 illus.

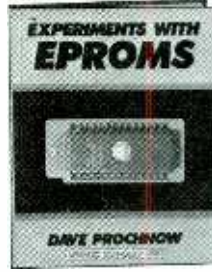

2962P \$17.95
 This complete EPROM instruction manual provides a detailed explanation of underlying theory, plus 15 different projects, including programmers, erasers, and EPROM-based circuits. 240 pp. *Softcover*



033559-XX \$29.95
 This up-to-date problem-solving guide covers all components, circuits, power supplies, operational amplifiers, and transistors. 592 pp., 800 illus. *Softcover Counts as 2*



050806-XX \$54.95
 This book emphasizes circuit, transformer, and magnetics design. Provides worked-out examples of transformers, currents, power levels, and more. 550 pp., 250 illus. *Counts as 2*



3279 \$36.95
 Perform routine maintenance and diagnose and repair any kind of computerized device. This popular reference covers large dynamic RAMs, 32-Bit processors, 80286, 80386, and Z8001-Z8002 processors. 570 pp.



037504 \$39.95
 Packed with simplified, circuit-by-circuit troubleshooting examples, this handbook provides the practical know-how you need to operate and troubleshoot modern RF equipment. 352 pp., 150 illus.

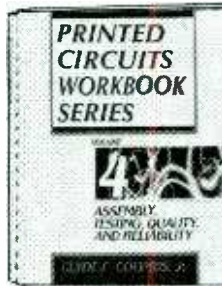

012742-XX \$26.95
 This sourcebook brings you up-to-speed on all the latest printed circuits manufacturing tools, techniques, and processes. 230 pp., Illus. *Softcover Counts as 2*

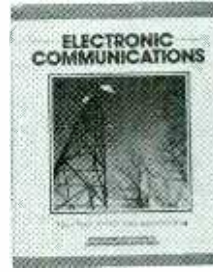

3365P \$24.95
 Both a professional reference and a study guide for the aspiring technician, this is a well-illustrated introduction to modern communications. Use it to prepare for your FCC General Radiotelephone Operator License or CET exam. 704 pp. *Softcover*



009522 \$47.95
 Stressing practical know-how, this unique guide helps you select and properly use the right test equipment. It's organized by electronic function and includes separate sections on analog and digital instruments, signal generators, and oscilloscopes. 320 pp., Illus.

Your source for quality, affordable and timely authoritative engineering books.

As a member of the Electronics Engineers' Book Club...

... you'll enjoy receiving Club bulletins every 3-4 weeks containing exciting offers on the latest books in the field at savings of up to 50% off of regular publishers' prices. If you want the Main Selection do nothing and it will be shipped automatically. If you want another book, or no book at all, simply return the reply form to us by the date specified. You'll have at least 10 days to decide. And you'll be eligible for **FREE** books through the **NEW Bonus Book Program**. Your only obligation is to purchase 3 more books during the next 2 years, after which you may cancel your membership at any time.

©1993 EEBC
 All books are hardcover unless otherwise noted. Publishers' prices shown. If you select a book that counts as 2 choices, write the book number in one box and XX in the next. If you select a Counts as 3 choice, write the book number in one box and XXX in the next 2 boxes. A shipping/handling charge & sales tax will be added to all orders.

If card is missing, write to: Electronics Engineers' Book Club, Blue Ridge Summit, PA 17294-0860

ELECTRONICS ENGINEERS' BOOK CLUB

Blue Ridge Summit, PA 17294-0860

YES! Please rush me the book(s) indicated below for just \$9.95 plus shipping/handling & applicable sales tax. Enroll me as a member of the **Electronics Engineers' Book Club** according to the terms outlined in this ad. If not satisfied, I may return the book(s) within 10 days without obligation and my membership will be cancelled.

--	--	--

If you select a book that counts as 2 choices, write the book number in one box and XX in the next. If you select a Counts as 3 choice, write the book number in one box and XXX in the next 2 boxes.

Name _____

Address _____

City/State _____

Zip _____ Phone _____

Offer valid for new members only, subject to acceptance by EEBC. Canada *must* remit in U.S. funds drawn on U.S. banks. Applicants outside the U.S. and Canada will receive special ordering instructions. A shipping/handling charge & sales tax will be added to all orders. DRE493

NEW LIT

Use The Free Information Card for fast response.

Fantastic Electronics: Build Your Own Negative-Ion Generator and Other Projects; by John Iovine. TAB Books, Division of McGraw-Hill Inc., Blue Ridge Summit, PA 17294-0850; Phone: 1-800-822-8138; \$17.95.

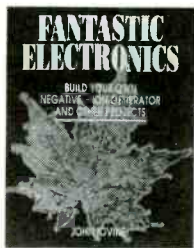

CIRCLE 24 ON FREE INFORMATION CARD

Electronic hobbyists whose interests include all aspects of science, and particularly the technologies of the future, will enjoy building the projects presented in Iovine's book.

The subjects of the 23 projects and experiments presented in the book include lasers, holography, Kirlian photography, alter-

nate energy sources, and even genetics. Included are a biofeedback/lie-detector, an ELF monitor, a Geiger counter, a magneto-hydrodynamic (MHD) generator, and an air-pollution monitor. As if that were not enough you'll find projects

on an expansion-cloud chamber, a pinhole camera, and a laser power supply for holography. Experiments show how synthetic gas and oil are made from coal, and how energy is generated from plants.

Each project has been designed and thoroughly tested by the author, and each chapter includes background references and historical information on the technology being explored.

The ECG Relays and Accessories CompuCross Cross Reference Program.

Philips ECG, 1025 Westminster Drive, Williamsport, PA 17701; Phone: 800-526-9354; \$11.95.

A floppy disk for IBM PC's and compatibles, available from CompuCross, contains the same reference data base as in the sixth edition of the ECG Relays and Accesso-



CIRCLE 25 ON FREE INFORMATION CARD

ONLY \$9.95 EACH

TTL-CMOS BONANZA

The Biggest Budget Buy an Experimenter, Circuit Designer, or Engineer would want!



5 compact pocket guides provide a comprehensive listing of all commonly used TTL and CMOS integrated circuits. All current families including: Standard, Low Power, Schottky, Low Power Schottky, Advanced Schottky, Advanced Low Power Schottky, High Speed and Fast Schottky, and all the commonly used CMOS devices.

They're easy to use! Each page describes one component only and is divided into eight parts, which offer the following: 1—The device's schematic diagram. 2—Logic description. 3—Data on the chip's operational characteristics such as signal levels, etc. 4—Major applications. 5—Summary of essential data. 6—Table of TTL families in which the component is available. 7—Device common name. 8—Type reference number highlighted at the bottom of page for rapid and easy reference.

ORDER THE COMPLETE SET TODAY!

ELECTRONICS TECHNOLOGY TODAY INC.
P.O. Box 240, Massapequa Park, NY 11762-0240

Paying by Check Please charge my Visa MasterCard
Card No. _____ Expiration Date _____
Signature _____
Name _____
Address _____
City _____ State _____ Zip _____

US and Canada orders only. Sorry, no Foreign orders.

Each Book is \$9.95

- TTL Pocket Guide 7400-74200, Volume 1
 - TTL Pocket Guide 74201-74640, Volume 2
 - TTL Pocket Guide 74641-7430640, Volume 3
 - CMOS Pocket Guide Standard Components, Volume 1
 - CMOS Pocket Guide Special Components, Volume 2
- Check Off the Books You Want

Shipping Charges

Under \$10.00	\$2.50
\$10.00 to \$20.00	\$3.50
\$20.01 to \$30.00	\$4.50
\$30.01 to \$40.00	\$5.50
\$40.01 to \$50.01	\$6.50
Over \$50.00	\$8.00
<input type="checkbox"/> Number of books ordered	
Total prices of books	\$ _____
Shipping (See Chart)	\$ _____
Subtotal	\$ _____
Sales Tax (NY Only)	\$ _____
Total Amount	\$ _____

ALL PAYMENTS MUST BE IN U.S. FUNDS

48 HOUR SHIPPING

ELENCO & HITACHI & B+K PRODUCTS AT DISCOUNT PRICES

TO ORDER
CALL TOLL FREE
1-800-292-7711
1-800-445-3201 (Can.)

ELENCO OSCILLOSCOPES

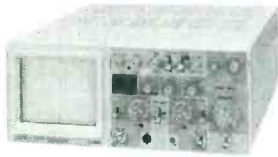

S-1325 25MHz \$349
Dual Trace Oscilloscope

S-1340 40MHz \$495
Dual Trace Oscilloscope

S-1360 60MHz
Dual Trace, Delayed Sweep
\$775

- Automatic beam finder
- Built-in component tester
- 1mV sensitivity
- Dual time base

B+K OSCILLOSCOPES

- 2120 - 20MHz Dual Trace _____ \$395
- 2125 - 20MHz Delayed Sweep _____ \$539
- 1541B - 40MHz Dual Trace _____ \$749
- 2160 - 60MHz Dual Trace, Delayed Sweep,
Dual Time Base _____ \$949
- 2190 - 100MHz Three Trace Dual Time Base,
Delayed Sweep _____ \$1,395
- 2522 - 20MHz / 10MS/s Storage _____ \$895
- 1442 - 20MHz Portable _____ \$1,229
- 1443 - 40MHz Battery / AC operated with
Cursor & Readouts _____ \$1,439

1.0GHz PORTABLE SPECTRUM ANALYZER Model 2610 \$2,595.95

- AC/DC operation (battery included)
- 70dB dynamic range
- Resolution bandwidth of 10kHz
- 50Ω and 75Ω input impedance (switch selectable)
- Fixed bandwidth setting for viewing TV signals
- Field calibratable with internally generated 100MHz, 80dB signal

Hitachi Compact Series Scopes

- V-212 - 20MHz Dual Trace _____ \$409
- V-525 - 50MHz, Cursors _____ \$975
- V-523 - 50MHz, Delayed Sweep _____ \$949
- V-522 - 50MHz, DC Offset _____ \$849
- V-422 - 40MHz, DC Offset _____ \$749
- V-222 - 20MHz, DC Offset _____ \$625
- V-660 - 60MHz, Dual Trace _____ \$1,095
- V-665A - 60MHz, DT, w/cursor _____ \$1,325
- V-1060 - 100MHz, Dual Trace _____ \$1,375
- V-1065A - 100MHz, DT, w/cursor _____ \$1,649
- V-1085 - 100MHz, QT, w/cursor _____ \$1,995
- V-1100A - 100MHz, Quad Trace _____ \$2,195
- V-1150 - 150MHz, Quad Trace _____ \$2,695

Hitachi RSO Series

RSO's feature: roll mode, averaging, save memory, smoothing, interpolation, pretriggering, cursor measurements.

- VC-6023 - 20MHz, 20MS/s _____ \$1,650
- VC-6024 - 50MHz, 20MS/s _____ \$1,950
- VC-6025A - 50MHz, 20MS/s _____ \$2,350
- VC-6045A - 100MHz, 40MS/s _____ Call
- VC-6145 - 100MHz, 100MS/s _____ Call

Digital Capacitance Meter



CM-1550B
\$58.95
9 Ranges
.1pf-20,000ufd
.5% basic acy.
Zero control w/ Case
Big 1" Display

Digital LCR Meter



LC-1801
\$125
Measures:
Coils 1uH-200H
Caps .1pf-200uf
Res .01-20M

Multimeter with Capacitance & Transistor Tester



\$55 CM-1500B
Reads Volts, Ohms
Current, Capacitors,
Transistors and
Diodes / with case

FLUKE MULTIMETERS

Scopemeters	(All Models Available Call)
Model 93	\$1,225.00
Model 95	1,549.00
Model 97	1,795.00
10 Series	
Model 10	\$62.95
Model 12	\$79.95
70 Series	
Model 7011	\$65.00
Model 7711	\$145.00
Model 7911	\$169.00
80 Series	
Model 87	\$289.00

Quad Power Supply XP-580



Fully regulated and short circuit protected

\$69.95

- 2-20V @ 2A
- 12V @ 1A
- 5V @ 3A
- 5V @ 5A

Triple Power Supply XP-620

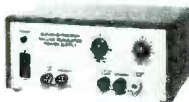

All the desired features for doing experiments.
Features short circuit protection, all supplies

Assembled \$75
Kit \$50

- 2 to 15V @ 1A,
- 2 to -15V @ 1A
- (or 4 to 30V @ 1A)
- and 5V @ 3A

AM/FM Transistor Radio Kit with Training Course



True RMS 4 1/2
Digit Multimeter
M-700T
\$135

Model AM/FM 108
\$27.95

14 Transistors • 5 Diodes
Makes a great school project

.05% DC Accuracy
.1% Resistance
with Freq. Counter
Data Hold

Sweep/Function Generator with Freq. Counter



Sine, Square, Triangle, Pulse, Ramp
.2 to 2MHz, Freq Counter .1-10MHz
Internal Linear & Logic Sweep

\$259

Elenco
Model GF-8026

Function Generator



Provides sine, triangle, square
wave from 1Hz to 1MHz
AM or FM capability

Blox

#9600

\$28.95

Kit
\$26.95

Learn to Build and Program Computers with this Kit

Includes: All Parts, Assembly and Lesson Manual



Model
MM-8000

\$129.00

Starting from scratch you build a complete system. Our Micro-Master trainer teaches you to write into RAMs, ROMs and run a 8085 microprocessor, which uses similar machine language as IBM PC.

Elenco Wide Band Signal Generators



RF Freq 100K-450MHz AM Modulation of 1KHz Variable RF output
SG-9500 w/ Digital Display & 150 MHz built-in Counter \$249

SG-9000 \$129

XK-500 Digital / Analog Trainer

A complete mini-lab for building, testing, prototyping analog and digital circuits Elenco's Digital/Analog Trainer is specially designed for school projects, with 5 built-in power supplies. Includes a function generator with continuously variable, sine, triangular, square wave forms. All power supplies are regulated and protected against shorts.

Power Supplies

- Variable Power Supply
- +1.25 to 20VDC @ 5 Amp (+1.25 to 15VDC @ 1 Amp)
- -1.25 to -20VDC @ 5 Amp (-1.25 to -15VDC @ 1 Amp)
- +12VDC @ 1 Amp
- -12VDC @ 1 Amp
- +5VDC @ 1 Amp
- 30VAC Center tapped @ 15VAC at 1 Amp

Analog - Section

- Function Generator Sine, Triangular, Square wave forms
- Frequency adjustable in five ranges from 1 to 100KHz
- Fine frequency adjust
- Amplitude adjust
- DC offset
- Modulation FM-AM

Digital - Section

- Eight data switches
- Two no bounce logic switches
- 8 LED readouts TTL buffered
- Clock frequency 1 to 100KHz
- Clock amplitude 5VPP square wave

Breadboards

- 2 breadboards, each contain: 840 tie points (total 1,680)



\$159.95

Assembled

\$129.95 Kit

WE WILL NOT BE UNDERSOLD

UPS SHIPPING: 48 STATES 5%
IL RES 7.5% TAX (\$3 min \$10 max)

PROBES INCL ALL SCOPES & METERS

C&S SALES INC.

1245 ROSEWOOD, DEERFIELD, IL 60015
FAX: 708-520-0085 • (708) 541-0710



15 DAY MONEY BACK GUARANTEE

FULL FACTORY WARRANTY

WRITE FOR FREE CATALOG

PRICES SUBJECT TO CHANGE

CIRCLE 109 ON FREE INFORMATION CARD

www.americanradiohistory.com

ries Catalog. Listed are designations for replacements of many different electromechanical relays. Among them are relays with specialized magnetic contacts as well as solid-state, reed, DIP, time-delay, and programmable relays. There are also references to electronic timers and standard and in-line input/output modules.

The expanded ECG cross-reference gives readers access to a database of more than 39,500 industry part numbers. They are cross-referenced to over 530 ECG relays and accessories. The CompuCross program displays a description of the relay, including style, and all pertinent specifications data such as input voltage, contact arrangement, and current rating. A list of manufacturers of the relays that can be replaced is included.

CompuCross requires 512K of RAM, a hard drive, and a 3½- or 5¼-inch floppy drive. The program is available on two standard-density or a single high-density 5¼-inch disk, or on a single standard-density 3½-inch disk.

The Television Gray Market; by Henry L. Eisenson. Index Publishing Group, 6755 Mission Gorge Road, Suite 6, San Diego, CA 92120; Phone: 619-281-2957; \$23.75.

An electronic underground is stealing billions of dollars worth of television programs from satellites, cables, and videotapes. It is also violating state anti-pollution laws. Ironically, the vendors of the equipment or devices needed to steal these services, and in other ways violate the law are legitimate manufacturers.

They include manufac-



CIRCLE 26 ON FREE INFORMATION CARD

turers and distributors of cable descramblers, descrambling IC's, and scanners that can be easily modified for eavesdropping on private conversations over cordless and even cellular telephones.

Other topics include a discussion of an industry that replaces original equipment automotive microcontrollers that meet the legal requirements of the states in which they are sold with modified versions that boost car performance by disregarding anti-pollution laws. And you can read about readily available surveillance "bugs" and cameras that you can buy retail or from mail-order houses.

They're all perfectly legal—as long as you don't use them. The "gray market" flourishes because no laws prohibit the manufacture, sales, distribution or purchase of those devices or products. Eisenson's book explores the gray market, describes legal issues, industry countermeasures, scrambling and descrambling methods, and the way certain equipment is modified illegally.

The author quotes members of the gray market and their customers. He also includes discussions with law-enforcement agencies. Appendixes include a description of the television spectrum with call letters for TV channels, and a comprehensive listing of gray-market vendors.

Aliasing Errors in A/D Converters. Alligator Technologies, 17150 Newhope Street, Suite 114, P.O. Box 9706, Fountain Valley, CA 92728-9706; Phone: 714-850-9984; Fax: 714-850-9987; free.

These application notes summarize the causes of aliasing errors for engineers and scientists who sample data with analog-to-digital converters. They explain how to select the best filter for each application. The notes also describe Alligator Technologies products—a front-end, low-pass filter board, the AAF-1.



CIRCLE 27 ON FREE INFORMATION CARD

Other topics covered include choosing the correct filter, setting and calibrating AAF-1 cut-off frequencies, using AAF-1 daughter boards in non-AAF-1 systems, and distinguishing between the six types of grounds and associated power sources. The subjects of the notes are:

- AP-301, *Aliasing Errors in A/D Converters*, describes the phenomenon of aliasing and explains the theory behind anti-alias filters and the benefits of using such filters.

- Note AP-302, *AAF-1 Filter Selection*, describes five switched capacitor filters available for the AAF-1 system.

- AP-303, *Setting and Calibrating AAF-1 Cutoff Frequencies*, explains how to use a built-in or external frequency clock source, with the AAF-1 and how to select the frequency range and how to measure the corner frequency.

- AP-304 covers pin connection, digital and analog grounds, clock frequency, and power supplies for the filtering daughter board of the AAF-1.

- AP-305, *Grounding in a System with AAF-1 Components*, discusses chassis, digital, analog, and three other types of ground references and their relation to signals in a data-acquisition system.

The MIDI Manual, by David Miles Huber. Sams, Division of Macmillan Computer Publishing, 11711 North College, Carmel, IN 46032; Phone: 800-428-5331 or 317-573-2500; Fax: 800-448-3804 or 317-573-2655; \$24.95.

This all-around guide to MIDI technology explains how you can improve your techniques for recording music and your performance with MIDI. It describes the industry's leading products, and explains how to integrate them with the IBM PC, as well as Macintosh, and Atari computers.

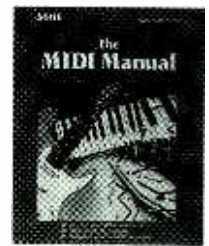

CIRCLE 28 ON FREE INFORMATION CARD

Illustrations and step-by-step lessons teach you how to set up an efficient MIDI system. The basic MIDI components and functions are explained, and there is detailed coverage of subjects such as production techniques, synchronization, combining MIDI and sync-pulse timing, and the art of sequencing. Ω



GET YOUR RECHARGE CATALOG FREE...EARN BIG \$\$ IN YOUR SPARE TIME—All supplies and Do-It-Yourself kits with complete instructions available. Supplies cost from **\$9.95** in qty and you can sell recharged toner cartridges for **\$40.00** to **\$55.00** each. Printers include HP Laser-Jet Series I, II, III, IV, Apple LaserWriter, QMS, etc. Canon PC Copiers also. **CHENESKO PRODUCTS, 2221 Fifth Ave., Suite #4, Ronkonkoma, NY 11779, 516-467-3205. FAX 516-467-3223, 1-800-221-3516**

CIRCLE 110 ON FREE INFORMATION CARD

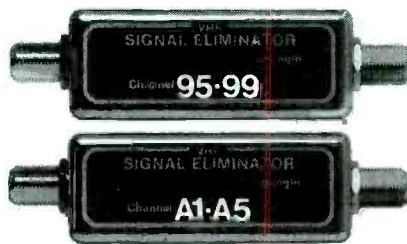

CABLE TV 50dB NOTCH FILTERS for interference removal or channel censoring. Filters are user-adjustable to desired channel # or frequency. Eight Models available, each for certain channels: 2 & 3; 4 to 6; 7 to 13; 14 to 17; 18 to 22; 23 to 29; 30 to 36; 95 to 99 plus 0 & 1. Just **\$30** each or 3 for **\$75**, includes shipping. **ONE MONTH MONEY BACK**, fast delivery. Visa, MC, check or M.O. (C.O.D. is **\$5** extra) Huge discounts for higher quantities. **STAR CIRCUITS, P.O. Box 94917, Las Vegas, NV 89193. Call 24 hours 1-800-535-7827.**

NEW JENSEN MASTER CATALOG Jensen's 1993 Master Catalog, available free, contains many innovative products for design, testing and repair of electronic equipment. Presents new instruments from Fluke, Beckman, Tektronix, Huntron, Leader, BK Precision, and others. Introduces latest inch and metric tools, tools kits, soldering supplies, cables, connectors, static control products, PC diagnostics and more. Enjoy free technical assistance and free shipping within the continental USA. **JENSEN TOOLS INC., 7815 S. 46th St., Phoenix AZ 85044 (602) 968-6231.**

CIRCLE 115 ON FREE INFORMATION CARD

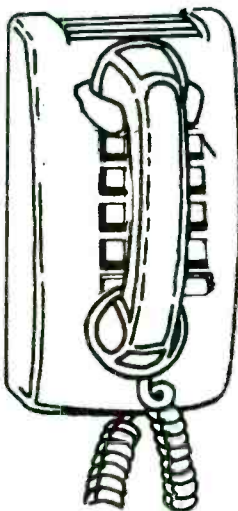

POMONA ELECTRONICS ELECTRONIC TEST ACCESSORY CATALOG—Pomona Electronics' new 142-page 1993/1994 Catalog of Electronic Test Accessories introduces several new individual DMM test accessory products and an expanded line of oscilloscope probe kits including an active differential probe kit. The all new catalog also introduces a helpful guide to offer accurate SMT test clip selection for new low-profile, fine-pitch packages such as SQPF, SSOP and PQFP styles and safety-designed products. **ITT POMONA ELECTRONICS, 1500 E. Ninth Street, P.O. Box 2767, Pomona, CA 91769, Telephone: 714-469-2900, Fax: 714-629-3317.**

CIRCLE 176 ON FREE INFORMATION CARD

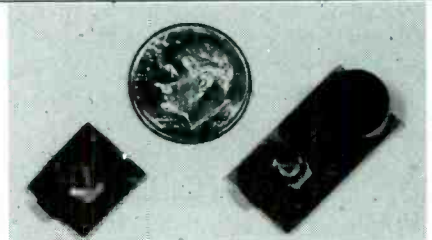

WORLD'S SMALLEST FM TRANSMITTERS! New Surface Mount Technology (SMT) makes all others obsolete! XST500 Transmitter—powerful 3 transistor audio amplifier, transmits whispers up to 1 mile. XSP250 Telephone Transmitter—line powered, transmits conversations up to ¼ mile. Both tune 88-108 MHz. Easy to assemble **E-Z KITS** (SMT components pre-assembled to circuit board)! XST500—**\$39.95**, XSP250—**\$29.95**, VISA/MC. COD add \$5. **XANDI ELECTRONICS, 201 E. Southern Ave., Suite 111, Tempe, AZ 85282. 1-800-336-7389.**

CIRCLE 181 ON FREE INFORMATION CARD

CALL NOW AND RESERVE YOUR SPACE

- 6 x rate \$940.00 per each insertion.
- Fast reader service cycle.
- Short lead time for the placement of ads.
- We typeset and layout the ad at no additional charge.

Call **516-293-3000** to reserve space. Ask for Arline Fishman. Limited number of pages available. Mail materials to: mini-ADS, ELECTRONICS NOW, 500-B Bi-County Blvd., Farmingdale, NY 11735.

FAX: 516-293-3115



TWO TRANSMITTERS IN ONE! 5 MINUTE ASSEMBLY! MONEYBACK GUARANTEE! New Law Enforcement grade device on a single chip is the most sensitive, powerful, stable room transmitter you can buy. Uses any 3V-12V battery. Or attach to telephone line to monitor all telephone conversations over 1 mile away without batteries! 100mW output! 80-130MHZ. Receive on any FM radio or wideband scanner. VT-75 microtransmitter. **\$49.95 + 1.50 S&H. VISA, MC, MO. COD's add \$4.00. DECO INDUSTRIES, Box 607, Bedford Hills, NY 10507. 914-232-3878.**

CIRCLE 127 ON FREE INFORMATION CARD

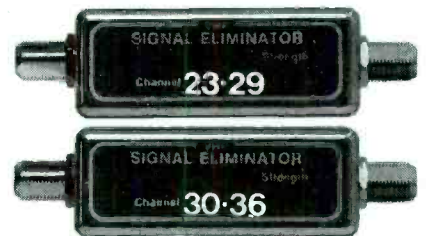

CABLE TV 50dB NOTCH FILTERS for interference removal or channel censoring. Filters are user-adjustable to desired channel # or frequency. Eight Models available, each for certain channels: 2 & 3; 4 to 6; 7 to 13; 14 to 17; 18 to 22; 23 to 29; 30 to 36; 95 to 99 plus 0 & 1. Just **\$30** each or 3 for **\$75**, includes shipping. **ONE MONTH MONEY BACK**, fast delivery. Visa, MC, check or M.O. (C.O.D. is **\$5** extra) Huge discounts for higher quantities. **STAR CIRCUITS, P.O. Box 94917, Las Vegas, NV 89193. Call 24 hours 1-800-535-7827.**

THE PARTS PLACE SM

TECHLINE™ Tools—The new standard in strength and precision!



Pocket-size digital multimeter

Take along anywhere! LCD autoranging/manual meter with continuity buzzer measures to 400 volts AC/DC and resistance. Includes carry case. #22-169 27.99



- Precision-crafted with top-quality materials
- Designed for long life and ease of use
- Backed by Radio Shack's 1-Year Limited Warranty

New TECHLINE tools represent Radio Shack's uncompromising dedication to quality. Each is precision-crafted of long-lasting, hard-working materials and employs the latest design innovations for comfort and ease of use. And, each is backed by our full 1-year limited warranty.



Portable Power Inverter. For camping, fishing, emergencies. Converts car/boat 12VDC to 115VAC for powering a TV, VCR, light or tool. Compact and efficient. Rated 140W continuous. #22-132 99.99



TECHLINE Swiss Army Knife. Tool kit for your pocket! You'll be prepared with a large blade, Phillips and slot screwdrivers, wire stripper, cutter, pliers, opener, tweezers and toothpick. #64-2001 29.95



TECHLINE Mini Hand Drill. Terrific for PC projects. Precision geared, fits comfortably in the palm of your hand. Four standard drill bits— $\frac{3}{32}$ ", $\frac{1}{8}$ ", $\frac{5}{32}$ " and $\frac{3}{16}$ "—store in shank. #64-1979 12.99



Hi-Current Car DC Adapter. Plugs into vehicle lighter socket. Provides 6, 9 or 12VDC. With four Adaptaplugs. #270-1562 15.95



Getting Started in Electronics. A great hands-on introduction to building your own electronic circuits. #276-5003 2.99



Anti-Static Spray. By STATX® brands. New high-tech cleaner and protector repels dust—cleans without scratching. #64-3310 . . . 3.99



Mini Audio Amp With Built-in Speaker. Many uses—test amp, signal tracer, phone amp and amplified PC speaker. #277-1008 11.95



Bench-Top Soldering Iron Holder/Cleaner. Safe way to hold hot iron while working. Sponge tip cleaner. #64-2078 6.49

Speedy service and low prices on thousands of parts and accessories!



- FREE delivery to Radio Shack on orders \$5 and up
- Semiconductors and ICs ■ Hard-to-find batteries
- CB and scanner crystals ■ Long-life vacuum tubes
- Phono cartridges/styli ■ SAMS® service books

Why pay more for mail-order? Your Radio Shack stocks 1000 electronic components, and another 15,000 are available *fast* from our special-order warehouse. Ordering is easy! Bring in the exact part number (or old part). We'll check availability and order by phone. Delivery time to your nearby Radio Shack for most items is a week.

Radio Shack® SINCE 1921
AMERICA'S TECHNOLOGY STORE™

CIRCLE 78 ON FREE INFORMATION CARD

Prices apply at participating stores and dealers.

BUILD THE AFG II



Turn your automobile into a concert hall on wheels with the Acoustic Field Generator II.

TOD T. TEMPLIN

WAY BACK IN JANUARY 1990, WE PUBLISHED plans describing the construction of the Acoustic Field Generator. That circuit, the AFG for short, will recover natural ambience and reflections hidden within any stereo audio signal. In other words, it will reconstruct a three-dimensional acoustic field by reproducing both direct and delayed indirect sound waves through a set of four speakers surrounding the listener. The AFG can also decode specially encoded surround sound material, and thus was intended primarily for use in a home theater system.

Many builders of the AFG were so impressed with it that they requested information on how to modify the circuit to operate from a 12-volt power supply for use in their automobiles. It seems that a good number of audiophiles are looking for a circuit to enhance the acoustic properties of their automotive sound systems.

The circuitry of the original AFG included a bipolar power supply and was not readily adaptable to 12-volt operation. For that reason, an entirely new circuit, the AFG II, has been designed for use in a car. However, the AFG II can also be powered from a 12-volt DC wall transformer, and can therefore become part of any audio system.

Description

The AFG II is a true stereo circuit. It's designed to be placed in the line-level signal path of your car's audio system between the output of the receiver and the input of the equalizer or power amplifier, which drives the rear speakers of your vehicle. Figure 1 is a block diagram of a typical system. The AFG II uses a pair of bucket-brigade devices to delay the sound that is fed to the rear speakers. The delay (in relation to the front speakers) can be adjusted from about 5 to 35 milliseconds. A feedback control adds variable reverberation (echo) to the delayed signals.

In addition to its simple delay mode, the AFG II has a differential mode in which it decodes any surround-sound or ambience signals present. Volume and reverberation level are controlled by an electronic volume control IC. As in the original AFG, an electronic crossover is provided to drive an external power amplifier for a subwoofer system.

The entire unit is built on a single-sided 4- by 5-inch PC board with all controls and input/output jacks mounted on it. The completed PC board slides into an attractive commercial enclosure, so the finished project is quite compact, looks professional, and is easily mounted in most vehicles.

Circuitry

Figure 2 shows a block diagram of the AFG II circuit. Note that the circuit consists of two identical audio channels which share a common power supply and bucket-brigade clock generator. Next refer to the schematic

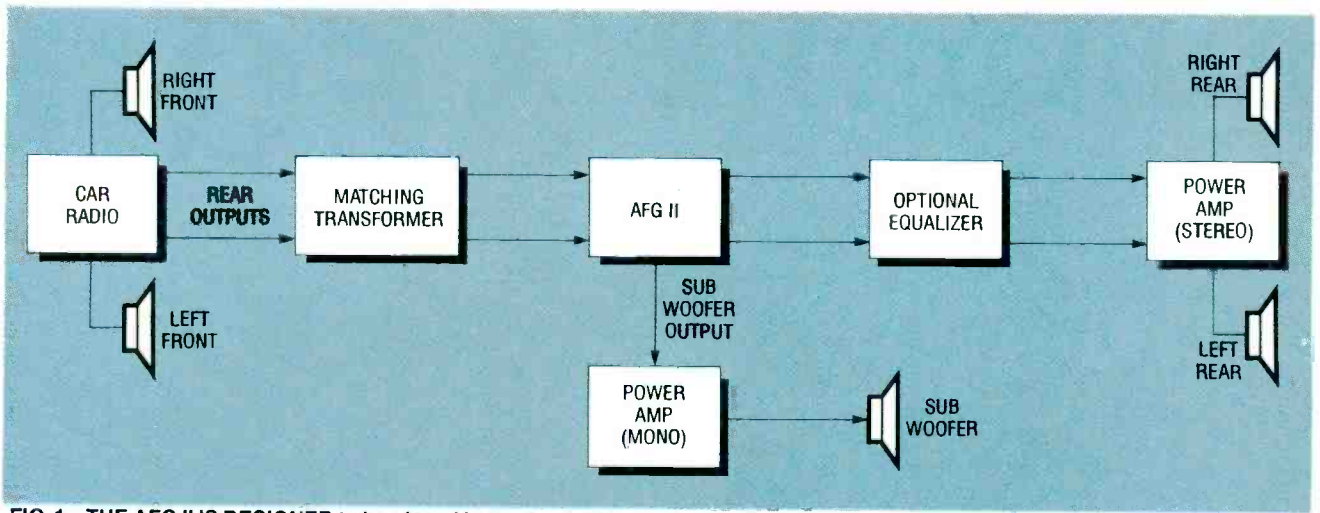

FIG. 1—THE AFG II IS DESIGNED to be placed in the line-level signal path of your car's audio system between the outputs of the receiver and the inputs of the equalizer or power amplifier, which drives the rear speakers.

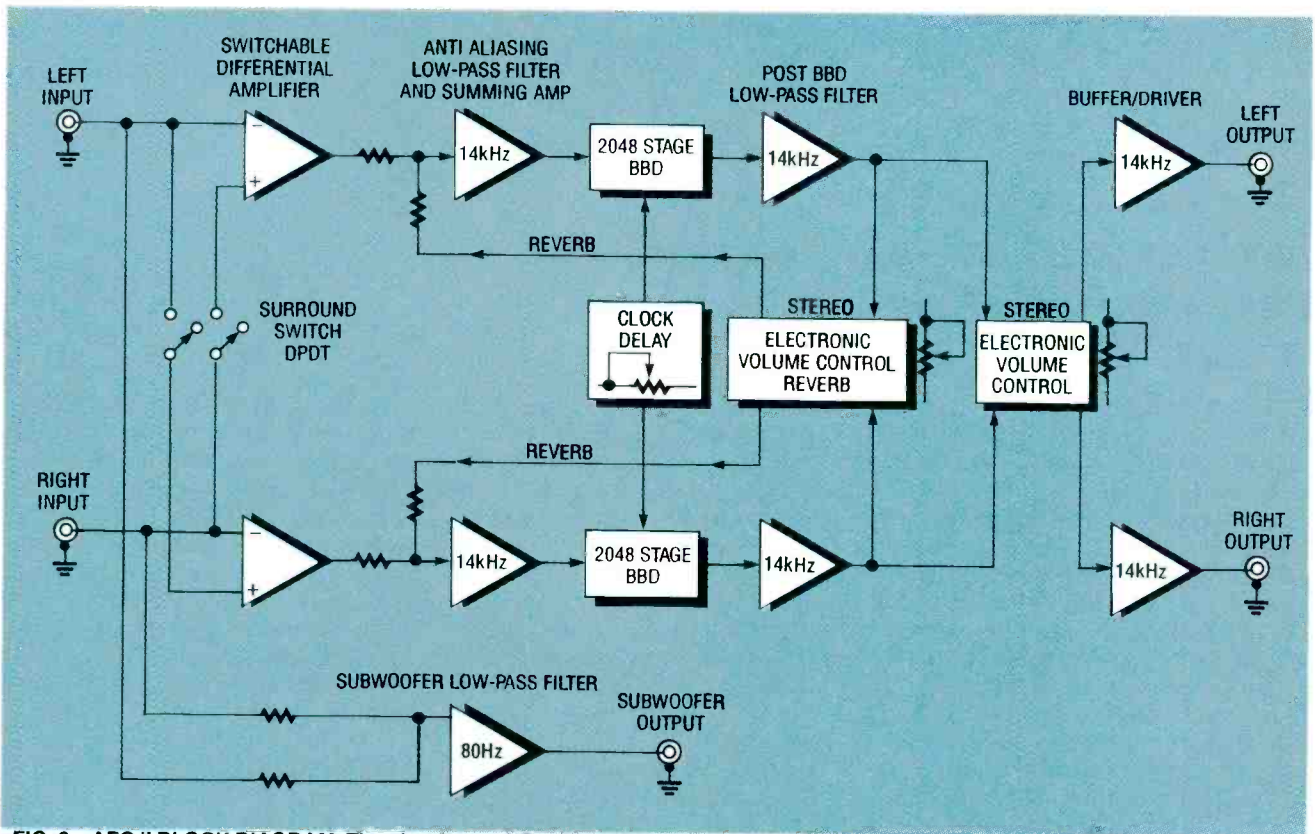

FIG. 2—AFG II BLOCK DIAGRAM. The circuit consists of two identical audio channels that share a common power supply and bucket brigade clock generator.

diagram shown in Fig. 3. An input buffer amplifier is made up of IC1-a and IC1-d. With SURROUND SELECT switch S1 open, IC1-a and -d act as simple inverting amplifiers, and have no effect on the input signal other than providing some gain and a low source impedance for driving the filter section of the following stage.

When S1 is closed, each op-amp becomes a differential am-

plifier because its non-inverting input is cross-connected, via R3-C6 and R4-C5, to the opposite audio channel of its inverting input. When operating in the differential mode, any audio information that is common to both channels (i.e., mono) is canceled from the output. Only the difference component (L - R and R - L) of the original signal remains. Operating the input amplifier stage in the differen-

tial mode decodes any ambience or surround information present in the incoming signal. Trimmers R73 and R74 provide a means for adjusting the overall circuit gain, thus compensating for the varying source signal levels of different components likely to be used with the AFG II.

When op-amps are operated from a single-ended power supply, their non-inverting inputs

should be biased at the same DC voltage as the inverting inputs; usually one half the supply voltage. To satisfy that requirement in our circuit, resistors R21 and R22 form a fixed voltage divider. Because the resistors have equal value, the divider splits the supply voltage in half. Capacitor C17 acts as a filter and ensures that no audio signal or noise is coupled to the non-inverting inputs of the op-amps. All of the op-amps in the entire circuit are biased in this manner. Op-amps IC1-b and IC1-c form a pair of anti-aliasing filters for the delay section (see Fig. 4).

The heart of the AFG II delay section consists of a pair of Panasonic MN3008 2048-stage analog bucket-brigade devices, or BBD (one for each channel), and a shared MN3101 two-phase variable-frequency clock-pulse generator. Each element in the BBD is one of 2048 series-connected stages. Each stage consists of a small capacitor

that stores an electric charge, and a tetrode transistor switches that charge from one capacitor to the next. Consider each of the 2048 capacitors to be a bucket in a fireman's brigade. A signal presented at the input to the BBD is transferred down the line of capacitors in the same manner in which firemen in a bucket brigade transfer a pail of water from one man to the next. The speed at which the signal is transferred down the line of buckets is controlled by the frequency of the clock signal applied. The more slowly the clock runs, the longer it takes for the signal to travel through the circuit and reach the far end.

When using delay lines, one must contend with a nasty property known as "aliasing." In this case, aliasing means "false signal." When the frequency of a signal applied to the input of a BBD is allowed to become higher (i.e., shorter) than one half of the clock pulse fre-

quency, the sample time duration becomes longer than the actual frequency being sampled. Put another way, the amplitude of that high-frequency signal has a value that changes during the sample time; thus the value stored in the capacitor is not an accurate representation of that instant in time, and the output of the BBD is not "true." To avoid aliasing and the resulting distortion, a low-pass filter is placed ahead of the BBD to limit the input-signal frequency to one half or less of the lowest clock frequency used. The low-pass filter used for this purpose is referred to as an anti-aliasing filter.

Another property of BBD's is that clock phase one drives all of the odd number stages, and clock phase two drives the even number stages. When the signal reaches the end of the line, the output of the last odd stage must be combined with the output of the last even stage to

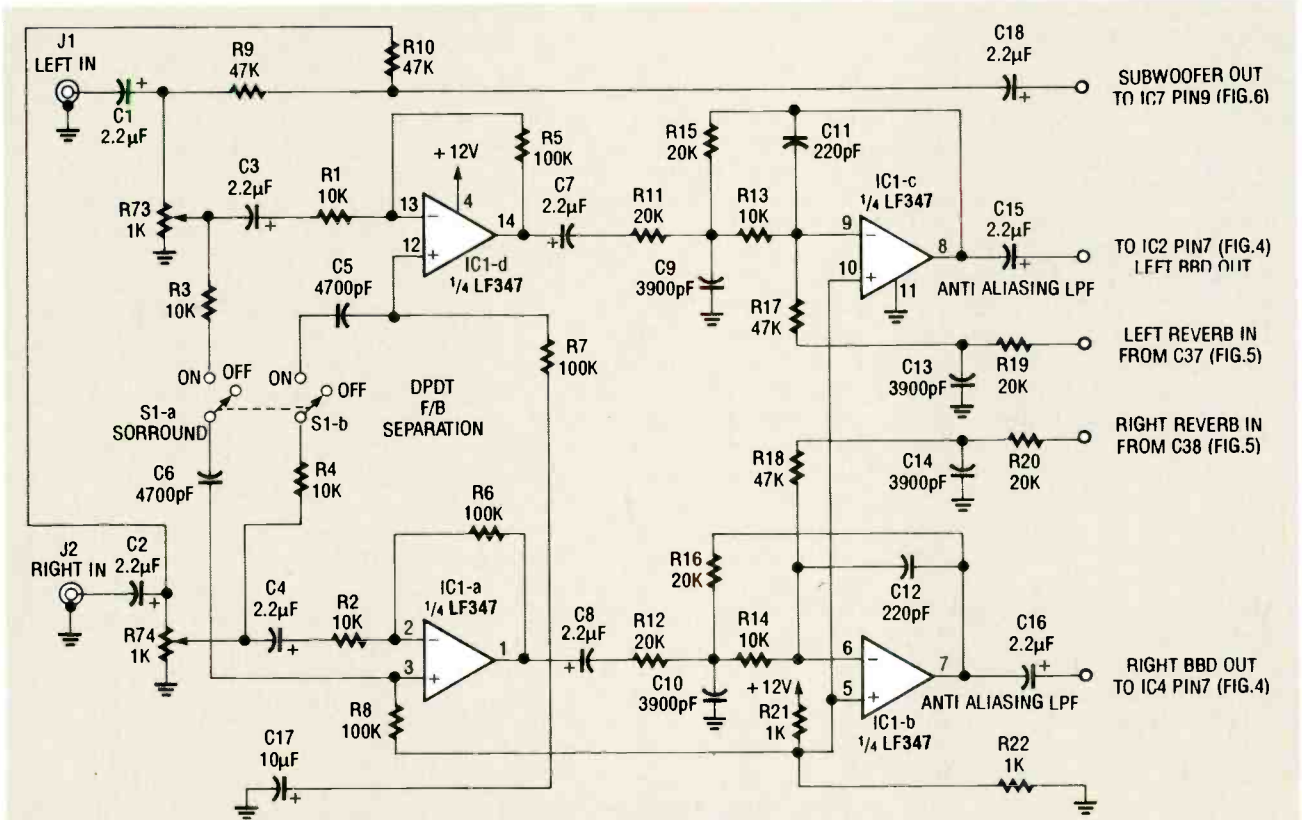

FIG. 3—WITH SWITCH S1 OPEN, IC1-a and IC1-d act as simple inverting amplifiers. With S1 closed, each op-amp becomes a differential amplifier because its non-inverting input is cross-connected to the opposite audio channel of its inverting input. The differential mode "decodes" any ambience or surround information.

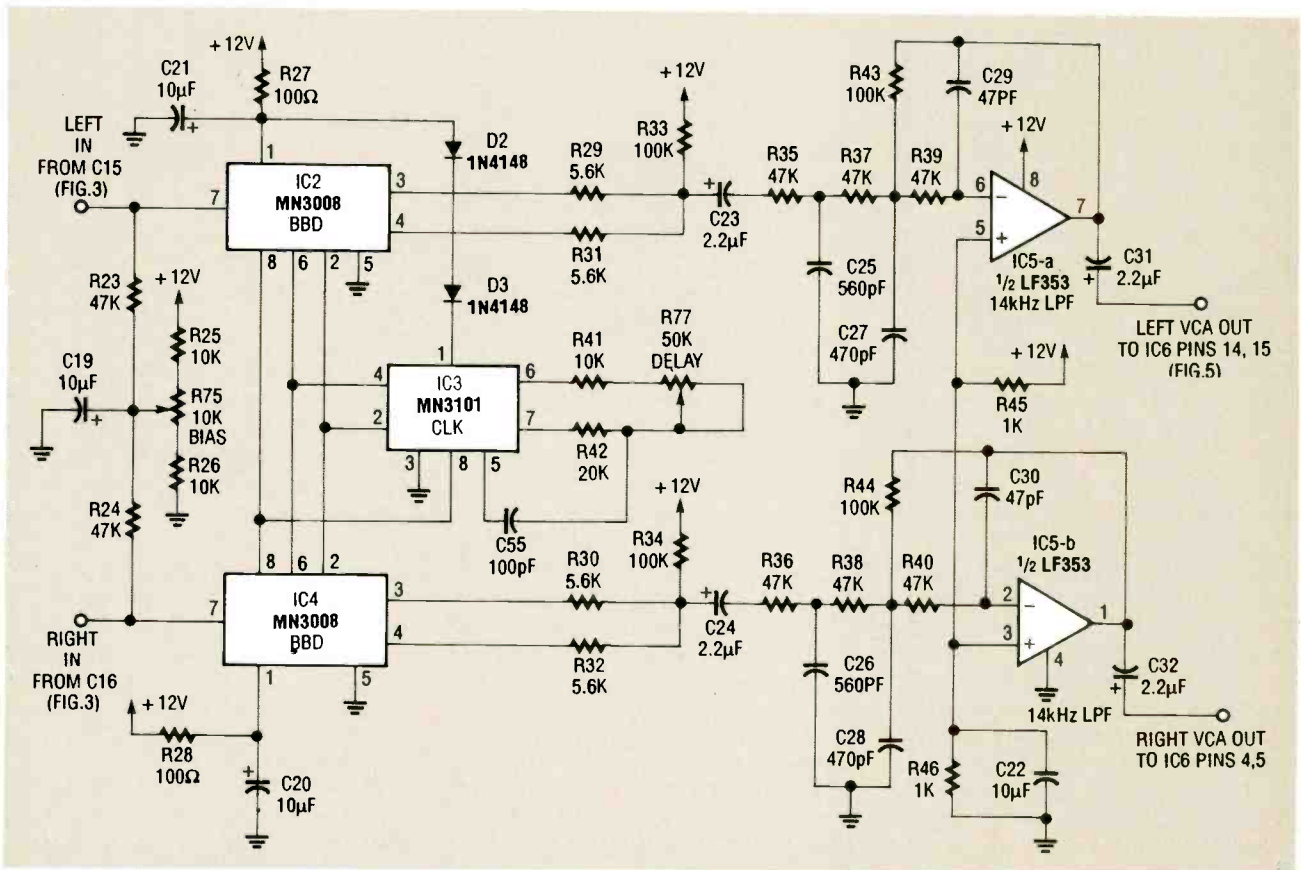

FIG. 4—THE AFG II DELAY SECTION consists of a pair of Panasonic MN3008 2048-stage analog bucket-brigade devices and a shared MN3101 two-phase variable-frequency, clock-pulse generator.

properly reconstruct the input signal. The purpose for doing that is to cancel the clock signal from the audio signal at the BBD output. In practice, a post-BBD low-pass filter with a very sharp cutoff frequency further reduces any clock component in the recovered audio signal.

The delay time available from a BBD is equal to the number of stages divided by twice the clock frequency. Using Panasonic's data for the MN3101 clock generator IC, values were calculated for the frequency-determining components (R41, R42, C55, and R77) to produce a clock frequency, adjustable by R77, which ranges from approximately 145 kHz to 40 kHz. That produces a corresponding delay time ranging from about 5 to 30 milliseconds—more than enough to recreate the ambience of a large concert hall.

The BBD is rated by the manufacturer to have an upper frequency response limit of 10 kHz and a signal-to-noise ratio of 55 dB at a clock frequency of 40

kHz. (Note that the S/N ratio of a BBD improves as the clock frequency rises.) Actual testing of the device has proven that it will work slightly beyond 12 kHz. In the AFG II, the anti-aliasing low-pass filter (LPF) and post-BBD LPF were designed to obtain the maximum performance available from the BBD.

Returning to the circuit diagram Fig. IC1-b and IC1-c form the anti-aliasing, low-pass BBD input filter. Although basically a second-order filter, component values have been selected to obtain a response curve which rises smoothly from 0 dB at 1 kHz until it peaks at about +5 dB at 10 kHz. The response then falls back to 0 dB at 14 kHz, and continues to drop at about 6 dB per octave. In Fig. 4, IC5-a and IC5-b form the post-BBD low-pass filter. Component values for this third-order Butterworth filter have been selected to produce a response curve nearly opposite that of the input filter circuit. This method of high-frequency

pre-emphasis followed by de-emphasis of the audio signal passing through the BBD results in an improved signal-to-noise ratio for the delay section of about 5 dB. The actual measured frequency response of the entire AFG II from input to output varies no more than 1 dB from 20 Hz to 10 kHz. The -3 dB point is 12 kHz, and response beyond 12 kHz drops at more than 36 dB per octave.

The next section, shown in Fig. 5, is the volume and reverb control stage. A TDA1074 two-section dual-ganged electronic volume control, or EVC (IC6), eliminates the need for an expensive dual-ganged potentiometers, as well as all the wires required to hook them up. Instead, a single control voltage applied to the control input of the EVC simultaneously adjusts the gain of a matched pair of amplifiers. The range of adjustment available is from infinite attenuation to unity gain. The VOLUME control (R78) adjusts the level of the signal being sent to the final output filter stage. The REVERB control (R79) adjusts the level of

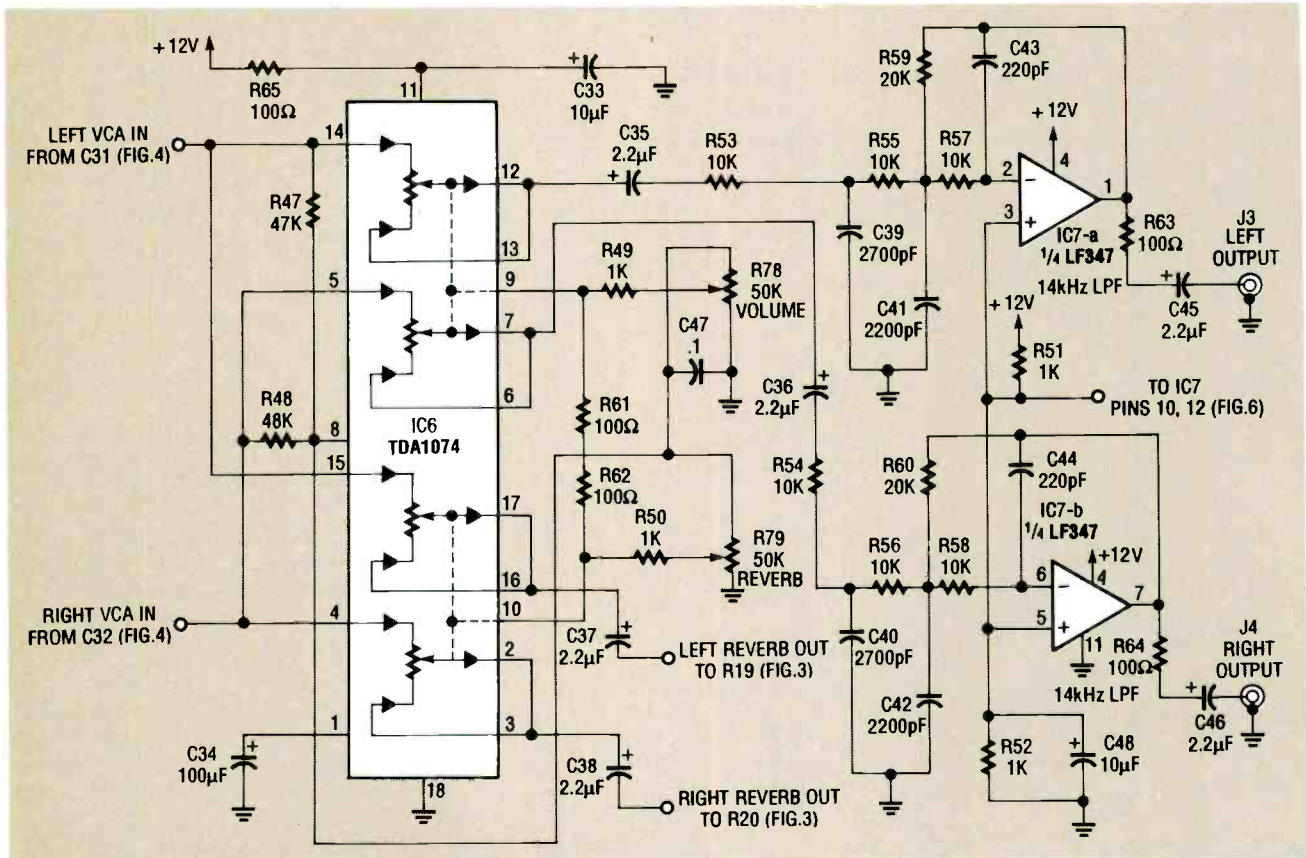

FIG. 5—A TDA1074 ELECTRONIC VOLUME CONTROL simultaneously adjusts the gain of a matched pair of amplifiers (IC7-a and -b). The volume control (R78) adjusts the level of the signal being sent to the final output filter stage, and the reverb control (R79) adjusts the level of the delayed signal being added back to the input.

the delayed signal being fed back to IC1-b and IC1-c where it is added back to the input signal to produce the reverberation effect. Components R17, R19, and C13, and R18, R20, and C14 form a pair of first-order LPF's to prevent ringing and match levels of the feedback signal. The output stage, IC7-a and IC7-b, is another pair of third-order LPF's with a corner frequency of 14 kHz. They provide for additional reduction of clock noise from the output signal as well as providing a low output-source impedance.

The other half of IC7 (IC7-c and IC7-d) forms an active crossover network for driving a subwoofer system; IC7-c sums the left and right channel inputs, inverts the summed signals by 180°, and provides a low driving impedance for the following low-pass filter stage (see Fig. 6). Potentiometer R76 adjusts the gain of this stage from unity to 3 times unity value. Op-amp IC7-d and its associated

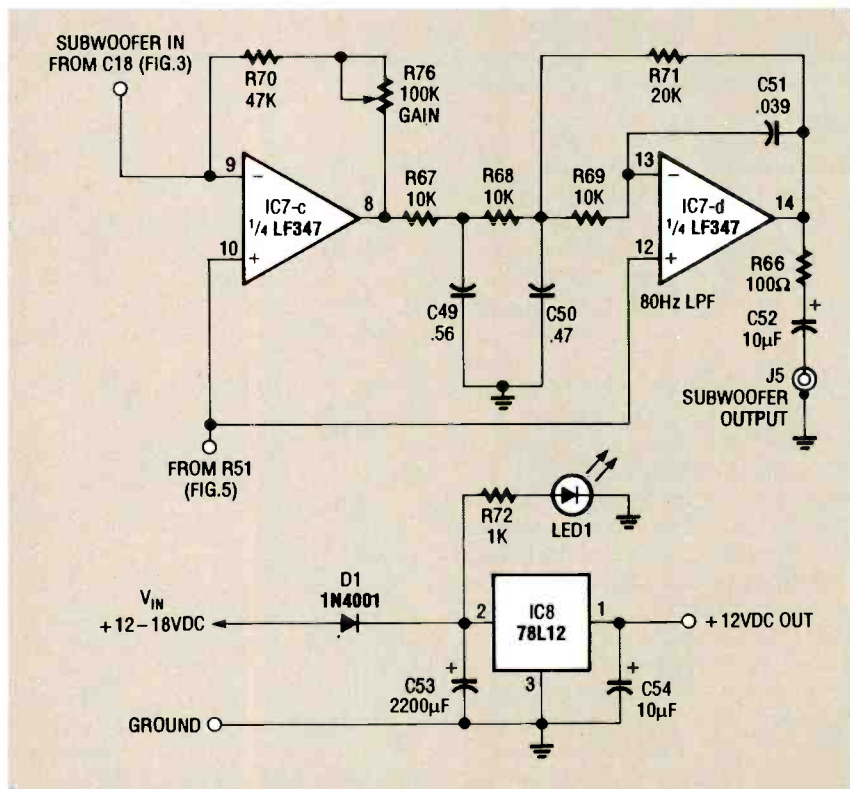

FIG. 6—AN ACTIVE CROSSOVER NETWORK for driving a subwoofer system is formed by IC7-c and -d. Potentiometer R76 adjusts the gain of this stage.

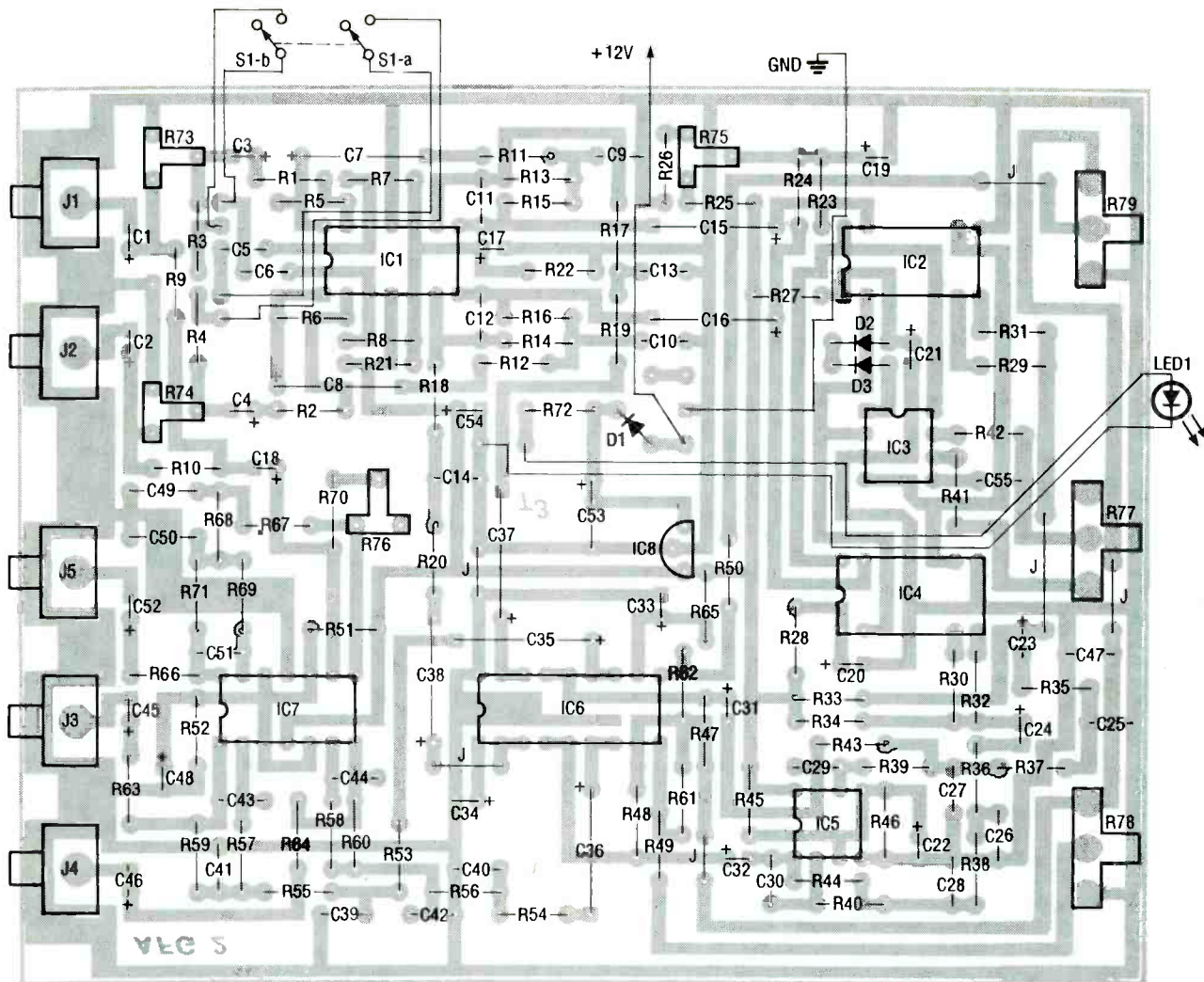

FIG. 7—ABOUT 150 COMPONENTS mount on the AFG II board. Don't forget to install the six jumpers, marked "J," where indicated.

RC network form an 80-Hz third-order low-pass filter. Because the filter inverts the signal another 180 degrees, the signal that appears at the output is back in phase with the signals at the inputs to the AFG II.

Finally, a brief word about the power supply. Rectifier D1, although unnecessary when operating the AFG II from an automotive DC electrical system, has been included in the circuit to serve as a protective device; it will protect about \$50 worth of IC's if you should accidentally connect the unit to a car's electrical system with the polarity reversed. The AFG II can be powered from any source capable of supplying 14 to 18 volts of noise-free DC. A small, well-filtered DC wall transformer is all that's required to bench test the AFG II, or adapt it

PARTS LIST

All resistors are 1/4-watt, 5%.

R1-R4, R13, R14, R25, R26, R41, R53-R58, R67-R69—10,000 ohms
 R5-R8, R33, R34, R43, R44—100,000 ohms
 R9, R10, R17, R18, R23, R24, R35-R40, R47, R48, R70—47,000 ohms
 R11, R12, R15, R16, R19, R20, R42, R59, R60, R71—20,000 ohms
 R21, R22, R45, R46, R49-R52, R72—1000 ohms
 R27, R28, R61-R66—100 ohms
 R29-R32—5600 ohms
 R73, R74—1000 ohms, horizontal PC-mount trimmer potentiometer
 R75—10,000 ohms, horizontal PC-mount trimmer potentiometer
 R76—100,000 ohms, horizontal PC-mount trimmer potentiometer
 R77, R78, R79—50,000 ohms, PC-mount potentiometer

Capacitors

C1-C4, C18, C23, C24, C31, C32, C45, C46—2.2 μ F, 50 volts, radial electrolytic
 C5, C6—4700 pF, 50 volts, Mylar or metal film, 5%
 C7, C8, C15, C16, C35-C38—2.2 μ F, 63 volts, axial electrolytic
 C9, C10, C13, C14—3900 pF, 50 volts, Mylar or metal film, 5%
 C11, C12, C43, C44—220 pF, ceramic disc, 5%
 C17, C19, C20-C22, C33, C48, C52, C54—10 μ F, 35 volts, radial electrolytic
 C25, C26—560 pF, ceramic disc, 5%
 C27, C28—470 pF, ceramic disc
 C29, C30—47 pF, ceramic disc, 5%
 C34—100 μ F, 16 volts, radial electrolytic
 C39, C40—2700 pF, 50 volts, Mylar or metal film, 5%

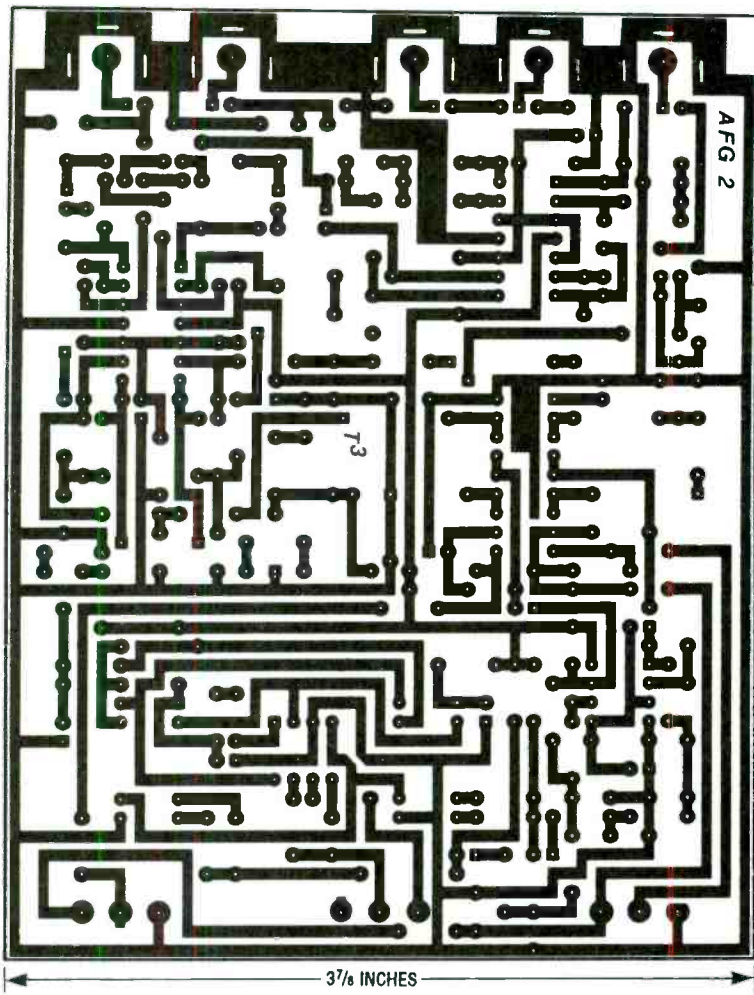

FOIL PATTERN FOR THE AFG II.

- C41, C42—2200 pF, 50 volts, Mylar or metal film, 5%
 C47—0.1 μ F, 50 volts, Mylar or metal film, 5%
 C49—0.56 μ F, 50 volts, Mylar or metal film, 5%
 C50—0.47 μ F, 50 volts, Mylar or metal film, 5%
 C51—0.039 μ F, 50 volts, Mylar or metal film, 5%
 C53—2200 μ F, 16 volts, radial electrolytic
 C55—100 pF, ceramic disc, 5%
Semiconductors
 IC1, IC7—LF347N quad op-amp
 IC2, IC4—MN3008N 2048-stage BBD (Panasonic)
 IC3—MN3101N clock generator (Panasonic)
 IC5—LF353 dual op-amp
 IC6—TDA1074 voltage-controlled amplifier
 IC8—78L12 12-volt regulator
 D1—1N4001 diode
 D2, D3—1N4148 diode
 LED1—red light-emitting diode

Other components

- S1—DPDT toggle switch
 J1—J5—PC-mount RCA jack

Miscellaneous: four 14-pin IC sockets, one 8-pin IC socket, one 18-pin IC socket, project case, knobs for R77—R79, wire, solder

Note: The following items are available from T3 Research, Inc. 5329 N. Navajo Ave., Glendale, WI.53217-5036:

- AFG II PC board only—\$12.00 + \$1.50 S&H
- Complete AFG II kit (includes all parts, PC board, and case)—\$95.00 + \$4.00 S&H
- A pair of 4096-stage MN3005 BBD's can be substituted for the MN3008's included in the standard kit—Add \$30.00 to kit price

Wisconsin residents must add 5½% sales tax to total amount before adding shipping charge.

for use with your home stereo system.

Construction

The AFG II is built entirely on one single-sided PC board. To make construction as easy and fast as possible, all of the components, including the input and output jacks, mount directly on the circuit board. Only the SURROUND SELECT switch and the power LED are mounted off the board; they are connected by short lengths of hookup wire. You can make the PC board yourself from the foil pattern provided, or you can order a finished board from the source listed in the Parts List. A complete kit of parts, including the custom case shown, is also available.

The printed-circuit board has many narrow foil paths and small pads which could be damaged by excessive heat during soldering. Use a low-wattage soldering pencil with a fine tip. And, be certain that you use rosin core solder.

The AFG II has about 150 electronic components mounted on its circuit board. To avoid errors, work slowly, and double check component values and polarity. Don't try to rush the project and build it in one night. Refer to the parts-placement diagram shown in Fig. 7, and begin construction by inserting the resistors on the circuit board first. Then, using some of the clipped resistor leads, install the six short jumpers (J) where indicated.

Two of the 14-pin IC sockets must be modified to match the unusual pin arrangement of the BBD IC's. Locate pin 1 of the socket, usually indicated by a notch or other unique indication at one corner. Referencing from pin 1, locate and carefully pry out or clip off pins 3—5 and 10—12 of both sockets. Examine the actual BBD IC if you are unsure of which pins to remove. Mount these and the remaining IC sockets next. Align pin 1 with the square-shaped pad on the circuit board. Don't install the IC's now; leave them in their protective shipping sleeve until called for later.

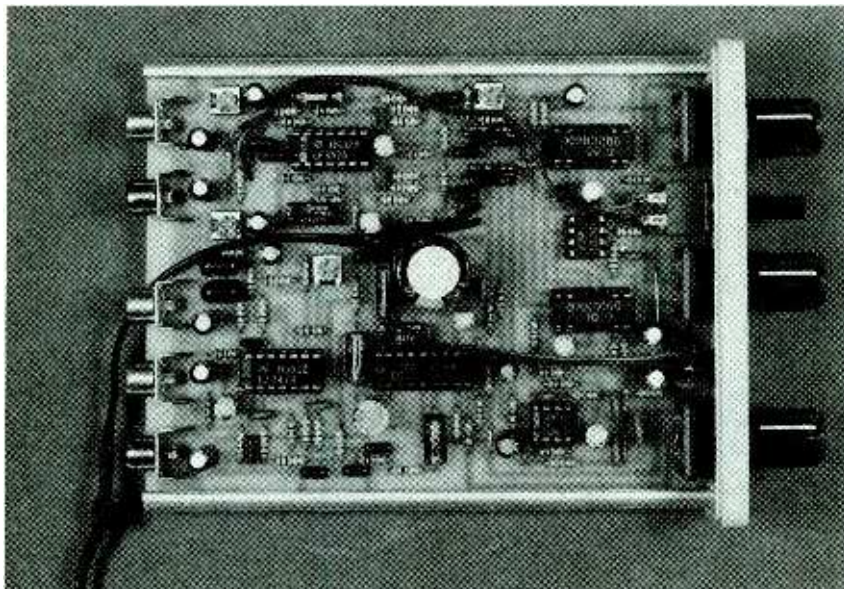

FIG. 8—Inspect the completed board for bridged foil paths and missed solder connections before you slide it into the guide rails of the case.

TABLE 1
SUBWOOFER CROSSOVER FREQUENCY

Corner Frequency	C49	C50	C51
50 Hz	.82 μ F	.68 μ F	.056 μ F
80 Hz	.56 μ F	.47 μ F	.039 μ F
100 Hz	.39 μ F	.33 μ F	.033 μ F
120 Hz	.33 μ F	.27 μ F	.027 μ F

All capacitors are 5% tolerance.

Continue by mounting the four trimmer potentiometers and the electrolytic capacitors. Match the negative lead of each capacitor to the square pad on the circuit board. Follow this by mounting the remaining disc and Mylar capacitors, then IC8, and diode D1. Finally, mount the five phono jacks (J1–J5) at the rear of the board and the three large potentiometers at the front of the board. Note: If the shafts of the potentiometers are too long for your application, cut them off *before* you mount them on the circuit board.

Use some insulated 26 to 28 AWG hook-up wire to make six jumper leads, each about five inches long. Solder these wires to the SURROUND switch and power LED first, then solder the other ends to the circuit board, being careful to match each lead to the proper pad. If you are using a wall transformer to power the AFG II, determine the polarity of its leads, and solder them to the board with the po-

larity indicated in Fig. 7. If you will be using the unit in your car, cut an appropriate length of 26 to 28 AWG hook-up wire to run between the AFG II and the power source in your vehicle. Solder the wires to the PC board first, and mark the positive lead for later reference.

All of the IC's in the AFG II are CMOS and, although they are rugged, handle them carefully to avoid ESD damage. If possible, try to keep one hand grounded while handling the IC's. Carefully place each IC in its socket as shown in Fig. 7. Make sure that none of the pins have become folded underneath the body of the IC. Figure 8 shows the inside of the completed prototype.

Setup

Use shielded patch cables to interconnect the AFG II to your audio system as shown in Fig. 1. If your auto radio does not have line-level outputs, you will need a matching transformer to go between the radio's rear speaker

outputs and the AFG II inputs. These can be purchased at electronic supply stores which sell automobile audio equipment. Connect the positive lead of the AFG II's power input to the switched power output of the radio (if present). If your radio doesn't have a switched power lead, you might have to connect directly to the car's fuse block. Connect the negative lead to ground, preferably at the same point at which the radio is grounded.

Although there are no critical adjustments in the AFG II, trimmers have been provided to calibrate the signal levels of the unit to the requirements of your particular system. Begin by setting each trimmer to the center of its range. Next, turn everything on.

If all is well, you should hear sound coming from your surround (rear) speakers. Check that the VOLUME, DELAY, and REVERB controls of the AFG II operate properly. Set the SURROUND SELECT switch to off and set the VOLUME control to about the center of its rotation. Now adjust R73 and R74 (input sensitivity) in equal amounts to get the level from the surround speakers about equal to the level from the front speakers. If you have a subwoofer in your system, adjust R76 for proper drive to the subwoofer amplifier. Potentiometer R75 adjusts the bias voltage to the bucket brigade devices; set it for minimum distortion, which is usually at the exact center of its range.

Each component in your finished audio system will probably have its own volume control. There will be one on the radio, one on an equalizer, if used, one on your power amplifier, and, of course, one on the AFG II. To get the best possible signal-to-noise ratio from the AFG II, the audio level fed into it should be at the highest possible level that does not cause any distortion. Since you will most likely want to use only the volume control on the radio to control the entire system volume, it might be necessary to perform

Continued on page 90

WATER TEMP
OIL PSI
BATTERY

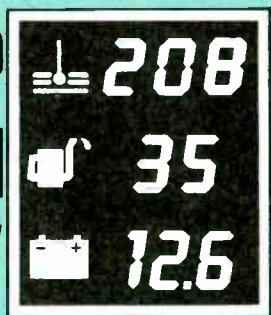

Build The

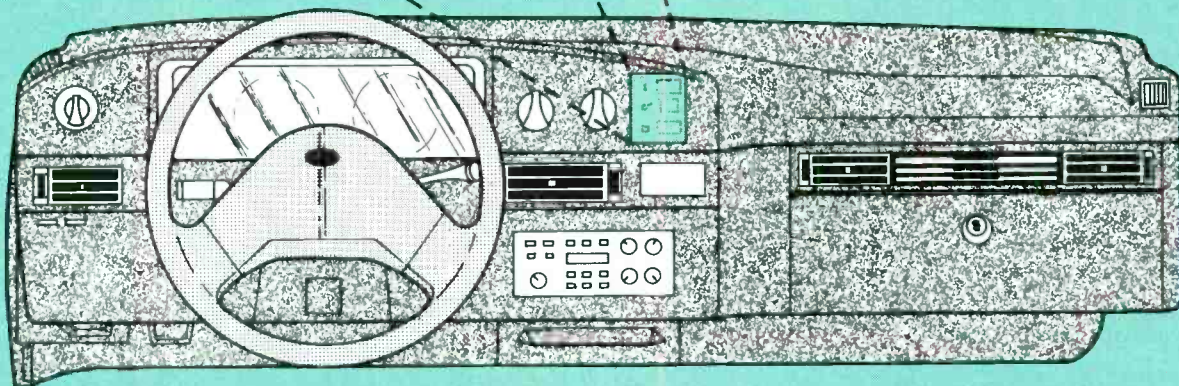

SMARTGAGE

***Build this dashboard instrument
and get precise readouts of your car's water temperature,
oil pressure, and battery voltage.***

N.J. & R.E. TUTHILL

MODERN AUTOMOBILE DASHBOARDS have a lot of warning indicator lights, but they don't give you, the driver, much meaningful information. When they light up, they tell you that there is some malfunction; some variable is outside of a vague limit. Unfortunately, when you get that warning, your engine or one of its support systems might already have been damaged. However, that cluster of lights is the only status reporting system that your car has.

Would you like a single miniature instrument on your dashboard that would give you a quantitative readout of water

temperature, oil pressure, and battery voltage—not just vague fault indications? Smartgauge, the subject of this article, does exactly that.

Smartgauge provides a digital readout of the three variables as well as an illuminated icon to indicate the nature of the fault. It supplements rather than replaces the existing instrumentation in your car. Before discussing Smartgauge in detail, it is useful to consider the accuracy of the existing status instruments in even the latest cars.

A survey of automobiles made within the last ten years reveals considerable tolerance varia-

tion in warning lights. For example, the temperature warning light of a typical General Motors car will not be illuminated until the engine has reached a temperature of between 245°F and 265°F. The tolerance of Ford car indicators was found to be similar.

The low oil pressure indicators installed by the two giant U.S. automakers are equally ineffectual. Ford cars indicate a lubrication problem when oil pressure has dropped to about 5 psi, and the warning light on GM cars turns on only when oil pressure is between 2 and 7psi. Table 1 summarizes the measurement limits for oil pressure

TABLE 1
WARNING LIGHT THRESHOLDS FOR TYPICAL AUTOMOBILES

Manufacturer	Temperature (°F)	Oil Pressure (PSI)	Model Year
Ford	239 – 251	4 – 7.5	1967 – 89
General Motors	245 – 265	2 – 7	1958 – 88
Chrysler	247 – 259	8 – 12	1962 – 82
Foreign	250 – 265	2.5 – 7.5	1962 – 85

and water temperature indicators for cars made by different manufacturers. There is no evidence to suggest that these limits have been tightened on 1992 model cars.

You could obtain more accurate readings if you installed separate electromechanical gauges, but each gauge would be larger than the multifunction Smartgauge. Moreover, aftermarket gauges are unsightly and are not compatible with the interior decor of a late-model car.

Smartgauge is a compact microcontroller-based system that can monitor and display three parameters. It has user-settable alarms that permit the driver to enter specific "safe-limit" conditions for water temperature, oil pressure, and battery voltage so they can be individually monitored. Smartgauge can be installed easily in most vehicles. Measuring only 2 × 2.5 inches, it smaller than a 1-inch stack of business cards.

How Smartgauge works

Whenever your car's ignition switch is turned on, Smartgauge beeps twice to tell you that it's in working order. First it displays all four alarm settings sequentially so that they can be checked, and then it displays the actual temperature, oil pressure and battery voltage. If a setting is exceeded, the OUT-OF-LIMIT display and annunciator flash, while the IN-LIMIT displays are blanked.

The speaker beeps ten times and then stays quiet for five minutes. During that time, the IN-LIMIT displays are unblanked, while the OUT-OF-LIMIT display continues to flash. At the end of the five-minute interval, the IN-LIMIT displays are again blanked and the speaker beeps ten more times. This cycle will continue until the alarm condition is corrected or readjusted.

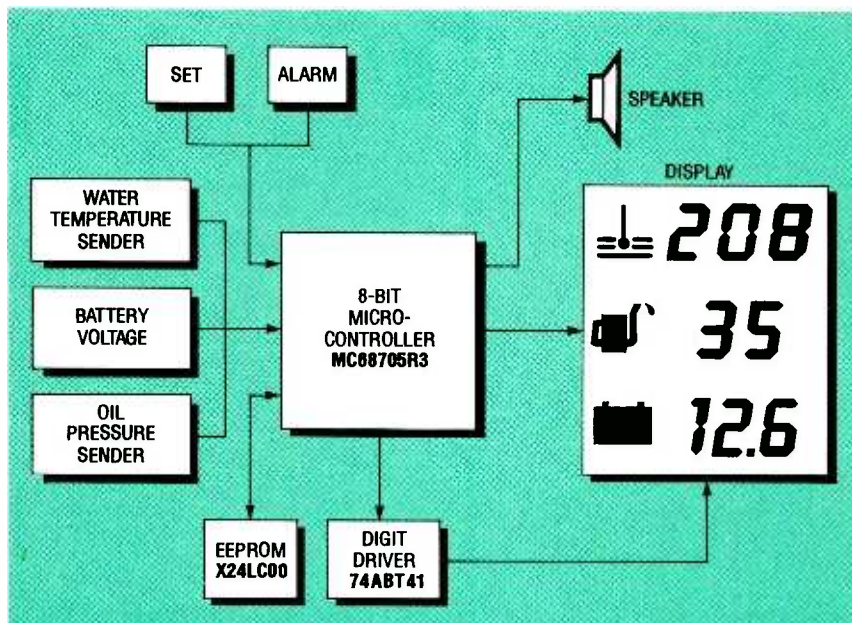

FIG. 1—SIGNALS FROM TRANSDUCERS for water temperature, battery voltage, and oil pressure are processed by the microcontroller for display and alarm.

Whenever the reading returns to an IN-LIMIT value, the alarm condition is reset automatically, and will stop the display from flashing and beeping. The highest alarm priority is given to oil pressure; next are water temperature, low-battery voltage, and finally high-battery voltage.

The alarm settings are stored in nonvolatile EEPROM, and are fetched and displayed sequentially whenever the ignition switch is turned on. Smartgauge includes a simple two-button alarm setting sequence.

Smartgauge theory

Figure 1 is a functional block diagram for Smartgauge. Input signals are supplied to the instrument from standard automotive transducers or senders available in most retail automotive parts stores. The inclusion of a software-driven microcontroller permits a low parts count. There are only four integrated circuits: voltage regulator, microcontroller, EEPROM, and display driver. The multidigit, seven-segment

LED display modules are multiplexed, a feature which further reduces circuit complexity and component count.

The functional block diagram for the Motorola MC68705R3, an 8-bit microcontroller with an

on-chip EEPROM, is given in Fig. 2. It has four eight-bit input/output ports permitting it to drive the multidigit LED display modules without external decoder IC's. Ports A, B, and C (clusters of eight pins) are programmable as either input or output lines under software control.

Figure 3 is the schematic for Smartgauge. The host vehicle's 12-volt battery provides the raw power, and the regulated 5-volt DC for the IC's is obtained from three-terminal positive voltage regulator IC1. Diodes D1 and D2 protect the circuit against negative voltages at the power input terminal, and capacitors C1 and C2 reduce noise voltages on the input and output sides of IC1.

Power is supplied to microcontroller IC3 at pin 4 (V_{CC}). Electrolytic capacitor C6 is connected to RESET pin 2. Capacitor C6 and a pull-up resistor within IC3 form a reset time-delay circuit. That time delay allows IC3's internal clock signal to stabilize before it begins program execution.

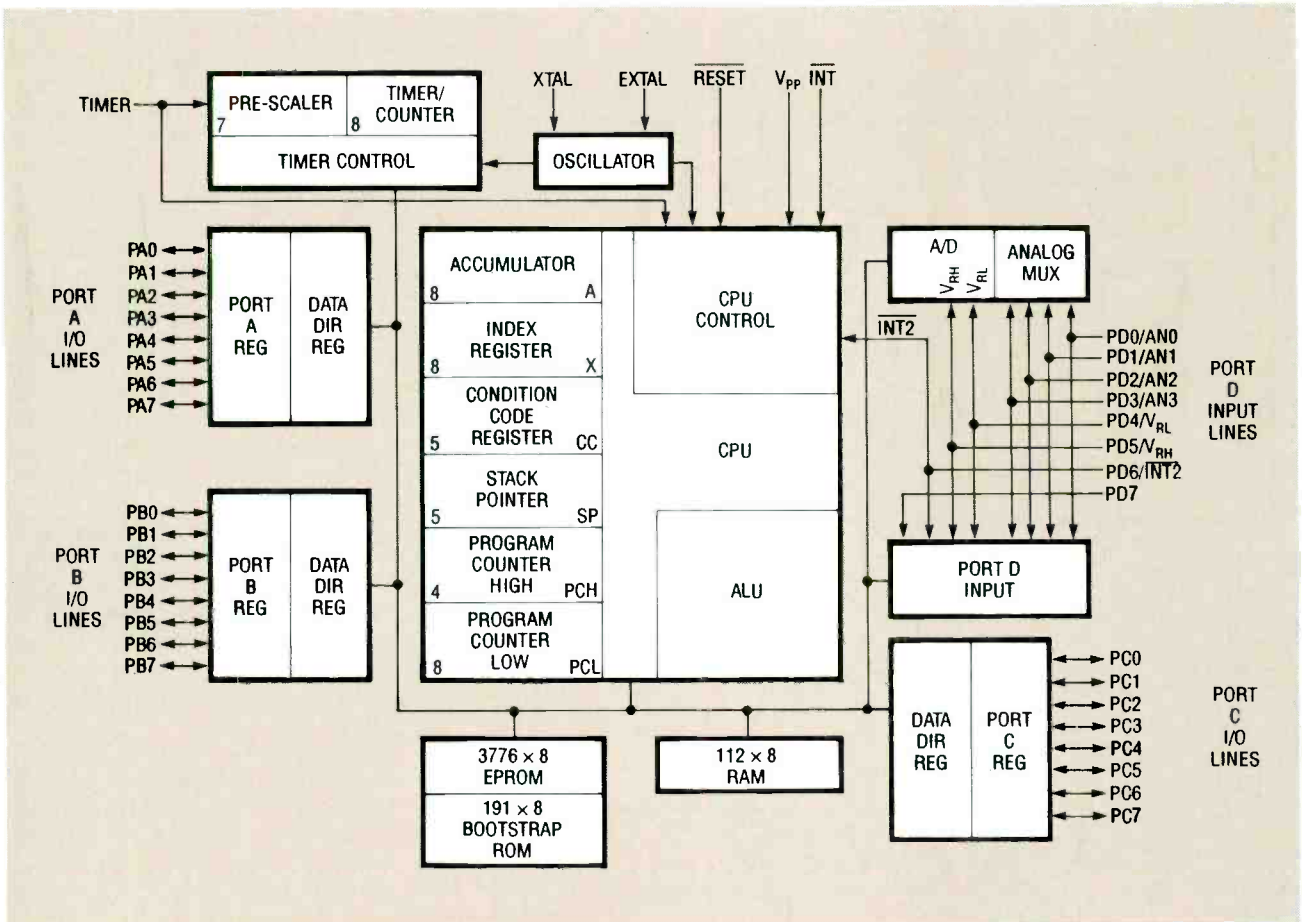

FIG. 2—BLOCK DIAGRAM OF THE MC68705R3 showing how the four ports and control pins are organized.

In Smartgage, Port B drives the segments and decimal points (a through g and d.p.) of the LED digital displays, and port C controls the anodes of the eight digits. Port A is assigned to several alarm function, and EEPROM communications tasks.

Two of the eight port A pins, PA0 (pin 33) and PA1 (pin 34), are assigned to serial data and serial clock for the EEPROM, which stores the alarm settings. Pin PA2 (pin 35) is assigned to ALARM switch S2, and PA3 (pin 36) is assigned to SET switch S1. Pin PA7 (pin 40) drives the speaker.

The port D input lines service IC3's internal analog-to-digital converter. Electrolytic capacitor C7 is connected between the two A/D converter reference voltage pins (PD4/V_{RL}) pin 20 and PD5/V_{RL}) (pin 19) to reduce any noise voltage.

Control for the on-chip clock oscillator is provided through

pin 5 (EXTAL) and pin 6 (XTAL) of IC3. A crystal resistor/capacitor combination or an external signal can be connected to these pins to provide clock pulses. Analog-to-digital conversion in IC3 is performed by successive approximation, so a crystal-controlled timebase is not necessary; an RC oscillator option was selected. A 15 K resistor between pin 6 and pin 4 (V_{CC}) provides an approximate 4-MHz clock frequency.

An important feature of the MC68705R3 for this application is its on-chip multi-channel eight bit A/D converter. It reads analog voltages and converts them to digital values. The converter processes analog input data for three inputs: battery voltage, oil pressure, and water temperature. One digital conversion is made for each analog input every 30 machine cycles.

Refer again to the schematic, Fig. 3. To initiate the alarms

connected to Port A, alarm settings must be stored when the car's ignition switch is off. Two options were considered:

- Storing alarm settings in CMOS static RAM and retaining the data in memory with the car battery as a standby power source.

- Installing an EEPROM which does not need standby power.

The CMOS SRAM was the least desirable option because data would be lost if the car battery were disconnected, as would occur if the battery were replaced. By contrast, an EEPROM is ideal because it can store alarm settings without data loss even if Smartgage is removed from the car. Whenever an alarm is set or changed, the new values are written serially to the EEPROM. Therefore, when the Smartgage is powered up, the settings are fetched and stored in the microcontroller's RAM for program execution.

The Xicor X24C00 in

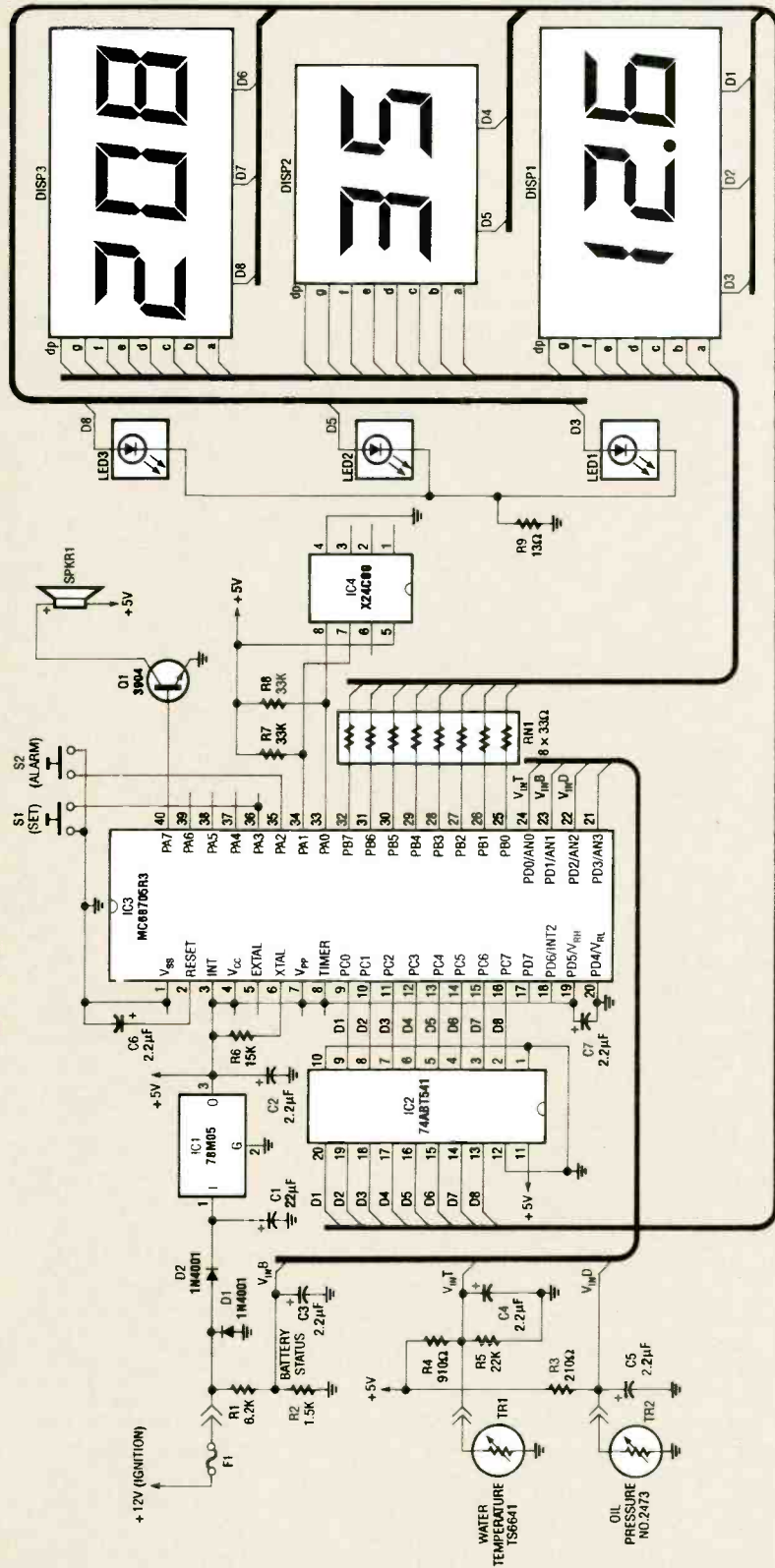

FIG. 3—SMARTGAGE SCHEMATIC. The water temperature and oil pressure senders are equivalent to variable resistors.

Smartgauge is a CMOS 128-bit serial EEPROM organized internally as 16 × 8 bits. It has a serial interface and a bidirectional bus permitting data transfer over only two wires. The microcontroller always initiates data transfer, and provides the clock pulses for both transmit and receive operations. In Smartgauge, all data transfers are done with byte reads and writes (eight bytes per operation). As stated earlier, pin 33 transfers data serially to and from EEPROM IC4, and Pin 34 (PA1) provides its serial clock signal.

The ALARM switch S1 and SET switch 2 interrupts (connected to pin 36 (PA3) and pin 35 (PA2), respectively, access the software. A more complete discussion of the alarm-setting procedure appears later in this article.

Miniature speaker SPKR1, which sounds an audible alarm, is driven by bipolar transistor Q1 from pin 40 (PA7). The transistor amplifies the alarm so that it can be heard above ambient noise within a moving car.

As stated earlier, port B pins PB0 to PB7 (pins 25 to 32) drive the segments and decimal points of the LED display modules DISP1, DISP2, and DISP3. A binary word with the desired segment-switching information is stored by IC3's software. Simultaneously, a digit enable pulse for each digit is stored in Port C—PC0 (pin 9) to PC7 (pins 16). These are labeled D1 to D8 in Fig. 3. The multiplexed switching sequence runs through all digits and then repeats itself.

Port B was assigned to switch all of the LED display segments and decimal points because it is the only port capable of sinking necessary 10-milliampere current. Resistor network RN1 contains the series current-limiting resistors needed to switch the segments and decimal points because IC3's input/output ports do not include internal resistors.

Common-anode LED display modules were selected so a worst-case current of only 80 milliamperes will still be able to

illuminate all eight segments when a number "8" is displayed. Because a current of that magnitude is not available from IC3, an octal noninverting buffer, IC2, is needed to drive the display module's anodes. The digits are time-division multiplexed by the microcontroller's program.

The annunciator light bars LED1, LED2, and LED3 are turned on sequentially to coincide with display module digits D8, D5 and D3. Thus, only the appropriate icon will be illuminated during the alarm-check, alarm-active, or alarm-setting modes.

Port D, configured as an input only port, supplies input information to the microcontroller's A/D converter. Pin 20 (PD4/V_{RL}) voltage reference low, and pin 19 (PD5/V_{RH}) voltage reference high, define the acceptable input voltage limits. Pins 21 through 24 (PD3/AN3 to PD0/AN0) are inputs for the four multiplexed channels of the A/D converter. Pin 17 (PD7) and pin 18 (PD6/INT2) are not used in Smartgage.

Pin 24 (PD0/AN0), designated V_{IN,T}, receives an analog input voltage from the temperature sender TR1 on the car's engine. The sender is an NTC (negative temperature coefficient) thermistor in a brass housing. Because the voltage across the sender is inversely proportional to temperature, a software instruction inverts that value before it is used by the program. Smartgage's temperature gauge reads from 0°F to 255°F.

Pin 23 (PD1/AN1), designated V_{IN,B}, is the battery voltage input. Battery voltage is scaled by voltage-divider R1-R2. The scale factor is approximately 5:1. Thus, a battery voltage of 13.8 volts DC is reduced to 2.7 volts DC before it reaches the A/D converter. When processed by the software program, that voltage produces an accurate voltage readout on display DISP1. Electrolytic capacitor C3 filters any AC noise present on the battery voltage input pin. The battery voltage readout has a range of 0 to 25 volts DC.

Pin 22 (PD2/AN2), designated

V_{IN,D}, is connected to the oil pressure sender TR2, a variable resistor. The signal from the oil pressure sender specified in the Parts List is directly proportional to pressure.

Software explained

Software gives Smartgage its ability to multiplex the analog-to-digital inputs, perform binary to BCD (binary-coded decimal) conversion, and do display scanning as well as alarm servicing. It also makes it possible to monitor three independent gauges with a single compact instrument.

The main program flow chart is shown in Fig. 4. The program begins at POWER-ON RESET with initialization. The alarm settings, which are stored in the

EEPROM, are fetched and written to microcontroller IC3's RAM memory. The program then multiplexes through the A/D inputs: temperature, oil pressure, and battery voltage. The analog voltages are converted to binary numbers by IC3's on-chip A/D converter and stored in the assigned memory locations.

The binary to BCD conversion subroutine is then called, and the stored binary numbers are converted to BCD. The converted numbers are then stored in a different memory location where they will be fetched by the display scanning subroutine of the program. In this section of the program, a timer interrupts to multiplex the display and update the eight digits individually and sequen-

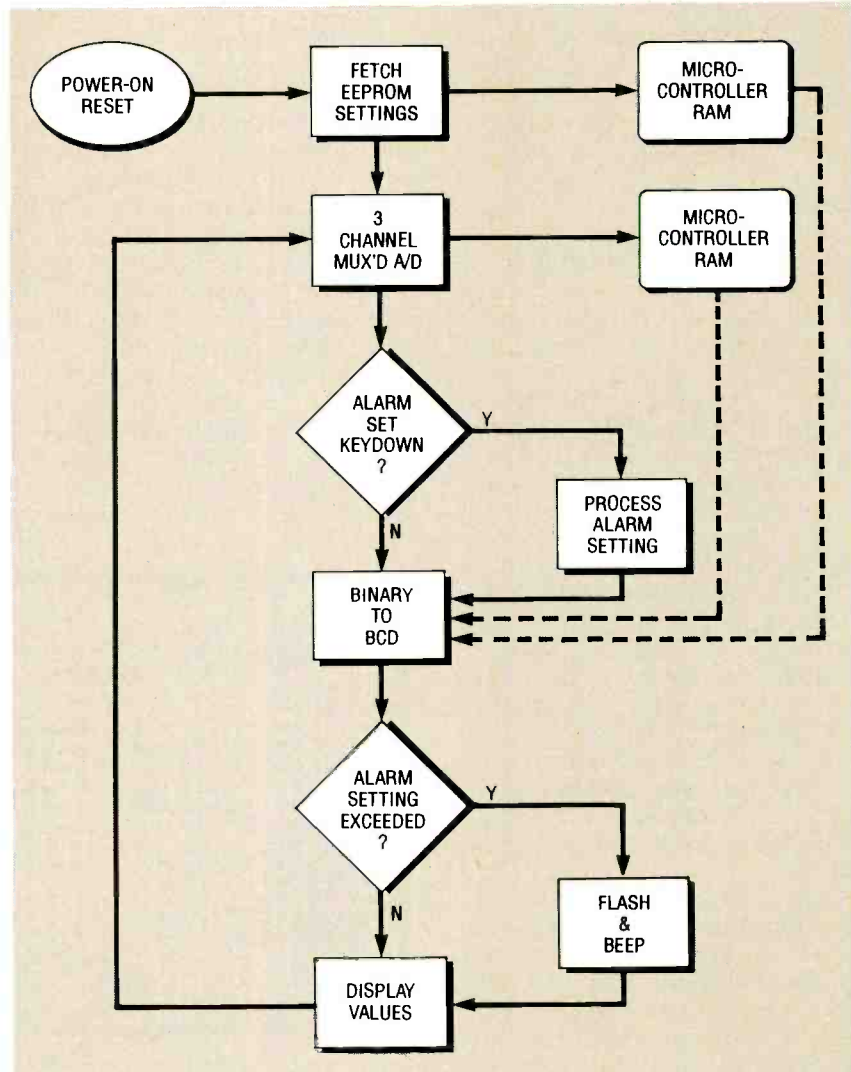

FIG. 4—MAIN PROGRAM FLOWCHART FOR SMARTGAGE showing the decision loops.

tially with new segment data about every 1.6 milliseconds. (The entire display is updated every 13 milliseconds.)

Alarm switch S2 is checked regularly during program execution to determine if an alarm setting condition has been set. If it has, the alarm setting subroutine is called. If any settings are changed, EEPROM IC4 is updated with the new values when the program exits the subroutine. The alarm settings that are fetched from IC4 at the start of the program are constantly compared with the values read from the sender to determine if an alarm condition has occurred.

The Smartgag firmware in the Motorola 5-record format is available from the address given in the Parts List or from the R-E BBS (526-293-3000; 1200/2400 baud 8, N, I as SMRTGAGE.519). If an EEPROM other than the one specified in the Parts List is substituted, it might not work correctly in this application.

Building Smartgag

Smartgag is built on two 2 × 2.5-inch single-sided printed circuit boards: a display board and a microcontroller board. Printed circuit board artwork is provided for both boards if you want to make them. However, they can be purchased from the source given in the Parts List.

The completed display board shown in the photograph, Fig. 5, contains the three LED multidigit display modules, three LED icon light bars, resistor R7, and the SET and ALARM switches, S1 and S2. Refer to the display board parts placement diagram Fig. 6. Position the display board with its foil side up on the benchtop, and position a 10-pin header (P1 or P2) so that the longer pins are directed downwards as shown in Fig. 7.

Carefully align the ends of the pins with the matching holes in the circuit board, and inset until the ends penetrate the board thickness and are flush with the surface on the component side. Repeat this step for the second header. Now reverse the board and solder the two end pins of

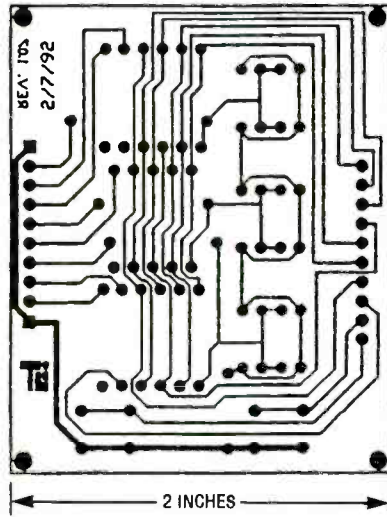

FOIL PATTERN FOR DISPLAY BOARD.

each header with a low-heat soldering pencil. Then solder the rest of the pins carefully, making sure that molten solder does not short any pins.

Before inserting any more components on the display board, position the board with its component side up and insert three fine bare wires J1, J2, and J3, as shown in Fig. 6 and solder them in place. (The jumper wires must be flush with the surface of the board because the solder flux cleaning gap under the modules limits the diameter of the jumper if the modules are to seat flush with the board.) Then insert the rest of the components, making sure that they are all mounted flush against the board surface

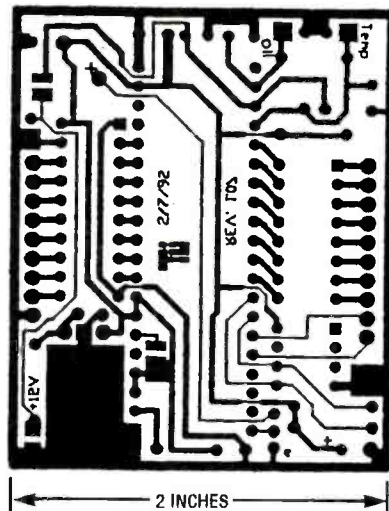

FOIL PATTERN FOR MICROCONTROLLER BOARD.

before soldering them in place.

Figure 8 is photograph of the completed microcontroller board. Refer to parts placement diagram Fig. 9 for the installation of components on that board. Start by soldering the surface-mount resistors (SMT) R1, R2, and R6 on the foil side of the board first. (Use fine tweezers to hold the chip resistors in place while you solder them). Use a low-heat soldering pencil with a fine tip and fine gauge solder wire. Only a small amount of solder is needed on each end of the chip resistors.

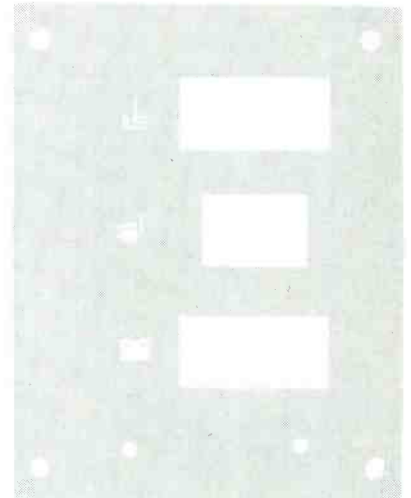

DISPLAY MASK showing the three icons and windows for LED display modules.

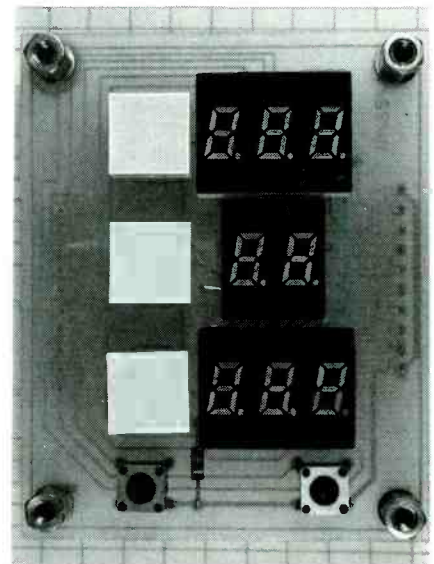
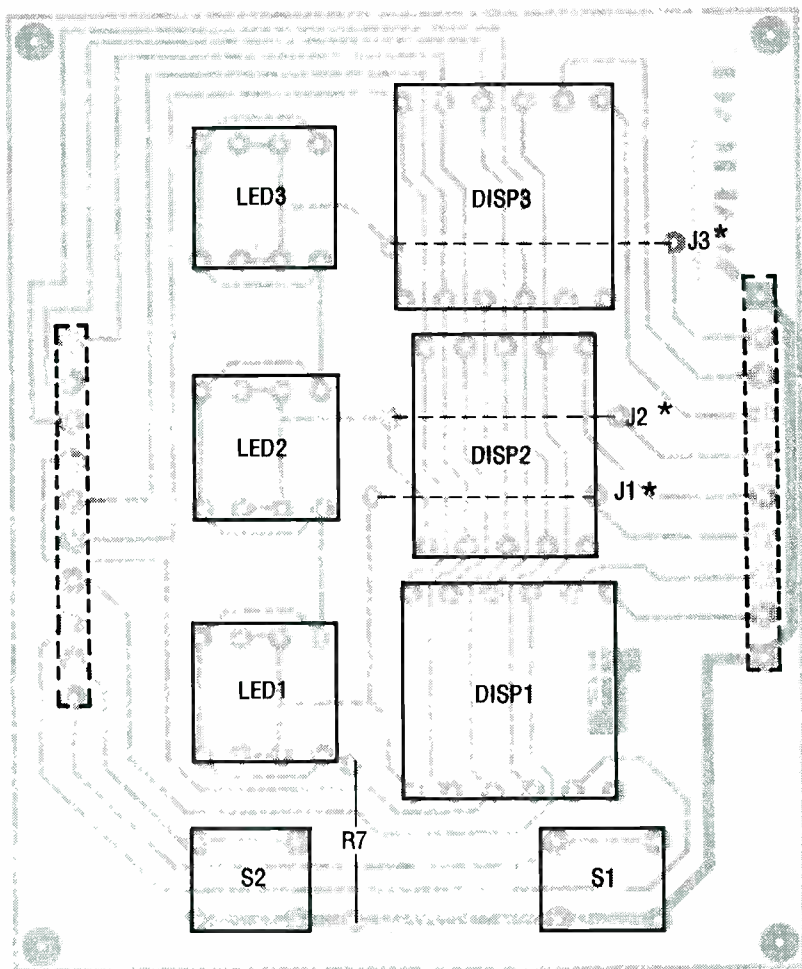

FIG. 5—DISPLAY CIRCUIT BOARD showing the three seven-segment LED display modules and three LED light bars (white squares at left).



* BARE WIRES ON COMPONENT SIDE

FIG. 6—PARTS PLACEMENT DIAGRAM for the display board.

Turn the board over, and insert the axial-leaded resistors and diodes first, making sure that each diode's polarity markings are observed. Next, insert the radial-leaded capacitors and transistor, making sure that their pins are oriented correctly before soldering all parts to the circuit board. Be sure that all of the parts on the component side of the board are installed so that highest surfaces are less than $\frac{3}{8}$ -inch above the board. Note: Figure 8 shows the three radial-leaded tantalum dipped resistors that were in the prototype, but these are replaced by the miniature aluminum electrolytic capacitors listed in the Parts List.

Insert voltage regulator IC1 so its three pins are positioned in

the correct holes in the board and its heat sink is flush with the board. Fasten the sink to the board with a No. 4-40 machine screw, lock washer, and nut through the punched holes in both sink and board. Insert IC2 and IC4 and resistor network RN1, observing their pin 1 positions. Solder all pins.

Insert and solder speaker SPKR1 last. For correct phasing and maximum speaker volume, observe the correct polarity. The plus indicator on the bottom of the speaker should be connected to Q1's collector—not to +5 volts. Finally, insert microcontroller IC3 in its socket. Carefully examine the completed circuit board for solder shorts, and check to see that all components have been in-

stalled correctly.

Cut a length of colored 0.050-pitch flat ribbon cable with 28 AWG conductors long enough to extend from the intended location of Smartgage on your dashboard, through the firewall to the senders on your car's engine block. With a razor knife, carefully slit the end of the cable to remove a ribbon of four connected conductors. (The colors selected are not important as long as you make note of the color of each wire and its intended function.)

In the prototype, a yellow wire was selected for water temperature, an orange wire for oil pressure, a red wire for 12-volt DC source, and brown wire for ground. This code is used in the remainder of this article and in all figures.

Strip both ends of all wires

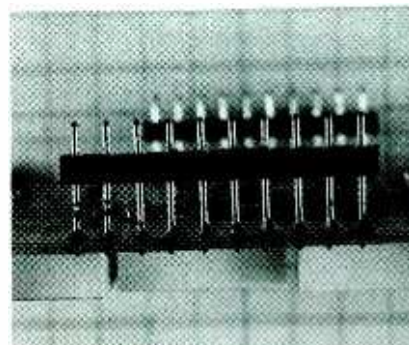

FIG. 7—TEN-PIN HEADERS ARE INSERTED so longer pins enter the foil side and are flush with the component side of the display board.

approximately $\frac{1}{4}$ -inch, and wrap the yellow, orange, and red wire ends around projecting leads at the locations shown in Fig. 9, and solder them in position. The brown ground wire can be secured to the board by loosening the bolt and nut on the heat sink of voltage regulator IC1, wrapping the bare end of the wire around the screw, and tightening the screw. Now trim any excess lead lengths.

A fuse holder with fuse should be inserted in the red wire between the microcontroller board and the battery power source. This can be done by carefully splitting out the red

wire at a convenient distance from the Smartgag (so it is out of sight under the dashboard in the final installation). Cut the red wire and splice in the fuse holder.

Set a DC power source between 12 and 15 volts DC, and connect test leads terminated with miniclips to the ends to the supply's output terminals. With the power supply off, attach the black miniclip (negative power supply lead) to the anode of diode D1 and the red miniclip (positive power supply lead) to

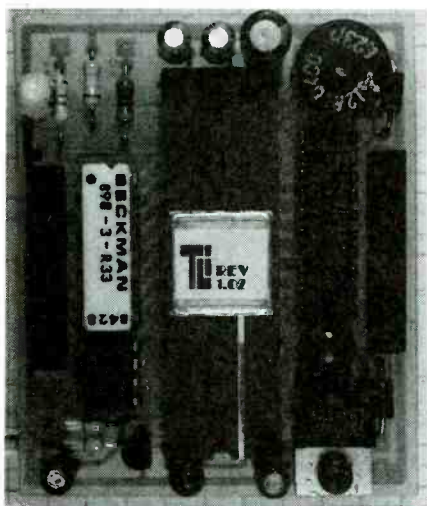

FIG. 8—MICROCONTROLLER CIRCUIT board with the microcontroller at center, and clockwise from the top, speaker, logic IC, voltage regulator, EEPROM memory, and resistor network

the cathode of D1. Now turn on the power supply, and adjust current to the 100- to 150-milliampere range. Voltage regulator IC1 should produce an output voltage of +5 volts DC \pm 10%.

If the circuitry is operating properly, after about a 10-second waiting period, the speaker will emit two short beeps. Approximately five seconds later ten beeps will be heard. If this test has been passed successfully, the two boards can now be connected.

Refer to exploded view Fig. 9. Position both boards component side up as shown with SET switch S1 on the display board above voltage regulator IC1 on the microcontroller board. Insert both sets of header pins into the matching holes on the microcontroller board. Be sure

PARTS LIST

Resistors (all are 1/4-watt, 5%, axial lead unless specified as surface-mount (SMT) or 1%)
 R1—6200 ohms, SMT
 R2—1500 ohms
 R3—210 ohms, 1%
 R4—910 ohms
 R5—22000 ohms
 R6—15000 ohms, SMT
 R7—13 ohms
 RN1—resistor network, eight 33 ohm-resistors, DIP package, (Beckman) 898-3-R33 or equivalent

Capacitors
 C1—22 μ F, 25-volt, electrolytic
 C2, C3, C4, C5, C6, C7, C8—2.2 μ F, 25 volt, electrolytic

Semiconductors
 IC1—MC78M05, 3-terminal voltage regulator (Motorola) or equivalent
 IC2—74ABT541, or 74ALS541, octal non-inverting buffer (Signetics) or equivalent
 IC3—MC68705R3, 8-bit microcontroller (Motorola) (See text)
 IC4—X24C00 serial EEPROM (Xicor) or equivalent
 Q1—2N3904, NPN transistor
 D1, D2—1N4001, diode
 DISP1, DISP3—three-digit LED 7-segment display module, (with decimal points), red, 0.3-inch character height, (Rohm) LB203VB, common anode, or equivalent
 DISP2—two-digit LED 7-segment display module, (with decimal points), red, 0.3-inch character height, (Rohm) LB202VB, common anode, or equivalent
 LED1, LED2, LED3—LED light bar, red, 10 mm \times 10 mm, (Hewlett Packard) HLMP 2655 or equivalent

Other components
 TR1—water temperature sender (Napa/Echlin) No. TS6641 or equivalent
 TR2—oil pressure sender (General Automotive Specialty Co.) No. 2473 or equivalent

SPK1—speaker, 7/16-inch diameter, Matsushita 12RT04CC or equivalent
S1, S2—pushbutton, miniature, NO. PC board mounting, Omron 83FNY7E or equivalent
P1, P2—10-pin header (0.1-inch spacing, 0.6-inch total pin length)
SO1, SO2—10-pin SIP edge connector (0.1-inch spacing)
Miscellaneous: display PC board, main PC board, 40-pin IC socket, plastic filter, red (see text), annunciator artwork film negative, 1-ampere fuse, in-line fuse holder, four 1/2 \times 4-40 machine screws with lockwashers and nuts, one 1/4 \times 4-40 machine screw, nut and lockwasher, four 1/4-inch stand-offs, two automotive sender tee fittings (see text), insulated hookup wire, length of four-wire colored ribbon cable (see text), solder, enclosure (optional), crimp-type spade lugs.

NOTE: The following parts are available from TLI, P.O. 2082, Corvallis, OR97339-2082 (503) 753-6723:

- A set of two etched and drilled printed-circuit boards—\$12.50
- A set of three Rohm LED display modules—\$15.00
- Motorola MC68705R3 microcontroller programmed with Smartgag code—\$24.95
- A kit containing all of the parts listed in the parts list except the water temperature and oil pressure senders and tee fittings—\$89.95
- A completely assembled and tested Smartgag (not including temperature and pressure transducers and tee fittings)—\$139.95

Please add \$3.50 for shipping and handling to all orders.

there is at least a 1/4-inch gap between the bottom of the display board and the top surface of any component on the microcontroller board. Solder all header pins on the foil side of the microcontroller board.

Cut an approximate 2 5/8 \times 2 1/2

inch rectangle from a sheet of red transparent plastic plastic about 0.080-inch thick. Carefully drill a 3/32-inch hole in each of the four corners to align with those in the corners of the display board. (You might also want to countersink the holes

so the four mounting screws can be inset). Then drill two 1/8-inch holes in the plastic at locations directly over the centers of switched S1 and S2. These will provide access for switch actuation with a paper clip or other fine wire.

Make a high-contrast photographic negative from the display mask artwork provided. (Most local photo shops will perform do this for you.) Trim the completed mask, punch four 1/8-inch holes in the corners to align with those of the filter, and punch two more holes to align with the access holes over switches S1 and S2.

Place the red filter over the mask as shown in Fig. 10. (The icons are over the LED light bars and the open frames are over the LED display modules.) Then carefully assemble the mask and filter to the display board as shown in Fig. 10 with 1/4-inch standoffs, screws, and lock washers. Before tightening the screws, carefully align the mask over the display modules and light bars.

Installation

Smartgauge can now be installed in your car. Select a location on your dashboard where the front face of the readout will be shielded from direct sunlight, or consider making a hood for it, perhaps as part of the packaging. (LED displays are difficult to read in direct sunlight.) The unit can be mounted directly to the dashboard or placed in any suitable enclosure. The way the instrument is packaged and mounted to the car dashboard is left to the discretion of the builder. If the instrument is to be enclosed in a case, be sure to leave adequate openings in the case for internal cooling.

Connect the end of red wire with the in-line fuse holder and fuse from the +12 volt DC pad on the microcontroller board to any point in the automobile's electrical system that is energized by the car's ignition switch. Then connect the brown wire between the ground pad and the automobile's chassis ground.

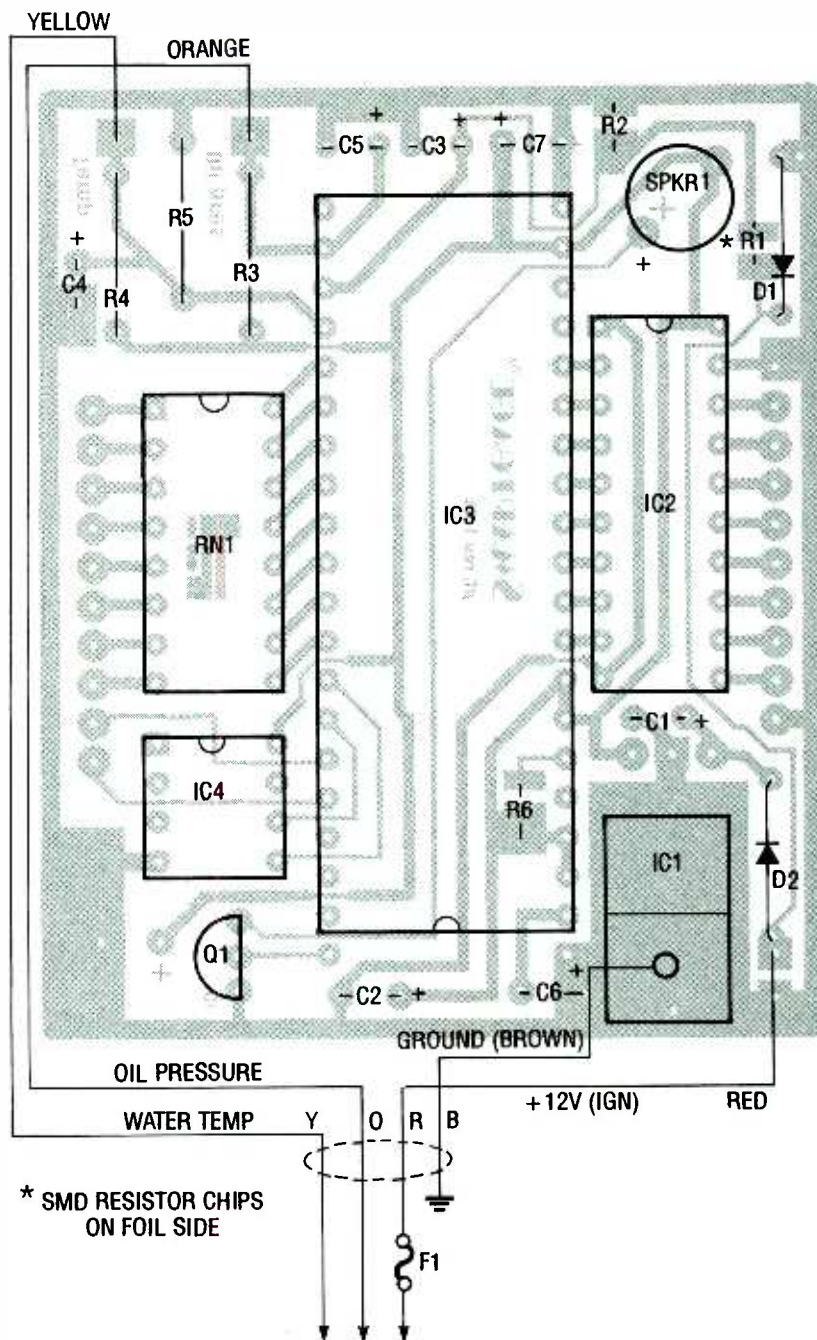

FIG. 9—PARTS PLACEMENT DIAGRAM for the microcontroller board.

It is recommended that the existing water temperature and oil pressure sensors that are connected to your car's temperature and pressure indicator lights be removed and remounted on brass "tees." This will give your car redundant backup warnings. (Brass sender tees are standard items that can be purchased in retail automotive parts stores.) Install the water temperature sender (TR1) and oil pressure transducer

(TR2) on the appropriate tees in parallel at the correct locations on the engine block of your car.

Run the paired yellow and orange wires through the firewall of your car at the nearest convenient location. Depress the rubber grommet and carefully thread the wire through. Secure the wires to the existing cable harness in the engine compartment with tie wraps so they will not contact any hot engine parts. Crimp spade lugs on the

Few gifts
actually
improve
with age.
Your bank
sells one
of them.



You can count on one hand
the gifts that actually get
better as they get older.
There's only one, though, you
can buy at your bank:
a U.S. Savings Bond.
Visit your bank for the gift
that improves with age:
a U.S. Savings Bond.
For more information, write:
Office of Public Affairs,
U.S. Savings Bonds Division,
Washington, DC 20226.



A public service of this magazine

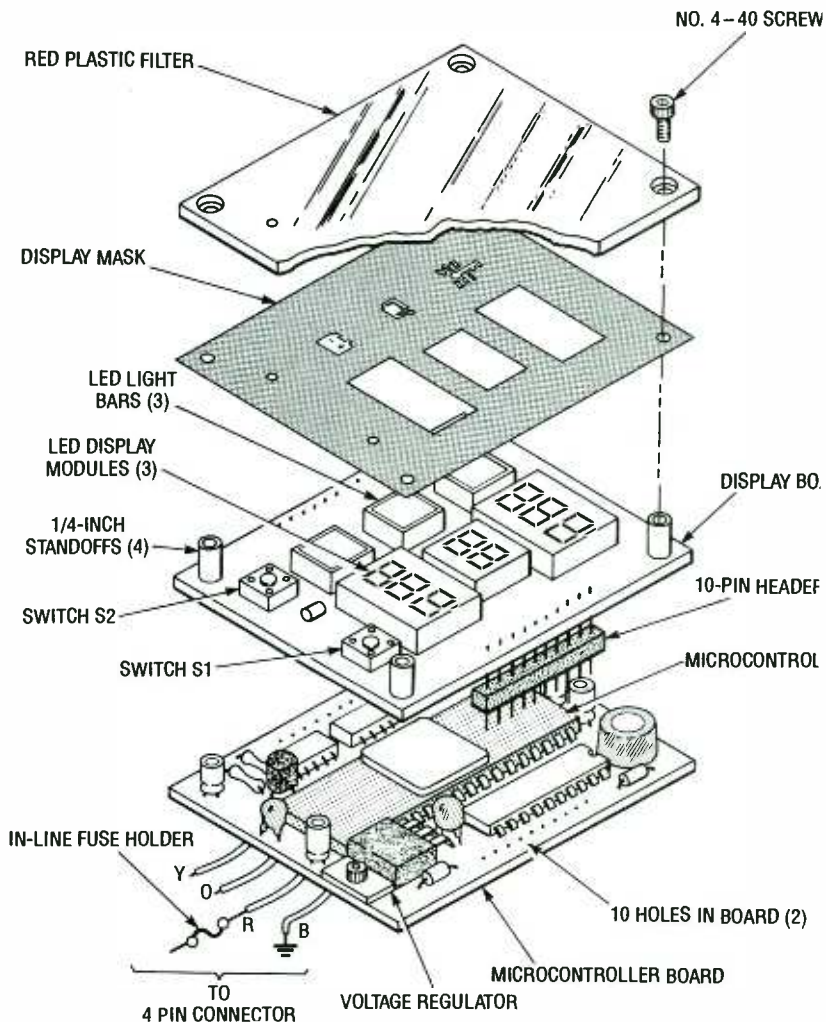

FIG. 10—EXPLODED VIEW OF SMARTGAUGE assembly. The assembled unit can be housed in a plastic box

wire ends and fasten them to the sensors TR1 and TR2.

Operation

With Smartgauge installed, the alarms can be set and the system will be ready for operation. After carefully checking the wiring, turn the your car's ignition switch ON. The speaker should beep twice, and then sequence through it's alarm check routine. After a ten-second delay, assuming that no alarm condition exists, the gauge will display all three readings.

To set the alarms, press the ALARM switch S2 (left side) with a wire through the front filter, and hold it down as the display sequences through the existing alarm settings. The temperature alarm setting is displayed first, then the oil pressure setting is displayed, followed by low battery, and high battery.

Release the ALARM switch when the alarm being set is displayed, and then press the SET switch S1 until the display is incremented to the desired setting. Release the SET switch and again push the ALARM switch to increment the display.

Each time the display returns to the actual readings, the EEPROM is updated with the new alarm settings. When the temperature alarm display reaches 255 (25.5 for both battery settings) or oil pressure is indicated as 55, the display will reset to 000. (Oil pressure must be cycled twice before resetting because the "1" or "2" most significant digit (MSD) is not displayed).

Smartgauge will also reset to internally programmed default settings when both the ALARM and SET switches are pressed simultaneously. Ω

A DIGITAL VOLTMETER, OR DVM, IS probably the first test instrument that most electronics enthusiasts buy, because it's a necessary instrument. Moreover, they don't cost much these days. However, one voltmeter is often not enough; a second voltmeter, allowing simultaneous measurements, is always handy.

Our DVM project fills the need for a second voltmeter that can be made at low cost. But, although our DVM is inexpensive to build, it has a full 4½-digit display. That allows measurement resolution of 10 microvolts on its most sensitive range, which is not possible with 3½-digit meters.

The input resistance of the voltmeter is about 11 megohms, which is comparable to that of commercial DVM's. Calibration of the instrument is very easy; it's accomplished by adjusting a single potentiometer.

An additional feature of this DVM is a continuity function that allows the instrument to locate opens or shorts in circuit wiring. Continuity is indicated not only by a CONTINUITY flag on the display, but also by the digital readout which gives an approximate indication of the resistance between the test leads. Also, an audio tone is automatically generated when the test leads are placed across a conductive path.

The circuit is relatively simple, containing just one IC and a handful of other components. There are four DC voltage ranges: 200 millivolts, 2 volts, 20 volts, and 200 volts full scale. The current draw by the circuit is only 1 milliamp from a 9-volt battery, which permits several hundred hours of operation from a fresh alkaline battery. A LOW BATTERY indicator is automatically energized when the battery nears the end of its useful life.

The circuit

The heart of this digital voltmeter is IC1, a Maxim ICL7129A 4½-digit A/D converter with LCD driver (see the schematic diagram in Fig. 1). The chip has a ±20,000-count resolution,

BUILD THIS SINGLE CHIP DVM



A 4½-digit voltmeter is usually pretty expensive—but it doesn't have to be when you build it yourself!

ANTHONY J. CARISTI

features high input impedance, and auto polarity indication. Only one active external component is required for voltage measurement: D1, a Harris 1.2-volt bandgap reference.

Power to IC1 is provided by 9-volt battery B1 that is connected to pins 23 and 24 of IC1 through power switch S1. The battery also drives the external reference voltage circuit composed of R6–R9 and D1. About 1.2 volts is developed across D1, and potentiometer R8 is adjusted during instrument calibration so that the voltage differential between pins 34 and 35 is set to 1 volt.

The dual-slope conversion technique of IC1 requires an oscillator circuit; in this DVM it's a 120-kHz crystal, XTAL1, and its associated components. A 120-kHz crystal allows maximum normal-mode rejection at 60 hertz, the standard U.S. power-line frequency. For countries where 50-hertz power-line frequencies are common, a 100-kHz crystal should be used.

The DVM chip, IC1, is designed to accommodate an RC oscillator instead of a crystal, as shown in Fig. 2. However, for 10-microvolt resolution, provided by the DVM's most sensitive range, a crystal oscillator is recommended.

The input voltage to IC1 is fed to pins 32 and 33. The test leads of the instrument, connected to J1 and J2, drive a voltage divider composed of R1–R4. The values of those resistors are chosen so that each step of RANGE switch S2-a results in a 10:1 reduction in the voltage presented to pin 33 of IC1. Components R11 and C5 form a low-pass filter to attenuate any noise or AC component appearing across J1 and J2. That helps by providing a more stable DC voltage reading.

Pin 37 of IC1, the digital input control terminal, sets the full-scale sensitivity of the A/D converter. When pin 37 of IC1 is connected to pin 36, digital common, the full-scale sensitivity is 200 millivolts. With a high-level logic input at pin 37, full-scale sensitivity is 2 volts. Switches S2-a and S2-b allow

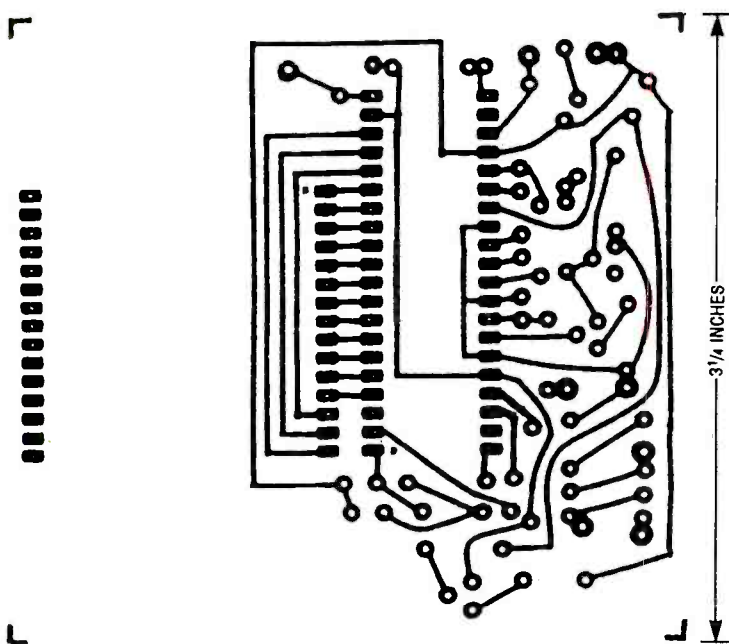

FOIL PATTERN for the DVM circuit.

PARTS LIST

All resistors are 1/4-watt, 5%, unless noted otherwise.

- R1—10 megohms, 1% metal-film
- R2—1 megohm, 1% metal-film
- R3—110,000 ohms, 1% metal-film
- R4—1100 ohms
- R5—270,000 ohms (crystal oscillator circuit only)
- R6, R7—5110 ohms, 1% metal-film
- R8—10,000 ohms, PC-mount potentiometer
- R9—10,000 ohms, 1% metal-film
- R10—22,000 ohms
- R11—100,000 ohms
- R12—150,000 ohms
- R13—470,000 ohms
- R14, R15—47,000 ohms
- R16—75,000 ohms (RC oscillator circuit only)

Capacitors

- C1—10 μ F, 16-volts, axial electrolytic
- C2—5 pF, 50-volts, ceramic disc (crystal oscillator circuit only)
- C3—10 pF, 50 volts, ceramic disc (crystal oscillator circuit only)
- C4—4.7 μ F, 10 volts, axial electrolytic
- C5—0.01 μ F, 50 volts, ceramic disc
- C6—1 μ F, 10 volts, radial electrolytic
- C7—51 pF, 50 volts, ceramic disc (RC oscillator circuit only)

Semiconductors

- IC1—ICL7129ACPL A/D converter/LCD driver (Maxim)

- D1—ICL8069CCZR 1.2-volt band-gap reference (Harris Semiconductor)

- Q1—BS170 FET transistor

Other components

- S1—SPST slide or toggle switch
- S2—3P4T non-shorting rotary switch
- S3—DPDT slide or toggle switch
- DISP1—353R3R03GHZ1 4½-digit triplexed LCD module (LXD)
- BZ1—piezo buzzer (Radio Shack 273-074 or equivalent)
- J1, J2—Banana jacks (1 red, 1 black)
- B1—9-volt battery
- XTAL1—120-kHz crystal (for crystal oscillator circuit only)

Miscellaneous: Test leads with banana plugs, 9-volt battery connector and mounting clip, enclosure, wire, 1.5-volt test battery, test voltmeter for calibration

Note: The following parts are available from A. Caristi, 69 White Pond Road, Waldwick, NJ 07463:

- Etched and drilled PC board—\$12.75
- IC1—\$25.50
- D1—\$3.75
- DISP1—\$24.95
- Set of six 1% metal-film resistors—\$6.25
- Q1—\$2.25

Please add \$4.00 postage and handling.

minals are used for the tri-multiplexing scheme. (Ordinary LCD displays contain just one backplane terminal.)

The segments of the display are in three groups, each controlled by its own backplane square-wave voltage. Driver IC1 generates the backplane signals that cause the appropriate elements of the display to be activated in sequence. The process takes place at such high speeds that all three sections of the display appear to have constant illumination. The LOW BATTERY indicator of the display is automatically energized when the supply voltage between pins 23 and 24 of IC1 falls below 7.2 volts.

Construction

The voltmeter circuit is constructed on a single-sided PC board. We've provided a foil pattern if you wish to make your own. However, the circuit layout is not critical, so it can be hard-wired on perforated construction board.

Figure 3 is the parts-placement diagram. Be sure to use a socket for IC1—it is well worth the slight additional cost, and permits easy IC removal should that ever be necessary. Do not insert the IC in its socket at this time.

Be sure to use the specified 1% metal-film resistors for R1, R2, and R3; the accuracy and stability of the voltmeter depend on the accuracy and stability of their values. Ordinary carbon resistors are temperature-sensitive and should not be used in this DVM.

Although a crystal oscillator is preferred, the alternate RC oscillator circuit (shown in Fig. 2) can be accommodated on the PC board using the extra pad on pin 2 of IC1. The existing pads on pins 1 and 40 can be used to mount R16 and C7 of the RC oscillator circuit.

The bandgap reference, D1, is packaged in a three-terminal transistor package. Only two of the terminals are active—the third is unused. Position it on the board as shown in Fig. 3.

The LCD module is packaged like an IC with 15 pins on each

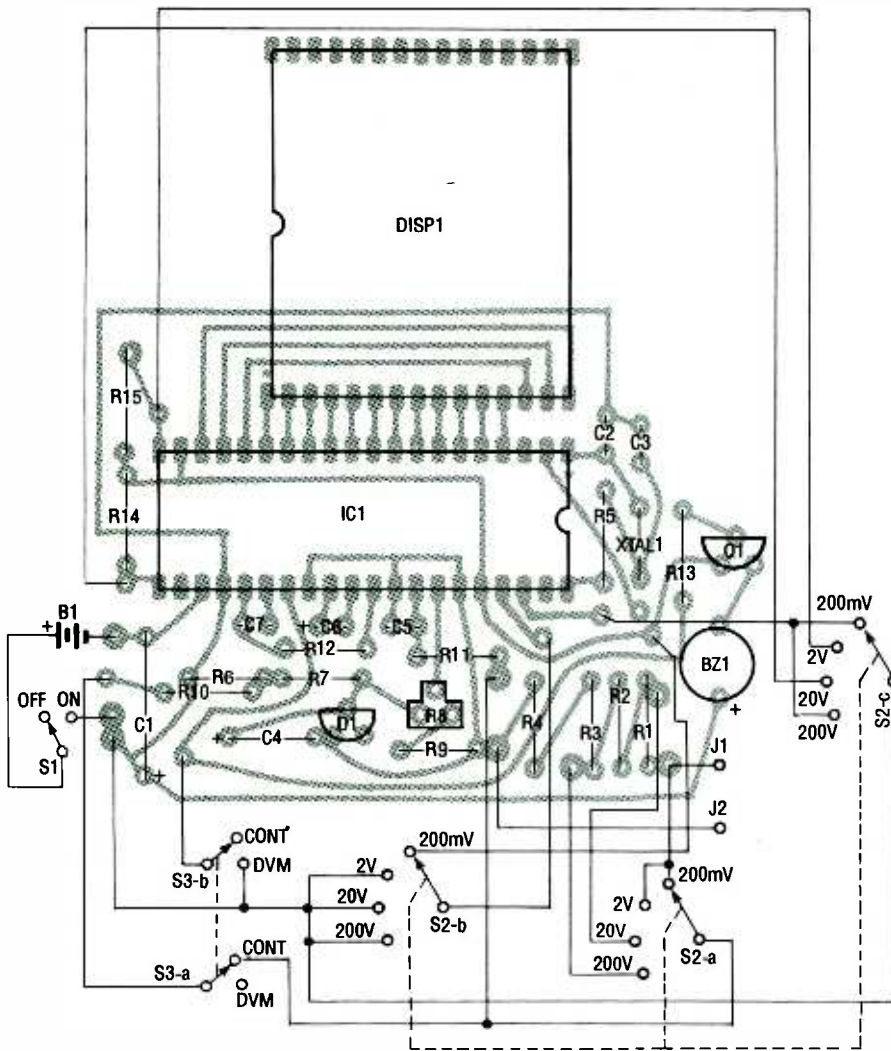

FIG. 3—PARTS-PLACEMENT DIAGRAM. Install a socket for IC1, and make two 15-pin SIP sockets for the LCD module from a 40-pin DIP socket.

side. However, only pins 1–15 (the row near the decimal points) are active. The other row of pins is used only for mounting. The module, which is fragile, can be directly soldered onto the PC board, but it is recommended that you make a socket for it by carefully cutting apart a 40-pin DIP socket to form two 15-pin SIP sockets. Note that the module is brittle, and can be fractured if excessive force is used during handling.

All of the switches and jacks are connected to the PC board with appropriate lengths of insulated wire. Refer to the Parts-Placement diagram as a wiring guide. Be sure to use stranded 24- or 26-AWG wire, as solid wire has a propensity to break. Make the connections to S2 first. Note that S2 has three

poles with four contacts each. Observe which pole terminal of the switch belongs to which set of four contacts. If you're in doubt, check with an ohmmeter to be sure. A wiring error here will require a lot of troubleshooting later. Next, make the connections to S1 and S2. Finally, install the 9-volt battery connector, observing proper polarity.

When the PC board is completely assembled, examine it thoroughly for opens, shorts, and cold solder joints before proceeding with the checkout.

Checkout procedure

The calibration of the instrument requires a DC voltmeter with an input resistance of at least 10 megohms. A 1.5-volt battery will be handy as a volt-

age source to calibrate the circuit. Prepare a set of test leads consisting of two banana plugs and lengths of red and black flexible wire. Insert the plugs into jacks J1 and J2, and short the ends of the wires together. Set FUNCTION switch S3 to "DVM" and RANGE switch S2 to 200 millivolts. Insert a fresh battery to power the DVM, and turn S1 on.

The normal display should be 00.00. The reading might flicker between 00.00 and 00.01. Rotate the range switch to the other three positions. A normal indication is .0000, 0.000, and 00.00 for the 2-, 20-, and 200-volt ranges, respectively. Again, the least significant digit might flicker between 0 and 1. The minus sign might appear intermittently.

If the display does not operate as described, troubleshoot the problem before proceeding. If the display is totally blank, measure the terminal voltage of the battery across C1 to be sure that it is delivering at least 7 volts to the circuit and the polarity is correct. Verify that IC1, C1, and D1 are properly oriented in the board. Also check all electrolytic capacitors to be sure they are installed correctly. Examine the board for any open circuits or short circuits. Resolder any solder joints that don't appear smooth and bright.

To verify that the oscillator circuit is operating, examine the wave shape at pin 40 of IC1 with an oscilloscope, using digital ground (pin 36) as the reference. A normal indication is a 5-volt peak-to-peak square wave at a frequency of about 120 kHz.

If the oscillator waveform is absent, check XTAL1 and its associated components. If a substitute crystal is not available, XTAL1, C2, C3, and R5 can be temporarily removed from the board and replaced with the RC oscillator circuit of Fig. 2. That will verify that the on-chip oscillator circuit within IC1 is operating correctly.

If the only problems are with the decimal-point display, check the wiring between S2-c and pin 38 of IC1. If the circuit seems to be working, but some

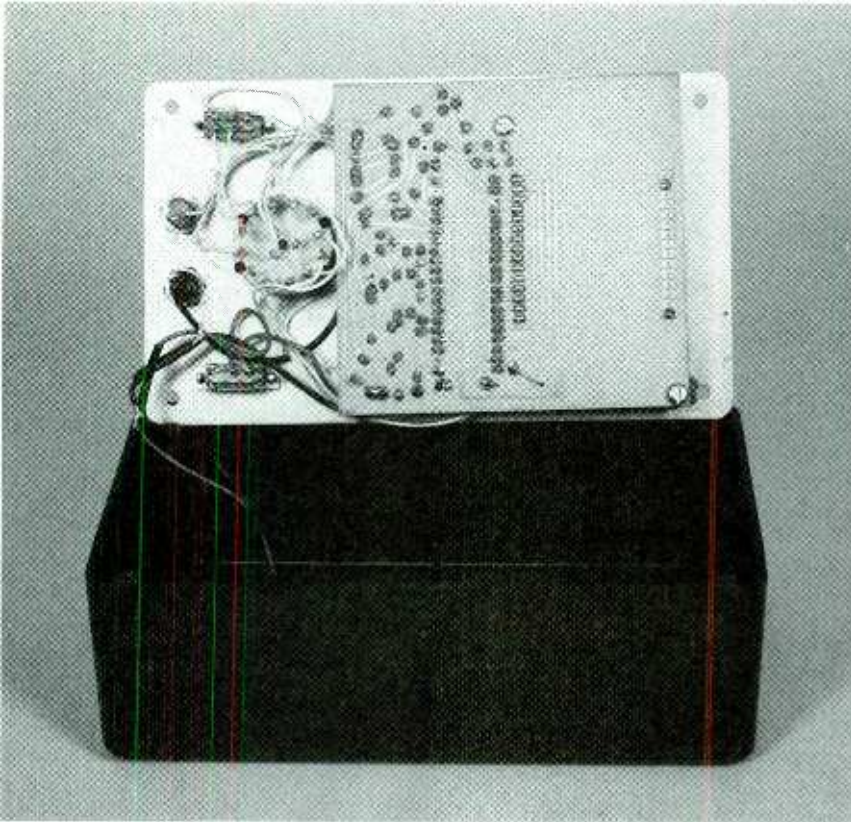

FIG. 4—THE DVM BOARD fits in a small plastic or metal enclosure.

of the digits are not fully illuminated, check the connections between DISP1 and IC1. Once the circuit is operating properly, proceed with calibration.

Calibration

Set R8 to mid-position, and the RANGE switch to the 2-volt scale. Connect a separate digital voltmeter and the test leads of this DVM across the 1.5-volt test cell, and compare the readings of the two voltmeters. Carefully adjust R8 to obtain a reading that is as close to the test voltmeter as possible. Check the reading with the polarity of the cell reversed to verify the operation of the minus sign.

Rotate the RANGE switch to the 20- and 200-volt range, and ascertain that the voltage display is still correct. Set the RANGE switch to 200 millivolts, and verify that the DVM goes into overrange with only a "1" displayed.

If the readings do not track within about 1% for the 2-, 20- and 200-volt positions of S2, measure the values of R1, R2, R3, and R4 to be sure they are correct. If the readings are off by

a factor of 10, check the wiring to S2-a, S2-b, and pins 36 and 37 of IC1.

Remove the 1.5-volt test battery and short the meter leads together. Set the FUNCTION switch to "continuity" and the RANGE switch to the 2-volt scale. The CONTINUITY indicator should be activated, and the piezoelectric buzzer should emit a tone. Disconnect the leads; the audio tone and CONTINUITY indicator should be extinguished, and the display should go off scale.

If the piezoelectric buzzer does not work, check the orientation of Q1 and the buzzer. Check the wiring to S3-b, and try a new transistor.

Final assembly

The entire DVM assembly easily fits in a small plastic or metal enclosure. Figure 4 shows the author's completed prototype. Before drilling holes in the enclosure for the control switches and jacks, determine the location for the LCD cutout by holding the board assembly next to the panel and measuring and marking carefully. A 1-

× 2-inch opening is suitable for the display module specified in the Parts List from LXI, Inc. of Beachwood, Ohio.

Once the LCD cutout has been made, locate the mounting holes for the PC board. Carefully drill both the board and front panel to accommodate the mounting hardware. Four machine screws, spacers, and nuts are recommended. Be sure the spacers are long enough to prevent the LCD module from contacting the front panel so that no stress will be put on the display.

With the board assembly temporarily mounted to the front panel, determine the desired location of switches S1, S2, and S3, and jacks J1 and J2; the jacks should be spaced 3/4-inch apart to accommodate a standard dual banana plug. Remove the PC board assembly before proceeding with the mechanical work on the panel. Remember to install a mounting clip for the 9-volt battery inside the case so it will not contact any of the DVM circuitry.

Using the DVM

Your new instrument works like any other DVM. When using the continuity function, the RANGE switch must be set to the 2-volt scale. The display will indicate about .0000 for a dead short between test leads, and will provide a relative reading for resistances up to 100K. Note that the continuity function is not calibrated, and can be used for relative resistance readings only.

When the battery is near the end of its service life, the LOW BATTERY indicator of the display will be activated. Replace the battery at that time with a new one, and be sure to turn off the instrument when it's not in use.

As with many other digital voltmeters, this meter will continue to operate for some time in the low-battery condition, its accuracy will be affected, and you will not be able to trust the displayed value. That situation can be inconvenient when you are measuring low voltages; it becomes dangerous when you measure high voltages. Ω

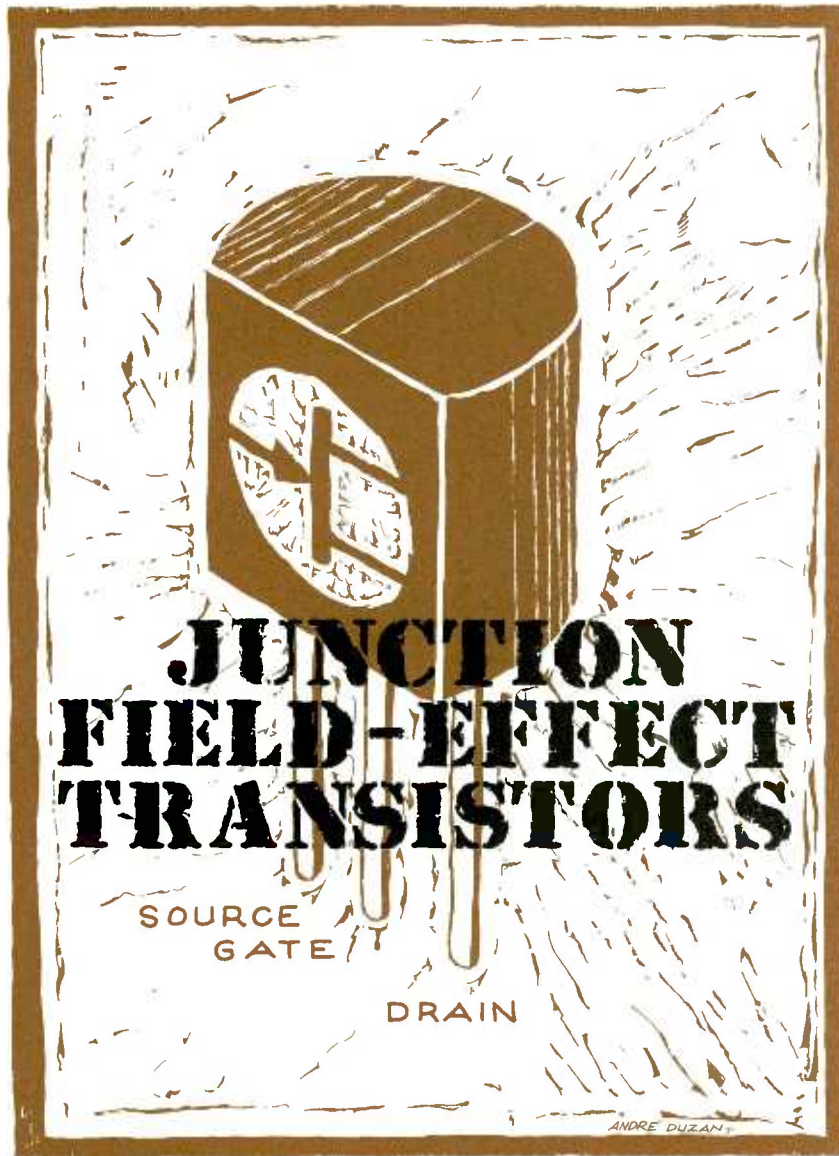

JFET, has the same terminals as other FET's: *source*, *drain* and *gate*. The JFET is a unipolar device whose operation depends only on the movement of majority carriers—electrons or holes—not both as in bipolar transistors. As a voltage-operated transistor, the appropriate voltage applied to the JFET's gate controls the flow of current between the drain and source.

Figure 1-a is a cross-section view of a modern diffused planar N-channel JFET showing its three terminals and three doped regions: *substrate*, *source-to-drain channel*, and *gate*. Figure 1-b is the schematic symbol for an N-channel JFET. The vertical bar represents the normally conductive channel region. (Symmetry within the JFET permits the source and drain terminals to be interchanged.)

Figure 2-a illustrates the structure of a P-channel JFET. It is made the same way as the N-channel JFET shown in Fig. 1-a except that N- and P-doped regions are interchanged. The schematic symbol for the P-channel JFET, shown in Fig. 2-b, has its arrow pointed away from the bar representing the channel.

All JFET's operate in the *depletion* mode. This means that maximum current flows in the source-to-drain channel when the gate bias is zero. To reduce

Learn how to bias junction FET's and apply them in practical amplifier, voltmeter, multivibrator, and converter circuits

RAY MARSTON

THE JUNCTION FIELD-EFFECT TRANSISTOR (JFET) has interesting characteristics that set it apart from the bipolar transistor. This article contains schematics for a selection of practical JFET circuits that range from amplifiers and analog voltmeters to a multivibrator and a DC- to AC-converter. Last month's article discussed the differences between JFET's and MOSFET's, and FET terms were defined.

You might want to read— or reread—last month's article before you tackle this one unless you are really "up to speed" on FET's, their operation, symbols and terms. The many combinations and permutations of N- and P-channel FET's operating in *enhancement* and *depletion* modes can be very confusing even for the experienced circuit designer.

The JFET reviewed

The subject of this article, the small-signal, general-purpose

(*deplete*) or entirely *pinchoff* that current, the gate must be reverse biased. In an N-channel JFET, a negative bias must be applied, while in a P-channel JFET, a positive bias must be applied.

Figure 3 is a family of drain characteristic curves for an N-channel JFET. Note that the amplitude of the drain current (I_D) decreases as gate bias (V_{GS}) becomes more negative from V_{GS} equals zero. The family of curves for a P-channel JFET are similar except that the bias val-

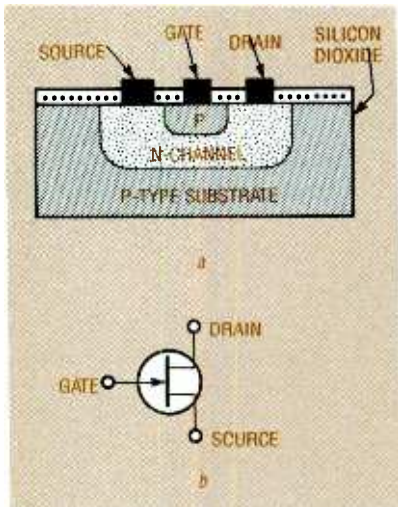

FIG. 1—AN N-CHANNEL DIFFUSED JFET (a), and schematic symbol (b).

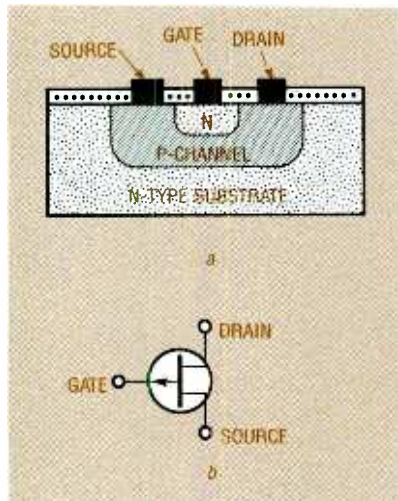

FIG. 2—A P-CHANNEL DIFFUSED JFET (a), and schematic symbol (b).

ues become more positive with decreasing drain current.

All of the schematics in this article are based on the classic 2N3819 N-channel JFET. First introduced more than 25 years ago, it is packaged in three-pin TO-92 plastic case. Table 1 gives the maximum ratings for this device at 25°C free-air temperature. If you want to build these circuits with an N-channel JFET other than the 2N3819, be sure that the substitute's electrical characteristics are closely matched to those of the 2N3819. Also, be sure that the pinout arrangements are similar.

Biasing the JFET

The JFET will work in digital as well as linear circuits. In a low-distortion analog amplifier, it must operated in its linear region by reverse biasing its gate relative to its source. There are three common JFET biasing techniques: *self-*, *offset-*, and *constant-current*.

Self-biasing is shown in Fig. 4. The JFET's gate is grounded through resistor R_G , and resistor R_S grounds the source. Any current flowing in R_S drives the source positive with respect to the gate, so the gate is effectively reverse-biased. If drain current (I_D) is to be set at 1 milliampere, and it is known that a gate-to-source bias voltage (V_{GS}) of -2.2 volts is needed, the

correct value of source resistor (R_S) must be determined.

This correct bias can be obtained with a 2200-ohm value of resistor R_S . By Ohm's law, if 2.2 volts appears across a 2200-ohm source resistor, a 1 milliampere current will flow. If the drain current decreases, gate-to-source bias voltage also decreases. This causes drain current to increase and counter the original change. Thus, the bias is self-regulating through negative feedback.

The value of gate-source bias needed to set a desired drain current can vary widely even among identical JFET's in actual circuits. Thus, the only sure way to set a precise drain current is to pick a source resistor by trial and error or use a potentiometer. Regardless of how it is obtained, self-biasing is satisfactory for most practical applications, and only a few external components are needed. That's why it is still the most popular way to bias a JFET.

The second scheme, *offset-biasing* is illustrated in Fig. 5-a. It gives more accurate gate biasing than self-biasing. Here, the voltage at the junction of resistors R_1 and R_2 is applied as a fixed positive bias to the gate through gate resistor R_G . The voltage at the source equals this bias voltage minus the negative value of the gate-source bias.

Therefore, if positive gate voltage is large with respect to gate-source bias, drain current is controlled mainly by R_S and gate-voltage; it is not greatly influenced by variations of gate-source bias between individual JFET's. Offset biasing permits drain current to be set accurately, avoiding the chore of individual resistor selection. Similar results can be obtained by grounding the gate and coupling the low-end of the source resistor to a high negative voltage, as shown in Fig. 5-b.

The third scheme, *constant-current biasing*, is illustrated in Fig. 6. The source resistor is replaced by NPN bipolar transistor Q2, which is organized as a constant-current generator. Consequently it determines the

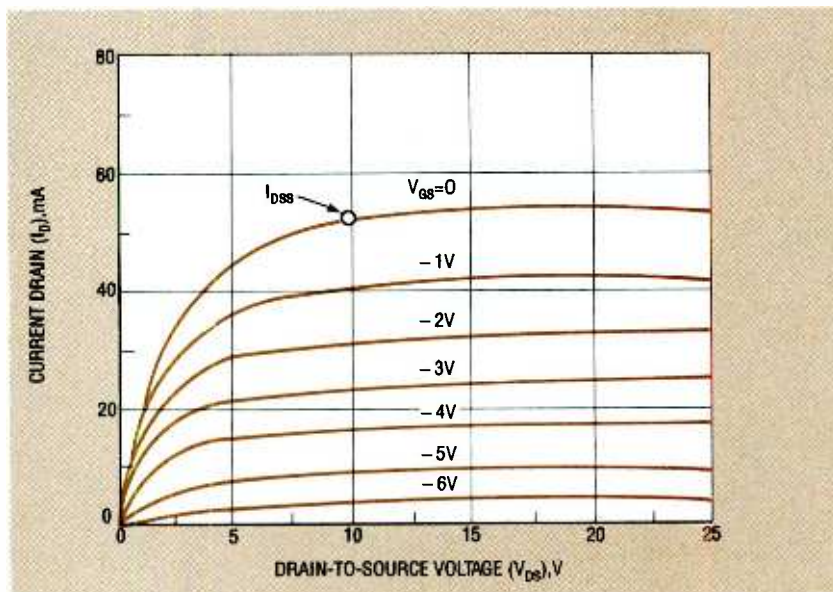

FIG. 3—N-CHANNEL JFET DRAIN characteristic curves.

TABLE 1
SILICON N- CHANNEL JFET: 2N3819
ABSOLUTE MAXIMUM RATINGS
(25°C Free air temperature)

Parameter		Unit
Gate-Source Breakdown Voltage	$V_{(BR)GSS}$	-40 V
Zero-Gate Voltage Drain Current	I_{DSS}	20 mA
Forward Transconductance	g_{fs}	7.0 mmho
Reverse Gate Leakage	I_{GSS}	-100 pA
"ON" Resistance	r_{DS}	500 ohms
Pinchoff Voltage	$V_{GS(OFF)}$	-6 V
Output Conductance	g_{os}	10 umho
Feedback Capacitance	C_{rss}	0.9 pF
Input Conductance	C_{iss}	4.0 pF
Power Gain	G_{ps}	12 dB
Power Dissipation		360 mW

drain current. The constant current is set by Q2's base voltage, which is set from the R1-R2 voltage divider and emitter resistor R3.

Resistor R2 can also be replaced by a Zener diode or other voltage reference. Thus, in this bias circuit, drain current is independent of JFET characteristics, and high biasing stability is obtained. However, this improvement is gained at the expense of additional components.

In the three biasing schemes, resistor R_G can have any value up to about 10 megohms. That limit is imposed by the voltage drop across the resistor caused by gate leakage currents, which could upset biasing conditions.

Source-followers

JFET transistors in a linear amplifiers are usually configured as either a common-source or common-drain (*source-follower*) amplifier. These are the JFET equivalents of the bipolar common-emitter and common-collector (emitter-follower) amplifier, respectively.

The source-follower amplifier offers very high input impedance and near-unity overall voltage gain. (That's why it's also called a *voltage-follower*). A simple source-follower amplifier is illustrated in Fig. 7. It is self-biasing, and drain current can be varied with potentiometer R4.

That self-biasing source-follower amplifier will work from any positive 12- to 20-volt supply. Potentiometer R4 should be set so that the quiescent voltage

across R2 is 5.6 volts, which provides a 1 milliamperere drain current. Expect a voltage gain of about 0.95 between input and output.

Because of the voltage division at the junction of potentiometer R4 in series with R1 and resistor R2, some *bootstrapping* is applied to R3. In this circuit where the output is taken from the emitter, the output voltage directly affects the bias. In this amplifier, negative output pulses cause an increase in the negative voltage at the input, and positive output causes a reduction in the negative voltage at the input.

The input is applied between the source and the gate. In this circuit bootstrapping multiplies the effective value of R3 by a factor of about five. The input impedance to the circuit is about 10 megohms, shunted by 10 picofarads. Therefore, input impedance can be as high as 10 megohms at very low frequencies. However, this value drops to about 1 megohm near 16 kHz, and on down to about 100 K at 160 kHz.

Figure 8 is an alternative source-follower amplifier that has offset biasing. Resistor adjustment is not needed in this amplifier, and its overall voltage gain is about 0.95. Electrolytic capacitor C2, which provides bootstrapping, boosts the effective value of gate resistor R3 about 20 fold. However, it is not required for normal amplifier operation.

With C2 out of the amplifier, the source-follower's input impedance is about 2.2 megohms,

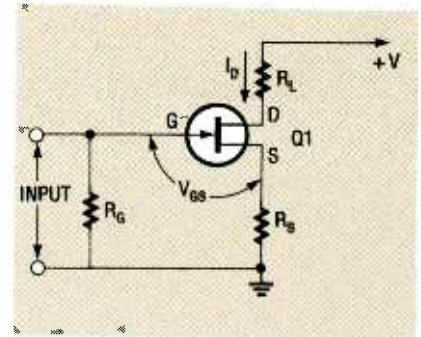

FIG. 4—A JFET SELF-BIASING scheme.

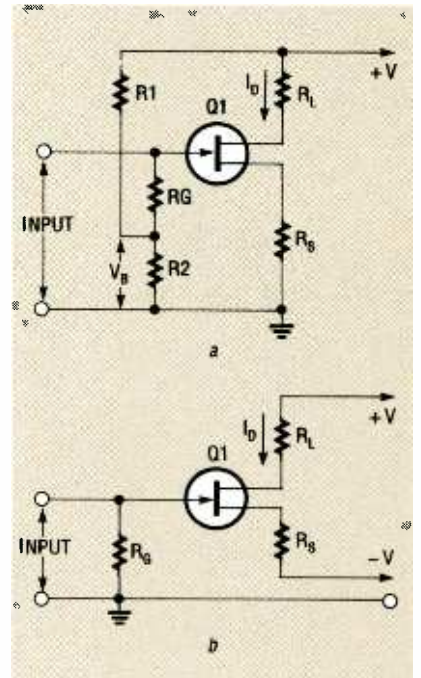

FIG. 5—JFET OFFSET-BIASING schemes for JFET's with +V supply (a) and +V and -V supplies (b).

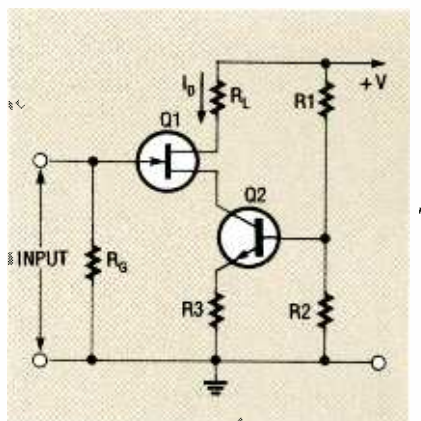

FIG. 6—A JFET CONSTANT-CURRENT biasing scheme

shunted by 10 picofarads; with C2 in place, input impedance is increased to about 44 megohms, also shunted by 10 picofarads. Alternative impedance values can be obtained by

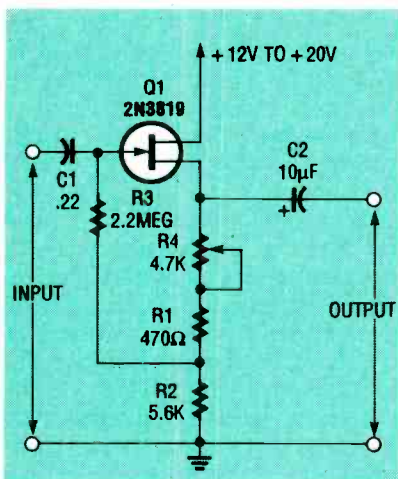

FIG. 7—A JFET SELF-BIASING source-follower with an input impedance of 10 megohms.

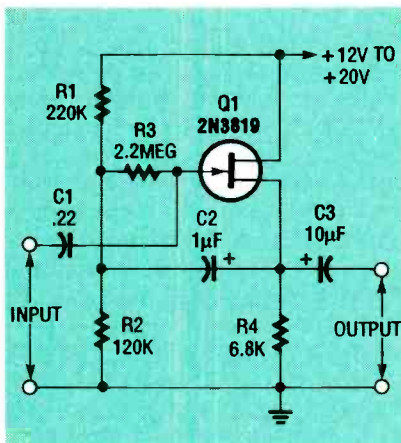

FIG. 8—THIS JFET SOURCE-follower with offset biasing has an input impedance of 44 megohms.

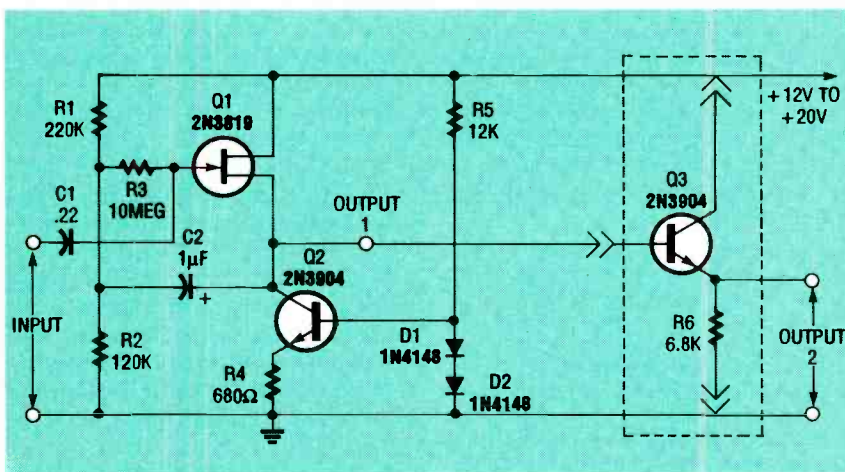

FIG. 9—THIS JFET SOURCE-FOLLOWER amplifier with bipolar transistors in its source circuit has an input impedance of 500 megohms.

increasing R3 up to a maximum of 10 megohms.

Figure 9 shows a JFET-bipolar "hybrid" version of a source-follower amplifier. Its in-

put impedance is about 500 megohms, shunted by 10 picofarads. Here, offset biasing is applied through a voltage divider formed at the resistor R1-R2 junction. This configuration is similar to that of Fig. 8, but source resistor R4 is replaced by a resistor-transistor-diode network (R4, Q2, D1, and D2).

This network makes "source load" Q2 act as a constant-current generator with a high output (collector) impedance, which causes a quiescent drain-to-source current of about 1 milliampere to flow in Q1.

As a result, Q1 functions as a source follower, and the collector of Q2, acting as its source load, appears as a high impedance. Because of the high effective value of this load, JFET Q1 has a voltage gain of about 0.99. Electrolytic capacitor C2 passes a bootstrap signal from the source of Q1 to R3 at the R1-R2 junction. The high-voltage gain of the circuit permits this bootstrap signal to boost the effective value of R3 100 times to about 1000 megohms.

As a result of bootstrapping, the actual input impedance of the source-follower in Fig. 9 is equal to 1000 megohms-shunted by the JFET's gate impedance of about 1000 megohms. The equivalent resistance turns

circuit high: The output can be coupled to external circuitry with another emitter-follower stage (shown enclosed in dotted lines in Fig. 9), or all loads to which it is coupled must have high impedances.

Common-source amplifiers

Figure 10 is a schematic for a simple self-biasing, common-source amplifier that can be powered from any 12- to 20-volt supply. Potentiometer R4 should be adjusted so that a quiescent 5.6 volts is developed across R3, providing a drain current of 1 milliampere. The biasing of potentiometer R4 in series with resistor R2 is decoupled by electrolytic capacitor C2.

The typical voltage gain for the circuit shown in Fig. 10 is about 21 dB (a multiplying factor of 12), and its frequency response is flat within 3 dB from 15 Hz to 250 kHz. The input impedance of the circuit is 2.2 megohms, shunted by 50 picofarads. This comparatively high value of shunt capacitance is the result of Miller feedback from drain-to-gate. That feedback boosts the JFET's internal gate-to-drain capacitance directly with respect to voltage gain.

Voltage-biasing potentiometer R4 in Fig. 10 can be adjusted so that the circuit accepts, with minimal distortion, strong input signals that generate large output-voltage swings. In applications where only low-level input signals are to be accepted (such as in preamplifiers), a fixed-bias network can be substituted for the potentiometer. Figures 11 and 12 show circuits with that substitution.

Figure 11 shows a simple amplifier for headphones with impedances of 1 K or greater. With an input impedance of 2.2 megohms, the amplifier includes an integral volume control potentiometer R3, and it can be powered from any 9- to 18-volt positive supply.

The circuit shown in Fig. 12 is a general purpose, add-on preamplifier that can be coupled to any amplifier operating from a single-ended 9- to 18-volt

out to be about 500 megohms, shunted by 10 picofarads.

There are two ways to keep both the effective source load and input impedance of this cir-

positive supply. The voltage gain from this preamplifier exceeds 20 dB, bandwidth exceeds 100 kHz, and its input impedance is 2.2 megohms.

When exceptional biasing accuracy is required, JFET common-source amplifiers can be designed with either of two constant-current offset biasing techniques. Figures 13 and 14 illustrate both options. The common-source amplifier in Fig. 13, with offset gate biasing, can only be powered by a 16- to 20-volt positive supply. However, the "hybrid" version shown in Fig. 14 can be powered with any 12- to 20-volt positive supply. Both circuits offer voltage gains of 21 dB, input impedances of 2.2 megohms, and -3 dB bandwidths from 15 Hz to 250 kHz.

DC voltmeters.

Figure 15 is a schematic for a simple three-range JFET analog voltmeter offering a nominal sensitivity of 22.2 megohms per volt. Its maximum full-scale voltage sensitivity is 0.5 volt, and its input resistance remains constant at 11.1 megohms on all ranges.

In the analog voltmeter shown in Fig. 15, potentiometer R9, resistor R6, potentiometer R9, and resistor R7 form a voltage divider across the 12-volt battery supply. With the proper setting of R9, 4 volts will appear across R7. The upper end of resistor R7 is connected to circuit ground (zero-volt reference), and its lower end is at -4 volts, setting the upper end of at +8 volts.

JFET Q1 is configured as a source-follower with its gate grounded through a resistor network consisting of R1 through R4. However, Q1's source is connected to -4 volts through source load resistor R5. As a result, Q1 is offset gate-biased, and its drain current is about 1 milliampere.

A closer look at the circuit shows that R6 in series with R9, and Q1 in series with R5 act as the arms of a Wheatstone bridge. The adjustment of potentiometer R9 balances the bridge, and no current flows in the meter unless there is an in-

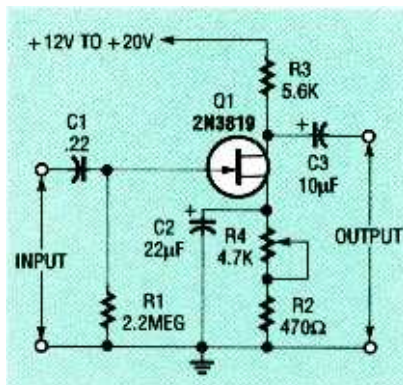

FIG. 10—A SELF-BIASING JFET common-source amplifier.

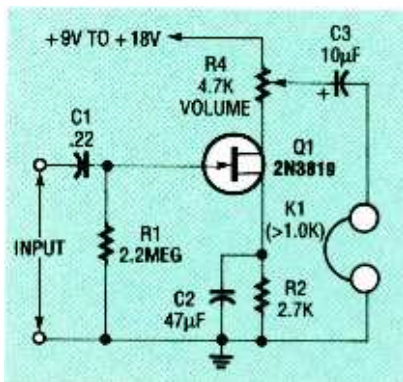

FIG. 11—A JFET HEADPHONE amplifier.

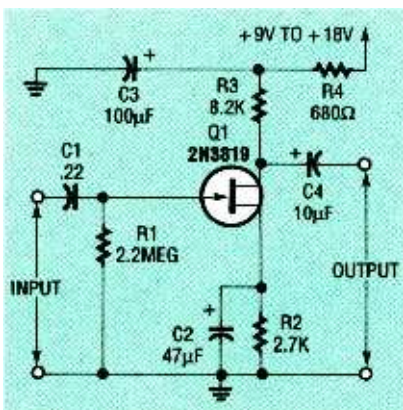

FIG. 12—A JFET GENERAL-PURPOSE add-on preamplifier.

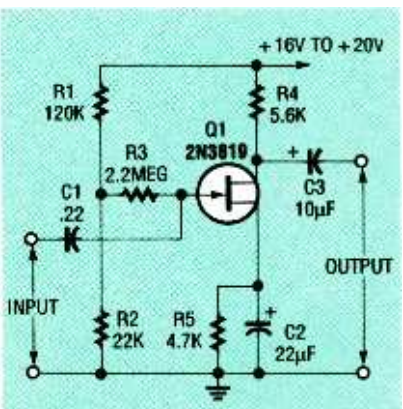

FIG. 13—A JFET COMMON-SOURCE amplifier with offset gate biasing.

put voltage at Q1's gate. Any voltage applied to Q1's gate unbalances the bridge by an amount that is proportional to that voltage. The value of the voltage can be read directly on the meter.

Series resistors R1, R2, and R3 form a multiplier network providing full-scale deflection (FSD) ranges of 0.5, 5, and 50 volts. Other resistor networks can be substituted to obtain different voltages. However, if the voltmeter is to be accurate, all the resistors must have tight tolerances. Resistor R4 prevents damage to transistor Q1 if the input voltage at the gate becomes excessive.

To use the voltmeter shown in Fig. 16, first adjust zero-set potentiometer R9 so that meter M1 reads zero when no input voltage is present. Then connect an accurate 0.5-volt source at the voltmeter's input terminals, and adjust R9 so that the meter reads full scale. If you are able to obtain consistent zero and full-scale readings, the voltmeter is ready for use.

Unfortunately, the circuit shown in Fig. 15 is inherently unstable because it tends to drift with changes in temperature and supply voltage. That makes it necessary to adjust zero-set potentiometer R9 frequently. However, drift can be greatly reduced if you power the circuit from a Zener-regulated 12-volt supply.

Figure 16 is the schematic for a low-drift version of the DC voltmeter shown in Fig. 15. JFET Q1 and resistor R5 form one arm of a differential amplifier, and JFET Q2 and resistor R6 form the other arm. Any drift that occurs in one arm will be automatically offset by a similar drift in the other arm. High stability is one benefit obtained with the bridge inherent in this circuit.

Ideally, Q1 and Q2 should be a pair of JFET's with their drain-to-source currents (I_{DS}) matched within 10%. This DC voltmeter circuit will work from any 12- to 18-volt positive supply. The calibration procedure is similar to that specified for Fig. 15.

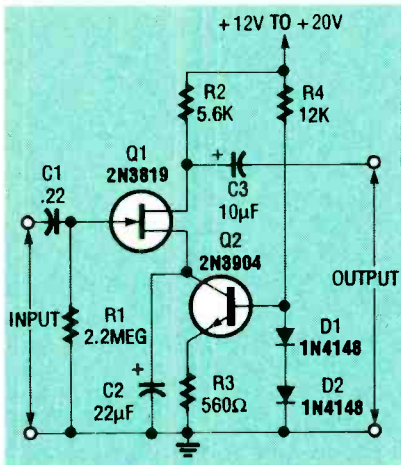

FIG. 14—THIS JFET COMMON-SOURCE amplifier has a bipolar transistor in its source circuit.

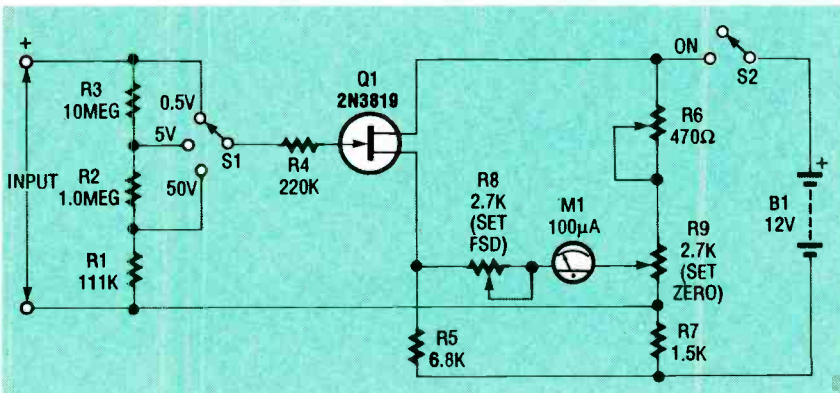

FIG. 15—THIS JFET-BASED VOLTMETER with three input ranges.

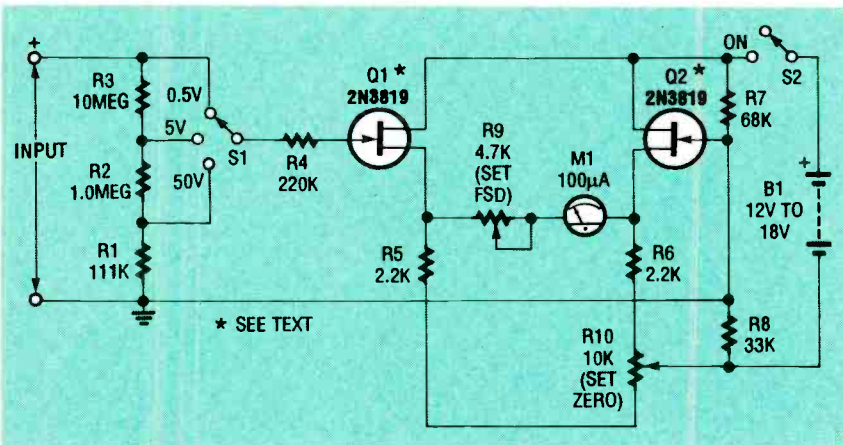

FIG. 16—THIS LOW-DRIFT JFET-BASED DC VOLTMETER has three input ranges.

Multivibrator and amplifier

Figure 17 is the schematic for a very low-frequency (VLF) free-running multivibrator that produces a squarewave output. The multivibrator's ON and OFF periods are controlled by the time constants from the resistor-capacitor pairs C1R4 and C2R3. Because of very high JFET input impedances, the re-

sistive factors of these time constants can be very large. This permits long time periods to be obtained with low capacitance values.

With the components shown in Fig. 17, the oscillator switches once every 20 seconds (0.05 Hz). Unfortunately, START button S1 must be held closed for at least one second to initiate the astable action. Because of this shortcoming, consider the circuit to be more of an experiment than a practical circuit.

Figure 18 illustrates how an N-channel JFET can be combined with a classical μ A741 operational amplifier to form a volt-

age (- V_E) appears at its gate. JFET Q1 acts as a virtual infinite resistance because its drain current (I_D) is pinched off. Because there is no input signal attenuation, the circuit functions as a high-gain amplifier. However, if the gate bias falls to zero, Q1 becomes a virtual short circuit. (Drain current is maximum and gate-to-source resistance falls to a few hundred ohms.) As a result, the input signal is heavily attenuated by the circuit.

Amplifier and converter

Intermediate values of signal attenuation and overall gain or loss can be obtained by varying the control voltage (V_{GD}) applied to the gate of Q1 between the zero bias and pinchoff limits.

Figure 19 is a schematic for a constant-volume amplifier that exploits the voltage-controlled resistor characteristics of the JFET. The amplifier produces an output signal that shifts only 7.5 dB when the input signal is varied over a 40 dB range (from 3 to 300 millivolts, rms). The amplifier can accept input signals as high as 500 millivolts, rms.

In Fig. 19, JFET Q1 and resistor R4 are in series to form a voltage-controlled attenuator that controls the input signal level to bipolar transistor Q2, which is in a common-emitter amplifier. Signal output from Q2 is buffered by bipolar transistor Q3.

Part of the output signal from Q3 is fed back to the gate of

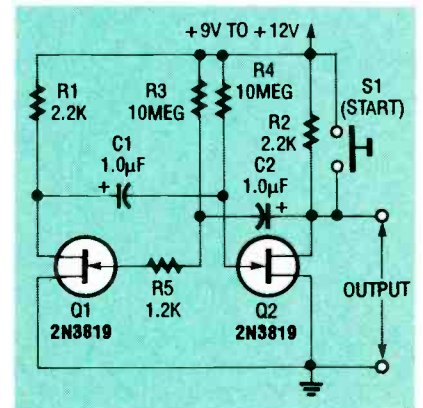

FIG. 17—THIS JFET ASTABLE multivibrator operates at very low frequencies.

age-controlled amplifier/attenuator. Here, the op-amp is connected as an inverting amplifier with its gain determined by the ratio of input resistor R2 to feedback resistor R3. Thus, JFET Q1 functions as a voltage-controlled resistor. The circuit can attenuate an input signal to the amplifier.

When a large negative control

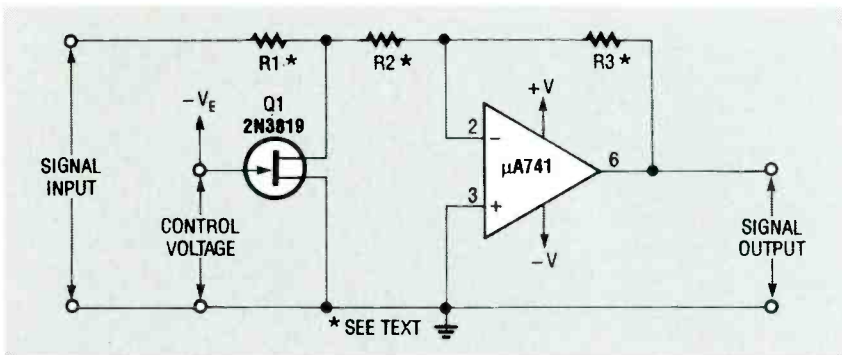

FIG. 18—A JFET CONTROLS AMPLIFICATION AND ATTENUATION for this op-amp.

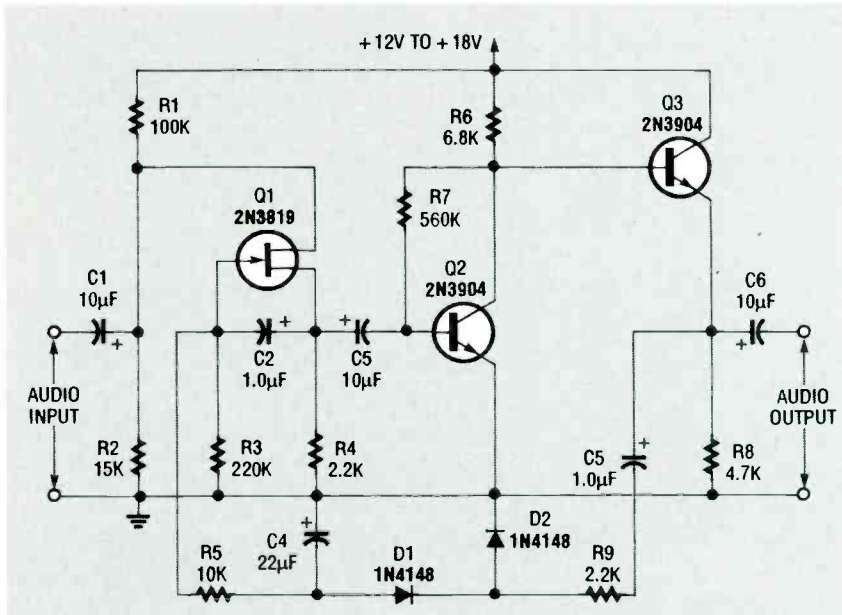

FIG. 19—THIS CONSTANT-VOLUME AMPLIFIER has a JFET in a closed loop for audio control.

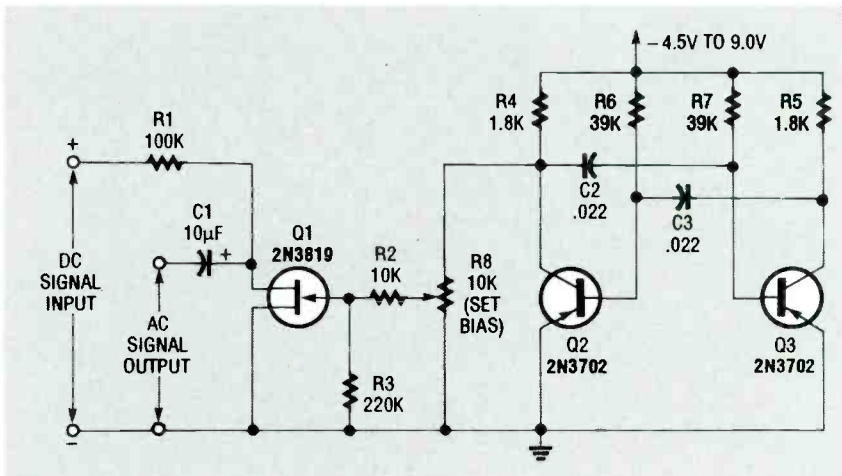

FIG. 20—THIS DC TO AC CONVERTER has a JFET switch and a bipolar multi-vibrator pulse generator.

JFET Q1 by the DC negative-feedback loop consisting of capacitor C5, resistor R9, diodes D1 and D2, capacitor C4, and resistor R5. The negative-feedback automatically adjusts the

constant-volume amplifier's voltage gain by holding the output signal level constant as the input signal level is varied.

When a small signal is applied to the audio input terminals of

the amplifier, the output at the emitter of Q3 is relatively small. Thus, very little negative bias is developed and fed to the gate of JFET Q1. JFET Q1 now acts like a low resistance and little signal attenuation occurs in the series resistance of the drop across Q1 and R4. As a result, most of the input signal is applied to the base of Q2.

However, when a large signal appears at the input terminals, the output at the emitter of Q3 is large. Thus, a large negative bias is developed and fed back to the gate of JFET Q1. In this condition, only a fraction of the input signal is applied to the base of Q2. Because of the negative DC feedback, the output level remains relatively constant over a wide range of inputs.

Figure 20 is the schematic for a DC-to-AC converter. The JFET acts as a switch, and a bipolar transistor flip-flop acts as the switching-signal generator. The converter produces a square-wave AC output with a peak amplitude equal to that of the DC input signal at its AC signal output terminals.

JFET Q1, the electronic switch, has its drain connected in series with input resistor R1 forming the positive DC terminal. JFET Q1 is switched on and off at a 1 kHz rate by the flip-flop consisting of bipolar transistors Q2 and Q3 and associated resistors and capacitors. The switching or "chopping" action converts DC to AC.

Potentiometer R8 varies the amplitude of the signal on Q1's gate. If Q1's gate signal is too large, its gate-to-source junction will avalanche, causing a voltage spike to appear at the drain. That transient will develop a small output signal at the drain of Q1 even when no DC input is present.

To prevent this glitch, connect a DC input to the converter, and adjust potentiometer R9 until the amplitude of the AC output just starts to decrease. JFET avalanching will not occur when this adjustment is made. As a result, the converter can reliably convert DC voltages with amplitudes as low as a fraction of a millivolt.



REMOTE CAR STARTER

Build this RF remote starter for your car.

MARTIN FOURNIER

THERE SEEMS TO BE A UNIVERSAL hatred of getting out of bed on a cold winter morning. But most people will agree that going outside and warming up a freezing cold car is even worse. It always leaves you shivering for at least fifteen minutes. Wouldn't it be great if you could have someone else go outside and start your car so that you could jump right into a warm car and drive away?

Well you can scratch that one off your wish list. Our remote car starter will let you start your car remotely, from indoors, so that it's warmed up and ready to go when you are. And starting the car is not all it will do; it will also let you control power doors, trunks, and other car accessories.

Although this project is not difficult to build, it should not be attempted by anyone who is not intimately familiar with automotive installations. It is impossible for us to give detailed hookup instructions because every car model will need a different installation procedure. A complete installation requires tapping into your car's ignition, starter, door-lock, and other systems. Professional, experienced installation assistance is strongly recommended.

How it works

The RF remote starter consists of two major systems: an

RF transmitter/receiver system and a starter control unit. Because RF remote controls are so difficult to tune, and expensive to build, the system uses a commercially made RF remote transmitter/receiver system, called the Enforcer, made by Seco-Larm. However, you can use any other RF remote-control system as long as it has a contact output. If you already have one, you might be able to modify it for use with this project.

The starter control unit is based on the 68HC705C8S microcontroller from Motorola. This chip consumes 4–10 milliamps in the operating mode and can go as low as a few microamps in its sleep mode. There are lots of microcontrollers that can do the job, but our choice was the 68HC705 with a "C8S" suffix which means that it's an extended temperature range device. Assembly-language source code for the microcontroller will be posted on the RE-BBS (516-293-2283, 1200/2400, 8N1), as a file called STAR-TER.ASM. If you can't program your own, a pre-programmed microcontroller is available from the source mentioned in the Parts List. Figure 1 shows the schematic of the starter control unit.

The starter control unit contains two power supplies. The ICL7660 (IC2) supplies the -5 volts for the LCD. The chip pro-

vides a stable -5 volts when you apply 5–12 volts DC to pin 8. The LM7805 (IC4) feeds all the circuitry with +5 volts derived from the car's 12-volt supply.

Software

The flowchart for the microcontroller's main operating program is shown in Fig. 2. When the operator pushes the transmitter button once for less than 3 seconds, the microcontroller unlocks the doors. If nobody opens the doors within 20 seconds it will automatically re-lock them. If the operator unlocks the doors and pushes the transmitter button again within 5 seconds, the trunk will open. When the operator holds down the button for more than 3 seconds, the microcontroller executes the start routine.

The start routine, whose flowchart is shown in Fig. 3, operates as follows: First assume that the engine isn't running. The start request is acknowledged by the flashing of the car's headlights. Then the program verifies that the engine is not running, and turns on the accessory power of the car for 4 seconds. That delay is sometimes needed to let the fuel injection pump raise the pressure. Next, the starter relay closes for at least 0.5 second, and the program again checks to see if the engine is running by monitoring the signal from

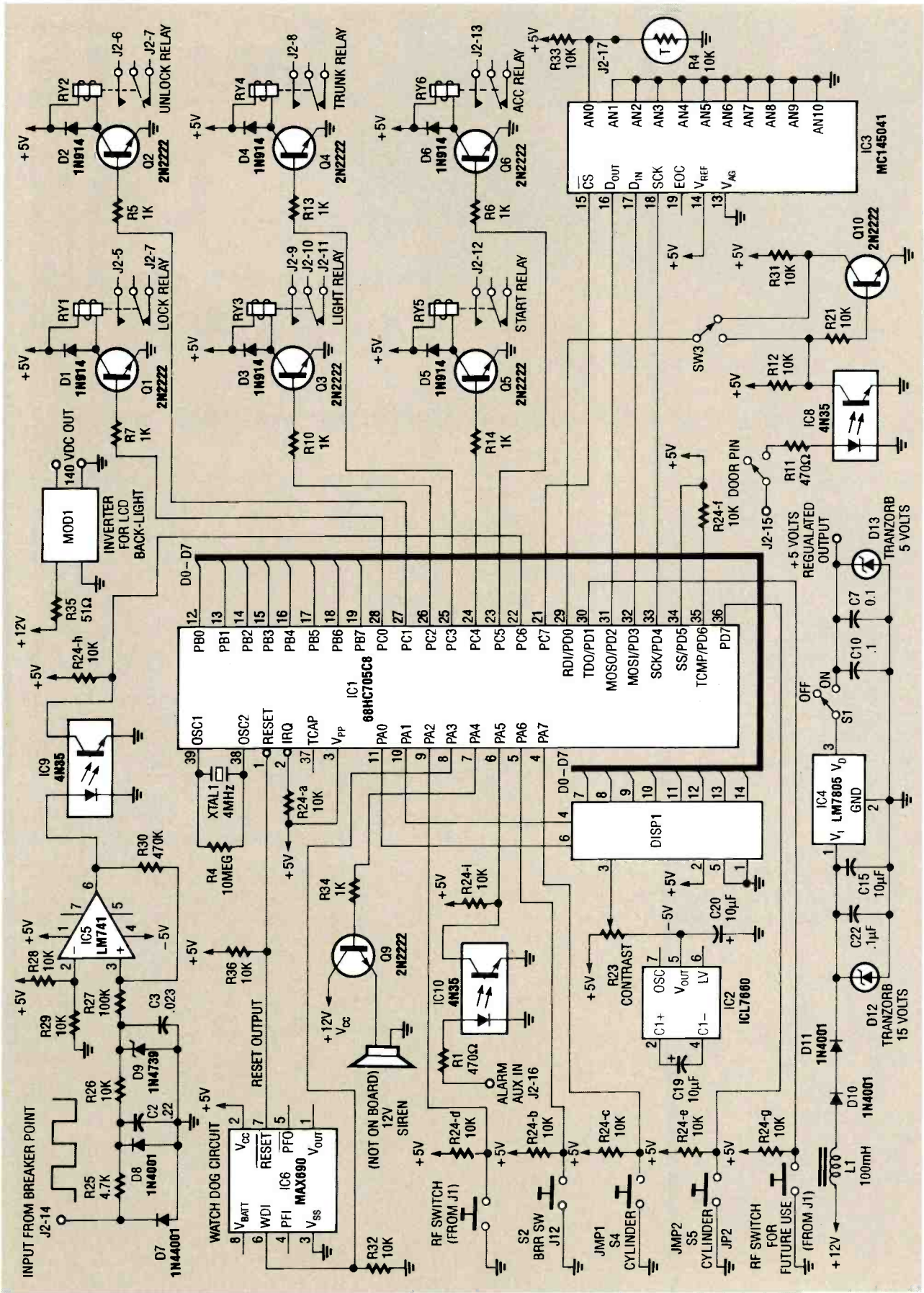

FIG. 1—STARTER SCHEMATIC. IC2 generates - 5 volts from a 5-12 volt DC source and IC3 generates + 5 volts from the car's 12-volt supply.

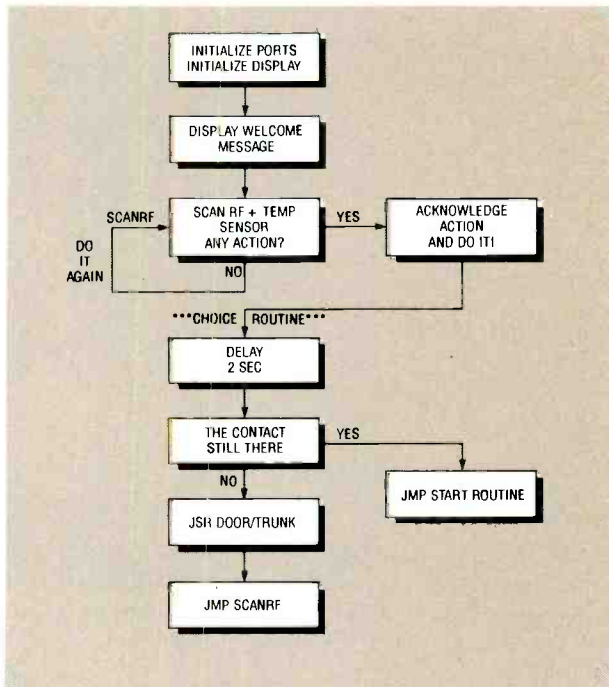

FIG. 2—THE MAIN PROGRAM. When the operator pushes the transmitter button once, the microcontroller unlocks the doors; if nobody opens them within 20 seconds, they automatically lock again.

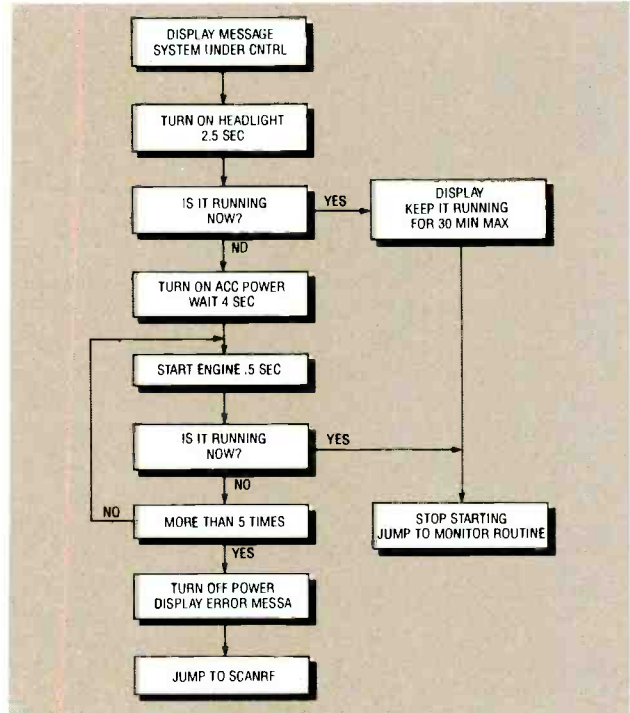

FIG. 3—THE START ROUTINE. The microcontroller turns on the accessory power of the car for 4 seconds, and then attempts to start the car.

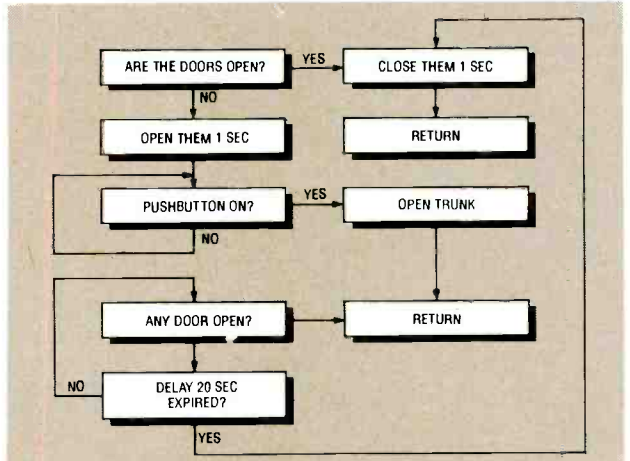
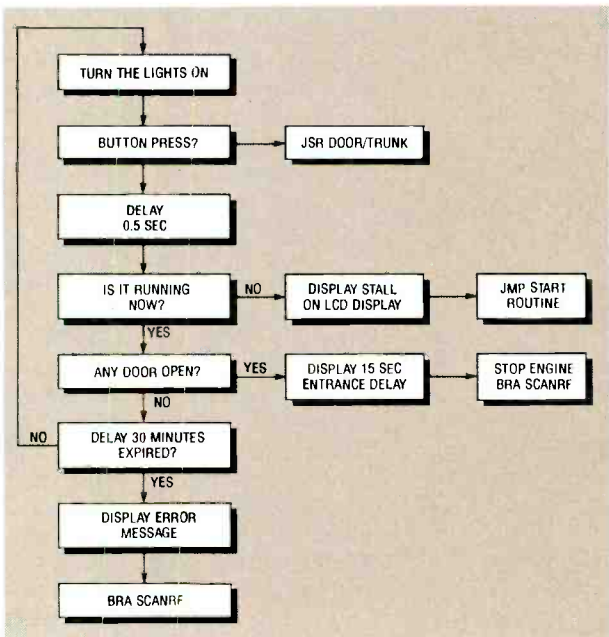

FIG. 5—DOOR/TRUNK ROUTINE. If the doors are open, the microcontroller locks them and waits for 5 seconds to see if the transmitter button is pressed.

FIG. 4—THE MONITOR ROUTINE. If the engine is running and somebody presses the button for more than 3 seconds, this routine will start.

the car's distributor points. If it isn't, the start process will repeat a maximum of 5 times. If the engine is not running after 5 tries, an error message is displayed on the LCD and the microcontroller is ready for another request. If the engine is running and somebody presses

the button for more than 3 seconds, the engine will stay on and the monitor routine, shown in Fig. 4, begins.

Because security is very important, if somebody opens any door when the car is in the monitor routine, they'll have only 15 seconds to put the keys

into the ignition before the engine shuts off. Also, if the engine is still running and after 30 minutes, an error message will be displayed.

Note that the operator can lock or unlock the doors or open the trunk at any time. Figure 5 shows the door/trunk routine.

PARTS LIST

All resistors are 1/4-watt, 5%, unless otherwise noted.

R1, R11—470 ohms
 R2, R8, R12, R21, R26, R28, R29, R31, R32, R33, R36—10,000 ohms
 R3, R9, R15—R20, R22—not used
 R4—10 megohms
 R5—R7, R10, R13, R14, R34—1000 ohms
 R23—10,000 ohms, potentiometer
 R24—10,000 ohms, SIP resistor
 R25—4700 ohms
 R27—100,000 ohms
 R30—470,000 ohms
 R35—51 ohms

Capacitors

C1, C7, C8, C10, C12, C22—0.1 μ F filter
 C2—0.22 μ F
 C3—0.023 μ F
 C4, C5, C6, C9, C11, C13, C14, C16, C21—not used
 C15, C19, C20—10 μ F, 12 volts, electrolytic
 C17, C18—15 pF

Semiconductors

IC1—68705C8S microcontroller
 IC2—ICL7660 voltage inverter (Signetics)
 IC3—MC145041 A/D
 IC4—LM7805 5-volt regulator
 IC5—UA741 op-amp
 IC6—MAX690 watchdog chip (Maxim)
 IC7—not used
 IC8, IC9, IC10—4N35 optoisolator (Signetics)

D1—D6—1N914 diode
 D7, D8, D10, D11—1N4001 diode
 D9—1N4739 9.1-volt Zener diode
 D12—15-volt Transorb
 D13—5-volt Transorb
 Q1—Q6, Q9, Q10—2N2222 NPN transistor
 Q7, Q8—not used
 MOD1—Optrex 140-volt DC inverter (included with backlit display module)

Other components

DISP1—Optrex LCD module
 RY1—RY6—12-volt relay (Omron)
 XTAL1—4-MHz crystal
 J1—RJ-11 telephone jack
 J2—18-position terminal strip
 S1—SPST on/off switch
 L1—100 mH coil

Miscellaneous: Project case, Enforcer RF remote control system (or equivalent), PC board, ribbon cable, wire, etc.

Note: The following items are available from Les Controles Micro-Tech enr., 147 14th Ave, Dolbeau Quebec Canada, G8L-2L9, 418-276-2477 (leave message):

- Remote starter, assembled and tested—\$300
- Complete kit—\$250
- PC board only—\$40
- Programmed microcontroller—\$25
- Case and hardware—\$40
- LCD module with inverter—\$60

— Write or call for quantity discounts.

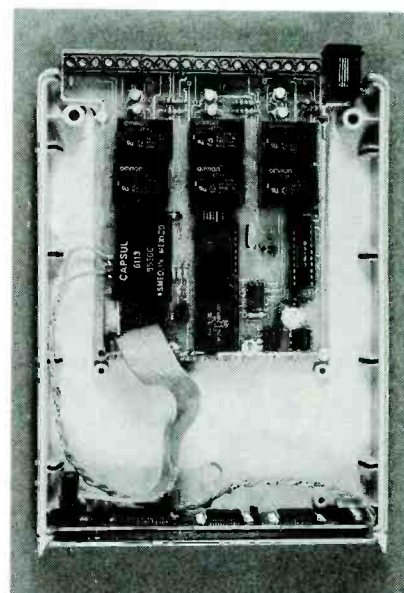

FIG. 7—THE FINISHED BOARD is shown here installed in its case.

When this routine is called, the program checks if the doors are open or not for 20 seconds. If the doors are open, the microcontroller locks them and waits for 5 seconds to see if the transmitter button is pressed. If it is, the processor opens the trunk and again checks to see if any doors are open and returns back to the main program. The 20-second delay is helpful in case you accidentally press the button once. The microcontroller will know that and will lock the doors if nobody opens them within 20 seconds.

The engine-run routine, shown in Fig. 6, waits for an input capture interrupt. After that the content of the timer is loaded in a memory location and the software waits again for another interrupt. When an interrupt occurs, the value of the timer is compared to a certain preset value to determine if the engine is running. A flag is set for engine running and clear for engine stop.

The engine-running feedback is taken from the breaker point of the car. Two jumpers, JMP1 and JMP2, are used to let the microprocessor know whether you have a 3-, 4-, 6-, or 8-cylinder engine. Note that information on setting those two jumpers is included in Fig. 1. The program will modify the

Continued on page 95

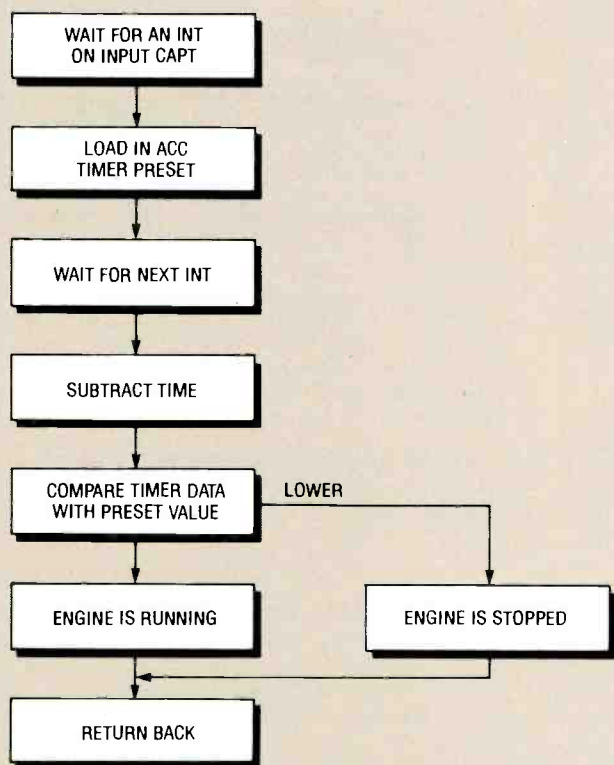

FIG. 6—ENGINE-RUN ROUTINE. The microcontroller waits for an input capture interrupt to determine if the engine is running.

HARDWARE HACKER

Using cubic splines, switchmode resources, electrorheological fluids, National's simple switcher, and non-ionizing radiation safety.

DON LANCASTER

Let's start with some updates to our earlier columns. Yet another approach to the \$5 Navicube is a plain-old low-cost mechanical gyro. That's the route that Gyration has chosen with its unique GyroPoint system. The entire gyro, the size of a film can, has been designed from the ground up for consumer applications.

Prototype costs, of course, are still totally outrageous. To me, spinning wheels seem a hopelessly outdated interim solution at best. There's no doubt that micro-machined silicon is ultimately the only way to go.

The CEO of a traditional gyro firm has assured me that it was "absolutely impossible" to create a \$5 rate gyro. Well, there are far too many emerging applications that demand a \$5 gyro replacement. The paradigm has shifted, and the time is long past due for stunning cost reductions here. The choice a traditional gyro CEO has is simple: bring out this inevitable product by yourself. Or else go down in flames.

Here are two more Asian electronic resources: There's now an EDN Asia version of this popular magazine. The Hong Kong Trade Development Council has a toll-free number that lists 52,000 manufacturers, importers, and exporters. Some other assistance is also available.

Cubic splines

There are lots of times and places where you would like a machine or a computer to create a graceful curve. Perhaps with a CAD/CAM mill, on an engineering graph, in a 3-D surface modeler, vinyl sign cutter, or for any other typography, plain or fancy.

I have recently been exploring a really great scheme to deal elegantly with graceful curves. These

are called *cubic splines*. They are sometimes called *Bezier curves*, after the French mathematician who explored them.

What do we ask of a curve-drawing method? First and foremost, the curve should look good. Second, we want the method to be largely *device independent*, working the exact same way for video screens, laser printers, typesetters, embroidery machines, or whatever. All done from the *same* ordinary text file.

Third, we'll want it to use *sparse data*, easily described with only a few size-independent values. Fourth, we'll want to be able to splice simple splines together into more complex curves without serious glitches.

Fifth and finally, we want it to be reasonably fast and easy to compute. And easy to understand.

The simplest way to build a curve is the *step method*, where you move over a click and up one notch. You keep repeating with different-sized clicks and notches until you step along the entire curve. You want the clicks and notches small enough for "smooth" results, but big enough so that you don't need a zillion of them.

Better yet, do your clicking and notching at the same time by using a *vector* or *stroke* method that's able to approximate your curve with straight line segments. This curve

looks a lot better than one from the step method, but there are still joint breaks. And an incredible amount of detail work is needed.

A fancier approach is to use little broken pieces of parabolas. This is the *quadratic spline* or *second order curve-fitting* method. But lots of pieces are still needed, and the results just do not look all that great. More on this another time.

I believe the "best" method for drawing simple and graceful curves involves a *cubic spline* technique.

There are two ways of looking at cubic splines, and you'll have to use both of them for full control. You can work in a *graph space*, where you are actually looking at the spline. Or you can work in an *equation space*, where you can precisely control your underlying math.

Figure 1 first shows a cubic spline in its graph space. Regardless of its size, only *four* points (or eight x-y data values) are needed to fully specify the spline...

- The *initial point* at x_0, y_0 tells you where the spline starts.
- The *final point* at x_3, y_3 tells you where the spline ends.
- The *first influence point* at x_1, y_1 should set the *direction* and *enthusiasm* with which your curve leaves the initial point.
- The *second influence point* at x_2, y_2 should set the *direction* and the *enthusiasm* that your curve enters the final point.

Other names for the enthusiasm are the *tension* or the *velocity*.

A line connecting the initial point and first influence point defines the initial *tangent* direction taken by the spline. The first tiny step along your spline should *always* head out in this direction. Similarly, a line connecting the second influence point and the final point defines the final *tangent* direction for your spline.

To build a cubic spline in the graph

NEED HELP?

Phone or write your Hardware Hacker questions directly to:
Don Lancaster
Synergetics
Box 809
Thatcher, AZ 85552
(602) 428-4073

space, set your end points. Then you move the influence points around to stretch and squeeze the spline into its intended shape. Typically, the influence points are well away from the curve itself.

Just like any middle management magician, you will find limits to the "rabbits" a single cubic spline can pull out of its hat. One spline can produce any straight line or smoothly curved path; some smooth curves with at most, one *inflection* point (such as a sine wave); some curves with a single *cusp* (or "point"); or certain curves with one single and simple loop in them. All of them are both graceful and sparsely defined.

For fancier stuff, use several splines end-to-end. We'll see more on this shortly.

Figure 1 also shows a cubic spline in its equation space. Instead of relating x to y , you relate them *both* to a new parameter, t . You can think of t as *time*. t will *always* range precisely from *zero* to *one* as your spline smoothly moves from its initial point to its final point.

One interesting way to look at the cubic splines is to think of a box in x , y , and t space. Inside the box is a three-dimensional snake-like curve. Look in the xy end of the box and you will see the spline. Look in the yt side, and you will see how y varies as t (or time) goes from 0 to 1. Or look down through the xt top to see how x varies, again as t goes from 0 to 1.

Note that x and y are independent of each other. Each is separately defined in terms of t . Knowing one does *not* reveal the other—unless you find t first. Note that t usually does *not* move uniformly along the curve. Instead t tends to move faster along the "more bent" portions of the curve and slower along the straighter portions.

Bopping between the equation and graph space is the key to controlling your splines. Figure 1 also shows the simple ninth-grade algebra needed to go from those influence points to the math equations, and vice versa. For some strange reason, this simple and obvious two-way math is very hard to find in text books.

Let's repeat the basic cubic spline equations here:

$$x = At^3 + Bt^2 + Ct + D$$

$$y = Et^3 + Ft^2 + Gt + H$$

Once again, t goes from zero to one as one goes from the beginning to the end of your spline.

The obvious reason we call these cubic splines is that the highest power of t involved is a third power cube. The cubic term is most effective on the *right end* of the curve. The quartic (squared) term does most of its useful work in the *middle*. The linear term sets the initial *slope*, and the final D value sets the *offset*. By suitably combining those four terms, a wide and useful variety of spline curves can be generated as needed.

But doesn't cubing sometimes take forever on typical computers? Well, you can get sneaky and eliminate any need for raising anything to the third power. Instead of calculating each individual coefficient, you rearrange the original equations as:

$$x = (((At) + B)t + C)t + D$$

$$y = (((Et) + F)t + G)t + H$$

Or, restating things in English, to fake cubing, take A and multiply it by t . Add B . Multiply by t again. Add C . Multiply by t again. And, finally, add D . Presto. A cubeless cube.

Inside the machine or computer, the actual details of getting from any cubic spline to a frame bitmap or the tool paths will vary. But, in general, all you will do is repeat the simple algebra of Fig. 1 to decide where you go next, consistent with your available step resolution.

Getting fancy

Although you might use any old computer language to explore cubic splines, I've found that the general purpose PostScript language is by far the fastest, easiest, and most pleasurable way to play with Bezier curves. I've now posted a group of Bezier and cubic spline exploration tools to my *GENie* PSRT. A few of these are also listed for you in Fig. 1.

For instance, following a suitable scaling and translation, here is how you request the Fig. 1 spline in PostScript:

```
2 3 moveto
3 7.5 7 7 8 4 curveto
stroke
```

Note that only a few dozen bytes are needed to specify *fully* the spline, *regardless of its final size or device resolution!* This is sparse data used at its very best.

By the way, if you don't have real PostScript, we now offer the shareware GHOSTSCRIPT emulator on PSRT, which runs fake PostScript on nearly *any* printer or on nearly *any* computer screen. Yes, the full source code is included in the offering.

Does a cubic spline have a length? Well, obviously. But only if you are not a mathematician. Go through the lengthy math, and a big ugly square root of some fourth-order polynomial (which is *much* worse than it sounds) should leap out, at you. After years of careful asking, I have yet to find *any* simple and exact closed-form solution for the length of a cubic spline.

Yet, knowing the length of a spline becomes very interesting for positioning typography on a curved surface, to fit fuzzy data, for correcting or creating distortions, or for

**NEW FROM
DON LANCASTER**

HARDWARE HACKER STUFF

Hardware Hacker Reprints II or III	24.50
Midnight Engineering Reprints	24.50
Resource Bin Reprints	16.50
Incredible Secret Money Machine	18.50
CMOS Cookbook	24.50
TTL Cookbook	24.50
Active Filter Cookbook	24.50
Micro Cookbook vol I or II	19.50
Lancaster Classics Library	119.50

POSTSCRIPT STUFF

Ask The Guru Reprints I, II or III	24.50
PostScript Secrets (Ile/Mac/PC)	39.50
PostScript Show & Tell	39.50
Intro to PostScript VHS Video	39.50
PostScript Beginner Stuff	39.50
PostScript Cookbook (Adobe)	16.50
PostScript Ref. Manual II (Adobe)	28.50
PostScript Program Design (Adobe)	22.50
Type I Font Format (Adobe)	15.50
LaserWriter Reference (Apple)	19.50
Real World Postscript (Roth)	22.50
PostScript Visual Approach (Smith)	22.50
Thinking in PostScript (Reid)	22.50
Undat PS Pgrmmg (Holtzgang)	29.50
The Whole Works (all PostScript)	349.50

BOOK-ON-DEMAND STUFF

Book-on-demand resource kit	39.50
GENie PSRT sampler (Ile/Mac/PC)	39.50

FREE VOICE HELPLINE VISA/MC

SYNERGETICS
Box 809-RE
Tatcher, AZ 85552
(602) 428-4073

CIRCLE 205 ON FREE INFORMATION CARD

(A) Here is a cubic spline shown in its *graph space*...

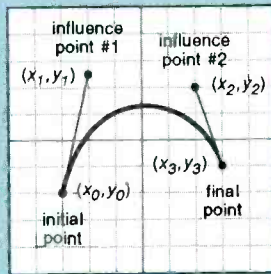

The first influence point sets the direction and enthusiasm that the spline leaves the initial point of the curve.

The second influence point sets the direction and enthusiasm that the spline enters the final point of the curve.

(B) Here is how a cubic spline appears in its *equation space*...

$$x = At^3 + Bt^2 + Ct + D$$

$$y = Et^3 + Ft^2 + Gt + H$$

t (or time) always goes from zero at the initial point to one at the final point

(C) A faster "cube-free" form of the *equation space* math...

$$x = (((At) + B)t + C)t + D$$

$$y = (((Et) + F)t + G)t + H$$

(D) How to get from graph space to equation space...

$$A = x_3 - 3x_2 + 3x_1 - x_0 \quad E = y_3 - 3y_2 + 3y_1 - y_0$$

$$B = 3x_2 - 6x_1 + 3x_0 \quad F = 3y_2 - 6y_1 + 3y_0$$

$$C = 3x_1 - 3x_0 \quad G = 3y_1 - 3y_0$$

$$D = x_0 \quad H = y_0$$

(E) How to get from equation space to graph space...

$$x_0 = D \quad y_0 = H$$

$$x_1 = D + C/3 \quad y_1 = H + G/3$$

$$x_2 = D + 2C/3 + B/3 \quad y_2 = H + 2G/3 + F/3$$

$$x_3 = D + C + B + A \quad y_3 = H + G + F + E$$

(F) Some cubic spline tools available on *GENie PSRT*...

#606	GNZOTRX2.GPS	New TEX-like Guru Gonzo utilities
#605	BEZIER1.PS	Distance from point to Bezier curve
#590	BEZIER.PS	Bezier curve fast evaluation.
#588	FUZZYBEZ.PS	Bezier curve from fuzzy data (!)
#530	SPHERE.PS	PS spherical nonlinear mapper
#214	GURU68.TXT	Bezier curvetracing fundamentals
#205	NUBANNER.FNT	Fast & accurate parade banner freefont
#202	TWIXTBEZ.FNT	Flagwaver freefont & Bezier ct utility
#161	SLEEZOID.PS	Avuncular sleezoid utility
#190	BEZLNPTH.PS	Bezier curve length utility
#077	MEOWRRRR.PS	PostScript puss de resistance

FIG. 1—CUBIC SPLINES are a useful and convenient way of handling smooth and graceful curves with a sparse data set. Here are some of the fundamentals you will need to start exploring these on your own.

that just-for-fun *avuncular sleezoid* surface you will find in Fig. 2.

So, what I'll do instead is chop up any cubic spline into a hundred or so pieces. I then assume each piece is a straight line, and add their lengths up. The answer is typically good enough for most graphical uses, and a mere hundred points usually

gives better than one part per thousand final accuracy.

By the way, if you know how to quickly and conveniently find the exact length of a cubic spline, please let me know. There's a free *Incredible Secret Money Machine II* for your trouble. Every math freak that I've talked to insists this is im-

Earn Your B.S. Degree in ELECTRONICS or COMPUTERS



By Studying at Home

Grantham College of Engineering, now in our 43rd year, is highly experienced in "distance education"—teaching by correspondence—through printed materials, computer materials, fax, and phone.

No commuting to class. Study at your own pace, while continuing on your present job. Learn from easy-to-understand but complete and thorough lesson materials, with additional help from our instructors.

Our Computer B.S. Degree Program includes courses in BASIC, PASCAL and C languages—as well as Assembly Language, MS DOS, CADD, Robotics, and much more.

Our Electronics B.S. Degree Program includes courses in Solid-State Circuit Analysis and Design, Control Systems, Analog/Digital Communications, Microwave Engr, and much more.

An important part of being prepared to *move up* is holding the right college degree, and the absolutely necessary part is knowing your field. Grantham can help you both ways—to learn more and to earn your degree in the process.

Write or phone for our free catalog. Toll free, 1-800-955-2527, or see mailing address below.

Accredited by
the Accrediting Commission of the
National Home Study Council

GRANTHAM
College of Engineering
Grantham College Road
Slidell, LA 70460

possible. They have almost convinced me.

Things become interesting when you splice cubic splines together. This is how you build fancy typography and other complex shapes. Ideally, you want to at least match the end points and the end point slopes. The rate of change of the curvature at each joint should also be constant, but this gets nasty in a hurry.

Picking the points gets tricky. Try to go too far with each spline and you lose accuracy. Don't go far enough, and you need too many splines, and the splines can be-

manically pick how many splines to use to produce the "best" possible results. This is not trivial, especially with noisy data.

You first have to decide how long each spline is to be and where it is to go. Then, you'll most often want to *constrain* all the intermediate splines, controlling both the entry angles and entry points. Or otherwise restricting them for continuity.

The "horses' mouth" paper on all of this is *Curvefitting with piecewise parametric cubics* by Michael Plass and Maureen Stone (with a little help by some guy named Warnock). This appeared in the July 1983

interesting.

There will be the usual *Incredible Secret Money Machine* book prizes, along with an all-expense-paid (FOB Thatcher, AZ) *tinaja* quest for two going to the very best of all.

Be sure to send your written entries to me at *Synergetics*, rather than to **Electronics Now** editorial. Any code can be directly uploaded to PSRT.

Non-ionizing radiation safety

Do power lines cause cancer? One recent movie and a lot of my helpline callers seem quite concerned over this. As with any controversy, your first step is to pick up accurate and unbiased data, and useful tools for your own research.

Start off with *Polarized Debate: EMF's and Cancer*, found in *Science* for December 11, 1992, pg. 1724-1725. This is an unbiased summary. There's also the *Microwave News: A Report on Non-ionizing Radiation*. This one is expensive and it has an alarmist tone about it.

As usual, any ongoing scientific controversy can be followed via the *Dialog Information Service*. And any newer important papers are likely to show up in those *Electric Power Research Institute* reports.

For instruments and components, two sources include *F. W. Bell and Walker Scientific*. And ads for similar products appear in *Compliance Engineering*, an engineering magazine.

One little noted fact: while high-voltage power lines sound strong and nasty, their field strengths, expressed in *volts-per-mil* at sane distances, are *much lower* than a normal internal electrical human cell potentials. And by far, the largest magnetic field that you've ever been exposed to is that of earth itself.

My own belief is that if there were any major problems here, they would have become obvious a long time ago. There probably are some observable effects, but they probably lie within acceptable risk bounds. Moreover, they are reasonably avoidable.

On the other hand, avoiding some really dumb stuff (such as building new playgrounds under high-volt-

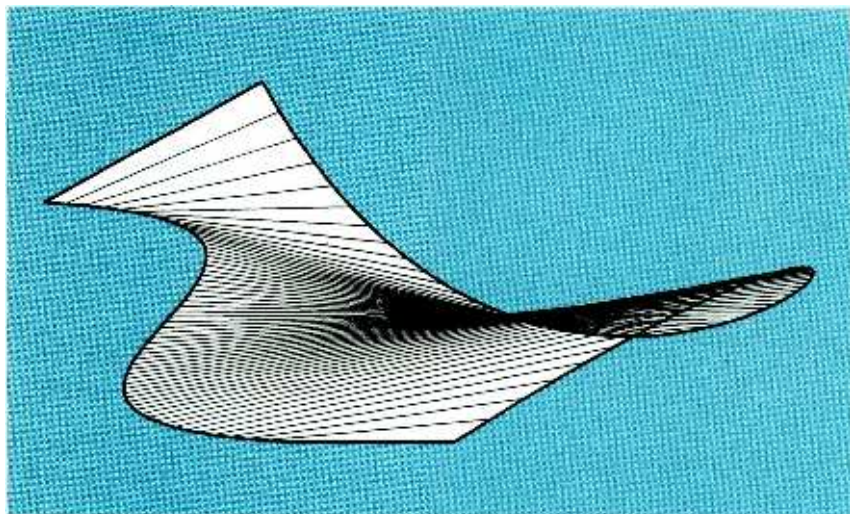

FIG. 2—THIS AVUNCULAR SLEEZOID is a just-for-fun example of how you can stop anywhere along a cubic spline. Note how the "t" parameter changes "faster" along the "more bent" portions of the curve.

come very noise-sensitive, creating nervous results.

I've written a simple *curve tracing* routine that's now in my *PostScript Secrets* book/disk combo. You throw some endpoints and slopes at it, and it builds up all of your splines for you. Curve tracing is really great for high-quality digitized signatures that need only tiny.file sizes.

Curve tracing is also superb for animation. Figure 3 shows *Meowwrrr*, our *Synergetics* puss de resistance. Curve tracing can give you precise and sharp results. Only a word processor is needed; there's no scanning involved. I have included a full curve tracing toolkit in my #517 GONZO15A.PTL.

Ideally, you'd like to throw some fancy and noisy artwork at a cubic-spline generator and have it auto-

Computer Graphics pg. 229-239, otherwise known as the SIG-GRAPH Proceedings for 1983. The math here is unbearably heavy and obtuse.

So, I decided to take this general "fancy but noisy data into a connected cubic splines" concept and I have generated somewhat similar results with #588 FUZZYBEZ.PS. It will create the best smooth cubic spline through any noisy data while keeping your choice of constraints. Only ninth-grade algebra is involved, and most of that is fully automated. Speed is around five seconds per spline.

We will have several contests this month. To start off, either find me a simple Bezier length formula (lots of luck!), or show me a new and unusual task for cubic splines. Or curve trace me something that is



FIG. 3—CURVE-TRACED CUBIC splines are ideal for animation and cartoon characters, such as the "puss de resistance" shown here. Only a word processor is needed to create this quality artwork. No scanner is used.

age lines or sitting on a police radar) is probably a good idea. However, utilities studiously avoiding any careful and unbiased research certainly is not. There is probably a hacker buck to be made providing low-cost monitoring instruments. And possibly a science-fair project or school paper can come out of your own surveys.

National's simple switcher

The *National Semiconductor* folks have been offering free sample kits of their new *simple switcher* series of voltage regulators. Figure 4 shows a typical circuit. Only five parts are needed to take raw 7–60 volts of input and provide a fixed +5-volt output. Other chips in the series give other values of fixed or adjustable output: step-up, step-down, and polarity-inverting circuits.

We've looked at these switchmode regulators in previous columns and in the *Hardware Hacker* reprints. The major advantage of any switchmode regulator is its potential efficiency. Stepping 40 volts

down to 5 volts with a one-amp linear regulator is, at best, only 12.5 percent efficient. For each watt of load power, you have to burn up an extra seven watts internally.

But a switching regulator can, in theory, be 100 percent efficient. And getting above 85 percent is very easy in the real world. Thus, you burn up only around 150 milliwatts internally for each watt of load power. That means less input power and less heat gets dumped. Heat-sinks can often be eliminated entirely from the circuit.

Any switching regulator does just that. It is a high-speed switch that is rapidly turned on and off at a chosen

duty cycle. The duty cycle sets the average current through the output inductor, and thus the load current. A feedback loop adjusts the time the switch is on. During times the switch is off, a *freewheeling diode* continues the inductor's current path.

In our 40-volt input example, the switch is on only for one eighth of the time. Thus, the average input current is only an eighth that of a comparable linear regulator. The frequency used is 50 kilohertz.

Full details appear on the related data sheets and application notes. There's also a companion diskette that lets you optimize all your exter-

SWITCHMODE RESOURCES

Allegro/Sprague

70 Pembroke Road
Concord, NH 03301
(603) 224-1961
CIRCLE 316 ON FREE INFORMATION CARD

Home Power

PO Box 130
Hornbrook, CA 96044
(916) 475-3179
CIRCLE 317 ON FREE INFORMATION CARD

Lambda Semiconductors

21 International Blvd
Corpus Christi, TX 78406
(512) 289-0403
CIRCLE 318 ON FREE INFORMATION CARD

Linear Technology

1630 McCarthy Blvd
Milpitas, CA 95035
(408) 432-1900
CIRCLE 319 ON FREE INFORMATION CARD

Maxim

120 San Gabriel Drive
Sunnyvale, CA 94086
(408) 737-7600
CIRCLE 320 ON FREE INFORMATION CARD

Motion

Box 6430
Orange, CA 92613
(714) 974-0200
CIRCLE 321 ON FREE INFORMATION CARD

Motion Control

800 Roosevelt Road E408
Glen Ellyn, IL 60137
(708) 469-3373
CIRCLE 322 ON FREE INFORMATION CARD

Motion Techniques

120 S chaparral Court #200
Anaheim, CA 92808
(714) 283-1123
CIRCLE 323 ON FREE INFORMATION CARD

Motorola

5005 E McDowell Road
Phoenix, AZ 85008
(800) 521-6274
CIRCLE 324 ON FREE INFORMATION CARD

National Semiconductor

475 Ellis Street
Mountain View, CA 94043
(800) 632-3531
CIRCLE 325 ON FREE INFORMATION CARD

PCIM

2472 Eastman Avenue #33-34
Ventura, CA 93003
(805) 658-0933
CIRCLE 326 ON FREE INFORMATION CARD

Power Techniques

120 S Chaparral Court #200
Anaheim, CA 92808
(714) 283-1123
CIRCLE 327 ON FREE INFORMATION CARD

SGS-Thomson

1000 East Bell Road
Phoenix, AZ 85022
(602) 867-6100
CIRCLE 328 ON FREE INFORMATION CARD

Siliconix

2201 Laurelwood Road
Santa Clara, CA 95054
(800) 554-5565
CIRCLE 329 ON FREE INFORMATION CARD

Texas Instruments

PO Box 401560
Dallas, TX 75240
(800) 336-5236
CIRCLE 330 ON FREE INFORMATION CARD

Unitrode Integrated Circuits

7 Continental Blvd
Merrimack, NH 03054
(603) 424-2410
CIRCLE 331 ON FREE INFORMATION CARD

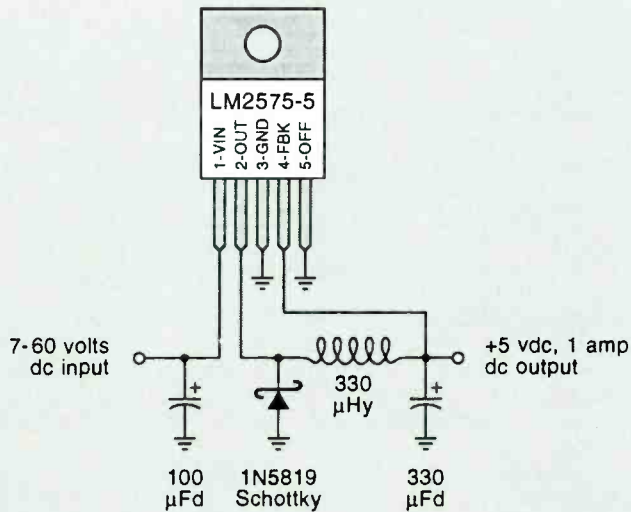

FIG. 4—THE SIMPLE SWITCHER series of chips from National let you build an efficient switchmode regulator with only five parts. Heatsinking can often be eliminated completely. Free kits are available on professional request.

Switchmode resources

For this month's resource sidebar, I have gathered together a few of the more obvious places to go for more information on these switching-mode techniques. Not only for regulators, but also for motor controls and power inverters. The listing is mostly a mix of semiconductor houses that provide switchmode chips and a collection of the leading electronics publications.

National's simple switcher is nice, but your best switchmode resource is *Maxim*. It offers bunches of freebie samples and evaluation boards of an incredibly wide selection of voltage regulators and converters. Lots of application notes, too.

Let me know if I've missed anyone important. There are scads of hacker opportunities here. Especially in the area of clean, stable,

NAMES AND NUMBERS

F W Bell

6120 Hanging Moss Road
Orlando, FL 32807
(407) 678-6900
CIRCLE 332 ON FREE INFORMATION CARD

Compliance Engineering

593 Massachusetts Avenue
Boxborough, MA 01719
(508) 264-4208
CIRCLE 333 ON FREE INFORMATION CARD

Data I/O

P.O. Box 97046
Redmond, WA 98052
(800) 3-DATAIO
CIRCLE 334 ON FREE INFORMATION CARD

Dialog

3460 Hillview Avenue
Palo Alto, CA 94304
(415) 858-2700
CIRCLE 335 ON FREE INFORMATION CARD

EDN Asia

275 Washington Street
Newton, MA 02158
(617) 964-3030
CIRCLE 336 ON FREE INFORMATION CARD

Electric Power Research Inst

PO Box 10412
Palo Alto, CA 94303
(415) 855-2000
CIRCLE 337 ON FREE INFORMATION CARD

Genie

401 N Washington Street
Rockville, MD 20850
(800) 638-9636
CIRCLE 338 ON FREE INFORMATION CARD

Gyration

12930 Saratoga Avenue, Bldg C
Saratoga, CA 95070
(408) 255-3016
CIRCLE 339 ON FREE INFORMATION CARD

Hong Kong Trade Council

219 East 46th Street
New York, NY 10017
(212) 838-8688
CIRCLE 340 ON FREE INFORMATION CARD

Microwave News

POB 1799, Grand Central Station
New York, NY 10163
(212) 517-2800
CIRCLE 341 ON FREE INFORMATION CARD

National Semiconductor

475 Ellis Street
Mountain View, CA 94043
(800) 632-3531
CIRCLE 342 ON FREE INFORMATION CARD

Philips

811 East Arques Avenue
Sunnyvale, CA 94088
(800) 447-1500
CIRCLE 343 ON FREE INFORMATION CARD

Science

1333 H Street NW
Washington, DC 20005
(202) 326-6400
CIRCLE 344 ON FREE INFORMATION CARD

Sound & Communications

25 Willowdale Avenue
Port Washington, NY 11050
(516) 767-2500
CIRCLE 345 ON FREE INFORMATION CARD

Sound & Video Contractor

9800 Metcalf
Overland Park, KS 66212
(913) 341-1300
CIRCLE 346 ON FREE INFORMATION CARD

Synergetics

Box 809
Thatcher, AZ 85552
(602) 428-4073
CIRCLE 347 ON FREE INFORMATION CARD

TDK

1600 Feehanville Drive
Mount Prospect, IL 60056
(708) 803-6100
CIRCLE 348 ON FREE INFORMATION CARD

Walker Scientific

Rockdale Street
Worcester, MA 01606
(800) 962-4638
CIRCLE 349 ON FREE INFORMATION CARD

nal component values. By the way, both the inductor and the freewheeling diode values are critical and exact brands and values must be

used. The circuit will not work with an inductor that has too high a DC resistance or one that saturates at higher current levels.

and low-cost power inverters.

New tech lit

New *Electrorheological Fluids* are

found in *Science* for October 30, 1992 on pages 761-766. These are fluids whose apparent viscosity can change with the applied voltage. Obvious applications would be in clutches, four-wheel drive-on-demand, and robots. Plus, of course, it is a "just-obscure-enough" student paper topic.

From *Philips*, there's a *Semiconductor Sensors Data Handbook*. It includes magnetic field sensors, temperature sensors, and proximity detectors. And through *TDK*, a similar *Sensors* short-form catalog on devices for infrared, humidity, current, surface potential, and even powder levels.

An enormous and free *Wall Chart of Programmable Devices* from *Data I/O* lists just about all the EPROM's, EEPROM's, PLD's, and similar devices.

Two magazines of interest to professional sound installers are the *Sound & Communications* and the *Sound & Video Contractor*.

A reminder that I stock just about all of the important PostScript books from all of the major authors. I have even gathered together one each of everything into our PostScript *Whole Works* package. And much more on everything PostScript appears on my *GENIE PSRT*.

I've just added a new way to write fancy math equations in PostScript that includes some TEX-like features. See GNZOTRX2.PS for details. Or try HACK61.GPS for an editable copy of our Fig. 1 example.

As usual, I've gathered a lot of the resources I've mentioned into the *Names and Numbers* and *Switchmode Resources* sidebars. Check here first before calling our tech helpline. Ω



For your Heart's sake get **PULSE STICK II**

Your very own sophisticated pocket health monitor, PULSE STICK II, checks your pulse rate quickly and accurately anywhere. Regular monitoring of your pulse rate during exercise will enable you to plan an exercise regimen suitable for your stage of fitness. PULSE STICK II provides an early warning that you may be exceeding your own capabilities.

PULSE STICK II photoelectrically measures the changes

in the pulsed intensity of infrared radiation emitted by superficial blood vessels below the skin of the thumb. The time intervals between pulses are automatically measured and analogued by the micro-processor based circuitry and displayed in a liquid-crystal display (LCD).

Before attempting any exercise program, consult your doctor. Ask for guidance regarding the recommended safe pulse ranges for your exercise program. Follow your doctor's instructions carefully.

Only
\$39⁹⁵



Uses three AA dry cells supplied with PULSE STICK II



Ideal for running, walking and aerobic training programs!

PSII-2

YES! Please send me _____ PULSE STICK II at \$39.95 each. Price includes shipping and handling charges.

Total amount of order \$ _____

Check or Money Order enclosed. Make check payable to **CLAGGK Inc. PULSE STICK II Offer**

Charge my Visa MasterCard

Account No. _____

Exp. Date ____ / ____

Credit Card Signature _____

Print Name _____

Address _____

City _____ State _____ Zip _____

No telephone orders or C.O.D. Signature required on credit card orders. All prices include postage and handling. Payments in U.S.A. funds only. New York residents must include local applicable sales taxes. No foreign orders.

Mail orders to CLAGGK Inc. Pulse Stick II Offer, P.O. Box 4099, Farmingdale, NY 11735.

FAX orders to 1-516-293-3115.

April 1993, Electronics Now

81



APRIL

Here's your opportunity to become a CET and join the ranks of the true pros in electronics servicing.

**LARRY STECKLER, EHF/CET
EDITOR-IN-CHIEF**

ELECTRONICS OF ALL KINDS ARE BECOMING more sophisticated even as they shrink in size and drop in price. This trend can be seen in all areas—military, industrial, commercial, and consumer. To complicate the issue, the rapid pace of new technology introduction is rendering last year's cutting edge product—VCR, TV, CD player or even PC—a candidate for the back shelf, basement—or worse—the junkyard.

This situation poses both a threat and a challenge to the qualified technician. Is it possible to extend the life of otherwise serviceable products by making cost-effective repairs? The payoff is in saving their employers' or customers' money, inconvenience, and perhaps even downtime.

Unfortunately, the number of qualified electronics technicians capable of maintaining, repairing or upgrading today's equipment has been declining. There is now a growing need for more technicians well versed in the latest analog and digital technology who can work productively. All too often, the cost of even minor repairs is a significant fraction of replacement cost. That frequently results in a buy vs. repair decision—and consequent waste of valuable hardware.

A skilled electronics technician has an opportunity to advance to more responsible supervisory or management positions—if he or she has some objective way to demonstrate his or her experience and skill.

For many, that is accomplished by on-the-job promotion or productivity awards. But for most, one of the best ways to gain that recognition is to become a Certified Electronics Technician (CET).

Despite the well publicized downsizing of some of the industry giants, and cutbacks as defense contractors attempt to retool for alternate work, most industry leaders agree that there will always be ample opportunities for capable, responsible, versatile electronics technicians. The turnaround has begun, and now is the time to become a CET. You are invited to join more than 35,000 Certified Electronics Technicians in a world-wide observance of "Electronics Technicians Day" on April 6, 1993.

Ernie Curtis, CET, Chairman of the International Society of Certified Electronics Technicians stated, "More so than ever before, we must assist qualified electronics technicians in attaining positions commensurate with their training and experience. Through our qualified recognition program of certification, we can assist Certified Electronics Technicians in their efforts to gain responsible employment."

ISCET recognizes that without this highly-skilled and specially-trained corps of Certified Electronics Technicians, breakdowns in modern complex electronics could quickly bring our society to an abrupt halt.

"ISCET's salient intention," Curtis continues, "is to focus international recognition on the high standards of performance and excellence main-

tained by professional electronics technicians."

Over 150 ISCET Certification Test Administrators, throughout the United States, have volunteered to give CET tests during the week of April 4 through 10 to honor Electronics Technicians Day. The complete list of all of these test sites, which includes this publication's offices, is included elsewhere in this article.

While the CET program is focused primarily in the U.S., technicians around the world seek CET certification, even in such war-torn countries as Slovenia, formally a part of Yugoslavia. In the summer of 1992, Drago Lumbar, CET, passed his Radar Option to become the first CET in that new nation. Lumbar, who studied electronics by correspondence from Cleveland Institute of Electronics, is employed at Lumbar & Co. in Ljubljana, Slovenia.

What is ISCET?

As the proud electronics technicians division of the National Electronics Service Dealers Association (NESDA), ISCET was founded in 1970 by a committee of Certified Electronics Technicians whose main purpose was to foster respect and admiration for their profession. By maintaining rigorous standards in its certification program, ISCET is able to separate the highly skilled and knowledgeable technicians from those with less experience. ISCET's main functions include direction and administration of the CET program, the national apprentice and training program, technical information-training and

6: ELECTRONICS TECHNICIANS DAY

upgrading programs, and the serviceability programs.

In addition, IS CET offers its members a continual source of technical material, including regular updates on new technology, training seminars, discounts on books, tapes, and software, newsletters, and a magazine. There is also an annual industry directory; and an annual convention with management and technical-training seminars, an instructor's conference, and a trade show.

The CET program is designed to measure the degree of theoretical knowledge and technical proficiency of practicing technicians. A technician with a CET certificate is considered in the industry to be one who possesses the training and expertise necessary to perform his job with professional competence. Since its inception, the CET program has continued to gain acceptance by technicians, manufacturers, and consumers. Many organizations encourage, and often require, their technical employees to be certified by IS CET.

Technician skills.

Just keeping up with the changes that seem to occur daily in equipment is a full-time task. To be able to service the latest electronic equipment with its new circuitry, new components, and new principles is a difficult challenge. Today's electronics technicians must constantly learn, constantly acquire new skills, and constantly develop new techniques. They must become familiar with new kinds of test equipment and advanced servicing techniques to

repair the latest electronics marvels.

Perhaps this was best summed up by Don Winchel, CET, IS CET's Immediate Past Chairman, when he said, "Because of the dynamic changes that have occurred in electronics during the past decade, all corners of our modern world now look to electronics technicians to keep our civilization ticking. The new techniques, devices, and technologies that have appeared in just one product, the camcorder, in the past few years alone are mind-boggling. Today's electronics technicians must be able to analyze complex problems instantly which places them in a select group of the world's work force that will see unprecedented rewards of a grateful industry in the 21st century."

The CET exam.

To become certified by IS CET, the electronics technician must pass both a 75-question Associate-level CET test, and a 75-question Journeyman-level test. To pass, the candidate must score a grade of 75 percent or better. An electronics technician or student with less than four years of experience may ap-



Keeping up with current equipment and technology is an important part of being a professional technician. Shown here is an IS CET seminar on Sencore servicing techniques.

ply for the Associate-level exam only, which covers the following subjects: Basic Mathematics, DC Circuits, AC Circuits, Transistors and Semiconductors, Electronic Components, Instruments, Tests and Measurements, Troubleshooting, and Network Analysis.

A fully certified technician must have four or more years of education or experience in electronics and must pass, in addition to the Associate-level test, one or more of the Journeyman options available in specialized fields of electronics. The Journeyman options are:

- Consumer—Subjects covered include antennas and transmission lines, digital and linear circuits in consumer products, TV and VCR servicing problems, and the use of appropriate test equipment.
- Industrial—Subjects include transducers, switches, power factor, differential amplifiers, closed-loop feedback, basic logic circuits and functions, elements of numeric control, thyratrons, and SCR controls.
- Communications—This test covers two-way radio transmitter theory and servicing, receivers, transmitters, basic communications theory, deviation sensitivity, quieting, and troubleshooting.
- Computer—This test covers operation of computer systems with basic emphasis on hardware. Subjects covered include basic arithmetic and logic operations, computer organization, input and output equipment, and memory and storage.
- Audio—Products covered in this option include turntables,

Continued on page 91

E-N Engineering Admart

Rates: Ads are 2 1/4" x 2 1/8". One insertion \$995 each. Six insertions \$950 each. Twelve insertions \$925 each. Closing date same as regular rate card. Send order with remittance to Computer Admart, Electronics Now Magazine, 500-B Bi-County Blvd., Farmingdale, NY 11735. Direct telephone inquiries to Arline Fishman, area code-1-516-293-3000. FAX 1-516-293-3115. Only 100% Computer ads are accepted for this Admart.

HIGH POWER AUDIO AMPLIFIER CONSTRUCTION

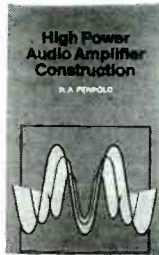

BP277—Here's background and practical design information on high power audio amplifiers capable of 300 ± 400 watts r.m.s. You'll find MOSFET and bipolar output transistors in inverting and non-inverting circuits. To order your copy send \$6.25 plus \$2.50 for shipping in the U.S. to Electronic Technology Today Inc., P.O. Box 240, Massapequa Park, NY 11762-0240.

DR. "CHIP" MUNK SAYS



6805/68HC05/68HC11
DEVELOPMENT TOOLS
QUALITY and SERVICE
AFFORDABILITY
TECI

"Chip" experts agree with Dr. Munk. TECI's PC based microcontroller development tools are the most cost effective for veterans or beginners.

- 6805 PRIMER FOR BEGINNERS \$195.00
- 6805/68HC05/68HC11 CROSS ASSEMBLERS. \$99.00
- 6805/68HC05 SIMULATOR / DEBUGGERS \$99.00
- 68705P3,P5,U3,U5,R3,R5 PROGRAMMERS FROM \$349.00
- 68HC705/68HC805 PROGRAMMERS FROM \$395.00
- COMPLETE PC BASED DEV. SYSTEMS FROM \$449.00
- 68HC05/68HC11 REAL TIME EMULATORS FROM \$895.00



CALL TOLL FREE 1-800-336-8321
The Engineers Collaborative, Inc.
Rt #3 Box 8C, Barton, VT 05822 USA
TEL:(802)525-3458 FAX:(802)525-3451

CIRCLE 188 ON FREE INFORMATION CARD

RADIOTELEPHONE—RADIOTELEGRAPH FCC LICENSE PREPARATION

Why Take Chances

The FCC has revised and updated the commercial license exam. The NEW EXAM covers updated marine and aviation rules and regulations, transistor and digital circuitry. OUR CURRENT HOME-STUDY GUIDES/AUDIO, VIDEO OR PC DISKS MAKE IT FAST & EASY. FEATURING NEW "CAREER GUIDE" 1000'S OF SATISFIED CUSTOMERS

FREE DETAILS

WPT PUBLICATIONS

7015 N.E. 61st Ave.
Vancouver, WA 98661
Phone (206) 750-9933 Dept. 50

CIRCLE 105 ON FREE INFORMATION CARD

DRAWING BOARD

continued from page 18

Don't get me wrong—decoding

like this is sometimes necessary, and if you're new to design, it's a good learning experience. But a smarter way to go about this is to use an EPROM, a one-chip solution to the problem.

You can use any EPROM you happen to have around, because we're interested in only two input addresses (24 and 257), and need only one or two data lines (depending on how we design the circuit that enables the manufactured or transmitted sync). The circuit is shown in Fig. 1, and the EPROM's truth table is shown in Table 1. I'm using two data lines to switch between sync

sources, but a design could easily be worked out that uses only a single data line.

This is easier to understand when you look at Fig. 2, a block diagram that shows all of the circuitry we've just been talking about. There are two possible sources of horizontal sync pulses: the ones from the original video signal, and the ones being generated by the phase-locked loop circuit. We want to use the transmitted sync during the vertical interval (it's sent in the clear during the vertical interval), and the generated sync for the rest of the time. We have 28 lines of signal with transmit-

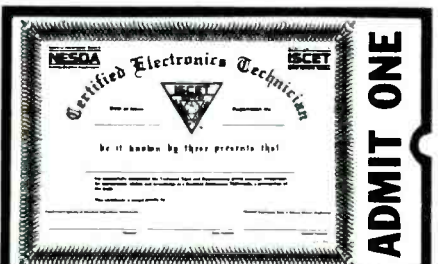

ADMIT ONE

Your Ticket To

SUCCESS

Over 28,000 technicians have gained admittance worldwide as certified professionals. Let your ticket start opening doors for you.

ISCET offers Journeyman certification in Consumer Electronics, Industrial, Medical, Communications, Radar, Computer and Video. For more information, contact the International Society of Certified Electronics Technicians, 2708 West Berry Street, Fort Worth, TX 76109; (817) 921-9101.

Name _____
Address _____
City _____
State _____ Zip _____

Send material about ISCET and becoming certified.

Send one "Study Guide for the Associate Level CET Test." Enclosed is \$10 (inc. postage).

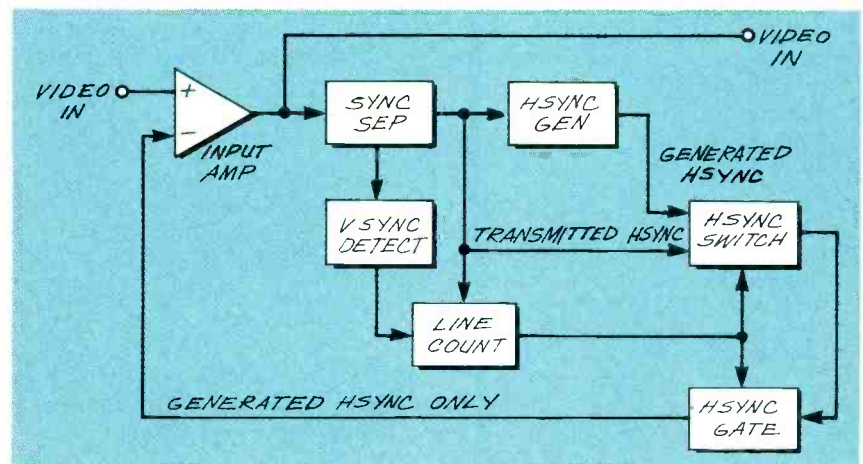

FIG. 2—SSAVI DESCRAMBLER BLOCK DIAGRAM. We use the transmitted sync during the vertical interval and the generated sync for the rest of the time.

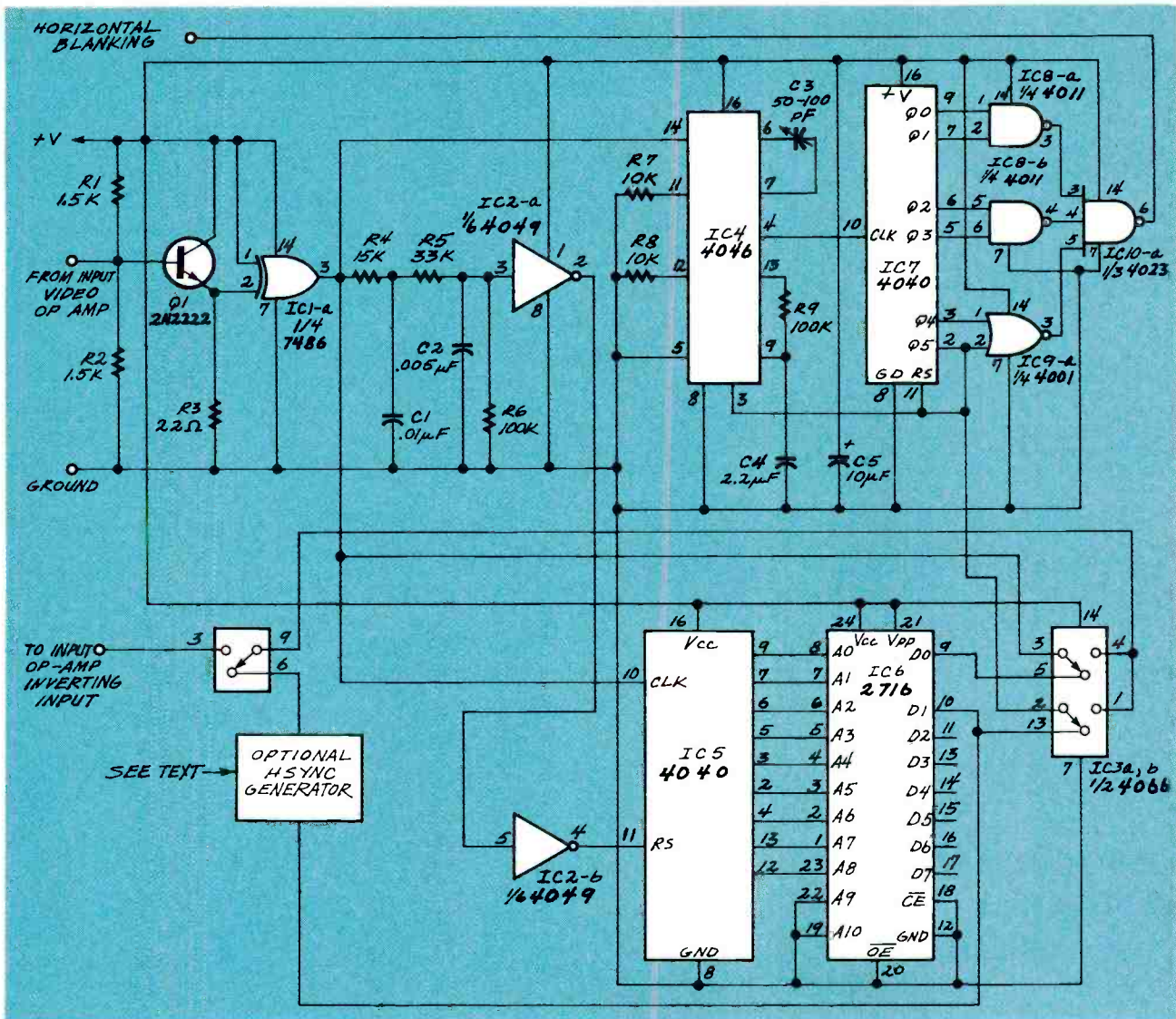

FIG. 3—THE SYNC SWITCHER is really just an electronic single-pole, double-throw switch. Here we've added the EPROM and the 4066 switch. The EPROM's data lines directly control the two 4066 control lines.

ted horizontal sync; they are lines 261 and 262 at the end of one frame, and lines 1–26 at the start of the next frame.

The sync switcher we need is really just an electronic version of a single-pole, double-throw switch, and the easiest way to put one of them together is to use a 4066 just as we did some months ago. Figure 3 shows our circuit so far, with the addition of the EPROM and the 4066 switch. Notice that the EPROM's data lines directly handle the two 4066 control lines. That can be done because the EPROM outputs change state only when the 4040 counter signals the arrival of either line 24 or line 257. If you use gates to decode the counter output,

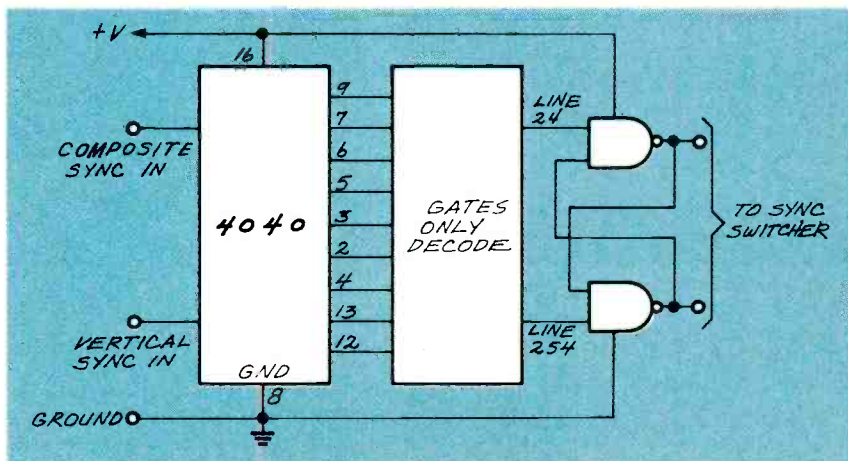

FIG. 4—INSTEAD OF AN EPROM, you can use some of the gates left over from last month's project to build a set/reset flip-flop.

you'll have to find a way to do the same thing. One approach would be

to use some of the gates left over from last month to build a set/reset flip-

Be an FCC LICENSED ELECTRONIC TECHNICIAN!



Earn up to \$30 an hour and more!

Learn at home in spare time. No previous experience needed!

No costly school. No commuting to class. The Original Home-Study course prepares you for the "FCC Commercial Radiotelephone License." This valuable license is your professional "ticket" to thousands of exciting jobs in Communications, Radio-TV, Microwave, Maritime, Radar, Avionics and more...even start your own business! You don't need a college degree to qualify, but you do need an FCC License.

No Need to Quit Your Job or Go To School
This proven course is easy, fast and low cost! **GUARANTEED PASS**—You get your FCC License or money refunded. **Send for FREE facts now. MAIL COUPON TODAY!**

COMMAND PRODUCTIONS

FCC LICENSE TRAINING, Dept. 90
P.O. Box 2824, San Francisco, CA 94126
Please rush FREE details immediately!

NAME _____
ADDRESS _____
CITY _____ STATE _____ ZIP _____

SUPER 12 HOUR RECORDER CALL TOLL FREE

Modified Panasonic Slimline,
6 hrs per side
120 TDK tape furnished.
AC/DC Operation.
Quality Playback.
Digital Counter.
Durable Lightweight Plastic.



\$119.00*

PHONE RECORDING ADAPTER

Starts & Stops Recorder Automatically When Hand Set is Used. Solid State!



FCC Approved

\$28.50*

VOX VOICE ACTIVATED CONTROL

Solidstate Adjustable Sensitivity. Voices & Sounds Activate Recorder Adjustable Sensitivity Provisions for Remote Mike



\$28.50*

* Add for ship. & handling. Phone Adapter & Vox \$2.00 each, Recorders \$5.00 each. Colo. Res add tax. Mail Order, VISA, M/C, COD's OK. Money Back Guar. Qty Disc. available. Dealer inquiries invited. Free data on other products.

AMC SALES INC. 193 Vaquero Dr. Boulder, CO. 80303

Phones (303) 499-5405 1-800-926-2488

FAX (303) 494-4924

Mon-Fri 8-5 MTN. TIME

CIRCLE 108 ON FREE INFORMATION CARD

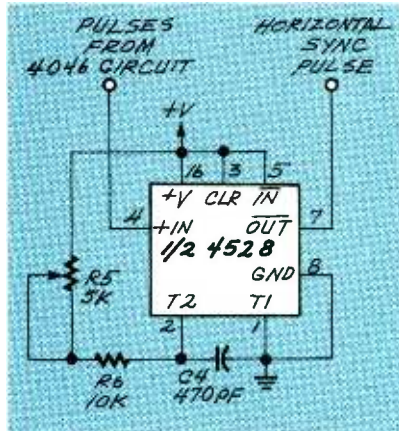

FIG. 5—IF THE 4046 PULSES WON'T TRIGGER the horizontal flyback in your TV, this circuit will generate 4.7-microsecond pulses when triggered by the 4046.

generate sync even if it has been left out.

The circuitry we've built so far will do a good job of restoring horizontal sync. Just about the only problem you might have relates to the width of the generated pulse. The official width of horizontal sync pulse, according to NTSC specifications, is 4.7 microseconds—and the closer you get to that, the better your chances are of having everything work properly. That leads us to the age-old question, "How close is close enough?"

The answer to that question depends on your TV's horizontal sync detector; some of them will recog-

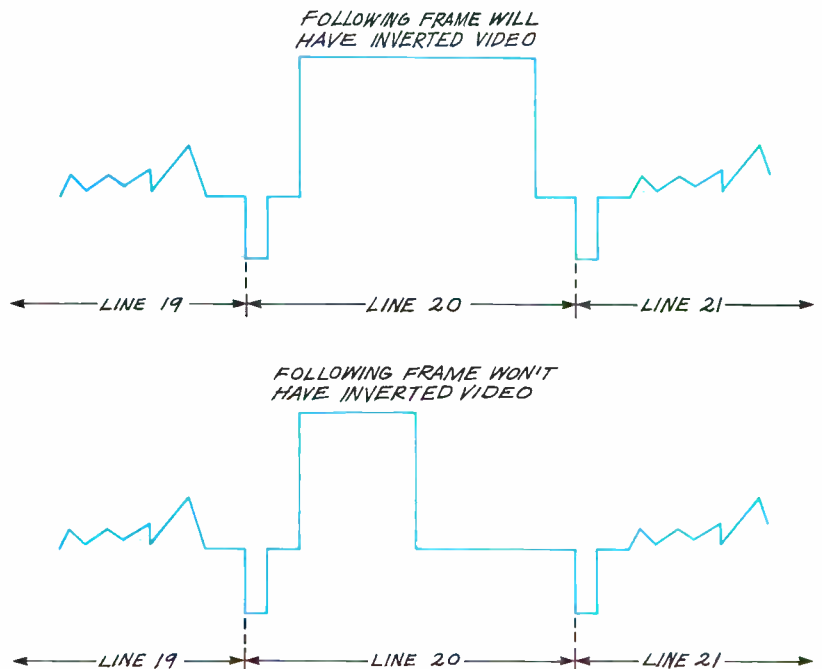

FIG. 6—TO CORRECT INVERTED VIDEO, we need the information buried in line 20.

flop whose control lines are triggered by the arrival of lines 24 and 257. The basic idea is outlined in Fig. 4.

Back to theory

Let's go over the general SSAVI theory for a minute. In the SSAVI system, there are two parts of the video signal that get messed up: the first is the horizontal sync pulse and the second is the polarity of the picture portion of each individual line of video. All the circuitry we've been developing so far has been aimed at taking care of horizontal sync. The circuitry has become a bit complicated, but we now have a way to

nize pulses that are as much as 50 percent off, while others will turn up their noses at any deviation beyond 25 percent. If you find that the 4046 pulses aren't triggering the horizontal flyback in your TV, you can use those generated pulses to trigger additional circuitry that will produce a pulse of exactly 4.7 microseconds. Then feed that to the input video op-amp instead of using the 4046 pulses directly to do the job. We designed a circuit to do exactly that, some months ago, when we built a video-sync generator. The circuit is shown in Fig. 5.

Now let's address the problem of inverted video. When we first start-

ed this project, we talked about how the SSAVI system encodes information about the polarity of the next frame of video. The original SSAVI system buried this information on line 20, as shown in Fig. 6. Now that we have circuitry to count the lines of video, it's a piece of cake to signal the arrival of line 20 and examine it.

Restoring inverted video is a completely separate deal, and we'll have to wait until next month to get into the nitty gritty of it. Ω



I have to strap batteries to him—my building doesn't allow pets!

LETTERS

continued from page 16

ardless of established conventions. Mr. Lancaster apparently wants to ignore the evidence of 75 years of vacuum-tube theory and development and their relevance to electricity just because "everybody" uses conventional flow (plus-to-minus) practices.

I am not confused about either theory or the symbols after 30 years of application of what I was taught in school. In search of truth, one should never be influenced by "might makes right" thinking.

ROGER L. RAVENSBORG
Saint Paul, MN

DISKETTE CONVERSION

I'm writing in response to William B. Proctor's letter (*Electronics Now*, January 1993), in which he listed his relevant background qualifying him to write with authority on the subject of converting double-density disks to high-density disks. While I

am impressed by his credentials, I do not agree with his "facts" and his conclusion that the conversion discussed is a bad idea.

Specifically, Mr. Proctor wrote, "we also found that we had to decrease the diameter of the hub to allow reliable recording at the innermost tracks." Excuse me, but I have a 3.5-inch double-density and a high-density disk in front of me, and I can measure no difference in their hubs with my pocket caliper.

Do you remember when single-density, single-sided, and 40-tpi were standard and manufacturers charged premium prices for double-side, double-density, and 80-tpi? Actually, the materials and manufacturing cost were the same.

People use converted disks every day with no problems. I am convinced that the only differences are the label and the price. Until someone can demonstrate that is not the case, I will continue to recommend the use of converted disks.

JAMES A. PILARSKI
Northglenn, CO

Ω

*Exciting Features, Projects, Reviews
& Columns And Much More!*

In the Next Issue of

Popular Electronics®

ON SALE

MARCH 18, 1993

WATCH FOR IT!

Pick up Popular Electronics at your favorite
Newsstand Bookstore or Supermarket

**Go ahead,
put on some weight**

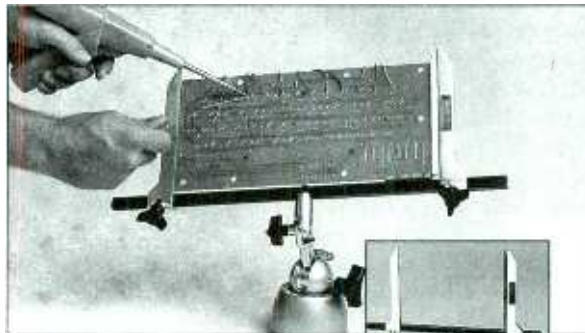

Introducing the improved 372 Circuit Board Holder. A longtime favorite for circuit board work, the 372 now comes with our redesigned 300 base. A new, patented, internal modification to the 300 split ball locking mechanism allows it to hold twice as much weight as its predecessor. Of course, the 372 still comes with the industry's best circuit board holder, the PanaVise 315, which can hold PCBs up to 12 inches wide (up to 28" with 30" 318 Accessory Cross Bars.) You can even handle multiple boards when you use additional 316 Circuit Board Arms. The new PanaVise 372 Circuit Board Holder. When circuit boards are your business.

PANAVISE

1485 Southern Way • Sparks, NV 89431 • (702) 353-2900 • FAX (800) 395-8002

CIRCLE 178 ON FREE INFORMATION CARD

AUDIO UPDATE

More audio Q's and A's from reader mail and my files

LARRY KLEIN

HQ query

Most new VCR's are advertised as having "HQ" circuitry, but I've never seen an explanation of what HQ is supposed to accomplish. Can you give me an answer?

R.A.

Cerritos, CA

HQ stands for "High Quality," and the technology was developed by the Victor Company of Japan (JVC) for VHS VCR's. Essentially, it is a collection of video signal-enhancement circuits that operate separately on various parts of the signal. The HQ circuits are designed to reduce luminance- and chrominance-signal noise (and thereby reduce "snow" or graininess), and color patching and streaking, respectively. White-clip level inadequacies are also reduced with a consequent improvement in image-edge sharpness.

Because different HQ circuits operate during recording and playback, some of the improved quality of HQ-recorded tapes will show up during playback on non-HQ machines. Older tape playback on an HQ machine will also be improved, but to a lesser degree. The improvements are most obvious at the slower tape speeds; it is claimed that tapes that are HQ recorded in the slow-speed EP mode will have the visual quality of conventional standard-speed tapes. Perhaps.

One caveat: The HQ logo on a VCR does not necessarily mean that it includes all of the different circuits in the HQ standard. I don't know how you could determine that with certainty for any machine without checking with the manufacturer.

Woofer flap

I am hoping that you can settle an argument. I've been told that violent movement of a woofer cone is due to some flaw in the recording or playback system. But a friend of mine says that woofers are sup-

posed to do that. Who is right?

T.P.

Barryton, MI

Woofers create sound by pushing (and pulling) air with their diaphragms. In general, the lower the audio frequency, the further the woofer cone must travel to create the same sound volume. Each time the bass response drops an octave, the woofer cone must travel four times the distance (assuming that it can) to reproduce it. You can see how cone movement might well be visible at the very lowest and loudest frequencies. However, you certainly should not see wild fluctuations on most program material—and the movement you see should coincide with and produce audible bass.

The amount of spurious woofer-cone movement usually relates to its enclosure's internal acoustical damping, but other factors certainly can have a contributing effect. An unstable amplifier, an LP turntable with severe infrasonic rumble, warped records, flexing of the floors, low-frequency acoustic feedback, and even misbehaving tapes and FM stations have all been known to produce excessive woofer-cone movement.

For the most part, what reaches a speaker system at infrasonic frequencies depends on the low-frequency design embodied in the accompanying preamplifier and power amplifier. If either unit has a built-in, low-frequency rolloff at 10 Hz—or even slightly higher—then the woofer won't have to undergo excessive excursions, and the distortions that are probably caused by them. For this reason, many designers believe that extending an amplifier's response down to DC (0 Hz), or close to it, causes nothing but trouble.

Once I saw an interesting article in a British technical journal sug-

gesting that the extended low-frequency performance of CD's would be extremely troublesome for conventional vented (bass-reflex) enclosures. Unlike acoustic-suspension systems, whose sealed boxes "load" the rear of the woofer cone down to infrasonic frequencies, vented designs usually provide little or no cone control below system resonance. However, in light of the sophisticated woofer-box computer-design programs now available, I suspect that the knowledgeable designer can house his woofer any way he wants without running into infrasonic troubles.

Power upgrade

I have a 40-watt-per-channel receiver that generally sounds good, but I suspect that it is clipping when played at high volumes. I am considering trading up to an 80-watt-per-channel receiver, and I wonder what improvement that will make.

A.C.

New York, NY

Not much. Generally, if you double the available power (as measured in watts) from your amplifier, you'll gain only 3 dB more signal headroom before signal clipping (overload) occurs. Of course, every bit of additional power helps, but if you are changing your equipment specifically to obtain greater power reserve, it makes sense to trade up to at least triple your present power.

When comparing amplifiers of equivalent cost and continuous-power ratings, it's a good idea to choose one that also has a high dynamic headroom rating; say, 3 to 6 dB. Such amplifiers can provide two to four times their continuous-power rating for brief musical peaks—which is precisely when you need more power.

Whether or not your present amplifier is clipping, would depend on your preferred listening levels, the

kind of music you like, the size and acoustics of your listening room, and the efficiency of your speakers. If you have access to an oscilloscope, you can visually monitor the musical output waveforms being sent to your speakers for indications of clipping. Clipping will appear as bright spots at the tops and bottoms of the highest waveforms.

Perhaps you can borrow a high-powered amplifier to substitute for your present amplifier to find out if you hear a difference at the levels at which you normally listen. If there is a difference to be heard, it will show up as a more "open" quality with greater detail during the very loud passages. There should also be a greater sense of dynamics in the music. Your listening tests should be done with music that has a wide dynamic range (lots of loud and soft passages) rather than with hard rock or similarly compressed, consistently loud material.

Overprocessed signals?

I'm appalled by the proliferation of signal processors—particularly equalizers—in the audio marketplace. What ever happened to the notion that a superior high-fidelity system is simply "a straight wire with gain"?

P.R.
Buffalo, NY

The idea is alive and well, although it is beset by philosophical confusion. While the concept has validity for, say, power amplifiers, it really can't be applied to the entire recording/reproduction chain. Straight-wire-with-gain audiophiles, for whom tone controls of any kind are anathema, appear to assume that whatever signal comes out of their carefully chosen disk player or tape machine somehow perfectly embodies an original performance. Anyone naive enough to harbor such a belief has, at best, a very unclear concept about to how sound is recorded and reproduced—and probably also owns shares in the Brooklyn Bridge.

Assuming that you had a perfect stereo recording of the sound field (at a specific location) of a live musical event—and that all the electromechanical and electronic elements of your playback system

were perfect—your speakers would still have the task of replicating the acoustics of a concert hall within the comparatively cramped environs of a conventional listening room. In short, the chances of exactly duplicating an original live sound field in your listening room is about zero.

Given the aberrations in frequency response, noise level, and dynamic range likely to be introduced—deliberately or otherwise—at every stage in the recording/playback process—plus the loss of rear ambience and reflections—I see nothing wrong with using the appropriate signal processors to minimize, ameliorate, or eliminate the various ill effects. As you might guess, I've long since given up any hope of reproducing the precise sound of any original musical performance in my home. But when I achieve plausible reproduction—meaning that I hear the music as it might be heard live in some adequate acoustic environment—then I'm satisfied that I've achieved high, if not absolute, fidelity. Ω

Try the
Electronics
NOW®

bulletin board
system

(RE-BBS)
516-293-2283

The more you use it the more useful it becomes.

We support 1200 and 2400 baud operation.

Parameters: 8N1 (8 data bits, no parity, 1 stop bit) or 7E1 (7 data bits, even parity, 1 stop bit).

Add yourself to our user files to increase your access.

Communicate with other R-E readers.

Leave your comments on R-E with the SYSOP.

RE-BBS
516-293-2283

SALE!

CABLE TV DESCRAMBLERS WE'LL BEAT ANY PRICE! CALL TOLL-FREE 1-800-284-8432

- JERROLD • TOCOM • ZENITH •
- OAK • PIONEER • HAMLIN •
- SCIENTIFIC ATLANTA •

24 HOUR SHIPMENTS!
QUANTITY DISCOUNTS!
MONEY BACK GUARANTEE!
FREE CATALOG & INFORMATION



MasterCard • American Express • Visa • C.O.D.
HAVE MAKE AND MODEL NUMBER OF EQUIPMENT USED IN YOUR AREA
1-800-284-8432

FOR ORDERS ONLY
For technical & customer service: 305-749-3122
ALL SHIPPING & HANDLING FEES AT CUSTOMER'S EXPENSE.

CABLE WAREHOUSE
10117 WEST OAKLAND PARK BLVD., SUITE 515, SUNRISE, FL 33351
NO FLORIDA SALES

CIRCLE 185 ON FREE INFORMATION CARD

www.americanradiohistory.com

Learn VCR repair at home!

MAKE GOOD MONEY IN YOUR OWN FULL- OR PART-TIME JOB



Professional-level home study course. You will master easy-to-learn, high-profit repairs *without* investing in high-tech instruments or a costly workshop. Want more independence and higher income? Send or call today!

Free career kit:
800-223-4542

Name _____
Address _____
City _____ State _____ Zip _____

The School of VCR Repair
2245 Perimeter Park Drive
Dept. VE342 Atlanta, Georgia 30341

CIRCLE 187 ON FREE INFORMATION CARD

VCR Repair Can Payoff Big

You Can Earn \$1000.00 a Week Working Part Time
from Your Own Home



Secrets Revealed . . .
No Special Tools or Equipment
Needed.

Sounds impossible but it's true. VCR technicians report earning \$80.00 an hour for simple VCR repairs. You can learn to be a VCR Technician in just a few short weeks.

Enroll in the Foley-Belsaw Institute of VCR Repair where you learn by the Viejo Method. Designed in a VCR Repair Shop to teach individuals with no electronic or VCR repair skills, the Viejo Method has been proven fast and efficient.

The Viejo Method works on the principle that the vast majority of VCR repairs are simple mechanical or electro-mechanical problems. You learn these simple repairs first to start earning money right away. These simple repairs then serve as the foundation for more complicated repair work.

You earn top dollar with your new skills. Just think, a cleaning procedure that takes less than an hour can earn you \$80.00 to \$120.00. If you are not happy or feel you can't reach your full potential in your present job, now is the time to act.

For your FREE Information Kit, mail the coupon below to: Foley-Belsaw Institute of VCR Repair, Dept. 62004, 6301 Equitable Road, Kansas City, MO 64120

Send me my FREE Information Kit on VCR Repair. There is no obligation and no salesman will call. Dept. 62004

Name _____

Address _____

City _____

State _____ Zip _____



Since 1926

CIRCLE 194 ON FREE INFORMATION CARD

AFGII

continued from page 44

some experiments with audio levels at various locations in the system to achieve optimum results.

Other considerations

Capacitors C49-C51 (surrounding IC7-d in Fig. 6) tune the crossover frequency of the subwoofer low-pass filter. The values indicated in the Parts List and Fig. 6 produce a filter that has its -3 dB point (corner frequency) at approximately 80 hertz, which is a good frequency for most automobile subwoofer systems. However, if you experience excessive resonance or "boominess", you can move the crossover point up or down by changing the values of the filter-tuning capacitors as indicated in Table 1. All three capacitors must be changed as a set, and they should have a tolerance of 5 percent.

The AFG II, as described here, is capable of providing ample amounts of delay and reverberation for most listening situations. However, it is possible to double the available delay by substituting MN3005 4096-stage bucket-brigade devices for the MN3008 2048-stage devices used in the prototype. The pinouts of the two IC's are identical, and no other changes to the circuit are necessary if you choose to use the 4096-stage devices.

Actual delay and reverberation adjustments are, of course, a matter of individual taste, but note that in live listening situations, the amount of delay and reverberation reaching the listener are a small percentage of the overall sound field. Also, using the AFG II in the surround mode will highlight any reverberation and delay which might exist in the original audio signal. To achieve the most realistic listening environment, judicious and sparing use of reverberation and delay are recommended. If you add too much, the sound becomes artificial and even annoying to some people. Ω

IT'S A TRAGEDY BEYOND DESCRIPTION.

96,000 acres of irreplaceable rain forest are being burned every day. These once lush forests are being cleared for grazing and farming. But the tragedy is without the forest this delicate land quickly turns barren.

The National Arbor Day Foundation, the world's largest tree-planting environmental organization, has launched Rain Forest



Rescue. By joining the Foundation, you will help stop further burning. For the future of our planet, for hungry people everywhere, support Rain Forest



The National Arbor Day Foundation

Call Rain Forest Rescue.
1-800-255-5500

FREE

Electronics & Computer Software
Education Catalog

- *Fast-Track Individual Learning Programs
- *State-of-the-Art Classroom Courses
- *The Best Values in Electronics Education

New

Career-Level Courses
Personal Computer Servicing
TV and VCR Servicing

New

Computer-Aided Instruction

DC & AC Electronics
Semiconductors
Electronic Circuits

The stunning animations, hypertext glossary, and easy-to-understand text make learning electronics a breeze...and fun!

Learn the easy and affordable way from the Masters in Electronics Training - Heathkit®. From Basic Electricity to Advanced Microprocessor Applications and more, Heathkit will provide you with an unparalleled learning experience at a fraction of the cost of other programs.

Heathkit®

Educational Systems

For your FREE Catalog, call

Toll-Free 1-800-44-HEATH
please mention this code when calling 107-010

CIRCLE 86 ON FREE INFORMATION CARD

ISCET CERTIFIED ADMINISTRATORS FOR CET EXAM

Cindy Johnson
Herzing Institute
1218 South 20th St.
Birmingham, AL 35205
(205) 933-8536

Tony C Jetton, CET
Wallace State Collg
801 Main St NW
Hanceville, AL 35077-9080
(205) 352-6403

David L Bryan, CET
Al Aviation & Tech Collg
PO Box 1209
Ozark, AL 36360
(205) 774-5113, Ext. 252

R T Van Iderstine, CET
14563 South Blvd
Silverhill, AL 36576
(205) 947-4441

Russell Scarpelli, CET
10529 W Desert Forest Circle
Sun City, AZ 85351
(602) 972-5438

Dennis P Blum, CET
Phoenix Inst Of Tech
2555 E University Dr
Phoenix, AZ 85034
(602) 244-8111

H J Paine, CET
4631 E 8th St
Tucson, AZ 85711
(602) 881-6784

Parviz Shams
Southern CA Inst Of Tech
10600 Katella Ave
Anaheim, CA 92804
(714) 520-5552

Edward A Belsky, CET
881 Palo Verde Dr
Barstow, CA 92312
(619) 252-81940

Billy J Edmonds, CET
1311-16th St
Baywood, CA 93402
(805) 547-7900, Ext. 4671

Donald R Parker
Chuchawalla Vly State Prison
19025 Wiley's Well Rd
Blythe, CA 92226
(619) 922-5300

John V Craig, CET
531 W Hueneme Rd
Oxnard, CA 93033
(805) 982-5228

David Marson, CET
PO Box 1245
Paso De Robles, CA 93447-1245
(805) 238-4040, Ext. 428

Raymond L Unser, CET
The Audio Specialist
3806 Muirwood Dr
Pleasanton, CA 94588
(408) 944-4210

Jon R Sturtz, CET
10840 Alandale Way
Rancho Cordova, CA 95670
(916) 635-6000

Kevin J Price, CET
N.E.C.
825 E Hospitality Ln
San Bernardino, CA 92408
(714) 885-3896

Dr Kenneth L Wilson, CET
San Diego City College
1313-12th Ave
San Diego, CA 92101
(619) 230-2601

Fredrick J Smith, CET
Educ Dept/Ca Mens Clny
PO Box 8101
San Luis Obispo, CA 93409-0003
(805) 547-7900, Ext. 4671

Howard Bardach, CET
The Audio Specialist
4381 Tjunga Ave
Studio City, CA 91604
(818) 763-3009

Romualdo Malarayap, CET
ITT Tech Inst
1530 W Cameron Ave
W Covina, CA 91706
(818) 960-8681

John F Stackhouse, CET
2665 S Peoria St
Aurora, CO 80014
(303) 750-2372

Marjorie Lona
Colorado Aero Tech
100 Technology Dr #100
Broomfield, CO 80021
(303) 466-1539

John F McMullen, CET
Denver Inst Of Tech Inc
7350 N Broadway
Denver, CO 80221
(303) 426-1808

Art Sorensen, CET
Arts Audio Video Svc
1416 N Lincoln Ave
Loveland, CO 80538
(303) 669-0883

Edward V Busch, CET
Porter & Chester Inst
124 Silas Deane Hwy
Hartford, CT 06109
(203) 529-2519

John E Depalma, CET
CT School Of Elect
566 Ella Grasso Blvd
New Haven, CT 06519
(203) 624-2121

Daniel J Shea, CET
CT School Of Elect
566 Ella Grasso Blvd
New Haven, CT 06519
(203) 624-2121

James Ewing, CET
Porter & Chester Inst
125 Silas Deane Hwy
Wetherfield, CT 06109
(203) 529-2570

Albert Moses, CET
PO Box 188
Cheswold, DE 19936
(302) 571-5402

James D Hite, CET
Pinellas Vo-Tech
6100 154th Ave N
Clearwater, FL 34620
(813) 531-3531, Ext. 226

Edward Guary Sr, CET
Eddy's Radio & TV Svce
1110 NE 4th Ave
Ft Lauderdale, FL 33304
(408) 763-2964

Karl A Hunter, CET
13850 Ketch Cove Dr
Jacksonville, FL 32224-1143
(904) 633-8143

John Steven Richards, CET
ITT Tech Inst
2600 Lake Lucien Dr #140
Maitland, FL 32751
(407) 680-2900

Noel Shevack
New England Inst Of Tech
1126 53rd Ct
Palm Beach, FL 33407
(305) 842-8324

Neil A Wertley, CET
U.E.I.
3924 Coconut Palm Dr
Tampa, FL 33619
(813) 626-2999

William S Brooks, CET
7112 N Habana Ave
Tampa, FL 33614-4365
(813) 933-1793

Dennis P Abell, CET
3433 Royal Oak Dr
Titusville, FL 32780
(305) 269-4208

Cal Reddick, CET
2413 Ave G NW
Winter Haven, FL 33880-2136
(813) 299-6514

Perry (Jim) Parks, CET/CA
1055 Hwy 434
Winter Sprgs, FL 32708
(407) 699-8811

W R Rooks, CET
176 Shiloh Rd
Americus, GA 31709
(912) 928-0283, Ext. 26

Roy Chastain, CET
N.G.T.I.
197 N
Clarkesville, GA 30523-0065
(404) 754-7751, Ext. 334

James P Van Sant, CET
Pickens Tech
100 Pickens Tech Drive
Jasper, GA 30143
(404) 692-3411

Mel Streeter
Lewis Clark St Collg
8th Ave 6th St
Lewiston, ID 83501
(208) 799-2301

Douglas E Minter, CET
Amer College Of Tech
1300 W Washington
Bloomington, IL 61701
(309) 828-5151

Eddie C Lane.
1501 Honeysuckle
Champaign, IL 61821
(217) 217-356-6996

F A Schwarzkopf, CET/CA
3708 W 83 Place
Chicago, IL 60652
(312) 767-4126

Larry Didway, CET
Carl Sandburg Jr Collg
2232 S Lake Shore Rd
Galesburg, IL 61401
(309) 344-2518

Paul K Tan, CET
915 Augusta St
Oak Park, IL 60302-1678
(312) 848-6327

Frank Teskey, CET
F J Teskey Enterprises
3094 Lafayette Rd
Indianapolis, IN 46222
(317) 926-2639

Russel Lynd
Indiana Tech Collg
590 Ivy Tech Dr
Madison, IN 47031
(812) 265-2580

Arval W Donovan, CET
Donovan's Elect Servc
818 Dewolf St
Vincennes, IN 47591
(812) 886-4666

Leonard E Bowdre, CET
125 SE Thornton Ave
Des Moines IA 50315
(515) 964-6484

James E Boyer, CET
Western IA Tech Comm Collg
4647 Stone Ave
Sioux City, IA 51102
(712) 274-8733, Ext. 1393

Stanley Creitz, CET
Nck Area Vo Tech
PO Box 507-West Campus Dr
Beloit, KS 67420
(913) 738-2279

Michael L Baughman, CET
Ks City Area Vo Tech
2220 N 59th St
Kansas City, KS 66104
(913) 334-1000, Ext. 48

Keith E Knos, CET
Knos Electronics
1206 Elm Blvd
Liberal, KS 67901
(316) 624-5908

Pat Dunaway
Manhattan Area Tech Center
3136 Dickens Ave
Manhattan, KS 66502-2499
(913) 587-2800

Dr G W Ko, CET
550 N Fountain
Wichita, KS 67208
(316) 686-4864

Lamar W Ritchie, CET
Hazard State Vo-Tech School
101 Vo-Tech
Hazard, KY 41701
(606) 436-3101

Edward J Kimmel, CET
Kimmel Electronics
2061 Eastern Parkway
Louisville, KY 40204
(502) 451-3457

Donald Johnson
Inst Of Elect Tech
509 S 30th St
Paducah, KY 42001
(502) 444-9679

Michael Dixon, CET
KY Tech-Somerset Campus
714 Airport Rd
Somerset, KY 42501
(606) 679-4303

Dr I F Creel, CET
Sullivan Tech Inst
1710 Sullivan Dr
Bogalusa, LA 70427
(504) 732-6640

Steven B Lumpkin, CET
164 Acadian Dr
Lafayette, LA 70503
(318) 233-6388

M G McCann/Jr, CET
Mccann Electronics
100 Division St
Metairie, LA 70001
(504) 837-7272

James R Sorrels, CET/CSM
110 Oakridge Dr
Shreveport, LA 71106-7113
(318) 797-2952

W H Hartzfeldt, CET
Delta-Quachita Vo Tech
609 Vocational Pkwy
W Monroe, LA 71291
(318) 396-7431

Aurel J Daigle, CET
74 Mountainview
Madawaska, ME 04756
(207) 728-4304

Earl Tickler, CET
Retis Tech Trng Cntr
1520 S Caton Ave
Baltimore, MD 21227
(301) 644-6400

Frank Serra, CET
Serra's TV Video
1686 Mass Ave
Cambridge, MA 02138
(617) 492-2667

Bob Bellers, CET
Washtenaw Comm. College
4800 E. Huron River Dr.
Ann Arbor, MI 48106
(313) 973-3316

Willard Rush, CET
485 Amberwood St
Auburn Hills, MI 48326-1129
(313) 333-2531

Geraid H Heyn, CET
55 E Riling St, Lot 113
Gwinn, MI 49841
(906) 346-6396

Julius A Acs
Molech Educa Cntr
35155 Industrial
Livonia, MI 48150
(303) 522-9510

Dr Joel Goldberg, CET
Macomb Comm Collg
14500 12 Mile Rdn
Warren, MI 48093
(313) 445-7343

E Eugene Ranta, CET
Macomb Comm Collg
14500 Twelve Mile Rd
Warren, MI 48093
(313) 445-7343

Dr Irving W Larson, CET
Bernidji State University
Bridgeman Hall 232
Bernidji, MN 56801
(218) 755-2950

John Baldwin, CET
Faribault Campus
1225 SW 3rd St
Faribault, MN 55021
(507) 334-3965, Ext. 129

Jim Hunsucker
North Cntrl Area Vo Tech
Box 445
Bethany, MO 64424
(816) 425-2196

Annabel L Gooch
Davis Hart Mavts
905 N Wade St
Mexico, MO 65265
(314) 581-5684

James D Everett, CET
Northland Career Cntr
PO Box 1700
Platte City, MO 64079
(816) 464-2442

Marion B Denny/Jr, CET
Audio-Video Service
1405 Corinne St
Hattiesburg, MS 39401
(601) 545-7606

W Clem Small, CET
426 S 4th St
Hamilton, MT 59840-2737
(406) 363-1577

Earl Fosler, CET
SE Community College
Rt 2 Box D
Milford, NE 68405
(402) 761-2131, Ext. 266

James Belanger, CET
Betronics Inc
19 Proctor Hill Rd Box 330
Hollis, NH 03049
(603) 465-2442

Joseph T Szumowski, CET
J T S Electronics
412 Pomona Rd
Cinnaminson, NJ 08077
(609) 829-9669

Mark A Ricciardi, CET
Plaza School Of Technology
Bergen Mall
Paramus, NJ 07652
(201) 843-0344

Dr Ronald P Hartman
Tech Training Inst
1320 S Solano
Las Cruces, NM 88001
(505) 522-6533

Ralph L Van Sickle, CET
Co-Op Electronics
4480 Gunnville Rd
Clarence, NY 14031
(716) 759-8198

Larry Steckler, EHF/CET
Gemsback Publications
500 B Bi-County Blvd
Farmingdale, NY 11735
(516) 293-3000

Hubert West, CET
20 Schuyler St
Lake George, NY 12845
(518) 668-9285

Gregory J Reiber, CET
13 Garmoch Ct
Liverpool, NY 13090
(315) 457-4917

Joseph A Passaretti, CET
Pyramid Electronics Ltd
353 E 76th St
New York, NY 10021
(212) 628-6500

Carl Meyer, CET
11 Hemlock Dr
West Seneca, NY 14224
(716) 674-7113

Wayne Smith, CET
224 St John St
Arden, NC 28704
(704) 255-7671

William H Mast, CET
Appalachian State Univ
Dept Of Tech
Boone, NC 28607
(704) 262-6352

Melvin E Talbert, CET
Heilig Meyer Service Co
PO Box 64189-2858 Owen Dr
Fayetteville, NC 28306-0189
(919) 483-0801

Bruce Ellington, CET
Electrical South
235 Burgess Rd-Drawer 49239
Greensboro, NC 27419-1239
(919) 668-4848

Linda Dickinson
Craven Community Collg
PO Box 952
Havelock, NC 28532
(919) 447-1141

Sammie C Thornton, CET
Wake Tech Comm Collg
9101 Fayetteville Rd
Raleigh, NC 27603
(919) 772-0553, Ext. 181

William D Barnette
Haywood Community Collg
10 Industrial Park Dr
Waynesville, NC 28786
(704) 452-1411, Ext. 23

Donald E Grinolds
GF AFB Education Center
310 Mssq/Mse
Grand Forks AFB, ND 58205
(701) 594-8192

Rod Schlingerman, CET
PVS Electronics Inc
3949 Cleveland Ave-Box 24400
Columbus, OH 43224
(614) 478-8200

Joseph Carney/II, CET
6365 Mills Creek Lane
N Ridgeville, OH 44039
(216) 871-8900, Ext. 241

John E Valerio, CET
Sencore
612 Lovers Lane
Steubenville, OH 43952
(614) 264-3001

David J Garwacki, CET
Sales & Service
4846 Oak Glen Dr
Toledo, OH 43613-3048
(419) 475-9221

Roy W Yonce
Tec-Ed Corporation
PO Box 1665
Broken Arrow, OK 74013
(918) 459-0200

J S Glosemeyer, CET
East OK Cnty Vb Tech
4601 N Choctaw Rd
Choctaw, OK 73020
(405) 390-9591

Curtis E Knight, CET
Central TV
203 East Idaho Ave
Ontario, OR 97914
(503) 889-2159

William H Manny, CET
Round-Up Elect Inc
2927 Riverside
Pendleton, OR 97801
(503) 276-3152

Larry Broschart, CET
14124, NE Knott St
Portland, OR 97230
(503) 255-6713

Vern Hartshorn, CET
2434 SE 158th St
Portland, OR 97233
(503) 667-7117

James C Shambow, CET
8035 NE 78th Ctr # 100
Portland, OR 97218
(503) 255-6500

Thomas V Gaudiello, CET
Rets Education Center
W Chester Pike & Malin Rd
Broomal, PA 19008
(215) 353-7630

Charles (Bill) Smith
Rets Education Center
West Chester Pike & Malin Rd
Broomal, PA 19008
1-800-336-7696

Gene Hedgepeth, CET/CA
2165 Alberdeen Rd
Mountaintop, PA 18707-9059
(717) 868-6566

Stanley A Salter, CET
Stan Salter Music Svc
826 Bat Blossom
Sumter, SC 29150
(803) 469-3022

Don Multerer, CET
Sencore Inc
3200 Sencore Dr
Sioux Falls, SD 57107
(605) 339-0100

William S Warren, CET/CSM
Warren's Audio-Video Svs
2540 Sutherland Ave
Knoxville, TN 37919
(615) 546-1121

Herman Patrick
3715 Lamar Ave
Memphis, TN 38118
(901) 362-8368

Jerry L Bunnell, CET
Techtronics
7801 N Lamar Unit B-156
Austin, TX 78752
(512) 832-0097

Henry W Corrie, CET
1460 C.R. 3413
Chandler, TX 75758
(903) 852-4140

F Gilbert Smith, CET
822 Creekridge Dr
Dallas, TX 75218
(214) 348-7734

Reiner Junge, CET
4710 Alabama
El Paso, TX 79930
(915) 566-9621

Robert M Griffin, CET
T.C.J.C.
5301 Campus Dr
Ft Worth, TX 76119
(817) 293-4327

Arthur J Ruppert, CET
30217 St Andrews
Georgetown, TX 78628
(512) 863-9157

Tom C Underwood, CET
Sony Service Company
3201 Premier #100
Irving, TX 75063
(214) 550-5270

Alden P Walther
Itt Technical Inst
9421 W Sam Houston Pkwy
Houston, TX 77099-1849
(713) 270-1634

James Harris, CET
3512 Chisholm Trail
Killeen, TX 76543-3172
(817) 288-2826

Elizabeth Sheets
American Commercial Collg
2007 34th St
Lubbock, TX 79411
(806) 747-4339

J W (Dub) Newson, CET
Advanced Electronics Inc
1310 19th St
Lubbock, TX 79401
(806) 763-8246

Loren R Hodges
3614-28th St
Lubbock, TX 79410
(806) 795-8617

Preston Wallace, CET
445 South Fuqua St
Rockport, TX 78382-4807
(512) 852-8022

Gerald Martin, CET
3347 Falcon Grove
San Antonio, TX 78247
(512) 496-1134

Joseph H Hudson, Jr, CET
Grayson County College
1500 Yarrowburgh Dr
Sherman, TX 75090-5545
(903) 892-9356

Russell R Offhaus, CET
PO Box 1116
Chincoteague, VA 23336
(804) 336-5980

Leonard M Cowherd, CET
Piedmont Tech Ed Cntr
PO Box 999
Culpeper, VA 22701
(703) 825-0476

Edward F Reilly, Jr, CET
9418 Starlit Ponds Dr
Fairfax, VA 22032
(703) 425-5468

Charles C Spiro, CET
Lord Fairfax Comm Collg
PO Box 47
Middletown, VA 22645
(703) 869-1120

Daniel C Bowling, CET
Southwest VA Comm Collg
PO Box SVCC
Richlands, VA 24641
(703) 964-2555

Cary D Thomas Jr., CET
2209 Eastover Dr
S Boston, VA 24592
(804) 572-6474

Jame Richerson, CET
Blue Ridge Comm College
Box 80
Weyers Cave, VA 24486
(703) 885-5960, Ext. 276

Michael Szymkewicz, CET
Olympic College
16th & Chester
Bremerton, WA 98310
(206) 478-4605

Ted Rodriguez, CET
Kagit Valley College
2405 College Way
Mt Vernon, WA 98273
(206) 428-1248

Arthur L Braden, CET
Phillips Jr College
N 1101 Fancher Rd
Spokane, WA 99212
(509) 535-7771

Carl E McDonald, CET
Sun Tech
417 S 6th
Sunnyside, WA 98944
(509) 837-8800

M B Hixenbaugh, CET
B N H Service
3635 S Lawrence
Tacoma, WA 98409
(206) 475-8861

Harry A Sanders, CET
1819 S Woodlawn
Tacoma, WA 98465
(206) 564-1334

David E Nida
National Education Center
5514 Big Tylor Rd
Cross Lanes, WV 25313
(304) 776-6290, Ext. 24

Larry Lambert, CET
PO Box 46
Culloden, WV 25510
(304) 743-3719

Richard K Evans, CET
PO Box 217
Wilkinson, WV 25653
(304) 752-7267

Duane Busby, CET
B, C & D Ent.
2027 Sherman Ave
Madison, WI 53704-5934
(608) 244-0339

Larry Geissler, CET
Indianhead Tech Collg
600 N 21st St
Superior, WI 54880
(715) 394-6677, Ext. 275

Jacob Klein, CET
Northcentral Tech Collg
1000 Campus Ave
Wausau, WI 54401
(715) 675-3331, Ext. 263

Thomas D Leitschuh, CET
Tdi Electronics
8014 W National Ave
West Allis, WI 53214-4554
(414) 774-2929

Robert Ing, CET
Atropos Telecom
1170 Bay St # 102
Toronto, Ontario, Can M5S 2B4
(416) 580-7508

Lew Thibeau, CET
Nova Scotia Comm Collg
Colchester Campus-60 Lorne St
Truro, Nova Scotia, Can B2N 3K3
(902) 895-7995, Ext. 142

Antonio M Avellanosa
Mt. Province Inst. of Technology
YMCA Bldg
Baguio City 2600, Philippines
442 6532

TECHNICIAN'S DAY

continued from page 83

tape decks, compact discs, and radios. The exam consists of digital and analog sections.

- **Medical**—The priorities of this option are safety and accuracy of calibration for electromedical instruments. The technician must be familiar with basic medical instrumentation, telemetry, measurements, and differential and operational amplifiers.

- **Radar**—A general knowledge of both pulsed and continuous-wave radar is necessary to take this Journeyman option. The test covers transmitters and receivers, CRT display systems and their power supplies, and antennas, transmission lines, and their characteristics.

- **Video**—The rapidly growing field of video is covered by this

exam. The technician must know the NTSC standards, video basics, test signals, and the operation of both the electronic and mechanical systems in VCR's and camcorders.

In addition, there is the new Certified Appliance Technician (CAT) exam, which is independent of the CET Associate or Journeyman certificate. The experience requirement is the same four years as for a Journeyman CET options, and the successful CAT receives a permanent wall certificate. CAT's are eligible to join ISCET. The exam consists of 100 multiple-choice questions covering electrical circuits and components, refrigerator systems, laundry equipment, cooking equipment, and dishwashers.

Fees and difficulty

The fee for the CET exam is \$25.00, which includes both the Associate exam and any one Journeyman option, if taken in one sitting. If the Journeyman option is taken separately from the Associate exam, each test is \$25.00. Each additional Journeyman option is \$25.00. If one fails any part, the first re-take is free, after a 60-day waiting period. The fee for any additional re-take is \$12.50. Don't underestimate the difficulty of the CET exam. Every year only 30 percent of those who take a CET test pass-it!

The best way to prepare for this exam is to study diligently. Tab Books publishes *The CET Study Guide* by Sam Wilson, which will help you prepare for some tests. ISCET also has additional study guides available.

If, after reading this article, you're interested in taking the CET exam and joining the growing ranks of Certified Electronics Technicians, contact any one of ISCET's volunteer test administrators listed in this article for details. The exams are scheduled to be given during the week of April 4 through 10, 1993. For any additional information or an order form listing all materials, contact ISCET directly at 2708 West Berry St., Fort Worth, TX 76109; Tel. 1-817-921-9101. □

MISSING TABLES

Our February 1993 issue featured Part 2 of "Crystal Oscillators" (page 47). Unfortunately, eight tables that were supposed to accompany the article never made it to print. Here are the missing tables. We apologize for any inconvenience we may have caused you.—Editor

**TABLE 1
COMPARISON OF FOUR CRYSTAL-CONTROLLED
OSCILLATORS**

	Colpitts		Pierce	Butler
	Standard	Semi-isol.*		
Frequency (MHz, max.)	60	60	75	100
Power output (mW)	0.3	15	0.3	15
Load resistance (ohms, typ.)	2-10 K	5-500	>1K	1K
Crystal power dissipation (mW)	1.0	0.5	1.0	0.75
Stability (short-term) (Hz)	±1 K	±1 K	±10	±1 K
Crystal Mode:	parallel	parallel	parallel	series

*Data applies to both versions.

**TABLE 2
COMPONENT VALUES FOR STANDARD COLPITTS
OSCILLATOR 1**

F (MHz)	C2(pf)	C5(pF)	C4(pF)	L1(μH)
Fundamental-mode crystal:				
1	2800	228	2300	556
	1600	141	1400	901
2	1200	119	1100	265
	976	104	1000	305
4	944	110	1100	72
	624	78	780	101
5	796	99	985	51
	645	82	821	62
10	798	114	1100	11
	585	85	852	15
15	527	84	844	6.7
	455	74	735	7.7
20	392	68	682	4.6
	338	59	595	5.3
25	287	54	538	3.8
	267	50	504	4.0
30	207	42	418	3.4
	196	40	400	3.5
Third-overtone crystal:				
35	218	48	602	1.7
	187	42	526	2.0
40	119	30	373	2.1
45	105	27	342	1.8
50	93	25	318	1.6
55	83	24	297	1.4
60	75	22	278	1.3

Note 1: The range of values corresponds to a crystal load capacitance between 32 and 12 picofarads for each frequency.

**TABLE 3
COMPONENT VALUES FOR SEMI-ISOLATED COLPITTS
OSCILLATORS 1**

F (MHz)	C2(pf)	C5(pF)	T1 (primary) 2	C3 C4(pF) 3
1	1828	2123	37μH, 80 trns No. 26/T-80-2	685
	1000	1186		
2	719	855	37μH, 80 trns No. 26/T-80-2	171
	616	740		
4	595	700	7.26μH, 36 trns No. 24/T-50-2	218
	381	465		
5	497	584	7.26μH, 36 trns No. 24/T-50-2	140
	397	475		
10	500	562	1.38μH, 20 trns No. 20/T-50-10	184
	357	409		
15	319	355	1.38μH, 20 trns No. 20/T-50-10	82
	270	304		
20	229	251	1.38μH, 20 trns No. 20/T-50-10	47
	192	214		
25	175	189	1.38μH, 20 trns No. 20/T-50-10	30
	145	161		
30	139	148	1.38μH, 20 trns No. 20/T-50-10	20
	114	125		

Notes 1: The range of values corresponds to a crystal load capacitance between 32 and 12 picofarads for each frequency.

2: Transformer primary turns wire gauge in AWG.

3: Values are for capacitors in parallel.

**TABLE 4
COMPONENT VALUES FOR SEMI-ISOLATED COLPITTS
OSCILLATORS 1**

F (MHz)	C2(pf)	C5(pF)	T1 (primary) 2	C3 C4(pF) 3
1	925	2919	37μH, 80 trns No. 26/T-80-2	171
	510	1630		
2	370	1190	7.26μH, 36 trns No. 24/T-50-2	218
	318	1030		
4	309	994	4.97μH, 32 trns No. 24/T-50-2	80
	201	662		
5	259	840	1.38μH, 20 trns No. 22/T-50-10	184
	209	683		
10	260	839	1.38μH, 20 trns No. 22/T-50-10	47
	189	619		
15	170	558	1.38μH, 20 trns No. 22/T-50-10	20
	145	483		
20	124	417	0.47μH, 15 trns No. 20/T-50-17	34
	106	361		
25	97	333	0.47μH, 15 trns No. 20/T-50-17	22
	83	288		
30	79	277	0.47μH, 15 trns No. 20/T-50-17	15
	67	239		

Notes 1: The range of values corresponds to a crystal load capacitance between 32 and 12 picofarads for each frequency.

2: Transformer primary turns wire gauge in AWG.

3: Values are for capacitors in parallel.

TABLE 5
COMPONENT VALUES FOR SEMI-ISOLATED COLPITTS
OSCILLATOR WITH OVERTONE SELECTOR 1

F (MHz)	C2(pf)	C5(pf)	C6(pf)	L1(μH)	T1 (primary)	T2	C3 C4(pf) 3
Third-overtone crystal:							
15	323	847	11000	0.50	1.38μH, 20 trns No. 22/T-50-10		82
	274	732	9600	0.60			
20	233	625	8300	0.38	1.38μH, 20 trns No. 23/T-50-10		47
	196	540	7200	0.44			
25	178	491	6700	0.30	1.38μH, 22 trns No. 22/T-50-10		30
	149	424	5800	0.35			
30	142	402	5600	0.25	1.00μH, 18 trns No. 22/T-50-10		28
	118	347	4800	0.29			
35	117	339	4800	0.22	0.80μH, 16 trns No. 22/T-50-10		26
	96	292	4100	0.25			
40	66	232	3200	0.24	0.47μH, 16 trns No. 20/T-50-17		34
	49	187	2700	0.29			
45	54	194	2900	0.22	0.47μH, 15 trns No. 20/T-50-17		27
	39	163	2400	0.26			
50	45	171	2600	0.20	0.47μH, 15 trns No. 20/T-50-17		22
	32	144	2200	0.23			
55	37	152	2400	0.20	0.47μH, 15 trns No. 20/T-50-17		18
	25	128	2000	0.21			
60	31	137	2200	0.16	0.30μH, 13 trns No. 20/T-50-17		24
	20	144	1800	0.19			

*

TABLE 6
COMPONENT VALUES FOR SEMI-ISOLATED COLPITTS
OSCILLATOR WITH OVERTONE SELECTOR 1

F (MHz)	C2(pf)	C5(pf)	C6(pf)	L1(μH)	T1 (primary)	T2	C3 C4(pf) 3
15	168	929	11600	0.48	1.00μH, 18 trns No. 22/T-50-10		28
	143	804	10000	0.56			
20	122	696	8800	0.36	0.47μH, 16 trns No. 20/T-50-10		34
	104	602	7600	0.42			
25	96	556	7000	0.29	0.47μH, 15 trns No. 20/T-50-10		22
	81	481	6000	0.33			
30	77	462	5800	0.24	0.30μH, 10 trns No. 20/T-50-17		24
	65	400	5100	0.28			
35	66	396	5000	0.21	0.28μH, 14 trns No. 26/T-25-17		18
	54	342	4300	0.24			
40	39	267	3400	0.23	0.28μH, 14 trns No. 26/T-25-17		14
	31	225	2900	0.28			
45	34	237	3000	0.21	0.28μH, 14 trns No. 26/T-25-17		11
	26	200	2600	0.25			
50	29	213	2700	0.19	0.10μH, 8 trns No. 24/T-25-17		25
	22	179	2300	0.22			
55	25	193	2500	0.17	0.10μH, 8 trns No. 24/T-25-17		21
	19	163	2000	0.20			
60	22	177	2300	0.16	0.10μH, 8 trns No. 24/T-25-17		18
	16	149	1900	0.18			

*

TABLE 7
COMPONENT VALUES FOR THE PIERCE OSCILLATOR

F (MHz)	C2(pf)	C3(pf)	C4(pf)	L1(μH)
Fundamental-mode crystal:				
1	2800	237	2200	528
	1600	147	2200	845
2	1132	120	13300	258
	980	107	13600	287
4	945	113	8000	68
	626	80	8000	96
5	923	115	6400	43
	650	87	6600	58
10	800	117	3800	11
	586	87	3800	14
15	528	65	2800	6.0
	455	74	2800	7.0
20	393	69	2300	4.4
	338	59	2300	5.0
25	312	58	1925	3.3
	268	50	1935	3.8
Third-overtone crystal:				
30	258	50	1700	2.6
	221	43	1700	3.0
35	219	47	1500	1.6
	188	41	1500	1.7
40	144	33	1400	1.7
	120	28	1400	2.0
45	127	30	1300	1.5
	105	26	1300	1.7
50	127	31	1170	1.1
	94	24	1190	1.5
55	102	26	1100	1.2
	84	22	1100	1.3
60	92	24	1100	1.0
	76	19	1044	1.2
65	84	23	1000	0.9
	64	18	1000	1.1
70	73	19	921	1.2
	66	17	930	1.3
75	64	17	880	1.1
	54	15	901	1.2

TABLE 8
COMPONENT VALUES FOR A BUTLER OSCILLATOR 1

F (MHz)	C4(pf)	C3(pf)	C1(pf)	L2(μH)	L1(μH)
Third-overtone crystal:					
20	590	57	1847	1.30	9.05
25	408	45	1500	1.00	5.80
30	241	27	890	1.20	4.00
35	338	38	1214	0.60	3.00
40	315	35	1130	0.50	2.30
45	280	32	1000	0.46	1.80
50	236	27	850	0.44	1.45
55	185	21	672	0.47	1.20
Fifth-overtone crystal:					
60	134	15	490	0.55	1.00
65	123	14	452	0.50	0.86
70	115	13	420	0.47	0.74
75	101	11	370	0.47	0.64
80	94	10	346	0.44	0.57
85	85	9	314	0.43	0.50
90	74	8	272	0.45	0.45
95	70	8	257	0.40	0.40
100	66	7	244	0.40	0.36

* Notes 1: The range of values corresponds to a crystal load capacitance between 32 and 12 picofarads for each load frequency.
 2: Transformer primary turns wire gauge in AWG.
 3: Values are for capacitors in parallel.

REMOTE STARTER

continued from page 74

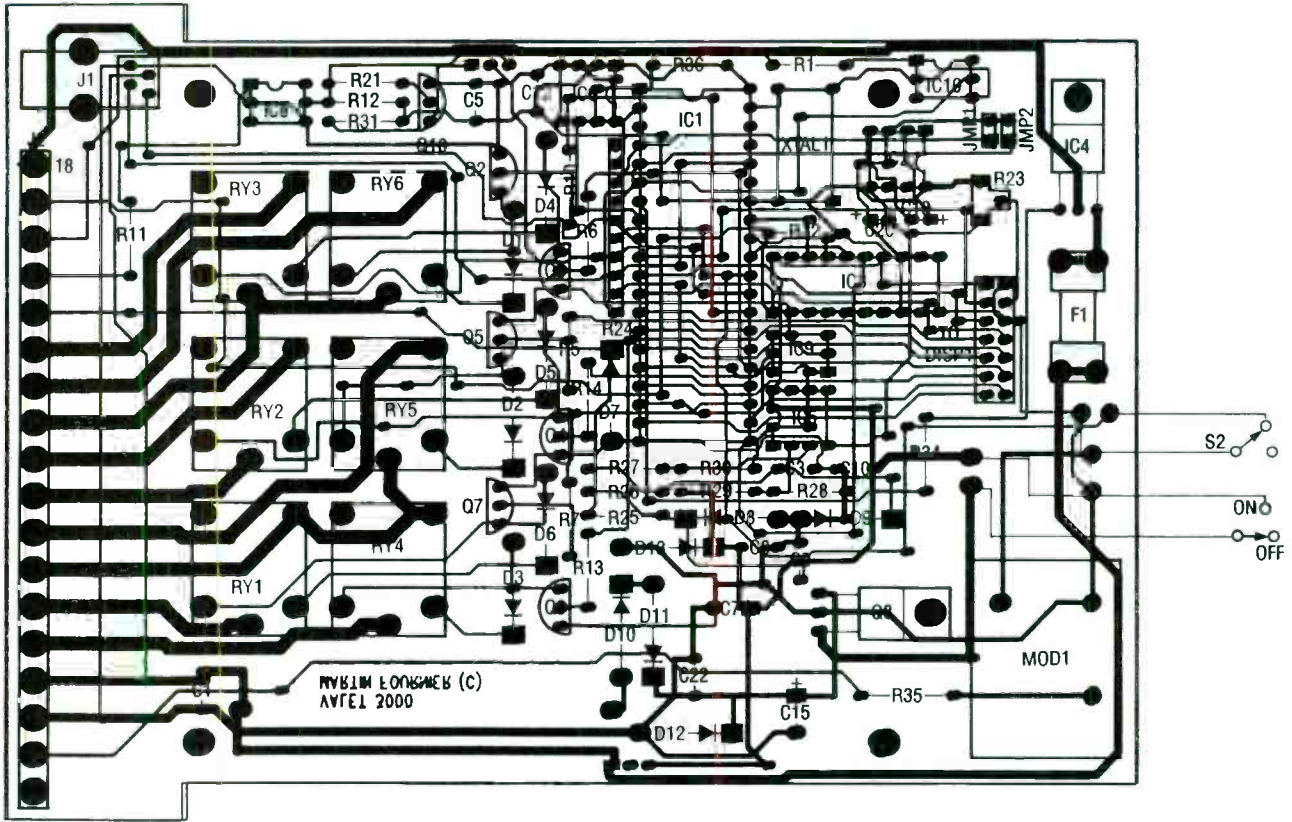
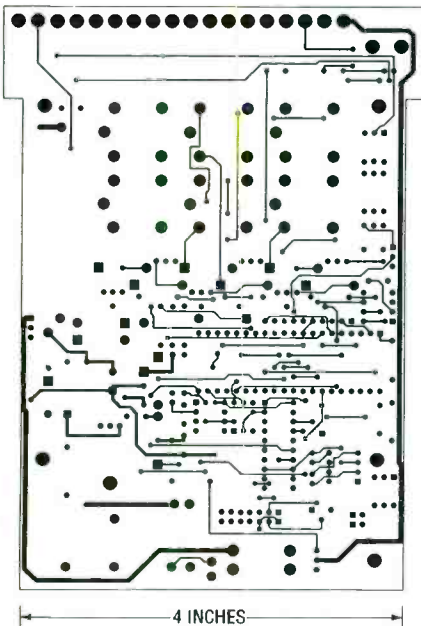
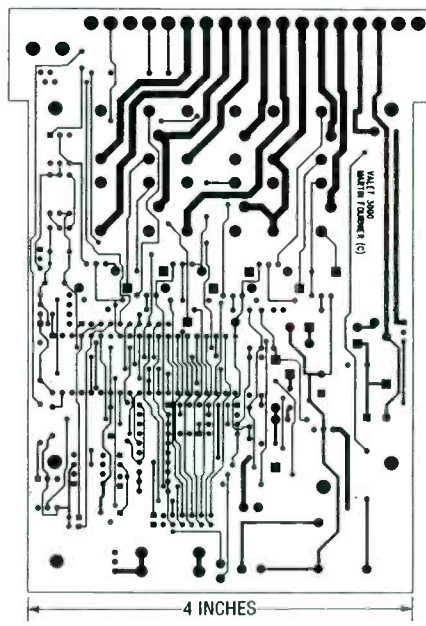

FIG. 8—PARTS-PLACEMENT DIAGRAM. The automatic starter is built on a double-sided PC board.



COMPONENT SIDE of the remote starter board, shown half-size.



SOLDER SIDE of the remote starter board, shown half-size.

preset frequency to adjust it with your car's engine. The frequency (f) is equal to:

$$\text{RPM} \times (\text{number of cylinders}/120).$$

Construction

The automatic starter is built on a double-sided PC board, for which we've provided foil patterns if you'd like to make your own. Otherwise, a board is available from the source mentioned in the Parts List. The author's prototype is shown in Fig. 7. Follow the Parts-Placement diagram in Fig. 3 when installing the components. Note that the Enforcer RF receiver plugs into the RJ-11-type telephone jack (J1) located on the remote starter PC board.

The finished board can be installed in any suitable case. Ω

COMPUTER CONNECTIONS

Microsoft and Intel take on the world.

JEFF HOLTZMAN

Computer operating systems have been a raging battleground for as long as there have been computers. The PC industry has been mostly immune to these battles ever since Microsoft introduced MS-DOS 1.0 back in 1981. However, rapid advances in hardware, along with corresponding increases in desired functionality, reliability, and security, have, in recent years, nudged PC-based operating systems closer and closer to proprietary mainframe and mini-computer operating systems. Skirmishes that have smoldered in the background over the past few years are on the verge of erupting into full-scale war. There are more than half a dozen participating companies and products in this battle. They are listed below in order of influence and likelihood of long-term survival:

- Microsoft: DOS, Windows, Windows for WorkGroups, LAN Manager, Windows New Technology (NT), and a full suite of applications programs
- Novell: NetWare, UnixWare
- IBM: OS/2, AIX
- Apple: System 7
- Other UNIX dialects from HP, DEC, and others
- Sun: Solaris
- Next: NextStep, NextStep 486.

Let's examine the contenders in reverse order, from the least to the most important.

Friday the 13th, part 79,482

UNIX is like the horror-flick creature that just won't die. No matter how many times you kill it, it keeps coming back for more. Despite its tenacity, UNIX never comes close to achieving the dominance to which it aspires. Every few years it comes back in some mutated form, threatening Microsoft's operating-system hegemony. The latest reincarnation arrives courtesy of Novell Corporation, of NetWare fame. We'll get to Novell in a minute. For

now, let's just state that the UNIX market has consistently misunderstood the PC "message" (power, personal productivity, local control, low pricing, intense competition, and continual innovation). However, there is little reason to believe that, even if it has now finally learned how to compete, it will be able to either shake off the UNIX onus or deflect Windows' momentum. IBM suffers from a similar problem with OS/2, which may offer technical superiority over Windows, but no compelling, innovative applications. We'll get to OS/2 in a moment.

The UNIX market has consistently overrated its importance in the overall scheme of things. Its strongholds include CAD, manufacturing, financial analysis, and, thanks to Next, multimedia development. But past fragmentation of the UNIX market, because of bitter competition among IBM, DEC, HP, Sun, and others, has all but eliminated serious support by influential PC software vendors. Yes, you can buy character-based versions of WordPerfect and Word that run under some version or other of UNIX. But except for a few innovative products like Lotus' Improv for the Next, there's precious little truly compelling technology that would entice or seduce users out of the Intel-based world and into the proprietary CPU's and UNIX dialects that have been prevalent.

That's the way things have been in the UNIX market for the past decade. Recently, however, Novell purchased the rights to the official UNIX code from AT&T. To understand the significance of that purchase, let's first take a closer look at Novell.

NetWare and UnixWare

Novell is the premier vendor of local-area networking (LAN) software. The company's NetWare

products together hold about 60–70% of the PC LAN market, which consists primarily of Intel-based PC's, but with connectivity to Macintoshes and UNIX systems running the TCP/IP protocol.

Despite its preeminent position in local-area networking, Novell is in dire straits because it is essentially a single-product company. Ten years ago, WordStar (then called MicroPro) dominated the word-processor market. The company is still alive today, but its market share is next to nil, and WordStar is hardly known for technological innovation. Lotus Development Corporation is in danger of falling prey to the WordStar syndrome, as is WordPerfect. But back to Novell.

To help shore up its withering position relative to Microsoft, Novell recently purchased from AT&T a company called UNIX Systems Laboratory (USL) for a reported \$350 million. USL, in which Novell already had a prior investment, owns the rights to the UNIX operating system originally developed by AT&T.

Now Novell owns all code and all rights to future development of UNIX. UNIX industry analysts are reacting positively to this development, because it brings a glimmer of hope that the until now fragmented UNIX market can be unified, thereby providing a real economic incentive for innovative software development native to UNIX platforms.

Novell also owns a company called Digital Research, whose CP/M operating system was the first successful general-purpose operating system for 8080- and Z80-based desktop computers in the late 1970's. In the mid 1980's, the company marketed a non-multitasking Windows competitor called the Graphical Environment Manager (GEM), whose only real success centered on its use by Xerox Corp. for Ventura Publisher.

GEM is now, for all practical purposes, dead. Also in the mid 1980's Digital Research developed several MS-DOS clones that provided multiuser and multitasking capabilities, none of which ever really caught on. Most recently, Digital Research focused its marketing on DR-DOS, a direct competitor of MS-DOS. DR-DOS has yet to catch on in a serious way; nonetheless, Microsoft has not been bashful about incorporating DR-DOS-like features into DOS 5 and the soon-to-be-released DOS 6. Microsoft has also angered Novell by including connectivity to NetWare networks in Microsoft's own Windows for WorkGroups.

95 million and counting

Microsoft, of course, owns MS-DOS, which is used on 95% of the 100 million Intel-based PC's worldwide. The remaining 5% is split among Digital Research and several smaller companies. Microsoft also owns Windows 3.x, which has catalyzed both software and hardware vendor activity to unprecedented levels, and has also incited intense user enthusiasm. Virtually all new hardware and software development in the PC industry is centered around Windows; products for other environments—DOS, OS/2, or UNIX—are ported from the Windows version, if at all. Upgrades to existing products often add Windows-like graphical features on a character-mode version, as witness recent versions of such popular programs as 1-2-3, Quattro Pro, Word, and WordPerfect.

Microsoft also owns a network product called LAN Manager that, in spite of significant technical improvement over the past few years, still plays a distant second fiddle to NetWare. This gap is the one serious chink in Microsoft's armor, and the one serious threat to the theory of the PC industry's future that will be outlined.

Then there is Windows for WorkGroups, a version of Windows that provides peer-to-peer networking to Windows (and DOS) PC's. WfW has Novell and Artisoft (of LANtastic fame) scared to death because it offers reasonable performance, easy installation, ease of

use, compatibility, and a clear upgrade to LAN Manager. Novell's own NetWare Lite has mostly been ridiculed in the press as a very weak competitor to LANtastic. And there have been persistent rumors that both Novell and Microsoft will include built-in network connectivity with the next versions of DR-DOS and MS-DOS.

Next comes Windows NT, which Microsoft has from the beginning promoted as an all-inclusive operating system that can support Windows, OS/2, and POSIX (the IEEE standard form of UNIX) application programming interfaces (API's)—should the market so desire. NT is a full 32-bit preemptive multitasking operating system that is more like OS/2 and UNIX than Windows 3.x. The difference is that porting application programs from 3.x to NT will be relatively simple, compared with porting them to OS/2 or UNIX. And that fact guarantees availability of applications, which are what people really buy.

Sure, performance and features might be lacking in the first version of NT, but they will improve over time. The point is that NT will hit the market at full stride, with full support from major applications vendors, and without a major discontinuity with past products. Currently, there is a lot of griping in the computer trade press about the "vaporware" quality of NT, but history—at least recent history—suggests that when ready, Microsoft will deliver a quality product. IBM, by contrast, has a history of announcing and releasing products before they're ready for prime time.

IBM

Now let's look at OS/2 2.0. In spite of impressive technical improvement, OS/2 marketing is still grossly mismanaged. The cover date of this issue marks the sixth anniversary of the introduction of OS/2. After six years, IBM's operating system still has to demonstrate a single compelling application. (And UNIX? Well, you can forget about it.)

Why is it that IBM has a habit of introducing technologies that do not provide continuity with the past? The Micro Channel Architecture

DIGITAL VIDEO STABILIZER ELIMINATES ALL VIDEO COPYGUARDS



While watching rental movies, you will notice annoying periodic color darkening, color shift, unwanted lines, flashing or jagged edges. This is caused by the copy protection jamming signals embedded in the video tape, such as Macrovision copy protection. THE DIGITAL VIDEO STABILIZER: RXII COMPLETELY ELIMINATES ALL COPY PROTECTIONS AND JAMMING SIGNALS AND BRINGS YOU CRYSTAL CLEAR PICTURES.

WARNING

THE DIGITAL VIDEO STABILIZER IS INTENDED FOR PRIVATE HOME USE ONLY. IT IS NOT INTENDED TO COPY RENTAL MOVIES OR COPYRIGHTED VIDEO TAPES THAT MAY CONSTITUTE COPYRIGHT INFRINGEMENT.

FEATURES

- Easy to use and a snap to install
- State-of-the-art Microchip technology
- 100% automatic
- Compatible to all types of VCRs and TVs
- The best and most exciting Video Stabilizer in the market
- Light weight (8 ounces) and compact (1x3.5x5")
- Uses a standard 9 Volt battery (last 1-2 years)
- Fast UPS delivery
- Air shipping available
- UNCONDITIONAL 30 day money back guarantee
- 1 year warranty

(Dealers Welcome)

FREE 20P Catalog

To Order: \$39.95 ea +\$4 for p & h
Visa, M/C, COD Mon-Fri: 9-6 EST

1-800-445-9285

ZENTEK CORP. DEPT. CRE0493
3670-12 WEST OCEANSIDE RD. OCEANSIDE, NY 11572

CIRCLE 191 ON FREE INFORMATION CARD

CABLE TV DESCRAMBLERS How You Can Save Money on Cable Rental Fees

Bullet Proof



1 Unit 5+

BEST Super Tri-Bi Auto/
Var. Gain Adjustment \$119.95...\$85
Jerrold Super Tri-Bi ... \$109.95...\$79
Scientific Atlanta \$109.....\$79
Pioneer \$109.....\$79
Panasonic TZPC145.... \$99.95....\$79
Stargate Converter..... \$95.....\$69
Digital Video Stabilizer. \$59.95....\$29
Wireless Video Sender...\$59.95....\$49.95

**US Cable'll Beat
Anyone's Price
Advertised in
this Magazine!**

30 Day Money Back Guarantee
FREE 20 page Catalog

Visa, M/C, COD or send money order to:

U.S. Cable TV Inc. Dept. KRE0493
4100 N. Powerline Rd., Bldg. F-4
Pompano Beach, FL 33073

1-800-772-6244

For Our Record

I, the undersigned, do hereby declare under penalty of perjury that all products purchased, now and in the future, will only be used on Cable TV systems with proper authorization from local officials or cable company officials in accordance with all applicable federal and state laws. FEDERAL AND VARIOUS STATE LAWS PROVIDE FOR SUBSTANTIAL CRIMINAL AND CIVIL PENALTIES FOR UNAUTHORIZED USE.

Date: _____

Signed: _____

No Florida Sales!

CIRCLE 192 ON FREE INFORMATION CARD

(also on its sixth birthday) is a prime example of IBM's habit. After years of proselytizing, IBM never succeeded in convincing either add-on developers or the general market that MCA offered real technical superiority over the At bus, which is now called the Industry Standard Architecture (ISA).

Meanwhile, out of the blue (so to speak) in the past year have come several implementations of so-called *local buses* that provide direct 32-bit interfaces to the host CPU. Ignoring the battle among these implementations (which will take another 12–18 months to sort out), the point is clear: local bus provides a *readily apparent* speed advantage over the ISA, EISA, and MCA buses. Local-bus video and hard-disk adapters provide ripping-fast performance compared with even the best traditional interface cards. Competing local-bus implementations have sprung from Intel and the Video Electronics Standards Association (VESA)—not IBM. IBM spawned a revolution in color graphics when it introduced VGA (another six year old), but subsequently dropped the ball with the 8514 and more recently the XGA video standards. The latter is being squashed by the performance of local-bus video.

In software, there were the pre-2.0 versions of OS/2, which never garnered serious industry support, and, in fact, offended many. There was PC-DOS 4.0, a bug-ridden version of DOS that sorely damaged the company's already poor reputation in software. There was TopView, a DOS-based multitasker whose poor quality helped ensure the success of Quarterdeck's DESQview. There was the desktop software unit, which was simply disbanded about 18 months ago, due to its inability to identify, develop, and market significant applications programs. IBM's version of UNIX, called AIX, has been successful because of the price/performance advantage of the RISC-based RS/6000 platform it runs on. IBM's partnership with Apple involves a project called Taligent, an object-oriented operating system about which little is known at the present time.

In sum, IBM has had a few hits and lots of misses. The hits have all been hardware related. IBM has never developed nor marketed any significant software product for the PC market. OS/2 will probably hang on, but it will never overcome either its self-inflicted onus or Microsoft's inexorable momentum.

Apple

Until very recently, Apple scorned the PC market. However, the company's software subsidiary, Claris, recently released a Windows port of a classic Macintosh database manager. In addition, Apple has tacitly acknowledged the PC's growing importance in multimedia technologies with the release of a QuickTime player for Windows. (As discussed here in the past, QuickTime is Apple's architecture for time-variant data, particularly sound and motion video.)

Historically, Apple's forte was user-interface design, but through the use of usability testing and product iteration, Microsoft is improving in this area tremendously, as witness Excel 4.0 and the Access database manager. Apple's recent partnerships with IBM indicate the degree to which both companies fear Microsoft. Apple has a lot to offer, and is not simply going to go away. The Macintosh operating system will probably survive at a low level like DR-DOS and OS/2, but Apple will substantially reinvent itself around portable stylus-input handheld computers.

A few good vendors

The computer industry has gone through wrenching changes the past decade—but even greater changes lie ahead. IBM and Digital Equipment are in deep trouble. Microsoft's dominance continues to grow, and that dominance angers and challenges many people. I think we are heading toward massive industry consolidation that will leave only a few hardware vendors and only a few software vendors. Take it a step further. There will be only a few *computer* vendors.

The distinctions among hardware, operating system, networking, and applications programs exist for technical reasons; most con-

sumers don't understand and could not care less. People buy cars, not engines, transmission, and chassis. Soon computers will be sold as complete units with CD-ROM's full of software. These CD-ROM's will be the equivalent of the Sears tool kit with so many different socket wrenches, screwdrivers, and pliers. The CD will have a basic set of software and many optional add-on modules for specific tasks. The add-on's will be encrypted; users will be able to gain access via an 800 telephone call and credit-card number—fonts are already sold that way.

Microsoft will have its own CD; another company will arise from the ashes of Borland, Lotus, WordPerfect, and Novell, which in concert might be able to cobble together something comparable to Microsoft's strengths in operating systems and applications. This new company's strong point will be networking. Microsoft and this other megacompany will outsource some modules, just as the big-three auto makers purchase tires, radios, and many other subassemblies from contractors.

IBM will team up with this megacompany to provide one leading computer brand. Microsoft will team up with Intel (which will merge with Gateway 2000 or Compaq or both) to provide the other. Hong Kong will produce a clone of the entire system, and quickly too, it is easier to copy an existing design than to invent a new one from scratch. Western Europe might even produce a version of its own.

The UNIX market will hang on for awhile, and eventually succumb to this emerging world order of mega-PC's. The shakeout will happen sooner than many people expect, due to increasingly rapid product innovation by Intel.

Like it or not, Microsoft is in control of the computer industry. Industry resentment of that fact will not change it. Recent FTC investigations of the company appear to be turning up irregularities in the way it markets DOS. But DOS is only a piece of the overall picture. The FTC never split up an auto company for having its hand in too many pots. I don't expect to see it in the computer industry either. Ω

Be a computer programmer!

Only NRI gives you hands-on training with the latest programming tools:

- A 486sx computer with 80 meg hard drive ■ Windows
- Visual Basic ■ Power C ■ QBasic ■ MS-DOS
- And much more!

Only NRI at-home training gives you real-world programming skills in three in-demand languages: QBasic, C, and Visual Basic, today's hot new language designed for writing popular Windows applications. Best of all, you get hands-on training with a powerful new 486sx-based computer system, complete with 80 meg hard drive, Windows, and professional programming software you keep!

NRI, the leader in at-home computer training, shows you how to take advantage of today's newest programming opportunities

Get in on the ground floor of one of today's fastest-growing career fields: computer programming. The Bureau of Labor Statistics forecasts that job opportunities for programmers will increase much faster than average over the next 10 years, with as many as 400,000 new jobs opening up by 2005.

And the fastest-growing segment of programming jobs will be PC programming, fueled by the phenomenal popularity of Windows, the efficient power of C, and the ascent of exciting new languages like QBasic and Visual Basic.

Now, with NRI at-home training, you can get the new skills you need to build a top-paying career — even a full- or part-time business of your own — in this high-growth, high-opportunity field.

NEW! The only programming course that includes a powerful 486sx-based computer, 80 meg hard drive, Windows, Visual Basic, and more — all yours to keep!

Right from the start, NRI gets you actively involved in the challenge of real-world programming. Step by step, you learn to create the kinds of full-featured, powerful programs today's employers and clients

NEW!
486sx/25 MHz
computer — the most
powerful computer
included in any
at-home training
program!



demand...including programs designed for use in a Windows environment!

Only NRI gives you first-hand programming experience with a state-of-the-art 486sx mini-tower computer system, complete with hard disk drive, a full megabyte of RAM, high-density floppy drive, mouse, monitor, and more — all yours to train with and keep!

Plus you explore the extraordinary capabilities of three in-demand programming languages. You learn to design, code, run, debug, and document programs in QBasic, C, and Visual Basic. Best of all, since Visual Basic is specifically designed for creating Windows applications, you learn to generate fully functioning Windows programs, complete with text boxes, command buttons, and other sophisticated graphical interface elements.

No previous experience necessary

Train with NRI, and immediately start getting the money-making job skills you need to be a computer programmer — no matter what your previous background.

NRI's step-by-step lessons and hands-on programming projects help you first master the design concepts used every day by successful PC programmers. Then, with the support of your experienced NRI instructor, you quickly move on to learn programming in three of today's hottest languages.

By the time you complete your course, you have a clear understanding of programming methods, languages, and techniques... and you're ready to handle any programming task with confidence.

Send today for your FREE catalog

See how NRI at-home training gives you the programming know-how, the computer, and the software you need to get started in this top-paying field. Send today for your FREE catalog!

If the coupon is missing, write to us at the NRI School of Computer Programming, McGraw-Hill Continuing Education Center, 4401 Connecticut Avenue, NW, Washington, DC 20008.

IBM PC/AT is a registered trademark of the IBM Corporation. Windows, QBasic, and Visual Basic are trademarks of Microsoft Corporation.

SEND COUPON TODAY FOR FREE NRI CATALOG!

NRI Schools

McGraw-Hill Continuing Education Center
4401 Connecticut Avenue, NW, Washington, DC 20008

For career courses
approved under GI Bill,
check for details

Check one FREE catalog only

COMPUTER PROGRAMMING

PC Applications Specialist

Programming in C++ with Windows

Other Computer Career Courses

Microcomputer Servicing

Desktop Publishing

Bookkeeping and Accounting

Computer-Aided Drafting

Name _____ (please print)

Age _____

Address _____

City/State/Zip _____

Accredited Member, National Home Study Council

5415-0493

BUYER'S MART

FOR SALE

TUBES. "oldest", "latest.". Parts and schematics. SASE for lists. **STEINMETZ**, 7519 Maplewood Ave., R.E., Hammond, IN 46324.

TUBES, new, up to 90% off, SASE, **KIRBY**, 298 West Carmel Drive, Carmel, IN 46032.

T.V. notch filters and bullet stopper, free brochure. **MICRO THinc.** Box 63/6025, Margate, FL 33063. (305) 752-9202.

FREE CATALOG

FAMOUS "FIRESTIK" BRANO CB ANTENNAS AND ACCESSORIES. QUALITY PRODUCTS FOR THE SERIOUS CB'er. SINCE 1962

FIRESTIK ANTENNA COMPANY
2614 EAST ADAMS
PHOENIX, ARIZONA 85034

TOCOM-Jerrold Impulse-Scientific Atlanta Converters, two year warranties, also test modules for your converters. Contact **NATIONAL CABLE**, (219) 935-4128 full details.

SECRET cable descramblers! Build your own descrambler for less than \$12.00 in seven easy steps. **Radio Shack** parts list and free descrambling methods that cost nothing to try, included. Send \$10.00 to: **HARRY WHITE**, PO Box 1790, Baytown, TX 77522.

CB RADIO OWNERS!

We specialize in a wide variety of technical information, parts and services for CB radios. 10-Meter and FM conversion kits, repair books, plans, high-performance accessories. Thousands of satisfied customers since 1976! Catalog \$2.

CBC INTERNATIONAL
P.O. BOX 31500RE, PHOENIX, AZ 85046

CABLE TV converters: Jerrold, Oak, Scientific Atlantic, Zenith & many others. "New MTS" stereo add-on: mute & volume. Ideal for 400 and 450 owners! 1 (800) 826-7623, Amex, Visa, M/C accepted. **B & B INC.**, 4030 Beau-D-Rue Drive, Eagan, MN 55122.

PREVENT descrambler damage. Don't bite the bullet!! Snooper Stopper Data Pulse Blocker \$33.95, with Surge Protection \$44.95... Wireless Video Sender \$54.95. **VCI**, 1 (800) 925-9426.

Quality Microwave TV Antennas

WIRELESS CABLE - IFTS - MMDS - Amateur TV
Ultra High Gain 50db(+) • Tuneable 1.9 to 2.7 Ghz

- 55-Channel Dish System \$199.95
- 36-Channel Dish System \$149.95
- 20-Channel Dish System \$124.95
- Optional Commercial Grid Antenna (not shown) Add \$50.00
- Yagi Antennas: Components, Custom Tuning Available
- Call or write (SASE) for "FREE" Catalog

PHILLIPS-TECH ELECTRONICS
P.O. Box 8533 • Scottsdale, AZ 85252
(602) 947-7700 (\$3.00 Credit all phone orders)

LIFETIME WARRANTY
MasterCard • Visa • American Express • CDD'S • Quantity Pricing

ENGINEERING software and hardware, PC/MSDOS. Circuit design/drawing, PCB layout, FFT analysis, mathematics, circuit analysis. Data acquisition, generation, I/O PCB's. Call or write for free catalog. (614) 491-0832, or fax (614) 497-9971, **BSOFT SOFTWARE, INC.**, 444 Colton Rd., Columbus, OH 43207.

300 Experimenters Circuits — Complete in 6 practical books using diodes, relays, FET's, LED's, IC 555's, and IC CA3130's for building blocks. Only \$33.00 plus \$5.50 for shipping. USA and Canada only. US funds. **ETT, INC.**, PO Box 240, Massapequa Park, NY 11762-0240.

PRINTED circuit boards fabricated from your design or schematic. Small or large runs — 25 years experience. **SHORE PRINTED CIRCUITS**, 36 Fairview Avenue, Little Silver, NJ 07739. 1 (800) 752-1574, (908) 747-6300 (NJ). Fax (908) 747-6301.

CLASSIFIED AD ORDER FORM

To run your own classified ad, put one word on each of the lines below and send this form along with your check to:

Electronics Now Classified Ads, 500-B Bi-County Boulevard, Farmingdale, NY 11735

PLEASE INDICATE in which category of classified advertising you wish your ad to appear. For special headings, there is a surcharge of **\$25.00**.

() Plans/Kits () Business Opportunities () For Sale
() Education/Instruction () Wanted () Satellite Television
() _____

Special Category: \$25.00

PLEASE PRINT EACH WORD SEPARATELY, IN BLOCK LETTERS.

(No refunds or credits for typesetting errors can be made unless you clearly print or type your copy.) Rates indicated are for standard style classified ads only. See below for additional charges for special ads. **Minimum: 15 words.**

1	2	3	4	5
6	7	8	9	10
11	12	13	14	15 (\$46.50)
16 (\$49.60)	17 (\$52.70)	18 (\$55.80)	19 (\$58.90)	20 (\$62.00)
21 (\$65.10)	22 (\$68.20)	23 (\$71.30)	24 (\$74.40)	25 (\$77.50)
26 (\$80.60)	27 (\$83.70)	28 (\$86.80)	29 (\$89.90)	30 (\$93.00)
31 (\$96.10)	32 (\$99.20)	33 (\$102.30)	34 (\$105.40)	35 (\$108.50)

We accept MasterCard and Visa for payment of orders. If you wish to use your credit card to pay for your ad fill in the following additional information (Sorry, no telephone orders can be accepted):

Card Number _____

Expiration Date _____

Please Print Name _____

Signature _____

IF YOU USE A BOX NUMBER YOU MUST INCLUDE YOUR PERMANENT ADDRESS AND PHONE NUMBER FOR OUR FILES. ADS SUBMITTED WITHOUT THIS INFORMATION WILL NOT BE ACCEPTED.

CLASSIFIED COMMERCIAL RATE: (for firms or individuals offering commercial products or services) \$3.10 per word prepaid (no charge for zip code)...**MINIMUM 15 WORDS**, 5% discount for same ad in 6 issues; 10% discount for same ad in 12 issues within one year; if prepaid (not applicable on credit card orders). **NON-COMMERCIAL RATE:** (for individuals who want to buy or sell a personal item) \$2.50 per word, prepaid...no minimum. **ONLY FIRST WORD AND NAME** set in bold caps at no extra charge. Additional bold face (not available as all caps) **55¢ per word additional**. Entire ad in boldface, \$3.70 per word. **TINT SCREEN BEHIND ENTIRE AD: \$3.85 per word. TINT SCREEN BEHIND ENTIRE AD PLUS ALL BOLD FACE AD: \$4.50 per word. EXPANDED TYPE AD: \$4.70 per word prepaid.** Entire ad in boldface, \$5.60 per word. **TINT SCREEN BEHIND ENTIRE EXPANDED TYPE AD: \$5.90 per word. TINT SCREEN BEHIND ENTIRE EXPANDED TYPE AD PLUS ALL BOLD FACE AD: \$6.80 per word. DISPLAY ADS:** 1" x 2 1/8"—\$410.00; 2" x 2 1/8"—\$820.00; 3" x 2 1/4"—\$1230.00. General Information: Frequency rates and prepayment discounts are available. **ALL COPY SUBJECT TO PUBLISHERS APPROVAL. ADVERTISEMENTS USING P.O. BOX ADDRESS WILL NOT BE ACCEPTED UNTIL ADVERTISER SUPPLIES PUBLISHER WITH PERMANENT ADDRESS AND PHONE NUMBER.** Copy to be in our hands on the 1st of the third month preceding the date of the issue. (i.e., Aug. issue copy must be received by May 1st). When normal closing date falls on Saturday, Sunday or Holiday, issue closes on preceding working day. Send for the classified brochure. Circle Number 49 on the Free Information Card.

Cable TV DESCRAMBLERS

30-day
Money Back
Guarantee



- The Most Complete Line of Descramblers
- Friendly, professional service
- FREE Catalog

ORDER
NOW!



1-800-228-7404

Go to the Source

NU-TEK ELECTRONICS

3250 Hatch RD
Cedar Park TEXAS 78613

CABLE test chips. Jerrold, Tocom, S.A., Zenith. Puts cable boxes into full service mode! \$29.95 to \$59.95. 1 (800) 452-7090, (310) 867-0081.

EPROMS, Assorted, i.e., 27128A-15 \$3.00 each minimum quantity 13 pieces. C.O.D., American Express. H.E.A.R.T. Inc., 1 (800) 677-3773.

CABLE Converters, accessories below wholesale! Immediate delivery from giant stock! COD orders only. 1 (800) 935-1749.

OAK Sigma descrambler, CH3 output, rare hard-to-find units. \$100.00 postpaid, only moneyorders please. **SURPLUS ELECTRONICS,** Box 10009, Colorado Springs, CO 80932.

WIRELESS CABLE RECEIVERS 1.9 to 2.7 GHz

36 CH 20" Parabolic Dish Sys.	\$173.90
36 CH 28" Rod Ant. Sys.	\$193.90
36 CH 16x20" Grid Ant. Sys. (photo)....	\$289.00
36 CH 24x36" Grid Ant. Sys.	\$314.95

SUN MICROWAVE INT'L. INC. Send \$1⁰⁰ for
PO BOX 34522 product catalog.
PHOENIX, AZ 85067 Dealer discounts available.
(602) 230-1245 FAX (602) 269-6069

VISA/MC/AMEX **ORDERS ONLY 1-800-484-4190 code 9793**

TEST-Aids for testing units in full service mode. Jerrold, \$40.00; Pioneer, clears error codes E2 thru E5, \$60.00; Pioneer cubes, will not alter internal serial number, \$125.00; Tocom mapping, \$40.00; Tocom 5503/5507, \$25.00; S.A. 8500, \$25.00; 8550 \$30.00; 8580, \$40.00; 8570/90, \$50.00; 8600, \$50.00; Zenith ZTac, \$25.00; security tools and remotes. **N.E. ENGINEERING,** (617) 770-3830.

RESTRICTED technical information: Electronic surveillance & schematics; locksmithing; cable phreaking; hacking; etc. **Free brochures:** MENTOR, Box 1549-Z, Asbury Park, NJ 07712.

CABLE TV converters. Jerrold, Zenith, Pioneer, Oak, Scientific Atlanta, and many more. 12 years experience gives us the **advantage.** Visa/MC Amex **COD ADVANTAGE ELECTRONICS, INC.,** 1 (800) 952-3916 1125 Riverwood Dr., Burnsville, MN 55337.

VIDEO tapes covering electronics, computers and communications. Demo \$3.50. **OCS,** PO Box 292, Fort Mill, SC 29715.

LASERS, light shows, plans, books, .5mw to 20 watts, free catalog call 1 (800) 356-7714 or write **MWK IND.,** 198 Lewis Ct., Corona, CA 91720.

CABLE converters, Tocom-VIP \$289.00, Jerrold DPV-5 \$189.00, SA85XX \$179.00. Hamlin CR66003M \$99.00, Oak RTC-56 \$99.00, Sylvania 4040 \$79.00, fully bullet proof. **MOUNT HOOD ELECTRONICS,** (206) 260-0107.



One tree can make
3,000,000 matches.



One match can burn
3,000,000 trees.



A Public Service of This Magazine
& The Advertising Council

**When someone
in your family
gets cancer,
everyone
in your family
needs help.**

Nobody knows better than we do how much help and understanding is needed. That's why our service and rehabilitation programs emphasize the whole family, not just the cancer patient.

Among our regular services we provide information and guidance to patients and families, transport patients to and from treatment, supply home care items and assist patients in their return to everyday life.

Life is what concerns us. So you can see we are even more than the research organization we are so well known to be.

No one faces cancer alone.

AMERICAN CANCER SOCIETY

TEST DRIVE SOME MCM ELECTRONIC PARTS!



There's only one way to fully appreciate just how much better MCM Electronics' parts and services are. Take us out for a test drive! See for yourself how we've fine-tuned our inventory of 22,000 parts and components and powered it with streamlined sales and service expertise. Then, you'll see why our track record is unbeatable.

For A FREE Catalog Call:
1-800-543-4330

To Order By FAX: 1-513-434-6959

For Product Questions:
1-800-824-TECH (8324)



MCM ELECTRONICS

650 CONGRESS PARK DR.
CENTERVILLE, OH 45459-4072

A PREMIER Company

RE-82

April 1993, Electronics Now

103

CIRCLE 87 ON FREE INFORMATION CARD

MARK V ELECTRONICS, INC.

Competitive Prices Fast Shipping Since 1985

▲ indicates the level of difficulty in the assembling of our Products. Special offer will be given to the purchase of Amplifier + Cabinet + Transformer

**** Toroidal Transformer Available! ****



AMPLIFIERS KIT ASSMB

MODEL	DESCRIPTION	KIT	ASSMB
AF-3	300W Mosfet Audio Mono Power Amplifier ▲▲▲	165.00	195.00
TA-28MK2	Digital Voice Memo ▲	32.00	
TA-50A/B	Multi-Purpose Melody Generator ▲	13.85	17.20
TA-50C	Multi-Purpose Melody Generator (Melody such as Happy Birthday, Wedding March, etc.) ▲	13.85	17.20
TA-120MK2	36W Class 'A' Main Power Mono Amp. ▲▲	31.50	42.80
TA-201	Microphone/Auxiliary Mixer, Power Amp ▲	14.74	27.74
TA-732	Wallman Booster/Aux Stereo Power Amp. ▲▲	28.50	38.50
TA-303	30W Multi-Purpose Stereo Channel Amp. ▲▲	25.50	37.50
SM-302	50W + 60W Stereo Power Amplifier (with Mic input case & transformer included) ▲▲▲	73.20	83.20
TA-323A	30W + 20W Stereo Pre-Main Amp ▲	31.50	41.80
TA-377A	State of the Art Fully Complementary system symmetrical Fet Pre-Amp. ▲▲▲	54.85	75.80
TA-400	40W SOLID STATE MONO AMP. ▲▲	28.20	34.20
TA-477	120W Mosfet Power Mono Amp. ▲▲	58.00	69.00
SM-720	120W + 120W AC/DC Stereo Hi-Fi + Pre-Main Amp (case & transformer included) ▲▲▲	75.00	89.00
TA-800MK2	120W + 120W Low Tim Pre-Main Stereo Power Amp. ▲▲	83.37	73.95
TA-802	80W + 80W Pure DC Stereo Main Power Amp. ▲▲▲	43.34	59.72
TA-1100A	120W Dynamic Class 'A' Main Power Mono Amp. ▲▲	25.50	37.50
TA-1503	100W+100W New Class 'A' DC Stereo Pre-Main Amp.▲▲▲	71.70	95.81
TA-2200	DC Fet Super Class 'A' Pre-Amp. ▲▲▲	41.70	54.24
TA-2530	HD Pre-Amp. w/10 band graphic equalizer ▲	48.30	53.57
TA-1803	81-FET IC Pre-Amp. w/3 way tone control ▲	48.30	53.57
TA-1009	Stereo Simulator (For Mono TV or Any Mono Source) ▲	32.00	42.00
TA-1603	300W HD Audio Power Mono Amp. ▲▲▲	83.65	115.00
SM-222	7 Band Stereo Hi-Fi Graphic Equalizer ▲▲▲	36.90	38.80
SM-328	4 Channel Professional Color Light Controller + Audio/Video Surround Sound Processor ▲▲		165.00
SM-333	Audio/Video Surround Sound Processor (case & transformer included) ▲▲▲▲	73.00	
SM-666	Dynamic Noise Reduction ▲	26.00	34.00
SM-888	Universal Audio/Video KARAOKE Mixer Pre-Amp. ▲		158.00

MISCELLANEOUS KIT ASSMB

TY-1AMKS	Battery Fluorescent Light Driver ▲	11.97	14.97
TY-7	Electronic Touch Switch ▲	9.92	11.92
TY-11A	Electronic Lotto ▲	15.00	21.00
TY-11B	Multi-Functional Control Switch ▲	8.50	10.50
TY-12A	Digital Clock-Timer ▲	25.50	32.50
TY-13	Color Led Audio Level Meter ▲	20.15	26.20
TY-14	Electronic Shock ▲	9.25	
TY-18	High precision Sound Control Switch ▲	10.22	14.50
TY-26	V-Cross color Led Level Meter ▲	21.45	28.00
TY-25B	3 Channel Color Light Controller +		75.00
TY-25	Stereo Loudspeaker Protector ▲	15.85	20.85
TY-26	FM Wireless Electronic Receiver ▲	12.50	16.50
TY-27	AC/DC Quartz digital Clock ▲	19.00	26.20
TY-36	Sound/Touch Control Switch ▲	12.00	16.50
TY-41MK5	Infrared Remote Control (Unit/Case transmitter & receiver included) ▲▲▲▲	28.00	38.50
TY-42	Bar/Dot Level Audio Level Display ▲	24.15	30.85
TY-45	20 Steps Bar/Dot Audio Level Display ▲▲	36.45	48.14
TY-47	Superior Electronic Receiver ▲	21.50	29.00
#016	1000uF 80V Capacitor (Suggested for TA-3600, TA-477, TA-1000A, TA-802) 28.00		
#017	8,200uF 50V Capacitor (Suggested for TA-802, TA-120MK2) 21.50		
#021	NOBEL (Single) Inductor Resistor (Suggested for TA-3600, TA-477, TA-1000A & TA-120MK2) 14.00		
#022	ALPS (Dual) Variable Resistor (Suggested for TA-377A, TA-2200 & TA-802) 19.00		

REGULATORS KIT ASSMB

TR-355A	0-15V Regulated DC Power Supply (case transformer not included) ▲	16.50	22.76
TR-355B	0-30V 3A Regulated DC Power Supply (case transformer not included) ▲	16.50	22.76
TR-503	0-50V 3A Regulated DC Power Supply w/Short Circuit & Overload Protection (Case transformer not included) ▲▲	17.75	24.55
TR-2025	6.5V to 18V 20A Regulated DC Power Supply (w/4 steps current-limiting & short-circuit protected) ▲▲▲	62.75	78.75

DIGITAL METERS AND COUNTERS KIT ASSMB

TY-43	3 1/2 Digit Digital Meter ▲	25.00	30.00
SM-43	3 1/2 Multi-Functional LCD D.P.M. (w/ABS Plastic Case) ▲▲	34.50	43.00
SM-48	4 1/2 Hi-Precision D.P.M. ▲▲▲	38.00	48.00
SM-48A	4 1/2 Hi-Precision D.P.M. (w/ABS Plastic case) ▲▲	41.30	50.00
SM-49	3 1/2 Multi-Functional LCD D.P.M. (w/Hold Function) ▲▲	35.00	44.50
SM-100	150 MC Digital Frequency Counter ▲▲▲	85.00	105.00

METAL CABINETS WITH ALUMINUM FRONT PANEL

MODEL	H x W x D	MATERIAL	PRICE
LG-1273	3" 12" 6"	TA-2800, TA-377A, TA-2200	23.00
LG-1684	4" 16" 6"	TA-323A, TA-377A, TA-2200	24.50
LG-1924	4" 19" 11 1/2"	TA-802, TA-1500, TA-120MK2, TA-900MK2, TA-1000A	34.50
LG-1925	5" 19" 11 1/2"	TA-477, TA-800MK2, TA-1500, TA-1000A, TA-3600, AF-3	36.00
LG-1983	2 1/2" 19" 6"	TA-377A, TA-2800, TA-2200, TA-120MK2	28.50

POWER TRANSFORMERS

MODEL	DESCRIPTION	MATCHING	PRICE
#001	28V x 2.6A TO 30V x 2.6A	TA-900MK2, TA-802, TA-1000A, TA-1500	28.00
#002	36V x 2.3A	TR-503, TA-323A, TA-400, TA-300	23.00
#003	40V x 2.6A	TA-477	30.00
#004	24V x 2.6A	TA-120MK2	23.00
#005	28V x 2.3A	TR-355B	17.00
#006	18V x 2.5A	TR-355A	17.00
#007	53V x 2.8A	TA-800	46.00
#008**	±28V x 2.30V x 2.6A	TA-900 MK2, TA-802, TA-1000A, TA-1500	36.00
#009**	±48V x 2.55V x 2.8A	TA-3500, AF-3	50.00
#010**	±30V x 2.30V x 2.400MA	TA-377A, TA-2200	29.00
#011**	±9V x 2.2A	TR-355	60.00

We accept major Credit Cards. Money Orders and Checks + We ship by UPS ground inside US (min. \$5.00) and ship by Us mail outside US. Please call our sales department for orders over 2 lbs or foreign orders + All assembled units have 30 days warranty + Quantity or Volume discount available upon request. We are not responsible for typographical errors

ORDER IN CALIFORNIA 1-800-521-MARK
ORDER OUTSIDE CA 1-800-423-FIVE
CATALOG & INFORMATION (213) 888-8988
ORDER BY FAX (213) 888-8988

8019 E. Slanson Ave., Montebello, CA 90640
CIRCLE 93 ON FREE INFORMATION CARD

RECEIVING TUBES

OVER 3000 TYPES IN STOCK!
Also hard-to-find transformers, capacitors and parts for tube equipment.
Send \$2.00 for our 32 page catalog.

ANTIQUE ELECTRONIC SUPPLY

6221 S. Maple Ave. • Tempe, AZ 85283 • 602-820-5411

REMOTE car starter.

Now from up to 750 ft. away, start or turn off car engine, heat, AC, lights etc., built-in antitheft/safety, easy to install. Fuel injected: \$69.95; carburetor engine: \$97.95, plus \$5.00 S/H satisfaction guaranteed. Send money order or cashiers check to: ZAMTECH CORP., 500 Carmans Rd., S. Farmingdale, NY 11735.

RETURN address labels: to make your mailing easier write to: LEON HARRELL & ASSOCIATES, PO Box 34787, Philadelphia, PA 19101.

STUN guns. Legal protection. Up to 120,000 volts knockdown power defender. \$29.95 + 4sh VEGAS IMAGES, 3355 Spring Mountain #27, Las Vegas, NV 89102. (702) 876-2340.

ANTIQUE RADIO CLASSIFIED

Free Sample!
Antique Radio's
Largest Circulation Monthly.
Articles, Ads & Classifieds.
6-Month Trial: \$15. 1-Yr: \$27 (\$40-1st Class).
A.R.C., P.O. Box 802-L9, Carlisle, MA 01741

ROOM surveillance — \$149.00; room and telephone — \$249.00; remote telephone recorder and room monitor — \$479.00. Catalog, \$3.00. LISTEN ELECTRONICS, 603 Elgin, Muskogee, OK 74401. 1 (800) 633-8277.

CONVERTER — descramblers, S.A. 85X \$170.00, Tocom VIP \$250.00, Jerrold Starcom 6 \$209.00, Zenith Ziac \$199.00, Oak RTC56 \$99.00, Oak M35B \$45.00, Hamlin CR66003M \$115.00, SA3B \$55.00. All makes in stock, COD ok. Full warranty. MT.HOOD ELECTRONICS, (206) 260-0107.

WATER powered watch, 2 year guarantee. Men's, women's, children's size S, \$12.50 each. ALPHA COMPANY, 2 Klarides Village Drive, Seymour, CT 06483.

TELEPHONE LISTENING DEVICE

Record telephone conversations in your office or home. Connects between any cassette or tape recorder and your telephone line. Starts automatically when phone is answered. Records both sides of conversation. Stops recorder when phone is hung up.

\$19.95 EACH Qty. Disc. Avail.

Super Powerful FM TRANSMITTER
Many times more powerful than other transmitters. Transmits up to 1/2 mile to any FM radio - Easy to Assemble Kit - up to 9V battery (not incl.)
For catalog of Transmitters, Voice Scramblers and other specialty items, enclose \$2.00 to USI Corp.

Call 407-725-1080 or send \$19.95 + \$1.00 shipping per item to: USI Corp., PO Box 113151, Melbourne, FL 32902-0051

PLANS AND KITS

FASCINATING electronic devices! Voice Disguiser! Vocal truth indicator! Lasers! Transmitters! Detectors! Free energy! High voltage! More! Kits/Assembled! Catalog \$4.00 (refundable). QUANTUM RESEARCH, 17919-77 Ave., Edmonton, AB. T5T 2S1.

HOBBY/broadcasting/HAM/CB/surveillance transmitters, amplifiers, cable TV, science, bugs, other great projects! Catalog \$1.00. PANAXIS, Box 130-F4, Paradise, CA 95967.

DESCRAMBLER kits. Complete cable kit \$44.95. Complete satellite kit \$49.95. Add \$5.00 shipping. Free brochure. No New York sales. SUMMIT RE, Box 489, Bronx, NY 10465.

SURVEILLANCE transmitter kits tune from 65 to 305 MHz. Mains powered duplex, telephone, room, combination telephone/room. Catalog with Popular Communications, Popular Electronics and Radio-Electronics book reviews of "Electronic Eavesdropping Equipment Design," \$2.00. SHEFFIELD ELECTRONICS, PO Box 377785-C, Chicago, IL 60637-7785.

60 SOLDERLESS Breadboard Projects in two easy-to-read pocket books. Complete with circuit descriptions, schematics, parts layouts, component listings, etc. Both books (BP107 & BP113) only \$11.90 plus \$3.50 for shipping. USA and Canada only. US funds. ETT, INC., PO Box 240, Massapequa Park, NY 11762-0240.

REMOTE CONTROL KEYCHAIN

Complete w/minor-transmitter and +5 vdc RF receiver. Fully assembled including plans to build your own auto alarm. Check Visa or M/C Add \$3 shipping

\$24.95
5 @ \$19.95, 10 @ \$14.95

Visitect Inc. Box 14156, Fremont, Ca. 94539
(510) 651-1425 Fax (510) 651-8454

DESCRAMBLING, new secret manual. Build your own descramblers for cable and subscription TV. Instructions, schematics for SSAV1, gated sync, Sinewave, (HBO, Cinemax, Showtime, UHF, Adult) \$12.95, \$2.00 postage. CABLETRONICS, Box 30502R, Bethesda, MD 20826.

VHF-FM amplifier plans. 75-110 MHz, 15-25 watts. \$16.00. PROGRESSIVE CONCEPTS, 1313 North Grand Ave., #291, Walnut, CA 91789.

WORLD famous! "Spy Shop the best in surveillance and countersurveillance equipment." Send \$6.00 for 140 page catalog. "SPY SHOP," PO Box 6703, Panama City, FL 32404.

LASER Speed Gun Jammer. Complete schematics, parts list and sources. \$9.95. MCS RESEARCH, 608 West Oak, Lafayette, CO 80026.

SINGERS! REMOVE VOCALS! Unlimited Backgrounds™

From Standard Records & CD's with the Thompson Vocal Eliminator™ Call for Free Catalog to Debra Record.
Phone: (404) 482-4189 Ext 72
Singer's Supply, Dept RL-1
7967 Hightower Trail
Lithonia, GA 30058
24 Hour Demo Info Request Line (404) 482-2485 Ext 72
Singer's Supply - We Have Anything & Everything For Singers

CONTROL the world with your computer. Control up to four AC or DC loads with any computer's parallel port. Quad Power Relay Control Board \$69.50/kit. Quad Triac Control Board \$79.50/kit. APOGEE R&D INC., 31 Nebo St., Medfield, MA 02052.

ELECTRONICS Monthly magazine — Projects, gadgets, gizmos, surface mount technology, articles and much more. One year subscription only \$24.95. Order today! ELECTRONICS MONTHLY, 17948-57 Ave., Edmonton, AB T6M 1X3 Canada.

TESLA coils Plans-kits-parts. Send \$2.00 for one tesla coil plan plus complete catalog. SUPER CIRCUITS CO., Rt 2, Box 334, Nunnally, TN 37137.

POWER supply, 5-15V. Complete schematic, parts list, and assembly drawings, \$2.00. Other kits available. EASTMAN ELECTRONICS, PO Box 81084, San Diego, CA 92138-1084.

STARTER kits that work! "Nuclear Physics" \$19.95, Electronics Engineering" \$19.95 (COD \$5.00 extra). FARAH, POB 2464, Sarnia, Ontario N7T 7T1. (519) 332-4824.

THREE phone lines for the price of one. If you have distinctive ringing phone service, Line-master allows you to assign each number to a separate device. Works with phone/fax/modem/answering machine. Info: UNIK, #230EN, 4340 S. Hopkins Avenue, Titusville, FL 32780.

Telephone Listening Device

FM Transmitter Inside Common Dual Modular Adapter - up to 1/4 mile range!

New "Soap FM" Kit - No wiring to phone!

*Super Powerful! Tuner - 88-108MHz

*Crystal clear reception

*Can be picked up on any FM Radio

*Transmits both sides of conversation

*Uses phone line for power and antenna!

\$25.95

Checks, money orders, Visa/MC (214) 255-7490 Sorry no catalog

Seymour-Radix Box 166055 Dept RE4 Irving TX 75016



CREDIT card encoding revealed, encoding info \$5.00, w/plans & software (PC) \$12.25, w/kit \$64.50 + \$4.50 S/H (USA). Assembled add \$10.00. BSC, Box 1841, Alexandria, VA 22314.

BUILD 0-50 volt regulated dual tracking power supply. Complete schematics and instructions. \$5.95 SMS ENGINEERING, RE 5932 West Bell Road, Suite D106, Glendale, AZ 85308.

INVENTORS

INVENTORS! Can you patent and profit from your idea? Call AMERICAN INVENTORS CORP. for free information. Serving inventors since 1975. 1 (800) 338-5656.

EDUCATION & INSTRUCTION

F.C.C. Commercial General Radiotelephone license. Electronics home study. Fast, inexpensive! "Free" details. COMMAND, D-176, Box 2824, San Francisco, CA 94126.

ELECTRONIC engineering. 8 volumes complete. \$109.95. No prior knowledge required. Free brochure. BANNER TECHNICAL BOOKS, 1203 Grant Avenue, Rockford, IL 61103.

ENROLL NOW - GET UP TO 50% OFF!

YOU TRAIN AT HOME



Master the skills you need with NEI, Personal service. Low tuition.

- Bookkeeping
- C Programming
- QBasic Programming
- PC Servicing

CALL TODAY!
1-800-552-0782

Name _____ Age _____

Address _____

City/State/Zip _____

NEI Dept. 7021-0493
2929 Windom Place, Washington, DC 20008

LEARN to earn. Electronic skills bring income. As low as \$49.50. Send \$2.00 for catalog to A&A PRODUCTS, Rt1 Box 482-L, Rockdale, TX 76567.

BUYING your first computer? Video tape of consultant's views. Send \$39.95 for tape: COMPETERS, Box 64526, Unionville, Ontario, L3R 0M9.

BUILD your own PC! Kit building is alive and well. Call PC-BUILD for free catalog. 1 (800) 798-6363.

MASTERCARD AND VISA are now accepted for payment of your advertising. Simply complete the form on the first page of the Market Center and we will bill. \$15.00 minimum.

THE ELECTRONIC GOLDMINE



The Electronic Goldmine has one of the greatest selections of unique electronic project kits available in the world. We have over 29 kits and over 2000 unique bargain priced components in our new 80 page catalog!

FREE CATALOG with over 2000 different items including 29 kits! Request your copy TODAY!

MINIATURE MOTOR

Precision high speed motor made by Mabuchi, their part# FF-050SH. Low noise. Fits into low profile enclosed case. Size about 1-1/8" x 9/16" shaft length 3/8". Great for robots, miniature fans etc. Upper limit 1.0VDC up to 9VDC. **G2846 .49 CEA**

2 CELL BATTERY HOLDER

White plastic holder for 2 standard AA batteries. Has long color coded flexible leads. **G971 3/1.00**

SPECIAL ITEMS

ULTRABRIGHT RED LED
Extremely bright clear lens red T34 Jumbo LED made by HP. Part# HLRP-3750. So bright it can be seen in any light conditions. **G3310 100/\$8 1000/\$75**

COPPER CLAD
Make your own PC boards with these double sided FR4 laminated copper clad panels. Each panel is .062 standard thickness with a size of 5" x 5". Pkcs of 5 **G3022 \$5.00**

MEDIUM INVERTER

Converts 9V or 12VDC to over 250 V when used with a 555 IC circuit. (Schematic included). Perfect for portable strobes, blacklight etc. **G993 \$1.75 EA. 100/\$160.00**

4KV TRIGGER COIL

These can be used with many different strobes. (Schematic included). Perfect for portable strobes, blacklight etc. **N1700 \$1.25 EA. 100/\$80.00**

TRANSFORMER

Bright xenon flash tube for making strobe lights. Includes schematic showing this tube and our standard 3 lead trigger coil. **G936 \$1.39**

STROBE TUBES

High quality assembly consisting of a 1-3/4" long xenon strobe tube mounted in a plastic reflector assembly (2-3/4" L x 1" H) includes snap on color corrected front lens. **A1033 \$2.49 10/\$22.00**

MINIMUM ORDER: \$10.00 plus \$3.50 shipping and handling \$5.00 for U.S. Mail. We accept MC, VISA and Money Orders. SEND ORDERS TO: THE ELECTRONIC GOLDMINE, P.O. Box 6488 Scottsdale, AZ 85261. PHONE ORDERS (602) 451-7454 FAX ORDERS (602) 451-9495

CIRCLE 125 ON FREE INFORMATION CARD

Triplet DMM

Large, easy to read 3-1/2 digit LCD display. Tests voltage in 5 ranges to 750VAC, resistance in 6 ranges to 20M, plus diode test with audible continuity, 6 current ranges to 10A. Built-in battery test and HFE test for NPN and PNP transistors. Test leads, instructions and carrying case included.



\$47⁰⁰ Each

#RN-390-140

6-1/2" Two-Way System

Perfect surround speakers. Customize your media room with these super quality, in-wall speaker pairs. Full size 6-1/2" woofer. Heavy duty 1" soft dome tweeter. Built-in crossover. Fits any standard 2 x 4 or larger wall. Retrofit design allows easy installation in new or existing walls. Response: 40-20,000 Hz. 8 ohm impedance. 40 watts RMS, 60 watts maximum. Includes provision for easy 70V/25V transformer mounting. Overall dimensions: 8-1/2" x 12". Net weight: 9 lbs.



\$95⁰⁰ (4 prs-up)

#RN-300-036

\$249⁹⁵ Sug List

Mini Electrolytic Cap Kit

This 60 piece kit contains a selection of 16 volt and 50 volt mini electrolytic capacitors. 5 pieces each of 10, 47, 100, 220, and 470 uf, 16 volt radial caps. 5 pieces each of 2.2, 4.7, 10, 22, 33, 4.7 and 100 uf, 50 volt radial caps. This convenient kit has many of the "low profile" caps used in camcorders, VCRs, portables and other products where space is limited. A \$27.00 value.

\$19⁹⁵ Each

#RN-024-900



340 E. First St., Dayton, Ohio 45402
Local: 513-222-0173
FAX: 513-222-4644

•30 day money back guarantee • \$20.00 minimum order • We accept Mastercard, Visa, Discover, and most C.O.D. orders. • 24 hour shipping • Shipping charge = UPS chart rate + \$1.00 (\$3.50 minimum charge) • Hours: 8:30 am - 7:00 pm EST, Monday - Friday, 9:00 am - 5:00 pm Saturday. Mail order customers, please call for shipping estimate on orders exceeding 5 lbs. Foreign destination customers please send \$5.00 U.S. funds for catalog postage.

Ultimate 5", 2 Way System

A perfect way to upgrade your car's sound system. 5", 2 way bridgeless speaker pair featuring paper cones that are impregnated with a special ingredient to prevent water damage. 1" aluminum voice coil, 6 oz. magnet. Impedance 4 ohm. Frequency response: 20-21,000 Hz. Power handling: 30 watts RMS, 55 watts maximum. SPL: 92 dB 1W/1M. Mounting depth: 1-3/4". Net weight: 4 lbs.



#RN-265-282

\$46⁹⁵ (1-3 prs)

\$43⁵⁰ (4 prs-up)

12" Pioneer Woofer

Ribbed paper cone with Pioneer special poly foam surround. Impedance: 8 ohm. Frequency response: 30-2,500 Hz. Sensitivity: 92 dB 1W/1M. Power handling capability: 60 watts RMS, 90 watts maximum. Magnet: 20 oz. Voice coil diameter: 1-1/2". Resonant frequency: 30 Hz. VAS= 11.78 cu ft., QMS= 2.217, QES= .425, QTS= .357. Hole: 10-7/8". Net weight: 5 lbs. Pioneer #A30FU20-52F.



#RN-290-105

\$29⁹⁵ (1-3)

\$27⁵⁰ (4-up)

Black Widow Challenger Remote Security System

Dollar for dollar, and feature for feature the Challenger security system outperforms most competitors in its class. Features include: Two-2 button remote transmitters, compact design for under dash or under seat installation, passive or active arming, visual/audible indication when arming/disarming, remote panic, 360 degree shock sensor, door lock output, starter disable with relay and harness. 120 dB siren, entry/tamper violation memory, built-in parking light flasher or horn sounding circuit, current and switch sensing, manual override switch. 1 positive and 2 negative triggers, flashing LED, RF safety lock-out, automatic reset, glass break sensor and more. Net weight: 3 lbs.



#RN-330-037

\$99⁹⁵ Each

The Ultimate Test CD

The Ultimate test CD was designed for use by both the audio amateur and the professional sound engineer. This CD can be used to test CD players, speakers, amplifiers, and for tuning instruments. The manual is written in easy to understand english and takes you step-by-step through each track of the CD and explains its purpose. The Ultimate test CD is a necessary tool for anyone who is serious about quality audio sound.



#RN-510-100

\$7⁹⁵ Each

FREE CATALOG



CALL TOLL FREE
1-800-338-0531

CIRCLE 56 ON FREE INFORMATION CARD

www.americanradiohistory.com

CABLE BOXES BELOW WHOLESALE

CREDIT CARD OR COD

DESCRAMBLERS

TBI-3 SUPER 7
TB-2 or 3 FTB-2 or 3
OAK N-12 SP-200D (PIONEER®)
SB-2 or 3 HAMLIN® MLD 1200

COMBINATION UNITS

JERROLD® : DRX-DIC, DRZ-DIC,
Tocom 5503
SCI-ATLANTA® : SA-8536 + , SA-8555,
SA-8580, SA-8590
SYLVANIA® : 4040-3 DIC-Ch 2 or 3
PIONEER® : BA-6110
ZENITH® : ST-Series
OAK® : RTC-56-Ch 2 or 3, M35B

CONVERTERS W/REMOTES

TIMELESS PRODUCTS®
PANASONIC® - JERROLD®

YOU MUST CHECK WITH YOUR LOCAL CABLE COMPANY AND PAY FOR ALL SERVICE YOU USE. IT IS NOT THE INTENT OF LAKE SYLVAN TO DEFAUD ANY TELEVISION OPERATOR AND WE WILL NOT ASSIST ANY COMPANY OR INDIVIDUAL IN DOING THE SAME.

LAKE SYLVAN SALES, INC.
SORRY NO MINNESOTA SALES

CALL FOR A CATALOG NOW!!
800-800-4582

CIRCLE 179 ON FREE INFORMATION CARD

LEARN TV/VCR REPAIR

Now you can train at home in spare time for a money-making career as a TV/VCR Repair Specialist. No previous experience necessary. No need to quit your job or school. Everything is explained in easy-to-understand language with plenty of drawings, diagrams and photos. We show you how to troubleshoot and repair video-cassette recorders and TV sets, how to handle house calls and shop repairs for almost any make of television or VCR. Tools are included with your course so you can get "hands-on" practice as you follow your lessons step by step. Send for free facts about the exciting opportunities in TV/VCR Repair and find out how you can start making money in this great career. **MAIL COUPON TODAY**

ICS SCHOOL OF TV/VCR REPAIR, Dept. ADE033S
925 Oak Street, Scranton, PA 18515

Please send me full information and color brochure on how I can learn TV/VCR Repair at home in my spare time. I understand there is no obligation and no salesman will visit me.

Name _____ Age _____
Address _____ Apt. # _____
City/State _____ Zip _____
Phone () _____

WANTED

INVENTORS: We submit ideas to industry. Find out what we can do for you. 1 (800) 288-IDEA.

ATTENTION! No fees to inventors! Call **INVENTORS AWARENESS GROUP, INC.** for a free brochure. 1 (800) 288-3938.

BUSINESS OPPORTUNITIES

YOUR own radio station! Licensed/unlicensed AM, FM, TV, cable. Information \$1.00. **BROADCASTING**, Box 130-F4, Paradise, CA 95967.

CABLE BOX WHOLESALE, INC.

BEST BOXES—BEST PRICES

Immediate Shipping—COD's

Satisfaction Guaranteed

FREE Catalog—Call Now

800-841-7835

LET the government finance your small business. Grants/loans to \$500,000. Free recorded message: (707) 449-8600. (KS1).

EASY work! Excellent pay! Assemble products at home. Call toll free 1 (800) 467-5566 Ext. 5192.

HOME assembly work available! Guaranteed easy money! Free details! **HOMEWORK-R**, Box 520, Danville, NH 03819.

MAKE \$75,000.00 to \$250,000.00 yearly or more fixing IBM color monitors. No investment, start doing it from your home (a telephone required). Information, USA, Canada \$2.00 cash for brochure, other countries \$10.00 US funds. **RANDALL DISPLAY**, Box 2168-R, Van Nuys, CA 91404 USA. FAX (818) 990-7803.

PAY TV AND SATELLITE DESCRAMBLING

***** 1993 EDITION *****

Includes programing cable box chips, hacking B-MAT, wireless cable (MVC) de scrambling, bullets, PLUS fixes and much more. ONLY \$18.95. Other **PAY TV** and **SATELLITE DESCRAMBLING** volumes, Volume 1 (BASICS), 1989, 1991, and 1992 \$15.95 each. Different turn-ons, bypasses, ECM's, schematics and counter ECM's in each. **THE COMPLETE WIZARD**. Using the VCI data stream. \$15.95. Any 3/\$32.95 or 5/\$54.95. **SCRAMBLING NEWS** monthly. Keep up with the latest in satellite and cable descrambling. Everything that's new. \$32.95/yr. **OUR BEST DEAL** everything here, the video and much more only \$129.95. New catalog \$1.

Scrambling News, 1552 Hartel Ave., #123, BUFFALO, NY 14216
Voice/FAX (716) 874-2088 COD's are OK. ADD \$6

SATELLITE TV

FREE catalog — Lowest prices worldwide. Satisfaction guarantee on everything sold — Systems, upgrades, parts, all major brands factory fresh and warrantied. **SKYVISION**, 1012 Frontier, Fergus Falls, MN 56537. 1 (800) 334-6455. Outside US (218) 739-5231.

CABLE TV DESCRAMBLERS
★ **CONVERTERS** ★
and **ACCESSORIES.**

**SAVE MONEY.
DON'T RENT!**

PANASONIC, JERROLD, OAK,
PIONEER, SCIENTIFIC ATLANTA
AND MORE. LOWEST PRICES. FREE CATALOG.

CABLE READY COMPANY (800) 234-1006

VIDEOCIPHER II descrambling manual. Schematics, video, and audio. Explains DES, Eprom, CloneMaster, 3Musketeeer, Pay-per-view (HBO, Cinemax, Showtime, Adult, etc.) \$16.95, \$2.00 postage. Schematics for Videocypher Plus, \$20.00. Schematics for Videocypher 032, \$15.00. Collection of software to copy and alter Eprom codes, \$25.00. **CABLETRONICS**, Box 30502R, Bethesda, MD 20824.

SUPER low satellite prices. Free U.S. and International catalog. **SATMAN**, (309) 692-4140 (Int'l), 1 (800) 472-8626 in U.S.

BEST BY MAIL

Rates: Write National, Box 5, Sarasota, FL 34230

FINANCIAL

8% **VISA'S, LOANS!!** It's a fact! Complete list \$4.00. 1-800-967-4960.

EARN UNLIMITED: Earn Six Figure Income As A Mortgage Regional Manager. 1-800-365-7550 Ext. 3464.

MONEYMAKING OPPORTUNITIES

MAKE THOUSANDS WEEKLY! Exposing Mail Order Frauds. FREE Information. Rush Stamped Envelope. Wealth Seeker, 1947 Southern St., Chattanooga, TN 37406.

HOMEWORKERS NEEDED! EXCELLENT Pay! Plus Sweepstakes — WIN MILLIONS!!! Send \$1P&H. **FORTUNE**, Box 4255-(RE), Lincoln, NE 68504.

OF INTEREST TO ALL

FREE CD OR CASSETTE (Specify) \$3 S&H GUARANTEED: KML, 827 Central #236, Dover, NH 03820-2506.

HOME FORTUNES FREE Catalogue: Worley Bailey, 785-(RE) Whitecloud, Boise, ID 83709.

AMAZING LOTTERY SECRET OF "31": POPBOOK, Box 6519-(RE), Burbank, CA 91510-6519.

CHINESE HOROSCOPE BASED On Birth Year — 24hrs. 1-900-443-0308 \$2/minute.

Thanks
for
sticking
with
us.



EASTER SEALS '93

Give the power to become.
Support Easter Seals.



THE POWER TO BECOME.

1·800·831·4242

Your Resource for Value. Only a Phone Call Away.

20
YEARS OF
EXCELLENCE
1973-1993

ABS SPEEDY BOXES

Will not crack or split when drilled or punched. Complete with four screws and lid. All sizes below are for interior dimensions.
Color: black

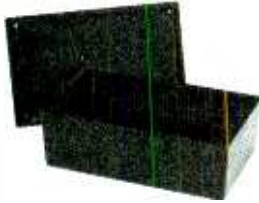

Part No.	Size (L x W x H)	Price
4R18921	3.125" x 2.0" x 0.875"	\$1.95
4R18913	4.875" x 2.5" x 1.5"	2.49
4R18892	6.0" x 3.5" x 1.875"	2.75
4R18905	7.5" x 4.25" x 2.25"	3.25

VECTOR PROTOTYPING BOARDS



4R37604

Prototyping boards with punched holes are convenient, economical tools for assembling circuit components — and cost effective alternatives to custom designs.

Part No.	Description	Size (LxW)	Price
4R63221	Epoxy Glass PC Board	6.5" x 4.5".....	\$4.75
4R37604	Epoxy Glass PC Board	17" x 4.5".....	10.95
4R37621	Epoxy Glass PC Board	17" x 8.5".....	19.95
4R37612	Phenolic PC Board	17" x 4.5".....	7.95

REGULATED POWER SUPPLY KITS

Build the power supply you've been needing for years. Ideal for home or instructional use. Select from three different versions. Each kit is complete with printed circuit board, electronic components, and user assembly instructions.



4R73613

Part No.	Product No.	Input Voltage (VAC)	Output Voltage (VDC)	Current (mA)	Dimensions (L x W x H inches)	Price
4R20360	JE200	120	+5	1000	3.5 x 5.0 x 2.0	\$14.95
4R20626	JE215	120	+5 to +15 -5 to -15	750 to 175 750 to 175	3.5 x 5.0 x 2.0	19.95
4R73613	JE225	120	+5 fixed +3 to +12 -3 to -12	1000 100 100	5.12 x 5.12 x 2.25	29.95

See our Catalog for more kits

Capacitors

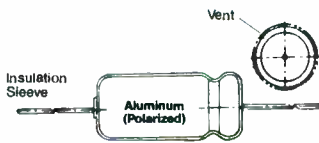

Axial Lead Electrolytic Capacitors

Part No.	Cap.	Volt.	Price
4R10866	1µF	50V.....	\$1.15
4R10997	22µF	50V.....	.29
4R10911	100µF	50V.....	.29
4R11121	470µF	50V.....	.49
4R11033	2200µF	16V.....	.69



Mylar Capacitors

Part No.	Cap.	Volt.	Price
4R26833	.001µF	100V.....	\$1.10
4R26884	.01µF	100V.....	.11
4R26956	.1µF	100V.....	.19
4R27001	1µF	100V.....	.69

Linear IC's*

Part No.	Product No	Price
4R33241	TL082CP.....	\$1.59
4R23579	LM317T.....	.65
4R23683	LM324N.....	.35
4R23771	LM336Z.....	1.09
4R23851	LM339N.....	.45
4R27422	NE555V.....	.29
4R24328	LM556N.....	.49
4R24467	LM723CN.....	.49
4R24539	LM741CN.....	.29
4R23131	LM1458N.....	.39
4R23157	LM1488N.....	.45
4R23181	LM1489N.....	.45
4R34278	ULN2003A.....	.69
4R24230	LM3914N.....	2.49
4R27385	NE5532.....	1.19
4R51262	7805T.....	.45
4R51334	7812T.....	.45

* Name brand IC's in stock

IC Sockets

Part No.	Product No.	Description	Price
4R51570	8LP	8-pin low profile.....	\$1.10
4R37161	14LP	14-pin low profile11
4R37372	16LP	16-pin low profile12
4R39335	24LP	24-pin low profile19
4R40301	28LP	28-pin low profile22
4R41110	40LP	40-pin low profile28

LEDs

Part No.	Product No.	Description	Price
4R34761	XC556G	T1 3/4, (green)	\$1.16
4R34796	XC556R	T1 3/4, (red)	.12
4R34825	XC556Y	T1 3/4, (yellow)	.16

Transistors And Diodes

Part No.	Product No.	Description	Price
4R28628	PN2222	TO-92 case.....	\$1.12
4R28644	PN2907	TO-92 case.....	.12
4R35991	1N4004	DO-41 case.....	.10
4R38236	2N2222A	TO-18 case.....	.25
4R36126	1N4735	DO-41 case.....	.25
4R38359	2N3904	TO-92 case.....	.12
4R36290	1N751	DO-35 case.....	.15
4R38421	2N4401	TO-92 case.....	.15
4R36038	1N4148	DO-35 case.....	.07
4R38308	2N3055	TO-3 case.....	.69



4R26622 4R21936

Switches

Part No.	Product No.	Description	Price
4R21936	JMT123	SPDT, on-on (toggle).....	\$1.15
4R38842	206-8	SPST, 16-pin (DIP).....	1.09
4R26622	MS102	SPST, momentary (push-button).....	.39

*Additional components available

Carbon Film 1/4 Watt 5% Resistors

Part No.	Ohms	Price	Part No.	Ohms	Price
4R29946	100	\$1.95/C	4R29911	10K	\$1.95/C
4R30867	330	1.95/C	4R30453	22K	1.95/C
4R29663	1.0K	1.95/C	4R29997	100K	1.95/C
4R30314	2.2K	1.95/C	4R29698	1.0M	1.95/C

Sold in packages of 100 pcs. (C=100 pcs.)

3/4 Watt Linear Taper-15 Turn Cermet Potentiometers

Part No.	Ohms	Price
4R41785	1K	\$.99
4R41822	10K	.99
4R41849	100K	.99
4R41806	1MEG	.99

Order toll-free 1·800·831·4242

Call or write for your
FREE 1993 Annual Catalog:
1·800·637·8471

JAMECO™
ELECTRONIC COMPONENTS
COMPUTER PRODUCTS

1355 Shoreway Road
Belmont, CA 94002

FAX: 1·800·237·6948 (Domestic)
FAX: 415·592·2503 (International)

For International Sales, Customer Service, Credit Department and all other inquiries: Call 415·592·8097 between 7AM-5PM P.S.T.

CA Residents please add applicable sales tax.

\$30.00 Minimum Order

Terms: Prices subject to change without notice. Items subject to availability and prior sale. Complete list of terms/warranties is available upon request.

© 1993 Jameco 4/93 All trademarks are registered trademarks of their respective companies.



April 1993, Electronics Now

Courteous Service • Discount Prices • Fast Shipping

ALL ELECTRONICS CORP.

Mail Order Electronic Parts And Supplies
P.O. Box 567 • Van Nuys, CA 91408

AUTOMOBILE ALARM

Protect your car and its contents with the Anes PRO-500 alarm system. The electronics and speaker of this passive anti-theft system are combined into one assembly making it easy to install, easy to operate. Automatically turns itself on and provides a 60 second exit delay when the ignition is turned off. Upon re-entry of the vehicle, you have 10 seconds to turn on the ignition and disarm the system. The alarm is triggered if any change in battery voltage occurs (courtesy lights, brake lights, dash lights). Sounds a high-pitched, high-low siren. Battery back-up feature protects even if battery cables are cut. Includes all necessary wiring, parts, window stickers and instructions. Not included, but recommended is a single pole "valet switch" for disarming the alarm. Originally sold for \$65.00 or more. These units were removed from store shelves, and some of the packages show signs of wear. The alarms are fully functional and guaranteed.



CAT# AL-500 \$20.00 each

10,000 Mfd 50 Vdc Capacitor

Sprague 81D1114
High capacity and voltage in a relatively small package. 1.385" diameter X 2.05" high. 0.05" dia. pc pins on 0.4" mounting centers. Also has 3 extra tabs for mounting stability.



CAT# CP-1050 \$2.25 each • 5 for \$10.00

8MM VIDEO CASSETTE TAPES (USED)

Sony 120 minute, Hi8 metal particle video cassettes. Used and bulk erased. In new condition, these high quality cassettes would sell for considerably more. A great deal for 8mm camcorder users.

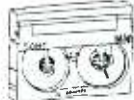

CAT# VCU-8 \$2.50 each 5 for \$11.00

130 Watt Switching POWER SUPPLY

Youngone Communication
Model # YP131-05
Input: 90-120 Vac or 180-250 Vac
Output: +5 Vdc/15 amp
5 Vdc/0.3 amp
+12 Vdc/4.2 amp, -12Vdc/0.3 amp.
Fan cooled switching power supply. Housed in vented metal cabinet 6" x 5.5" X 3.65" high. Requires IEC type power cord. CSA and UL listed. Output leads terminate to 0.1" single row connectors.



CAT# PS-130 \$23.50 each

(USED) RECHARGEABLE AA BATTERIES

Standard 1.20 Vdc 500 mAh nickel cadmium rechargeable batteries. Guaranteed.



CAT# NCB-AAU \$1.00 each

TOLL FREE ORDER LINES

1-800-826-5432

CHARGE ORDERS to Visa, MasterCard or Discover

TERMS: Minimum order \$10.00. Shipping and handling for the 48 continental U.S.A. \$3.50 per order. All orders including AK, HI, PR or Canada must pay full shipping. All orders delivered in CALIFORNIA must include state sales tax (7.25%, 7.5%, 7.75%, 8.25%, 8.5%). Quantities Limited NO C.O.D. Prices subject to change w/out notice.

Call or Write For Our
FREE 64 Page Catalog

(Outside The U.S.A. Send \$2.00 Postage)

ALL ELECTRONICS CORP.
P.O. Box 567 • Van Nuys, CA • 91408

ADVERTISING INDEX

Electronics Now does not assume any responsibility for errors that may appear in the index below.

Free Information Number	Page	176	Pomona Electronics.....	35
108	AMC Sales	86	Pulse Stick II	81
107	All Electronics	108	Radio Shack	36
—	Amazing Concepts	12	Star Circuits	35
98	B.I.—A Division of WaveTech	5	Silicon Chip	25
109	C & S Sales	33	TECI	84
—	CIE	21, 27	Tektronix	26
185	Cable Warehouse	89	The School Of VCR Repair	89
54	Chemtronics	13	U.S. Cable	97
110	Chenesko Products	35	WPT Publications	84
—	Command Productions	86	181 Xandi Electronics	35
183	Deco Industries	35	191 Zentek Corp.	97
193	Demax Corp.	12		
125	Electronic Goldmine	105		
—	Electronics Book Club	28, 17		
—	Electronic Tech. Today	32		
121	Fluke Manufacturing	CV2		
194	Foley-Belsaw Company	90		
190	Global Specialties	7		
—	Grantham College	77		
86	Heathkit	90		
177	Hewlett Packard	CV4		
—	ISCET	84		
189	Interactive Image Tech	16		
114	Jameco	107		
115	Jensen Tools	35		
186	Kelvin	23		
179	Lake Sylvan Sales, Inc.	106		
87	MCM Electronics	103		
93	Mark V. Electronics	104		
182	Mini-Circuits	3		
—	NRI Schools	11, 101		
71	NTE Electronics	15		
184	Optoelectronics	CV3		
178	Panavise	87		
56	Parts Express	105		

ADVERTISING SALES OFFICE

Gernsback Publications, Inc.
500-B Bi-County Blvd.
Farmingdale, NY 11735
1-(516) 293-3000

President: Larry Steckler

For Advertising ONLY
516-293-3000

Fax 1-516-293-3115

Larry Steckler

publisher

Christina Estrada

assistant to the President

Arline Fishman

advertising director

Denise Mullen

advertising assistant

Kelly McQuade

credit manager

Subscriber Customer Service

1-800-288-0652

Order Entry for New Subscribers

1-800-999-7139

7:00 AM - 6:00 PM M-F MST

ADVERTISING SALES OFFICES

EAST/SOUTHEAST

Stanley Levitan, Eastern Advertising Sales Manager

Electronics Now

1 Overlook Ave.

Great Neck, NY 11021

1-516-487-9357, 1-516-293-3000

Fax 1-516-487-8402

MIDWEST/Texas/Arkansas/Okla.

Ralph Bergen, Midwest Advertising Sales Manager

Electronics Now

One Northfield Plaza, Suite 300

Northfield, IL 60093-1214

1-708-446-1444

Fax 1-708-559-0562

PACIFIC COAST/Mountain States

Electronics Now Magazine

Pamela Kuster

Pattis/3M

1800 North Highland Avenue

Suite 717

Hollywood, CA 90028

1-213-462-2700

FAX 1-213-463-0544

EN Shopper

Joe Shere, National Representative

P.O. Box 169

Idyllwild, CA 92549

1-714-659-9743

Fax 1-714-659-2469

Electronics Now, April 1993

The Fastest Counter Starts with the Fastest Chip

Optoelectronics Puts the OE10 Inside

Since the 70's the frequency counter chip most used was the 7216 (8 digits,

10 million counts per second). The only way to have a faster more reliable counter was to design our own chip. So we did —

the OE10. Faster — 10 digits, 220 million counts per second. Reliable — zero field failures.



And now we have added a microprocessor to unleash the power of the OE10.

Optoelectronics introduces the 3000A Multifunction Micro HandiCounter[®] with these new and exciting features:

- **Digital Filter Technique** (patent pending)
Filters stable signals from background clutter
- **Digital Auto Capture** (patent pending)
Holds present reading and stores previous reading for hands free unattended operation
- **Works Even in Presence of Strong RF Signals**
- **Stores Frequencies**
- **Increased Sensitivity**
- **Synchronous RF Detection**
Super sensitive 16 segment bargraph operates independently from counter
- **High Speed ASIC**
220 million counts per second.
- **10Hz-3GHz**
- **Multifunction HandiCounter[®]**
- **Dual High Impedance Amplifiers**
For ratio and time interval functions
- **High Resolution**
Direct count to over 200MHz
- **Extended Battery Use**
- **1 Year Full Warranty**
- **All This and More for the Low Price of \$279.**

Options for the NEW 3000A

- TCXO30**
± .2ppm \$100.
- BL30/Backlight** 45.
- Antenna - TA100S**
Telescoping Whip Antenna 12.
- Antenna Pack 2**
Includes RD27, RD50, RD100
RD440, RD800 - Save \$32 99.
- CC30**
Padded black vinyl carrying case 15.

Factory Direct Order Line

1-800-327-5912

305-771-2050 • Fax 305-771-2052

5821 NE 14th Ave, Ft. Lauderdale, FL 33334

5% Ship/Handling (Max \$10) U.S. & Canada. 15% outside continental U.S. • Visa, Master Card, C.O.D. (Cash or Money Order only).

OPTOELECTRONICS
BE SURE YOU HAVE AN OE10 INSIDE

Within budget. Without compromise.



Get more of what you want in a 6½ digit DMM for just \$995.

The HP 34401A gives you more performance than any other DMM for the price. More resolution. Better accuracy. The highest reading speed. Fastest throughput. And widest AC bandwidth.

It has more standard features. Like HP-IB, RS-232 and built-in SCPI commands for more system flexibility. Plus ten extended functions including continuity, diode test, limit test, reading hold, dB and null to give you greater flexibility on the bench.

What more could you want? The HP 34401A also comes with a 3-year warranty, standard.

☎ For more information, or same-day shipment from HP DIRECT, call 1-800-452-4844*. Ask for Ext. TB26. And we'll send you a data sheet.

HP 34401A Digital Multimeter	
DC Accuracy (1 year)	0.0035%
AC Accuracy (1 year)	0.06%
Maximum input	1000 Vdc
Reading speed	1000/sec
Resolution	100 nV, 10 nA, 100 μΩ

* U.S. list price

** In Canada call 1-800-387-3867, Dept. 434

There is a better way.

 **HEWLETT
PACKARD**