

BUILD A TELEPHONE PAGING SYSTEM

MAY 1993

Electronics

NOW

Combined with
Radio Electronics

A look at the contenders in the race for the **DIGITAL HDTV** system of tomorrow

How do they get **SO MUCH BASS** out of **SUCH LITTLE SPEAKERS?**

A look at **MOSFET's** in theory and practice

We show you how to get **FCC TYPE APPROVAL** for all your phone-circuit designs!

Build a novel **TALKING PHONE RINGER**



\$3.50 U.S.
\$3.95 CAN

A
GERNSBACK
PUBLICATION

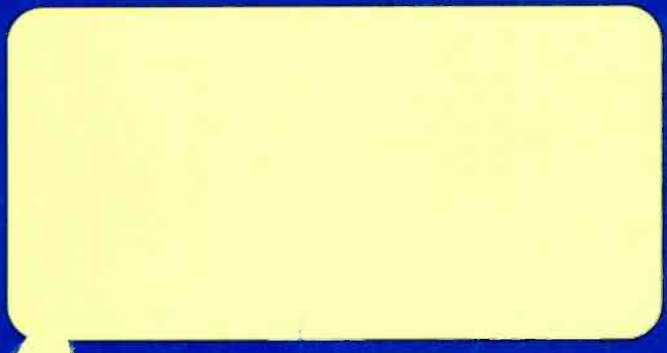

Multi-Choice.

Whether you're doing first-level troubleshooting or component-level diagnosis, Fluke meters offer you one of the widest choice of capabilities and price ranges in the industry. Choices ranging from the basic Fluke 12 with auto function V-Chek™ and Continuity Capture™. To the classic Fluke 77

with Auto Touch Hold® and current measurements.

Fluke 77
The classic
Multimeter
\$169.00

To the advanced Fluke 83 with Min/Max/Average recording,

Frequency, Duty Cycle and Input Alert™. Plus a full

line of quality accessories to extend those

capabilities even further. No matter which Fluke

meter you choose, you can count on precise, reliable, consistent performance year in and

year out. Plus, strong customer support and product warranties that measure up to any

in the industry. Make the choice

that gives you the most choices.



Fluke 83
Full-featured
Multimeter
\$255.00



for the tools you need to get the job done right.

See your Fluke distributor, or call 1-800-87-FLUKE

for a catalog and the name of the

distributor nearest you.

Look to Fluke

Fluke 12
Auto-function
Multimeter
\$89.95



FLUKE 12	FLUKE 77	FLUKE 83
The Fluke meters listed above feature DC/AC voltage, resistance, audible continuity and diode test.	Auto Touch Hold®	Auto Touch Hold® and Relative modes
Capacitance measurements	Current measurements	Current measurements
V Chek™ (auto function)	Analog Digital display	Analog/Digital display
Min/Max Record with Relative Time Stamp	Two-year warranty	Three-year warranty
Continuity Capture™	Three-year warranty	Three-year warranty
Basic accuracy 0.9%	Yellow holster with Flex Stand™	Yellow holster with Flex Stand™
	Basic accuracy 0.3%	Input Alert™
		Capacitance measurements
		Frequency and Duty Cycle
		Min/Max/Avg. Recording
		Basic Accuracy 0.3%

John Fluke Mfg. Co., Inc.
P. O. Box 9090, Everett, WA 98206
For more information call:
(416) 890-7600 from Canada
(206) 356-5500 from other countries

© Copyright 1992 John Fluke Mfg. Co. Inc. All rights reserved.
Prices subject to change. Suggested U.S. list price.
Ad No. 00276

FLUKE®

CIRCLE 121 ON FREE INFORMATION CARD

BUILD THIS

41 TALKING TELEPHONE RINGER

Replace your phone's ringer with spoken messages or your favorite tune!

Steve Lympany

45 THE PHONE PAGER

Don't yell—use our at-home pager to let a family member know there's someone on the phone!

John E. Carter, K8YVT

56 PART-68 INTERFACE

Use this interface to make all your phone-based projects meet FCC Part-68 specifications.

Mike Hagans and Kyle Magrill

TECHNOLOGY

33 THE NEW WORLD OF HDTV

A look at the four digital high-definition TV systems vying for FCC approval.

Aubrey Harris

59 WORKING WITH MOSFET's

Learn how they work, and how to make them work in your projects.

Ray Marston

67 HOW DO THEY GET SO MUCH BASS OUT OF SUCH LITTLE BOXES?

The engineering secrets behind bookshelf speakers.

Dale Blackwell

DEPARTMENTS

6 VIDEO NEWS

What's new in this fast-changing field.

David Lachenbruch

16 EQUIPMENT REPORT

Elenco Digital Multimeter Kit.

73 HARDWARE HACKER

Piezoelectric fundamentals, and more.

Don Lancaster

81 DRAWING BOARD

Detecting video levels.

Robert Grossblatt

84 AUDIO UPDATE

An excellent reference book.

Larry Klein

87 COMPUTER CONNECTIONS

The PC industry.

Jeff Holtzman

AND MORE

100 Advertising Sales Offices

100 Advertising Index

95 Buyer's Mart

14 Letters

28 New Lit

18 New Products

12 Q&A

4 What's News

Electronics NOW[®]

Hugo Gernsback (1884-1967) founder

Larry Steckler, EHF, CET,
editor-in-chief and publisher

EDITORIAL DEPARTMENT

Brian C. Fenton, editor

Marc Spiwak, associate editor

Kim Dunleavy,
assistant technical editor

Teri Scaduto, assistant editor

Jeffrey K. Holtzman
computer editor

Robert Grossblatt, circuits editor

Larry Klein, audio editor

David Lachenbruch
contributing editor

Don Lancaster
contributing editor

Kathy Terenzi, editorial assistant

ART DEPARTMENT

Andre Duzant, art director

Injae Lee, illustrator

Russell C. Truelson, illustrator

PRODUCTION DEPARTMENT

Ruby M. Yee, production director

Janice Box,
editorial production

Karen S. Brown
advertising production

Marcella Amoroso
production assistant

CIRCULATION DEPARTMENT

Jacqueline P. Cheeseboro
circulation director

Wendy Alanko
circulation analyst

Theresa Lombardo
circulation assistant

Michele Torrillo, reprint bookstore

Typography by Mates Graphics
Cover photo by Sony Corp.

Radio-Electronics is indexed in
Applied Science & Technology Index
and *Readers Guide to Periodical Literature*.

Microfilm & Microfiche editions are
available. Contact circulation department
for details.

Advertising Sales Offices listed
on page 94.

Radio-Electronics Executive and
Administrative Offices
1-516-293-3000.

Subscriber Customer Service:
1-800-288-0652.

Order Entry for New Subscribers:
1-800-999-7139.



Audit Bureau
of Circulations
Member



Boost Your Earning Power with these Practical Guides from TAB/McGraw-Hill



SECRETS OF RF CIRCUIT DESIGN
Design and build your own radio frequency amplifiers, preselectors, signal generators and inductor coils. Also, find how-tos for using: antennas, microwave circuits, and other devices. 436 pp., 116 illus. #3710H, \$32.95

BUILD YOUR OWN UNIVERSAL COMPUTER INTERFACE Use your computer to control home security...run laboratory experiments...collect data...and more. You get instructions for building interfacing circuits that enable almost any computer to control external devices. 285 pp., 224 illus. #3122H, \$21.95

PASS THE CET EXAMS WITH EASE!
CET STUDY GUIDE—3rd Ed.
"...this book will be a great help."—*Electronic Servicing & Technology*. Find everything you need to pass the tests, including basic theory and workbench techniques. 280 pp., 188 illus. #4076H, \$27.95

THE CET EXAM BOOK—3rd Ed.
This new edition covers every level of CET certification and the Journeyman options, and is best used in conjunction with the study guide. You get sample quizzes on each topic. 304 pp., 265 illus. #4199H, \$27.95

SAVE 15%—Order both guides (#586274-3) for only \$47.50—regularly \$55.90

MICROCONTROLLERS: Architecture, Implementation, & Programming Unleash the power of the latest generation of controller designs. Implement a controller into hardware such as anti-lock brakes, cash registers, robotic systems, and more. 496 pp., 125 illus. #028977-8, \$48.00

MASTERING TECHNICAL MATHEMATICS Step-by-step, illustrated instructions and techniques guide you through solving electronic problems in arithmetic, algebra, geometry, trigonometry, and calculus. 586 pp., 420 illus. #3438H, \$39.95

HOME VCR REPAIR ILLUSTRATED Save time and money by servicing your own VCR—even learn how to repair for profit. 450+ photographs guide you through every step of repair—from getting inside the VCR to examining the remote control. 400 pp., 459 illus. #3711H, \$29.95

SIMPLIFIED PRACTICAL FILTER DESIGN Learn how to layout and assemble your own filters. You get techniques for building: low-pass, high-pass, bandpass, band rejection, M-derived, composite and crystal filters. 200 pp., 137 illus. #3355H, \$26.95

THE LASER GUIDEBOOK—2nd Ed. Get techniques for using over 25 lasers, including beam characteristics and applications. Features all-new chapters on X-ray, free-electron, fiber, and semi-conductor lasers. 512 pp., 98 illus. #4307P, \$29.95

MAINTAINING AND REPAIRING VCRS—3rd Ed. You've got the know-how—now get the repair tips you need to repair any VCR. This new third edition takes a problem-solving approach to fixing VHS, 8mm, and camcorder in the business—from diagnosing the problem to servicing broken power supplies. 400 pp., 400 illus. #4204H, \$29.95

THE ENCYCLOPEDIA OF ELECTRONIC CIRCUITS, Vol. 1 through 4 There's never been any circuit references like these before. For projects, designs, or applications, you'll use these references to find over 4000 circuitry components in • computers • telecommunications • modern circuit design • laser • fiber optics • voltage references • thermal reactors • sensors • antennas and alarms • and more.
Order all 4 volumes, #586148-8, for only \$149.95 (regularly 240.00)

INTERNATIONAL ENCYCLOPEDIA OF INTEGRATED CIRCUITS—2nd Ed. Finally—the circuits you need without having to turn to manufacturers' data books. You'll find descriptions of circuit functions, pinout diagrams, internal schematics, and tables listing manufacturers' documentation. 1,168 pp., 4,000 illus. #3802H, \$84.95

FREE 30-DAY EXAM

Please cut along dotted line

3 EASY WAYS TO ORDER:

- CALL 1-800-822-8158 (24 hours a day)
- FAX 1-717-794-2080 (24 hours a day)
- Mail Coupon to: TAB/McGraw-Hill, Inc.
Blue Ridge Summit, PA 17294-0840

Please send me the book(s) indicated below for a free 30-day exam:

Book#	Title	Qty.	Total Price

Name _____

Address _____

City/State/Zip _____

Signature _____

Order invalid without signature. Order subject to credit approval. Orders outside the U.S. must be prepaid in U.S. dollars drawn on U.S. banks and include \$5.00 for shipping and handling. Orders over \$150.00 require prepayment.

Satisfaction Guaranteed—Within 30 days, pay the amounts stated plus postage, handling, and state and local sales tax, or return the books you order and owe nothing.

WHAT'S NEWS

A review of the latest happenings in electronics.

Visual problem-solving

International Business Machines Corporation has developed what it calls the IBM Power Visualization System (PVS)—a computer that merges high-resolution color displays and animation with supercomputer-based simulation. The parallelized, multiuser visualization supercomputer permits scientists to gain insights into complex problems by presenting them in two- or three-dimensional visual formats.

Scientists at the Thomas J. Watson Research Center, where PVS was developed, say that the system was optimized for speed at every step of data processing from raw data input to image display. They say it will be of value in all scientific and engineering discipline, as well as for entertainment and television advertising.

For high-speed internal processing, PVS includes a dedicated visualization server containing up to 32 Intel i860 RISC processors. It has a bandwidth that exceeds 1 gigabyte per second, a 16-megabytes per processor of memory, and up to 2 gigabytes of shared global memory. IBM says that this is about eight times as much memory as in a typical high-end graphics workstation.

High-speed input/output is assured by high-performance parallel interface (HIPPI) channels that sustain transfer rates of up to 100 megabytes per second. This, according to IBM, is five to ten times faster than those of conventional workstations.

For high-speed data storage, there is an external parallel disk-drive array with linkable high-capacity drives (up to 170-gigabyte each). Its data transfer of up to 55 megabytes per second is ten times faster than that of typical graphics workstations.

For high-speed image transfers the system has a video controller

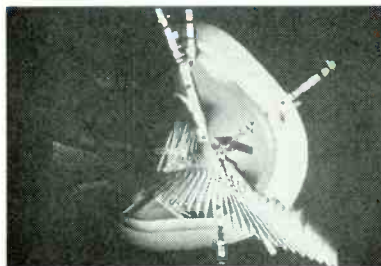

a



b

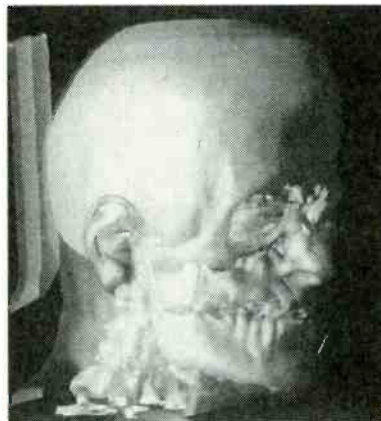

c

IMAGES PRODUCED ON IBM'S POWER Visualization System. The electron density of a water molecule shows multiple isosurfaces with specific values. The inner surface is mapped with the density gradient in color. The isosurfaces represent three-dimensional contours of the probability of finding electrons in free space. Colored arrows show the computed magnitude and direction of the gradient, (a). A frame from an animated movie shows the system's ability to simulate the appearance of different materials with light reflecting off "metal" and refracting through "glass," (b). An image obtained from a CT-scan of a patient who needs face and skull reconstructive surgery. The surface rendering of the skull can be covered with "skin" of any degree of opacity, (c).

capable of delivering images fast enough for real-time animation, at resolutions high enough to be reproduced as high-definition images for television.

A dedicated IBM RISC system 6000 support processor handles system diagnostics and control, as well as communications to remote workstations over Ethernet, Token-Ring, or FDDI networks.

The system is accessed through the integrated IBM Power visualization Data Explorer (DX), developed for the PVS. It can handle imported and derived multidimensional data in a wide variety of representations, geometries and groupings. It is also offered by IBM as a separate unit for use with computers made by other manufacturers.

The rendering functions available include volume rendering of regular and irregular data, opaque and translucent surfaces, and opaque or translucent lines and points. The images can be two- or three-dimensional, and there is a wide selection of shading and lighting. There is an unlimited choice of viewing angle and complete flexibility in combining volumes, surfaces, and lines in the same image.

Simultaneous multiple views of the image can be seen in the same front or rear visualization window, and simultaneous views of different images can be seen in different visualization windows. The images can be orthographic or in perspective. The object can also be sectioned by an arbitrary plane show inner views.

Data Explorer permits non-visual functions for the manipulation, transformation, and analysis of the data before and after it is displayed. Once images have been generated, they can be stored, called up, or sent to other recorders over networks. Data Explorer works in a
continued on page 98

Countersurveillance

Never before has so much professional information on the art of detecting and eliminating electronic snooping devices—and how to defend against experienced information thieves—been placed in one VHS video. If you are a Fortune 500 CEO, an executive in any hi-tech industry, or a novice seeking entry into an honorable, rewarding field of work in countersurveillance, you must view this video presentation again and again.



CALL NOW!

1-516-293-3751

**HAVE YOUR
VISA or MC CARD
AVAILABLE**

Wake up! You may be the victim of stolen words—precious ideas that would have made you very wealthy! Yes, professionals, even rank amateurs, may be listening to your most private conversations.

Wake up! If you are not the victim, then you are surrounded by countless victims who need your help if you know how to discover telephone taps, locate bugs, or "sweep" a room clean.

There is a thriving professional service steeped in high-tech techniques that you can become a part of! But first, you must know and understand Countersurveillance Technology. Your very first insight into this highly rewarding field is made possible by a video VHS presentation that you cannot view on broadcast television, satellite, or cable. It presents an informative program prepared by professionals in the field who know their industry, its techniques, kinks and loopholes. Men who can tell you more in 45 minutes in a straightforward, exclusive talk than was ever attempted before.

Foiling Information Thieves

Discover the targets professional snoopers seek out! The prey are stock brokers, arbitrage firms, manufacturers, high-tech companies, any competitive industry, or even small businesses in the same community. The valuable information they filch may be marketing strategies, customer lists, product formulas, manufacturing techniques, even advertising plans. Information thieves eavesdrop on court decisions, bidding information, financial data. The list is unlimited in the mind of man—especially if he is a thief!

You know that the Russians secretly installed countless microphones in the concrete work of the American Embassy building in Moscow. They converted

what was to be an embassy and private residence into the most sophisticated recording studio the world had ever known. The building had to be torn down in order to remove all the bugs.

Stolen Information

The open taps from where the information pours out may be from FAX's, computer communications, telephone calls, and everyday business meetings and lunchtime encounters. Businessmen need counselling on how to eliminate this information drain. Basic telephone use coupled with the user's understanding that someone may be listening or recording vital data and information greatly reduces the opportunity for others to purloin meaningful information.

The professional discussions seen on the TV screen in your home reveals how to detect and disable wiretaps, midget radio-frequency transmitters, and other bugs, plus when to use disinformation to confuse the unwanted listener, and the technique of voice scrambling telephone communications. In fact, do you know how to look for a bug, where to look for a bug, and what to do when you find it?

Bugs of a very small size are easy to build and they can be placed quickly in a matter of seconds, in any object or room. Today you may have used a telephone handset that was bugged. It probably contained three bugs. One was a phony bug to fool you into believing you found a bug and secured the telephone. The second bug placates the investigator when he finds the real thing! And the third bug is found only by the professional, who continued to search just in case there were more bugs.

The professional is not without his tools. Special equipment has been designed so that the professional can sweep a room so that he can detect voice-activated (VOX) and remote-activated bugs. Some of this equipment can be operated by novices, others require a trained countersurveillance professional.

The professionals viewed on your television screen reveal information on the latest technological advances like laser-beam snoopers that are installed hundreds of feet away from the room they snoop on. The professionals disclose that computers yield information too easily.

This advertisement was not written by a countersurveillance professional, but by a beginner whose only experience came from viewing the video tape in the privacy of his home. After you review the video carefully and understand its contents, you have taken the first important step in either acquiring professional help with your surveillance problems, or you may very well consider a career as a countersurveillance professional.

The Dollars You Save

To obtain the information contained in the video VHS cassette, you would attend a professional seminar costing \$350-750 and possibly pay hundreds of dollars more if you had to travel to a distant city to attend. Now, for only \$49.95 (plus \$4.00 P&H) you can view *Countersurveillance Techniques* at home and take refresher views often. To obtain your coupon, complete the coupon or call.

CLAGGK INC. EN
P.O. Box 4099 • Farmingdale, NY 11735

Please rush my copy of the Countersurveillance Techniques Video VHS Cassette for a total cost of \$53.95 each (which includes \$4.00 postage and handling).

No. of Cassettes ordered _____
Amount of payment \$ _____
Sales tax (N.Y.S. only) _____
Total enclosed _____
Bill my VISA MasterCard
Card No. _____
Expire Date ____/____/____
Signature _____
Name _____
Address _____
City _____ State _____ ZIP _____

All payments in U.S.A. funds. Canadians add \$4.00 per VHS cassette. No foreign orders.

VIDEO NEWS

What's new in the fast-changing video industry.

DAVID LACHENBRUCH

● **Judging HDTV systems.** As the contest for high-definition supremacy comes closer to the wire, the FCC has found no digital system markedly superior to any other. According to leaks from the Advanced TV Advisory Committee during its deliberations, the extensive testing did not find an easy winner. Increasingly, there appears to be pressure to conduct another series of tests. Only the analog MUSE system proposed by Japan's NHK appears to be out of the running, having turned in the poorest results during the tests.

Meanwhile, the European Community's attempt to inaugurate satellite broadcasting using the D2-MAC system has failed. It was originally seen as a good preparation for analog high-definition HD-MAC transmissions. Its failure appears to have been caused by the United Kingdom's vote against subsidizing broadcasting and TV-set manufacturing for the new standards. Instead, the EC is expected to push widescreen TV sets for use with existing standards, with a stated goal of developing a digital high-definition system, or possibly using whatever system is approved for the U.S.

In Japan, HDTV transmissions are beamed from satellite to homes eight hours a day in the analog Hi-Vision system. Broadcasters and TV manufacturers there are nervously eying America's progress toward a digital system for terrestrial broadcasting. Increasingly, proposals are being heard for the institution of digital broadcasting as an alternative or substitute for the analog system being used by NHK, Japan's public broadcaster. So it now appears that the U.S., a relative Johnny-come-lately in HDTV, will lead the way to the true 21st-century TV broadcast technology, despite trailing behind both Japan and Europe in developing a system.

● **HD-VCR's.** With all the talk about high-definition TV transmission, high-definition VCR's can't be far behind. In fact, the proposals are pouring in. Quite likely the first to go on the market will be JVC's W-VHS, designed to record wide-screen and high-definition images on metal tape in a standard VHS cassette shell. It will record and play back standard low-definition VHS tapes as well. This analog system, scheduled for sale in Japan this fall, breaks the standard helical VHS track into three thinner tracks, dividing the scanning lines of the high-definition picture (1125 in the case of the Japanese Hi-Vision system) into two tracks, each recording alternate lines. In playback, signals from the two tracks are combined. The third track is used for digital audio and other signals. JVC says that the recorder will work with any HDTV system, analog or digital, because the unit records the base-band signal.

W-VHS has the merit of preserving compatibility with current VHS standards. However, several competitors hope to move directly to digital recording. Sony and Hitachi both have shown lab prototypes of home digital HD recorders designed to record digital broadcast signals just as they are transmitted, leaving the decompression and decoding to the HDTV receiver. Engineers with both of those companies have hinted that their systems are capable of such high recording density that a cassette far smaller than the current VHS type—or possibly a tiny recordable disc—could be used. To date, however, there has been no specific proposal—other than a desire for industry-wide standardization to avert a new Beta-VHS battle.

However, digital recording systems have been proposed that preserve some measure of compatibility with existing analog home

taping methods. Zenith and Gold-Star have disclosed a system that can record encoded and compressed digital signals on a standard S-VHS cassette and can also record and play back regular analog low-definition tapes. Toshiba showed a prototype of a digital recorder that uses a standard 8mm cassette.

● **Movies on CD's.** Is the analog laserdisc due to be replaced as a movie carrier by the digital CD? Several companies are pushing very hard in that direction. One, ironically, is JVC—the same company that is proposing an analog system for high-definition videotape. JVC is already marketing its Digital Vision karaoke system in Japan; it can store 360 CD's containing up to 6120 songs, accompanied by full-motion video, using the existing standard developed by the Moving Picture Experts Group, known as MPEG-1.

While that kind of motion is considered adequate to amuse inebriated pub crawlers at sing-along sessions, JVC plans to wait for the next standard, MPEG-2, for movies on five-inch discs. However, at its recent "Technofair" in Yokohama, JVC showed a simulated prototype that presumably anticipates high-definition as well as standard resolution movies.

JVC's prototype has five-inch CD's with quadruple the capacity of today's CD's. Those CD's run faster and have narrower tracks but provide 74 minutes of full-motion video.

A completely different approach was used in a recent demonstration by the British recording company Nimbus Engineering & Technology. It showed standard audio CD players producing full-motion video with a stereo sound track when played through a special video adapter into a TV set.

continued on page 94

FROM

\$19⁹⁵
Standard



\$199⁹⁵
High Performance

GREAT
VALUE!

Standard Features - Models 100, 150, 200 & 400

- AC & DC VOLTAGES ● DC CURRENT ● RESISTANCE
- CONTINUITY TESTER - Buzzer ● DIODE TEST ● 3 1/2 Digit LCD
- LOW BATTERY INDICATOR ● ACCURACY +/- 0.5% RDG

Kelvin Meters backed by a
2 Yr Warranty - Parts & Labor

PRO 400



100 Basic



150 Basic+



200 Advanced



PRO 400

- | | | | |
|---------------------------|-----------------------------|--|---|
| BATTERY TEST | TRANSISTOR hFE BATTERY TEST | TRANSISTOR hFE CAPACITANCE AC/DC CURRENT | 20MHz FREQ COUNTER AC/DC CURRENT CAPACITANCE LOGIC TEST TRANSISTOR hFE LED TEST - VERIFY GOOD/BAD |
| KELVIN
990087 | KELVIN
990090 | KELVIN
990091 | KELVIN
990092 |
| 100 Basic | 150 Basic+ | 200 Advanced | PRO 400 |
| \$19⁹⁵ | \$29⁹⁵ | \$39⁹⁵ | \$69⁹⁵ |

Protective Cases

- For Models 100, 150, 200 \$4.⁹⁵ (990088)
Case For Model Pro 400 \$9.⁹⁵ (990094)



Model 92
PERFORMANCE PLUS



Model 93
DIAGNOSTIC PLUS



Model 95
ENGINE ANALYZER PLUS

Standard Features - Models 92, 93, 94 & 95

- DC/AC VOLTMETERS ● AC/DC CURRENT ● OHM METER
- FREQUENCY COUNTER to 4 MHz ● AUDIBLE CONTINUITY TESTER
- DIODE TESTER ● MAX/MIN AVERAGE MEMORY RECORD
- RELATIVE MODE ● 10A HIGH-ENERGY FUSE PROTECTION
- DATA HOLD ● AUTO SLEEP & AUTO POWER OFF

PERFORMANCE PLUS Model 92 # 990109
\$99⁹⁵
Complete with above **Standard Features** plus WATER RESISTANT (92 & 94 Models only), 2 YEAR WARRANTY, YELLOW HOLSTER, PROBES, BATTERY, FUSE, STAND

DIAGNOSTIC PLUS Model 93 # 990110
\$129⁹⁵
Complete with **Standard & Model 92 Features** plus LOGIC PROBE, CAPACITANCE TESTER, TRANSISTOR TESTER, TEMPERATURE TESTER & K-TYPE PROBE, HIGH VOLTAGE WARNING BUZZER

ENGINE ANALYZER PLUS Model 95 # 990112
\$199⁹⁵
Complete with **Standard & Model 92 Features** plus TEMPERATURE, TACHOMETER & DWELL ANGLE TESTER, DUTY CYCLE, 10 MEGA OHM IMPEDANCE, ANALOG BAR GRAPH, K-TYPE TEMP PROBE, ALLIGATOR CLIP TEST LEADS, INDUCTIVE PICKUP CLIP, 6' TEST LEADS & CARRY CASE

KELVIN 10 HUB DRIVE MELVILLE, NY 11747
M/C & VISA
(800) 645-9212 Established 1945
(516) 756-1750 (516) 756-1763/FAX

The Ultimate Meter
TRUE RMS - LCR - Hz - dBm

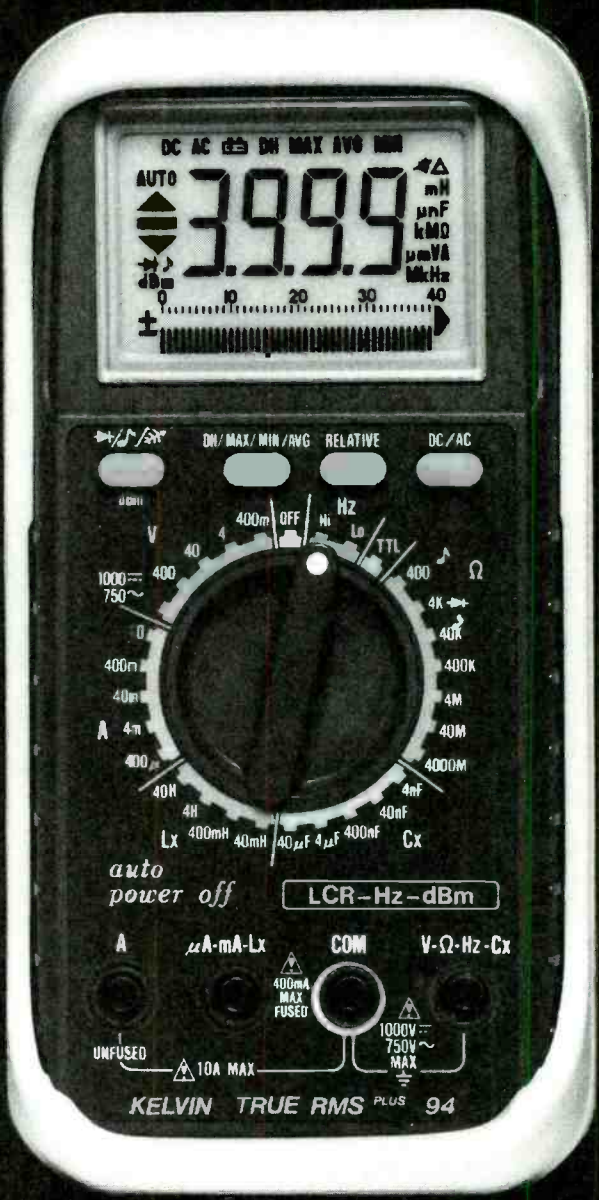

12 INSTRUMENTS IN ONE - DC VOLTMETER, AC VOLTMETER, OHMMETER, AC CURRENT, DC CURRENT, DIODE TESTER, AUDIBLE CONTINUITY TESTER, dBm, FREQ COUNTER, CAPACITANCE METER, INDUCTANCE METER, LOGIC PROBE

\$199⁹⁵ MODEL 94 #990111

0.1% ACCURACY on DC Voltages Water Resistant

- 10 MEGA OHM IMPEDANCE
- RELATIVE MODE / DATA HOLD
- MAX/MIN AVERAGE MEMORY RECORD
- 10A HIGH-ENERGY FUSE PROTECTION
- AUTO SLEEP & AUTO POWER OFF with Bypass

COMES COMPLETE WITH YELLOW HOLSTER, PROBES, BATTERY, FUSE, STAND

Freq Counter to 20 MHz

Cases for 90 Series Meters
Regular Padded Zippered \$9.⁹⁵ (#990116)
Deluxe Padded Zippered \$14.⁹⁵ (#990115)

This meter is designed in accordance with relevant safety requirements as specified in IEC-348, UL-1244 and VDE-0411.

May 1993, Electronics Now 7

Other Schools The Best Computer At NRI, We Graduates Do

Train With The Leader—NRI

Train with NRI and prepare for a high-paying position as a computer service technician, even a computer service business of your own! Regardless of your previous electronics background, you can succeed with NRI, the leader in career-building at-home electronics training for over 78 years. You begin with the basics, rapidly building on the fundamentals of electronics to master today's advanced microcomputer concepts.

Learn By Doing

NRI's highly acclaimed learn-by-doing approach gives you a complete understanding of the intricate electronics behind the 1 meg RAM, 32-bit CPU computer system included in your course. You perform hands-on electronics experiments with your NRI Discovery Lab and digital multimeter, then build and test the powerful 486sx/25 MHz computer you train with and keep. You install the 1.2 meg, 5-1/4" floppy disk drive, learning disk drive operation and adjustment. Later, you dramatically improve your computer's data storage capacity by installing a powerful 80 meg IDE hard drive. You even learn to diagnose and service virtually any computer

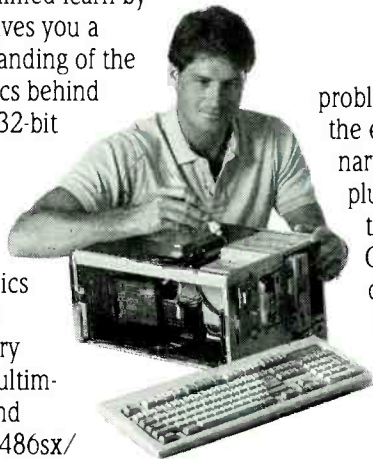

problem with the extraordinary R.A.C.E.R. plug-in diagnostic card and QuickTech diagnostic software included in your course.

Study At Your Own Pace

With NRI, you study in the privacy and convenience of your own home — with your personal instructor and NRI's team of technical professionals behind you every step of the way. You learn at your own pace — no classroom pressures, no night school, no need to quit your present job until you're ready to make your move. Step by step

V. Bender
Calgary, Alberta

"I recommend NRI to anyone looking for a change, success, and REAL challenge. The Action Learning Kits allow you to build what you study — lessons — no better way exists to learn to troubleshoot and service computers!"

R. Buda
Tinley Park, IL

Just two years after finishing the NRI training in microcomputer servicing, I set up my own computer service business. I contract myself out to several computer retailers as their service technician. I have never regretted taking the NRI course and now have control of and confidence in my business.

C. Bane
Chicago, IL

"With four NRI courses under my belt, I've set up a workshop at home repairing everything from TVs to VCRs to appliances and now, computers! The computer I received in the micro course is a lifesaver in keeping track of my customers, invoicing, inventory of supplies, and personal finances. I have prospered financially as a result of my NRI training, owing to the income my small business generates — and to my regular salary increasing three times since completing the first NRI course!"

you're guided through the assembly of a powerful 486sx-based computer system — the centerpiece of your coursework — complete with monitor, floppy drive, 80 meg hard drive, operating and applications software. You get the hands-on experience you need to work with, troubleshoot, and service any IBM PC/AT-compatible computer, plus the confidence to tackle any service job you take on.



Say They Offer Service Training... Let Our The Talking.

service business of your own — you'll be well prepared, continuously drawing on the real-world experience of your NRI training. Master electronics and computers the NRI way and master your future!

Learn More About NRI Today

Let NRI hear from you next. Send today for NRI's free, full-color catalog which describes every aspect of NRI's innovative micro-computer training, as well as hands-on training in other growing high-tech fields. If the coupon is missing, write to NRI Schools, McGraw-Hill Continuing Education Center, 4401 Connecticut Avenue, NW, Washington, DC 20008.



IBM is a registered trademark of International Business Machines Corp. R.A.C.E.R. and QuickTech are registered trademarks of Ultra-X, Inc.

"No doubt, the excellent back-up of your staff was a significant factor in my swift completion of NRI's microcomputer servicing training. Their helpfulness, by phone or by letter, has been nothing short of amazing. I can see why you are so proud of your training I read in your catalog was

*N. Tenerelli, II
Millington, IN*

*gh many technical training courses I've
t are almost 100% theory-oriented, NRI
hat a technician's ability to troubleshoot
r equipment is where 'the rubber meets
As a result, NRI graduates are more*

*As a family man, a home study course was the only way
to go. It has up to me to spend as much or as little
time as I needed on course material - skimming down on
the tough stuff and racing through the familiar.
After completing NRI's microcomputer course, new doors
began to open for me. I literally created the job I
now hold and am considered "the one to call"
in the event someone needs help with computer
hardware or programs.*

*J. Preusker
Angston, SA Australia*

*D. Gattin
Carrollton, GA*

wide-open opportunity and become a high-paid computer service technician. Whether you choose a full- or part-time job — or start a computer

What's more, you work with today's most popular integrated software package, Microsoft Works, learning to use its word processing, spreadsheet, database, and communications utilities for your own personal and professional applications.

Master Your Future

The Department of Labor forecasts over 220,000 jobs for computer service technicians by the year 2005 — a 38 percent increase over today's level. With the right training and skills, you can cash in on this



NRI Schools

McGraw-Hill Continuing Education Center
4401 Connecticut Avenue, NW, Washington, DC 20008

For career courses approved under GI Bill, check for details

- Check one FREE catalog only
- Microcomputer Servicing
 - TV/Video/Audio Servicing
 - Industrial Electronics & Robotics
 - Basic Electronics
 - Computer-Aided Drafting
 - Computer Programming
 - Desktop Publishing & Design
 - PC Applications Specialist
 - Programming in C++ with Windows

Name (please print)

Age

Address

City/State/Zip

Accredited Member, National Home Study Council

3-0593

May 1993, Electronics Now

11

Write to Q & A, Electronics Now, 500-B Bi-County Blvd., Farmingdale, NY 11735

INFRARED TARGET

I've been experimenting with infrared (IR) transmission and would like to build a target game. I have two problems that I hope you can help me with. First, I need some way to narrow the transmitter's beam. Second, I need a simple circuit that can work as an IR detector. The beam has to be narrow to make the game work, and the receiver has to be really simple because the game uses only one transmitter but a lot of receivers. Any suggestions would be appreciated.—B. Sherif, Bamford, NY

Target games like that are a neat idea. I seem to remember that a few years ago a toy company used the same principle in a game that sold sixty gazillion copies over the Christmas season. If you have the same luck, I hope you remember who helped you out. Just kidding.

Simple infrared receivers are easy to build. You didn't tell me what kind of output you want from the receiver, but since this is going to be a game, I'm assuming all you want to do is drive a beeper, LED, or something like that. The circuit shown in Fig. 1 is just about the simplest IR receiver you can build. The parts are cheap, the layout's not at all critical, and a 9-volt battery will last a long time.

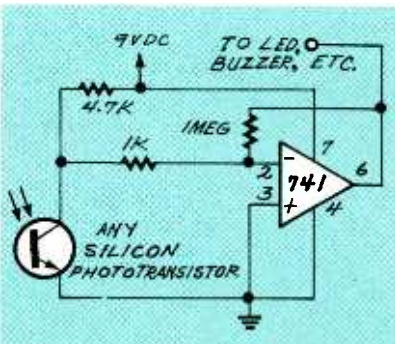

FIG. 1—THIS CIRCUIT is just about the simplest IR receiver you can build. The parts are cheap, the layout's not at all critical, and a 9-volt battery will last a long time.

Even though I've used a 741 op-amp, you can use any one you happen to have around. After all, that's exactly the why I picked a 741. Several common op-amps, including the 741, are made to operate on a split supply, but in applications like this one, a single-ended supply is fine. However, we're cutting into the frequency response of the op-amp and degrading its slew rate.

One part of the circuit that's not shown in the illustration is the IR filter that must be in front of the phototransistor. Remember that while the phototransistor's sensitivity to infrared is excellent, it also has high sensitivity to visible light. The success of your game hinges on the fact that only IR light will cause a "hit" on the target.

Kodak makes IR filters in a gel (the Wrattan No. 87), but they are expensive and available only at camera shops that cater to professionals. A reasonable substitute is a piece of unexposed, developed Kodachrome film—the tail end from a roll of slides is perfect. For under ten bucks, you can buy a roll of Kodachrome 25, have it developed, and wind up with a six-foot length of infrared filter.

Getting a narrow beam from the transmitter is a different kind of problem. Although you didn't specify it in your letter, I'm pretty sure you're using IR LED's and not lasers. If that's the case, you have to use lenses to collimate the beam coming from the open end of the transmitter. One lens supplier that comes to mind is Edmond Scientific—try calling them at 1-609-573-6879.

DUTY CYCLE

I'm building a circuit in which a 555 timer generates clock pulses. Everything is working perfectly, but I need some way to produce output pulses from the 555 that have a 50% duty cycle. Do you have a simple circuit that

can do that?—G. Gillian, Montrose, IN

If you set the resistors correctly, the 555 will output pulses that are close to a 50% duty cycle. But when it must be exactly 50%, you have to adjust some of the components in the basic 555 oscillator circuit. The standard 555 circuit is shown in Fig. 2. The way to get a 50% duty cycle can be seen from the formula that determines the output frequency of the oscillator:

$$f = 1.44/((R1 + R2)C)$$

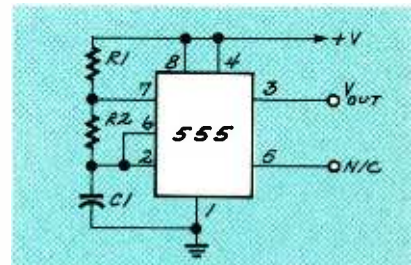

FIG. 2—BY CAREFULLY CHOOSING the components in this 555 oscillator circuit, you can get very close to a 50% duty cycle.

As you can see, the duty cycle is going to depend on the relative values of the two resistors since the capacitor charges through both R1 and R2, but discharges through only R2. This means that the duty cycle of the output frequency is:

$$\text{Duty cycle} = (R1 + R2)/R2$$

and the way to control it is to make R2 really large in comparison to R1. If the ratio of the two resistors is a thousand to one, the duty cycle is going to be only one tenth of a percent away from a perfect 50%.

Since the 555 always charges through two resistors and discharges through one, you'll never be able to get exactly 50% by just playing with the resistor values. There are other things that can be done with the basic 555 circuit to get more control of the duty cycle, such as diode-isolating the capacitor's charge and discharge cycles. □

Electronic Paperbacks at Special Prices

BP325—A CONCISE USER'S GUIDE TO WINDOWS 3.1 . . . \$7.95. Come to grips with Windows 3.1 in the shortest and most effective way. Learn how to manipulate Windows screens and DOS by Windows graphics interface. Master its word processor, Paintbrush and data base along with Notepad, Macro Recorder, PIF Editor, and Calculator.

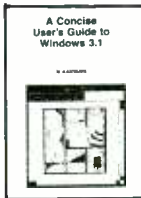

BP311—AN INTRODUCTION TO SCANNERS AND SCANNING . . . \$7.95. Radio scanners have opened a realm of exciting radio listening. Understand radio wave propagation, types of transmissions, antennas, band assignments—the straight dope on what to hear and where to hear it! Comes complete with index, glossary of important terminology.

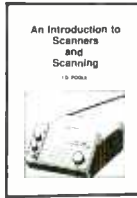

BP287—A REFERENCE GUIDE TO PRACTICAL ELECTRONICS TERMS . . . \$8.95. More than just a dictionary of practical electronics terms, the book goes a step further in getting down to fundamentals. A reference volume that can be read casually by a reader seeking knowledge.



BP248—TEST EQUIPMENT CONSTRUCTION . . . \$5.95. Details construction of simple, inexpensive, but extremely useful test equipment. AF Gen, Test Bench Ampl, Audio Millivoltmeter, Transistor Tester and six more.



BP267—HOW TO USE OSCILLOSCOPES AND OTHER TEST EQUIPMENT . . . \$6.95. Mastering the oscilloscope is not really too difficult. This book explains all the standard controls and functions. Other equipment is also described.



BP265—MORE ADVANCED USES OF THE MULTIMETER . . . \$5.95. Use these techniques to test and analyze the performance of a variety of components. Also see how to build add-ons to extend multi-meter capabilities.



BP256—INTRO TO LOUDSPEAKERS AND ENCLOSURE DESIGN . . . \$5.95. We explore the variety of enclosure and speaker designs in use today so the reader can understand the principles involved.

CMOS1—CMOS POCKET GUIDE 1 . . . \$18.95. Works like the TTL Guides but covers all commonly used CMOS standard devices. Six major sections. The first shows the device schematic. Next is a brief description of the component and is followed by full operating details. The fourth section lists major applications, while the 5th and 6th sections present essential data for that device and a list of the relevant manufacturers. The final two sections are a valuable cross-reference.



BP299—PRACTICAL ELECTRONIC FILTERS . . . \$6.95. Presents a dozen filter-based practical projects with applications in and around the home or in the constructor's workshop. Complete construction details are included.



BP249—MORE ADVANCED TEST EQUIPMENT CONSTRUCTION . . . \$6.95. Eleven more test equipment construction projects. They include a digital voltmeter, capacitance meter, current tracer, etc.



Digital Audio Projects

BP245—DIGITAL AUDIO PROJECTS . . . \$5.95. Practical circuits to build and experiment with. Includes A/D converter, input amplifier, digital delay line, compander, echo effect and more.



BP247—MORE ADVANCED MIDI PROJECTS . . . \$5.95. Circuits included are a MIDI indicator, THRU box, merge unit, code generator, pedal, programmer, channelizer, and analyzer.



BP257—INTRO TO AMATEUR RADIO . . . \$6.95. Amateur Radio is a unique and fascinating hobby. This book gives the newcomer a comprehensive and easy to understand guide to the subject.

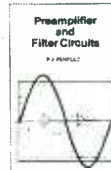

BP309—PREAMPLIFIER AND FILTER CIRCUITS . . . \$6.95. Provides circuits and background info for a range of preamplifiers, plus tone controls, filters, mixers and more. All are high-performance circuits that can be built at a reasonable cost.

BP303—UNDERSTANDING PC SOFTWARE . . . \$6.95. This book will help you understand the basics of various types of business software in common use. Types of software covered include word processors, spelling checkers, graphics programs, desktop publishing, databases, spreadsheets and utilities.



BP251—COMPUTER HOBBYIST HANDBOOK . . . \$8.95. A wrapup of everything the computer hobbyist needs to know in one easy to use volume. Provides a range of useful reference material in a single source.



PCP115—ELECTRONIC PROJECTS FOR HOME SECURITY . . . \$10.00. 25 projects ranging from a single-door protection circuit that can be completed in an hour or two, to a sophisticated multi-channel security system. Each project is described in detail with circuit diagrams, explanations of how it works, instructions for building and testing, and how to adapt circuits to meet special requirements.



- BP190—ADVANCED ELECTRONIC SECURITY PROJECTS . . . \$5.95.** Includes a passive infra-red detector, a fiber-optic loop alarm, computer-based alarms and an unusual form of ultrasonic intruder detector.
- BP235—POWER SELECTOR GUIDE . . . \$10.00** Complete guide to semiconductor power devices. More than 1000 power handling devices are included. They are tabulated in alpha-numeric sequence, by technical specs Includes power diodes, Thyristors, Triacs, Power Transistors and FET's.
- BP234—TRANSISTOR SELECTOR GUIDE . . . \$10.00.** Companion volume to BP235. Book covers more than 1400 JEDEC, JIS, and brand-specific devices. Also contains listing by case type, and electronic parameters. Includes Darlingtons transistors, high-voltage devices, high-current devices, high power devices.
- BP117—PRACTICAL ELECTRONIC BUILDING BLOCKS—Book 1 . . . \$5.75.** Oscillators, Timers, Noise Generators, Rectifiers, Comparators, Triggers and more.
- BP195—INTRODUCTION TO SATELLITE TV . . . \$9.95.** A definitive introduction to the subject written for the professional engineer, electronics enthusiast, or others who want to know more before they buy. 8 x 10 in.

- BP239—GETTING THE MOST FROM YOUR MULTIMETER . . . \$5.95.** Covers basics of analog and digital meters. Methods of component testing includes transistors, thyristors, resistors, capacitors and other active and passive devices.
- BP97—IC PROJECTS FOR BEGINNERS . . . \$5.50.** Power supplies, radio and audio circuits, oscillators, timers, switches, and more. If you can use a soldering iron you can build these devices.
- RADIO—100 RADIO HOOKUPS . . . \$3.00.** Reprint of 1924 booklet presents radio circuits of the era including regenerative, neutrodyne, reflex and more.
- BP42—SIMPLE LED CIRCUITS . . . \$5.50.** A large selection of simple applications for this simple electronic component.
- BP122—AUDIO AMPLIFIER CONSTRUCTION . . . \$5.75.** Construction details for preamps and power amplifiers up through a 100-watt DC-coupled FET amplifier.
- BP92—CRYSTAL SET CONSTRUCTION . . . \$5.50.** Everything you need to know about building crystal radio receivers.

BP255—INTERNATIONAL RADIO STATIONS GUIDE . . . \$7.95. Provides the casual listener, amateur radio DXer and the professional radio monitor with an essential reference work designed to guide him or her around the more than ever complex radio bands.

CHECK OFF THE BOOKS YOU WANT

ELECTRONIC TECHNOLOGY TODAY INC.
P.O. Box 240, Massapequa Park, NY 11762-0240

Name _____
Address _____
City _____ State _____ Zip _____

SHIPPING CHARGES IN USA AND CANADA

\$0.01 to \$5.00	\$1.50
\$5.01 to \$10.00	\$2.50
\$10.01 to \$20.00	\$3.50
\$20.01 to \$30.00	\$4.50
\$30.01 to \$40.00	\$5.50
\$40.01 to \$50.00	\$6.50
\$50.01 and above	\$8.00

SORRY No orders accepted outside of USA & Canada

Total price of merchandise . . . \$ _____
Shipping (see chart at left) . . . \$ _____
Subtotal \$ _____
Sales Tax (NY State only) . . . \$ _____
Total Enclosed \$ _____

Number of books ordered

All payments must be in U.S. funds

EN593

LETTERS

Write to Letters, *Electronics Now*, 500-B Bi-County Blvd., Farmingdale, NY 11735

MOVING TOWARD MOV'S

As an applications engineer for Harris Semiconductor, a participant in metal-oxide varistor (MOV) technology, I feel an obligation to comment on Tom Petruzzellis' article "Fax/Modem Protector" (*Electronics Now*, December 1992). Although his explanation of the basic MOV structure was both clear and accurate, his suggestion that the MOV is far less responsive than Zener diodes was both misleading and sadly overstated.

The most significant detriment to transient clamping response is the suppressor's lead inductance. Harris has demonstrated that with proper attention to lead inductance, a MOV will clamp an otherwise destructive transient within 500 picoseconds! In addition, a MOV is inherently more rugged than a Zener diode because power is dissipated across the entire disc as opposed to a single PN junction in the Zener diode.

Harris Semiconductor offers a wide selection of surface-mount and PIN varistors with essentially no lead inductance. The company recently introduced a new family of transient voltage suppressors based on a zinc-oxide, multilayer technology.

Those devices have significantly higher energy densities and enhanced clamping ratios in downsized surface-mount packages. Aside from meeting the most demanding requirements for transient protection, this technology promises to dismiss, once and for all, misconceptions about varistor response time.

JOHN RICE
Harris Field Applications
Carmel, IN

50-OHM TERMINATION

I believe the answer to the 50-ohm termination question in *Q&A* (*Electronics Now*, December 1992) is flawed. While 50-ohm termina-

tions are common in computer networks, the reason for their popularity generally has more to do with preventing reflections of high-frequency energy from the open (unterminated) ends of transmission lines than with preventing device damage.

Every wire, cable, or PC-board etch has a non-zero impedance. This means that an electrical connection will impede signals at one frequency in a way that differs from its response at other frequencies. With low-frequency circuits (such as audio), the effect is usually negligible. However, at higher (radio and microwave) frequencies, the effect becomes more noticeable.

Although home computers usually run at less than 50 MHz, their logic families switch logic levels much faster than this. If rise and fall times are about the same as (or shorter than) the propagation delay from one end of a cable to the other, transmission line effects and wire impedance must be considered.

To deliver a signal properly from one end of a transmission line to the other, the impedances of the source and load should match the characteristic impedance of the transmission line. If those impedances are not well matched, the signal will not be coupled from the source into the line, or from the line into the load. One example of this can be seen in CB radios where the antenna must be tuned to minimize the voltage standing-wave ratio (VSWR) and maximize power coupled to the CB antenna.

In computers, transmission lines must be terminated to prevent reflections and signal distortions from degrading transmitted data. A resistor with about the same value as the characteristic impedance of the line is placed at the end of the line. Then, high-frequency energy contained in logic-level switching is coupled into the resistor, not reflected back into the line. You will see the

difference if you compare the signal on a properly terminated line with the signal on an unterminated line.

A poorly terminated line will exhibit "overshoot" and "ringing" (typically side effects from transmission-line mismatches), whereas a correctly terminated line will display a clean, square transition.

Note that if the termination is placed in the middle of a line, a reflection will occur because of mismatch at the middle and at the unterminated end of the line. That reflection could cause signal distortion and degraded data.

A complete discussion of line matching can be found in most texts on transmission lines, antennas, control of EMI, and RF circuit design. An example of pulse reflections on a long line between two computers can be found in example 5.4b in the second edition of *Fields and Waves in Communication Electronics*, by Ramo, Whinnery, and Van Duzer (Wiley, 1984).

My answer to the reader's question is that he purchased a PC control card that probably has high-speed output drivers. The 50-ohm terminating resistors simply minimize unwanted reflections. If the reader is using this card to drive relays or motors directly, then I doubt if the addition of terminating resistors will make much difference. Logic-line reflections won't have enough energy to open or close a relay or drive a motor; even if they did, logic switching transients would be damped out long before the relay or motor could react.

However, if the reader is trying to connect fast logic families (such as AS or high-speed CMOS) over long cables (more than a foot long), then terminating resistors could be a requirement for reliable operation. I would also recommend twisted-pair or ribbon cable, with one ground or return line per signal for any connections made to fast logic families.

The *Q&A* answer also suggested

that leaving stereo-amplifier outputs open (i.e., "Infinitely" loaded) causes strain on output transistors. Such an "infinite" load really represents a very high resistance and, therefore, a light or imperceptible load. I have been hearing that rumor since I was in high school, and have not been able to track down its source—even after designing military electronics for seven years.

Considering the ready availability and low cost of semiconductors, I cannot imagine anyone designing a consumer stereo that could be damaged if the amplifier outputs were left open. The designer's company would soon be run out of business because speaker connections are so commonly broken or left open. In addition to that, the only damage mechanism that I can imagine might be present would be excessive base or gate overdrive, which might be caused by poor circuit design.

The semiconductor stereo amplifier I have owned for the past 15 years disables the speakers by disconnecting them from the amplifier output. It even drives the "B" speakers by placing them in parallel with the "A" speakers. The amplifier has served me well, and shown no perceptible degradation. I suspect most stereo amplifiers operate in a similar fashion.

I'd be interested to know if anyone could provide me with a concrete example and explanation of damage or strain caused by open speaker connections.

CARL OTT
Carrollton, TX

FLOATING-GROUND CAR RADIOS

I noticed that the answer to a question in Q&A (*Electronics Now*, January 1993) about connecting outputs on a car radio did not mention floating-ground radio units. If you connect a floating-ground stereo as shown in that column, you might soon be replacing the stereo. The first step that should be taken is to determine if the unit is using a floating ground. Some manufacturers use floating-ground outputs to save money.

I have been installing automotive-stereo units for many years, and have encountered floating-ground

systems many times. I have found that the best way to determine the presence of a floating-ground system is to use the ohm scale on a multimeter and read the value of the output's negative lead to ground.

A high resistance to ground measurement is a good indication of the presence of a floating ground. One can also use a high-resistance reading between the output's negative output as a good indicator of a floating ground. If you have a floating-ground situation, use isolation

transformers on the outputs before connecting them. Several manufacturers offer adapters for floating-ground systems.

JAMES MAYBERRY
Fort Madison, IA

AN AMIGA-PHILE SPEAKS OUT

Good Heavens! I hope Don Lancaster is prepared for an onslaught of mail from Amiga-philes following his comment (*Hardware Hacker*, *Electronics Now*, February 1993):

continued on page 27

New Tool Kit™ Series THE MOST PRACTICAL, COMPACT, INEXPENSIVE DMMs AVAILABLE

MODEL 2703A 2704A 2706 2707

DCV ● ● ● ●

RES ● ● ● ●

CAP ● ● ● ●

FREQ ● ● ● ●

LOGIC ● ● ● ●

PRICE \$39 \$59 \$79 \$89

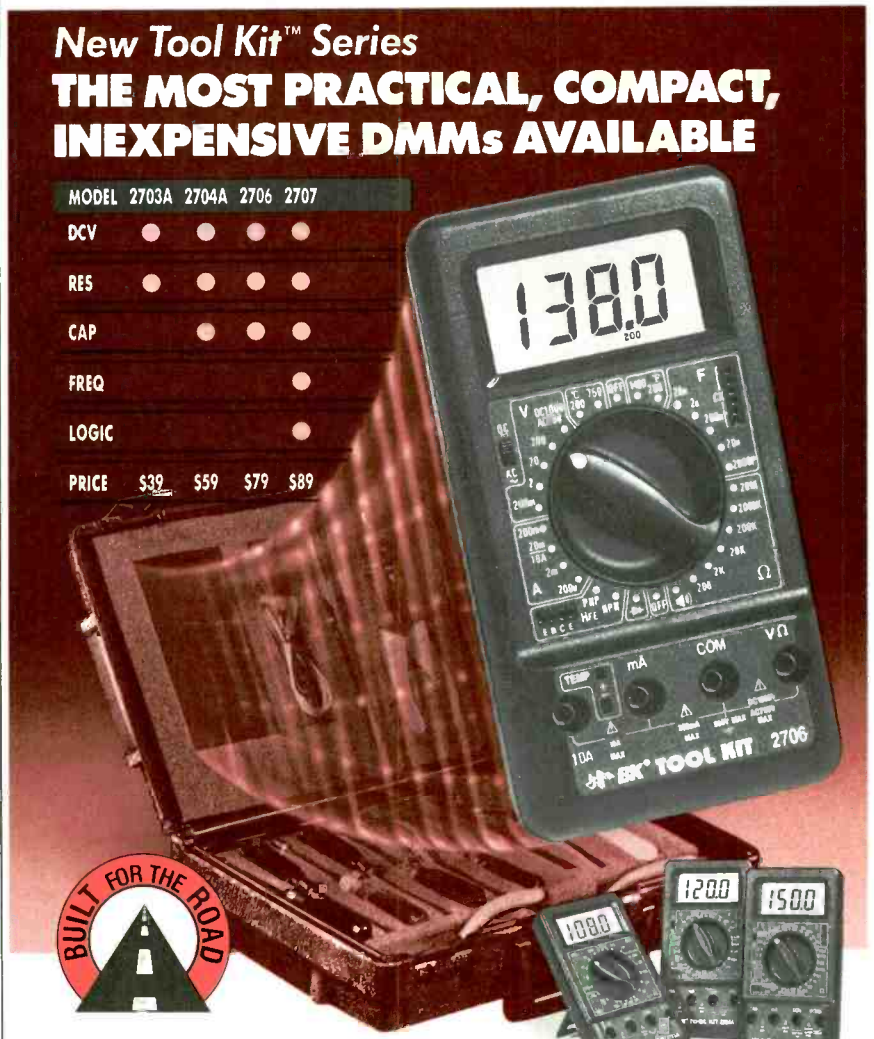

Measures voltage resistance and current, and lots more! 0.5% DC accuracy. Prices start at \$39.95!

New Tool Kit™ DMMs from B+K PRECISION are the industry's best values for performance, features and dependability. Compare these ruggedized testers against all comers — at up to twice the price. You'll be sold on Tool Kit.

All four Tool Kit™ DMMs measure DC current to 10 amps, have large 3½ digit LCD readouts

and a continuity beeper. The Model 2704A adds AC current, capacitance and transistor tests. The Model 2706 adds temperature measurement. The Model 2707 is similar to the 2704A with added frequency counter and logic probe functions.

See your local distributor for immediate delivery.



BK PRECISION
MAXTEC INTERNATIONAL CORP.

Domestic and International Sales
6470 W. Cortland St., Chicago, IL 60635
312-889-1448 • FAX: 312-794-9740

CIRCLE 77 ON FREE INFORMATION CARD

More Lessons!

More Services!

A Shocking Offer!

Now you don't have to be enrolled at CIE to receive our introductory Electronic and Electricity Lesson Modules. This program is available for a limited time to non-students for the shockingly low price of only \$99.50.

With CIE's patented AUTO-PROGRAMMED method of learning you will quickly learn and then master the basics of electronics and electricity and then move on to... DC/AC circuit theories, fundamentals of bi-polar junction transistors (BJT), field effect transistors (FET), wiring, diagram and schematic readings, component identification, soldering techniques... and much, much, more. This introductory offer includes the first 39 lessons in CIE's Associate in Applied Science in Electronic Engineering Technology Degree.

Your commitment to CIE ends with your payment, but CIE's commitment to your success just begins when you receive your lessons, exams, binder and equipment. This special introduc-

tory price includes all the benefits and assistance CIE normally extends to its full time students. You'll be entitled to unlimited access to CIE's faculty and staff to assist you in your studies via a toll free 800 number six days a week, 24-hour turnaround on grading your submitted exams, CIE bookstore privileges, a patented learning method, reference library, access to CIE's electronic bulletin board and a free issue of CIE's school newspaper The Electron.

And best of all, when you decide to continue your electronics education in any of CIE's programs you'll receive full academic credit for successful lessons submitted and a \$100.00 Tuition Credit Certificate.

All this knowledge and support will put you on the road to understanding digital electronics, automotive and industrial electronics, microprocessing principals, computer systems, telecommunications and much, much, more.

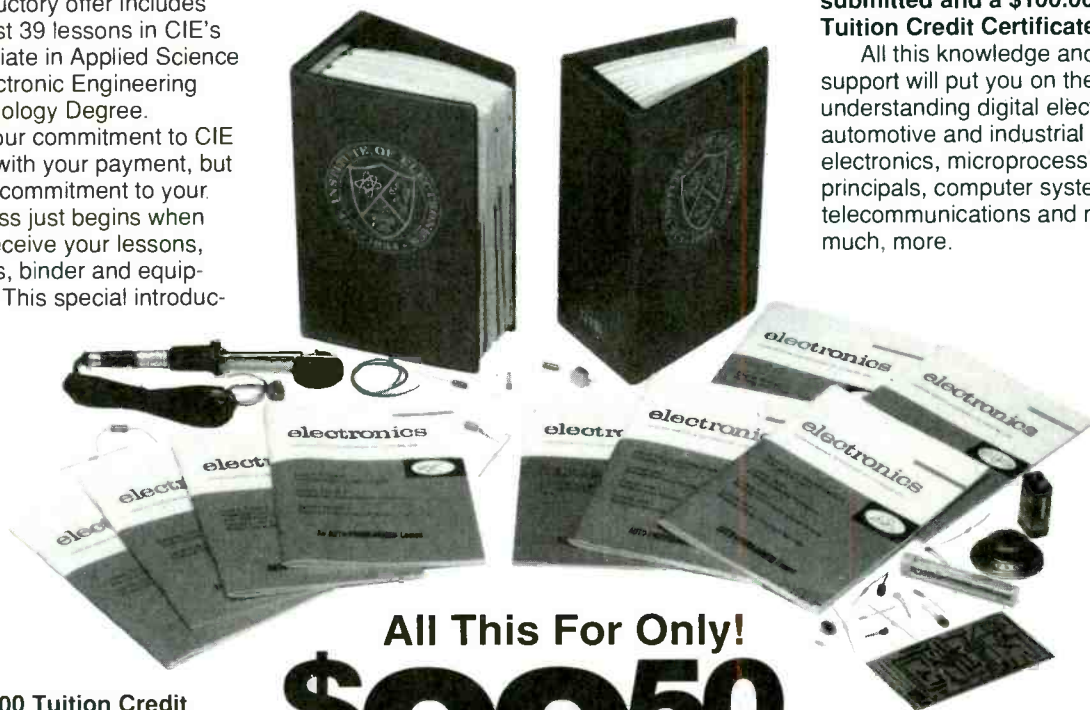

All This For Only!

\$99.50

- \$100.00 Tuition Credit
- Academic Credit
- Free issue of The Electron
- Build your personal burglar alarm
- Toll Free Instructor Assistance
- 24-hour grading
- CIE bookstore privileges

- 39 theory and hands-on training lessons and exams.
- Patented learning method
- CIE electronic bulletin board privileges

Yes! Send me CIE's Introductory Electronic and Electricity Lessons and Equipment. A7321

Name: _____
 Street: _____ Apt#: _____
 City: _____
 State: _____ Zip: _____
 Age: _____ Phone: (____) _____

Total Merchandise: _____ \$99.50

Ohio Residents add 7% Sales Tax: _____

California Residents add 6 1/2% Sales Tax: _____

Total This Order: _____

Shipping and Handling Charge: _____ \$5.00

Method of Payment/Amount Enclosed: _____ \$

Personal Check or Money Order

Master Card Visa Discover

Card Expiration Date: _____

Signature: _____



BOOKSTORE
1776 East 17th Street
Cleveland, Ohio 44114



CHARGE BY PHONE!

9 AM to 4:30 PM Eastern Time;
1-800-321-2155 ext. A7321

May 1993, Electronics Now 17

NEW PRODUCTS

Use the Free Information Card for more details on these products.

EMI/EMC MEASUREMENT SYSTEM. Tektronix has responded to the recently announced tougher electromagnetic interference (EMI) and compatibility (EMC) standards and regulations issued both by the FCC and the European Community. That response is the 27120 EMC Pre-/Post-Certification Measurement System.

The system combines all of the instruments and devices necessary for testing to FCC, VDE, VCCI, EC '92, and other EMC requirements. PC-based software provides instrument control, data collection, analysis, and presentation. The 27120 system is intended to allow manufacturers to perform in-house EMC pre-certification testing so they can save the cost of testing by an outside agency, and improve their chances for obtaining formal certification on the first try.

The 27120 system consists of a 2712 spectrum analyzer, a 2706 stepping

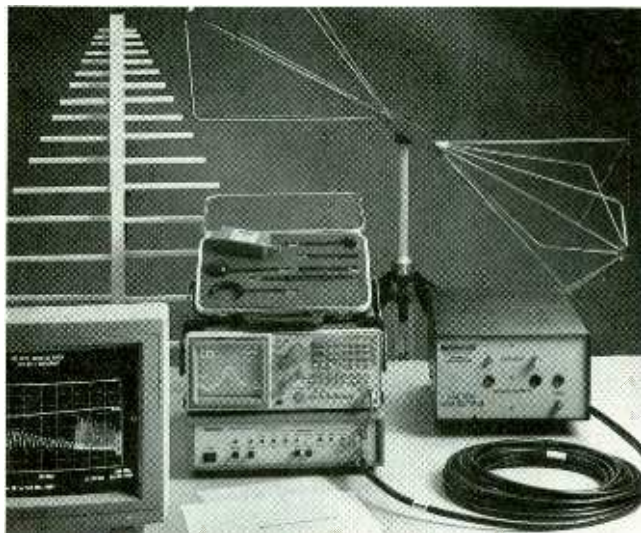

CIRCLE 16 ON FREE INFORMATION CARD

RF preselector, a transient limiter, a line-impedance stabilization network, and biconical and log-periodic broadband antennas. Also included in the system are an RF probe set and S26EM12 EMI software.

Correction factors for the system's antennas are programmed on floppy disks, and the software automatically applies them to measurement data. A personal computer can be the

system controller. Results can be color-enhanced on the PC's display for faster interpretation. Programmable pre-selection helps to avoid measurement distortions.

The 27120 EMC Pre-/Post-Certification Measurement System is priced at \$25,985.—**Tektronix, Inc.**, Test & Measurement Group, P.O. Box 1520, Pittsfield, MA 01202; Phone: 800-426-2200.

memory. The write-protected blocks can be un-protected, updated, and reprotected with software.

DS1650 Partitionable Nonvolatile SRAM's are priced at \$323.10 in quantities of 1000.—**Dallas Semiconductor**, 4401 South Beltwood Parkway, Dallas, TX 75244; Phone: 214-450-0448.

300-MHz FREQUENCY COUNTER. The Philips/Fluke PM 6685 portable 300-MHz frequency counter, with a resolution of 10 digits per second, has a base input frequency range from DC to 300 MHz. A choice of optional RF inputs extends its upper frequency range to 1.3, 2.7, or 4.5 GHz.



CIRCLE 18 ON FREE INFORMATION CARD

According to *John Fluke Mfg.*, the frequency counter's high stability can be maintained with its internal rechargeable battery. Depressing an AUTOSET button gives fast, error-free, "connect-and-go" measurements. The instrument can execute up to 1600 measurements per second to internal memory or 1000 measurements per second with the optional GPIB data interface.

The PM 6685 can make measurements of non-repetitive events, television

PARTITIONABLE NON-VOLATILE STATIC RAM.

Dallas Semiconductor claims that its new 4-megabit DS1650 partitionable, nonvolatile static RAM (SRAM) is the first SRAM with that capacity capable of storing digital data for more than 10 years without refreshing.

The company reports that data can be preserved for this length of time because it uses 512K \times 8 static RAM's rather than



CIRCLE 17 ON FREE INFORMATION CARD

the four 128K \times 8 SRAM's more widely used. It claims that the 4:1 reduction in chip count reduces power consumption and increases product life.

Its partitioning feature permits the DS1650 to store both program and data memory on a single chip. The control circuitry on each module divides the memory into 16 equivalent data blocks which can be write-protected together or individually.

Individual write-protected blocks provide a single-device solution to memory applications that would normally require many different kinds of

You're zooming up a single shot 10 ns spike, an event you simply cannot see on any \$3,000 digital scope. Unless it's the new TDS 320 with its incredible over sampling. Truly the world's first affordable 100MHz digital real-time scope.

At 500 Megasamples/sec, our new TDS 320 combines the storage and data manipulation benefits of digital with the signal fidelity of analog real-time. So you can make precise, confident measurements quickly. What's more, its intuitive user interface means you'll actually spend more time working with this digital scope than learning how to use it. And finally, we consider its price tag (a mere \$2,795) yet another spike the competition can't catch. So call your authorized Tektronix distributor today. Or call us at (800) 426-2200, ext. TDS3 to place our order.



Tektronix

signals, pulse trains, and amplitude-modulated waveforms not possible with conventional counters. Its standard pulse-width and duty-factor functions also allow the user to analyze pulse-train signals.

The counter is capable of measuring both the carrier frequency and the pulse-repetition frequency without an external sync signal. It can also measure pulsed-RF signals such as radar bursts.

The *PM 6685* frequency counter is priced at \$1860.—**John Fluke Mfg. Co., Inc.**, P.O. Box 9090, Everett, WA 98206; Phone: 800-44-FLUKE.

MULTIMODE LASER DIODE.

ROHM Corporation has introduced its *RLD-83* series of multimode laser diodes, said to be the first able to read and write magneto-optical disks effectively.

The diodes emit at 830 nanometers, and have maximum threshold currents of 60 milliamperes. They provide high optical output and longitudinal multimode oscillation below 7 milliwatts, a value which corresponds to the read power for magneto-optical disks.

Magneto-optical disks reflect a significant amount of light, which causes feedback noise. That noise can be reduced by replacing a longitudinal, single-mode oscillation laser diode with one capable of longitudinal multimode oscillation. A multimode laser diode oscillates simultaneously over a large frequency range, permitting it to absorb returned noise over a wide wavelength span.

RLD-83 Series offers signal-to-noise ratios equal to or greater than 60 dB at 3 milliwatts, continuous wave, and 720-kHz frequency. Bandwidth is 120



CIRCLE 19 ON FREE INFORMATION CARD

kHz, and the operating temperature for all devices is -10°C to $+60^{\circ}\text{C}$. Their optical power output ratings are:

- *RLD-83-M/N/P-30*—30 milliwatts.
- *RLD-83-M/N/P-40*—40 milliwatts.
- *RLD-83-M/N/P-31*—30 milliwatts with a peak optical output of 40 milliwatts when pulsed.

Prices for the *RLD-32 Series* multimode laser diodes range from \$74 to \$118 in quantities of 1000.—**ROHM Corporation**, 3034 Owen Drive, Antioch, TN 37013; Phone: 615-641-2020; Fax: 615-641-2022.

SOUND COMMANDER. The *Sound Commander* from **Electron Processing** switches a car's speakers to a monitor installed in the car whenever a call comes in. Thus monitor enthusiasts will never have to miss a scanner call.

The manufacturer says that it is easy to connect *Sound Commander* to your car radio's speaker leads and mobile scanner. *Sound Commander* can be used



CIRCLE 20 ON FREE INFORMATION CARD

with car radios having up to four speakers with outputs of 25 watts or less per channel.

Sound Commander is priced at \$80 plus \$5 shipping and handling.—**Electron Processing**, P.O. Box 68, Cedar, MI 49621; Phone: 616-228-7020.

CAD SOFTWARE UTILITY.

Douglas Electronics' GerberViewer is a software utility for Macintosh computers. It graphically displays Gerber-format CAD files in exact production form. The utility is the newest model in the company's Professional CAD/CAM System for the Macintosh.

The utility can also be used as a stand-alone program. By allowing engineers to view and verify PC-board designs before they go into production, it is said to reduce the overall costs and time-to-market of PCB's.

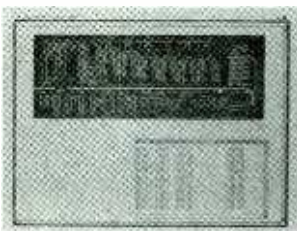

CIRCLE 21 ON FREE INFORMATION CARD

GerberViewer acts as an electronic light table that lets engineers measure, manipulate, print, and edit real-time graphical representations of their designs. It also allows them to produce PostScript-compatible composites of the designs. It reads Gerber and aperture files created by the Gerber File Creator and other PC-board design systems.

Designers can use *GerberViewer* to examine and measure board designs in increments as small as one micron, and

the program's full-color display allows users to view all layers of a multilayer board at the same time.

GerberViewer costs \$250.—**Douglas Electronics, Inc.**, 2777 Alvarado St., San Leandro, CA 94577; Phone: 510-483-8770; Fax: 510-483-6453.

AUTORANGING DIGITAL MULTIMETERS.

American Reliance is offering four new autoranging, auto-data-hold DMM's with large LCD readouts.



CIRCLE 22 ON FREE INFORMATION CARD

● The *Model 33* has a $3\frac{1}{2}$ -digit $\frac{3}{4}$ -inch-high LCD display, and it offers 0.5% accuracy. It performs diode and audible-continuity checks.

● *Models 35* and *37* have $3\frac{1}{4}$ -digit, 0.67-inch-high LCD displays, and offer 0.3% basic accuracy. The true-RMS meters have analog bargraphs, min/max memory, and they can count frequency.

● *Model 39* is a $3\frac{3}{4}$ -digit, 4000-count, autoranging, true RMS DMM with a 0.25% stated accuracy. It has min/max memory, counts frequency and measures capacitance and temperature. Its display can be updated every 50 milliseconds. It also has au-

Introducing Australia's Leading Electronics Magazine...



SILICON CHIP®

Packaged in a specially prepared format guaranteed to excite the electronics hobbyist with new ideas, novel projects, extraordinary features and down-right good reading.

Inside **Silicon Chip** you will discover how the other side of our world—down under—approaches the same hobby interests as you do, with ramifications that will amaze you.

Detailed construction projects to appear in upcoming issues of Silicon Chip include:

- 4-Channel Guitar Mixer**
- Adjustable 0-45V, 8A Power Supply**
- Interphone Digital Telephone Exchange**
- 1.5V to 9V DC Converter**
- Multi-Sector Home Burglar Alarm**
- 1-Megabyte Printer Buffer**



Exciting and imaginative Features like:

- Understanding Computer Memory**
- How to Interlink Musical Instruments**
- What's New in Oscilloscopes**

If you are fascinated by electronics, especially the hobby aspects related to construction projects, theory, applications in home and shop, and latest developments, if you are compelled to experiment and "fix-it," then **Silicon Chip** is your kind of magazine.

Silicon Chip is available exclusively by subscription. So take advantage of this great opportunity and start your Charter Subscription today.

SILICON CHIP, 500-B Bi-County Boulevard, Farmingdale, New York 11735 EN593

I'm convinced! Enroll me as a Charter Subscriber. Enter my subscription as designated below.

United States of America		Canada	
<input type="checkbox"/> 12 issues for \$29.95	<input type="checkbox"/> 24 issues for \$49.95	<input type="checkbox"/> 12 issues for \$40.61	<input type="checkbox"/> 24 issues for \$70.57
		(Includes postage & G.S.T.)	
<input type="checkbox"/> Payment enclosed	Please charge my	<input type="checkbox"/> VISA	<input type="checkbox"/> Mastercard

For your convenience, if paying by credit card: To avoid any interruption in service, your subscription will be renewed automatically at 12-issue intervals, at the then prevailing Introductory rate, until you advise us to cancel it.

Signature _____

Account No. _____ Expiration Date _____

Offer valid in the U.S.A. and Canada only. No foreign Orders.

Name _____

Address _____

City _____ State _____ Zip _____

All orders payable in U.S.A. funds only. Allow 6-8 weeks for delivery.

Earn Your B.S. Degree in ELECTRONICS or COMPUTERS



By Studying at Home

Grantham College of Engineering, now in our 43rd year, is highly experienced in "distance education"—teaching by correspondence—through printed materials, computer materials, fax, and phone.

No commuting to class. Study at your own pace, while continuing on your present job. Learn from easy-to-understand but complete and thorough lesson materials, with additional help from our instructors.

Our Computer B.S. Degree Program includes courses in BASIC, PASCAL and C languages — as well as Assembly Language, MS DOS, CADD, Robotics, and much more.

Our Electronics B.S. Degree Program includes courses in Solid-State Circuit Analysis and Design, Control Systems, Analog/Digital Communications, Microwave Engr, and much more.

An important part of being prepared to *move up* is holding the right college degree, and the absolutely necessary part is knowing your field. Grantham can help you both ways—to learn more and to earn your degree in the process.

Write or phone for our free catalog. Toll free, 1-800-955-2527, or see mailing address below.

Accredited by
the Accrediting Commission of the
National Home Study Council

GRANTHAM
College of Engineering
Grantham College Road
Slidell, LA 70460

tomatic power turn-off, a continuity beeper, and it can test diodes and measure current continuously up to 20 amperes.

The DMM Models 33, 35, 37, and 39 are priced at \$59.95, \$89.95, \$99.95, and \$199.95, respectively.—**American Reliance, Inc.**, 9952 East Baldwin Place, El Monte, CA 91731; Phone: 800-654-9838 or 818-575-5110; Fax: 818-575-0801.



CIRCLE 23 ON FREE
INFORMATION CARD

MONOLITHIC LOGDAC'S.

Analog Devices' single-channel AD711A and stereo AD7112 monolithic digital-to-analog converters (LOGDAC's) are single-chip converters intended for automated volume-control applications.

The LOGDAC's offer guaranteed dynamic ranges of 88.5-dB per channel, attenuation resolution to 0.375-dB increments, and glitch impulse to 10-nanovolt-seconds. They also offer -91-dB total harmonic distortion performance at 1 kHz with 6-volt RMS inputs, and they can function under digital control because of their on-chip latches and control logic.

The AD711A and AD7112 require only a single +5-volt power supply and three-wire microprocessor /DSP interface for complete, automatic operation. They can be set to accept data in just 25 nanoseconds, and their 57-nanosecond pulse widths are compatible with standard microprocessors. They are compatible with Analog Devices' AD7524 and AD7528 multiplying DAC's, respectively.

LOGDAC's can also be used in mixers, audio attenuators, loudspeaker systems, noise-cancellation systems, and audio-

signal-processing add-on boards. Both devices are housed in either 16-pin DIP's or SOIC's, and they are available in die form.

Prices in 1000 quantity begin at \$4.15 for the AD711A and \$5.60 for the AD7112.—**Analog Devices, Inc.**, 181 Ballardvale Street, Wilmington, MA 01887; Phone: 617-937-1428; Fax: 617-821-4273.

DATA ACQUISITION KIT. This data acquisition kit offers a method for uploading and downloading waveforms and data between the memory card in the manufacturer's test instrument and a personal computer for reference and storage.

The Model 300-PC kit from *Leader Instruments Corp.* works with its Model 300 handheld digital storage oscilloscope/ digital multimeter. The kit includes software on a 5¼-inch disk, a memory card reader/writer, interconnect cable, and an owner's manual. The software permits computer control of stored waveforms.

File identification labels can be entered for each display of waveform data. The waveform data for processing, analysis, and statistics can be included in text or spread-sheet reports. Data can be output



CIRCLE 24 ON FREE INFORMATION CARD

in ASCII format for data filing, and the PC's printer is supported with the MS-DOS graphics command.

Previously stored data can be transferred to memory cards and mailed. This feature allows on-screen comparison of reference data with data taken in the field.

The *Model 300-PC* data acquisition kit has a price of \$600.

Leader Instruments Corp.
380 Oser Avenue
Hauppauge, NY 11788
800-645-5104
(516-213-6900 in NY)

BURN-IN SOCKETS. A new family of test and burn-in sockets from *3M Electronic Products Division* reduces tooling costs for new styles of integrated-circuits by eliminating cost-



CIRCLE 25 ON FREE INFORMATION CARD

ly and time-consuming dedicated tooling for each new package design. One size accepts packages up to 23 mm square, and another accepts packages up to 38 mm square—both at 50 mil or 1.5 mm pitches. These new test sockets can accommodate both ce-

ramic and plastic packages, and solder-ball or flat-pad styles.

The sockets feature a clam-shell design that is adaptable to auto-load and -unload processes. Flat surface contacts minimize solder-ball deformation, and a point-contact option is available for flat pad lands.

3M Electronic Products Division

6801 River Place Blvd.
Austin, TX
787-26-4599
(800) 328-0411

SPEAKER PHASE TESTER.

The *Speak-Rite* phase tester from *Smart Products* is said to permit speaker phase to be determined quickly and easily when only the speaker wires are accessible.

By determining the



CIRCLE 26 ON FREE INFORMATION CARD

phase consistency of an audio system, the instrument simplifies the task of making connections in new audio installations. The phase tester can check phase through speaker wires or by feeding a low-level signal through the aux input of an amplifier.

The *Speak-Rite* phase checker, with all necessary cables, is priced at \$79.95.
Smart Products
3188-F Airway Avenue
Costa Mesa, CA 92626
800-533-2131. Ω

HAMEG® Instruments

**UNMATCHED
PRICE/PERFORMANCE RATIO**
Analog: 2x100MHz
Digital: 2x40MS/s

HM1007

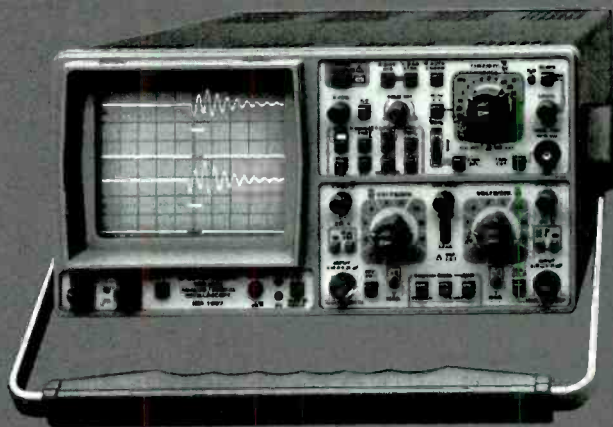

Price: 1988.00 \$

- 2 Channels 100MHz / 40MS/s
- 4x2048x8bit Record length
- Refr.-, Single-, Roll-, XY-mode
- Pretrigger, Trig.-Level Display
- X-Magnifier: x5, x10 and x50
- Reference Waveform Storage
- Battery-backed Memory
- Delay line, 6"-CRT / 14kV
- Built-in 1MHz Scope-Calibrator
- Multifunction-Interface (Opt.):
IEEE 488 / RS232 / Centronics

**For your scope solution
Call Toll-free at: 800.247.1241**

HAMEG Inc.
1939 Plaza Real
OCEANSIDE, CA 92056
Phone (619) 630-4080 FAX (619) 630-6507

CIRCLE 182 ON FREE INFORMATION CARD

When the measurement matters, take matters in hand.



With a Tektronix 220 Series scope, you can count on getting results which are clearly, visibly better. Anytime, every time.

All at the touch of a button. No other handheld scopes offer as much in the way of performance or convenience for rugged applications, from troubleshooting industrial PLCs and vehicle electronics to power systems, motor controls and medical electronics.

The 222A, 224 and 222PS Power Scout™ make routine work of measurements that pose a danger to users or tax the capabilities of other so-called "scopes." At a mere 4½ pounds, they pack a lot more power than their size and price suggest:

■ **IsolatedChannel™ ARCHITECTURE.**

Two fully isolated input channels ensure safe, easy floating measurements with no danger to you or your equipment.

■ **SUPER SHARP CRT.** Industry-leading technology delivers excellent viewability at all angles at any temperature, even in direct sunlight.

■ **DIGITAL STORAGE.** Powerful features include 10 MS/sec sampling on two channels simultaneously and 100 ns glitch capture at any sweep speed.

■ **FAMILIAR FRONT PANEL.** The logical grouping of front panel controls makes operation remarkably intuitive.

■ **AUTO SETUP.** Just push a button for signal acquisition and display.

■ **AUTO TRIGGER.** Automatically locates trigger points and selects the correct voltage for a stable display of complex waveforms, even in video and motion control applications.

■ **SAVE/RECALL.** Pre-define and store up to four front-panel displays, and recall them instantly.

■ **SAVE REFERENCE MEMORY.** Acquire up to four waveforms for later analysis.

■ **RUGGED CONSTRUCTION.** High-strength, impact-resistant plastic gives ample protection in harsh environments.

■ **DETACHABLE PROBES.** An attached carrying case provides convenient storage and prevents loss.

On-board rechargeable batteries, an RS-232-C interface and 3-year warranty are included. Tektronix offers a wide range of accessories from printers and current probes to computer software. And each scope is UL and CSA certified — for the ultimate in quality and safety. To order, contact your authorized Tektronix representative or distributor.

	224	222PS	222A
Useful Storage BW			
Single Shot	1 MHz	1 MHz	1 MHz
Repetitive	60 MHz	10 MHz	10 MHz
Channels	2	2	2
Sensitivity Range	50 mV – 500 V/div	50 mV – 500 V/div	5 mV – 50 V/div
Max. Sampling Speed	10 MS/sec	10 MS/sec	10 MS/sec
Record Length	512 bytes	512 bytes	512 bytes
Vertical Resolution	8 bits	8 bits	8 bits
Timebase Range	20 sec – 50 ns	20 sec – 50 ns	20 sec – 50 ns
Horizontal Magnifier	X10	X10	X10
Glitch Capture	100 ns	100 ns	100 ns
Custom Triggers	video	motor	N/A
Maximum Safe Input Voltage	+850 V dc + peak ac 600 VAC, 6 kV peak surge	+850 V dc + peak ac 600 VAC, 6 kV peak surge	+400 V dc + peak ac
Price	\$2750	\$2950	\$2450



Tektronix

Just pick up the phone!

Take matters in hand: call your authorized Tektronix representative or distributor and order your 220 Series scope today.

Frigid North, ALASKA, (907) 561-4633

Jensen Tools, ARIZONA, (800) 426-1194

Metermaster, ARIZONA, (800) 366-3837

Carlton-Bates, ARKANSAS, (800) 482-9313

Instrument Engineers, CALIFORNIA, (800) 444-6106

ITC Electronics, CALIFORNIA, (800) 225-5482

Marshall Industries, CALIFORNIA, (800) 877-9834, ext. 422

Mitchell Instrument Co., CALIFORNIA, (619) 744-2690

EMSCO Division/Hammond Electronics, FLORIDA,
(800) 275-3554

Dow Electronics, GEORGIA, (800) 627-2910

Tycom Industries, Inc., GEORGIA, (404) 378-6160

Joseph Electronics, ILLINOIS, (800) 323-5925

Klaus Radio Supply, ILLINOIS, (800) 545-5287

Allied Broadcast, INDIANA, (317) 962-8596

Electronics Supply, KANSAS, (800) 669-3752

HARCO Electronics, MARYLAND, (800) 638-7616

TESSCO, MARYLAND, (800) 638-7666

Contact East, MASSACHUSETTS, (508) 682-2000

MSB Tool, Inc., MASSACHUSETTS, (617) 551-0190

Kendall/Great Lakes Electronics, MICHIGAN,
(800) 321-8434

R.S. Electronics, MICHIGAN, (800) 366-7750

Instrumentation Services, Inc., MINNESOTA, (612) 544-8916

Stark Electronics, MINNESOTA, (800) 334-6154

Olive Electronics, MISSOURI, (314) 997-7709

Beta Lambda, Inc., NEW JERSEY, (800) 282-5632

Brownell Electro, NEW JERSEY, (800) 828-1552

Transcat, NEW YORK, (800) 828-1470

Electronic Parts, NEW MEXICO, (800) 456-0057

Inotek Technologies, NORTH CAROLINA, (704) 527-5000

NW Test & Measurement, OREGON, (503) 645-9000

Leff Electronics, Inc., PENNSYLVANIA, (412) 351-5000

Sunshine Instruments, PENNSYLVANIA,
(800) 343-1199

Dixie/Resource Electronics, SOUTH CAROLINA, (803) 779-5332

EnTest, TEXAS, (800) 955-0077

Inotek Technologies, TEXAS, (800) 492-6767

Radar Electric, WASHINGTON, (206) 282-2511

Dist-Tron, Inc., WISCONSIN, (608) 835-5527

For more information, you can also
call Tektronix toll-free: **1-800-426-2200**.

Tektronix

LETTERS

continued from page 15

"Commodore might have a temporary and illusory lead on genlocking, but the Mac color image generation and editing has long ago passed up the Amiga...."

I don't want to start another platform war here (I would have to admit, after all, that the Mac is a far more established and popular computer), but I must point out that Amiga's lead in genlocking has lasted since the computer's introduction in 1985. (Genlocking was demonstrated along with a 4096-color display—the Mac was a black-and-white machine at the time.)

The Amiga remains a leader in color-image generation and editing in the video-production industry, where (according to the December 1990 issue of *Videography*) it outnumbered Macintoshes two-to-one in 1990. Thanks to the Amiga's unique video architecture, it's possible to get a full, broadcast-quality, 24-bit image capture, paint, and real-time animation system for less than \$1000. This breaks out as an Amiga 500 for \$299, a DCTV 24-bit frame capture and display (including 24-bit paint and animation software) for \$395, and the video monitor of your choice for \$300.

Nobody will challenge the lock on the business community held by IBM compatibles, or Mac's dominance in desktop publishing. But Amiga's niche is video production, and it's already too late for another platform to "catch up." Remember when the Mac had to fight for respect like that?

DAVE MUSE

Southfield, MI

DISK-DENSITY DEBATE

I read with interest the letter from William Proctor (*Electronics Now*, January 1993). I am sure that everything he said is correct, but he is wrong. The reason that he is wrong is that he is right!

From a logical viewpoint, one can see that if media reliability is kept constant, data integrity decreases as data density increases. However, for any given data density, there will still be a failure rate. There is no

medium (as far as I know) that is 100% reliable at one density, and 100% unreliable at another. There's always a trade-off.

Mr. Proctor worked as a supplier of disks. For him to keep his reputation, he had to provide disks that were extremely reliable (99.95%). With that high a reliability at the rated data density, there could also be a reasonably high reliability at greater data densities. In my experience with small batches, no disk ever lost any data by doubling its capacity, although there has been some media defect that keeps the disk from formatting at double its rated density.

The loss never amounts to more than 20 kilobytes (usually, no more than 5 kilobytes are lost), unless the disk is about to fail catastrophically. That is comparable to some of the disks that I've formatted to specification.

Unfortunately, that high level of integrity has not been reached by the commercial doublers; all the disks that I formatted with commercial doublers failed catastrophically within a few months. The culprit, I suspect, is plastic particles that contaminate the media. I found a method for converting disks that has been 100% reliable in my small batch samples.

I have also tried converting 5.25-inch disks, and found that it is not worth the bother. If you are trying to double the storage on the disk, results are not so bad, but they are worse if you are trying to triple the storage.

Allow me to take this opportunity to encourage suppliers to avoid using 5.25-inch disks. The method of arranging data on a 5.25-inch disk is inferior to that used on a 3.5-inch disk; the two densities of a 5.25-inch disk are not exactly interchangeable (speaking of media un-dependability ...). Moreover, 5.25-inch disks are not as well protected from shock and dirt, and they take up far too much room for their storage capacity. If a manufacturer wants to use the 5.25-inch format, he should stick with double density; high-density 5.25-inch disks are dinosaurs today!

RICHARD ALEXANDER

Albuquerque, NM

NEW LIT

Use The Free Information Card for fast response.

Don Lancaster's Incredible Secret Money Machine II; by Don Lancaster. Synergetics Press, Box 809, Thatcher, AZ 85552; \$18.50 plus \$2 shipping and handling.

If you are the kind of person who can't wait to get to your home office, shop, or studio to fiddle with your computer or get your hands on some craft or do-it-yourself project, this book can show you how to turn your hobby time into your own "Incredible Secret Money Machine." Don Lancaster, author of the "Hardware Hacker" column in **Electronics Now**, puts his experience and irreverent style into this "not-just-another-get-rich-quick book."

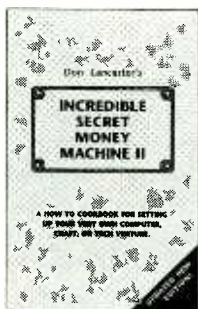

CIRCLE 40 ON FREE INFORMATION CARD

Lancaster's philosophy seems to be: Get totally into your craft, stay in control, don't seek money for money's sake, and treat others and the environment with respect. In this book he tells you how to set up and run your own business. He warns that it won't necessarily make you rich, but you will be your own boss. He tells you how to combine your knowledge gained on the job with your special inter-

ests so you can work at what you love doing—and set your own personal lifestyle.

Lancaster says his advice is both realistic and proven. He gives you ways to reduce your taxes, lower or eliminate your utility bills, and profit on investments. He even tells you how to get free (or even paid) vacations, obtain free insurance, and find the ways to get startup financing for your new business enterprise.

Radios of the Baby Boom Era: 1946 to 1960; Prompt Publications, Howard W. Sams & Company, 2647 Waterfront Parkway, E. Dr., Indianapolis, IN 46214; Phone: 800-428-7267; \$16.95 each or \$96.50 for all six.

These six volumes will help radio receiver collectors identify their finds in flea market sales, cellars, or attics. They form a comprehensive reference to radios made in the post-World War II years of 1946 to 1950. Compiled by Sams' editors and technicians, this series of books contains photos and pertinent information on classic radios.

The volumes in this series are:



CIRCLE 39 ON FREE INFORMATION CARD

- Volume 1 covers Admiral to Clearsonic.
- Volume 2 covers Co-op to Gelo.
- Volume 3, covers General Electric to Monitoradio.
- Volume 4, covers Motorola to RCA Victor.
- Volume 5, covers Real-tone to Stratovox.
- Volume 6, covers Stromberg-Carlson to Zenith.

Each volume contains photographs of the popular radio models from that period, including radio/phonograph combinations and clock radios. They are arranged by brand name and year of introduction.

Each entry includes such data as number of tubes in the radio, its power supply type, its tuning range, manufacturer or vendor, and the Photofact set number.

Hot Links: The Guide to Linking Computers; by Mark Eppley & David Hakala; Osborne McGraw-Hill, 2600 Tenth Street, Berkeley, CA 94710; Phone: 510-549-6600; Fax: 510-549-6603; \$29.95.

This computer linking guide explains how to solve the frustrating problems that arise when you want to link computers to share information. It explains the essential basics of computers, and includes information on parallel and serial ports, synchronous and asynchronous communications, cables, and cable connectors.

This guide to linking computers will come in handy whether you're concerned with mainframes or personal computers. The PC's can be Mac's or IBM



CIRCLE 38 ON FREE INFORMATION CARD

compatibles, and they can be located in one room or around the world.

Low-cost alternatives to local-area networks (LAN's) for transferring files or sharing printers and modems are explained, as is LAN terminology. After reading this book you can make informed purchasing decisions, and use modems and on-line services.

You will find out about how to set up modem software for file transfers and electronic mail, how to take over another computer by remote control, and how to start your own BBS. For laptop users, the book explains disk-sharing links, LAN adapters, and docking stations.

This guide also discusses on-the-road communications over pocket modems, cellular phones, and packet-radio networks. Moreover, it comments on the future cellular, palmtop, and pen-based computer technologies. It even explains how to link IBM-compatible MS-DOS PC's to Apple Mac's, and link both to a mainframe computers. And you'll be able to understand how to use infrared light or radio frequencies to connect computers in "wireless" networks. Ω

Graduate as a Fully Trained Electronics Professional!

If you want to learn about electronics, and earn a good income with that knowledge, then CIE is the best educational value you can receive.

CIE's reputation as the world leader in home study electronics is based solely on the success of our graduates. And we've earned our reputation with an unconditional commitment to provide our students with the very best electronics training.

Just ask any of the 150,000-plus graduates of the Cleveland Institute of Electronics who are working in high-paying positions with aerospace, computer, medical, automotive and communications firms throughout the world.

They'll tell you success didn't come easy...but it did come...thanks to their CIE training. And today, a career in electronics offers more rewards than ever before.

CIE'S COMMITTED TO BEING THE BEST...IN ONE AREA...ELECTRONICS.

CIE isn't another be-everything-to-everyone school. CIE teaches only one subject and we believe we're the best at what we do. Also, CIE is accredited by the National Home Study Council. And with more than 1,000 graduates each year, we're the

largest home study school specializing exclusively in electronics. CIE has been training career-minded students like yourself for nearly sixty years and we're the best at our subject...ELECTRONICS...BECAUSE IT'S THE ONLY SUBJECT WE TEACH!

CIE PROVIDES A LEARNING METHOD SO GOOD IT'S PATENTED.

CIE's AUTO-PROGRAMMED® lessons are a proven learning method for building valuable electronics career skills. Each lesson is designed to take you step-by-step and principle-by-principle. And while all of CIE lessons are designed for independent study, CIE's instructors are personally available to assist you with just a toll free call. The result is practical training...the kind of experience you can put to work in today's marketplace.

LEARN BY DOING..WITH STATE-OF-THE-ART EQUIPMENT AND TRAINING.

CIE pioneered the first Electronics Laboratory Course and the first Microprocessor Course. Today, no other home study school can match CIE's state-of-the-art equipment and

training. And all your laboratory equipment, books and lessons are included in your tuition. It's all yours to use while you study and for on-the-job after you graduate.

PERSONALIZED TRAINING....TO MATCH YOUR BACKGROUND.

While some of our students have a working knowledge of electronics others are just starting out. That's why CIE has developed twelve career courses and an A.A.S. Degree program to choose from. So, even if you're not sure which electronics career is best for you, CIE can get you started with core lessons applicable to all areas in electronics. And every CIE Course earns credit towards the completion of your Associate in Applied Science Degree. So you can work toward your degree in stages or as fast as you wish. In fact, CIE is the only school that actually rewards you for fast study, which can save you money.

SEND FOR YOUR CIE COURSE CATALOG AND WE'LL SEND YOU A FREE 24-PAGE CIE ELECTRONIC SYMBOLS HANDBOOK.

FREE!

SEND FOR YOUR CIE HOME STUDY COURSE CATALOG AND RECEIVE A FREE 24 PAGE CIE ELECTRONIC SYMBOLS HANDBOOK!

Includes hundreds of the most frequently used electronic symbols. Published exclusively by CIE for our students and alumni. Yours free when you request a CIE Course Catalog.

electronics



YES! I want to get started. Send me my CIE course catalog including details about the Associate Degree Program. (For your convenience, CIE will have a representative contact you - there is no obligation.)

AE50

Please print clearly

Name _____

Address _____

City _____ State _____

Zip _____ Age _____

Phone No. (____) _____

Check box for G.I. Bill Benefits

Veteran Active Duty

CIE 1776 East 17th Street
Cleveland, Ohio 44114

A School of Thousands.
A Class of One. Since 1934.

GET THE LATEST ADVANCES IN ELECTRONICS

WITH A SUBSCRIPTION TO

Electronics

Radio Combined with
Electronics®

NOW

®

Electronics Now gives you exciting articles like:

- Buyer's Guide to Digital Oscilloscopes
- Build A Scanner Converter
- Single-Chip Voice Recorder
- Build A MIDI Interface for your PC
- Troubleshoot Microprocessor Circuits
- Build A High-Power Amplifier for your Car
- Add Music On Hold to your Phone
- All About Binaural Recording
- VGA-to-NTSC Converter

ENJOY THE WORLD OF ELECTRONICS EACH MONTH!

Subscribe to the best electronics magazine—the one that brings you the latest high-tech construction projects, feature articles on new technology, practical troubleshooting techniques, circuit design fundamentals, and much more.

Electronics Now looks to the future and shows you what new video, audio and computer products are on the horizon. What's more you'll find helpful, monthly departments such as Video News, Equipment Reports, Hardware Hacker, Audio Update, Drawing Board, Computer Connections, New Products, and more. All designed to give you instruction, tips, and fun.



FOR FASTER SERVICE CALL TODAY

1-800-999-7139

DON'T DELAY SUBSCRIBE TODAY!

Just fill out the order card in this magazine and mail it in today.

AUBREY HARRIS*

HIGH-DEFINITION TELEVISION (HDTV) is coming sooner than you might think. According to plans outlined by the Federal Communications Commission (FCC), TV stations might begin broadcasting high-definition television as early as the end of 1996. By 2008, all TV broadcasts might be in HDTV, and broadcasters will cease using standard TV signals.

What will the new HDTV format be? During the past year, five competing HDTV systems underwent a comprehensive series of tests at the Advanced Television Test Center in Alexandria, Virginia. The only analog system, the one from NHK of Japan, has dropped out of the competition. This article describes the four fully digital transmission systems.

The Advisory Committee on Advanced Television Service is evaluating the results of the tests and it will recommend an HDTV system to the FCC. The selection process was expected to be complete by the end of this year. That no longer appears likely, however, because all of the systems exhibited flaws during testing.

The four competitors (see Table 1) have improved their systems to eliminate the problems that showed up in tests. Their systems will be retested, which might delay the introduction of HDTV by about a year.

By FCC mandate, the system selected will have to operate for many years concurrently with existing broadcast television

stations, without causing interference to or receiving interference from them. The FCC has also mandated that the selected HDTV system must operate within the standard 6 MHz-wide TV channels. There are 68 such channels, 12 in the VHF band and 56 in the UHF band. Not all channels are occupied in any one particular region because of interference considerations. Only every other VHF channel and every sixth UHF channel can be assigned to any one area. It is on the unused UHF channels (often called the "taboo channels") that the new HDTV services will be carried.

The FCC will assign one addi-

tional TV channel to each existing station to be used for simulcasting HDTV broadcasts, while the existing channel would broadcast conventional NTSC television. However, at the end of the year 2008, NTSC transmissions would cease, and the stations will have to relinquish their NTSC channels; the FCC will then be able to allocate that spectrum space for other purposes.

There are two prime motivators behind the substantial and intensive HDTV engineering development efforts: First is the desire for high resolution; that is, the capability of reproducing finer detail on the

receiver screen. Public expectations generally assume a thousand or more scanning lines on the screen with twice the horizontal and vertical resolution of present-day TV, resulting in picture quality approaching that of 35-mm movies. The second is the desire for a wider screen aspect ratio; that is, the ratio of the picture's width to its height. Both require an increase in the video bandwidth.

TV system bandwidth

The four major factors that determine the bandwidth of a video transmission are the aspect ratio of the picture, the scanning method (interlaced or progressive), the picture repetition rate, and the number of scanning lines in each frame.

That last factor is important because the increase in bandwidth varies as the square of the increase in the number of lines. That is, when the number of

THE NEW WORLD OF HDTV

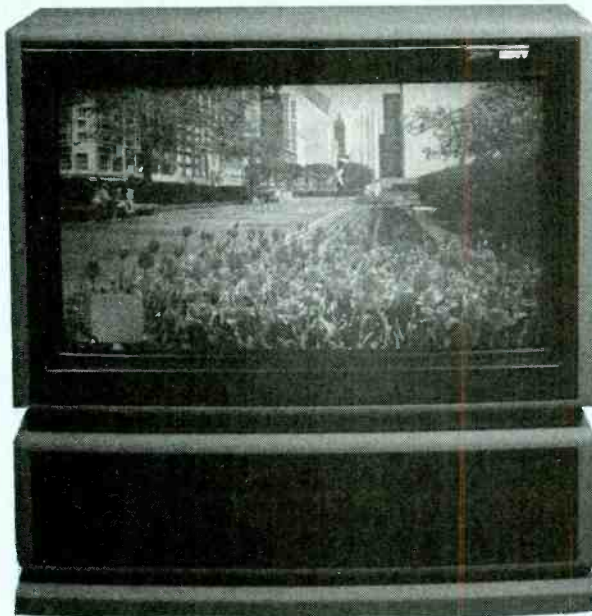

High-definition television is coming! Here we examine the competing digital HDTV proposals and how they work.

*Aubrey Harris is Chief Engineer for the Stanford Instructional Television Network.

TABLE 1—HDTV COMPETITORS

SYSTEM	DIGICIPHER	DIGITAL SPECTRUM COMPATIBLE (DSC)	ADVANCED DIGITAL TELEVISION (ADTV)	CHANNEL-COMPATIBLE DIGICIPHER (CCDC)
PROponents	American Television Alliance (ATVA) General Instrument Corp. Massachusetts Institute of Technology	Zenith/AT&T Zenith Electronics Corp. AT&T Scientific-Atlanta	Advanced Television Research Consortium (ATRC) Thomson Consumer Electronics Philips NBC David Samoff Research Center Compression Laboratories Inc.	American Television Alliance (ATVA) General Instrument Corp. Massachusetts Institute of Technology
SCAN LINES PER FRAME	1050	787.5	1050	787.5
FRAMES PER SECOND	29.97	59.94	29.97	59.94
SCAN FORMAT	2:1 Interlace	Progressive	2:1 Interlace	Progressive
HORIZONTAL LUMINANCE PIXELS	1408	1280	1440	1280
VERTICAL LUMINANCE PIXELS	960	720	960	720
HORIZONTAL CHROMINANCE PIXELS	352	640	720	640
VERTICAL CHROMINANCE PIXELS	480	360	480	360
LUMINANCE BANDWIDTH (MHz)	21.5	34	23.6	34
CHROMINANCE BANDWIDTH (MHz)	5.4	17	11.8	17
VIDEO SAMPLING FREQUENCY (MHz)	53.65	75.3	56.64	75.5
VIDEO DATA RATE (Mbps)	17.47/12.59	17.1/8.6	17.73	18.88/13.60
AUDIO SAMPLING FREQUENCY (kHz)	48	47.203	48	48
AUDIO DATA RATE (Mbps)	0.503	0.5	0.512	0.755
AUDIO DYNAMIC RANGE (dB)	85	96	96	94
ERROR CORRECTION OVERHEAD (Mbps)	6.17	1.3/2.4	5.64	6.54
TRANSMISSION DATA RATE (Mbps)	24.39/19.51	21.0/11.1	24.0/4.8	26.43/21.15

lines is doubled, the bandwidth required is quadrupled. Furthermore, progressively scanned video requires twice the bandwidth required by interlaced video.

To illustrate the effect that the number of lines has on bandwidth, consider that the present 525-line, 60-field per second interlaced system, with its aspect ratio of 4 × 3 (1.33:1), has a video bandwidth of 4.2 MHz. If the number of lines were doubled to 1050 per frame, the bandwidth needed would increase to nearly 18 MHz! Conformance with the internationally accepted HDTV wide-picture aspect ratio of 16 × 9 (1.78:1) would further increase the required bandwidth to about 23.5 MHz. And if progressive, rather than interlaced scanning were used, the bandwidth needed would double to about 47 MHz. Such bandwidth—almost eight times as wide as that occupied by a single NTSC channel—obviously could not be accommodated in the proposed 6-MHz HDTV channel allocations.

All broadcast TV systems now use interlaced scanning to reduce bandwidth. With such scanning, the odd-numbered lines in the picture are transmitted in one field (line numbers 1, 3, 5, etc.), and the even-numbered lines are transmitted in the next field (line numbers 2, 4, 6, etc.). Each field is transmitted in one-sixtieth of a second in the NTSC system. The images, rapidly following one another, and abetted by persistence of vision at the eye, blend and give the appearance of a full frame.

The main criticism of interlacing is that, depending on the content of the picture, flickering can often be seen between adjacent display lines, and unpleasant visible artifacts can be caused by on-screen moving objects. Progressive (or sequential) scanning lays down each successive scan line directly following its predecessor (line 1, followed by lines 2, 3, etc.). Progressive scanning results in a steadier picture.

As you will no doubt appreciate, the big challenge for the

contending system designers has been the squeezing of high-definition TV into the spectrum space that was intended for NTSC transmissions. The need clearly exists for aggressive TV bandwidth reduction techniques.

NTSC bandwidth economy

Although it is not always realized, our present color TV transmission system uses several techniques to lower the bandwidth required for transmission. The NTSC system was developed in the 1950's as a means of transmitting color TV in the same spectrum space that was used for black and white TV. (Back then, the system was often called "compatible color TV.") Without any bandwidth reduction, a 525-line, 60-frame per second, progressive-scan, color TV system with an aspect ratio of 1.33:1 would need about 8.4 MHz for each of the three primary colors (red, green, and blue). The total bandwidth required would be just over 25 MHz.

As mentioned earlier, inter-

laced scanning cuts the bandwidth required by one half. Matrix encoding of the three primary colors, reducing the bandwidth of the color-difference signals to less than 1.5 MHz, and using phase-coding to define the color spectrum brings down the bandwidth required to 4.2 MHz—a reduction ratio of six-to-one.

Digital processing for HDTV

The signal coming from a high-definition TV camera before it has been compressed has a very high bit rate—about 900 to 1,300 megabits (Mbits) per second. Several statistical and computer compression techniques can reduce the rate significantly. But that's not the only advantage to a digital TV system. Others include:

- The error-free regeneration of the digital bit stream at the various processing and relay points in the transmission path renders the digital signal virtually immune to the noise, distortion, and degradation which accumulate and plague analog TV systems. In digital systems the information is carried by the digital coding and timing information, whereas in an amplitude-modulated analog system the integrity of the transmission is determined by the wave-shape of the signal.
- Multiple sound channels (maybe four, five, or six), having the quality of compact disc recordings, are easily incorporated.
- Additional bit streams for text, captioning, data, and control, can be interleaved along with the video and audio signal data.
- Multipath (ghost) images can be canceled easily, and ignition noise and other impulse interference problems can be greatly reduced or eliminated at the TV receiver.
- Interfacing with current and future digital data communication and recording protocols is easier with digital than with analog systems.
- Digital electronics allows complex processing of signals (e.g., filtering) that would be extremely cumbersome and ex-

pensive, if not impossible, in the analog form.

- Low RF transmission power requirements.

Bandwidth reduction

There are a number of psycho-visual and statistical attributes of images which, when put together with various signal-processing techniques, allow very significant reductions in the amount of information and bandwidth needing to be transmitted. Among them:

- The eye does not need a high degree of detail for color in an image as long as the full detail is presented by the brightness (luminance) signal. All present-day color TV systems (NTSC, PAL, and SECAM) take advantage of that phenomenon by reducing the transmitted chrominance bandwidth by fifty percent or more.
- Fine detail cannot be observed while an image is in motion. (To illustrate this, move this page back and forth across your field-of-view fairly rapidly several times and notice that print detail cannot be clearly discerned until the motion is slowed or ceases altogether.)
- Although it is important that the HDTV system be capable of reproducing very fine detail, fine detail is seldom necessary over the whole of any one particular frame. Look at almost any TV image, picture, or scene, and you will notice that the amount of high-frequency information (edges of objects and fine pattern detail) is quite small; the actual portion of a typical TV image that requires high-frequency response is seldom large.
- In most TV images there is high correlation between picture elements (pixels) adjacent to each other, both vertically and horizontally.
- It is not unusual for significant portions of TV pictures to remain static over the duration of many frames and, even where motion is present, many areas remain unchanged for relatively lengthy periods. "Talking head" pictures are a common example of this.

By taking advantage of

psycho-visual and statistical factors, it is possible to compress HDTV signals greatly. While the raw data taken directly from an HDTV camera is characterized by data rates close to 1 gigabit per second, compression techniques enable the rates to be reduced by factors of 30 to 40 or more. That, combined with modulation techniques that allow multiple bits per hertz of bandwidth, make terrestrial transmission of HDTV possible.

The DigiCipher system

The DigiCipher system from the American Television Alliance (ATVA) operates with a 1050-line analog RGB input. The scan is interlaced 2:1, and the field rate is 59.94 Hz. The line rate, twice that of NTSC, was chosen to allow easy conversion of signals between the two systems. A simplified block diagram of the DigiCipher system is shown in Fig. 1.

DigiCipher video is first digitized and compressed. Then it is multiplexed with four digital audio channels, a data/text channel, and a control channel. The resulting data transmission rate is 24.39 megabits per second (Mbps). Many of the features of DigiCipher are common to other HDTV systems.

The analog RGB signals from program-origination equipment are low-pass filtered, digitized, and fed through an RGB-to-YUV matrix that produces a luminance signal (Y) and two color-difference signals (U and V). The conversion from RGB to YUV reduces the amount of data required to represent an image without causing any perceptible loss of image quality. The resolution of the chrominance signals is then reduced horizontally by a factor of four, and vertically by a factor of two. This reduction of chroma information can be done without affecting picture quality because the human eye is considerably less sensitive to color detail than to brightness detail.

The luminance and chrominance signals are sequentially multiplexed and then follow two paths. One path directs the YUV

signal—after combination with the motion compensated product that we'll describe shortly—to a discrete cosine transform (DCT) stage. (See box on page 38 for a description of the DCT process.)

The coefficients in the DCT frequency array are significant primarily for their DC (gray level) component and for their low-frequency information. The coefficients have low or zero amplitude for the higher frequencies in many images.

The coefficients of the frequency array are arranged in order of ascending frequency and (usually) decreasing amplitude. In a process known as *run-length coding*, the value of each non-zero coefficient is encoded together with the number of zero-value terms between it and the succeeding non-zero coefficient. That results in a considerable reduction in the amount of data needed to describe the majority of pixel blocks.

In the quantizer block, weighting factors are applied to give higher priority to the higher-magnitude (low-frequency) coefficients, and decreasing priority to the lower-amplitude (higher-frequency) coefficients.

Motion estimation/compensation

The second path from the multiplexer feeds a motion-compensator stage. As already noted, in many television images the difference in actual pic-

ture content from one frame to the next is quite small, particularly so where there is little motion in the image. Even when quite fast movements take place and where there is not a great deal of detail, frame-to-frame correlation is still quite high.

The difference in picture content between successive frames is determined by comparing the current image frame with the immediately previous, reconstituted (inverse-transformed and inverse-quantized) frame. A differential pulse code signal is generated and subtracted from the incoming current frame before the DCT process. In this way, only the estimated differences between frames is transform coded, rather than the entire frame.

A further reduction in the data rate is possible by assigning short code words to certain values in the data stream that occur more often than others. Longer code words need be used only for values occurring less frequently. An example of that technique can be seen in the International Morse Code where letters A, E, I, M, N and T are represented with just one or two dots or dashes. By contrast, less frequently used letters (for example J, Q, and X) and numbers are assigned four or five symbols. In HDTV, variable-length Huffman coding is used.

The content of TV pictures can vary dramatically; for example, the image of a sports an-

chor can be followed immediately by speeding race cars at Indy. Different data rates are generated for each scene. The changes in the amount of data that must be processed result in a wide variation of the bit rate in the data stream following variable length coding (VLC). A FIFO (first-in, first-out) buffer regulates the varying data rate, and provides a constant output bit rate into the system multiplexer, where the data streams from the audio, control, and data/teletext sub-systems are added.

Forward error correction minimizes the effects of transmission-channel errors on the integrity of the received signal. That helps eliminate car-ignition and other impulse noise pulses with up to three microseconds duration.

The DigiCipher quadrature amplitude modulation system is designed to operate at two different data rates. A lower mode at 19.51 megabits per second is said to provide error-free reception at a carrier-to-noise ratio (CNR) as low as 12.5 dB. When operating at the higher rate of 24.39 megabits per second, higher video quality is received, but a CNR of 16.5 dB is required for error-free reception.

Advanced Digital Television

The baseband input for the ADTV system is also 1050 lines, 2:1 interlaced, and 59.94 fields/second. Source coding is based on the ISO (International Standards Organization) MPEG

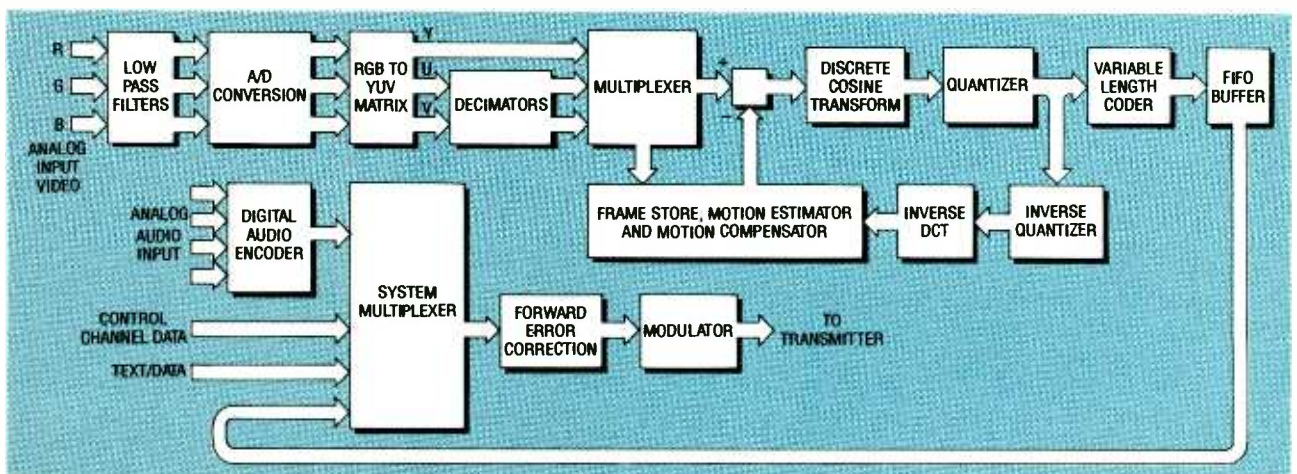

FIG. 1—HDTV FUNCTIONAL BLOCK DIAGRAM: The DigiCipher system shown here has many features that are common to all of the proposed systems.

(Moving Picture Expert's Group) draft specification for the transportation of moving images over communication data networks. ADTV has modified the MPEG standard to handle the more stringent requirements of HDTV, and it refers to its scheme as "MPEG++."

Some conditions require the encoding system to process a large amount of new data. Examples are scenes containing much motion and fine detail. In such cases, data are separated into two streams in order of their importance to overall system operation. Data critical for maintaining the basic integrity of received pictures—typically the gray-scale levels, audio signals, data-cell headers and motion descriptors—are assigned high priority (HP). The low-frequency coefficients and then the higher frequency (fine detail) coefficients form the standard priority (SP) data stream. Assignment states are adaptive, so SP data can transcend to the HP stream when HP loading is light.

The two streams are formatted into separate 148-byte data transport cells. The cell format, shown in Fig. 3, has certain similarities to asynchronous-transfer-mode data packets on data communications networks. The structure of ADTV data cells is such that they are readily transcodeable for transmission on broadband integrated services digital networks (ISDN).

The two data streams are quadrature amplitude-modulated onto separate carriers contained within a 6-MHz band. The spectrum of the ADTV transmission is shown in Fig. 4. The HP channel is 960 kHz wide; the SP channel occupies 3.84 MHz, and is filtered to have minimum power at the NTSC carrier frequencies. ADTV receivers have similar functioning filters so that a co-channel NTSC station does not interfere with HDTV reception.

The HP channel is radiated at a level that is 5 dB higher than the SP channel. If the carrier-to-noise ratio of the SP channel drops below threshold, but the

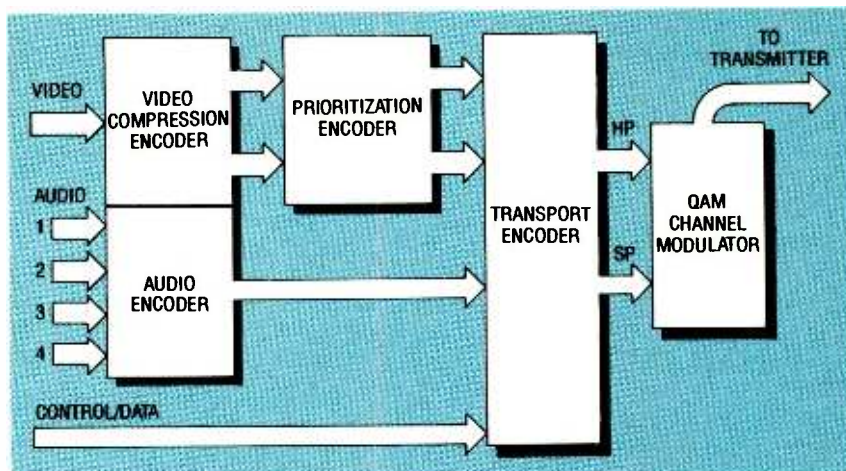

FIG. 2—THE ADTV SYSTEM. After video and audio signals are digitized and encoded, the transport encoder directs about one quarter of the data into a high-priority (HP) stream. The HP data is radiated at a higher power level than the standard-priority data, which provides reliable, albeit somewhat degraded, fringe-area reception.

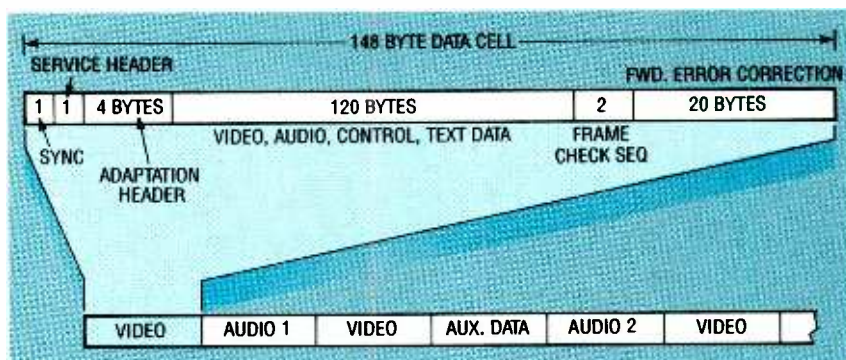

FIG. 3—THE 148-BYTE ADTV TRANSPORT CELL is similar to data-communication packets. The single-byte service header identifies the type of data being carried in the main 120-byte block.

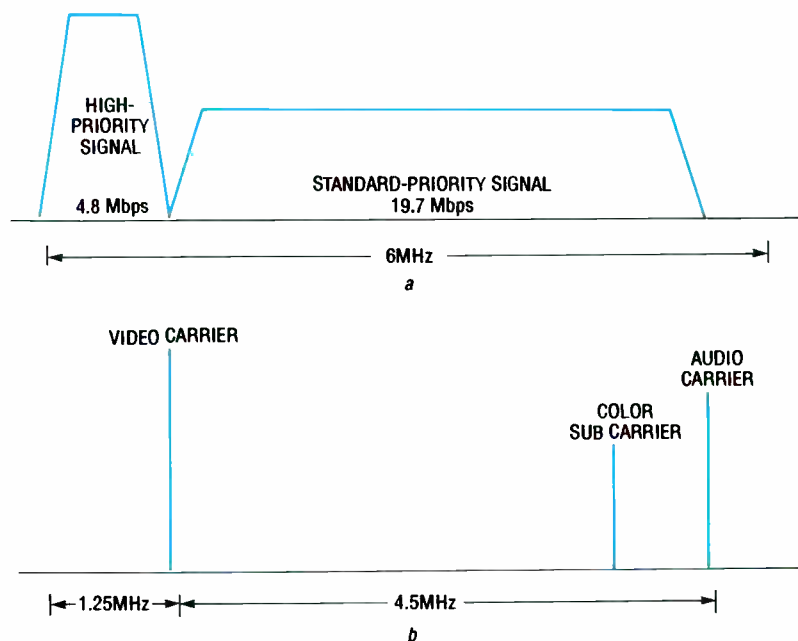

FIG. 4—ADTV QAM/NTSC SPECTRUM (a) in relation to the spectrum of an NTSC signal (b) assigned to the same channel. ADTV transmitter-output filters and receiver-input filters have minimum response at the NTSC video and audio carrier frequencies. That reduces the likelihood of mutual interference between NTSC and ADTV transmissions.

THE DISCRETE COSINE TRANSFORM

The Discrete Cosine Transform (DCT) does not, in itself, compress or reduce the number of picture components. HDTV baseband signals are divided into blocks of pixels for analysis. The blocks represent the brightness amplitude levels of a fixed number of elements (usually 64) in each portion of the image. Then the DCT converts each block into an array of the same number of frequency coefficients. In subsequent processes, the number of terms, and the amount of data necessary to define the image can be reduced.

When many TV pictures are analyzed and divided into 8×8 pixel blocks, it is often found that very little high-frequency information is contained within each block. Sometimes the low-value, high-frequency components can be rounded off or ignored, because their contribution to the fidelity of the image is quite small.

Typically, arrays of picture elements representing intensity levels of portions of a video image in 8×8 blocks are sampled in turn, and subjected to the discrete cosine transform (DCT) process, until the whole image frame has been transformed.

The DCT is a mathematical process closely related to the Fourier transform. It is used to produce a two-dimensional array of frequency coefficients from a luminance or chrominance intensity block. The coefficients represent the amplitudes of the frequency components obtained from the original block. They are deliberately placed in the array such that the zero-frequency, gray-level (DC) term, which defines the gray level of the whole image block, is at the top left side of the block. The other coefficients relating to the values of increasing frequency in the horizontal dimension of the spatial array are arranged from left to right in the transformed array, and those representing values of increasing vertical frequency, from top to bottom.

In one common image-processing scheme, the coefficients in the transformed (frequency) array are read out serially in a zig-zag manner. Thus, following the DC term, the second coefficient gives the amplitude of the lowest frequency in the horizontal dimension of the array. The next value represents the amplitude of the lowest frequency in the vertical dimension, and succeeding values reveal the magnitudes of incrementally higher frequencies. The final value, the 64th coefficient, indicates the amplitude of the highest frequency in both the horizontal and vertical directions.

Depending on the total number of pixels in the TV image, a 64-pixel block covers an area of typically less than one twenty-thousandth of the full picture. For many TV pictures a large number of the individual pixels in a block will be of similar or of the same brightness or chrominance value as there is a high degree of

1280 PIXELS HORIZONTALLY
 x 720 PIXELS VERTICALLY

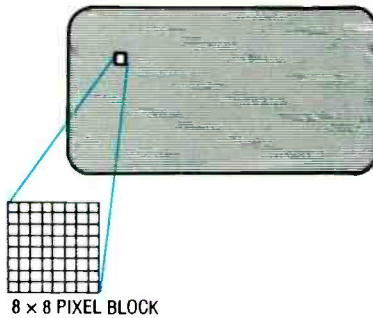

THE HDTV CAMERA SIGNAL, which in this example contains over 900,000 pixels, is analyzed in blocks of 64 pixels before the discrete cosine transform process.

horizontal and vertical correlation (or redundancy) between adjacent pixels. For example, in pictures containing the human face, clothing, or outdoor scenes, many transformed blocks are described solely and completely by the DC level. Other blocks contain many low-frequency coefficients and few low-magnitude higher-frequency coefficients. High-amplitude, high-frequency terms occur only where there are marked, sudden changes in intensity in the televised image. In typical TV pictures, the number of areas in the image that contain those kinds of transitions is small. Therefore the number of data bits required to define such pixel blocks is drastically lower in the frequency domain than in the spatial domain.

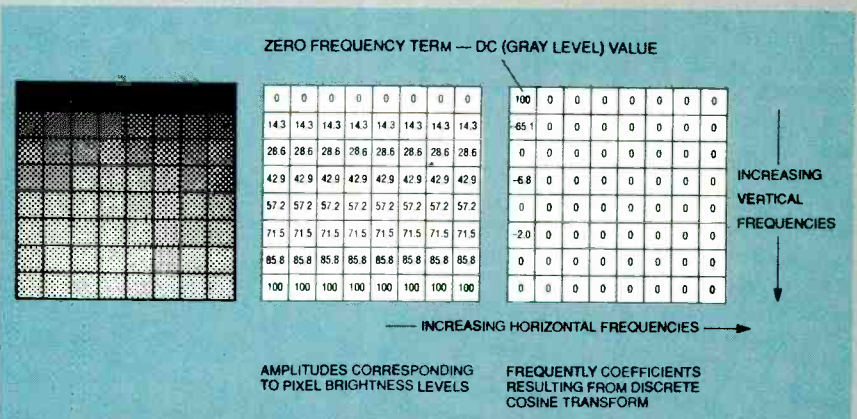

THE 64-PIXEL BLOCK (left) represents a small shaded portion of an HDTV image. The array of the numbers (center) indicates the brightness values of that picture area. A new array (right) is generated by the discrete cosine transformation; it consists of the coefficients of the frequency components. Because there is no variation in the brightness values from left to right in the original pixel block, there are no horizontal frequency terms. The only values are the gray level and vertical frequency terms, which are produced because there are vertical value changes in the original image.

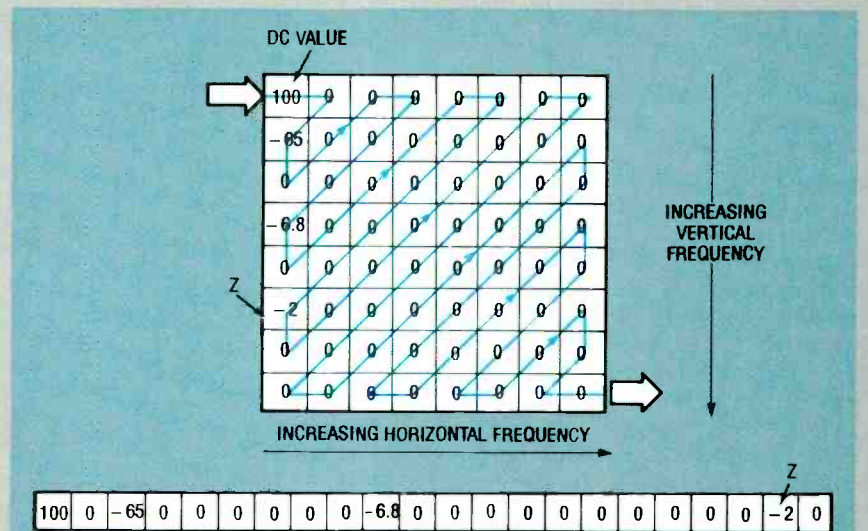

ZIG-ZAG SERIAL READOUT of discrete-cosine-transformed 8×8 pixel block. This technique places the lowest frequency terms and the gray level in the early portion of the readout. Where there are long runs of zeros only the number of zeros need be transmitted. In this example, after 'z' (the 21st term), no further data that needs to be processed. That is one of the benefits of the DCT.

**BRIGHTNESS OF PIXELS
IN 8x8 BLOCK**

**AMPLITUDES
CORRESPONDING TO PIXELS
BRIGHTNESS LEVELS**

**FREQUENCY COEFFICIENTS
RESULTING FROM DISCRETE
COSINE TRANSFORM**

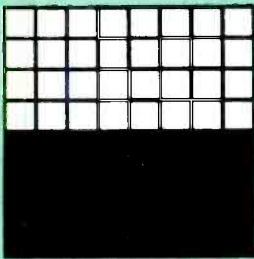

100	100	100	100	100	100	100	100
100	100	100	100	100	100	100	100
100	100	100	100	100	100	100	100
100	100	100	100	100	100	100	100
0	0	0	0	0	0	0	0
0	0	0	0	0	0	0	0
0	0	0	0	0	0	0	0
0	0	0	0	0	0	0	0

100	0	0	0	0	0	0	0
-90.0	0	0	0	0	0	0	0
0	0	0	0	0	0	0	0
31.8	0	0	0	0	0	0	0
0	0	0	0	0	0	0	0
21.3	0	0	0	0	0	0	0
0	0	0	0	0	0	0	0
18.0	0	0	0	0	0	0	0

This represents a 64-pixel block in which the upper portion is all white and the lower portion is black. The transformed array does not have any horizontal frequency terms because there are no horizontal variations across the image from left to right. If the original image block were to be transmitted in analog, each of the 64 pixels would have to be sent. After DCT, only five values are significant. All other terms are zero.

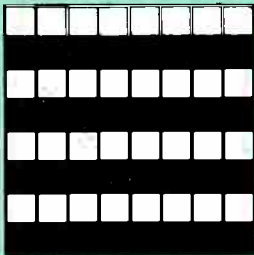

100	100	100	100	100	100	100	100
0	0	0	0	0	0	0	0
100	100	100	100	100	100	100	100
0	0	0	0	0	0	0	0
100	100	100	100	100	100	100	100
0	0	0	0	0	0	0	0
100	100	100	100	100	100	100	100
0	0	0	0	0	0	0	0

100	0	0	0	0	0	0	0
18.0	0	0	0	0	0	0	0
0	0	0	0	0	0	0	0
21.3	0	0	0	0	0	0	0
0	0	0	0	0	0	0	0
31.8	0	0	0	0	0	0	0
0	0	0	0	0	0	0	0
90.0	0	0	0	0	0	0	0

The transformed array here also has no horizontal frequency terms because there are no changes in image brightness from left to right. The main difference from the previous example is that the higher-frequency coefficients are larger because the vertical black-to-white alternation in the original image block occurs more frequently.

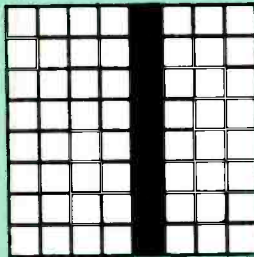

100	100	100	100	0	100	100	100
100	100	100	100	0	100	100	100
100	100	100	100	0	100	100	100
100	100	100	100	0	100	100	100
100	100	100	100	0	100	100	100
100	100	100	100	0	100	100	100
100	100	100	100	0	100	100	100
100	100	100	100	0	100	100	100

175	6.9	32.6	-19.6	-25.0	29.3	13.5	-34.6
0	0	0	0	0	0	0	0
0	0	0	0	0	0	0	0
0	0	0	0	0	0	0	0
0	0	0	0	0	0	0	0
0	0	0	0	0	0	0	0
0	0	0	0	0	0	0	0
0	0	0	0	0	0	0	0

In this case, the image consists of a solid vertical narrow bar on a white field. There are very pronounced level changes from left to right, but not from top to bottom. The frequency transform shows no vertical frequency coefficients, but significant values for the horizontal frequency terms.

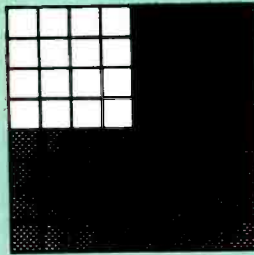

100	100	100	100	10	10	10	10
100	100	100	100	10	10	10	10
100	100	100	100	10	10	10	10
100	100	100	100	10	10	10	10
10	10	10	10	10	10	10	10
10	10	10	10	10	10	10	10
10	10	10	10	10	10	10	10
10	10	10	10	10	10	10	10

65	40.8	0	-14.3	0	9.5	0	-8.1
40.8	36.9	0	12.9	0	8.7	0	7.3
0	0	0	0	0	0	0	0
-14.3	-12.9	0	4.6	0	-3.0	0	2.6
0	0	0	0	0	0	0	0
9.5	8.7	0	-3.0	0	2.0	0	-1.7
0	0	0	0	0	0	0	0
8.1	-7.3	0	2.6	0	-1.7	0	1.5

Here the image is a 25% white square against a dark gray background, and there are variations in both horizontal and vertical directions. As expected, this results in horizontal and vertical frequency terms in the transformed array. The significant values are predominantly in the low-frequency area, and more than half the values are zero.

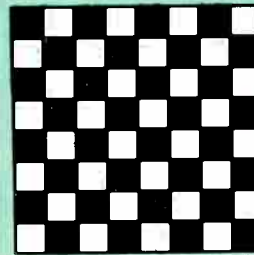

0	100	0	100	0	100	0	100
100	0	100	0	100	0	100	0
0	100	0	100	0	100	0	100
100	0	100	0	100	0	100	0
0	100	0	100	0	100	0	100
100	0	100	0	100	0	100	0
0	100	0	100	0	100	0	100
100	0	100	0	100	0	100	0

100	0	0	0	0	0	0	0
0	-3.2	0	-3.8	0	-5.7	0	-16
0	0	0	0	0	0	0	0
0	-3.8	0	-4.5	0	-6.7	0	-19
0	0	0	0	0	0	0	0
0	-5.7	0	-6.7	0	-10	0	-28
0	0	0	0	0	0	0	0
0	-16	0	-19	0	-28	0	-82

The input image has the highest possible number of black-to-white transitions because every pixel is different from its neighbors. However, there is a pattern evident, and the transformed array shows a very high value in the lower right corner caused by high vertical- and horizontal-transition rates in the original image area.

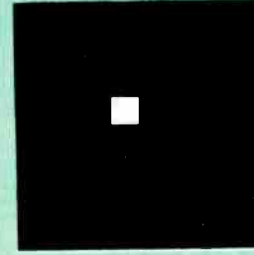

0	0	0	0	0	0	0	0
0	0	0	0	0	0	0	0
0	0	0	0	0	0	0	0
0	0	0	100	0	0	0	0
0	0	0	0	0	0	0	0
0	0	0	0	0	0	0	0
0	0	0	0	0	0	0	0
0	0	0	0	0	0	0	0

3.1	0.9	-4.1	-2.5	3.1	3.7	-1.7	-4.3
0.9	0.2	-1.1	-0.7	0.9	1	-0.5	-1.1
-4.1	-1.1	5.3	3.2	-4.1	-4.8	2.2	5.7
-2.5	-0.7	3.2	1.9	-2.5	2.9	1.3	3.4
3.1	0.9	-4.1	-2.5	3.1	3.7	-1.7	-4.3
3.7	1	-4.8	2.9	3.7	4.3	-1.9	-5.1
-1.7	-0.5	2.2	1.3	-1.7	-1.9	0.9	2.3
-4.3	-1.1	5.7	3.4	-4.3	-5.1	2.3	6

A single white pixel near the center of a dark image block is transformed into an array which has coefficients at every frequency location. The largest value is at the highest frequency point, but the great majority of the values are extremely low and could probably be quantized out to zero without any degradation being seen on the received picture.

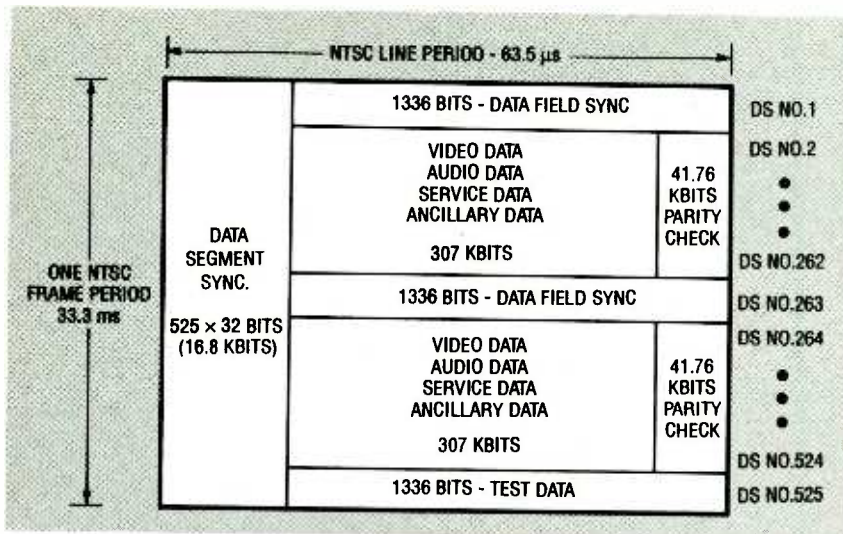

FIG. 5—DATA FORMAT FOR DSC-HDTV. Data is encoded into time blocks that are equal in period to NTSC frames. There are 525 data segments; each of which consists of 1368 bits. The first 32 bits of each data segment are used for data sync.

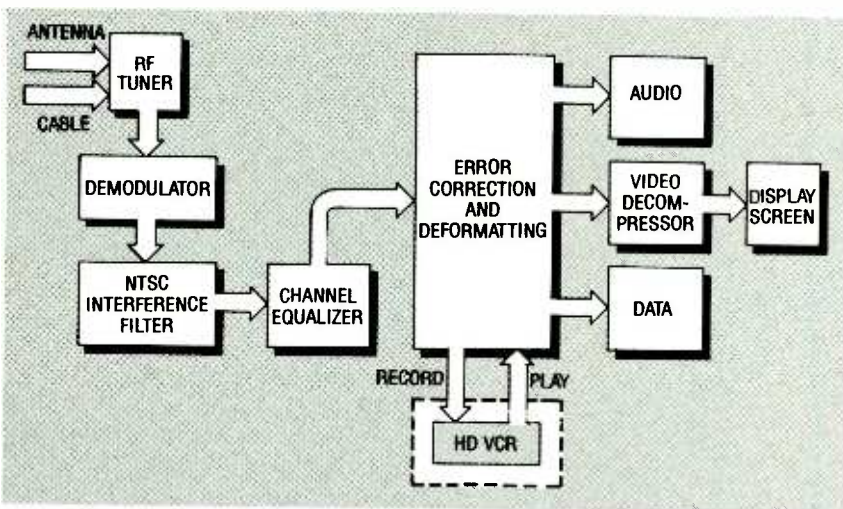

FIG. 6—ZENITH DSC RECEIVER BLOCK DIAGRAM with connections to a digital high-definition VCR. Note how the VCR does not perform any compression or decompression function.

As noted earlier, progressive scanning eliminates inter-line flicker and motion artifacts, but the penalty is that the video bandwidth requirement is doubled. With present video compression limitations (on the amount of compression which is practicable) DSC has to be content in its progressive scan system with only 787.5 lines (1.5 times as many as NTSC) rather than being able to double the NTSC line rate to 1050 lines as is possible with the interlaced formats. DSC also uses the discrete cosine transform coding as a basis for its spatial compression.

For transmission, the compressed data are formulated into frames corresponding to NTSC time parameters. As Fig. 5 shows, the coded data are embedded in two fields along with field and segment sync, test data, and parity-check signals. The data are formed into two streams. The one that contains high-priority data is radiated at higher power, providing a more robust received signal that has 7-dB CNR threshold advantage over the low-priority data stream.

This technique is conceptually similar to that developed for other proposed HDTV systems. It counters a frequent criticism of digital transmission systems where, with a minor decrease of carrier signal level, error rates rise close to the noise threshold abruptly, giving little margin to a sudden loss of received signal. A further advantage claimed for this system is that the DSC transmitter power required would be 14.5 dB less than that needed for an NTSC transmitter, to cover a similar service region; this makes for less interference to other stations operating in the vicinity, both NTSC and HDTV.

Zenith Electronics Corporation, one of the partners in DSC, has developed with the Goldstar company a new digital videocassette recorder using existing VHS head geometry, which will record and play both HDTV and NTSC standards. For high-definition, the machine

continued on page 72

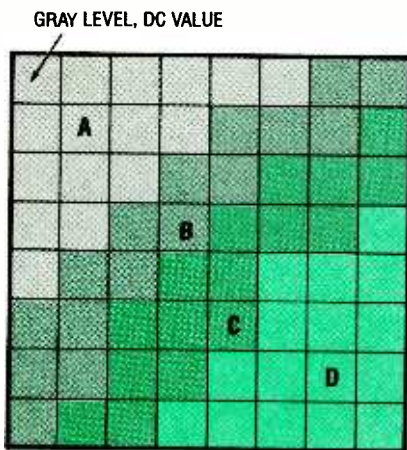
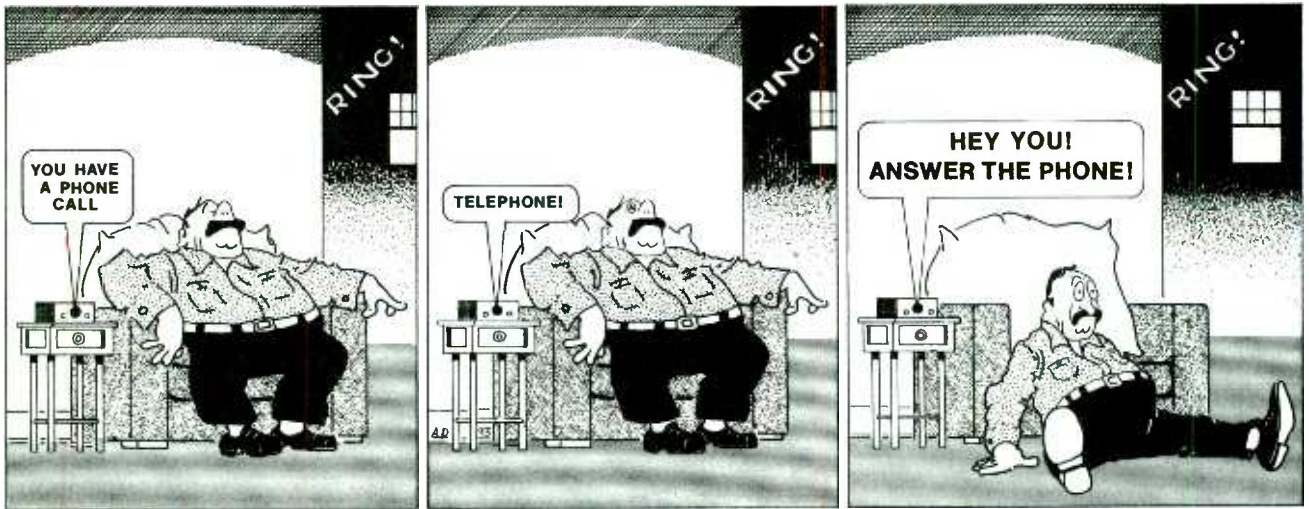

FIG. 7—VECTOR-CODING FORMAT (DCT readout blocks) for Channel-Compatible DigiCipher. The DCT frequency transform array is partitioned into four areas, each containing 16 terms.

HP signal is still above threshold, the received service will "degrade gracefully," without a sudden and complete loss of signal. The quality of system performance will decline (i.e., less detail will be displayed), but there will not be a complete loss of signal.

DSC HDTV

The Digital Spectrum Compatible (DSC) HDTV system starts with progressively scanned baseband video at 787.5 lines per frame and 59.94 frames per second. The line-scan rate is 47,203 Hz, three times that of the NTSC system to permit easy conversion between the two systems.



TALKING TELEPHONE RINGER

TELEPHONES RING AND THAT'S about all there is to it. True, some phones buzz, beep, or chirp, but that's hardly exciting. However, with the advent of IC's like the ISD 1016 Voice Messaging System, you can build our talking telephone ringer and record personalized messages that will be played whenever someone telephones. You'll never have to listen to the same old bell again!

With the recording capabilities of our ringer, you can include your own spoken messages, musical selections, your college fight song, or any other interesting sounds that you might want to try. You can also program several different messages that play in sequence with each ring. Using that capability, the author has programmed his ringer to produce the following sequence:

- 1st ring: "The phone is ringing" (in a polite voice)
- 2nd ring: "I said, the phone is ringing!" (in a slightly aggravated voice)
- 3rd ring: "Get the phone!" (in a noticeably irritated voice)
- 4th ring: "Pick up the phone!" (this time in a hysterical voice)

You may choose to program something a little kinder and gentler—the possibilities are limitless.

The ringer device, which does

Don't listen to that annoying bell—build our talking telephone ringer and customize the way your phone rings.

STEVE LYMPANY

not interfere with normal telephone operation, plugs into one of your telephone jacks, and also requires external power from a 9-volt DC wall adapter. When someone calls you, the incoming ring signal triggers the message to be played.

Circuit operation

Figure 1 is the block diagram of the circuit. When a ring signal appears across the telephone line, the ring detector sends a start signal to the message-storage chip. The counter and logic sections tell the message-storage chip which message to play, based on how many times the phone rings.

Turn now to the schematic diagram in Fig. 2. A 20-Hz ring signal of 40 to 150 volts, present at P1's Tip and Ring (Green and Red, respectively), is divided down by R1, R2, and R3. Cur-

rent then flows through C1 to pins 1 and 2 of IC1, a 4N25 optocoupler, which isolates the rest of the circuitry from the telephone line. The current flow through the input side of IC1 causes pin 5 to go low, which signals a start-playback request from the ISD 1016 messaging chip, IC4.

The sensitivity of the ring-detection circuit is set by R6; the 12K value was obtained assuming a nominal 100-volt incoming ring signal. If the ring voltage coming in on your phone line is lower than 100 volts, you may need to increase R6 to a value between 15K and 30K.

Metal-oxide varistor MOV1 protects the ringer from tran-

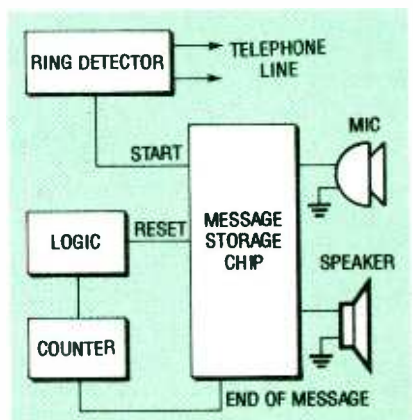

FIG. 1—BLOCK DIAGRAM showing the ring detector, a counter, and an audio storage and playback integrated circuit.

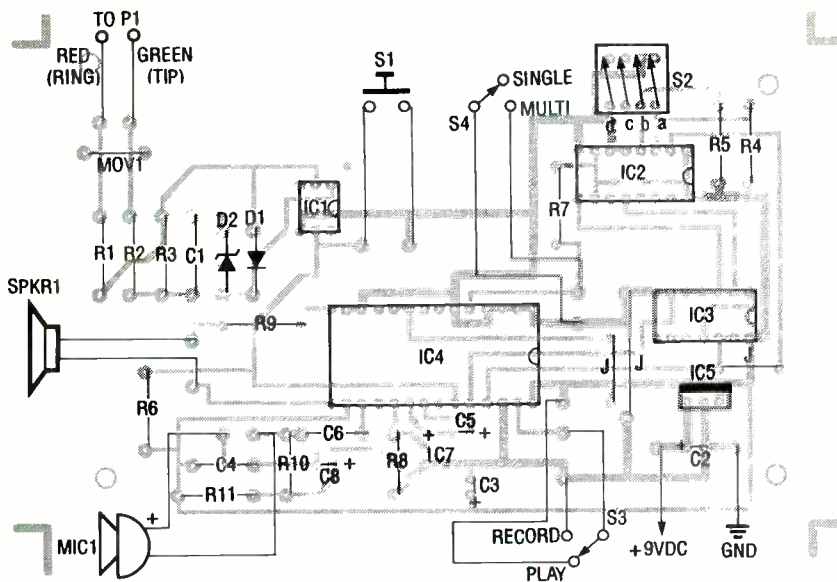
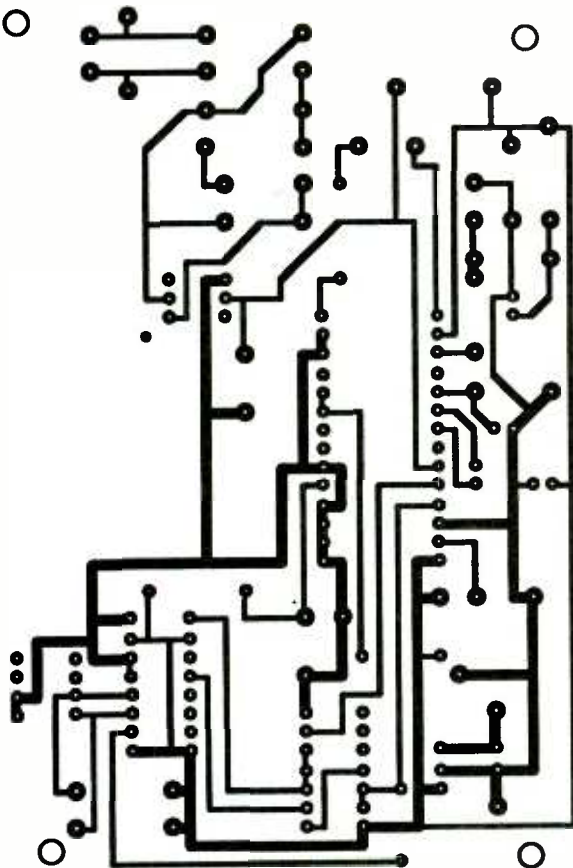

FIG. 3—PARTS-PLACEMENT DIAGRAM. Use a 28-pin DIP socket for IC4. Install wire jumpers at all locations marked "J."



FOIL PATTERN for the single-sided board.

PARTS LIST

All resistors are 1/4-watt, 10%, unless otherwise specified.

- R1, R2—33,000 ohms
- R3—10 megohms
- R4, R5, R7, R10—10,000 ohms
- R6—12,000 ohms
- R8—470,000 ohms
- R9—10 ohms
- R11—2000 ohms

Capacitors

- C1—0.22 μ F, 250 volts, metal film
- C2, C3—47 μ F, 35 volts, electrolytic
- C4—0.1 μ F, 50 volts, ceramic disc
- C5—1 μ F, 16 volts, tantalum electrolytic
- C6—0.22 μ F, polystyrene
- C7—4.7 μ F, 16 volts, tantalum electrolytic
- C8—22 μ F, 16 volts, tantalum electrolytic

Semiconductors

- IC1—4N25 NPN-transistor-output optocoupler
- IC2—74LS161 counter
- IC3—74LS00 quad NAND gate
- IC4—ISD 1016 Voice Messaging Chip (Information Storage Devices)
- IC5—7805 5-volt regulator
- D1—1N4758A 56-volt Zener diode
- D2—1N4148 diode

Other components

- MOV1—metal-oxide varistor
- P1—telephone line cord
- S1—momentary pushbutton switch
- S2—2-position DIP switch
- S3, S4—SPDT toggle switch
- SPKR1—8-ohm speaker
- MIC1—electret microphone

Miscellaneous: 9-volt AC adapter, enclosure, mounting hardware, wire, solder, rubber grommets

Note: The ISD 1016, \$28.00 at the time of this writing, is available through Information Storage Devices, Inc., 2841 Junction Avenue, Suite 204, San Jose, CA 95134. An etched, drilled, and plated PC board is available for \$14.00 by requesting PC board "SquakerRevA" from Atlas Circuits Company, P.O. Box 892, Lincolnton, NC 28092.

or replace any defective components before proceeding.

Once you obtain the proper +5-volt reading from IC5, disconnect power from the ringer, and install IC4 in its socket. Power up the ringer again and place S4 in the SINGLE position and S3 in the RECORD position. While pressing and holding S1, speak a test message into the

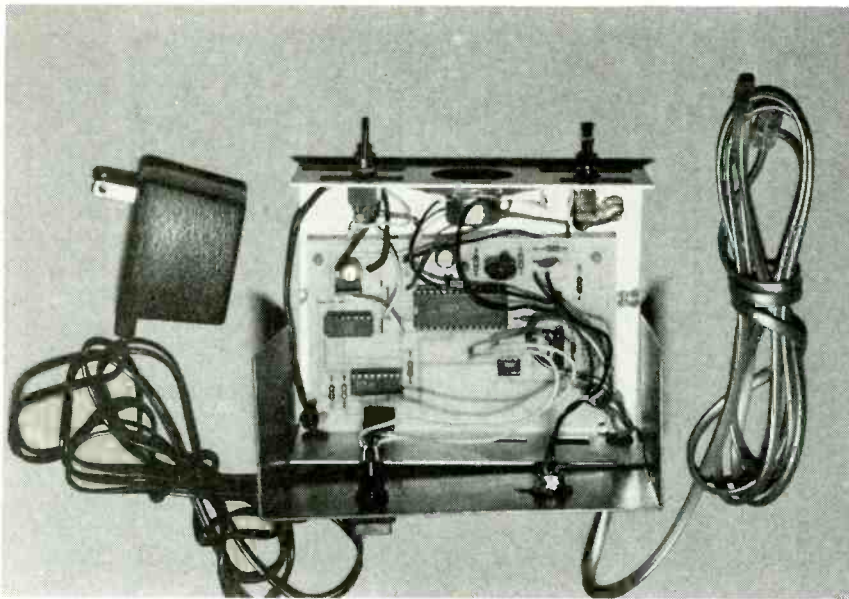

FIG. 4—THE AUTHOR'S completed prototype, shown here installed in a metal project case.

TABLE 1—SWITCH SETTINGS

Desired Number of Messages	S4	S2-a	S2-b
1	Single	X	X
2	Multi	L	L
3	Multi	H	L
4	Multi	L	H
5	Multi	H	H

microphone. Then release S1 and place S3 into the PLAY position. A momentary pressing of S1 should now result in the playback of your test message. If those results are obtained, your ringer is ready to be mounted in an enclosure.

Any plastic or metal enclosure that will accommodate the PC board, switches, and speaker will suffice. Drill the selected enclosure to provide mounting

holes for the circuit board assembly, S1, S3, S4, SPKR1, MIC1, and access holes for the power cord and the telephone line cord. If you are using a metal enclosure, deburr all holes and insert rubber grommets for the AC line cord and the telephone cord.

Mount the circuit-board assembly in the enclosure using ½-inch spacers. Then mount all off-board components in their

respective mounting holes. Pass the AC cord and the telephone cord through their rubber grommets and tie a knot in each one, about 5 inches from the free ends inside the enclosure to serve as strain relief for each cord. Strip the ends of each wire and tin them with solder. Then solder the free ends in their respective circuit board holes, referring to Fig. 3 for details. Figure 4 shows the author's completed prototype installed in a metal enclosure.

Once the unit is complete, plug the adapter into an AC outlet and plug the telephone cord from the ringer into an unused telephone jack. If you need to attach the unit to a jack that already has a phone connected to it, you'll need a duplex jack. It is a "Y" adapter that lets you plug two phones into one jack, permitting you to use the voice ringer and the telephone at the same time. You also might want to shut off the telephone's internal ringer, so you can clearly hear the voice ringer and its unusual message.

Recording tips

To record multiple messages, perform the following procedure:

1. Place S4 in the MULTI position.
2. Set S2-a and S2-b as listed in Table 1 for the number of messages you desire.
3. Press and hold S1 to record the first message.
4. Release S1.
5. Press and hold S1 again to record the second message.
6. Release S1.
7. Repeat steps 5 and 6 for each additional message.
8. Place S3 in the Play position after recording your last message.
9. Test the sequence by successively pressing S1 for each message.

Since a standard ring signal is on for 2 seconds and off for 4 seconds, you'll want to make your messages at least 2 seconds long to prevent successive triggering by one ring cycle. This can easily be accomplished, even on short messages, by holding the record button down for at least 2 seconds for each message. Ω

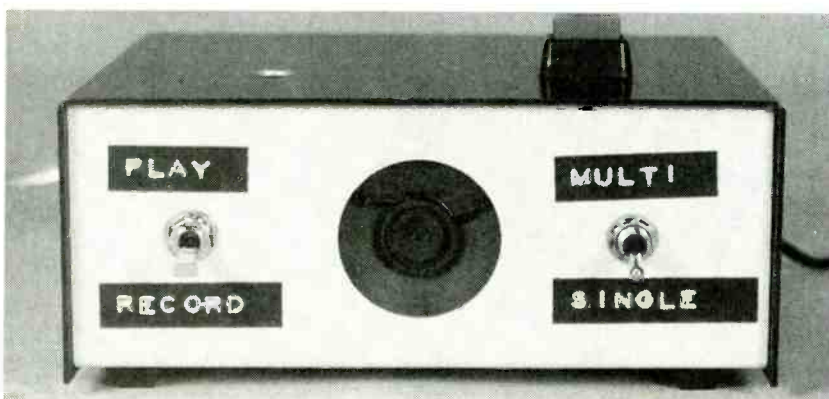

FIG. 5—HERE'S THE FRONT PANEL of the author's prototype.

THE PHONE PAGER

**Build this pager
for your
telephone
system,
and save
yourself
a lot of yelling
and running up
and down stairs**



JOHN E. CARTER, K8YVT

THE PHONE PAGER IS A TELEPHONE system accessory that will simplify telephone communications within your home or workplace. It contains an electronic circuit that, when connected to your telephone, becomes an audio pager. It will save you or other members of your family a lot of yelling or running up and down stairs to notify someone else that he or she has a call waiting. (It could be a call for you!)

Phone Pager is a stand-alone unit housed in a small box that is plugged into a phone with a length of telephone line cord, and takes its power from a wall-mounted AC/DC adapter. Its internal speaker permits you (or any other person called) to hear a short message anywhere in the room where a Phone Pager-equipped telephone is located—bedroom, den, basement, or wherever. You (or the other person being called) then picks up

the telephone handset and accepts the call.

Phone Pagers connected to all of the phones in your house will form an intercom system that works even if the telephone is not in use. One Phone Pager will permit voice communication between any phone and Phone Pager-equipped phone on the same line. A caution here—Phone Pager was designed for standard phone lines, and it might not work in an office with a PBX system.

Phone Pager permits you to talk directly to anyone in hearing range of the Phone Pager's speaker. Simply press the assigned activation key on the keypad of your standard Touch-Tone telephone and talk. (You don't have to have a Phone Pager attached to the phone from which you make the paging call, but the person you are paging must be near a Phone Pager-equipped phone.)

You'll have four to six seconds to make an a short statement—

"This call is for you, Joe," or "I've got it, Martha—it's for me"—before you are cut off. Wait for the person paged to answer, and when he or she does, just hang up. If the person you are trying to contact does not answer, take a message with pencil and paper. With a Phone Pager installed, the caller can hear both you and the person being paged because you're all on the same phone line.

Phone Pager works well as an intercom. If someone in your house wants to announce "Soup's on, come and get it," he or she goes to the nearest phone, presses the activation key, and makes the statement. The dial tone is silenced by pushing the activation key, so the announcer won't be interrupted by it. Most telephone systems include a delay of 10 to 15 seconds before the jarring "off-hook" tone sounds. That will give you enough time to say something meaningful before being interrupted.

After a selectable time period has passed, the Phone Pager automatically returns to its normal silent state, waiting for the next key actuation to turn it on again. It can be activated at all times, whether the phone line is in use or not, because it is always connected to the line.

The asterisk or "*" key was selected for the prototype because of its convenient location at the lower left corner of a telephone keypad, but any of the other 11 keys on the pad can be organized as the Phone Pager activation key.

When used as an intercom, Phone Pager can call children playing in some remote part of the house. It can also keep you in touch with a disabled person elsewhere in your home who might need assistance. And, of course, it can be used on the job in an office or factory if the phone system will permit its use.

The Phone Pager can screen calls if you have an answering machine. It's easy for you to screen calls if you are near the answering machine when it sounds off, but obviously this can't be done if you are out of earshot of the machine.

If you have friends or relatives whose calls you are always willing to accept, give them instructions in how to activate any Phone Pagers in your home. For example, if an "approved" person calls you from outside your home and gets your answering machine, he or she will know which key to press to activate your Phone Pagers. (For this feature, the value of a "tip" resistor in the circuit must be changed, but this will be explained later in this article.)

The Phone Pager will also come in handy if you are an amateur radio operator and you use your telephone as an auto patch for a repeater at home. The auto patch looks like another phone across the line. Phone Pager will permit you to make calls from a mobile unit to a Phone Pager installed in your radio room.

Depress the assigned activation key once to get a dial tone (or go off-hook), and depress it a second time to activate the

Phone Pager. Anyone in hearing range of the Phone Pager can then use it to make a short reply to your call, or he or she can switch on your radio transmitter for a longer conversation with you.

During normal TouchTone dialing, the key is usually depressed for less than a quarter of a second. However, to activate the Phone Pager, you must hold down the key for a little more than a half second. As a result, the detect circuitry ignores the shorter bursts initiated by normal dialing.

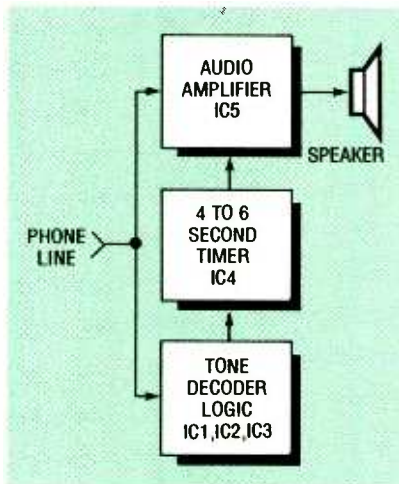

FIG. 1—PHONE PAGER block diagram. Circuitry is partitioned by function.

How Phone Pager works

Figure 1 is the block diagram for Phone Pager, and Fig. 2 is its schematic diagram. The Tone Decoder Logic block of Fig. 1 consists of two LM567 tone decoder IC's and the quad two-input NAND gate IC3. Timer IC4 performs the 4- to 6-second timing function, and audio amplifier IC5 boosts the audio. When the designated activation key is depressed (in the prototype it is "*",), one LM567 is tuned to 941 Hz, and other is tuned to 1209 Hz.

Refer now to the schematic Fig. 2. Both of the output pins numbered 8 of tone decoders IC1 and IC2 go low when the correct tone is present on their inputs. They are connected to three sections of IC3, the CD4011 two-input NAND gate which is configured as an OR gate. (The fourth section is a spare.) Pin 11 of IC3-a goes low

when there is a simultaneous low at both sets of input pins (1 and 2) of IC3-a and (5 and 6) of IC3-b. This condition is met when both tones are present.

Resistor R7 and capacitor C9 (between the output of IC3-d and pin 2 of IC4) inhibit the triggering of the 555 timer IC4 until their RC time constant has timed out. If either C9 or R7 are increased, holdoff time increases; if they are decreased, holdoff time decreases. This RC time delay performs three important functions:

- Eliminates false triggering of the 555 when normal ringing is present.
- Prevents false triggering by normal conversation.
- Retains the use of the selected key for normal TouchTone phone keying.

The negative-going pulse at pin 2 of IC4 causes its output pin 3 to go high for the period determined by another RC time constant set by the product of R8 (between pins 7 and 8) and C10 (between pins 1 and 6). Four to six seconds is generally enough time to give a simple message. The time constant determined by 33-kilohm resistor R8 and 100-microfarad capacitor C10 yields about that much time.

The same relationship applies to R7 and C9, but you can substitute other values for R8 and C10 if you are not satisfied with that time constant. Diode D1 allows the voltage at the input of IC4 to return instantly to +5 volts when the output of IC3-d returns to normal.

Timer IC4 powers the amplifier, which is bridged across the phone line allowing your voice to be heard. After the RC time constant of C10 and R8 times out, the Phone Pager returns to its normal quiescent state.

Building Phone Pager

All of the components listed in the Part List are standard components readily available from most mail-order electronics parts distributors or retail stores. You will get the best looking circuitry by mounting all the components on a printed circuit board. However, if cir-

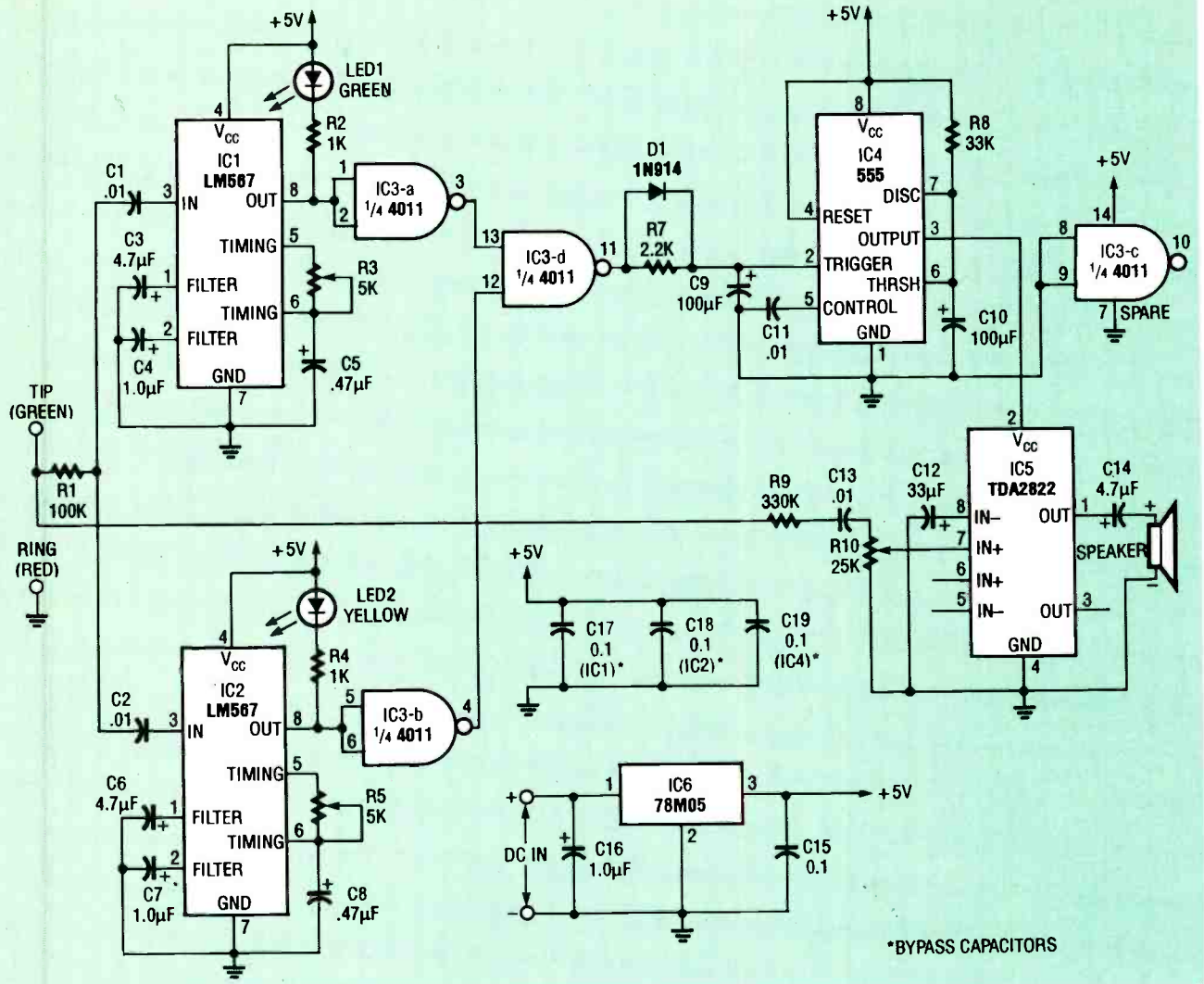

FIG. 2—PHONE PAGER SCHEMATIC showing connections to the telephone line and 5-volt power source.

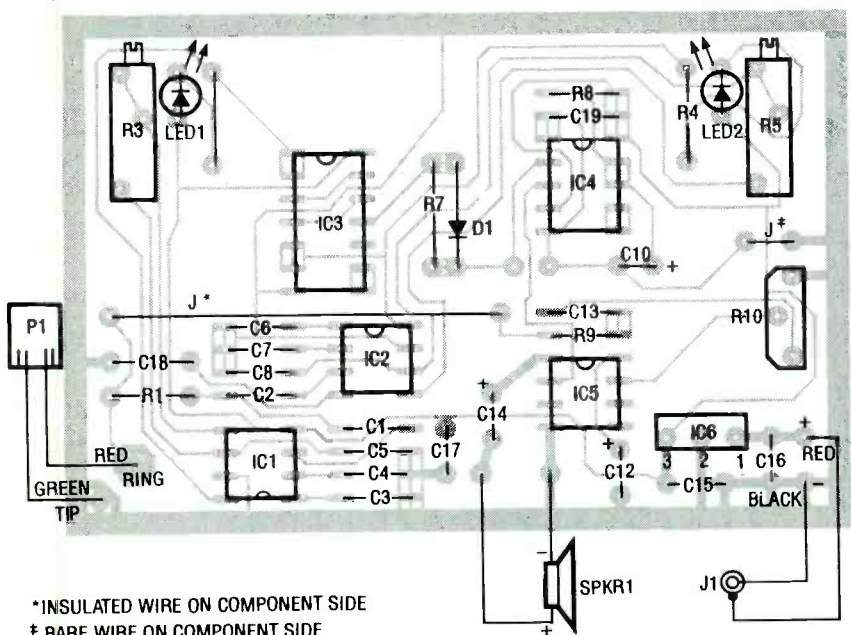

FIG. 3—PARTS PLACEMENT DIAGRAM for the Phone Pager. Note the positions of the two wire jumpers.

circuit appearance is not that important to you, you can use standard perforated board and point-to-point wiring and still obtain satisfactory results.

To provide for all options, the foil pattern for the circuit board is included in this article if you want to make your own board. However, you can purchase a completed circuit board from the source given in the Parts list.

Figure 3 is the Parts Placement diagram. There is nothing critical about parts placement in this project. Notice, however, that resistor R9 must be connected across a large gap between the phone input (green TIP) and capacitor C13. To eliminate any coupling problems that might arise if a copper circuit board trace spans this gap, it is closed by a length of insulated hookup wire positioned where shown.

PARTS LIST

Resistors (all are ¼-watt, 10%, unless otherwise specified)

R1—100,000 ohms
 R2,R4—1000 ohms
 R3, R5—5000 ohms, multitrn trimmer, Bourns 3006-1-502 or equivalent
 R7—4700 ohms
 R8—33,000 ohms
 R9—330,000 ohms
 R10—25,000 ohms, single-turn trimmer, Bourns 3355 or equivalent
 R11—200 ohms (test circuit)

Capacitors

C1,C2,C11,C13—0.01 µF, 35 volts
 C3,C6—4.7 µF, 35 volts, tantalum
 C4,C7,C16—1.0 µF, 35 volts, tantalum
 C5,C8—0.47µF, 35 volts, tantalum
 C9,C10—100µF, 25 volts, aluminum electrolytic
 C12,C14—33µF, 25-volt, aluminum electrolytic
 C15,C17,C18,C19—0.1µF, 50-volt, ceramic multilayer

Semiconductors

IC1, IC2—LM567CN tone decoder, National Semiconductor or equivalent
 IC3—MC14011 quad two-input NAND gate, Motorola or equivalent
 IC4—NE555 timer, Signetics or equivalent
 IC5—TDA2822M, 1-watt audio amplifier, SGS-Thomson
 IC6—78M05, 5-volt, 500-mA voltage regulator, TO-220, Texas Instruments or equivalent
 LED1—light-emitting diode, yellow,

T-1, Hewlett-Packard HLMP-1400 or equivalent
 LED2—light-emitting diode, green, T-1, Hewlett-Packard HLMP-1503 or equivalent

Other components

J1—Power jack, coaxial, PCB-mount (for AC/DC adapter)
 SPKR1—8-ohm speaker, 0.3-watt, 2-inch diameter
 P1—plug, four-conductor telephone, RJ1¼

Miscellaneous: plastic electrical outlet box (3-½ × 2 × 2-½ inches); plastic wall outlet cover (4-½ × 2-¾), AC-to-DC wall adapter, 12-volt, 500 milliamperes with coaxial plug; telephone line cord 1/14 modular plug, seven feet; modular "Y" telephone adapter RJ11/14(1 plug, 2 jack) duplex; 9-volt alkaline transistor battery; grommet.

Note: The following parts are available from JEC TECH, 13962 Olde Post Road, Pickerington, OH 43147

• Complete kit including wall-outlet AC/DC adapter, all components (except battery), circuit board, duplex telephone adapter, plastic outlet box, drilled faceplate and speaker. \$48.95

• Printed circuit board with the 2822M (IC5) audio amplifier soldered in place, \$12.95 Add \$4 for shipping and handling. Ohio residents add appropriate state sales tax.

Strip about ⅛-inch of insulation from each end of a wire about ¼-inch longer than that necessary to span the gap, and bend and insert its ends in the associated holes from the component side of the circuit board. Cut another shorter length of bare, tinned copper wire and insert it from the same side of the board as the longer jumper between one side of C10 and ground, as shown in Fig. 3. (It is located between trimmers R5 and R10.)

Observe the polarities of the aluminum and tantalum electrolytic capacitors because this circuit will not work if any of them are reversed. Insert the IC's carefully to avoid damaging their pins. Also, use extra care when soldering the IC pins to the circuit board to prevent excessive heat from delaminating adjacent copper conductors. After all soldering is complete, carefully check your work. If you can spot no errors, trim any excess lead lengths close to the board.

Figure 4 is a photograph of the completed circuit board showing the wiring to the speaker, telephone line and AC/DC adapter.

Note: The values shown on the schematic Fig. 2 provide a hold off time of approximately 0.5 second, adequate for most Phone Pager applications. However, if, after completing all assembly and test routines, you are not satisfied with that holding time, you can go back later and substitute different values of resistors and capacitors in small increments to get the time constant you want.

Packaging Phone Pager

The prototype Phone Pager was housed in a standard plastic electric outlet box with a 3-½-inch inside length to accommodate the circuit board. These boxes are available in most building or electrical supply stores.

The faceplate for the Phone Pager is a blank plastic electric outlet cover with two molded holes and screws with threads that fit the threaded holes in the outlet box. Drill a pattern of

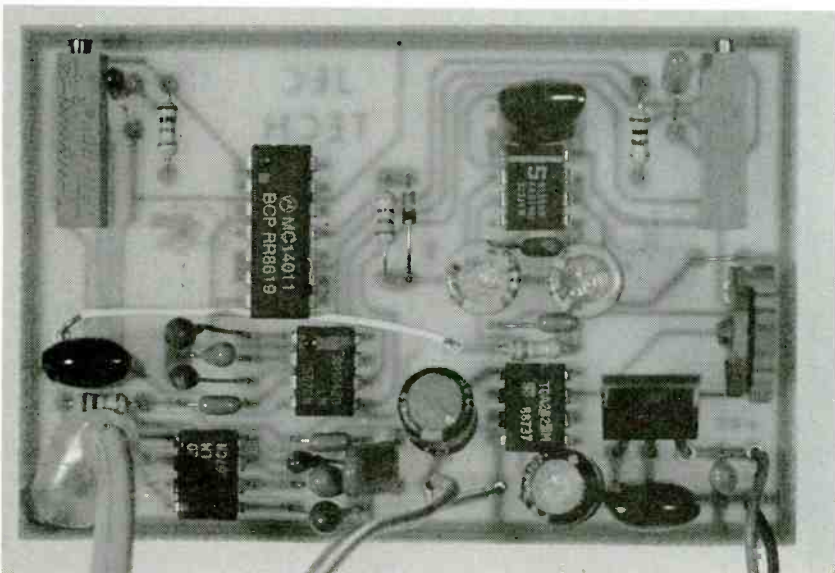

Fig. 4—COMPLETED CIRCUIT BOARD showing wiring to power jack, speaker and telephone plug.

holes about 0.30-inch in diameter within a two-inch circle through the cover to act as a speaker grill. Drill enough holes to permit the speaker tone to be heard clearly, but not so many that the faceplate is weakened and subject to damage.

The 2-inch speaker SPKR1 on the prototype was selected so that it would fit in the outlet box after it was bonded to the back surface of the outlet cover/grill. Apply a thin bead of RTV silicone or other suitable adhesive around the rim of the speaker, and clamp it in position until the adhesive sets up. Avoid spilling any adhesive on the speaker cone.

Drill a 1/4-inch hole in one side wall of the outlet box to admit

the coaxial plug from the AC/DC adapter as shown in Fig. 5, and mount the power jack J1. Drill any adjacent holes needed to secure the jack bracket to the box wall with rivets or small screws and nuts. Drill a hole in the opposite wall of the box large enough to admit the telephone line cord and a clamping grommet, also as shown in Fig. 5. Install the grommet.

Strip the insulation from both ends of about a six-inch length of a black and red twisted pair of hookup wires, and insert and solder the wires to the circuit board, as shown in Fig. 3 and to the lugs on the power jack J1, also as shown in Figs. 3 and 5, observing the color coding shown. Cut about a six-inch

TABLE 1
VOLTAGE MEASUREMENTS
PIN-TO-GROUND (RING)

Pin Number	IC3	IC4	IC5	IC1/IC2
1	3.6	0	0.28	3.9
2	3.5	5.0	0	3.8
3	0	0	0	2.1
4	0	5.0	0	5.0
5	3.5	3.3	0.03	2.4
6	3.5	0	0.85	0
7	0	0	0	0
8	0	3.5	0.28	3.5
9	0			
10	5.0			
11	5.0			
12	0			
13	0			
14	5.0			

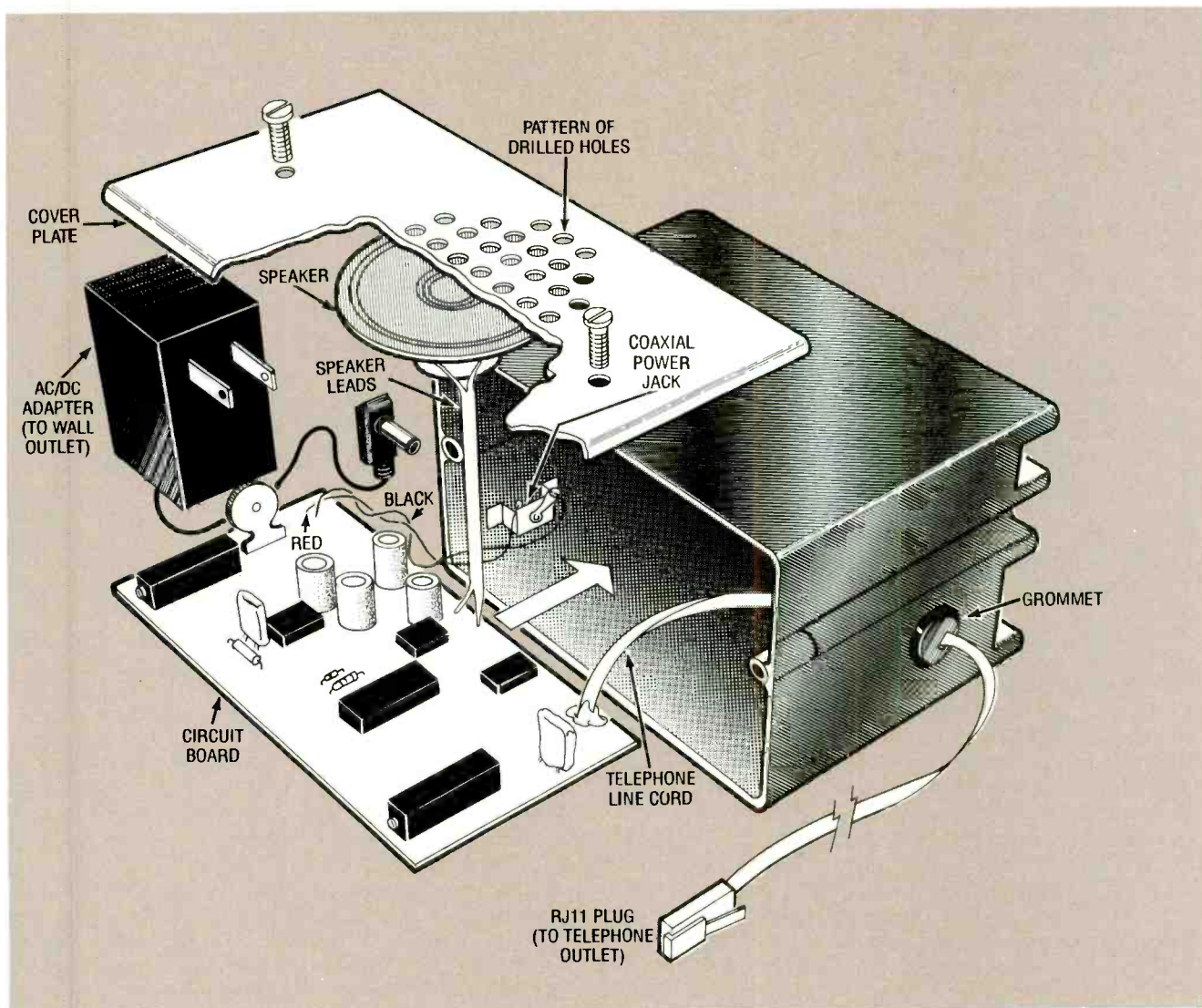
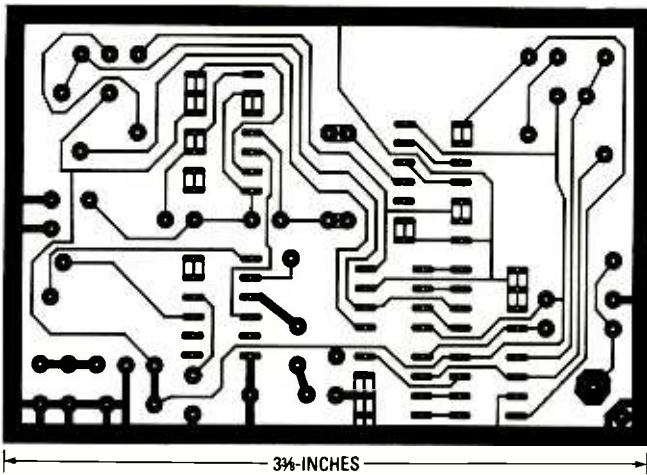

FIG. 5—EXPLODED VIEW OF THE PHONE PAGER ASSEMBLY. The speaker can be bonded to the inside of the cover, and the circuit board can be bonded to the inner wall of the case with RTV silicon or other suitable adhesive.



FOIL PATTERN for Phone Pager single-sided circuit board.

length of miniature twinlead, strip the insulation from the wire ends, insert them and solder the connections between the circuit board and the terminals on the speaker SPKR1, as shown in Figs. 3 and 5.

Cut about a seven-foot length of standard telephone line cord, strip back the insulation at both ends and install a modular RJ11/14 telephone jack on one end. Pull about four inches of the other end of the cable through the grommet and clamp it in position. Solder the red wire to the RING terminal and the green wire to the TIP terminal on the circuit board as shown in Fig. 3.

Phone Pager is now complete enough to permit test and alignment. Do not perform the final assembly procedures on the Phone Pager until you have completed the testing.

Test and alignment

Plug the wall-outlet-mounted AC/DC adapter in the AC outlet, and insert the plug at the end of its line cord in the power jack in the outlet box. Obtain a suitable voltmeter to make voltage measurements, and begin by measuring the adapter output to ground (the RING terminal shown in Fig. 3.). Its output should be between 13 and 15 volts. Next, measure the output of the 5-volt regulator IC7 to verify that it is 5 volts.

Referring to Table 1, make individual voltage measurements between each of the pins on in-

tegrated circuits IC1 to IC6 and ground while comparing them with the values listed in Table 1. If any measurements differ by more than a few volts from those listed in Table 1, check to see if you can find a reason. Any major discrepancy indicates a fault that needs to be found and corrected.

If all of the voltage measurements are satisfactory, start aligning the decoders. A Touch-Tone telephone, a duplex "Y" adapter, and the test circuit shown in Fig. 6 are used in the testing. Connect a fresh 9-volt transistor battery, a 220-ohm resistor R11, and hookup wire to form the test circuit. Either a surface-mount RJ11/14 jack or a wall plate with an RJ-11/14 jack will be needed.

Plug the duplex adapter into the RJ11/14 jack to which you have wired the battery and resistor. This provides the telephone voice voltage that generates the tones. Plug the Touch-Tone phone into one of the jacks on the adapter and plug the Phone Pager into the other one. Power up the Phone Pager, pick up the telephone handset, depress one of the keys, and listen for the tone. If you can't hear a tone, recheck the connections on the test circuit.

Monitor the green and yellow LED's on the Phone Pager. They should light up when a tone is detected. The tuning ranges of trimmers R3 and R5 were selected so that either is capable of being tuned from 697 Hz to

1477. In the prototype, tuning was done only to 941 Hz and 1209 Hz.

First tune one of the decoders to 941 Hz and the other to 1209 Hz so that the "*" can be detected. It is important that you be able to confirm that you are tuned to both frequencies, and that both decoder IC1 and IC2 are not tuned to the same frequency. A simple method to determine this will be discussed later.

Start by tuning in at least one frequency. Hold the "*" key down temporarily. (A large rubber band can be stretched over the telephone's keypad to hold down an eraser set on the key.) Tune either trimmer resistor R3 or R5 until its corresponding LED lights up. Then find the middle of the trimmer's response range. This can be done

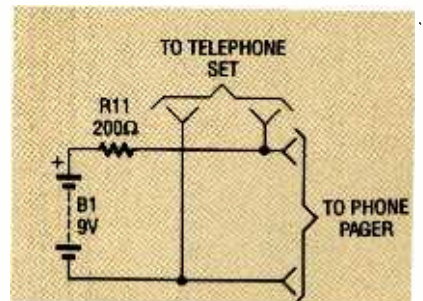

FIG. 6—PHONE PAGER TEST CIRCUIT consisting of a 9-volt transistor battery, a resistor, and wiring

by turning the trimmer shaft in one direction until the LED goes out. Note that position, and then turn the shaft in the other direction, counting those turns, until the LED goes out again.

The desired shaft setting is the position midway between the two end settings. If the LED does not light, the value of resistor R1 is probably too high. Temporarily bridge a 10,000-ohm resistor across R1 to see if it causes the LED to light. If either of the LED's remains illuminated continually, check the polarities of all electrolytic capacitors against schematic Fig. 2, and remove and reposition any one of them if you have made a mistake.

A determination of the optimum value for resistor R1 can be performed later. The value

given in Fig. 2 should be considered as a starting point for any substitutions.

When a trimmer is set at its midpoint for a desired frequency, determine if it is locked to the low (941 Hz) or the high (1209 Hz) frequency. Figure 7 shows the frequency matrix of a TouchTone keypad. It consists of three high-group frequencies along the horizontal axis and four low-group frequencies along the vertical axis. You can easily determine if you're tuned to a low or high frequency by depressing an adjacent key to see if the related LED still lights up.

In tuning the "*" key, press the "0" (zero) key, and if the LED still lights up, you are tuned to the low 941-Hz tone. Similarly, press the "7" key, and if the LED still lights, you're tuned to the 1209-Hz tone. Note: The LED should not light up when you press either the "0" or the "7". If it does, it indicates that either the capacitors are faulty so that tuning is not sharp enough, or a component is incorrectly wired.

The LM567 will respond to tone levels down to about -15 dB when it is tuned. Those levels were measured on the prototype at pin 3 with a Hewlett-Packard HP-3551 transmission test set in the bridged-reading mode. The bandwidth of the response curve was approximately ± 25 hertz, depending on the level of the tone. Note that the bandwidth varies according to the change in frequency at the time the reading is taken.

However, you will probably not need to use a transmission test set if you have carefully followed the alignment directions given here. The setting should be close to optimum without having to make any additional measurements.

If all tests have been passed at this time, tune in the other frequency. Depress the "*" key again and tune the other trimmer (either R3 or R4) for mid-range on the other frequency, following the same procedures that were given earlier. You should hear tones from the speaker during the timing cycle

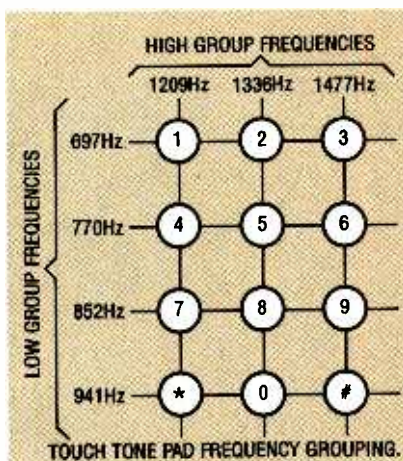

FIG. 7—MATRIX OF FREQUENCIES activated by the keys of a touch-tone telephone.

when you decode the second frequency. Retune each trimmer until you are satisfied that they are both at midrange. Caution: Be sure that the decoder/timer is not activated by any other keys on the TouchTone pad while performing this procedure.

Observe the LED's while depressing different keys. The only time both LED's should light simultaneously is when the key you want to detect is pressed. Even if the circuit operates, you might not be satisfied with the output audio from the speaker. That volume depends on a number of factors: input level related to the make of your telephone, and the voltage provided by your local phone company. You can substitute another value for Tip resistor R1, which controls the level of the audio input to the tone decoders. Make trial-and-error substitutions in increments of about 20,000 ohms.

If the level is too high, you might experience false tripping with normal speech level on the line. If the level is too low, the decoders might not be able to decode the tones properly. If you experience false "tripping," substitute a higher value for resistor R1, again in increments of about 20,000 ohms, until you find one that works well. The optimum value is one that still allows the tones to be decoded, but doesn't trip during normal conversations. Substitute a lower value for R1 when the de-

coders are unable to decode the tones.

If you want to use the Phone Pager in conjunction with an answering machine, as was mentioned earlier, reduce the value of resistor R1 in increments of about 20,000 ohms until you find a value that gives a satisfactory audio output. It should be comparable to that generated when Phone Pager is connected directly to a telephone.

When the Phone Pager is complete, apply small spots of RTV silicone or other suitable adhesive to the corners of the circuit board on the foil side. Then position the board in the outlet box as shown in Fig. 5, and press it into position. After the adhesive has set, carefully arrange the wiring within the case to avoid any twists or interference with any component, and close the cover with speaker mounted on the inside. Secure the cover to the case with the two screws provided. The Phone Pager is now finished and ready for use.

Phone Pager can be organized so that any of the other 11 keys on the TouchTone keypad phone can be used for activation. If you want to use a key other than the "*" key, refer to the frequency matrix in Fig. 7 and tune the trimmers accordingly.

Installation

Decide where you want to place your Phone Pager. For a final Phone Pager installation, disconnect your phone from its standard RJ11/14 jack and plug a duplex adapter in its place. Then re-connect the phone plug in one jack and Phone Pager in the other. Plug the AC/DC adapter in the wall outlet, and put the adapter plug in the jack in the case. Phone Pager is ready to work for you.

At a minimum you'll probably want one at any extension phone, assuming that you consider the kitchen or hall phone to be your "base" primary phone. After you have tested your Phone Pager and found out how well it works, you'll probably want one on every phone in your home. Ω

PART-68 INTERFACE

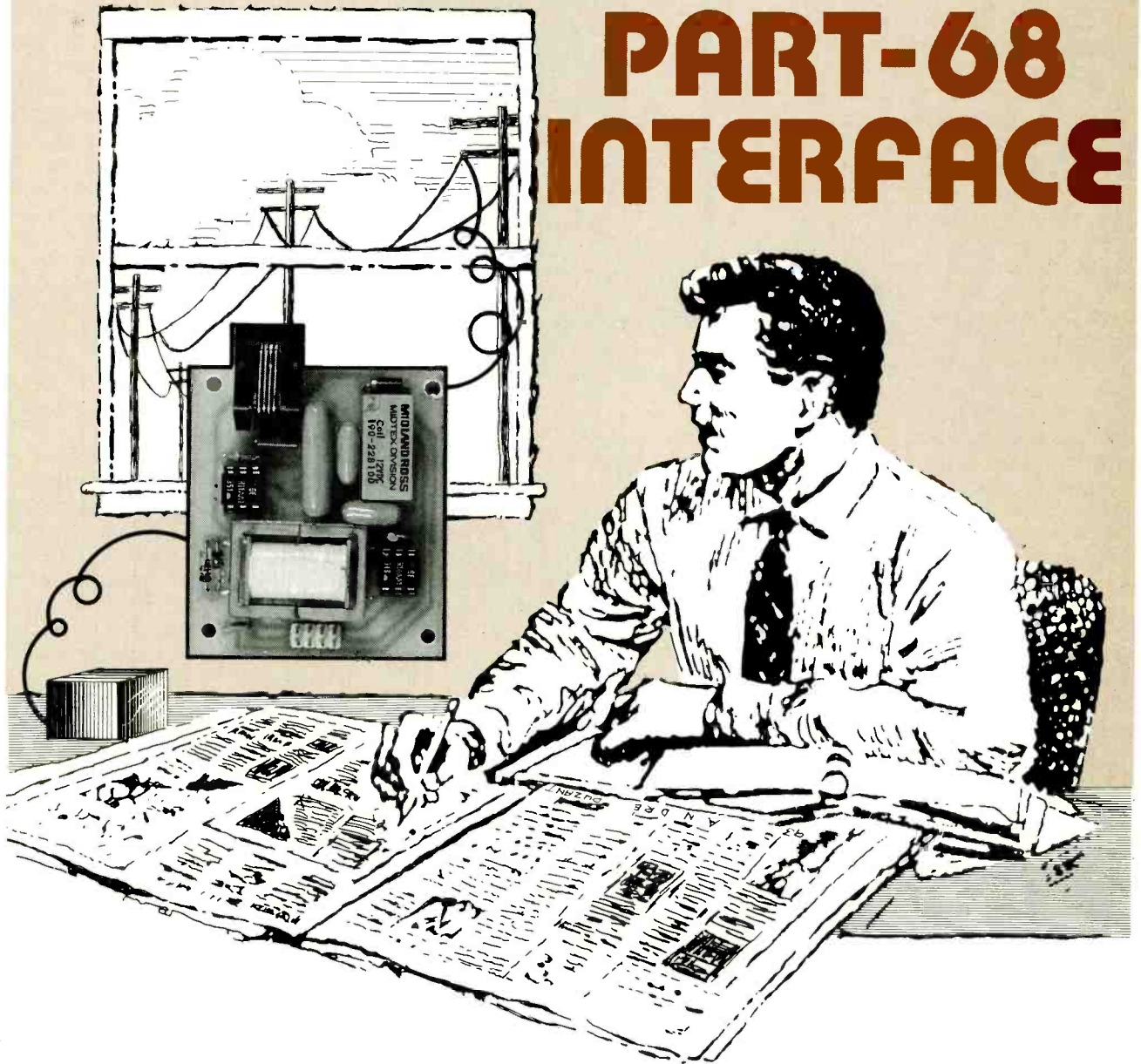

With the MPC-2 Part-68 approved phone-line interface, you can make all of your telephone projects FCC type-approved!

MIKE HAGANS and KYLE MAGRILL

MANY POPULAR PROJECTS REQUIRE some kind of connection to your phone line. The list includes telephone remote controls, conversation-recording devices, modems, auto dialers, caller-ID boxes, and even some of the projects in this issue such as the Talking Ringer and the Phone Pager. This article pre-

sents a type-approvable protective voice coupler. The interface meets all technical requirements in Part 68 of the FCC rules, and is caller-ID compatible. The coupler's features include ring detection and line-current detection.

Until 1979, it was illegal to hook anything up to your phone

line without connecting it through an AT&T-leased coupler. Anyone caught with a second phone or other product connected to his phone system risked having it confiscated. In 1976 the FCC drafted some basic rules that were intended to standardize connections to the phone network and make it

possible for anyone to build a product that could be certified for use on the network. That was the beginning of Part 68 of the FCC's rules. AT&T, trying to protect its monopoly, fought the new rules all the way to the Supreme Court where it eventually lost. Since that day, there have been over 100,000 products licensed, and Part 68 is now several hundred pages long.

Three major objectives are at the heart of the rules. First, the FCC wants to make sure that anything connected to the phone line is safe for the user. Because phone lines are subject to occasional high-voltage strikes from lightning and over-voltages from other sources, connected devices must be able to withstand and dissipate a significant energy surge.

Second, it is important that the device not be able to damage the phone line or injure phone-service people. If an improperly designed device's power supply were to fail while it was connected to the line, it could place dangerous voltages on the line. Not only would that damage the system, it could be fatal to an unsuspecting technician.

Third, whatever happens to your phone line should not degrade your conversation or anyone else's. Malfunctioning or poorly designed equipment can cause distortion, hum, and low audio levels on your phone. Phone lines often run many miles in unshielded, twisted pairs. Your conversation might travel that entire distance in wires only a few microns away from other pairs carrying conversations or data. The system works because the phone company goes to great lengths to be sure that each pair is perfectly balanced and filtered, and that all signals are below specified levels. If your line becomes unbalanced or you exceed the signal limits, you might cause problems for yourself and everyone else who shares a cable with you. It is amazingly easy to mess up a phone line. Just connect one side of the line to ground. You will probably get so much hum and noise on your line that you won't be able to use it.

The FCC also knows that even well-designed, well-built equipment will eventually fail. The equipment must be constructed so that when it fails, it fails completely and is unusable. The reason for that rule is to make sure that the user knows there is a problem with his equipment and to be sure that malfunctioning gear can't damage the system. If you know the rules though, it is easy to design an inexpensive interface that can meet the FCC requirements.

Your phone line

Before we can begin the design process, we need to know a little about how the phone line works. The phone line coming into your home is terminated with an RJ11 (modular) jack. For a single-line installation, two conductors called TIP and RING make up the phone line that connects your telephone equipment to the phone company's Central Office, or CO.

When your telephone instrument is on-hook (hung up), there is about 48 volts DC, called battery voltage, between the TIP and RING conductors. Note that the battery voltage is current-limited, varies between companies, and is *not* referenced to ground. When your handset is picked up, the battery voltage is loaded down, and the voltage drop on your line is detected by the CO. The CO takes the drop in battery voltage as a signal that you want to make a call; it switches a dial tone onto the line and waits for the dial pulses or DTMF (dual-tone multi-frequency) tones that are initiated by your dialing a number.

When you are on the receiving end of a call, the CO switches a ring generator onto your line, which produces a low-frequency AC ring-signal pulse that rides on the DC voltage. Most telephone capacitor-couple the ring signal to an attention getter such as a bell or piezoelectric buzzer. When you pick up the handset, the CO "sees" the DC voltage drop, stops ringing your line, and connects you to the calling party.

An obscure but important thing to note is that when the calling party hangs up, the vast majority of CO's in the U.S. send a short battery-reversal or zero-voltage signal to the receiving party (if it's still off-hook) followed by another one about eight seconds later. Most CO's also dump a dial tone back on the line after a short time, as well.

We acknowledge that we've left out a lot of details about how the phone system works. But this article is about a telephone interface, and we've included enough basic technical information here so that you can begin to design a working protective voice coupler.

If you are really interested in the rather complicated overall operation of a phone system, we heartily recommend Radio Shack's *Understanding Telephone Electronics*; it is an extremely well-written, surprisingly complete, and an inexpensive source of accurate information.

How the MPC-2 works

The MPC-2 was designed to be a very simple and very flexible coupler. The electronic components involved are inexpensive and easily obtainable. Because of the protective (isolation) properties of the coupler, it must be built exactly as described in this article to be type-approved. Any variation from the construction details given in the article or from the component values specified might greatly reduce the likelihood of your coupler qualifying as FCC type-approved.

Figure 1 is the schematic diagram of the MPC-2 coupler. The telephone TIP and RING lines attach to the coupler board through RJ-11 jack J1. The TIP line is connected to C1, a 0.56 μ F capacitor rated at 250 volts DC, which allows the AC component of the incoming ring signal to reach pin 2 of IC2; an H11AA1 AC-input optocoupler. Pin 1 of IC2 is connected to the phone line's RING conductor through current-limiting resistor R1. The output of IC2 is connected to the header J2; the output can

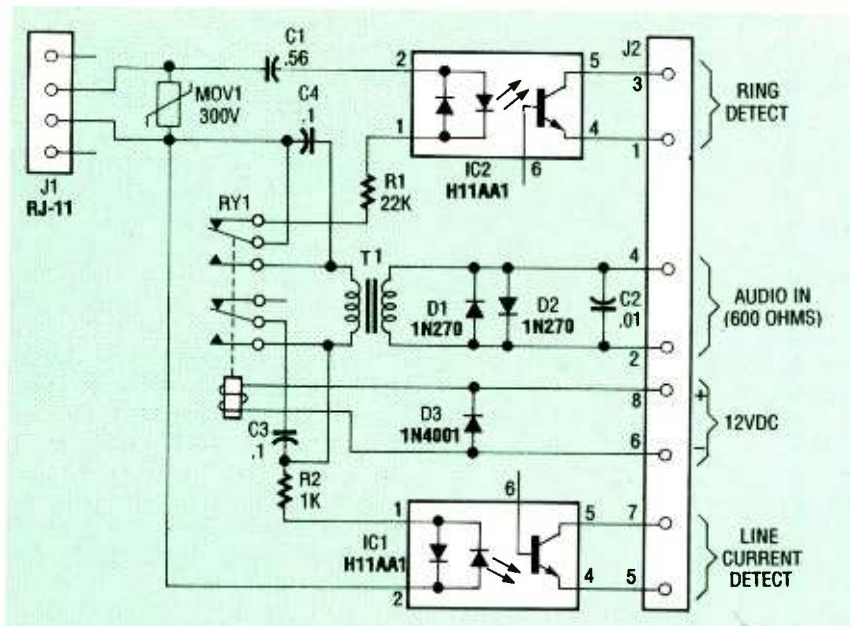

FIG. 1—MPC-2 SCHEMATIC. The interface meets all the technical requirements in the FCC rules, Part 68.

be used to signal your logic whenever a ring is received.

Note that the designations *TIP* and *RING* come from the old days when telephone calls were manually switched by an operator on a big switchboard. The connections were then made by cables with standard ¼-inch phone plugs on them; *TIP* and *RING* referred to the tip and ring of the connector.

The *TIP* line is also connected to C3, a 0.1 microfarad, 250-volts DC capacitor which, along with C4, passes caller-ID data to transformer, T1. The transformer is critical to the operation of the circuit. It provides 1,500-volt isolation from the phone line and the correct DC resistance to tell the CO that the line is in use. It also ensures that the phone line will be properly balanced.

Relay RY1 is a standard PC-mount DPDT unit with a 12-volt DC coil. Note that there is a 1N4001 diode across the coil of RY1 to suppress back-EMF when the relay energizes. That makes the relay connection polarity-sensitive. When de-energized, C3 and C4 are connected to T1, allowing the monitoring of the phone line by caller-ID readers or other devices. When RY1 is energized, *TIP* and *RING* are connected directly to T1, seizing the line and passing au-

dio to the secondary.

Optocoupler IC1 senses line current. When the unit is on-line (when RY1 is energized), the potential between *TIP* and *RING* turns on IC1. When the battery reversal occurs at the end of a call, IC1 shuts off for a moment, signalling your external logic that the call is over. 300-volt MOV1 is used because some phone systems, particularly rural routes, might have elevated operating voltages. It is not uncommon to find a phone line with a nominal 75-volt DC on-hook value and a ring voltage of 100 volts. In that case, a 300-volt MOV provides sufficient overhead to prevent clipping the phone company's voltages.

The final components in our coupler provide signal limiting and waveform shaping to meet FCC specs. The two germanium diodes, D1 and D2, limit signals to the required -9 -dBm limit set by the FCC. Because -9 dBm corresponds to about 0.25 volts at the nominal 600-ohm line impedance, only diodes with a very low threshold voltage will work. You cannot use either standard silicon or any type of Zener diode as a limiter because the required junction voltages are too high. Fortunately, some germanium diodes do conduct at about the

right voltage. A 0.01 microfarad ceramic disc capacitor (C2) absorbs high-frequency harmonics either generated by the clipping action of the diode limiter or introduced at the audio-input terminals. While frequencies above 3 kHz are filtered in the phone system, the rules require some high-frequency suppression to prevent crosstalk with other pairs in your trunk line.

The MPC-2 passes the limited audio from *TIP* and *RING* to pins 2 and 4 of the 8-pin header J2 whether the unit is on- or off-hook. That feature makes the unit compatible with many caller-ID systems. Incoming ring voltage causes an isolated open-collector output at pins 1 and 3 of J2. When the unit is on-line, an open-collector output occurs at pins 7 and 5 of J2. When the calling party hangs up, the optocoupler turns off momentarily, signaling that the call is over. Applying 12-volts DC to J2 pins 6 and 8 will cause the MPC-2 to go off-hook. Simple logic circuits can control the MPC-2 while monitoring its *RING DETECT* and *LINE-CURRENT DETECT* lines.

Construction

Building the MPC-2 should be straightforward. You can make the PC board from the foil pattern we've provided, or purchase one from the source mentioned in the Parts List. Completed, fully registered (therefore fully legal to use) MPC-2's are also available from the source in the Parts List, as are type-approved (but not type-approved) kits to build them.

Individual parts can be purchased from various vendors. However, be very careful about the quality of the RJ11 jack if you purchase it separately. The RJ11 jack's pins *must* be gold-plated, to a thickness of 50 microns, to be legal for connection to the Public Switched Telephone Network.

Figure 2 is the Parts-Placement diagram. When installing the RJ11 jack (J1), be careful not to bend the pins under the jack.

continued on page 71

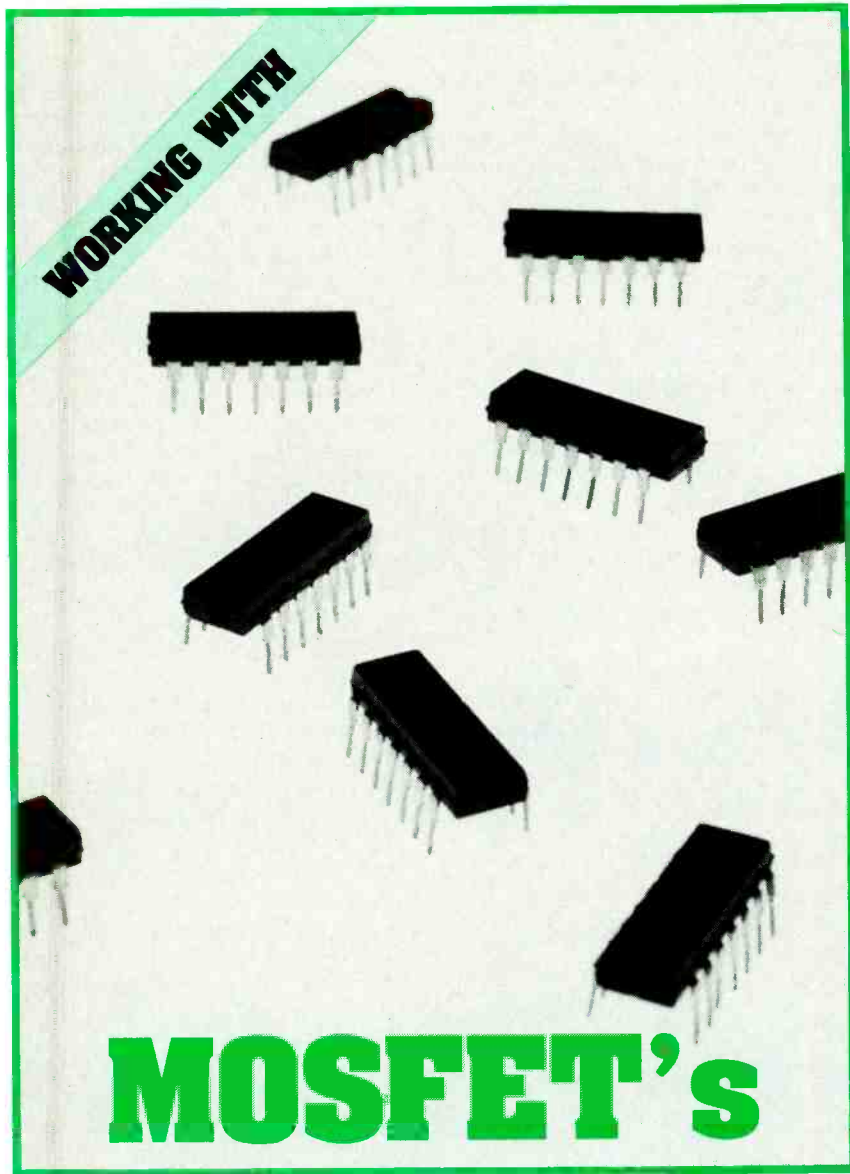

Learn about MOSFET's: how they are made, how they work, and how to put them to work in practical circuits

RAY MARSTON

THE METAL-OXIDE-SEMICONDUCTOR field-effect transistor (MOSFET) is similar in many ways to the junction FET (JFET). Both are voltage-driven unipolar devices that depend on either electron or hole movement—but not both, as does the bipolar transistor. However, there is a fundamental structural difference between the two field-effect transistors: The JFET has three layers while the MOSFET has only two. The MOSFET's simpler construc-

tion has given it a performance edge over the JFET, and made it the world's most popular transistor style.

Earlier articles in this series stated that the MOSFET's controlling gate voltage is applied directly to its channel region across a thin layer of insulating oxide, as shown in Fig. 1-a. This geometry contrasts with that of the JFET, which is controlled by switching an internal PN junction. The MOSFET will work from lower power than the

JFET, and its simpler design is reflected in lower production costs. That is why it has become the basis for all CMOS digital logic IC families.

The last two articles in this series discussed FET's. The basic principles of JFET's and MOSFET's were explained in the first article (*Electronics Now*, February 1993) and the words that describe them were defined. The second article (*Electronics Now*, March 1993) focused on JFET's, and included practical JFET circuit schematics.

This article concentrates on the enhancement-mode MOSFET, and it includes practical MOSFET circuit schematics based upon small-signal MOS transistors available in a low-cost CMOS integrated circuit. You might wish to review the first two articles to refresh your general knowledge of FET's before reading this article.

MOSFET basics

There are both N- and P-channel MOSFET's just as there are both N- and P-channel JFET's. In the cross-section view of an N-type enhancement-mode transistor, Fig. 1-a, you can see the thin layer of silicon dioxide (glass) that electrically isolates the metal gate from the channel between the N-doped source and drain regions. The presence of that insulated gate is

why the MOSFET has also been called an IGFET (for *insulated-gate FET*). However, that term is now considered to be obsolete.

As shown in Fig. 1-a, the channel between the N-type source and drain of an N-channel, enhancement-mode MOSFET is the substrate P-type material. This MOSFET can be turned ON so that current flows between source and drain only when a positive forward bias is placed on the gate. As a result, the enhancement-mode

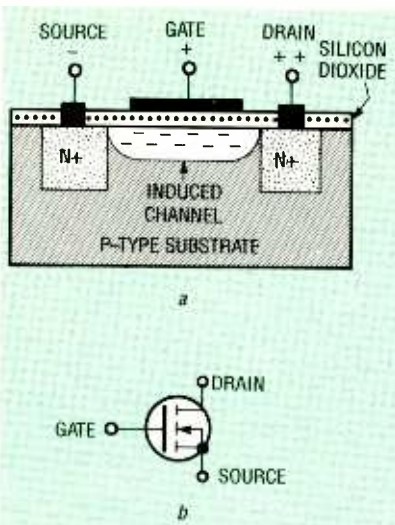

FIG. 1—AN N-CHANNEL, ENHANCEMENT-mode planar MOSFET shown in section view (a), and its standard schematic symbol (b).

P-channel, enhancement-mode MOSFET ON. Its operation depends on the movement of holes, which have lower *mobility* than electrons. This means that an N-channel MOSFET can switch faster than a P-channel MOSFET.

As in the JFET, signal voltages or biases applied between the gate and source terminals of the MOSFET control the magnitudes of signal currents flowing between the drain and source terminals.

N- and P-channel MOSFET's are said to be *complementary* because the doping of their substrate, source, and drain materials as well as their forward bias polarities are opposite. However, as will be seen, advan-

both FET's are connected. Figure 1-b shows the schematic symbols for N- and P-channel MOSFET's that are integrated into the CMOS chip shown in Fig. 1-a. A CMOS IC provides the small-signal transistors needed for the experiments described in this article.

In passing, it is worth stating that, although they are organized in a similar manner, the most advanced CMOS logic families have polysilicon rather than metal electrodes. Polysilicon, a pure form of silicon, is a conductor.

Figure 3 shows typical drain-to-source output characteristic curves for an N-channel, enhancement-mode MOSFET. Drain current (I_D) increases with increases in positive gate-to-source bias. These curves were obtained from a MOSFET transistor within a CMOS circuit that will be discussed in detail later. The characteristic curves of a P-channel MOSFET are similar except that drain current increases as its bias becomes more negative.

Figure 4 illustrates the gate-to-source transfer characteristics for the same enhancement-mode, N-channel MOSFET shown in Fig. 3. It shows how drain current (I_D) increases directly (and almost linearly) with positive gate-to-source voltage (V_{GS}), while the DC supply voltage (V_{DD}) remains constant at 15 volts. Note that no significant drain current flows until the gate voltage rises to a threshold (V_{TH}) value of a few volts. (This can also be seen in Fig. 3.)

Before proceeding with this discussion of MOSFET's, it is important to point out that protective precautions must be taken when handling *all* MOSFET devices. All MOSFET's are susceptible to damage from the discharge of electrostatic energy between any two pins. The extremely high input impedance of these devices lends itself readily to the buildup of electrostatic charges. Because the oxide that insulates the gate of a MOSFET typically breaks down with the application of about 80 volts, damage or de-

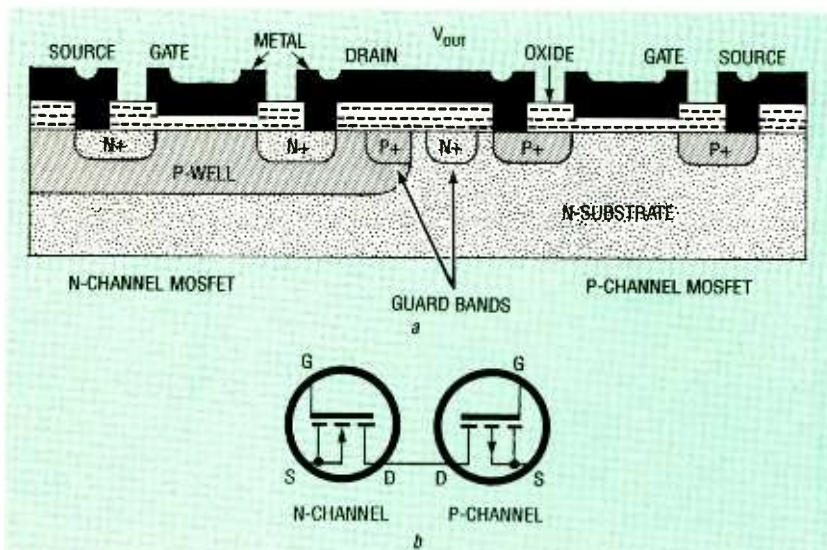

FIG. 2—A SECTION VIEW OF N-CHANNEL and P-CHANNEL MOSFET's integrated on the same chip (a) and their individual schematic symbols. (b).

MOSFET is said to be "normally off." Its operation depends on electron flow.

Recall from last month's article that all JFET's are depletion-mode or "normally on" devices. They are turned OFF by applying reverse bias. Depletion-mode MOSFET's are being made today for high-frequency radio applications.

A P-channel, enhancement-mode MOSFET has a cross section that is identical to that shown in Fig. 1-a except that the substrate is N-type material and the source and drain regions are P-type material. A negative forward bias is needed to turn a

gate is taken of those characteristics in complementary MOS (CMOS) logic families and some of the circuits discussed here.

Figure 1-b is the schematic symbol for an enhancement-mode N-channel MOSFET. The dotted vertical line between the drain and the source represents a "normally-off" channel. (The symbol for complementary P-channel device is similar except that its arrow points outwards.)

Figure 2-a shows a cross section of a monolithic CMOS IC with both N- and P-channel MOSFET's integrated on the same substrate. The drains of

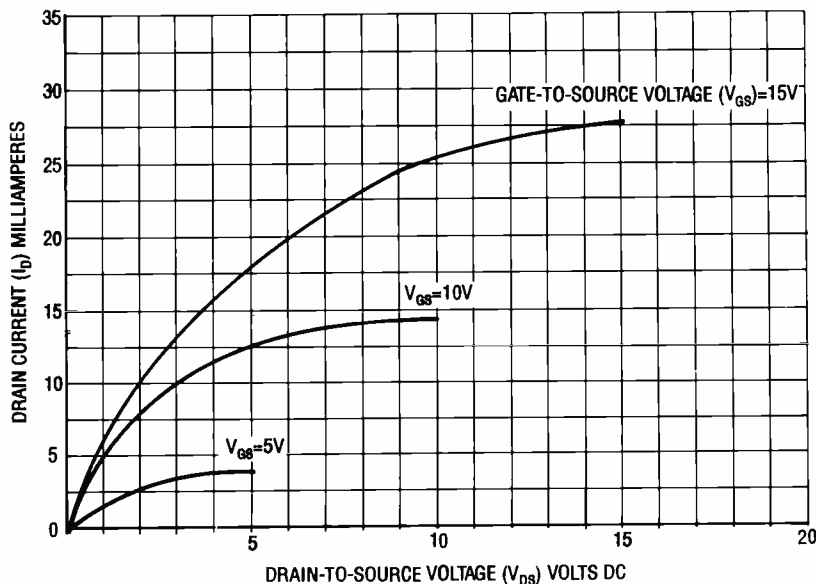

FIG. 3—A TYPICAL FAMILY OF DRAIN-TO-SOURCE OUTPUT characteristic curves for a CD4007UB N-channel, enhancement-mode MOSFET showing drain current increasing with positive bias.

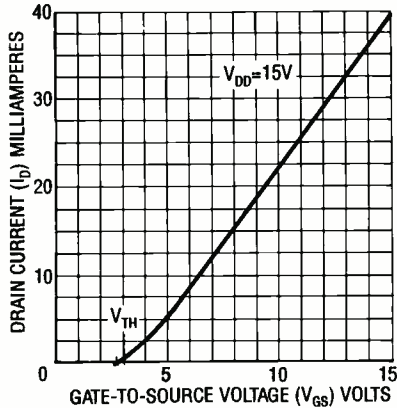

FIG. 4—A TYPICAL GATE-TO-SOURCE transfer curve for a CD4007UB N-channel, enhancement-mode MOSFET showing drain current rising almost linearly with positive bias.

struction of the devices can be caused by higher levels of electrostatic discharge (ESD).

Protective circuitry has been built into many discrete MOSFET's and protective networks are now included in most CMOS IC's. However, the high electrostatic charge generated simply by scuffing your shoes on a carpet and then touching the pins of a "protected" device can overwhelm those defenses and damage or destroy the part.

Ideally, all MOSFET parts handling should be done only at a workstation organized to protect against ESD. In the event that is not practical, at the very

least a grounded wrist strap should be worn, and all CMOS parts handling should be done on a grounded conductive work surface.

Complementary pair

A small-scale, industry-standard CMOS IC that contains a number of accessible N- and P-channel enhancement-mode transistors is an excellent source of MOSFET's for experiments. Figure 5 shows the schematic of a CD4007UB, a dual complementary pair plus inverter. It has six accessible MOSFET transistors: two pairs are unconnected and the third pair is connected as a CMOS inverter or NOT gate.

There are many sources for The CD4007UB, known generically as the 4007. Prefixes identify the manufacturer. The CD4007UB, for example, is made by Harris Semiconductor; it is pin-for-pin compatible with the Motorola MC14007UB. These versatile parts are useful as digital logic parts as well as for linear applications in amplifiers, pulse-shapers, and crystal oscillators.

The suffix "UB" indicates a CMOS series whose gates and inverters are constructed with a single inverting stage between input and output, which results in decreased gain. However, this characteristic is useful when these normally digital logic products are operated in the "linear" regions of their characteristic curves.

Figure 5 is the schematic for the 4007UB in a 14-pin DIP package. The MOSFET's have been labeled Q1 to Q6. Transistors Q1, Q3, and Q5 are P-channel devices, while Q2, Q4, and Q6 are N-channel devices. Pin access is given to all three terminals of transistors Q1 to Q4, but transistors Q5 and Q6 are permanently configured as an inverter. The typical output and transfer characteristics of Figs. 3 and 4 were obtained from an N-channel MOS transistor Q2 of a 4007UB.

Figure 6 is the pin assignment diagram for the 4007UB. It has been supplemented with labels that relate pin numbers

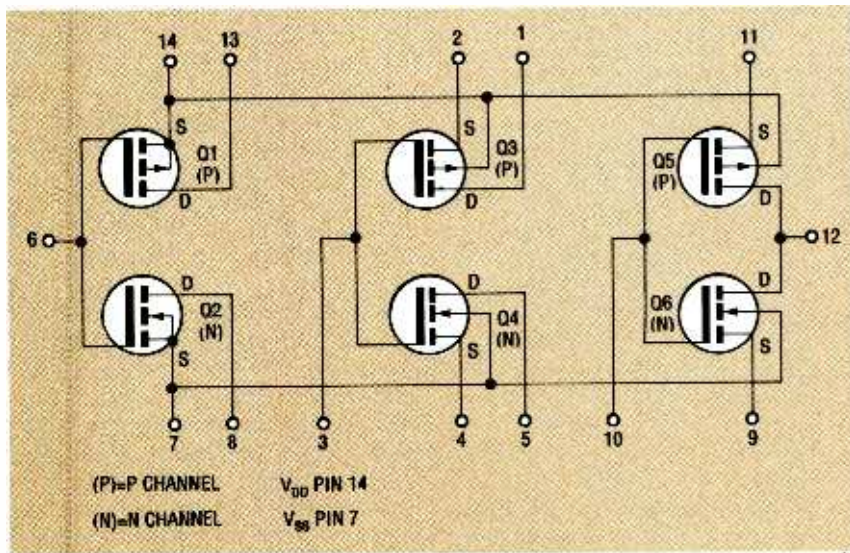

FIG. 5—A SIMPLIFIED SCHEMATIC FOR A CMOS CD4007UB dual complementary pair plus inverter showing accessible pairs of MOSFET's and a CMOS inverter.

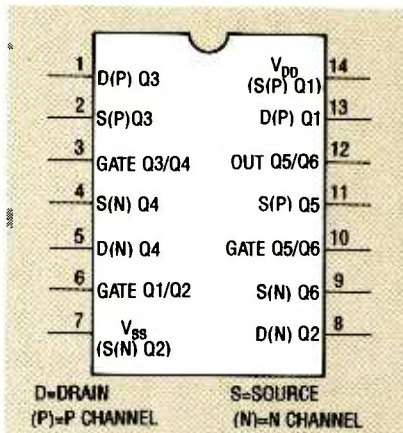

FIG. 6—PIN ASSIGNMENT for the CMOS CD4007UB dual complementary pair plus inverter used in the MOSFET circuits described in this article.

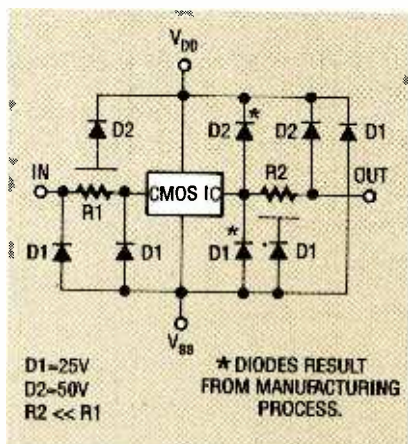

FIG. 7—AN ON-CHIP PROTECTIVE network protects the CD4007UB against ESD. Some diodes result from the manufacturing process.

to the functions they perform in the schematic, Fig. 5. Table 1 presents the outstanding characteristics of the 4007UB. Figure 7 shows the protection network for the CD4007UB. Input diode D2 is a distributed resistor-diode network that appears as two diodes to V_{DD} .

Application rules

Here are some simple rules to keep in mind when working with the 4007UB:

- In any application, *all* unused elements of the device *must* be disabled. Complementary pairs of MOSFET's can be disabled by connecting them as standard CMOS inverters, as shown in Fig. 8 (gate-to-gate and source-to-source), and grounding their inputs. Refer to Fig. 5 to interpret the pin numbers given in the figure. (The tri-

TABLE 1
PERFORMANCE OF THE CD4007UB

Characteristics	Value	Units
DC Supply Voltage (V_{DD})	3 to 18	V
Input or Output Voltage (1)	-0.5 to $V_{DD} + 0.5$	V
Input or Output Current (1)	± 10	mA
Device Dissipation/Package (2)	500	mW
Dissipation/Transistor (1)	100	mW
Propagation Delay @10 V_{DD} (2)	30	ns

(1) Maximum (2) Typical

angle symbol used here to designate a complementary pair of transistors is the digital logic symbol for an inverter.)

- Individual MOSFET's can be disabled by connecting their sources to their substrates and leaving their drains open-circuited.
- Input terminals must not be allowed to rise above the supply

voltage (V_{DD}) or fall below zero volts (V_{SS}).

- To use an N-channel MOSFET, the source must be tied directly to V_{SS} or through a current-limiting resistor. Similarly, to use a P-channel MOSFET, the source must be tied directly to V_{DD} or through a current-limiting resistor.

Linear operation

Figure 9 shows how to connect Q2, an N-channel MOSFET in the 4007UB as a linear inverting (common-source) amplifier. Resistor R1 is the drain load of Q2, and series resistors R2 and R_x form a voltage divider that biases the gate so that Q2 operates in the linear region. The value of R_x is selected to give the desired quiescent drain voltage. It is normally in the range 18,000 to 100,000 ohms.

Figure 10 shows how the Fig. 9 circuit is modified to give it very high input impedance. The 10-megohm isolating resistor R3 is placed between the junction of resistors R2 and R_x and the gate of Q2.

Figure 11 shows how to connect Q2 as a unity-gain, non-inverting (common-drain) amplifier or *source-follower*. If the gate of Q2 is biased at half-supply voltage by the voltage divider made up of R2 and R3, the source pin assumes a quiescent value that is slightly more than the threshold voltage V_{TH} below the gate value. The circuit has an input impedance equal to the values of resistors R2 and R3 in parallel (50,000), but this value can easily be increased to greater than 10 megohms by inserting resistor R4 as shown in the figure.

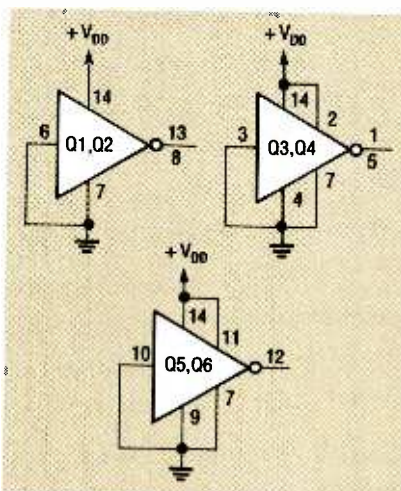

FIG. 8—ANY PAIR OF MOSFET'S (Q1 to Q6) on the CD4007UB can be disabled by connecting them as CMOS inverters and grounding their inputs.

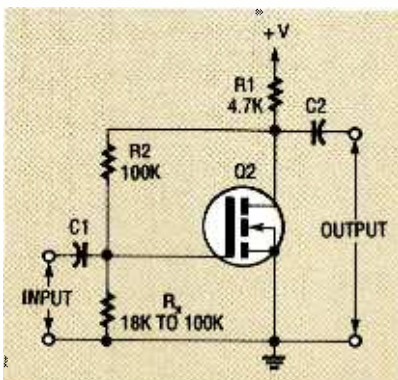

FIG. 9—A MEDIUM-IMPEDANCE biasing method for an N-channel MOSFET (Q2) on the CD4007UB for use as a linear inverting amplifier.

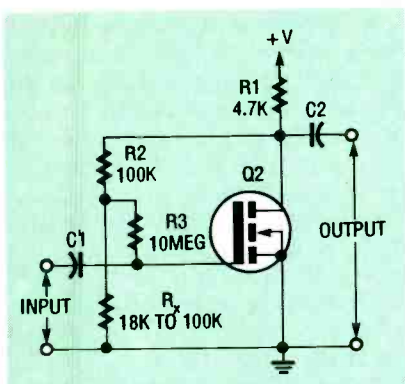

FIG. 10—A HIGH-IMPEDANCE BIASING method for an N-channel MOSFET (Q2) on the CD4007UB for use as a linear inverting amplifier.

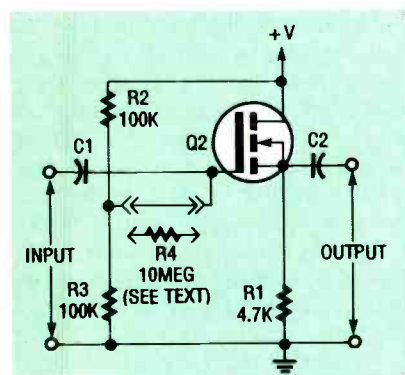

FIG. 11—BIASING METHODS on an N-channel MOSFET (Q2) on the CD4007UB for a unity-gain non-inverting amplifier or source-follower.

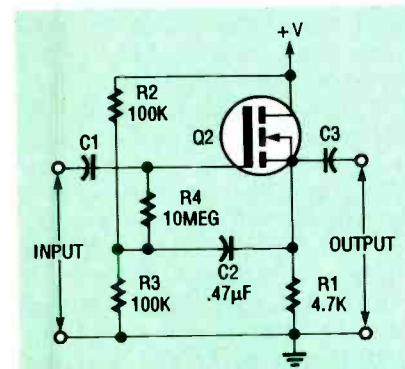

FIG. 12—BOOTSTRAPPED SOURCE-follower formed from an N-channel MOSFET has a high input impedance.

Alternatively, the input impedance of the circuit in Fig. 11 can be raised to several hundred megohms with the "bootstrapped" source-follower configuration shown in Fig. 12. The output signal from Q2 is fed back to the junction through capacitor C1. As a result, near-identical input signals appear at each end of resistor R4,

which, in turn, passes near-zero signal current and appears (to the input signals) as a near-infinite impedance.

It can be seen from the previous descriptions that an enhancement-mode MOSFET acts like a bipolar transistor, except that:

- It exhibits very high input impedance.
- It has a self-limiting drain-to-source current.
- It has a substantially larger input-offset voltage than a bipolar transistor.

The base-to-emitter offset of a bipolar transistor is typically 600 millivolts, while the gate-to-source offset of a MOSFET is typically 2 volts. If one allows for those differences, a small-signal MOSFET can replace a small-signal bipolar transistor in many kinds of bipolar transistor circuits.

The CMOS inverter

The most basic CMOS circuit is a complementary pair of N- and P-channel MOSFET's connected in series to form an inverter. The inverter shown in Fig. 13-a was specifically intended for digital circuitry where it performs the NOT operation. Fig. 2 is a section view of N- and P-channel MOSFET's integrated on the same chip with a common drain connection. This device can be converted to the CMOS inverter shown in Fig. 13-a by connecting the gates of P-channel MOSFET Q1 and N-channel MOSFET Q2 to form input ter-

minal V_{IN} , and taking the output V_{OUT} from the common drain. The source of Q1 is connected to the positive power supply V_{DD} , and the source of Q2 is grounded at V_{SS} .

Consider the P-channel MOSFET Q1 to be the driver and the N-channel MOSFET Q2 to be the load. Recall that an N-channel MOSFET conducts with a positive gate bias, and a P-channel enhancement mode MOSFET conducts with a negative gate bias.

When the voltage at the input terminal V_{IN} is low (logic zero), the voltage on the gate of Q1 is negative, causing it to conduct and short the supply voltage V_{DD} to the output terminal V_{OUT} . Because Q2 is off (its gate voltage is zero), a high-impedance path exists between V_{OUT} to ground V_{SS} . As a result the voltage at V_{OUT} is V_{DD} .

Alternately, when the input voltage is high (logic 1), the situation is reversed: Q1 is cut off, forming a high-impedance path between V_{DD} and V_{OUT} and Q2 conducts, forming a low-impedance path from V_{OUT} to ground V_{SS} , causing the output voltage to fall to zero.

This response makes the circuit a logic inverter or NOT gate. As can be seen in the truth table, Fig. 13-b, a low (logic 0) input results in a high (logic 1) output; conversely, a high (logic 1) input results in a low (logic 0) output.

In either logic state one enhancement-mode MOSFET is ON while the other is OFF. Because of this, the quiescent cur-

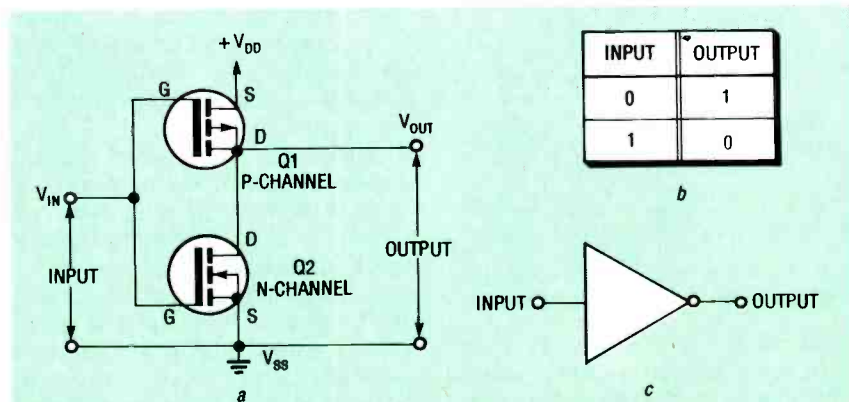

FIG. 13—CMOS DIGITAL INVERTER formed by connecting Q1 and Q2 (a), the truth table (b), and the logic symbol (c).

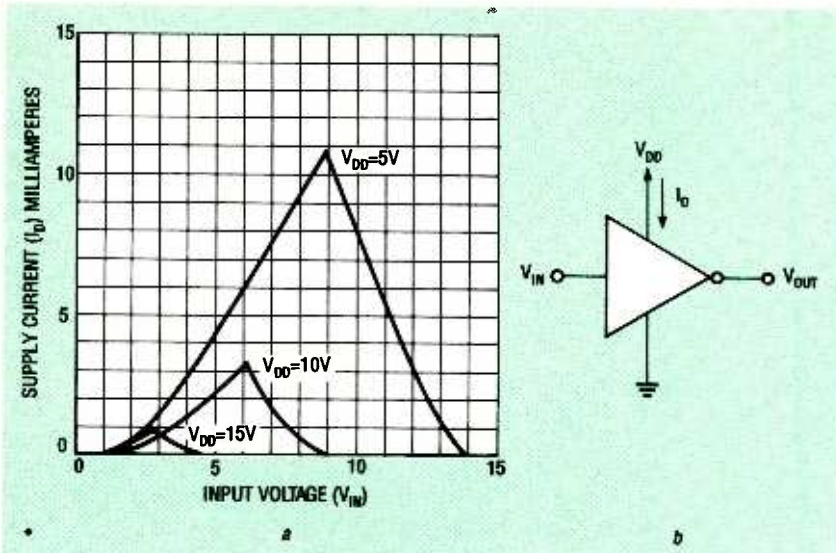

FIG. 14—TYPICAL DRAIN-CURRENT TRANSFER characteristics for the CMOS inverter with three different supply voltages.

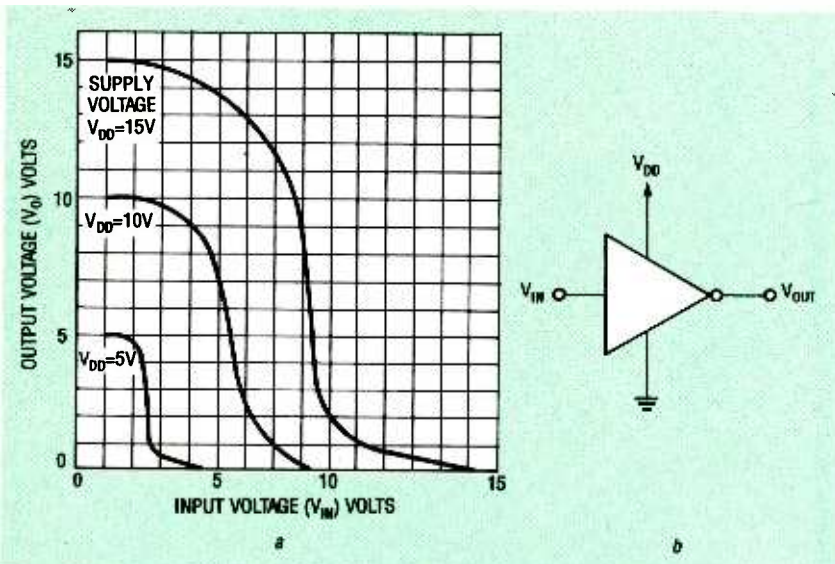

FIG. 15—TYPICAL INPUT-TO-OUTPUT VOLTAGE transfer characteristics for the CMOS inverter with three different supply voltages.

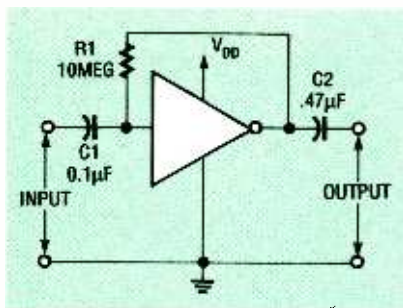

FIG. 16—A METHOD FOR BIASING the CMOS inverter for linear operation.

When the input to the digital inverter is at logic-1, the output is effectively shorted by Q2 to ground, so significant current can be drawn through Q2 from a load connected between the output and the positive supply. This is another very important feature of the CMOS digital inverter circuit.

A CMOS inverter can become a linear inverting amplifier by biasing its input terminal V_{IN} at a value intermediate between the logic-0 and logic-1 levels. In this situation Q1 and Q2 are both partly biased on, so the inverter passes significant quiescent current.

Figure 14 shows the typical drain-current transfer characteristics of the linear inverting amplifier under this intermediate condition. Drain current (I_D) is effectively zero when the input voltage (V_{IN}) is either at zero or full supply volts. However, drain current rises to its maximum value when the input voltage is approximately half the supply voltage.

Three different supply voltage (V_{DD}) conditions are shown in Fig. 14: 5, 10, and 15 volts. These result in drain currents of 0.5 milliampere, 4 milliamperes, and 10.5 milliamperes, respectively. Under these conditions both inverter MOSFET's are biased on equally.

Figure 15 shows typical input-to-output voltage-transfer characteristics for a CMOS inverter at three different power supply voltage V_{DD} values: 15, 10, and 5 volts. With a 15-volt supply, for example, the output voltage changes only a small amount when the input voltage is shifted between the V_{DD} and zero-volt levels.

However, when V_{in} is biased at roughly half the supply voltage, a small change of input voltage causes a large change of output voltage. In the half-supply condition, the inverter typically provides a voltage gain of about 30 dB when used with a 15-volt supply, or 40 dB with a 5-volt supply.

Figure 16 shows a CMOS inverting amplifier. This circuit is biased automatically by connecting 10-megohm resistor R1

Figure 13-c is the accepted logic symbol for a NOT gate. (This symbol was used in Fig. 8 to simplify the discussion of disabling unused complementary pairs.)

Although the CMOS digital inverter consumes zero quiescent current, it can source (feed) or sink (absorb) significant current into or out from external loads. When the input is at logic-0, the output is effectively shorted by Q1 to the positive power supply, so substantial current can feed through Q1 into a load connected to its output.

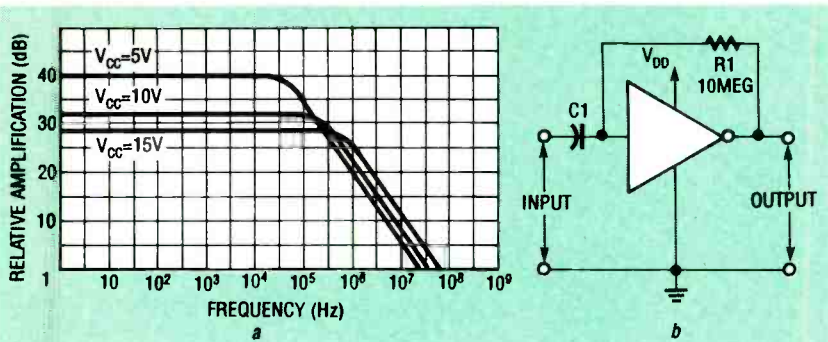

FIG. 17—TYPICAL GAIN VS. FREQUENCY CHARACTERISTICS for a linear-mode CMOS amplifier.

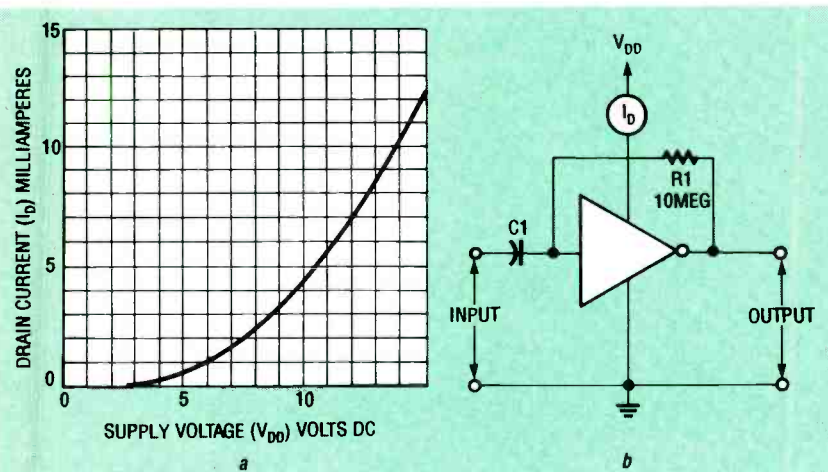

FIG. 18—TYPICAL DRAIN CURRENT VS. SUPPLY VOLTAGE characteristics of the linear-mode CMOS amplifier.

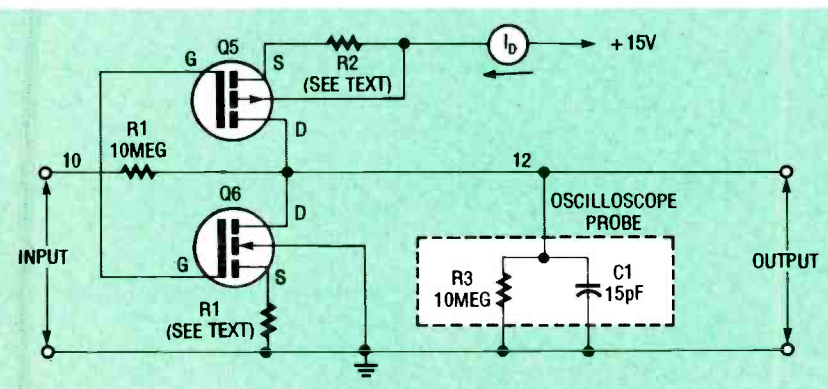

FIG. 19—MICROPOWER LINEAR AMPLIFIER based on the inverter in the CD4007UB CMOS linear amplifier, showing a method for reducing drain current.

between the input and output terminals. As a result, the output self-biases at approximately half the supply voltage.

Figure 17 shows typical voltage gain and frequency characteristic curves for a CMOS inverter stage when it is powered at three different levels: 15, 10, and 5 volts. These curves were obtained when the amplifier output fed into the

high impedance of a 10-megohm, 15-picofarad oscilloscope probe. Under this condition, the circuit has a bandwidth of 2.5 MHz when operated from a 15-volt supply.

As might be expected from the voltage transfer curves in Fig. 15, the distortion characteristics of the CMOS linear amplifier are not very good. The linearity is acceptable with small-

amplitude signals whose output amplitudes reach 3 volts peak-to-peak with a 15-volt supply. However, distortion increases progressively as the output approaches the upper and lower power supply limits. Unlike a bipolar transistor circuit, the CMOS amplifier does not "clip" excessive sinewave signals; it progressively rounds off their peaks.

Figure 18 shows the typical drain-current vs. supply-voltage characteristics of the CMOS linear amplifier. The drain current (I_D) typically swings from 0.5 milliamperes at 5 volts (V_{DD}) to 12.5 milliamperes at 15 volts (V_{DD}).

In many applications the quiescent supply current of the 4007UB CMOS amplifier can be reduced with a penalty of reduced amplifier bandwidth by placing external resistors in series with the source terminals of the two MOSFET's of the CMOS stage. This is illustrated as the micropower circuit of Fig. 19.

Table 2 shows the measured results of placing different values of resistor in the source circuits of transistors Q5 and Q6. With changing values of both R1 and R2, a constant supply voltage (V_{DD}) of 15 volts, and the output loaded by a 10-megohm, 15-picofarad oscilloscope probe, the results can be read across the table. They are drain current (I_D), voltage gain, and upper 3dB bandwidth.

The additional resistors shown in the circuit of Fig. 19 increase the output impedance of the amplifier. (The output impedance is roughly equal to the R1-voltage gain product.) This impedance and the external load resistance and capacitance has a significant effect on the overall gain and bandwidth of the circuit.

When the values of R1 and R2 are 10,000 ohms, it can be seen that if the load capacitance is increased from 15 picofarads to 50 picofarads, the bandwidth falls to about 4 kHz. However, if the capacitance is reduced to 5 picofarads, the bandwidth is increased to 45 kHz. Similarly, if the resistive load is reduced from 10 megohms to 10,000

TABLE 2
PERFORMANCE VARIATIONS FROM CHANGING DRAIN
RESISTOR VALUES OF A LINEAR AMPLIFIER

Resistors R1, R2 (ohms)	Drain Current ID (milligrams)	Voltage Gain	Bandwidth (kHz) @ 3dB Point
0	12.5	20	2700
100	8.2	20	1500
560	3.9	25	300
1000	2.5	30	150
5600	0.6	40	25
10,000	0.37	40	25
100,000	0.040	30	2
1 MEG	0.004	10	1

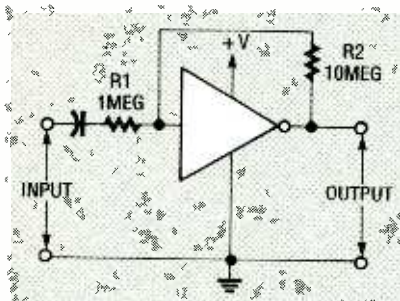

FIG. 20—AN X10 INVERTING AMPLIFIER
 formed from a linear CMOS amplifier.

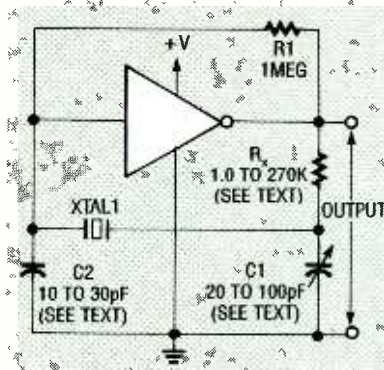

FIG. 23—A CRYSTAL OSCILLATOR
 based on a linear CMOS amplifier.

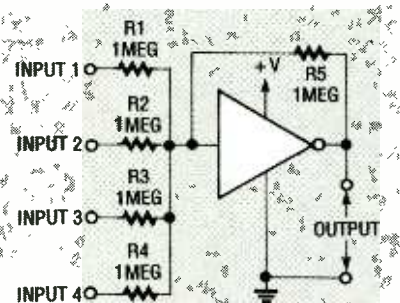

FIG. 21—THE UNITY-GAIN FOUR-INPUT
 audio mixer shown here is based on a
 linear CMOS amplifier.

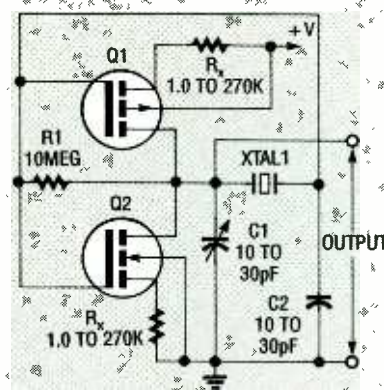

FIG. 24—A MICROPOWER VERSION
 of the crystal oscillator based on a CMOS
 inverter.

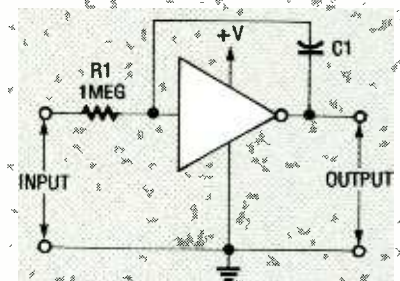

FIG. 22—AN INTEGRATOR based on a
 linear CMOS amplifier.

ohms, the voltage gain falls to unity. Thus, to obtain significant gain, the load resistance must be large relative to the output impedance of the amplifier.

The basic (unbiased) CMOS

Practical CMOS circuits.

A CMOS linear amplifier will function in either its standard or micropower forms to provide a wide range of fixed-gain amplifiers, mixers, integrators, active filters, and oscillators. Figures 20 to 24 are examples of some of the possible circuits derived from the amplifier

Figure 20 shows the practical circuit of a $\times 10$ inverting amplifier. The CMOS stage is biased by feedback resistor R2, and the voltage gain is set at $\times 10$ by the ratio of resistor R2 to resistor R1. The input impedance of the circuit is 1 megohm, and that equals the value of resistor R1.

Figure 21 shows how the circuit in Fig. 20 can be modified to become an audio mixer or analog voltage adder. The circuit has four input pins, and the voltage gain between each input and the output pin is held at unity by the relative values of the 1-megohm input resistor and the 1-megohm feedback resistor. Figure 22 shows how the basic CMOS amplifier is organized as a simple integrator.

Figure 23 shows how a linear CMOS amplifier can function as a crystal oscillator. The CMOS amplifier is biased into the linear region by resistor R1, which provides a 180° phase shift. The pi-type crystal network formed from R_X , C1 and C2, and XTAL1, provides the additional 180° of phase shift at the resonant frequency to cause the circuit to oscillate.

If you only want the circuit to oscillate at a frequency accurate to within about 0.1%, resistor R_X can be replaced with a shorting wire and both capacitors C1 and C2 can be omitted. For ultra-high accuracy, however, the correct values of R_X , C1, and C2 must be individually determined.

Figure 24 shows the schematic for a micropower version of the CMOS crystal oscillator. In this circuit, R_X is included in the amplifier. The output of this oscillator can be fed directly to the input of another CMOS inverter stage if you want a more precise waveform shape and higher amplitude.

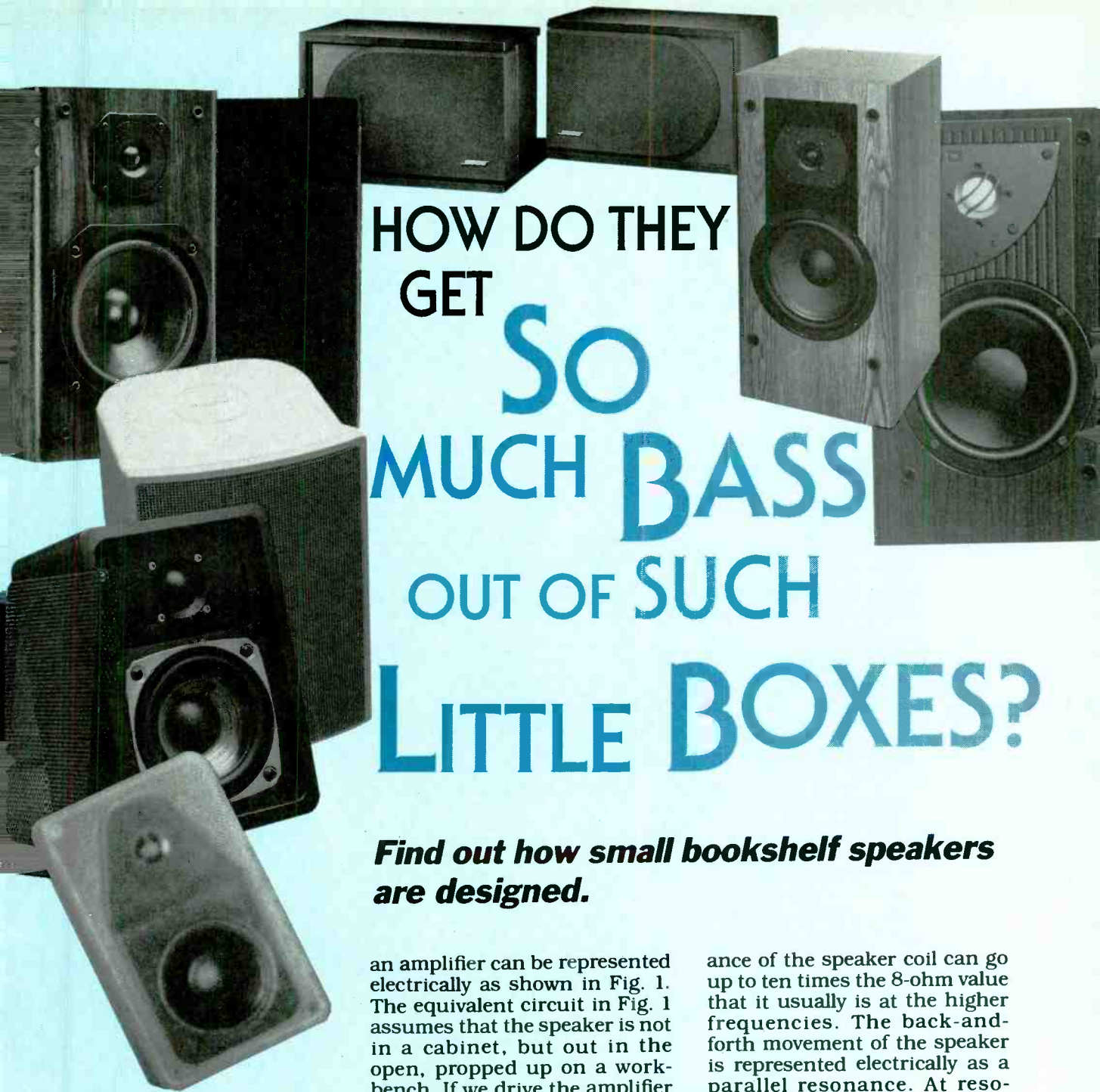

HOW DO THEY GET SO MUCH BASS OUT OF SUCH LITTLE BOXES?

Find out how small bookshelf speakers are designed.

DALE BLACKWELL

HAVE YOU EVER NOTICED THAT many very small stereo speakers can output more bass than others that are much larger? Why don't speakers have to be as large as they used to be? Is it modern engineering or wizardry that enables these small "bookshelf" speakers to produce such good sound? To explain all this, we'll first delve into a bit of theory about speaker and enclosure design.

A speaker that's hooked up to

an amplifier can be represented electrically as shown in Fig. 1. The equivalent circuit in Fig. 1 assumes that the speaker is not in a cabinet, but out in the open, propped up on a workbench. If we drive the amplifier from an oscillator, and use the amplifier to drive the speaker through a 500–1000-ohm resistor, a voltmeter can show the voltage generated across the speaker terminals at various frequencies.

The voltage across the speaker terminals from 1 kHz down to 20 Hz will be like that shown in Fig. 2. Note that the voltage doesn't change much except at the low frequencies where it peaks. The peak in voltage shows the speaker's resonance frequency, and the high voltage is present because the imped-

ance of the speaker coil can go up to ten times the 8-ohm value that it usually is at the higher frequencies. The back-and-forth movement of the speaker is represented electrically as a parallel resonance. At resonance, if you physically prevent the cone from moving, the voltage will drop, proving that the peak is due to the motion of the speaker cone assembly.

For a more accurate representation of the speaker, we have to add the electrical equivalents of the mechanical and acoustical elements of the speaker, and its coupling to the air, to our speaker model. That representation, shown in Fig. 3, has been simplified and shows only the major elements. Capacitor C1 represents the stiffness of the speaker-cone suspension, and induc-

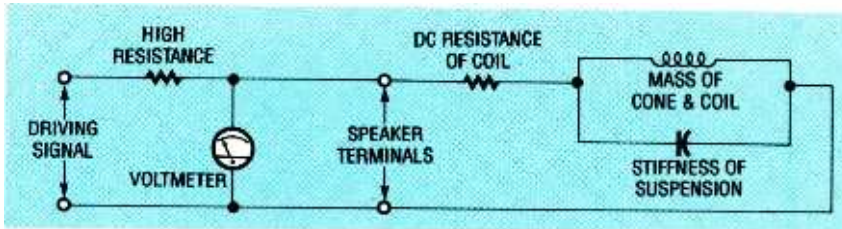

FIG. 1—ELECTRICAL REPRESENTATION of a speaker (with no cabinet) hooked up to an amplifier. The voltmeter can show the voltage generated across the speaker terminals at various frequencies.

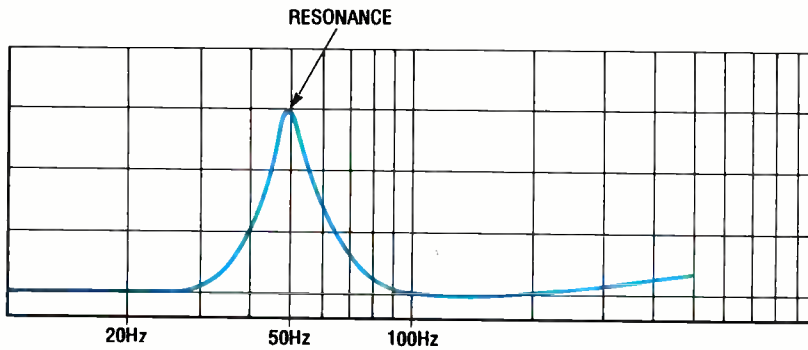

FIG. 2—TERMINAL VOLTAGE from 1 kHz down to 20 Hz. The voltage doesn't change much except in the low frequencies where it peaks.

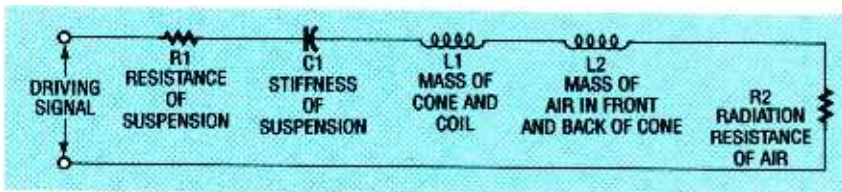

FIG. 3—THE ELECTRICAL EQUIVALENTS of the mechanical and acoustical speaker elements have been added to our speaker model.

tance $L1$ represents the mass of the cone and voice coil. Inductance $L2$ represents the mass of the air in front of and in back of the cone, and $R2$ represents the air's radiation resistance. The dissipation of power in the radiation resistance is what actually delivers sound to our ears.

At the resonant frequency of the circuit in Fig. 3, the speaker cone is moving to a very high amplitude with very high current flow and a large dissipation in $R2$. The reactance of $L1$ is low up to 1 kHz, and the reactance of $C1$ drops with increasing frequency, so neither presents a problem. At resonance, the reactance of $C1$ and $L1$ in series with $L2$ cancels out, so there is no problem here either. The major dissipation of power is in $R2$, the radiation resistance. The resistive losses in the suspension are very minor, and will not be considered.

If we now put our speaker into a cabinet, we have to add one

more element to our equivalent circuit. That element is series-capacitor $C2$ shown in Fig. 4. If the cabinet is perfectly sealed, $L3$ and $R3$ do not exist because there is no opening to the outside air. With $C1$ and $C2$ in series, their combination value drops to less than the value of the lowest of the two. That raises the resonance frequency of the speaker in the cabinet to the valves where the reactance of $L1$ and $L2$ in series is equal to the higher reactance of the new lower value of capacitors $C1$ and $C2$ in series.

If the cabinet is small, the resonance frequency rises to a point where it's too high to be acceptable with ordinary speakers (see the curve in Fig. 5). Putting a larger speaker—that requires a larger cutout—in the small cabinet only aggravates the problem, because the cabinet "looks" even smaller with the reduced inside surface area.

Note that the bass response is

good only down to resonance. Below that, the response drops off at 12 dB per octave as the speaker's amplitude remains constant with decreasing frequency, rather than the increase in amplitude with decreasing frequency above resonance. Many older speaker systems had very big cabinets with 12-inch or larger speakers (that radiate bass effectively) and still had a flat response down to 50 or 60 hertz. The capacitance of $C2$ was high enough so that it did not significantly lower the series value of $C1$ and $C2$; hence it did not raise the resonance much.

For many years, popular speakers were designed with very soft suspensions so that the value of $C1$ was very large. As a result, the resonance as measured in free air (as in Fig. 1) is located at 20 hertz or below. When such a speaker is put into a bookshelf-size cabinet, the increase in the resonance is less dramatic than with a speaker having a stiff suspension.

One more thing that can be done to get the resonance down to where it's acceptable is to make $L1$ larger. The added mass of the cone and coil drops the resonance—but we can't get something for nothing! As the reactance of $L1$ goes up to move the resonance down, the impedance of the circuit goes up and there is less current flow, hence less dissipation in $R2$. In other words, the efficiency of the system is reduced.

One way to increase the efficiency is by adding an acoustic port found on many speakers. In Fig. 4, the mass of air in the port is represented by $L3$, and the radiation resistance of the port, by $R3$. The most efficient way to set up $L3$ is to make it resonate with $C2$ at the speaker's resonance frequency (the resonance frequency measured with the speaker out of the cabinet as in Fig. 1.) As shown in the response curve in Fig. 6, the dissipation in $R2$ (the cone) drops to virtually zero at resonance, while the dissipation in $R3$ (the port) is maximum due to the resonance in the loop.

Remember that $L3$ and $C2$

have a very high impedance at resonance, with high loop current and high dissipation in R3, but the current through R2 is low due to the very high impedance of the whole circuit. That was the approach used in designing bass-reflex cabinets in the 1940's and 50's. A speaker with a 50-Hz resonance could be put into a box with a port tuned to resonate at 50 Hz, and there was no increase in speaker resonance with loss of bass as shown in Fig. 7. The box had to

be big enough so that the port could be at least half of the area of the speaker for it to radiate a significant amount of acoustic energy. Still, the port had to be made to resonate with the box at the same frequency as the speaker in free air.

If you were to look at the speaker cone at resonance in a bass-reflex speaker, you would find that it is virtually motionless, but if you checked the air motion at the port with a candle flame, you would see vio-

lent disturbance of flame. That's proof that the equivalent circuit in Fig. 5 does represent the mechanical and acoustical circuit of a bass-reflex speaker. Note that below resonance, the speaker starts to radiate again, but the radiation from the port is out-of-phase with the speaker and cancels the effective output so the response drops at 18-dB per octave. What happens below resonance is that when the cone moves into the box, the air inside just gets pushed out of the port and fills in the low-pressure area in front of the cone.

The problem in port design is that the mass of air in the port decreases (L3 goes down) as the area increases. The mass of air can be increased by making the port into a duct or a tube that extends into the box. The effective box size (volume of air) is reduced by the volume occupied by the duct. That makes C3 smaller (higher reactance), hence the resonant frequency is higher. In the bookshelf designs of today, the main radiation is from the speaker itself, and the port contributes little due to its small area. The volume of the tube for the port reduces the volume inside the box.

One factor that lowers the efficiency is that the smaller diameter speakers have to have higher amplitudes to radiate the same sound pressure level as a speaker of 12-inch diameter or larger. Consequently, the voice coil has to be longer so that the motion does not cause it to move out of the magnetic field. If that happens, it produces a "flat top" on the waveform, which is basically just distortion. The coil turns that are out of the magnetic field do not contribute to moving the speaker cone, but they do have DC resistance, hence the additional loss. The total loss from inefficiency in today's speakers results in output levels from 5 to 10 dB lower than those of speakers made in the 1940's and 1950's. Today's higher-power amplifiers offset that reduction.

Another approach to port design is to make the port an actual speaker cone that is suspended in the opening. That

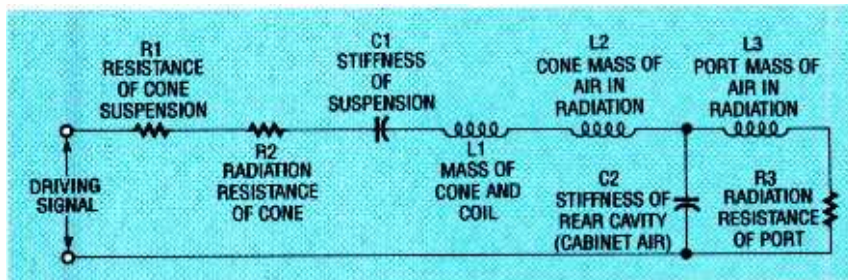

FIG. 4—WE ADD SERIES-CAPACITOR C2 to our model when we put our speaker into a cabinet.

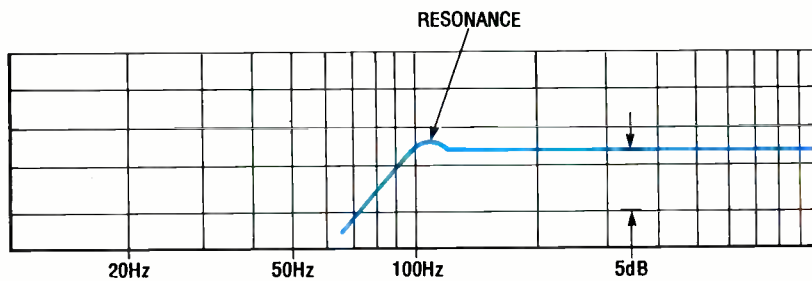

FIG. 5—WITH A SMALL CABINET, the resonant frequency rises to a point where it's unacceptable with ordinary speakers.

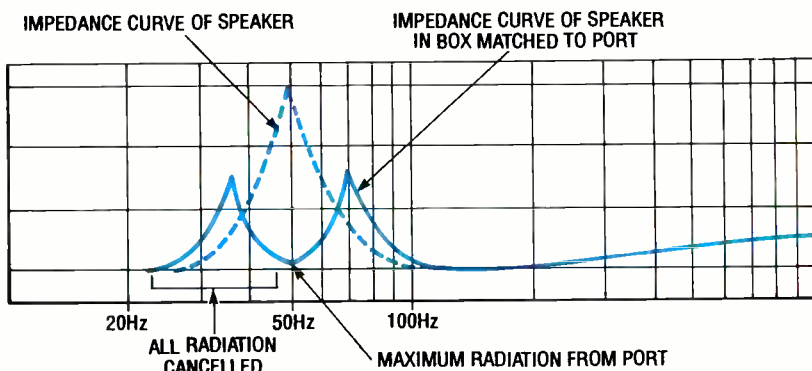

FIG. 6—HERE L3 IS SET UP to make it resonate with C2 at the speaker's natural resonance frequency.

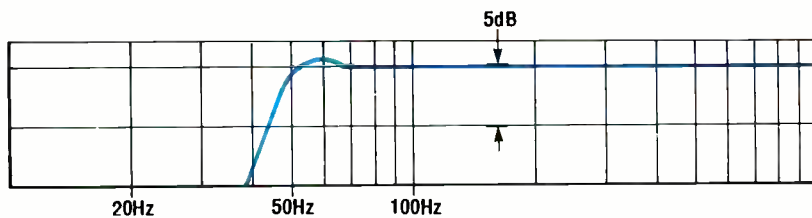

FIG. 7—BASS-REFLEX DESIGNS had a speaker of 50-Hz resonance in a box with a port tuned to resonate at 50 Hz.

- | | |
|---|--|
| <ul style="list-style-type: none"> <input type="checkbox"/> 223 Popular Electronics (1993 back issues) \$5.00
Write in issues desired _____ <input type="checkbox"/> 222 Popular Electronics (1992 back issues) \$5.00
Write in issues desired _____ <input type="checkbox"/> 221 Popular Electronics (1991 back issues, Jan., Mar. not available) \$5.00
Write in issues desired _____ <input type="checkbox"/> 220 Popular Electronics (1990 back issues) \$5.00
Write in issues desired _____ <input type="checkbox"/> 119 Popular Electronics (1989 back issues) \$5.00
Write in issues desired _____ <input type="checkbox"/> 118 Hands-On Electronics (1988 back issues) \$5.00
Write in issues desired _____ <input type="checkbox"/> EH93 Experimenters Handbook (1993) \$5.00 <input type="checkbox"/> EH92 Experimenters Handbook (1992) \$5.00 <input type="checkbox"/> EH91 Experimenters Handbook (1991) \$5.00 <input type="checkbox"/> EH90 Experimenters Handbook (1990) \$5.00 <input type="checkbox"/> EH88 Experimenters Handbook (1988-89) \$5.00 <input type="checkbox"/> HH93 Hobbyist Handbook (1993) \$5.00 <input type="checkbox"/> HH92 Hobbyist Handbook (1992) \$5.00 <input type="checkbox"/> HH91 Hobbyist Handbook (1991) \$5.00 <input type="checkbox"/> HH90 Hobbyist Handbook (1990) \$5.00 <input type="checkbox"/> HH89 Hobbyist Handbook (1989) \$5.00 <input type="checkbox"/> GIZ Gizmo—The Consumers Guide to Electronics \$5.00 <input type="checkbox"/> 213 Radio-Electronics/Electronics Now (1993 back issues) \$5.00
Write in issues desired _____ <input type="checkbox"/> 212 Radio-Electronics (1992 back issues) \$5.00 <input type="checkbox"/> 211 Radio-Electronics (1991 back issues) \$5.00
Write in issues desired _____ <input type="checkbox"/> 210 Radio-Electronics (1990 back issues) \$5.00
Write in issues desired _____ | <ul style="list-style-type: none"> <input type="checkbox"/> 109 Radio-Electronics (1989 back issues) \$5.00
Write in issues desired _____ <input type="checkbox"/> 108 Radio-Electronics (1988 back issues) \$5.00
Write in issues desired _____ <p style="text-align: center;">REPRINTS REPRINTS</p> <ul style="list-style-type: none"> <input type="checkbox"/> 170 High-Voltage Project for Fun and Science Book 1 \$4.00 <input type="checkbox"/> 170A High-Voltage Projects for Fun and Science Book 2 \$4.00 <input type="checkbox"/> 169 Think Tank (133 Circuits) \$3.50 <input type="checkbox"/> 169A Think Tank Vol. 2 \$3.00 <input type="checkbox"/> 168 Fact Cards (#34-66) \$4.00 <input type="checkbox"/> 168C Fact Cards (#67-99) \$3.50 <input type="checkbox"/> 168D Fact Cards (#100-132) \$3.50 <input type="checkbox"/> 167 Designing With IC's \$4.00 <input type="checkbox"/> 166 Collected Works of Mohammed Ullyses Fips (62 pages, April Fools Collection) \$5.00 <input type="checkbox"/> 165 How to Repair CD Disc Players \$5.00 <input type="checkbox"/> 164 Modern Electrics (April 1908) \$3.00 <input type="checkbox"/> 163 Receiving Satellite TV \$5.00 <input type="checkbox"/> 162 Build Your Own Satellite TV Receiver \$5.00 <input type="checkbox"/> 161 Descrambling (Feb. 1984) \$4.00 <input type="checkbox"/> 160 New Ideas - 42 Circuits \$3.50 <input type="checkbox"/> 159 Low Frequency Receiving Techniques Building and using VLF Antennas. \$5.00 <input type="checkbox"/> 158 Electro Importing Co. Catalog (Circa 1918) \$5.95 <input type="checkbox"/> 157 All About Kits \$2.00 <input type="checkbox"/> 156 How To Make PC Boards \$2.00 <input type="checkbox"/> 154 How To Repair VCR's \$3.50 |
|---|--|

To order any of the items indicated above, check off the ones you want. Complete the order form below, include your payment, check or money order (DO NOT SEND CASH), and mail to **Claggk Inc.**, Reprint Department, P.O. Box 4099, Farmingdale, NY 11735. Please allow 4-6 weeks for delivery.

To place a credit card order by phone, Visa or Mastercard only, of \$15.00 or more not including shipping and handling,

call: 516-293-3751.

For orders over \$15.00 you may use your Visa or Mastercard.

Bill my Visa Mastercard

Card No. _____

Exp. Date _____

Signature _____

MAIL TO: Claggk Inc.

Reprint Bookstore, P.O. Box 4099, Farmingdale NY 11735

All payments must be in U.S. funds

SHIPPING CHARGES IN USA & CANADA

\$0.01 to \$5.00	\$1.50	\$30.01 to 40.00	\$5.50	SORRY — We only ship to USA & Canada
\$5.01 to \$10.00	\$2.50	\$40.01 to 50.00	\$6.50	
\$10.01 to 20.00	\$3.50	\$50.01 and above ...	\$8.00	
\$20.01 to 30.00	\$4.50			

Total price of merchandise	\$ _____
Shipping Charge (see chart)	\$ _____
Subtotal	\$ _____
Sales Tax (New York State Residents only)	\$ _____

Name _____ Total Enclosed

Address _____

City _____ State _____ Zip _____

593

way the area can be maximized for good radiation at resonance, and the cone can be loaded with mass so that resonance is at the desired frequency.

The simplification of our equivalent circuits has left out second-order elements to keep our discussion from getting too complex. However, the basic principles hold true, and they help to explain the differences in the "big old boxes" of the past and the present-day bookshelf designs.

To sum everything up, we can say that the older speaker designs with 12-, 15-, and even 18-inch woofers had enough area to radiate the low frequencies well. However, they required large cabinets so that they could have a low resonance by keeping C2 large. The bass-reflex approach allowed a speaker with a reasonably low resonance (say 50 Hz) to be put in a cabinet with the port tuned to 50 Hz, and still be able to radiate 50 Hz. The cabinet had to be big enough to allow for a port that could resonate with the cabinet at 50 Hz. Those speakers sounded very good, but many people did not appreciate having those behemoths sitting in their living rooms.

The approach today is to design the speaker-cabinet package as a system. The best units are designed where the speaker and box parameters are calculated using network theory. The smaller woofers are designed to have longer-travel cone systems, low enough free-air resonance, and sufficient mass so that in a bookshelf-size cabinet, the resonance is in the 60-Hz range. The trade-off of lower efficiency for low resonance in a small cabinet size is offset by today's very affordable high-power amplifiers.

Today's bookshelf speakers make the most of most music. Only if you are a pipe-organ enthusiast do you need something with a lower response of 30 Hz and below. And if that's your musical preference, you either have to shell out the money for big speakers or build them yourself—but that's another story for another time.

PART-68

continued from page 58

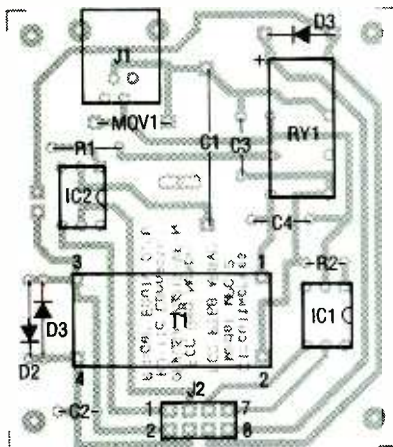
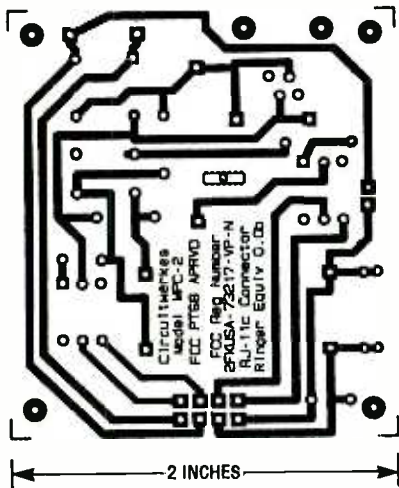

FIG. 2—PARTS-PLACEMENT DIAGRAM. The MPC-2 must be built exactly as described if it is to be type-approved.



and make sure it's firmly seated before soldering it. We recommend that you use DIP sockets for the two optocouplers. Note that the lettering on transformer T1 should be toward the center of the PC board so that the transformer's primary and secondary windings are oriented properly. The 2 × 4 eight-pin male header (J2) is optional; you can solder wires directly to the pads on the PC board. If you purchase the type-approved MPC-2 from the source in the Parts List, it includes a matching female IDC-type header connector and a short piece of eight-conductor ribbon cable for connecting the

PARTS LIST

All resistors are 1/4-watt, 5%.

R1—22,000 ohms

R2—1000 ohms

Capacitors

C1—0.56 μ F, 250-volts, Mylar

C2—0.01 μ F, 50-volts, ceramic disc

C3, C4—0.1 μ F, 250-volts, Mylar

Semiconductors

IC1, IC2—H11AA1 AC-input optoisolator (GE)

D1, D2—1N270 germanium diode

D3—1N4001 diode

Other components

J1—RJ-11C right-angle, PC-mount telephone jack (must be 50 micro-inch gold-plated)

J2—8-pin male header, 2 × 4, and matching female IDC connector (optional, see text)

T1—Telco line-isolation transformer (Dale TA-40-01 or equivalent)

MOV1—300-volt axial-leaded, metal-oxide varistor

RY1—12-volt DPDT relay (Midland Ross I90-22B100 or equivalent)

Miscellaneous: PC board, two 8-pin DIP sockets, ribbon cable.

Note: the following items are available from CircuitWerkes, 6212 SW 8th Place, Gainesville, FL 32606 (904) 331-5999, Fax (904) 331-6999:

- MPC-2 PC board only—\$9.00

- Complete kit for the MPC-2 (not type-approved)—\$19.95

- Assembled, type-approved MPC-2 (a stand-alone 2 × 2-inch board)—\$29.95

All parts orders must include \$3.50 postage and handling for each coupler. AZ residents add 5.5% tax.

Testing the MPC-2

You should test the MPC-2 before you connect it to your phone line. The tests should confirm the following:

- There is no DC path from TIP to RING (with RY1 de-energized)
- There is no DC path from TIP or RING to any of J2's pins
- Verify that T1 is oriented properly, and that the two limiter diodes are oriented in opposite directions.

Type approval

In addition to stating the technical requirements for telephone equipment, the FCC rules require that every piece of equipment connected to the phone lines be registered with the FCC, no matter what its function. It is not enough to design a device that meets the specifications: Every product must be tested, certified, and registered. The rules are very clear. Individuals who connect non-registered devices to the phone line risk penalties from equipment confiscation up to fines of \$10,000 per day for each device they have. In addition, the use of a non-registered device makes one liable to the phone company for any damages incurred as a result.

So with all that at stake, why doesn't everyone register his gear? Well, you start with the \$155.00 fee that the FCC charges each time you register a new device. Usually, that \$155 is just the tip of the iceberg. The tests required are complex, and some unusual and expensive equipment is needed. Certification by a testing lab can run from \$1,500 to \$3,500 for a simple one-line device. The prospect of spending upwards of \$1,500 could be daunting if you're a hobbyist and want to make a little phone project for yourself. That's why we are offering our MPC-2 as a pre-assembled, type-approved unit with Part-68 registration that can be transferred to your projects.

Next month we'll detail the construction of an auto-answer/auto-disconnect coupler kit based on the MPC-2 voice-protective coupler.

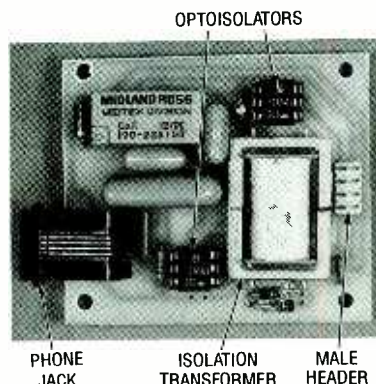
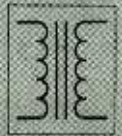

FIG. 3—AN ASSEMBLED MPC-2. You can purchase an identical one from the source in the Parts List.

MPC-2 to your projects. Figure 3 shows a completed MPC-2 phone-line interface.

FUN WITH ELECTRONICS

Coil Design and Construction Manual



◀ **160—COIL DESIGN & CONSTRUCTION MANUAL** \$5.95. How to make RF, IF, audio and power coils; chokes and transformers. Practically every possible type is discussed.

PCP113—THE PC MUSIC HANDBOOK \$13.95.

Learn the basics of computer music systems. For the professional musician, gifted amateur or just plain curious.



◀ **BP297—LOUDSPEAKERS FOR MUSICIANS** \$6.25. Loudspeaker design from the musician's point of view! All you need to know, and you should be able to design your own after reading this.

BP277—HIGH POWER AUDIO AMPLIFIER CONSTRUCTION \$6.25.

Here's background and practical design information on high power audio amplifiers capable of 300 ± 400 watts r.m.s. You'll find MOSFET and bipolar output transistors in inverting and non-inverting circuits.



◀ **BP302—A CONCISE USER'S GUIDE TO LOTUS 1-2-3 RELEASE 3.1** \$6.25. If you are a PC user and want to upgrade to Lotus 1-2-3 release 3.1, this book can teach you how to do that in the shortest and most effective way.

BP298—A CONCISE INTRODUCTION TO THE MACINTOSH SYSTEM AND FINDER \$6.25.

This introduction for those new to the Mac, this book also serves as a quick refresher for experienced owners that have not used the machine in some time.



MAIL TO: **Electronic Technology Today, Inc.**
P.O. Box 240
Massapequa Park, NY 11762-0240

SHIPPING CHARGES IN USA AND CANADA

\$0.01 to \$5.00	... \$1.50	\$30.01 to \$40.00	... \$5.50
\$5.01 to \$10.00	... \$2.50	\$40.01 to \$50.00	... \$6.50
\$10.01 to \$20.00	... \$3.50	\$50.01 and above	... \$8.00
\$20.01 to \$30.00	... \$4.50		

SORRY, No orders accepted outside of USA and Canada

Total price of merchandise \$	_____
Shipping (see chart) \$	_____
Subtotal \$	_____
Sales Tax (NYS only) \$	_____
Total Enclosed \$	_____

Name _____
Address _____
City _____ State _____ Zip _____

HDTV

continued from page 40

will record the digitally encoded combined video, audio and data signals from the receiver prior to decompression. The data rate at this point is approximately 21 megabits per second. On playback, the signal is returned to the receiver for error correction, de-formatting, and display.

Figure 6 illustrates how the VCR is incorporated into the receiving system. It is a very economical arrangement; the VCR does not need any video compression or decompression processing as all of that circuitry is in the receiver. The HD-VCR will record and play two hours of programming on a standard ST-120 Super-VHS tape; the VCR is expected to cost about \$1000 when it is introduced.

areas, each of which contains 16 coefficients as illustrated in Fig. 7.

That approach cleverly separates the coefficients which are most vital for describing the image. Area A includes the gray scale (DC term) together with the low-frequency components, which are the most likely to have significant value. The areas B, C, and D contain successively increasing frequencies with successively diminishing importance.

In each of the areas, a unique codeword is assigned to every possible combination of coefficients, and Huffman (variable length) coding is then used to lower the average bit rate. That vector-coding technique is said to provide a perfect decoded reproduction at the receiver of the image input to the DCT at the transmitter.



SONY'S HDC-500 HIGH-DEFINITION 3-CCD studio camera outputs video at 1125 lines, 60 fields per second. Such cameras are used for electronic cinematography, but they are not compatible with the digital HDTV schemes under consideration.

Channel Compatible DigiCipher

The Channel-Compatible DigiCipher (CCDC) HDTV system operates with the same baseband standards as the DSC system. The discrete cosine transform is once again used to derive frequency coefficients. But for CCDC, another form of readout from the frequency array has been developed. It is a vector-coding arrangement in which the 8 × 8 transformed array is partitioned into four

The future

The FCC does not have an enviable job in selecting a TV system that, for better or for worse, will be with us for many years. The stakes are high for each of the companies involved in the competition and for all of us. It now appears possible, however, that the Advanced TV Advisory Committee might select an HDTV standard that will be a combination of the best parts of DigiCipher, ADTV, DSC, and CCDC. □

HARDWARE HACKER

Video-game repair, piezoelectric fundamentals, Curie points, EDM machining, and some stunning new IC's.

DON LANCASTER

Every once in a while, a new hacker opportunity comes by that is absolutely stunning. An entire book crammed full of them is an even rarer event.

So, drop what you are doing right now and *run* out and grab your free a copy of the new *Integrated Circuit Systems* data book.

These folks have just come out with an unbelievably mind-blowing assortment of exciting integrated circuits. Figure 1 is a quick summary of some of their more interesting products. Included are VGA-to-NTSC genlocks; 25-voice, CD-quality synthesizers; 5-channel, digitally controlled mixers; and SMPTE-to-MIDI time-code chips.

Compared to those wonderments, their new fast battery-charging chips and the unique new caller-ID devices seem hardly worth mentioning at all!

Oops. A major boo-boo. Back in the resistance-wire story, I should have said that 17.58 watts is a heating *rate* of one BTU *per minute*.

Another good source for Nichrome substitutes is *Hoskins*, a producer of alloys for higher-temperature heater elements. Their brand name is *Chromel*.

Piezoelectricity

Piezoelectric devices are really great for hacking. But a lot of helpline callers seem badly misinformed over what you can and cannot do piezo-wise. Let's take a closer look.

As Fig. 2 shows, certain dielectric (or insulating) materials exhibit a *piezoelectric* effect. If you bend a piezo material, a charge will appear on its surface. Reversibly, if you apply an electrical charge to a piezo material, it should bend. Or at least try to bend, creating a force against whatever is restraining it. Thus, you can use a piezo material to convert mechanical forces or motions into

electrical signals. Or vice versa.

The classic piezo material is quartz. That material can be sliced up and plated for use in frequency-standard crystals, filters, accelerometers, time-delay lines, or force transducers.

A quartz oscillator crystal is just a rock—a highly mechanically resonant rock that has a few wires added to it. Depending on the application, the crystal will appear electrically as a very low-impedance series-resonant circuit. Or as a very high-impedance *parallel*-resonant circuit. Positive feedback applied externally to the quartz crystal might cause it to oscillate at its resonant frequency or at a chosen overtone. The frequency can be very stable because of the temperature stability and very high *Q* of the mechanical system involved.

We'll get further into crystals some other time. My favorite source for the lower-frequency crystals is *Statek*, while *Crystek* is one of many places to go for small quantities of custom higher frequencies.

If at all possible, there are only *two* crystal frequencies that a hacker should select. Those are 32.768 kilohertz (used in digital clocks), or 3.579545 megahertz (the NTSC colorburst reference). Crystals at those two "magic" frequencies are ridiculously cheaper and easier to get than any other choice. Even if you have to divide or multiply to get what you really want,

you'll usually end up far ahead by starting with those.

Another traditional piezo material was *Rochelle salt*, otherwise known as potassium sodium tartrate. That material was used in "crystal" phono cartridges and "crystal" microphones. But Rochelle salt was not all that stable or sensitive. You also had to chop up whole crystals, rather than forming it in the precise shape you really were after. Rochelle salt has largely been replaced by better and cheaper-to-process materials.

But you can buy Rochelle salt at your drugstore (it is also a laxative) and can easily grow your own piezo materials. See *Crystals and Crystal Growing* in the Doubleday Science Series for more information.

One group of improved materials for resonators are the "technical ceramics" barium titanate or "PZT" lead zirconate titanate. Those ceramics can be molded into almost any shape before they are fired. The resonant structures, which are similar to quartz crystals, are used as filters, especially for radio and TV intermediate-frequency amplification stages. *Murata-Erie* is one leading supplier.

Fancier piezo resonant structures are *surface acoustic wave devices*. By carefully controlling the metal patterns on a piezo surface, you can launch and recover acoustical energy. The patterns can give you precise higher order filtering, time delays, or an equalization response. One big advantage of SAW devices is that they are pre-tuned and need no adjustments. The important uses include cable TV, television IF filters, cellular phones, and microwave applications. Ads for these show up in *Microwaves New Product Digest*.

Larger flat piezo *benders* resonate at audio frequencies and can form beepers or squawkers. You'll

NEED HELP?

Phone or write your **Hardware Hacker** questions directly to:
Don Lancaster
Synergetics
Box 809
Thatcher, AZ 85552
(602) 428-4073

find a wide selection at *Radio Shack*, while a leading volume supplier is *Projects Unlimited*. Note that a bender does *not* oscillate by itself. It has to be used for feedback in a transistor or a logic inverter circuit. Some benders have taps provided to make their feedback easier. A pair of oscillators can be used to produce a series of beeps, instead of a continuous tone.

Smaller benders form ultrasonic microphones. These were once used as ultrasonic Doppler burglar alarms before all those new pyroelectric "people detectors" blew them out of the water—and for remote controls before infrared diodes did them in. Ultrasonic microphones are still used for the electronic measuring devices used by contractors and rug installers. And to annoy dogs and mosquitoes. (Near as I can tell, all those really do is make the mosquitoes hungry.)

Piezo devices in sheet or strip form can be used for hi-fi tweeters and higher-quality, low-cost electret-style "condenser" microphones. Unlike the traditional electrostatic

GSP500 –

A VGA to NTSC video genlocking processor. Allows VGA and super VGA text and graphic images to be displayed on standard NTSC televisions or recorded on a VCR. Also genlocks and synchronizes external camcorder or VCR inputs.

ICS1399 –

A music synthesizer for high performance professional keyboard instruments. Includes 25 voices and on-board real time digital filters and digital-to-analog conversion. Synthesis is by way of table lookup, so virtually any real or imagined instrument can be emulated.

ICS2101 –

A digitally controlled audio mixer that accepts five stereo input pairs and provides one stereo output pair. Log attenuation at half a decibel per step over a sixty decibel range. Optional panning mono mode. Intended for audio cards in multi-media personal computers.

ICS2008 –

A SMPTE Time Code receiver and generator. Offers both the older LTC longitudinal time code and the newer CIRC vertical interval codes. These codes are often used in video editing and to synchronize multimedia events. Supports NTSC, PAL and film rates.

ICS2010 –

A MIDI compatible SMPTE time code processor. Allows you to use standard video time codes to control and sequence any MIDI music environment. Supports MIDI quarter frame messages. Selective video overlay is available as an option.

ICS1700 –

A "Quicksaver" controller for Nickel-Cadmium batteries. Does a full charge in twenty minutes. Uses a temperature sensing and rate of charge termination to determine a fast yet safe charging rate. Ideal for notebook computers and portable video applications.

ICS1660 –

A telephone caller id chip that includes ring detection and calling party number extraction. When provided by the phone company, the caller id signals appear between the first and second rings and are extracted by FSK modem techniques. Includes power down features.

FIG. 1—EXCITING NEW HACKER CHIPS from the latest Integrated Circuit Systems data book. These will take years to sort out. What new can you do with them?

mikes, no bias voltage supply is needed.

Larger, higher-power piezo transducers can be used for ultrasonic machining and cleaning, and for underwater sonar applications. One source of ultrasonic cleaning transducers is *Branson*, while *EDO Acoustics* offers custom higher power piezo devices. Surplus sonar devices are sometimes provided by *Fair Radio Sales*. One leading sonar piezo manufacturer is *International Transducer*.

A sudden mechanical force applied to a stack of piezo elements creates a sparking barbecue lighter or a gas furnace striker. You can

check your local hardware store for these.

A shorter and far more controlled stack makes a *piezo micropositioner*, a device that can adjust things to micron-sized distances required for microscopy, integrated-circuit manufacturing, or for DNA research. Surprisingly high forces are now available. One micropositioner source is *NEC*. Various other sources advertise in the *Laser Focus World* and *Lasers and Optronics* trade journals.

Piezo fans have been built by resonating a pair of Mylar blades. That can be an interesting way of handling low-power spot cooling, but

**NEW FROM
DON LANCASTER**

HARDWARE HACKER STUFF

Hardware Hacker Reprints II or III	24.50
Midnight Engineering Reprints	24.50
Resource Bin Reprints	16.50
Incredible Secret Money Machine	18.50
CMOS Cookbook	24.50
TTL Cookbook	24.50
Active Filter Cookbook	24.50
Micro Cookbook vol I or II	19.50
Lancaster Classics Library	119.50

POSTSCRIPT STUFF

Ask The Guru Reprints I, II or III	24.50
PostScript Secrets (Ile/Mac/PC)	39.50
PostScript Show & Tell	39.50
Intro to PostScript VHS Video	39.50
PostScript Beginner Stuff	39.50
PostScript Cookbook (Adobe)	18.50
PostScript Ref. Manual II (Adobe)	28.50
PostScript Program Design (Adobe)	22.50
Type I Font Format (Adobe)	15.50
LaserWriter Reference (Apple)	19.50
Real World Postscript (Roth)	22.50
PostScript Visual Approach (Smith)	22.50
Thinking in PostScript (Reid)	22.50
Undst PS Pgrmmg (Holtzgang)	29.50
The Whole Works (all PostScript)	349.50

BOOK-ON-DEMAND STUFF

Book-on-demand resource kit	39.50
Genie PSRT sampler (Ile/Mac/PC)	39.50

FREE VOICE HELPLINE VISA/MC

SYNERGETICS
Box 809-RE
Thatcher, AZ 85552
(602) 428-4073

CIRCLE 191 ON FREE INFORMATION CARD

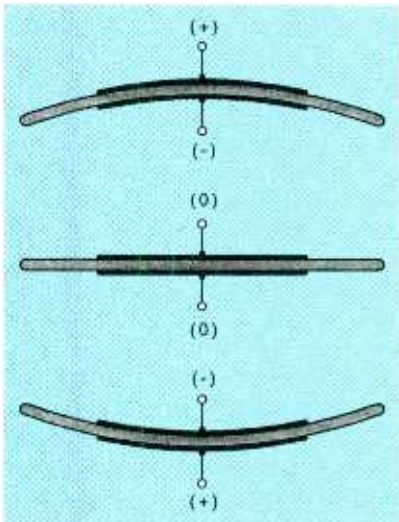

FIG. 2—THE PIEZOELECTRIC EFFECT in certain dielectric materials converts an input voltage to a mechanical motion or vice versa. Important uses include filters, beepers, sonar, ultrasonics, micro-positioners, gyros, microphones, miniature fans, strain gauges, accelerometers, and furnace igniters.

will unlikely replace traditional cooling fans. The main supplier is *Piezo Electric Products*. While some interesting piezo steppers and motors have been offered, they have so far been commercial failures.

Other emerging piezo uses include accelerometers, rate gyros, and for applications involving pressure transducers.

An exciting new variant of piezo material has been developed by *Atochem/Pennwalt*. The material is produced by heating ordinary *Kynar* plastic films above their *Curie Points* and applying a strong electric field. When cooled, the electric field gets "locked in," thus creating a piezo device known as an *electret*.

You will now find zillions of new applications for this thin, light, and ultra low-cost *Kynar* piezo material. They include infrared people detectors (the films can be both piezoelectric and pyroelectric), driveway traffic detectors, bounceless pushbuttons, impact sensors, electronic drums, shock detectors, handicapped aides, and bunches of others.

Atochem has free sample piezo transducers available for you, along with instructions on how to assemble microphones, flame detectors, touch switches, and lots of other hacker stuff with them—using

nothing but business cards and foam coffee cups. Atochem also offers a series of piezo development kits.

Technical information on piezoelectric devices and applications tends to be spread a little thin. I know of no piezo-industry trade journal, and the older *Piezoceramic Manufacturer's Association* appears to be long gone. There is a small *Ultrasonic Industry Manufacturer's Association*.

Some piezo material appears in the *IEEE Transactions on Sonics and Ultrasonics*. Also check the *Journal of the Acoustical Society of America*. And, of course, you can thoroughly and cheaply research any technical topic through the *Dialog Information Service*.

The problems

As I see it, there are two serious hacker misconceptions over piezo devices that seem to be causing a lot of helpline grief. These are the facts that *most piezo devices must be kept cool*, and that *most piezo devices are AC-only* and will not in any manner respond to continuous, steady-state, or DC inputs.

Any piezo device has a critical temperature called the *Curie point*. Above the *Curie point*, *all piezo effects are lost*. And the effects stay lost unless the material is put through a fancy and critical "re-charging" process.

For most of the high-volume, low-cost materials, the *Curie point* lies somewhat above the temperature of boiling water.

You must be extremely careful when you solder a piezo device to make sure you avoid reaching the *Curie Point*. Those ancient "crystal" phono cartridges were especially susceptible to soldering damage.

Yes, there are piezo materials with higher *Curie points*. But most of them are expensive and out of the mainstream. *Piezo Kinetics* is one innovator here.

A piezo device is nothing but a capacitor that swaps charge back and forth. Figure 3 gives us a closer look at what really happens here. Say you apply a positive voltage. The device will bend when the voltage is applied and unbend after-

Cable TV Descrambler Kits

Universal Kit.....\$59.95

Includes all parts and PC Board. Not included is the ac adaptor or enclosure.

Tri-Mode Kit.....\$39.00

Includes all parts, PC Board and AC Adaptor. Not included is the enclosure.

SB-3 Kit.....\$29.00

Includes all parts, PC Board and AC Adaptor. Not included is the enclosure.

Universal Tutorial.....\$9.95

Includes an in depth study of the technology used and has troubleshooting hints.

Tri-Mode Tutorial.....\$9.95

Includes a gate by gate study of the circuit and has troubleshooting hints.

Snooper Stopper.....\$39.00

Protect yourself from descrambler detection and stop the "bullet".

**Call Toll Free
1-800-258-1134
C.O.D.**

**M & G Electronics, Inc.
301 Westminister Street
Providence, RI. 02903**

CIRCLE 186 ON FREE INFORMATION CARD

Be an FCC LICENSED ELECTRONIC TECHNICIAN!



No costly school. No commuting to class. The Original Home-Study course prepares you for the "FCC Commercial Radiotelephone License." This valuable license is your professional "ticket" to thousands of exciting jobs in Communications, Radio-TV, Microwave, Maritime, Radar, Avionics and more...even start your own business! You don't need a college degree to qualify, but you do need an FCC License.

No Need to Quit Your Job or Go To School This proven course is easy, fast and low cost! **GUARANTEED PASS**—You get your FCC License or money refunded. **Send for FREE facts now. MAIL COUPON TODAY!**

COMMAND PRODUCTIONS

FCC LICENSE TRAINING, Dept. 90
P.O. Box 2824, San Francisco, CA 94126
Please rush FREE details immediately!

NAME _____
ADDRESS _____
CITY _____ STATE _____ ZIP _____

PIEZO RESOURCES

Atochem/Pennwalt

3 Parkway
Philadelphia, PA 19102
(215) 587-7000
CIRCLE 316 ON FREE INFORMATION CARD

AVX Corporation

PO Box 867
Myrtle Beach, SC 29577
(803) 448-9411
CIRCLE 317 ON FREE INFORMATION CARD

Branson Ultrasonics

41 Eagle Road
Danbury, CT 06813
(203) 769-0400
CIRCLE 318 ON FREE INFORMATION CARD

Bruel & Kjaer

185 Forest Street
Marlborough, MA 01752
(508) 481-7000
CIRCLE 319 ON FREE INFORMATION CARD

Channel Industries

839 Ward Drive
Santa Barbara, Ca 93111
(805) 967-0171
CIRCLE 320 ON FREE INFORMATION CARD

Channel Products

7100 Wilson Mills Road
Chesterland, OH 44026
(216) 423-0113
CIRCLE 321 ON FREE INFORMATION CARD

Crystek

2371 Crystal Drive
Fort Myers, FL 33906
(813) 936-2109
CIRCLE 322 ON FREE INFORMATION CARD

EDO Acoustics

2645 South 300 West
Salt Lake City, UT 84115
(801) 486-2115
CIRCLE 323 ON FREE INFORMATION CARD

Fair Radio Sales

PO Box 1105
Lima, OH 45802
(419) 227-6573
CIRCLE 324 ON FREE INFORMATION CARD

Int'l Transducer Corp

869 Ward Drive
Santa Barbara, CA 93111
(805) 683-2575
CIRCLE 325 ON FREE INFORMATION CARD

K-tech Corp

901 Pennsylvania Ave, NE
Albuquerque, NM 87110
(505) 268-3379
CIRCLE 326 ON FREE INFORMATION CARD

MG Electronics

32 Ranick Road
Hauppauge, NY 11788
(516) 582-3400
CIRCLE 327 ON FREE INFORMATION CARD

Motorola Ceramic Products

4800 Alameda blvd, NE
Albuquerque, NM 87113
(505) 822-8801
CIRCLE 328 ON FREE INFORMATION CARD

Murata-Erie

2200 Lake Park Drive
Smyrna, GA 30080
(404) 436-1300
CIRCLE 329 ON FREE INFORMATION CARD

NEC

PO Box 7241
Mountain View, CA 94039
(800) 632-3531
CIRCLE 330 ON FREE INFORMATION CARD

Piezo Electric Products

212 Durham Avenue
Metuchen, NJ 08840
(908) 548-2800
CIRCLE 331 ON FREE INFORMATION CARD

Piezo Kinetics

PO Box 756
Bellefonte, PA 16823
(814) 355-1593
CIRCLE 332 ON FREE INFORMATION CARD

Projects Unlimited

3680 Wyse Road
Dayton, OH 45414
(513) 890-1918
CIRCLE 333 ON FREE INFORMATION CARD

Shogyo

287 Northern Blvd
Great Neck, NY 11021
(516) 466-0911
CIRCLE 334 ON FREE INFORMATION CARD

Statek

512 N Main Street
Orange, CA 92668
(714) 639-7810
CIRCLE 335 ON FREE INFORMATION CARD

Ultrasonic Industry Association

PO Box 5126
Old Bridge, NJ 08857
(201) 679-9666
CIRCLE 336 ON FREE INFORMATION CARD

Valpey-Fisher Corp

75 South Street
Hopkinton, MA 01748
(508) 435-6831
CIRCLE 337 ON FREE INFORMATION CARD

ward. There will be no current before the voltage is applied. There will be a *positive current only while your bending is taking place*. The energy goes into the physical motion work load and raising the internal charge state of the piezo device. After your bending is finished, you'll still need to apply a voltage to *keep* the device bent, but there will be zero current, either into or out of the device.

When you remove the voltage, the device returns to its flat state. This time there should be a net *negative current out* of the device as the higher internal energy state gets released. Some of this negative energy may get spent overcoming any air resistance, producing internal heating, or doing other mechanical work.

At any rate, the key point here is that *there is only a net energy flow into or out of a piezo device whenever the applied voltage or your mechanical force is changing*. The steady-state response is zero. Just as with any other capacitor.

Now let's look at it backward. Put a "perfect" voltmeter on your piezo device and push on the device. What happens? As soon as you press, there is a net surface charge that your voltmeter measures. As long as you are pushing, the voltmeter will *still* read the voltage resulting from this charge. But, *if there is any external or internal resistive load at all, the charge will rapidly drain off*.

Use a "real" voltmeter instead, and you will get a positive pulse when you first apply your pressure, and a negative pulse when you release it. Why? Because the resistance load inside the voltmeter drains off the previous charge.

Thus, piezo devices are inherently AC devices that only respond when the force, motion, or electrical signal is *changing*. There is no "DC," "constant voltage," or "steady state" energy conversion response.

Many popular piezo devices have a natural time constant of one second or so. They can be used at sub-audio frequencies. But their DC steady state response is zero. Piezo devices are thus largely unsuited for such things as weight

scales, accelerometers, position transducers, or pressure-to-voltage converters—unless you get really sneaky and use fancy chopper, carrier, or integrator stunts.

Piezo power generation?

Several helpline callers have asked whether piezo devices are suitable for commercial power generation. The possibilities look very grim here. By far the highest power piezo electricity generator I know about is the lighter for the carbide light on my caving helmet, which is just a modified gas-furnace igniter. And while small-wattage piezo fan motors do exist, they don't exactly have the entire air-conditioning industry quaking in its boots.

Yes, there are higher-power piezo transducers. Hundreds of watts for ultrasonic cleaners and machining. And perhaps thousands of watts for sonar. But I know of none of these ever producing electricity.

For piezo power generation, the mechanical work input would have to be oscillatory and usually has to be resonantly coupled. Piezo devices also must be kept cool. If they get anywhere near their Curie point, all piezo effects stop.

Worse yet, the best efficiencies of the high-power units are often fifty percent or less. That leads to very bad economics and internal heating.

Worst of all, most piezo elements are inherently very high-impedance devices—usually in the ten-megohm range. For maximum power transfer out of any system, the impedances of your source and load *must* be made equal. This means you'll usually get a high-voltage, higher-frequency, high-impedance output from any piezo device. Tens of kilovolts or higher for larger devices. Efficiently converting this into recoverable power is not a trivial task. It's also not at all obvious to me how you can combine the multiple outputs from several piezo devices efficiently and cheaply.

Finally, unless you are in an "Uh, compared to what?" situation in outer space or on a desert island, the first and foremost question in any power generation scheme is "What are the economics?" If the rate of the energy production can-

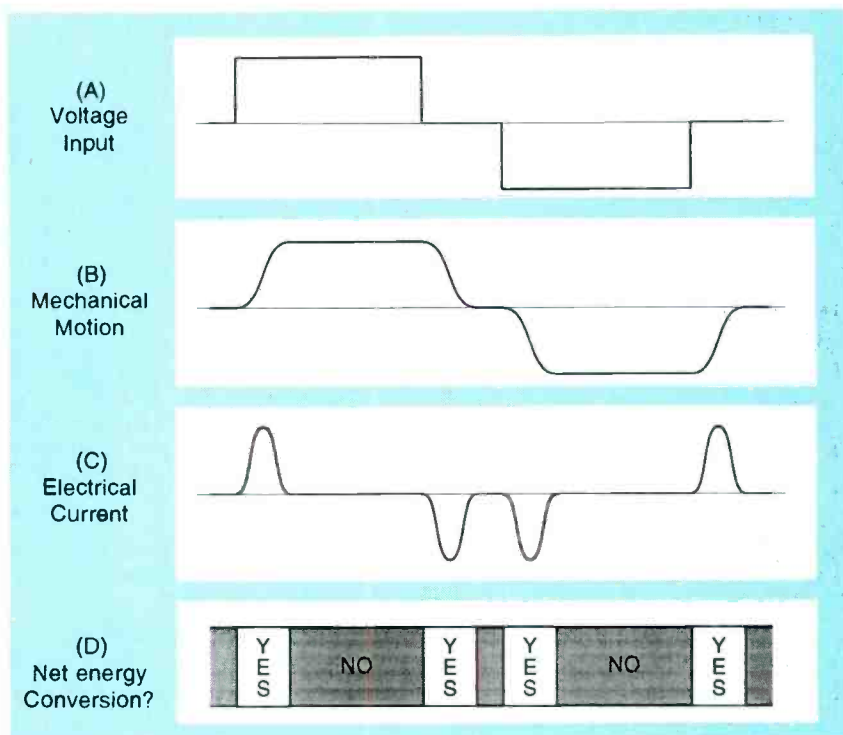

FIG. 3—JUST LIKE ANY OTHER CAPACITOR, a piezo device obeys an "AC only" response. The only time you will get any energy transfer between electrical and mechanical inputs is when one or both of them are changing in some manner.

CFC Free
Electro-Wash® 2000:
Today's Degreaser

Thoroughly cleans and degreases electronic parts and equipment.

- Non-ozone depleting
- Effectively removes dirt, grease and other contaminants
- Evaporates instantly
- Excellent material compatibility

THE SURVIVAL KIT

The Right Products For The Long Run

Chemtronics®

For technical assistance, call 1-800-TECH-401

not more than pay for the time value of the money used in construction, then your conversion scheme is totally useless.

Viable alternatives to piezo power generation are covered in depth in *Electric Power Research Institute* and the *Association of Energy Engineers* publications.

Piezo resources

I've gathered some of places to go for more piezo information into our resource sidebar. Most of the sources shown but not covered above are suppliers of materials and devices.

For this month's contest, either (A) tell me about a piezo trade journal, or (B) show me any new and hacker friendly piezo application that does not violate the "no DC response" and "low temperature only" rules. There will be all of my *Incredible Secret Money Machine II* book prizes, plus an all expense paid *tinaja quest* (FOB Thatcher, AZ) for two going to the very best.

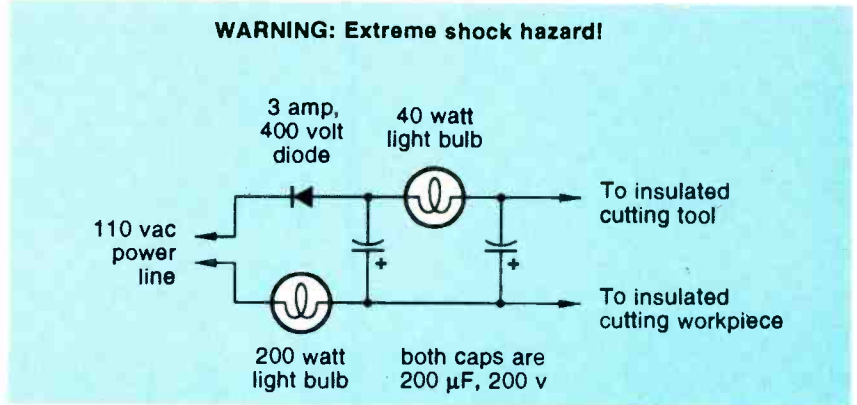

FIG. 4—AN ULTRA-SIMPLE EDM LASHUP. The lamps act as dynamic regulators, with the smaller one setting your sparking rate. Be certain to keep the tool and workpiece insulated from ground at all times. A dielectric fluid must be used.

As usual, send your entries directly to me here at *Synergetics* and not to **Electronics Now** editorial.

More on EDM machining

Warning: What follows can involve severe shock and fire hazards. Do not try this trick at home unless you know exactly what you are getting into!

But this one seems far too cute to

ignore. Awesome, even.

I've had a lot of helpline requests for more details on the EDM electric-discharge machining we looked at two columns back. It turns out that a very cheap, stunningly elegant, and ultra-simple scheme for EDM machining first appeared in the March 1968 issue of *Popular Science*, and was reworked in the January 1991 issue of *Home Shop*.

Every Cleaning Task Made Easier with New Brushes, Swabs & Wipes

Whether you're tackling the dirtiest job, or cleaning a precision piece of equipment, Tech Spray has a cleaning product that makes the task easier.

Tech Spray has expanded its line of brushes, swabs and wipes to cover the wide variety of cleaning and maintenance needs in the electronic industry.

All TechBrushes™, Techswabs™ and Techclean™ Wipes are precisely manufactured under Tech Spray's rigid specifications.

Tech Spray takes special care throughout the manufacturing process and in its packaging to maximize cleanliness and protection against electrostatic discharge.

For a sample of these, or any Tech Spray product, contact our Technical Assistance Department toll free at 1-800-858-4043.



A sampling of TechBrushes™, Techswabs™ and Techclean™ Wipes



TECH SPRAY, Inc.
P.O. Box 949
Amarillo, TX 79105-0949
(806) 372-8523

©1992 TS

Exciting Features, Projects, Reviews & Columns And Much More!

In the Next Issue of

Popular Electronics®

ON SALE

APRIL 20, 1993

WATCH FOR IT!

Pick up Popular Electronics at your favorite Newsstand Bookstore or Supermarket

NAMES AND NUMBERS

Alpec

55 Oak Court
Danville, CA 94526
(510) 820-1763
CIRCLE 338 ON FREE INFORMATION CARD

Amusement Business

Box 24970
Nashville, TN 37202
(615) 321-4250
CIRCLE 339 ON FREE INFORMATION CARD

Assoc Energy Engineers

4025 Pleasantdale Rd, Ste 420
Alanta, GA 30340
(404) 447-5083
CIRCLE 340 ON FREE INFORMATION CARD

Carnivorous Plant Newsletter

Fullerton Arboretum, CSUF
Fullerton, CA 92634
(714) 773-3579
CIRCLE 341 ON FREE INFORMATION CARD

Dialog

3460 Hillview Avenue
Palo Alto, CA 94304
(415) 858-2700
CIRCLE 342 ON FREE INFORMATION CARD

Electric Power Research Inst

PO Box 10412
Palo Alto, CA 94303
(415) 855-2000
CIRCLE 343 ON FREE INFORMATION CARD

Elsworth Adhesives

1610 North I-35, Ste 208
Carrollton, TX 75006
(214) 446-8000
CIRCLE 344 ON FREE INFORMATION CARD

Randy Fromm

1944 Falmouth Drive
El Cajon, CA 92020
(619) 593-6131
CIRCLE 345 ON FREE INFORMATION CARD

GENie

401 N Washington Street
Rockville, MD 20850
(800) 638-9636
CIRCLE 346 ON FREE INFORMATION CARD

Hoskins

10776 Hall Road
Hamburg, MI 48139
(313) 231-1900
CIRCLE 347 ON FREE INFORMATION CARD

Integrated Circuit Systems

PO Box 968
Valley Forge, PA 19482
(215) 666-1900
CIRCLE 348 ON FREE INFORMATION CARD

Journal Acoustical Society

335 E 45th Street
New York, NY 10017
(212) 661-9404
CIRCLE 349 ON FREE INFORMATION CARD

MCM Electronics

650 Congress Park Drive
Centerville, OH 45459
(800) 543-4330
CIRCLE 350 ON FREE INFORMATION CARD

Synergetics

Box 809
Thatcher, AZ 85552
(602) 428-4073
CIRCLE 351 ON FREE INFORMATION CARD

Teltone Corp

22121 20th Avenue SE
Bothell, WA 98021
(800) 426-3926
CIRCLE 352 ON FREE INFORMATION CARD

Unitrode

7 Continental Blvd
Merrimack, NH 03054
(603) 424-2410
CIRCLE 353 ON FREE INFORMATION CARD

Machinist. Their circuit appears in Fig. 4.

All you have is a half-wave DC power supply driving a relaxation oscillator, with the *insulated* tool being negative and the *insulated* work being positive. Any old three-amp, 400-volt power diode from *Radio Shack* can be used as the rectifier. Fresh and very high-quality electrolytics are recommended—200 volts minimum. Older or very cheap ones could possibly explode in this circuit. A "bomb shelter" type of case is recommended.

The light bulbs have much lower resistances when they are cold than

hot. These sneakily act as dynamic regulators to limit the current should your tool get stuck. This is elegant simplicity at its best. The size of the smaller lamp sets your cutting rate.

Both the tool and the workpiece must be fully and totally insulated from ground! If you want to ground your workpiece (a darn good idea), a large isolation transformer *must* be added to your AC input.

While you might use plain old kerosene as a dielectric cutting fluid, it is highly flammable. Although it's not remotely as nasty as gasoline, it's very much a fire hazard just the same. I would instead recommend

Learn VCR repair at home!

MAKE GOOD MONEY IN YOUR OWN FULL- OR PART-TIME JOB



Professional-level home study course. You will master easy-to-learn, high-profit repairs *without* investing in high-tech instruments or a costly workshop.

Want more independence and higher income? Send or call today!

Free career kit:
800-223-4542

Name _____
Address _____
City _____ State _____ Zip _____

The School of VCR Repair
2245 Perimeter Park Drive
Dept. VF342 Atlanta, Georgia 30341

CIRCLE 179 ON FREE INFORMATION CARD



Using Windows™ 3.1 and your sound card

Audio Frequency

FUNCTION GENERATOR

Send \$35 plus \$3.50 shipping & handling
(NM residents please add sales tax)

In check or money order to:

TEYNHAM AUDIO SYSTEMS
7120 Wyoming NE, Suite 349
Albuquerque, NM 87109

Or phone: 1-800-793-1150
for information or COD Orders
(No credit cards accepted)

Please indicate 3 1/2" or 5 1/2" disk

CIRCLE 181 ON FREE INFORMATION CARD

SUPER 12 HOUR RECORDER

CALL TOLL FREE

Modified Panasonic Slimline,
6 hrs per side
120 TDK tape furnished.
AC/DC Operation.
Quality Playback.
Digital Counter.
Durable Lightweight Plastic.



\$119.00*

PHONE RECORDING ADAPTER

Starts & Stops Recorder
Automatically When
Hand Set is Used.
Solid State!



FCC Approved

\$28.50*

VOX VOICE ACTIVATED CONTROL

Solidstate Adjustable
Sensitivity. Voices &
Sounds Activate Recorder
Adjustable Sensitivity
Provisions for Remote
Mike



\$28.50*

* Add for ship. & handling. Phone Adapter & Vox \$2.00 each, Recorders \$5.00 each. Colo. Res add tax. Mail Order, VISA, M/C, COD's OK. Money Back Guar. Qty Disc. available. Dealer inquiries invited. Free data on other products.

AMC SALES INC. 193 Vaquero Dr.
Boulder, CO. 80303
Phones (303) 499-5405 1-800-926-2488
FAX (303) 494-4924
Mon-Fri 8-5 MTN. TIME

CIRCLE 108 ON FREE INFORMATION CARD

CABLE TV DESCRAMBLERS

How You Can Save Money on
Cable Rental Fees

Bullet Proof



1 Unit 5+

BEST Super Tri-Bi Auto/ Var. Gain Adjustment	\$119.95-\$85	US Cable'll Beat Anyone's Price Advertised in this Magazine!
Jerrold Super Tri-Bi ...	\$109.95-\$79	
Scientific Atlanta	\$109.....\$79	
Pioneer	\$109.....\$79	
Panasonic TZPC145.....	\$99.95.....\$79	
Stargate Converter.....	\$95.....\$69	
Digital Video Stabilizer.	\$59.95.....\$29	
Wireless Video Sender.	\$59.95.....\$49.95	

30 Day Money Back Guarantee
FREE 20 page Catalog

Visa, M/C, COD or send money order to:
U.S. Cable TV Inc. Dept. KRE0593
4100 N. Powerline Rd., Bldg. F-4
Pompano Beach, FL 33073

1-800-772-6244

For Our Record

I, the undersigned, do hereby declare under penalty of perjury that all products purchased, now and in the future, will only be used on Cable TV systems with proper authorization from local officials or cable company officials in accordance with all applicable federal and state laws. FEDERAL AND VARIOUS STATE LAWS PROVIDE FOR SUBSTANTIAL CRIMINAL AND CIVIL PENALTIES FOR UNAUTHORIZED USE.

Date: _____

Signed: _____

No Florida Sales!

CIRCLE 187 ON FREE INFORMATION CARD

using the "real" water-based dielectric resins we saw back in the EDM survey. You'll have the best luck with a drill press or a mill that has a slow controllable rate vertical power feed.

The most obvious use is to remove broken taps or stuck drills. Be sure to remember that a continuous flow of dielectric fluid between tool and work must be maintained at all times.

New tech lit

From Teltone, there's a new *Design Solutions* data book on tone receivers, call progress detector IC's, and phone signalling devices—along with some good application notes. From Unitrode, there's a new *Linear Circuits Handbook*. It's mostly on drivers, power-supply chips, and battery-charger circuits.

Randy Fromm's *Big Blue Book of Really Great Technical Information* tells you bunches about commercial video game repair in a readable and well-organized format. Randy also offers videos on video monitors and on game repairs and refurbishment.

Speaking of video games, *MCM Electronics* offers \$8 bit drivers that let you remove the tamper-proof *Sega* or *Nintendo* game cartridges.

If you are about to come unglued, check out *Elsworth Adhesives*. They do seem to stock just about all major epoxies, hot melts, cyanoacrylates, silicones, and such from nearly all of the major glue suppliers.

The price of laser pointers is still in free fall. The cheapest this week is the \$72 model from *Alpec*. Range is 55 yards or so.

Our two unusual magazines for this month are *Amusement Business* and the *Carnivorous Plant Newsletter*.

A reminder here that I have autographed copies of my revised *Incredible Secret Money Machine II* here for you at my own *Synergetics*. This book is a must if you are starting up your own technical venture. Plus a reminders about my Hardware Hacker RoundTable on *GEnie* PSRT at (800) 638-9636. And our no-charge voice technical helpline can be reached via (602) 428-4073. Best calling times are 8-5 weekdays, Mountain Standard time. Ω

VCR Cross Reference

**NOW Find the right Part
for your VCR**

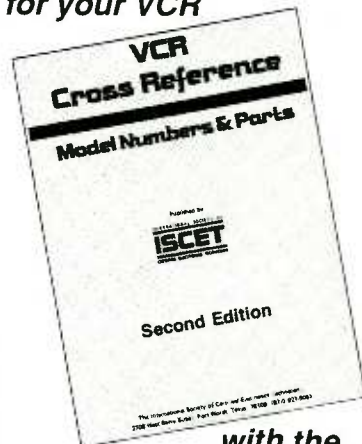

**with the
ISCET VCR**

CROSS REFERENCE

This 272-page reference contains both model and part-number cross-references and now includes the FREE 56-page 1991 updates.

VCR's are made in a few factories from which hundreds of different brand names and model numbers identify cosmetically-changed identical and near-identical manufactured units. Interchangeable parts are very common. An exact replacement part may be available only a few minutes away from you even though the manufacturer supplier is out-of-stock. You may be able to cannibalize scrap units at no cost!

The ISCET VCR Cross Reference and 1991 Update pages are pre-punched for standard loose-leaf binding....\$38.00 plus \$3.00 for shipping for each reference.

Electronics Technology Today Inc.
VCR CROSS REFERENCE OFFER
P.O. Box 240,
Farmingdale, New York 11735

Name _____

Business _____

Address _____

City _____

State _____ Zip _____

Phone _____

Enclose **\$38.00** for the ISCET VCR Cross Reference and 1991 Update Reference and **\$3.00** for shipping for each reference.

I have ordered _____ ISCET VCR Cross Reference(s).

The total amount of my order is \$ _____.

Check enclosed—do not send cash.

or please charge my credit card:

Visa MasterCard Exp. Date ____/____/____

Card No. _____

Signature _____

New York State residents must add applicable local sales tax to total.

DRAWING BOARD

Detecting video levels and inverted video.

ROBERT GROSSBLATT

When we built last month's divide-by-32 circuit (Fig. 1), we added some gates to the output of the counter to create a pulse that was approximately equal to the transmitted horizontal blanking pulse in both polarity and width. I also mentioned that the 2-microsecond period of the phase-locked loop's clock would turn out to be a very useful tool—and you will soon see why.

Since we can identify the beginning of the horizontal blanking pulse, we can use the 504-kHz clock pulses to sample the video at any 2-microsecond multiple along the line. All we have to do is use the arrival of the horizontal blanking pulse (its falling edge) as a starting point, count the desired number of 504-kHz pulses, and sample the video to get the DC levels we want. Picking the points to sample for black-and-white DC levels is critical because they're needed to keep the picture brightness from changing when the signal switches between normal and inverted video.

The best line to use for this sampling is the same one that tells us whether the video is going to be inverted or not—I'm talking about line 20. As you can see in Fig. 2, when this line appears, the black level can be read from the back porch, and the correct white level can always be gotten from the first half or so of the picture portion of the line (immediately after the rising edge of the horizontal blanking pulse).

Because the clock pulses from the phase-locked loop are slightly less than 2 microseconds wide, a single pulse sample can be taken four clock pulses after the leading (falling) edge of the horizontal blanking pulse to lock in the black level. The white-level sample can be taken

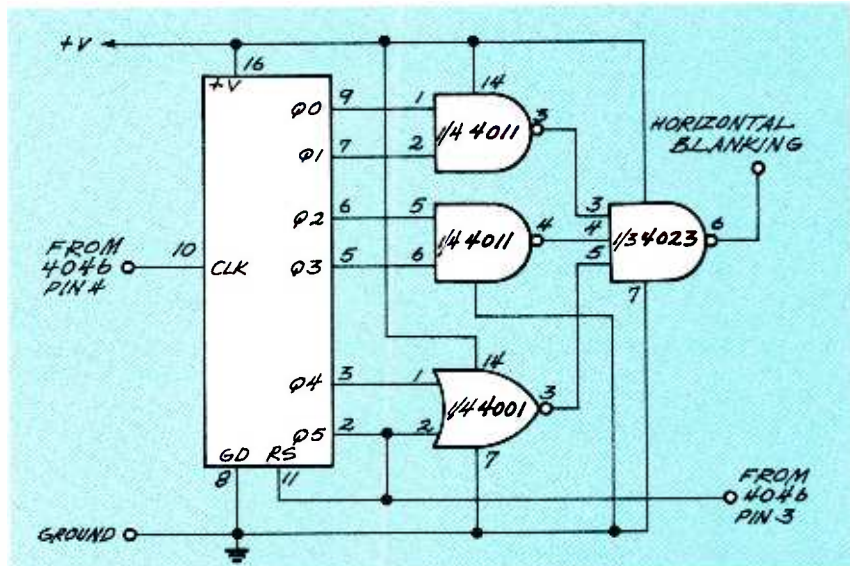

FIG. 1—THE GATES WE ADDED to last month's divide-by-32 circuit (shown here) create a pulse that's approximately equal to the transmitted horizontal blanking pulse in both polarity and width.

two clock pulses after the end of the horizontal blanking interval (the rising edge of the pulse); it can be as much as four clock pulses wide. You can understand this by examining Fig. 3.

After using line 20 to establish the correct DC levels for the following frame, we have to sample a portion of the last part of the line to see whether the picture will be inverted or not. A reasonable location to pick is about 50 microseconds into the line, which would be some 25 clock pulses after the leading edge of the horizontal blanking pulse. If the sample taken is high, we know that the next frame is going to be inverted—if the sample is low, the frame will be normal.

All this may sound complex but, if you think for a moment, you'll realize that most of the needed circuitry has already been designed. The low-order output (Q0) of the 4040 that's counting the 504-kHz pulses from the phase-locked loop is giving

you a series of 2-microsecond pulses, and the gates hanging off the 4040 outputs are producing a synchronous analog of the horizontal blanking pulse. To sample the line as I just described, all you have to do is detect the leading or trailing edge of the blanking pulse (whichever one you need), count up the appropriate number of 2-microsecond pulses, and sample the video line.

All the signals you need to determine the DC levels and polarity of the following frame can be obtained by decoding the outputs of the 4040. That can be done using the same techniques we used earlier to recreate the horizontal blanking pulse. Since the period of a line of video is about 64 microseconds, and we have a clock pulse with a period of 2 microseconds, we can think of each video line as being divided into 32 segments. By counting and decoding properly, we can examine any segment of the line in

LEARN VCR

Cleaning/Maintenance/Repair
Earn up to \$1000 a Week, Working Part Time from Your Own Home!



Secrets Revealed! ...
NO Special Tools or Equipment Needed ...
Train at Home in Your Spare Time!

IF you are able to work with common small hand tools. IF you possess average mechanical ability, and have a VCR on which to practice and learn... then we can teach YOU VCR Maintenance and Repair!
FACT: Up to 90% of all VCR malfunctions are due to simple Mechanical or Electro-Mechanical breakdowns!
FACT: Over 86 million VCRs in use nationwide! Average VCR needs service or repair every 12 to 18 months!

For FREE Information Package!

Send coupon to: Foley-Belsaw Institute of VCR Repair, Dept 62018 6301 Equitable Rd., Kansas City, MO 64120

Foley Belsaw Since 1926 Dept. 62018

Check for FREE Lifetime Career Kit on VCR Repair.

Name _____

Address _____

City _____

State _____ Zip _____

CIRCLE 176 ON FREE INFORMATION CARD

Master Electronics for Just \$2.88 per Experiment



Gain vital, practical skills for today's high-tech world. With Demax, you learn by doing, not memorizing and repeating. Experts know that you learn more, understand better with our hands-on method, plus you definitely have more fun.

Order our 3 course package, *Mastering the Digital Multimeter, Direct Current, and Alternating Current*, and get a special 2 hour video, showing set-up and results for all 104 experiments. Package also includes deluxe digital multimeter, learning module w/self-store case, 3 kits of parts, and 3 clearly written, well illustrated books w/simple, step-by-step instructions for just \$299+\$10S&H (less meter save \$50). Act today: take command of basic electronics!

Items also sold separately. Call for prices.

Demax Corporation

PO Box 946, Benton Harbor, MI 49022
VISA/MC orders, 1-800-79DEMEX

CIRCLE 188 ON FREE INFORMATION CARD

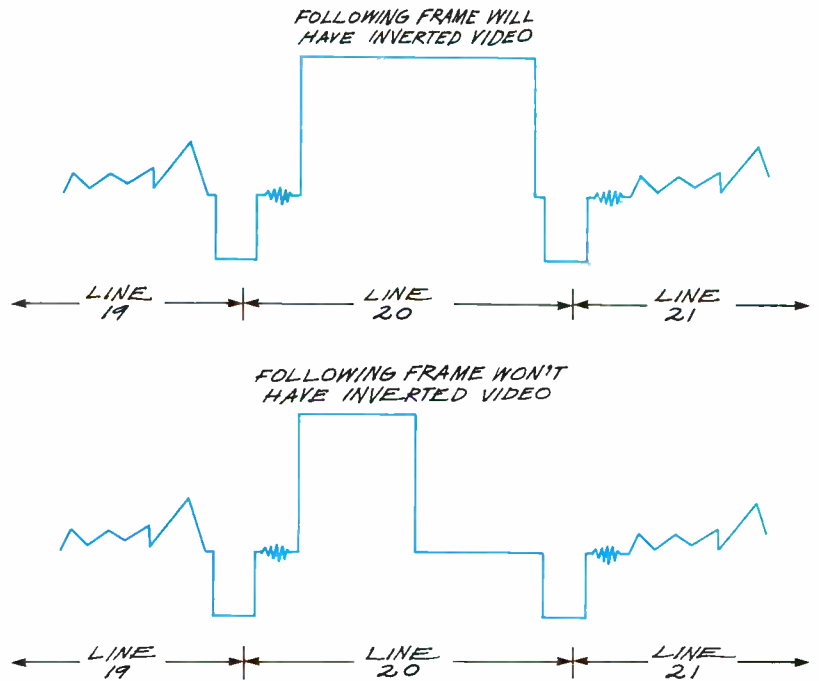

FIG. 2—WHEN LINE 20 APPEARS, the black level can be read from the back porch, and the white level can be obtained from the first half of the picture portion of the line.

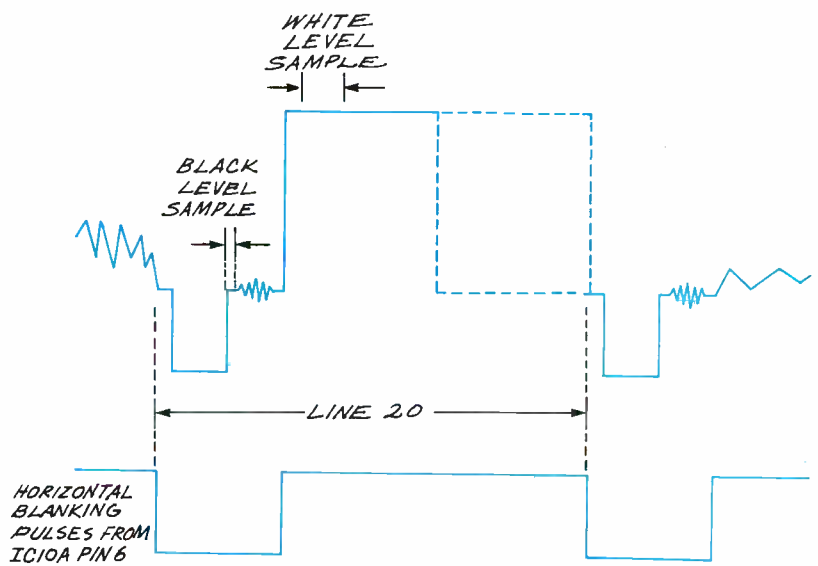

FIG. 3—TO LOCK IN THE BLACK LEVEL, a sample can be taken four clock pulses after the leading edge of the horizontal blanking pulse, and the white level can be taken two clock pulses after the end of the horizontal blanking interval.

any 2-microsecond multiple width. The polarity sample, for example, would be a 4-microsecond (2 clock-pulse) segment taken 25 clock pulses after the 4040 has been reset to zero. That will also mark the beginning of the decoded horizontal blanking interval.

Once the polarity sample has been taken, the same technique used to switch between generated and transmitted sync can be used to correct the video polarity if we

find that it's been inverted. The two unused switches in the 4066 have to be configured, once again, as a single-pole, double-throw switch. The output of the gate that reflects the state of the polarity sample triggers a set/reset flip-flop that, in turn, toggles the SPDT switch.

The output of the amplifier at the front of the circuit contains both the received video and, except during the vertical interval, the generated horizontal sync signals created to

stabilize each line of video. If the polarity wasn't a problem, we could send the signal off to the output stage of the descrambler and then directly to the back of a TV set. Since, however, the "VI" part of SSAVI stands for "video inversion," we have to have available an inverted version of the video as well.

The received video with the corrected horizontal sync pulses is sent through an inverter that's built in exactly the same manner as the single-transistor buffer at the front of the decoder. This inverted version of the video is sent to one side of a polarity switch, and the plain video is sent to the other side of the switch. Each signal has its horizontal interval corrected by the circuitry that was designed to restore the sync signals.

The flip-flop built to indicate the presence of either normal or inverted video controls whether the normal or inverted video is routed to the descrambler's output.

Even though the descrambler's circuitry seems to have grown at an alarming rate, its overall operation is not hard to understand. If you've been following this from the beginning, you should have a pretty good handle on what's going on. We've regenerated horizontal sync and created a signal to tell us if the picture has been inverted. At the descrambler's output, we're using an electronic switch to make sure the video sent to the back of your TV set always has the correct polarity. This has been done by decoding the state of the transmitted video from line 20, and using that information to channel either a straight or an inverted version of the sync-restored video to the output of the descrambler.

The last piece of hardware business comes up because the horizontal sync is *never* inverted in the SSAVI system. Since the first thing we did to unscramble the video was to restore the horizontal sync pulses, the video coming out of our inverter (the video being sent to the invert side of the 4066 switch), will have the entire horizontal interval inverted as well. Fortunately, this is pretty easy to correct. We have to make sure that during the horizontal interval, only the non-inverted video is routed to the descrambler output.

The way to accomplish this is to gate the output of the polarity indicator (the flip-flop) with the horizontal blanking pulse. We want the normal video signal sent to the descrambler output during the horizontal blanking interval, regardless of the polarity of the video signal.

When you're building a SSAVI descrambler like this, there are a few rules to keep in mind as you work your way through the design. We've gone over all of them, but listing them out will make it much clearer:

1. Since the vertical interval is always sent in the clear, the descrambler has to be disabled for this period of time.
2. During the horizontal interval, the transmitted video signal must be sent to the descrambler output.
3. If you don't have a scope, you won't be able to build a SSAVI, or any other video descrambler.

If you've been following this topic from its beginning some months ago, you now have all the information you need to design and build a working descrambler. I admit that it's been a lot of work, but it's a low price to pay because the descrambler, when combined with the service manual for your TV, will let you use all the features in a cable-ready set.

I started writing on this subject because my local cable company began scrambling *all* the cable channels, not just the premium ones. A lot of people, myself included, have spent a lot of money to buy a TV that offers picture in picture, super stereo, and a bunch of other features. Using a box from the cable company completely wipes out most of those features, to say nothing about not being able to use the TV's remote control.

Because cable boxes are fairly expensive, even when purchased in quantity by the cable companies, the boxes provided with cable service don't provide the same range of functions as those built into a high-end TV set. Some boxes have audio and video outputs but, at least in my area, the audio is in mono—I didn't even know that mono was still a viable option.

The mentality of the cable companies today is on a par with that of the phone company twenty years ago.

Not only were you charged for line service, but the phone company also insisted on billing you for all the hardware, wire, and installation as well.

It took a lot of legal work and lawsuits to convince the phone company that it was more profitable to concentrate on selling services than it was to keep a stranglehold on everything from your mouthpiece to my earpiece. For once, a bunch of lawyers did something that was worthwhile!

Until the cable companies learn the same lesson that was force fed to the phone company, we're going to have to deal with the problem of the limitations of cable TV's proprietary hardware vs. the cable-ready TV set. If basic cable service includes 25 non-premium, non pay-per-view stations, I shouldn't need a cable box to get those channels. The big-brother, total-control mentality of the cable television companies is going to be ended, I fear, only by lawyers. Ω

FREE
*Electronics & Computer Software
Education Catalog*

*Fast-Track Individual Learning Programs
*State-of-the-Art Classroom Courses
*The Best Values in Electronics Education

New
Career-Level Courses
Personal Computer Servicing
TV and VCR Servicing

New
Computer-Aided Instruction
DC & AC Electronics
Semiconductors
Electronic Circuits

*The stunning animations, hypertext
glossary, and easy-to-understand text make
learning electronics a breeze...and fun!*

Learn the easy and affordable way from the
Masters In Electronics Training - **Heathkit**®.
From Basic Electricity to Advanced Microprocessor
Applications and more, Heathkit will provide
you with an unparalleled learning experience at a
fraction of the cost of other programs.

Heathkit®
Educational Systems
For your FREE Catalog, call
Toll-Free 1-800-44-HEATH
please mention this code when calling 202 011

CIRCLE 86 ON FREE INFORMATION CARD

AUDIO UPDATE

An excellent reference book

LARRY KLEIN

The words we use to describe our world are constantly evolving—and some are disappearing. How many of you know what an antimacassar is, what a button hook does, or where Nubia was located? Our grandparents knew about these things, but today most of us don't have a clue about them. (Why did one need to hook buttons, anyway?) Similarly, As technology changes, so does the language that we use to describe it.

Dictionaries are enormously helpful in keeping up with changes, despite the fact that every new edition has to be updated to acknowledge such new words as quarks, black holes, fullerenes, and baby boomers. Specialized dictionaries that focus on a particular subject are particularly useful for anyone wishing to learn about subjects that the general dictionaries don't cover adequately.

The glossary of terms that apply to audio technology with all of its ramifications is a good example, involving as it does acoustics, psychoacoustics, and the very rapidly evolving field of consumer audio electronics.

This brings us to the subject of Glenn D. White's *The Audio Dictionary*, which is actually more of an encyclopedia than a dictionary. A hefty 426-page paperback book, the new \$19.95 second edition acknowledges the rapid evolution of the audio arts with the addition of 100 extra pages and 500 new entries beyond the 1987 first edition.

As a reviewer, it is my task to read critically. I must say I was surprised at how seldom I disagreed with the author's definitions in subject areas in which I am knowledgeable. Moreover, I was impressed by how much of interest I learned. As a fellow technical writer, I particularly appreciated Mr. White's lucid prose style and his wide-ranging knowledge (or ability to tap excellent reference sources).

In addition to the alphabetized dictionary entries, the dictionary contains a 41-page appendix covering such diverse topics as acoustics, musical scales, the tuning of musical instruments, the balance line, and audio measurements.

The least helpful (and most dated) section is on "How to Subdue a Hi-Fi Salesman." Other than that small nitpick—and a few other equally minor disagreements—I wholeheartedly recommend *The Audio Dictionary*. It is the single most helpful and interesting reference for those seeking to expand their understanding of audio that I have ever seen.

If White's dictionary is not available at your local technical bookstore, it can be ordered directly from the publisher. For more information you can call the University of Washington Press at 1-800-441-4115.

A reader's letter

I have letter that's a good takeoff point for a discussion of several subjects that seem to be of continuing concern for readers.

Mike Marks of Milwaukee writes: "Does a tube amplifier really sound better than a MOSFET, bipolar, or IGBT transistor amplifier? If so, why?" He goes on to cite promotional materials from Carver and Toshiba that discuss the more audibly pleasant even-order harmonics generated by tubes, VMOS, and IGBT transistors vs. the unpleasant odd-order distortion produced by conventional transistor-output amplifiers. Marks ends his letter by asking, "So what does all of this mean? Does the ear really like the even-order harmonics that tubes generate?"

Despite my best efforts, I guess I haven't managed to communicate one of the prime truths of hi-fi marketing. Listen up, you readers! Each year, every amplifier manufacturer seeks to incorporate technical fea-

tures in his new models that will differentiate them from his competitors' new models—or his own product of last year.

Every circuit variation, however subtle (or insignificant), will be seized on to promote the new models. These include lateral feedback circuits to eliminate newly discovered sources of side-slip distortion and similar themes. They'll be hyped in multicolored ads and brochures in hopes of enticing avid audiophiles to buy a specific brand or model.

From my point of view—one that I've maintained for at least 15 years—amplifiers might be getting better because they are becoming smaller and lighter or they run cooler; they might even be more efficient and cheaper (for given power rating) *but they ain't going to sound better!* For many years the distortion levels of properly designed amplifiers have been far below audibility when they are reasonably loaded and not overdriven.

I'm fully aware that "new" distortions are discovered regularly by manufacturers and academics. But, until the audibility of such theoretical distortions is confirmed in commercial equipment by careful A-B listening tests, I regard them as irrelevant to the real world of hi-fi reproduction.

Such "nouveau distortions" fuel the audio fantasies of the mystically minded. They support the myth of electronic aberrations subtly sully the listening experience that can only be exorcised by inspired engineers producing very expensive, limited-production equipment. The truth of the matter is that the audible differences in audio amplifiers, when they do show up, are practically always due to minor, but barely measurable, frequency-response deviations.

Accordingly, "tube sound" is usually not a product of the tubes *per*

se. More than likely it is the result of the relatively high output impedance of a transformer-coupled output circuit interacting with a speaker system's varying impedance curve. (See Fig. 1.)

Aside from the fact that today's amplifiers produce distortions of all flavors in miniscule sub-audible amounts, there is some evidence to support the contention that the human ear, in some situations, responds positively to certain distortions. For example, older Fender guitar tube amplifiers were always valued over the newer transistor amplifiers that offered lower distortion. However, musicians simply preferred the sound of overloading tubes to that of transistors.

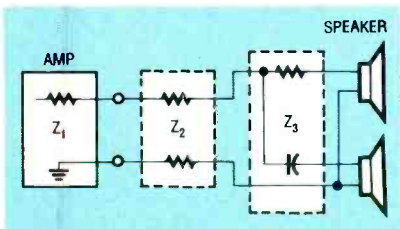

FIG. 1—THE IMPEDANCES FOUND in a typical speaker connection.

The Apex Aural Exciter, which is used in studios to add even-order harmonic distortion to the vocals in multi-track pop recordings, provides another example of deliberate distortion for "enhancement" purposes. I can think of other examples, but in both of the situations mentioned, we are dealing with sound production rather than sound reproduction.

Those who extol the "sonic warmth" of tubes should know that they are really hearing the impedance curve of their speakers rather than any magic wrought by electrons traveling in a vacuum.

As I've suggested in a previous column (April, 1991), you can introduce tube sound quality to transistor equipment by simply wiring an approximate 1-ohm, 10-watt resistor in series with each of your speakers. This simulates the high output impedance of tube amplifiers. The small change spent on a pair of resistors makes a lot more sense to me than the thousands of dollars you can spend on new tube- or IGBT-output amplifiers. Ω



GET YOUR RECHARGE CATALOG FREE...EARN BIG \$\$ IN YOUR SPARE TIME—All supplies and Do-It-Yourself kits with complete instructions available. Supplies cost from \$9.95 in qty and you can sell recharged toner cartridges for \$40.00 to \$55.00 each. Printers include HP LaserJet Series I, II, III, IV, Apple LaserWriter, QMS, etc. Canon PC Copiers also. **CHENESKO PRODUCTS, 2221 Fifth Ave., Suite #4, Ronkonkoma, NY 11779, 516-467-3205. FAX 516-467-3223, 1-800-221-3516**

CIRCLE 110 ON FREE INFORMATION CARD

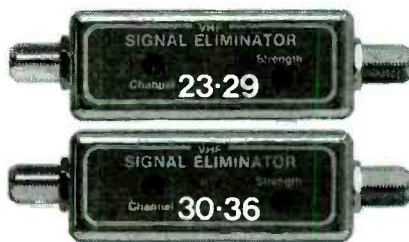

CABLE TV 50dB NOTCH FILTERS for interference removal or channel censoring. Filters are user-adjustable to desired channel # or frequency. Eight Models available, each for certain channels: 2 & 3; 4 to 6; 7 to 13; 14 to 17; 18 to 22; 23 to 29; 30 to 36; 95 to 99 plus 0 & 1. Just \$30 each or 3 for \$75, includes shipping. **ONE MONTH MONEY BACK**, fast delivery. Visa, MC, check or M.O. (C.O.D. is \$5 extra) Huge discounts for higher quantities. **STAR CIRCUITS, P.O. Box 94917, Las Vegas, NV 89193. Call 24 hours 1-800-535-7827.**

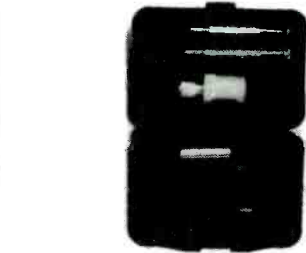
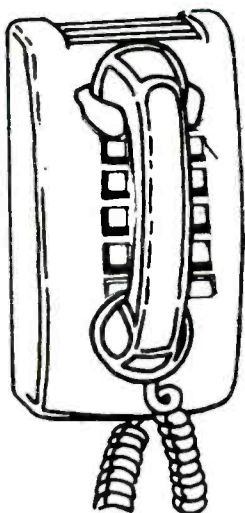

ELEVEN-PIECE RATCHET TOOL KIT Includes reversible ratchet handle, extension bar, six bits, two precision screwdrivers, and a cutter. Comes in fitted case. Get one for your shop, another for your car, another for your tool kit. To order send \$11.75 USA shipping only. **ELECTRONIC TECHNOLOGY TODAY INC., PO Box 240, Massapequa Park, NY 11762-0240.**

CALL NOW AND RESERVE YOUR SPACE

- 6 x rate \$940.00 per each insertion.
- Fast reader service cycle.
- Short lead time for the placement of ads.
- We typeset and layout the ad at no additional charge.

Call 516-293-3000 to reserve space. Ask for Arline Fishman. Limited number of pages available. Mail materials to: mini-ADS, ELECTRONICS NOW, 500-B Bi-County Blvd., Farmingdale, NY 11735.

FAX: 516-293-3115

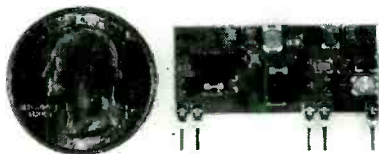

TWO TRANSMITTERS IN ONE! 5 MINUTE ASSEMBLY! MONEYBACK GUARANTEE! New Law Enforcement grade device on a single chip is the most sensitive, powerful, stable room transmitter you can buy. Uses any 3V-12V battery. Or attach to telephone line to monitor all telephone conversations over 1 mile away without batteries! 100mW output! 80-130MHZ. Receive on any FM radio or wideband scanner. VT-75 microtransmitter. \$49.95 + 1.50 S&H. VISA, MC, MO. COD's add \$4.00. **DECO INDUSTRIES, Box 607, Bedford Hills, NY 10507. 914-232-3878.**

CIRCLE 127 ON FREE INFORMATION CARD

ASAP • JIT • MRP

OUR DISTRIBUTORS HELP
ABBREVIATE YOUR
PROCUREMENT CYCLE!

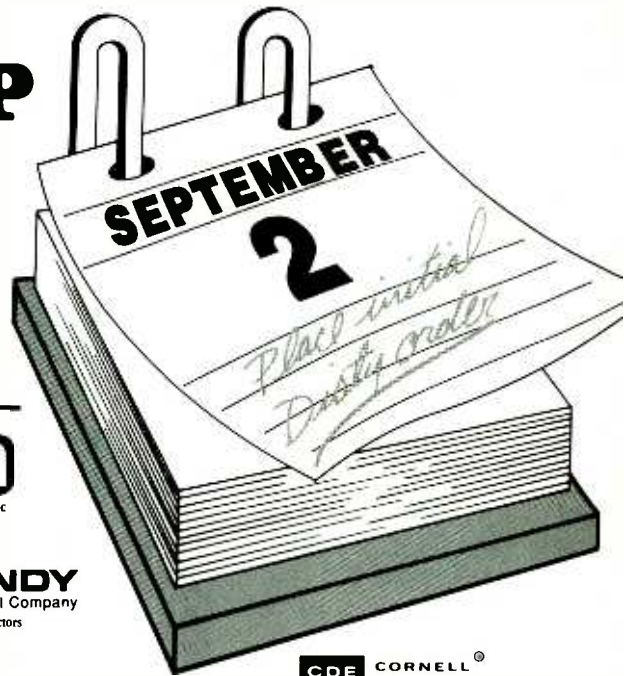

Aero M, Inc.
Aluminum Electrolytic Capacitors for DC Applications and AC Motor Starting

Aerovox®
DC Film and RFI Suppression Capacitors, AC Oil Capacitors, EMI Filters

alpha
Wire, Cable, Tubing, Electronic Interconnect Products

AMP
Electrical/Electronic Connectors, IC Sockets, PCB Switches

AVX CORPORATION
A KYOCERA GROUP COMPANY
MLC, Tantalum and Thin Film Capacitors, Resistors, Networks, Trimmers, Oscillators, Resonators, Filters and Piezo Devices

BURNDY
an FCI Company
Electronic Connectors

CAROL
CAROL CABLE COMPANY INC.
Electronic and Electrical Wire and Cable and Power Supply Cords

COLE FLEX
Tubing, Conduits, Hose, Sleeveings, Splices, Insulation and Cable Harness Products

COOPER
Bussmann
Fuses, Fuseholders, Fuse Blocks, and Fuse Accessories

CDE CORNELL DUBILIER®
Capacitors — Aluminum Electrolytics, MICA, AC Oil, Film and Relays

A COMPANY OF
DALE

Dale Electronics, Inc.
Resistors, Networks, Oscillators, Displays, Inductors & Thermistors

DI DANTONA INDUSTRIES, INC.
BATTERIES: Computer, Cordless Phone, Scanner & R/C.
ANTENNAS: Cordless Phone (metal & rubber), Scanner Bumpers, Grommets and Stik-On Feet

DEARBORN WIRE AND CABLE INC.
Wire Lions
Wire, Cable and Tubing

Du Pont Connector Systems

DU PONT

An expanding line of reliable Interconnections, Packaging, and Subsystems

KOA SPEER ELECTRONICS, INC.
Resistors, SMT Tantalum Capacitors Inductors, Resistor Networks, SMT Thermistors

EATON
Eaton Corporation, Commercial & Military Controls Operation
Switches, Relays, Displays and Keyboards

A PUBLICATION
GERNSBACK
Popular Electronics Magazine
Electronics Now Magazine

GENERAL DEVICES
Electronic Hardware Manufacturers
Slides, Chassis, Cable Carriers, Shelves, Racks, Cabinets, Enclosures

KEMET®
Electronics Corporation
Solid Tantalum, Multi-Layer Ceramic, and Surface Mount Capacitors

MALLORY
North American Capacitor Company
Tantalums, Aluminums, Sonalerts Ceramics, Films, AC's and RFI Filters

Manhattan
ELECTRIC CABLE CORPORATION
Electrical and Electronic Wire, Cable and Connectors

NTE ELECTRONICS, INC.
A WORLDWIDE REPUTATION FOR QUALITY, SERVICE AND VALUE
Semiconductors, Resistors, Capacitors, Relays

A COMPANY OF
SPRAGUE

Tantalum Capacitors, Wet & Foil Capacitors, Resistor Networks, Resistor Capacitor Networks, Filters

Philips ECG
A North American Philips Company
Semiconductors, Test Equipment, Relays, A/V Parts and Chemicals

MURATA ERIE®
MURATA ERIE NORTH AMERICA
Monolithics, Discs, Variable Capacitors, Oscillators Potentiometers, RFI/EMI Filters, Microwave, Surface Mount Capacitors

Quam
Loudspeakers and Commercial Sound Products

ROEDERSTEIN
Film, and RFI Suppression Capacitors, Aluminum and Tantalum Electrolytic Capacitors, and Resistors

Switchcraft
A Raytheon Company
Switches, Connectors, Jacks, Plugs, Jackfields & Audio Accessories

TECH SPRAY
Cleaners/Degreasers, Swabs/Wipes, Brushes and Wick

Thomson Consumer Electronics, Inc.
Distributor and Special Products Replacement parts for RCA and GE consumer electronics products.

Whenever you need electronic products, make your initial call to a distributor. Distributors help speed up your time to market, providing the convenience, the economy, the value, and above all, the service that helps make you competitive.

The sponsors of this message know how important it is — to us and to your MRP — to get product ASAP or JIT. Another important abbreviation is EIA. Our participation in the Electronic Industries Association's Components Group makes us all more competitive, through

fostering better working relations and coherent industry standards, and through the sharing of ideas to help both buyers and sellers.

In choosing your component supplier, look for the marks of leadership — availability through distribution and membership in the EIA.



Electronic Industries Association/Components Group
2001 Pennsylvania Avenue, N.W. 11th Floor
Washington, D.C. 20006
Phone: (202) 457-4930 Fax: (202) 457-4985

Committed to the competitiveness of the American electronics producer

COMPUTER CONNECTIONS

The PC is the computer industry

JEFF HOLTZMAN

IBM just posted its worst-ever yearly loss—a \$5 billion doozy. Yet “clone” companies like Dell, Compaq, and Gateway 2000 are growing like crazy. Even Apple is doing well. Telephone companies are experimenting with digital delivery of video services. Entertainment companies are playing with all sorts of new-media hardware and software. Consumer-electronics companies are adding more and more digital features to their wares, and computer companies are starting to build consumer-electronics devices. And the publishing industry is just waking up to the fact that CD’s are not just for playing music.

What’s going on here? Just what is the computer industry? What does it consist of? On what other industries does it have an impact—and which have an impact on it? Where is it headed?

Those are tough questions; they are also important questions, particularly for the technical readers of **Electronics Now**. A complete answer would fill a very thick volume. Nonetheless, an answer is required. Here’s my stab.

Pushing the pendulum

First we’ll start with a business viewpoint; all data cited comes from recent DataQuest reports. (DataQuest, of San Jose, CA, is a leading computer-industry market-research firm.) Market researchers typically break the computer industry down by system size: supercomputer, mainframe, midrange, workstation, and personal computer. The total value of 1992 computer hardware was about \$104.5 billion; sales in each category (represented as a percentage of the total, not as dollar values) for 1991 and 1992 break down as shown in Fig. 1.

- The tallest bars in the graph represent personal computers;
- PC’s by themselves account for almost half the market, a whopping

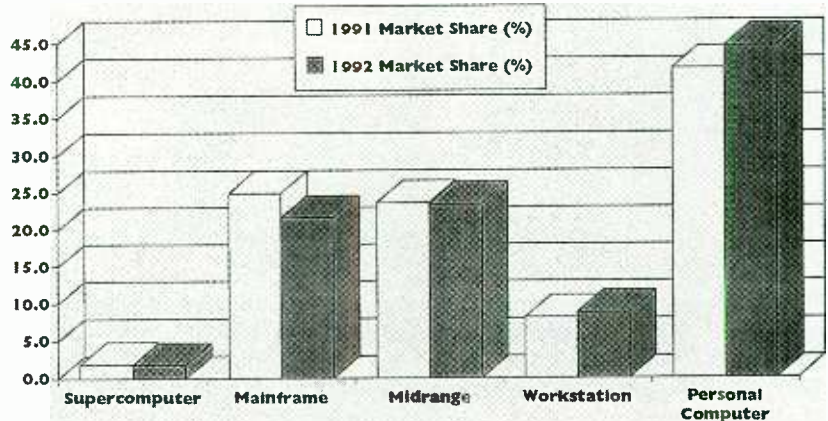

FIG. 1—PERSONAL COMPUTERS CONTINUE TO STOMP mainframes, minicomputers, and UNIX-based workstations.

\$46.5 billion;

- PC’s represent nearly twice the share of each of the closest competitors, mainframes and midrange systems; and
- PC’s represent about seven or eight times the share of the workstation (UNIX) market.

Keep those figures in mind the next time some mainframe, mini, or UNIX bigot starts railing about the unimportance of the PC market.

It’s interesting to note that, in spite of its worries, IBM still ap-

pears among the top five vendors in all five categories. In fact, Big Blue is first in mainframes, minis, and PC’s; and it is third in both supercomputers and workstations. IBM’s problem is that industry-wide mainframe and minicomputer sales have shrunk continuously throughout the late 80’s and early 90’s, and IBM’s share of the PC market has also eroded steadily.

Now look at Fig. 2, which shows the personal-computer portion of the market (as of year-end 1992).

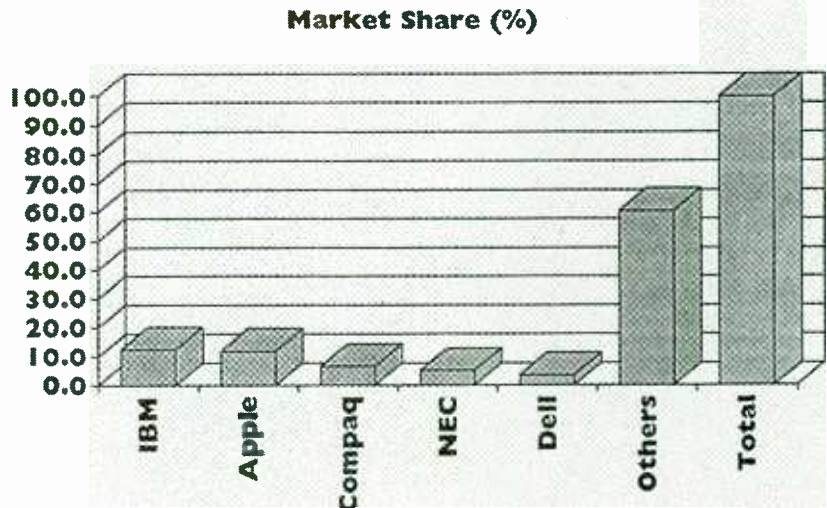

FIG. 2—IBM BARELY HELD ITS LEAD in market share of personal computers; together the top five accounted for less than 40% of the total.

Note first that IBM holds just over 12% of the market, and Apple, just under 12%. DataQuest estimates that last year, for the first time in history, *Apple actually sold more personal computers than IBM*. Note second the figure on the bottom: more than 60% of the market is controlled by clone vendors too numerous to list. That's almost two thirds of the market! It wasn't long ago when IBM alone held that much.

Today things are different. No single vendor controls the PC hardware market. That is good—but there is a danger involved. It is good because it fosters intense competition—we've seen prices fall about 50% during the past year and a half. The danger is that without strong leadership, the industry can fragment. In other words, small segments of the industry could develop competing yet incompatible technologies, which would only drive prices back up.

Take local-bus video, for example. As a technology, it shows clear benefit for the user in the incredible speed improvement it can supply over traditional video systems. On the other hand, there are two competing standards, VL bus and PCI, not to mention several early implementations that adhere to no standards whatsoever. Purchasers of the latter are clearly orphaned already; it remains to be seen which, if either, of the would-be standards will take hold. It will take a year or two for the fallout to settle, but when it does, some users may well get burned. (Owners of ESDI hard drives know how this works. ESDI battled IDE and SCSI for years and has now lost. It's getting harder and harder to find ESDI controllers and drives.)

A strongly fragmented industry spells trouble in another way. Owners of equipment sold by losing vendors are likely to end up with orphaned equipment. Everex, an almost billion-dollar company, filed for Chapter 11 bankruptcy protection near the end of 1992; it is only one of the more significant examples of what is happening with increasing frequency.

On the other hand, the emergence of new software products and technologies has already

helped solve this problem and will continue to do so. The operative word here is *hardware independence*. Windows and OS/2 were designed from the ground up to support multiple printers, video cards, and even memory architectures (XMS, EMS, DPML); next-generation products even promise CPU independence. For example, Windows NT and next-generation OS/2 are already running on non-Intel CPU's. The point is that the raging popularity of Windows is pushing software and hardware vendors to innovate; but on the other side of the coin, proprietary operating systems are depriving customers of rapid hardware evolution.

Now let's back up and look at the hardware market from a broader perspective. The mainframe and minicomputer markets are eroding. They're not going to die, but they are going to be seen more and more as peripheral (both metaphorically and literally) to the PC market. Workstations are not in quite as bad shape, because they have become cost-competitive over the past few years. All five of the top workstation vendors (Sun, H-P, IBM, DEC, SGI) now sell basic units for under \$10,000. On the other hand, 50-MHz 486-based PC's cost under \$4000, so clearly the workstation vendors have a problem.

What I conclude is that the PC market is driving all other segments of the industry. There are some things you can do today only on workstations, only on minis, and only on mainframes. But there are fewer and fewer of those things. Intel's Pentium, due to be released about the time you read this, will push the pendulum even further.

The software side

So far we've talked only about hardware; now let's take a look at what's happening in PC software. Figure 3 shows the main trend here: graphical environments (Windows, OS/2, and Macintosh) are on the upswing, and command-line environments (DOS) are going down. By far the single biggest change was in the Windows segment, which more than doubled in just a year. By contrast, DOS decreased about 14%. And OS/2 increased only about 6%, an interesting figure when you consider IBM's claim that the company has shipped more than two million copies.

Where did this growth come from? Figure 4 provides a pretty clear picture. Microsoft approximately doubled, from about \$1.6 to \$3.2 billion in sales. The other members of the top five did well, albeit not as well. Borland in particular has been in dire straits the past year or so, because of delays in releasing Windows versions of its database packages (dBASE and Paradox).

Another interesting fact is that the big five controlled 74% of the software market, a big jump from 60% in 1991. This indicates a bleak trend for startup outfits, because they will be competing against huge companies with lots of support and distribution. That 74% figure contrasts with that of the hardware industry, where as we saw in Fig. 4, 60% of the industry is controlled by a cacophony of small clone makers.

Microsoft's slice of the overall software pie turns out to be about 44%. This means that all by itself, *Microsoft commands almost half the PC software market*. That is what is leading to strange alliances

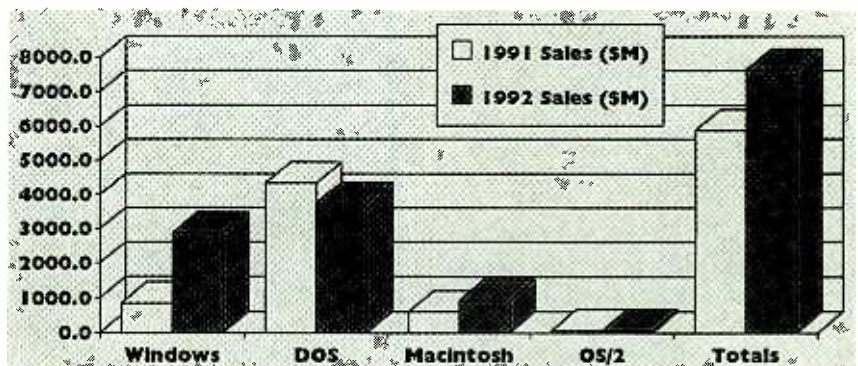
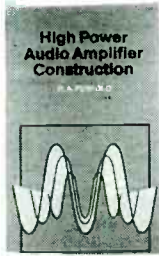

FIG. 3—GRAPHICAL OPERATING ENVIRONMENTS are in; command-line environments are out. The Windows market nearly tripled in size.

E-N Computer Admart

Rates: Ads are 2 1/4" x 2 7/8". One insertion \$995 each. Six insertions \$950 each. Twelve insertions \$925 each. Closing date same as regular rate card. Send order with remittance to Computer Admart, Electronics Now Magazine, 500-B Bi-County Blvd., Farmingdale, NY 11735. Direct telephone inquiries to Arline Fishman, area code-1-516-293-3000. FAX 1-516-293-3115. Only 100% Computer ads are accepted for this Admart.

HIGH POWER AUDIO AMPLIFIER CONSTRUCTION



BP277—Here's background and practical design information on high power audio amplifiers capable of 300 ± 400 watts r.m.s. You'll find MOSFET and bipolar output transistors in inverting and non-inverting circuits. To order your copy send \$6.25 plus \$2.50 for shipping in the U.S. to Electronic Technology Today Inc., P.O. Box 240, Massapequa Park, NY 11762-0240.

PRACTICAL ELECTRONIC DESIGN DATA

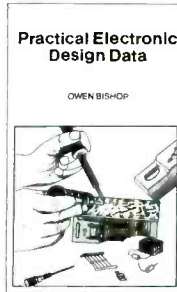

BP316—A comprehensive ready-reference manual for electronics enthusiasts, be they hobbyists, students or professionals. To order your copy send \$8.95 plus \$2.50 for shipping in the U.S. to Electronic Technology Today Inc., P.O. Box 240, Massapequa Park, NY 11762-0240.

PC-BUS POWER MONITOR CARD

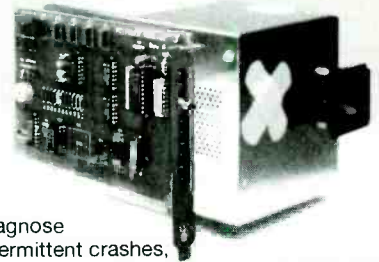

Diagnose intermittent crashes, detect power disturbances, and spot bad power supplies in PC, AT and EISA systems. It checks all four supply voltages, and remembers momentary out-of-tolerance operation.



Wintek Corporation
1801 South Street
Lafayette, IN 47904

Phone: 800-742-6809 or (317) 448-1903

CIRCLE 178 ON FREE INFORMATION CARD

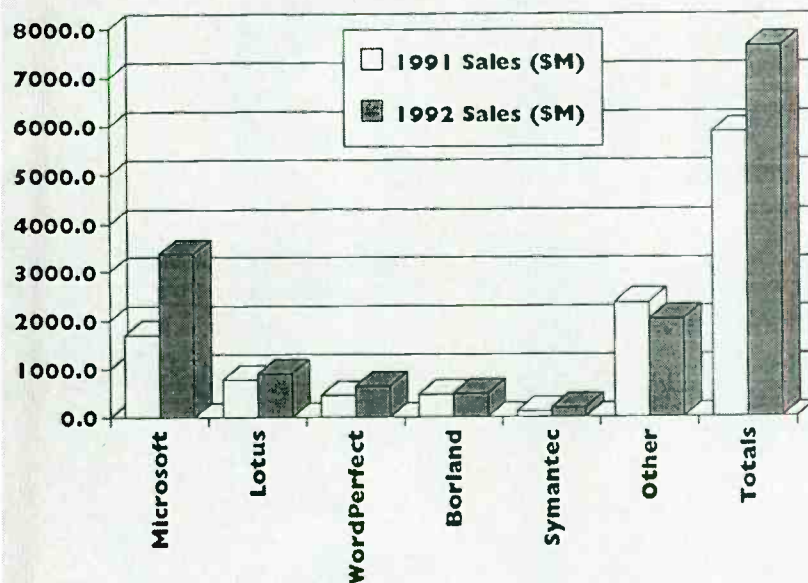

FIG. 4—MICROSOFT'S 1992 SALES topped \$3 billion, almost half the total PC market, and 15% more than the next four largest competitors combined.

among IBM, Apple, Novell, Borland, Symantec, et al.

Together the next four largest PC software vendors command only about 29% of the market. In other words, even if the "little four" somehow merged, they still would have only two-thirds the sales of Microsoft. Problem is, the success rate of such partnerships is not high.

Microsoft's unclear future

Nonetheless, there is lots of fear and uncertainty about what Micro-

soft will do. The company clearly intends to have a major influence on (if not total command over) all significant software technologies. For users, that could be good. Gates and Co. have a unified vision of where this technology is leading. The company developed that vision a long time ago, and stuck to it, even though initial efforts were often ridiculed. You have to give them credit for that. On the other hand, without competition, what's to keep Microsoft honest?

Microsoft is fast becoming the General Motors of the software industry; some combination of the "little four" may provide a Ford. It doesn't seem likely that a Chrysler will emerge. But I wouldn't be surprised to see a Toyota and a Hyundai.

The biggest chink in the armor is networking. Novell controls about two thirds of the market; Microsoft, perhaps 2%, and the difference is tremendous. The company is making strides with Windows for Workgroups and the forthcoming Windows NT. However, Novell still has a commanding market lead; technically, all indications are that NT networking, though powerful, will not stand up to NetWare 4.0, due out this spring.

Conclusions

So that's the state of the computer industry, circa late 1992. A lot more could be said, but the trends are evident. Personal computers dominate the computer industry, but the lack of a distinct leader and broadly accepted standards heralds continued rapid evolution and vendor turmoil. Who knows—IBM may yet regain lost strides. In software, Microsoft is the undisputed king, and its dominance continues to grow. Yet a weakness in networking spells trouble.

**TROUBLESHOOTING
AND REPAIRING
AUDIO & VIDEO
CASSETTE
PLAYERS
& RECORDERS**



3795 \$29.95

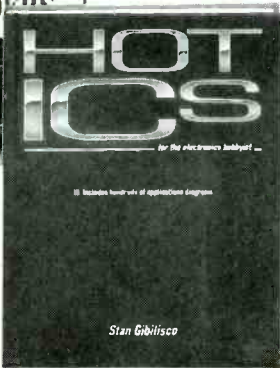

4122 \$36.95

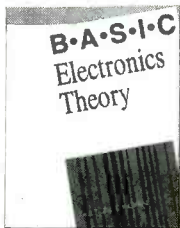
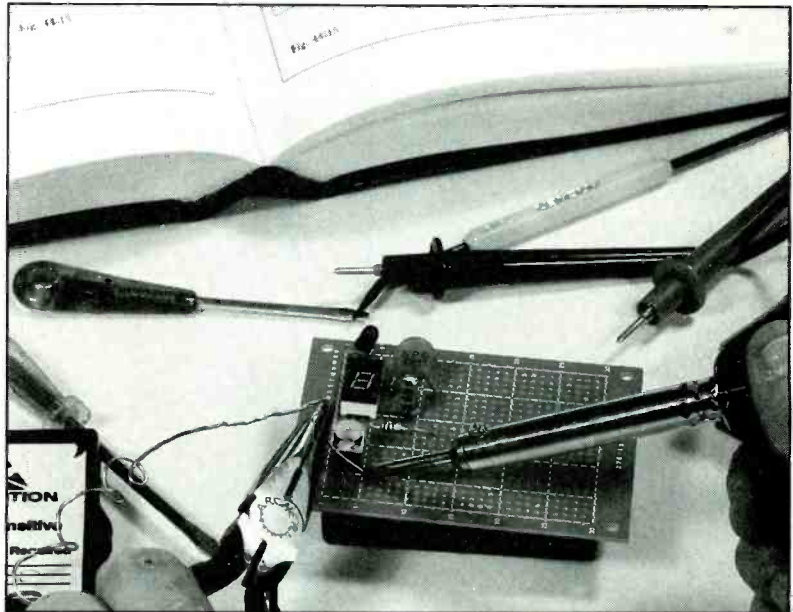

3195P-XX \$22.95
Counts as 2/Softcover

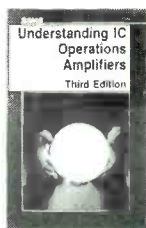

585120 \$12.95
Softcover

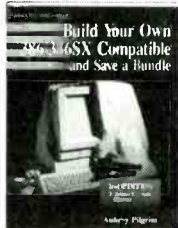

4089P \$18.95
Softcover

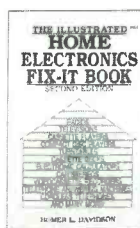

2883P \$18.95
Softcover



3540 \$26.95



070439-XX \$60.00
Counts as 2



2613P \$18.95
Softcover



585107-XX \$24.95
Counts as 2

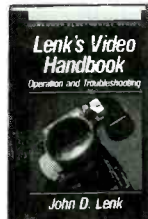

10018 \$39.95



1367P \$29.95
Softcover

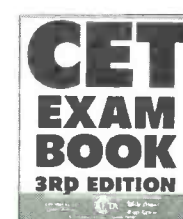

4199 \$27.95

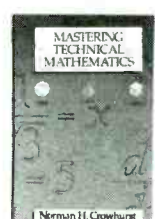

3438-XX \$39.95
Counts as 2



3677-XX \$34.95
Counts as 2



3671P \$18.95
Softcover

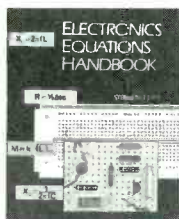

3241P \$16.95
Softcover



3374P \$16.95
Softcover



3107P \$18.95
Softcover

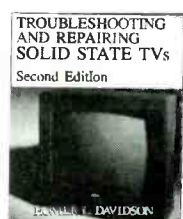

3700-XX \$36.95
Counts as 2



1604P \$17.95
Softcover



011019-XX \$40.00
Counts as 2

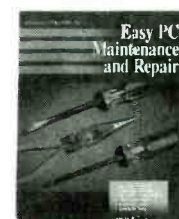

4143 \$22.95

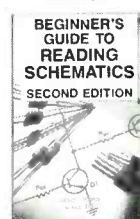

3632P \$10.95
Softcover

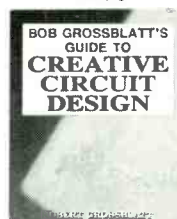

3610 \$28.95

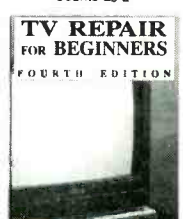

3627 \$29.95

Select any 5 books for only \$4⁹⁵

when you join the **ELECTRONICS BOOK CLUB**[®] (values up to \$179.75)



2724P \$17.95
Softcover

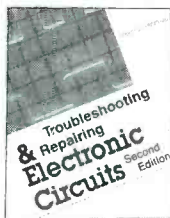

3258P \$19.95
Softcover



3765P \$18.95
Softcover

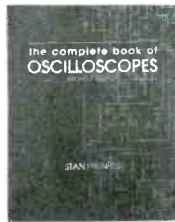

3825 \$26.95

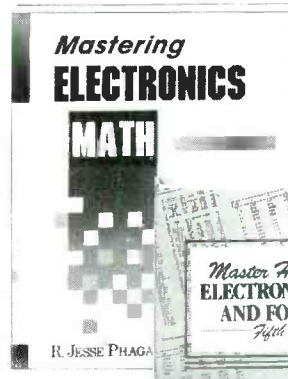

3589 \$27.95

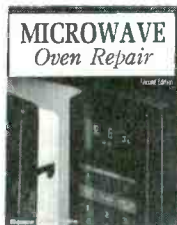

3457-XX \$29.95
Counts as 2

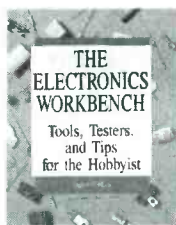

3672P \$18.95
Softcover

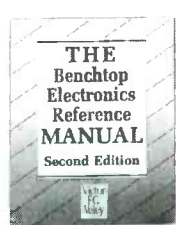

3414-XX \$39.95
Counts as 2

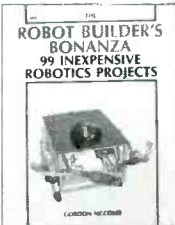

2800P \$17.95
Softcover

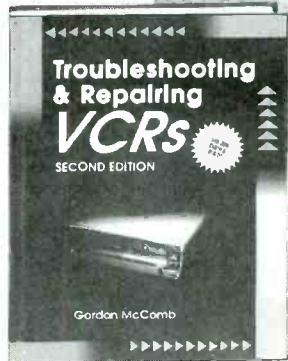

3739 \$39.95

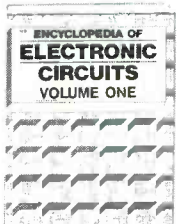

1938-XXX \$60.00
Counts as 3

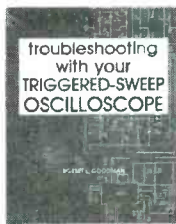

3669 \$27.95

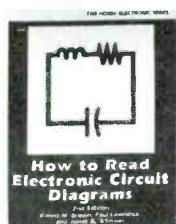

2880P \$14.95
Softcover

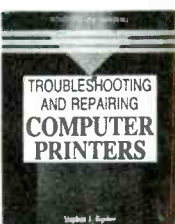

3923 \$32.95

If coupon is missing, write to: Electronics Book Club, Blue Ridge Summit, PA 17294-0810

As a member of the Electronics Book Club . . .

. . . you'll enjoy receiving Club bulletins every 3-4 weeks containing exciting offers on the latest books in the field at savings of up to 50% off of regular publishers' prices. If you want the Main Selection do nothing and it will be shipped automatically. If you want another book, or no book at all, simply return the reply form to us by the date specified. You'll have at least 10 days to decide. And you'll be eligible for **FREE** books through the **NEW** Bonus Book Program. Your only obligation is to purchase 3 more books during the next 12 months, after which you may cancel your membership at any time.

(Publishers' Prices Shown)

All books are hardcover unless otherwise noted. ©1993 EBC. A shipping/handling charge & sales tax will be added to all orders. If you select a book that counts as 2 choices, write the book number in one box and XX in the next. If you select a Counts as 3 choice, write the book number in one box and XXX in the next 2 boxes.

Your most complete and comprehensive source for the finest electronics books

ELECTRONICS BOOK CLUB[®]

Blue Ridge Summit, PA 17294-0810

YES! Send the 5 volumes listed below, billing me just \$4.95 plus shipping/handling & tax. Enroll me as a member of the **Electronics Book Club** according to the terms outlined in this ad. If not satisfied, I may return the books within ten days and have my membership cancelled. A shipping/handling charge and sales tax will be added to all orders.



If you select a book that counts as 2 choices, write the book number in one box and XX in the next.
If you select a Counts as 3 book, write the book number in one box and XXX in the next 2 boxes.

Name _____

Address _____

City _____ State _____

Zip _____ Phone _____

Valid for new members only, subject to acceptance by EBC. Canada *must* remit in U.S. funds drawn on U.S. banks. Applicants outside the U.S. and Canada will receive special ordering instructions. RE593C

EQUIPMENT REPORTS

continued from page 16

tance. It also provides a diode-test function and the ability to measure transistor DC current gain (+beta or h_{FE}).

The meter provides five DC voltage ranges (200 mV to 100 V) and five AC voltage ranges (200 mV to 750 V, 50 Hz–400 Hz). Five DC and AC current ranges (200 μ A to 20 A) are also featured. Six resistance ranges (200 ohms to 20 megohms) and five capacitance ranges (0.002 to 20 μ F) are provided. To test transistor gain, the meter delivers 10 microamperes at 2.8 volts. The maximum current in the diode test mode is 1.5 mA.

Whether it's built in a classroom setting or as a hobby pursuit, the Elenco M-2665 is an excellent choice for anyone trying to learn a little more about electronics. Its \$49.95 price would be a worthwhile investment for any student of electronics, because it teaches you as you build it. And it teaches you even more when you put it to work. Ω

Think of the computer industry as a circle. Now imagine it intersecting other circles that represent the telephone, publishing, consumer electronics, and entertainment industries. The areas of intersection are small today, but they are growing faster and faster. These are the areas where new fortunes will be made—and lost. Who will be the Microsoft of the coming age of multimedia?

News bits

Cirrus Logic introduces a new fax/voice/data chip, the CL-MD9624EC2, for PCMCIA use.

- Startup 3DO has announced that they will produce a \$700 CD-based multimedia player with stunning 3D graphics.

- A beta version of OS/2 2.1 has begun circulating with full support for Windows 3.1 and a speedy 32-bit graphics engine.

- Microsoft has announced a data-compression standard, the Microsoft Realtime Compression Interface (MRCI), which will first be seen in a disk-doubling product to be included with DOS 6, expected this spring.

- Stac Electronics, maker of the current market leader in disk doublers, promptly slapped Microsoft with a suit.

- TI and Hitachi have announced an agreement for joint development of a 256-megabit DRAM using 0.25-micron technology, expected around the end of the decade.

- IBM and Canon have introduced a 25-MHz 80486SLC-based notebook computer with built-in ink-jet printer, presently for the Japanese market only.

- Market Intelligence Corp. predicts by 1998 a \$25 billion market in multimedia. Ω

VIDEO NEWS

continued from page 6

The Nimbus disc, like JVC's, has additional capacity, but uses it differently. Nimbus reduced the width of the track on the disc, and also slowed down the disc's speed slightly. But its engineers say that modern CD players can easily cope with the slower speed without being modified. Those two changes combined can double the disc playing time to more than two hours of MPEG-1 encoded movies while staying within the operational range of existing lasers and speed-control circuits. Nimbus expects those double-density discs and video adapters to be available within a year.

At a recent demonstration of the new system, observers agreed that the Nimbus disc player exceeded VHS standards, but they noted that the system lacked the interactivity of such CD-based systems as CD-I. Nimbus is proposing its system as a standard to the film and music industries. Ω

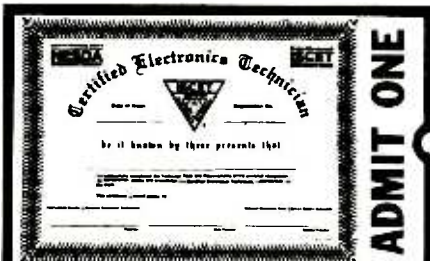

Your Ticket To

SUCCESS

Over 28,000 technicians have gained admittance worldwide as certified professionals. Let your ticket start opening doors for you.

ISCET offers Journeyman certification in Consumer Electronics, Industrial, Medical, Communications, Radar, Computer and Video. For more information, contact the International Society of Certified Electronics Technicians, 2708 West Berry Street, Fort Worth, TX 76109; (817) 921-9101.

Name _____
Address _____
City _____
State _____ Zip _____

Send material about ISCET and becoming certified.

Send one "Study Guide for the Associate Level CET Test." Enclosed is \$10 (inc. postage).



Says he's the world's fastest computer.

Try the

Electronics NOW[®]

bulletin board system

(RE-BBS)
516-293-2283

The more you use it the more useful it becomes.

We support 1200 and 2400 baud operation.

Parameters: 8N1 (8 data bits, no parity, 1 stop bit) or 7E1 (7 data bits, even parity, 1 stop bit).

Add yourself to our user files to increase your access.

Communicate with other R-E readers.

Leave your comments on R-E with the SYSOP.

RE-BBS
516-293-2283

BUYER'S MART

FOR SALE

TUBES. "oldest", "latest". Parts and schematics. SASE for lists. **STEINMETZ**, 7519 Maplewood Ave., R.E., Hammond, IN 46324.

TUBES, new, up to 90% off, SASE, **KIRBY**, 298 West Carmel Drive, Carmel, IN 46032.

CABLE Converters, accessories below wholesale! Immediate delivery from giant stock! COD orders only. 1 (800) 995-1749.

OAK Sigma descrambler, CH3 output, rare hard-to-find units, \$100.00 postpaid, only moneyorders please. **SURPLUS ELECTRONICS**, Box 10009, Colorado Springs, CO 80932.

CLASSIFIED AD ORDER FORM

To run your own classified ad, put one word on each of the lines below and send this form along with your check to:

Electronics Now Classified Ads, 500-B Bi-County Boulevard, Farmingdale, NY 11735

PLEASE INDICATE in which category of classified advertising you wish your ad to appear. For special headings, there is a surcharge of **\$25.00**.

() Plans/Kits () Business Opportunities () For Sale
() Education/Instruction () Wanted () Satellite Television
()

Special Category: \$25.00

PLEASE PRINT EACH WORD SEPARATELY, IN BLOCK LETTERS.

(No refunds or credits for typesetting errors can be made unless you clearly print or type your copy.) Rates indicated are for standard style classified ads only. See below for additional charges for special ads. **Minimum: 15 words.**

1	2	3	4	5
6	7	8	9	10
11	12	13	14	15 (\$46.50)
16 (\$49.60)	17 (\$52.70)	18 (\$55.80)	19 (\$58.90)	20 (\$62.00)
21 (\$65.10)	22 (\$68.20)	23 (\$71.30)	24 (\$74.40)	25 (\$77.50)
26 (\$80.60)	27 (\$83.70)	28 (\$86.80)	29 (\$89.90)	30 (\$93.00)
31 (\$96.10)	32 (\$99.20)	33 (\$102.30)	34 (\$105.40)	35 (\$108.50)

We accept MasterCard and Visa for payment of orders. If you wish to use your credit card to pay for your ad fill in the following additional information (Sorry, no telephone orders can be accepted.):

Card Number

Expiration Date

Please Print Name

Signature

IF YOU USE A BOX NUMBER YOU MUST INCLUDE YOUR PERMANENT ADDRESS AND PHONE NUMBER FOR OUR FILES. ADS SUBMITTED WITHOUT THIS INFORMATION WILL NOT BE ACCEPTED.

CLASSIFIED COMMERCIAL RATE: (for firms or individuals offering commercial products or services) \$3.10 per word prepaid (not available as all caps)...**MINIMUM 15 WORDS.** 5% discount for same ad in 6 issues; 10% discount for same ad in 12 issues within one year; if prepaid (not applicable on credit card orders). **NON-COMMERCIAL RATE:** (for individuals who want to buy or sell a personal item) \$2.50 per word, prepaid....no minimum. **ONLY FIRST WORD AND NAME** set in bold caps at no extra charge. Additional bold face (not available as all caps) **55¢ per word additional.** Entire ad in boldface, \$3.70 per word. **TINT SCREEN BEHIND ENTIRE AD: \$3.85 per word. TINT SCREEN BEHIND ENTIRE AD PLUS ALL BOLD FACE AD: \$4.50 per word. EXPANDED TYPE AD: \$4.70 per word prepaid.** Entire ad in boldface, \$5.60 per word. **TINT SCREEN BEHIND ENTIRE EXPANDED TYPE AD: \$5.90 per word. TINT SCREEN BEHIND ENTIRE EXPANDED TYPE AD PLUS ALL BOLD FACE AD: \$6.80 per word. DISPLAY ADS:** 1" x 2 1/8"—\$410.00; 2" x 2 1/8"—\$820.00; 3" x 2 1/4"—\$1230.00. **General Information:** Frequency rates and prepayment discounts are available. **ALL COPY SUBJECT TO PUBLISHERS APPROVAL. ADVERTISEMENTS USING P.O. BOX ADDRESS WILL NOT BE ACCEPTED UNTIL ADVERTISER SUPPLIES PUBLISHER WITH PERMANENT ADDRESS AND PHONE NUMBER.** Copy to be in our hands on the 1st of the third month preceding the date of the issue. (i.e., Aug. issue copy must be received by May 1st). When normal closing date falls on Saturday, Sunday or Holiday, issue closes on preceding working day. Send for the classified brochure. Circle Number 49 on the Free Information Card.

PAY TV AND SATELLITE DESCRAMBLING

***** 1993 EDITION *****

Includes: programming cable box chips, hacking B-MAT, wireless cable, MARS/5 descrambling, bullets, PLUS files and much more. **ONLY \$18.95.** Other PAY TV and SATELLITE DESCRAMBLING volumes: Volume 1 (BASICS), 1989, 1991, and 1992 \$15.95 each. Different turn-ons, bypasses, ECM's, schematics and counter ECM's in each **THE COMPLETE WIZARD!** Using the VCI data stream, \$15.95. Any 3/32 95 or 5/32 95 **SCRAMBLING NEWS** monthly. Keep up with the latest in satellite and cable descrambling. Everything that's new, \$32.95/yr. **OUR BEST DEAL** everything here, the video and much more only \$129.95. New catalog \$1

Scrambling News, 1552 Hertel Ave., #123, BUFFALO, NY 14216
Voice/FAX (716) 874-2088 COD's are OK. ADD \$6

ENGINEERING software and hardware, PC/MSDOS. Circuit design/drawing, PCB layout, FFT analysis, mathematics, circuit analysis. Data acquisition, generation, I/O PCB's. Call or write for free catalog. (614) 491-0832, or fax (614) 497-9971, **BSOFT SOFTWARE, INC.**, 444 Colton Rd., Columbus, OH 43207.

CABLE test chips. Jerrold, Tocom, S.A., Zenith. Puts cable boxes into full service mode! \$29.95 to \$59.95. 1 (800) 452-7090, (310) 867-0081.

TOCOM-Jerrold Impulse-Scientific Atlanta Converters, two year warranties, also test modules for your converters. Contact **NATIONAL CABLE**, (219) 935-4128 full details.

SECRET cable descramblers! Build your own descrambler for less than \$12.00 in seven easy steps. Radio Shack parts list and free descrambling methods that cost nothing to try, included. Send \$10.00 to: **HARRY WHITE**, PO Box 1790, Baytown, TX 77522.

CABLE TV converters: Jerrold, Oak, Scientific Atlantic, Zenith & many others. "New MTS" stereo add-on: mute & volume. Ideal for 400 and 450 owners! 1 (800) 826-7623, Amex, Visa, M/C accepted. **B & B INC.**, 3584 Kennebec, Eagan, MN 55122.

PREVENT descrambler damage. Don't bite the bullet! Snooper Stopper Data Pulse Blocker \$33.95, with Surge Protection \$44.95... Wireless Video Sender \$54.95. **VCI**, 1 (800) 925-9426.

300 Experimenters Circuits — Complete in 6 practical books using diodes, relays, FET's, LED's, IC 555's, and IC CA3130's for building blocks. Only \$33.00 plus \$5.50 for shipping. USA and Canada only. US funds. **ETT, INC.**, PO Box 240, Massapequa Park, NY 11762-0240.

EPROMS, Assorted, i.e., 27128A-15 \$3.00 each minimum quantity 13 pieces. C.O.D., American Express. **H.E.A.R.T. Inc.**, 1 (800) 677-3773.

Be a TV/VCR Repair Specialist

Now you can train at home in spare time for a money-making career as a TV/VCR Repair Specialist. No previous experience necessary. No need to quit your job or school. Everything is explained in easy-to-understand language with plenty of drawings, diagrams and photos. We show you how to troubleshoot and repair video-cassette recorders and TV sets, how to handle house calls and shop repairs for almost any make of television or VCR. Tools are included with your course so you can get "hands-on" practice as you follow your lessons step by step. Send for free facts about the exciting opportunities in TV/VCR Repair and find out how you can start making money in this great career. **MAIL COUPON TODAY** K03C

SCHOOL OF TV/VCR REPAIR, Dept. ADE043S
(SINCE 1980) 925 Oak Street, Scranton, PA 18515

Please send me full information and color brochure on how I can learn TV/VCR Repair at home in my spare time. I understand there is no obligation and no salesman will visit me.

Name _____ Age _____
Address _____ Apt. # _____
City/State _____ Zip _____
Phone (____) _____

ANTIQUE RADIO CLASSIFIED

Free Sample!

Antique Radio's

Largest Circulation Monthly.
Articles, Ads & Classifieds.



6-Month Trial: \$15. 1-Yr: \$27 (\$40-1st Class).
A.R.C., P.O. Box 802-L9, Carlisle, MA 01741

TEST-Aids for testing units in full service mode. Jerrold, \$40.00; Pioneer, clears error codes E2 thru E5, \$60.00; Pioneer cubes, will not alter internal serial number, \$125.00; Tocom mapping, \$40.00; Tocom 5503/5507, \$25.00; S.A. 8500, \$25.00; 8550 \$30.00; 8580, \$40.00; 8570/90, \$50.00; 8600, \$50.00; Zenith Z Tac, \$25.00; security tools and remotes. **N.E. ENGINEERING**, (617) 770-3830.

RESTRICTED technical information: Electronic surveillance & schematics; locksmithing; cable phreaking; hacking; etc. Free brochures: **MENTOR**, Box 1549-Z, Asbury Park, NJ 07712.

CABLE TV converters. Jerrold, Zenith, Pioneer, Oak, Scientific Atlanta, and many more. 12 years experience gives us the advantage. Visa/MC Amex COD **ADVANTAGE ELECTRONICS, INC.**, 1 (800) 952-3916 1125 Riverwood Dr., Burnsville, MN 55337.

VIDEO tapes covering electronics, computers and communications. Demo \$3.50. **OCS**, PO Box 292, Fort Mill, SC 29715.

ROOM surveillance — \$149.00; room and telephone — \$249.00; remote telephone recorder and room monitor — \$479.00. Catalog, \$3.00. **LISTEN ELECTRONICS**, 603 Elgin, Muskogee, OK 74401. 1 (800) 633-8277.

WATER powered watch, 2 year guarantee. Men's, women's, children's size S, \$12.50 each. **ALPHA COMPANY**, 2 Klarides Village Drive, Seymour, CT 06483.

TEST equipment pre-owned now at affordable prices. Signal generators from \$50.00, oscilloscopes from \$50.00. Other equipment available. Send \$2.00 U.S. for catalog refunded on first order. **J.B. ELECTRONICS**, 3446 Dempster, Skokie, IL 60076. (708) 982-1973.

TEKTRONIX 465 100MHz oscilloscope \$950.00, Cushman 4400 communications monitor \$4,500.00, Singer FM10C communications monitor \$1,800.00, Beckman handheld DMM \$50.00. For more information or sales brochure call **ADVANCED TEST EQUIPMENT**, (619) 483-2832.

ATTENTION consumer electronics technicians! "The Dog Catcher" is a new program which gives instant access to the latest repair tips from a network of America's finest technicians. Monthly updates, and your own tips can be added to the database of VCR, camcorder, TV and stereo repairs. Take advantage of the introductory price now! \$99.95 **DATABASIC**, 1 (800) 967-5924.

PRECISION — set of 6 decade multiple (10-1 meg) 1/10% metal film resistors. First quality. Check your DVM! \$6.00 ppd. **C-LABS**, 3710 Kingston Vale, Houston, TX 77082.

CABLE TV descramblers — All major brands. Have make/model used in your area when calling, 1 (800) 327-3407. For a free catalogue write: **K.D. VIDEO**, PO Box 29538, Minneapolis, MN 55429.

CABLE TV filters. Cylinder type. Best made. All channels available. Low prices. Quantity discounts. Call 1 (800) 331-2156 ext.156.

BUY BONDS

CABLE TV DESCRAMBLERS

... VIDEO STABILIZERS AVAILABLE & Bullet Protectors ...

MULTI-VISION ELECTRONICS, 2710 W. 10TH ST., TERRELL, OKLAHOMA, NE 73454

1-800-835-2330

BEST BUY'S BEST SERVICE STARTS WITH A FREE CATALOG

1-800-327-8544

TECH LINE (402) 331-3228



BY PURCHASING CABLE EQUIPMENT FROM MULTIVISION ELECTRONICS, THE PURCHASER AGREES TO COMPLY WITH STATE & FEDERAL LAWS REGARDING PRIVATE OWNERSHIP OF CABLE TV EQUIPMENT. IF YOU ARE UNLAWFUL OF THESE LAWS CHECK WITH YOUR LOCAL OFFICIALS.

PLANS AND KITS

FASCINATING electronic devices! Voice Disguiser! Vocal truth indicator! Lasers! Transmitters! Detectors! Free energy! High voltage! More! Kits/Assembled! Catalog \$4.00 (refundable). **QUANTUM RESEARCH**, 17919-77 Ave., Edmonton, AB. T5T 2S1.

HOBBY/broadcasting/HAM/CB/surveillance transmitters, amplifiers, cable TV, science, bugs, other great projects! Catalog \$1.00. **PANAXIS**, Box 130-F5, Paradise, CA 95967.

DESCRAMBLER kits. Complete cable kit \$44.95. Complete satellite kit \$49.95. Add \$5.00 shipping. Free brochure. No New York sales. **SUMMIT RE**, Box 489, Bronx, NY 10465.

SURVEILLANCE transmitter kits tune from 65 to 305 MHz. Mains powered duplex, telephone, room, combination telephone/room. Catalog with **Popular Communications, Popular Electronics and Radio-Electronics** book reviews of "Electronic Eavesdropping Equipment Design," \$2.00. **SHEFFIELD ELECTRONICS**, PO Box 377785-C, Chicago, IL 60637-7785.

60 SOLDERLESS Breadboard Projects in two easy-to-read pocket books. Complete with circuit descriptions, schematics, parts layouts, component listings, etc. Both books (BP107 & BP113) only \$11.90 plus \$3.50 for shipping. USA and Canada only. US funds. **ETT, INC.**, PO Box 240, Masapequa Park, NY 11762-0240.

REMOTE CONTROL KEYCHAIN



Complete w/min. transmitter and +5 vdc RF receiver. Fully assembled including plans to build your own auto. alarm. Check Visa or M/C. Add \$4 shipping. \$24.95. 5 @ \$19.95, 10 @ \$14.95.

Visitect Inc., Box 14156, Fremont, Ca. 94539
(510) 651-1425 Fax (510) 651-8454

DESCRAMBLING, new secret manual. Build your own descramblers for cable and subscription TV. Instructions, schematics for SSAVI, gated sync, Sinewave, (HBO, Cinemax, Showtime, UHF, Adult) \$12.95, \$2.00 postage. **CABLETRONICS**, Box 30502R, Bethesda, MD 20824.

VHF-FM amplifier plans. 75-110 MHz, 15-25 watts. \$16.00. **PROGRESSIVE CONCEPTS**, 1313 North Grand Ave., #291, Walnut, CA 91789.

CREDIT card encoding revealed, encoding info \$5.00, w/plans & software (PC) \$12.25, w/kit \$64.50 + \$4.50 S/H (USA). Assembled add \$10.00. **BSC**, Box 1841, Alexandria, VA 22314.

CONTROL the world with your computer. Control up to four AC or DC loads with any computer's parallel port. Quad Power Relay Control Board \$69.50/kit. Quad Triac Control Board \$79.50/kit. **APOGEE R&D INC.**, 31 Nebo St., Medfield, MA 02052.

TESLA coils Plans-kits-parts. Send \$2.00 for one tesla coil plan plus complete catalog. **SUPER CIRCUITS CO.**, Rt 2, Box 334, Nunnely, TN 37137.

3 electronic projects to get in trouble with! Shock box! F.M. bug! T.V. jammer! Free plans! **DESERT ELECTRONICS**, PO Box 1642-E, El Centro, CA 92243.

0-24 volts power supply plan. First equipment needed on your bench. Send \$10.00US money order to **SRE SYSTEMS**, C.P. 131 Jean Talon, St-Leonard, Que H1S 2Z1.

IT'S A TRAGEDY BEYOND DESCRIPTION.



96,000 acres of irreplaceable rain forest are being burned every day.

These once lush forests are being cleared for grazing and farming. But the tragedy is without the forest this delicate land quickly turns barren.



In the smoldering ashes are the remains of what had taken thousands of years to create. The life-sustaining nutrients of the plants and living matter have been destroyed and the exposed soil quickly loses its fertility. Wind and rain reap further damage and in as few as five years a land that was teeming with life is turned into a wasteland.

The National Arbor Day Foundation, the world's largest tree-planting environmental organization, has launched Rain Forest Rescue. By joining the Foundation, you will help stop further burning. For the future of our planet, for hungry people everywhere, support Rain Forest Rescue. Call now.



The National Arbor Day Foundation

Call Rain Forest Rescue NOW.
1-800-255-5500

1-800-831-4242

Your Resource for Value. Only a Phone Call Away.

20
YEARS OF
EXCELLENCE
1973-1993

Metex Digital Multimeters



5R27158

Handheld high accuracy
Measures AC/DC voltage,
AC/DC current, resistance,
diodes, audible continuity test,
transistor hFE
Manual ranging w/overload
protection
Comes with probes, batteries, case
and manual
One-year warranty

7086 & 27158 only:
Also measures frequency and capacitance

Part No.	Description	Price
U27078	3.5 digit multimeter	\$59.95
U27086	3.5 digit multimeter w/frequency & capacitance	74.95
R27115	3.5 digit multimeter	39.95
R27140	4.5 digit multimeter, w/tach/dwell	59.95
R27158	4.5 digit w/frequency & capacitance & data hold switch	99.95

Jameco Solderless Breadboards



5R20757

Our long-lasting bread-boards feature screen printed color coordinates and are suitable for many kinds of prototyping and circuit design. Larger models feature heavy-duty aluminum backing with voltage and grounding posts.

Part No.	Terminal Strips	Bus Strips	Contact Points	1-9
5R20343	0	2	200	\$3.49
5R20600	1	2	400	4.95
5R20669	1	0	630	5.95
5R20722	1	2	830	6.95
5R20757	2	1	1,360	12.95
5R20773	2	4	1,660	17.95
5R20790	3	5	2,390	24.95
5R20811	4	7	3,220	32.95

Function Generator Kit

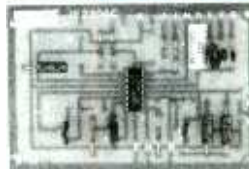

Great for prototyping electronic circuits, whether analog or digital!
Produces sinusoidal, triangular (saw-tooth), and square wave-forms at frequencies continuously variable from 1 kHz to 100 kHz.
(Requires 12 VDC supply or ± 6 VDC split supply; recommended power supply #20626)

Part No.	Product No.	Price
5R20685	JE2206	\$19.95

Fiberoptics Kit



Discover the intriguing principles of fiber optics data communications. The kit includes separate transmitter and receiver circuit boards, fiber optics cable and all connectors for interfacing cables with the circuit boards. Either a square-wave or TTL signal from 200 Hz to 5 kHz can be inputted.

Part No.	Product No.	Price
5R21135	JE310	\$19.95

See our Catalog for more kits

Crystals



Part No.	Product No.	Frequency	Price
U4533	CY3.57	3.579545MHz	\$1.19
U4592	CY4	4.0000MHz	1.19
U4681	CY6	6.000MHz	1.19
U4402	CY12	12.000MHz	1.19
U4517	CY20	20.000MHz	1.19

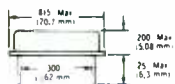

Clock Oscillators

Part No.	Product No.	Frequency	Price
U27861	OSC1	1.0000MHz	\$3.95
U27991	OSC8	8.0000MHz	3.95
U27941	OSC32	32.0000MHz	3.95
U77489	OSC80	80.0000MHz	4.95

Integrated Circuits*

Part No.	Product No.	Price
R48979	7400	\$2.29
R49015	7402	.39
R49040	7404	.39
R49091	7406	.45
R49120	7407	.45
R49146	7408	.45
R49189	7410	.29
R49728	7417	.35
R50008	7420	.29
R50235	7432	.45
R50420	7447	.89
R50551	7474	.25
R50593	7476	.59
R50665	7486	.39
R50681	7489	2.95
R50690	7490	.79
R49322	74121	.49
R49912	74192	.99
R49939	74193	.99

*Name brand IC's in stock

Radial Lead Electrolytic Capacitors



Part No.	Cap.	Volt.	Price
5R29831	1 μ F	50V	\$.12
5R29891	10 μ F	50V	.13
5R31114	47 μ F	50V	.15
5R29962	100 μ F	50V	.19
5R30015	1000 μ F	16V	.35

Dipped Tantalum Capacitors



Part No.	Cap.	Volt.	Price
5R33486	.1 μ F	35V	\$1.19
5R33662	1 μ F	35V	.25
5R33734	2.2 μ F	35V	.25
5R33806	4.7 μ F	35V	.45

Machine Tooled Low Profile Tin Plated IC Sockets



Part No.	Pins	Price
5R51625	8 pin	\$.55
5R37196	14 pin	.59
5R37401	16 pin	.69
5R39351	24 pin	.99
5R40328	28 pin	1.09
5R41136	40 pin	1.25

*Additional components available

Carbon Film 1/4 Watt 5% Resistor Assortments

Part No.	Description	Price
5R10719	5 each 70 values (every other value from R10 ohm-R5.6 meg) 1/4 Watt C.F. Resistor Values (350 pcs.)	\$9.95
5R10663	100 each (27 values) 1/4 Watt C.F. Resistors R10 thru R10M (2,700 pcs.)	39.95

1/2 Watt Linear Taper- Single Turn Cermet Potentiometers

Part No.	Ohms	Price
5R42964	1K	\$.89
5R43001	10K	.89
5R43027	100K	.89
5R42981	1MEG	.89



Order toll-free 1-800-831-4242

Other Jameco Resources

- Test/Measurement and Prototyping Equipment
- Computer Upgrade and Accessory Products
- Full line of Integrated Circuits and Electronic Components
- Call for kit pricing



Call or write for your
FREE 1993 Annual Catalog:
1-800-637-8471

JAMECOTM
ELECTRONIC COMPONENTS
COMPUTER PRODUCTS

1355 Shoreway Road
Belmont, CA 94002

FAX: 1-800-237-6948 (Domestic)
FAX: 415-592-2503 (International)

For International Sales, Customer Service, Credit Department and all other inquiries: Call 415-592-8097 between 7AM-5PM P.S.T.

CA Residents please add applicable sales tax.

\$30.00 Minimum Order

Terms: Prices subject to change without notice. Items subject to availability and prior sale. Complete list of terms/warranties is available upon request.

© 1993 Jameco 5/93 All trademarks are registered trademarks of their respective companies.



BUILD stoplight for garage. New and useful idea. Complete plans and instructions send \$12.50 check or money order to **STOPLIGHT**, PO Box 891422, Oklahoma City, OK 73189-1422.

CREDIT card, ATM, bank program yourself. Info \$5.00. **CPU ADVANCE**, Box 1089, Waltham, MA 02154.

STOP thefts with the vehicle dummy alarm. Simple construction, arms and disarms automatically. Also home dummy alarm. Parts easily obtainable. Complete plans \$8.00US each, \$10.00 for both. **P. NICHOLLS**, PO Box 60529, Hamilton, Ontario, Canada L9C 7N7.

UNUSUAL fascinating electronic kits. Listening devices, scramblers, electronic detection, ham keyers and QRP, etc. Large SASE for catalog. **KRYSTAL KITS**, PO Box 445, Bentonville, AR 72712.

**CABLE TV
DESCRAMBLER LIQUIDATION!**
FREE CATALOG!
Hamlin Combos \$44, Oak M35B \$60 (min. 5), etc.
WEST COAST ELECTRONICS
For Information: 818-709-1758
Catalogs & Orders: 800-628-9656

**How To Get A High-Paying Job In
ELECTRONICS**



Become more competitive in the job market with **EDUCATION**

Specialized Associate degree and diploma programs in electronics technology, computer repair, communications, and industrial electronics by

DISTANCE EDUCATION
Call or write for college catalog and booklet "How to Get a High-Paying Job in Electronics."

1-800-765-7247

PEOPLES COLLEGE OF INDEPENDENT STUDIES
233 Academy Drive • P.O. Box 421768
Kissimmee, FL 34742-1768
Member, D.L. Peoples Group • Accredited Member, NHSC

**Cable TV
DESCRAMBLERS**

30-day Money Back Guarantee



► The Most Complete Line of Descramblers
► Friendly, professional service
► FREE Catalog

ORDER NOW!

DISCOVER C.O.D.

1-800-228-7404

Go to the Source
NU-TEK ELECTRONICS
3250 Hatch RD
Cedar Park TEXAS 78613

WHAT'S NEWS

continued from page 4

standard interface environment: OSF/Motif and X Window System.

As an example of how the PVS/DX system is being put to use, consider the many different subjects that are being studied with it by the Cornell Theory Center at Cornell University:

- The effect of temperature, pressure, and rock structure on the flow of petroleum through a fault in a sedimentary basin.
- The aberrant behavior of an artificial comet launched years ago by NASA.
- How the presence of an undersea mountain range changes the speed and direction of a tsunami (earthquake-caused tidal wave) and its effects on shorelines after an underwater earthquake.

R&D spending forecast

The amount of money spent on research and development in the United States this year is expected to reach \$162 billion, according to a forecast from Battelle (Columbus, OH). That figure is \$4.6 billion more than the \$157.4 billion estimated by the National Science Foundation (NSA).

However, the Battelle figures represent only a 2.9% increase—not much less than the 10-year-average 3.1% increase since 1982. Unfortunately, more than 2% of that increase will be absorbed by increases in inflation.

"The economy shows signs of an upswing, but not enough to stimulate a strong growth in R&D investments," reports Dr. Douglas Olesen, Battelle president and CEO, adding, however, that "the funding trend will be turning around."

More than half the \$162 billion (\$83 billion or 51.2%) is expected to come from private industry. The government is expected to ante up \$70.1 billion, less than the amount proposed in ex-President Bush's budget. Academic and other non-profit organizations will provide \$8.9 billion.

Private Industry is expected to perform less than 70% of all re-

search (some \$112.7 billion worth). This compares with the anticipated \$18.2 billion to be spent by government labs, while universities will spend \$31.1 billion.

Jet-fuel degradation monitored by quartz sensor

A quartz sensor that monitors the decomposition of jet fuel at high temperatures is expected to prove useful in developing aviation fuel that is better able to withstand heat without breaking down. Developed by researchers at Sandia National Laboratories (Albuquerque, NM), the new sensor makes real-time measurements of the mass of solids that accumulate on metal surfaces in aircraft fuel systems.

When jet fuel is heated, it tends to coagulate and clog valves and fuel lines with a residue. Because jet fuel is used as a coolant in high-performance aircraft, it absorbs large amounts of frictional heat when the aircraft flies at high speeds, thus accelerating the coagulation process.

The Sandia-developed sensor, a quartz wafer known as a crystal microbalance, measures the amount of solids deposited when heated fuel degrades. While the sensor is suspended in jet fuel, an alternating voltage is applied across gold electrodes on each of its faces, causing the crystal to oscillate. Accumulated residue on the sensor's surface reduces its resonant frequency, and damps the amplitude of the oscillations.

Instrumentation connected to the quartz sensor measures the ratio of current flow to applied voltage over a range of frequencies to determine the sensor's resonant frequency. Changes in the resonant frequency can be correlated with the mass of residue that accumulates on the sensor's surface. That build-up permits the sensor to measure deposition rates of a few atomic layers per minutes.

The data obtained in this U.S. Air Force-sponsored program is expected to be valuable in studying the physical and chemical processes involved in fuel degradation. The results of the research are applicable to commercial as well as military aircraft.

SATELLITE TV

FREE catalog — Lowest prices worldwide. **SKYVISION**, 1012 Frontier, Fergus Falls, MN 56537. 1 (800) 334-6455. See full page ad the Shopper section.

VIDEOCIPHER II descrambling manual. Schematics, video, and audio. Explains DES, Eprom, CloneMaster, 3Musketeeer, Pay-per-view (HBO, Cinemax, Showtime, Adult, etc.) \$16.95, \$2.00 postage. Schematics for Videocypher Plus, \$20.00. Schematics for Videocypher 032, \$15.00. Collection of software to copy and alter Eprom codes, \$25.00. **CABLETRONICS**, Box 30502R, Bethesda, MD 20824.

SUPER low satellite prices. Free U.S. and International catalog. **SATMAN**, (309) 692-4140 (Int'l), 1 (800) 472-8626 in U.S.

CABLE TV DESCRAMBLERS ★ CONVERTERS ★ and ACCESSORIES.

SAVE MONEY. DON'T RENT!

PANASONIC, JERROLD, OAK,
PIONEER, SCIENTIFIC ATLANTA
AND MORE. LOWEST PRICES. FREE CATALOG.
CABLE READY (800) 234-1006
COMPANY

CABLE BOX WHOLESALE, INC.

BEST BOXES—BEST PRICES
Immediate Shipping—COD's
Satisfaction Guaranteed
FREE Catalog—Call Now
800-841-7835

TELEPHONE LISTENING DEVICE

Record telephone conversations in your office or home. Connects between any cassette or tape recorder and your telephone line. Starts automatically when phone is answered. Records both sides of conversation. Stops recorder when phone is hung up.

\$19.95 EACH (Qty Disc. Avail.)

Super Powerful FM TRANSMITTER

Many times more powerful than other transmitters. Transmits up to 1/4 mile to any FM radio - Easy to Assemble Kit - up to 9V battery (not incl.) For catalog of Transmitters, Voice Scramblers and other specialty items, enclose \$2.00 to USI Corp.

Call 807-235-1000 or mail \$19.95 + \$1.00 shipping per item to: USI Corp. - PO Box E.N. 23172, Melbourne, FL 32902. COD's OK.

EDUCATION & INSTRUCTION

F.C.C. Commercial General Radiotelephone license. Electronics home study. Fast, inexpensive! "Free" details. **COMMAND**, D-176, Box 2824, San Francisco, CA 94126.

ELECTRONIC engineering. 8 volumes complete. \$109.95. No prior knowledge required. Free brochure. **BANNER TECHNICAL BOOKS**, 1203 Grant Avenue, Rockford, IL 61103.

COLOR TV repair the easy way, 300 priceless secrets. Free information: **CHEKMATE COMMUNICATIONS**, 385 South 2nd St., Brooklyn, NY 11211.

WANTED

INVENTORS: We submit ideas to industry. Find out what we can do for you. 1 (800) 288-IDEA.

ATTENTION! No fees to inventors! Call **INVENTORS AWARENESS GROUP, INC.** for a free brochure. 1 (800) 288-3938.

INVENTORS

INVENTORS! Can you patent and profit from your idea? Call **AMERICAN INVENTORS CORP.** for free information. Serving inventors since 1975. 1 (800) 338-5656.

CB RADIO OWNERS!

We specialize in a wide variety of technical information, parts and services for CB radios. 10-Meter and FM conversion kits, repair books, plans, high-performance accessories. Thousands of satisfied customers since 1976! Catalog \$2.

CBC INTERNATIONAL

P.O. BOX 31500RE, PHOENIX, AZ 85046

THE AMERICAN HEART ASSOCIATION MEMORIAL PROGRAM

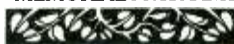

American Heart Association

This space provided as a public service.

THE ELECTRONIC GOLDMINE



The Electronic Goldmine has one of the greatest selections of unique electronic project kits available in the world. We have over 29 kits and over 2000 unique bargain priced components in our new 80 page catalog!

FREE CATALOG
with over 200 different items including 29 kits! Request your copy TODAY!

MINIATURE MOTOR

Precision high speed motor made by Mabuchi, their part# FF-050SH. Low noise type with low profile enclosed case. Size about 1-1/8" x 9/16" shaft length 3/8". Great for robots, miniature fans etc. Operates from 1.0VDC up to 9VDC. **G2846 .49¢EA**

2 CELL BATTERY HOLDER

White plastic holder for 2 standard AA batteries. Has long color coded flexible leads. **G971 3/1.00**

SPECIAL ITEMS

ULTRABRIGHT RED LED
Extremely bright clear lens red TO-18 Jumbo LED made by HP. Part# H-1MP-3750. So bright it can be seen in any light conditions. **7/\$1.00**
G3310 100/\$8 1000/\$75

COPPER CLAD
Make your own PC boards with these double sided FR4 laminated copper clad panels. Each panel is .042 standard thickness with a size of 5" x 6". Pkcs of 5 **G3022 \$5.00**

MEDIUM INVERTER TRANSFORMER

Converts 9V or 12VDC to over 250 V when used with a 555 IC circuit. (Schematic included) Perfect for portable strobes, blacklight etc. **G993 \$1.75 EA. 100/\$160.00**

1KV TRIGGER COIL

These can be used with many different strobes. Output is 40V and will work with the tubes below. **N1700 \$1.25 EA. 100/\$80.00**

STROBE TUBES

Bright xenon flash tube for making strobe lights. Includes schematic showing this tube and our standard 3 lead trigger coil. **G936 \$1.39**

High quality assembly consisting of a 1-3/4" long xenon strobe tube mounted on a plastic reflector assembly (2-3/4" L x 1" H). Includes snap on color corrected front lens. **A1033 \$2.49 10/\$22.00**

MINIMUM ORDER: \$10.00 plus \$3.50 shipping and handling. \$5.00 for U.S. Mail. We accept MC, VISA and Money Orders. SEND ORDERS TO: THE ELECTRONIC GOLDMINE, P.O. Box 5436 Scottsdale, AZ 85261. PHONE ORDERS: (602) 451-7454 FAX ORDERS: (602) 451-9495

CIRCLE 125 ON FREE INFORMATION CARD

The Time Has Come...



...to send for the latest copy of the free Consumer Information Catalog.

It lists more than 200 free or low-cost government publications on topics like money, food, jobs, children, cars, health, and federal benefits.

Send your name and address to:

**Consumer Information Center
Department TH
Pueblo, Colorado 81009**

Courteous Service • Discount Prices • Fast Shipping

ALL ELECTRONICS

P.O. Box 567 • Van Nuys, CA 91408

ULTRASONIC TRANSDUCERS MATCHED SET

Panasonic transmitter/ receiver pair.
Ideal for remote control systems,
burglar alarms, flow rate detectors etc.

Transmitter: # EFR-OHB40K24
0.5" dia. X 0.37"

Receiver: # EFR-RUB40K25.
0.63" dia. X 0.48"

Center frequency: 40 KHz. Band width: 4KHz +
CAT# UST-23 \$2.00 per set



TWO CHANNEL COLOR ORGAN

Create your
own light shows.
Electret mike on
control board
responds to
music or other
sounds causing
lights to brighten and dim



depending on frequency and volume. 120 Vac input and
output. Provisions for two light strings, up to 200 watts
per channel. Separate sensitivity controls for each
channel. 0.25" qc terminals for output. Lights not includ-
ed. 4.25" X 3.85". Hook-up diagram included.
CAT# CORG-1 \$6.50 each

12 VDC 500 MA WALL TRANSFORMER

Panasonic # KX-A11
WHITE - U.L. listed.
12 Vdc wall transformer.
2.1 mm co-ax plug
with center negative.



CAT# DCTX-125W
\$4.50 each • 10 for \$30.00 • 100 for \$265.00

12 VDC 20 AMP RELAY

P & B# S86R-1007 (house number)
DPDT 20 amp power relay. 12 Vdc,
32 ohm coil. Solenoid-type actuator
activates dual snap-action switches.
Ideal for vending machines, laundry,
HVAC and machine control systems.
2.13" X 1" footprint and mounting
flanges extending out to 1.9".
1.93" high. 0.25" qc terminals.

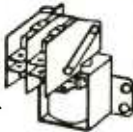

CAT# RLY-140 \$2.00 each

12 VDC COOLING FAN

Elina Fan
MDA 120925LB
12 Vdc, 110 ma. Black
thermoplastic housing and
5 blade impeller.
3.63" square X 1" thick.
14" pigtail leads.
CAT# CF-128
\$7.50 each



TOLL-FREE ORDER LINES 1-800-826-5432

CHARGE ORDERS to Visa, MasterCard or Discover

TERMS: Minimum order \$10.00. Shipping and handling
for the 48 continental U.S.A. \$4.00 per order. All others
including AK, HI, PR or Canada must pay full shipping.
All orders delivered in CALIFORNIA must include state
sales tax (7.25%, 7.5%, 7.75%, 8.25%, 8.5%). Quantities
Limited. NO C.O.D. Prices subject to change w/out notice.

Call or Write For Our

FREE 64 Page Catalog

(Outside The U.S.A. Send \$2.00 Postage)

ALL ELECTRONICS CORP.

P.O. Box 567 • Van Nuys, CA • 91408

ADVERTISING INDEX

Electronics Now does not assume any
responsibility for errors that may appear
in the index below.

Free Information Number	Page
108	AMC Sales 80
107	All Electronics 100
77	B&K Precision 15
—	CIE 17
54	Chemtronics 77
110	Chenesko Products 85
—	Command Productions 75
127	Deco Industries 85
188	Demax Corp. 82
125	Electronic Goldmine 99
—	Electronics Book Club 3, 90
—	Electronic Tech. Today 80, 89
121	Fluke Manufacturing CV2
176	Foley-Belsaw Company 82
—	Grantham College 24
182	HAMEG Instruments 25
86	Heathkit 83
—	ISCET 94
114	Jameco 97
183	Kelvin 7
186	M&G Electronics 75
184	Mini-Circuits CIV
—	NRI Schools 8
185	Optoelectronics CIII
—	Radio-Electronics Video Offer ... 5
—	Star Circuits 85
177	Tech Spray 78
92,189	Tektronix 19, 26
181	Teynham Audio Systems 79
179	The School Of VCR Repair 79
178	Wintek 89
187	Zentek Corp. 80

Gernsback Publications, Inc.
500-B Bi-County Blvd.
Farmingdale, NY 11735
1-(516) 293-3000
Larry Steckler, EHF/CET
President

Christina Estrada
assistant to the President

For Advertising ONLY
516-293-3000
Fax 1-516-293-3115

Larry Steckler
publisher

Arline Fishman
advertising director

Denise Mullen
advertising assistant

Kelly Twist
credit manager

Subscriber Customer Service
1-800-288-0652

Order Entry for New Subscribers
1-800-999-7139
7:00 AM - 6:00 PM M-F MST

ADVERTISING SALES OFFICES

EAST/SOUTHEAST

Stanley Levitan
Eastern Advertising
1 Overlook Ave.
Great Neck, NY 11021
1-516-487-9357
Fax 1-516-487-8402

MIDWEST/Texas/Arkansas/Okla.

Ralph Bergen
Midwest Advertising
One Northfield Plaza, Suite 300
Northfield, IL 60093-1214
1-708-446-1444
Fax 1-708-559-0562

PACIFIC COAST

Pamela Kuster
Pacific Advertising
Pattis/3M
1800 North Highland Avenue
Suite 717
Hollywood, CA 90028
1-213-462-2700
FAX 1-213-463-0544

Electronic Shopper

Joe Shere
National Representative
P.O. Box 169
Idyllwild, CA 92549
1-909-659-9743
Fax 1-909-659-2469

The Fastest Counter Starts with the Fastest Chip

Optoelectronics Puts the OE10 Inside

Since the 70's the frequency counter chip most used was the 7216 (8 digits,

10 million counts per second). The only way to have a faster more reliable counter was to design our own chip. So we did — the OE10. Faster — 10 digits,

220 million counts per second. Reliable — zero field failures.



And now we have added a microprocessor to unleash the power of the OE10.

Optoelectronics introduces the 3000A Multifunction Micro HandiCounter® with these new and exciting features:

- **Digital Filter Technique** (patent pending)
Filters stable signals from background clutter
- **Digital Auto Capture** (patent pending)
Holds present reading and stores previous reading for hands free unattended operation
- **Works Even in Presence of Strong RF Signals**
- **Stores Frequencies**
- **Increased Sensitivity**
- **Synchronous RF Detection**
Super sensitive 16 segment bargraph operates independently from counter
- **High Speed ASIC**
220 million counts per second.
- **10Hz-3GHz**
- **Multifunction HandiCounter®**
- **Dual High Impedance Amplifiers**
For ratio and time interval functions
- **High Resolution**
Direct count to over 200MHz
- **Extended Battery Use**
- **1 Year Full Warranty**
- **All This and More for the Low Price of \$279.**

Options for the NEW 3000A

- TCXO30
± .2ppm\$100.
- BL30/Backlight45.
- Antenna - TA100S
Telescoping Whip Antenna12.
- Antenna Pack 2
Includes RD27, RD50, RD100
RD440, RD800 - Save \$3299.
- CC30
Padded black vinyl carrying case15.

Factory Direct Order Line

1-800-327-5912

305-771-2050 • Fax 305-771-2052

5821 NE 14th Ave, Ft. Lauderdale, FL 33334

5% Ship/Handling (Max \$10) U.S. & Canada. 15% outside continental U.S. • Visa, Master Card, C.O.D. (Cash or Money Order only).

OPTOELECTRONICS

BE SURE YOU HAVE AN OE10 INSIDE

CIRCLE 185 ON FREE INFORMATION CARD

www.americanradiohistory.com

DC-2000 MHz AMPLIFIERS

In plastic and ceramic packages, for low-cost solutions to dozens of application requirements, select Mini-Circuits' flatpack or surface-mount wideband monolithic amplifiers. For example, cascade three MAR-2 monolithic amplifiers and end up with a 25dB gain, 0.3 to 2000MHz amplifier for less than \$4.50. Design values and circuit board layout available on request.

It's just as easy to create an amplifier that meets other specific needs, whether it be low noise, high gain, or medium power. Select from Mini-Circuits' wide assortment of models (see Chart), sketch a simple interconnect layout, and the design is done. Each model is characterized with S parameter data included in our 740-page RF/IF Designers' Handbook.

All Mini-Circuits' amplifiers feature tight unit-to-unit repeatability, high reliability, a one-year guarantee, tape and reel packaging, off-the-shelf availability, with prices starting at 99 cents.

Mini-Circuits' monolithic amplifiers...for innovative do-it-yourself problem solvers.

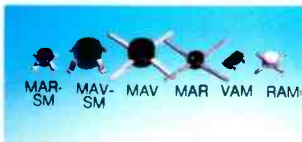

Models above shown actual size

from **99¢** Unit price \$ (25 qty)

	++VAM-3 1.45		+VAM-6 1.29		++VAM-7 1.75		
PLASTIC SURFACE-MOUNT							
add suffix SM to model no. (ex. MAR-ISM)	MAR-1 1.04	MAR-2 1.40	MAR-3 1.50	MAR-4 1.60	MAR-6 1.34	MAR-7 1.80	MAR-8 1.75
	MAV-1 1.15	+MAV-2 1.45	+MAV-3 1.55	MAV-4 1.65			MAV-11 2.15
CERAMIC SURFACE-MOUNT	RAM-1 4.95	RAM-2 4.95	RAM-3 4.95	RAM-4 4.95	RAM-6 4.95	RAM-7 4.95	RAM-8 4.95
PLASTIC FLAT-PACK	MAV-1 1.10	+MAV-2 1.40	+MAV-3 1.50	+MAV-4 1.60			MAV-11 2.10
	MAR-1 0.99	MAR-2 1.35	MAR-3 1.45	MAR-4 1.55	MAR-6 1.29	MAR-7 1.75	MAR-8 1.70
Freq.MHz,DC to	1000	2000	2000	1000	2000	2000	1000
Gain, dB at 100MHz	18.5	12.5	12.5	8.3	20	13.5	32.5
Output Pwr. +dBm	1.5	4.5	10.0	12.5	2.0	5.5	12.5
NF, dB	5.5	6.5	6.0	6.5	3.0	5.0	3.3

Notes: + Frequency range DC-1500MHz ++ Gain 1/2 dB less than shown

designer's kit, KH-1 available only \$59.95 includes
40 AMPLIFIERS* 10 MAR-1, 10 MAR-3, 10 MAR-4, 10 MAR-8
150 CAPACITORS* 50 100 pf, 50 1,000 pf, 50 10,000 pf

740 page RF/IF DESIGNER'S HANDBOOK

- MIXERS • POWER SPLITTER/COMBINERS • AMPLIFIERS • ELECTRONIC ATTENUATORS
- I&Q/QPSK MODULATORS • ATTENUATORS/TERMINATIONS • DIRECTIONAL COUPLERS
- RF TRANSFORMERS • DIGITAL ATTENUATORS • PHASE DETECTORS • SWITCHES/DRIVERS
- FILTERS • LIMITERS • FREQUENCY DOUBLERS

*values or models may be substituted without notice depending on supplies.

Typical Circuit Arrangement

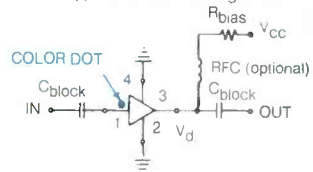

finding new ways ...
setting higher standards

Mini-Circuits™

WE ACCEPT AMERICAN EXPRESS AND VISA

P.O. Box 350166, Brooklyn, New York 11235-0003 (718) 934-4500 Fax (718) 332-4661

Distribution Centers NORTH AMERICA 800-654-7949 • 417-335-5935 Fax 417-335-5945 EUROPE 44-252-835094 Fax 44-252-837010

CIRCLE 184 ON FREE INFORMATION CARD

www.americanradiohistory.com