

Electronics NOW

Combined with
Radio Electronics

Build this
**COMPUTERIZED
WEATHER STATION**
and track temperature,
pressure, wind, and humidity!

A look at
**PC-BASED TEST
EQUIPMENT**

Use our
CIRCUIT COOKBOOK
to build working
transistor circuits!

Build a triple-output
POWER SUPPLY
for your test bench!

How to use
HEAT MANAGEMENT
techniques to protect
your projects!

Learn
TV SERVICE
techniques by example!



\$3.50 U.S.
\$3.95 CAN.

A
GERNSBACK
PUBLICATION

***** CAR-RT SORT ** CR11
450992TQM0077M099 10 P81

|||||

MAY 86
RE

B THOMPSON
77 WALTHAM ST
MAYNARD MA 01754-2427

The Fluke 79: More Of A Good Thing

More high-performance features. More advanced measurement capabilities. More of the vital information you need to troubleshoot even the toughest problems — with both analog and digital displays.

Meet the latest, greatest member of our best selling 70 Series II family — the new Fluke 79 digital multimeter.

It picks up where the original family left off. In fact, it's a quantum leap forward — in performance, value and affordability.

It's got the features you'd expect from Fluke. Including high resolution. Fast autoranging. Patented, automatic Touch Hold®. A quick continuity beeper. Diode test. Automatic self-test. Battery-conserving sleep mode. And it's just as rugged and reliable as the rest of the 70 Series II family. Easy to operate, too — with one hand.

And thanks to the Fluke 79's proprietary new integrated circuit technology, that's only the beginning. When it comes to zeroing in on tough electrical problems, the Fluke 79 leaves the competition behind:

Hz

Frequency: The Fluke 79's built-in frequency counter lets you measure from below 1 Hz to over 20 kHz. And while you view frequency on the digital display, the analog bar graph shows you AC voltage. So you can see if potentially hazardous voltage is present.



Fast 63-segment analog bar graph: The Fluke 79's bargraph moves as fast as the eye can see, updating at a rate of 40 times per second to simulate the functionality of an analog needle. You get the high speed *and* high resolution you need to detect peaking, nulling and trending.



Capacitance: No need to carry a separate dedicated capacitance tester; the Fluke 79 measures capacitance from 10 pF to 9999 µF.



Actual Size

40Ω

Lo-Ohms range: Our proprietary Lo-Ohms function lets you measure resistance as low as 0.01 ohms. High noise rejection and a test lead Zero Calibration function make the Fluke 79 ideal for detecting small resistance changes.

SMOOTHING

Smoothing™: Our exclusive new Smoothing mode gives you a stable digital readout for unstable signals — by displaying the running average of eight readings. No more jitter or "digit rattle" due to noisy signals.

Get a good thing going: To put more meter to work for you — at a price that works for you, too — head for your nearest Fluke distributor. For the name of your nearest distributor, or for more product information, call **1-800-87-FLUKE.**



The Fluke 79 comes with a yellow holster and patented Flex-Stand™ — easy to hang from a door or pipe, clip onto a belt or tool kit, or stand at virtually any viewing angle. There's even storage space for test leads.

Fluke 79 Series II

\$185*
4000 Count Digital Display (9999 in Hz, capacitance, and Lo-Ohms)
63-segment Analog Bar Graph
0.3% Basic DC Voltage Accuracy
Automatic Touch Hold
Diode Test, Audible Continuity Beeper
Autoranging, Manual Ranging
Holster with Flex-Stand
Frequency Counter to over 20 kHz
Capacitance, 10 pF to 9999 µF
Lo-Ohms Range with Zero Calibration
Smoothing
700 Hours Battery Life (alkaline)
3-Year Warranty
* Suggested U.S. list price

CIRCLE 121 ON FREE INFORMATION CARD

FLUKE®

BUILD THIS

31 COMPUTERIZED WEATHER STATION

Unlock the secrets of the weather with this meteorological station.

Ronald M. Jackson

48 TRIPLE-OUTPUT DC POWER SUPPLY

Put this handy power source to work in your home and shop.

John F. Keidel

TECHNOLOGY

39 PC-BASED TEST EQUIPMENT

A survey of what's available.

T.J. Byers

44 TV CASE HISTORY

A step-by-step lesson in TV repair.

Cleo Zymaris

57 COMMON COLLECTOR AMPLIFIERS

Learn how they work and how you can use them.

Ray Marston

62 HEAT MANAGEMENT TECHNIQUES

Keeping your components cool can lengthen their lives.

Stephen J. Bigelow

DEPARTMENTS

6 VIDEO NEWS

What's new in this fast-changing field.

David Lachenbruch

71 HARDWARE HACKER

An update on free energy, and more.

Don Lancaster

82 AUDIO UPDATE

What's happening?

Larry Klein

88 COMPUTER CONNECTIONS

The eyes and the ears of the world.

Jeff Holtzman

AND MORE

98 Advertising Sales Offices

98 Advertising Index

92 Buyer's Mart

14 Letters

26 New Lit

22 New Products

12 Q&A

4 What's News

Electronics NOW[®]

Hugo Gernsback (1884-1967) founder

Larry Steckler, EHF, CET,
editor-in-chief and publisher

EDITORIAL DEPARTMENT

Brian C. Fenton, editor

Marc Spiwak, associate editor

Neil Sclater, associate editor

Teri Scaduto, assistant editor

Jeffrey K. Holtzman
computer editor

Robert Grossblatt, circuits editor

Larry Klein, audio editor

David Lachenbruch
contributing editor

Don Lancaster
contributing editor

Evelyn Rose, editorial assistant

ART DEPARTMENT

Andre Duzant, art director

Injae Lee, illustrator

Russell C. Truelson, illustrator

PRODUCTION DEPARTMENT

Ruby M. Yee, production director

Karen S. Brown
advertising production

Marcella Amoroso
production assistant

Lisa Rachowitz
editorial production

CIRCULATION DEPARTMENT

Jacqueline P. Cheeseboro
circulation director

Wendy Alanko
circulation analyst

Theresa Lombardo
circulation assistant

Michele Torrillo
reprint bookstore

Typography by Mates Graphics

Cover photo by Diversified Photo

Services. Background by Betts

Anderson, Unicom Stock Photos.

Electronics Now is indexed in *Applied Science & Technology Index*, *and Readers Guide to Periodical Literature*, *Academic Abstracts*, and *Magazine Article Summaries*.

Microfilm & microfiche editions are available. Contact circulation department for details.

Advertising Sales Offices listed on page 98.

Electronics Now Executive and Administrative Offices

1-516-293-3000.

Subscriber Customer Service:

1-800-288-0652.

Order Entry for New Subscribers:

1-800-999-7139.



Audit Bureau
of Circulations
Member



HOME-WORK For Electronics

MADE IN
U.S.A.



Custom Molded Carrying Case
folds into briefcase size

Compartment for text books/
manuals and/or wire jumper kit
(optional)

Function Generator
...sine, square, triangle...plus TTL

Large Breadboard area holds
24 ICs...2,500 tie points

Holds Digital Multimeter
PROTO-METER® 4000
(optional)

Triple Power Supply...+5V fixed,
plus two variable 5-15V

Debounce Push-Buttons

8 TTL Logic Probe Indicators

Two BNC Connectors for
oscilloscopes and counters

Audio Speaker

Just
\$349.95

Here's PB-503-C. It has every feature that our famous PB-503 offers, but we added one more, portability. Work on your projects at the office or school, take it home at night... it's for the engineer or student who wish to take their lab with them. **Instrumentation**, including a function generator with continuously variable sine, square, triangle wave forms and TTL pulses. **Breadboards** with 8 logic probe circuits. And a **Triple**

Power Supply with fixed 5VDC, plus two variable outputs (+5 to +15VDC). Throw-in 8 TTL compatible LED indicators, switches, pulsers, potentiometers, audio experimentation speaker... plus a life-time guarantee on all breadboarding sockets! And, because it's portable you will always have everything you need right in front of you! PB-503-C, one super test station for under \$350! Order yours today!!



**GLOBAL
SPECIALTIES®**

CIRCLE 181 ON FREE INFORMATION CARD

 **FOR MORE INFORMATION
CALL 1-800-572-1028**

Global Specialties®, 70 Fulton Terrace, New Haven, CT 06512
Tele: 203-624-3103/Fax: 203-468-0060 - ©1990, Interplex Electronics
All Global Specialties® breadboarding products are made in the U.S.A.
Proto-Board is a registered trademark of Global Specialties® **A033**  an
Interplex
Industries
company

WHAT'S NEWS

A review of the latest happenings in electronics.

Ultra-high-density disks

Scientists at IBM's Almaden Research Center in San Jose, CA have demonstrated a blue-laser optical recording system that can read and write data at a record-breaking density of 2.5 billion bits (gigabits) per square inch on a removable magneto-optical disk.

According to IBM, its technique depends on a blue-laser device and extensions of current technologies to achieve a density five times higher than that available in today's most sophisticated rewritable optical disk drives based on infrared lasers.

The blue laser has a higher frequency than infrared light, so it can be focused to a smaller spot, allowing more data bits to be written within the same area. At the new density, a standard 5¼-inch disk could hold 6.5 gigabytes of data—the equivalent of 6500 250-page printed books.

In the demonstration, IBM scientists wrote a pattern of data bits onto a rotating glass disk coated with a film of magneto-optic material optimized for use with blue light. The solid-state blue-laser device converts the infrared light output of an aluminum-gallium-arsenide (AlGaAs) diode laser into blue light by passing it through a frequency-doubler.

The scientists then read back the pattern at a rate of 2 million bits per second with the same accuracy, and the same relatively low power consumption of existing infrared lasers. High-density edge data-encoding and advanced sampled servo tracking positioned the laser's read/write head over the correct data tracks on the grooveless, low-noise disks.

The device demonstrated was about the size of a VHS videotape cassette. IBM says it will probably find its first application in optical-disk based database "jukeboxes" in banks, insurance companies, and



IBM SCIENTIST Dr. William J. Kozlovsky demonstrates a blue-laser that writes and reads data on a removable magneto-optical disk at a world-record density of 2.5 gigabits per square inch.

hospitals for the storage of large amounts of data.

The IBM team plans to miniaturize the blue-laser device so it will fit inside a personal computer. It hopes to make high-data disks available within five years at a cost comparable to today's rewritable optical discs—between \$50 and \$100.

Quantum leap?

Bellcore (Red Bank, NJ) physicist Dr. Mark Johnson has invented and successfully tested a device that might lead to the production of circuits with 0.01-micron wide elements, compared with today's one-micron wide standard. According to Bellcore, the device could pack trillions of transistors onto a single, powerful computer chip.

Dr. Johnson's "spin transistor" device is based on a facet of quantum mechanics previously untapped by electronics researchers: electron spin. In normal electric current, electrons spin in a random mix of quantum states, called simply up

and down. The spin transistor orders the movements of the electrons in a process similar to the polarization of light, into all up or all down states. That creates the "off" and "on" states that are fundamental to digital electronics.

Although only a prototype device has been constructed, even at this early stage it has demonstrated two properties that are particularly exciting: The smaller its size, the better it works, and it is made of from highly conductive metals. In theory, at least, metal spin transistors can be miniaturized to micron sizes and still produce strong signals.

The basic spin transistor device is a "sandwich" of thin gold film between two magnetic strips. An electric current causes polarized electrons to move from the first strip into the gold film. They exit through the second magnetic strip—turning the circuit "on" in the process.

The electron and the second magnetic strip must have the same polarity. Dr. Johnson says it is easy to change the polarity of the second strip by generating a weak magnetic field in it with a nearby wire. The condition for conduction is that the electron spins must be either all "up" or all "down." Because the polarity of the second magnetic strip is "remembered" even after the current is turned off, the sandwich has a "memory."

Bellcore believes that devices made up of arrays of spin transistors could store information without electric power consumption. Moreover, it says future research could lead to logic processors made up of arrays of spin transistors.

Cryogenic conditions are needed for a superconducting magnet to create precise magnetic fields. The present operating temperatures are -298° and lower. Nevertheless, Dr. Johnson expects to create spin transistors that operate at room temperature. Ω

There's Big Profits In Electronics If you have the Proper Training

Foley-Belsaw can give you that training. Training that will provide high income potential in the 90's and on into the twenty-first century. The right training can give you the potential for a bright, economically, rewarding and fascinating future. You can take control of your future by choosing one of these highly profitable career fields. Our experience proves when you're in a field you're interested in you'll earn more and advance farther than you ever will in a field where you lack interest.

If you're unhappy with your present job, not satisfied with your income, or if you feel you can't reach your full potential, now is the time to act. There is no obligation to get a free Career Kit from Foley-Belsaw. Just check the coupon - mail it to us - we'll send your Career Kit free.

VCR Repair

VCR Technicians report earning \$80.00 and more per hour. That's because this career field lacks the qualified technicians to handle the demand. We use the Viejo Method by Foley-Belsaw to quickly teach you VCR Repair without all the unnecessary basic electronics. The Viejo Method has been proven best right in the VCR repair shop.

The vast majority of VCR repairs are mechanical or electromechanical. You learn these simple repairs first so you start earning right away. These basic repairs become the foundation on which you build your career.

Personal Computer Repair

If you have used a computer or are interested in how computers work you've probably got what it takes to become a computer repair specialist. This field continues to grow as personal computers are being used in almost every office and many homes.

You can cash in on this big demand quickly when you learn personal computer repair by the Foley-Belsaw method. This quick learning method teaches you the basics of computer repair so you start earning quickly as you continue to learn more complicated procedures. In a short time you'll be earning \$80, \$100 or more an hour.

Other Career Opportunities

Beside VCR and Computer Repair Foley-Belsaw can offer you specialized training in other high paying electronic fields. These courses all provide the knowledge you need to start a business of your own. A business where you're the boss. A business that provides both financial and personal security.

Foley-Belsaw can also provide you with nationally acclaimed training in several high paying mechanical career fields. Just check the coupon for your area of interest. We'll rush you a free career kit with all the exciting details.

FREE Kit

For a free information kit in one of these high paying career fields, contact:



Foley-Belsaw Institute
6301 Equitable Road
Kansas City, MO 64120

Since 1926

CIRCLE 176 ON FREE INFORMATION CARD



VCR Technician



Computer Technician



Since 1926

Foley-Belsaw Institute, 6301 Equitable Road
Kansas City, MO 64120

Check One Box Only, Please.

Electronic Courses

- VCR Repair, Dept. 62080
- Computer Repair, Dept. 64010
- Basic Digital Electronics, Dept. 69010
- Fax Machine Repair, Dept. 67010
- Printer Repair, Dept. 68010
- Camcorder Repair, Dept. 66010

Mechanical Courses

- Locksmithing, Dept. 12360
- Small Engine Repair, Dept. 52303
- Saw and Tool Maintenance, Dept. 21259
- Upholstery, Dept. 80892
- Woodworking, Dept. 43227

Name _____

Address _____

City _____

State _____ Zip _____

What's new in the fast-changing video industry.

DAVID LACHENBRUCH

Digital VCR standards.

The next VCR you own might use 1/4-inch tape and record and play back digitally—giving you an option of recording and playing back standard TV or virtually any digital high-definition system. A group of 10 major VCR manufacturers—eight Japanese companies and Philips and Thomson—has called a conference to consider consumer video-recording standards for the digital age.

Based on work already done by many manufacturers, the group defined some "basic specifications" as groundwork for the standards-defining effort. It envisions a system compatible with the existing NTSC, PAL, or SECAM standards and one that it hopes will accommodate any or all of the world's digital HDTV standards. The recording medium would be 1/4-inch metal evaporated tape or equivalent in cassettes of two sizes. The smaller cassette, about half the size of an 8mm cassette, would record for one hour in NTSC or PAL and 30 minutes in HDTV, presumably for camcorders. The larger cassette—half the size of a VHS cassette—would record for 4½ hours in current formats and just half that in HDTV.

The system would use digital recording for video, with revolving heads similar to existing VCRs. Audio recording would use pulse-code modulation (PCM) for two- or four-channel sound. When there is agreement on the specifications, they will be submitted to the International Electrotechnical Commission (IEC) for designation as a worldwide standard.

The proposal assumes that any digital HDTV recording system will use magnetic tape, as does today's consumer system. However, with the development of magneto-optical disc recording for Mini Discs, there is bound to be increasing agitation to make the next consumer video-recording system a disc-based product.

"Video CD."

Another proposed standard—this one much closer to reality—has been endorsed by 10 companies, including Sony, Matsushita, Philips, and JVC. This is for full-motion video on standard compact discs. The "Video CD" format, developed by Philips and JVC, and already in use by JVC and Sony in Japan for karaoke, makes possible up to 73 minutes of digital video and audio on a single five-inch disc.

Discs made for the system are non-recordable and linear—that is, they are designed to play straight through, without interactivity. They would be compatible with such existing systems as Philips' CD-I and computers with CD-ROM drives and decoders for MPEG (Moving Picture Experts Group) compression protocol, as well as modified audio CD players and specially designed CD Video movie players.

Britain's Nimbus Engineering & Technology, which already has demonstrated a system it also calls "Video CD" that can be played back on a standard CD player connected to a TV set through a special adapter, protested that the new system would turn off consumers that are already suffering from "format fatigue."

Nimbus said that its own system would work with "tens of millions of CD players worldwide and a decoder which would cost under \$200," as opposed to the new system, which it said would require expensive modification of audio CDs for compatibility. Nimbus said that the two "Video CD" systems were similar except for one major difference. Both discs are essentially CD-ROM data discs. All current data discs contain a digital flag in their table of contents to mute their output when played on a standard audio CD. The multi-company system retains this flag but requires a modification in audio CD players to tell them to ignore the flag.

IBM in video games.

A new home video-game system designed to compete with Nintendo and Sega, as well as the sophisticated new 3DO standard, has been announced by game veteran Atari, which has signed a contract with IBM to manufacture it on a custom basis. The Atari Jaguar system—proudly announced as all American-made—uses a 64-bit RISC processor with 24-bit true-color graphics "manipulated in a real-time world," according to Atari. A 32-bit expansion port is to be designed for future connection to cable and telephone networks. It will also play audio CDs, CD Plus Graphics, and Photo CD discs. The game's audio will use 16-bit stereo to permit realistic sound effects as well as human voices. All this is promised for sale starting this fall or winter at a suggested list price of \$200, as opposed to the \$700 price tag on the first 3DO game consoles, made by Panasonic.

Apple's TV guide.

Add another entry to the burgeoning list of on-screen TV program guides for the 500-channel age: Apple Computer. As pointed out here last month, the field is already getting crowded with systems called StarSight, Trakker, Prevue Networks, Your Choice TV, and TV Guide On Screen.

Apple's system, called "eztv," is designed to be built into the converter supplied by cable systems and to use a special handheld remote control. The viewer would be able to scroll through program listings, which could be arranged by type of program and by various sub-categories. The system would also permit previewing of pay-per-view programs, instant tele-shopping, and one-button VCR taping. In addition, it could eventually provide on-screen data on demand—such as baseball statistics during a live game.

Ω

KELVIN

ELECTRONICS

10 HUB DRIVE, MELVILLE, NY 11747

(800) 645-9212
(516) 756-1750
(516) 756-1763/FAX

Established 1945
M/C & VISA \$20 Minimum Order
KELVIN CATALOG \$3
Stock No. 650412

COMPONENTS

WHOLESALE PRICES!



Stock No.	TYPE	(10 Pk. Min.) YOUR COST
600021	555 TIMER	\$.20 ea
600029	556 DUAL TIMER	\$.40 ea
600039	LM566 PPL FUNCTION GENERATOR	\$.60 ea
600018	741C OP-AMP INTERNALLY COMPENSATED	\$.30 ea
600026	1458 OP-AMP DUAL 741C OP-AMP	\$.35 ea
630041	2N2222	\$.20 ea
630383	PN2222	\$.08 ea
600023	7805 Voltage Reg	\$.36 ea
SILICON CONTROLLED RECTIFIER (Similar to GE C106C1) 4.0 amp, 100PIV 600014 \$.89 ea \$.79 ea/10+		

THERMISTOR - 100 ohm
110097 \$1.35 ea \$1.00 ea/20+
THERMISTOR - 10K ohm
110097 \$1.35 ea \$1.00 ea/20+

PROJECT PARTS

Project Speaker
2", 8 Ohm, 1 Watt
Stock No. 350009
59¢



Project BUZZER
3-9 Volt DC, 80 db
Stock No. 680089
\$1.59 ea
\$1.39 ea / 10+ Qty



Soldering IRON
with **STAND**
LONG LIFE TIP
Stock No. 990098
\$3.95 ea



LED 1 3/4
Stock No. Color 100+ Qty 1000+ Qty
260020 RED \$.05 ea \$.045 ea
260027 GREEN \$.08 ea \$.07 ea
260026 YELLOW \$.08 ea \$.07 ea
260078 2 COLOR RED/GREEN \$.32 ea \$.29 ea



XENON STROBE TUBE
Stock No. 260050
\$2.95 ea
\$2.50 ea / 20+ Qty



TRIGGER COIL
for Xenon Strobe Tube
Stock No. 320037
\$1.25 ea
\$.89 ea / 20+ Qty



INFRARED LED
IR Pair, LED Infrared
transmitter and receiver
Stock No. 260061
\$1.95 ea



NEON LAMP
NE2, 2" Lead
Stock No. 260003
\$1.15 ea
\$.12 ea / 100+ Qty



PHOTO CELL
Photo Cell - 450 ohm
Stock No. 260017
\$.65 ea **\$.45 ea / 20+ Qty**
Photo Cell - 1.5K ohm
Stock No. 260018
\$.65 ea **\$.45 ea / 20+ Qty**



PUSH-BUTTON SWITCH
PUSH-ON, PUSH-OFF
Stock No. 270021
\$.55 ea
\$.49 ea / 100+ Qty



SUB-MINIATURE MOMENTARY SWITCH
Stock No. 990002
\$.35 ea
\$.28 ea / 100+ Qty



MINIATURE TOGGLE SWITCH
Stock No. 270034
\$.90 ea Type-SPST
\$.79 ea / 50+ Qty



150 LE - Student 200 LE - Technician 400 LE - Engineer

Standard Features - ● AC & DC VOLTAGES
● DC CURRENT ● RESISTANCE ● TRANSISTOR
● CONTINUITY TEST - Buzzer ● DIODE TEST
● 3 1/2 Digit LCD ● 10M ohm INPUT IMPEDANCE
Designed to meet IEC-348 & UL-1244 safety specifications

BATTERY TEST
DC CURRENT
10 Amp

FREQ COUNTER
up to 20MHz
CAPACITANCE
from 1pF to 20uF
AC/DC CURRENT
10 Amp

INDUCTANCE
Resolution 1uH
FREQ COUNTER
up to 20MHz
CAPACITANCE
from 1pF to 200uF
AC/DC CURRENT
DUTY %
20 Amp

150 LE Stock # 990122 **\$29.95**
200 LE Stock # 990123 **\$49.95**
400 LE Stock # 990124 **\$79.95**

2 Year Warranty (Parts & Labor)

KELVIN 100 Basic
990087
\$19.95

- AC & DC VOLTAGES
- DC CURRENT
- RESISTANCE
- CONTINUITY TEST - Buzzer
- 3 1/2 Digit LCD
- LOW BATTERY INDICATOR
- DIODE TEST ● BATTERY TEST



INSTRUMENTS

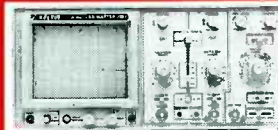

20 MHz SCOPE
Dual Trace 2 Yr Warranty-Parts & Labor
Stock No. 740085 **\$385**

40 MHz SCOPE
Dual Trace with Delayed Sweep
2 Yr Warranty-Parts & Labor
Stock No. 740086 **\$655**

100 MHz SCOPE
3 Channel, 8 Trace with Delayed Sweep
2 Yr Warranty-Parts & Labor
Stock No. 740089 **\$1,295**

2 MHz FUNCTION GENERATOR
Output: SINE, TRIANGLE, SQUARE WAVE,
PULSE, RAMP SLEWED SINE WAVE
Stock No. 720098 **\$199.95**

100 MHz MULTIFUNCTION COUNTER
8 DIGIT LED DISPLAY WITH DECIMAL POINT
Stock No. 720099 **\$189.95**

150 MHz RF SIGNAL GENERATOR
100KHz to 150MHz COVERAGE
450MHz IN HARMONICS, AM MODULATION,
INTERNAL OR EXTERNAL, 0 - 100%
Stock No. 720022 **\$219**

DC POWER SUPPLY
CONTINUOUSLY VARIABLE-
TWO SEPARATE LED DISPLAYS, GREEN
READOUT FOR VOLTAGE & RED READOUT
FOR CURRENT
Stock No. 690038 ... 30V @ 3A **\$295**
Stock No. 690039 ... 60V @ 1.5A **\$295**

LOGIC PROBES
MEASURES TTL, DTL, RTL, CMOS
Stock No. Model YOUR COST
740071 LP10A - 17 MHz **\$19.95**
740087 LP25A - 25 MHz **\$39.95**
740088 LP50A - 50 MHz **\$49.95**

LOGIC PULSER
SWITCHABLE 0.5/400 PULSE RATE, 100mA
Stock No. Model YOUR COST
740073 PR41 **\$49.95**

TEST ACCESSORIES

SCOPE PROBES
60 MHz, X1 & X10
SPECIAL
700072 **\$18.95**
150 MHz, X10
700073 **\$39.95**

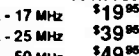

IC CLIPS
SOLDER TYPE
SPRING LOADED
Stock No. COLOR COST 25+ Qty
990104 BLACK \$.65 ea \$.50 ea
990105 RED \$.65 ea \$.50 ea



DC TOY MOTORS

DC Toy Motor -
Stock No. 850647
\$.80 ea
\$.75 ea / 50+ Qty 6V DC High Speed



Solar Motor Stock No. 850646
\$.60 ea 1.5V DC
\$.55 ea / 50+ Qty



Solar Cells
Stock No. 260099 **3 3/4" L x 2 9/16" W**
\$.95 ea **1000mA .45V**
\$.50 ea / 3+ Qty



DIGITAL TRAINER



Laptop Digital Trainer comes with 100 page instruction manual, power supply, built-in 1 digit true hexadecimal display, two independent clocks with user adjustable freq & duty cycles, 4 data bit switches and 4 LED displays. Assembled
Stock No. 840460 **\$99.95**

BINARY QUARTZ CLOCK w/Alarm

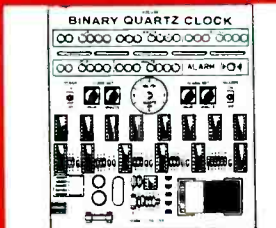

ORIGINAL DESIGN - 24 Hr. Binary Quartz Accurate Clock with 2 color LED's. Built-in Alarm and Alarm Display in binary code. DESIGNED FOR LEARNING about digital circuitry & binary code. Built with individual IC components. Battery Memory Loss Prevention. Comes with rechargeable battery, DC wall transformer and detailed instruction manual. Advanced Level Kit
Stock No. 840589 **\$89.95**

Electronic VOICE PAD

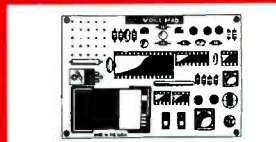

An electronic note pad, able to record your message & replay it later. It has a built-in photo cell & as soon as it senses your presence, it will automatically playback the message left for you. The components are PC mounted. The IC can record a message up to 20 seconds & no mechanical parts or tape - only a digital integrated circuit.
Intermediate Level Kit
Stock No. 840606 **\$49.95**

BREADBOARDS



Stock No. Post Contacts YOUR COST
680093 0 500 **\$ 4.25**
680097 0 840 **\$ 5.95**
680098 2 1380 **\$11.75**
680100 4 2390 **\$22.95**

WIRE JUMPER KIT
Pre-cut, Pre-Stripped
330289 140 Piece Set **\$ 4.95**
330290 350 Piece Set **\$ 8.95**



Popular Electronics
Reviewed - May 1993

"Not only does the Kelvin 94 boast alot of features ... the features go the extra distance."

"If we had to run into a burning building to do some emergency trouble-shooting and could carry in only one piece of equipment, the Kelvin 94 would be it!"

KELVIN 94 The Ultimate Meter

LCR Hz dBm True RMS Logic Probe
The only meter with 0.1% Accuracy on DC Voltages, built-in True RMS, Freq Counter to 20MHz Res: 10 Hz, LCR-Inductance Tester Res: 10 uH, DC/AC Voltages Res: 0.1mV, Ohm Meter Res: 0.1 ohms

TRUE RMS PLUS 12 INSTRUMENTS IN ONE - AC & DC VOLT METERS, AC & DC CURRENT, dBm, OHM METER, DIODE TESTER, AUDIBLE CONTINUITY TEST, 20 MHz FREQ COUNTER, CAPACITANCE METER, INDUCTANCE METER, LOGIC PROBE

ENGINE ANALYZER PLUS

Model 95 #990112 **\$199.95**

A Must For Auto Mechanics

*** Standard Features** - Models 94 & 95
● DC/AC VOLT METERS ● AC/DC CURRENT ● OHM METER ● DATA HOLD ● RELATIVE MODE ● FREQ COUNTER to 4 MHz (Model 95) ● AUDIBLE CONTINUITY TEST ● DIODE TEST ● MAX/MIN AVERAGE MEMORY RECORD ● 10A HIGH-ENERGY FUSE PROTECTION ● AUTO SLEEP & AUTO POWER OFF

DC TOY MOTORS

DC Toy Motor -
Stock No. 850647
\$.80 ea
\$.75 ea / 50+ Qty 6V DC High Speed



Solar Motor Stock No. 850646
\$.60 ea 1.5V DC
\$.55 ea / 50+ Qty

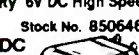

Solar Cells
Stock No. 260099 **3 3/4" L x 2 9/16" W**
\$.95 ea **1000mA .45V**
\$.50 ea / 3+ Qty



Learn computer programming computer system, Windows

Only NRI at-home training gives you real-world programming skills in three in-demand languages: QBasic, C, and Visual Basic, today's hot new language designed for writing popular Windows applications. Best of all, you get hands-on training with a powerful new 486sx-based computer system, complete with 80 meg hard drive, Windows, and professional programming software you keep!

NRI, the recognized leader in at-home computer training, shows you how to take advantage of today's newest programming opportunities

Get in on the ground floor of one of today's fastest-growing career fields: computer programming. The Bureau of Labor Statistics forecasts that job opportunities for programmers will increase *much* faster than average over the next 10 years, with as many as 400,000 *new* jobs opening up by 2005.

And the largest number of new programming jobs will be in PC programming, fueled by the the phenomenal popularity of Windows and the growth of exciting new languages such as QBasic, C, and Visual Basic.

Now, with NRI at-home training, you can get the new skills you need to build a top-paying career — even a full- or part-time business of your own — in this high-growth, high-opportunity field.

NEW! The only programming course that includes a powerful 486sx-based computer, 80 meg hard drive, Windows, Visual Basic, and more — all yours to keep!

Right from the start, NRI gets you actively involved in the challenge of real-world programming. Step by step, you learn to create the kinds of full-featured, powerful programs today's employers and clients demand...including programs designed for use in a Windows environment!

Only NRI gives you first-hand programming experience with a state-of-the-art 486sx mini-tower computer system, complete with hard disk drive, 5 full megabytes of RAM,

high-density floppy drive, mouse, monitor, and more — all yours to train with and keep!

Plus you explore the extraordinary capabilities of *three* in-demand programming languages. You learn to design, code, run, debug, and document programs in QBasic, C, and Visual Basic. Best of all, since Visual Basic is specifically designed for creating Windows applications, you learn to generate fully functioning Windows programs, complete with text boxes, command buttons, and other sophisticated graphical interface elements.

No previous experience necessary

Train with NRI, and immediately start getting the money-making job skills you need to be a



as you train with a 486sx Visual Basic, and more!

**ALL
NEW!**

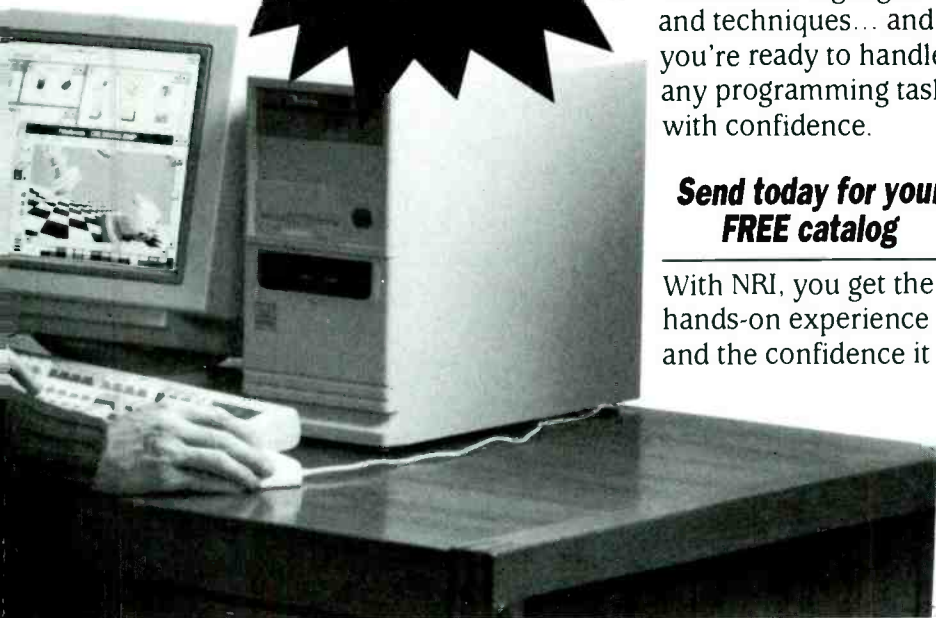

By the time you complete your course, you have a clear understanding of programming methods, languages, and techniques... and you're ready to handle any programming task with confidence.

**Send today for your
FREE catalog**

With NRI, you get the hands-on experience and the confidence it

takes to master today's programming challenges. And, by creating and running your own full-length programs, you build skills you'll be proud to show any prospective employer or client.

So prepare now for a high-paying career as a computer programmer! See how NRI at-home training in Computer Programming gives you everything you need for a fast start in this top-growth field. Send today for your FREE catalog.

If the card is missing, write to us at NRI Schools, McGraw-Hill Continuing Education Center, 4401 Connecticut Avenue, NW, Washington, DC 20008.

IBM PC/AT is a registered trademark of the IBM Corporation. Windows, QBasic, and Visual Basic are trademarks of Microsoft Corporation.

computer programmer — no matter what your previous background.

NRI's step-by-step lessons and hands-on programming projects help you first

master the programming design concepts used every day by successful PC programmers.

With your experienced NRI instructor always ready to help, you go on to learn programming in three of today's hottest languages.

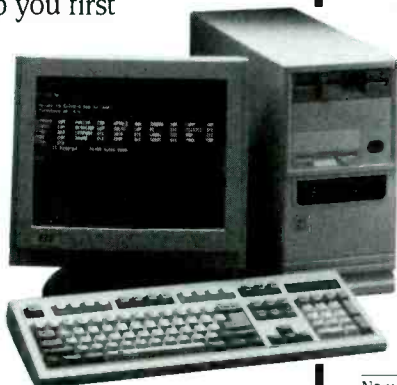

SEND TODAY FOR FREE NRI CATALOG!

NRI Schools

McGraw-Hill Continuing Education Center
4401 Connecticut Avenue, NW, Washington, DC 20008



For career courses approved under GI Bill, check for details

YES! Send me the FREE catalog I've checked and show me how NRI can give me the skills and confidence to earn good money in an exciting new career or business of my own.

- Check one FREE catalog only
- COMPUTER PROGRAMMING**
- PC Applications Specialist
- Programming in C++ with Windows

Other Computer Career Courses

- Microcomputer Servicing
- Desktop Publishing
- Bookkeeping and Accounting
- Computer-Aided Drafting

Name (please print) Age

Address

City/State/Zip Accredited Member, National Home Study Council **5415-1093**

Write to Q & A, Electronics Now, 500-B Bi-County Blvd., Farmingdale, NY 11735

MUTING CIRCUIT

I would like to build the Phone-Activated Audio Muting Circuit that was published in the January 1990 issues of *Radio Electronics*, page 43. I can't seem to contact the kit supplier for that project, and there's a discrepancy between the parts list and the schematic as to the correct part number for IC2. Can you help me out?—C.I. Mendes, Lakeland, FL

The beauty of a magazine like this one is that the projects can usually be built years after publication—unless, of course, printed mistakes prevent people from doing so. The correct part number for IC2, is an LM393, which is a dual voltage comparator made by National Semiconductor. Also note that the labels for pins 2 and 3 of IC2-a should be transposed in Fig. 1, and a connection dot should exist between R5, R6, and the line going to pin 8 of IC2-b (see Fig. 2). One last item; RY1 is a 12-volt relay, and not 5 volts as indicated in the parts list.

AUDIO MIXER

I'd like to be able to mix several audio signals together and have them at a single output. Because some of the inputs will be microphone-level and some will be line-level, I can't do the job with just a handful of resistors. Can you help me?—B. Weinberg, Mapleshade, NJ

What you're really trying to do is build an audio mixer. Those circuits have been around ever since the invention of the vacuum tube.

There's no end to the designs that will do the job you want done, but the circuit in Fig. 1 is one of the easiest to build and the most reliable. All you need is one IC and a handful of parts to mix a variety of audio signals. I've designed the circuit around an LM3900 quad op-

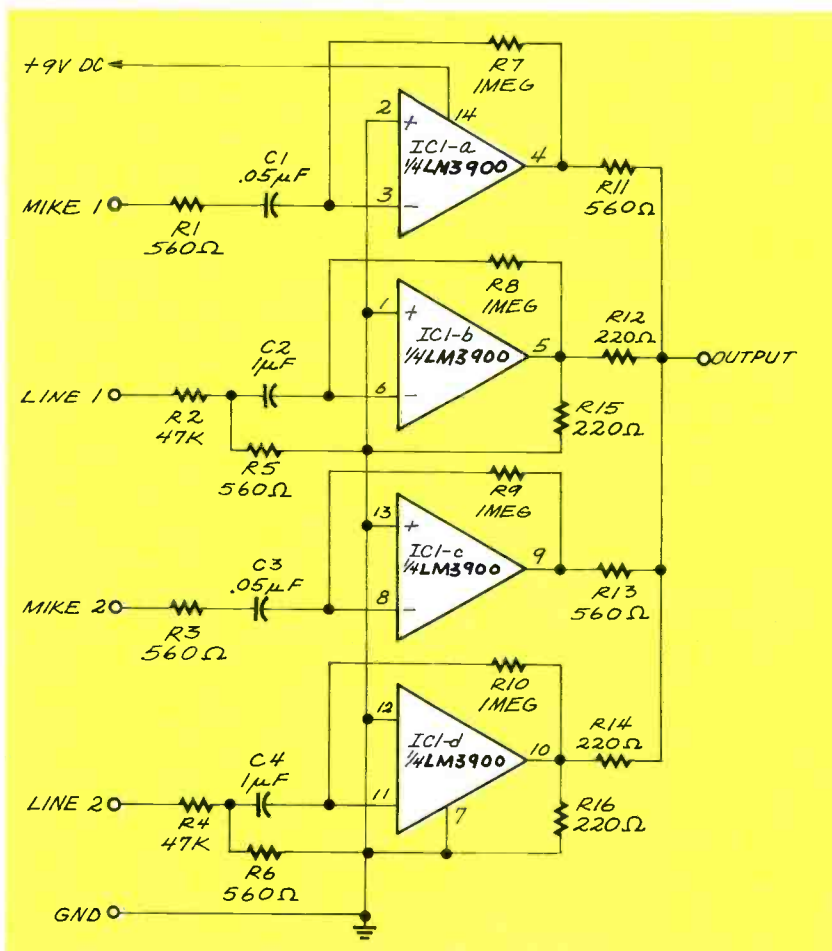

FIG. 1—THIS AUDIO MIXER is designed around an LM3900 quad op-amp.

amp, but there's no reason why you can't use a different chip—the basic circuit would still be the same. The LM3900 uses a single-sided power supply and it's inexpensive.

I've laid out the circuit to have two microphone and two line inputs, but you can change it around any way you want. The whole thing can be put together with wire wrap or you can design a printed circuit board.

The circuit is really handy to keep around so, if there's any chance that you'll ever want more than one of these things, I'd think it would be well worth the time to do a printed-circuit board.

SKIPPING CD PLAYER

I have a CD player that skips regardless of how well I clean the discs. I suspect that the problem is caused by interference that is generated by my computer, which is on the same AC line. Can you suggest a filter that would help?—G. Elder, Panama City, FL

It's unlikely that the skipping or mistracking problem is a result of RF interference from your computer. The leading cause of CD mistracking is dirty discs. But apparently you've ruled out that possibility. A dirty lens in the laser receiver can

also cause tracking problems. Laser lens cleaners for CD players are available from hi-fi shops and some music stores. Since a cleaner is not expensive (under \$20), trying one is a logical next step.

If a dirty lens is not causing the mistracking, solving the problem is going to be more complex and more expensive. Before you can stop the mistracking, you must understand how a correctly functioning CD player maintains tracking.

A single laser beam is split into three beams by a diffraction grating or beam splitter. The middle beam reads the data from the transition between the pits and flats on the disc. The two outside beams follow the blank areas between the data track being read and the two adjacent tracks. If an outside beam hits some pits, a photodiode array detects the strike, and a tracking-error signal is generated by a differential amplifier. The error signal is then fed to tracking actuator coils, which move the head in one direction or the other to restore proper tracking of the disc.

A tracking problem can also be caused by a weak laser—a solid-state CD laser does not have an unlimited lifespan—or a malfunctioning photodiode in the sensor array. Actuator coils can also cause mistracking if they burn out.

Another common cause of tracking problems is the spindle motor that turns the disc. A little dirt can cause the bearings to wear prematurely. That causes the disc to wobble as it spins. The actuator coils can't keep up with the wobble, and the disc skips. Unfortunately, replacing the motor is time-consuming and expensive. If you do not have experience servicing CD players, don't attempt any repair other than cleaning. Even before doing that, however, it is recommended that you obtain instructions on how to service your CD player from its manufacturer.

MONITOR REPLACEMENT

I use a computerized engraving machine that has a monochrome composite-video monitor. The monitor has bitten the dust, and I'd like to convert the system so I can use a TTL

monitor. Is there any converter on the market that will accept NTSC video at the input and give me TTL video at the output?—E. Wandasiewicz, Wilkes-Barre, PA

The answer to your question is probably yes, but I don't think it makes a lot of sense economically. You can buy a replacement NTSC monitor for about fifty bucks from many of the suppliers who advertise in this magazine. They're still used for some computers such as the current Apple II series. (Apple monitors are expensive, but there

are lots of other models around as well.) A bit of library research on your part will give you the names of companies that have NTSC monitors in stock.

As an alternative, you can probably feed any video input with the output from your engraver. That includes the video inputs on the back of TV's and VCR's. And while we're talking about the consumer market, I'll bet that you can get a small black-and-white TV for next to nothing—certainly less than what a converter will cost.

Ω

Electronics Workbench® The electronics lab in a computer™

"...you can do 10 times as many experiments with Electronics Workbench than you'd get done with the real stuff."

—Jerry Pournelle, Ph.D., Byte Magazine

Building and testing circuits is fast and easy with *Electronics Workbench*. Just click-and-drag with a mouse to add parts, run wires, and adjust instruments. The traces on the simulated instruments are the same as you'd get on real equipment.

DOS Professional Version - \$299

DOS Personal Plus Version - \$199

Macintosh Version - \$199

Prices are in US dollars. Shipping \$15. Offer valid in the USA and Canada only. Macintosh and DOS Personal Plus versions are in monochrome only. All trademarks are the property of their respective owners.

Includes two independent modules:

- **Analog Module** with passive and active components including transistors, diodes, and op-amps; a function generator, an oscilloscope, a multimeter, and a Bode plotter.
- **Digital Module** with gates, flip-flops, adders, a word generator, a logic analyzer, and a unique logic converter and simplifier.

Call 800-263-5552

Fax: (416) 368-5799

Interactive Image Technologies Ltd.

908 Niagara Falls

Boulevard

North Tonawanda, NY

14120-2060

700 King St. W., Ste 815

Toronto, Ontario

Canada

M5V 2Y6



**30-DAY
Money Back
Guarantee**

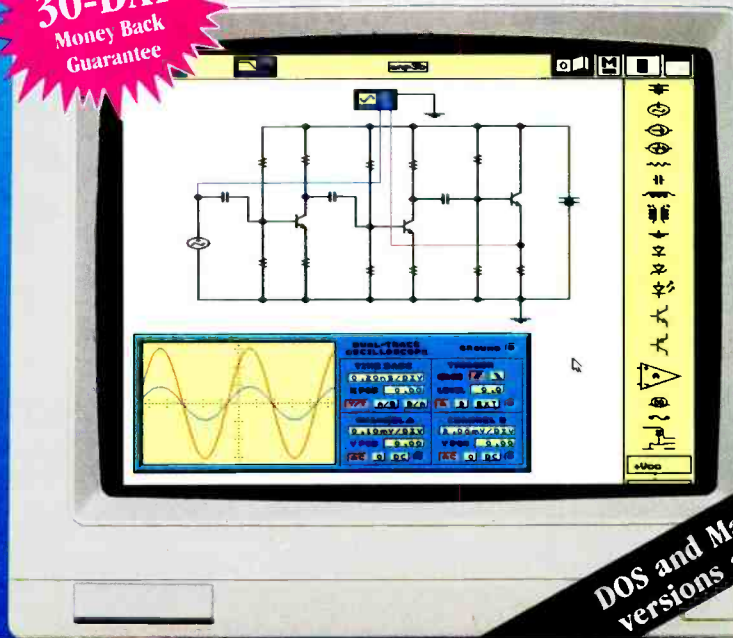

**DOS and Macintosh
versions available**

CIRCLE 189 ON FREE INFORMATION CARD

LETTERS

Write to Letters, *Electronics Now*, 500-B Bi-County Blvd., Farmingdale, NY 11735

EVOLVING JOB REQUIREMENTS

In his *Computer Connections* column about a bit meter in every basement (**Electronics Now**, July 1993), Jeff Holtzman said that many jobs will be eliminated by automation, and that most new future jobs will be related to computer programming or software.

Unfortunately, my own experience seems to bear out Holtzman's dire prediction. Trained as a hardware-oriented electronics technician, I find my future in electronics clouded by the trend toward disposable circuits and the increasing emphasis on a working knowledge of computers and programming—skills that I lack.

After obtaining a two-year Associate's Certificate in electronics in 1974, I found work as a technician

for a U.S. Department of Energy research laboratory. My duties included research building, testing, and maintaining electronics at the circuit-board level. I earned a good reputation there, and learned a lot that helped me in my career.

However, I was laid off in 1985 due to Federal budget cutbacks. The best job I could get near home (the south suburbs of Chicago) was in a two-way radio repair shop. Here at work, I see products becoming more microprocessor- and software-dependent. Moreover, modern fabrication methods such as surface-mount technology make it almost impossible to repair many faulty circuits economically. Typically they become disposable modules that are just thrown away.

My employer is finding ways to

cut the technical staff. He is putting increasing emphasis on reducing the time spent making repairs, and is making employees account for that time. Those circuit boards that can be economically repaired will probably soon be sent to a central depot.

The DOE lab where I worked obtained more funds, and its activity has picked up, so I sought re-employment. However, my former group leaders told me that the work I did is no longer being done. Although I have written several small assembly-language programs, this experience is not enough to qualify me as a full-time programmer. I have been told that most of those jobs require a master's degree, or at least a bachelor's degree.

No doubt that qualification re-

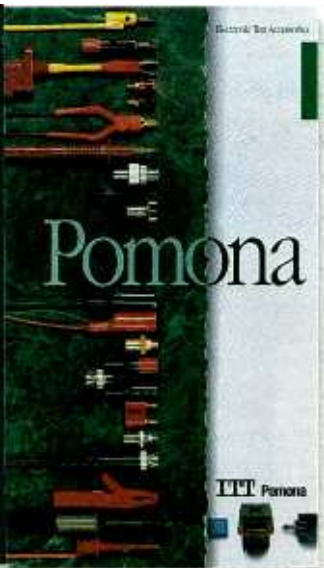

QFP, SQFP and SSOP Test Clips provide testable upper pins or PGA platforms for simultaneous lock-on access of every lead.



Safer DMM Test Lead Kits like this model 5901 Bench Test Kit featuring silicone insulated wire, fully insulated clips, interchangeable tips.



Plugs, Jacks, Adapters and Cable Assemblies designed for safe, positive electrical connections.



100-300MHz Oscilloscope Probe Kits featuring modular tips, fast rise times and best-signal cable lengths. 11 versatile kits.



High Quality Boxes for building integral networks, voltage dividers, attenuators for noise-free interfaces.



Differential Probe Kit safely analyzes floating signals, extends scope functionality.

Simple Math For DMM & Scope Users Or Anyone Who Plays It Safe.

Nothing else equals Pomona's 142-page 1993-1994 *Electronic Test Accessories Catalog*. You will find over 6,000 solutions for testing leading-edge devices, interfacing with instrumentation or making reliable connections that will make your job easier. ■ Designed to meet new safety standards ■ 22 DMM & Scope Kits that extend testing capabilities ■ Unparalleled quality and reliability ■ Selection, availability. The answer is simple. Get the book. It's FREE. Call or write today. ITT Pomona Electronics 1500 E. Ninth Street P.O. Box 2767 Pomona, CA 91769 Phone: (909) 469-2900 Fax (909) 629-3317.

ITT Pomona
AN ITT CANNON COMPANY

CIRCLE 101 ON FREE INFORMATION CARD

quirement is due, in part, to an oversupply of skilled persons even in that field. Apparently those with the highest level of computer training are being hired first. However, the last data I saw indicated that less than 30% of the adult U.S. population has any college degree—and most of those degrees were not in technology.

As I see it, the prosperity of the United States has been built upon opportunity and the availability of jobs. In the past, nearly everyone willing to work could earn a comfortable standard of living. I can understand that technological change will alter the available jobs and the qualifications necessary to hold them, but the trend is out of control.

In my view, that accelerating rate of change should be slowed somehow to permit displaced personnel to be retrained. In that way the economy can reabsorb them in meaningful jobs. Government, business, labor unions, and the general public must be willing to forsake immediate economic gains to assure long-term economic stability for all of the people.

At the present time, too many educated and trained people willing to work are just being cast off as excess labor or forced into early retirement. If that trend continues, the U.S. will become another third-world country where an elitist class will own and run almost everything.

I fear that the majority of the population will be relegated to jobs that cannot be turned over to computers (such as driving taxis or mowing lawns), or will just become burdens on the government. If this trend is allowed to continue, there will be rebellion by those who have been pushed aside by technological change. They will become desperate and fight to regain what they once had.

MICHAEL KILEY
Crestwood, IL

PARITY-CHECKING PRIMER

The answer to H. Bansh's question about parity checking (*Q&A, Electronics Now*, July 1993) caused my blood to boil. Rarely have I seen a better example of misinformation used to cover up an author's ignorance of a subject.

Let me start with the comment "... and the BIOS decides that everything you've been doing for the last couple of hours should be lost." For the *Q&A* columnist's information (obviously needed), parity check is done at every memory-read cycle, and processing stops *instantly* with the parity message (provided by BIOS) on the screen. Thus there can be no "couple of hours" lost work!

Allow me to enlighten the *Q&A* author on the benefits of parity checking:

First, to give credit where due, some form of parity checking has been incorporated in IBM equipment since it introduced punched-card accounting machines years ago. IBM's equipment at that time was almost fanatically over-designed to prevent undetected digital errors.

IBM knew it was not possible to prevent errors, so it designed parity circuits that would stop the equipment *instantly* if a digital error were detected. That instant stop prevented an error from being compounded. The reason was obvious. Any industry or business engaged in large-scale "number crunching" involving billions of dollars or a threat to public safety can't afford the consequences of incorrect data. The consequences range from law suits to bankruptcy!

Bank failure or the financial ruin of thousands of customers is one thing; the failure of a bridge or the crash of an aircraft causing death and injury that is due to faulty design is another. Arithmetic errors, unchecked, can lead to disaster.

I'm appalled by the sentence, "All it takes is one error to make the entire computer lock up." Isn't it obvious to *Q&A* that if you're running data for any critical numerical application, that's *exactly* what you want? There's no way to distinguish between one-time glitches and either unreliable or previously reliable "bit-cell" failure.

Q&A's response made it seem as if one error is trivial, and nothing that trivial should be allowed to interfere with ongoing computer operation. If your computer is generating memory bit errors—even one—you ought to be aware of it!

Continued on page 25

Earn Your B.S. Degree in ELECTRONICS or COMPUTERS



By Studying at Home

Grantham College of Engineering, now in our 43rd year, is highly experienced in "distance education"—teaching by correspondence—through printed materials, computer materials, fax, and phone.

No commuting to class. Study at your own pace, while continuing on your present job. Learn from easy-to-understand but complete and thorough lesson materials, with additional help from our instructors.

Our Computer B.S. Degree Program includes courses in BASIC, PASCAL and C languages — as well as Assembly Language, MS DOS, CADD, Robotics, and much more.

Our Electronics B.S. Degree Program includes courses in Solid-State Circuit Analysis and Design, Control Systems, Analog/Digital Communications, Microwave Engr, and much more.

An important part of being prepared to *move up* is holding the right college degree, and the absolutely necessary part is knowing your field. Grantham can help you both ways—to learn more and to earn your degree in the process.

Write or phone for our free catalog. Toll free, 1-800-955-2527, or see mailing address below.

Accredited by
the Accrediting Commission of the
National Home Study Council

GRANTHAM
College of Engineering
Grantham College Road
Slidell, LA 70460

EQUIPMENT REPORTS

Micro Scope V5.0 Diagnostic Software

*A helping hand
for PC service
technicians*

CIRCLE 14 ON FREE
INFORMATION CARD



Anyone who is responsible for maintaining or repairing IBM-standard personal computers will want to have the latest release of Micro Scope PC diagnostic software from Micro 2000, Inc. (1100 East Broadway, Suite 301, Glendale, CA 91205; 818-547-0397).

Unlike most diagnostic software, Micro Scope works independently of the PC's operating system; the disk on which the diagnostic software is distributed contains its own operating system, called Microdos.

There are some important advantages to Micro Scope's DOS-independence. For example, its memory-test routine can access more base memory than would be possible with a diagnostic program running under MS-DOS. Another advantage is Micro Scope's ability to access the boot sector on a hard disk drive, which is also unavailable under MS-DOS. That makes it possible to restore a disk that has been made unbootable by a computer virus. (It won't guarantee success but, because 90% of viruses hide in the boot loader program, the chances of recovery are pretty good.) Partition tables, which tell the operating system how a disk drive is segmented, can also be restored with the help of Micro Scope.

The Micro Scope program is supplied with two serial loopback plugs

(one 9-pin and one 25-pin) and one parallel loopback plug that are required for some tests. An informative 178-page technical manual is also provided. The program is supplied on both 5¼ and 3½-inch floppy disks.

Micro Scope can be run under MS-DOS, and there are some instances where that is desirable. (Troubleshooting a floppy drive with boot-up problems, for example.) For full functionality, however, the program should be loaded from the self-booting disk. Once the Microdos operating system has been loaded, a menu provides two options: load base memory tests or load diagnostics.

The base memory tests take up only two kilobytes of base memory, allowing all other base memory to be tested. (Because virtually any error in the first 2 kilobytes of base memory would make a PC unbootable, the test, in effect, verifies that all of the base memory is functioning.) Choosing to load the full diagnostic program brings up the program's main menu, which presents five options: System Information, Batch Menu, Diagnostics, Utilities, and Quit or reboot.

System information

The System Information menu calls up a five-entry submenu that provides access to information about the motherboard, plug-in

adapters, interrupt (IRQ) assignments, network adapters, and more. The computer system's configuration is determined from information gathered by Micro Scope from the computer's CMOS memory, power-on self test (POST), and proprietary routines. The information presented on-screen includes the computer's system type (e.g., AT, XT), the revision date of the BIOS (basic input/output system), CPU type, detected hardware (floppy and hard drives, video adapters, I/O ports, base memory, extended memory, video memory, and more), and the CMOS memory settings. Any conflicts between the contents of the CMOS memory and what Micro Scope detects are flagged with an asterisk.

Micro Scope can also search for adapter cards that contain an active ROM BIOS. (Many plug-in cards, including network adapters and video cards, contain programs that serve as extensions to the computer's main BIOS.) Micro Scope can identify the starting and ending addresses of the BIOS extensions so that addressing conflicts—one common frustration encountered when new cards are installed—can be identified.

The status (disabled, enabled, or active) of IRQ or interrupt assignments can be displayed, along with their associated I/O ports, devices, and interrupt vectors. Interrupt conflicts, which can be diagnosed with the help of Micro Scope, are another common problem encountered when new hardware and software is installed in a system.

The physical-partition table of the computer's hard-disk can be studied. The partition table and volume-boot sector can also be edited—or corrected to restore a virus-infected or damaged disk. By studying the partition table, the properties of the drive installed in the computer can be identified; the number of heads,

Continued on page 94



1367P \$29.95



4089P \$18.95



3107P \$18.95

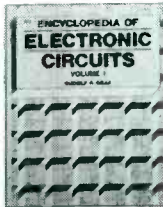

1938H-XXX \$60.00
Counts as 3/Hardcover

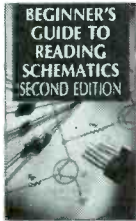

3632P \$10.95

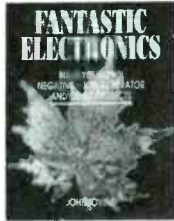

3975H \$29.95
Hardcover



3795P \$19.95

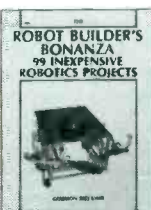

2800P \$17.95

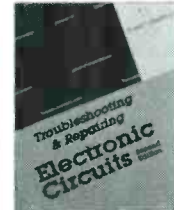

3258P \$19.95

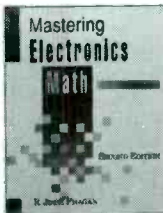

3589H \$27.95
Hardcover

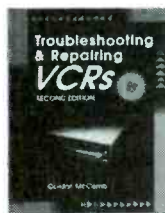

3777H-XX \$32.95
Counts as 2/Hardcover



3671P \$18.95



3627P \$19.95



3672P \$18.95



3886P \$13.95

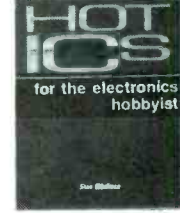

4122H-XX \$36.95
Counts as 2/Hardcover

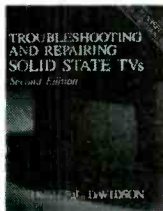

3700H-XX \$36.95
Counts as 2/Hardcover

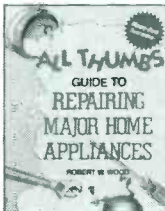

4061P \$9.95



3485H \$27.95
Hardcover

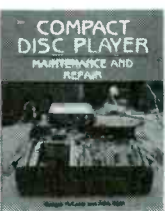

2790P \$15.95



4111H \$27.95
Hardcover



3279P \$24.95



4179H \$27.95
Hardcover

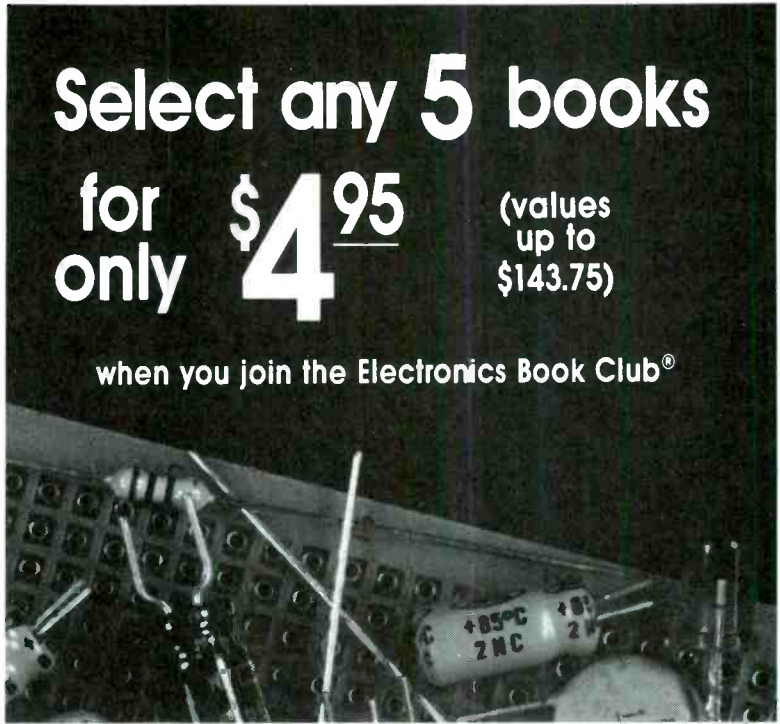

Select any 5 books for only \$4⁹⁵

(values
up to
\$143.75)

when you join the Electronics Book Club®

If coupon is missing, write to: Electronics Book Club, Blue Ridge Summit, PA 17294-0810

As a member of the Electronics Book Club . . .

. . . you'll enjoy receiving Club bulletins every 3-4 weeks containing exciting offers on the latest books in the field at savings of up to 50% off of regular publishers' prices. If you want the Main Selection do nothing and it will be shipped automatically. If you want another book, or no book at all, simply return the reply form to us by the date specified. You'll have at least 10 days to decide. And you'll be eligible for FREE BOOKS through our Bonus Book Program. Your only obligation is to purchase 3 more books during the next 12 months, after which you may cancel your membership at any time. (Publishers' prices shown)

If you select a book that counts as 2 choices, write the book number in one box and XX in the next. If you select a Counts as 3 choice, write the book number in one box and XXX in the next 2 boxes. A shipping/handling charge and sales tax will be added to all orders. All books are softcover unless otherwise noted. ©1993 EBC

Your most complete and comprehensive source for the finest electronics books.

Electronics Book Club®

Blue Ridge Summit, PA 17294-0810

YES! Please send me the books listed below, billing me for just \$4.95 plus shipping/handling & tax. Enroll me as a member of the Electronics Book Club according to the terms outlined in this ad. If not satisfied, I may return the books within 10 days without obligation and have my membership cancelled.

--	--	--	--	--

If you select a book that counts as 2 choices, write the book number in one box and XX in the next. If you select a Counts as 3 choice, write the book number in one box and XXX in the next 2 boxes.

Name _____

Address _____

City/State _____

Zip _____ Phone _____

Valid for new members only, subject to acceptance by EBC. Canada must remit in U.S. funds drawn on U.S. banks. Applicants outside the U.S. and Canada will receive special ordering instructions. All books are softcover unless otherwise noted. Publishers' prices shown. A shipping/handling charge & sales tax will be added to all orders. RPIE1093

October 1993, Electronics Now

24 HOUR SHIPPING

ELENCO • HITACHI • B&K PRODUCTS
GUARANTEED LOWEST PRICES

TO ORDER
 CALL TOLL FREE
 1-800-292-7711
 1-800-445-3201 (Can.)

AFFORDABLE - HIGH QUALITY
2 YEAR WARRANTY

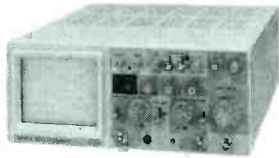

STANDARD SERIES
S-1325 25MHz \$349
S-1340 40MHz \$495
S-1365 60MHz \$849

Features:

- High Luminance 6" CRT
- TV Sync
- 1mV Sensitivity
- 2 - x1, x10 Probes
- X-Y Operation
- Complete Schematic
- Voltage, Time, + Frequency differences displayed on CRT thru the use of cursors (S-1365 only)
- Plus much, much more

ELENCO OSCILLOSCOPES

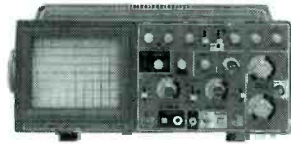

DELUXE SERIES
S-1330 25MHz \$449
S-1345 40MHz \$575
S-1360 60MHz \$775

Features:

- Delayed Sweep
- Automatic Beam Finder
- Z Axis Modulation
- Built-in Component Test
- Plus all the features of the "affordable" series
- Dual time base
- Illuminated internal grid

Hitachi Compact Series Scopes

V-212 - 20MHz Dual Trace	\$399
V-525 - 50MHz, Cursors	\$995
V-523 - 50MHz, Delayed Sweep	\$949
V-522 - 50MHz, DC Offset	\$895
V-422 - 40MHz, DC Offset	\$795
V-222 - 20MHz, DC Offset	\$649
V-660 - 60MHz, Dual Trace	\$1,149
V-665A - 60MHz, DT, w/cursor	\$1,325
V-1060 - 100MHz, Dual Trace	\$1,395
V-1065A - 100MHz, DT, w/cursor	\$1,649
V-1085 - 100MHz, QT, w/cursor	\$1,995
V-1100A - 100MHz, Quad Trace	\$2,495
V-1150 - 150MHz, Quad Trace	\$2,895

B&K OSCILLOSCOPES

2120 - 20MHz Dual Trace	\$389
2125 - 20MHz Delayed Sweep	\$539
1541B - 40MHz Dual Trace	\$695
2160 - 60MHz Dual Trace, Delayed Sweep, Dual Time Base	\$949
2190 - 100MHz Three Trace Dual Time Base, Delayed Sweep	\$1,395
2522A - 20MHz / 20MS/s Storage	\$875

Digital Capacitance Meter



CM-1550B
 by Elenco
\$58.95

9 Ranges
 .1pf-20,000ufd
 .5% basic accy.

Big 1" Display Zero control w/ Case

Digital LCR Meter



LC-1801
\$125

Measures:
 Coils 1uH-200H
 Caps .1pf-200uf
 Res .01-20M

by Elenco

Digital Multimeter



DVM-638
\$39.95

11 Functions with Case

FLUKE MULTIMETERS

Scopemeters (All Models Available Call)	
Model 93	\$1,225.00
Model 95	\$1,549.00
Model 97	\$1,795.00
10 Series	
Model 10	\$62.95
Model 12	\$79.95
70 Series	
Model 70II	\$65.00
Model 77II	\$149.00
Model 79II	\$169.00
80 Series	
Model 87	\$289.00

Quad Power Supply XP-580



\$79.95
 2-20V @ 2A
 12V @ 1A
 5V @ 3A
 -5V @ .5A

Fully regulated and short circuit protected
 Made in USA by Elenco

Triple Power Supply XP-620



Assembled \$75
 Kit \$50

2 to 15V @ 1A,
 -2 to -15V @ 1A
 (or 4 to 30V @ 1A)
 and 5V @ 3A

Made in USA by Elenco
 All the desired features for doing experiments.
 Features short circuit protection, all supplies.

AM/FM Transistor Radio Kit

with 52 page Training Course

\$27.95

Elenco
 AM/FM 108
 14 Transistors ♦ 5 Diodes
 Makes a great school project
 AM Radio Kit AM550 \$18.95



True RMS 4 1/2 Digit Multimeter

M-700T
\$135

.05% DC Accuracy
 1% Resistance
 with Freq. Counter
 Data Hold
 by Elenco

Sweep/Function Generator with Freq. Counter



\$239
 Elenco
 Model GF-8026

Sine, Square, Triangle, Pulse, Ramp
 .2 to 2MHz, Freq Counter .1-10MHz
 Internal Linear & Logic Sweep

Function Generator Blox #9600



by Elenco
\$28.95

Provides sine, triangle, square wave from 1Hz to 1MHz
 Kit \$26.95 AM or FM capability

XK-500 Digital / Analog Trainer

A complete mini-lab for building, testing, prototyping analog and digital circuits
 Elenco's Digital/Analog Trainer is specially designed for school projects, with 5 built-in power supplies. Includes a function generator with continuously variable, sine, triangular, square wave forms. All power supplies are regulated and protected against shorts.

Power Supplies

- Variable Power Supply
- +1.25 to 20VDC @ 5 Amp (+1.25 to 15VDC @ 1 Amp)
- -1.25 to -20VDC @ 5 Amp (-1.25 to -15VDC @ 1 Amp)
- +12VDC @ 1 Amp
- -12VDC @ 1 Amp
- +5VDC @ 1 Amp
- 30VAC Center tapped @ 15VAC at 1 Amp

Analog - Section

- Function Generator Sine, Triangular, Square wave forms
- Frequency adjustable in five ranges from 1 to 100KHz
- Fine frequency adjust
- Amplitude adjust
- DC offset
- Modulation FM-AM

Digital - Section

- Eight data switches
- Two no bounce logic switches
- 8 LED readouts TTL buffered
- Clock frequency 1 to 100KHz
- Clock amplitude 5VPP square wave

Breadboards

- 2 breadboards, each contain: 840 tie points (total 1,680)



\$159.95

Assembled

\$129.95 Kit

Learn to Build and Program Computers with this Kit

Includes: All Parts, Assembly and Lesson Manual

Model
MM-8000

\$129.00

by Elenco

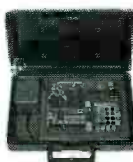

Starting from scratch you build a complete system. Our Micro-Master trainer teaches you to write into RAMs, ROMs and run a 8085 microprocessor, which uses similar machine language as IBM PC.

Elenco Wide Band Signal Generators



SG-9000 \$119

RF Freq 100K-450MHz AM Modulation of 1KHz Variable RF output

SG-9500 w/ Digital Display & 150MHz built-in counter \$239

WE WILL NOT BE UNDERSOLD

UPS SHIPPING: 48 STATES 5% OTHERS CALL
 IL RES add 7.75% TAX

PROBES INCL ALL SCOPES & METERS

C&S SALES INC.

1245 ROSEWOOD, DEERFIELD, IL 60015
 FAX: 708-520-0085 • (708) 541-0710



15 DAY MONEY BACK GUARANTEE

FULL FACTORY WARRANTY

WRITE FOR FREE CATALOG

PRICES SUBJECT TO CHANGE

CIRCLE 109 ON FREE INFORMATION CARD

Just like these Fully Trained Electronics Professionals



"Thanks to CIE I have tripled my previous salary, and I am now in a challenging and rewarding new field where only the sky is the limit."

Daniel Wade Reynolds
Industrial Electrician
Ore-Ida Foods



"CIE was recommended to me by my boss. It was appealing since I could study at my own pace at home and during business travel."

Dan Parks
Marketing Manager/Consumer Products
Analog Devices, Inc.



"I loved the flexibility CIE offered. It was the only way I could continue both school and my demanding job."

Britt A. Hanks
Director of Engineering
Petroleum Helicopters, Inc.



"I liked the way the school was set up with laboratory assignments to enforce conceptual learning. The thing which impressed me the most about CIE's curriculum is the way they show application for all the theory that is presented."

Daniel N. Parkman
Missile Electro-Mechanical Technician
U.S. Air Force



"Completing the course gave me the ability to efficiently troubleshoot modern microprocessor based audio and video systems and enjoy a sense of job security."

Tony Reynolds
Service Manager/Technician
Threshold Audio & Video

Graduate with an Associate Degree from CIE!

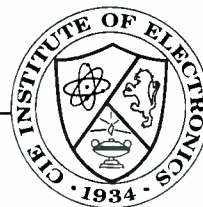

CIE is the best educational value you can receive if you want to learn about electronics, and earn a good income with that knowledge. CIE's reputation as the world leader in home study electronics is based solely on the success of our graduates. And we've earned our reputation with an unconditional commitment to provide our students with the very best electronics training.

Just ask any of the 150,000-plus graduates of the Cleveland Institute of Electronics who are working in high-paying positions with aerospace, computer, medical, automotive and communications firms throughout the world. They'll tell you success didn't come easy...but it did come...thanks to their CIE training. And today, a career in electronics offers more rewards than ever before.

CIE'S COMMITTED TO BEING THE BEST...IN ONE AREA...ELECTRONICS.

CIE isn't another be-everything-to-everyone school. CIE teaches only one subject and we believe we're the best at what we do. Also, CIE is accredited by the National Home Study Council. And with more than 1,000 graduates each year, we're the largest home study school specializing exclusively in electronics. CIE has been training career-minded students for nearly sixty years and we're the best at our subject...
ELECTRONICS... IT'S THE ONLY SUBJECT WE TEACH!

CIE PROVIDES A LEARNING METHOD SO GOOD IT'S PATENTED.

CIE's AUTO-PROGRAMMED® lessons are a proven learning method for building valuable electronics

career skills. Each lesson is designed to take you step-by-step and principle-by-principle. And while all of CIE's lessons are designed for independent study, CIE's instructors are personally available to assist you with just a toll free call. The result is practical training... the kind of experience you can put to work in today's marketplace.

LEARN BY DOING...WITH STATE-OF-THE-ART EQUIPMENT AND TRAINING.

CIE pioneered the first Electronics Laboratory



Course and the first Microprocessor Course. Today, no other home study school can match CIE's state-of-the-art equipment and training. And all your laboratory equipment, books and lessons are included in your tuition. It's all yours to use while you study and for on-the-job after you graduate.

PERSONALIZED TRAINING...TO MATCH YOUR BACKGROUND.

While some of our students have a working knowledge of electronics others are just starting out. That's why CIE has developed twelve career courses and an A.A.S. Degree program to choose from. So, even if you're not sure which electronics career is best for you, CIE can get you started with core lessons applicable to all areas in

electronics. And every CIE Course earns credit towards the completion of your Associate in Applied Science Degree. So you can work toward your degree in stages or as fast as you wish. In fact, CIE is the only school that actually rewards you for fast study, which can save you money.



YES!

I want to get started. Send me my CIE course catalog including details about the Associate Degree Program. (For your convenience, CIE will have a representative contact you - there is no obligation.)

Please Print Clearly

AE55

Name _____

Address _____

City _____

State _____ Zip _____ Age _____

Phone No. _____

Check box for G.I. Bill Benefits.

Veteran

Active Duty

Cleveland Institute of Electronics, Inc.
1776 East 17th Street
Cleveland, OH 44114

A School of Thousands.
A Class of One. Since 1934.

Send for CIE's FREE Course Catalog and See How We Can Help Your Career Too!

NEW PRODUCTS

Use the Free Information Card for more details on these products.

MULTISTANDARD TV SIGNAL GENERATOR.

The *Fluke and Philips, PM 5418 Video Pattern Generator* is said to be able to produce all the signals needed for testing TV sets, VCRs and computer monitors. These include more than 100 test patterns that meet the NTSC, PAL, and SECAM video standards.

The signal generator offers both caption and text modes in either of two operating channels. The closed-caption information is present in line 21 of the NTSC video signal.

The *PM 5418* generates high-precision signals for geometry alignment, 16:9 and 4:3 aspect ratio patterns, and special patterns for VCR and 100-Hz improved definition TV (IDTV) testing. Mono, stereo, and



CIRCLE 16 ON FREE INFORMATION CARD

NICAM sound test signal are also available.

In addition, the instrument contains test configurations for Teletext TOP/FLOF, VPT and Antiope test signals, programmable PDC (program delivery control), VPS and closed-caption test signals. The *IEEE-488 programmable PM 5418* offers full radio-

frequency coverage from 32 to 900 MHz with internal/external modulation, RGB, Y/C (S-VHS/Hi-8), CVBS and audio outputs.

Prices for the *PM 5410* family of TV signal generators begin at \$2200.

John Fluke Mfg. Co., Inc.
P. O. Box 9090
Everett, WA 98206
Phone: 800-44-FLUKE

MEMORY-EXPANDABLE GRAPHIC CALCULATOR.

Hewlett-Packard has introduced two new graphics calculators, the *HP 48GX* and the *HP 84G*.

The *HP 48G* offers expandable memory, graphics, calculation, and computer programming capabilities. It can perform 3-D plotting, a feature HP says has never before been available in any handheld calculator.



CIRCLE 18 ON FREE INFORMATION CARD

HANDHELD TEST BENCH METERS.

B + K Precision is offering two new digital multimeters: the *Models 390 and 391*.

The *Model 390* is a 4000-count, 3¾-digit DMM offering 0.01% DC voltage accuracy. It has a 42-segment analog bargraph display. Up to 40-ampere AC and DC current and resistance up to 40 megohms can be measured. Five capacitance ranges extend to 40 microfarads. The DMM can count frequency to 500 kHz, and it can measure temperature from -50°C to +1300°C, ±2°C. The *Model 390* offers relative mode, data-hold memory, min/max average, and auto

or manual ranging.

The *Model 391* has a full 4½-digit, 20,000-count liquid-crystal display. Up to 20-ampere DC and AC current can be measured. It can count frequencies to 200 KHz. This DMM can indicate logic state (1 or 0) in TTL voltage-level digital circuits. It also has data-



CIRCLE 17 ON FREE INFORMATION CARD

hold and a duty-cycle measurement capability.

Both models can test diodes and have audible continuity beepers. Both DMMs are overload protected and fused on both the microampere/milliamperere and 20-ampere current ranges. The DMMs are covered by three-year warranties and are enclosed in drop-resistant cases with impact-absorbing rubber boots. *Model 390* is priced at \$159 and *Model 391* is \$179.

B + K Precision

Division of Maxtec International Corp.
6470 West Cortland Street
Chicago, IL 60635
Phone: 312-889-1448
Fax: 312-794-9740

The *HP 48GX* includes 128 kilobytes of RAM, and it accepts plug-in cards that contain extra memory or programs to extend its basic functions. The calculator includes a serial interface for connecting it to IBM-compatible or Macintosh personal computers with two-way infrared links. Its graphics are integrated with calculus functions, symbolic-math functions, and built-in libraries of engineering equations and engineering constants.

Two expansion slots permit the addition of up to 4 megabytes of programs or memory. Enhanced graphics include a form-driven user-interface, shading, 3-

D plots, trace, and simultaneous plots. Optional fill-in-the-blanks input forms guide the user through applications. Dialog boxes provide access to calculator functions, and a stack-based interface is available.

The HP 48G has 32 kilobytes of RAM and all the features of the HP 48GX except the expansion capability for those who don't require it.

The price of the HP 48GX is \$350 and the price of the HP 48G is \$164.

Hewlett-Packard Company
Inquiries Manager
1000 N.E. Circle Boulevard
Corvallis, OR 97330
Phone: 503-752-7736
(between 8 AM and 3 PM Pacific Daylight Time)



CIRCLE 19 ON FREE INFORMATION CARD

DB-25 connectors. The package price is \$399. Optional accessories available from Electronic Product Design include prototyping kits, microcontrollers, and an ultraviolet EPROM eraser module.

Electronic Product Design Inc.

6963 Bluebelle Way
Springfield, OR 97478
Phone: 503-741-0778

PC-BASED DEVELOPMENT

SYSTEM. The *Micro Controller Tool (MCT)* PC-based development system from Electronic Product Design is IBM-compatible for designing the Signetics 87C751 and 87C752 single-chip microcontrollers into products.

The integrated, menu-driven MCT package includes a project manager, text editor, assembler, and programmer. The MCT software allows users to develop and produce products that include the 87C751 and 87C752. Program development is simplified with the included sample start-up programs.

An expandable library that includes 32-bit mathematics and serial communications routines is also included. A project-oriented main menu simplifies the design process.

The MCT development system is sold with a microcontroller handbook, operator's manual, software, and serial programming modules. Also included are an AC adaptor and RJ-11 to

PHOTODIODE AMPLIFIER.

Centronic's CA-100 photodiode amplifier, an alternative to a pico ammeter, amplifies low-level input signals to make them more distinguishable and readable by instruments.



CIRCLE 20 ON FREE INFORMATION CARD

The amplifier converts the signal from Centronic detectors into a voltage that can directly drive oscilloscope deflection plates or other voltage-sensing instruments. It generates ± 2 volts from eight gain settings ranging from 10^3 to 10^{10} volts per ampere with high-gain accuracy and low noise. The input can vary from 200 picoamperes full scale to 2 milliamperes in eight ranges.

In its normal current-

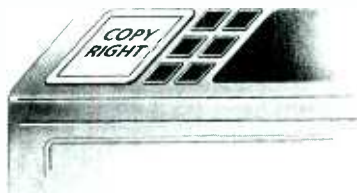

THE MOST
AN IMPORTANT PART OF YOUR PHOTOCOPIER ISN'T PART OF YOUR PHOTOCOPIER

Having a machine may not permit you to photocopy books, journals, newsletters and magazines.

The Copyright Clearance Center CAN.

Contact us to find out how you too can COPY RIGHT!SM

COPYRIGHT CLEARANCE CENTER

27 Congress Street, Salem, MA 01970 □ Tel. (508) 744-3350 □ Fax (508) 741-2318

© 1993 Copyright Clearance Center

QUALITY TV & VCR PARTS

REPLACEMENT SEMICONDUCTORS

BU208A	10/up \$1.99ea		STR30120	4.95ea
2SD869	10/up \$1.99ea		STR30123	\$5.95ea
2SD1397	10/up \$1.99ea		STR30130	\$10.95ea
2SD1426	10/up \$1.99ea		STK4273	10/up \$7.95ea
2SD1427	10/up \$1.99ea		STK0080	10/up \$13.50ea
			STK5481	10/up \$10.95ea

REPLACEMENT FLYBACKS

154-040	GOLDSTAR	\$19.95ea
154-074E	GOLDSTAR	\$19.95ea
1-439-254-11	SONY	\$29.95ea
1-439-357-11	SONY	\$29.95ea
3214003	EMERSON	\$24.50ea
3220011	EMERSON	\$29.95ea
2434391	HITACHI	\$29.95ea
TLF14423F	PANASONIC	\$29.95ea
TLF14530F	PANASONIC	\$29.95ea
FCC1415AL	SAMSUNG	\$19.95ea

VCR IDLERS

164113	ORIGINAL	\$3.25ea	10/up \$2.99ea
VXP0521	ORIGINAL	\$3.25ea	10/up \$2.99ea
143-0-4202-00400	REPLACEMENT	\$2.95ea	10/up \$2.75ea
NPLY0107GEZ	REPLACEMENT	\$2.50ea	\$8.95ea
NIDL0006	REPLACEMENT	\$2.50ea	10/up \$1.99ea
433-015A	REPLACEMENT	\$2.50ea	10/up \$1.99ea

POPULAR CAPACITORS

100M/63V	20/up \$1.50ea
100M/100V	10/for \$10.00
100M/160V	10/for \$10.00
100M/200V	10/for \$10.00
100M/250V	10/for \$12.50
4.7M/250V	10/for \$5.50
10M/350V	10/for \$7.50



MAE ELECTRONICS

975 JAYMOR ROAD
SOUTHAMPTON, PA 18966

CALL TOLL-FREE
1-800-628-1118



CIRCLE 89 ON FREE INFORMATION CARD

meter mode, the CA-100 displays the photocurrent directly on its front-panel display. The amplifier can also function in the optical-power mode. A calibration adjust knob sets the amplifier to a known optical power, and the liquid-crystal display presents the optical power reading directly.

The CA-100 photodiode amplifier is priced at \$675.

Centronic Inc.

2088 Anchor Court
Anchor Business Park
Newbury Park, CA 91320
Phone: 805-499-5902
Fax: 805-499-7770

BENCH-TOP POWER SUPPLIES.

Kepeco is offering a line of 360-watt benchtop power supplies with communications capabilities. A serial two-wire communications port that complies with IEEE-1118 is provided for long-distance (300 meter) communication, and an optional built-in, single-board computer (SBC) provides a choice of IEEE-488-2 short-range parallel communications or RS-232C control.

The *MBT Series* of digital power supplies is available in eight output combinations. They range from 0 to 6 volts at 32 amperes for the *MBT 6-32MG* to 0 to 150 volts at 2.4 amps for the *MBT 150-2.4MG*

The stand-alone power supplies offer direct-entry keyboard control of voltage, current, and protective settings with slew up/down buttons for convenient incrementing. A pair of knobs controls optical encoders. A two-line, 16-character panel display shows menu selections, control settings, and output readings. These functions can be read back on any of the supply's external communications buses.

The *MBT Series* power supplies with the single-



CIRCLE 21 ON FREE INFORMATION CARD

board computer are priced at \$2499, and the supplies without the computer board are priced at \$1899.

Kepeco, Inc.

131-38 Sanford Avenue
Flushing, NY 11352
Phone: 718-461-7000
Fax: 718-767-1102

LED TESTER. The *LED-Tester Box* from *Lumex Opto/Components* is a compact, handheld instrument for testing, evaluating, and checking the quality of discrete light-emitting diodes.

The tester has individual sockets with fixed current levels of 2, 5, 20, and 30 milliamperes, and seven sockets rated for 10 milliamperes so that comparable LEDs can be compared for color and brightness. A single 9-volt transistor battery powers the pocket-sized, 3-ounce unit.

The *LED-Tester Box* is priced at \$38, with a battery included.

Lumex Opto/Components Inc.

292 East Hellen Road
Palatine, IL 60067
Phone: 708-359-2790
Fax: 708-359-8904



CIRCLE 22 ON FREE INFORMATION CARD

DATA ACQUISITION BOARD.

BSOFT Software is offering a new *ANA201* eight-channel, 12-bit, programmable-gain data acquisition board. An on-board 8- or 16-bit data-mode jumper block permits the *ANA201* to plug into any half or full slot of an IBM PC/XT/AT or compatible computer.

Channel conversion speed is either 10 microseconds for the *ANA201* or 3 microseconds for the alternative *ANA201/A* version. It is intended for digital signal processing, audio instrumentation, and telecommunications.

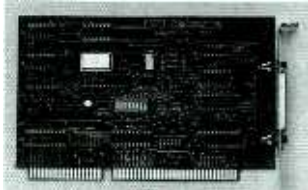

CIRCLE 23 ON FREE INFORMATION CARD

The *ANA201*, complete with a user's manual and a demonstration disk of programming examples, is priced at \$129.

BSOFT Software, Inc.

444 Colton Road
Columbus, OH 43207
Phone: 614-491-0832
Fax: 614-497-9971

SURFACE-MOUNT TRANSFORMERS.

Associated Components Technology is offering two new lightweight surface-mount transformers. The *CCFL16* and *EL16* transformers, in 28.55 x 17.5 x 8.5-mm packages, offer current-handling capabilities comparable to those of conventional board-mounted transformers.

The *CCFL16* has a rated output of 500 to 1500 volts peak-to-peak with an input voltage of 3 to 20 volts. Its maximum power dissipation is 5 watts at 25 kHz. The transformer can operate at 20 to 40 kHz.



CIRCLE 24 ON FREE INFORMATION CARD

The *EL16* has a rated output of 50 volts rms, with an input voltage of 3 to 20 volts. Its maximum power dissipation is 2.5 watts at 25 kHz, and its normal operating frequency is 1.5 kHz. It can be a component in DC-to-AC inverters for halogen lamp drivers.

Both transformers are said to be 85% efficient, 25 to 35% more efficient than conventional transformers.

In 5000 quantities, the *CCFL16* and *EL16* are priced at \$3.15 each.

Associated Components Technology

11576 Trask Avenue
Garden Grove, CA 92643
Phone: 714-636-2645
Fax: 714-636-8276



CIRCLE 25 ON FREE INFORMATION CARD

DIGITAL AC LINE MONITOR.

If you need a simple way to monitor AC line voltages, then consider the *Datel DMS-20PC-1-LM Digital AC Line Monitor*. The \$45 device plugs into any AC outlet and can display from 85 to 264 VAC at 47-63 Hz on a 3-digit LED display.

DATTEL, Inc.

11 Cabot Boulevard
Mansfield, MA 02048
508-339-3000

LETTERS

continued from page 15

What happens to "crude" parity errors? When data are stored in the memory bit-cells and/or in a memory that is read into a data register, only two abnormal things can happen: The data can "drop" a bit or it can "pick up" a bit. In other words, a zero can become a one (pickup), or a one can become a zero (drop).

First, set out the bits with values associated with the positions of each bit:

8 4 2 1
X X X X

Thus, a bit in a specific position as shown above gives the string of bits a value. For example, 4 is represented by binary as 0100 (the one bit is in the 4 position, the other bits are zero), 6 is binary 0110 (add another one bit in the 2 position), etc.

With this bit-value representation in mind, it can easily be seen that "dropping" or "picking up" bits can alter numbers.

In computers, parity checking is performed when the binary data is written to memory. The eight data bits are examined for either an *odd* or *even* number of one bits, and the parity bit is added to make the total nine bits *odd* or *even*.

In the *odd* scheme, for example, note how the check bit status (0/1) is determined. The numbers 0-9 are represented in hexadecimal as 30H-39H. All numbers are represented by eight bits—two groups of four bits each. The first group is always 3 (binary 0011); the second group can be from 0 to 9 in bits (binary 0000 to 1001), so a 7 is represented as binary 0011 0111, while a 2 is binary 0011 0010. Each eight-bit group is examined for its number of one bits.

In the *odd* scheme, there must be an odd number sum for the nine bits. Because 7 (binary 0011 0111) and a 2 (binary 0011 0010) already have an *odd* number of one bits, the parity bit is set to zero; thus the *total* remains odd. A 6 (0011 0110) or a 5 (0011 0101), however, have an even

number of one bits, so the parity bit is set to one to yield an *odd* total.

Nine-bit parity checking does not catch even multiple-bit failures that occur simultaneously, but it does catch *odd*, multiple-bit failures.

By analyzing its large failure database, IBM discovered that about 99% of all bit failures (from either mechanical or electronic causes) were single-bit failures. The data showed that multiple-bit failures are more common in magnetic-memory storage.

In examining the data on the very small percentage of multiple-bit failures, IBM found the odds to be 50-50 that they would be either *odd* or *even*. Thus, about half of those could be caught with a nine-bit parity scheme.

Clearly, no prudent engineer or anyone else engaged in large-scale "number crunching" would be without parity checking—particularly if those calculations involve large sums of money or public safety.

JAMES W. BIGGER
San Diego, CA

Ω

From Not-Working to Networking!

Troubleshooting Local-Area Networks!

Now, complete for the first time in one detailed booklet!

Gain a fuller knowledge of network fundamentals and how they developed from the early days of main frames, from XNS to Ethernet technology, the OSI stack for interconnecting different computers, basic and specialized test instruments, etc. Several tough LAN case histories bring from theory to the practical side of troubleshooting.



ONLY \$5.00

CLAGGK Inc., Reprint Bookstore
P.O. Box 4099, Farmingdale, NY 11735

Please rush my copy of "From Not-Working to Networking." I enclosed payment of \$5.00 which includes shipping charges.

Name _____

Address _____

City _____ State _____ ZIP _____

Sorry, no orders excepted outside of United States and Canada. All Payments must be in U.S. funds. Send check or money order payable to CLAGGK Inc.—do not send cash or stamps. New York State residents add applicable sales tax.

FREE CATALOGUE

ACTIVE KITS

ELECTRONIC PROJECTS

1-800-465-KITS

A029..8-CHANNEL STEPPER MOTOR DRIVER

EVERY ACTIVE KIT CONTAINS:

- All components including printed circuit board and solder
- Complete assembly instructions and schematic diagrams

A001.. 1-24VDC Regulated Power Supply.....\$21.95	A019.. Remote InfraRed Switch.....\$16.95
A002.. 16 LED Light Chaser.....\$19.95	A020.. Digital Timer.....\$29.95
A003.. 2000 Watt Colour Light Organ.....\$22.95	A021.. Stepper Motor Controller #2.....\$33.95
A004.. 2 Channel Audio LED Power Meter.....\$16.95	A022.. 8 Channel 120V Light Chaser.....\$20.95
A005.. Variable Strobe Light.....\$16.95	A023.. Electronics 101.....\$38.95
A008.. 1 MHz Function Generator.....\$33.95	A024.. Logic Probe.....\$19.95
A009.. Stepper Motor Controller.....\$29.95	A025.. Fire Ball.....\$29.95
A010.. 8 Watt Audio Amplifier.....\$21.95	A026.. Bug Off.....\$8.95
A011.. Electronic Siren.....\$21.95	A027.. 100W High Power Audio Amplifier.....\$42.95
A012.. Power Supply +12V@2.5A; +15V,-15V@1A.....\$25.95	A028.. Low Voltage Strobe.....\$16.95
A013.. Digital Capacitance Meter.....\$38.95	A029.. 8 Channel Stepper Motor Driver.....\$50.95
A014.. Digital Volt Meter.....\$23.95	A030.. Unreg. Power Supply +/- 45VDC.....\$59.95
A015.. 12 Volt Fluorescent Ballast.....\$12.95	A031.. Speaker Switch Box
A016.. 9 Volt Digital Dice.....\$16.95	A032.. 10-30V, 3A Reg. Power Supply
A017.. Battery Level Monitor.....\$12.95	A033.. Resistor Switch
A018.. LED Light Sweeping Star.....\$16.95	

MANY MORE TO COME
CALL 1-800-465-5487

All kits quoted in U.S. dollars. No C.O.D. orders please.

ACTIVE KITS — 345 QUEEN ST. W., TORONTO, ONT. M5V 2A4

CIRCLE 194 ON FREE INFORMATION CARD

NEW LIT

Use The Free Information Card for fast response.

Creating Artificial Life: Self-Organization; by Edward Rietman. Windcrest/McGraw-Hill, Blue Ridge Summit, PA 17294-0850; Phone: 1-800-233-1128; Fax: 717-794-2103; \$29.95.

This book explores several different possible explanations for the intriguing question—when does a system become a *living* system? After exploring several definitions of life, the author explains the mathematical techniques that scientists use to simulate many different complex, dynamic systems.



CIRCLE 40 ON FREE INFORMATION CARD

Mr. Rietman's book, based on actual, ongoing research into artificial life, tells you how you can "create" your own artificial life forms on a personal computer with programs written in BASIC, C, and Pascal. You will learn how to model everything from genetic codes and computer viruses to cellular automata, self-organizing systems, and mathematical bioforms on your personal computer.

The book includes a disk that contains source code for all of the programs listed. Many tables, drawings, and photographs will help you to gain a better

understanding and appreciation of this exciting new branch of science.

Custom and Standard Connectors Selector and Reference Guide; Regal Electronics Inc., 471 Gianni Street, Santa Clara, CA 95054; Phone: 800-882-8086; Fax: 408-988-2797.

Regal's 24-page guide illustrates and lists the company's complete line of more than 260 standard and custom connectors. These include IDC, BNC, D-subminiature, DIN, SCSI-II, and filter connectors. A complete line of pin headers, sockets, noise filters, and hardware is also included. The guide contains a full-page custom-cable design guide.



CIRCLE 39 ON FREE INFORMATION CARD

New products from Regal include surface-mount connector products and backshells with grommets. Intended as a guide for product designers, the catalog and guide provides a picture and brief description of each product. It also discusses Regal's custom manufacturing. You are invited to call the company's toll-free number to request detailed drawings and specifications.

The ARRL Technician Class License Manual For Novice Class Licensees; edited by Larry D. Wolfgang, WR1B, Joel P. Kleinman, N1BKE, and Jim Kearman, KR1S. The American Radio Relay League, 225 Main Street, Newington, CT 06111; Phone: 203-666-1541; Fax: 203-665-7531; \$6.00.

Radio amateurs with Novice Class licenses who are ready to upgrade to Technician Class will find this American Radio Relay League's (ARRL) manual a helpful study guide. Upgrading will reward the novice with additional operating privileges—you can roam the complete spectrum allocated to the Amateur Service above 30 MHz. Moreover, it is no longer necessary to master the Morse Code.

This manual, one of ARRL's License Manual Series, offers a brief description of the Amateur Radio Service focusing on the Technician Class license. Subsequent chapters cover operating procedures, radio-wave propagation, amateur radio practice, electrical principles, circuit components, signals and emissions, and antennas and feed lines.

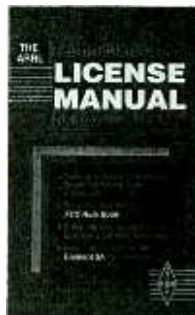

CIRCLE 38 ON FREE INFORMATION CARD

The manual also includes sample tests consisting of questions drawn from the question pool that is used for actual exams. Answer keys and page references are also provided. They permit the reader to locate the appropriate text that explain the correct answers to the test questions included.

Mobile Robots: Inspiration to Implementation; by Joseph L. Jones and Anita M. Flynn. A. K. Peters, Ltd., 289 Linden Street, Wellesley, MA 02181; 617-235-2210; Fax: 617-235-2404; \$39.95.

Mobile Robots offers step-by-step procedures for building two inexpensive but fully functional robots that have a wide range of abilities. The proj-

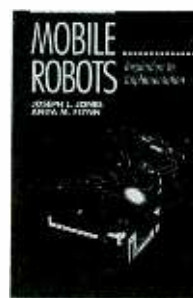

CIRCLE 37 ON FREE INFORMATION CARD

ects are intended to serve as stepping stones to the book's main goal—to expand the readers' background in electronics and artificial intelligence, and provide them with the basic skills and knowledge of tools needed to enter and be successful in the field of robotics.

The authors' enthusiasm for their subject is infec-

Introducing a New Era In Technical Training.

World College, an affiliate of the Cleveland Institute of Electronics, was created to provide a four year, independent study, technical degree program to individuals seeking a higher education. The Bachelor of Electronics Engineering Technology Degree, offered by World College, prepares students for high-paying careers in electronics, telecommunications, electrical power, computer and control systems. World College's curriculum is taught in an effective, time-proven, independent study environment. With World College's flexible study schedule, students have the opportunity to work or spend time with their family without having to worry about rigid scheduling residential colleges offer.

A Quality Education with a Flexible Schedule.

In a world heavily dependent on electronic equipment, people who understand electronics will have no problem putting their knowledge to work... in high-paying careers. The staff and faculty of World College have invested over ten years developing, what we believe to be, the finest independent-study, baccalaureate degree program available. World College's mission is to instill in each student the knowledge, education, and training that employers are seeking for the many technical positions available today. It's a program created to provide the best education and training possible with a flexible schedule to match your busy lifestyle.

World College is currently seeking approval to confer the Bachelor Degree from the Virginia Council of Higher Education.



Earn A Bachelor of Electronic Engineering Technology Degree from



**WORLD
COLLEGE**
Bringing Technology Home!

Lake Shores Plaza
5193 Shore Drive, Suite 113
Virginia Beach, VA 23455-2500

Send For Your Free Course Catalog.

Take the first step towards a new start in life. Send for World College's Free Independent Course Catalog today and discover how easy and affordable it is to get started on your **Bachelor Degree**.

World College is affiliated with



Complete the Entire Degree Program Under One Roof. Yours!

Only World College offers an independent study, four year technical degree which can be completed through one school. All lab equipment*, parts, and software are included in your tuition and the program's 300-plus laboratory experiments can be completed in your own home.

You Pay Only For Time Actually Used.

World College not only provides a means to earn a Bachelor Degree while fulfilling current obligations, but there are no restrictions on how fast you can complete the program. At World College, you pay tuition only for the actual upper-level semesters it takes to graduate. The quicker you complete the program, the less you pay in tuition. It's an effective way to keep you motivated in order to complete the course and move on to a better paying position as quickly as possible.

Currently not available in Ohio.

* Student must have access to a personal computer system.

YES! Please send me World College's Free Course Catalog detailing the full curriculum.

Name: _____

Address: _____

Apt: _____

City: _____

State: _____ Zip: _____

Phone: (_____) _____

Age: _____

Return to: WAE02
World College
Lake Shores Plaza
5193 Shore Drive, Suite 113
Virginia Beach, VA 23455-2500

tious. The book and its projects will appeal to readers at all levels of home project construction expertise. For the inexperienced, chapters on the fundamentals of building an electronic/electromechanical project are included. A list of basic tools needed to get started is also included in the book.

The TuteBot (for Tutorial Robot) is a simple, obstacle-avoiding robot. It is easy to build, and can serve as a "warm-up exercise" for the more challenging Rug Warrior. The software-controlled Rug Warrior has many sensors and actuators that give it the ability to chase people, hide in the dark, avoid obstacles, play music, and move toward noise sources.

This book by Jones and Flynn includes all of the necessary schematics and parts lists to build the robots. It also includes the Rug Warrior software program. A directory of commercial sources for the materials and components needed to build the robots is given. For those who wish to inquire more deeply into the subject, there is a bibliography of books and robotic publications.

In Plain English: DOS; by Jack Nimersheim. World-Comm, 65 Macedonia Road, Alexander, NC 28701; Phone: 704-252-9515; Fax: 704-255-8719; \$9.95 (U.S.), \$12.95 (Canada).

Here is another self-help book on the DOS operating system. Mr. Nimersheim says that personal computers don't have to be bewildering, and neither does the popular MS-DOS operating system. By minimizing the computer jargon, he helps readers master DOS, including version 6.0.



CIRCLE 36 ON FREE INFORMATION CARD

His book explains the basics—what DOS is, what it does, how it works, and how to install it. It also outlines the differences between the older versions of DOS, that required precise commands to be typed on the prompt line, and the relatively new graphics-based DOS shell.

Included is information that describes how the PC user can function in both DOS environments. It covers the preparation and management of disks, the use of organizing files and directories, and the customizing of DOS to meet specific needs. As advertised, Mr. Nimersheim's book is written in plain English; glossaries at the end of each chapter help the reader become computer-literate.

Project Studio Blueprint: A Guide to Design, Installation, and Management; by Greg Galluccio. Howard W. Sams & Company, 11711 North College, Carmel, IN 46032; Tel: 800-428-5331; Fax: 800-448-3804.

Galluccio's book explains everything you'll



CIRCLE 35 ON FREE INFORMATION CARD

need to organize and build an audio studio. It is intended to help readers put their own studio design ideas on paper. Topics covered include how to budget the costs of building and maintaining a studio, how to do the best sound proofing to obtain the best acoustics, how to install audio connections and patch bays properly, and how to troubleshoot equipment and connections.

This book is for those who are willing to spend about the same amount of money building a studio that would be needed to buy a new car. The latest audio technologies are explored. Included are explanations of multimedia capabilities for your studio. Practical tips, checklists, proven business strategies, and a sample business plan show how to turn a profit from your recording studio.

The Modem Reference: Third Edition; by Michael A. Banks. Brady Publishing, 11711 N. College Avenue, Suite 140, Carmel, IN 46032; Phone: 800-428-5331.

This complete guide to personal computer communications shows you how to connect your computer to a vast on-line world of information. Text and illustrations explain how to get the most from modern communications.

Beginners in computer communications will find hundreds of tips, hints, and ideas to get them up and running. Banks covers everything from selection, installation, and basic operation to advanced data transmission and troubleshooting techniques. The book includes a shopper's guide for on-line services, communications hardware, and software.



CIRCLE 34 ON FREE INFORMATION CARD

An included disk contains DON.MAC, a script that "talks" with other computer users on CompuServe and ZABTOOLS, which helps "unpack" programs and other files downloaded from BBS or on-line services. Quick-Select Batch File will assist the user in configuring his system.

Relays and Accessories Cross Reference and Technical Guide (RC-003). NTE Electronics, Inc., 44 Farrand Street, Bloomfield, NJ 07003; Phone: 800-631-1250 (including Canada) or 201-748-5089; Fax: 201-748-6224.



CIRCLE 33 ON FREE INFORMATION CARD

This 136-page catalog from NTE describes its expanded line of UL- and CSA-approved electromechanical and solid-state AC and DC relays, input-output modules, sockets, and accessories. More than 16,000 industry part numbers from 166 manufacturers are cross-referenced to the NTE line. They include all manner of relays: general purpose, power, latching, circuit-board mount, reed, automotive, and solid-state. Ω

Countersurveillance

Never before has so much professional information on the art of detecting and eliminating electronic snooping devices—and how to defend against experienced information thieves—been placed in one VHS video. If you are a Fortune 500 CEO, an executive in any hi-tech industry, or a novice seeking entry into an honorable, rewarding field of work in countersurveillance, you must view this video presentation again and again.



CALL NOW!

1-516-293-3751

**HAVE YOUR
VISA or MC CARD
AVAILABLE**

Wake up! You may be the victim of stolen words—precious ideas that would have made you very wealthy! Yes, professionals, even rank amateurs, may be listening to your most private conversations.

Wake up! If you are not the victim, then you are surrounded by countless victims who need your help if you know how to discover telephone taps, locate bugs, or “sweep” a room clean.

There is a thriving professional service steeped in high-tech techniques that you can become a part of! But first, you must know and understand Countersurveillance Technology. Your very first insight into this highly rewarding field is made possible by a video VHS presentation that you cannot view on broadcast television, satellite, or cable. It presents an informative program prepared by professionals in the field who know their industry, its techniques, kinks and loopholes. Men who can tell you more in 45 minutes in a straightforward, exclusive talk than was ever attempted before.

Foiling Information Thieves

Discover the targets professional snoopers seek out! The prey are stock brokers, arbitrage firms, manufacturers, high-tech companies, any competitive industry, or even small businesses in the same community. The valuable information they filch may be marketing strategies, customer lists, product formulas, manufacturing techniques, even advertising plans. Information thieves eavesdrop on court decisions, bidding information, financial data. The list is unlimited in the mind of man—especially if he is a thief!

You know that the Russians secretly installed countless microphones in the concrete work of the American Embassy building in Moscow. They converted

what was to be an embassy and private residence into the most sophisticated recording studio the world had ever known. The building had to be torn down in order to remove all the bugs.

Stolen Information

The open taps from where the information pours out may be from FAX's, computer communications, telephone calls, and everyday business meetings and lunchtime encounters. Businessmen need counselling on how to eliminate this information drain. Basic telephone use coupled with the user's understanding that someone may be listening or recording vital data and information greatly reduces the opportunity for others to purloin meaningful information.

The professional discussions seen on the TV screen in your home reveals how to detect and disable wiretaps, midget radio-frequency transmitters, and other bugs, plus when to use disinformation to confuse the unwanted listener, and the technique of voice scrambling telephone communications. In fact, do you know how to look for a bug, where to look for a bug, and what to do when you find it?

Bugs of a very small size are easy to build and they can be placed quickly in a matter of seconds, in any object or room. Today you may have used a telephone handset that was bugged. It probably contained three bugs. One was a phony bug to fool you into believing you found a bug and secured the telephone. The second bug placates the investigator when he finds the real thing! And the third bug is found only by the professional, who continued to search just in case there were more bugs.

The professional is not without his tools. Special equipment has been designed so that the professional can sweep a room so that he can detect voice-activated (VOX) and remote-activated bugs. Some of this equipment can be operated by novices, others require a trained countersurveillance professional.

The professionals viewed on your television screen reveal information on the latest technological advances like laser-beam snoopers that are installed hundreds of feet away from the room they snoop on. The professionals disclose that computers yield information too easily.

This advertisement was not written by a countersurveillance professional, but by a beginner whose only experience came from viewing the video tape in the privacy of his home. After you review the video carefully and understand its contents, you have taken the first important step in either acquiring professional help with your surveillance problems, or you may very well consider a career as a countersurveillance professional.

The Dollars You Save

To obtain the information contained in the video VHS cassette, you would attend a professional seminar costing \$350-750 and possibly pay hundreds of dollars more if you had to travel to a distant city to attend. Now, for only \$49.95 (plus \$4.00 P&H) you can view *Countersurveillance Techniques* at home and take refresher views often. To obtain your copy, complete the coupon or call.

EN

CLAGGK INC.
P.O. Box 4099 • Farmingdale, NY 11735

Please rush my copy of the Countersurveillance Techniques Video VHS Cassette for a total cost of \$53.95 each (which includes \$4.00 postage and handling).

No. of Cassettes ordered _____

Amount of payment \$ _____

Sales tax (N.Y.S. only) _____

Total enclosed _____

Bill my VISA MasterCard

Card No. _____

Expire Date ____/____/____

Signature _____

Name _____

Address _____

City _____ State _____ ZIP _____

All payments in U.S.A. funds. Canadians add \$4.00 per VHS cassette. No foreign orders.

GET THE LATEST ADVANCES IN ELECTRONICS

WITH A SUBSCRIPTION TO

Electronics Radio Combined with Electronics® NOW®



ENJOY THE WORLD OF ELECTRONICS EACH MONTH!

Subscribe to the best electronics magazine—the one that brings you the latest high-tech construction projects, feature articles on new technology, practical troubleshooting techniques, circuit design fundamentals, and much more.

Electronics Now looks to the future and shows you what new video, audio and computer products are on the horizon. What's more you'll find helpful, monthly departments such as Video News, Equipment Reports, Hardware Hacker, Audio Update, Drawing Board, Computer Connections, New Products, and more. All designed to give you instruction, tips, and fun.

Electronics Now gives you exciting articles like:

- Buyer's Guide to Digital Oscilloscopes
- Build A Scanner Converter
- Single-Chip Voice Recorder
- Build A MIDI Interface for your PC
- Troubleshoot Microprocessor Circuits
- Build A High-Power Amplifier for your Car
- Add Music On Hold to your Phone
- All About Binaural Recording
- VGA-to-NTSC Converter



FOR FASTER SERVICE CALL TODAY
1-800-999-7139

DON'T DELAY SUBSCRIBE TODAY!

Just fill out the order card in this magazine and mail it in today.

WEATHER STATION

Build a computer-controlled weather-monitoring station and become an expert on local weather conditions.

RONALD M. JACKSON

THE BAROMETRIC PRESSURE IS falling rapidly, dropping by almost an inch of mercury in 12 hours. A big storm is on the way. Relative humidity begins a slow rise as cloud cover increases. The wind rapidly picks up speed. Gusts peak at over fifty miles an hour. The relative humidity increases sharply and air temperature drops. Steady heavy rains begin, sending the relative humidity over 96%. The downpour lasts an hour. Over one inch of rain falls in that time. The wind direction changes from southwest to northwest as the storm front passes. Front passage is confirmed as the barometric pressure begins a slow rise. As the cold air scours out the warm, the temperature drops ten degrees. With the weather station presented in this article, your computer can monitor every facet of the storm.

A weather monitor

The weather affects everyone. But instead of just being a source of rained-out picnics, the weather can be a source of endless fascination. Driven by the forces of heat from the sun and the rotation of the earth,

modified by both continental and local topology, the weather is a constantly changing panoply of winds, heat, moisture, and pressure. This month's project is a professional caliber instrument that will help you unlock the secrets of the weather.

This computerized meteorological station uses the Experimenter (presented in the July and August issues of **Electronics Now**) to link weather instruments to your computer. Any PC-compatible computer with CGA, EGA or VGA graphics can be used. A Macintosh software version is in development, and may be available by the time you read this. Because of the extensive measurement capabilities built into the Experimenter, the electronics for this project are relatively simple.

With the standard software package, this project can measure and display a wide range of weather conditions with great

accuracy. However, a professional version of the software can be purchased. It permits measurements to be stored on disk so that they can be recalled and displayed graphically on the screen or printed on laser or dot-matrix printers. Minute-by-minute information can be recorded for 24-hour periods to aid in weather forecasting. Hourly data and daily minimum/maximums are stored for historical analysis.

By using the alarm capabilities in the software, along with the relay and eight driver outputs on the Experimenter, you can program the station to take actions based on weather conditions. Perhaps you would like to automate a greenhouse so that when the temperature drops too low or rises too high, an exhaust fan or heater will be activated; if the relative humidity dropped too low, a mist system or lawn sprinklers could be triggered.



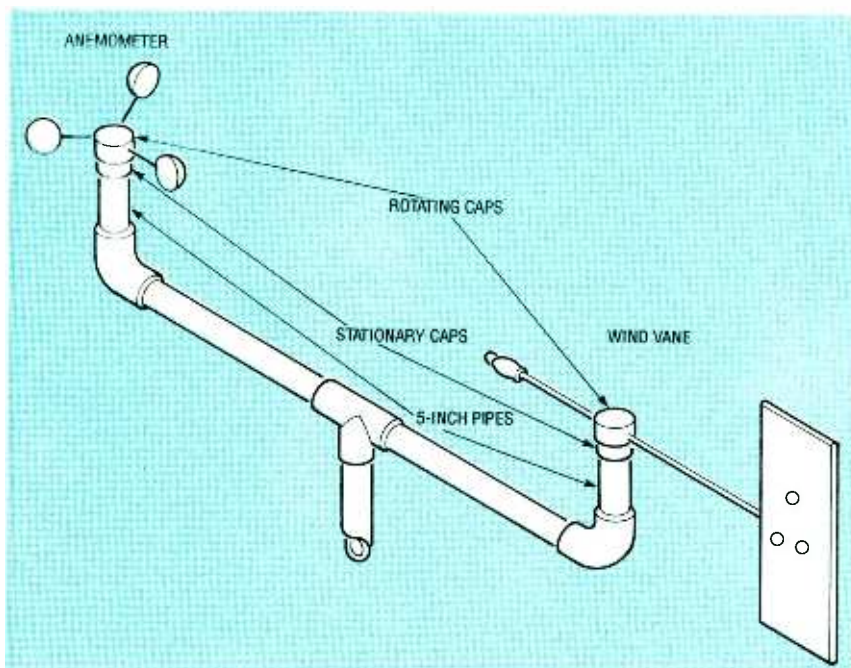

FIG. 1—THE ANEMOMETER AND WIND VANE mount on a single PVC pipe assembly.

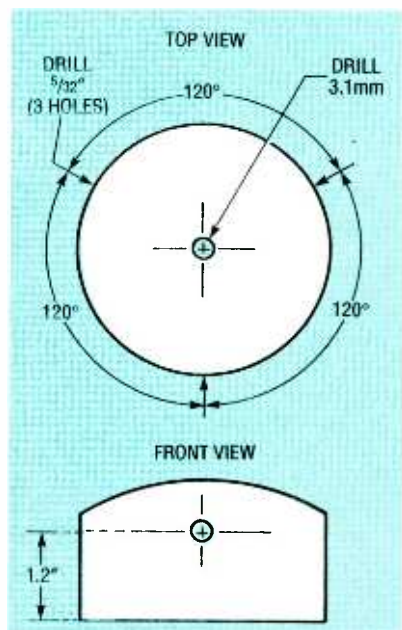

FIG. 2—ANEMOMETER ROTATING CAP. Drill three $\frac{5}{32}$ -inch holes, evenly spaced, in a 2-inch PVC end cap, 1.2 inches up from the open end of the cap. Drill one 3.1 mm hole in the exact center of the top of the cap.

Because we've already covered the electronics in the Experimenter, most of this article is mechanically oriented. Let's get right down to building the mechanical elements of the weather station.

Construction

You might want to build only part of the weather station be-

cause the software can be easily configured for the particular sensors you choose to include. You can have a system working with as little as one instrument.

Instruments can be purchased completely assembled and tested, or you can build them yourself. Complete kits of pre-drilled, ready-to-assemble parts are also available for quick and easy construction. For those with a well-equipped shop, kits with only the hard-to-find parts are also available.

All instruments can be calibrated to professional levels of accuracy. Calibration procedures that do not require special equipment are included for each instrument.

The electronics are simple enough to be added in the wiring-grid area on the Experimenter. For those who dislike point-to-point wiring, or want the most reliable system possible, a circuit board can be made from the foil patterns that will be provided next month, or one can be purchased from the kit supplier.

Wind and rain

Which way is the wind blowing? Is it a gale or a zephyr? How much rain fell last night, and how much fell in that last downpour? The wind vane, anemometer, and rain gauge are

easy to assemble. If you choose to assemble those instruments from the kits of already drilled parts, you can skip the sections on preparing materials. But, if you have a well equipped shop and know your way around a hardware store, you can use the hard-to-find parts kit and buy the other components locally. The wind vane and anemometer are mounted on a single assembly composed mostly of PVC pipes and fittings, as shown in Fig. 1.

Building the anemometer

The anemometer consists of a rotating assembly (including wind cups and a rotating cap), and a stationary base. The rotating cap turns a stainless steel shaft which is supported vertically on a sharp pin, and horizontally by a sintered bronze bushing. Rotation is detected by a magnetic switch. If you are using the complete kit you can skip this section on preparing materials and go right to the section on assembly.

The rotating and stationary caps are made from schedule 40 PVC end caps, available at most plumbing supply stores. Be sure to use only schedule 40 PVC pipe and fittings; lighter grades might not hold up well in cold or rough weather.

Figure 2 shows the construction of the rotating cap. Drill three $\frac{5}{32}$ -inch holes evenly spaced around a 2-inch PVC end cap, 1.2 inches from the open end of the cap. Drill a 3.1-millimeter hole through the exact center of the top of the cap. Be sure that the holes are perpendicular to the cap. If they are not, the anemometer's accuracy will be degraded.

The stationary cap is shown in Fig. 3. Some PVC caps have molding bumps on their outside diameters. If the $\frac{1}{2}$ -inch stationary cap has any that could rub on the inside of the rotating cap, they must be sanded or filed off. The stationary cap requires two holes: In the exact center of the cap drill a $\frac{1}{4}$ -inch hole for the sintered bronze bearing. At $\frac{9}{16}$ -inch from the center, drill a $\frac{5}{16}$ -inch hole for the magnetic sensor.

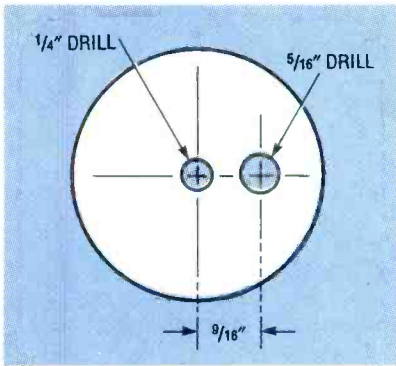

FIG. 3—ANEMOMETER STATIONARY cap. Drill a 1/4-inch hole in the exact center of the top of a 1 1/2-inch PVC end cap. Drill a 5/16-inch hole offset 9/16-inch from the center of the top.

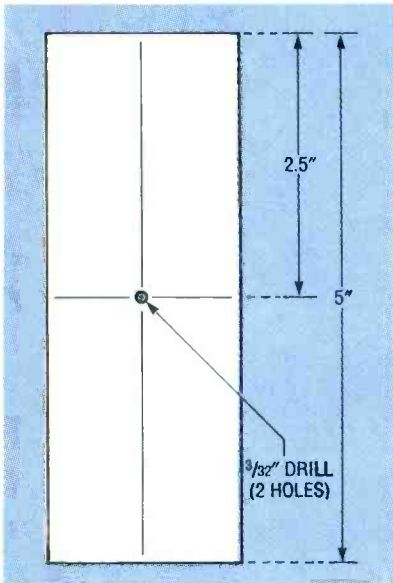

FIG. 4—ANEMOMETER VERTICAL pipe. Cut a 5-inch long piece of 1 1/2-inch PVC pipe. Drill two 3/32-inch holes on opposite sides of the pipe, 2 1/2 inches from each end.

The stationary cap mounts on a 5-inch piece of 1 1/2-inch diameter schedule 40 PVC pipe. Drill two 3/32-inch holes on opposite sides of the PVC pipe, 2.5 inches from each end. See Fig. 4. The wind cups are hemispheres of tough, pliable plastic (actually non-perforated Wiffel balls cut in half), with holes on opposite sides made near the cut edge. The pieces of the anemometer are now ready for assembly.

For best appearance and longest life, use only stainless-steel hardware on the anemometer. The wind cups are fastened to the rotating cap with 4-inch 8-32 machine screws. See Fig.

5. Slip a lock washer and a flat washer on a 4-inch screw, then push the screw through one of the holes into a wind cup. Slip another lock washer and thread two nuts on the screw. Slip lock washer, then screw through the other hole and out of the wind cup. Slip another lock washer on the screw. Move and tighten the nuts to clamp the wind cup in place. Adjust the nuts so that the wind cup is round. Repeat for the other two wind cups.

Now attach the wind cups to the rotating cap. Thread a nut about 1/2-inch on the screw, then slide on a lock washer. Thread the screw into one of the holes in the side of the rotating cap. On the inside of the cap, slip on a lock washer and then thread a nut onto the screw. Adjust the inside nut so it is flush with the

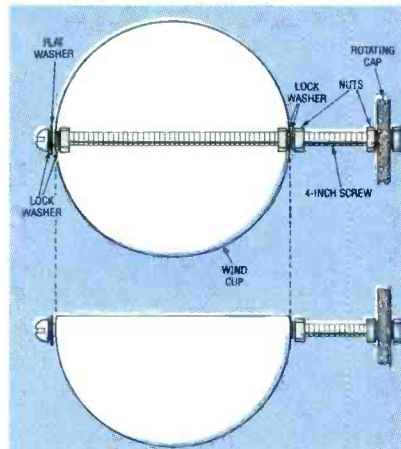

FIG. 5—ATTACHING THE WIND CUPS. The wind cups secure to the rotating cap with 4-inch long machine screws.

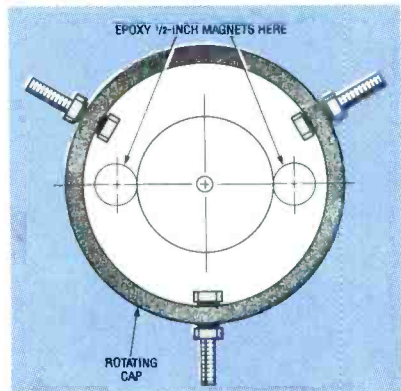

FIG. 6—ANEMOMETER MAGNETS. Two 1/2-inch diameter magnets must be epoxied under the top of the rotating cap.

hex-head sheet-metal
the point of the in
the wood block. Th
stainless steel sha
the dish area
screw. See Fig. 8
Slip the rota
over the station
shaft lock on
steel shaft (up
from the bro
tighten it in
vent the rot
slipping of
in a strong
coating of
steel sha
grease o
Althoug

nc
E,
disk
magne
sides of
ing cap (s
tioning of
critical to b
the unit and n
curacy. The rota
plied in the com
recesses for the m
chined in the plastic
precise positioning. A
epoxy to harden, and th
ing assembly is finished.

Gently tap the bronze bearing into the center hole of the stationary cap, from the inside of the cap outward. The flange on the bearing should be pressed flush against the inside surface of the cap. The fit should be tight enough that the bearing is held solidly. Using the plastic nuts provided, secure the magnetic switch in the second hole so that it extends 3/8-inch above the top of the stationary cap. See Fig. 7.

Cut a 1 1/2-inch long piece from a one-by-two cedar board (which actually measures about 3/4- by 1 1/2-inch). This will form part of the support for the rotating assembly. Sand or file the corners of the wood block as necessary so that it fits snugly into the pipe. Slip the wood block into the pipe, and slip the stationary cap lightly in place. Slip the stainless steel shaft through the brass bearing and press it lightly into the wood to make a small indentation. Remove the rotating assembly, stationary cap, and the wood block. Install a No. 10 1/2-inch

al screw at
entation in
e end of the
ft will rest in
on top of the

ating assembly
ary cap, slide a
to the stainless
to about 1/2-inch
ze bushing), and
place. This will pre-
ating assembly from
of the stationary cap
g wind. Apply a light
f oil to the stainless
ft and a dab of lithium
on the hex-head screw.
gh the bearing is impreg-

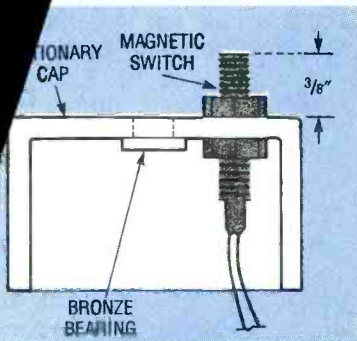

FIG. 7—THE BEARING AND MAGNETIC switch install in the stationary cap as shown here.

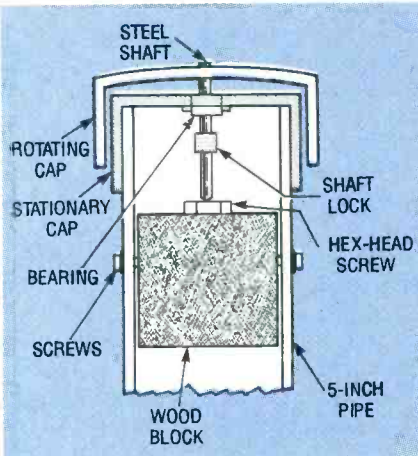

FIG. 8—THE ANEMOMETER SECTIONS go together as shown here.

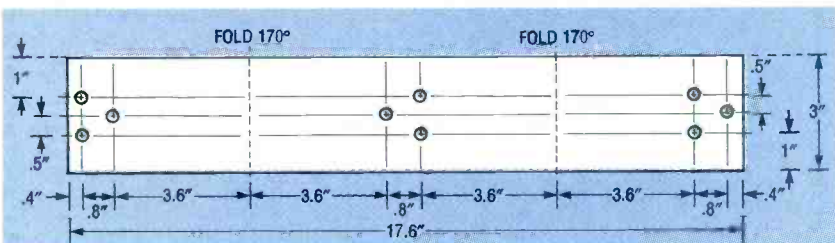

FIG. 9—WIND VANE TAIL. This can be made from aluminum flashing, available at hardware stores.

nated with oil, this will help to reduce friction further.

Push the wood block back into the tube. Align the 3/4-inch sides of the block with the 3/32-inch holes in the side of the 5-inch pipe. The stationary cap will mount on the end of the tube nearest the hex-head screw on the wood block. Slip the magnetic switch wires out through the tube through the large space along the side of the wood block. Grasping the sides of the stationary cap only (do not press down on the rotating cap), force the stationary cap solidly onto the tube.

By reaching through the open end of the tube, adjust the vertical position of the wood block so that the point of the shaft supports the rotating assembly. Rotate the assembly to verify that the magnets do not hit the magnetic switch, and that the nuts do not drag on the stationary cap. The anemometer should turn easily when you blow on the cups. If not, determine the cause of the drag. Rotate the assembly while using an ohmmeter to verify that the magnetic switch opens and closes. Secure the wood block in position with two No. 4 1/2-inch sheet-metal screws, threaded through the 3/32-inch holes in the tube. The anemometer is now finished.

Building the wind vane

Like the anemometer, the wind vane consists of a rotating assembly (including the tail, counter balance, and rotating cap), and a stationary base. Wind direction is translated into two voltages by a dual-wiper potentiometer. The rotating assembly is fastened to a ball bearing unit, press fit into the stationary cap. A length of flexible tubing links the rotat-

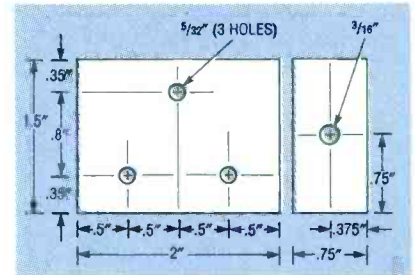

FIG. 10—TAIL MOUNTING BLOCK. The wind vane tail mounts on a wood block.

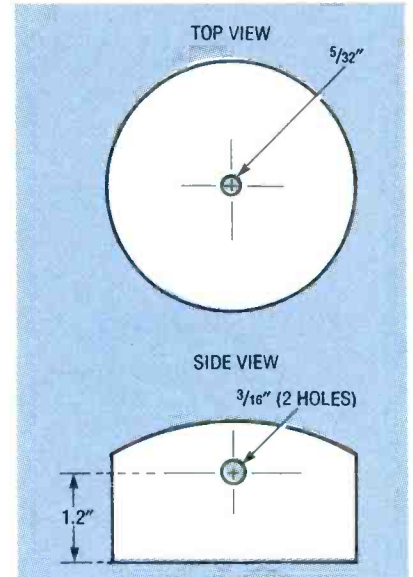

FIG. 11—WIND VANE ROTATING CAP. Make the wind vane rotating cap from a 2-inch PVC end cap.

ing assembly to the potentiometer shaft.

If you purchase a complete kit, you can skip this section on preparing materials and go right to the assembly. To prepare the tail, cut a 3- by 17.6-inch piece of thin-gauge aluminum. Aluminum flashing, available at many hardware stores, has the right thickness. Punch nine 5/32-inch holes in the aluminum as shown in Fig. 9. Fold it along the lines indicated in the figure, both toward the same side. The tail in the kit is anodized for improved corrosion resistance; if you are making your own, and you live in a wet climate, you might want to paint it. Painting the aluminum will increase the tail's weight, so you might need to use a larger counterweight.

The tail mounts on a wood block with the measurements shown in Fig. 10. Use a durable, moisture-resistant wood such

as Cedar. Drill three $\frac{5}{32}$ -inch diameter holes in the face of the block, and one $\frac{3}{16}$ -inch diameter hole down the length of the block as shown in the figure.

Make the counterweight for the wind vane from a 1½-ounce, egg-shaped fishing weight. Drill a $\frac{3}{16}$ -inch diameter hole through the weight lengthwise so that it will slide onto a No. 10 screw. Since lead is a soft metal with a low melting point, use a fresh drill bit, a low drill speed, and a dab of oil to avoid melting the lead.

As with the anemometer, the parts for the wind vane are made from schedule-40 PVC. Make the rotating cap from a 2-

inch PVC end cap as shown in Fig. 11. Drill a $\frac{5}{32}$ -inch diameter hole in the exact center of the top of the cap. Drill two $\frac{3}{16}$ -inch diameter holes on exactly opposite sides of the cap, 1.2-inches up from the open end of the cap. Be sure that these holes are perpendicular to the cap.

Make the stationary cap from a 1½-inch PVC end cap. Sand or file off any molding bumps that might rub on the inside of the rotating cap. Drill a $\frac{39}{64}$ -inch hole in the exact center of the cap. A $\frac{5}{8}$ -inch outside diameter, $\frac{1}{4}$ -inch inside diameter flanged ball bearing unit installs in this hole. Using a reaming bit, enlarge the hole to a few thousandths under $\frac{5}{8}$ -inch to permit press-fitting of the ball bearing unit.

Cut a 5-inch length of 1½-inch PVC pipe. Drill two $\frac{5}{32}$ -inch holes on opposite sides of the pipe, 2.5 inches from one end; the potentiometer mounting bracket will bolt inside through these holes. The holes are drilled in the same positions as in the anemometer tube, but the drill bit is larger.

Construct the potentiometer mounting bracket from a 0.8-inch by 2.8-inch piece of 0.032-inch thick aluminum. Punch one $\frac{3}{8}$ -inch diameter hole, two $\frac{3}{16}$ -inch diameter holes, and one $\frac{1}{8}$ -inch diameter hole as shown in Fig. 12. Then make two 90° folds in the bracket in the indicated positions. It is essential that the folds be made at exactly the same distance from the $\frac{3}{8}$ -inch potentiometer mounting hole. If the distances are wrong, the potentiometer will be off center, which will degrade the sensitivity of the wind vane. The pieces of the wind vane are now ready to be assembled. Be sure to use only stainless-steel machine screws and other hardware on the wind vane.

Use Fig. 13 as a visual aid for the following procedures. Slip a lock washer and a flat washer on a 6-inch long No. 10-24 screw, then slide the screw through the $\frac{3}{16}$ -inch diameter hole running the length of the wood block. Slip another flat washer and lock washer on the screw, and secure with a hex nut.

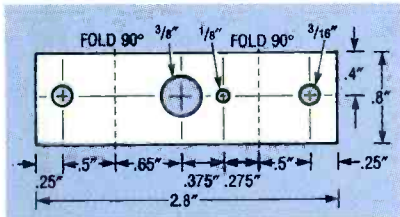

FIG. 12—POTENTIOMETER MOUNTING bracket. Make the potentiometer mounting bracket from a 0.8- by 2.8-inch piece of 0.032-inch thick aluminum.

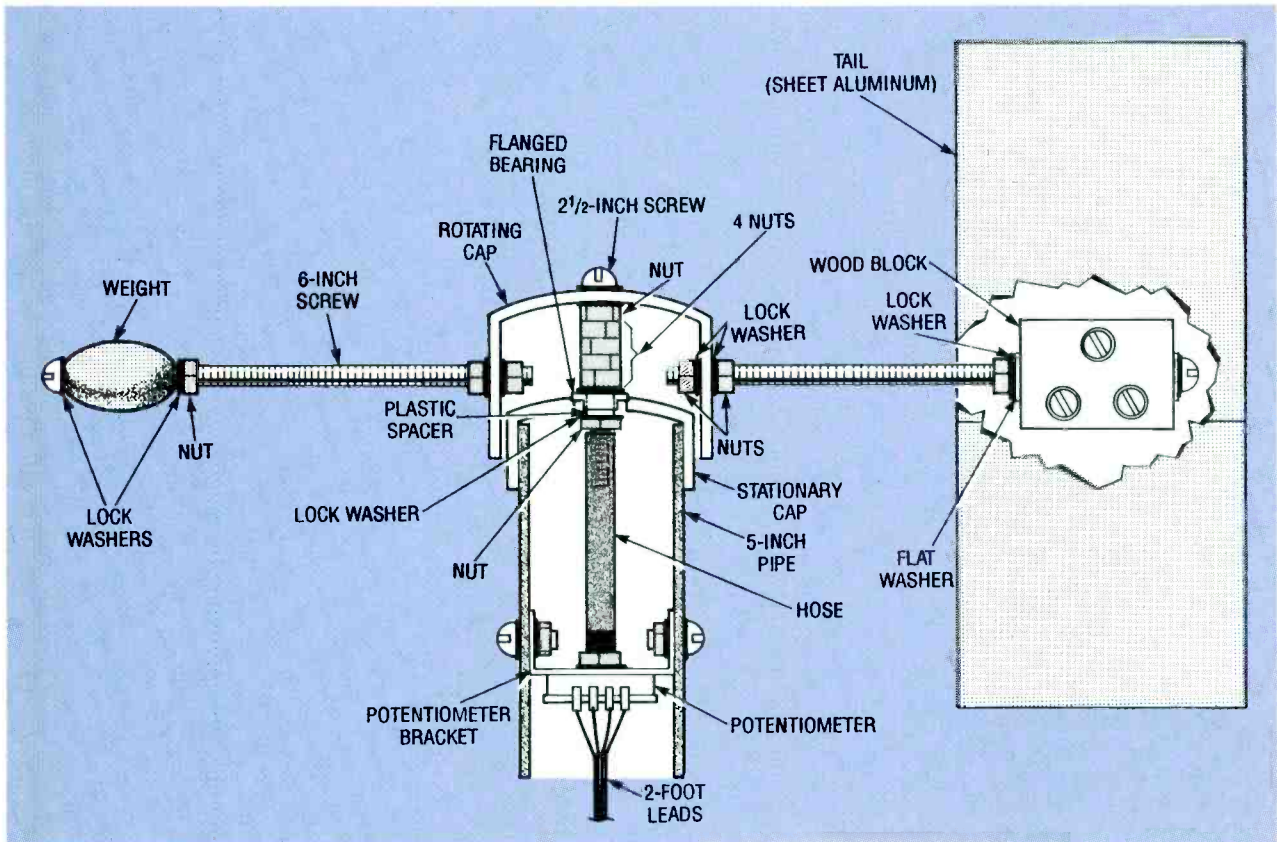

FIG. 13—THE WIND VANE SECTIONS go together as shown here.

Thread a hex nut about 1/2-inch on the screw, slip on a lock washer, then run the screw into one of the 3/16-inch holes in the side of the rotating cap. Slip a lock washer and thread on a hex nut so that it is flush with the end of the machine screw. Rotate the screw so that the wood block is vertical with the two holes below and the single hole above, then securely tighten the hex nut against the outside of the rotating cap.

Slip a lock washer down the length of the other 6-inch screw. Slide the lead weight on next, followed by another lock washer. Thread a hex screw down to the lead weight and tighten it. Thread another hex nut about 1-inch on the screw, slip on a lock washer, and run the screw into the 3/16-inch hole opposite the tail. Slip on a lock washer then thread on a hex nut. The hex nuts will be adjusted later on so that the lead weight exactly balances the tail.

Use a vise to press the ball bearing unit into the stationary cap from the top side. Place blocks of wood on either side of the center hub so that the jaws of the vise press only on the flange and do not put pressure on the ball bearings. Press in the flange flush with the outside of the cap.

Slip a lock washer on a 2 1/2-inch No. 8-32 machine screw, and thread the screw down the 5/32-inch hole in the top of the rotating cap. Slip another lock washer on the screw, thread on a hex nut, and tighten it securely. Thread another four hex nuts on the screw and tighten. Slip a lock washer on the screw, then push the plastic spacer on. Slide the stationary cap with the bearing in it over the screw and onto the plastic spacer. Slip on a lock washer, thread on a hex nut, and tighten it. Verify that the rotating assembly turns freely, without rubbing on the stationary cap.

Now slip the tail section over the wood block and align the three holes. Secure it in place with three 1-inch No. 6-32 machine screws. Be sure to use lock washers under the screw heads and hex nuts.

Turn the wind-vane assembly sideways, and run the counter weight screw in or out as necessary to precisely balance the weight of the tail. When balanced, remove the stationary cap from the rotating assembly and tighten the hex nuts on the counter-weight screw to secure it in position.

PARTS AND KITS

The following kits are available from Fascinating Electronics, PO Box 126, Beaverton OR 97075-0126. You can call 1-800-683-KITS with VISA and Mastercard orders, catalog requests, and technical questions 24 hours a day, 7 days a week. Please include \$3.40 for US shipping and handling with any order. Canadian shipping and handling is \$5.00, with payment in US dollars. Foreign orders, please inquire for prices and availability. **NOTE:** The following kit descriptions are also to be used as parts lists. If you are gathering the parts together on your own, you'll need all parts listed under the "Complete Kit" headings to build each unit.

ANEMOMETER

• Complete kit—\$37.50

- (3) 3-inch diameter plastic hemispheres, punched
- (1) oil-impregnated bronze bearing, 0.126- x 0.252- x 3/8-inch, flanged
- (1) stainless-steel shaft, 0.1247- x 3-inch, pointed on one end
- (1) shaft lock, 1/8-inch
- (1) magnetic switch, 1.5- x 5/16-inch, with hex nuts
- (2) disk magnets, 1/2-inch diameter
- (1) 2-inch schedule-40 PVC cap, precision drilled
- (1) 1 1/2-inch schedule-40 PVC cap, precision drilled
- (1) 1 1/2-inch schedule 40 PVC pipe, 5 inches long, drilled
- (1) wood block, 3/4- x 1 1/2- x 1 1/2-inches
- (2) No. 4 stainless-steel sheet-metal screws, 1/2-inch long
- (3) 8-32 stainless-steel machine screws, 4 inches long
- (15) 8-32 stainless-steel hex nuts
- (3) No. 8 stainless-steel flat washers
- (18) No. 8 stainless-steel lock washers, internal tooth
- (1) No. 10 stainless-steel hex-head sheet-metal screw, 1/2-inch

Hard-to-find parts kit—\$17.50

- (3) 3-inch diameter plastic hemispheres, punched
- (1) oil-impregnated bronze bearing, 0.126- x 0.252- x 3/8-inch, flanged
- (1) stainless-steel shaft, 0.1247- x 3-inch, pointed on one end
- (1) shaft lock, 1/8-inch
- (1) magnetic switch, 1.5- x 5/16-inch, with hex nuts

WIND VANE

• Complete kit—\$39.90

- (1) dual-wiper potentiometer
- (1) ball bearing, 1/4-inch ID, 5/8-inch OD, flanged
- (1) plastic spacer, 1/8-inch ID, 1/4-inch OD
- (1) tail fin, anodized aluminum, punched and folded
- (1) potentiometer mounting bracket, punched and folded
- (1) 1 1/2-oz. lead egg-shaped fishing weight, drilled
- (1) 2-inch schedule-40 PVC cap, precision drilled
- (1) 1 1/2-inch schedule-40 PVC cap, precision drilled
- (1) 1 1/2-inch schedule-40 PVC pipe, 5 inches long, drilled
- (1) wood block, 3/4- x 1 1/2- x 2-inches, drilled
- (1) hose, 1 1/2 inches long, 1/8-inch ID
- (3) 6-32 stainless-steel machine screws, 1-inch long
- (3) 6-32 stainless-steel hex nuts with lock washers
- (6) No. 6 stainless-steel flat washers
- (3) No. 6 stainless-steel lock washers
- (1) 8-32 stainless-steel machine screw, 2 1/2 inches long
- (2) 8-32 stainless-steel machine screws, 1/2 inch long
- (6) 8-32 stainless-steel hex nuts
- (2) 8-32 stainless-steel hex nuts with lock washer
- (6) No. 8 stainless-steel lock washers
- (2) 10-24 stainless-steel machine screws, 6 inches long
- (7) 10-24 stainless-steel hex nuts
- (2) No. 10 stainless-steel flat washers
- (8) No. 10 stainless-steel lock washers

• Hard-to-find parts kit—\$15.50

- (1) dual-wiper potentiometer
- (1) ball bearing, 1/4-inch ID, 5/8-inch OD, flanged

• Assembled and tested anemometer & wind vane on "T" mount with 100 foot cable and modular connector—\$159.90

Attach 2-foot wires to the four terminals on the dual-wiper potentiometer. Label the wires 1 through 4 from left to right. Fasten the potentiometer to its bracket with its 3/8-inch hex nut and lock washer. The potentiometer shaft should point in the direction opposite that of the bracket flanges.

Run a 1 1/2-inch long piece of 1/8-inch inside-diameter hose about 0.5-inch onto the No. 8 screw in the rotating assembly. Push the other end of the hose down the length of the potentiometer shaft. Grasping the assembly carefully, press the stationary cap onto the 5-inch pipe while watching for the holes in the potentiometer

RAIN GAUGE

- **Complete kit—\$29.90**
 - (1) magnetic switch, 1.5- x 5/16-inch with hex nuts (Hamlin Mfg)
 - (1) disk magnet, 1/2-inch diameter
 - (1) downspout adapter, 2- x 3- x 3-inches, drilled
 - (1) measuring spoon, Rubbermaid #2235 1/2 TBSP, drilled
 - (1) plastic funnel, 8-inch diameter (spout smaller than 1/2-inch in diameter)
 - (1) 3-inch diameter schedule-40 PVC pipe, 3 inches long, drilled
 - (1) brass rod, 1/32-inch diameter, 2.75 inches long
 - (2) No. 6 stainless-steel sheet-metal screws, 1/2-inch long
 - (2) cocktail straw sections, 3/4-inch long

- **Hard-to-find parts kit—\$5.90**
 - (1) magnetic switch, 1.5- x 5/16-inch with hex nuts (Hamlin Mfg)
- **Assembled and tested rain gauge with 50-foot cable and modular plug—\$59.90**

SENSORS

- **Temperature sensor kit—\$15.90**
 - (5) LM334Z current sources (National Semiconductor)
 - (5) 2.26-kilohm, 1% resistors
 - (5) 0.01 μF capacitors
 - (1) dual-wall heat-shrink tube, 3/16-inch diameter, 6 inches long
 - (1) DB25M connector, with shell
- **Humidity sensor kit—\$29.90**
 - (2) humidity sensors (Philips 2322 691 9001)
 - (2) 555 timer ICs
 - (2) 0.1 μF disk capacitors
 - (4) 1-megohm, 1% resistors
 - (1) dual-wall heat-shrink tube, 1/2-inch diameter, 3 inches long

- **Assembled and tested temperature and humidity sensors—\$99.90**

Includes:

 - One humidity sensor and one temperature sensor on a 50-foot cable with a modular plug
 - Four temperature sensors and one humidity sensor connected to a DB25 connector with shell
 - One humidity sensor and one temperature sensor on a 10-foot cable
 - One temperature sensor on a 50-foot cable
 - Two temperature sensors on 30-foot cables

(Custom cable lengths are available, inquire for pricing.)

bracket to line up with the holes in the side of the pipe. It might be necessary to remove the assembly and adjust the position of the hose on the screw and potentiometer shaft to get the bracket holes to line up when the assembly is pushed fully in place. Install two 1/2-inch No. 8-32 machine screws, with lock

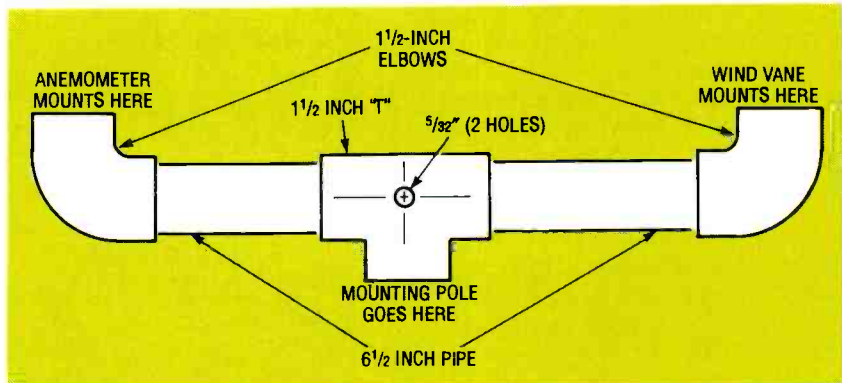

FIG. 14—WIND INSTRUMENT MOUNTING. A simple, yet sturdy mount for the wind instruments can be made from PVC pipe.

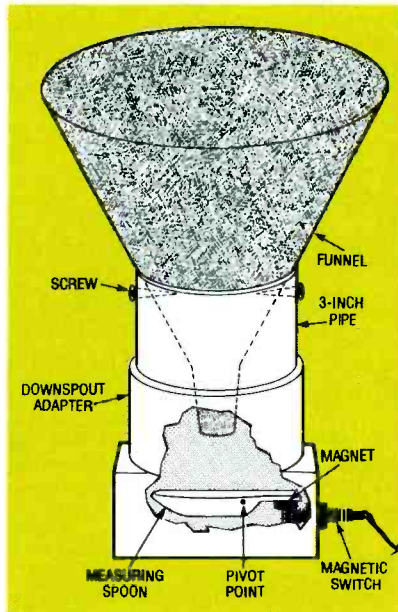

FIG. 15—THE RAIN GAUGE is configured as shown here.

washers, through the holes. Use hex nuts with captive lock washers inside the tube to secure the bracket to the screws. The wind vane is now finished.

Mounting

A simple yet sturdy mount for the wind instruments can be built from two 6 1/2-inch sections of 1 1/2-inch schedule-40 PVC pipe, two 1 1/2-inch 90° elbow fittings, and one 1 1/2-inch "T" fitting (see Fig. 14). Use cement formulated specifically for PVC (available where the pipe is sold) to bond the pieces together. Directions for using the cement are provided on the label; you won't use much, so buy the smallest amount available.

Drill a 5/32-inch diameter hole in the center of both sides of the "T" fitting. Cement the two 6 1/2-

CONDITIONING BOARD AND BAROMETER

- **Signal conditioning board and barometer kit—\$49.90**
 - (1) signal conditioning board
 - (2) TLC2274 op-amps (National Semiconductor)
 - (1) 74HC393 dual counter (Harris)
 - (1) AD621 instrumentation amplifier (Analog Devices)
 - (1) SCC15A pressure sensor (Sensym)
 - (1) 20-kilohm multiturn potentiometer
 - (16) 0.1 μF disk capacitors
 - (2) 1-megohm, 5%, 1/4-watt resistors
 - (2) 10-kilohm, 5%, 1/4-watt resistors
 - (5) 499-kilohm, 1%, 1/4-watt resistors
 - (7) 100-kilohm, 1%, 1/4-watt resistors
 - (1) 28.0-kilohm, 1%, 1/4-watt resistor
 - (1) 13.7-kilohm, 1%, 1/4-watt resistor
 - (1) 12.7-kilohm, 1%, 1/4-watt resistor
 - (1) 10.0-kilohm, 1%, 1/4-watt resistor
 - (1) 2.87-kilohm, 1%, 1/4-watt resistor
 - (1) 1-kilohm, 1%, 1/4-watt resistor
 - (1) DB25M connector
 - (3) 6-contact modular jacks

- **Bare signal-conditioning PC board only—\$19.90**

- **Assembled and tested signal-conditioning board and barometer—\$99.90**

Includes:
Signal conditioning circuitry for all sensors
Both DB25 and modular connectors installed
Barometer that requires calibration to your location

SOFTWARE

- **Professional version software for PC—\$39.90**
- **Professional version software for MAC—\$49.90**

THE EXPERIMENTER

- **Experimenter kit—\$149.90**
 - **Optional analog supply—\$4.90**
 - **Assembled and tested Experimenter with analog option—\$199.90**
- For more information on the Experimenter, see the July and August 1993 issues.

inch pipe sections in the arms of the "T." Cement the elbows on the pipe sections, setting the assembly on a table top to make all the connections line up properly. Run a 2½-inch long No. 8-32 machine screw through the hole, and secure it with a hex nut and lock washer. Slip the wind instruments into the two elbows. Run their wires through the pipes and out through the "T." Tie the connecting cable to the No. 8-32 screw, then connect the wires to the wind instruments. An appropriate length of pipe can be fitted to the bottom of the "T" to support the assembly. Run the cable down the inside of the supporting pole, and cement the pole to the "T."

Telephone wire is suitable for the cable, and is available in six-conductor cables. Be sure to record which signal connects to which color wire! If you use a flat cable, connect the magnetic switch to the first two conductors, then the four numbered potentiometer wires, in sequence, to the next four conductors.

Building the rain gauge

The rain gauge, shown in Fig. 15, is built around a 2-inch by 3-inch downspout adapter. A 3-inch diameter PVC pipe connects the downspout adapter to a large funnel. The funnel collects rain water and channels it into a small measuring spoon, which acts as a tipping bucket. The measuring spoon is hinged and balanced so that when sufficient water collects, the spoon tips, dumping the water. A small magnet mounted on the spoon triggers a magnetic switch each time the spoon tips. With the components specified, the rain gauge has a resolution greater than one hundredth of an inch. If you purchase the complete kit you can skip this section on preparing materials and go right to the section on assembly.

Drill the downspout adapter as shown in Fig. 16. Drill a 5/16-inch diameter hole for the magnetic switch in the middle of the 2-inch wide face of the downspout adapter, 1 inch up from

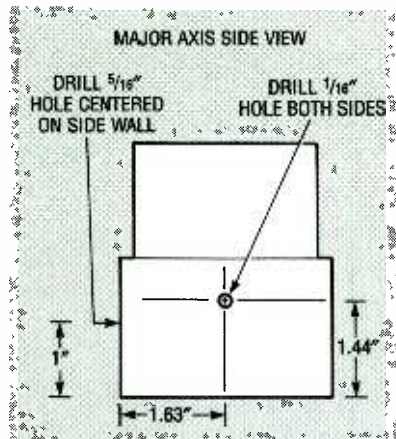

FIG. 16—RAIN GAUGE DOWNSPOUT adapter. A 2-inch by 3-inch downspout adapter forms the base of the rain gauge.

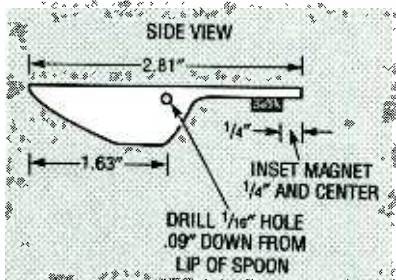

FIG. 17—RAIN GAUGE MEASURING spoon. The measuring mechanism in the rain gauge uses a ½-tablespoon measuring spoon.

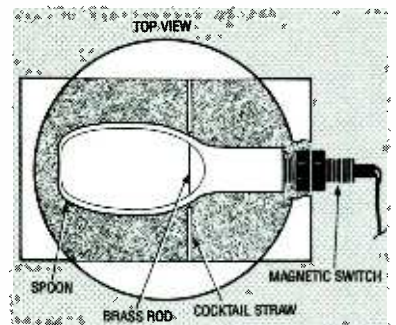

FIG. 18—MEASURING SPOON installation. The top view of the downspout adapter is shown.

the bottom. Drill a 1/16-inch diameter hole on each of the 3-inch wide faces, 1.63 inches from the face with the magnetic switch hole, and 1.44-inches up from the bottom.

Cut the excess length off of the measuring-spoon handle as shown in Fig. 17, reducing the overall length to 2.81 inches. Drill 1/16-inch diameter holes on each side of the spoon's bowl, 1.63 inches from the front edge

and 0.09-inch down from the top. Glue the ½-inch diameter magnet to the handle of the spoon, ¼-inch from the end of the handle.

Referring to Fig. 18, cut a 2¾-inch long section of 1/32-inch diameter brass rod, and cut two ¾-inch long sections from a cocktail straw. Cut a 3-inch long section of 3-inch diameter schedule-40 PVC pipe, and drill two 1/8-inch diameter holes on opposite sides of the pipe 0.375 inch from one end.

Using the plastic nuts provided, install the magnetic switch in the 5/16-inch diameter hole in the downspout adapter with the switch's wire leading outside the adapter. Adjust the nuts so that the other end of the switch extends ¾-inch inside the adapter.

Insert the 2¾-inch long brass rod through one of the 1/16-inch diameter holes into the downspout adapter. Slip a ¾-inch long section of plastic cocktail straw on the brass rod. Then slip the rod through the two holes in the measuring spoon, through the other ¾-inch long piece of cocktail straw, and into the other 1/16-inch diameter hole in the downspout adapter. The handle on the spoon should rest on the magnetic switch. Seal the holes with the tip of a soldering iron to prevent the brass rod from slipping out.

Insert a 3-inch section of 3-inch diameter schedule-40 PVC pipe into the downspout adapter. Place an 8-inch plastic funnel on top of the PVC pipe. Make sure that the spout on the funnel is centered over the spoon bowl and is perpendicular to the adapter. If the separation from the funnel spout and the bowl of the spoon is too great, trim the 3-inch PVC pipe shorter. Secure the funnel to the pipe with two No. 6 sheet-metal screws through the 1/8-inch diameter holes in the pipe.

Next month

That's all we have room for this month. Next month we'll make the electrical connections to the mechanical devices that you should have finished by then.

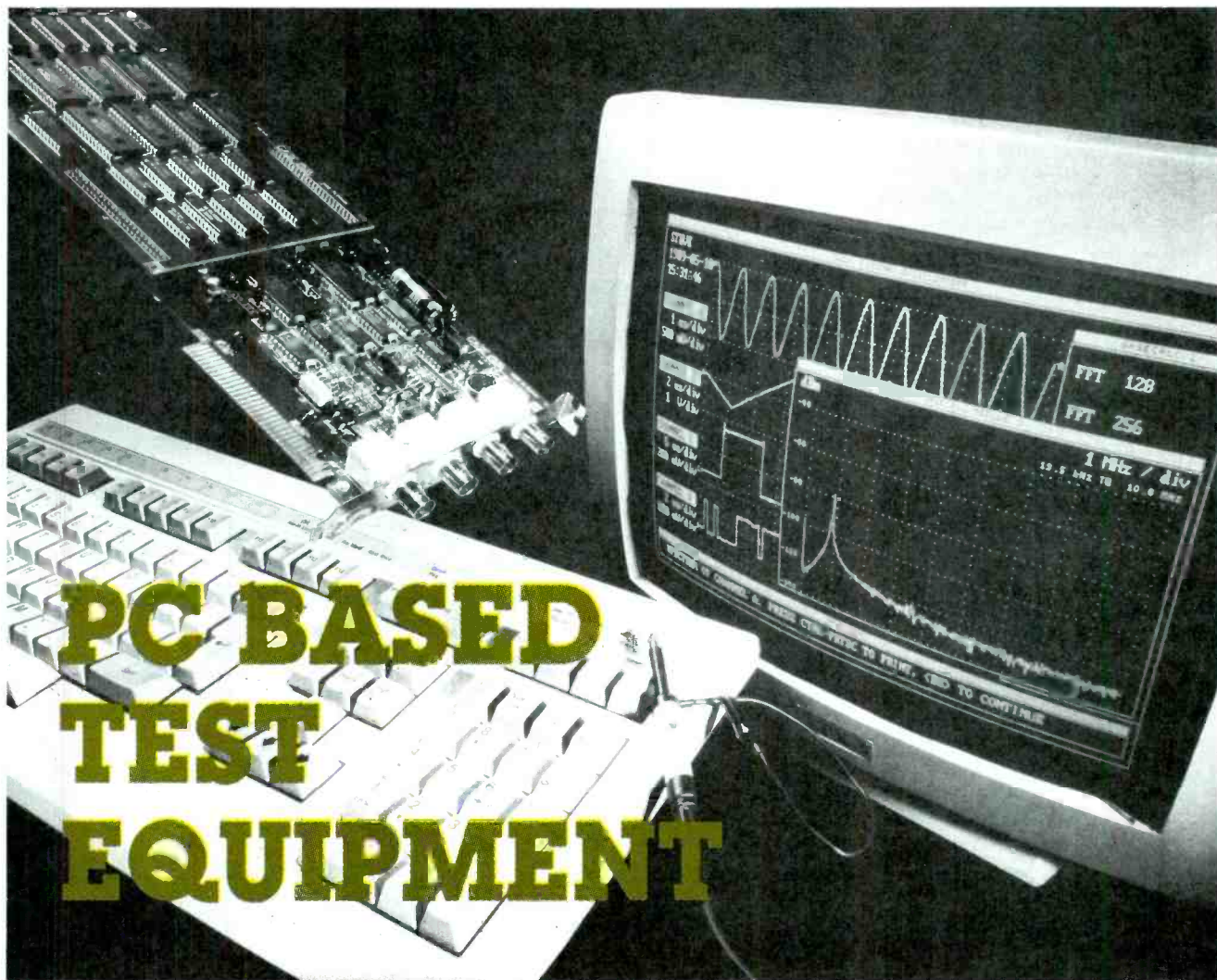

Boards that plug into computers are attractive alternatives to conventional instruments for many test and measurement applications

T J BYERS

IT IS DIFFICULT TO FIND ANY HUMAN activity today that hasn't been drastically changed by the personal computer. The PC has had a dramatic impact on the industrial test and measurement field, where PC-controlled automated test equipment and instrument clusters are now reported to outnumber stand-alone instruments.

PC-based instruments are fundamentally plug-in circuit boards supported by appropriate applications software that permit the computer to take on the functions that were formerly those of stand-alone electronic test measurement instruments. Most PC instru-

ment circuit boards plug into ISA-bus (Industry Standard Architecture) slots in IBM-PC/AT computers or compatibles, generally, but not exclusively, desktop models.

Early sales of PC-based test instruments never reached expectations because they were mistakenly targeted as direct replacements for benchtop, stand-alone instruments. Because PC-based instruments operate in the digital domain and require that analog input signals be first converted to digital signals, they can't respond in real time as rapidly as, for example, a permanent-magnet, moving-coil meter movement.

It takes a finite amount of time to digitize and process the data, which puts PC-based instruments at a disadvantage in performing and displaying real-time measurements. Add to that the cost of analog-to-digital conversion electronics. This reason alone ruled out the possibility that PC-based instruments would ever be direct replacements for most standard test instruments.

However, PC instrument advocates, typically software and hardware vendors, finally convinced the industry that PC-based test equipment's real strength is in its versatility and flexibility—it can respond

rapidly to changing test situations. Because it is PC-based, its characteristics can be readily changed with software.

In addition, several PC-based instruments can be linked together to form an instrument console or automated test equipment (ATE) station. A single computer enclosure can hold more test instruments in the form of plug-in boards than a workbench full of conventional instruments. This feature saves space and improves test and measurement productivity. Moreover, PC-based instruments, unlike the conventional instruments, can log data automatically and store it for delayed processing.

Surveying the market

Personal computer plug-in boards fall into two categories: controller/interface (mostly those conforming to the IEEE-488 standard), and analog/digital signal processing.

The IEEE-488 bus, widely known as the General Purpose Interface Bus (GPIB), is a digital system that permits up to 15 instruments or devices to communicate with each other. Its primary purpose is to integrate conventional dedicated instruments from the same or different vendors. For example, an oscilloscope from Hewlett-Packard can be integrated with a signal generator from Tektronix into an instrument cluster. Unfortunately, the data transfer rate between connected and properly interfaced instruments is quite slow, usually less than 20 kilobytes per second.

Plug-in signal processing boards have the speed and power to meet many of the latest demands for high-speed automated testing. In the time it takes a GPIB-interfaced device to acknowledge a request to send, a PC-based digital sampling oscilloscope can log 1000 measurements. These boards are sold as either general-purpose data converters for analog-to-digital or digital-to-analog conversion, or as instrument-specific boards that emulate such functions as an oscilloscope or frequency counter.

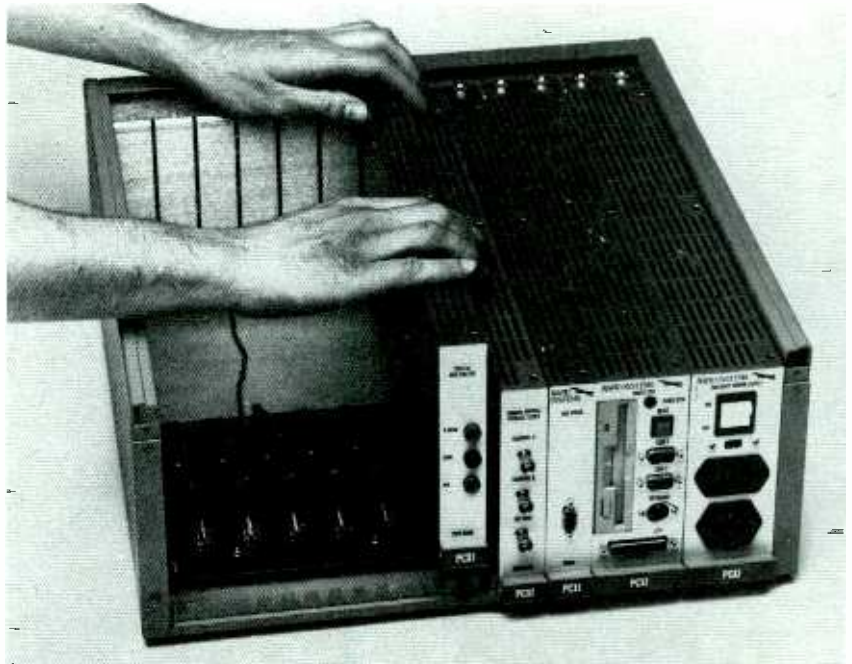

A BACKPLANE ENCLOSURE THAT ACCEPTS MANY PC-BASED INSTRUMENT and overcomes noise and interference problems inherent in desktop computers. Rapid Systems' PCXI includes 7 to 13 ISA or EISA slots and a 200-watt power supply.

The only difference between the two kinds of boards is that instrument-specific boards are sold with software that automatically makes the adapter card look and act like a conventional benchtop instrument.

Some plug-in boards perform functions that cannot be performed by conventional instruments, yet others offer superior performance at lower cost. A prime example is Guide Technology's GT650 time interval analyzer. It costs less than half the price of a comparable time-interval analyzer from Hewlett-Packard, yet provides 2000 times the memory and 50 times the throughput. However, this particular specification might not take into account all of the differences in performance or features that would govern a specific purchase.

General-purpose digital signal processing boards offer high performance, but the user must write his own program or buy it from a software vendor such as Hyperception. There is a lot to be said for creating your own PC-based instruments because certain qualities can be emphasized. This is especially true if the user is constrained by specific price or performance goals.

For example, when a Spectrum Signal Processing analog-to-digital converter board with 16-bit resolution and a sampling rate of 153 kilosamples per second is paired with Hyperception's AMPS Windows software program, the combination can emulate four different instruments:

- High-speed digital storage oscilloscope
- Fast Fourier Transform (FFT) spectrum analyzer
- Programmable digital filter
- Digital chart recorder

Alternatively, you can elect to save money and buy Keithley MetraByte's DAS-1200 ADC board with QuickBASIC support. It can create a 16-trace digital storage oscilloscope or digital chart recorder for only \$449. The company says its product is suitable for multimedia applications.

PC-based instruments can be expensive when compared with their conventional counterparts. They could cost nearly three times as much as the stand-alone instrument. But when you cluster a number of instrument boards in a single computer enclosure, or configure one data converter board for multiple functions, pricing can

favor the PC-based setup. As with any buying decision, you must shop wisely. The following is an overview of a selection of available PC-based test instruments with a commentary on what to look for when buying each one.

Digital sampling oscilloscope

The most popular PC-based test instrument is the digital sampling oscilloscope because it has the widest range of applications, and it takes advantage of the computer monitor's large display screen. These instruments are available from most PC instrument vendors, and they range in price from \$595 to over \$7000.

The core of the PC-based oscilloscope is the analog-to-digital converter (ADC). The resolution of the sampled input is determined by the number of ADC bits, which typically range from 8 to 16. On-board random-access memory (RAM) initially captures the sampled waveform. As the on-board RAM is used, the computer moves the data from the on-board RAM to its system memory, where it is processed by the video circuitry for display on the monitor.

The amount of RAM determines the length of the waveform that can be captured. At high sampling rates, the memory is used very quickly. So make sure that the system you specify will not only sample as fast as required (see the sidebar—Analog-To-Digital, and Back Again), but also for as long as required. To avoid losing data from memory overflow, captured waveforms can be stored on hard disk with special software programs called *streamers*.

Most PC-based multichannel oscilloscopes consist of a single-channel, analog-to-digital converter (ADC) and an input multiplexer, as shown in Fig. 1. The multiplexer time shares the input signals by allowing each of them to be sampled independently. To find the maximum sample rate per channel, the sampling rate of the ADC must be divided by the number of channels sampled. For example, if an eight-channel board has a

performance specification of 1 megasample per second, each of the eight channels would have a sample rate of only 125 kilosamples per second.

The maximum sample rate might be specified with all channels set at the same gain. Changing the gain from channel to channel can slow the overall sampling rate.

One of the fastest PC-based digital oscilloscope boards available is Signatec's DA500. It has a sample rate of 500 megasamples per second, a 350-MHz bandwidth, and is sold with 256 kilobits of RAM that can be expanded to 32 megabits.

At \$595, the CompuScope LITE from Gage Applied Sciences seems to be the lowest cost digital oscilloscope board available. It offers a 40 megasample per second rate, a 7-MHz bandwidth, and is sold with 16 kilobits of RAM that is

expandable to 64 kilobits.

Spectrum analyzer

Another common PC-based instrument is a spectrum analyzer that examines the frequency domain of the acquired input data. The PC-based version makes frequency domain measurements with the fast Fourier transform (FFT) technique. It digitally processes a signal over a specific period of time to provide frequency, amplitude, and phase information. It can analyze periodic and non-periodic signals.

Unlike the most common common swept-spectrum or superheterodyne spectrum analyzer architecture, the FFT architecture can display the data in a large number of formats. These include rectangular, triangular, exponential, and extended cosine bell—plus the classical Kaiser-Bessel

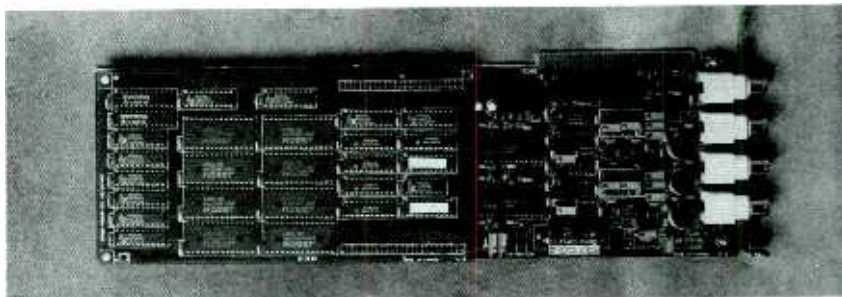

PC-BASED TEST INSTRUMENT BOARDS such as CompuScope's 220 plug into any ISA or EISA PC expansion slot.

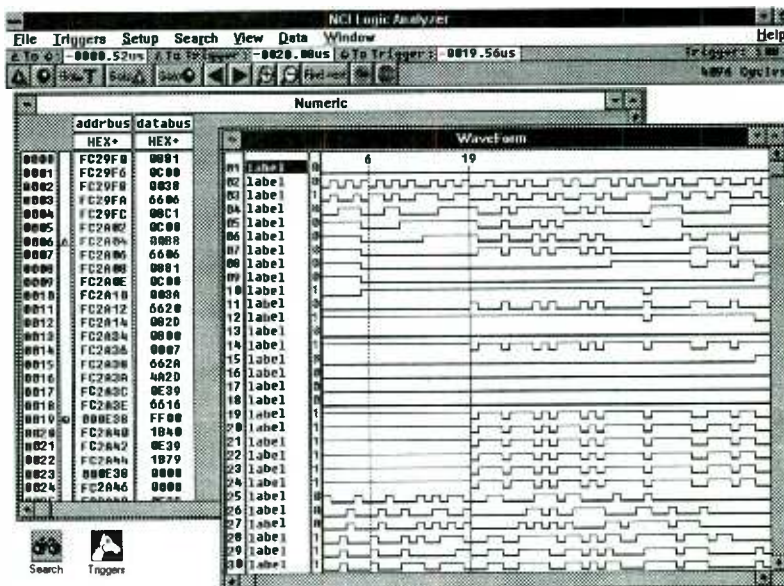

PC-BASED INSTRUMENTS USE Windows 3.1. An example is NCI's PA485 logic analyzer. Its operating screen is shown here.

ANALOG-TO-DIGITAL AND RETURN

The heart of all PC-based test instruments is either an analog-to-digital or digital-to-analog converter—ADC or DAC. Some products have both of those functions on the same board, or built within the same function.

Central to the operation of an ADC is a clock that generates pulses to drive the conversion electronics. The time taken to perform one complete conversion cycle in an ADC is called the sampling rate, and it is usually specified in kilosamples per second or megasamples per second.

General sampling theory—commonly referred to as the Nyquist theorem—states that the minimum sampling rate must be at least twice as fast as the highest frequency component in the input or output signal being sampled. To sample a 2-MHz sine wave, for example, the sampling rate must be at least 4 megasamples.

The maximum sample rate for a board depends on its ADC. There are three principal circuit architectures for converting analog signals to the digital output that the computer needs to process the data: dual-slope, successive approximation, and flash conversion. Of these, only successive approximation and flash converters can perform the conversions fast enough for instrumentation emulation.

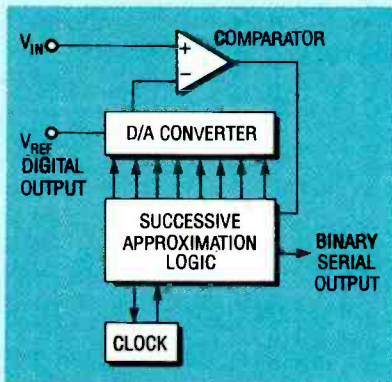

FIG. 2—SUCCESSIVE APPROXIMATION analog-to-digital converter block diagram.

A successive approximation (SA) converter consists of a comparator, a DAC, and successive approximation counter and logic as shown in Fig. 2. The analog input signal is first buffered and conditioned by the comparator. The converter compares an unknown analog voltage against a group of weighted references in a process that is analogous to the weighing of an unknown quantity on a precision balance.

In that process a set of weights in descending order of value is tried, starting with the largest. Any weight that tips the scale is removed. At the end of the process when balance is achieved, the

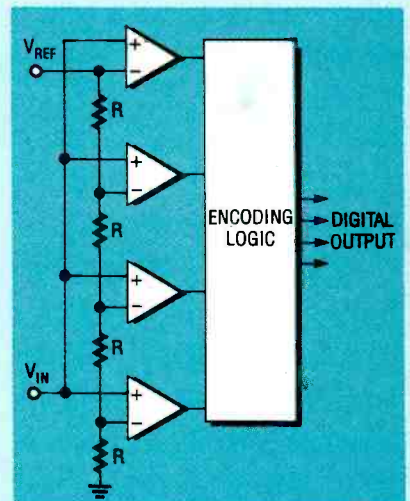

FIG. 3—BLOCK DIAGRAM OF A FLASH analog-to-digital converter.

sum of the weights remaining on the scale represents the unknown value.

Similarly, after successive stepping, the successive approximation DAC's digital output equals the unknown input voltage. A ten-bit SA converter, for example, can make 10-bit conversions of an unknown voltage in less than 20 microseconds.

A flash converter is an ADC for high-speed, high-resolution conversion. As shown in the simplified block diagram Fig. 3, it consists of a parallel array of voltage comparators, a weighted resistor network, and encoding logic. It performs analog-to-digital conversion with one comparator for each possible level, and it feeds the input signal to all comparators. The digital output is taken from the encoding logic. Flash converters require $2^n - 1$ comparators for an n -bit binary word.

The SA DAC take more time to settle on a digital output value than the flash converter. However, an SA DAC in integrated circuit form costs less than a flash converter DAC IC, so now it is the DAC most widely used in the present generation of PC-based instruments.

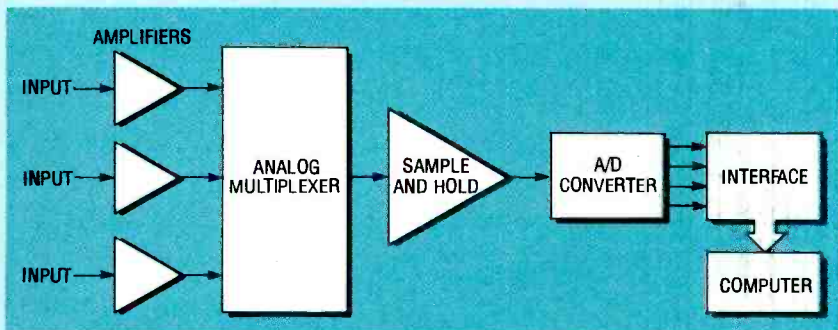

FIG. 1—MULTI-CHANNEL PC-BASED instruments include a single A/D converter and an input multiplexer that switches each channel.

and Hamming formats.

Most PC-based FFT spectrum analyzers process the data collected by a digital sampling oscilloscope through an FFT software program. The price of the FFT software varies according to manufacturer and display options, but can cover the rather wide range of \$100 to \$1000. While each program is dedicated to the PC board for which it is written, one can purchase software packages from

vendors such as Geotest and Hyperception that support a variety of boards from different vendors.

The FFT calculations are done by the PC's CPU, so the faster the processor, the faster the data throughput. In some cases, installing a math coprocessor chip, such as an Intel 287 or 387, can improve throughput up to 10 fold. However, Intel's 486 processor with its built-in math coprocessor

dramatically reduces calculation time.

Nevertheless, there are test situations in which even a 486-based PC with an FFT board isn't fast enough. This can occur when more than one channel of data is being processed.

However, adding a digital signal processor (DSP) integrated circuit to the ADC board can improve FFT throughput. By moving the FFT calculations from the computer to the DSP device,

WHERE TO BUY

Gage Applied Sciences, Inc.

5465 Vanden Abeele
Montreal, Quebec
Canada H4S 1S1
(514) 337-6893
CIRCLE 360 ON FREE INFORMATION CARD

Geotest

18242 West McDermott St.
Suite A
Irvine, CA 92714
(714) 263-2222
CIRCLE 361 ON FREE INFORMATION CARD

Guide Technology Inc.

920 Saratoga Ave.
Suite 215
San Jose, CA 95129
(408) 246-9905
CIRCLE 362 ON FREE INFORMATION CARD

Hyperception

9550 Skillman LB 125
Dallas, TX 75243
(214) 343-8525
CIRCLE 363 ON FREE INFORMATION CARD

Keithley Metrabyte Corp.

440 Myles Standish Blvd.
Taunton, MA 02780
(508) 880-3000
CIRCLE 364 ON FREE INFORMATION CARD

NCI

6438 University Dr.
Huntsville, AL 35806
(205) 837-6667
CIRCLE 365 ON FREE INFORMATION CARD

Optoelectronics Inc.

5821 NE 14th Ave.
Fort Lauderdale, FL 33334
(800) 327-5912
CIRCLE 366 ON FREE INFORMATION CARD

Quatech, Inc.

662 Wolf Ledges Pkwy.
Akron, OH 44311
(216) 434-3154
CIRCLE 367 ON FREE INFORMATION CARD

R.C. Electronics Inc.

6464 Hollister Ave.
Goleta, CA 93117
(805) 685-7770
CIRCLE 368 ON FREE INFORMATION CARD

Rapid Systems Inc.

4307 Leary Way NW
Seattle, WA 98107
(206) 784-4311
CIRCLE 369 ON FREE INFORMATION CARD

Signatec, Inc.

357 Sheridan St. No. 119
Corona, CA 91720
(714) 734-3001
CIRCLE 370 ON FREE INFORMATION CARD

Spectrum Signal Processing Inc.

100 Production Ct.
8525 Baxter Pl.
Burnaby, BC V5A 4V7
(604) 421-5422
CIRCLE 371 ON FREE INFORMATION CARD

the CPU is relieved of a heavy burden, giving it more time for other tasks.

Here again, Gage Applied Sciences seems to be offering the lowest-priced plug-in FFT spectrum analyzer. It costs only \$100 more to add 1024-point FFT capabilities to the company's \$595 CompuScope LITE digital oscilloscope board.

The most impressive FFT software program is VIEWDAC.

PC-BASED TEST INSTRUMENTS GO PORTABLE

Not all PC-based test instruments are anchored to the electronic workbench. They are just as much at home in the field as their conventional counterparts—and a lot more versatile. Many PC-based boards, such as Optoelectronics' PC10 Universal Frequency Counter, are sized to fit the current crop of laptop personal computers.

The 9-inch PC10 card easily fits in many PC/XT half-length slots, weighs under 6 ounces, and consumes just 2 watts of power. Moreover, this \$335 board outperforms many handheld counters that cost ten times as much. It measures frequencies from sub-audio to 2.4 GHz with 10-millivolt sensitivity and 10-digit resolution. It also does something no portable counter can—it can save the data to disk for later study and analysis.

distributed by Keithley Metrabyte. This 32-bit Windows-based program is compatible with a large number of different PC boards from several vendors. It can execute a 25,000-point FFT in less than 25 seconds, and run through an FFT of 1024 points in just 57.7 milliseconds.

Signal generator

It would be hard to find a test lab or ATE setup that does not have a reliable, accurate signal generator. That instrument provides the test signals needed to "shake down" new designs or do quality assurance testing on parts in production.

Signal generators are based on three architectures: function, arbitrary, and pulse. The simplest is the function generator that can deliver sine, square, triangular, or pulse waveforms over a wide range of frequencies. An arbitrary gener-

ator allows the waveshape to be defined by plotting it on a grid, dot by dot, so it can be repeated as many times as desired. A pulse generator provides transistor-transistor logic (TTL)-compatible signals of varying widths and repetition rates.

All PC-based signal generators have a core of a digital-to-analog converter (DAC). Regardless of the shape of the waveform, each point is defined by a binary quantity that the DAC converts to an analog voltage. Normally, the waveform is stored in on-board RAM. The amount of RAM needed increases directly with the complexity of the waveform and the number of resolution bits.

Arbitrary waveform generators are versatile because some can fill all three requirements, but they cost no more than a comparable function or pulse generator. They carry an average price of about \$1300. However, good arbitrary waveform generators are available for less than \$1000.

Frequency Counter

The universal frequency counter is reported to be losing sales to the versatile digital sampling oscilloscope, which can also display frequency and time measurements as well as waveforms. But recent advances in counter technology have resulted in new class of instruments called *time-interval analyzers*. Like a sampling oscilloscope, a time interval analyzer samples a small "window" of information and stores it for display or analysis. However, the counter characterizes the dynamic variation of time intervals or frequency, rather than the dynamic variation of the voltage.

A typical time-interval analyzer application is in the demodulation of an FM signal in near-real time. A significant advantage of this technique is attributable to its extraordinary dynamic range of more than 1000:1—while maintaining a high 1 part per million (ppm) resolution.

As with any sampling mea-
Continued on page 69

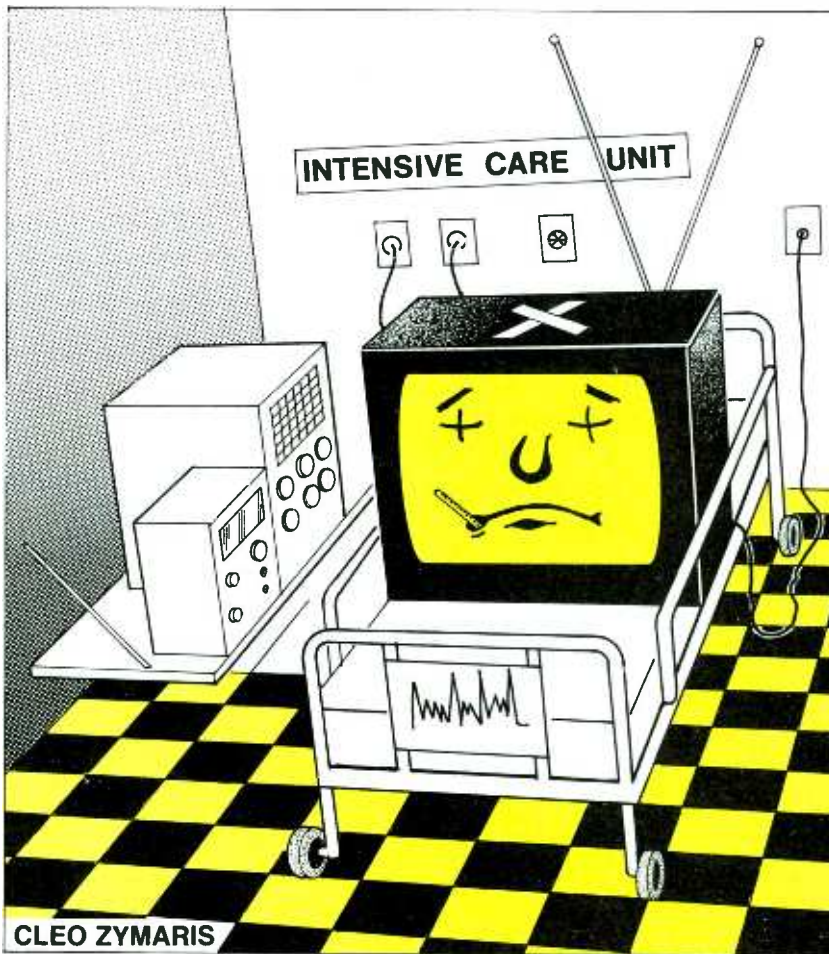

TV Service Case History

Learn about TV service from this step-by-step description of the repair of a faulty receiver.

BUSINESS STUDENTS LEARN MANAGEMENT techniques by studying business histories, and medical students learn to treat patients by studying medical case histories. Now you can learn how to repair a common problem in TV receivers by studying a service case history. The procedure is broken down into three steps: fault analysis, diagnosis, and repair.

The TV set discussed here is typical of many now in service around the world, and the fault is a common one and widely encountered, particularly after the set has been trouble-free for several years.

Case of the mute TV

The "patient" was a Sylvania CX-1161W 19-inch color TV receiver. It was brought in for repair because the owner reported that after turning it on, there was no picture, no sound, and no raster. These symptoms immediately suggested trouble in the power supply. Figure 1 is a pictorial of the main circuit board that contains the components which were tested to determine the location of the fault in the circuit.

Two schematic diagrams, Figs. 2 and 3, are simplified copies of applicable sections of the manufacturer's schematics

with the manufacturer's component designations included; they do not follow **Electronics Now** drawing standards.

The hand tools needed to perform this repair were those that are basic for all TV service, and include screwdrivers, needle-nose pliers, and a 40-watt soldering pencil. The test equipment used included a general-purpose oscilloscope, a digital multimeter with continuity checker, a plug-in isolation transformer, a variable transformer, and a laboratory, benchtop DC power supply with a built-in voltmeter and an ammeter.

The first step in the repair was the removal of the back cover from the set, giving access to the main circuit board. The principal components involved in this TV service case history are shown in Fig. 1, a drawing of part of the circuit board. Two fuses (FS500 and FS501) were mounted on the board. Figure 2 is a simplified schematic for the SCR-regulated power supply.

Because the power supply was suspected, the fuses were tested while the set was disconnected from the power line. Fuse FS501 was found to be blown. Figure 3, a simplified schematic of the horizontal deflection circuit, shows that FS501 is in the B+ line of that circuitry.

An ohmmeter check was made between the load side of fuse FS501 and ground and it showed a short circuit. The screws holding horizontal output transistor Q402 (in a TO-204 metal case) to the heat-sink were removed, and the transistor was removed from its socket. Another ohmmeter check showed a collector-to-emitter short. The ohmmeter also confirmed that with Q402 out of the circuit, the short between FS501 and ground was cleared.

This TV set had an SCR-regulated, low-voltage power supply with a full-wave bridge rectifier

connected directly across the 120-volt AC power line. An isolation transformer (it has separate primary and secondary windings to isolate it from the power line) was inserted between the AC outlet and the line plug of the TV set to insulate the TV set from earth ground. This transformer reduces the risk of electrical shock from the "hot" chassis, and permits grounded electronic test equipment to be used for servicing.

In Fig. 2, it can be seen that the raw DC output of the bridge rectifier is regulated by SCR513, which, in turn, is triggered by

horizontal-output sweep pulses modified by the pulse-width regulator (SCR-gating circuit). All other voltages, including those for the cathode-ray tube heater, are generated by windings on horizontal output transformer T402 shown in Fig. 3.

When the TV set power switch S1 is turned on, approximately 158 volts of unregulated DC flows from the bridge rectifier through resistor R512, zener diode SC512, and diode SC518 to the gate of SCR513, dropping to a value of about 82 volts, which is sufficient to initiate TV set turn-on. (This 82-volt gate bias

will not control SCR513 once it is on and +112 volts DC appears at its cathode.)

SCR513 conducts for the required duration of the horizontal sweep interval during each raster line under the control of the pulse-width regulator (SCR-gating circuit) to maintain the +112-volts DC output of SCR513. Notice that the winding between pins 22 and 24 of horizontal output transformer T402 is in series with the anode of SCR512. A negative spike from T402 turns off the SCR at the end of each conducting cycle interval in preparation for

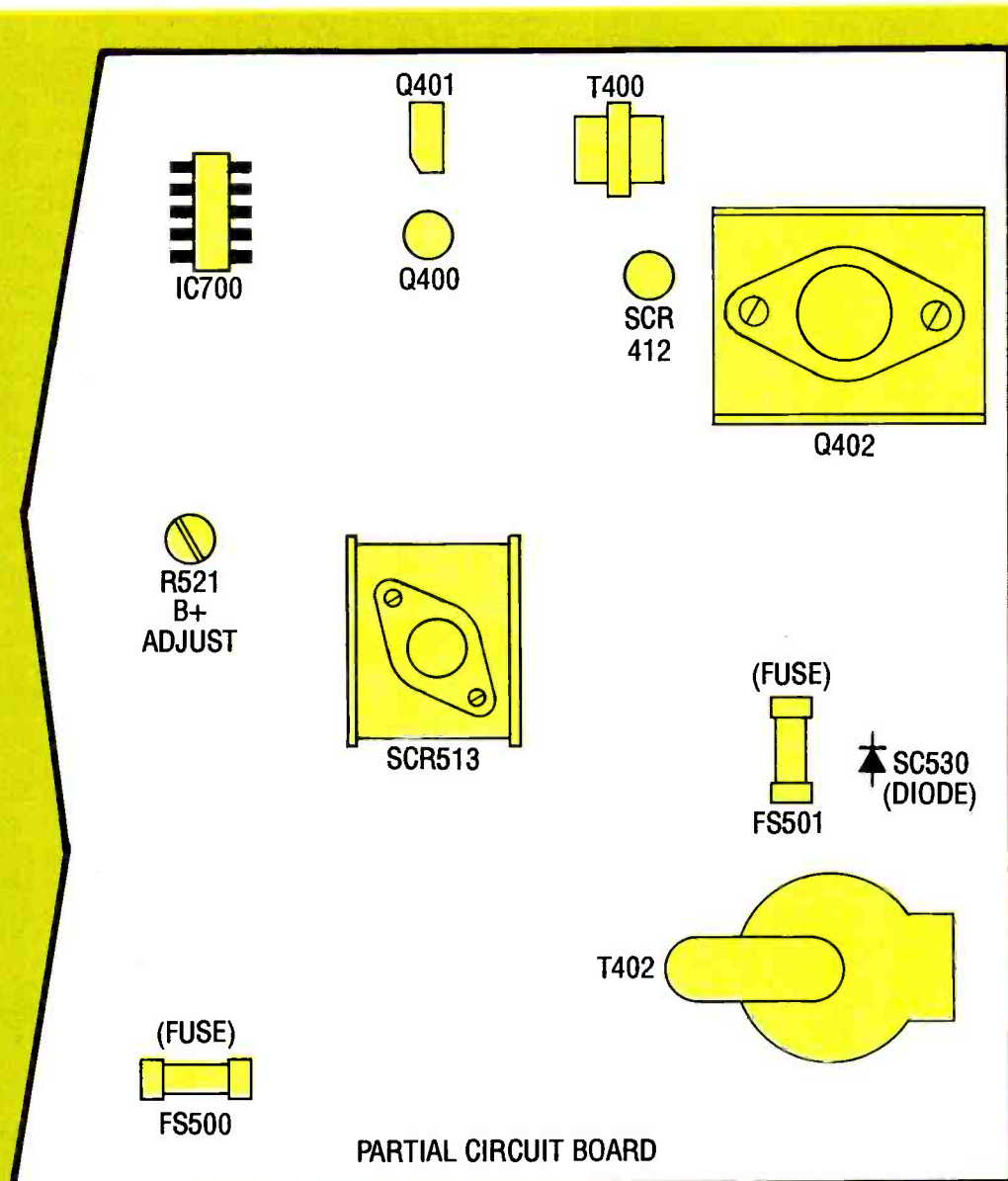

Fig. 1—LOCATION OF THE PRINCIPAL COMPONENTS on one end of a circuit board discussed in this case study of a TV repair.

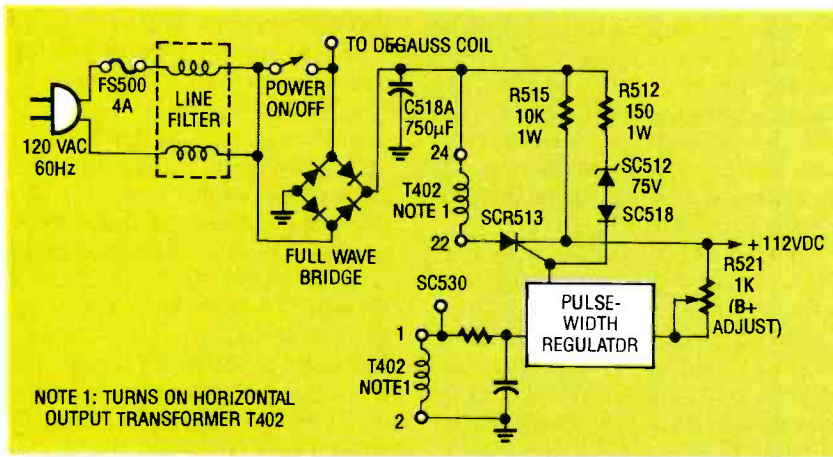

FIG. 2—SCHEMATIC OF THE SCR-REGULATED POWER SUPPLY for the color TV receiver discussed in this case history.

the next gate actuation. Also notice that the winding between points 1 and 2 of T402 is the source for the waveform that is controlled by the pulse-width regulator.

Immediately after the +112-volt line has been energized, current will flow through resistor R421 (see Fig. 3) to forward bias startup transistor Q400. Collector current flows through resistor R460. The resulting voltage at Q400's emitter is clamped to about 8.2 volts by diode SC404 and zener diode SC403. This voltage appears at pin 9 of the horizontal oscillator IC700, starting the oscillator.

Once the oscillator is started,

rectifier SC530 rectifies the pulse voltage across pins 1 and 2 of T402 to develop +25 volts. That voltage is applied to diode SC706 and dropped by resistor R726 to appear at pin 9 as 8.6 volts at pin 9 of IC700 as 8.6 volts due to IC700's internal shunt zener regulator.

Horizontal deflection and, as a consequence the high voltage, can increase if a fault in the low-voltage regulator allows the voltage on the +112-volt line to increase beyond safe limits. It could result in a possible X-ray emission hazard. If this excessive voltage occurs, SCR412 turns on. With SCR412 conducting, the voltage at pin 9 of IC700 is grounded through di-

ode SC404.

The gate of SCR412 senses the +112-volt and +220-volt lines. If either of these voltages is sufficient to cause the breakdown of zener diode SC409 (by sensing +112 volts) or SC409 and SC406 (by sensing +220 volts), SCR412 is turned on.

Repairing the TV

The proper operation of the horizontal deflection circuit was checked simply by substituting the proper voltage from an external power source. It was then possible to determine if the proper drive was being applied to the base of the horizontal output transistor Q402.

To make that test, a +25-volt supply was connected to the cathode of diode SC530 (the +25-volt source) and returned to chassis ground. Surprisingly, the 8.6-volt line at pin 9 of IC700 did not rise to its proper value. Was this due to a circuit fault or a sneak path?

Schematic Fig. 3 shows that current can flow from the +25-volt source (cathode of diode SC530) through the series string of diode SC706, 560-ohm resistor R726, and diode SC404 to the base of Q400 and on through its collector (which is only reverse biased when +112 volts is present). The path then

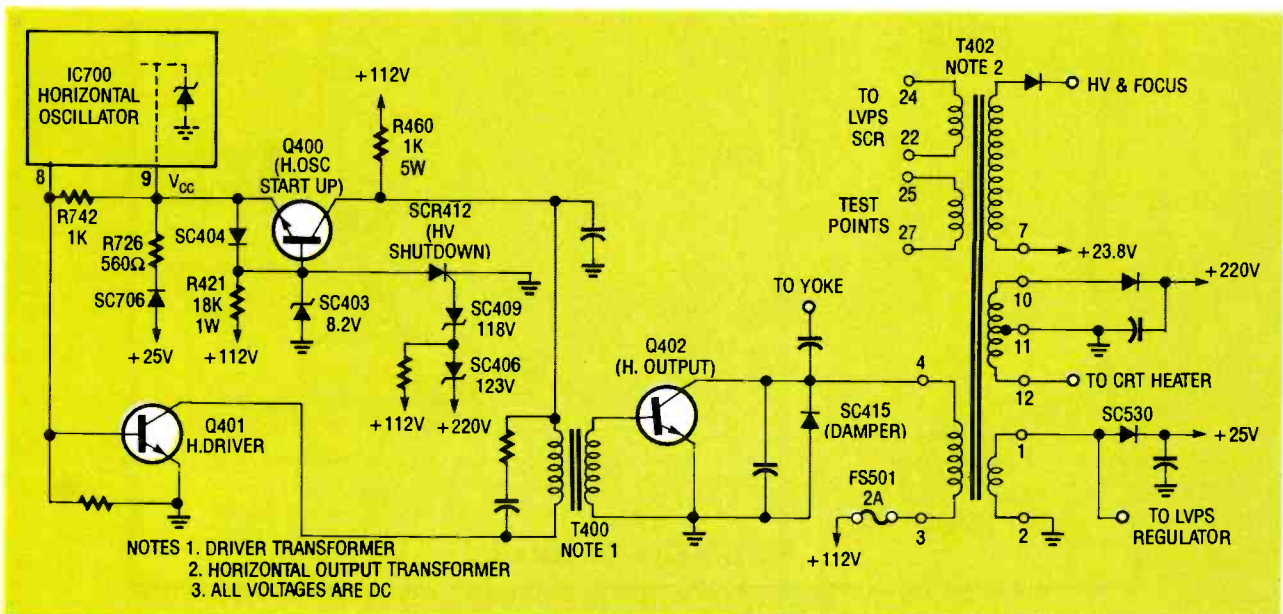

FIG. 3—SCHEMATIC FOR THE HORIZONTAL DEFLECTION CIRCUIT of the color TV receiver discussed in this case history.

goes through the primary of driver transformer T400 and on through the collector and emitter of horizontal driver Q401 to ground.

Transistor Q401 conducts under these static conditions because its base is forward biased by resistor R742. It is necessary, then, that Q400's collector be reverse biased. This was accomplished by applying about +40 volts to the +112-volt line. A convenient access point to the +112-volt line was found at fuse FS501. (This voltage is high enough to perform the reverse-bias function, and low enough to minimize damage to other components if there are circuit faults).

By applying both external voltages to the circuit and monitoring the base lead of horizontal output transistor Q402 with an oscilloscope, it was seen that horizontal drive was being generated. It shows up as a positive-going square wave that lasted about one half a line with an amplitude of approximately 0.7 volts (due to base-emitter clamp) and about 10 volts of negative spike at turn-off.

Transistor Q402 was replaced, and its collector was monitored with the oscilloscope. The waveform showed random pulses between the normal horizontal deflection pulses, as shown in Fig. 4-a. From experience, it can be expected that this symptom will be caused by one of the three following faults:

- Circuit loading due to shorted turns in the horizontal output transformer T402.
- A bad yoke on the cathode-ray tube (CRT).
- Excessive loading on one of the voltages developed by transformer T402.

In applying the external 40-volt test voltage, it was known that transistor Q402 would not be damaged because only 40 volts was being applied to the +112-volt line. However, as expected, the temperature of Q402's case rose. After the CRT yoke was disconnected at its plug, the waveform did not improve. The plug was then recon-

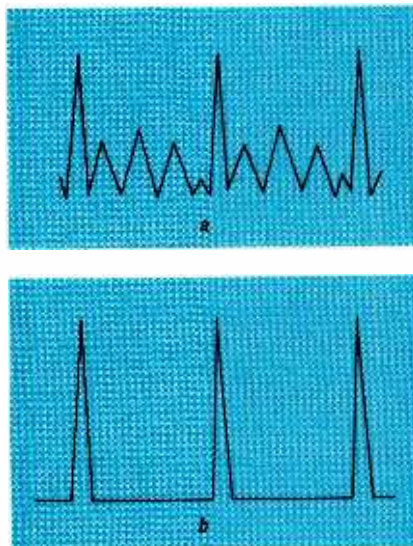

FIG. 4—OSCILLOSCOPE PATTERNS of spikes from horizontal output transistor Q402: with defective output transformer (a), and with new transformer (b)

nected to the yoke.

Transformer T402 was then removed from the PC board and all of its wires were disconnected. Pins 3, 4, and 7 were reconnected with alligator-clip-terminated jumpers. With the application of the test voltages, the collector waveform of Q402 remained abnormal. The waveforms across the open windings were checked with an oscilloscope. The attempt to measure across pin 12 to pin 11 (ground) resulted in a half-inch spark discharge.

The spark discharge was an indication that transformer T402 had an internal short in its high-voltage winding. The short did not show up with a continuity check, indicating that the breakdown occurred only when voltage was applied to the transformer.

Transformer T402 was replaced, and all wiring connections were resoldered. The 25- and 40-volt test voltages were applied as before. The oscilloscope waveform taken at the collector of Q402 showed a waveform with only "clean" vertical pulses, as shown in Fig. 4-b.

The external power supplies were removed and fuse FS501 was replaced. It was now clear that the faulty transformer was the cause of the problem. Power

was applied through the isolation transformer in series with a variable transformer.

The oscilloscope was connected to test points 25 and 27 of T402, and the voltage was slowly increased while the oscilloscope pattern was observed. In addition, the +112-volt DC line was monitored with a digital voltmeter. When the voltage reached about 90 volts on that line, a picture appeared on the CRT screen.

The AC line voltage was increased further until the +112-volt DC line reached its nominal value. Further increases in the input AC voltage did not cause a corresponding increase in voltage on the +112-volt DC line. This was an indication that the pulse-width regulator was functioning properly and not contributing to the problem.

The variable transformer was set to 120 volts on the AC line. Then a digital voltmeter was set to its DC-voltage scale, and its probes were placed between the +112-volt line (FS501) and ground. Potentiometer R521 was adjusted until a reading of +112 volts DC appeared on the meter. That measurement showed that B+ was properly set. The TV set was then turned off and the test equipment was disconnected.

To verify that the TV set had been repaired, it was powered up again and allowed to run for several hours to see if any problems would occur. A visual and touch test was made on the operating TV set to confirm that there was no abnormal heating. The vertical sweep controls were adjusted so that the picture filled the screen properly. This completed the repair. The TV set was then ready to be returned to the customer.

The repair would not have been successful if the three basic steps of successful TV servicing were not carried out. The first step, as obvious as it might seem, is to correctly identify the symptoms of the fault. Second is to study the circuitry to diagnose the cause of the problem. Only then can the repair be undertaken with the hope of successfully completing the job. Ω

TRIPLE-OUTPUT DC POWER SUPPLY



Build a triple-output power supply—a power source you'll find quite useful around the home and shop.

JOHN F. KEIDEL

A DC POWER SUPPLY IS REQUIRED for nearly all electronic circuits. Some circuits are passive and don't need a power supply, and others draw power from some other source. However, all stand-alone active circuits need a power supply. It is difficult to find an off-the-shelf benchtop power supply that's both versatile and inexpensive—that's why you want to build it yourself. If you are looking for a multiple-output, bench-type power supply, look no further.

The power supply in this article features metered voltages on all sources, vernier controls (based on 10-turn potentiometers) on its plus and minus 1.3- to 20-volt outputs, and separate adjustments or dual-tracking operation for those same supplies. It also has a precise, fixed 5-volt logic supply that's com-

pletely independent of the variable supplies.

This triple-output power supply boasts exceptional line regulation: less than 1 millivolt output change for a 10% change in line voltage. Ripple and noise figures are less than 1 millivolt peak-to-peak at full-load. The maximum current available at each of the variable outputs is 200 milliamperes, and the fixed 5-volt supply can output 300 milliamperes.

Design considerations

Preregulator circuits precede the output regulators on all three supplies. The preregulators dissipate heat and maintain the voltage across the output regulators at a constant 3 volts. Also, a 30- to 40-milliamper thermal-stabilizing current is drawn by all supplies.

That improves load regulation, and keeps the voltage-reference element contained within each output regulator at a constant temperature. The normally high heat dissipation of the regulators is greatly reduced by the preregulators.

Circuit operation

Figure 1 is the schematic of the positive and negative variable supplies; look at the positive supply. Tracking preregulator IC1, an LM317T, maintains a constant 3-volt drop across output-regulator IC2. The preregulator works as follows: Resistor R1 in conjunction with IC1's internal reference voltage (1.25 volts) causes a specific current to flow through R2 which, in turn, drops 1.7 volts across it. Those two voltages added together equal approximately 3

volts, which always appears across IC2.

Regulator IC2 establishes a programming current (1.25 volts divided by R3) that flows through front-panel control R18 (a 10-turn potentiometer), which thereby sets a positive output voltage equal to the adjustable drop across R18 plus the 1.25-volt reference. Resistor R4 provides the thermal-stabilizing current that was previously explained.

Capacitor C4 improves output ripple rejection. Capacitors C2, C3, and C5 bypass and stabilize their respective regulators by preventing spurious oscillations.

Regulator IC2 is protected from capacitive discharges caused by short circuits external to the supply. Diode D2 prevents C4 from discharging through IC2 by providing an alternate path.

Dual tracking keeps the positive and negative variable outputs at the same voltage level, but with opposite polar-

ities. The dual-tracking function is made possible by IC5, a TLO71 JFET op-amp configured as an inverting amplifier. In that configuration, IC5 tries to adjust its output so that both input voltages are equal. Since pin 3 of IC5 is tied to ground, it will therefore adjust its output in an attempt to make pin 2 equal to 0 volts.

Note that regulator IC4 is contained within the negative feedback loop of IC5 when S3 is in the DUAL TRACK position. Resistor R20 is the input to the IC5 inverting amplifier and R21 is its feedback resistor. Set up that way, IC4 automatically adjusts its output so that the voltage at the R20-R21 junction (pin 2 of IC5) is at 0 volts, thus matching the voltage at pin 3 of IC5. Because the value of R20 is equal to R21, and because the voltage at pin 2 of IC5 should equal 0 volts, IC4's output must match IC2's output, but with opposite polarity.

In the dual-tracking mode, R18 controls both output volt-

ages. When switch S3 is in the SEPARATE position, R19 controls the negative voltage output while R18 still controls the positive output.

Because the circuit arrangement and operation of both the negative variable supply and the 5-volt logic supply shown in Fig. 2 are virtually the same as those for the positive supply, operating details of those two supplies will not be given. Note, however, that the 5-volt supply has a different ground (and ground symbol on the schematic) than the variable supplies.

Figure 3 shows the meter circuit. Switch S4 selects the output voltage to be displayed on the meter, and also handles the polarity and switches in the appropriate multiplier resistor (R24 to R26). Resistor R23 compensates for variations in different meters. Note that the ground connections for the bipolar supply and the logic supply are independent of each other, so unlike symbols are used in Fig. 3.

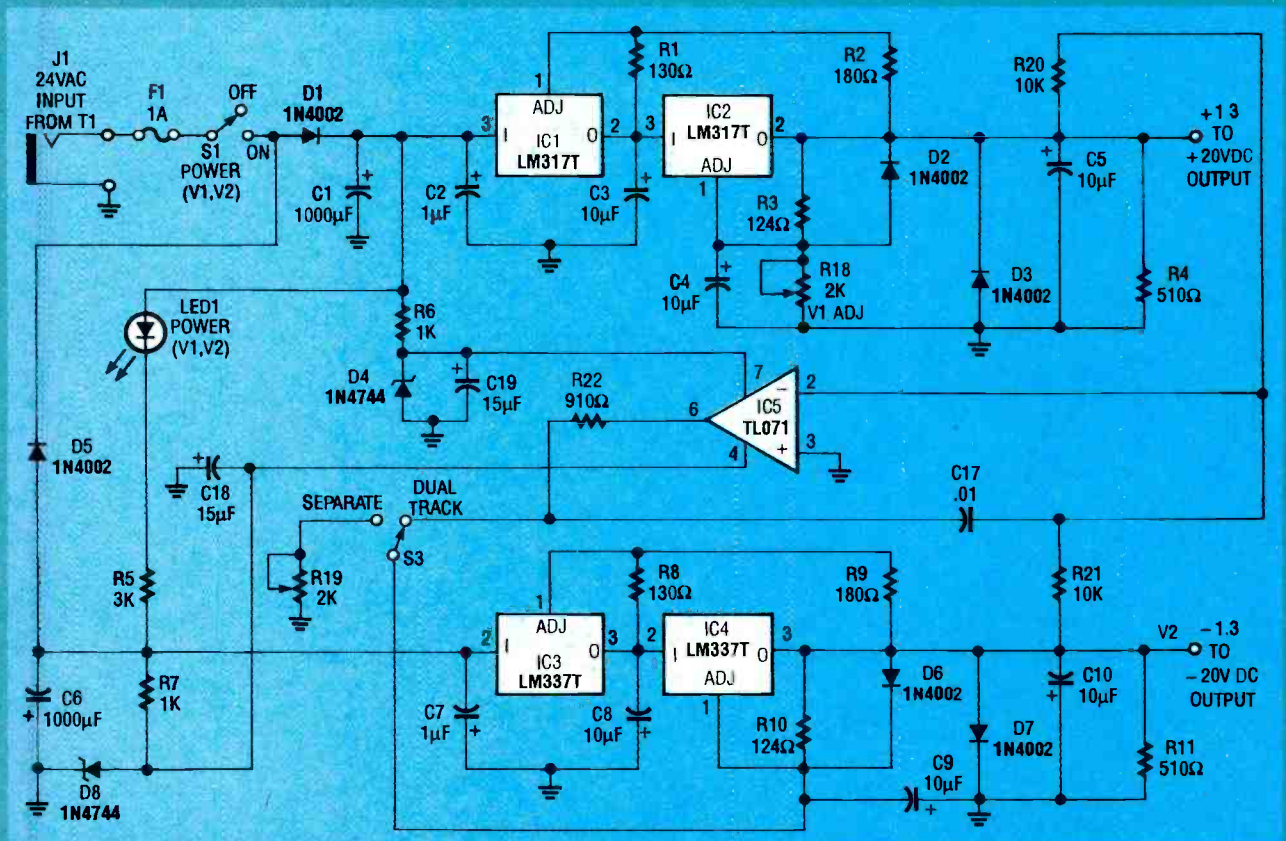

FIG. 1—SCHEMATIC DIAGRAM of variable bipolar 20-volt supplies. Switch S3 controls the dual-tracking option.

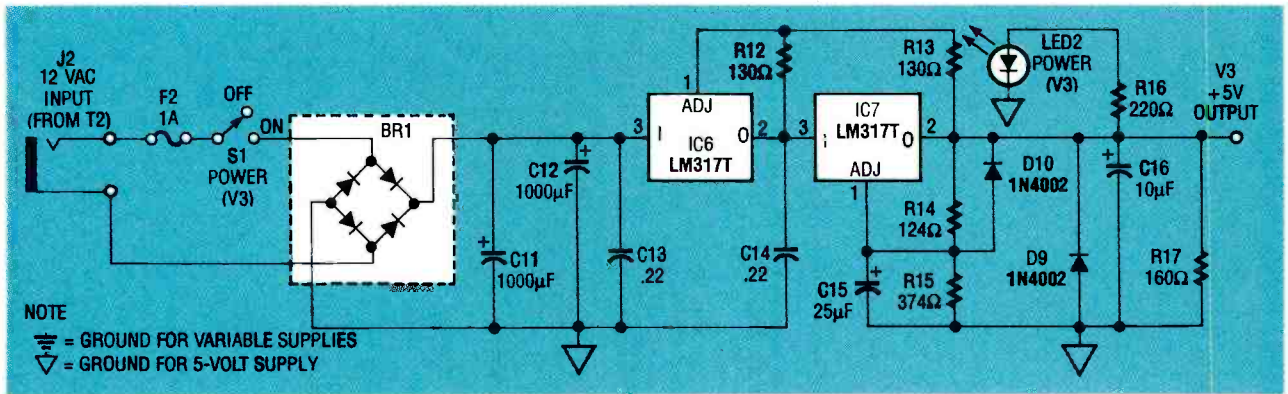

FIG. 2—FIVE-VOLT SUPPLY. The operation of this circuit is similar to the variable supplies, although it has a separate ground.

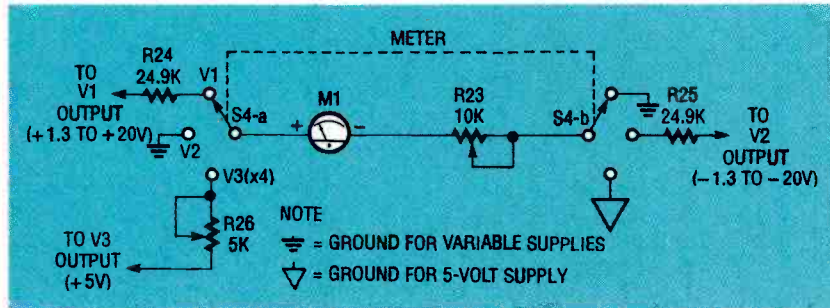

FIG. 3—METER CIRCUIT. This circuit allows the meter to display the output voltage.

Construction

A PC board is strongly recommended for the assembly of the

power supply. You can make your own board using the foil pattern provided here, or order

one from the source given in the Parts List. Mount all components as shown in parts-placement diagram Fig. 4. Check to see that all diodes, the bridge rectifier, and electrolytic and tantalum capacitors are positioned with the proper polarity before soldering them. A socket is recommended for IC5.

If the PC board is mounted in the recommended case, mounting bosses are provided as an integral part of the case. However, if you use a metal case rather than a plastic one, make sure the heatsinks don't touch the metal side panel. Similarly,

PARTS LIST

All resistors are ¼-watt, 5%, unless otherwise indicated.

- R1, R8, R12, R13—130 ohms
- R2, R9—180 ohms
- R3, R10, R14—124 ohms, 1%, metal film
- R4, R11—510 ohms, 2 watts
- R5—3000 ohms, 2 watts
- R6, R7—1000 ohms, 2 watts
- R15—374 ohms, 1%, metal film
- R16—220 ohms
- R17—160 ohms, ½ watt
- R18, R19—2000 ohms, 10-turn cabinet-mounted potentiometer (Digi-Key 73JB202-ND or equivalent)
- R20, R21—10,000 ohms, 1%, metal film
- R22—910 ohms
- R23—10,000 ohms, PC-mount potentiometer
- R24, R25—24,900 ohms, 1%, metal film
- R26—5,000 ohms, PC-mount potentiometer

Capacitors

- C1, C6—1000 µF, 50 volts, electrolytic
- C2, C7—1 µF, 50 volts, tantalum
- C3—C5, C8—C10, C16—10 µF, 35 volts, tantalum

- C15—25 µF, 25 volts, tantalum
- C11, C12, 1000 µF, 25 volts, electrolytic
- C13, C14—0.22 µF, 50 volts, ceramic disc
- C17—0.01 µF, 50 volts, ceramic disc
- C18, C19—15 µF, 35 volts, tantalum

Semiconductors

- IC1, IC2, IC6, IC7—LM317T adjustable positive regulator Motorola or equivalent
- IC3, IC4—LM337T adjustable negative regulator Motorola or equivalent
- IC5—TL071 JFET-input op-amp
- D1—D3, D5—D7, D9, D10—1N4002 diode
- D4, D8—1N4744 15-volt, 1-watt zener diode
- LED1, LED2—red panel-mount light-emitting diode
- BR1—Bridge rectifier, 1-amp, 50-volt (Digi-Key DB101-ND, or equivalent)

Other components

- M1—15-volt DC panel-mount meter (Radio Shack 270-1754, see text)
- J1, J2—Coaxial power-input jack (Radio Shack 274-1563 or equivalent)

- S1, S2—Panel-mount SPST switch
- S3—Panel-mount SPDT switch
- S4—Panel-mount, 2-pole, 3-position rotary switch (Mouser Electronics 10WA155 or equivalent)
- F1, F2—1-amp, 120-volt slow-blow fuse
- T1—120 to 24 VAC wall transformer with female plug (Jameco Electronics AC2410 or equivalent)
- T2—120 to 12 VAC wall transformer with female plug

Miscellaneous: project case (Jameco Electronics H2507), five binding posts, three instrument knobs, four 5-watt heat sinks (for IC2, IC4, IC6 and IC7, Digi-Key HS116-ND); two 10-watt heat-sinks (for IC1 and IC3, Digi-Key HS114-ND), one 6-pin IC socket, two fuse holders, two LED sockets, wire, solder, hardware.

Note: The following is available from Instrumex, PO Box 490, Blue Bell, PA 19422:

- Ready-to-use PC board and silkscreened plastic front panel, both to fit case noted above—\$23.00 + \$2.00 S&H

PA residents include 6% sales tax. Allow 4 weeks for delivery.

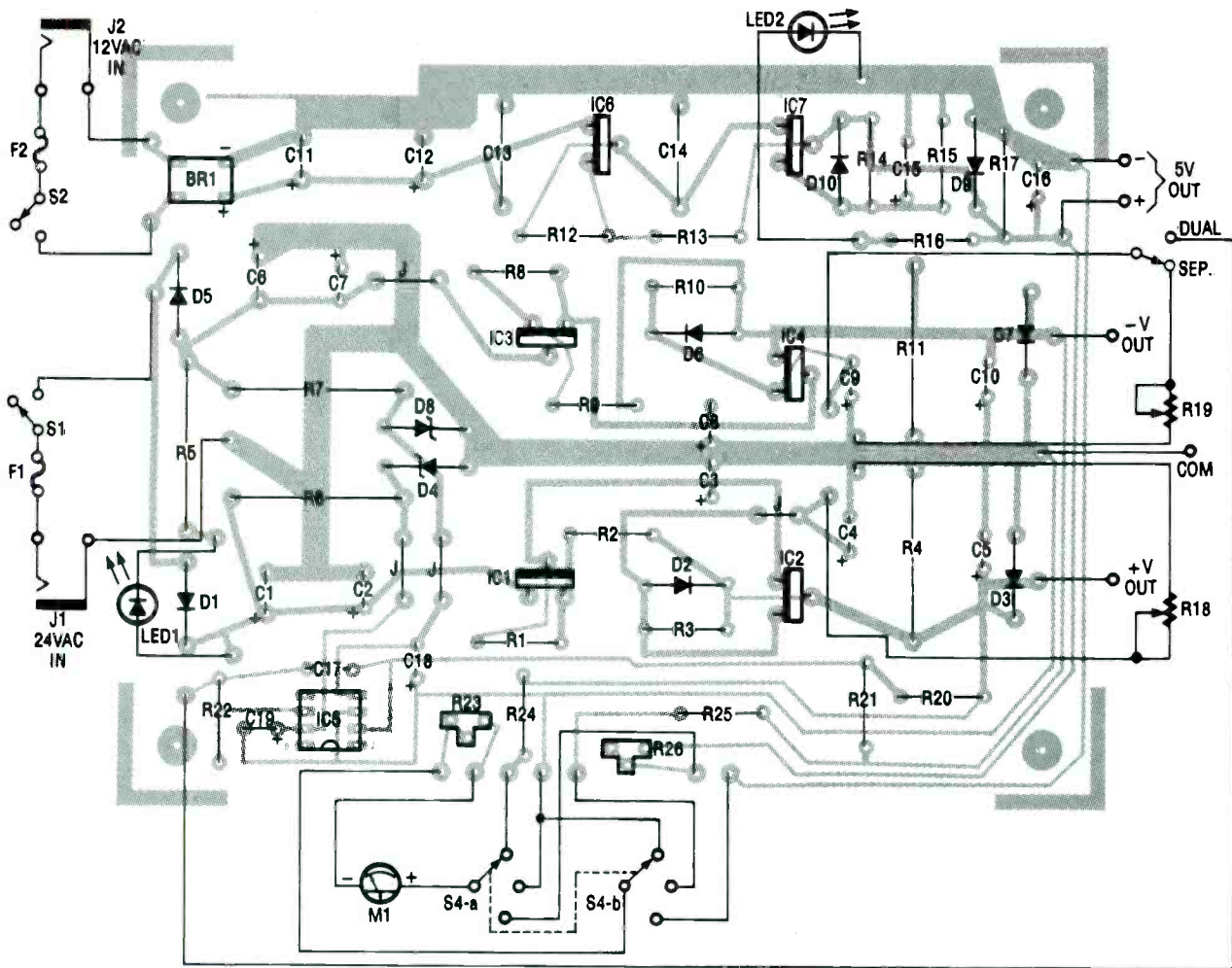

FIG. 4—PARTS PLACEMENT DIAGRAM. Be sure to heatsink the voltage regulators.

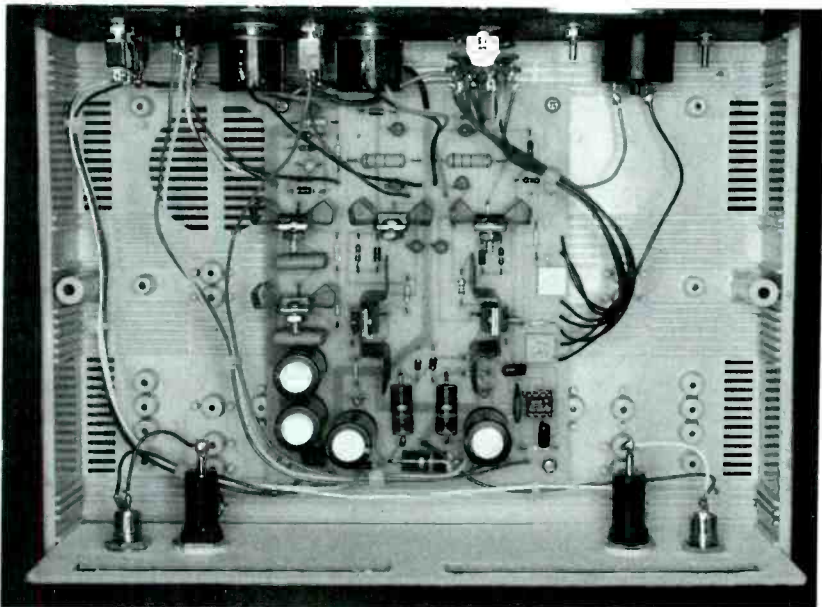

FIG. 5—THE CIRCUITRY IS INSTALLED in a plastic case with slots cut into the rear panel to allow heat to escape. Power input jacks and fuse holders are located below the vent slots.

if the supply is constructed on perforated circuit board, make sure that the heatsinks for the

different sources cannot touch one another.

Figure 5 shows the inside of

the prototype unit. Notice the wiring arrangement for the back- and front-panel controls. Power line wires run along the side of the case from their respective fuse holders to power switches S1 and S2, and then they return to input pads on the rear of the PC board.

Use short lengths of 18-AWG copper wire from output pads on the PC board to the binding posts. Be sure to account for all the wiring connections shown in Fig. 4.

Meter M1 can be re-labeled to read from 0 to 30 volts, but that task requires a lot of care. Remove the meter's bezel and use white paper correction fluid to cover the original numbers. Then carefully remove the adhesive-backed meter face and apply new numbers (0, 10, 20 and 30) using rub-on transfer numbering.

When labeled replace the meter face and shift the pointer as required with the zerp ad-

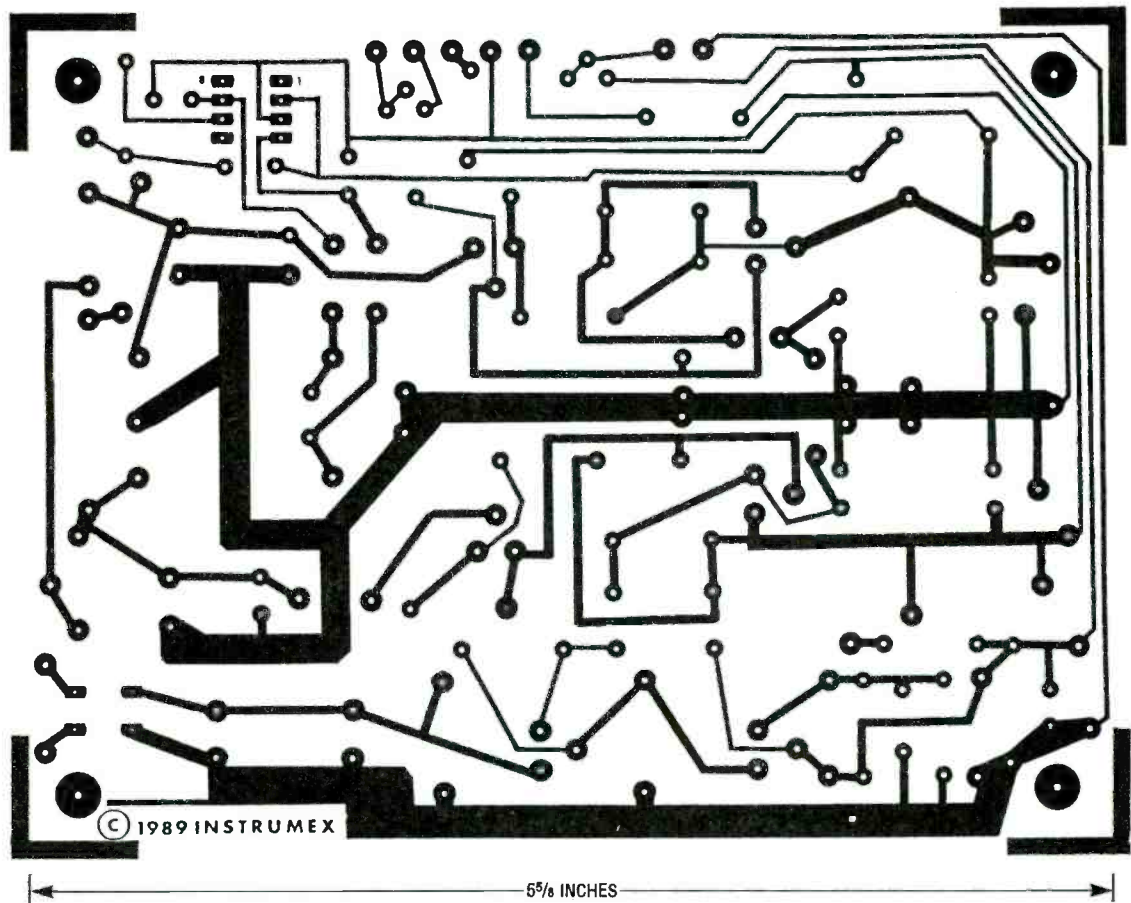

FOIL PATTERN for the power supply.

justment. Avoid touching the fragile meter pointer!

The plastic case specified in the Parts List is the recommended choice for the project. However, holes in the panels can be difficult to drill because the plastic is brittle and is easy to crack. Alternatively, the panels can be made from sturdy 0.1-inch art board (rigid cardboard) purchased from a stationary or art-supply store. All holes can then be made with a hobby knife. You can also buy a silkscreened front panel from the source given in the Parts List.

Venting the cabinet is very important. Two 4-inch slots, 1/2-inch wide, were cut in the rear panel to let heat escape. Large rubber feet, although not included with the case, provide that "store-bought" look and prevent the power supply from sliding on the bench.

Calibration

Set the meter switch S4 to the V1 position and S3 to the "sepa-

rate" position. Adjust the output of the positive variable supply to an exact 20 volts with an accurate external voltmeter. Adjust trimmer potentiometer R23 until the panel meter M1 reads exactly 20 volts. Next, set S4 to the V3 ($\times 4$) position, and adjust R26 until M1 reads 20 volts ($5 \text{ volts} \times 4$). An external voltmeter can be used to verify the exact 5.0-volt output.

Using the supply

The variable bipolar and fixed logic power sources are completely independent of one another, so they can even be used to power separate projects. Both sources are also "floating," which permits a variety of configurations. For example, by connecting across the outputs of both variable supplies, a 2.6- to 40-volt output of either polarity, at 200 milliamperes can be obtained. By connecting the fixed logic source in series with the arrangement just described (aiding or opposing), a +7.6- to +45-volt or -2.4 to +35-volt

output, respectively, at 200 milliamperes is produced.

When powering op-amps that require equal and opposite voltage sources for $+V_{CC}$ and $-V_{EE}$, use the power supply's dual tracking mode. When S3 is set to the "dual" position, potentiometer R18 simultaneously adjusts both variable bipolar sources. Otherwise, leave switch S3 in the "separate" position for independent adjustment.

All outputs are protected against short circuits in the external load by current limiting and thermal overload protective devices, which are built-in features of the voltage-control output regulators.

Any one binding post of a given supply can be connected to the common return of the circuit being powered. Also, that same terminal can be connected to earth ground for optimum safety, if required. Avoid electrically elevating the supplies by connecting them in series with other supplies.

Ω

Learn about common-collector bipolar junction transistor (BJT) transistor amplifiers and apply this knowledge to the circuits that you design.

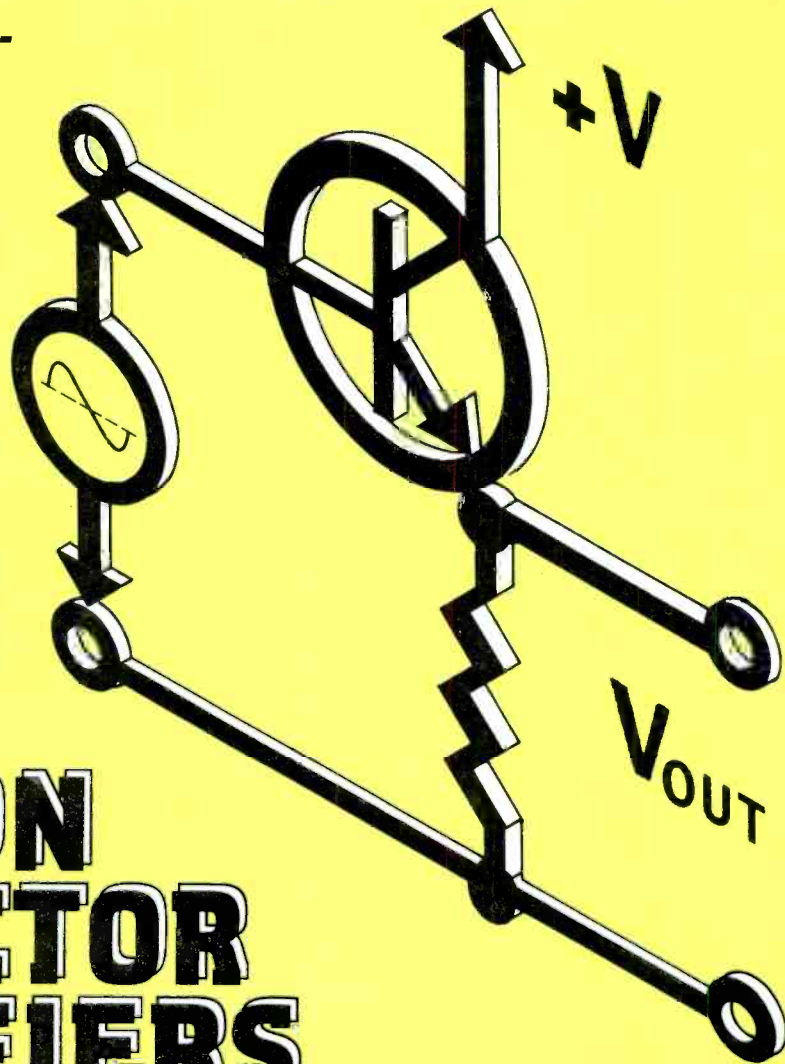

COMMON COLLECTOR AMPLIFIERS

RAY MARSTON

BIPOLAR JUNCTION TRANSISTOR (BJT) amplifiers are still widely used in modern electronic circuitry. This article focuses on practical variations of the common-collector or emitter-follower amplifier based on discrete transistors and Darlington pairs. Figure 1 shows the basic common-collector amplifier and compares it with the common-base and common-emitter amplifiers. Table 1 sums up the performance characteristics of these three bipolar amplifiers.

The fundamentals bipolar of transistors were presented last month and the specifications of two widely available and typical discrete devices, the NPN 2N3904 and the PNP 2N3906

were given. The 2N3904 is included in most of the schematics in this article.

The expression h_{FE} in Table 1, known as a hybrid parameter, is the common-emitter DC forward-current gain. It is equal to the collector current divided by the base current ($h_{FE} = I_C/I_B$). The value of this variable for the 2N3904 NPN transistor is typically between 100 and 300, but in this article it is considered to be 200.

A lot of useful information can be gained simply by studying both Fig. 1 and Table 1. The common-collector amplifier (also widely known as the *emitter-follower*) has its input applied between its base and collector and its output is taken

across its emitter and collector. The circuit is also referred to as the *grounded-collector* amplifier. In practical configurations its load resistor is in series with its emitter terminal.

The mathematical derivations of the results shown in Table 1 can be found in most basic electronics texts. However, for the purposes of this article, the important characteristics of the common-collector/emitter follower amplifier to keep in mind are:

- High input impedance
- Low output impedance
- Voltage gain approximately equal to unity
- Current gain approximately equal to h_{FE}

By contrast, notice that while

TABLE 1
CHARACTERISTICS OF THE THREE BASIC TRANSISTOR AMPLIFIERS

Parameters		Common Collector	Common Emitter	Common Base
Input impedance	Z_{IN}	High ($\approx h_{FE} \times R_L$)	Medium ($\approx 1.0K$)	Low ($\approx 40\Omega$)
Output impedance	Z_{OUT}	Very low	$\approx R_L$	$\approx R_L$
Voltage gain	A_V	≈ 1	High	High
Current gain	A_I	$\approx h_{FE}$	Low	≈ 1
Cutoff Frequency	—	Medium	Low	High
Voltage phase shift.	—	0°	180°	0°

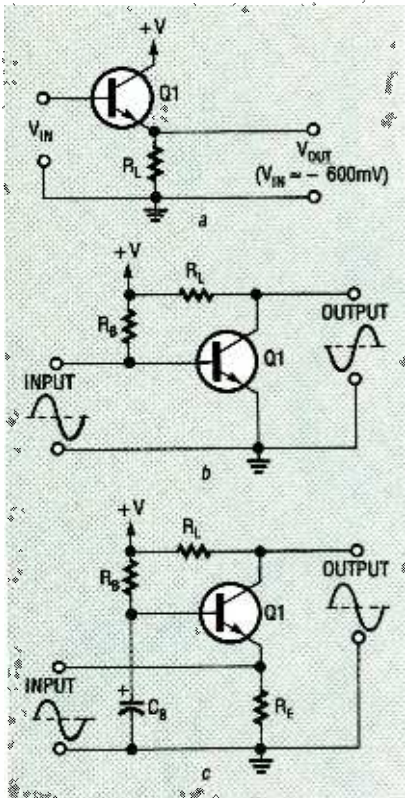

FIG. 1—THREE BASIC BIPOLAR transistor amplifier configurations.

the common-emitter and common-base amplifiers provide high voltage gain they offer only low-to medium input impedance. The applications for these circuits are governed by these characteristics.

Digital amplifiers

Figure 2 is the schematic for a simple NPN common-collector/emitter-follower digital amplifier. The input signal for this circuit is a pulse that swings between zero volts and the positive supply voltage. When the input of this circuit is at zero volts and the transistor is fully cut off, and the amplifier's output is also zero volts—indicating zero voltage phase shift.

When an input voltage exceeding +600 millivolts (the minimum forward bias for turn-on) appears across the input terminals, the transistor turns on and current I_L flows in load resistor R_L , generating an output voltage across R_L . Inherent negative feedback causes the output voltage to assume a value that follows the input voltage. The output voltage is

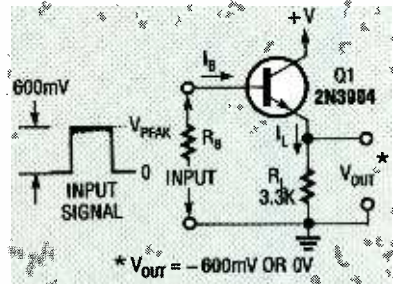

FIG. 2—COMMON-COLLECTOR digital amplifier.

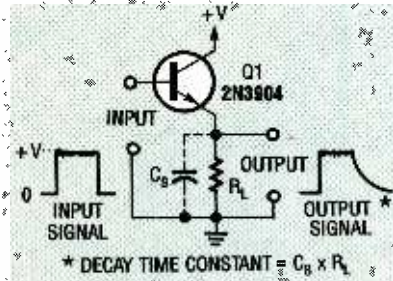

FIG. 3—EFFECT OF CAPACITOR C_S on output pulses.

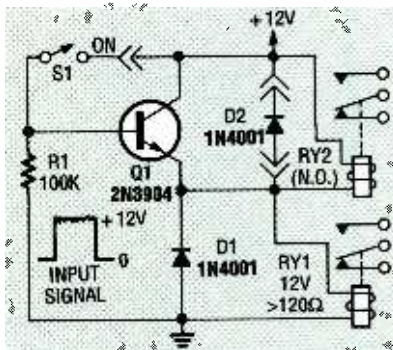

FIG. 4—EMITTER-FOLLOWER RELAY driver.

equal to the input voltage minus the voltage drop across the base-emitter junction (≈ 600 millivolts).

In the Fig. 2 schematic, the input (base) current is calculated as:

$$I_B = I_L/h_{FE}$$

Because the circuit can have a maximum voltage gain of one, it presents an input impedance calculated as:

$$Z_{IN} = R_L \times h_{FE}$$

Inserting the values shown in Fig. 2 yields: $Z_{IN} = 3300 \text{ ohms} \times 200 = 660,000 \text{ ohms}$

The circuit has an output impedance that approximately equals the value of the input signal source impedance (R_S) divided by the h_{FE} value of the transistor.

Because the circuit shown in Fig. 3 exhibits all of the common-collector amplifier characteristics previously discussed, it behaves like a unity-gain buffer circuit. If high-frequency pulses are introduced at its input, the trailing edge of the output pulse will show the time constant decay curve shown in Fig. 3. This response is caused by stray capacitance C_S (represented by dotted lines) interacting with the circuit's load resistance.

When the leading edge of the input pulse switches high, Q1 switches on and rapidly sources or feeds a charge current to stray capacitance C_S , thus producing an output pulse with a sharp leading edge. However, when the trailing edge of the input pulse goes low, Q1 switches off and effective capacitor C_S is unable to discharge or sink through the transistor.

However, C_S can discharge through load resistor R_L . That discharge will follow an exponential decay curve with the time to discharge to the 37% level equal to the product of C_L and R_L .

Relay drivers

The basic digital or switching

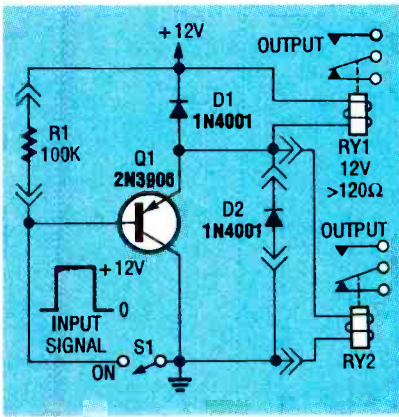

FIG. 5—PNP VERSION OF EMITTER-follower relay driver.

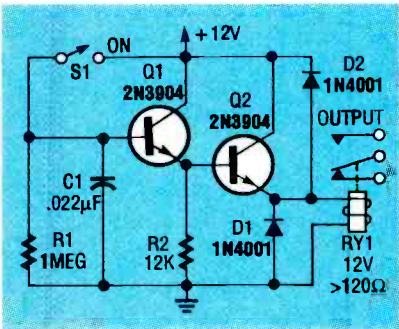

FIG. 6—NPN DARLINGTON EMITTER-follower relay driver.

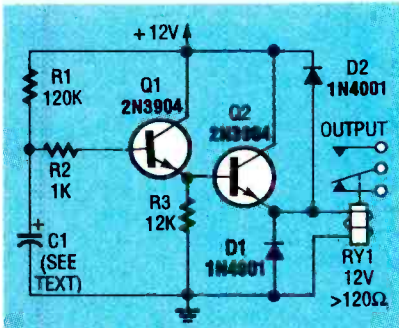

FIG. 7—DELAYED SWITCH-ON relay driver.

circuit of Fig. 2 can be put to work driving a wide variety of resistive loads such as incandescent filament lamps, LEDs or resistors. If the circuit is to drive an inductive loads such as a coil, transformer, motor, or speaker, a diode must be included to limit an input-voltage surge that could destroy the transistor when the switch is closed.

The schematic in Fig. 4 is a modification of Fig. 3 with with the addition of diode D1 across the load, in this case a relay coil, and switch S1 in the collector-base circuit. It can act in either

the *latching* or *non-latching* modes. The relay to be actuated either by the input pulse or switch S1.

Relay RY1's contacts close and are available for switching either when a pulse with an amplitude equal to the supply voltage is introduced or S1 is closed. The relay contacts open when the input pulse falls to zero or S1 is opened.

Protective diode D1 damps relay RY1's switch-off voltage surge by preventing that voltage from swinging below the zero-volt supply level. Optional diode D2 can also be included to prevent this voltage from rising above the positive power supply value. The addition of normally open relay 2 (RY2) makes the circuit self-latching.

Figure 5 shows a same relay driver circuit organized for an PNP transistor. Again, the relay can be turned on either by closing S1 or by applying the input pulse as shown.

Both the circuits shown in Figs. 4 and 5 increase the relay's sensitivity by a factor of about 200 (the h_{FE} value of Q1). Consider a relay requires an activating current of 100 milliamperes and has a coil resistance of 120 ohms. The effective input impedance of the circuit (Z_{IN}) will be:

$$Z_{IN} = R_L \times h_{FE} = 120 \times 200 = 24,000 \text{ ohms}$$

Only an input operating current of $1/200$ of 100 milliamperes or 0.5 milliamperes is required.

Circuit sensitivity can be further increased by replacing transistor Q1 with the Darlington transistor pair of Q1 and Q2, as shown in Fig. 6. This circuit presents an input impedance of about 1 megohm and requires an input operating current of about 12 microamperes. Capacitor C1 protects the circuit from false triggering by high-impedance transient voltages, such as those induced by lightning or electromagnetic interference.

The benefits of the Darlington pair are readily apparent in relay-driving circuits that require time delay, such as those shown in Figs. 7 and 8. In those circuits, the voltage divider

formed by resistor R1 and capacitor C1 generates a waveform that rises or falls exponentially.

That waveform is fed to the relay coil through the high-impedance Q1-Q2 voltage-following Darlington buffer. The circuit forces the relay to change state at some specified delay time after the supply voltage is applied. With the 120 K resistor R1 shown in both Figs.

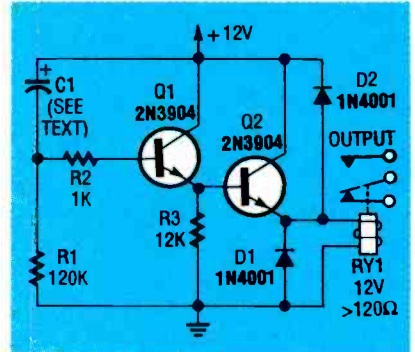

FIG. 8—AUTOMATIC TURN-OFF time-delay circuit.

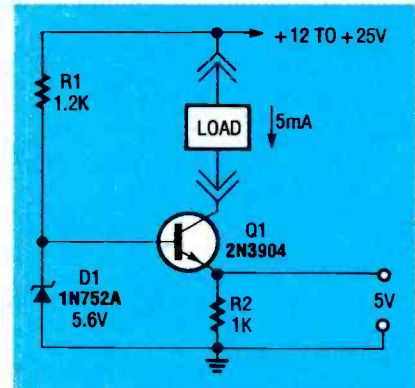

FIG. 9—CONSTANT-CURRENT generator provides 5-milliamperes.

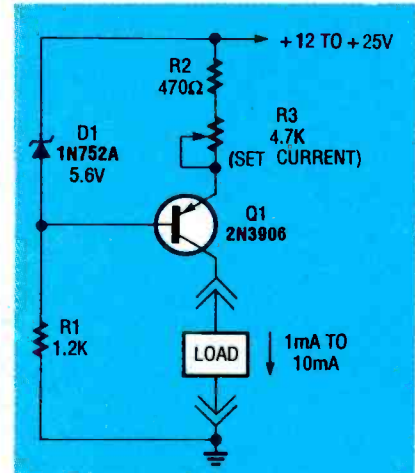

FIG. 10—GROUND-REFERENCED variable constant-current generator (1 to 10 milliamperes).

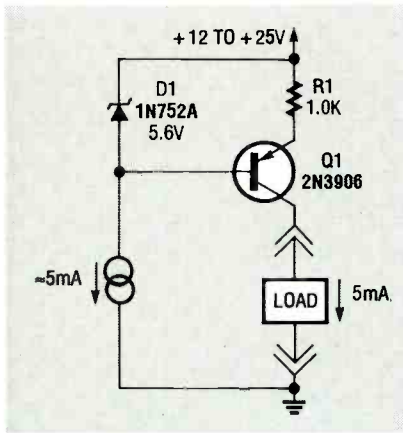

FIG. 11—PRECISION CONSTANT-current generator.

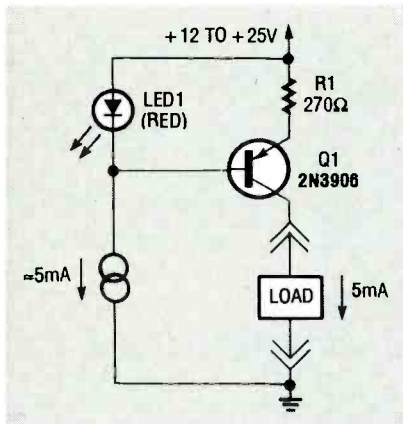

FIG. 12—THERMALLY STABILIZED constant-current generator with a LED voltage reference.

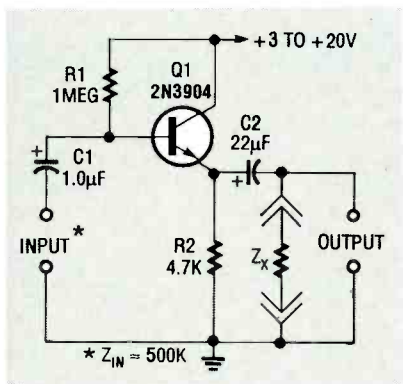

FIG. 13—SIMPLE EMITTER-FOLLOWER.

7 and 8, operating delays will be about 0.1 second per microfarad of capacitor value. For example, if C1 equals 100 microfarads, the time delay will be 10 seconds.

In the Fig. 7 circuit, consider that C1 is fully discharged so that the R1-C1 junction is at zero volts and relay RY1 is off (contacts open) when the power supply is connected. Capacitor C1 then charges exponentially

through R1, and the increasing voltage is fed to the relay circuit through Darlington pair Q1 and Q2. That causes relay RY1's contacts to close after a time delay determined by the product of R1 and C1.

Consider that capacitor C1 in the Fig. 8 circuit is also fully discharged when the power supply is connected. The junction of R1 and C1 is initially at the supply voltage, and the relay contact close at that moment. Capacitor C1 then charges exponentially through R1, and the decaying voltage at the R1-C1 junction appears across the coil of relay RY1. The contacts of RY1 open after the delay determined by R1 and C1 times out.

Constant-current generators

A BJT can serve as a constant-current generator if it is connected in the common-collector topology and the power supply and collector terminals function as a constant-current path, as shown in Fig 9. The 1000-ohm resistor R2 is the emitter load. The series combination of resistor R1 and zener diode D1 applies a fixed 5.6-volt reference to the base of Q1.

There is a 600-millivolt base-to-emitter drop across Q1, so 5 volts is developed across emitter resistor R2. As a result, a fixed current of 5 milliamperes flows through this resistor from Q1's emitter.

Because of a BJT's characteristics, emitter and collector currents are nearly identical. This means that a 5-milliamper current also flows in any load that is connected between Q1's collector and the circuit's positive supply. This will occur regardless of the load's resistance value—provided that the value is not so large that it drives Q1 into saturation. Therefore, these two points are constant-current source terminals.

Based on the previous discussion, it can be seen that constant-current magnitude is determined by the values of the base reference voltage and emitter load resistor R2. Consequently, the value of the

current can be changed by varying either of these parameters.

The Fig. 10 circuit takes this concept a step further. It can be seen, for example, that the circuit of Fig. 9 was inverted to give a ground-referenced, constant-current output. Adjustment of trimmer potentiometer R3 provides a current range of from 1 to about 10 milliamperes.

The most important feature of the constant-current circuit is its high dynamic output impedance—typically hundreds of

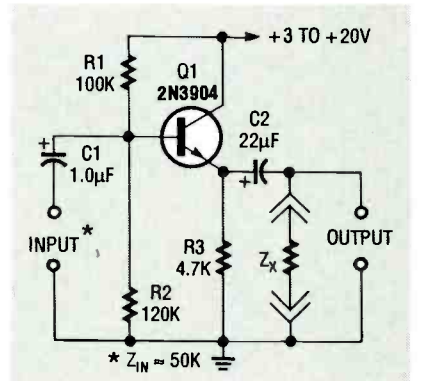

FIG. 14—HIGH-STABILITY EMITTER-follower.

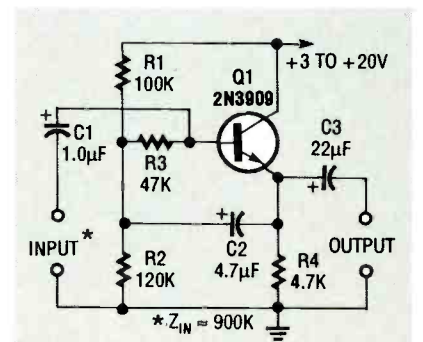

FIG. 15—BOOTSTRAPPED EMITTER-follower.

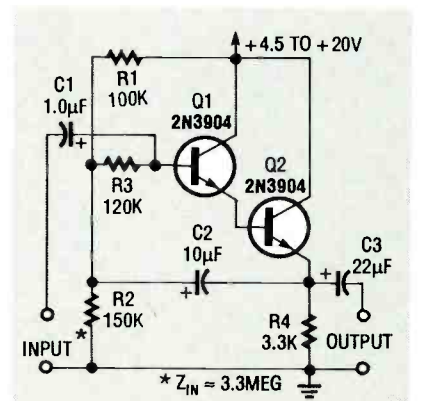

FIG. 16—BOOTSTRAPPED Darlington emitter-follower.

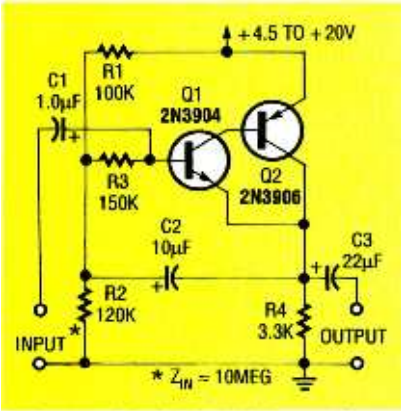

FIG. 17—BOOTSTRAPPED complementary feedback pair.

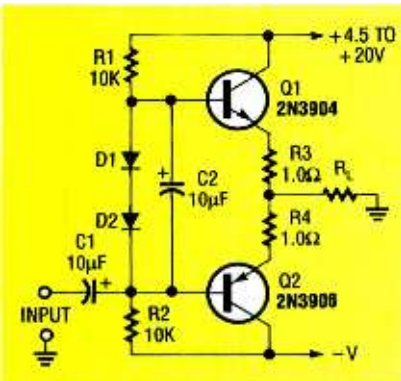

FIG. 18—COMPLEMENTARY emitter-follower with a split power supply and direct-coupled output load.

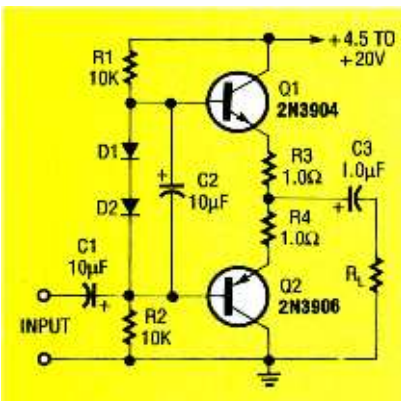

FIG. 19—COMPLEMENTARY emitter-follower with a single-ended supply and AC-coupled output load.

kilohms. The precise magnitude of constant current is usually unimportant in practical circuits. The circuits shown in Figs. 10 and 11 will work satisfactorily in many practical applications.

If more precise current generation is required, the characteristics of the reference voltages of these circuits can be improved to eliminate the effects of power source varia-

tions and temperature changes.

A simple way to improve the circuits in Figs. 9 and 10 is shown in Fig. 11. Resistor R1 in both circuits can be replaced with a 5-milliampere constant-current generator. (The symbol for a constant-current generator is a pair of overlapping circles.) With a constant-current generator installed, the current through zener diode D1 and the voltage across it is independent of variations in the supply voltage.

True high precision can be obtained if the industry standard reference zener diode D1 is replaced with one having a temperature coefficient of 2 millivolts/°C to match the base-to-emitter temperature coefficient of transistor Q1. However, if a zener diode with those characteristics cannot be located, satisfactory results can be obtained by substituting a forward-biased light-emitting diode, as shown in Fig 12.

The voltage drop across LED1 is about 2 volts, so only about 1.4 volts appears across emitter resistor R1. If the value of R1 is reduced from 1000 to 270 ohms, the constant-current output level can be maintained at 5 milliamperes.

Analog amplifiers

The common-collector/emitter-follower amplifier can ampli-

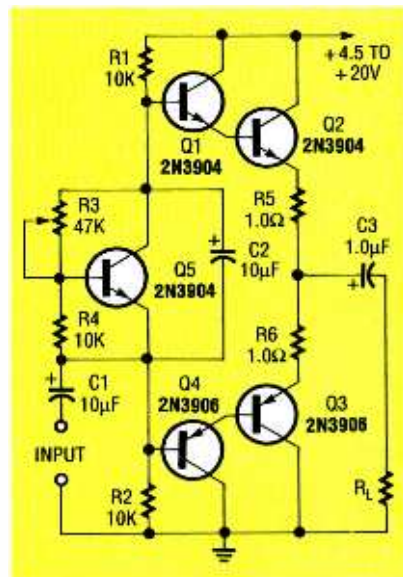

FIG. 20—DARLINGTON complementary emitter-follower with "amplified diode" biasing from transistor Q5.

fy AC-coupled analog signals linearly if the transistor's base is biased to a quiescent value of about half the supply voltage. This permits maximum signal swings without distortion due to clipping. As shown in Figs. 13 and 14, the analog signals are AC-coupled to the base with capacitor C1, and the output signal is taken from the emitter through capacitor C2.

Figure 13 shows the simplest analog common-collector/emitter-follower circuit. Transistor Q1 is biased by resistor R1 connected between the voltage source and base. The value of resistor R1 must be equal to the input resistance R_{IN} of the emitter-follower stage to obtain half-supply biasing. Input resistance R_{IN} (and thus the nominal R1 value) equals the 4.7 K value of R2 multiplied by the h_{FE} value of the Q1. In this circuit:

$$R_1 = 200 \times 4700 \approx 1 \text{ megohm}$$

A slightly more elaborate biasing method is shown in Fig. 14. However, its biasing level is independent of variations in transistor Q1's h_{FE} value. Resistors R1 and R2 function as a voltage divider that applies a quiescent half-supply voltage to Q1's base. Ideally, the value of R1 should equal the value of R2 in parallel with R_{IN} . However, the circuit works quite well if resistor R1 has a low value with respect to R_{IN} , and resistor R2 is slightly larger than R1.

In the circuits shown in Figs. 13, and 14, the input impedance looking directly into the base of transistor Q1 equals $h_{FE} \times Z_{load}$, where Z_{load} is equal to the combined parallel impedance of R2 and any external load Z_X that is connected to the output.

In these circuits, the base impedance value is about 1 megohm when Z_X is infinite. In practical circuits, the input impedance of the complete emitter-follower circuit equals the combined parallel impedance of the base and bias network. The circuit shown in Fig. 13 has an input impedance of about 500 kilohms, and the circuit shown

Continued on page 83



Proper heat management ensures that components have a long and healthy life.

STEPHEN J. BIGELOW

WHENEVER CURRENT FLOWS through an electronic component, that component dissipates power. The power that the part dissipates depends on both the current flowing through the part and the voltage across it, and can be expressed by the relationship $P=IV$. Heat is an unavoidable byproduct of power dissipation.

For many circuits and components, heat generation is negligible or so small that the component can easily shed its heat buildup directly into the air. Some components, however, can not give up heat fast enough, and excessive heat buildup occurs. When that hap-

pens, the device can be permanently damaged. Thermal management techniques, such as the two common heatsink arrangements shown in Fig. 1, must be used to improve the component's heat dissipation. This article will explain the concepts of heat management and show you how to use manufacturers' specifications to optimize component operation. You can use these techniques with most semiconductor devices.

Thermal circuits

A *thermal circuit* is a graphic representation of thermal energy's path from its source to ambient air. In many ways, thermal circuits are analogous to elec-

tronic circuits as shown in Fig. 2.

Notice that there is resistance to the flow of heat between the heat source and the air. Such thermal resistance is generally defined as the difference in temperature across two points, divided by the power being dissipated between those two points. Thermal resistance is symbolized by the Greek letter theta (θ) and is measured in degrees Celsius per watt ($^{\circ}\text{C}/\text{W}$). As a rule, thermal resistance should be as small as possible between the power-dissipating semiconductor junction(s) and the ambient air. Low thermal resistance between junctions ensures minimum junction temperature.

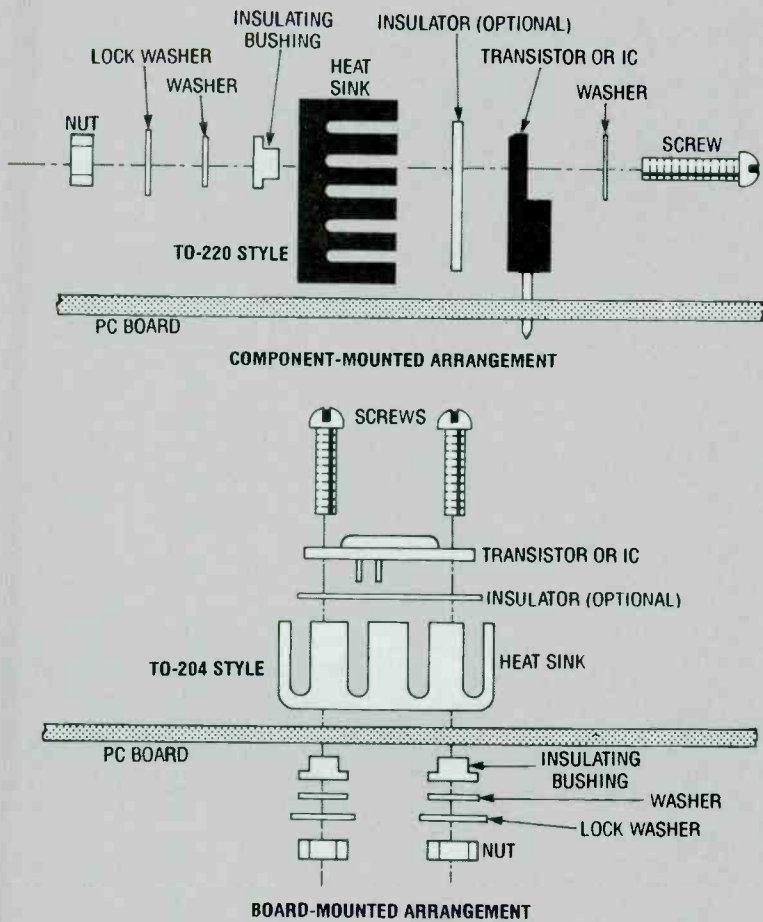

FIG.1—THERMAL MANAGEMENT TECHNIQUES, such as these two common heatsink arrangements, must be used to improve a component's heat dissipation.

Heat sources

Heat is generated by a semiconductor device when it dissipates power. A diode dissipates power at its anode-cathode junction. Junction power can be defined as the current through the junction multiplied by the voltage drop across the junction (typically 0.6 volt DC for a silicon diode). Power dissipated by a transistor is the voltage drop between the collector and emitter multiplied by the collector current. The power dissipated by an integrated circuit is the total power dissipated by all of the integrated circuit's transistors.

Thermal resistance

The heat generated in a semiconductor junction does not dissipate directly to the ambient air. Instead, a number of thermal resistance factors must be taken into account. The use of an external heatsink typically involves three major thermal re-

sistances: (1) between the semiconductor junction and the device's case, (2) between the case and the attached heatsink, and (3) between the heatsink and the ambient air. Additional thermal resistance might be encountered if an electrical insulator is included between the case and heatsink.

For components that do not use an external heatsink, two thermal resistances must be considered: (1) between the semiconductor junction and the case, and (2) between the case and the ambient air. The total thermal resistance of a semiconductor arrangement can be summarized as shown in Table 1.

The junction-case resistance (θ_{JC}) represents the flow of heat from a device's junction(s) to its outer case. The value of θ_{JC} is specified by the manufacturer in his data sheet. A smaller number represents better heat flow. Junction-case thermal re-

sistance is dependent on a number of physical characteristics. These include the size and shape of the semiconductor die and its mount, the quality of the die-to-mount bond, and the thermal conductivity of the die, mount, bond, and any interconnecting wires.

Although you have no control over θ_{JC} , you can select a particular case style that minimizes the thermal resistance. Figure 3 shows what the different case styles look like. For example, a transistor in a TO-220 case has better (lower) θ_{JC} than a similar device in a TO-92 case. Table 2 shows a selection of typical θ_{JC} values for a variety of case styles. If you do not have access to manufacturer's data, Table 2 can provide a good approximation.

The use of a heatsink can have a tremendous impact on a component's operating temperature. For some devices, a good heatsink can mean the difference between a successful project and a failure. The goal of a heatsink is to move as much heat as possible away from the device's junction, and that's accomplished through the choice of heatsink, mounting arrangement, and mounting materials.

Thermal resistance at the case-sink barrier (θ_{CS}) is a function of many factors: (1) the cross-sectional contact area be-

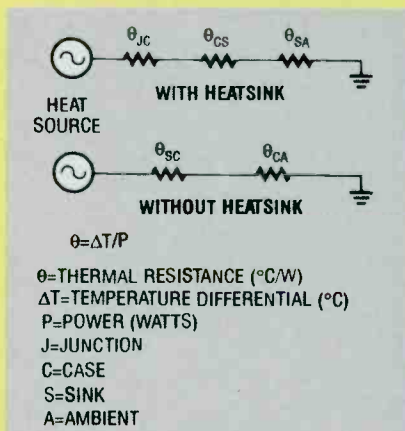

FIG.2—A THERMAL CIRCUIT is a graphic representation of thermal energy's path from its source to ambient air. Thermal resistance is defined as the difference in temperature across two points, divided by the power being dissipated between those two points. Thermal resistance should always be as small as possible.

TABLE 1—THERMAL RESISTANCE SUMMARY

$\theta_{JA} = \theta_{JC} + \theta_{CS} + \theta_{SA}$	A) Total thermal resistance with a heatsink only.
$\theta_{JH} = \theta_{JC} + \theta_{CS} + \theta_{INS} + \theta_{SA}$	B) Total thermal resistance with a heatsink and electrical insulator.
$\theta_{JA} = \theta_{JC} + \theta_{CA}$	C) Total thermal resistance with no heatsink.
θ_{JA} = thermal resistance, junction to ambient θ_{CS} = thermal resistance, case to sink θ_{JC} = thermal resistance, junction to case θ_{SA} = thermal resistance, sink to ambient θ_{INS} = thermal resistance, of electrical insulator θ_{CA} = thermal resistance, case to ambient	
*All values of θ are in °C/W.	

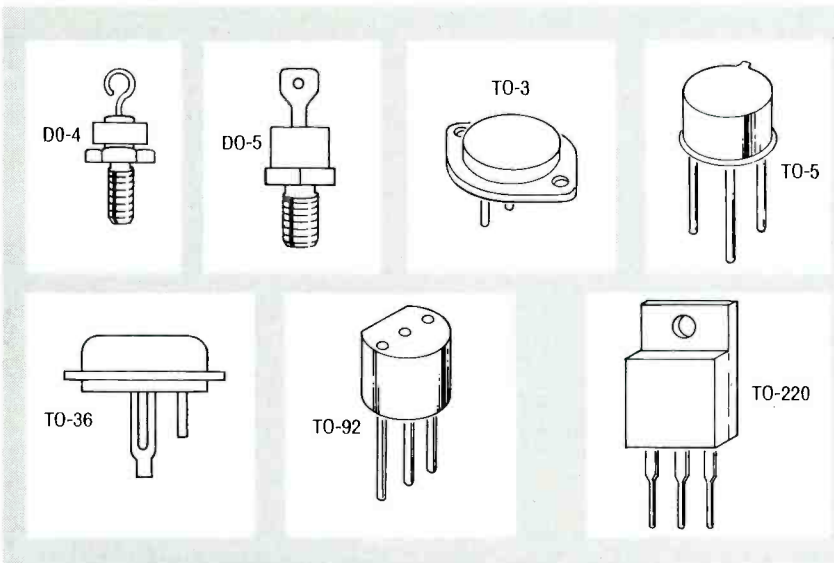

FIG. 3—DIFFERENT COMPONENT PACKAGES vary in their ability to dissipate excess heat. Here are some of the more popular styles.

TABLE 2— θ_{JC}

Device Case	Thermal Resistance (°C/W)		
	Low	Typ.	High
DO-4	2.0	—	7.0
DO-5	1.0	—	1.5
TO-3 (TO-204)	0.5	1.5	6.0
TO-5	20.0	35.0	50.0
TO-6	0.5	0.8	1.0
TO-8	1.5	7.0	15.0
TO-36	0.5	0.8	1.0
TO-61	0.5	1.0	2.0
TO-63	0.4	1.0	2.0
TO-66 (TO-213)	1.5	7.0	15.0
TO-92 (TO-226)	175.0	—	200.0
TO-116 (kovar)	59.0	—	91.0
TO-116 (copper)	30.0	35.0	40.0
TO-225	4.0	9.5	15.0
TO-127	1.0	—	2.0
TO-202	15.0	20.0	25.0
TO-220	1.7	3.0	5.0

tween the case and sink, (2) the mating surface finish and flatness, (3) the contact force (or pressure) applied between mating surfaces, and (4) the thermal resistance of any electrical insulating material needed between the case and sink. You have a lot of options in determining each of these factors.

There are some general rules to follow in determining the characteristics of your heatsink. It is important that the surface areas of the component case and heatsink be as flat and smooth as possible. Thermal joint compound conducts heat very well, and can be applied between the case and heatsink to help overcome any surface irregularities. Large contact areas between the case and heat sink are helpful because larger mating areas will improve heat conduction. Wherever screws are used to attach a heatsink to a case, be sure they are securely fastened to flatten any concave or convex mating surfaces and achieve good contact pressure.

The actual θ_{CS} for a heatsink is specified for each particular model in a manufacturer's catalog, but Table 3 provides a typical range of thermal resistance values for several major classes of heatsinks.

When electrical insulators are used to isolate a case from a heatsink, heat must still be transferred as effectively as possible. Unfortunately, most electrical insulators will add some thermal resistance (θ_{INS}) to the case-sink interface. Table 4 shows a selection of various electrical insulators. If your mounting arrangement requires the use of an insulator, add θ_{INS} to θ_{CS} from Table 3. Notice that an insulator's thermal resistance depends on the type of semiconductor package being insulated.

The ability of any heatsink to dissipate heat depends on a complex combination of conduction, convection, and radiation. With all three of these factors working together, it's difficult to calculate the specific thermal resistance of any one particular heatsink. Fortunately, manufacturers typ-

ically list the sink-ambient thermal resistance (θ_{SA}) of their various models. However, if you don't have manufacturer's information, Table 5 lists values that permit good approximations.

As a general rule, larger, thicker heatsinks with more substantial surface area have a lower θ_{SA} than small, thin heatsinks. Also notice that Table 5 shows θ_{SA} for both still and moving air; when air is in motion, the effect of convective cooling is enhanced, and more heat is carried away—in other words θ_{SA} is much lower.

Every kind of semiconductor case differs in its ability to dissipate heat directly into the air, but no case does this as well as heatsinks. The major reason is that air does not support conduction or radiation very well—most heat is carried into the air by convection. When a heatsink is used, heat from a device's case is carried into the heatsink directly by conduction. Without a heatsink, however, a device must rely solely on convection to take the heat away. As a result, the thermal resistance from a case to the ambient air (θ_{CA}) is usually quite high, and heavily dependent on the size and shape of the particular case. Generally speaking, larger metal cases (such as a TO-3) dissipate heat better than small, low-

profile plastic cases (such as a TO-92).

Manufacturer's specifications for a device might list θ_{CA} along with θ_{JC} , but don't count on it. Table 6 shows some common values of θ_{CA} for a variety of case styles. Note that small cases can have large thermal-resistance values that can seriously limit the device's ability to handle power.

Total resistance

Here is a practical example of how to calculate total thermal resistance from the junction to ambient air (θ_{JA}) for a TO-3 case transistor using a large metal heatsink in still air with no electrical insulator. Remember that a TO-3 is a metal-case-mounted semiconductor. From Table 2 you know that θ_{JA} is the sum of θ_{JC} , θ_{CS} , and θ_{SA} . Junction-case thermal resistance can be found on a manufacturer's data sheet, or approximated from Table 2 (typically 1.5 °C/W). Case-sink thermal resistance for a metal-cased, case-mounted semiconductor can be approximated from Table 3 (0.5 °C/W). Table 4 is not needed because we're not using an insulator. The sink-ambient thermal resistance for a large metal heatsink operating in still air can be found in manufacturer's data for the heatsink, or approximated from Table 5 (5.0 °C/W).

These characteristics yield a total thermal resistance of 1.5 + 0.5 + 5.0, or a θ_{JA} of 7 °C/W.

As a second example, under the same conditions as the previous example, you can determine the total thermal resistance when no heatsink is used. From Table 1 you know that the value of θ_{JA} —with no heatsink—is the sum of θ_{JC} and θ_{CA} . Junction-case thermal resistance remains the same as in the previous example (1.5 °C/W), but the value of case-ambient thermal resistance is now obtained from Table 6 (30 °C/W). This yields a new θ_{JA} of 1.5 + 30.0, or 31.5 °C/W—a very significant increase.

Safe operation

It is often desirable to estimate the junction temperature of a semiconductor to determine if it will work within its safe operating range. This technique can be handy for estimating heatsink performance.

The maximum junction temperature (T_j) of a semiconductor device is normally specified on the manufacturer's data sheet. However, maximum junction temperature will not exceed 100 °C for a germanium device, or 200 °C for a silicon device. If T_j is exceeded, even for a brief period of time, the device will probably be destroyed.

Junction temperature can be calculated from the relationship shown in Table 7. Power dissipation (P_d), total thermal resistance (θ_{JA}), and ambient temperature must be known. For most practical purposes, ambient temperature can be considered to be room temperature, or 25 °C. Steady-state power dissipation in a semiconductor device can easily be calculated from Ohm's Law as the voltage drop across a device multiplied by the current flowing through the device. Total thermal resistance can now be approximated from the contents of Tables 2 through 6.

By comparing the specified maximum junction temperature with the value calculated from present operating conditions, you can estimate a device's operating temperature. If

TABLE 3— θ_{CS}

Heatsink Application, Type	Typical (w/ joint compound)	Common Devices Covered
Metal-case, case-mounted	0.1 to 0.7	TO-3, 66
Plastic-case, lead-mounted (screw-on sink)	0.9 to 1.3	TO-126, 127, 220
Plastic-case, lead-mounted (clip-on sink)	1.0 to 2.5	TO-126, 127, 220
Plastic-case, lead-mounted (clip-on sink)	2.0 to 5.0	TO-92
Metal-case, lead-mounted (screw-on sink)	1.5 to 2.7	TO-5, 8, 18
Metal-case, lead-mounted (clip-on sink)	0.9 to 1.5	TO-5, 8, 18
IC's (screw-on sink)	0.5 to 1.2	DIP 0.3 in. wide
IC's (clip-on sink)	2.0 to 5.0	DIP 0.3 in. wide

TABLE 4— θ_{INS}

Insulator Material	Device	Thermal Resistance (°C/W)
Beryllium oxide	TO-3 (TO-204)	0.22
	TO-66	0.45
	TO-220	1.4
Mica	TO-3 (TO-204)	1.6
	TO-66	1.6
	TO-220	5.2
Plastic	TO-3 (TO-204)	0.8
	TO-66	1.6
	TO-220	5.2
Silicone rubber	TO-3 (TO-204)	1.2
	TO-66	2.4
	TO-220	7.9
Other elastomers	TO-3 (TO-204)	0.7
	TO-66	1.4
	TO-220	4.6

Note: Joint compound is assumed to be used with all insulators except those with silicone rubber and other elastomer insulation.

TABLE 5— θ_{SA}

Heatsink Application,	Type	Range	Small	Medium	Large
Metal-case, Case-mount	Still air	4.0–29.0	20.0	13.0	5.0
	Moving air	1.5–8.0	8.0	5.0	15.0
Plastic-case, Lead-mount (screw)	Still air	5.0–30.0	30.0	17.0	6.0
	Moving Air	2.0–10.0	10.0	6.0	2.0
Plastic-case, Lead-mount (clip)	Still air	30.0–40.0	40.0	35.0	30.0
	Moving air	9.0–10.0	10.0	9.5	9.0
Plastic-case, Lead-mount (clip)	Still air	83.0–150	150	130	85.0
	Moving air	60.0–77.0	77.0	68.0	60.0
Metal-case, Lead-mount (screw)	Still air	6.0–33.0	32.0	18.0	6.0
	Moving air	3.0–11.0	10.0	7.0	3.0
Metal-case, Lead-mount (clip)	Still air	40.0–150	150	80.0	40.0
	Moving air	15.0–45.0	45.0	30.0	15.0
IC's (screw)	Still air	7.0–30.0	30.0	20.0	7.0
	Moving air	3.0–18.0	18.0	12.0	3.0
IC's (clip)	Still air	21.0–30.0	30.0	25.0	20.0
	Moving air	7.0–10.0	10.0	8.5	7.0

your calculations indicate a temperature well below the maximum T_j , the device will probably run safely. If, however, your calculations indicate a temperature close to or higher than the maximum T_j , the device will be in a region where it can destroy itself. Power dis-

sipation, thermal resistance, or ambient temperature must be reduced to reduce the junction temperature to a safe level. Although ambient temperature can be adjusted, it is usually impractical to do so.

Here are some basic examples. According to a manufac-

turer's data sheet, the maximum junction temperature for a TO-220 transistor is 150 °C. Determine if the transistor is operating safely if it's dissipating 2 watts of power in still air. It has a medium-sized, bolt-on heatsink and a beryllium oxide insulator attached.

Because power dissipation (2 watts) and ambient temperature (assumed 20°C) are known, it is necessary to estimate the value of total thermal resistance. Total thermal resistance (θ_{JA}) is the sum of θ_{JC} , θ_{CS} , θ_{INS} , and θ_{SA} . From Tables 2 through 5 you know that the junction-case thermal resistance is 7.0°C/W (Table 2), case-sink thermal resistance for a plastic-cased, lead-mounted semiconductor is 1.1°C/W (Table 3), insulator thermal resistance is 1.4°C/W (Table 4), and the thermal resistance for the associated heatsink is 17.0°C/W (Table 5). Therefore, the total thermal resistance is 26.5°C/W.

Next, the junction temperature can be calculated from the relationship given in Table 7. A device consuming 2.0 watts of power at 26.5°C/W yields a temperature rise of 53.0°C (2.0°C × 26.5°C) above ambient temperature. Adding the ambient temperature yields a junction temperature of 78°C (53.0°C + 25.0°C). Since the calculated value of T_j is far below the specified maximum of 150°C, the TO-220 transistor should be operating safely within its limits.

As another example, remove the heatsink and insulator from the transistor in the previous example and determine whether or not the transistor will still be operating safely. Keep in mind that power dissipation (2 watts), maximum specified T_j (150°C), and ambient temperature (25°C) remain the same—the factor that changes substantially is the total thermal resistance. Without a heatsink, θ_{JA} can be estimated as the sum of junction-case and case-ambient thermal resistance. Since the transistor remains unchanged, the junction-case thermal resistance remains unchanged at 7.0°C/W (Table 2). The case-ambient

thermal resistance for a TO-220 transistor can be estimated from Table 6 (60°C/W). That yields a total thermal resistance of 67.0°C/W (7.0°C + 60.0°C). Using the formula of Table 7, the new junction-temperature rise would be 134.0°C (2.0 × 67.0) above ambient. The junction temperature would then be 159°C (134.0°C + 25.0°C).

Our calculations indicate that, without a heatsink, power dissipation will result in a destructive temperature at the device junction of 159°C which exceeds the specified limit of 150°C. Although the device might work for some time at that level, thermal breakdown is almost inevitable. To prevent damage to the device, it is necessary to replace the heatsink or reduce power dissipation.

Maximum power

Instead of calculating a junction temperature to determine whether or not a semiconductor is operating safely, you can use the formula in Table 7 to calculate the maximum allowable power dissipation for a desired set of operating conditions. This approach allows you to select a desirable junction temperature (below the specified maximum T_j) and then find the maximum power dissipation that will not exceed the desired junction temperature.

The first step in calculating maximum power is to determine the maximum junction temperature for the semiconductor device that you are using. A T_j rating is usually listed on a manufacturer's data sheet. Power dissipation can then be calculated from the relationship given in Table 8. Ambient temperature is still considered to be 25°C. The total thermal resistance (θ_{JA}) can be estimated from Tables 2 through 6.

It is usually undesirable to operate the device at or around its maximum T_j . Use a smaller value in your calculations to allow a safety margin. For example, a 20% safety margin for a maximum T_j of 160°C would be 128°C (160 - (160 × 0.2)). A 50% safety margin would be 80

TABLE 6— θ_{CA}

Device Case	Thermal Resistance (typical)
TO-3 (TO-204)	30.0
TO-5	150.0
TO-8	75.0
TO-18	300.0
TO-36	25.0
TO-39	150.0
TO-46	300.0
TO-60	70.0
TO-66	60.0
TO-92	100.0
TO-126	80.0
TO-127	70.0
TO-220	60.0

TABLE 7— T_j FORMULA

$$T_j = (P_d)(\theta_{JA}) + T_a$$

- T_j = Junction temperature (°C)
- P_d = power dissipation (watts)
- θ_{JA} = total thermal resistance (°C/W)
- T_a = ambient temperature (°C)

TABLE 8— P_d FORMULA

$$P_d = \frac{T_j - T_a}{\theta_{JA}}$$

- P_d = Power dissipation (watts)
- T_j = desired junction temperature (°C)
- T_a = ambient temperature (°C)
- θ_{JA} = total thermal resistance (°C/W)

°C (160°C - (160°C × 0.5°C)). Incorporating a safety margin into the calculations ensures that the device will be running within safe limits at all times.

Look at another example. A transistor in a TO-66 case has a maximum T_j of 180°C. The transistor has a metal case and a case-mounted, medium-sized heatsink with a mica insulator. You want a 40% safety margin for the junction temperature, so you can estimate the maximum allowable power dissipation for the device in still air.

First estimate the total thermal resistance of the arrangement from Tables 2 through 5. Total thermal resistance (θ_{JA}) is the sum of θ_{JC} (7°C/W from Ta-

ble 2), θ_{CS} (0.5°C/W from Table 3), θ_{INS} (1°C/W from Table 4), and θ_{SA} (13°C/W from Table 5). That yields a sum of 21.5°C/W total thermal resistance.

The desired junction temperature is the maximum specified T_j minus a 40% safety margin. That works out to a desired junction temperature of 108°C (180°C - (180°C × 0.40°C)).

Finally, use the formula in Table 8 to determine the maximum allowable power dissipation for the device. With a temperature difference of 83.0°C (108°C - 25°C) and a thermal resistance of 21.5°C/W, the maximum allowable power dissipation (P_d) for the device is 3.9 watts (83/21.5).

With the same transistor and desired junction temperature from the previous example, let's estimate the maximum allowable power dissipation for the device in still air with a large heatsink and no insulator. A large heatsink and no insulator will substantially reduce the total thermal resistance of the arrangement. Total thermal resistance is now the sum of θ_{JC} (7°C/W from Table 2) θ_{CS} (0.5°C/W from Table 3), and θ_{SA} (5.0°C/W from Table 4); θ_{JA} is now 12.5°C/W, a large decrease from the last example. The desired junction temperature stays the same at 108°C, so the temperature difference between junction and ambient remains constant at 83°C. Finally, use Table 8 to find the value of maximum allowable power dissipation. The value of P_d is 6.6 watts (83/12.5).

As you can see, just using a larger heatsink and removing the insulator can virtually double the allowable power of the device, and still keep the device's junction temperature 40% below its maximum rating. After allowable power is calculated, you can work backwards with Ohm's law to gauge the appropriate voltage and current for operating the transistor. In some instances, minor circuit changes might be necessary to limit voltage or current.

Power derating

The power that a device can

dissipate is closely related to its junction temperature. Once a certain junction temperature is reached, the maximum allowable power drops off in a linear fashion as junction temperature continues to increase—and the junction temperature can only climb to T_j before permanent device damage occurs.

Most manufacturers will show a detailed plot of power dissipation vs. junction temperature with their specifications. This type of plot, known as a *power derating curve*, is illustrated in Fig. 4. The derating factor (DF) is essentially the slope of the line that represents how quickly allowable power will drop off as temperature increases. Expressed another way, DF is the inverse of the junction-case thermal resistance ($1/\theta_{JC}$). Remember that power derating is for the device alone—it does not consider the

TABLE 9—MAXIMUM POWER	
$P_x = P_M - (T_x - T_O)DF$	
P_x	= Allowable power dissipation (watts)
P_M	= maximum power dissipation (from derating curve) (watts)
T_x	= desired temperature point (°C)
T_O	= derating temperature knee (°C) (from derating curve)
DF	= derating factor (W/°C)

effects of an attached heatsink.

The maximum safe power rating anywhere within the linear region of the derating curve is given by the formula in Table 9. To determine power at any linear point, calculate the derating factor from either the line's slope, or from the inverse of θ_{JC} . Then use the relationship in Table 9. Look at the following example.

Using the power derating curve of Fig. 3, find the maximum allowable power dissipation

find allowable power at the desired temperature point (130°C). Allowable power (P_x) is equal to 6.25 watts ($10 - ((130 - 100) \times 0.125)$).

Notice that when its junction temperature is below 100°C, the device can dissipate up to its maximum power of 10 watts. Above a junction temperature of 100°C, the amount of power that the device can dissipate will decrease at a rate of 0.125 watts for every 1°C of junction temperature increase. If a heatsink is used, junction temperature will be reduced and the device can dissipate increased power.

Conclusion

Whether you are evaluating the design of a project, or designing a project of your own, heat management plays an important role in your work. When a component must handle any sizable amount of power, the inevitable byproduct—heat—can destroy or damage part's opera-

Be an FCC LICENSED ELECTRONIC TECHNICIAN!



Earn up to \$30 an hour and more!

Learn at home in spare time. No previous experience needed!

No costly school. No commuting to class. The Original Home-Study course prepares you for the "FCC Commercial Radiotelephone License." This valuable license is your professional "ticket" to thousands of exciting jobs in Communications, Radio-TV, Microwave, Maritime, Radar, Avionics and more...even start your own business! You don't need a college degree to qualify, but you do need an FCC License.

No Need to Quit Your Job or Go To School
This proven course is easy, fast and low cost! **GUARANTEED PASS**—You get your FCC License or money refunded. **Send for FREE facts now. MAIL COUPON TODAY!**

COMMAND PRODUCTIONS
FCC LICENSE TRAINING, Dept. 90
P.O. Box 2824, San Francisco, CA 94126
Please rush FREE details immediately!

NAME _____
ADDRESS _____
CITY _____ STATE _____ ZIP _____

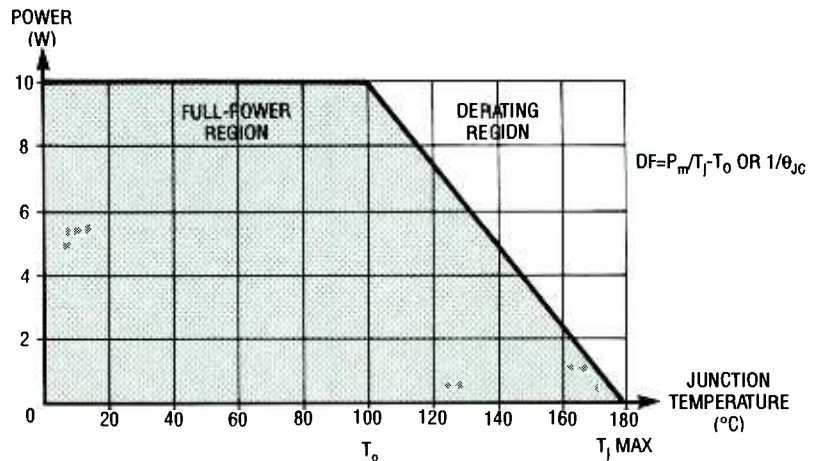

FIG. 4—A POWER DERATING CURVE shows how allowable power drops off as temperature increases.

tion for the device at a junction temperature of 130°C. First it's necessary to calculate the power derating factor (DF) of the curve. Figure 3 shows that DF is equal to the maximum allowable power (10 watts), divided by the difference between the maximum junction temperature (180°C) and the temperature where derating begins (100°C). The DF is then 0.125 ($10 / (180^\circ\text{C} - 100.0^\circ\text{C})$). Then, use the formula in Table 9 to

tion and overall reliability. The objective of heat management is to carry enough heat away from the power-dissipating junctions of a device to allow reliable, long-term operation. The ample use of heatsinks is an effective and economical means of removing heat from a device. But there are a variety of important thermal resistance factors that must be considered to ensure that a heatsink arrangement will function as desired. □

PC TEST EQUIPMENT

continued from page 43

surement, the counter must sample data at a rate sufficient to satisfy the Nyquist criterion. (See the box entitled analog-to-digital and return.) Most time-and frequency-measurement applications require at least 1000 samples per second.

Any universal frequency-counter board that is compatible with Guide Technology's product, (the most popular counter board today), can be converted into a time-interval analyzer with Guide Technology's VIEWMOD software. This does not mean, however, that there is no longer a need for a universal frequency counter. One attractive model is Optoelectronics' PC10, selling for only \$335, that can measure frequencies up to 2.4 GHz.

Related test devices

The PC-based test instrument market is flooded with support instruments such as digital multimeters (DMM) and interface multiplexers. These can be used in conjunction with other instruments to round out an ATE setup or instrument cluster. Choosing the support device that's right for an specific system should be done on an individual basis.

From dream to reality

As the number of installed personal computers increases, more PC-based testing applications are being developed. In the same way word processing led to desktop publishing, PC-based test instruments are leading to new methods for making tests and measurements not previously visualized.

The economies of production and improved manufacturing processes made possible by the worldwide proliferation of entertainment electronics and the price battle among the world's personal computer makers has forced down the price of many of the key components in PC-based test instruments. The result is that you can get more for your money. Ω



WORLD'S SMALLEST FM TRANSMITTERS! New Surface Mount Technology (SMT) makes all others obsolete! XST500 Transmitter—powerful 3 transistor audio amplifier, transmits whispers up to 1 mile. XSP250 Telephone Transmitter—line powered, transmits conversations up to ¼ mile. Both tune 88-108 MHz. Easy to assemble E-Z KITS (SMT components pre-assembled to circuit board)! XST500—\$44.95, XSP250—\$34.95, VISA/MC. COD add \$6. **XANDI ELECTRONICS, 201 E. Southern Ave., Suite 111, Tempe, AZ 85282. 1-800-336-7389.**

CIRCLE 178 ON FREE INFORMATION CARD



NEW JENSEN MASTER CATALOG Jensen's 1993 Master Catalog, available free, contains many innovative products for design, testing and repair of electronic equipment. Presents new instruments from Fluke, Beckman, Tektronix, Huntron, Leader, BK Precision, and others. Introduces latest inch and metric tools, tools kits, soldering supplies, cables, connectors, static control products, PC diagnostics and more. Enjoy free technical assistance and free shipping within the continental USA. **JENSEN TOOLS INC., 7815 S. 46th St., Phoenix AZ 85044 (602) 968-6231.**

CIRCLE 115 ON FREE INFORMATION CARD



GET YOUR RECHARGE CATALOG FREE...EARN BIG \$\$ IN YOUR SPARE TIME!—All supplies and Do-It-Yourself kits with complete instructions available. Supplies cost from \$9.95 in qty and you can sell recharged toner cartridges for \$40.00 to \$55.00 each. Printers include HP LaserJet Series I, II, III, IV, Apple LaserWriter, QMS, etc. Canon PC Copiers also. **CHENESKO PRODUCTS, 2221 Fifth Ave., Suite #4, Ronkonkoma, NY 11779, 516-467-3205. FAX 516-467-3223, 1-800-221-3516**

CIRCLE 110 ON FREE INFORMATION CARD

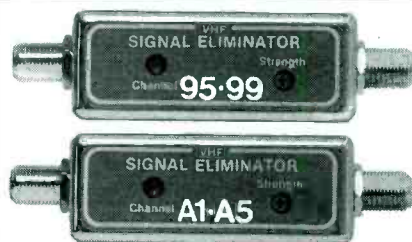

CABLE TV 50dB NOTCH FILTERS for interference removal or channel censoring. Filters are user-adjustable to desired channel # or frequency. Eight Models available, each for certain channels: 2 & 3; 4 to 6; 7 to 13; 14 to 17; 18 to 22; 23 to 29; 30 to 36; 95 to 99 plus 0 & 1. Just \$30 each or 3 for \$75, includes shipping. **ONE MONTH MONEY BACK**, fast delivery. Visa, MC, check or M.O. (C.O.D. is \$5 extra) Huge discounts for higher quantities. **STAR CIRCUITS, P.O. Box 94917, Las Vegas, NV 89193. Call 24 hours 1-800-535-7827.**

CALL NOW AND RESERVE YOUR SPACE

- 6 × rate \$940.00 per each insertion.
- Fast reader service cycle.
- Short lead time for the placement of ads.
- We typeset and layout the ad at no additional charge.

Call 516-293-3000 to reserve space. Ask for Arline Fishman. Limited number of pages available. Mail materials to: mini-ADS, ELECTRONICS NOW, 500-B Bi-County Blvd., Farmingdale, NY 11735.

FAX: 516-293-3115

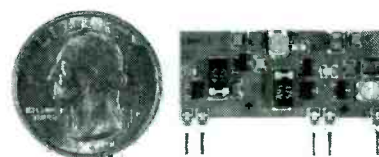

TWO TRANSMITTERS IN ONE! 5 MINUTE ASSEMBLY! MONEYBACK GUARANTEE! New Law Enforcement grade device on a single chip is the most sensitive, powerful, stable room transmitter you can buy. Uses any 3V-12V battery. Or attach to telephone line to monitor all telephone conversations over 1 mile away without batteries! 100mW output! 80-130MHZ. Receive on any FM radio or wideband scanner. VT-75 microtransmitter. \$49.95 + 1.50 S&H. VISA, MC, MO. COD's add \$4.00. **DECO INDUSTRIES, Box 607, Bedford Hills, NY 10507. 914-232-3878.**

CIRCLE 127 ON FREE INFORMATION CARD

How to Get a High-Paying Job In Electronics

Launch your career as an electronics professional.

Your key to career success and personal happiness can be summed up in one word. . . EDUCATION!

Thousands of great jobs become available in electronics every year. To land one of those great jobs, you must have the educational credentials, knowledge and skills that employers not only want and need, but also demand.

Let Peoples College prepare you for an exciting job and a secure future in electronics.

Peoples College offers Specialized Associate Degree and Diploma programs by distance education to prepare you for one of the many high-paying jobs. As a graduate of one of our programs you can qualify for jobs such as field service engineer, electronics technician, laboratory assistant, PC specialist, or even start your own business!

In addition to providing you with a rock-solid foundation in electrical and electronic fundamentals and computer concepts, we offer in-depth training in these specialties:

- Personal computer servicing — how to test, troubleshoot and repair electronic devices including personal computer and electronic control circuits.
- Communications electronics — radio communications, cellular communications, satellite communications, fiber optics, facsimile and more.
- Industrial control — electronics and microprocessors are crucial to the operations systems that keep automobile manufacturers, large defense contractors and thousands of others in business.

New PC Programming courses also available — MS-DOS, Windows, LANS, languages like BASIC, Pascal, C and object-oriented programming with C++, assembly language, UNIX and graphics.



Distance learning—Peoples College comes to you.

With distance education, you learn in your own home at your convenience. You can join the thousands of others who have studied through the easy, proven methods of distance education. There are no classes to prepare for, no commuting, no parking problems. You can complete our programs in your spare time without giving up your present job. Learn while you earn. You go as fast as you want. Our instructors are standing by to answer your questions if you need help.

What makes Peoples College programs so special?

While there are other schools offering similar training, ours is unique! Here are just a few reasons why Peoples College programs give you more:

- Standard college texts, not lessons
- Video training which makes critical subjects come alive
- Accelerated Learning System—a scientifically proven study system that lets you learn faster and easier than ever before
- Computer-based training software for selected software subjects
- Industry certification preparation

Here is a partial list of some of the hardware you receive with a Peoples College program:

- 486sx 25 MHz PC with 80 MB hard drive, 3.5" 1.44 MB floppy drive, VGA color monitor and mouse in selected programs
- Microprocessor trainer (8-bit CPU), digital multimeter, breadboard with function generator, power supplies and logic probe
 - Oscilloscope included in some programs
 - Portable cellular telephone in the communications programs
- All programs include Electronics Experience Labs for hands-on training

Don't delay—Your future starts today! For more information fill out and mail the attached coupon.

We'll send you our color brochure, catalog and our new booklet "How to Get a High-Paying Job in Electronics." Get your career started today. Do yourself a big favor and send for this information now!

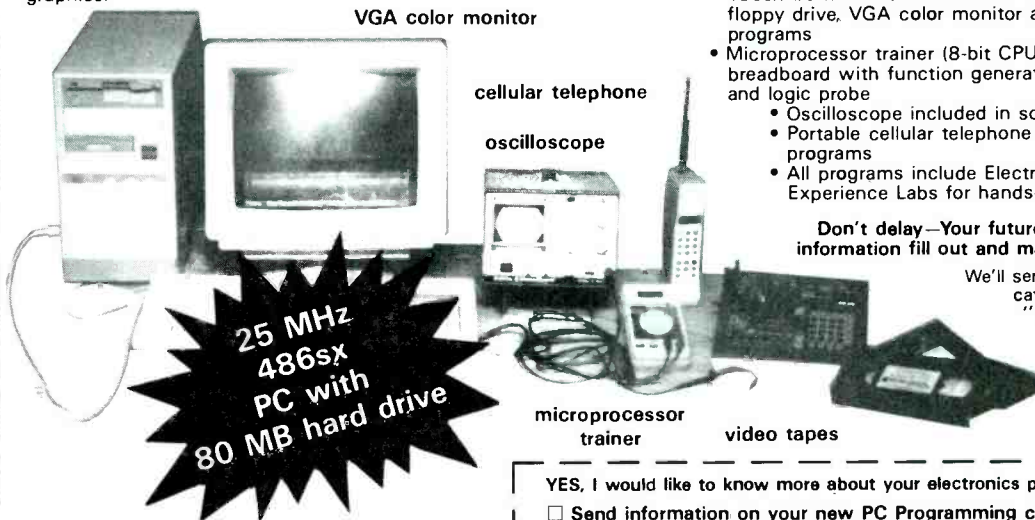

**25 MHz
486sx
PC with
80 MB hard drive**



233 Academy Drive • P.O. Box 421768
Kissimmee, FL 34742-1768

Accredited member, National Home Study Council
Member, D.L. Peoples Group

YES, I would like to know more about your electronics programs!

Send information on your new PC Programming courses too.

Check here if you want details on our programs approved under the GI Bill.

Name _____

Address _____

City _____

State _____ Zip _____

Phone (____) _____

AO993

HARDWARE HACKER

Pulse monitor secrets, an update on free energy, a new wireless communication magazine, thermoelectric guidelines, and aerobic exercise software.

DON LANCASTER

An update to last month's free energy resource sidebar: The *International Association for New Science* newly released their 540 page proceedings from their latest *International Symposium on New Energy*. At \$49.50.

All of the usual topics are covered—antigravity, Reed motors, pulsed magnetics, zero point scalar energy, homopolar generators, Tesla earth resonance, perpetual motion, element transmutation, cancer cures, alternate fusion, the whole bit.

My view is that the proceedings are a fascinating and wondrously bizarre work of fiction. Many of the papers presented emit an aura of outright hogwash.

On the other hand, the first step in researching any controversial topic is to find out who is doing what to whom. Even totally absurd and "not even wrong" notions can lead to useful and innovative new concepts. Forums should exist for all controversial thought. Which makes the symposium worth a look.

Thermoelectric review

Judging by the helpline calls lately, there seems to be a lot of interest in the solid-state thermoelectric coolers that are now cropping up in surplus channels. Sadly, most hackers don't pick up on the fact that there are several very rude surprises awaiting when they try to use these in the real world.

So, one more time: These thermoelectric modules are *extremely* inefficient and need *extremely* good heatsinks. They are strictly limited to very low power uses. They also demand simple and obvious heat flux calculations which most hackers positively refuse to make. For most hacker uses most of the

time, the *thermoelectric cooling modules simply do not work*.

Let's see why this is so.

Solid-state thermoelectric modules using the *Peltier* cooling effect were developed over three decades ago and have not changed or improved one whit since. The players change every few years in an industry that's been chronically unprofitable. One supplier is *Melcor*. They offer data sheets and design notes.

Figure 1 shows a typical heat pumping curve for a 20-watt module. Applying a DC current across the device causes heat to be moved from one surface to another. This module might need 15 volts at 3 amps for operation.

Note that the heat pumped depends inversely on the temperature drop across the device. Yes, you can pump 20 watts of heat through a zero temperature difference. Or you can pump zero watts of heat across a 50-degree temperature difference. That would be, of course, with zero efficiency.

More typically, you'll want to both pump heat and have a high *delta-T*, or change in temperature. A typical operating point might be a 25-degree drop when pumping 10 watts.

The data sheets seem to bury the module efficiency figures for most normal operating points. Often, *three watts of energy are required to*

move one. This is an EER (*Energy Efficiency Rating*) of a laughable 0.33. Compare this against a US air conditioner with an EER of 12. Or a Japanese one with a superb EER of 17.

Low efficiency would not be all that bad if all of the excess heat was not generated in the wrong place at the wrong time. But what you have done when you use a thermoelectric module is *add* heat precisely where you are trying to eliminate it.

It is trivially easy to get more delta-T rise between your module hot side and ambient than the delta-T cooling the module is providing!

Let's use an aquarium cooler as an example. Now, there is another name for any large aquarium. It is called a *super efficient heatsink*. So, let's take our super efficient heatsink and then remove some heat from it. Because of the thermoelectric module's inefficiency, we may have to add three new watts of heat for every one removed and put it into a new heatsink.

Naturally, we would not want the new heatsink to rise up as far above ambient as the aquarium goes below, or we will simply be heating up the ambient air. So, we'll shoot for an output temperature rise of only a quarter the cooling drop.

Your final heatsink will have to be 16 times better than your aquarium! A handy heatsink would be a second aquarium that is 16 times larger than the one you want to cool.

Just how much heat are we talking about here? That's what doing heat flux calculations is all about. Let's review the basics.

The two key numbers you have to look for are your *watts of cooling required* and your *heatsink thermal impedance*. Going back to square one, a *BTU*, or *British Thermal Unit* is the amount of energy needed to

NEED HELP?

Phone or write your **Hardware Hacker** questions to:

Don Lancaster
Synergetics
Box 809-EN
Thatcher, AZ, 85552
(602) 428-4073

For fast **PSRT** access, modem (800) 638-8369, then an HHH. Then **XTX99005,SCRIPT**.

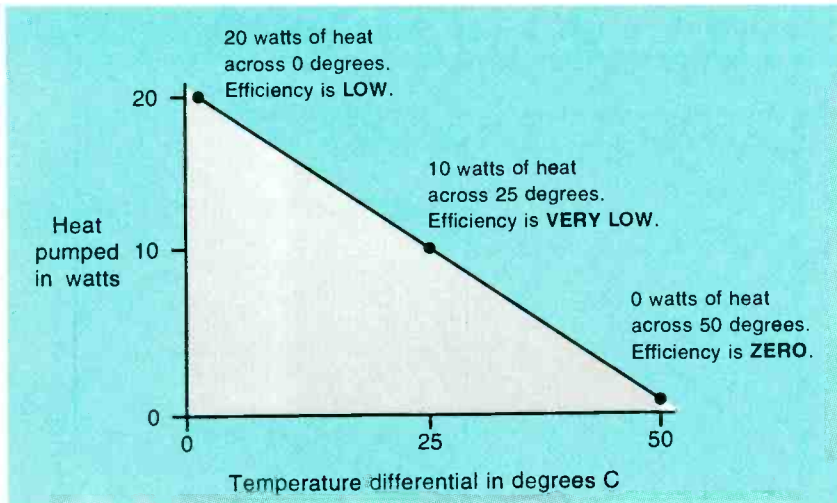

FIG. 1—TYPICAL HEAT PUMPING CURVE for a larger thermoelectric module. Note that the efficiency goes down as the temperature differential increases.

raise or lower the temperature of one pound of water by one degree Fahrenheit.

There are around eight pounds of water per gallon, so eight BTU 's are needed to shift the temperature of a gallon of water by one degree F. A temperature rate of one BTU per minute will occur when 17.58 watts

of power are input to the system.

Heat flux ends up proportional to temperature difference. For a given heatsink, you'll get twice the delta-T for twice the watts passed through. Math similar to plain old Ohm's law defines the *thermal impedance*.

A typical heatsink might have a thermal impedance of between 2 and 10 degrees Celsius per watt. If the thermal impedance is 5 degrees per watt, and if you are transferring 8 watts, the thermal rise will be a total of 40 degrees.

To get below 1 degree per watt, you usually have to go to forced-air cooling. To get under half a degree per watt, a pumped-water cooling system is often the best choice.

The key problem is that *the heat rise of the hot side of the ther-*

moelectric module above ambient can easily exceed the net cooling of the module itself!

For instance, you might have your module doing a 30-degree cooling, but your heatsink hot side might have a 40-degree rise above ambient. The net result is 10 degrees of *heating*. That's the exact opposite of what you are trying to do. The module also operates at a much less efficient point on the thermoelectric response curve.

In the case of the aquarium, you can easily measure your heat flux. The results will depend on the surface area of the aquarium, the ambient air flow, the temperature drop required, and the amount of water present.

Temporarily remove the fish and fill the aquarium with ice water. But otherwise let it run with the usual lights, pumps, and whatever. Next, carefully measure your temperature versus time as the ice melts and slowly reaches room temperature. The *Radio Shack #277-0123* digital thermometer is ideal for this.

Then plot the temperature rise versus time on a graph. Next, find the *slope* of the warming curve at *your target temperature*, in degrees per minute. To hold the target temperature, the degrees-per-minute cooling needed will equal the degrees per minute warming taking place.

Multiply the pounds of water times the degrees per minute of cooling needed to get the BTU 's

**NEW FROM
DON LANCASTER**

HARDWARE HACKING

Incredible Secret Money Machine II	18.50
Hardware Hacker Reprints II or III	24.50
Blatant Opportunist Reprints	24.50
Resource Bin Reprints	24.50
The Case Against Patents	24.50
Ask The Guru Reprints I, II or III	24.50
CMOS Cookbook	24.50
TTL Cookbook	24.50
Active Filter Cookbook	24.50
Micro Cookbooks I or II	19.50
Lancaster Classics Library	119.50

POSTSCRIPT STUFF

PostScript Secrets (Ile/Mac/PC)	39.50
Book-on-demand resource kit	39.50
Intro to PostScript VHS Video	39.50
PostScript Beginner Stuff	39.50
PostScript Show & Tell	39.50
PostScript Cookbook (Adobe)	18.50
PostScript Ref. Manual II (Adobe)	29.50
PostScript Program Design (Adobe)	24.50
Type I Font Format (Adobe)	15.50
Acrobat Reference (Adobe)	24.50
LaserWriter Reference (Apple)	19.50
PostScript by Example (McGilton)	29.50
Real World Postscript (Roth)	22.50
PostScript Visual Approach (Smith)	22.50
Thinking in PostScript (Reid)	22.50
Undst PS Pgrmmg (Holtzgang)	29.50
The Whole Works (all PostScript)	349.50

FREE VOICE HELPLINE VISA/MC

SYNERGETICS
Box 809-RE
Thatcher, AZ 85552
(602) 428-4073

CIRCLE 205 ON FREE INFORMATION CARD

1. The area to be cooled *must* be superinsulated. All avoidable sources of heat gain *must* be carefully excluded.
2. Realistic heat flux calculations and heatsink thermal impedance calculations *must* be carefully made ahead of time.
3. Current thermoelectric modules are an inappropriate solution if more than twelve watts of actual cooling are called for.
4. The rise of the module hot side temperature above ambient *must* be kept as low as possible. This rise *must never* exceed a small fraction of the total temperature drop desired.
5. Very large and extremely high quality heatsinking is a must. Use forced air cooling at the very least. Pumped water cooling may be required to achieve an acceptable efficiency.
6. Power sources *must* have very low ripple and hum, since the ripple peaks heat much worse than the troughs cool.
7. Surfaces contacting the module *must* be ultra-flat. 100% contact is essential. Thermal grease *must* always be used.

FIG. 2—USE THESE GUIDELINES for all of your thermoelectric module designs. Otherwise, you are likely to end up heating instead of cooling!

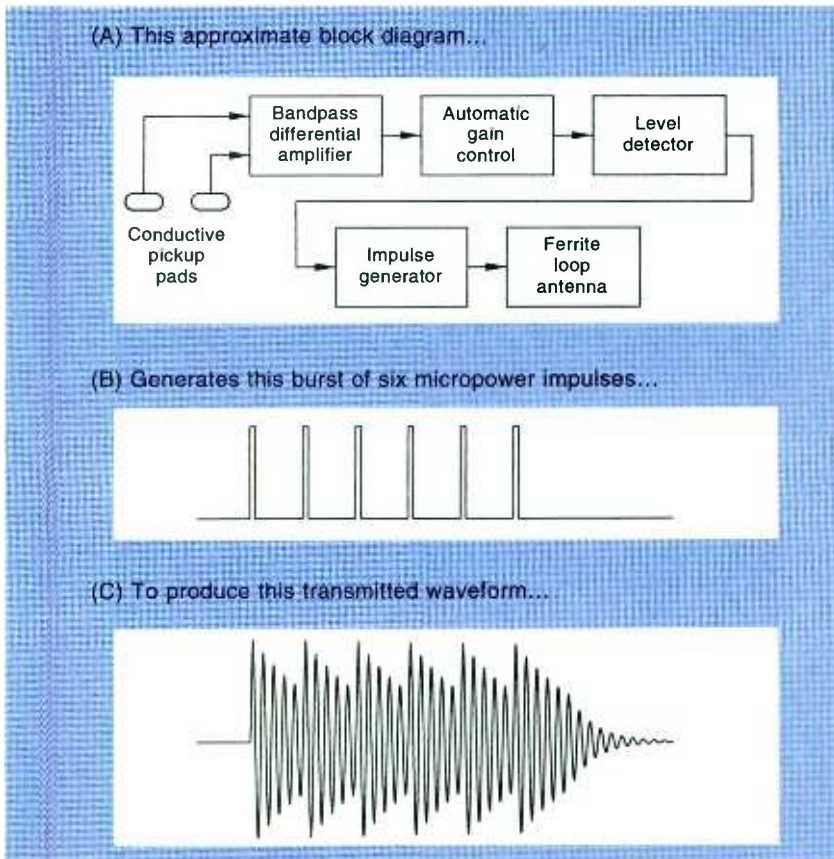

FIG. 3—THE MYSTERY WAVEFORMS inside a typical “chest type” pulse monitor revealed. The transmitted signal approximates a 36 cycle burst of 5 kiloHertz sine-waves. One burst per pulse event. What you really have here is plain old inductive coupling using an air core transformer.

per minute required. Multiply that by 17.58 to get the cooling watts needed. Finally, multiply the result by some fudge factor like 1.5 for a safety margin.

The chances are that the final cooling power required will be *hundreds* of times higher than what can be done using thermoelectric modules.

I haven't actually run this warming test, but I'd guess that 300 watts of cooling would not be an unreasonable value for keeping a large aquarium fairly cool. And if you do burn up 3 watts of inefficiency for every single watt pumped, something like 1200 watts of heat will have to go out through your heatsink. With a 1-watt per degree C rise heatsink, the thermoelectric module's hot side temperature will try to go to 1200 degrees. *Thirty* of the 20-watt modules would be needed!

Do those new CPU thermoelectric coolers work? I'd be willing to bet that if you removed the cooler and coupled the heatsink di-

rectly to the CPU case itself, the results would end up as good or better—simply because you are not adding extra heat at a 3:1 premium where you don't want it.

A related story: Years ago there was this total federal solar fiasco involving a school in the rural south. This was to be a pilot demonstration project of a solar adsorption cycle cooler. The results weren't quite as good as expected, so they added a new five-ton evaporative cooler to the output to improve the heatsinking to ambient air. Sure enough, the cooling then met the specification.

Then someone asked this rather embarrassing question: How much evaporative cooling would have been needed if the solar adsorption cooling was not in use at all? The answer? *Three tons!*

Using thermoelectric modules for many hacker applications can end up the same as building a bonfire inside an icebox.

Are there any applications at all for thermoelectric modules? Cer-

If you thought that last piece of Test Equipment you had purchased cost too much, **IT PROBABLY DID!**

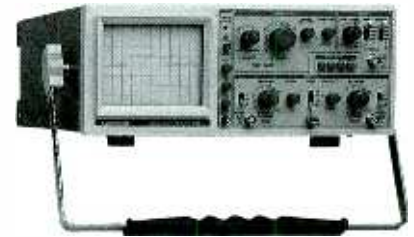

OS-9060D
60MHz OSCILLOSCOPE



DM-232
3 1/2 DGT DMM
4 1/2 DGT FREQUENCY
COUNTER



FG-8002
2MHz SWEEP
FUNCTION
GENERATOR

Consider a sensible source.

You can choose from a variety of High Quality Analog Oscilloscopes, (20 MHz to 100MHz), Cursor Control and CRT readout Oscilloscope (20MHz & 40 MHz). Digital Multimeters (3 1/2, 3 3/4, & 4 1/2 Dgt.) reciprocating frequency counters, sweep function generators and power supplies to meet your test instrument needs.

Call, FAX, or Write today for a free catalog.

GoldStar Precision

13013 East 166th St., Cerritos, CA 90701
tel: 310-404-0101 • fax: 310-921-6227
CIRCLE 185 ON FREE INFORMATION CARD

PULSE MONITOR RESOURCES

ACT USA

Box 5490
Evanston, IL 60204
(708) 491-9628
CIRCLE 316 ON FREE INFORMATION CARD

Bicycling Magazine

33 East Minor Street
Emmaus, PA 18098
(215) 967-5171
CIRCLE 317 ON FREE INFORMATION CARD

Creative Health Products

5148 Saddle Ridge Road
Plymouth, MI 48170
(800) 742-4478
CIRCLE 318 ON FREE INFORMATION CARD

Dialog

3460 Hillview Avenue
Palo Alto, CA 94304
(415) 858-2700
CIRCLE 319 ON FREE INFORMATION CARD

Medical Electronic Products

2994 W Liberty Avenue
Pittsburgh, PA 15216
(412) 343-9666
CIRCLE 320 ON FREE INFORMATION CARD

Medical Equipment Designer

29100 Aurora Road #200
Solon, OH 44139
(216) 248-1125
CIRCLE 321 ON FREE INFORMATION CARD

Polar

99 Seaview Blvd
Port Washington, NY 11050
(516) 484-2400
CIRCLE 322 ON FREE INFORMATION CARD

Precise International

15 Corporate Drive
Orangeburg, NY 10969
(914) 365-3500
CIRCLE 323 ON FREE INFORMATION CARD

Pulse Stick II/Claggk Inc

PO Box 4099
Farmingdale, NY 11735
(516) 293-3751
CIRCLE 324 ON FREE INFORMATION CARD

RacerMate, Inc

3016 NE Blakeley Street
Seattle, WA 98105
(800) 522-3610
CIRCLE 325 ON FREE INFORMATION CARD

REI

1700 45th Street East
Sumner, WA 98352
(800) 426-4840
CIRCLE 326 ON FREE INFORMATION CARD

Synapse Enterprises

Box 35311
Canton, OH 44735
(216) 455-1162
CIRCLE 327 ON FREE INFORMATION CARD

Trek

801 W Madison Street
Waterloo, WI 53594
(800) 879-8735
CIRCLE 328 ON FREE INFORMATION CARD

Vetta/Orieander USA

14553 Delano St, Ste 210
Van Nuys, CA 91411
(818) 780-8808
CIRCLE 329 ON FREE INFORMATION CARD

modynamic laws. But, of course, they do not.

A vortex cooler is simply a magic Tee-shaped pipe that contains no moving parts at all. Ordinary air is blown into the middle. Hot air comes out one end, and cold air out the other—down to -40 degrees Fahrenheit.

Leading suppliers include *Vortec* and *Exair*. Some important applications for vortex coolers are for cooling electronics and stopping needle breakage on industrial sewing machines.

I would guess that a vortex CPU cooler could be produced very simply and easily. And it would work much better than a thermoelectric module. As far as I know, nobody has even tried.

Pulse monitor discoveries

Warnings: Do not ever modify an EKG-type pulse monitor in any way for any reason! Do not ever attempt to build your own units of this type! What follows is not in any manner to be construed as medical advice.

I've been developing some aerobic exercise software for a client—using PostScript, of course. I have found it to be the greatest universal hacker's language anywhere ever. I have also been looking closely at the pulse monitors and have found some fascinating new electronic concepts that you might like to expand upon in one way or another. These concepts should apply beautifully to short-haul telemetry applications.

But *please* be careful to heed all the above warnings.

One way to deal with exercise, of course, is to get yourself a corned beef and pork fat sandwich, add a helping of eggs Benedict, and chow down until the urge goes away. There are others who feel that sustained exercise programs provide positive benefits towards longevity, physical conditioning, well being, and can be beneficial in medical therapy.

The harder you exercise, the higher your heart rate. The goal of an *aerobic* (or "with oxygen") exercise is to reach an elevated pulse rate *target zone* and maintain it for a fairly long time. Say half an hour to an hour of cycling, group aerobics,

tainly. *If* you have carefully made your heat flux measurements. And *if* you are moving only tiny amounts of heat out of a superinsulated region. And *if* you are dumping into a big heatsink with a very low delta-T.

You also have to use super smooth surfaces, proper thermal grease, and avoid *all* ripple in your power supply. The tiniest amount of ripple will foul things up because the ripple troughs heat six times better than the peaks will cool.

Figure 2 shows guidelines for proper use of thermoelectric modules. These modules can be a sure-fire winner for any science fair, where you can easily feel all the heat going from your thumb to your finger, even with a single "D" cell. They are also useful for chilled-mirror dewpoint instruments. And handy in high-vacuum applications where moving parts are a no-no.

Thermoelectric modules are great for cooling microscope stages, special astronomy instruments, and infrared detectors. But the modules don't seem useful for cooling the low-noise amplifiers used in satellite dishes because the gain drops faster than noise figure improves.

What are the practical alternates to thermoelectric modules? Small compressors are not that big a deal. Obvious sources are drinking fountains, refrigerators, icemakers, and reworked auto air conditioners. One source of info on these is *HVAC Contractor*. A drinking-fountain compressor will need only 60 watts of new energy to pump 300.

But the neatest substitute for thermoelectric modules are called *vortex coolers*. These second cousins to perpetual motion machines seem to blatantly violate ther-

swimming, jogging, or fast walking.

A conditioning target zone might be 60 to 75 percent of the maximum heart rate. The maximum rate in turn depends upon sex, age, and upon the advice of your physician or aerobics instructor. For instance, a 30-year-old male might have a target zone of 114 to 142 beats per minute.

The old "thumb and stopwatch" method of measuring pulse rate has some problems, not the least of which is that it woefully disrupts the program in progress. There are two alternative methods to measure pulse, the *plethysmograph*, and the *EKG (electrocardiogram)*.

The plethysmograph is based on finger or toe capillaries expanding and contracting with each pulse beat. Shine infrared light through your finger, and its transmission will vary with your pulse. Opacity depends on how much blood is present. The variations can be amplified, conditioned, and digitally averaged to extract the current pulse rate. The method is cheap, simple, and noninvasive.

Infrared plethysmographs are easy to find, even as \$19.95 specials at K-mart. Unfortunately, many of these simply do not operate properly in aerobic exercise situations. The main problem involves *motion artifacts*. Any relative motion between sensor and finger will give a false output and highly erratic, near-useless results.

Better yet, there are *EKG-style* or "chest type" monitors that directly measure the electrical activity of the heart. These are usually offered in two pieces, a small chest strap, and a stopwatch-type display that is either worn on your wrist or mounted on the exercise gear.

The cost of these systems is often in the \$70 to \$200 range. But they are totally free of motion artifacts. And you can *instantly* check your pulse at any time during the activity by simply glancing at the display. Many systems also offer settable alarms that trip if you wander outside your target zone. Clock and stopwatch functions are included.

One typical unit is the *Edge Heart Rate Monitor* distributed by *Polar* and stocked by such yuppie outdoor stores as *REI*. I tried that one in

AMAZING ELECTRONIC PRODUCTS and KITS

Remember those Martian Space Ships in HG Wells War of the Worlds?



MYSTERY Levitating Device

Objects float on air and move to the touch. Defies gravity! Amazing gift, conversation piece, magic trick or great scientific project.

ANT1K Easy-Ass'y Kit/Plans \$19.50



3 MILE FM Wireless Microphone!

Crystal clear, ultra-sensitive pickup transmits voices, sounds to any FM radio. For security, monitoring children, invalids. Be the local DJ!

MVP1 Plans \$7.00
MVP1K Kit/Plans \$39.50

3 MILE Telephone Transmitter!



Automatically transmits 2 sides of phone conversation to any FM radio. Tunable, easy-assembly PC board. Operates only when phone is in use.

VWPM7 Plans \$7.00
VWPM7 Kit/Plans \$39.50



TV & FM Joker/Jammer

Pocket size device lets you remotely disrupt TV or radio reception. Great gag! Discretion required. Easy-build electronic kit. EJK1KM \$19.50

100,000 V - 20' Range Intimidation Device!

Electronic module, may be enclosed for handheld, portable, or fixed uses. ITM2 Plans (creditable to kit) \$10.00
ITM2K Kit & Plans \$49.50

READY-TO-USE, AUTOMATIC Phone Recording System

Complete with extended play tape recorder & line interface switch. Automatically records both sides of conversation. Check Local Laws on Proper Use! Ready-to-Use System. TAP20X System \$149.50

INFORMATION UNLIMITED

Dept RE-4 Box 716, Amherst NH 03031
Phone 603-673-4730 FAX 603-672-5406
MC, VISA, COD, Check Accepted. ADD \$5 S&H.

Order by Mail, or by
24 Hr Order Phone:
800-221-1705

Laser Pen

Pen sized laser, great for movies, drive-ins, pointer. Ready to use, with batt's. LAPN1 Laser Pen .. \$149.50

Pocket Laser Kit

3mw or 5mw kits, with solid state 670nm diode. Caution, Class IIIa item. VRL3KM 3mw Laser Kit ... \$99.50
VRL5KM 5mw Laser Kit .. \$119.50

MORE Laser Kits!

LAS1KM 1mw Laser, 632nm, HeNe Easy to Build Kit \$69.50
LAS4KM 3mw Version, Kit \$99.50

LAT05 Low Cost HeNe Laser Tube! .5mw Tube & Plans .. only \$24.50
Other parts available separately.
Great Low Budget Science Project!

Shocker Force Field Vehicle Electrifier



Make hand shock balls, shock wands electrify objects, charge capacitors. Great pay back for those wise guys! SHK1KM Easy-Assembly Kit \$24.50

CATALOG!

with many more items!
FREE with order, or send \$1 P&H

Superior 100 MHz Probe

The new generation of TPI's SP100 - the world's most popular probe

- 1x - 10x switchable
- Fits all scopes
- Faster risetime - equal to a 200 MHz probe
- Sharper pulse response - clean leading edge
- Replaceable ground lead and probe tip
- Slim design for easier handling
- Satisfaction guaranteed - 10 day return privilege

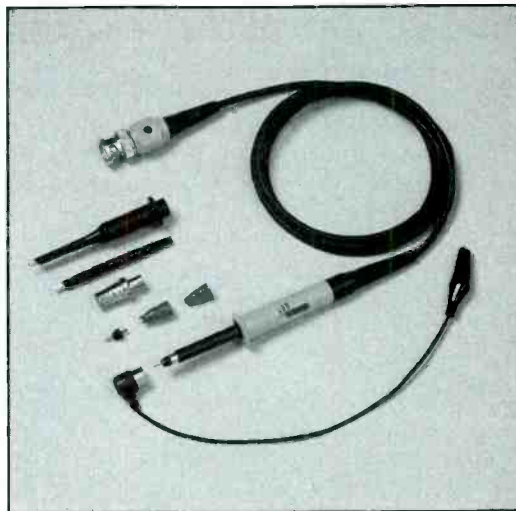

Model SP100B
\$45

Call for free catalog of probes to 500 MHz - Active Probes - Differential Probes - Test Leads and Accessories

TEST PROBES, INC.



9178 Brown Deer Road • San Diego, CA 92121
TEL: 619-552-2090 • FAX: 619 535-1260
Toll Free: 1-800-368-5719

CIRCLE 123 ON FREE INFORMATION CARD

EN Engineering Admart

Rates: Ads are 2 1/4" x 2 7/8". One insertion \$995 each. Six insertions \$950 each. Twelve insertions \$925 each. Closing date same as regular rate card. Send order with remittance to Engineering Admart, Electronics Now Magazine, 500-B Bi-County Blvd., Farmingdale, NY 11735. Direct telephone inquiries to Arline Fishman, area code-1-516-293-3000. FAX-1-516-293-3115. Only 100% Engineering ads are accepted for this Admart.

YOU! Be the Judge



Of 6805, 68HC05 and 68HC11 Development Tools

TECI is committed to providing high quality, low cost tools suited to a wide range of tasks. We believe in customer satisfaction with 30 day money back guarantee, 6 month warranty and free tech support. Call for your free catalog.

6805 Primer for Beginners	\$195
6805/68HC05/68HC11 Cross Assemblers	\$99
6805/68HC05 Simulator/Debugger	from \$99
68705 P3, P5, U3, U5, R3, R5 Programmers	from \$349
68HC705/68HC805 Programmers	from \$395
Complete PC Based Development Systems	from \$449
68HC05/68HC11 Real-Time Emulators	from \$895
Call for Current Special Offers and Combination Packages	

TECI The Engineers Collaborative Inc.
RR #3, Box 8C, Barton, VT 05822, USA

800-336-8321

TEL: 802-525-3458 FAX: 802-525-3451

CIRCLE 183 ON FREE INFORMATION CARD

RADIOTELEPHONE—RADIOTELEGRAPH FCC LICENSE PREPARATION

Why Take Chances

The FCC has revised and updated the commercial license exam. The NEW EXAM covers updated marine and aviation rules and regulations, transistor and digital circuitry.

OUR CURRENT HOME-STUDY GUIDES/ AUDIO, VIDEO OR PC DISKS MAKE IT FAST & EASY. FEATURING NEW "CAREER GUIDE" 1000'S OF SATISFIED CUSTOMERS

FREE DETAILS

WPT PUBLICATIONS

7015 N.E. 61st Ave.

Vancouver, WA 98661

Phone (206) 750-9933 Dept. 50

CIRCLE 105 ON FREE INFORMATION CARD

HIGH POWER AUDIO AMPLIFIER CONSTRUCTION

High Power
Audio Amplifier
Construction

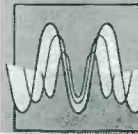

BP277—Here's background and practical design information on high power audio amplifiers capable of 300 ± 400 watts r.m.s. You'll find MOSFET and bipolar output transistors in inverting and non-inverting circuits. To order your copy send \$6.25 plus \$2.50 for shipping in the U.S. to **Electronic Technology Today Inc.**, P.O. Box 240, Massapequa Park, NY 11762-0240.

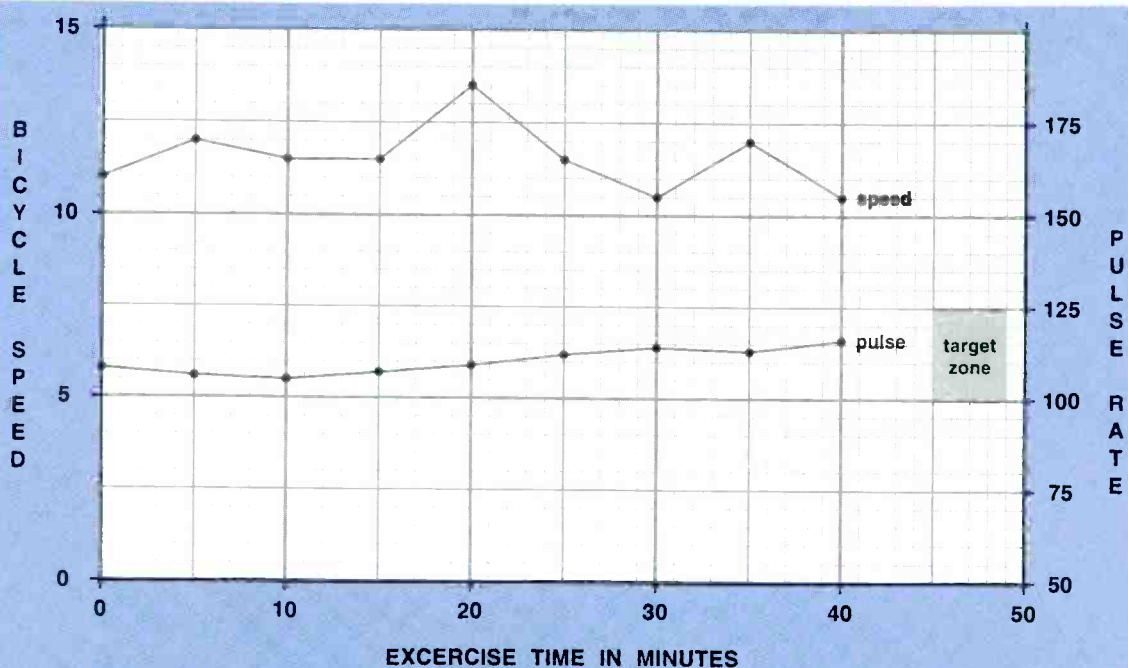

Marvin Griblinski
Tuesday, June 22, 1993

Route: Whitlock loop
Distance: 7.4 miles.
Maximum speed: 14.5 mph.
Average speed: 11.0 mph.
Miles to date: 1145

Previous resting pulse: 74
Previous standing pulse: 86

Recovery pulse at 0 seconds: 110
Recovery pulse at 20 seconds: 107
Recovery pulse at 40 seconds: 104
Recovery pulse at 100 seconds: 97

Comments: Good day. Mild winds. Loose gravel improving.

FIG. 4—AEROBIC EXERCISE RECORD written in PostScript. Fully editable source code appears on GENie PSRT.

combination with a *Trek* bicycling computer. A second brand is *Favor*. Combination monitor and bike com-

puters in one unit are available, such as the *Vetta* HR-1000 also offered by *REI*. At \$95 list.

How do they work?

The chest unit is totally sealed and has an internal battery. In normal use, it gets replaced every year or two. The internal battery is pur-

NAMES AND NUMBERS

Antique Radio Laboratories

Rt 1, Box 41
Cutler, IN 46920
(317) 268-2214
CIRCLE 330 ON FREE INFORMATION CARD

Exair

1250 Century Circle North
Cincinnati, OH 45246
(513) 671-3322
CIRCLE 331 ON FREE INFORMATION CARD

GEne

401 N Washington Street
Rockville, MD 20850
(800) 638-9636
CIRCLE 332 ON FREE INFORMATION CARD

Heath Nostalgia

4320 196th SW, Ste B-111
Lynnwood, WA 98036
CIRCLE 333 ON FREE INFORMATION CARD

HVAC Prod News/Contractor

1350 East Touhy Avenue
Des Plaines, IL 60018
(708) 635-8800
CIRCLE 334 ON FREE INFORMATION CARD

Intl Assn for New Science

1304 S College Avenue
Fort Collins, CO 80524
(303) 482-3731
CIRCLE 335 ON FREE INFORMATION CARD

Linear Technology

1630 McCarthy Blvd
Milpitas, CA 95035
(408) 432-1900
CIRCLE 336 ON FREE INFORMATION CARD

Maxim

120 San Gabriel Drive
Sunnyvale, CA 94086
(408) 737-7600
CIRCLE 337 ON FREE INFORMATION CARD

Melcor

1040 Spruce Street
Trenton, NJ 08648
(609) 393-4178
CIRCLE 338 ON FREE INFORMATION CARD

Mondo-tronics

524 San Anselmo Avenue #107
San Anselmo, CA 94960
(415) 455-9330
CIRCLE 339 ON FREE INFORMATION CARD

Oughtred Society

8338 Colombar Court
San Jose, CA 95135
(408) 238-8082
CIRCLE 340 ON FREE INFORMATION CARD

Resources UN-LTD

8030 South Willow Street
Manchester, NH 03103
(603) 668-2499
CIRCLE 341 ON FREE INFORMATION CARD

Synergetics

PO Box 809
Thatcher, AZ 85552
(602) 428-4073
CIRCLE 342 ON FREE INFORMATION CARD

TriQuint Semiconductor

3625A SW Murray Blvd
Beaverton, OR 97005
(503) 644-3535
CIRCLE 343 ON FREE INFORMATION CARD

Vortec

10125 Carver Road
Cincinnati, OH 45242
(800) 441-7475
CIRCLE 344 ON FREE INFORMATION CARD

Wireless Design & Development

Box 650
Morris Plains, NJ 07950
(201) 292-5100
CIRCLE 345 ON FREE INFORMATION CARD

posely *not* replaceable to guarantee that the unit remains unmodifiable. There are very stringent regulations that govern anything electronic that directly attaches to your chest.

Obviously, the chest unit acts as a transmitter and the wrist unit serves as a receiver. The effective range is typically four feet or so. But what gets transmitted how? The answer to this one is yet another stunningly beautiful find in our ongoing quest for elegant simplicity.

What we really have here is short-haul telemetry. But one that has to remain totally sealed, be compact and lightweight, reliably run under micropower, and literally be a throwaway item with a five-buck

maximum manufacturing cost.

The secret is a plain old inductive coupling. Figure 3 shows the secret waveforms involved. What you really have here is a 5-kilohertz air-core transformer, with the primary in the chest unit and the secondary in the wrist or handlebar receiver. Each pulse is converted into a 36-cycle burst of 5-kilohertz sinewaves.

You can easily monitor these waveforms. Just take any old coil, such as a fifty foot roll of hookup wire. Add an iron core, such as a handy pair of pliers. Center the coil near the chest unit. And then watch the results on your scope.

A pair of conductive pads pick up
continued on page 82

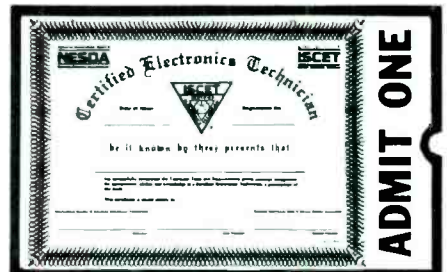

**Your Ticket To
SUCCESS**

Over 28,000 technicians have gained admittance worldwide as certified professionals. Let your ticket start opening doors for you.

IS CET offers Journeyman certification in Consumer Electronics, Industrial, Medical, Communications, Radar, Computer and Video. For more information, contact the International Society of Certified Electronics Technicians, 2708 West Berry Street, Fort Worth, TX 76109; (817) 921-9101.

Name _____
Address _____
City _____
State _____ Zip _____

Send material about IS CET and becoming certified.

Send one "Study Guide for the Associate Level CET Test." Enclosed is \$10 (inc. postage).

"INTEGRATING TECHNOLOGIES IN THE DIGITAL ERA"

**The Society of Motion Picture and
Television Engineers**

presents

**The 135th SMPTE Technical Conference and
Equipment Exhibit
(Including Media Integration)**

OCTOBER 30-NOVEMBER 2, 1993
L.A. Convention Center Los Angeles, California

The SMPTE Conference offers the most comprehensive program, to satisfy all levels of expertise. From the basics of motion imaging, to the most advanced technologies.

SMPTE '93 HAS IT ALL!

- Tutorials • Technical Sessions • Equipment Exhibit • Workshops
- Creativity Clinics • Bonus Certificates • Student Education Fair
- HDTV Theaters • Panel Discussions

To receive more information, complete the form below and mail to:
SMPTE Registration

595 W. Harborside Ave., White Plains, N.Y. 10607
Tel: (914) 761-1100 Fax: (914) 761-3115

Check all that apply #EN
Please send me: Registration Information Exhibitor Information

Name _____ Title _____
Company _____ Tel: (____) _____
Address _____ Fax: (____) _____
City _____ State _____ Country _____ Postal Code _____

October 1993, Electronics Now

SALE!

**CABLE TV
DESCRAMBLERS
WE'LL BEAT
ANY PRICE!
CALL TOLL-FREE
1-800-284-8432**

- JERROLD • TOCOM • ZENITH •
- OAK • PIONEER • HAMLIN •
- SCIENTIFIC ATLANTA •

**24 HOUR SHIPMENTS!
QUANTITY DISCOUNTS!
MONEY BACK GUARANTEE!
FREE CATALOG & INFORMATION**



Mastercard • American Express • Visa • C.O.D.
HAVE MAKE AND MODEL NUMBER OF EQUIPMENT USED IN YOUR AREA

1-800-284-8432

FOR ORDERS ONLY
For technical & customer service: 305-749-3122
ALL SHIPPING & HANDLING FEES AT CUSTOMER'S EXPENSE
Anyone implying theft of service will be denied assistance

CABLE WAREHOUSE

10117 WEST OAKLAND PARK BLVD., SUITE 315, SUNRISE, FL 33351
NO FLORIDA SALES

CIRCLE 184 ON FREE INFORMATION CARD

SUPER 12 HOUR RECORDER

CALL TOLL FREE

Modified Panasonic Slimline,
6 hrs per side
120 TDK tape furnished.
AC/DC Operation.
Quality Playback.
Digital Counter.
Durable Lightweight Plastic.



\$119.00*

PHONE RECORDING ADAPTER

Starts & Stops Recorder
Automatically When
Hand Set is Used.
Solid State!



FCC Approved

\$28.50*

VOX VOICE ACTIVATED CONTROL

Solidstate Adjustable
Sensitivity. Voices &
Sounds Activate Recorder
Adjustable Sensitivity
Provisions for Remote
Mike



\$28.50*

* Add for ship. & handling. Phone Adapter & Vox
\$2.00 each, Recorders \$5.00 each. Colo. Res add
tax. Mail Order, VISA, M/C, COD's OK. Money Back
Guar. Qty Disc. available. Dealer inquiries invited.
Free data on other products.

AMC SALES INC. 193 Vaquero Dr.
Boulder, CO. 80303
Phones (303) 499-5405 1-800-926-2488
FAX (303) 494-4924
Mon-Fri 8-5 MTN. TIME

CIRCLE 108 ON FREE INFORMATION CARD

FAX DIRECTORY LISTING

COMPANY	FAX NUMBER
Accord Electronic Systems, Inc.	(305) 772-2568
Alfa Electronics, Inc.	(609) 275-9536
A.M.C. Sales, Inc.	(303) 494-4924
B.G. Micro	(214) 271-2462
Caig Laboratories, Inc.	(619) 451-2799
Chemtronics, Inc.	(404) 717-2111
Communications Specialists, Inc.	U.S. - (800) 424-3420 Int'l - (714) 974-3420
C&S Sales, Inc.	(708) 520-0085
Danbar Sales Company	(909) 592-2940
Electronic Rainbow, Inc.	(317) 291-7269
Fair Radio Sales Co., Inc.	(419) 227-1313
Fusion Electronics, Inc.	(516) 599-6495
Global Specialties	(203) 468-0060
Goldstar Precision Co. Ltd.	(310) 921-6227
Hameg Instruments	(619) 630-6507
Interactive Image Technologies Ltd.	(416) 368-5799
Jameco Electronic Components & Computer Products	(800) 237-6948
Mark V Electronics, Inc.	(213) 888-6868
MCM Electronics	(513) 434-6959
Moody Tools, Inc.	(401) 885-4565
Mouser Electronics	(817) 483-0931
MWK Industries	(909) 278-4887
Northeast Electronics	(508) 695-9694
Number One Systems Ltd.	011 44 480 494042
PC Boards	(205) 933-2954
People's College of Independent Studies	(407) 847-8793
Print Products International	(800) 545-0058
Howard W. Sams & Company	(317) 298-5604
Sencore, Inc.	(605) 339-0317
Sibex, Inc.	(813) 726-4434
Startek International, Inc.	(305) 537-5577
Suncoast Technologies	(904) 596-7599
The Engineers Collaborative, Inc. (TECI)	(802) 525-3451
Toroid Corp. of Maryland	(410) 860-0302
Wavetek Corp. (formerly Beckman Industrial)	(619) 565-9558

Electronics NOW®

FAX FORM

DIRECT READER/MFR CONTACT



**Need data
in a hurry?**

Don't worry!

Just clip this form
carefully along
the dotted lines,
fill it out
(PLEASE PRINT)
and fax it
to the company
of your choice today!

Electronics Now provides this fax form as a service to its readers. A quick response from you indicates your company's willingness to do business with the sender.

Electronics FAX RESPONSE NOW®

TO: _____

Company Name

Fax Number

I urgently need more information about your _____ products.

I saw your products on Page _____ in the _____ issue of **EN**;
(Month/Year)

ADDITIONAL NOTE:

FROM: _____

Sender's Name

Title

Company Name:

Street

City

Country

Phone

Fax

We are a(n) manufacturer service center engineering company
 R&D center/laboratory other (_____)

Electronics NOW®

500-B Bi-County Boulevard, Farmingdale, NY 11735 Tel: 1-516-293-3000 Fax: 1-516-293-3115

What's happening?

LARRY KLEIN

We live in strange times. Despite the stagnant economy, home electronics, like most other high-tech areas, continues to progress. For several years now, new and competing electronic entertainment formats have been introduced regularly, apparently faster than consumers are prepared to absorb—or pay for—them.

The Japanese and other overseas manufacturers seem to believe that you can separate consumers from their cash—however depressed the economic conditions—if new products are whiz-bang enough.

Deja vu?

Today's inert consumer reaction to the proliferation of new audio formats reminds me of what happened during the years of the four-channel follies (1969–1977). There were at least five competing quad formats, the technology didn't work very well much of the time, and the public, despite the massive hype campaign, just wasn't very interested.

In contrast, today's MiniDisc (MD) and Digital Compact Cassette (DCC) both work well and deliver near CD-quality sound. And, in certain areas (size and playing stability for MD, fidelity for DCC), they are superior to their predecessors. Are audio consumers rushing to trade in and up? It appears not. Of course, there's some question whether the data-compression techniques used in both formats cause fidelity problems, but I don't think that's the stumbling block. For the vast majority of listeners, both formats sound fine. The lagging sales, I suggest, are because of price, not performance. In other words, as someone once said, "It's the economy, stupid!"

With the recordable MiniDisc, you can dub your existing musical

library onto the new format, but given the time, effort, and expense involved, it doesn't seem like a sensible undertaking. The ability of the DCC decks to play conventional cassettes, in my view, made them a winner. But according to one industry friend, neither one of the formats is selling very well. I can understand the MiniDisc getting off to a slow start, but as some readers may remember, I thought DCC was going to take off.

Given my miscall on DCC I decided that it might be time to recalibrate my crystal ball. After several hours of conversations with several knowledgeable industry friends, this is what I found to be happening hi-fi marketwise.

Home theater up, stereo down

Dolby Pro Logic home-theater electronics represent an important part of today's home equipment marketplace. But to put that fact in perspective, you should be aware that, overall, the hi-fi marketplace is in deep doldrums. True, Dolby Pro Logic home-theater sales are up, but at the expense of medium-priced, conventional stereo gear. High-end audiophile equipment is suffering less, but their usual level of overseas sales are down because the strong dollar has significantly raised the costs of this equipment to foreign consumers.

Big speakers are out, and small speakers and subwoofer/satellite systems have taken up the slack—which makes sense given the need for five or more separate speakers in a full-fledged home-theater setup.

Overall, it appears that the interest in home theater is unfortunately not dragging the rest of the audio industry out of its recession. One of my audio consultants was able to put the situation succinctly: He said

that home-theater systems are an important part of what's left of the hi-fi stereo business.

A sales manager of a well-respected U.S. electronics company raised an interesting point. He claimed that some manufacturers are cutting corners (and costs) in their multichannel units, thus causing them to fall short in power, current capability, and bandwidth. As an example, he cited some units rated at 100 watts per channel that are likely to clip at under 80 watts when measured with standard EIA test techniques.

I hope this does not presage a return to the bad old days. Old timers will remember the years when amplifier power ratings had a very poor fantasy-to-fact ratio. Even the good guys who were trying to maintain legitimacy in their ratings found that they had to fudge their specs in order to remain competitive in the power numbers game.

It appears that the intense competition for a piece of the shrinking hi-fi pie has driven some manufacturers to skimp on their power supplies. That lowers the price of the product, but also its performance. Given the fact that the mainstream audio magazines are also struggling very hard to keep their heads above water as advertising revenues continue to fall, don't expect to see any front cover power rating exposes any time soon.

If you are about to invest in some extra amplification for a home-theater installation, look long and hard at the power ratings, making sure that the per-channel wattage is rated with all channels driven. *Caveat emptor!*

Speakers

To switch subjects slightly... Ever since I became involved in audio, speakers have been a special inter-

est. To my mind, loudspeakers have always inhabited a sort of twilight zone where psychoacoustics, acoustics, physics, and electronics meet, not always felicitously, in an effort to reproduce music.

Forty-odd years ago, during the early days of consumer hi-fi, no two home-speaker models—even from the same company—sounded alike. Each had its characteristic colorations. Although few audiophiles at the time would admit it, you picked a speaker by choosing a model whose deficiencies annoyed you least.

In the late 1950's, things changed for the better. At the point when I was in charge of the component-testing program at *Stereo Review*, there were at least two consistently good brands, whose products were all based on the acoustic-suspension design developed by Edgar Villchur, then president of Acoustic Research. For an encore, Villchur invented the dome tweeter, which was also destined to become an industry standard.

Time marched on, and while more and more manufacturers switched to acoustic-suspension systems, the bugs were being worked out of the venerable bass-reflex/tuned-port configuration. A point was reached about 12 to 15 years ago when it was rare that a really bad speaker of either design was submitted to the magazines for testing—although they still existed in the marketplace.

Once they had a handle on the basic bandwidth and distortion problems, designers began to seriously investigate the speaker/room/ear interface questions. The studies have gone far beyond the wide dispersion/omnidirectional/bounce-the-sound-off-the-wall intuitions of the early days to far more profound analyses.

Roy Allison was one of the early investigators of the speaker/room interface. In a 1974 Audio Engineering paper, "The Influence of Room Boundaries on Loudspeaker Power Output," he spelled out in detail—including measurements—the bass performance problems engendered by typical bookshelf loudspeaker installations in typical rooms. In a nutshell, these turn out to be irreg-

ularities ranging from about 5 to 12 dB, depending upon mounting location. Allison subsequently went on to design a series of excellent systems that minimized or eliminated such problems.

I was saddened to hear early this year that Allison Acoustics had been taken over by their major foreign investor and Roy Allison was out. Edgar Villchur (remember Edgar Villchur?) apparently was also upset and rode to the rescue with an infusion of cash and, hopefully, good advice.

A new company was founded—Room Design Loudspeakers (RDL) with Allison as president and chief designer, and Villchur as a corporate director. RDL is now shipping products on a direct-sale basis to consumers—a move that Villchur had contemplated during his heyday at Acoustic Research.

For further information: write to RDL Acoustics, 26 Pearl Street, #15-EN, Bellingham, MA 02019 (800 227-0390). Ω

Try the
**Electronics
NOW[®]**

**bulletin board
system**

**(RE-BBS)
516-293-2283**

**The more you use it the more
useful it becomes.**

**We support 1200 and 2400 baud
operation.**

**Parameters: 8N1 (8 data bits, no
parity, 1 stop bit) or 7E1 (7 data
bits, even parity, 1 stop bit).**

**Add yourself to our user files to
increase your access.**

**Communicate with other R-E
readers.**

**Leave your comments on R-E with
the SYSOP.**

**RE-BBS
516-293-2283**

FREE

**Electronics & Computer Software
Education Catalog**

*Fast-Track Individual Learning Programs
*State-of-the-Art Classroom Courses
*The Best Values in Electronics Education

New
Career-Level Courses
Personal Computer Servicing
TV and VCR Servicing
New
Computer-Aided Instruction

DC & AC Electronics
Semiconductors
Electronic Circuits

*The stunning animations, hypertext
glossary, and easy-to-understand text make
learning electronics a breeze...and fun!*

Learn the easy and affordable way from the
Masters in Electronics Training - **Heathkit[®]**.
From Basic Electricity to Advanced Microproces-
sor Applications and more, Heathkit will provide
you with an unparalleled learning experience at a
fraction of the cost of other programs.

Heathkit[®]
Educational Systems

For your FREE Catalog, call
Toll-Free 1-800-44-HEATH
please mention this code when calling 020-014

CIRCLE 86 ON FREE INFORMATION CARD

**Learn VCR
repair at home!**

**MAKE GOOD MONEY IN YOUR
OWN FULL- OR PART-TIME JOB**

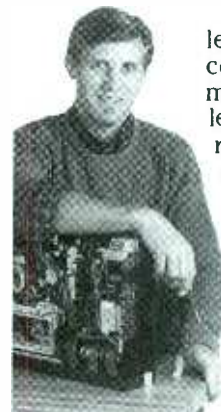

Professional-level home study course. You will master easy-to-learn, high-profit repairs *without* investing in high-tech instruments or a costly workshop. Want more independence and higher income? Send or call today!

**Free career literature:
800-223-4542**

Name _____ Age _____
Address _____ Phone (____) _____
City _____ State _____ Zip _____

The School of VCR Repair
6065 Roswell Road
Dept. VL342 Atlanta, Georgia 30328

CIRCLE 180 ON FREE INFORMATION CARD

the EKG signals on either side. These microvolt-sized signals are strongly amplified in a bandpass amplifier. There is probably some type of AGC (Automatic Gain Control) loop to standardize the output levels. Then, a comparator of some sort derives a digital output for each pulse event.

Each pulse event then generates a series of six digital impulses. Each impulse is around 80 microseconds wide and has an interpulse spacing of one millisecond for a one-kilohertz repetition rate.

If very low power is your goal, you cannot use any kind of linear amp for your transmitter. Instead, the antenna is simply a 5-kilohertz resonant coil. The plots found in my *Active Filter Cookbook* tell us the Q of this coil is around 20 or so.

To transmit a signal, the resonant antenna coil gets whapped *once every five cycles*. The high Q of the coil fills in during the intermediate cycles. If you look at your scope display carefully, you will observe the modest exponential decay of the intermediate cycles between impulse whappings. The long run-down time after the last whapping is also quite obvious.

Only the bandpass amplifier draws continuous current. Both *Maxim* and *Linear Technology* make suitable amplifiers that consume only microamps. In absence of any pulse input, there is no output and no transmitted signal. Even when a burst is sent, the duty cycle to generate the burst is 10:1 and the duty cycle of the burst itself is typically 80:1 or so.

The average current ends up quite low. Very elegant.

X-raying the unit revealed a few surprises. A large lithium coin cell is used. The antenna is a ferrite rod with its long axis horizontal that is apparently tuned by unwrapping a few turns. It is resonated by a polystyrene capacitor. A 14-pin integrated circuit drives the antenna. It is probably a plain old grunt CMOS quad gate.

The majority of the input circuitry is discrete and consists of nine

SOTs (Small Outline Transistors) and 24 assorted resistors and capacitors. Special techniques are required for proper noise rejection and ultra low power operation.

The receiver is just a resonant coil and a bandpass amplifier that inputs into typical micro-current stopwatch circuitry. The amplifier apparently shuts itself down in the absence of any transmitted signals. The receiver battery can be replaced and lasts a year or more. An averaging algorithm is used to smooth out the results for a stable display.

A sample printout for a routine exercise session is shown in Fig. 4. The complete PostScript code to custom run these on your favorite word processor appears on *GENie* PSRT as #751 EXERCISE.GPS.

You could build up an automatic data acquisition system to automate the whole process. But it is simpler and cheaper just to use a one-hand cassette recorder every five minutes and talk the speed and pulse rate to it.

I've gathered several places to go for more information on pulse monitors into our resource sidebar for this month. *Creative Health Products* offer a free comparison guide for many popular monitors.

This month's contests

Let us have a bunch of different contests this month. Show me some other uses for inductive coupling in short-haul telemetry. Or find me the actual schematic of some EKG-type pulse monitor. Or find a hackable source of pulse-monitor chips.

That should be ideal for one of my *isopod* power line monitors.

Or run the aquarium ice warming test. Or show me a genuinely useful hacker application for thermoelectric modules that works in the real world. Or show me some other off-the-wall uses of PostScript for new data-to-plot applications.

There'll be all the usual *Incredible Secret Money Machine II* book prizes along with an all-expense-paid (FOB Thatcher, AZ) *tinaja quest* for two going to the best of all.

New tech lit

Up the Infinite Corridor is a new book on the history of engineering

at MIT by Fred Hapgood. It's a really good read. But by far the best part is Fred's revival of a very ancient seven-word definition of what engineering is all about: *A sense for the fitness of things*. That says it all.

Lots of night-vision electronics and surplus infrared viewers are available from *Resources Unlimited*. A free brochure is available.

There's a new \$9.95 book on the history of *Heathkit* from *Heath Nostalgia*.

Antique Radio Laboratories has a free catalog on its products for radio restoration buffs. Included are custom pins, adapters, bases, and coil forms. They also stocks manuals for older test equipment.

The *Oughtred Society* exists for the collectors of traditional slide rules and calculating instruments. It's named for the seventeenth century slide rule inventor. Meetings and classified ads cost \$20.

Motorless Motion is a project book from *Mondo-tronics* on working with the shape memory "muscle wires" for robotics and similar uses. Included are fifteen easy-to-build projects and layout templates. The book is \$18; \$29 for the book and wires.

From *TriQuint Semiconductor*, a new *Data Communication Products* data book. It's mostly on new microwave integrated circuits such as low-noise amplifiers, mixers, down-converters, and AGC stages.

Wireless Design & Development is a new trade journal on new products for the emerging personal microwave communication services.

As we've seen a number of times in past columns, any hardware hacker involvement with the patent system is virtually certain to end up a net loss of time, energy, money, and sanity, mostly because of all the outrageous popular mythology that surrounds patents and patenting.

I have put together a new *Case Against Patents* reprint package that includes several hundred pages of proven alternates to patenting. A big directory of hundreds of inventor organizations is included. See my nearby *Synergetics* ad.

A reminder that I have arranged for a new and faster *GENie* signup for my PSRT RoundTable. Refer to the *Need Help?* box for full details. Ω

COLLECTOR AMPLIFIERS

continued from page 61

in Fig. 14 has an input impedance of about 50 kilohms.

Both the Fig. 13 and 14 circuits offer a voltage gain that is slightly less than unity; the true gain is given by:

$$A_V = Z_{load} / (Z_B + Z_{load})$$

Where $Z_B = 25/I_E$ ohms and I_E is the emitter current in milliamperes

With an operating current of 1 milliamperes, these circuits provide voltage gains of 0.995 when the $Z_{load} = 4.7$ kilohms, or 0.975 when the load = 1.0 kilohm. The significance of these gain figures will be discussed shortly.

Bootstrapping

The relatively low input impedance of the circuit in Fig. 14 can be increased significantly by *bootstrapping* as illustrated in Fig. 15. The 47-kilohm resistor R3 is located between the R1-R2 biasing network junction and the base of transistor Q1, and the input signal is fed to Q1's base through capacitor C1.

Notice, however, that Q1's output signal is fed back to the R1-R2 junction through C2, so that almost identical signal voltages appear at both ends of R3. Consequently, very little signal current flows in R3. The input signal "sees" far greater impedance than the true resistance value.

To make this point clearer, consider that the emitter-follower circuit in Fig 15, has a precise voltage gain of unity. In this condition, identical signal voltages would appear at the two ends of R3, so no signal current would flow in this resistor, making it "appear" to be an infinite impedance. The input impedance of the circuit would "appear" to equal R_{IN} , or 1 megohm.

Practical emitter-follower circuits provide a voltage gain that is slightly less than unity. The precise gain that determines the resistor *amplification factor*, or A_R , of the circuit is:

$$A_R = 1 / (1 - A_V)$$

For example, if circuit gain is

0.995 (as in Fig. 13), then A_R is 200 and the R3 impedance is almost 10 megohms. By contrast, if $A_{svV} = 0.975$, A_R is only 40 and the R3 impedance is almost 2 megohms. This impedance is effectively in parallel with R_{IN} so, in the first example, the complete Fig. 15 circuit exhibits an input impedance of about 900 kilohms.

The input impedance of the circuit in Fig. 16 circuit can be further increased by substituting a 520Darlington pair for Q1 and increasing the value of R3, as shown in Fig 16. This modification gives a measured input impedance of about 3.3 megohms.

Alternatively, even greater input impedance can be obtained with a bootstrapped *complementary-feedback pair* circuit as shown in Fig. 18; it offers an input impedance of about 10 megohms. In this instance, Q1 and Q2 are both connected as common-emitter amplifiers but they operate with nearly 100% negative feedback. As a result, they provide an overall voltage gain that is almost exactly one. This transistor pair behaves like a near-perfect Darlington emitter-follower.

Emitter-followers

Recall from the previous article on bipolar transistors, **Electronics Now** in September 1993, a standard NPN emitter-follower can *source* current but cannot *sink* it. By contrast, an PNP emitter-follower can *sink* current but cannot *source* it. This means that these circuits can only handle unidirectional output currents.

A *bidirectional* emitter-follower (that can source or sink currents with equal ease) has many applications. This response can be obtained with a complementary emitter-follower topology—NPN and PNP emitter followers are effectively connected in series. Figures 18 to 20 illustrate some basic bidirectional emitter-follower circuits.

The circuit in Fig. 18 circuit has a dual or "split" power supply, and has its output is direct-coupled to a grounded load. The

series-connected NPN and PNP transistors are biased at a quiescent "zero volts" value through the voltage divider formed with resistors R1 and R2 and diodes D1 and D2. Each transistor is forward biased slightly with silicon diodes D1 and D2. Those diodes have characteristics that are similar to those of the transistor base-emitter junctions.

Capacitor C2 assures that identical input signals are applied to each transistor base, and emitter resistors R3 and R4 protect the transistor against excessive output currents.

Transistor Q1 in Fig. 18 sources current into the load when the input goes positive, and transistor Q2 sinks load current when the input goes negative. Notice that input capacitor C1 is non-polarized.

Figure 19 shows an alternative to the circuit of Fig. 18 designed for operation from a single-ended power supply and an AC-coupled output load. In this circuit, input capacitor C1 is polarized.

Notice that output transistors Q1 and Q2 in Figs. 18 and 19 are slightly forward biased by silicon diodes D1 and D2 to eliminate crossover distortion problems. One diode is provided for each transistor.

If these circuits are modified by substituting Darlington pairs, four biasing diodes will be required. In those versions, a single transistor "amplifier diode" stage replaces the four diodes, as shown in Fig 20.

The collector-to-emitter voltage of Q5 in Fig. 20 equals the base-to-emitter voltage drop across Q5 (≈ 600 millivolts) multiplied by $(R3 + R4)/R4$. Thus, if trimmer potentiometer R3 is set to zero ohms, about 600 millivolts are developed across Q5, which then behaves as a silicon diode. However, if R3 is set to its maximum value of 47 kilohms, about 3.6 volts is developed across Q5, which then behaves like six series-connected silicon diodes. Trimmer R3 can set the voltage drop across Q5 precisely as well as adjust the quiescent current values of the Q2-Q3 stage. Ω

If society is an organism, and if information is the lifeblood of the organism, then by comparison, its sensory systems must be viewed as primitive and disjointed. The effect is that of a beast that can in some limited ways see, hear, taste, smell and touch, but that is unable to transform those raw sensory stimuli into understanding, decision, and action.

A new strategic initiative, spearheaded by Microsoft but brought forth in conjunction with more than 60 leading vendors in most areas of technological interest, promises to link the eyes and ears of this organism with the rest of the nervous system. In so doing, it will endow it with the intelligence needed to evolve into a higher form of life, the type required for survival in the 21st Century. Table 1 summarizes some of the major and many of the minor players whose support Microsoft has enlisted for MAW, or Microsoft at Work.

This initiative promises to enable communications among PCs, fax machines, fax boards, printers, copiers, telephones, and handheld computers. In this scenario, all those devices would be networkable and would contain lots of intelligence. All would contain some form of the Windows GUI (Graphical User Interface) to enable features that in many cases already exist, but that go unused because of a difficult user interface. Networking would be used to provide additional capabilities, particularly integration among disparate varieties of office equipment.

For example, today one might print a document, run it through a copy machine, manually distribute some copies, fax others, and send yet another by courier. Instead, under the new, intelligent scheme, one

might "print" the document directly to a copy machine, complete with instructions on who should receive copies, and to a fax machine (or server) for transmission when rates are favorable.

By my count, this initiative is actually the third wave in Microsoft's increasingly grandiose vision for the computing future. Wave 1 came in Fall 1990, when Bill Gates announced "Information At Your Fingertips," his vision of a multimedia future in which everything one could possibly want to know about anything representable in digital form would be readily accessible.

Wave 2 followed about a year and a half later, with the "Windows Everywhere" strategy, which was designed to put Windows technology on a range of computing devices ranging from small hand-held units to desktop PCs, to RISC-based workstations, to enormous multi-processor desktop servers.

Wave 3, Microsoft at Work (MAW), unites Waves 1 and 2 in a less visionary but much more pragmatic approach.

MAW architecture

The MAW architecture consists of five major components: A real-time, pre-emptive multitasking operating system; messaging and interactive communications; rendering technology that promises to achieve visual consistency across display screens, printers, copiers, and faxes; the Windows GUI; and software that will allow the desktop PC to function as a hub for information flow, control, and distribution. Let's examine each component in more detail.

• **Operating System** This is where Microsoft's biggest technical challenge lies. The MAW operating system must provide true pre-emp-

tive multitasking, and must be economical in its use of RAM. On both counts, the Windows 3.1 that you and I know and love (and sometimes hate) strikes out. However, the company has in the past delivered a "small-footprint" version (Tandy's Visual Information System, discussed here in the December 1992 column), and has undoubtedly learned a few things since then. Other goals for the MAW operating system include modularity and extensibility, basic support for existing Windows API (Application Program Interface) calls (to minimize training that would be required by developers), and a PC-hosted development environment.

• **Communications** The MAW architecture will support two basic forms of communication: message-based and real-time. The message-based component will be used for enhanced Email type functions, such as a PC-based message-management system that would allow you to sort through Email, voice-mail, and faxes via a single inbox. Regardless of format (text, voice, fax), each item in the inbox would be identifiable by sender and other information, thus allowing easy prioritization. Other capabilities include "read-only" documents that can be printed, but not edited, as well as fully editable documents. For example, a "fax" might contain both a bit-mapped representation of a document and the complete set of text and graphics objects of which it is composed. The system will also support data encryption, compatibility with existing fax machines, integration with MAPI, Microsoft's Messaging API, currently used primarily for Email.

The other form of MAW communications is bidirectional and interactive. For example, as in Micro-

TABLE 1—MICROSOFT AT WORK SUPPORTERS

Technology Area	Company
Systems, system software, applications, peripherals	Microsoft, HP, Intel, Toshiba, WordPerfect Corp.
PC Based Telephone Management	Active Voice, Centigram, Dialogic, Octel
LCDs and Touch Screens	ALPS Electric
Telephone and WAN Communications	AT&T Easy Link, Bell Atlantic, BT North America, McCaw Cellular, MCI, Motorola, Sprint, US West
PC-based fax Modems, Cards, and Software	Brooktrout Technology, Cardinal Technologies, The Complete PC, DataRace, Digital Communications Associates, Delrina, Digicom, Phoenix/Eclipse, Expervision, GammaLink, GVC Technologies, Hayes, National Semiconductor, Nuko, OAZ Communications, Optus, Pacific Image, Practical Peripherals, Smith Micro Software, Supra Corp., Thought Communications, U.S. Robotics, Inc., Yamaha Corp. of America, ZOOM Telephonics
PC-based OCR Software	Caere Corp., Calera
Standalone copy and fax machines	Canon, Minolta, Mita, Murata/Muratec, NEC, OKI, Ricoh, Tokyo Electric, XEROX
Network-based fax servers	Castelle, Cheyenne Software, SofNet, VMX
Hand-held computers/communicators	Compaq Computer Corp., Casio
Telephone systems (PBXs, etc.)	Ericsson, NEC, Northern Telecom, Philips, Rolm
Ingrated circuits and chip sets	Exar, Casio, National Semiconductor, Rockwell Intl., Sierra Semiconductor, Toshiba
Test products	Genoa Technology

soft's current Windows Printing System, a printer could provide aural and on-screen feedback about machine status (paper jam, paper out, toner low, estimated time of completion of current job, etc.).

● **Rendering** The rendering component of MAW would provide a consistent imaging model on all computing devices. This amounts to using Windows' Graphics Device Interface (GDI) for imaging, and TrueType fonts for text. Presently, GDI calls must at some point be translated to a specific device format, be it PostScript, PCL, Group III fax, or what have you. A single imaging/font model would be desirable on numerous counts; however, the present incarnation of GDI—in

Win31 (Windows version 3.1), anyway—is insufficiently rich to accomplish everything that other, more robust solutions (particularly PostScript) can do. The enhanced GDI in Windows NT does provide PostScript-like functionality, but NT has even higher resource (CPU/RAM) requirements than Win31. It's hard to imagine a standalone fax machine running NT.

In addition, the installed base of PostScript devices and applications are not things that Microsoft will be able to overcome overnight, if ever. Device drivers—and their attendant development and maintenance responsibilities—between GDI sources and output devices are likely to be with us for a long time.

● **GUI** Microsoft's intent in this area appears not so much to be intent on making the Win31 GUI canonical as in making GUIs in general ubiquitous. For example, people would probably make much greater use of advanced features of today's standard office telephones if those features had some sort of visual representation and prompting. Look for the appearance of large LCD-based touch screens, whose contents vary extensively according to task, on all sorts of common office equipment.

● **Desktop Software** All the components of this vision will come together at the individual user's desktop. By means of the technologies described here, the individual user will be able to control voice mail, Email, and faxes from his or her desktop; system administrators will be able to manage phone logging, software updates, and maintenance requirements from a central location; users will be able to keep portable organizer-style PCs synchronized with desktop and network servers; and users will ultimately gain more control over how they communicate, with whom, and when.

Vision

Microsoft has developed a compelling vision of the office of the near future. It is also a comprehensive vision, much more so than anything promoted in recent years by Digital, HP, IBM, or Sun. As reported here last time, these big companies have rallied around various efforts at cloning or circumnavigating the Windows API. Meanwhile, Gates and Company have expanded the scope of that API by developing agreements with many major providers of telecommunications and office equipment. If I were a strategic marketer for one of the big four, I'd be worried.

But as a consultant and user, I'm excited. I'd like to be able to use my PC to control my copy machine, my fax machine, and my telephone in an integrated manner. If Microsoft Windows is the underlying technology that allows me to do so, so be it.

Realistically, MAW is a *vision* kind of thing. There are no products that support it yet, and it's within the

EN Computer Admart

Rates: Ads are 2 1/4" x 2 1/2". One insertion \$995 each. Six insertions \$950 each. Twelve insertions \$925 each. Closing date same as regular rate card. Send order with remittance to Computer Admart, Electronics Now Magazine, 500-B Bi-County Blvd., Farmingdale, NY 11735. Direct telephone inquiries to Arline Fishman, area code-1-516-293-3000. FAX 1-516-293-3115. Only 100% Computer ads are accepted for this Admart.

PC-BUS POWER MONITOR CARD

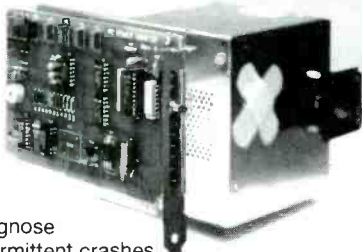

Diagnose intermittent crashes, detect power disturbances, and spot bad power supplies in PC, AT and EISA systems. It checks all four supply voltages, and remembers momentary out-of-tolerance operation.



Wintek Corporation
1801 South Street
Lafayette, IN 47904

Phone: 800-742-6809 or (317) 448-1903

CIRCLE 179 ON FREE INFORMATION CARD

New BUFFERED PC/AT BUS(ISA) EXTENSION CARD PROTECTS PC MAKES TESTING EASIER



- ★ Prevent PC damage from testing unit plugging/unplugging.
- ★ Save PC rebooting time to speed up testing.

Order NOW! Model No.: **IF001**
One year factory hardware warranty

TC INSTRUMENTS®

4 Village Loop Road, Unit B3, Pomona, CA 91766
Tel: (909) 397-5870 Fax (909) 397-5875

CIRCLE 192 ON FREE INFORMATION CARD

Get Started in Lotus 1-2-3 The Easy Way



If you are getting started in Lotus 1-2-3 at any release level, you'll want these power-packed duo publications designed for first-time users and those who need refresher orientation. To get both (BP261 and BP302) send \$12.20 plus \$2.50 for shipping in the U.S. only to **Electronics Technology Today Inc.**, P.O. Box 240, Massapequa Park, NY 11762-0240.

NEW PC BASED TEST TOOLS! LOW COST!

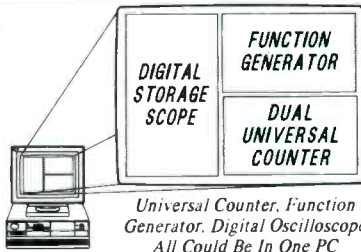

Universal Counter, Function Generator, Digital Oscilloscope
All Could Be In One PC

Multi-Tasking With Windows 3.X. No IEEE 488 Hassel

Each testing tool is a PC peripheral card, operated under Windows 3.X., works well individually or corporately.

- Speeding up testing with on board process
- Ideal for field service and remote calibration
- Programmable with C or BASIC language

TC INSTRUMENTS®

4 Village Loop Road, Unit B3, Pomona, CA 91766
Tel: (909) 397-5870 Fax (909) 397-5875

CIRCLE 193 ON FREE INFORMATION CARD

The Intelligent DVM!

THE ULTIMATE IN CONVENIENCE & VERSATILITY

INCLUDES AMAZING SOFTWARE PACKAGE FOR MICROSOFT WINDOWS VALUED AT OVER \$500

- Excellent for:
- experimentation
 - temperature
 - strain gauge
 - portable PCs

5 1/2 Digit Resolution



The Intelligent DVM is a high precision auto-ranging DVM with digital inputs and outputs. Software allows complete control of display, recording and outputs. Graphing includes curve fitting, printing and other advanced features. Three models from \$229.95.



DELTAQUEST
Opening New Doors

Tel: (408) 997-8644
Fax: (408) 997-6730

CIRCLE 190 ON FREE INFORMATION CARD

GET THE MOST FROM YOUR PC'S HARD DISK



If you are disorganized and use your hard disk inefficiently, you need this book to help you organize your files, use batch files, and use backup and security procedures. To get your copy (BP280) send \$6.95 plus \$2.50 for shipping in the U.S. only to **Electronics Technology Today Inc.**, P.O. Box 240, Massapequa Park, NY 11762-0240.

realm of possibility that there never will be. But I don't think so. I think Microsoft really has uncovered a glaring need, one that was staring us all in the face, if not knocking us upside the head with increasing urgency the past several years.

Several fax manufacturers have stated that MAW-compliant products will be released by the end of 1993. However, it will probably take a minimum of 12-18 months before it will be possible to build up a robust, integrated suite of MAW-compliant devices and applications. When that happens, our social or-

ganism, fueled as it is by information in multiple media formats, will become infinitely smarter and more competitive internationally. When that happens, there will be a fundamental change in the way many of us do business. Those who don't change the way they do things won't be conducting anything—except maybe a funeral dirge.

Digital paper

Less ambitious, but more focused, are competing products recently introduced by Adobe Systems and No Hands Software. Both

software packages are in a sense attacking a subset of the problem that MAW purports to solve: efficient document distribution.

Common Ground (from No Hands) and Acrobat (from Adobe) both function as printer drivers and allow highly accurate, electronic versions of documents to be created complete with fonts and graphics. The two products differ in their underlying file formats, font treatment, costs and licensing arrangements, document fidelity, RAM and disk requirements, and overall product versatility.

No Hands Software distinguishes among three types of font treatments: font replication, font substitution, and font embedding. Common Ground uses font replication, which works by rasterizing font information at several resolutions, currently 72, 100, 200, and 300 Dots Per Inch (DPI). It stores this information in a file, along with the text and graphics. As long as you view or print at one of the pre-defined resolutions, you will see a very accurate representation of your document.

Acrobat, on the other hand, uses font substitution, which is based on Adobe's Multiple Master typefaces, which can emulate the height and width characteristics of many Adobe Type 1 PostScript fonts. (Common Ground supports both Type 1 and TrueType fonts.) The idea is that if a given font does not exist on a recipient's system, Acrobat will maintain line and page breaks by creating, on the fly, a multiple master typeface that mimics the original typeface.

CG's font replication provides more-accurate document representation; Acrobat allows smaller file sizes. (Microsoft has defined a system of font embedding, which allows end users to embed fonts in documents in one of two modes: read-only and read-write. A read-only embedded font may be transferred as part of another document to another machine and used in that document only; a read-write font may be transferred in one document and installed for use in other documents. However, font vendors have expressed resistance to using this scheme, which could easily promote an already high incidence of font piracy. Currently, the only product I know of that supports font embedding is PowerPoint 3.0.)

To view an electronic document created by either Acrobat or Common Ground, a special viewer is needed. Adobe is selling its viewer in single-user quantities for \$50; No Hands is giving a mini viewer away for free (via BBSs and on-line services). The company is also selling a more capable viewer for \$189 list.

Both products function essentially as the final stage of a unidirectional publication process. It is

necessary to run a "source file" through a "document compiler" to produce a distribution file. In addition, Acrobat files can be post-edited to provide hypertext links and other features. The problem is that the one-way process ensures inefficient document maintenance. In other words, if you add hyperlinks to an Acrobat electronic document and subsequently need to update the source document, you would need to re-run the compiler and add the links again.

Acrobat functions as a limited subset of the PostScript programming language, in which strings are embedded in lines of program code. This makes text searching difficult and inefficient. (In fact, the first version of Acrobat has no search function at all.) Common Ground stores text in a more compressed format for efficient searching.

CG is currently available for the Mac, with a Windows version scheduled for release about the time you read this. Acrobat has released both Mac and Windows versions, and plans to release DOS and UNIX versions.

Because of the one-way authoring process, I find both products severely limited. In addition, Acrobat's pricing structure is less hospitable than Common Ground's. I would consider using Common Ground for small, limited-distribution projects—e.g., a README file in a software release—but neither is really suitable for large-scale information-development and distribution projects. The concept behind these products is valid; what's needed is a more universal solution. Ω



"HUH?!"

42,398

ELECTRONIC COMPONENTS

Whether you order 1 part or all 42,398...MOUSER stocks and...ships same day!!

CALL...
(800) 992-9943

for your
FREE
CATALOG

2401 Hwy 287 N.
Mansfield, TX 76063

MOUSER ELECTRONICS

Sales & Stocking Locations Nationwide

CIRCLE 117 ON FREE INFORMATION CARD

CABLE TV DESCRAMBLERS

Best Prices in the U.S.A.!

Guaranteed to Work!

QUANTITY DISCOUNTS



JERROLD PANASONIC
SCIENTIFIC ATLANTA PIONEER

The Newest & the Latest

- DMTB-A - all Jerrold Impulse & Starcom series
- SA3-DFA - all Sci. Atlanta incl. 8536, 8536+, 8580, Drop-field
- PN-3A - all Pioneer systems

ALSO

FTB3, SA3, TZPC145G

24 HOUR SHIPMENTS
30 DAY MONEY BACK GUARANTEE
FREE CATALOG & INFORMATION

1-800-772-6244

M-F: 9-6 EST

U.S. Cable TV, Inc. Dept.: KEN103

4100 N. Powerline Rd, Bldg. F-4 Pompano Beach FL 33073
NO FLORIDA SALES!

CIRCLE 187 ON FREE INFORMATION CARD

Get 3 Books for only \$9⁹⁵

Values to \$230.00

plus 1 book FREE upon prepayment when you join the *Electronics Engineers' Book Club*[®]

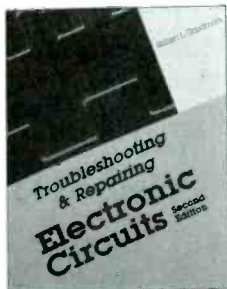

3258P **\$19.95**
This book offers up-to-date instructions for troubleshooting and repairing all major brands of equipment, with hundreds of diagrams, specs, and schematics. Covers TVs, VCRs, CD players, and much more. 310 pp. *Softcover*

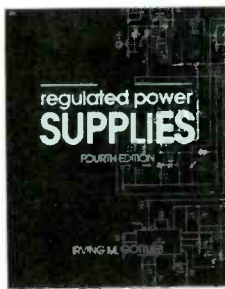

3991H **\$39.95**
Engineers and technicians will find full coverage of standard power supply sources. Covers new frequency devices including insulated-gate bipolar transistors (IGBT) and mos-controlled thyristors (MCTs). 464 pp., 365 illus.



9255H-XXX **\$105.50**
"Outstanding, extensive reference to current technology of electronics. Covers everything from principles to applications."
—Computer Book Review
2,528 pp., 1,800 illus.
Counts as 3

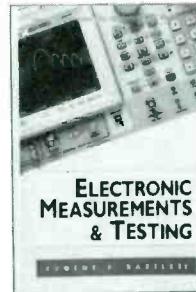

003961H **\$40.00**
Here's your guide to basic electrical measurements, component measurements, system tests, and performance verification. Most of the methods and procedures you'll find here use available off-the-shelf test equipment. 224 pp., 180 illus.

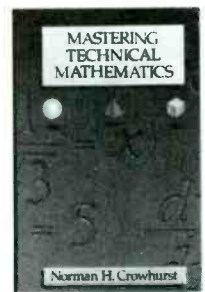

3438H **\$39.95**
Promotes true understanding by explaining how and why mathematics principles work. Step-by-step instructions and alternative techniques are provided for solving problems in basic arithmetic, algebra, geometry, trigonometry, and calculus. 512 pp., 481 illus.

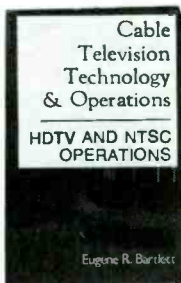

003957H-XX **\$50.00**
From practical troubleshooting to large-scale system upgrades, this is the place to turn for step-by-step guidance on the design, manufacture, and maintenance of today's cable TV systems. 400 pp., illus. *Counts as 2*

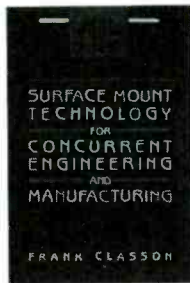

011200H **\$45.00**
Take advantage of the valuable miniaturization and cost-saving benefits of SMT with this guide. It shows how your company can integrate several key functions—design, manufacturing, testing, and management—saving both time and money at every step in the process. 300 pp., 225 illus.



021291H-XX **\$59.50**
Covering virtually every facet of transformers and related ferromagnetic devices, this reference reflects the latest technological advances. This source addresses specifications, testing, mechanical design, magnetic device economics, and more. 464 pp., 200 illus. *Counts as 2*

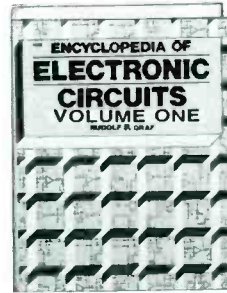

1938H-XX **\$60.00**
For quick-reference and on-the-job use, this sourcebook puts over 1,300 state-of-the-art designs at your fingertips. From A (alarm circuits) to Z (zero crossing detector circuits) this compendium excels in content, scope, and design. 768 pp. *Counts as 2*

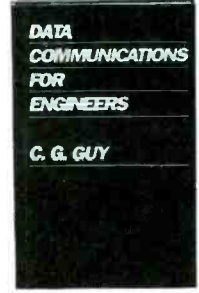

025354H **\$30.00**
Understand the latest data communications software systems and how they interface with hardware. This hands-on guide emphasizes the practical side of the field while keeping mathematical theory to a minimum. 192 pp., 30 illus.

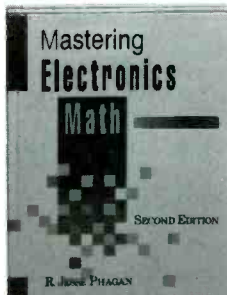

3589H **\$27.95**
A practical toolbox reference for anyone in the electronics field. Phagan guides you through the practical calculations needed to design and troubleshoot circuits and components. 352 pp., 270 illus.

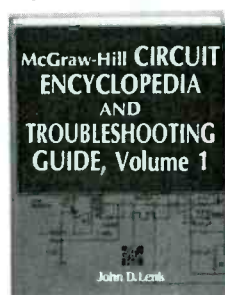

037603H **\$59.50**
This provides both a collection of over 700 of the latest commonly used integrated and discrete-component circuits and authoritative testing and troubleshooting methods on each type of circuit. 664 pp., 703 illus.

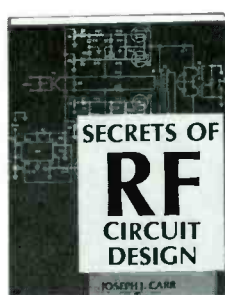

3710H **\$32.95**
Understand the basics of receiver operation, the proper use and repair components in RF circuits, and principles of radio signal propagation from low frequencies to microwave. 416 pp., 411 illus.

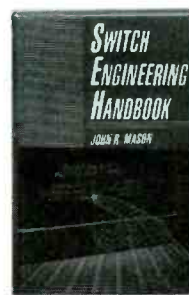

040769H **\$60.50**
Confidently select the right switches for any application—and reduce costs while enhancing performance. Minimize the time you spend in technology trade-offs, selection and specification of a product, and switch source searches. 512 pp., 158 illus.

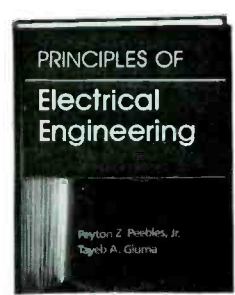

049252H-XX **\$58.29**
This practical, on-the-job reference provides easy-to-follow guidance on electronic devices and circuits ... computers and digital devices ... electrical communications systems ... and power systems and electrical machinery. 784 pp. Illus., *Counts as 2*

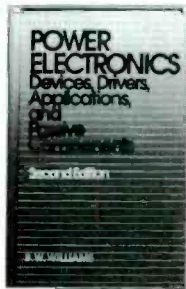

070439H-XX \$60.00
Confidently select the right high-power device for any application with the guidance of this completely revised and updated version of a highly successful reference. 558 pp. *Counts as 2*

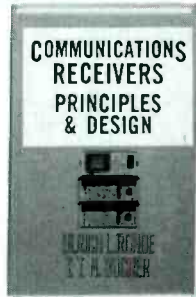

053570H-XX \$65.00
Successfully design and work with all types of communications receivers—including shortwave, broadcast (AM-FM), military, radar, aeronautical, direction-finding, and marine. 608 pp., 402 illus., *Counts as 2*

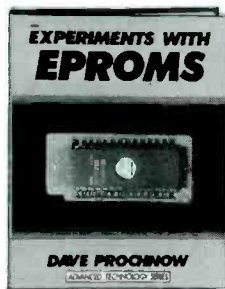

2962P \$18.95
This complete EPROM instruction manual provides a detailed explanation of underlying theory, plus 15 different projects, including programmers, erasers, and EPROM-based circuits. 240 pp. *Softcover*

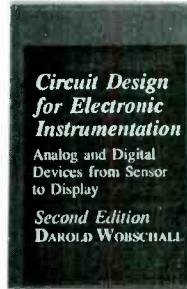

071231H \$60.00
Create sound electronic instrumentation circuit designs with this step-by-step guide. You'll find information on semiconductors, sensors, flow meters, filters, oscillators, digital circuits, multiplexers, and more. 377 pp., 430 illus.

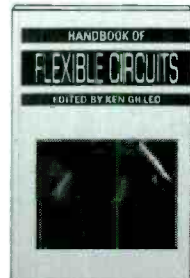

586166H-XX \$59.95
This handbook methodically guides you to the optimum use of flexible circuit technology—how to avoid both under-using features and over-stressing products. 288 pp. *Counts as 2*



3279P \$24.95
Perform routine maintenance and diagnose and repair any kind of computerized device. This popular reference covers large dynamic RAMs, 32-bit processors, 80286, 80386, and Z8001-Z8002 processors. 570 pp., *Softcover*

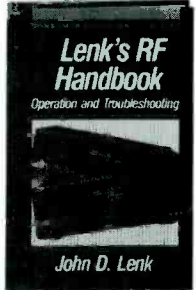

037504H \$39.50
Packed with simplified, circuit-by-circuit troubleshooting examples, this handbook provides the practical know-how you need to operate and troubleshoot modern RF equipment. 352 pp., 150 illus.

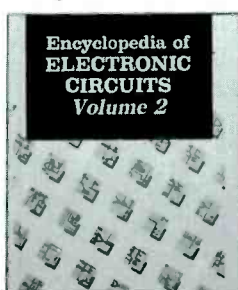

3138H-XX \$60.00
A GIANT "Circuit Book" of over 700 of the most widely-used, state-of-the-art electronic and integrated circuits ever compiled in a single source! The perfect sourcebook for all levels of electronics practitioners. 738 pp. *Counts as 2*

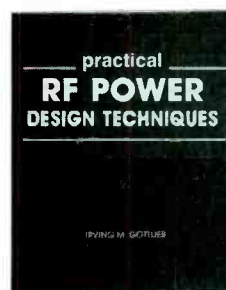

4228H \$32.95
Translate RF theory into functioning hardware. The author shows you how to design working RF power circuits with practical, real-world components and component values. 304 pp., 219 illus.



009522H \$49.00
This unique guide helps you select and properly use the right test equipment. It's organized by electronic function and includes separate sections on analog and digital instruments, signal generators, and oscilloscopes. 320 pp., *Illus.*

Your source for quality, affordable and timely authoritative engineering books.

As a member of the Electronics Engineers' Book Club...

... you'll enjoy receiving Club bulletins every 3-4 weeks containing exciting offers on the latest books in the field at savings of up to 50% off of regular publishers' prices. If you want the Main Selection do nothing and it will be shipped automatically. If you want another book, or no book at all, simply return the reply form to us by the date specified. You'll have at least 10 days to decide. And you'll be eligible for **FREE BOOKS** through the Bonus Book Program. Your only obligation is to purchase 3 more books during the next 2 years, after which you may cancel your membership at any time.

©1993 EEBC
All books are hardcover unless otherwise noted. Publishers' prices shown. If you select a book that counts as 2 choices, write the book number in one box and XX in the next. If you select a Counts as 3 choice, write the book number in one box and XXX in the next 2 boxes.

A shipping/handling charge & sales tax will be added to all orders.

If card is missing, write to:
Electronics Engineers' Book Club, Blue Ridge Summit, PA 17294-0860

Cut along dotted line

ELECTRONICS ENGINEERS' BOOK CLUB

Blue Ridge Summit, PA 17294-0860

YES! Rush me the following title(s), billing me just \$9.95 (plus shipping/handling & sales tax). Enroll me as a member of the Electronics Engineers' Book Club according to the terms outlined in this ad. If not satisfied, I may return the book(s) within 10 days for a full refund and my membership will be cancelled. I agree to purchase just 3 more selections at regular Club prices during the next 2 years and may resign anytime thereafter.

Bill me (FREE book not available with this payment option.)

SPECIAL OFFER! Prepay your order by check, money order, or credit card and receive a 4th book of your choice **FREE**.

YES! I want the **FREE BOOK** indicated at right. Code # of my **FREE BOOK:**

My introductory payment of \$9.95 plus \$9.95 shipping/handling* and applicable sales tax is enclosed.

Code number(s) of my book(s) for \$9.95

--	--	--

If you select a book that counts as 2 choices, write the book number in one box and XX in the next. If you select a Counts as 3 choice, write the book number in one box and XXX in the next 2 boxes.

Check or money order enclosed made payable to: McGraw-Hill, Inc.
Please charge my: VISA MasterCard American Express Discover

Acct. No. _____ Exp. Date _____

Name _____ Signature _____
(required on all credit card orders)

Address/Apt. # _____

City/State/Zip _____ Phone _____

Offer valid for new members only, subject to acceptance by EEBC. U.S. orders are shipped 4th Class Book Post. Canada must remit in U.S. funds drawn on U.S. banks. Canadian orders are shipped International Book Post—add \$12.50 shipping/handling. Applicants outside the U.S. and Canada will receive special ordering instructions. A shipping/handling charge & sales tax will be added to all orders. DRE1093C

October 1993, Electronics Now

BUYER'S MART

FOR SALE

TUBES. "oldest", "latest". Parts and schematics. SASE for lists. **STEINMETZ**, 7519 Maplewood Ave. RE, Hammond, IN 46324.

TUBES, new, up to 90% off, SASE, **KIRBY**, 298 West Carmel Drive, Carmel, IN 46032.

CABLE test chips. Jerrold, Tocom, S.A., Zenith. Puts cable boxes into full service model! \$29.95 to \$59.95. 1 (800) 452-7090, (310) 867-0081.

SECRET cable descramblers! Build your own descrambler for less than \$12.00 in seven easy steps! Radio Shack parts list and free descrambling methods that cost nothing to try, included. Send \$10.00 to: **INFORMATION FACTORY**, Dept. 4, PO Box 1790, Baytown, TX 77522.

CABLE TV converters: Jerrold, Oak, Scientific Atlanta, Zenith & many others. "New MTS" stereo add-on: mute & volume. Ideal for 400 and 450 owners! 1 (800) 826-7623, Amex, Visa, M/C accepted. **B & B INC.**, 3584 Kennebec, Eagan, MN 55122.

CABLE TV descramblers — All major brands. Have make/model used in your area when calling, 1 (800) 327-3407. For a free catalogue write: **K.D. VIDEO**, PO Box 29538, Minneapolis, MN 55429.

VCR repairs, over 1,600, all makes, 60 pages, \$35.00. **CI ELECTRONICS**, 1115 N. Higley Rd., Suite 106-119, Mesa, AZ 85205.

Quality Microwave TV Antennas

WIRELESS CABLE - IFTS - MMDS - Amateur TV
 Ultra High Gain 50dbi(+) • Tuneable 1.9 to 2.7 Ghz
 • 55-Channel Dish System \$199.95
 • 36-Channel Dish System \$149.95
 • 20-Channel Dish System \$124.95
 • Optional Commercial Grid Antenna (not shown) Add \$50.00
 • Yagi Antennas, Components, Custom Tuning Available
 • Call or write (SASE) for "FREE" Catalog

PHILLIPS-TECH ELECTRONICS
 P.O. Box 8533 • Scottsdale, AZ 85252
 (602) 947-7700 (\$3.00 Credit all phone orders)
 LIFETIME WARRANTY MasterCard • Visa • American Express • COD's • Quantity Pricing

300 Experimenters Circuits — Complete in 6 practical books using diodes, relays, FET's, LED's, IC 555's, and IC CA3130's for building blocks. Only \$33.00 plus \$5.50 for shipping. USA and Canada only. US funds. **ETT, INC.**, PO Box 240, Massapequa Park, NY 11762-0240.

EPROMS, Assorted, i.e., 27128A-15 \$3.00 each minimum quantity 13 pieces. C.O.D., American Express. **H.E.A.R.T. Inc.**, 1 (800) 677-3773.

CABLE Converters, accessories below wholesale! Immediate delivery from giant stock! COD orders only. 1 (800) 995-1749.

FREE CATALOG

FAMOUS "FIRESTIK" BRAND CB ANTENNAS AND ACCESSORIES. QUALITY PRODUCTS FOR THE SERIOUS CB'er. SINCE 1962

FIRESTIK ANTENNA COMPANY
 2614 EAST ADAMS
 PHOENIX, ARIZONA 85034

RESTRICTED information: surveillance & schematics, locks, cable, hacking, more. Details: **MENTOR**, Box 1549-Z, Asbury, NJ 07712.

CABLE TV converters. Jerrold, Zenith, Pioneer, Oak, Scientific Atlanta, and many more. 12 years experience gives us the **advantage.** Visa/MC Amex COD **ADVANTAGE ELECTRONICS, INC.**, 1 (800) 952-3916 1125 Riverwood Dr., Burnsville, MN 55337.

CB RADIO OWNERS!

We specialize in a wide variety of technical information, parts and services for CB radios. 10-Meter and FM conversion kits, repair books, plans, high-performance accessories. Thousands of satisfied customers since 1976! Catalog \$2.

CBC INTERNATIONAL
 P.O. BOX 31500RE, PHOENIX, AZ 85046

POWER inverter portable 115V AC 12V DC 100W from built in rechargeable battery 13 lbs. \$85.00 plus \$15.00 S/H. Was \$185.00 last year, now close out. **HILL CO.**, 13222 Carolyn St., Cerritos, CA 90701.

REVOLUTIONARY technology makes for most affordable, smallest, and fastest Eprom programmer in world! Hours of fun. (602) 968-8771.

CABLE TV descramblers. Nobody beats our price! Quantity discounts. 24 hour shipping — all brands. Call **V.C.I.**, 1 (800) 677-0321.

PREVENT descrambler damage. Don't bite the bullet! Snooper Stopper Data Pulse Blocker \$34.95 — Data Blocker with dual surge protection \$54.95 — wireless Video Sender \$54.95 — remote control A/B switch \$39.95 — **VIDEO CONNECTIONS**, 1 (800) 925-9426.

TV notch filters. Professionally manufactured. COD, Visa, MC accepted. Theft of cable service is illegal. Call 1 (800) 331-2156 ext. #2156.

EPROMS 15 for \$10.00 used, still coded, grab bags 2716 to 27256. Coin-op video game boards \$20.00. **SIMTRONICS**, (806) 832-4622.

RECEIVING TUBES
OVER 3000 TYPES IN STOCK!
 Also hard-to-find transformers, capacitors and parts for tube equipment.
 Send \$2.00 for our 32 page catalog.

ANTIQUE ELECTRONIC SUPPLY
 6221 S. Maple Ave. • Tempe, AZ 85283 • 602-820-5411

TEST equipment pre-owned now at affordable prices. Signal generators from \$50.00, oscilloscopes from \$50.00. Other equipment including manuals available. Send \$2.00 U.S. for catalog refunded on first order. **J.B. ELECTRONICS**, 3446 Dempster, Skokie, IL 60076. (708) 982-1973.

CABLE descramblers, test turn-on kits, bullet stoppers. We have the lowest prices in the industry, because we have no catalog, and no 800 number! Call everyone else, then call us for the best price. We buy, sell and trade. No Florida sales. (305) 425-0751.

DESCRAMBLING secrets revealed. Free 24 hour hotline reveals secret satellite and cable descrambling information. (718) 390-7130.

DESCRAMBLERS for cable and satellite. Kits and assembled units. All types. Guaranteed. From \$19.95. Free catalog. (212) 330-8035.

BEST BY MAIL
 Rates: Write National, Box 5, Sarasota, FL 34230
 OF INTEREST TO ALL

BLACKJACK MONEY MAGNET Amazing System. Lose \$ Consecutive Hands And Still Make \$2,000/Day. Send \$10 to **FRISON**, Box 16466, North Hollywood, CA 91615.

LOTTERY RESEARCHERS INVITED Send \$2 SASE: LMT, Box 37645-(RE), Jacksonville, FL 32205.

BUY \$200 IN Groceries For Under \$25, GUARANTEED! CALL 1-800-358-2962.

COLLECTIBLES
ORIGINAL MARTIAN MONUMENTS LITHOGRAPH. Limited Edition 800, \$69 to **COSMIC ORIGINALS**, POB 6422-(RE) Whittier, CA 90609-6422.

MONEYMAKING OPPORTUNITIES
FULL TIME INCOME Mailing Flyers. SASE Brings Details: **FLYERS**, Box 1143-(RE), Clinton, MD 20735.

Amem
LOW WAREHOUSE PRICES!

1MB SIMM 80ns \$32
4MB SIMM 80ns \$139

TYPE	PKG.	100ns	80ns	60ns
256K x 4	DIP	\$3.95	\$4.25	\$4.35
1M x 1	DIP	\$3.59	\$3.89	\$3.96
256K x 9	SIMM	\$6.99	\$9.64	\$10.92
		80ns	70ns	60ns
1M x 9 3 chip	SIMM	\$32.00	\$34.00	\$36.00
1M x 9 9 chip	SIMM	\$34.50	\$34.75	\$36.50
4M x 9 9 chip	SIMM	\$139.00	\$146.00	\$159.00
1M x 36 72 pin	SIMM		\$149.00	

MATH CO-PROCESSORS/CPUs

80387-SX	16-25	INTEL	\$76.47
80387-DX	16-33	INTEL	\$82.35
835X87	16-25	CYRIX	\$56.47
83DX87	16-33	CYRIX	\$63.52
83D87-40		CYRIX	\$73.00
ODP486-DX2	66MHZ	INTEL	\$592.00
ODP486-DX2	50MHZ	INTEL	\$456.00

CACHE MEMORY ALSO IN STOCK!

408-559-0603
FAX 408-559-0301
 2059 Camden Ave., #330 San Jose, CA 95124

All electronics 100% guaranteed. We accept VISA, MC, Discover and compare PD's with your approval. Price, delivery and manufacturer subject to change. Minimum order \$100. Returns require RMA, non-defective returns subject to a 15% restocking fee.

CABLE TV DESCRAMBLERS ((FEATURING))

*** VIDEO STABILIZERS AVAILABLE & Bullet Protectors ***

MULTIVISION ELECTRONICS 2700 50 123RD CT. STE #126 OMAHA, NE 68114

1-800-835-2330 BEST BUYS BEST SERVICE STARTS WITH A FREE CATALOG

1-800-327-8544 TECH LINE (402) 331-3228

BY PURCHASING CABLE EQUIPMENT FROM MULTIVISION ELECTRONICS, THE PURCHASER AGREES TO COMPLY WITH STATE & FEDERAL LAWS REGARDING PRIVATE OWNERSHIP OF CABLE TV EQUIPMENT. IF YOU ARE UNABLE OF THESE LAWS CHECK WITH YOUR LOCAL OFFICIALS.

1. Call Identifiers
2. Power Antennas
3. Blind-Machines
4. Wireless Cable Receivers T.V. 1.9-2.7 GHz
5. Stun-Guns
6. Surveillance
7. Dual Deck VCR

1-800-831-4242

Your Resource for Value. Only a Phone Call Away.

20
YEARS OF
EXCELLENCE
1973-1993

Metex Digital Multimeters

- Handheld high accuracy
- Measures AC/DC voltage, AC/DC current, resistance, diodes, audible continuity test, transistor hFE
- Manual ranging w/overload protection
- Comes with probes, batteries, case and manual
- One-year warranty



OR27158

OR27086 & OR27158 only:

- Also measures frequency and capacitance

Part No.	Description	Price
OR27078	3.5 digit multimeter	\$59.95
OR27086	3.5 digit multimeter w/frequency & capacitance	74.95
OR27115	3.5 digit multimeter	39.95
OR27140	4.5 digit multimeter, w/tach/dwell	59.95
OR27158	4.5 digit w/frequency & capacitance & data hold switch	99.95

Jameco Solderless Breadboards

Our long-lasting breadboards feature screen printed color coordinates and are suitable for many kinds of prototyping and circuit design. Larger models feature heavy-duty aluminum backing with voltage and grounding posts.



OR20757

Part No.	Terminal Strips	Bus Strips	Contact Points	Price 1-9
OR20343	0	2	200.....	\$3.49
OR20600	1	2	400.....	4.95
OR20669	1	0	630.....	5.95
OR20722	1	2	830.....	6.95
OR20757	2	1	1,360.....	12.95
OR20773	2	4	1,660.....	17.95
OR20790	3	5	2,390.....	24.95
OR20811	4	7	3,220.....	32.95

Regulated Power Supply Kits

Build the power supply you've been needing for years. Ideal for home or instructional use. Select from three different versions. Each kit is complete with printed circuit board, electronic components and user assembly instructions.



OR73613

Part No.	Product No.	Input Voltage (VAC)	Output Voltage (VDC)	Current (mA)	Dimensions (L x W x H inches)	Price
OR20360	JE200	120	+5	1000	3.5 x 5.0 x 2.0	\$14.95
OR20626	JE215	120	+5 to +15 -5 to -15	750 to 175 750 to 175	3.5 x 5.0 x 2.0	19.95
OR73613	JE225	120	+5 fixed +3 to +12 -3 to -12	1000 100 100	5.12 x 5.12 x 2.25	29.95

See our Catalog for more kits

EPROMS

Part No.	Product No.	Price
OR33611	TMS2716	\$5.95
OR39909	2708.....	4.95
OR40002	2716	4.49
OR40125	2732A-25	4.49
OR40230	2764A-20	4.75
OR39829	27C64-15	4.49
OR39933	27128-25	7.75
OR39968	27128A-20	4.95
OR39984	27128A-25	3.95
OR39677	27C128-15	5.75
OR40037	27256-15	5.49
OR40061	27256-25	4.75
OR39714	27C256-15	5.25
OR39722	27C256-20	4.95
OR40150	27512-20	6.95
OR39781	27C512-15	6.49
OR65699	27C020-15	10.95
OR43692	68766-35	4.95



OR26622

OR21936

Switches

Part No.	Product No.	Description	Price
OR21936	JMT123	SPDT, on-on (toggle).....	\$1.15
OR38842	206-8	SPST, 16-pin (DIP)	1.09
OR26622	MS102	SPST, momentary (push-button)39



National, Intel & TI Databooks

Part No.	Product No.	Description	Price
OR79071	400061	National Operational Amplifier Linear Devices Databook	\$14.95
OR79089	400060	National Linear Application Specific IC's Databook	12.95
OR41208	400015	National Data Acquisition Linear Devices Databook	11.95
OR79062	400062	National Power IC's Linear Devices Databook	11.95
OR88225	—	Texas Instrument LS/S/TTL Databook	24.95
OR39280	230843	Intel Memory Databook	24.95
OR39870	270645	Intel Embedded Controller Processors Databook	24.95

3/4 Watt Linear Taper-15 Turn Cermet Potentiometers

Part No.	Ohms	Price
OR41785	1K	\$.99
OR41822	10K99
OR41849	100K99
OR41806	1MEG99



1/2 Watt Linear Taper- Single Turn Cermet Potentiometers

Part No.	Ohms	Price
OR42964	1K	\$.89
OR43001	10K89
OR43027	100K89
OR42981	1MEG89



SMT product now available!
Call for price and availability

Other Jameco Resources

- Test/Measurement and Prototyping Equipment
- Full line of Integrated Circuits and Electronic Components
- Call for computer parts

Integrated Circuits*

Part No.	Product No.	Price
OR48979	7400	\$.29
OR49015	740239
OR49040	740439
OR49091	740639
OR49120	740739
OR49146	740839
OR49189	741029
OR49728	741735
OR50008	742035
OR50235	743239
OR50420	744789
OR50551	747439
OR50593	747659
OR50665	748639
OR50681	7489	2.95
OR50690	749079
OR49322	7412L49
OR49912	7419299
OR49939	7419399

*Name brand IC's in stock

Order toll-free 1-800-831-4242

Call or write for your FREE August Component Catalog:
1-800-637-8471

JAMECO™
ELECTRONIC COMPONENTS

COMPUTER PRODUCTS

1355 Shoreway Road
Belmont, CA 94002

FAX: 1-800-237-6948 (Domestic)
FAX: 415-592-2503 (International)

For International Sales, Customer Service, Credit Department and all other inquiries: Call 415-592-8097 between 7AM-5PM P.S.T.
CA Residents please add applicable sales tax.

\$30.00 Minimum Order

Terms: Prices subject to change without notice. Items subject to availability and prior sale. Complete list of terms/warranties is available upon request.

© 1993 Jameco 10/93 All trademarks are registered trademarks of their respective companies.

CIRCLE 114 ON FREE INFORMATION CARD

ALL ELECTRONICS

P.O. Box 567 • Van Nuys, CA 91408

AA NICKEL CADMIUM BATTERY CHARGER

Sanyo# NC-452

Battery charger for 2 or 4 AA nickel cadmium rechargeable batteries. Plugs into wall outlet and charges batteries in 8 to 10 hours. Can be folded for easy carrying and storage. 3.25" X 1.6" X 1.81" when folded. UL listed. **CAT# AAC-1** \$2.50 each



EXPERIMENTER'S DELIGHT VHF TO UHF BLOCK CONVERTER



Channel Master# 0746 This is one of those deals that's too good to be true. Brand new, in the box, Channel Master block converters. They used to be quite popular back in the early days of cable television, before there were a lot of cable-ready TVs. Somewhere in the world we know there is still a demand for them--especially at this price. Designed to convert television VHF channels 2 through 13 and A through W to UHF channels 36 through 76. The box alone, is a great project box. The 10 ft. AC power cord, the interior components, F connectors and AC receptacles are well worth the price. **CAT# CM-0746** \$2.00 each • 10 pieces for \$18.50

6VDC, 4PDT KH STYLE RELAY

SPECIAL PURCHASE!!

Omron # MYQ4-02-VH-6VDC

6 Vdc, 37.5 ohm coil. PC pins. 4PDT,

5 amp contacts. 1.07" X 0.82" X 1.41" high.

CAT# 4PRLY-6PC \$2.50 ea • 10 for \$20.00



REDUCED PRICE! 4 (USED) AA RECHARGEABLE BATTERIES

Battery pack with 4 AA nickel-cad batteries in series to make a 4.8 volt pack.

Batteries have solder tabs and can be separated and reconfigured

CAT# NCB-41AAU SPECIAL I \$2.00 per pack



VIDEO/RF MODULATOR

Originally made for use with the Commodore computer, these good quality video modulators were probably

designed for 9 Vdc use, but they operate

well on 6-12 Vdc. They accept color video and audio, and a selector switch is provided for output to channel 3 or 4. Easy to hook-up. Requires a 6-12 Vdc power supply or wall transformer and a connector to interface with your audio/video source. RCA jack output. Hook-up instructions included. 3" X 1.47" X 0.75"

CAT# AVMOD-3 \$5.00 each



TOLL FREE ORDER LINES

1-800-826-5432

CHARGE ORDERS to Visa, MasterCard or Discover

TERMS: Minimum order \$10.00. Shipping and handling for the 48 continental U.S.A. \$4.00 per order. All others including AK, HI, PR or Canada must pay full shipping.

All orders delivered in CALIFORNIA must include state sales tax (7.25%, 7.5%, 7.75%, 8.25%, 8.5%). Quantities Limited. NO C.O.D. Prices subject to change w/out notice.

Call or Write For Our

FREE 64 Page Catalog

(Outside The U.S.A. Send \$2.00 Postage)

ALL ELECTRONICS CORP.

P.O. Box 567 • Van Nuys, CA • 91408

EQUIPMENT REPORTS

continued from page 16

bytes per sector, sectors per cluster, and other useful information is contained in the table.

The final entry in the System Information menu displays the contents of the computer's CMOS memory, and permits the contents to be edited. Micro Scope can become a convenient replacement for the setup boot diskette that is usually required to access the CMOS memory on older IBM-standard AT computers.

Diagnostics menu

The Diagnostics menu permits system hardware to be tested. One series of routines verifies the proper operation of the microprocessor, math coprocessor, direct memory access (DMA) controllers, and programmable interrupt controllers. Memory tests are available for base memory, cache memory, expanded memory, and extended memory.

A sequence of tests for floppy-disk drives can help to locate the cause of disk-related problems. Even 2.8-megabyte floppy drives (as found on some of IBM's latest machines) can be tested.

Hard-disks can be tested with a similar battery of tests. Unlike most diagnostic software, Micro Scope can perform a low-level format on an IDE (intelligent drive electronics) drive. That feature can make Micro Scope pay for itself, because IDE drives that contain a bad sector or that are incorrectly formatted no longer need to be returned to the factory for reformatting.

Tests for serial and parallel ports are also included in Micro Scope, as are modem tests. A number of video tests can help to locate problems with video monitors or display adapter cards. They permit the verification of proper display attributes, screen alignment, text modes, graphics modes, and screen paging. Video memory up to two megabytes can also be tested.

Batch menu

The Batch menu allows multiple tests to be run in an automatic, unattended mode, which is especially

useful for diagnosing intermittent problems, or for "burning in" new systems. Any of the tests mentioned previously can be selected; test routines can be saved to a floppy disk which can then be loaded conveniently into other systems. An error log can be printed, or it can be saved to a floppy disk. Tests can be run continuously, or the software can be set to run the tests for a user-specified number of passes.

Utilities

Several utilities are provided to help make Micro Scope a complete solution for computer service. A memory display shows the contents of memory in hexadecimal and ASCII. With that feature, it is possible to find such details as the copyright information for the system BIOS or for the ROM BIOS extensions on adapter cards. A floppy-disk editor displays the contents of a disk in both hex and ASCII, and permits the data to be modified. A similar function is available for hard drives.

One utility, which is unique as far as we can tell, rebuilds the master boot sector of a hard disk with a generic DOS boot loader program mentioned earlier, it can bring many virus-damaged systems back to life.

Micro Scope is a complete diagnostics tool that will be appreciated by PC service technicians, network administrators, and advanced computer hobbyists who want a thorough understanding of PC operation. Priced at \$499, it might be too expensive for casual use. But in professional applications, Micro Scope's ability to do low-level formatting of IDE drives—along with its time-saving convenience—will make the program pay for itself in short order. Ω



"Your father is very good with tools. Give him a chance to fix your computer."



Learn to fix computers!

Home study. Earn great money repairing troubleshooting, upgrading, and installing PCs. Free literature: 800-223-4542.

Name _____ Age _____
Address _____
City _____ State _____ Zip _____
The School of PC Repair, Dept. JL342
6065 Roswell Road, Atlanta, Georgia 30328

EDUCATION & INSTRUCTION

F.C.C. Commercial General Radiotelephone license. Electronics home study. Fast, inexpensive! "Free" details. **COMMAND**, D-176, Box 2824, San Francisco, CA 94126.

ELECTRONIC engineering. 8 volumes complete. \$109.95. No prior knowledge required. Free brochure. **BANNER TECHNICAL BOOKS**, 1203 Grant Avenue, Rockford, IL 61103.

ELECTRICITY/Electronics training series used by U.S. military. 23 volumes, other courses available. Free info: **FEDERAL TECHNICAL PUBLISHERS**, Box 1061 N, Glen Lake, MN 55345.

FREE INFO!

BECOME A HAM RADIO OPERATOR THE FAST, EASY, FUN WAY —NO MORSE CODE REQ'D!

You'll be on the air in no time—making new friends—with the ARRL's all-new Technician Class Video Course.



It's everything you need to start exploring your new, exciting world of Amateur Radio: 3 full-length video tapes, 164-page course book, 6 practice exams, even optional review software—all with an iron-clad money-back guarantee.

We've been helping people become hams for more than 75 years—we won't let you fail!

Get in on the fun of ham radio. Call the toll-free number and ask for our free video course info kit. **Call Today!**

ARRL • 225 Main St • Newington, CT 06111

1-800-32-NEW HAM

CABLE TV TURN-ON KITS

SUPER Cable TV "Test Chips". Provides full mode activation. Includes: instructions & illustrations. **Jerrold: Starcom-6**..Starcom-7. **Scientific Atlanta:** 8500 thru 8600. **Tocom:** 5503-VIP,5507. **Zenith:** ST-1000 thru ST-5000. **Call now!! MASTER COMPONENTS.** 1 (800) 233-0570. MasterCard /Visa.

**CABLE TV
DESCRAMBLERS**
1-800-233-9388
FREE CATALOG
GUARANTEED BEST PRICES • IMMEDIATE SHIPPING
APPLE ELECTRONICS
3389 Sheridan St. • Suite 257
Hollywood, FL 33021

CABLE DESCRAMBLING MANUAL \$12.95
VCII SATELLITE DESCRAMBLING \$14.95
VCII software \$25, VCII Plus ,software \$30.00
SCHEMATICS,VCII PLUS or VCII032 \$20.00
CABLETRONICS,Box 30502D
Bethesda,MD 20824

BUY BONDS



MCM ELECTRONICS

A PREMIER Company

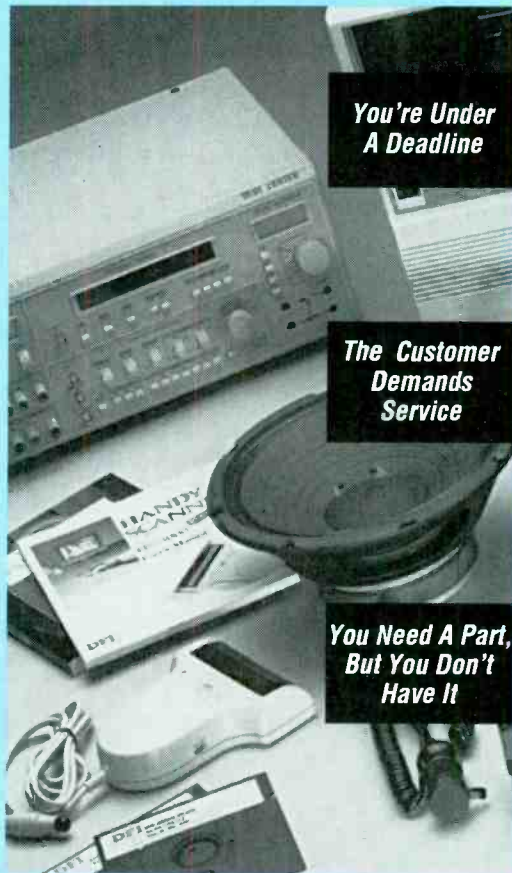

*You're Under
A Deadline*

*The Customer
Demands
Service*

*You Need A Part,
But You Don't
Have It*

Call MCM. Our computer-managed inventory of over 20,000 high-quality electronic parts and components means that special part you need will ship in less than 24 hours and if you need advice, you can call our Toll-free Technical Assistance Line. So when you're in a jam, call MCM. Fast, reliable service is what we're all about.

*There Is Only
One Solution...*

FOR A FREE
CATALOG CALL
1-800-543-4330
FAX: 1-513-434-6959

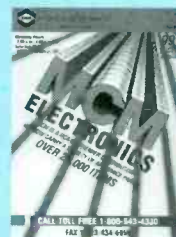

MCM ELECTRONICS FOR ALL YOUR PARTS NEEDS.

MCM IS NOW A RCA/GE PREMIER DISTRIBUTOR

EN-84

October 1993, Electronics Now

95

CIRCLE 87 ON FREE INFORMATION CARD

CABLE BOX WHOLESALE, INC.

BEST BOXES—BEST PRICES
Immediate Shipping—COD's
Satisfaction Guaranteed
FREE Catalog—Call Now

800-841-7835

CABLE/SATELLITE

UNDETECTABLE cable/satellite descrambler will work on all systems guaranteed! Send SASE/info, \$94.95/kit, \$14.95/plans. **MYSTICAL ELECTRONICS**, PO Box 867, Stonington, CT 06378.

PAY TV AND SATELLITE DESCRAMBLING

***** 1993 EDITION *****

Includes programming cable box chips, hacking II-MAT, wireless cable (MVIC) descrambling, bullets, PLUS fixes and much more. ONLY \$18.95. Other **PAY TV** and **SATELLITE DESCRAMBLING** volumes, Volume 1 (BASICS), 1989, 1991, and 1992 \$15.95 each. Different turn-ons, bypasses, ECM's, schematics and counter ECM's in each. **THE COMPLETE WIZARD**. Using the VCI data stream. \$15.95. Any 3/\$32.95 or 5/\$54.95. **SCRAMBLING NEWS** monthly. Keep up with the latest in satellite and cable descrambling. Everything that's new. \$32.95/yr. **OUR BEST DEAL** everything here, the video and much more only \$129.95. New catalog \$1.

Scrambling News, 1552 Hertel Ave., #123, BUFFALO, NY 14216
 Voice/FAX (716) 874-2088 COD's are OK. ADD \$6

CABLE BOXES BELOW WHOLESALE

CREDIT CARD OR COD

DESCRAMBLERS

TBI-3	SUPER 7
TB-2 or 3	FTB-2 or 3
OAK N-12	SP-200D (PIONEER®)
SB-2 or 3	HAMLIN® MLD 1200

COMBINATION UNITS

JERROLD® : DRX-DIC, DRZ-DIC, Tocom 5503
SCI-ATLANTA® : SA-8536 +, SA-8555, SA-8580, SA-8590
SYLVANIA® : 4040-3 DIC-Ch 2 or 3
PIONEER® : BA-6110
ZENITH® : ST-Series
OAK® : RTC-56-Ch 2 or 3, M35B

CONVERTERS W/REMOTES

TIMELESS PRODUCTS®
PANASONIC® - **JERROLD®**

YOU MUST CHECK WITH YOUR LOCAL CABLE COMPANY AND PAY FOR ALL SERVICE YOU USE. IT IS NOT THE INTENT OF LAKE SYLVAN TO DEFRAUD ANY TELEVISION OPERATOR AND WE WILL NOT ASSIST ANY COMPANY OR INDIVIDUAL IN DOING THE SAME.

LAKE SYLVAN SALES, INC.
 SORRY NO MINNESOTA SALES

CALL FOR A CATALOG NOW!!
800-800-4582

CIRCLE 177 ON FREE INFORMATION CARD

PLANS AND KITS

SURVEILLANCE transmitter kits tune from 65 to 305 MHz. Mains powered duplex, telephone, room, combination telephone/room. Catalog with **Popular Communications**, **Popular Electronics** and **Radio-Electronics** book reviews of "Electronic Eavesdropping Equipment Design," \$2.00. **SHEFFIELD ELECTRONICS**, PO Box 377785-C, Chicago, IL 60637-7785.

ALL-in-One catalog. AM/FM/Ham/Spy transmitters/amplifiers, voice disguisers, descramblers, audio/TV/science projects. Start your own licensed/unlicensed radio station, books/plans/kits for import and export. 60 mouth-watering pages for \$1.00. **PAN-COM INTERNATIONAL**, PO Box 130-F10, Paradise, CA 95967.

MEMBRANE SWITCH KITS!

These highly durable water resistant flat-panel keypads can be assembled in minutes with YOUR legend! Available in 4, 12, 16, 24 & 40 Key models. Steel "clickdomes" optional. Connector and bezel included.



Call for free brochure
 Sil-Walter 880 Cable Piano, Unit N,
 Camarillo, CA 93012
 (805) 389-9100 FAX (805) 484-3311

BUILD 0-50 volt regulated dual tracking power supply. Complete schematics and instructions, \$5.95. **SMS ENGINEERING**, RE 5932 West Bell Road, Suite D106, Glendale, AZ 85308.

ADULT/surveillance electronics, unusual information. Catalog \$2.00 (credited). **EXCELSIOR ELECTRO**, 3-1750 The Queensway, Suite 525, Etobicoke, Ontario, Canada M9C 5H5.

ANNOUNCING OmniAlert! (pat. pend.) Designed by F-18 tactical radar engineer. Revolutionary photosensitive alarm safeguards your home, office, car, & valuables. Professionally engineered board & plans, guaranteed foolproof! \$11.95. **DRALIN DESIGNS**, PO Box 04, Ellenburg Depot, NY 12935.

DESCRAMBLE cable with Radio Shack R.F. modulator, add simple circuit, instructions \$8.00. **TELCOM**, PO Box 832E, Brusly, LA 70719.

SINGERS! REMOVE VOCALS!
Unlimited Backgrounds™
 From Standard Records & CD's with the Thompson Vocal Eliminator™. Call for Free Catalog & Demo Record.
 Phone: (404) 482-2485 Ext. 72
 Singer's Supply, Dept. 86-1
 7987 Hightower Trail
 Lithonia, GA 30058
 24 Hour Demo/Info Request
 Line (404) 482-2485 Ext. 72
 Singer's Supply - We Have Anything & Everything For Singers

60 SOLDERLESS Breadboard Projects in two easy-to-read pocket books. Complete with circuit descriptions, schematics, parts layouts, component listings, etc. Both books (BP107 & BP113) only \$11.90 plus \$3.50 for shipping. USA and Canada only. US funds. **ETT, INC.**, PO Box 240, Massapequa Park, NY 11762-0240.

CABLE TV DESCRAMBLERS
★ CONVERTERS ★
 and ACCESSORIES.

**SAVE MONEY.
 DON'T RENT!**

PANASONIC, JERROLD, OAK, PIONEER, SCIENTIFIC ATLANTA AND MORE. LOWEST PRICES. FREE CATALOG
CABLE READY (800) 234-1006
COMPANY

DESCRAMBLER built right into your TV. Complete plans and instructions. Send \$15.00 to **BERGER ENTERPRISES**, Route 6, Box 209T, Murphy, NC 28906.

CREDIT card, ATM, read/write theory \$29.00, backup your credit cards, system for PC schematic \$39.00, info \$5.00. **CPU ADVANCE**, Box 1089, Waltham, MA 02154.

BUGGED? Telephone tapped? Find out fast! Free catalog of fantastic counter-surveillance equipment! **1 (800) 732-5000.**

FASCINATING, useful, fun and educational! Lasers, voice changers, message recorders, software, detectors, talking clocks and more. We supply all the parts. You build using our detailed manuals. Send \$1.00 (refundable) for catalog: **LNS TECHNOLOGIES**, 20993 Foothill Blvd., Suite 307R, Hayward, CA 94541-1511.

BUSINESS OPPORTUNITIES

EASY work! Excellent pay! Assemble products at home. Call toll free **1 (800) 467-5566** Ext. 5192.

HOME assembly work available! Guaranteed easy money! Free details! **SASE. HOMEWORK-R**, Box 520, Danville, NH 03819.

MAKE \$75,000.00 to \$250,000.00 yearly. Learn **IBM monitors** repairs. (solutions most brands). New home based business program. Software available. Information: **USA-Canada \$3.00 cash** (no checks), dealers wanted worldwide (\$35.00) **US funds. RANDALL DISPLAY**, PO Box 2168 R, Van Nuys, CA 91404 USA.

LET the government finance your small business. Grants/loans to \$500,000. Free recorded message: **(707) 449-8600.** (KS1).

INVENTORS

INVENTORS! Can you patent and profit from your idea? Call **AMERICAN INVENTORS CORP.** for free information. Serving inventors since 1975. **1 (800) 338-5656.**

**CABLE TV
 DESCRAMBLER LIQUIDATION**
FREE CATALOG!
 Hamlin Combos \$44, Oak M35B \$60 (min. 5), etc
WEST COAST ELECTRONICS
 For Information: 818-709-1758
 Catalogs & Orders: 800-628-9656

ANTIQUE RADIO CLASSIFIED
Free Sample!
 Antique Radio's
 Largest Circulation Monthly.
 Articles, Ads & Classifieds.
 6-Month Trial: \$16.95. 1-Yr: \$29.95 (\$44.95-1st Clar)
A.R.C., P.O. Box 802-L11, Carlisle, MA 0174

WANTED

INVENTIONS, new products. You can profit from your ideas! Rapidly expanding mfg/mktg Co. looking for electronic consumer products. Send ideas to **NEW PRODUCTS DEPT.**, PO Box 4670, Scottsdale, AZ 85261-4670.

BOOK schematics about digital, audio, speech encryption, scrambler, descrambler. Send price, include airmail, to **E. OLIVEIRA**, Av. Entre Rios 966 4P "I", (C.P. 1080), Buenos Aires, Argentina.

“ My life without an education would be no job, no life and nobody to love. ”
 Gary Hinton, Jr.
 7th grade

America needs more schools that encourage our children to fulfill their promise.

KEEP THE PROMISE.

For information on how you can help change the schools in your community, call 1 800-96-PROMISE.



Education Excellence Partnership

Look to the Future
 With Your Own
 Cable Converter & Descrambler !

1-800-228-7404



3250 Hatch Rd.
 Suite 1 C
 Cedar Park, TX 78613

ALL MAJOR BRANDS

NU-TEK ELECTRONICS
 FREE CATALOG!



SATELLITE TV

FREE catalog — Lowest prices worldwide. Satisfaction guarantee on everything sold — systems, upgrades, parts, all major brands factory fresh and warrantied. SKYVISION, 1012 Frontier, Fergus Falls, MN 56537. 1 (800) 334-6455. Outside US (218) 739-5231.

SUPER low satellite prices. Free U.S. and International catalog. SATMAN, (309) 692-4140 (Int'l), 1 (800) 472-8626 in U.S.

THE ELECTRONIC GOLDMINE



The Electronic Goldmine has one of the greatest selections of unique electronic project kits available in the world! We have over 29 kits and over 2000 unique bargain priced components in our new 80 page catalog!

FREE CATALOG
 with over 2000 different items including 29 kits! Request your copy TODAY!

CONTROL PANEL 10 POSITION DIP SWITCH

Burglar fire alarm keyboard panel was made for use in making professional alarm systems. Has 6 LEDs and 12 position keyboard panel with cable and connector. No other into-NEW



Brand new precision made 10 position dip switch. These are standard size for replacement or new construction



G2904 \$1.95

100 PCS \$40.00
 Blowout price G3312 2/\$1.00

SPECIAL ITEMS

ULTRABRIGHT RED LED
 Extremely bright clear lens red T3/4 Jumbo LED made by TOSHIBA. So bright it can be seen in any light conditions.
 6/\$1.00
 G3313 100/\$10 1000/\$80

50 PIECE PC BOARD ASSY
 Super assortment contains different sizes of thick and thin double sided glass epoxy copper clad. This is prime PC board material with pieces from about 2"x7" to 6"x5" or larger
 G3500 \$7.95 50 PCS

MEDIUM INVERTER TRANSFORMER
 Converts 9V or 12VDC to over 250 V when used with a 555 IC circuit. (Schematic included) Perfect for portable strobes, backlight etc. Size: 1 1/2" square
 G993 \$1.75 EA. 100/\$160.00

4KV TRIGGER COIL
 These can be used with many different strobes. Output is 4KV and will work with almost any strobe tubes.
 N1700 \$1.25 EA. 100/\$80.00

UHF WIRELESS TRANSMITTER

Compact remote was made to emit a UHF tone frequency transmission to control a satellite receiver remotely. These are brand new but the 9V battery that was installed inside has gone dead from storage, so we are selling them cheap. Great experiments item and is easy to change the battery—just remove 1 screw. Slightly case has 2 pushbutton controls.



G2962 \$1.29 10/\$10.00

MINIMUM ORDER: \$10.00 plus \$4.00 shipping and handling. \$5.00 for U.S. Mail. We accept MC, VISA and Money Orders. SEND ORDERS TO: THE ELECTRONIC GOLDMINE P.O. Box 5408 Scottsdale, AZ 85261 PHONE ORDERS (602) 451-7454 FAX ORDERS (602) 451-9495

CIRCLE 125 ON FREE INFORMATION CARD



CALL TOLL FREE
 1-800-338-0531

*Thirty day money back guarantee
 *\$20.00 minimum order *We accept Mastercard, Visa, Discover, and company C.O.D. orders *24 hour shipping *Shipping charge = UPS chart rate + \$1.00 (\$3.50 minimum charge) *Hours: 8:30 am - 7:00 pm EST, Monday - Friday, 9:00 am - 5:00 pm Saturday *Mail order customers, please call for shipping estimate on orders exceeding 5 lbs. *Foreign destination customers please send \$5.00 U.S. funds for catalog postage.



6-1/2" Polydax Fiberglass Woofer/Midrange

This woven fiberglass cone features a rubber surround, high sensitivity and superb sonics. Ideal for 2 or 3 way systems.



*Impedance: 8 ohms *SPL: 90 dB
 1W/1m *Vas: 1.24 cu. ft. *Qts: .37 *Fs
 44Hz *Power handling: 50 watts RMS.
 #296-070 \$49⁹⁰ (1-3) \$46⁵⁰ (4-UP)

8" Two-Way Ported In-Wall Speaker System



8" paper cone woofer with polymer resin coating and a 1" textile dome tweeter. Ported plate speaker system for better bass response. Integral crossover with a tweeter protector and pushbutton terminals. 8 ohm impedance. Frequency response: 30-25,000 Hz. 50 watts RMS. 100 watts maximum power handling capability. Sensitivity: 92 dB 1W/1m. Dimensions: 10-5/8" (W) x 13" (L). Net weight: 17 lbs. per pair. \$274.95 list price.

#300-425 \$169⁹⁰ (1-3 PRS) ... \$159⁹⁰ (4 PRS-UP)

Quick Box Software

This versatile program was created to allow rapid design of sealed, vented and 4th order bandpass enclosures. The program calculates enclosure volume, vent size and even plots predicted low frequency response. Knowledge of loudspeaker theory and terminology is required. Runs on IBM compatibles with DOS 3.0 or higher. Supports Hercules, CGA, EGA color and VGA color monitors. Includes both 5-1/4" and 3-1/2" diskettes.



#500-915 \$34⁹⁵ EACH

Audiophile Test CD

Best of Chesky Jazz and More Audiophile Tests/Vol. 2. Part One of this CD begins with 12 tracks of very natural sounding jazz, recorded with minimalist miking techniques. No overdubbing or enhancement is used. Part Two offers eight test tracks that check for imaging, dynamics and resolution. Excellent for fine tuning your system.



#510-130 \$18⁹⁵ EACH

THE B.I.R.D., Battery Powered Infrared Detector Pen



The B.I.R.D. instantly recognizes infrared light from television, VCR, stereo remote controls, and thousands of other IR controlled products. No longer do you need to turn the lights out to see the phosphor on an infrared detector card.

#390-200 \$34⁹⁵ EACH

Minor Camcorder Repair Video

This instructional video will introduce you to the profitable field of camcorder maintenance. Step by step, you'll be guided through cover removal, disassembly and proper cleaning and lubricating procedures. Belt replacement, common adjustments and alignment are also covered. VHS format. 48 minutes.



#505-040 \$39⁹⁵ EACH

Idler Tire Kit



This comprehensive idler tire kit contains 180 of the most commonly used tires in an easy-to-use case. Includes a cross reference with 80 manufacturer assembly numbers crossing to over 200 VCR model numbers. Net weight: 1-1/2 lbs.

#400-900 \$39⁹⁵ KIT

340 E. FIRST ST. • DAYTON, OHIO 45402 • LOCAL 513/222-0173 • FAX 513/222-4644

CIRCLE 56 ON FREE INFORMATION CARD

MARK V ELECTRONICS, INC.

Same Day Shipping • Special Offer Discount

▲ Indicates the level of difficulty in the assembling

300W MOSFET AUDIO MONO POWER AMPLIFIER AF-3 ▲▲▲(7 lbs.)



Kit \$165.00
Assmb. & Tested: \$195.00

Power Output: 300W into 4 ohms RMS (0.1% THD), 200W into 8 ohms RMS (0.02% THD) * Frequency Response: 10 Hz - 20 KHz. * Total Harmonic Distortion: < 0.03% * Input Sensitivity and impedance at 1 KHz, 1V 47 K * Load Impedance: 4 - 16 ohms. * Power requirements: +55 to +65V DC 8A. May use Mark V Model 009 Transformer * Suggested Capacitor 10,000uF100V Model 019 * Suggested rack mount cabinet: Model LG-1925

120W MOSFET POWER AMPLIFIER (MONO) TA-477 ▲▲(3 lbs.)



Kit \$68.00
Assmb. & Tested: \$85.00

T.H.D.: Less than 0.007% * Power Output: 120 watts into 8 ohms RMS * Frequency Response: 8 Hz - 20 KHz, +0.4 dB, 2.8 Hz to 65 KHz, +5 -3dB * Sensitivity: 1V * Power Requirements: 50 VDC @ 3 amps. May use Mark V Model 003 Transformer * Suggested Capacitor 10,000uF80V-100V Model 019 * Suggested rack mount cabinet: Model LG-1925

120W + 120W LOW TIM PRE AND MAIN STEREO AMPLIFIER TA-800MKII ▲▲ (4 lbs.)



Kit \$63.92
Assmb. & Tested: \$73.95

Power Output: 120 watts RMS per channel into 4 ohms load, 72 watts RMS per channel into 8 ohms load * Frequency Response: 10 Hz - 20 KHz. * Total Harmonic Distortion: < 0.01% * Tone Control: Bass: +12dB, Mid: +8 dB, Treble: +8 dB * Sensitivity: Phono Input, 3 mv into 47K, Line, 0.3 v into 47K. Signal to noise ratio 86 dB * Power Requirements: 40V DC @ 6 amps. May use Mark V Model 001 or 008 Transformer * Suggested rack mount cabinet: Model LG-1924 or LG-1925

80W + 80W PURE DC STEREO MAIN POWER AMPLIFIER TA-802 ▲▲(4 lbs.)



Kit \$45.94
Assmb. & Tested: \$59.72

Power Output: 80 watts per channel into 8 ohms * Total Harmonic Distortion: < 0.05% at rated power. * Intermodulation Distortion: < 0.05% at rated power * Frequency Response: DC to 200 KHz, -0 dB, -3dB, @ 1 watt * Power Requirements: 30VAC x 2 @ 6 amps. May use Mark V Model 001 or 008 Transformer * Suggested Capacitor 8,200uF50V Model 017 * Suggested rack mount cabinet: Model LG-1924 or LG-1925

FULLY COMPLEMENTARY SYMMETRICAL FET STEREO PRE-AMP TA-377A ▲▲▲(1 lb.)



Kit \$59.95
Assmb. & Tested: \$75.00

Frequency Response: 10 Hz - 100 KHz. * RIAA Curve Deviation: +0.2 dB, 30 to 15,000 Hz * Total Harmonic Distortion: < 0.007% at rated output * Channel Separation at 1 KHz: Better than 70 dB * Hum and Noise: Phono: Better than 70 dB, Aux: Better than 90 dB, Phono Sensitivity: 2 mV @ 47K * Output: 1.5V (0.01% T.H.D.) * Record Output: 150 mV * Maximum Output at 0.1% Distortion: 15V * Power Requirements: 30 V x 2 @ 400 mA. May use Mark V Model 010 Transformer * Power Consumption: 12W * Suggested rack mount cabinet: Model LG-1983 or LG-1924 * Suggested Volume Control: ALPS 100K ohm dual V.R. # 022

VIDEO / AUDIO SURROUND SOUND PROCESSOR SM-333▲▲▲ (5 lbs.)



Kit \$73.00
Assmb. & Tested: \$85.00

Frequency Response: 20 Hz - 20 KHz. * Total Harmonic Distortion * Front Channel: 0.05% * Rear Channel: Less than 0.25% * Input Signal Voltage: 0.1 to 3.5V * Output: Front Channel: 0.1 to 3.5V * Rear channel: 6.6V * Delay Time: 5 to 50 milliseconds * Input Impedance: 47K * Power Requirements: 100 - 120 VAC, 60 Hz (Case & Transformer are included)

(**TOROIDAL) POWER TRANSFORMERS

MODEL DESCRIPTION

#001	28V x 2 6A, 30V x 2 6A	\$28.00
#002	36V x 2 3A	\$23.00
#003	40V x 2 6A	\$30.00
#004	24V x 2 6A	\$23.00
#005	26V x 2 3A	\$17.00
#006	18V x 2 5A	\$17.00
#007	53V x 2 8A	\$45.00
#008**	28V x 2, 30V x 2 6A	\$38.00
#009**	48V x 2, 53V x 3 8A	\$66.00
#010	30V x 2, 36V x 2 400mA	\$ 8.50
#011**	9V x 2, 22A	\$60.00



METAL CABINETS WITH ALUMINUM FRONT PANEL

MODEL	H"	x W"	x D"	
LG-1273	3"	12"	7"	\$23.85
LG-1884	4"	16"	8"	\$28.50
LG-1924	4"	19"	11 1/2"	\$34.50
LG-1925	5"	19"	11 1/2"	\$38.00
LG-1983	2 1/4"	19"	8"	\$32.50



We accept major Credit Cards, Money Orders and Checks * We ship by UPS ground inside US (min. \$5.00) and ship by US mail outside US. Please call our sales department for orders over 2 lbs or foreign orders * All assembled units have 30 days warranty * Dealer Inquiries Welcome. We are not responsible for typographical errors.

Outside CA 1-800-423-FIVE (Orders Only)

In CA 1-800-521-MARK (Orders Only)

Order by Fax (213) 888-6868

Catalog & Information (213) 888-8988

8019 E. Slauson Ave., Montebello, CA 90640

ADVERTISING INDEX

Electronics Now does not assume any responsibility for errors that may appear in the index below.

Free Information Number	Page
108	AMC Sales 78
107	All Electronics 94
—	AmRam 92
—	Amazing Concepts 75
109	C & S Sales 18
—	CIE 21
—	CLAGGK Inc. Video Offer 29
184	Cable Warehouse 78
110	Chenesko Products 69
—	Command Productions 68
—	Copyright Clearance Ctr, Inc. 23
127	Deco Industries 69
190	DeltaQuest 86
—	Elec. Industry Association CV3
125	Electronic Goldmine 97
—	Electronics Book Club 17, 88
121	Fluke Manufacturing CV2
176	Foley-Belsaw Company 5
181	Global Specialties 3
185	Goldstar Precision 73
—	Grantham College 15
86	Heathkit 81
—	ISCET 77
189	Interactive Image Tech 13
114	Jameco 93
115	Jensen Tools 69
182	Kelvin 7
177	Lake Sylvan Sales, Inc. 96
89	MAT Electronics 23
87	MCM Electronics 95
93	Mark V. Electronics 98
188	Mini-Circuits CV4
117	Mouser 87
—	NRI Schools 8
56	Parts Express 97
191	People's College 70
101	Pomona Electronics 14
—	Soc. of Motion Pict. & TV Eng. 77
—	Star Circuits 69
192,193	TC Instruments 86
183	TECI 76
123	Test Probes 75
180	The School of VCR Repair 81
105	WPT Publications 76
179	Wintek 86
—	World College 27
178	Xandi Electronics 69
187	Zentek Corp. 87

Gernsback Publications, Inc.
500-B Bi-County Blvd.
Farmingdale, NY 11735
1-(516) 293-3000
Larry Steckler, EHF/CET
President

Christina Estrada
assistant to the President

For Advertising ONLY
516-293-3000
Fax 1-516-293-3115

Larry Steckler
publisher

Arline Fishman
advertising director

Denise Mullen
advertising assistant

Kelly Twist
credit manager

Subscriber Customer Service
1-800-288-0652

Order Entry for New Subscribers
1-800-999-7139
7:00 AM - 6:00 PM M-F MST

ADVERTISING SALES OFFICES

EAST/SOUTHEAST
Stanley Lovitan
Eastern Advertising
1 Overlook Ave.
Great Neck, NY 11021
1-516-487-9357
Fax 1-516-487-8402

MIDWEST/Texas/Arkansas/Okla.
Ralph Bergen
Midwest Advertising
One Northfield Plaza, Suite 300
Northfield, IL 60093-1214
1-708-446-1444
Fax 1-708-559-0562

PACIFIC COAST
Blake Murphy
Pacific Advertising
Pattis/3M
1800 North Highland Avenue
Suite 717
Hollywood, CA 90028
1-213-462-2700
FAX 1-213-463-0544

Electronic Shopper
Joe Shere
National Representative
P.O. Box 169
Idyllwild, CA 92549
1-909-659-9743
Fax 1-909-659-2469

What Do These Prestigious Companies Have In Common?

Aerovox*
DC Film and RFI Suppression Capacitors.
AC Oil Capacitors, EMI Filters

AMP
Electrical/Electronic Connectors.
IC Sockets, PCB Switches

AVX CORPORATION
A HYDRA GROUP COMPANY
MLC, Tantalum and Thin Film
Capacitors, Resistors,
Networks, Trimmers,
Oscillators, Resonators, Filters
and Piezo Devices

BERG
ELECTRONICS
High Density and Industry Standard
Connectors/Subsystems

BURNDY
an FCI Company
Electronic Connectors

CAROL
CAROL CABLE COMPANY INC
Electronic and Electrical Wire and Cable
and Power Supply Cords

COLE FLEX
Tubing, Conduits, Hose, Sleeveings, Splices,
Insulation and Cable Harness Products

Communications Instruments, Inc.
Relays and Solenoid Relays

COOPER
Belden
Multi Conductor, Paired, Coaxial, Flat,
Fiber Optic, Instrumentation/Process
Control, LAN, Special Application Cables,
Power Supply Cords & Molded Cable
Assemblies

COOPER
Bussmann
Fuses, Fuseholders, Fuse Blocks,
and Fuse Accessories

CORNELL DUBILIER
Capacitors-Aluminum
Electrolytics, Mica, AC Oil, Film,
MICA Paper and Relays

A COMPANY OF
DALE
Dale Electronics, Inc.
Resistors, Networks, Oscillators, Displays,
Inductors & Thermistors

DI DANTONA INDUSTRIES, INC.
BATTERIES: Computer, Cordless
Phone, Scanner & R/C.
ANTENNAS: Cordless Phone (metal &
rubber), Scanner Bumpers,
Grommets and Stik-On Feet

DEARBORN WIRE AND CABLE L.P.

EATON
Eaton Corporation, Commercial
& Military Controls Operation
Switches, Relays, Displays and Keyboards

A
GERNSBACK
PUBLICATION
Electronics Now Magazine

KOA SPEER ELECTRONICS, INC.
Resistors, SMT Tantalum Capacitors Inductors,
Resistor Networks, SMT Thermistors

MALLORY
North American Capacitor Company
Tantalums, Aluminums, Sonalerts®
Ceramics, Films and AC's

M-tron
Quartz Crystal Clock Oscillators
and Special Hybrid Products

MURATA ERIE
MURATA ERIE NORTH AMERICA
Monolithics, Discs, Variable Capacitors,
Oscillators, Potentiometers, RFI/EMI Filters,
Microwave, Surface Mount Capacitors

NTE ELECTRONICS, INC.
A WORLDWIDE REPUTATION FOR QUALITY SERVICE AND VALUE
Semiconductors, Resistors,
Capacitors, Relays

Philips ECG
A North American Philips Company
Semiconductors, Test Equipment,
Relays, A/V Parts and
Chemicals

Quam
Loudspeakers and Commercial Sound
Products

ROHM
Rohm Electronics Division
Resistors, Ceramic Capacitors,
Transistors/Diodes,
Opto Components and IC's

SELECTA
ELECTRONIC PRODUCTS
Switches, Relays, Terminals,
Indicator/Pilot Lights, LED Indicators,
Test Clips, Test Leads, Cable Ties and
Heat Shrinkable Tubing

A COMPANY OF
SPRAGUE
Tantalum Capacitors, Wet & Foil
Capacitors, Resistor Networks,
Resistor Capacitors Networks, Filters

Switchcraft
A Raytheon Company
Switches, Connectors, Jacks, Plugs,
Jackfields & Audio Accessories

TECH SPRAY
Non-CFC Cleaners/Degreasers,
UV Cured Compounds, Swabs, Wipes,
Brushes, Wick, Cleanroom Supplies, and
Static Control Products.

They sell through distributors. They belong to the E.I.A. They belong on your vendor list.

Leadership in electronics is not just a matter of designing products better and manufacturing them better, but also of marketing them better. And the sponsors of this message understand that better service to customers *requires* effectively involving distributors as part of their marketing teams.

Distributor involvement means lower prices, quicker deliveries, better service over-all. The Buyer wins... the Seller wins.

Distributors help achieve marketing leadership. So does the manufacturer's involvement in the Components Group of the Electronic Industries Association. EIA fosters better industry relations, coherent industry standards, and the sharing of ideas, which helps one another *and* serves customers better.

In choosing your component supplier, look for the marks of leadership —

availability through distribution
membership in the E.I.A.



Electronic Industries
Association/Components Group
2001 Pennsylvania Avenue, N.W. 11th Floor
Washington, D.C. 20006
Phone: (202) 457-4930 Fax: (202) 457-4985

Committed to the competitiveness of the
American electronics producer

Mini-Spur[®] 1.0

turns your PC into a Spectrum Analyzer



Spot Spurious Signals Easily...
choose the best mixer for your design problems

\$49⁹⁵



Introducing Mini-Spur[®], the software simulation program for analysis of system spurious responses. Using actual data on Mini-Circuits mixers, spurious signal levels are calculated and then displayed.

Operation is simple. The user defines the input frequency and power level, the program then graphically displays the various outputs including all the spurs (up to 10xLO ± 10xRF) falling within the user-defined IF filter bandwidth. As the user tunes the frequency, the output spectrum scrolls across the screen just like that of a sophisticated spectrum analyzer.

Required hardware; IBM AT or compatible with 640k memory, and EGA or VGA display. Optional, dot matrix, laser printer or plotter. So maximize design efficiency...use Mini-Spur[®] only from Mini-Circuits.

finding new ways
setting higher standards

Mini-Circuits[®]

WE ACCEPT AMERICAN EXPRESS AND VISA
P.O. Box 350166, Brooklyn, New York 11235-0003 (718) 934-4500 Fax (718) 332-4661

Distribution Centers NORTH AMERICA 800-654-7949 • 417-335-5935 Fax 417-335-5945 EUROPE 44-252-835094 Fax 44-252-837010

For detailed specs on all Mini-Circuits products refer to • THOMAS REGISTER Vol. 23 • MICROWAVES PRODUCT DIRECTORY • EEM • MINI-CIRCUITS' 740-pg HANDBOOK.

CUSTOM PRODUCT NEEDS... *Let Our Experience Work For You.*

F167 REV. ORIG.

CIRCLE 188 ON FREE INFORMATION CARD