

# ANNUAL 1985

\$2.50-US/\$2.95-CANADA

## ELECTRONICS in PHOTOGRAPHY

The life and times of...  
**NIKOLA TESLA**

## CABLE-TV DESCRAMBLING

How to Design  
**DC POWER SUPPLIES**

Home  
Control  
Computer

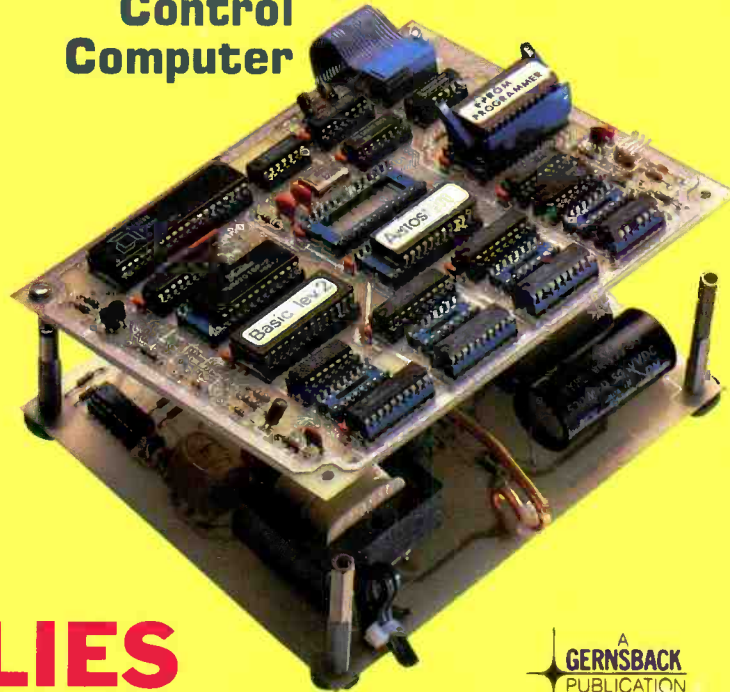

A  
**GERNSBACK**  
PUBLICATION

Exhaust  
Analyzer  
for your car



C-QUAM  
Stereo-AM  
Decoder



# Now! Tek quality and expert advice are just a free phone call away!

**100 MHz dual time base scope.** Easy-to-read CRT; bright, full-sized 8x10 cm; 14 kv accelerating potential complete with BEAM FIND, separate A/B dual intensity controls, FOCUS and TRACE ROTATION.

**Wide range vertical sensitivity.** Choose from 2 mV/div (1x probe) to 50 V/div (10x probe); color-keyed for 1x and 10x probes; variable control increases scale factor by 2.5 to 1.

**Two 100 MHz, high sensitivity channels.** 3.5 ns risetime; dc to  $\geq 100$  MHz bandwidth from 5 V/div to 5 mV/div; extended sensitivity of 2 mV/div at  $\geq 90$  MHz.

**A/B sweep selection.** Calibrated A sweeps from 50 ns/div to 0.5 s/div; B sweeps from 50 ns/div to 50 ms/div; variable control for up to 2.5 to 1 reduction and 10x magnification for sweeps to 5 ns/div.

**Dual time base measurements.** Select either A or B sweeps, or both alternately with A intensified by B.

**B trigger slope and level.** Use B trigger level to select B-triggered or run-after-delay modes; use B TRIGGER SLOPE to select transitions.

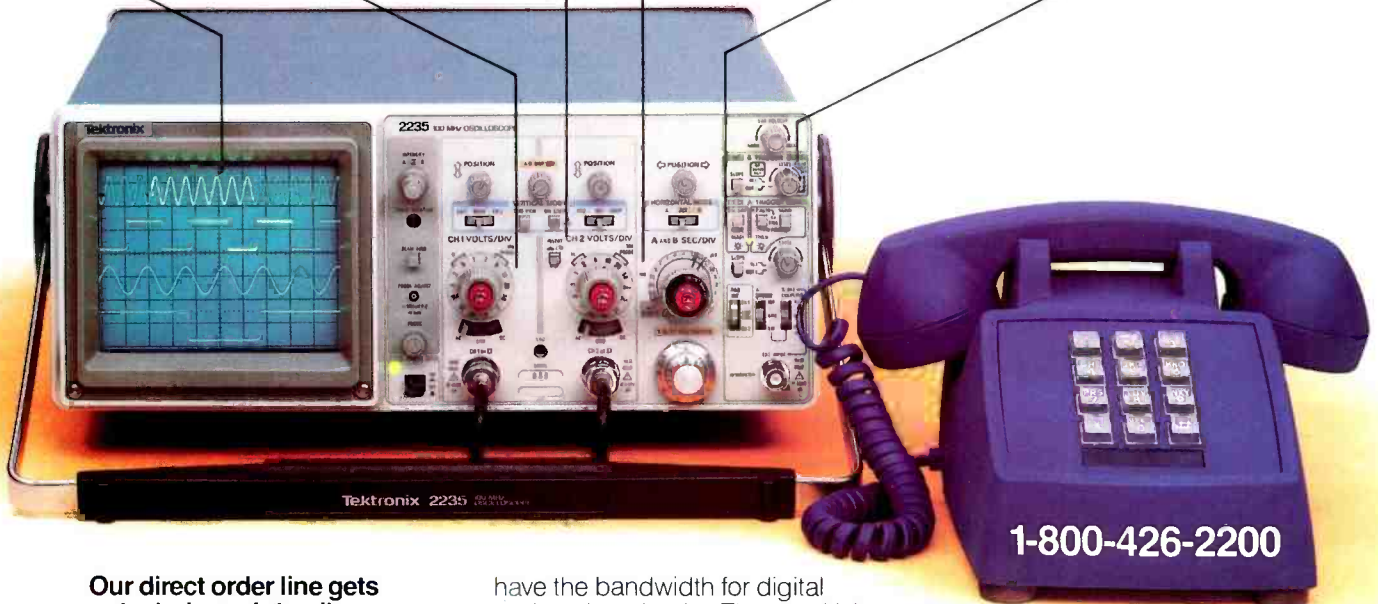

**Our direct order line gets you the industry's leading price/performance portables... and fast answers from experts!**

The 60 MHz single time base delay 2213A, the 60 MHz dual time base 2215A and the 100 MHz dual time base 2235 offer unprecedented reliability and affordability, plus the industry's first 3-year warranty\* on labor and parts, CRT included.

**The cost: just \$1200 for the 2213A, \$1450 for the 2215A, \$1650 for the 2235.**† Even at these low prices, there's no scrimping on performance. You

have the bandwidth for digital and analog circuits. The sensitivity for low signal measurements. The sweep speeds for fast logic families. And delayed sweep for fast, accurate timing measurements. All scopes are UL Listed and CSA approved.

**You can order, or obtain literature, through the Tek National Marketing Center.** Technical personnel, expert in scope applications, will answer your questions and expedite delivery. Direct orders include comprehensive 3-year warranty\*, operator's

manual, two 10X probes, 15-day return policy and worldwide service backup.

**Order toll free: 1-800-426-2200, Ask for Rick.**

In Oregon, call collect: (503) 627-9000. Or write Tektronix, Inc. P.O. Box 1700 Beaverton, OR 97075

**Tektronix®**  
COMMITTED TO EXCELLENCE

# EDITORIAL

## A Picture is Worth a Thousand Words!

I can remember the day when I bracketed my photographic shots, plus and minus half-stops, to be sure that at least one of the negatives obtained would be good enough for making a black-and-white 5 x 7 print. Now I shoot with abandon! My camera measures the light, automatically selects the correct focus, fires the strobe, makes an exposure, and the results are fantastic full-color snaps available that same day. Electronics made it all possible.

We can't cover all the electronics advancements in photography in one issue of a magazine, let alone in one issue of a thick book; but we open this issue of the **Radio-Electronics Annual 1985** with an expanded story on electronics in photography that everyone should read. In fact, if you are a nostalgia buff, save this issue—we predict that ten years from today what we say here will be old hat as is the brownie camera of Grandma's day.

Our cover displays three construction projects that, quite frankly, we hope will bring excitement to you as they did to us. In fact, check out the contents page and discover a few other interesting project articles. We included a few macro projects that we know will get you thinking about designing your own projects.

Of course, the issue is packed with many other features—the life and times of Nikola Tesla, cable-TV descrambling, designing power supplies, unique test equipment, inside logic analyzers, and a lot more. Dig in, friends, and enjoy this issue of **Radio-Electronics Annual 1985**.

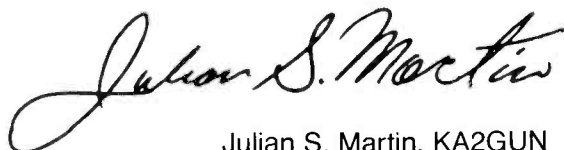

Julian S. Martin, KA2GUN  
Editor

### BUSINESS AND EDITORIAL OFFICES

Gernsback Publications, Inc.  
200 Park Ave. South, New York, NY 10003  
President: M. Harvey Gernsback  
Vice President: Larry Steckler

### PACIFIC COAST Mountain States

Marvin Green  
Radio-Electronics  
413 So. La Brea Ave.  
Los Angeles, Ca. 90036  
(213) 938-0166

### ADVERTISING SALES East

Stanley Levitan  
Radio-Electronics  
200 Park Ave. South  
New York, NY 10003  
212-777-6400

### MIDWEST Texas/ Arkansas/Okla.

Ralph Bergen  
The Ralph Bergen Co.  
540 Frontage Road—Suite 325  
Northfield, Illinois 60093  
312-446-1444

## SUPER LONG PLAY TAPE RECORDERS

10 Hour Model — \$95.00\*  
14 Hour Model — \$159.00\*

Modified Panasonic Slimline.  
high quality, AC-DC  
Recorders provide 5 or 7  
continuous hours of quality  
recording & playback on  
each side of cassette for a  
total of 10 or 14 hours  
depending on model. Built-in  
features include • Voice  
level control, • Digital  
counter, etc. TOK DC 180  
Cassette Furnished.



### PHONE RECORDING ADAPTER

Records calls automatically. All Solid  
state connects to your telephone  
jack and tape recorder. Starts  
recording when phone is lifted.  
Stops when you hang up. **\$24.50\***  
FCC APPROVED



### VOX VOICE ACTIVATED CONTROL SWITCH

Solid state. Self contained. Adjust-  
able sensitivity. Voices or other  
sounds automatically activate and  
control recorder. Uses either re-  
corder or remote mike. **\$24.95\***



\*Add for ship & hdg. Phone Adapter & Vox \$1.50 ea.  
Recorders \$4.00 ea. Cal. Res. add tax. Mail order. VISA  
MIC. COD's OK. Money Back Guarantee. Qty. disc.  
avail.. Dealer inquiries invited. Free data.  
**AMC SALES INC.** Dept R 9335 Lubec  
St., Box 928. Downey, CA  
90421 (213) 869-8519

CIRCLE 267 ON FREE INFORMATION CARD

Radio-  
Electronics

# ANNUAL STAFF

Hugo Gernsback (1884-1967) founder

M. Harvey Gernsback, editor-in-chief

Larry Steckler, CET, publisher

Art Kleiman, editorial director

Julian S. Martin, KA2GUN, editor

Carl Larson, associate editor

Brian C. Fenton, assistant technical editor

Ruby M. Yee,  
production manager

Robert A.W. Lowndes, production  
associate

Karen S. Tucker, production associate

Dianne Osias,  
production assistant

Jacqueline Weaver, circulation director

Arline R. Fishman,  
advertising coordinator

Composition and interior design by  
Mates Graphics



# ANNUAL 1985

## CONTENTS PAGE

- 21 ELECTRONICS IN PHOTOGRAPHY**—all areas of photography have benefitted from the use of electronics in photographic equipment
- 21—Introduction
  - 23—The All-Electronic Mavica
  - 27—The New Disc Cameras
  - 31—Auto Exposure and Auto Focus Systems
  - 38—Photo Accessories
  - 42—Electronics in the Darkroom
- 46 Audio Frequency Generator**—designed with a quick-reading, digital readout
- 51 The Life and Times Of Nikola Tesla**—he made possible much of what we take for granted today
- 59 C-QUAM AM Stereo Converter**—one chip brings stereo to your AM receiver
- 65 Unique Test Equipment**—a look at what's new, what's sophisticated, and what's unusual
- 71 Solid-State Barometer**—state-of-the-art device you can build
- 75 How to Design Power Supplies**—all about unregulated and regulated power supplies, and over-voltage protection circuits
- 79 Home Control Computer**—it can do the job and free your home computer for other purposes
- 94 TRS-80 Telephone Dialer**—go automatic with this program
- 95 Automotive Exhaust Analyzer**—lets you tune up for emission requirements
- 107 Cable TV Descrambling**—how they do it and undo it
- 111 Making Measurements Electronically**—how transducers make it all possible
- 116 Upgrade Your Printer**—add new features and flexibility
- 121 All About Logic Analyzers**—the digital equivalent to the oscilloscope **MACRO PROJECTS**
- 106 Sliding-Tone Doorbell**
- 106 Plant-Water Monitor**
- 130 Crystal Tester**
- DEPARTMENTS**
- 1 Editorial**—one picture is worth a thousand words!
  - 4 New Products**—hot items in the marketplace
  - 14 Equipment Reports**
    - 14—Ungar Electronic Soldering Iron System 9000
    - 14—Regency Programmable Scanner Model Z30
    - 127—Triplett Model 3500 Autorange Digital Meter
    - 128—Beta Electronics Pro-Kit 1 PC Board Fabrication Kit
    - 129—Kaypro 10 Hard-Disk Computer

Radio-Electronics Annual is published yearly by Gernsback Publications, Inc., 200 Park Avenue South, New York, NY 10003. Single copies \$2.50 plus \$1.00 postage and handling for U.S., Canada and Mexico. U.S. funds only. All other countries add \$2.00. © 1984 by Gernsback Publications, Inc. All rights reserved. Printed in U.S.A.

As a service to readers, Radio-Electronics Annual publishes available plans or information relating to newsworthy products, techniques and scientific and technological developments. Because of possible variances in the quality and condition of materials and workmanship used by readers, Radio-Electronics Annual disclaims any responsibility for the safe and proper functioning of reader-built projects based upon or from plans or information published in this magazine.

# Take home a world champion.

**\$85\*** gets you a technical knockout.  
**The Fluke 70 Series.**  
**Winners of the digital vs. analog battle.**

Since their debut, they've become the worldwide champions of the industry.

Never before have such tough, American-made meters offered so many professional features at such unbeatable prices.

Each comes with a 3-year warranty, 2,000+ hour battery life, and instant autoranging.

You also get the extra resolution of a 3200-count LCD display, plus a responsive analog bar graph for quick visual checks of continuity, peaking, nulling and trends.

Choose from the Fluke 73, the ultimate in simplicity. The feature-packed Fluke 75. Or the deluxe Fluke 77, with its own protective holster and unique "Touch Hold" function\*\* that captures and holds readings, then beeps to alert you.

So don't settle for just a contender. Take home a world champion.

For your nearest distributor or a free brochure, call toll-free anytime

**1-800-227-3800, Ext. 229.** From outside the U.S., call 1-402-496-1350, Ext. 229.

**FROM THE WORLD LEADER  
IN DIGITAL MULTIMETERS.**



## FLUKE 73

\$85\*  
Analog/digital display  
Volts, ohms, 10A, diode test  
Autorange  
0.7% basic dc accuracy  
2000+ hour battery life  
3-year warranty

## FLUKE 75

\$99\*  
Analog/digital display  
Volts, ohms, 10A, mA, diode test  
Audible continuity  
Autorange/range hold  
0.5% basic dc accuracy  
2000+ hour battery life  
3-year warranty

## FLUKE 77

\$129\*  
Analog/digital display  
Volts, ohms, 10A, mA diode test  
Audible continuity  
"Touch Hold" function  
Autorange/range hold  
0.3% basic dc accuracy  
2000+ hour battery life  
3-year warranty  
Multipurpose holster

\* Suggested U.S. list price, effective July 1, 1984.  
\*\* Patent pending.

**FLUKE**®

# NEW PRODUCTS

**DIGITAL PANEL METER**, the model *X-34 Thriftmeter*, is an LED-readout digital panel meter with a 0.5-inch depth behind the case. The 3½-digit, 2000-count meter features

automatic polarity indication for positive and negative input voltages, out-of-range overload indication, and accuracy to 0.001 volt.

The 0.563-inch LED readout, with programmable decimal point, is readable from 30 feet. The meter is designed for scientific analytical equipment, medical equipment, and test and process-

## VIEW 8 TRACES ON YOUR SINGLE OR DUAL TRACE SCOPE WITH THIS LOW COST DEVICE!!

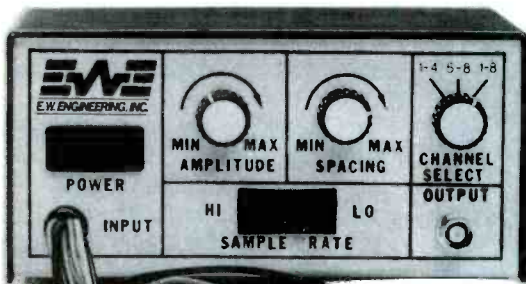

Now you no longer have to spend thousands on an expensive multi-trace oscilloscope - our single trace Hitachi scope combined with this module will allow you to view up to 8 simultaneously occurring analog or digital (or both) signals in their real time and amplitude relationship. The MPX 101 may be used on any oscilloscope, whether single, dual or multiple traces. Its low cost makes it a particular favorite for designers, testers, hobbyists and repairmen who want to compare and analyze displayed signals in a timing diagram format. The controls on the front panel of the metal case allow you to vary amplitude and spacing of the displayed signals.

**MODEL MPX101  
FULLY ASSEMBLED & TESTED!**



**NOT  
A  
KIT**

**\$99<sup>88</sup>**

**FULL 1  
YEAR  
REPLACE-  
MENT  
WARRANTY**

- Made In The United States -

### SPECIFICATIONS

Inputs: 8 signals plus ground via 9 input leads terminated with alligator clips  
Bandwidth: ± 1dB to 5 MHz  
Impedance: 10.9 K  
Input Voltage: ± 5V peak (diode clamped to ± 5 Volt supplies)  
Output: Staircase waveform summed with input signals, 0-800 mV full scale  
Step Amplitude: Variable 0 to 150 mV/ step  
Signal Voltage: Variable 0 to

150 mV/step @ 5V Input  
Multiplex Rate: Switch selectable, 40 KHz or 4 KHz  
Impedance: 50 Ohms  
Power: 105-135 VAC @ 1 V a  
Dimensions: 6.25" x 3.25" x 4.75" (WxHxD)  
Operating Temperature: 0-40°C  
Weight: 1 lb. 10.5 oz.  
Warranty: one year full replacement warranty from date of purchase  
Lighted on/off power switch  
Wood grain finished metal case

**DISTRIBUTOR AND REPRESENTATIVE INQUIRIES INVITED**



VISA, MASTERCARD, AMEX TELEPHONE ORDERS ACCEPTED!  
6 Herman Drive, E. Granby, CT 06026 □ 203/651-0285



**CIRCLE 231 ON FREE INFORMATION CARD**

control equipment, as well as applications for hobbyists and electronics experimenters. Calculations involving meter loading are eliminated, in most cases, by the high-impedance input.

The model *X-34 Thriftmeter* comes with a case, red readout-filter, and mounting hardware, and is priced at \$38.50.—Non-Linear Systems, 533 Stevens Avenue, Solana Beach, CA 92075.

**TEST LINE SIMULATOR**, model *TLS-2*, is designed to provide a telephone/telephone system installer a means to perform operational and functional checks of telephone and system installations when central-office lines are not available.

The model *TLS-2* includes the following features: It provides loop and ground-start operation; two lines are provided with sepa-



**CIRCLE 232 ON FREE INFORMATION CARD**

**CIRCLE 214 ON FREE INFORMATION CARD**

**PARTIAL LISTING ONLY - PLEASE CALL OR WRITE FOR FREE CATALOG.**

**STATIC RAMS**

2114	1024 x 4 (450ns)	8/9.95
2114.25	1024 x 4 (250ns)	8/10.95
2114L-2	1024 x 4 (200ns) (LP)	8/13.95
TMM2016-200	2048 x 8 (200ns)	4.15
TMM2016-150	2048 x 8 (150ns)	4.95
TMM2016-100	2048 x 8 (100ns)	6.15
HM6116-4	2048 x 8 (200ns) (cmos)	4.75
HM6116-3	2048 x 8 (150ns) (cmos)	4.95
HM6116LP-4	2048 x 8 (200ns) (cmos) (LP)	5.95
HM6116LP-3	2048 x 8 (150ns) (cmos) (LP)	6.95
HM6264	8192 x 8 (150ns) (cmos)	39.95

LP = Low Power

**DYNAMIC RAMS**

4116-250	16384 x 1 (250ns)	8/7.95
4116-200	16384 x 1 (200ns)	8/12.95
4116-150	16384 x 1 (150ns)	8/14.95
4164-200	65536 x 1 (200ns) (5v)	9/49.00
4164-150	65536 x 1 (150ns) (5v)	9/49.00
TMS 4164-15	65536 x 1 (150ns) (5v)	8.95

5v = Single 5 volt supply

**EPROMS**

2708	1024 x 8 (450ns)	3.95
2716	2048 x 8 (450ns) (5v)	3.95
2716-1	2048 x 8 (350ns) (5v)	5.95
TMS2532	4096 x 8 (450ns) (5v)	5.95
2732	4096 x 8 (450ns) (5v)	4.95
2732-250	4096 x 8 (250ns) (5v)	8.95
2732-200	4096 x 8 (200ns) (5v)	11.95
2732A	4096 x 8 (250ns) (5v) (21vPGM)	9.95
2732A-2	4096 x 8 (200ns) (5v) (21vPGM)	13.95
27128	16384 x 8 (300ns) (5v)	29.95

5v = Single 5volt supply 21vPGM = Program at 21 Volts

**SPECTRONICS CORPORATION**

EPROM ERASER PE-14, 9chip capacity 83.00

**8000**

8039	5.95
8080	3.95
8085	4.95
8087	175.00
8088	29.95
8155	6.95
8748	24.95

**8200**

8203	39.95
8205	3.50
8212	1.80
8216	1.75
8228	3.49
8237-5	21.95
8243	4.45
8250	10.95
8251	4.49
8253	6.95
8253-5	7.95
8255	4.49
8255-5	5.25
8259	6.90
8259-5	7.50
8275	29.95
8279	8.95
8282	6.50
8284	5.50
8286	6.50

**Z-80**

Z80-CPU	3.95
Z80-PIO	3.95
Z80A-CPU	4.49
Z80A-CTC	4.95
Z80A-PIO	4.49
Z80A-SIO/0	12.95
Z80B-CPU	9.95

**6500**

6502	4.95
6522	6.95
6502A	6.95

**6800**

6802	7.95
6809E	14.95
6821	2.95
6845	14.95
6850	3.25
6883	22.95

**DISK CONTR**

1771	24.95
1791	24.95
1793	26.95
2791	54.95
2793	54.95

**INTERFACE**

8728	1.89
8797	.89
DM8131	2.95
DP8304	2.29
9334	2.50
9368	3.95

**CLOCK CHIPS**

MM5369	3.95
MM58167	12.95
MSM5832	3.95

**DATA ACQ**

ADC0804	3.49
ADC0809	4.49
ADC0817	9.95

**SOUND CHIPS**

76488	5.95
AY3-8910	12.95

**CRYSTALS**

32.768 khz	1.95
1.0 mhz	3.95
1.8432	3.95
2.0	2.95
2.4576	2.95
3.276	2.95
3.579545	2.95
4.0	2.95
5.0	2.95
5.0688	2.95
6.0	2.95
6.144	2.95
8.0	2.95
10.0	2.95
10.738635	2.95
14.31818	2.95
15.0	2.95
16.0	2.95
17.430	2.95
20.0	2.95

**DISCRETE**

KBP02 Bridge	.45
1N751 5.1v zener	.25
1N759 12v zener	.25
2N2222	.25
PN2222	.10
2N2905	.50
2N2907	.25
2N3055	.79
2N3904	.10
2N3906	.10
1N4004	10/1.00
1N4148	25/1.00

**74LS00**

74LS00	.24	74LS157	.65
74LS02	.25	74LS158	.55
74LS03	.25	74LS161	.65
74LS04	.24	74LS163	.65
74LS05	.25	74LS164	.69
74LS08	.28	74LS165	.95
74LS09	.29	74LS169	1.75
74LS11	.35	74LS173	.69
74LS14	.59	74LS174	.55
74LS20	.25	74LS191	.89
74LS21	.29	74LS193	.79
74LS27	.29	74LS194	.69
74LS30	.25	74LS195	.69
74LS32	.29	74LS221	.89
74LS33	.55	74LS240	.95
74LS38	.35	74LS241	.99
74LS42	.49	74LS242	.99
74LS47	.75	74LS243	.99
74LS51	.25	74LS244	1.29
74LS73	.39	74LS251	.59
74LS74	.35	74LS257	.59
74LS75	.39	74LS258	.59
74LS76	.39	74LS259	2.75
74LS85	.69	74LS260	.59
74LS86	.39	74LS266	.55
74LS90	.55	74LS273	1.49
74LS92	.55	74LS279	.49
74LS93	.55	74LS280	1.98
74LS107	.39	74LS283	.69
74LS109	.39	74LS290	.89
74LS112	.39	74LS293	.89
74LS122	.45	74LS299	1.75
74LS123	.79	74LS323	3.50
74LS125	.49	74LS365	.49
74LS126	.49	74LS367	.45
74LS132	.59	74LS368	.45
74LS133	.59	74LS373	1.39
74LS136	.39	74LS374	1.39
74LS138	.55	74LS377	1.39
74LS139	.55	74LS390	1.19
74LS148	1.35	74LS393	1.19
74LS151	.55	74LS640	2.20
74LS153	.55	74LS670	1.49
74LS154	1.90	74LS682	3.20
74LS156	.69	74LS688	2.40

**74S00**

74S00	.32	74S86	.50
74S02	.35	74S112	.50
74S04	.35	74S124	2.75
74S05	.35	74S138	.85
74S08	.35	74S157	.95
74S10	.35	74S175	.95
74S11	.35	74S240	2.20
74S20	.35	74S280	1.95
74S32	.40	74S287	1.90
74S74	.50	74S288	1.90

**7400**

7400	.19	7447	.69
7402	.19	7473	.33
7404	.19	7474	.34
7405	.25	7475	.45
7406	.29	7476	.45
7407	.29	7486	.35
7408	.24	7490	.35
7410	.19	7492	.50
7411	.25	7493	.35
7414	.49	74121	.29
7416	.25	74123	.49
7417	.25	74132	.45
7420	.19	74151	.55
7425	.29	74154	1.25
7430	.19	74157	.55
7432	.29	74164	.85
7438	.29	74168	1.00
7442	.49	74192	.79
7445	.69	74193	.79

**CMOS**

4001	.25	4069	.29
4011	.25	4070	.35
4013	.38	4071	.29
4015	.39	4081	.29
4016	.39	4093	.49
4017	.69	14411	11.95
4020	.75	4511	.85
4024	.65	4518	.89
4027	.45	4520	.79
4040	.75	4553	5.79
4042	.69	4584	.75
4046	.85	74C00	.35
4049	.35	74C04	.35
4050	.35	74C74	.35
4051	.79	74C925	5.95
4066	.39	74C926	7.95

**ORDER TOLL FREE**

**800-538-5000**  
**800-662-6279**  
(CALIFORNIA RESIDENTS)

**D-SUBMINIATURE CONNECTORS**

DB09P	Male 9 Pin D-Sub	\$2.08
DB25P	Male 25 Pin D-Sub	2.50
DB25S	Female 25 Pin D-Sub	3.25
DB25SR	Female 25 Pin Right Angle PC	4.42
GREY HOOD	For DB25 Connectors	1.25

**IDC CONNECTORS**

IDS26	26 Pin Ribbon Socket	2.43
IDS34	34 Pin Ribbon Socket	3.15
IDS50	50 Pin Ribbon Socket	4.65
IDE34	34 Pin Ribbon Edge Card	3.25
IDP16	16 Male Pin Dip Plug	1.65
RC50	50 Conductor Ribbon Cable	1.38/ft.

**JUMBO LEDS**

1-99	100-up
RED	.10 .09
GREEN	.18 .15
YELLOW	.18 .15

**MOUNTING HARDWARE**

.10 EA. 100/.09 EA.

**DISPLAYS**

MAN 72	CA.3"	.99
MAN 74	CC.3"	.99
FND-357	CC.375"	1.25
FND-500	CC.5"	1.49
FND-507	CA.5"	1.49

**ELCOMP**

Hardware Handbook  
Mfr's Specs: LOGIC,  
MEMORY, MPU's & more  
**800 pgs \$14.95**

**CAPACITORS**

10pf	56pf
22pf	82pf
27pf	100pf
33pf	220pf
47pf	.001uf

**MONOLITHIC**

.01uf-mono	50V	.14
.047uf-mono	50V	.15
.1uf-mono	50V	.18
.47uf-mono	50V	.25

**ELECTROLYTIC**

1uf	25V	.14
47uf	35V	.18
470uf	25V	.30
2200uf	16V	.60

**AXIAL**

1uf	50V	.14
22uf	16V	.14
47uf	50V	.20
220uf	25V	.30

**COMPUTER GRADE**

44,000uf	30V	3.95
----------	-----	------

**PERIPHERALS**

**JDR HALF-HEIGHT DISK DRIVE**

\* TEAC MECHANISM - DIRECT DRIVE  
\* 100% APPLE COMPATIBLE - 35 TRACK  
\* 40 TRACK WHEN USED WITH OPTIONAL CONTROLLER  
\* 1 YEAR WARRANTY

**\$169.95**

40 TRACK CONTROLLER \$49.95

**FD-35 FULL HEIGHT DISK DRIVE**

\* MADE IN USA  
\* SHUGART MECHANISM  
\* FULL 1 YEAR WARRANTY

**\$179.95**

CONTROLLER FOR FD-35 \$49.95

BMX-80 80cps Bi-Directional \$249.00

JDR 16K RAM Card \$39.95

Power Supply 4amp Model \$49.95



**JDR Microdevices**

1224 S. Bascom Avenue, San Jose, CA 95128

800-538-5000 • 800-662-6279 (CA)

(408) 995-5430 • Telex 171-110

© Copyright 1984 JDR Microdevices APPLE IS A TRADEMARK OF APPLE COMPUTER CO.

**VISIT OUR RETAIL STORE**

HOURS: M-W-F, 9-5 T-Th., 9-9 Sat. 10-3

## NEW PRODUCTS

continued from page 6

rate battery feeds; it accepts tone and rotary input; it has a unique station number for each line; there is a ringing-voltage source with short-circuit protection, and there are three ways to apply ringing to on-hook lines. The *TLS-2* sells for \$290.00.—**Teltone Corporation**, 10801 120th Avenue, NE, PO Box 657, Kirkland, WA 98033.

**TEST SET**, model *HX-93*, is designed for testing installed cables. The unit features interchangeable adapter plates for one cable end, while the remote cable end connects to a passive connector block. All lines are checked electronically for shorts and opens, as well as miswires. Testing can be initiated at either end; a PASS/FAIL indicator is included on the remote-connector block.

Spring-loaded probes on the tester assure reliable connection to the adaptor plates. The model



CIRCLE 233 ON FREE INFORMATION CARD

*HX-93* is priced at \$1195.00.—**Hollex, Inc.**, 81 W. Wyoming Avenue, MA 02176.

**SATELLITE RECEIVER**, the *System 70*, features detent tuning, polarity control, a signal-strength meter, built-in modulator, scan tuning,



CIRCLE 234 ON FREE INFORMATION CARD

and wide and narrow audio-filters. It is available either as the standard model 70x or the stereo version, model 70s, which decodes both matrix and discrete stereo sound.

The *System 70x* is priced at \$750.00; the *System 70s* costs \$900.00.—**Lowrance Electronics, Inc.**, 12000 E. Skelly Drive, Tulsa, OK 74128.

**INTERFACE**, model *200-C488*, is an IEEE-488 GPIB (General Purpose Interface Bus) interface that provides talker-listener functions for the full series of Bertan's expanded *205A/210* laboratory high-voltage power supplies now available. (Those supplies have output voltages to 75 kilovolts and output power to 250 watts.)



CIRCLE 235 ON FREE INFORMATION CARD

Commands that are implemented via the interface include output-voltage setting, voltage limit, and current limit. In response to a controller request, the interface supplies power-supply status and output data. It can be programmed to automatically shut down a power supply and request service for an overvoltage or over-current condition.

The model *200-C488* interface is priced at \$1,000.00.—**Bertan Associates, Inc.**, 3 Aerial Way, Syosset, NY 11791.

continued on page 10

## Radio-Electronics REPRINT BOOKSTORE

- |  |         |  |        |
|--|---------|--|--------|
| <input type="checkbox"/> Build Your Own Satellite TV Receiver .....    | \$7.00  | <input type="checkbox"/> Special Projects (Spring 1981) .....          | \$4.50 |
| <input type="checkbox"/> 8-Ball Satellite TV Antenna .....             | \$5.00  | <input type="checkbox"/> Special Projects #4 (Summer 1982) .....       | \$4.50 |
| <input type="checkbox"/> Build Your Own Robot .....                    | \$12.00 | <input type="checkbox"/> Special Projects #5 (Winter 1983) .....       | \$4.00 |
| <input type="checkbox"/> TV Descrambler (January, February 1981) ..... | \$3.00  | <input type="checkbox"/> Special Projects #6 (Spring 1983) .....       | \$4.00 |
| <input type="checkbox"/> Radio-Electronics back issues (1984) .....    | \$3.00  | <input type="checkbox"/> Special Projects #7 (Summer 83) NOT AVAILABLE |        |
| <input type="checkbox"/> Radio-Electronics back issues (1983) .....    | \$3.50  | <input type="checkbox"/> Special Projects #8 (Fall 83) .....           | \$4.00 |
| Write in issues desired .....  |         | <input type="checkbox"/> Special Projects #10 (Spring 84) .....        | \$3.00 |
| <input type="checkbox"/> Radio-Electronics back issues (1982) .....    | \$4.00  | <input type="checkbox"/> Radio-Electronics Annual 1983 .....           | \$3.50 |
| (January 1982 not available)   |         | <input type="checkbox"/> Radio-Electronics Annual 1984 .....           | \$2.50 |
| Write in issues desired .....  |         | <input type="checkbox"/> How to Make PC Boards .....                   | \$2.00 |
| <input type="checkbox"/> Radio-Electronics back issues (1981) .....    | \$4.00  | <input type="checkbox"/> All About Kits .....                          | \$2.00 |
| (Jan., Feb., March, Dec. 1981 not available)                           |         | <input type="checkbox"/> Modern Electronics (Vol. 1, #1 .....          | \$2.25 |
| Write in issues desired .....  |         | April 1908)  |        |
| <input type="checkbox"/> Etch your own PC boards .....                 | \$3.00  | <input type="checkbox"/> Electro Importing Co. Catalog .....           | \$4.95 |
|  |         | (1918) (176 pp)  |        |
|  |         | <input type="checkbox"/> Low Frequency Receiving Techniques .....      | \$6.00 |
|  |         | Building and using VLF Antennas  |        |

To order any of the items indicated above, check off the ones you want. Complete the order form below, include your payment, check or money order (DO NOT SEND CASH), and mail to Radio-Electronics, Reprint Department, 200 Park Ave. South, New York, NY 10003. Please allow 4-6 weeks for delivery.

If you need a copy of an article that is in an issue we indicate is unavailable you can order it directly from us. We charge 50¢ per page. Indicate the issue (month & year), pages and article desired. Include payment in full, plus shipping and handling charge.

ARTICLE \_\_\_\_\_

MONTH \_\_\_\_\_ YEAR \_\_\_\_\_

PAGES \_\_\_\_\_

TOTAL PAGES \_\_\_\_\_ @ 50¢ each TOTAL PRICE \_\_\_\_\_

MAIL TO: **Radio-Electronics** AN5  
Reprint Department, 200 Park Ave. South, New York, NY 10003 All payments must be in U.S. funds

Total price of order .....	\$ _____
Sales Tax (New York State Residents only) .....	\$ _____
Shipping & Handling (U.S. & Canada only) (Includes FIRST CLASS POSTAGE) \$1.00 per item .....	\$ _____
All other countries (\$2.00 per item, sea mail) .....	\$ _____
(\$4.00 per item, air mail) .....	\$ _____
Total Enclosed .....	\$ _____

Name \_\_\_\_\_

Address \_\_\_\_\_

City \_\_\_\_\_ State \_\_\_\_\_ Zip \_\_\_\_\_



Hold it! I ordered two MICRO-farads!



7400

Number of Pins of each IC

Table listing 7400 series components including Part No., Pins, Price, and descriptions for various logic chips.

Table listing 74LS series components including Part No., Pins, Price, and descriptions for low-power Schottky logic chips.

Table listing 74S/PROMS series components including Part No., Pins, Price, and descriptions for static CMOS PROMs.

Table listing CA-LINEAR series components including Part No., Pins, Price, and descriptions for linear ICs.

Table listing CD-CMOS series components including Part No., Pins, Price, and descriptions for CMOS logic chips.

Table listing CD4000 series components including Part No., Pins, Price, and descriptions for CMOS logic chips.

MICROPROCESSOR COMPONENTS

Table listing MICROPROCESSOR CHIPS including Part No., Price, and descriptions for various microprocessors.

Table listing 8000 SERIES components including Part No., Price, and descriptions for 8000 series microprocessors.

Table listing DISK CONTROLLERS including Part No., Price, and descriptions for disk controller chips.

Table listing LOW PROFILE (TIN) SOCKETS including Part No., Price, and descriptions for low profile sockets.

Table listing SOLIDTALOR STANDARD (TIN) components including Part No., Price, and descriptions for solidtolor standard components.

Table listing DYNAMIC RAMS including Part No., Price, and descriptions for dynamic random access memory.

Table listing NEW 256K DYNAMIC RAM including Part No., Price, and descriptions for 256K dynamic RAM.

Table listing PROMS / EPROMS including Part No., Price, and descriptions for programmable read-only memory.

Table listing DATA ACQUISITION components including Part No., Price, and descriptions for data acquisition hardware.

Table listing WIRE WRAP SOCKETS (GOLD) LEVEL #3 including Part No., Price, and descriptions for wire wrap sockets.

Table listing WIRE WRAP SOCKETS (GOLD) LEVEL #3 including Part No., Price, and descriptions for wire wrap sockets.

Table listing WIRE WRAP SOCKETS (GOLD) LEVEL #3 including Part No., Price, and descriptions for wire wrap sockets.

Digitalker™

DT1050 — Applications: Teaching aids, appliances, clocks, automotive, telecommunications, language translations, etc.

DT1050 is a standard DIGITAL KER IC encoded with 137 separate and useful words, 2 tones, and 5 different silence durations.

DT1057 - Expands the DT1050 vocabulary from 137 to over 260 words. Includes 2 ROMs and specs. \$24.95 ea.

Table listing Digitalker™ components including Part No., Price, and descriptions for various digital ker chips.

30009 1983 INTERSIL Data Book (135pp) \$9.95

NEW PRODUCT! 74HC High Speed CMOS

Table listing 74HC series components including Part No., Price, and descriptions for high-speed CMOS logic chips.

74C-C/MOS

Table listing 74C-C/MOS series components including Part No., Price, and descriptions for C-MOS logic chips.

LINEAR

Table listing LINEAR series components including Part No., Price, and descriptions for linear ICs.

Advertisement for JAMECO ELECTRONICS VISA, featuring a logo and contact information for their store in Belmont, CA.

# Radio-Electronics Software Store

New for our readers....A mailorder source of software for Atari 400, Atari 800, IBM P C, Commodore VIC-20, Apple II, and other personal computer systems.

## IBM PC



**FLIGHT SIMULATOR** by Microsoft ... List \$49.95. Our price ... \$43.00. Highly accurate simulation of flight in a single-engine aircraft. Working instruments. Out the window graphics. Real-time flight conditions. (IBM P C, 64k, color graphics, disc)

**EASYWRITER II** by Information Unlimited ... List \$350.00. Our price ... \$300.00. Turns your computer into a word processor. You see everything on the screen. There are no imbedded commands. (IBM P C, disc)

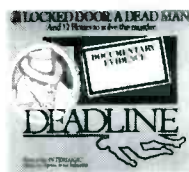

**DEADLINE** by Infocom ... List \$49.95. Our price ... \$43.00. A locked door. A dead man. You have 12 hours to solve the mystery. One false move, and the killer strikes again. (IBM P C, 48k, disc)

**ALGEBRA, Vol. 1** by Eduware ... List \$39.95. Our price ... \$34.00. A first year algebra tutorial covering definitions, number line operations, sets, etc. (IBM P C, 48k, color graphics, disc)



**MICRO/TERMINAL** by Microcom ... List \$94.95. Our price ... \$83.00. Allows access to remote mainframes and minis, information data banks, and other personal computers. (IBM P C, disc)

**PC TUTOR** by Comprehensive Software ... List \$79.95. Our price ... \$69.00. Interactive program teaches you how to use your IBM Personal Computer, including hardware and software. (IBM P C, 64k, disc)



## APPLE



**PRISONER2** by Interactive Fantasies ... List \$32.95. Our price ... \$28.00. Escape is hardly possible. The island keeps you under surveillance. Just try and get out! (Apple II, 48k, disc)

**PRISONER2** by Interactive Fantasies ... List \$39.95. Our price ... \$34.00. (Atari disc)

**THE MASK OF THE SUN** by Ultrasoft Inc ... List \$39.95. Our price ... \$34.00. An animated adventure through a series of hi-res screens. An ultimate adventure challenge. (Apple II, 48k, disc)



**MASTERTYPE** by Lighting Software ... List \$39.95. Our price ... \$34.00. A typing instruction system in an exciting hi-res game format. Learn to type while battling waves of attacking enemy words. (Apple II, 48k/64k, disc)

**THE GRAPHICS MAGICIAN** by Penguin Software ... List \$59.95. Our price ... \$53.00. Make your own animated graphics. Handles up to 32 independent objects. Stores hundreds of color pictures. (Apple II, 48k, disc)



**RENDEZVOUS** by Eduware ... List \$39.95. Our price ... \$34.00. In four phases, simulates an actual space-shuttle flight from Earth Liftoff through Orbital Rendezvous and Approach to Alignment Docking with a space station. Hi-res graphics (Apple II, disc)

**SAT WORD ATTACK SKILLS** by Eduware ... List \$49.00. Our price ... \$43.00. A tutorial for mastering vocabulary, deciphering new or unfamiliar words, and taking tests. (Apple II, disc)



## COMMODORE VIC-20



**PIPES** by Creative Software ... List \$39.95. Our price ... \$34.00. Connect a pipeline from the water supply tank to every house. Watch out for leaks. Use as little pipe as possible. 5 skill levels. (Commodore VIC-20 cartridge)

**SHAMUS** by Human Engineered Software ... List \$39.94. Our price ... \$34.00. Only you can stop the Shadow's mad reign of terror. Two levels with 20 rooms each. A joystick challenge. (Commodore VIC-20 cartridge)



**HOUSEHOLD FINANCE** by Creative Software ... List \$17.95. Our price ... \$15.00. Home utility program records and analyzes your monthly income, expenses and budget in 16 categories. (Commodore VIC-20 tape cassette)

**HOME OFFICE** by Creative Software ... List \$29.95. Our price ... \$25.00. Combines VICPRO, a flexible and efficient word processor with VICDATA a powerful and sophisticated information storage and retrieval system. (Commodore VIC-20, cassette tape, 8k additional memory required)



## ATARI



**SUBMARINE COMMANDER** by Thorn EMI ... List \$49.95. Our price ... \$43.00. A submarine patrol simulator to hunt and destroy enemy ships. 9 skill levels. Plug-in cartridge. (Atari Cartridge 400/800)

## APPLE

**MINER 2049** by MicroLab ... List \$39.95. Our price ... \$34.00. Chase into a Uranium mine thru 10 levels of traps and capture Yukon Yohan. Scale ladders, jump from moving platforms, and win—if you can. (Apple II, 48k, disc)



## Radio-Electronics Software Store

200 Park Avenue South  
New York, NY 10003

AN5

Number of items ordered

Total Price of Software ..... \$ \_\_\_\_\_

Sales Tax (NY State Residents Must Include) ..... \$ \_\_\_\_\_

Shipping (\$2.00 per item) ..... \$ \_\_\_\_\_

TOTAL ENCLOSED (Sorry, No COD's) ..... \$ \_\_\_\_\_

Name \_\_\_\_\_

Address \_\_\_\_\_

City \_\_\_\_\_ State \_\_\_\_\_ ZIP \_\_\_\_\_

**SORRY - NO CREDIT CARD OR COD ORDERS**



# CABLE-TV PRICE SLASH!

ITEM	OUTPUT CHANNEL <i>(Circle the one used on your system)</i>		REG.	NOW	QTY.	PRICE
	CH. 2	CH. 3				
JERROLD 400 CONVERTER (58 CH.)	CH. 2	CH. 3	109.00	<b>90.00</b>	.....	.....
(10 or more)	CH. 2	CH. 3	82.00	<b>75.00</b>	.....	.....
JERROLD 450 CONVERTER (66 CH.)	CH. 2	CH. 3	134.00	<b>105.00</b>	.....	.....
(10 or more)	CH. 2	CH. 3	110.00	<b>90.00</b>	.....	.....
EAGLE COMTRONICS 400 MHz CONVERTER	CH. 2	CH. 3	109.00	<b>90.00</b>	.....	.....
(10 or more)	CH. 2	CH. 3	82.00	<b>75.00</b>	.....	.....
SB ADD-ON UNIT	CH. 2	CH. 3	129.00	<b>99.00</b>	.....	.....
(10 or more)	CH. 2	CH. 3	79.00	<b>58.00</b>	.....	.....
<b>BRAND NEW</b> SB TRIMODE COMPLETE UNIT	CH. 2	CH. 3	Please call for price quotes and details.		.....	.....
SB TRIMODE CONVERSION KIT	CH. 2	CH. 3	Please call for price quotes and details.		.....	.....
MINICODE (N-12)	CH. 2	CH. 3	109.00	<b>89.00</b>	.....	.....
(10 or more)	CH. 2	CH. 3	79.00	<b>56.00</b>	.....	.....
MINICODE (N-12) VARISYNC	CH. 2	CH. 3	119.00	<b>99.00</b>	.....	.....
(10 or more)	CH. 2	CH. 3	86.00	<b>62.00</b>	.....	.....
C-1000 ADD-ON (COMPATIBLE—ALL ZENITH SYSTEMS)	CH. 2	CH. 3	260.00	<b>225.00</b>	.....	.....
(5 or more)	CH. 2	CH. 3	220.00	<b>185.00</b>	.....	.....
MLD-1200-3	CH. 3 ONLY		129.00	<b>99.00</b>	.....	.....
(10 or more)	CH. 3 ONLY		85.00	<b>58.00</b>	.....	.....

**IMPORTANT: WHEN CALLING FOR INFORMATION —**  
Please have ready the make and model # of the equipment used in your area.  
*Thank You*

Name \_\_\_\_\_ Sub-Total .....

Street \_\_\_\_\_ Shipping .....

City/State/Zip \_\_\_\_\_ TOTAL .....

Phone Number Area Code \_\_\_\_\_ Number \_\_\_\_\_

**Sale of De-scramblers may be prohibited in some states. If in doubt, check with local authorities. No Ohio orders accepted.**

**MUST BE SIGNED AND RETURNED WITH YOUR ORDER**  
*I understand that the purchase of these cable T.V. products does not authorize their use on any cable T.V. system. I agree to obtain the proper authorization from local officials or cable company officials in my area.*

Signed \_\_\_\_\_

**Add \$2.00 per unit shipping or call for specifics. Payment is accepted by money order or Cashier's check only. COD's & credit cards are not accepted as our low prices prohibit their use.**

**Transamerican Cable Distributors**  
449 BROADWAY AVE. • BEDFORD, OHIO 44146 • (818) 956-5839  
*Please—No Collect Calls*

## NEW PRODUCTS

*continued from page 6*

**COLOR-VIDEO CAMERA**, model *CV-301*, weighs 1.6 lbs and is compatible with all VHS-format video-cassette recorders. It is adaptable to Beta-format video-cassette recorders with a standard adapter cable.



**CIRCLE 236 ON FREE INFORMATION CARD**

The unit delivers horizontal resolution of 270 lines; a minimum required luminance of 35 Lux; image signal-to-noise ratio of 45 dB; video-output signal of 1.0-volt p-p/75 ohms, and an audio-output level of -20 dB (1000 ohms).

Other features of the model *CV-301* include a unidirectional electret condenser microphone, and f/1.5 manual 3-to-1 zoom lens with 10 - 30mm focal length, a through-the-lens optical viewfinder with in-finder LED to indicate recording low-light and power warnings, and a light balance control to match four separate color temperatures.

The model *CV-301* has a suggested retail price of \$795.00.—**Konica, Konishiroku Photo Inc. USA Inc.**, 440 Sylvan Avenue, Englewood, Cliffs, NJ 07632.

**TOOL KIT**, model *JTK-87*, is a deep polyethylene case with a removable document portfolio. A recess in the outside of the lid accommodates a locking, black, vinyl portfolio for documents and schematics. It is secured to the lid with velcro fasteners, and can be detached when necessary to do paperwork while traveling, or slipped into the case for shipping.

**CIRCLE 238 ON FREE INFORMATION CARD**



The case measures 17¼ × 12¾ × 6½ inches and also features two removable gate-wing pallets. That permits easy access to tools, parts, and equipment carried in the case bottom. The model *JTK-87* is available with a selection of over 100 tools, and is priced at \$509.00. The portfolio case only is priced at \$189.00.—**Jensen Tools, Inc.**, 7815 South 46th St., Phoenix, AZ 85040.

**POWER SUPPLIES**, the *PAB-A* series, featuring 3½-digit LED readouts that are green in the voltage mode and red in the current mode. They are available in five models, with outputs ranging from 350 volts at 0.2 amperes to 5.0 amperes at 8 volts, with 0.02% regulation.



**CIRCLE 237 ON FREE INFORMATION CARD**

The features include constant-voltage or constant-current operation; remote-voltage programming; overcurrent protection; series or parallel operation; auto-ranging in voltage mode, and independent external-voltage readout using the supply's digital meter.

The *PAB-A* series has a design MTBF of over 10,000 hours, and prices range from \$175.00 to \$350.00.—**Kikusui International Corporation**, 17819 South Figuerola St., Gardena, CA 90248.

**DIRECT-DRIVE TURNTABLE**, model *DP-15F*, is a complete non-contact system that senses and corrects for record imperfections such as warps. The tonearm provides for improved tonearm/cartridge matching, because it responds to the combined tonearm/cartridge mass.

The *DP-15F* has a flat-twin direct-drive motor, microprocessor-controlled automatic operation with front-panel soft-touch controls,



**CIRCLE 239 ON FREE INFORMATION CARD**

and magnetic head-speed detection.

The model *DP-15F* has a suggested list price of \$199.00.—**Denon America, Inc.**, 27 Law Drive, Fairfield, NJ 07006.

**SIGNAL GENERATOR**, the model *LSG-215A*, is a programmable synthesized AM/FM RF signal generator featuring convenient keyboard control of frequency and output level. Semi-automatic operation is available by pre-programming up to 100 different test conditions. Two kilobytes of memory stores frequency, output level, and modulation data for each test condition.

The model *LSG-215A* offers an output-frequency range of 0.1 to 120 MHz in two bands: 0.1 to 30 MHz in 100-Hz steps, and 30 to 120



**CIRCLE 240 ON FREE INFORMATION CARD**

MHz in 1-kHz steps. Output-level range is -10 to 120 dBμ.volt in 1-dB steps.

The model *LSG-215A* is designed particularly for use in the communications industry, but is a general-purpose signal generator as well. It is priced at \$2,795.00.—**Leader Instruments Corporation**, 386 Oser Avenue, Hauppauge, LI, NY 11788. **R-E**

**UNINTERRUPTIBLE POWER SYSTEM**, the *LINE-SAVER™*, model *LS-240*, is a standby system for use in the home and small-business computer market. It is available for 120/240 volt, 60/50Hz systems, and has 240-VA, 150 watt capacity. The unit uses pulse-width modulation (PWM) technology to regulate the AC output voltage for greater efficiency to various load conditions. The PWM-AC output will also increase battery efficiency to

*continued on page 13*

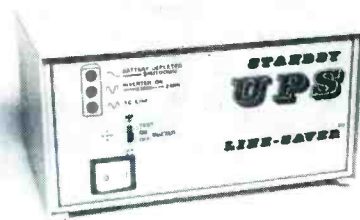

**CIRCLE 241 ON FREE INFORMATION CARD**

# KENWOOD

...pacesetter in amateur radio

## R-11 portable receiver

### R-11

Kenwood's R-11 is the perfect "go anywhere" portable receiver. It covers the standard AM and FM Broadcast bands plus nine additional short wave bands. The R-11's selectivity is greatly enhanced by the use of double conversion on short wave frequencies above 5.95-MHz. High sensitivity coupled with a dual antenna system (telescopic and ferrite core) allow it to

reach out and bring in those distant stations from all over the world.

Simplicity of operation is enhanced by a band-spread type tuning control. Electronic band switching, with LED band indicator, along with a tuning meter to indicate received signal strength, combine to provide you with superior listening capability. Safety Hold-Release switch prevents accidental station loss. Large front mounted speaker provides excellent sound quality. Tone switch adjusts for high, low and voice transmission.

Optional HS-7 micro-head phones a low for private listening pleasure.

All this along with a record output jack, external antenna terminal and a rugged and attractive carrying case make the R-11 portable receiver the perfect travel companion!

More information on the Kenwood receivers is available from authorized dealers of Trio-Kenwood Communications 1111 West Walnut Street, Compton, CA 90220.



**R-2000** Top-of-the-line general coverage receiver • 150 kHz to 30 MHz • Ten memories • Dual 24-hr clock with timer • Scanning • 100-240 VAC (Opt. 13.8 VDC) • Opt. VHF (110-174 MHz converter).

**R-1000** High performance receiver • 200 kHz - 30 MHz • digital display/clock/timer • 3 IF filters • PLL UP conversion • noise blanker • RF step attenuator • 120-240 VAC (Optional 13.8 VDC).

**R-600** General coverage receiver • 150 kHz - 30 MHz • digital display • 2 IF filters • PLL UP conversion • noise blanker • RF attenuator • front speaker • 100-240 VAC (Optional 13.8 VDC).



CIRCLE 213 ON FREE INFORMATION CARD

COLLECTORS PREMIER EDITION

From the Publishers of  
Radio-Electronics

# Hands-on Electronics

THE MAGAZINE FOR THE ELECTRONICS ACTIVIST

\$2.50 U.S.  
SUMMER 1984  
\$2.95 CANADA

48784

**The Great Power Supply Issue!**

**Build the  
DUAL POWER SUPPLY** ▸

**Tips on  
DESIGNING SUPPLIES**

Complete plans for  
**AUDIO BOOSTER AMP  
ELECTRONIC CROSSOVER  
DIGITAL AUTOTACH**



**Plus**

- **ALCULATOR**—Analog computer measures blood alcohol level
- **TONE RINGER**—Replace your phone's bells with a warbling tone
- **UPGRADE RAM/DISK**—Speed up disk data retrieving and storing

**Also**

- ✓ Resistor Bank for rapid ohmic substitution
- ✓ Breakout Box brings RS-232 back to standard
- ✓ Solar Cell Converter steps up the voltage



**LOOK FOR OUR  
NEW NAME!**

**HANDS-ON  
ELECTRONICS**

**FORMERLY  
SPECIAL PROJECTS**

**Get every issue!**

**SUBSCRIBE  
TODAY!**

**Use the order  
form below.**

## Subscribe Today!

■ IF YOU'RE THE KIND OF READER that doesn't want to wait, you can order your next copy of **Hands-on Electronics** now. **Hands-on Electronics** is crammed full of electronic projects that you won't be able to wait to build for yourself. You can expect top-notch digital projects, fun-to-play electronic games, valuable add-on computer projects, BCB and shortwave receivers, photographic/darkroom gadgets, devices to improve your car's performance, test equipment ideas, and more in every issue of **Hands-on Electronics**.

■ TO HELP YOU TO BE SURE that you don't miss any future issues of **Hands-on Electronics**—SUBSCRIPTIONS ARE NOW AVAILABLE!

■ YOU CAN HAVE THE NEXT FOUR ISSUES of **Hands-on Electronics** delivered directly to your home for only \$10.00. We pay the postage. If you want the next eight issues, you can even save a dollar off the newsstand price. Get eight issues for \$19.00

■ EVERY ISSUE OF **Hands-on Elec-**

**tronics** will continue to contain a variety of construction articles to suit every taste. In addition, feature articles on electronics fundamentals, test equipment and tools will round out each issue. Of course, **Hands-on Electronics** will continue to provide new product and literature listings to keep you up to date on the latest developments in electronic technology.

■ GET IN ON THE ACTION! Order your next issue of **Hands-on Electronics** today. Use the convenient order coupon below. Be sure to send check or money order—no cash!

<b>Hands-on Electronics SUBSCRIPTION</b>	Detach and mail today to: HANDS-ON ELECTRONICS SUBSCRIPTION DEPT. P.O. BOX 338 MOUNT MORRIS, IL 61054	CASH WITH ORDER ONLY Allow 6-8 weeks for the first issue to arrive.	AANN5
	<input type="checkbox"/> I want to be sure I don't miss any issues. Send me the next four issues of Hands-on Electronics for \$10.00 starting with #2. Postage is free in U.S. For Canada add \$2.00. Foreign add \$7.00	Please print _____ (Name)	_____ (Street Address)
<input type="checkbox"/> I want to be sure I don't miss any issues and want to save \$1.00 too. Send me the next eight issues of Hands-on Electronics for \$19.00: starting with #2. Postage is free in U.S. For Canada add \$4.00. Foreign add \$14.00.	_____ (City)	_____ (State)	_____ (Zip)
<input type="checkbox"/> Send me _____ copies of Hands-on Electronics #2 at \$2.50 plus \$1.00 postage and handling for U.S., Canada and Mexico \$1.00 per copy. U.S. funds only.			

## NEW PRODUCTS

continued from page 10

increase back-up time: 5–10 minutes full load, 20–25 minutes half load, 35–40 minutes 1/3 load.

In addition there is an internal 12-volt sealed rechargeable battery, four voltage-surge protected and EMI/RFI filtered AC outlets, audible and visual power-failure warnings systems, test-mode indicator and switch, and replaceable external fuses.

The unit comes complete with a 6-foot, detachable, 3-prong, heavy-duty cord-set with a 40-pin DIP clip. A special plug-in module adapts the unit so that it is suitable for use with most microprocessors.

There are seven output jacks on the front panel for monitoring pulse duration and timing relationships with an oscilloscope. There are sixteen input lines and six user-definable control lines.

*Addtrace I* is available in kit form for \$199.95. (Factory-wired prices are available on request.)—**BMH Company, Inc.**, 224 Vasar Street, Reno, NV 89502.

**TWO-WAY FM RADIOS**, the basic medium-power Midland *SYN-TECH* mobiles and base stations have had their transmit and receive bandwidths increased.

The bandwidth of the 50-watt low-band (29–54 MHz) VHF models is being doubled from 1 MHz to 2 MHz. The 40-watt mid-band (66–88 MHz) models will have an increased bandwidth from 2 MHz standard to 8 MHz (transmit) and 3 MHz (receive).



CIRCLE 242 ON FREE INFORMATION CARD

Inexpensive conversions kits are available for field installation on existing units. The total cost of the enhanced-bandwidth conversion kits, including installation, is expected to be under \$20.00.—**Midland LMR**, 1690 N. Topping, Kansas City, MO 64120.

**CORDLESS STEREO HEADPHONE** system works with any audio source: stereo systems, TVs, and radios. It consists of a transmitter and stereo headphone receiver, or transmitter and stereo receiver for use with any headphones.

The components use infrared light to transmit audio information normally carried by wire. The transmitter, *IRT-200*, installs easily; hookup is by phone plug, and adapters are included. With both headphones and re-



CIRCLE 243 ON FREE INFORMATION CARD

ceivers, the range is about 35 feet. The system can be used for either stereo or mono.

The stereo headphones, model *IRH-210* have full frequency response, 50–15,000 Hz. The infrared sensor is on top of the headphones for optimum reception. Any number of headphones can be used with the *IRT-200* transmitter.

The *IRSR-220* infrared stereo receiver works with any stereo earphones. Two can listen at once with the unit, which can be placed up to 35 feet from the audio-source/*IRT-200* transmitter hookup.

The system has a retail price of under \$100.00.—**Nady Systems**, 1145 65th Street, Oakland, CA 94608. **R-E**

## A QUALITY TRIPLE-REGULATED POWER SUPPLY AT A LOW, LOW PRICE!!

NOT A KIT!

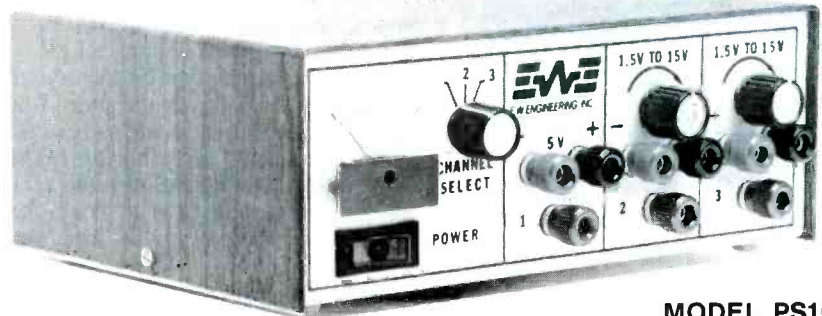

MODEL PS101  
FULLY ASSEMBLED & TESTED!

\$ **119** <sup>88</sup>  
FULL 1 YEAR REPLACEMENT WARRANTY

— Made In The United States —

This DC triple regulated variable power supply has all the features you could ask for plus a full 1 year guarantee. Fully adjustable from 1 1/2 VDC to 35 VDC! Three completely independent supplies that offer many advantages! They can be either a pos. supply or a neg. supply...they can also be stacked in series so that a 5V and two 15V supplies can total a 35 VDC supply or any combination of the three... (after one of the terminals is grounded to give it a reference)...for the first time you can now purchase this American made fully adjustable power supply at a price that is one-half of what you'd expect to pay!

### SPECIFICATIONS

3 outputs:  
Fixed 5 VDC  $\pm$  0.2V  
2 variable  $\leq$  1 1/2 V to  $\geq$  15 VDC  
Polarity—floating; can be used as pos. or neg.  
Ripple less than 10mV at full load,  
Regulation  $\leq$  1% no load to full load,  
Line Regulation  $<$  0.2% 108 VAC to 135 VAC.  
Current:  
Fixed supply 1.0 amp max.  
Variable supplies 0.5 amp max.

Protection built in, current limiting, with thermal shutdown.  
Power: 108–135 VAC.  
Dimensions: 8 1/4" x 3 1/4" x 7 1/4" (WxHxD)  
Wood grain finished metal case.  
Weight: 4 lbs., 9 ozs.  
Lighted on/off power switch, easy-to-read Voltmeter and large binding posts.  
Warranty: one year full replacement warranty from date of purchase.

DISTRIBUTOR AND REPRESENTATIVE INQUIRIES INVITED

**E.W.**  
**E.W. ENGINEERING, INC.**

VISA, MASTERCARD, AMEX TELEPHONE ORDERS ACCEPTED!  
6 Herman Drive, E. Granby, CT 06026 □ 203/651-0285

CIRCLE 215 ON FREE INFORMATION CARD

# EQUIPMENT REPORTS

## Ungar Electronic Soldering System 9000

This soldering system lets you set the iron temperature precisely

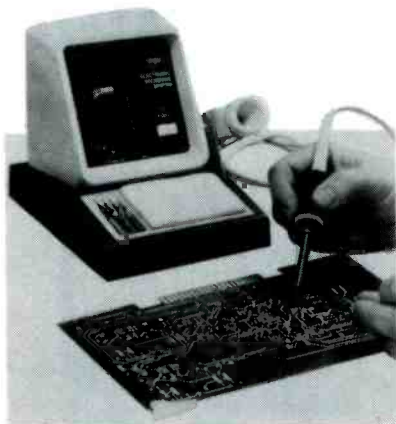

CIRCLE 244 ON FREE INFORMATION CARD

WHETHER YOU ARE BUILDING AN electronics project or repairing a piece of equipment, the most critical part of the job is the soldering. That's because even a single cold solder joint or solder bridge can cause a device to fail, and tracking down the source of that failure can often be next to impossible.

Of course, the most important part of the soldering operation is the iron itself. Well, for those who need or demand the best, Ungar (Division of Eldon Industries, Compton, CA 90220) offers their *Electronic Soldering System 9000*. That unit offers a selectable-temperature precision soldering iron, a built-in iron stand, and a large capacity sponge tray.

The unit is designed for maximum flexibility and convenience. The soldering station can be placed directly on a workbench using the base provided, or, if desired, the system control module, which houses the unit's electronics, can be re-

moved from the base and placed under the workbench or on a shelf. The system control module can also be mounted under a shelf or on a wall using an optional mounting bracket. In addition, the iron holder and the sponge tray can be positioned to accommodate either right-handed or left-handed users.

### Setting the temperature

But what really sets that unit apart is the adjustable temperature scale. Since the idling temperature can be adjusted over a range of 420°F to 800°F (215.5°C to 426.6°C), the user can set the idling temperature according to the requirements of a specific application. The settings are arranged in increments of 20°F over two ranges. Once set, the system will maintain the temperature to within  $\pm 10^\circ\text{F}$ .

An LED-bargraph-type display is used to show the actual iron temperature. That type of display is used so that you can see clearly and directly that the unit has reached or is maintaining the selected temperature. A pulsating LED on the display indicates slight variations in iron temperature.

The system control module and base are made of attractive black and beige plastic. As is appropriate in this type of device, all the plastics are self-extinguishing to reduce any chance of a fire. Also for safety, the system is three-wire grounded, burn-resistant cords are used, and circuit-breaker protection is provided.

Operation of the unit is simplicity itself. The unit is switched on using a front-panel POWER switch, and the desired tem-

perature is selected using the RANGE switch and TEMPERATURE slide control. Once the well-balanced iron with cool grip has reached the proper temperature, you're set to go. All controls and the readout are located on the system-control module.

Calibration of the unit is done against room-temperature. The procedure is done with a cold iron by turning the unit off, placing the RANGE switch in the center CALIBRATION position, and then turning the unit on. Once that's done, the ADJ control is rotated—using a slotted screwdriver—until the temperature readout, disregarding the the last zero, indicates the room temperature. That is, for a room temperature of 70°F, the readout should indicate 700°F.

As you might expect, the instruction manual is really no more than a four-page flyer. It covers some of the features of the unit, and briefly goes over its installation, use, calibration, and maintenance. Also included are some pointers on the preparation and care of soldering-iron tips. There is no information regarding the theory of operation, or a schematic. A list of user-replaceable parts, and their Ungar part numbers, is provided.

With its list price of \$190.00, the *Electronic Soldering System 9000* is obviously not aimed at the occasional user. But, if you do a lot of building or repairing, and you are serious about the work that you do, then this unit, with its combination of precision and convenience features, is going to be hard to beat.

## Regency Model Z30 Programmable Scanner

*Listen in on the excitement of the public-service bands*



CIRCLE 245 ON FREE INFORMATION CARD

THERE'S A LOT OF ACTIVITY AND EXCITEMENT to be found on the VHF and UHF bands. Police, fire, government, mobile telephone, amateur radio, and many other services use that portion of the spectrum for communications, and listening in on those communications has become a popular pastime.

Because of the wide range of frequencies we are dealing with, and because some exciting activity can be taking place

on any one or more of those frequencies at any time, the most effective way to listen in is with a scanning radio. One such radio that we recently had a chance to examine is the Regency Electronics (7707 Records St., Indianapolis, IN 46226) model Z30 programmable scanner.

That unit is a programmable 30-channel, three-band, FM scanner receiver. It also incorporates a digital alarm clock. It

*continued on page 20*

Ungar	9000									
OVERALL PRICE	1	2	3	4	5	6	7	8	9	10
EASE OF USE	1	2	3	4	5	6	7	8	9	10
INSTRUCTION MANUAL	1	2	3	4	5	6	7	8	9	10
PRICE/VALUE	1	2	3	4	5	6	7	8	9	10
	Poor	Fair	Good	Excellent						



# Electronics Paperback Books

## Quality Paperbacks at Affordable Prices



- 30 SOLDERLESS BREADBOARD PROJECTS BOOK-1.** \$5.75. Whenever possible the same parts are used in several projects. Even a first-time builder can complete these circuits.
- HOW TO GET YOUR ELECTRONIC PROJECTS WORKING.** \$5.00. Helps you troubleshoot and repair home-built projects of every description.
- MINI-MATRIX BOARD PROJECTS.** \$5.00. A variety of projects that can all be built upon a mini-matrix board that has 10 strips and is 24 holes long.
- MODERN OP-AMP PROJECTS.** \$5.00. Wide range of specialized op-amp circuits including lo-noise, lo-distortion, ultra-hi input impedance, etc.
- MULTI-CIRCUIT BOARD PROJECTS.** \$5.00. 21 fairly simple projects that can all be built on a single printed-circuit board. All are powered by a 9V battery.
- IC PROJECTS FOR BEGINNERS.** \$5.00. Inexpensive digital and linear IC's are used to assemble this selection of circuits intended for the beginner.



- THE ART OF PROGRAMMING THE 1K ZX81.** \$6.25. Topics include full screen, scrolling, PEEK & POKE, plus actual working programs.
- THE 6809 COMPANION.** \$5.00. Written for the average assembly language programmer. A discussion of 6809 features & reference work for the 6809 programmer.
- PRACTICAL COMPUTER EXPERIMENTS.** \$4.50. Fills in background to microprocessor by constructing typical computer circuits using discrete logic components.
- ART OF PROGRAMMING THE 1K ZX81.** \$5.00. How to use the features of the ZX81 in programs that fit the 1K machine and are still fun to use.
- INTRODUCTION TO BASIC PROGRAMMING TECHNIQUES.** \$5.00. Based on author's own experience in learning BASIC and helping others to learn to program.
- A MICROPROCESSOR PRIMER.** \$4.50. Painless approach to computing for the beginner. Step-by-step explains computer operations and assembly.

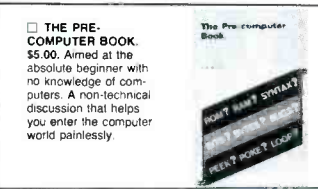

- THE PRE-COMPUTER BOOK.** \$5.00. Armed at the absolute beginner with no knowledge of computers. A non-technical discussion that helps you enter the computer world painlessly.
- AN INTRODUCTION TO VIDEO.** \$5.00. Perfect for the person just about to buy a VCR. Discusses pros & cons of the various formats; video discs; videotext, tape copying and more.



- POWER SUPPLY PROJECTS.** \$4.50. Contains designs and construction details for almost any power supply the experimenter is likely to need.
- ELECTRONIC PROJECTS USING SOLAR CELLS.** \$5.00. Simple circuits that have numerous applications around the home.
- ELECTRONIC TIMER PROJECTS.** \$5.00. Timing circuits for almost any application the experimenter might need. A most valuable reference.

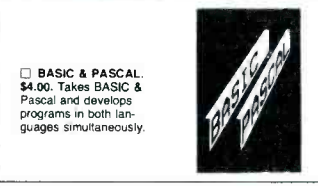

- BASIC & PASCAL.** \$4.00. Takes BASIC & Pascal and develops programs in both languages simultaneously.
- FIRST BOOK OF TRANSISTOR EQUIVALENTS & SUBSTITUTES.** \$3.75.
- PRACTICAL COMPUTER EXPERIMENTS.** \$4.50.
- ELECTRONICS SIMPLIFIED CRYSTAL SET CONSTRUCTION.** \$4.50.
- ELECTRONIC HOUSEHOLD PROJECTS.** \$4.50.

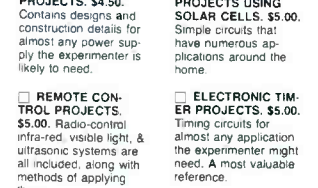

- COUNTER DRIVER AND NUMERICAL-DISPLAY PROJECTS.** \$4.50. Construction details of a wide range of test equipment the experimenter can build at home.
- ELECTRONIC TEST EQUIPMENT CONSTRUCTION.** \$4.50. Construction details of a wide range of test equipment the experimenter can build at home.
- SEMICONDUCTOR TECHNOLOGY.** \$5.75. Everything you always needed to know about solid state devices in one volume.
- COMMUNICATIONS.** \$7.50. Covers most modern communication systems. Line, microwave, submarine, satellite, digital multiplex, radio & telegraphy.
- FIRST BOOK OF HI-FI SPEAKER ENCLOSURES.** \$4.50.
- SOLID STATE NOVELTY CIRCUITS.** \$3.50.
- 28 TESTED TRANSISTOR PROJECTS.** \$4.25.



- PRACTICAL ELECTRONIC BUILDING BLOCKS—Book 1.** \$5.00. All electronics circuits consist of simple building blocks. When you know how to make the blocks you can easily create your own projects.
- HOW TO MAKE WALKIE TALKIES.** \$5.00. Describes equipment for low-power handheld operation. 112 pages of must reading for the dedicated experimenter.
- ELECTRONIC CALCULATOR USERS HANDBOOK.** \$3.95. Presents formulae, data, methods of calculation, conversion factors & more from the view of the calculator user.
- LINEAR IC EQUIVALENTS AND PIN CONNECTIONS.** \$8.25. Shows equivalents & pin connections of a popular user-oriented selection of linear IC's.

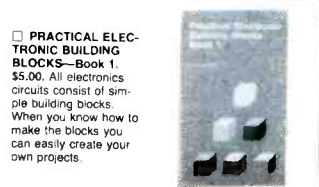

- PRACTICAL ELECTRONIC BUILDING BLOCKS—Book 2.** \$5.00. Circuits that process signals. Combines with those in Book 1.
- SPECIAL OFFER Book 1 & Book 2 PRACTICAL ELECTRONIC BUILDING BLOCKS.** \$9.00. Shipping Included. Save \$1.75.
- RADIO CONTROL FOR BEGINNERS.** \$4.50.
- ELECTRONIC GAMES.** \$4.50.
- SINGLE IC PROJECTS.** \$4.25.
- RADIO CIRCUITS USING IC'S.** \$4.50.



- ANTENNA PROJECTS.** \$5.00. Covers practical antenna designs including active, loop & ferrite types that are easy & inexpensive to build.
- RADIO STATIONS GUIDE.** \$4.75. Comprehensive listing of transmitters around the world. Presents location, frequency, power.
- LONG DISTANCE TV RECEPTION (TVDX) FOR THE ENTHUSIAST.** \$5.00. Practical & authoritative introduction to this unusual aspect of electronics.
- CB PROJECTS.** \$5.00. A number of useful and interesting designs for CB accessories. Speech processor. Interference filter & more.
- CRYSTAL SET CONSTRUCTION.** \$4.50. Packed full of easy to duplicate designs for crystal radio receivers.
- AN INTRODUCTION TO RADIO DXING.** \$5.00. Listen in your home, to broadcasts originating thousands of miles away. Tells how you can do it.

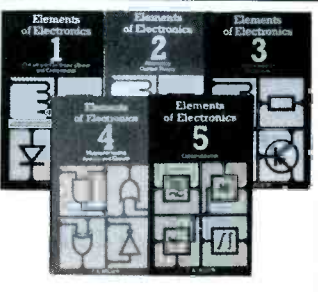

- THE SIMPLE ELECTRONIC CIRCUIT & COMPONENTS.** \$5.75. All the fundamental theory needed to lead to a full understanding of the simple electronic circuit and its components.
- ALTERNATING CURRENT THEORY.** \$5.75. Alternating current theory without which there can be no comprehension of speech, music, radio, or television.
- MICROPROCESSING SYSTEM & CIRCUITS.** \$7.50. A truly comprehensive guide to all of the elements of a microprocessing system.

**ELECTRONIC TECHNOLOGY TODAY INC.**  
P.O. Box 240, Massapequa Park, NY 11762

AN5

Number of books ordered

Total Price of Books ..... \$ .....

Sales Tax (NY State Residents) .....

Shipping (75¢ 1st two books, 30¢ ea additional) .....

TOTAL ENCLOSED ..... \$ .....

Name \_\_\_\_\_

Address \_\_\_\_\_

City \_\_\_\_\_ State \_\_\_\_\_ ZIP \_\_\_\_\_

# Radio-Electronics

Copyright © Glenview Publications Inc., 1988

## SPECIAL REPRINT BUILD A BACKYARD SATELLITE TV RECEIVER

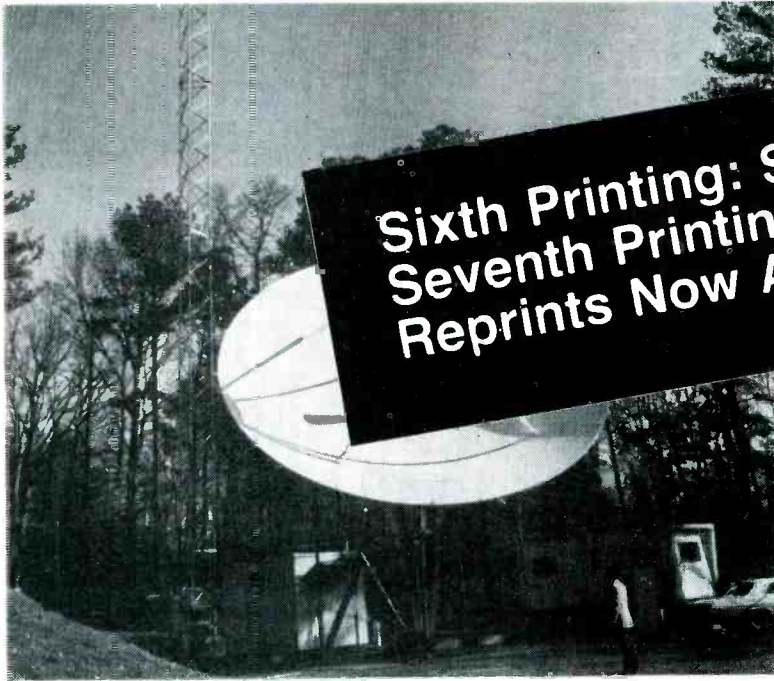

## Don't miss out again!

Send away today for your 36-page booklet containing a complete reprint of all seven articles in the series on Backyard Satellite TV Receivers by Robert B. Cooper Jr.

This all-inclusive report gives you all the data you need to build your own Backyard Satellite TV Receiver.

- TELLS ALL ABOUT domestic satellite communications, with full details on how you can pull those elusive TV signals from space.
- LEGAL REQUIREMENTS, technical specifications, and how you, the

home constructor, can meet them. Find out what mechanical and electronics skills you need.

■ RECEIVER CHARACTERISTICS, technical details and specifications, along with examples of actual receivers built at comparatively low cost.

■ ANTENNA DESIGN... and exactly how you can build a spherical antenna, while keeping total earth-station cost for the complete system under \$1,000.

■ THE FRONT END is critical when you build your own system. We help you explore several different ap-

proaches to making one that will work for you.

■ RECEIVER-SYSTEM hardware, and how it goes together to bring you direct-from-satellite TV reception in your own home.

To order your copy: Complete coupon and enclose it with your check or money order for \$7.00, plus \$1.00 for postage and handling. We will ship your reprint within 6 weeks of receipt of your order. All others add \$4.00 for postage. New York State residents must add 58c sales tax.

**Radio-Electronics**

Satellite TV Reprints  
45 East 17th Street  
New York, N.Y. 10003

Please print

AN5

(Name)

(Street address)

(City)

(State)

(Zip)

I want \_\_\_\_\_ reprints @ \$7.00 each, plus \$1. Handling & Postage.  
I have enclosed \$ \_\_\_\_\_. N.Y. State residents must add sales tax.

# ONLY NRI GIVES YOU TOTAL COMPUTER SYSTEM TRAINING

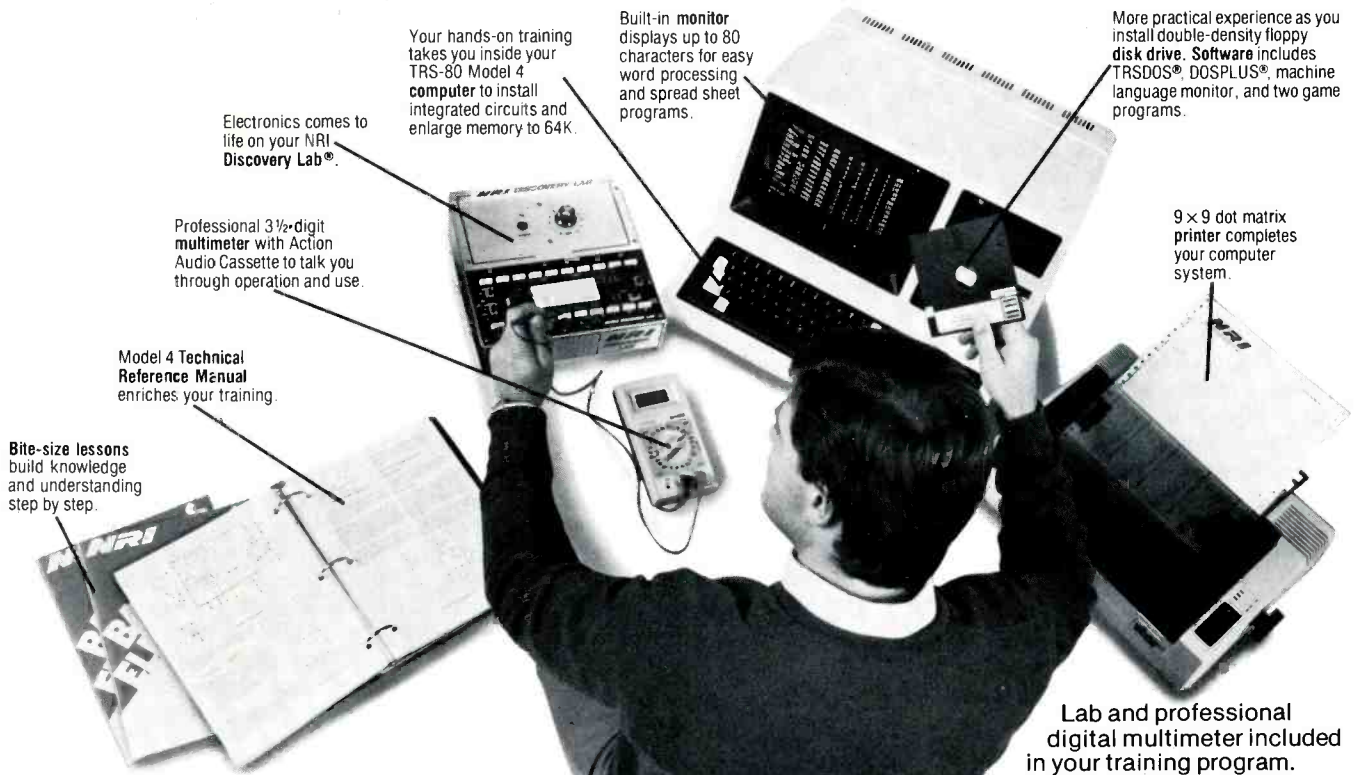

**COMPUTER • MONITOR •  
DISC DRIVE • PRINTER  
• AND SOFTWARE...**

**It's all included with NRI at-home training in Microcomputers and Microprocessors. And only with NRI training.**

If you really want to learn how to work on computers, you have to learn how to work on computer systems. Only NRI includes a complete system with your training... total training that gives you hands-on experience with computers, peripherals, and software. Training that builds the knowledge, skill and confidence you need to become a computer professional.

## **Get Inside the Famous TRS-80 Model 4 Computer**

Learn programming techniques for troubleshooting... go inside to expand its RAM to a powerful 64K... even install a double density floppy disc drive.

You'll become familiar with computer languages... BASIC, the most popular microcomputer programming language, and machine language for diagnosis and repair work. You'll run software that demonstrates computer operation, even learn to do your own programming. You'll become proficient at modifying programs to fit your business or family computing needs.

## **Add High Performance Peripheral Printer**

Only NRI gives you a total system training by including the flexible Gemini 10X printer as part of your hands-on learning. Working with it, you'll get practical experience in adding peripherals, learn maintenance and servicing operations. And you'll use it for hard copies of important programs, business records, and word processing.

## **Understanding Built On Experience**

You start with the basics, rapidly build on the fundamentals of electronics with bite-size lessons to master advanced concepts like digital logic, microprocessors, and computer memories.

You'll reinforce this new understanding with hands-on, practical demonstrations and experiments that give you real-world experience and build almost intuitive skills. You'll use the exclusive NRI Discovery Lab® to see what makes transistors tick, build and test working electronic circuits that duplicate key computer circuitry, construct digital logic circuits that demonstrate computer performance. And, you'll probe into the very heart of your computer using the Discovery

## **Do It at Home in Your Spare Time**

NRI trains you in your own home at your convenience. You learn at your own pace, backed at all times by your own NRI instructor and the entire NRI staff of educators and engineers. They're always ready to answer questions and help you over the rough spots to keep you moving toward your goal.

## **Free Catalog Tells Much More... Send Today**

See all the interactive training equipment you get in this state-of-the-art course in today's technology. Look over the lesson outlines and descriptions of the exciting experiments you'll perform. And look at other high-tech career fields like Robotics, TV/Video/Audio Servicing and Data Communications.

Mail the postage-paid card today to see how NRI can give you the skills and confidence you need to start a good-paying career as a microcomputer technician. If the card has been used, please write.

# **NRI** SCHOOLS

**McGraw-Hill Continuing Education Center**

3939 Wisconsin Avenue, N.W.  
Washington, DC 20016

**We'll give you tomorrow.**

(TRS-80 is a trademark of the Radio Shack division of Tandy Corp.)



## EQUIPMENT REPORTS

continued from page 14

can be powered from either the 117-volt line or from a 12-volt negative-ground DC supply such as found in a car, truck, or boat. To simplify mobile installation, a DC power cord is included. Also included is a detachable telescopic antenna.

The unit is compact, measuring  $10\frac{3}{4} \times 2\frac{7}{8} \times 8\frac{3}{8}$  inches, and weighs  $2\frac{3}{4}$  pounds. It is housed in a brown plastic case, with a simulated wood-grain finish.

Turning to the receiver itself, it is a double-conversion, superheterodyne circuit. It receives narrow-band FM communications over three bands: 30–50, 144–174, and 440–512 MHz. The unit boasts a sensitivity that varies by frequency from 0.7 to 1.5  $\mu\text{V}$  (12 dB Sinad, maximum), and a selectivity of  $\pm 7.5$  kHz at 6 dB and  $\pm 18$  kHz at 50 dB.

### Use

Aside from an ON/OFF switch and VOLUME and SQUELCH slide controls, all functions and frequencies are entered

using a front-panel keypad called the Program Panel. (As you would expect in a unit of this type, except for the one used as a reference, there are no crystals. Instead, a microprocessor-controlled frequency synthesizer is used.)

The keys on the Program Panel are grouped into two types: the mode keys and the program keys. The mode keys are used to place the unit in one of its various modes. They are also used to activate or deactivate the unit's special features and to control the built-in alarm clock. The program keys are used for entering frequencies and for selecting the channel number during programming.

Frequencies, channel numbers, and the time of day during periods that the unit is turned off, are displayed on a blue vacuum-fluorescent readout. In addition, the readout can display a variety of prompting messages to alert the user to a particular condition. For instance, if the frequency entered is not within one of the bands that the unit covers, a FR ERR message is displayed. Also, a variety of annunciators are used to alert the user to which special functions and features are active. Finally, the brightness of the display can be con-

Regency										Z30
OVERALL PRICE										
EASE OF USE										
INSTRUCTION MANUAL										
PRICE/VALUE										
	1	2	3	4	5	6	7	8	9	10
	Poor			Fair			Good			Excellent

trolled using the DISPLAY DIM key.

The unit has three primary modes of operation: search, scan, and manual. The search mode is used to find new frequencies. To use that mode, the PROGRAM key is pressed and upper and lower search limits are entered. Once that is done, the search is initiated by pressing the SEARCH key. The band of frequencies selected is then searched continuously in 5-kHz (VHF) or 12-kHz (UHF) increments.

Once you have found a frequency of interest, it can be entered into the unit by placing it into the manual mode. Entering frequencies is a very simple operation. It involves merely pressing the MANUAL key, entering the frequency using the program keys, pressing the ENTER key, and finally entering the channel (from 1 to 30) that you want the frequency stored in.

After you have programmed the frequencies of your choice, they can be scanned automatically by using the scan mode. That mode is entered by pressing the SCAN key.

The Z30 has several special functions that are designed to give the unit maximum flexibility. In the scan mode, you may want to delay the resumption of scanning after activity on a channel has ended so that you might hear a reply that might otherwise be missed. Pressing the DELAY key causes the unit to pause for about 2 seconds before resuming the scan. In the search mode, the DELAY key is used to select between a 4-second delay and a hold function. If the hold function is selected, the unit will remain on a previously active frequency until either the SEARCH or DELAY key is pressed. (Note that pressing the DELAY deactivates the hold function.)

Other special functions include a priority mode that lets you sample a favorite frequency every two seconds during the scanning process. Channel 1 has been set aside for that function. A channel-lock-out feature lets you force the scanner to skip over any channel that you select.

The manual that accompanies the unit is, as you would expect, pretty much just an instruction manual. It covers the operation of the unit in step-by-step fashion, but has little in the way of technical details such as theory of operation, schematics, parts lists, or parts-placement diagrams.

continued on page 127

## WHY SPEND A FORTUNE ON A DIGITAL CAPACITANCE METER?

The MC100A comes completely assembled and calibrated and at \$79.95 is an outstanding value. The extensive range of 1 pF to 9,999 uF (no external meters required) and true hand held portable size (only  $4\frac{3}{4}'' \times 2\frac{1}{2}'' \times 1\frac{1}{2}''$ ) make the MC100A an extremely practical and easy to use instrument for the hobbyist technician or engineer.

### CHECK THESE OTHER FEATURES

\*Basic accuracy 1% ( $\pm$  one count) on pF, nF ranges, 3% ( $\pm$  one count) on uF range.

\*Uses single 9V battery (not included).  
\*Decimal points light up when battery is low or when capacitor is overrange.

\*Full 4 digit high efficiency LED display uses special circuitry to save on batteries.

\*Constructed with a tough impact resistant plastic case.

### ONE YEAR PARTS & LABOUR WARRANTY



**DAETRON**  
SUITE 105  
1748 MAIN STREET  
BUFFALO, N.Y. 14211  
(416) 255-9701  
DEALER ENQUIRIES INVITED



1 pF to 9,999 uF

**\$79.95**

Now we can detect a breast cancer smaller than this dot.

At such an early stage, your chances of living a long, healthy life are excellent. But we need your help. The only proven way to detect a cancer this small is with a mammogram. A mammogram is a low-radiation x-ray of the breast capable of detecting a cancer long before a lump can be felt. If you're over 50, a mammogram is recommended every year. If you're between 40 and 50, or have a family history of breast cancer, consult your doctor. In addition, of course, continue your regular self-examinations.

American Cancer Society

### PLEASE SEND ME

\_\_\_\_ (Quantity) MC100A(s) @ \$79.95 U.S. \$ \_\_\_\_\_

SHIPPING AND HANDLING \$2.75 (per instrument) \$ \_\_\_\_\_

I ENCLOSE CHECK  MONEY ORDER  BILL MY VISA TOTAL \$ \_\_\_\_\_

VISA CARD NO. \_\_\_\_\_

EXPIRY DATE \_\_\_\_\_ SIGNATURE \_\_\_\_\_

Immediate shipping on orders with money orders or VISA.

Personal checks please allow 2 to 3 weeks for clearance.

NAME \_\_\_\_\_

ADDRESS \_\_\_\_\_

CITY \_\_\_\_\_ STATE \_\_\_\_\_ ZIP CODE \_\_\_\_\_

CIRCLE 210 ON FREE INFORMATION CARD

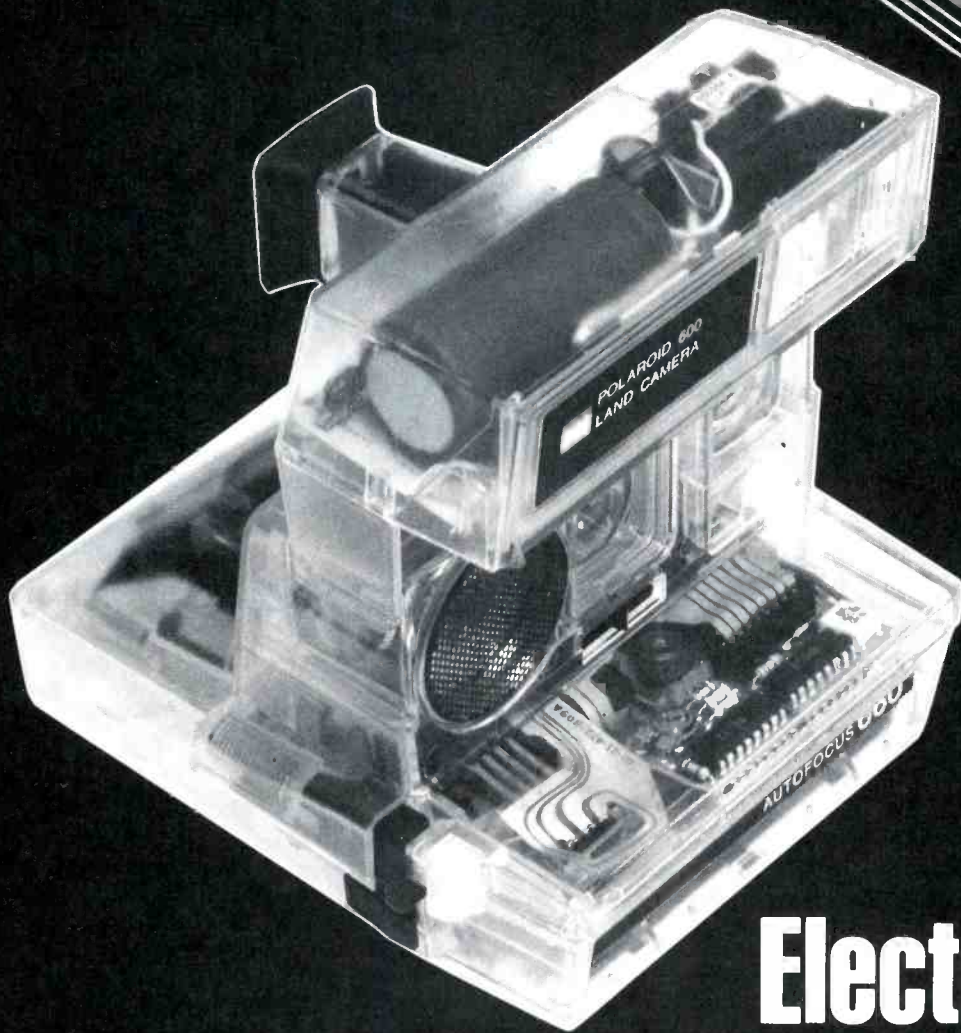

# Electronics and Photography

MARC STERN

*Picture taking—and all areas of photography—have benefited from the introduction of electronics into the equipment used. In this special section we'll examine some recent advances in this area.*

WHILE MANY CAMERAS ON THE MARKET TODAY LOOK MUCH the same as cameras some 25 years ago, they are hardly in the same class. Cameras today are "smart." All a photographer has to do is bring the camera up to his eye and press the shutter release. No longer does he have to worry about whether a scene is too bright or too dark. Photosensors take care of reading the brightness of a scene, setting the exposure, and even activating strobe circuits if extra light is needed.

Some cameras on the market even save the photographer from worrying about focusing. Instead, using sonar or one of several infrared rangefinding-techniques, they determine the camera-to-subject distance and cause the lens to be focused for the photographer in a fraction of a second. There are cameras available from Kodak, Polar-

oid, and other companies that have this feature.

All these cameras allow the photographer what is known as "decision-free" photography, freeing him to be creative. In other words, it's point-and-shoot photography, just as in the days of the box Brownie, but now the cameras are far more sophisticated and the results are much better.

In fact, the whole picture-taking process is far simpler, because "decision-free" photography also extends into the realm of accessories. There are now light meters on the market that do virtually all the thinking for the photographer. He no longer has to spin dials or match needles; instead, a liquid-crystal display gives him all the information he needs.

It's much the same with strobe units, too. Instead of letting the photographer worry about distances, lens openings, and other factors that can affect a flash exposure, dedicated strobe units communicate directly with the camera, presenting exposure information through the accessory "hot shoe." The camera's logic circuitry handles the input from the strobe and sets the correct exposure. If a strobe is not designed to connect directly to the camera, it will present its information on an LCD display so the photographer just has to dial it in.

Further, using photosensors, the strobe will determine when it has delivered enough light, and then shut itself off.

"Decision-free" photography even extends to the darkroom, where the photographer will find microprocessor-driven enlargers that remember correct exposure settings. There are also digital color-analyzers that interface with enlargers and set the correct color-filter combinations. That leaves the photographer free to create. (For the photographer who likes more control of things, there are still manual adjustments that can override the settings determined by the microprocessor.)

### How we got here

To be fair, some cameras were fairly automated a few years ago, but they still required a great deal of work on the part of the photographer. For example, light meters have been an integral part of cameras for years. However, they have usually required the photographer to handle either setting the aperture or shutter speed, or both, himself. In the late 1960's, an advanced camera might have had a match-needle system that determined the correct exposure. The photographer had to change aperture or shutter speed settings until the needle was centered. The needle was electrically actuated, but mechanically linked to the camera's aperture- and speed-setting mechanisms.

Autofocus, too, was available some years ago, but the apparatus using it was large and clumsy.

What has changed the picture? Integrated circuits. If a camera or accessory manufacturer had tried to make today's type of camera 10 or 15 years ago, it probably would have been as large as the photographer himself. However, as circuit-integration technology headed from small scale through medium- and large-scale and up to very-large-scale, more and more components could be squeezed into a single device. Today, for instance, camera manufacturers are relying on 42-pin and 48-pin flat-pack type integrated circuits to perform the information processing they need. Those circuits accept information about film and lighting conditions and their preprogrammed logic determines what actions to take.

For example, imagine that a photodiode positioned in the camera's viewfinder finds that the light level is too low for available-light photography. It therefore sends a message to the master logic-circuitry that indicates a low-light situation. The logic circuitry, after receiving the message, activates the driver circuitry for the electronic flash, and the strobe fires automatically when the shutter release is pushed. Thus, the photographer never has to think about when to use the strobe because the camera makes the decision for him. That's just one example of what goes on inside the body of a modern camera.

Imagine trying to do that with the discrete componentry of 10 or 15 years ago. The camera would have been enormous! Yet, as a look in any photo store or catalogue will tell you, many automatic cameras—some of them sophisticated 35mm

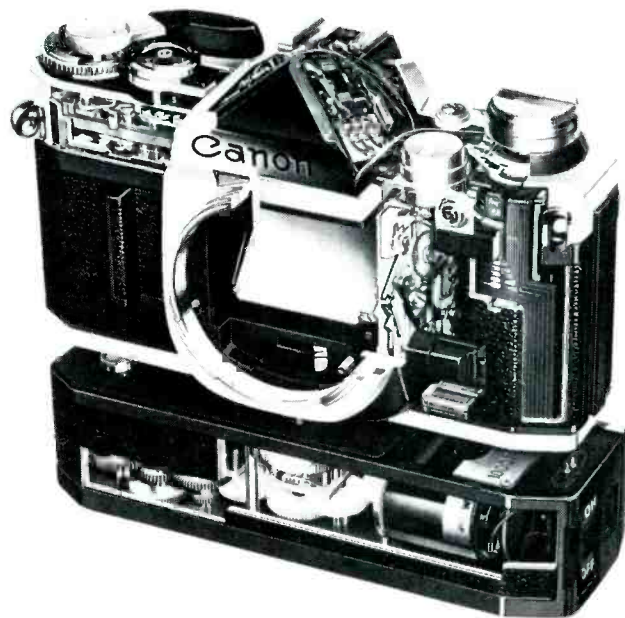

Although cameras are getting more and more complex, the electronics they contain make them easier to use than ever.

devices—are small enough to fit in a photographer's shirt pocket. If large-scale-integration techniques hadn't been used, that would have been impossible.

### All-electronic photography

And, while changes have been taking place in camera and photographic accessories, the photographic medium, too, is changing. While recent developments have improved film quality while reducing the amount of silver used in making that material, silver is still expensive, and not getting any less so.

It's possible, though, that in the near future the photographer won't even need silver-halide-based film. Instead, *totally* electronic photography will take its place. The concept has been admirably demonstrated in Sony Corp.'s Mavica photographic system.

Borrowing heavily from video and recording technology—and creating quite a bit of its own—Sony has developed a completely film-free system. Its Mavica camera, a marvel of electronic technology, is very little larger than the standard 35mm film camera with which we are all familiar. But, while it looks normal enough on the outside, things are very different inside. It still uses a lens, but rather than focusing the photographic image on the film plane, the image is focused on a solid-state high resolution charge-coupled device. The resulting electrical signal is then processed and recorded on a miniature floppy disk, a miniature version of the sort used by computers.

The images stored on the disk can be viewed on a TV screen when the disk is inserted into a special player; as is the case with videotape, the pictures can be viewed instantly. Yes, it's true that you can get instant pictures from Polaroid or Kodak cameras, but you have to keep buying film for them; the Mavica's "film" can be reused.

If you decide you want to save a special photo for the family album, the Mavica system includes a printer that can make a color print on ordinary paper in five minutes. You can even send a Mavica picture by telephone; imagine how that could speed up news reporting!

Because the Mavica system is all-electronic, it may be possible in the future to integrate Mavica photos with microcomputer technology and write letters with your word processor that include pictures for Grandma.

These are only a few of the ways that electronics is affecting the world of photography. For a fuller description of what's happening, please continue reading.

R-E

# The all-electronic MAVICA

*Sony has developed a photographic system that does away with film completely. To do so, its engineers had to create an entirely new technology.*



MARC STERN

FOR NEARLY 160 YEARS, SINCE THE DAY NICEPHORE NIEPCE exposed a piece of silver-bromide-coated glass to the sunlight and ended up with a picture of his yard, we have relied on silver-based materials for photography.

With the shortages of the last few years, we have begun to realize that natural resources are finite and will one day run out. Silver is one of those natural resources, and as it has become increasingly harder to find and process, its price has increased. That has resulted in a corresponding increase in the cost of silver-based products, including those used for photography, and has led photographic researchers to search for new ways of taking snapshots.

One of the avenues into which they have turned is electronics, and the result is in all-electronic still-photo system from Sony Corporation (Sony Drive, Park Ridge, NJ 07656) called the Mavica System.

Mavica stands for *M*agnetic *V*ideo *C*amera, and it combines electronics and electromagnetic technology into a non-silver-based photographic system. First introduced two years ago, though not yet marketed, it represents a potential giant step in the history of still photography. Imagine a press photographer in the field hurrying a photo disk, not to a lab, but to a telephone, and almost instantly sending his pictures back to a newspaper or wire service.

Or, how about an amateur photographer taking pictures of a birthday party? Instead of having to send the his film out for photofinishing, he can load the results of his work into a Mavipak viewer for instant viewing on a home television-set, and can then use a Mavigraph printer to produce as many prints as he

needs on the spot. In that way, party-goers can have instant souvenirs of their party.

Let's look at the basic Mavica system, beginning with the camera.

## The Mavica camera

Figure 1 shows the Mavica camera. About the same size as a conventional 35mm camera, about the only thing the Mavica has in common with one is its optics. Inside, they are as different as day is from night.

Instead of using a roll of film, the Sony camera uses a Mavipak recording disk—constructed much like the floppy disks used by microcomputers—to store pictures. The image produced by the lens is focused onto the face of an integrated circuit called a CCD (Charge-Coupled Device), which converts it into electrical energy. That energy is converted into a signal that can be recorded on the magnetic disk, which is capable of holding 50 pictures.

The Mavica acts much like a video-recording system. It uses the same general principles but, instead of using a vacuum tube for image conversion, it uses a CCD. Most video terminology can be applied to it.

The CCD is an 11 × 12.1-mm integrated-circuit chip with an image area of 6.6 × 8.8 mm. It is the heart of the Mavica system.

The resolution of the CCD is high—the image formed by it consists of an array of 570 × 488 pixels (a pixel is a picture element). The signal generated on the image area is sent to a storage area on the chip during the vertical blanking-interval. In

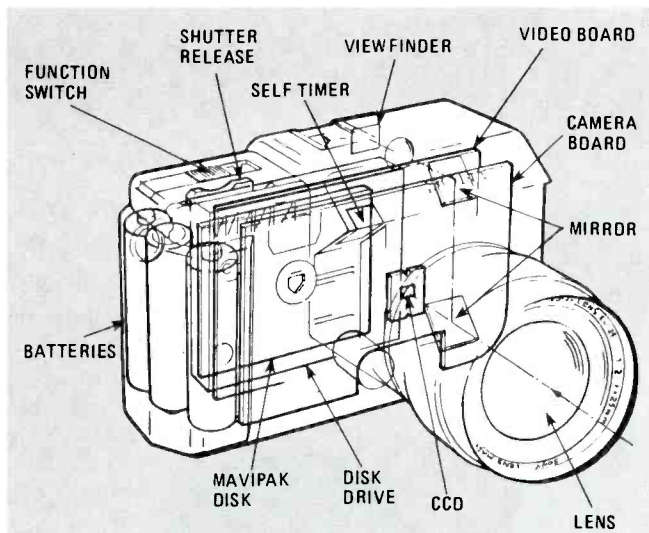

FIG. 1—THE MAVICA CAMERA is about the size of a large 35mm camera but has little in common with it save for its shape and optical system—it is entirely electronic.

response to a clock pulse, the image is then read out of the storage area into a readout register after the vertical blanking-interval. Color filtering is handled by a filter with red, green, and cyan stripes.

The Mavica's CCD was designed to take advantage of the "narrow-channel" effect—when the width of a MOS transistor electrode is narrowed to about 2 micrometers ( $\mu\text{m}$ ), a change in electric potential can be produced across it if it is excited by light. The small size of the channels means that the CCD can have simple, densely packed, image-sensing cells. The uncomplicated geometry also means that the driving circuitry can be reduced to simple two-phase clocks, and that the power requirements are low.

With the light falling directly on the CCD unit, its spectral response (sensitivity to a wide range of colors) is high. To counteract "blooming" (image degradation caused by excess electrons spilling from one sensor cell to its neighbors), an overflow drain was added to the chip; Sony claims that the drain causes only an insignificant reduction of sensitivity.

### The Mavica disk

In the standard photographic process, the storage medium is silver-halide-coated film. The film captures the image, and is later developed to make the latent image visible. However, in the Mavica system, images are recorded on a magnetic-material-coated disk, the Mavipak (see Fig. 2), which is inserted into the camera.

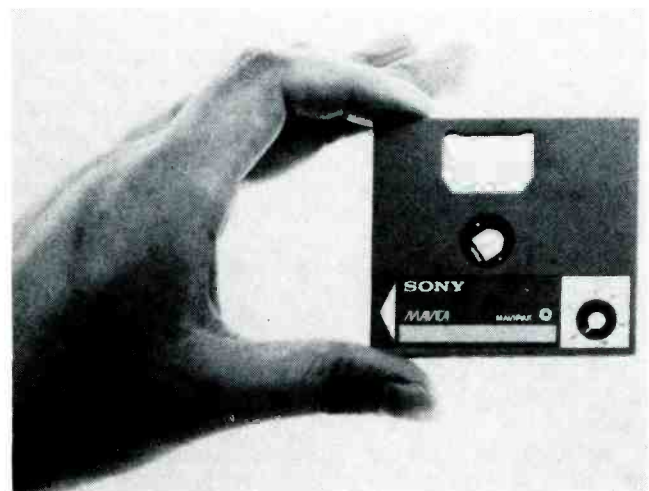

FIG. 2—THE MAVIPAK DISK measures only about two-inches square, yet can store 50 pictures.

The Mavipak is inserted into a disk-drive unit that revolves at a speed of 60 revolutions-per-second. A compact motor that is controlled by servo-circuitry ensures that the speed remains constant.

One would think that due to the high speed of the disk's rotation, there would be some stability problems, but Sony claims otherwise. Because of its small size, the disk is only minimally affected by aerodynamics or centrifugal force. Any tendency for the video disk to move away from the recording head is limited by a guide plate. Instead, because of the position of the guide plate, an air cushion is formed that helps keep the disk-to-recording head relationship constant at 0.07 micrometers as shown in Fig. 3.

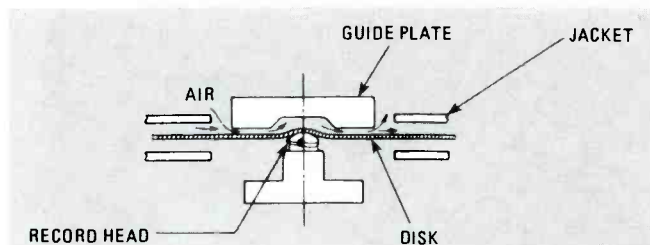

FIG. 3—A SPECIALLY DESIGNED GUIDE PLATE uses air pressure to keep the Mavipak disk in contact with the record head.

Since that arrangement ensures stability, there is no need to have other pressure exerted to bring the head and disk together, and that, in turn, ensures a considerably longer working life for the recording disk.

Head-to-track alignment is also very important, and is a must for quality picture-reproduction. If the head and track being recorded or read are not within  $\pm 10 \mu\text{m}$  of one another (a lateral measurement), the signal-to-noise ratio becomes too high and quality deteriorates. However, Sony admits in published papers that that figure is hard to achieve (it has been found that temperature variations alone can cause the figure to vary by as much as  $\pm 30 \mu\text{m}$ ) and has been accommodated for by tracking-error-correction circuitry incorporated within the playback unit.

Like a computer's floppy disk, the Mavica's recording medium is a circular sheet of thick plastic film, coated with a magnetic material. It is housed in a plastic jacket measuring about  $2\frac{3}{8} \times 2\frac{1}{8} \times \frac{1}{8}$  inches, and the entire assembly weighs only eight grams (a little over  $\frac{1}{4}$  ounce).

Because the magnetic Mavipak disk is erasable, it can be used over and over again.

The first image is recorded on the outermost track of the disk, with subsequent images recorded on tracks closer and closer to its center.

To keep the size of the disk small, Sony engineers had to develop a high-density recording method. To obtain the best possible magnetic characteristics, the development team turned to a ferromagnetic metal alloy—similar to that used in high-quality audio cassettes—rather than using a metal-oxide powder. That coating meant an 8-dB improvement in output level, and permitted the use of a disk half the size of a metal oxide one.

However, that development is only half the picture. To achieve true high-density recording, the surface of the disk must be extremely smooth. Smoothness helps limit modulation noise and the losses resulting from the short wavelengths used for recording. The Mavipak disk is able to boast a 0.05-micrometer peak-to-peak smoothness. The magnetic characteristics of the disk are extremely even—output level along a track varies by no more than  $\pm 1 \text{ dB}$ . The result of Sony's efforts is a disk that can record wavelengths of  $0.8 \mu\text{m}$ —equivalent to signals with a frequency of 3.75 MHz.

### Signal processing

The concepts embodied in the Mavipak system go a long way toward ensuring that picture quality will be good. But there are



other necessities, Sony has found.

To produce high-quality, reproducible images, it is necessary to have luminance and chrominance signals with good resolution and a good signal-to-noise ratio. Accomplishing that is not easy because, due to the limited space available within the Mavica, the circuitry cannot be too complex.

To keep things simple, the Mavica uses a single-track, line-sequential recording system; instead of being recorded simultaneously, the R-G and B-G signals are mixed separately with the luminance-plus-sync signal, and recorded one after the other. That, Sony admits in published technical papers, causes some deterioration in the vertical resolution of the chrominance signal. But, while the amount of deterioration is on the order of 50 percent, it is not noticeable because the horizontal resolution, determined by the one-MHz bandwidth of the chrominance signal, is still less than the vertical resolution. Other single-track recording methods were dismissed because of potential jitter problems that would have led to hue fluctuations.

The recording circuitry is pretty straightforward. When a photographer using a Mavica camera captures a scene, the image of that scene is converted by the CCD into an analog electrical signal. That signal is then broken down into four components—luminance, red, green and cyan—by sample and hold circuits. The green and cyan circuits are used to produce the blue signal and all of them are then fed to processing amplifiers.

The processing amplifiers output the processed luminance, red, green, and blue signals, with the luminance signal then being added to the sync signal and fed to a frequency modulator.

The red, green, and blue signals take a path through a matrix circuit and are then converted to color-difference (R - G and B - G) signals. From that point, the signals are selected line-sequentially and are then fed to a second frequency modulator.

The two signals are passed through low- and high-pass filters to narrow their bandwidth and are then fed to the recording amplifier. It is that final signal that is recorded on the disk.

Those functions are handled by specially developed LSI IC's and hybrid modules.

### The Mavica player

The final part of the basic Mavica system is the playback unit, which converts the signals recorded on the disk into a picture that can be viewed on a television receiver. The playback head of the player is analogous to the record head in the Mavica camera. However, while the record head can only move from track to track from the outside toward the center of the disk, the playback head can move from one track to another in either direction; that allows pictures to be accessed at random.

As was mentioned earlier, the tracking error induced in the Mavica camera can be sizeable. The microprocessor-controlled tracking-error-correction circuitry incorporated in the player works by sensing where the RF signal is strongest on the disk

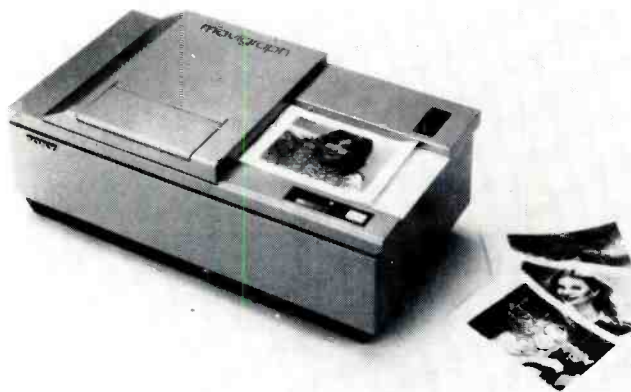

FIG. 4—THE MAVIGRAPH PRINTER can produce a color print from the Mavica or other still-video source in about five minutes.

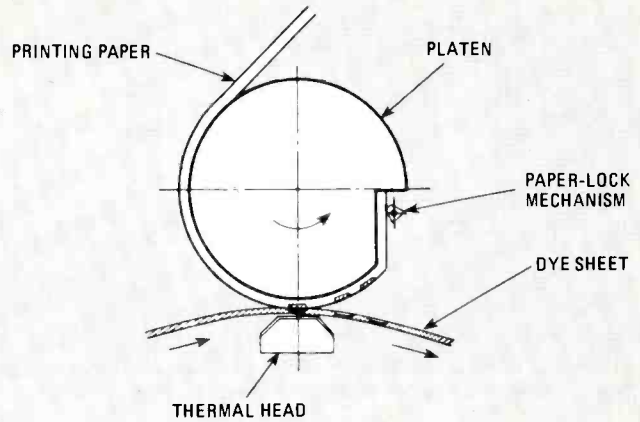

FIG. 5—IN THE PRINTING PROCESS the paper, wrapped around a platen, is brought into contact with a series of dye sheets and the thermal elements that transfer the dye to it.

and maintaining the playback head in that position.

Each track on a Mavipak disk contains one picture consisting of 262.5 video lines. That's the equivalent of one video field; two fields make up a complete video frame of 525 lines. Because the Mavica pictures are still pictures, each track is played over and over as the picture is viewed. To generate a standard full-frame NTSC video signal, several sets of delay lines are used in the player. One set takes the line-sequential chrominance information and restores it to NTSC format; one  $\frac{1}{3}$ .3- $\mu$ s delay line and two 63.5- $\mu$ s delay lines are used for that purpose.

To generate a 525-line picture, every other field is synthesized from the information contained in the 262.5-line recorded fields.

The horizontal resolution (the resolution in the horizontal direction—not the number of horizontal scan-lines) of the Mavica picture is 240 lines; that figure is due primarily to the number of picture cells on the CCD imaging element. The recording capability of the Mavica disk is approximately 350 lines (horizontal resolution), which means that we may see a considerable improvement in picture quality in the future.

### The Mavica printer

Although the Mavica system represents a breakthrough in "filmless" photography, it would be of little value if it were limited only to viewing photos on a television receiver or monitor. Recognizing that, Sony has also developed the thermal color video printer shown in Fig. 4.

It is capable of taking the color output-signals from the Mavica—or any other color-video system—and turning those signals into color prints. It can accept either composite-video or RGB (Red-Green-Blue) signals.

The Mavigraph, as the printer is called, uses a thermal dye-transfer system. As shown in Fig. 5, a sheet of paper—which can be ordinary writing paper, although a special polyester-coated type gives better results—is wound over a platen. A thermal printing-head is pressed against the platen so the paper and a sheet of material containing dye come into contact with each other. As the platen and the printing paper turn together, the dye sheet is drawn at the same speed over the printing head. The intensity of the heat produced by the print head—which determines how much dye will be evaporated and transferred to the paper—is controlled by the level of the video signal.

Four colors are used in the printing process: yellow, magenta, cyan, and black (these are the same colors used to print the covers and color pages of this magazine); they are the printing equivalents of the video signal's blue, green, red, and black, respectively. Each color is contained on a separate dye-sheet, and the colors are transferred sequentially, in the order indicated above. First, the entire yellow portion of the print is produced. Then the platen carrying the paper returns to its original starting position and the magenta portion of the print is laid down... and

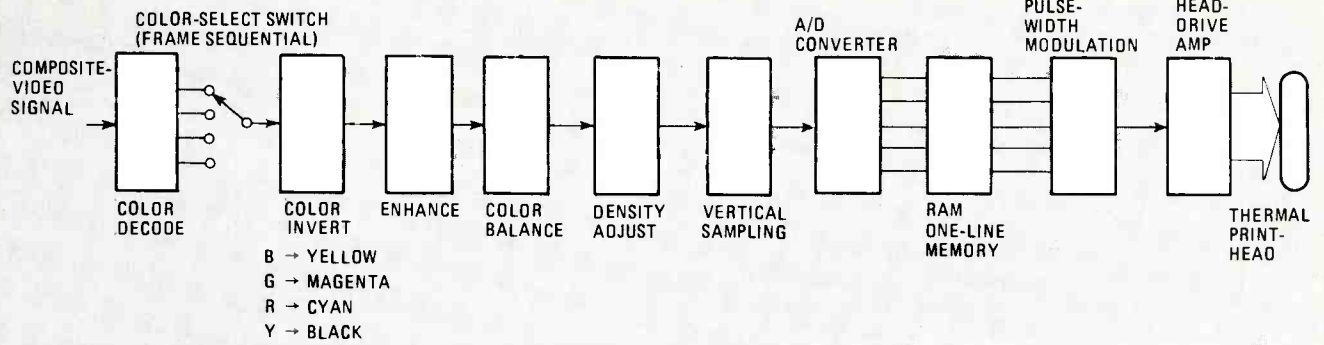

FIG. 6—TO MAKE A MAVIGRAPH PRINT, the video chrominance (blue, green, and red) and luminance signals are inverted to produce their opposites—yellow, magenta, cyan, and black.

so forth. For black-and-white prints, only the black dye-sheet is used. The flow of the printing process is illustrated in Fig. 6. In some versions of the printer, the dyes are contained, one after another, on a single piece of material wound into a roll. The finished print is laminated in plastic both for protection and to enhance the image.

The printer scans the video image vertically—from top to bottom across the scan lines—rather than horizontally (along the scan lines) as you might expect, and the picture is reproduced on paper from left to right. It takes about five minutes for a complete print to be produced.

The thermal print head used in the Mavigraph contains a row of 512 elements—four per millimeter—to produce a picture measuring  $4\frac{1}{4} \times 6\frac{1}{3}$  inches. The compactness of the print head is due to 16 special IC's, each of which contains a 32-bit shift/store register and 32 drivers.

The Mavigraph can be used to produce any number of color prints of a still picture taken by a Mavica or a video camera, or of a single frame or field of an image displayed by any video device, including a television receiver, computer, or VTR.

A home-video camera can be used to convert existing color film negatives or positives into video signals suitable for reproduction by the Mavigraph. The fact that the amounts of red, green, and blue in the print can be controlled allows the Mavigraph user to adjust the color balance of his prints to his taste, and to experiment with unusual color-effects. Sony expects to open an entirely new market for the combined use of conventional photography and electronic Mavigraphy.

This printer and the system it supports have been termed a new era in video technology that adds a new dimension to video. For instance, the system can be used to produce hard color-copies from signals received from teletext or videotex systems. It can also be used as an image printer for an x-ray machine, CAT scanner, or other medical equipment. It can even serve as a terminal printer for office computers and as a color facsimile printer.

How will that be done? Sony's engineers have done some thinking about the matter, and have come up with a system they believe will work. It's much like an amateur radio slow-scan television setup, except that it works via telephone.

### Photos by phone

Settling on transmission using amplitude modulation, the Sony engineers designed a system (the receiving end of which is illustrated in Fig. 7) that links a transmitting unit and a receiving unit via phone circuits. The system also includes memory storage-devices because of the transmission-time constraints imposed upon it by the phone system.

It takes about  $63 \mu\text{s}$  to display one horizontal line on a TV screen. However, because of the telephone system's limited bandwidth, it takes about 400 ms for the information contained by that same line to be transmitted over a telephone line. That means that some sort of memory buffer must be used to store and transmit each line as the system can handle it. A similar situation holds at the receiving end, except that the entire picture is captured in the receiver's buffer. As each line is received, it is read out, along with the lines that have already preceded it into the buffer, and becomes part of an image displayed on the receiving television set's screen via high-speed video processing circuitry.

Since the system uses voice-grade telephone lines, the analog signal transmitted must be able to fit within the restrictions they impose. The engineering team looked at the various means of modulation—amplitude, frequency, and amplitude-phase—and decided to use double-sideband AM for reliability.

The engineers also had to keep the system's maximum bandwidth in mind when defining their parameters. Using a maximum range of 300 Hz to 3400 Hz as boundaries, Sony's engineers chose an 800-Hz image frequency and a 1500-Hz carrier frequency for best transmission quality, recognizing not only the limitations imposed by the phone system, but also the potential for fluctuations in level, for line noise, and for system leakage.

The video output of the Mavica is sampled at a rate of about 14 MHz and digitized. The digital information is read into memory and is then read out at a much slower rate—2.2 kHz. After digital-to-analog conversion, a signal suitable for telephone-line transmission is obtained.

One problem with magnetic-reproduction devices (like the Mavica playback unit) is jitter. While it is not apparent on a TV screen, it is something better done without. To eliminate the

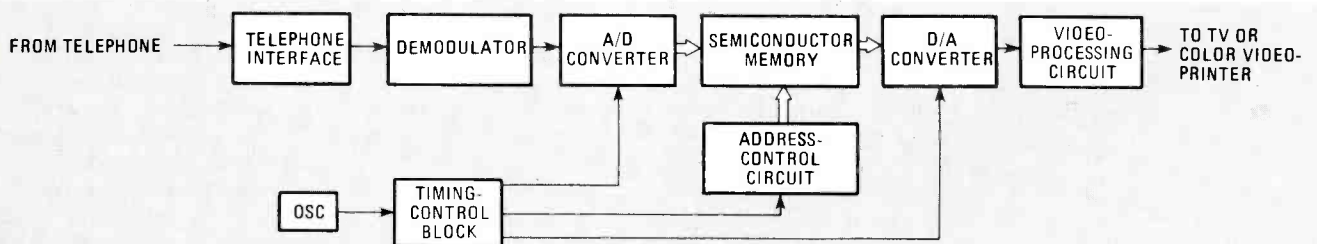

FIG. 7—THE TELEPHONE-LINE RECEIVER converts the slow incoming analog information to digital form so it can be stored, then converts it back to a high-speed analog signal for display.

continued on page 78



# The New Disc Cameras

*In this article we'll look inside Kodak's new disc camera—a good example of how electronics have made the picture-taking process easier than ever.*

**MARC STERN**

THE EARLY ADVERTISING CLAIM OF EASTMAN KODAK, "You push the button; we do the rest!" is now more true than ever. When Kodak was designing their new disc camera, their intention was to develop a decision-free photo system. And thanks to the miniaturization allowed by the continuing advances in microelectronics, that camera maker has been able to produce small but sophisticated snapshot cameras that allow the photographer to simply aim and shoot. While other camera manufacturers have followed Kodak and are producing their own disc cameras, we will discuss only those from Kodak.

What are the features of the disc cameras? There are four models from which to choose: the 3000, 4000, 6000, and 8000. Essentially the four models are the same, but they differ in some features and, of course, price. (The models' price range is from \$56.95 to \$142.95.) Let's first look at the features that all models have in common; then we will look at the differences.

Each model has a 4-element,  $f/2.8$ , 12.5-mm, fixed-focus (four feet to infinity) lens. Each also has two automatic exposure settings. The flash is built in and operates automatically when

needed. Without the flash, pictures can be taken every 0.4 seconds. With the flash, that increases to about one second, due to the flash-capacitor charging time. There is no exposure indicator needed and the film advance is automatic. Needless to say, all four models use disc film.

Now that we've seen the similarities, let's look at the differences between the four disc camera models. First, we'll look at "extra" features. Both the 6000 and 8000 have a close-up lens (18 inches to 5 feet) that is simply slid (with a lever) in front of the normal lens. A close-up indicator is seen in the viewfinder when that lens is chosen. All of the models have a metal carrying strap, but the 6000 and 8000 also have a protective handle/cover that covers the entire front of the camera. (It can also be used to stand the camera up.) Only the 3000 is not powered by two 3-volt lithium batteries. Instead it uses a replaceable 9-volt alkaline battery. In the other models, the lithium batteries are considered to be an integral part of the camera and, as such, are covered by the five-year warranty.

The 8000 has three features that none of the other models have: a motor drive that permits rapid firing by holding down the shutter button; a 10-second self timer (with flashing LED and audible beeper), and, located in the cover, a digital alarm clock with its own power supply.

## Nothing could be easier

Before we look at the electronics inside of the Kodak disc cameras, let's take a look at how you would operate one of them. The first step, of course, is to load the film. The film-loading

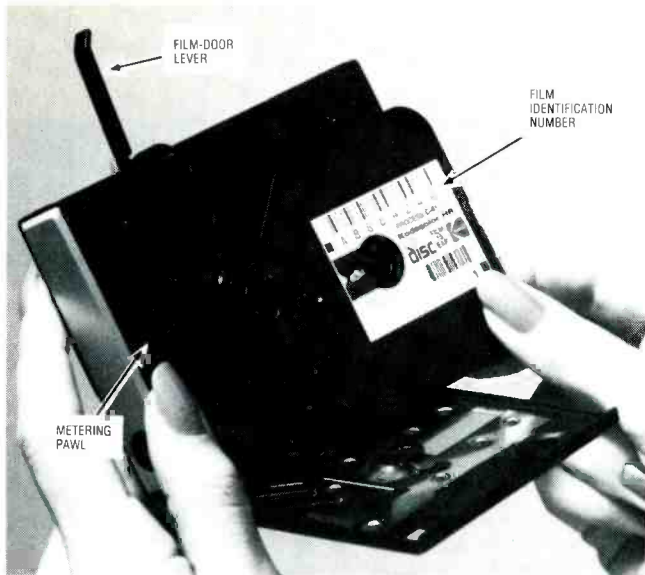

FIG. 1—THE DISC CAMERA might be the easiest-loading camera yet.

process consists of lifting a lever which locks and unlocks the camera door, then dropping the disc film in place, as shown in Fig. 1, and then closing and locking the film door.

That is a pretty simple method of doing things, and the film can be inserted in only one direction. However, that simple action launches an intricate interplay between camera and film as a complex locking and disc-engagement sequence begins. When the disc is inserted into the camera, teeth on the core of the film disc engage lugs in the camera. Those lugs drive the film and work in conjunction with notches in the film and a *metering pawl* in the camera to automatically position individual negatives for exposure.

Locking the camera door actuates a lever in the camera which rotates the disc's *dark slide*. That slide protects the undeveloped film from light. When the camera is opened, the dark slide is swung back into its protective, locked position.

With the camera ready for action, the photographer opens the lens cover, places the camera to his eye, looks through the viewfinder, and presses the shutter button.

### Decision-making electronics

We could say that it is at this point that the electronics developments enter the picture. But that's not really true. Actually, the electronic process is initialized when lens cover or the cover/handle is opened, or when the shutter button is lightly touched. Those actions "wake up" the camera's electronics and start the charging of the flash-capacitor.

The major portion of the disc camera's electronics is contained in two custom IC's—the *light-sensing IC* and the *control IC*. Those IC's and the rest of the camera's circuit board is shown in Fig. 2. We'll look closer at those two IC's in a little while. First, though, let's take a look at what they and the rest of the electronics do.

Figure 3 is a simplified flowchart of the camera operation. Although we would like to show the complete decision-making process, that flowchart is simply too big. Also, the flowchart for the model 8000, because it contains a rapid-sequence mode and a self timer, is quite complex. Therefore our simplified flowchart does not cover the 8000. Also, to avoid confusion, we will say here that for the rest of the article, unless we specify otherwise, we will be referring to the model 4000.

The electronic process begins when the lens or camera cover is opened. When that happens, switch S1 in the camera is closed, and power is applied to the circuit board. (Figure 4 shows some of the camera's switches and their locations and Table 1 lists the functions of those switches.) That starts the "wake-up" routine and initializes the DELAY 8 routine. (That is one of several delay times that are used by the camera in its

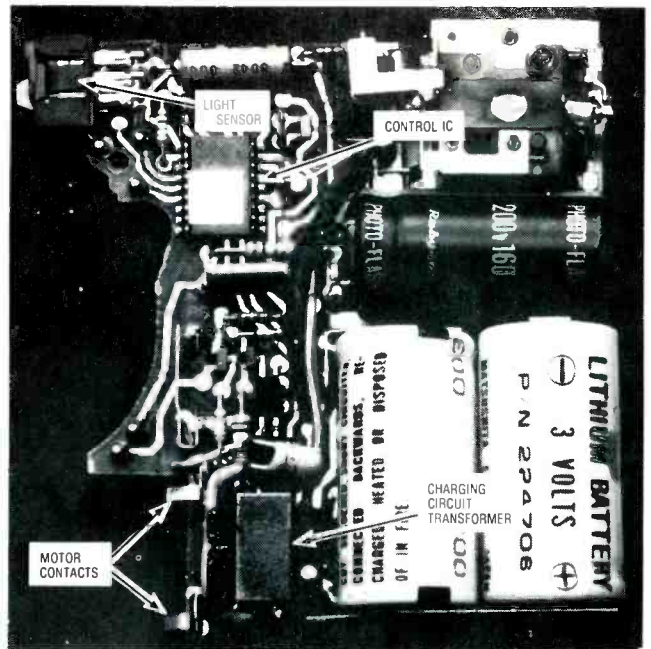

FIG. 2—COMPONENT SIDE of the disc camera's circuit board.

TABLE 1

Switch	Function
S1	Power switch. Actuated by camera cover or lens cover.
S2-a	Soft-touch shutter switch. Starts wake-up.
S2-b	Shutter switch. (Shutter button must be fully pressed.) Starts picture-taking cycle.
S3	Synchronizes flash with opening of shutter.
S4	Tells control IC when film advance should start and stop. This switch is open when the metering pawl is extended (in a film perforation).
S5	Works in conjunction with S4 to tell control IC when the film is finished.

decision-making process. All of the delay times are listed in Table 2; their function will become clear as we discuss them.) The DELAY 8 routine is the maximum time allowed for a camera cycle to occur. After that time, the camera will automatically go into its battery-conserving "doze" mode. For example, if you push the shutter button with no film in the camera, the motor will run for only 2.4 seconds. As you can see from the flowchart, the 18-pin Kodak-designed control IC is also activated (S1 is closed) whenever the shutter button is lightly touched.

We should take some time here to talk about the shutter switch. The contacts for that switch can be seen in Fig. 4. Unlike

TABLE 2

Delay time	Function	Model 4000 6000	Model 8000
1	Delay for measuring exposure	10 ms	12.8 ms
2	Maximum time to top-off flash charge	716 ms	1 sec
3	Protects against S4 bounce	3.36 ms	3.36 ms
6*	Self-timer: 1-second interval for beeper/flashing LED	—	7.37 sec
7	Total time for self timer	—	9.83 sec
8	Maximum time allowed for picture-taking cycle	2.4 sec	3.2 sec

\*Delay-times 4 and 5 are not presently used by Kodak.

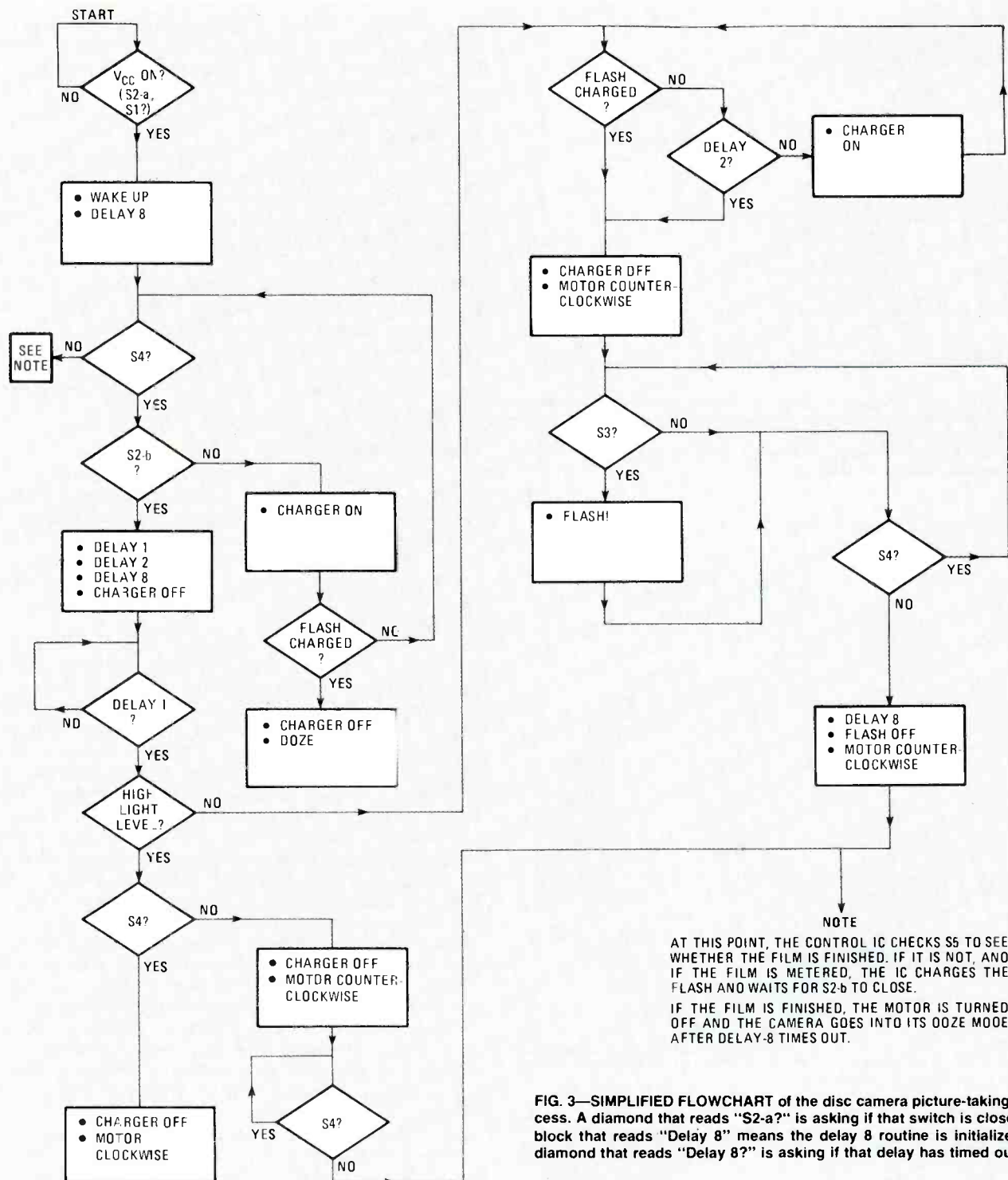

**FIG. 3—SIMPLIFIED FLOWCHART** of the disc camera picture-taking process. A diamond that reads "S2-a?" is asking if that switch is closed. A block that reads "Delay 8" means the delay 8 routine is initialized. A diamond that reads "Delay 8?" is asking if that delay has timed out.

most cameras, the switch is electronic, not mechanical. Actually it's a bit unfair to say that—the switch was well engineered mechanically. Whenever it is even just lightly touched, S2-a closes and the charging circuit tops off the capacitor charge. Because most people usually rest their finger on the shutter before they actually press it, S2-a is an almost fool-proof method of keeping the flash circuit ready to shoot.

After the camera is in its wake-up mode and the flash capacitor is charged, the next thing the control IC does is to check S4—the switch connected to the metering pawl. That switch lets the control IC know whether or not the pawl is in one of the film's perforations. If the film is metered (if the pawl is in a perforation), then S2-b, the shutter button is checked. If the switch is not closed, the control IC will charge the flash capacitor, if necessary, and will then put the camera into the shutdown or doze mode.

### Pushing the button

However, if the shutter button is fully depressed (thus closing S2-b), the camera shifts into its "photo mode." As shown in the flowchart, the control IC first initializes various delay times and the flash charger is turned off. Next, the camera has to decide between a high- and low-light state. During DELAY 1, the control IC checks the output of the photo-sensor IC. That IC measures the ambient light level and acts as a comparator, determining whether or not the light is above 125 fL (footlamberts—a unit of luminance).

If the output of the photo-sensor IC indicates that the light level is above the 125-fL level, the control IC initiates the high-light mode. The charger is turned off; and the motor is turned clockwise. The clockwise motion of the exposure cam, which is driven by the motor, sets the shutter speed to 1/200 second; sets the aperture to f/6; cocks the shutter, and then snaps

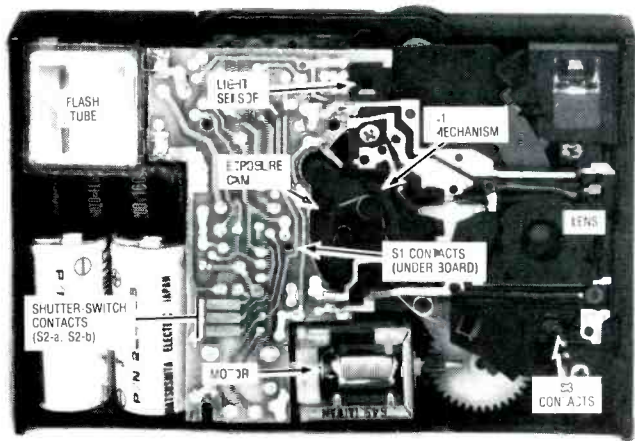

FIG. 4—THE DISC CAMERA consists not only of electronics. Various mechanical sensors are essential for its operation. Don't open your disc camera to look at them, though. First, you will probably damage the camera and void your warranty. Second, you might damage yourself—the flash capacitor is a very real shock hazard.

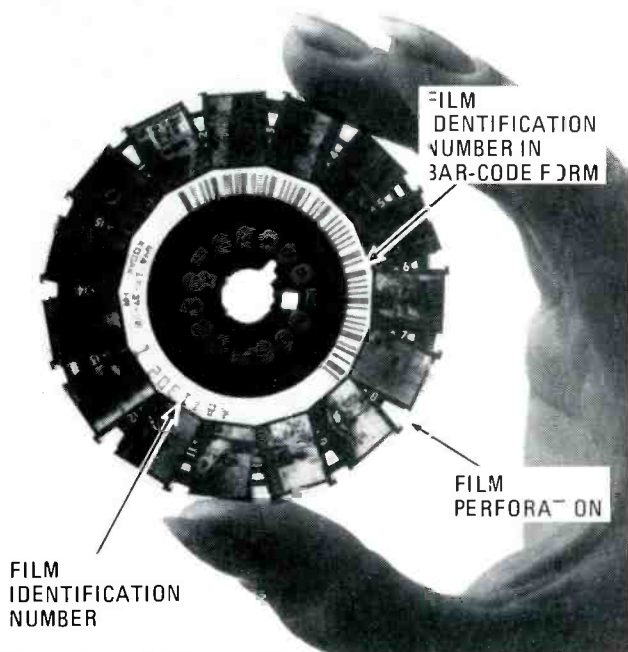

FIG. 5—A DEVELOPED FILM DISC. Note that each frame is numbered. That makes ordering reprints very easy.



FIG. 6—THIS CONSOLE lets the operator encode information in the disc's magnetic core. That information can be read automatically by special printers.

the shutter. The last thing that the exposure cam does in its cycle is to pull the metering pawl out of the perforation in the film. That is important—as you can see in the flowchart, when the pawl is out of the film perforation, the control IC knows that the picture has been taken. It then orders the motor to turn counterclockwise to advance the film.

If the light level is below 125 footlamberts, then the light-sensing IC sends that information to the control IC. That initiates another series of actions—the low-light mode. First the charge on the flash capacitor is checked until either the charge is sufficient or until DELAY 2 has timed out. Then the charger is turned off and the motor is turned counterclockwise. This time, however, turning the motor counterclockwise does not advance the film because the metering pawl is still in one of the film perforations. Instead the counterclockwise motion of the exposure cam sets the shutter speed to about 1/100 of a second and opens the aperture of  $f/2.8$ . Next the control IC looks at S3. That switch is closed whenever the shutter opens and is used to trigger the flash.

### After the picture

After commanding the motor to turn, the control IC checks S4. (Remember, the last thing that the exposure cam does in its cycle is to pull the metering pawl out of the film perforation. That closes S4.) When that switch closes, it indicates that the picture has been taken. The control IC then turns off the charger and drives the motor counterclockwise to advance the film.

### Two custom IC's

As we mentioned previously, the major portion of the camera electronics is contained in two Kodak-designed custom IC's. Let's look first at the control IC.

The control IC is an LSI integrated-injection logic (I<sup>2</sup>L) integrated circuit. That type of logic was used because it allows combining both power and logic control on the same device. (About one half of the chip's area contains power transistors.) When the camera's motor is running, the control IC's output drivers can sink up to two amps and dissipate over 1.5 watts. On the other hand, when the camera is in its doze mode, the IC uses only 90 microwatts. If a more familiar approach, such as CMOS technology, was used, both power control could not have been included on the single IC. Thus, using I<sup>2</sup>L helps keep costs, size, and power consumption to a minimum.

The control IC contains an on-chip voltage regulator. That's necessary because during the picture-taking cycle, the battery voltage varies (from 2 to 8 volts) as the motor is used. Also on the chip is a 10 kHz clock. As you can see from our discussion on the delay times, that clock, plays a very important role in the decision-making process of the disc cameras. In the 8000, it also controls the self-timer. That includes flashing an LED and pulsing a beeper—and doubling the flashing/pulsing frequency about 2.5 seconds before the exposure.

The light-sensing IC measures the ambient light level and sends a one-bit output to the control IC to tell it whether or not the light level is over 125 fL. The photometer and the threshold-detection circuitry are on the same chip. That helps to reduce the chance of electrical noise causing an error.

The clock in the control IC and the detect circuitry in the light-sensing IC are both *wafer calibrated*. That means that the chip is modified while it is still in wafer form. That helps to reduce costs because it eliminates the need for further calibration in the camera. It also helps to achieve better quality control.

Once you've finished taking the pictures, the electronics processes don't stop—they continue during the photofinishing process. On each film label and on the disc itself (see Fig. 5) is a bar code pattern called the film identification number or FID. And the film core is magnetic—styrene impregnated with iron oxide. That means that instructions can be recorded there to be read by special photofinishing equipment. Figure 6 shows a console that prepares disc negatives for reorders. Reprint quantities, frame number, and even color/density corrections can be recorded on the film's magnetic core.

R-E

# Auto exposure and Auto focus Systems

*Autofocus and auto-exposure systems have revolutionized modern photography. In this article we'll look at those systems and see how they've made picture taking simpler than ever imagined.*

MARC STERN



HAVE YOU EVER STOPPED TO THINK ABOUT HOW PHOTOGRAPHY has changed over the past few years? For one thing, taking a picture, even under adverse conditions, has become simpler than ever. Powerful electronic circuits provide so much control over the various camera functions that essentially all a photographer has to do is focus and shoot. And, with some cameras he doesn't even have to focus; that chore is handled for him by an autofocus system.

All this has been made possible by the microelectronics "revolution" and the resulting development of LSI (Large-Scale-Integration) techniques. Using LSI technology, camera manufacturers have been able to combine many control functions on a single IC. The result is a generation of "cameras that think."

Highly sophisticated electronics can be found in everything from "simple" snapshot cameras to professional photographic equipment. One example of the state of the art in 35mm photography is the Minolta (101 Williams Drive, Ramsey, NJ 07446) X-700 system. It offers just about every camera feature currently available and consists of the camera itself, an autoflash, a motor drive, a multifunction back, and a wireless remote control. We'll discuss those accessories shortly, but first let's look at what makes this camera so special.

The X-700, shown in Fig 1, features a new faster-speed-priority program-mode, plus an aperture-priority auto mode and a metered/full-manual mode. Those modes allow a photographer the choice between automatic and manual picture taking.

In the program mode, the camera automatically selects both aperture and shutter speed for the best exposure. The system

logic is designed to maintain the fastest possible shutter speeds as light dims. If the shutter speed will be  $\frac{1}{30}$  second or slower, the camera will give an audible signal (assuming that feature is switched on) to warn the photographer that blur from subject/camera movement is possible.

In the aperture-priority auto mode, the photographer sets the aperture manually and the camera automatically sets the best shutter speed.

In the metered/manual mode, the photographer can take advantage of the X-700's through-the-lens center-weighted averaging meter system, while maintaining full manual control over the exposure setting. When using that mode, both the shutter-speed and the aperture can be varied to achieve any desired effect.

All important information is displayed in the viewfinder. Simply placing your finger on the touch-sensitive shutter release begins metering and activates all of the viewfinder displays; the displays remain active for 15 seconds, or for however long your finger remains on the button.

In the program mode, a green "P" lights in the viewfinder above the shutter-speed scale. Red LED's along the shutter-speed scale indicate which shutter speed is being set by the camera. Because the shutter-speed settings are stepless, if two LED's light, the shutter speed is between the two indicated values. The minimum aperture of the lens you are using appears in the aperture window at the bottom of the viewfinder (that is not necessarily the aperture at which the picture is taken). The lens should be set at its minimum aperture in the program mode. If it is not, or if a non-Minolta MD-type lens is used, the green "P" in the viewfinder will flash. That indicates that the cam-



FIG. 1—THE MINOLTA X700 represents the ultimate in autoexposure technology and flexibility. It features a program mode in which both the aperture and the shutter speed are determined by the camera, an aperture-priority automatic mode, and a fully metered manual mode.

era's range is reduced, and brighter subjects can not be accommodated. New Minolta MD lenses can be locked at their minimum aperture.

Similarly, a red "A" lights above the shutter-speed scale to indicate when the camera is set in the aperture-priority automatic mode. Once again, LED's light along the scale to show which shutter speed is being set by the camera. The lens aperture that you select is clearly visible in the window at the bottom of the viewfinder.

In the metered manual mode, a red "M" lights in the viewfinder, the aperture setting is shown at the bottom of the viewfinder, and an LED lights next to the shutter speed that will provide proper exposure according to the light metered through the lens. Note that this is not the actual shutter speed; both the aperture and the shutter speed must be set manually, and either setting can be adjusted without affecting the other, affording maximum flexibility.

The camera also has two features that allow for more creative control and better results when using automatic exposure-setting under unusual lighting conditions. The  $\pm 2EV$  exposure adjustment allows you to vary the automatic exposure setting up to more or less two *f*-stops from normal in the program and automatic modes. When that feature is used, a  $\pm$  LED blinks in the viewfinder. The auto-exposure lock feature is useful when the subject makes up but a small part of the total picture. It is especially useful, for example, if your subject is in the shadows but his background is strongly lighted. Normally, the camera would be "fooled" and set its exposure by the bright light—but not with the auto-exposure lock. When that feature is used, the subject is metered at close range and the AE-lock switch is pressed down. While that switch is held down, all you have to do is move back, recompose the picture, and then release the shutter.

In-the-viewfinder indicators of the status of the autoflash are also displayed when that unit is attached. Among the information available is whether the flash is fully charged, insufficiently charged, or off. In the last two cases, the settings for the ambient light conditions are displayed and, if the shutter is released, those are the settings at which the camera will operate. Once the shutter has been released, another in-viewfinder indication shows if the proper exposure has been made.

### What's inside

The Minolta X-700 uses five integrated circuits. At the heart of the camera is a 32.768-kHz oscillator that provides 1/30,000-second accuracy. The output from that oscillator feeds a 42-pin CMOS IC that controls the timing of most of the camera's functions. Those functions include shutter release, aperture

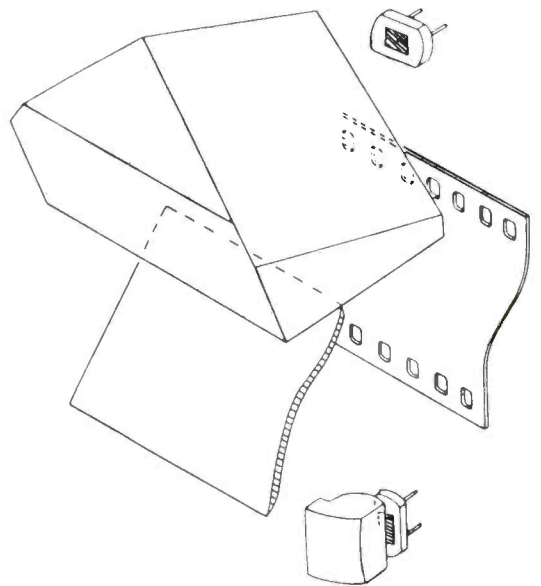

FIG. 2—TWO PHOTOCELLS are used for metering. One, on the camera's pentaprism, measures ambient light. The other, located next to the mirror box, is used for direct autoflash metering.

stopdown, and mirror lift. A 42-pin BiMOS IC handles metering, calculations, and controls. Metering is done through two silicon photocells. One of them, on the camera's pentaprism, measures ambient light, while the other, located next to the mirror box, is for direct autoflash metering (see Fig. 2). The output from the photocells is fed to the BiMOS IC, which amplifies and processes the signal. Of the remaining IC's, a 42-pin bipolar device handles mode selection and program-mode operation; a 44-pin I<sup>2</sup>L (Integrated Injection Logic) dot-display driver handles the viewfinder displays, and a 12-pin bipolar device handles the electromagnetic shutter release and power control.

To better appreciate all of the complex functions that this control system must handle, let's take a closer look at all the steps involved in producing a successful photograph. To keep things as simple as possible, we'll only look at what happens in the program mode.

As we said earlier, in the program mode the camera sets both the aperture and shutter speed, with preference given to using the fastest practical shutter speed. Touching the camera's touch-sensitive operating switch inputs preset camera-setting information and scene brightness into the program-mode circuitry. When the operating button is fully depressed, the camera retrieves a programmed aperture value from the camera's memory based on that information. The aperture is then set, and the light passing through the aperture is re-metered as a final check before shutter operation; sensitive metering and fast reaction time allows the settings to change instantly with changing light conditions. All of that happens in milliseconds.

The camera's electronics also control the flash, when that unit is required. When the flash capacitor is fully charged, a signal is fed from the flash unit to the camera. When the shutter is released, the shutter speed is automatically reset to 1/60 second and the appropriate aperture is determined. After the mirror lifts, the flash emits light simultaneously with full shutter opening so that light reflected from the subject strikes the film surface. The silicon photocell next to the mirror box collects a sample of that reflected light and shuts off the flash at the precise moment for best exposure. A feedback system indicates both in the camera's viewfinder and on the back of the flash whether the exposure was correct.

### Accessories

The Minolta X-700 system includes all of the accessories you would expect to find in such a camera system, and more (see





FIG. 3—ACCESSORIES for the X-700. Of particular interest are the dedicated flash, the multifunction back, and the remote-control set.

Fig. 3). Aside from the wide variety of lenses, motor drives, etc., those accessories include an automatic flash, a multifunction back, and a wireless remote control. We'll next look at those three units and see what makes them special.

We've already looked at the *Electroflash 280PX* autoflash unit a bit. It is a clip-on programmed/automatic/manual flash unit with special contacts for both camera control and through-the-lens, off-the-film flash metering. The flash duration varies between 1/50,000 and 1/1,000-second, depending on light conditions. No adjustments or settings are made on the flash unit itself because that unit receives all needed information, including the speed of the film being used, from the camera.

Perhaps the most interesting accessory for the camera is a unique multifunction back. Containing its own dedicated processing unit, that device mounts in place of the X-700's regular back. What makes it so interesting is that it offers camera-control modes for time-lapse photographs, timed long-exposures, and multi-frame sequences. In addition, it features six data-imprinting modes to be used for identifying and classifying photographs.

A highly accurate quartz clock and auto calendar that runs from 1981 through 2099 imprint the time in hours, minutes, and seconds, or the date. Once set, the calendar will advance, taking into account leap years and differing month lengths. The calendar will also print the date in any order of year/month/day preferred. Other modes imprint any number from 1 through 999,999 for any coding scheme you like, or will sequentially count the frames.

All of that would make that accessory nice in its own right, but there is much more. For one thing, long, unmanned exposure times of up to several hours are possible. Another feature is unmanned interval-photography. That allows the camera to take photographs automatically at pre-determined intervals of between 1 second and 99 hours, 59 minutes, 59 seconds. Once the interval between photographs is determined, the camera is simply set up and left alone. Interval flash-photography is even possible: the multifunction back turns on the flash unit one minute before the interval expires. That feature requires the use of an autowinder or motor drive.

All the special back's functions are accessed and programmed using six keys and a slide switch that are concealed under a cover on the rear of the camera when not needed. The data imprinting is handled by a series of LED's within the back and the interfacing between the back and the electronics of the camera itself is done through three spring-loaded electrical-contact pins.

The last accessory we'll look at is one that is usually associated with cameras costing far more—a wireless-controller set. The set consists of a small transmitter that resembles a spot lightmeter and a receiver that resembles a small flash unit. The

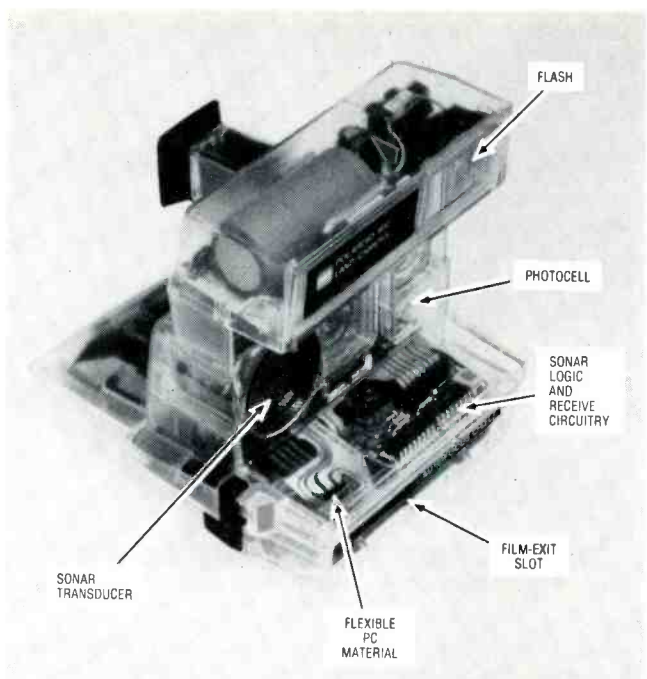

FIG. 4—INSIDE THE POLAROID 660. This autofocus camera uses an active sonar system.

receiver is designed to attach to the camera's accessory shoe, or to a special bracket included in the set.

The wireless control uses near-infrared pulses for communications. That technique avoids problems such as interference and spurious signals so common to radio control. (But the range of the unit can be affected by adverse weather conditions such as direct sunlight or fog and Minolta recommends that operation under actual conditions be checked before any photographs are taken.) Under ideal conditions, communication over distances as great as 200 feet are possible. That communication need not be line-of-sight—the infrared pulses can be bounced around corners or off surfaces. Finally, the unit boasts three independent channels so that up to three cameras, or three groups of any number of cameras, can be controlled independently.

### Autofocus

Autoexposure is just one way that electronics has changed the way we take pictures. There are, of course, others. Consider autofocus, for instance. A few years ago, those circuits were bulky, expensive affairs. With the introduction of integrated circuits and large-scale integration, the autofocus circuitry can now be placed on IC's little larger than a postage stamp; what's more important for consumers and manufacturers alike is that the IC's are not costly to manufacture. Autofocus has thus become common on many relatively inexpensive cameras.

Autofocus systems can be grouped into two classifications: active and passive. In an active system, the camera bounces a signal of some type (usually an ultrasonic tone or infrared pulse) off of an object, and uses the reflection to calculate the distance and set the focus. In a passive system no signal is emitted; the camera judges the distance from the subject using optical and electronic means.

Let's first examine active systems. The principles behind a sonar system, such as that used in Polaroid's (549 Technology Square, Cambridge, MA 02139) 660, should be familiar to most. The camera emits an ultrasonic pulse and measures the time it takes for the echo to return.

Let's take a close look at the 660 (see Fig. 4). When the shutter button on the camera is first pressed, a 50-kHz sound burst is generated by a transducer mounted on the front of the camera. When the sonar echo returns to the camera, it is processed by the sonar logic and receive circuitry, shown in Fig. 5,

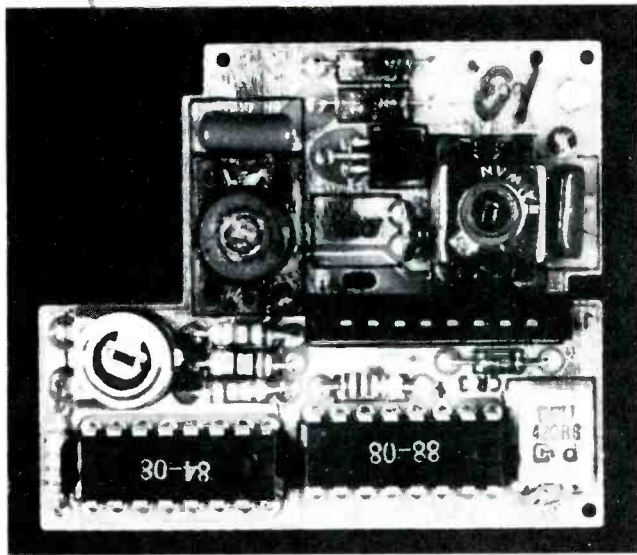

FIG. 5—THIS PC BOARD holds the 600's sonar logic and receive circuitry.

which computes the elapsed time and stores it. From that information, the camera selects the proper supplementary lens (there are four mounted on an internal disc) and rotates it into position, where it is latched and held. With that lens in position, the camera will be properly focused.

At the moment that the disc is latched, a solenoid releases the shutter blade and a silicon photodiode measures the ambient light level. Information from that photodiode is instantly evaluated by the camera's electronics. If the light is greater than 10 candles-per-square foot, the fill-flash mode is selected; at lower light levels, full flash is selected. The flash will fire for all exposures unless manually overridden. As the shutter blades continue to open, the flash fires at the precise moment and at the correct aperture as selected by the camera's exposure-determining logic circuitry. Those factors are determined by the distance between subject and camera. The measured ambient light level is used to determine the duration of the flash, and the distance and the light are used to determine how long the shutter remains open.

The camera's electronics complement consists of the photodiode, an analog circuit that controls the transmission and reception of sonar signals, a voltage-to-frequency converter, a power IC, and the exposure-mechanism logic network.

The camera, including the flash system, is powered by flat batteries developed especially for the 600 series of cameras. Those batteries are part of each film pack.

An active infrared system, such as that used in Kodak's (Rochester, NY 14650) Kodamatic 980L, measures the brightness of a reflected pulse. That system can run into difficulty, however, if the object being photographed is more reflective than average. Fortunately, most objects reflect infrared about the same way, and though the system is not totally foolproof, the slight differences that do occur are unimportant considering the camera's small-aperture lens.

A variation on the infrared technique uses triangulation to determine distance. In that system, the baseline runs between the camera's infrared emitter and detector and the peak of the triangle is at the photographic subject. The distance from the camera to the subject is then found by measuring the base angle of the triangle. That measurement can be done either electronically or mechanically. For instance, a camera might use a set of photodiodes in a rotating mount. That mount is tied to a motor that rotates the diodes until the signals at both are equal. When that happens, it means that both are pointed at the area that reflects the most infrared, which is the object to be photographed. The same motor is also tied to the lens in such a way that it is focused on the area that is indicated by the triangulation. The system described is used by Chinon (43 Fadem Rd., Springfield, NJ 07081) and is shown in Fig. 6.

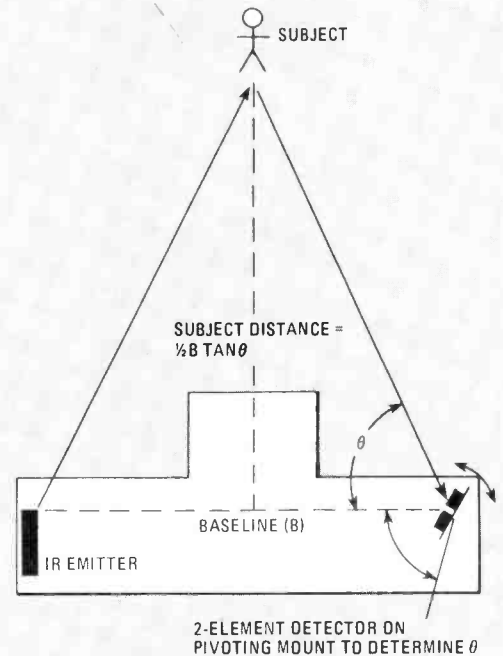

FIG. 6—AN ACTIVE IR autofocus system. This technique, used by Chinon, is based on triangulation.

Turning to passive autofocus systems, most use either triangulation or analyze the image produced by the lens to determine focus.

Passive triangulation systems work much like manual range-finder cameras in that the camera is focused by moving the lens until the two images in the viewfinder correspond. Typical of such systems are Honeywell's (Honeywell Plaza, Minneapolis, MN 55408) *Visitronic* and Canon's (One Canon Plaza, Lake Success, NY 11042) *SST* or *Solid State Triangulation*.

Those systems use arrays of photodiodes to compare the images. Where the systems differ is in how they compare those images. The Honeywell system uses one moving image and one fixed one, much like manual rangefinders. The images are examined by the arrays until they coincide. In the *SST* system, the images are fixed. Two arrays of photodiodes examine the images, and the signals from those devices are analyzed to determine the difference, and hence the distance.

There are two autofocus systems that work by analyzing the image: contrast detectors and focal-plane detectors. Contrast detecting systems, used in cameras such as the Canon *AL-1* and the Pentax (35 Inverness Dr. E., Englewood, CO 80112) *ME-F*, are based on the premise that when the contrast is at a maximum (that is, when the variation in brightness from point-to-point is at a maximum) the image is in focus. Photodetector arrays that are centered around the focal plane, but located at slightly varying distances from the lens, and a microprocessor are used to measure that variation in contrast.

Focal-plane detectors are a bit more complicated, at least in concept. They work on the principle that the light from different points on an out-of-focus subject strikes each point in the film. If those points have contrast (that is if their brightness varies) the aperture will appear to be unevenly illuminated. Conversely, the image will be in focus only if the aperture is evenly illuminated. Thus, to check for focus all that need be done is to use a matched pair of photodetectors to look through opposite halves of the aperture. When both detectors see the same thing, the camera is focused.

From what we've seen so far one thing is clear—that thanks to new advances in microelectronics the nature of photography has changed dramatically. Although it may appear that you're only pushing a button, what's going on inside the camera is making it possible to take pictures under all kinds of conditions with amazing results.

# WITH CIE, THE WORLD OF ELECTRONICS CAN BE YOUR WORLD, TOO.

Look at the world as it was 20 years ago and as it is today. Now, try to name another field that's grown faster in those 20 years than electronics. Everywhere you look, you'll find electronics in action. In industry, aerospace, business, medicine, science, government, communications—you name it. And as high technology grows, electronics will grow. Which means few other fields, if any, offer more career opportunities, more job security, more room for advancement—if you have the right skills.

## SPECIALISTS NEED SPECIALIZED TRAINING.

It stands to reason that you learn anything best from a specialist, and CIE is the largest independent home study school specializing exclusively in electronics, with a record that speaks for itself. According to a recent survey, 92% of CIE graduates are employed in electronics or a closely related field. When you're investing your time and money, you deserve results like that.

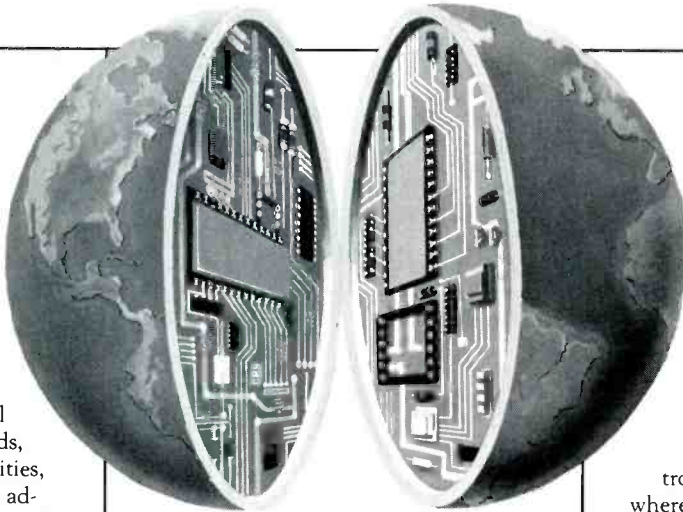

## INDEPENDENT STUDY BACKED BY PERSONAL ATTENTION.

We believe in independent study because it puts you in a classroom of one. So you can study where and when you want. At your pace, not somebody else's. And with over 50 years of experience, we've developed proven programs to give you the support such study demands. Programs that give you the theory you need backed with practical experience using some of the most sophisticated electronics tools available anywhere, including our Microprocessor Training Laboratory with 4K of random access memory. Of course, if you ever have a question or problem, our instructors are only a phone call away.

## START WHERE YOU WANT, GO AS FAR AS YOU WANT.

CIE's broad range of entry, intermediate, and advanced level courses in a variety of career areas gives you many options. Start with the Career Course that best suits your talents and interests and go as far as you want—all the way, if you wish, to your Associate in Applied Science Degree in Electronics Engineering Technology. But wherever you start, the time to start is now. Simply use the coupon below to send for your FREE CIE catalog and complete package of career information. Or phone us at 1-800-321-2155 (in Ohio, 1-800-362-2105). Don't wait, ask for your free catalog now. After all, there's a whole world of electronics out there waiting for you.



## Cleveland Institute of Electronics, Inc.

1776 East 17th Street  
Cleveland, Ohio 44114  
216-781-9400

A half century teaching electronics.



## Cleveland Institute of Electronics, Inc.

1776 East 17th Street, Cleveland, Ohio 44114

RA-05

YES...I want to learn from the specialists in electronics—CIE. Please send me my FREE CIE school catalog, including details about CIE's Associate Degree program, plus my FREE package of home study information.

Print Name \_\_\_\_\_

Address \_\_\_\_\_

City \_\_\_\_\_ State \_\_\_\_\_ Zip \_\_\_\_\_

Age \_\_\_\_\_ Area Code/Phone No. \_\_\_\_\_ / \_\_\_\_\_

Check box for G.I. Bill bulletin on educational benefits:  Veteran  Active Duty

MAIL TODAY!

IF YOU'VE BEEN AN AMATEUR PHOTOGRAPHER for more than just a few years, you probably remember when the state of the art in photo accessories was a strobe unit that was about the size of a hammer and weighed just about as much. They were the ones that also required an outboard 9- or 12-volt battery pack to drive the flash tube. And after a couple of hours of use they felt as if they weighed several hundred pounds.

Obviously, the scene has changed radically today—many cameras, even inexpensive ones, have built-in strobe units that are powered by a couple of penlight batteries. But the serious amateur photographer has available to him “smart” strobes that can communicate with “intelligent” cameras to produce high-quality photos. These smart strobes boast the same light output as their ancient relatives, but they do more, and are much smaller. In fact, some are so small they can literally fit in your shirt pocket with room to spare.

And strobes aren't the only photo accessories that have seen some radical changes during the last 20 years. Remember the old light meters? They were handheld affairs that offered good accuracy, but using one required spinning dials and matching needles.

Today's advanced light meters, while still about the same size as their counterparts from the 1960's, have lost all of their dials and needles. Now built-in microcomputers and LCD readouts make finding the right exposure setting easier than ever.

# Photo Accessories

*Camera accessories have not been left out of the “electronic revolution.” Microprocessors, memories, and LCD's are among the features that you'll see.*

MARC STERN

## Strobe units

Before we look at individual strobe models, let's take a look at what a strobe does, how it works, and some features it might contain.

Some strobe units cannot be adjusted—they flash for a given length of time. They usually contain a “computer” dial. To use them, you first dial in the film's ASA number. Then you can dial in the distance from the subject and read off the *f*-stop you need to use a particular aperture you can dial the *f*-stop up on the calculator dial, and it will tell you the distance that you should be from the subject. When the strobe is used, the camera is set to its *x* position; that sets the shutter speed (usually to about a sixtieth of a second) and causes the camera to close a switch that sets off the flash when the shutter opens.

## Dedicated strobes

There is another type of flash unit called the *dedicated strobe*. When the word “dedicated” is applied to strobe units, it means that that unit is tied to being used with one particular camera—or at least one made by a particular manufacturer. If you want a smart unit—a strobe that communicates with the camera to set

the shutter speed, select a suitable aperture, activate viewfinder information (such as a flash-charge indicator), and control flash duration—then what you need is a dedicated strobe unit.

What makes one strobe setting different from another is not how *bright* the unit fires. Rather, it is the length of time that it fires. With the non-automatic strobe that time is constant, and to obtain the correct exposure you have control only over the *f*-stop setting and the distance from the subject.

Automatic strobes, on the other hand, use a photo cell to “look” at the amount of light that is reflected by the subject. When it determines that it has received enough light for the proper exposure, it then shuts off. An example of a dedicated electronic flash is the *Speedlight 166A*, from Cannon (One Canon Plaza, Lake Success, NY 11042) shown in Fig. 1. It mounts in the accessory shoe of Canon's *AL-1*. When the flash is fully charged, it automatically sets the camera's shutter speed to  $\frac{1}{60}$  second, and a light on the flash tells you that it's ready. The flash gives you a choice of two apertures; it displays them in a window on the back of the flash. The settings depend on the speed of the film that you're using. The distance ranges that are available with the selected *f*-stop are shown on a table on the

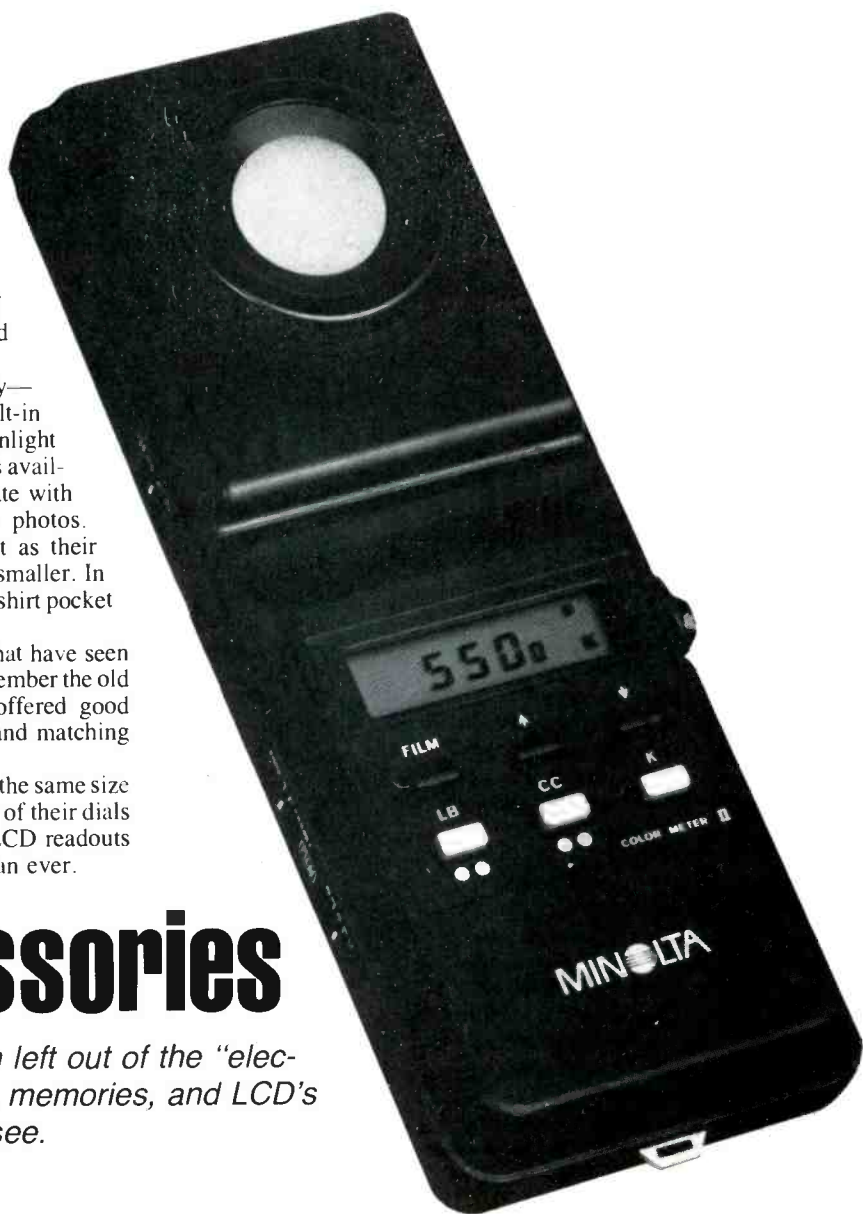



FIG. 1—A DEDICATED ELECTRONIC FLASH. The Speedlight 166A from Canon fires from 1/50,000 to 1/1000 second.

back of the flash unit. When you take the picture, the strobe fires for anywhere from 1/50,000 to 1/1000 second—automatically controlled.

If you want a smart—therefore, dedicated—strobe for your camera, you don't have to be limited to buying one from your camera's manufacturer. Thanks to the flexibility afforded by microelectronics, it is now possible for one manufacturer to build a strobe unit that can be dedicated to a number of different cameras. An example of that is Vivitar's 3000 series of dedicated flash systems. It is designed to work with cameras from the Canon, Minolta, Olympus, Nikon, Pentax, Yashica, and Contax lines, as well as just about any of the other popular single-lens reflex (SLR) cameras on the market—provided that you buy the correct Vivitar dedicated module.

Like many other strobes now on the market, the Vivitar (1630 Stewart St., PO Box 2100, Santa Monica, CA 90406) 3500 uses energy-saving circuitry to keep the flash recycling-time down. On units without that circuitry, when the flash has fired long enough for correct exposure, the rest of the charge on the flash capacitor is "dumped." With the energy-saving circuitry, however, the unused charge can be recycled, thus saving the batteries and reducing the flash charging-time. That means that the flash can sometimes be used with an autowind camera, depending on the distance to the subject. (The farther the distance, the longer the flash has to fire, and thus the longer the recycling time.)

Vivitar's 5600, though, is a better example of an electronically advanced strobe unit. It is shown in Fig. 2. Like the 3000 series, dedicated processor modules are available that let you interface the 5600 to a wide range of popular cameras. Another module is available with a PC cord that allows you to adapt the flash unit to non-dedicated cameras. The feature of this strobe that sets it apart from others is its LCD readout. That readout eliminates confusing calculator dials and mathematical computations—all the information you need to know is displayed in easy-to-read form. Let's take a look at how you would use that strobe, first in its automatic mode. As we discuss the LCD readout, refer to Fig. 3

When you first put the flash unit in its automatic mode, an AUTO indicator is displayed and the unit beeps three times. (That, and all of the unit's audible indicators, can be switched off if silence is necessary.) Then you tell the 5600 the speed of your film (using either ASA or DIN standards). Next you tell the unit the *f*-stop (eight choices from *f*/1.4 to *f*/16) you want to use. The flash range then appears on the display (in either meters or feet) on a bar graph. Also, the maximum distance is displayed



FIG. 2—THE LCD DISPLAY of the 5600 modular flash system from Vivitar makes this unit very easy to use.

numerically. If you change the *f*-stop, the display recalculates the range. The flash duration range is from 1/30,000 to 1/1000 second.

The flash operates a little differently in its manual mode—the most significant difference being that the flash duration is always 1/1000 second (it does not adjust automatically). When switched into the manual mode, the unit signals with three double-beeps. When you program in the *f*-stop, the display shows the distance for the correct exposure. In the manual mode you have a choice of 12 different *f*-stops (as compared to eight in the auto mode). As you change the *f*-stop, the readout changes the display to show the optimum distance to the subject. (In the manual mode the distance to the subject is more critical than in the automatic mode because of the fixed light-output.)

At the heart of the 5600 is a custom microprocessor that drives the LCD display and accepts inputs from the strobe's photosensor unit. This unit not only accepts user inputs, but also compares those inputs against preprogrammed, proprietary logic and derives the display figures. This unit also controls the flash output in the auto mode and contains all the system driver-circuits.

In the AUTO mode, you can check whether or not the exposure selected will work by firing the flash manually (without snapping a picture). If an acceptable picture will result, the AUTO symbol flashes. (An audible signal can also be enabled.) The AUTO symbol will also flash after you take a picture if the amount of light was sufficient for proper exposure.

The LCD also indicates the angle of coverage for the flash head being used. (There is a variety of heads available for the 5600, including a zoom head.)

Special voltage-sampling/timing circuitry also enables the microprocessor to flag weak batteries. If the batteries fail to recycle the unit within 35 seconds, the battery-replacement symbol is activated. (The normal recycle time is less than 12 seconds if alkaline batteries are used, and less than 7 seconds if the optional nickel-cadmium battery pack is used. A "starburst" is seen in the display when the flash is fully charged.) The warning symbol indicates that the batteries can still be used, but that they are in a weakened condition and should be replaced soon.

Like the other strobes in this line, it is possible to use this one with any of the popular single-lens reflex cameras by employing special processor modules. These modules contain the necessary electronics for interfacing the strobe head with the electronics inside the new generation of "intelligent" cameras.

Vivitar isn't alone in offering this type of flash, either. The major camera manufacturers, among them Pentax, Minolta, and Canon, also offer dedicated units that interface with, and take advantage of, the electronic circuitry in their equipment.

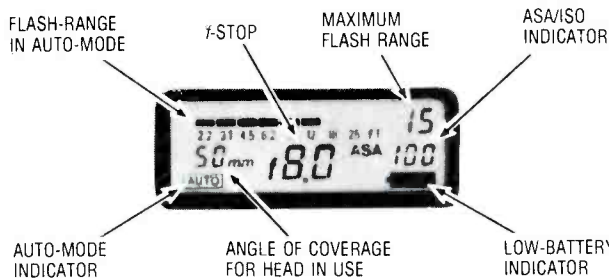

FIG. 3—A CLOSE UP VIEW of the 5600's LCD display shows just how much exposure information it can provide.

## Light meters

Most photographers rely only on their camera's built-in light meter for their exposure measurements. And with the quality of those built-in meters, you might be wondering why anyone would want to use anything else. Serious photographers, however, often *do* want to use an accessory meter. That's because there are many instances when the readings from the built-in meter are too general. And that's why the hand-held light meter is still around. It can help eliminate a lot of the extra exposures and guesswork that often go along with getting just the right shot. But today's light meters are not what they were even a few short years ago.

Before we start discussing how they have changed, let's clarify what we mean by saying that there are situations when should use an accessory light meter. Assume that your subject is standing in the shadows with strong backlighting. Your built in light meter would provide you with an exposure setting based on the overall lighting that it sees, and the resulting picture would be underexposed—the portion you were interested in would be not much more than a silhouette. However, with a hand-held light meter, you could determine the proper exposure setting by measuring the amount of light reflected by or falling on just the subject, and not have to rely on a possibly erroneous overall reading.

This discussion of light meters will not try to be a roundup of manufacturers' products; we just want to give you an idea of what features are available due to advances in electronics. Therefore, we will use one manufacturer's (Minolta's) line as an example.

The first meter we will look at is Minolta's (101 Williams Drive, Ramsey, NJ 07446) *Auto Meter III*, shown in Fig. 4. We find it is built around a custom-built microprocessor, the "brain" of the unit. Its LCD readout makes it easy to use—No longer does a photographer have to twirl dials and match numbers to find correct exposure settings.

A memory in the *Auto Meter III* allows you to store one or two measurements, which can be recalled and compared to the third one being taken. To make the comparison easier, the *f*-stops of all three measurements are displayed on what Minolta calls a "dot-array display." They can be recalled one at a time as desired.

Let's look at how you would use the meter. The first thing that you have to do is to set the film speed and the shutter speed desired. Then, simply pressing the measurement button causes the meter to compute the *f*-stop or EV number (you choose which one you want) that is required for proper exposure. The number is displayed both digitally and by a dot on the dot-array display.

By depressing the memory key, you can then enter that value into the unit's memory. You can then take a second meter reading (at a different shutter speed) and enter that one in memory.

If you need a third measurement, you can take one and it will be instantly displayed. Then, with the **RECALL** key, you can recall the two previous readings. The *f*-stop (or EV) settings for



FIG. 4—ALTHOUGH COMPLEX INTERNALLY, the *Auto Meter III* from Minolta is a snap to use.

all three readings are always displayed on the dot array.

That the microprocessor provides versatility is apparent from the fact the photographer can change the film speed set, or the shutter speed, even after the measurements have been taken. When they are changed, the microprocessor automatically adjusts for the changes and indicates the new data in the display.

One of the beauties of an all-electronic meter is its reliability. Since there are few moving parts, mechanical failure or wear is nearly nonexistent.

## Spotmeters

A spotmeter, which is a special type of reflected-light meter, is a meter for the more advanced photographer. When such a meter is aimed at the subject it allows him to measure the amount of light from a very small area, so that he can determine the proper exposure setting with great precision. Minolta's *Spotmeter M*, shown in Fig. 5, has a one-degree viewing angle.

That meter uses the same type of microprocessor control and LCD readout as the one we previously discussed, but, being a spotmeter, it allows the photographer to measure the lighting on the exact spot he wants to measure—a highlight or shadow, for example.

Three buttons, labeled **S**, **H**, and **A** (shadow, highlight, and average), are included. When the "shadow" button is pressed the microcomputer recomputes the exposure settings so that the measured spot will be exposed as a shadow. The "highlight" button is pressed for the exposure settings so that the measured spot will be exposed as a highlight, while the "average" key will give the average of the other two readings. That feature is especially useful when taking portrait shots—it allows you to be more creative because it lets you get precisely the effect that you want without a lot of guesswork.

Another type of electronic spotmeter is represented by Minolta's *Auto-Spot II* and *Auto-Spot II Digital*. Like the *Spotmeter M*, they are hand-held spot meters. The interesting feature of the *Auto-Spot II*-line is a "total-information" viewfinder that indicates all necessary information at a glance for proper exposure. With this meter, the scales in the finder move continuously until the trigger is released—then the readings are locked. The key difference between the two meters is that the *Digital* presents a digital readout, while the *Auto-Spot II* presents an analog one (on rotating scales).

Today's light meters are very different from light meters of the past. Their main advantage is that they can be used more accurately. That's not to say that the meters used years ago were



FIG. 5—THE SPOTMETER is a special type of reflected-light meter. Shown is the *Spotmeter M* from Minolta.

not accurate—in many cases they were. But because they were more difficult to use, and because they could be misused easily, the chance of error—usually the fault of the photographer—was high.

With older meters, the light falling on a photocell generates a voltage that then moves a meter needle which is read by the photographer and, based on that reading, dials are turned so that the correct exposure settings can be determined. Today's meters read the light level, take into consideration the user's inputs (such as film speed and shutter speed), and then tell him the correct exposure settings and camera-to-subject distance in an easy-to-read form.

In the 1960's, selenium cells were used primarily, but they

were not as accurate as other types of devices and they suffered from several shortcomings. They were replaced in the early 1970's by CdS (cadmium sulfide) photoconductive cells. Those allowed for more precise measurements, but they also had their drawbacks. One of the more troublesome problems was that they could develop "memories." That effect, called the light-history effect, means that the conductance of the photocell is a function of not only the light that it "sees" now, but it is also a function of the cell's previous exposure to light.

The photography industry found the answer to that problem in silicon cells, which can be used as accurately as the cadmium-sulfide cells, but don't suffer from the same problems.

Two other byproducts of electronic technology are flash meters, such as Minolta's *Flash Meter III*, and color meters. Essentially different types of light meters, they, too, use large-scale-integration and LCD technology to assist the photographer. For instance, the flash meter provides precise incident or reflected-light readings of electronic or bulb flash, or continuous illumination, or combinations of them. At the push of a button, a microprocessor turns the results of those readings into a display indicating the correct *f*-stop for a given situation so that the camera can be set correctly. The color meter allows a photographer to determine what filters, if any, are needed to ensure accurate color reproduction.

A relatively new camera accessory that is becoming increasingly popular is the electronic camera-back. Some such backs can imprint the date or time of exposure; the film type and exposure settings, and some can even operate the camera automatically for time-lapse or long-exposure photos. We won't go into more detail at this time; a multifunction back was discussed in a previous article in this section.

As you can see, photographic accessories have come a long way in the last two decades, thanks to the microelectronics revolution. They have given every photographer the chance to produce high-quality photos, something that everyone strives for.

R-E

## THE ALL-ELECTRONIC MAVICA

*continued from page 26*

affects of jitter on transmission, it is effectively cancelled by extracting the jitter signal from the video and using it to modulate the 14-MHz sampling clock. Since both signals then contain identical amounts of the same jitter component, it is nullified, and the sampled signal is free of that annoyance. The jitter-free digitized video is then stored in the memory of the transmitting unit.

The 800-Hz signal derived from the digital-to-analog conversion process is fed to a lowpass filter to eliminate spurious signals, and its level adjusted to meet the requirements of phone-line transmission.

At the receiving end of the system, further steps are taken to ensure the highest possible image quality. Because phone line signal-levels fluctuate greatly, an automatic-gain-control circuit using a reference signal contained in the system-control signals that start each image transmission is used to adjust the received signal to the proper level. The Sony engineers also realize that the phone system has a rather poor signal-to-noise ratio, and have adjusted the image signal to take that into account. In their system, the extremes of the image signal are the levels representing black and white. The horizontal-sync signal, which is normally "blacker-than-black," is inverted and extended to equal the peak white-level. Because the circuitry may have problems differentiating between a signal that represents pure white and one that represents horizontal sync, a vertical sync signal (also at the 100% level) is transmitted during the interval that contains no image. It, and the fact that the horizontal-sync pulses occur at regular intervals, prevent the sync and image signals from becoming confused. Figure 8 shows a comparison of a standard

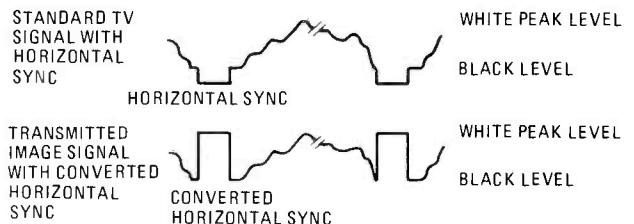

FIG. 8—STANDARD VIDEO SIGNAL (a) compared to signal used over telephone lines (b). Note how sync is inverted and maintained at white-level (as opposed to blacker-than-black) in the latter.

TV signal (a) and the one transmitted over the phone line by the Sony system (b).

The received signal is stored in memory and undergoes digital-to-analog conversion (essentially the reverse of what was done at the transmitting end). The image can then be viewed on a TV screen, or printed by the Mavigraph. (You can also record the digital signals on a standard audio cassette, and play them back when you desire.) It takes about four minutes to transmit one picture by this method.

Although this is a somewhat simplified explanation of what goes on, it describes what is perhaps the most important use of filmless electronic photography and demonstrates the ability to combine video with many different forms of media.

Since the Mavica system is based on electronic video signals, it is also compatible with other electronics equipment. It will be possible, then, in the long run, to use and integrate photos and other pictorial matter with computer-generated reports or to access and use pictorial matter in other electronic ways.

The Mavica system has a great deal of potential in many realms, and though we may have to wait a while before we can use it at birthday parties, we are certain to see it widely used commercially.

R-E



# Electronics in The Darkroom

*Precise timing and repeatability of results are essential in the darkroom—especially for color processing. The use of electronics in what were previously all-mechanical devices allows a new degree of accuracy to be attained.*

MARC STERN

NOT TOO LONG AGO MAKING COLOR PRINTS WAS SO DIFFICULT—especially for the amateur—that many who were proficient in black-and-white darkroom techniques absolutely refused to get involved with color. Processing times and temperatures were critical, filtration and exposures were hard to determine, and the chemicals were a nightmare! It could take an entire evening to make just one satisfactory print. The chemistry end of color processing was simplified about ten years ago, but it wasn't until recently that electronics made color printing really easy. We're going to discuss some of the ways it has done so.

## Temperature control

One of the most critical factors in color processing is the temperature of the chemicals used. Color work is much more temperature critical than black-and-white—some of Kodak's processes require the chemicals to be within  $\pm 1/4$ -degree of a certain temperature (usually around 100° F.)

To measure temperatures accurately, an electronic digital thermometer like the Omega CF-20 can be used. Employing large-scale circuit integration and a solid-state sensor, the thermometer displays almost laboratory-precise readings on a 3½-digit LED readout. The thermometer, which is calibrated to

National Bureau of Standards guidelines, has a range of 59° F. to 140° F., and is accurate to  $\pm .25$ -degree F. Its probe is made of chemical- and heat-resistant plastic, and is designed to hang on tanks and trays without slipping or rolling. The thermometer can be powered by four 1.5-volt "AA" cells or a rechargeable nickel-cadmium battery pack.

## Color analyzers

One of the trickiest parts of color printing is color balancing—it's like adjusting the hue control on an old color-TV set for correct flesh-tones, only harder. A number of variables are involved, including the lighting conditions under which a picture was taken and—more critical—the particular emulsion batches used for the film and printing paper. (Each batch of paper or film produced by a manufacturer varies slightly from the ideal specifications for color properties. These have to be compensated for in the printing process through the use of filters.)

Color balancing is simplified by a device called a color analyzer, which measures the color content of the light projected through the negative or slide and, "knowing" the filtration requirements of the particular paper and film being used, de-





FIG. 1—OMEGA'S SCA 300 DIGITAL COLOR ANALYZER can accept user-programmable RAM modules that greatly reduce setup time.

termines the filter values that must be used. It should be mentioned that some filtration is *always* required; the exact amount depends on a number of factors. Because of their cost, color analyzers used to be considered luxury items, but today they almost have become necessities as the costs of paper, chemicals, and other photographic materials have climbed through the roof. Any waste of those items is needless and it is also rather expensive.

A good example of the state of the art in color analyzers is provided by Omega's (Omega Division, Berkey Marketing Companies, 25-20 Brooklyn-Queens Expressway West, Woodside, NY 11377) microprocessor-controlled SCA 300. The SCA 300, shown in Fig. 1, can accept computer-type RAM (Random Access Memory) programmable memory-modules; each module is programmed by the photographer for a specific film/paper combination. With one of the modules installed, the analyzer allows him to make any number of prints without missing a beat—without his having to retest, reset, or reprogram anything. When a photographer uses a particular combination again, all he has to do is insert the correct module.

The probe contains a set of three silicon cells with matched dichroic and narrow-bandpass filters. In use, it is placed on the printing easel, in place of the paper, and the cyan, magenta, yellow and exposure readings taken in sequence. Each reading is displayed on a 3½-digit variable-intensity LED readout. When all the filter values and the exposure time have been determined and set, the probe is removed, the paper put in place, and the exposure made.

The analyzer, which includes a feature that allows adjustment of the overall color-sensitivity level without affecting stored programs, is capable of selectively displaying the amounts of cyan, magenta, and yellow filtration needed, and the proper exposure time, with the push of a button. It also allows a photographer to recall any previously stored information from memory. The unit has built-in voltage and temperature stabilization and can operate from 117 or 230 VAC, 50/60 Hz.

A device that can be used if you need only to determine exposure times is the *Volomat* light integrator from Karl Heitz (937 Third Avenue, New York, NY 10022), which is a densitometer for black-and-white prints, or for color prints from slides.

The sensor is a cadmium-sulfide cell, whose output, after processing, lights one of a series of LED's. The readings are accurate to one-third of an *f*-stop. The 12 LED's correspond to light values from 0 to 2 lux, and the exposure times that can be read range from 0.7-second to 430 seconds.

Battery powered, the densitometer features a green-LED test light that also indicates when there is too much light on the easel. A chart on the instrument can be used to determine exposure times for seven different paper grades. In normal use, a light



FIG. 2—THE GRALAB 20 DIGITAL DARKROOM TIMER can sound a short tone each second to permit the darkroom worker to carry out time-critical operations like dodging and burning-in without having to watch the time display.

diffuser is placed in front of the lens of the enlarger, but the device can also be used to take spot readings to determine contrast, or from specific parts of a negative.

### Timers and color analyzers

With the correct exposure information and timing information in hand thanks to devices like the ones just described, the photographer then can program an all-electronic darkroom timer to turn on the enlarger for the correct length of time. Those devices can either be simple stand-alones, like the Gralab (Dimco-Gray Company, 8200 S. Suburban Rd., Centerville, OH 45459) model 500 or 520 (the latter is shown in Fig. 2), or they can have additional features. We'll see an example of that shortly.

The Gralab 500/520 timers use a quartz crystal timebase to eliminate interference from power lines, and to ensure accuracy regardless of line-frequency variations. They can be pushbutton-programmed for times from 0.1-second to 99 minutes, 59.9 seconds.

The timers provide readouts on four-digit red-LED displays. The intensities of the displays can be set bright for high lighting-levels or low for good readability in total darkness. The timers have grounded outputs for enlarger and safelight control; the enlarger and printer can be switched on or off either manually or by the timer. Both units can repeat the selected time as often as desired, ensuring fast production and identical exposures for large print-runs. They can also generate a metronome signal at one-second intervals (useful if you have to time a process but can't watch the display), and a two-second signal indicating that the timer has reached the end of its count. The model 520 allows the photographer to program two different time settings, each of which can be instantly recalled. The two settings will remain in the unit's memory until cancelled.

The more sophisticated microprocessor-controlled Omega CT-40 timer/controller (see Fig. 3) allows up to 17 sequential time-intervals to be stored in memory. It can be programmed to stop after each step, or to pause for 10 seconds after each interval and then continue automatically to the next; there is even an independent time-of-day clock. Seven different audible signals can be selected for use with each step. The device is extremely valuable for timing multi-step processes such as making color prints or developing color film, which involve several chemical baths and water rinses.

The CT-40 uses a membrane keyboard, something of a necessity in the harsh chemical atmosphere of a darkroom where strong processing agents can easily ruin a device. The keyboard has luminous markings, which makes it easy to use under darkroom conditions. A tone is heard each time the microprocessor registers an input.

The 4-digit red-LED display indicates the elapsed time and, when the unit is in the PROGRAM mode, the current sequence-step. That provides visual confirmation of the audible sequence selected.

The clock has an accuracy of  $\pm 0.5$  percent, and timing



FIG. 3—THE OMEGA CT-40 DIGITAL TIMER/CONTROLLER allows the user to program up to 17 consecutive time intervals. This feature is extremely useful for complex multi-step color-processing procedures.

functions can be entered in either “minutes:seconds” or “seconds:tenths-of-seconds” form. There are two timing ranges: the first covers a range of 0.1-second to 9 minutes, 99.9 seconds in 0.1-second steps; the other goes from 1 second to 99 minutes, 99 seconds in 1-second steps. The timer can be stopped and restarted at any time without affecting the timing sequence.

An optional expansion-interface allows the use of pre-programmed plug-in process-control cartridges for automatic operation. Those cartridges automatically program the timer for all popular photographic processes, including Cibachrome, Ektaflex, R-14, and others. A single cartridge can contain information for about 60 steps.

The expansion interface also permits the use of additional darkroom accessories: an exposure probe for automatically setting the correct exposure time, a temperature probe (with read-outs in both Fahrenheit and Centigrade), a digital PH-indicator probe, and others. It also has a built-in self-test program for the CT-40 that checks all 17 program steps, all the digits and indicators, and runs through a 10-second timing check—all in just 20 seconds.

An even more sophisticated device is the Omega SCA 400 automatic digital color analyzer/timer, which combines both color analyzer and timer functions in one microprocessor-controlled unit.

Featuring eight programmable memories, and four-channel simultaneous digital readout of color filtration and exposure time, the analyzer can compute the weighted sum of the yellow, magenta and cyan filter values and automatically set the exposure time. (Of course, if you want, the time can also be set manually.)

The eight memories allow eight different settings for specific paper/film combinations to be stored in nonvolatile RAM; the settings are retained when the unit is turned off. Only two keystrokes are required to access and program the memories. If more—or less—light is required from the enlarger, the unit automatically displays the words “LO” or “HI.”

A line of similarly sophisticated solid-state timers and analyzers is also available from Beseler Photo Marketing Co., Inc. (8 Fernwood Rd., Florham Park, NJ 07932).

## Enlargers

Enlargers have gotten very smart, too. One example of *how* smart is provided by Omega’s D5500 enlarger system, shown in Fig. 4.

The system starts with an automatic dichroic lamphouse. Repeatability is extremely important in color printing—when you dial in a certain combination of filter values, the color output



FIG. 4—THE D5500 COLOR ENLARGER SYSTEM is unique in that the color head has no user-operable controls—all adjustments are made either automatically or from a console keyboard.

of the color head (the lamphouse together with its dichroic filters) should always be the same. Over time, though, what you want may not be what you get, due to lamp aging, the darkening of reflecting surfaces, and other factors. A specially designed quartz-halogen lamp from General Electric helps reduce that problem: the D5500 lamphouse *corrects* for it by constantly monitoring its own color output using a set of three silicon-cell color sensors.

The outputs of those cells are fed to a microprocessor-controlled circuit that “knows” what the normal color-output should be and automatically corrects the filtration as needed. The three dichroic filters, whose positions in the light path determine the color output of the head, are moved to the correct positions by separate DC motors in response to the output of the color-control circuit. Those motors are also used to introduce the amount of filtration selected by the photographer for printing; unlike other color heads, that of the D5500 has no external color-control knobs—everything is controlled electrically or electronically.

The heart of the D5500 system is its auto CLS (Closed Loop System) controller, which can also be seen in Fig. 4. It connects to the lamphouse, and allows all timing and filter settings to be made from one console.

The controller has a backlit membrane keyboard that is used to enter filter and exposure data for the enlarger’s color head. Four 3-digit LED displays show the filter values and time selected; the intensity of both the displays and the keyboard lighting is adjustable.

Filtration values can be entered from a numeric pad, or



FIG. 5—BESELER's *DICHO 45* enlarging system is programmable by means of plastic cards with magnetic stripes.

increased or decreased step-by-step by "up/down" keys. Exposure times can be entered in two ranges: from 0.1 second to 99.9 seconds (in 0.1-second increments) or from 100 seconds to 999 seconds (in 1-second increments). Whenever the controller requires information to be input, the appropriate key is illuminated to call the operator's attention to it. This feature is especially useful when several steps have to be entered in a particular sequence—the keys will light up one after the other. That makes it difficult to make a mistake.

Two controller models are available. The first is the *Auto CLS Controller* just described. The second, the *Auto CLS Translator/Controller*, offers several additional features.

In addition to doing everything its smaller cousin can, the translator/controller can be connected to a video color-negative analyzer like those used in high-volume operations, and the color-correction factors determined using that device will be fed directly to the color head of the enlarger. The translator/controller also comes with a density probe for making on-easel exposure measurements.

If desired, the unit can be connected to a color analyzer (like the CA 400 described earlier), and the output of the analyzer converted directly into signals to control the color head. In addition, it has a 25-pin "computer-type" connector, which, Omega says, allows for future interfacing with external memory storage-devices, magnetic-card or paper-tape readers, and various on- and off-easel densitometric devices.

The translator/controller has 19 program memories and includes a number of automatic diagnostic features. Among them are a line-frequency check, a temperature check (for the lamp-house), and a "high-low" light-intensity check (when the density probe is used).

A recently introduced option for the system is a parallel computer-interface, which answers the need for computer control of laboratory processes. The reason Omega chose a parallel interface is because its research showed that most of the computers with which its system would be interconnected used a parallel printer port. The company has solved interface problems associated with interconnecting parallel ports by using a BASIC program and supplying listings that show how to customize the

program for particular computers. Among the computers supported are the Apple computers, the *TRS-80*, the *IBM PC*, and others that use Microsoft BASIC.

Another computer-controlled enlarging system is the Fujimoto *G70*. Although not as automated as the Omega system, its color analyzer—which is built into its base—allows precise determination of filter requirements and repeatability of results. It is marketed by Colourtronic (9650 Topanga Canyon Place, Chatsworth, CA 91311).

The Beseler *Dichro 45* system, shown in Fig. 5, uses a microcomputer-controlled dichroic-head color system similar in some respects to Omega's. It, too, checks the quality of the light it outputs. Instead of automatically changing the position of the filters, however, it changes the figures displayed by the 7-segment LED's that indicate the color makeup of the light inside the head's mixing chamber. A switch allows you to see the actual value of the filter pack, or its effective value. The color head contains a 3870 microprocessor, custom-programmed by the company, that serves as the basic function-controller for the electronics package.

Though only about one-quarter-inch square, the microprocessor chip can collect data, make decisions and calculations, and provide output, commands and control signals. Other electronic components in the color head include a quartz-crystal oscillator and nine integrated circuits (including three MOSFET op-amps and three opto-isolators).

When the photographer turns on the system, three solid-state photodetectors read the actual color of the light within the mixing chamber of the color head. The particular devices used were chosen because they are extremely sensitive and don't have the infrared-response problems associated with silicon photodiodes. They also closely match the spectral sensitivity of color photographic-materials.

The signals from the detectors are fed into three MOSFET operational amplifiers, and from there to a multi-channel analog-to-digital converter. The microcomputer reads and stores the data, processes it, and outputs two simultaneous signals. The first is a BCD (*Binary-Coded Decimal*) signal that is sent to a BCD-to-decimal decoder which then provides a signal to select the proper LED display. The second signal supplies the display selected with the appropriate information. The information is updated every tenth of a second, so that any variation in the color of the light is immediately detected and can be corrected for.

The microprocessor also performs a number of other functions, including a self-test diagnostic routine.

Signals to and from the color head can be controlled by what Beseler calls its Data Access Timer Analyzer module, or D.A.T.A. The module is connected to the head by a 24-pin connector.

While the D.A.T.A. module allows you to program the color head manually, it also has a built-in magnetic-card reader that enables it to read data from or write it to a specially designed D.A.T.A. card (which looks much like an ordinary credit card).

The module can store and make use of many types of data, including analyzer programs; color-head-memory offsets; specific information about a particular negative or slide; and information for automatic variable-contrast control and paper/film-emulsion and density control.

With a probe containing three photodetectors, the module can act as a color analyzer. A timer function lets it address the quartz-crystal oscillator built into the color head, providing an enlarging timing capability and exposure repeatability controlled by the on-board microcomputer.

It can also perform as a multiple-memory digital color analyzer with a one-button push-to-program feature. Any number of color-analyzer programs can quickly be stored on D.A.T.A. cards for later use.

As you can see, the nature of the darkroom has changed, thanks to microelectronics. And, since we have progressed this far, can the totally automated, computer-controlled darkroom be far away? Only time will tell.

# BUILD THIS

## Audio-Frequency



## Generator

*Here's an audio-frequency generator with a digital frequency-readout that is easy to build, align, and use, yet is precise enough for servicing today's sophisticated audio equipment.*

**RICHARD SCHROEDER**

TO SAY THAT BOTH HOME AND PROFESSIONAL sound installations have become extremely sophisticated would be an understatement. For example, a  $\frac{1}{3}$ -octave band equalizer as well as lowpass and highpass filters are integral parts of virtually all professional sound systems. In fact, these days equalizers, tone controls, and lowpass and highpass filters are considered to be necessary even in home or auto systems.

Today's consumer demands more in the way of performance, which means more precision is required when servicing audio devices and circuits. Because of that, old-fashioned frequency generators often prove to be inadequate. Among other things, they suffer from inaccurate frequency dials, require range switching, and often their output level changes as the frequency is varied. What we need, then, is an audio-frequency generator that has an accurate output-frequency indicator, a "flat" output level as the frequency is varied, and one that is free of any range switching, thereby allowing the operator to "sweep" the entire audio range with

just a "twist of the wrist."

Well, look no further, because the audio-frequency generator described in this article has all the above-mentioned desirable qualities and a few more. Let's look at some of its features and specifications.

It has a frequency range of 10 Hz to 50 kHz. That range is continuous, which eliminates the need for range switching. For increased precision, two controls are used to set the frequency. The COARSE FREQUENCY control is used to set the approximate frequency while the FINE FREQUENCY control is used to zero it in precisely.

The amplitude of the generator's sine-wave output is adjustable from 0- to 6-volts RMS into a high-impedance load or 0- to 3-volts RMS into a 600-ohm load. The device's output impedance is 600 ohms. The sinewave has a distortion figure of less than 1% (THD), and its output level doesn't vary more than a few tenths of a dB as the frequency is changed over the entire range. The unit also boasts a simultaneous squarewave output with a low source impedance and a fixed 5-volt level

for TTL or CMOS logic work.

One unique feature is a built-in frequency counter that continually monitors the output frequency. The device can also be wired so that the counter can be used to measure external signals. That frequency counter not only allows you to make precise frequency settings, but also eliminates the need for usual large, cumbersome dial with its myriad of marks and numbers. Generators using that type of frequency "readout" have always been difficult for the hobbyist to build and calibrate.

The frequency counter itself features autoranging and a large, four-digit LED display. For frequencies up to 9,999 Hz, the display reads out in Hz with 1-Hz resolution. For higher frequencies, the counter automatically switches to the kHz mode, which features 10-Hz resolution. You can tell which mode the generator is in by the absence or presence of the decimal point. In the kHz mode, a decimal point appears after the first two significant digits.

All of the components except the power

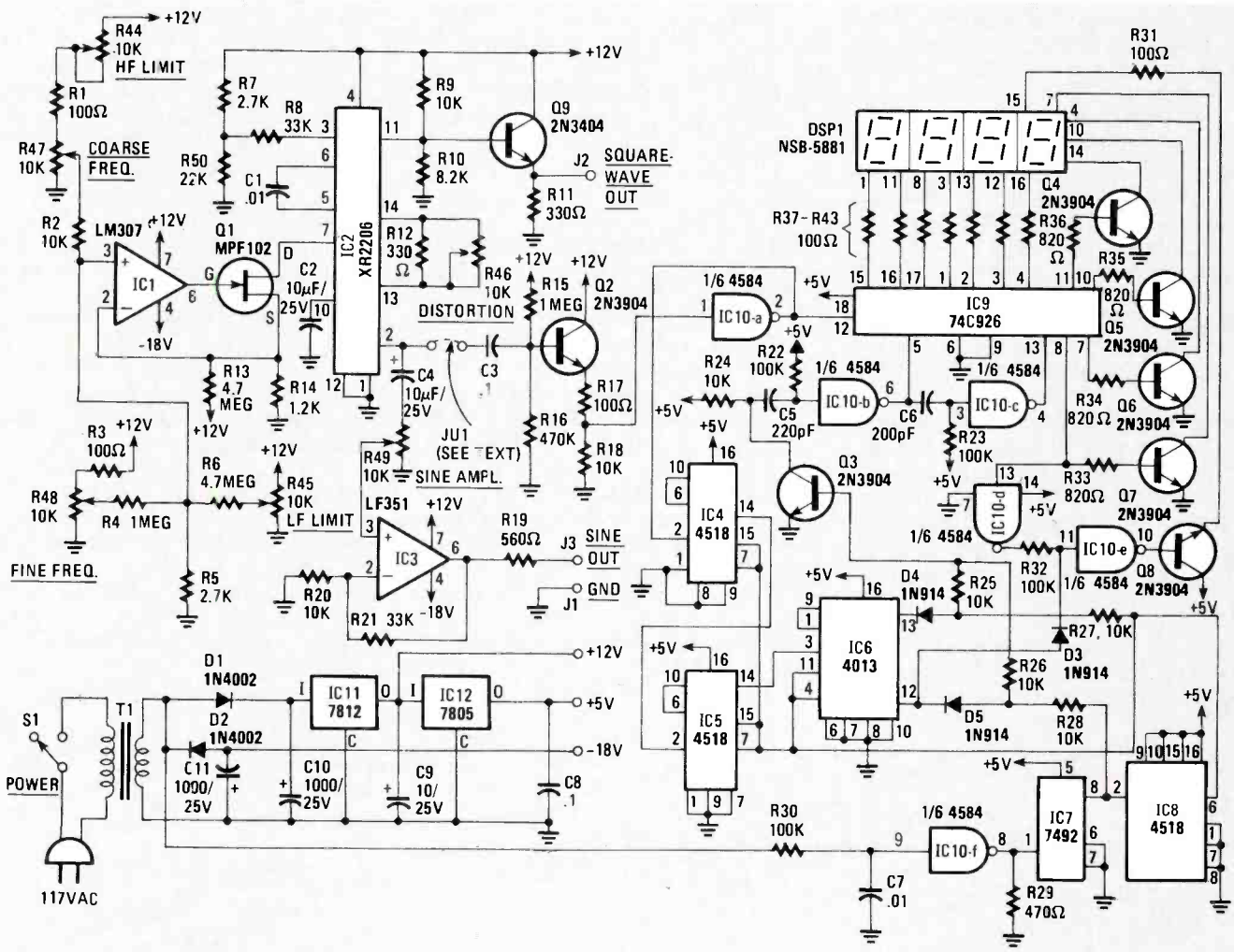

FIG. 1—SCHEMATIC DIAGRAM of the audio-frequency generator. If you want to use the built-in frequency counter to measure external signals, jumper JU1 should be replaced with a SPDT switch (see text).

transformer, potentiometers, display, and output connectors mount on a single PC board. The completed project can be housed in a small, metal cabinet.

In short, this is an audio-frequency generator that provides high-quality performance at a low cost, along with some unique features.

### How the circuit works

A schematic diagram of the unit is shown in Fig. 1. Let's start with the audio-frequency-generator section. Positive voltage is applied to the COARSE FREQUENCY potentiometer, R47, through trimmer potentiometer R44 (labeled H.F. LIMIT) and resistor R1. In a similar manner, positive voltage is applied to the FINE FREQUENCY potentiometer R48, through

resistor R3. Depending on the settings of those potentiometers, some voltage will be fed to the non-inverting input of op-amp IC1 through resistors R2 and R4. Note that a very small voltage will reach that same input through R6 in conjunction with trimmer potentiometer R45 (labeled L.F. LIMIT). That arrangement sets the low-frequency limit of the generator when the COARSE and FINE FREQUENCY potentiometers are set to their low-frequency positions, which, of course, is when both wipers are all the way toward ground. Trimmer potentiometer R44, in setting the maximum voltage that is applied to R47, in turn sets the generator's high-frequency limit when R47 is set to maximum.

Op-amp IC1, along with transistor Q1

and its associated components make up a voltage-to-constant-current converter, the current of which controls the output frequency of function-generator IC2. The sinewave output signal from IC2 (pin 2) feeds the SINE AMPLITUDE potentiometer, R49, through capacitor C4. Depending on the setting of the potentiometer, some voltage will be fed to the non-inverting input of op-amp IC3. That op-amp amplifies the signal, which is then fed to the SINE output binding post through resistor R19.

Note that the sinewave signal from IC2 also feeds the base of transistor Q2 through a jumper wire and capacitor C3. That transistor is configured as an emitter follower and acts as a buffer between the audio-frequency generator section and the frequency-counter section.

The squarewave output signal from

function generator IC2 (pin 11) feeds the base of transistor Q9. That transistor is configured as an emitter follower and serves as a level shifter, buffer, and impedance matcher to provide a squarewave level of 5 volts from a low-impedance source at the SQUARE output binding post.

Trimmer-potentiometer R46 (labeled DISTORTION) sets the sinewave distortion to its lowest possible point. The other capacitors and resistors associated with IC2 set its frequency range and sinewave-amplitude levels.

Let's now turn to the frequency-counter section. Sinewave signals from the output of emitter-follower Q2 (actually the junction of resistors R17 and R18) are fed to the input (pin 1) of one of the six Schmitt triggers contained in IC10. That stage "squares up" the sinewave signal and feeds it to the input (pin 12) of the four-digit counter IC9. That IC counts or totals the squarewave "events," and because the counter is reset at 1- or  $\frac{1}{10}$ -second intervals, it causes the readout to display in either Hz or kHz. Resistors R37 through R43, along with transistors Q4 through Q7 and their associated resistors, make up the segment and digit-drive system.

Note that the "squared up" signal that feeds the four-digit counter also feeds the input (pin 2) of dual decade-counter IC4, and that IC4's output feeds the input (pin 2) of another dual decade-counter, IC5. Those four counters connected in cascade make up a divide-by-10,000 counter that produces an output only when the fre-

quency to be counted is equal to or greater than 10 kHz. That serves as the detector that determines which mode the auto-range system will settle on. The output of that counter (pin 14, IC5) feeds the input (pin 3) of flip-flop IC6. That device, and its associated components, serves to determine whether 1-second- or .1-second-period signals from the timebase (to be discussed shortly) ultimately reach the latch and reset points on the main four-digit counter, IC9.

Transistor Q3, IC10-b, IC10-c, and their associated components make up pulse generators that supply the latch and reset signals for the four-digit counter, IC9.

The circuit composed of IC10-d, IC10-e, Q8, and their associated components make up the gated decimal-point-drive system. That system works with signals from flip-flop IC6 to display a decimal point only when the frequency counter is in the kHz mode.

Next we turn to the timebase for the frequency counter. AC voltage from the secondary of power transformer T1 is fed to the input (pin 9) of Schmitt trigger IC10-f through resistor R30. That stage "squares up" the 60-Hz signal and feeds it to the input (pin 1) of the divide-by-six counter, IC7. The output of that counter (pin 8), with its frequency of 10 Hz and period of .1 second, is fed to a resistor/diode system that works with flip-flop IC6 and transistor Q3 to ultimately become the timebase for the kHz mode. That same

10-Hz signal is also fed to the input (pin 2) of divide-by-ten counter IC8. The output of that counter (pin 6), with its frequency of 1 Hz and period of 1 second, is also fed to the resistor/diode system to ultimately become the timebase for the Hz mode. That latter signal is also fed to the reset points on IC4, IC5, and IC6.

The regulated DC power supply is made up of two half-wave rectifiers configured in such a way as to produce both positive and negative voltages from the 12-volt secondary of power transformer T1. The positive voltage is fed to the input of voltage-regulator IC11, which produces at its output a stable 12-volts DC that powers the audio-frequency-generator section. That same 12-volts DC is fed to the input of voltage-regulator IC12, which produces at its output 5-volts DC, which powers the frequency-counter section. AC power is switched on or off with power switch S1.

We mentioned earlier that the frequency counter could also be used to monitor an external signal. That is where jumper J1 comes in.

That jumper should be wired as shown on the schematic diagram if you want the frequency counter to always measure the output frequency of the generator. If you would prefer that the frequency counter be able to also measure external signals, then omit the jumper, and wire an SPDT switch with its pole connected to the input of the frequency counter (the jumper terminal that connects to C3). Of the other

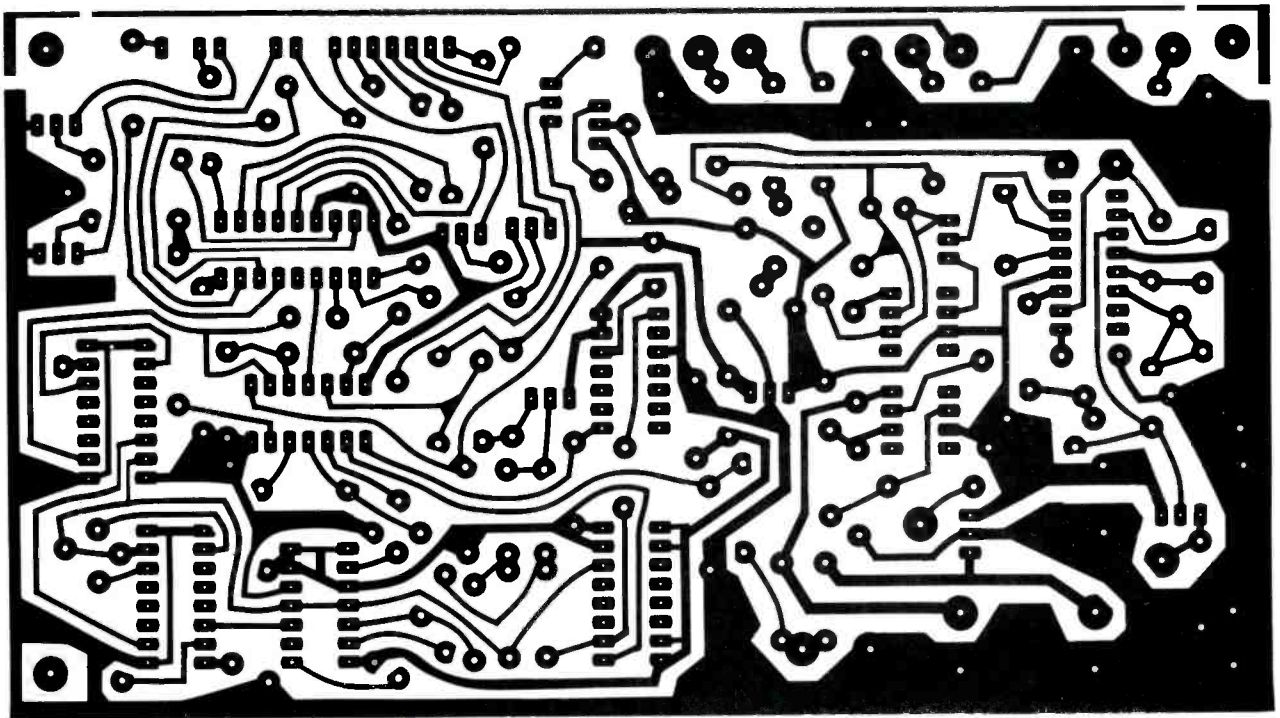

6-9/16 INCHES

FIG. 2—ALTHOUGH POINT-TO-POINT wiring could be used, it is recommended that the project be built using the PC board above. That board is shown full-sized.

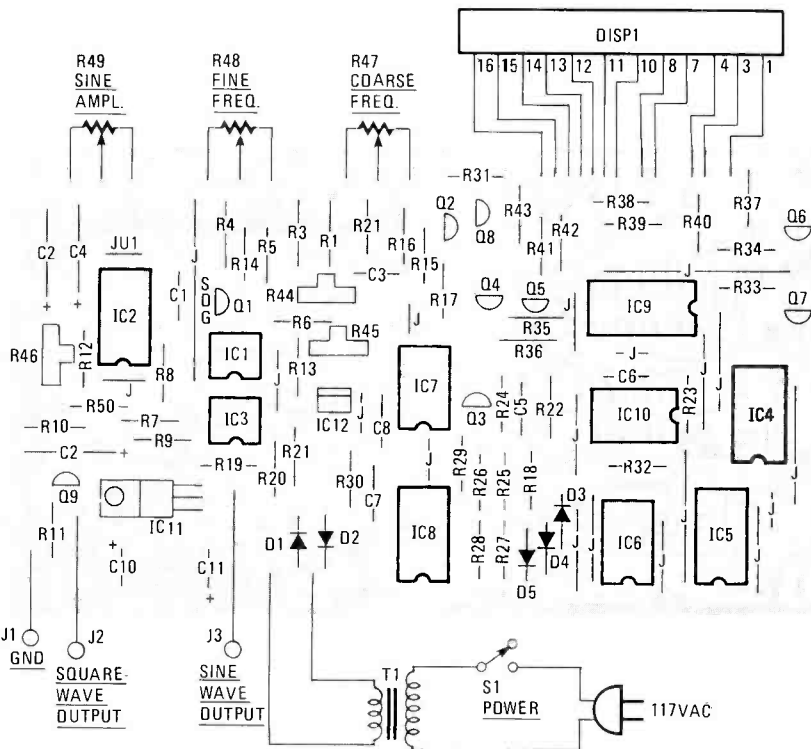

FIG. 3—THE PARTS-PLACEMENT diagram for the PC board shown in Fig. 2 is shown here. Note that even if you are using perforated construction board and point-to-point wiring it is recommended that you follow the layout shown.

two switch contacts, connect one to the jumper terminal that connects to pin 2 of IC2; the other switch contact becomes the "external" input terminal.

### Construction

Several methods of construction are possible. You may choose to mount the components on perforated construction-board (with .1 inch hole spacing) and use point-to-point wiring. A much better idea is to use a PC board. A foil pattern for an appropriate board is shown in Fig. 2; a parts-placement diagram for the board is shown in Fig. 3. If you decide to use perforated construction-board and point-to-point wiring, it is recommended that you lay out the components much as they are in the PC, board layout to avoid ground loops, noise, and other undesirable characteristics.

If you plan to use a PC board, and will be drilling it yourself, you will find that a No. 60 drill bit works well for all holes except those for the trimmer potentiometers and external wires. For those, a No. 55 bit is needed; and, of course, the holes for mounting the three terminal voltage regulators and the PC-board mounting holes will require a larger bit, say 1/8 inch.

After the PC board has been drilled, it should be thoroughly burnished with steel wool or very fine sandpaper to remove the photochemicals and tarnish. That will definitely contribute to better solder connections. All soldering should be done with a high-quality rosin-core solder and a pencil-type iron. The newer type metal-

clad tips are highly recommended.

Use special care to properly install polarized components such as diodes, transistors, IC's, and electrolytic capacitors, because those are very unforgiving when put in backwards. If you follow the parts-placement layout shown in Fig. 3 you should have no problems.

Although IC sockets are not required, their use is recommended. If nothing else, it will make servicing and troubleshooting the instrument easier later on.

Note several things in regard to mounting the three-terminal voltage regulators. The 12-volt regulator, IC11, is mounted with a 5/32 x 1/2-inch brass bolt and a 1/4-inch hex nut, with the excess bolt length extending upward. The bolt provides a small but adequate heat sink for the voltage regulator. The 5-volt regulator, IC12, mounts in a vertical position and it, too, has a brass bolt mounted to it for heat-sinking purposes. The excess bolt length should extend toward the rear of the PC board. Be sure to install the regulator with its bare-metal side facing the panel-mounted potentiometers (see Fig. 4).

The three panel-mounted potentiometers connect to the PC board by means of short wires that hold their solder lugs about 1/8 to 1/4 inch above the surface of the PC board. That is done to allow the potentiometers some flexibility, so that when they are finally tightened against the front panel they will align properly without breaking. It would be best to attach those wires first to the solder lugs and then solder them to the board. Make sure that

each wire passes through the lug hole with the wire being wrapped several times around the lug and soldered. Be sure that when finally soldering the wires to the PC board that you not only make allowance for the required clearance, but that you keep that clearance uniform for all three potentiometers so as to have them reasonably in line horizontally.

In a similar manner, the four-digit display is supported mechanically by its twelve signal wires. The attaching of the wires is best done by soldering a two- to three-inch length of bare No. 22 solid wire to each of the twelve appropriate connectors on the display board. Note that there are 16 total connectors on the display, but that four of them are not used. As an aid to getting the wires soldered to the proper points, tape or clamp the display to your work table with the viewing surface facing downward and the solder connectors closest to you. The connector on the left front corner can be considered as connector 16 and the one on the right as connector 1.

Solder wires then to the following connectors: 16, 15, 14, 13, 12, 11, 10, 8, 7, 4, 3, and 1. Be very gentle in soldering and handling the display because the foils are very thin and breakable. When all the wires have been attached, bend them downward (toward you) with the right-angle bends made close to the connectors. The display with its attached wires can now be installed on the PC board. Insert the display wires into the appropriate PC-board holes and be sure to hold the display level with its horizontal center line about an inch above the PC-board surface before soldering the signal wires into place. After soldering, cut off any excess wire.

When choosing your cabinet be sure that it is large enough to accommodate the board and the off-board components comfortably. Also, using a vented cabinet is a good idea.

At some point, you will need to drill the various holes and a rectangular opening in the cabinet for the potentiometers, display bezel, PC-board mounting bolts, transformer, etc. Plan ahead and carefully measure everything so that it will all fit well. Although most cabinets have a thin coat of paint when purchased, the drilling process usually puts some nicks and scratches in it. Most find that re-painting at least the front panel and then applying press-on lettering gives the instrument a professional appearance.

The PC board is supported about 1/4 inches above the bottom of the cabinet with four 5/32 x 1/2-inch bolts. Each bolt has three 5/32 x 1/4-inch hex nuts attached; one holds the bolt to the cabinet and the other two sandwich the PC board at the proper height.

When all the PC-board components have been soldered in place, it's a good idea to thoroughly check the parts place-

## PARTS LIST

All resistors ¼ watt, 5% unless otherwise specified

R1, R3, R17, R31, R37-R43—100 ohms  
 R2, R9, R18, R20, R24-R28—10,000 ohms  
 R4, R15—1 megohm  
 R5, R7—2700 ohms  
 R6, R13—4.7 megohms  
 R8, R21—33,000 ohms  
 R10—8200 ohms  
 R11, R12—330 ohms  
 R14—1200 ohms  
 R16—470,000 ohms  
 R19—560 ohms  
 R22, R23, R30, R32—100,000 ohms  
 R29—470 ohms  
 R33-R36—820 ohms  
 R44-R46—10,000 ohms, trimmer potentiometer, upright mount, thumbwheel  
 R47—10,000 ohms, potentiometer, panel mount, audio taper  
 R48, R49—10,000 ohms, potentiometer, panel mount, linear taper  
 R50—2200 ohms

### Capacitors

C1—.01  $\mu$ F, 100 volts, mylar or polyester  
 C2, C4, C9—10  $\mu$ F, 25 volts, electrolytic  
 C3, C8—.1  $\mu$ F, 50 volts, ceramic disc  
 C5, C6—220 pF, 50 volts, ceramic disc  
 C7—.01  $\mu$ F, 50 volts, ceramic disc  
 C10, C11—1000  $\mu$ F, 25 volts, electrolytic

### Semiconductors

IC1—LM307 op-amp  
 IC2—XR2206 function generator (Exar)  
 IC3—LF351 op-amp  
 IC4, IC5, IC8—4518 dual decade counter  
 IC6—4013 D flip-flop  
 IC7—7492 divide-by-six counter  
 IC9—74C926 4-digit counter/driver  
 IC10—4584 hex Schmitt trigger  
 IC11—7812 voltage regulator  
 IC12—7805 voltage regulator  
 DSP1—NSB-5881 4-digit LED display  
 Q1—MPF-102 FET  
 Q2-Q9—2N3904 NPN or equivalent  
 D1, D2—1N4002  
 D3-D5—1N914  
 T1—117-volt primary, 12- or 12.6-volt secondary, .5 to 1 amp  
 S1—SPST, miniature toggle.  
 J1-J3—binding posts

**Miscellaneous:** PC board, cabinet, display bezel with red filter, knobs, line cord,  $\frac{5}{32}$  nuts and bolts, etc.

**An etched and drilled printed-circuit board is available from: E<sup>2</sup>VSI, PO Box 72100, Roselle, IL 60172 for \$21.00 (check or money order) postpaid. Shipping by UPS or best way 3-5 days after receipt of order.**

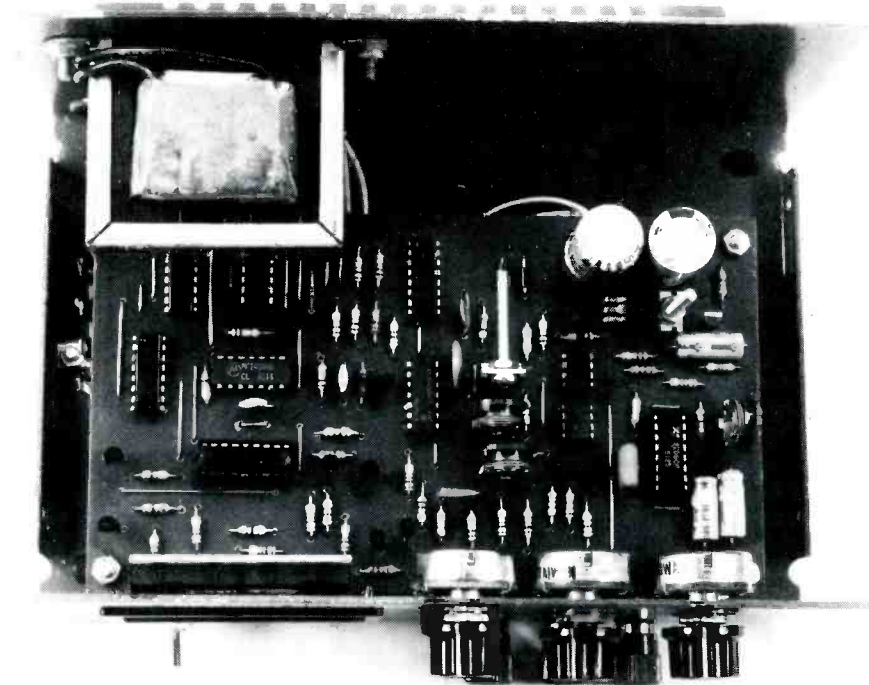

FIG. 4—THE COMPLETED BOARD is shown here mounted inside the case. Note the orientation of IC12.

ment, and the solder connections to be sure all is correct. When that has been done, it's time to "fire up" the device to test and calibrate it. Although that can be done with the PC board and transformer mounted in the cabinet, it is usually best to at least do the initial testing and calibration with the "electronics" out on the bench.

### Testing and calibration

All you will need in the way of calibration equipment is an oscilloscope to check the squarewave and sinewave outputs. The frequency-limit adjustments, of course, can be made using the built-in frequency counter.

Before applying power, set all the trimmer and front-panel potentiometers to their approximate mechanical midrange. Connect the oscilloscope to the sinewave output and apply power. The oscilloscope should display a sinewave, although it may be distorted, and the frequency counter should display the frequency of the waveform. Confirm that the frequency changes as the COARSE FREQUENCY and FINE FREQUENCY controls are rotated. Set the frequency at approximately 1 kHz and adjust the DISTORTION trimmer potentiometer (R46) for a sinewave that looks normal on the oscilloscope. If you're a purist you'll need a distortion meter or spectrum analyzer for that adjustment, but for most of us, the eyeball method works well enough. Next, check the squarewave using the oscilloscope. It should look the way the name implies and have a peak-to-peak value of around five volts.

The next step is to adjust the L.F. LIMIT

and H.F. LIMIT potentiometers. Rotate the COARSE FREQUENCY and FINE FREQUENCY controls to their lowest-frequency positions (fully counter-clockwise) and adjust the L.F. LIMIT potentiometer (R45) for a frequency of 10 Hz. Then, rotate the COARSE FREQUENCY control to its highest-frequency position (fully clockwise) and adjust the H.F. LIMIT potentiometer for a frequency of 50 kHz. Check the FINE FREQUENCY control by rotating it to its extremes while observing the frequency change. It should have a total range of around 500-700 Hz, regardless of where the COARSE FREQUENCY control is set. That completes the testing and calibration procedure.

If you experience some problems, here are some troubleshooting hints that may be helpful:

As experience has shown, most problems in home-built instruments are caused by poor solder connections, solder bridges between two adjacent foils, or components installed backwards. It would be wise then to first check for those troublemakers.

If you still can't track down the problem, the use of a multimeter is required. With it, check the three major DC power-supply points at various points on the PC board with respect to the ground foil. The output side of the 12-volt regulator (IC11) should of course measure  $+12 \text{ volts} \pm .5 \text{ volt}$ , and the output of the 5-volt regulator (IC12) should of course measure  $5 \text{ volts} \pm .25 \text{ volts}$ . The negative voltage bus (the negative side of C11) should measure around  $-17 \text{ volts}$ .

It should be noted that the voltage regulators normally operate quite hot to the

touch and the same holds true for the main four-digit counter IC. So, if the voltages are normal, don't let that be a source of concern.

If a problem exists in the frequency-counter section, some key points to check would be the 60-Hz, 10-Hz, and 1-Hz points on the time-base system and also the squarewave signal that constitutes the frequency to be counted. That latter point can be found at the input of the main four-digit counter IC9, at pin 12.

R-E



## The Life and Times of

ASK ANY ELECTRICAL ENGINEERING student today to tell you something about Nikola Tesla, and you are likely to get a blank stare. Or the counter-question: Who was Tesla? It seems preposterous that our educators should have ignored entirely the "father" of our AC age, but such is the fact. Something should be done about our technical education system.

Born July 9, 1856 in the village of Smiljan in what is now Yugoslavia, Tesla rose from relative obscurity to a top position in the scientific world. He became a millionaire at age 32 through his important inventions, but later faded into obscurity and died nearly penniless.

His father was a clergyman. His mother, though she never learned to read and write, was known in the community as an inventor of domestic labor-saving devices, and it is to her that Tesla attributed much of his inventive genius. The young Tesla, opposing his father's urging to study for the ministry, insisted on a career in engineering. His mother encouraged him. He attended the polytechnic school at Graz (now part of Austria), specializing in physics and mathematics, and continued his education at the University of Prague. There he took a course in foreign languages so that he would be able to read foreign technical literature. He became proficient in English, French, and Italian, in addition to German and his native Serbian.

Finishing at Prague in 1880, he took a post-graduate course in Budapest, where he debated the merits of alternating current with his professors. He then went to work for a Paris telephone company, where he acquired considerable experience with DC dynamos and motors.

In those early days, direct current was universally acknowledged to be the only practical medium for generating, transmitting, and using electricity for heat, light, or power. But DC resistance losses were so great that a power plant was needed for every square mile served. Early incandescent lamps, glowing none too brightly on 110 volts even close to the power plant, became pitifully dim on the power that dribbled from the lines less than a mile away. And everyone believed that motors could run only on DC. An alternating-current motor was considered an impossibility.



## NIKOLA TESLA

*Although now largely forgotten, Nikola Tesla was either responsible for, or predicted, much of the technology we now take for granted. Here's a look at the life and achievements of that fascinating man.*

That was the picture when, in 1884, young Tesla stepped off a ship in New York, his head full of ideas, and four cents in his pocket. His experience had convinced him that the commutator in direct-current motors and dynamos was an unnecessary complication, causing endless troubles. He realized that the "DC generator" actually produced AC, which was converted to DC by the commutator. Then, to get that DC to produce rotary motion in a motor, the process had to be reversed. The armature of each electric motor was equipped with a rotating switch (commutator) that changed the polarity of its magnetic poles just at the right instant as it rotated to supply AC to the motor.

To Tesla, that was sheer nonsense. It seemed much more logical to eliminate the commutator at both generator and motor, and use AC through the whole system. But no one had ever built a motor that could operate on alternating current, and Tesla struggled mentally with the problem. Then one day in February, 1882, while strolling with a classmate named Szigetti in a Budapest park, he suddenly blurted out: "I've got it! Now watch me reverse it!" At that moment he had visualized the rotating magnetic field, which would revolutionize the whole electrical industry. He saw the magnetic pull racing around the stationary field (stator) of his motor while the armature (rotor), attracted by the moving field, chased around after it faster and faster until it was revolving at the same rate. He would need no switching to the rotating element—no commutator!

Subsequently he worked the whole alternating-current electrical system out in his mind—including alternators, step-up and step-down transformers for economical transmission and delivery of electric power, and AC motors to supply mechanical power. Impressed by the wealth of available water power going to waste around the world, he visualized the harnessing of that great supply with hydro-electric plants capable of distributing the power to where it was needed. He started fellow-students in Budapest by announcing: "Some day I will harness Niagara Falls."

The opportunity and fortune Tesla sought in the promised land did not come easily. When he met Edison, then actively engaged in developing a market for his incandescent lamp through his pioneer Pearl Street plant in New York, Tesla

launched with youthful enthusiasm into a description of his alternating-current system. "You are wasting your time on that theory," the great man told him, dismissing the idea promptly and finally.

For a year the tall, gaunt Yugošlav struggled to keep from starving in this strange land. At one point he dug ditches to make a living. But the foreman of the Western Union ditch-digging project on which he was working listened to the visionary descriptions of new electrical systems that Tesla related during lunch hours, and introduced him to a company executive named A. K. Brown. Fascinated by Tesla's vivid plans, Brown and an associate decided to take a flyer. They put up a limited amount of money, with which Tesla set up an experimental laboratory at 33-35 South Fifth Avenue (now West Broadway). There Tesla set up a complete demonstration of his system, including generator, transformers, transmission line, motors, and lights. He worked tirelessly, and without drawings; the plans for every detail were indelibly etched in his mind. He even included two-phase and three-phase systems.

Professor W. A. Anthony of Cornell University examined the new AC system, and promptly announced that Tesla's synchronous motor was equal in efficiency to the best DC motors.

### Alternating-current arrives

Tesla attempted to patent his system under a single comprehensive patent covering all its components. The Patent Office would not approve the all-in-one application, insisting on separate applications for each important idea. Tesla's applications, filed in November and December of 1887, resulted in the granting of seven U.S. patents in the next six months. In April 1888, he filed for four more patents, covering his polyphase system. Those too were promptly granted, as were 18 more U.S. patents later in the year. Numerous European patents soon followed. Such an avalanche of patents, so promptly issued, was without precedent. But the ideas were so novel—completely absent was any element of interference or "anticipation"—that the patents were issued without a single challenge.

Meanwhile Tesla staged a spectacular lecture and demonstration of his AC system—single-phase and polyphase—at a meeting of the AIEE (now the IEEE) in New York. The engineers of the world were made aware that the limitations on electric-power transmission by wire had been removed, opening the door to tremendous expansion.

But who would adopt this obviously better system? Certainly not the established Edison-General Electric organization—it would have made their whole investment obsolete. Apparently Tesla was stuck with no market, no customer for what he had to offer.

It was at that moment that George Westinghouse walked into Tesla's laboratory and introduced himself. Tesla was then 32 years old, Westinghouse 42. Both were capable inventors, accomplished engineers, and electrical enthusiasts. Westinghouse listened to Tesla's explanations, watched his demonstration, and quickly made up his mind.

"I will give you one million dollars cash for your alternating current patents, plus royalties," offered Westinghouse.

"Make that royalty one dollar per horsepower, and it's a deal," replied Tesla, without apparent excitement. As simply as that, the two men arranged the historic deal and shook hands on it.

Tesla had arrived. But he was not a man to forget those who had placed their faith in his ideas, and promptly signed over half his million-dollar fee to Brown and his associate, who had financed his laboratory. Although Westinghouse's backers later forced him to get a release from Tesla on the dollar-per-horsepower part of the agreement, such was the friendship that had developed between the two men that an amicable settlement was quickly reached. Tesla relinquished the royalties that would have supported him and his research efforts for the rest of his life.

The phenomenal success of the Westinghouse AC-systems across the nation made it clear to General Electric engineers that

they would have to get a license from Westinghouse if they were to keep up with the rapidly expanding electrical industry. The license—negotiated at a handsome fee—was a feather in Tesla's cap; he never forgot Edison's statement that there was no future in alternating current and that experimenting with it would be a waste of time.

### A dream realized

In 1890, the International Niagara Commission began its search to find the best way of using the power of Niagara Falls to generate electricity. The scientist Lord Kelvin was appointed chairman of the Commission, and immediately announced that a DC system would obviously be best! It was not easy to challenge that world-famous authority, but Kelvin eventually came to realize that if power were to be transmitted even the 26 miles to Buffalo, AC would be necessary. Thus, it was decided to use Tesla's system and generate AC with massive water turbines. Bids were invited by the newly formed Cataract Construction Co. in 1893. Westinghouse won the contract for the ten 5000-horsepower hydro-electric generators, and General Electric the contract for the transmission system. The whole system including the line and the step-up and step-down transformers followed Tesla's two-phase design. He designed the big alternators with external revolving fields and internal stationary armatures, to minimize the weight of the moving members.

That historic project created a sensation, for nothing of that magnitude had been attempted up to that time. The ten big 2250-volt alternators, revolving at 250 rpm and delivering 1775 amperes each, produced an output of 50,000 horsepower, or 37,000 kilowatts, 25 Hz, two-phase. The rotors were 10 feet in diameter and 14 feet long (actually, 14 feet high in those vertical generators) and weighed 34 tons each. The stationary members weighed 50 tons each. The voltage was stepped up to 22,000 for transmission.

### Remote radio control

Tesla's pioneer work in radio ("wireless" as it was then called) went beyond just Morse code communication. In 1898 he staged a spectacular demonstration of remote control without wires at the original Madison Square Garden in New York City. The first annual Electrical Exhibition was then in progress, and in the center of the vast arena where Barnum and Bailey's circus usually performed he had a large tank built and filled with water. Afloat on that small lake he had a 3-foot iron-hulled boat. Inside the hull was a radio receiver and an assortment of electric motors, driven by a storage battery, to perform various ship-functions. The receiver's antenna was mounted on the boat's mast.

From the opposite end of the auditorium, Tesla put the vessel through a variety of maneuvers, including sailing forward, steering left and right, stopping, reversing, and lighting the lights in its rigging in response to audience requests. The impressive demonstration of course "stole the show" and made the front page of the daily newspapers. But how many dreamed that one day, using those same radio-remote-servo-control principles, we would land a man on the moon?

### Mathematical wizardry

Tesla's mathematical genius stood him in good stead in the design of the AC equipment for Westinghouse and GE. (In his early student days, he solved complex problems in his head, without pencil and paper. His teachers suspected him of cheating, but young Tesla, it turned out, had memorized whole logarithmic tables!) The now established frequency of 60 Hz stems from Tesla's mental calculations, which convinced him that it was the most practical frequency for commercial use. At higher frequencies, AC motors would become inefficient; at lower frequencies they would require too much iron. Lights would also flicker at low frequencies.

Though the original Niagara Falls plant was designed for 25 Hz to accommodate the limitations of the early Westinghouse turbine generators, subsequent expansion included conversion

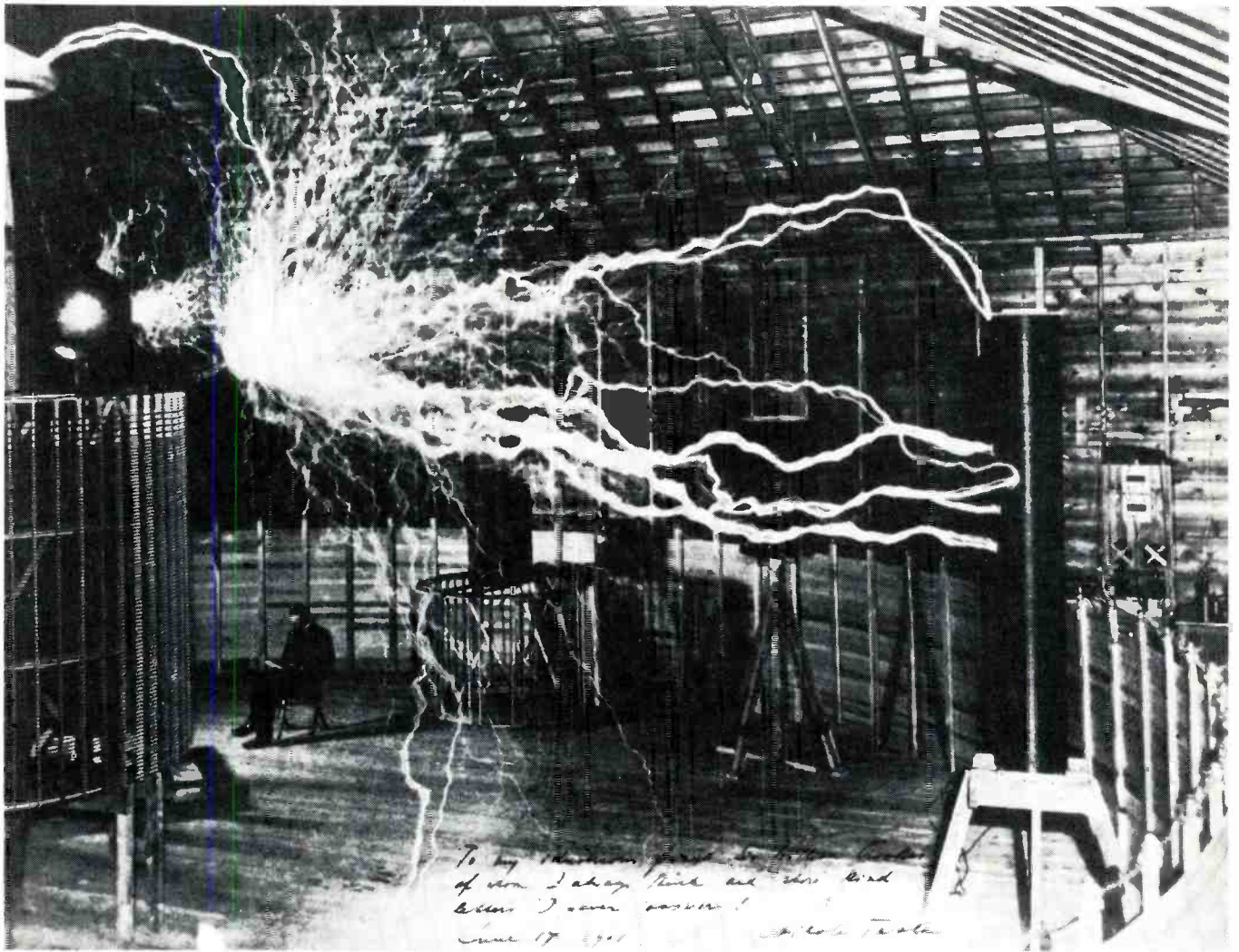

FIG. 1—TESLA AND HIS COILS. Tesla sits in his Colorado research station while 12 million volts of manmade lightning slash around him.

to 60 Hz. Today power from Niagara is transmitted all the way to New York City, 360 miles away, and at times is fed over the Northeast power grid for much greater distances. Remember, when Tesla arrived in New York, the limit for efficient power transmission was less than a mile!

### High-frequency pioneering

During his research in high voltage and high frequency, Tesla adopted a most sensible practice. When handling high-voltage apparatus, he always kept one hand in his pocket. He insisted that all his laboratory assistants take that precaution, and to this day that is always done by sensible experimenters when working around potentially dangerous high-voltage equipment.

Tesla's work with high frequencies and in the field of high voltage paved the way for modern electronics, although the word had not yet even been coined. With his unique high-frequency transformers, now called Tesla coils (see Fig. 1), he showed that he could actually pass millions of volts harmlessly through his body to glow-tube lamps held in his bare hands. They would light up to full brilliancy from the high-frequency, high-voltage currents. In those early days he was actually demonstrating neon-tube and fluorescent-tube lighting!

Tesla's experiments with high and low frequencies sometimes had unexpected results. Studying slow mechanical vibrations, he caused a virtual earthquake in the vicinity of his new laboratory on Houston St. in New York City. His mechanical oscillator, operating at close to the natural period of the building itself, threatened to tumble the old structure. Furnishings in a

police station over a block away began to dance around mysteriously as Tesla confirmed his mathematical theories of resonance, vibration, and "natural periods."

### World's most powerful transmitter

Investigations of high-voltage and high-frequency electrical transmission led Tesla to build and operate the world's most powerful radio transmitter on a mountain near Colorado Springs (see Fig. 2). Around the base of a 200-foot mast, he built a 75-foot diameter air-core transformer. The primary was only a few turns of wire. The secondary within it was 100 turns, 10 feet in diameter. Using power from a generating station several miles away, Tesla created the first man-made lightning. Deafening bolts 100 feet long leaped from the 3-foot copper ball at the top of his mast. He was using voltages of the order of 100 million—a feat not to be equalled for half-a-century.

Tesla burned out the power-plant generator with his first experiment, but repairing it, continued his experiments until he was able to transmit power without wires for a distance of 26 miles. At that distance he was able to light a bank of 200 incandescent lamps—a total of 10 kilowatts. Fritz Lowenstein, later to become famous for his own radio patents, witnessed that spectacular accomplishment, as Tesla's assistant on the project.

By 1899, Tesla had somehow spent the last of the money he got from Westinghouse for his AC patents. Colonel John Jacob Astor came to his financial rescue, and put up the necessary \$30,000 for the Colorado Springs experiments. Now that money was also gone, and Tesla returned to New York.

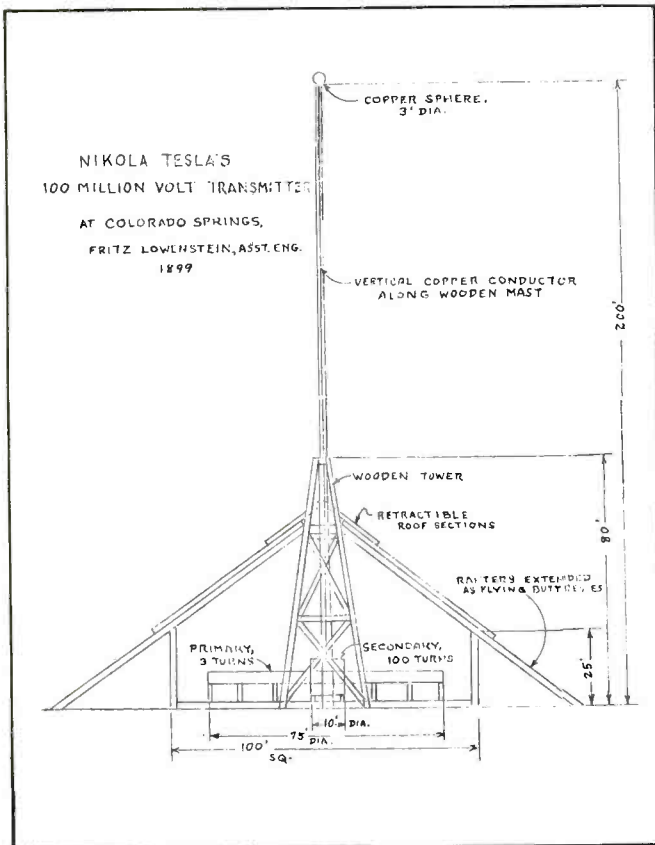

FIG. 2—WORLD'S MOST POWERFUL TRANSMITTER. Using this installation, Tesla generated voltages on the order of 100 million, a level not to be equalled for nearly half a century.

### Enter J.P. Morgan

In New York, Tesla was prevailed upon by his friend Robert Underwood Johnson, editor of *Century* magazine, to write a feature story describing his accomplishments at Colorado Springs. But the story Tesla turned out proved to be an involved discourse on the subject of philosophy and "the mechanical process of humanity." Although of the highest literary quality, the treatise said little about the powerful transmitter at Colorado Springs. Johnson had to return the manuscript three times before getting some coverage of the subject he had requested.

In the end, the article was published under the title "The Problem of Increasing Human Energy." It created a sensation when it appeared in print. One of the readers who was deeply impressed was John Pierpont Morgan, who had financed the General Electric Co. in its pioneer DC days, and later in its part in the Niagara Falls project. Morgan was fascinated by the genius of Nikola Tesla, by his spectacular accomplishments, and by his winning personality. Tesla soon became a regular guest at the Morgan home. Impeccably dressed, always the polished gentleman with European manners and cultured speech in several languages, Tesla became a favorite of New York and Newport society. Many prominent matrons regarded him as a "good catch" for their daughters, but Tesla insisted that there was no room in his life for women and romance—they would interfere with his research efforts.

Historians differ on what motivated Morgan to finance Tesla's next big project. Some believe that he was genuinely interested in the wireless transmission of power. Others argue that—in the light of subsequent developments—it seems obvious that Morgan's interest was in getting control of Tesla and his achievements to protect the Morgan investments in the electrical industry.

Finding that Tesla was broke again, Morgan agreed to underwrite Tesla's project of transmitting electric power without wires. In 1904, Tesla acknowledged in *Electrical World and Engineer*: "For a large part of the work I have done so far I am

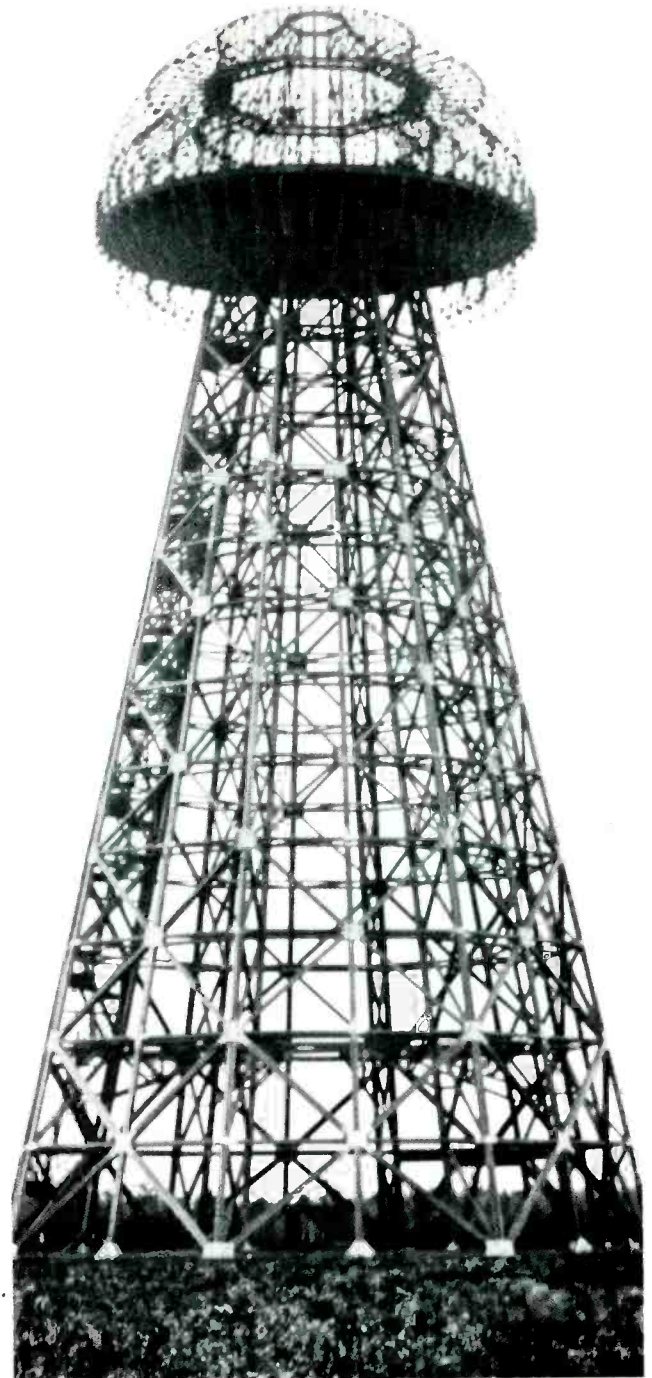

FIG. 3—THE WORLD-WIDE WIRELESS TOWER. Built on Long Island, the mysterious project was never completed.

indebted to the noble generosity of Mr. J. Pierpont Morgan."

From that alliance sprouted the fantastic "world-wide-wireless" tower erected on Long Island; that tower is shown in Fig. 3.

### World-wide wireless

The strange structure that slowly rose near Wardencliff, in the hilly portion of Long Island, mystified all observers. Resembling a huge mushroom, except that it was not solid, it had a lattice-work skeleton, broad at the base and tapering toward its 200-foot top. There it was capped by a 100-foot diameter hemisphere. The structure was made of stout wooden members joined by copper gussets bolted to the wood with sturdy bronze bolts. The hemispherical top was draped over its upper surface with copper mesh. There was no ferrous metal in the entire structure.

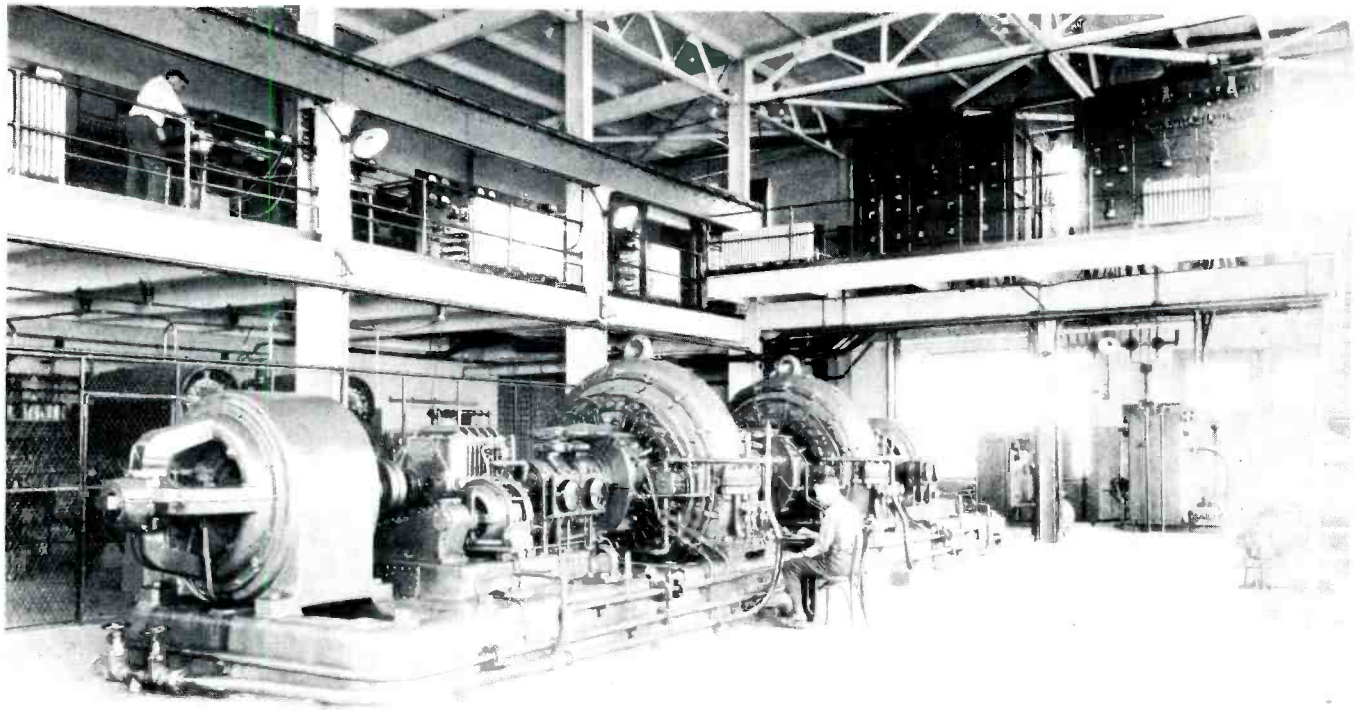

FIG. 4—RF ALTERNATORS, such as this first one installed in New Brunswick, NJ, provided the first reliable transatlantic radio communications.

The famous architect Stanford White became so interested in the project that he did the design work without charge, assigning one of his best designers, W.D. Crow, to the task.

Tesla commuted daily to the construction from his quarters in the old Waldorf-Astoria Hotel on 34th St., riding the streetcars to the East 34th St., ferry, then the paddle-wheel steam ferry to Long Island City and the Long Island Railroad to Shoreham. The railroad's dining service prepared special meals for him so that his supervision of the project would not be interrupted.

When the 100-foot-square brick power plant was completed near the base of the big tower, Tesla began moving his Houston St. laboratory into the structure. Meanwhile, various annoying delays were encountered in the manufacture of the radio-frequency generators. Several glassblowers were busy fashioning special tubes, the design of which remains a mystery to this day.

#### Tesla's vision

Meanwhile, Tesla issued a descriptive brochure that revealed his far-reaching insight into the future of the great industry that at that time (1904) was limited to dot-and-dash telegraphy. That document has persuaded many that the man was actually clairvoyant. He announced that the world-wide wireless system was being prepared to provide a variety of facilities, most of which we take for granted today. They included the interconnection of the existing telegraph exchanges all over the world; the establishment of a secret and non-interferable and non-interfering government telegraph service; the interconnection of all telephone exchanges in the world; a worldwide news distribution service in connection with the press; a worldwide private communication service, the interconnection of all stock tickers of the world; inexpensive clocks that required no attention yet were very accurate; the transmission of typed or handwritten characters; the establishment of a marine navigation system, and more. Much of what he described became reality within his lifetime.

#### Morgan's support ends

In the *Electrical World and Engineer* of March, 1904, Tesla revealed that the Canadian Niagara Power Co. had offered him inducements to locate his wireless power-transmission project at

their plant, and that he proposed to use those facilities to distribute 10,000 horsepower at a potential of 10 million volts.

The Niagara project never materialized, but may have had some influence on the fate of the spectacular Long Island project. For reasons that have never come to light, J.P. Morgan had a change of heart, and Tesla's financial fountain suddenly went dry. At first Tesla refused to believe that Morgan would not arrange for the nearly finished job's completion, but Morgan's withdrawal was abrupt and final. Historians of the industry wonder why. Did Morgan lose patience? Did engineers of high repute convince him that Tesla's visions, so openly revealed in the brochure, were nonsense, and that he was wasting his money on a hopeless dream? Did he suspect that Tesla was diverting time and money to the Niagara project? The facts will probably never be known. Tesla said, however, that Morgan "carried out his generous promise to the letter and it would have been most unreasonable to expect from him anything more." But almost in the same breath, Tesla said, "I am unwilling to accord to small-minded and jealous individuals the satisfaction of having thwarted my efforts. These men are to me nothing more than microbes of a nasty disease. My project was retarded by laws of nature. As for the tower, it was dismantled, although with considerable difficulty, for "security" reasons during World War I.

#### The radio-frequency alternator

As early as 1890 Tesla built high-frequency AC generators. One, which had 384 poles, produced a 10-kHz output. He later produced frequencies as high as 20 kHz. More than a decade was to pass before Reginald Fessenden developed his RF alternator, which had an output of 50 kilowatts. That machine was scaled up to 200 kilowatts by General Electric, and put on the market as the Alexanderson alternator, named after the man who had supervised the job, and who had built some of Fessenden's earlier alternators.

When it appeared that British interests (already in control of most of the world's cables) were about to acquire the patents for that machine, the Radio Corporation of America was organized at the urgent suggestion of the United States Navy. The new company was formed in 1919, around the Marconi Wireless Telegraph Co. of America, and the powerful but inefficient

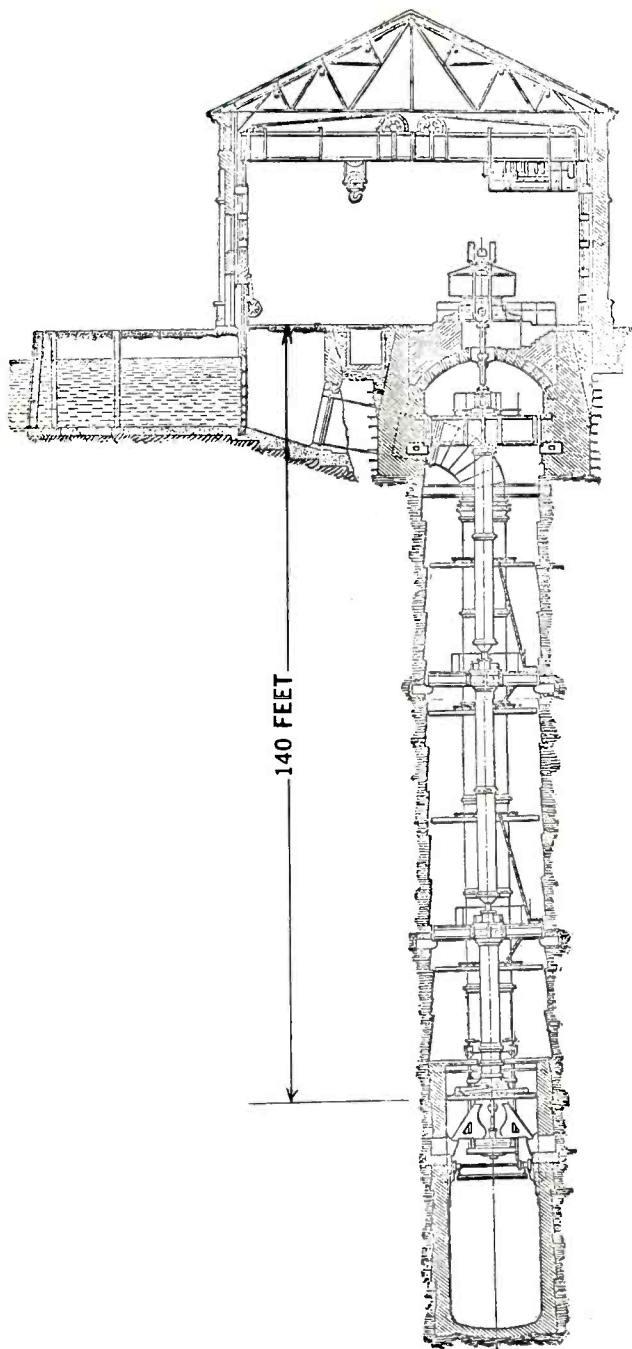

**NIAGARA FALLS HYDRO-ELECTRIC** power plant, the largest of its time. One of the 5000-horsepower Niagara Falls units built by Westinghouse.

Marconi spark transmitters were replaced by the highly successful RF alternators. The first one, shown in Fig. 4, was installed in New Brunswick, N.J. at station WII. It produced a 200 kilowatt, 21.8-kHz signal, and handled commercial business that previously was transmitted over cable. That was the first continuously reliable trans-Atlantic radio service. Those alternators performed so well that a whole battery of them was ordered; they were installed at Radio Central, Rocky Point, Long Island. Ironically, it would have been almost in the shadow of Tesla's tower, if that structure had still been standing.

Thus Nikola Tesla's world-wide wireless dream was fulfilled some three decades after he initiated the project, and right where he started it, using the type of transmitter he devised.

One of the giant radio-frequency alternators has been preserved in the Smithsonian Institute. That one originally served at

*Author's note:* I am indebted to the late Hugo Gernsback, friend and confidant of Nikola Tesla; to *Prodigal Genius*, the biography of Tesla by John J. O'Neill; to the *Proceedings of the AIEE*, and to various publications for their help and information.

trans-Atlantic transmitter station WSQ at Marion, Massachusetts.

### Radar and turbines

Tesla continued active research in many fields. In 1917 he suggested that distant objects could be detected by sending shortwave impulses to them and picking up the reflected impulses on a fluorescent screen. (If that doesn't describe radar, what does?) He described cosmic rays 20 years before other scientists discovered their existence.

At various times up to 1929, he devoted his attention to a "bucketless" high-speed turbine for steam or gas. Friction between the increasingly irascible Tesla and some of those working with him on tests at the Edison Waterside power plant and in the Allis-Chalmers factory did not help his cause, but many respected engineers today agree that we have not heard the last of the Tesla turbines with their smooth rotor discs.

As the years passed, less and less was heard from him. Occasionally some reporter or feature writer would look him up and manage to get an interview. His prophecies became increasingly strange and involved, leaning toward the abstract and delving into the occult. He never acquired the habit of writing notes, always claiming (and proving) that he was able to retain complete detailed data on all his research and experiments in his mind. He said that he intended to live to 150, and upon reaching age 100, would write his memoirs, which would include a detailed record of all of the data he had compiled. At his death, during World War II, the contents of his safe were impounded by military authorities, and nothing has been heard since as to what records, if any, were there.

One of the peculiar inconsistencies of Tesla's character was revealed when two high honors were offered him, and he rejected the one but accepted the other. In 1912 it was announced that Nikola Tesla and Thomas A. Edison had been chosen to share the Nobel Prize, including the \$40,000 honorarium. Tesla could well have used the \$20,000 at the time. Nevertheless, he flatly refused to share an honor with Edison. However, when in 1917 the AIEE's Edison Medal—founded by anonymous friends of Edison—was awarded to Tesla, he was persuaded to accept it, after first refusing.

### The esteemed eccentric

Tesla's natural demeanor was that of the aristocrat. With the passage of time and depletion of his resources, he sank into a condition of genteel poverty. Continuing to live in the best hotels, his credit would become exhausted and he would be forced to seek other quarters. Finally, moving into the newly opened New Yorker, he found his problems solved. Some of the organizations for which he had made millions arranged with the hotel management to take care of the aging genius.

Tesla insisted on carefully wiping each item of silverware, china, and glass before starting a meal, using a fresh napkin for each. In view of that effort to achieve perfect sanitation, it seems inconsistent that the maids reported Tesla's room to be an "unholy mess." It wasn't Tesla's untidiness they complained about—it was the pigeons! When he was not feeding them out in the park, he fed them in his room, where he left the window open so they could come and go.

The gold-plated telephone beside his bed, over which he could speak to anyone anywhere in the world without charge, was the roost of his favorite pigeon, a white one with grey-tipped wings. "When she dies, I will die," predicted Tesla. And so it was that one day in January 1943, that favored bird paid him her last visit. "She was dying," lamented the lonely, unhappy Tesla. "I got her message, through the brilliant beam of light from her eyes."

One of the maids, observing that the "Don't Disturb" sign had been hanging on Tesla doorknob for an unusually long time, used her pass key to investigate. Tesla had passed to his reward, leaving his gaunt 87-year-old frame peacefully in bed. The maid fed the mourning pigeons, gently ushered them out, and closed the window.

R-E

# BUILD THIS

# C-QUAM AM STEREO CONVERTER

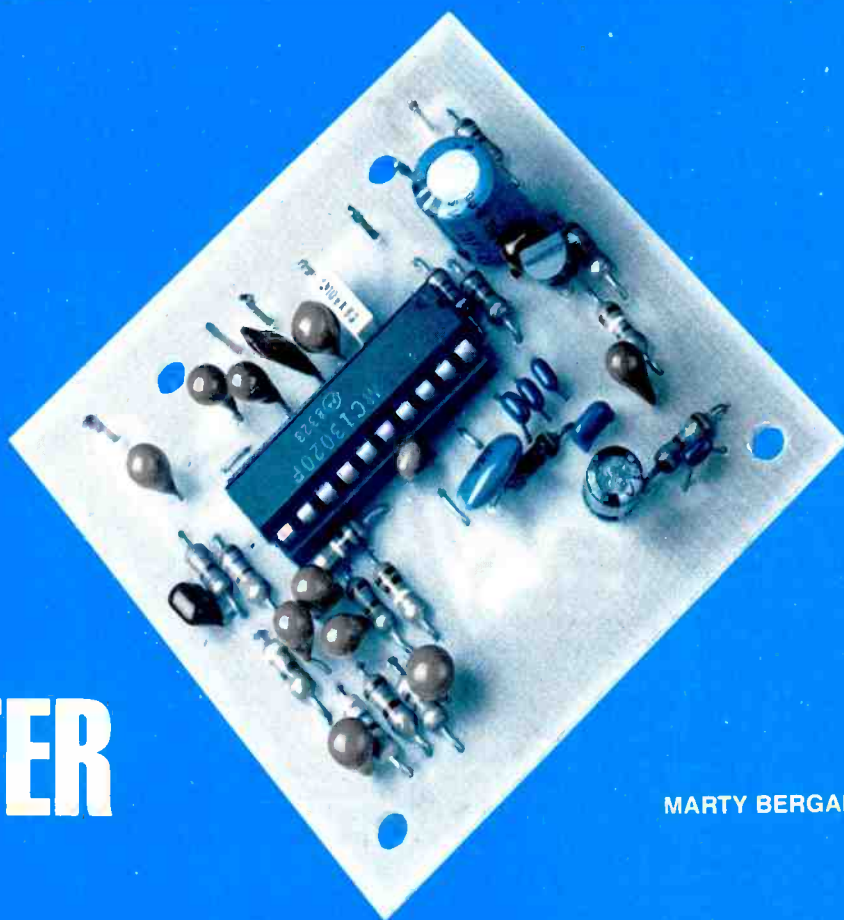

MARTY BERGAN\*

*AM stereo broadcasting is now well under way and more stations are beginning stereo broadcasts every week. Hear for yourself what all the fuss is about by converting your AM radio to receive C-QUAM stereo broadcasts.*

STEREO BROADCASTING BY AM RADIO stations was authorized in March, 1982 by the Federal Communications Commission (FCC). AM broadcasters hoped that the introduction of stereo would help to bring back many of the listeners they lost to FM radio. If you want to find out what AM stereo sounds like, it's easier than you think. You don't have to go out and buy some special receiver—you can convert your present AM radio to receive stereo C-QUAM broadcasts.

The C-QUAM system, designed by Motorola, is one of four systems that the FCC authorized for AM stereo broadcasting. (The Commission declined to determine which of several competing technologies would become the industry standard and instead took a "wait-and-see" attitude. In that way, the marketplace could decide which system would become the standard.) In this article, we will take a look at what the C-QUAM system is and then we'll look at how an AM radio

can be converted to decode stereo.

Let's say right from the start, though, that many radios are simply not capable of handling stereo. We'll explain the reasons for that and we'll explain ways around some of the problems. Because AM radios now on the market were not designed to accommodate stereo requirements, you might convert a radio but then be disappointed by the results. We'll give you some pointers on how to choose a good candidate for conversion.

Each of the hundreds of radio designs will probably behave and sound a little different. But each radio's problems can be resolved with the right know-how and test equipment. For those of you who are not equipped to handle such problems, the stereo conversion may be a disappointment, and you might be better off to wait a few months until the AM stereo receivers become available in the marketplace. But if you want to learn about this new system, and you have a good receiver to start with, then the conversion described here should be accomplished easily and successfully.

C-QUAM is a Motorola Registered Trademark

## What is C-QUAM?

C-QUAM is an acronym for *Compatible QUadrature Amplitude Modulation*. That's certainly a mouthfull—let's see what it means. The most important word there is *compatible*. That means that any ordinary (monaural) AM radio can receive a C-QUAM broadcast and produce the same results as it would if it received a monaural signal. In other words, the C-QUAM system does not make standard radios obsolete—as is necessary to gain FCC approval. C-QUAM is a *quadrature* system. That means that it somehow uses the relationship between two periodic functions that differ in phase by 90°. We'll take a closer look at that shortly. But let's first say that the final term in the acronym indicates that the transmitted signal is amplitude-modulated by each of the two periodic functions that we just mentioned.

A quadrature system combines and transmits two signals that are 90° out-of-phase with each other. Of course, those two signals must be separated again at the receiver, and that's the purpose of this

\*Linear Applications, Motorola Inc., Semiconductor Products Sector

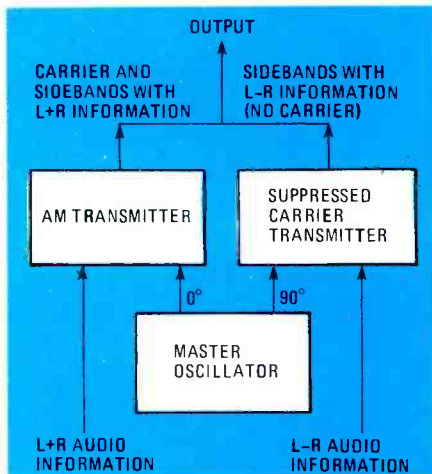

FIG. 1—YOU CAN THINK of a quadrature transmitter as one actually made up of two transmitters that are out of phase by 90°.

decoder. AM stereo is not the only place that quadrature modulation is used. For example, color information for TV broadcasts is transmitted in a similar way.

You can think of the quadrature transmitting system as one with two transmitters, as shown in Fig. 1. One transmitter is a standard AM transmitter at, say, zero phase. It transmits a carrier as well as sidebands that contain audio information (the I sidebands). The second transmitter operates 90° out-of-phase with the other. Because a carrier already exists to provide a phase reference for the receiver, we do not want another to be generated. So the second transmitter cancels out the carrier and produces only sidebands (the Q sidebands). Now, since those Q sidebands are generated from a carrier that is 90° out-of-phase from the original carrier, they are 90° out-of-phase with the I sidebands. In other words, the I and Q sidebands are in quadrature.

What information do the I and Q sidebands contain? The I sidebands contain the sum of the left- and right-channel audio information, or  $L + R$  signals. The Q sidebands contain the difference of the information of the two audio channels, or  $L - R$  signals.

There is a problem with quadrature-modulated signals, though. They produce distortion in the envelope detectors of normal AM radios. So a quadrature stereo system is not compatible with existing radios. That's because the envelope detectors in normal AM radios don't see the I and Q sidebands separately—they see the sum of the two, as shown in Fig. 2-a. One vector represents the  $L + R$  information that is modulated on the carrier (at what we'll call 0°). The other vector is the  $L - R$  information that is modulated on the suppressed carrier (at what we'll call 90°). The magnitude of the sum of those two vectors—which the receiver's envelope detector sees—is:

$$\sqrt{(L + R)^2 + (L - R)^2}$$

However, the envelope detector in a standard AM radio expects to see simply the

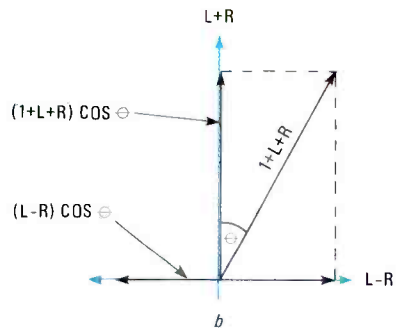
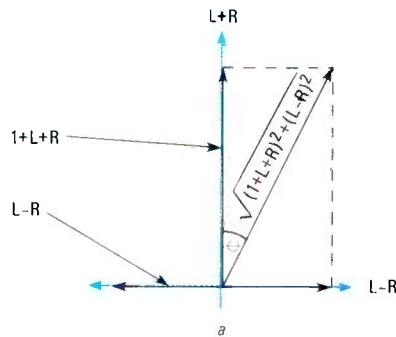

FIG. 2—QUADRATURE SIGNALS are not directly compatible with the detectors used in AM radios. Therefore, they must be converted into signals that will not produce distortion.

the carrier and the left- and right-channel audio, or  $1 + L + R$ . That difference or error is the cause of the distortion or incompatibility problem.

Motorola found, however, that they

could eliminate that error by multiplying each carrier axis by the cosine of the angle that resulted from the addition of the  $L + R$  and  $L - R$  signals. Figure 2-b shows that when that is done, the result is the  $1 + L + R$  that we want—the standard AM radio sees this signal as the same signal received from a monaural AM broadcast. Thus we have complete compatibility.

The C-QUAM system adds a 25-Hz pilot tone to the  $L - R$  information at 4% modulation that serves several purposes. It signifies that a stereo transmission is present; it permits decoding of the  $L - R$  signal, and it aids in control of mono-stereo switching.

### The MC13020P

The MC13020P decoder IC is housed in a 20-pin, standard dual in-line package, or DIP. A block diagram of the IC is shown in Fig. 3. The associated circuitry needed to build a complete decoder is made up of inexpensive components, and, in most cases, no coils or adjustments are necessary. A schematic of the decoder circuit is shown in Fig. 4. The schematic does not show the exact connection of the C-QUAM decoder circuit to the radio to be converted, or an exact external-oscillator circuit. But we'll give details later.

Taking an overall look at the block diagram of the decoder IC (Fig. 3), we see that the decoder takes the output of the AM IF amplifier, decodes the C-QUAM signal, and provides left- and right-channel audio outputs. In the absence of a good stereo signal, it will produce an undegraded monaural output from both channels.

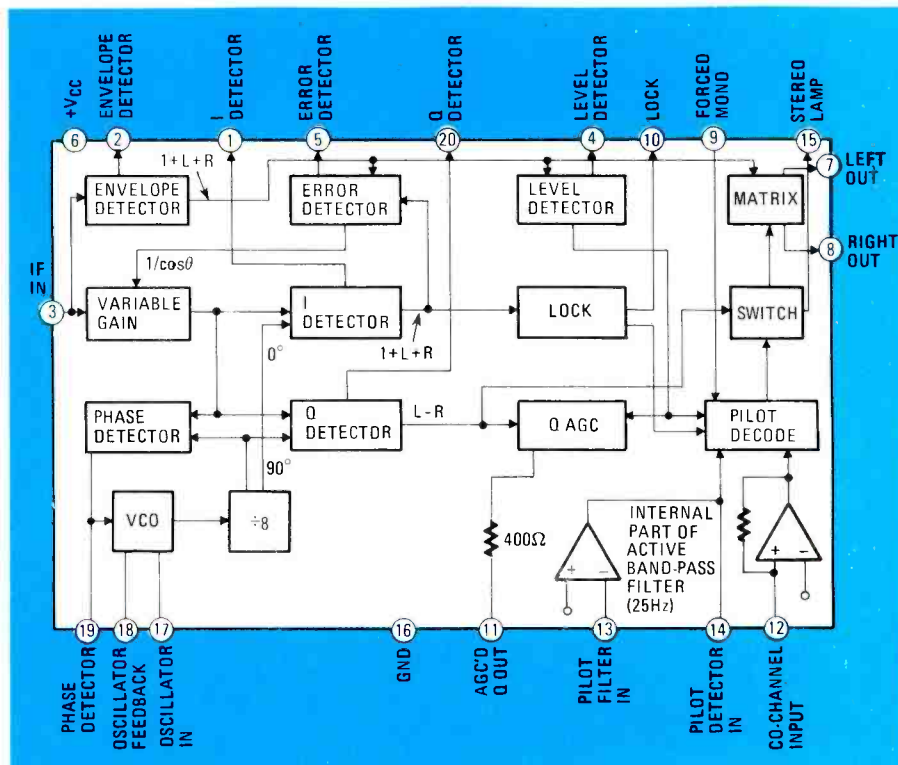

FIG. 3—A BLOCK DIAGRAM of the MC13020 AM-stereo decoder IC.



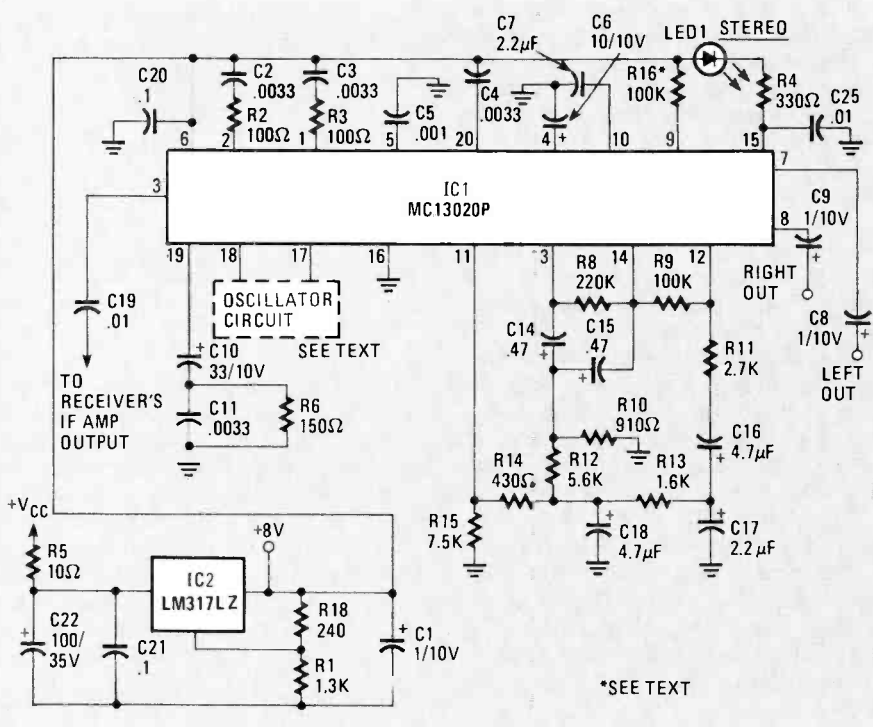

FIG. 4—THE SCHEMATIC OF THE decoder shown here does not show the VCO circuit.

The first step in decoding the stereo information is to convert C-QUAM to QUAM. That conversion is accomplished by comparing the outputs of the envelope detector and the I (L + R) detector in the error detector. Let's say, for example, that the incoming signal is monaural. Then it consists only of L + R information, and the envelope detector and I detector see the same signal. Therefore the error detector does not produce an error signal. However, when the incoming signal is stereo, there will be an error signal produced. That's because the envelope detector sees the same signal as it did before—the sum of the I + L + R and L - R signals—because it is not sensitive to the phase modulation. But the I detector—because it is sensitive to phase modulation—sees only the I + L + R information. When both signals are sent to the error detector, a  $1/\cos\theta$  correction factor is produced.

In the variable-gain block, the incoming C-QUAM signal is multiplied by that  $1/\cos\theta$  factor. The resulting product is a conventional quadrature or QUAM signal—not the C-QUAM that is compatible with standard AM-radio envelope detectors. It can be detected (synchronously) by conventional means.

The process to detect or demodulate the conventional quadrature signal involves first deriving a reference phase from the transmitted signal. That's the purpose of the phase-locked-loop (PLL) that we'll now describe. The phase detector is a product detector—its output is equal to the product of the two input signal voltages (in this case, a reference carrier from the VCO and the QUAM signal from the variable-gain block). If the two signals are

of the same frequency and  $90^\circ$  out of phase, the DC output of the detector will be zero. That DC output of the phase detector is fed back to the VCO as an error signal. Thus, the frequency of the VCO "zeros in" and locks on the input carrier frequency and we have our phase reference to the I and Q demodulators.

The internal VCO operates at eight times the IF input frequency. That ensures that the VCO's frequency is outside the AM band, even if the receiver's IF is 262 kHz. (Typically, a 450-kHz IF is used with synthesized front ends. But the IF of many auto radios—even if synthesized—is 262.5 kHz.) A 450-kHz IF places the VCO at 3.6 MHz, so you can use an economic ceramic resonator instead of a crystal. (See the Parts List.) But, as we mentioned before, the oscillator configuration will be discussed later in the text.

In the PLL filter at pin 19, C10 is the primary factor setting a loop corner frequency of 8–10 Hz. An internally controlled fast pull-in is provided. (Pull-in time is the time required for achieving synchronization in a phase-locked loop.) Resistor R6 slightly overdamps the control loop, and C11 prevents high-frequency instability. The value of C10 can be increased to 68  $\mu$ F to lower the filter corner frequency—that may be necessary to accommodate synthesized receivers. It may also be necessary if the filter affects the 25-Hz pilot signal (which must be 0.5 to 0.7 volts P-P at pin 14.). Resistor R6 may also affect the pilot amplitude, and can be decreased slightly if it's necessary to increase the pilot voltage to the required level.

The level detector senses carrier level and operates on the Q AGC block to

provide a constant amplitude of the 25-Hz pilot signal at pin 11. It also sends information on signal strength to the pilot decoder.

The Q AGC output drives a low-pass filter, made up of a 400-ohm internal resistor, C18, and R15. From that point, an active filter (made up of both internal and external components) is coupled to the pilot decoder, pin 14, and another low-pass filter is connected to the co-channel input, pin 12.

### Stereo/mono switching

A 50% reduction in the level of the 25-Hz pilot signal sent to the pilot-decode circuit will cause the system to go to monaural. A signal at a selected level to the co-channel input will also cause the system to go into its monaural mode.

That co-channel input signal contains any low-frequency beat notes caused by interference from a source very close in frequency to the desired signal. The level of the input that will cause the pilot-decode circuit to go into monaural can be adjusted by changing R11. The values that are shown in the schematic set the "trip" level at about 7% modulation.

The pilot decoder has two modes of operation. On a strong signal, the decoder will switch to stereo after it sees seven consecutive cycles of the 25-Hz pilot waveform. When conditions are bad, pilot decoder detects the interference and waits until it sees thirty-seven consecutive cycles of the 25-Hz pilot (that takes about 1.5 seconds) before it goes into the stereo mode. (In a frequency-synthesized radio, the logic that mutes the audio during tuning can be connected to pin 9 of the decoder to hold that pin low until the synthesizer and decoder have locked onto a new signal.) When pin 9 is held low, the decoder is held in its monaural mode and switches to the short count.

If no pilot is detected for seven consecutive counts, it is assumed the incoming signal is a monaural station and the decoder is switched to the long count (37 consecutive cycles of pilot). That reduces the possibility that noise or signal-level fluctuations will cause stereo triggering. The decoder will also switch to the long count if the PLL is out of lock, or if interference is detected by the co-channel detector before seven cycles are counted. (Each disturbance will reset the counter to zero.) The level detector will keep the decoder from going into stereo if the IF input level drops 10 dB, but will not affect the pilot counter.

Once the decoder has entered the stereo mode, it will switch instantly back to monaural if either the lock detector at pin 10 goes low, or if the carrier level drops below the preset threshold. Seven consecutive counts of no pilot also will cause the switch to monaural.

In stereo mode, the co-channel input is disabled. Then, co-channel or other noise is detected by negative excursions of the I

detector. When those excursions reach a level caused by about 20% negative modulation of the L-R signals, the lock detector switches the system to monaural, even though the PLL may still be locked. Here, the higher tolerance to co-channel and other interference prevents chattering in and out of stereo because of a marginal signal or high noise-levels (such as during a thunderstorm). If you wish to decrease the effectiveness of the interference sensing (to keep the decoder in its stereo mode in the presence of some narrow spike type of interference) the 2.2  $\mu$ F capacitor, C17, may be increased to as much as 47  $\mu$ F.

When all inputs to the pilot-decode block are correct, and the appropriate (long or short) count is complete, the switch block is enabled. That block turns on the stereo-indicating LED and passes the L-R information to the matrix block, which outputs stereo audio signals.

### Selecting a radio

Not every AM radio can be converted to receive broadcasts in stereo. But if you are careful when you examine the radio's capabilities, the conversion should go smoothly. Since there are literally hundreds of different radio designs on the market, we can't discuss the details of converting a particular radio. But we can give you some general pointers:

1. **Old vacuum-tube radios** are unacceptable. You'll undoubtedly have problems because of the high voltages and temperatures involved.

2. **Cheap pocket radios**, clock radios, small table radios, and the like should not be used in most cases. They typically have narrow bandwidths, poor sensitivity, and self-generated phase and frequency modulations that can seriously degrade channel separation and increase distortion and noise. (The C-QUAM system uses phase-related information, so the decoder is sensitive to phase variations or modulation.)

3. **Manually tuned radios**, whether variable-capacitor or variable-inductor types, may cause audible microphonics when in stereo mode. (Microphonics are electrical noise signals caused by mechanical disturbances of circuit elements.) Radios with self-contained speakers may be subject to microphonic problems because of the speaker vibrations. Those vibrations may generate phase modulation and the associated problems of poor separation, distortion, and noise.

4. **The local oscillator** must be stable and produce a reasonably clean sinewave. An unstable oscillator or a severely distorted waveform may cause a fluttering or warbling in the audio in the stereo mode. Disturbances of the front end and local oscillator introduce phase noise or ringing.

5. **Radios with synthesizer front ends** or logic-controlled varactor tuning are best adapted to AM stereo because of the more precise, automatic tuning, and bet-

ter immunity to tuning disturbances. However, those types of receivers are not guaranteed to be trouble free. Phase modulation can originate from the PLL comparison frequency and may appear as an audible tone. Extra filtering may be needed on the control voltages from the logic circuits.

6. **The AGC system** of the radio should be checked to determine that it is effective enough to control the system gain to provide a generally constant IF input to the decoder from all stations. The AGC should also be slow enough in its response so that distortion is not introduced in the 25-Hz pilot-tone area. In some radios which use an IC for the AM tuner section, it is not possible to gain access to the AGC'd signals. It is important to test for AGC response after all AGC'd stages.

7. **A problem with AM tuners** using an IC is an IF output voltage that is too low—often only a few millivolts. In this case, a simple, one-transistor amplifier stage must be added to provide the needed 200–350-mV RMS signal to the decoder.

8. **A major advantage** is a radio with a tuned RF amplifier at the front end. The increased sensitivity and selectivity aid in stereo reception and stability.

9. **The IF bandwidth** should be at least 5 kHz and reasonably flat. The bandwidth



FIG. 5—HERE IS A FULL-SIZE foil diagram of the single-sided decoder board.

of AM radios can vary from 2 kHz to more than 10 kHz. The wider the bandwidth, the better the performance and audio quality. (The fact that so many radios have narrow bandwidth has prompted radio stations to pre-emphasize the upper audio frequencies—anywhere from 2 kHz on up—to improve sound quality. Such pre-emphasis will be reduced in the future as AM stereo encourages better receiver designs.

You can see that determining whether a particular radio is suitable for conversion to AM stereo is really the more difficult part of the conversion process. Once the radio has satisfied (or has been modified

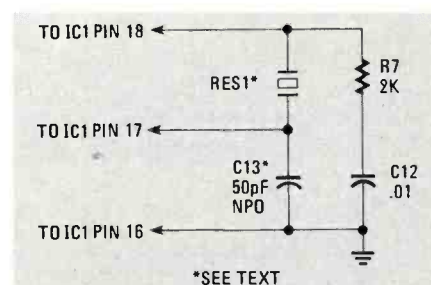

FIG. 6—THE OSCILLATOR CIRCUIT shown here needs an input IF of 450 kHz.

to satisfy) all the requirements, the only remaining need is to find a suitable DC-voltage source in the radio to power the decoder circuit. The source should be 11–30 volts when using the on-board regulator (IC2). Or it should be between 6 and 12 volts if the on-board regulator is not used. The regulator provides about 8.2 volts to the IC, and its use is recommended. The source must be able to deliver up to 40 mA continuously.

### Constructing the decoder assembly

Figure 4 shows the complete schematic of the AM stereo decoder circuit and Fig.

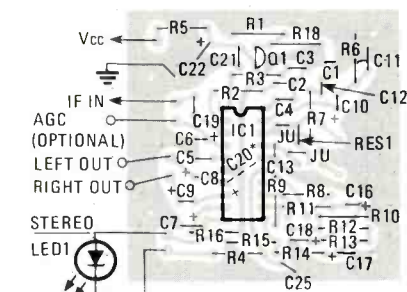

FIG. 7—THE PARTS-PLACEMENT diagram shown here corresponds to the VCO circuit of Fig. 6. Note that C20 is mounted on the foil side of the board.

5 shows a full-size foil pattern for a single-sided printed-circuit board. Before we talk about parts-placement, though, we have to select an oscillator circuit. We will discuss three.

The requirements of the VCO circuit design are not terribly critical—it must provide a one-volt P-P clean sinewave at 8 times the IF frequency to pin 14 of the MC13020P. One circuit that we can use is shown in Fig. 6. The corresponding parts-placement diagram for the decoder is shown in Fig. 7.

Of the three designs we'll discuss, the ceramic oscillator with its matched NPO (temperature-compensated) capacitor is preferred for its stability and simplicity. Both the ceramic resonator (RES1) and its matched (nominally 50 pF) capacitor are available from the source indicated in the parts list.

A quartz crystal can be used instead of RES1, but that will result in an extremely narrow pull-in range—only suitable for stable, accurate digital front ends. The

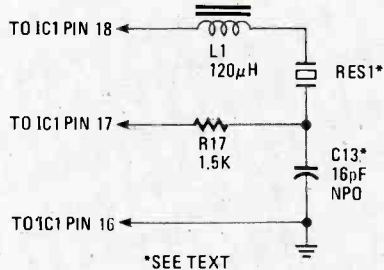

FIG. 8—THIS VCO CIRCUIT can be used if you need to broaden the tuning area to pull the resonator into lock at the required frequency. (Manually tuned radios may require that.)

ceramic resonator permits a much broader pull-in range, but it does have two drawbacks. The available resonator oscillates at 3.6 MHz—that requires a 450-kHz IF input to the decoder. Radios with a 455-kHz IF will have to be re-aligned. The second drawback concerns manually tuned radios. Tuning to the station's center frequency is quite critical. (That's not likely to be a problem with synthesized tuners.) To broaden the tuning area, R7 is added to lower the Q of the VCO. Capacitor C12 provides a DC block.

If greater broadening is needed, L1 and R17 may be added, and C13 changed, as shown in Fig. 8. (The corresponding parts-placement diagram is shown in Fig. 9.) That aids the circuit in pulling the resonator into lock at the required frequency. If L1 and R17 are not used, each must be replaced with a jumper wire as shown.

If your radio does not readily tolerate re-alignment, or if it has an IF of 260 or 262.5-kHz, or if you prefer not to attempt re-alignment, an alternative VCO, using a tunable L-C oscillator circuit, is shown in Fig. 10. It replaces the ceramic-resonator circuit and is very stable. The coil must be tuned so that the oscillator frequency is 8 times the radio's IF frequency. The circuit shown accommodates the 260-262.5-kHz IF range. Coil L2 is an adjustable RF coil made up of 60 turns of No. 36 enamelled wire tightly wound on a 1/8-inch-diameter form with a No. 2 ferrite core, a pot core (ferrite shield) and a shield can.

## PARTS LIST

All resistors 1/4 W, 5%, carbon film

- R1—1300 ohms
- R2, R3—100 ohms
- R4—330 ohms
- R5—10 ohms
- R6—150 ohms
- R7—2000 ohms
- R8—220,000 ohms
- R9, R16—100,000 ohms
- R10—910 ohms
- R11—2700 ohms
- R12—5600 ohms
- R13—1600 ohms
- R14—430 ohms
- R15—7500 ohms
- R17—1500 ohms
- R18—240 ohms

### Capacitors

- C1, C8, C9—1 µF, 10 Volts, electrolytic
- C2, C3, C4, C11—0.0033 µF, ceramic disc, 25–50 volts
- C5—0.001 µF ceramic disc, 25–50 volts
- C6—10 µF, 10 volts, electrolytic
- C7, C17—2.2 µF, 10 volts, tantalum
- C10—33 µF, 10 volts, electrolytic
- C12, C19, C25—0.01 µF ceramic disc, 25–50 volts
- C13—NPO. See Text and Figs. 6, 8, and 10
- C14, C15—0.47 µF, 10 volts, tantalum
- C16, C18—4.7 µF, 10 volts, tantalum
- C20, C21, C24—0.1 µF ceramic disc or monolithic
- C22—100 µF, 35 volts, electrolytic
- C23—see text and Fig. 10

### Semiconductors and other components

- IC1—MC13020P C-QUAM decoder (Motorola)
- IC2—LM317LZ adjustable regulator
- LED1—standard red LED, 20 mA
- L1—120 µH choke
- L2—55 µH coil; 60 turns of #36 enamelled wire tightly wound on 1/8-inch diameter form with No. 2 ferrite core and shield can.
- RES1—Ceramic resonator, Murata CSA2.60MT7 with matching capacitor (C13), Murata CSC500K7

The following are available from Circuit Specialists, Box 3047, Scottsdale, AZ 85257: Complete kit, including PC board and all parts (including parts for the VCO circuit as in Fig. 6 only), \$24.95; Circuit board only, \$4.95; Ceramic resonator RES1 with matching NPO capacitor (as in Fig. 6) only, \$3; MC1320P decoder IC, \$3.50. All prices include postage inside the US.

You can use the circuit in Fig. 10 (it's parts-placement is shown in Fig. 11) with an IF of 450 or 455 kHz by making C13 39 pF NPO and C23 10 pF NPO, and adjusting L2 so that the oscillator's center frequency is eight times the input IF.

Except, perhaps, for some of the oscillator parts, the components required for the decoder circuit are common parts. We recommend that you use tantalum capacitors for the polarized capacitors in the filter circuits at IC pins 10–14. They have

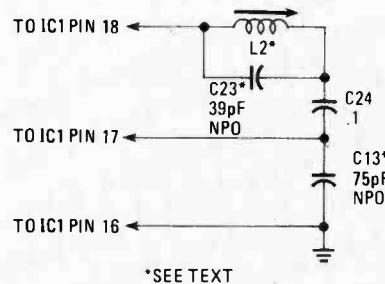

FIG. 10—THIS VCO CIRCUIT can be used to replace the ceramic-resonator circuit if your radio has an IF of 260 or 262.5 kHz. You can also use it with an IF of 450 or 455 kHz if you change the value of C13.

better tolerance and small size. But regular electrolytics, if accurate, can be used with no sacrifice of performance. Non-polarized capacitors may be ceramic-disc types unless otherwise specified in the parts list. The 0.1-µF capacitor, C20—shown in Fig. 4 connected from IC1 pin 6 to ground—should be soldered on the circuit side of the PC board under the IC from pin 6 ( $V_{CC}$ ) to pin 16 (ground); use short leads when installing that unit. Note that there is intentionally no provision for this capacitor in the board layout.

## Converting the radio

The input signal to the decoder must be at least 160 mV RMS for stereo. But for quiet, clean reception, it should be 200–350 mV. That is a typical range for most AM radios. In the radio, the stereo decoder goes where the detector would normally go—after the last IF stage before the detector diode. The radio's detector circuit may be disconnected by removing the diode or disconnecting one lead. In some radios, AGC voltages are obtained from the detector circuit and, in that case, the detector should be left connected. In most instances it won't interfere with the operation of the decoder. In any case, the audio output from the radio's detector must be disconnected, to avoid conflict with the two audio channels coming from the MC13020P.

The decoder assembly may be mounted in any convenient place, but try to keep it

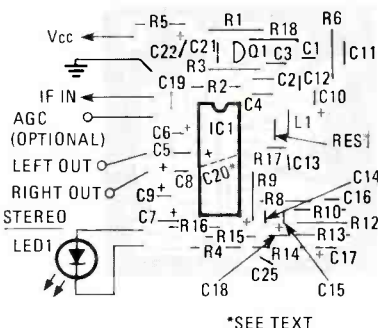

FIG. 9—THIS PARTS-PLACEMENT diagram corresponds to the VCO circuit shown in Fig. 8. Capacitor C20 is the only component mounted on the board's foil side.

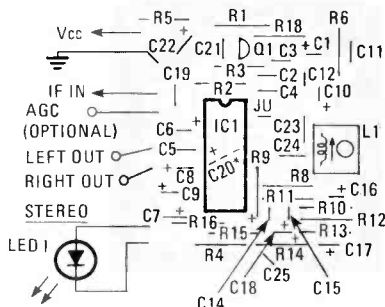

FIG. 11—THE PARTS-PLACEMENT diagram shown here corresponds to the VCO circuit of Fig. 10.

away from major heat sources such as a power transformer, output transistors, and heat sinks.

If the interconnecting wires are more than a couple of inches in length, or if they will pass near power-supply components or wires, then you should use shielded cable. Connect the cable shields to ground at one end only. The ground return wire from the decoder assembly should be connected to the radio's ground bus at the radio's IF output or detector circuit. To avoid ground loops, *this should be the only common ground connection.*

If the receiver has a high IF output (over 350 mV RMS) a series resistor can be added to drop the voltage to the desired level of 200-350 mV RMS at pin 3, the decoder input. The input impedance of the decoder is about 27 kilohms.

Pin 9 of the IC is the FORCED MONO control pin. Grounding that pin locks the decoder in its monaural mode. For automatic mono/stereo switching, pin 9 can be pulled up with a 100-kilohm resistor to the 8-volt supply (as shown in the schematic), or it can be connected to pin 10. (That permits the most rapid re-acquisition of stereo after retuning.) If you look closely at the parts-placement diagrams, you'll notice that, although the jumper is not shown, pads are provided on the board so that you can easily tie pin 9 to pin 10. You could also bring pin 9 out to a switch and manually force the decoder to its monaural mode by switching pin 9 to ground. If that is the case, the 100K resistor must be added. But be sure to remember: Do not add the resistor if you jumper pins 9 and 10.

The left and right audio outputs are "tuner-level" signals (100-200 mV RMS) and can be connected directly to the tuner or auxiliary inputs of a stereo amplifier. If the conversion is in an AM/FM receiver, one that has its own stereo amplifier, the decoder outputs should be connected through the band switch. Capacitors C8 and C9 will provide the necessary AC coupling to the audio circuits.

### Troubleshooting

If the decoder will not go into the stereo mode even with a strong signal, then you should troubleshoot the circuit as we'll describe. Of course, before you start troubleshooting, you have to know that the local radio station is transmitting Motorola C-QUAM stereo—feel free to call the station to be sure.

When you're certain that a C-QUAM signal is being received, (we'll assume that you've checked that the power supply is working correctly and that 8 volts DC is supplied to pin 6) then, using an oscilloscope, look at the following signals:

1. Pin 3—The input signal. The signal envelope (and that at the IF output of the receiver) should show modulation at the top and bottom edges symmetrically. The average amplitude must be 1 volt peak-to-peak,  $\pm 0.4$  volt.

### WHERE TO LISTEN

As we went to press, these stations (listed alphabetically by city) were broadcasting C-QUAM stereo, with almost 50 orders on backlog. (Those stations wished to remain confidential.)

KRZY	1450	Albuquerque, NM	CKNW	980	New Westminster, BC
WSAN	1470	Allentown, PA	KXXY	1340	Oklahoma City, OK
WCHL	1360	Chapel Hill, NC	CJSB	540	Ottawa, ONT
WAIT	820	Chicago, IL	KGW	620	Portland, OR
WFAA	570	Dallas, TX	CJCI	620	Prince George, BC
WJR	760	Detroit, MI	WHWH	1350	Princeton, NJ
KQWB	1550	Fargo, ND	KIPN	1350	Pueblo, CO
WKQT	1010	Garyville, LA	KKLS	920	Rapid City, SD
WGSW	1350	Greenwood, SC	KKYX	680	San Antonio, TX
CKOC	1150	Hamilton, ONT	KFMB	760	San Diego, CA
WIRE	1430	Indianapolis, IN	KYA	1260	San Francisco, CA
WNDE	1260	Indianapolis, IN	KRDZ	1230	Steam Boat Springs, CO
CKOV	630	Kelowna, BC	KJOY	1280	Stockton, CA
WITL	1010	Lansing, MI	CFRB	1010	Toronto, ONT
CFPL	980	London, ONT	KRMG	740	Tulsa, OK
KFI	640	Los Angeles, CA	CJVB	1470	Vancouver, BC
KZLA	1540	Los Angeles, CA	CKWX	1130	Vancouver, BC
WISM	1480	Madison, WI	CKLW	800	Windsor, ONT
WSM	650	Nashville, TN			

2. Pin 17—The VCO input. The oscillator input should be a sine wave of about 1-volt P-P at 8 times the input IF.
3. Pins 7 and 8—The left and right audio outputs. These signals should typically be about 200 mV P-P, centered on a DC level of about 1 volt.
4. Pin 14—Pilot tone. You should see a 25-Hz sine wave that is steady and 0.5-0.8 volts P-P. The amplitude can be increased, if necessary, by decreasing the value of R12 (but to no less than 1.8K). The pilot signal will be present, of course, only if the radio is properly tuned to a station transmitting C-QUAM stereo.
5. Pin 1—L + R signal. This signal looks like the audio signals on pin 7 and 8 but it is centered on a DC level of about 6 volts.
6. Pin 20—L - R signal. This should appear about the same as L + R signal. (If you observe closely, you should also see the 25-Hz pilot tone as a low-amplitude component of the complex waveform.)
7. Pin 10—DC lock voltage. The voltage should be 4 volts in lock, 0 volt out of lock. If it's out of lock, the VCO is not at 8 times the input IF. Adjust the VCO or re-align the radio's IF.
8. Pin 9—FORCED MONO. If wired to pin 10, it must have the same voltage condition as pin 10. If not wired to pin 10, pin 9 must have +4 V DC or higher via a 100k pull-up resistor (R16) to the 8 V supply. If the voltage at pin 9 is at or near 0 V DC, the decoder is held in monaural mode.

If all the above conditions are satisfied, the decoder will switch into the stereo mode. Failure at this point indicates a workmanship problem, defective component, a fault in the receiver system, or an incoming signal that is not correct for C-QUAM stereo detection.

### Proven conversions

In preparation of this article, three radios were converted in our lab. The first was an AM (only) portable radio, a Realistic (Radio Shack) model 12-656A. (It is not listed in Radio Shack's latest catalog.) That radio was chosen because it has an FET-tuned RF amplifier in front, no ceramic filters, (they usually narrow the bandwidth), three tuned IF stages, and a substantial AGC system. Our testing showed that its 3-dB bandwidth was 12 kHz with a very flat response. One AGC voltage is developed from the detector circuit, so the detector was left connected as is. The IF was re-aligned to 450 kHz. The speaker and battery holder were removed to make room for the decoder circuit and a complete 4-watt-per-channel stereo amplifier with volume, balance, bass, and treble controls. The radio's original audio section was disconnected. The radio lent itself readily to the conversion with only one problem. As previously discussed, manually tuned radios often prove to be microphonic. The 12-656A was no exception. The main culprit was the oscillator coil. Filling the coil assembly with beeswax to stop vibration greatly improved it. The tuning capacitor also was sensitive, but no attempt was made to suppress it because of the possibility of damage. Even so, at this point it took a substantial rap on the cabinet to get a little "ping" sound. The radio was connected to a pair of Radio Shack's *Minimus-3.5* speakers that presented a full, clean stereo sound with both laboratory equipment as the C-QUAM signal source and a commercial radio station in Chicago.

The second radio converted was a Sears model 564.50800, a car radio with digitally controlled varactor tuning, FM stereo, and an 8-track tape player. The unit presented a different challenge because of its compact assembly and complexity. The selected frequency is digitally dis-

*continued on page 128*

# TECHNOLOGY



# UNIQUE TEST EQUIPMENT

CHESTER H. LAWRENCE

*A look at what's new, what's sophisticated, and what's unusual  
in test equipment today.*

ELECTRONIC TEST EQUIPMENT ARE THE POTS AND PANS OF AN electronics lab. Without the meters, scopes, generators and all the other devices we use to measure, examine and regulate the electronic equipment that surrounds us in today's world we would soon drown in a maze of very beautiful and sophisticated, but inoperative electronics hardware.

But what is test equipment? The answer to that simple question is complicated. It depends on who you are and what you do. To some, a multimeter is test equipment. In fact, it may be the

only test equipment they need, own or use. To others it's a scope, or a function generator, or an RF signal generator. Most of us have used a digital multimeter, scope, generator, and various component testers. But have you ever used a logic analyzer; a network analyzer; or a portable oscilloscope that has a liquid-crystal display and also sports a memory? These are just some of the very sophisticated and unusual electronic test equipment that can be found in labs around the world. Let's take a look at some of these special instruments.

### LCD digital storage scope multimeter

On the front cover of this issue is one of the most fascinating pieces of test equipment that I have seen lately. It's a simple portable oscilloscope. But that's where the simple ends and the exciting new technology begins. Note the liquid-crystal display and the memory. Take a measurement, carry the instrument away and the measurement is still there in the scope's memory.

The *M 2050* from BBC Metrawatt is a unique combination of a low-frequency digital oscilloscope, a 3½ digit multimeter and a transient recorder with two independent memories tucked into one neat portable package. An expensive oscilloscope if you compare it to conventional equipment, but if you look at the kinds of special jobs it can perform you will soon agree that the price is fully justified.

If there is any disadvantage to the unit it is in its frequency range. Because of the limitations imposed by the display, top frequency is 50 kHz. The price of this unit is \$1795.

First take a look at how small this instrument is—a mere 257mm × 169mm × 88mm when folded, and it weighs only 1.95 kg. Since the display is an LCD device it draws very little power and the battery-powered unit runs other battery-powered scopes into the ground. Thanks to the memory you can capture a waveform while working in a cramped corner, then walk away and examine that pattern and compare it with the ones in your service data later. All-in-all a great example of what technology can do.

When using the instrument, measurements can be evaluated more accurately because the scope and multimeter operate simultaneously. For example, while the scope portion of the display is used to evaluate signal characteristics, the DMM portion can be used to display the true RMS value of the signal. Because the inputs were designed with the voltage- and current-handling characteristics of a digital multimeter in mind, the Digital Scope Multimeter can be used directly for high-voltage measurements. Up to 500 volts can be applied to the 200-mV range without damaging the instrument. On all other voltage ranges 780-volt overload protection is provided.

Operating as a scope, the *M 2050* digitizes analog signals at a 500 kHz rate. At 10 samples per cycle, the effective bandwidth is 50 kHz. The transient recording capability of the instrument enables the operator to use two independent 0.5K × 8-bit memories to record data. It can capture events as brief as 2 ns. Once recorded, data from either memory can be recalled and displayed for analysis. Waveforms can be retained in memory for months. An analog output makes it possible to make a hard copy of the data when connected to a strip recorder.

### Logic analyzer

As stated in the latest Hewlett-Packard catalog, logic ana-

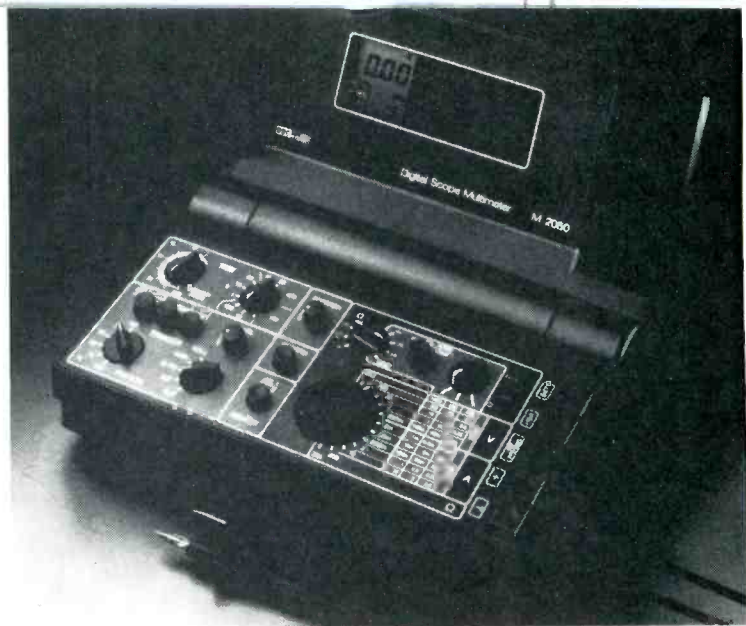

**NEW FLAT-PANEL OSCILLOSCOPE**, model M 2050, from BBC-Metrawatt/Goerz combines the functions of a digital oscilloscope, a 3½-digit multimeter, and a transient recorder into a single, portable instrument.

lyzers are powerful measurement tools for today's complex digital systems. They are essential during the critical phase of integrating hardware and software. Costly design errors can be avoided.

When digital products are in production or operational, a logic analyzer is the instrument that quickly isolates a problem and decreases downtime. In a new line of logic analyzers recently introduced by Racal-Dana a new dimension is added to this instrument's capability—a fast, easy-to-use, effective software debugging tool. The model 205, an example of a top-of-the-line instrument, is priced at \$6995. It offers 48 channels of state analysis and 16 channels of waveform plus many significant features, including a 16-channel word generator, 12K bytes of non-volatile memory and a GPIB (General Purpose Interface Bus) interface. A more detailed discussion of the GPIB appears later in this article.

Applications for logic analyzers are not limited to the laboratory. Data and information gathered by using these instruments during design and development does not have to be put up on a shelf leaving the people in production, testing, quality control, and service to rediscover facts already known. With good planning and design, physical connections and simple routines for logic analyzers can be built right into the equipment the instrument has helped to design. This will provide for quick troubleshooting and efficient maintenance even after the product is in use.

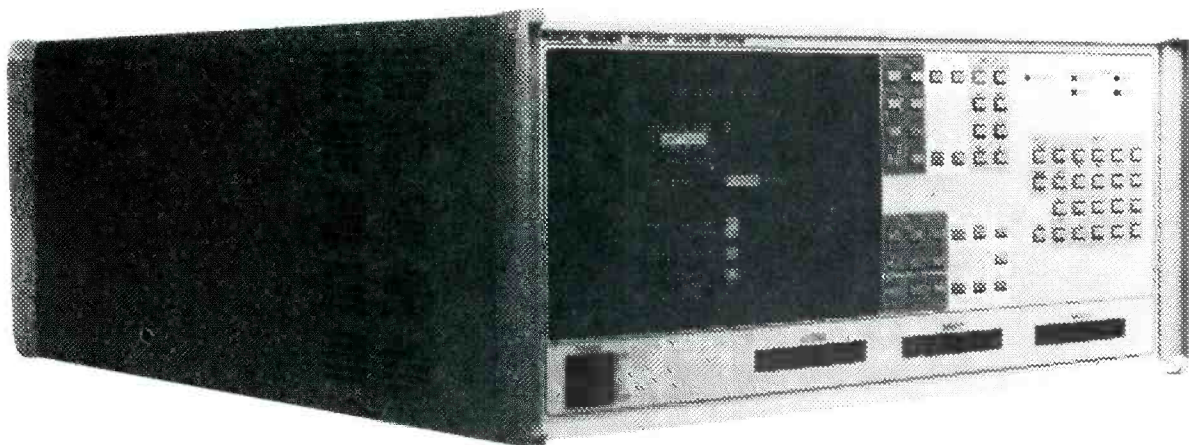

**FULL-FEATURED LOGIC ANALYZER** from Racal-Dana offers 48 channels of state analysis and 16 channels of waveform. The model 205 also includes a 16-channel word generator, 12K bytes of non-volatile memory and a GPIB interface standard.



**NEW LINE OF DIGITAL MULTIMETERS**, the 70 Series from Fluke, introduces some significant changes in DMM technology. The bar pattern across the bottom of the digital display is an analog display that greatly enhances the capabilities of the instruments.

### Digital multimeters

If you want to look at extremes, here are two instruments, both with the same name, but each at opposite ends of the DMM spectrum. The John Fluke Manufacturing Company is a major manufacturer of digital multimeters. At the top end of the spectrum they produce their model 8506A, a unit that they claim delivers performance at the edge of technology. I must agree. This instrument has  $7\frac{1}{2}$  digits of resolution, a 24-hour accuracy of 120-parts-per million from 40 Hz to 20 kHz and a stability of 30 parts-per-million. The instrument's top notch accuracy is attributed to the use of a thermal-RMS detection technique based on the heat dissipated by a resistor. As a result the instrument's response is relatively independent of the input signal's waveform and full accuracy can be guaranteed for a wide range of input signals.

The only problem with this instrument is that it represents drastic overkill for most digital-multimeter applications. It's a lot like hiring a Greyhound bus to take one person from place to place instead of using a taxi.

At the other end of the spectrum is Fluke's newest and least expensive digital multimeters, a line of three instruments in the 70 Series. Starting at \$85 and packed with a variety of high-priced features, including an analog liquid-crystal display for reading peaks. I think that this meter represents a new standard for the test-equipment industry and foretells the future of portable-multimeter technology. For more details on this instrument see the Equipment Report elsewhere in this issue.

### Synthesized signal generator

Over its entire range of 80 kHz to 520 MHz, all you need do is punch out the frequency, the modulation and the RF level of the desired signal on the front-panel keyboard and you have it at the output. Designed by Marconi Instruments to test transmitters and transceivers, frequency resolution is within 10 Hz at all frequencies. RF output up to +13 dBm is available at all frequencies and microprocessor control provides operating simplicity and speeds up routine measurements. A non-volatile memory stores up to 10 generator settings and a further 40 carrier-frequency values. The memory also stores calibration information. Microprocessor-aided fault diagnosis lets the user, from the front panel of the instrument, pinpoint the section of this instrument that is not functioning properly.

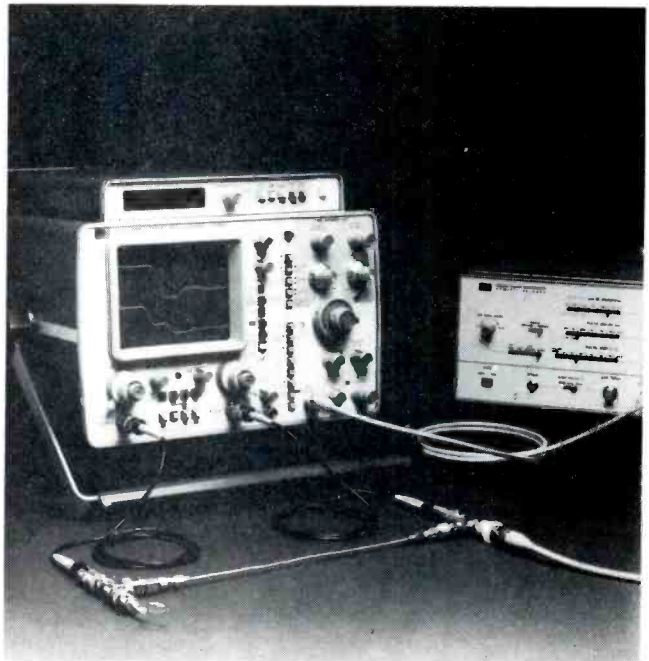

**PROPAGATION DELAY CAN BE MEASURED ACCURATELY** with the HP 1726A time-interval oscilloscope. In this photo a 10-inch length of semi-rigid coax cable has a delay of -1.43 ns. The minus sign indicates that the channel A signal occurs later than the channel B signal.

### Time-interval oscilloscope

Offering 50-picosecond accuracy and 10-picosecond resolution the new Hewlett Packard HP 1726 scope makes fast, reliable timing measurements on complex repetitive signals. The instrument combines counter and oscilloscope technologies. It has the viewing and measuring capabilities of a 275-MHz scope and the ease of use of a time-interval counter. That is particularly useful to those making frequent timing measurements.

Designed to make precise timing measurements, the HP 1726 uses a crystal-referenced time base in conjunction with a CRT and stable triggering circuits. This combination makes it possible for the instrument to display the signal being tested as well as to measure the designated interval with up to 50-picosecond accuracy. At \$7,675, the HP 1726 is far from cheap, but for the high-technology and high-performance portion of the electronics industry it meets the requirement found in fundamental areas of research-and-development labs, production, and service. As a diagnostic tool the unit is excellent for characterizing designs, processes and entire test systems.

### Digital module tester

The most advanced automatic test equipment technology in a compact 28-pound package is the way Bendix introduces its model 9070 digital module tester. The primary purpose of this instrument is to separate bad circuit-card assemblies from good ones. It can handle GO/NOGO screening and fault isolation diagnostics on everything from a simple circuit card to a complex system. It works in the field, on the bench, or on the production line. The highly sophisticated instrument tells the operator what to do—step by step; it signals when a fault is detected and displays test results instantly.

In the field, the portability of the 9070 makes it possible to take the tester to the problem and find the fault there. This does away with board swapping and cuts down on the number of boards in the service pipeline. Good boards stay on the job. Obviously this is not used in simple systems or where the boards being tested are relatively inexpensive. In those instances, simple board swapping is more efficient and less expensive. At the repair shop the unit finds faults that need repair in bad boards quickly and automatically, delivering the kind of quick turnaround and throughput that is needed for an efficient shop testing operation.

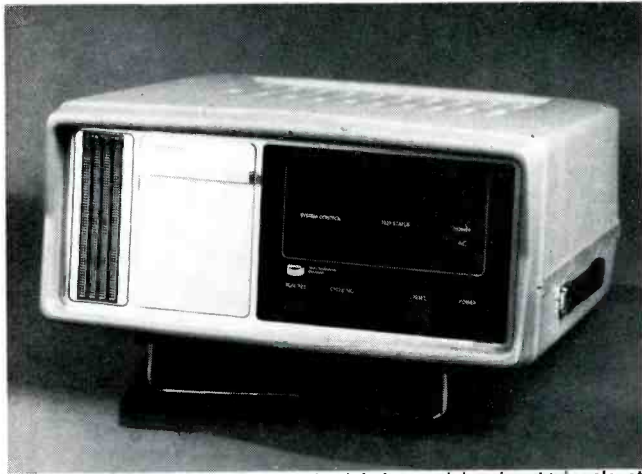

**DIGITAL MODULE TESTER** does its job by applying input signals at designated input pins and certifying predicted responses at designated output pins. This tester is the Bendix Model 9070.

To do its job the 9070 applies input signals at designated input pins and verifies predicted responses at designated output pins. Any sequence or combination of the following input signals may be used for each individual test:

- Input logic pattern
- Change of state at one pin or simultaneous change of state at multiple pins
- Sequential change of state at selected pins
- Single or multiple clock pulses at individual or group of pins

Output response may be verified by any of the following methods:

- Full output go pattern
- Change in output at single or multiple pins from prior test
- Specific logic level at single or multiple pins

Maximum system capability is 256 active input/output pins. All pins are programmable; no dedicated adapter is required.

### Universal disturbance analyzer

Anomalies on the AC power lines can affect computers and other sensitive microprocessor-based instruments. To counter this problem is the Dranetz Technologies Series 626—*Universal Disturbance Analyzer*. This is a modular, portable microprocessor-based instrument made up of a mainframe and up to five individual plug-in modules. By choosing the appropriate plug-ins the user can monitor single-phase AC, 3-phase AC, DC voltages, common-mode AC voltages, and logic event changes-of-state.

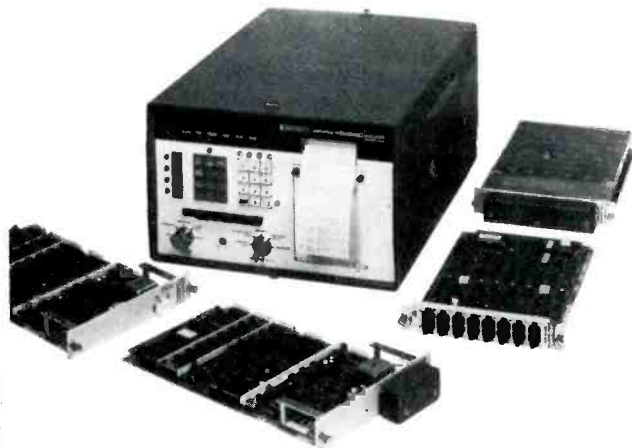

**TOGETHER WITH SOME OF ITS INPUT MODULES** is the Series 626 Universal Disturbance Analyzer from Dranetz. This unit can spot and record anomalies that affect computers and other sensitive microprocessor-based instruments.

The *Universal Disturbance Analyzer* is specifically designed for use in the computer field-service industry and continuous on-site monitoring of computer operations. Voltage disturbances are printed out in industry-standard terms of sags, surges, and impulses (including impulse duration). In addition, the 626 will have applications in the analysis of power problems associated with telecommunications systems, industrial process-control systems, medical instrumentation and, of course, the entire range of microprocessor-based equipment.

### Testing cellular-radio receivers

What do you use to test these state-of-the-art receivers? Boonton Electronics says try their model 1021 programmable RF signal generator. It has a frequency range to 1.08 GHz and covers all of the requirements for high-speed testing of cellular receivers. Switching time between channels is 50 ms. Output levels to +16 dBm, SSB noise of less than -113 dBm, residual FM below 12 Hz at 900 MHz, and FM distortion of 0.05%. In addition, the low-distortion, internal, modulation oscillator can be used as an audio oscillator with programmable frequency and level. The generator can be controlled manually, automatic via GPIB, or preset to recall up to 250 complete panel setups from an integral non-volatile memory. Oh, about the price....a mere \$16,950.



**IF YOU'RE SERVICING CELLULAR RADIO** equipment, a programmable RF signal generator like the Boonton Electronics model 1021 is what you need. The special feature is that it covers the requirements for high-speed testing of cellular receivers.

### Component and circuit tester

The *TR-1 Tracer* from Non-Linear Systems is not an expensive instrument, but it is a fascinating one because of the wide range of tests it will perform. How does one describe it? Well it is an in-circuit and out-of-circuit tester of components and networks. Signature analysis patterns provide the key to rapid fault finding. The unit tests all parameters simultaneously of circuit boards or individual components without power-up. Dual inputs make it snap to compare a known good component with a suspect.

When testing equipment the *TR-1* locates shorts, opens, and wrong parts in a minimum of time. Since the unit works equally well in or out-of-circuit it can also be used in receiving inspection for qualitatively checking a variety of components. Because the unit conducts dynamic testing rather than static testing it can detect faulty parts suffering from defects such as noise leakage, temperature instability and intermittent deficiencies that might go undetected using other methods. You are sure to find many additional applications for this device. Battery powered and easily portable, it's a handy companion in the field.



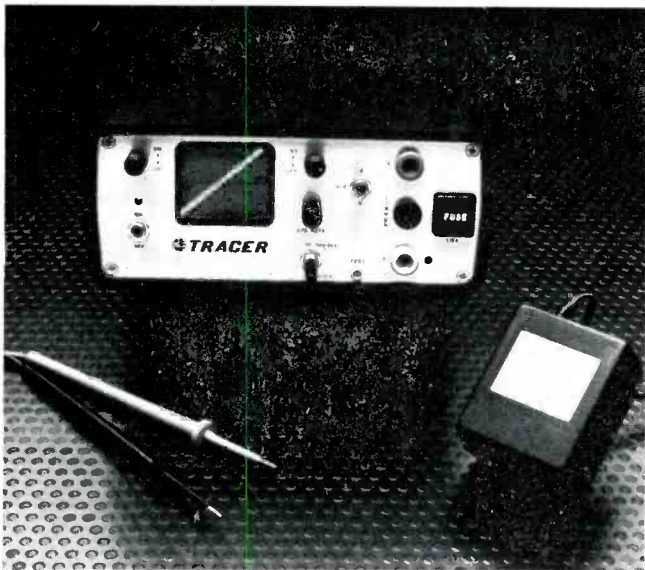

IN-CIRCUIT OR OUT-OF-CIRCUIT the Non-Linear Systems Tracer checks out and troubleshoots circuits, subassemblies and components rapidly and accurately. All tests can be performed without powering-up the circuit being checked.

### Inexpensive frequency counter

Not all good things must be expensive. Here's a frequency counter that ranges from 5 Hz to 1 GHz, yet costs only \$575. It's the Global Specialties model 6002. It also measures period from 1  $\mu$ S to 200 ms. Also, there are three selectable resolutions with LED indicators and simple push-button control. A 10-MHz crystal oven oscillator time-base assures  $\pm 0.5$  ppm,  $\pm 1$  ppm/year stability.

The unit is intended for use for audio/VHF in communications, data processing, process control, RF design, digital design, quality control, and maintenance. There's an 8½-digit display featuring leading-zero blanking, 0.43-inch tall characters and a contrast-enhancement filter.



ARE 8½ DIGITS ENOUGH in a frequency-counter display? The model 6000 frequency counter from Global Specialties provides that display of the frequencies it measures.

### Calibration standard

DC voltage/current portable calibration standard that's NBS (National Bureau of Standards) traceable is a handy instrument to have around. And the Data Precision model 8200 delivers higher effective resolution, higher stability, exceptional accuracy and great flexibility in a unique new way. This instrument is an extremely accurate microcomputer-based, remotely programmable, line-powered portable standard for the transfer of NBS reference values to instrumentation and equipment in a broad range of working environments—in the lab, in the quality-acceptance quality-control department, and on the production floor.

When operating in the manual mode, the 8200's 6-digit control network is controlled by setting its associated rotary switches to any reading between 000000 and 1048575 plus polarity indication, with appropriate decimal point location. (The internal microcomputer translates from binary to BCD, so you read

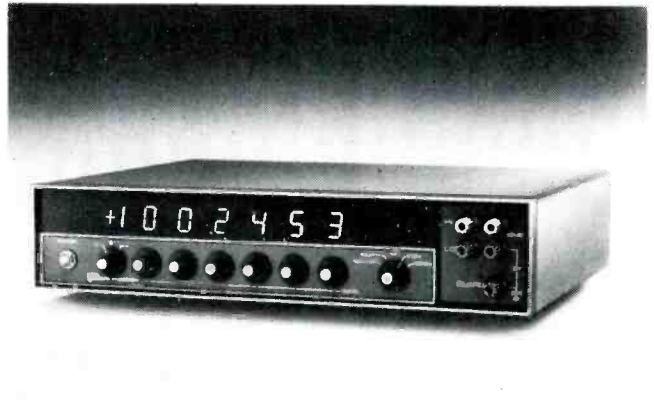

INCREMENTATIC DC VOLTAGE/CURRENT portable calibration standard allows unlimited use of any one decade with full borrow/carry to and from all more significant digits. This instrument is the model 8200 from Data Precision.

the output in decimal values.) The desired values appear above the rotary switches displayed on a set of LED's. The unusual *Incrementatic Control Feature* enables the operator, using any one rotary switch to control not only that particular decade, but all of the successive significant digits.

Thus external instruments can be exercised down to any resolution, step after step, using only one knob for a particular test-run resolution. This feature is extremely useful when measuring linearity of D/A and A/D converters, as well as the transfer function and linearity of analog function modules such as multipliers and dividers.

### Arbitrary waveform generator

So you want to generate custom waveforms. The Wavetek model 175 will do that job for you. It lets you tailor your own waveform. Any waveform that can be drawn can be entered into this versatile instrument and then generated as an output.

This unusual device stores waveforms as digital points on a 256  $\times$  255 data grid. These points are sampled by a crystal-controlled clock at selectable times up to 200 nanoseconds. Amplitude can be varied a full 20 volts peak-to-peak with 3-digit resolution. Waveform shape data is entered in any one of four RAM memories through the front-panel keyboard or the GPIB. You enter the data for each change-of-slope location and the internal microprocessor connects these points. In addition, plug-in sockets are provided for four PROM's so you can create a permanent library of your most used waveforms. One place that this instrument is invaluable is in medical electronics where you can create the many irregular waveforms that are often required.

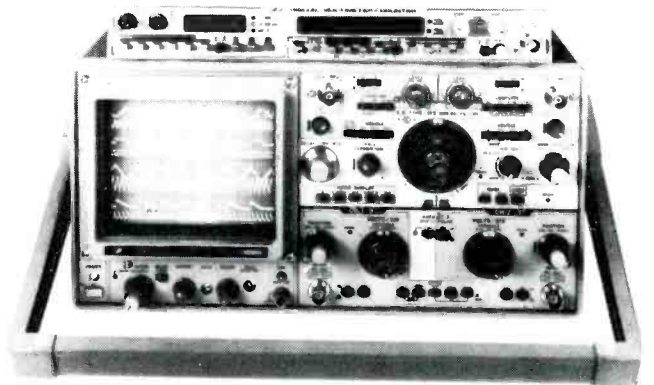

THE MODEL SS-5711D four-input, eight-trace, portable oscilloscope from Iwatsu. It also features a digital multimeter.

## MANUFACTURER LIST

**BBC-Metrawatt/Goerz**  
6901 West 117 Avenue  
Broomfield, CO 80020

**Bendix Corporation**  
Test Systems Division  
Teterboro, NJ 07608

**B&K Precision**  
6460 West Cortland Street  
Chicago, IL 60635

**Boonton Electronics**  
499 Pomeroy Rd.  
Parsippany, NJ 07054

**Data Precision Corp.**  
Elect Avenue  
Danvers Indl Pk  
Danvers, MA 01923

**Dranetz Engineering Labs**  
1000 New Durham Road  
Edison, NJ 08817

**John Fluke Manufacturing Co.**  
PO Box C9090  
Everett, WA 98206

**Global Specialties Corp.**  
70 Fulton Tr.  
PO Box 1942  
New Haven, CT 06509

**Hewlett-Packard**  
3000 Hanover St.  
Palo Alto, CA 94304

**Iwatsu Instruments**  
120 Commerce Rd.  
Carlstadt, NJ 07072

**Marconi Instruments**  
100 Stonehurst Ct.  
Northville, NJ 07647

**Nicolet Instrument Corp.**  
5225 Verona Rd.  
Madison, WI 53711

**Non-Linear Systems**  
533 Stevens Avenue  
Solana Beach, CA 92075

**Racal-Dana**  
4 Goodyear St.  
PO Box C-19541  
Irvine, CA 92713

**Tektronix**  
PO Box 1700  
Beaverton, OR 97075

**Wavetek Inc.**  
9045 Balboa Avenue  
San Diego, CA 92123

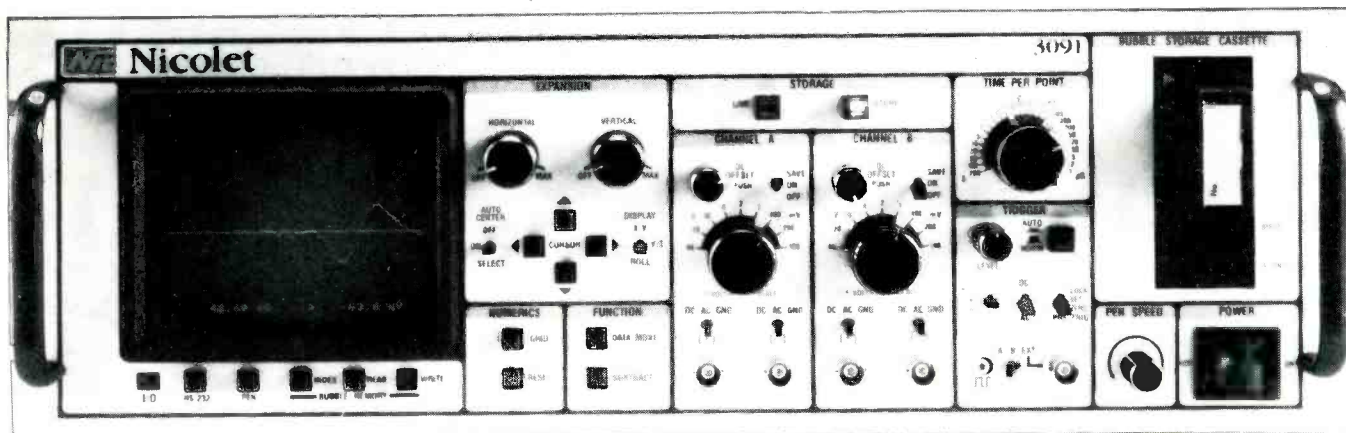

THIS RACK-MOUNT oscilloscope, the 3901 from Nicolet, features a digital readout and a bubble memory for storage.

### NTSC Color-Bar Generator

With all the attention that video gets these days, thanks to the VCR, videodisc player and video cameras, a good NTSC generator is increasingly valuable. One moderately-priced, yet quality unit is the model 1250 made by B&K. It is a cost-effective unit for broadcast, CATV, and industrial television applications. It's also useful for aligning and troubleshooting VCR's.

This unit accurately generates the standard NTSC bar pattern with an 1WQ signal occupying the lower quarter of the pattern as well as the full-screen color-bar pattern. There's also a five-step staircase pattern with selectable chroma levels. Dot, cross-hatch, dot-hatch, center-cross patterns, and color raster are also available.

### Fiber-optic cable tester

With the importance of fiber-optic cables in electronic communications constantly growing an electronic device to test these cables was sure to be close behind. Enter the Tektronix OF150 Fiber Optic TDR. This high-performance, easy to use instrument performs repeatable, accurate distance and loss measurements on multi-mode optical cables. Typical applications include: splice measurement though a one-way cable loss of up to 21.5 dB within  $\pm 0.1$  dB; detection of fiber ends though a one way cable loss of up to 42.5 dB; and measuring distance to discontinuities to 19.9 km, with 1-meter resolution.

The OM150 delivers direct LCD readout of results. A built-in chart recorder provides a permanent record of the waveform.

### GPIB compatibility

The General Purpose Interface Bus (GPIB) was established in 1975. Three years later, in 1978 the IEEE standard defining this bus was further refined, defining an interfacing system that has become a widely accepted instrument industry standard. The major areas it specifies are:

Mechanical—the interface connector and cable.

Electrical—the logic signal levels and how the signals are sent and received.

Functional—the tasks an instrument's interface may perform (such as sending data, receiving data, triggering the instrument) and the protocols to be used.

Today, a wide variety of instruments include interfaces conforming to this mechanical, electrical and functional standard. With GPIB compatibility, measurement capability can be chosen off-the-shelf and simply cabled with standard bus cables in either a linear or star configuration.

### Some closing comments

Obviously an article of this nature cannot include every exciting new instrument, nor can we possibly mention every manufacturer of quality test equipment. Please don't think that the instruments and manufacturers mentioned in this article are the only ones that we have seen. Scores of new instruments are announced each month and what we have tried to do here is bring you a sampling and cross-section of those that have interesting and sometimes different features.

R-E

# BUILD THIS

## Solid State BAROMETER

Measuring and charting the atmospheric pressure has long been recognized as an effective way to make weather forecasts. Now you can build this state-of-the-art barometer and make your own weather predictions.

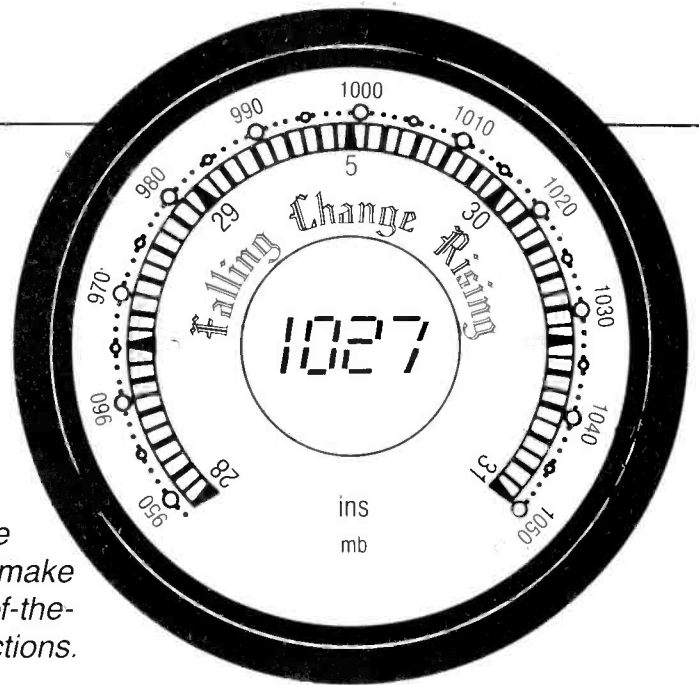

SUDHIR K. GUPTA

BEFORE WEATHER SATELLITES CAME INTO use, the barometer was perhaps the most useful instrument for providing information about future changes in the weather. Both mercury and aneroid barometers have long been used to measure the atmospheric pressure. But we're going to show you a new type of barometer—a barometer that uses a state-of-the-art solid-state pressure transducer and gives a digital readout of atmospheric pressure.

The barometer that we'll build can be thought of as being made up of four basic building blocks. As shown in Fig. 1, they include the pressure transducer, power supply, signal conditioner, and the measurement-and-display section. Let's look at each separately.

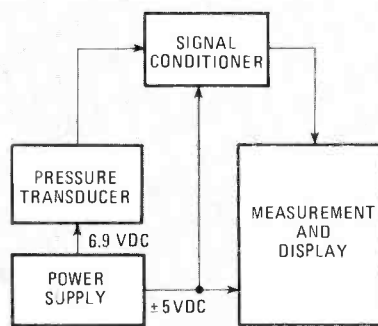

FIG. 1—THE SOLID-STATE BAROMETER can be thought of as being made up of four blocks of circuitry.



FIG. 2—THE LX0503A pressure transducer is ideal for barometric applications.

resistance of the piezoresistive elements changes as the pressure changes, and thus the output voltage changes. The voltage on pin 6 ( $V_1$ ) increases with an increase in pressure. The voltage on pin 5 ( $V_2$ ) decreases (or goes negative) with increasing

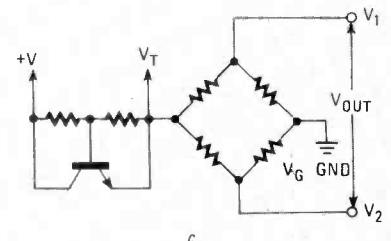
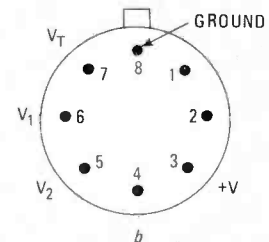
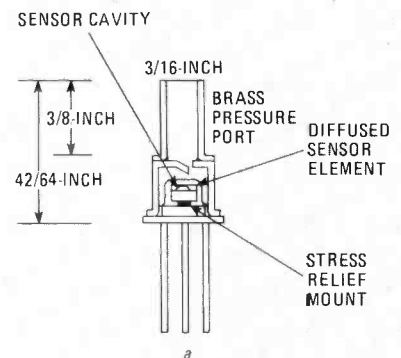

FIG. 3—THE STRUCTURE of the LX0503A is shown in *a* and its pinout is shown in *b*. The schematic of the device is shown in *c*. We will not use the  $V_T$  pin, which is normally used for temperature compensation.

pressure.

The signal-conditioner section is necessary to provide zero and offset corrections for the transducer output. The signal

from the transducer (about 40 millivolts) is amplified to about 1 volt. That corresponds to a display of 100 kilopascals (abbreviated kPa). We'll discuss that unit, and others, shortly.

We want the power-supply section to provide +5 volts DC for the signal-conditioning and measurement section as well as 6.9 volts DC for transducer excitation. Therefore we can use an AC adapter that provides 8–11 volts DC. Such adapters are readily available from many sources, including Radio Shack. The adapter's output is filtered and regulated by IC3, a 7805 5-volt regulator. A monolithic voltage converter, IC4 (an ICL7660 from Intersil) provides –5 volts DC. Finally, a Zener diode is used to provide 6.9 volts DC to the transducer.

The measurement-and-display section is based on a single-IC A/D converter from Intersil: their ICL7106. The author's prototype used Intersil's ICL7106 EV panel-meter evaluation kit for a display. It is capable of displaying 199.9 millivolts or 1.999 volts full-scale. In our application, the full-scale reading is set to 1.999 volts.

### Circuit description

Conventionally, the pressure transducer is powered by a 10–15-volt DC power supply, and a 6.9-volt Zener diode is shunted across the supply terminals (pins 3 and 8). That provides an excitation voltage of 6.9 volts DC. Unfortunately, when that is done, there is a common-mode voltage of about 1.8 volt DC at the signal-output terminals (pins 5 and 6). We do not want the small transducer output signal of 30–40 millivolts to ride on such a large common-mode signal.

To get around that problem, we can either use an expensive instrumentation amplifier with large common-mode rejection ratio (CMRR), or we can play a trick. That is, we can use a bipolar supply of  $\pm 5$  volts DC instead of a 10–15 volt DC supply. As shown in Fig. 4, we can connect pin 3 directly to +5 volts DC and we can connect pin 8 through a dropping resistor to –5 volts DC. (We can obtain the –5 volts from the ICL7660 that we discussed earlier; the power-supply schematic is shown in Fig. 5. The ICL7660, incidentally, is listed in this year's Radio Shack catalog.) A precision Zener reference across pins 3 and 8 regulates the voltage to 6.9 volts DC. That technique reduces the common-mode voltage to a mere 100 millivolts. Now it is feasible to use a conventional op-amp (like the LM324) as a differential amplifier.

One quarter of that quad op-amp (IC1-a) is used as a differential amplifier. It amplifies the input signal by a factor of about 22. We use IC1-b, another section of the LM324 quad op-amp to introduce the offset that will be required to calibrate the barometer. The signal is further ampli-

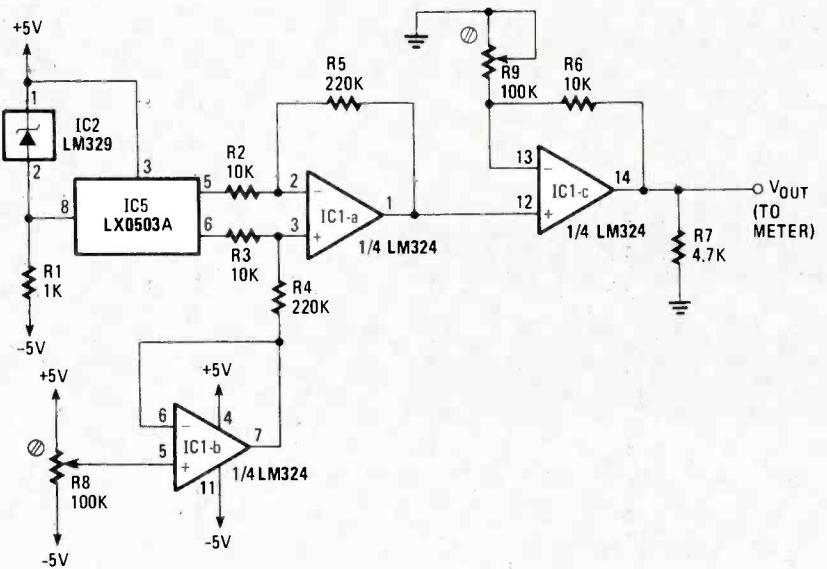

FIG. 4—A ZENER DIODE is used to regulate the transducer's input voltage to 6.9 volts.

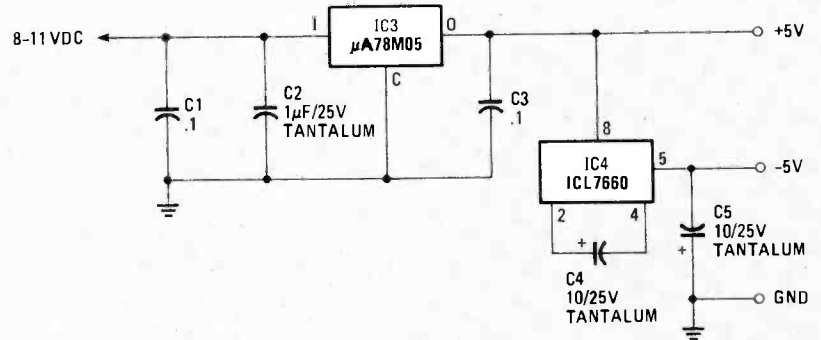

FIG. 5—THE POSITIVE 5-volt supply is easily converted to a bipolar supply by using the ICL7660 voltage converter.

fied by IC1-c to about 1 volt. That gives us a scaling factor of 10 millivolts per kilopascal.

### Scaling the display

Barometric pressure is expressed in a variety of units, including pounds-per-square-inch (psi), bars, millibars, pascals, inches of mercury, atmospheres, torr, etc. Table 1 is a conversion chart to help you convert from one unit to another. To use that chart, look across the top for the unit you want to convert *from* then look down the side for the unit you want to convert *to*. Multiply the units you have by the conversion factor indicated by the table, and your answer will be in the units you want.

Because we are using a 3½-digit display, the maximum resolution is obtained when the pressure is displayed in kilopascals (millibar/10) or millibars. A barometric scale of 95 kilopascal (28 inches of mercury) to 105 kilopascal (31 inches of mercury) more than covers the useful barometric pressure range. You may think that using the unit of pascal (a unit that you've probably never heard of) is not a

good idea. However, that's not necessarily so. The pascal is the standard unit for pressure or stress in the International System of Units (SI). ANSI (the American National Standards Institute) has adopted the pascal as its standard pressure unit. It is equal to one newton per square meter (N/m<sup>2</sup>). Weather reports often give barometric readings in millibars as well as in inches of mercury just as they give temperature readings in both Fahrenheit and Celsius. Conversion from kilopascals to millibars is simply a matter of multiplying by a factor of 10.

### Construction

The project is built in two parts; the transducer/power-supply board, and the display board. A suggested layout for a printed-circuit transducer board is shown in Fig. 6. A parts-placement diagram is shown in Fig. 7. However, it's not really necessary to use a PC board. It is just as well to use perforated construction board and point-to-point wiring. We do, however, recommend that you use IC sockets for all IC's.

As we mentioned before, the display

## PARTS LIST

All resistors 1/4 watt, 5% unless otherwise noted

R1—1000 ohms

R2,R3,R6—10,000 ohms

R4,R5—220,000 ohms

R7—4700 ohms

R8,R9—100,000 ohms, multiturn trimmer potentiometer

### Capacitors

C1,C3—0.1  $\mu$ F, ceramic disc.

C2—1  $\mu$ F, 25 volts, tantalum

C4,C5—10  $\mu$ F, 25 volts, tantalum

### Semiconductors

IC1—LM324 quad op-amp.

IC2—LM329 6.9-volt precision voltage reference

IC3— $\mu$ A78M05 5-volt regulator (Fairchild) or similar

IC4—ICL7660 voltage converter (Intersil)

IC5—LX0503A pressure transducer (SenSym)

**Miscellaneous:** IC sockets PC or perforated construction board, Intersil evaluation board ICL 7106 EV kit or any meter with a 2-volt range, AC adapter, 8–11 volts DC

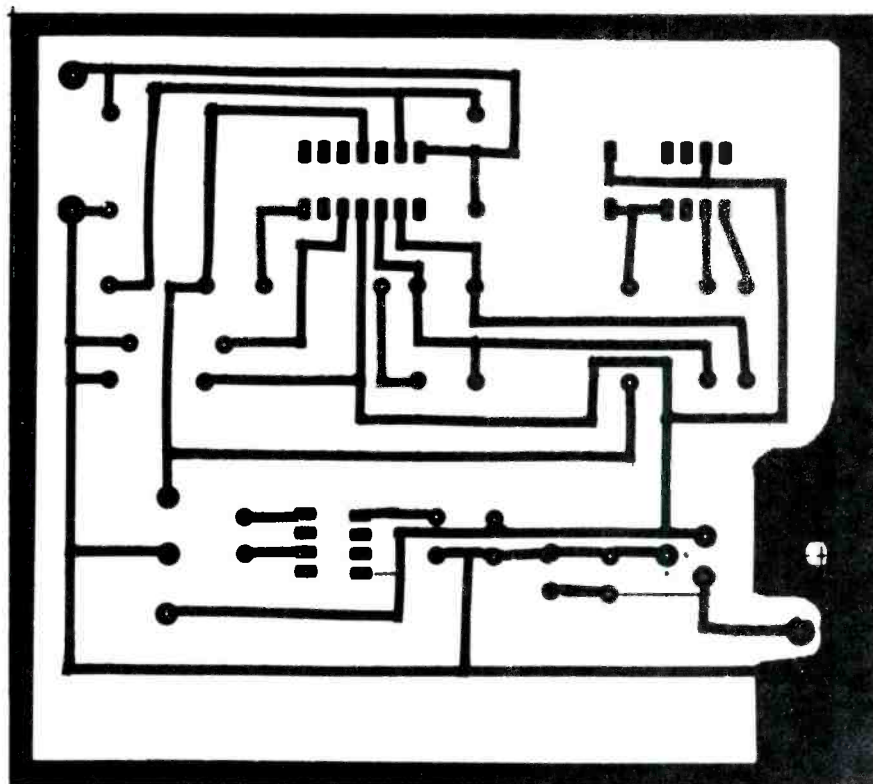

FIG. 6—FOIL PATTERN for the barometer is shown full-size above. The layout is not critical, and point-to-point wiring can be used—but be sure to use a socket for the transducer.

section of the author's prototype is based upon an evaluation board from Intersil—their ICL 7106 EV kit. That was used as a dedicated display. If you want to avoid the expense of that kit (about \$35), you can use an ordinary digital voltmeter or even an analog meter with a full-scale range of 2 volts DC.

If you do use the Intersil evaluation board, follow the instructions that are supplied with it to set the full-scale display to 2.000 volts. Keep in mind that there is no need to use a battery to power the ICL7106 EV—the transducer/power-supply board generates  $\pm 5$  volts that can be used for powering the display board. Connect +5 volts to the  $v+$  input on the evaluation board and -5 volts to the  $v-$  input. We should note here that the current drain from the +5-volt supply should be limited to a few milliamperes. Otherwise, degradation of -5-volt supply will result. You

should, however, have no problem powering the display.

As we mentioned before, the use of IC sockets is strongly recommended. The pressure transducer can be installed in an eight-pin socket. But don't install it—or any IC's—yet. First install all resistors, capacitors, potentiometers, and IC sockets. Check for solder bridges and clean all of the flux off the board. If you used point-to-point wiring, be especially careful of cold-solder joints. When you have double-checked your work, you can install all the IC's except the transducer.

Apply 8–11 volts DC to the transducer/power-supply board and check for  $\pm 5$  volts DC at the output indicated in the parts-placement diagram of Fig. 7. Also check for 6.9 volts DC at the transducer socket. Bend the transducer pins, recheck the orientation, turn off the power, and install it in the socket. If you wish, you may install the transducer remotely and connect it to the transducer board through a four-wire shielded cable.

You can mount the unit in just about any cabinet, but you should keep the transducer outside the cabinet, or make

TABLE 1—CONVERSION FACTORS

	PSI	PASCAL	kPa	MILLIBAR	in.Hg	mm Hg	ATM	TORR
PSI	1	$1.4504 \times 10^{-4}$	0.1450	$1.4504 \times 10^{-2}$	0.49118	$1.9337 \times 10^{-2}$	14.696	$1.9337 \times 10^{-2}$
PASCAL	$6.8946 \times 10^3$	1	1000	.100	$3.3865 \times 10^3$	133.32	$1.0132 \times 10^5$	133.32
kPa	6.8946	$1 \times 10^3$	1	10	3.3865	0.13332	$1.0132 \times 10^2$	0.13332
MILLIBAR	68.946	$1 \times 10^{-2}$	10	1	33.865	1.3332	$1.0132 \times 10^3$	1.3332
in.Hg	2.0359	$2.9529 \times 10^{-4}$	0.2953	$2.9529 \times 10^{-2}$	1	$3.9368 \times 10^{-2}$	29.920	$3.9368 \times 10^{-2}$
mm Hg	51.714	$7.5006 \times 10^{-3}$	7.5006	0.75006	25.401	1	760.00	1
ATM	$6.8045 \times 10^{-2}$	$9.8692 \times 10^{-6}$	$9.8692 \times 10^{-3}$	$9.8692 \times 10^{-4}$	$3.3422 \times 10^{-2}$	$1.3158 \times 10^{-3}$	1	$1.3158 \times 10^{-3}$
TORR	51.714	$7.5006 \times 10^{-3}$	7.5006	0.75006	24.401	1	760	1

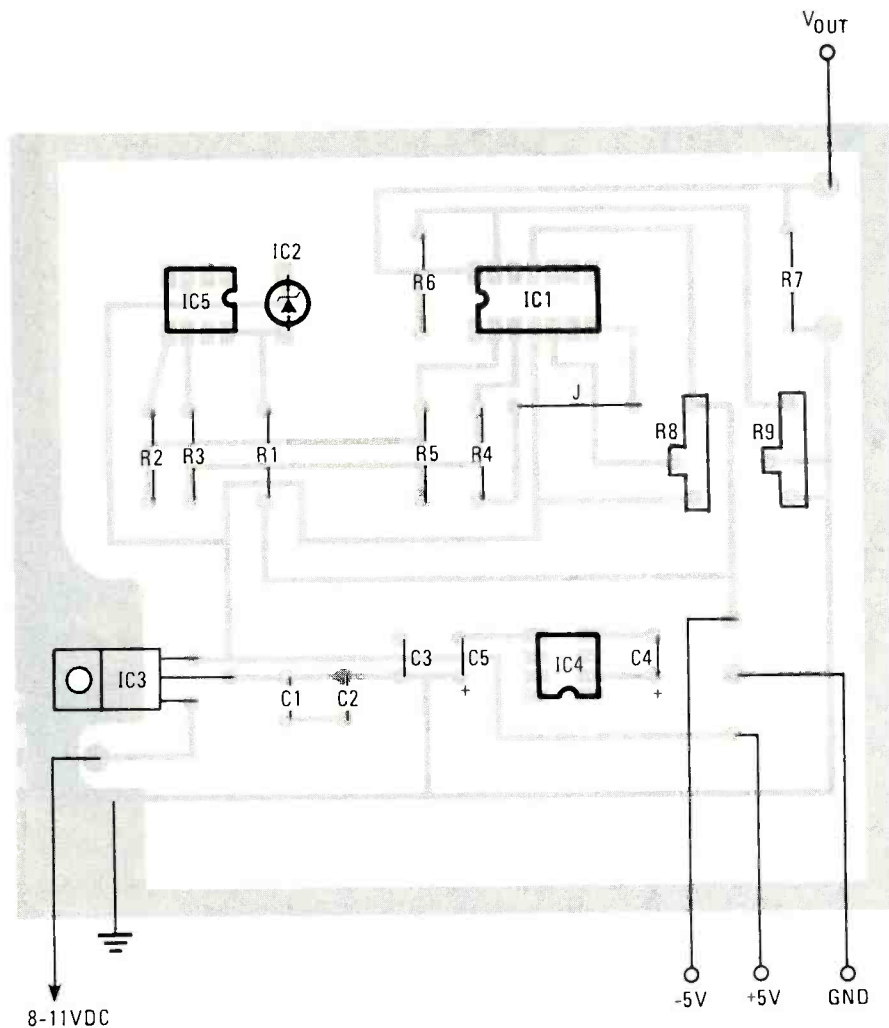

FIG. 7—THE PARTS-PLACEMENT diagram for the foil pattern shown in Fig. 6.

sure that your cabinet is not-tight fitting. The best place to mount the unit is in an old aneroid barometer. Then you not only have an interesting conversation piece, but you can also use the old barometer's pressure scale as a conversion scale!

### Transducer calibration

A typical transducer requires a two-point calibration to correct for offset and gain over the entire operating range. In the case of this barometer, the actual operating range is limited to  $\pm 5\%$  of the top of the scale (95–105 kPa). Therefore, a single-point calibration performed at the middle of the range (100 kPa) may be acceptable. So that we can please everyone, we'll discuss both methods.

Before doing any calibration, switch the unit on and let it warm up for about an hour. Set potentiometer R8 to its middle position. Obtain the barometric pressure (using the local weather forecast or a barometer that you know to be accurate). Using Table 1, convert the barometer's reading to kilopascals or millibars. (The closer the reading is to 100 kilopascals, the better.) All that is to be done for sin-

gle-point calibration is to adjust potentiometer R9 until the meter displays the barometric pressure.

If you can, it is best to use two-point calibration. That's because a typical transducer requires an offset correction as well as slope correction.

As a first step, perform the single-point calibration that we just discussed and leave the unit operating over a period of a few days. Try to obtain two readings: one at the low end of the scale (around 98 kPa) and the other at the high end of the scale (around 102–104 kPa). On both those days, note the actual barometric pressure as well as the corresponding meter readings. We'll use a little mathematics to arrive at the calibration values. Following are some sample calibrations.

Let the old barometric pressure,  $P_1 = 98$  kPa and the corresponding meter reading,  $M_1 = 972$  mV.

Let the present barometric pressure,  $P_2 = 102.5$  kPa and the present meter reading,  $M_2 = 1030$  mV.

The change in barometric pressure is  $P_2 - P_1 = 102.5 - 98$  kPa = 4.5 kPa

The change in the meter reading is, of

### How to use your barometer to predict the weather.

Although some of you will build this barometer simply because you enjoy building electronic projects, many more will actually want to use it to predict the weather. So that you can do that, here's a crash course on what barometric-pressure changes usually mean.

High-pressure cells generally bring fair weather. In the northern hemisphere, the air circulation is clockwise and winds are usually light. The temperature can be warm or cold, but will remain constant for relatively long periods of time.

Low-pressure cells generally bring cloudy weather, with rain or snow. In the northern hemisphere, the air circulation is counter clockwise, and winds are usually strong. Tropical lows are warm, but other lows are cold, or change to cold.

A steady barometer usually indicates unchanging weather for one or two days.

Any rapid fall usually indicates that rain or unsettled weather is on its way. (A rapid rise or fall in barometric pressure is generally considered to be 0.05 to 0.09 inches (0.16–0.30 kPa) over 3 hours.) The lower the pressure before the rapid change, the sooner the rain will approach. For example, if the pressure is 29.8 inches (100.9 kPa) and falling rapidly, a severe storm will pass within a few hours. A rapid rise signals that the storm is ending, and clear and colder weather is on its way.

A suggestion to make the barometer more useful is to interface it with a computer (such as the control computer that concludes with Part 3 in this month's issue). Then you could automatically chart the changes in pressure and record the highs and lows that occur. We'd like to hear about your successes (and failures).

course,  $M_2 - M_1 = 1030 - 972$  mV = 58 mV.

The generated slope is  $\Delta M/\Delta P$  or  $(M_2 - M_1)/(P_2 - P_1) = 58/4.5$  mV/kPa or 12.88 mV/kPa.

The slope that we require is 10 mV/kPa. Therefore, the change in the gain required is  $10/12.88 = 0.776$ .

What we are going to do is to reduce the gain generated by the op-amp by a factor of 0.776. An example of how to do that follows.

Measure the voltage at the output of IC1-a. We'll call it  $V_1$ . Presume that  $V_1 = 755$  millivolts. Then the gain of IC1-c =  $M_2/V_1 = 1030/755$ . The required gain, however, is  $1030/755 \times 0.776 = 1.059$ . So the required output at IC1-c is  $1.059 \times V_1 = 1.059 \times 755 = 799$  mV.

Adjust the gain potentiometer, R9, until the meter reads 799. Now adjust the offset potentiometer, R8 until the meter reads 1025 millivolts, corresponding to the present barometric pressure. That completes the calibration. Now you can substitute your own values in the calculations and perform the calibration on your digital barometer.

R-E

# How to Design Power Supplies

MANNIE HOROWITZ

*All about unregulated and regulated power supplies, IC regulators, and overvoltage-protection circuits.*

IN THIS, THE FINAL INSTALLMENT IN OUR series, we will turn our attention to power supplies for analog circuits. All circuits require some source of power to operate and the most convenient source of such power is an AC wall outlet. Unfortunately, many electronic circuits cannot make use of AC directly. Instead, some way to convert the AC to DC is required.

Let's look once again at the junction diode. You will recall that in our previous discussions of that device we saw that it only conducts when its anode is positive with respect to its cathode. That property is important when we are dealing with AC. If the diode were connected in a series circuit along with an AC supply and a load, its presence would mean that current could only flow through the load during the half of the AC cycle when the anode was positive with respect to the cathode. During the other half cycle the diode would not conduct and no current could flow.

Such an arrangement is referred to as a half-wave rectifier because only half the waveform (i.e. alternate half-cycles) is allowed to pass freely. The other half of the waveform is cut off.

The presence of those half-cycles of current causes pulsating DC to be generated across the load. The amount of voltage variation in that pulsating DC can be reduced by wiring a "filter" capacitor across the load. The amount of ripple in the output is then determined by the values of the capacitor and the load.

## Full-wave rectifiers

When dealing with electronic circuits such as amplifiers, the power source should be as stable (i.e. free of ripple) as possible. The ideal power source then is a battery, as all DC voltages that are derived

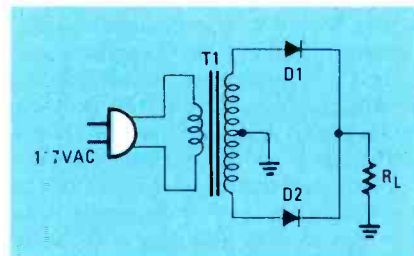

FIG. 1—A SIMPLE full-wave rectifier using a center-tapped transformer.

from an AC supply have some ripple. Using a battery is not always possible or practical, but fortunately most circuits can tolerate the presence of ripple if it is sufficiently attenuated.

One way to minimize ripple is to use a full-wave rectifier. Such a circuit is shown in Fig. 1-a. Note that the circuit consists of a center tapped transformer, with the tap grounded, and two diodes. Let's see how this circuit works. We'll start by looking at what happens during the positive half-cycle. During that half-cycle the polarity of the applied voltage is such that the upper terminal of the transformer's secondary is positive with respect to the center tap and the lower terminal. Also, during that half-cycle the polarity across D1 is such that the anode of the diode is positive with respect to its cathode and the device conducts. Thus, current flows from the upper transformer terminal, through D1 and  $R_L$ , and back to the center tap through the ground. Note that the voltage during this half-cycle varies in phase from  $0^\circ$  to  $180^\circ$  and that the current varies from zero, to some peak value, and then back to zero. Because of that varying current, the voltage developed across  $R_L$  varies identically with the input waveform. Finally, during the positive half-cycle the cathode of D2 is more positive than its anode, so the diode does not conduct and no current

flows through it.

The polarity of the voltage across the transformer is reversed during the negative half-cycle. Now, the bottom terminal of the transformer is positive with respect to ground and with respect to the top terminal. Diode D1 ceases to conduct because its cathode is more positive than its anode. But as for D2, its anode is now positive with respect to its cathode and the device conducts. Thus, current flows from the lower terminal of the transformer, through D2 and  $R_L$ , and back to ground and the center tap, and a positive half-cycle of voltage is developed across  $R_L$ . Note that here, once again, the voltage across  $R_L$  varies identically with the input waveform, but the polarity of the voltage across the resistor is reversed—it is positive.

That sequence repeats during the succeeding positive and negative half-cycles. Note that current always flows through  $R_L$  in the same direction so that only a positive voltage with respect to ground is across the load. That is true regardless of the instantaneous polarities of the AC voltage applied to the circuit.

The advantage of the full-wave rectifier over the half-wave rectifier lies in the fact that in the half-wave circuit no voltage is developed across the load during negative half-cycles. Because of that, the ripple in the output of the half-wave rectifier is higher.

For ripple to be minimized in either type of circuit, some type of filtering must be used. To do so, a large capacitor is usually placed across  $R_L$ . That capacitor is charged to the peak voltage,  $V_p$ , during the first half-cycle. Between peaks, it discharges slowly through  $R_L$ . But it does not have enough time to discharge substantially before the next half-cycle appears and recharges it.

Without the capacitor, the ripple voltage across  $R_L$  varies from  $+V_p$  to 0 volts. But with the capacitor present, it varies from  $+V_p$  to whatever its voltage

dropped to before the next half-cycle appeared to recharge it. From that, you should be able to see why the ripple is easier to filter in a full-wave rectifier. The reason is that the filter capacitor is recharged once during each half-cycle in a full-wave circuit, while in the half-wave arrangement it is recharged only once during each full cycle. Because of this longer recharge cycle, the voltage across the capacitor drops to a lower level. The ripple voltage, the voltage variation from  $+V_p$  to that discharge voltage level, is therefore larger for the half-wave than the full-wave circuit.

In both circuits, the amount of ripple at the output is related to the values of the filter capacitor and the load resistor. For a full-wave circuit, ripple will be kept within reasonable limits if the product of the values of the load resistor and the filter capacitor is about 0.1. To keep the ripple to the same levels in a half-wave circuit, that product must be about 0.15. In other words, since we must assume the load to be fixed, the value of the capacitor must be more than 50% higher than for the full-wave circuit.

We want to mention one more thing about ripple before we move on. If the voltage across the filter capacitor varies during the cycle, the mean DC voltage output will be somewhat less than its possible maximum. Thus, for maximum DC output, the ripple must be very low.

### Full-wave bridge

The circuit shown in Fig. 2 shows another type of full-wave rectifier, the full-wave bridge. Notice that it does not normally require the use of transformer, although one can be used if the input voltage needs to be stepped up or down.

Let's see how that circuit works. During positive half-cycles, current flows through D1,  $R_L$ , and D4. During the negative half-cycle current flows through D2,  $R_L$  and D3. Note that the current always flows in the same direction regardless of the polarity of the input voltage and that the end of  $R_L$  marked + is always positive with respect to the end marked -. As before, a capacitor is usually wired across the load resistor to filter out the ripple.

### Voltage doubler

When a transformer is used in a rectifier

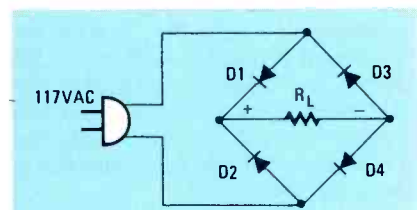

FIG. 2—A FULL-WAVE BRIDGE RECTIFIER uses four diodes but eliminates the need for a transformer.

circuit, the output, or DC voltage across the load, is determined by the peak voltage across the secondary of the transformer (or across one-half the secondary of a center-tapped transformer if a full-wave rectifier is being used). Should one of the previously described rectifiers be used without a transformer between it and the voltage source, the DC voltage at its output seems to be limited to the peak voltage of the AC source. But a voltage-doubler circuit can be used to increase the level of the rectified DC. Two circuits involving doublers are shown in Fig. 3.

In the circuit shown in Fig. 3-a, C1 is charged to the peak level of the supply voltage through D1 during the positive half-cycle. On the negative half-cycle, C2 is charged through D2 to the same peak level. Since the series combination of the two capacitors is across the load, the voltages across them add; and that sum is applied to the load,  $R_L$ .

In the circuit shown in Fig. 3-b, during positive half-cycles, C1 is charged to the peak supply voltage through D1. During negative half-cycles D2 conducts, allowing C2 to be charged to the peak supply voltage. In addition, the previously charged C1 discharges through D2 to C2. The supply voltage and the voltage across C1 are then summed in C2; and that sum, which is nearly twice the supply voltage, is applied to the load,  $R_L$ , when the waveform goes positive and D2 is once again cut off.

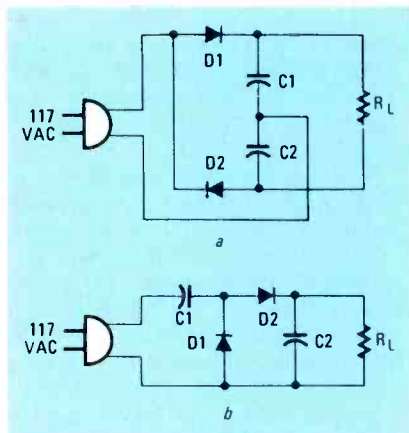

FIG. 3—TWO VOLTAGE DOUBLERS. These circuits are used between the AC source and the rectifier circuit to nearly double the level of the DC output.

Combinations of these circuits can be used to form triplers, quadruplers, and so on. A tripler is shown in Fig. 4-a. In it, the portion of the circuit involving D1, D2, C1, and C2 is identical to the circuit shown in Fig. 3-b, while the D3-C3 portion behaves just as the D2-C2 circuit of Fig. 3-a. The sum of the voltages across C2 and C3 are applied across  $R_L$ .

As for the quadrupler circuit, shown in Fig. 4-b, two circuits similar to the one shown in Fig. 3-b, are used. After the two double voltages are developed across C2

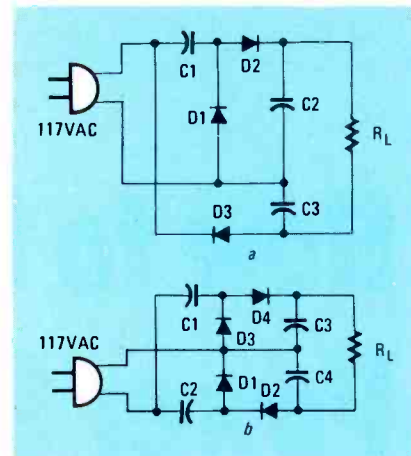

FIG. 4—TWO OR MORE voltage doublers can be combined to form voltage triplers, such as the one shown in a, or a voltage quadrupler, such as the one shown in b.

and C4 they are applied across  $R_L$ .

### Specifying the diode and transformer

When the rectifying diode is not conducting, twice the peak supply or transformer secondary voltage may be across the device. This is true for all full-wave, half-wave and, voltage-multiplier circuits with the exception of the full-wave bridge. So when designing a power supply circuit, be certain that the diodes have a sufficient voltage rating.

The average current flowing through the diode is equal to the voltage across the load resistor divided by its resistance. The diode once again must be capable of accommodating that amount of current.

Power dissipation capabilities of the diode are limited. Information as to just what these limits are is supplied by the manufacturer and can be found on data sheets. The power the diode must be able to dissipate is equal to the average current it passes in the forward direction multiplied by 1 volt. At times, it may be necessary to mount the diode on a heat sink so that its operating temperature will not exceed its specified limit.

When a circuit involving a diode is first turned on, the filter capacitor being charged by the DC behaves as a short circuit. Because of that, a large initial current surges through the diode. That surge current is equal to the supply-voltage peaks divided by all resistance in the circuit other than the resistances wired across the shorting capacitor. If the surge current is more than the diodes being used can accommodate, the device will be damaged. The best way to avoid damage is to use diodes that can safely handle that initial current surge. Alternately, you can connect a small resistor in series with each diode to limit current surges to safe levels.

As for the transformer, it, too, can over-heat if it conducts excessive quantities of current. To check if a transformer is operating within reasonable temperature lim-



its, first measure the cold resistance of one winding while noting the ambient temperature in °C. Refer to that as  $R_C$ , the cold resistance. Then apply power to the transformer while its output is loaded as it would be normally. Be sure that all environmental factors (ambient temperature, etc.) are what they would be under normal operating conditions and run the transformer for eight hours. After that time, remove the power from the circuit. Immediately after removing the power, check the hot resistance,  $R_H$ , of the winding. Be sure that nothing is connected across this winding. The temperature rise of the transformer, in °C is:

$$\Delta T = 254 \left( \frac{R_H - R_C}{R_C} \right)$$

Add the value you get for  $\Delta T$  to  $R_C$ . If the total exceeds 90°C you should start to be concerned. If it exceeds 105°C, then the transformer is overheating and a different transformer should be used in the circuit.

### Regulated power supplies

Throughout the discussion, it was assumed that the line voltage is fixed at 117-volts AC and that the load does not change in resistance but remains a constant  $R_L$ . If anyone assumes that to be a realistic condition, then he is living in a dream world. Line voltage fluctuates from minute to minute. Over time it can vary  $\pm 10\%$  or more. During periods of extremely heavy usage, power companies have been known to greatly reduce voltage levels.

As for the load, it is seldom a fixed resistor. If the supply is feeding an audio, RF, or electronic-switching circuit, the load impedance varies, sometimes from instant-to-instant, with the signal or switch current fed to it.

A fixed, stable voltage is frequently required when powering an electronic circuit. That constant voltage is not present when there are either supply-voltage or load variations. As we discussed earlier in this series, a fixed voltage developed across a Zener diode can be used to stabilize the voltage across a load if the Zener is placed across that component or circuit. That is fine where low currents are involved. But when large quantities of current must flow through the load, the Zener diode can seldom be used economically as the sole regulating device for the circuit. Series, parallel, and feedback circuits using Zener diodes along with one or more transistors have been developed as practical regulators.

### Series regulators

In the series-regulator circuit, DC current flows from the unregulated portion of the DC power supply through a transistor to the load. If the circuits are like the ones shown in Fig. 5, the voltage across the load is regulated. In both of those circuits, current flows through  $R_1$  and Zener diode

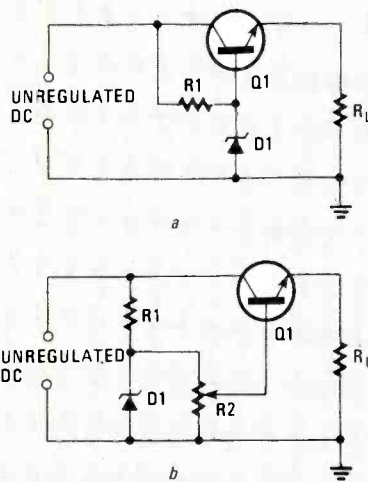

FIG. 5—SERIES REGULATOR CIRCUITS. The one in a provides a fixed voltage while the output from the one in b can be varied using R2.

D1 which causes a fixed voltage to be developed across D1. In Fig. 5-a, current flowing through  $R_1$  also flows through the base-emitter junction of Q1. A fixed voltage, about 0.6 or 0.7 volt, is developed across this junction, turning on Q1. The voltage between the emitter of Q1 and ground, or across  $R_L$ , is about 0.7 volt plus the voltage across D1. That fixed voltage is across  $R_L$  regardless of supply-voltage or load variations.

In that circuit, little current flows through the Zener diode. What does flow is limited to safe values by  $R_1$ . The current that is supplied to  $R_L$  flows through Q1. If the required load current is high, Q1 should be rated adequately and mounted on a heat sink. Circuit components must be chosen so that the transistor is not in saturation at any time.

The regulated output-voltage can be varied by simply placing a potentiometer across the Zener diode and connecting its wiper, rather than the cathode of D1, to the base of Q1. That is shown in Fig. 5-b. Now, the voltage across  $R_L$  is the sum of the voltages between the wiper of the potentiometer and ground, which is the voltage between the base and emitter of the transistor. Resistor  $R_1$  must be selected so

that the proper current is available at the base of Q1 to keep it turned on and out of saturation at all times.

Several improvements can be made in the circuit shown in Fig. 5-a. Those are shown in Fig. 6.

In order to achieve good regulation, the Zener diode should see a high impedance. In Fig. 5-a it sees an impedance equal to  $R_L$  multiplied by the beta of Q1. To increase the impedance, a Darlington circuit can be used rather than an individual pass transistor. Such a Darlington pair is shown in Fig. 6 as Q1 and Q2. The impedance seen by D1 in that circuit is essentially the product of the betas of the two transistors multiplied by  $R_L$ .

To further improve regulation, a constant current should be applied to D1 and to the base-emitter circuits of the series transistors. The circuit around Q3 establishes that constant current. Current flows through D3, D4, and  $R_1$  due to the voltage from the unregulated DC supply. The voltage across the two forward-biased diodes, D3 and D4, is relatively fixed at 1.4 volts (0.7 volt across each diode). That voltage is between the upper end of  $R_2$  and the base of Q3. Because the base-emitter junction of Q3 is turned on at 0.7 volt, the balance of the 1.4 volt, or 0.7 volt, is across  $R_2$ . The fixed emitter current, in milliamps, is  $0.7/R_2$ . The collector current is just about equal to the emitter current of Q3 and the collector and emitter currents do not fluctuate to any degree. The collector current is applied to the Zener diode and base of Q2. Resistor  $R_2$  is selected to set the current at the desired level.

In the event that a short is placed accidentally across  $R_L$ , excess current will flow through Q1, which is likely to destroy the device. The circuit around Q4 performs the function of protecting Q1 in the event of a short.

Transistor Q4 is turned off when the current flow through the circuit is at its normal level. It remains off until the current flowing through  $R_4$ , which is also the current through the load, is sufficient to develop about 1.4 volts across the resistor. Notice in Fig. 6 that Q4's collector is

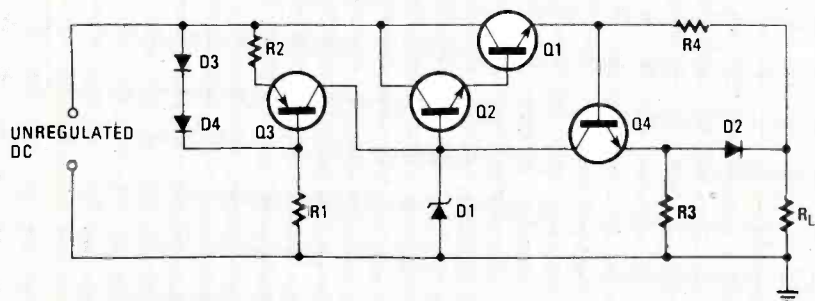

FIG. 6—THE BASIC SERIES regulator circuit can be improved by using a Darlington pair in place of Q1 and adding a constant-current source.

connected to the junction of Q2, Q3, and D1. When Q4 is on, it draws the bulk of the current from Q3 so that insufficient current remains to fully turn on the base-emitter junctions of Q1 and Q2. That also reduces Q1's collector current. Thus, less power is dissipated by Q1, preventing it from being destroyed due to the presence of an excessively heavy load.

### Parallel regulators

There are two types of parallel regulator circuits—one supplying a voltage that is only slightly lower than the breakdown voltage of the Zener diode used in the circuit, and one supplying a voltage that is considerably higher than that of the diode. Both are shown in Fig. 7.

In Fig. 7-a, current flows through R1, D1, and the base-emitter junction of Q1. Fixed voltages are developed across D1 and the base-emitter junction of Q1. The sum of those two voltages is the regulated voltage applied across R<sub>L</sub>.

In Fig. 7-b, current flows through R1, R2, the base-emitter junction of transistor Q1, and Zener diode D1. A fixed voltage is developed between the emitter and collector of Q1. The circuit's regulated output, V<sub>R</sub>, which is across R<sub>L</sub>, is equal to the sum of the Zener voltage, V<sub>Z</sub>, and the voltage developed across Q1. It can be shown that that voltage is equal to:

$$V_Z \left( \frac{R_2 + R_3}{R_3} \right)$$

Resistor R4 is critical in and must be selected by trial and error. That resistor should be selected for the minimum variation of voltage across R<sub>L</sub> as the unregulated input voltage is varied from its minimum to its maximum.

Performance can be improved by using Darlington pairs rather than individual transistors and by replacing R1 with a constant-current source.

### Feedback regulators

A commonly used series regulator-circuit using feedback is shown in Fig. 8.

Current from R2 flows into both the collector of Q3 and the base of Q2. Because of D1, the emitter of Q3 is at a fixed voltage with respect to ground. Note that the regulated voltage is across R<sub>L</sub> as well as across R3 so that R3 can be used to adjust the voltage across R<sub>L</sub>.

Should voltage V<sub>R</sub> across R<sub>L</sub> increase above the desired level, the voltage at the base of Q3 rises. That transistor conducts more heavily than when V<sub>R</sub> was at its proper level. The base of Q3 is then more positive with respect to its emitter than it was when the level of V<sub>R</sub> was correct. That causes the transistor to draw more current than it did before from R2, reducing the amount of current previously available for the base of Q2. Because current through Q2, and consequently the current through Q1, are reduced, less cur-

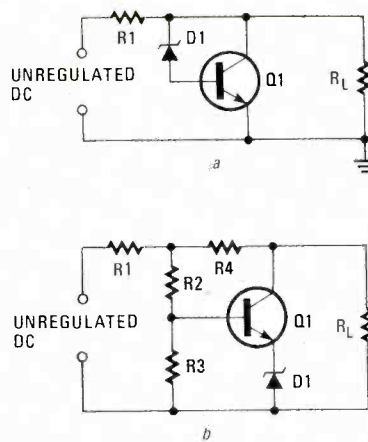

FIG. 7—PARALLEL REGULATOR CIRCUITS. The output from a is 0.7 volt above the Zener breakdown voltage; the output from b is considerably higher.

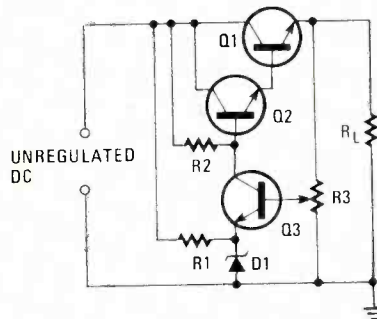

FIG. 8—THIS REGULATOR circuit uses feedback.

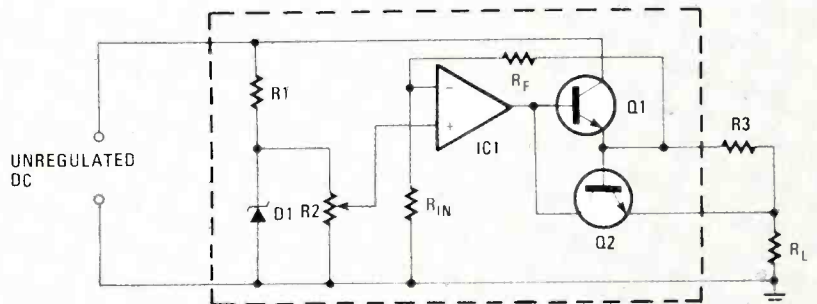

FIG. 9—REGULATOR CIRCUITS are commonly found in IC form. The circuitry within the dashed box is usually contained in the IC.

rent than before remains for R<sub>L</sub>.

In the opposite condition, when the voltage across R3 and R<sub>L</sub> is below the desired fixed level, less current flows through Q3. More current is now available to flow through Q2 and Q1, rebuilding the output voltage to its desired level.

### IC regulators

Figure 9 shows a typical IC regulator and some of its surrounding circuitry; the part of the circuit enclosed by the dashed box is usually part of the IC.

A fixed voltage is developed across D1. A portion of that voltage, as set by R2, is applied as a reference voltage to the non-

inverting input of the op-amp. The output from the op-amp is passed on to Q1. The voltage at the emitter of Q1, which is close to the voltage at the output of the op-amp, is fed back through R<sub>F</sub> to the inverting input terminal of the op amp. That inverting input is connected to ground through R<sub>IN</sub>. The voltage at the inverting input, and at the emitter of Q1, is equal to the voltage at the non-inverting input multiplied by 1 + (R<sub>F</sub>/R<sub>IN</sub>). The output voltage is therefore fixed by the voltage across D1, the setting of R2, and the ratio of resistors R<sub>F</sub> and R<sub>IN</sub> at the inverting input.

In Fig. 8 we've added a circuit to protect against damage in the event there is a demand for excessive current from the regulator. Excess current flow can not only damage a transistor, but can destroy an op-amp, and consequently an IC. Transistor Q2 is in the IC to protect it from being damaged. When excess current flows, sufficient voltage is developed across R3 to turn on Q2. When turned on, the base-collector circuit of Q2 is across the base-emitter circuit of Q1, preventing it from conducting excess current.

### Crowbar circuits

A crowbar circuit is used to prevent damage to a regulated power supply in the event a high voltage is applied across the load. In the arrangement shown in Fig. 10, the inverting input of the op-amp is fixed at the breakdown voltage of D1. Resistors R2 and R3 are selected so that with normal voltage across R<sub>L</sub>, the voltage at the non-inverting input of the op-amp is

less than the voltage at the inverting input and the output from the op-amp is negative. The gate of SCR1 is then also negative with respect to its cathode so that the SCR remains off.

When a high voltage is applied across R<sub>L</sub>, the voltage across D1 and at the inverting input of the op-amp, remain fixed. But the voltage at the non-inverting input increases. Divider resistors R2 and R3 should be selected so that the voltage at the non-inverting input exceeds that at the inverting input when a high voltage from an external source is applied across R<sub>L</sub>. When such a high voltage is across R<sub>L</sub> the

*continued on page 134*

# BUILD THIS

# HOME CONTROL COMPUTER

*If you've ever wanted to use your computer to control external appliances or systems—but didn't want to tie up your computer solely for that purpose—then this controller is for you!*

STEVEN E. SARNS

HOW OFTEN HAVE YOU THOUGHT: "IF ONLY I COULD hook my computer up to that furnace (or model train, coffee pot, security system, etc.), then I could really get it to do what I want"? You probably gave up the idea for one of two reasons. First, your computer is too expensive to be relegated to turning on a coffee pot 15 minutes before you wake up (especially when you can buy inexpensive timers to do the same thing). Second, your computer is not designed for such control tasks and requires some modifications.

Those are good reasons to abandon the idea. But what if you had an inexpensive computer that could be programmed easily and had an I/O structure designed *specifically* for control applications? Then you could put some of your ideas into action. This control computer that you can build has—along with its many other I/O capabilities—the ability to control BSR-type wireless remote-control modules. And the computer can be programmed in BASIC using any terminal (or a computer configured as a terminal) that has an RS-232 serial port.

Let's take a quick look at the abundance of applications for a control computer that surround you—some of which you've probably considered and, perhaps, some you've never even thought of. We won't go into detail on how to use the controller for the following applications. Keep in mind that your programming capabilities may limit what you want to do. (You need to know at least BASIC programming to use the controller.) But we will explain how to use the control computer in enough detail so that you'll be able to tailor it to your own applications.

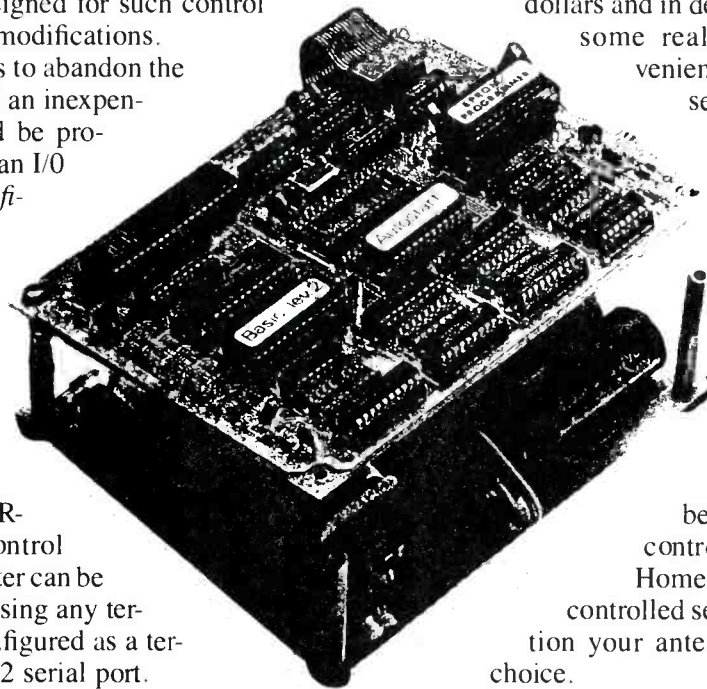

**Security systems:** A "smart" security system could arm itself in your absence. And the alarm could be dependent on the type or source of breach. For example, with external circuitry, the system could be interfaced to the telephone to alert the police if it sensed a break-in, or it could phone the fire department if it sensed a fire.

**Robotics:** Even the most drole robot requires some amount of "smarts." Now you can afford—both in dollars and in development time—to give him some real power. Imagine the convenience of independent drive- and sensory-systems. Imagine how much faster your development would be with a complete computer system for each function.

**Model control:** Imagine the complexity that you could build into a computer-controlled model-train layout, or the acrobatic maneuvers that could be programmed into your radio-controlled model airplane.

**Home entertainment:** A computer-controlled servo tracking system can position your antenna on the satellite of your choice.

**Home energy management:** (This is what the author's prototype was designed for.) The living-room thermostat could be the first target—it could automatically set back when you are at work and warm up before you return (but not on weekends). If you have electric heat, and if your electric company has peak and off-peak rates, your electric bills could be cut in half by averaging your power requirements instead of turning everything on at once. Remember—any equipment you purchase for energy management or control might be a tax credit for you. You'll have to check your own state's

laws. If you're lucky, you might effectively cut the cost of your project in half!

### Features of the controller

The underlying design goal for this controller was a small, inexpensive, yet powerful control computer with its own development system. That design had to achieve a successful balance: We wanted the board size and the cost to be kept down, yet we still wanted to include as many features as we could. However, if we tried to give the board too many bells and whistles, the resulting high cost would limit its practical (economical) applications. On the other hand, a cost-conservative approach would result in a board with only limited applications. Of course, we searched for a happy medium.

The result was a rather small board (about 5½ × 6½ inches) that has enough power to do its job at a competitive cost—take a look at the controller's features:

- A total of 46 inputs and outputs: Seven high-current, individually addressable outputs; 7 individually addressable inputs; 2 eight-bit input ports, and 2 eight-bit output ports.
- An RS-232 serial port: a terminal can be used for program entry.
- An eight-channel, 8-bit analog-to-digital converter with provisions for digital-to-analog conversion.
- A choice of two operating systems: BASIC or Forth. The high-level language will cut your programming time by 90%.
- An on-board EPROM programmer makes a permanent copy of your RAM-based program.
- A real-time clock for time-of-day functions.
- Auto start of ROM-based programs.
- BSR-type remote controller is on a companion power-supply board. That system communicates to readily available receiver modules that you simply plug into the AC lines. All of the hassles of stringing wires from the controller to the control point are eliminated.

### A closer look

Now that we have an idea of the basic features of the controller, let's discuss some of the theory behind it. Unfortunately, we won't be able to cover all of the points that we just mentioned this month—they will be discussed in upcoming installments of this article.

We'll start by describing the microprocessor and the support circuitry required to test, debug and program the basic system. The design will be discussed in enough detail so that even those who are not familiar with microprocessor design techniques will be able to get an overview of the process. The control computer's schematic is shown in Fig. 1.

The microprocessor selected for this project is the Intel 8088—the 16-bit microprocessor that forms the heart of IBM's

personal computer. (Anyone who owns an IBM PC has a complete set of development tools for this board.) The 8088 can be thought of as being made up of two units: The first is the BIU or *Bus Interface Unit*, which prefetches instructions while the rest of microprocessor (the EU—*Execution Unit*) is working on the current instruction. Besides speeding execution, that has an even more fortunate (economical) effect: Memory IC's with access times as slow as 400 ns will work on the board.

### The bus structure

The microprocessor is connected to the memory and I/O through the *data bus*, the *address bus* and the *control bus*. Those busses are shown in the computer's schematic in Fig. 1.

The data bus is the group of eight lines (D0–D7) over which data can be transferred between the microprocessor and any memory or I/O (*Input/Output*) device.

The address bus is made up of 20 lines, some of which are time multiplexed. Don't worry about that now—we'll get to it shortly. You should know, however, that the microprocessor uses the address bus to select the desired memory address or I/O device to send data to or receive data from. That address is represented by the unique combination of address-line states.

We will be concerned with three lines of the control bus. The  $\overline{READ}$  ( $\overline{RD}$ ) and  $\overline{WRITE}$  ( $\overline{WR}$ ) lines determine whether the data is to be transferred to (read by) or from (written by) the microprocessor on the bi-directional data lines. The third line,  $\overline{IO/\overline{M}}$ , is used to distinguish between a memory access or an I/O access.

The 8088 can address 1 megabyte (2<sup>20</sup>) of memory with its 20 address lines. If we use only the lower 16 lines, we can address 64K. The 8088 combines the data bus and the lower eight address lines into what is called a time-multiplexed bus. That was done so that the 8088's package could be kept to 40 pins. The first design question is to decide whether to demultiplex the data and address bus or use it as is. Intel (and others) supports the multiplexed bus with an extensive range of products. Leaving the bus multiplexed will result in a smaller board that is easy to lay out. (That is one of our design goals.) However, because of the popularity of the non-multiplexed bus, peripheral IC's designed for it are more available and are less expensive. Because another of our design goals is to design a low-cost board, we must stick to popular components—or at least ones that we expect to become popular. Fortunately, demultiplexing the bus is an easy matter; it requires only a set of latches. A 74LS373 octal latch (IC15) is used. It is enabled by the ALE (*Address Latch Enable*) pin of the microprocessor (pin 25). Now we have 8 high-order ad-

dress lines, A15–A8, (IC18 pins 39, 2–8), and 8 low-order address lines coming from the latch outputs, A7–A0, (IC15 pins 7, 12, 6, 15, 5, 16, 2, 19). We also have 8 bi-directional data lines, AD7–AD0 from the input side of the latch (IC18 pins 9–16). Note that the data lines still contain the multiplexed address-information. They will contain data at the time the appropriate control line ( $\overline{RD}$  or  $\overline{WR}$ ) is active.

The memory field must be divided into appropriate banks (or peripheral IC's). We must make sure that only a single peripheral IC can be active at any one time. If more than one device attempts to place data on the bi-directional data bus simultaneously, a condition known as *bus contention* rises. The result of bus contention is an undefined bus state and, consequently, undefined operation. Thus the output of our memory decoder will be a one-of-N type—only one output will be active at any one time. Each of those outputs will be connected to the chip-enable ( $\overline{CE}$ ) input of a peripheral IC.

The selection of the size and type of memory is heavily influenced by our need to convert our finished program into ROM. If we can simply remove a RAM IC and replace it with a pin-compatible ROM, we will have a compact yet flexible board. The 2016 2K × 8 RAM and the 2716 2K × 8 EPROM are pin-compatible, so they will be used. We also need memory space for ROM-ed development tools that can be used during the program testing, and an empty socket for the blank EPROM to be programmed.

Throughout the remaining description of the board, the highest order address lines (A19–A16) will be ignored. The address lines A15–A8 will be called the high-order address lines. The most significant high order address line (A15) can be used to chip-select the system ROM. Address lines A11 and A12 are used as the inputs to a 74LS139 one-of-4 decoder (IC16), which will be used to chip-select the other memory IC's. We have mapped our system ROM and 4 memory sockets uniquely into the 64K address space. Table 1 shows

TABLE 1—MEMORY MAP

Address (hex)	IC/Function
0000–07FF	1C12/RAM
0800–0FFF	IC10/RAM
1000–17FF	IC13/ROM
1800–1FFF	IC14/ROM and EPROM programming socket
8000–FFFF	IC9/System ROM

a memory map of our system. Note that A15 is inverted by IC19 to select the system ROM and that the one-of-4 decoder (IC16) is qualified by IC17-d: when A15 and the  $\overline{IO/\overline{M}}$  lines are low, a memory-field operation is indicated.

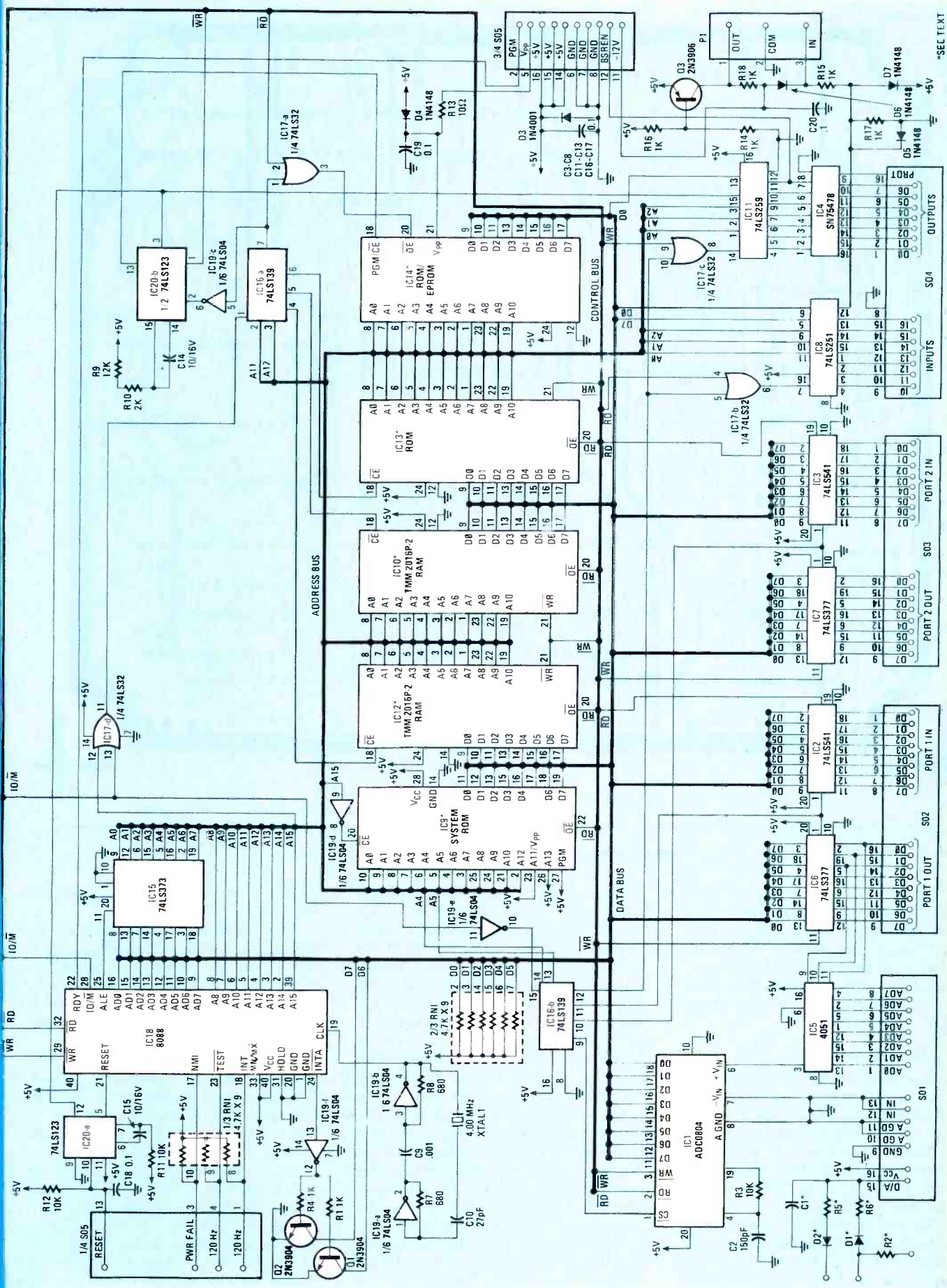

FIG. 1—THE CONTROL COMPUTER SCHEMATIC. Note that IC9 is the system memory. It is contained in ROM and is available from the supplier indicated in the Parts List. Then pin numbers shown for IC9 are socket pins. If a 2732 or 2764 is used, then pin 23 should be connected to A11 and not 5 volts. Also, pin 26 should be connected to A13, and not 5 volts. In both cases, you have to cut a trace and add a wire jumper.

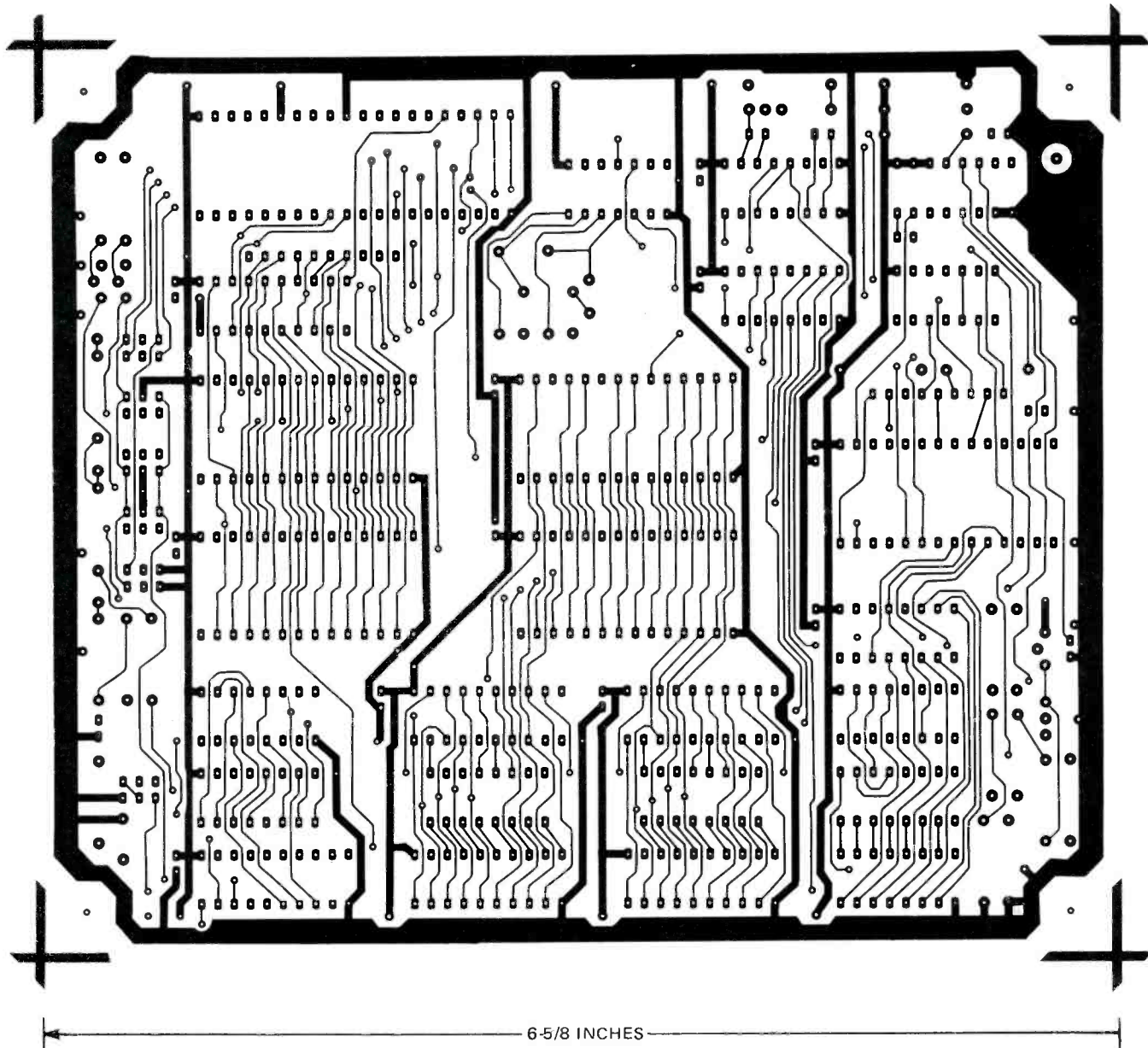

FIG. 2—THE FOIL PATTERN FOR the control computer's component side is shown above.

When the 8088 is reset, it will begin execution at address FFFF0H. That means our system ROM should occupy the highest memory position. (Remember that we're not decoding the highest-order address lines, so that when the 8088 looks at address FFFF0, it will see the system ROM.)

#### EPROM programming

Programming the 2716 EPROM is a simple matter. The programming voltage may be applied as a DC voltage to pin 21, the  $V_{pp}$  pin. The address and data must be stabilized for 50 milliseconds, and during that time, a single TTL-level pulse is applied to the  $\overline{CE}/PGM$  pin (pin 18). (It is pulsed from low to high.)

Rather than the more usual method of surrounding the EPROM being programmed with a bi-directional latch, the address and data information will be

taken directly from stabilized address and data busses. The disadvantage of our approach is that the microprocessor cannot be doing anything else during that 50-ms interval when the busses are stabilized—including timing the 50 milliseconds. We will have to use a hardware timer. The advantages of our method are fewer components, software simplicity, and a small board size. (Figures 2 and 3 show full-sized foil patterns for the double-sided printed-circuit computer board. The power supply for the computer is contained on a second board. We'll talk about that board in a future installment of this article.) In fact, the EPROM programmer is completely invisible to the software—the EPROM appears to the operator as a very slow-to-write RAM-like device.

We will operate the 2716 from the microprocessor bus by externally qualifying  $\overline{RD}$  and  $\overline{CS}$  with IC17-a. The output of that

OR gate is applied to the 2716  $\overline{OE}$  pin (pin 20).

The 2716's  $\overline{CE}/PGM$  line (pin 18) will be normally low and go high whenever  $\overline{CS}$  and  $\overline{WR}$  are true. Those two signals (at IC20, pins 1 and 2) are the trigger conditions for the 74LS123 50-ms one shot whose output (IC20, pin 4) is connected to the 8088 RDY input and the 2716  $\overline{CS}/PGM$  input. Whenever the RDY line is low, the 8088 inserts wait states into the current microprocessor instruction. The wait state holds the current bus status (for 50 ms, as determined by C14 and R10) until the RDY line is returned high.

The specifications for the programming voltage are  $+25 \pm .5$  volts DC at 30 milliamps. We have found that reliable programming can be achieved with a programming voltage as low as 22 volts. (A programming voltage of 24 volts has worked well for us.) The maximum  $V_{pp}$

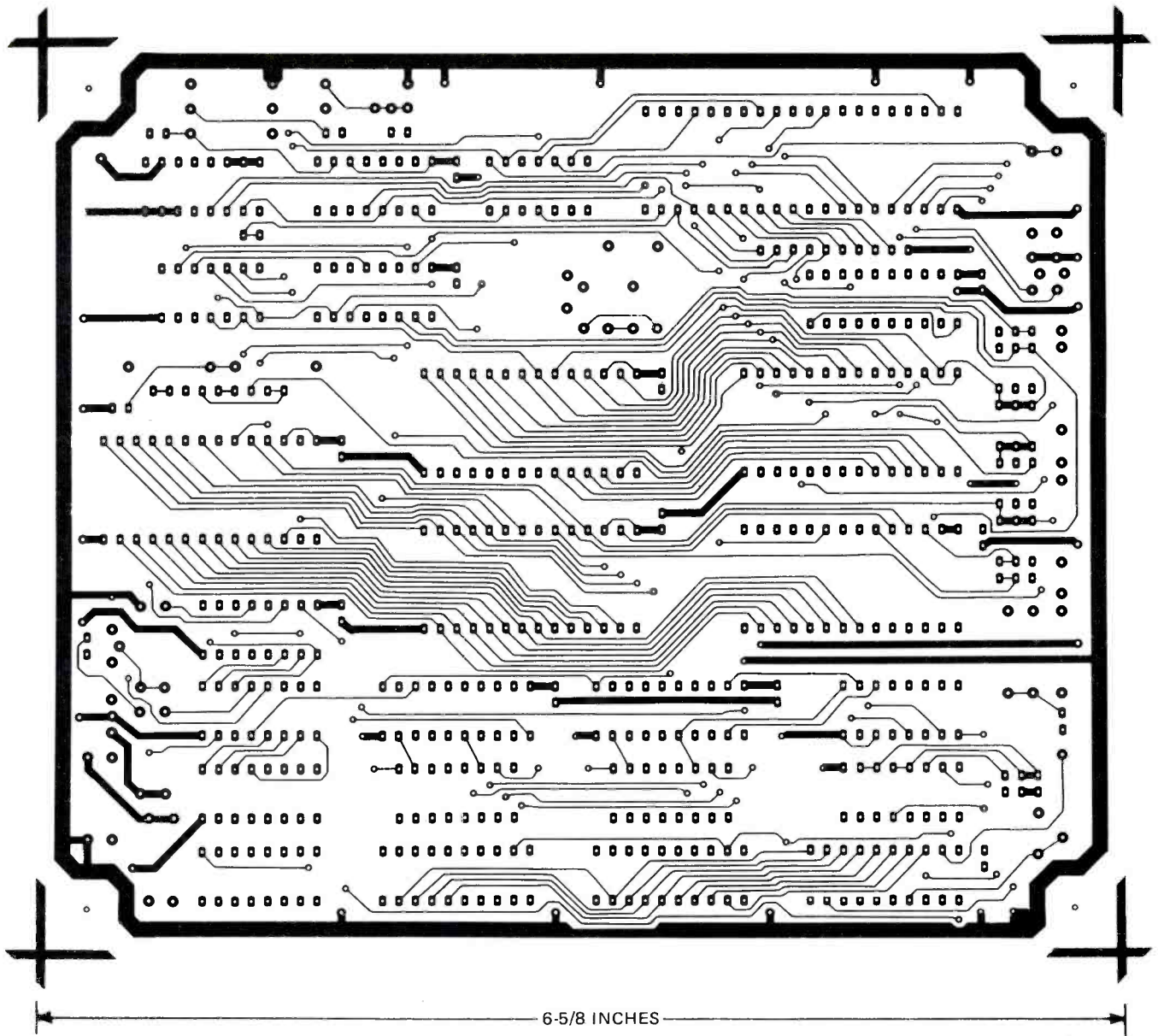

FIG. 3—THE SOLDER SIDE of the computer printed-circuit board.

voltage specification is an extremely important one to follow. We met up with disaster with a programming voltage of 26 volts. If the  $V_{pp}$  voltage is exceeded *even for a few nanoseconds*, the EPROM will fry! That means that the  $V_{pp}$  supply must not overshoot during turn-on or turn-off. Because we need to control the ramp-on and -off characteristics we will use a power supply design that always switches the supply on and off for each byte programmed. (The switching supply makes the control computer more versatile because it allows you to use other EPROM's—for example the 2732—that require a switched  $V_{pp}$  supply. The 2716 doesn't require a switched supply.) That switching programming supply is located on the separate power supply board. We'll discuss that circuit and its construction in a future part of this article.

Programming an EPROM involves

only setting appropriate locations to "0." A fully erased EPROM has all of its memory locations filled with 1's.

The time will come—either because of a programming mistake or because you no longer need a particular program—that you'll want to erase your programmed EPROM. You can erase the EPROM's by exposing them to ultraviolet light. Direct sunlight will erase an EPROM in about a week. Room-level fluorescent light will erase an EPROM in about 3 years. (Although that's not an efficient erasure method, it is still a good idea to cover the window with a label to block out room/sun light.) A commercial EPROM eraser is simply a source of ultraviolet (UV) light that irradiates the EPROM. You can make one yourself with a General Electric G15TB 18-inch germicidal bulb in a conventional fluorescent-lamp holder. **Do not look into the bulb when it is on.** The

light is much more intense than it appears and quickly damages the eyes. Place the EPROMs to be erased within one inch of the bulb and leave it on for 10–15 minutes. That should change all the bits in the EPROM to 1's.

The microprocessor requires a system clock signal, which we obtain with a conventional TTL-type crystal oscillator (IC19, XTAL1, and other associated components). The frequency of the clock is 4.00 MHz, even though the 8088 could run at 5 MHz. The 33% duty-cycle constraint on the clock signal would require either a special clock generator or additional TTL chips.

A reset pulse is also required by the 8088, which we generate by using one-half of a 74LS123 (IC20-a) during power-up or whenever the reset line is grounded and released.

*continued overleaf*

## The I/O

The RS-232 port is really part of the I/O system, which we'll be discussing in a future installment of this article. However, we must introduce it now because it is required for any operator I/O. It also must be used to confirm proper operation of the basic system.

The RS-232 port can be implemented in two distinctly different manners. The first and easiest is to use a UART (Universal Asynchronous Receiver Transmitter) IC. The UART constantly waits for an incoming character, receives it according to whatever protocol has been programmed, and stores the character in a

holding register until the microprocessor requires it. Transmission is simply a matter of writing the character to the UART's transmit register.

The other alternative—the one that we'll use—is to use one input and one output of the board to send and receive the serial data. That method requires the microprocessor to assume control of the entire process of data reception and transmission. However, it eliminates the requirement for a large and expensive component. The principal limitation of this approach is that the microprocessor must know when to expect a character and it must be executing its input routine before the character is sent to the board. That's not a problem for most applications. In the case of BASIC, it means that all console commands and program INPUT statements are handled easily. However, there can be no INKEY\$ statement.

The eighth output and eighth input of the bit-addressable I/O port will be used to implement the RS-232 port. The requirement for a negative voltage supply for the RS-232 link can be avoided with a bit of foxy circuit design. The incoming RS-232 signal is normally at the "mark" or negative level. Every character transmission ends with a stop bit designed to return the line to the negative level. We can generate our level from the incoming RS-232 line. That approach works fine for cables of less than 10 feet long. If longer cables are used, a separate negative supply between -5 and -12 volts DC should be used. Such a supply is available from the power-supply board, which—as we mentioned previously—we'll discuss in a future installment.

When examining serial asynchronous waveforms, remember that a logic one is less than -3 volts DC and a logic zero is greater than +3 volts DC. The line is held in the mark or one state when not active. The transmission always begins with a start bit = 0 and ends with a stop bit = 1. The stop bit returns the line to the mark state.

Full duplex serial operation that means separate wires carry data to and from the control computer (and terminal). Pin 2 of the RS-232 connector is transmitted data to the computer. Pin 3 is received data from the computer. At the terminal, those two pins are reversed so that pin 2 is an output and pin 3 an input. If you are using a personal computer as a terminal, you must determine if the RS-232 port of your computer is configured as a terminal or as a computer. Whatever the case may be, connect the board's input to the terminal's output and vice versa.

### Building the control computer

The actual assembly of the controller requires no special techniques for the builder. You can use a printed-circuit board (we showed the foil patterns for the

## PARTS LIST— COMPUTER BOARD

### All resistors ¼-watt, 5% unless otherwise noted

R1,R4,R14—R18—1000 ohms  
R2,R5,R6—user-determined. To be discussed next month  
R3,R11,R12—10,000 ohms  
R7—680 ohms  
R8—390 ohms  
R9—12,000 ohms  
R10—2,000 ohms  
R13—10 ohms  
RN1—4.7K × 9 resistor network

### Capacitors

C1—user-determined.  
C2—150 pF, ceramic disc  
C3—C8,C11—C13,C16—C20—0.1 μF, ceramic disc  
C9—0.001 μF  
C10—27 pF  
C14,C15—10 μF, 16 volts, electrolytic

### Semiconductors

IC1—ADC0804 A/D converter (National)  
IC2,IC3—74LS541 octal buffer and line driver  
IC4—SN75478 seven high-current darlington drivers (TI, also Sprague ULN-2003, Motorola MC1413)  
IC5—4051 8-input analog multiplexer  
IC6,IC7—74LS377 octal latch  
IC8—74LS251 8-input digital multiplexer  
IC9—System ROM. 2716, 2732, or 2764. 450 ns maximum access time.  
IC10,IC12—TMM 2016P-2 (Toshiba or similar) 2K × 8 static RAM, 450 ns.  
IC13—Programmed EPROM (2716)

IC14—EPROM to be programmed  
IC11—74LS259 8-bit addressable latch  
IC15—74LS373 octal latch  
IC16—74LS139 dual 2-to-4 line decoder/multiplexer  
IC17—74LS32 quad OR gate  
IC18—8088 microprocessor  
IC19—74LS04 hex inverter  
IC20—74LS123 dual one-shot  
Q1,Q2—2N3904  
Q3—2N3906  
D1,D2, D4—D8—1N4148  
D3—1N4001

**Miscellaneous:** IC sockets, PC board, mounting hardware, etc.

**The following are available from Vesta Technology, Inc., 2849 W. 35th Ave., Denver, CO 80211: KIT 1—Kit of all parts needed to control 7 LS-TTL outputs, monitor 7 inputs, program EPROM's, RS-232 serial port, and 2K RAM (does not include operating system—see below), \$99.95; KIT 2—Kit of all parts for full-capacity I/O and 4K RAM (does not include operating system—see below), 169.95; Operating systems contained in ROM: BASIC I operating system, \$12.95; BASIC II operating system, \$29.95; Forth operating system, \$79.95; Assembled, tested, and burned-in control computer with BASIC II operating system, \$279; RS-232 cable, \$24.95; 2716 EPROM, \$6.95. Add \$6 for shipping, handling, and insurance.**

## PARTS LIST—POWER-SUPPLY/BSR LINK BOARD

### All resistors ¼ watt, 5% unless otherwise noted

R1,R19—200 ohms  
R2,R7,R8,R20—100 ohms  
R3,R4,R11,R12,R15—1000 ohms  
R6,R10—4700 ohms  
R9—1 ohm (a jumper works fine)  
R13—10,000 ohms trimmer potentiometer  
R14—15,000 ohms  
R16—270 ohms  
R17—10,000 ohms  
R18—470 ohms

### Capacitors

C1,C2—10 μF, 16 volts, electrolytic  
C3,C5—0.01 μF, ceramic disc  
C4,C6—0.047 μF, ceramic disc  
C7—10 μF, 35 volts, tantalum  
C8—.001 μF, ceramic disc  
C9—0.1 μF, ceramic disc  
C10—0.14 to 0.47 μF, 150 volts, electrolytic  
C11—3300 μF, 16 volts, electrolytic  
C12—500 μF, 50 volts, electrolytic

### Semiconductors

IC1—ULN2003 darlington array

(Sprague)  
IC2—TL497 switching regulator  
IC3—74LS00 quad NAND gate  
IC4—LM340-5 +5-volt regulator  
IC5—LM320-5 -5-volt regulator  
Q1—2N3904  
Q2—2N3906  
D1,D3,D5,D6,D10—1N4001  
D2,D4,D7—D9—1N4148  
T1—11Z2100 1:1:1 pulse transformer (Sprague)  
T2—16 volts, center tapped, 0.4 amps. (Signal ST-4-16 or similar)  
S1—normally open momentary pushbutton switch

**Miscellaneous:** line cord, printed-circuit board, IC sockets, heat sink for regulator, mounting hardware, etc.

**The following are available from Vesta Technology, Inc., 2849 W. 35th Ave., Denver, CO 80211: Power-supply/BSR-link kit, including all components, \$59.95; Assembled, tested, and burned in power supply, \$109. Add \$6 for shipping, handling and insurance.**



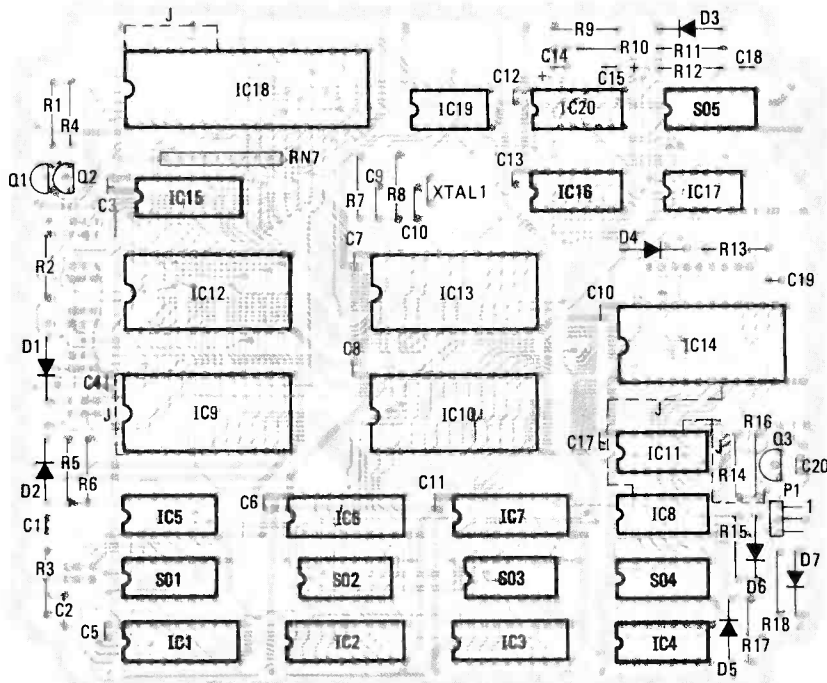

FIG. 4—PARTS-PLACEMENT DIAGRAM for the computer board. The dashed lines represent foil-side jumpers. There are many "unused" pads; they are for future expansion and experimentation. For example, note that a 28-pin socket is provided for the 24-pin 2716 (IC14). That allows larger EPROM's to be programmed. Simply plug the 2716 (or other 24-pin device) into the socket leaving pins 1 and 2 of the socket unoccupied.

double-sided board in Figs. 2 and 3) or you can wire-wrap the project. You are probably better off with the PC board. Troubleshooting will be easier, and assembly will be quicker—about an hour, assuming you already have the board. (If you are not able to make your own board, see the Parts List for a supplier.) Wire-wrapping the project will take about 16 hours. One note on wire-wrapping: Do not give in to the temptation of wire-wrapping directly to the leads of the discrete components. The integrity of a wire-wrap joint depends on the square corners of the posts.

If you have the printed-circuit board, simply follow the parts-placement diagram in Fig. 4. Be careful not to create solder bridges, and when you are finished, wash the board in flux solvent. That will remove any flux residues left on the board. Don't forget that we've shown the foil and parts-placement diagrams for only the computer board. The power supply and BSR-type controller will be located on a separate board of the same size. We'll discuss that single-sided board next time, and we'll give you some more hints on the control computer's construction.

### Troubleshooting

After you install all the parts, carefully inspect your board. You should check that all IC's are in the correct sockets and that they are correctly oriented. Transistors and diodes should also be checked. Then measure the power-supply voltages. Although we have not yet discussed the

board for the power supply and BSR-type controller, you can test the computer board if you have a +5-volt DC regulated supply.

Regardless of what supply you use, ensure that it is the correct voltage, and be sure to orient it correctly. Reversing the power-supply polarity is like reversing an IC, only it's more efficient—it will burn out *all* of the IC's. The BASIC operating system should be inserted into the system ROM socket (IC9). The first memory socket (IC12) should contain a 2016 RAM IC. Do not insert additional memory yet. Also, unneeded I/O should be removed. Get your terminal to the proper protocol (4800 baud, no parity, 8 data bits, full duplex, caps lock on) and connect it to the board. Apply +5 volts DC. If the BASIC prompt (>) appears, we can assume that the basic microprocessor circuits are correct. (If you use the BASIC II operating system, then you do not have to set your terminal to 4800 baud. Simply hit the space bar within 7 seconds after the board is turned on or reset.)

If the BASIC prompt does not appear, then we have some troubleshooting to do. IF YOU DO NOT GET THE PROMPT, TURN OFF the power and disconnect the board. If you are using a wire-wrap or other prototype system, check *every* line with an ohmmeter. If you use a printed-circuit board, examine the board closely (with a magnifying glass) for solder bridges or splats, cold solder joints, solder-flux residue, or "whiskers" of PC material under the solder mask. Use an ohmmeter to

check adjacent pins and lines for whisker shorts. Check every IC to insure that no pin has been folded under during insertion. Use an ohmmeter to check the orientation of every diode. It is unfortunately not uncommon to find the markings reversed. If those basic troubleshooting steps don't work, reapply +5 volts DC and check the state of the pins on the microprocessor according to Table 2.

Reset the board and observe the RS-232 output pin. If there is any activity on this pin shortly after reset, then the prompt is being sent, but the terminal is not responding correctly. Check the communications settings on the terminal. (Although we said that the terminal should be set to 4800 baud, that's not essential. Simply type a space within 8 seconds after reset, and the computer will adapt.) Examine the input of the RS-232 port; this line should be at a TTL low level. Typing any character on the terminal should produce a short series of positive-going pulses.

When you get the BASIC prompt, and your terminal and the control computer are communicating properly, you are ready to enter your first program:

```
OK
>NEW
OK
>1 PRINT "HELLO",
>2 GOTO 1
>RUN
```

We hope that everything worked as it should have, and your screen is now full. We'll now leave our discussion of the computer board and begin our discussion about the computer's power supply and wireless remote control.

You may think we're getting ahead of

TABLE 2—8088 PIN STATES

Pin	Function	State
1,20	GROUND	ground
21	RESET	low
23	TEST	high
31	HOLD	low
19	CLOCK	4 MHz
17	NMI	low
40	V <sub>CC</sub>	+5 VDC
22	READY	high
24	INTA	high
33	MN/ $\overline{M\bar{X}}$	high
18	INTR	low

ourselves because we haven't finished discussing the computer circuitry yet—specifically, the I/O system. But some people will not be able to test out the basic system until they build a power supply. So now we'll discuss the power-supply board. After we've done that, we'll return to the computer board with a look at its I/O capabilities.

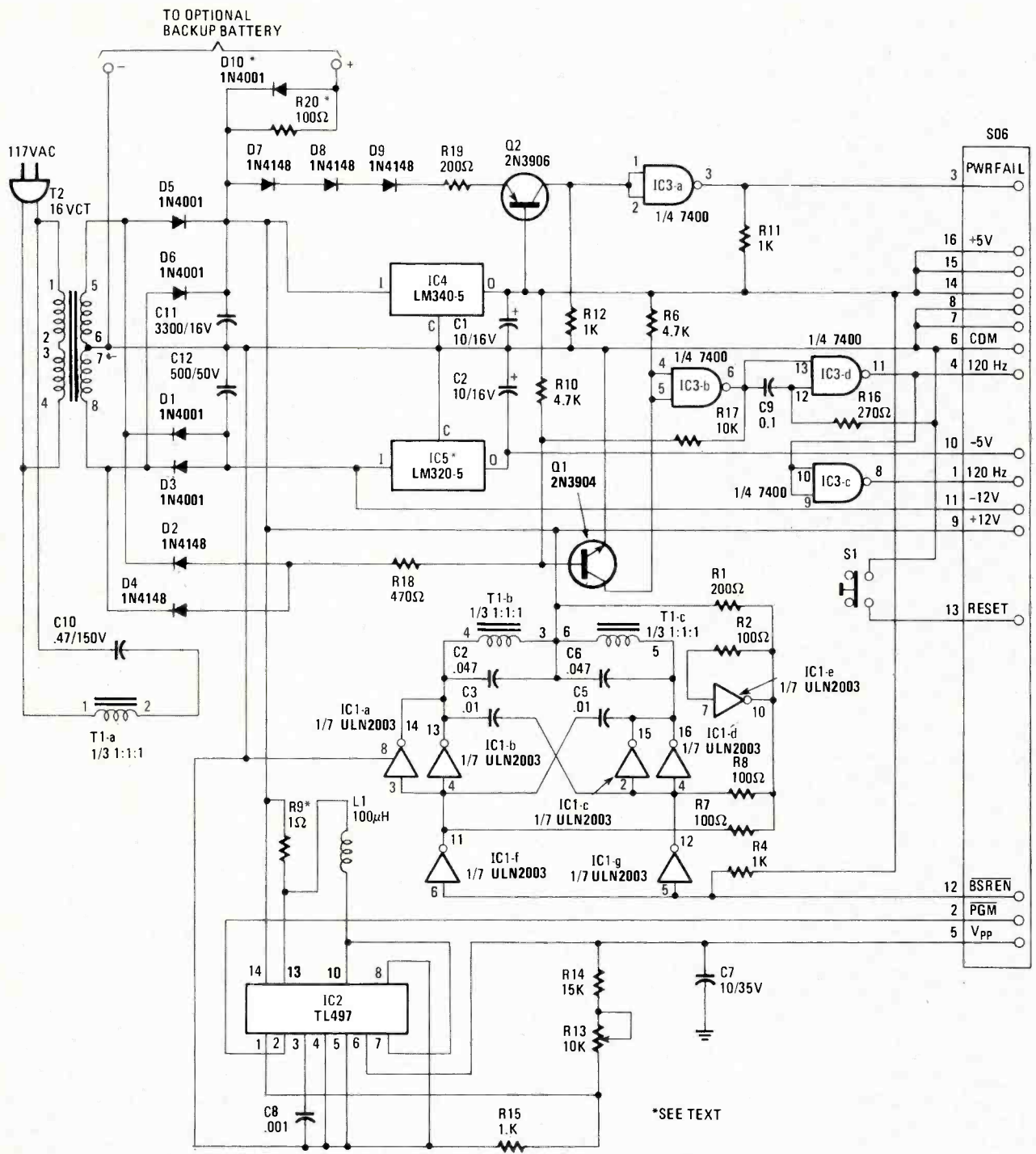

FIG. 5—POWER-SUPPLY/REMOTE CONTROLLER schematic. Components that are marked with an asterisk are optional. Note that some component values do not agree with the Parts List that appeared earlier. Those have been updated in the Parts List on page 90.

### The second board

As we mentioned last time, we know that the computer board requires a supply of +5 volts DC at less than 1 amp. If you plan to use an RS-232 cable longer than 10 feet, then you'll also need a -5-volt supply to establish the RS-232 "mark" level. And if you'll want to program EPROM's, you'll need a higher-voltage supply—the 2716 EPROM requires a 25-volt DC supply at 30 mA.

Other EPROM's require other supplies. For example, the 2732 requires a 21-volt switched supply at 20 mA, while the 2764

requires a 21-volt supply at 30 mA. We mention the requirements for other EPROM's because, as you may remember, the first installment of this article made note of some "unused pads" on the board, some of which are for jumpers to select various options (including the option to program EPROM's other than the 2716). Unfortunately we cannot go into detail on all the possible options—we'll discuss a basic configuration and leave the experimenting up to you. We strongly recommend that you have the board working correctly using 2K × 8 RAM's like the

TMM 2016P and 2K × 8 EPROM's like the 2716 before you start making changes.

Presuming that everything is working correctly, then you can begin to change the board configuration. Let's say, for example, that you want to program a 2732 or 2764 EPROM. You will have to connect pin 23 of the socket (remember—we're using 28-pin sockets even though the 2716 and 2732 have 24 pins) to A11. And you'll have to cut the trace that now brings  $V_{pp}$  there. Pin 20 of the socket should be connected to IC16, pin 7 instead of IC20 pin 13. Study the data sheets and pin functions carefully so that you understand

why those changes have to be made—before you make any changes.

### A look at the power supply

The schematic of the power supply we'll use is shown in Fig. 5. It can supply all of the  $V_{pp}$  options. (The level of  $V_{pp}$  can be varied by trimmer potentiometer R13.) The power-supply board also provides some signals that are used—but not required—by the control computer itself. Those signals include:  $PWRFAIL$  (which tells the computer that the AC power has failed) and a 120-Hz TTL-level pulse that is used for time-of-day routines.

The  $\pm 5$ -volt DC power supply is made up of simple linear-IC regulators (IC4 and IC5). The  $V_{pp}$  supply must supply only 30 mA, but it must be switched on and off for the 2732 type EPROM. The switching is

accomplished with IC2, a TL397 switching regulator. Besides giving us the ability to program 2732's, there is an additional benefit to switching the  $V_{pp}$  supply: We can control its turn-on characteristics. That's important because most EPROM's specify the programming voltage to within .5 volt. If the supply goes any higher, the device can be destroyed. Unfortunately, many power supplies generate an overshoot greater than .5 volt when they are switched on or off. Even a few nanoseconds of ringing on the line is enough to cause some EPROM's to crowbar the +5-volt supply.

The power-fail circuit is a simple common-base, level-detection circuit that monitors the voltage across the +5VDC regulator. When that voltage falls to less than 4 diode drops, the  $PWRFAIL$  signal is

activated. That allows approximately 30 milliseconds of warning before the output of the +5-volt supply falls below 4.75 volts. The  $PWRFAIL$  signal is fed (through SO6 and SO5) to the non-maskable interrupt (pin 17) of the microprocessor. The microprocessor will enter a wait state until its  $\overline{TEST}$  pin (23) goes low, which will happen when a 120-Hz signal is detected. The 120-Hz signal will be detected, of course, when AC power is restored.

That 120-Hz signal is a positive-going pulse at AC zero cross. That signal is important for several reasons. It allows the control computer to be used for time-of-day applications. (A time-of-day routine has been included in the BASIC interpreter. See the Parts List for ordering information.) The second use of the AC zero-cross signal is to synchronize the control

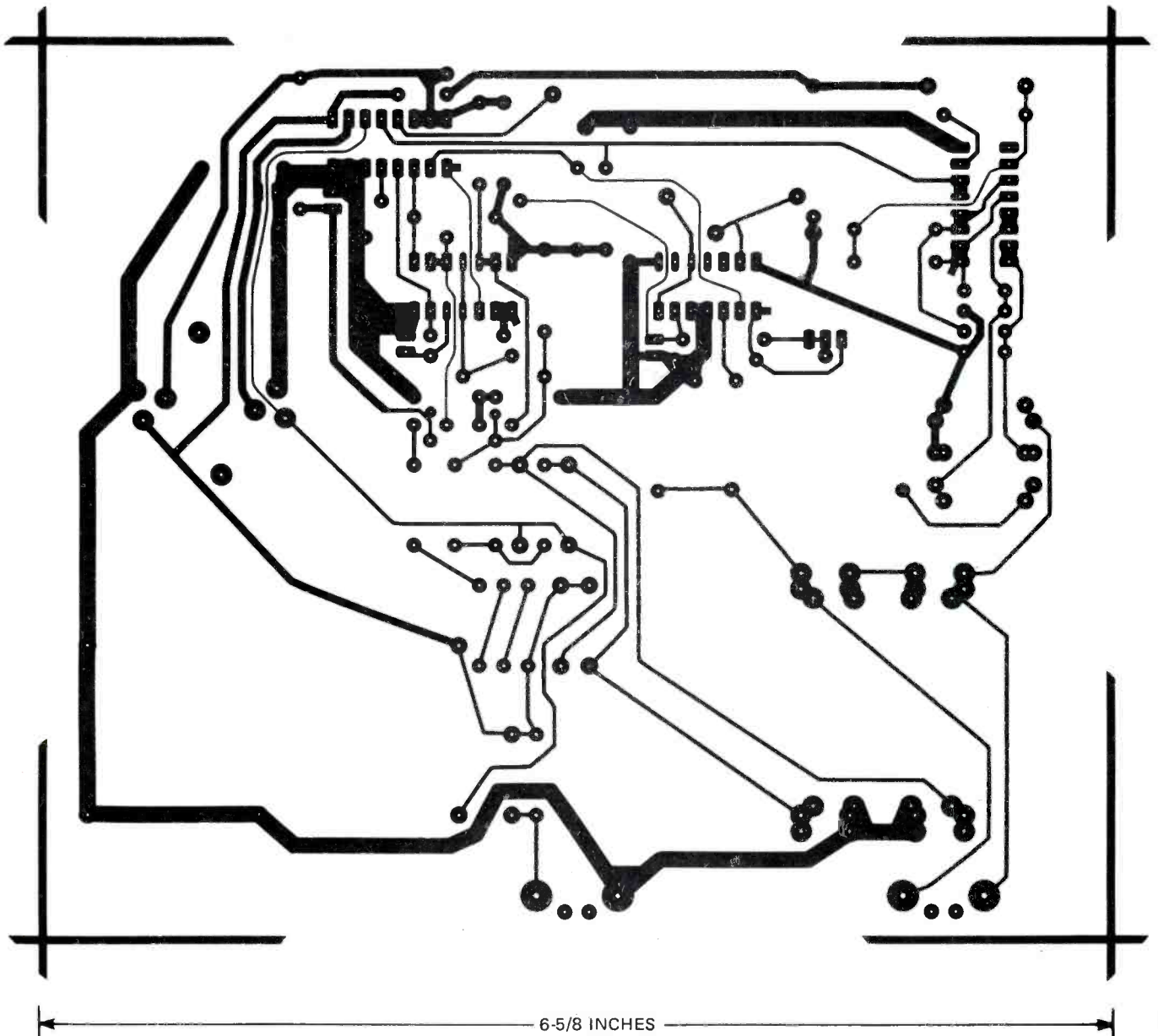

FIG. 6—FOIL PATTERN for the power supply/remote controller. The single-sided board is the same size as the computer board.

computer to the AC line. Many types of machinery require switching on or off at AC zero-crossing to minimize the amount of interference generated. More important for us is that the remote-control link requires that transmissions be synchronized to AC zero crossing. We'll discuss that shortly. Transistor Q1 is connected in a common-emitter configuration, driving IC3.

If you're worried about power failures and brownouts, you can make the power supply uninterruptable by adding an optional backup battery, D10, and R20. That approach is simple and effective for small systems such as this, where an 8-volt, 4 amp-hour *Gel-Cell* will give you about 6 hours of backup operation. Unfortunately, while a battery-backup system will protect the contents of RAM, it will not protect the time-keeping function, which relies on the 60-Hz line frequency.

The foil pattern for the single-sided power-supply/remote-control board is shown in Fig. 6. Note that it's the same size as the computer board that we showed to you earlier. The parts-placement diagram for the board is shown in Fig. 7.

Building the power supply is simply a matter of "stuffing the board." There are a few points that we should mention, though. Figure 8 shows the assembled board of the author's prototype. Note that only one regulator is installed. That's because the -5-volt supply is necessary only for RS-232 cables longer than 10 feet. Up at the top of the board is SO6—a standard 16-pin IC socket. A 16-conductor cable that leads to the computer board is simply plugged in there.

The flat PC-mounted transformer and the heatsink for the regulators bring the overall height of the power supply to less than 1.5 inches. That means that even with the computer board mounted directly on top of the power supply, the total height can be kept well below three inches.

### The remote-control link

The greatest feature of the power-supply board is the wireless remote-control link that allows the computer to control instruments and appliances without the hassles of stringing wires to the control point. Signals are sent via the power lines and are decoded at the control site so that remote control is simply a matter of plugging the unit that you want to control into a remote module, and transmitting the appropriate codes to the module under control of a BASIC program. (We're getting a little ahead of ourselves here; we haven't yet discussed the computer's I/O system that enables us to do that. But we'll get to the details on that shortly.)

The best way to familiarize you with the remote-control system is to compare it to the BSR model X-10—a remote-control system based on the carrier-current method. A transmitter superimposes a high-

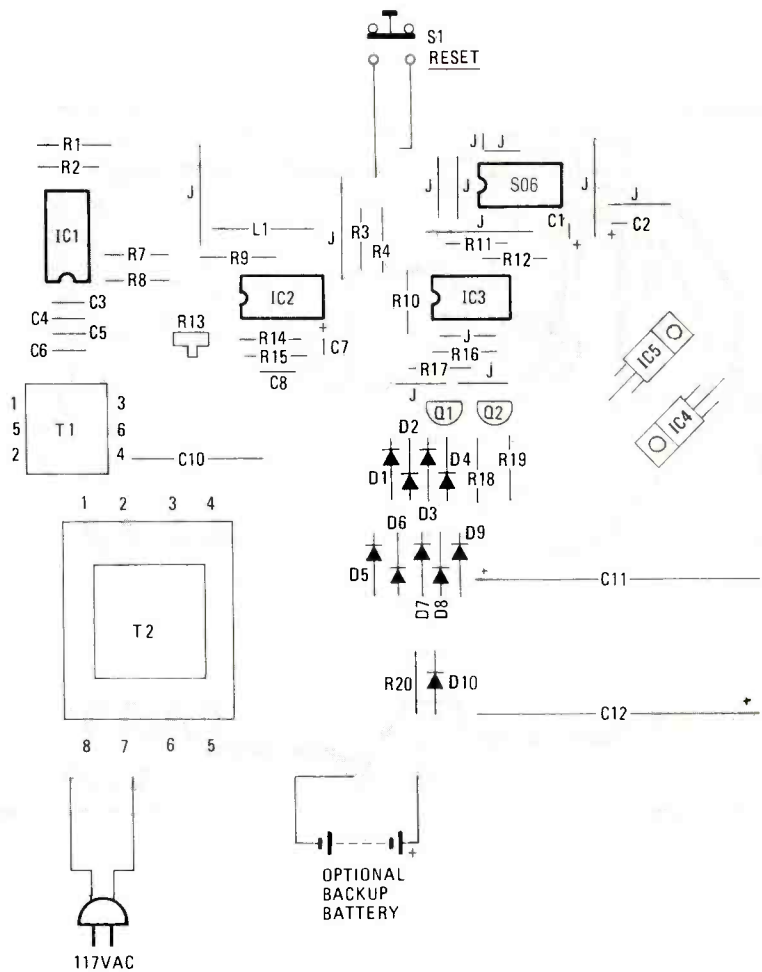

FIG. 7—PARTS-PLACEMENT diagram for power supply/remote controller.

frequency signal onto the AC power lines. That signal contains information that is decoded by the receiver module. There are many advantages to using carrier-current communications. First, the wires are already there—there is no need to drill, cover, or hide the wires around the home. Second, the system is highly portable—because there are no wires, it is not built into your existing location. Another advantage is that the system is popular—Radio Shack, Heath, Sears Roebuck, and Advance Electronics are among the largest suppliers. The receiver modules are inexpensive (\$8–\$17) and are available for a wide variety of functions. Plug-in modules (see Fig. 9), wall-mounted switches, and dual outlets are the most common.

There are two basic types of receivers. The lamp controller uses a Triac as the control element and can regulate the AC power into resistive loads up to 300 watts. The appliance modules contain a relay that can be used to switch loads that draw up to 15 amps.

It should be noted that this system does not include "handshaking." No response from the receiver is expected; it cannot indicate that the message was received or that the command was executed. The transmitter simply transmits and assumes

that everything is all right. Because of that, you should be very careful if you plan to use this system in any application that requires high reliability. However, in the home environment where the system was designed to operate, it is as secure and reliable as possible for the low module cost.

There are several possible problems with transmitting information over the AC power lines. First, if you live in an apartment complex, you may find that your transmissions control your neighbor's units as well as your own. But because there are 256 unit codes available, a bit of coordination will easily solve that problem. The second problem occurs when attempting to transmit from one branch of the AC line to the other. When 230 volts AC is brought into the home at the service entrance, the home circuits are shared between the two phases. A transmitter on one leg may not be able to communicate with a receiver on the other. Many times, however, appliances that are connected between the 230-volt phases will serve as a high-frequency bypass path between the legs. If a problem is encountered, a 0.1 $\mu$ F capacitor connected across the legs should solve it. (The capacitor provides a high-frequency bypass path around the transformer to the other leg.)

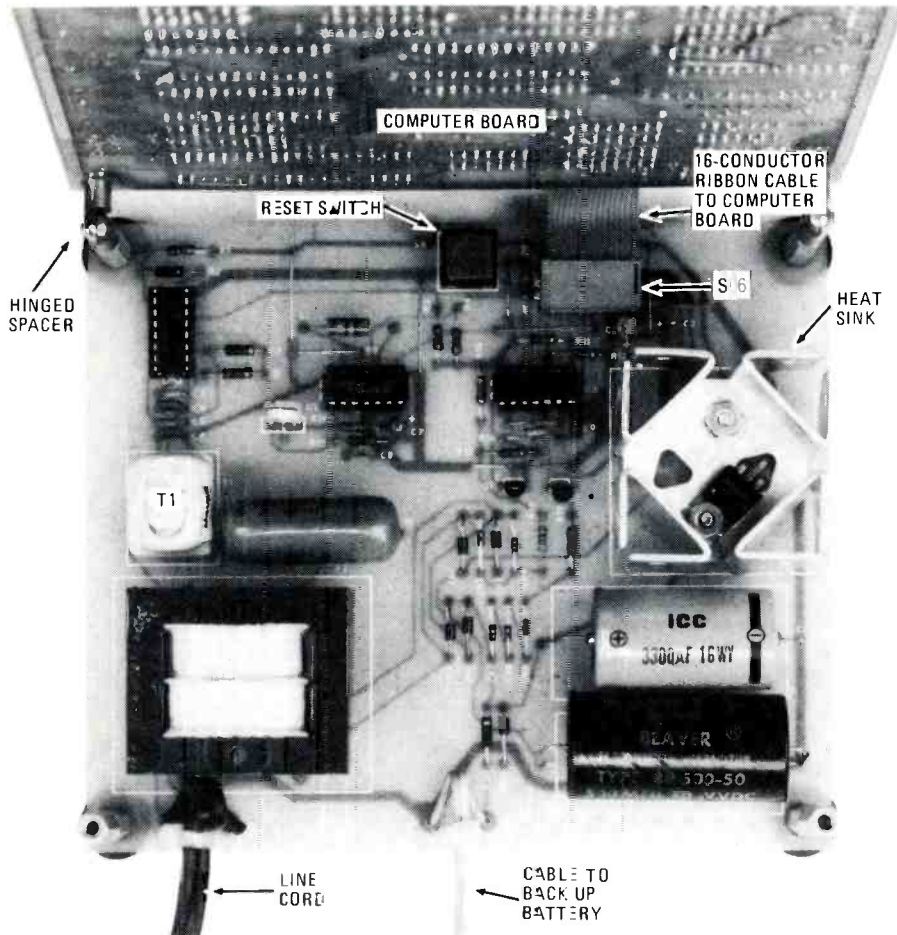

FIG. 8—THE ASSEMBLED board. Note that IC5 was not installed in the author's prototype.

We mentioned that the remote-control system requires that the code transmission be synchronized to AC zero crossing—the transmission must begin within 100 microseconds of zero cross. A data "one" bit is defined as 3 bursts of 120 kHz starting immediately after zero cross, lasting 1.0 milliseconds, and spaced 1.6 ms apart. A data "zero" bit is defined as no transmission of 120 kHz after zero cross. Fig. 10 shows one cycle of 117-volts AC,

over which is superimposed first a one and then a zero. Notice that each bit of data is sent during one-half AC cycle. Therefore, the data-transmission rate is 120 Hz.

Each message sent to the control module is made up of 22 bits of data as shown in Fig. 11. That data is organized as follows: First a start sequence of 1,1,1,0 is transmitted. (That takes two full cycles.) Next the 9-bit address/command code is transmitted. Following each transmitted data bit, the complement of that bit is transmitted on the next AC zero cross. The complete message, including the start sequence, takes 11 full AC cycles.

The 9-bit (18 bits if you include the

complements) data packet consists of 4 bits that determine the "house code" (A-P) followed by 5 bits that contain either the command or unit code. A typical control-command sequence consists of two transmissions. First, for example, house code M, unit 3 is transmitted. That causes all modules that are set to code M—except for any modules set to unit 3—to ignore the next transmission. (Of course, any modules that are not set to house-code M will also ignore the next transmission.) That next transmission would be, for example, house-code M, ON. And module 3—which is the only module "paying attention" responds by turning on.

Table 3 lists the house codes and Table 4 lists the command codes that are available in the system. Notice that if you select house code M, the upper 4 bits are always zero. The data word transmitted then consists of only the following 5-bit word—the decimal value shown in Table 4. If you wish to use other house codes, simply form the 9-bit word by placing the house code bits in front of the command bits. We'll look at an example shortly.

The hardware required to transmit the commands is surprisingly simple. The AC zero-cross detector is already a part of our system. The 120-kHz transmitter is an inductive multivibrator that can be enabled with a TTL signal (B5REN from pin 11 of SO5). This multivibrator consists of 4 open-collector inverters (IC1) connected in an astable configuration. Each stage is formed by paralleling two gates for increased reliability. A fifth IC inverter is connected in a negative-feedback configuration, biased at the same level as the multivibrator stages to provide a stable bias source. The multivibrator is controlled through two additional (open-collector) gates connected to the inputs of the astable gates. Those will clamp the astable inputs to ground in order to disable the oscillator.

The software required to drive the BSR remote-control link is, unfortunately, not as simple as the hardware. Because of the



FIG. 9—THE BSR LAMP-CONTROL MODULE. The house and unit codes are easily set using thumbwheel switches.

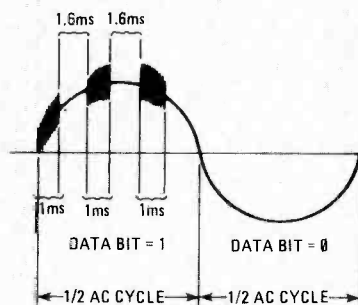

FIG. 10—ONE CYCLE of a 60-Hz waveform showing a superimposed control signal.

TABLE 3

House Code	D8	D7	D6	D5
A	0	1	1	0
B	1	1	1	0
C	0	0	1	0
D	1	0	1	0
E	0	0	0	1
F	1	0	0	1
G	0	1	0	1
H	1	1	0	1
I	0	1	1	1
J	1	1	1	1
K	0	0	1	1
L	1	0	1	1
M	0	0	0	0
N	1	0	0	0
O	0	1	0	0
P	1	1	0	0

## PARTS LIST—COMPUTER BOARD

All resistors ¼-watt, 5% unless otherwise noted

- R1, R4, R14–R18—1000 ohms
- R2, R5, R6—user-determined. To be discussed next month
- R3, R11, R12—10,000 ohms
- R7—680 ohms
- R8—390 ohms
- R9—12,000 ohms
- R10—2,000 ohms
- R13—10 ohms
- RN1—4.7K × 9 resistor network

### Capacitors

- C1—user-determined.
- C2—150 pF, ceramic disc
- C3–C8, C11–C13, C16–C20—0.1 μF, ceramic disc
- C9—0.001 μF
- C10—27 pF
- C14, C15—10 μF, 16 volts, electrolytic

### Semiconductors

- IC1—ADC0804 A/D converter (National)
- IC2, IC3—74LS541 octal buffer and line driver
- IC4—SN75478 seven high-current darlington drivers (TI, also Sprague ULN-2003, Motorola MC1413)
- IC5—4051 8-input analog multiplexer
- IC6, IC7—74LS377 octal latch
- IC8—74LS251 8-input digital multiplexer
- IC9—System ROM. 2716, 2732, or 2764. 450 ns maximum access time.
- IC10, IC12—TMM 2016P-2 (Toshiba or similar) 2K × 8 static RAM, 450 ns.
- IC13—Programmed EPROM (2716)

- IC14—EPROM to be programmed
- IC11—74LS259 8-bit addressable latch
- IC15—74LS373 octal latch
- IC16—74LS139 dual 2-to-4 line decoder/multiplexer
- IC17—74LS32 quad OR gate
- IC18—8088 microprocessor
- IC19—74LS04 hex inverter
- IC20—74LS123 dual one-shot
- Q1, Q2—2N3904
- Q3—2N3906
- D1, D2, D4–D8—1N4148
- D3—1N4001

**Miscellaneous:** IC sockets, PC board, mounting hardware, etc.

The following are available from Vesta Technology, Inc., 2849 W. 35th Ave., Denver, CO 80211: KIT 1—Kit of all parts needed to control 7 LS-TTL outputs, monitor 7 inputs, program EPROM's, RS-232 serial port, and 2K RAM (does not include operating system—see below), \$99.95; KIT 2—Kit of all parts for full-capacity I/O and 4K RAM (does not include operating system—see below), 169.95; Operating systems contained in ROM: BASIC I operating system, \$12.95; BASIC II operating system, \$29.95; Forth operating system, \$79.95; Assembled, tested, and burned-in control computer with BASIC II operating system, \$279; RS-232 cable, \$24.95; 2716 EPROM, \$6.95. Add \$6 for shipping, handling, and insurance.

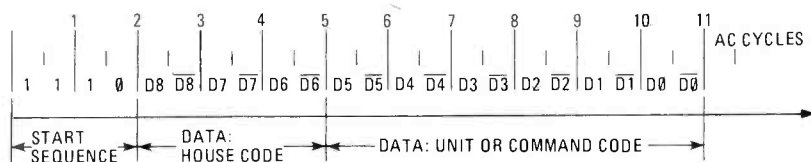

FIG 11—ONE TRANSMISSION consists of a start sequence, a house code, and a unit or command code. (Remember—the complete command transmission consists of two separate transmissions; the first ends with the unit code, and the second ends with the command code.)

TABLE 4

ADDRESS/COMMAND	D4	D3	D2	D1	D0	DECIMAL VALUE
Unit 1	0	1	1	0	0	12
Unit 2	1	1	1	0	0	28
Unit 3	0	0	1	0	0	4
Unit 4	1	0	1	0	0	20
Unit 5	0	0	0	1	0	2
Unit 6	1	0	0	1	0	18
Unit 7	0	1	0	1	0	10
Unit 8	1	1	0	1	0	26
Unit 9	0	1	1	1	0	14
Unit 10	1	1	1	1	0	30
Unit 11	0	0	1	1	0	6
Unit 12	1	0	1	1	0	22
Unit 13	0	0	0	0	0	0
Unit 14	1	0	0	0	0	16
Unit 15	0	1	0	0	0	8
Unit 16	1	1	0	0	0	24
CLEAR	0	0	0	0	1	1
ALL UNITS ON	0	0	0	1	1	3
ON	0	0	1	0	1	5
OFF	0	0	1	1	1	7
DIM	0	1	0	0	1	9
BRIGHTEN	0	1	0	1	1	11

## PARTS LIST—POWER-SUPPLY/BSR LINK BOARD

All resistors ¼ watt, 5% unless otherwise noted

- R1, R19—200 ohms
- R2, R7, R8, R20—100 ohms
- R3, R4, R11, R12, R15—1000 ohms
- R6, R10—4700 ohms
- R9—1 ohm (a jumper works fine)
- R13—10,000 ohms trimmer potentiometer
- R14—15,000 ohms
- R16—270 ohms
- R17—10,000 ohms
- R18—470 ohms

### Capacitors

- C1, C2—10 μF, 16 volts, electrolytic
- C3, C5—0.01 μF, ceramic disc
- C4, C6—0.047 μF, ceramic disc
- C7—10 μF, 35 volts, tantalum
- C8—0.01 μF, ceramic disc
- C9—0.1 μF, ceramic disc
- C10—0.14 to 0.47 μF, 150 volts, electrolytic
- C11—3300 μF, 16 volts, electrolytic
- C12—500 μF, 50 volts, electrolytic

### Semiconductors

- IC1—ULN2003 darlington array (Sprague)
- IC2—TL497 switching regulator
- IC3—74LS00 quad NAND gate
- IC4—LM340-5 +5-volt regulator
- IC5—LM320-5 -5-volt regulator
- Q1—2N3904
- Q2—2N3906
- D1, D3, D5, D6, D10—1N4001
- D2, D4, D7–D9—1N4148
- T1—11Z2100 1:1:1 pulse transformer (Sprague)
- T2—16 volts, center tapped, 0.4 amps. (Signal ST-4-16 or similar)
- S1—normally open momentary pushbutton switch

**Miscellaneous:** line cord, printed-circuit board, IC sockets, heat sink for regulator, mounting hardware, etc.

The following are available from Vesta Technology, Inc., 2849 W. 35th Ave., Denver, CO 80211: Power-supply/BSR-link kit, including all components, \$59.95; Assembled, tested, and burned in power supply, \$109. Add \$6 for shipping, handling and insurance.

submillisecond timing requirements, BASIC cannot be used. However, the transmitter driver routine has been incorporated into the BASIC interpreter. (See the Parts List for information on availability of the interpreter.) The command "XMIT" eliminates all of the inconvenience of developing and debugging a machine-code routine. For example, to turn on unit 6, house code M, the proper sequence of commands is:

```
XMIT(18)
XMIT(5)
```

The first command alerts any units that are set to house code M, unit 6. The second command turns those units on. Just to make sure you understand how to use the command/address codes, how would you turn off house-code N, unit 6? If you

study Tables 3 and 4 and our discussion, you should see that the commands

```
XMIT(151)
XMIT(135)
```

would do it. The first command sends the house/address code 0100/10010 (151 decimal) and the second command sends the house/command code 0100/00111. (135 decimal).

One final point that we should make about the remote-control system is that it is a low-power communications device operating between 10 kHz and 490 kHz and is therefore subject to FCC regulation part 15, paragraph 15.111 (Operation below 1600 kHz) and 15.102 (Interference) which states: "Notwithstanding the other requirements of this part, the operator of a low power communication device which causes harmful interference to an authorized radio service, shall promptly stop operating the device until the harmful interference has been eliminated."

### The I/O systems

Now that we have taken a look at the power-supply board, we can return to the computer and discuss its input and output capabilities. (We briefly mentioned some of those I/O capabilities when we talked about the remote-control system and the RS-232 port.)

A computer's only link to the outside world is through its inputs and outputs. If we take, for example, a personal computer, the input is usually a keyboard and the output device is usually a CRT screen. A control computer's I/O is oriented more toward hardware. Individual lines can sense external conditions while other lines control external devices.

The number and type of those control lines are very important specifications of a control computer—they are what determine whether or not the computer can do the task that you have in mind.

A microprocessor interfaces with I/O devices in the same manner as it does with memory: An address is sent out on the address bus, data is transferred over the data bus, and the control bus controls the actual transfer. In many systems, I/O devices are treated exactly as memory, in which case they are said to be *memory mapped*. Memory mapping of I/O functions may be done to save hardware (additional decoders), or it may be done because the microprocessor has no provision for separate memory and I/O space.

The alternative to memory mapping is *I/O mapping*, which our system uses. In that case, the control bus has an additional line called  $\overline{IO}/\overline{MEM}$  that determines if the data will be transferred between the microprocessor and memory or between the microprocessor and I/O. The 8088 has an I/O space of 64K (which is equal to the memory space of many microprocessors).

The various types of inputs and outputs

are implemented with various types of IC's that are enabled onto the data bus whenever their address is present on the address bus. We will decode the I/O space in much the same way that we did for memory. In fact we will use the other half of the same IC (IC16-b, a 74LS139 dual 2-to-4 line decoder/multiplexer) plus a few additional gates. (Refer back to Fig. 1 at the beginning of this article.) The signal  $\overline{IO}/\overline{MEM}$  will be used to enable that half of the decoder—that prevents an I/O device from responding to an address meant for memory. We will use address lines A4 and A5 to select which of the four outputs will be active (low).

Further decoding is required to separate the input devices from the output devices. Two OR gates (IC17-b IC17-c) provide that function for those IC's that do not have two ENABLE inputs. The memory map that results from that decoding is shown in Table 3.

### Digital I/O—bit-addressable

The inputs of a control computer are used primarily to sense the status (high or low) of an external device. Outputs are generally used to turn something on or off. Bit-addressable I/O allows us to act on or read only one bit of information—that bit is isolated from all of the other inputs and outputs. Although bit-addressable I/O is neither the simplest to implement nor the most common type of I/O, it is, in most cases, the easiest to use.

All we have to do to get our outputs is to connect an addressable latch onto data-bus line D0. By using IC11, a 74LS259, we can latch and output 8 individually-addressable bits to the "real world."

Inputs are no more difficult than outputs. The hardware for bit-addressable inputs consist of a multiplexer (IC8—74LS251) that selects the desired line that will be connected to data-bus line D7. In the case of both the input multiplexer and the output latch, the address lines A0, A1, and A2 are connected to the address inputs of the IC.

Before we go any farther we should remind you that the last bit-addressable input and the last bit-addressable output are used by BASIC for the RS-232 port. *Do not change the state of the output or connect anything to the input if you are using a terminal for communications.*

TABLE 5

Port "Address"	Description
0-7*	BIT-ADDRESSABLE, SO4
16	8-BIT I/O - PORT 1, SO2
32	8-BIT I/O - PORT 2, SO3
48	A/D CONVERTER SO1

\*PORT 6 IS USED TO ENABLE REMOTE-CONTROL TRANSMITTER.  
PORT 7 IS USED FOR RS-232 PORT.

A glance at the software required to exercise these I/O functions will give you an idea of how easy it will be to start using the computer. For example, to set the first output high we simply execute the OUT (port,value) statement: "OUT(0,1)." That BASIC statement outputs to I/O location 0, the value 1. (See Table 5 for other port "addresses.") The latch will hold that value on the output line. Reading an input is just as easy. In this case we must assign the result to a variable as in the statement: "LET A = INP(0)." Then the status of the first input line, I0 determines the value of A.

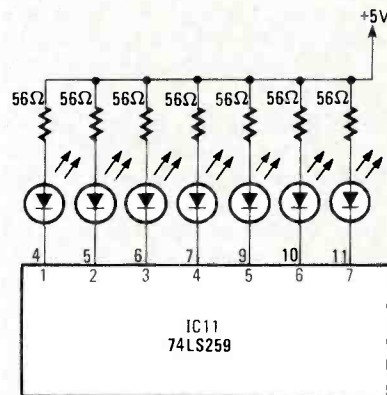

FIG. 12—TO TEST THE bit-addressable output port, you can use this simple circuit. If you install IC4, then you can test the output at socket SO4, pins 1-7.

Note that the BASIC INP and OUT statements are used instead of PEEK and POKE. That's because we are exchanging the data in the I/O space, not in memory.

The output line of the multiplexer is connected to data-line D7, the Most Significant Bit (MSB) of the data bus. Because of that, we can check the state of the input line with a single statement that tests whether the data on the bus is greater than 127 (or less than 128). If you wanted to use data-line D0 (which is connected to the inverted output of the multiplexer) you would have to mask off the unused bits.

At last we can start using our computer for control. As a demonstration, let's connect 7 LED's to the 7 outputs as shown in Fig. 12. Also connect a single, normally open, pushbutton switch between the first input, I0, and 5 volts DC.

First we should initialize all LED's to the off state (note that because the LED's are connected to +5, off is high).

```
10 FOR I = 0 TO 6
12 OUT(1,I)
14 NEXT I
```

Having turned all of the LED's off, we will wait until the switch is turned on before going further:

```
20 LET I = INP(0)
22 IF I < 120 GO TO 20
```

This will loop until the switch state is turned "on".

```
30 FOR I=0 TO 6
32 OUT(1,0)
34 NEXT I
```

Those three lines will turn all LED's on.

```
30 FOR J=0 TO 50
40 FOR I=0 TO 6
42 OUT(1,0)
44 OUT(1,1)
46 NEXT I
50 NEXT J
60 GO TO 10
```

Lines 30 to 60 will blink the LED's and then return to the switch-monitoring loop.

The 74LS251 can sink/source one LST-TL load. If we are not concerned too much about the logic high or logic low voltages, then we can sink or source many times that amount. The practical limits of the output drive capacity is limited to about 15mA in the low state and about 10mA in the high state. The output capacity can be increased by using IC4, an open-collector Darlington array. The generous sink capacity of this device makes it handy for controlling relays. A snubber diode is included in the package, which is important if you will be switching any type of inductive load. Without it, the inductive kickback would cause intermittent problems when running a program (or it could destroy the computer outright).

### Digital I/O—8-bit port

The next type of I/O consists of 8 parallel bits—often referred to as a byte-wide I/O port. The byte-wide port is a natural extension of the microprocessor data bus and, as such, it is the most convenient method of transferring data to or from peripheral devices, such as printers, voice synthesizers, or BCD thumbwheel switches.

A BASIC interpreter for the control computer is available (see Ordering Information). BASIC I can operate on 26 variables, and includes commands such as:

LIST	NEW
RUN	LET
IF	FOR/NEXT
GOTO	GOSUB/RTN
PRINT	INPUT
STOP	REM
XMIT	PEEK
POKE	INP
OUT	

The BASIC II operating system includes all that is contained in BASIC I. In addition, it can operate on 52 variables and 1 array, and contains about twice as many commands. Those extra commands include FILL, STAT, DUMP, EPROM (which programs an EPROM with the current program) MOD, ONERROR, and many others.

The 8-bit parallel I/O port is the easiest to design. All that is required for inputs is to enable 8 buffers onto the data bus for each port. That job is done by IC2 and IC3, which are 74LS541 buffers. For outputs, all we have to do is to latch the status of the data bus, for which we use IC6 and IC7, 74LS377 D-type flip-flops.

While the byte-wide port is best suited to data transfer, it is possible to use it for bit-wise control as well—but it's not always easy to isolate the single bit that's of interest. In the case of input testing, it involves a mathematical process called *bit masking*. If the output port is used for single-bit control, a record of the state of the port must be maintained in the program so that the proper output word can be formed, that will toggle the desired bit but leave all of the other bits unchanged.

The same simple software commands used for the bit addressable ports are used to control the 8-bit parallel ports. For example, "OUT(16,0): OUT(16,255)" will set all 8 outputs first to zero then to 1. The command "LET A=INP(16)" will assign a value to A in the range of 0 to 255 depending on the status of the 8 inputs.

### Analog inputs

Most natural processes appear to us as analog or continuous-time functions. The temperature, pressure, humidity, sound levels, and light levels surrounding you are analog quantities. But the measuring process can convert the analog function into a discrete digital function. For example, we know that the temperature does not change in steps. But if your thermometer is only accurate to one-half degree, then the temperature will appear to change in 1/2-degree steps. If you used a thermometer with higher resolution, you could extend the number of digits used to express the temperature. But no matter how accurate the thermometer, you cannot express the temperature exactly.

In order for the computer to be able to "understand" analog quantities, they have to be converted into digital quantities. That's the purpose of the analog-to-digital (A/D) converter.

The first parameter used to describe our A/D converter is the number of bits the result will be—the resolution of the measurement. The smallest increment or change of the result is always one *least-significant-bit* (LSB). An 8-bit conversion resolves to one part in 256. The next parameter is the *span* of the conversion. That is the physical range that is represented by the zero and full-scale values of the A/D output. Thus, if our 8-bit converter had a span from 0° to 255°, each bit of output would represent one degree. If the span were reduced to 125°, each bit would represent 1/2°. The number of bits of the conversion determines the resolution of the converter. The span of the conversion determines the resolution of the physical

quantity. Increasing the number of bits or decreasing the span will increase the resolution of the result.

The accuracy of the A/D conversion takes into account not only repeatability, but the absolute accuracy of the output compared to the input. That is really a measure of the accuracy of the standard used during the conversion process. If a reference diode defines full-scale as 2.55 volts, and if that reference should drift to 2.56 volts, then 2.56 volts will be required at the A/D input to produce a result at the output of 255. That potential source of inaccuracy can be eliminated by using a technique called ratiometric measurement. Ratiometric measurements are made using the same source for both the reference and the transducer. Thus any variations will be present in both and will cancel out.

The last parameter we should consider is the number of channels—the number of inputs that can be connected to the A/D converter. Obviously with 2 A/D converters, we can measure 2 different points. However, by equipping a single A/D converter with an analog input multiplexer we can also measure several points (but not simultaneously).

There are two common methods of performing the conversion. The first is called integration. The input voltage causes a proportional input current to charge a capacitor to a specific voltage level. The time required to charge the capacitor is inversely proportional to the input voltage. The second method is called successive approximation (SAR). In that method, the analog input is compared to the output of a digital to analog (D/A) converter. The D/A converter is adjusted until its output matches the unknown analog input. The input to the D/A converter that produces the match becomes the output of the A/D converter.

The number of tries before a match is made is never more than the number of

### ORDERING INFORMATION

The following are available from Vesta Technology, Inc., 2849 W. 35th Ave., Denver, CO 80211: KIT 1: Kit of all parts needed to control 7 LS-TTL outputs, monitor 7 inputs, program EPROM's, RS-232 serial port, and 2K RAM (does not include operating system—see below), \$99.95; Operating systems contained in ROM: BASIC I operating system, \$12.95; BASIC II operating system, \$29.95; Forth operating system, \$79.95; Assembled, tested, and burned-in control computer with BASIC II operating system, \$279; RS-232 cable, \$24.95; 2716 EPROM, \$6.95; Power-supply/BSR-link kit, including all components, \$59.95; Assembled, tested, and burned in power supply, \$109. Add \$6 for shipping, handling and insurance.



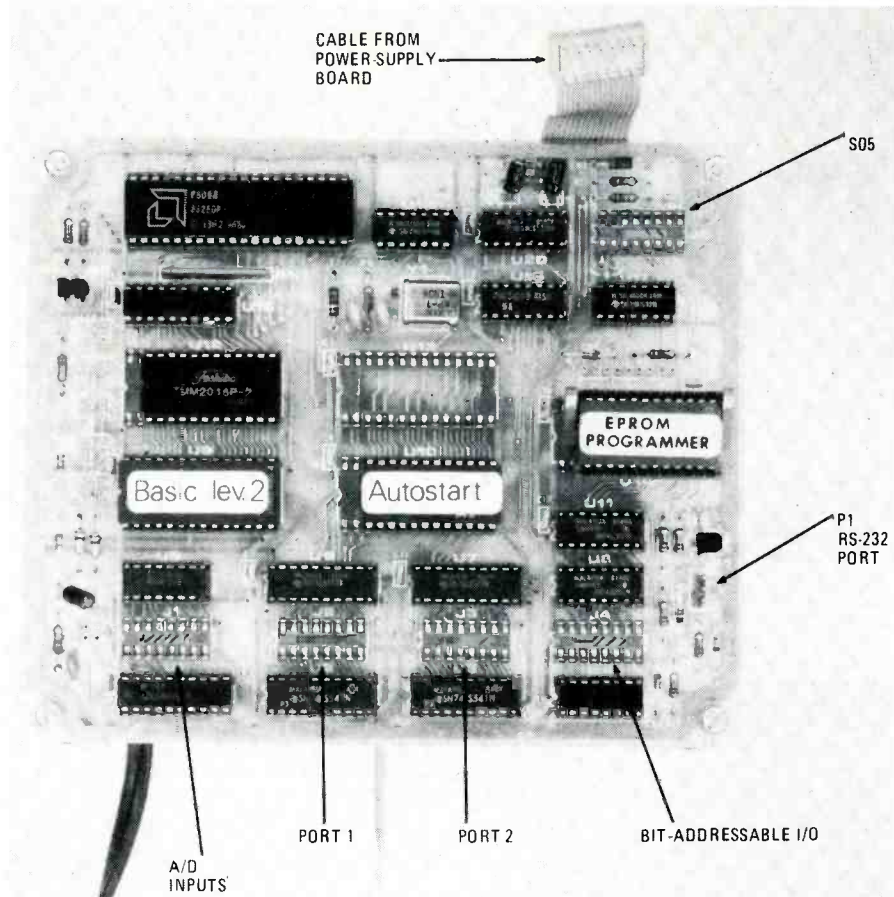

COMPUTER BOARD. Note how the 24-pin devices are plugged into the 28-pin sockets leaving pins 1 and 2 empty.

bits of resolution. Thus an 8-bit A/D will find a match in no more than 8 tries.

Integrating A/D's are very accurate but slow. Twelve- and 14-bit conversions take tens of milliseconds. Successive approximation (SAR) A/D's are fast, but are not as accurate. Eight-bit conversions may take only a few microseconds.

The A/D converter selected for our computer is IC1, the ADC0805 from National Semiconductor. That 8-bit SAR converter can span input voltages as low as .25 volts. Provision has been made for ratiometric or absolute conversion. The converter has true differential inputs and zero-offset adjustment. An analog multiplexer is included in the circuit that accommodates up to 8 input channels.

The ADC0805 is designed to be used with microprocessors, so all we have to do is to connect it to the data and control buses.

A conversion is initiated by writing (anything) to the A/D converter. The result will be available by the time BASIC interprets the next program statement. The channel-select controls of the input multiplexer (IC5 pins 9, 10, and 11) are connected to three outputs of the 8-bit port at SO2. That doesn't mean that you have to use the port, only the A/D converter—it can be used for data transfer. The only

requirement is that the multiplexer's control inputs be stable when the A/D converter is making a measurement.

Using the A/D converter is a simple 1-2-3 procedure. First, select the channel (using the 8-bit output port). Second, write to the A/D to start the conversion. Third, read the result. In BASIC, we could write:

```
10 OUT(16,0)
20 OUT(32,0)
30 PRINT INP(32)
```

Line 10 selects channel 0, line 20 writes a

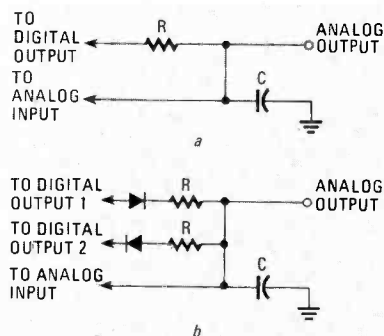

FIG. 13—TWO SIMPLE D/A circuits. The circuit shown in *b* is also shown in Fig. 1, the schematic of the computer. The values of the components depend on your particular application.

zero to the A/D to start conversion, line 30 prints the result.

### Digital-to-analog conversion

Most of the same parameters that we noted for A/D conversion also apply in D/A conversion. Although the control computer doesn't have D/A capabilities, they can be added with very little effort. As shown in Fig. 13-a, a simple resistor-capacitor network is the only hardware required. Remember the description of the SAR A/D converter? We can implement a D/A converter in a similar manner with the components we have on the board and some software.

One of the bit-addressable outputs and one input of the A/D converter must be dedicated to each D/A channel. The digital output is used to charge a capacitor through a resistor, and the A/D input measures the voltage on the capacitor. That measured voltage is compared to the desired value (which is stored in the program). If the voltage is too low, the output is turned on. If the voltage is too high, the output is turned off. The selection of the R-C time constant, and the frequency that the output is corrected by the program, determine the accuracy of that simple approach.

The major limitation of that approach is that the ripple and response time of the circuit are directly related. If minimum ripple is required, a long response time is the result. That can be avoided with a slightly more sophisticated circuit, such as the one shown in Fig. 13-b.

That circuit uses one bit-addressable output to charge the capacitor and another to discharge it. When the voltage is correct, the capacitor is neither being charged nor discharged. Thus, the only contribution to ripple is the discharge current imposed by the load. The response time can be made as fast as it takes the software to decide if the capacitor requires charging or discharging. Note that the circuit shown in Fig. 13-b is also shown in the computer's schematic (Fig. 1). The open circles shown at diodes D1 and D2 (or R2) are for connection to the bit-addressable port. The analog signal is output at SO1 pin 15. (That output also gets connected to one of the A/D inputs.)

### Digital thermometer

As an example of the simplicity and flexibility that smart control can provide, we'll look at how we could use the control computer to measure the temperature. The first step is to select the transducer. There are several options. We could use National Semiconductor's LM335, which has a linear output of 10 mV/°C. Another possible choice is Analog Devices' AD590, which has a current output that is also a linear function of temperature.

*continued on page 132*

# TRS-80 TELEPHONE DIALER

Turn your computer into an automatic telephone dialer.

HOWARD BERENBON

IF YOU OWN A TRS-80 COMPUTER AND want something unique to do with your computer system, then this project may be what you've been looking for. With just a couple of components, you can build a telephone interface that will let a TRS-80 dial a telephone number. That may be the missing link to your automated telephone directory or your computerized burglar alarm.

In addition to the interface circuit, there is a short BASIC program that is presented to drive the interface circuit. Since that circuit is connected to the cassette-tape I/O port, you should be able to connect it to just about any computer with a cassette port and modify the BASIC program to fit your system if you know the port address.

The actual BASIC program is listed in Table 1. It is a Level 2 program that drives the interface circuit through the remote-control relay inside the computer that is connected to the remote-control plug. All that is required is the simple phone interface circuit shown in Fig. 1. The circuit is connected to the remote-control plug of your cassette interface cable.

The interface consists of a relay, a silicon diode, one 9-volt rectangular battery, and a microphone jack. That's about \$4.00 worth of parts. Simply connect the contacts of the relay in series with the green telephone wire. Since the relay is a normally-closed type, it will not interfere with the normal operation of your telephone. However, before you actually connect the telephone, you must contact your local telephone company to insure compliance with local telephone-company regulations.

The BASIC-language program uses the OUT command to access the I/O port (port FF) and thus dial the phone. It pulses the cassette remote-control relay that is connected to the telephone line via the interface circuit.

The dialer is set to dial one phone number, and print the number on the CRT screen as it is dialed. The program simulates the operation of a rotary dial, by pulsing out the digits to the phone interface. It will function with both rotary dial and pushbutton phones. Any length phone number is placed in the DATA statement at line 1000, with commas separating each digit. The last number enter-

TABLE 1—PHONE DIALER PROGRAM

10 PRINT "TRS-80 PHONE DIALER PROGRAM"	190 GOSUB 500
20 PRINT "COPYRIGHT © 1979 BY HOWARD BERENBON"	200 OUT 255,0
30 PRINT	210 GOSUB 550
40 PRINT "ENTER AN 'A' TO DIAL"	220 C=C-1
	230 IF C=0 THEN 110
50 INPUT A\$	240 GOTO 180
60 IF A\$<>"A" THEN 40	400 FOR A=1 TO 90
70 CLS:Q=14:R=14	410 NEXT A
80 REM DIAL THE NUMBER IN THE DATA STATEMENT	420 RETURN
90 X=200	500 FOR A=1 TO Q
100 PRINT "DIALING"	510 NEXT A
110 READ C	520 RETURN
120 IF C=55 THEN 700	550 FOR A=1 TO R-5
130 PRINT @ X,C	560 NEXT A
140 IF C=0 GOSUB 800	570 RETURN
150 X=X+2	700 PRINT
160 REM DIAL THE PHONE NUMBER ONE DIGIT AT A TIME	710 PRINT "DIALING COMPLETE"
170 GOSUB 400	720 END
180 OUT 255,4	800 C=10
	810 RETURN
	990 REM DATA STORAGE FOR PHONE NUMBER
	1000 DATA 1,8,0,0,5,5,5,1,2,1,2,55

ed is "55." That is used to flag the end of the phone number.

To dial, lift the telephone receiver and listen for a dial tone. Then type the letter "A" at the keyboard. The program will print each digit of the phone number as it's dialed.

To test the dialer without connecting the telephone to the interface circuit, lis-

ten to the relay as a phone number is being dialed. When dialing is in progress, the pulses generated by the program can be heard.

Though as shown in Table 1, the BASIC program is limited to dialing one phone number, it may be modified for dialing several numbers rather easily. To do that, the program can be used as a subroutine, with a phone-number access program written around it.

The BASIC program simply uses the OUT command to pulse the remote-control relay, which is addressed at I/O port FF. To activate the cassette remote-control relay, the number 4 is output to port FF (see line 180). To deactivate the relay, a "0" is output to port FF (see line 200). **R-E**

## PARTS LIST

- D1—1N914 diode
- RY1—SPDT relay, 5 or 6-volt 500-ohm DC coil.
- B1—9-volt rectangular battery
- J1—phone jack

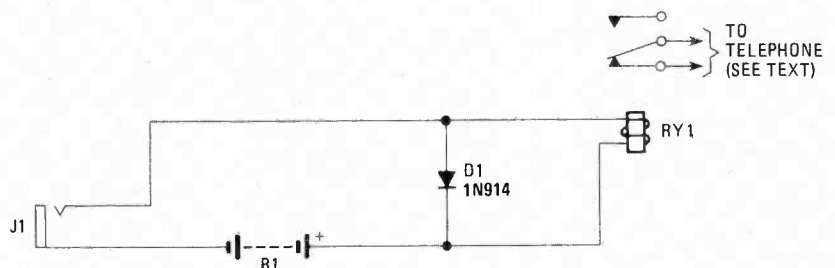

FIG. 1—TELEPHONE INTERFACE circuit can be built on perboard. The relay contacts are connected in series with the green telephone wire.

# BUILD THIS

# AUTOMOTIVE EXHAUST ANALYZER

*Build this useful automotive test instrument and stop guessing about your car's emissions.*

PHILIP M. VAN PRAAG

THE GROWING NUMBER OF STATE AND federal auto-emission requirements has added yet another burden on just about every motorist. Not only do you have to worry about monthly payments, insurance, and sufficient maintenance to keep your car running down the road, now you also have to worry about the next emissions test. Will your car pass, or will you have to go through the time and often considerable expense to have it "tuned up" and then retested?

Worse yet, even if you are a do-it-yourselfer with an "army" of tools, timing lights, and dwell meters, you are still at a disadvantage with regard to emissions tuning. Those items alone are not enough to do the job, and doing what we did in the "good old days"—that is, simply replacing the plugs and points, setting timing and dwell, and then "tweaking" the carburetor until the engine runs smoothly and performs well—just won't cut it anymore.

Indeed, often the best low-emission settings for your car will be quite different from those settings that provide the best performance. There is simply no way to optimize those adjustments for, nor adequately predict the results of, an emission test with common service equipment. That's why you need the digital exhaust-gas analyzer that will be described in this article.

That device is a small, easy-to-use diagnostic aid. In a general sense, it monitors combustion efficiency of the engine system. That is vitally important as combustion efficiency directly affects exhaust-gas content. More efficient combustion means more complete burning of

the gasoline. That translates to smaller amounts of hydrocarbons and carbon monoxide (CO) in the exhaust. Hydrocarbons and CO are the "polluters" typically monitored by govern-

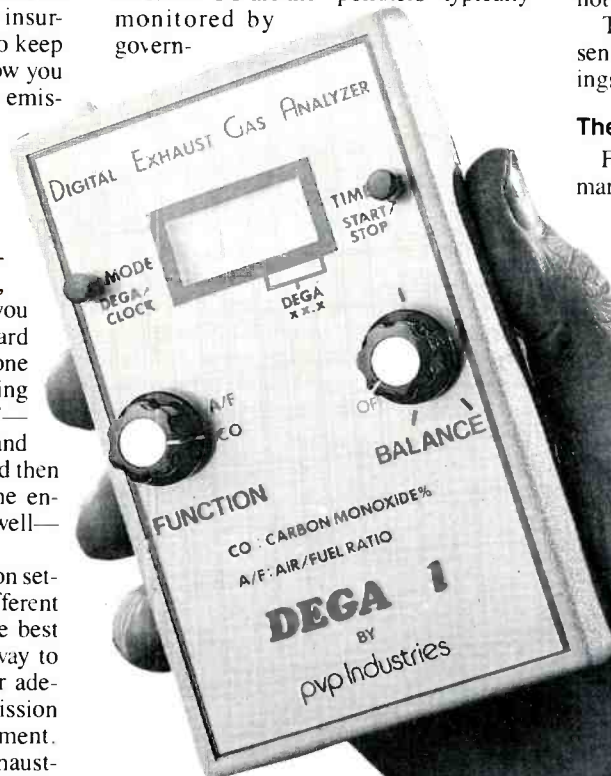

ment test facilities. (More about the relationship between combustion and exhaust makeup later.) Specifically, the unit displays CO in concentrations of less than 1% to about 10%, and air/fuel (A/F) ratios from 14.5 down to about 11.0.

The project consists of three parts: an

exhaust-gas probe, which is inserted into the auto tailpipe; a "conversion box," which transforms part of the exhaust into a proportional electrical signal; and a display unit, which amplifies and digitizes the signal for easy viewing. The unit can be used either while the car is stationary, allowing you to make adjustments, or while it is in motion, allowing you to verify those adjustments under dynamic operating conditions.

To simplify the circuitry, a commercially-available clock/timer module is used for the display. It contains an LCD readout, providing easy viewing under almost any lighting conditions. The module's crystal-controlled timing is also used by the project's A/D converter to ensure a stable timebase throughout the system. An interesting side-benefit to using the clock module is that the unit can be used as an ordinary clock or stopwatch when not being used to measure exhaust gas.

The unit also contains low-voltage sensing circuitry to prevent faulty readings due to inadequate battery voltage.

## Theory of operation

Figure 1 is a block diagram of the primary circuit functions. Exhaust-gas conversion takes place in a thermal-conductivity cell (TCC). The TCC produces an electrical signal that varies with the difference in temperature between a "test" temperature sensor exposed to exhaust gas and a "control" sensor exposed only to ambient changes that affect both sensors. The sensors are self-heated identically, so that they will be at the same temperature when no exhaust gas is present.

When exhaust gas enters

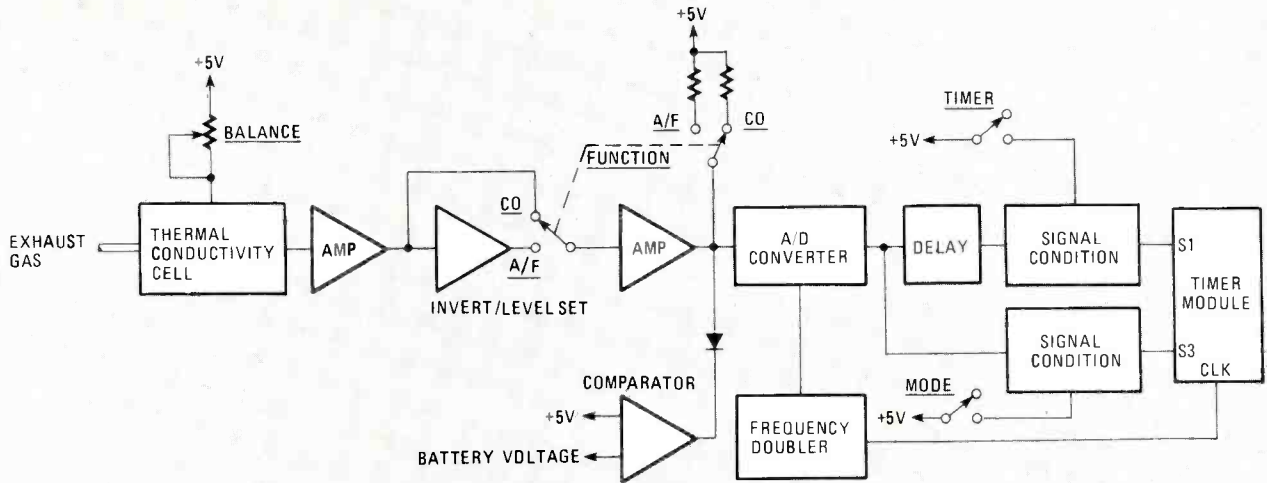

FIG. 1—ALL CRITICAL circuit functions are shown in this block diagram of the exhaust-gas analyzer.

the test-sensor area, the thermal conductivity of the air changes. That affects heat dissipation away from the sensor, thus altering the test-sensor temperature. Changes in sensor temperature cause its resistance to change. In this application, sensor temperature never changes more than a few degrees centigrade, but that is sufficient. It produces enough resistance change to unbalance the TCC. Because of the narrow operating-temperature range, sensor resistance changes linearly with changes in temperature.

At first glance, the difference between thermal conductivity and temperature measurement may not seem clear. They both involve electrical-output changes in response to sensor-temperature changes. In a common "thermometer," the change in temperature is due to an ambient-air temperature change. In the TCC, however, the temperature change is due to an ambient-air thermal-conductivity change. That is, the ability of heat to dissipate away from the sensor is a function of heat conductivity through the gas mixture. By the time the exhaust gas gets to the test sensor, it has essentially cooled down to ambient temperature. Thus, it is not the temperature of the gas that affects the sensor, but rather the thermal conductivity of the gas.

Thermal conductivity of exhaust gas differs from that of air. The exhaust consists of water vapor, carbon dioxide, hydrocarbons in various gaseous states, and CO. The exact proportions of the different hydrocarbon gases and CO, and their precise relationship to the thermal conductivity of the mixture, is very complex, beyond the scope of absolute measurement for this unit. Fortunately, there are predictable relationships over the temperature ranges of the exhaust gas commonly emitted from a 4-cycle internal-combustion, gasoline-drive engine; those can be used to help us in performing auto-emission adjustments. Over those ranges, reasonable accuracy and (more important) repeatability can be achieved.

The unit's CO and A/F functions bear an inverse display-relationship to each other. Thus, as the TCC output signal is amplified, an inverted version is also made available. The CO and A/F display ranges differ for those functions, so different amplifier output-voltage ranges and levels are also provided.

A digital display was chosen because it is easier to read than an analog meter. That is particularly important if the unit is used while driving. Conversion of the analog sensor-signal to digital form is performed by an A/D converter whose operation is shown in Fig. 2. Clock pulses from the timer module are counted, and the results of that count are used by an adder to generate a ramp. Comparator 1 is then used to compare that ramp with the analog sensor-signal. The output of the comparator is a pulse. The duration of the pulse is determined by the amplitude of the sensor signal; that is, the comparator's output is high as long as the ramp amplitude is greater than the sensor amplitude.

When the ramp amplitude dips below the sensor amplitude, the comparator's output goes low. The duration of the ramp

(2 seconds), and hence the test-cycle length, is determined by the nature of the counter (divide by 128) and the clock frequency (64 Hz).

The output signal is used as a gate to allow a certain number of timer pulses to be counted by the timer module for each test cycle. That output is used to reset the timer from the previous count and define the start and stop of the current count.

The remaining task of counting and displaying the pulses is accomplished by the clock-timer module. Figure 3 shows the basic timer-module operation. The module is operated in its stopwatch mode, and has a resolution of 10 ms. That means that the display advances by one count every 10 ms. A series of internal counters divide a crystal-controlled 32-kHz oscillator signal down to the desired count rate. The stopwatch START/STOP and RESET switches are operated electrically when power is applied.

The unit uses the three least-significant digits of the display, with an implied decimal point between the two rightmost digits. Thus, a display of 00040 in the CO mode would be a reading of 4.0%, while a 00131 display in the A/F mode would be a reading of 13.1. Note that CO content is expressed as a percentage, while the A/F (air/fuel ratio) is expressed, naturally enough, as a ratio.

### Circuit description

Figure 4 is a schematic diagram of the gas-analyzer circuit. The test and control sensors are precision-matched thermistor glass beads. Those beads are extremely tiny, about .014-inch in diameter. The small mass of the glass bead gives the unit a fast response time. The beads are pre-mounted in fixtures, as they would be impossible to handle otherwise. (The bead leads are only .001-inch in diameter!) The fixtures and their housings comprise the TCC within the conversion box. A four-conductor cable routes the sensor signals and ground between the box and the display unit.

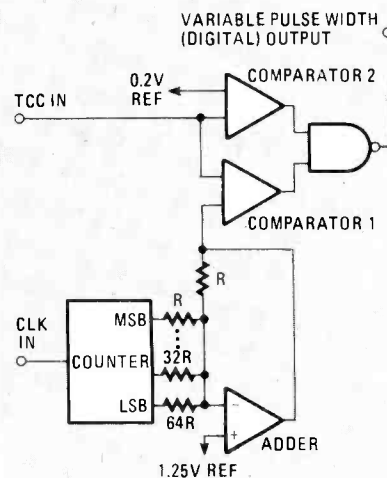

FIG. 2—HOW THE A/D CONVERTER works. Note that for simplicity, only 3 of the 7 resistors at the counter's outputs are shown.

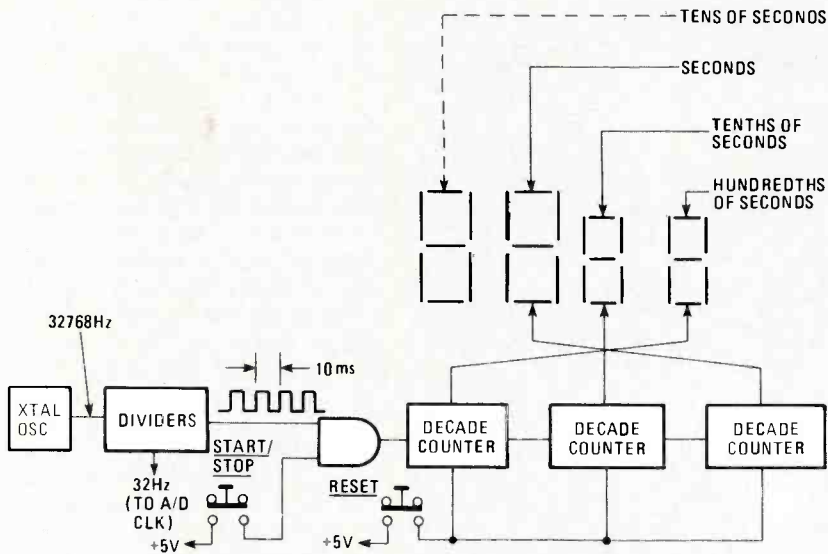

FIG. 3—THE TASK OF COUNTING and displaying the result is handled by a clock/timer module. The basic operation of that module is illustrated here.

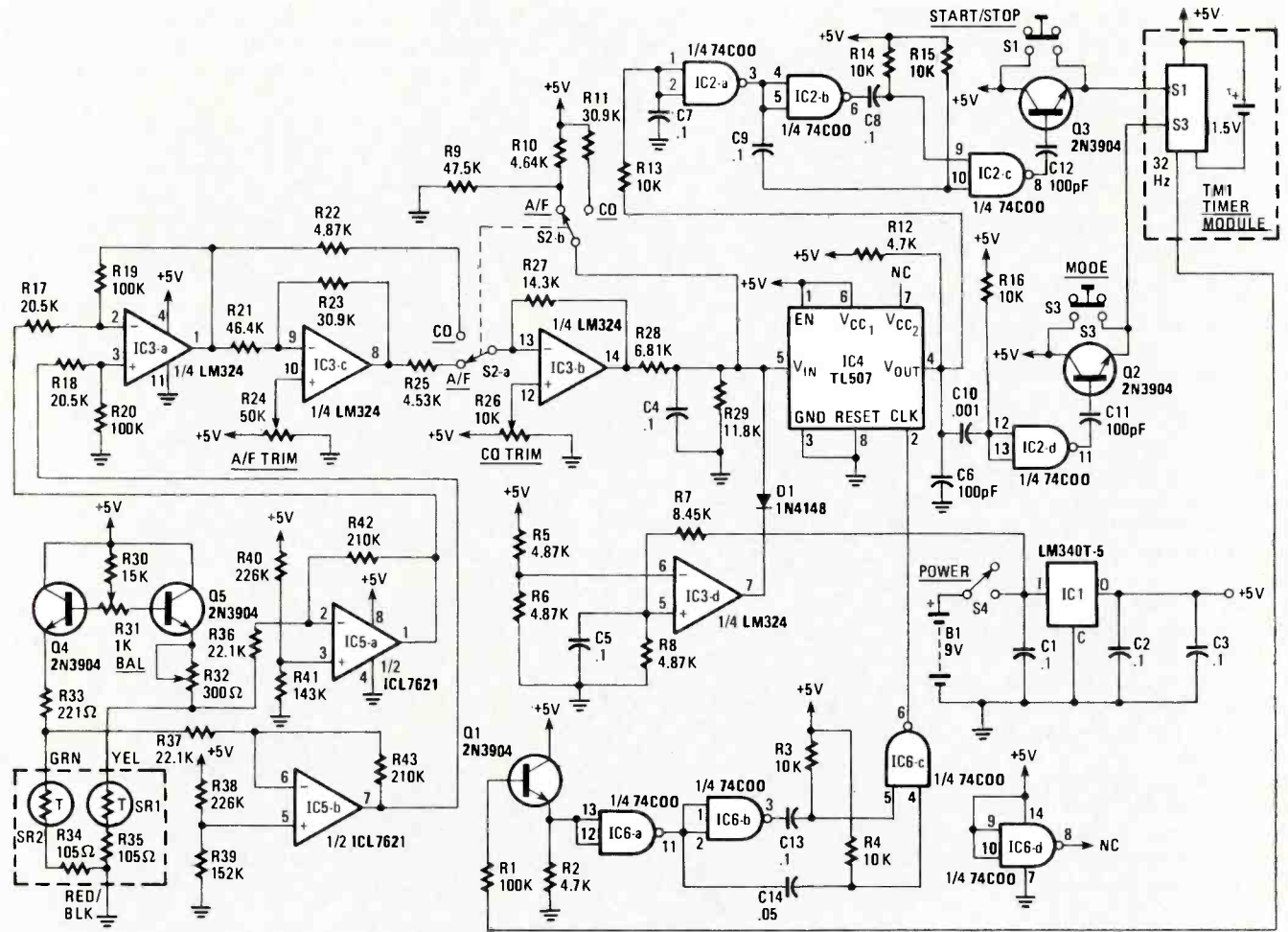

FIG. 4—AN AUTOMOTIVE EXHAUST-GAS ANALYZER. The circuitry enclosed by the dashed box in the lower left-hand corner is located on the TCC PC-board, which is mounted in the conversion box. All remaining circuitry is housed within the display-unit cabinet. Note that many of the resistors have tolerances of 1% (See Parts List).

All other circuitry is housed in the display unit. Transistors Q4 and Q5 translate BALANCE control (R31) changes into the

very subtle bridge adjustments needed to "balance" the currents to the test sensors under ambient conditions. The two sec-

tions of IC5, a dual op-amp, are used to amplify the TCC outputs, and inject a fixed bias between them to provide a proper operating point for the next stage.

One section of an LM324 quad op-amp, IC3-a, is used to amplify the TCC outputs, and convert them to a single-ended signal. Another section, IC3-c inverts that signal and provides level translation for the A/F mode. Resistor R24 is a trimmer used to calibrate for the desired A/F ambient operating point. Final amplification is provided by IC3-b; that device also provides the CO operating-point calibration. The fourth section of IC3, IC3-d, functions as a voltage comparator, sensing the battery input-voltage to regulator IC1. If the voltage drops below 7.2, the pin 7 output goes to ground, which loads down the output of IC3-b, causing the device to stop update testing. Then it's time to replace the battery.

Transistor Q1, and IC6 and its associated circuitry, prepare clock pulses for the

A/D converter (IC4) using a 32-Hz intermediate-countdown signal obtained from the timer module. Transistor Q1 shifts the timer voltage-levels, while IC6 functions as a frequency doubler to provide the 64-Hz signal needed by the A/D converter to

define the two-second test interval.

Resistors R9 and R10 determine the final ambient voltage-level for the A/F mode, while R11 determines the final ambient voltage-level for the CO mode. Those voltage levels define particular A/D pulse durations, which, in turn, define particular display readouts.

The A/D output is conditioned so that it can be used to control the clock module by IC2 and the Q2-Q3 circuit. One section of the IC, IC2-d, along with C10 and R16 are used to differentiate and invert the A/D output's leading edge to form the S3 reset pulse. Another section of the device, IC2-a, delays the A/D output from reaching the stop/start circuitry until the reset pulse has been applied to the timer module. The IC2-b-IC2-c circuit is a "double differentiator" that provides short trigger pulses on the delayed leading and trailing edges of the A/D output signal. Those pulses are used to start and stop the timer. By presenting a very high impedance to the timer when the unit is switched off, Q2-C11 and Q3-C12 allow the timer module to be used as an ordinary clock or stopwatch when the unit is not being used for exhaust analysis.

### Display cabinet and timer module

**Caution:** Before proceeding with any modification to the clock-timer module, be certain that it is functioning correctly in all modes of operation. Once it has been modified the manufacturer will not honor warranty claims.

Figure 5 shows display-cabinet preparation details for the cabinet available from the source mentioned in the parts list. (If you purchase the complete kit, the cabinet will already have been completely prepared.) The cutout for the LCD display can be done by first drilling a number of holes within the cutout border, then carefully filing to eventually produce a clean rectangular hole. The bottom of what was intended to be a battery compartment must be cut out to provide a mounting fixture for the clock/timer module. The detail for that is shown in Figure 5-c.

Figure 6 shows how the timer is modified and mounted in the clock/timer-module cabinet. Figure 6-a shows the ridges on the sides of the timer that must be filed off to allow it to slip-fit into the flanges that are formed when the battery compartment is modified. You will also need to file off a portion of the timer's case rear to allow a 9-volt battery to be inserted into the battery compartment: remove a  $1/16$ -inch section to a depth of  $3/32$ -inch as shown. Doing that will disable the S1 and S3 switches on the timer module, but their functions are replaced by the analyzer's switches. Figure 6-b shows the final alignment of the timer in the display cabinet. A tiny amount of contact cement can be used to secure the timer to the cabinet, but it may not be needed if the

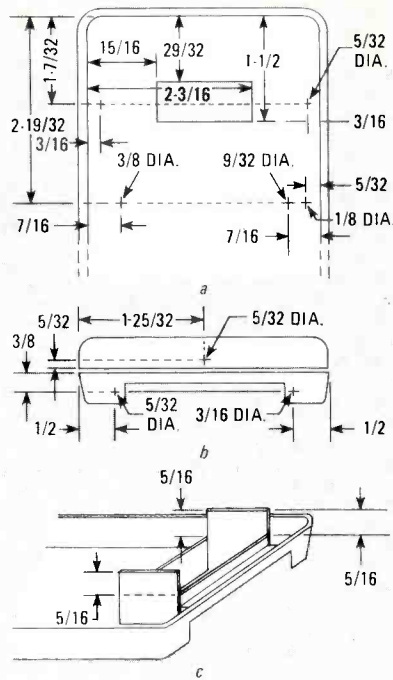

FIG. 5—IF THE CABINET available from the source given in the Parts List is used, it is drilled and modified as shown above.

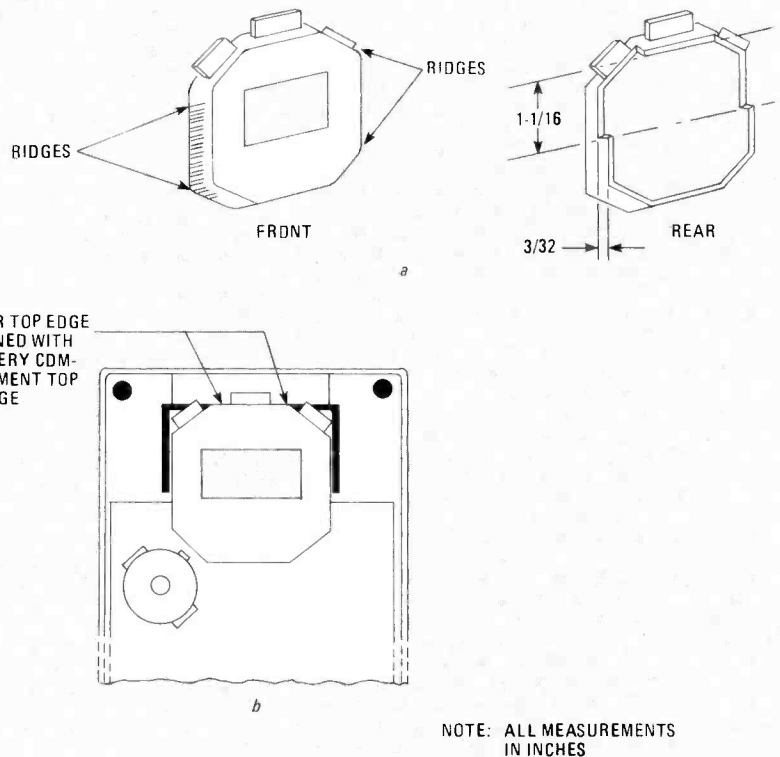

FIG. 6—A POPULAR WATCH/TIMER is used in this project. That timer's case must be modified as shown in a so that both it and a 9-volt battery will fit in the display unit cabinet. How the timer is mounted in the cabinet is shown in b.

side ridges are carefully filed just to the point of allowing a light press fit in the cabinet. In any event, provision must be made to allow the module to be removed, as must be done to insert or remove the PC board. Removal may also be needed to

change the timer battery, although if the bottom battery retaining-clamp screw is left a little loose it is possible to change the battery through the battery-compartment access lid.

Four wires have to be added to the timer module to interface it with the rest of the circuitry. Figure 7-a shows where three of those wires are attached: shown there is the side of timer's PC board that's seen when the timer's back cover is removed. The fourth wire is attached to the other side of that board as shown in Fig. 7-b. To gain access to the timer-circuit board, pry off the back cover, then very carefully remove the four small chrome Phillips-head screws that hold the mechanism in place. Note the locations of the screws as well as the orientation of the battery retaining clamp. You should now be able to lift the molded black plastic lid away from the circuit board. Carefully solder three fine (30-gauge) wires in place, using very little solder and trying to keep the wires and solder close to the edge of the PC board.

Next, very carefully lift out the spring-steel switch strip using a pair of needle-nosed pliers; note the position of the

strip—it is over two small red-plastic studs. Then, remove the circuit board by gently lifting from beneath at various points along the edge of the board. When the PC board is removed, the LCD display will probably stick to it. If it does, care-

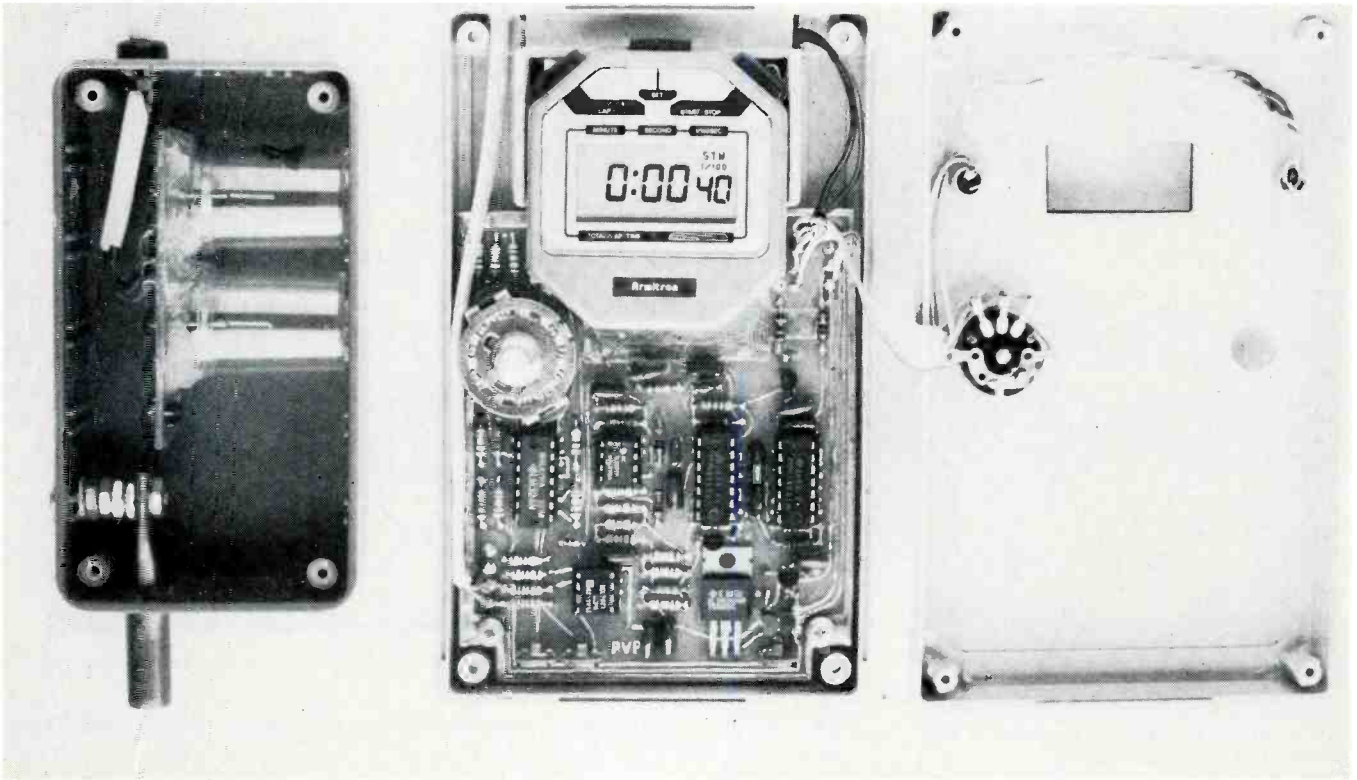

A LOOK INSIDE the exhaust-gas analyzer. The completed display unit and conversion box are shown here with their cases open.

**All resistors 1%, 1/4-watt unless otherwise noted**

- R1—100,000 ohms, 5%
- R2, R12—4700 ohms, 5%
- R3, R4, R13—R16—10,000 ohms, 5%
- R5, R6, R8, R22—4870 ohms
- R7—8450 ohms
- R9—47,500 ohms
- R10—4640 ohms
- R11, R23—30,900 ohms
- R17, R18—20,500 ohms
- R19, R20—100,000 ohms
- R21—46,400 ohms
- R24—50,000 ohms, miniature potentiometer, linear taper, vertical PC-board mount
- R25—4530 ohms
- R26—10,000 ohms, miniature potentiometer, linear taper, vertical PC-board mount
- R27—14,300 ohms
- R28—6810 ohms
- R29—11,800 ohms
- R31—1000 ohms, miniature potentiometer, linear taper, panel mount, with SPST switch (S4)
- R32—300 ohms, miniature potentiometer, linear taper, vertical PC-board mount
- R33—221 ohms
- R34, R35—105 ohms
- R36, R37—22,100 ohms
- R38, R40—226,000 ohms
- R39—152,000 ohms
- R41—143,000 ohms

**PARTS LIST**

- R42, R43—210,000 ohms
- Capacitors**
- C1—C5, C7—C9, C13—0.1 $\mu$ F, ceramic disc
- C6, C11, C12—100 pF, ceramic disc
- C10—.001  $\mu$ F, mylar
- C14—.05  $\mu$ F, ceramic disc
- Semiconductors**
- IC1—LM340T-5 or 78M05 + 5 volt regulator
- IC2, IC6—74C00 CMOS quad NAND gate
- IC3—LM324 quad operational amplifier
- IC4—TL507C A/D converter
- IC5—ICL7621DCPA dual operational amplifier
- Q1—Q5—2N3904 NPN silicon transistors
- D1—1N914 or 1N4148 general purpose diode
- SR1, SR2—G126 precision matched thermistor pair (Fenwal Electronics, 63 Fountain St., Framingham, MA 01701)
- TM1—timer module, model U01 sport stopwatch (Armitron Corporation, 29-10 Thompson Ave, Long Island City, NY 11101)
- S1, S3—SPST momentary normally open pushbutton (C & K 8631 or equivalent)
- S2—4PDT rotary, panel mount
- S4—SPST potentiometer switch, part of R31
- B1—9-volt battery

**Miscellaneous:** PC boards, display and conversion-box cabinets, IC sockets, 9-volt battery terminal clip, modular telephone extension cord, 25 feet, with plug and receptacle (MCM TA625 or equivalent), vinyl thin-wall tubing (3/8-inch I.D., 1/2-inch O.D., 48-inch length), copper tubing (3/8-inch O.D., 1/32-inch wall thickness, 14-inch length), spray bottle caps (see text), alligator clip, cable strain-relief (5/16-inch mounting hole), silicone glue, Velcro strip (1 1/2 inches wide by 3 inches long), double-sided carpet tape, 30 gauge wire, 8-conductor ribbon cable, knobs, hardware, etc.

The following are available from PVP Industries, P.O. Box 35667, Tucson, AZ 85740: Etched and drilled epoxy-glass PC boards for display cabinet and conversion box for \$14.95; SR1, SR2 sensor pair for \$22.95; PC board set, both cabinets (not drilled), timer module, front panel decal for display cabinet, and modular extension cord for \$49.95; complete kit of all parts (except glue and battery), including pre-drilled cabinets for \$98.95; completely assembled, calibrated, and tested unit for \$129.95. The above prices are postpaid in the continental U.S. Arizona residents add 5% sales tax. Readers of Radio-Electronics are invited to send a SASE to the above address to receive free updates on this project, along with user tips as they become available.

fully separate it from the board, noting its orientation and setting it back into the case exactly as it was before the board was

removed. (That is important because there is usually no pin identifications on those displays.) Using a jeweler's screwdriver,

very carefully scrape the green lacquer coating off the PC pattern at the point  
*continued overleaf*

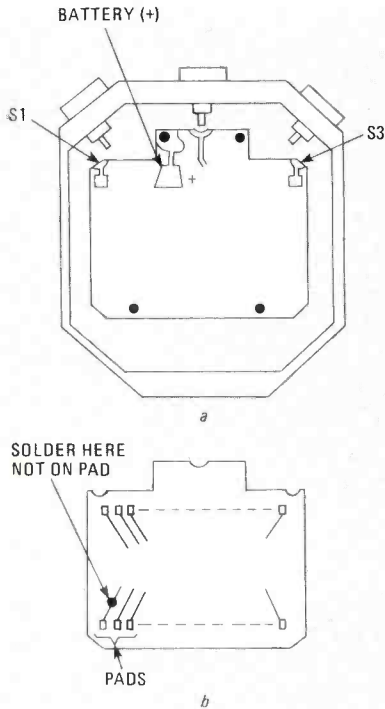

FIG. 7—FOUR WIRES must be added to the timer's PC board as shown above.

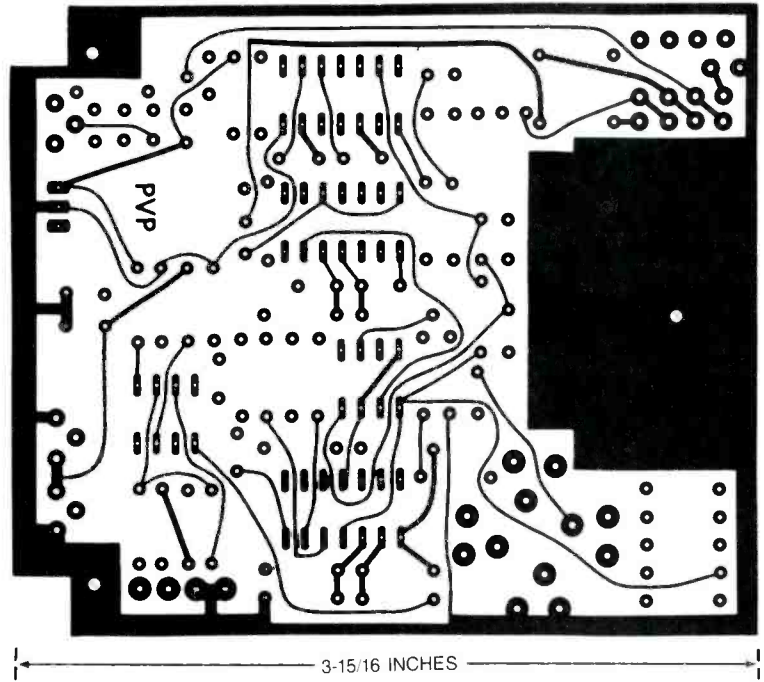

FIG. 9—THE COMPONENT SIDE of the double-sided display PC board. It, too, is shown full sized.

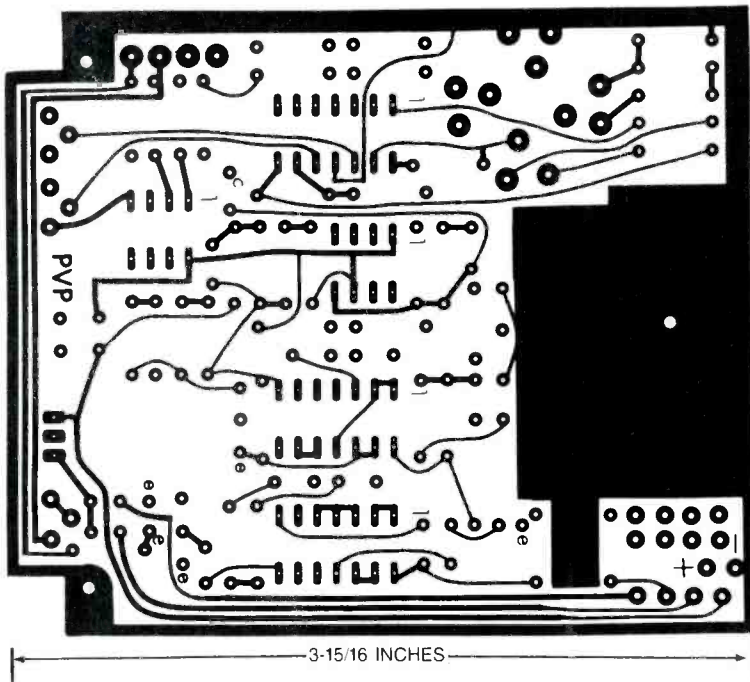

FIG. 8—THE FOIL SIDE of the double-sided display PC board is shown here full sized. Its parts-placement diagram will be shown next month.

shown in Fig. 7-b. Do not touch any of the pads that mate with the LCD display. Using a very fine-tipped soldering iron, and a small amount of solder, tin both the exposed copper foil and the wire to be attached. Do not allow any solder or flux to contact the pad located below the trace. Touch the wire and the iron to the point that was tinned to attach the wire.

Next, set the PC board into the case along with the switch-contact strip. Reinsert the molded black plastic lid and the screws (do not over tighten), dress the wires up out of the way, and make a note of the wire colors for later identification when connecting them up to the gas analyzer's PC board. The timer's back cover will not be used in the cabinet.

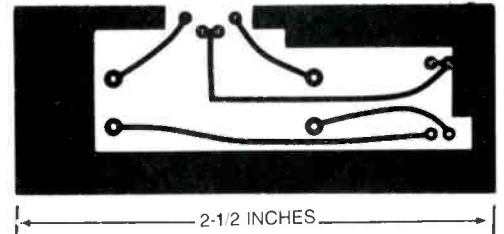

FIG. 10—FULL-SIZED FOIL PATTERN for the TCC board. That board mounts in the conversion box.

### Display-electronics construction

Full-size PC-board patterns are shown in Figs. 8, 9, and 10. We recommend using PC boards, as that will considerably reduce construction and debugging time. It will also help eliminate the possibility of any high-impedance-leakage paths or spurious-signal pickup. The use of IC sockets is recommended as those allow easy IC removal/replacement should servicing ever be required.

Full-size foil patterns for the double-sided display PC board are shown in Figs. 8 and 9. If you choose to etch your own board, and cannot provide plated-through holes, you will have to solder all component leads on both sides of the board. In addition, you will have to insert a wire into all pads that do not contain component leads, then solder those feed through wires on both sides of the board.

Figure 11 is the parts-placement diagram for the display board; Fig. 12 is the parts-placement diagram for the TCC board. Note that the four-conductor cable on the TCC board (Fig. 12) is installed on



the foil side. Be careful to orient all IC's, diodes, and polarized capacitors as shown. Use a 25-watt iron with a fine pointed tip, and .030-inch solder.

One point should be made here about the resistors. Note that the majority are precision 1% units. Such resistors are now available from a number of sources, including Digi-Key (Highway 32 South, PO Box 677, Thief River Falls, MN 56701). A less expensive alternative for those who have well stocked junkboxes is to test more common 5% resistors with a DMM until ones with the precise value called for are found.

Study Figs. 11 and 12 before starting construction of the boards, and decide upon a method of attack for inserting the components. Although individual styles differ, the following sequence should work well. The idea here is that by sequencing the parts installation according

sistors in place, trim the leads flush with the solder mounds. Next, install the IC sockets, making sure that the notch, or dot, on one end of the socket is aligned with pin 1. Note that the IC's themselves, with the exception of IC1, are not to be installed now. As IC1 is a voltage regulator, it is not socketed. Instead, solder that device directly to the board at this time. Then mount the diodes making sure that they are oriented properly. Next, install the capacitors beginning with the physically smaller types. Next, mount the trimmer potentiometers: R24, R26, and R32. Then mount transistors Q1-Q5.

The function switch (S2) shaft must be trimmed to a 3/8-inch length. When that has been done, mount it on the PC board, but only after the cabinet top has been drilled and can be used to check switch alignment. That is important since the switch cannot be moved once it is sol-

cover will fit without binding at the switch shaft clearance hole. When satisfied, remove the PC board and complete the contact soldering.

The four-conductor cable interface between the display unit and the conversion box is made using a modular telephone-extension cable with plug and receptacle assembly. Cut a 9-inch section of the cable at the plug end, and use that to connect the PC boards. Figures 11 and 12 show how the boards are interconnected. The color scheme indicated is not mandatory, but following it will minimize any chance of confusion. Note that the receptacle is mounted on the conversion box and wired to the TCC board. Doing that allows the conversion box to be disconnected from the display unit when not in use.

Figures 11 and 12 show how the boards are interconnected. The color scheme indicated is not mandatory, but following it will minimize any chance of confusion. Note that the receptacle is mounted on the conversion box and wired to the TCC board. Doing that allows the conversion box to be disconnected from the display unit when not in use.

Turning to the off-board components, use small-gauge, color-coded wires for the connections to S1 and S3. Twist them rather tightly to prevent spurious ignition-noise pick-up that otherwise could occur with some automobiles. (The noise pick-up would cause erratic timer triggering and occasional faulty display readings.)

When construction of the display board is complete, clean off all solder-flux residue with isopropyl alcohol or commercial spray flux-remover. If using a commercial flux remover be sure to read the directions as some of those are harmful to plastics.

### Conversion box preparation

Figure 13-a shows the conversion-box preparation details for the box available from the supplier mentioned in the parts list. Also shown is the probe and tubing assembly (Fig. 13-b). The probe is built using 3/8-inch outside diameter (O.D.) copper tubing, with an alligator clip added to make sure that the probe remains in the auto-exhaust pipe when it is placed there. A 48-inch length of 3/8-inch I.D. (Inside Diameter), 1/2-inch O.D., vinyl tubing connects the probe to the con-

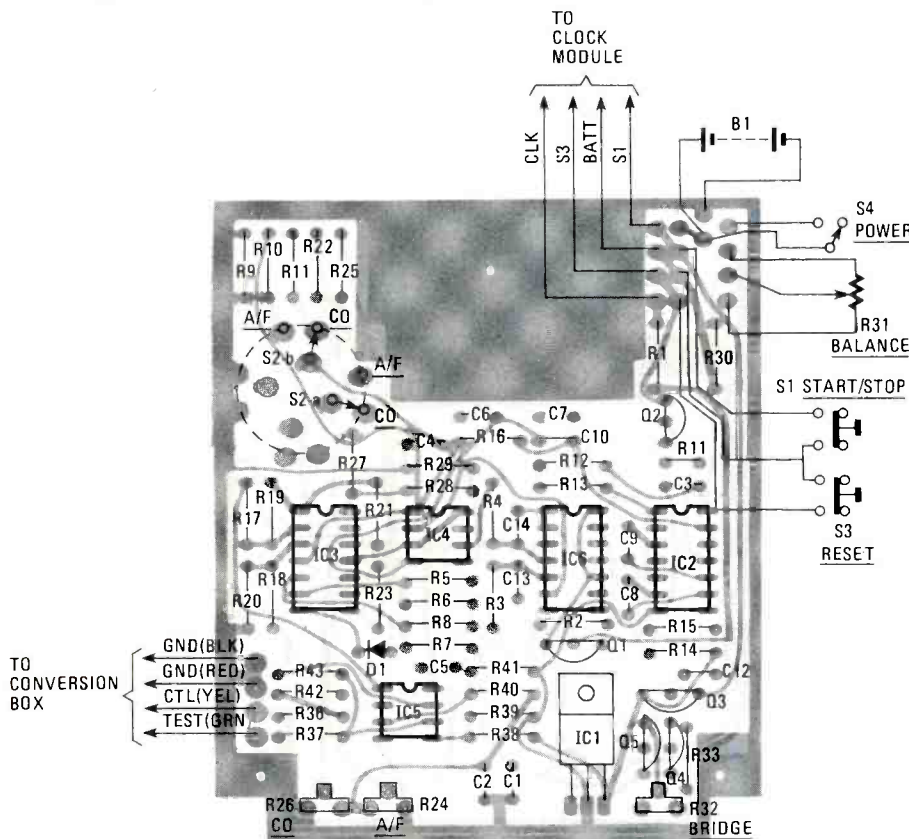

FIG. 11—PARTS PLACEMENT DIAGRAM for the display board. Study the board carefully before beginning construction.

to the height of the components, several similar components can be inserted on the board before the board is inverted and the parts soldered in place. That should speed things up a bit.

First, install the horizontal-mount fixed 1/4-watt resistors, slightly bending the leads after insertion to avoid mispositioning when the board is inverted for soldering. (To help in troubleshooting, should it become necessary, orient the resistors so that all the first bands point in the same direction. That also makes the project look a lot neater.) After soldering the re-

dered in place. If it is crooked when installed, it will not allow the top to be attached properly. Set the switch into the board (noting the rotational alignment shown by the tab position in Fig. 6-b). It may be necessary to straighten some of the contacts before it can be smoothly inserted. The switch should be inserted in the board to a depth such that about 1/16-inch of the solder contacts protrude but beyond the bottom of the board. Then lightly solder one or two contacts and temporarily install the PC board in the cabinet bottom. Check to see that the top

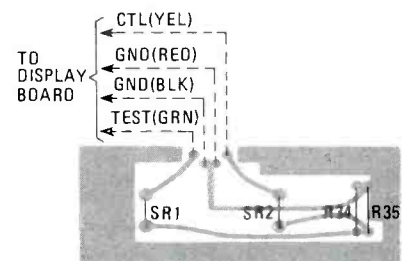

FIG. 12—THE FOUR-CONDUCTOR CABLE is installed on the foil side of the TCC board. Note that Fig. 10 shows an "X-ray" view of the board, not the foil-side as was stated last month.

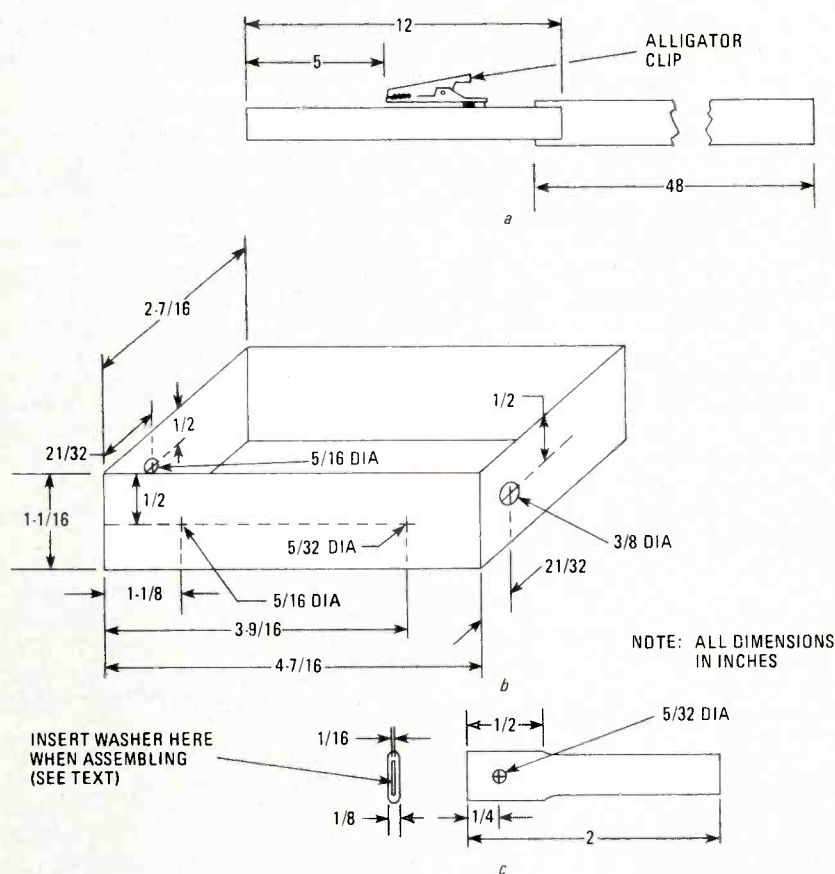

FIG. 13.—DETAILS for preparing the conversion box (a), the probe and tubing assembly (b), and a tube stub (c).

version box. (Note that if you purchase the complete kit from the source mentioned in the parts list, all cutting and drilling will already have been done.)

A 2-inch copper tube stub (see Fig. 13-c) is needed to attach the vinyl tubing to the conversion box. Crimp a  $\frac{1}{16}$ -inch length of one end in a vise to obtain the flattened dimensions indicated. Then drill a  $\frac{5}{32}$ -inch hole where shown. Insert a No. 6 flat washer ( $\frac{3}{8}$ -inch O.D.,  $\frac{1}{32}$ -inch thick) into the flattened portion when assembling as discussed below. Flattening of the stub and inserting the washer creates a controlled inlet aperture. That aperture limits the exhaust-gas flow rate into the conversion box, ensuring adequate gas cooling before exposure to the TCC.

Velcro strips can be used to allow attachment of the conversion box to the automobile. First, glue the "fabric" portion of the strip to the back of the conversion box. Then, double-sided carpet tape can be applied to the mating Velcro strip for attachment to the bumper. (Never stick the tape onto a painted portion of the car, as the paint is likely to come off when removing the strip later on.)

Figure 14 shows the component and board placement within the conversion box. As shown, the sensors should be mounted  $\frac{1}{4}$ -inch above the PC board. Plastic spray-bottle caps (with approxi-

mate dimensions as shown) should then be glued to the board over the sensor assemblies. Try to center the caps around the sensor fixtures. Silicone glue may be used, although 3M windshield adhesive (available at automotive-parts stores) is even more effective. Apply the glue to the mating surfaces only. When the caps are in place, coat the outer cap and the board surfaces with additional glue to be certain of a good seal. Once the glue is firm, melt a hole into the test-sensor cap where shown in Figure 14. (The hole should face the side of the conversion box that contains the strain-relief/cable assembly.) Holding a  $\frac{1}{4}$ -inch diameter screw with a pair of pliers, heat the screw with a candle flame and use it to melt a hole through the plastic. The cap/board assembly should then be silicone glued to the side and bottom of the conversion box. Be sure to use ample amounts of silicone glue around the control sensor, as it is vital that no exhaust gas be allowed to reach it.

Assemble the tube stub as shown in Fig. 14 using four 6-32 nuts to space the stub from the side edge. Don't forget to place a No. 6 washer inside the flattened tube end before tightening the outside 6-32 nut. When the four "spacer" nuts are snug, tighten the outside nut with a small wrench or pliers until the tube end is compressed against the washer inside the

tube. Thus, gas will be allowed into the box only at the top and bottom of the washer, and to a small degree through the outer sides.

### Battery operation

Two self-contained batteries are used by the unit. One is a hearing-aid type 1.5-volt cell. The other is a common 9-volt transistor-radio-type battery. The 1.5-volt cell is used in the timer module and its life expectancy is over one year.

The 9-volt battery powers all of the remaining circuitry. Current drain is rather high due to the required thermistor heating. Therefore, the unit should only be turned on when exhaust measurements are needed. Also, when replacing the battery, be sure that the unit is off (to prevent damage).

### Checkout and calibration

The following calibration/test procedures are performed with the probe exposed to ambient air-conditions only. Do not allow exposure to exhaust gas at this time. Double-check all connections and component orientation. Do not install the IC's into the sockets yet. (Only IC1, which is soldered in place, should be installed to this point.)

If you haven't re-installed the timer battery yet, do so now, and verify that all that all of the timer's functions operate as described in its owners booklet. With no external power applied to the unit, all timer functions should be just as they would be normally. If that is not the case, do not proceed until you have isolated and corrected the problem. Try disconnecting the four wires from the display PC board. If operation returns to normal, then something is probably miswired in the Q1, Q2, or Q3 circuitry. If timer operation is still faulty, then either the wire connections on the timer board are bad (for example, solder bridging across two circuit paths) or the timer module is bad.

Before connecting the conversion-box cable to the display unit, apply power via S4. Check the voltage at IC12. It should be +5 volts. Leave the power applied for a few minutes, then touch IC1. It should be just slightly warm, not hot. If all is well, remove power, connect the conversion-box cable, and install the remaining IC's. Then set the BALANCE control (R31) and trimmer potentiometers R24, R26, and R32 to their midpoint positions, and set the FUNCTION to the CO position.

If the timer had been in the normal clock mode, you must change it to timer mode by holding S3 depressed for a few seconds until the display changes to all zeros. Now re-apply power. After several seconds, the display should begin to respond to the initiation of tests about every two seconds.

If the word LAP appears on the display (below the two smaller digits on the right),

that means the count/reset sequence is out of step. That may occasionally happen after power up. Simply depress the **TIMER** switch one time. That should clear the counting abnormality within two or three test cycles.

Now proceed with the calibration process, as follows. Again, be certain that there is no exhaust gas near the conversion box, and that its temperature is stable. Also, orient the conversion box as shown in Fig. 14. (That is the orientation that will be used during actual exhaust testing.)

**1. Connect a DVM** between the display-board pads for the green and yellow leads to the TCC board. Adjust R32 for a reading of exactly 0 volts. There will be some settling time required, so leave the DVM connected for about 30 seconds.

**2. Adjust R26** for a display of 4.0%. Take your time in doing that step as it is rather critical. Make the adjustment in small increments until the reading changes with each test cycle. If movement in one direction doesn't produce a display change, go back to midrange and try the other direction. When you do start seeing a change, continue to adjust, but in even smaller increments, until the display reads 4.0 consistently on several subsequent tests.

**3. Switch to the A/F mode**, and adjust R24 for a 13.1 display. Follow the procedure outlined in the previous step.

That completes the checkout and calibration process. The settings of R24, R26, and R32 should not require readjustment under normal circumstances. The **BALANCE** control should give you enough of an adjustment range to compensate for any subtle variations due to component aging or imbalances at particular ambient temperatures.

**WARNING:** Exhaust gas is poisonous! Do **NOT** ever perform any exhaust-gas tests in an enclosed or poorly ventilated area! Even being inside a car with the windows rolled up is no assurance of safety. While the system itself is designed so that gas is sampled and converted to an electrical signal outside the car, exhaust gas can seep into the car in many other ways. **Do NOT take chances!**

### Setup

The first step is to attach the conversion box to the rear-bumper area. Choose a position that allows the tubing and probe to reach the exhaust tailpipe without stretching or sharply bending the tubing. Also, observe the mounting direction as outlined earlier. Velcro strips may be used to attach the box, but they may not be suitable for all applications. Other alternatives may be necessary, such as masking tape. An especially sturdy mounting is not needed unless the unit is to be used while driving, in which case adequate means must be provided to prevent a change of position or the device even fall-

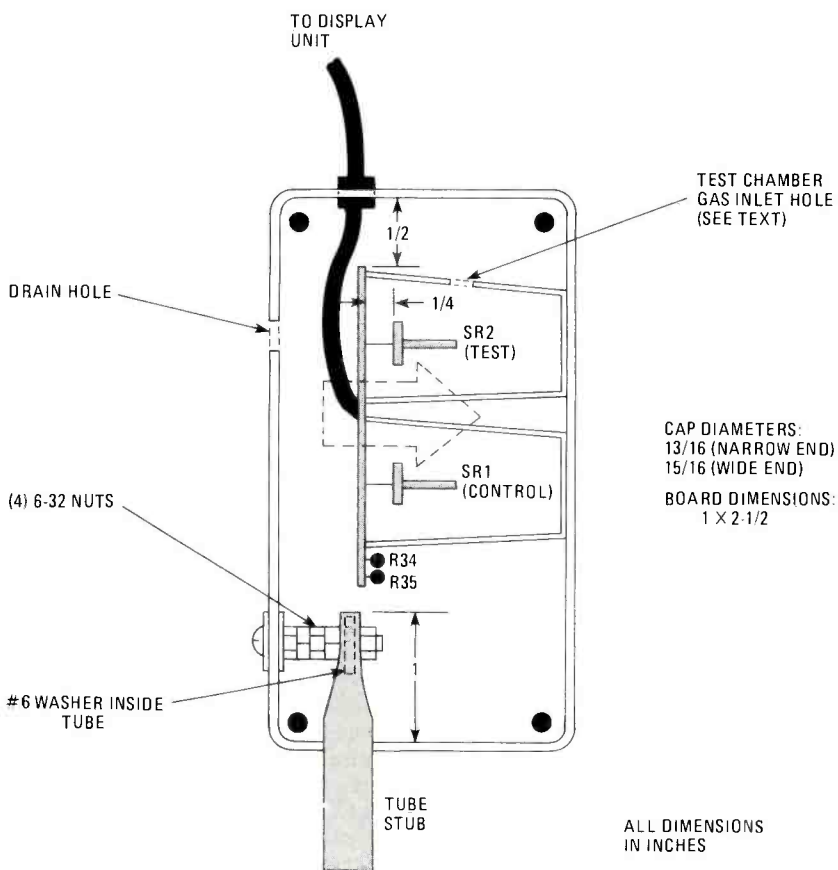

**FIG. 14—THE TCC BOARD is mounted inside the conversion box. Note that all exhaust tests are made with the conversion box oriented as indicated by the arrow.**

ing off the car. Do not attach the probe until after the balance operation described below has been performed.

Before the unit can be used, two things must be allowed to happen: One is that the engine must be allowed to reach its normal operating temperature (about 10 minutes in mild weather), and the other is that the test unit must be allowed to stabilize (about 1 minute). If you warm up the car while allowing the unit to stabilize, be sure that no exhaust gas is allowed to reach the conversion box until after the balance operation is performed. Also, never start the engine while the probe is inserted in the tailpipe, as the initial surge of exhaust is extremely "dirty," and could coat the TCC, altering the unit's accuracy. A small piece of tape may be placed over the conversion-box gas-inlet stub and drain hole during warmup to ensure that exhaust gas will not enter at that time.

In use, all functions are displayed when the timer is in the stopwatch mode. If the timer is in the clock mode, depress the **MODE** switch for a few seconds until the display reads all zeros. That can be done whether or not power has been applied. In fact, if power is not applied, the unit can be used as an ordinary stopwatch. Once power is applied and the unit is placed in the **STOPWATCH** mode, the display should

begin to change in response to each test cycle.

The unit uses the three rightmost display digits for readout, with an assumed decimal point between the rightmost two digits. Thus, a 134 display in the **A/F** mode indicates a 13.4 air/fuel ratio while a 036 display in the **CO** mode indicates a CO content of 3.6%.

To activate the unit, rotate the **BALANCE** control from its off position to about mid-range. As explained above, allow a brief warmup period. That allows time for pre-heating the TCC sensors, and generally allows the system to become acclimated to ambient conditions in the test environment. Once the display stabilizes, adjust the **BALANCE** control for a reading of 4.0 in the **CO** mode or 13.1 in the **A/F** mode.

When the engine is running at normal operating temperature, insert the probe into the tailpipe, and attach the tubing to the conversion box. There will be a very brief response lag-time encountered as the display changes to reflect the thermal conductivity of the gas sample. (Note that a new sample test is performed about every two seconds.) It is normal for some fluctuation "drift" in adjacent readings, particularly if the engine is idling rough, or if the engine system routinely changes idle speed, timing, or carburetor mixture

in response to engine temperature.

If your automobile has a catalytic converter, accurate readings can best be obtained by sensing the exhaust gas before the converter. While some autos have a port available for this testing, it will probably be necessary to remove the exhaust-gas recirculation (EGR) valve and insert the probe at that point in the system. (It will then be necessary to close off the EGR line to the intake manifold to ensure accurate readings.) The catalytic converter changes much of the hydrocarbons and CO into water and carbon dioxide. That "new" gas/vapor mixture presents a different composite thermal conductivity to the TCC, thus affecting accuracy.

### Adjustments.

When making adjustments, be sure to allow time for the display to respond. It takes time for the engine system to stabilize on the new setting(s), and then it takes a short time for unit to respond to the different exhaust-gas content. If the unit is to be used on more than one vehicle during a session, allow several minutes for remaining exhaust to clear the conversion box before connecting it to the next vehicle. When making adjustments that typically have a broad range, it is best to make small incremental changes, pausing after each and then noting the display. That method makes it easy to "zero-in" on the optimum setting without losing control; that is, getting things so far out of adjustment that the engine dies, or that it is difficult to return to the original settings.

The following emission-related component topics are intended for general information only. Specific adjustments for your auto should be made in accordance with the auto makers' prescribed methods. Occasionally, emissions tuneup procedures and data will be included on decals in the engine compartment. Otherwise, consult an appropriate service manual for details. It is a good idea to take a CO reading before making any repairs or adjustments so that you can later measure your progress by "before/after" comparison.

It is wise to begin by checking the ignition components: replace, clean, or re-gap spark plugs as needed; set point dwell and ignition timing to manufacturer specifications; check spark plug wires; and clean/inspect distributor cap.

Equipment added to modern automobiles to reduce emissions include (in part) the following items. They should be inspected, cleaned, replaced, or adjusted as recommended by the auto maker.

1. Air-inlet temperature damper (routes preheated air to carburetor during engine warmup).
2. Air pump (pumps air into exhaust manifold area to improve combustion efficiency).
3. Charcoal vapor-evaporator (routes

stored fuel vapor to carburetor).

4. EGR (routes portion of exhaust back to carburetor).
5. PCV (Positive Crankcase Ventilation system—routes "blow-by" gases back to carburetor, and allows fresh air to enter crankcase).
6. Spark-timing advance (three common types: deceleration-vacuum control, transmission-gear-shift control, and engine temperature thermostat-vacuum control).
7. Thermostat-engine coolant (higher temperature thermostats being used).

Proper carburetor operation is vital to minimizing exhaust pollutants. All passages and internal/external components must be clean, and gaskets must be secure to prevent air or fuel leaks. Once that has been accomplished, the various adjustments must be set to the manufacturer's instructions. Those adjustments typically include float, choke, throttle, and air/fuel mixture, but may include other things, such as multi-carburetor synchronization. While "in the old days" simple cookbook adjustment procedures could be given (for example: "tighten down mixture screw, then back off 3 turns..."), today that is just not possible. The importance of using a CO meter and strictly following the auto makers' adjustment instructions is no better exemplified than with the carburetion setup.

### Readings

As mentioned earlier, auto makers typically provide emissions-adjustment information in the engine compartment. That information often includes CO and A/F readings that should be attainable if all systems are functioning properly. Tune-up manuals will also provide that information. Of course, it is also important to know your state's prescribed maximum CO limits for your make, engine, and year auto. Those limits vary considerably.

In Arizona, for example, a 1972 Ford Pinto with a 4-cylinder engine is allowed 6% CO maximum. A 1981 Dodge Aries, also with a 4-cylinder engine, is only allowed 1.5% CO maximum. A 1973 12-cylinder Jaguar XKE is allowed 5.5% CO. Some auto types seem to be rather amenable to achieving even very stringent requirements, while others (like the Jaguar mentioned above) just barely squeak by relaxed requirements, and then only after considerable effort. In general, however, 10- or 15-year-old cars should be able to deliver about 3%–4% CO, while the very latest cars should be down to about 1%.

Air/fuel ratio measurements are especially meaningful when making carburetor adjustments. Once again, it is important to consult the manufacturer's data for recommended procedures and readings. It can be injurious to the engine valve system, for example, to set the mix-

ture too lean. The few pennies saved in fuel will be more than offset by subsequently having to repair burned valves, due to excessive combustion temperatures. Air/fuel readings above about 14.0 indicate a lean mixture (i.e., more air, less fuel) while readings below about 12.0 indicate a rich mixture.

The advantage of using the unit while driving is to verify A/F carburetor settings and general carburetor/accelerator pump response under actual operating conditions. At cruising speeds, with a light engine load, the A/F reading will normally be a little leaner (by about .3 or .4) than when the auto is stationary. After sudden, brief acceleration the reading should diminish considerably, then gradually rise back to nominal. Service data for your auto should provide specific load readings.

### Suspicious readings

Sooner or later, you will probably encounter readings that just don't seem to make sense. There can be many sources of inaccuracy, but first it is important to determine the general cause. There are three general causes to consider: the automobile, the setup, or the unit itself. Once the general cause is found, the specific problem is much easier to track down.

One common auto symptom is the carburetor-mixture control not having any effect on CO readings. That is a "normal" occurrence if the carburetor needs overhauling. What has happened is that blockages or leaks in the carburetor have disrupted normal operation enough to make the relatively minor mixture-screw changes ineffective. It is also possible that the air filter is clogged. To verify, note the A/F reading, then remove the air-cleaner element, re-attach the air-cleaner cover, and retest. If A/F ratio is now more than .2 or .3 higher than before, the filter probably needs replacing.

Another source of potential trouble from the automobile, as mentioned earlier, is "swamping out" of the TCC due to an unusually dirty exhaust blast, such as that which would occur if the engine is started with the probe attached. Swamping can also occur if an adjustment is made, while testing, that causes a very dirty exhaust. Swamping typically is manifested by a suspiciously low CO reading, or a suspiciously high A/F reading. (In extreme cases, the CO reading may "attempt" to reach zero. When that happens, the display will stop updating entirely. The display will remain "frozen" until the TCC clears—typically 10–15 minutes after the offending gas mixture is removed.) The best way to correct that is to shut off the engine and allow the TCC to "breathe" ambient air for 15 minutes or so. Another solution is to deliberately force a rich mixture situation (such as by temporarily blocking part of the air intake

to the carburetor) until the CO percentage swings up a few percent (or the A/F reading is down considerably); then allow normal air flow and check the reading after about a minute. If it returns to the same super-low CO, or super-lean A/F, then that's most likely the real situation, unless one of the remaining two possible trouble areas is at fault.

If the setup is suspected, re-check the setup conditions mentioned earlier. It is important that all conditions be met, such as positioning of the conversion box and allowing sufficient time for the system to stabilize before balancing and then beginning the test. It is also possible that accuracy could be affected if a significant temperature change occurs in the conversion box area after balancing has been performed. An example of that might be if the sun came out from behind a cloud and significantly changed the ambient temperature conditions around the conversion box. Although immune to subtle changes in ambient temperature due to the "control" sensor presence, very large temperature-changes can cause a shift in the balance point. To re-balance, the TCC

needs to again "breathe" ambient air for several minutes; then reset the BALANCE control.

A particularly perplexing symptom is where the display is erratic; that is, where the unit is obviously performing tests, but with significantly different readings on each trial. Verify that swamping or improper setup is not influencing the readings by shutting off the engine and observing the readings over several minutes, making sure that the conversion box remains in the same position and ambient temperature. If the readings remain erratic, there is a problem with the unit's electronics. But, if the readings stabilize, there is either something wrong with the setup or you have a really weird exhaust mixture.

The whole business of emissions testing is very tricky. Those of you who own "marginal" cars (remember that Jaguar we mentioned?) know what we mean. Each emission test can bring new surprises—sometimes good, sometimes bad. The same car, with the same tank of gas, with the same emission settings, can produce different readings at different

times. There always are reasons, but sometimes they can be quite difficult to determine. In states such as Arizona that allow "conditioning mode" testing if the initial test fails, the auto is run at accelerated engine speeds, in gear on rollers, for about 30 seconds and is then retested—often with dramatically lower readings. Everything is exactly the same as before, except that some of the excess combustion byproducts (built up, perhaps, during the long wait in line to be tested) have been blown out.

The message here is: Don't be alarmed if any particular readings appear to be somewhat different from the last readings taken. To best determine the state of exhaust emissions, you really need to average the readings. In particular, take note of subtle changes in test conditions that can affect the results. Paying attention to those details will improve the overall usefulness of the unit and rectify the emissions from your automobile, thus improving the quality of air we breathe—and that's what it's all about! **R-E**

## Typewriter word counter

HERE'S A PROJECT THAT CAN SAVE YOU some time when you need a manuscript of a specific length, such as for a school project, a classified advertisement, etc. It will keep track of how many words you've typed, and display the total. The circuit uses Hall-effect switches (Sprague UGN-3020T, or equivalent) to detect keystrokes and spaces.

The Hall-effect switches are sensitive to the presence of a magnetic field. In this project, permanent magnets are used to turn the switches on and off. When the magnet is near the switch, the output from the switch is logic 0; when the magnet moves away, the switch opens and, because of the 10,000-ohm pull-up resistor, the output

goes to logic 1.

The switches are connected to  $\frac{1}{4}$  of a 4043 RS flip-flop. After the circuit has been reset, the output from that flip-flop is at logic 1. At the first keystroke, the output from the Hall-effect switch goes to logic 0, pulling the flip-flop's output to logic 0. The output from the flip-flop drives the MC14553 three-decade counter. That counter is negative-edge triggered, so the transition of the flip-flop's output from logic 1 to logic 0 increments the counter. The counter's BCD output is then fed to the 4511, a BCD-to-7-segment display decoder/driver, which in turn controls the  $3\frac{1}{2}$ -digit LED display.

Each subsequent key stroke is ignored

until the space bar is hit. Hitting the space bar opens the space-bar Hall-effect switch, which in turn resets the RS flip-flop. Subsequent spaces are ignored until the next keystroke is entered, and the entire cycle is repeated. If the space bar and a key are struck at the same time, the flip-flop's output is logic 1, and the next keystroke increments the counter.

When the count reaches 999, the next negative transition will clear the counter but set its overflow high. That overflow output is latched by a second flip-flop,  $\frac{1}{4}$  of the 4043, driving the display's most significant digit (the 1 on the display) on. The procedure then repeats, for a maximum count of 1999 words.

For this circuit to work, the Hall-effect switches and the magnets must be mounted inside the typewriter itself. One switch and magnet should be mounted so that they are close together normally, but move apart when any key is struck. The second switch and magnet should be mounted so that they move apart when the space bar is hit. The switches and magnets are mounted using epoxy glue. Both sets of switches and magnets should be positioned so that the thick side of the switch (the side opposite the dot) is normally near the magnet's south pole.

You can power the circuit any way you wish. One good way would be to use a wall-plug transformer with a 9-volt output. You could also use a 9-volt battery. If you do that, you may want to devise a display blanking circuit to extend battery life. —Larry Dighera

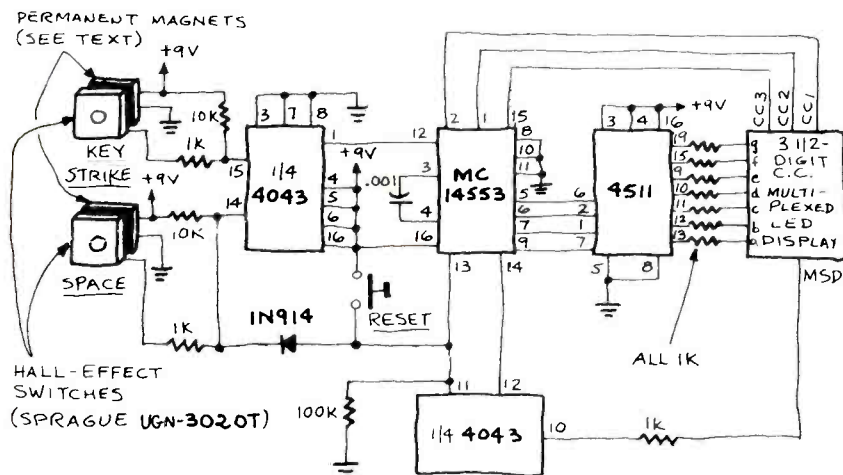

FIG. 1

## SLIDING-TONE DOORBELL

HAVE YOU EVER BEEN STARTLED BY YOUR own doorbell? I have heard some doorbells that are so harsh and startline that they are sure to wreck anyone's nerves. But my doorbell is not of that type—at least not any more.

But if your bell *is* of that type, don't despair. I'll show you a way to prevent your quiet home from being disturbed. You can replace your harsh-sounding, nerve-wracking bell with what I'll call a "mild dose of sound stimulation." When the doorbell is pushed, you'll hear a low tone that will "slide up" to a higher frequency.

Figure 1 shows the sliding-tone doorbell circuit. It's made up of two main parts: an AF (Audio Frequency) oscillator and a variable resistance.

The frequency of the AF oscillator is determined by two factors. The first is the value of the coupling capacitor, C1. The second is the value of the resistance connected between the base of Q1 and ground. That resistance, which we'll call  $R_{BG}$ , is equal to  $(R1 + R2) \parallel R3$ .

When either of those two factors increases, the frequency of oscillation will

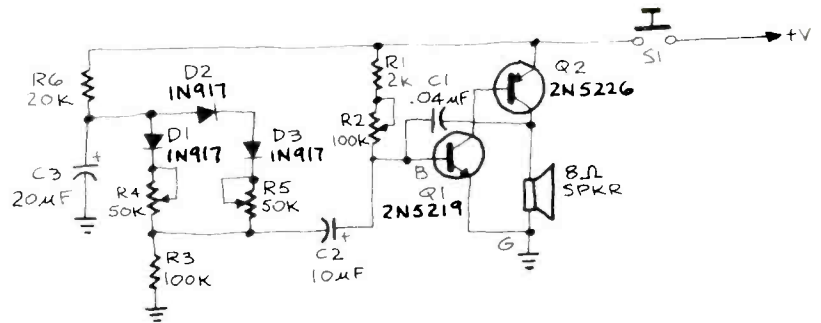

FIG. 1

decrease. Thus, whenever  $R_{BG}$  or C1 decreases, the frequency will increase.

First, assume that S1 is closed and R2 has been adjusted to produce a pleasant, low-frequency tone. Capacitor C1 will charge through R6 until it reaches such a voltage that will cause diode D1 to conduct. When that happens, the value of  $R_{BG}$  is paralleled by R4. Thus, because the total resistance  $R_{BG}$  decreases, the output tone slides up in frequency. Capacitor C3 will continue to charge until the voltage across D2 and D3 causes those diodes to conduct. Then  $R_{BG}$  is paralleled

also by R5, the total resistance again decreases, and the oscillator's frequency again increases.

If you're not satisfied with how the "bell" sounds, there are several things you can do. First, if you want to change the tone variation, feel free to try different values for R2, R4, and R5. And if you want to vary the sliding speed of the tone, then you can try different values of R6.

As with the rest of this easy-to-build circuit, the transistor types are not critical. Feel free to experiment!—Tseng C. Liao

## PLANT-WATER MONITOR

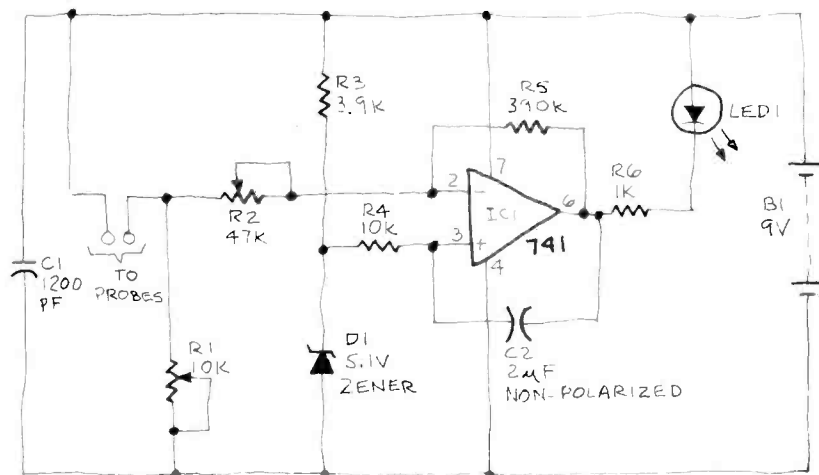

FIG. 1

ONE OF THE MOST CRITICAL FACTORS IN A plant's well-being is the amount of water it receives. A plant that receives too little, or, for that matter, too much water will soon be in poor condition. As for house plants, you, their owner, determines how much or how little water to give them, but

how do you know when to water them? Just looking at the soil can be misleading because it's the moisture at the root level that's critical. Thus, soil that's dry at the top of the pot could be quite moist at the root level and adding more water could put the plant in jeopardy.

That's where this project idea comes in. It's a plant-water monitor and is used to test the moisture of the soil at root level. When the soil is moist, an LED glows. If the moisture falls below a certain predetermined level, the LED begins to flash. If there is still less moisture, the LED turns off.

The schematic diagram of the device is shown in Fig. 1. It can be built on a small piece of perforated construction-board and housed in a small plastic case-or experimenter's box. The probes are two slender metal rods. They should be tinned to prevent corrosion. For convenience, you can mount the probes on the case.

Calibrating the monitor is easy. Just connect the battery and insert the probe into a container of dry soil. Set R1 to its maximum value then reduce that resistance until the LED begins to flash. The range over which the LED flashes before going out is adjusted using R2.

If you wish, you can reverse the operation of the circuit. That is, you can have the LED off when there is enough water, and on when more water is needed. That's done by simply switching the positions of R1 and the probes in the circuit.—Sreekumar, J.

# CABLE-TV DESCRAMBLING



Learn the theory behind cable-TV signal-scrambling techniques by investigating a descrambling circuit.

FRED MEANS

IT IS ESTIMATED THAT BY THE END OF THIS decade, almost ninety percent of all households will be wired for cable television. One reason for cable TV's popularity is the excellent reception of local television broadcasts that it provides. Another reason is that several premium (pay) channels—that cannot be received without cable service—are offered. To prevent unauthorized persons (or non-subscribers) from viewing those premium channels, the signals are often *scrambled*. That is, the video signals are processed so that they can't be viewed on a normal TV—even one that is wired for cable—unless some device is used to decode or descramble them.

There are several techniques that cable-TV companies are now using to scramble their signals. In this article, we'll take a look at one of the more popular methods

## WARNING

The legality of the use of privately owned or built devices to receive or decode cable TV broadcasts is currently a subject of much controversy, debate, and litigation.

In certain instances, the TV cable companies and the FCC have taken the position that receiving and decoding cable-TV broadcasts without paying for them is "theft of service."

This article merely explains how one decoding device functions and is constructed. Prior to your using such a device, however, you are advised to obtain independent advice as to the propriety of such use based upon your individual circumstances and jurisdiction.

used today: the *inband gated-sync* method. We will explain the theory behind inband gated-sync scrambling/descrambling; and to further help you to understand and become familiar with the theory, we'll discuss a descrambling circuit that you can experiment with.

## How is a signal scrambled?

Before we can understand what a scrambled signal is, we have to take a look at a normal signal. Such a normal signal contains horizontal- and vertical-synchronizing pulses that are sent during the horizontal- and vertical-blanking intervals respectively. (During those blanking

intervals, the picture tube's electron beam is cut off as it retraces horizontally or vertically.) Those synchronizing pulses are among the most important parts of a standard TV signal. They are picked up by synchronizing circuits in the television set and are used to stabilize the picture.

Figure 1-a shows part of a normal, demodulated, television signal that you would see, for example, after the TV's video-detector stage. The horizontal-blanking pulse can be seen in its proper place in the signal. (The vertical-blanking interval—when the electron beam snaps back to the top left corner of the screen to begin a new picture field—is not shown.)

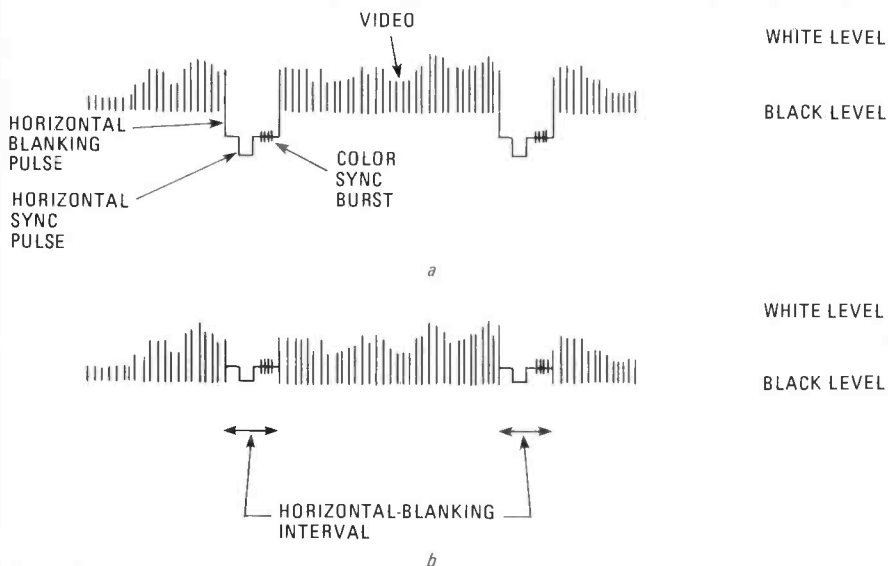

FIG. 1—THE INBAND GATED-SYNC scrambling method moves the horizontal-blanking pulse of a normal signal (a) into the video portion of the signal (b).

Now we can explain how the inband gated-sync scrambling method works. In that scrambling method, the level of the horizontal-sync and colorburst information is changed so that it is the same as that of the video information, as shown in Fig. 1-b. (The suppressed information is still within the signal's 6-MHz bandwidth, thus the word "inband." The "gated-sync" portion of the term means that during the horizontal-blanking interval, a gating signal is used to change the level of the signal.)

Because of the change (about 6 dB) in the level of the horizontal-blanking pulse, the TV's horizontal- and color-synchronization circuits do not pick up the pulses they need for synchronization. Therefore, the picture that you see is not stable—it is out of horizontal sync and the picture's color is also poor. The audio is not affected, though. Unlike many of the over-the-air scrambling schemes, the audio is not scrambled in the inband gated-sync method; it is simply passed through.

### Descrambling the signal

We can see that to descramble the signal, it will be necessary to place the horizontal-blanking and -sync pulses back into their proper location. But first we must locate the hidden pulses. In the inband gated-sync signal, the horizontal-sync pulses are modulated on the sound

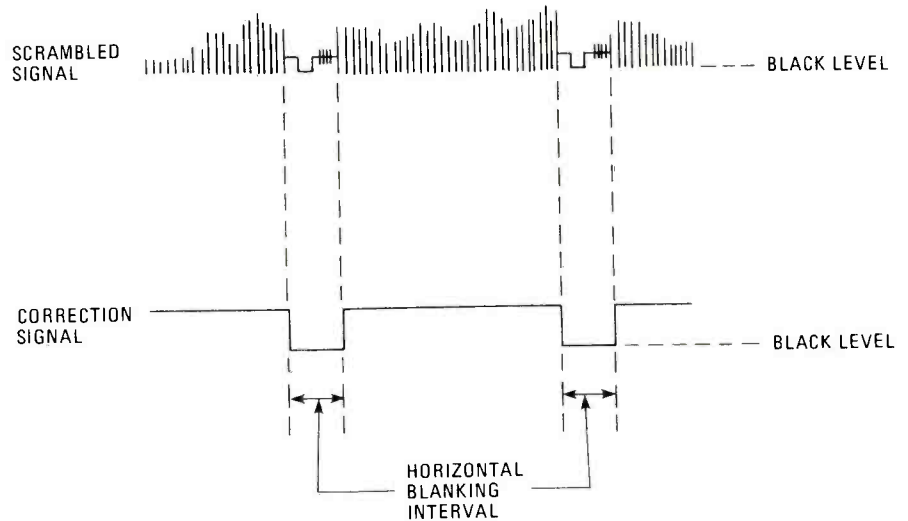

FIG. 2—WE CAN DECODE A SCRAMBLED SIGNAL by adding a correction signal to it, thus restoring the horizontal-blanking pulse to its proper location.

carrier of the video signal. And because the sound carrier is 4.5 MHz above the picture carrier, we know where to look for the hidden sync pulses. For example, channel 3, whose picture carrier is at 61.25 MHz, has its sound carrier at 65.50 MHz. Therefore, if you wanted to decode signals from a cable system that used channel 3 as its output, you would have to look for the horizontal-sync pulses at 65.50 MHz. However, for a cable system that has its output on channel 2 (55.25

MHz), the horizontal-sync pulses are on 59.75 MHz, and so on.

Once we extract the horizontal-sync pulses, they can be used, along with the aid of some time-delaying circuits, to create a correction signal. The correction signal can then be added to the input signal to put the horizontal-blanking and -sync pulses back where they are supposed to be. What we want to do is to add a small DC voltage to the input signal *but only during its video portion*, not during

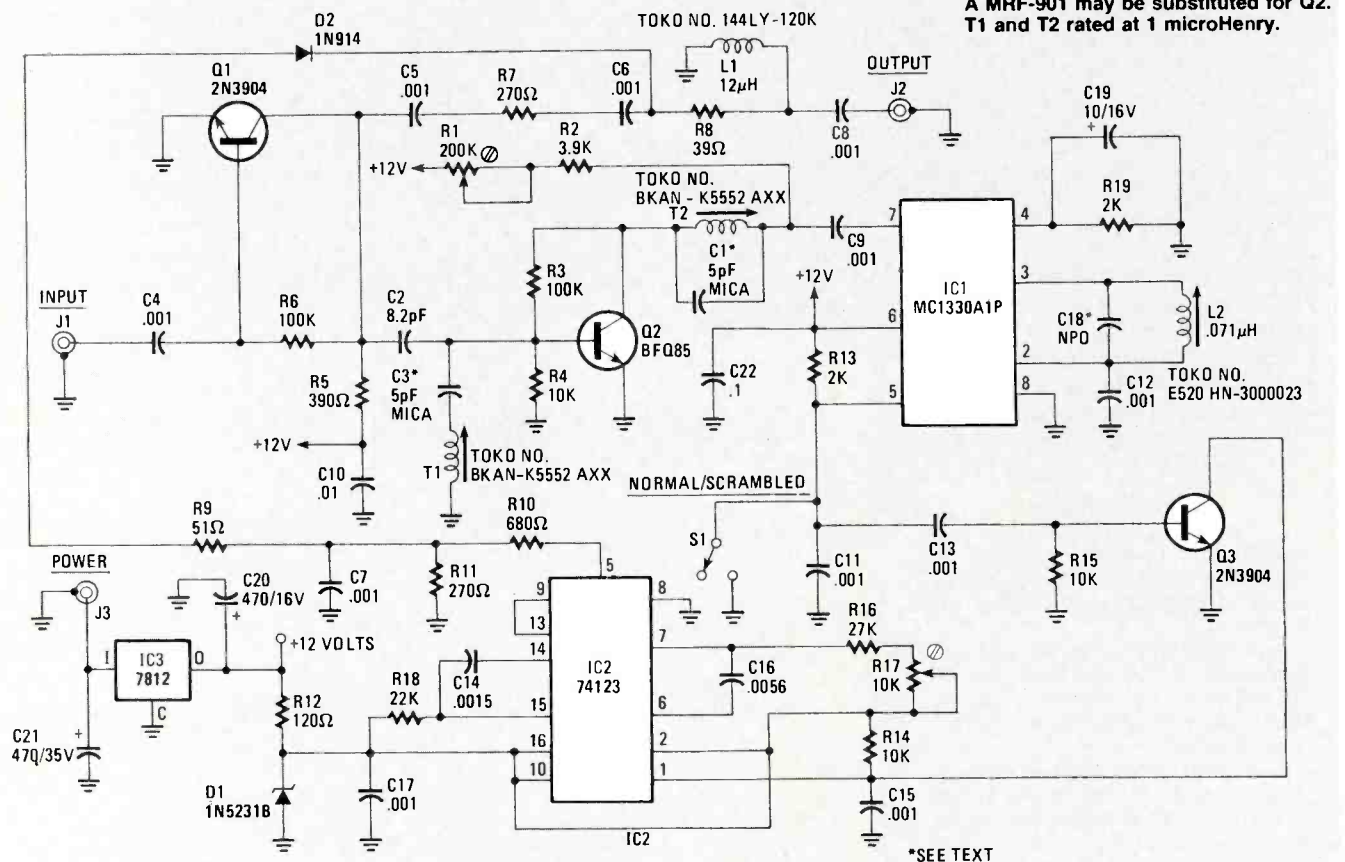

FIG. 3—THE SCHEMATIC of the descrambler is shown here. Note that the values of some components should be changed for operation at different frequencies. The descrambler can be used even with cable-ready sets. See the text for information.



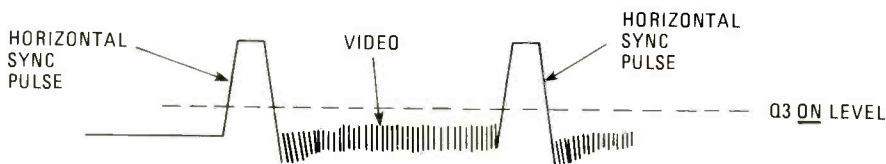

FIG. 4—THE OUTPUT OF IC1 (pin 5) should have a minimum amount of video between the sync pulses.

the blanking interval. That process is shown in Fig. 2. The result of the descrambling process should be the original waveform shown in Fig. 1-a.

### Circuit description

The schematic of a circuit that will do what we want is shown in Fig. 3. First we'll look at the power supply. The circuit can be powered by an AC adapter that has an output from 14 to 18 volts DC at 100 mA. The 7812 regulator, IC3, provides 12 volts DC to the rest of the circuit. The input and output of the regulator are filtered by capacitors C20 and C21. Zener diode D1 is used to provide +5 volts for IC2, a 74123 dual retriggerable monostable multivibrator.

Transistor Q1 provides a small amount of gain to the input signal—that compensates for any losses caused by the descrambling circuit. Transistor Q2, a BFG85, is also used as an amplifier. But it will amplify only signals of a certain frequency. That frequency is determined by the setting of two tuned circuits. The first tuned circuit is made up of T1 and C3. Its resonant frequency will be set to shunt the video portion of the input signal to ground, while letting the audio portion of the signal through. The other tuned circuit is made up of T2 and C1. That is set to

pass only the audio portion of the input signal. Potentiometer R1 can be used to vary the level of the signal at the output of the tuned circuit. Adjustment may be necessary because the inputs to the decoder from different cable-TV systems often are at different voltage levels.

After being amplified by Q2 and passed through the C1-T2 filter, the signal is fed into IC1, an MC1330A1P low-level video detector. (That signal contains the audio information of the input signal—where the sync pulses are hidden.) The tuned circuit (L2 and C18) associated with IC1 is also tuned to the frequency of the audio carrier of the input signal. That is, 65.50 MHz for channel-3 operation, 59.75 MHz for channel-2 operation. So, if operation on channel 3 is required, the value of C18 must be 68 pF. Operation on channel-2 requires C18's value to be 82 pF.

By changing the resonant frequency of the tuned circuits, the descrambler can be used at other frequencies than those of channel 2 or 3. For example, if your TV is "cable-ready" you would want to descramble the output of the tuner section. The output of the tuner is usually at 45.75 MHz (video carrier). The audio carrier is therefore located at 50.25 MHz. The tuned circuits could be adjusted for those frequencies by changing capacitors C1

and C3 to 10 pF, and changing the value of C18 to 130 pF.

The output of IC1 (pin 5) is the demodulated horizontal-sync pulses, as shown in Fig. 4. Most of the video on pin 5 of IC1 should be filtered by C13 and the input of Q3 (provided that the video is below the level that is needed to turn Q3 on). However, there will still be a small amount of video present between the horizontal-sync pulses. That video has to be reduced—which can be done by fine-tuning L2. (The result of too much video at pin 5 is false triggering of IC2. That shows up as streaking horizontal lines across the picture.)

When watching non-scrambled signals, we do not need the sync pulses from pin 5 of IC1. Therefore switch S1 is provided to shunt the sync pulses to ground. When the switch is open, however, the sync signals are sent to transistor Q3, which is used as a buffer. From there, the horizontal-sync signals are sent to IC2, a 74123 dual monostable multivibrator.

We use IC2 to form the horizontal-blanking interval from the demodulated sync signals. (The horizontal-sync pulses from IC1 are not the proper pulse width that we need.) The two R-C timing circuits associated with IC2 (at pins 6 and 7 and at pins 14 and 15) determine the pulse width of the output. Potentiometer R17 can be adjusted to "fine tune" the output for the pulse width that is needed—11 microseconds.

Once the proper pulse width is obtained for horizontal blanking, the signal from pin 5 of IC2 is fed to a voltage divider made up of R10 and R11. (The value shown for R11 works well when the input signal's level is between 50 to 70 millivolts. However, because different cable systems have different signal levels, it may be necessary to increase or decrease the value of R11.) From the voltage divider, the signal is fed to diode D2, where it is used to raise the DC level of the input signal—but as we mentioned before, only during the video portion of the signal.

During vertical blanking and horizontal blanking, no DC level is added to the signal. In effect, by increasing the DC level on the video—and only during the video—we are returning (with the help of the DC-restoration circuit in the TV) the horizontal-blanking pulse and colorburst information to their proper location on the composite-video signal.

### Building the circuit

For those of you who want to experiment with the circuit we have been describing, we have included foil patterns for a double-sided board in Figs. 5 and 6. Although a double-sided printed-circuit board is used, plated-through holes are not necessary. That's because there are only seven connections that need to be

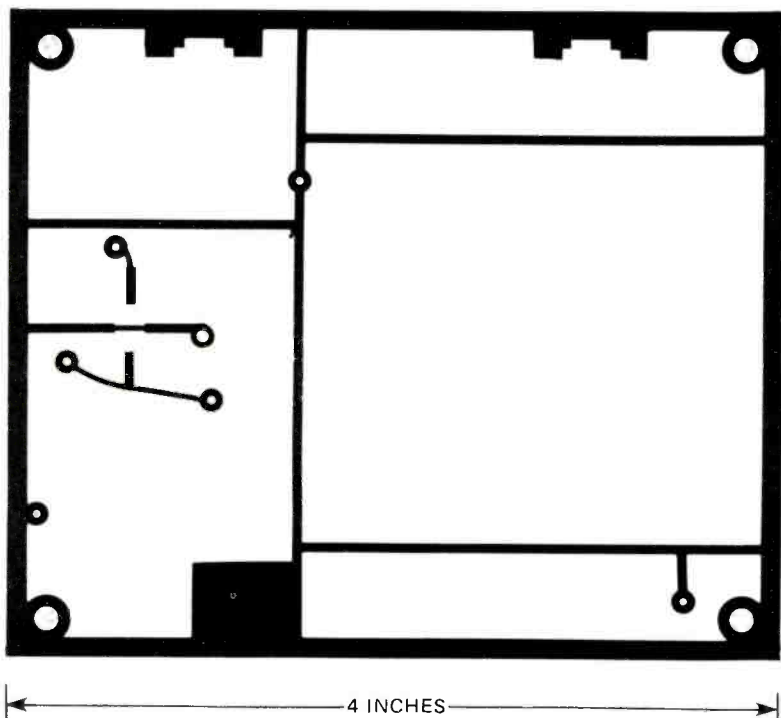

FIG. 5—THE COMPONENT SIDE of the decoder board. Note that there are only 7 connections to be made on this side of the double-sided board, so plated-through holes are not necessary.

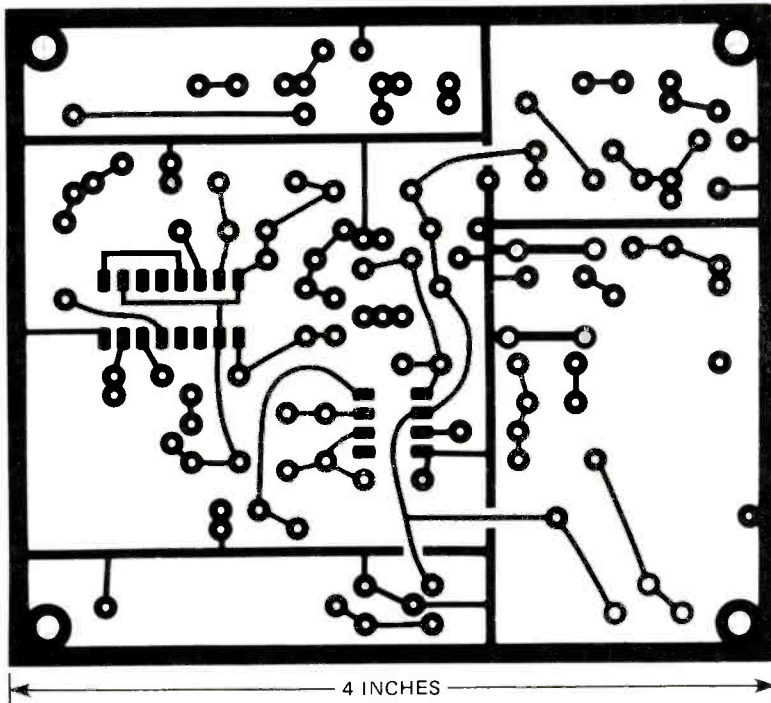

FIG. 6—THE FOIL SIDE of the decoder board is shown here.

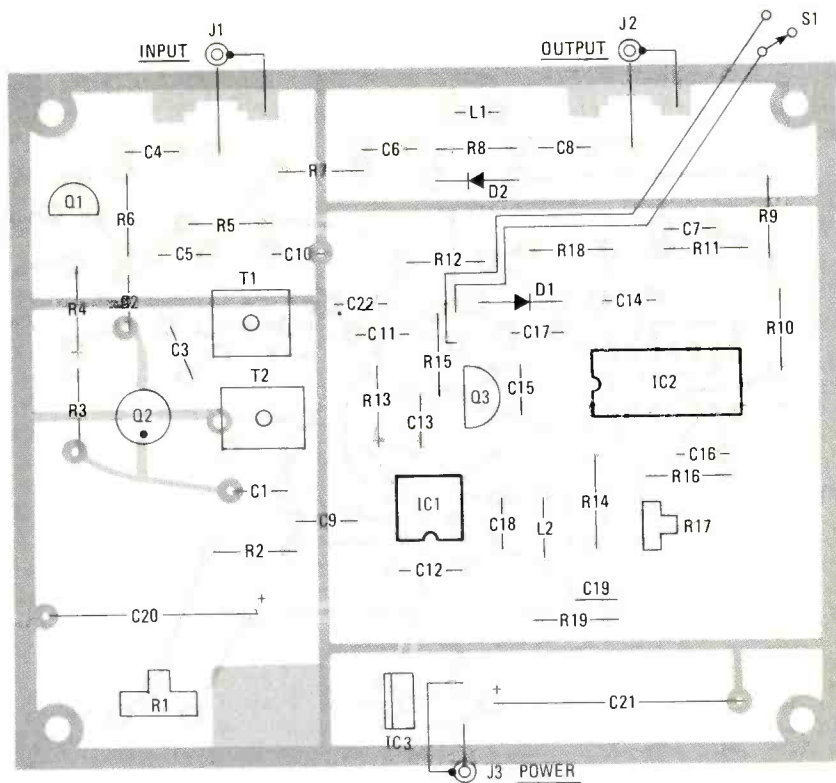

FIG. 7—PARTS-PLACEMENT and off-board connections are shown here. Note that the jacks used depend on your power source and RF connections. (We used a 1/8-inch jack and F-type connectors.)

soldered on both sides. Figure 7 is a parts-placement diagram for the board. Mount the components as close to the PC board as possible. When installing the electrolytic capacitors (C19, C20, and C21), be careful to check for proper polarity. The same holds true for the two diodes.

Transformers T1 and T2 must be modified so that they will fit into the holes on the PC board. That is, one of the pins—

the one on the side of the transformer with the part number—on each has to be cut off. Be sure that when you install the transformer, the pin that you cut does not contact the PC-board's ground trace that runs under it.

To provide the regulator (IC3) with a heat sink, it should be mounted with its flat portion soldered to the board's foil. The leads of transistor Q2 (BFQ85) do not

need to be placed through holes in the board. You can simply place it flat on the PC board and solder the leads to the foil (tack solder). Note that the dot on the parts-placement diagram indicates the collector lead. (Note that there is a dot on the transistor's package, too.) When we assembled our prototype, we mounted it in a plastic box and used an 1/8-inch jack for the input from the AC adapter, and F-type connectors for the signal input and output. The connectors that you use in your setup depend on what type of plug your AC adapter has, and what type of RF connectors you need to connect to your TV and cable converter.

### Checkout and alignment

Do not hook up this device unless you are properly authorized to do so. As we continue, we will presume that you have received the proper authorization.

The first step is to plug the output from the AC adapter into J3. Using a voltmeter, check for +12 volts at the positive side of C20. Then check that you have +5 volts at pin 16 of IC2.

The next step is to tune to a scrambled station and connect the circuit between a cable-TV converter and your television. (Jack J1 is the input jack, and J2 is the jack for output to your TV.) Make sure that switch S1 is in the open position (not shorting the output of IC1 to ground). Then adjust potentiometers R1 and R17 to approximately the "12 o'clock" position. To set the coils in their approximate location, turn the slugs counterclockwise until the top of the slug is even with the top of the coil. Then turn the slugs clockwise as follows: T1, 2 1/2 turns; T2 and L2, 3 turns. With those adjustments in their approximate locations, you can go on to the fine tuning of the circuit.

Using an oscilloscope, check the input signal level. If it is between 50 to 70 millivolts, adjust R1 so that you have about 4 volts on the collector of Q2. (As mentioned previously, the value of R11 may also have to be changed.) If the input signal is higher than 70 mV or lower than 50 mV, you will have to increase or decrease the voltage on the collector of Q2 proportionally. Next use an oscilloscope to look at the signal at pin 5 of IC1. Adjust the 3 coils to keep the level of the video to a minimum between the horizontal-sync pulses. (See Fig. 4.) When adjusting the coils, adjust them only 1/4 turn at a time. Those adjustments are critical and have to be accurate. If you see streaking horizontal lines through the television picture at this point, it's because you are getting too much video and are false firing IC2.

Now, using an oscilloscope, look at the signal at pin 5 of IC2. Adjust R17 until the signal has a pulse width of 11 microseconds. When the pulse width is correct, you will be correctly gating the video sig-

*continued on page 132*

# ALL ABOUT

# Making Measurements



## ELECTRONICALLY

HARRY L. TRIETLEY

*In this article, we'll take a look at thermocouples, thermistors, piezoelectric crystals, and other types of transducers. We'll also look at some techniques that will help you use transducers more effectively.*

ELECTRONIC MEASUREMENTS HAVE BECOME a part of everyday life. It can even be seen in your car, where microprocessors—using electronic sensors—control fuel-injection and ignition systems. Even your auto-exposure camera uses electronic sensors. Electronic thermometers and weather stations are becoming commonplace, as are microcomputer-controlled appliances. And those are just a few examples of where transducers are used in consumer applications. In science and industry, the need for transducers for precision measurements, logging, and automatic control also abound.

In this article, we'll take a look at some of the most common transducers and their applications. We'll see how they can be used to measure temperature, pressure, flow, force, vibration, liquid level, conductivity, and other variables.

### Position measurement

The best known and understood position transducer (see Fig. 1) is the potentiometer. Precision single-turn potentiometers can provide accuracy (linearity) to 0.5% and better, and repeatability to 0.1%. They are available with wirewound, metal-film or conductive-plastic elements. Multiturn potentiometers offer the same specifications; they are used for applications where rotation may exceed 360 degrees. Potentiometers are available with different, nonlinear responses—such as logarithmic and square-root.

Because of the potentiometer's high electrical sensitivity, amplification- and readout-circuitry may be simple, or even nonexistent. An ohmmeter might be used to read the potentiometer's resistance directly—but that's not recommended. While the potentiometer's linearity may



FIG. 1—THIS POSITION TRANSDUCER provides a signal proportional to the extension of a stainless steel cable.

be one percent or better, its end-to-end resistance is typically within only  $\pm 3$  to  $\pm 10\%$ . Its contact resistance may add further readout inaccuracy. A better approach is to connect a known voltage

across the potentiometer and use a high impedance voltage readout to measure the wiper position. By properly selecting the voltage, the output may be read directly as inches, millimeters, degrees of rotation, etc. Or, the voltage may be fed to an A/D converter for computer input or data logging.

Potentiometers are not limited to measuring angular and linear position—they can be used to sense any variable which can be converted to position. For example, pressure often is sensed by using a bellows that is linked mechanically the wiper of a potentiometer. A bimetallic element will transform temperature to position, while liquid level may be measured using a float. Companies that produce such assemblies commercially often use custom-designed potentiometer elements rather than standard products.

### Transformer transducers

Another widely used position transducer is the Linear Variable Differential Transformer, or LVDT. The LVDT is an electromechanical device that produces an output proportional to the displacement of a separate, movable core. It consists of three coils around a cylindrical form. The primary is wound at the center of the form, with a secondary wound at either side. A free-moving rod-shaped core inside the coil assembly links the primary's magnetic flux with the two secondaries.

If the secondaries are connected series-opposing, the net output of the LVDT will be the difference between their voltages. That voltage will be zero when the core is at the center, or null, position. When the core is moved, the induced voltage in the coil toward which the core moves increases, while the opposite coil's output drops. As shown in Fig. 2, that produces a differential voltage output that varies linearly with changes in the core position, the phase changing by 180° as the core moves from one side of null to the other.

Straight-line LVDT'S with linear travel from under 0.1 inch to one-half or three-quarters of an inch are most popular, (see Fig. 3) but devices with travel up to 24 inches are available. Linearities from 0.5 to 0.1% are normal. Units that operate from 115 volts at 60 Hz are available, but operating frequencies from 1 to 20 kHz at one to ten volts are more common. Average sensitivity for each 0.001 inch travel is a few millivolts (per volt of input), but long-travel units are less sensitive.

An LVDT may be read out by connecting its secondaries series-opposing and measuring the output AC voltage. That's less than ideal, however, for several reasons. First, the AC readout will read upscale regardless of which direction the core moves. Second, even when the core is at the center position, the output will not be zero—there will be a residual,

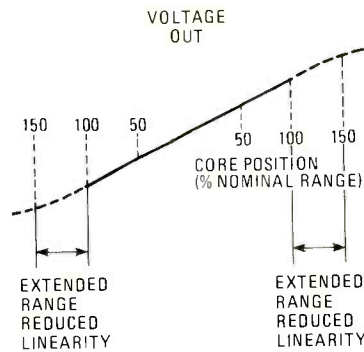

FIG. 2—AN LVDT produces a voltage output as a function of the core position.

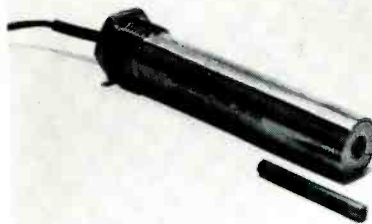

FIG. 3—AN LVDT. Note the separate, free-moving core.

phase-shifted null signal. Another problem is that the output sensitivity may change with temperature due to changes in the resistance of the windings.

The circuit shown in Fig. 4 solves those problems. The secondaries' outputs are rectified, filtered and fed to an amplifier that responds to their difference (a differential amplifier). The outputs are also fed to a summing amplifier that controls the amplitude of the primary voltage source. As the core moves toward secondary 1 or 2, that secondary's output increases while the other drops. The differential amplifier responds to both magnitude and direction; also, the amplifier's output at null is zero. Meanwhile the summing amplifier sees a constant signal, since the increase in one output exactly

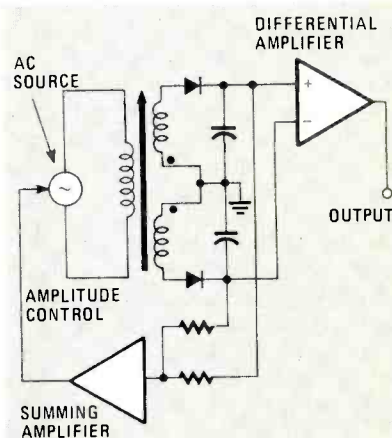

FIG. 4—THIS LVDT circuit provides a linear, bidirectional, regulated readout of core position.

matches the decrease in the other in the linear region. If temperature or other influences affect the primary-to-secondary ratio, feedback alters the AC source to compensate.

Although LVDT's require a bit more circuitry than potentiometers, they're still relatively straightforward to use and offer good sensitivity. Being essentially frictionless they offer long life and excellent resolution and repeatability. LVDT's with built-in oscillator and amplifier circuitry are available to provide DC-in, DC-out operation.

Like potentiometers, LVDT's are used to sense position, pressure or any other variable which may be transformed into position. Also like potentiometers, LVDT's may be custom designed for specific applications.

### Strain gages

The strain gage is a simple, no-moving-parts device that transforms strain, force, or pressure directly into electrical resistance. To understand its operation, consider stretching a length of wire. As it is stretched, its length will increase and its cross-sectional area will decrease. Therefore its resistance will increase. If the wire isn't stretched too far (past its elastic limit), it will recover. Thus we have a transducer that provides a resistance that goes up or down with applied strain.

Most strain-gage elements consist of etched metal foil or wire arranged in a zig-zag pattern for maximum sensitivity. Figure 5 shows two examples. The foil usually is bonded to a high grade plastic or other flexible film and etched, much like a flexible circuit board. Wire may be similarly bonded or it can be stretched unbonded between support points.

Many conductor alloys and backing materials are available (depending on the

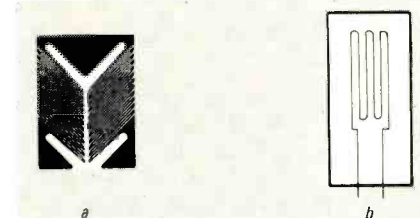

FIG. 5—STRAIN GAGES can be made from foil (as in a) or from wire (as in b)

sensitivity and temperature range required). Silicon strain-gages, which exhibit much higher sensitivity (typically thirty times that of wire or foil) are also available. Unfortunately they also have higher temperature coefficients and more limited temperature ranges, requiring care in application.

Strain gages usually are connected in a Wheatstone-bridge configuration such that the bridge imbalance varies with strain. Since the sensor's resistance is low

and changes generally less than a percent with strain, the bridge output is small. Amplifying electronics must have high gain and good DC stability: High-grade op-amps or instrumentation amplifiers are normally used. Alternately, the bridge may be excited from an AC source, using AC amplification followed by phase-sensitive demodulation for measurement. The bridge voltage should be kept low to minimize errors (resistance shift) due to resistive heating of the sensor.

Achieving precision results with strain gages requires a fair degree of mechanical sophistication. Electrical sophistication also is needed; for example, look at Fig. 6. That system uses temperature-sensitive resistors ( $R_{T1}$  and  $R_{T2}$ ) to compensate for changes in zero and sensitivity caused by temperature changes. Fixed resistors ( $R1$  and  $R2$ ) are used to trim sensitivity and zero. Temperature-related errors are caused not only by the strain gage elements, but also by mechanical expansion and contraction of the measuring assembly.

Strain-gage resistances usually are low enough (typically 350 ohms) that the resistance of the leads between the regulator and the bridge have to be considered. (The resistance of the leads can lower the bridge voltage, reducing its sensitivity.) When long leads are necessary, errors may be eliminated using a *four wire* regulator. Such a regulator uses an extra pair of wires to sense and control the regulator's output directly at the bridge's input. This is not necessary if long leads are not used.

Many companies offer a wide variety of strain-gage load-cell assemblies for force and weight measurement, and pressure-sensor assemblies to measure liquid and gas pressure. Examples are shown in Fig. 7. Typical specifications for such assemblies include 350-ohm bridge resistance, 10-volt maximum excitation, 0.1 to 0.5% nonlinearity, and a full-scale sensitivity of 2 or 3 millivolts per volt of excitation. Load capacities range from a few pounds to a hundred tons or more; similarly, pressures from a few to hundreds of thousands of pounds per-square-inch may be measured. Such devices are used to measure weight, fullness of a bin (using the weight of the bin), liquid level (using fluid pressure at the bottom of a tank), barometric pressure, and many other variables.

The flow rate of liquid or gas is also measured using strain gages (or, for that matter, any other pressure sensors). By placing a restriction in a pipe (as shown in Fig. 8) and measuring the pressure drop across it, the flow velocity may be determined. The most common restriction is the *orifice plate*, a thin metal plate that has an opening that's smaller than the diameter of the pipe. Pressure-measurement taps, at precisely located points above and below the plate, are connected to an as-

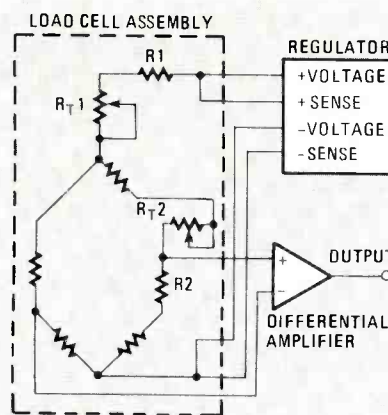

FIG. 6—A COMPLETE STRAIN GAGE bridge compensates for temperature shifts in zero and sensitivity. A four-wire regulator is used to compensate for lead-wire resistances.



FIG. 7—STRAIN GAGE load cells and pressure sensors are available in a wide variety of configurations, some of which are shown here.

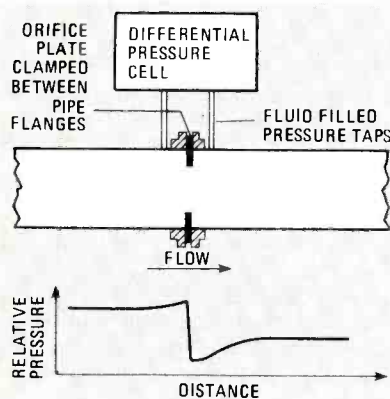

FIG. 8—PLACING A RESTRICTION in a pipe causes a pressure drop that can be used to measure flow.

sembly designed to measure differential pressure. With such an arrangement the flow rate is proportional to the square root of the pressure difference, requiring a square-root amplifier in the electronics.

There are other arrangements that are also used to measure flow rates. For example, the pressure difference between the inside and outside radii of an elbow-shaped band in the pipe can be used to calculate the rate of flow. For large, open

streams, the liquid height behind a specially-shaped notched dam known as a weir is used. (The relationship between height and flow depends on the shape of the notch, but is not linear.)

## Piezoelectrics

Quartz and other natural and manmade crystals generate a small voltage between their opposite sides when stressed. Therefore they're ideal for making force and pressure measurements. (Microphones and phonograph cartridges are examples of other ways that effect is used.) Although useless at DC, such devices are superior to strain gages for measuring high-frequency vibrations or impulses with fast risetimes.

Piezoelectric crystals are not conductive; they act as a high impedance AC source. More precisely, they act as an AC-voltage source in series with a small capacitor. A change in the voltage,  $\Delta V$ , causes a small charge,  $\Delta Q$ , to flow on or off the plates of the capacitor. Outputs of piezoelectric transducers are generally specified as picocoulombs per unit force (for example, picocoulombs per psi). Voltage amplifiers for piezoelectric transducers must have a very high input impedance (just as amplifiers for microphones or phono pickups must). The capacitive loading due to input cables can become a problem.

A circuit that minimizes those problems is the charge amplifier shown in Fig. 9. In that circuit, an op-amp (or other high-gain, high-impedance inverting amplifier) is provided with  $C_F$ , a negative-feedback capacitor. The high negative feedback holds the voltage at the input to near zero—nearly all the charge from the transducer flows onto  $C_F$ . Also, since the input voltage is zero, the cable capacitance stores no charge, and so causes no errors.

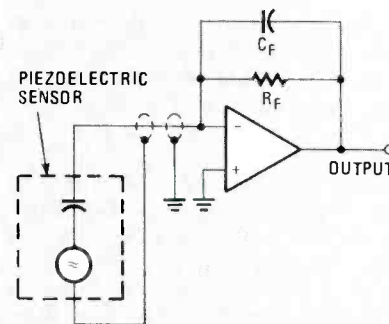

FIG. 9—A CHARGE AMPLIFIER completely transfers the piezoelectric sensor's AC charge output signal to the feedback capacitor, producing a proportional AC output voltage. The feedback resistor (which should be large) stabilizes the DC output level.

The voltage on the feedback capacitor is given by  $\Delta V = \Delta Q/C$ . Therefore the charge amplifier's output is  $1/C$  volts per coulomb. This output is directly propor-

tional to the AC force or strain on the piezoelectric crystal. The design of a suitable amplifier involves a tradeoff between using a large feedback capacitor (for high negative feedback) and using a small capacitor (for high gain.)

Accelerometers can be made by connecting a mass to a piezoelectric crystal. Any change in velocity causes the mass to push or pull on the crystal, producing an output proportional to the rate of acceleration. Accelerometers are used to study the vibration and shock response of mechanical designs and to measure shock, acceleration and vibration in engines and vehicles. They also are used to monitor seismic vibrations as well as the vibrations of structures such as bridges. A crystal may also be mounted directly between an object under test and the point of impact to measure peak forces during impact testing. The crystals themselves are fairly rugged and capable of withstanding high peak loads.

Piezoelectric sensors are especially valuable in measuring explosions, blasts and pressure surges. Depending on their design, response times to one microsecond are possible. Applications include gun and ammunition testing, engine-cylinder and even atomic-blast measurements. Industrial measurements range from plastic injection molding pressure to the impact force of punch presses.

### Temperature measurements

Perhaps the most common uses for transducers is to measure temperature. Electronic temperature-sensors fall into three classes: resistive (thermistors and wirewound), thermocouples, and integrated circuits.

The resistance of both thermistors and wirewound sensors changes with temperature—but that's where their similarity ends. Thermistors are highly sensitive (typically 4%/°C), nonlinear devices with negative temperature coefficients and a narrow range. Wire wound sensors are less sensitive (typically 0.4%/°C), fairly linear, have positive temperature-coefficients, and are wider-range devices.

### Thermistors

Thermistors are formed by mixing together various powdered metal-oxides, forming them into desired shapes, and firing them at temperatures around 1000°C (1832°F). They may be formed by pressing the powder into discs, washers, rods, squares, sheets, or other shapes before firing. Another method is to dip platinum-alloy wires into a slurry of the oxides and fire directly to form small beads. The oxides form a semiconductor material whose resistance decreases as temperature goes up. An almost limitless variety of sizes, shapes and tolerances are available, with resistances at room temperature running from 100 ohms to a megohm.

Small discs and beads are commonly used for precision temperature measurement. Discs, generally under 0.1 inch in diameter, may be ground to a precise resistance and are available with accuracies up to  $\pm 0.1^\circ\text{C}$  or better. Since their construction usually involves soldered connections and epoxy coatings, their service temperatures often are limited to 150°C (302°F) or less. Glass-encapsulated discs are available for use at higher temperatures: they provide superior stability plus a hermetic seal. Bead thermistors may be much smaller and generally operate at higher temperatures. Because of their small size and method of construction, they cannot be ground to tolerance. (Selected or matched units may be ordered, however.)

Designing with thermistors is easy because their high sensitivity means that precise measurements may be achieved using ordinary components. At 4% per-degree, a one-percent error is equivalent to only 0.25°C. Figure 10 shows two basic circuits: a Wheatstone bridge and a parallel network. The bridge provides an output that increases with temperature, while the parallel network's resistance decreases with an increase in temperature. When designing thermistor circuits, the power dissipation should be kept low (0.1 mW or less) to avoid self-heating errors.

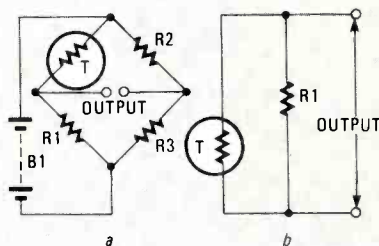

FIG. 10—THERMISTOR CIRCUITS. The Wheatstone bridge output increases with temperature, while the resistor network's resistance decreases.

The bridge may be made to read temperature differentials by replacing R2 with a second, identical precision thermistor. Such a circuit is useful for measuring heat-exchanger or solar-collector performance or for measuring the difference between a wet- and dry-bulb thermometer.

If the circuits in Fig. 10 are changed by adding a series resistor-thermistor combination in parallel with the thermistor, then the bridge and the parallel network may be made to provide linearity to 0.2°C and better over temperature ranges as wide as 100°C. Calculation of the best combinations of resistors and thermistors is not easy, but some thermistor manufacturers offer preselected component sets.

Thermistors often are mounted in probe assemblies or other housings for protection. Figure 11 shows a variety of assemblies such as sheathed probes, surface

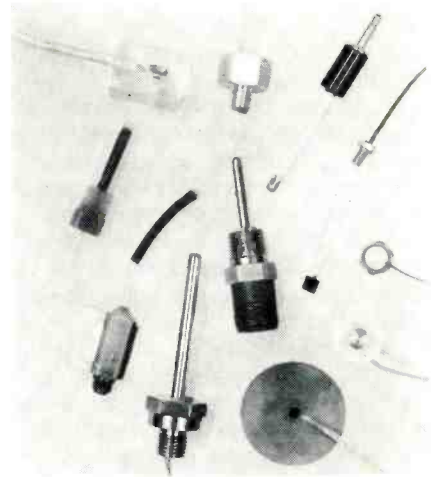

FIG. 11—THERMISTORS AND OTHER temperature sensors are available in a wide variety of sensor assemblies.

mounts, thermistors mounted in screw heads etc.

Thermistors offer a variety of uses besides temperature measurement. They often are used as temperature-compensating components in electronics. One example is compensating the temperature-induced changes in a copper meter-coil. Large, nonprecision thermistors are used as current-inrush limiters (their resistance drops as the current heats them up). Large, washer-shaped thermistors monitor temperature in such applications as motor overtemperature protection.

### Resistance thermometers

Resistance thermometers generally are made of a length of fine-gauge wire wound on a ceramic (or other insulating) support. Surface-temperature sensors are made of wire or foil sandwiched between flexible plastic films.

Platinum is the most common metal used, but many sensors use nickel, copper and other metals. (Platinum need not be expensive: a typical element uses only 20 inches of 0.001 inch diameter wire.) International-standard (DIN, IEC, ASTM) platinum sensors have a resistance of 100 ohms at 0°C and 138.5 ohms at 100°C. Common temperature ranges go down to  $-200^\circ\text{C}$  ( $-328^\circ\text{F}$ ) and up to between 500°C and 800°C (932°F and 1472°F), with a tolerance of  $\pm 0.25^\circ\text{C}$  at zero. Other resistances, ranges and tolerances are available. Wirewound sensors generally are cylindrical, under 0.1 inch diameter, one half to one inch long.

Resistance thermometers have a lower sensitivity and lower resistance than thermistors. For example, 100-ohm platinum sensors change by 0.4 ohms per degree C—one ohm equals a change of 2.5°C (4.5°F). Therefore the lead wires or cables used with them can introduce appreciable errors. To avoid those errors it is common to use readout circuits which either ignore or compensate for lead resistance. Figure

12 shows one such circuit, which requires four interconnecting leads. In that circuit, a constant current is fed through one pair of leads, and the voltage drop across the sensor is read via a second pair. The energizing current does not flow through the measurement leads, so the readout sees only the  $I \times R$  volt drop across the sensor itself.

Figure 12 also shows a method of compensating for the nonlinear temperature response of platinum. (Platinum's sensitivity drops slightly at higher temperatures.) A small amount of positive feedback causes the current source to increase at higher temperatures, offsetting the drop in sensitivity. With proper design, linearity as good as  $\pm 0.1\%$  from 0 to 500°C is possible. This method does not necessarily work for sensors other than platinum.

Resistance thermometers are widely used for the measurement and control of chemical, refinery, food and other manufacturing processes and in precision testing of jet engines, large diesels, etc. Platinum offers the best precision of any electronic temperature sensor, with stability and repeatability better than  $\pm 0.1^\circ\text{C}$  after use at 500°C (932°F) and beyond. They are available in most of the same assemblies shown in Fig. 12, but are generally enclosed in sheathed probes.

### Thermocouples

A thermocouple is nothing more than two dissimilar wires joined together. It is based on the principle that if two different metals are joined together, they will produce an output voltage that is dependent on the temperature of their junction. Over the years, specific wire pairs have become standardized, with published voltage-vs.-temperature tables and agreed-upon letter designations. Types J, K, T, and E designate various combinations of chromel, constantan, iron, alumel and copper. Among them they cover the temperature range from  $-200^\circ\text{C}$  ( $-328^\circ\text{F}$ ) to  $1250^\circ\text{C}$  ( $2282^\circ\text{F}$ ). Types R, S and B use combinations of platinum alloys to cover temperatures up to  $1800^\circ\text{C}$  ( $3272^\circ\text{F}$ ). All seven

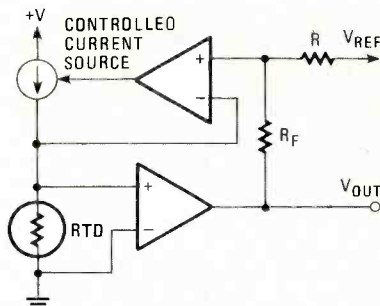

FIG. 12—FOUR-WIRE MEASUREMENT eliminates errors due to lead resistances when measuring with RTD's. A small amount of positive feedback compensates for sensor nonlinearity when using platinum RTD's.

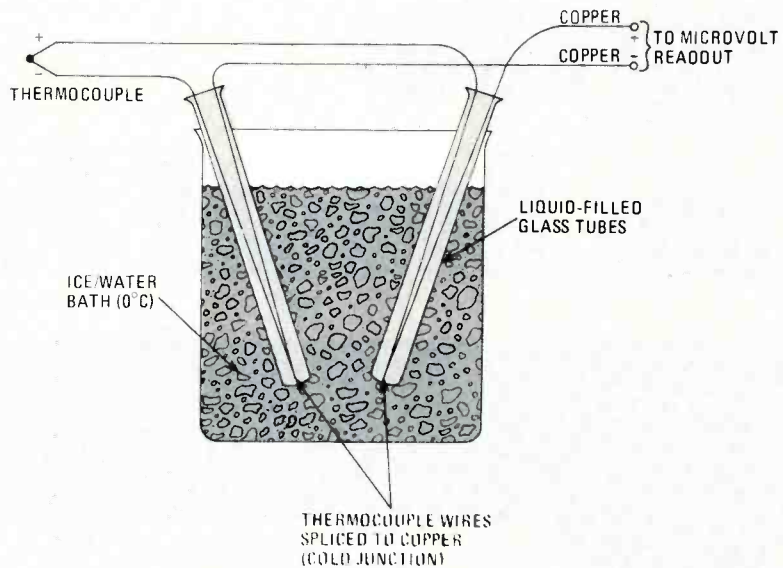

FIG. 13—THERMOCOUPLE COLD JUNCTIONS must be kept at a constant temperature for correct readings. Electronic temperature-compensation could also be used.

### TRANSDUCER MANUFACTURERS

This list does not pretend to be complete. Each manufacturer listed makes a variety of transducers.

Analog Devices  
PO Box 820  
Norwood, MA 02062

BLH Electronics  
42 Fourth Ave.  
Waltham, MA 02254

Bournes Instruments  
6135 Magnolia  
Riverside, CA 92506

Celeco  
7800 Deering Avenue  
PO Box 1457  
Canoga Park, CA 91304

Entran Devices  
10 Washington Ave.  
Fairfield, NJ 07006

Fenwall Electronics  
63 Fountain Street  
Framingham, MA 01701

Gould Inc., Measuring Systems  
2230 Statham Blvd.  
Oxnard, CA 93030

Micro Switch  
11 W. Spring St.  
Freeport, IL 61032

Schaevitz Engineering  
130 Union Ave.  
Pennsauken, NJ 08110

Sensym  
1255 Reamwood Avenue  
Sunnyvale, CA 94089

Weston Instruments  
Div. of Sangamo Weston, Inc.  
614 Frelinghuysen Ave. Newark, NJ 07114

Yellow Springs Instrument Co.  
PO Box 279  
Yellow Springs, OH 45387

conform to tables developed by the National Bureau of Standards, and are covered by specifications issued by the American National Standards Institute (ANSI). Other types of thermocouples are in use and may be covered by future standards.

Thermocouples lack the sensitivity, accuracy, and stability of resistance thermometers or precision thermistors. They are usable at much higher temperatures, however, and are much more versatile with generally lower cost. Types J, K, T and E have sensitivities around 40 to 60 microvolts per °C while the platinum couples (R, S, and B) trade lower sensitivity (8 to 12  $\mu\text{V}/^\circ\text{C}$ ) for higher temperature use. Response is roughly linear. Standard accuracies are around  $\pm 2.2^\circ\text{C}$  or  $\pm 0.75\%$  of the temperature being measured, whichever is greater.

Thermocouples present a unique readout problem in that their connection to copper circuitry creates additional couples. Known as *cold junctions*, those connections produce additional voltages that vary with temperature. The actual readout will be the difference between the measured temperature and that of the cold junctions.

In the laboratory, the cold junctions may be held in an ice bath as shown in Fig. 13. Published thermocouple tables assume that the cold junction temperature is  $0^\circ\text{C}$ . In test or control systems that contain many thermocouples, it is not uncommon for all the cold junctions to be placed in a constant-temperature heated block. Most modern instruments, however, include "cold junction compensation" using a thermistor or semiconductor sensor to automatically offset the cold junctions' voltages.

continued on page 134

# Upgrade Your Budget Printer

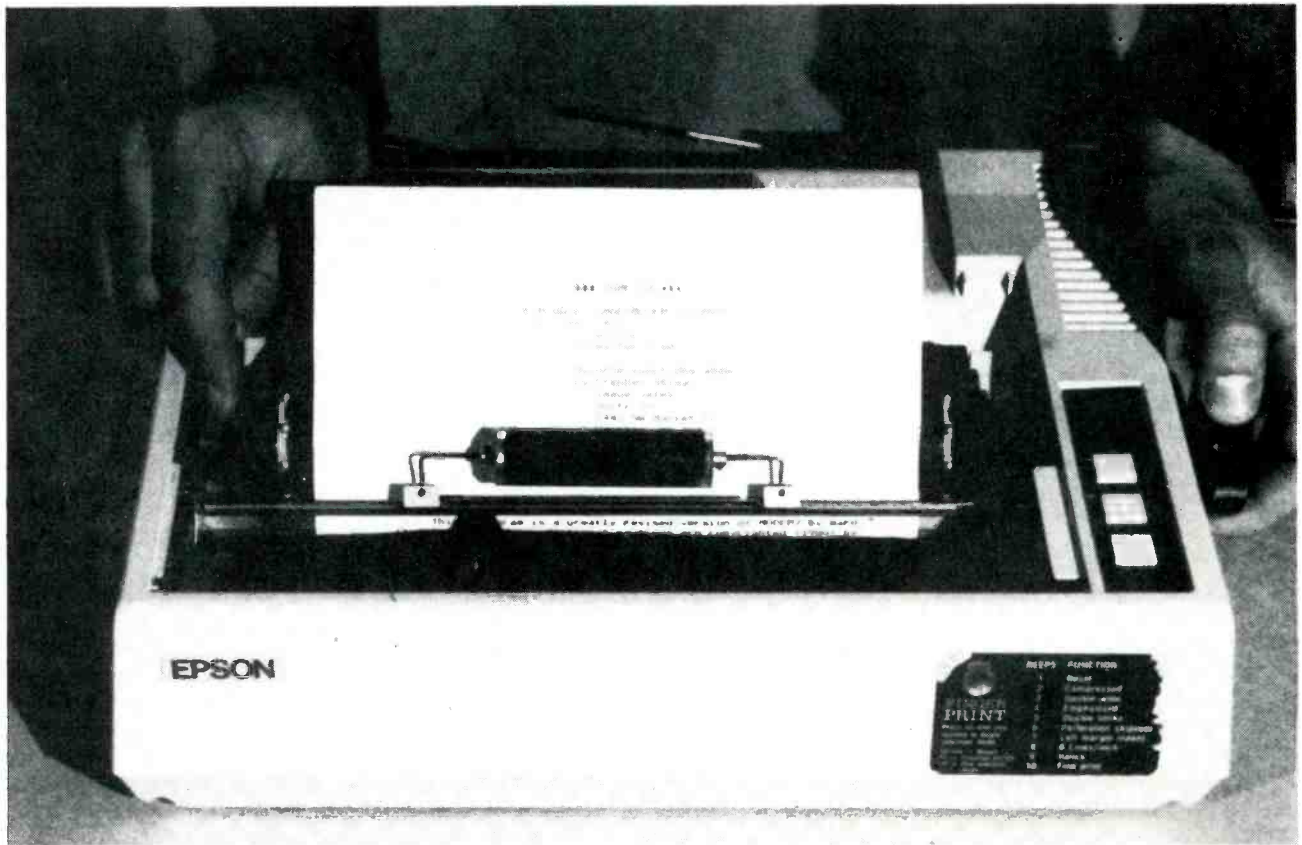

*Many low-priced printers can be easily upgraded to give them new features and greater flexibility. Here's a look at some of the upgrade kits currently available for two of the most popular of those printers.*

## HERB FRIEDMAN

■ If you have been into personal computing from its "hobbyist" days, or have built your system on a tight budget, it's odds-on that you have either an Epson MX-80 matrix printer or Smith-Corona TP-1 (or TP-2) daisy printer. Either, or both, have probably given you years of trouble-free service, but lately you find that more and more software can't be used with your printer, or you want to upgrade the computer but find your printer can't quite hack it as an up-to-date printer with the new computer hardware.

Essentially, what you have is still functional equipment that's been made obsolete by modern software, or by modern uses for a personal computer.

The Epson MX-80 printer, which could be used with any computer having a Centronics-compatible parallel printer output, was intended primarily for the Radio

Shack TRS-80 Model 1, the most popular computer of its day, hence the MX-80 featured a Radio Shack graphics mode. Much of the modern software, however, is written for the graphics mode of the newer MX-80 printers, which has the graphics capability for the present most popular 8-bit computers, the Apple II and IIe. Even if the software is for other than Apple computers the graphics will most likely be intended for the graphics capability of the most recent version of the MX-80.

The MX-80 (and its clones such as the Texas Instruments and IBM printers) accommodates only tractor-feed paper. If you want to print on single sheets, such as letterhead, the only way to do it is to use a special plastic tractor/pin feed "carrier," some of which are prone to damage the printhead when pushed



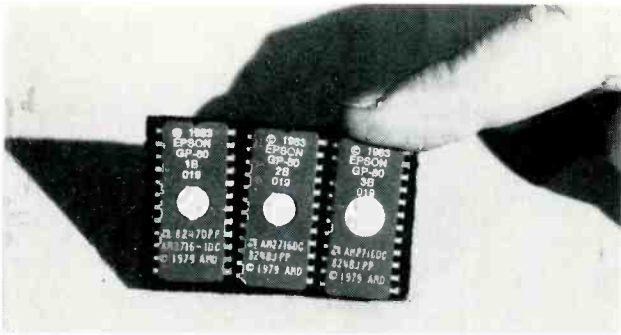

EPSON'S OWN *Graftrax-Plus* upgrade consists of three ROM's supplied on a strip of conductive foam

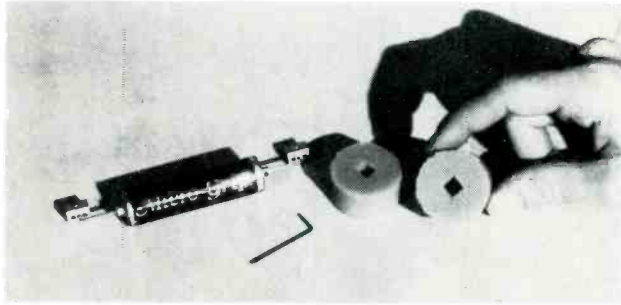

THE *MICRO-GRIP* single sheet upgrade kit. Its use does not interfere with tractor operation.

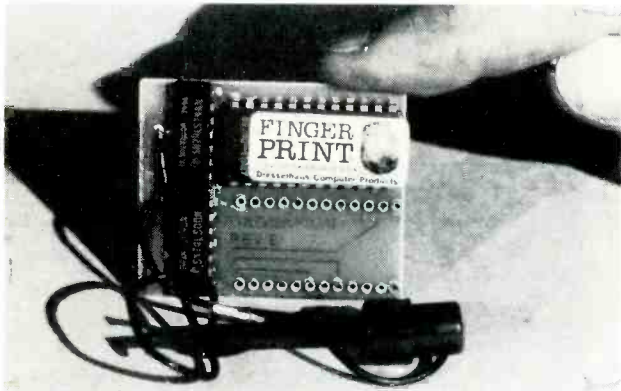

THE *FINGERPRINT* module plugs directly into an Epson ROM socket. The existing ROM is moved to the empty socket on the board.

through the printer mechanism. While the original *MX-80* has a host of features such as compressed or enhanced printing it lacks a backspace, which precludes underscoring from some of the less expensive (but otherwise excellent) word processors that are available.

The "letter quality" Smith-Corona daisy printer *TP* family, which consists of the *TP-1* and the newer *TP-2*, is the "buy of buys" when it comes to letter-quality printers for home-and-family and small businesses. The *TP-1* was the first under-\$1000 daisy printer, which by early 1984 was selling for as little as \$250. Thousands upon thousands of personal computer users who could not otherwise possibly afford a letter quality daisy printer struck gold in the *TP-1/TP-2*—the price might very well be the reason you decided to get a letter quality printer even though you already had a matrix printer. (If a type 251 ribbon is used—which was not mentioned in the early documentation—the *TP-1*

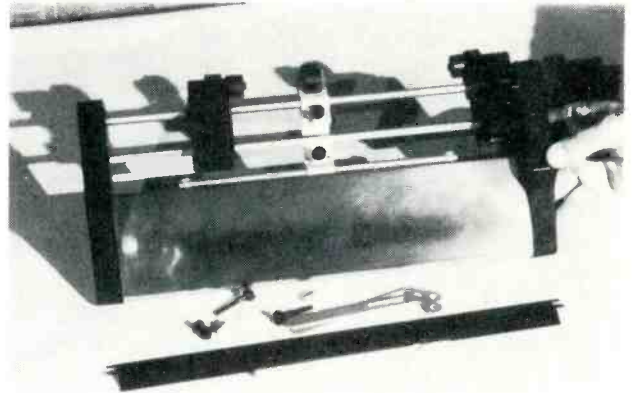

THE *PASSIVE TRACTOR FEED* upgrade kit for the Smith-Corona printers. The main section is supplied as a complete assembly.

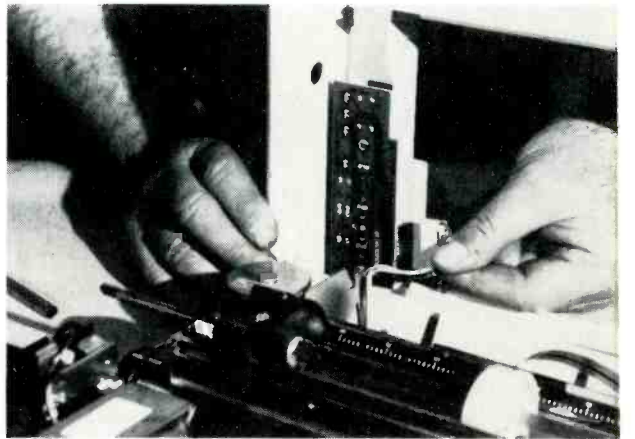

EPSON TELLS YOU to work on the printer with the cover attached, but don't do it—"pull the plug" instead.

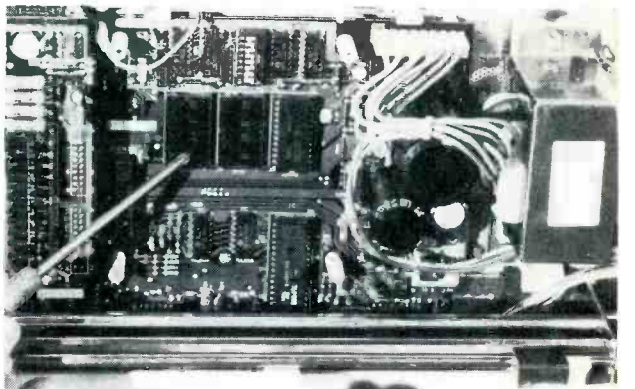

THE THREE ROM sockets located in the base of the *MX-80* printer. If you have an original *MX-80* two of those are empty and one is filled.

can produce "camera ready" print quality the equal of machines costing well over \$1000 because it is essentially the printer end of a Smith-Corona electronic typewriter with an accessory interface for computer output.)

The problem with the *TP-1* and the *TP-2* is that they were intended for single-sheet documents such as business letters, etc., which is logical because it is really the printer mechanism from a typewriter. But today, much modern software is intended for continuous forms printing, such as checks, labels, IRS

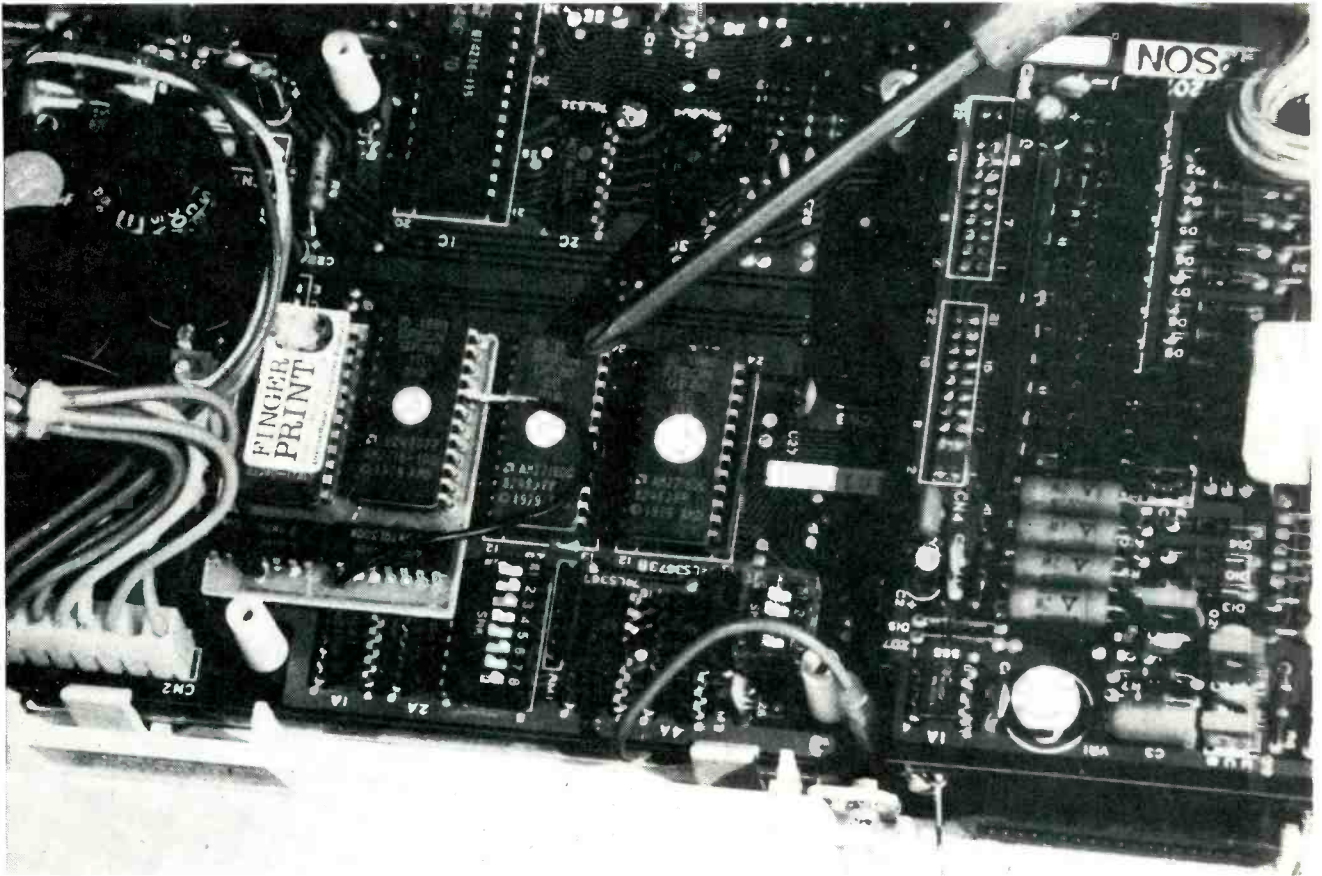

THE *FINGERPRINT* assembly snaps into ROM socket 1B, while the ROM that normally goes in that socket is installed on the *Fingerprint* assembly.

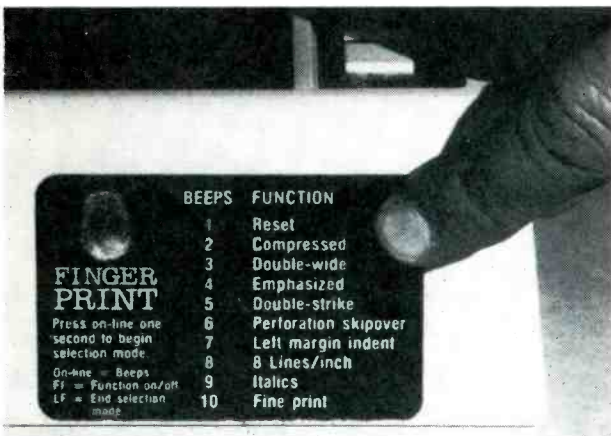

AN ADHESIVE MYLAR LABEL you affix to the front of the printer lists the new functions provided by the *Fingerprint*.

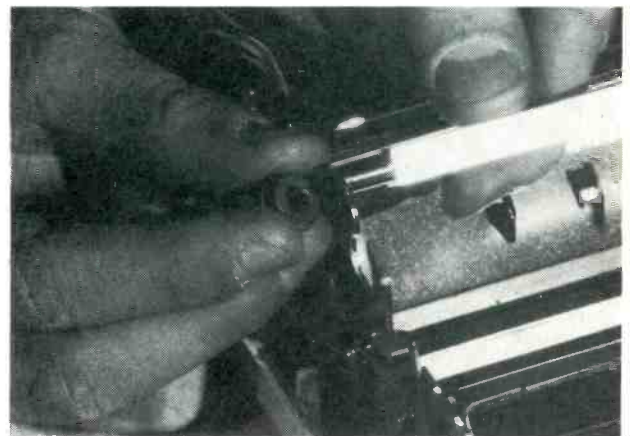

TO ADD the *Micro-Grip* single sheet feed to the *MX-80* you simply remove the collar securing the drive bar on the left side.

schedules, even business stationery—which includes letterheads and envelopes. To insure precise alignment of the printing, continuous forms must be tractor or pin fed.

So what we have is a popular tractor-feed matrix printer that needs at least new graphics capability and the ability to feed single sheets, and a daisy printer that needs a tractor feed in order to accommodate continuous forms. Let's see what we can do to satisfy those important needs.

### Upgrading the printers

Regardless of why you purchased the *MX-80* or *TP-1*

in the first place, user-installed retrofit kits are available that will upgrade either printer to accommodate modern needs. While some of the retrofits are better or more convenient than others, we know those discussed here will really work exactly as promised because we actually tried them out.

The first of the user-installed *MX-80* retrofits was Epson's own *Graftrax*, which consisted of three ROM's, two of which plugged into empty sockets in the base of the printer while the third replaced an existing ROM. Among other things, the *Graftrax* upgrade provided for dot-addressable graphics, italics printing, and even more important, backspacing. It was terrible

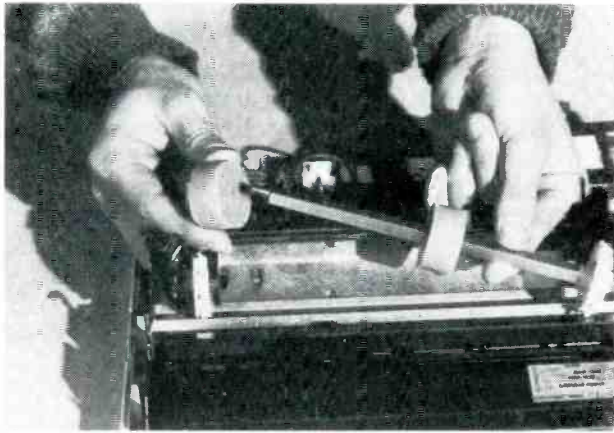

**SLIDE THE ORIGINAL plastic paper guide roller from the driver bar and slide the two Micro-Grip rubber rollers on the bar. Then replace the collar.**

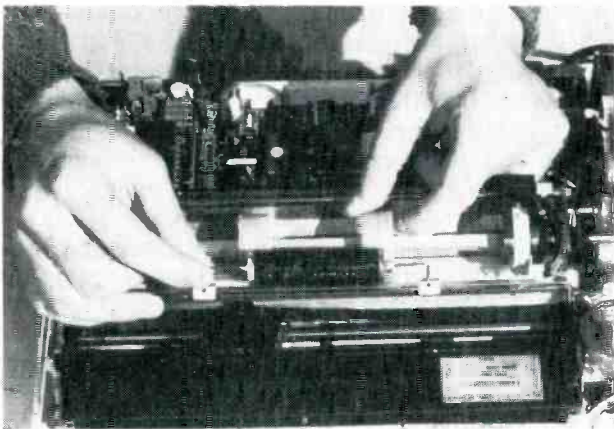

**ATTACH THE PRESSURE roller assembly to the paper bail and the single sheet retrofit is finished.**

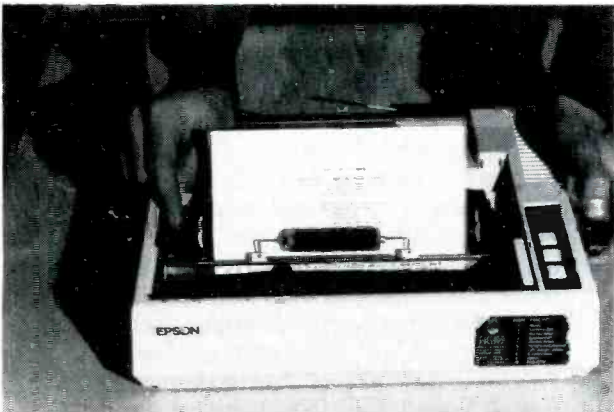

**A SINGLE SHEET** being printed by the *MX-80*. Be certain the pin-feed mechanisms are against the sides of the paper it feeds straight.

backspacing because the printhead returned to the extreme left and then advanced for each backspace, but it was adequate for general word processing: underscore, kerning, etc. Unfortunately, a graphic printout would cycle the head continuously until the drive motor could be heard slowing to a crawl.

The latest retrofit available from Epson dealers is *Graftrax-Plus*, which gives your old model *MX-80* the advanced features of the latest model. Among the *Graftrax-Plus* highlights are the Apple-compatible graphics (no more Radio Shack Model 1 graphics), a



**WHEN WORKING ON** the Smith-Corona *TP-1*, you cannot separate the casing top because the leads to the fan are too short.

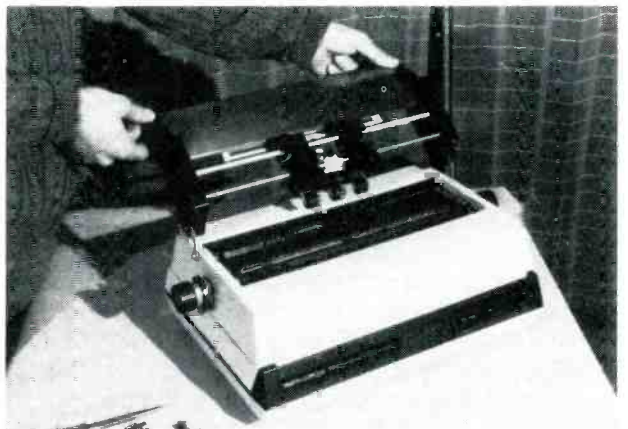

**IT APPEARS TO BE** permanently installed, but the tractor mechanism goes on and off in seconds.

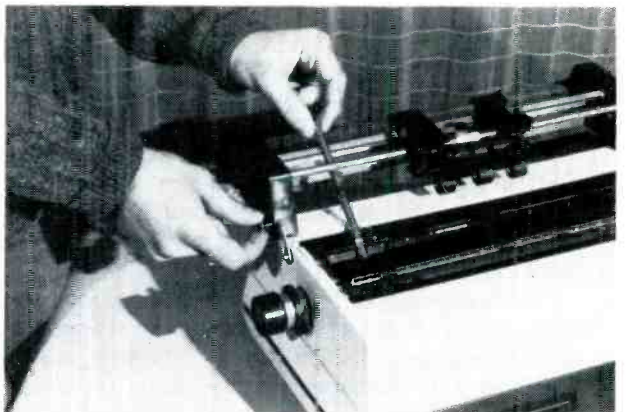

**SLIDE THE SUPPLIED GAUGE**—actually a notched rod—on the drive bar, tighten two screws, and the tractor assembly is adjusted for use.

true backspace that puts graphic printouts in high gear and relieves the strain on the printer's printhead-drive motor; a "fine print" that can be used for superscripts and subscripts; automatic perforation skipover (no more program listings printing on the perforations); and a continuous underscore that can be turned on and off from within a program or word processor. (A continuous underscore is formed simultaneously with the character; the head does not backspace for the underscore.)

The *Graftrax-Plus* retrofit kit consists of three ROM's

and the latest Epson-with-Grafrax printer manual—which explains all the “bells and whistles.” The *Grafrax-Plus* retrofit has the same kind of installation as for the original *Grafrax* upgrade—just plug the ROM’s into the correct sockets. One “caveat” however: The Epson instructions leave the top of the printer attached when you open the printer by separating the top and bottom; it has you delicately balancing the cover on its end. If you look closely you’ll see the wires to the switches in the cover are attached through a connector. Mark the orientation of the connector with a pencil or pen and then separate the connector and put the cover in a safe place until you’re finished.

### Pushbutton control

As long as you have the printer open consider a retrofit called *Fingerprint* (Dresselhaus Computer Products, 837 E. Alosta Ave., Glendora, CA 91740), which allows the three printer control pushbuttons to also program ten operating modes: compressed print; double-wide; emphasized; double-strike; perforation skipover; left margin indent; 8 lines/inch spacing; italics, and fine print. For example, just touch the printer’s ON-LINE button twice and the printer shifts to compressed type without any commands from the computer.

*Fingerprint* is supplied on a small printed-circuit board that swaps for the ROM in a socket 1B, the one that’s replaced in the *Grafrax* retrofit. Instead of substituting for the ROM in socket 1B, install the *Grafrax* ROM in the *Fingerprint* socket and then snap the *Fingerprint* assembly into socket 1B. You clip two attached *Fingerprint* leads where indicated and you now have both the *Grafrax* and the *Fingerprint* retrofits, and with virtually no extra effort required on your part.

### Single sheets

If you quit now you’ll have one heck of a matrix printer, but you can go one step farther and add a real single-sheet feed by installing a *Micro-Grip Friction Feed* (Bill Cole Enterprises, Box 609, Wollaston, MA 02170). The *Micro-Grip* retrofit does not interfere with the tractor operation, but it does permit single sheets to be fed directly through the printer without the need for a plastic carrier.

The *Micro-Grip* kit consists of three components: two rubber rollers that replace the existing Epson paper guide roller (which is sandwiched between the two tractor pin feed mechanisms), and a rubber-roller pressure assembly that clamps to printer’s paper bail—the bar that holds the paper down for printing.

To install the *Micro-Grip* retrofit it is necessary to very slightly dismantle the printer’s feed mechanism so the rubber rollers can be fitted to the tractor-drive bar (instructions are provided in the kit). It is, however, a minor disassembly, and the whole installation shouldn’t take more than 10 or 15 minutes. Just be certain you don’t push or bend anything while you are doing the work—do everything very, very gently.

When you see the *Micro-Grip* installed you won’t believe it will work, but it does. The only problem is the paper tends to skew, and the instructions on how to “fine tune” the paper feed really don’t do much of anything. You’ll spend more time fussing with the “fine

tuning” than printing. Just ignore the “fine tuning” instructions. Instead, gently slide the tractor pin-feed devices against the sides of the paper and apply their locks, thereby locking them in position against each side of the paper. The pin feed assemblies will guide the paper so it rolls through nice and straight. The adjustment of the pin-feed mechanisms are “permanent” as long as you keep using single sheets. To use continuous form tractor paper you simply slide the two rubber rollers to the side and reset the tractors, or leave the rollers where they are and pull the paper bail (with its roller) away from the paper; the Epson will print on continuous tractor feed forms just as well without the bail.

### Installing a tractor feed

The tractor feed upgrade for the Smith-Corona *TP-1/TP-2* isn’t really a retrofit because it does not really become a permanent part of the printer, it can be easily removed in seconds. The tractor feed mechanism, which is available from some (not all) Smith-Corona dealers and the Smith-Corona service centers is a “passive” tractor feed, meaning it’s really a guide that insures precise registration even though the paper is really driven by the normal platten mechanism—just like a single sheet.

While installing the tractor feed upgrade can be a user-performed task, Smith-Corona does not provide the first three pages of the documentation with the kit; the pages that show how to do it yourself. Smith-Corona service centers will do the installation for \$10 if you deliver the printer to the center.

What’s missing are these instructions. First, remove the casing top by loosening two screws at the top front and then prying the top out of the three clamps in the base, thereby separating the casing top from the base. The three clamps are across the rear of the base; you’ll need to use a large screwdriver as a pry bar and you’ll swear you’re breaking the case but that’s what it takes to release the three clamps at the back of the casing. Don’t disconnect any wires even though they are short; just flip the cover up.

Use common sense and remove the combination dust cover and paper rest, and install the supplied black metal strip (which is called an “electronics cover”) so it spans the two screws that originally held the paper rest’s pivots—remove the rest with its pivots. Remove the hinge-screws that hold the paper rest to the casing top. Drive out the hinge pins into which the screws fit and gently drive in the new, supplied, hinge pins with a small soft-face hammer—or the back end of a screwdriver. That’s it—reassemble the cabinet.

The supplied documentation shows how to install and adjust the tractor mechanism itself, all of a 10 minute job at the very worst. A special gauge is provided in the kit for alignment of the tractor mechanism. The whole project looks much more difficult than it is. Actually, separating the back of the casing top from the base will be the most difficult part of the upgrade.

With the tractor-mechanism upgrade the *TP-1/TP-2* can accommodate either single sheets, tractor-fed sheets, or tractor-fed forms and labels. As with the Epson retrofits, you lose nothing; you only gain. ◀▶

# TEST EQUIPMENT



## All About Logic Analyzers

THE LOGIC ANALYZER CAN BEST BE thought of as the digital equivalent to the (analog) oscilloscope. However, unlike the oscilloscope—which displays events as they happen—the logic analyzer samples digital signals and stores them as logic-level 1's and 0's so they can be reviewed later. Because of that fundamental difference, the operation of a logic analyzer may, at first glance, appear intimidating.

In order to dispel that feeling, we'll discuss the basic operation of logic analyzers and take a close look at a relatively low-cost (\$2075/\$2475) unit: the model LA-1020/25 (manufactured by B&K Precision 6460 W. Cortland, Chicago, IL 60635). We'll also build a simple, single-IC logic analyzer. Although limited in its capabilities, it can be used to demonstrate some of the logic-analyzer techniques we'll describe.

### Applications of logic analyzers

Although logic analyzers can be used to monitor any logic circuit, they are mainly used on microprocessor-oriented circuits, usually to monitor the logic states of the address bus. That way, you can follow the execution of the program steps in a program.

That's helpful because a program is rarely executed in a straight-line manner. Instead, it will frequently branch off or jump from one address to another at different parts of the program. That action is analogous to a hobbyist on his way home from work. He will not always travel in a

*The logic analyzer is a not-too-well-understood test instrument. We'll try to make you more familiar with it by taking an in-depth look at one.*

### KENNETH PIGGOT

straight-line manner. Instead he may stop at the computer store, parts shop, etc.

In the real world we can observe the path taken by the hobbyist simply by looking at him. However, in the world of the microprocessor, our senses fail us and we must rely on instruments—like the logic analyzer that uses techniques such as address-state analysis—to see what is happening.

When the address bus is monitored by a B&K Precision logic analyzer during each instruction-fetch cycle, 250 steps of the processor's program sequence will be stored in its memory. By using various trigger modes (we'll discuss those later), you can begin the storage of program steps at any selected point of the program's execution.

The B&K Precision models LA1020 and LA1025 logic analyzers feature many of the capabilities of larger, more expensive machines. (The two models are identical except for the inclusion of signature-analysis capability in the LA1025.) The

LA1020 allows you to monitor and store 250 16-bit TTL-level data samples. In a typical microprocessor system, you would monitor the address, data, and control buses.

To hook the analyzer up to the system under test, two *data pods*, like the one shown in Fig. 1, are used. Each data pod or probe samples eight TTL-level data lines, one QUALIFIER line, and one CLOCK line. The QUALIFIER and CLOCK lines will be explained in the "Triggering" section. Each data pod also contains the circuitry to terminate the sampling leads and to drive the connecting ribbon cable between the data pod and the main unit. The logic analyzer's MODE switch can be turned to the POD ACTIVITY position. When in that position, each data pod acts as an 8-bit logic probe with the display

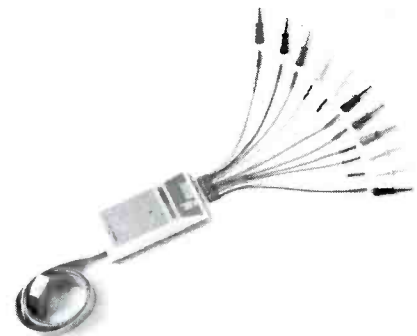

FIG. 1—THE LP1 DATA POD or probe that is used with the LA1020/25. Each pod monitors eight bits of data, a qualifier line, and a clock line.

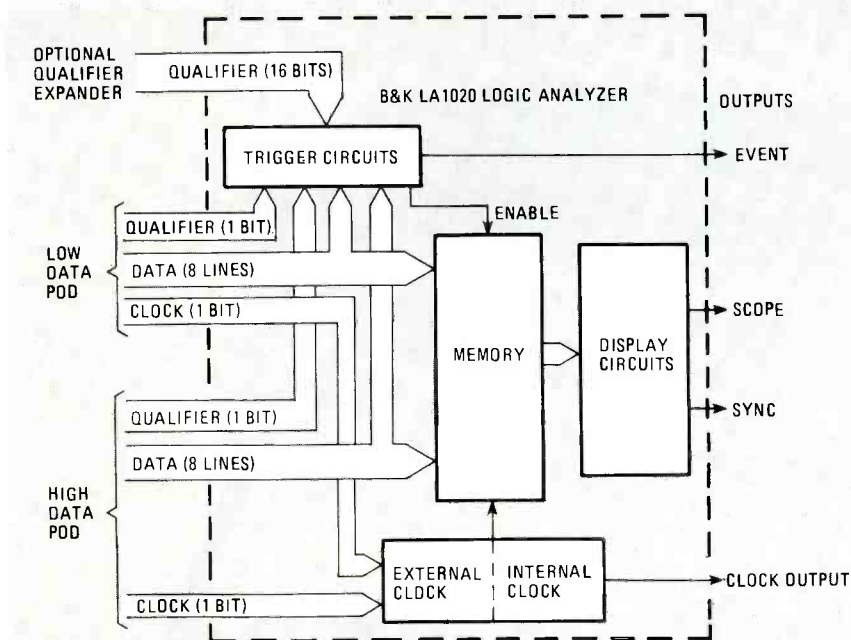

FIG. 2—SIMPLIFIED BLOCK DIAGRAM of the LA1020 showing the external inputs and outputs.

indicating 0's, 1's, or P's (pulses), depending on the logic activity on each data line.

As can be seen in the block diagram in Fig. 2, the two 8-bit sets of data samples from the data pods are routed to the logic analyzer's memory and trigger circuits. As previously mentioned, the LA1020 can store up to 250 16-bit samples in its internal memory. Data sampling can occur at sample rates of up to 20 MHz. (That equates to a minimum time between samples of 50 nanoseconds.)

### Triggering

The trigger circuit of the logic analyzer lets you select the starting point for storing data samples. It continuously compares the incoming data bits to a user-selected trigger word. That trigger word is selected by throwing each of the 16 three-position TRIGGER BITS switches on the front panel to either 1, 0, or X, where the X stands for "don't care." In the "don't care" position, the incoming data line will satisfy the trigger requirements whether it is a logic 1 or a logic 0.

The LA1020 also monitors a QUALIFIER line from each of the data pods. That bit is not stored in memory and is only used by the trigger circuit. Each of the qualifier bits has a corresponding switch that operates identically to the TRIGGER BITS switches. The easiest way to describe the purpose of the qualifier lines is to give an example of how they could be used. If you hooked one of the qualifier lines to a control signal such as a microprocessor's READ line, data storage would be triggered only when the READ pin was high (or low, depending on how the qualifier switch was set). If the two qualifier lines are not used, their trigger switches can be set to the "don't care" position and they

will be ignored.

An optional LP-3 qualifier pod (seen in Fig. 3) adds 16 more trigger bits to the trigger word. With it, you could monitor a system's data lines while triggering from the address lines that are connected to the qualifier pod. Sixteen three-position switches on the qualifier pod can also be set to a logic 0, 1, or a "don't care" position. That optional expander pod is plugged into a connector on the rear panel of the logic analyzer.

The easiest way to picture the operation of the trigger circuit is as a multi-input AND gate for which the active levels can be user-defined by setting the TRIGGER BITS switches. When the logic levels on the 16 DATA lines and the QUALIFIER lines being sampled match those set on the TRIGGER BIT switches, the memory-storage process will be enabled.

Before the various trigger modes are described, it would be appropriate to examine how the 250 samples are loaded into memory.

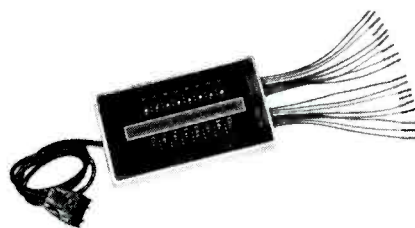

FIG. 3—THE LP3 TRIGGER EXPANDER PROBE or qualifier pod adds 16 more trigger bits to the trigger word.

### Clocking

Once the trigger circuit enables the storing of data samples, it no longer has any effect on sample loading—the storing

of the data samples occurs in conjunction with the clock circuit.

The clock circuit tells the memory when the incoming data samples are valid. You can select between two external clock lines (one located on each data pod) or an internal clock. If you decide to use the external clock signals, either clock line—and whether the rising or falling edge of the signal on that line is used—can be selected. It is important to note that the clock as it is referred to here is not necessarily the microprocessor system's clock. It can be any control signal that's used to indicate when the sampled data is valid.

The appropriate control-bus signal for clocking the logic analyzer will vary with the type of data being observed and the particular microprocessor in the system. For example, if you wanted to look at the address lines of a Z80 microprocessor during the instruction-fetch cycle, the clock line would be hooked to the  $\overline{\text{READ}}$  line and the clock edge would be set to FALLING EDGE. Or, even better, a qualifier line would be connected to the  $\overline{\text{M}}$  line with the corresponding trigger switch set to logic 0.

When the internal clock is used, data will be stored at one of eight user-selected sampling rates ranging from 10 MHz (a sample every 100 ns) to 1 Hz. That means it can take a minimum of 24.9 microseconds or a maximum of 249 seconds to fill the logic analyzer's memory.

The internal clock allows you to observe a circuit that has no clock signal available. You could set the logic analyzer to begin storing samples when a particular set of inputs occurs and then store periodic samples over the user-selected period of time. (See Fig. 4.)

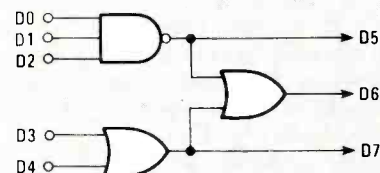

FIG. 4—A TTL CIRCUIT THAT can be monitored by a logic analyzer. The TRIGGER-BIT switches would be set for the desired logic levels for D0–D4, and for X for D5–D15. The internal-clock selector is used to set the sampling rate.

### Data storage

Once the trigger word and the clock source have been selected, the machine is simple to use. You simply push the ARM button to activate the trigger circuit. When the data on the incoming lines match the trigger word, the analyzer will begin storing samples in conjunction with the selected clock. During the data-storing process, the TRIGGER LED will light. When all 250 samples have been stored, the TRIGGER LED will go out and the COMPLETED LED will light.

Let's consider, however, the real-life situation where the incoming data never matches with the trigger word. That typically occurs when a program locks up in a loop. You can manually initiate storage of the data samples by pushing the TRIGGER button. In that instance, if you are sampling the address lines, the data stored will be the locations of the program instructions then being executed. Also, if you were to encounter an instance where a program halted before 250 samples were stored, you could manually complete the sampling process by pushing the COMPLETE button. Once the sampling process is complete, you can view the analyzer's stored data.

### Data display

The display circuit shown on the block diagram in Fig. 2 lets you observe the stored samples. The LA1020 will display its stored information one word at a time on its LED display when in the DISPLAY mode. By pushing the + and - TRIGGER switches you can examine, individually, each of the 250 data samples stored in the LA1020's memory. You can select your choice of displaying the memory in a decimal, octal, binary, or hex format by turning the MODE switch to the appropriate position. In addition to the data being displayed, the location of the data word in the logic analyzer's memory is also displayed. The display circuit also supplies the synchronizing and vertical-input signals to allow an oscilloscope to be used as a 16-word by 16-sample display. The data displayed on the oscilloscope will scroll as you scroll through the logic analyzer's memory.

There are two additional outputs on the logic-analyzer unit. One is a CLOCK output. When you select an internal clock rate, an output at the same rate is available from a BNC connector on the rear panel. The other output is the EVENT output.

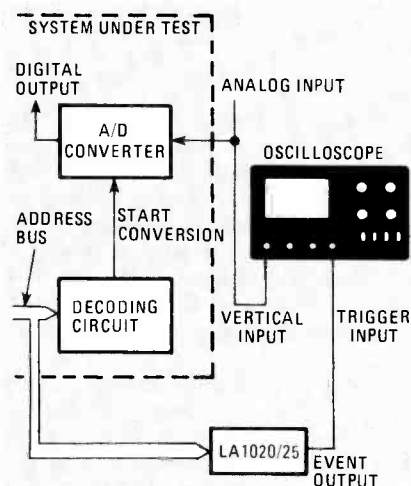

FIG. 5—THE LOGIC ANALYZER can be used as a digital trigger for an oscilloscope. If the selected trigger word is the starting address of the A/D conversion routine, the scope will be triggered every time the conversion is started.

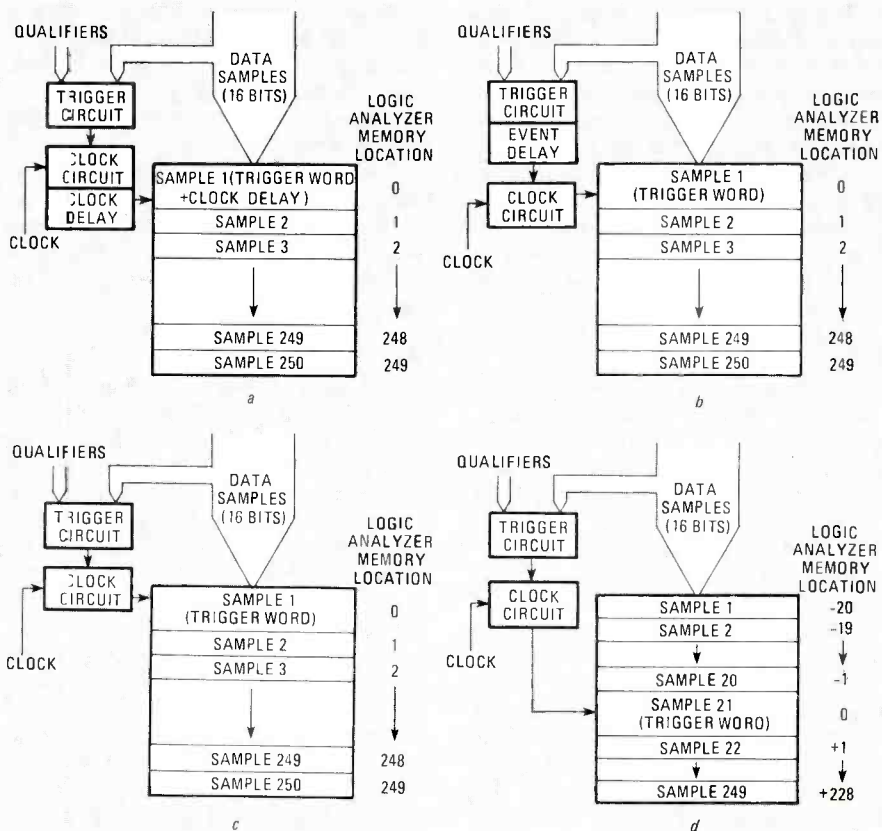

FIG. 6—TRIGGER MODES OF THE LA1025. The basic mode is shown in a; the event-delay mode in b; the clock-delay mode in c, and the trigger-position mode in d.

When the logic analyzer's MODE switch is changed to the EVENT position, the logic analyzer acts as a digital trigger for an oscilloscope. Whenever the incoming data sample matches the trigger word as selected on the TRIGGER BIT switches, a pulse that can be used to trigger an oscilloscope will be generated on the EVENT output line.

A typical application would be to troubleshoot the analog input of an erratic A/D converter. By hooking the data-sampling lines to the address lines and setting the trigger bits to the starting address of the A/D conversion routine, as shown in Fig. 5, the oscilloscope can monitor the stability of the input voltage to the A/D converter.

### Trigger modes

The real versatility of the logic analyzer lies in its triggering modes. We have already discussed the basic trigger mode—the configuration when the logic analyzer is powered up. As shown in Fig. 6-a, the logic analyzer's trigger circuit monitors the incoming 16 data sampling lines and qualifier bits. When the incoming data samples match the user-selected 16-bit trigger word, a condition we'll call the *trigger event* occurs and the storage of data samples on subsequent clock signals begins. In this mode, the first word stored in the logic analyzer's memory will be the trigger word. (If some of the trigger bit switches are set to the x or "don't care"

position, the actual data stored in the corresponding bit position may be either a logic 1 or 0).

The basic trigger scheme can be altered when the MODE switch is turned to the STAT (status) position. In that position, you can select any combination of event-delay, clock-delay, or trigger-position modification.

Figure 6-b shows the effect of the event delay, which can probably best be thought of as a loop delay and can be used in the following way: Let's assume that you want to look at a program with a 300-step loop that is going astray in its tenth pass through the loop. In the basic triggering mode shown in Fig. 6-a, the logic analyzer would trigger and fill its 250-word memory on the first pass through the loop. Using the event delay you can trigger the logic analyzer on the tenth pass through the loop. To accomplish that, the MODE switch is set to the STAT position and, for the example above, the event delay is set to 9 by using the + and - EVENT DELAY switches. By setting 9 as the event delay, you are instructing the logic analyzer to ignore the first 9 trigger-word matches (events) and to enable the logic analyzer's memory when the tenth trigger event occurs. The event delay can be user selected to any number from 0 (no event delay) to 999. As with the basic triggering mode (Fig. 5-a), the first data sample stored in memory will be the sampled data that matches the triggering requirements.

The previous problem brings to light another problem. The loop length in our example above is 300 program steps and our logic analyzer can only store 250 of those. Let's assume for this example that we want to see only the last 250 program steps. To further complicate the problem, the beginning of the program contains ten program steps that are followed by subroutine "A" (a ten-step subroutine). What's more, that subroutine is followed by twenty-five program steps, a repeat of subroutine "A," and then by the remainder of the program.

Note that since subroutine "A" executes both from step 11 through step 20 and step 46 through step 55, we cannot set the trigger word to an address in subroutine "A" to capture the last 250 steps in our loop. That's because subroutine "A" also occurs before the loop's program-step 50.

Keep in mind that we have already used our loop delay to trigger on the tenth pass through our loop. The LA1020/25, however, has a trigger mode that allows you to delay the storage of data samples by a preset clock delay. That is shown in Fig. 6-c. For our example above, you would set the TRIGGER BIT switches to the beginning address of our loop and set the clock delay to 50 by using the + and - CLOCK DELAY switches. The result is that after the event delay (Fig. 6-b) is satisfied (it has priority over the clock delay), the unit will not store any samples until the 51st clock pulse occurs. The remaining samples will then be loaded on subsequent clock pulses. In that manner, the clock-delay feature gives you another tool for "zeroing in" on the portion of the program that you want to observe. The clock delay can be set for values from 0 (no clock delay) to a maximum of 999.

The last triggering modification to be discussed is the trigger position (Fig. 6-d). With the + and - TRIGGER POSITION switch, you can locate the trigger event anywhere within its 250 word memory. If, for example, 20 was set into the TRIGGER POSITION register and the trigger event occurs, 20 samples prior to the trigger event will be stored in the first 20 words of the logic analyzer's memory. The trigger word will be stored in the 21st position in the logic analyzer's memory and then 229 samples will be stored after the trigger word.

This example, of course, assumes that the clock delay was not set. The trigger-position feature is perhaps the most useful on the logic analyzer. Let us look at an example where you have a program that contains a subroutine where the program is locking up. The trigger word can be set for the starting address of the subroutine (found by manually triggering the unit) and the trigger position set to 125. (The trigger-position register can be set to any number from 0 to 249.) Now, when the sampling process is completed, you will not only be able to view the trigger word

and the 124 samples after the trigger word, but also the 125 samples immediately preceding the trigger event. You can then see the data samples that occurred before the entry was made into the subroutine.

As previously mentioned, these three trigger modes can be combined for the desired effect. Although that task may seem overly complicated to perform at first glance, it really becomes easy after a little experience.

### An example

As another example, let us assume we are looking at a problem with multiple interrupt routines for the 8080, 8085, or Z80 (mode 0). As there are 8 levels of interrupts possible, the program could go to any one of eight locations, depending on the application. These locations are shown in Table 1.

In order to see which interrupt routine occurs, the address bus would be monitored by the logic analyzer and the trigger bits would be set to 0000 0000 00XX X000 (binary A15-A0) where X represents a "don't care" state. That means that the logic analyzer will trigger any time an interrupt occurs. By modifying the trigger position, you can see not only what interrupt occurs but the address of the program steps occurring before the

TABLE 1

Interrupt level	Subroutine starting address (hex)
0	0000
1	0008
2	0010
3	0018
4	0020
5	0028
6	0030
7	0038

interrupt. If the interrupt routine were a long one, the clock-delay function could position the start of the sampling process anywhere within the interrupt routine.

### Extended bus monitoring

In the case of monitoring a system with extended addressing (more than 16 bits), the LP3 qualifier probe (Fig. 3) is useful. Even though the logic analyzer will only store 16 bits at one time, the extended address bits can be used to trigger the unit with the LP-3 qualifier pod. Then, by knowing the address location of the trigger word, the 16 stored bits would generally be enough to follow the program sequence.

A similar situation occurs when monitoring the data buses. Eight- and sixteen-bit data buses can be monitored without problems. A trade-off must be made, however, when you want to monitor both the address and data bus; let's see what's involved.

With an eight-bit data bus, eight address lines (usually the lower eight bits) can be stored in addition to the eight data lines. The high-order address lines could then be used as part of the trigger word by using the LP3 qualifier pod. Similarly, when monitoring a 16-bit data bus, the address lines could only be used for triggering. It is important to note that we are confronted with the basic design limitations of a 16-bit machine—only 16 bits of data can be stored at one time. Two alternatives are possible. One is to run two LA1020/25 units in tandem. The other would be to buy a unit with more than 16 bits of data storage. Generally, though, a unit with 16 bits of data storage is sufficient for most requirements.

### A single-IC analyzer

So far we have explored a commercially available logic analyzer. Unfortunately, not everyone can afford more than \$2000 for such a logic analyzer. Recently, I found myself in the same situation. The B&K unit that had been loaned to me wasn't available any longer and I didn't have the money to spend for one. Yet, the project I was working on—a stand-alone printer interface card with an on-board Z80 microprocessor—was giving me a rough time. The program just wasn't executing as it should. Fortunately, a circuit that I had recently run across, was adaptable to my needs. Based on that circuit, I was able to design a one-IC "logic analyzer" to perform the function of address-state analysis.

Obviously, a one-IC logic analyzer will have many limitations. The first limitation with ours is that it will only work on Z80 microprocessors. The second limitation is that the output from the circuit under test has to be fed into 2 parallel ports on a host computer.

Figure 7 shows the typical hookup between the circuit under test and the host computer for address-state analysis. Figure 8 shows an alternative method of displaying the data if you don't have 2 extra parallel ports.

### How it works

The circuit (its schematic is shown in Fig. 9) is really quite simple. It causes the microprocessor under test to enter a wait state at the beginning of every instruction-fetch cycle. While the microprocessor is in its wait state, the address lines are sampled by the host computer. The host computer then clears the wait signal and the microprocessor completes the instruction cycle.

When the next instruction fetch occurs, the  $\overline{\text{WAIT}}$  signal again goes low and the whole cycle begins again. A limitation that you should be aware of is that, unlike the B&K logic analyzer, which samples the circuit in real time (without slowing down the program's execution), this circuit halts the program's execution after each program step. Therefore, it is possi-



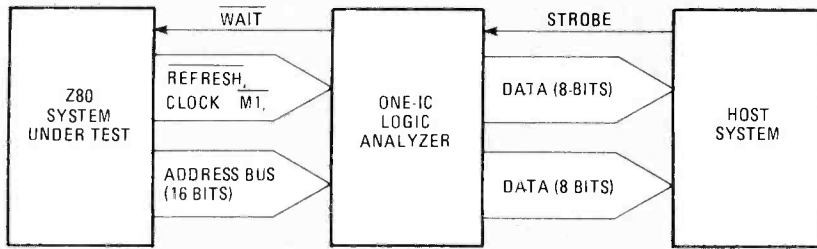

FIG. 7—INTERCONNECTION BETWEEN the logic analyzer host system and the test system.

ble that this circuit could cause some strange occurrences in programs that have critical timing loops.

The heart of the circuit is a simple dual D-type flip-flop. When the Z80's instruction-fetch cycle begins and the  $\overline{M1}$  line goes low, the next clock pulse toggles the flip-flop, and the  $\overline{WAIT}$  line is pulled low via Q1. That transistor functionally acts as an open-collector output. Pin 24, the  $\overline{WAIT}$  line on the Z80, should be connected to a pull-up resistor. To protect any other non-open-collector gates hooked up to the  $\overline{WAIT}$  line, they should be disconnected. Since a wait state occurs each instruction cycle when using this logic analyzer, that shouldn't cause too many difficulties. When a positive-going strobe is sent from the host system, the second flip-flop is toggled and the wait state ends. The  $\overline{REFRESH}$  line prevents the wait cycle from repeating until it goes high during the next

the start of the wait state until the host takes its sample—for the address lines to settle for a stable sample. Nonetheless, it is strongly recommended that the length of the connections between the tested system and the host system be kept as short as possible.

When the program in Table 2 is entered, a "\*" is printed as a prompt. You can then press any number between 1 and 9 on the keyboard. That number of program-step addresses will be displayed on

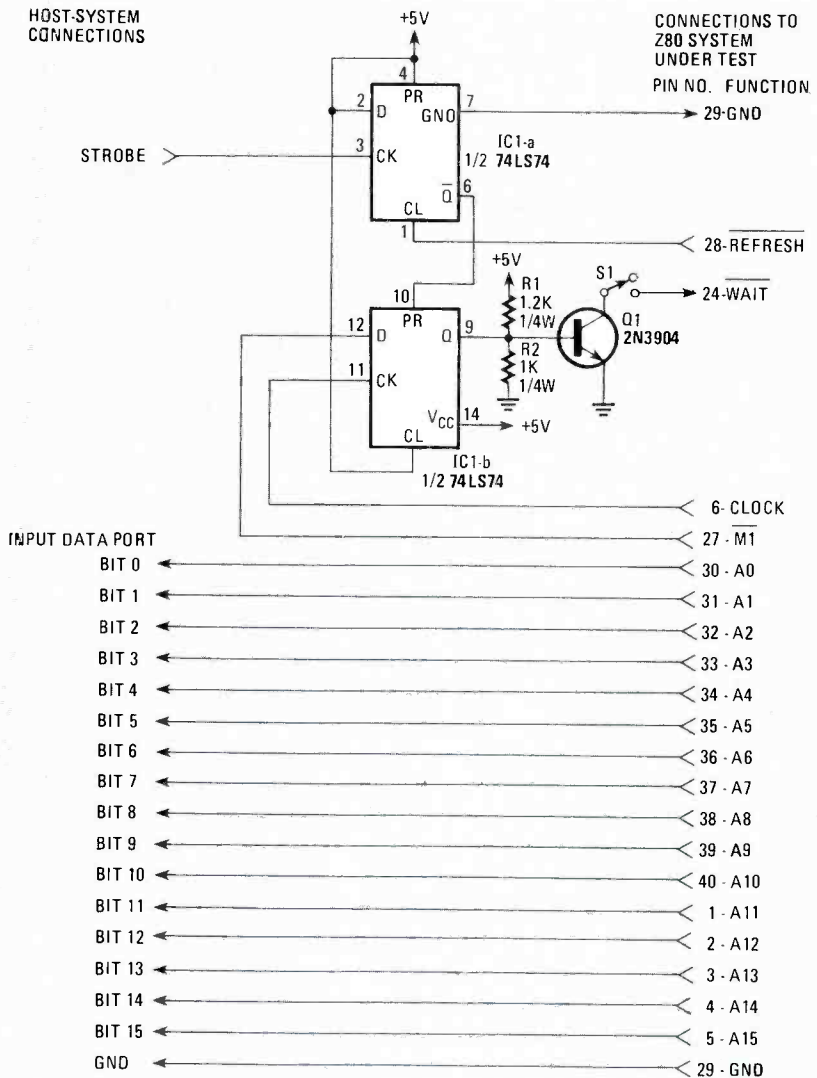

FIG. 9—SCHEMATIC OF THE LOGIC ANALYZER. No on-board buffering is provided because enough time for the data to settle is provided in software. When S1 is closed, the analyzer controls the test system. When open, it has no effect on the test system.

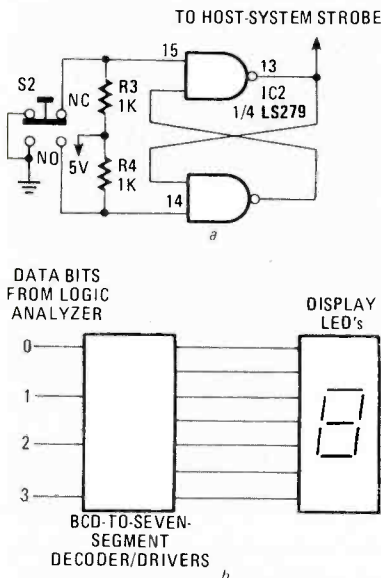

FIG. 8—AN ALTERNATE METHOD to display data from the one-IC logic analyzer. The circuit in a will cause an additional data sample to be taken each time S2 is pressed. Three additional BCD-to-decimal decoder/drivers and LED's are needed to display the value of the 16 data bits.

instruction cycle. At the end of this article we'll explore some options to expand the capabilities of this circuit.

The circuit was built on a small piece of

perf board using wire wrap techniques and is shown in Fig. 10. The connection to the host system was made by a 25-conductor ribbon cable with DB-25 connectors at each end. Connection to the system under test was accomplished by using a 40-pin clip with standard DIP spacing that attached to the Z80. No buffering was used on the address lines between the system under test and the host system. The software (Table 2) that I used leaves a long enough delay time—from



FIG. 10—THE ONE-IC LOGIC ANALYZER doesn't look elegant, but it does work! It was built using wire-wrap techniques. Connection to the Z80 test system is by a 40-pin clip.

TABLE 2—LISTING

This is a simple program to display the addresses of instructions as they are executed. When run, the program displays an "\*". The user then selects a number between 1-9 on the keyboard. That number of program steps will then be displayed on the console. If the RETURN key is hit, the system reboots. This program is written in 8080 code for the ASM assembler.

```

BDOS EQU 100H          ;BDOS ENTRY POINT
CONOUT EQU 5           ;CONSOLE OUT
CONIN EQU 2            ;FUNCTION CODE
CONIN EQU 1            ;CONSOLE IN
1XI SP,200H           ;LOAD NEW STACK
PMT: MVI E,0DH         ;PRINT LINE FEED &
                        ;CARRAGE RETURN
MVI C,CONOUT
CALL BDOS
MVI E,0AH
MVI C,CONOUT
CALL BDOS
MVI E,2AH             ;PRINT PROMPT
MVI C,CONOUT
CALL BDOS

MY SYSTEM I/O PORTS ARE:
STROBE OUT PORT = 03H
STROBE OUT BIT = 02H
LOW ADDRESS INPUT PORT = 06H
HIGH ADDRESS INPUT PORT = 05H
PORTS AND BITS SHOULD BE CHANGED
TO REFLECT YOUR SYSTEM

MVI C,CONIN           ;GET THE NUMBER OF
                        ;STEPS
CALL BDOS
CPI 0DH               ;COMPARE TO
                        ;CARRAGE RETURN
JZ 0                   ;YES- THEN JUMP TO
                        ;CPM
CPI 20H                ;CHECK FOR SPACE
                        ;BAR
JNZ INC                ;YES-THEN ENTER 1
MVI A,31H              ;ENTER 1
ORA A                  ;CLEAR CARRY FLAG
SBI 30H                ;MAKE ZERO RELATIVE
MOV D,A                ;PUT RESULT IN D
                        ;REGISTER
PUSH D                 ;SAVE IT
MVI E,20H              ;OUTPUT A SPACE ON
                        ;THE CONSOLE

MVI C,CONOUT
CALL BDOS
POP D                  ;GET COUNT BACK
PUSH D                 ;SAVE LOOP COUNT
MVI A,2                ;OUTPUT STROBE
OUT 03H
CALL DELAY             ;ALLOW SIGNALS TO

; SETTLE
; GET UPPER 8 DATA
; BITS
; PRINT HEX NUMBER
; GET LOWER 8 DATA
; BITS
; PRINT HEX NUMBER
; OUTPUT A SPACE ON
; THE CONSOLE

MVI C,CONOUT
CALL BDOS
POP D                  ;GET LOOP COUNT
                        ; BACK
DCR D                  ;DECREMENT LOOP
                        ; COUNT
JNZ LOOP               ;LOOP UNTIL OUTPUT
                        ; IS DONE
JMP PMT                ;DONE - PROMPT
                        ; USER

; SETTLING DELAY - ALLOW DATA LINES TO SETTLE
DELAY: MVI C,10        ;LOAD DELAY
TLOOP: DCR C           ;DECREMENT COUNT
JNZ TLOOP              ;LOOP UNTIL DELAY IS
                        ; OVER
RET                     ;DONE - RETURN

; PRINT TWO HEX NUMBERS ON CONSOLE
PRTHX: PUSH PSW        ;SAVE REGISTER
CALL ASCII              ;OUTPUT ONE
                        ; CHARACTER
POP PSW                 ;GET CHARACTER
                        ; BACK
JMP BYPASS              ;SKIP ROTATION
                        ; POSITION DIGIT
ASCII: RLC
RLC
RLC
RLC
BYPASS: ANI 0FH        ;MASK HIGH FOUR
                        ; BITS TO ZERO
CPI 0AH                 ;CHECK FOR HEX A-F
JC PASS                 ;NOT THEN SKIP
                        ; NEXT
ADI 7                    ;INDEX TO "A"
ADI 30H                  ;INDEX TO ASCII
MOV E,A                  ;POSITION OUTPUT
MVI C,CONOUT            ;OUTPUT IT
CALL BDOS
RET
END

```

the terminal's CRT. In that way, the execution of the program can be followed. When you want to exit the program, simply press the carriage return.

It's possible that you would like to see all memory accesses by the Z80 in addition to the instruction fetches. The memory-request signal (Z80 pin 19— $\overline{MREQ}$ ) and the READ and WRITE signals (pins 21 & 22) are candidates for triggering signals that could be used in place of the  $\overline{M}$  signal to trigger the unit.

If you use a microprocessor other than

the Z80, the requirement for the refresh signal can be eliminated by adding an inverting gate from a 74LS00 or 74LS04. The input of that gate would be connected from pin 12 of the 74LS74 and the output of the gate would be connected to pin 1 of the 74LS74, eliminating the requirement for the resetting of the logic analyzer via the Z80 refresh signal. Although I haven't actually tried it, the address latch enable (ALE) of the 8085 or the valid memory address ( $\overline{VMA}$ ) of the 6800 should take the place of the  $\overline{M}$  signal in triggering this

circuit. Caution should be used to insure that any restrictions on the maximum duration of the wait signal should not be exceeded. (The Z80 has no restriction on the maximum duration of the wait signal).

Despite its limitations, this simple logic analyzer enabled me to successfully complete my project and saved me the cost of an expensive logic analyzer. With a little work with the software, many of the features of the commercial logic analyzer we previously discussed could be implemented.

R-E

## EQUIPMENT REPORTS

continued from page 20

In fact, the company discourages any user adjustments by stating that such unauthorized adjustments will invalidate the unit's one-year warranty. One bit of useful information that is provided is a list of national frequency allocations. The model Z30 sells for \$269.95. **R-E**

### Triplett Model 3500 Aurorange Digital Multimeter

A "user friendly," hand-held multimeter for the hobbyist or professional



CIRCLE 246 ON FREE INFORMATION CARD

OF ALL THE DIFFERENT TYPES OF ELECTRONICS test equipment available, the instrument that's bought more than any other is the multimeter. The handheld digital multimeter seems to be the type favored by most buyers today. We recently had the opportunity to examine a good representative of that class of instruments—the model 3500 from Triplett Corporation (One Triplett Drive, Bluffton, Ohio 45817).

Although the 3500 is an autorange model, its measurement ranges can be selected manually. Let's take a look at those ranges—it's perhaps the best way to get an idea of what the 3500 can do. Its voltage ranges are: 0.2, 2, 20, 200, and 1000 volts DC and 2, 20, 200, and 600 volts AC. Its DC and AC current ranges are 20 mA, 200 mA, and 10 amps. And its resistance ranges are 200, 2K, 20K, 200K, and 2 megohms. A low-power-ohms measurement mode is also offered, with ranges of 2K, 20K, 200K, and 2 megohms. In that mode, you can measure in-circuit resistances that are shunted by a silicon diode or other such junction device without turning on the junction. (The

maximum open-circuit voltage is less than .4 volt in the LPO mode.)

Another good way to get an idea of the capabilities of the 3500 is to take a look at the face of the unit and its controls. A 10-mm, 3½-digit LCD readout dominates the top half the unit, while a large rotary switch (which lets you choose voltage, resistance, or one of three current ranges) dominates the bottom half. Three push-push switches are located beneath the display. The first lets you choose AC or DC modes (when measuring voltage or current) or normal or low-power ohms (when measuring resistance). The second button, RANGE SELECT, lets you choose the proper resistance or voltage range. (When first turned to the VOLT or OHM mode, the unit is in its auto mode until the RANGE SELECT button is pressed. The current ranges are chosen only with the rotary switch.) The third button, ZERO ADJUST, is used to zero the resistance reading when the leads are shorted together. It can also be used in the voltage or current modes to make offset measurements (as long as the two least-significant digits are less than 19).

Three input jacks are centered at the bottom of the unit. The only time the leads have to be changed is when making current measurements in the 10-amp mode. All of the jacks are of the recessed.

The accuracy specifications of the 3500 should suit the professional as well as the hobbyist. When measuring DC voltage, your measurements will be, at worst, accurate to within .75% of the reading  $\pm 1$  digit (when the meter is correctly calibrated). For AC voltage measurements, the worst-case specification is 1% of the reading,  $\pm 3$  digits (for signals between 40 and 500 Hz). In either resistance mode, you can expect your measurements to be accurate within 1.5%,  $\pm 1$  digit. The accuracy of the 3500 drops when measuring current: 1.7%  $\pm 1$  digit DC, 1.7%  $\pm 3$  digits AC.

If you plan to make in-circuit measurements with your multimeter, there are some additional specifications that you should look at. One of those is the input impedance, which is at least 10 megohms on all voltage ranges. When making current measurements, the voltage drop across the instrument is, at worst, 2/10 volt. For in-circuit resistance measurements, the open-circuit voltage drop across the leads is important. That voltage is less than .4 volt in the low-power-ohms mode, and less than 1.5 volts in the high-power-ohms mode.

#### User features

The most "user-friendly" feature of the 3500 is its autorange capability. When making voltage or resistance measurements, there is no need to select a measurement range. However, you can, as we mentioned earlier, select ranges manually

by depressing the RANGE SELECT button. When you do that, the AUTO annunciator will disappear from the display. As you step through the ranges, the decimal point on the display will change, as will the unit annunciator.

One advantage of using the manual range mode is that the meter's response time is improved for some measurements. For example, while the response time when making resistance or AC voltage measurements is 5 seconds (maximum) in the autorange mode, it is only 3 seconds (maximum) in the manual mode. The response time for DC voltage measurements is the same in either the auto or manual modes, about 3 seconds maximum. The maximum response time for current measurements is about 3 seconds for DC and 5 seconds for AC current. (Remember, autorange capability is not available for current measurements.)

A useful "extra" feature of the 3500 is

Triplett		3500									
OVERALL PRICE											
EASE OF USE											
INSTRUCTION MANUAL											
PRICE/VALUE											
		1	2	3	4	5	6	7	8	9	10
	Poor		Fair		Good				Excellent		

its audible tone. In the voltage or current modes the tone is used (along with a blinking initial "J" in the display) to indicate that the tester is overranged. In the resistance mode, the tone is used for a continuity indicator—it will sound when the two least-significant digits are less than 19 (in any range). Those of you who find those tones annoying will be happy to know that the feature can be turned off.

#### Protection

No matter how careful you are, it's all too easy to put excessive voltage across the meter probes. For example (although no-one likes to admit it), almost everyone has at one time or another tried to measure a voltage with a multimeter that was in its resistance mode. That is, of course, why manufacturers design protection circuits into their meters. For voltage measurements, the 3500 is protected up to 1000-volts DC and 600-volts AC. In the resistance and current modes, the unit is protected up to 250 volts AC. As for other types of protection, its rugged plastic case should protect it against rough handling.

The 3500 requires 2 "AA" cells—you can expect 300 hours of operation from two alkaline batteries. A low-battery indicator appears in the display when there are less than about 50-hours of operating life remaining.

turn page

## AM STEREO

*continued from page 64*

played along with the band, mono-stereo mode and tape track. The IF is 262.5 kHz, and the bandswitching is all-electronic. The section of the tuner that is not in use has its DC supply turned off. Therefore a single-transistor switch was added to appropriately operate the AM-stereo decoder-circuit. The entire AM-receiver section is a single IC but, fortunately, its IF output voltage is high enough. In fact, we had to decrease it by using a 4.7K resistor in series with the decoder input. The decoder VCO circuit shown in Fig. 10 was used to match the 262.5-kHz IF. The audio outputs were connected in parallel with the outputs of the FM multiplex decoder. Since power is switched for band selection, the connected audio outputs did not interfere with each other. Series resistors had to be inserted in the decoder's audio outputs because their level was higher than that of the FM section of the radio. Doing that kept the sound level about the same when switching between bands. Also, we made up a special PC board for the decoder so that we could fit it inside the tightly packed radio.

The stereo system worked well, but the digital control-system caused phase-generated tones at about 600 Hz and also at about 10 Hz (fluttering). The tuner PLL loop compensation frequency was sneaking through the DC control lines to the varactor in the tuner section, causing phase modulation and some frequency modulation that appeared loud and clear in the audio. Rolling off the audio response below 50 Hz with smaller coup-

ling capacitors at the AM decoder outputs took care of that low-frequency problem. An RC filter on the DC line to the varactors eliminated the 600 Hz tone.

That Sears radio worked out very well. Although it is not microphonic, it is sensitive to phase changes. Faint modulation from other stations can sometimes be heard when the selected station is quiet or has very low modulation. That would probably not be a problem in an automobile. Its bandwidth is much narrower than the Realistic portable which is noticeable in the audio-frequency response. But it's still acceptable, especially for automotive use.

The third conversion was installed in a home stereo receiver, a Technics model SA-222. This receiver has a fully synthesized control and tuning system that's operated by a microprocessor. The synthesizer presented noise problems in the very-low-frequency area and required a minor modification to a filter in the preset tuning circuit.

A small resistor was added to the loop-antenna circuit to lower the Q of the loop. That helped maintain a satisfactory band-pass over the entire AM band. The original detector circuit was also modified to smooth AGC response and control. (The detector circuit, although not used for stereo reception, generates AGC voltages and had to be kept intact.) That modification could have been skipped, but a noticeable improvement resulted in output from stations across the band with widely varied signal strengths.

Audio outputs were connected in parallel with the outputs from the FM multiplex system. The stereo indicator already in the receiver could be driven directly from the AM decoder lamp drive through

a 470-ohm resistor. The result with this receiver was excellent AM stereo, although the lack of a front end RF amplifier made reception of some stations difficult.

### Final suggestions

In radios that are AC powered, it may be necessary to suppress noise caused by rectifier circuit diodes. If a sharp buzz is heard, it may be the result of these power-switching diodes. The problem can usually be corrected by installing a .05  $\mu$ F, 250-volt (minimum) ceramic disc capacitor across each diode in the power supply circuit.

Household devices such as lamp dimmers or remote-control units that operate lights and appliances can generate tremendous noise, which is distributed by the building's electrical wiring like a huge antenna. AM radios will pick up this noise and make listening very unpleasant if not altogether impossible. The manufacturers of these devices may be able to offer methods or reducing the problem. Otherwise, they will have to be turned off or disconnected when using the AM receiver.

Installation of an outdoor, long-wire antenna for the broadcast band may alleviate most of those interference problems. Another, perhaps more important benefit is that an outdoor antenna will provide a greater source of stereo signals.

In the near future, when many major, music-program AM stations have introduced C-QUAM stereo broadcast, you'll no longer be limited to hearing good stereo from local FM station whose range is limited roughly to line-of-sight. You'll be able to hear the AM stations from hundreds of miles away (as you can now, especially at night), but in full stereo! **R-E**

## EQUIPMENT REPORTS

*continued from page 127*

The instruction manual that's supplied with the meter is adequate. It includes—along with a listing of specifications and instructions—a parts list, schematic, and a parts-placement diagram.

The 3500 has a suggested price of \$140, which is about what you'd expect to pay for an instrument with similar specifications. It comes equipped with two test probes with screw-on alligator clips. Other accessories are also available, including a temperature probe, two high-voltage probes (6 kV and 30 kV), a 20-amp external shunt, and a variety of carrying cases. You'll probably want to get one of the cases—the  $3\frac{1}{2} \times 6 \times 1\frac{3}{8}$ -inch unit is too large for a shirt pocket.

*You'll find more Equipment Reports in every issue of **Radio-Electronics**. Check 'em out!*

### Beta Electronics Pro-Kit I PC-Board Fabrication Kit

*Using a stencil is the best way to make a group of printed-circuit boards that use the same circuit pattern.*

MOST OF THE CONSTRUCTION PROJECTS presented in the pages of **Radio Electronics** require the use of a printed-circuit board. Even when it's not mandatory, it's usually a good idea to use one—PC boards can reduce wiring errors and make troubleshooting easier. But if a prepared board isn't available, what do you do?

One solution might be to make your own, using a PC-board fabrication kit such as *Pro-Kit I* from Beta Electronics (2081-A 3rd Street, Riverside, CA



CIRCLE 247 ON FREE INFORMATION CARD

92057). The kit is best suited for making more than one board at a time—once you've done one board, it's not much more work to do twenty more. That makes *Pro-Kit I* well suited for club or school projects that require many boards of the same type. But because the results from *Pro-Kit I* are close to professional quality, you could even use it in business applications.

*Pro-Kit I* uses a screening method (the same method that's used professionally):

you first make a stencil (photographically) of your PC-board layout and apply resist ink to a copper-clad board using the stencil—but it's not as easy as all that, as you'll see as we go through the process step by step.

Once you have your artwork completed, you'll need a right-reading emulsion positive which is used to expose the stencil material in the contact printer that's included with the kit. (The stencil material can be exposed in direct sunlight, or under a sun lamp.) After exposing the stencil material, you have to develop it, rinse it, and then place it on the screen.

Beta Electronics		Pro-Kit I												
OVERALL PRICE														
EASE OF USE														
INSTRUCTION MANUAL														
PRICE/VALUE														
		1	2	3	4	5	6	7	8	9	10			
		Poor		Fair		Good		Excellent						

After blotting up the excess water with newspaper, block-out is applied around the stencil material. That, when dry, will prevent the resist ink from flowing through the screen. (It helps to save ink and keeps the work area cleaner.)

When everything is dry (about 2 hours later), you can pull off the stencil material—but all that is removed is the plastic sheet—the emulsion stays on the screen in the area where you want the copper removed (and prevents the resist ink from being applied to the copper). The combination of the block-out and emulsion on the screen makes up the stencil.

Now that the stencil is all prepared, you place your copper-clad board under the screen and then pour resist ink on the screen and “pull” it over the stencil. When the resist dries, you can etch the board. All that's left to do is to clean up.

### The advantage of screening

You might wonder what the advantage of the *Pro-Kit* method is. After all, you could have gotten the same results, with fewer steps by using a photo-resist method. But what if you wanted to make another board? If you used a photo-resist method, you'd have to expose another board and worry about the exposure times, rinsing, etc. And if you wanted to expose five more boards, you'd have to do the same thing five times more. With *Pro-Kit I*, all you'd have to do is to place another copper-clad board under the screen and “pull” some more ink over it—you no longer have to worry about exposure times. Beta claims that, with practice (a lot of practice, as far as we could tell), you should be able to get

enough speed to print 75 or more of the same images in one setup. (If you let the screen sit too long, the ink will dry on the screen. But even if that happens, and you still want to print the image more, you can use lacquer thinner to clean off the ink without disturbing the stencil.)

Another advantage of the screening method is that it can be used for things other than applying resist ink to copper-clad boards. For example, you can (using the appropriate ink) print component legends on PC boards, or the legends on the front panel of your next project, or use it to print the PC-board solder mask. And you can use it for non-electronics hobbies too. For example you can print posters or designs on fabric (but you'll probably need a vacuum-frame contact printer for best results).

Of course, there are some disadvantages to this method as well. It can be very messy, and it takes quite a lot of practice to get consistently good results. That's why our rating chart shows only a “fair” mark for “Ease of Use.” Of course there's no easy way to make PC boards—until you get the hang of things. The *Pro-Kit* takes a bit longer to learn than other methods, but it can do more as well.

Another disadvantage to the kit is that you'll be working with some dangerous chemicals. Of course that's true whenever you make a PC board, but there are more of them in *Pro-Kit I*. The only chemicals that don't have to be mixed are the resist ink and block-out. The etchant (ammonium persulfate), ink stripper (trisodium phosphate), and developer (chemical name not given) must be mixed with water.

The developer for the photostencil film comes as two packages of powder which must be mixed together with one gallon of distilled water. Unfortunately, you must discard the solution at the end of the day. (If stored, it forms a powerful gas.) But the manual gives instructions for making

2 cups of developer at a time.

### What you get

Let's see what is contained in *Pro-Kit I*: a workboard and a screen (15 × 15 inches); a 12 × 12-inch contact printer (a felt-covered wood base with a glass cover); photostencil material (8 × 42 inches); a squeegee for ink pulls; a spreader for block-out; an 8 × 12 inch plastic tray for developing and etching, stencil developer (two packages of powder that are mixed with water), two single-sided copper clad boards (4 × 12 and 6 × 12 inches), and two double-sided copper-clad boards (4 × 12 and 6 × 12 inches).

The instruction manual is 16 pages and is—as its introduction states—written with the hobbyist in mind. The manual isn't perfect, but it's much better than most. It's amply illustrated and is laid out in a logical and organized manner. What is missing from the manual is a brief overview of the process before the step-by-step instructions. If you're unfamiliar with silk-screening, you'll have to read through the manual a few times to get the idea of it. We did like to see the following note at the beginning: “Practice makes perfect...the more you use your kit, the better your results will be.”

With *Pro-Kit I*, you can make near-professional-quality PC boards. It's not suited for the casual hobbyist. But if you're a serious hobbyist, and make a lot of PC boards, then *Pro-Kit I* might be a good way to go—especially if you make a few boards of the same pattern. If you don't make a lot of boards, then the \$99.95 cost is probably too expensive.

Beta Electronics offers a copper-plating and solder-plating service at \$.05 per square inch (\$3 minimum). They will also drill your board for \$.04 per hole and can produce your photography (\$5 for 5 × 7 inch artwork), and they can do the complete fabrication of your PC board (\$75 minimum). **R-E**

## Kaypro 10 Hard Disk Computer

This portable computer comes complete with a hard disk and bundled software.

FOR JUST A FEW DOLLARS MORE THAN THE cost of adding a separate hard-disk unit to an existing computer system, you can have a full-featured portable computer with hard-disk mass storage from Kaypro Inc. (533 Stevens Ave., Solana Beach, CA 92075). The computer system, priced at \$2795, features a built-in 10-megabyte

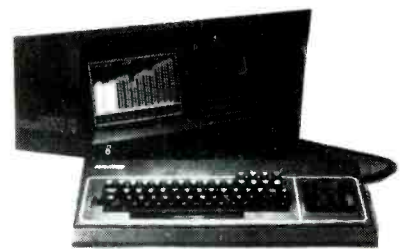

CIRCLE 248 ON FREE INFORMATION CARD

hard disk, a double-density two-sided floppy-disk drive, and most of the software you'll ever need.

### Description

Outwardly, the *Kaypro 10* closely resembles the well-known *Kaypro II* in overall size and appearance, though it's

slightly heavier at 31 lbs. The computer is housed in a metal cabinet with a carrying handle on the top. When placed flat on a table, two catches release the keyboard unit revealing the front panel of the computer. The typewriter-style keyboard contains four-way directional keys and a separate 14-key calculator-style numeric keypad. The front panel of the computer contains an 80-column × 24-row 9-inch green monochrome anti-glare CRT display. To the right of the display there's a power-indicator lamp, a hard-disk-ready lamp, and a vertically mounted half-height floppy-disk drive.

A swing-out tilt bracket elevates the front of the computer so that its bottom is level with the top of the keyboard. The tilt bracket allows easy access to the floppy-disk drive. It also positions the display screen so that it's tilted directly toward the user's eyes, making it one of the few computer displays that won't give you a stiff neck after extended use. Unfortunately, most computer displays are too high, and you'll really appreciate having the tilt bracket after several hours at the computer punching in data.

In addition, the display is recessed so that it's shielded from overhead lights and its face is etched to sharply reduce the affects of room glare. The screen position and antiglare precautions make that display one of the best we've seen for long-term viewing.

Turning to the rear of the computer we find a power-cord receptacle along with storage clips for the cord, the power switch, a reset switch, a brightness control, and a parallel-printer output with a Centronics-type connector. The rear panel also contains two standard RS-232 I/O ports—one that can be used for a serial printer and the other for a modem—and a modular telephone connector for an optional light pen. In addition, there is another modular connector for the connecting cable that is used to connect the keyboard to the computer.

The main features of the *Kaypro 10* are the internal 10-megabyte hard-disk, a CP/M operating system, and an extensive bundle of software. (Bundle means software supplied with the computer at no additional cost.) The hard disk has a basic capacity of 10-megabytes and is automatically partitioned to function as drives A and B. Almost all the software is duplicated on drives A and B and is so extensive that it uses more than 2.5-megabytes of storage, thus the hard disk comes with almost 6 megabytes already in use.

If the user inadvertently "blows" (erases) a program on, say, drive A; it can be copied on drive A from drive B using the PIP (copy) command. The floppy-disk drive is used as drive C and provides 390K of storage. That drive can be used to make back-up copies. Almost all the software can be transferred to floppy

Kaypro					Kaypro 10					
OVERALL PRICE	1	2	3	4	5	6	7	8	9	10
EASE OF USE	1	2	3	4	5	6	7	8	9	10
INSTRUCTION MANUAL	1	2	3	4	5	6	7	8	9	10
PRICE/VALUE	1	2	3	4	5	6	7	8	9	10
	<div style="display: flex; justify-content: space-between; width: 100%;"> <span>Poor</span> <span>Fair</span> <span>Good</span> <span>Excellent</span> </div>									

disk, thereby freeing the hard disk for data storage. (As you can see from the preceding, the system is extremely flexible and easy to handle.)

### Software

The list of software provided by Kaypro at the time this report was prepared included: *MBASIC*, an easy-to-use BASIC language for the beginner and experienced programmer; *SBASIC*, an advanced BASIC language that you can use to write your own programs. There's also *Perfect Writer* (a word-processor program) and *Perfect Speller* (a spelling checker), *The Word Plus* (a highly rated spelling checker), and *Perfect Filer* (a database program). In addition there's *Perfect Calc* (a "What If...?" program), *Profit Plan* ("What If...?" business planning), and a game package. Also included are the usual CP/M utilities such as PIP and SUBMIT, as well as some unusual but extremely convenient routines. For example, one utility allows the user to instantaneously select the baud rate for the modem RS-232 port, while another utility allows the simultaneous selection of a different baud rate for the second RS-232 port. (Since two serial ports have been provided, you, of course, can have both a modem and a serial printer connected at the same time; the modem does not disable the printer.)

*SAFETY* is the software that permits the hard disk to be truly portable. As you might have wondered, how does one pre-

vent knocks and jolts from causing the hard disk's heads from crashing into the disk and damaging the magnetic surface? The very last thing the user does before shutting down is to run the short and fast *SAFETY* program that parks the heads on a safe area of the disk. With the heads parked, knocking the computer around causes no damage to the surface of the hard disk.

Keep in mind that in the past Kaypro has continuously upgraded and changed the software bundled with their computers, so that by the time you read this report the bundled software that is being provided with the computer might be completely different. There might even be several different packages. In that case, you might even be allowed to choose between different software packages at no extra cost.

### Instructions

We had the fourth draft of Kaypro's own preliminary operating manual for the computer. It was excellent: notably clear, well organized, with an excellent table of contents (among the best operating manuals we have seen). Unfortunately, the same cannot be said for the other software, whose documentation is the original from the software houses. Except for *The Word Plus* documentation, the remainder of the software documentation was the usual wordy, dull, tutorial style that has come to characterize personal-computer manuals.

The only real complaint with the computer is the female Centronics-type socket connector used for the parallel printer output; it's the wrong gender. A socket is generally used on a printer. The computer should have a plug connector so a standard extension or connecting cable can be used. (And anyone who's ever looked knows, it's not easy to locate a male-to-male cable in local computer stores.)

Other than the printer connector there are no complaints, not even nit-picking. The *Kaypro 10* does exactly what it's supposed to do—and it does it remarkably well.

## CRYSTAL TESTER

IF YOU FREQUENT HAMFESTS, ELECTRONICS flea markets, or any other type of surplus outlet, you know the pros and cons of buying from those sources. On the one hand, they're an excellent source of hard-to-get parts as well as a haven for bargain hunters. On the other, however, just about everything is sold "as is," with no guarantee of any kind—it's strictly "let the buyer beware." If you've ever come home with a pile of components, only to find out that half of them were useless, you know that not all bargains are what they seem.

The ideal solution to that problem, of

course, is to find some way to weed out the obviously bad parts before you buy them. The circuit I'll be describing here has proved useful for just that purpose when digging through stacks of crystals, as well as in troubleshooting my equipment. It is small, easy-to-build, and will, at a glance, let you know if a particular crystal will oscillate. Let's look at the circuit shown in Fig. 1.

Transistor Q1, a 2N3563, and its associated components form an oscillator circuit that will oscillate if, and only if, a

*continued on page 134*

# Radio- Electronics

BUILD FOR LESS THAN \$10  
DIGITAL LOGIC PROBE

57.25 AUG. 1988

6 audio test accessories to build  
Tuning in worldwide SW  
Step-by-step TV alignment

**AVAILABLE — COMPLETE  
for the FIRST TIME!**



## BUILD YOUR OWN ROBOT!

Send today for your 52-page (8½ × 11") booklet containing complete reprints of all eleven articles in the Build Your Own Robot series by Jim Gupton.

This all-inclusive reprint gives you all the data you need to build your own Robot.

■ TELLS EVERYTHING YOU NEED TO KNOW to build the Unicorn-1 Robot without the need for an engineering degree or special equipment.

The robot is fully mobile with manipulator arms to grasp, lift and carry.

■ MANIPULATOR ARMS and end-effectors (hands) are what enable the robot to perform useful tasks. Details of construction techniques and considerations are fully explored.

■ MOBILITY BASE is not a lunar space station. It is the drive system that permits the robot to move from here to there. Full construction details along with a discussion of power sources is included.

■ THE BODY—FRAME AND ROTATION MECHANISM. This is the part that makes Unicorn-1 look like a robot. Wood and Formica are the materials for the body. Motors and gears are what make it function.

■ COMMUNICATIONS. How you can tell your robot what to do. Preprogramming techniques....radio control ....computer control are all detailed.

■ SENSORS. How to add sensors so your robot doesn't bump into things.

**Radio-  
Electronics**

Robot Reprints  
200 Park Ave. South  
New York, N.Y. 10003

AN5

Please print

I want to order \_\_\_\_\_ reprints @\$12.00 plus \$1.00 postage and handling for U.S., Canada and Mexico. Add 96¢ sales tax for New York State residents only. U.S. Funds only.

I want to order \_\_\_\_\_ reprints @\$12.00 plus \$3.00 Air Postage and handling for all other countries. U.S. Funds only.

Allow 6-8 weeks for delivery.

(Name) \_\_\_\_\_

(Street address) \_\_\_\_\_

(City) \_\_\_\_\_

(State) \_\_\_\_\_

(Zip) \_\_\_\_\_

We do not bill, check must be enclosed.

## HOME CONTROL COMPUTER

*continued from page 93*

Both of those devices can be connected directly to one of the A/D converter's input channels and the result can be scaled to read degrees. But suppose you just reach into the junk box and come out with an unmarked, unknown thermistor. You can connect it to the input of the A/D converter with a pull up resistor to +5VDC. Using IF statements, your program can find the correct temperature:

```
100 OUT(16,0):REM CHANNEL 0
    CONNECTED TO THER-
    MISTOR
110 OUT(32,0):REM START CON-
    VERSION
120 LET A = INP(32):REM ASSIGN
    RESULT TO A
200 IF A = 0 PRINT "45"
201 IF A = 1 PRINT "44"
202 IF A = 2 PRINT "42"
```

```
455 IF A = 255 PRINT "5.8"
500 PRINT "DEGREES"
510 GOTO 100
```

Although that program will make any professional programmer shudder, it works, it's simple, and it doesn't require hours of debugging. One of the features that makes this computer so powerful is that it can be up-and-running in a minimum of development time.

Now, suppose we wanted the output of our digital thermometer to go to a DVM instead. The simple D/A plus the pull-up

resistor for the thermistor are all that is required. The software to drive that circuit is just as simple:

```
700 OUT(16,1): REM A/D CHAN-
    NEL 1
710 OUT(32,0): REM START CON-
    VERSION
720 LET B = INP(32): REM D/A
    OUTPUT VOLTAGE IS
    STORED IN B
740 REM VARIABLE C CONTAINS
    DESIRED OUTPUT
750 REM RC IS CONNECTED TO
    BIT ADDRESSABLE OUTPUT
    0
770 IF B < C OUT(0,1): REM
    CHARGE UP CAPACITOR
780 IF B > C OUT(0,0): REM DIS-
    CHARGE CAPACITOR
```

If you wanted to compute the average temperature since the unit was turned on:

```
800 LET D = D + 1: REM THE
    NUMBER OF SAMPLES
810 LET E = E + A : REM THE AC-
    CUMULATED TEM-
    PERATURES
820 LET F = E/D: REM THE AVER-
    AGE TEMPERATURE
```

That illustrates the advantages of smart control over a traditional thermistor/linearizer/meter approach. Although more complex initially, the control computer is unlimited in its adaptability.

Of course, now that you have the temperature information inside the computer, you can use this data to control any of the outputs. Those can control your home heating system etc. **R-E**

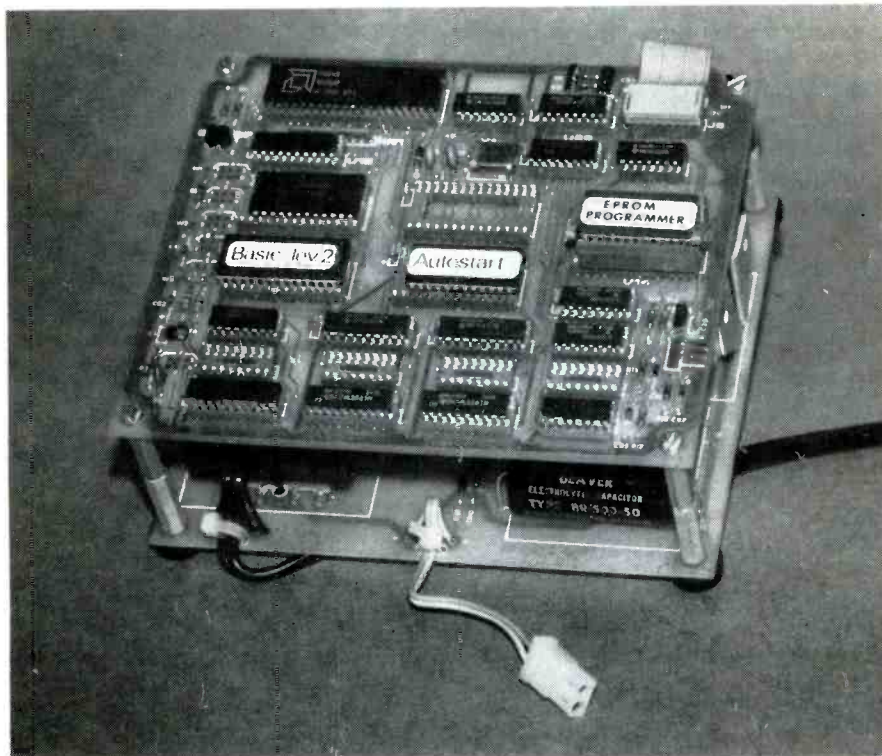

**THE FINISHED PRODUCT.** The hinged spacers at the rear of the board let you tilt the computer board up, giving you easy access to both boards, while keeping the size of the system down.

## CABLE DESCRAMBLING

*continued from page 110*

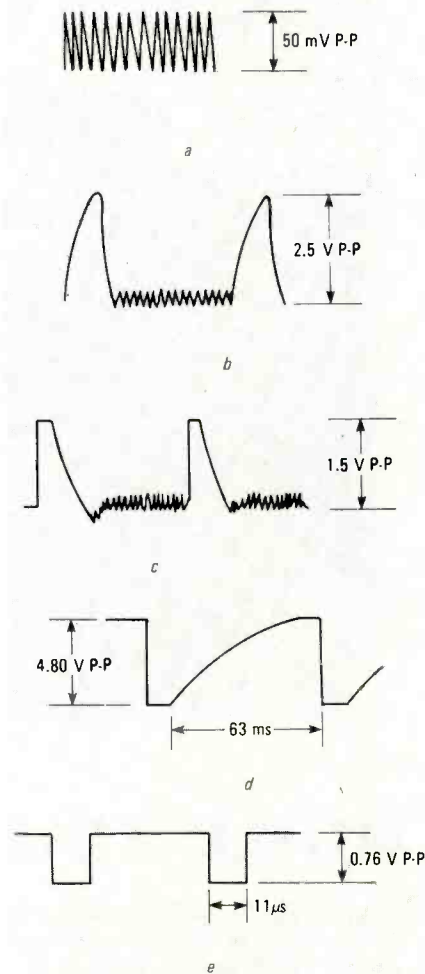

**WHEN TESTING THE DECODER,** look for the following signals: The input should look something like what's shown in a. The signal in b should be seen on pin 5 of IC1. The signals in c and d should be seen at the base and collector of Q3 respectively. The waveform shown in e should be seen at the junction of R10 and R11.

nal to return the horizontal-blanking pulse (which contains the horizontal sync and colorburst information) back into its proper location. The scrambled video should be clear.

Once the circuit is working properly on one scrambled channel, you will have to switch to other scrambled channels to see if the circuit is tracking properly. If it isn't (and some channels are not being properly descrambled), some minor, final touch-up adjustments will have to be made.

Remember that switch S1 has to be open to view a scrambled channel, and must be closed to view a non-scrambled channel. Unless you modify the circuit with a bypass-switch arrangement, it will be necessary to leave this circuit on whenever you watch TV. **R-E**



STOP WRONG NUMBERS!  
BUILD A TELEPHONE ADD-ON

# Radio Electronics

MAR 1984  
COMPUTERS - VIDEO - STEREO - TECHNOLOGY - SERVICE

This will be coming to you when you subscribe to **Radio-Electronics:**

- **HELPFUL CONSTRUCTION ARTICLES**
  - Test Equipment
  - Hi-Fi Accessories
  - Telephone Accessories
  - Music Synthesizers
  - Computer Equipment
  - Automotive Equipment
  - Intruder Alarms
  - Home & Car Video Accessories

- **NEWS ON NEW TECHNOLOGY**
  - Computers
  - Microprocessors
  - Satellite TV
  - Teletext
  - Automotive Electronics
  - Speech Synthesizers
  - IC Applications

- **FASCINATING "HOW TO DO IT" ARTICLES**
  - Build Your Own Projects
  - Make Your Own PC Boards
  - Wiring Techniques
  - Soldering and Desoldering
  - Design and Prototyping

Build this deluxe **VIDEO TEST GEN** with gen-lock, multiburst, and more

Who's in control? **JET LANDING SYSTEMS** How they work

Will this work with that? **COMPUTER COMPATIBILITY** Know before you buy

Build an **AUDIO GENERATOR** with digital frequency display

How to design **POWER SUPPLIES** to fit your needs



PLUS:  
★ Hobby Corner ★ Equipment Reports ★ Drawing Board  
★ Service Clinic ★ New-Idea ★ State-Of-Solid-State



**Radio-Electronics** covers all aspects of the fast moving electronics field . . . featuring **COMPUTERS • VIDEO • STEREO TECHNOLOGY • SERVICE COMMUNICATIONS • PROJECTS**

# Get it all!

- **HOW YOU AND THE COMPUTER CAN BE FRIENDS**
  - Getting Started
  - Programs, Circuit Design, Games
  - A/D-D/A Interfacing
  - Peripheral Equipment

- **NEW AUDIO DIMENSIONS FOR YOUR PLEASURE**
  - Noise-Reduction Devices
  - How to Connect that Extra Add-On
  - Hi-Fi Accessories
  - New Technology

- **TV WONDERS FOR YOUR FUTURE**
  - Latest Receivers and Circuits
  - The Home Entertainment Center
  - Projection TV Today
  - Satellite TV Receivers
  - Jack Darr's Monthly Service Clinic
  - Service Problems and Solutions

- **AND you also get these regular MONTHLY FEATURES:**

- **LOOKING AHEAD** by Dave Lachenbruch
- **HOBBY CORNER** by "Doc" Savage
- **STATE-OF-SOLID-STATE** by Bob Scott
- **WHAT'S NEWS**, new products, stereo news
- **VIDEOGAMES**, new products, game reviews
- **and NEW IDEAS, STEREO PRODUCTS, NEW COMPUTER PRODUCTS FOR HOME/JOB and MUCH MORE!**

Subscribe today to **Radio-Electronics** Don't miss a single issue and...you save as much as \$22.83 off the single-copy price.

When you select one of the subscription offers listed on the handy coupon—you'll be assured of having your copy reserved, even if it sells out on the newsstand. Make sure you get all the excitement in every issue of **Radio-Electronics**, every month, by filling in and mailing the coupon, today.

Mail to: **Radio-Electronics**  
P.O. Box 2520, Boulder, CO 80322

**Every Month!**  
**Get the Best—Mail Today!**

7AN55

- 1 Year - 12 issues only \$12.97 (You save \$10.43 off the single-copy price.)
- 2 Years - **SAVE MORE!** - 24 issues - \$23.97. (Save \$22.83 off the single-copy price.)

- Payment Enclosed
- Bill Me

Name \_\_\_\_\_ (please print)

Address \_\_\_\_\_

City \_\_\_\_\_ State \_\_\_\_\_ Zip Code \_\_\_\_\_

Offer Valid in U.S. and Canada Only.  
Allow 6-8 weeks for delivery of first issue.

Canada—Add \$3.00 per year  
Offer Valid in U.S. Funds Only.

## MAKING MEASUREMENTS

continued from page 115

Another problem when reading at a distance is the cost of long runs of thermocouple wire. This is partially solved by splicing the thermocouple to "extension wire", less expensive thermocouple wire specified over a narrower temperature range. The savings are particularly important when using platinum thermocouples, since the extension wires are made from nonprecious metals.

The low sensitivity of thermocouples requires good first-stage stability in the readout circuitry. For precision measurements, low-drift amplifiers or chopper-stabilized inputs must be used. (Chopper stabilization improves the DC drift of an amplifier.)

Thermocouples are linear enough that no linearization is needed for moderate accuracy over moderate temperature ranges. Nonlinearity above 0°C is generally 1% to 5%, depending on the thermocouple and the temperature range.

Thermocouple applications are almost limitless. The wires are available in large or small gauges, in cables using a wide variety of insulations and in ceramic insulating tubes for very high temperature use. The sensing junction, formed by welding the two wires together, may be put into enclosures such as those shown in Fig. 11. The junction may be welded, epoxied or glued directly to a surface or may be exposed directly to air or liquid for fast response. The temperature of molten steel, for example, is measured by plunging the two wires directly into the steel.

### Integrated Circuits

Integrated-circuit temperature sensors are fairly new and are not at all standardized. At this time at least five device families exist, each unique in design and output. They generally make use of the fact that the voltage drop across a forward-biased diode or transistor junction decreases by about 2 millivolts per degree C. IC sensors are generally offered in transistor or IC packages: they are not yet available in the same variety of assemblies as other sensors.

Despite the lack of standardization, some generalizations are possible. Operating temperatures are similar to IC's; -55 to +150°C (-67 to +302°F) or some portion thereof. Accuracies generally are several degrees, requiring user calibration for tighter measurements. Selected sensors as close as ±1°C are available, but are expensive. Stability at high temperatures is not as good as with most other temperature sensors. IC's are linear, sensitive and easy to interface with readout circuitry. But look for specifications to improve in the future.

R-E

## CRYSTAL TESTER

continued from page 130

good crystal is connected to the test clips. The output from the oscillator is then rectified by the two 1N4148 diodes and filtered by C1, a .01-μF capacitor. The positive voltage developed across the capacitor is applied to the base of Q2, another 2N3563, causing it to conduct. When that happens, current flows through LED1, causing it to glow. Since only a good crystal will oscillate, a glow-

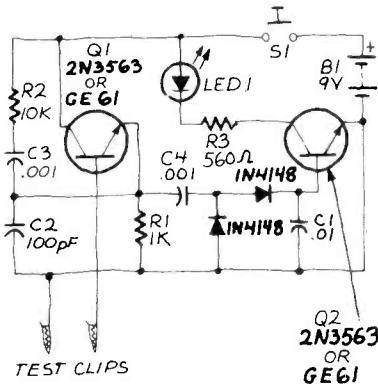

FIG. 1

ing LED indicates that the crystal is indeed OK. The circuit is powered by a standard nine-volt transistor-radio battery and the SPST pushbutton power-switch is included to prolong battery life.

The circuit is easy to build, with size—for easy portability—the only real consideration. While just about any construction technique will work well, it's easiest to use a small piece of perforated construction-board.

To use the crystal tester, simply connect a crystal to the test leads and close the SPST pushbutton power-switch. If the crystal is OK, the LED will glow brightly. If the LED does not glow, or just glows dimly, the crystal is bad and should not be used.

One note on the intended use for the tester is in order here, however. This tester will check any crystal for oscillation. However, it will not necessarily make the crystal oscillate at the frequency that it is supposed to; so you can't use this tester with a frequency counter to test for that. What the circuit will do is give you a way to quickly weed out crystals that are obviously bad, and, after all, that is half the battle.—*Jack Fernandes*

**AMERICAN  
LUNG  
ASSOCIATION**  
The Christmas Seal People®

Space contributed by the publisher as a public service.

## POWER SUPPLIES

continued from page 78

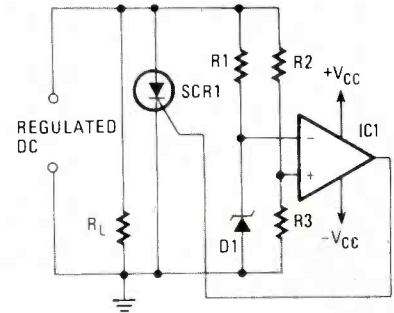

FIG. 10—AN OVERVOLTAGE crowbar circuit can be used to protect the power supply and the load in the event that an excessively high voltage is applied to the load.

output from the op-amp is positive. That positive voltage is applied to the gate of the SCR, turning it on. When on, the SCR acts like a short circuit across  $R_L$ , protecting both the load and the supply.

If the connections to the inverting and non-inverting inputs to the op-amp in Fig. 10 were interchanged, we would have an undervoltage protection circuit. The load and regulated supply would be shorted by the SCR when the voltage across  $R_L$  drops below a specific level.

R-E

*Imagine*  
**the USO  
helping the  
whole family**

Well, it does ... the whole service family ... As USO's 40,000 volunteers like to say, "We're a family affair." Information, classes, tours, crisis intervention and more help families during the good times and the bad times. Why? "Because life's toughest battles aren't always fought in the field."

Support USO through the United Way, OCF, or local USO campaign.

## Advertisers Index

267	AMC Sales	1
216	AP Products	Cover 4
217	Beckman	Cover 3
—	CIE	35-37
210	Daetron	20
—	Electronic Technology Today	15
214,215	Electronic Warehouse	4,13
—	Fluke Manufacturing	3
212	Jameco	7
211	JDR Microdevices	5
—	NRI	17-19
—	Tektronix	Cover 2
—	Transamerican Cable	9
213	Trio Kenwood	11



Drop-proof

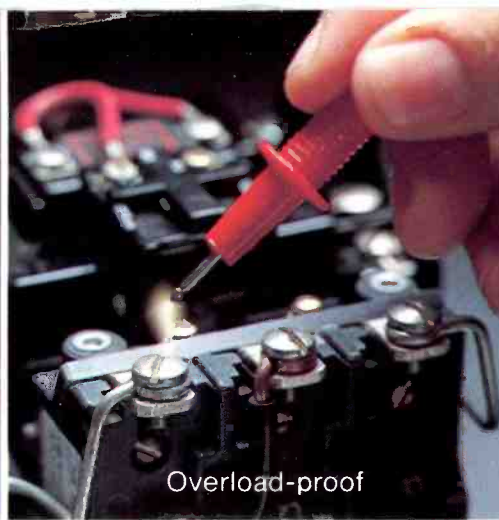

Overload-proof



Contamination-proof

# Oops proof.

Now there's a new breed of Beckman Industrial Corporation hand-held DMMs tough enough to withstand accidental drops, input overloads and destructive environments.

The new HD100 and HD110 DMMs are drop-proof, packed with overload protection and sealed against contamination. You won't find a more rugged meter than our HDs.



## Drop Proof

Constructed of double-thick thermoplastics, the HD100 series DMMs resist damage even after repeated falls. All components are heavy-duty and shock mounted.

## Contamination Proof

The HD series meters are designed to keep working even around dirt, heavy grime, water and oil. The special o-ring seals, ultrasonically-welded display window and sealed input jacks protect the internal electronics of the HD meters. The oops-proof meters are sealed so tightly, they even float in water.

## Accidental Overload Protection

All DC voltage inputs are protected up to 1500 Vdc or 1000 Vrms. Current ranges are protected to 2A/600V with resistance ranges protected to 600 Vdc. Transient protection extends up to 6KV for 10 microseconds.

## More Meter for Your Money

For starters you can get 2000 hours of continuous use  
CIRCLE 217 ON FREE INFORMATION CARD

from a common 9V transistor battery. You can run in-circuit diode tests and check continuity. You even

get a one year warranty.

The 0.25% basic dc voltage accuracy HD meters serve you with 7 functions and 27 ranges. The HD 110 also gives you 10 AMPS ac and dc. With one simple turn of the single selector switch, you can go directly to the function and range you need. There's less chance of error.

Also available is the electrical service kit. It includes the meter of your choice, a current clamp, deluxe test leads and a heavy-duty case designed to carry both meter and accessories, conveniently.

Feature for feature you can't find a more dependable meter with prices starting at just \$169 (U.S. only).

To locate your nearest distributor, write Instrumentation Products Division, Beckman Industrial Corp. A Subsidiary of Emerson Electric Company, 630 Puente Street, Brea, CA 92621 (714) 773-8111.

**Beckman Industrial™**

# LITTLE THINGS MEAN A LOT

Being the first company to make solderless breadboards isn't necessarily what makes us the best. It's all the little things you don't see, like our spring clip terminals, that make A P® Products ACEBOARDS so big on reliability.

From our largest ACEBOARD with over 5000 tie points, to a single tie point block, our spring clip terminals give you nothing but good, solid contact on every connection. They accommodate a wide variety of leads and have the best electrical properties, because our spring clips are solid alloy, not plated nickel. We've even developed enough normal force to break through any oxides which could occur on solder plated leads. You've come to trust our test clips for the same reason.

Since one bad connection can ruin a whole circuit, we pay close attention to how well our spring clip terminals sit within the insulator cell areas. Spring clip edges are never exposed at the insertion window.



Leads won't buckle, clips won't oxidize, it all adds up to longer life.

Even from the outside, there's more to an ACEBOARD than meets the eye. Our durable Acetal Copolymer plastic body is a good insulator with excellent dielectric properties. And special manufacturing techniques in the insertion of the contacts into the plastic body insure that your ACEBOARD will always remain flat. No skimping or planned obsolescence here. Again, just good solid contact on every connection.

Turn an ACEBOARD over and you'll discover another key to its reliability.

The double-sided adhesive foam you'll see there



is more than a pressure sensitive mount. It also insulates the ACEBOARD from the PC to prevent shorts and seals the bottom of the individual spring clip cells. If solder shavings from resistors or component leads drop into the cell, they can't spread into other cells to short them out.

Once you take a closer look at our ACEBOARDS, you won't have to look any further. A P Products has the biggest and most complete line of breadboards. It's also our

commitment to you that if your ACEBOARD doesn't work perfectly, bring it back to your A P Products distributor. He'll replace it, no hassles.

To help you see for yourself what a big difference the little things make, we're offering you a 10% discount on any A P Products ACEBOARD. Just fill out the coupon and present it to your A P Products distributor.



For the name of the distributor nearest you, call TOLL FREE (800) 321-9668 (In Ohio, call collect: (216) 354-2101).

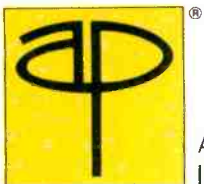

A P PRODUCTS INCORPORATED

9450 Pineneedle Drive, Box 540, Mentor, Ohio 44060, (216) 354-2101 TWX: 810-425-2250

In Canada, call Lenbrook Electronics • (416) 477-7722

CIRCLE 216 ON FREE INFORMATION CARD

This coupon is worth 10% off the purchase price of any size ACEBOARD. Offer expires 12/31/84.

Your Name \_\_\_\_\_

Address \_\_\_\_\_

City \_\_\_\_\_ State \_\_\_\_\_ Zip \_\_\_\_\_

Dealer Name \_\_\_\_\_

ACEBOARD # \_\_\_\_\_

Limited 5 ACEBOARDS per coupon. Offer valid only at participating A P Products distributors.