

Radio and Television Maintenance

J
U
L
Y

1951
7th Year

TRADE JOURNAL FOR RADIO AUDIO VIDEO

*Largest
Selling Booster*

AT ANY PRICE!



Editor's Page



To the Editors of Good Housekeeping, Pageant, American Magazine, etc., etc.

IT is no secret among editors of consumer publications that sparkling, news-type features are tough to come by. Few subjects are *hot* enough to meet the early deadlines and reader requirements of the slick monthlies.

Commercial items are always good, but they have to be big enough in scope or romantic enough to hold interest. Few of these come along.

Your fathers, or even you—if you're one of the old timers now holding down the desk—will remember the good ones: the telephone, the automobile and the flying machine.

Now a bonanza is here—Television! It's fair game for all editors. It has one hundred percent public interest . . . a product with news value . . . one as good as the telephone, automobile and the flying machine.

We know you editors have story-angle problems. Television is progressing so rapidly that it is difficult to type it with a "get a horse" slogan or cartoon an oversized crank on a bell box. Your writers feel this problem of story angle, too, and are grasping at straws to do the "different" story. Unfortunately—or fortunately—this is a tough assignment!

A big, complex part of the television industry is service. Everyone who owns a TV receiver or plans to own one is affected by the serviceman. In that service of receivers is now handled by thousands of individuals and companies, it is not difficult for a reporter to dig up some who are not doing their jobs the way the rest of the industry would like to see it done and is doing it.

It is not difficult to base a lengthy article on these servicemen of doubtful ability and/or integrity. Just give the story a little twist—generalizing here and there—and you come up with an angle that hits the entire television service industry.

You've worked this angle to the hilt, gentlemen! It's getting a little stale. It's not even good reading any more.

Just the other day, gentlemen, our car was inspected by the state after having been completely overhauled by a local garage. It failed; wheels out of line. Three times the car went back to the garage before it passed its

→ to page 13

NEWSLETTER

PUBLIC WILL DECIDE ON TV COLOR SYSTEM. FCC'S color decision notwithstanding, it appears that John Q. Public will be the boy who gives the final nod to the color system. Both CBS and RCA are working feverishly to prove to the public the qualities of their respective systems. CBS hopes it can convince enough people, through its color broadcasting to a limited number of sets, that its color system is good enough to buy. It feels that if it can keep RCA from getting FCC'S okay on a compatible system for about two years, it will win the fight. RCA's color tests hope to convince the public that a compatible system is the only one in the public interest. RCA hopes to convince FCC soon, too. RCA's big worry is that competitor manufacturers might jump in with CBS and give color promotion and color TV sales a real whirl. Defense orders and priorities are on RCA's side. Most manufacturers may have trouble producing any quantity of color equipment in the not too distant future.

TV PRODUCTION OFF 28 PERCENT. The Radio-Television Manufacturers Association reports that television set production for May was 28 percent below April and 54 percent under the monthly average of the first quarter. The output of radio receivers increased three percent over the preceding month and declined by three percent under the quarter's average.

FM GETTING A SHOT IN THE ARM. Plans for cooperation between broadcasters and manufacturers in channeling the distribution of FM-equipped radio receivers into shortage areas, and in the promotion of the benefits of FM reception, evolved from a recent meeting of RTMA and NARTB representatives. While there was disagreement between the broadcasters and the manufacturers on the figures for receiver distribution, it was unanimously agreed that broadcasters will report future shortages in their respective areas to the manufacturers.

ELECTRONICS INDUSTRY GROWING LIKE A WEED. The present slump in receiver sales is a poor barometer of the industry's condition. The stability and growth of the industry can be measured by the investment being made in new facilities for production. RCA has opened a new electron-tube manufacturing plant in Cincinnati. The new one-story plant occupies a tract of 17 acres. Raytheon Manufactur-

NEWSLETTER

ing Company is building a new power tube plant in Waltham, Mass., and plans to double its power tube output. General Electric has announced that it will construct a 20,000 square-foot manufacturing building in Springfield, N. J., for Precision Laboratories, a unit of the company's components division. G. E. is also going to build a six-million-dollar receiving tube plant at Anniston, Ala. Amperex Electronic Corporation, Brooklyn, will build a new plant on a seven-acre tract on Long Island, N. Y., which will double its production. Walsco just opened its new Los Angeles Plant which has 31,000 square feet of space. If additional evidence is needed to prove the growth of the industry, note that Pioneer Electronics, Santa Monica, Cal., in operation just one year, has become the West Coast's leading producer of television picture tubes and has just been awarded a quarter-of-a-million-dollar contract from the Army Signal Corps for the manufacture of radar tubes.

TV SERVICING TO FOLLOW AUTO SERVICING SYSTEM. W. A. Blee, vice-president and general sales manager of Crosley division of Avco Mfg. Corp., predicted that the servicing of television sets, in time, is going to be like the servicing of automobiles, and customers will have to realize that they'll have to pay for this service just as they now pay for auto service. Speaking at the mid-year meeting of the National Appliance & Radio Dealers Assn., Blee said good service operations can be profitable, but only through good management.

STOCKHOLDERS OKAY CBS-HYTRON MERGER. CBS is now assured of manufacturing facilities for its color system with the stockholders of CBS and Hytron, Radio and Electronics Corp. approving the merger of the two companies. Sets for TV color reception will be manufactured by Air King Products, wholly owned subsidiary of Hytron, starting in September.

INSTITUTE TO PROMOTE INTERCOMMUNICATION SYSTEMS. A plan was announced for the establishment of the Institute for Intercommunication Research, an independent not-for-profit foundation to encourage college post-graduate study in the saving manpower through the use of intercommunications systems. Equipment and research facilities are to be made available to college students pursuing post-graduate study in sound intercommunication and allied electronics research to determine how these systems may best be utilized by industry and government agencies to conserve manpower.

AUTO RADIO BUSINESS LOOKS GOOD. Keep your eye on automobile radio servicing as a healthy portion of your business future. Almost half of the families living in 15 major city areas own automobile radios, according to a survey by The Pulse, Inc. The survey showed that 45.5

NEWSLETTER

percent of families surveyed are car-set owners. Detroit and Los Angeles showed the greatest proportion of auto receivers while Philadelphia and Boston showed the smallest.

HOLLYWOOD PRODUCERS FAVOR PHONEVISION. The Independent Motion Picture Producers are urging FCC "to speedily license worthy systems of subscription television." The unanimous endorsement of Phonevision and similar systems by the movie makers is a direct reversal of their original stand.

DEALERS HIT MANUFACTURERS AT CONFERENCE. The recent FCC-sponsored trade rules conference was an outlet for heated discussion from many segments of the industry. Representatives of dealers enumerated many charges against manufacturers. The grievances included: sets are poorly made, falsely advertised, shipped carelessly, remodeled too frequently, and inadequately guaranteed. Quoting a Better Business Bureau survey, a spokesman for the dealers reported: "Of the approximately 12,000,000 television sets now in use, at least 4,000,000 were defective when received by the dealers."

NO DEFROSTING OF CHANNEL ALLOCATIONS. Approximately 400 statements filed in opposition to FCC's plans to lift the freeze of TV channels in U. S. territories is slowing down possible allocations. The best guessers say early '52 will see a defrosting.

WAYNE COY TO REMAIN IN SADDLE. Wayne Coy has been okayed unanimously by the Senate for a new seven-year term as chairman of the Federal Communications Commission.



Marconi Didn't Know Either

FROM the new biography of Guglielmo Marconi by Orrin Dunlap comes a new story about the great inventor. After an all-night test of his invention, Marconi remarked to his friend David Sarnoff (now of RCA): "There is one thing I would like to know before I die—why this thing works."

**RADIO AND TELEVISION
MAINTENANCE**

is published monthly by
International Publishing
Corporation at
16 Union St.,
Somerville, N. J.,
U. S. A.

EXECUTIVE OFFICES
Ambassador Hotel
Atlantic City, N. J.
Phone: 4-3474

Entered as second class
matter October 16, 1950
at Post Office, Somer-
ville, New Jersey, under
Act of March 3, 1879.

PUBLISHER

Paul Roberts

EXECUTIVE EDITOR

Robert Letwin

EDITOR

Maurice de Angeli

EASTERN EDITOR

Rudolf F. Graf

CONTRIBUTING EDITORS

Morton G. Scheraga

Norman L. Chalfin

CIRCULATION

MANAGER

Lee Rand

TECHNICAL ART DIR.

Harry Shane

ADVERTISING

REPRESENTATIVES

Cleveland

Horold L. Stuart

852 Leader Bldg.

Moin 1-9357

Chicago

Prendergast and

Minohan

168 No. Michigan Ave.

Financial 6-0993

West Coast

Keith H. Evans

3757 Wilshire Blvd.

Los Angeles 5, Cal.

DUnkirk 8-2981

Subscription rates: U. S.
and U. S. possessions,
\$4.00 per year by mail.
Conodo, \$5.00 per year
by mail. All other coun-
tries, \$6.00 per year.



CONTENTS

Microwave Communication	8
Test Your TV Vocabulary.....	12
Customers Handle Delivery.....	14
Automatic Radio Weather Station.....	15

TECHNICAL SECTION

The 40-50 Megacycle IF.....	18
Installation and Service Hints for 2-Way Mobile Radio	22
Self-Generating Photo Sensitive Circuits.....	27
Television Sound Systems.....	30
Hints	37
Fix on the Facts.....	35

DEPARTMENTS

Editor's Page.....	2
Newsletter	3
Out of the Editor's Mailbag.....	7
Products for the Trade.....	42
What's Your Problem.....	47
Trade Literature	50
What They're Saying.....	61

Change of address should be sent to RADIO AND TELEVISION
MAINTENANCE, BOX 867, Atlantic City, N. J. Change requires
four weeks' notice. When notifying of change of address, please
furnish stencil impression from a recent issue.

OUT of the Editor's Mail Bag

Thinks We're Sincere

Dear Editor:

I read your magazine, when time permits, from cover to cover as everything in it is an education for those in the servicing game.

I have found many times that certain articles seem to bridge the gaps that seem to exist so many times in the various textbooks, notwithstanding the fact that a book does have an excellent author.

Another point I want to bring out, too, is the advertising your magazine carries. It is not cluttered with page after page of wholesale prices as some others are. This is another reason why I want to continue my subscription and leads me to believe that you are really interested in helping the service industry.

There has been a great deal said about the Public needing protection from the serviceman, and I don't doubt but that there are many such incidents, but I have wondered many times if the high service charge may have come about because of the serviceman having to compete with the wholesaler on the price of parts.

I have sort of wandered off the subject I started on and hope you will pardon me for expounding on a pet peeve, but when I think someone is trying to give the serviceman a break, I can't seem to resist getting into the wholesale and distributor setup as I see it.

At any rate I want to express my ap-

→ to page 60

NOW!

another great VEE-D-X
Single Channel
sensation

AND
ONLY
\$1995
LIST



it's the

VEE-D-X Outboard BOOSTER

Here is the greatest development to improved single channel TV reception since the VEE-D-X "J" Series Yaqi. Pre-set for any desired channel, the VEE-D-X Outboard costs much less than any tuned booster, yet delivers 18 db gain with full 5 megacycle band width. Individual slug tuned grid and plate coils assure perfect alignment—6J6 push-pull cross-neutralized amplifier will not oscillate—unique RF assembly is compact and precision engineered—plus many more outstanding features that revolutionize single channel reception. For complete information contact your local supply source or write direct to The La-Pointe-Plascomold Corporation, Windsor Locks, Connecticut.

An industrial network with 1,000 miles of repeater stations provides efficient communications for oil company

Microwave Communication

A THOUSAND-mile multi-channel microwave relay system, extending from Longview, Texas, to Lima, Ohio, has been installed by Motorola, Inc., and is in operation for the Mid-Valley Pipeline Company of St. Louis.

The communications network, jointly owned by the Standard Oil Company of Ohio and the Sun Oil Company, employs carrier frequencies in the 6575-6875 megacycle range. Motorola, along with Sohio's C. B. Lester and Sun Oil's Burgess designed the \$800,000 network, the most extensive privately owned operating system of its kind in the world.

Onto the carrier wave of the Mid-Valley system are impressed signals from:

1. Two voice frequency circuits assigned to party-line dial-telephone.
2. Three voice frequency circuits as-

signed to private-line dial-telephone.

3. One party-line teletype circuit.
4. Two circuits for V.H.F. drop-off communications with Mid-Valley 2-way radio equipped cars and trucks.

Additional circuits are available for future requirements.

The network includes 36 repeater stations spaced 14 to 37 miles apart. Starting at the Longview, Texas, terminal, the line runs east to near Haynesville, Louisiana, to Mayersville, Mississippi, up northeast to Abbeville, Mississippi; Denver, Tennessee; Clarkson, Kentucky; to near Cincinnati, Ohio, and to Lima. It follows the pipeline.

The single antenna for both transmission and demodulation, and the 45-degree flat passive reflectors at the top of the towers of Mid-Valley's microwave communications system were first used by Motorola in practical systems.

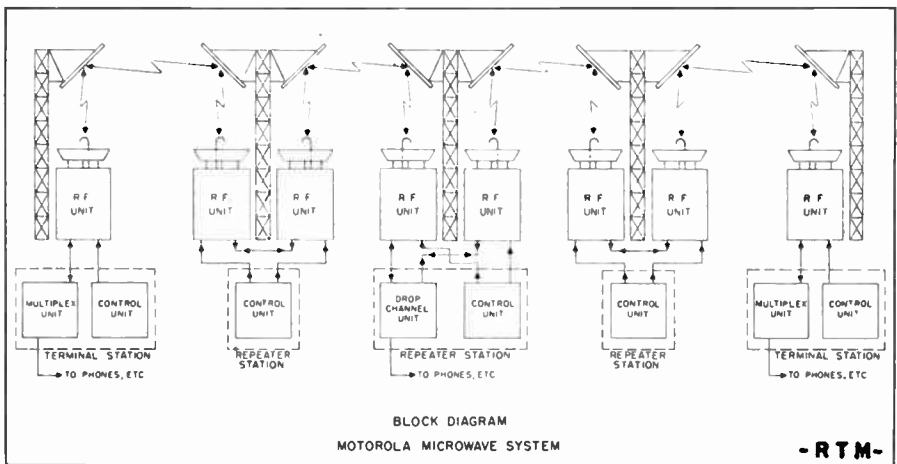

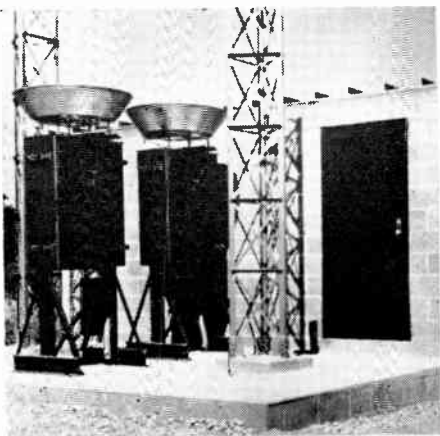

Microwave relay radio equipment mounted on the ground beneath reflector towers. This is one of the typical repeater stations along the 1,000-mile system designed and constructed by Motorola.

The passive tower-top reflector, a special sheet of reinforced metal perforated to reduce wind resistance, has no cable, waveguide, or other electrical connection to the ground-level installation. The reflector requires no further adjustment after initial tower-top installation and orientation are completed.

The RF and IF, and video amplifier stages of the system are housed in aluminum, waterproof cabinets installed at ground level directly beneath the tower-top passive reflectors.

On top of each housing is mounted an integrated waveguide-horn and 40-inch parabolic reflector. At the terminal stations a single parabolic reflector projects the microwave beam, with a 3-1/2 degree angle, to the flat passive reflector to be redirected horizontally toward the tower of the first relay station, about 20 miles or so away. The beam, striking an intervening reflector, is cast downward to a paraboloid reflector assembly beneath it.

Two outdoor weatherproof RF housings are installed, along with other neces-

sary equipment, at each microwave relay point. At some sites the RF cabinets are erected within specially-designed walled-in patios built into the station houses. The beam is amplified, and re-transmitted from the antenna atop the second RF housing to the reflector above, and then on to the next relay station. This process continues until the signals arrive at the terminal point or a desired intermediate station.

A microwave-controlled VHF transmitter and receiver unit for mobile communications is mounted on each major relay station tower along the Mid-Valley system. The network is divided into seven sections for mobile communications, any one or more of which may be activated at one time. The transmitted signals move over the microwave carrier to all repeater stations within the desired section, where these signals are superimposed on carrier waves of the Mid-Valley mobile FM 2-way radio frequency.

Automatic Standby

Complete automatic switchover standby-equipment, including separate cabi-

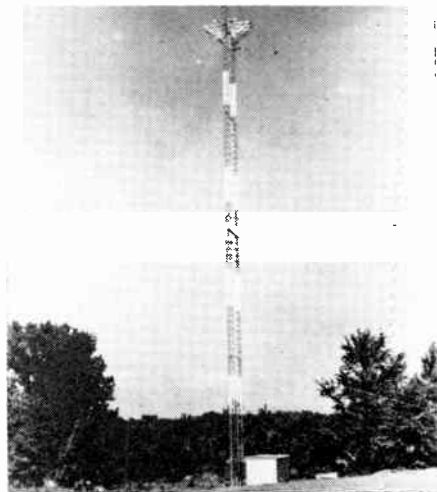

Microwave repeater tower at Abbeville, Miss., on the Mid-Valley route.

nets and power supplies, is incorporated into the system to assure circuit reliability. RF housing are constructed to include two complete transmitter-demodulator units—one for regular operation, one for standby use.

Sensing circuits built into the equipment can recognize a failure of any tube or component and automatically switch over to the standby gear with only instantaneous interruption to communications.

The Mid-Valley system's RF sections incorporate two klystrons, one in the transmitter and one in the local oscillator section of the demodulator.

The equipment is built for the 6575-6875-Mc frequency band as a result of field tests and propagation studies, particularly those conducted by the federal agencies.

It must be low enough to avoid attenuation caused by rainfall, snow or fog absorption and yet high enough for the use of compact, high-gain antennas with resulting good features of de-icing, anti-fading, and non-interference with other systems.

The 6700 Mc band allows for the use of waveguides, permanent structures of plain piping which last indefinitely without maintenance when short sections are used.

Also, this frequency band was chosen because it provides an opportunity to obtain maximum advantage of the excellent klystron tube characteristics, particularly in respect to long life and low cost maintenance.

On Mid-Valley's network, with a frequency band 10 megacycles wide, the subcarrier channels are continuously multiplexed so that many messages or control circuits function simultaneously without interference from each other.

Research has shown double-FM subcarrier multiplex to be ideal for private systems which require 10 basic communications channels or less. Structure of the subcarrier transmitters and receivers is relatively simple, party line usage is flexible, channels can be dropped and reinserted with ease, and the cost of the equipment is comparatively low.

Motorola equipment on the Mid-Valley system incorporates a double frequency-modulation system. Each input voice channel modulates an individual subcarrier transmitter on a frequency in the 120 Kc. to 1 Mc. range.

Each miniature plug-in subcarrier transmitter employs two double triode tubes, both 6SL7's. One triode is a voice limiter, another is an oscillator, the third is a frequency modulator, and the fourth is a cathode follower.

The output of these subcarrier transmitters is collected into one cable which in turn connects to the transmitter klystron to produce the modulated carrier. Wide band deviation of ± 5 Mc. is standard.

At a relay point, the microwave demodulating unit, equipped with a discriminator, recovers the subcarrier frequencies. This signal then is applied to modulate the transmitter directly in the case of a repeater station, or can be applied to the subcarrier receivers for complete audio detection at the terminal station.

The subcarrier circuits detect the FM signals with conventional limiters and discriminators capable of recovering voice frequencies with excellent quality of reproduction.

The Motorola system is designed to concentrate its energy field into a narrow path and direct it with very high power effect to a distant point.

Research and practical experience substantiate the theory that the maximum signal-to-noise ratio is most economically gained with compromise between beam width, RF power, and demodulator sensitivity. In building high-gain antennas it is vital to select a beam angle wide enough to avoid excessively rigid tower stability requirements, and still directive enough to attain adequate signal-to-noise ratios with full consideration of the practical economics of RF system design.

The Mid-Valley system is designed to allow easy addition of telemetering and supervisory control circuits. With the incorporation of these circuits, the positions of all switches, and valves, and the readings of all important meters can be displayed at any or all dispatch points. The remotely controlled system will be able, then, to provide for adjustment and operation of any number of valves, switches, or other unattended devices by simply activating the proper circuits.

HEATHKITS OFFER UNMATCHED ADVANTAGES

You'll find unmatched advantages in HEATHKITS—the most complete line of test equipment in kit form. Careful engineering and extensive laboratory testing in the development of each kit, coupled with the use of only highest quality components give you RUGGED, DEPENDABLE, and ACCURATE test equipment.

You SAVE MONEY when you build your own because all expensive factory wiring and construction costs are completely eliminated . . . All kits are COMPLETE and a real pleasure to build—Every part necessary is furnished—and the clear, detailed instruction manual makes construction easy and educational. (And, the finished kits are truly professional in appearance.)

Order your HEATHKIT today and enjoy these tremendous advantages!

- Heathkit OSCILLOSCOPE KIT** \$39.50
- Heathkit TUBE CHECKER KIT** \$29.50
- Heathkit VACUUM TUBE VOLTMETER KIT** \$23.50
- Heathkit TV ALIGNMENT GENERATOR KIT** \$39.50
- Heathkit SIGNAL TRACER KIT** \$19.50
- Heathkit ELECTRONIC SWITCH KIT** \$19.50
- Heathkit CONDENSER CHECKER KIT** \$19.50
- Heathkit AUDIO GENERATOR KIT** \$34.50
- Heathkit IMPEDANCE BRIDGE KIT** \$69.50
- Heathkit RF SIGNAL GENERATOR KIT** \$19.50
- Heathkit BATTERY ELIMINATOR KIT** \$22.50
- Heathkit HAND TESTER KIT** \$13.50

HEATH COMPANY
BENTON HARBOR 10, MICHIGAN

EXPORT AGENT: ROCKE INTERNATIONAL CORP., 13 EAST 40th STREET, NEW YORK CITY 16

Test Your TV Vocabulary

Know the language of your industry?

By ED BUKSTEIN

EACH new development in the field of radio-electronics has produced a corresponding increase in the technician's vocabulary. New terms to describe new circuits and concepts are being continually added to the jargon of the profession. Television has brought with itself an abundant crop of these new words and names. You can check your knowledge of this television terminology by pairing the number of each term listed below with the correct letter in the column of definitions. A score of 18 or more correct is excellent, 12 to 17 is average, and 11 or less correct indicates much room for improvement.

- 1. damper
- 2. Yagi
- 3. blocking oscillator
- 4. reactance tube
- 5. RF power supply
- 6. nonsinusoidal waveform
- 7. trap
- 8. linear saw-tooth
- 9. vestigial-sideband transmission
- 10. parasitic element
- 11. differentiator
- 12. AFC
- 13. marker generator
- 14. visual alignment

- 15. mosaic
- 16. series peaking
- 17. stagger tuning
- 18. intercarrier
- 19. contrast control
- 20. interlacing

A. A system of transmission in which frequencies to one side of the carrier are partially but not completely eliminated.

B. A gain control for the picture signal.

C. A method of adjusting tuned circuits to obtain the required response curve on the screen of an oscilloscope.

D. A type of receiver in which the same stages serve as both picture IF and sound IF amplifiers.

E. That part of an antenna array having no wired connections to the transmission line.

F. Alignment of successive circuits to slightly different frequencies in order to increase the pass-band.

G. A circuit which automatically corrects any tendency of oscillator drift.

H. A stage in which the components in the grid circuit are so chosen and adjusted that the tube is cut-off at regular, repeating intervals.

I. The photosensitive globules in a television camera tube.

J. A type of antenna having parasitic directors and reflectors.

K. A tube used to reduce shock excited oscillations.

L. A method of increasing the bandwidth of a video amplifier by connecting an inductance in series with the coupling capacitor.

M. A circuit whose output waveform corresponds to the rate of change of the input waveform.

N. A tube made to behave like an inductance or capacitance across an oscillator tank.

O. A high voltage source in which the output of an oscillator is rectified.

P. A voltage or current which increases in magnitude at a constant rate and then decreases rapidly.

Q. A system of presenting picture information by scanning alternate lines.

R. Generator used in conjunction with visual alignment in order to determine the frequency of points on the response curve.

S. Any repeating waveform other than a sine wave.

T. A tuned circuit designed to absorb, block or otherwise eliminate certain frequencies.

Answers on Page 66

Editor's Page continued

→ from cover 2

regular inspection. This sort of thing probably happens dozens of times. . . . BUT, would you print it? Naturally not. It's not news. Do we condemn the automobile service industry because of this or similar incidents?

No one would think of charging the entire automobile service industry with malpractices because scattered incidents of poor or unreliable service are noted. Cars are complicated mechanisms; mistakes happen. So it is with television!

Television is a great American product. Its complexity offers untold servicing problems. However successfully the industry has kept pace with the developments of television, isolated service complaints do occur, unsound business practices are recorded from time to time—but is that news! It happens every day in businesses and industries that are not beset by the problems of newness and complexity with which television servicemen must daily contend.

We're certain that you'll have to close the book, gentlemen, on those TV service angles for your stories. They've lost their punch.

But don't worry, the most sensational and news-worthy stories are yet to be written about television. You won't run out of material in the near future, but watch your pencils. Don't let your writers sneak in the old stuff that has been passed around for fact.

We thought the newspapers played this story to its bitter end. We're surprised, gentlemen, that you got caught with your pencils down. Let's keep our pencils sharp, men! The television servicemen have done and are doing a remarkable job!



Philadelphia TV service dealer Mort Farr (left) accepts congratulations of RCA's Vic Williams on his "cash and carry" service plan.

Customers Handle Delivery

MORT FARR, Philadelphia television service-dealer, is often able to promise his customers one-day service on their TV sets. That's not a promise very many outfits can make—but other companies spend time in pickup and delivery, while Farr has to a large extent eliminated the troublesome procedure.

He encourages set owners to bring their work in, early in the morning, and to stop for it later in the day. The gimmick, of course, permits the shop to do a larger volume of business than it could otherwise handle, and it has the added attraction that the technician's time can be spent efficiently doing actual work on the receivers, instead of spending half his working day driving a truck.

From the other point of view, that is, from the customer's angle, the proposition is at least equally attractive. Most set owners want their receivers in working condition as much of the time as is

possible. That means they strenuously object to having them out of the house for any longer than is absolutely necessary. Under this plan, the whole servicing job is done in a minimum of time. Besides, the labor cost can be cut considerably if it does not involve hauling the set.

Farr is an innovator. One of the first dealers to install a multiple antenna system to get the best reception for store demonstration, he is alert to any new methods that will put his business in the top rank of dealer-service organizations (see *RADIO AND TELEVISION MAINTENANCE*, June 1950). With his new scheme of customer-delivery, he says his technicians repair "a sizeable quantity of different receivers" each day. As shown in the illustration, his test equipment bench has to be fully equipped for the best and fastest work. It includes a VTVM, seven-inch oscilloscope, television calibrator, and sweep generator, all RCA equipment.

Automatic Radio Weather Station

The National Bureau of Standards has developed a flexible parachuting device to aid in transmitting weather data by radio from inaccessible territory

A SELF-CONTAINED automatic weather station, which transmits weather data by radio, has been developed by Percival D. Lowell and William Hakkarinen of the National Bureau of Standards for the Navy Bureau of Ships. Named the "Grasshopper," the device can be parachuted from aircraft onto inaccessible territory. Developed during World War II, it will automatically set itself up and periodically make and transmit weather observations. It may also be used as a radio marker beacon.

After the station has parachuted to earth, controlled explosive charges are used to disengage the parachute, raise the station to an upright operating position, and erect a telescoping antenna. Weather-responsive devices then cause resistance changes which switch a radio transmitter on and off at a rate susceptible of translation by a receiving station into temperature, pressure, and humidity readings.

Designed in the shape of a bomb, and packing its own parachute, the weather station is loaded on the bomb rack of an aircraft. When the unit is released over a desired location, the parachute is automatically opened by a line rigged from the aircraft. Simultaneously, an electric clock, which controls subsequent operations of the station, is turned on.

The impact of landing sets off a small explosive charge which disengages the parachute and prevents the station from being pulled along the ground.

Either immediately or after a pre-set dormancy period, another explosive charge causes the station to rise to an upright operating position. This is done through an arrangement of six legs to which springs are attached; the explosive charge operates a release, permitting the springs to pull the legs into position. A third charge extends a telescopic vertical antenna to a height of some 20 feet. The station is then ready for automatic transmission at intervals predetermined by the built-in timing mechanism.

Devices Adaptable

The automatic station could be adapted to transmit various kinds of information, but in the standard design only temperature, pressure, and humidity data are reported. Separate mechanisms responsive to changes in these atmospheric conditions each cause an associated resistor to vary. At predetermined intervals the timing mechanism turns on the radio transmitter and connects one resistor after another to a critical point in the transmitter circuit. The transmitter is designed so that the emitted radio signal pulses on and off

at a rate proportional to the value of the resistor. The station is calibrated before use by subjecting it to known temperatures, pressures, and humidities and measuring the resulting pulse rates. At the receiving station, the transmitter pulse rate can then be read as temperature, pressure or humidity, depending on the phase of the predetermined clock-work cycle.

The radio transmitter proper consists of a crystal oscillator followed by a radio-frequency amplifier stage. A relay in the plate circuit of a separate relaxation oscillator turns the crystal oscillator on and off at a rate proportional to the value of whatever resistor is temporarily inserted (by the clock mechanism) into the relaxation oscillator circuit. When the station is to be used as a beacon, the radio transmitter and its control mechanisms may, of course, be simplified.

Correction Factor

The clock, in addition to inserting the several weather-responsive resistors into the circuit in a predetermined sequence, connects two other resistors at appropriate intervals. These are a reference resistor and an identification resistor, both of constant value. The pulse rate produced by the fixed reference resistor is observed during initial tests of the transmitter. Any subsequent deviation in the reference resistor pulse rate warns the receiving station that a correction factor must be applied to the pulse rates of the weather-responsive resistors. Such deviation could arise from transmitter damage or aging. The identification resistor is of a value selected to produce a pulse rate characteristic of the particular station; this enables the receiving station operator to identify the station.

→ to page 66

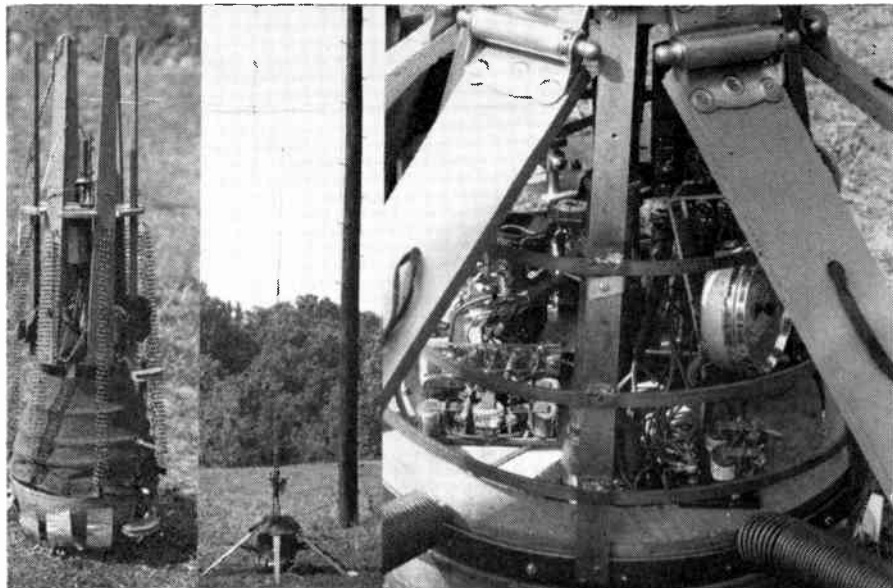

Dropped by parachute, the automatic radio weather station is disengaged from the 'chute' by means of an explosive charge. The station (left) contains a second charge which releases its six legs (center) which are pulled into position by springs and raises an antenna. A close-up of the mechanism is shown (right).

Radio and Television Maintenance

TECHNICAL SECTION

**The 40-50 Megacycle IF
Installation and Service Hints for 2-Way Mobile Radio
Self-Generating Photo Sensitive Circuits
Television Sound Systems
Logarithmic Scale for Dc VTVM
Keep Those Dial Drives in Shape**

The 40-50 Megacycle IF

New intermediate frequencies for television have many advantages over the old values

By BRUCE RICHARDS

NOW that the RTMA has published standard *REC 109 B*, establishing the intermediate frequency for television receivers at 41.25 Mc for the sound carrier and 45.75 Mc for the picture carrier, the industry has been adopting the new IF gradually. There were many engineering changes to be made and innumerable problems incident upon any change in such a basic component as the IF coil. Many of the 1951 models now have the new value, but some still continue with the older and now outmoded 20-30 Mc IF.

General Electric got into the picture early. One of their engineers was a key man in the adoption of 21.25-to-21.9 Mc for sound IF and the 26.75-to-27.4 Mc for picture; this same design engineer was also a member of the committee studying the adoption of the new 40-50 Mc IF.

There never has been, and there probably never will be an IF value that eliminates all major objections; each engineering decision is a compromise of factors. The 20-30 Mc IF was a good choice, probably the best possible choice in 1945, but the problems engendered by oscillator radiation were generally annoying.

From 1945 to 1949 there came up complaints involving such servicing dif-

iculties as double conversation effects, direct IF amateur interference, industrial equipment pickup, medical diathermy nuisance, interference on the international short wave broadcasts, and image interference from FM stations.

The highest practical IF that may serve both VHF and UHF receivers is at 40-50 Mc, unless there is double conversion. This value will be practical at UHF only if the FCC follows the recommendations made by the RTMA and the JTAC: that any station allocation plan should provide image protection for the IF now approved and in widespread use.

Advantages

With the new IF, all the disadvantages of the old 20-30 Mc IF are either eliminated entirely or reduced to such a negligible factor as to be unobjectionable. Study of data indicates that oscillator radiation at the 20-30 Mc value is possible on 5 of the 12 channels; but oscillator radiation is *not* a source of TVI at 40-50 Mc.

It is desirable that the oscillator frequency be *above* the carrier for all 12 channels with the 40-50 Mc IF. The interference from 144 Mc amateurs is sporadic and occasional. An important consideration is that all image interference is considerably attenuated at the higher IF.

In one example of the higher IF, the carrier is at 41.25 on channels 2-6 and at 47.25 for channels 7-13. This is the condition for the oscillator on the high side of the signal for channels 2-6 and on the low side for channels 7-13. These two carriers are chosen to place both the sound and picture carriers at their proper places on a symmetrical response IF curve for both positions of the oscillator.

One of the most important advantages of the 40-50 Mc IF is that it is eminently suitable for the UHF TV bands. Receivers capable of covering the present 12 channels and any new allocations by the FCC may be readily designed around a common IF. The RTMA has suggested channel assignments which will insure freedom from oscillator radiation interference for the UHF proposed band of 469 to 721 Mc, or whatever it will finally become. It would be desirable for the FCC to issue minimum oscillator standards for all new front end tuners, both for VHF and UHF.

Although the FCC has not yet issued

specifications on oscillator radiation, the RTMA has suggested that front ends meet its specifications. Most of the front ends now being manufactured do meet the RTMA specifications, and nearly all have approximately 10 microvolts or less of oscillator radiation across a 300 ohm antenna. The difficulty is that, without standards, maximum oscillator radiation may be of the order of 7500 microvolts at the antenna terminals in some tuners.

The chief disadvantages of the old IF are:

1. Receiver oscillator radiation. This sometimes causes interference in a nearby TV receiver tuned to some higher channel.

2. FM interference. A powerful FM transmitter relatively close may cause interference of an image frequency nature on some channels in a television receiver.

3. Industrial interference. Industrial electronic equipment or medical diathermy equipment, may cause highly objectionable interference amounting to practical picture destruction.

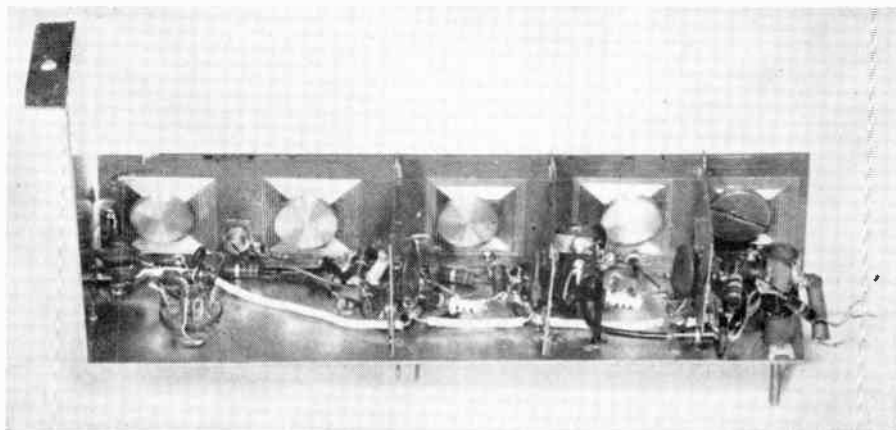

The layout of parts in an amplifier strip. Note that the sockets are over the interstage shielding strips and that layout is most compact.

Technical Section

4. Amateur interference. Some ham transmitters have frequency assignments within the 20-30 Mc band; this may cause serious interference in certain sections of the country.

Diathermy interference may be serious at times with the 20-30 Mc IF, because diathermy equipment generates an FCC approved 27.12 Mc signal. The 40-50 Mc IF receiver is not susceptible to the most intense radiation at 27.12 Mc.

Stations on the present FM band are transmitting on frequencies which create image problems with a 20-30 Mc IF, particularly on channel 2. Such image interference is entirely eliminated with the 40-50 Mc IF.

Oscillator Radiation

The major difficulty with the 20-30 Mc IF has been the problem of oscillator radiation.

Radiation from the oscillator of one TV receiver may cause interference in another receiver tuned to a higher channel or to a lower channel, depending on the frequency of the oscillator. This basic oscillation of a given receiver does

not cause any difficulty in the receiver causing the oscillations, but it does stir up hob for viewers of receivers nearby. The large number of receivers sold in metropolitan areas has magnified the problems of oscillator radiation and has made the undesirable aspects of the 20-30 Mc IF more pronounced.

Any type of television interference affects the quality of the received picture and is in general more annoying than sound distortion—the eye tires more readily than the ear. Evidence of radiation from a nearby receiver tuned to another channel may appear in several forms. If the offending receiver is located at some distance the effect may be diagonal lines. If the offending receiver is sending out medium strength radiations it may show up as reduction in picture contrast. Very strong radiations may make the picture appear negative.

The common servicing procedures on the receiving end, which have sometimes proved effective against oscillator radiation, include:

1. Reorienting the antenna, or relocating it.

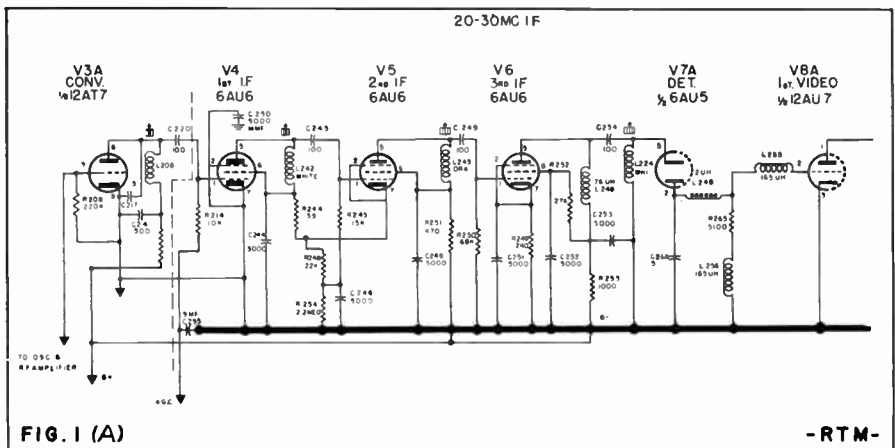

2. Using a highly directional antenna.

3. Using an open stub wave trap.

If you can find him you might persuade the fellow with the oscillator-radiating receiver to add an RF stage for the purpose of isolating his oscillator.

Design Considerations

Nothing new is ever achieved without difficulty. There is more instability in a 40-50 Mc IF amplifier than in the 20-30 Mc IF. The matter of rejection at trap frequencies is a formidable problem.

Because oscillator stability is simplified with the use of intercarrier sound, most of the 40-50 Mc receivers use this system. 6AG5, 6AK5, 6BC5, and 6CB6 type tubes are common in these amplifiers, although the 6AU6 will perform reasonably well at reduced gain. The best circuits are of the stagger tuned design, although other types of IF amplifier systems are also being used. Short grid and plate leads are much more important in the new system than in the old one.

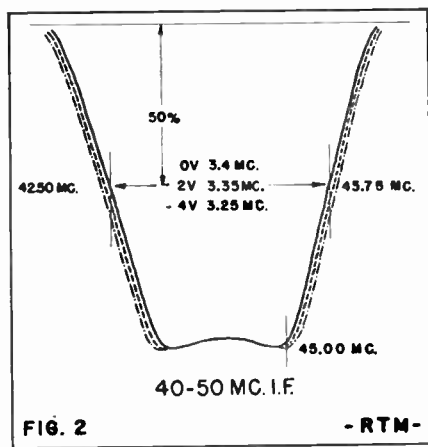

FIG. 2

- RTM -

Franklin 44-Mc IF Strip

One ready-made 40-50 Mc IF strip, the Franklin design, employs two stagger tuned and one overcoupled, double-tuned stage to provide good overall gain and selectivity. All coils for these stages are stamped simultaneously, on one sheet of high grade bakelite, from a thin sheet of copper. Brass slugs are provided to adjust for coupling and inductance. There are three 6CB6 tubes and one 6AL5 for the video detector.

→ to page 66

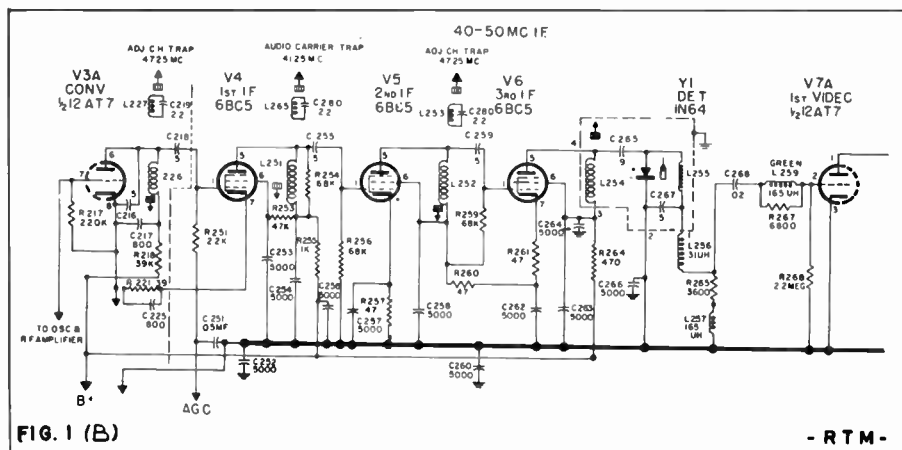

FIG. 1 (B)

- RTM -

Installation and Service Hints for 2-Way Mobile Radio

By JACK DARR

TAXICABS, REA co-operatives, U. S. Forest Rangers, police, firemen, pipe-line crews, power utilities, game wardens—there is no end to the list of people today who are making their job faster and easier by the use of two-way FM radio equipment. These compact, powerful sets fill a very definite need in our high-g geared industrial complex, and will fill a still greater need in civil defense, when and if they are needed. There is an opportunity here for many a serviceman to pick up interesting, profitable business in installing and maintaining these systems.

Any service work on transmitters must be performed by, or under the immediate supervision of, a man holding at least a second-class radiotelephone operator's license. Therefore, we're not going into the theory of operation too deeply; if you've got the blue ticket, you know that by now. However, there are several hints that will make this work a little easier, if you've never worked on these sets.

Installations

Properly handled, these mobile sets shouldn't present any more problems than a conventional auto-radio, outside

of the number of units. Transmitters and receivers in passenger cars are usually mounted in the trunk, as much out of the way as possible, and so arranged that they won't be damaged by spare tires or luggage, being thrown on top of them. The control cables and power supply cables are routed either underneath the car or inside, along the floorboards up to the front seat, where a control head and speaker are mounted under the dash. We much prefer the inside mounting, because of the possibility of damage to cables running under the car. However, if they must be run there, put them all together in one bundle, and cover the whole thing with a good layer of friction tape. This may be coated with shellac, if you want to be very particular. We only last week pulled an installation made two years ago, to transfer to another vehicle, taped up this way, and the cables were as good as new, despite some very heavy going. If you run inside the car, lift the floor-mats at each edge, and fasten one pair of cables down each side, holding them down with cable-clamps and small self-tapping screws. On late model cars, there is usually a thick padding under the floor-mats, which may be trimmed

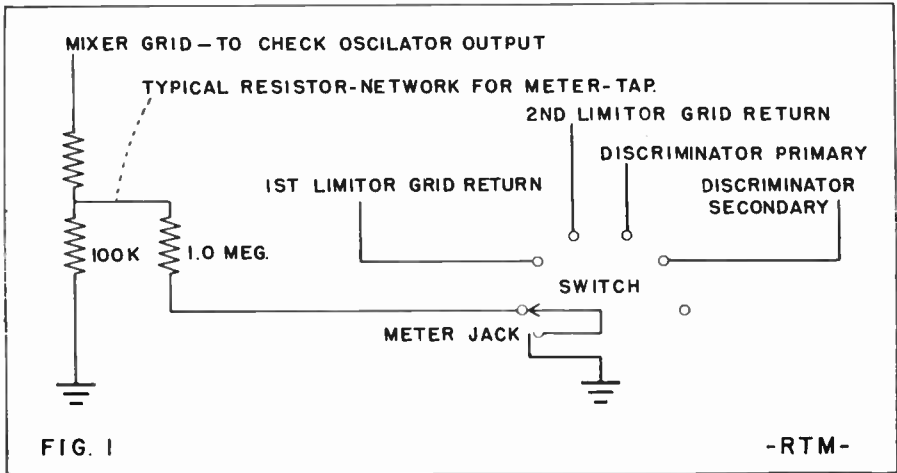

Conventional switching circuit for testing mobile FM receiver. Transmitter uses similar arrangement (see text).

with tin-shears, leaving enough space so the mats go back down with no perceptible bumps.

Antennas

The antennas are very small, quarter-wave units, for the 152-162 Mc band, usually mounted in the center of the roof on passenger cars. To mount them, locate the center line of the roof by sighting down the hood, and choose a location as near as possible to the back, so that the cable run will be short. Give yourself at least the length of the antenna rod on as flat a surface as possible, for best radiation characteristics. Bore a hole of the correct size, as indicated in the installation sheet, and run a piece of fairly stiff wire, bare, with a short loop flattened out on one end, down through the space between the top and the headlining. Work this down until it comes out into the trunk, on the side nearest to the transmitter. Next, fasten the end of the small coaxial cable to the loop, and pull it back up through the car to

the top. Antennas vary somewhat in their type, so we'll not try to give specific instruction for assembly. Seal the top insulators well with some kind of good cement, when finishing, to prevent leaks into the headlining. *Caution:* when working the wire through the headlining, see that your hands are clean! The light colored material used in upholstery will show every fingerprint, and they're hard to get off!

Control head and speaker installation is usually simple. Follow standard practice, and you'll get along fine. Mount this stuff all pretty solidly; it will get some rough treatment, at times, especially the transmitter and receiver. These units should be checked at least once a month to see that they haven't worked loose. In an especially rough-riding unit, you may have to drill holes in the fastening bolts, and 'safety' them down, with wire or cotter pins.

A pickup or other truck will generally use a heavy metal cabinet, large

Technical Section

enough to hold both transmitter and receiver. This may be mounted on the bed of the truck, crosswise, or, (unless you're in a thick brush country, as we are) on top of the cab of the truck. Try to locate a place where it will not be covered up by the normal load of the vehicle, to make service easier. If you have to unload a whole cargo, every time you want to check the set, you'll be pretty sorry. On small pickup service trucks, for REA and power companies, watch out for ladder-racks or other equipment on the cab roof, next to the antenna. We cured some very peculiar directional characteristics on one pickup by moving the metal ladder-rack about 15 inches toward the back!

Transmitters

Mobile FM transmitters are crystal-controlled units, although the crystals aren't held to as close tolerances as a BCL transmitter. They're usually provided with thermostat and heater, or just a heater, to keep the crystal and housing at around 85 degrees. Fre-

quency stability, as required by FCC, is .005 percent of the center frequency of the unmodulated carrier, for frequencies from 50-220 Mc. Fundamental frequencies of the crystals range from 3.0 to 3.5 Mc, which is multiplied 45-48 times, in the 152-162 Mc transmitters. For instance, one transmitter uses a quadrupler, a doubler, tripler, then a doubler-driver stage, which feeds the final.

As this is FM, modulation is low-level, usually in the stage following the oscillator. Some sets use the "angular-balanced" modulator, using two tubes in a push-pull circuit. Part of the RF signal from the oscillator is tapped off, shifted in phase by the modulation (audio) voltage, and then recombined with the original signal in a mixer stage. This gives a PM, or phase modulation, which, when multiplied through all the rest of the stages, comes out with sufficient swing to meet requirements. 15 Kc swing equals 100 percent AM modulation.

With frequency multiplier stages, extremely accurate tuning is required. To

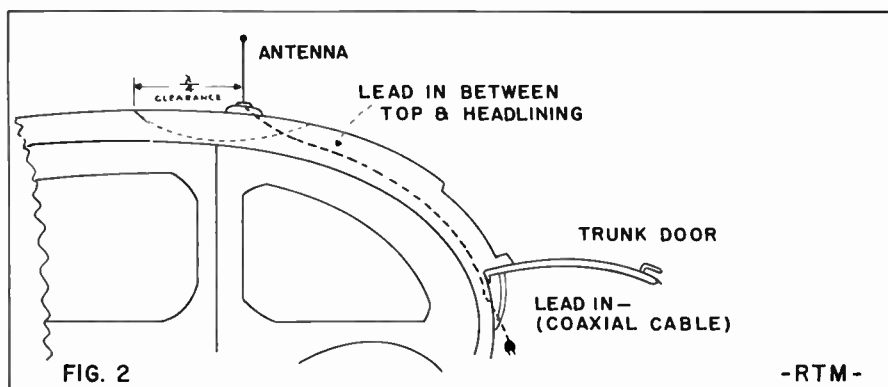

Profile view of antenna installation. Antenna should be mounted on a fairly flat section of the car roof, but not too far forward of the trunk, to prevent excessive lead-in losses.

avoid the need for high-range meters, a switching circuit is built into each transmitter, which shunts a microammeter (0-50, usually) across small shunts in the grid returns of each stage, so that they may be tuned by reading maximum deflection. Maximum RF grid current in each stage is used to indicate perfect tuning of the preceding stage. The finals are tuned by inserting the meter into a separate jack, across a 1-ohm resistor in the plate return. Caution: if your meter is not the same make and model as the one specified in the instructions, check it against one of these to compare readings, as differing internal meter resistances may upset indicated reading and cause you to mistune the final stage. For example, on our Motorolas, the book specified a final plate loading of 34 micro-amps indicated, on a 50-microamp scale. We used a Triplett, with a 60-microamp scale, and eventually found out, after some trouble, that our reading was 17 microamps! There are provisions, on most transmitters, for unhooking the 1-ohm shunt and taking the actual plate current reading, if necessary.

Handy Circuit

The meter-switching circuit provides a handy way of isolating trouble in the transmitter. Readings are taken from every stage, starting with the crystal, and all you have to do is run up the line until one stage fails to give the proper reading, or refuses to peak; there's your trouble! This built-in signal tracer proves to be awfully convenient, as you go along.

Watch out for broken wires, loose tubes, and other symptoms of mechanical shock in transmitters. Most of the

trouble we have encountered, outside of tubes, has been from broken connecting wires, on coils, etc. These are usually #20 solid, and extreme vibration can cause them to break, or causes solder joints to come loose. Once you've isolated the trouble to one particular stage, replacement of the tube or a thorough voltage and resistance check will find the trouble in short order.

Periodic Check

FCC regulations require checking of the operating frequency, deviation, and swing at least once every six months. Modulation monitors and frequency meters are, or soon will be available for these tests. While these are rather expensive, they are very necessary, both for fulfilling the FCC requirements, and for general service work.

Results of these measurements must be entered in the station log. All service work done to each transmitter should be entered in the service record of each unit. These records should be kept at the central operating point, not with the units themselves. For the base or fixed stations, the plate input tower, to the final, must also be measured every six months, and the results entered in the station log.

You should have a copy of FCC "Rules governing Industrial Radio Services," Part II, in your station files. Write the Superintendent of Documents, Washington, D.C., and send a dime for each copy.

Receivers

Most of the receivers used are double superheterodynes. They also use crystal control, in a novel way. The umpteenth harmonic of the crystal is

Technical Section

beat against the incoming VHF carrier, and the resultant beat-note run through the '1st IF.' This is then put into a mixer, and beat with the fundamental of the crystal, and the resultant of the operation is the 2d IF, which is amplified and fed into a conventional Foster-Seeley discriminator, with at least two limiters. The ratio detector, however, may be seen in some of the newer sets.

As in any FM receiver, the old faithful output meter cannot be used as a tuning indicator. Most of the sets use the limiter grid current, read across a small shunt with the built-in meter, for an aligning indicator. The meter is switched from one circuit to another, just as in the transmitter. You can read first limiter grid current, second limiter grid current, discriminator balance, and oscillator crystal current this way.

Most all of these receivers use some form of squelch to prevent the constant roaring of the sensitive receiver from driving the operator mad. This is adjustable at the control head, with the SQUELCH CONTROL, which adjusts the threshold of squelch action. Sometimes, operators set this control too tight, and then complain about the lack of sensitivity of the set. It should be set to a point where it is just barely shut off; after each transmission it should "puff" for one second or less.

The receivers use a reversible, synchronous vibrator power supply, which is familiar to every auto-radio man. The transmitters use a dynamotor, which furnishes about 400-425 volts DC. Care and maintenance of these is relatively

easy. Check brushes and commutators every three or four months; replace brushes worn too short, and blow brush-dust out of the whole thing with an air-hose. Very little lubrication is required, as most of them are factory-packed with grease sufficient for years of operation. If lubrication is required, use "Andok-C" grease, made by Standard Oil of New Jersey. If the grease seems too stiff, put one drop *only* of light oil into each bearing. Be sure that all fiber washers, spacers, etc. are replaced when reassembling.

If the transmitter develops a howling or whining noise (in the received signal) check brushes for sparking or binding in the holders. Shorts or opens in the high-voltage end of the dynamotor will cause a severe vibration while running, loss of speed, or no voltage. The only cure for this is replacement. You ought to have at least one spare dynamotor, so that defective units may be replaced, without being kept out of service for too long. If you find a defective armature, leave it alone, unless you're a qualified armature man. You'll waste more time trying to repair it than a new one would cost! Send them for repairs to some place equipped to handle them.

This work is sometimes done by the job and sometimes on a contract basis, where the serviceman agrees to furnish the labor to keep a certain number of units in operating condition, for a fixed fee per unit per month. The most satisfactory contract will depend upon the circumstances, so take your choice.

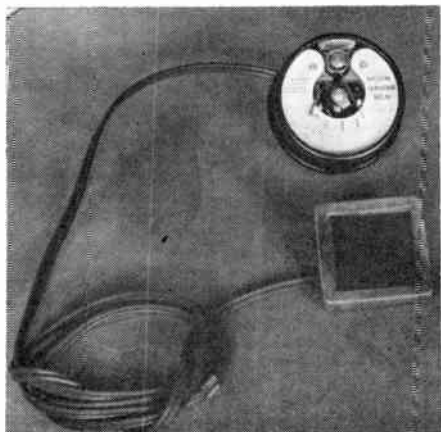

Here, a self-generating photocell is connected directly to a sensitive meter-type relay. Relay closes when cell is illuminated.

Relays made from photocells useful in applications where operating economy is desired

By RUFUS P. TURNER

Self-Generating Photo Sensitive Circuits

SELF-GENERATING photocells, unlike phototubes, require no polarizing voltage. When illuminated with a satisfactory amount of light, the self-generating cell produces a DC voltage which is useful for many purposes. The voltage disappears upon removal of the light. Most cells of this type now available are of the selenium type. The most familiar common application of the modern photocell is in the photographic exposure meter.

Aside from its use in light meters, the self-generating photocell may be employed in greatly simplified photoelectric relays. Such relay units employ no tubes, and therefore afford considerable operating economy, as well as simplicity, in industrial and household applications. Moreover, a relay unit containing a photocell requires no periodic tube replacement or adjustment of voltages, and it needs little or no care. In an installation of this type, there is no operating cost, like that associated with the power

supply and amplifier which are necessary with phototube relays.

Initial Cost

The initial cost of the self-generating photocell relay is higher than that of the tube-type device, because the sensitive DC relays which operate directly on the low-voltage output of the photocell are relatively expensive. This initial outlay is more than offset, however, by the total absence of standby power in most installations and the extreme simplicity of the arrangement. In some cases, an additional economy is affected in the initial installation by being able to dispense with amplifiers.

Electronic technicians and designers should give close consideration to tubeless light-controlled relays in all installations where simplicity, freedom from idling power supplies, bare-minimum operating costs, completely unattended service, and foolproof operation are more important than initial cost.

A typical tubeless photocell relay setup

Technical Section

is shown in Fig. 1. The self-generating cell is connected directly (by means of a low-resistance cable of desired length) to the input terminals of a sensitive DC meter-type relay, RY_1 . The output terminals of relay RY_1 are connected in series with a 6-volt DC voltage source and the coil of a 6-volt DC relay (RY_2) having contacts heavy enough to handle the current required by the controlled device. The latter may be a lamp; signal light, bell, or horn; electromechanical counter; lock; safety device; door opener; motor; solenoid; or other equipment.

The auxiliary relay is necessary because the fine contacts of the meter-type relay, RY_1 , will not handle currents in excess of a few milliamperes. Note that neither the 6-volt source nor the 115-volt source is required to furnish any current except during the intervals when the system actually is in operation.

Commercial Relays

The meter-type relay closes on small direct currents. A number of models

are available, for this application, with closures on selected currents ranging from a few microamperes to about 1 milliampere. The technician should select the unit which best suits his requirements. One such relay is the Weston Model 705 *Sensitrol* unit shown in the illustration, connected to the Type DP5 photocell manufactured by International Rectifier Corp. The Sensitrol relay has a unique method of operation. Current from the photocell deflects a movable coil which is part of a movement similar to a conventional d'Arsonval DC microammeter. Instead of a pointer travelling over a scale, however, the movable relay coil has a light arm, on the free end of which is attached a light contact. The stationary contact mounted at the end of the arc of travel is a tiny permanent magnet which attracts the movable contact after the contact has been deflected upscale a short distance. A positive "make" is obtained when the two contacts thus are drawn together. Once made, the contact must be broken manually turning a small re-set knob.

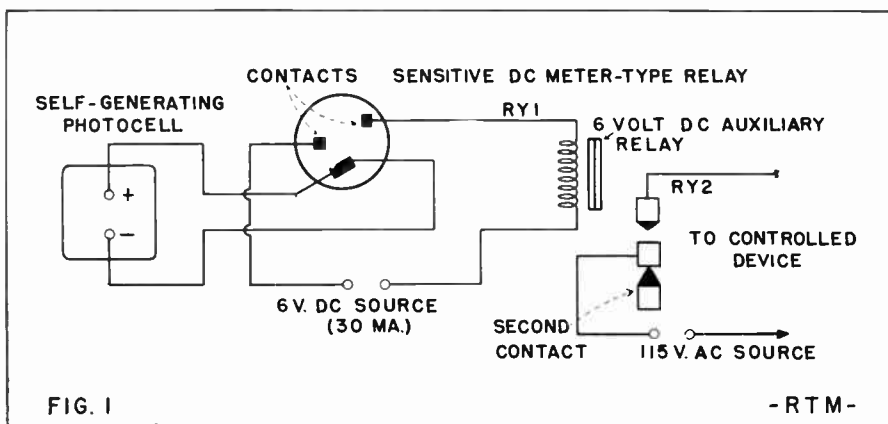

Several models of Sensitrol relays are supplied with electrically-operated re-sets.

In some installations, the necessity to re-set the relay may be objectionable. Counting operations would fall into this category. The burglar alarm might make good use of the re-set feature by keeping an alarm bell sounding until safety personnel arrived on the scene. For non-reset applications, non-magnetic meter-type relays also are available. These latter relays release automatically whenever the photocell current is interrupted. One such relay is the Weston Model 813. This unit is supplied to operate on currents as low as 50 microamperes or voltages as low as 50 millivolts. The circuit arrangement using the non-magnetic relay is the same as the one shown in Fig. 1 for the Sensitrol magnetic type.

Non-Magnetic Relay

The non-magnetic relay is furnished with center zero and consequently can close in either direction, depending upon

polarity of the applied voltage. The two contacts available thus can be wired in so that one circuit is closed when the illumination falls to a certain level and the other circuit closed when illumination rises to a predetermined level.

The circuit as shown in Fig. 1 is arranged for operation on application of light. Numerous applications require that operation result instead from *interruption* of a light beam. If the latter type of operation is desired, the lower contact of the auxiliary relay should be used. This arrangement causes the relay contacts to be held open as long as the light is applied, and to close each time the light is interrupted.

The photocell shown in the illustration has an active area of 2.25 square inches and produces 750 microamperes average output (assuming 100 ohms load resistance) at 100 foot-candles. A smaller-sized cell, Type B10M (International Rectifier Corp.) has 1.17 square inches of active area and produces 350 microamperes average output into 100 ohms load resistance.



What A Spot For A Shop

BRITISH technicians must have had a field day recently. It was reported in the London papers that 30,000 TV receivers produced by a British firm had to be modified immediately "for safety reasons." The matter was so urgent that teams were sent out from the factory on a nation-wide check of the offending model.

TELEVISION SOUND SYSTEMS

design and service data on FM sound in TV receivers

By DAVID T. ARMSTRONG

UNDER normal conditions a receiver is tuned for the best sound so that the center frequency of the sound IF falls right in the center of the pass band of the sound IF channel and the video IF of the picture carrier is 50 percent down on the response curve, to compensate for the vestigial-side-band transmission. With this type of tuning, a picture having the best detail is obtained coincident with the most desirable sound.

The average television serviceman will usually save himself considerable time and annoyance by combining the best results of his training and experience to help him find the source of the trouble. He needs to use his eyes to recognize defects in the picture pro-

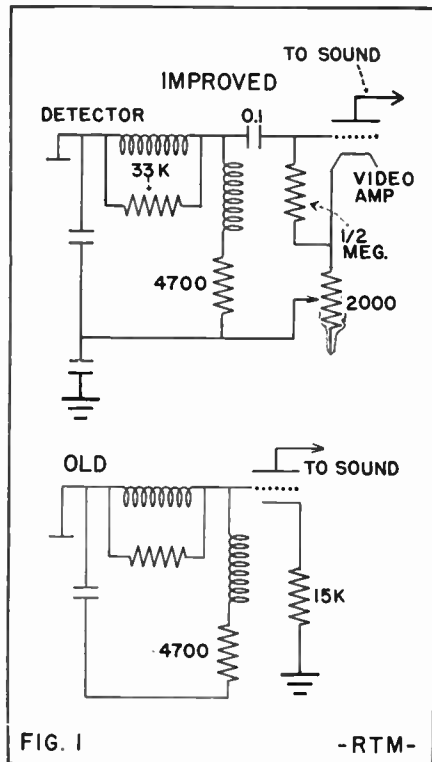

FIG. 1

-RTM-

duced and his ears to note sounds that are likely to indicate the presence of trouble or incipient difficulties.

For no sound, intermittent sound, or weak sound check the audio section tubes, the audio IF, the limiter-discriminator or the ratio-detector. For no sound at all with the audio tubes and the circuit checking OK, oscillator alignment in the front end or oscillator trouble at the front end may be indicated.

With intercarrier sound one of the essentials for the proper functioning of the system is the shaping of the video IF amplifier pass band to obtain a proper voltage ratio between the video IF carrier and the sound IF carrier at the input to the video detector. Here,

the video detector actually functions as a mixer for the two carrier frequencies and the resultant beat frequency takes on the combined characteristics of the two signals.

Therefore, the input to the second detector must be properly dominated by the picture of the IF carrier. When the picture carrier is down 50 percent from maximum, the sound carrier must be attenuated approximately 95 percent or more. The service technician must bear in mind that this relationship is fundamental and must be maintained whenever an intercarrier system is aligned.

Intercarrier Buzz

The intercarrier buzz is usually most noticeable on a test pattern with a 400 or a 1000 cycle tone modulation.

If, however, the buzz is objectionable on a live program, particularly when the contrast control has been moved counterclockwise, the following hints may be of value:

1. Check the sound alignment. This frequently eliminates all cause for complaint.
2. Check the video IF or align the strip to make absolutely certain that the 24.75 and the 22.0 Mc markers are precisely at the 50 percent points. Either or both of these servicing procedures usually eliminate all complaints for intercarrier buzz on a receiver that otherwise functions perfectly.

"Ringing" is a peculiar complaint which may sometimes yield to correction by changing the value of the capacitor across the horizontal deflection coils, midway between the white and the blue leads. 75 to 100 mmf is a common value here, but the substitution of a 47 mmf capacitor sometimes eliminates annoying ringing. If the correct

value is not at hand, two 75 mmf or two 100 mmf capacitors in series will often reduce the capacitance sufficiently to improve reception.

Solving Buzz Problems

In some listening areas, audio or station buzz is annoyingly apparent on some channels. Changing the heater connection lead from the front end tuner section to an audio tube or to some other tube may eliminate this difficulty in many instances. The manner in which the heaters are connected may be a cause for audio buzz, particularly when the first audio filament lead is connected directly to the oscillator filament lead.

It is characteristic of receivers having intercarrier sound that a 60 cycle station buzz is heard in the sound. This occurs under certain conditions of non-standard picture transmission (over-modulation or phase shift), misalignment, or improper tuning of the receiver controls. The buzz in the sound is the result of amplitude modulation (picture content) contained in the 4.5

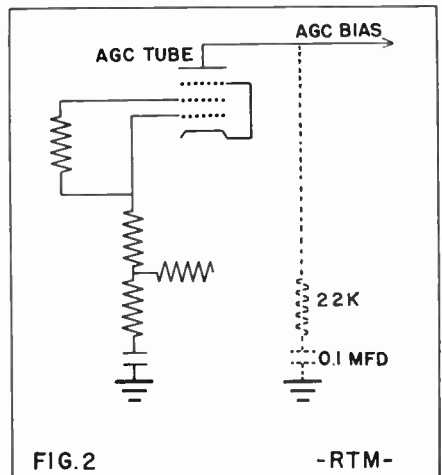

FIG. 2

Technical Section

Mc beat FM IF carrier to such a high level that it is passed through an FM ratio-detector, without being completely eliminated. It will not usually be present in receivers which employ a good limiting circuit at the sound detector.

Improper Tuning

In general, objectionable buzz is commonly due to improper tuning of a receiver. The fine tuning control may be misadjusted or the contrast control may be turned too far clockwise; this overloads the video amplifier. The receiver should be tuned for the best picture with the most satisfactory sound. When a clearly defined picture with satisfactory sound is not obtainable with rotation of the fine tuning control, it may be necessary to make some adjustment of the individual channel oscillator.

Overloading of a video amplifier, caused by improper setting of the contrast control, should normally disappear when the contrast control is moved slightly in the counterclockwise direction.

These are not the only conditions which may cause objectionable audio buzz. Misalignment of the oscillator, either individual channel or overall oscillator, may cause buzz. If the buzz is still present after the oscillator is correctly aligned, it may be due to misalignment of the secondary tuning slug on the ratio detector. When both these have to be adjusted it is well to repeat adjustment on the oscillator and retouch the secondary tuning slug on the ratio-detector; but once the secondary of the ratio-detector is properly adjusted for one channel it will not be necessary to readjust it for any change made on the oscillator of any other channel.

Buzz may be caused by overloading the video stages with a very strong television signal. This is more likely to show up on one or two channels located in the same general direction than it is on all channels. An attenuation pad between the receiver and the transmission line will decrease incoming signal strength sufficiently to normal desired input signal level. Misalignment of the video IF stages, or changes in the values of resistors or capacitors, or faults in electrolytic condensers also may cause some audio buzz.

Transmitter Fault

It is important to remember that station buzz is not always an indication of a fault in a receiver. The defect may also be caused by the transmission of a non-standard picture signal (over-modulation or phase shift) by the transmitting station. However, before one blames everything on the transmitter it should be remembered that such a condition is only momentary and is most likely to occur when maximum white is transmitted; furthermore, it will not appear on another channel.

The video amplifier circuit may be modified slightly to minimize audio buzz. Figure 1 shows the changes that may be made in a conventional video amplifier for this effect. The elimination of the grounded cathode resistor, the addition of the 0.1 mfd capacitor and the use of the 1.2 megohm grid leak bias will help.

"Vertical buzz" is a condition which has gained its descriptive title from the fact that the buzz changes its frequency when the vertical frame control is rotated. This is a tough one to find, but the following hints may be helpful. Move the unshielded hot ends of audio

leads away from the leads of the first audio tube, or shield them. The vertical oscillator transformer laminations may be vibrating mechanically. This noise may be eliminated by crimping the lamination strap with large pliers. Sometimes this difficulty may be obviated by rerouting the lead from the vertical height control to the resistor in the vertical blocking oscillator circuits. This lead is usually yellow. Have it follow a path as far removed from the grid of the first audio tube as possible; it may even be rerouted around the perimeter of the chassis.

AUDIO hum may sometimes be successfully corrected in TV receivers by connecting a length of bonding braid under the bracket holding the webbing for the picture tube on the side near the audio lead. Connect the other end of this braid to a ground on the power supply chassis near the audio

lead. This braid picks up the hum and isolates it from the audio lead.

When audio hum is present and may be tuned out at some particular setting of the fine tuning control, it may be eliminated from the circuit entirely by connecting a 22,000 ohm resistor and a 0.1 mfd capacitor in series from the plate of the AGC tube. This is shown in dotted line in Figure 2.

Tunable hum is usually caused by overloading the tuner in a very strong signal area. It may sometimes be eliminated by refining the FM alignment. The addition of a 4 to 8 mfd 25 volt capacitor from the AGC bus to ground may cut out tunable hum. If this type of hum occurs on only one or two channels the installation of an attenuating stub may do the trick for the troublesome channel.

Network Modification

The sound output filter network may be modified to decrease hum where it

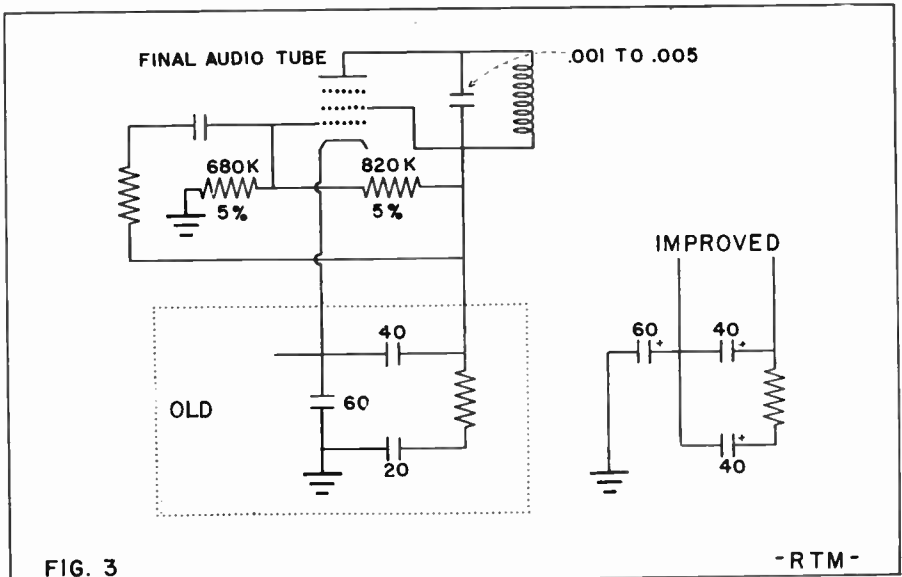

FIG. 3

-RTM-

Technical Section

is objectionable and does not resolve itself with ordinary conventional measures. Suggested circuit improvements are shown in Figure 3. These may seem minor, but they do minimize hum. They have the advantage of using the same components and making the improvement simply by changing the leads.

The addition of a coupling capacitor between the de-emphasis network and the volume control results in removing direct current from the volume control. See Figure 4. The net result is an improvement in audio signal fidelity.

It is an unusual complaint for a TV receiver, but there are situations in which the bass response seems over-emphasized. This condition may sometimes be much improved by changing the value of the capacitor shunting the primary of the sound output transformer. Substitute a value like 0.001 to 0.005 for the 0.01 to 0.05 which are sometimes designed into a receiver at this point. Overemphasis of the bass response can frequently be determined by mechanical vibrations, such as the rattle of the cabinet grille.

Sound may be distorted if there is any misalignment of the ratio-detector transformer. Such misalignment may be due to frequency drift of the ratio

detector. If realignment of this component corrects this trouble for only a short period of time after which realignment is again required, the permanent correction for this difficulty is to connect a 20 mmf, 750 temperature coefficient, ceramic condenser in parallel with the condenser connected across the secondary of the ratio detector transformer. Or substitute a temperature compensating ceramic capacitor for the capacitor built into the ratio detector transformer secondary. In either instance it will be necessary to realign the circuit after adding the replacement.

Sound Troubles and AGC

The anomaly of weak sound in a high signal strength area sometimes eludes all normal possibilities. Everything will check and all components and voltages will be functioning properly. One would hardly suspect that the AGC is functioning too well. Connect the AGC lead that goes to the RF tube to the decoupling resistor on the AGC bus side of the first video IF tube. The reconnection of this lead will increase the gain of the RF amplifier tube and this will improve the sound as well as the video signal.

Microphonics

One of the known sources of micro-

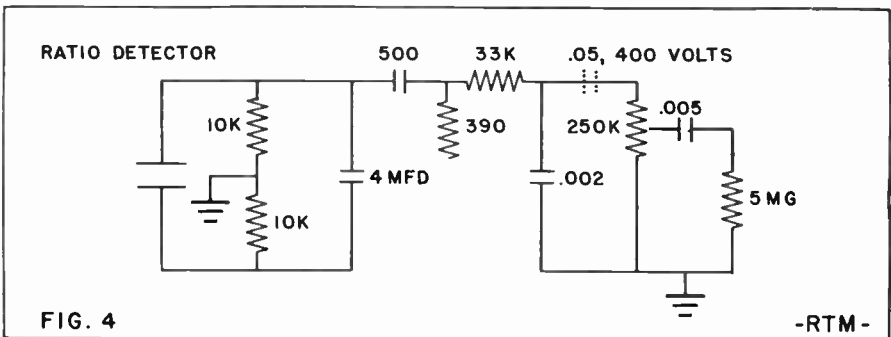

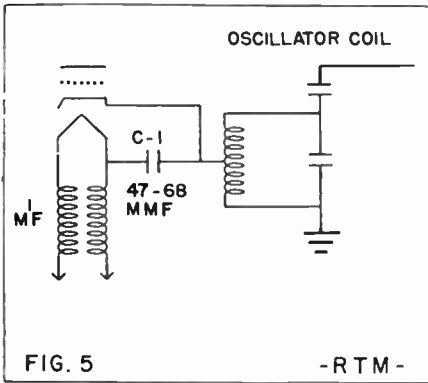

phonics in an oscillator tube is variation in the basic heater-cathode capacitance. These variations are produced for the most part by vibrations at the audio frequencies. The loudspeaker is one of the chief sources of vibrations and whenever acoustic feedback takes place an objectionable howl results.

In a Hartley type oscillator, the cathode is connected to a tap on the tank coil and the heater-cathode capacitance is, therefore, across part of the tank circuit. When there is movement of the heater in the cathode sleeve at an audio frequency, caused by vibrations, the heater-cathode capacitance will vary at an audio frequency. This will modulate

the frequency of the oscillator. Microphonics, although they may not be eliminated entirely, may be minimized in such a circuit if an arrangement is made to limit the effect of the heater-cathode capacitance variations on the local oscillator. This effect may be reduced to an unobjectionable minimum by tying the ground heater lead to the cathode. The other heater lead should have an RF choke to prevent the heater from loading the oscillator. The ground return for the heater is then provided through the cathode tap on the oscillator. A value for the RF filament choke of about 1 microhenry is adequate. In a series heater circuit, if the oscillator tube is not at the ground end of the heater string, use the variation shown in Figure 5. The value of the capacitor C_1 should be such that it effectively shorts the heater to the cathode for TV and FM frequencies. It is, of course, important to bear in mind that both the choke and the high frequency oscillator coil have to be designed to be able to carry the heater current.

Problems With the 6BN6

The 6BN6 tube is becoming common in television intercarrier sound systems

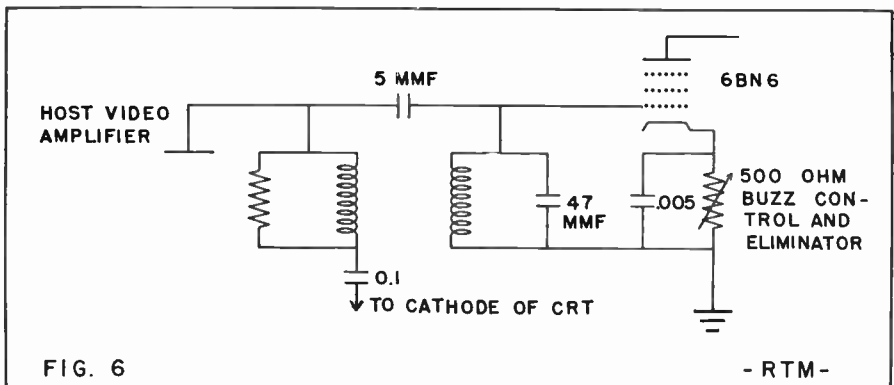

Technical Section

to discharge two basic functions: limiting and FM detection. The limiting action is accomplished by the property inherent in a 6BN6 of maintaining constant current between the accelerating grid and the cathode regardless of the amplitude variations applied to the first grid. FM detection is governed by grid 3, the control grid of the tube. Changes in potential are sharply reflected in plate current variations. By tuning the circuit of this element and the circuit of grid 1 to 4.5 Mc, an AC voltage is developed on the third grid when the 4.5 Mc signal is fed to the stage. This AC voltage is in quadrature with the 4.5 Mc input voltage. Frequency variations of the input signal result in amplitude variations of the AC voltage developed on the third grid. Plate current flow is directly affected by the potential of the grid; therefore, any frequency variations on grid 1 are proportionately reflected in plate current changes. This is essentially the function of any FM detector.

There are some desirable circuit precautions to be followed with the use of the 6BN6 in an intercarrier sound system. To obtain and to maintain proper 90 degree phasing between the limiter

and the quadrature grids very little capacitive coupling should exist between them. The direct interelectrode capacitance for the 6BN6 is less than 0.004 mmf between the limiter and quadrature grids. It is also important to be careful in the wiring during servicing to avoid any additional coupling. Mounting a metal shield across the socket between pins 4-5 and pins 1-7 helps minimize stray coupling difficulties.

The 6BN6 should be located as far as possible from magnetic fields. A relatively small magnetic field is capable of deflecting the beam current sufficiently to produce plate current cutoff. The magnetic fields of the loudspeaker and power transformer can produce hum modulation in the output. If a 6BN6 is improperly positioned on a chassis and there are hum difficulties or magnetic field interferences, little can be done to move the tube, but the magnetic fields might be shielded.

A buzz control is desirable for most receivers using intercarrier sound with the 6BN6. Where buzz is objectionable a circuit like that shown in Figure 6, or some suitable modification thereof, may be built into the receiver.



Enthusiasm Doesn't Wane

CONTRARY to early predictions, TV receiver owners do not watch programs less after having their sets more than a year. Two separate surveys conducted in TV areas on the East and West Coasts reveal that new set owners watch TV approximately three to four hours a day, and owners for one and two years still have the sets going three hours a day.



**Simple diode
input circuit
adapts
instrument**

LOGARITHMIC SCALE FOR DC VTVM

LOGARITHMIC VT voltmeters are available for AC measurements and are in wide use for audio testing. No comparable DC instrument ordinarily is obtainable which will allow a voltage spread of 100 to 1 on one scale and still have the lower end of the range spread out for accurate reading. A DC instrument of this type would permit wide-range voltage checking without time-consuming range switching and meter "pinning."

Fig. 1 shows how a biased diode tube may be connected ahead of any 3-volt DC vacuum tube voltmeter to give the expanded 50-volt scale shown in Fig. 2. While this scale is not truly logarithmic, it does have the desirable features of wide coverage and an expanded low-voltage end.

This circuit makes use of the limiting action of a biased diode. In this instance, a 3-volt positive potential is applied to the cathode of one section of a 6AL5 tube. The tube accordingly can pass no current until the unknown DC input voltage applied to its plate exceeds the 3-volt bias. Because the tube draws no current up to 3 volts,

there will be little or no drop across the series resistor R, and the high-resistance VT voltmeter "sees" approximately the full input voltage. The meter response therefore is, at first, linear. But this linearity exists only a short distance after zero.

Decreasing Rate of Increase

As the input voltage is increased and the tube begins to conduct, current passing through the diode creates a voltage drop across the resistor, and the voltage reaching the meter becomes somewhat less than the input voltage at that instant. (The meter voltage equals the input voltage minus the IR drop across the resistor.) As the input voltage is increased still further, the diode current rises and the meter sees some fraction of the increase in input voltage. The net result is that the voltage reaching the meter increases progressively more slowly after the point at which diode conduction starts. Thus, while the input voltage increases linearly, the meter voltage increases linearly at first and then rises at a constantly decreasing rate.

The bias voltage also bucks out the steady no-signal voltage (contact poten-

Technical Section

trial) developed by electron emission in the tube. Contact potential often becomes a nuisance when a tube-type diode is connected to a DC voltmeter. No provision need be made, therefore, for suppressing spurious non-signal deflection of the meter.

No Battery Switch

No current is drawn from the battery when the tube is non-conducting, although the tube may be burning, so no battery switch is required. A pair of penlight cells will furnish the 3-volt bias satisfactorily. In a permanent instrument, the bias voltage might be obtained from the VT voltmeter power supply. Heater voltage for the 6AL5 likewise may be obtained from the meter power supply.

With the circuit shown in Fig. 1, the maximum current drain from the voltage source under test was measured as 90 microamperes when the input voltage was 50 v. This amounts to a little better than 10,000 ohms per volt at 50 v. The ohms-per-volt rating increases considerably as the input voltage is decreased to lower values.

The circuit shown in Fig. 1 was

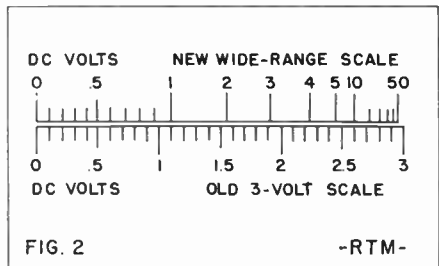
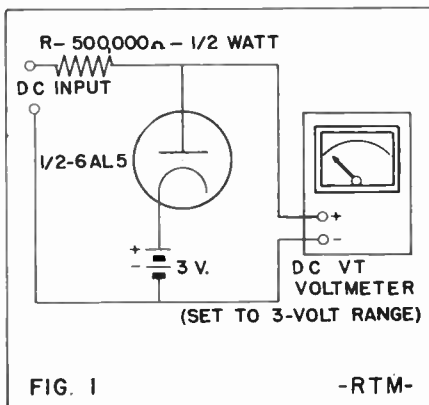

breadboarded for measurements between 1 and 50 volts. The range may be increased or decreased, however, to suit individual demands. For example, R may be increased to 1 megohm and the bias voltage to 10 v. to give a 0-500 v. range in which the 0-10 volt range is spread out at the lower end of the scale. This range might prove useful to service technicians measuring a variety of voltages between 5 and 500 in radio and television receivers.

It is important to point out that a high-resistance DC vacuum tube voltmeter is essential as the indicator. Lower-resistance non-electronic meters (even the 20,000 ohms-per-volt variety) will not permit full limiting action in the diode circuit, because of their loading effect. It should be noted also that the crystal diode is *not* satisfactory in this circuit because back conduction of the crystal will give a spurious deflection of the meter as a result of the bias voltage.

TUBE-SAVING TRICK

Ordinarily, 6SN7 tubes are used in the *horizontal multivibrator* and *vertical oscillator-amplifier* stages in Hallcrafters 512C, 513, 515, 520E, 521E, and 524 TV receivers.

As the tubes age, the 6SN7 in the horizontal circuit seems to slip out of positive operation sooner than the one

→ to page 65



Fix on the Facts

by Frye

Keep those dial drives in shape!

HAVE you ever had a set come into the shop humming like a B-29 with wide-open filter condensers, so low on sensitivity that only the local stations can be picked up, and suffering from a half-dozen other major radio ailments; yet when you turn over the tag and look at the owner's complaint, it reads simply: "Dial knob slips a little?"

This often-repeated experience certainly puts the spotlight on the importance that the customer attaches to the dial-driving mechanism; and, if you intend to stay in business, what is important to the customer is important to YOU. That is why it is necessary to make sure that the entire dial assembly is functioning perfectly on every set that leaves your shop. Probably no other part of the receiver, in the eyes of the customer, reveals so quickly the carefulness or carelessness of the serviceman. To his untrained ear, noise and hum may

be caused by mysterious "conditions," and if the receiver does not pick up all the stations it should, that could be the result of not having an outside aerial; but when he turns this little tuning knob here and that little pointer there refuses to budge, then, to quote Little Abner, "any fool can plainly see" that something is wrong.

Slipping and breaking dial cords can be and quite frequently are the fault of poor engineering. Some of those Rube Goldberg contraptions that employ a yard or so of cord strung all around the receiver in a regular cat's cradle and still depend upon rough wooden pulleys or, worse yet, no pulleys at all to carry the over-burdened cord, can be expected to last only about as long as the RMA guarantee. When a cord on such a sloppily-engineered receiver keeps on breaking in spite of all your efforts, the best thing to do is to show the customer exactly what kind of construction he has received for his money and encourage him to write his reaction to the manufacturer. A few letters of that kind may do some good.

But in all honesty it must be admitted

Technical Section

that dial cord failure is more often the result of improper installation by the serviceman. There are so many ways to make a mistake in this tedious and uninspiring branch of servicing that it will not hurt to review a few of them.

A very common mistake is to employ a dial cord that is either too small or too large. Sometimes this happens because the customer has tried to install the cord himself and, after admitting defeat, has thoughtlessly thrown away the old cord (and quite often the dial pointer along with it!), leaving the serviceman no indication of the size of the cord originally used. Then again, the technician may be of the opinion that the diameter of the cord is not important or, lean toward the theory that the larger the cord is the better it will perform. In many cases, both of these assumptions are wrong.

The important characteristics of a dial cord include its breaking strength, its flexibility, its tendency to stretch, its ability to withstand rubbing friction, and its gripping strength on the drive shaft. Unfortunately, a single one of these desirable characteristics is often obtained at the expense of one or more of the others. For example, a heavy cord will undoubtedly have greater tensile strength than will a thinner cord; and, because of its increased diameter, it *should* press more surface against the shaft and have more resistance to slipping. When a thick cord is used with a small-diameter driving shaft, however, its lack of flexibility tends to prevent its making the small loops necessary if it is to cling tightly to that shaft, and such a cord will frequently slip badly while a "thin" or "very thin" cord will work well.

Really, tensile strength is not too important a factor, for in a properly working dial drive system, rarely more than a pound or pound-and-a-half of pulling pressure is exerted on the cord. Of course, if excessive friction is present in the bearing of the tuning condenser, or in the pulleys, or in the pointer-slide, more than this amount of force will be applied. That is why it is important to check all such items for freedom of movement before the new cord is installed. In making the check, apply lateral pressure on the pulleys in the same direction that the cord will apply the pressure. Sometimes a worn pulley will turn quite freely until pressure is applied to it, and then it will not turn at all. If any item is found to be binding, the cause should be ferreted out and corrected. Gum is usually the arch-villain, and it should be washed away with carbon tetrachloride; then fresh, non-gumming lubrication, in sparing amounts, should be applied. Take care to see that no oil can reach the cord itself. In the case of wooden pulleys, oil should not be used at all, but a little powdered graphite should be sifted into the pulley bearing.

In a few cases I have found a tuning condenser hard to turn because of excessive pressure and friction exerted by the thrust-bearing in the end of the condenser shaft. Unscrewing the pressure screw, putting a drop of oil on the ball bearing itself, and then screwing the thrust assembly back into place so that the rotor plates are evenly spaced between the stator plates usually corrects the condition. But don't forget to tighten the locknut securely on the pressure screw, or you will get that set back *pronto!*

Quite often a set comes in with a slipping cord, but an inspection reveals no fraying or obvious wear of the cord. The temptation is always present (a) to increase the cord-tension beyond that normally needed, (b) to roughen the drive shaft with a file, or (c) apply some sort of "dope" to the dial cable. The idea, of course, is to get out of putting in a new cord. My advice, born of considerable experience, is: don't do it; replace the cable.

Some of the dodges mentioned will probably cure the trouble for a little while, but the set will soon be back with the cord slipping again or with it broken. Increasing the tension beyond a normal value by shortening the spring or replacing it with a stiffer one puts added strain on all parts of the mechanism, pulls the pulleys out of alignment, and materially reduces the life-expectancy of the dial cable. Roughening up the shaft where the cords goes around it with anything except the finest sandpaper is certain to throw up sharp edges that will quickly cut the fibers of the cord and cause it to break. As for the various dial-dressing compounds designed to prevent slipping, I have not tried them all, but I have tried several, and my experience with them has not been too happy. They tend to gum up the dial-drive mechanism and to be very temperature-sensitive; a treated cord may work very well when warm but slip badly when cold—or vice versa.

The old cord, when seen under a microscope, will be seen to have its fibers flattened and smoothed out so that they cannot grip the shaft; furthermore, if you look closely, you will see tiny flakes of metal imbedded in the cord so as

literally to armor-plate it and guarantee slippage!

When replacing the cord, follow the manufacturer's recommendation slavishly if possible. Personally, I have found Howard W. Sams' "Dial Cord Stringing Guide," Volumes I and II, worth many times its cost in showing quickly and conveniently exactly how the cord should go. The information can be found in one of these handy volumes while you are thinking about looking it up in a regular service manual. On top of that, when I encounter a radio that is not listed in the manuals, a judicious examination of similar dial-drive systems clearly shown in these little books gives me enough clues so that I am able to arrive at the proper method.

In conclusion, let me add a few hints drawn from stringing several miles of dial cords:

A six-inch length of thin piano wire with an eye formed at one end makes an excellent threading needle to lead the end of the cord around the various pulleys and bends.

Never forget to put a drop of cement on the cord knots to keep them from slipping.

When puzzling out a tough job, use cheap wrapping twine for experimenting. Then, when you are sure you have it right, the twine will give you the exact length of cord needed.

Don't use fish-line or other substitutes for regular dial cord. They only *seem* cheaper. Dial cables are really scientifically engineered for the job they are intended to do.

With a pair of surgeon's artery-clamps and a little practice, you can tie a knot in the end of a cord in unbelievably tight quarters.

products



for the

trade

The speaker is attached by means of machine screws which fasten into anchor nuts set into the back of the panel.

— R T M —

ELECTRONIC COUNTER

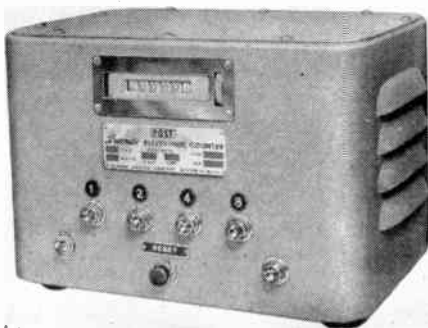

The Post Machinery Company, a subsidiary of Reid Bros., Beverly, Mass., in collaboration with the General Control Company, has adapted its Electronic Counter for general-purpose counting in several variations, including total count, rate of count, and pre-determined count.

The Counters will be known as the "Post Promatic Electronic Counters."

Capable of counting in excess of 10,000 units per second, the operation of this new counter may be either accumulative or pre-determined. The high-speed count is obtained through the use of photo-cell and electronic circuits. Miniature parts, as well as large bulky units,

SIMPLIFIED SPEAKER MOUNTING

Good looks combine with utility to make a speaker cabinet by Jensen Manufacturing Company a logical and adaptable design.

The new cabinet, known as the Customode Imperial, comes in either blonde or cordovan mahogany finish, to match other basic units.

The pictures show how speaker installation and removal can be accom-

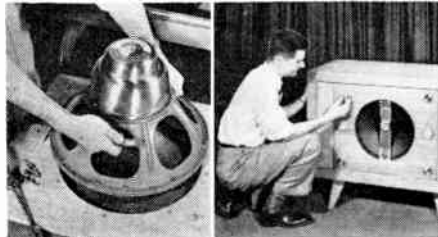

plished from the front of the cabinet. Earlier, the procedure involved considerably more time and effort—the entire back (fastened with numerous wood screws) had to be removed. The problem was aggravated when the cabinet was built into the room along with other units.

On this model, four brass knobs at each corner of the rectangular wood panel are decorative fastenings which may be removed so that the entire front panel—with the speaker—can be taken out from the front.

may be easily counted with the device, the maker states. The Counter automatically energizes an external circuit for the purpose of segregating batches at the end of the predetermined count.

A visual six-digit totalizer indicates the exact count, while a Rate Meter shows at all times the rate of count per hour.

— R T M —

SOCKET WRENCH

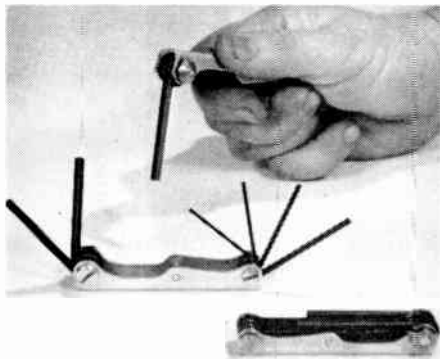

A single hand tool that fits the smaller size, standard socket head screws and bolts has been developed by the H. D. Hunter Company, 3499 E. 14th Street, Los Angeles 23.

A smaller copy of the standard "Smitty" 5-in-1 hand tool, the new "Smitty Jr." has six individual socket wrenches, sizes .050, 1/16, 5/64, 3/32, 1/8, and 5/32 inch. They fold into a single handle. The tool is small enough to fit into a pocket, yet its design permits great leverage at every angle.

— R T M —

TV ANTENNA ROTATOR

Walco Products, Inc. of 60 Franklin Street, East Orange, New Jersey, has announced full production on a new television antenna rotator.

Called the "Walco Rotenna," the unit supplies a guaranteed minimum of 50 inch-pounds of starting torque from a motor weighing less than 3½ pounds and measuring only 4 by 4 by 7½ ins. It is equipped with a selsyn motor type

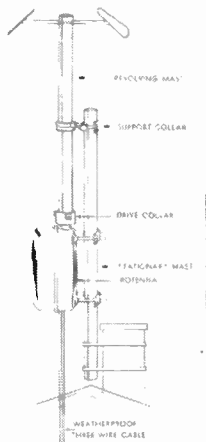

dial indicator which shows the exact position of the antenna.

The indicator is calibrated at each individual location, small numbers are supplied loose and may be fixed to the dial face when each channel position has been established.

Standard equipment includes an out-board support collar to permit distribu-

SPEAKER PARTS SPECIALS!

UNIVERSAL TYPE CONES

(less voice coils)

4" x 6" oval,	9/16" V.C.	ea. 10c	12/1.00
4" O. D.,	9/16" V.C.	ea. 7c	15/1.00
4½" O. D.,	9/16" V.C.	ea. 10c	12/1.00
5½" O. D.,	9/16" V.C.	ea. 6c	20/1.00
6" O. D.,	¾" V.C.	ea. 10c	12/1.00
7" O. D.,	1" V.C.	ea. 12c	10/1.00



4" to 12" CONE ASSORTMENT (incl. free-edge) 12/\$1.98

SPEAKER REPAIR KIT... Liberal assortment of Spiders, Rings, Shims, V.C. forms, Cement, Felt, Chamois Leather & Instructions ..\$2.49

SPECIAL: \$1.98 CONE & REPAIR KITS \$3.95 (All Cones Less Voice Coils)

"FACTORY SPEAKER REPAIRS SINCE 1927"

Min. Order \$3.00 20% deposit on all C.O.D.'s Full Remittance with foreign orders. Please add sufficient postage—excess refunded.

LEOTONE

RADIO CO.
67-A Dey Street
New York 7, N. Y.

tion of stresses over widely separated points on the mast.

The motor is completely gasketed and sealed in from weather. When not in use, the motor and mast are firmly locked so the antenna cannot turn, nor can it coast when power is turned off.

— R T M —

ELECTROSTATIC CENTERING DEVICE

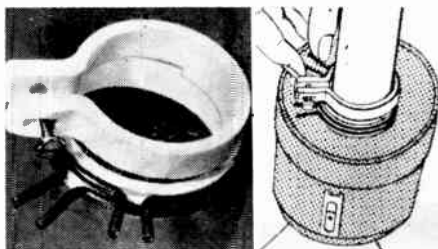

Perfection Electric Company, 2635 South Wabash Avenue, Chicago, Illinois, is introducing a new picture centering device for electrostatic television tubes which use no focus coil.

The new device, called the "Perfection Kine-Center," consists of two metal rings which can be rotated independently to adjust the television picture in the tube and center it. The rings are mounted on a special form which is clamped to the neck of the tube. The design permits placing the rings close to the deflection yoke and to the tube neck. The rings are stabilized magnetically.

The device can be quickly mounted and can be operated by finger-tip control. The two rings are rotated either independently or together to center the picture.

When the tabs of both rings are parallel and they are rotated together around the neck of the tube, the picture will rotate in a circle.

When the tabs are directly opposite one another and the entire mounting is rotated around the tube, the picture moves very slightly, if at all. When the tabs are placed at any position other than opposite each other, the amount of

adjustment of the picture will be between the maximum and minimum, depending upon the position of each tab. Straight line movement of the picture is obtained by rotating one ring and allowing the other to remain stationary.

— R T M —

PHONO NEEDLE PACK

A new aid to phono needle dealers is the No. 32 Jensen dealer pack, with automatic inventory. As each needle is removed, the information on what to reorder appears on the bottom of the case. The case itself, made of clear plastic, is sturdy and contains a balanced



assortment of 32 needles. The pack can be obtained from distributors or by writing to Jensen Industries, Inc., 329 S. Wood St., Chicago 12, Illinois.

— R T M —

CHANNEL CONVERTER

In the development of community master antenna systems, the losses of signal strength, when the higher TV channel frequencies are transmitted through long lengths of cable, have presented some problems. In order to overcome this difficulty, Technical Appliance Corporation, Sherburne, N. Y., has designed a "Channel Converter," for use with its master antenna system.

The new converter beats the higher channel signals down to a low-band open



channel. For example: if Channel 13 is operating in a region where the only other channel is 4, the channel converter, located at the antenna, converts the signal to Channel 2 and transmits that signal through the cables. The operator tunes his receiver to Channel 2 to pick up the Channel 13 signal.

The converting is done with a crystal oscillator, so that there is no drift in the frequency. Power connections are provided from the Tacoplex Master Amplifier Chassis for the unit.

— RTM —

SAFETY LADDER



Especially designed for use with stock carts, a new four-step ladder has hangers that are adjustable for push bar heights

from 30 to 38 inches and is mounted on ball bearing casters for easy movement without lifting. With the weight of a person on the ladder, the casters automatically retract, putting two rubber tipped legs into firm contact with the floor. The maker states this tends to prevent rolling action of either ladder or cart.

"Stockart" ladders are all steel with $\frac{3}{4}$ " steel tubing frames and expanded steel non-slip steps, welded for maximum strength and long life. Manufactured by the Ballymore Company, Wayne, Pa.

— RTM —

NEW FOLDED-VEE

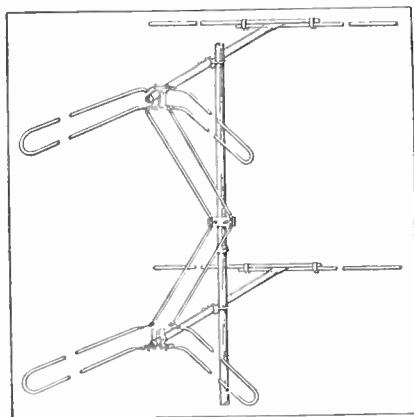

A new all-band television antenna is announced by Technical Appliance Corporation, Sherburne, N. Y.

The new antenna is known as the "Folded Vee." It is available as either a single antenna, or stacked array. The antenna element is a folded dipole with a forward angle for covering all 12 vhf television channels. The reflector is a straight rod spaced for maximum gain and front-to-back ratio.

The folded-vee is recommended for strong to medium signal strength areas. As a single antenna it is suited for use with a rotator due to its low wind resistance.

The new antenna is constructed with

the "Jiffy-Rig" device, making assembly possible in a few minutes, by swinging the antenna elements open, and tightening pre-assembled screws.

— R T M —

NEW 'SCOPE

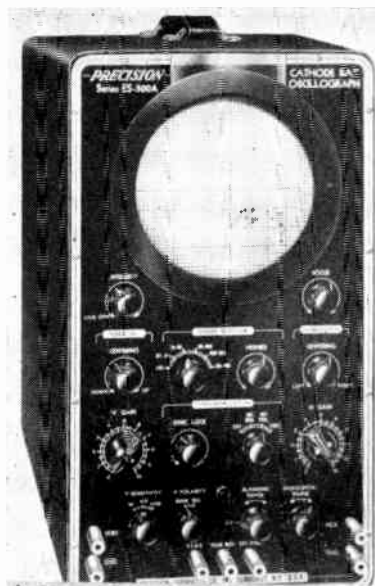

A new high sensitivity cathode-ray oscillograph, Series ES-500A, has been introduced by Precision Apparatus Co., Inc.

This new unit is a 5-inch laboratory type with extended range, voltage regulated, push-pull amplifiers for multi-purpose industrial, AM, FM and TV applications. Its features include: Extended range, push-pull vertical amplifier with response beyond 1 Mc 2 Megohm input resistance, about 20 mmfd. input capacity. Voltage regulated for stability. Better than 20 Millivolts-per-inch vertical amplifier sensitivity for direct alignment or adjustment of low gain circuits and examination of minute signal levels.

Calibrated, frequency compensated, wide band "V" input step-attenuator: XI, X10, X100. Extended range, push-pull horizontal amplifier response be-

yond 1Mc. $\frac{1}{2}$ Megohm input resistance, approx. 20 mmfd. input capacity. Multi-vibrator type internal linear sweep circuit affords direct coverage from 10 cycles to 30 Kc.

A vertical phase-reversing switch for inversion of test patterns. Four-position sync. selection: INTERNAL NEG., INTERNAL POS., EXTERNAL and LINE. Internal, phasable 60 cycle beam blanking plus "Z" axis beam modulation input terminals. Built-in horizontal phasing controls.

Audio monitoring phone jacks are provided at rear of cabinet plus direct access to all four H and V deflection plates.

The ES-500A employs 13 tubes, including two rectifiers, voltage regulator and CR tube.

For additional information, write to G. N. Goldberger, Precision Apparatus Co., Inc., 92-27 Horace Harding Blvd., Elmhurst, Long Island, N. Y.

— R T M —

TV LINE PAD

The Daven Company, of Newark, New Jersey, has announced a new video line pad (Type V-102), assembled in

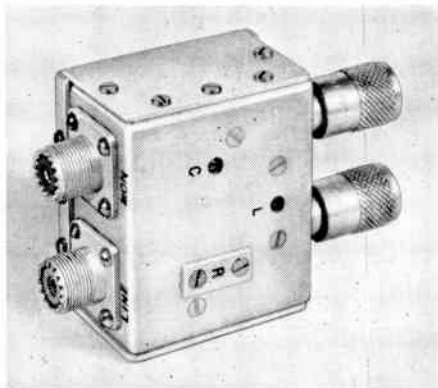

an aluminum case, and provided with connectors for connecting one or two line amplifier outputs, line input and monitor input.

This network is designed to feed

→ to page 55

What's your problem?



This department of **RADIO AND TELEVISION MAINTENANCE** is devoted to helping to solve the difficult service problems of our readers. Tough ones of general interest will be printed, and readers will send in answers. The best solutions will be printed in later issues. If only one answer to a problem appears here, its originator will receive \$5.00 in cash. If two or more different ways of beating the poser are of nearly equal merit in the opinion of RTM editors, the second best will be worth \$3.00 to the man who submits it, and the third best will bring home \$2.00. Send your question or solution to: Problem Editor, **RADIO AND TELEVISION MAINTENANCE**, P. O. Box 867, Atlantic City, N. J.

BROKEN ADJUSTING SCREW

Last month, this department printed the problem of Reader Paul Wellnitz, who was having trouble with an old RCA Victor radio. The screw adjustment on the variable condenser had been turned too much at one time, he said, and now he could not bring in any stations at all.

To make matters worse, he added, replacement condensers on the set were no longer available. So he wanted a way to repair this unusual trouble.

*The **RADIO AND TELEVISION MAINTENANCE** prize of \$5.00 for the best answer to the question goes to Reader I. Horowitz, of Brooklyn, who seems to solve the difficulty very neatly.*

GENTLEMEN:

In answer to the problem of Paul Wellnitz in the June issue—where he couldn't fix an adjustment on a radio tuning condenser, I suggest that he remove the screw entirely, since it is prob-

ably shorting the condenser.

Then, to replace the lost adjustable capacitance, he should install a small padder condenser in parallel with the defective unit.

The new padder can then be adjusted just as was done with the original unit.

—I. HOROWITZ
Brooklyn, N. Y.

ANTENNA PROBLEM

GENTLEMEN:

My son and I have been testing various types of antennas to bring in distant stations—we have only one station here, but we are located in a fringe area with regard to about five other stations. At present, our best results have been with a double-V, double-stacked arrangement.

Naturally, the Yagi types would give us the best results, but we would be handicapped for room.

I would like to know whether I could make folded dipole antennas from alu-

minum tubing one inch in diameter—double bay—for channels 13, 9, 5 and 3, mounting the elements in a row on a supporting member, with the highest channel unit towards the stations, followed by the increasingly longer dipoles, with a reflector at the rear end.

Would such an arrangement work? And if so, what would be the spacing? I plan to use a separate lead-in for each of the dipoles. Would the signal be better with smaller tubing? Or would I get better results with a conventional high-low antenna with separate lead-ins? Can any of your readers suggest a high-low antenna that is definitely superior?

The idea came to me from reading your magazine?

—EUGENE L. DIMEO
Ellwood City, Pa.

AC INDUCTION

GENTLEMEN:

I get an unusual effect with a little two-tube headphone radio I have.

This set, a battery-operated job using two 1S5's, as converter and detector-

audio stage, will not bring in any stations loud, but just gives on a very, very faint signal, *unless* an antenna wire is wrapped, or merely bunched, around an AC power line in the room. It doesn't make any difference, of course, whether the lights are on or off.

With the antenna coupled this way to the power line, the set still goes dead if I touch the antenna wire with my hand.

What is the cause of this situation? Is it some sort of 60-cycle heterodyning, or is the power line simply acting as an extension of the antenna? The RF and oscillator coils are wound in opposite directions; could they be bucking each other?

While I'm at it, there's an entirely different question that's got me, too. On some cars, the ammeters are built with just a permanent magnet, as far as I can see, and no coil at all. The device works, but how does it do its job?

Thanks for any explanations you can give me.

—CLYDE E. MAURER
Bremerton, Washington



Electronic Pollster?

HENRY A. RAHMEL of Evanston, Ill., is said to have invented a device to determine what stations are being listened to on radios in a specific area. The newly patented instrument could be mounted on a truck, parked at an intersection, and count the number of sets tuned to a particular program.

trade LITERATURE

WALCO NEEDLE CHART

A new "Walco" replacement phono needle chart covers several needles now being installed in new models.

It gives the name of the maker, the



needle model by maker's number, illustrates the actual needle, gives Walco's replacement number and the list price.

It also bears a diamond symbol alongside those needles which Walco is making available with diamond tips.

Dealers desiring a copy are invited to write to Electrovox Co., Inc., 60 Franklin Street, E. Orange, New Jersey. It will be sent free of charge.

— R T M —

SOLDER PAMPHLET

Federated Metals Division, American Smelting and Refining Company, has published an educational brochure on the nature, properties, and uses of solder. The 36-page book is illustrated.

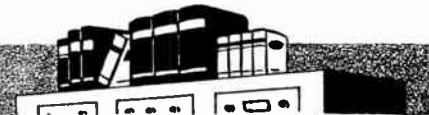

Solder alloys have been in use since the days of the Roman Empire, but standards of quality and mass production were not attained until late in the nineteenth century. Current production of solder is phenomenal; in 1949, the last year for which figures are available, over 100 million pounds were used in the United States alone. Of this, the automotive industry swallowed up 45%, largely in the manufacture of radiators where large bars or pigs are melted and used in a hot dip operation. Most of the remainder consumed by the automotive industry is used as body filler to provide smooth surface on body panels before the finish is applied.

Second biggest consumer of solder is the tin can industry, where about a quarter of the total solder tonnage is used in a hot dip operation to seal the seams of cans. Fifteen per cent of the tonnage goes to electrical equipment manufacturers, where solder in a number of forms, particularly wire solder, is used in production of an astronomical variety of

electrical equipment. Bar solders in many sizes and weights are used in addition to the wire solders. The remaining 15 per cent is used in miscellaneous manufacturing, maintenance, and repair work; in sheet metal and roofing operations, in refrigeration and air conditioning equipment manufacture, in the fabrication of gas meters and dairy equipment, and for various repairs.

The subject matter in the catalog is indicated by the table of contents. Separate sections are devoted to thermal effects, mechanical properties, principles of soldering, and fluxes. Next, the selection of the proper solder for a job is explained; fusible alloys, a remarkable group of alloys with low melting points, are described. Following a list of practical applications and a comprehensive description of all Federated solders is a resume of specifications and technical data. This section includes the melting range of tin-lead solders; ASTM, SAF, Federal, and Military Specifications, as well as wire tables.

The booklet is available upon request to Federated Metals Division, American Smelting and Refining Company, 120 Broadway, New York City, N. Y.

— R T M —

SPRAGUE CATALOG

A new 16-page catalog just issued by Sprague Products Company, North Adams, Mass. provides complete data on modern capacitor types for practically



every radio and television service, amateur radio, experimental, laboratory and other needs.

Included are details on Sprague "Koolohm" wire-wound resistors, interference filters, capacitor mounting hardware and the Sprague "Tel-Ohmike" universal capacitor and resistor analyzer. Of particular importance from a television servicing standpoint are the complete listings of "Telecap" molded tubular capacitors, "Twist-Lok" prong mounting dry electrolytics, "Ceramate" disc ceramics, "Bulplate" multiple ceramics, "doorknob" high-voltage ceramics and numerous other recent developments that are finding widespread use in present day equipment.

The catalog, C-607, is now available free of charge from Sprague parts distributors or may be obtained direct from the manufacturer.

— R T M —

SCREWDRIVER CATALOG

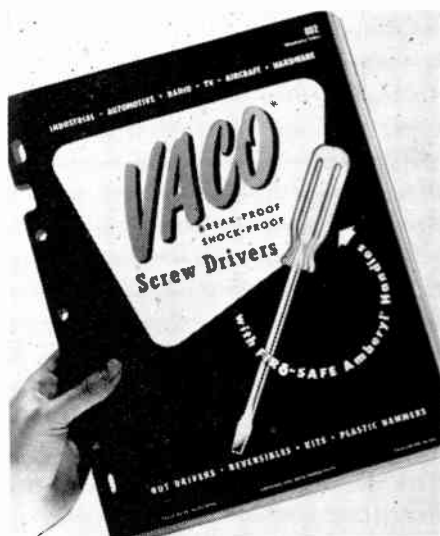

The new 32-page screwdriver catalog-handbook of the Vaco Products Co., 317 East Ontario Street, Chicago 11, has just been announced for distribution. It presents a picture of the most complete array of screwdrivers, nutdriver kits and other hand tools ever offered, the company claims. The catalog is sent free upon request.

Illustrated in three colors, the catalog has numerous perforations in several different sizes and shapes to permit fitting into any holder or portfolio.

There is also a handy screw chart and screw reference data on the inside front cover. This illustrates all types and sizes of screws for quick reference.

— R T M —

G-E HANDBOOK

A new 107-page pocket-size handbook, listing essential characteristics of every type of receiving tube likely to be found in a home receiver—AM, FM or television, has been published by the General Tube Divisions.

Prepared primarily for the service technician, the reference handbook contains ratings and other data for trouble shooting. Basing diagrams for each of the 856 different tube types listed are shown with the data.

The electronics engineer, amateur, or experimenter will also find the book a valuable quick-reference for tubes currently in use.

Included in the handbook are many new receiving tubes recently announced for use in television applications; a comprehensive coverage of subminiature tubes; and a section listing essential physical and electrical characteristics of television picture tubes.

To aid in the proper evaluation of information presented in the handbook, a section entitled "Interpretation of Ratings and Technical Data" has been included.

A chart of recommended types provides the service technician with a valuable guide to tubes likely to be found in late-model receivers.

Information presented in the handbook is industry-wide in scope, and inclusion of a tube in the publication does not necessarily imply the availability of that type from GE.

Priced at 35 cents, the book is available only through General Electric and Ken-Rad tube distributors.

— R T M —

TAPE RECORDER BULLETIN

A new bulletin on the "Concertone" magnetic tape recorder has just been released by the manufacturer. This bulletin illustrates and describes the basic recorder, its carrying case, and console cabinet. Complete specifications and prices are given. Also shown in the bulletin are schematic diagrams and frequency response.

Copies of the bulletin may be obtained by writing to Berlant Associates, 4917 W. Jefferson Blvd., Los Angeles 16, Cal.

— R T M —

PRECISION POTENTIOMETERS

Helipot Corp., So. Pasadena, Cal., makers of precision potentiometers and other electronic items, has compiled a quick reference technical data chart that provides all pertinent data on the various types of Helipot potentiometers.

Electrical and mechanical characteristics, physical dimensions with accompanying sketches, power ratings, accuracies and similar engineering data are included to furnish users of potentiometer-rheostats with a handy guide to available stock units in single-turn and multi-turn designs.

Copies are available without charge from D. C. Duncan, chief engineer, 912 Meridian St., So. Pasadena.

— R T M —

RIDER'S TV VOL. 7

The latest volume in Rider's Television Manual Series—Volume 7—is now in production.

This volume, the largest to date, is scheduled for publication in July. Seventy-four manufacturers contributed data

for the period Fall 1950 to Summer 1951. Taking up where TV Manual Volume 6 leaves off, the latest manual includes servicing information on 776 models. All models are accessible with the cumulative index for Rider TV Manual Volumes 1 through 7.

TV 7 contains schematics, chassis views, voltages, resistance readings, alignment procedures, test patterns, waveforms, parts lists and parts values, boosters, tuners, and up-to-date changes on previously published information. Circuit action descriptions and unpacking and installation data round out the features of this volume. It is priced at \$24.00.

— R T M —

TUBE GUIDE

Sylvania Electric has announced a new vest pocket TV Tube Selector listing more than 100 TV picture tube types, and indexing them as to round or rectangular shape; metal or glass construction; clear, grey, aluminized or frosted face plates; and presence or absence of external conductive coating. The selector was prepared particularly for the convenience of television servicemen and dealers.

The TV tube guides are supplied by Sylvania tube distributors as a free service item for use by dealers and TV servicemen. It was designed to give them a quick indication of the differences between similar tube types having different suffix letters, such as 19AP4, 19AP4A, 19AP4B, etc.

— R T M —

STANCOR LISTING

Standard Transformer Corporation's new television catalog and replacement guide, listing more than 1500 models and chassis built under seventy-nine brand names, is now available.

The guide and catalog, in addition to

listing replacement items by model number, manufacturer's part number and Stancor stock number, identifies each by code number signifying power transformer; filter reactor; horizontal output transformer; vertical output transformer; horizontal blocking-oscillator transformer; vertical blocking-oscillator transformer; audio output transformer; deflection yoke or focus coil.

All manufacturers are listed alphabetically and the models and chassis are listed in numerical order. A separate section lists all Stancor TV transformers and related components by part number.

— R T M —

PARTS SUPPLEMENT

Eighteen supplementary pages to the General Electric Company's "Radio and TV Replacement Parts Catalog" have been mailed to GE distributors and holders of the catalog, it was announced by the company's Receiver Division.

These pages bring parts information for all postwar GE radios and television sets up to date as of May 1, 1951. Holders of unregistered catalogs can obtain the additional pages by writing Mrs. E. B. York, General Electric Company, Building 1, Syracuse, N. Y.

— R T M —

VIBRATOR GUIDE

A new vibrator replacement guide has just been published by the James Vibrapowr Company. Called the "James Blue," it covers the firm's complete line of vibrators, besides giving detailed cross-reference information. Also included are complete base wiring diagrams.

Copies of the new replacement guide are available from James distributors and The James Vibrapowr Company, 4036 North Rockwell Ave., Chicago 18, Illinois.

— R T M —

CONVERSION INSTRUCTIONS

Instructions for converting small-screen TV receivers to the larger sizes are now being offered by the Electronic Parts of the Allen B. Du Mont Laboratories, Inc., East Paterson, N. J.

Step-by-step procedures have been compiled in the instructions, which are available through Du Mont jobbers.

The instructions give procedures for installing the Du Mont Inputuner, deflection yoke, horizontal output and H. V. transformer and linearity and width controls.

— R T M —

ENGINEERING TEXT

A NEW light in the McGraw-Hill display of technical books in its "Electronic Engineering Series" is "Electric Transmission Lines," by Hugh H. Skilling of Stanford University.

Like the other works in the series, "Electric Transmission Lines" is a thoroughgoing work, full of the theory and mathematics of its subject, and carrying the thought from the most basic phenomena and applications to the most complex.

For the engineering student, the book promises to be one of those standbys that are always useful, both for learning and for reference. For the radio or television technician, there is some doubt. More than likely, there are fewer than ten per cent of the 450 pages in the book that would be of direct use to the serviceman.

The subjects covered include traveling and standing waves, lossy lines; line parameters; artificial lines; skin effect; and others in the first, theoretical section of the volume. In the second section, which gets away from the theory to some extent, and deals with application of the various types of lines, the book covers telephone lines;

filter design and use; power lines; RF lines; waveguides and similar applications. The third and final section is concerned with transient traveling waves, and really goes into some high-powered material—information requiring a thorough background of engineering for proper study.

This text, which costs \$6.50, is not intended to be a definitive treatment with everything that could possibly be of use to the engineer. Rather, as the author points out in his preface, it is intended for a fairly general course of study, and its material will be applicable, for the most part, to all frequencies of transmission.

—A. G. C.

— R T M —

HANDBOOK

ONE of the many all-inclusive works for the beginner in electronics is the "Radio Handbook," now in its 13th edition.

Published by Editors and Engineers, Ltd., it is unquestionably in the upper ranks of electronic primers. The book contains 700 pages of tightly packed information, including explanations of all the things that are not obvious, and concrete examples of many of the circuits and problems that are commonly seen.

Just about all the different aspects of radio are gone into—basic electricity, operation of components, vacuum tube principles, amplifier design, transmission and reception at various levels, power supplies, antennas, and even shop practice.

Unquestionably, the "Radio Handbook" will be worthwhile to the beginner. For that matter, it might well be worth the attention of the experienced radioman who wants to do a little brushing up, or wants to clarify in his

mind a few details—the basic mathematics of radio functions, perhaps.

Considering how many entirely different topics the handbook dwells on, it is amazing how thoroughly the authors manage to go into each one. On crystal oscillators, for example, there are about four pages, which give, surprisingly, not only the origin and mechanical handling of crystals, but present a clear picture, with illustrations and diagrams, of the circuits which the crystals govern—not to mention an understanding of *why* crystal oscillators are used when a stable single-frequency note is desired.

Further, both the theory and practice of modulation and transmission are given, as is a fairly complete section on power supplies of various types.

We recommend this book highly for its chief merit—a roundup of the electronic knowledge that is useful rather than simply abstract, and a well-put-together compendium of facts for the beginning technician or amateur.

—A. G. C.

VOLTMETERS

John F. Rider's "Vacuum Tube Voltmeters," in its second edition, is without doubt the most complete work there is on the subject. Although it is not one of those indispensables for the ordinary technician, and although its subject is one of the more specialized, it still has considerable value in the field.

It not only gives the operation and fundamental circuits of the different kinds of VTVM's, but also presents data and schematic diagrams on practically *all* the electronic voltmeters now being produced.

In separate sections, the book gives the operation of diode, triode, rectifier-amplifier, tuned, amplifier-rectifier, and slide-back meters, as well as material on probes and other accessories for special uses.

With 432 pages, the volume is reasonably priced at \$4.50.

—A. G. C.



Products for the Trade

→ from page 46

from a 73 ohm source to a 73 ohm line with zero loss, and at the same time to provide a branch circuit containing 14 Db of isolation, for the connection of a high impedance monitor. It provides a simple method for the direct monitoring of the outgoing signal between the output of the line amplifier and the line without disturbing the transmission characteristics. At the same time the network provides sufficient isolation so that the line characteristics do not influence the quality of the connected monitor.

Screw driver controls are provided for compensating for the shunt capacities encountered in the monitor input cables, for band width adjustments and amplitude calibration.

If further information is required, write the Daven Company, 191 Central Avenue, Newark 4, New Jersey.

— R T M —

TWO-CHANNEL AMPLIFIER

The newest addition to the Newcomb "E Series" line of low cost utility amplifiers is a high powered model that provides two individual 25 watt channels

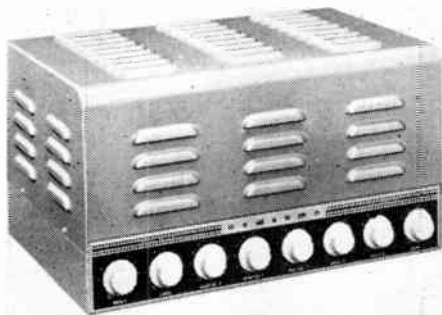

on separate controls for a total of 50 watts of undistorted audio power.

It has inputs for three microphones and one phonograph.

Inverse feedback provides output regulation. Distortion, less than 5% each 25 watt channel, the manufacturer claims. An amplifier jack on chassis permits connecting of another E-50D amplifier, thus providing a total of 100 watts from four separately controlled channels.

The unit is manufactured by Newcomb Audio Products Co., 6824 Lexington Ave., Hollywood 38, California.

— R T M —

TROUBLE LIGHT OFFER

Effective from July 15 to September 1, the Radio Tube Division of Sylvania Electric Products Inc. will offer, through distributors, a heavy duty 40-foot extension and trouble light. It will go free

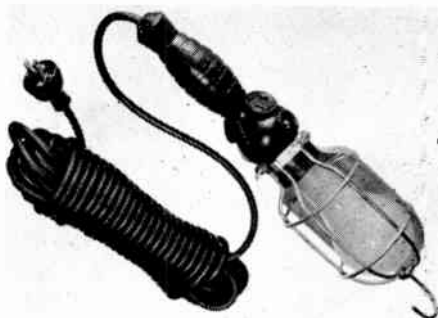

with three Sylvania TV picture tubes purchased by television service-dealers. The cord and trouble light are molded of soft rubber and include off-on switch plus two outlets for plug-in of radio or TV sets, test equipment, soldering iron or other accessories. The Bulb shield is made of plated steel.

— R T M —

TV WALL PLATE

A new "Javex" antenna wall plate is a means for providing more than one point at which a TV set can be plugged in. To be used with Javex antenna dis-



tribution systems, the new wall plate is for remote extension.

Constant impedance is a feature of the new TV outlet plate. It can be flush mounted without the usual wall box.

Further information and literature are available from dealers or from Javex, Garland, Texas.

— RTM —

HORIZONTAL OUTPUT UNIT

A new TV replacement unit, the A-8130 Horizontal Deflection Output and High Voltage Transformer, has been added to the Standard Transformer Corporation line, it was announced recently.

The Stancor unit is for use in pulse-operated single-rectifier power supplies to deliver up to 14,000 volts of anode potential with adequate sweep for full horizontal scan of 65-70 degree kine-

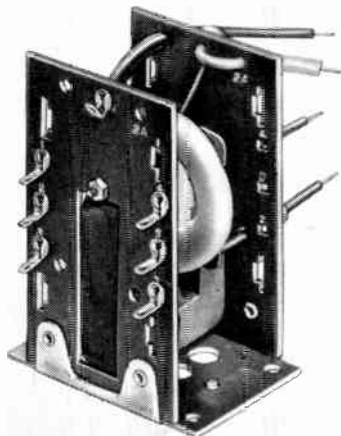

scopes with up to 24 inch screens. It may be used for conversion of older TV receivers to take newer picture tube types, and requires 3-27 Mh. width control coil. Overall height of the unit is 4-1/16 inches, with a base area of 2-7/8 x 2-3/16 inches.

— RTM —

NEW TV BOOSTER

A new TV Booster that is claimed to give particularly good channel performance has been put on the market by Stanley Sales, 600 West Third Street, Owensboro, Kentucky.

Using new techniques of tuned circuit design, the so-called SEC Booster minimizes loss of signal voltage on higher channels, gives high amplification with low noise and "snow" level. The feature is said to be most noticeable on

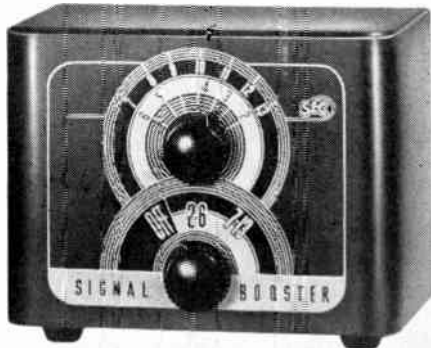

ACT NOW!

Save money! Take advantage of old rate before the deadline. See back cover.

the high channels, which have previously presented the greatest technical problems in the design of TV boosters.

The booster is installed in a shielded metal cabinet. Specifications: Tube complement, single 6J6; coverage, Channels 2-13 incl.; input, 75-300 ohms; output, 75-300 ohms; current, 110-120v, 60 cycles.

— R T M —

TAPE RECORDER

The new Masco Sound Reel Dual Speed Dual Track Magnetic Tape Recorder combines features found most desirable for commercial, professional, educational and home uses.

It records at speeds of either 3.75 in./sec. or 7.50 in./sec. The higher speed offers finer tone quality. The slower speed provides economy. Recordings are made at both speeds on the same track. Dual Track permits full two-hour recording on a single 7" reel (1,200 ft.).

Six models are available, several with built-in AM radio. The recording unit

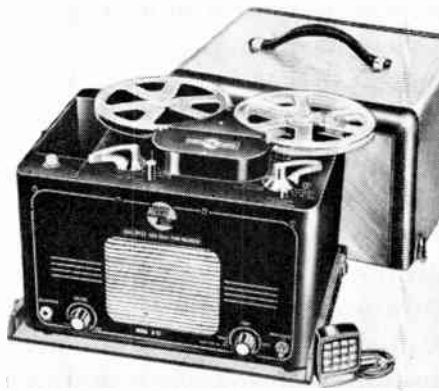

is built into an aluminum housing, which fits into the portable carrying case.

A volume level indicator (neon bulb) assures best quality recording at all times. Reel spindles are threaded to permit bolting down of reels.

The machine is made by the Mark Simpson Mfg. Co., New York.

MULTIMETER



Electronic Instrument Co., Inc., 276 Newport Street, Brooklyn 12, N. Y., designers and manufacturers of EICO instruments and kits, has engineered into the new Model 526 1000 ohms/volt multimeter wide capabilities for an instrument of its type.

It has 31 different ranges, with a zero-to-one volt range in its AC and DC Voltage Ranges—a feature never before designed into this type instruments, the maker states.

The 3-1/2" meter has a 400 μ a movement. Resistors have 1% or better accuracy. The integral dual rectifier has separate low and high voltage calibration in AC ranges. The ohm ranges are designed for minimum battery-drain.

Ranges: AC & DC Voltage: Zero to 1, 5, 10, 50, 100, 500, 5000, at 1000 ohms/volt. DC Resistance: Rx1, Rx10, Low Ohms. AC & DC Current 0.1 ma, 10 ma, 0.1 a, 1 A. Db range: -20 to +69 db. DC Accuracy: $\pm 3\%$ of full scale. AC Accuracy: $\pm 5\%$ of full scale.

— R T M —

HV TRANSFORMER

A new Du Mont horizontal deflection output and high voltage transformer—

Type H1A1—is now available to the trade for conversion or replacement purposes.

The new unit features a high-efficiency design with a Ferrite core and special windings. It is capable of supplying 12 to 13 kilovolts to a 70° tube. It will be useful for conversion of a TV receiver using a smaller size CRT to a larger size. Mounting has been so designed so that the unit lends itself to either horizontal or vertical mounting without any special hardware. Holes are provided for the use of #8 self-tapping screws.

Through the utilization of the Ferrite core and special windings, size and weight have been kept to a minimum, the manufacturer states.

— R T M —

NEW CAPACITOR LINE

A complete metallized paper tubular line of capacitors for general purpose use, is being introduced by the Cornell-Dubilier Electric Corporation. Among their features are compactness and light weight, combined with high insulation resistance, low power factor, and self-healing characteristics.

The new line is available in three basic types—the "Pup," "Sealpup," and "Metapup." They are extremely small, representing a 50 to 75 per cent size

reduction over foil or conventional types of paper dielectric capacitors.

The Pup is a capacitor with metal end caps and enclosed in a wax impregnated paper tube. It may be used over a temperature range from -40° to $+60^{\circ}$ C. without derating. Available in a range of nine capacities from .01 to 2.0 mfd at 200, 400, and 600 volts DCW, it is particularly suitable for portable equipment where space is limited.

The Sealpup is an extraordinarily small type of metallized paper tubular capacitor, with a positive seal against moisture. It ranges in size from .175 x 11/16 to .750 x 2-3/16 inches diameter and length. It is available in a complete eleven-capacity range, from .01 to 2.0 mfd at 200, 400, and 600 volts DCW.

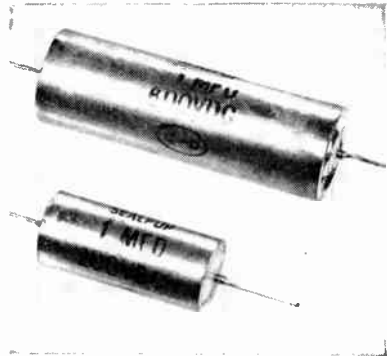

→ to page 64

Trade Literature

→ from page 54

HALLDORSON CATALOG

The Halldorson Company, 4500 Ravenswood Avenue, Chicago 40, has recently brought out a new catalog, No. 19. It lists a complete line of Radio and Television transformers. Many items listed are of interest to a wide range of industries. Among such items are isolation, stepdown, filament and voltage-regulating transformers. A copy may be obtained on request.

— RTM —

RCA SERVICE—VOL. 6

The sixth bound volume of RCA Victor service data, which provides service and technical data on all 1950 models of RCA Victor television sets, as well as radio receivers and phonographs, is now available to servicemen through RCA distributors.

Designed as a permanent reference volume, the book contains the information provided by the single service-data booklets issued during 1950 for individual RCA Victor instruments.

The contents include servicing information such as schematic and wiring diagrams, electrical and mechanical specifications, alignment and adjustment procedures, complete service parts lists, chassis layouts, and other service data on RCA sets.

The new volume contains 472 pages. The price is \$5.50.

— RTM —

NEW RIDER CATALOG

John F. Rider Publisher, Inc., has made its Spring 1951 catalog available.

The 8-page 8½ by 11-inches catalog is a complete listing of Rider Manuals and textbooks. It also contains information on Rider's "Continuous Diagram Service," a service that supplies factory-

authorized servicing data for individual model numbers between publications of Rider Manuals.

Copies of the catalog are available from the organization's distributors or directly from the publisher.

— RTM —

'SLIDE RULE' NEEDLE CHART

A simplified phonograph needle chart and replacement guide has just been developed for the retail and jobbing trade by Jensen Industries, Inc.

The new needle guide resembles a graphic calculator type of slide rule. It embodies all the necessary variables and characteristics a serviceman or clerk needs to know in the absence of the exact model or replacement number, including the three turntable speeds, and

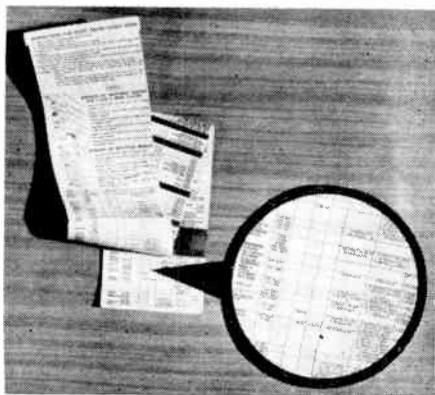

the methods of switching and of mounting needles. In addition, silhouettes of the 70 different needle styles are shown with their respective cartridges.

With cartridges listed on one side and phonographs on the other, the sliding element is brought up to the desired position and the required information is then speedily ascertained.

A feature of the "Jensen Needle Guide" is that it is not necessary to know model number of the phonograph, cartridge number, or any other information that is not readily available.

The guide and full information on the

Jensen line of replacement needles may be obtained from local distributors or by writing direct to Jensen Industries, Inc., 329 South Wood Street, Chicago 12, Illinois.

— RTM —

CARTRIDGE GUIDE

The Astatic Corporation, Conneaut, Ohio, has just published a new phonograph cartridge directory and replacement guide. The directory has listing of cartridge models of all major manufacturers. Cartridges made by Astatic competitors are listed alphabetically and numerically, and the recommended Astatic replacement for each is indicated.

The guide includes illustrations of all Astatic cartridges and needles, together with complete performance data on each. Another section carries a listing, also in table form for easy, quick reference, of discontinued Astatic cartridges and the proper, current replacements for them.

Available in quantities, the new directory may be obtained by writing The Astatic Corporation, Conneaut, Ohio, specifying Form No. S-168.

— RTM —

The Editor's Mailbag

→ from page 7

preciation and hope you will keep up the good work.

G. W. Winter
Cleveland, Ohio

(Ed. Note: *Thanks. Subscribers like you help us retain a few of our graying hairs.*)

— RTM —

Wants February Issue

Dear Editor:

I just recently received one of your advertising folders relative to subscriptions and in the folder noticed that in your February, 1951, issue there was an article on Square Wave Analysis of

Audio Equipment. Would it be possible to still secure a copy of that issue?

Alter L. Hause

Albuquerque, New Mexico

(Ed. Note: *Why, sure!*)

— RTM —

Interested in Meter

Dear Editor:

Regards articles in May issue of RTM, Hints by Harper. He mentions a meter by International Instrument Co. Please send me full address so I may check on price and availability. Thank you.

TV of Nassau

Westbury, N. Y.

(Ed. Note: *We'll mail the info right away.*)

— RTM —

Likes TV Articles

Dear Editor:

I like your publication and enjoy reading it very much, especially the articles pertaining to TV service.

Geo. W. Arnold

Jennings, Missouri

— RTM —

Wants Less TV

Dear Editor:

How about cutting down on TV servicing and giving us more radio and audio? Until the freeze unfreezes, there's still a lot of us who have audio servicing only.

S. T. Holman

Portland, Oregon

— RTM —

Inquiring About Subscription

Dear Ed:

Some time ago I saw one of your magazines and it seemed very good. I am finally getting around to inquire as to the subscription rates. Also, I would like to know if it is possible to get all of your back issues if available. Hoping to hear from you soon.

Irving Goldstein

Brooklyn, New York

What they're saying . . .

. . . about color

Benjamin Abrams, president, Emerson Radio and Phonograph Corporation

"A compatible color system will come as a natural sequence and with all the benefits of the constant developments and progress now being made in black-and-white television. This will be concretely demonstrated to the public through comparison of the limited entertainment value of the mechanical color system with the strides made in black-and-white reception. When the public is presented with all the facts and understands the true picture, I feel confident that the sale of present-day black-and-white receivers will be greatly stimulated."

David Sarnoff, chairman of the board, Radio Corporation of America

" . . . Regardless of when that {RCA color} approval may come, black-and-white broadcasts will remain the backbone of the television industry for a number of years to come. It is one thing to produce color equipment in the laboratory and another thing to be able to make it available in sufficient quantity and uniform quality, at a price within the reach of the average buyer. Engineers must design the equipment for home use, factories must be tooled up for mass production, and new techniques must be perfected for broadcasting color programs satisfactorily. All of this, and public acceptance, too, do not come overnight.

"We have a parallel in the motion picture industry. Color films have been made for many years, and yet most of the movies are still in monochrome. So, while color television is sure to come, we must not lose sight of the fact that there is still much work to be done to bring it even to the present state of black-and-white television. And there is still room for improvement in present television."

Allen B. Du Mont, president, Allen B. Du Mont Laboratories, Inc. (telegram to Wayne Coy)

"Have just observed operation of tri-color tube in our own laboratory. For the first time I have seen color pictures which I consider eminently satisfactory and practical for home receivers. Recommend that you consider postponement of opening of CBS color until you have observed this. Could show it to you Monday morning if you wish."

. . . about UHF

Glen McDaniel, president, Radio-Television Manufacturers Association

"I believe the demonstrations make it clear that owners of VHF television receivers have nothing to fear from UHF. Manufacturers will be ready

What they're saying . . .

with simple and relatively inexpensive conversion equipment once the Federal Communications Commission is prepared to issue construction permits for UHF television stations.

"Of course, many VHF set owners may not feel the need of the UHF equipment for some time, since there is no intention of curtailing the present VHF service which in many areas provides all the network programs. But even in areas which now have inadequate service and where UHF stations will supplement VHF telecasting, there is no need for anyone to wait for VHF-UHF combination receivers.

"The industry is agreed that UHF telecasting is satisfactory from a technical point of view and will be a welcome addition to our present limited VHF telecasting channels. It will make possible a nation-wide telecasting system, eventually embracing as many as 2,000 TV stations. Consequently, we look forward to its early entry into the television field.

"However, any extensive development of UHF telecasting will take considerable time to achieve—even after the FCC opens the UHF channels for commercial operation—and it may be a long time before UHF stations are erected in cities now well served by VHF outlets.

"Regardless of the timing, no present television set will be made obsolete by the advent of UHF telecasting. Where UHF stations are added to present VHF stations, ample conversion devices will be available. Meanwhile, anyone who waits for UHF-VHF sets will be depriving his family and himself of many hours of enjoyment."

. . . about business

Glen McDaniel, president, Radio-Television Manufacturers Association (telegram to Federal Reserve Board Chairman)

"On behalf of 336 manufacturers of television sets and component parts, who are members of the Radio-Television Manufacturers Association, and also non-members of the association cooperating with us, I urge that the Federal Reserve Board take prompt action to relieve the distress conditions of our industry by suspending Regulation W for ninety days. Also that when the Regulation is reimposed after the suspension period television sets be classified as home furnishings so that the down payment will be 15 percent rather than 25 percent. Sales are at a standstill all over the country. Factory production has dropped from an average of 200,000 sets per week last fall to 50,000 sets per week now. Television production lines are completely shut down in many plants and in some instances entire plants are closed. Factory inventory is 600,000 sets against an average of 50,000 last fall. Reports by less than half of the members of the Association show over 50,000 unemployed in those plants alone.

"A pronounced disservice to the mobilization program is being caused by

these widespread layoffs of employees who will be needed later for military contracts. Regulation W as applied to our industry has created a condition of depression contrary to intent of the enabling legislation which was to restrain inflationary pressure but not to create depression. Relaxation of Regulation W as applied to our industry will help in the fight against inflation by transferring buying pressure from areas in the economy where genuine inflation exists to this area where acute deflation exists. The problem is of the utmost urgency and we plead for prompt action by the board."

. . . about the future

Walter A. Buck, vice-president and general manager, RCA Victor Division

"The variety of uses for electronic equipment in industry and communications, as well as in the home, has increased greatly in recent years, and future applications are limited only by man's imagination and his ability to engineer and design the equipment. This has been called the Electronic Age, but its fulfillment lies ahead, in the days when we shall work and live in a true peacetime economy."

Anthony Wright, vice-president in charge of engineering for consumer products division, Caphart-Farnsworth Corporation

"I would imagine that in the minds of many of you, the current state of the television industry is one of utter confusion. I think that you will agree with me when I say that it is amazing that the television industry has come along so well and so fast considering the many road blocks that we have faced in the past few years. This, in retrospect, gives me sufficient courage to predict that a healthy and satisfying business is ahead of us and that possibly the troubles that beset us at the present time will be resolved within the next two years to the extent that we will not need too much of a crystal ball to see where we are going.

"It is the belief of the majority of manufacturers that the third and fourth quarters of 1951 will be a period of shortages. Every lull in business is followed by a period of great activity. This is historically so. It may well be that a second buying wave will occur just as soon as people's pocketbooks have been fattened up and shortages will develop. For instance, a rush may be in prospect to beat the proposed increase in excise tax. Employment is at an all time high and with the expansion of rearmament operations incomes will also increase. It takes no crystal ball to tell you that there are insufficient black and white receivers to go around and it certainly is not in the cards for color receivers to be abundant or that color programming will be of such order to encourage the sale of such receivers. For the remainder of this year the present inventory of black and white receivers in both finished and unfinished form will not suffice to provide a profitable business for all."

Products for the Trade

→ from page 58

The Metapup is a hermetically sealed capacitor enclosed in a one-piece metal tubular case, pressure sealed. It is available in a range of twelve capacities from .01 to 6.0 mfd at working voltages up to 600 volts DCW.

— R T M —

TV GENERATOR



An all-purpose video generator designed as a test instrument to identify and localize trouble in any section of a TV receiver—independent of station operation—is the new Hickok "Vidometer."

Developed after three years of research and engineering testing, and crystal controlled for electronic accuracy, it is reported to be ideal for on-location fringe area servicing.

Called the Model 650, the instrument has RF output directly calibrated in microvolts for TV receiver sensitivity checks. It contains a line voltage scale for instantaneous check on line voltage fluctuation—a common cause of picture trouble. The device also includes horizontal and vertical sawtooth voltages which can be directly substituted for vertical and horizontal oscillator in a TV receiver.

Amplitude is sufficient to give full raster deflection, and in the case of fly-back type high voltage power supplies, the horizontal sawtooth can be used to light up the picture tube.

It can also be used as a TV transmitter to simultaneously transfer a program to any number of TV receivers on any desired channel.

For complete information, write to Hickok Electrical Instrument Company, 10634 Dupont Avenue, Cleveland 8, Ohio.

— R T M —

QUICK CONSTRUCTION YAGIS

The T-V Products Company of 152 Sandford St., Brooklyn, N. Y., has added 5-element Yagi Antennas to its line.

Designed with the new "Quick-As-A-Wink" construction, these antennas have only 2 bolts to tighten. The entire antenna is completely pre-assembled, and requires only a few seconds to open. The

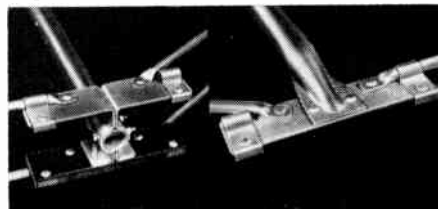

tempered spring construction is designed to lead the various elements into position; and once there, to hold them permanently in place.

A new catalog illustrating the entire line is now available, and will be furnished upon request to T-V Products Co.

— R T M —

TV DISTRIBUTION SYSTEM

A new TV distribution system has been announced by Electro-Voice, Inc., Buchanan, Michigan.

The System provides a convenient means for simultaneous operation of more than one Television Receiver from a common antenna, the maker says. The Model 3100 provides sufficient isolation between the TV Receivers to prevent

interference resulting from local oscillation. In addition, the Distribution System properly matches the antenna impedance to each receiver input, it is claimed.

The model 3100 permits some flexibility in installation. One hook-up will service four TV Receivers. In more elaborate installations, combinations of distribution systems in series serve a large number of receivers.

The system is housed in a ventilated gray hammertone steel case. Six Cinch-

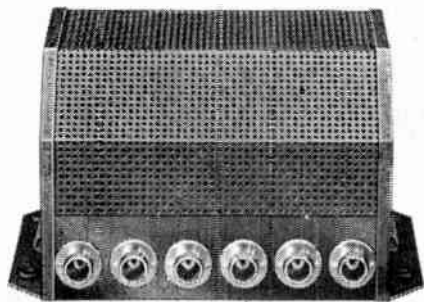

Jones coaxial sockets provide access to four receiver outlets, the signal input and the signal output. The unit includes an AC line cord and plug and a terminating resistor. The case, equipped with rubber grommet feet, may be mounted horizontally or vertically. The use of 72 ohm shielded coaxial cable for all leads assures best results.

— RTM —

NEW 5YP CRT

The Instrument Division of Allen B.



Du Mont Laboratories, Inc., announces the "Type 5YP-" cathode-ray tube. The tube is designed for low- and medium-voltage operation and is suited especially for wide-band equipment.

For this category of operation, it is claimed to be the most sensitive tube commercially available. One inch of vertical deflection can be obtained with an input to the deflection plates of 12 volts peak, per kilovolt of accelerating potential applied to the second anode. It also employs an intensifier for increased brightness and smaller spot size.

The elongated vertical deflection plates of the tube are similar to those of the Du Mont "Type 5XP-."

The plates have been spaced to provide maximum sensitivity commensurate with distortion-free performance over the 3 inch usable vertical scan of the tube.

— RTM —

HINTS BY HARPER

→ from page 38

in the vertical circuit. The tell-tale indication is loss of horizontal sync beyond any restoration by means of adjustments. With 6SN7's scarce, the service

Have a new address?

When you move or plan to move, tell us about it! Make sure that your copies of RTM reach you at your new address. Send your old and new address to: **Circulation Dept., Radio and Television Maintenance, Box 867, Atlantic City, N. J.**



technician will be glad to learn that these two tubes may be switched in position.

The "fresh" 6SN7 from the vertical stage will restore operation of the horizontal multivibrator, and the original horizontal tube works satisfactorily in the vertical stage although it will not perform properly in the multivibrator.

J. J. HARPER.

— R T M —

THE 40-50 MEGACYCLE IF

→ from page 21

Only four connections are necessary for installation, namely: B+, filament, AGC, and video amplifier input. These amplifiers are available individually or as composite units. The illustration shows the layout of parts in an amplifier strip. Note that the sockets are over the interstage shielding strips and that the layout is most compact.

A comparison of Fig. 1, (A) and (B), indicates the chief changes made in a typical 20-30 Mc IF system as compared to a 40-50 Mc IF system. Stagger tuning is employed in both systems.

According to the engineers who worked on this conversion project the most difficult aspect of the changeover was to make the system stable for all values of AGC or contrast bias.

Fig. 2 shows a bandpass curve of a 40-50 Mc IF amplifier of the type shown at 1 (B), for different values of bias voltage. The symmetry of this curve approximates the ideal shape. It is interesting to point out that this is a better response curve than that obtainable for the amplifier shown at (A) in Fig. 1.

In perfecting this amplifier, the variables to be tracked down included the usual refinements made on any electronic system, such as making lead lengths very short, the adjustment of leads on critical

bypass capacitors to provide series resonance, bypassing to the best spots on the chassis or socket pins, elimination of common impedances, shielding, decoupling, etc.

The improvement in both gain and bandwidth for the 40-50 Mc amplifier over the 20-30 Mc system is in part due to the use of a better type tube—the 6BC5. Both gain and bandwidth show an increase with a tube like the 6CB6, which seems to be the best all round tube for the 40-50 Mc IF.

— R T M —

AUTOMATIC RADIO WEATHER STATION

→ from page 16

Counteracts Friction

A special technique is used to insure maximum accuracy of the transmitted data despite possible deformation of the weather-responsive mechanisms due to landing impact: a buzzer vibrates each weather-responsive device for a short time before its associated resistor is inserted in the relaxation oscillator circuit. This forced vibration counteracts friction, which may have been increased by landing-impact deformation, and thus aids in the attainment of a true equilibrium condition.

The developmental model of the weather station had an output of the order of 5 watts. Operating on a frequency in the neighborhood of 5 megacycles, it performed reliably over land at ranges of more than 100 miles. The dry batteries used provided power for transmission of weather reports at 3-hour intervals for more than 15 days.

ANSWERS TO VOCABULARY QUIZ

→ from page 13

K-1	S-6	M-11	L-16
J-2	T-7	G-12	F-17
H-3	P-8	R-13	D-18
N-4	A-9	C-14	B-19
O-5	E-10	I-15	Q-20

What Happens in August?

AFTER nearly seven continuous years of publishing in the conventional 8½" by 11" size, RADIO and TELEVISION MAINTENANCE wore a new dress this month. The dress size, 5½" by 8½", gave the field the first easy to read, easy to handle "digest" size magazine.

NO CUT IN CONTENTS

No cut, but rather a substantial increase in pages and total editorial content appears in this issue. In addition, the new dress has been adorned with many new features, an increased news section and more technical art.

While RTM's editorial superiority in the field has always been tied in with the office slogan "subscriber preference," steps have been taken to tie these two guides even closer together . . . giving the subscriber more and more of the technical data he needs and wants in the field of radio, audio and video.

100 PAGES COMING

Effective August 31, 1951, RTM rates will be brought up to those of other publications. At the same time the editorial pages will again greatly increase. This increase to 100 pages in August is part of RTM's policy to advance with the growth of the industry, putting forth on the printed page all the latest technical information, news and features that the serviceman has asked us to give him.

While giving our present subscribers the benefit of the enlarged content, we also are making a low-rate offer available so that they may enjoy the bigger, better content at the old rates. (See the back cover.)

You Can Still Subscribe At the Old Rate

New Rates Take Effect August 31, 1951

The subscription price of Radio and Television Maintenance has been raised in line with the rates of other publications and to offset the increased costs of producing the expanded publication on its way. New subscribers may take advantage of the old \$2-per-year rate until August 31, 1951. Present subscribers will be permitted to extend their subscriptions by one or two years (or renew) at the old rate until August 31, 1951.

**Save \$4.00
Get RTM 2 Years
for Only \$3.00**

By starting a new subscription now, or extending your present subscription, you may take advantage of the old rate of \$3 for two years. After August 31, 1951, the two-year rate is \$7. Save \$3 by acting right away! Clip and mail the form below with your remittance today! Remember, this offer is good until midnight, August 31, 1951.

**100 PAGES
IN AUGUST**

The current issue contains 68 pages. The August issue is jumping to 100 pages. This increase in pages, features, writers, schematics and photographs is part of a general program to bring you more of the material you have asked for, and to make RTM more valuable to you each month.

NEW RATE: 1 Year—\$4, 2 Years—\$7, Canada (add \$1), Foreign (add \$2)

OLD RATE: 1 Year—\$2, 2 Years—\$3, Canada (add \$1), Foreign (add \$2)

OLD RATE SUBSCRIPTION ORDER

(Not Valid after Midnight, August 31, 1951)

Renewal New Subscriber Extension of Subscription

Name

Occupation or Job Title

Address

City Zone State

Enclosing: Check Money Order Cash

Old Rate: One year—\$2, Two Years—\$3, Canada—add \$1, Foreign—add \$2

Mail to: Circulation Dept., Radio and Television Maintenance, Box 867, Atlantic City, N. J.