

CIRCULATION LARGER THAN ALL OTHER RADIO MAGAZINES COMBINED

RADIO NEWS

REG. U.S. PAT. OFF.

20 Cents
December
1921

Over 100 Illustrations
Edited by H. GERNSBACK

LOCATING ORE BY RADIO

SEE PAGE 490

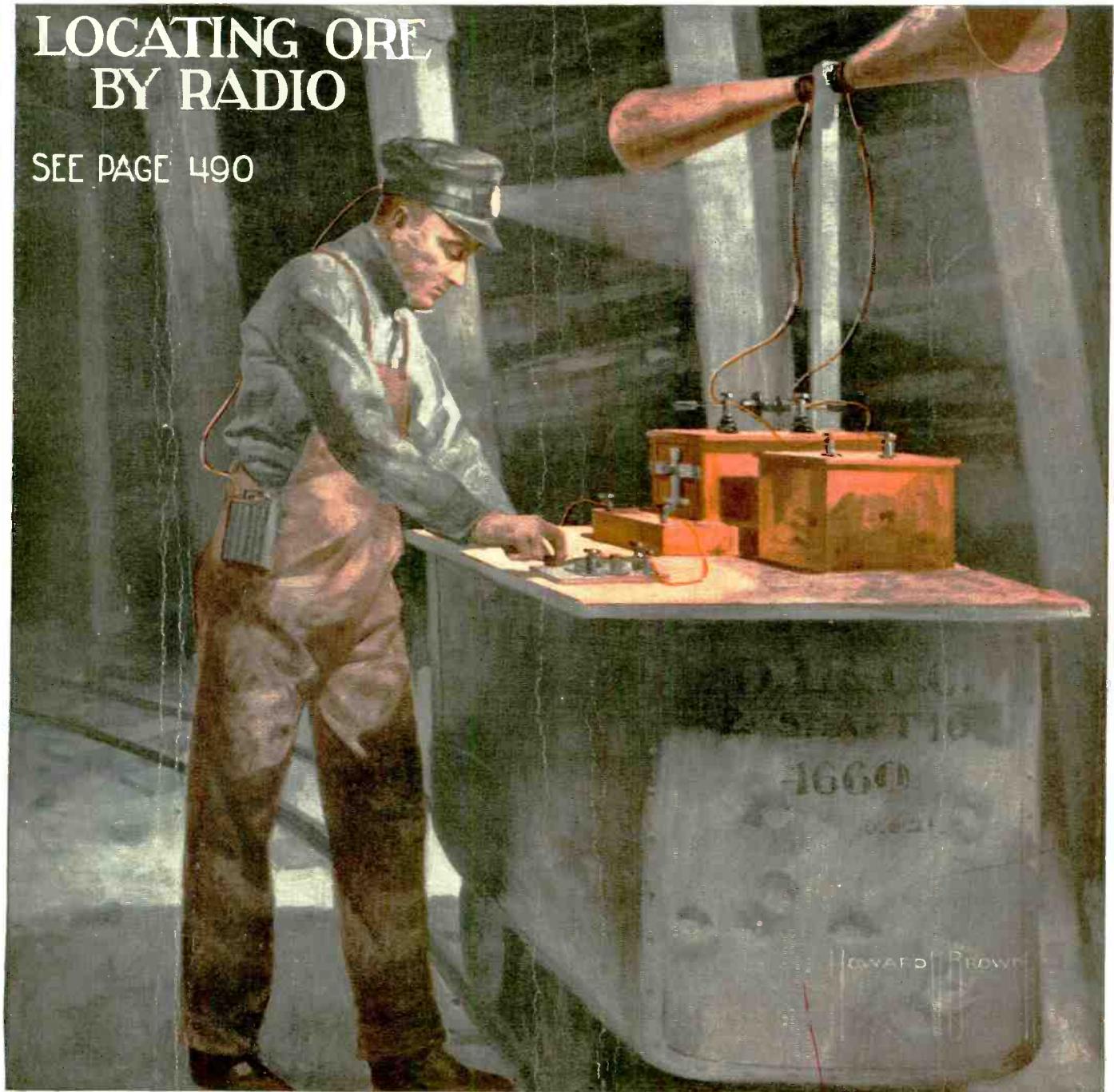

"THE 100% WIRELESS MAGAZINE"



Cunningham
C-300
Gas Content
Detector

\$5.00

Announcing the New Home of

CUNNINGHAM VACUUM TUBES AND REMLER RADIO APPARATUS

THE strict adherence to quality in the manufacture of Cunningham Tubes and Remler apparatus has been largely responsible for the nationally recognized merit and increased sales of our product which has necessitated the enlargement of our plant facilities. With our Chicago office functioning as a central and Eastern distributing center under the direction of Herbert H. Frost and our enlarged San Francisco home office and plant we are now in a position to render a more highly perfected service to our valued clientele.

If you have not received our new 32 page catalogue of Remler Apparatus and Cunningham Tubes send your name and address today for free copy.

General Manager

REMLER RADIO MFG. COMPANY
AUDIOTRON MFG. COMPANY

248 First Street
San Francisco, Calif.

154 West Lake Street
Chicago, Illinois

REMLER APPARATUS RADIATES QUALITY
CUNNINGHAM TUBES MEET EVERY AMATEUR REQUIREMENT

Acme

C.W. APPARATUS

**ONE OUT OF A THOUSAND
COME BACK**

DURING all the time ACME has built C.W. apparatus, less than one instrument out of every thousand has come back for replacement, or even repairs.

Take the uncertainty OUT of C.W. by using ACME apparatus thruout.

Acme was the first to prepare for C. W. Years ago we began to develop an Acme instrument to anticipate C. W. need. Today Acme has the most complete line of C. W. apparatus in existence. Each instrument is the fruit of

exhaustive research, and all are designed with careful reference to the others. Before you start your C.W. outfit, get the Acme bulletins. And when you do build use Acme apparatus throughout!

ACME APPARATUS CO.

188 MASSACHUSETTS AVENUE
CAMBRIDGE, 39, MASS.



And don't forget the little Acme detector and amplifier unit, Compact, efficient, guaranteed, reasonably priced. Equipped with "A" battery potentiometer. At all dealers.

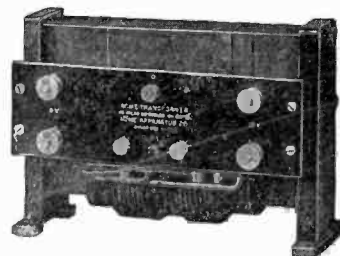

Filament Heating Transformer

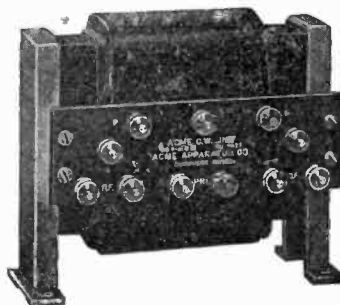

C. W. Power Transformer

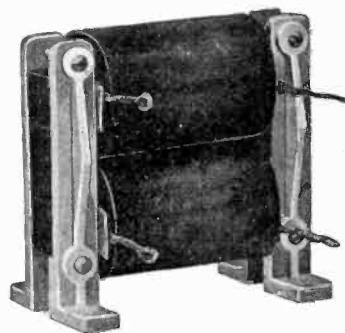

1½ Henry Choke Coil

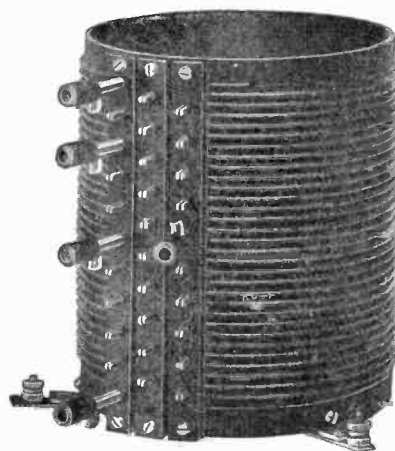

C.W. Inductance

RADIO NEWS



CONTENTS

VOL. 3

FOR DECEMBER

No. 6

	PAGE		PAGE
Editorial.....By H. Gernsback	479	Winning the Public to Radio, By Raymond Francis Yates	494
President Harding Opens the World's Largest and Most Powerful Radio Station.....By Pierre Boucheron	480	An Adaptation.....By C. L. Whitney	495
The WJZ Radiophone Broadcasting Sta- tion at Newark, N. J.....	482	Panel Mounting for Spider-Web Coils, By H. S. Morris	495
Radio on a New York Newspaper, By Arthur H. Lynch	483	A Compact Variable Condenser, By D. H. Watkinson	495
A Complete Portable Receiver.....	484	Radio Digest	496
A New Tuner and Amplifier.....	484	Who's Who in Radio—John Hays Ham- mond, Jr.	497
Radio in Department Stores, By Victor Rawlings	485	The Story of Radio Telegraphy, Prof. Branly's Account of the Great Inven- tion.....By Leon Lansberg	497
Radio for All.....	485	The Radio Constructor—An Audion Con- trol Cabinet for Amateur Use, By Paul G. Watson	498
A Two K.W. Vacuum Tube Set for Panama	486	A Triple Purpose Key, By Charles Bloom	499
A New Departure in Short Wave Recep- tion.....By H. L. Arthur	486	A Variometer Unit, By Charles E. McGuire	499
A Highly Efficient Receiver, By Charles M. Srebroff	487	C.W. Transformers... By Florian J. Fox	500
Must We Abandon Dots and Dashes? By Austin C. Lescarbourea	488	A Type of Honeycomb Variometer, By Harry Olson	501
Choke Coil Amplifiers... By J. P. Jessup	489	"So This is the Wireless," By Stanley Edgar	502
Locating Ores by Radio.....	490	"World's Record"-----By Clyde C. Young	503
Tikker Reception of C.W.....	490	With the Amateurs.....	504
Modulation Systems of C.W. Which Will Give Satisfaction in Your Station, By Arthur H. Lynch	491	Junior Radio Course.....	506
Some Notes About My Station, By J. L. Leistra	492	Junior Constructor.....	507
Shielding Your Panel, By Howard S. Pyle	493	Correspondence from Readers.....	508
Radial Inductances Eliminating QRM, By Fred G. Ehlert	493	Club Gossip	509
		Dictionary of Technical Terms Used in Radio	509
		I-Want-To-Know	510
		The American Radio Operator, By Edward T. Bicak	565

RADIO NEWS is published on the 25th of each month at 233 Fulton Street, New York. There are 12 numbers per year. Subscription price is \$2.00 a year in U. S. and possessions, Canada and foreign countries, \$2.50 a year. U. S. coin as well as U. S. Stamps accepted (no foreign coins or stamps). Single copies, 20 cents each. A sample copy will be sent gratis on request. Checks and money orders should be drawn to order of EXPERIMENTER PUBLISHING CO., INC. If you should change your address notify us promptly, in order that copies be not mis-carried or lost. No copies sent after expiration.

All communications and contributions to this journal should be ad-dressed to: Editor, RADIO NEWS, 233 Fulton Street, New York.

Unaccepted contributions cannot be returned unless full postage has been included.

Published by EXPERIMENTER PUBLISHING CO., INC.

233 Fulton Street, New York City

Publishers of Radio News and Science and Invention

H. GERNSACK, President

S. GERNSACK, Treasurer

B. W. DE MOTT, Secretary

included. ALL accepted contributions are paid for on publication. A special rate is paid for novel experiments; good photographs accompanying them are highly desirable.

RADIO NEWS, Monthly. Entered as second-class matter June 4th, 1919, at the Post Office at New York, N. Y., under the Act of March 3, 1897, Title registered U. S. Patent Office. Copyright, 1921, by E. P. Co., Inc., New York. The Experimenter Publishing Co., 233 Fulton Street, N. Y., N. Y. The Contents of this magazine are copyrighted and must not be reproduced without giving full credit to the publication.

RADIO NEWS is for sale at all newsstands in the United States and Canada; also at Brentano's, 37 Avenue de l'Opera, Paris.



Confucius has said =
 "Only two
 classes of men
 never change -
 the wisest of the
 wise and the
 dullest of the dull."
 The owner of a
 Grebe Receiver
 will never
 change it -
 he is the
 wisest of the wise

Doctor Wu

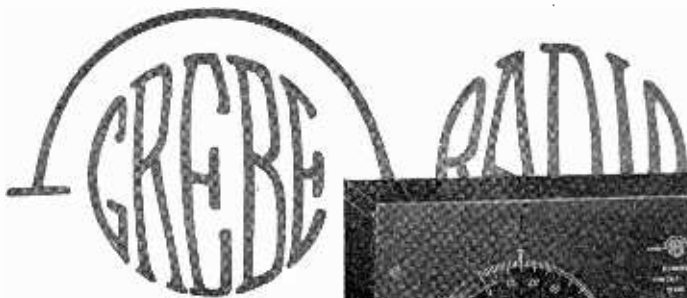

The Grebe CR-5 Receiver

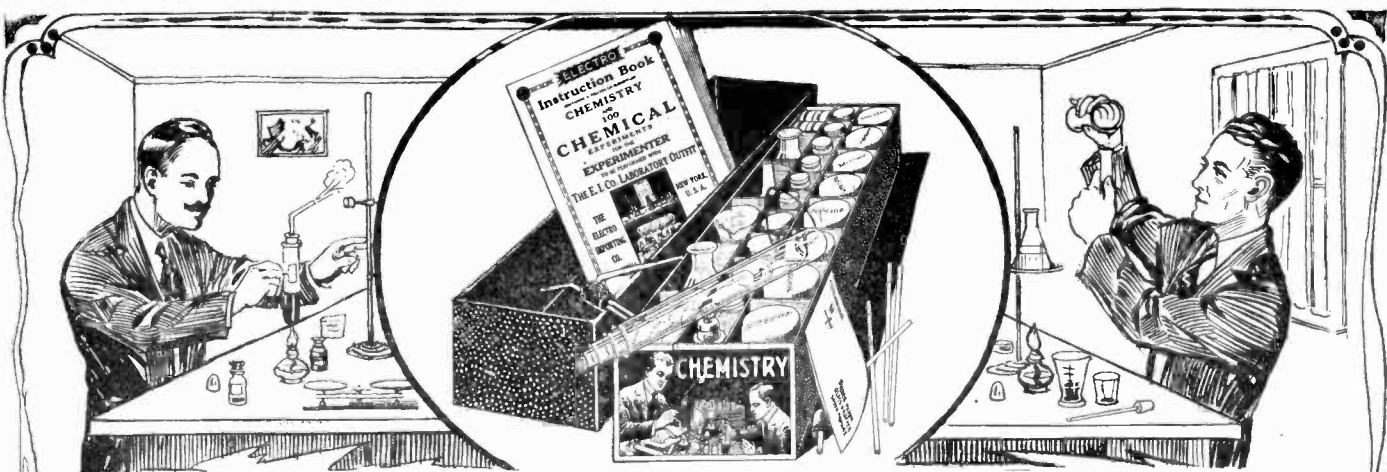

A REAL Chemical Laboratory

The new E. I. Co. Chemical Laboratory contains real chemicals and apparatus to perform real chemical experiments. This outfit is not a toy, put up merely to amuse, but a practical laboratory set, with all the chemicals, apparatus and reagents necessary to perform real work and to teach the beginner all the secrets of inorganic chemistry. With this outfit we give free a book containing a **Treatise in Elementary Chemistry**, useful data and recipes, and 100 instructive and amusing experiments.

Complete
as shown
\$7.50

DESCRIPTION OF THE OUTFIT

The outfit consists of forty-four (44) Chemicals and Reagents all C. P. (chemical pure) put up in appropriate wooden boxes, glass bottles, and hermetically closed jars. The acids are put up in glass bottles, with ground-in glass stoppers and there is a sufficient quantity of chemicals supplied (mostly one to two ounces) to make dozens of experiments with each.

The apparatus furnished are all of the best obtainable make and of standard laboratory size and shape.

The **Instruction Book** is a real Chemistry Course for the Beginner. Some of the Contents are: **Division of Matter:** This is a Treatise on Elementary Chemistry and deals with the theory of the Elements, Molecules and Atoms, etc. **Chemical Nomenclature:** This explains in simple language the derivation of the chemical names of the elements and their compounds. There is a chapter on **Laboratory Operations; Glass Working; First Aid;**

Fire Extinguishers; Experimenters' Aphorisms, etc. A good part of the book is devoted to **Weights and Measures.** The Metric System, The English system and the U. S. System are fully explained.

The following tables are furnished: Symbols and Atomic weights of the Elements; Measures of Weights, Volume, Capacity and Length; per Cent solutions; Conversion of Measure expressed in parts; poisons and their antidotes; Technical and common name of chemical substances; Formulas for Cleaning various substances, etc., etc.

Among the 100 Experiments are:

How to make chemical tricks; How to make invisible and magic inks; How to test flour; How to test soil; How to Make Chlorine Gas and smoke (German War Gas); How to bleach cloth and flowers. How to produce Oxygen and Hydrogen; How to make chemical colors; How to test Acids and Alkalies and hundreds of interesting hints and formulas.

Contains the Following Chemicals and Apparatus:

Chemicals and Reagents		Apparatus
Alum $Al_2(SO_4)_3 \cdot (NH_4)_2SO_4$	Chloride of Zinc ($ZnCl_2$)	One Standard Washbottle
Antimony (powdered) (Sb)	Copper Sulphate ($CuSO_4$)	One Alcohol Lamp
Ammonium Aqua ($NH_3 + H_2O$)	Ferrous Sulphate ($FeSO_4$)	One Conical Glass Measure
Ammonium Carbonate ($(NH_4)_2CO_3$)	Ferrous Sulphide (FeS)	One Erlenmeyer Flask
Ammonium Chloride (NH_4Cl)	Glycerol (Glycerine) $C_3H_5(OH)_3$	One Glass Funnel
Ammonium Sulphate ($(NH_4)_2SO_4$)	Hydrochloric Acid (HCl)	One Delivery Tube
Barium Chloride ($BaCl_2$)	Iodine (I)	Six Assorted Test-Tubes
Boric Acid (H_3BO_3)	Iron Chloride ($FeCl_2$)	One Test-Tube Holder
Brimstone (Sulphur) (S)	Iron Oxide (Fe_2O_3)	Ten Sheets of Filter Paper
Calcium Chloride ($CaCl_2$)	Lead Acetate Pb ($C_2H_3O_2$):	One Glass Dropper
Calcium Oxide (CaO)	Litmus Paper	One Spoon Measure
Calcium Sulphate ($CaSO_4 \cdot 2H_2O$)	Magnesium Carbonate ($MgCO_3$)	Glass Tubing
Charcoal (Carbon) (C)	Manganese Dioxide (MnO_2)	One Book containing Treatise on Elementary Chemistry and 100 Chemical Experiments to be per- formed with this outfit.
	Mercury (Quicksilver) (Hg)	
	Nickel Chloride ($NiCl_2$)	
	Oxalic Acid ($H_2C_2O_4$)	
	Sodium Bicarbonate ($NaHCO_3$)	
	Sodium Borate ($NaBO_3$)	
	Sodium Carbonate (Na_2CO_3)	
	Sodium Chloride (NaCl)	
	Sodium Nitrate ($NaNO_3$)	
	Sodium Phosphate (Na_2HPO_4)	
	Sodium Sulphate (Na_2SO_4)	
	Sodium Sulphite (Na_2SO_3)	
	Stannous Chloride ($SnCl_2$)	
	Sulphate of Nickel ($NiSO_4$)	
	Sulphate of Zinc ($ZnSO_4$)	
	Sulphuric Acid (H_2SO_4)	
	Tin (Granulated) (Sn)	
	Zinc (Metal) (Zn)	
	Zinc Carbonate ($ZnCO_3$)	

Price Complete \$7.50 **Shipping Weight 10 lbs.** **(Can be shipped by Express only)**
We guarantee shipment within 24 hours after your order is received.

JUST SIGN AND MAIL THE COUPON

Electro Importing Co.
231 Fulton St., New York City.

Please ship to me at once, C. O. D., the E. I. Co. Chemical Laboratory with privilege of examination. It is understood that I do not have to accept the outfit unless it pleases me.

Name.....

Address.....

City.....State.....

R. N. 19-91.

SEND NO MONEY

We have so much confidence in this set that we desire to ship it to you by express C.O.D. with the privilege of inspection. In other words, we practically ship the outfit on approval. It does not cost you one cent to take a good look at the outfit, and see if it comes up to your expectations. If it does, pay the express man \$7.50, plus express charges. If you do not think that the outfit is all that we claim for it, you need not accept it, and we will pay the return charges as well.

Electro Importing Co., 231 Fulton St., N. Y. City



FROST-RADIO \$40.00

SHORT WAVE

Regenerative Receiver

Range 150-650 Meters

REMLER
DIALS

REMLER
KNOBS

REMLER
SWITCH

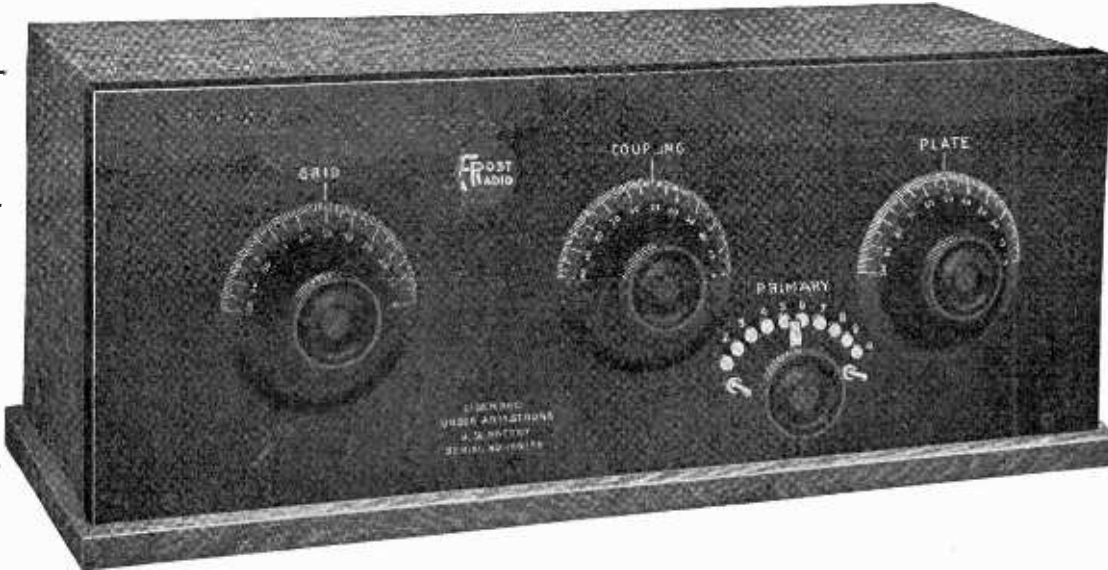

REMLER
VARIO-
METERS

REMLER
VARIO-
COUPLER

180
DEGREES
PLATE

Unexcelled REMLER Parts Combined to Make
AN UNEQUALLED RECEIVER!

Completely Wired and Licensed under Armstrong Patent No. 1113149

Read the Specifications and Order at Once

VARIOMETERS. Remler Type 500, Moulded Bakelite.

VARIOCOUPLERS. Remler Type 503, Bakelite, 180°.

PANEL. Formica Sheet, highly polished surface. Size 16 3/4 x 6 1/2 inches, 3/16" thick.

CABINET. Quarter Sawed Oak, Shellaced and Waxed. Medium dark finish.

DIAL. Remler No. 100, Bakelite, with Knob.

SWITCH LEVER AND CONTACTS. Remler No. 95 Switch and No. 88 Contacts, Polished Nickel Plated.

ASSEMBLY. Complete unit mounted on Oak sub-base which slides into Cabinet. Panel is fitted to sub-base and entire unit can be removed from Cabinet by unscrewing one thumb nut. Binding Posts extend through Formica Panels in rear of Cabinet and all terminals are marked with engraving. Wiring is of approved bus bar type. Shipping weight about 20 lbs., packed individually.

DEALERS

Write for
Wall
Poster
and our
Sales
Proposi-
tion

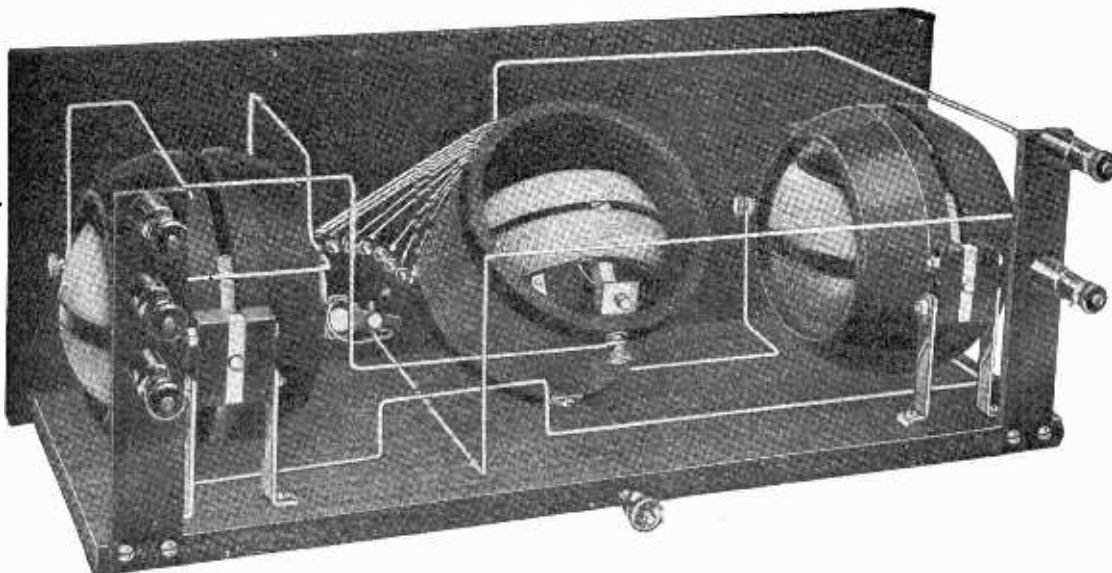

Amateurs

This
Receiver
is
Absolutely
Guaranteed
in
every way

HERBERT H. FROST,

154 West Lake Street
CHICAGO, ILL.

CENTRAL-EASTERN DISTRIBUTOR REMLER RADIO AND CUNNINGHAM TUBES

THE RASCO "BABY"

The smallest and most efficient detector in the world—as well as the cheapest. Our illustration is an actual photograph, and while the various details can be seen at a glance, we feel so enthusiastic about it that we must tell you all of its good points. First, there is a solid hard rubber composition base, size 1 1/2" x 1 1/2". We have not forgotten two holes to screw down the detector.

Then we have the nickel holder and binding post combined which holds the sliding, knurled, hard rubber composition knob. As you see, this knob not only revolves in its holder, but can also be moved back and forward in order to explore each point of the detector crystal.

Next we see the patent nickel detector cup and binding post combined. This is a little marvel all by itself and will not fall to avenge your admiration. No clamps, no soft metal to fuss with. You simply unscrew the knurled cap and insert your crystal into the stand, screw home the cap which leaves a goodly portion of the crystal exposed. The contact is perfect, while the crystal can be exchanged quickly in less than three seconds. By slightly unscrewing the cap, the crystal can be changed in position, in order to explore other sensitive spots. The catwhisker is of phosphor bronze and is attached to the horizontal bar by means of a blister head screw. Can be readily exchanged in less than two seconds. Wires can be connected to the binding post in a jiffy. All metal parts are nickel plated, and you will be proud of this little masterpiece.

No. 1898 Rasco Baby Detector complete with galena crystal, prepaid..... **50c**
 No. 1899. The same but furnished with an additional piece of tested radiocite crystal, prepaid..... **75c**

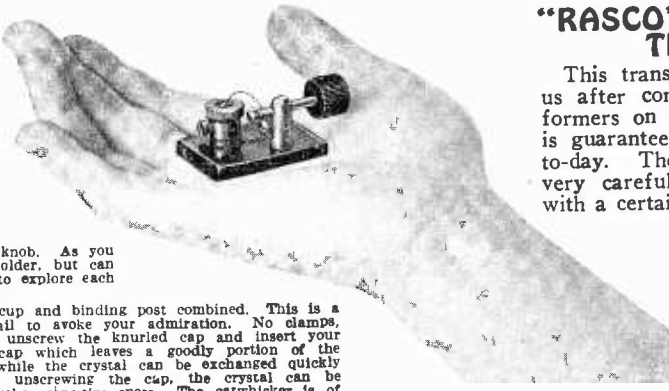

"RASCO" AUDIO FREQUENCY TRANSFORMER

This transformer has been developed by us after comparing all the various transformers on the market. This transformer is guaranteed to equal any on the market to-day. The primary and secondary are very carefully built and are impregnated with a certain wax in vacuum. The stampings are of the best silicon steel. Only the very best material is used throughout.

Realizing the fact that most amateurs desire to "make their own" we furnish this transformer unassembled. Directions which accompany the transformer

are such that anyone can put the parts together in about ten to twelve minutes. This saves you considerable money, for the reason that manufacturers who assemble the transformers must charge you for the assembling work.

Illustration as shown is in full size. The weight complete is ten and one-half ounces. Note also that we ship all goods prepaid.

No. 1100 "Rasco" Audio Frequency Transformer NOT ASSEMBLED, prepaid

INCREASE CURRENT		INCREASE CURRENT	
VACUUM TUBE			
SERIES	TRANSMIT	RECEIVE	
3 RD STEP	2 ND STEP	1 ST STEP	
TICKLER	GRID VARIOMETER	PLATE VARIOMETER	
SECONDARY CONDENSER	B BATTERY	A BATTERY	
OUTPUT	INPUT	PRIMARY CONDENSER	
TELEPHONE	PARALLEL	DETECTOR TUBE	
+ -	COUPLING		

"RASCO" NAME PLATES

Our name plates are of brass with a black background. The name is nickel-plated, standing out well upon the black background. Illustrations are in full size. Each plate has two screw holes. Order by name.

The two top plates, "Increase current," list at 10c each, illustrations full size. All others are 5c each. We also have these, not illustrated: Phones, Loading Coil Aerial, Ground, Secondary, Primary, Audion, Detector, Off. On, each 8c. In dozen lots, 50c prepaid.

NEW. The white plate in the lower right-hand corner is blank, and made of such material that you can write your own lettering on it with pencil, ink, or China ink. Price each 5c.

\$2.65

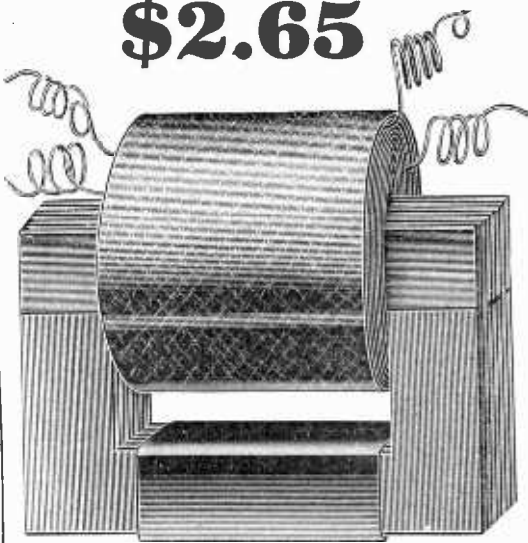

WE GUARANTEE EVERY ORDER SHIPPED WITHIN 24 HOURS

DEALERS GET OUR SPECIAL PROPOSITION

THE "RASCO" CATALOG A COLOSSAL EVENT

There are many radio catalogs, but the "Rasco" catalog marks a radical change for the simple reason that it **CONTAINS 50 VACUUM TUBE HOOK-UPS**

This is the one and only radio catalog containing such wonderful free information. Complete hook-ups of all important vacuum tube circuits are given in clear diagrams with complete explanation. Just to name a few.—The V.T. as a detector; detector and one-step amplifier; regenerative circuit; De Forest ultratradion; V.T. to receive undamped and spark signals; Armstrong circuits; one step radio frequency amplifier and detector; three stage audio-frequency amplifier; short wave regenerative circuits; V.T. radio telephone; 4-stage radio frequency amplifiers; radio frequency amplifier, inductively coupled amplifier; Armstrong superautodyne; radio frequency amplifier and audio frequency amplifier; C.W. transmitters; self-rectifying 2 tube C.W. transmitter; V.T. transmitter with 6 volt battery; radio-crystal detector; C.W. transmitters; self-rectifying 2 tube C.W. transmitter and receiver; experimental radiophone; radiophone using Colpitt oscillator circuit.

This list is only a partial one. You must positively see this wonderful book to appreciate it. It is made to fit the pocket—has heavy covers to withstand the wear and tear which it is sure to have at your hands because it will be your constant companion.

And Oh yes! Before we forget it. If you are in need of the following remember "Rasco has it." These are only a few things contained in this catalog. Lugs, Nuts, Dials, Knobs, Bakelite Sheets, Washers, Crystals, Litz Wire, Selenium, Cord Taps, Cap Nuts, Tin Foils, Name Plates, Spring Posts, Switch Parts, Metal Ribbon, Carbon Balls, Sliding Posts, Switcn Points, Switch Levers, Carbon Grains, Metal Pointers, Contact Points, Low Melting Metal, Carbon Diaphragms, Screws, Copper Strip, "Spaghetti" Name Plates, Sliders, Mica Switches, Resistance Wire, Varicoaster Rotors, Test Clips, Condenser Plates, Antenna Connectors, Threaded Brass Rod, Ground Clamps, Etc., Etc.

The catalog contains 200 illustrations. On account of its great cost, this catalog cannot be distributed free of charge. It will only be mailed upon receipt of **15c in stamps or coin.**



96-98 PARK PLACE, NEW YORK CITY

Remember that this business was originated with the sole purpose to cater to the amateur who has small orders. **ALL OF OUR ORDERS ARE SMALL** and that is why your small order will never be side-tracked by us. A trial order will make you a life customer. You can order from the above illustrations. "We can only stick you once." Try us with a 50c order.

Factories: Brooklyn, N. Y.—Elkridge, Md.

"RASCO HAS IT."

Radio Specialty Co.

96-98 Park Place
New York



RADIO NEWS

H. GERNSBACK—Editor
ROBERT E. LACAULT—Associate Editor



Vol. 3

DECEMBER, 1921

No. 6

THE RADIOTROLA

The careful observer, during the past six months it has become apparent that we are finally headed in the right direction as far as popularizing radio is concerned. We may say that we are now right in the midst of a revolution, as far as radio and the great public are concerned. We see the weather marks everywhere. The newspapers are becoming enthusiastic about radio, and devote more and more space to it. The man in the street is beginning to take a lively interest in all things radio. The editor's desk is beginning to become flooded with letters, not from radio bugs alone, but from the layman, who does not know the difference between a detector and a telephone receiver—all of which is a healthy sign, and we may say that radio is entering into its last and final stage, as far as the public at large is concerned.

Most of this, of course, is due to the radio telephone. Take for instance, the Westinghouse Electric and Manufacturing Co., with its broadcasting radio telephone stations at Pittsburgh, Pa.; Newark, N. J., and Springfield, Mass., as well as Chicago, Ill. (roof of the opera theatre), is doing the one thing that is needed to popularize radio. These stations operate from 10:00 A. M. to 10:00 P. M. each and every day. They broadcast not only radio telephone talk, but jazz music, singing by the best opera artists, violin and piano concerts, etc.

The progressive daily newspaper, the "Newark Call," now has a daily, as well as a Sunday section containing nothing but radio. All the various radio activities are truly reported in these pages and that is not all. This newspaper works in conjunction with the Westinghouse broadcasting station at Newark, and thus, for instance, they send twice a week at 7:00 P. M., a story for children, supposed to be told by "The man in the moon." This has been going on for some time, and has proven a huge success, and there are now countless children within a radius of several hundred miles listening in on these good-night stories, which are spoken by the authoress into the phone at the broadcasting station.

At the Westinghouse broadcasting station at Newark, lectures are also given. Thus, for instance, the writer, early last month, delivered a lecture on radio which was heard by thousands of amateurs who were within range.

Then recently in New York one of the progressive amateurs started to broadcast Sunday sermons by a well-known minister, and this service will be continued right along. No wonder that the man in the street is beginning to become interested in radio when the air is full of music, talk, jazz, and what not. Hence, the day of the "radiotrola" is approaching with ever-increasing speed.

The writer coined the word radiotrola, from Victrola, for which he may be pardoned. If you turn to page 494, you will better understand what the radiotrola looks like. We are fast approaching the time when some enterprising company will manufacture precisely such an instrument. We all know that a layman does not want to be bothered with circuits, loops, tubes, and a lot of other—to him—useless junk.

The telephone would never have become as popular as it is to-day if you had tried to sell each man an instrument that he had to connect himself, and in order to do so learn all the "how and why" of telephony. That may be all right for the telephone engineer and specialist, but not for the business man, who wishes to use the instrument.

We cannot expect the future wireless radio enthusiast to buy the parts of an outfit, and put it up himself. He will never do it. What he wants is a sort of radiotrola that is all connected up for him, and, with a few intelligible instructions, can be used as easily by the young hopeful as by grand-dad.

As our illustration shows, all we require is a nice cabinet which contains all the instruments readily put up. In front, there should be a knob that could be turned for any desired entertainment, such as jazz, lectures, good-night stories for children, grand opera, etc. To be sure it will be necessary to send out the different entertainments on different wavelengths, and we are coming to exactly this. Thus, for instance, in the future let us say, jazz will be sent out on 250 meters, grand opera on 350 meters, etc.

Then the radiotrola, at the bottom, will contain a few batteries that can be slid in just like flashlight batteries, without having to bother with wires and nuts. No adjustments should be necessary outside of turning the loop one way or another to intensify the sound coming in through the loud talker.

Perhaps you think all this is very fantastic. Indeed it is not, as the editors have built precisely this instrument. The loop in question measured only one foot across, and in the crowded downtown New York section, surrounded by steel buildings, and skyscrapers, we have been able to receive all the music and talk as sent out by the Newark broadcasting station, the sounds coming in strong enough to be heard all over a large floor.

Only one adjustment was necessary, and that is a variometer. All the other adjustments, rheostats, etc., were fixed. This outfit will be described in an early issue.

We are indeed in the millenium of radio. As one of our manufacturers said to us the other day: "Radio is getting to be such a tremendous thing, that I am becoming afraid of it."

That is just the sentiment to-day, and it seems a healthy condition.

H. GERNSBACK.

NOTICE—Do not miss the January issue of SCIENCE AND INVENTION containing the \$300.00 prize contest, "The Simplest Radio Outfit"! Here is a chance for every amateur to win a big prize. See January issue of SCIENCE AND INVENTION for full details.

President Harding Opens the World's Largest and Most Powerful Radio Station

By PIERRE BOUCHERON

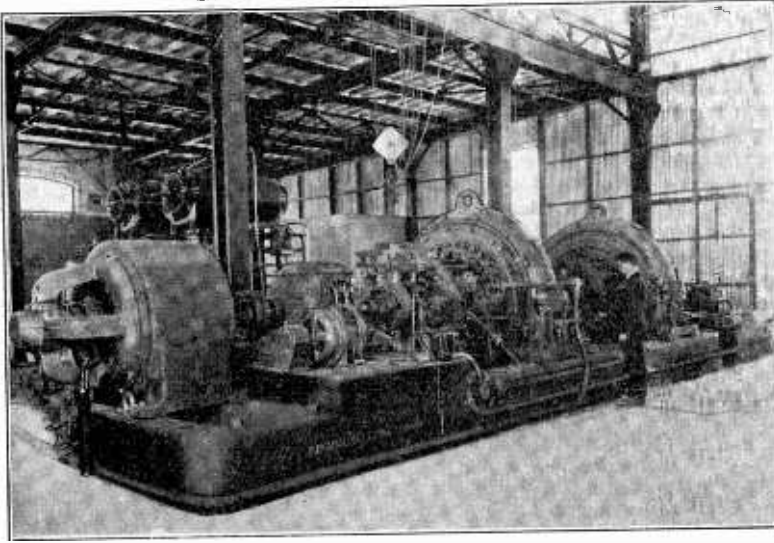

This photograph shows the two high frequency Alexanderson alternators, which are the heart of the big station. They are driven by powerful motors, one of which may be seen on the extreme left, and deliver in the antenna 200 kilowatts each.

BACK in 1897, little did Marconi think that but twenty-four short years would pass when the world would be linked by radio from a central point. Indeed, this vision has been amplified a thousand fold, for when he was asked how far a dispatch could be sent, he replied, "Twenty miles."

Twenty miles in 1897—World-wide Wireless in 1921.

Seventy miles from New York, near Port Jefferson, L. I., is located Radio Central, the world's largest and most powerful station, designed and built for international wireless telegraph communication by combined engineering skill.

With the opening of Radio Central, New York becomes the focal point of world-wide wireless communication. This means that existing radio and cable facilities to such leading commercial nations as Great Britain, France, Norway and Germany are now supplemented by a direct radio telegraph service.

Commerce, as we know it today, depends upon complex and highly specialized factors for success. One of its most important agencies is communication, bringing as it does, the parts of the world within easy reach of all. Indeed, without this vehicle, world trade would fail utterly. Thus, it has come to pass that the art of radio communication has slowly but surely taken its place as a necessary supplement to present commercial circuits, and not only is Europe and the Orient covered by this American system, but the new station just opened has been designed to eventually provide an additional and direct circuit to South America, thereby linking all commercial nations together.

RADIO CENTRAL—ITS PURPOSE AND HOW IT FUNCTIONS

Unlike many industries, radio communication is essentially international in its operation and world-wide in its scope. For this reason, it has been the dream of communication engineers for several years to erect a huge transmitting station at a centrally located point in such wise as to command a world-wide field of activity. Radio Central is the realization of this vision.

In the pioneer days of high power radio telegraphy, a station functioned alternately

as a transmitter, a receiver and a telegraph office. This involved much loss of time and

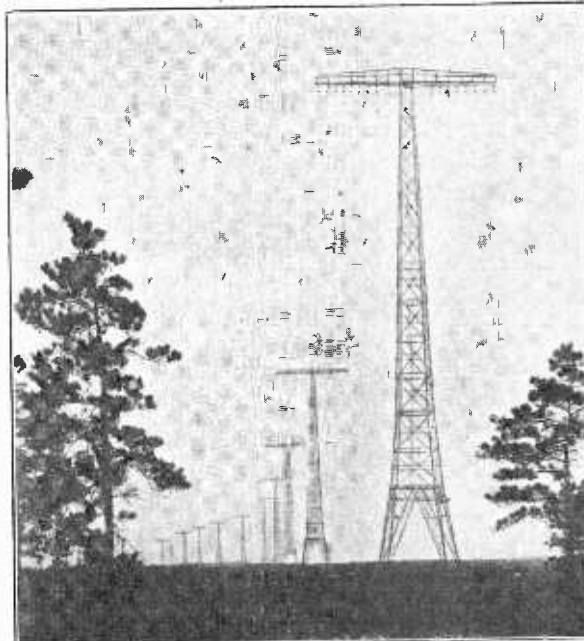

The Twelve 450-foot Towers of Radio Central at Port Jefferson, L. I., N. Y.

Here is the receiving station of Radio Central, installed 16 miles away from the transmitter. Reception is effectuated on loop aerials with sensitive amplifiers and filter circuits, eliminating interference and statics.

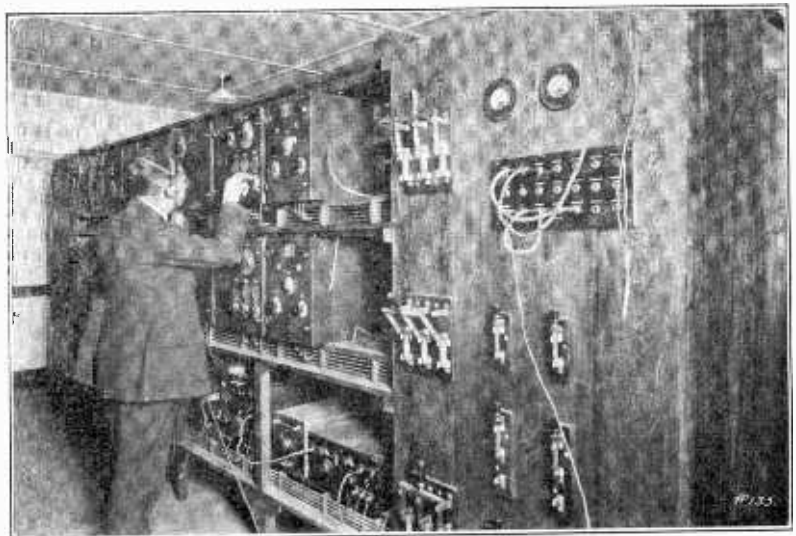

greatly reduced traffic facilities, for a station had to stop sending while it received, and vice versa. It, therefore, became apparent that the ideal radio station should comprise three separate but closely connected units operating by remote control and employing a transmitting unit, a receiving unit and a central traffic office, the latter preferably in the heart of the business district of large cities.

The new radio station, therefore, comprises these three units which are:

RADIO CENTRAL.—A high power multiplex transmitting station, located on Long Island some distance from New York City, planned to have several separate antennae systems each designed to communicate with a given country with telegraphic control, taking place at a remote distance suitable to the handling of traffic.

RIVERHEAD, L. I.—A multiplex receiving station, also located some distance from New York, but separated by 16 miles from the transmitter and so planned and arranged as to simultaneously receive all radiograms destined to the United States from as many foreign countries as take part in the world-wide wireless system.

CENTRAL TRAFFIC OFFICE, NEW YORK CITY.—The traffic center of the new system where all actual radio telegraph operating takes place. Here radiograms are gathered from various sources and directly radioed to foreign points through Radio Central and other high power stations. This direct transmission is accomplished through the use of a special remote control system whereby operators at New York City do all necessary transmitting work.

In a like manner, reception is accomplished with similar direct advantages where the incoming signals are made audible at Riverhead, L. I., and automatically transferred over land-lines to the central traffic office located in the heart of New York's financial district. These signals are interpreted and recorded on typewriters by skilled telegraph operators at high speed or are automatically received by ink-recorders. Final delivery is then effected through a special messenger service from the central traffic office or its supplementary branch offices located in New York, or dispatched by telegraph when the point of destination is other than New York City.

OUTSTANDING FACTS ABOUT RADIO CENTRAL

RADIO CENTRAL STATION is designed for World-wide Wireless communication which includes Europe, South America and the Far East.

THIS SUPER-STATION is situated at Rocky Point (seven miles east of Port Jefferson) on the northern shore of Long Island, 70 miles from New York City. The station site covers 6,400 acres or 10 square miles.

THE CONSTRUCTION of Radio Central began July, 1920, and the first test signals were sent in October, 1921, or a little more than a year, a record in itself when one considers the great amount of work accomplished.

1,800 TONS of structural steel were used to erect the first 12 towers, each tower employing approximately 150 tons.

EACH TOWER is 410 feet in overall height and the cross arm, or bridge, supporting the antenna wires at the top, is 150 feet long.

8,200 TONS of concrete were employed for the foundations of 12 towers, the base of each tower leg being sunk nine feet below the ground with a total base area of 360 square feet.

THE DISTANCE between two adjacent towers is 1,250 feet, or nearly three miles from the first to the twelfth tower.

EACH ANTENNA consists of 16 silicon bronze cables $\frac{3}{8}$ " in diameter stretched horizontally from tower to tower. In all, 50 miles of this cable has been used for the first two antenna systems.

THE GROUND SYSTEM for both antennae consists of 450 miles of copper wire buried in the ground of the entire antenna system in starfish and gridiron fashion.

THE FIRST POWER HOUSE SECTION covers a space of 130 feet by 60 feet and accommodates two 200 K.W. high frequency transmitting alternators with auxiliaries and equipment.

A SENDING SPEED of 100 words per minute is at present possible with the use of each transmitting unit at Radio Central. This means a combined sending capacity of 200 words per minute for the two completed units.

THE ERECTION of additional antenna units forming the huge wheel, and further improvements which are being made, will correspondingly increase the transmitting capacity of the big station.

THE TRANSMITTING RANGE of Radio Central is practically world-wide, as demonstrated by preliminary tests when the station was heard in all

Placed just opposite the alternators is this main switchboard on which are mounted all the necessary switches for the remote control of the station. On the panel in the background may be seen the manipulation relays which are operated from the New York City office.

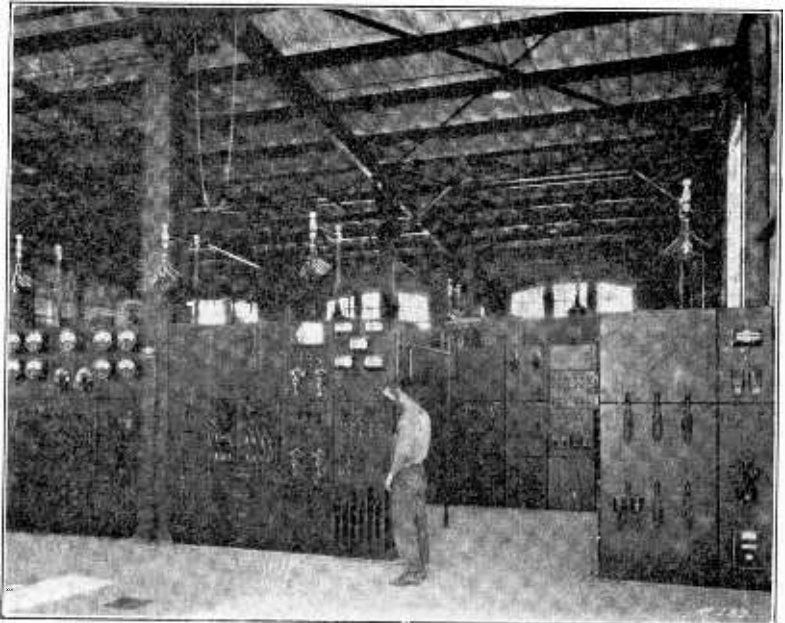

parts of Europe, as well as Australia, South America and Japan.

THE COOLING POND for cooling the water

after it has circulated through the high speed alternators covers a ground space of 64 feet by 42 feet and is 7 feet deep. The pond is equipped with four spray heads which, when operating, present a beautiful and ornamental appearance.

THE COMMUNITY HOUSE for the staff is a low one-story building closely resembling an exclusive country club. It contains 16 single rooms, an official suite, a large living room and dining room, as well as quarters for servants.

THE ENGINEER IN CHARGE with a staff of 15 assistants comprises the personnel necessary to maintain the huge station in operation at present.

THE CONSTRUCTION FORCE has varied day to day from 100 to 250 men.

THERE ARE NO RADIO OPERATORS at Radio Central, the actual transmission taking place by remote control from the Central Traffic Office in New York City.

THE RECEIVING STATION, working in conjunction with Radio Central, is located at Riverhead, L. I., 16 miles away. No operators are located here, for the distant signals are first received by radio, automatically transferred to wire lines and received at audible tones at the central traffic office, New York City. The action is simultaneous from the time the signals are transmitted abroad, picked up by the aerial, to the moment of actual transcribing by the receiving operators in New York.

CENTRALIZED CONTROL, as accomplished at Radio Central and receiving station at Riverhead, has solved the problem of multiplex operation and has made possible this practical communication service now at the disposal of the American business man.

THE FINAL INSTALLATION at Radio Central will comprise 12 antenna units supported by 72 towers, forming, so to speak, the spokes of a giant wheel nearly three miles in diameter. Ten high frequency alternators will be employed, which in total will give a power output of 2,000 kilowatts or 2,700 horsepower. The electrical force thus brought into play at Radio Central permits the realization of the vision of communication engineers to transmit messages to all points of the world from a single centrally located source.

The call letters of the new station are WQK, and transmission is made on a wavelength of 16,400 meters.

During the transmission of President Harding's message on November 5, all the large stations of the world were listening in and received the message very QSA.

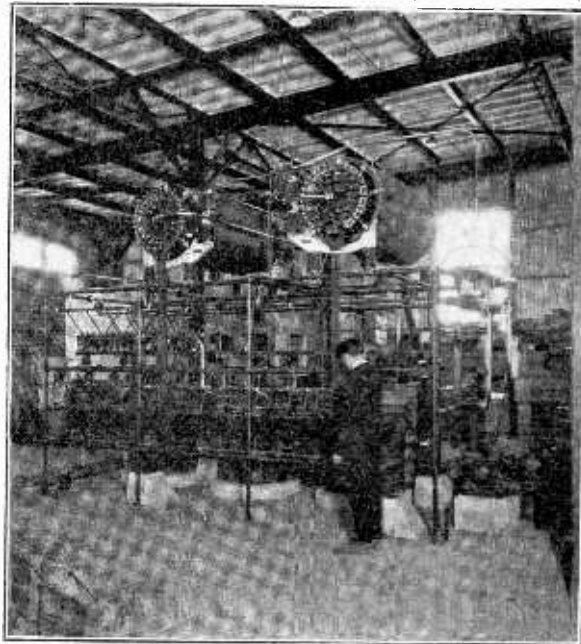

This View Shows the Condenser Rack, and the High Frequency Transformers Mounted on Concrete Bases are the Magnetic Amplifiers.

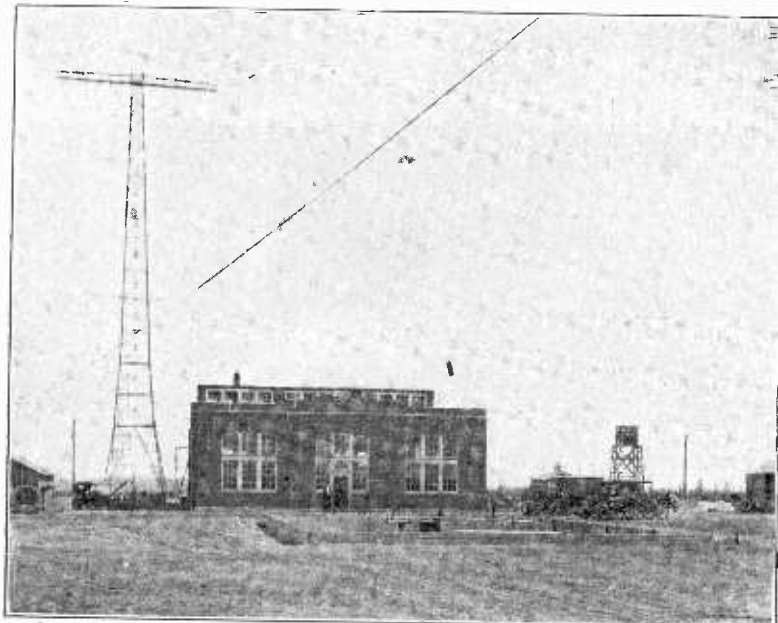

Front view of the power house of Radio Central, showing the cooling pond for the water circulating in the liquid rheostat and other machines. The lead in of the aerial, composed of sixteen wires may be seen on the right and above the building.

The WJZ Radiophone Broadcasting Station at Newark, N. J.

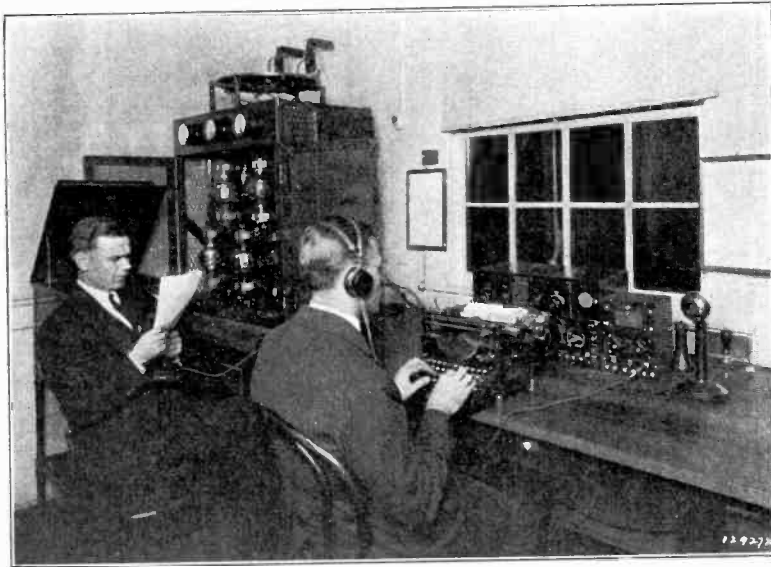

The photograph on the left shows the sending set installed in a special room of the Westinghouse building. The receiving set on the table is used to receive the news which is immediately broadcasted by phone; also, the Arlington time signals. Below is a view of the transmitting set entirely enclosed in a grounded cage.

FOR the past few months radio experimenters within a few hundred miles of New York have been receiving nightly concerts, news reports, radio lectures and other special features from "WJZ," the radio telephone plant of the Westinghouse Electric & Manufacturing Co. at Newark, New Jersey. In fact, the radio waves from this new station have traveled to far greater distances, and letters expressing appreciation of the programs have been received from points as far away as Florida, Canada, Wisconsin, and six hundred miles out to sea. Never before has a radio telephone station sent out broadcast, on a regular schedule day after day, so complete and satisfactory a musical and bulletin service; as a result of this, literally thousands of new receivers are being put into operation every week, and a tremendous interest in radio telephony has been aroused.

The Newark station is located upon the roof of the Westinghouse factory building at Plane and Orange streets, near the Lackawanna Railroad station in Newark. The antenna and counterpoise are supported between a steel stack which extends 114 feet above the roof level and a special 60-foot mast mounted on top of the building about 150 feet from the stack. The aerial consists of four wires equally spaced on 20-foot spreaders; the counterpoise is identical, but instead of swinging from the tops of the stack and the mast is mounted about 20 feet above the roof. Thus the effective separation of the two sections forming the radiating system is about 94 feet at one end and 40 feet at the other, giving a net effective height of about 65 feet. Six-wire cage downleads run from both parts of the aerial to the radio station, which is in a special building on the roof, and are connected through double-throw grounding switches. The natural wave-length of the antenna-counterpoise structure is not far from 500 meters, so that for transmission on 360 meters (the normal operating wave-length for broadcasting) series condensers of 0.0005 microfarad are inserted in each connection. These are clearly shown directly below the lead-in insulators in the illustration of the interior of the station.

The radio telephone transmitter is shown

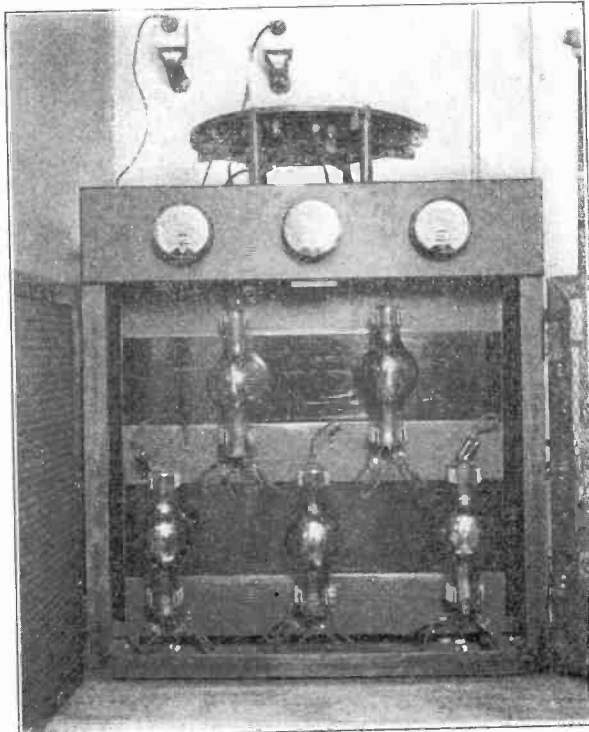

This is the studio where the artists sing and play. It is installed on the first floor of the building and a remote control system, which may be seen on the wall, enables the operator to control the set from this room.



at the left of this same photograph. Two 250-watt three-electrode vacuum tubes are used as oscillators, and three somewhat similar but specially designed high-impedance tubes modulate the radio frequency currents generated by the other pair. The antenna, counterpoise, grid and plate leads are all connected in the splitcoil oscillation circuit to the flat spiral inductance illustrated on top of the radio set. This coil has 21 turns of $\frac{3}{8}$ " x $\frac{1}{2}$ " flat copper strip mounted on micarta spokes, and is grounded at the minimum potential point nearly midway between antenna and counterpoise.

The oscillator and modulator tubes run on 2,000 volts direct current, which is produced by a single-commutator generator driven by a direct-connected 2-phase 60-cycle 5-h.p. motor. Special filter circuits are provided to suppress the commutator hum of this machine, with the result that outgoing speech and music is heard with very little extraneous noise from the dynamo. The filaments of the five large tubes are lighted by alternating current at 10 volts, this being drawn from a divided-circuit transformer of small capacity; in this circuit again it has been found necessary to provide a grounded filter arrangement to eliminate the foreign noise of the 60 cycle alternating current used.

The three modulator tubes are connected on the plate-modulation plan, and are supplied with voice-frequency current from a speech amplifier containing two 50-watt three-element vacuum tubes. An ingenious arrangement compensates for the inherent distortion which is so often found when vacuum tube transmitters are operated at full power for radio telephony, and the clarity of the speech and music sent out from WJZ is limited only by the characteristics of the standard long-distance wire line microphones used to pick up the sound waves and transfer them in electrical form to the speech amplifier.

Since the antenna is normally operated at a wave-length (360 meters) on which it shows comparatively high radiation resistance, the usual antenna current is only 5.5 amperes. At a total antenna resistance of 16 ohms this represents an aerial circuit power of nearly 500 watts, a large percentage of which is actually radiated.

(Continued on page 552)

Radio on a New York Newspaper

By ARTHUR H. LYNCH

FROM time to time we hear of various newspapers throughout the country using radio for one purpose or another, but if we watch the performance of the radio stations of these papers for any little time, we find that most of them are abandoned, for one reason or another. Such stations are frequently given a great deal of publicity and photographs and long descriptions of what the station is to do and the changes it is to make in the newspaper field are given. After the first splurge, little is heard of the stations, and where it is possible to learn the facts, it is generally found that the installation of radio has been a great disappointment and a failure, even though some were merely installed for advertising purposes.

However, there are a few stations, in this country, which are run on a systematic basis, in conjunction with the varied and complicated machinery of a modern newspaper. Distinctive among these stations is that controlled by the New York Times, which has been in continuous operation for a little more than two years. This station is of interest to amateur and commercial operators alike, for it bears some of the distinguishing marks of both. We will consider some of this station's most important characteristics, some of which will be of interest to the man in the street who knows nothing of radio but likes to know how newspapers get their news as rapidly as they do, while others will be of interest to every radio "fan."

TIME STATION WORKS UNDER DIFFICULTIES

When the original installation was made, it was described in RADIO NEWS by the writer. The original station was in the tower of the Times Building, New York City, but this was so far from the editorial rooms of the paper, which are located two blocks from the original station, that the station was shifted to the Times Annex, where the editorial staff and the presses are located. In making this change several difficulties were



The Four Operators of the Station: Messrs. Wm. Collins, R. J. Iverson, B. G. Seutter and F. E. Meinholtz.

A corner of the receiving room at the "Times" radio station. On the right may be seen the automatic phonograph recorders for the reception at high speed. On the tuner and on the extreme right may be seen the two cups won by Mr. Seutter in the code speed contests.



encountered, not the least of which is the fact that the antenna of the new station is in a part of the city which is practically surrounded by massive steel buildings. For

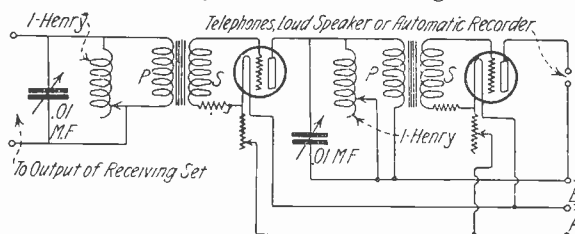

The "Trap" Circuit Used at the Times Station for the Elimination of Statics and Interferences.

this reason a great deal of absorption and distortion of the electrical waves was noticed and this was found to be so bad that it has had to be combatted by a combination of special antenna and audio-frequency amplifying circuits.

Another very serious difficulty experienced by the station is its proximity to the station operated by a commercial radio company, which works between New York, Buffalo and Detroit. Forced by this station, and the interference which is caused by commercial vessels in New York, to resort to every form of interference prevention, the "Times" station must necessarily be manned by operators of great skill. It not infrequently happens that reception from European stations must be carried on through static and the transmitting of a number of different stations, operating on almost the same wave length. This work calls for long receiving experience and the utmost concentration.

STATION OF GREAT BENEFIT TO PAPER

The fact has been well established that trans-ocean reception is subject to varying intensity, in different sections of the country. For instance, a receiving station, located in New York may have difficulty in receiving from POZ, Nauen,

Germany, while another receiving station, located in Maine may be able to make perfect copy, and vice versa. This is of great value to the newspaper editors, even though

the paper's own station cannot copy the entire message. Let us suppose that the operator listening for "Times" dispatches, from some station in Europe is able to receive nothing more than the preamble of the message and that the body is then known to contain 200 words. Throughout the body of the message, it is generally possible for the operator to pick up a few words here and there, so as to let the editor know something of what the subject matter is. The 200 words may

be amplified, by men familiar with the matter to which the message refers, to a half column or more. It is then possible for the editor to figure on the space he will allow for the item and hold the space open for the "story" to be written, after the message has been delivered to the paper through the regular channels.

The story is not written until the message has been received, but the necessary space for it is reserved. If the message does not reach the newspaper office before it is time to go to press, it is then only necessary for the editor to authorize the publication of some other matter which will occupy the reserved space. In this way the paper is able to be certain of giving its readers the pick of the news, upon which it has a double check, without going to a great deal of trouble in rearranging the edition, when an important message arrives at the last moment.

Of course this does not take into consideration the fact that a great many of the press messages sent from European stations to the paper are picked up directly by the paper's own station and find their way into print and on the newsstands, before delivery is made through the regular channels. This form of receiving is the most important work a newspaper station has to do, for it gives them a jump on the papers which have to rely upon the regular sources of supply for their news.

In addition to the value of radio, in keeping ahead of the news from the other side of the sea, a radio station offers an opportunity to be a jump ahead of its competitors in the matter of local news, espe-

(Continued on page 526)

A Complete Portable Receiver

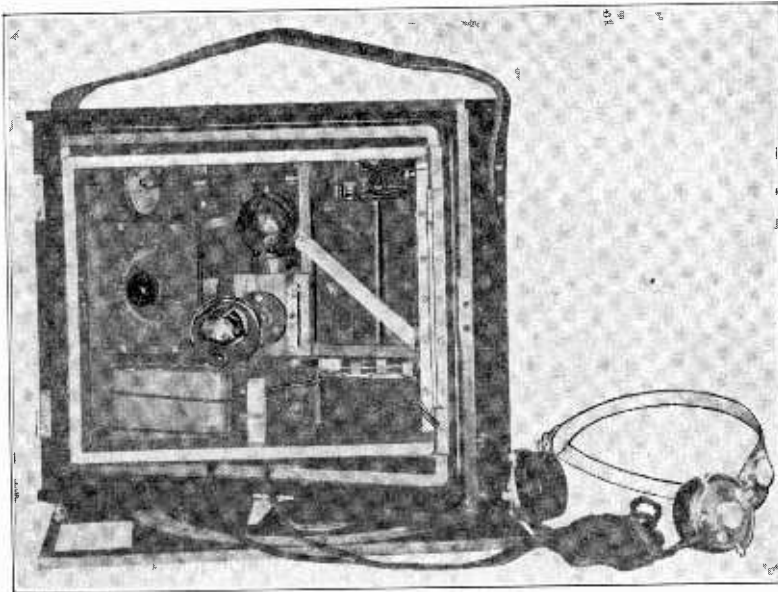

Fig. 1. In this cabinet only 13 inches square, are mounted the tuning, amplifying and detecting instruments, including the filament and plate batteries for the V.T.s. The set using a loop aerial may be used as a direction finder when mounted on its cover, as shown in this view.

THANKS to radio frequency amplification, it has become possible to reduce greatly the size of the antennae and loop aerials which are used in direction-finding work and Transatlantic reception. The regenerative effect discovered by Major Armstrong, when combined with this method of amplification, further increases the sensibility of the receiving system.

We recently saw, in England, the complete receiver shown in the two photographs illustrating this article. As may be seen in Fig. 1, the receiving and amplifying instruments, as well as the necessary batteries for the filament and plate of the two vacuum tubes, are contained within the cabinet, in which are also mounted, two small loop aerials, one of them being connected in the plate circuit of a tube and acting as a reaction inductance.

The inner loop, wound on a wooden frame, is hinged to the larger one, so that the coupling between the two may be varied to adjust the regenerative effect in the circuit. A various condenser is connected across the main inductance and calibrated so that it is possible to know the wave length tuned in. Another feature of this unique portable receiver is that it may be used as a direction finder. The cover of the cabinet on which is painted a dial with the indication of the compass, and which

is fitted with a small compass, may be used as a base upon which the cabinet containing the complete receiving instrument can pivot, allowing the operator to ascertain the direction from which the signals are coming.

This small, compact radio compass set, will prove very valuable to the operator aboard ship who cannot erect a loop antenna for direction-finding work, and to the amateur who wishes to carry with him a sensitive receiver for time signals, weather

reports, radiophone transmission, etc.

With a pair of good telephone receivers, such as the Brown, having an adjustable diaphragm, this little set, 13 in. square, gives wonderful results, and may be used in conjunction with some other form of amplifiers, if in a station or other place where additional apparatus may be obtained.

The arrangement of the different parts is clearly shown in Fig. 1. On the left is the tuning condenser with, just above, the radio frequency transformer. In the center may be seen the two vacuum tubes, one of which is used as a detector, and on the right the storage battery, supplying the filament current. In the compartment below are the two high tension batteries and the telephone transformer. On the edge of the base of the cabinet and in the center, is the pointer showing the direction the signals are coming from.

In Fig. 2, the cover is shown mounted on the hinges. When it is desired to close the cabinet for transportation, and in order to save space the vacuum tube mounted in the center is removed from its socket and held by a clip fixed on the smaller loop, as shown.

The main advantage of this receiver is its simplicity of operation. The tuning is accomplished by means of a single variable condenser, controlling the wave length of the circuit, and the regenerative effect adjusted by varying the coupling of the inside loop, which is connected in the circuit of the detector tube. There is no rheostat and the filament control consists merely of a small switch which is "on" or "off," fixed filament resistances being used.

Fig. 2. This photograph shows the set ready for transportation, the base being removable and used as the cover of the cabinet. Note the two loop aerials; the inner one acts as plate inductance to obtain a regenerative effect.

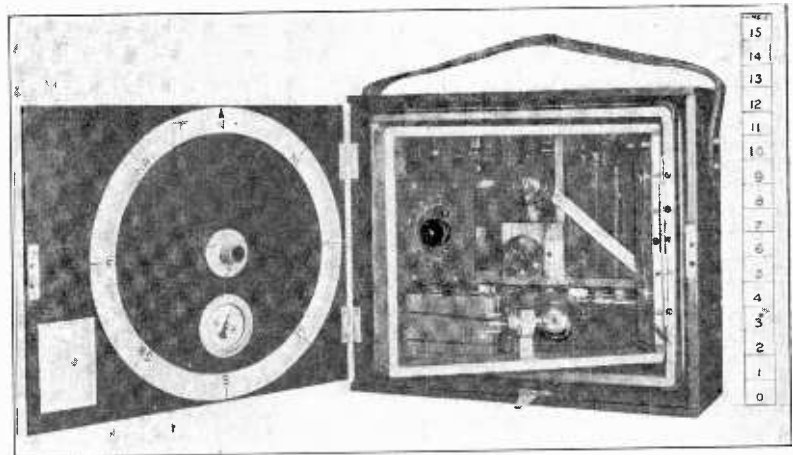

A New Tuner and Amplifier

TO short wave regenerative tuner is better than the inductances comprising it. The vario-couplers and variometers used in this instrument are specially designed to eliminate distributive capacity and excessive solid dielectric. With the latter factors minimized, the tuner transfers to



This Detector and Two-Stage Amplifier is Fitted With a Potentiometer and Other Interesting Features.

the detector maximum energy from each antenna impulse.

A Vernier control consisting of Vernier variometers constitutes a great improvement over mechanical devices or small variable condensers for obtaining precise tuning. The two Verniers in the grid and plate circuits eliminate undesirable capacity and provide a very delicate adjustment, especially valuable for tuning C. W. or telephone. The range of each Vernier is approximately equivalent to two divisions on either variometer dial.

The inductances are mounted between the front and rear panels, which are rigidly connected by an aluminum frame. With all binding posts mounted on the rear panel, the assembly functions entirely independent of the four sided mahogany cabinet, which serves merely as a case. The front panel measures 15 by 15 inches and is secured to the cabinet by nine thumb nuts.

Normal wave-length range of this regenerative tuner used with an average 60 foot antenna is 170 to 360 meters. Within this range the tuner operates at peak efficiency. Two pairs of binding posts in the antenna and grid circuits make provision for the reception of longer wavelengths. Where the tuner is used with a long antenna the primary circuit wave-length may be reduced by

(Continued on page 530)



Here is a New Compact Tuner for Short-Wave Reception. A Loading coil Which May be Seen on the Left is Used for Longer Wave-length.

Radio in Department Stores

By VICTOR RAWLINGS

ON the roof of a downtown department store in Los Angeles, California, is located one of the most up-to-date and modern radio stations found in the west. The station is a 5-watt installation, the current going into the antenna when the station is in operation is 1.6 amperes, with 500 volts applied on the plates of the 5-watt tube. The station has a sending day range of 100 miles and a night range of twice that distance. Its official call letters are 6XAK.

With the installation of this equipment on the roof of Hamburger's department store, commerce and science joined hands and met on a common ground. The station will be used for experimental purposes, and in its use the firm aims to aid in the popularizing of radio work in the southwest, and at the same time to carry on considerable worth-while publicity for the firm as well.

As yet only telephone equipment is in use, but telegraphy will be added later.

Every afternoon, from four to five the store gives a free radio concert to all stations in Southern California who desire to tune to the Hamburger wave-length (310 meters) and listen in. These concerts are becoming more and more popular, and it is estimated that several thousand stations daily enjoy them by wireless.

Classes in radio operation, code work, theory of wireless, and so forth are being planned by the store, and since the first of November, 300 boys have been taking at least one lesson a week in the Hamburger

This complete radiophone station was recently installed in a large store in California. It is used to broadcast music and news, and for advertising purposes.

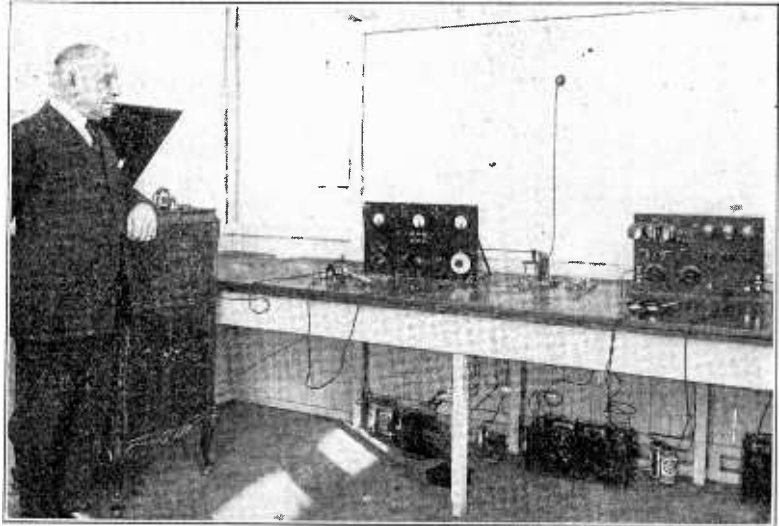

station. A class room with a capacity of 40 boys is being fitted up, and it is planned to hold from eight to ten classes a week.

The day classes open, all boys who have registered will attend a Hamburger's "at home" on the roof, a special program for this day being worked out. Moving pictures of the event will be taken, these pictures to be later released by one of the moving picture weekly services. Colonel Hersey, head of the Los Angeles Weather Bureau, and during the war in charge of the Balloon school at Fort Omaha, will lecture to the boys on the need of wireless at war times. The boys will then be marched through the wireless rooms, given time to inspect the installation, and then assigned to class days.

So rapidly did the fame of the Hamburger wireless spread, that when the Scotti Grand Opera Co. was in Los Angeles, in October, four famous opera singers sought out the management of the store, and arranged to sing into the wireless transmitter. Arrangements for this event had been made some time in advance and considerable publicity given it, with the result that thousands were listening in on in-

struments all over Southern California. Several ships at sea staged afternoon concerts and entertained their passengers with real grand opera coming from the store roof. The singers who participated in the concert that afternoon doubtless sang to the largest audience any singer ever had the privilege of appearing before.

Results of the world series, play by play, were broadcasted each day the players were waging their strife at the Polo Grounds, and many a station located in the mountains and deserts of California had news of the plays long before Baseball Fans on Manhattan Island.

The store operates the station as one of its services, no charge being made for the lessons to boys, or for any of the other features being handled out of the station.

Close co-operation has been established between the radio station on Hamburger's roof and the various physics classes of Southern California High Schools, and a number of professors who are teaching in the High Schools are coming to the store in order that they may view the operations of a radiophone station. At this time the store classes will deal with the fundamentals of radio, only, later, however, it is planned to put in a large commercial installation and then instruction will be given in advanced theory, and boys will be given work that will enable them to take the examination for a commercial operator's license.

THE GLOBE, TORONTO, TUESDAY, SEPTEMBER 20, 1921.



Or, Better Still, Come in and Look Over the New Section just Opened Up on the Sixth Floor of the Home Furnishings Building, Where There Has Been Installed a Complete Stock of

Radio Supplies for Amateurs and Experimenters

Featuring Specially Mignon Receiving Sets of Various Types and a Large Range of De Forest Equipment

The Radio Section is in charge of a licensed operator who had wide and thrilling experience in merchant marine wireless during the war, and has since held the post of radio instructor in various schools. He is at your service for the supplying of information and for helping you with any problems relating to this very vital and fascinating development of telegraphy and telephony.

Listen for Eaton Concerts by Wireless, 4 to 4.30 p.m. daily, and 12 to 1 Saturdays.

If you want to order radio supplies by wireless you may do so at any time from 4.30 to 5 p.m. daily. The call signal is "9 B A"—wave-lengths of 300 metres. Answered on continuous wave. Home Furnishings Building, Sixth Floor.

This Up-to-date Advertisement Was Published in a Canadian Paper Recently.

Radio for All

MOVEMENT has been started recently to popularize radio so that everybody may have a radio receiver in their homes as they have today a phonograph or a camera. This movement can only be efficient if the public can find some form of apparatus, simple to operate, and which will bring in radiophone, news, music and time signals, as well as weather reports and other informations. At the present time, very few of these sets may be found and those of the simple type still look complicated to the man who knows nothing about radio. Besides, to sell some radio sets to the public, it is necessary to place the sets in other show windows than those of the radio shops.

Some manufacturer got wise to this idea and a complete receiving outfit may be seen in several places where one does not expect to see radio apparatus. We recently

saw, in a department store, a complete outfit with necessary instructions for its operation so that even a boy may install this set in his house and receive all the inter-



This Complete Little Radio Outfit Will Help to Popularize Radio, for it is Simple to Operate and Can Tune Up to 2,600 Meters.

esting messages, and music which are constantly in the air. A little Radio manual explaining the principles of Radio communication is also furnished, so that the user may understand the functioning of the set and what "happens inside." The outfit is comprised of a single circuit tuner with which wave-lengths up to 2,500 meters can be tuned, so that with a sufficient length of wire, used as an aerial, time signals can be received.

The telephone receiver is a standard 1,000-ohm unit and the set throughout looks to be of very good construction.

Undoubtedly, this outfit will help greatly to popularize radio, for, being of a reasonable price, it is the thing which will awaken the interest of many, and go into several homes, bringing in music and the latest news, showing to the average man that radio is not, after all, such a mystery.

A Two K. W. Vacuum Tube Set for Panama

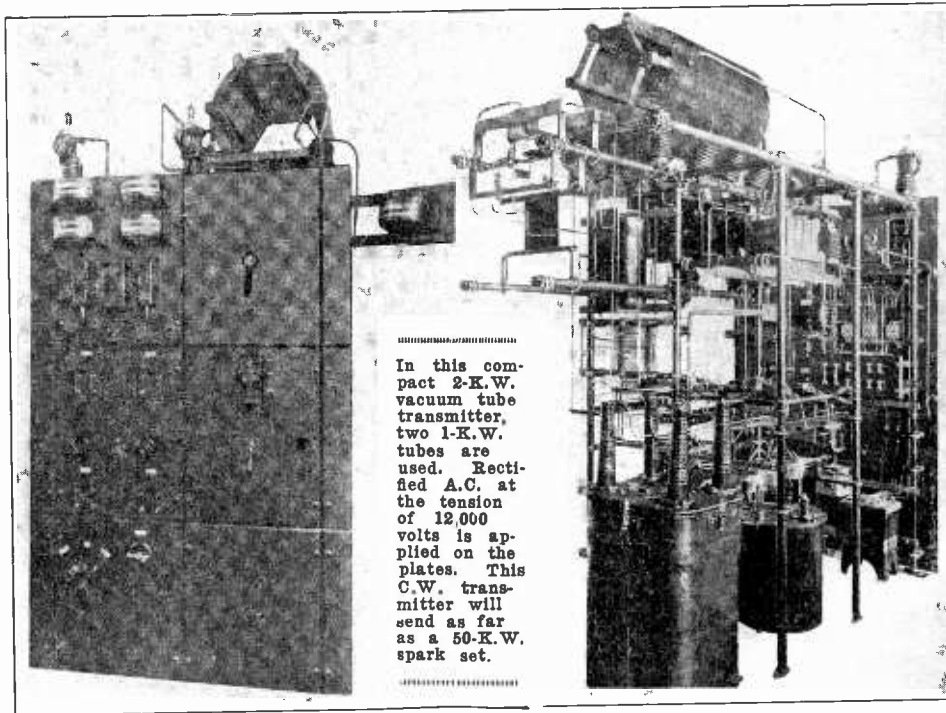

In this compact 2-K.W. vacuum tube transmitter, two 1-K.W. tubes are used. Rectified A.C. at the tension of 12,000 volts is applied on the plates. This C.W. transmitter will send as far as a 50-K.W. spark set.

Photo by courtesy of the Radio Corporation of America.

A TWO K.W. radio tube transmitter, now installed and in operation at Almirante, Panama, has recently been completed. Not only is this transmitter unusually powerful for a tube transmitter, but it was designed and built in record time, being finished, tested and ready for shipment three months after the receipt of the order.

The set consists essentially of equipment designed to supply direct current at 12,000

volts for the plate supply of the Radiotron tubes, and for converting this power into radio frequency. Power is supplied to the transmitter at 440 volts, single phase, 60 cycles, and stepped up to high voltage by means of a transformer, the output of which is fed into the rectifying system.

The rectifying system consists of two 2-K.W. Kenetron tubes which supply 12,500 bolts D.C. to the plate circuits of the Radiotron generators. The ripple in the output

of the rectifying system is smoothed out by means of a suitable filter system. The radio frequency power is generated by a system consisting of two 1-K.W. Radiotrons with the necessary grid and plate coils, together with an antenna loading coil. Provision is made for controlling the power by a power change switch which alters the voltage on the primary of the plate transformer. The filaments of all tubes, Kenetrons and Radiotrons are operated on A.C. through transformers which step the supply voltage down to the operating voltages of the filaments.

The set is equipped with a wave changing switch, which by a single operation, changes the transmitted wave to any one of three lengths—600, 1,000 and 3,000 meters. The switch automatically selects predetermined points on the loading, plate and grid coils. Provision is also made for transmitting on interrupted continuous (I.C.W.) as well as on continuous waves (C.W.). This is accomplished by means of a motor-driven interrupter in the grid circuit of the Radiotron tubes, which starts and stops oscillations in the antenna at audio frequency, approximately 1,000 interruptions per second.

The rating of the transmitter is based on the power input of the antenna circuit, instead of on the output of the power equipment, as is usual with spark transmitters. The rating of the tube transmitter is the product of the antenna resistance, times the antenna current squared, equalling two kilowatts. While it cannot be predicted exactly what the range of this set will be, it is expected that it will equal, if not exceed, the range of a 50-K.W. spark transmitter. As an example of its initial effectiveness, the set is now carrying on reliable and most satisfactory communication from Almirante, Panama, to New Orleans, La., not only at night, but during the daylight period as well.

A New Departure In Short Wave Reception

By H. L. ARTHUR

FOR the amateur who has struggled with multi-layer coils, in an effort to receive satisfactory signals on short waves, there is still hope. For the fellow who has long been compelled to confine his activities to long waves because he has felt a short wave receiver of modern vintage a little beyond the limits of his purse, there is even more hope.

Herbert B. Pearson, formerly Radio Sergeant, 302nd Field Signal Battalion, 77th Division and ex-Ensign Walter J. Roche, have developed a new receiving device which may be instantly inserted in any honeycomb coil mounting, for the reception of short waves.

This device is quite out of the ordinary in a number of very important respects. As may be seen from the illustration, there is a bracket in the rear of the unit which serves the dual purpose of holding it in

place and connecting the various circuits without necessitating the change of a single wire of the long-wave receiver. This entire device, which comprises three separate windings, is very compact, as may be seen by comparing it to the size of the set in which it is shown.

HOW THE UNIT IS MADE

In this little unit, which can not very well be classified as a receiving set or a tuner, we find that common sense has been the basis of its design, throughout. There are two windings which are identical, each wound on a ball, similar to those who find in common use as rotors for variometers and vario-couplers. These balls are mounted on metal shafts and are rotated by means of the dial-knobs on the front of the unit. The third winding is made around the longer of two composition tubes, spaced in such a manner as to have half of the winding within the field of one rotor and half within the field of the other. This winding is covered with a second composition tube for protection.

The dials are made of metal and the knobs are of molded bakelite, as are the brackets which may be seen in the front and rear of the unit.

THE CIRCUIT

Inasmuch as this unit has been developed for use with a honeycomb coil mounting, it is well to consider its circuits in conjunction with those which are generally in use for this form of long wave reception. The circuit is more or less standard and we will

adhere to it, defining the difference between its connections and those which are found when the new unit is being used. The rotary coil at the left of the unit takes the place of the coil which is used for the primary; the stationary coil takes the place of what was considered the secondary in the honeycomb coil arrangement and the right-hand rotor replaces the tickler coil in the plate circuit. That is about all there is to it and it takes much less time to make the change than it does to tell about it.

IN OPERATION

When we desire to use this device for re-
(Continued on page 526)

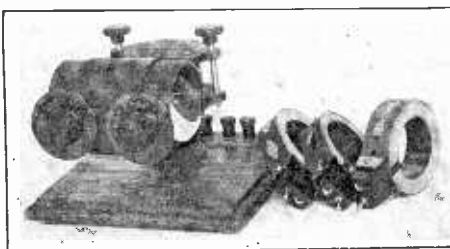

This View Shows Clearly How the New Short-Wave Regenerative Tuner is Substituted for the Coils on a Three Coil Mounting.

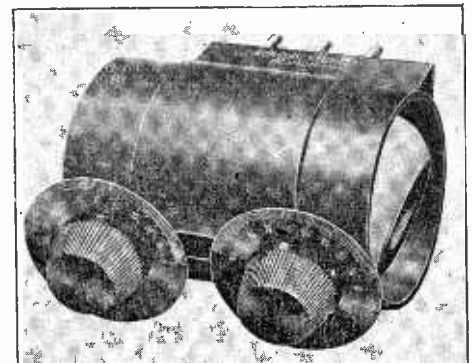

This Compact Unit Which May be Used Instead of Honeycomb Coils for Short-Wave Reception Comprises Three Circuits and Allows Sharper Tuning.

A Highly Efficient Receiver

for 180 to 3000 Meter Wave Lengths

By CHARLES M. SREBROFF

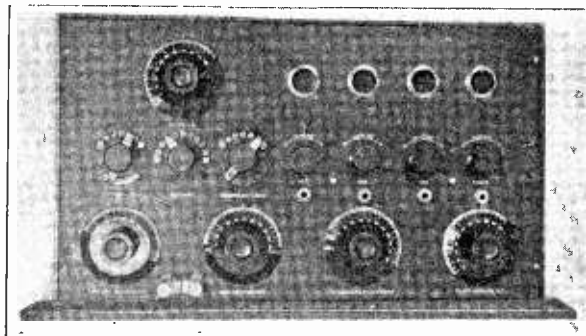

This complete and efficient receiver is well adapted for all-round work. It tunes all wave-lengths from 180 to 3,000 meters and gives powerful amplification, thanks to the three-step amplifier incorporated in the set. On the left may be seen the complete apparatus and on the right, the back and top views of the inside. Note the shielded panel, and compactness.

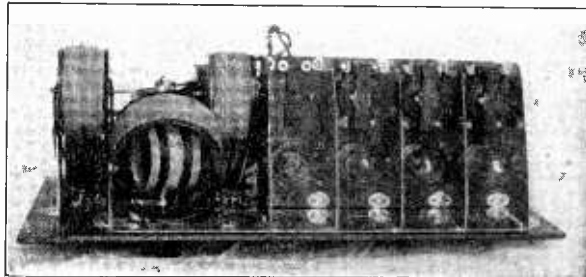

A REGENERATIVE receiver that has a wave-length range of 180 to 3,000 meters will be described in this article. This set will function efficiently on all the lower wave-lengths without any losses in dead ends.

The author's idea is to bring before the amateurs, several new features. These may be incorporated in various types of receivers, or else the reader may construct the one described.

The wiring diagram in Fig. 4 shows that this outfit comprises the well-known regenerative receiver, that is, the grid and plate circuits are tuned by means of variometers. There also can be seen the primary and secondary loading coils with the dead end switch arrangement. The schematic wiring connections of this switch will tend to immediately show how it operates. In the construction of this dead end arrangement, the builder must possess a lathe, and must follow out the constructional ideas shown in Fig. 1; this is necessary, but the same dead-end eliminating effect can be secured by using two switches; see Fig. 2.

Of course, the arrangement in Fig. 1 is neater and more flexible in operation. When receiving on 200 meters, the loading coils must be completely cut out of the circuit, or else the losses will greatly depreciate the efficiency. Fig. 1 shows sufficient details for its construction.

The loading coils used in this set are the bank wound type, and the primary and secondary coils are identical in all respects. Both have four banks of No. 22 D.C.C. wire wound 32 turns per inch on a cylindrical block of wood $3\frac{1}{2}$ " in diameter. The total winding space covers 2 inches.

Wood is used for the winding form for three reasons: It can be easily obtained; it can be readily worked on a lathe; and threads are very easily cut.

To succeed in bank winding, either a thread must be chased on the form to be wound, or else a string can be wound on with the equivalent number of turns per

inch. A point to be remembered is the making of the bends very sharp when lapping over; many failures can be attributed to this fact. Four equal types are taken off, and each one of the inductances and leads are brought out to contact points on the panel. The primary of the coupler consists of 42 turns of No. 22 D.C.C. wire wound on a bakelite tube $4\frac{1}{2}$ " in diameter. Eight equally spaced taps are taken off. The secondary is wound with 55 turns of No. 26 wire on a tube $2\frac{1}{2}$ " diameter. The primary is placed at 45° to the secondary as can be seen in the rear view of panel.

There are several well constructed variometers now available to the amateurs. It is better to purchase the variometers than to try to construct them; the moulded type now

over 1,500 meters this condenser must be shorted. This device is extremely simple and can be plainly seen in the rear view of the set.

Filament control telephone jacks are used in this design, by means of which the flexibility of the set is increased.

The grid condenser may be seen in the detector tube compartment. It has a capacity of approximately .0005 mfd. After the set has been put in operation and a signal is tuned in, the grid leak is made. Between the two terminals of the grid condenser, lines of india ink are drawn until the incoming signal shows loudest audibility. Howling is often overcome by careful adjustment of the leak.

Shielding the set and the various tubes and radio frequency transformers, helps greatly to minimize howling and capacity effects caused by the operator's hand. Aluminum has a neat appearance and keeps its rigidity and No. 22 B. & S. gauge will be found suitable for this purpose.

The various tubes may be shielded from each other by cutting pieces of aluminum, as shown in Fig. 3. When completely cut and drilled, the projecting portions are bent at right-angles, serving as means for fastening them, and at the same time can also be used to support the shelf holding the tubes and transformers.

The best way to proceed when building a set of this size is to first obtain all the various individual units. A full sized drawing is then made of the front panel and the different pieces are moved about on paper until a suitable position has been arrived at. By proceeding this way, all mistakes in assembling can be eliminated. The drawing is then completed, showing all the holes that are required in their relative positions. It is then placed on the panel and used as a drilling templet. The panel and aluminum shield are drilled together and clamped at the same time; by so doing the holes in each piece will coincide. Next, the shield holes are either reamed or drilled out larger so as to allow the different shafts to pass

(Continued on page 522)

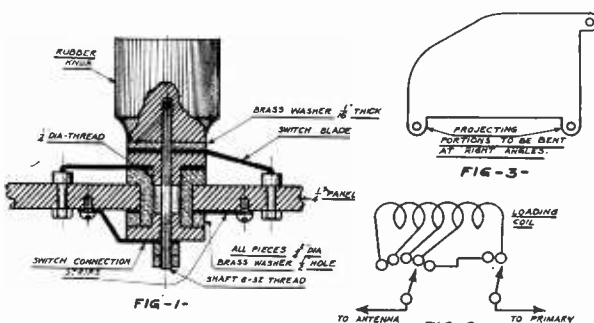
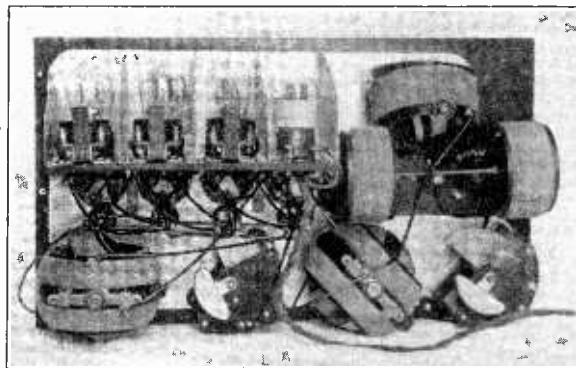

Fig. 1 Shows the Constructional Details of the Loading Coil Switch, While Fig. 3 Shows the Shape of the Metallic Flanges Mounted Between Each Step of Amplification.

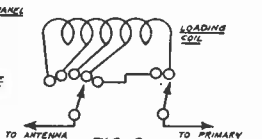

Fig. 2 - TO ANTENNA TO PRIMARY

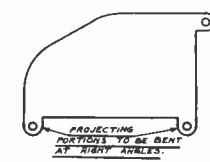

FIG-3-

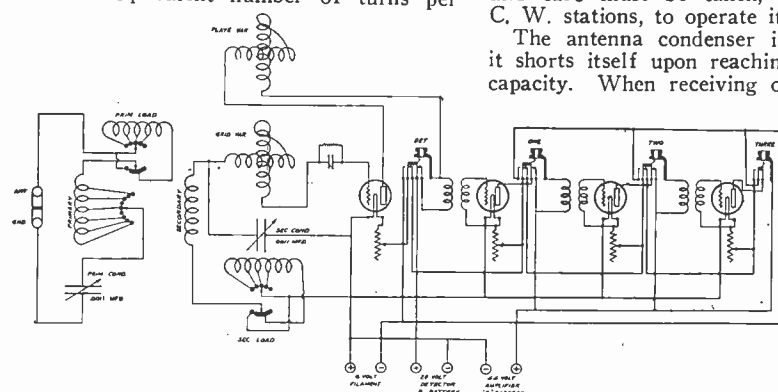
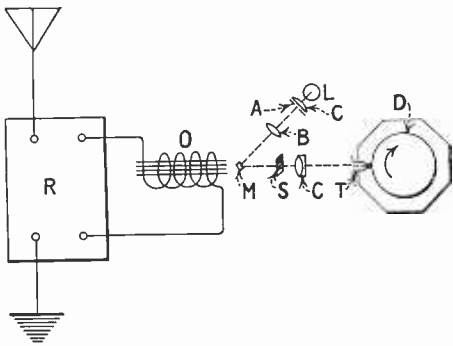

Fig. 4. Here is the complete diagram of connections of the combined receiver and three-step amplifier. Note the automatic filament control jacks.

Must We Abandon Dots and Dashes?

A Less Sensational But More Practical Phase of the Belin System of Image Transmission That May Revise Radio

By AUSTIN C. LESCARBOURA



Schematic Presentation of the Reception Apparatus Employed in the Belin System of Image Transmission.

L—Special arc lamp for supplying beam of light which passes through lens C, aperture A, lens B, and falls on tiny mirror M, which is mounted on a pair of silver wires of the Blondel oscillograph. The wires of the oscillograph are warped by the varying strength of current coming to them from the radio receiving set. The mirror, in turn, is deflected, and consequently throws its reflected beam to one side or the other of the graduated screen S. The light rays passing through the screen S and directed by the lens C to the aperture tube T and fall on the sensitized surface of the cylinder D, contained in a light-proof case. O, Oscillograph. R, Radio receiving sets and amplifier.

AFTER all, the dot and dash language of radio intercourse is crude. It is slow and awkward beside shorthand; it is not altogether accurate compared with longhand, especially in long-distance radio reception, where the operator must strain his ears to catch the attenuated waves amid the roar of static and other parasitic disturbances, but we have always used the dot and dash language in radio and have never questioned its practicability, because nothing better had suggested itself.

Now, however, thanks to the most ingenious system devised by M. Edouard Belin, of Paris, France, it becomes quite feasible to transmit photographs and images of all kinds by land wire and by radio, producing at the receiving end a faithful replica with all the wealth of detail of the original. At first blush this system gives rise to a wealth of possibilities, such as the transmission of photographs of Europe within an hour or two after they have been taken. And true enough, the Belin system can be applied to such purposes, although it is still somewhat premature to count on the transmission of photographs by radio over such long distances, for reasons that will be explained further along, but in the main, the major application of the Belin system today is toward the end of substituting facsimile transmission in place of the usual dot and dash language in the handling of radio traffic over short or long distances.

The importance of such a radical change in handling radio traffic cannot be appreciated without giving considerable thought to the subject. It means the speeding up of traffic; it means remarkable accuracy, for we are transmitting the actual facsimile matter and not a mere substitution of dots and dashes that must be translated back into the words of the original; it means the handling of traffic both positively and accurately even when static conditions are such as to preclude the handling of radio

traffic with the present dot and dash system; it means the handling of Chinese messages, which, hitherto, have presented a grave problem, for this language cannot be handled over the telegraph code with any degree of success because it makes use of so many signs, each one of which represents a thought. Hitherto, Chinese has generally been transmitted over wires by being first translated into some other language, and then translated back into Chinese, with considerable errors, as might well be expected.

First of all, why not a brief description of the Belin system? This system is one that makes possible the transmission of images, such as photographs, paintings, drawings, manuscripts, typed matter, handwriting, typewritten matter, maps, charts, shorthand notes, and so on. The transmission and reception may be adjusted to handle either half-tone subjects, in which all gradations of black and white photography, from solid black to gray and then to white, are to be reproduced at the distant receiving station, or so-called line subjects, in which just black and white, without gradations of any kind, are to be handled. The line subjects, with which we are more particularly interested in this discussion, are the simplest to handle by radio.

The way in which M. Belin accomplishes his end is quite simple, and was described at length over a year ago on the occasion of his first experiments in this country, when he demonstrated the practicability of his system by transmitting photographs over telegraph wires between St. Louis and New York. In the transmission of half-tone subjects, the first step is the preparing of the transmitting record. The subject to be transmitted is photographed or printed on to a sheet of special photographic paper, which in turn is wrapped about a brass cylinder or mandrel which has been so treated that the image from the paper will be transferred on to its face. The brass cylinder is then treated until the image is reproduced in relief; that is to say, some parts are more raised than others, so that the image appears as an engraving or even a shallow

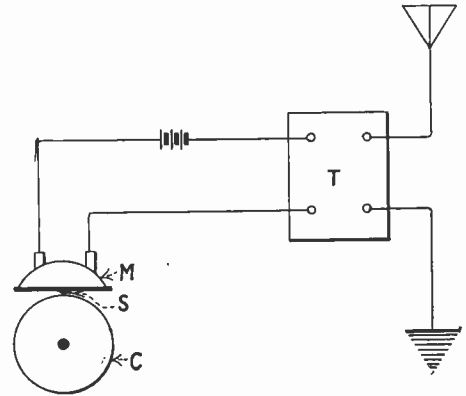

Schematic Presentation of the Transmission Apparatus Employed in Image Transmission.

C, Cylinder with image in relief, on which rests the stylus S which is directly connected to the diaphragm of the microphone M. The modulated current is impressed on the continuous wave transmitter by means of a suitable modulator arrangement, which in turn sends out the radio waves.

sculpture, so far as the effect is concerned. So much for the record.

The next step is to place this record in the transmitter, which resembles nothing so much as a phonograph of the old-style cylinder design. As the record is revolved, there travels along its face a fine point or stylus, which is fastened to a carbon microphone. Obviously, as the point or stylus rises and falls over the uneven surface of the cylinder, it varies the resistance of the current flowing through the microphone. Thus we obtain a modulated current, which is the basis of the transmitting end.

Now then, this modulated current can be sent over wires, in the case of wire or cable work, or by radio. At the receiving end this modulated current is picked up and passed through a Blondel oscillograph—a highly sensitive electrical instrument which has two thin vertical silver wires placed at right angles to the poles of a very powerful electromagnet. The wires are the carriers of a tiny mirror, and are placed in a tube containing oil, the action of said oil being to dampen the movement of the wires and the tiny mirror. As more or less current flows through the wires, they cause the mirror to deflect more or less from its normal plane.

Little more remains to be explained. A beam of light from a powerful illuminant is thrown on the tiny mirror. The mirror, in turn, reflects the light on to a graduated screen—that is, a screen that is opaque or impenetrable to light at one end, and absolutely transparent at the other, the section between being carefully graduated so as to have many values of transparency. Behind this graduated screen is a condenser, which causes the light rays passing through any part of the screen to be directed toward a narrow slot further on. Behind this slot is a sheet of photographic film or paper, placed on a cylinder or mandrel and in a light-proof container. The cylinder turns all the while, in absolute synchronism with the transmitting cylinder, the synchronism being effected by a novel but simple system of synchronizing signals that are quite automatic. Obviously, as the transmitter stylus comes to a high spot representing a black section of the photograph, it transmits a strong current, which at the transmitting

(Continued on page 512)

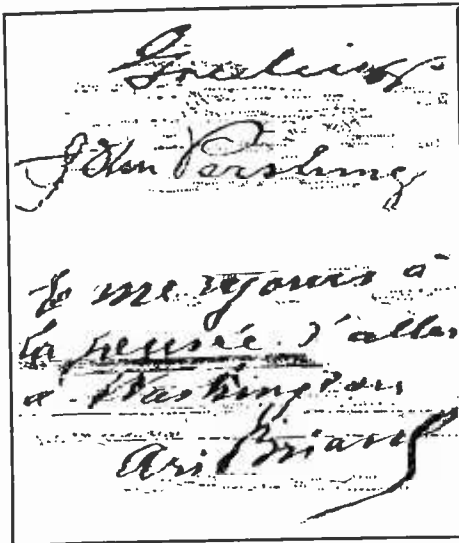

Two Samples of Writing Sent by Radio with the Belin Apparatus. Note the Numerous Dots and Lines Produced by Atmospheric. If Received in Code These Message Would Have Been Unreadable, While They are Quite Plain with the Belin Apparatus.

Choke Coil Amplifiers

By J. P. JESSUP

THE statement has been made to me that "what couldn't be heard on a detector, wouldn't be heard on a two-step." After listening to that person's two-step, I understood why. His two-step is made up of inefficient amplifying transformers, and although well built, gives poor results. It has very poor amplification, compared to a "choke coil" two-step. This same person has a wonderful cabinet with a three-step included. That three-step works almost as good as a choke coil two-step. My "choke coil" three-step works 500 per cent. better than his three-step of amplifying transformers. Where he had fairly loud signals, I would have been unable to bear the phones on my ears. Choke coils have been proven superior to amplifying transformers, time after time.

This choke coil idea is by no means new. Chokes were used in 1917, or possibly 1916, but never very successfully. During the war, the Army took hold of them and experimented with them, and got very good results. An ex-Army man, 2ACQ, brought the idea back with him to Ridgewood, N. J. He and 2AGF experimented and improved on the hook-ups. In a short time, many amateurs in town built choke coil amplifiers and very successful ones, too. I built a two-step and used it very successfully all winter. Meanwhile, 2AGF had built a four-step of chokes. The intensity of his signals was terrific. When the Carpentier-Demsey fight came, I put a three-step together. I wish the chap whom I mentioned before could have heard the tremendous amplification that I had, compared to his. Later I built a choke coil three-step in panel form on a panel 7" x 11". It certainly was compact. Just before I left, on my vacation, I finished a panel type four-step, of Myers tubes. The panel measured 7" x 18". I used it only two nights, but I nearly fractured both ear drums from the terrific signals; 2AGF also finished a five-step, and you can hardly stay in the same room with it.

In the matter of cost, chokes are by far the cheapest. An amplifying transformer "two-step" costs about \$18 without tubes, when home made. A choke coil two-step costs \$10 at the most without tubes and will give louder signals. My four-step cost me \$21 without tubes and \$35 with Myers tubes. You could not build an amplifying transformer amplifier up to four stages for less than \$40 or \$50 without tubes, or \$65 with tubes, a net saving of about \$30 at least. The choke coil amplifier would give amplification many times better than the other. My one-step cost \$3.50, without the tube. You cannot beat chokes for cheapness or efficiency. An audion company has built a choke coil and plans to furnish amplifiers up to four steps. Mr. Myers showed me a six-

Owing to the tighter coupling of the circuits, greater amplification is obtained with this type of amplifier provided the coupling capacities are of the correct value. This diagram shows a detector and three-step choke coil amplifier with automatic filament control jacks.

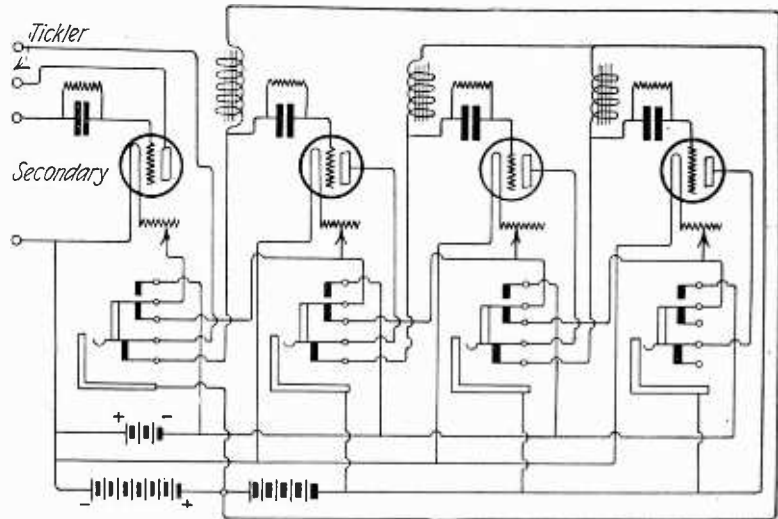
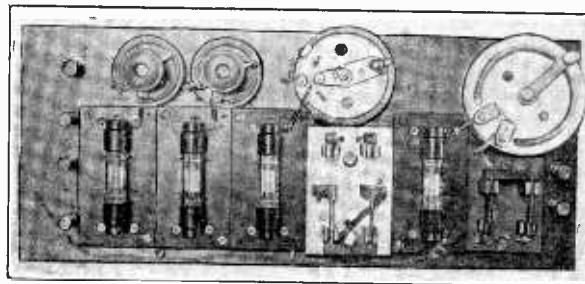

FIG. 2

step, fitted up with chokes; it was the most compact and efficient set I ever saw.

The accompanying sketches show the circuits of choke coil amplifiers with a different system of control to vary the number of stages of amplification used. Fig. 1 is the hook-up for a detector and three-step amplifier in which SPDT switches are used to take any desired number of steps of amplification; this method of control is the simplest.

Another system consists of using auto-



Mr. Jessup's Experimental Amplifier. Using Myers V.T.'s.

matic filament control jacks with a plug attached to the telephone cord so that the filament circuit of the unused tubes is automatically cut out when plugging the phones at any stage.

A common "B" battery is used. This had better be variable, as different sized chokes require different plate voltages on different tubes. Flashlight batteries are best. The chokes are secondaries of spark coils, with a good iron core inside. The unused primary may be removed or left in, just as you please. If removed, fill in space with core

wire. My chokes still have the unused primary inside and work very well. Ford coils make excellent chokes. Larger coils also work very well.

The grid condensers are very important. In my own set I merely take whatever condensers I have on hand and shift them around until I get the best results. I used a Murdock phone condenser on grid of the first step, and a larger phone condenser on grid of the second step. Each tube seems to require different condensers. Here are capacities that 2AGF uses for Moorehead tubes:

- Det. — .0005 mfd.
- 1 step— .005 mfd.
- 2 step— .05 mfd.
- 3 step— .5 mfd.
- 4 step— 4. mfd.

Here are capacities for Myers tubes, as advised by Mr. Myers:

- Det. — .00009 mfd.
- 1 step— .001 mfd.
- 2 step— .01 mfd.
- 3 step— .25 mfd.
- 4 step— 2. mfd.
- 5 step— 4. mfd.

However, on my Myers four-step, I find that a 4-mfd. condenser works very well on the fourth step. The closer you come to those capacities, the better results you will get.

In hooking up a set of this kind, do not be discouraged if it does not work the first time. Try different condensers or rearrange the chokes. Always be sure the condensers and chokes are in working condition. Try different plate voltages. No matter what amplifier you are trying out, be sure the "A" and "B" batteries are in good condition. No good work can be done with the best of amplifiers unless the "A" and "B" batteries are fully charged. If all the joints are soldered, you will get the best results. The grid circuits should be short and the chokes should be at right angles to each other. Moorehead and Myers tubes will work O.K. with chokes. Western Electric tubes are also O.K.

I have built seven amplifiers so far and they have all worked very well. About a year ago, I had an amplifying transformer in a one-step. I heard of the choke coil stunt and I merely shifted the primary leads over on to the secondary and used the secondary as a choke. It worked better than before. It is possible to use separate "B" batteries with chokes, but you seem to sacrifice some signal strength by so doing.

(Continued on page 532)

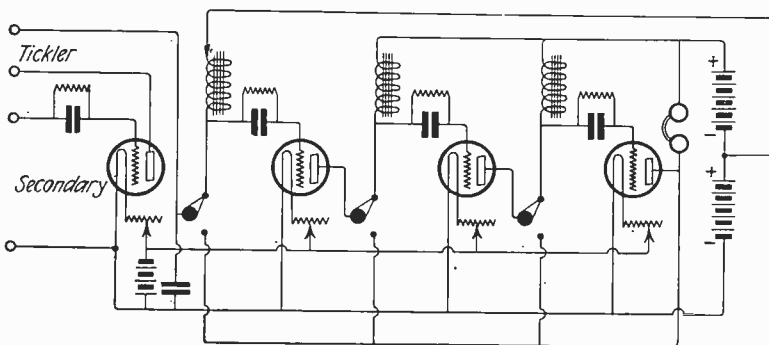
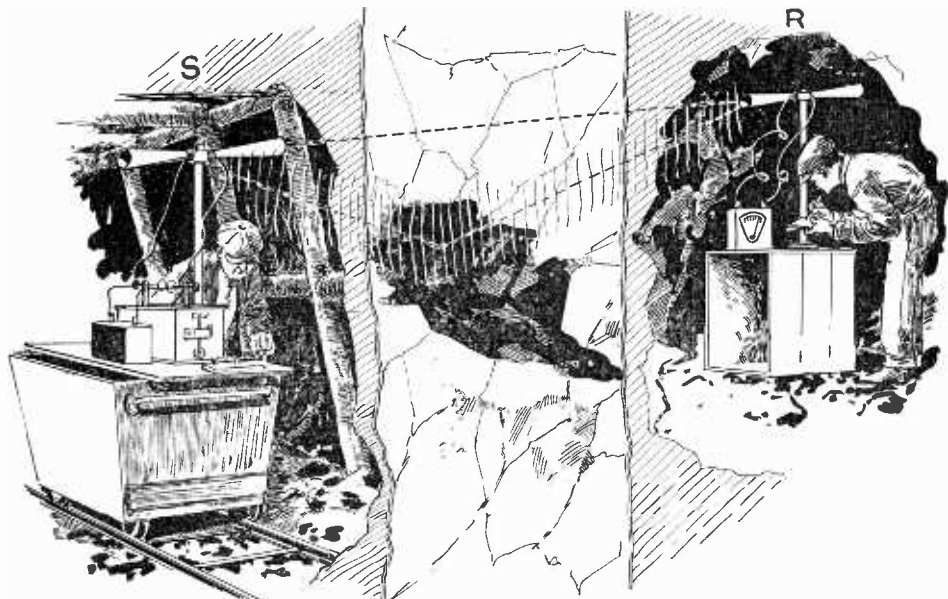

FIG. 1

This circuit is the same as Fig. 2, but S.P.D.T. switches are used instead of jacks to vary the number of stages of amplification to be used.

Locating Ores By Radio



This Drawing Clearly Shows How the Position of an Ore or Coal Vein May Be Ascertained by Radio. The Phenomenon of Refraction of Electromagnetic Waves is Used in This System.

RECENT systems using the refraction properties of electromagnetic waves have been developed in Europe for locating ore, coal or water bodies. This work was conducted with a view to ascertaining the position of the veins in the ground so that the boring could be effectuated in the proper places, saving a great deal of labor, expense and time.

One of the simplest methods uses two stations in line with each other as shown in the illustration, which are so arranged

that the waves will be reciprocally received, only coming in the direction of the arrows. If the waves can develop unhindered, which is the case in the mines when they go through a non-conducting block, then the sending station does not affect the other one. If the waves in any way confined in the interior of the earth, in a conducting place, which may be a vein of ore or a course of water or the moist stone, the waves then are refracted exactly as a ray of light is refracted by a prism, and thereby affects the other stations so that it registers a cur-

rent. The method has been so highly developed by its inventor in practical work for many years that today it is employed in very many ways: For example, in potash lines for determining if the country rocked between two shafts is free from water and from potash solution so that it can be safely penetrated; if the mining laws require a convincing proof to be shown for every operation, it is an absolute necessity; as they have to often go through wide stretches of entirely unknown rock, such an examination from the places on each side of the rock is of the greatest importance. Also, in the interior of potash mines, the method is used for seeking small distorted strata, for there are often old borings brought down by the weight of the earth above them, into which fresh water can penetrate. To get at such openings, which may bring water into the work, one has to leave a plentiful supply of heavy pillars standing, if he does not wish to put the whole place in danger. The lay of the disturbing element is often only imperfectly known, because its direction, especially when the boring has been done a long time before, often differs greatly from the perpendicular. Therefore it is of the greatest importance that the behavior of the radio waves makes it possible to exactly ascertain their lay and behavior in underground stations without having to go near them.

Speaking in an impressive way, one can seek for a mass of non-conducting rock, for a straight scalloped mass of metallic mineral, if at some properly separated stations borings are sunk, into which the sending and receiving radio systems are suspended. By using proper combinations of pairs of holes, a map giving the distribution of the veins of ore can be outlined.

Tikker Reception of C. W.

THE best system of reception of continuous waves consists in using the autodyne or heterodyne method, the former consisting in using a vacuum tube detector, which is made to oscillate to produce oscillations at such a frequency that they interfere with the incoming oscillations producing beats of audible frequency. The heterodyne method is, in fact, the same, except that an ordinary receiving circuit is used in conjunction with a separate oscillator.

This necessitates, of course, the use of vacuum tubes and is not always within the reach of the amateur still using a crystal detector, on account of the impossibility to charge the batteries, or for some other reason. The purpose of this article is to describe a method of reception of continuous waves with the tikker system, which, although not as flexible as a V.T. oscillator, may give fairly good results when properly adjusted.

The purpose of the tikker is to cut the continuous waves received in the antenna into trains, so that these wave trains may act upon the detector as those produced by a spark set would do, with the difference that the tone may be changed by adjusting the frequency of the make and break of the tikker. The tikker in this case acts as a chopper, the only difference being that it is installed in the receiving station, instead of the sending one.

While receiving spark signals, each wave train, which is damped and rectified by the detector, causes the diaphragm of the telephone to be attracted at the same frequency as that of the wave trains, producing each time it comes back to its normal position, a sound which may be heard by the human ear. When receiving continuous waves, the diaphragm of the telephone remains attracted permanently during all the time the signal is being sent, producing only a small click at the beginning and the end of each signal, if they are sufficiently strong.

It is, therefore, necessary to cut these signals into trains of audible frequency, so that the telephone diaphragm can vibrate and produce an audible sound. This is easily accomplished by means of a tikker which may be connected either in the primary or the secondary circuit; a good way to connect it, is between the crystal detector and the telephone receiver in the secondary circuit.

CONSTRUCTION OF A TIKKER

A simple form of mechanical tikker may be built using a phonograph as a source of power to run the make and break system which consists of a phonograph record, upon which is glued a piece of tinfoil or

copperfoil, of the shape shown in Fig. 1. The contact is made on this apparatus by two short lengths of silver wire soldered to pieces of heavy copper wire, which in turn are fixed to binding posts mounted on a bakelite strip. This piece of bakelite should be fixed to the arm supporting the tone arm of the phonograph, which is removed as in Fig. 2.

The length of the bakelite strip should be such that one of the silver wires is in permanent contact with the tinfoil disc, while the other one slides over its teeth producing a make and break between the two binding posts to which are connected the leads from the receiving set.

Using the speed control of the phonograph, it is possible to adjust the frequency of the make and break so that the tone of the received signals is made more readable and clear.

Using such a tikker, it becomes easy to receive short and long wave C.W. transmissions, adding much interest for the amateur who can only use a crystal detector.

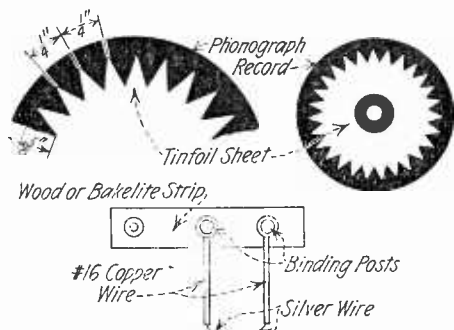

Fig. 1. Details of the Tinfoil Sheet and Contacts Used in the Mechanical Tikker.

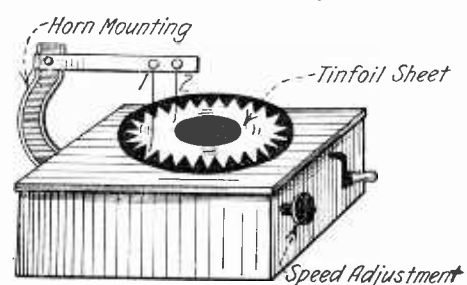

Fig. 2. With a Tikker Made of a Phonograph, it is Possible to Receive Continuous Waves With a Crystal Detector or a Non-Oscillating Circuit.

Modulation Systems for C.W. Which Will Give Satisfaction in Your Station

By ARTHUR H. LYNCH

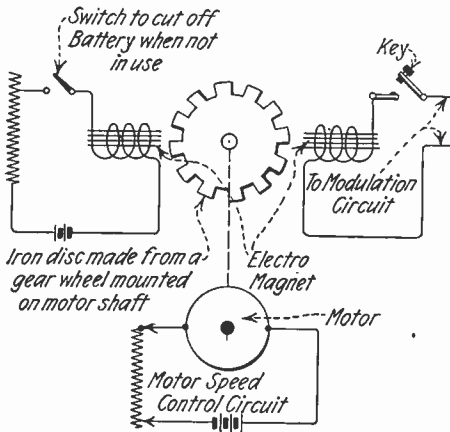

Fig. 2. This System of Modulation for C.W. Gives Better Results Than the Others, for Almost Hundred Percent Modulation of the Output May be Obtained With it.

It makes but little difference what form of transmitting circuit you are using, so long as it is some form of tube set, it is necessary for you to have some system of modulation. There are three modulation systems which have come to the writer's attention, lately, which, though very good, are not in general use. Perhaps one of them would be of value to you.

There is no need of adding more apparatus to your present equipment, nor is it necessary to make any very great change in the circuit you are now using, regardless of its character, for there is a scheme for any need. Of course, there are certain limits within which the various arrangements will work satisfactorily, determined by the conditions at the station, for instance, the third scheme to be described should not be attempted on transmitters of greater than twenty watts output unless the modulation device is placed on the grid circuit rather than in the antenna circuit, as shown in the diagram.

PHONOGRAPHIC MODULATION

Heretofore there has not appeared a system of phonographic modulation which was not subject to a great many imperfections. The phonograph in itself is subject to more or less sound distortion so that it is practically impossible to have sound produced by it fed into a wireless telephone circuit without this distortion, which in most cases is considerably increased by improper acoustic relations between the phonograph sound box and the microphone. Many schemes have been employed for sending out phonograph music, but the most common, is to place the microphone either in or directly in front of the phonograph horn. In stations, which have been built with the special purpose of broadcasting phonograph music, we find that the combination of sound-box, microphone and tone-arm has been made to form one unit, which may be applied to any talking machine of the disc type. Even in this advanced type of transmitter we can not look for entire satisfaction for the reason that there are certain records, which, when played with most sound-boxes will "blast." The blast is then carried to the microphone and sent into the air in an accentuated manner, for the tone arm or the phonograph horn, as the case may be, amplifies the blast before it reaches the microphone.

In order to reduce to a minimum any impure acoustic effect on the microphone actuated by a phonograph record, it is advisable to mount the microphone di-

rectly on the metal piston which actuates the diaphragm of the phonograph-box. By mounting the microphone on some sort of clamp, which may be slid up or down the piston and held in any desired place, it is possible to regulate the vibrations which the microphone will be subject to and the amount of current variation in the circuit which the microphone controls. The same effect may be had by using needles designed to produce various tones from the same records. Where only one form of needle is available it is possible to alter the tone volume of the record and the character of the vibrations to which the microphone is subject by changing the length of the needle, which is done by merely placing it all the way in or withdrawing it partly from the needle receptacle and fastening it in the desired position by means of the binding screw.

The amount of vibration to which the diaphragm of the sound-box is subject is determined by the relation between the length of the piston which actuates it, measured from the center of the diaphragm to the axis at the basis of the sound-box and the distance between the same axis and the point of the phonograph needle. If it is found that the amount of vibration at any point along the piston is insufficient to properly actuate the microphone, a small rod, about one-half to three-quarters of an inch long and not less than one thirty-second inch in diameter, may be soldered to the top of the piston and the microphone then mounted on it.

In addition to obviating to a very marked degree the distortion, caused by imperfect acoustics, between the various elements which are introduced between the phonograph record and ultimate wave produced by the transmitter, there is a very marked reduction in the "scratch" which accompanies all phonograph music. With a microphone button, such as illustrated in Fig. 1, it is not reasonable to expect to use this form of transmission where the power of the set is more than the microphone will carry, but suitable circuits may be arranged, in which the circuit from the microphone will actuate an electronic relay and operate satisfactorily with almost any power, especially where magnetic amplifiers are brought into service. For the low-powered phone set, however, we find that the best results are obtained by running the

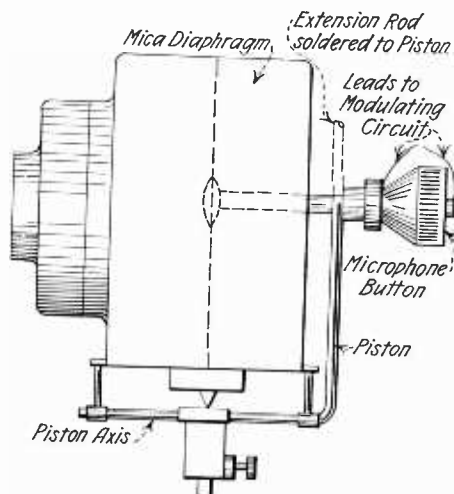

Fig. 1. This Method of Mounting the Microphone of a Radiophone Set, for the Transmission of Phonograph Music, Greatly Reduces the Scratch and Provides Better Modulation.

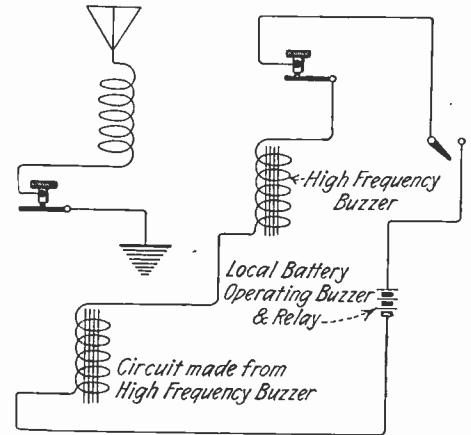

Fig. 3. For I. C.W. Transmission it is Best to Use Two Buzzers Having Their Windings in Serie, One Acts as Interrupter the Other One as Make and Break in the Aerial Circuit.

leads from the microphone to a modulation transformer, through the tone-arm of the phonograph, which is hollow. If it is to be made part of a permanent installation, or the phonograph is to be used repeatedly for wireless telephony, it will be well to mount two binding posts, on the side of the machine, below the tone arm, to which the wires leading from the microphone may be attached.

MOTOR-DRIVEN MODULATOR

Fig. 2 represents two electro-magnets, mounted diametrically opposite each other, on suitable supports, having a solid iron, toothed wheel rotating between them, so that the teeth of the wheel cut through the lines of force found at the end of the core of the magnets. These magnets may be taken from any telegraph sounder, relay or old electric bell and connected as shown in the drawing. The action of the device is not new, but it has not been generally applied to modulated C.W.

The magnet is merely connected in series with a local battery, which may be of four volts. For fine regulation of the current which passes through this magnet, it may be advisable to put a rheostat in series with it, but this is not necessary, though an effort should be made to use no more current than is necessary to bring the magnet to a point of saturation.

The terminals of the second magnet are connected to the key circuit, in the manner shown, and it makes no difference whether the key is in series with a modulation transformer or is directly connected in the grid circuit.

The iron, toothed wheel is mounted on a motor shaft and the speed of the motor is variable, made possible by having a rheostat in series with it. It will be found that the results obtained will vary materially as the speed of the disc is changed. When the device is operating at its best, which may be determined by watching the hot wire ammeter in the antenna circuit, it will be found that it is very much superior to any other form of modulating device. By reason of the fact that there are so many variable factors, it will be necessary for the experimenter to make a few comparisons which should be jotted down on paper for reference before the best results will be obtained.

The greatest advantage of this form of modulator is that it will enable modulation to be effected which is well above ninety per cent. of the entire output current of the

(Continued on page 520)

Some Notes About My Station

By J. L. LEISTRA

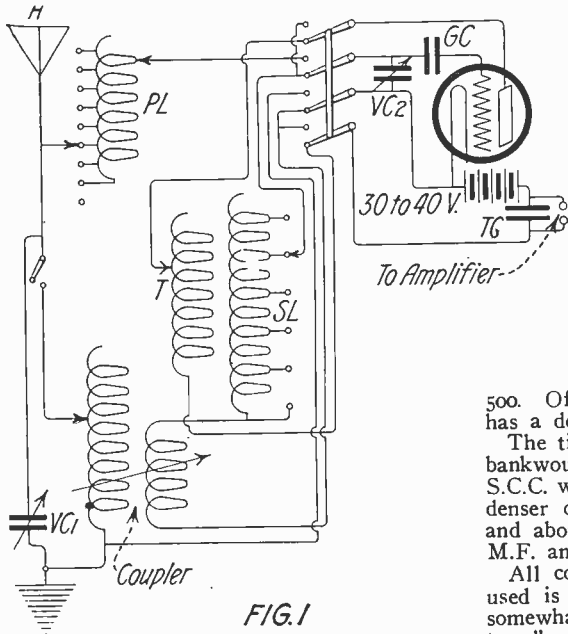

FIG. 1

By Means of a Four P.D.T. Switch it is Easy to Change From "Standby" to "Tune" Position.

UPON request of many amateurs, who have asked me constructional details about my receiving station, I give the following data for the benefit of those interested.

Since the photo that was published in RADIO NEWS for August was taken, the set has been enlarged considerably. The short-wave set has been replaced by honeycomb coils of the ordinary panel type; a Telefunken (German) short-wave, intermediate circuit receiver has been added, and at present some experiments are carried out with a high frequency amplifier with "double grid valves," which may be obtained here for amateur use. The long-wave set works best on waves above 2,000 meters and up to 25,000. It is mounted in an oak cabinet; outside dimensions are about 25" x 12" x 12". A complete diagram of the set is given in Fig. 1.

When the four-pole switch is thrown to the right, the set has a tuned secondary circuit and aperiodic tickler (T).

In the other position a direct coupled circuit is used, with tuned plate circuit.

For long waves (above 3,000) the last system gives much better results than the inductively coupled system.

The dimensions of the coils are as follows: Primary loading coil (P.L.) is 16" long, 6" diameter, wound full with No. 30 enameled wire.

This coil has nine taps, taken at regular intervals.

The coupler primary has a diameter of about 6", and is also wound with No. 30 enameled wire. Its length is 4".

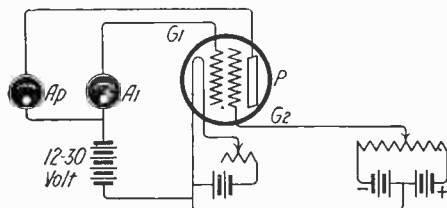

FIG. 4

Coupler secondary: Diameter 4", length 3 1/2", wire No. 30 enameled.

The primary has 10 taps, the secondary has no taps.

The secondary loading coil consists of two parts, one honeycomb coil in which the tickler coil rotates, and another separated honeycomb coil.

The first section has a diameter of 4", length 2", and consists of 500 turns, with taps at 50, 100, 200, 350 and 500.

The second part is an ordinary honeycomb coil of 1,500 turns with a tap taken at about 500. Of course, the secondary loading coil has a dead end switch.

The tickler, diameter 3" and length 1", is bankwound with three layers of No. 36 S.C.C. wire. V.C.1 is a Clapp-Eastham condenser of .001 M.F. V.C.2 is home-made, and about .0005 M.F. G.C. is about .0003 M.F. and F.C. equals .001 M.F.

All coils are hand-wound, and the valve used is a Dutch "Philips" valve, which is somewhat similar to the well-known "Audio-tron."

The second set, which is for intermediate waves (500 to 4,000 meters) has nothing unusual in it. It merely consists of a coil mounting panel, and two variable condensers.

The valve used in this set is a Telefunken RE16.

The short-wave set is a so-called "Telefunken F Empfaenger;" a diagram, somewhat simplified, is given in Fig. 2.

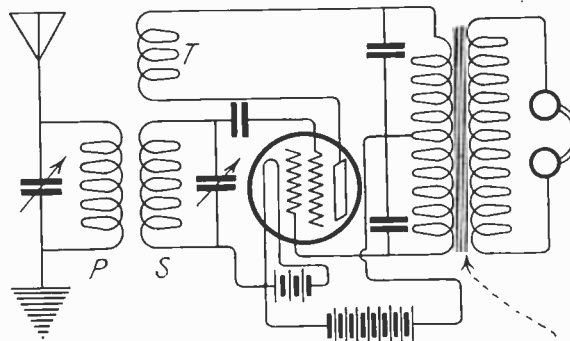

Phone Transformer with Tap in the Center of Primary Winding

FIG. 5

Hook-up of a Double Grid Tube Used as a Detector.

The intermediate circuit is exactly calibrated and can be excited by shunted burner, and therefore be used as a wavemeter, for waves from 120 to 800 meters. I have altered the connection insofar as at present it can be easily connected to the audion of the medium wave tuner, so that an oscil-

Fig. 4 on the left shows the method of determining the characteristics of the double grid V.T.'s, while Fig. 7 shows how these tubes are used for radio frequency amplification.

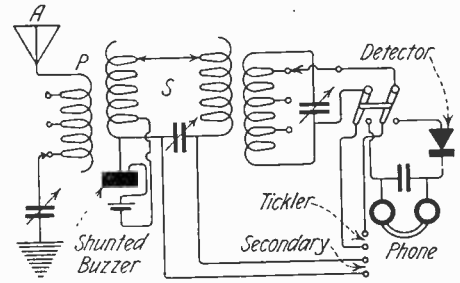

FIG. 2

Diagram of Connection of the Telefunken Type F Receiver Used for Short-Wave Reception.

lating audion may be used instead of the crystal detector.

In this case the detector circuit is used as a tickler. The reception with this set is extremely fine, and the selectiveness is nearly incredible.

A diagram of the low frequency amplifier is given in Fig. 3.

The first transformer has a primary winding with a resistance of 5,000 ohms, and a secondary of 80,000 ohms (ratio 1:16). The first valve is a Telefunken EVE171.

The second transformer has the following dimensions: Primary, 1,000 ohms; secondary, 6,000 ohms.

The second valve is a Telefunken EVE173.

The low frequency amplifier may be connected to each of the two tuners by means of the double-pole-double-throw switch. The high frequency amplifier, however, embodies some entirely new features.

Recent measurements have proved that when a negative potential is impressed on the second grid (G₂ in Fig. 4) the plate current decreases (as in an ordinary valve). The milliammeter connected with the first grid indicates, however, an increase of current.

Although the current in the plate circuit is much less than the current indicated by ammeter A₁, the decrease of same is nearly equal to the increase of the other, with a given negative grid potential. Therefore, when different negative potentials are impressed on the second grid, the total current delivered by the 20-volt battery will be constant.

A very effective circuit for reception of Radio signals is given in Fig. 5.

The decrease of the plate current, as well as the increase of the first grid current, is used to affect the secondary of the telephone transformer.

A diagram for multi-stage low frequency amplification is given in Fig. 6.

After the foregoing explanation, the high

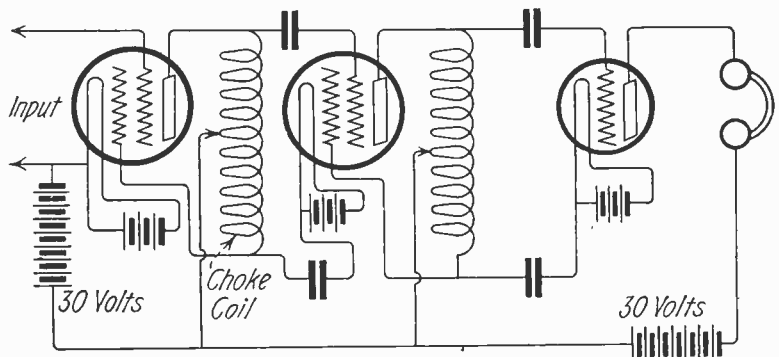

FIG. 7

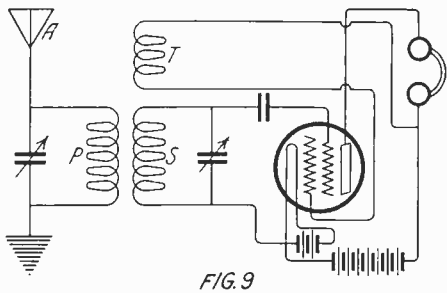

FIG. 9

frequency amplifier, of which a diagram is given in Fig. 7, may be readily understood. For very short waves Fig. 8 is recommended.

A very typical circuit is given in Fig. 9. The tickler coil is connected in this case to the first grid.

Even with a small tickler coil, this circuit oscillates very reliably with no plate battery at all (telephone and tickler connected to positive terminal of storage battery).

With a plate battery of 12-20 volts, a tickler coil L100 (honeycomb coil) is sufficient for waves up to 20,000 meters.

For all foregoing diagrams the tickler coil can be placed in series with the first grid as well as with the plate.

When a double grid valve is carefully adjusted, the signals can be stronger than with an ordinary valve, using one-step of low frequency amplification.

For portable stations it is very suitable as two or three flashlight batteries will give the necessary plate voltage.

The explanation of the fact that when a negative potential is impressed on the second grid, the current in the first grid circuit increases, is very simple. When no negative potential is impressed on the second grid, a part of the electrons omitted by the filament will reach the first grid, the other part will fly through the first grid and reach the plate.

When now a slight negative potential is applied on the second grid, a good deal of the electrons will be kicked back to the first grid. Now the plate current decreases and the first grid current increases.

When a high negative potential is put on

The hook-up Fig. 8 is that of a radio frequency amplifier with tuned circuit. Fig. 9 shows the connections of the double grid tube in a regenerative circuit.

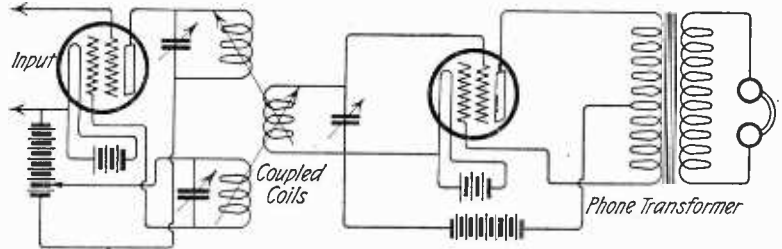

FIG. 8

the second grid, the electrons emitted by the filament will be kicked back before they have reached the first grid.

In that case the first grid current will be under its normal value.

Measurements have proved that there is a very sharp limit for each type of valve, under which the current increases when the negative potential increases, and above

valve rectifier with so-called cold cathode vacuum tubes about which an article appeared in one of the foregoing numbers of RADIO NEWS.

Shielding Your Panel By HOWARD S. PYLE

It is generally conceded by all modern radio experts, that a shielded panel is desirable in a number of respects, chief among which is the elimination of capacity effects from the operator's hands while manipulating the tuning controls.

It is thought to be an expensive, or at least a difficult mechanical job, to properly shield the rear of an amateur receiving set panel, and it is, without proper tools, when considering using a copper plate shield.

The writer recently overcame the high cost and difficulty of construction of such a shield by a remarkably simple process, and at a cost of 20 cents for a panel 12" x 18", and the results are all that can be expected, even from a standard Navy copper shield.

The first step is to cover the rear of the panel with a thin coat of shellac, thinned down with wood alcohol. A book of aluminum leaf, such as is used by sign painters, is then procured at a paint store, and while the shellac is very "tacky" or sticky, lay the leaf on the panel, sheet by sheet, in such a way as to completely cover the entire surface. It will surprise you to see what a perfect coating will result, the aluminum leaf laying on the panel like plating on metal.

Allow the panel to set overnight and rub lightly the following day with a soft cloth, to remove all surplus aluminum. The holes are then drilled in the panel and where they come through the leaf, it is scraped away so as not to form contact with any part of the circuits. The coating is grounded to the earth post of the receiver. The interior of the receiving cabinet may also be coated in the same way, making a complete metal housing about the receiver. Should the very highest conductivity be desired, silver leaf may be used, but aluminum is very satisfactory.

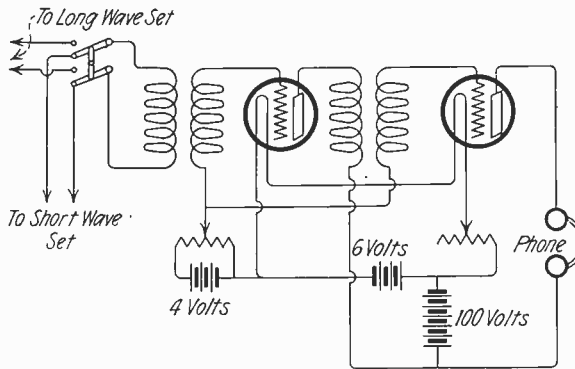

FIG. 3

Hook-up of the Two-Stage Audio Frequency Amplifier Used in Conjunction With the Various Sets in Mr. Leistra's Station. Note the Potentiometer for Adjusting the Potential on Grids.

which the current decreases, when the negative potential increases. And it seems that this limit is of vital importance for the quality of the valve.

I believe that it depends also entirely upon this limit, if the valve will be especially for high frequency amplification or detection, etc.

I hope that this information may be of use to those who intend to start work with a double grid valve.

For charging my storage battery, I use a

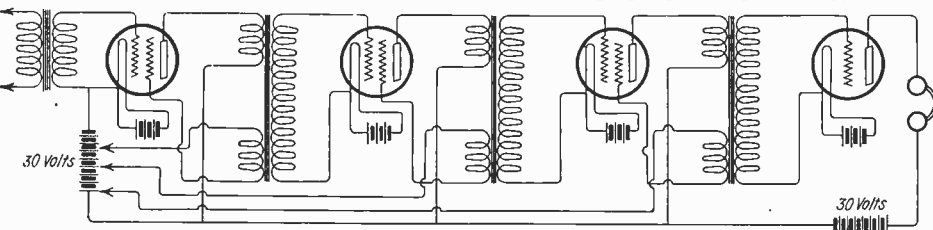

FIG. 6

Hook-up of a Four-Step Audio Frequency Amplifier Using Double Grid Tubes. Separate "A" Batteries Are Shown for Clearness, But Only One Should be Used.

Radial Inductances Eliminating QRM

By FRED G. EHLERT

FOLLOWING the publication of my first article about the radial inductances in the September issue of RADIO NEWS, I received a great number of letters from every part of the country asking me for more detailed information about these new coils and where they could be obtained. I will endeavor in this second article to supply all the fellow amateurs with the information they want and give a little more "dope" about the new inductances.

The radial inductances were invented on account of the QRM experienced in the vicinity of New York City at one of the Government Radio Stations. All of you

professional operators, or amateurs know how the QRM gets on everybody's nerves sometimes while tuning in for a certain station. The QRM got, in the same way, on Mr. Bogdanoff's nerves while handling Government traffic and he tried every possible means to eliminate the terrific interference.

After altering and trying to improve each element of the circuit he was using, he found that the remedy was in the inductance, and this led him to design several hundred coils of various sizes and shapes until finally he turned out the radial inductance, which is the most efficient type of winding to be used for the elimination of

interference. This was proved by experiments during very severe tests in a Government station.

The coils, which are patented, consist of a disk of bakelite or hard fiber 3" in diameter, upon which is wound one layer of Litz wire in a rather peculiar way. Two coils are mounted on the same shaft, one acting as the primary, the other as the secondary, the latter being wound with a different size of wire. If these coils have not the proper number of turns, they will not function properly and the tuning qualities will be lacking. When mounted on a shaft and

(Continued on page 540)

Winning the Public to Radio

By RAYMOND FRANCIS YATES

A Heart to Heart Talk With the Amateur, Dealer and Manufacturer. Telling How They Must Work Together to Popularize Radio

VERY little sober thought is needed to convince one that an era of great prosperity and expansion is directly ahead of the radio manufacturer and the radio dealer. Before this prosperity can be enjoyed to its fullest extent, there are certain things that must be done to win the public to radio. It is well at this time to prepare for a psychological battle that must be waged with the man on the street to convince him of the fun, entertainment and education that can be brought into his own home by the spirit voice of radio. The average man today looks upon radio as a thing utterly beyond him. It is a thing that fills him with awe. To him radio is an alluring mystery, a black art understood only by high-brow college professors and curious youngsters who have grasped the fundamentals, and who, through infinite patience and care, have assembled a crude radio equipment with which they listen in on the world.

There is much to be done before the public will accept radio in the same whole-hearted spirit with which it has accepted the phonograph and other instruments that have brought entertainment into the home. Contrary to general opinion, the public will not pounce upon radio like a thing that it has been waiting for. The public must be educated, and that education is going to take time and much painstaking effort, not only on the part of the manufacturers but on the part of the radio dealers as well. Even the amateur must take an important part in this program.

It is true that even at the present time, radio as a dealer's proposition is very profitable and attractive, but a lot of work must be done in the way of proper advertising and publicity before radio apparatus will become the fast-selling article that it deserves to be.

Those of us who have spent a few moments in the radio cabin on board ship have probably come to understand the attitude of the average man toward radio communication. He stops and peers into the radio room awe-inspired. To him this hurling of messages through infinite space is a thing quite apart from his daily affairs. He shows a great respect for the radio operator, looking upon him as a little god vested with almost supernatural powers. The ladies stop at the wireless cabin and say, "Oh, my! What a marvelous thing this radio must be!"

This frame of mind must be corrected. The subject of radio must be humanized and sugar-coated through carefully planned advertising of a national character and through well-engineered publicity.

The radio manufacturers must start at the very bottom of the matter. The instruments they have designed for the use of the seasoned amateur and the dyed-in-the-

wool enthusiast must be changed. That will be the first, and most important, step toward the popularization of radio communication. The wireless instruments of today look too scientific with their many adjusting knobs, their calibrated scales, their vacuum tubes, switches and jacks. The writer is free to admit that in the final analysis they are not as scientific as they appear to be, but the public is not easily convinced of this fact. The appearance of the radio receiving set at the present time is enough to scare the wits out of the ordinary man. To be sure, "this is only a condenser," "that is only an inductance" and "this is only a

when it fails to work, just as he takes his phonograph motor when he breaks a spring.

The radio manufacturer cannot go too far with the idea of reducing the operation of a radio receiving outfit to a "turn the knob" proposition. If the buyer of the outfit wants to go deeper into the study of radio he can do so, but nine out of ten men will prefer to let the mysteries of radio entertain those whom they may.

Every tradition of present day radio advertising must be violated in the copy that is going to win the public to radio. One need only pick up one of the radio magazines to understand why radio appeals only

to those who have a deep interest in it, and those who are of a studious turn of mind. From the standpoint of popularity the radio advertising of today is simply preposterous. It reads like Greek to the man who knows nothing of the science. He is confronted with such terms as microhenries, inductances, B-batteries, C.W. apparatus, amplifying coils, variometers, regenerative receivers, etc. His mind is set in a whirl with these mystifying terms. If he ever entertained any idea of installing a radio receiver in his home, his enthusiasm certainly suffers no little amount of cooling off, upon being confronted with this terminology. It is, of course, just the kind of advertising that appeals to the man who knows, but we are not considering that individual now, we are considering the man whose mind is a blank as far as radio knowledge is concerned.

Radio manufacturers and dealers must devise a new code of advertising

with every word conveying the thrill of radio and every line chock full of human interest. The battle of winning the public to radio must not only be fought with words as ammunition, but pictures as well. The manufacturers and dealers must learn to speak in the language of the layman. Every picture used must be aglow with human interest and full of human appeal. The services of some of our best artists must be enlisted to picture this "home radio" idea the way it should be pictured. Every illustration can be made to speak volumes.

The literature provided to the dealers must emphasize the entertainment and education that is available in the air. The radio evenings that can be enjoyed at home must be described with the most careful choice of words. In every folder and pamphlet, radio must fight for its place beside the phonograph. The reader must be told that radio music can be brought in by simply "turning the knob." The idea of unsightly outside wires must also be overcome. There are "one hundred and one" things that must be mentioned in literature of this kind,

(Continued on page 546)

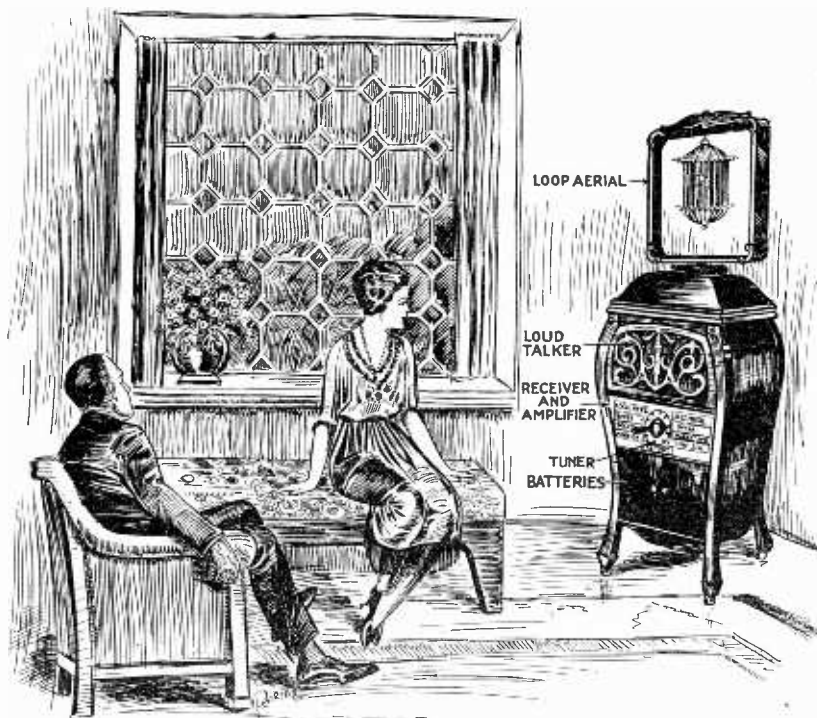

Here is the "Radiotrol" which will take the place of the phonograph in our homes soon. It could be so designed that only one adjustment would be necessary to tune in music, news, etc., which could be sent at the same time on different wave-lengths.

reostat," but what do these terms mean to him? Absolutely nothing. In fact, such explanations only complicate matters and cause him to regard the apparatus with even greater suspicion.

In designing the apparatus, the radio manufacturer must work on the basis of "the less seen the better." All of the mysterious looking instruments that go into the make-up of a receiving set must be hidden from view as much as possible, the writer would even advise taking the usual calibrations off the adjusting knobs. The simple "on and off" idea must be used as far as possible. The apparatus must be put up to resemble an ordinary box as much as possible—a radio box—that is what it must be. If the driving mechanism of our phonographs was visible, the phonograph would not be as popular as it is today, because it would look too complicated. As long as there is simply a revolving disc and a handle in sight all is well and good. The prospective radio buyer must be told that he does not need to know the "ins and outs" of all the "junk" stored within the box. He must be told that he can take his radio box to his dealer and have it repaired

An Adaptation

By C. L. WHITNEY

HERE is a hook-up that works, for spark or C.W. reception on waves from 200 meters up as high as one cares to go. Although for efficiency it can be beat on 200 meters, it cannot be beat on waves higher than about 500 meters. At least, I have found it so. This method of receiving C.W. is not new to the amateur world, but in practically every case it is looked upon as an interesting method and nothing more.

To equip a station to receive waves from 200 to 25,000 meters by accepted practice means that at least a dozen honeycomb (or duo-lateral) coils have to be secured in addition to at least two .001 mfd. variable condensers, and a suitable mounting for the coils. This method requires a separate control, for each of the following must be provided: 1—Primary coupling; 2—Primary variable condenser; 3—Secondary variable condenser; 4—Tickler coupling. When so many controls are used, it requires some juggling to tune a station in, as anyone who has used this system knows, and to change from one wave to another (say from 600 to 14,000 meters) takes at least 30 to 40 seconds, if not more, even when the proper adjustments are known beforehand, such as a system of marked coupling and condenser settings, etc., are used.

To change "tune" from 600 to 14,000 meters on the tuner described below, takes practically two to three seconds, using one hand only. As regards the difference in price, well, think it over yourself.

As shown in the accompanying diagram, two separate inductances are used, one being the largest size of honeycomb (or duo-lateral) coil with three taps taken off; and the other being a cylindrical coil $4\frac{1}{2}$ " long and 4" in diameter, wound for $\frac{1}{4}$ " of its length with No. 28 or No. 30 S.C.C. magnet wire, with a tap taken off every half inch. This latter coil is used for waves up to 2,500 to 3,000 meters on an average aerial. Dead-end switches can be used if

This single circuit tuner is particularly adapted for the reception of long waves. It has the advantage of quick tuning and, an auto-dyne effect being produced, it becomes possible to receive arc stations. Being compact, it may be easily transported, if a small storage battery is used for the V.T. detector.

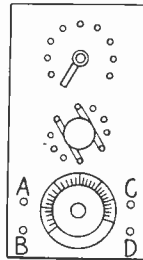
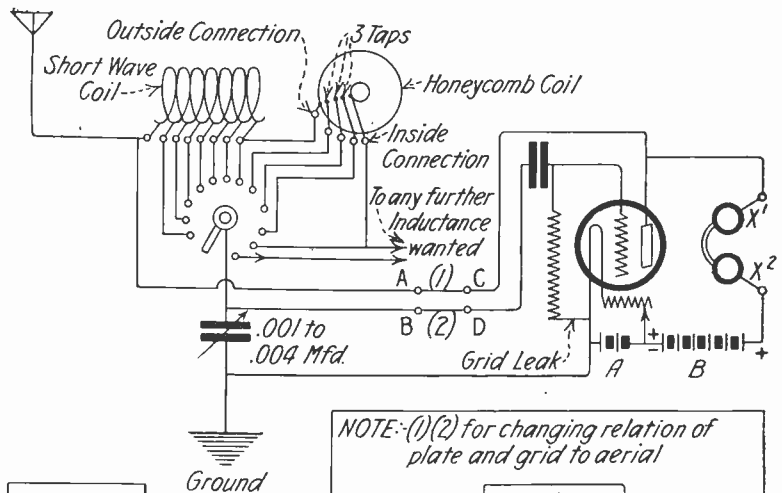
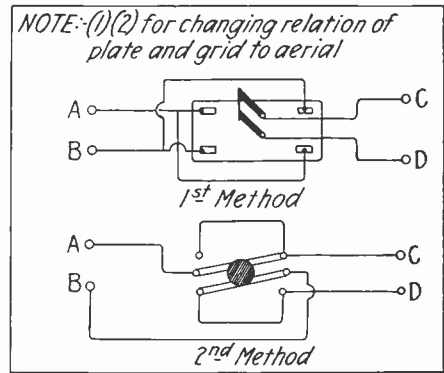

FIG. 2



wanted, and the two coils mounted at right-angles to each other, although in actual practice no decrease in signal strength was found without these accepted methods or ideas.

A double-pole, double-throw switch can be inserted at 1 and 2 to allow the grid to be connected to the aerial side of the inductances, if wanted. Some bulbs oscillate better with the plate to the aerial side,

and some with the grid to the aerial side.

Amplifiers can be used with this circuit, just as with any other circuit, when the primary is connected in place of the phones, at X¹ X².

For mounting, a panel may be used with the inductance switch mounted at the top and variable condenser knob at bottom with the D.P.D.T. switch in between, as shown in Fig. 2.

Panel Mounting for Spider-Web Coils

By H. S. MORRIS

WHEN it is desired to incorporate spider web inductances in a cabinet set, it is necessary to provide a system of control, for there is none installed

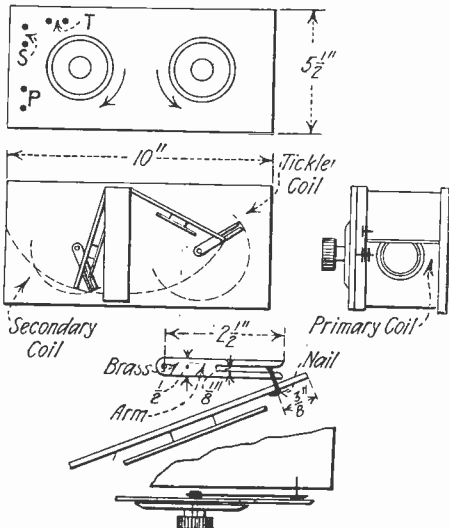

With This Arrangement Spider Web Coils May be Mounted in a Cabinet and the Coupling Controlled by Means of Dials.

on the spider web cabinet itself, the coils being moved by hand. In the construction of a receiver for short waves using these coils, I designed the panel mounting shown in the accompanying sketch, by means of which the primary and tickler coil couplings may be varied from the front of the panel by means of dials.

As may be seen in the illustration, the main part of the control system which is to be built, is a fork, dimensions for which are given in the sketch, mounted on the shaft supporting the dial and rotating with it. The motion radius of this fork is shown in the drawing, as well as the opening of the little doors upon which are mounted the coils in the spider web cabinet.

The secondary and tickler coils are moved apart from the primary by means of a nail driven into the door and sliding in the slot of the fork, when the latter is turned by means of the dial mounted outside of the panel. A top view of this arrangement is shown in the lower drawing of the illustration.

With this method of mounting, the cabinet in which the coils are fixed may be used in a panel set.

The coupling, which should be closely adjusted for the reception of C.W. and Radiotelephony, is varied with dials, easy to equip with a vernier system of control.

A Compact Variable Condenser

By D. H. WATKINSON

THE following is a description of a variable condenser which is useful in effecting the economy of space so desirable in all radio installations.

The form is exactly similar to the usual type of interleaving condenser, the only difference being the use of two sets of fixed and moving plates, instead of only one.

The whole condenser is assembled in the usual manner, but the two sets of moving plates are mounted on each side of the spindle, interleaving with the two fixed sets.

(Continued on page 540)

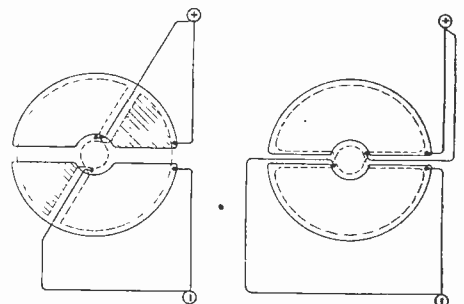

By Using Two Sets of Fixed and Movable Plates in a Variable Condenser, Greater Capacity May be Obtained Under a Smaller Volume.

Radio Digest

LONDON PHONE TO HOLLAND.

The establishment of regular wireless telephone connection between London and Holland requires only the approval of the Postoffice. The plan is to lay land wires to Southwold, Suffolk, and from Vandvoort to Rotterdam and Amsterdam. The North Sea is to be crossed by wireless. Tests already have proved successful.

"The great expense is the only obstacle to similar service between London and New York," said a Marconi official.

RADIO STOCK TICKERS FOR SHIPS.

The tired business man will no more get a respite from the ticker's noise by taking a trip abroad. They are going to install tickers on ocean liners and the voice of the ticker will mingle with what the wild waves are saying. The idea and its execution is due to the Bowman group of hotels, according to Robert J. Kennedy, the Biltmore representative. Mr. Kennedy says:

"A powerful wireless equipment has been installed on the Commodore roof by direction of John McE. Bowman, President of the Bowman hotels. The wireless room has every facility and modern bit of apparatus for sending and receiving radio messages, with expert wireless operators in the charge of Marshall C. Wright, chief radio operator."

NEW RADIO CONCERTS.

The De Forest Radio Telephone & Telegraph Company is planning to re-establish its broadcasting station in New York City for the benefit of amateurs within a radius of 400 miles. Feeling that there is a demand for radio telephone news and music in that territory, three nightly concerts of one hour each, to be preceded by a general news program, is being planned. The wavelength, time, etc., will be announced later.

RADIO RESEARCH STATION IN CANADA.

La Prairie, a small town six miles from Montreal, is to be the site of one of the most complete wireless experimental research stations in the world, according to a statement made by A. R. Morse, managing director of the Marconi Wireless Telegraph Company of Canada.

BERLIN-COPENHAGEN RADIO-PHONE SERVICE.

A wireless telephone service between Berlin and Copenhagen has just been established, following successful experiments. Four kilowatt Poulson transmitters are used.

The inauguration of a general service marks progress in the experiments which have been carried on since December, 1920, when music was transmitted by wireless telephone from Berlin. Wireless telephone stations in England, at Sarajevo and at Moscow reported having heard it.

Experiments have proved successful with ships 900 miles out at sea.

RADIOPHONE INSTALLED IN FIRE CHIEF'S AUTO

Chief McGill, of the Trenton Fire Department, has had a wireless telephone set installed in his automobile and will hereafter be able to keep in communication with fire headquarters without having to leave the scene of fires. Tests have been made and the radio apparatus found to be efficient in every detail.

VENEZUELA BUILDS FOUR RADIO STATIONS.

Wireless stations are being erected in Caracas, La Guaira, Maracay, Valencia and

the other principal cities of the country, according to an announcement of the Venezuelan Commercial Agency in New York City. The one at Caracas is to have exceptionally long range and is to be capable of communicating with similar stations in this country and in Europe. The other Venezuelan stations, a number of which are already in operation, are to be employed in transmitting official and private messages.

Importers and exporters have complained for some time of the inadequate cable facilities provided between the United States and Venezuela, and it is thought that the new wireless plant at Caracas will do much toward obviating these difficulties. At the same time the Government is planning the erection of a dozen or so lighthouses along the coast. Bids for these have been requested in this country, and the contract will probably go to an American firm.

9YY BROADCASTING STATION

We are informed that the University of Nebraska, 9YY, is now broadcasting twice

Radio Articles Appearing in the December Issue of Science and Invention

The World Series By Radiophone—With diagrams and descriptions showing the unique installation of a loud-speaker in the lobby of a large New York hotel, with grounded return circuit, the radio set being located on the 12th floor of the hotel. By Arthur H. Lynch.

A Short Wave Regenerative Set—With drawings and full description of an efficient audion receiving set requiring but one bulb, and very simple tuning arrangements. By William H. Grace, Jr.

Radio in a Nut-shell.

Learn and Work While You Sleep—Impressing radiophone lessons on subconscious minds. By H. Gernsback, Member of the American Physical Society.

Invisible Ray Signaling—It rivals Radio.

Question and Answer Column.

daily, at noon and at 7:30 P. M., radiophone music with the newly installed 200-watt set. The station has a range of several hundred miles and being the only high-powered phone in this part of the country, its concerts will certainly be much appreciated by amateurs in this region.

RADIO FOR CAPTURING BANDITS.

At a convention of the sheriffs' association of California at Sacramento, last summer, it was decided that a state association of state, county and municipal peace officers was imperative as a method of combating an unprecedented crime wave. A committee, headed by Captain of Detectives Matheson, of San Francisco, was appointed to carry out the plan.

Last week the new organization, which has taken the name of the California Peace Officers' Association, announced its plans. One of these is to enlist the aid of amateur radio operators all over the state, to work in conjunction with the city and county authorities.

Because it has more than enough improved highways to form a belt around the

world, officers said criminals find the state "easy picking." Hold-up men are plentiful along the highways, and even in the suburbs of the larger cities. With such a network of avenues of escape, the bandit can escape before the authorities can reach all of the nearby towns by telephone. It was pointed out that with a state-wide organization of amateur radio operators, descriptions could be flashed simultaneously to many nearby towns, and the work of the peace officers would be simplified.

The plan of payment for the operators was that rewards were to be paid for the capture of criminals, of which the radio operators concerned were to receive a share.

GRAND OPERA TRANSMITTED BY RADIO TELEPHONE.

Grand Opera transmitted over an area of 750,000 square miles by radio telephone is the feature initiated by the Westinghouse Co. in establishing its fourth Radio Broadcasting Station on the Edison Building, Chicago, Illinois. This feature arranged by George Foster, of the Commonwealth Edison Company, with Mary Garden, General Director of the Chicago Opera Company, allows thousands of persons throughout the central part of the country to enjoy the benefits of the Opera. Small transmitters at the Auditorium Theater pick up the singing of the artists and music of the orchestra. These transmitters are connected through a telephone line to the Radio Station KYW, where the sound waves are sent broadcast, on a 360 meter wave-length, without relaying. The first regular Opera to be broadcast was "Samson and Delilah," the wonderful solos and striking storm effects being reproduced perfectly. It is planned to broadcast Opera every night during the season of the Chicago Opera Company. In addition news service will be given from the Station similar to those broadcasted from the Westinghouse Stations WBZ at Springfield, Mass., WJZ at Newark, N. J., and Station KDKA at East Pittsburgh, Pa.

With the Station operating at Chicago for a few days only letters have been received from great distances regarding the Opera by Radio. Radio operators from Texas, North Carolina, Vermont, Canada, Minnesota, and many other places report that they are hearing the Opera distinctly.

The schedule of station KYW at the present time is from 7:30 P. M. until 11:00 P. M. Central Time, operating on a 360 meter wave-length.

DUTCH EAST INDIES WIRELESS SERVICE.

It is announced from Washington that a commercial wireless service between the United States and the Dutch East Indies has been established.

ELECTIONEERING BY RADIO.

For the first time in the history of electioneering, candidates were able to talk to the public without the latter leaving their homes, when arrangements were made in Pittsburgh by the Westinghouse Co. to send broadcast by radio the speeches by the candidates. The nominations for Mayor proved a very bitter fight in Pittsburgh recently, and radio was called into play to get the messages of the candidates to the people. In this way thousands of persons were addressed at one time without the inconvenience of leaving their own radio sets. Each candidate for Mayor was sent to the broadcasting station, where he was allowed five minutes to tell the reasons why he should be elected to the office. This proved to be quite popular, and excited a great deal of interest in Pittsburgh and vicinity.

Who's Who in Radio

No. 11

JOHN HAYS HAMMOND, Jr.

JOHN HAYS HAMMOND, JR., was born April 13, 1888, at San Francisco, Cal., son of John Hays Hammond, mining engineer, and Nathalie Harris Hammond. He was educated in the preparatory schools of England, France and the United States, graduating from the Yale-Sheffield Scientific School, 1910.

His work since that time has consisted of the development of the system of radio control for torpedoes and other moving bodies. He is the inventor of a type of torpedo for coast defense controlled by wireless energy from coast fortifications, which was recommended to Congress for exclusive purchase in the United States by the Board of Ordnance and Fortifications of the United States Army.

Mr. Hammond is also the inventor of an improved system of automobile torpedo firing, tested in the U. S. Navy, as well as aluminothermic incendiary projectiles, tested by the Army Ordnance Department. During bombing tests recently made by the U. S. Navy, Mr. Hammond's inventions were used on the ship "Towa," which was entirely controlled by radio.

The system of disappearing masts for use on land, to control the movements of vessels or torpedoes at sea, and that of coastal patrol by airplanes, which has been adopted by most of the coast states, are also among Mr. Hammond's achievements, as well as the system of selective



Mr. John Hays Hammond, Jr., Inventor of Several Radio Devices Including Practical Systems of Radio Control.

radio telegraphy, testing approved by the U. S. Navy, the U. S. Signal Corps and the U. S. Army, and the system of aerial coast surveying, adopted by the Bartlett Expedition for Polar Exploration.

He is the author of a very complete treatise on the art of Teledynamics, comprising four volumes in which are described his inventions and details of the researches that led him to perfect the various radio control apparatus of which he is the inventor.

The Hammond Radio Research Laboratory, Gloucester, Mass., has produced, under Mr. Hammond's patents, a system of radio signalling which has passed all of the Government tests in regard to selectivity, non-interferableness and secrecy. These tests have been made by both the Army and Navy, and have been most stringent. This system was developed incidentally from the control of torpedoes, but it will doubtless find a wide field of utility in the general transmission of signals.

Mr. Hammond was delegate to the London International Radio Telegraphic Conference in 1912. He received the honorary degree of Doctor of Science at the George Washington University in June, 1919. He is treasurer of the Institute of Radio Engineers and Manager and Chairman of the Committee on Admissions. He is also Associate Member of the American Society of Mechanical Engineers and of the Institute of Electrical Engineers.

The Story of Radio Telegraphy

Prof. Branly's Account of the Great Invention

By LEON LANSBERG

THE various claims and counter-claims which have been made concerning the invention of wireless telegraphy, have centered attention upon Professor Branly, the famous French savant, as the real discoverer. Recently, Messrs. Armand Givelet, vice-president, and Alexander Bergouinioux, chief of the information service of the Radio Club of France, called upon him to hand him the last subscriptions received by them for his laboratory, and in particular the sum of 2,200 francs contributed by *Le Figaro*, and took this occasion to interview him on the question of the discovery of wireless telegraphy, the results of which are published in *Le Figaro*.

M. Branly saw at once to what their conversation might lead, and in order to put an end to certain injustices, to throw the greatest light on the still contested and perfidiously obscured origin of wireless telegraphy, the great savant for a whole hour gave his visitors an ample and magnificent expose of the whole question.

"Nothing is worse set forth," said he, "in the special books, in the technical publications, than the origin of wireless telegraphy. They abound in fastidious explanations, they are encumbered with calculations and figures. And then, do they render to everyone the justice due? I, myself, am going to publish, very soon, a work on wireless. I intend to pass lightly over the developments of a theoretical nature; I shall, above all, insist upon the historical side, which it is high time to establish.

"Yes, I know that there is the German, Hertz; the Englishman, Lodge; the Italian, Marconi. These are physicists of the highest merit, and none better than I pays them just homage. Hertz has found that the electric waves have properties analogous to those of light waves. His works are quite remarkable. But has he thought of wireless telegraphy? Never. He could never make the presence of his waves felt for more than a dozen meters. As to Lodge, do you know that they went so far as to call the famous tube which I discovered, the Lodge tube? A professor of the Sorbonne in one of his courses, before 1900, called this tube the tube of the Englishman, Lodge. Henri Poincare, before the Academy of Sciences, called the same tube the Lodge and Branly tube. Upon my express demand, he has publicly retracted himself. Besides, to answer these discussions, in my files is a letter from Lodge himself in which he asks that justice should be rendered me.

"There is, finally, Marconi. What is his part? He has applied my discoveries. Everyone knows the famous telegram which he sent me from Dôvre when he made his experiment between England and France. He attributed to my work a preponderant part in the results obtained. I have learned since that had he at that moment been on the French coast in Boulogne, he would never have dared to send me that telegram, because he knew that all French scientists were against me.

"Recently, the Italian Ambassador came to see me and had a conversation with me on this subject. He gave me the most curious details, the least known on the debuts of Marconi.

Marconi had repeated my experiments at the Righi laboratory, in Boulogne, about 1895. He never thought of wireless telegraphy. It was an Italian admiral, a friend of his family, who decided his future, by advising his mother to have her son enter the Navy."

The master rises. Near a window on a small table are disposed his old apparatus. His gaze has fixed itself upon them. We step nearer. The great inventor then shows up his first experiments. They are like documentary proofs that reveal the successive stages of his prodigious discovery. What museum will gather later these precious documents?

"Here you see what I have recently shown to the Minister of Public Instruction who honored me with his visit. They are the first elements of my researches. Here is first of all the glass plate covered with a translucent gold sheet presenting very slight intervals of continuity. The conductivity of the plate augments when a spark is emitted nearby. Here is an iron plate covered with fine porphyryzed copper. The resistance is of several million ohms. When an electric spark is emitted in its proximity, its resistance falls to but a few ohms and can then let pass a current. Here, finally,

(Continued on page 548)

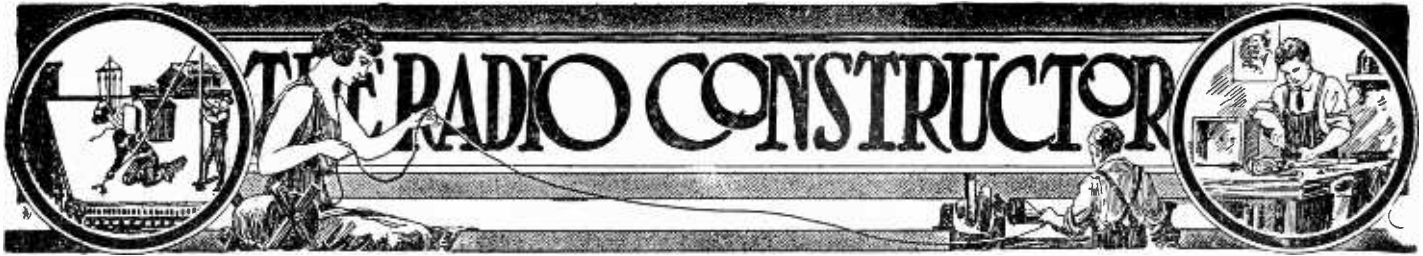

An Audion Control Cabinet for Amateur Use

By PAUL G. WATSON

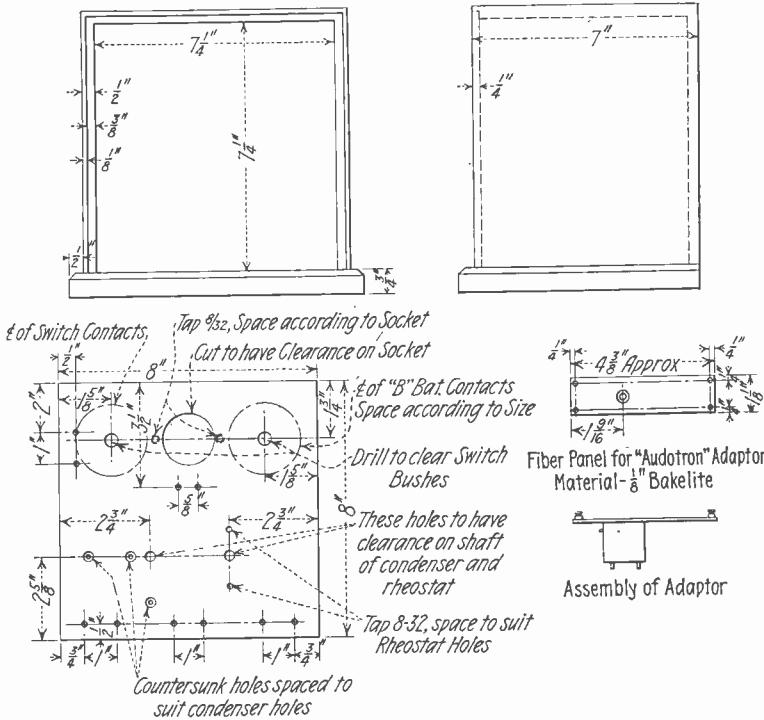

Constructional details for the cabinet and adaptor, as well as the layout of the front panel, are shown in this drawing.

A VERY satisfactory audion detector using either the old style tubular audions or the new style bulbs fitted with "Shaw" four-pronged bases is described in this article and in the drawings.

A panel 8" square and 1/4" thick was used, giving a much firmer panel than the 3/16" or 1/8" panels used by some amateurs. In this connection it can be pointed out that all commercial Naval apparatus is mounted on thick panels, the U. S. Navy type "SE143" receiver being a good example of heavy panels. It is mounted on 1/2" bakelite. This receiver is the U. S. Shipping Board standard and holds up under hard usage on shipboard.

It is recommended that a "General Radio" socket be used in this audion. Many amateurs like to try transmitting and other types of tubes in their sets and by using this socket, any type of American four-prong tube can be used. To use "Audotrons" in this audion an old "AP" or other tube fitted with a good grade of brass base was taken, the glass and cement broken out, and short

leads spliced to the four wires inside the base. A wooden plug was fitted loosely inside the base and the top cut off flush with the top of the base. Four grooves should be cut in the sides of the plug to pass the four leads to the contacts. The wooden plug is fastened in place with sealing wax melted and run in the base around the plug. A piece of bakelite, the size shown in the drawings should have a small "Quad" type binding post mounted on each corner. In the absence of these binding posts, two binding nuts off screw top dry cells can be used on a five-eighths 8-32 machine screw, drawing one down tight on the bakelite and using the other to clamp the wire from the tube. To each of these four binding posts a lead from the base is brought, care being taken to see that none of the wires touch the brass base, grounding them. Four small grooves, filed in the top of the base will let these wires pass clear. In connecting the wires from the base to the binding posts, the plate lead should go to the bottom of the strip and the grid lead to the top, the other two being filament connections. By having the grid at the top, the vibration and resultant singing is reduced to a minimum. To fasten the bakelite strip to the base, a hole is drilled and countersunk, as shown in the drawing, and a 5/8" brass wood screw (flat head) is used to screw the strip to the wood block, which is fastened inside the base. The fibre strip should be arranged so that the short end is the bottom, giving good clearance to the knobs on the panel.

To return to the construction of the audion proper: The grid condenser used in this case was the "DeForest" 90° air con-

denser with a maximum capacity of .0005 mfd. In mounting this condenser, the fixed or stationary element should be placed as shown by the screw holes in the panel to the left and bottom of the shaft hole. A spacer or collar 3/16" high should be placed on the screws holding the condenser, allowing the arm of the rheostat to move under the condenser without touching. There are several advantages in this condenser, ruggedness of construction, ease of mounting and the compactness.

A varied selection can be made for a rheostat, several good ones being on the market. A rheostat with a minimum of fiber parts is desirable, since the fiber deteriorates with the heat and falls away.

The "B" battery switch has six "live" contacts and six "dead" ones, arranged in alternate order to avoid short circuiting the sections of the battery as the switch passes from point to point. The "B" battery used in the original was composed of ten flashlight batteries, taps being taken from the last five outside connectors and from each end. Some amateurs prefer the molded battery, giving closer and lower voltage, but in either case connect the taps to alternate contacts.

The "Audion Ultraudion" switch should be of the same type of construction as the "B" battery switch or a little smaller, if desired. A dead contact should be placed between the two contacts of this switch to avoid a short-circuit when changing from one contact to the other.

The "Grid Leak" used was the "DeForest" pencil-marked leak and has proved very satisfactory. A little experimenting to get the proper line, and then covering it up with shellac makes it permanent.

In mounting the socket and rheostat on the panel, 8-32 screws were used, the panel being tapped and the screws placed from the back and cut off flush with the panel front.

Eight bakelite binding posts are provided, two for the filament, two for phones, two for tickler, and a pair for the secondary. These should be mounted in the holes provided around the edge of the panel.

(Continued on page 532)

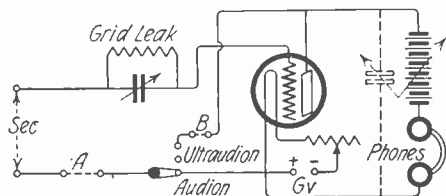
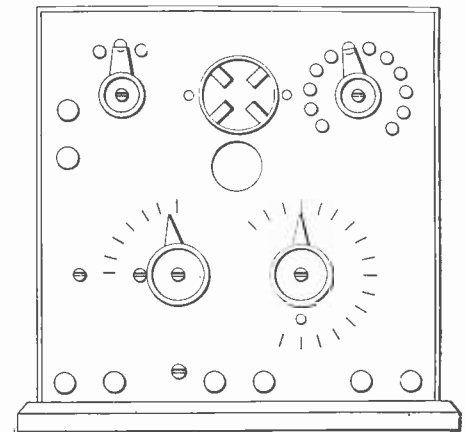

Diagram of the Connection of the Detector Control. The Tickler Coil May be Connected Either at A or B, Forming, With the Secondary, a Variometer if Connected at A



Front View of the Completed Unit

A Triple Purpose Key

By CHARLES BLOOM

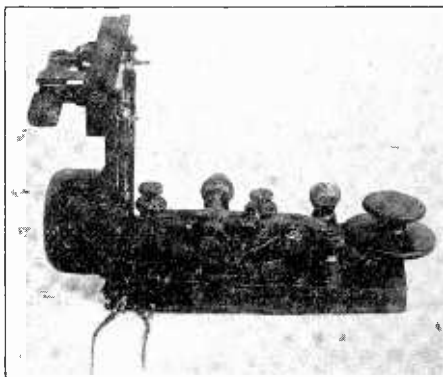
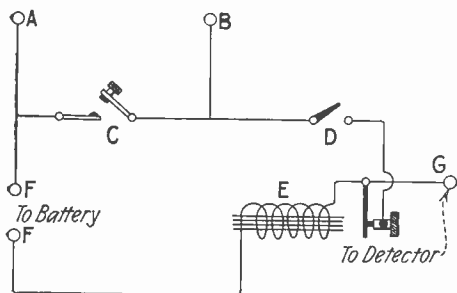

The Three Photographs Show the Front and Back Views of a Combination Key, Which May be Used With a Spark Set, a C.W. Transmitter or as a Practice Set. On the Left is the Hook-up.

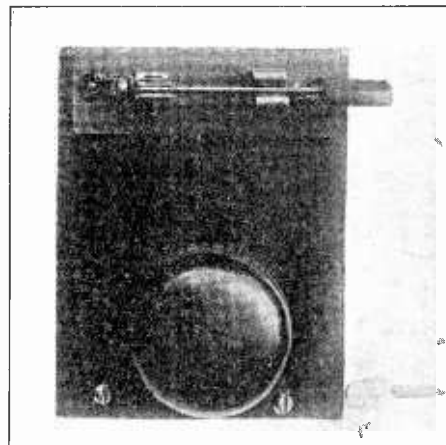

RECENTLY, I was desirous of constructing a buzzer practice-set. Finding that I had but one key, which was attached to the transmitting set, I was perplexed for a while, but soon "doped" out the idea contained herewith.

The hook-up shown here is the one used, and I believe it is original, having drawn it up to suit my own needs.

It is self-explanatory, and is quite simple. However, to make certain of its being understood, I will enumerate the different items.

"A" and "B" are two heavy binding posts connected to the key. "C" is the one and only key. "D" is a single pole, single throw switch. "E" is a Mesco buzzer. "F" are the binding posts to which are connected the battery to work the buzzer. "G" is a single wire lead to the crystal detector.

All that are necessary are the aforementioned articles and a strip of bakelite, very small, on which to mount the s.p.s.t. switch and the buzzer, as shown in accompanying photograph.

The key I have was already mounted on an oak base, so I soldered extra leads on the bottom, which were drawn through the wooden base. After mounting the buzzer and switch to the bakelite panel, I fastened

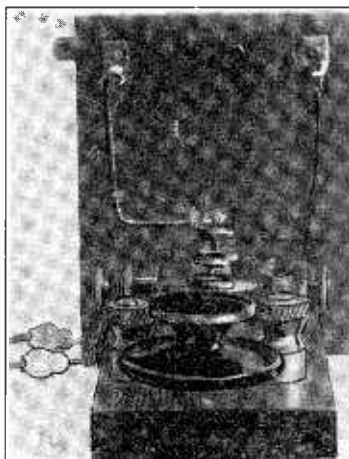

it to the base of the key, as shown in photograph.

All connections were then soldered, before which I had bared the wire and scraped the ends and covered it with "spaghetti" tubing.

The spring binding-posts shown in photograph herewith are easily made by winding a bit of No. 18 wire around an ordinary nail to the length desired; to make connection, a small plug arrangement is used.

By keeping the switch closed, as shown in the photographs, one may practice the code, tune a crystal set, and even transmit by buzzer if desired, by opening the cover of the buzzer and attaching aerial and ground leads. To transmit with your radio set, I mean your high-powered one, all that's necessary is to open the switch.

When concluded the instrument, if neatly made, will present a commercial appearance, of which the amateur may be justly proud.

A Variometer Unit

By CHARLES E. MCGUIRE

THE variometer shown in the drawing can be made out of the odds and ends which the average amateur has about his station. The coils E and F are wound

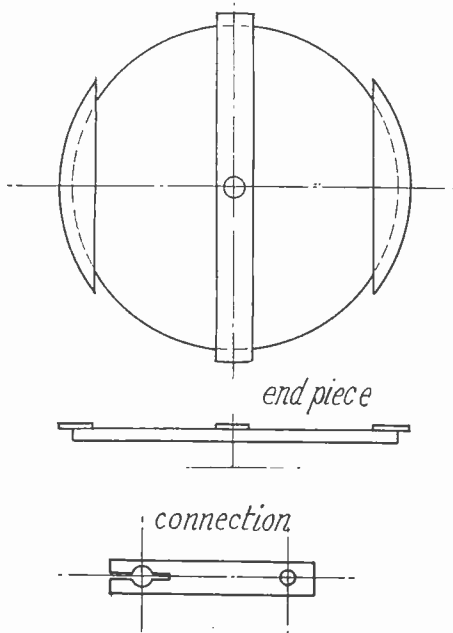

on cardboard tubes A and B at right-angles to the usual way. The end pieces must first be made and grooved to keep the wire from slipping. Make two, so that they will fit tightly, and fasten the stud G to the center of one and the machine screw D to the center of the other. The machine screw D must have a sharp point. Connect one end of the wire to the stud and start the winding at the small end. Wind one side and then fasten the end of a wire to the machine screw and start the other end. Be sure you are winding in the same direction. Now make the ends for the larger coil, drilling the center of each so as to allow the stud and machine screw to pass. The smaller coil must be put inside the larger before starting the winding. Wind the same as the smaller, and allow plenty of wire for connections. The strap H makes a connection between the stud and the binding post. The bottom fits over the outside of the larger coil and has a machine screw with a countersunk end, so that the machine screw D will turn on it. If you wrap the coil in paper or thin cardboard and then fit it into the bottom and top, it will give the instrument a business-like appearance. I have left out all dimensions because I know everyone will build it his own way.

This type of variometer gives very sharp tuning, for it is possible, by using cardboard tubes fitting just inside of one another, to have the windings very close, thus giving maximum inductance and maximum variations. This variometer may be built in any size and large tubes may be used

for a variometer for long-wave reception, in conjunction with a loose coupler of the ordinary type, forming a long-wave regenerative set, as sensitive and flexible as the types for short waves actually on the market. For this purpose, a variometer 6" long and about 5" in diameter, wound with 120 turns on both the stator and the rotor, would be quite suitable.

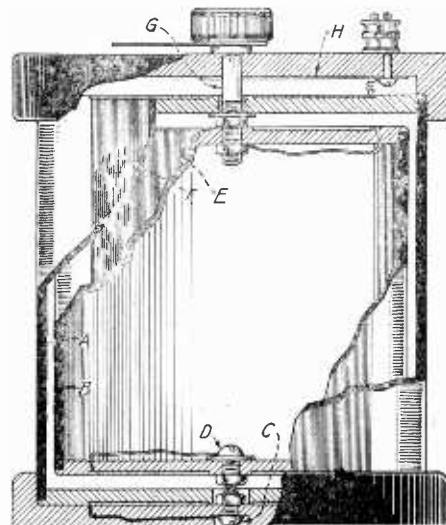

For Experimental Work This Type of Variometer is Well Adapted, as it May be Used as a Separate Unit.

Details of Construction of the Variometer, Showing the Pieces Stopping the Winding.

C.W. Transformers

By FLORIAN J. FOX

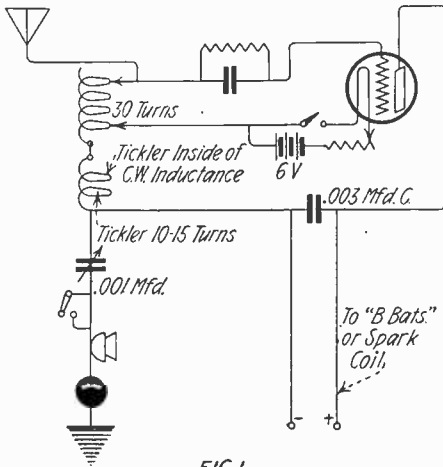

FIG. 1

A Simple C.W. Hook-up Which Gives Good Results.

HERE are many amateurs in the country who would have C.W. sets if it were not for the high first-cost of their plate voltage, especially nowadays when we cannot spend money as freely as formerly.

For the man who has no city current (alternating) there are only two alternatives; "B" batteries and spark coils. Unless a man has funds at his disposal, "B" batteries are out of the question. A phone operating on batteries is unquestionably the best, from the standpoint of "quality of modulation," but it is costly, especially if any distances are desired. High voltage storage batteries are also expensive in the long run, bulky, and mussy. The spark coil, although not suitable for "phones" makes a very good source of plate voltage. A one-quarter to one-half inch coil is large enough and should be shunted by a fairly large condenser, depending on the size of the coil. I found that a condenser of .003 m.f.d. was large enough, although a larger one would have done more good perhaps. With this arrangement using a simple plate feed-back circuit (Fig. 1) I was able to radiate .3 of an ampere on one UV-202 tube. I worked 1FQ Meriden, Conn. regularly (18 miles) and he reported me three times as loud as when I used a one inch coil spark set, also radiating .3 amperes. He told me that he worked a station in New York City at times who was using the same kind of I.C.W. If the coil is equipped with a good vibrator, a very pleasing tone can be obtained. I experimented with different sizes of secondaries but found none more satisfactory than the regulation 1/4" coil size. If you have a 1" coil you need not discard it, for it will work too, only the condenser will have to be larger. The condenser is very important for it serves both to reduce the potential and acts as a by-pass for the high frequency surges.

It is not absolutely necessary to have a power tube. It was found that two Marconi V.T. receiving tubes in parallel, using 6 volts on the filament also gave a radiation of .3 ampere. It is not advisable to run more than one power tube from this source because the spark coil cannot furnish power enough as a rule. One or two UV-201 tubes are also very good for this

arrangement. Audiotrons are not recommended.

The best way to find which post of the secondary is predominantly positive is by means of an electroscopes, which can be made in a few minutes, or by experiment. Try a soft tube and burn the filament brightly and change the poles until you see a "blue glow" in the tube. That will indicate that the positive pole has been connected to the plate. Don't be discouraged if you do not get results at first for the tuning of a CW set is hard at first. One turn of wire on the inductance more or less may throw the set completely out of tune, so go at it very carefully. It may amuse the reader to know that it took me almost two weeks to "tune up" my first CW set, just because I thought it was like tuning a spark coil set.

Now for the benefit of my fellow "hams" who have "juice" I shall put down my experiences with transformers. My first transformer was made of stove pipe iron cut to size by hand, but because I got blisters I gave it up and assembled what iron was cut, making allowances for the cross section of the core when winding. However I overestimated the quality of the iron (assumed 60,000 lines) and also did not carefully insulate the laminations and the result was it got too hot and only supplied 5 watts instead of 50 or more. So if you intend to use stove pipe iron, be

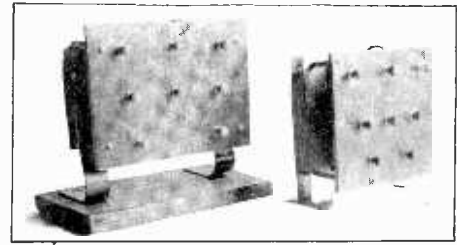

Front View of C.W. Transformers Built by the Author.

fiftieth turn and the secondaries are done. The wires above mentioned are tied around the outside of the coil and the ends of the form removed. Since the core is tapered it will come out easily by tapping it a little. Now tape the whole coil not latitudinally but longitudinally; that is, over the outside and through the center lengthwise. The tape will have to be cut into three or four foot lengths for this.

Some experimenters may have patience enough to wind the secondary in layers, in which case 4100 turns are wound with a tap at 2050. (The use of this tap will be taken up later). In this case the same form may be used. However the prospect did not appeal to me. I made a form half as long as required and as described for primary. Through the center I drilled a hole and on one corner of one of the

boards I drove a nail to use as a crank. A nail or rod was clamped horizontally in a vice and the form placed so that the rod was inside the hole in the form. A little rack was made for the spool of wire. The wire was guided by hand. I did not bother to wind the wire perfectly flat, and so in about ten minutes one coil was wound. It was removed and taped in the same manner as the primary and then the second one wound. It is well to wind a couple of

layers of empire cloth or fish paper over the wooden form before winding and tape it in with the rest of the coil. This serves to prevent "grounds" especially when assembling laminations. **Caution: Never use enameled wire on the secondaries if wound at random!** That lesson cost me a lot of labor and material.

If the laminations are of the four-piece type the coils may be put on two of the legs before assembly of the complete core. In my case the laminations were of the

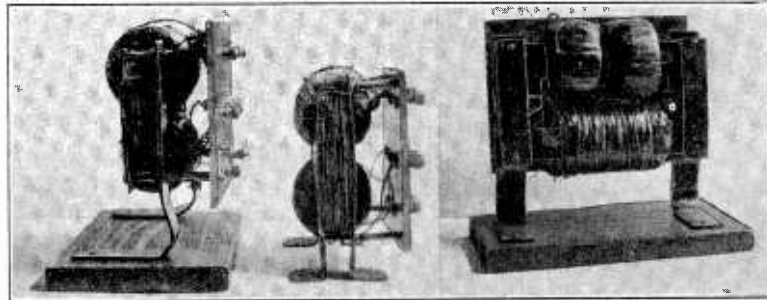

These Photographs Show Clearly How the Completed Transformers May be Mounted

sure to varnish the laminations and have a core cross section of at least two square inches. The best thing to do is to procure some silicon steel for transformer core or take the laminations out of some old transformer. I shall not specify what size core to use as that will depend on what you can get. My present transformer is made of high grade laminations which I obtained from a local electrician, size (outside) 4 1/2" x 8"—cross section 1 1/4" x 1 1/4". Winding data. Primary winding 450 turns No. 16 asbestos. Filament secondaries 50 turns (each) No. 14 asbestos. Secondaries (500 V. each) 2050 turns (each) No. 28 D.C.C. (or asbestos). (D.C.C. will serve just as well as asbestos insulation). This transformer is designed for about 200 watts output, delivers about 11 volts at the filament terminals and 500 volts at each secondary.

It is advisable in any case to wind the primary on a slightly tapered wooden form a little larger (1/8"-1/4" all around) than the core cross section and as long as the winding is to be. Screw square pieces of wood at either end and wind coil on the form. A couple of pieces of wire laid lengthwise along the core before winding will serve to hold the core together when being removed, if the ends of the wires are tied together before removing. The filament heating secondaries may be wound right over the primary. Wind on a hundred turns of wire taking a tap at the

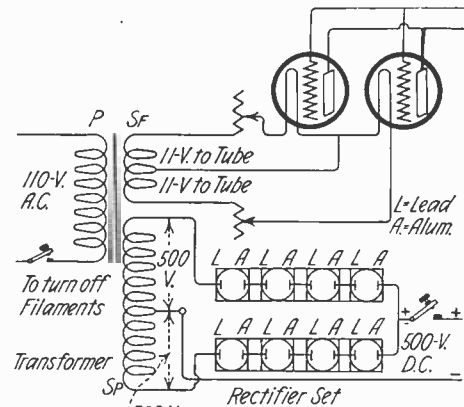

Connections of A Power Transformer Supplying the Filament and Plate Current to the Oscillator Tubes. Note the Connections to the Electrolytic Rectifier.

"U" type and so I had to place the coils the right distance apart and then slip the laminations into place. The core assembly should offer no obstacles to building a transformer as it is comparatively simple. The transformer is easily mounted by cutting four pieces of iron about 1" wide x 1/8" thick into lengths which will be long enough to clamp the side legs and then extend downwards so that they may serve as feet. (See photographs and Fig. 6.) The builder may get some good ideas of transformer mounting if he looks through some catalogs. The clamps are held together by long threaded rods, brass bushings 2 1/2" long are placed over these rods (the rods are all allowed to project from one side a distance of about 3") and a panel can now be mounted on the front of the transformer by drilling holes into which the rods will fit. Panel may be held in place by ordinary nuts, or if a nicer job is desired, by means of end nuts. Before assembling panel and soldering leads it is desirable to give the transformer a good coat of Asphaltum paint, or electricians' "PB."

For the benefit of those who may desire a transformer with different voltages from those of the described instrument, I shall state a simple relation which will enable the experimenter to change the secondary voltages to any value he may desire. I do not advise anyone to change the number of primary turns if he uses good iron with ample cross section, if, however, the iron is of poor quality, or the cross section is altered (diminished) more wire must be added and wire added to the secondaries also.

Relation of turns to voltages:

$$\frac{E_{pri}}{T_{pri}} = \frac{E_{sec}}{T_{sec}}$$

Example: $\frac{110\text{-volts}}{450\text{ turns}} = \frac{500\text{ volts}}{x}$

solving for x we have $x = 2045$ (approx.)

Since transformers are never 100% efficient it is well to add a few turns for good measure. Hence for 500 volts use about 2050 turns.

Some readers may have to change the number of primary turns because of different cross section area of core or poorer quality of iron. The number of turns necessary can be found from the relation:

$$E = 4.44 \frac{F \times N \times A \times B}{10^8}$$

where

- F = frequency
60 cycles per sec.
25 cycles per sec.
- N = number of turns
- A = area of core in square inches
- B = Flux density of iron in lines per square inch (60,000)
- E = primary volts (110) (220)

Solving for N we have

$$N = \frac{E \times 100,000,000}{4.44 \times F \times A \times B}$$

Example

Assume $E = 110\text{ V. } B = 60,000 \frac{\text{lines}}{\text{in}^2}$

$F = 60\text{ V. } A = 2\text{ in}^2$

$$N = \frac{4.44 \times 60 \times 2 \times 60,000}{6875}$$

$$N = \frac{19.98}{19.98} = 344\text{ turns under the assumed conditions.}$$

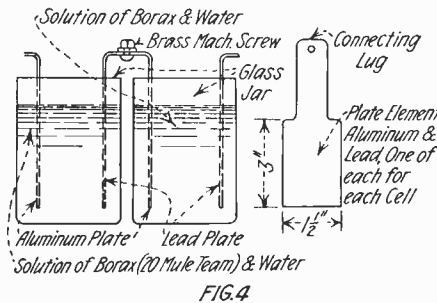

This Sketch Shows the Electrode Dimensions and Details of the Electrolytic Rectifier to be Used With the C.W. Transformers Described in This Article.

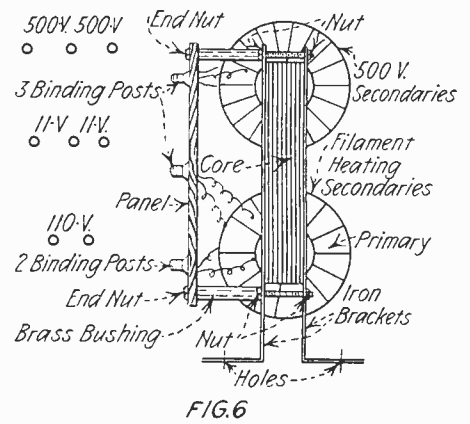

Detail of the Transformer Mounting and Arrangement of the Binding Posts Upon the Panel.

This was a rather generous core, however, it shows the method of attack. The wire size is determined by the power the transformer is meant to deliver and hence draw.

The best way to use the transformer is to build an electrolytic rectifier and rectify both halves of the cycle. Or else a self rectifying circuit may be employed.

The rectifier consists of sixteen to twenty small jars with plates of aluminum and lead cut so that they will fit into them. The plates need not be larger than 1" x 3", lugs being left for connections. Fig. 4. Since the transformer has two 500 volt secondaries we can obtain direct current at about 500 V. pressure. This arrangement rectifies both halves of the cycle and makes an ideal arrangement for both C.W. telegraphy and radiophone work. Although I have not had the set working long enough yet to have made any distances, I radiate over one ampere, using the transformer described, home made inductance and one UV-202 tube with counterpoise antenna system.

I shall be pleased to furnish further information if it is desired.

A Type of Honeycomb Variometer

By HARRY OLSON

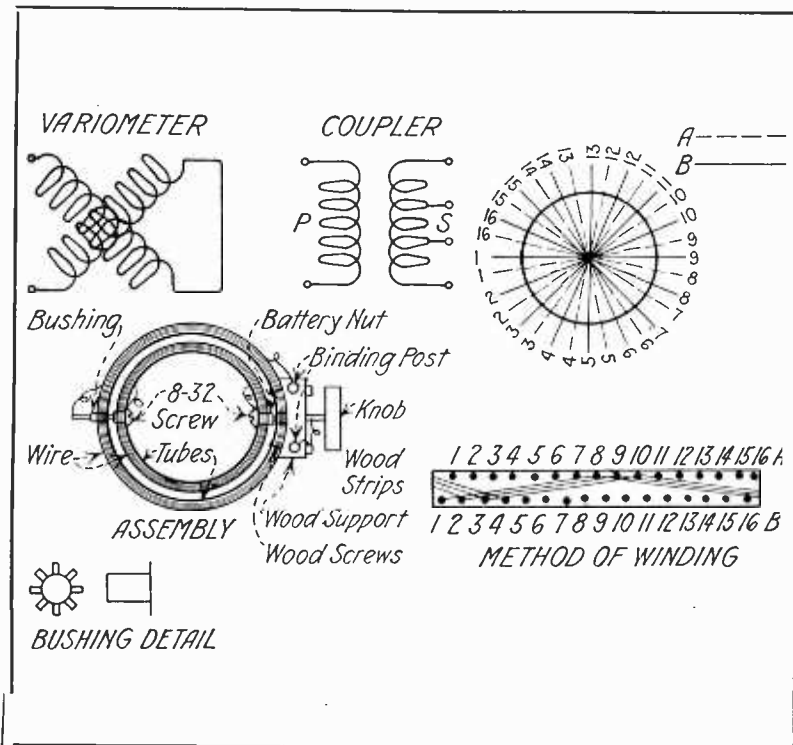

Very efficient variometers may be built using the honeycomb system of winding. Details of their construction are shown in this sketch.

THE VARIOMETERS

The maker must procure six winding forms of cardboard tubes. The two primaries and two secondaries for the variometer, and one primary, and one secondary for the variocoupler. All three primaries should each be 1" long, and 3/8" inside diameter; all three secondaries should be 1" long and 2 1/2" outside diameter. The tubes should be given a coat of shellac and allowed to dry. Now the holes for the shaft, which is 8-32 thread, should be bored. The holes must be exactly on the semi circumference or the tubes will probably rub. Now along the edge of each tube should be punched 16 evenly spaced holes just large enough to pass No. 20 B. & S. wire. The holes on opposite ends should not line up, but should be staggered, as shown in the

(Continued on page 518)

"So This is the Wireless!"

By STANLEY EDGAR

WE had just left New York and I was in a most amiable mood.

In my rush to get down to the ship in time I had missed my breakfast and cut my face with the razor. In the subway, somebody had stood on my foot from Seventy-second Street to Times Square and on reaching the ship I had almost made the top of the gang-plank when I slipped and gracefully slid down to the bottom. When I succeeded in at last reaching the deck, a small child asked me if I wouldn't please do it again—it was so funny and George hadn't seen it.

The only girl in all the world had arrived on the scene a few minutes later and wept bitter tears all over the shoulder of my new suit, as her hero departed on his perilous voyage to Florida and back. This last act had been well rehearsed, however. Each week we left New York, we went through the same heart-rending process of departure; it had become almost a rite and I had learned just the things to say and when to say them in order to create as little of a scene as possible.

We sailed and I repaired to the Wireless Room, where I belong. The small child who had asked me to repeat my little performance on the gang-plank for the especial benefit of his brother dashed madly between my legs as I was about to ascend the companion way, possibly in the hope that I would provide him with some added entertainment by further contortions on the stairs. His fond mother stood by and smiled at the antics of her angel child. I patted his head and commented to the mother on his intelligent expression. I had to say something to overcome my insane desire to use the small child as a football.

In the Wireless Room my partner was "tuning up his instruments," as the guide-book of the Line so charmingly and vaguely describes our duties.

I took the first watch and had just seated myself, fitted the headband of the receivers in the grooves they had worn in my skull and adjusted the phones in such a position that they would give the least annoyance to the corn on my left ear, when the doorway was darkened by the form of a beaming young gentleman with horn-rimmed glasses, who greeted me familiarly with:

"Well, Sparks, any news?"

"No, sir," I replied. "No news."

He was joined by his companion who inquired:

"Any news about the ball game?"

"Wireless has made wonderful progress during the last few years," I replied, severely, "but we have yet some considerable distance to travel before we will reach the stage where we are able to record events before they actually take place. The ball game commences in half an hour from now."

They departed, assuring me they would be "up to see me again," and their place was taken by the replica of the small child with whom I had become acquainted earlier.

This, I decided, must be "George."

But George displayed none of the exuberance of spirits of his brother. He stood in the doorway with his mouth wide open

and an expression of extreme wonderment and admiration on his face, but essayed no remark or explanation of his presence.

After he had favored me with a silent scrutiny for almost ten minutes, I began to feel slightly uncomfortable and told him to "go away."

He backed away one step, but continued to gaze at me from this new vantage.

I began to think that perhaps the shiny brass braid on my uniform coat was the attraction so I removed the coat. George followed my every move with his eyes, but remained at his post.

Then I decided that his brother must have pointed me out to him as the "funny gentleman" he had seen on the gang-plank and George was waiting patiently for me to begin.

"What's your name, boy?" I asked him.

No answer.

"Is your name George?"

He solemnly nodded his head in affirmation.

I was making progress.

"What are you standing there for?"

No reply. The child must be dumb.

"Why don't you go away or say something?"

Still George preserved a discreet silence.



"As I explained to This Gentleman Previously, the Clock You See on That Switchboard, Being Tuned to the Harmonic of 'G' Records the Waves Sent on 'C' Which Are the Only Ones We Want to Receive."

We were interrupted in our decidedly one-sided conversation by the arrival of an old gentleman and his spouse who took their stand in the doorway, shutting out most of the light and air from the small operating room.

"So this is the Wireless!" he said, beaming benignly upon me.

"Yes," I replied, wearily. "This is the wireless."

"And can you tell me when we will pass Hatteras?" he asked.

I referred to my list of "Answers to Foolish Questions," and informed him.

"Do you think it will be rough?" inquired his wife.

"It undoubtedly will," I answered.

I always tell them that. It gives me a strange and malignant pleasure.

"How can you tell you are going to receive messages?" was the next one.

"The hand on that clock up there jumps up and down every time they want me," I replied, pointing to the voltmeter, and praying for forgiveness.

"Well, it certainly is a wonderful invention," they remarked and departed, leaving me alone once more with George.

Just then I heard one of the New York stations calling me with a message. I

started the motor to reply and George's eyes almost left their sockets in his silent and admiring amazement. Evidently he thought the show was now going to begin and this was the sort of music beforehand.

The general alarm was given and from all sides the passengers dashed madly to the wireless room to see me "send a message."

Luckily, the signals were strong, or I would never have been able to read them through the volley of questions which were being shot at me and the frantic and wild explanations of the young gentlemen in the assembled mob who "knew all about it—your brother used to have one at home, you know."

The message spelt itself out to a Miss Kitty Kirchner, and assured Kitty that the sender was missing her dreadfully, and sent her all his love and kisses.

Having acknowledged this important communication and made a mental note that I would see Kitty later to find out how she was standing up under the strain, I rang for the boy to deliver the radiogram and turned my attention to a few of the more persistent seekers after information who were assembled outside the door.

"How does it work?"

"What do you hear?"

"Where do they come from?"

"How far can you receive?"

"What do those little lamps do?"

"Why do they call it wireless with all those wires?"

"How long does it take to learn how to be a wireless operator?"

These were only a few of the questions I was expected to answer and still retain my senses.

I looked them over, and wondering how much they would stand, I began:

"Wireless waves are propagated with equal facility through ether, chloroform or other insulating conductor and run in a general direction from the north to the south pole

with harmonics in the opposite direction. It is with these harmonics that we are chiefly concerned. If the operator at the transmitting station strikes the note of 'C' with his oscillating variometer, we tune our instruments, as the guide book tells you, to the Key of 'G.' The waves pass through the water until they meet an obstacle in their path which, in our case, is the ship.

"As we explained to this gentleman previously, the clock you see on that switchboard, being tuned to the harmonic of 'G' records the passage of waves of the Key of 'C' which are, by previous arrangement, the only waves we want to receive.

"Then, by means of these little electric lamps you see here, which, by the way, are closely related to Marconi's own 'Thermojonic' valve, we reduce the waves to an audible frequency, which enables them to work this little phonograph you see here, and so the messages are received. Listen!"

And I put the loud speaker into operation and let them hear the signals.

They all nodded their approval and seemed to have completely and intelligently understood what I had told them, which was rather remarkable, although, for that matter, it was about as clear and truthful an

(Continued on page 534)

World's Record

By CLYDE C. YOUNG

"MAN, ah sho' am disgusted," ejaculated Aloysius McFlatfoot, in conversation with the family cook as they lounged in the garage quarters of the former.

"Disgust, which?"

"Disgust foahevahmoah. Disgust so dat I cain't beah to see dese cullud buzzuds perambulating up and down de main stem with nuthin' on theah brains but curls and ruby lips. I heahs also wheah dat coon Mistah Pollud is makin' reckuds foah de graphafoam people. Dat's a lie, dat is. De only reckud he evah made is in the police station."

"Das a fac'," humored cookey.

"Fac' is a meah mythe. It's not only a fac', but a ster'lized, mater'lized, unsofisticatin' pro rata cinch. What ah says, ah knows, an dey futhuh gossipates dat nig-gah has doe. He ain't got no doe, I tell yo'. He am so flat bust, dat he had his false teeth cut down to fit de boy."

"Do tell. Hot patootie, an' what did de boy do?" enjoined the cook.

"Do! Why, he did jess what I 'spected him to do. He tol' de ole man he was old 'nuf to pick his own teeth."

"Don't say."

"Ah do say an' ah knows. An' de ansuh am dis. Cleah out o' heah an' let me think. Ise gonna drive dat guy outa de papah so fah dat he couldn' get in again if he killed de King of Blooey-Blooey. Ahse mad. And when ahse mad, ahse bad."

Aloysius McFlatfoot, probably so named on account of his huge understandings, was commonly known as the "peppiest nigger what ever had pep" in Chicago's negro section. Outside of taking a number 18 shoe, he had other accomplishments, namely: He was chauffeur of one of the most prominent families in the fashionable environs of Knob Hill, and when it came to handling an automobile, Aloysius had no peer. He was ambitious, sober, intellectual, partly educated and other qualifications, which, of course, were the outstanding features that decided Roger W. King, millionaire lumberman, to enlist his services as chauffeur. Mrs. King was entirely satisfied with the man, and, therefore, he remained.

Mr. and Mrs. King had long since discharged the Oriental help for negroes, and now had ten of the most "cultured pussons" from the "high brown" clientele, that money could secure.

It was in the late autumn and one of those evenings that make one feel he would rather remain by the fireside than venture out in a driving rainstorm. Aloysius McFlatfoot, after the disappearance of his friend, sat pawing over an assortment of magazines. He stopped as he noticed the familiar cover of RADIO NEWS and began to examine it with growing interest, as he turned the pages. The following advertisement caught his eye:

WANTED
YOUNG MEN TO LEARN WIRELESS
WE GUARANTEE COMPLETE
SATISFACTION
WE TEACH BY MAIL
LET US HEAR FROM YOU AT ONCE.

This was supplemented with particulars that pointed out the great opportunities in the field.

Aloysius lost no time. He sat down and despatched a letter, with three dollars enclosed, for the first lesson. He again called in the indispensable cook, Exonius Smith. Smith had the faculty of giving advice on the question propounded, by years of experience with an electric toaster.

"Mistah Smif, dis book heah tells me dat I can do great things wid wyaluss. Theah-foah ah has written foah de fus' lesson. Now I may have to call upon yo' all foah a lil' help now and then, so what does yo' know 'bout 'lectricity?"

If there was anything that tickled Mr. Smith, it was to be placed in the position of adviser. He rubbed his hands together and bowed his head as though in deep thought. It was fully three minutes before he replied. Aloysius sat in respectful silence waiting for his elder to communicate.

"Well, de fac' is son, ah'se had cunsid'ble 'sperience long dem lines. In fac', de 'ast 'sperience ah had was with elaborately over 200 volts. These ovah 200 volts did many strange things from which I learned several

framed and placed in a conspicuous spot on the wall of his garage abode. He now felt that he was a promoter of science and did not hesitate to tell his many friends as much. They regarded him as a miracle. He had given several demonstrations in the way of concerts with his apparatus. He had also received the big fight and other fetes that were heretofore unknown in negrodom.

Up to the present time, Mr. King had not learned of his chauffeur's activities, but one night, some two weeks later, he was interrupted in a telephone conversation by thunderous handclapping, followed by cheers. He thought perhaps a parade might be going on and investigated. The racket, instead of coming from the street, came from the rear, near the garage, he thought. Then there came to him laughing and more handclapping. He rushed into the garage and beheld a ball room scene. Negroes were in attendance by the dozens, while in the center of the room stood a contraption absolutely foreign to him. This was nothing short of a disgrace in a community of exclusiveness. Already the neighbors must have heard the commotion.

He cleaned out the gathering in short order.

"What was that terrible racket?" asked Mrs. King of her husband, as he returned to the house.

"Niggers. More niggers than I ever saw. I wish you would tell that chauffeur to keep them away from here, or I will fire him."

"Well, of all the nerve," replied his wife, "I certainly will."

"And now, dear, I must leave for New York to-night on business," said her husband, whereupon he departed.

Aloysius did not dismantle the outfit as ordered, but instead carried on his work in a more secretive fashion. He had been reading in the paper where a celebrity had been working on a very delicate machine with which he

hoped to communicate with spirits. If he, Aloysius, could invent such a contraption. He dare not think of what might be the outcome, but he figured this person did not have anything on him. He had just passed the age of 21 and he was a man. Didn't he learn wireless? And that was something no other nigger could do, and too, he soliloquized, maybe this celebrity was a wise man, but he bet he couldn't wind a loose coupler.

"Now Aloysius McFlatfoot, heah am de chancet of a lifetime. Get busy and invent a machine ten times as delicate as dis heah receivevah, and den yo' can talk wid de spiruts. Golly, if ah can only beat dis fellow at his own game, man, ah could drive a Packard of mah own. Dis heah King man don' scare me any."

He started working on a loose coupler of some 100,000 meters capacity and from day to day added other strange devices that were known only to himself. He spent days of tireless toil on his new idea.

Paul Andrew Peterson, employed as manager of an electric store, had noticed Aloysius purchasing different apparatus

(Continued on page 556)

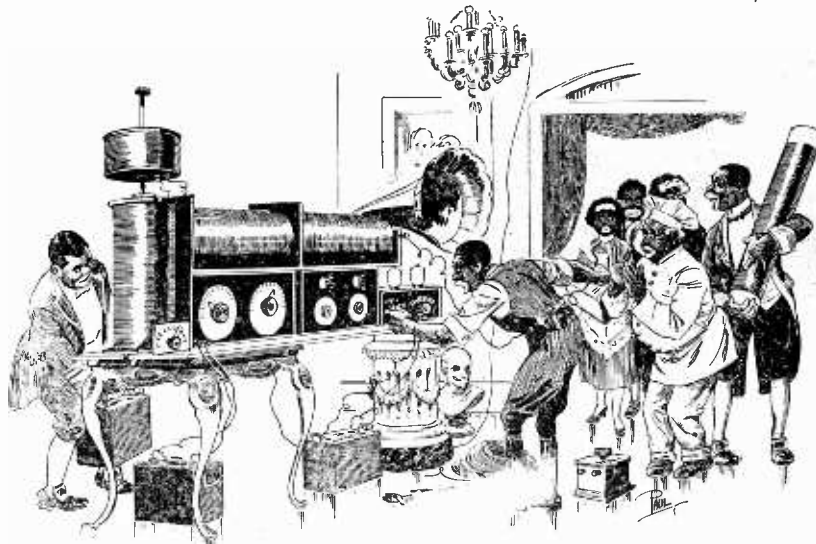

It Was Saturday Night and the Apparatus Was All Set with Strange Devices. Aloysius Was Working Over the Apparatus With the Help of Mr. Smith, the Cook.

fundamentals of the juicy currents."

"Meanin'?"

"Hot dawg, boy, didn't yo' nevah get a shock?"

"Sev'ral. De fus' one I got was when I saw my intended wife wid dat niggah Johnson."

"You kin forget dat shock, but a high tenshushock. . . Nevah. My advice is lay off of dat stuff what kin put moah life into yo' system in one forty-millionths of a twentieth part of a watch tick dan if a train whistled under yo' coat tail; but when yo' get hol' of a hot wyah like dis heah wyaluss puts out, den all I got to say is yo' break all reckuds fo' de broad jump. Dat is, of cose, if yo' can let loose, but if yo' can't let loose, may dey have mercy on yo' poah hide."

Having departed this bit of information from his system, the good cook arose, yawned, bent both knees slowly up and down to see if they were in good working order and left for his kitchen for a little "African crowkay wid de secon' cook."

Six months later Aloysius had qualified for a diploma in the Wireless Institute of America. This diploma was carefully



THIS Department is open to all readers. It matters not whether subscribers or not. All photos are judged for best arrangement and efficiency of the apparatus, neatness of connections and general appearance. In order to increase the interest in this department, we make it a rule not to publish photographs of stations unaccompanied by a picture of the owner. We prefer dark photos to light ones. The prize winning pictures must be on prints not smaller than 5 x 7". We cannot reproduce pictures smaller than 3 1/2 x 3 1/2". All pictures must bear name and address written in ink on the back. A letter of not less than 100 words giving full description of the station, aerial equipment, etc., must accompany the pictures.
PRIZES: One first monthly prize of \$5.00 All other pictures published will be paid for at the rate of \$2.00.

F. H. Lester's Station, 9VK at Oak Park, Ill. This Month's Prize Winner



Mr. Lester has indeed a first-class station and we extend to him our compliments for the neatness and appearance of his apparatus. The transmitter is a 1-K.W. spark type and the receiver a home-made regenerative set.

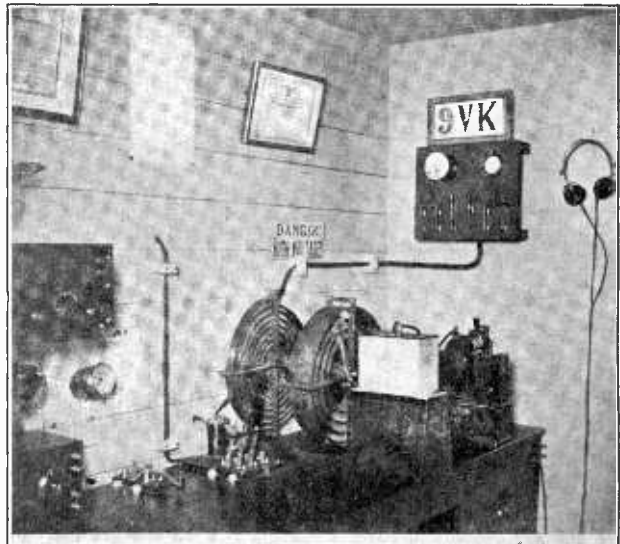

RECEIVING equipment at my station 9VK consists of a short-wave regenerative set (of my own make), a long-wave set using honeycomb coils, audiotron detector and two-step amplifier, using Radiotrons as amplifiers. The cabinet in which the tubes are mounted is also of my own make, using plug and jack system, which I find very convenient. I have a system of switches so that I can change from long to short waves, or vice-versa, at will.

I employ two variable condensers, as you can see. The Murdock, which is mounted on the wall, is used as grid condenser when the short-wave set is in operation, and when the long-wave set is in operation it is used to shunt the secondary coil. The Chelsea condenser, which is mounted on the desk, is used in the ground circuit of the long-wave set only. I am using Brandes Navy and Superior phones.

The transmitting equipment consists of

1 K.W. Acme transformer, Dubilier condenser, .007 Cap., Benwood Rotary quenched gap (which is located back of the O.T. and condenser) 16 teeth, coupled to a G.E. 1/8 H.P., 3,600 R.P.M. induction motor, O.T. is remodeled Thordarson. I have replaced the one-inch ribbon on the primary for a three-inch one. I use Boston Key and Clapp-Eastham antenna switch.

I have had a private power line installed.
(Continued on page 520)

Thomas W. Scott's Station, 8BJV at Connellsville, Pa.

AS a constant reader of RADIO NEWS and with interest in the future of Amateur Radio I am enclosing a print of my station 8BJV, which I think may be of interest to others as theirs have been to me through the pages of your magazine.

I have a radio transmitting consisting of four 5-watt Radiotron tubes hooked up as two oscillators and 2 modulators, on a modified Heising-Colpitt circuit; this set used voice, buzzer modulation and C. W. The power is furnished by an "Esco" 500 volt, 75 watt generator direct connected to a 110 volt motor. I use between 350 and 500 volts

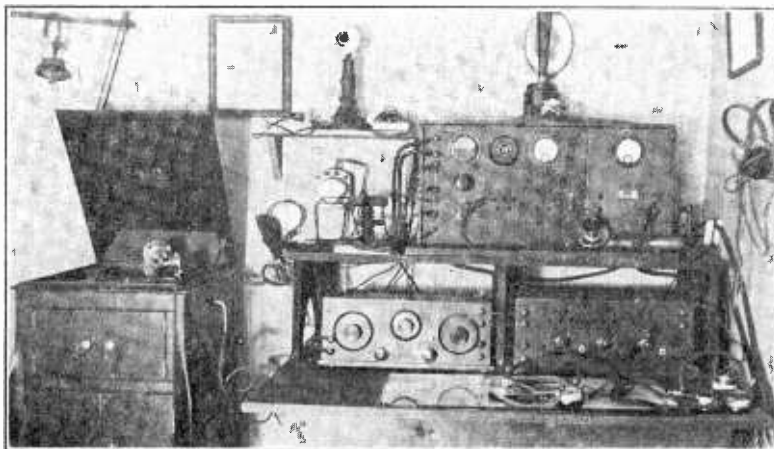

This Home-made Station Comprises a Radiophone and C.W. Transmitter Using Four Five-Watt Tubes in a Heising-Colpitt Circuit.

on plate, at about 180 milliamperes, which gives me radiation amounting to 1.85 amperes in the aerial; the aerial is 85 feet long with the free end 55 feet high and lead-in end 30 feet high. Aerial consists of four wires spaced 2' 0" centers. I use a counterpoise of four wires fanned out to a spreaded 8 feet long spaced 2' 8" centers, and 10 feet above the ground.

My receiving set consists of assembled Radisco units for the short wave set and a detector, two-step amplifier using Radiotron tubes. I also have a long wave set (not shown) which I change for the short wave
(Continued on page 530)

P. W. Lister's Station 8II at Detroit, Mich.

THE following is a description of my station which consists of a ZRF regenerative set, used in conjunction with a home-made detector and two-stage amplifier. The transmitter is a home-made radiophone using two 5-watt tubes and radiating from $1\frac{3}{4}$ to 2 amperes. The high tension for this set is obtained through a 200-watt transformer used with electrolytic rectifier.

The antenna consists of four wires 65' long and 55' high, with a spread of 9'. A regular ground is used in connection with a counterpoise giving very low resistance of the antenna circuit and high efficiency of the transmitter.

This station has, on different occasions, worked from 400 to 500 miles on the phone, and has been heard about 1,200 miles, when using straight C.W.

The radiophone and amplifier of this station are home-made, built by Mr. Lister, the proud owner, who may be seen in the photograph. Pretty good work, isn't it?



E. Mateos Perez's Station at Santiago, Cuba

THE accompanying photograph shows the experimental radio station of the Perez Radio School in Santiago. Various apparatus are used to teach the students the functioning and operation of them. This station is also used for amateur work and corresponds regularly with other amateur stations in Cuba. On the left may be seen the transmitting apparatus consisting of helix coils of various sizes and Leyden jar condensers of various capacities which may be combined for transmission, with the inductances, so as to form different circuits which are found in commercial transmitters aboard ships.

On the table are some spark coils which

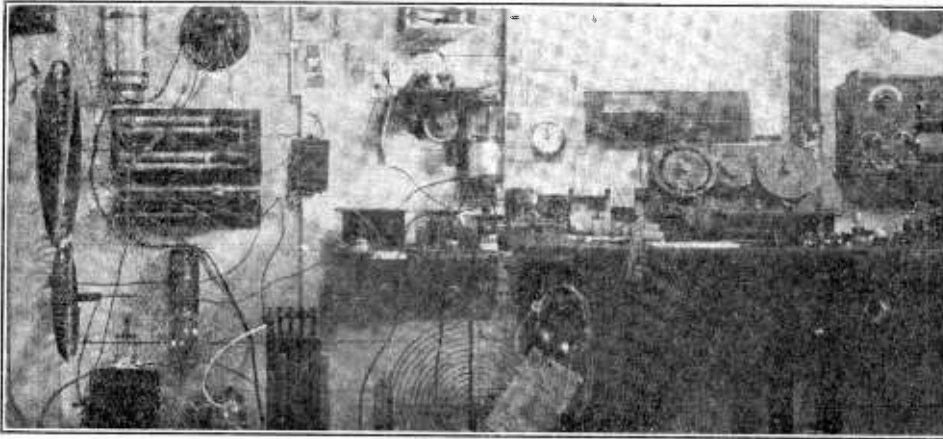

This Experimental Station is the One of a Radio School at Santiago, Cuba. It is Used Chiefly to Teach the Students the Role of Each Apparatus and Its Use.

may be taken out and used as different stations for practice, each operator having a complete station and sending messages in the same form as is done in commercial work. This method trains them to receive through interference and exactly as aboard ships. On the right of the photograph are

the receiving apparatus, part of them only being visible. The large tuner on the table is for the reception of long waves and consists of a coupler with intermediate circuit and the necessary condensers. The loose coupler just above is used for short-wave reception.

On the extreme right of the photograph is another tuner and just below, the vacuum tube detector and amplifier units, which may be switched to any one of the tuners. This station has made some good records with the spark transmitter, and is well known by all Cuban amateurs and others on the Coast.

Lacret Baja 8,
Santiago, Cuba.

A. T. Hill's Receiving Station at Brooklyn, N. Y.

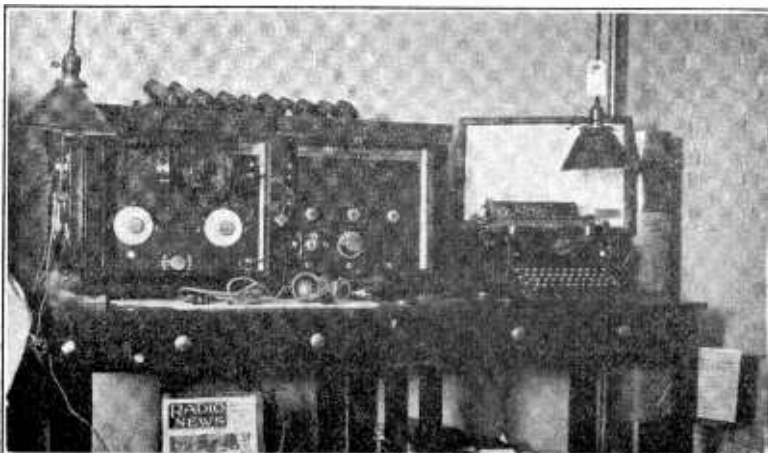

Another example of good amateur work. This very complete receiver is neat looking and is suitable for reception of all wave-lengths.

IN looking over my RADIO NEWS, I always find quite a number of receiving stations, and I am sending you a picture of mine, hoping it will appear in your Amateur Department.

This receiving set is entirely home made, and honeycomb coils are used for tuning any wave-length from 160 to 25,000 meters. As may be seen in the accompanying picture, the set consists of two panels, one of them being the tuner, the other the detector and two-step amplifier, in which Western Electric VT-1 tubes are used.

To get maximum amplification, I use four 22-volt "B" batteries on the plate of the amplifying tubes and use a crystal detector instead of the tube for the reception of nearby stations, thus saving the batteries.

The antenna, which is 80 ft. long and consists of four wires about $2\frac{1}{2}$ ft. apart, is erected on the top of a six-story building with the lead in coming through my window.



Junior Radio Course

Radio Control PART II.

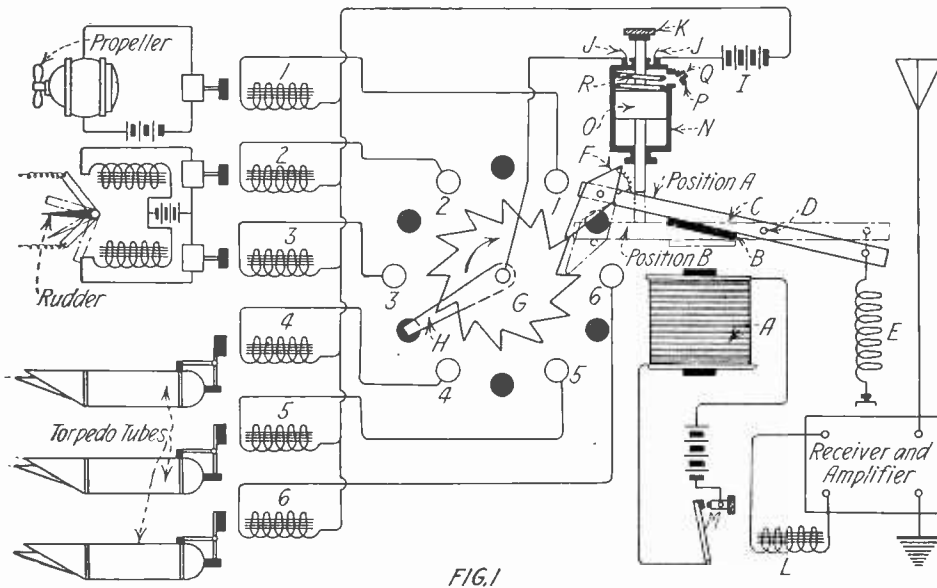

FIG. 1

This Drawing Shows the Connections of a Radio Control System to Operate a Ship by Radio. The Detailed Sketch is That of the Selectors, Which Connects the Various Circuits Automatically at the Will of the Operator of the Transmitting Station.

IN the last lesson was described the simplest radio control device, which was designed by Professor Branly, inventor of the coherer, and with which it was possible to control from a distance various apparatus connected to a radio receiver. In this lesson will be described another system, which, although not the best, is much more perfected and flexible in operation for the control from a distance of either an automobile, ship, torpedo, etc.

The transmitting and receiving apparatus used in connection with this system, being of the ordinary type, we shall not describe them more fully, as they are well known by our readers. The transmitter may be either a spark coil or a powerful transmitter and the receiver may consist of either a single circuit tuner with amplifier, or a sensitive apparatus with several stages of radio and audio frequency amplification. For the best operation, and in order to prevent the radio controlled craft to be operated accidentally by interference, or atmospheric discharges, tuned circuits should be used in both receiver and transmitter and adjusted for a very sharp tuning.

The heart of the system, which is the selector, is shown in Fig. 1, with, connected to the various points of the automatic switch. The relays closing or opening each local circuit. Of course, any number of controls may be used by providing the automatic switch with the proper number of points, but for the sake of clearness, only a few are shown in the drawing. As may be seen in Fig. 1, the selector consists of an electromagnet A attracting an armature B, fixed on a movable arm C pivoting on the axle D, and supporting a finger F, which moves the

ratchet wheel each time the armature B is attracted by the magnet. This motion of the ratchet wheel G moves the switch blade H from one point to the next, at each stroke of the finger F. The motion of the arm C is clearly shown by the dotted lines representing the arm in position B, attracted by the electromagnet.

Between each of the points, which are numbered from 1 to 6, are shown dead points to which other relays may be connected. If this device alone was used, each circuit would be closed when the blade would touch the point to which it is connected and to prevent this, a special device is used, which closes the circuit only a certain time after the blade is on the point. It may be understood that if the armature C is attracted in rapid succession by the magnet A, the blade passes over all the points without closing the circuits, for, the time switch which is shown above the magnet, cannot close the circuit before a certain time, say one second.

This time switch may consist, as shown in the sketch, of a small cylinder, fitted with a valve P, in which a very small hole Q is drilled; inside of the cylinder moves up and down a piston O, to which is fixed an insulated contact K, closing the local circuit of the relays when in contact with the two blades J. This piston is pushed down by a spring R when the arm C, supporting the finger F, is attracted by the magnet, as in position B; for normally it is pushed up in the cylinder by the arm C pulled by the spring E, as in position A.

When the armature is down, the piston O, pushed by the spring R, produces a suction effect in the cylinder, causing the valve P to be closed and allowing the air to fill the

cylinder very slowly through the small hole Q, thus slowing down the motion of the piston supporting the blade K, which consequently cannot close the circuit between J and J immediately after the arm C is attracted by the magnet. Each time the arm C comes back to position A, it strikes up the piston which can be pushed up quickly, for the valve P opens under the inside pressure, which does not oppose any resistance to the upward motion of the piston O.

OPERATION

To make the operation of this control system clearer, we can give an example. Suppose the blade H is as shown in Fig. 1: if a dot is transmitted, the sensitive relay L closes the circuit of the electromagnet at M, the armature B, attracted by the electromagnet A, pulls down the arm C and the finger F, pushing the ratchet wheel G the length of one tooth, moving the blade to point 3. If another dot is sent quickly after the first one, the same operation happens, moving the blade to the next point and so on, up to the point, preceding the proper one, controlling the apparatus which it is desired to operate. For instance, if the motor is to be started, the blade should be moved to the point between points 1 and 2; if, then, a dash is sent by the transmitter, the armature moves the blade to point 1 and stays in position B for a sufficient time to allow the piston O of the times device to come down and the blade K to close the circuit between J and J.

The circuit of the local battery I being closed, the control relay No. 1 attracts its armature to which is fixed a switch of the same type as those described in the last lesson. Each of the other instruments is similarly operated, and the operation of the steering relays and of the torpedo tubes being already explained in the first part of this lesson, we shall not emphasize this part of the question.

The advantage of this radio control system is that it is much more flexible than the one designed by Professor Branly. In the latter it was necessary to wait a certain length of time until the proper segment of the distributor was in contact with its cor-

(Continued on page 550)

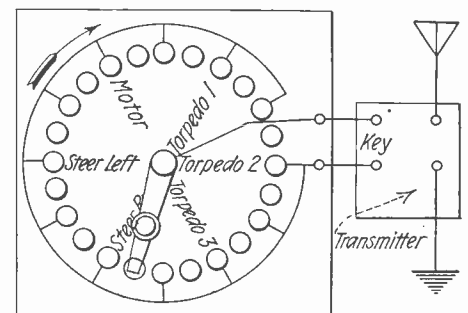

FIG. 2

This is the Controller of the Transmitting Stations, the Contact Blade of Which is Always in Synchronism With the One of the Selector at the Receiver.

Junior Constructor

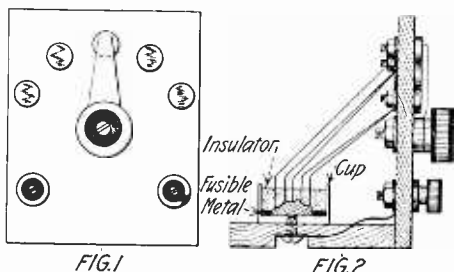

FIG. 1
FIG. 2
This Crystal Detector With Several Points Which May be Connected by a Switch, is Very Practical and Steady in Operation.

PANEL TYPE CRYSTAL DETECTOR.

Many amateurs would like to mount the crystals on their panel. The following method will be found very good.

Any detector cup may be used, a fusible metal poured into the cup, some magnet wire is cut in short lengths and placed on different parts of the crystal and a good insulating material is poured in to fill the rest of the cup. Each wire is connected to a tap on the panel.

The drawing is self explanatory.
Contributed by JOHN SHUTE.

IMPROVING THE VARIABLE CONDENSER.

When using a regenerative receiving set it was necessary to have a very accurate adjustment on my variable condenser and I happened to strike on the following idea which worked very well.

I used the Perfection condenser, but almost any condenser that can slightly loosen the rotary plates and be tightened can be used; the idea is to loosen the movable plates and spread them in fan form; in this way the capacity is varied as to the spread

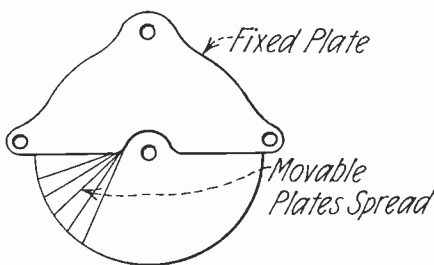

A Clever Idea Which Allows Easier and Sharper Tuning With a Variable Condenser.

of the fan. I know the fellows need some condenser of this sort.

Contributed by LAWRENCE F. PELLETIER.

A SIMPLE LEAD-IN INSULATOR PANEL.

I have noticed that many amateurs think they have to bore holes through the walls of their houses for a lead-in. This takes time and expense and is not necessary.

Take a measurement of your window between the two slits on each side where the window slides up and down, and measure off about a quarter of an inch to allow for the putting in of the board when it is finished. Next secure a piece of board about four inches wide and three-quarters of an inch thick. Cut the board off to the measurement that you have taken of

the window. Now bore a hole in the middle of the board and put your lead in insulator in and fasten it. Next, coat with paint. After the paint is dry put the board in the window so that when the window is lowered the bottom of it will rest on the top of the board. Little chips may be put in at the ends to keep the board from moving.

The diagram that accompanies this explains nearly everything.
Contributed by JAMES EDDY.

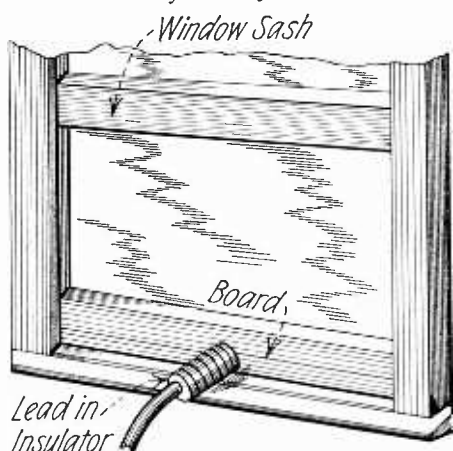

If You Cannot Drill a Hole for Your Lead in Insulator you May Mount it Like This.

CONSTRUCTION OF A TRIPLE VACUUM-TUBE SOCKET.

I herewith present details of a triple vacuum bulb socket which cost me but 30 cents. The bill of materials consist of a block of wood, a dozen small wood screws, and several small pieces of thin brass.

Three holes, all in a row, are bored in a piece of white pine (any dry wood will do), each hole being $1\frac{1}{8}$ " in diameter and 2" apart. The length of this wooden block and the separation between the holes can, of course, be varied to suit the design of any particular amplifier cabinet. There are two more operations after this. First, the cutting out of the bayonet joints; second, the mounting of the brass prongs on the base to make contact with the audion terminals.

The bayonet joint is made by cutting through one side of each hole an upright L, at the end of each of which is bored a small hole (See Fig. 2).

The prongs on the base of the block are then mounted. A tube should be placed in the socket, so that the proper location of each brass prong can be noted. Each prong is then fastened to the bottom by two small wood screws. Fahnstack binding posts may be fastened to the ends of the prongs, but they are not really necessary, as the connections can be soldered directly

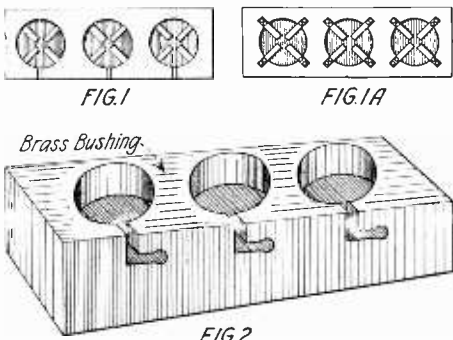

With a Piece of Hard Wood You May at the Same Time, Cut Some V.T. Sockets and the H. C. of Radio Apparatus.

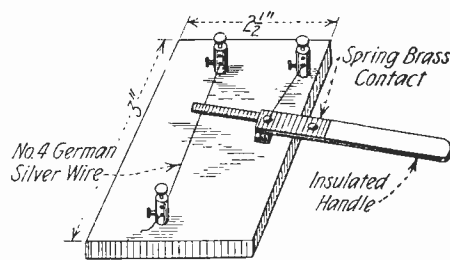

Here is a Simple Type of Vernier Rheostat for Fine Adjustment of the Filament Current of a V.T.

to the ends of the prongs. The socket-unit is now ready and it can be conveniently mounted on the back of the amplifier panel very easily, with several flat-headed screws.

If these few directions are followed, you will have a very neat and serviceable triple socket unit minus the electrical defects of the manufactured electrical socket.

Contributed by SAMUEL W. ELLNER.

AN EASILY MADE VERNIER RHEOSTAT.

Being discontented with my rheostat because it did not give a fine enough filament adjustment on C.W., I set about to make a vernier rheostat. After experimenting with various kinds of sliders, I hit upon the idea shown in the drawing.

With a long insulated handle I did away with body capacity effects.

I am sending this to you because I thought that it might interest other "hams."
Contributed by C. M. ROBINSON.

HOW TO CONSTRUCT CARDBOARD TUBES.

For the radio "bugs" who wish to construct their own cardboard tubes, I think this is a good idea. First procure a wooden dowel, $\frac{1}{8}$ " smaller than the outside of the tube to be constructed. Wrap a strip of cardboard B, $\frac{1}{2}$ " thick and about 4" or 5" wide, the length depends on the size

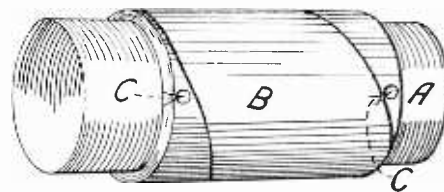

When You Wish to Make a Coil of a Certain Diameter, it is Easy by This Method to Make a Cardboard Tube of the Proper Size Yourself. In the Drawing is Shown the First Layer of Cardboard; A—Dowel; B—Tube; C—Thumb-Tacks.

of the tube, diagonally around so that the edges just meet, as shown in the diagram.

Fasten the edges with thumb tacks. Give the tube a heavy coat of shellac and wrap another layer of cardboard around the tube in the same manner but in the opposite direction and remove the thumb tacks and tie with string. Bake it in the oven for about a half hour. Then take out the tube and remove from the form and give a good coat of shellac and bake for another half hour. The result will be a very rigid cardboard tube, as good as the manufacturers can make and will not shrink if made according to directions. Ordinary cardboard tubes can be dipped in shellac and baked in an oven and will come out good looking, stiff cardboard tubes.

Contributed by KENNETH NEBEL.
(Continued on page 542)

Correspondence From Readers

ABOUT THE AMERICAN EXAMINATION.

Editor, RADIO NEWS:

Who is this Op. James E. Sellan, of Tampa, who in last month's issue attempted to "bawl me out" in regards to my recent article, "Should the Govt. Exams. Be More Severe?" Is he a ship operator? If so, then I presume he was afraid to tell the name of the vessel he is on, for fear that I may have heard him while at sea, testing, QRA'ing or CQ'ing. If he is a ship's radio man, I am surprised that he should make the remarks he did in his letter. If he is not a seagoing radio man—well—we can't expect anything different. He begged that I answer his letter and so—here goes.

For almost three months, I carefully went about preparing that article, which seems to have caused so much comment. You can rest assured that I was very careful not to say anything which I could not prove or could not give examples of. A great deal of the data was obtained from radio men of importance and of long sea and land experience. In regard to conditions I stated were to be found aboard many of our American ships, I am capable of explaining that personally and, if Mr. Sellan still demands that I answer his page of questions, I shall do so providing he communicate with me personally. My address appears on the page opposite his letter. It would require too much space to prove every statement through the columns of RADIO NEWS. Of course there are two sides to every story and we all have different points of view and ideas. Mr. Sellan did not have the same ideas as I. I never thought about asking him for his opinion regarding the Govt. exams. before it was published as I did not have the pleasure of knowing him.

I am very sorry that my article did not please him, but I am sure the Government inspectors will find a great deal of truth in it. More than once have I heard them voice their opinions of American operators. It was my idea to help the fellows who are contemplating becoming commercial radio men, and to give them hints and pointers which would assist them in fulfilling the requirements of real good operators. As for the "Limies," I did not say they were the best operators. I told of the Government examinations they are compelled to pass. Often have I visited numerous English vessels and the Marconi offices in London, just for the purpose of obtaining information about their tests. If Mr. Sellan likes, I will send him a list of their questions, but I guess he would have a terrible time answering them, seeing that he thinks the American examinations are so terribly difficult.

CHARLES A. REBERGER.

Roselle Park, N. J.

SUPPOSE WE HAD TO PAY \$5.60 PER!

Editor, RADIO NEWS:

Having been a regular subscriber to RADIO NEWS for a considerable time, I thought a line or two telling you what we amateurs in Australia think of your journal would not be out of place. Believe me, we look for the next RADIO NEWS like a new office boy does to his first pay.

You seem to have the happy knack of putting things so simply that the raw amateur can readily understand them, and I'm sure that is appreciated by all.

I suppose you would like to hear a word or two regarding the position of the Wireless Amateur in Australia. Well, compared to our American friends, we are very badly off. Whereas the American amateur appears to enjoy the support of the Govern-

ment, we here in Australia are more or less discouraged. We are licensed for receiving only, for which privilege we are compelled to pay the exorbitant sum of £2 (\$5.60) per annum.

Before a license to use a valve is granted, it is necessary for the applicant to tender to the authorities a certificate to the effect that he is capable of operating at least 12 words per minute.

Some of us get what we consider very good results. Using a single audiotron, and honeycomb coils, and also "Burndept" (all coils home-made) we can copy most of the high power stations. Every morning we hear Lyons and Bordeaux very distinctly, as well as some of your American stations, such as NSS, NPM, NPO, NPG, etc.

I think this speaks volumes for the audiotron as a detector.

We have in Australia a Wireless Institute, with a section in each state. Meetings are held monthly, and we find that the lectures are of great assistance to use.

The Institute has recently adopted a standard design of pennant to be flown from the aerial mast, and it bears the letters W. I. A. It is of navy blue bunting, with the letters in white.

This serves to distinguish the members, and it no doubt widely advertises the Institute.

Our section (South Aus.) has just applied for a transmitting license, and we live in hopes of hearing our Secretary's rotary very soon. As you are no doubt aware, Australia cannot boast a high power station, but judging from present appearances it won't be long before our American friends will hear an Australian warbler in their Murdocks.

Wish RADIO NEWS and all American amateurs the best of luck.

KEN J. MARTIN.

Adelaide, Australia.

DREAMLAND OF RADIO.

Editor, RADIO NEWS:

Your editorials are wonderful! They and the cover of the RADIO NEWS were really the things that brought me into the "Dreamland of Radioland."

Yours is the magazine I like to see. You are straightforward and not afraid of criticisms from critics.

You publish the knocks (I do not see how anyone can find anything wrong with your magazine) and the boosts (there ought to be plenty of them).

I have followed up the "Junior Radio Course" and find it very interesting.

PAUL GLEN.

New York City, N. Y.

A CRY FROM AUSTRALIA.

Editor, RADIO NEWS:

From continuously reading your magazine while residing in Australia, I believe that you publish it, as you say, in the interests of all Radio amateurs. It is in the interests of the Australian amateur that I am now writing to you. Your very valuable magazine is not unknown in that far distant country, and it does not seem impossible to me, when I suggest that you may use it as a medium for bringing together many Australians and, indirectly, increase your own sales and those of many American Radio apparatus companies. I was unable to do any really good work out there because my pocket was small, and the charges large. Sydney, N. S. W., has but one proper Radio store, and since he is the only one, he is able to charge as much as he pleases. \$6.00 valves go for \$12.00 and \$15.00, switch contacts are 18c and 20s, and other things range accordingly. What

can a boy or young man do under such circumstances?

He gets a poor opinion of wireless. The fellows at school used to laugh at me because I was always "broke." Radio was the reason, so many took the opportunity to learn a lesson, and let radio alone.

I formed a club at school, but owing to the high cost of radio apparatus, the membership fell from thirty in the first month to ten or twelve at the end of the year. I have since had word that the club has gone out of business.

Transmission is prohibited by law at present, but when there are enough amateurs to raise a kick, transmitting will be permitted and the price of a license will be reduced.

Australians look to RADIO NEWS for guidance, both in apparatus matters and in club possibilities. It was RADIO NEWS which started our club, and it was and still is RADIO NEWS which supplies all the useful circuits and hints for receiver sets.

Your editorial is always worth reading, and I would suggest that when you are hard up for some "dope" that you write one for Australians and others like them.

At the present rate of progress, it will not be long before transmission by amateurs will make transcontinental work look small, but Australia can only read and sigh. America has the brains of the world, and she is known the world over for generosity to those in need. Perhaps the American amateur will show his generosity by suggesting a way out for the Australian cousin.

LEONARD C. RENNIE.

Late of Sydney, N. S. W.

HIS CRITICISM.

Editor, RADIO NEWS:

Receiving your card, "What Do You Think of RADIO NEWS?" I would like to make a few suggestions.

I agree with Mr. Dreesner in July issue, that fiction is a mistake and harmful to your magazine. I think most of your readers, like myself, can find all the stories they desire in other papers which are published especially for fiction readers.

Instead of the stories, give us one or two more "How to Make It" articles, or some additional write-ups such as Mr. Jessup's (who, by the way, is a fine young man) in the April issue. Also you could answer more questions in the "I Want to Know" department.

Not wishing to be too hard on our good editor, I would allow him to exhaust his "laughing gas" by a comic cover illustration occasionally.

I think RADIO NEWS is the best in its class and that is why I get it. I make the above remarks with the object of improving your good paper to our mutual advantage.

D. C. KURTZ.

R. 4, Mechanicsburg, Pa.

HE LIKES 'EM.

Editor, RADIO NEWS:

Upon getting my copy of RADIO NEWS yesterday I turned at once to your editorial, the place I always look first.

I was very surprised to see that anyone would have the nerve to say that they thought your editorials were a waste of paper.

I am not a "Radio Bug" but I am interested in Radio and its development. It was your articles, both editorials and others, that first caught my attention. I have not missed very many since. I don't aim to miss as many in the future as I have in the past.

I think I am correct in saying that your editorials every month are of great importance. They always tell something, or they

(Continued on page 538)



THE RADIO CLUB OF LONG ISLAND

The Radio Club of Long Island, with headquarters at the laboratory of the Ship Owners' Radio Service, 80 Washington St., New York, begins the activities of the 1921-22 season with a membership of over 40 enthusiastic amateurs.

President J. Bruce Ferguson and the other officers announce that one of the first activities of the club will be efforts toward the reduction of the terrific interference which is now the pest of those whose desire it is to enjoy the fruits of endeavors and to promote the better interests of the game.

Indication that the Radio Club of Long Island is in earnest is the fact that Traffic Manager Browne (2BRS) has already begun to warn violators of the laws regulating wave-lengths. In this he has the Executive Radio Council and the local radio inspector behind him. It might be well to remind those who are careless in this respect that cancellation of license awaits an offender.

A cordial invitation is extended to all "citizen radio men" who live on the northern half of Long Island to join the club. The meetings are set for 8.15 p.m. every other Tuesday, beginning November 15.

As an affiliated member of the Executive Radio Council, the club is planning to put into effect in its district rules and regulations laid down by that body for the betterment of operating conditions. For the further education of its members, it is planned to have a lecturer at each of the meetings. An invitation is also extended to visitors.

The club's officers are as follows: President, J. Bruce Ferguson (2CAP); vice-president, William Reuman (2RB); secretaries, William Novotny (2AUL) and William Eckert (2BZV); treasurer, Edward Fenn; publicity manager, Donald W. Exner (2BNF).

THE RADIO CLUB OF AMERICA

At the last meeting of the Radio Club of America, held at Columbia University, New York City, Mr. Eltz, manager of the Radio Department of the Manhattan Electric Supply Co., delivered a very interesting lecture on "Radio and Audio Frequency Amplification," giving most valuable "dope" for the construction of efficient amplifiers and describing the causes of howling and the remedy in both resistance and transformer coupled amplifiers. After this lecture Major E. H. Armstrong talked a little about vacuum tubes and the necessity of using radio frequency amplification for the reception of weak signals owing to the poor sensibility and very small current of the detector tubes actually on the market.

Mr. Paul Godley, designer of the well known Paragon receiver, spoke of the new "baby" born to the Paragon family; that is, the small radiophone transmitter, with which he obtained wonderful results during the experiments he carried out with the set.

GALILEO RADIO CLUB OF SAN FRANCISCO

A new radio club has been formed and its name is Galileo, in honor of our school. We can now boast of 35 members, five of whom are girls. Mr. Bernard Euphrasim is president, Mr. Edward Billington, vice-president; Mr. Ziedler, treasurer, and Miss G. Meriwether secretary. We hope to have all our members commercially licensed very soon.

Our present equipment is a Colin B. Kennedy receiving set, long and short range, consisting of one audion-detector and two amplifiers, coupled inductively with honeycomb coils. Our transmitting set includes a 1/2-K.W. transformer, a Dubilier condenser, a Boston key, a Murdock rotary spark gap and Murdock oscillation transformer.

The monthly dues of 35 cents per capita will be used in purchasing additional supplies, a loud speaker being our next investment.

We will gladly answer all inquiries from any co-operative clubs. Address all communications to secretary, Miss G. Meriwether, care Galileo H. S.

BUSHWICK EVENING TRADE SCHOOL RADIO CLUB, BROOKLYN, N. Y.

The Bushwick Radio Club wishes to announce that it is preparing to organize a special unit in code practice for those amateurs and radio men who are now receiving 15 words a minute, and are desirous of attaining greater speed in order that they may obtain commercial licenses, and also for those who wish to avoid becoming "rusty."

The class will meet four evenings each week at the clubroom, Bushwick Evening Trade School, 400 Irving Ave., from 7.30 to 9.30 P.M.

The young men desiring to take advantage of this opportunity will please state in detail their ability and experience. Applications will only be accepted through mail. Address all communications to Miss Sonia Soberg, 400 Irving Ave., Room 351.

BUHL AGAIN IN THE LEAD

Local radio fans have organized the Buhl Radio Club. What is believed to be the first radio club in the State of Idaho, was organized recently at the home of A. E. Dickey, in Buhl.

The club will have a social as well as an educational value, as it provides for weekly meetings of those interested, at which the various problems of the members will be generally discussed and worked out.

With the completion of the stations contemplated by the members, Buhl will take her place beside the most progressive cities of the East where the wireless telephone in particular has attained a degree of popularity that is amazing in so short a time.

The Westinghouse Electric & Mfg. Co. is broadcasting a pre-announced program of band concerts and musical entertainments every night that can be received, and with a very moderate priced equipment amplified so that it can be heard as well as your phonograph.

Quite recently an amateur in one of the New England States sent the music from his phonograph floating out on the ether by wireless and it was heard in Scotland.

The big Government stations are now sending out crop, time, market and weather reports daily, of which a great many people are taking advantage.

Those present at the recent meeting were Laurence Peck, George Harvey, Clarence Lane, Jack Warner, Edward Joyce, Claud Lane and A. E. Dickey.

The following officers were elected for the first quarter: George Harvey, president; Edward Joyce, secretary; A. E. Dickey, treasurer. The club will meet every Friday night at 7.30 sharp.

THE PREP. RADIO CLUB—3XJ

Unique among the high school clubs of Philadelphia is the St. Joseph's Prep. Radio Club. It numbers about 50 members, some of whom are licensed operators and maintain their own stations, while all are enthusiastic in radio and ambitious of becoming proficient amateurs. Membership is limited to students of the high school department of St. Joseph's College and the more advanced in radio technique are allowed the privilege of working in the college wireless room of St. Joseph's College, one of the best equipped in the city. Meetings are held weekly in the physics lecture hall of St. Joseph's College. The following officers were elected for the current year: Raymond A. Ryder, president; John J. Guinan, vice-president; Joseph B. Gadurgis, secretary. Correspondence is invited. Address Joseph B. Gadurgis, secretary, the Prep Radio Club, St. Joseph's College, Philadelphia, Pa. Radio call, 3XJ.

SOUTH DAKOTA RADIO CONVENTION

The first meeting of radio amateurs in South Dakota will be held in Sioux Falls, on December 28 and 29, 1921, under the name of "South Dakota Radio Convention." The affair is being staged by our club, with the assistance of a few of the leading amateurs in other parts of the State.

A convention hall has already been engaged and some of the details of the meeting have been worked out. We intend to have at least two speakers of some prominence in radio, and also to have display of apparatus. There will be the usual big banquet and stunts.

We hope to draw amateurs from the neighboring States of Minnesota, Iowa and Nebraska, as well as from all parts of this State, and we see no reason why it should not prove to be quite an event.

It will please us greatly if you will give us a little publicity about the convention in *RADIO NEWS*, which is read quite generally by amateurs in this part of the country.

Dictionary of Technical Terms Used in Radio

(Continued from previous issues)

Tikker—Detector used in C.W. working. Consists of a rapid working contact maker periodically causing main condenser of receiving circuit to charge another condenser placed across phones. When "Tikker" is open main condenser becomes momentarily charged by incoming oscillations; when tikker closes circuit containing telephones, the other condenser becomes charged which upon re-opening of "tikker," discharge across phones, producing audible ticks.

Torque—Tendency to turn anything about an axis. Also called Couple, and Angular Force. Turning Moment Unit is Pound-foot (not foot-pound) and is that Torque which is exerted by force of one pound at a radius of one foot.

Train of Waves—A group of oscillations is sent out from an aerial at each discharge of the condenser, if the transmitter is arranged on the spark system. If a number of trains of oscillations are sent out at equidistant intervals, the number per second is called the train frequency or group frequency, and this must be distinguished from the oscillation frequency.

Tune—See Resonance.

Tuner—An instrument capable of various adjustments of inductance and capacity in the receiving circuit. See Multiple Tuner.

Tuning Lamp—A four-volt lamp in series with an inductance coil shunted across small portion of aerial.

Turning Moment—See Torque.

Twin Wire—Two separately insulated wires twisted together to form one wire.

Two Circuit Windings—See Wave-Wound.

Two-Phase Alternator—Really a double single-phase machine, having two pairs of slip rings which give off two distinct alternating E.M.F.'s of equal amplitudes but with a phase difference of a quarter of a period.

Ultraudion—Explained in Reaction Circuit. See Audion.

Ultra Magnifier—See Reaction Circuit.

Ultra Violet Rays—See Light.

Umbrella Aerial—One whose component wires radiate from a central pole or mast like the ribs of an umbrella.

Undamped—A train of oscillations of constant amplitude. Having no damping.

Unidirectional—Flowing in one direction only as Direct Current.

Unilateral—One direction only taken into consideration.

Unit B.O.T.—1,000 Watt-hours.

Unit of Acceleration—F.P.S. One foot per second. C.G.S. One centimeter per second.

Unit of Capacity—Farad. Conductor has capacity of one farad when a charge of one coulomb raises its potential one volt. Practical unit is micro-farad.

Unit of Conductance—Mho, which is the reciprocal of the Ohm.

Unit of Current—Ampere. Current that when passed through a particular solution of Silver Nitrate in water deposits 0.001,118 gramme of Silver per second. Flow of one Coulomb per second. Current passing through a resistance of one Ohm when a uniform pressure of one Volt is applied.

Unit of Force—F.P.S. is Poundal, and is that force which acting on a mass of one pound gives it a velocity of one foot per second. C.G.S. is Dyne, and is that force which acting on a mass of one gramme gives it a velocity.



THIS Department is conducted for the benefit of our Radio Experimenter. We shall be glad to answer here questions for the benefit of all, but we can only publish such matter of sufficient interest to all.

1. This Department cannot answer more than three questions for each correspondent.
2. Only one side of the sheet should be written upon; all matter should be typewritten or else written in ink. No attention paid to penciled matter.
3. Sketches, diagrams, etc., must be on separate sheets. This Department does not answer questions by mail free of charge.
4. Our Editors will be glad to answer any letter, at the rate of 26c for each question. If, however, questions entail considerable research work, intricate calculations, patent research, etc., a special charge will be made. Before we answer such questions, correspondents will be informed as to the price charge. You will do the Editor a personal favor if you make your letter as brief as possible.

TUNING CONDENSERS

(289) Duane Menough, of Pittsburgh, Pa., asks whether it makes any difference if two .001 mf. variable condensers are used instead of one .001 and one .0015 mf., in a receiving circuit using honeycomb inductances.

A. No, .001 mf. variable condensers may be used in both primary and secondary circuits, with very good results.

TRANSMITTING VT'S

(290) Arthur Kemp, of Three Rivers, Que., Canada, wants to know:

Q. 1. What kind of vacuum tube should be used in connection with the C.W. transmitter, using a 6-volt storage battery, published in the November, 1920, issue of Radio News.

A. 1. Any type of transmitting tube may be used; either Radiotron UV 202, or Moorhead oscillator.

Q. 2. Could the set mentioned above be used for radio telephony?

A. 2. No, this set cannot be used for telephone transmission as the high tension supplied by the spark coil is not direct current.

SHORT RANGE RADIOPHONE

(291) Henry Seaman, of Ocean Side, L. I., N. Y., asks the following:

Q. 1. Please publish a circuit of a short range radiophone using "B" batteries as high tension source.

A. 1. You will find on page 707, April, 1921, RADIO NEWS, a hook-up of such a transmitter, in which it is only necessary to short circuit the key and connect the microphone between the grid of the V.T. and the aerial. At least 80 volts should be used on the plate.

"B" BATTERY POTENTIOMETER

(292) William Baker, of Brooklyn, N. Y., wants to know:

Q. 1. Does it make much difference whether potentiometer is connected across the "B" battery, or in series with it?

A. 1. A "B" battery potentiometer should be connected across the battery to be effective, as it would be practically useless if connected in series with it.

LOOP AERIAL

(293) Leroy A. Mather, of Philadelphia, Pa., asks:

Q. 1. What size wire and what kind of insulation should be used on a 4-foot loop?

A. 1. No. 20 BS wire, either bare or S.C.C., is suitable for winding on a loop aerial.

LOOP AERIAL WAVE-LENGTHS

(294) J. Brown, of Bayonne, N. J., sends in the following questions:

Q. 1. What is the natural wave-length of a loop 3 feet square wound with 21 turns?

A. 1. The natural wave-length of such a loop when shunted by a .001 variable condenser, is about 1,100 to 1,800 meters.

Q. 2. Please publish a radiophone hook-up, sending about three miles.

A. 2. See answer 291, on this page.

RADIOPHONE RECEPTION WITH CRYSTAL DETECTOR

(295) Yale Schellenger, of Waukegan, Ill., would like to know:

Q. 1. Can a loop aerial be used with a crystal receiving set?

A. 1. A crystal detector may be used with a loop aerial, but does not give very good results, owing to the poor sensibility of this kind of detector compared with a V.T. Unless the loop is of large size, it is not advisable to use a crystal receiver in conjunction with it.

Q. 2. Can radiophone messages be received with a crystal set?

A. 2. Yes, radiophone may be received with a crystal set, but will be very faintly heard for the reason explained above. However, if the receiving station is in the neighborhood of the transmitter, the voice may be quite clear and understandable.

Q. 3. Which vacuum tube is best as a detector?

A. 3. The V.T. detectors actually on the market are almost all of the same sensibility, if properly adjusted and controlled with suitable instruments.

RECEIVING AERIAL

(296) Louis R. Huber, of Tipton, Iowa, wishes to know:

Q. 3. Which make of amplifying transformer would work best with A.P. tubes.

A. 3. The Federal, or Clapp-Eastham amplifying transformers would give you good results with these tubes.

LIGHTNING SWITCH

(298) M. Belais, of West End, N. J., inquires as follows:

Q. 1. Is it necessary to install a 100 amp. lightning switch with an aerial used for receiving only?

A. 1. Yes, a lightning switch must be installed with any type of aerial, when erected outside of the house.

Q. 2. Must the ground wire be No. 6 rubber covered, with the above mentioned aerial?

A. 2. It is not absolutely necessary to have rubber covered wire for the ground connection, and either C.C. or bare wire may be used.

Q. 3. Must the lead in be rubber covered?

A. 3. Yes, the lead in should be well insulated where it enters the house. If a lead in insulator is used, the lead in from the antenna to this insulator may be of bare wire.

COMBINATION LONG AND SHORT WAVE RECEIVER

(299) A. B. Cromwell, of Norfolk, Va., would like to know if it is possible to change from a honeycomb receiver to a regenerative set, using variometers, by means of only one switch.

A. The hook-up of such a combination of long and short-wave receiving set was published on page 621 of the March, 1921, issue of RADIO NEWS.

SHIELDING OF PANEL

(300) Ralph E. Turner, of Medford, Mass., wants to know:

Q. 1. Is it advisable to paste copper foil on the back of the panel in a receiving set, and ground it to prevent capacity effects from the hand when tuning?

A. 1. Yes, this is especially useful in a short-wave regenerative set, in which a small change of capacity produces a great variation in the tuning of the circuit. With a shielded panel, this capacity effect of the operator's body is suppressed.

Q. 2. Please describe the action of the grid leak in a V.T. detector circuit.

A. 2. For a complete description of the functioning of a grid leak, we would refer you to the lesson of the Junior Course on the detector tube, published on page 376, of the December, 1920, issue of RADIO NEWS.

COMBINED TRANSMITTER AND RECEIVER

(301) B. Starton, of Chicago, Ill., asks us:

Q. 1. Could I use, by means of a switch, the hard tube of my one-stage amplifier for transmitting, and use it as well for amplification, when receiving? Please give a hook-up.

A. 1. The hook-up requested, appears on this page. All the connections from transmission to reception are made by means of the four-pole double throw switch, so that the amplifier tube, which is a hard one, is used as an oscillator when transmitting, while the detector tube is cut off.

RADIOPHONE RECEPTION

(302) William Mays, of Alderson, W. Va., asks us the answers to the following questions:

Q. 1. What size of aerial should I use for reception of short-wave length from 150 to 600 meters?

A. 1. An aerial for short waves may consist of a flat top of four wires, three to four feet apart, and 50 to 60 feet long erected 50 to 60 feet from the ground.

(Continued on page 536)

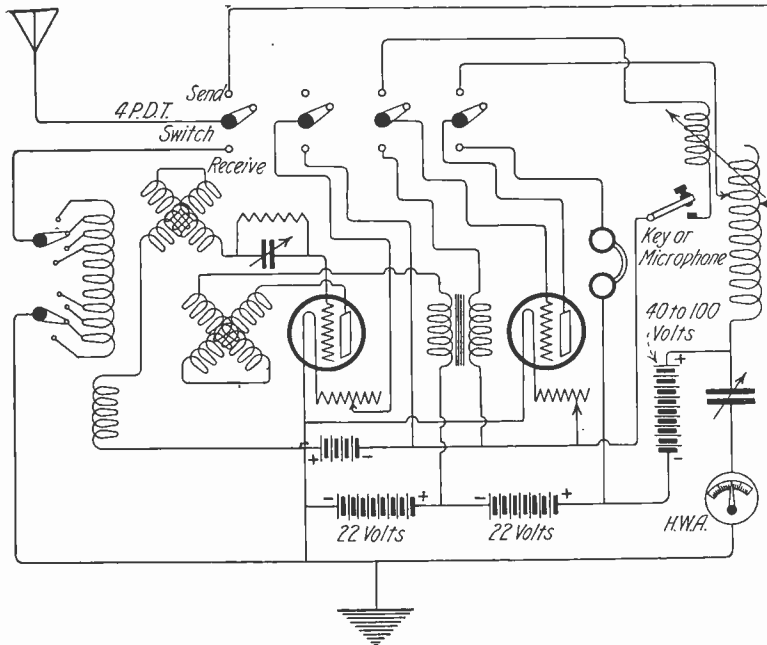

(Q. 301). This Diagram Shows the Connections of a Complete Short-Wave Set With Detector and One-Step Amplifier, in Which the Amplifier Tube is Used as Oscillator When Transmitting. This Set May be Used for Telephony or C.W., and All Connections are Changed Automatically by Means of a 4 P.D.T. Switch.

Q. 1. Which is the most essential for a receiving antenna, the height, number of wires, or length?

A. 1. The most efficient is the highest one, especially for short waves, but for long-wave reception, a long antenna erected about 20 to 40 feet above the ground gives very good results, if used with the proper receiving set.

Q. 2. Is a Fleming valve made of an automobile bulb using an external grid, as good or better than a crystal detector?

A. 2. From our personal experience, we may say that a good crystal detector will give better and steadier results than such a valve, which should be considered only as an experimental instrument.

AMPLIFIER

(297) Richard H. Phillips, of Cazenovia, N. Y., wants to know:

Q. 1. Would A.P. amplifying tubes work all right in connection with an audiotron detector?

A. 1. Yes, this combination will give you good results, provided the proper voltage is applied on each of the tubes.

Q. 2. Please give a diagram of a two-stage amplifier with the above mentioned detector.

A. 2. This hook-up is given on page 397, November, 1921, RADIO NEWS.

ANNOUNCING

MURDOCK

RECEIVERS

No. 56

(Patented.—Other Patents Pending)



**2000
OHM COMPLETE
DOUBLE SET
\$5.00**

**3000
OHM COMPLETE
DOUBLE SET
\$6.00**

The MURDOCK No. 56 Radio Receiver is a reproduction, with notable improvements, of the MURDOCK No. 55, which have deservedly earned a reputation of UNUSUAL SENSITIVENESS and LONG-LIVED DEPENDABILITY. Years of experience in production have so simplified our manufacturing processes that there is NOTHING QUITE SO GOOD AT SO LOW A COST. Every guarantee that has gone for the last 14 years with MURDOCK Radio Receivers is behind the MURDOCK No. 56.

Receivers encased in MURDOCK moulded insulation; magnet of best quality steel, embedded in case with pole pieces attached permanently and unchangeably; all receivers are by-polar; spools are wound with fine size pure copper wire with enamel coating, this method of winding ensuring a maximum number of effective layers; diaphragm is selected stock of thickness experimentally determined best; special attention is given to a most important feature of receiver efficiency, namely, the proper seating and clamping of the diaphragm; the cap or ear piece is MURDOCK moulded of size and shape best fitted for comfort and exclusion of outside noises; cords supplied with sets are five feet in length with durable mercerized finish. The headband wires are spring phosphor bronze and are covered with black-covered webbing. The design of the MURDOCK No. 56 Headband is unique because of the absence of screws on either Head Band or Receiver Adjusting Bale. The construction plan is the acme of firmness, strength, durability and service, all parts being riveted together.

A WONDERFUL VALUE

2000 ohms	\$5.00
3000 ohms	6.00
1000 ohms Receiver only.....	1.75
1500 ohms Receiver only.....	2.25
Double Head Band.....	1.50

GUARANTEE

Fourteen days' trial allowed in competition with any other receivers. If prior to, or at the expiration of the trial period, the receivers are not found to be completely satisfactory, the purchase price will be refunded upon return of the receivers.

“PERFECT SATISFACTION GUARANTEED OR YOUR MONEY BACK”

BUY THEM FROM YOUR DEALER

SEND FOR BULLETIN No. 21

WM. J. MURDOCK CO. 50 CARTER STREET
CHELSEA, MASS.

509 MISSION STREET, SAN FRANCISCO, CALIF.

BUY IT from THE NAVY

Surplus Navy Radio Materials FOR SALE At Attractive Prices

RECEIVING SETS

suitable for receiving ship, amateur, or long wave signals.

SPARK TRANSMITTERS

complete with motor generators or gas engine driven generators.

ACCESSORIES

(except Vacuum Tubes)

of every description suitable for experimental or research purposes.

This is an EXCELLENT OPPORTUNITY for Colleges, Radio Schools and Amateurs to buy NAVY—R—A—D—I—O—Equipment at ATTRACTIVE PRICES.

Write today for Navy Radio Catalogue No. 601-71

The surplus materials the Navy has available for sale have been grouped as shown below and catalogues describing these materials will be sent on your request.

LIST OF SURPLUS MATERIALS

- All Materials.
- Aeronautical Equipment.
- Aluminum.
- Bath Room Fittings and Plumbing Supplies.
- Blankets.
- Boats.
- Books.
- Brass.
- Canvas and Tents.
- Chemicals.
- Cloth and Textiles.
- Clothing.
- Copper.
- Electrical Equipment and Supplies.
- Furniture.
- Hardware.
- Iron.
- Lead.
- Machinery.
- Mess and Galley Equipment. (Kitchen and Dining Room.)
- Monel.
- Musical Instruments.
- Navigating Instruments of Precision.
- Oils and Greases.
- Paint and Paint Materials.
- Provisions.
- Radio Equipment.
- Rope and Twine.
- Stationery and Office Equipment.
- Steel.
- Tin.
- Tools, Hand, Machine and Contractors'.
- Valves and Fittings.
- Zinc.

CENTRAL SALES OFFICE

Navy Dept. Washington, D. C.

漁船用無線電信の研究 (下)

電氣試験所技師 北村政次郎

第一圖は送信装置接続圖に於てAは空中線Sは送受機に於ては接地Tは振動機を構成する。Rは火花放電機を構成する。Cはコンデンサーを構成する。Lはコイルを構成する。Kは電鍵を構成する。Mはモーターを構成する。Nはネオン管を構成する。Pはパイロットランプを構成する。Qはクランプを構成する。Rはリレーを構成する。Sはスイッチを構成する。Tは接地を構成する。Uはアンテナを構成する。Vは真空管を構成する。Wはワット計を構成する。Xはキルヒホフ管を構成する。Yはイヤホンを構成する。Zはゼネラルスイッチを構成する。

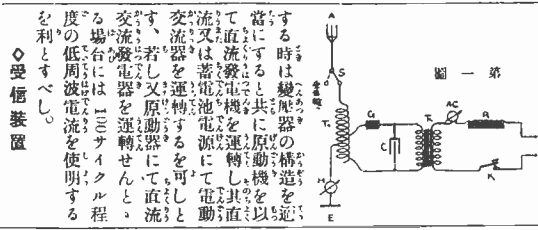

第二圖は受信装置接続圖に於てAは空中線Sは送受機に於ては接地Tは振動機を構成する。Rは火花放電機を構成する。Cはコンデンサーを構成する。Lはコイルを構成する。Kは電鍵を構成する。Mはモーターを構成する。Nはネオン管を構成する。Pはパイロットランプを構成する。Qはクランプを構成する。Rはリレーを構成する。Sはスイッチを構成する。Tは接地を構成する。Uはアンテナを構成する。Vは真空管を構成する。Wはワット計を構成する。Xはキルヒホフ管を構成する。Yはイヤホンを構成する。Zはゼネラルスイッチを構成する。

第三圖は送信装置接続圖に於てAは空中線Sは送受機に於ては接地Tは振動機を構成する。Rは火花放電機を構成する。Cはコンデンサーを構成する。Lはコイルを構成する。Kは電鍵を構成する。Mはモーターを構成する。Nはネオン管を構成する。Pはパイロットランプを構成する。Qはクランプを構成する。Rはリレーを構成する。Sはスイッチを構成する。Tは接地を構成する。Uはアンテナを構成する。Vは真空管を構成する。Wはワット計を構成する。Xはキルヒホフ管を構成する。Yはイヤホンを構成する。Zはゼネラルスイッチを構成する。

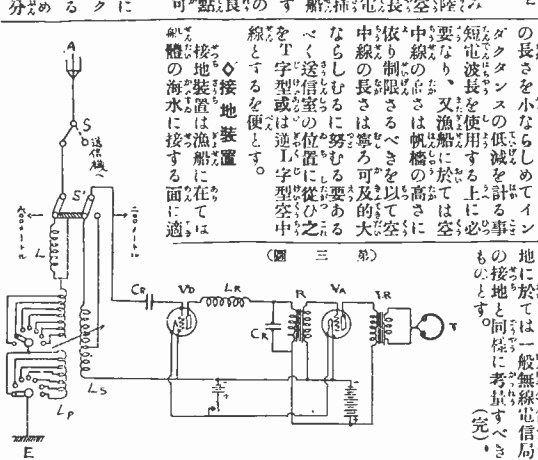

第四圖は送信装置接続圖に於てAは空中線Sは送受機に於ては接地Tは振動機を構成する。Rは火花放電機を構成する。Cはコンデンサーを構成する。Lはコイルを構成する。Kは電鍵を構成する。Mはモーターを構成する。Nはネオン管を構成する。Pはパイロットランプを構成する。Qはクランプを構成する。Rはリレーを構成する。Sはスイッチを構成する。Tは接地を構成する。Uはアンテナを構成する。Vは真空管を構成する。Wはワット計を構成する。Xはキルヒホフ管を構成する。Yはイヤホンを構成する。Zはゼネラルスイッチを構成する。

Here is a Page for the Beginner, Taken From Our Japanese Contemporary, the Name of Which May be Read on the Top of the Page. As May be Seen, the Theory of the Functioning of Transmitting and Receiving Circuit is Very Clearly Explained and Should Not Fail to Interest Those Who Find Radio Too "Dry."

Must We Abandon the Dots and Dashes

(Continued from page 488)

end causes the beam of reflected light to fall on the opaque section so that little or no light passes through to the sensitized film or paper, thus producing a negative effect from which prints can be made. If desired, the graduated screen can be reversed, so that a positive effect will be obtained on the sensitized paper or film.

So much for half-tone transmission and reception. For line transmission the process is fundamentally the same, but a great deal simpler. The transmitting simply makes use of a stylus connected with a delicately adjusted make-and-break arrangement. Simply make-and-break signals are transmitted, in this case. These, when picked up at the receiving end, are passed through the same Blondel oscillograph as already described, but instead of using a graduated screen, the light beam either falls on the little narrow

slot or does not fall on it. There is no use here for graduated light, it is evident; and the light either is allowed to impress itself on the sensitized receiving surface or it is not.

When we come down to radio, we at once appreciate the difficulty of modulating a powerful transmitter to achieve such transmission of half-tone subjects. The average speed of transmission is eight minutes for an ordinary photograph, and the fluctuations of current are of such varying amplitude and so frequent that it is almost impossible to obtain a ready response from a powerful transmitter. Obviously, the modulations are of such a delicate character that undamped waves must be employed, generated by a high-frequency alternator, an arc generator, or powerful vacuum tubes.

And now for a little current history which

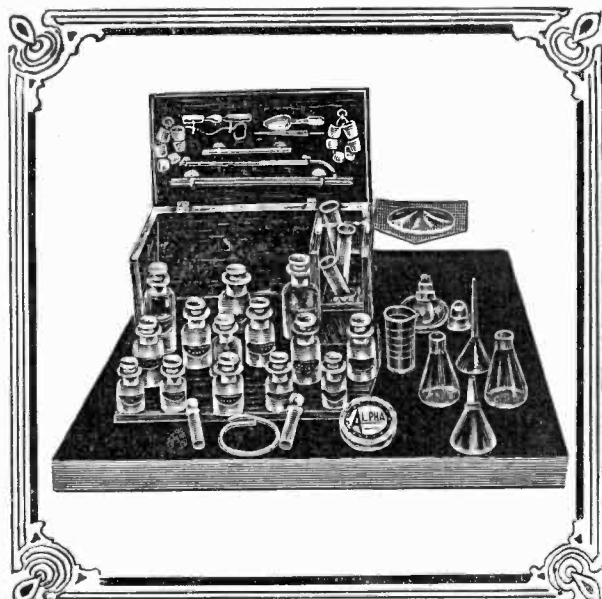

This outfit would cost at least \$25.00 at any chemical supply house. It includes 42 pieces of laboratory apparatus and supplies and 18 chemicals and reagents. A fitted, heavy wooden box, hand finished, serves as a case for the outfit and as a laboratory accessory for chemical experiments.

This Valuable Chemistry Outfit GIVEN FREE To Every Student

TO every student enrolling for our home study course in chemistry, we furnish this big, complete chemistry outfit absolutely free of charge. We even pay the shipping charges no matter where you live. The outfit comes to you complete without one cent of expense on your part. With our course there are no extras to buy—no apparatus—we furnish, or teach you how to make, everything needed for the entire course. You know before you start just what it will cost to become a chemist.

Enter An Uncrowded Profession Study Chemistry At Home

What Well-Known Authorities Say About Our Course

From Hudson Maxim,
"Dr. Sloane has done a much-needed work in a much better way than anything of the kind has, heretofore, been done."

"Dr. Sloane has a remarkable faculty of presenting Science for self-instruction of the student in such a clear and understandable way as to be most readily grasped and assimilated."

"I, therefore, unreservedly recommend and place my highest indorsement on his work."

From Dr. W. W. de Kerlor.
"I can not recommend your course too highly and I congratulate both you and Dr. Sloane on same."

From John A. Tennant.
"This is something which has long been needed. Your long experience in the teaching of chemistry... assurance that the course will be practical as well as plain to the untrained students."

What the Students Say:

"This is just like reading some fascinating fiction story."

"Your course is just what a person wants to start in the wonderful science of Chemistry."

"I am very well pleased with the two lessons of the course I have received."

"I find that your course is very interesting. I wait patiently for the next lesson."

"I find the study of chemistry more and more interesting at every lesson and so I may be sure that I am getting into scientific habit even more than I ever did even in my school days."

"I am well pleased with your course and I think, from the way it starts out, I have found a good teacher and school."

"Enclosed are my answers to lesson No. 2 of your excellent course in chemistry."

"Your course is sure wonderful, easy to understand, and so well laid out. I like it immensely."

"The lessons are fine and I like them."

"I have written to different people about your course and they speak very highly of same."

"If I don't learn it isn't your fault for I find that your lessons contain a whole lot"

(Names and addresses on request)

Chemistry offers greater opportunities today than any other vocation. The demand for trained chemists right now is tremendous and it is constantly increasing. The field offers wonderful possibilities for those who enter while it is still in its infancy. Everything today is chemistry—everyone is talking about the marvels of the science—the papers are full of the subject. Each day brings new discoveries and new announcements that presage greater things to come.

Many industrial processes are crude and wasteful—the world's supply of many necessities is running low. Fortunes and undying fame await the chemists who can devise new methods or discover synthetic products to take the place of the natural substances. The great aniline dye industry was started by a 17-year-old boy chemist who, as a result of his discovery, became rich and world-famous.

Big Salaries Paid Chemists In All Lines

The world has never seen such opportunities as today exist for chemists. Industrial plants of all kinds pay tempting salaries to their valued chemists whose work makes their existence and continued progress possible. Salaries of \$10,000 to \$15,000 a year are quite common. The Belgian Steel Works paid Mr. Anton Beran, its chief chemist, a salary of \$20,000.

Learn Chemistry Under A Famous Chemist

Dr. T. O'Connor Sloane, one of the leading authorities on chemistry—a man whose books and writings are known all over the world, and a chemist of fifty years' practical experience and success, who has in addition taught chemistry for years at college, will personally train you if you enroll with the Chemical Institute of New York.

The United States Government, after many years of research work, has announced in a recent bulletin, that the home extension method of teaching is just as effective as the resident school method.

Our home study course is practical, logical and remarkably simple. No special education is required—if you can read and write plain English you can understand every word. Nothing has been overlooked, but all needless frills and superfluities have been eliminated. Dr. Sloane knows, through his years of experience, just what the student needs. Our method saves you weeks of time.

Easy Monthly Payments

The price of our course is very low, and includes everything. We give, at only a fraction of the cost, the same chemical education that you would receive at a University. You can pay in small monthly amounts as you go along. Our plan of monthly payments places a chemical education within the reach of everyone.

Special 30 Day Offer

For a short time only, we are making a special 30-day offer that will save you money. You owe it to yourself to find out about it. Write today for full information and free book "Opportunities for Chemists." Send the coupon right now while it is fresh in your mind. Or just write your name and address on a postal and mail it to us. But whatever you do, act today before this offer is withdrawn.

CHEMICAL INSTITUTE OF NEW YORK,
Home Extension Division,
140—R Liberty St., New York City

Please send me at once without any obligation on my part, your free Book "Opportunities for Chemists," and full particulars about the valuable chemistry outfit given free to every student. Also please tell me about your plan of payment and your special 30 day offer.

NAME

ADDRESS

CITY

STATE

R. N., Dec., '21.

CHEMICAL INSTITUTE OF NEW YORK, Inc.

140—R LIBERTY ST. Home Extension Division NEW YORK CITY

RADIOGRAMS

RADIOGRAM

For ordinary station u s e.
Size 5½x8½ in. Per pad, 30c; \$2.70 for 10 pads. Postpaid.

RELAY RADIOGRAMS

RELAY RADIOGRAM

For maintaining a systematic record of all relay traffic. Per pad, 85c; \$8.15 for 10 pads. 100 sheets to pad. Postpaid.

RADIO POSTALGRAMS

RADIO POSTALGRAM

For forwarding your out-of-town messages. Printed on a Government postal. 25 for 50c; \$1.70 per 100. Postpaid.

THE ABOVE PRODUCTS ARE SOLD BY THE FOLLOWING RELIABLE DEALERS:

Anderson Motor Sales Co., Hubbard, O.
Ashtabula Radio Sales Co., Ashtabula, O.
Karlowa Radio Co., Rock Island, Ill.
Southern Radio Supply Co., Clearwater, Fla.

If your dealer cannot supply you with these forms, send your order direct to us. We will ship it by C. O. D. parcel post, the same day as received.

DEALERS: WRITE FOR OUR PROPOSITION

AMERICAN RADIOGRAM CO.

DEPT. R-3
305 BROADWAY, NEW YORK CITY

Specials For December

Regenerative Receivers	\$35.00
Regenerative Receivers with audion control	45.00
Control Panels	4.50
Crystal Detectors	1.25
Crystal Receiving Sets.....	16.00

Newark Wireless Exchange
87 Halsey St. Newark, N. J.

You can be quickly cured, if you

STAMMER

Send 10 cents for 288-page book on Stammering and Stuttering, "Its Cause and Cure." It tells how I cured myself after stammering 20 yrs. B. N. Bogus, 877 Beque Bldg., 1147 N. Ill. St., Indianapolis.

has not been divulged before. For a long time M. Belin has been operating his system in Europe on a practical scale, supplying one of the leading Parisian newspapers with its photographs from all parts of Europe. If anything happens at Nice, Brussels, London, Rome, Rotterdam or Prague, a Belin transmitter, which is quite portable and readily connected in any telegraph or telephone line, sends the photographs to Paris a few minutes after they have been taken and developed.

It was altogether natural that this same Parisian newspaper should have taken a keen interest in the Dempsey-Carpentier boxing match. Who wouldn't? Hence the editor asked M. Belin if he could send the photographs of the little scrap across the ocean without waste of time, so that this newspaper could score the scoop of the century. It was impossible to do so by cable, for many business and technical reasons, but there was some chance of doing it by radio, although as yet radio, in this connection, was still a doubtful quantity. However, M. Belin dispatched two of his engineers to the States, seemingly with several days to spare before the match so as to make the necessary arrangements.

As luck would have it—radio luck, which is the hardest kind—these engineers were held up three days by fog. They arrived practically on the eve of the great fight. Half-tone transmission was out of the question, so they decided on line transmission. Permission was secured to utilize at odd moments between traffic peaks the Annapolis Naval station, which has a powerful arc generator. On the evening following the fight, when all the world knew the results, these two engineers endeavored to transmit a drawing showing the French challenger measuring his length on the canvas, while the champion stood over him with fists ready for further action, and with the referee near by taking the count. The drawing was received at Malmaison, near Paris, on a loop antenna. However, the results, due to insufficient preparation, were not sufficiently clear and complete to permit of using the drawing in the newspaper; but let it not be forgotten that if the French lost the great ring fight, they scored the credit of having transmitted the first image across the Atlantic by radio.

The experiments were continued, with the Annapolis station as the transmitter. The great difficulty in all these experiments was to obtain the rapid modulation of the transmitter. The Annapolis station has something like sixty relays to modulate the transmitted energy, and it must be patent to anyone familiar with relays that there must be considerable lag. It is unavoidable. Even with the speed greatly reduced, the French engineers found the line signals piling up on many occasions, so rapid did the make-and-break impulses follow each other.

Then came the second phase of the experiments. M. Belin, wishing to push the results still further, decided to come to the States and try his luck in the opposite direction; that is to say, sending the images from France to this country. For this purpose he made use of the American-built radio station at Bordeaux, known as the Lafayette station to us Yankees. Preliminary to these tests, M. Belin, in France, had transmitted images by land wire to the Bordeaux station, where they were automatically sent out by radio and intercepted by a loop antenna at Malmaison, only some ten miles or so away from the transmitter at Paris which was sending the images. Then by telephone the experimenters could check up on the result.

The Bordeaux station gave better results than Annapolis, because less relays were employed and the response was more rapid.

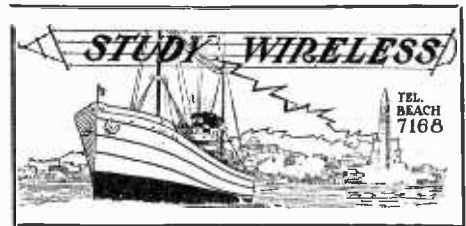

Do You Want a First Class Commercial License?

When you decide to train for the wireless service bear in mind the fact that the Mass. Radio and Telegraph School has graduated more first grade and first class licensed operators during the past 11 months and has TODAY a larger enrollment than any other Radio School in New England. Send for our 44-page catalog giving full particulars to prospective students.

RADIO ENGINEERING

Classes meet each Thursday evening at 6:00 P.M.—enrollment limited. Subject. Design of Commercial Tube Transmitter.

MATHEMATICS

Course in Applied Radio Mathematics one evening per week. Write for information.

AMATEUR CLASSES

Every Saturday morning from 10 A.M. to 12 noon—prepares for amateur license.

SALES—C—W—SERVICE

We carry a full line of Radio equipment and are counsellors on all radio problems especially complete receiving and transmitting installations—order from any standard catalog—mail orders filled. Our technical staff is at your service.

OPEN EVENINGS

Open three evenings per week. Monday, Wednesday and Friday until 9:30 P.M. and Saturday afternoon.

G. R. ENTWISTLE, Radio Director
R. F. TROP, Telegraph Director

MASSACHUSETTS RADIO and TELEGRAPH SCHOOL, Inc.

18 Boylston St. Boston, Mass.
Formerly Boston School of Telegraphy
Established 1903

Enamel Wire No. 22 to 30, lb. .\$.85

7 Strand Antenna Wire, per 100 ft. 75

Bakelite Panels, 10"x15"x3/16" 2.65

Bakelite Panels 5"x5"..... 45

A. C. Voltmeters, 0-15 Volt... 8.00

The Quaker Light Supply Co.

728 ARCH STREET
PHILADELPHIA

Write For Our FREE BOOKS On

PATENTS

MUNN & CO.

631 Woolworth Bldg. NEW YORK
Scientific American Bldg. WASHINGTON, D. C.
Tower Bldg. CHICAGO, ILL.
Hobart Bldg., 582 Market St., San Francisco, Cal.

\$10.00
C-W Course
FREE

Learn C-W at Our Expense

This is the famous C.W.C. course for which hundreds of operators have paid the price of \$10.00. You can get it FREE. It's time you knew this subject from A to Z. C.W. is modern Wireless. Everyone is interested but few know it. Be a leader in your district. Read carefully conditions below.

You Pay Standard Prices for Equipment

All you do is order \$100 worth of apparatus. There isn't a hitch regarding prices. Take any standard catalog issued in any part of the United States and choose the instruments you need. Send descriptions and prices to us. We ship you immediately the same guaranteed goods you want at the same standard prices. You pay no more and the ten complete C.W.C. lessons are yours FREE.

Know More Than Your Friends

Because you will be in demand as an advisor to your friends regarding C.W. it is easy to get them to order through you to make up the necessary \$100 order. Tell them you want this course and you will help them if they assist you. It's easy!

Learn These Subjects

These are a few of the subjects you master when you read the C.W.C. course. Principles and Theory of C.W.—Best Results from Vacuum Tubes—Power of Any Kind Adapted to Any C.W. Set—Transmitting Circuits—How to Construct C.W. Set—Correct Values of Inductance, Capacity, Resistance, etc.—Greatest Radiation and Longest Range—Hundreds of Other Subjects Illustrated. Don't delay. Send your order now!

Let Your Set Know It Is Christmas!

When your Dad, Mother, Sister, Brother or relative asks you what you want for Christmas show this advertisement and pick any of these special values. If it is not here, order from any catalog at standard prices. Our service is famous. Ask the man who has bought from us.

These Christmas Suggestions Will Help You Get the Course

Remler Detector Panel.....	\$8.00	DeForest Hand Type Transmitters.....	7.00
Cunningham Detector Tubes.....	5.00	Acme Modulation Transformer.....	4.50
Cunningham Amplifier Tubes.....	6.50	Omnigraph, 15 Dial.....	28.00
Magnavox Loud Speaker.....	45.00	Federal Universal Phone Plug.....	1.75
Vocaloud Station Type.....	30.00	Radio Corp. "A" Battery Potentiometer.....	2.00
Grebe Detector and 2-stage Amplifier.....	75.00	Grebe CR-5 Regenerative Receiver.....	80.00
Westinghouse Detector and 2-stage Amplifier.....	65.00	Grebe CR-8 Regenerative Receiver.....	80.00
Aerial Wire, per foot.....	.01	Gen. Radio Rheostat 2.5 amp.....	2.50
Radeco 45 volt unit B Battery.....	3.60	Fada Rheostat.....	1.00
Acme C.W. Inductance.....	8.00	Paragon Rheostat.....	2.50
Acme 50 Watt 350 volt C.W. Transformer.....	15.00	Gen. Radio Socket.....	1.50
Acme 200 Watt 350 volt, 550 volt, C.W. Transformer.....	20.00	Chelsea Socket.....	1.00
Acme 500 Watt, 1000 volt-1500-volt C.W. Transformer.....	25.00	Brown English Navy Phone.....	18.00
Conn. Microphone Transmitters.....	4.00	Murdock No. 56, 3,000 ohms.....	6.00

Become acquainted with Radeco Service. Because we know the value of money it is our policy to sell you what you want the first time. We can't stand dissatisfaction. Try us and save money, worry and delay.

RADIO EQUIPMENT CO., 630 Washington Street, BOSTON, MASS.

Mail Orders!

In ordering by mail send cash, money order or certified check.

RADECO SAFETY FUSES

(Pat. Pending)

The famous fuse that prevents Vacuum Tubes against shorts. Use this Tube protector and your bulb will last indefinitely. Sizes 1, 1¼, 1½, 2, 2½, 3 Amp. Send cash or money order today.

Four for

\$1

Special XMAS OFFER

With every order amounting to \$100 of standard radio equipment the Radio Equipment Co. will give ABSOLUTELY FREE 10 complete printed lessons in elementary and advanced C.W. This is the famous C.W.C. course which includes literature, bulletins, charts, diagrams and a free consulting bureau to all members. Course to be mailed to you as you progress. This is to be determined by written examinations taken at frequent intervals. There are no restrictions. The first lesson accompanies your order.

DO IT NOW!

Supply Limited

ORDER FROM ANY STANDARD CATALOG

**Type DT 600 DeForest
EVERYMAN
RADIO PHONE RECEIVER**

Gives excellent results on all wave lengths up to 700 Meters. The set is provided with a plug attachment so that you receive longer lengths by simply adding a Honeycomb Coil. Complete with dust proof Crystal Detector and Brandes Superior Headset. All in wonderful cabinet, with complete instructions. Price, \$25.00. Order Now.

VARIOMETERS	
Fischers	\$4.50
Baldwin	7.00
J J N	4.50
Simplex	6.00
VARIOCOUPERS	
J J N. 380 Meters	4.00
J J N. 600 Meters	5.00
Fischers	6.00
Simplex	6.00
Baldwin	8.00
AUDIOTRON	
Genuine Two Filament with adaptor. Special until December 25	6.00
METERS	
Pocket Type, 0-8V. 0-30 amp. combination	1.80
Panel Type, flush, 0-50 Volt Japan finish	4.50
Pocket Type, 0-35 amp	1.80
Panel Type, flush, 0-35 amp. Japan finish	4.50
Euraco Mica Grid Condenser, 00025 Mfd. to fit standard grid leak base	.60
Radial Coils, cuts out QRM with beautiful DeForest dial.	6.00

We carry a full line of **EBY Binding Posts** and all good makes of **Wireless Apparatus**. Mail orders filled with dispatch from Dept. "R"

Beacon



Radio & Electric Co.
McNish & Owen
246 Greenwich St., New York City
TEL. Barclay 3189

MERRY CHRISTMAS—AMATEURS

COMPLETE LINE OF RADIO APPARATUS AND SUPPLIES

Write for Special Price List—We Can Save You Money

W. A. HOTZ & CO.
6325 S. Peoria Street
Chicago, Ill.

Do you know that you can get a pound of enameled wire, one piece best quality on a pulley spool from "Holmes the Wireman" at the following reduced prices?
No. 22, 66c; No. 24, 72c; No. 26, 78c; No. 28, 84c; No. 30, 90c. Add Parcel Post.

This is your chance to try out that experiment you have been planning.

HOLMES the WIREMAN
2530 N. 19th St. Philadelphia, Pa.

M. Belin, with one of his engineers, went to the Naval receiving station at Otter Cliffs, near Bar Harbor, Me. He obtained good results. Autographed messages of General Pershing and Premier Briand were received in good shape, despite the most annoying static disturbances. Just one item to strengthen this bald statement: M. Belin, requiring storage battery current for the driving motor of his receiving apparatus, so as to obtain absolutely constant speed which is so necessary to good results, was unable to find any at the station. It was either a case of obtaining storage batteries or giving up the attempt. With characteristic French initiative, he succeeded in gathering a fair collection of nondescript batteries from automobiles.

But after all, the transmission of handwriting, drawings, and even the more difficult photographs, is secondary in the commercial sense. The experiments have proved one point beyond a doubt, and that is the certainty and accuracy with which messages may be sent through even when the Transatlantic stations are absolutely blocked because of atmospheric conditions. The transmission of dispatches by this system of facsimile reproduction is not broken up by static, for the reason that it depends on an image made up of a large number of impulses and not on an arrangement of dots and dashes and spaces the varying of any of which changes the whole sense of a dispatch. Thus when static breaks up telegraph signals so badly that they cannot be read, the same disturbance merely causes tiny breaks in the outlines of M. Belin's dispatches.

What does this mean? Well, it requires no great stretch of imagination. It is generally known that commercial stations are tied up at times because of static, and commercial messages are piled up until conditions again permit the resumption of traffic. M. Belin has proved to the satisfaction of all those who have looked into his work that he can transmit under practically all conditions with positive results. His facsimile messages can be read no matter how much they may be broken up by static and other parasitic disturbances, for he depends on large and bold outlines rather than the delicate arrangement of dot and dash and space, which can be so easily misinterpreted, whether received by the audible or photographic tape recorder method.

Obviously, the Belin dispatches do not have to be sent by longhand, for that would require too much surface on the transmitting record. Instead, the dispatches can be typewritten and then transferred on to a transmitting record, or they can even be written in perfect shorthand. Imagine expert shorthand operators at both ends of a Transatlantic radio system, writing one thousand or even two thousand words on a small piece of paper which could be readily treated and then transferred on to the transmitting record, for transmission in four minutes' time or less. The speed, let alone the accuracy, surpasses anything we now have in the way of automatic operation. And then there are so many languages that could be handled by this facsimile system. Turkish, Hebrew, Chinese, Japanese, Arabic, Greek—all these languages could be handled without change or improvisation of any kind. From a legal aspect, the application of the image system should be of interest.

But all this does not mean that the dot and dash system is to be abandoned today or tomorrow. It will continue in use for many years to come, for it is simple and good enough in its way. Yet the plain truth is that something better is looming up on the radio horizon, and that we have a vision of the wonders of future radio.



Now is the time to ask—Mother, Father or Sister, for that long wanted Radio Set. We have complete receiving sets—that will give enjoyment to every member of the family. From \$15 to \$30. The New Grebe Sets are here.
CR8\$80.00
CR9130.00

KELLY & PHILLIPS

312 Flatbush Ave., Brooklyn, New York

The Technical or Scientific Book You Need

Turn to our 96-page catalog and find just the book you need on any scientific or practical subject—the latest book by the best author. This is the most complete catalog of its kind issued. You'll refer to it constantly in your work. Only 380 copies remain.

With the catalog will be sent the supplements for 1919 and 1920 and new 32-page book list for 1921. Prices are not yet entirely stabilized, but those in the supplements will be 80% correct. If there is any change in price you will be notified before your order is filled.

Send for catalog today. It's free. There will be no obligation for you to buy and we want you to know our extensive book department.

SCIENTIFIC AMERICAN PUBLISHING CO.
Munn & Co.,
227 Broadway New York City

INSTEAD OF JACKS!

Here is something entirely new. Our Rotary Amplifier Control Switch with Automatic Filament Control. Takes the place of plugs and jacks. With our switch you can change from detector to any desired stage instantly by slight turn of knob, filaments of unused tubes being automatically extinguished. Built of phosphor bronze and brass mounted on bakelite. The neatest, quickest and most convenient control ever brought out. Panel space 1 1/2" x 1 1/2" x 2 1/2". For detector and 1-2 or 3 stage amplifier complete. knob with pointer and diagram. Picture and more complete description in our folder sent free. Introductory price until January 15th.....\$5.00 Our Edgewise-wound C.W. Inductance will increase the efficiency of your C.W. or phone. 35 turns 1/4" x .05" copper strip, 5/16" in diameter. Heavy bakelite supports insure perfect insulation. Mounted on finely finished green weathered-oak base furnished with three clips with insulated handles. Photo on request. Price.....\$9.00 Here is your chance to get a real Oscillation Transformer. Pancake hinged type, pri. and sec. 1" brass ribbon on heavy bakelite. Regular price \$12.00. While they last.....\$6.50 Complete stock of Magnet Wire 18 to 32 B-S D. C. C. and S. C. C., 1/4 lb. spools or any quantity reasonable prices. Fine Navy type Knob 1 1/2" diameter with polished aluminum pointer. For 1/4" shaft or with 10-32 threaded bushing. With pointer.....35c Without pointer.....15c We will be pleased to quote lowest possible prices on any raw materials, parts or apparatus you may require. All goods carry our money back guarantee, if not satisfactory.

STORM-LEE RADIO APPARATUS CO.
742 Highland Avenue Newark, N. J.

WIRELESS TELEGRAPHY

Make your own "Wireless," also Dynamos, Batteries, Motors, Telegraph, Telephone, Lights, Bells, Alarms, Coils, Current Reverser, Electric Engines, etc. Book with 75 illustrations; by experts so anyone can understand it. With Catalog. All 10c, 2 for 25c pp

J. C. DORN
705 So. Dearborn St., Dept. 21, Chicago, Ill.

TELEGRAPHY
(Morse and Wireless) and RAILWAY ACCOUNTING taught thoroughly. Big salaries; great opportunities. Oldest, largest school. Endorsed by Telegraph, Railway, Radio, and Government officials. Expenses low—opportunities to earn large portion. Catalog free. BRIDGE'S INSTITUTE, 3 Street, Valparaiso, Ind.

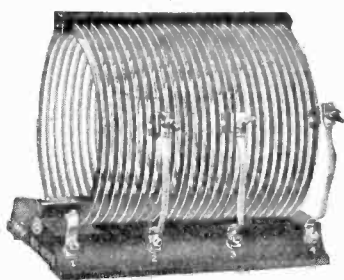

C. W. Oscillation Transformer
\$11.00

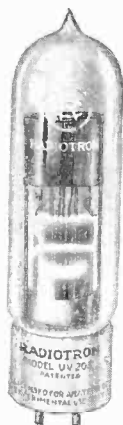

50-Watt Radiotron
\$30.00



5-Watt Radiotron
\$8.00

C. W. APPARATUS for the Radio Amateur

Have you received your copy of the new catalog of Amateur Radio Equipment?

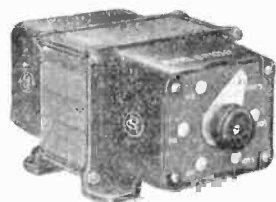

750-Watt C. W. Power Transformer
\$38.50

The instructions given in the catalog enable the radio novice to place a Tube Transmitter into practical operation within a few hours after delivery of the equipment. Either telegraph or telephone communication can be obtained by connecting Radio Corporation sets directly to an A. C. power source.

Radio Corporation's C. W. accessories now available at your nearest dealer.

The Radio Corporation's C. W. Tube Transmitters consist of scientifically co-ordinated parts, which, when connected together provide a thoroughly reliable C. W. Tube Transmitter. All uncertainty of operation is eliminated.

The demand for R. C. A. Continuous Wave Apparatus is unprecedented.



325-Watt C. W. Power Transformer
\$25.00



C. W. Transmitter Grid Leak
\$1.10

The illustrations shown here cover a few of the



.002 MFD—C. W. Condenser
\$2.00

FOR RECEPTION

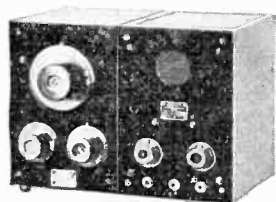

Receiver for "DX" Work
\$125.00

The two Receivers illustrated here have met with instant favor in the amateur field. The "Aeriola Junior" is the ideal set for the beginner or the novice. The type RC Receiver is pre-

eminently the most suitable set for "DX" stations. Watch our advertisements for future announcements which will be of the utmost importance to radio experimenters.

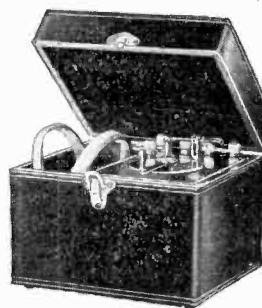

"Aeriola Jr." Receiver
\$25.00

If you have not already secured your copy of our combined instruction book and catalog, send 25 cents today to

Sales Division, Commercial Department, Suite 1805

Radio  **Corporation**
of America

233 Broadway, New York City

Wonderfully Perfected RTS STANDARD Detector Panel



RTS

Price
\$5.95
without
tube

Prepaid by
Insured
Parcel Post

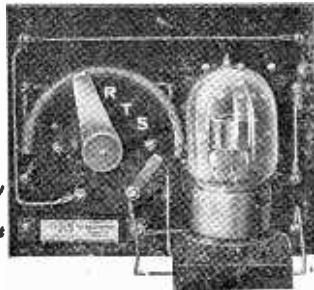

Install this efficient R.T.S. Panel and you possess a correctly designed Detector Panel capable of producing signal strength unequalled by any other tested in our laboratory. It is guaranteed.

Write for Circular

RADIO TESTING STATION
Dept. 4, 25 Sturges St.
Binghamton, New York

AMATEURS EXPERIMENTERS DEALERS

We beg to announce our appointment as distributors for

Baldwin, Brandes, Murdock,
Clapp Eastham, Chelsea,
Firth, ABC, DeForest,
Marshall Gerken
and others.

Exclusive Distributors 8th District
for

IDEAL G-W APPARATUS
**PITTSBURGH RADIO AND
APPLIANCE CO., Inc.**
112 Diamond St. Pittsburgh, Pa.
"Pittsburgh's Radio Shop"

VARIOMETERS, inside windings, \$3.75; Varlo-Couplers, BAKELITE TUBES, \$3.75; WOODEN BALLS, 55 cents each; 20/38 LITZ, 2 cents per foot; OAK CABINETS, 7 x 18 x 6 inches deep, \$3.50; other sizes in proportion; 22 DCC MAGNET WIRE, 30 cents quarter pound, all sizes carried. Hard maple stators for variometers, \$.80 Windings in place..... 1.20 Bakelite Tubes wound for primary variocoupler..... 1.50 Variometer and variocoupler balls with axles and wound..... 1.20
Oak cabinets 7 x 18 x 6" deep..... \$3.50
" " 12 x 14 x 6" deep..... 4.00
" " 10 x 7 x 6" deep..... 2.25
" " 12 x 7 x 6" deep..... 2.50
" " 7 x 7 x 6" deep..... 1.50
" " 6 x 14 x 6" deep..... 2.50

Dealers Write for Proposition
MEADE BAKELITE & RADIO APPARATUS
522 Central Ave., Brooklyn, N. Y.

A Type of Honeycomb Variometer

(Continued from page 501)

diagram. Now 96 iron wires, 4" long, and No. 20 B. & S. gauge should be procured, and inserted as shown in the diagram. Now the 8-32 screws are put in place on the secondary, and the battery nuts put on. The purpose of these nuts is twofold, namely, to tighten the screws on, and to keep the wire from abrasion on the shaft.

No. 26 B. & S. gauge D.C.C. wire is used for winding. Beginning by numbering the pegs or wires as shown in the diagram, the wire is started on 1 B, and goes to 8 A, from there to 2 B, then to 9 A and so on, until 16 turns have been wound. Now the winding is given a coat of shellac, and allowed to dry. Then, doing the same thing again, another 16 is wound over the preceding, and shellacked, and allowed to dry. This should be continued until 80 turns have been wound on each of the two variometer secondaries. When the shellac has dried, the iron wires may be removed, and the winding is complete. The shellac is sufficient to hold the windings in place if care is taken in removing the pins.

Now the two primaries of the variometers are wound, the pins being in place. The bushings which are six pieces of tubing large enough to just slip over the shaft, and split, and bent, as shown in the diagram. Now these bushings are glued in place with split edges against the tube. The bushings are the bearings, and also prevent the shaft from rubbing against the wire. Now the tubes are wound, and shellacked, just like the secondaries. No. 26 wire is used and 64 turns put on, and when dry, the iron pins are removed.

The secondary of the coupler is made like the secondary of the variometer, except that 64 turns of No. 26 B. & S. D.C. wire is used.

The primary of the coupler is tapped. The coupler is wound and constructed just like the primary of the variometer, but at the second turn a tap is taken off, then off the fourth, the sixth, the eighth, the 10th and the 12th; this is the fine adjustment. Then on the 25th turn, a tap is taken, then the 36th, then the 48th, then the 60th, then the 72nd, then the 84th, and the winding is complete.

Very much shellac should be used that the winding of the coupler primary may stay in place. The fine adjustments of the coupler should be brought out on one side and the coarse on the other, also the taps should be tagged so that one knows which is which, when connecting up.

The supports are made of a block of wood 2" x 1" x 3/4". It has 1/4" hole through the center, as shown. The block is carved down to fit the primary, as shown in assembly. Three supports are required.

The supports hold two binding posts each, which should be small, and placed as shown.

The support is fastened to the primary by four small wood screws which pass through the tube and between the honeycombs in the wire and then into the support. It might be well to put a washer under the head, so it will not tear the tube.

The shaft screws are then partly removed, and the secondary put in place as shown in assembly. The two secondary wires are connected to these screws, and flexible leads are connected to the shaft, as shown in the diagram. The hook-up shows how the variometers are connected up, and the taps of the coupler go to switch points.

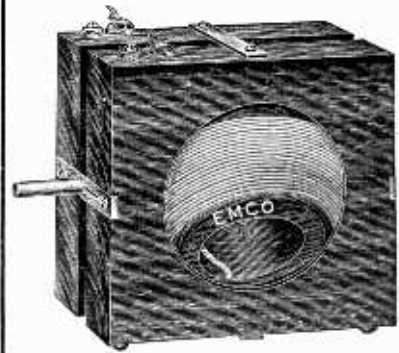

BUY famous EMCO variometers and couplers direct from the maker at big savings! Read these prices: EMCO Variometer, \$5.50; with EMCO 4" dial and knob, \$6.75; EMCO Varlo-Coupler, \$5.50; with CHELSEA dial and knob, \$6.25; EMCO short-wave regenerative set, unwired, \$45.00 complete. Thousands will read this ad. so act quickly for immediate attention!

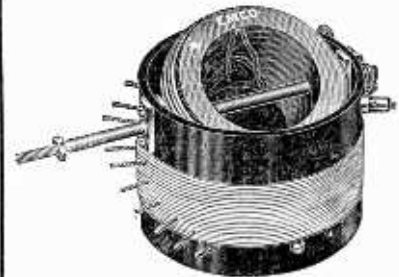

WE are retailing standard radio makes of radio apparatus at important savings. Call or write for prices.

We have a splendidly-equipped shop, capable of engraving your panels or assembling complete instruments according to your own specifications at extremely low cost. Estimates given without obligation.

Emco Radio Products Co.
1856 85th St. Brooklyn, N. Y.

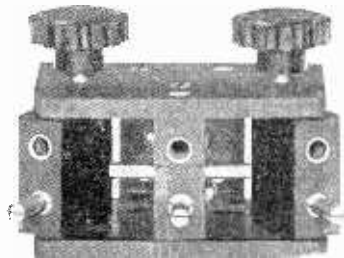

3 COIL MOUNTING, \$5.00 Postpaid

All brass parts nickel plated and polished. No moulded parts. Ease of movement controlled by adjusting screws within shaft.

PHOSPHOR BRONZE CLIPS
(Nickel Plated)



Make your own grid leak and condenser mountings. 12 for 25c. Dealers send for proposition.

If your dealer can't supply you, send money order direct.

MONTROSE MFG. CO.

619 St. John's Pl., Bklyn, N. Y.

MAKE A LOUD SPEAKER

Use the STRAMCY COUPLER to hold your telephone receiver to your phonograph horn.

Made to fit Baldwin Receiver but you may adjust it to fit any radio telephone.

Will fit Victor and Columbia phonographs,—or use it with a horn which you can make with paper. Telephone may be changed from ear to horn or vice versa in a second's time.

Price of Coupler, ONE, \$.60; TWO, \$ 1.00
Stramcy Products, P. D. Box 435 Newark, N. J.

"ATLANTIC RADIO" DECEMBER BULLETIN

COMPLETE ENJOYMENT OF THE HOME RADIO STATION REQUIRES THE PROPER SELECTION OF MODERN EQUIPMENT

The Following Complete Outfits Are Representative of Up-to-Date, Dependable and Efficient Apparatus.

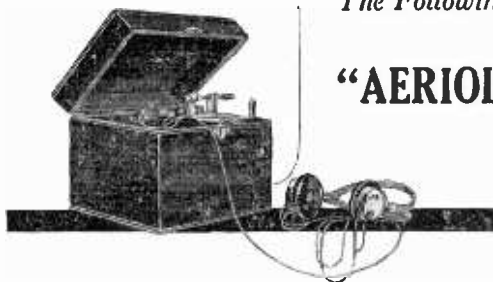

"AERIOLA, JR." CRYSTAL RECEIVER

An ideal receiver for the beginner in radio. Complete with tuner, Crystal detector, and double head set, in special cabinet with hinged cover. Ready to connect directly to antenna and ground. Tuning range up to 500 meters. Receives Radiophone Music.

With antenna Equipment, \$32.50. **Price \$25.00**

ANTENNA EQUIPMENT

This standard antenna equipment includes 150 feet of No. 14 Copper Weld wire, one splicer, two Micarta Receiving insulators, two screw eyes, three Porcelain Knobs with holding screws, one porcelain Wall Tube, 50 feet of insulated ground wire, one ground clamp and one receiving antenna protective Device. The latter is a complete safety gap and fuse protection, so constructed that it insures protection from lightning or from power lines.—

PRICE, COMPLETE \$7.50

Vacuum Tube Outfit No. 1 Receiving

Incorporating the Westinghouse R.A. Tuner
 Westinghouse R.A. Tuner.....\$65.00
 Paragon Detector Unit..... 6.00
 1 "Radiotron" U.V. 200 Detector Tube..... 5.00
 1 Murdock No. 56 2000 ohm Headset..... 5.00
 1 Eveready "B" Battery..... 3.00

Storage Battery not included.....\$84.00

Type R.A. Short-Wave Tuner, style 307189, as shown in illustration, responds to a wave length of 180 to 700 meters and is especially selective. Type D.A. detector-amplifier, 307190, combines a vacuum tube detector with a two-stage amplifier. Type R.C. combines type R.A. and type D.A. in one cabinet. Both units are mounted on Micarta panels attached to a polished mahogany cabinet. Simple in design, easy to operate, single tuning circuit; highly efficient.



Westinghouse Type DA Tuner

Vacuum Tube Outfit No. 2 Receiving

Incorporating the Westinghouse R.C. Tuner.
 Westinghouse R.C. Receiver.....\$125.00
 3 Radiotron UV-201 Vacuum Tubes..... 19.50
 Type C.B. Loading Coil..... 5.00
 2 Cell "B" Battery, Eveready..... 6.00
 1 W. E. Signal Corps Headset..... 15.00
 1 Patent Plug Adapter..... 2.00

Storage Battery not included.....\$172.50

Distant radio telephone, amateur and ship stations may be received at any wave-length within its range of 180 to 700 meters.

The addition of the loading coil allows the reception of signals on 1600 to 2800 meters wave-length such as Arlington time.

The Following Radio Bulletins Will be Sent FREE Upon Request

- "BULLETIN 14"
- "Radio in the Home"
- "DeForest Catalog E"
- "Brandes Matched Tone Headsets"

C. W. OPERATION—"The New Manual of The Radio Corporation" - 25c Postpaid

Atlantic Radio Company, Incorporated

727 Boylston St. Boston, Mass.

Branch

15 Temple St.

Portland, Me.

HEADQUARTERS for "Radio Corporation" Equipment

THE NEW DX RADIO FREQUENCY AMPLIFYING TRANSFORMER

HIGHLY EFFICIENT: 150 to 12000 METERS

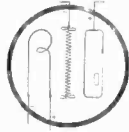

IT USES AN IRON CORE

THE UNIQUE DESIGN (patent pending)
ELIMINATES CAPACITY EFFECTS

CLOSE ELECTROMAGNETIC COUPLING
LOSSES AT AMATEUR WAVELENGTHS,
NEGLIGIBLE

The DX Radio Frequency Amplifying Transformer is suitable for use with RAC-3, Radiotron and A. P. Tubes.

Send Stamp for Bulletin 10E
Sheet of circuit diagrams 25c

RADIO INSTRUMENT COMPANY

HUTCHINS BUILDING

WASHINGTON, D. C.

F. H. Lester's Station, 9UK

(Continued from page 504)

giving me 110 volts. I run my 110-volt line to slate panel, mounted on the wall, (which is of my own make), with an A.C. voltmeter in the line. At the slate panel the current is distributed to gap and transformer by means of D.P.S.T. switches. Between the panel and transformer is a Dubilier kick-back preventer, protecting my instruments.

I have a S.P.D.T. switch in the primary circuit of the transformer, enabling me to change from low to high power or vice-versa. I have my set tuned so that I get $\frac{1}{4}$ amp. radiation on $\frac{1}{2}$ k.w. and 4 amp. on 1 k.w., on a hot wire ammeter located on the right side of the slate panel.

The antenna used is a four-wire "T" type, of stranded phos-bronze wire spaced $1\frac{1}{2}$ ' apart, 50' high and 80' long.

I use separate grounds for transmitting and receiving. The receiving ground consists of two $\frac{3}{4}$ " iron rods driven into the ground about seven feet. The transmitting ground consists of one $\frac{3}{4}$ " iron rod driven about seven feet into the ground, steam pipes, water pipes, back yard fence and a ground consisting of four pieces of No. 4 bare copper wire buried in the ground about 10'. After digging the hole for the ground, which is about 10' deep, I struck water and drove two of these copper wires about three feet in water and made a spiral of the other two wires and set them in the water and filled the hole about halfway up with fine coke screenings; then I put a piece of two-inch pipe from the top of the coke to the top of the ground for the purpose of pouring water on the coke to keep it wet and making a positive ground, filled the rest of the hole to top with clay. The four wires are drawn together at the top of the ground, and the ground connection is soldered to them.

I have a Tungar charger for charging my 6-v., 60 amp. H.R. storage battery, which I find a great convenience.

I would appreciate it very much to hear from any DX fellows hearing my signals.

F. H. LESTER,
Oak Park, Illinois.

Modulation Systems for C.W. Which Will Give Satisfaction in Your Station

(Continued from page 491)

transmitter, which can hardly be claimed for any other device. It is better than the buzzer form of modulator for the reason that it is steady, and the note produced at the receiving station is constant, depending for its tone quality upon the number of teeth on and the speed of the revolving disc.

DOUBLE BUZZER MODULATION

Buzzer modulation has been in vogue almost since the inception of C.W., but it is not entirely satisfactory, in fact, it is generally unsatisfactory for a number of reasons. One of the most serious difficulties with buzzer modulation is the variation of the tone of the buzzer, caused by a tendency of the platinum points to become pitted which causes them to stick. The arrangement shown in Fig. 3, will not entirely eliminate this draw-back, though it will permit it to be reduced by suitable regulation of the voltage supplied the buzzer and condensers shunted across the buzzer contacts.

With buzzer modulation, as it generally exists, we find that the buzzer is either

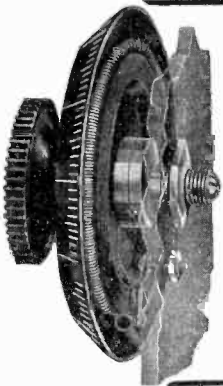

WE USED OUR BEAN in designing

THE PARKIN DIAL TYPE RHEOSTAT (Pat. pending) and by mounting the resistance element in a circular groove in the back of a 3" molded Bakelite dial eliminated one part and saved you the cost of a dial. The groove being recessed, allows the dial to clear the panel by the usual distance of $1/16$ ". An off position is provided and a stop on the dial engages the stationary contact at the extreme positions. The 360 degree rotation insures fine adjustment. A brass bearing insures a true running dial and smooth action. All figures and graduations are filled with brilliant white enamel. All brass parts nickel plated. Bakelite knob. Resistance is 5 ohms, carrying capacity 2 amps.

No. 77 Parkin Dial Type Rheostat Postpaid \$1.75
FOR SALE BY ALL LEADING DEALERS

Send for free catalog No. 5 describing our complete line. Dealers Write for proposition.

PARKIN MFG. CO. SAN RAFAEL, CALIF.

READ the CLASSIFIED ADVERTISEMENTS on PAGES
572-574 YOU'LL FIND MANY GOOD THINGS THERE.

RADIO APPARATUS

Distributors of Reliable Radio Apparatus to Dealers, Schools, Colleges, Radio Clubs and Experimenters All Over the World!

"PITTS CO"
SERVICE DISTRIBUTES "RADIO CORPORATION'S" PRODUCTS ALL OVER THE WORLD!
TRY US AND SEE!



"PITTS CO"
NOW HAS TWO STORES! BOTH CARRY "RADIO CORPORATION'S" COMPLETE LINE. ORDER TODAY

RADIO CORPORATION'S PRODUCTS

No. UV-200 Radiotron, Detector.....	\$ 5.00
No. UV-201 Radiotron, Amplifier.....	6.50
No. UV-202 Radiotron 5 Watt tube.....	8.00
No. UV-203 Radiotron 50 Watt tube.....	30.00
No. UV-204 Radiotron 250 Watt tube.....	110.00
No. UT-501 End-mountings for UV-204.....	2.50
No. UT-502 End-mountings for UV-204.....	2.50
Per pair.....	4.50
No. UB-542 Porcelain Socket.....	1.00
No. UB-552 Bakelite Socket.....	1.50
No. UT-541 Porcelain Socket for UV-203 and UV-217 "Kenotron" tubes.....	2.50
No. UV-216 20 Watt "Kenotron" tube.....	7.50
No. UV-217 150 Watt "Kenotron" tube.....	26.50
No. UP-1368 325 Watt C.W. Trans.....	25.00
No. UP-1016 750 Watt C.W. Trans.....	38.50
No. UL-1008 Oscillation Transformer.....	11.00
No. UP-1343 Magnetic Modulator, 1/2 to 1 1/2 Amps.....	9.50
No. UT-1357 Magnetic Modulator, 1 1/2 to 3 1/2 Amps.....	12.50
No. UT-1367 Magnetic Modulator 3 1/2 to 5 Amps.....	17.00
No. UP-1626 Filter Reactor, 160 MA.....	11.50
No. UP-1627 Filter Reactor, 300 MA.....	15.75
No. UP-415 Plate Circuit Reactor.....	5.75
No. UC-1631 Filter Condenser, 1/2 MFD, 750 Volts.....	1.35
No. UC-1632 Filter Cond. 1 MFD, 750 volts.....	1.85
No. UC-1634 Filter Cond. 1/2 MFD., 1750 volts.....	1.50
No. UC-1635 Filter Cond. 1 MFD. 1750 volts.....	2.00
No. UP-1719 Trans. Grid leak, 5000 ohms.....	1.10
No. UP-1718 Trans. Grid leak, 5000 ohms, for UV-203 and UV-204 Tubes.....	1.65
No. UM-530 Hot Wire Meter, 0-2 1/2 Amps.....	6.00
No. UV-533 Hot Wire Meter, 0-5 Amps.....	6.25
No. UQ-809 Sending Key for C.W. Trans.....	3.00
No. UP-414 Microphone Transformer.....	7.25
No. PR-535 Filament Rheostat for UV-200, 201 and 202 tubes.....	3.00
No. PR-537 Filament Rheostat for UV-203 and UV-204 Tubes.....	10.00
No. PX-1638 Rotary Grid Chopper.....	7.25
Shaft Bushings for 1/4" or 5/16" motor shafts each.....	.20
No. UC-1015 Antenna Series Condenser, 7500 V., .0003, .0004, .0005 MFD., 3 values.....	5.40
No. UC-1014 Plate and Grid condenser, 3000 V., .002 MFD.....	2.00
No. UC-1803 Special Condenser, 10,000 Volts .000025 MFD.....	5.00
No. UC-1806 Special Condenser, 6000 Volts .002 MFD.....	7.00
No. UV-712 Amplifying Transformer.....	7.00
No. UP-538 "A" Battery Potentiometer.....	2.00
No. UC-567, .00025 MFD Grid and Plate Condenser.....	1.20
No. UC-568, .0005 MFD Grid and Plate Condenser.....	1.35
No. UC-569, .001 MFD Grid and Plate Condenser.....	1.50
No. UP-570, .0025 MFD Grid and Plate Condenser.....	2.00
No. UP-509 to UP-527 Grid leaks, .05 to 5 megohms, each.....	.75
No. UX-543 Grid leak mounting.....	.50

Note.—Radio Corporation's C.W. Instruction Book giving hook-ups and complete information..... 25

GREBE APPARATUS

No. RORH Audion Control panel in cabinet with tickler connections.....	17.00
No. RORK Two step amplifier with automatic filament control jacks.....	55.00
No. RORD Det. and two step amplifier with automatic filament control.....	75.00
No. CR-3 Regenerative receiver, 175-680 meters, "Relay Special".....	65.00
No. CR-3A Reg. Receiver, 175-375 Meters, complete set, special value at.....	35.95
No. CR-5 Reg. Receiver, 150-3000 meters, complete set, ideal for phones, music and time signals.....	80.00
No. CR-6 Reg. Receiver, 175-680 meters with 2 step amplifier self contained, complete set, splendid unit.....	200.00
No. CR-7 Reg. Receiver, 500-20000 meters, complete set, ideal for arcs.....	210.00
No. CR-8 Reg. Receiver, 175-1000 meters, "Relay Super-Special," complete set.....	80.00
No. CR-9 Receiver, 150-3000 meters, with 2 step amplifier self contained, complete set, Grebe's latest.....	130.00
No. ROCC Fixed mica condenser, .0002 MFD.....	1.00
No. ROCD Fixed mica condenser, .0005 MFD.....	1.20
No. ROCE Fixed mica condenser, .001 MFD.....	1.60
No. ROCF Fixed mica condenser, .005 MFD.....	3.80
No. ROCA Grid cond., .0002 MFD and 1/2 Meg. leak.....	1.20
No. ROCB Grid cond., .0002 MFD and 3 Meg. leak.....	1.20
No. RPDB Crystal Detector, dustproof.....	2.73

(Grebe apparatus always in stock)

WESTINGHOUSE APPARATUS

No. RA Short Wave tuner, 180-700 meters, very selective and desirable unit.....	65.00
No. CB Loading Coil, for use with Short Wave Tuner for time signals.....	5.00
No. DA Detector and 2 step amplifier, for use with Short Wave Tuner.....	65.00
No. RC Short Wave tuner and Det. and 2 step amplifier, complete set.....	125.00
No. DB Double crystal detector.....	5.00
No. DE Spare crystals for above detector.....	1.00
No. DD Spare crystals for above detector.....	1.00
No. RE "Aerola" J.R., Crystal Receiver, complete set, ideal for music.....	25.00
No. ME Motor-generator set, 100 Watts, 110 Volts, 60 Cycle, AC motor, 500 Volts DC Generator.....	85.00
No. MH Motor-Generator set, 250 Watts, 110 Volts, 60 Cycle AC motor, 1000 Volts DC generator.....	145.00

Send "PITTS CO" Your Orders for Westinghouse Apparatus.

Announcement

The policy of the F. D. PITTS CO. has been and will be to render a "Superior Service," a service based on carrying in stock for immediate delivery all desirable radio apparatus, to serve our customers promptly and intelligently and to make them feel that we are truly grateful for their patronage.

In order to accommodate our ever increasing business we take pleasure in announcing the opening of OUR NEW STORE at PROVIDENCE, R. I., in the WOOLWORTH BLDG., at 193 Westminster Street, the very heart of the business section.

Mr. H. H. Tilley, experienced member of our organization will be in charge. His experience is wide and diversified, having in turn been an Amateur, Commercial Operator, Engineer, Instructor and Sales-Manager. You are cordially invited to visit our new store and experience real SERVICE.

If at any time you are interested in Radio to the extent of desiring instruction, Amateur or Commercial; Spark, Arc or Vacuum tube, let the EASTERN RADIO INSTITUTE train you—New England's Oldest, Largest and Best equipped Radio School. For over six years I was Chief Instructing Engineer at this Institute, and I am in a position to know! Over 4,000 satisfied graduates tell the story best! Our organization with Years of phenomenal Results and Success is behind every man who enrolls.

F. D. PITTS,
President and General Manager.

"Let 'PITTS CO' products, super-service and delivery solve your Holiday problems"

SEND US YOUR ORDERS TODAY!

Send ten cents for Catalog No. 22. Over 100 pages, over 150 illustrations, over 600 items

F. D. PITTS CO., Inc.

12 Park Square, Boston, Mass. Branch, Woolworth Bldg., 193 Westminster St., Providence, R. I.



**EASTERN
RADIO**

INSTITUTE

TEL.
BACK BAY
5 9 6 4

899 BOYLSTON ST.
BOSTON, MASS.



SPARK--ARC--VACUUM TUBE

The Revised Examinations for Commercial Operators including ARC and VACUUM TUBE is carefully and fully covered by the Course of Instruction offered by the EASTERN RADIO INSTITUTE. Intelligent students INSIST on being taught upon ACTUAL apparatus!

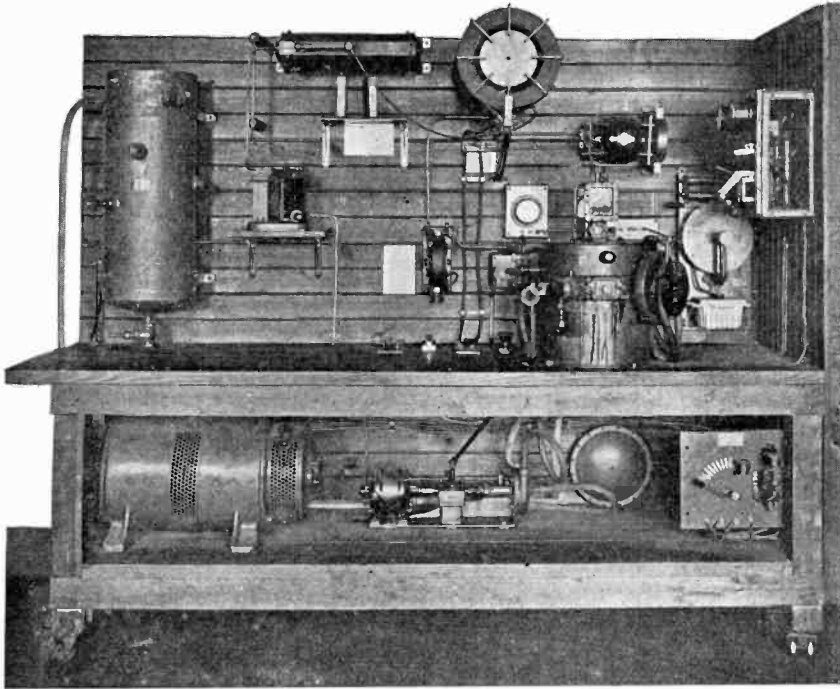

"The EASTERN RADIO INSTITUTE'S 2 K.W. 'ARC'"

The EASTERN RADIO INSTITUTE is the OLDEST, LARGEST and BEST EQUIPPED Radio School in New England. The Pioneer school that has always led the way! Ask any man in Radio—he will tell you!

New Students can begin to advantage in the Day or evening school on any Monday.

REMEMBER:—Our ORGANIZATION with YEARS of PHENOMENAL EXPERIENCE and SUCCESS is behind every man who enrolls. Ask any man in Radio he will tell you! OVER 4000 satisfied graduates TELL OUR STORY BEST! Why not be one?

Our illustrated prospectus is free. If you cannot visit the Institute send for one.

F. D. PITTS, Director

VERNIER RHEOSTAT

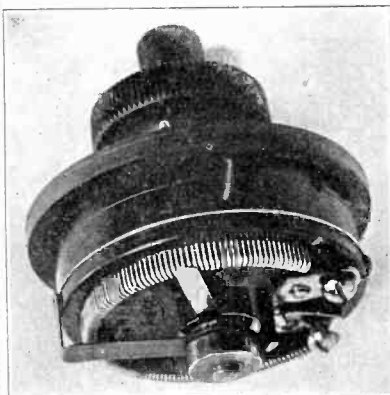

- ←VERNIER
- ← MAIN UNIT
- ←PANEL
- ← RESISTANCE
- ←ADJUSTABLE CONTACT

LIST PRICE \$2.90

Another New Step in Radio

Vernier Rheostat. No flickering of lights. Smooth running and adjustable to one milliamperere. This article will fill a long-felt need in the Radio field. No A or B potentiometer necessary with this vernier rheostat.

Save your money and use these on your new control panels.

Buy of your dealer or from us.

TECO RADIO CO.

P. O. Box 3362 BOSTON, MASS.

connected directly in the antenna circuit or put in the grid circuit, either directly or through some form of transformer. In either case we find that, even when the battery current which actuates the buzzer is on by reason of the vibrating and stationary contacts touching each other, a certain portion of the antenna current passes through the windings of the buzzer magnets. Even though the amount of this current would seem inconsequential, it is very important when we consider that we are dealing with a form of transmission, which at best can not amount to more than a few watts. I am speaking of the ordinary amateur transmitting station, where small power tubes are employed.

However, if we resort to the method shown in Fig. 3, it is possible for us to make an absolute break in the current and an absolutely direct path for the current in the antenna circuit, which has no external elements as components. We may also make any alterations of the buzzer, such as adding the condenser across the points to prevent excessive sparking without in any way changing the wave length of or the energy in the antenna circuit, for the second buzzer, will be acting as a relay, controlled by the vibrating current in the line, as determined by the period of vibration of the first buzzer.

Both the buzzer and the relay should be capable of delicate adjustment as regards distance between contact points and the spring tension on the vibrating lever. The most suitable form of relay may be made by altering the connections on practically any well made high frequency buzzer to conform to the circuit shown in the illustration and it is then only necessary to adjust both the buzzer and the relay, so that they will operate in synchronism, in order to have the best modulation which may be expected from a buzzer.

A Highly Efficient Receiver

(Continued from page 487)

through without grounding.

Engraving the panel is optional with the builders, although a more finished piece of work is had thereby. The same piece of paper which was used as drilling templet, can again be brought into use. Lay out the exact locations of the engraving and take both this plan and the panel to some concern doing this work. The price is reasonable and the effect is immense.

No definite dimensions are given for the construction of this outfit, as most amateurs will proceed according to their own means. The panel size used here is 20" long by 12" high and the cabinet is 10" deep.

Aerial and ground connections are made on the front, while the filament battery connections are in the rear. Both detector and amplifier "B" batteries are located in the rear of the cabinet.

It is possible with this set to operate on three steps of audio frequency amplification without experiencing any howling. Signals may be brought in to an enormous degree of loudness. Arlington Time Signals copied with this outfit and using a well-known make of loud talker, have been heard 300' away. There is no distortion of telephone, speech or music, even when working on the third step. Every word or note is clear and can easily be made audible to a large gathering.

HIGH-TENSION DISCHARGE

Teacher: "Why is Jack Dempsey like a tuning coil?"

Student: "Give it up; what is it?"

Teacher: "He licks" (helix).

By STEVE HORTON.

Get a Handy Binder for your RADIO NEWS. Holds and preserves twelve issues, each of which can be inserted or removed at will. Price 65c. Experimenter Pub. Co., Inc., Book Dept., 236-A Fulton St., New York.

STEPPING-STONES TO BETTER SIGNALS



Every FADA instrument, be it detector and two-stage amplifier or only a simple inductance switch, is a real asset to your station. Step by step as you progress from your crystal detector set to vacuum tubes, regenerative circuits and radiophone work you will find that FADA supplies are necessities, and what is more, necessities that can be purchased from your own dealer at most reasonable prices for the value you receive.

INDUCTANCE SWITCH

The neatest switch on the market and the easiest one to adjust. Has the FADA Thermoplax knob. 1 1/4 inch radius. Each...\$0.50

With eight switch points and two switch stops complete. Each...\$0.75

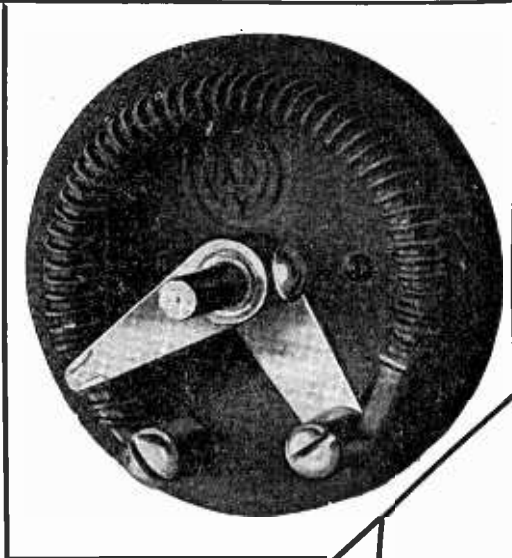

PANEL-MOUNTING RHEOSTAT

FADA rheostats are made with a heat proof Thermoplax base. The resistance is 6 ohms and it will carry 1 1/2 amperes. Supplied with the FADA conical Thermoplax knob. Adjustment very smooth. Without question the best value obtainable for.....\$1.00

FADA CRYSTAL DETECTORS

are used in thousands of amateur stations with mighty good results. Beautiful in appearance, convenient to adjust, and supplied with a super-sensitive galena crystal that enables long distance reception. Each.....\$2.25

FADA POWER TUBE RHEOSTATS

are made using our regular Thermoplax base (2 3/8") and knob and are wound with heavy Nichrome wire. Resistance 1 1/2 ohms, current carrying capacity 5 amperes. Just the rheostat for two 5 watt UV-202 Power Tubes. The price is the best—only\$1.35

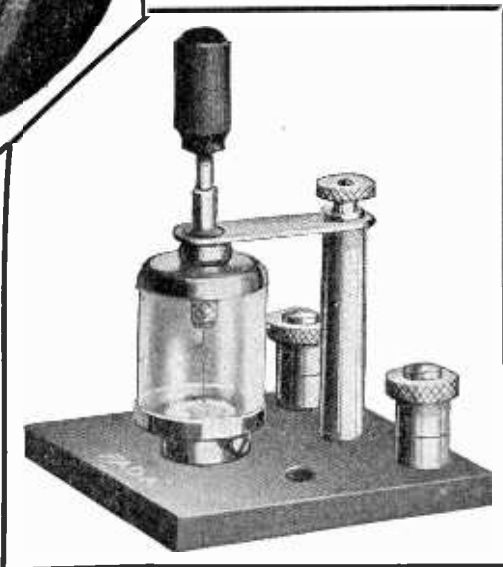

SERIES-PARALLEL SWITCH

Another FADA switch that is very popular. 1 1/2 inch radius, Thermoplax knob. Each \$0.75

Complete with eight switch points and two stops. Each.....\$1.00

A BEAUTIFUL FADA CATALOG

of instruments will be mailed upon receipt of ten cents. Contains complete description and illustrations of all FADA instruments and supplies. You should study this catalog before purchasing any equipment.

RADIO SUPPLY DEALERS

FADA products are fast sellers that stay sold. The sales prices are reasonable and your profits good. Write for catalog and terms.

FRANK A. D. ANDREA

Manufacturer of FADA Radio Products

1882-A JEROME AVE.

NEW YORK CITY

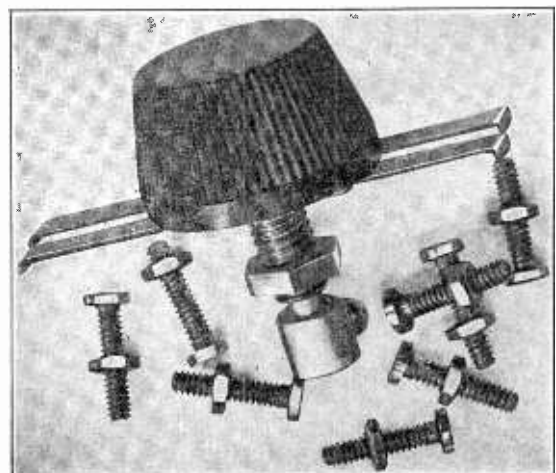

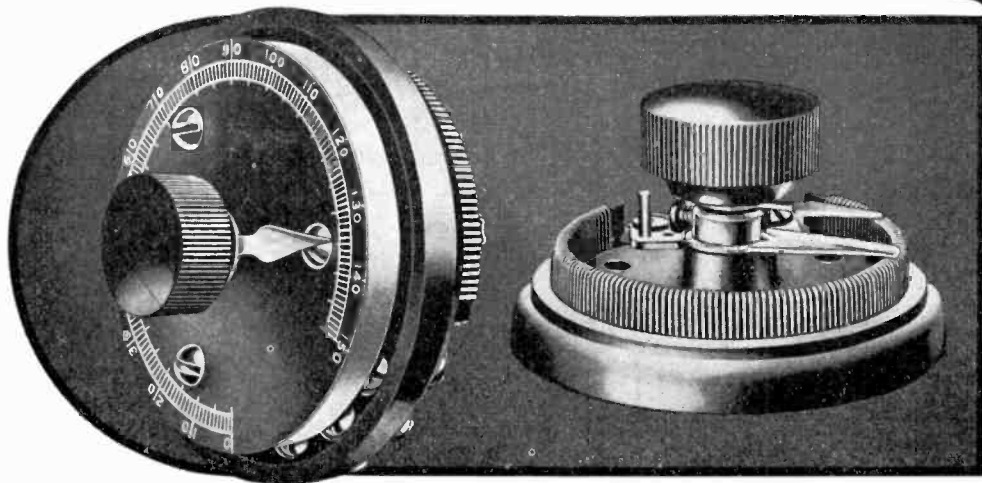

NEW MURDOCK RHEOSTAT \$1.00

Your choice of two types: one for front or back of panel mounting; the other for front of panel or table mounting. This arrangement is for your convenience, as each type is instantly interchangeable from one style of mounting to the other.

The resistance element is mounted in groove on a "Murdock-Moulded" Bakelite base. The center bearing and phosphor bronze contact insure smooth-running positive operation. 6 ohm resistance. Graduated dial, screws and nuts for mounting, all provided with each rheostat.

Literally thousands of these rheostats are already in use. And in spite of the price—only \$1.00—they are delivering complete satisfaction. Equip all your VTs with Murdock Rheostats. Buy them for their quality, the low price is incidental! Doubly guaranteed by Radisco and Murdock! Now on sale at all Radisco agencies.



THER
IN TE
FOR N
THE "
SATIS
FORM

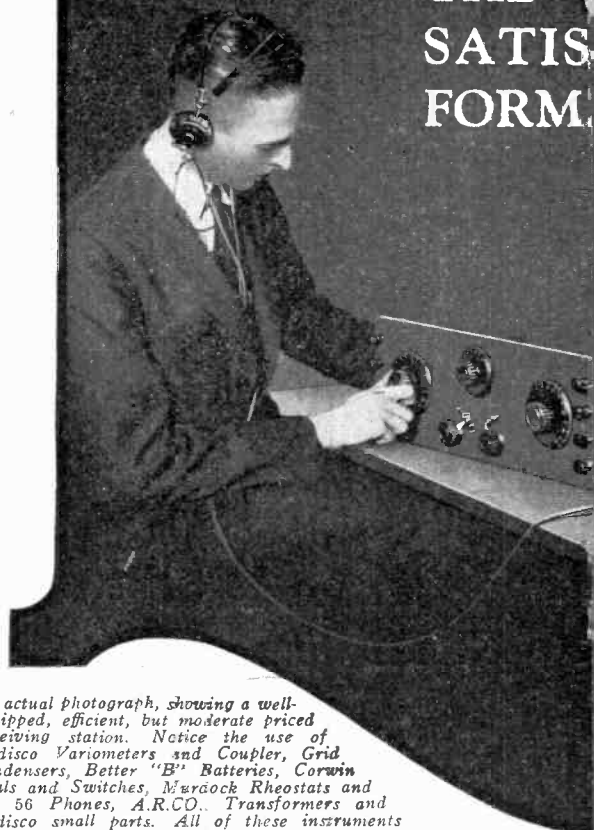

An actual photograph, showing a well-equipped, efficient, but moderate priced receiving station. Notice the use of Radisco Variometers and Coupler, Grid Condensers, Better "B" Batteries, Corwin Dials and Switches, Murdock Rheostats and No. 56 Phones, A.R.CO. Transformers and Radisco small parts. All of these instruments are sold by the Radisco dealers listed here.

RADISCO AGENCIES

ALBANY, N. Y.
Shotton Radio Mfg. Co.
8 Market St.

ASHEVILLE, N. C.
Hi-Grade Wireless In-
strument Co.

ATLANTIC CITY, N. J.
Paramount Radio Supply,
Arkansas & Pacific Aves.

BOSTON, MASS.
Atlantic Radio Co.
727 Boylston St.

BROOKLYN, N. Y.
Kelly & Phillips
312 Flatbush Ave.

EUREKA, ILL.
Klaus Radio Co.

KANSAS CITY, MO.
McCreary Radio Supply
4th and Delaware Sts.

McKEESPORT, PA.
K & L Electric Co.
427 Olive St.

NEWARK, N. J.
A. H. Corwin & Co.
4 West Park St.

NEW ORLEANS, LA.
Rose Radio Supply
604 Gravier St.

OMAHA, NEBRASKA
O. B. Radio Supply Co.
406 Brown Building

NEW BRUNSWICK, N. J.
Geo. N DeLaplaine
306 George St. and
8th and Magnolia Sts.

RAD

"Your Assurance of Sc

WHEN YOU BUY
ANY RADISCO
INSTRUMENT,
IT IS INCLUDED
WITH THE PURCHASE,
WITHOUT ANYTHING EXTRA,
THE ASSURANCE OF
"FACTORY PERFORMANCE"

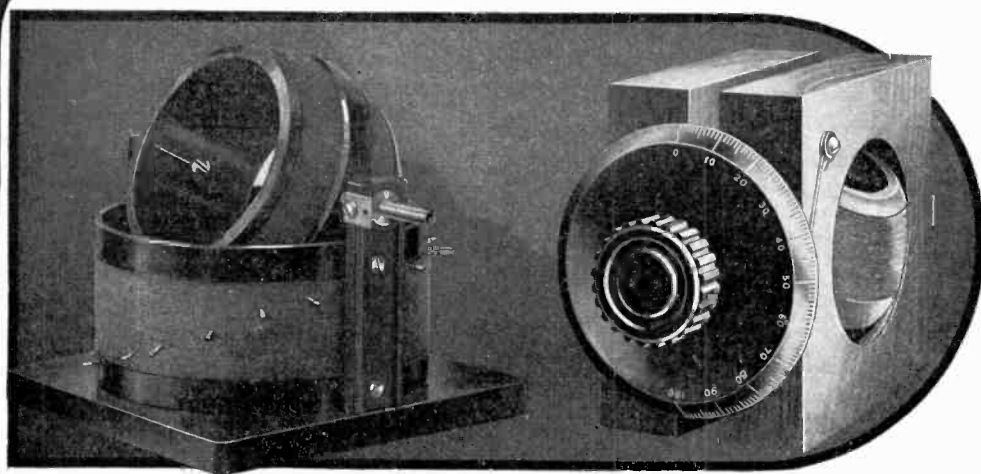

TWO FAMOUS RADISCO INSTRUMENTS

Radisco couplers and variometers have formed the heart of many a successful station.

If you haven't such a set, why not build one now? Here's the exact material you need: two Radisco variometers, a Radisco coupler, three Corwin Dials, two Corwin improved switches, six binding posts, a dozen switch points, and a Bakelite panel. This outfit gives you a set, uniform in appearance, easily assembled, and with individual parts purposely made to work together!

With reasonable care in assembling, this set will be highly selective and sensitive. It tunes up to about 600 meters. And it will cost you only about \$30.00—mighty good value for the exceptional service you'll get!

All Radisco agents can supply you with these parts, and will gladly tell you how to assemble them.

RADISCO

"Satisfactory Performance"

RADISCO
PHILADELPHIA, PENN.
Philadelphia School of
Wireless Telegraphy
1533 Pine St.

PITTSBURGH, PENN.
Radio Electric Co.
3807 Fifth Ave.

PLAINFIELD, N. J.
Paul R. Collier
154 E. Front St.

PORTLAND, ME.
Atlantic Radio Co.
15 Temple St.

PROVIDENCE, R. I.
Rhode Island Electrical
Equipment Co.
45 Washington St.

AGENCIES
SCRANTON, PENN.
Shotton Radio Mfg. Co.
P. O. Box 3
Branch 8, Kingsbury St.
Jamestown, N. Y.

SEATTLE, WASH.
Northwest Radio Service
609 Fourth Ave.

WASHINGTON, D. C.
Eastern Radio and Elec.
Co., 1405 Florida Ave.,
N. W.

Canadian
MONTREAL, QUEBEC
J. B. Miller
136 Vendome Ave.,
N. D. G.

TORONTO, ONTARIO
The Vimy Supply Co.
567 College Street

Easy to Get \$35 to \$100 a week Making Drawings like these

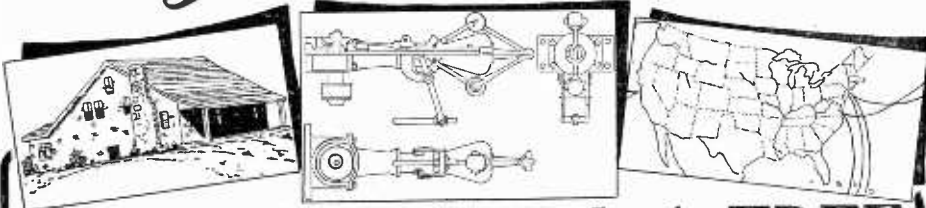

Drawing Outfit Furnished **FREE**

You need no artistic talent or "pull". In a few months with our help you can be earning real money—living comfortably—laying something aside.

Learn Mechanical Drawing—Drafting, or mechanical drawing is specialized knowledge in a vitally necessary branch of industry. It is power to succeed. It is a profession you can be proud of.

Big Salaries—\$35 to \$55 a week is only a beginning. You can earn as high as \$100 a week or more as a practical draftsman. Openings for Draftsmen in U. S. Government Departments carry starting salaries ranging from \$5.20 to \$15.04 a day. Many of them carry a bonus of \$240 a year additional.

Quick Promotion—You can climb from draftsman to Chief Draftsman—to Chief Engineer—to Production Manager—to a business of your own. But you need practical training first.

Permanent Employment—You won't have to stand around waiting for a job. Properly trained draftsmen are always in demand. Industrial concerns, Building and Construction Companies, Manufacturers, Government Departments employ thousands.

Get the Right Training—Roy C. Claffin's "Columbia" training is simple and sure, yet complete and practical. By this method you can become a master mechanical draftsman in a few months of pleasant easy home study, under Mr. Claffin's personal supervision. No fancy theories, no difficult mathematics—just plain common sense "brass tacks" of drafting. And after that, if you want it, free Post Graduate training in a specialized Branch of Drafting.

"Columbia" trained draftsmen always in demand.

The largest concerns in the country, including the U. S. Government employ Columbia trained Draftsmen. Free professional drawing outfit of 16 pieces and 11 piece set of highest grade drafting instruments in plush lined case will be given you when you enroll at the Columbia School of Drafting. These fine instruments are yours to keep.

Free illustrated book, "Your Future in Drafting," will be sent you Free on request. Send in this coupon to-day. Get started now.

COLUMBIA SCHOOL OF DRAFTING

ROY C. CLAFLIN, President

Dept. 1581, 14th and T Sts.

WASHINGTON, D. C.

MAIL THIS COUPON NOW

COLUMBIA SCHOOL OF DRAFTING
Dept. 1581, 14th & T Sts., N. W.,
Washington, D. C.

Without obligation to me, please send me your free illustrated book on Drafting, telling how I can secure your complete home study course and your help in securing a position as draftsman.

Name Age

Address

City State

A SUPER REGENERATIVE TUNER —

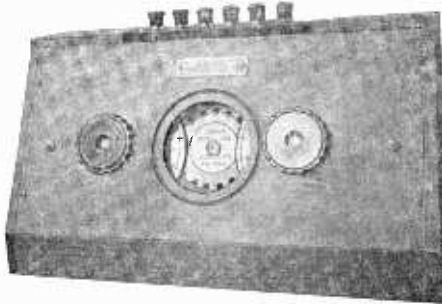

Size 10 x 1/2 x 9 x 4

Shipping weight three pounds
PRICE ONLY \$15.00

Phone Spark | You don't know what the wireless phone is until you have heard it on a "DUPLEX."

ORDER ONE AT ONCE

You will be dumfounded with the marvelous results. There are no taps or switches to provide leaks. The Bureau of Standards are using Spider-Webs.

J. H. BUNNELL & CO.,
32 Park Place, New York
Special Eastern Distributors.

HEROLD LABS.,
San Jose, Cal.,
Pacific Coast Agents

The New Spider-Web-Duplex

180-1000 Meters

An entire new form of regenerative coil set tuning 180-1000 meters with great precision and an amplifying constant far greater than heretofore obtained.

FEATURES

Fixed coupling, new control, 180-1000 meters, 180 degree scales enclosed behind glass window with fine index line, direct vision.

IF YOU ALL OWNED ONE

Your transmitting and receiving range would be increased two-fold. Complete data sent free on request.

EUGENE T. TURNEY LABS.
RADIO HILL

HOLMES NEW YORK

A New Departure in Short-Wave Reception

(Continued from page 486)

ceiving, we find that it has a great many characteristics of the regular regenerative receivers, all other circuits being left intact. Wave length, in the antenna circuit is changed by altering the capacity of the condenser which may either be in series or shunt with that circuit, depending upon the position of the condenser switch. Coupling between the antenna circuit and the fixed secondary circuit is varied by rotating the primary coil by means of the dial-knob. Wave length in the secondary circuit may be changed by increasing or decreasing the capacity of the secondary tuning condenser, which is in shunt with it and should not have a maximum capacity of more than .005 mfd. The reason for this is that the secondary winding has a natural period of approximately 150 meters.

Regulation of the regeneration circuit is made possible by altering the position of the right-hand rotor. When an oscillating condition has been set up in the plate circuit, it is very seldom necessary for the operator to make any further adjustments in that circuit, tuning being carried on as though there was nothing more delicate than a loose-coupled receiver where it is merely necessary to bring the primary and secondary circuits to resonance with the incoming waves. In operation, it has been found that C.W. stations can be tuned in or out, with the coupling at nearly zero.

One of the greatest points of interest in connection with this little unit is that it requires no shielding, for it is not subject to any body capacity effects; in fact, the hands may be placed right on the windings without causing any noticeable effect on the incoming signals.

With a single detector tube and no amplification, stations of the First, Second and Third Districts have been copied on both spark and C.W., stations in the Fourth and Fifth have been copied on C.W., and many in the Eighth and Ninth have been copied on both spark and C.W. In Brooklyn, N. Y., 4 G L, Savannah, Georgia, operating a ten-watt tube transmitter has been heard frequently, as well as 8 D E, Akron, Ohio, both coming in Q S A.

Radio on a N.Y. Newspaper

(Continued from page 483)

cially news of a maritime nature. For this purpose a short-wave receiving set is being used by the "Times" station and the operators listen in on it when there is nothing of importance coming in from abroad.

The following may be considered as typical of the "scoops" which this short-wave set has brought to the "Times."

The New York Police Department used to transmit a list of automobiles, including their names, numbers and motor numbers, which were stolen in New York. This list was copied by the paper and published in the first morning edition. This list started with a few cars, but eventually ran up to about 35. This increase in the number of stolen cars caused quite a little comment and the Police Department has discontinued the broadcasting.

On the fifteenth of last March, a "Times" operator managed to get in on an SOS from the S.S. "Madawaska," which was rammed in a collision off the Jersey Coast. The next morning the first edition carried a story of the accident which could have been little better had the operator been able to witness the scene.

Again, on May 2, last, the "Times" operators intercepted the QST "Strike call",

During the month of December SORSINC will ship all mail orders from any Branch Store postage prepaid. This applies to the SORSINC "B" Battery (the largest "B" known), and all standard makes of equipment.

Take this opportunity to get acquainted with SORSINC service.

Dealers: We are jobbing all the important lines. Immediate service at all times. Write for discounts.

TUNIT

THE SORSINC

160 to 600 Meters

THE SORSINC "TUNIT", when attached to your Honeycomb coil set, duplicates the performance of the most expensive short wave sets, on 160 to 600 meters, at a price any amateur can afford. It consists of a stationary coil and two rotors. Black metal dials and moulded knobs are used. In fact, every *essential* is provided in highest quality and workmanship to give you best value per dollar!

Use the SORSINC "TUNIT" in your present standard triple coil mounting.

"TUNIT" will be on the market in December. Examine it at your dealers' or at any of the SORSINC Branch Stores listed below.

PRICE \$15.00

Photograph $\frac{2}{3}$ actual size, of "TUNIT", the sensational new, shortwave tuning attachment.

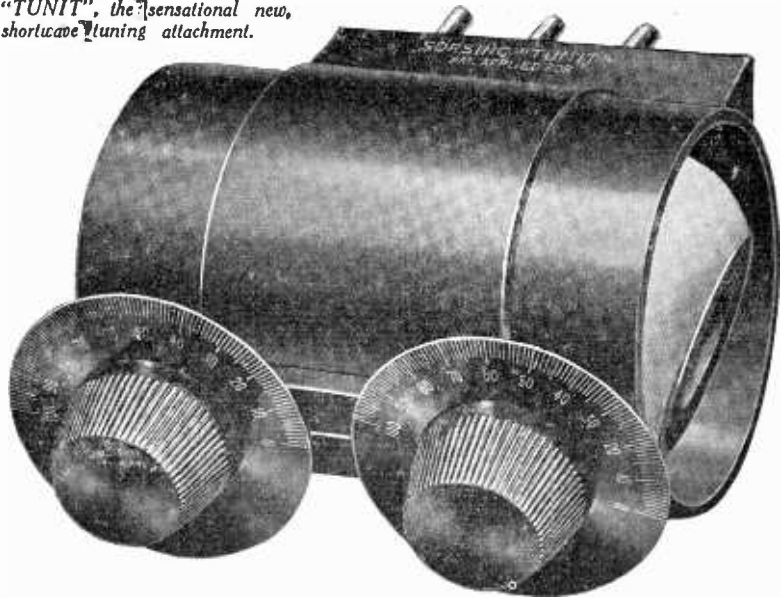

Showing "TUNIT" in standard Honeycomb triple coil mounting

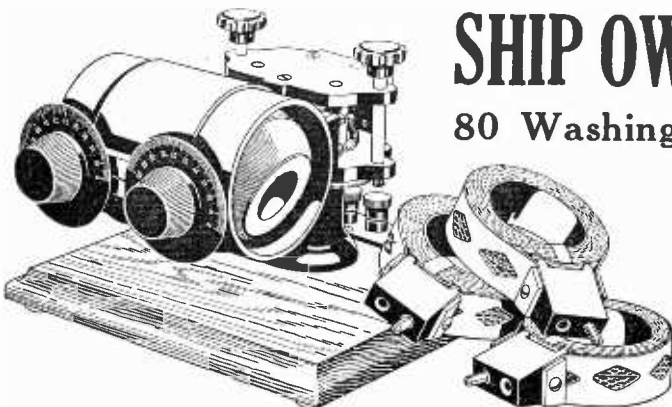

SHIP OWNERS RADIO SERVICE, Inc.

80 Washington Street

New York City

"The Largest Radio Chain Store System in the World"

Branch Office Stores:

NEW ORLEANS, 710 Maison Blanche Annex
 BALTIMORE, 403 Lobe Bldg.
 NORFOLK, 26 Haddington Bldg.
 SAVANNAH, 230 Broughton St., East
 PHILADELPHIA, 2006 Columbia Ave.
 PORTLAND, ORE., 622 Worcester Bldg.
 HONOLULU, 408 Boston Bldg.

Branch Offices:

BOSTON, 175 Commercial St.
 SAN FRANCISCO, 24 California St.
 SEATTLE, 3451 East Marginal Way
 LONDON, 15 City Chambers,
 65 Fenchurch St., E. C.

QUALITY **CE** SERVICE

COLORED varnish, shining insulation, nickel plate and lacquered brass don't make wireless equipment better, but merely better looking. C. E. Radio Products are finished with a nice regard for handsome appearance. They are ornamental to any station. But the qualities of C. E. radio equipment that count most with real radio men are the qualities of efficient dependable performance in service. C. E. apparatus is as good as it looks.

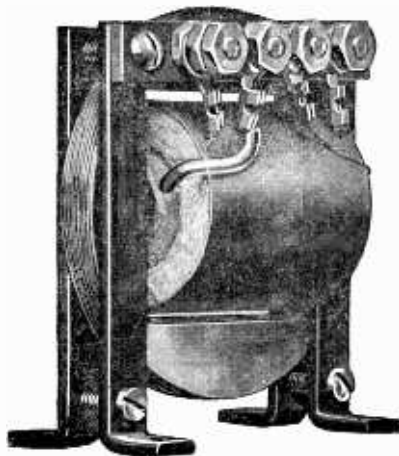

Amplifying Coil

Increases strength of signals to many times original intensity. Designed for high efficiency operation with vacuum tube detectors. \$6.50 mounted with panel. \$4.00 without panel.

\$38 Regenerative Receiver

Licensed under Armstrong U. S. Patent, No. 1,113,149.

Type Z.R.F. 175-600 Meters. Needs only batteries, telephones, tube and tube panel to complete set capable of remarkable results in long distance short wave work.

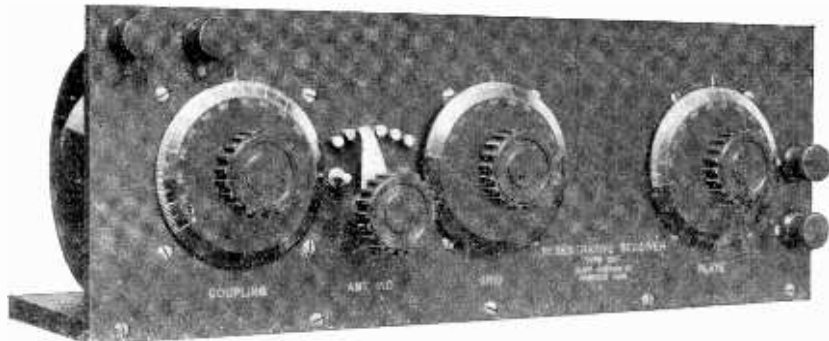

CLAPP-EASTHAM COMPANY

RADIO ENGINEERS *and* MANUFACTURERS
120 Main Street CAMBRIDGE, MASS.

California Representative:
LEO J. MEYBERG CO., SAN FRANCISCO AND LOS ANGELES 127-9

Portable Wireless Phone & C.W. Transmitter

Voice Range 15 miles using Amateur Aerial and 90 volts-Flash Light Batteries.

Phone	\$45.00	Increased range with 90V. Battery \$10.00 higher voltage. Easy to operate. Knocked down parts \$35.00
Transmitter	\$6.00	
Bulb UV202	\$8.00	
TRESCO TUNERS—one for every wave length	\$10.00	

TRESCO CONDENSERS—All kinds; see us before buying elsewhere.

10c Brings Our Catalog—24 Pages

TRESCO - DAVENPORT - IOWA



and men of other crafts engaged in shipping on the Shipping Board vessels that a strike had been called.

On July 1, last, the N. Y. Times station was requested by the Cleveland Plain Dealer to listen for messages addressed to the latter paper from the S.S. "Monterey," which was returning from a trip to Mexico. The "Times" station received the messages and notified the Plain Dealer that three criminals, aboard the vessel had been taken into custody.

Speed is essential in newspaper making, and this station has been responsible for editions of the "Times" being the first on the street, with various stories, received "out of the air."

THE APPARATUS

Three distinct receiving sets are maintained: One is used for copying Bordeaux, France; one for other European stations; and the third for short-wave reception of the character referred to previously. The vacuum tube circuits, used in conjunction with these receiving sets require a comparatively great amount of current and the storage batteries used for this purpose are of a heavy amperage type. The circuit used for most of the trans-ocean reception is a simple loose coupled outfit, made up of lattice-woven inductances and variable condensers. The V.T. circuit includes one stage of radio frequency, a detector tube and two stages of audio-frequency amplification and an external heterodyne circuit. From the output circuit of the second stage audio-frequency amplifier, the signals are passed through two-tone traps, which aid materially in reducing the interference, which would otherwise be obtained. After passing from the tone traps, the signals are either lead to the customary headset, a magnavox or the twin recorders, shown in the accompanying illustration. The circuit of the tone traps is shown in an accompanying illustration. The twin dictaphone recorders have been made specially for this station and are used for copying high speed messages, from the other side, which would merely be a mass of unintelligible sounds without them.

Special receivers are fitted into the tubes which are ordinarily connected to the speech tube on these recorders and the entire outfit is operated by a single electric motor. When one of the recording cylinders has been filled, the receiving is automatically transferred to the other, although certain portions of the records are duplicated, near the end of one and the beginning of the other, in order to insure continuity of the matter they contain. The records are rotated at a comparatively high speed and, when filled, are put on a transcribing machine and run at a much lower speed, which makes it possible for the operator to untangle the otherwise unfathomable dots and dashes. The loud speaker is only used for stand-by purposes and serves to let the operators know when any desired station begins transmission.

The station is under the direction of Mr. F. E. Meinholtz, and the operators, from left to right in the photograph, are Wm. Collins, B. G. Seutter and R. J. Iverson. The two loving cups have been won by Mr. Seutter, in open competitive receiving tests, in which he attained the highest speed.

A WORD TO OTHER NEWSPAPERS

From time to time an effort has been made in various sections of the country to show newspapers the value of using radio equipment, for obtaining news "off-the-bat," but many of them have worked out in a very unsuccessful manner. There are a number of such instances which have come to the writer's attention and the failure is generally found to be caused by the same error. In some instances, radio dealers



FIRST ON THE MARKET RADIO FREQUENCY TRANSFORMERS

We are offering the first Radio Frequency Transformer. A transformer of special type R. F. iron core construction. (Patent pending).
A transformer having complete shielding.
A transformer covering the amateur wave-length range efficiently.
A transformer giving maximum amplification per stage.
A transformer designed by former Government radio engineers.
Also R. F. transformers for commercial and special ranges supplied.
For information and prices address
Radio Service Laboratories, Inc., Asbury Park, New Jersey

YOU CAN'T BUY ANYTHING BETTER

PACENT UNIVERSAL PLUG



The Navy radio experts know a good thing when they see it, you will agree. They endorsed this plug because it met with every requirement that could be expected from such a device. Then, too, it was the *first* real universal plug. No solder is needed and connections are made in a jiffy. Positive contact which cannot become loose. Insist on the original. Don't take substitutes.

No. 50 Pacent Universal Plug..... \$2.00

PACENT RADIO JACKS

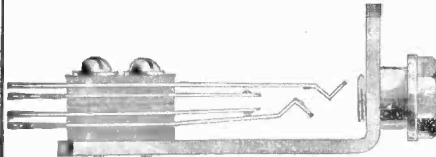

The Pacent Radio Jack is a fit companion for the Pacent Universal Plug. In fact, one is not fully complete without the other, for they have both been designed especially for radio work and for each other in particular. Pacent Radio Jacks are made in both standard and automatic types and there is a type for your purpose. The proof that these are the best jacks for radio is the fact that commercial radio companies have standardized on them.

Price—Open, Closed and Two Circuit..... \$.70, .85 and \$1.00 ea.
Three and Five Spring Automatic.... \$1.00 and \$1.20 each.

DUBILIER CW CONDENSER

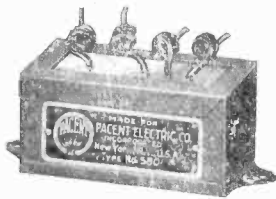

You can't distinguish a good condenser from a bad one by appearance—you must try them. Buying and trying is expensive. Why not take advantage of Dubilier superiority and buy a perfect condenser the first time? Type 580 is designed for use in series with the antenna. Built with ruby mica. Constant capacity. Extremely compact and easily mounted. Handles 4 amperes at 5000 volts.

Prices—Single Capacities .001 to 0.2 mfd..... \$4.00 each
Triple Capacity .0003, .0004 and .0005 mfd..... 4.50 each

PACENT STANDARD VT BATTERIES



A VT battery can be no better than the materials that are used in its construction. Perfect insulation, control of electrolysis and the very best ingredients obtainable have made this the battery of batteries. It costs no more than the rest, but in reality it is cheaper because it lasts longer. We are not making a cardboard box full of flashlight cells. This is a VT battery honestly made.

Price From \$1.50 to \$3.50

PACENT DUO-LATERAL COILS

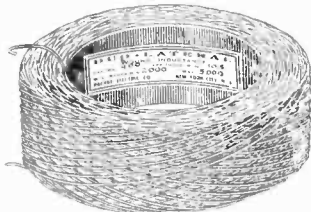

Certainly you have heard about them, but have you tried them? Hearing about a good thing will not do you any good—buy it and use it. Duo-Lateral Coils have low natural period, low high-frequency resistance, low distributed capacity. They may look like other coils—but try them and find the difference. Accept none but the genuine.

Prices \$.74 to \$2.96

PROTECTION



DO YOUR RADIO SHOPPING WITH PACENT

Why waste time and money by buying at a dozen different places? Go to a Pacent dealer. Send five cents in stamps and we will mail you a catalog R1 of Pacent Radio Essentials which includes the name and address of the nearest dealer.

*If you are a progressive dealer or jobber
you should have our latest proposition.*

Wicony Apparatus Dubilier Condensers Rawson Instruments
Standard VT Batteries Pacent Plugs Pacent Radio Jacks

Special Distributors for Brandes Phones and
Westinghouse Equipment.

PACENT ELECTRIC COMPANY, Inc.

LOUIS GERARD PACENT, President

150 NASSAU STREET

Telephone Beekman 5810

NEW YORK CITY



NO RADIO SET COMPLETE Without Ace "B" Batteries Better Service - Longer Life

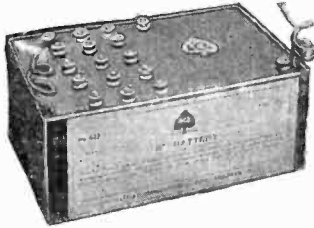

The new "Ace" No. 627-45 Volt Variable "B" Battery is rapidly creating a remarkable reputation as to "Price," Quality, Service and Weight. The special size cell construction guarantees from 50% to 75% longer life than any 2 small size "B" Batteries. 16 Taps, 30 Voltage readings of from 1 1/2 to 45 Volts obtained. Absolutely the best "B" Battery offer ever made. Size 6 in. x 5 in. x 2 3/4 in.—weight 3 3/4 lbs. Price \$3.50. Demand "ACE." If your dealer does not carry "Ace," write to us. This list contains the six popular type "ACE" "B" Batteries.

Cat. No.	Size	Voltage	Lbs.	Taps.	Price
623	Plain 2 1/2 x 2 x 3 3/4	22 1/2	1	1	\$1.50
623	Variable 2 1/2 x 2 x 3 3/4	22 1/2	1	5	1.75
625	Plain 3 x 4 x 6 3/4	22 1/2	5	5	2.50
625	Variable 3 x 4 x 6 3/4	22 1/2	5	5	3.00
626	Plain 3 x 8 x 6 3/4	45	10	10	5.00
626	Variable 3 x 8 x 6 3/4	45	10	6	6.00

Write for Catalog No. 20

Ace Batteries are silent, moisture proof and absolutely guaranteed.

DEALERS—Get in on this fast selling item.

LIST OF DEALERS

- Alamo Radio Supply Co., San Antonio, Texas.
- Ashtabula Radio Sales Co., Ashtabula, Ohio.
- Beacon Radio & Electric Co., New York, N. Y.
- F. Claxton, Paterson, N. J.
- Continental Elec. Supply Co., Washington, D. C.
- Continental Radio & Elec. Corporation, New York, N. Y.
- Dreyfuss Sales Corporation, New York, N. Y.
- Wm. B. Duck Co., Toledo, O.
- Keystone Radio Co., Greenville, Pa.
- John R. Koch, Charleston, W. Va.
- A. K. Laling Radio Co., Pelham Manor, N. Y.
- Liberty Radio Supply Co., Chicago, Ill.
- Lancaster Elec. Supply & Construction Co., Lancaster, Pa.
- Lehigh Radio Co., Bethlehem, Pa.
- Manhattan Electrical Supply Co., New York, N. Y.
- Midwest Radio, Cincinnati, O.
- Mutual Purchasers' Assn., New York, N. Y.
- Oklahoma Radio Shop, Oklahoma City, Okla.
- Paris Radio Elec. Co., Paris, Tex.
- F. D. Pitts Co., Boston, Mass.
- Quaker Light Supply Co., Philadelphia, Pa.
- Radio Art Store, Acorn, Akron, O.
- Radio Development Co., Springfield, Mass.
- Chas. Rosewall, Brooklyn, N. Y.
- Scheib Elec. Radio Co., Pittsburgh, Pa.
- Southern Radio Supply, Clearwater, Fla.
- F. H. Stewart Electric Co., Philadelphia, Pa.
- Stratton Electric Co., Greenfield, Mass.
- U of I Supply Store, Champaign, Ill.
- Vimy Supply Co., Toronto, Can.
- Whitall Electric Co., Springfield, Mass.
- Wilcox Laboratories, Inc., Lansing, Mich.

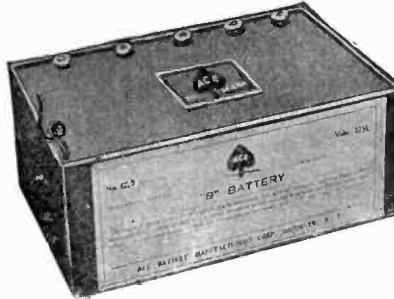

MORE THAN A TRADE MARK

A SIGN OF "B" BATTERY QUALITY



ACE BATTERY MFG. CORP.
264 ATLANTIC AVE. BROOKLYN, N. Y.

have tried to take advantage of the papers and have sold them a great deal of apparatus, which for newspaper use was practically worthless. The papers involved will not look very favorably upon the efforts of some other dealer, who is really in a position to do them some good. Mr. Newspaper Man will be found to be of an open mind, generally, but he hates to be taken in. Even if the apparatus is capable of doing what is claimed for it, it should be operated by none but the best of operators. One station of this character was opened for a paper by a man who was well versed in radio technique, but who did not know how to copy more than a few words per minute. He expected to carry on his watch by listening to trans-ocean stations and differentiating between them by locating their wave lengths, and then using some form of automatic recorder, from which another operator would copy the news, when he came on duty, in addition to getting whatever came through, while carrying on his own work. The plan has proven to be impracticable.

Mr. Radio Dealer, if you want to get the support of the dailies (which is just about as good support as we may expect) try to live down the temptation of unloading a lot of apparatus, even if it is good apparatus, on the paper. If you can help a paper to become modern, it is up to you to do so, but do not give radio a "black eye" by failing to take into consideration that your business does not end with the installation of the apparatus. It is up to you to be certain that it performs in exactly the manner you paint to the paper's business manager.

Thomas W. Scott's Station, 8BJV

(Continued from page 504)

set when desired.

All of my set was assembled and wired by me and is giving excellent results. I send out concerts several times a week and use a Magnavox tone arm which gives maximum results.

My set has been reported from points 120 miles distant QSA and as yet I have not tried for distance on C. W., but will do so soon, and I shall be glad to arrange a schedule with anyone desiring to work.

The secret of a radiophone set using Radiotron 5 watt tubes lies in the voltage used on the filaments and at 7.5 volts I am able to get 1.85 amperes radiation. With a Heising-Colpitts circuit the use of a counterpoise is essential to prevent draining tubes, as is the case with a ground. I used Brandes phones throughout and Western Electric microphone Type 282W on 6 volts of battery.

One of the best results obtained with my transmitting set came after I rewired it throughout with No. 8 copper wire to cut down resistance. I use a filter circuit of two 1 1/2 henry Acme choke coils, 500 milli-ampere capacity, with three 1-microfarad condensers on each side of it; this gives good results in reducing commutator ripple.

THOMAS W. SCOTT,
Radio 8BJV.

A New Tuner and Amplifier

(Continued from page 484)

inserting a .0005 mfd. or .0001 mfd. fixed condenser. This eliminates the necessity of using a series variable condenser to permit reception of short wave-lengths with a long antenna.

The panel is provided with a shield which

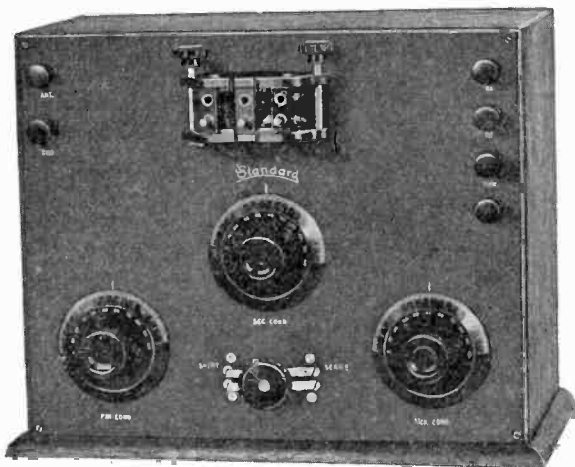

Wire Your Own

The Standard Assembling Co. does all the panel drilling, mounting, etc., which is essentially machine work, and leaves the wiring (hand work) for you to do yourself. Only in this way can you get the appearance and results of properly assembled apparatus at a price but little over the cost of the parts.

In the case of the multiple wave tuner shown here, this plan saves you a clear \$5.00. This instrument receives all classes of signals on all known wave-lengths, 150 to 25,000 meters. Sent anywhere in the U. S. on receipt of one-third the purchase price. If satisfactory, remit balance, if not, return instrument for refund.

PRICE FOB NEW YORK

WIRED .. \$50.00

UNWIRED... \$45.00

Send stamp for details.

STANDARD ASSEMBLING CO. 19 Bridge St., New York

Consistent Results

can only be obtained by using our STORAGE "B" BATTERIES in your plate circuit. Batteries built in sizes from 24 volts up to 100 volts.

Amateurs and Dealers, send for descriptive literature.

HUGHES ENGINEERING COMPANY
P. O. Box 57, Terrace Park, Ohio

Panels for Your Set

Black fiber, 7 x 20 x 1/4, \$2.00; suitable for regenerative set, or cut to your size at \$0.01 1/2 per square inch.

This material is inexpensive, easy to work and takes nice finish.

We pay postage

ECONOMY RADIO SUPPLIES CO.
232 Sanford St. East Orange, N. J.



No. 766 Eveready Wireless Station Battery
Standardized for use in U. S. Navy

What gives the Eveready Wireless B Battery its extra long life?

THE high quality of materials used—the refinement of process—thorough research and experiment—the suppression of corrosion—the perfect insulation of cell from cell.

Hitch an Eveready to your receiving set, and enjoy the marked increase in effectiveness. Go to your radio equipment dealer—or write us.

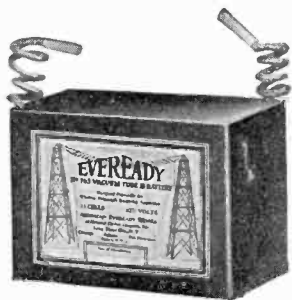

No. 763 Eveready Airplane Wireless Battery. Standardized for use in U. S. Signal Corps Aviation Section

AMERICAN EVEREADY WORKS
of National Carbon Company, Inc.

226 Thompson Ave., Long Island City, New York
Chicago Atlanta San Francisco

EVEREADY

FLASHLIGHTS AND BATTERIES

Every wireless operator has use for an Eveready Flashlight

Discriminating Radio Men Insist On



Telmaco Short Wave Receivers Unwired Type TR-1



Telmaco's policy is to give better values. That's why we are forced to work overtime to fill orders. The Telmaco Short-Wave Receivers are completely assembled; lugs are in place on which to solder wires; No. 14 silver finished wire, as well as necessary tubing is furnished.

TELMACO VARIOMETERS AND VARIOCOUPLER

with flush type bearing plates and spring washer bearing contactors are used, thus assuring perfect electrical connections permanently for ball windings without "pig-tailing." Dials are Remler 3 in. polished molded bakelite. Lettering on panel is pantograph machine engraved, filled with the best grade white enamel.

The Cabinet is constructed of quarter sawed oak, stained inside and out, with waxed finish. Panel is of grade M 8/16 in. Formica, 6 1/4 in. x 16 3/4 in., satin grained finish, mounted on special drawer sub-base. Metal parts are nickel plated and oxidized. Binding Post Construction is of Telmaco special design extending through back of cabinet, thus removing all external wiring from front of panel.

Special Beginners' Set

Telmaco beginners' complete receiving outfit includes 2000 ohm double phones, detector, mineral condenser, double slide tuner, 160 ft. aerial wire, insulators, and book of instructions. A first-class outfit, very popular.

Price\$12.00

Order direct
from this
ad.

Satisfaction guaranteed always or money refunded. Send for our complete catalog. You'll find it interesting.

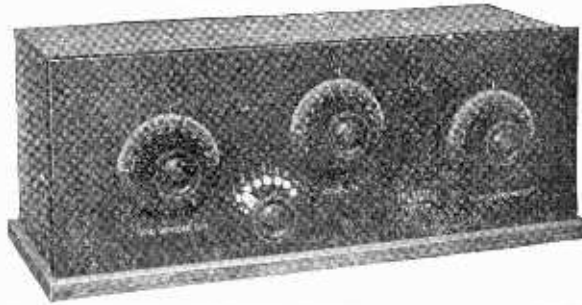

TR-1 Telmaco Short Wave Receiver, Unwired \$35.00
TRD-1 Telmaco Short Wave Receiver and Detector, Combined, Unwired \$45.00

DEALERS! We are distributors for nearly all Standard Lines. Write for our Special Proposition.

Your Panels engraved with our GORTON ENGRAVER Price 3 cents per letter. Minimum charge \$2.00.

RADIO DIVISION

TELEPHONE MAINTENANCE COMPANY, 17 N. LaSalle St., Chicago, Ill.

Famous "Chi-Rad" K-D Variometer Set

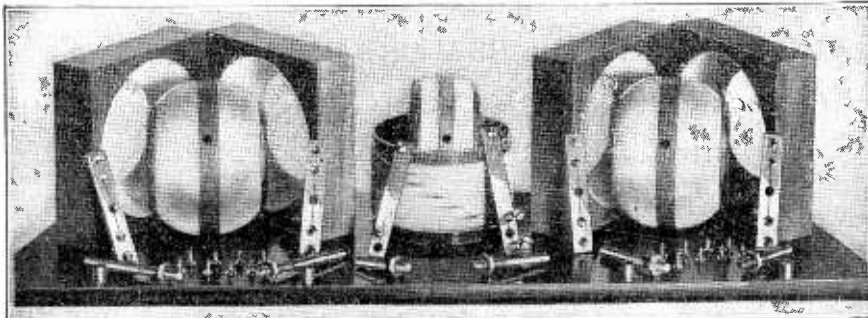

All parts to build two variometers and one coupler. ALL WINDINGS IN PLACE—nothing to do but screw on bearings and connect up. Complete set can be assembled in 30 minutes. The biggest value on the market—order a set today. Immediate Delivery. Price complete as shown \$10.00 Add PP on 6 lbs.

Specifications

Variometer forms 4 1/2" Sq., 3" wide when assembled. Coupler primary Bakelite 3/8" Diam., 3 1/2" high. All shafts 1/8" diameter. 7 Primary Taps. Range 150-475 meters. Special condenser to shunt secondary and increase range to 650 meters supplied for 35c extra. Made specially for panel mounting—all screws covered by dials when assembled. Immediate Delivery—Money Back Guarantee.

Chicago Amateurs—Come and inspect our stock—largest in the Middle West. Open all day Saturday.

Dealers—Write for attractive discounts on "Chi-Rad" K-D Variometers. Your customers want them!

CHICAGO RADIO APPARATUS CO., Inc.

508 South Dearborn Street

(Second Floor)

CHICAGO, ILL.

Insure your copy reaching you each month. Subscribe to *Radio News*—\$2.00 a year. Experimenter Pub. Co., 236-A Fulton St., N. Y.

minimizes the capacity effects of the hand when making critical adjustments. For a like reason each dial is insulated from each shaft upon which it is mounted.

The detector two-stage amplifier is the complement of the regenerative tuner and especially designed to work with it. Panel and cabinet dimensions are identical, and the same characteristic exterior features prevail. Rheostats and potentiometer are mounted on the panel interior directly behind each dial. Amplifying transformers, tube sockets, grid leak, grid condenser, and fixed by-pass condenser are securely mounted in an aluminum frame which makes front and rear panels integral.

The two amplifier tubes are controlled by one rheostat of ample current carrying capacity. A three position cam switch connects the telephones to the detector only, and to the combined stages of amplification and in the "off" position opens the A battery circuit extinguishing all filaments.

An Audion Control Cabinet for Amateur Use

(Continued from page 498)

The connections to the various pieces of apparatus should be made with heavy wire, at least No. 18 B. & S. gauge, and soldered at all possible points to avoid loose and noisy connections. Wires to binding posts should be soldered to brass washers and these placed under the screw rather than placing the wire itself, which, in time, will work loose.

The circuit used is shown in an accompanying diagram. This circuit was used in connection with the "Honeycomb Coil Timer" described in the May issue of this magazine. This circuit, using the tickler in either place, "A" or "B," works very well on all ranges of wave-length. A "Regenerative" effect can be had on short wave by proper use of the tickler coil giving many of the advantages of the regular regenerative receiver, using variometers.

To graduate scales for the rheostat and grid condenser, a fine pointed instrument, similar to a divider point, should be used, going over the mark several time, very lightly, getting a fine smooth groove which has sharp edges and if cut hurriedly and heavily a ragged edge will result, looking very bad when filled with white lead.

In addition to the holes shown in the panel drawing, holes should be provided for fastening the panel in the case, four being sufficient and spaced according to personal taste.

The case for this audion was constructed to match the case of the "Honeycomb" tuner and is made of oak, sizes of which are in the drawings.

In case of scratching the panel while drilling and cutting, it can be repolished by smoothing off with emery cloth and then polishing with crocus cloth and oil.

In using this audion, in connection with the tuner already described, and a two-step amplifier, signals from many amateur, commercial and naval stations, including arc and alternators have been received. Particularly fine results were secured using a pre-war "Audotron" in the adapter described herewith.

Choke Coil Amplifier

(Continued from page 489)

My reasons for using chokes are: First, the marked superiority of signal strength; second, the cheapness in price; and third, the compactness that is possible.

Using an indoor aerial, honeycomb coils

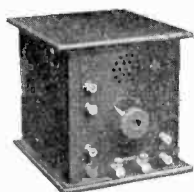

Type ATC Detector Cabinet.
Price \$12.00



Type A-2 Two-Stage Amplifier
Price \$40.00

ACE



ACE C.W. Inductance
Price \$6.50

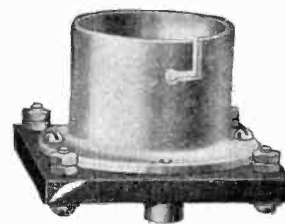

ACE Vacuum Tube Socket
Price \$1.50

"Merry Christmas" To All

In extending the Season's Greetings to our many friends and patrons, we wish to express our appreciation of their hearty cooperation and many favors.

Equip Your Station With "ACE" Apparatus

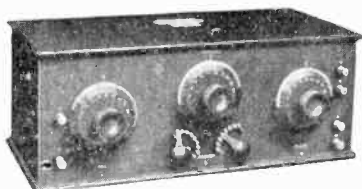

Type AVA Regenerative Tuner
175-475 Meters. Price \$45.00

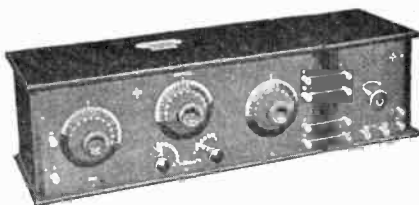

Type AVC Short Wave Regenerative receiver, 175-475 Meters, Price, \$56.00

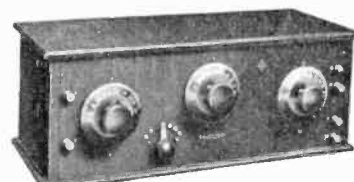

Type AVB Regenerative Tuner
150-475 Meters. Price \$32.00



ACE 6-Volt, 80 Amp. Hr. Storage Battery. Price \$18.00

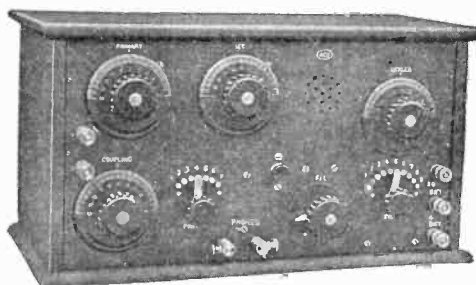

Type TTR Regenerative Receiver—150-3000 Meters. Price \$75.00



ACE Hard Rubber Dial
Price \$1.50

We carry in stock at all times a complete line of reliable Radio Supplies for the Amateur and Experimenter.

SEND 5c IN STAMPS FOR CATALOG
TO DEPT. A

AMATEURS!
If your dealer cannot supply you write us direct
Radio 8XB

THE PRECISION EQUIPMENT CO., INC.
Manufacturers and Distributors
PEEBLES CORNER, CINCINNATI, OHIO

DEALERS!
Write us for trade Proposition
CABLE ADDRESS, "ACE" Cincinnati



Learn Telegraphy

(Wireless or Morse)

AT HOME

In Half the Usual Time

Let the OMNIGRAPH Teach You Wireless

"Just Listen—The Omnigraph will do the teaching"

The Omnigraph is an *Automatic Transmitter* that teaches you both the Wireless and Morse Codes, at home, without any expense except the cost of the machine itself. Merely connect to battery and your Buzzer, or Buzzer and Head Phones, or to your Sounder and the Omnigraph will send unlimited messages by the hour, at any speed you desire.

USED BY THE U. S. GOVERNMENT

Write for Free Catalogue

For a few dollars you can have a complete outfit that will make you an experienced operator in the shortest possible time. No hard, laborious work—just learn by listening. The omnigraph is adjustable so you can start receiving messages slowly, gradually increasing the speed as you become proficient.

You'll be surprised how quickly you will attain speed. Even if you are already an operator the Omnigraph will help you. It will make you more proficient, more accurate and more confident. Thousands of Omnigraphs are in use today and thousands of operators owe their success to them.

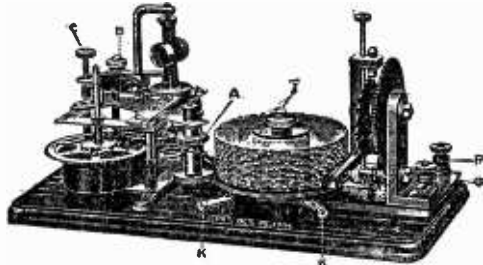

The Omnigraph Mfg. Co., 26-H Cortlandt St. N. Y.

Gentlemen:—

As per your ad in Radio News please mail me your free catalog of Omnigraphs.

Name.....

Address.....

City..... State.....

The Omnigraph Mfg. Co.

26-H Cortlandt St. New York City

"ILLINOIS" THE RELIABLE MADE RIGHT - STAYS RIGHT



STYLE No. 1

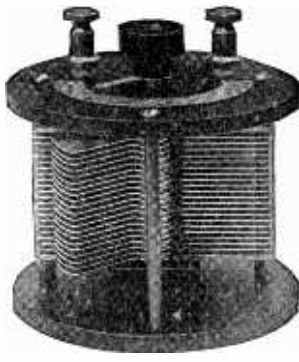

STYLE No. 2

Three Styles: No. 1, Panel; No. 2, Open Type as shown; No. 3, Fully Encased. Anti Profiteer. Less than pre-war prices. Fully assembled and tested.

Style No. 1	No. 2	No. 3
67 Plates,	\$7.00	\$8.00 \$8.50
43 "	3.50	4.50 4.75
23 "	2.75	3.75 4.00
13 "	2.25	3.25 3.50

Money back if not satisfied. Just return condenser within 10 days by insured Parcel Post.

Options:— With Style No. 1—instead of Scale and Pointer, a 3-inch Metal Dial at 50 cents extra, or a 3-inch Bakelite Dial at \$1.00 extra. Large Knobs. Both excellent values. Or we will, if desired, supply the Condenser with smooth 3-16 inch center staff, without Scale, Knob and Pointer, at 15 cents off the list to those who prefer to supply their own dial.

Vernier with single movable plate applied to 13, 23 or 43 plate condenser, \$3.00 extra.

We allow no discounts except 5 percent on orders of 6 or more.

Sent Prepaid on Receipt of Price

Except: Pacific States, Alaska, Hawaii, Philippines and Canal Zone, add 10c. Canada add 25c.

Foreign Orders other than Canada not solicited.

G.F. JOHNSON, 625 Black Ave., Springfield, Illinois.



VERNIER

and two steps, I heard 1,000 amateurs from October, 1920, to August, 1921. That includes 110 "nines," 260 "eights," etc. The 14 stations farthest away were in North Dakota, South Dakota, Nebraska, Kansas, Texas and New Mexico. Also, I heard many DX stations in August. On August 28, I heard NPW, a 600-meter station at Eureka, California, on my four-step amplifier.

"So This is the Wireless!"

(Continued from page 502)

explanation as the average newspaper reporter gives the gullible public.

Most of my audience were satisfied and left.

Several said:

"Well, it certainly is a wonderful invention," in a slightly original and authoritative manner.

Others limited themselves to:

"Wonderful, isn't it?" in a dreamy, floating voice.

The remainder chimed:

"It certainly is."

But a few had not quite finished with me.

One young lady wanted to know if they call the left side of the ship the port side because it goes up against the dock.

I assured her that, although her explanation of the origin of the term seemed a trifle strained, I had no doubt it was the true one.

She also wanted to know how far we were off shore, which side the shore was on, how long it took to go to Jacksonville, exactly when we would arrive there and whether it was always rough at Cape Hatteras, all in one breath.

These were fairly simple to answer.

Having satisfied her strange thirst for knowledge, she departed, followed by a few others who had remained to the end.

All except George.

George remained true to his self-appointed duty and was evidently rather pleased that he again had an unobstructed view of my shining countenance. His mouth was still open and he still elected to remain silent.

"George," I told him, "you are overdoing it. You are going to the opposite extreme. You refuse to speak to me at all and ask me nothing.

"But you do not appear to be deaf. You can hear me, can't you?"

George showed some signs of intelligence and I almost thought he was going to say something, but he merely nodded his head.

"You are a remarkable child, George," I said. "If only all the other passengers were like you, my life would be an easy one."

His gaze left me for a few moments, to wander over the wireless apparatus.

"Yes, George," I said, "that's the wireless. Now why don't you tell me it certainly is a wonderful invention? Everybody else does, you know."

But George refused to be inveigled into conversation.

"Thank you, George," I said. "Thank you for your most comforting silence. You are the most interesting person I have conversed with for many a trip."

Out of the corner of my eye I could see an old lady coming down the deck, all sheets to the wind and heading in the general direction of the wireless room.

When she saw the sign over the door she gave evidence of considerable excitement and swooped down on the entrance cackling:

"So this is the Wireless!"

I stood up. This was too much for one day.

Evidently she had much more to say and many questions to ask, but, Lord, she was ugly and she was at least eighty.

"Yes, madam," I replied. "This is the wireless, to use your own quaint phraseology, which also seems to find favor with

DUCK'S NEW CATALOG No. 16

275 Pages A Catalog Deluxe

Stands 12c today (stamps or coin) for copy of the greatest radio catalog ever put between the cover of two pages.

Type "Q" Receiver

An Ideal Receiving Set for Long and Short Wave and Radio Telephone Reception.

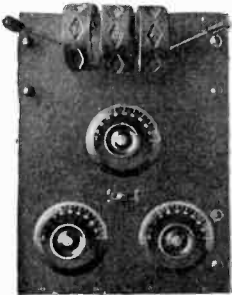

This set is the most flexible receiving set on the market. With the use of the various sizes of Honeycomb Coils everything in the range of radio telegraph and telephone reception from 200 to 25,000 meters is brought into your home. Consists of a three coil mounting and three Variable Condensers of proper capacity. Tuning extremely sharp. Remler dials.

Price Without Detector
\$35.00

Price With Detector
\$40.00

Never in the history of radio has there been such a catalog.

The radio data and diagrams embracing upwards of fifty pages, gives the experimenter more valuable and up-to-date information than will be found in many textbooks selling for \$2.00, and \$1.00 could be spent for a dozen different radio catalogs before you could gather together the comprehensive listing of worth while radio goods found in this great catalog.

A brief summary of the radio goods listed in this catalog:

The entire radio catalog of the Radio Corporation, with a wealth of scientific and technical data on C. W. transmitting sets, and all the diagrams for the assembling of these sets; the complete Remler catalog, which embraces 25 pages, the Westinghouse, Firth, Murdock, Federal, DeForest, Clapp-Eastham, Brandes, Connecticut Company, Thordarson, Turney, Magnavox Company catalogs, the best products of Adams-Morgan, Signal and countless other manufacturers, including our own complete line of radio apparatus, and many individual items and parts used in radio work today.

Send only 12c for copy of this wonderful catalog. You will need no other when you have Duck's, and you cannot find in all others combined what you will find in Duck's Wonder Catalog.

A Characteristic Testimonial

The Wm. B. Duck Co.,
Toledo, Ohio.—Middletown, O.
Sept. 27, 1921.

Yours 26th. I am very glad to give you my opinion on your variometers. I find that they give excellent service and permit very sharp tuning. A friend of mine tried them in comparison with a set using — moulded variometers and found them much superior. Consequently he intends to order two from you in the near future. Altho I have only used them a short while I have received music and speech from Richmond, Ind., Cincinnati, Ohio; Hamilton, Ohio and Pittsburgh, Penn. very clearly in spite of bad QRN. These variometers are all you claim for them and then some. I am glad to be of service to you and if I can give you any other information just write me.
FOSTER HANSELL.

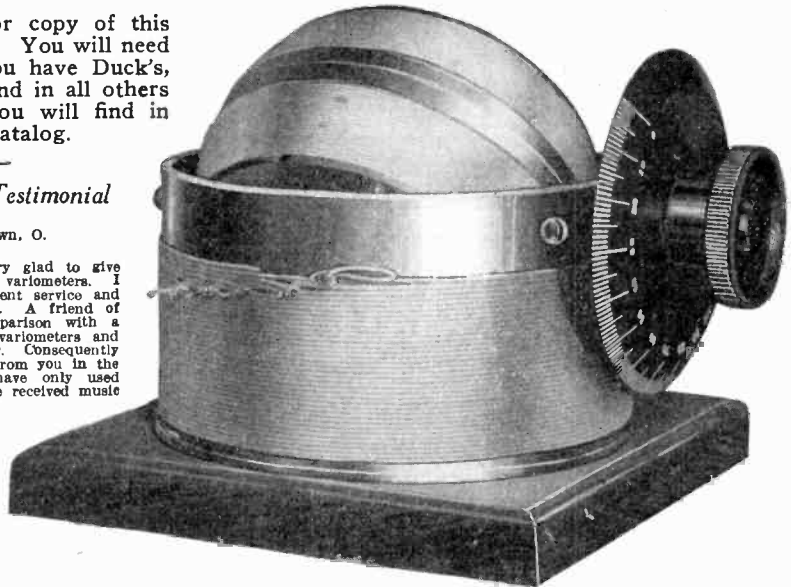

Our variometers and variocouplers are beyond doubt without a peer and it is our enormous quantity production that makes possible the attractive prices. Space does not permit of a comprehensive description of these instruments in this advertisement. It is sufficient to say that while there is an apparent sameness in the looks of all variometers and variocouplers, there may be a wealth of radio thought and design not apparent to the eyes of the novice, but manifesting itself strikingly when the instrument is put into actual operation. Over two pages are devoted to this subject in our catalog.

A feature of our variocouplers is in the inductance being varied by means of two six point switches. The first switch cuts in single turns, and the second cuts in six turns per point. This is a very important feature of our variocoupler. Without this arrangement you simply cannot get maximum efficiency.

No. A600 Plate Variometer, less knob and dial.....	\$4.90	No. A604 Variocoupler, less knob and dial.....	\$4.90
No. A601 Plate Variometer, with knob and dial.....	5.90	No. A605 Variocoupler, with Remler knob and dial.....	5.90
No. A602 Grid Variometer, less knob and dial.....	4.90	No. A610 Switch Parts, complete including Stop Pins and wire.	1.75
No. A603 Grid Variometer, with knob and dial.....	5.90		

DEALERS

We want live responsible dealers in every city and town in the United States, both for the sale of our extensive line of radio apparatus and all other worth while lines of radio goods on all of which we can quote attractive dealers discounts. We can offer you facilities and advantages that no other radio house can offer.

THE WILLIAM B. DUCK CO., 231-233 Superior St., Toledo, Ohio



S.O.S. to Santa Claus

Tell Old Nick you want a Headset.

Whether you are an amateur or a regular operator, you'll slap yourself on the back if you get a Brandes—the wonderful MATCHED-TONE Receivers.

Brandes Headsets "get everything"; under all conditions; often when others fail. Give yourself the best.

Send 5c for catalog G—now, in time to get ahead of the Christmas rush.

Dealers WRITE FOR OUR PROPOSITION

C. BRANDES, Inc. Room 823, 32 Union Sq. New York City



BRANDES Matched-Tone HEADSETS

LEARN WIRELESS AT HOME

The Demand for Good Wireless Operators Far Exceeds the Supply

The New York Wireless Institute will make you an operator—AT HOME—in your spare time—quickly, easily and thoroughly. No previous training or experience required. Our Home Study Course has been prepared by Radio Experts. Experts able to impart their practical and technical knowledge to YOU in an easy to understand way. The graded lessons mailed you will prove so fascinating that you will be eager for the next one. The instruments furnished free will make it as easy to learn the Code as it was to learn to talk. All you will have to do, is to listen.

TRAVEL THE WORLD OVER

A Wireless Operator can visit all parts of the world and receive fine pay and maintenance at the same time. Do you prefer a steady position without travel? There are many opportunities at the numerous land stations or with the Commercial Wireless or Steamship Companies.



FREE INSTRUMENTS AND TEXT BOOKS

This wonderful Set for learning the Code furnished FREE with our Course. We furnish free to all students, during the course, the wonderful receiving and sending set exactly as produced in the illustration. This set is not loaned, but GIVEN to all students completing the Course. The Transmitter shown is the celebrated Omnigraph used by several Departments of the U. S. Government and by the leading Universities, Colleges, Technical and Telegraph Schools throughout the U. S. and Canada. Start the Omnigraph, place the phone to your ear and this remarkable invention will send you Wireless Messages, the same as though you were receiving them, through the air, from a Wireless Station hundreds of miles away. When you apply for your license, the U. S. Government will test you with the Omnigraph—the same model Omnigraph as we furnish to our students. Ask any U. S. Radio Inspector to verify this.

FREE Post-Graduate Course

A one month's Post-Graduate Course, if you so desire, at one of the largest Wireless Schools in N. Y. City, New York—the Wonder City—the largest port in the World and the Headquarters of every leading Wireless and Steamship Company.

BIG SALARIES

Wireless operators receive salaries from \$125 to \$200 a month and it is only a stepping stone to better positions. There is practically no limit to your earning power. Men who but yesterday were Wireless Operators are now holding positions as Radio Engineers, Radio Inspectors, Radio Salesmen at salaries up to \$5,000 a year.

EASY PAYMENTS

A small payment down will enroll you. We will make the payments so easy that anyone ambitious to enter the fastest growing profession—Wireless—may do so.

Send or FREE Booklet Without obligating you in any way, send for our booklet "How to Become an Expert Wireless Operator"—it is free. Mail the coupon below, or postal or better—but do it today.

NEW YORK WIRELESS INSTITUTE
Dept. 281, 253 Broadway, New York City

NEW YORK WIRELESS INSTITUTE

Dept. 281, 253 Broadway, New York City

Send me, free of charge, your booklet "How to Become an Expert Wireless Operator," containing full particulars of your Course, including your Free Instrument offer.

Name

Address

City or Town..... State.....

the vast majority of the traveling public. "Furthermore, we are roughly 50 miles from the coast, the distance from New York to Jacksonville is 860 miles, the ship makes 14 miles per hour, we pass Hatteras Lightship at 11:00 a. m. and arrive at Jacksonville on Sunday about noon, the barber shop is on the opposite side of the ship, and any additional information may be obtained at the Purser's Office on the next deck. And I agree with you in advance that wireless is certainly a wonderful invention. Good afternoon."

She retired in confusion, evidently convinced that I was quite mad.

Again taking advantage of the remarkable listening abilities of my young friend George, I addressed him:

"They tell me, George, that wireless operators have nothing to do. That isn't true. But their duties do not necessarily pertain to wireless. No, not by any means.

"To be an efficient wireless operator, one must possess a general knowledge of everything under the sun, have a brain like an encyclopedia and be prepared to answer the most astonishing questions on the most astounding subjects.

"You have heard a few of these this afternoon.

This afternoon's performance will be repeated with slight variations this evening, tomorrow, and the next day, if the weather holds good, until we arrive in Jacksonville. It will then commence all over again with an entirely new set of passengers, on our return to New York, who will all do the same things, say the same things and—Ye Gods—they will all ask the same questions!

"We will remain in New York two days and begin the same performance with our departure. And so on, ad infinitum.

"One day, George, I shall go Berserker; meantime I am going to my dinner to entertain a number of sword-swallowers who are about to partake of the first real meal they will appear to have enjoyed in a number of years. They will devour their food with many strange noises and sit glowering at one another until I start some idiotic conversation. And throughout, I shall appear to be thoroughly enjoying myself and later suffer violent indigestion as a result.

"And so, George, I bid you *au revoir*. I suggest you go to your dinner now, but I have no doubt you will return to your post later and we shall have some more interesting conversations together.

"And, George, May I give you this parting admonition? If you ever learn to speak—never ask foolish questions."

I Want to Know

(Continued from page 510)

Q. 2. Can I receive the KDKA radiophone with a 2,500-meter loose coupler and a vacuum tube detector, using a two-wire aerial 100 feet long, 40 feet high with 100 feet lead in?

A. 2. This aerial seems to be a little too long for the reception of the KDKA concerts, but may give good results with a primary condenser of about .001 mf. capacity, connected in series in the aerial circuit.

Q. 3. Can I use some dry batteries to supply the filament of my V.T.?

A. 3. Dry batteries can be used instead of a storage battery for the filament of a detector tube, but unless several of them are used in series parallel they will polarize in a short time and prevent continuous reception for any length of time.

V.T.'s FOR THE SUPERAUTODYNE CIRCUIT (303) Lewis Ernst, of St Johns, Mich., wants to know:

Q. 1. What type of radiotron tubes should be used in each of the several stages of an Armstrong superautodyne circuit described in the February, 1921, issue of Radio News.

A. 1. A U.V. 200 tube should be used for the detector and U.V. 201 tubes may be used for the oscillator and various stages of amplification.

Q. 2. May the U.V. 202 be used instead of the U.V. 201 if the plate voltage is obtainable?

A. 2. Yes, they may be used instead of U.V. 201 tubes, but it is not necessary, as the high tension required in this circuit is only 40 to 80 volts.



The Recognized Symbol of Superior Performance

For the Operator Who Builds His Own

	Bulletin Price
Variometer, for Panel Mounting, Basket Weave	O \$6.10
Vario-coupler, for Panel Mounting, Basket Weave	O 6.90
Vernier Variometer, for Panel Mounting	N 1.50
Filament Rheostat for Panel Mounting	N 1.00
Ampliformer, Unmounted	N 3.75
Ampliformer, Mounted in Special Case	N 6.00
Knob and Dial, Beveled Type, 100 or 50 scale	N .65
Knob and Dial, Flat Type, 180 or 90 scale	R .50
Fixed Condenser, Cartridge Type, 7 capacities	N .45
Grid Leak, 5 Values, 1/2-5 Megohms	N .50
Tube Base, no electrical leakage, fits Radiotron UV 200, 201, 202 or V.T. 2	N .75
"A" Battery Potentiometer	N 1.25
Formica Panels, 10x10x3/16 in.	— 3.25

Twin R Synchronous Motor endorsed by leading amateurs, a quality product at a reasonable price. Described in Bulletin T. Price \$25.00.

Special: Stranded Copper Antenna Wire, No. 24—7 strands twisted—125 ft. to the coil—from our terminated war contracts—Exceptional value, per coil, 50c.



Showing Interior of Short Wave Tuner, 2596 Viewed from the rear

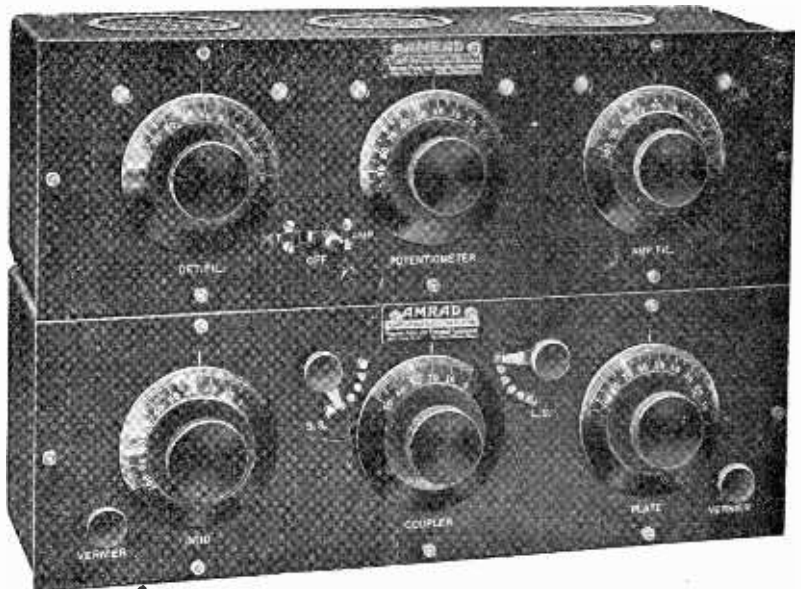

The Amrad Receiving Set, illustrated above, is ideal for CW radiophone reception because of its extreme sensitivity due to precise and modern shop practice.

For Christmas— Efficient Receiving Units In Solid Mahogany Cabinets

Short Wave Tuner 2596 includes two Amrad basket weave Variometers and a Vario-Coupler. This fact alone justifies the instrument to the discriminating amateur. Chief among other features are the selective electrical vernier controls for running down the wary CW; back connections; aluminum frame construction; and quality appearance and workmanship throughout. Price \$45.00.

If there were any better Detector 2-Stage Amplifiers to go with the Amrad Tuner, they would have been adopted. The Amrad design, No. 2634, includes two well-known Amrad Ampliformers assuring utmost amplification without distressing howls or squeaks. One of its distinct refinements is the Switch controlling the Detector and Amplifier Filaments. When using the Detector only, the Amplifier Filaments are automatically extinguished, thus saving much battery current and filament life. The same high-class workmanship and appearance, inside and out, as characterizes the Tuner has been followed in every detail. Price \$47.50.

Go to your nearest dealer and insist upon obtaining these efficient, individually tested Receiving Units. If your dealer won't satisfy you, write us for full details contained in Bulletin L.

Send 10c for Complete Amrad Catalog Listing Entire Line of 85 Items.

AMERICAN RADIO AND RESEARCH CORPORATION

General Office, Factory and Laboratory

New York District Office
15 Park Row

203 College Avenue, Medford Hillside, Mass.
(SUBURB OF BOSTON)

Chicago District Office
600 So. Dearborn St.



FACTS ABOUT INSULATION YOU SHOULD KNOW

A material for radio use must meet certain mechanical requirements or the most splendid electrical properties, will be of no avail.

Condensite in addition to its high dielectric strength is exceptionally strong mechanically.

The DeForest Radio Company use Condensite in the manufacture of their instruments. They only use the best.

Condensite-Celoron, a water-proof fibre manufactured by the Diamond State Fibre Co., Bridgeport, Pa., is especially adaptable for panel work.

Make sure your next equipment is made of Condensite before you buy it.

Condensite Company of America
BLOOMFIELD, N. J.

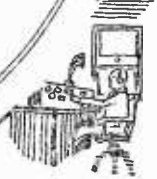

I hope that all the following issues of "our magazine" are as good as the ones that have preceded them.

JOHN HUSTON (6UK).
Phoenix, Ariz.

THE POLITE JAPS.

Editor, RADIO NEWS:

Having read Mr. Prescott Smith's criticism in the August issue, I have a few words that must be let out in regard to the Japanese. If Mr. Smith could have the pleasure of sitting around for three or four hours with from fifteen to twenty messages on the hook, and absolutely no chance of getting them off, while a couple of Japanese ship operators exchange their positions, life's history and the Lord only knows what else, he would be absolutely convinced that they have a code of their own and use it to good advantage.

I have often heard Japanese ships working when I was sailing in the Gulf so cannot understand how he has failed to hear them.

As an example, we can get a "Thanks" off our chest by TKS, TNX, etc., whereas nine dashes and thirteen dots are used by the Japanese, — — — — — — — — — —; others seem to be about as long.

They just about rule the air out this way, and absolutely refuse to QRX except by a request in their own code.

I hope this will enlighten Mr. Smith in the matter and that he has the pleasure of hearing some "J" stuff.

C. MORENUS,
S. S. Maui.

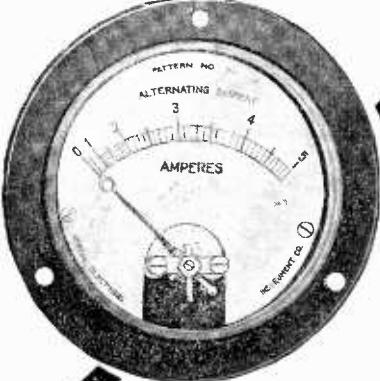

INSURE THE LIFE OF YOUR POWER TUBES

Standard 5 watt tubes should be run at 7.5 volts, 50 watt tubes at 10 volts, and 250 watt tubes at 11 volts.

A small increase in the filament voltage will result in a premature burnout.

A Jewell pattern 74 A. C. Voltmeter, 0-15 volts scale value, will enable you to work the filaments at their rated voltage.

Pattern 54 instruments for D. C. are also supplied.

PRICE \$8.00

Order From Your Dealer

JEWELL ELECTRICAL INSTRUMENT COMPANY
1650 Walnut Street Chicago

A Compact Variable Condenser
(Continued from page 495)

The two sources of energy are each connected to one set of moving and one set of fixed plates, as shown in the illustration. With the plates in the position shown, it is obvious that there will be no capacity effect, as the adjacent plates all have the same sign.

If, however, the moving plates be rotated through 180°, the opposing plates have opposite signs and the condenser has maximum capacity, while intermediate positions give variable capacity values.

It will be seen that a condenser of a given capacity made in this form, need only occupy half the space necessary when the usual type is employed.

This device is patented and must, therefore, be made for personal use only.

Radial Inductances Eliminating QRM
(Continued from page 493)

placed close together, the two coils form a variocoupler having 180 deg. coupling variation. If we take one coil and study it, we find that we have a concentrated magnetic field lying in the coil, just as a bar horseshoe magnet, which proves that there is in each coil a north and south pole which are very close to each other.

There are no taps available, the tuning being made entirely with variable condensers. There is no magnetic leakage, as the field is a concentrated one, and there is also less distributed capacity than in any other type of coil known. If the two windings are connected in series, the two coils form the best type of variometer that can be made, and using one of these variometers in the grid circuit and another one in the



New! NEW! New!

Bunnell **MULTIPLE RHEOSTAT 28 OHMS**

Our *New Radio Catalog*

No. 44R is now ready for distribution. Send 5c stamps for copy. It has many new and interesting devices.

J. H. BUNNELL & CO.
32 Park Place New York

Mail \$3.00

WITH A BED SPRING AS AN AERIAL FLORIDA TO CALIFORNIA

READ THIS →

Mr. Proudfoot—I received your plug several days ago, and I thank you very much. The amplifier which I purchased from you certainly does work well. I am able to read NPL, San Diego, Cal., using my bed-spring as an aerial with only one step of amplification. Thanking you very much for your courtesy, I remain, very truly yours,
CHARLES CROWLEY, Box 386, Clearwater, Fla.

← READ THIS

DETECTOR AND TWO-STEP AMPLIFIER

\$35.00

Highest Quality Lowest Prices

Detector and One-Stage Amplifier

\$25.00

is duplicate of above only one unit less.

LOUDEST AND CLEAREST SIGNALS

Made possible by SPECIAL DESIGN—(Different ratios of winding in transformers in each step of amplification.) The smoothest working rheostat—inlaid resistance units, do away with ugly screw heads in panel. Very sensitive adjustment.

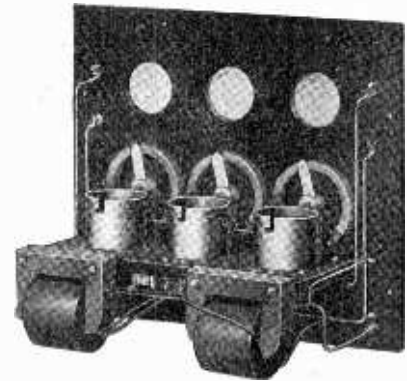
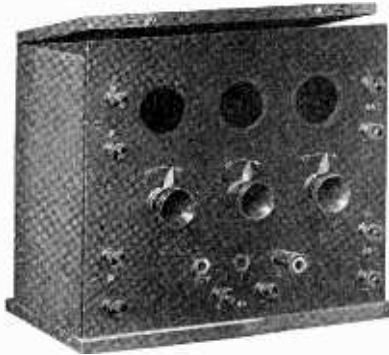

Panel 3/16 in. hand rubbed and engraved with white letters. Instruments look better than photographs. Cabinet 5 in. deep. Bakelite is 7½ in. x 8¾ in. Plug for fones furnished with each instrument.

\$35.00

The Operating Characteristics of All Our Instruments Are Equal to Any on the Market Regardless of Price.

CABINETS
QUARTER SAWED OAK WITH
WAX FINISH MAHOG-
ANY FINISH IF
DESIRED

NOTICE
CLEAN CUT WIRING

MANUFACTURERS' PRICE
Instruments being sold direct
from Manufacturers to you—thus
saving you 30 to 40%.

This instrument has a range of 140 to 3500 meters, base of 18 x 6 inches and wire of green silk covered copper. The metal is a polished nickel and the woodwork is a fine hand rubbed mahogany finish. Panel 9/32 inch hard rubber.

NAVY TUNING COUPLER

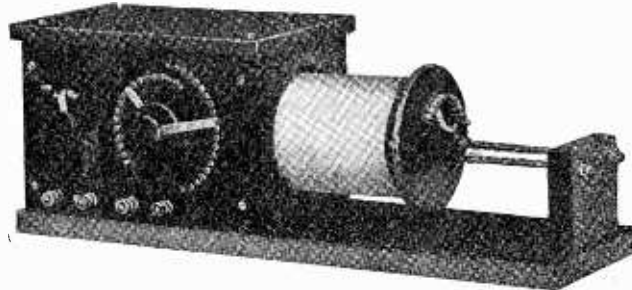

ALL INSTRUMENTS
TESTED IN LABORATORY
AND
UNDER WORKING
CONDITIONS

EVERYTHING
GUARANTEED

MONEY BACK AFTER 3 DAYS
If you are not satisfied as represented. The primary has 16 spaced taps, 18 single taps, so that a very fine tuning can be obtained. This feature along with 12 taps in secondary and dead end switch shown at left in panel, makes this instrument reliable for experimental work in schools and laboratories.

361 E. OHIO STREET

G. M. PROUDFOOT

CHICAGO, ILLINOIS

We manufacture our own jacks, which allows shortest connections possible and more permanent construction than with telephone jacks. Automatic filament control by plug, \$10.00 additional.

Any Apparatus ordered from WHITALL MAIL ORDER SERVICE is guaranteed to be shipped at once—and to arrive in perfect condition—and to give complete satisfaction. All goods shipped prepaid.

VACUUM TUBES				
UV200 gas content detector	\$5.00	No. 3680-23 plate .0005 mfd. 3.25		
UV201 Pilotron amplifier	6.50	No. 3681-23 plate .0005 mfd. 3.50		
UV202-5 watt transmitter	8.00	No. 3682-23 plate .0005 mfd. 4.25		
Moorehead amplifier	8.00			
Electron relay detector	5.00	TELEPHONES		
Audiotrons	4.15	Murdock No. 55 2000	4.50	
(We supply full directions with tubes)			Murdock No. 55 3000	5.00
AMPLIFYING TRANSFORMERS			Murdock No. 56 2000	6.00
Clapp-Eastham type 26, unmounted	4.00	Murdock No. 56 3000	6.00	
Clapp-Eastham type 26, mounted	5.00	Connecticut 2000	6.50	
Acme core and coil assembled	4.50	Connecticut 3000	6.50	
Acme semi-mounted	5.00	Baldwin type C	13.75	
Acme fully mounted	7.00	Baldwin type D	15.00	
UV712 Radio Corp	7.00	Baldwin type E	16.25	
Saco Clad	5.00	Baldwin type F	9.50	
VARIABLE CONDENSERS			Baldwin loud speaker unit	12.00
Connecticut .001 encased	6.50	AUDION CONTROLS		
Connecticut .001 panel type	6.50	Clapp-Eastham ZRD Detector	10.50	
Murdock 366-43 plates		Remier No. 330 detector	8.00	
.001 mfd. full mounted	4.75	Amrad type	12.00	
No. 367-43 plate .001 mfd.	4.50	SHORT WAVE SET MATERIALS		
No. 368-23 plate .0005 mfd.	4.00	Murdock variometers	7.50	
No. 3660-43 plate .001 mfd.	4.00	Murdock variocouplers	8.50	
No. 3661-43 plate .001 mfd.	4.25	CLAPP-EASTHAM MAKE		
No. 3662-43 plate .001 mfd.	5.00	ZRD Variometer without dial	5.75	
		ZRD Variometer with 3" dial	6.50	
		ZRC Variocoupler with knob & dial	7.50	
		ZRC Variocoupler with switch & points	9.00	
		STORAGE BATTERIES		
		Weeco 6 volts 50 amp.	15.00	
		"B" BATTERIES		
		Weeco No. 623 plain 22½ volts	1.50	
		Weeco No. 623 variable 22½ volts	1.75	
		Weeco No. 625 plain 22½ volts	2.50	
		Weeco No. 625 variable 22½ volts	2.50	
		Weeco plain 45 volts	6.50	
		Eveready variable 22½ volts	3.00	
		The Radio Magnavox	Prepaid .45.00	
		VT SOCKETS		
		Murdock	1.00	
		Radio Corp.	1.00	
		General Apparatus	1.00	
		Signal	1.50	
		Remier	1.50	
		WESTINGHOUSE		
		Complete Stock New Westinghouse Apparatus		
		"Aerola Jr." crystal rec.	25.00	
		Type RA Tuner amp.	65.00	
		Type DA Detector amp.	65.00	
		Type RC Receiver, complete, includes RA Tuner and DA Detector amp.	125.00	
		6 amp. Rectagon Battery Charger	28.00	

THE WHITALL ELECTRIC COMPANY, SPRINGFIELD, MASS.

Reg 9356

Reg 9356



Another Marshall-Gerken Creation "READ 'EM" BINDING POSTS

ENGRAVED and INLAID—NOT STAMPED

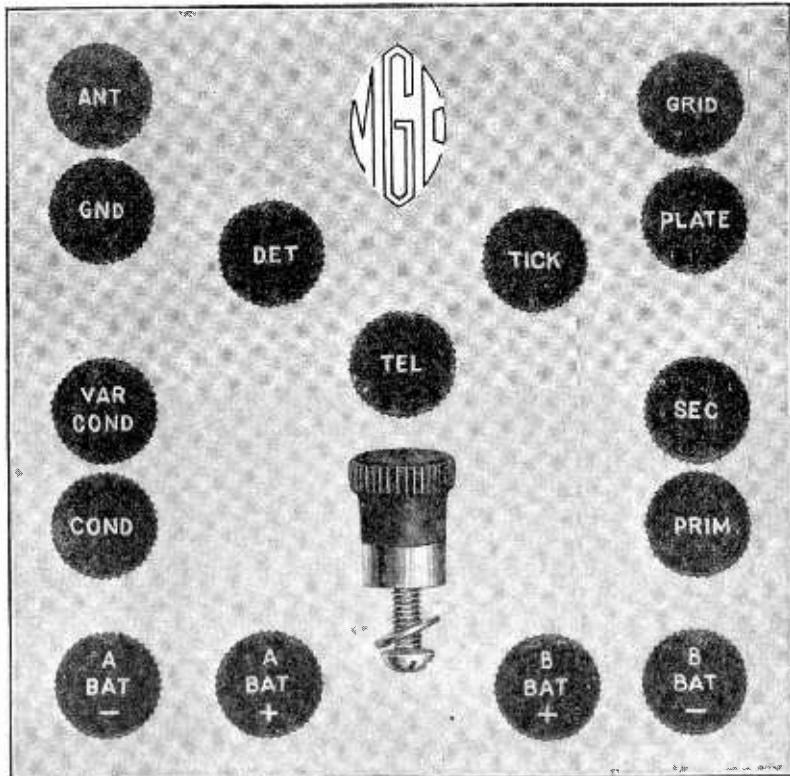

MADE IN 15 STYLES—Knobs and Posts Complete, 25c Each

These "Read 'Em" Binding Posts are a practical necessity for successful operating. They add to the appearance of your outfit and at the same time give specific directions to the operator at all times. They do away entirely with the necessity for engraving panels, thus saving expense, time and confusion. They can readily be incorporated in any set without dismantling. They are for both Front and Rear Posts and meet an obvious and general need for both beginners and experienced operators. Manufacturers can well afford to incorporate them with their regular sets. Dealers: "Read 'Em" Posts will boost your business. An inquiry gets our special dealers' proposition.

The Marshall-Gerken Company
MANUFACTURERS AND JOBBERS
32 Radio Bldg. Toledo, Ohio, U. S. A.



A REAL BARGAIN

Send your order in today. Cuts approximately full size.



No. 60 binding post, polished nickel with knurled hard rubber top
was 12c now **08c.**

Send 2c stamp for descriptive catalogue R-21.



No. 110 switch lever, polished nickel with finely knurled knob. Bushing also furnished with this lever
was 60c now **45c.**

DAVID KILLOCH COMPANY, 57 Murray St., NEW YORK

plate circuit of a short-wave set, extremely sharp tuning may be obtained, which, in conjunction with the elimination of interference, makes the set, thus constructed, the most efficient that can be had.

The smallest set of coils has a wavelength range of 180 to 450 meters, while other coils are designed for a range of 450 to 2,500 meters, with some others for very long wave reception.

While listening to a radio concert in the vicinity of New York City, it was possible, using the coils for short waves, to eliminate a high power Navy station which caused much interference. This, in itself, is a proof of the efficiency of the radial inductance. If any additional information is desired, the writer, whose address is Queens Village, Long Island, N. Y., will be glad to supply it, with circuit and other data.

Junior Constructor

(Continued from page 507)

AN EASILY MADE VARIABLE CONDENSER.

By John D. Adams.

A very satisfactory variable condenser may be made from two pieces of tin and a small piece of board. Compared with the usual condenser in the cylindrical glass container, it occupies much less space, but its capacity is much greater than would appear at first glance, by reason of the fact that the space between the plates may be greatly reduced. For long-distance receiving, where a fine adjustment is desired, it will not replace the standard form of condenser, but for average amateur purposes it will be found to render good service.

Procure two pieces of heavy sheet tin about five inches square that are as flat as possible, and then round the corners and edges with a file. Next select a piece of half-inch wood at least an inch wider and longer than the plates. Boil it in paraffin, and then cover the upper side with a piece of paraffined paper. Slightly warm one of the plates and press it down on top of the paper. Coat the plate with shellac, and cover with another piece of paper large enough to project one-quarter of an inch on three sides and about an inch on the fourth. Press until thoroughly dry, and then coat the upper side with shellac. The projecting end of the paper may then be brought over the upper plate and fastened with shellac to serve as a hinge. Connect each sheet of tin to a suitable binding post.

The adjustment may be made in several ways. A screw and nut arrangement may be adopted and if the condenser is to be used on a panel, only the screw need show in front. A strip of brass is soldered edge-wise to the upper plate, so that it will be held at any point where it may be set merely by friction between it and the two vertical strips screwed to the base board.

A NOVEL FIXED VARIABLE CONDENSER.

In constructing a condenser, whether for use in the sending or receiving hook-ups, the amateur usually is up against something that makes him lose sleep at nights. The fixed variable is another nightmare, and the switching is usually accomplished by the use of a fan type of switch.

The condenser described herein is a departure from the type generally used and makes use of no fan switch. The condensers are hooked up in series instead of in parallel and therefore need no complicated switch arrangement.

The capacity of the condenser depends upon the use to which it is to be put. If a condenser of high capacity is desired and the space kept down, the amateur must use a

dielectric of high inductivity. A condenser built up of certain sizes of plates and a certain number of plates, placed a certain distance apart, with mica sheets as the dielectric, will have about eight times the capacity of one built to the same dimensions, but using the air spaces as the dielectric. If the condenser is to be used for sending, the unlike plates must be well insulated and this insulation must be able to withstand the required voltage. The inductivity of different materials varies; the table given here is correct.

K—Inductivity or Specific Inductive Capacity. K

Air	1.0000
Manila Paper	1.500
Paraffine	1.68 to 2.30
Hard Rubber	2.86
Shellacked Paper	2.74
Glass (Good grade)	6.00
Mica	4.00 to 8.00
Porcelain	4.38

The capacity of any condenser can be found by using this formula.

$$C \text{ (in mfs.)} = \frac{885 \text{ A K}}{1000000000 d}$$

\$1.00 BRINGS YOU

- 1 Switch Lever, 1 3/4" Radius.
- 12 Switch Points complete with nut
- 2 Switch Stops complete with nut
- 2 Non-Removable top Binding Posts

ALL BEAUTIFULLY NICKLE PLATED.

GET THE ENTIRE GROUP for \$1.00 From Your Dealer

or direct from

PREMIER DENTAL MFG. CO.
60 N. 2d ST. PHILADELPHIA, PA.

Screw Machine Products

Get Our Literature.



Crosley V-T Socket

60c

"Better -- Costs Less"

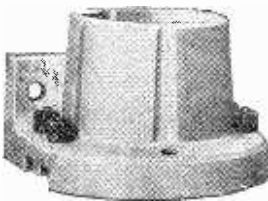

The reason for its tremendous success is not low price, but because it is BETTER. The bayonet catch is now imbedded in a much heavier wall instead of being cut clear through. This eliminates the possibility of breakage through careless handling.

The whole socket has been greatly reinforced. It is now practically unbreakable. Dropping it on the floor will not break it. The springs are phosphor bronze, nickel plated; screws and nuts brass nickel plated.

It is built for base or panel mounting, an exclusive feature. It is the prettiest thing you ever saw assembled in a set. Now used by several manufacturers as standard equipment. Made of one piece porcelain; no metal shell, hence no ground hum. Better for power tube work, as it withstands heat and will not melt. Patent pending. Every progressive dealer now handles the CROSLY V-T SOCKET or will obtain them for you. If your dealer can't supply you, send us his name and order direct. We will ship prepaid. Every socket is GUARANTEED to give satisfaction or money refunded.

The Crosley Variable Condenser

(Pat. Pend.)

"BETTER—COSTS LESS"

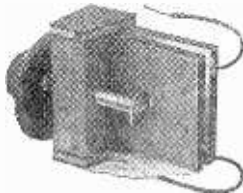

This Condenser works on an entirely new principle. The two plates are hinged and are opened and closed like a book by means of a specially designed cam. The plates are surfaced with copper. One copper sheet is covered with mica so

that when the two plates are clamped tightly together the maximum capacity is obtained. The maximum capacity of this Condenser will average about .0008. We rate it conservatively, however, at .0005.

This Condenser has several advantages over the ordinary type of air condenser. Will stand 1000 volts without breaking down. It can therefore be used for C.W. work. Has no body or hand capacity effect. Has much greater signal strength due to the fact that mica is a much more efficient dielectric than air. The calibration curve of this Condenser is almost a straight line. Has unusually low zero capacity—.00006.

Price without knob and dial.....\$1.25
With knob and dial.....1.75
Mounted in cabinet with knob and dial.....2.50
Knob and dial only for 3/16" shaft......50

Sold on a GUARANTEE of absolute satisfaction or money refunded.

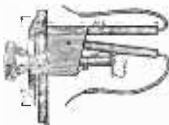

Crosley Cabinets

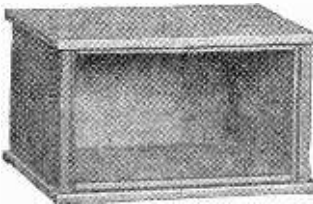

The tendency in the radio field today is to put apparatus in cabinets not only for appearance's sake, but as a protection from dust, dirt, atmospheric conditions, etc. Realizing the demand for attractive stock cabinets of various sizes, we are building them in quantities in our large wood working plant. These cabinets are all uniform in style. The panels are rabbeted in to the front. As the outside dimensions and inside dimensions are either larger or smaller than the panel itself, we show panel size and also inside dimensions. Prices quoted do not include the panels. Wood used is either gum or mahogany in dark antique or red mahogany finish or in quartered oak in natural or antique finish. Specify type of wood and finish in ordering. Lids or tops are hinged. Sizes and prices are:

For Panel Size	CABINETS Inside Dimensions			Mahogany or Quartered Oak	
	High	Wide	Deep	Gum	Oak
6 x 7	5 1/2"	6 1/2"	7"	\$2.50	\$3.85
6 x 10 1/2	5 1/2"	10"	7"	2.75	4.40
6 x 14	5 1/2"	13 1/2"	7"	3.30	5.55
6 x 21	5 1/2"	20 1/2"	7"	3.90	7.30
9 x 14	8 1/2"	13 1/2"	10"	3.70	6.80
12 x 14	11 1/2"	13 1/2"	10"	4.40	8.80
12 x 21	11 1/2"	20 1/2"	10"	5.25	10.60

Cash must accompany order. No C.O.D.'s. We pay transportation charges.

FORMICA PANELS

We can furnish genuine formica panels 3/16" thick, cut to the following dimensions: 6 x 7; 6 x 10 1/2; 7 x 9; 6 x 14; 7 x 12; 6 x 21; 7 x 18; 9 x 14; 12 x 14; 14 x 18; 18 x 21. Price of panels—2 1/2c per square inch. For odd sizes order the next largest size; we will trim. We pay postage.

HARKO RADIO RECEIVER



The most compact and complete efficient crystal receiving outfit on the market. Designed for the amateur who wishes to get started in this wonderful game. The illustration shows complete outfit ready to hook to aerial, fones and ground wire. Will tune from 200 to 600 meters.

bringing in spark, voice and music with average amateur antenna. NAM, Norfolk, Va. and ships at sea copied in Cincinnati.

20 Watt Radiophone copied 25 miles with addition of the Crosley Variable Condenser in series with antenna. Radiophones copied five to ten miles without condenser. A wonderful little instrument. Price complete with battery, interruptor for testing crystal, instructions, etc., \$9.00. One thousand ohm single head set, 125 ft. antenna wire, insulators, etc., \$6.00 extra. Complete outfit, \$15.00. If your dealer cannot furnish, we will ship direct prepaid.

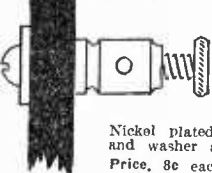

CROSLY BINDING POSTS

Barrel 5/8" x 1/2". Not too small nor too large. Just the right size.

Nickel plated. Complete with base screw and washer as illustrated. Price, 8c each or 90c per dozen.

CROSLY RHEOSTATS

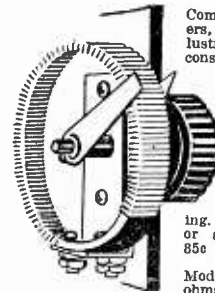

Complete with knob, pointers, etc., as shown in illustration. Our unique construction permits mounting on panel of any thickness up to and including 3/8"; non-corrosive resistance wire.

Model "A"—overall diameter 1 1/2". Resistance 7 ohms, one ampere without heating. Suitable for detector or amplifier tubes. Price 85c each.

Model "B" Resistance 4 ohms; will carry 3 amperes without heating. Suitable for detector, where very accurate adjustment is required and for 5 watt power tubes. Price \$1.50.



CROSLY MAGFON

No radio station complete without it. Built in horn; amplifies signals, voice or music, making head phones unnecessary except on weak signals. Uses one watch case receiver, any make; simply insert it in back of cabinet. Beautiful antique mahogany finish. Price, \$10.00.

CROSLY TAP SWITCH

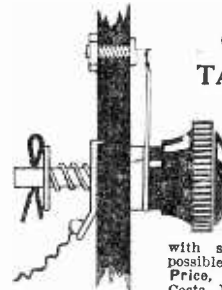

Note unique construction assuring constant tension. Composition knob, nickel plated switch arm and bushing. Note stationary washer with soldering lug, making possible buss wire connection. Price, 45c each. Better—Costs Less.

Switch Taps for above, brass nickel plated, complete with brass nut, 3c each, 30c per dozen or \$2.50 per hundred.

Every article bearing the name "CROSLY" is GUARANTEED to give absolute satisfaction or money will be refunded.

We shall be pleased to send literature describing the above mentioned and other radio apparatus to any one free of charge upon request. Get your name on our mailing list to receive latest Bulletins of other new Crosley products. If your dealer does not handle our goods, order direct and send us his name.

DEALERS—It will pay you to handle our lines. Write for full particulars.

CROSLY MANUFACTURING CO.
Radio Dept. No. R-6 CINCINNATI, OHIO

READY FOR CHRISTMAS



We are pleased to announce that our new short-wave coils are ready for distribution. They are not "freak" coils but designed upon the solid fundamentals of radio practice. They are, however, adapted for use with our standard unit mounting fixtures. With a given condenser these coils all have a greater wave-length range, than the honeycomb coils.

But most important—note the H.F. resistance values and decrement of three of the secondary coils compared with three old type honeycombs.

	External Capacity	Wave-Length	H.F. Resist.	Power Factor	Decrement
Old Type 25....	.0001mf.	147	64	.0820	.257
	.0004mf.	244	11	.0340	.107
New Type 1s....	.0001mf.	147	12	.0154	.048
	.0004mf.	273	3	.0083	.026
Old Type 50....	.0001mf.	283	134	.0891	.280
	.0004mf.	475	23	.0364	.114
New Type 2s....	.0001mf.	305	26	.0160	.050
	.0004mf.	588	8	.0102	.032
Old Type 100...	.0001mf.	540	314	.1091	.343
	.0004mf.	900	40	.0334	.105
New Type 3s....	.0001mf.	623	71	.0212	.067
	.0004mf.	1160	11	.0072	.022

Facts are facts. We place them before you to use when buying inductances. And will furnish more for the asking.

COTO-COIL CO. 87 WILLARD AVENUE
PROVIDENCE, R. I.



Sidson Radio B Battery

Rechargeable Variable

- No. 1001 24 volts—size 1 3/4 x 4 x 2 1/2 \$3.00
- No. 1002 44 volts—size 3 1/2 x 4 x 2 1/2 4.50
- No. 1003 80 volts—size 7 1/2 x 4 x 2 1/2 8.00

The Sidson Battery is a rechargeable and variable battery especially designed for vacuum tube work on the plate or transmission circuits. It is far superior to any dry battery now on the market, for the Sidson B Battery is a storage battery built with plates of a special composition, and so constructed that it can be recharged in from 3 to 5 minutes, when connected with any charging line or a battery. (Directions Come with Battery).

The Sidson B Battery will operate in a circuit of three vacuum tubes and is variable from 2 volts up.

Buy yourself a Sidson B Battery and get continuous service and at the same time save money. We guarantee them for one year.

DEALERS.—You will find that the Sidson B Battery is just what we claim it to be—the best and most salable battery made to-day, and every sale means not only profit—but a pleased customer. Write for proposition.

Isaacson & Kaufman, 5229 B'way, New York City

NOTICE

Reduced Prices

Buy that new C-W set and short wave receiver now and save money. We offer you 10% off on our entire stock Dec. 15th to Jan. 15. New Amrad Short Wave Set, \$42.75; Det. 2 Step Amplifier, \$40.50; Tubes: UV-200, \$4.50; -201, \$5.85; -202, \$7.20; -203, \$27.00. We carry the most complete line in the South, stocking practically all goods listed in this magazine. Detector Control Panel, complete with tube, \$10 Postpaid.

SOUTHERN RADIO SUPPLY CO.

11 N. Ft. Harrison Avenue

Clearwater, Fla.

Southern Amateurs

Christmas Sale

NOTICE

One Month Only

WE PAY TRANSPORTATION

On all receiving apparatus and parts, anywhere in the United States.

Send 2c stamp for our latest lists.

WE WILL SAVE YOU MONEY.

ASHTABULA RADIO SALES CO.,
49 McGovern Ave., Ashtabula, Ohio

CARDBOARD TUBING

In any length up to 25"—
3" and 3 1/2" Dia. 3 1/2 cents per inch or fraction—
30 cents per foot; 4" and 4 1/2" Dia. 4 cents per
inch or fraction—35 cents per foot; 5", 4 1/2 cents
per inch or fraction—42 cents per foot; 3", 3 1/2"
and 4" has 1/2" wall; 4 1/2" and 5" has 5/32"
wall. Postage Extra. Shipping weight about
1 1/2 lbs per foot. Dealers write for discounts.

Circular for stamp.

JEFFERY-CRAWFORD COMPANY
2173 Hilltop Ave. Detroit, Mich.

A is area of dielectric (r side) in sq. cms.
K is taken from above list.

d is average thickness of dielectric in cms.

If the experimenter has on hand a small telephone condenser of about 1 mf., he can easily make a small condenser that will reach from .000007 to .003 mfs. capacity. A condenser is first made that has a capacity equal to the maximum wanted, another is made like it. If connected in series these will have a total capacity of only one-half that of each one separately.

If, for instance, you wanted a condenser of .02 mfs. maximum, you would take 1/50 of the 1 mf. condenser and make it into small units. Now another of the same size is constructed, and one using only 1/100 of the area of the 1 mf. condenser. These have the following capacities when connected in series:

- a—.02 mfs. a and b in series —.01 mfs.
- b—.02 mfs. a, b and c in series —.005 mfs.
- c—.01 mfs. b and c in series —.0066 mfs.

Of course, the experimenter will want capacities, and so I give only general details.

$$\text{Condensers in series } C = \frac{1}{\frac{1}{c} + \frac{1}{c'}} \text{ etc.}$$

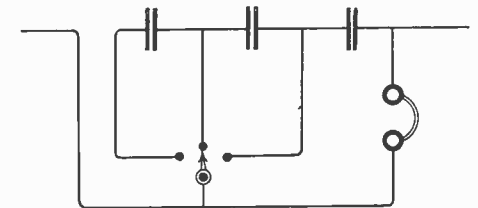

By Connecting Fixed Condensers in Series Only an Ordinary Type of Switch is Used to Vary the Capacity.

Hook up the separate capacities the same as you would inductances with a rotary switch, and although this method requires more condensers, these are not hard to make and it gives just as many adjustments if constructed properly.

Bugs, load your variable and get increased range out of your honeycombs.

Contributed by RALPH F. LIPPI.

NEW USES FOR BROKEN GRAMOPHONE RECORDS

Unused or broken records can be heated with a blow lamp, rolled up and worked into all shapes while hot. They can then be pressed into moulds, and screw-heads can be heated and pressed into the surface. The moulded material can be turned at slow speed in a lathe, using paraffine oil on the tool and a finish can be put on with a fine emery cloth and oil, finishing with a dry cloth. It can be rolled out into thin plates, if placed between hot metal plates and passed through the mangle. Its uses are innumerable for switch handles, etc.

When cutting slots in disc records for coils, clamp the disc between two flat pieces of wood and saw through the three. This leaves a nice clean cut and prevents breaking the disc. The thickness of slots can be varied by using fine hack-saws and placing one, two, three or four together in the frame to get the proper thickness of slot.

To make a very hard and tenacious cement for all purposes, and one that is easily applied, procure some old broken flat gramophone discs and powder them up with a hammer; put the powder into a small tin and add the same amount of methylated spirits, or alcohol; place the tin in a water bath the same as glue is melted, and stir constantly. The resultant paint or mixture makes a splendid cement for electrical purposes, and sticks to anything. If made thick, it can be used for holding in loose nipples, etc.

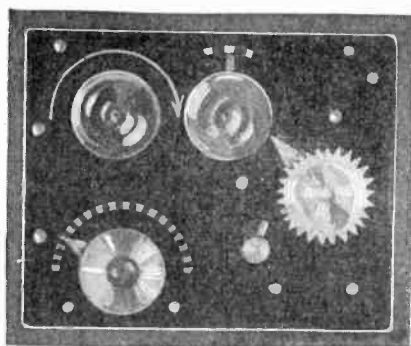

Condensite Celoron is Real Radio Insulation

Use the highest type insulation made. Produced expressly for radio and wireless work. Adaptable to every machining process and ready for every use—panels, plates, bases, rods, tubes, bushings, handles, cleats, etc.

To high resistivity and extreme water resistance. Condensite Celoron adds every other good quality demanded of an efficient insulator. It puts wireless insulation a step ahead. This Bureau of Standard test tells why:

Wave Length Meters	Approximate Frequency Cycles per second	Phase Difference Degrees	Dielectric Constant-K
373	804,000	2.0	4.7
1,295	231,500	1.8	4.8
3,067	97,800	1.8	4.9

Condensite Celoron is regularly supplied in standard size sheets, rods and tubes ready for all machining purposes—for experts and amateurs. Sold by radio equipment dealers everywhere. If your dealer cannot supply you, write us.

Diamond State Fibre Company

Bridgeport (near Philadelphia), Pa.

Branch Factory and Warehouse, Chicago
Offices in Principal Cities

In Canada, Diamond State Fibre Company
of Canada, Ltd., Toronto

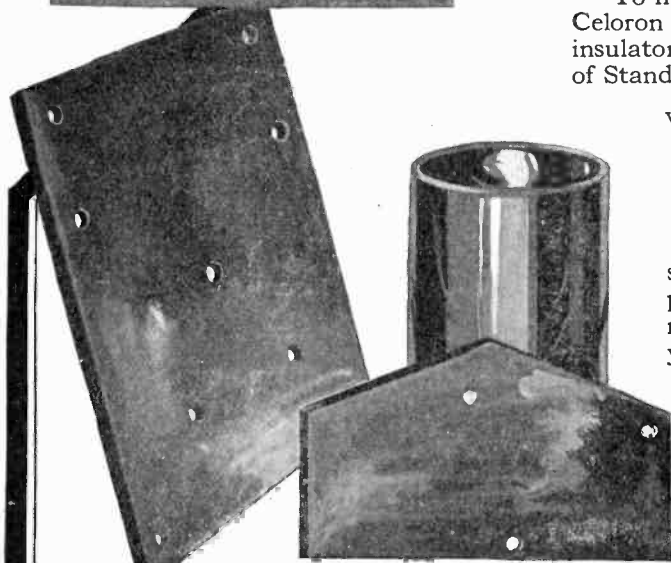

Reg. 9356

Reg. 9356

New Moulded Variometer With Positive Pigtail Contact

Price

\$6.50

Type M. V. G. for Grid

Type M. V. P. for Plate

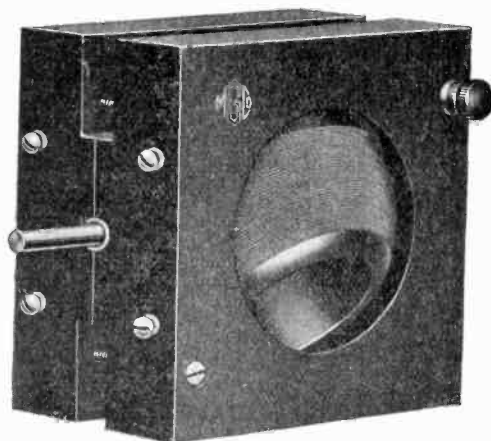

This New Moulded Variometer of exactly correct weight is the only variometer on the market today with POSITIVE PIGTAIL CONTACT. This new feature has made this variometer standard equipment with discriminating users. Constructed for either table or panel mounting.

Fitted with 1/4" rod for dial. Overall size 4 1/2 x 4 1/2 x 2 3/4". Wave length 150-750. Type M. V. G. for Grid—Type M. V. P. for Plate.

Dealers should order their supply now for prompt shipment

The Marshall-Gerken Company

MANUFACTURERS AND JOBBERS

32 RADIO BLDG.

TOLEDO, OHIO, U. S. A.

Reg. 9356

Reg. 9356

CW Transmitter and Receiver Parts

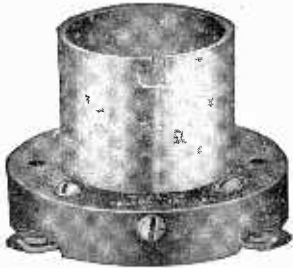

TYPE 156 SOCKET

The experimenter who has had previous experience with the assembly of receiving and transmitting sets has learned the necessity of having every unit perfect. Entirely aside from the gain in efficiency, he has found the advantage of using apparatus in which the greatest care has been given to construction details.

General Radio apparatus is designed with this end in view. A noteworthy example is the Type 156 Vacuum Tube Socket.

This socket is adapted to any of the standard American four-prong transmitting or receiving tubes. It is adapted to the Western Electric VT-2 tube, as well as to the Radiotron UV-200, 201 or 202 tubes. The contact springs are sufficiently rugged to carry the filament current of the five-watt transmitting tubes without arcing.

PRICE \$1.50

This is but one example. Others are Amplifying Transformers, Modulation Transformers, Tuning Inductances, Hot Wire Meters, etc. SEND FOR FREE BULLETIN 909-N, describing these and other instruments.

GENERAL RADIO COMPANY

MASSACHUSETTS AVENUE AND WINDSOR STREET

CAMBRIDGE 39

MASSACHUSETTS

Standardize on General Radio Equipment Throughout



Reg. U. S. Trademark

We Have
Complete
Stock of

RADIO PHONE PARTS

including

Radio Corporation Products
and Many Others of Merit

We have a large stock of all reliable makes and ship same day order is received.

**PHILADELPHIA SCHOOL OF
WIRELESS TELEGRAPHY**

Jobbers and Dealers in Radio

1533 Pine Street

Philadelphia, Pa.

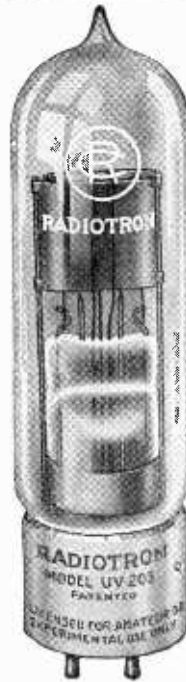

CANADIAN AMATEURS!

**HEADQUARTERS FOR THE BEST
RADIO EQUIPMENT!**

Write for Price List

SCIENTIFIC EXPERIMENTER, Limited
33 MCGILL COLLEGE AVENUE MONTREAL

Winning the Public to Radio

(Continued from page 494)

which the writer cannot go into in the short space of this article.

The following paragraphs are taken from a piece of copy that the writer prepared some time ago for a radio manufacturer; it was prepared for newspaper work.

JUST TURN THE KNOB AND LISTEN TO THE WIRELESS MUSIC

Wireless is not a black art! There is no mystery about it. It is as simple as A, B, C. Operating a small radio receiver is just like focusing a camera or playing the phonograph. There are no accurate or painstaking adjustments to be made, no fuss, no bother. "Turn the knob and listen," that is all there is to it. No wires to string outside, no expensive installing to do. The thrill that radio brings can be experienced by anyone any place.

"PLUG" YOUR HOME IN ON THE "RADIO LINE"

There is always wireless music in the air. You can listen to it. You don't have to bother with connections. You put your "radio box" on the table and turn the knob. Wireless "jazz" will pour in. You will hear speeches, vaudeville sketches, operas and sporting news. Lots of fun for these cold winter nights. Think of pulling music out of the silent, gray wintry sky! Fun for everybody!

AS EASY AS LISTENING ON THE TELEPHONE

"Listening in" on the "sky jazz" is as easy as listening over the telephone—no more trouble and just as positive. Wireless should be in every home. It means oodles of fun, education and entertainment for all. Concerts every day and night and you get the news by radio before you read it in the newspapers. Outfits inexpensive. Cost nothing to operate. Surprise your friends and visitors with a modern wireless concert. Farmers use wireless. Why not city folks?

A slogan must be adopted that will tend to put the desire for the radio receiver in the heart of everyone. This slogan must be flung far and wide and used on every piece of copy that is prepared. It must become as famous as "The Voice With The Smile Wins," or the many other slogans that have been used for various purposes. Then the manufacturers must choose between the word *radio* and *wireless* once and for all. Today people think there is a difference between radio and wireless. In fact, the writer heard of one very learned person who thought that radio had something to do with radium. One word or the other must be brought into universal use by mutual agreement. The use of two words is confusing and will tend to harm the popularization of communication without wires.

The writer looks forward to the day when we will see notices like the following in our daily papers:

HOFFMAN RADIO CONCERT TONIGHT.

Turn the knob of your selector to position 8 and listen in at seven o'clock sharp. Mr. Hoffman will play Valse Brillante, The Jugglers, The Hunting Sons and Selections from Rigoletto.

A more suitable plan of co-operation between dealers and manufacturers must be worked out. The dealer is in a position to offer a great deal of assistance in the popularization of radio. He can interest every person who comes into his store. With



32 Long Hours

he wore Brown Phones

HIS SHIP slowly sinks—37 lives depend on him—for 32 hours operator Powell feverishly stuck to his post, while his hand grew numb at the key. At last his heroism was rewarded, and thru the Brown Phones that had become a vital part of his experience, came the strained-for answer to his S.O.S.

Would it be out of place to say that those phones, with their super-sensitive reproducers and extreme light weight (only 9 ounces) at least contributed somewhat to saving those 37 lives? Powell himself says the light weight of his Browns saved him from exhaustion hours sooner.

You can enjoy this same comfort and light weight daily. Brown Phones, with conical aluminum diaphragms and rugged protecting shells, are now for sale at leading radio dealers at these reduced prices:

Type A (adjustable) was \$22.00, now \$18.00
Type D (for phone work) was \$20.00, now \$16.00
(Either type equipped with Firco Round Plug for \$1.50 extra)

John Firth and Co. Inc. 18 Broadway, N. Y., Distributors.

BROWN PHONES

For Christmas—a MAGNAVOX with the big new 14" horn

Get a Magnavox now for Christmas, the one reproducer that will give you all the volume you want, without any distortion and without injuring your apparatus. Specify Type R-3 MAGNAVOX and get the big, new 14" horn without any additional cost—price complete \$45.

Throw away the uncomfortable head set that chains you to your outfit. Get a MAGNAVOX. Delight your friends with radio concerts and wireless dance music. Make your set the source of pride and center of enjoyment it should be.

And be sure it's a MAGNAVOX, the *only* reproducer with the *movable coil*. Look for the trademark on the horn. If your dealer cannot supply you, write us direct. Do not accept a substitute.

PRESENT MAGNAVOX OWNERS may purchase the new horn alone for \$15, but no exchanges will be accepted.

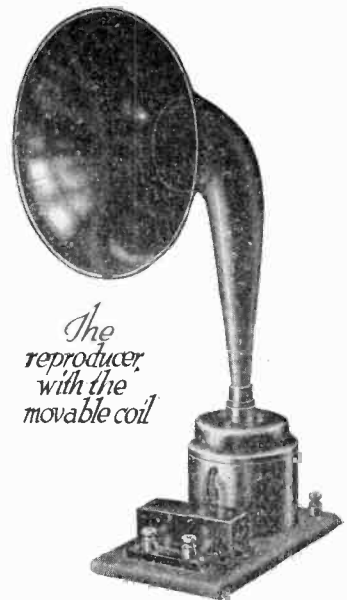

*The
reproducer,
with the
movable coil*

The Radio MAGNAVOX

—the reproducer with the movable coil (Patented), the one instrument that will faithfully reproduce sounds and signals in any volume desired, without distortion and without injury to the apparatus. No set complete without one. Anyone can operate it. Full instructions free with each outfit. Type R-2 with 22" horn, price \$110.

Type R-3 with new 14" horn, price \$45.

At your dealer or direct from factory.

REG. U.S. PAT. OFF. AND FOREIGN COUNTRIES

Dealers—Write for Proposition

WRITE FOR FREE FOLDER

—illustrating and describing the construction and operation of the Radio MAGNAVOX, and the famous movable coil, also the new MAGNAVOX Two-step Amplifier, especially designed for use in connection with the distortionless reproduction of wireless music. Other MAGNAVOX apparatus also described and illustrated. This folder FREE. Write for it to-day.

GENERAL OFFICES and FACTORY
OAKLAND - CALIFORNIA
 NEW YORK OFFICE
 370 Seventh Avenue, Penn. Terminal Bldg.



Unwired Regenerator

\$22.50

These apparatus are constructed with the best materials and workmanship. They have no superior at any price. Apparatus fully guaranteed. Send for descriptive bulletin immediately.

DETECTOR & TWO STAGE AMPLIFIER

\$25.⁰⁰/₁₀₀ WITH 3 LICENSED TUBES MATCHED TO TRANSFORMERS



\$40.00

FREDERICK WINKLER, JR.
304 COLUMBUS AVENUE
NEW YORK, N. Y.

CINO WISHES



to extend to our many friends and admirers, our thanks for your support and good will during the past year, and to extend to you our sincere hopes that you may enjoy unbounded good health, happiness and prosperity through the coming year. May yours be the happiest of Christmases and the Happiest of New Years.

Cino apparatus is going bigger than ever and here is our Yuletide Offering
We are **GIVING AWAY ABSOLUTELY FREE** to each purchaser of a CINO Tuner and Detector Control, a detector tube and "B" battery, tested with our personal OK attached to each individual shipment, the order for which is in our hands prior to midnight December 31st, 1921.

CINO Tuner	\$50.00	CINO Variometer parts	\$2.50
CINO Detector	18.50	CINO Variometers, wound only	4.50
CINO Two Step amp	40.00	CINO Variometers, complete	6.00
CINO Variocoupler, wound and tapped but not assembled, \$4.50		CINO Variocoupler, complete	
CROSLEY PORCELAIN SOCKET		\$.60	

Send for parts price lists of complete CINO units if you build your own



Cino Radio Mfg. Co.
218 West 12th Street
Cincinnati Ohio



FREE ONE VICTOR VT SOCKET TO EVERY PURCHASER OF AT LEAST \$7.00 WORTH OF RADIO APPARATUS FREE

This is a Christmas present to you from the P. A. RADIO LAB. OR we will give a socket with each UV-201 purchased. This VICTOR socket is a little wonder. It is fused for one amp. for the rec. tubes or Moorhead transmitters and also can be obtained fused for Radiotron 5W transmitters. A transmitting socket with every UV-202 purchased.

Every prong on tube base furnishes contact surface of 3/8" x 1/4" to the VICTOR socket. Think of that! No microphonic contact there and you can't PUT OUT THAT LIGHT!

Due to the fuse, \$1.00 each, or free as mentioned. Offer above good only for December. Dealers write, we are distributors. The VICTOR has no rivals.

DID YOU READ ABOUT THE KLAUS SWITCH THE LAST TWO MONTHS?

Well we have it! The blade and knob are the only moving parts of this excellent product. Solder direct to the shaft. No chance of either switch or connection coming loose. You'll get no funny noises with the Klaus Switch. 60c each. Special with 6 switch points, 65c.

We are distributors of the Klaus non-competitive line. Dealers write for a really attractive offer.

We have lots of other junk. We handle no complete sets, but can obtain them for you. Parts for everything. Complete Remier line. Order from their ads. Chi-Rad vars. in parts or assembled. Order from Chicago Radio Apparatus Co. ads. Baldy type E's, \$15.00. Murdock 3,000 ohm 56's, \$6.00. SACO CLAD amplifying transformers, \$5.00. Electrore insulators, 10 inch, 68c; Ball 30c; Formica 2 1/2c square inch. Try our second hand service. Order it if it's a part and watch us ship.

Watch for next month's bargain.

We calibrate that wavemeter to 1000M at 85c point, \$1.00 for three points. Ship care-fully packed and insured.

PORT ARTHUR RADIO LABORATORY, PORT ARTHUR, TEXAS

little or no trouble he can put a radio receiver on his showcase and let the customers operate it themselves to see how easily it is done. Once they get the thrill that comes with the first music that is picked out of space, half the battle is won.

In the near future the popularization of radio should be started off with a radio week. That would mark the beginning of the first real serious effort to win the public over to radio. A program could be planned and carried out that would do a great deal toward overcoming the prejudice that is now quite evident. The radio week would mark the beginning of an era of intensive progress and unparalleled prosperity for those of us who have unshakable faith in radio as an entertainer and an educator. No plan could be too ambitious. The whole thing is so alluringly possible, that it resolves down simply to this, "Let's go."

The amateur can play a very important part in this great scheme also. He can invite friends to his station and, instead of trying to mystify them with a lot of meaningless phrases to create a respect for his profound knowledge, he can explain things in a simple non-technical way to increase the confidence of his listeners. If he is not good at explaining things he can simply tell them that radio is a very easy thing to learn. Indeed, the amateur can do a great deal toward the popularization of the subject by passing the good word along. Of course, the selfish, small-minded fellow may say, "What good is that going to do me?" It will do him a lot of good in the end. More people interested in radio, mean greater activity on the part of the manufacturers and this means increased production, which will bring down the price of radio apparatus. It will not only do this, but it will cause the manufacturers to make serious efforts at broadcasting and this in turn will benefit everyone concerned.

The Story of Radio Telegraphy

(Continued from page 497)

a cup which I filled with iron filings. These filings were pressed by a vertical piston that was more or less charged. After having made my fundamental discovery, I experimented on the action of light on the conductivity of certain bodies. The luminous scurce was electrical. I noticed that its action made itself felt even when the light did not reach the body in question. It had then to be admitted that this action was due to something else. The "other thing" was the disturbance of the ether, produced by the spark."

"It is then undeniable," observed M. Givelet, "that you are the first scientist to have found the means of making the Hert-zian waves felt to an appreciable distance."

M. Branly, then checked himself. And always standing, supported at the table, he went on to explain to us, little by little, fragmentarily by these rapid confidences, with an extreme precision of details, the pathetic story of his prodigious life of struggles, persecuted independence and indefatigable researches. He tells us of his debuts as pupil in the normal school, his first functions as chief of works at the Sorbonne, his souvenirs of the war of 1870-'71, when with the physicist Fernel, he served in the army of Ducrot during the siege of Paris, his collaboration at the secretariate of the Academy of Sciences, his election at the Institute. The school—that means the Normal School—was the first to disown him. The Sorbonne bestirred itself to render homage to foreign scientists and encourage their works. A certain French scientist aided with all his power Marconi's claims. Another treated Bran-ly's researches as "pure rubbish." And

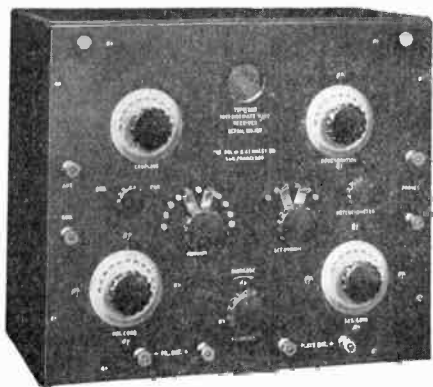

Type 220 Intermediate Wave
Regenerative Receiver

Licensed under Armstrong
U. S. Patent No. 1,113,149

KENNEDY
EQUIPMENT

QUALITY SUPREME

THE enviable reputation possessed by Kennedy radio receiving equipment has been built up by strict adherence to the very highest standards of quality.

WE have been equally careful in the selection of our distributors. The purchaser of Kennedy Equipment must have service in keeping with the quality of the apparatus and we have therefore chosen only firms of the highest standing to represent us. The present distributors are listed below. Arrangements are being made for others in centers where we are as yet not represented.

BALTIMORE—Jos. M. Zamoiski Co.
CHICAGO—Commonwealth Edison Co.
CLEVELAND—Newman-Stern Co.
DETROIT—W. J. Hartwig Co.
KANSAS CITY—Central Radio Co.
LOS ANGELES—Electric Lighting Supply Co.
Southern California Electric Co.
MINNEAPOLIS—Sterling Electric Co.

NEW YORK—Manhattan Electrical Supply Co.
PHILADELPHIA—Frank H. Stewart Electric Co.
PITTSBURGH—Doubleday-Hill Electric Co.
PORTLAND, ORE.—Stubbs Electric Co.
ST. LOUIS—Manhattan Electrical Supply Co.
SAN FRANCISCO—Warner and Linden
SEATTLE—H. E. Williamson Electric Co.
TORONTO—J. A. Paquin.

THE COLIN B. KENNEDY COMPANY

RIALTO BUILDING

INCORPORATED

SAN FRANCISCO

Using An Inefficient Condenser is Like Carrying Water in a Sieve

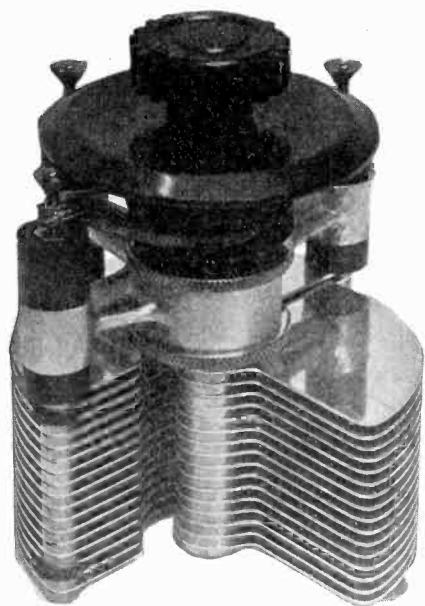

The same judgement used in the purchase of radio equipment that you use unconsciously in everyday affairs will invariably lead you to select COTOCO condensers. Users are unanimous in proclaiming them "the best."

This condenser used in conjunction with our inductance units will enable you to build a set that you will be proud to own.

*If your dealer cannot supply
you with our products, advise
us, and send us his name.*

COTO-COIL CO., 87 Willard Ave., Providence, R. I.

RADIO SUPPLIES and APPARATUS SPECIALS

V.T. Detector	\$5.50	Step Amplifier	31.00
V.T. Detector with Murdock 2000 ohm navy type telephones	10.00	With Radiotron detector tube and amplifier tube	41.00
One Step Amplifier	11.75	New Paragon V.T. Socket	1.00
One Step Amplifier with Murdock 2000 ohm navy type telephones	16.00	Fada Rheostat with new type knob	1.00
Signal Superior Detector and One		Fada Power Rheostat with new type knob	1.35
		Radio Corp. C.W. Instruction Book25

All makes of Radio apparatus carried in stock; all parts from contact points to cabinets and Bakelite; everything for the Radio amateur. Send 10c. for our new catalogue which will be credited against first two dollar purchase.

See last month's copy of RADIO NEWS for special prices on Magnet Wire. Aerial Wire No. 14, pure copper, NOW 65c. per 100 feet.

DREYFUSS SALES CORPORATION

WIRELESS AMATEURS' HEADQUARTERS

179 GREENWICH ST. Near Cortlandt NEW YORK
Around the Corner from the Tube Visit our Clubroom

"FOR IMMEDIATE SHIPMENT"

VARIABLE CONDENSERS		RHEOSTATS	
Chelsea .0006 for panel mounting	\$4.25	Remier	1.00
Chelsea .0011 for panel mounting	4.75	Fada	1.25
		Paragon	1.50
DIALS		"B" BATTERIES	
Chelsea 3" dial	1.00	Cyclone 22½ volt (small)	1.00
Paragon 2¼" rheostat dial80	Cyclone 22½ volt (large)	2.00
Paragon 3" dial	1.00	Cyclone 45 volt (large size variable)	4.04
Paragon 4" dial	1.75	Eveready 22½ volt (large variable)	3.00
Tuska 4" dial	1.50	Turney short wave regenerative tuner	5.04
Empire 2¼" dial25	Paragon socket	1.00
VACUUM TUBES		Tuska C.W. Inductance	3.75
Radiotron U.V.200 detector tube	5.00	Empire series-parallel switch85
Radiotron U.V.201 amplifier tube	6.80	Aome amplifying transformers (mounted)	5.00
Radiotron U.V.202 5 watt power tube	8.00	Remier detector panel	8.00
Audiotron double filament	6.00	Remier amplifier panel	8.00
VARIOMETERS AND VARIOCOUPERS			
Empire variometer	6.00		
Empire variocoupler	8.80		
Tuska moulded variometer with dial	7.25		

Send 10c for catalogue, money credited to first dollar purchase.

Empire Radio Equipment Co.

Manufacturers and Distributors of Radio Apparatus

271 West 125th Street New York City

HYGRADE Specials Save You Money

Paragon Control Panel with U.V. 200 Radiotron Tube	\$10.50	MARKO STORAGE BATTERIES	
Audiotron Tube-Two-Filaments	5.50	4 Volt 40 Amp.	\$7.50
Radiotron U.V. 200 with a combination grid leak	5.00	4 Volt 60 Amp.	10.50
No. 55 Murdock 2000 Ohm Wireless Head Sets	4.00	6 Volt 40 Amp.	10.50
No. 56 Murdock 2000 Ohm Wireless Head Sets	4.50	6 Volt 60 Amp.	14.50
No. 55 Murdock 3000 Ohm Wireless Head Sets	5.00	6 Volt 80 Amp.	18.00
No. 56 Murdock 3000 Ohm Wireless Head Sets	5.50	6 Volt 40 Amp. U. S. Battery	10.00
22½ Volt Small Cyclone B. Battery90	6 Volt 60 Amp. U. S. Battery	13.75
22½ Volt Large Cyclone B. Battery	1.60	6 Volt 80 Amp. U. S. Battery	17.50
22½ Volt Eveready Variable B. Battery (New Type)	2.50	Binding Posts, Rubber Cap, per doz.80
45 Volt large Variable B. Battery	2.75	.002 M.F. Phone Condensers25
Binding Posts, Nickel Plated, per doz.70	.005 M.F. Grid Condensers25
		Variable Grid Leak, ½ to 3 Meoms.65

Above Batteries are fully charged when shipped. We do not charge for Crating. Little Wonder Portable Radio Set Complete with Murdock 2000 Ohm Head Set, Aerial Wire, Insulators, Blue Print and Instruction Book, \$14.00

The above prices are F.O.B. New York. We Guarantee Every Order Shipped Within 12 Hours

HYGRADE ELECTRICAL NOVELTY CO.

41 West 125th STREET NEW YORK

when the tardy hour of justice arrived, when Branly presented himself at the Institute, another Academician, and not one of the least, not satisfied with voting against him even went as far as to importune even in his bed a dying colleague, and as the unfortunate had not the strength to write, he himself wrote for him the negative ballot.

There is no grudge, no acrimony in the words of the illustrious scientist. He simply recalls these facts in order to make the story complete. One still feels it in that feeble yet implacable and resolute body. Old age advances. The years augment. Has he not the right, as long as it is yet time, to defend his work, to estimate himself its extent, to fix the just and far limits? Another sentiment we see appear in his attitude. It is not envy to formulate a terrible accusation, to arm a redoubtable repatee. It is rather like an undefinable regret, a noble and grave disappointment. Therefore, weighing his words and thus indirectly their enduring import the genial inventor, while showing us out, concluded:

"Had my colleagues of the University and the Institute, had the scientists of all those courses, consented to assist me in my researches, wireless telegraphy would have been exclusively French."

Junior Radio Course

(Continued from page 506)

responding blade to operate any of the relays closing the local circuits of the instruments. In the one described in this lesson any control may be operated at any time by moving the blade to the proper point, by a rapid succession of dots sent by the transmitter and then by a dash to close the circuit.

THE CONTROLLER

To simplify the operation of this system and to allow the operator at a transmitting station to know which point the blade H is on, a sort of controller is used, which is shown in Fig. 2. It consists of a panel upon which is mounted the double number of points as in the selector, half of them being dead ones, with a switch handle moving always in the same direction making contact upon them. The connections of these points and the handle to the transmitting set may be seen in Fig. 2, this arrangement being nothing more than a make and break contact closing the primary circuit, as a key would do.

Each point being marked, it is easy to control the ship or other craft from a distance by moving the handle rapidly to the dead point preceding the control, which it is desired to operate, thus closing the circuit of the transmitter for a very short time, when the handle passes over each connected point. These short contacts make the same effect as a dot sent in code, operating the electro-magnet A at the same speed and moving the blade H over the same number of points as explained previously. This is called preparation, for this may be accomplished in advance, if a control such as the firing of a torpedo at the precise moment is to be accomplished quickly; in fact, the blade H may be carried on the proper point in advance and the control operated by a single dash, moving the blade over the desired point and at the same time allowing the time device to close the circuit.

For instance, supposing the controlling handle of the transmitter controller is as shown in Fig. 2, and it is desired to fire torpedo No. 3, the handle should be moved in the direction of the arrow, up to the dead point preceding the one marked "Torpedo 3." Then, at the proper instant, the handle is moved to the next point corresponding in the selector to the relay operating the tor-

INTRODUCING THE AMPLITRON

PAT. APP. FOR

A REAL LOUD SPEAKER

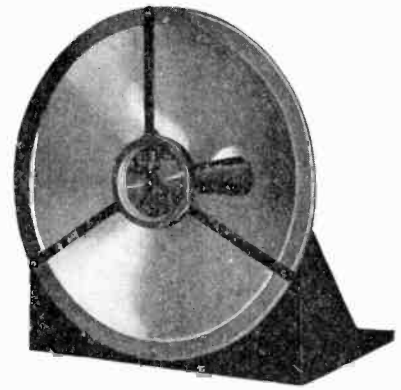

The Amplitron is a product of the Radio Service laboratory and has been designed and constructed especially for radio work. It gives surprising results. The Amplitron has been developed to meet the long felt want for a loud speaker which, at the same time, meets both the requirements of price and efficiency. It reproduces radio phone speech and music without distortion—equally good for code.

*No exciting batteries or adjustments necessary.
Uses a Baldwin Type "C" single phone.*

A WONDERFUL CHRISTMAS GIFT

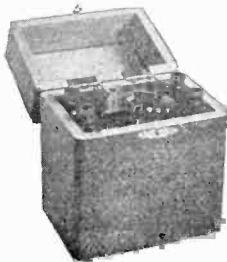

The Little Wonder Portable
Radio Set

The only complete practical radio set now obtainable. Complete, including Type S8 receiver, Murdock 2,000 ohm headset, complete aerial equipment, an 85-page book on the operation of radio apparatus and a blue print of instruction f o r only \$15.00 Postpaid
Type S8, receiver only 7.50 Postpaid

Just what you need to entertain
your friends on Christmas

Amplitron less telephone receiver \$10.00
(use your own Baldwin Type "C")
Amplitron equipped with Baldwin Type "C"
phone and cord \$16.25

For sale by all reliable dealers or direct from us.

Radio Service & Mfg. Co.

Sales Division
110 West 40th St., New York City

Factory
Lynbrook, L. I.

Condenser
No. 3

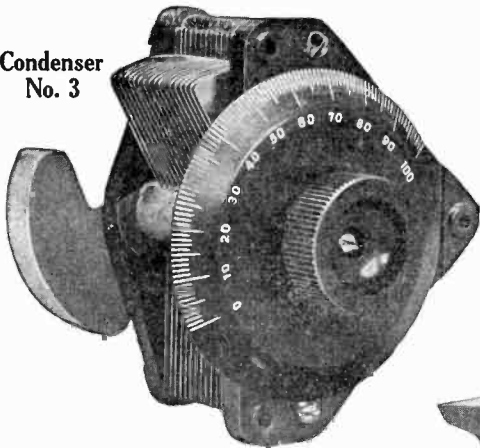

CHELSEA

Variable Condensers
(Die-Cast Type)

No. 1.—.0011 m. f. mounted\$5.00
No. 2.—.0006 m. f. mounted 4.50
No. 3.—.0011 m. f. unmounted 4.75
No. 3.—.0011 m. f. unmounted, without dial 4.35
No. 4.—.0006 m. f. unmounted 4.25
No. 4.—.0006 m. f. unmounted, without dial 3.85

Top, bottom and knob are genuine bakelite, shaft of steel running in bronze bearings, adjustable tension on movable plates, large bakelite dial reading in hundredths, high capacity, amply separated and accurately spaced plates.

Unmounted types will fit any panel and are equipped with counterweight.

Purchase from your dealer; if he does not carry it, send to us.



NO. 50 PRICE AS SHOWN, \$4.50



"CHELSEA" BAKELITE DIAL NO. 41.

The Chelsea dials are made of genuine bakelite, beautifully finished, and bear a 100 division semi-circular scale.

The dial is 3 1/4 inches in diameter, 1/4 inch thick, with a long, sloping, easily read marking. Chelsea bakelite dials run true and will not warp.

The complete dial and knob is made to fit either 3/16, 1/4 or 5/16 inch shaft. Specify size when ordering, otherwise the 1/4 inch hole will be furnished.

Chelsea dials are beautiful in appearance low in price accurate and durable in service, unexcelled by any, at any price.

Dial and knob complete.....\$1.00

Purchase from your dealer.

The Chelsea Amplifying Transformer is a supreme attainment in the design of Audio Frequency Transformers. It embodies the highest grade of materials obtainable and proper design, which reflects the result attained namely high amplification factor. It is unequalled either in electrical characteristics or good appearance.

CHELSEA RADIO CO., 150 Fifth Street, Chelsea, Mass.

Manufacturers of Radio Apparatus and Moulders of Bakelite

SAVE MONEY ON YOUR "B" BATTERIES

FROM MANUFACTURER TO USER
ALL BATTERIES SENT POSTPAID

Buy direct from the manufacturer and receive a Fresh Battery



All Wizard Batteries are absolutely guaranteed

ANNOUNCING WIZARD'S 2 NEW IMPROVED TYPE "B" BATTERIES
No. 1632—1 tap 45 Volt Var. Battery, Size 6x3x2 3/4 in. Price \$2.80 (Weight 3 1/2 lbs.)
No. 1630—6 tap 27 Volt Var. Battery, Size 6x3x2 3/4 in. Price \$1.80 (Weight 2 1/2 lbs.)

These new types are not made of the same size cells as a small size "B" Battery. The volume of one of the cells in these types is 4.7 cu. inches as compared with 3.5 cu. inches, the volume of a cell used in small "B's". You can easily see that the life of these two types are almost double the life of the small "B's".

OTHER WIZARD TYPES

Cat. No.	Size	Taps	Voltage	Weight	Price
1623 Plain	2 1/2 x 2 x 3 3/4	2 1/2	1 lb.	\$1.00	
1623 Variable	2 1/2 x 2 x 3 3/4	5	1 lb.	1.25	
1625 Plain	3 x 4 x 6 3/8	2 1/2	5 lbs.	1.85	
1625 Variable	3 x 4 x 6 3/8	5	5 lbs.	2.25	
1626 Plain	3 x 8 x 6 3/8	4 1/2	10 lbs.	3.75	
1626 Variable	3 x 8 x 6 3/8	6 1/2	10 lbs.	4.15	

Write for Bulletin No. 6
Send all money orders to
WIZARD BATTERY CO.
1315 42nd St., Brooklyn, N. Y. Dept. R

pedo, and left on this point a sufficient time to allow the time device to close the local circuit, as explained previously; after this it is pushed on the next dead point.

As may be understood, the blade H in the selector moves always in the same direction, as well as the handle of the controller, making it possible to have both controls in synchronism at any time. In Fig. 2, the connected points of the controller, intermediated between the dead points and bearing no indication of control, correspond to the unused point in the switch of the selector, this being only for the sake of clearness in the diagrams.

The WJZ Radiophone Broadcasting Station at Newark, N.J.

(Continued from page 482)

On 600 meters wave-length the antenna resistance drops to a point which permits an aerial current of 12 amperes. The output power is quite fully modulated.

Not the least interesting feature of the station lies in the completeness with which its details have been worked out. The com-

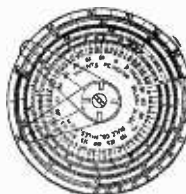

The Midget "FIVE-IN-ONE" Slide Rule is a combination Mannheim, Log-Log, Add and Subtract, Polyphase and Binary Slide Rule. It will instantly add, subtract, multiply and divide any combination involving whole numbers, fractions, decimals and mixed numbers. Gives every possible root and power of every quantity. The graduations are printed on metal coated with white celluloid and are grease and waterproof. While it is the most versatile calculator ever invented, its operation is simple and easily understood. Diameter 4 1/2 inches.

Price with 18 page Instruction Book, \$1.50. Leatherette carrying case 50c extra. Catalog free. Your money back if you are not satisfied. **Glison Slide Rule Co., Niles, Mich.**

plete radio transmitter is enclosed in metal screening and glass, and a blower is provided to hold the tube temperature at the best operating value. A switchboard is mounted on the right-hand side of the transmitter so that the set may be connected to the station microphone for announcements, etc., to the shielded pick-up device used for phonograph reproductions, or to the studio which has been built on the first floor of the factory building for concert work. A completely interlocked light-signal and switch system has been arranged for control of the set from the studio, where special microphones for transmission of vocal, piano-forte and other instrumental music are installed.

The radio station is also equipped with a standard Westinghouse medium wave receiver, with a wave-length range of 150 to 2,300 meters wave-length. After the nightly musical program, which runs from 8:30 to 9:15 p. m., the 9:55-10:00 time signals from Arlington are received on this outfit, using a long single-wire antenna, and transferred electrically to the radio telephone transmitter. Thus the time-signals themselves, with the characteristic spark tone of Arlington "NAA," are retransmitted on 360 wave-length for the benefit of listeners having short-wave receivers. Obviously there is no appreciable time lag in this retransmission, and consequently accurate Naval Observatory time is made available in the amateur wave-length range. At 10:03 each evening a weather forecast is sent out by radio telephone.

The Westinghouse Company also maintains complete radio telephone broadcasting plants at its East Pittsburgh, Penna., and East Springfield, Mass., factories. These stations operate on schedules similar to that of Newark; other stations are being installed to serve other sections of the country, and one at Chicago has just been opened. The service is being extended in point of time and character, also, so that before long the owner of a small radio receiver will be able to enjoy in his own home, anywhere in the United States, a complete program of concerts, news and weather dispatches, market reports, church services, and even selections direct from the stages of the theatres.

W. J. Z. WEEKLY BROADCASTING PROGRAM

- Monday**
- 10:00-10:15 Résumé of the news of the day, musical selections.
 - 10:55-11:00 Weather forecast for New York and New Jersey.
 - 11:00-11:15 Musical program.
 - 12:00-12:15 Résumé of the news of the day, musical selections.
 - 1:00-1:15 Résumé of the news of the day, musical selections.
 - 2:00-2:05 Musical program.
 - 2:05-2:10 Marine news.
 - 2:10-2:20 Musical program.
 - 3:00-3:15 Résumé of the news of the day, musical selections.
 - 3:55-4:00 Weather forecast for New York and New Jersey.
 - 4:00-4:15 Musical program.
 - 5:00-5:15 Résumé of the news of the day, musical selections.
 - 6:00-6:15 Résumé of the news of the day, musical selections.
 - 7:00-7:45 Miscellaneous program.
 - 7:45-7:50 Broadcasting of suppliers of receiving equipment.
 - 7:55-8:03 Tuning for regular evening program.
 - 8:05-9:15 General news, résumé of football games, music and artists.
 - 9:55-10:00 Arlington time.
 - 10:03-10:06 Weather forecast for New York and New Jersey.
 - 10:06-10:07 W. J. Z. Good night.
- Tuesday**
- 10:00-10:15 Résumé of the news of the day, musical selections.



"MARVEL" Complete Receiving Outfit

An Ideal Christmas Present

The "MARVEL" is the best crystal Receiver at moderate price for telephone concerts, etc., amateur traffic, and long wave spark stations. New distance records established nightly. Write for details of prize contest. The "MARVEL" RADIO RECEIVER, model 101, (Patents Applied For), is a Scientifically designed. Highly efficient single circuit tuner with a 15 contact, multipoint, rotary inductance switch, and a super-sensitive, Tested, galena crystal detector. All parts are mounted on a panel of approved insulating material. A fixed bridging condenser of 0.0025 mfd. is connected across the telephone terminals. Cabinet is of handsomely finished mission oak.

Quality Apparatus—Designed by Engineers—Popularly Priced

- 1—The ONLY crystal receiver on the market, with a wavelength range of 180 to 2600 meters.
 - 2—A completely enclosed instrument; therefore not exposed to or affected by moisture, dust, etc.
 - 3—An efficient, compact receiver, that will last as long as your station and costing less than the price of unmatched and unknown parts.
- COMPLETE "MARVEL" RADIO RECEIVING OUTFIT model 105 (as shown in picture above), consisting of a "MARVEL" RADIO RECEIVER, model 101, 150 feet solid copper antenna wire, 5 porcelain insulators, 1000 ohm Murdock telephone, leather-covered head-band, telephone cord, antenna switch, ground clamp, code chart, abbreviation chart, booklet of 35 lessons in Wireless and full instructions for installation and operation **\$15.00**
- Model 110. Same outfit with 2000 ohm Murdock double head set **\$18.00**
- Model 115 "MARVEL" RADIO RECEIVER only, Model 101, with MURDOCK NO. 56, 2000 ohm Double headset, headband, telephone cord. Code Chart, Abbreviation Chart and Instructions, all attractively packed **\$14.00**

EFFICIENT AT LOW COST BY ENGINEERING DESIGN
"MARVEL" RADIO RECEIVERS are obtainable at all progressive Radio and Electrical Dealers, or will be sent prepaid on receipt of Postal or Express Money Order. Also sent Parcel Post C. O. D. ORDER NDW—DON'T DELAY.
LOOK FOR THE REGISTERED TRADE MARK ON EVERY GENUINE "MARVEL" RADIO RECEIVER, (PATENT APPLIED FOR) OTHERS ARE IMITATIONS
Bulletin N-101 on request.

DEALERS: "MARVEL" RADIO RECEIVERS are nationally advertised; they are the most popular of crystal receivers. Get your share of Christmas business by selling them. Liberal discounts and selling co-operation are part of our sales campaign. **ORDER NOW!**

RADIO MANUFACTURING COMPANY
Offices and Sales Department, 170 Fifth Avenue New York City



Wonderful Natrometer Gives You Code-Speed in Half Usual Time

What is your speed in sending and receiving now? You can easily and quickly double it through an amazing new invention, the Natrometer. This device, patented and owned exclusively by The National Radio Institute, enables you to build up your speed to a figure you never thought possible. No matter whether you want greater speed in order to qualify for a license or whether you want to be able to copy better and to catch professional messages, this is your chance.

Exclusive Features in This Amazing Invention

The Natrometer will send you messages in a human and not a mechanical manner at a rate which you can vary from 3 to 30 words per minute. There are 10 different dials, enabling you to send 600 different messages. Each purchaser of the Natrometer gets the privilege of exchanging dials at any time without additional cost. The Natrometer will run steadily for 20 minutes. It is noiseless, can be wound while running, sends smoothly without choppiness. The effect of static interference may be added to the messages being copied. The Natrometer occupies half the space of any other similar machine. A beginner can quickly learn the alphabet from our A dial.

Yet with all these advantages, making it superior to any other device of its kind, it costs no more. In fact, it is less expensive than any other machine of this type, and is undoubtedly one of the most important inventions for wireless instruction purposes.

Write for Full Description

Let us mail you an interesting free booklet and descriptive literature about this truly remarkable invention. It will explain fully just how this wonderful Natrometer works and what it will do for you. Send no money, simply fill in coupon below and mail it today.

SALES DEPARTMENT

National Radio Institute

DEPT. 112-B

1345 Pa Ave., NW. Washington, D. C.

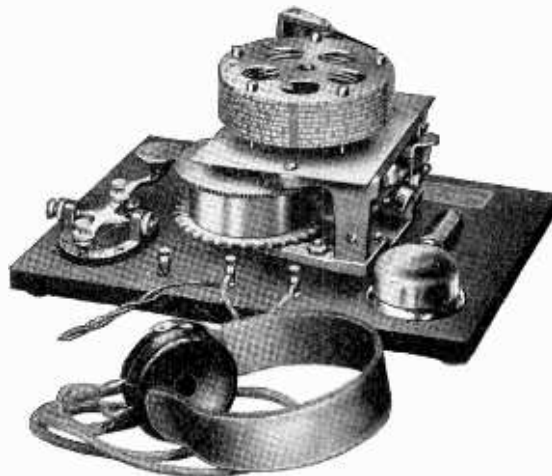

Sales Department, Room No. 112-B,
National Radio Institute, Washington, D. C.

Gentlemen: Please send me by return mail your free booklet giving complete information about the Natrometer. This obligates me in no way.

Name

Address

City..... State.....

Just Out!

This book, "New License Quiz Book for Government First Class License Examinations," is the first edition printed with the new rules, regulations and gradings laid down by the Government on July 1st, 1921. Every amateur expecting to take examination for license needs this book. It gives the answers to 250 questions, many of which will be helpful in the examination. It gives a full description of various hook-ups, new devices, practical equations, international laws and regulations, official gradings, diagrams, definitions and other important information— invaluable to the candidate for government examinations.

"License Quiz Book for Government First Class License Examinations"

This is the first edition ever printed of this book of 250 important questions. It is just off the press, compiled and published by the National Radio Institute, the world's best-known wireless school. No amateur or wireless professional can afford to miss it. Nicely bound with 80 fine illustrations and chock-full of information you need—now only \$1 with the coupon below.

When are you going to take your examination? You will find this volume the greatest possible help. Don't run a chance of failing your exams! This book gives the very latest information on the very things you must know. Not only the new government rules, regulations and gradings, but also lots of information about the latest inventions and discoveries.

The Contents panel at the left shows how complete this book is. Mail coupon to Dept. 112-A with \$1 today. DEALERS and AGENTS write for our proposition today!

SALES DEPT.

National Radio Institute
Dept. 112-A Washington, D. C.

Contents

- 106 Pages.
- 250 Questions With Answers.
- More than 80 Illustrations and Drawings.
- Information Concerning Method of Conducting Examinations and Places Where They Are Held.
- Radio Symbols.
- Technical Words and Terms Made Clear.
- Life and Duties of an Operator.
- Terms and Definitions.
- Radio Instruments.
- Transmitters Covering Spark, Arc, and Tube Sets.
- Types of Antennae and Aerials.
- Damped Wave Receivers.
- Latest types of undamped Receivers.
- International and U. S. Radio Laws and Abbreviations.
- Radio Compass and Its Uses.
- Exhaustive Treatise of the Storage Battery
- Helpful Equations and Tables for Solving Radio Problems.
- Continuous Wave Receivers.
- Valuable information to help you in securing your license examination.



NATIONAL RADIO INSTITUTE,
Dept. 112-A, Washington, D. C.

Gentlemen: Please send me by return mail the "License Quiz Book for Gov't. First Class License Examinations." I enclose \$1.

Name..... Age.....

Address

City..... State.....

SPECIAL PRICES for the XMAS TRADE

Radio apparatus is a highly appreciated Xmas gift. Place your orders with us and benefit by the saving in cost. Get the same high grade equipment and more for the same money.

Every piece of apparatus we sell is "FIRST TESTED—THEN SOLD." This test by expert radio men assures you of equipment in perfect condition. Make up your list NOW.

Buy these Lines of Apparatus from Us

Remler Apparatus
Radio Corporation
Murdock Parts
Grebe CR8 and CR9
Acme Apparatus

Magnavox
Baldwin Phones
Brandes Phones
Chelsea Cond. and Dials

Tuska Apparatus
DeForest Sets
Paragon Apparatus
Clapp-Eastham Supplies

L. G. S. Products
Moorhead Tubes
Jewell Meters
Radison Coils
R. & M. Motor Generators

RADIO CITIZENS—We allow 5 percent discount on orders of \$10.00 or more and pay postage in 1st and 2nd zones. Write for prices.

PEORIA RADIO SALES CO.

Dept. B Peoria, Ill.

DEALERS—Write for our trade schedules. We represent some large manufacturers exclusively. Get our new lowest prices.

KLAUS RADIO COMPANY

Dept. 200 Eureka, Ill.

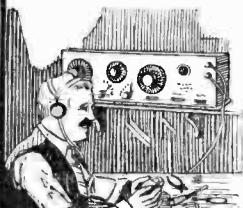

FIRST TESTED—THEN SOLD

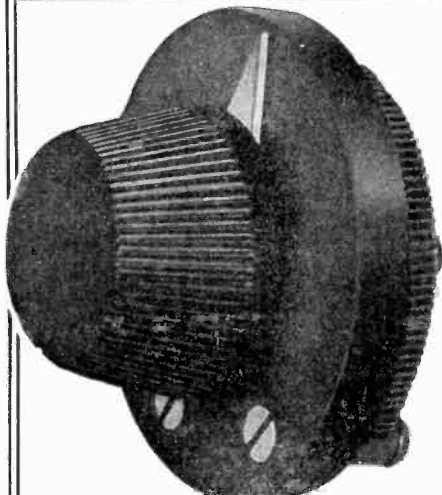

The "QSA" Line of Radio Equipment

QUALITY in the apparatus we sell, is an essential part of our dealings with you. Here is shown a panel mounting rheostat which, from the standpoint of quality, well deserves a place in our "QSA" line. Base of Thermoplas (2 1/4 in. dia.), polished nickel-plated pointer and new Thermoplas knob. Resistor unit wound to 6 ohms and will safely carry 1 1/2 amperes.

A high grade rheostat, very reasonably priced, at only\$1.00 ea.

OUR CATALOG

—is now ready. You cannot afford to be without it. It lists the cream of apparatus made by the leading Radio manufacturers. Each item a leader in its class, carefully selected by our expert. Generously illustrated. Don't do any buying until you see our catalog. You'll be glad we tipped you off. Sent for 10 cents in stamps or coin. This amount will be refunded on your initial purchase amounting to \$1.00 or more.

Send for it TODAY.

A FEW "QSA" ITEMS TAKEN FROM OUR CATALOG

U.V.712 Intertube Transformer.....	\$7.00	Acme 1 K.W. Spark Transformer.....	\$28.00
U.V.201 V.T. Amplifier.....	6.50	Acme Amplifying Transformer.....	5.00
FADA Detector Comp. with crystal.....	2.25	Brandes Navy Type Phones.....	14.00
"COMBAT" 6V. 80 A.H. A real STORAGE BATTERY for RADIO WORK. This Month only at..... 21.00			

Ask for a "COMBAT" circular.

INDEPENDENT RADIO SUPPLY CO.

3716 W. DOUGLAS BLVD. Dept. R-12 CHICAGO, ILL.

"Better Results With Less Effort."

U. S. GOVERNMENT RADIO BLINKER SIGNAL SET

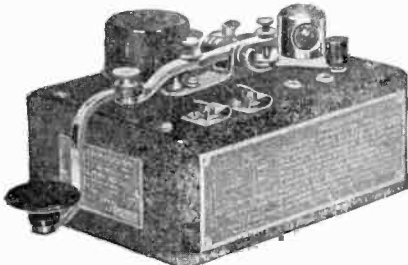

A model of perfection and all-around utility, officially adopted by the U. S. Army Air Service, U. S. Marine Corps and Navy Department Bureau of Steam Engineering. It is a self-contained unit, and may be operated on the table, in the lap, or in any position desired. Note detachable arm.

Special Price \$6.00

Ask your dealer or write us.

Frank B. Perry & Sons
Newton Center, Mass.
Providence, R. I.

Of high grade construction, designed for the purpose of instruction in audible or visual signals, with the International or other codes based on the dot and dash principle. It is scientifically made for efficiency, simplicity, compactness and durability.

- 10:55-11:00 Weather forecast for New York and New Jersey.
- 11:00-11:15 Musical program.
- 12:00-12:15 Résumé of the news of the day, musical selections.
- 1:00- 1:15 Résumé of the news of the day, musical selections.
- 2:00- 2:05 Musical program.
- 2:05- 2:10 Marine news.
- 2:10- 2:20 Musical program.
- 3:00- 3:15 Résumé of the news of the day, musical selections.
- 3:55- 4:00 Weather forecast for New York and New Jersey.
- 4:00- 4:15 Musical program.
- 5:00- 5:15 Résumé of the news of the day, musical selections.
- 6:00- 6:15 Résumé of the news of the day, musical selections.
- 7:00- 7:30 Man-in-the-moon story.
- 7:30- 7:45 Very soft music in harmony with man-in-moon story.
- 7:45- 7:50 Broadcasting of suppliers of receiving equipment.
- 7:55- 8:03 Tuning for regular evening program.
- 8:05- 9:15 General news résumé of football games, music and artists.
- 9:55-10:00 Arlington time.
- 10:03-10:06 Weather forecast for New York and New Jersey.
- 10:06-10:07 W. J. Z. Good night. *Wednesday*
- 10:00-10:15 Résumé of the news of the day, musical selections.
- 10:55-11:00 Weather forecast for New York and New Jersey.
- 11:00-11:15 Musical program.
- 12:00-12:15 Résumé of the news of the day, musical selections.
- 1:00- 1:15 Résumé of the news of the day, musical selections.
- 2:00- 2:05 Musical program.
- 2:05- 2:10 Marine news.
- 2:10- 2:20 Musical program.
- 3:00- 3:15 Résumé of the news of the day, musical selections.
- 3:55- 4:00 Weather forecast for New York and New Jersey.
- 4:00- 4:15 Musical program.
- 5:00- 5:15 Résumé of the news of the day, musical selections.
- 6:00- 6:15 Résumé of the news of the day, musical selections.
- 7:00- 7:45 Miscellaneous program.
- 7:45- 7:50 Broadcasting of suppliers of receiving equipment.
- 7:55- 8:03 Tuning for regular evening program.
- 8:05- 9:15 General news, résumé of football games, music and artists.
- 9:55-10:00 Arlington time.
- 10:03-10:06 Weather forecast for New York and New Jersey.
- 10:06-10:07 W. J. Z. Good night. *Thursday*
- 10:00-10:15 Résumé of the news of the day, musical selections.
- 10:55-11:00 Weather forecast for New York and New Jersey.
- 11:00-11:15 Musical program.
- 12:00-12:15 Résumé of the news of the day, musical selections.
- 1:00- 1:15 Résumé of the news of the day, musical selections.
- 2:00- 2:05 Musical program.
- 2:05- 2:10 Marine news.
- 2:10- 2:20 Musical program.
- 3:00- 3:15 Résumé of the news of the day, musical selections.
- 3:55- 4:00 Weather forecast for New York and New Jersey.
- 4:00- 4:15 Musical program.
- 5:00- 5:15 Résumé of the news of the day, musical selections.
- 6:00- 6:15 Résumé of the news of the day, musical selections.
- 7:00- 7:30 Broadcasting for benefit of radio amateurs.
- 7:35- 7:45 Miscellaneous program.

READ the CLASSIFIED ADVERTISEMENTS on PAGES 572-574. YOU'LL FIND MANY GOOD THINGS THERE

use A-P tubes for efficiency

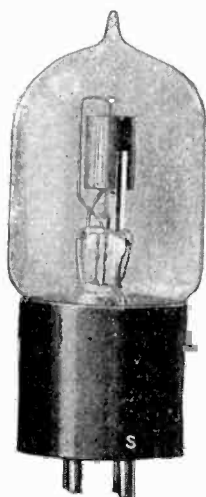

THE A-P VT
AMPLIFIER
OSCILLATOR

—the Amplifier used
by the U. S. Navy.
“Use the tube the
Navy uses.”

Price \$6.50

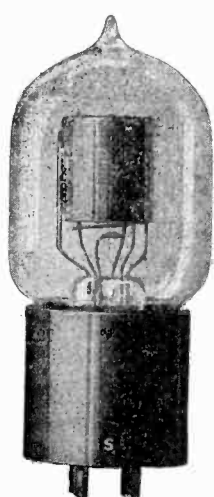

THE A-P
ELECTRON
RELAY

—the most sensitive
detector of spark sig-
nals, known to the
radio art.

Price \$5.00

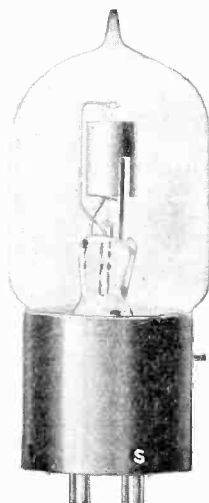

THE A-P
TRANSMITTER
TUBE

—an efficient un-
damped wave trans-
mitter for use in
radiotelephony.

Price \$7.50

A-P Tubes are licensed by the Radio Corporation of America under DeForest
Audion and Fleming patents for amateur and experimental use in Radio
communication.

*Order from your Dealer or direct from

ATLANTIC PACIFIC RADIO SUPPLIES CO.

National Distributors for The Moorhead Laboratories, Inc.

638 Mission Street, San Francisco, California
HENRY M. SHAW, President

**EXHAUSTIVE
TESTS**

by The Magnavox Co.
prove A-P Tubes so
much more efficient

THE MAGNAVOX CO.

have designed their new
two and three step
Power Amplifiers to be
used with—

**A-P TRANSMITTER
TUBES EXCLUSIVELY**

Magnavox Co. tests prove these more effi-
cient than any other tubes on the market,
for the following reasons: 1. High vacuum;
2. High amplification; 3. Low filament cur-
rent; 4. No adjustments necessary.

Use A. P. Tubes for Efficiency

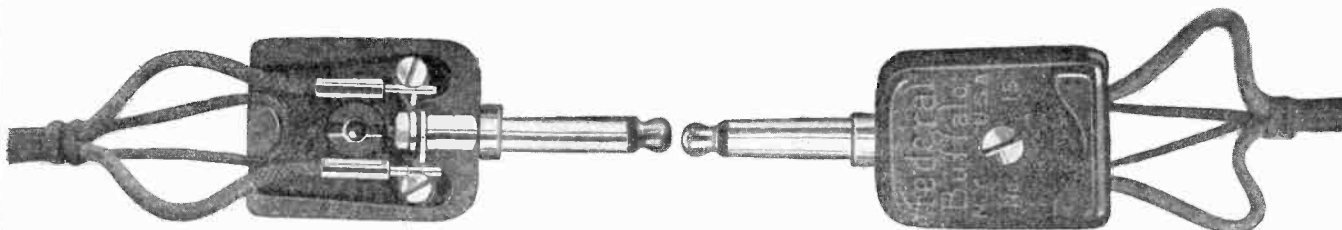

HERE IT IS

This is the plug you have been waiting for. It is entirely different from anything on the market.

**FEDERAL UNIVERSAL
PLUGS**

made of Bakelite and designed to take any
type of conductor without soldering; are at-
tractive in appearance; simple in construction.

For plugging in head telephone sets, power
supply, microphone transmitters, transmitting

keys, or as many other things that an ingeni-
ous radio operator may think of.

A decided improvement over the ordinary tele-
phone switchboard plug.

Price \$1.75

Dealers write for special proposition

FEDERAL TELEPHONE & TELEGRAPH CO., Buffalo, N.Y.

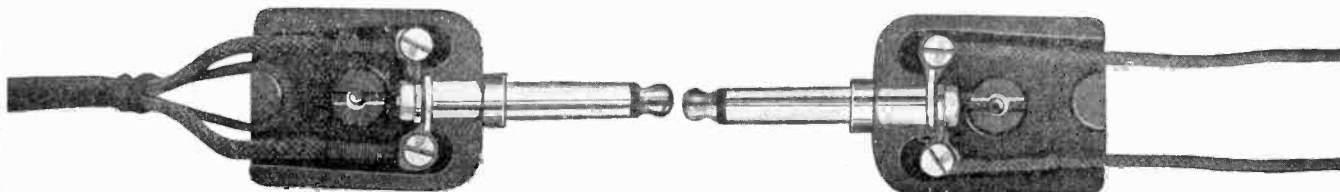

MEMORIZE CONTINENTAL CODE ALMOST INSTANTLY BKUMA YRLSBUG

Two Hundred Beginners in Forty-Four States Have Reported Mastered Code in 30 Minutes. In 45 Minutes. In One Hour, One Evening, Etc., Etc.

Anybody who can read can learn code quickly and easily.

Dear Sir.—To encourage beginners can say I memorized Continental Code by your Short Cut in 45 minutes and same was a great help. It is a wonderful little chart and as it has helped me so will it help others. Thanking you.

Later—Now have a licensed station all right, and would say again sincerely hope your Chart which made Continental Code so very plain and simple may be used by many and prove as helpful as in my case.

David E. Day, Winston-Salem, N. C.

Call 4BM P. O. Box 48.
Worthless methods are advertised as best, easiest, quickest and other enticing titles. To avoid disappointment purchase no Code Memorizing Chart, Card or Device until satisfied by statement from actual user that same has proven efficient in use as well as in theory.

By Using DODGE RADIO SHORT CUT Beginners Do

Master the Code easily, quickly, permanently. Once tiresome task—now pleasant pastime.

Those Who Have Failed after diligently trying all Methods heard of Do succeed with Dodge Short Cut.

Radio Operators Do gain better command of the Code and consequently do increase their speed.

Morse Operators Do change to Radio quickly, easily—no mix-up. Reports in 28-Page Booklet Do tell the story; also give local addresses.

Save Ten Cents For Copy and learn what others are doing. The dime will apply whenever you purchase.

These Reports Are the concrete and tangible expression of desire by our highly successful students to aid and encourage present and future beginners to equally quick progress over that rocky place in the road to Amateur Success—Perfect mastery of the Code. The amateur of today will be the top notch operator of tomorrow.

INVESTIGATE

NO BEGINNER CAN AFFORD TO IGNORE quick and easy success of those who have used DODGE ONE DOLLAR RADIO SHORT CUT WHICH TEACHES WITHOUT INSTRUMENTS AND HOLDS THE RECORD FOR SIMPLICITY, EFFICIENCY, ECONOMY AND QUICK RESULTS.

C. K. DODGE

Box 200 MAMARONECK, N. Y.

ATTENTION! 4th District

Do you know there is a first-class RADIO SUPPLY HOUSE NEAR YOU? WE ARE DISTRIBUTORS OF HIGH GRADE RADIO APPARATUS WITH THE BEST OF PRICES AND SERVICE

A FEW ITEMS FROM OUR CATALOGUE

FORMICA PANELS	
6 x 9 x 3/16	\$1.00
6 x 12 x 3/16	1.35
6 x 18 x 3/16	2.00
9 x 12 x 3/16	2.00
12 x 18 x 3/16	2.75
12 x 18 x 3/16	3.85
12 x 24 x 3/16	5.35

RADIOTRON TUBES & SUPPLIES

UV-200 Detectors	\$5.00
UV-201 Amplifier	6.50
UV-202 5 Watt Oscillator	8.00
UV-203 50 Watt Oscillator	30.00
FADA Rheostats	1.00
FADA Power Tube Rheostat	1.35
FADA Crystal Detector	2.25
Baldwin Type C Phones	13.75
Baldwin Type E Phones	15.00
Baldwin Type F Phones	16.25
Ceco 1/8 x 3/16 N. P. Switch Points, Per Doz.	.35

POSTAGE ADDITIONAL

WRITE FOR OUR CATALOGUE
TRY OUR SERVICE

CARTER ELECTRIC CO.

RADIO DEPT.
63 Peachtree St. Atlanta, Ga.

ATTENTION!

Our STORAGE "B" BATTERIES give years of service without expert attention, saving you REAL money in the end. One charge lasts from three to six months in the detector plate circuit. All batteries shipped complete with rechargers and full Directions.

Plain batteries with clips for adjustment at the following prices: 32 volts, \$8; 48 volts, \$10; 60 volts, \$12. With control panels 32 volts, \$10; 48 volts, \$12; 60 volts, \$15. Satisfaction guaranteed or money refunded.

KIMLEY ELECTRIC CO.

290 Winslow Ave. Buffalo, N. Y.

- 7:45-7:50 Broadcasting of suppliers of receiving equipment.
- 7:55-8:03 Tuning for regular evening program.
- 8:05-9:15 General news, résumé of football games, music and artists.
- 9:55-10:00 Arlington time.
- 10:03-10:06 Weather forecast for New York and New Jersey.
- 10:06-10:07 W. J. Z. Good night.
- Friday*
- 10:00-10:15 Résumé of the news of the day, musical selections.
- 10:55-11:00 Weather forecast for New York and New Jersey.
- 11:00-11:15 Musical program.
- 12:00-12:15 Résumé of the news of the day, musical selections.
- 1:00-1:15 Résumé of the news of the day, musical selections.
- 2:00-2:05 Musical program.
- 2:05-2:10 Marine news.
- 2:10-2:20 Musical program.
- 3:00-3:15 Résumé of the news of the day, musical selections.
- 3:55-4:00 Weather forecast for New York and New Jersey.
- 4:00-4:15 Musical program.
- 5:00-5:15 Résumé of the news of the day, musical selections.
- 6:00-6:15 Résumé of the news of the day, musical selections.
- 7:00-7:30 Man-in-the-moon story.
- 7:30-7:45 Very soft music in harmony with man-in-moon story.
- 7:45-7:50 Broadcasting of suppliers of receiving equipment.
- 7:55-8:03 Tuning for regular evening program.
- 8:05-9:15 General news, résumé of football games, music and artists.
- 9:55-10:00 Arlington time.
- 10:03-10:06 Weather forecast for New York and New Jersey.
- 10:06-10:07 W. J. Z. Good night.
- Saturday*
- 10:00-10:15 Résumé of the news of the day, musical selections.
- 10:55-11:00 Weather forecast for New York and New Jersey.
- 11:00-11:15 Musical program.
- 2:00-5:00 Broadcasting of football game.
- 7:00-7:45 Miscellaneous program.
- 7:45-7:50 Broadcasting of suppliers of receiving equipment.
- 7:55-8:03 Tuning for regular evening program.
- 8:05-9:15 General news, résumé of football games, music and artists.
- 9:55-10:00 Arlington time.
- 10:03-10:06 Weather forecast for New York and New Jersey.
- 10:06-10:07 W. J. Z. Good night.
- Sunday*
- 7:55-8:03 Tuning for regular evening program.
- 8:05-9:15 General news, music and artists.
- 9:55-10:00 Arlington time.
- 10:03-10:06 Weather forecast for New York and New Jersey.
- 10:06-10:07 W. J. Z. Good night.

World's Record

(Continued from page 503)

there. Mr. Peterson, being a man of business, paid attention to his own affairs. However, a Negro purchasing radio material is apt to create something more than passing interest, and so it was that Mr. Peterson came to inquire of a clerk, one Arnold Fassett.

"I notice we have a new customer, a colored man. Did he give any special reason for buying so much wire? Judging from the amount he bought, I should think

DON'T READ THIS

IF YOU ARE A MILLIONAIRE

Magnet Wire per 1/2-lb. Spool	
B.&S. Ga.	S.C. S.S. Enam.
20 to 24.....	\$.70 \$.85 \$.60
26 to 30.....	1.00 1.40 .70
32 to 36.....	1.50 2.20 .85

For 1-lb. spools add 75% to above prices.
Aerial Wire, 100 ft. 250 ft. 500 ft. 1000 ft.
Stranded 7-22 \$.75 \$1.80 \$3.50 \$6.00
No. 14 solid. .50 1.15 2.00 3.75

WESCO Mounted Amplifying Transformers. \$ 3.45
Detector Panels, Reg. Price \$12.00..... 7.00
Amplifier Panels, Reg. Price \$18.00..... 11.50
Bakelite 1/2" cut to size 1 1/2c per sq. inch.
CW Inductance Wire No. 11 square copper, 50 ft. 75c
Bakelite CW Inductance tube, 6" dia., 7" long \$2.00
The famous DRAGON RADIO STORAGE BATTERY, 6v-90amp. 25.00
TRESKO 20,000 meter couplers. 8.50
We carry a complete stock of all apparatus and make immediate shipments.

Send a stamp for our new literature.
Attractive proposition for dealers.

WILMINGTON ELECTRICAL SPECIALTY COMPANY

705 Adams St., Dept. R, WILMINGTON, DEL.

RADIO

TELEPHONE & TELEGRAPH APPARATUS OF MERIT

K20A Rotary Enclosed Gap.....	\$25.00
K20B Same without motor.....	20.00
K1 Open Rotary Gap.....	18.00
UV900 Radiotron Detectors.....	5.00
UV201 Radiotron Amplifiers.....	6.50
UV202 5-Watt Transmitter.....	8.00

Send 4c for our 65-page Catalog.
Full of illustrations, information
and prices that will prove attractive

KARLOWA RADIO CO.

611 Best Bldg., Rock Island, Ill.

NEWMOTORS

FOR ALL PURPOSES
STANDARD MANUFACTURERS
PROMPT DELIVERY
ALL SIZES UP TO 5 H.P.

We Specialize In Small Motors & Generators
ALL PHASES AND FREQUENCIES IN STOCK AT ALL TIMES
Largest exclusive Mail Order Small Motor dealers in the world.

CHAS. H. JOHNSTON, Box 123, West End, Pittsburgh, Pa.
WIRELESS TELEPHONE GENERATORS
500 VOLT - 100 WATT - 3400 R. P. M.
FOR MOUNTING MOTOR GENERATOR SETS.

\$28⁵⁰ EACH
WRITE FOR CATALOG

Q. S. T.

We are distributors for all Standard makes of Radio Apparatus and can make Immediate Delivery. Give us a trial and we will give you SERVICE.

APEX RADIO SHOP
1105 W. 69th St. CHICAGO, ILL.

YOU CW MFN LOOK HERE

Manufacturers of
C.W. Inductance Grid Tickler, 32T, No. 10 Cu.
Bakelite Insul. \$6.00
C.W. Chemical Rectifiers, complete, 500 mill-amp.
Cap.—14 jars will handle 1/2 Amp. at 1000 Volts or
less. In cabinet \$9.50
200 Watt C.W. Transformer, 110 V.—Prim—500
V. Sec. mounted \$12.00
JONES ELEC. & RADIO MFG. CO.
120 E. Lexington St. Baltimore, Md.

VARIOMETERS \$5.60 each
VARIOCOUPERS 3.00 each
Completely assembled, postpaid anywhere in U. S. A.
Just the thing for that Regenerative Set you wish to
construct. Wave length Range 175 to 450 meters, which
may be increased to 650 by special condenser to shunt
secondary. Specify whether Grid or Plate for Variometer,
when ordering. Large stock, immediate delivery. YOUR
ORDER IS ON ITS WAY ONE HOUR AFTER IT IS
RECEIVED BY US. A postcard will bring our bulletins.
"UNEXCELLED SERVICE"

CITIZEN RADIO SUPPLY COMPANY
Mattoon P. O. Box 155 Ill. 61905

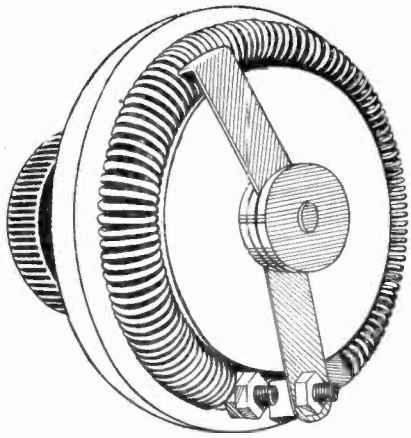

SHRAMCO REOS

for all your VTs—

GET THE BEST service out of your expensive tubes by using good rheostats. Shramco Reos, with genuine "Nichrome" resistances allow unusually accurate and delicate variation of the filament current. All metal parts brass. Spring phosphor bronze blades. Mounted on a solid block of asbestos insulation.

3" base. Price \$2.00 plus postage for two pounds. Also the Shramco Midget Reo, 5 ohm resistance, 2½" base. Price \$1.50 plus postage.

For Transmitting Tubes—Shramco Reo type 90T, 1.5 ohm resistance. Current capacity 6 amperes. Price \$2.00 plus postage for 1 pound.

For Detector and Amplifier Tubes—Shramco Reo, type 90. 6 ohm resistance,

At leading dealers or by mail Satisfaction Guaranteed.

SHRAMCO SWITCHES

Either of these two styles will distinguish itself by smooth operation and sure contacts, in addition to the handsome appearance. Both have polished nickel finish and are furnished with large Marconi type knob. Bearing block and panel bushing ¾" in diameter. For use on all panels up to ½" thick. Blades, spring phosphor bronze. No. 750 type has spring tension adjustment; switch radius, 1½".

No. 751-S-1 type is provided with split lock nut; blades have 1" radius, ½" from center to center, and are securely held in place. If your dealer cannot supply you, send your order direct, postage extra.

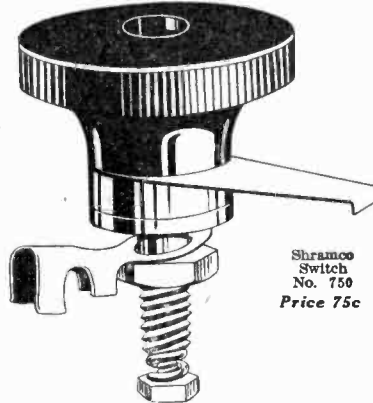

Shramco Switch No. 750 Price 75c

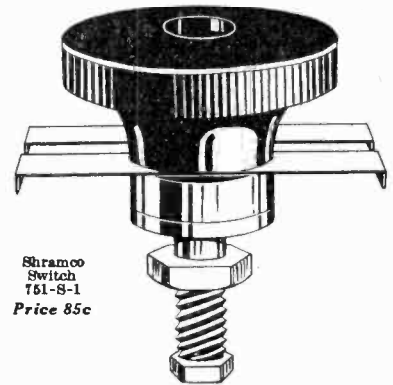

Shramco Switch 751-S-1 Price 85c

SHOTTON RADIO MFG. CO., INC.

8 Market Street, Albany, New York

DEALERS—Shramco Reos and Switches bring you good profits because they sell so fast and give complete satisfaction. Write for liberal discounts.

Buy By Mail With A Guarantee

The standard products listed below are guaranteed to be mechanically perfect. They can be bought from us with the same assurance of quality that you would have if you bought them from a local dealer.

RHEOSTATS		TELEPHONES		DETECTOR PANELS	
Paragon (new low price).....	\$1.42	Brown (ENGLISH NAVY) adjustable.....	17.10	Adams Morgan.....	5.70
Fada (new low price).....	.95	Brown non adjustable.....	15.20	Remler with B Battery control.....	16.15
Murdoch.....	.95	Baldwin Type E.....	14.75	Grebe RORH Det panel.....	16.15
Gen. Radio.....	2.38	Murdoch (latest) No. 56 2000.....	16.00	Pirco Midget with tickler.....	11.00
TeCo Vernier Rheostat (new).....	2.00	Murdoch (latest) No. 56 3000.....	5.75	Fada Detector panel with tickler.....	16.15
Radio Corporation.....	3.00	Western Electric.....	13.75		
Remler.....	.95	Brandes Superior.....	7.60		
		Brandes Navy Type.....	11.40	TELEPHONE PLUGS	
		Brandes Trans-Atlantic.....	13.30	Pirco (BULL DOG) round type.....	2.50
				Pirco (BULL DOG) flat type.....	2.00
				Federal (NEW).....	1.66
REGENERATIVE TUNERS		LOUD SPEAKERS		DIALS	
Grebe CR-5 150 to 3000.....	76.00	VocaLoud.....	25.00	Chelsea Radio.....	1.00
Grebe CR-8 150 to 1000.....	76.00	Federal (NEW).....	13.30	Remler with knob.....	.95
Grebe CR-9 with two stage.....	123.50	Magnox.....	42.75	Clapp-Eastham.....	.70
AMPLIFYING TRANSFORMERS		MICROPHONE TRANSMITTERS		VARIABLE CONDENSERS	
General Radio (new type).....	4.75	Connecticut type 5176-A.....	3.80	Chelsea Mounted, .001.....	5.00
Pirco (non howling).....	5.00	Federal Hand Type.....	6.65	Chelsea Mounted, .0005.....	4.50
Chelsea Radio (NEW).....	4.50	JK Hand Type.....	5.70	Chelsea Unmounted, .001.....	4.75
Radio Corporation.....	7.00			Chelsea Unmounted, .0005.....	4.25
MODULATION TRANSFORMERS		SOCKETS		AMPLIFIERS	
General Radio Unmounted.....	4.25	Crosley.....	.57	Pirco Midget two stage.....	30.00
General Radio Semi-Mounted.....	4.75	General Radio.....	1.42	Grebe RORH two stage with automatic control.....	55.25
General Radio Mounted.....	6.65	Remler.....	.95	Amrad two stage.....	30.82
VARIO COUPLERS		REMIOTERS			
Remler Type 504.....	5.13	Remler type 500 with knob and dial.....	6.65		
Chirad.....	4.80	Chi Rad knock down type variometers one vario coupler.....	9.50		
B BATTERIES		METERS			
Small size 22½ volt.....	1.42	Type J Millimeter 0 to 50, 0 to 100.....	5.70		
Radio Equipment 45 v. variable box and Jiffy connectors.....	3.60	Type KK AC Volt 0 to 15.....	7.60		
Long Life Sorsinc.....	3.80	Type JT Radiation Meter thermo Jet 0 to 1.5, 0 to 5, 0 to 10.....	11.40		
FIXED CONDENSERS		ACCESSORIES			
Grid Condenser 0005, 0003, 0002, 00025 with leak.....	.38	TeCo Audiotron adapters.....	1.66		
CW and Phone 2000v, 00025, 0005, 001, 002.....	.73	Honey Comb Coil Adapters, per pair.....	1.42		
Western Electric 1 MF or 2 MF.....	2.37	Radeco Fuses (four for).....	.95		
WIRE		REMIOTERS			
7 Strand No. 22 tinned copper, per hundred feet.....	.95	Remler type 500 with knob and dial.....	6.65		
No. 4 Double covered weather proof ground wire, per foot.....	.07	Chi Rad knock down type variometers one vario coupler.....	9.50		
ACCESSORIES		METERS			
Large insulated binding posts.....	.15	Type J Millimeter 0 to 50, 0 to 100.....	5.70		
Small insulated binding posts.....	.10	Type KK AC Volt 0 to 15.....	7.60		
Consolidated short wave regenerative set of blue prints.....	.47	Type JT Radiation Meter thermo Jet 0 to 1.5, 0 to 5, 0 to 10.....	11.40		
Bakelite Panels size 9 by 19 three-sixteenth stock, each.....	3.00	General Radio Flush Type 0 to ¼, 0 to ½, 0 to 1, 0 to 2.5, 0 to 5, 0 to 10.....	7.25		
Bakelite tubing 5-inch diameter, 6-inch long.....	1.50				
100 Ampere Lightning switch 600 v asbestos base.....	4.55				

For any article you want, not listed, deduct 5%

TECO RADIO CO.,

P. O. Box 3362

BOSTON, MASS.

AMATEURS—LOOK Radio 9XAB

We are the authorized jobbers in the following States, (Missouri, Kansas, Nebraska, Oklahoma, Texas, Arkansas, Louisiana, Iowa, Arizona) for Radio Corporation products. Largest stock west of Chicago. Always fresh. We also carry all standard makes of apparatus. Listen for our 250 watt phone set, 11:30 A.M., 2:00 P.M., U. S. Government Markets and Weather sent out on above schedule. Concerts at 7:30 and 8:30 P.M. Dealers write us.

WESTERN RADIO CO.
6 WEST 14th ST.
KANSAS CITY, MO.

Unconditionally Guaranteed for 1 Year

U. S. Storage Batteries

Supreme for wireless Xmas tree lighting, toys, etc.

6 Volts 40 amp. (4 Volt \$7) \$10.00
6 Volts 60 amp. (4 Volt \$10) \$13.75
6 Volts 80 amp. (4 Volt \$12) \$17.50

When the least money buys the best, why not save the difference.

U. S. STORAGE BATTERY CO.
FAR ROCKAWAY, N. Y.

New York Distributors

Dreyfuss Sales Corporation.....179 Greenwich St.
Carlye Rubber Company.....4 Barclay St.
P. M. Dreyfuss.....152 Chambers St.
Broadway Electrical Nov. House.....324 Bowery
Hygrade Electrical Novelty Co....41 West 125th St.
Lyknu Auto Co.....608 Bergen Ave., Bronx
Benjamin Timares.....4416 18th Ave., Brooklyn
U. S. Storage Battery Co.....2849 Atlantic Ave
Far Rockaway

Radio Amateurs of COLORADO
UTAH, NEBRASKA and WYOMING

DO YOU KNOW

DENVER

HAS THE LARGEST WIRELESS SUPPLY
STORE in the MIDDLE WEST

A complete stock of all standard Radio Supplies.
We are Distributors of

REMLER, COLIN B. KENNEDY CO.,
DE FOREST RADIO and W. J. MURDOCK

Equipment and Parts
We Make Immediate Delivery

Start with the "Inter panel" systems and thus
avoid discarding apparatus.

Write for our Bulletins and Price List.
We will give prompt Mail Order Service by
Parcel Post or Express, as requested.

Our "REYNARD" Short-wave Coils are
best on the market—\$2 each.

REYNOLDS RADIO CO., Inc.
613 19th Street, DENVER, COL.

GUARANTEED NEW
STORAGE BATTERIES
FOR WIRELESS USE

100 Ampere Hour—Six Volt—Batteries
shipped direct from factory—order now.

\$14.80

Remit by check or money order

TRIPLEX BATTERY CO.
1111 TACOMA BLDG. CHICAGO, ILL.

he was going into the business of making loose couplers for the market.

"Oh, no," replied Fassett, "simply a nut who talks of holding communications with the spirits. When they get that way, I lay off of them."

Mr. Peterson indulged in a widening grin; he had a plan.

"Listen Fassett," he said, "get Jimmy Beringer, Bessie Lambert and the bunch together and we will run this coon ragged tonight. Don't fail. Be at my station at ten o'clock sharp tonight with them. I'll do the rest."

Mr. Peterson, by some means known only to those of his profession, obtained the telephone number of the garage wherein Mr. McFlatfoot sojourned.

"Hello," he said, "is this the young man who is interested in radio advancement?"

"Dat's me, Bruthuh," replied Aloysius, wondering who on earth it could be calling him on something he had guarded so carefully.

"Well, I am interested in the same line. I have done much research work and delved into spiritualism also. I wish to inform you that if you will listen in on your set promptly at 10.00 P.M., you will hear something of much interest to you and it may be a stimulus to your endeavors."

With this, the strange person rang off, leaving Aloysius in a quandary.

"Lan' sakes, dat pusson sho' was polite. Ah wondah if he was spoofin' wid me. Anyhow I'll be on han' wid dis loose couplah boy. So do."

It was just 9.00 o'clock and Aloysius had one hour before the time aforementioned—10.00 P.M. He had been thinking all evening as to whether he would make the test by himself or have company. At times he almost decided to let no one in, when again he did not know just how he would act if a real "spook" said hello to him. He wondered if they would talk just naturally or whether they would speak in jerky, meaningless sentences, or whether they would talk at all.

The wind was blowing outside, and it was a creaking noise in the room below that convinced him he needed company. He picked up the house phone and rang the kitchen:

"Mistah Smif, yo' presence am sho' necessary. May I hold confab wid yo' in mah room heah in less than two minutes from present?"

"Ah yo' gwine to fool aroun' and give me a shock?" wailed the cautious hash slinger.

"Lawd, no. Ise gonna need yo' 'sistance in a lil 'sperimental capacity. No shocks. Dey is barred outright. Hones'."

"Oakay, brothuh, Ise be out deah in shoht odah."

Bang, came a knock at the door as Aloysius was listening in and waiting for the cook. Aloysius jumped clean off the chair and landed on the table. His nerves were in a terrible state.

"Who come?" he called in a weak voice.

"Who come what?" shouted the cook.

"Didn' yo' tell me come, let me in outa dis heah downpoh."

Aloysius felt ashamed of himself and unlatched the door.

"What's all dis regaliah?" inquired Mr. Smith, sizing up the immense coupler of some 10 feet in length.

"Dat's de biggest invention what evah invented. I intend to tlk wid de spirits wid dat animal," remarked the manipulator, as he stretched out his chest and strutted around the room like learned persons really do.

"Spirits?"

"No, not spirits, but s-p-i-r-u-t-s," he spelled, "dem things what fly aroun' in de air, but what yo' don't see."

"Yo' can't see them?"



Varliometer Price \$6.00
Varlo-Coupler " \$6.00
Junior Crystal Receiving Set " \$9.50

Send for Bulletin No. 11-A describing these instruments and our unit panel sets. See them at your dealer. Discounts furnished to the trade.

SIMPLEX RADIO COMPANY
1013-15 Ridge Ave., Phila., Pa.

BUY NOW

Prompt Service — Best Prices

When in need of Wireless Apparatus and Supplies, consult us first.

Send 10 cents for illustrated catalog. Money back on first purchase of \$1.00 or more.

NEW JERSEY RADIO EQUIPMENT & INSTALLATION CO.

120 Bidwell Ave., Jersey City, N. J.
Tel. Bergen 531W

Swing 4 in., 11 in. between centers, 17 in. total length. Shipping weight 13 lbs. Bed of lathe is machined. Workmanship first-class. Equipped with wood turning chuck. Can be fitted with 3 in. face plate and drill chuck as special equipment. Order one today.



Price \$6.00 cash with order. Made also in larger sizes. SYPHER MFG. CO. Dept. A TOLEDO, OHIO

Bound Volume of RADIO NEWS

THE second year Bound Volume of RADIO NEWS Magazine is ready for shipment. Volume No. 2 contains twelve numbers, starting with July, 1920, and ending with June, 1921.

There are 936 pages, containing over two thousand articles and over three thousand illustrations, bound in red cloth, gold stamped.

With its wide variety of original articles, editorials, suggestions and drawings, this bound volume forms a valuable reference book on all questions of radio. Mail coupon below.

Send your orders at once, as we have only a very limited supply on hand.

COUPON

Experimenter Publishing Co., Inc.,
233 Fulton St., New York City

Gentlemen: Enclosed find \$2.50 for which please send me bound Vol. No. 2 of RADIO NEWS as described above. Send by Express collect. Send by Parcel Post and find enclosed \$..... extra for Postage (8 lbs.). (Indicate mode of transportation.)

Name

Address

Town..... State.....

COMPLIMENTS OF THE SEASON

We wish our many friends and customers a Merry Christmas and Happy New Year and beg to offer the following suggestions to make this year a RADIO CHRISTMAS.

AMPLIFIERS		BINDING POSTS		PLUGS AND JACKS	
Grebe Type RORD two step amplifier and detector unit	\$75.00	No. 11 nickle-plated with knurled round thumb nut08	Rhamstine plug and jack complete..	1.50
Grebe Type RORL one step amplifier and detector unit	51.00	No. 2P double binding post nickle-plated20	Rhamstine plug only75
Grebe Type RORK two step amplifier with filament control jack	55.00	No. 10E special finished in black...	.10	Rhamstine jack only85
AMPLIFYING TRANSFORMERS		CONDENSERS		REGENERATIVE RECEIVERS	
Radio Corporation Type UV-712 intervalve transformer-shielded type...	7.00	Murdock No. 3662-43 plate .001 MF. with dial and extension handle...	4.75	Grebe CR-3 special—175-680 meters..	65.00
Rhamstine amplifying transformer...	3.50	Murdock No. 3681-23 plate .0005 MF. with knob, pointer and extension handle	3.50	Grebe CR-5 tunes from 175-3000 meters with tube control	80.00
Acme fully-mounted type	7.00	Murdock No. 366-43 plate with oil-proof case	4.75	Grebe CR-3A 175-375 meters with tube control, a complete set at..	40.00
Acme semi-mounted type	5.00	Murdock No. 368-23 plate for table mounting	4.00	Grebe CR-8—tunes to 1,000 meters; tube control	80.00
Acme unmounted type	4.50	DeForest CV-500-25 plate .0005 MF. built ruggedly for C.W. work...	4.50	RHEOSTATS	
AERIAL WIRE		GRID LEAKS		Murdock No. 560B back or front mounting	
No. 12 Pure solid copper aerial wire, 50 ft. to the pound; include postage; per 100 ft.80	Radio Corporation UP-523 2 megohm on base	1.25	DeForest No. F-500 reversible	1.65
No. 14 Pure solid copper aerial wire, 80 ft. to the pound; include postage; per 100 ft.50	Radio Corporation UP-1719 transmitter grid leak—5000 ohms	1.10	Mesco porcelain rheostat	1.25
"B" BATTERIES		HOT WIRE METERS		SOCKETS	
Small 22½ volt size, shelf life guarantee 8 months	1.50	Radio Corporation U.M.-530—0-2.5 amps.	6.00	Rhamstine bakelite base	1.00
Large 22½ volt size, shelf life guarantee 8 months	2.25			Murdock No. 550	1.00
				Amrad75
				DeForest bakelite all-over	1.25

ELECTRICAL SPECIALTY COMPANY

48-50 South Front Street

COLUMBUS, OHIO



The high quality and reasonable price of DeForest Radio Apparatus is graphically featured in the equipment illustrated. Note carefully how these parts are designed to extend the amateur's present outfit in a logical standardized way.

**Audion Control Panel
Type MP-100**

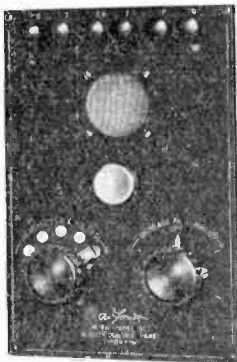

**Single Stage Amplifier
Type MP-200**



**Midget Radiophone Transmitter
Type OT-3**

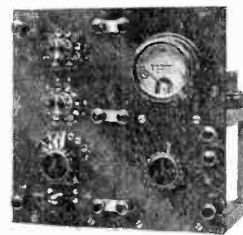

Interpanel Audion Control and Amplifier Units provide for expansion without discarding previously purchased apparatus. Each panel constitutes a complete piece of apparatus in itself and is designed to be combined with other panels, thus forming a set as complete as may be desired. It is the application of the Unit idea of sectional bookcases. Panels of moulded bakelite—positive smooth contact—bakelite covered binding posts, and bakelite moulded receptacles, mounted in the rear of panels. Transformer of the shell type. Workmanship and design throughout of the highest order.

Type MP-100 Audion Control Panel	\$13.50
Type MP-200 Single Stage Amplifier	16.50
Cabinet for Audion Control and Single Step Amplifier	9.00
Cabinet for Two Step Amplifier	8.00
Extra Cord and Plug	1.50

Any Amateur Can Talk 30 miles by this Midget Radiophone Transmitter—Type OT-3. Most remarkable telephone of its size ever made. Works on any source of direct or alternating current supplying up to 500 volts. Tuning done by tapped switches. Only one 6-volt storage battery required for filament and microphone. B battery, rectifier or motor generator supply may be used.

Oscillating Circuit Panel	\$55.00
Power Tube Panel and Meters	45.00
Cabinet for OT-3 Transmitter	5.00
So designed that it may be combined with other Interpanel Units to make a neat set.	

HEAD TELEPHONES

Guaranteed Standard makes of head telephones below cost—	
Federal No. 53W—2200 ohms	7.00
Federal No. 52W—3000 ohms	8.50
Red Head—3000 ohms	7.50

DeForest Radio Telephone & Telegraph Company, 1391 Sedgwick Ave., New York City
Pacific Coast Distributors—Atlantic & Pacific Radio Supplies Co., 638 Mission St., San Francisco, Calif.

FREE 60 DAY OFFER

Your Choice of either a Standard V. T. Socket or Duo-Lateral Coil Free With Every Order of \$10. Or Both Free with Every \$20. Order

This offer applies to any goods in our stock. A complete stock of all leading standard wireless equipment always on hand ready for immediate shipment.

SAVE MONEY BESIDES

Read these Specials at tempting price reductions

	Reg-ularly	Special at
Western Elec. Phones...	\$15.00	\$11.00
Lightning Switches, 100 amp., 600 volts	4.50	3.45
Murlock Antenna Switches	5.00	4.15
Roller Smith Radio Frequency Amp. Meters..	7.50	5.75
Interphone House Sets..	13.00	10.00
B Batteries Variable, large size	3.00	2.50
Large size Variometers	5.00	6.75
Smaller size Variometers.	6.00	4.40
Small Size Honeycomb Coil Mountings	7.50	6.00
Hard Rubber Binding Posts	.10	.07
De Forest One-Step Amplifiers. Type P100	69.00	35.00
Honeycomb Coils, any size, 30% Off.		
Unmounted Chokes, Special at .05		
And Hundreds of Other Bargains, Including Over 100 Different Size Motors, A. C. and D. C., at Corresponding Savings.		

Order Today While Our Offer Holds Good Or Send 10 Cents for Complete Catalog of Wireless and Electrical Goods of All Kinds

AMERICAN ELECTRO TECHNICAL APPLIANCE CO.

235-R Fulton St., New York

MAGNET WIRE

Price per 1/4 lb. Spool 1/4 lb. Spool

B.&S. Ga. Enameled	Double Cotton	Double Silk
No. 20 \$0.65	\$0.80	\$0.50
No. 22 .70	.90	.55
No. 24 .75	1.00	.65
No. 26 .80	1.10	.75
No. 28 .85	1.20	.85
No. 30 .90	1.30	.95

Cardboard Tubes

3x12	3 1/2x12	4x12	4 1/2x12	5x12	1/2 Wall
\$0.30	\$0.35	\$0.40	\$0.45	\$0.50	

Prices net parcel post prepaid anywhere in U. S. Send for our catalog FREE.

24 Hour Service Inductance Coils

25 Turns... \$0.50	500 Turns... \$1.20
35 " .55	600 " 1.40
50 " .60	750 " 1.60
75 " .65	1000 " 1.85
100 " .70	1250 " 2.40
150 " .75	1500 " 2.80
200 " .80	
250 " .85	We can supply any number of turns or taps desired.
300 " .90	
400 " 1.00	Mounted extra.

THE KING RADIO CO.

113 Sheridan Avenue
Pittsburgh, Pa.



MAGIC MONEY MAKER A MYSTIFYING NOVELTY

With a Solid Brass Stamp you apparently stamp from plain tin discs brand new dimes—carry it in your pocket and mystify your friends—Complete apparatus and full instructions 25 cents. Big Illustrated catalog of Magic Tricks, Illusions, Novelties, Jokes, Mindreading included free of charge. Send a quarter today. HEANEY MAGIC CO. Desk 8 Berlin, Wisconsin

"Absocertainly, dat's what ah said."
"Well, den why?"
"Why, what?"
"Why does yo' know dey is dere?"
Now here was a technical question. Aloysius scratched his head and took on a new pose, only not quite so reassuring.

"Dhat is one of dem questions, mistah Smif, what ansuhs foah demselves. I will inawgrate a practicall demonstrashum at 10.00 P.M. sharp. Stick 'roun' an' see de fire wucks."

"But ah deman' an ansuh to mah question," persisted the cook.

"An' ah say dat question will be ansuhed, Jess hol' yo' shirt by de sleeves."

He wasn't exactly sure whether it would or not, but at any rate it was too late to turn back now. The clock said 9.55.

Aloysius tickled around with the detector, first starting on 200 meters and working up to about 75,000 on his strange device. After taking in all the fourth dimension and then some, he dropped back down to 390. Both negroes now had on the phones.

"Mistah Smif did yo' heah somethin'?"

"I wasn't sho, but if I hadn' been drinkin' so much gin last night I would say somethin' moah definite. I thot as how I heard yo' name through dese phoams."

They both listened attentively. There was not a sound but the beating of the rain on the roof and the wind whistling around the corners of the garage.

"Hello, Mr. McFlatfoot. Hello Mr. McFlatfoot," rang out a voice cold and clear through the apparatus.

"Foah de lan' sakes," moaned Aloysius, "go 'way, go 'way, run 'long 'lil spirut I nevah done nothin' wrong in mah whole life."

The goose pimples were dancing merrily on his flesh. His circulation failed to do proper duty and hence his body became very cold. His mouth opened to dangerous proportion, while his perspiration found an outlet by way of his chin.

Mr. Smith made a leap high and wide toward the door, but Aloysius was too fast for him. He was not to be left alone in this predicament.

"Come back heah yo' dawgone cowahd. Come back heah and stay wid a whole he-man what has whiskus on his gizzard. Lissen wese gonna have ouah name in de papahs fo' all dis."

"Yo' bet," whined Mr. Smith, "in de fun'ral notices."

Mr. Smith could not leave. While talking, Aloysius had pocketed the key. He was going to see this thing through even though he was to lose weight in the attempt. After much persuasion he induced the cook to again don the headgear.

"Mr. McFlatfoot," the voice went on in a high musical tone, "I am the soul of an Indian princess and at your service. I admire your progressiveness, your intelligence and you are bound to succeed in your work. Mr. McFlatfoot, I salute you. Goodbye until you listen in again. The chorus will now chant for you."

"Great glory to de debil," roared out the cook in a thunderous tone that was heard in the house. "I won't nevah play no moah craps with loaded bones and I promise mah wife dat I will nevah steal her wash money. Don' take me 'way down Mistah Spirit, ah want to remain on dis heah earth long as pos'ble."

At the end of this talk, he rolled around on the floor moaning with such gusto that Aloysius was awakened from a faint into which he had fallen.

"Get up yo' crazy nigger, yo' will have de police on us."

"De police am de mos' welcome individual I evah knew," moaned Smith, "may dey cum and cum quick to save a life. Man ah sho' a sick right heah," and he rubbed his stomach with care and precision. His question was answered, there was something he

Better Service— a share in the profits— thru' co-operation:

Members of the Mutual Purchasers' Association enjoy prompt, accurate service, not equalled elsewhere, on standard makes of radio apparatus and supplies.

Doesn't it seem reasonable to have all your needs, filled at one time, on one order, direct from headquarters? Hundreds of members now think so, and are getting better service than they ever did before, by ordering everything they need in radio thru the Mutual Purchasers.

And in addition, members share in the big savings that result from co-operative wholesale buying. Try sending your next order to the Mutual Purchasers' Association. In the meantime, send stamped, self-addressed envelope for details of the plan.

MUTUAL PURCHASERS ASSOCIATION
2 Stone Street Dept. R47, New York

U. S. STORAGE BATTERIES FOR WIRELESS USE

Special Prices

Volts	Amps.	Price
6	20	\$7.25
6	40	9.75
6	60	13.50
6	80-100	22.00

One year unconditional guarantee, free repair or a new battery at our option, shipped fully charged, ready for use.

Add \$.50 for special crating.

Distributors—Jobbers—Dealers—write for discounts and exclusive territories. If your dealer hasn't it, send check or money order direct.

P. M. DREYFUSS

Fourth Floor

150 Chambers St.

New York City

Most complete Radio Catalog! Send for it now!

Agents for Grebe, Radio Corp. Remler, Federal, Acme, Signal, Murdock, Burgess, Jewel, etc.

Bakelite or Formica Panels cut any size. 1/8" thick 2c per sq.in; 3/16" @ 3c and 1/4" @ 4c.

DETROIT ELECTRIC CO.
434 Shelby Street, 8TV, Detroit, Mich.

GONNETTIGUT RADIO EQUIPMENT

Variable Condensers, Transmitters, Head Bands, Panel Switches, Etc.

Connecticut Tel. & Elec. Co., Meriden, Conn.

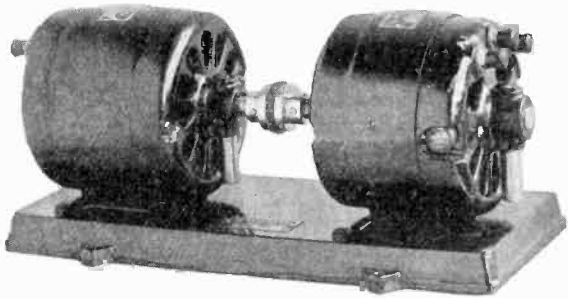

YOUR STATION

to be an **EFFICIENT STATION** should be **EQUIPPED WITH** the **PARAGON RADIO TELEPHONE** and the **PROVEN RAY-DI-CO MOTOR GENERATORS.**

THE RAY-DI-CO MOTOR GENERATOR

Capacity 40 watt is the **LOGICAL POWER PLANT** for this set. 350 volt for the plates, gives **MAXIMUM RESULTS** with the U. V. 202 tubes

THE PARAGON RADIO TELEPHONE

is **EXTREMELY FLEXIBLE.** Either **VOICE, STRAIGHT C.W. or BUZZER MODULATED C.W.** can be had by **TURNING A SWITCH.** **NO COMPLICATED TUNING, EASILY ADJUSTED TO ANY ANTENNA** in a moment. **PERFECT MODULATION IS SECURED.**

THINK OF IT

An Efficient C. W. SET For \$163.15 Complete

PARAGON radio telephone, type 2-5-U . . .	\$70.00
RAY-DI-CO motor generator, type ST4 . . .	71.15
2-U. V. 202 vacuum tubes	16.00
Hand microphone	6.00
	<u>\$163.15</u>



WHY PAY MORE AND RECEIVE LESS ?

ALL BETTER RADIO APPARATUS is to be secured from RAY-DI-CO PROMPT and PARTICULAR ATTENTION given to MAIL ORDERS

THE RAY-DI-CO ORGANIZATION

1547A N. WELLS ST., CHICAGO, ILLINOIS

H. H. BUCKWALTER, 713 LINCOLN ST., DENVER, COLO., Representative Colorado, Nebraska, Wyoming, Utah, Western Kansas, Northern New Mexico, Deadwood and Lead, S. Dakota

PARAGON

MEANS

"PERFECT MODEL OF EXCELLENCE"

AND IT IS FOUND ONLY ON
 RECEIVERS
 AMPLIFIERS
 DETECTORS
 V. T. CONTROLS
 CONDENSERS
 RHEOSTATS
 RADIOFONES
 SOCKETS
 KNOBS
 VARIOMETERS
 SWITCHES
 DIALS, ETC.

Manufactured by

ADAMS - MORGAN CO.

UPPER MONTCLAIR, NEW JERSEY

MOST DEALERS STOCK PARAGON PRODUCTS

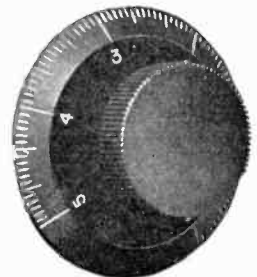
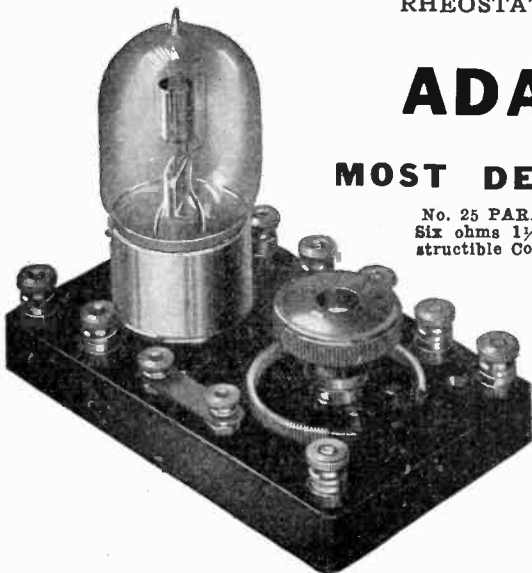
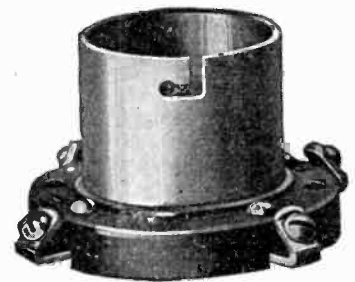

No. 25 PARAGON RHEOSTAT \$1.50.
 Six ohms 1 1/2 amps. max. Either panel or table mounting. Indestructible Condensite base. Highest grade on the market.

No. 30 PARAGON SOCKET \$1.00.
 A real socket at a right price. Highly polished nickel shell and Condensite base. Indestructible. Laminated springs give smooth firm contact.

No. 70 VT CONTROL \$6.00.
 Strictly high grade instrument. Does better work than many high priced cabinets. Finely finished indestructible Condensite panel embraces socket, rheostat, condenser, leak and nine terminals. Metal parts polished nickel.

WE'VE A DIAL FOR EVERY PURPOSE and they all match. Cut shows 270 degree dial for our rheo. and potentiometer. Superb finish. Indestructible. Fits 1/4 inch shaft. Price 90c. Molded of Condensite.

THE IMPROVED VICTOR PIN SOCKET



Insert tube prongs in slotted pins and you get a contact surface of $\frac{3}{8}$ " x $\frac{1}{4}$ " positive and permanent. Fused with new type fuse on each filament and plate lead. You can't

"PUT OUT THAT LIGHT"

1 $\frac{1}{4}$ " screws at corners for mounting and connecting. $\frac{1}{4}$ " machined Bakelite base. Lettered and filled with white as shown. N. P. screws and supports. The price is \$1.00 by mail post paid, and it's worth it. This socket fused for filament protection only. If you want to mount your own pins only 10 cents each. Extra fuses new copper mica type, 10 cents each. State tube. SPECIAL 3 SOCKET MOUNTING. Lettered for leads and det. 1-Amp., 2-Amp., on $\frac{1}{4}$ " machined base. Fused of course. A well made beautiful unit just the thing for det. and 2 step Amp. $\frac{7}{8}$ " by $\frac{3}{4}$ " overall, postpaid, \$4.50. Three contact plus. Mounted in bakelite. Offset type. You can't insert wrong. Use 3 slotted pins for jacks. Fine for 6-40 volt control. \$1.00 postpaid. Fuse block with any desired capacity fuse (double), 50 cents P.P.

VICTOR Sockets and Products for sale by the following distributors: Carter Electric Co., Distributors, Atlanta, Ga.; Hi-Grade Wireless Inst. Co., Asheville, N. C.; Reynolds Radio Co., Inc., 613 Nineteenth St., Denver, Colo.; Port Arthur Radio Lab., 2048 Fifth St., Port Arthur, Texas. Dealers Write for Prices

V. H. LAUGHTER
P. O. BOX 75
MEMPHIS TENN.

Wireless Amateurs ATTENTION!

If you want service, order from us. We carry a large stock of High Grade Wireless Apparatus of our own and other manufacturers.

SPECIAL!

Vacuum Tube Sockets.....\$1.25
Rheostats 1.25
22 $\frac{1}{2}$ Volt "B" Batteries..... 1.50
Rasco Dials60
Rubber Binding Posts..... .20
Tested Galena40
Lateral Wound Coils. All sizes.

Send 5c for our large illustrated catalog.

J. M. PAQUIN
THE ELECTRICAL SHOP
787 QUEEN ST. WEST
TORONTO, ONT.

BANGERT ELECTRICAL CO., INC.

Jamaica Hempstead Freeport

GREBE - CR9 - CR8

EVEREADY "B" BATTERY RADIOTRONS

MURDOCK SUPPLIES

Rheostats, Sockets, Dials, Phones, Variometers, Switch Points, Switches, Keys, Detectors, Transformers, Insulators, Binding Posts, Variables, Ground Clamps, Potentiometers.

RADIO CORP. of AMERICA SUPPLIES
MAGNET AND AERIAL WIRE

couldn't see, but could head. He would tell the pop-eye world as much.

Peterson and the "gang" might just as well have eliminated the music, as the two negroes did not stop to hear it.

A few days later Aloysius was interrupted in his work by a call from the house to the effect that Mrs. King wished to go for a ride. He immediately put on his uniform and in less than five minutes was in front of the house with the car. As Mrs. King came out, he was quick to notice that she was in trouble. He, being a servant, must keep his place and did not like to inquire as to the cause of her perturbation. He drove along the boulevard slowly as per her instructions and when opposite the lake she was sobbing bitterly. This was too much for the soft-hearted negro.

"Mrs. King am yo' awful sick??" he inquired timidly.

There was no reply and he stopped the machine.

"Drive on," she said, "there is nothing you can do. I received a telegram this morning that Mr. King was killed in an automobile accident."

Mr. King dead. The blow struck him like a knife. The last time he had personal contact with Mr. King, he seemed in first class shape. Now his opportunity had arrived. He would get in touch with the spirit of Mr. King through his wireless apparatus. He made up his mind then and there that if anyone could, he could. If he should fail, then he would go to this great celebrity that he had read so much about and consult him. They might put their heads together and do more.

He worked on his set all that evening trying to get in touch with the Indian princess. About midnight he heard voices, but they were indistinct and far away, but they were there nevertheless and sounded very much like spirits talking among themselves.

He could see the headlines in the papers when they would hear about his great invention. He could see his pictures on the front pages and in the great art galleries of the world. What could be a greater reward than to be placed beside great men, gone long since? And above all he could please his employer. He could let her talk with her husband each night as long as the battery held out. Then perhaps she would buy him a more elaborate outfit and also a rectifier to charge his waning currents. All of these things ran through his mind as he fell asleep and dreamed of talking to great men, men of the American history.

Two weeks later Aloysius made up his mind to broach the subject to Mrs. King. He asked permission to talk with her in private. Mrs. King, wondering what could be his object, granted the request and met him in the reception room. He took a seat to which she motioned and nervously launched into his subject.

"Mrs. King, ah s'pose yo' all know dat ah am spermentin' wid wyaluss telefoamy. Dat which am de fourth dimension consteetootin' accilations, fundamentals, micra-ferris and oder contraptions, known only, to me and very few othah men of prominent electrical inducements. Now dat word inducements may need some explanation. What ah mean to say is dis, to induce a magnet of fluctuisms to concentrate and magnetate spirits. In shoht, Mrs. King, I am heah to say ah can speak to yo' husband in de land of de great beyond."

Mrs. King was taken by surprise and could not speak for a full minute. She was undecided whether to call the police or public health department. She scrutinized Aloysius carefully, but he did not seem to take on any of the characteristics of the maniac. All to the contrary. He was perfectly calm and collected now.

"Don't quite understand you, Mr. Mc-Flatfoot. Do you mean to say you have arrived at a point whereby you can get in

Send for

ABC

Catalogue



Here is a catalogue you cannot afford to miss, because it describes in detail the unusual mechanical and electrical features and simplicity of the complete **ABC** line

Sixteen pages, clearly illustrated, in two colors. Every price quoted in this catalog represents a new low level for apparatus of recognized quality.

Send 10c for latest **ABC** catalog, "Professional Radio Equipment at Amateur Prices." Request Catalog CR12.

WIRELESS EQUIPMENT CO., Inc.
32 Austin Street, Newark, N.J.

A New Service—Panels Cut to Order

There is no need of using panels cut to make-shift sizes. We cut them exactly to the size you require and they cost you no more.

Bakelite	Formula	Fiber
sq. in.	sq. in.	sq. in.
1/16" . . . \$.01 1/2	1/16" . . . \$.01 . . .	1/16" . . . \$0 1/2
3/16"02 1/2	3/16"02 . . .	3/16"01 1/2
1/4"03 1/2	1/4"03 1/2	1/4"02
5/16"04 1/2	5/16"04 . . .	5/16"03
3/8"05	3/8"05 . . .	3/8"04

DRILLING

We drill holes to your specifications up to $\frac{1}{4}$ " in diameter at a price of 3c each.

ENGRAVING

We engrave letters or figures to your specifications at 5c each, 180 scale at 75c each, arrow at 30c each. Postage 15c on any size panel.

WIRELESS CATALOG

10c in stamps or coin brings new 100-page loose-leaf catalog, giving all instruments needed for wireless receiving and sending sets; places you on mailing list to receive regular bulletins, keeping you posted on latest developments in wireless telegraph and telephone. Write NOW.

The Kuebler Radio Co.
Successors to Retail Dept.
The Marshall-Gerken Co.
32 Gibbs Bldg
Toledo, Ohio

New Catalog E6 FREE

Just off the press



Keep up-to-date. Learn about all the big recent improvements in radio apparatus.

84 pages chuck full of best and biggest values of America's 51 leading manufacturers. Most complete, includes everything.

TWO N-S LEADERS
Red-Head Radio
phones, 8000
ohms, military
head band with
cord complete.
Arlington - Tested
Crystals, Galena
or Silicon, Certi-
fied sup'r-sensi-
tive.

\$8.00
per pair
25c
per crystal

Write for Big Free Catalog Today
THE NEWMAN-STERN CO.
Newman-Stern Bldg. Cleveland, Ohio

AN UNUSUAL RADIO CATALOG FREE.

CRAIG & LOUGHBOROUGH
NORWOOD (CINCINNATI) OHIO

touch with a dead person by actual voice?"
 "Dat's jess it. Dat's jess it," he said excitedly, and was glad that she grasped the situation so quickly. "Ah not only mean to say ah can do it, but ah has done it. Now if yo' all will permit I will do so right heah in dis room next Sat'd'y night as de clock strikes de bewitchin' houh ob midnight, but ah must have assistants in de form of de house servants to help me wid connections and other things that go with such an undertaking. Dere is to be in this room only yo-se'f and de servants."

She thought for some time without answering. These negroes had been very good to her since the death of her husband and why not humor them just once? At any rate it could do no harm. The reply was given in the affirmative and Aloysius went at once to his room to prepare for the great debut of his young life.

It was Saturday night and the parlor was all set with strange devices. Aloysius was working over the apparatus with the help of Mr. Smith, the cook.

"Heah, Mistah Smif, drag yo'sef ovah heah and help me collect dese connections togethuh. Take dat loose end to de secondary."

"Secondary"?

"Yes, secondary, meaning de secon' pah't ob de fust."

"Ah don' see no secon' pah't. Dey is many parts. Fum which does de fust stah't?"

"De fust stah'ts wheah ah says it stah'ts. Now ah will explain dis fundamentahl onlv once and den yo' get it, understand? Now we hook up."

"Hoah. Stop right dere. Hook up? Does ah perceive dat to mean ah is to be hooked foah a shock?"

"Yo' perceive dat to mean dat very shohtly ah will hit yo' so hahd dat it will take a shock to bring yo' back to life. Don' spoke befo' yo' is spoken. Don' be so nervous. Dey ain't no spooks in dis set. Ah am gwine to talk to de spooks, dat's all. Now find de primary and han' it to me foah de common side ob de "B" battery, which focuses on de "A" battery. Bein' a cook, yo' would better to stay as a cook wheah yo' roun' worl' am an onion; and den ah s'pose yo' would want it sliced, peeled an' de tears removed."

The servants looked on in bewilderment while this weird cadenza emanated from under the loose coupler where Aloysius was busy hooking up and belching forth a rapid fire of select English that was as "clear as mud" to them.

Mr. Smith was grabbing wires left and right at the bidding of the inventor. His respect for Aloysius was now imminent. Mrs. King, assiduously knitting near the fireplace, paid little attention to their chatter.

As the clock struck twelve, everything was in readiness. The lights were turned out and Aloysius started the bulbs. Mr. Smith's heart began doing strange things, fearing a repetition of the garage incident. "What the devil is this," a voice roared out from the direction of the doorway.

It was Mr. King's, without a doubt. The lights were turned on and there he stood in the doorway. A real live spook.

Niggers were leaving in all directions. Some by the doors and others by the windows. There was no special care taken as to direction.

Aloysius stood still for a full two minutes, let out a shrill cry and did an Annette Kellerman through the window.

Practically at the same moment, a messenger boy rang the bell and handed the confused Mr. King a telegram. It read: "Mrs. R. W. Kink, 242 Alameda Drive, Chicago.

"Deplorable mistake, Your husband not dead; only slightly injured. Mixup in records here. I. M. Bixley, Supt."

SAVE MONEY ON YOUR RADIO SUPPLIES

STANDARD GOODS AT LOW PRICES

THIS GUARANTEE PROTECTS YOU. Examine the goods we ship you. They must suit you in every respect. If you're not satisfied return the goods at once and we will refund the price you paid.

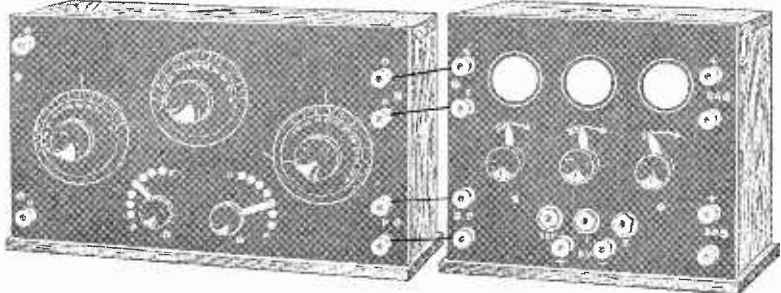

Regenerative Tuner, Price \$32.50

This is a standard make Armstrong licensed set which is sold regularly for \$45.00. Guaranteed first class. Range from 180 to 600 meters. Will tune sharply and bring in signals strong even under difficult conditions. Fine Mahogany finished large size cabinet. Satin finished formica panel. Two high grade variometers, with variocoupler for closest tuning. Engraved dials, knobs, switches, binding posts for all necessary connections, etc.



Variometer, Each \$3.95

Perfect in design and construction. Accurate wood forms. Correct induction ratios. Solid baked windings. Positive circuit contacts. Highest efficiency. Will operate perfectly indefinitely. Make your own regenerative set and save money.

Loose Coupler, Each \$3.95

With this loose coupler and two variometers together with the necessary other parts a highly efficient regenerative set can be made. Easily mounted on panel. Five taps of five turns each and five taps of two turns each. Windings on formica tubes. Inductively coupled for 180 to 600 meters.

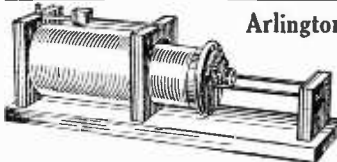

Arlington Receiving Transformer Each \$6.85

Tunes in all government time stations. Works up to 4,000 meters. Silk covered windings on formica tubes. High grade mahogany finished woodwork. Slider controls primary, 12 point switch secondary. Can be tuned very close.

Phones, Per Set \$4.10

A high grade double receiver set. Complete with adjustable head band and five foot connecting cord. Very sensitive. 2,000 ohm resistance.



1/4 H.P. Motor Price \$15.50

For use on 110 volt 60 cycle A. C. A high grade standard motor complete with pulley, ten foot cord and attaching plug. For rotary spark gaps, washing machines, lathes, etc.

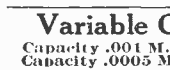

Variable Condenser

Capacity .001 M. F. Each \$4.05
 Capacity .0005 M. F. Each \$3.60

Standard 43 and 23 plate condensers. Aluminum plates accurately spaced. Permanent, high efficiency. Complete with knob and dial. Also supplied for panel mounting. State which is desired.

Detector-Two Step Amplifier, Price \$31.00

A very sensitive instrument. Signals that cannot be heard with detector will be brought in strong. Has one detector and two amplifying circuits. Standard tube sockets, grid condenser in detector circuit, two amplifying transformers, 3 jacks and a plug. Satin finished Formica Panel. Fine Mahogany finished large size cabinet. Hinged top. Interior easily accessible. Binding posts for all necessary connections.

SPECIAL OFFER

Regenerative Tuner and Detector and Two Step Amplifier. The two for \$60.00

Our regenerative tuner in connection with our Detector-Two Step Amplifier make a combination unequalled for long distance short wave receiving. Signals can be brought in clearly over long distance even against interference and static. With a good outdoor aerial the range is only limited by the power of the transmitting set. With an indoor loop antenna some wonderful results are obtained, making this outfit especially desirable where an outdoor aerial cannot be put up.

Vacuum Tubes

Standard Brands.
 Detector, Each.....\$4.45
 Amplifier "..... 5.95
 5-Watt Transmitter..... 7.25
 20-Watt Rectifier..... 6.95
 Porcelain Sockets for Vacuum Tubes.
 Each 60c. Three for \$1.65



Amplifying Transformers

Mounted, each \$3.95. Unmounted \$2.95
 A properly designed highly efficient transformer. Will increase incoming signals up to ten times the original audibility.

1-20 H. P. Universal Motor, Each \$7.50

Runs on either D. C. or A. C. 100-125 volts. Speed 5,000 R. P. M. under load. For spark gaps, sewing machines, fans, etc.



"A" Storage Battery, Each \$13.95

Six volts 60 ampere hours. A very high grade automobile type battery. Standard Ford size starting and lighting battery. Can be supplied with binding posts or Ford terminals. State which is wanted.

"B" Batteries

"Signal Corps" type sizes 2 1/2 x 2 x 3 3/4—15 cells 22 1/2 volts. Each 95c.
 "Navy" type size 6 1/2 x 4 x 3—15 cells 22 1/2 volts. Each \$1.60.
 Variable "Navy" type. 9 taps giving range from 10 1/2 to 22 1/2 volts in 1 1/2 volt steps. Each \$2.10.
 Double "Navy" type. Size 6 1/2 x 4 x 6—30 cells—45 volts. Suitable for amplifier circuits and power tube use. Two or more of these units in series may be used in C. W. and radio phone circuits. Each \$2.95.

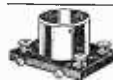

Vacuum Tube Sockets Each \$1.35

Moulded of Bakelite. Suitable for panel or table mounting. Four binding post connections.

THE BARAWIK CO., 26 N. Desplains Street, CHICAGO, ILL.

"THE BLANK RADIO CALL BOOK FOR AMATEURS"

A wonderful help to all. * * * An absolute necessity for the reception of C.W. signals. A blank page like this printed in red to make the call letters prominent, filled in as shown—

Station	Coupling	Primary	Grid Plate		Location	Notes
			Var.	Var.		
AA						
AA						
AA						
SAH	25°	11 Turns	32°	36°	140 m. n.	C. W. tunes sharply on from 11 pm. to 2 am.

will make it easy to work that distant station next time. Throw that obsolete note book away when you have copied its data into this new station help. Can be used with any type of receiver, over 4900 calls, pages 8x11, printed on bond, \$1.50, by return mail or order from your dealer.

F. M. ENDE, PUBLISHER

FORT RILEY, KANSAS

Insure your copy reaching you each month. Subscribe to Radio News —\$2.00 a year. Experimenter Pub. Co., 236 A Fulton Street, N. Y.

SOMETHING NEW IN RADIO MAKE YOUR OWN

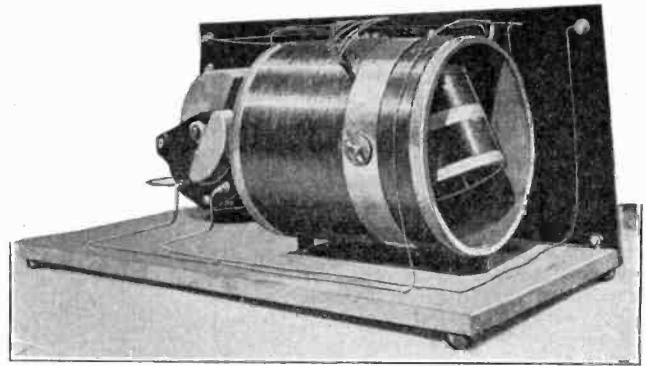
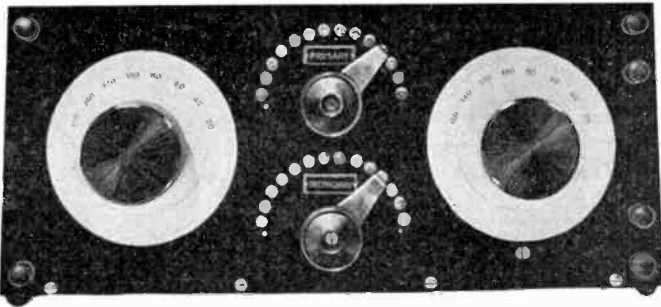

You can build this regenerative receiver easily without a machine shop. With the set of patterns especially designed it becomes a simple and easy work to make and assemble the parts comprising this set with which spark, C. W. signals and Radiotelephony may be received.

WE hereby offer the first of our series of "Make Your Own" apparatus set, the first one being a

Complete short wave regenerative set.

One of the foremost Radio engineers has constructed this set for us, specially for the amateur, and by our modern, novel methods of construction, anyone is able to make an efficient apparatus for the reception of wave-lengths up to 800 meters.

The circuit used is of the single inductance type and is the same as that used in new and well-known expensive sets recently placed on the market. With this circuit, a good selectivity is obtained, owing to the fact that the resistance of the winding in this set is rather low and so does not practically affect the resistance of the aerial, which consequently operates as a wave collector with maximum efficiency.

Another benefit resulting from the use of this circuit is the simplicity in tuning, a factor not to be neglected by the amateur not having had a long experience with regenerative circuits, in the reception of damped, undamped and radio telephone signals.

In building a Radio apparatus the lack of mechanical knowledge often handicaps

the amateur in such a way that the instrument he builds has not the standard made appearance which is desirable in any Radio apparatus. In order to remedy this, and give the amateur a chance to turn out an efficient and handsome looking instrument, we have designed a special set of patterns enabling anyone to make a standard receiver with all the improvements that can be found in expensive ready-made apparatus.

With this set of patterns and by following the instructions given it is very easy with the use of only a few tools to turn out the short wave regenerative receiver shown in our two photographs.

The novel departure in this set of patterns is that we do not merely give you pictures of how the apparatus looks, and mere diagrams—**BUT EACH AND EVERY PATTERN SUPPLIED IS FULL SIZE.**

Take for instance the pattern for the panel. It is printed on heavy blue-print paper exactly the size of the panel to be

used. The position of the holes and other markings are exact, so that all you have to do is to paste the pattern on top of your bakelite panel by means of ordinary library paste, and when dry drill right through the pattern wherever the marks are located.

This does away with all fussing and calculating as we have done all the laying out in our own shop, and you need not worry that the final instrument does not come out right.

Similar methods are used for winding the tubes, where a complete pattern is furnished so you cannot go wrong. For instance, the pattern is wound upon the tube; then you can wind the wire right on top of this, if you wish. *We have done the thinking for you.*

BEFORE SELLING YOU THIS PATTERN WE HAVE GONE TO THE TROUBLE OF ACTUALLY BUILDING THE OUTFIT AND WE KNOW THAT IT IS ABSOLUTELY RIGHT IN ALL PARTICULARS.

The original may be inspected at any time. Only standard parts are used in making the outfit. It is possible to build the entire set as illustrated for about \$12 to \$15.

Complete and very explicit directions go with the pattern which is furnished in a heavy envelope 9 x 12".

Complete pattern for short wave regenerative set each prepaid

50c.

Either Direct from us or for sale by the following responsible Dealers:

Am. Electro Tech. App. Co., N. Y. City	Hall Electric Co., Wm. Dayton, O.	Noll & Co., E. P., Philadelphia, Pa.	Sears, Roebuck & Co., Chicago, Ill.
Alamo Sales Corp., Indianapolis, Ind.	Hico Wireless Sup. Co., Marion, Ill.	Northwest Radio Serv. Co., Seattle, Wash.	Service Radio School, Washington, D. C.
American Hdw. Stores, Bridgeport, Conn.	Hickson Electric Co., Rochester, N. Y.	N. S. W. Bookstall Co., Sydney, Australia	Shotton Radio Mfg. Co., Scranton, Pa.
Atlantic Radio Co., Boston, Mass.	Holt Electric Util. Co., Jacksonville, Fla.	Pacnet Electric Co., New York City	Smith Bros., Sarnia, Ont., Canada
Bamberger & Co. L., Newark, N. J.	Hughes Elec'l. Corp., Syracuse, N. Y.	Paramount Radio Sup. Co., Atlantic City	Smith Novotoy Elec. Inc., Charlotte, N. C.
Benwood Speciality Co., St. Louis, Mo.	Jenkins, Lester L., New Bedford, Mass.	Pearlman's Book Shop, Washington, D. C.	So. California Elec. Co., Los Angeles, Cal.
Broda Electric Co., Los Angeles, Cal.	Karlowa Radio Corp., Rock Island, Ill.	Penn Radio Apparatus Co., Reading, Pa.	Southern Elec'l. Sup. Co., San Diego, Cal.
Brown, J. Edw., Glenbrook, Conn.	Katzenbach & Co., F. S., Trenton, N. J.	Penn. Marconi Wireless Schl., Phila.	Southwest Radio Sup. Co., Dallas, Tex.
Bullock's, York, Neb.	Kendall Co., W. D., Worcester, Mass.	Phila. Schl. of Wireless Tele., Phila., Pa.	Sprout-Shaw Schl., Vancouver, B. C.
Bunnell & Co., J. H., New York City	Killoch Co., David, New York City	Piedmont Electric Co., Asheville, N. C.	Sterling Electric Co., Minneapolis, Minn.
Burham & Co., Deptford, S. E., England	Klaus Radio Co., Eureka, Ill.	Pioneer Electric Co., St. Paul, Minn.	Stubbs Electric Co., Portland, Ore.
California Elec. Co., San Francisco, Cal.	Kluge, Arno A., Los Angeles, Cal.	Pitts Co., F. D., Boston, Mass.	T. & H. Radio Co., Anthony, Kans.
Catton, Neill & Co., Honolulu, T. H.	Krause & Co., A. F., Detroit, Mich.	Pitts Radio Sup. Co., Pittsburgh, Pa.	United Elec. Co., Hartford, Conn.
Central Radio Co., Independence, Mo.	Kusel Co., D. & F., Watertown, Wis.	Pitts. Radio & App. Co., Pittsburgh, Pa.	United Elec. Co., Braddock, Pa.
Central Radio Co., Kansas City, Mo.	Lehigh Radio Co., Bethlehem, Pa.	Post Office News Co., Chicago, Ill.	Warner Bros., Oakland, Cal.
Chase, Geo. H., Newport, R. I.	Liberty Radio Sup. Co., Chicago, Ill.	Precision Equipment Co., Cincinnati, O.	West'n Radio Elec. Co., Los Angeles, Cal.
Chicago Radio Ap. Co., Chicago, Ill.	Linzee Elec'l. Sup. Co., St. Louis, Mo.	Radio Distributings Co., Newark, N. J.	Whitall Electric Co., Westley, R. I.
Con. Radio & Elec. Corp., N. Y. City	Luther, H. E., Centerville, Ia.	Radio Electric Co., Pittsburgh, Pa.	White Co., The, Columbus, Ga.
Cutting & Washington, New York City	McCarthy Bros. & Ford, Buffalo, N. Y.	Radio Equipment Co., Boston, Mass.	White & Boyer Co., Washington, D. C.
Delancy-Felch & Co., Pawtucket, R. I.	Manhattan Elec. Sup. Co., N. Y. & Chic.	Radio Equip't. & Mfg. Co., Minneapolis	Williamson Elec. Co., Seattle, Wash.
Detroit Electric Co., Detroit, Mich.	Marshall-Gerken Co., Toledo, O.	Radioelectric Shop, Cleveland, O.	Wilmington Elec. Spec. Co., Wilmington
Dewey Spig. Goods Co., Milwaukee, Wis.	Meter Elec'l. Const. Co., Oshkosh, Wis.	Ray-Di-Co., Chicago, Ill.	Winner Radio Co., Aurora, Colo.
Doubleday-Hill Elec. Co., Pittsburgh, Pa.	Meyberg Co., Leo J., San Francisco, Cal.	Reuter Electric Co., Cincinnati, O.	Wireless Mfg. Co., Canton, O.
Dunn, J. J., Pasadena, Cal.	Mohawk Elec'l. Sup. Co., Syracuse, N. Y.	R. I. Elec. Equip't. Co., Providence, R. I.	Wireless Press, New York City
Electric Motor & Eng. Co., Canton, O.	Nat'l Radio Institute, Washington, D. C.	Riverside Laboratory, Milwaukee, Wis.	Wolfe Electric Co., Omaha, Neb.
Electric Importing Co., N. Y. City	New Era Shop, Milwaukee, Wis.	Rose Radio Supply, New Orleans, La.	Y. M. C. A., Los Angeles, Cal.
Findley Electric Co., Minneapolis, Minn.	Newman-Stern Co., Cleveland, O.	Roy News Co., Frsk J., Toronto, Can.	Zamolski Co., Jas. M., Baltimore, Md.
Fuller Co., Seth W., Boston, Mass.	Nichols Radio Sup. Co., B'win Green, Ky.	Sayre-Level Radio Co., Phila., Pa.	Zibart Bros., Nashville, Tenn.
Gurd & Co., Wm., London, Canada	Nola Radio Co., New Orleans, La.	Schmidt & Co., R., Rochester, N. Y.	

Consolidated Radio Call Book Co., Inc., 98 Park Place, New York City

The American Radio Operator

By EDWARD T. BICAK*

Recent discussions in RADIO NEWS and in one of New York's leading newspapers, concerning the professional radio operator lead one to conclude that there actually must be something wrong with the American radio operator if he can arouse so many comments of an unfavorable nature. Let it not be assumed that the articles appearing against him were the products of minds bereft of reason. On the other hand, it should be recalled that the commercial radio-operator in the American Marine Service has notably distinguished himself on more than one occasion. Hence any attempt to place him on trial should be made with careful consideration of his good, as well as his bad qualities and then only with perfect attention to all details in the case.

There is no reason why the American radio operator cannot command the respect of his fellow officers aboard ship, of the radio fraternity throughout the world, and of the American public in general, if he so wishes. Two-thirds of the necessary requirements are directly under the operator's control. The question is, *does he or does he not* desire to make himself the outstanding figure that a man in his position should rightfully be? Does he not wish to fortify his position so as to discourage harmful comment? Does he not desire to make himself worthy of more remuneration? In general, has he not the ambition to acquire an irreproachable character and unquestionable fitness for his task?

It is, of course, true that not all commercial radio men, operating stations on ships of American registry, strictly observe Article VI of the International Service Regulations or No. 209 of the U. S. Regulations. These regulations prohibit the transmission of superfluous signals by any ship or coastal station. *Trials and practices are forbidden except under such circumstances as to preclude the possibility of interference with other stations.* This has, to a greater extent than probably any other wrong, been responsible for the recent unfavorable criticism of American operators. It also brings to mind a recent experience when the writer was invited aboard a large British vessel docked at New York, to inspect one of the new British C.W. sets. There were three radio operators assigned to the vessel and each seemed to bear a grudge against "Yankee" operators. When asked why it was that they spoke unfavorably of American operators, they all voiced the same reply, that is, American operators were entirely too eager to "play" with the key while the transfer switch was in the "send" position. Nothing the writer said could influence them to think otherwise and it was rather discouraging to leave with the thought that our American operators failed to command the respect of their foreign cousins.

That the U. S. Shipping Board has spent rather large sums of money for the repair and maintenance of the radio equipment aboard its ships is also well known. The exposé of the "Shipping Board" by one of New York's newspapers brought out some interesting facts. This again makes the fitness of the commercial radio operator to carry out his duties questionable. It gives rise to the questions, "Are the requirements for a commercial radio operator's license really sufficient?" and "Why have several organizations that hire the operators adopted the policy of examining each man before employing him, in spite of the fact that their licenses attest to the knowledge and skill of the operators?"

*Head of the Department of Radio Engineering, Extension Division, United Y. M. C. A. Schools.

More Good News Mr. Radioman!

Our special offer in November "Radio News" made such a hit that we decided to make further inducements. We will allow you either a 5% discount or your choice of a tapered grid or phone condenser on any order amounting to \$2.00 or over. Thousands will take advantage of this offer. Why not be one of them OM?

BIG HIT

5% DISCOUNT

5% DISCOUNT

Buy All of Your Radio Supply Needs From Us and Save Money

PUT YOUR CHRISTMAS MONEY TO GOOD ADVANTAGE. ORDER DIRECT FROM THIS AD. SAVE TIME AND MONEY.

PROMPT AND RELIABLE MAIL ORDER "SERVICE." REMEMBER WE PAY THE SHIPPING CHARGES TO ANY POINT IN U. S. A., WHICH IS A BIG ITEM IN ITSELF.

Make Your Selection of Radio Equipment from the Following Specials

AMPLIFYING TRANSFORMERS		MODULATION TRANSFORMERS	
Acme	\$5.00	Acme mounted	5.00
Radio Corporation U.V.-712	7.00	PHONES	
Rhamstine	3.50	Murdock, No. 55, 2000 ohms, double	4.50
Saco Clad, shielded	5.00	Murdock, No. 55, 3000 ohm, double	5.00
BATTERIES		Baldwin type, "C" Mica Diaphragm, double	13.75
Ace "B" No. 623 Plain, no taps, 22½ volts	1.25	RECEIVING TRANSFORMERS	
Ace "B" No. 623 Variable, 5 taps, 22½ volts	1.50	Murdock, 150-1000 meter, loose-coupler	9.00
Ace "B" No. 627 Variable, 16 taps, 45 volts	3.25	Murdock, 2 slide tuning coil	4.00
Gould, 6 volt, 60 ampere filament storage battery	15.75	RHEOSTATS	
BINDING POSTS		Murdock, new type for panel mounting	1.00
Nickel plated pillar, hard rubber top	.09	Fada, new type knob, reduced to	1.00
CHOKO CDILS FOR C.W.		General Radio, for 5 watt power tubes	2.50
Acme, single coil 1½ Hen. 150 MA.	4.00	Radio Corporation, for use with UV-200, UV-201 and UV-202 tubes	3.00
Acme, single coil 1½ Hen. 500 MA.	6.00	SOCKETS	
CRYSTAL DETECTORS		Murdock, moulded type	1.00
Murdock	.70	Radio Corporation, for UV-200, UV-201, UV-202 and UV-216 tubes	1.00
DeForest Signal Corps type (enclosed)	2.50	Ace, with grid leak mounted on base	1.50
CONDENSERS		Crosley, entirely porcelain	.60
Grid Condenser .0005 mfd.	.35	Victor, latest type, filament protected by fuses on leads	1.00
Grid Condenser with leak	.50	SWITCH POINTS	
Phone Condenser .001 mfd.	.35	Nickel Plated ¼x¼ in. with screw, each	.35
Chelsea Variable, with knob and dial for panel mounting, .0011 mfd.	4.75	Nickel Plated ½x¼ in. with nut, each	.35
Chelsea Variable, with knob and dial for panel mounting, .0006 mfd.	4.25	Nickel Plated 3-16x3-16 in. with screw, per doz.	.35
1 mfd. tested to 1,000 volts (for C.W.)	2.00	Switch Stops, nickel plated, ½ in. high, each	.06
AUDION DETECTORS AND AMPLIFIERS		SWITCHES (ROTARY PANEL)	
MIRACO, type MW-8 V.T. Detector Unit	7.85	Nickel Plated 1¼ in. lever, bakelite knob	.50
MIRACO, type MW-9 One-step Amplifier	12.95	TRANSFORMERS (Filament)	
DIALS		Acme, 75 watt, mounted	12.00
Chelsea, 3¼ in. bakelite and knob for ¼ in. or 3-16 in. shaft	1.00	Acme, 150 watt, mounted	16.00
INDUCTANCES CW		TRANSFORMERS (CW power)	
Radio Service, table or panel mounting, 3 clips	8.50	Acme, 50 watts, 350 volts, mounted	16.00
JACKS AND PLUGS		Acme, 200 watts, 350-550 volts, mounted	20.00
Rhamstine, jack only	.75	VARIOMETERS AND VARIOCOUPLERS	
Rhamstine, plug only	.75	Variometer type MW-6, 500 meters	5.00
LOUD SPEAKERS		Variocoupler type MW-7, 500 meters	4.00
Magnavox, latest type	43.00	VACUUM TUBES	
MICROPHONE TRANSMITTERS		Radotron UV-200 Detector	5.00
Panel type, nickel plated, with adj. bracket	2.50	Radotron UV-201 Amplifier and detector	6.50
Hand type, black corrugated handle	6.00	Radotron UV-202 5 watt transmitter	8.00

OUR MAIL ORDER SERVICE EXTENDS

ALL OVER THE COUNTRY

WHY NOT LET IT REACH YOU

Merry Christmas

We wish to extend to our many customers and friends our best wishes for a very Merry Christmas and a Happy and Prosperous New Year.

Order NOW

"EVERYTHING FOR THE RADIOMAN"

MIDWEST RADIO COMPANY
 3423 DURY AVE. Dept. A CINCINNATI, OHIO
FREE CATALOG

SPECIAL COMBINATION

"A" Storage Battery with Cunningham Tube C 300

Volts	Amps.	Battery only	With C300 Tube
6	40	\$9.90	\$14.50
6	60	12.65	17.15
6	80	13.95	18.45
6	100	17.50	22.00
6	120	19.95	24.45

All batteries fully guaranteed for one year.
 Tube only, prepaid, \$5.00. Batteries by express collect.

JACKSON BATTERY CO., 1124 JACKSON BLVD. CHICAGO, ILL.

STOP! LOOK! and ACT!

We supply free of charge with each 50 watt U.V. 203 power tube, price \$30.00, the standard General Electric V.T. socket, price \$2.50; and with each 5 watt U.V. 202 power tube, price \$8.00, your choice of 4 ampere C.E. rheostat, porcelain or Improved Murdock V.T. socket. Unsatisfactory Radotron tubes will be replaced at once. No risk. Shipped postpaid and insured. Immediate delivery.

THE KEHLER RADIO LABORATORIES, Dept. R, ABILENE, KANSAS

MAGAZINE Prices Slashed



THIS IS THE TIME OF THE YEAR WHEN MILLIONS OF MAGAZINE SUBSCRIPTIONS EXPIRE. NOW is the time to enter your subscription order for your favorite magazine at a big saving in money to you.

BY ORDERING NOW YOU WILL SAVE BIG MONEY

In announcing these wonderful prices it is with the absolute knowledge that our readers are offered the lowest prices for standard Magazines that it is possible to obtain anywhere. Only by special arrangement with the respective publishers are these prices made possible, and to take advantage of them, you must act quickly. Don't delay, do it now. This offer is so good that of necessity it must be limited in time. A subscription to his or her favorite magazine is a most appropriate present for your friends. It will be a constant reminder for a whole year of a considerate friend. Just glance over our wonderful prices, and see how we enable one dollar to bring you two dollars' worth, and then make up your list. When sending in your order, don't forget to state where magazines are to be sent. Sit down now and make out your order. To-morrow means you may forget and you will miss this wonderful opportunity. All prices quoted are for subscribers in U. S. A. only, Canadian and Foreign subscriptions require additional postage.

The Publishers Will Mail the Magazine Direct From Their Own Office to You

Radio News\$2.00 Science & Invention.....2.50 Practical Electrics2.00 \$6.50	Our Price \$4.50	Radio News\$2.00 Boys' Life2.00 \$4.00	Our Price \$3.50	Radio News\$2.00 American Magazine.....2.50 Woman's Home Companion2.00 \$6.50	Our Price \$6.05	Radio News\$2.00 Wireless Age2.50 Illustrated World8.00 \$7.50	Our Price \$6.55
Radio News\$2.00 Q. S. T.2.00 Pacific Radio News.....2.00 \$6.00	Our Price \$5.00	Radio News\$2.00 Popular Science3.00 \$5.00	Our Price \$4.05	Radio News\$2.00 Practical Electrics2.00 Pathfinder1.00 \$5.00	Our Price \$3.60	Radio News\$2.00 Popular Science8.00 Science & Invention.....2.50 \$7.50	Our Price \$5.80
Radio News\$2.00 Science & Invention.....2.50 Wireless Age2.50 Q. S. T.2.00 \$9.00	Our Price \$7.40	Radio News\$2.00 Boys' Magazine1.50 Practical Electrics2.00 \$5.50	Our Price \$4.00	Radio News\$2.00 Physical Culture3.00 \$5.00	Our Price \$4.30	Radio News\$2.00 True Story3.00 \$5.00	Our Price \$4.30
Radio News\$2.00 Wireless Age2.50 Science & Invention2.50 \$7.00	Our Price \$5.55	Radio News\$2.00 Everybody's2.50 Delineator2.50 \$7.00	Our Price \$6.05	Radio News\$2.00 Brain Power3.00 \$5.00	Our Price \$4.30	Radio News\$2.00 Farm Mechanics1.00 \$3.00	Our Price \$2.30
Radio News\$2.00 Scientific American4.00 \$6.00	Our Price \$5.05						

Special Clubbing Prices of Radio News with :

Club No.	Mag.	Reg. Price	With R. N.	Club No.	Mag.	Reg. Price	With R. N.
120	Adventure	\$8.00	\$7.85	70	Mentor	4.00	5.05
50	All Outdoors	2.50	4.05	37	Modern Priscilla	2.00	3.40
50	American Mag.	2.50	4.05	43	Motion Picture Classic	2.50	3.70
60	Amer. Review of Reviews	4.00	4.55	43	Motion Picture Magazine	2.50	3.70
60	Asia	3.50	4.55	45	Open Road	3.00	3.80
35	Boy's Life	2.00	3.50	70	Outing	4.00	5.05
25	Boy's Mag.	1.50	2.80	17	Pathfinder	1.00	2.40
35	Christian Herald	2.00	3.30	50	Pictorial Review	2.50	4.05
40	Colliers	2.50	3.55	50	Popular Science	3.00	4.05
90	Country Life	5.00	6.05	35	Saucy Stories	2.00	3.50
70	Current Opinion	4.00	5.05	70	Scribners	4.00	5.05
45	Delineator	2.50	3.80	61	Shadowland	3.50	4.80
35	Designer	2.00	3.30	70	Smart Set	4.00	5.05
60	Educational Review	3.00	4.55	35	Success	2.50	3.80
35	The Etude	2.00	3.30	40	Sunset	2.50	3.55
45	Everybody's	2.50	3.80	60	System	3.00	4.55
60	Factory	3.00	4.55	45	Wireless Age	2.50	3.80
45	Field & Stream	2.50	3.80	40	Woman's Home Companion	2.00	3.55
50	Garden Magazine	3.00	4.05	70	World's Work	4.00	5.05
55	Illustrated World	3.00	4.30	80	Yachting	4.00	5.55
80	Literary Digest	4.00	5.55	50	Youth's Companion	2.50	4.85
20	McCall's	1.00	2.55				

For computing together Magazines listed separately, add Class Numbers before title and multiply by 5, giving our price to you in dollars and cents.

Write for Special Prices on ANY Publication not listed here
We will save you money

SEND ALL ORDERS TO "CIRCULATION DEPARTMENT"
EXPERIMENTER PUBLISHING CO., Inc
236a Fulton Street, New York City, N. Y.

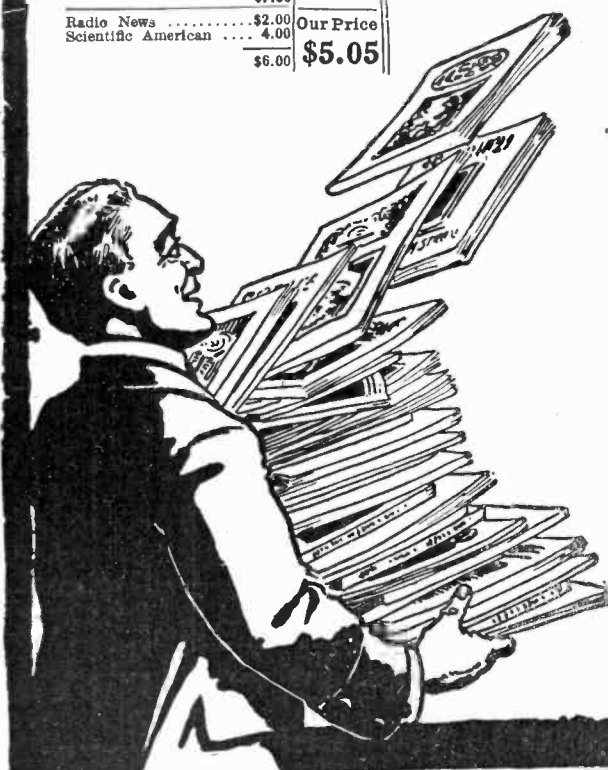

The cultivation of a fancy or eccentric style of sending is another factor in bringing harmful publicity upon the operator. Quite frequently an American operator is found who actually believes himself clever in having been able to develop a more or less original style of sending that causes the receiving operator to make more effort to copy him than is ordinarily required. He introduces a jerk in his "H's," "P's," "C's," "3's," "4's," "5's," "Y's" and "Q's," and makes one of the dashes of "J," "I" and such letters a trifle longer than the other dashes. When such an operator transmits to a foreign operator, it is only natural that he should become the subject of a grudge and that his dignity in the eyes of the other man should be lowered. Sometimes it is the schools that are to blame for permitting an operator to develop a tricky swing when sending, but in the majority of cases the operator makes an earnest effort to master the "funny" stroke after he has had some experience at sea.

Then there is the personal appearance of the commercial radio operator which has provoked comment. One making a tour of inspection finds, on boarding one American vessel, a radio operator neatly attired in a uniform giving every indication that its wearer is a gentleman and worthy of being respected. As he stands near the rail another well groomed young man approaches and it is readily discernible by the slight variation in a mark common on the uniforms of both men that one man is the chief radio operator while the other is the second operator. On boarding a second American ship it is surprising to be told that the man with the overalls on who leisurely stands outside the radio cabin is the radio operator. The other radio operator is then pointed out as the man in his shirt sleeves who is chatting with the cook. The American radio operators of a third vessel are observed to be wearing an entirely different type of uniform than those first observed and the second operator gives every indication by a stripe on his sleeve, and otherwise, that he is the chief operator; whereas the chief operator who has no stripe on his sleeve and who hasn't the bearing of his subordinate, makes one doubt who he actually is.

There are other factors which have had a tendency to encourage those who are ever anxious to slight the American radio operator. The reader should understand, however, that it is in no way the purpose of this article to add to the unfavorable criticism previously advanced. Rather, it is intended to set forth the deficiencies of the commercial radio operators on American vessels only as an introduction to a discussion of how the commercial radio operators can become more prominent figures in shipping circles; what course they must pursue to gain the respect of others in the radio field and of the public in general; in brief, what must be done to elevate the status of the American operator.

No one will doubt the sincerity of the commercial operator to render service efficiently; to stand by his station in times of distress; and to even perform deeds which are not ordinarily expected of him. The writer recalls the wreck of the S. S. Yukon in the Bering Sea some years ago. To be exact, it was on June 11th, 1913. After help had been summoned and all passengers and practically the entire crew had taken to the lifeboats, the radio operators sent a final radiogram when the rescuing vessel was but a short distance away and then dismantled the entire station. Piece by piece the parts comprising a one K.W. "United Wireless" transmitter and type "D" tuner were lowered into a spare lifeboat. Everything was included, from the light protective devices to the heavy Robbins & Meyers motor-generator and the bulky transformer. Even the antenna was rescued and with the other material, was brought to Seattle. This

SEND US YOUR ORDER TODAY

We carry in stock the largest supply of Radio Meters in the U. S. and make immediate delivery. These are made to order for us by Jewell and bear our exclusive guarantee. Any meter purchased from us, if damaged in use, is subject to our "At Cost" repair service.

Our Somerville CW Condensers are now carried in stock by alert dealers. Their low cost, adaptability and dependable service receives favorable comment everywhere. Tested at 2,000 volts, guaranteed at 1,000 volts. Four capacities: .00025, .0005, .001, .002 Mfd. 75c postpaid from us or from your dealer.



**Type JK
HAND
MICROPHONE
\$6.00**

Used in some of the most prominent amateur stations. Has six-foot mercerized cord and moulded rubber handle. Metal parts are heavily nickelled and buffed. An extra large microphone button, with polished carbon faces and large granules is the secret of efficiency.

A Superfine Indicator With Every Desirable Feature. Insist Upon

SOMERVILLE DIAL INDICATORS

When ordering material for your next set, 4" silverplated and lacquered dial clockwise rotation and calibration space, electro-chemical engraving. Genuine BAKELITE knob of correct size. The knob is an example of master moulding; 2 1/4" at flange, 1 3/4" at knurl and may be bought separately for 85c without setscrew or 90c with setscrew.



PRICE \$2 postpaid or from your Dealer.



Wimco CW Inductance, 25 turns, assembled..... \$10.00

Complete set of parts for 25 turn inductance \$8.50

Made entirely of sheet Formica, ruggedly and accurately assembled, and will safely carry output currents up to, and including 100 watts. Five positive contact clips are provided.

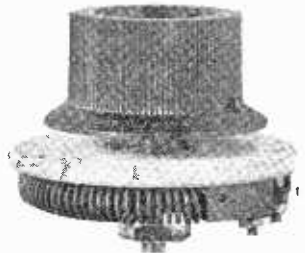

Somerville 6 Ampere Rheostat, \$2.75

This is composed of a Shramco resistance unit of 6 amperes and 1 1/2 ohms NICHROME resistance wire on an asbestos base. The bearings are extra heavy and very smooth running. An "off" position is provided. The handle is our famous Bakelite Somerville Knob Indicator with raised arrow. With the exception of the bronze blade, metal parts are of brass. Diameter 3 in. May be fastened to the panel by a single hole, by means of the threaded bushing. Unconditionally Guaranteed.



WE CARRY A FULL STOCK OF
GREBE RADIO
EQUIPMENT,
NOTABLY THE

- CR-5 at \$80
- CR-8 at 80
- CR-9 at 130

REMEMBER
WE PAY POSTAGE
IN THE
FIRST FIVE ZONES

SOMERVILLE RADIO LABORATORY, Sales Office, 178 Washington St., BOSTON, MASS.

Get acquainted with our snappy service and up-to-date stock!

Arnold Navy Model Loose Coupler Back to Pre-War Price, \$15.00

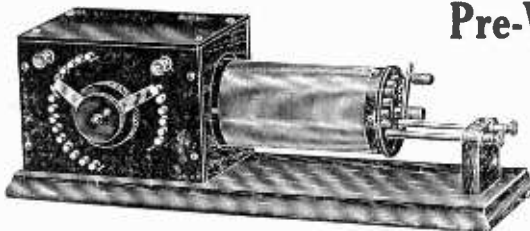

The most consistent piece of Radio apparatus to hear the Radio telephone "Without distortion."

Range from 200 to 3,000 meters. Send 3c stamp for literature describing Arnold made "Audion Detectors, Amplifiers, Short Wave and Arc Sets.

SPECIAL
Any make of Radio set repaired—re-wired—rebuilt. Your pet idea built to order "reasonable."

J. F. ARNOLD, 2082 Lexington Ave., NEW YORK
ESTABLISHED 1910 TEL. CONNECTION

Get a Handy Binder for your RADIO NEWS. Holds and preserves twelve issues, each of which can be inserted or removed at will. Price 66c. Experimenters Pub. Co., Inc., Book Dept., 236-A Fulton St., New York.

KEYSTONE WIRE

Wire for every Wireless Purpose

MAGNET WIRE

We are prepared to furnish best grade magnet wire on 1/4 and 1/2 lb. spools at the following revised prices:

PRICE PER 1/4 LB. SPOOL				
B&S Ga.	Single Cotton	Double Cotton	Single Silk	Enameled
No. 22	\$0.56	\$0.68	\$0.82	\$0.45
No. 24	.60	.77	.87	.47
No. 26	.65	.88	.71	.49
No. 28	.75	1.10	.85	.52
No. 30	.85	1.24	.97	.53
No. 32			1.15	.55
No. 34			1.52	.59
No. 36			1.77	.69

Price on 1/2 lb. spools double above list.

All prices are net and include cost of spool and delivery charges via Parcel Post to any Post Office address in the United States; safe delivery guaranteed.

Send for Circular 21-A giving prices on other sizes, insulations and quantities of Magnet Wire. This circular lists "WIRE FOR EVERY WIRELESS PURPOSE."

Dealers—write for our proposition.

KEYSTONE WIRE COMPANY

P.O. BOX 120 SCRANTON, PA.



BROWNS

4000 and 8000 Ohm Receivers

\$12.25

Postage and Insurance extra

These Receivers are surplus stock repurchased from the Admiralty by Messrs. Browns.

EVERY PAIR NEW AND FULLY GUARANTEED. ADJUSTABLE.

The supply is limited. All orders will be filled in rotation. This opportunity will not come again. So get busy, Canadian and American Amateurs.

Our stock is complete, for all our regular lines. Let us have your inquiries.

Price List 5 Cents

THE VIMY SUPPLY CO.
567 COLLEGE STREET TORONTO

65c

The Plug



A.K. Laing Radio Co.
Pelham Manor, N. Y.

RADIO CLUB PINS

Radio Clubs Everywhere have a special club pin. We make them to order, 25c to \$10.00 each. 1922 catalog of 48 pages showing designs of Radio School and Fraternal pins and rings FREE. Samples loaned to officers.

METAL ARTS CO., INC.
7755 South Ave. Rochester, N. Y.

is only one instance in which the operators did more than they were actually required to do. Many other examples of creditable work are on record, although strange to say, more is said to discredit the commercial operator as a rule than to praise him.

This is a period of reconstruction. Every commercial radio operator sailing under the United States flag can, if he so chooses, make a determined effort to stamp out the evils which are undermining radio operating as a fruitful occupation. To do this will require that every American radio operator learn to make intelligent use of the international abbreviations. It will mean that his procedure in dispatching traffic be carefully planned, giving as much attention to brevity as to clarity. If he will be business-like, he must be *brief, concise, to the point*. His service messages must be condensed into the least number of words necessary to convey his thoughts clearly. Oh, what a golden opportunity this one phase of his work affords for improvement. No nation in the world can really boast of 100 per cent. efficient operators, or in fact, can any nation lay claim to an organization of radio operators that cannot be improved considerably. Hence the American radio operator has everything in his favor to rise head and shoulders above the crowd; to be the subject of praise wherever foreign operators and radiomen in general meet. He should adopt for his slogan the proverb "Silence is Golden" and practice it within limits. That is, he should avoid using his transmitter unless it means revenue for his station, or unless he is required to help someone in danger.

Practically every operator has observed the engineer force at work aboard ship. The oilers have been seen to make periodic trips around the engine, dropping a little oil here and there where lubrication is constantly required and where no automatic oil feeding arrangement is attached. The operator has noted that the brass surfaces about the engine room are highly polished, and is aware that such surfaces do not become polished of their own accord. He probably has watched the engineer on duty and noted the serious manner in which the latter goes about his work and the attention the engineer gives to details. Has the operator ever compared the engine room to his radio station? Commercial radio apparatus and auxiliary equipment is expensive. They require that a regular program be followed to maintain the station equipment in its most efficient condition. Where lead-acid cells are employed as an auxiliary source of power it is particularly necessary that such a program be faithfully followed. If the radio operator has any opportunity at all to make a good impression upon the traveling public, it is surely by keeping his apparatus in such a clean and efficient condition that it will be a source of pleasure to anyone to be given the privilege to see his apparatus.

When an operator has occasion to transmit he would do well among other things, to keep the man at the receiving end in mind. If he desires to dispatch his business quickly it is most important that he consider the other operator, since any failure on the part of the latter to make a perfect copy of the first transmission only means delay. If the sending operator forms his telegraphic characters carefully and sends at a moderate speed he will have less need for repetition. Any style of sending which makes it unnecessarily difficult for the average operator to copy is detrimental to the sending operator's best interests and should be avoided.

When a radio operator from any British passenger or cargo vessel steps ashore in uniform he is immediately recognized by most people as a radio officer in the British merchant marine service. Why? That is a very easy question to answer. The radio

"LISTEN IN"

You Can't Beat This!

Hot off the press is the biggest, most complete and most interesting catalog of Radio Apparatus ever assembled. Not only that, but it is made up in loose leaf form so that we can send you new sections as fast as they are published. YOUR CATALOG will then be always up-to-date. It will be an authority on the latest and best equipment. Don't be a "Back Number"! Get this catalog and know the latest and best in Radio.



HERE IT IS!

And with this catalog you will receive ONE YEARS' subscription to the Live, Peppy, Popular bi-monthly magazine called "LISTEN IN" devoted to all the latest dope on What's What and Who's Who in the Radio World. These two books are worth many times the small sum we ask, but for a limited time we will send them to you by return mail upon receiving 25 cents in stamps or money with your name and address. Don't miss this chance! YOUR copy of this BIG CATALOG and your first copy of "LISTEN IN" is ready for you. Write today!

CENTRAL RADIO CO.
Kansas City, Missouri

AMPLIFY YOUR RADIO SIGNALS WITH



Practical Instruments for Commercial & Scientific Purposes
Super-Sensitive Detectagraph Transmitter No. 2, Price \$8.00 complete.
Adjusted Model No. 60 Horn, High Grace Loud Talking Receiver, Cord Plugs and Desk Stand Base, Price \$15.00 complete.
Our New Special Loud Talking Receiver No. 25, Price \$7.50.
Detectagraph Rheostat, especially made for amplifying circuits, Price \$2.00 complete.
Write for our free descriptive new catalog showing our complete Super-Sensitive Hearing and Talking Devices

G. BOISSONNAULT COMPANY (Inc.)
25 Dey St., New York City

Do You Know That—

1. BI-LATTICE COILS (duo-lateral) are the best type of inductances for long wave reception?
 2. SINGLE LAYER COILS, for short wave reception, can be approached only by the best regenerators?
 3. OUR UNIT INDUCTANCES will solve your receiving problem?
- Four Cents will bring you Bulletin "A" containing prices and engineering data on Bi-Lattice and Single Layer Coils.
- Price Postpaid
- Triple Coil Mounting for screwing to table or other support \$4.25
Set of Three Mounting Plugs (for panel) 3.00
Coil Plugs (Bakelite) with Fibre Strip75
Plugs, alone65
Fibre Strip, per foot10

P. J. STOCKWELL
Box 157-C READING, MASS.



NEWARK RADIO SCHOOL

284 Market Street
Newark, N. J.

Theoretical and Practical Instruction in Wireless Telegraphy and Telephony under Competent Instructors. Evening classes formed monthly. For particulars write or call.

operators of Great Britain have, by standardizing their uniforms, educated the public throughout the world to know them on sight and to respect them. Their uniforms are relatively simple and add dignity to their positions. The number of wavy gold stripes on the lower part of the uniform sleeve indicates whether the wearer is the chief operator or one of the assistant operators. The idea is hundreds of years old, but it has taken our American operators a long time to see the psychology of it. When an American operator comes ashore in uniform, or even when he is aboard ship, no stranger can recognize him as an operator without as a rule making an inquiry. It is seldom that as many as a half dozen American operators are found in port with identical uniforms. And as to knowing who is the chief operator and who the second operator, that is indeed a puzzle. Surely, the American operator does not wish to be mistaken for an elevator runner, a bell hop, or anything but an American radio operator. a radio officer in the American Marine Service? Hence it is quite imperative for his welfare to adopt a *standard* uniform which will carry with it the dignity he requires. Furthermore, the uniform should clearly indicate a distinction between the chief radio operator and the second operator.

The writing of this article and the suggestions included therein were inspired by the many criticisms recently published and voiced by those who have occasion to come in contact with the radio operator. Upward of two thousand operators have received their training at the hands of the writer and he has, therefore, felt that their interests were to a certain extent his own. It would obviously mark the opening of a new and better era in commercial radio communication if the operators, as a body, would decide on a definite program which would elevate their status, and by bringing it to the attention of the proper officials, make it known that the American radio operator stands ready to prove himself beyond doubt the most efficient in the world.

Increasing the Output of a Rectifier

Here is the result of an experiment which I performed recently and which raised the ampere flow from my "Type FF" magnetic receiver, from a maximum of four amperes to a maximum of ten amperes.

I took a large "horseshoe" magnet, which I had in my "junk box," and placed the poles of this magnet against those of the magnet on the rectifier.

Immediately I noted an increase of current of three amperes. Reversing the position of the poles of this magnet, in relation to those of the magnet on the rectifier I noted a still further increase. I then adjusted the brushes on the rectifier and found that when starting to charge a weak battery, it would draw from 9-10 amperes, and after charging a number of hours, the amperage would drop to a minimum of four amperes.

Before trying this experiment, the maximum output of the rectifier was five amperes and the minimum three amperes.

Contributed by CHAS. A. PURDY.

THAT'S WHY WE HAVE POOR INSULATION.

1st Bug—"Say, did you know that RADIO News was behind the times?"

2nd Bug—"How so?"

1st Bug—"It is not a supporter of prohibition."

2nd Bug—"How is that?"

1st Bug—"The only thing dry in it is the ink."

MARION ARVIN.

Xmas Bargain \$11.75 1/4 H.P. Electric Motor Fully Guaranteed, As Low as

AS we have only about 1,300 motors left, the following prices can be quoted only while this stock lasts:

- 100 lots, each. \$11.75
- 25 lots, each. 12.00
- 12 lots, each. 12.25
- 6 lots, each. 12.50
- 3 lots, each. 13.00
- Single motors. . 13.50

F. O. B. CHICAGO

This is a motor that is giving splendid satisfaction to the owners of hundreds of thousands of electric household washing machines, churns, cream separators, ventilating fans, lathes, drills, grinders and similar devices. It is remarkably sturdy in construction, simple in design and efficient in operation.

Motor is 1/4 hp (tested at factory for 50% overload) Single phase, 110 volt, 1740 rpm, 60 cycle split-phase induction type: Furnished in two styles as illustrated. In ordering, state which you wish.

ONE YEAR GUARANTEE

We guarantee every motor sold for one year (not six months, the usual custom). Each motor bears a guarantee tag, entitling the owner to

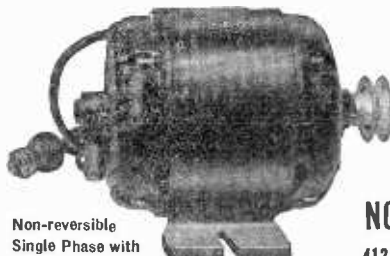

Non-reversible
Single Phase with
Cord and Plug Terminal

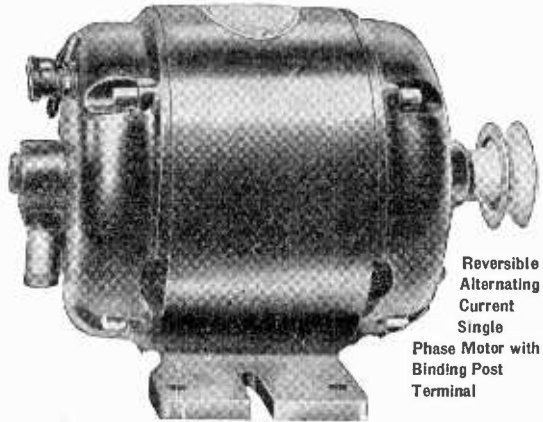

Reversible
Alternating
Current
Single
Phase Motor with
Binding Post
Terminal

a new motor, express prepaid, should anything go wrong with this motor within the first year of service.

A Motor in his "Stocking" At About 60% of Usual Cost

A million boys are this minute longing for an electric motor, to drive some pet contraption or to use in their amateur workshops.

Write out a list of all the boys whom you wish to make happy on Christmas, and decide which of them would rather have an electric motor than anything else you could give them.

Then send us an order for shipment of the motor described above; direct to the various addresses; enclosing a check covering the quantity price; as, for instance, \$75.00 for six motors.

Cash Must Accompany Order

or you can have them shipped by express to your own address C. O. D.

NORTHWESTERN ELECTRIC COMPANY
412 S. Hoynes Ave. CHICAGO



The Rhamstine* VT Battery

Panel Equipped—Variable

\$3.00

Add 30c for
Postage and
Packing. West of
Rocky Mountains
50c.

This latest addition to the Quality Rhamstine* Line must be seen to be appreciated. Complete with plated switch and special binding posts on bakelized panel. Variable from 1 1/2 to 23 1/2 volts. Designed for use beside the set. Large cells, made of the best materials obtainable, assure long life. Overall size 2 3/4 x 4 1/2 x 7 1/2. Quietness, convenience and attractive appearance characterize this high grade product.

Dealers wanted everywhere. Circulars upon request.

Manufactured by

J. THOS. RHAMSTINE*
2152 E. Larned St. Detroit, Mich.

HAVE YOU SOMETHING TO SELL OR EXCHANGE?
A classified ad in Radio News will reach over 50,000 at a cost of only six cents a word.

LEARN ELECTRICITY



The BOY'S ELECTRIC TOYS

As Shown
\$7.50
Complete

Teaches you all the principles of electricity by the "Learn by Doing" Method. Entertaining, Instructive, More Fascinating than any game. The most complete electrical experimenters' outfit that has ever been put on the market.

Valuable Electrical Instruction Book With Each Outfit

With each outfit we furnish free a very comprehensive book of electrical instruction. All the fundamentals of this fascinating science are clearly explained so even a layman can understand every word. Profusely illustrated. The instructions for building the apparatus are given in such a simple and easily grasped manner that anyone can make them without the least trouble. Over a hundred experiments that can be performed with the outfit are listed in the instruction book, nearly all of them illustrated with superb drawings.

A Sample of What You Can Do With This Outfit

This illustration, made from an actual photograph, shows only a very few of the many instruments that can be made with the Boy's Electric Toys: Electric Pendulum, Electric Galvanometer, Electric Telegraph, Current Generator, Electric Dancing Spiral, Galvanometer.

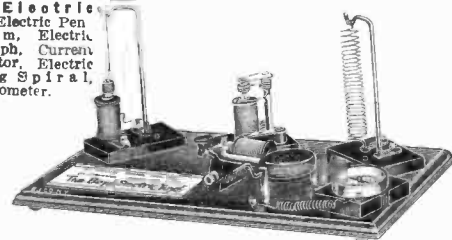

The outfit contains 114 separate pieces of material and 24 pieces of finished articles ready to use at once. Among the finished material are included: Chromic salts, lamp socket, mercury, core wire, iron filings, three spools of wire, carbons, machine screws, flexible cord, wood bases, glass plate, paraffine paper, binding posts, screw-driver, etc., etc.

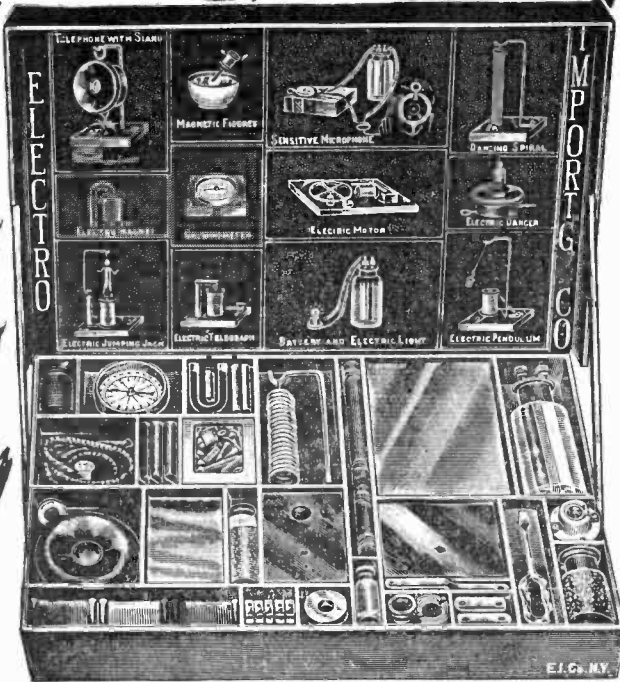

Teaches You How To Build Electrical Apparatus

THE BOY'S ELECTRIC TOYS' contains enough material to make and complete over twenty-five different electrical apparatus without any other tools, except a screwdriver furnished with the outfit. The box contains the following complete instruments and apparatus which are already assembled:

Student's chromic plunge battery, compass-galvanometer, solenoid, telephone receiver, electric lamp. Enough various parts, wire, etc., are furnished to make the following apparatus:

Electromagnet, electric cannon, magnetic pictures, dancing spiral, electric hammer, galvanometer, voltmeter, hook for telephone receiver, condenser, sensitive microphone, short distance wireless telephone, test storage battery, shocking coil, complete telegraph set, electric riveting machine, electric buzzer, dancing fishes, singing telephone, mysterious dancing man, electric jumping jack, magnetic geometric figures, rheostat, erratic pendulum, electric butterfly, thermo electric motor, visual telegraph, etc., etc.

ELECTRO IMPORTING CO.,
231 Fulton St., N. Y.

As per your advertisement, ship to me at once, C.O.D., the Boy's Electric Toys with privilege of inspection. It is understood that if I do not like the outfit I can refuse it.

Name

Address

City..... State.....

(RN 12-21)

Shipment guaranteed within 24 hours.

SEND NO MONEY

We have so much confidence in this set that we desire to ship it to you C. O. D. with the privilege of inspection. It does not cost you one cent to take a good look at the outfit, and see if it comes up to your expectations. If it does, pay the postman \$7.50, plus shipping charges. If it does not, you need not accept it, and we will pay the return charges as well.

THE ELECTRO IMPORTING CO.
231 Fulton St., N. Y. City

Correspondence From Readers

(Continued from page 540)

POLICING THE ETHER

Editor, RADIO NEWS:

In view of the many attempts on the part of the Navy Department and Commercial Companies to put the amateur out of business by passing restrictive laws, due in a large part to unnecessary interference and QRM on wave-lengths usually about 250 to 300 meters, would it not be a good thing for the Radio magazines to advocate and encourage the various Radio Associations throughout the country to use the big stick, by installing observation stations in each community, equipped with reliable wave meters and decimeters. Much of the trouble comes from the fellow who is ambitious to have a good sending set, spends all he can earn, begs, borrows or steals to get a good set, then has no means to purchase the instruments to properly tune his set. Result—Ignorance of true decrement and wave-length and almost always high wave-length, broad, but not always inefficient as one can readily attest by listening in on any clear night. A word to the wise is usually sufficient, and a card from the observer to the offender, giving wave-length and decrement would in most cases be appreciated, particularly if the offender is invited therein to reduce his wave-length and decrement and to ask for a second observation and report.

Reliable wave-meters and decimeters are expensive, and after once being used, are not often required, and yet the writer is of the opinion that the average station owner is anxious to know his wave and decrement, but has no means of obtaining this information.

There are always a number of real big-hearted fellows in each district or club, who devote valuable time to helping their weak brother, and no club or association would have any trouble getting observers, provided the instruments and necessary postal card forms were furnished.

The observer can use the big stick on the persistent offender, and this form of self-regulation would soon stop all cause of complaint from the Powers who are insisting on our extermination.

WM. W. SHOOP, 8HY.

Vandergrift, Pa.

(An excellent idea, preached for many years—with variations—by us. "Policing the ether" should be the first and greatest duty of any club. Most offenders are innocent, or rather ignorant that they break the law. They should be told.—Editor.)

FIVE WATT RECORD.

Editor, RADIO NEWS:

Reading of the two different phone sets in the Pacific N. W. region, it may be of interest to know that I receive the 5-watt set of the *Post-Intelligencer* here, 640 miles direct air line. You must know this is great work for such a small set. With ultra audion hook-up, I received it with wonderful modulation and audibility. I get much QRM, and receive it fairly well. On the other hand, I get 6XAK in Los Angeles O.K. better than the San Francisco phone sets. We are in a high altitude in Lake County (famous for Bartlett pears and string beans); it is a very mountainous section. Could you explain my predicament? I have about 500 ft. Z-shaped line aerial.

THOMAS F. MAHER, 6PF.

Kelseyville, Lake Co., Calif.

TUSKA



Tuska Moulded Variometer with Dial, \$7.25

The original and peerless

Moulded Variometer

Maximum Inductance Range—Minimum Distributed Capacity

High in Quality—Low in Price

Unmounted Price, \$12.00

A C. W. Transformer of real merit

Designed and Built in Tuska Fashion.

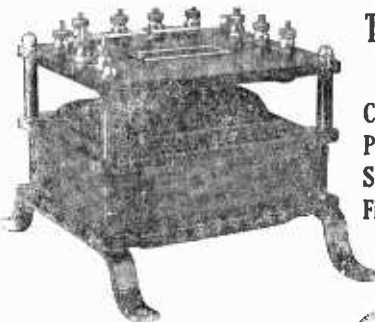

Tuska C. W. Transformer
Type 240
Mounted \$15.00

Capacity,	100 Watts
Primary,	110 or 220 Volts
Secondary,	2-800 Volt windings
Filament,	2-7.5 " "
Core,	Shell type

Tuska Variocoupler

Type 230 Price \$7.50

Secondary, 45 turns, No. 22 green silk on moulded ball.

Primary, 96 turns, No. 22 green silk or Formica Tube, 4 inches diameter. Electrically efficient and mechanically perfect.

Send 5 cents for our Catalog and Bulletin No. 2

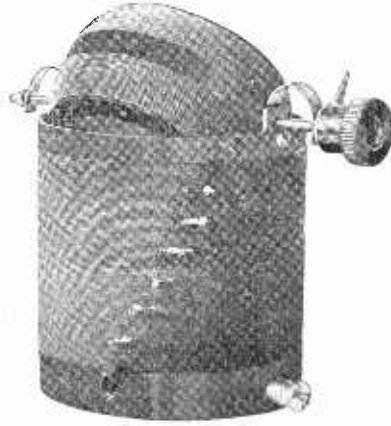

The C. D. Tuska Company

265 High Street Hartford, Connecticut

Send us your Orders for

RADIO EQUIPMENT

Highest Quality—Lowest Price—Prompt Service



Distributors for Grebe, DeForest, Chelsea, Radio Corporation of America, Murdock, Signal, Magnavox and other highest grade Radio Apparatus. All sizes of Radiotron Vacuum tubes always in stock.

Get the new Grebe Regenerative Receiver CR-9—the ideal equipment for C-W and radiophone reception. 150-3,000 meter wave-length—all the latest Grebe features including moulded variometers, rubber-tired verniers, etc. The final word in simplicity of operation.

Send for "Radio Corporation of America C-W Booklet" giving expert information and diagrams for amateurs. We carry complete line of C-W transmitting apparatus and accessories listed—booklet mailed, postpaid **25c** for

Mail orders promptly filled — Dealers—Write for Discount

DOUBLEDAY-HILL ELECTRIC CO.

715 Twelfth St., N. W., Washington, D. C. Radio Dept.—Desk B 719-21 Liberty Ave., Pittsburgh, Pa.

10c CHARGES YOUR STORAGE BATTERY AT HOME WITH AN F-F BOOSTER

and your station will never be closed because of a discharged battery. Is it not gratifying to feel that your flameless battery will always be ready when you want it and that you will never have to give up in disgust when working a distant station?



F-F Battery Boosters charge automatically, operating unattended. Screw plug in lamp socket, snap clips on battery terminals and see the gravity come up.

Both waves of current are rectified through adjustable and easily renewable carbon electrodes, which maintain a constant efficiency and last for thousands of hours. Also charges batteries right in Autos. No skill required. AMMETER shows you the amount of current flowing. EVERYTHING COMPLETE IN ONE COMPACT, SELF-CONTAINED, PORTABLE CHARGING UNIT. F-F Battery Boosters are Magnetic Rectifiers for 105-125 Volt, 60 Cycle, Alternating Current. PRE-WAR PRICES Bantam Type 6 Charges 6 Volt Battery at 6 Amp. \$15 Bantam Type 12 Charges 12 Volt Battery at 5 Amp. \$15 Type 166 Charges 6 Volt Battery at 12 Amperes. \$24 Type 162 Charges 12 Volt Battery at 7 Amperes. \$24 Type 1626 Charges Both 6 and 12 Volt Batteries. \$36 The Larger Types are for heavy batteries, or where time is limited. Shipping Weights 12 to 15 Pounds. Order from your Dealer or Send Check for Prompt Express Shipment. If via Parcel Post have remittance include Postage & Insurance Charges. Or have us ship Type desired C.O.D. Other F-F Battery Boosters Charge Batteries from Farm Lighting Plants & D. C. Circuits.

For GROUP CHARGING use the Full Wave, Automatic F-F ROTARY RECTIFIER of 100 Volt, 36 cell capacity. Order Now or Write Immediately for Free BOOSTER Bulletin No. 32 or ROTARY Bulletin No. 32A

Offices & Works: THE FRANCE MFG. CO. Cleveland, Ohio, U.S.A. Canadian Rep: Battery Service & Sales Co., Hamilton, Ontario

Keep the Man Going Who Keeps Industry Going

What oil is to the machine, health is to the worker. The efficiency of both is essential to good business.

An average of 2 1/2 years of productivity would be added to the life of every individual who reaches the age of 17, if there were no fatal cases of tuberculosis. The economic loss to America due to tuberculosis is more than \$500,000,000 annually.

It is your responsibility to combat this human and economic waste.

Do it with Christmas Seals.

Christmas Seal your Christmas Mail

The National, State and Local Tuberculosis Associations of the United States

NEW ORLEANS RADIO APPARATUS and SUPPLIES
ROSE RADIO SUPPLY
604 Gravier St., New Orleans, La.
Send 10c for Latest Catalog

The Western Canada Radio Supply
[Victoria, B. C.]
Extends the Season's Greetings to its Many Customers

(Continued from page 573)

(Exchange continued)

Exceptional Bargain.—Special Model Grebe C. R. 7. Long wave regenerative receiver, complete, without detector, will sell \$110 cash. Write L. Room 210-120 Liberty St., New York.

For Sale.—Radio apparatus in first class condition. Write for list. Louis Ratisseau, 3812 Ave. P, Galveston, Texas.

For Sale.—DeForest cabinet style RS-200 honeycomb receiver, unused detector bulb, Murdock 366 variable condenser, and 3000 ohm phones, all for \$50. Richard Prowell, Tuscaloosa, Ala.

Send 25 cent postal order for 2 money saving C.W. hook-ups. Harry Pase, 29C New Aberdeen N. S., Canada.

Sell.—5 dial omnigraph, 25 dials, \$9. Arthur Macer, Westfield, New York.

For Sale.—Complete honey comb coil receiver. Write for price and description. Clarence Ott, 2121 Sheffield Ave., Chicago, Ill.

Two-Stage Amplifier, \$18; R. L. C. 5 Universal spark receiver, \$20; and on control and spider web. \$8; H. A. Paxton, 415 Greenbrier Ave., Charleston, W. Va. (C. O. D.'s accepted.)

For Sale.—Wireless receiving apparatus, cheap to quick buyer. Write Wireless Information Bureau, 206 Greenwood Ave., Punxsutawney, Pa.

Sell—Exchange.—110 volt, 1/2 H.P. motor. R. L. Sharp, South San Antonio, Tex.

For Sale or Trade.—6v. 150 amp. Exide battery, loose coupler, tuning coil. Want audion detector, Henry Simonson, Alden, Minn.

Sacred Regenerative Set, Paragon R. A., ten detector and two-stage amplifier phones, C. Melody saxophone with case, cost \$175, will sell for \$100. Write or call 7 P. M. evenings. R. Strauss, 1381 Ave. A, New York City.

Sell.—Regenerative, guaranteed, \$14. Other equipment cheap. Radio R.2, Box 155, Cedar Rapids, Iowa.

Grebe Special CR 3, \$45. Raymond Schlegel, 1118 N. Negley Ave., Pittsburgh, Pa.

Sell.—Honeycomb coils, variable condensers, etc. All fine condition. cheap. Wesley Robinson, Jr., St. Mary's, Georgia.

Regenerative Cabinet Long Distance Receiver, \$19. Navy transformer, \$6; transformer 20 thousand meters, \$7; Remler tube control, \$6. Phones, condensers, switches. James Rich, Hbart, New York.

Prices Smashed on regenerative receivers, Arlington receiving sets, storage batteries, Tesco tuners and other apparatus. C. C. Perkins, Sanguerville, Maine.

For Sale.—Radio apparatus at a bargain. List on request. C. C. Perkins, Sanguerville, Maine.

For Sale.—Natrometer, \$12.50; 6-80 Exide starting battery, never used, \$13.75. Samuel Taylor, Reedsville, Pa.

Bargains.—1/2 K.W. Blitzen transformer with condenser \$12, and other apparatus cheap. H. R. Van Dyke, Greenwich, Conn.

For Sale.—Two DeForest inter-panel amplifiers, each \$13. Almost new. Want Tesco BS tuner. E. Versfelt, Upper Montclair, N. J.

Bargain.—New 5 bar telephone generator, \$2.50. Knapp dynamo-motor, \$3; E. I. Co. chemical laboratory, \$2.50. Vernie Vanatta, Manistique, Michigan.

Attention Amateurs! Loop aerials 3 foot high, knocked down, \$2.50. Sent postpaid. J. Vossalotti, 256 126th St., Rich Hill, N. Y.

For Sale.—Tesla high frequency apparatus, suitable for demonstration. 2 1/2 ft. gap, \$200 cash. Information, photographs, on request. C. H. Guile, 249 Willow Ave., W. Somerville, Mass.

Sell.—Baldwin phones, type B, \$13. 14 DeForest honeycomb coils, \$25; 1500, \$20; Federal transformer, \$4; DeForest 3 coil holder, \$5; 3 Moorhead tubes, hard, \$4 each. All good as new. W. Hanks, Tuckerton, N. J.

Factory Built Universal regenerative receiver, with phones, detector, amplifier, and new tubes (wavelength range 180 to 24,000 meters), and ten watt self-rectifying CW transmitter, with AC transformer. Sacrifice both for \$88. Unused \$65 short wave regenerative panel receiver (a beauty), \$28. P. H. Craig, 3397 Glenmore Ave., Cincinnati, Ohio.

Trade for Wireless.—\$10 Chemcraft Set, sell for \$7. \$40 bicycle, both in A-1 condition. Need transformer. Copass Bowen, Lubbock, Texas.

For Sale.—15 dial omnigraph complete with telephone buzzer and key, \$20. Also loose coupler variable from 200 meters to 3500 meters, \$12. Hyman Block, 237 Henry St., New York City.

Wanted.—1/2 K.W. coil, 1/2 quenched gap, aerial ammeter. C. L. White, Stockdale, Ohio.

\$11 Takes Complete Set of short and long wave honeycomb coils, mounted in cabinet with switches, contacts, and miniature plugs and jacks. Two Remler rheostats, \$1.50. Russell Widener, 72L Wheeler Ave., Scranton, Pa.

Make Your Own with these units—Switch levers, 25c; rheostats, 90c; audion sockets, 50c; potentiometers, 65c; grid condensers, 25c. Above items \$9.20 postpaid. Fiddle-Piz detectors, \$1. We pay postage on dollar orders. Descriptive bulletin "R" free. Walsh, Wireless Co., Jacksonville, Ill.

Sell or Trade.—Receiving set, \$13. Complete drum outfit, \$60. Mele, 39 Foxon, East Haven, Conn.

Exchange.—No. 3 Premo Camera, F6.9 planatograph lens. D. C. motor, 25 H. P., 12 in. fan motor, Kodak film tank, 25 cal. automatic pistol. Want receiving apparatus. Robert M. Oates, 1504 So. Center Blvd., Springfield, O.

Bargain.—15,000 meter loose coupler, good condition, \$10. Uriah Morris, 128 South Prince St., Princeton, Indiana.

Duck 5BB loose coupler, \$10. Turney spider web, \$3. Murdock fones, \$3 cash. James Mugos, East Pittsburgh, Pa.

Prices Reduced on all makes of Radio goods. Send us your requirements. Standard Radio Co., 41 S. Orange Ave., Newark, N. J.

We Buy Your Used Radio Apparatus. Send description. Standard Radio Co., 41 S. Orange Ave., Newark, N. J.

(Continued on next column)

WIRELESS CATALOGUE

Whether you are interested in a complete radio receiving outfit, or a half a dozen binding posts, you'll find the particular instrument, best for your needs, in Corwin's catalogue. Send 10 cents (credited to your first order), for your copy today! Where's the nearest mailbox?

A.H. CORWIN & CO.
4 West Park St. Dept. B
Newark New Jersey

THE NEW AJAX POCKET LEARNER'S SET



With Battery, Key, Hytone Buzzer and Code. All complete, Price.....\$2.00

HYTONE BUZZERS
Easily tuned. Adjusting screws on top of case. Price 60 cents. We pay postage.

AJAX ELECTRIC CO.
18 Palmer St., Cambridge 38, Mass.

DON'T BE A WAGE EARNER CHEMISTRY

offers greater opportunities than any other vocation. Dr. T. O'Connor Sloane will teach you chemistry right in your own home. See full page ad on page 513



Actual Size
For mounting on wireless apparatus. Solid brass. Double complete. 1 doz 15/-d. 2 38/-d postpaid Trade supplied. Dept. R. 614 Old Ford Rd. Bow., London, Eng.

(Continued from preceding column)

(Exchange continued)

Bargain.—Western Electric open circuit plug and jack—One Dollar. Standard Radio Co., 41 S. Orange Ave., Newark, N. J.

Fifteen Panel DeForest Set, Sixty Dollars. Photo and description in October Radio News. Fine set. Mahogany cabinet for back. El C. Smith, Weedman, Ill.

Look and Weep.—1 Universal receiver, tuner and detector, 1 year old. Brings in phone and signals. Cost \$125. Will sell for \$70, or trade for Radiophone. Kenneth Storch, Beecher, Ill.

Sell.—Packard one kilowatt, twentyfive dollars. Condenser, twenty dollars; gap, fifteen dollars. O. T., ten dollars. Bayard Shumate, Lebanon, Indiana.

Long Wave Panel, New.—Containing geared triple coil mounting, condenser, bakelite dials, primary switch, seven DL coils, \$27. Write Victor, 306 West 121st St., New York City.

Trade.—Fifteen watt CW and fone set complete, un-assembled, with new VT-2 tubes and 350 volt dynamotor. Want half kilowatt spark set. Pyle, 810 Warren, Brenton, Wash.

Best Offer takes any or all. Arlington coupler, 5 dial omnigraph, 23 plate variable, Century buzzer, rheostat, socket, Murdock 3,000 ohm phones, jack and plug. Chester Park, Mountain View, Mo.

Dial Indicators with Knobs, 3", \$.90; 2 1/2", \$.75. Other sizes. Beautiful V.T. sockets for front panel mounting, \$1. Other radio apparatus. Write Radion Laboratories, RR No. 1, Dayton, Ohio.

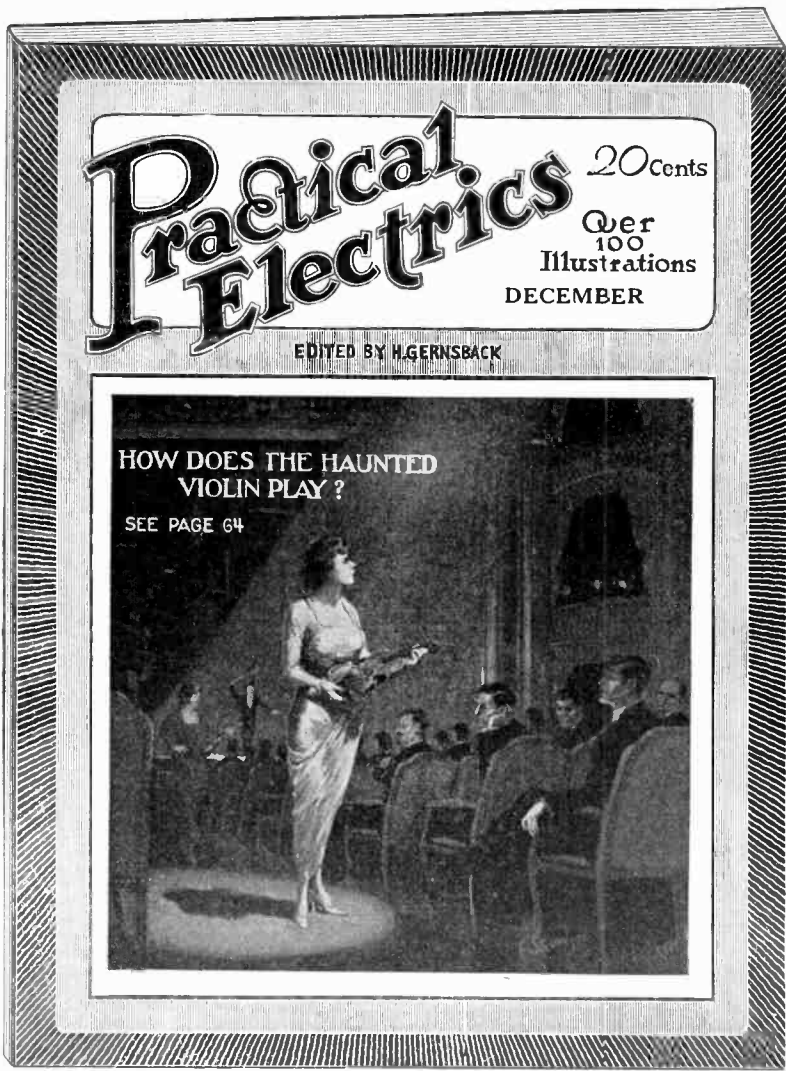

100 Articles
100 Illustrations

FOR SALE
AT ALL NEWS
STANDS

20c.
The Copy
\$2.00
A Year
Canada and Foreign
\$2.50 A Year

SEND
20c. FOR
SAMPLE
COPY
TODAY

SEE COUPON BELOW FOR
SPECIAL OFFER

"The Electrical Magazine for Everybody"

PRACTICAL ELECTRICS is probably the most novel magazine of its kind ever conceived. It is personally edited by H. Gernsback, editor of SCIENCE & INVENTION and RADIO NEWS. Mr. Gernsback, who founded the old MODERN ELECTRICS as well as the ELECTRICAL EXPERIMENTER, knows thoroughly what the public wants and has wanted for many years. In presenting this new magazine he but heeds the thousands of letters received by him to establish a new 100% electrical magazine that will beat the best that was in MODERN ELECTRICS and ELECTRICAL EXPERIMENTER.

Electricity covers such a tremendous field that the man who does not keep abreast with it does himself a great injustice. PRACTICAL ELECTRICS covers that field from every angle. It is written in plain every-day language that all can understand. It portrays the

entire electrical development of the month faithfully in non-technical language. It caters to everyone interested in electricity, be he a layman, an experimenter, an electrician or an engineer—each will find in this magazine a department for himself and plenty more.

The December issue now on the news-stands contains 48 pages and over 100 different articles and close to 100 illustrations, with an artistic cover in two colors. Professor T. O'Connor Sloane, Ph.D., is associate editor of the magazine.

This issue also contains articles by some of the greatest living electrical writers, workers and students and the magazine will prove a revelation to any one interested in electricity.

Inasmuch as the new magazine has a circulation of only 25,000 copies, we urge you to place your monthly standing order with your newsdealer at once. Or if you wish, fill out the coupon below for your subscription and take advantage of our special offer.

Every issue besides its many other features contains the following departments:

- "New Things Electric"
- "Experimental Electrics"
- "Electrical Digest"
- "Junior Electrician"
- "My Laboratory"
- "Elec-Tricks"
- "Motor Electrics"
- "Short Circuits"
- "How and Why" (Questions and Answers.)

Make all checks payable to: Practical Electrics Co."

PRIZES

This magazine offers a number of prizes, as follows:
\$100.00 Household Wrinkle Contest.
\$3.00 for the best picture of your electrical workshop.
\$3.00 for the best article on Elec-Tricks, the new department.
\$3.00 for the best "short-circuit," the semi-humorous department.
In addition to this, the magazine pays high prizes for all electrical experiments, electrical articles, etc.
See Current Issue for Full Details.

SPECIAL OFFER

Gentlemen:
Although your regular price is \$2.00 per year, you will accept my subscription at \$1.75 per year (Canada and foreign \$2.25) and enroll my name as a charter subscriber. I enclose the money herewith and I have written my name and address in margin below.

THIS OFFER VOID AFTER
R.N. 12 DECEMBER 31st

PRACTICAL ELECTRICS CO., 236 Fulton Street, New York

CONTINENTAL NEWS

DECEMBER, 1921

PUBLISHED EVERY MONTH IN RADIO NEWS BY THE CONTINENTAL RADIO AND ELECTRIC CORPORATION

PARAGON—reduced!

Was \$85.00, now only \$69.50

IN AN EFFORT to reduce the H.C. of Radio, we announce this important price reduction. It is based on present day replacement costs for raw materials; on increased production; and on our willingness to sacrifice profits to start things moving in the right direction.

The famous R.A. Ten—now \$15.50 lower than ever before. The identical instrument that hundreds of amateurs have endorsed so heartily!

All the famous Paragon features are still the same: the remarkable amplification that has astonished all hearers, the wide range to which Paragon Engineers have applied this am-

plification, the 24% greater sensitiveness and selectivity than ever the noted R.A. 6 and all the little niceties of design that have made Paragon the most admired receiver in the world.

Now is your opportunity to make your station the pride of your district. Buy a genuine Paragon at this revised price, and save enough for a VT Detector outfit.

Continental stands back of every Paragon to see that you get full value out of its years of service. Ask your radio dealer to show you the splendid construction of a Paragon receiver. If he has'nt one in stock, he will gladly get it if you ask him.

Mail Order Service—

The Continental Store in New York has long been famous as the fairest, pleasantest, and quickest place to buy radio goods in the city.

The Continental Mail Order Dept. is now becoming even more noted, throughout the United States, for these same reasons.

Let Continental Service serve you, order direct from this advertisement, and expect:

Accuracy: Speed: Courtesy

Or, send for Free bulletin, direct to

CONTINENTAL RADIO AND ELECTRIC CORP.

Dept. C71, 6 Warren Street
New York City

WESTERN AMATEURS:

Examine Paragons at these enterprising dealers:

Ray-Di-Co.
1547 North Wells Street, Chicago, Ill.,
and

The Benwood Company
13th and Olive Streets, St. Louis, Mo.

2ZL SAYS:

The Paragon has proved especially satisfactory in C.W. work, because of the entire absence of any capacity effect.



Licensed Under Armstrong and Marconi Patents

2ZM SAYS:

Heard a number of DX stations that were never heard before, even in the winter time, with my other receivers.

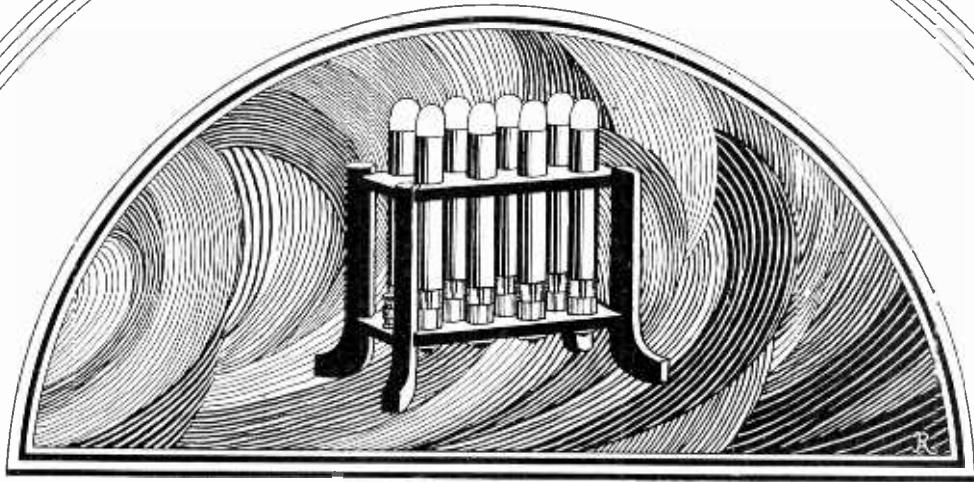

HAVE you seen one of these relics? It was used in 1908 for transmitting.

In the Radio world this seems like a long time ago, and yet ten years before Marconi sent his first message, the Manhattan Electrical Supply Co. was an established electrical supply house.

The foresight which placed it in this position caused us to manufacture and sell radio material; and this antiquated piece of apparatus unknown to the average amateur, was absolutely the latest design when it was placed on the market.

Then as now the newest material was added to our stock and the trade posted on new developments. With a line changing rapidly in design, this meant constantly exercising great care to prevent the accumulation of obsolete articles.

Today Manhattan is better equipped than ever. The Manual has just been revised. It is up to the minute. The stock of standard lines has been increased to the largest in the Country, and the service of our Mail-Order Department made better than ever.

Several "Broadcasting Stations" have recently been started, and probably more will be built during the coming year. This is creating a tremendous interest in radio. Many who had never thought of Wireless have become enthusiasts. We want them as well, to know our history, service and position in the radio world. When your friends ask you where to select dependable radio equipment, tell them—

"MANHATTAN" — "RADIO HEADQUARTERS"

If you cannot personally visit one of our five stores, our Mail-Order Department will give courteous and quick service.

MANHATTAN ELECTRICAL SUPPLY CO. INC.



A National Institution



New York City: 17 Park Place, 110 W. 42nd St., 127 W. 125th St.

Chicago: 114 South Wells St.

St. Louis: 1106 Pine St.

Get a Real Radio Education and Step Into A BIG PAYING Wireless Position

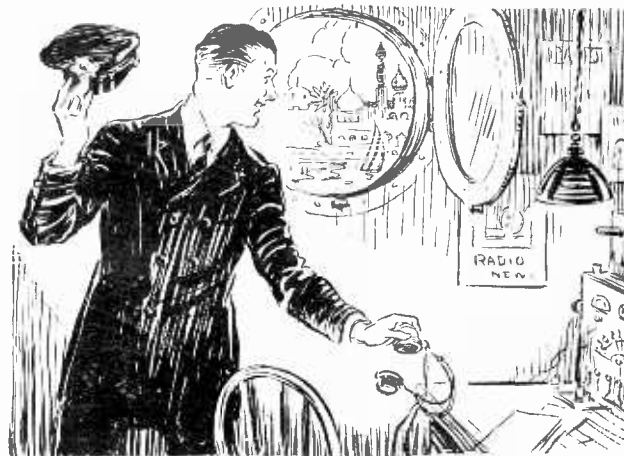

You amateurs who have started to study radio. Why not finish it? And you who know nothing of radio yet,— have you stopped to think what a wonderful career you can have in the field of radio communication? Look upon radio as something more serious than a mere hobby. It is the fastest growing field in the world. We are just entering upon the radio era. Twenty years ago, radio was a scientific plaything. What do you think is going to happen within the next ten years? Why not train yourself in a professional way and cash in on some of the opportunities that are presenting themselves in the radio field? Do not be a stay-behind. Do not let the other fellows beat you to the high-paying jobs when they are within your grasp at this very moment. Many thousand trained radio men will be needed next year. Prepare yourself

now and step into a real radio job next spring. You can operate on land or sea.

Put the Final Polish to Your Training Do Not Stop Half Way

Many wireless amateurs are so absorbed in the fascinating work of radio that they do not realize that big opportunities await them in the commercial field. They love the work and yet they do not seem to appreciate how badly the field of radio communication needs trained men. Some of them do, however. We can name twenty-five big radio men, whom you know, who have climbed to their present position by putting the final polish on their radio education. You can do the same thing. America's largest and oldest radio school is holding out its hand to you. It will help you to the last step. It will broaden you out into a professional radio man, with a keen insight into the commercial side of radio communication. It will also complete your technical education and put you in a position of a trained radio expert.

New Easy Four-step Method of Practical Teaching

This is the day of learning by doing. That is why we have backed up our wonderful fourteen copyrighted lessons with four wireless instruments that will be sent to you without charge. You learn by actual practice in your own home, or you can come to Washington if you wish and join our resident school. Have you heard of our wonderful Natrometer? It is an almost human machine that will teach you the code. You listen and learn, the Natrometer will do the rest. In Step No. 1 you learn to send correctly. In Step No. 2 you start to learn to receive correctly by slow transmission. In Step No. 3 the Natrometer will send to you automatically with perfect accuracy at any speed. In Step No. 4 you learn to receive from other operators with a real receiving outfit. Hand in hand with this practical training you will receive our regular lessons and your work with them will be guided by trained experts in our employ.

Learn By Doing in Your Own Home



Instrument No. 1
Permanently adjusted. The beautiful key and buzzer which is used in connection with our code lessons for practical training in transmission.



Instrument No. 2
The hand operator transmitter used in connection with the buzzer outfit. You can send to yourself with this device.



Instrument No. 3
The wonderful Natrometer which will send to you automatically at any speed. This frees both hands so that you can copy messages.



Instrument No. 4
The beautiful portable receiver with 'phones with which you can learn to copy other wireless operators.

Big Salary Just Ahead of You

Wireless operators receive upwards from \$110 per month and their expenses paid. Experts receive anywhere from \$2,400 per year to \$10,000 and there is no danger of them losing their jobs, because the radio field is not overcrowded. You can probably save more as a wireless operator than you now earn. Then think of the beautiful outfit you could have in your own home? You could have all the instruments you have ever wished for. You can have an outfit that will be the envy of all your amateur friends, and moreover you can

give it professional attention. Many other amateurs have cashed in on the opportunities in radio. Why don't you do the same? There is nothing to prevent you. A few hours each week and a few cents a day will complete your training within four months. Start now. Send for our beautiful booklet, "Wireless, The Opportunity of Today." It is yours for the asking with no obligation attached.

Your copy is waiting to be addressed.

The Oldest and Best Radio School Will Help You



We have trained eight thousand men since 1914. Our school is recognized by the United States Department of Commerce and it is located in Washington, the center of all radio development. Our diploma is recognized officially and you will receive extra counts in your license examination. You can have a post graduate course in our big resident school if you wish, absolutely free.

National Radio Institute
Dept. 112 Washington, D. C.



National Radio Institute,
Dept. 112, Washington, D. C.

Send me your free booklet, "Wireless, The Opportunity of Today." Tell me about the opportunities open in wireless, about your Institute, and about your Special Limited Offer.

Name Age.....
Address
City..... State.....

- I am interested in a sea position.
- I am interested in a land position.